

Electronics World

OCTOBER, 1967
60 CENTS

AUDIO INTEGRATED CIRCUITS—What's Available?
INFRARED RADIOMETRY TECHNIQUES
SUN AND SPACE SOLAR MEASUREMENTS

SWITCHES

**SPECIAL
ISSUE**

W0568 514700HIN2724LM05K
M J HINDMAN
2724 E LINWOOD
SPRINGFIELD MA 65804

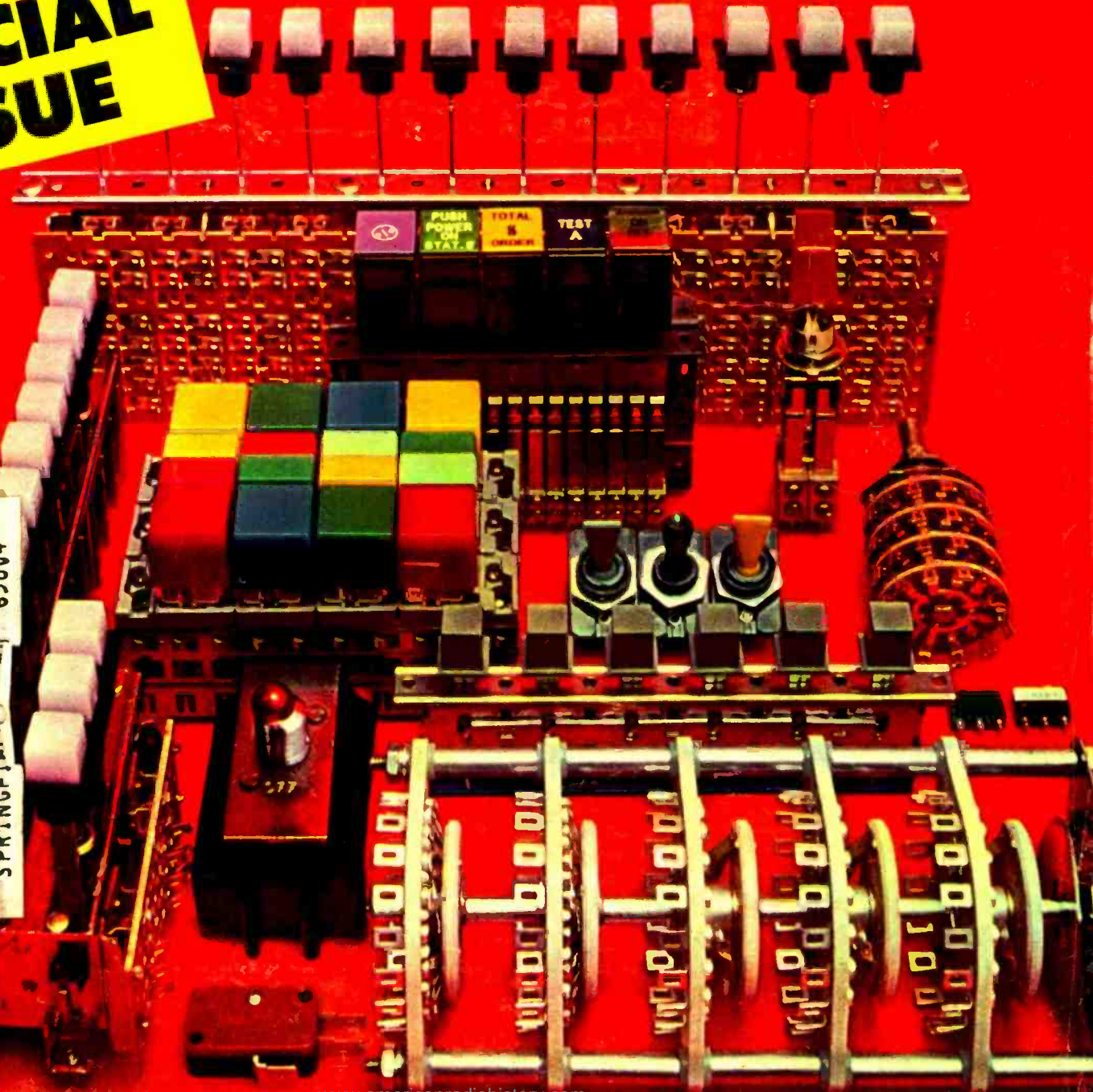

The New Look In Instruments



A New! Deluxe Solid-State Volt-Ohm Meter . . . High impedance . . . AC or Battery Powered . . . DC Volts from 500 millivolts . . . AC Volts from 500 millivolts . . . Resistance, 10 ohms center scale, 7 ranges.

B New! Deluxe Solid-State Volt-Ohm-Milliammeter . . . High Impedance — AC or Battery Powered . . . Current from 15 μ A Full Scale . . . DC Volts from 150 Millivolts . . . AC Volts from 150 Millivolts . . . Resistance, 10 ohms center scale, 7 ranges.

C New! Heathkit FM Stereo Generator . . . For RF, IF And Multiplex FM Alignment.

D New! Heathkit Variable High Voltage Regulated Power Supply . . . Fills Hundreds Of Requirements For The Engineer, Service Technician, Experimenter Or Physics Student.

E New! Solid-State Low Voltage Regulated Power Supply With New Zener Reference And Improved Immunity To Transients.

Comes From Heath

Now from Heath... the most exciting innovation in electronic instrumentation... new ultra-functional cabinet styling. These new Heathkit instruments feature a cabinet frame consisting of front and rear panels with side rails that completely support the component chassis independent of the top and bottom cabinet shells... allows complete freedom for assembly, checkout and calibration. You'll like the

clean bold panel & meter markings for easier reading... the easier-to-grasp knobs... the compact size... and the retractable carrying handles that are concealed in the side rails. The die-cast front panel bezel styled in chrome and black, the black side rails, and the special two-tone beige front panels and cabinet shells give these new instruments an appearance as up-to-date as their performance.

A NEW! IM-16 Solid-State Volt-Ohm Meter... Battery Plus Built-In AC Power

Features 8 DC and 8 AC voltage ranges from 0.5v to 1500 v. full scale; 7 ohmmeter ranges x1 (10 ohms center scale), x10, x100, x1k, x10k, x100k and x1 megohm; 11 megohm input resistance on DC ranges; 1 megohm on AC ranges; internal battery or 120 240 v., 50/60 Hz AC power for portable or "in-shop" operation; large, easy-to-read 6" 100 uA meter; separate switches for individual functions; single test probe with finger-tip flip switch for all measurements; simple circuit board construction. 10 lbs.

B IM-25 Solid-State High Impedance Volt-Ohm-Milliammeter

All silicon transistors plus FET's. Features 9 AC and 9 DC voltage full scale ranges down to 150 mv; 11 current ranges from 15 uA to 1.5A full scale; 7 resistance ranges (10 ohms center scale) measure one ohm to 1000 megohms; AC plus battery power for portability; 6" 200 uA meter with zero center scale for \pm & $-$ voltage measurements without switching; accuracy of $\pm 3\%$ full scale on DC volts, $\pm 5\%$ on AC volts; separate range switches for each function; 1% precision resistors; 10-turn thumbwheel zero adjustment; fast circuit board construction. 10 lbs.

C NEW! IG-37 FM Stereo Generator For RF, IF and FM Stereo Alignment

Produces virtually all signals for trouble-shooting & aligning multiplex adapters, FM tuners and receivers. Generates mono FM or composite stereo FM signals. Crystal-controlled 19 kHz (± 2 Hz) pilot signal, adjustable from 0 to 10% for checking tuner lock-in range. Switch-selection of 400 Hz, 1000 Hz, 5000 Hz, 19 kHz, and 65 kHz or 67 kHz SCA signals for complete alignment capability. 100MHz sweep signal (adjustable ± 2 MHz) for overall RF and IF alignment. Built-in crystal controlled marker oscillator for IF and dial tracking checks. Phase test capability. No balance adjustment needed for equal right and left channel modulation levels. 12 lbs.

D NEW! IP-17 Variable Regulated High Voltage Power Supply

Features 6v. and 12 v. AC filament voltages; also furnishes B+ from 0 to 400 volts DC, bias from 0 to -100 volts DC; separate panel meters monitor B+ output voltage & current; voltmeter switched to read C- volts; output terminals isolated for safety; high voltage and bias may be switched "off" with filaments still "on" for maximum testing efficiency and safety. 17 lbs.

E NEW! IP-27 Solid-State Regulated Low Voltage Power Supply

New Zener reference-voltage power supply. New up-dated circuit that is virtually immune to overload from exotic transients. Relay-protected against short circuit & overload. Provides 0.5 to 50 volts DC with better than ± 15 millivolts regulation. 4 current ranges: 50 mA, 150 mA, 500 mA & 1.5 A. Adjustable current limiter: 30 to 100% on all ranges. Panel meter shows output voltage or current. Choice of kit or assembled versions. 16 lbs.

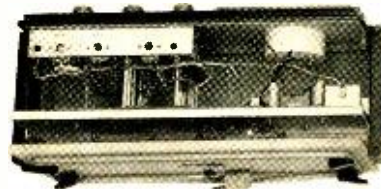

Kit IM-16
\$44⁹⁵
Wired IMW-16
\$64.95

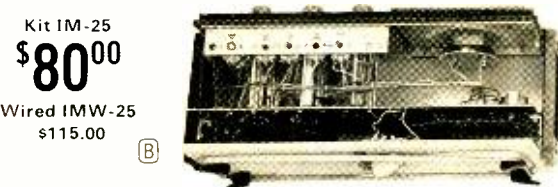

Kit IM-25
\$80⁰⁰
Wired IMW-25
\$115.00

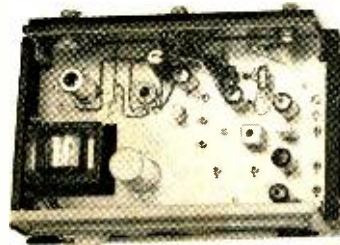

Kit IG-37
\$79⁹⁵

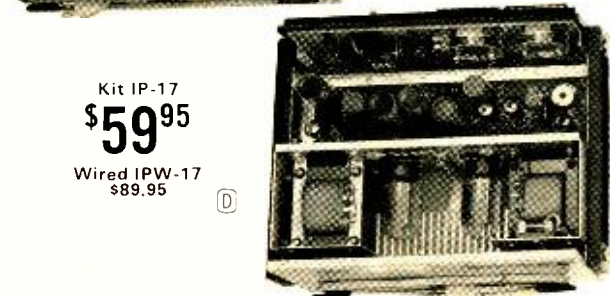

Kit IP-17
\$59⁹⁵
Wired IPW-17
\$89.95

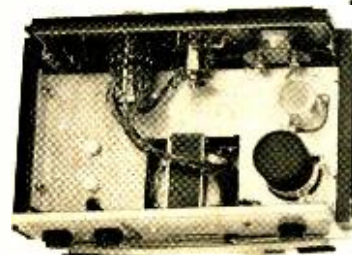

Kit IP-27
\$76⁹⁵
Wired IPW-27
\$119.95



NEW
FREE 1968
CATALOG!

Now with more kits, more color. Fully describes these along with over 300 kits for stereo/hi-fi, color TV, electronic organs, electric guitar & amplifier, amateur radio, marine, educational, CB, home & hobby. Mail coupon or write Heath Company, Benton Harbor, Michigan 49022.



HEATH COMPANY, Dept. 15-10
Benton Harbor, Michigan 49022
In Canada, Daystrom Ltd.

Enclosed is \$ _____, including shipping.

Please send model (s) _____

Please send FREE Heathkit Catalog.

Name _____

Address _____

City _____

State _____

Zip _____

Prices & specifications subject to change without notice.

TE-167

CIRCLE NO. 104 ON READER SERVICE CARD

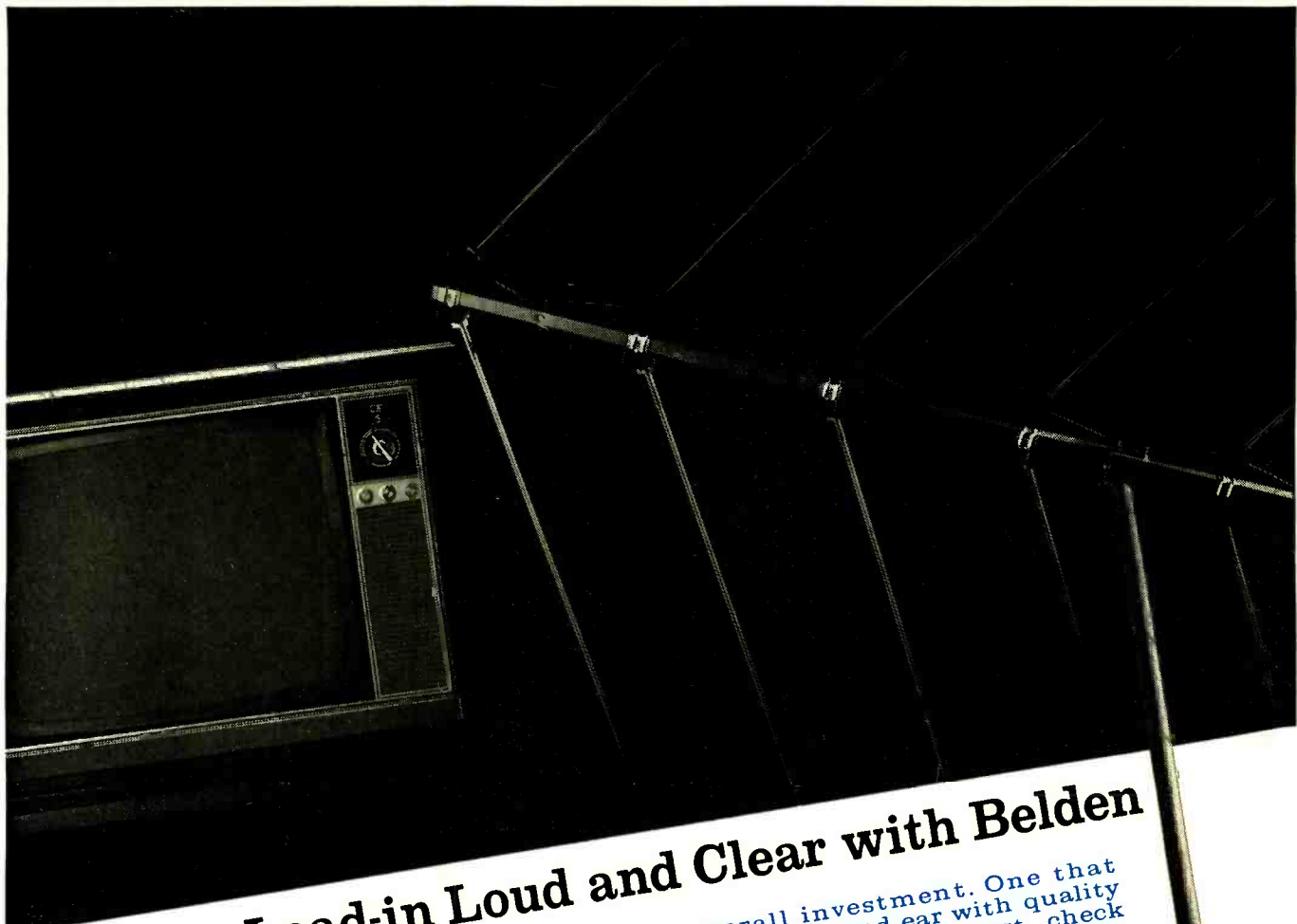

Step up...Lead-in Loud and Clear with Belden

TV lead-in. Belden makes all kinds. Indoor, outdoor, for color and black and white reception. All have one thing in common: for price and performance you won't find better lead-in anywhere. They provide a picture-perfect link between antenna and set. Since no two installations are alike, Belden gives the right choice for every situation. But don't skimp on your lead-in. Step up... choose one that gets the most out of the cus-

tomers overall investment. One that will delight the eye and ear with quality reception. For the absolute best, check out 8285 and 8290: the Color Twins. You won't find anything comparable for all-channel black and white as well as living color. Your Belden Distributor has all the facts. Talk to him today. Belden Corporation, P.O. Box 5070-A, Chicago, Illinois 60680.

*Belden Trademark, and Belden U.S. Pat. 2,814,666

don't forget to ask them what else needs fixing?



...the missing link in perfect picture reception

BELDEN 
BELDEN CORPORATION
 P.O. Box 5070-A • Chicago, Ill. 60680

CIRCLE NO. 123 ON READER SERVICE CARD

8-5-7A

ELECTRONICS WORLD



THIS MONTH'S COVER illustrates the theme of our Special Issue dealing with the important subject of "Switches." We have grouped a number of representative examples of the types of switches discussed fully in our Special Section. Several types of push-button switches are shown, along with toggle switches, snap-action, and open-frame rotary types. With the increasing importance of color for functional and aesthetic purposes, we are now finding a wide variety of switches with brightly colored push buttons and operating handles. Colored lighting is also used. Examples of such switches are included. Our thanks to the following manufacturers who supplied us with examples of their products: Centralab, Cutler-Hammer, Micro Switch, Oak, and Switchcraft. Photograph by Bruce Pendleton.



Publisher
PHILLIP T. HEFFERNAN

Editor
WM. A. STOCKLIN

Technical Editor
MILTON S. SNITZER

Associate Editor
P. B. HOEFER

Assistant Editor
MARSHA JACOBS

Contributing Editors
WALTER H. BUCHSBAUM
Prof. ARTHUR H. SEIDMAN

Art Editor
HERBERT L. SILBERMANN

Art and Drafting Dept.
J. A. GOLANEK

Advertising Sales Manager
LAWRENCE SPORN

Advertising Service Manager
ARDYS C. MORAN

October, 1967

Electronics World

OCTOBER 1967

VOL. 78, No. 4

CONTENTS

- 23 Infrared Radiometry** *John R. Collins*
Everything above Kelvin zero emits heat that can be converted into infrared photos by radiometers. These instruments are widely used in medicine, for mechanical inspection in industry, and by our Armed Forces for locating the hidden enemy.
- 28 Recent Developments in Electronics**
- 30 Using the New Constant-Current Diodes** *Donald E. Lancaster*
- 32 The Sun and Space Solar Measurements** *Joseph H. Wujek, Jr.*
- 34 Audio Integrated Circuits—What's Available?** *Donald E. Lancaster*
A large number of low-cost IC's are now obtainable for low-power audio circuits. Here's a rundown on what's available now with new ones coming out almost daily.

SPECIAL SECTION: SWITCHES

- 37 Miniature Switches** *A.F. Contarino*
- 39 Enclosed Rotary Switches** *Robert H. Tillack*
- 40 Lighted Switching Devices** *Walker Smith*
- 43 Precision Rotary Commutating Switches** *Peter Wazny*
- 44 Slide Switches and their Ganged Arrays** *Bernard J. Golbeck*
- 46 Pressure-Sensitive Switches**
- 47 Toggle Switches** *Ronald G. Rezel*
- 49 Popular Switch Contact Configurations & Circuit Terminology**
- 50 Stacked Switches and their Ganged Arrays** *James Bailey*
- 53 Snap-Action Switches and their Ganged Arrays** *Harry H. Meyer*
- 56 Check List for Ordering Switches**
- 57 Open-Frame Rotary Switches** *William Sefton*
- 60 Switch Kits for Designers**
- 79 Variable Low-Voltage Power Supply** *Murray S. Rifkin*
- 88 G-E Offers Bonus for H.V. Regulator Tubes**

-
- 14 EW Lab Tested**
Sherwood S-8800-FET Receiver
Ampex Model 2161 Tape Recorder
- 63 Pipe and Leak Locating** *John Frye*
- 74 Test Equipment Product Report**
Hewlett-Packard Models 6215A and 6217A D.C. Power Supplies
Seco Model 260 Transistor Analyzer
Sencore Model CR143 CRT Tester and Rejuvenator
-

MONTHLY FEATURES

- | | |
|-----------------------------------|-------------------------------------|
| 4 Coming Next Month | 68 Radio & TV News |
| 6 Letters from Our Readers | 90 Electronic Crosswords |
| 66 Book Reviews | 93 New Products & Literature |
-

Electronics World: Published monthly by Ziff-Davis Publishing Company at 307 North Michigan Ave., Chicago, Illinois 60601. One year subscription \$6.00. Second Class Postage paid at Chicago, Illinois and at additional mailing offices. Subscription service: Portland Place, Boulder, Colorado 80302. Copyright © 1967 by Ziff-Davis Publishing Company. All rights reserved.



Leadership presents

the **NEW**

Computer Logic Control Pro 800 Transport



MODEL SX 824

In the league of nimble-fingered tape-handlers there exists a recurrent problem. It has been demonstrated time and again that anyone can ruin a valuable tape by absentmindedly outsmarting the interlock system of an otherwise safe tape recorder.

In answer to this problem and similar problems arising in automated and remote control applications, the CROWN Pro 800 was designed. This recorder has a computer logic system using IC's which prohibit all such destructive operations.

The CROWN computer stores the last command given it in its memory (forgetting all previous commands) and by a continuous knowledge of the operating state of the machine (motion and direction), it takes all the necessary measures and executes the command. This is all done *without* time-wasting delay mechanisms.

Computer Logic Control brings to you rapid error-free tape handling. It is actually impossible to accidentally break a tape. Call your CROWN dealer NOW!

MOST PERFECT REPRODUCTION

- ☞ Performance as yet unequalled
- ☞ Four years proven Solid State circuitry
- ☞ Extremely low noise electronics

FINEST TAPE HANDLING

- ☞ Computer smooth operation
- ☞ True straight line threading
- ☞ Patented Electro-Magnetic brakes never need adjusting

Write to **Crown International**
Box 1000, Dept. EW-10
Elkhart, Indiana 46514

MADE ONLY IN AMERICA

CIRCLE NO. 119 ON READER SERVICE CARD

COMING NEXT MONTH

SPECIAL FEATURE ARTICLES ON: DIGITAL VOLTMETERS

This issue will feature two timely and important articles on the subject: The New Breed of Digital Voltmeters by Arthur H. Seidman in which the author explores the new applications for d.v.m.'s on the production line, in service shops, and in all types of OEM systems—thanks to their newly reduced cost; and Digital Voltmeters by John D. Lenk offering comparative performance and principles of operation on a wide range of electromechanical and all-electronic digital voltmeters.

THE INSTRUMENTATION TAPE RECORDER

Widely used to record data in the lab and industry, these special-purpose, multi-channel instruments are capable of using any of the recording systems for analog recording: direct-record, FM, or PDM. In this first of two articles, the author reveals how these recorders were developed, their special tape-transport mechanisms, and critical head construction.

DIGITAL U.H.F. FREQUENCY MEASUREMENTS

Three basic techniques are involved in making it possible to measure frequencies as high as 15,000 MHz. In one, using the transfer oscillator, an accu-

racy of 300 Hz in 1000 MHz is obtainable. William Barden explains how it is done.

ALIGNING FM-STEREO RECEIVERS WITHOUT A GENERATOR

The method described is fast, accurate, and easy to learn. It requires only a scope and the received signal. With a little practice, anyone can perform a good alignment.

LOW-COST CD IGNITION SYSTEM

Circuit details and performance of a simple, non-critical capacitive-discharge system that will cut ignition-system maintenance and give the old car new pep.

All these and many more interesting and informative articles will be yours in the November issue of *ELECTRONICS WORLD* . . . on sale October 19th.

ZIFF-DAVIS PUBLISHING COMPANY

William B. Ziff
Chairman of the Board (1946-1953)

William Ziff
President

W. Bradford Briggs
Executive Vice President

Hershel B. Sarbin
Senior Vice President

Philip Sine
Financial Vice President

Walter S. Mills, Jr.
Vice President, Circulation

Stanley R. Greenfield
Vice President, Marketing

Phillip T. Heffernan
Vice President, Electronics Division

Frank Pomerantz
Vice President, Creative Services

Arthur W. Butzow
Vice President, Production

Edward D. Muhlfeld
Vice President, Aviation Division

Irwin Robinson
Vice President, Travel Division

Radio & TV News • Radio News • Radio-Electronic Engineering Trademarks Reg. U.S. Pat. Off.

SUBSCRIPTION SERVICE: All subscription correspondence should be addressed to Electronics World, Circulation Department, Portland Place, Boulder, Colorado 80302. Please allow at least six weeks for change of address. Include your old address, as well as new—enclosing if possible an address label from a recent issue.

EDITORIAL CONTRIBUTIONS must be accompanied by return postage and will be handled with reasonable care; however publisher assumes no responsibility for return or safety of art work, photographs, or manuscripts.

ELECTRONICS WORLD (October, 1967, Vol. 78, No. 4). Published monthly at 307 North Michigan Avenue, Chicago, Illinois 60601, by Ziff-Davis Publishing Company—also the publishers of Airline Management and Marketing, Boating, Business & Commercial Aviation, Car and Driver, Cycle, Flying, HiFi/Stereo Review, Modern Bride, Popular Aviation, Popular Electronics, Popular Photography, Skiing, Skiing Area News, and Skiing Trade News. (Travel Weekly is published by Robinson Publications, Inc., a subsidiary of Ziff-Davis Publishing Company.) One year subscription rate for U.S., U.S. Possessions, and Canada, \$6.00; all other countries, \$7.00. Second Class postage paid at Chicago, Illinois and at additional mailing offices. Authorized as second class mail by the Post Office Department, Ottawa, Canada and for payment of postage in cash.

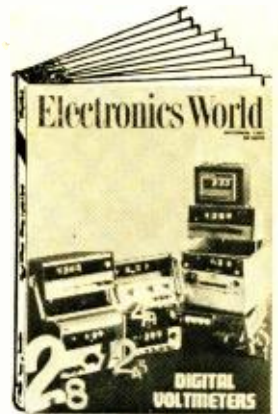

Editorial and Executive Offices
One Park Avenue
New York, New York 10016 212 679-7200

NEW YORK OFFICE 212 679-7200
James J. Sullivan
Joseph E. Halloran

MIDWESTERN OFFICE
307 North Michigan Avenue
Chicago, Illinois 60601 312 726-0892
Midwestern Advertising Manager, Royce Richard

WESTERN OFFICE
9025 Wilshire Boulevard
Beverly Hills, California 90211
213 CRestview 4-0265; BRadshaw 2-1161
Western Advertising Manager, Bud Dean

JAPAN
James Yagi
Ishikawa Mansion
2-4, Sakuragaoka
Shibuya-ku, Tokyo
462-2911-3

CIRCULATION OFFICE
Portland Place, Boulder, Colorado 80302



Member
Audit Bureau of
Circulations

ELECTRONICS WORLD

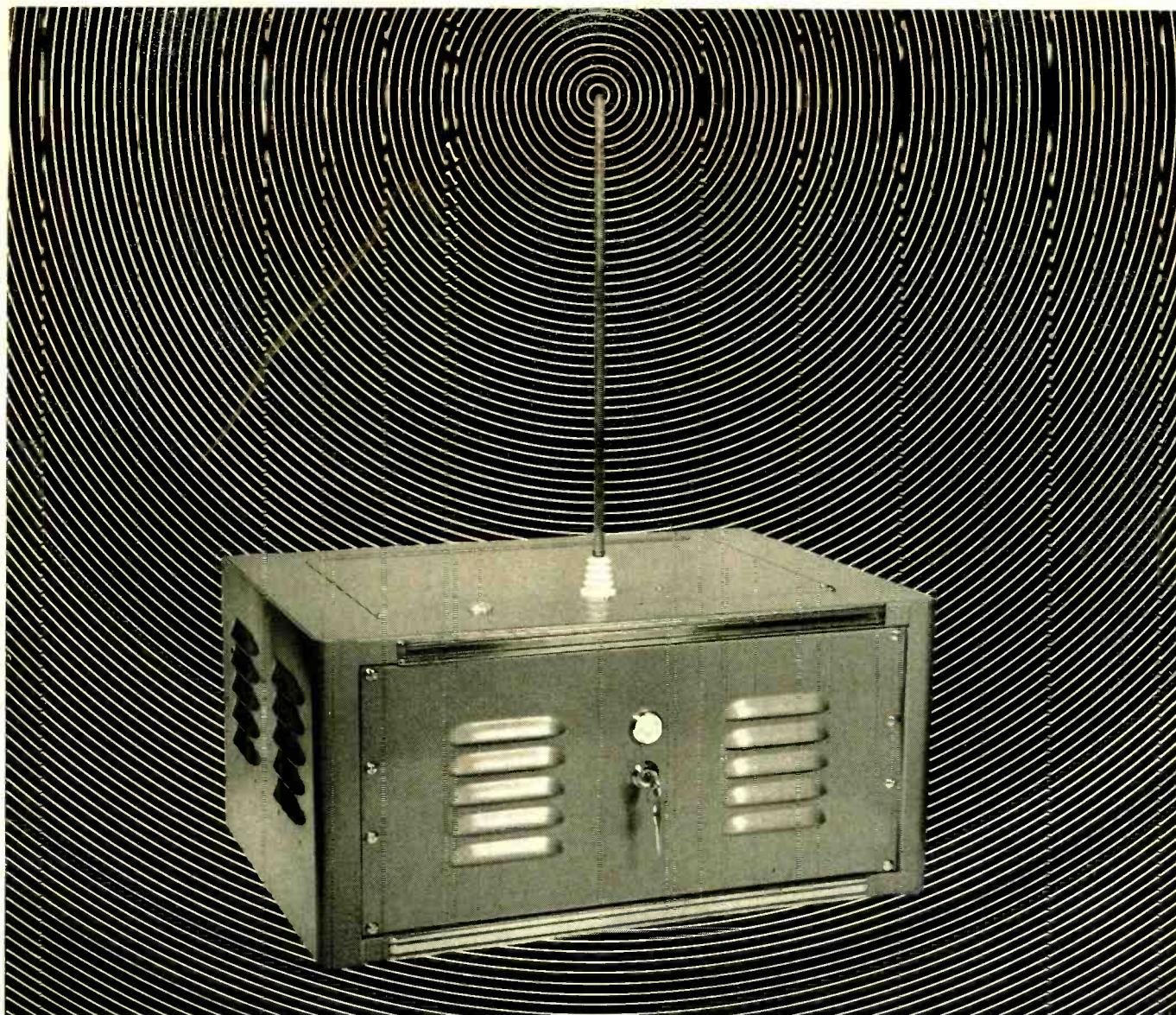

You are now in Radar Sentry Alarm's r.f. microwave field. Don't move a muscle!

This security system is so sensitive, it can be adjusted to detect the motion of your arm turning this page.

And if this Portable Model Unit were within 35 feet of you and you moved . . . people up to a half-mile away could hear the siren. Plus with optional equipment, it can detect fire . . . turn on lights . . . even notify police.

What does a burglar alarm have to do with you?

Just this: Radar Sentry is no ordinary alarm. It is the most modern and effective security system available. And it's also electronic.

That's why we need you. We need Dealers with technical knowledge. For the most successful Dealers for Radar Sentry Alarm are men who know electronics. This is a product that sells itself when demonstrated properly.

It's been proven time after time. In fact, many of the more than one thousand readers of electronics magazines who became Dealers in the past year — sold a system on their *first* demonstration.

And that's why we need men with technical knowledge and experience.

Men like you.

How about it?

Do you want to start a business of your own . . . or expand your present business with a product that in 8 years has become the world-wide leader in its field?

Do you want to earn up to \$5,000 a year in your spare time?

Do you want to earn \$20,000 and more full time? We'll show you how.

O.K., now you can move.

Fill out the coupon and get complete Dealer/Distributor information . . . free.

Mail to: RADAR DEVICES MANUFACTURING CORP.
22003 Harper Ave., St. Clair Shores, Michigan 48080



Please tell me how I can have a business of my own distributing Radar Sentry Alarm Systems. I understand there is no obligation.

Name _____

Address _____

City _____ State & Code _____

EW 10

Listen!



Hang it fast and easy then forget it!

The new Jensen VH-100 Series horn speakers were designed for fast installation and a lower installed cost. Their new and exclusive features let you install three VH-100's for the labor penalty previously charged for two.

KWIKON® connectors, an easily detached base, universal angle adjustment, accessible power control and an optional pre-integrated transformer are but a few of the many advantages of these rugged new weatherproof 32 watt speakers.

Our new brochure tells all.

Write Jensen Manufacturing Division, The Muter Company, 6601 South Laramie Avenue, Chicago, Illinois. 60638.

jensen

CIRCLE NO. 103 ON READER SERVICE CARD

LETTERS FROM OUR READERS



ELECTROSTATICS

To the Editors:

I have read with particular interest your article on "Static Electricity" in the July issue.

Some years ago, I developed a method of controlling an electrostatic charge on a moving vehicle. This technique is applicable to bodies in outer space since it does not require a corona discharge. Enclosed is a U. S. Patent (No. 3,095,167) issued to me in 1963.

In my classes here, I have been teaching that the area of electrostatics has been a woefully neglected field of physics. Our real basic understanding of the nature of static charge, its storage, its movement, and its conversion into current electricity are still areas of physics which need major research.

H. C. DUDLEY, Chrmn. and Prof.
Dept. of Physics
Univ. of Southern Miss.
Hattiesburg, Miss.

* * *

ELECTRONIC EAVESDROPPING

To the Editors:

Your article on electronic eavesdropping in the April issue was extremely interesting. However, a couple of questions arise. How does one go about detecting a bug, and why do the advertised bugs cost so much? I have seen several ads in which a bug costs a couple of hundred dollars or more.

FRED C. CAMPBELL
Miami, Fla.

It would take an article as long as the original one to properly cover the subject of "electronic mopping" a room. Briefly, as a general rule, a search starts with a close physical examination of all electrical devices within the room, including the lighting system, any intercoms, and the telephone, coupled with a careful search of all furniture, desk accoutrements, walls, floor, window edging, and possibly the ceiling. Paying particular attention to carvings, pictures, other displays, nail heads, small holes, or bumps or cracks in plaster or wallpaper will, in most cases, turn up a mike or r.f. bug implant. Always be on the alert for any type of conductor for a mike feed. Be suspicious of all briefcases, packages (especially sealed ones), and recent "presents."

As far as r.f. is concerned, almost any frequency ranging from very low r.f. (several hundred kHz as used in wireless intercoms) for transmission down a power line to frequencies above the FM band for direct r.f. transmission can be used. This makes the job of an r.f. field detector very difficult, but not impossible. Operation of an r.f. field detector depends upon the type of detector being used.

Concerning price, a knowledgeable technical reader of this magazine should recognize the circuits shown in the article and realize that he can duplicate them for a few dollars. (We intentionally omitted parts values from the circuits in order to discourage duplication, either by electronically naive individuals or those who might use the devices to invade the privacy of others.) This low construction cost is a far cry from the hundreds of dollars that these units sell for. It is the aura of secrecy that enables these units to command such high prices, and the "James Bond syndrome" that encourages many people to purchase them.—Editors

* * *

HANDS-OFF AIRPLANE LANDINGS

To the Editors:

Your article in the July issue on electronic challenges in the SST program was very interesting. However, in the discussion concerning "hands-off" landings, it neglected to mention the very important fact that fully automatic landings of commercial jets are already here. On February 27, 1967, a Pan American Boeing 727 jetliner with 98 fare-paying passengers on board made a fully automatic landing at John F. Kennedy International Airport in New York.

This was accomplished by use of the Sperry Phoenix SP-50 automatic flight-control system as a result of combined Boeing/Sperry efforts.

ROLAND R. MILLER
Phoenix, Ariz.

* * *

ELECTRIC CARS

To the Editors:

Your May issue seems to indicate that the electric car is not just a dream but practically an actuality. But I understand that with our present knowledge (Continued on page 12)

CIRCLE NO. 197 ON READER SERVICE CARD →

\$695.00
 (and at last)
**No Needless
~~Needles~~**



WHY?

Because Non-Linear Systems introduces (X-3), a solid-state integrated circuit DVM "(VTVM)" with extras for \$695.

DC Volts:

- 10 mv to 10K v
- .1% ± 1 digit
- 100 Megohm input impedance, entire range
- 10 Microvolts resolution

AC Volts:

- 200 Millivolts to 300 volts

- 10 Millivolts resolution
- 3% Accuracy
- 20 Hz to 500 MHz
- 10 Megohms Input Impedance

Resistance:

- 10 Ohms to 2000 Megohms
- .1% ± 1 digit to 200K

Current:

- 10 Nano Amps to 200 Milliamps
- .1% ± 1 digit

Yes, all these extras for \$695 (including probes)

LOOK AT THESE EXTRAS

- 100% Over-range Digit
- Over-load Indicator
- Over-load Protection
- Automatic Polarity
- Display Storage
- High CMR
- Unique Low, Medium, and High Range Selector



Originator of the Digital Voltmeter
NON-LINEAR SYSTEMS, INC.
 DEL MAR, CALIFORNIA 92014
 (714) 755-1134/TWX: 910-322-1132

EXPERIENCE IS STILL YOUR BEST TEACHER



That is why NRI has invested more in Professional Lab Equipment than all other home-study schools combined. It makes training

at home in Electronics fast and fascinating. Your hands are trained as well as your head.



**OLDEST AND LARGEST
SCHOOL OF ITS KIND**

Accredited by the Accrediting Commission of the National Home Study Council

You get more for your money from NRI

—more value, more solid experience so essential to careers in Electronics. NRI's pioneering "discovery" method is the result of more than half a century of simplifying, organizing, dramatizing subject matter. In each of NRI's major courses you learn by doing. You demonstrate theory you read in "bite-size" texts programmed with NRI designed-for-learning professional lab equipment. Electronics comes alive in a unique, fascinating way. You'll take pleasure in evidence you can feel and touch of increasing skills in Electronics, as you introduce defects into circuits you build, perform experiments, discover the "why" of circuitry and equipment operation.

Almost without realizing it, the NRI discovery method gives you the professional's most valuable tool—practical experience. You learn maintenance, installation, construction and trouble-shooting of Electronic circuits of any description. Whether your chosen field is Industrial Electronics, Communications or TV-Radio Servicing, NRI prepares you quickly to be employable in this booming field or to earn extra money in your spare time or have your own full-time business. And you start out with training equivalent to months—even years—of on-the-job training.

NRI Has Trained More Men for Electronics Than Any Other School

—By actual count, the number of individuals who have enrolled for Electronics with NRI could easily populate a city the size of New Orleans or Indianapolis. Over three-quarters of a million have enrolled with NRI since 1914. How well NRI training has proved its value is evident from the thousands of letters we receive from graduates. Letters like those excerpted below. Take the first step to a rewarding new career today. Mail the postage-free card. No obligation. No salesman will call. NATIONAL RADIO INSTITUTE, Electronics Division, Washington, D.C. 20016.



L. V. Lynch, Louisville, Ky., was a factory worker with American Tobacco Co., now he's an Electronics Technician with the same firm. "I don't see how the NRI way of teaching could be improved."



G. L. Roberts, Champaign, Ill., is Senior Technician at the U. of Illinois Coordinated Science Laboratory. In two years he received five pay raises. Says Roberts, "I attribute my present position to NRI training."



Don House, Lubbock, Tex., went into his own Servicing business six months after completing NRI training. This former clothes salesman just bought a new house and reports, "I look forward to making twice as much money as I would have in my former work."



Ronald L. Ritter of Eatontown, N.J., received a promotion before finishing the NRI Communication course, scoring one of the highest grades in Army proficiency tests. He works with the U.S. Army Electronics Lab, Ft. Monmouth, N.J. "Through NRI, I know I can handle a job of responsibility."

APPROVED UNDER NEW GI BILL. If you served since January 31, 1955, or are in service, check GI line on postage-free card.

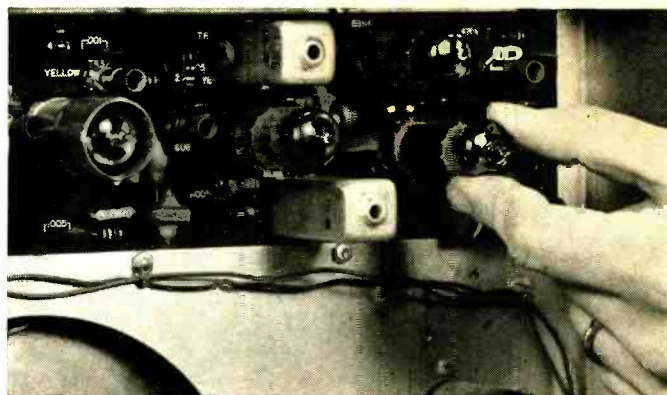

COLOR TV CIRCUITRY COMES ALIVE

as you build, stage-by-stage, the only custom Color-TV engineered for training. You grasp a professional understanding of all color circuits through logical demonstrations never before presented. The TV-Radio Servicing course includes your choice of black and white or color training equipment.

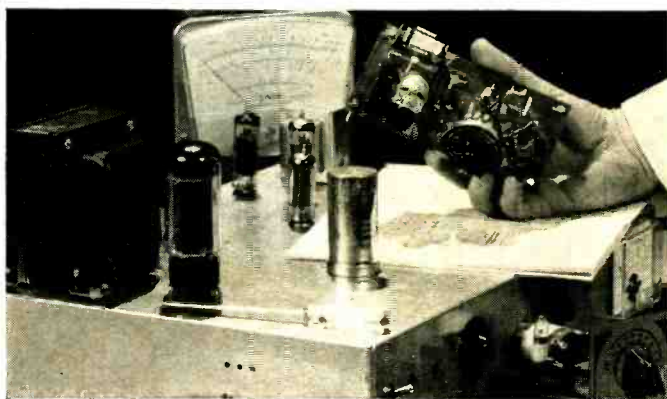

COMMUNICATIONS EXPERIENCE

comparable to many months on the job is yours as you build and use a VTVM with solid-state power supply, perform experiments on transmission line and antenna systems and build and work with an operating, phone-cw, 30-watt transmitter suitable for use on the 80-meter amateur band. Again, no other home-study school offers this equipment. You pass your FCC exams—or get your money back.

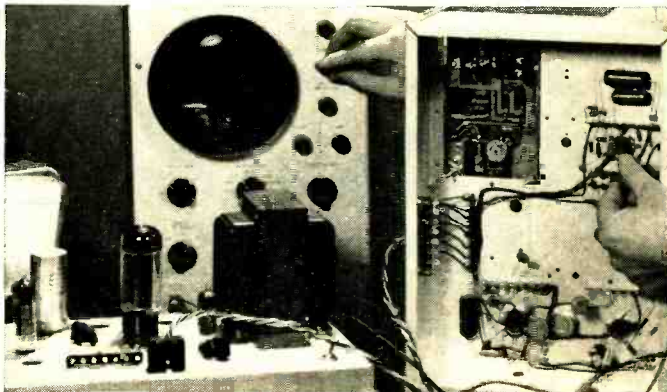

COMPETENT TECHNICAL ABILITY

can be instantly demonstrated by you on completing the NRI course in Industrial Electronics. As you learn, you actually build and use your own motor control circuits, telemetering devices and even digital computer circuits which you program to solve simple problems. All major NRI courses include use of transistors, solid-state devices, printed circuits.

Get Top **PERFORMANCE** from
 your Car! **Buy The Best!**
 DELTA'S Remarkable, Proven
MARK TEN CAPACITIVE DISCHARGE
 IGNITION SYSTEM

ONLY
\$44.95
 ppd.

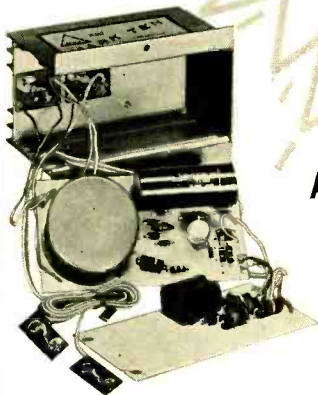

Available in Easy-to-Build

DELTAKIT®

ASSEMBLE IT
 YOURSELF!

ONLY
\$29.95
 ppd.

You've read about the Mark Ten in Radio Electronics, Electronics World, Mechanix Illustrated, Electronics, Popular Mechanics and other leading publications! Now discover what dramatic improvement in performance with capacitive discharge ignition is yours for your car, truck, jeep, boat—any vehicle! Delta's remarkable electronic achievement—on the market since 1963 and so unique that a patent has been granted—saves on gas, promotes better acceleration, gives your car that zip you've always wanted. Even Detroit has finally come around. Delta's Mark Ten, the original, the proven winner from Sebring to Suburbia, has set new records of ignition benefits attested to by thousands of satisfied purchasers. No re-wiring necessary. Works on literally any type of gasoline engine. Satisfaction guaranteed.

Order from coupon below, specifying car make, voltage and polarity. Like to build your own? Order a Deltakit® and save!

COMPARE THESE PROVEN BENEFITS!...

- ▲ DRAMATIC INCREASE IN ACCELERATION
- ▲ LONGER POINT AND PLUG LIFE
- ▲ IMPROVED GASOLINE MILEAGE
- ▲ MORE COMPLETE COMBUSTION
- ▲ SMOOTHER PERFORMANCE

Order Your Mark Ten Today! Shipped Postpaid at Once.



DELTA PRODUCTS, INC.

P.O. BOX 1147 EW — GRAND JUNCTION, COLORADO 81501

Enclosed is \$_____ Ship prepaid. Ship C.O.D.
 Mark Tens (Assembled) @ \$44.95 Mark Tens (Deltakit®) @ \$29.95
 (12 volt positive or negative ground only)

Specify 6 Volt: Negative Ground only.
 12 Volt: Specify Positive Ground Negative Ground

Car Year _____ Make _____
 Name _____
 Address _____
 City/State _____ Zip _____

CIRCLE NO. 118 ON READER SERVICE CARD

(Continued from page 6)

any battery-operated automobile would not be feasible for more than going to the market and back since it would need to be recharged every fifty miles or so. Is this true and, if so, who would buy one? Picture driving along the New England Thruway late at night and running out of electricity. Can you walk a mile up the road and get a can of electrons? How can electronics be used to solve this problem?

SUSAN HALL
 New York, N.Y.

If electric cars are to be used for more than just local shopping sprees, they will have to compete with the present gasoline-driven cars on the basis of speed and distance. All the research in the field is now directed toward that end. We suspect, though, that we will probably see the gas-turbine engine in wider use along with more anti-pollutant devices added to gas-engine cars before the electric automobile emerges in a truly competitive position.—Editors

REPRINT AVAILABILITY

To the Editors:

I am inquiring about the availability and cost of the articles listed on the attached sheets. If reprints of these are available, would you please send me cost information? If these are not available, would it be possible to get permission to run off copies locally?

I am presently employed at Puget Sound Naval Shipyard in Bremerton, Washington as an electrical engineer. I find your articles to the point and enjoy the basic approaches that your authors take. Too often in college the instructor takes such a rigorous mathematical route that the student loses him because he can't see the forest for the trees. Yours is indeed an excellent magazine.

I shall soon be going to Cuernavaca, Mexico to undertake language training in preparation for (I hope) a fruitful involvement in helping in the technological development of Latin America. The articles I have listed are specifically intended for reference when I get to Mexico and find myself short on references.

MAX J. GREVSTAD
 Olalla, Wash.

We are certainly glad to grant permission to Reader Grevstad to duplicate his long list of articles. Some of these articles are in the special sections we have run in past issues. Most of these sections are available from us at 25¢ a copy. Although we are out of stock on the fixed resistors and fixed capacitors sections, we still have a supply of special sections on batteries, semiconductor diodes, chokes and coils, variable resistors, relays, and transistors.

—Editors ▲

Amazing "power tool" for electronics men

Still working electronics problems with that old-fashioned manual tool, the pencil? You're not alone. And that's kind of a shame in this wonderful age when power tools have speeded up so many manual jobs. Now here is an amazing "power tool" that zips through electronic calculations like a power saw through soft pine. The CIE Electronics Slide Rule. It has a special scale that works reactance problems in seconds. And another scale that does the same for resonance problems. Plus two more scales that tell exactly where the decimal points go.

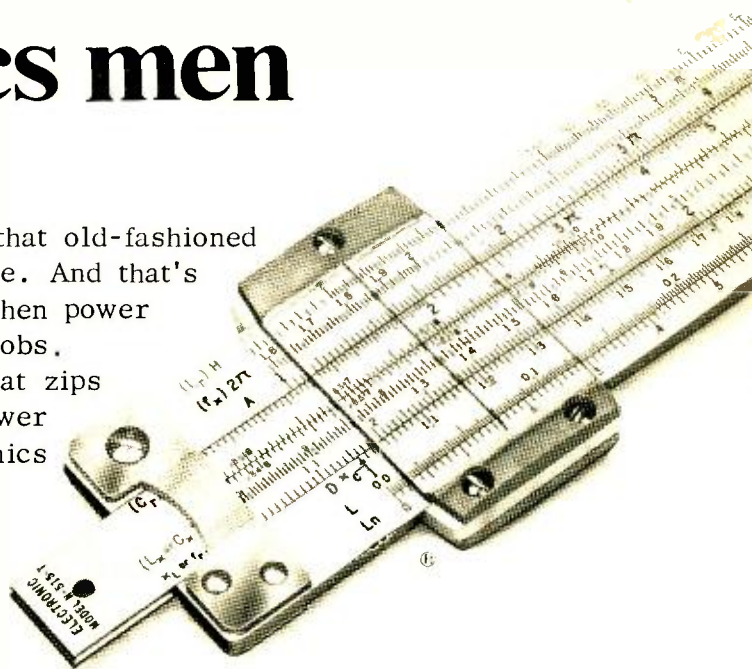

No guesswork. No paperwork. No rough calculations. You get an accurate answer in 20 seconds or less.

It also does the things ordinary slide rules do. Like multiply, divide and extract square roots in one setting. Or find reciprocals for resistance formulas, logarithms for decibel formulas, and trigonometric functions for AC circuitry formulas. And work the formulas in seconds.

The Electronics Slide Rule is easy to use even if you've never worked a slide rule before. It was developed by CIE, one of America's leading electronics schools. And it comes with a 4-lesson course that turns you into an expert. Not just an instruction manual, but a real Instruction Course. With assignments you may send in for grading by our instructors. And when you finish, a Certificate of Achievement that "tells the world" you're an electronics slide rule expert.

The slide rule and course are sold together -- for about half what we think they're worth. It's our way of getting acquainted with men around the country who want to get ahead in electronics.

Mail the coupon for FREE booklet describing this Electronics Slide Rule. Or write to Cleveland Institute of Electronics, Dept. EW-144, 1776 E. 17th Street, Cleveland, Ohio 44114. No charge or obligation.

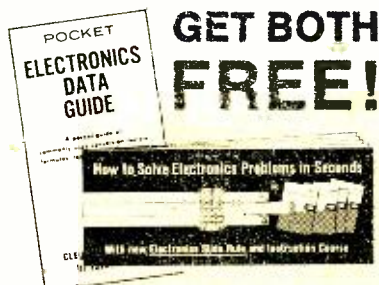

SEND COUPON TODAY →

CIE **Cleveland Institute of Electronics**
1776 East 17th Street, Cleveland Ohio 44114

Please send me without charge or obligation your FREE booklet, "How To Solve Electronics Problems In Seconds," describing the CIE Electronics Slide Rule and Instruction Course.

Name _____ (please print)

Address _____

City _____ State _____ Zip _____

Also free if you act now—our famous shirt-pocket Electronics Data Guide with useful formulas, conversion tables, color codes, and more.

Accredited Member National Home Study Council • A Leader in Electronics Training... Since 1934

EW-144

CIRCLE NO. 121 ON READER SERVICE CARD

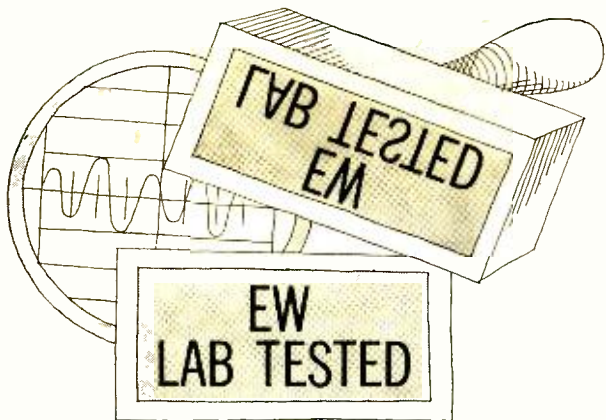

HI-FI PRODUCT REPORT

TESTED BY HIRSCH-HOUCK LABS

**Sherwood S-8800-FET Receiver
Amplex Model 2161 Tape Recorder**

Sherwood S-8800-FET Receiver

For copy of manufacturer's brochure, circle No. 36 on Reader Service Card.



THE Sherwood S-8800-FET is the latest version of the company's finest FM stereo receiver, featuring a field-effect transistor front-end and a new "Instamatic" overload protection circuit which safeguards the output transistors. In most other specifications it is similar to the predecessor S-8800 model, an all-silicon, solid-state receiver with 1.6 μ V rated IHF usable sensitivity and a pair of 40-watt amplifiers.

The tuner of the S-8800-FET has a neutralized FET r.f. stage, an FET converter, and a bipolar transistor oscillator. Amplified a.g.c. voltage is fed to the r.f. stage, with direct a.g.c. applied to the first two i.f. stages. The three neutralized i.f. stages are followed by two limiter stages and a wide-band Foster-Seeley discriminator. This also represents a slight departure from the earlier S-8800 models which used a ratio detector. The company found that the discriminator circuit results in slightly lower distortion. An interstation noise squelch circuit is operated by the effect of the a.g.c. on the second i.f. stage.

The change in collector current when a signal is received is amplified and used to unclamp the first limiter stage so that the signal can be heard. In the absence of a signal the background is totally silent.

The multiplex demodulator is simple, yet effective. The 19-kHz pilot carrier is separated from the composite detected signal, doubled to 38 kHz, and used to gate a four-diode balanced modulator. The program portion of the detected signal is demodulated into left- and right-channel components in this section of the receiver. A multiplex threshold amplifier, gated by the a.g.c. signal applied to the first i.f. stage, cuts off the 38-kHz doubler in the absence of a signal of sufficient strength for good stereo reception. Another transistor amplifier, actuated by the 38-kHz signal, lights a lamp on the dial face to indicate stereo reception.

The audio section has preamplifiers with equalization for RIAA record and NAB tape head sources. The gain of the preamplifiers is adjustable, by

means of a small shaft on the front panel, to match the levels of phono and tuner sources. The bass and treble tone controls use feedback circuits to allow control of the frequency extremes without affecting the major portion of the audio spectrum. The S-8800-FET has provisions for tape monitoring from a three-head recorder, a sharp cut-off (12 dB/octave) low-pass filter for hiss reduction, and independent speaker switches for local or remote speakers. These functions are controlled by four rocker-type switches.

The loudness control has Fletcher-Munson compensation permanently built in, which boosts the lows as the volume is lowered. Tone controls are ganged for both channels and the balance control has a pull-on switch which parallels both channels for mono reproduction from any source (this also disables the FM stereo modulator). In common with every other Sherwood receiver or tuner we have used over the years, the S-8800-FET has an effortless flywheel tuning mechanism, which is aided by a zero-center tuning meter.

One of the chief weaknesses of some transistor amplifier designs is the tendency for the output transistors to be destroyed by a momentary overload, such as could be caused by shorted speaker leads or driving a speaker with insufficient impedance. The "Instamatic" overload protection circuit monitors the current drawn by the output transistors and, upon sensing an overload,

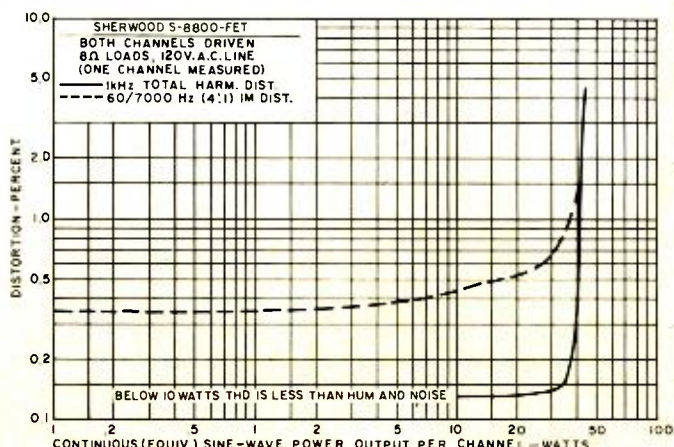
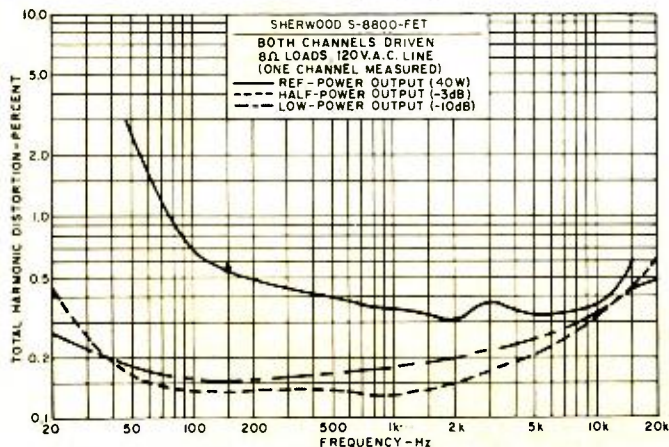

Your Sylvania distributor is up-to-date on your business. Use him: it's like adding an electronic consultant to your staff... free.

We keep him up-to-date with frequent reports and analyses of your maintenance and design needs. We give him plant tours and technical training. And ready access to Sylvania product and applications engineering staffs.

He knows the features of each and every tube we make. And he knows how *you* use them. He's up on the latest developments. He knows our competitors' tubes inside out, too.

Get a free analysis, by your Sylvania distributor, of your tube and semiconductor replacement needs. He can prevent emergencies, prepare an inventory—and save you money. He's an expert. Depend on him for service and for fast delivery—in any quantity.

Sylvania Electronic Tube Division, Electronic Components Group, Seneca Falls, New York 13148.

SYLVANIA
SUBSIDIARY OF
GENERAL TELEPHONE & ELECTRONICS **GT&E**

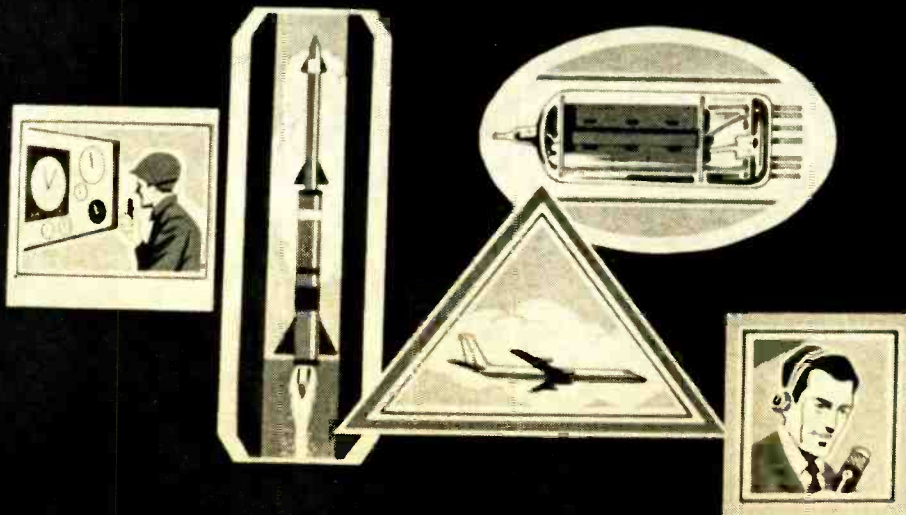

TELEX \$25,000 STEREO STAKES



WIN

one of five complete hi-fi component systems, made up of highest-quality components from the finest manufacturers in the field! Altec Lansing, Acoustic Research (AR), BASF, Dual, Electro-Voice, Fisher, J.F.D., Koss/Acoustech, Magnecord, Marantz, Pickering, Koss/Rek-O-Kut, Sherwood, Stanton, Telex, University and Viking . . . plus

FREE

Telex Serenata II Stereo Headphones to winners of special drawings from each participating dealer. A guaranteed winner from every store!



TELEX • MAGNECORD • VIKING
DIVISIONS OF THE TELEX CORPORATION
5600 ALICIA AVE., SOUTH, MINNEAPOLIS, MINN. 55420

Fill out coupon below and deposit in Stereo-Stakes Entry Box at hi-fi equipment dealer's

RULES:

1. Entries must be mailed to or deposited at official participating dealership.
2. No purchase required (however, if winner has purchased Magnecord or Viking tape recorder or Telex headphone during contest period, cash refund equivalent to retail price will be made.)
3. Contestants must be 18 years of age or older.
4. Employees of Telex, Magnecord, Viking, their advertising agencies, and families of same not eligible.
5. Winners to be selected by random drawing. All decisions of the judges will be final.
6. Contest void in states where prohibited by law.*
7. Entries must be postmarked or deposited at dealer's before midnight, November 30, 1967.
8. Winners will be notified by mail within 30 days of close of contest.

* Wisconsin residents mail entries to: Stereo Stakes Contest, Box 7626, Tulsa, Oklahoma 74105

OFFICIAL ENTRY FORM
TELEX \$25,000. STEREO-STAKES

Name _____

Street Address _____

City _____ State _____ Zip _____

Area Code _____ Tel No. _____

Hi-Fi Dealer _____

City _____

CIRCLE NO. 84 ON READER SERVICE CARD
16

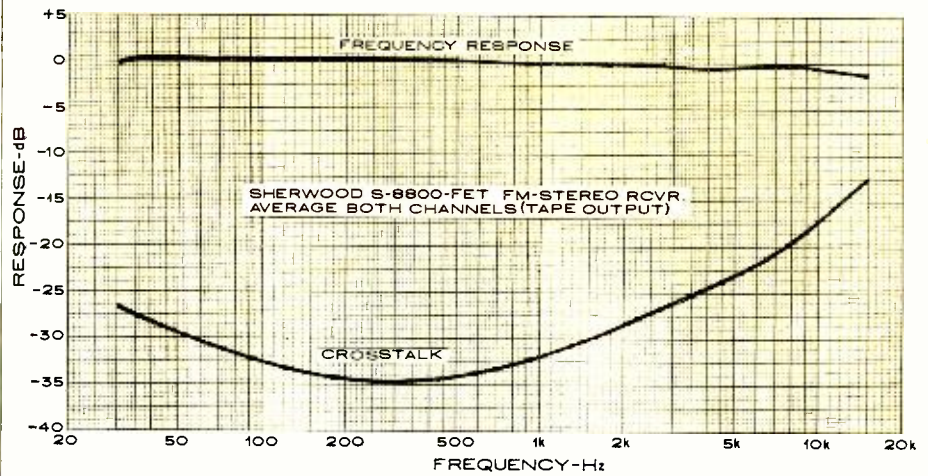

instantaneously removes the drive signal from the first stage of the power amplifier section. To restore normal operation, the receiver must be switched off for about 15 seconds, after which it can be turned on and used as before. As far as we could tell, it is a foolproof system, for we tripped the overload many times during testing, while driving the amplifier to full power, with no effect on its performance.

Our measurements on the S-8800-FET confirmed its performance specifications completely, as far as we were able to test them. We measured an IHF usable sensitivity of 1.8 μ V and the stereo separation varied from 35 dB at middle frequencies to 27 dB at 30 Hz and 17 dB at 10,000 Hz. The distortion of the FM tuner was as low as we have ever measured, and probably represents the residual distortion of our signal generator. It was -48 dB, at 100% modulation.

The amplifiers delivered their rated 40 watts over most of the frequency range, into 8-ohm loads, with both channels driven, at less than 0.5% distortion. At 20 watts or lower outputs, the distortion was under 0.2% over most of the range and did not exceed 0.6% from 20 to 20,000 Hz. The RIAA phono equalization was very good, within ± 1 dB from 20 to 20,000 Hz. The NAB tape equalization was within ± 4 dB over the same range. The scratch filter was excellent, cutting off sharply above 5000 Hz, and the tone controls combined an unusually wide range with the ability to make moderate corrections at very low or very high frequencies without affecting the mid-range.

Into 16-ohm loads, the amplifiers delivered about 22 watts per channel and into 4 ohms the output was 65 watts per channel. These were continuous power readings which indicated clearly

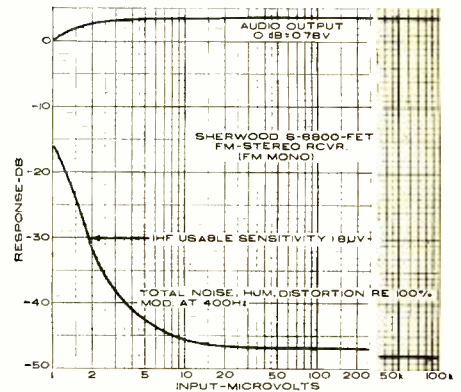

that the amplifier could deliver its rated 140 watts total music power into 4-ohm speakers.

The amplifiers of the S-8800-FET have unusually high gain, needing only 0.6 mV from a phono cartridge to develop a room-filling 10-watt output. At maximum gain, the hiss and some hum were quite audible, but at any usable gain setting the amplifier had a dead quiet background.

We were very favorably impressed with the performance of the receiver. It sounded superb, with clean audio at any volume level and the FM tuner was as sensitive and free from distortion as our measurements would suggest. We did not, however, care for the loudness compensation, which could not be disabled and often produced undesirably "bassy" sound with speakers of moderate to high efficiency. The bass tone control could be used to correct some of this effect, but a disabling switch would be preferable.

The Sherwood S-8800-FET receiver sells for \$369.50. Vinyl clad metal or oiled walnut cabinets are available for \$9.00 and \$28.00, respectively. The same receiver, with the addition of AM tuning facilities, is available as the S-7800 for \$409.50. ▲

Ampex Model 2161 Tape Recorder

For copy of manufacturer's brochure, circle No. 37 on Reader Service Card.

THE Ampex 2100 Series tape recorders are three-speed, four-track machines with a unique automatic-re-

versing system which allows an entire stereo tape to be played without inter-

(Continued on page 84)

The hottest thing in electronics hardly gets hot at all



(RCA's solid integrated circuit, that is)

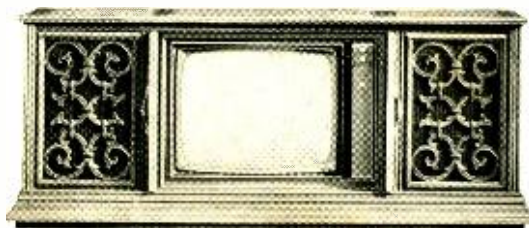

With the tiny chip there are few heat problems and low power consumption. And because integrated circuits run cooler, parts can be placed closer together to enhance design convenience. One day you may see stereo cabinets with more real storage space, and color TV sets the size of a transistor radio. At RCA Victor we've taken a

step into tomorrow by using integrated circuits now in new color and black and white TV and stereo phonographs. They're not only the most advanced products of their kind, they are more reliable than ever before.



The Most Trusted Name in Electronics

™mk(s)®

10 Reasons why RCA Home Training is Your best investment for a rewarding career in electronics:

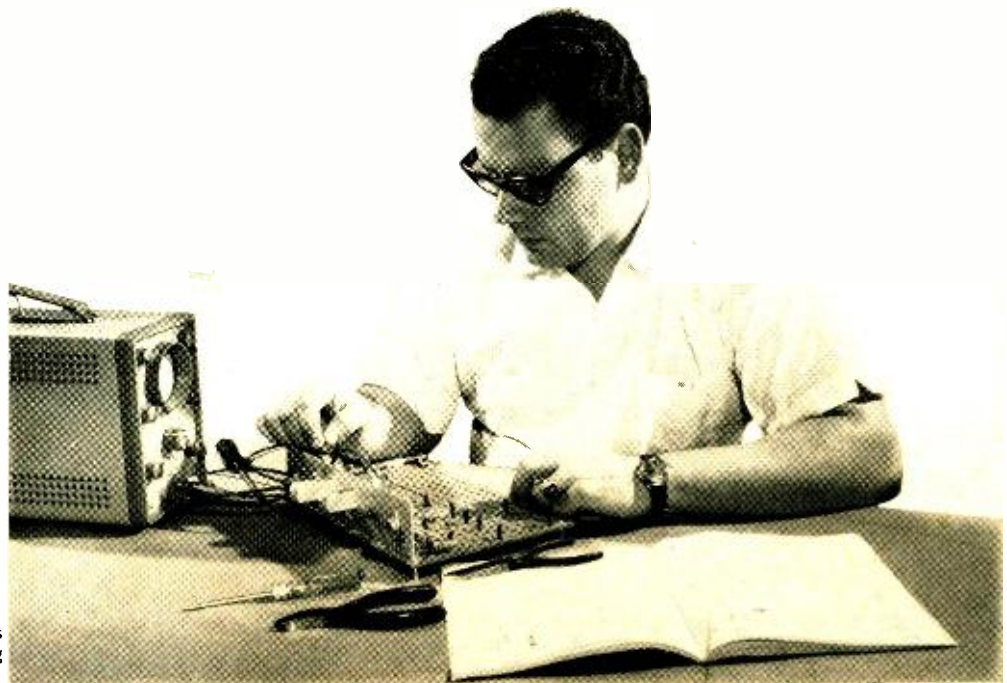

Performing transistor experiments on programmed breadboard — using oscilloscope.

1 LEADER IN ELECTRONICS TRAINING

When you think of electronics, you immediately think of RCA...a name that stands for dependability, integrity and pioneering scientific advances. For over a half century, RCA Institutes, Inc., a service of Radio Corporation of America, has been a leader in technical training.

2 RCA AUTOTEXT TEACHES ELECTRONICS FASTER, EASIER, ALMOST AUTOMATICALLY

Beginner or refresher, AUTOTEXT, RCA Institutes' own method of programmed Home Training will help you learn electronics more quickly and with less effort, even if you've had trouble with conventional learning methods in the past.

3 THOUSANDS OF WELL PAID JOBS ARE NOW OPEN TO MEN SKILLED IN ELECTRONICS

RCA Institutes is doing something positive to help men with an interest in electronics to qualify for rewarding jobs in this fascinating field. Every year, literally thousands of high paying jobs in electronics go unfilled just because not enough men take the opportunity to train themselves for these openings.

4 WIDE CHOICE OF CAREER PROGRAMS

Start today on the electronics career of your choice. On the attached card is a list of "Career Programs", each of which starts with the amazing AUTOTEXT method of programmed instruction. Look the list over, pick the one best suited to you and check it off on the card.

5 SPECIALIZED ADVANCED TRAINING

For those already working in electronics or with previous training, RCA Institutes offers advanced courses. You can start on a higher level without wasting time on work you already know.

6 PERSONAL SUPERVISION THROUGHOUT

All during your program of home study, your training is supervised by RCA Institutes experts who become personally involved in your efforts and help you over any "rough spots" that may develop.

7 VARIETY OF KITS YOURS TO KEEP

To give practical application to your studies, a variety of valuable RCA Institutes engineered kits are included in your program. Each kit is complete in itself. You never have to take apart one piece to build another. At no extra cost, they're yours to keep and use on the job.

8 FROM RCA INSTITUTES ONLY - TRANSISTORIZED TV KIT, VALUABLE OSCILLOSCOPE

Those enrolled in RCA's television course or program receive complete transistorized TV Kit. All students receive a valuable oscilloscope—both at no extra cost and only from RCA Institutes.

9 UNIQUE TUITION PLAN

With RCA Home Training, you progress at the pace that is best for you! You only pay for lessons as you order them. You don't sign a long-term contract. There's no large down-payment to lose if you decide not to continue. You're never badgered for monthly

bills. Even if you decide to interrupt your training at any time, you don't pay a single cent more.

10 RCA INSTITUTES GRADUATES GET TOP RECOGNITION

Thousands of graduates of RCA Institutes are now working for leaders in the electronics field; many others have their own profitable businesses. This record is proof of the high quality of RCA Institutes' training.

CLASSROOM TRAINING ALSO AVAILABLE

If you prefer, you can attend classes at RCA Institutes Resident School, one of the largest of its kind in New York City. Coeducational classroom and laboratory training, day and evening sessions, start four times a year. Simply check "Classroom Training" on the attached card for full information.

FREE PLACEMENT SERVICE, TOO!

In recent years, 9 out of 10 Resident School students who used the Free Placement Service have been placed before or shortly after graduation. This Service is also available to Home Study students.

SEND ATTACHED POSTAGE PAID CARD TODAY! FREE DESCRIPTIVE BOOK YOURS WITHOUT OBLIGATION! NO SALESMAN WILL CALL!

All RCA Institutes courses and programs are approved for veterans under the New G.I. Bill.

RCA INSTITUTES, INC. EW-07
350 West 4th Street
New York, N.Y. 10014

ACCREDITED MEMBER NATIONAL HOME STUDY COUNCIL



The Most Trusted Name in Electronics

Construction of Multimeter.

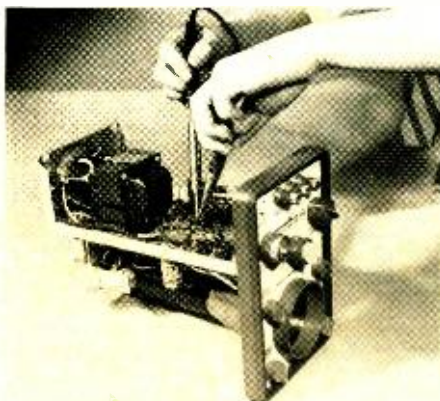

Construction of Oscilloscope.

Temperature experiment with transistors.



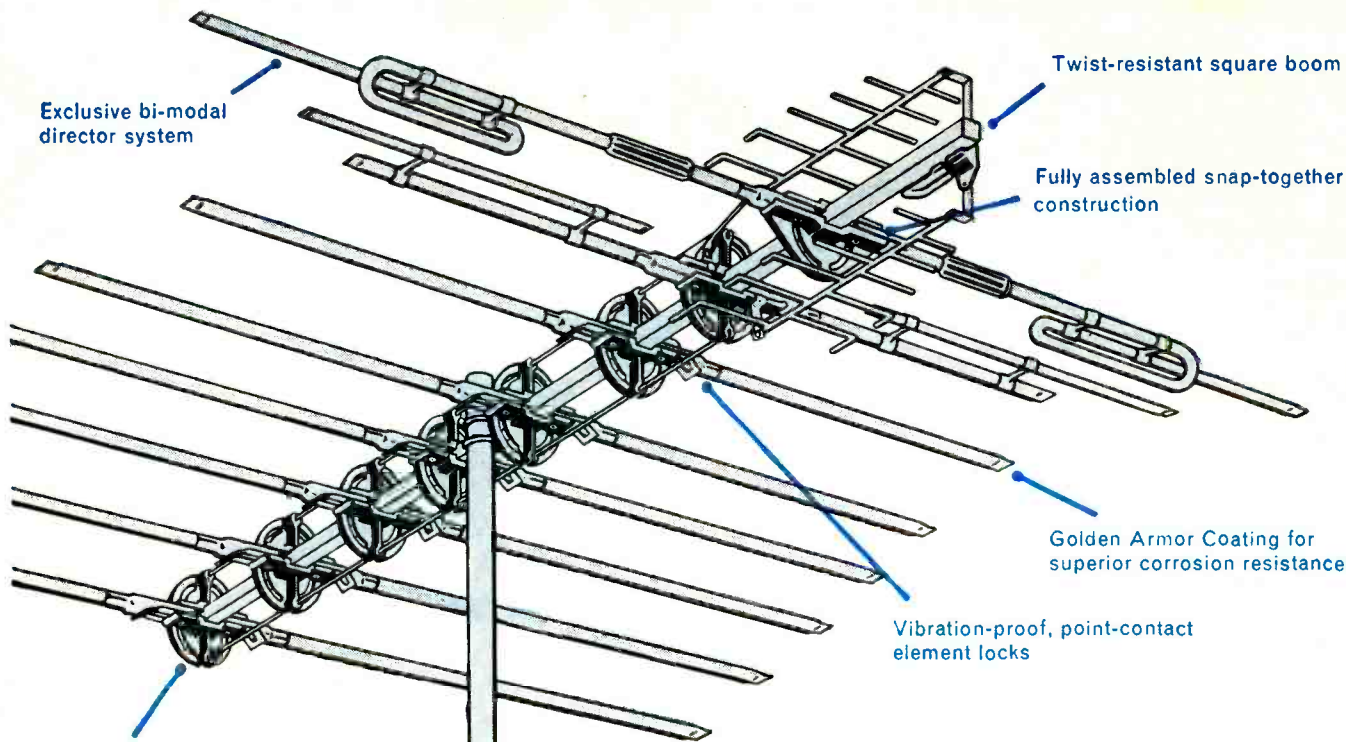

82-channel signal grabber

The Jerrold VUfinder® Antenna. The first 300-ohm UHF-VHF-FM antenna designed—from the ground up—for uncompromising color and black-and-white excellence across the entire TV spectrum. Models available for metropolitan to deepest fringe areas.

- Sharp directivity eliminates color ghosts
- Flat response (± 1 db per channel) for optimum color fidelity
- Exclusive bi-modal director system for extra gain

VUfinders are easy to put together, can't possibly fall apart. The quality that's built in stays in. Quickly convertible to 75-ohm Color-axial performance. VUfinders come in 5 models. Each is supplied with a UHF/VHF frequency splitter. And the list prices range from \$17.95 to \$79.95. There's no better performance per dollar than this—anywhere.

For the most efficient 300-ohm signal grabber in Jerrold's Spectrum '67, see your Jerrold Distributor *today* about the Jerrold VUfinder antenna.

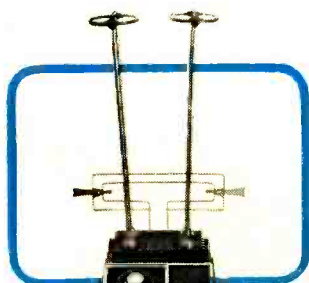

Indoor antennas

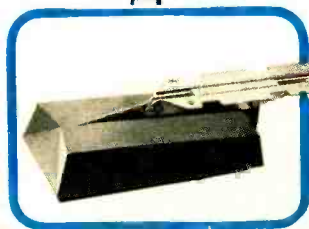

Home pre-amplifiers

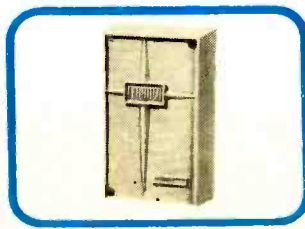

Distribution equipment



*Focusing on one thing...
better reception*

CIRCLE NO. 102 ON READER SERVICE CARD

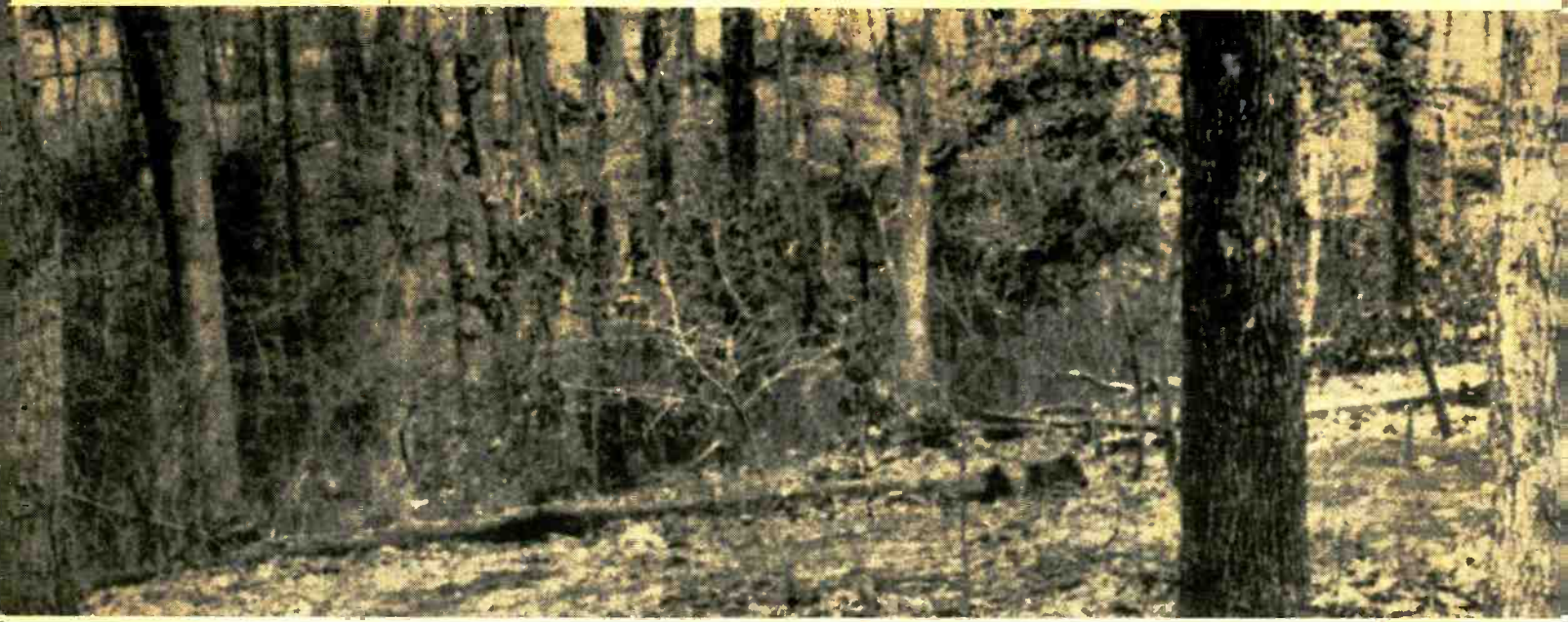

INFRARED RADIOMETRY

By JOHN R. COLLINS

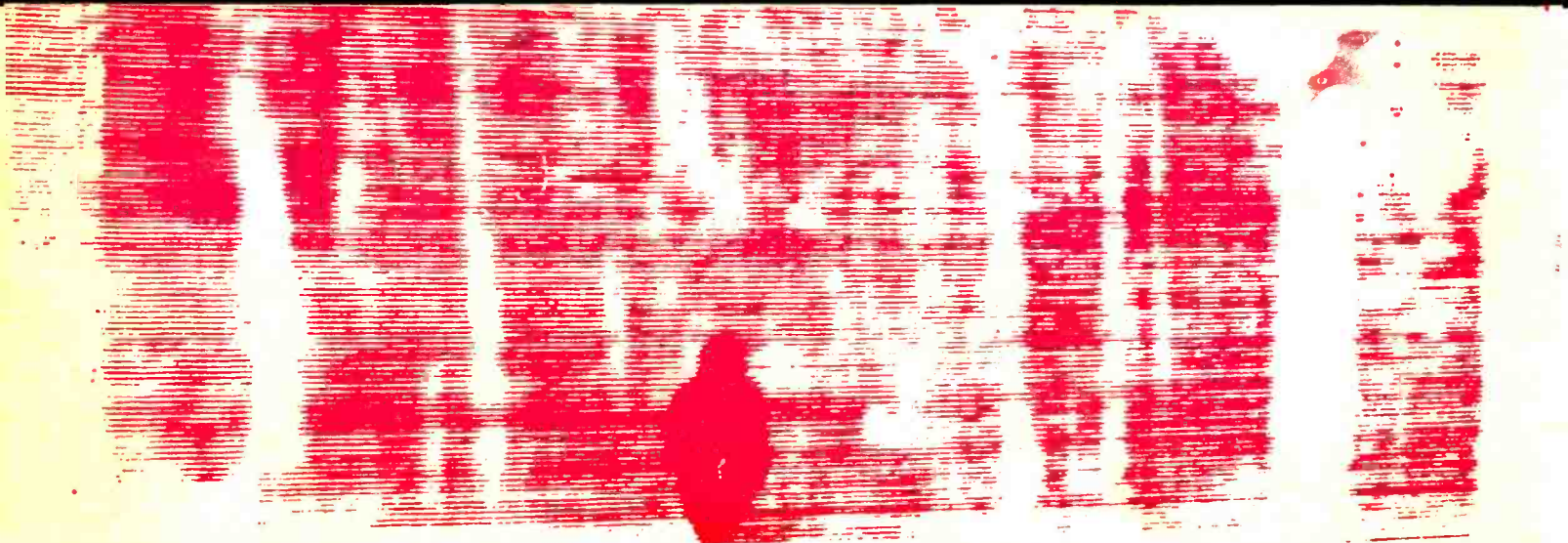

Techniques for revealing camouflaged men and vehicles are being investigated by U.S. Army Engineering Research and Development Labs. The concealed man in the woods is instantly shown up by the corresponding thermogram of this same scene.

Everything above Kelvin zero emits heat that can be converted into infrared photographs by radiometers. These useful instruments find wide application in electronics, medicine, mechanical inspections, and by the Armed Forces for locating camouflaged men and vehicles.

DESPITE a limited amount of scientific research, the infrared portion of the electromagnetic spectrum was, until recently, an almost unknown region with unsuspected potentialities. With the development in the past few years of faster, more sensitive infrared detectors and associated display devices, that situation has changed dramatically and infrared is now rapidly expanding into one of the most important and promising instrumentation fields.

Initial interest in infrared was largely military, and military research has yielded an impressive list of devices—equipment for passive surveillance, early warning, missile detection and tracking, aerial mapping, secure commu-

nications, etc. In competition with radar, an infrared system can readily resolve the individual engines of several twin-engine planes at a distance at which radar is unable to distinguish the separate aircraft. Coupled with this is the fact that infrared systems are small, portable, and jam-proof.

More recently, infrared equipment has been designed for industrial and medical use. It is now finding increasing application in the factory as a tool for quality control and non-destructive testing, in the research laboratory as an aid in the study of materials, and in the medical clinic for early detection of cancer and circulatory diseases.

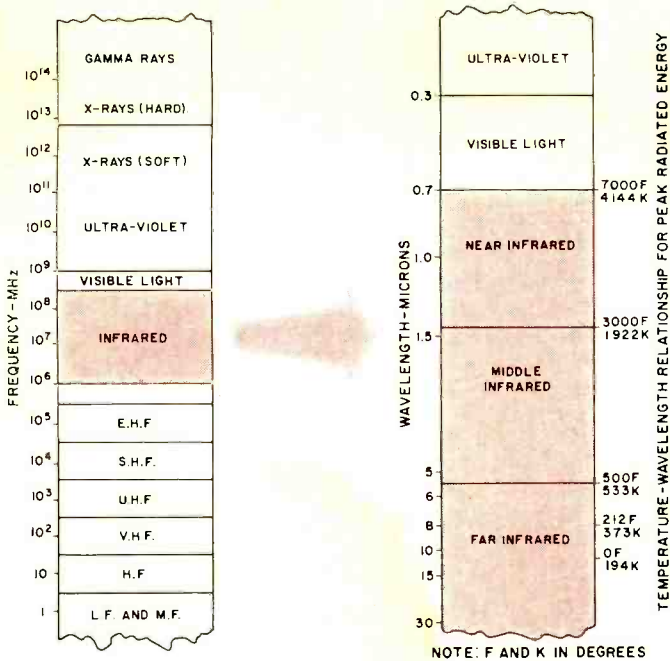
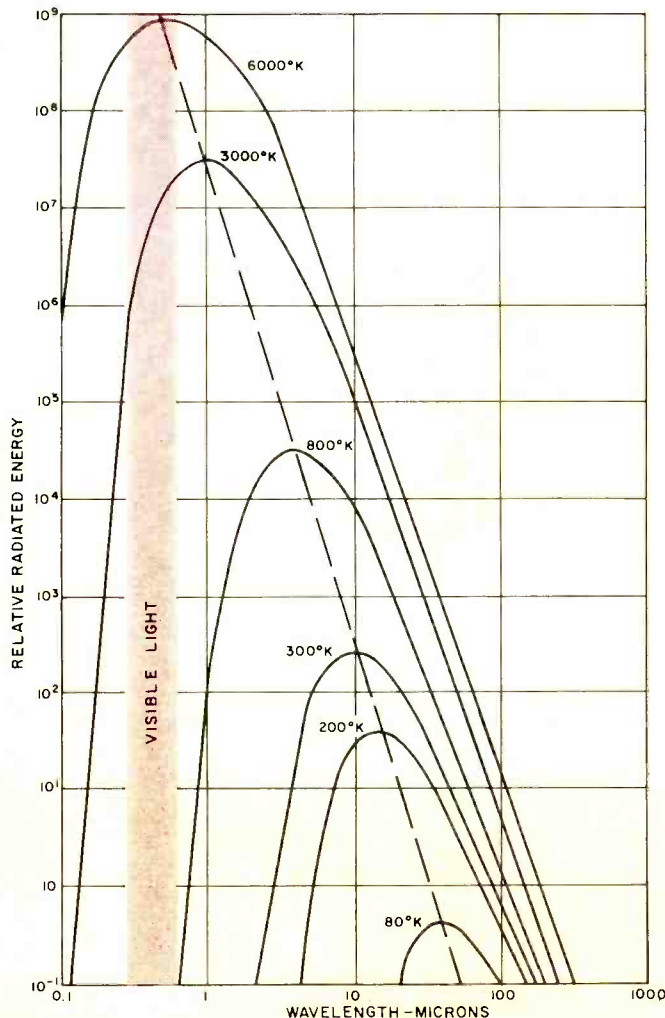

Fig. 1. The electromagnetic spectrum shows that infrared is between visible light and communications frequencies. Note also that the infrared region may be further subdivided into the near, middle, and the far infrared bands.

Fig. 2. The relationship between energy and wavelength. Note that the wavelength of peak radiation in microns can be determined approximately by dividing the number 3000 by the temperature in degrees Kelvin. This is represented by the dashed line cutting the peaks of the curves. This rule is accurate enough for most estimates.



The infrared region of the electromagnetic spectrum lies between the longest wavelength of visible light (red) and the shortest radio wavelength (e.h.f.), as shown in Fig. 1. It is subdivided into the near, middle, and far infrared regions. Infrared radiation differs from visible light and radio waves in the fact that it is constantly emitted by every object in the universe that is not at a temperature of zero Kelvin, that is, -273°C or -460°F . (In fact, nothing is.) This radiation is generated by the thermal agitation of molecules that is characteristic of all matter that is not at a temperature of absolute zero.

The spontaneous nature of infrared emission is obviously one of its most interesting and important qualities. Of equal importance, however, is the fact that the wavelength of the peak radiance emitted by an object is directly related to its temperature. It is thus possible to determine the temperature of an object without making contact with it by observing the wavelength of its peak emitted energy. Such measurements can be accurate to a very small fraction of a degree.

The hotter an object becomes, the more infrared energy it will radiate. Furthermore, when infrared radiation from one source strikes another object, it induces heat in it by adding to the agitation of its molecules. However, infrared radiation should not be confused with heat. It is more closely related to light in the manner in which it is transmitted instantly over great distances and because it can be focused by means of an optical system.

The relationship between radiated energy and wavelength is shown in Fig. 2. The largest curve represents the radiation from an object, such as the sun, having a surface temperature of 6000°K . Its peak radiance is in the visible range at a wavelength of about $\frac{1}{2}$ micron (μ). The next largest curve, 3000°K , approximates the radiation from a tungsten lamp filament when it is white hot. Although most of its energy is in the infrared at a peak wavelength of about $1\ \mu$, significant radiation also falls in the visible range so that tungsten lamps are commonly used for illumination. At about 800°K an object ceases to glow visibly, but its radiation can readily be detected, even at some distance, by the warmth it induces in an outstretched hand.

The 300°K curve, which peaks at $10\ \mu$, is especially significant because it is representative of objects at about room temperature ($300^\circ\text{K} = 27^\circ\text{C} = 81^\circ\text{F}$). Most radiometry is concerned with objects whose radiance peaks in the 8- to $13\text{-}\mu$ spectral range. Considered on the Kelvin scale, the difference in temperatures from the tropics to the polar regions is comparatively small, and it is convenient to remember that the infrared radiation from most terrestrial objects at ambient temperature peaks at $10\ \mu$.

Fig. 3. Response curves of a group of infrared detectors.

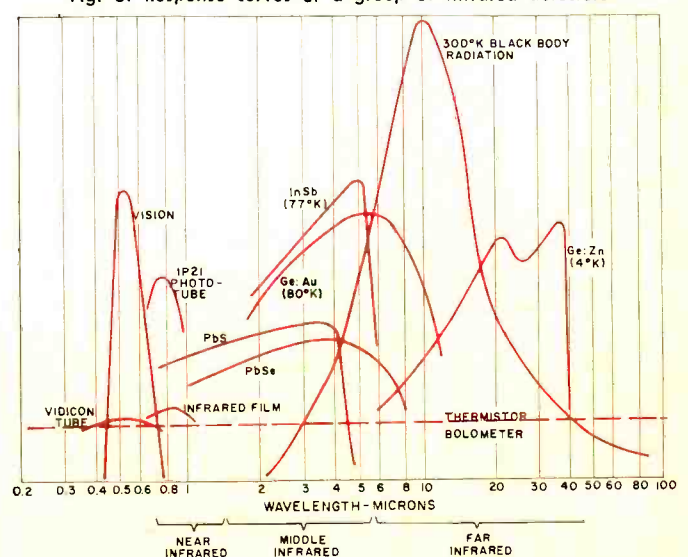

Reference to Fig. 2 will show that the wavelength of peak radiation in microns can be determined approximately by dividing the number 3000 by the temperature in degrees Kelvin. Thus, the 6000° K curve peaks at $\frac{1}{2} \mu$, the 3000° K curve at 1μ , and the 300° K curve at 10μ . This rule is accurate enough to estimate either temperature or wavelength of peak radiance when the other factor is known.

The final curve, at 80° K, represents the infrared radiation from a body at liquid nitrogen temperature. It illustrates the fact that even objects at that reduced temperature continue to emit infrared radiation, even though in very small quantities and at very long wavelength.

Infrared Detectors

Exploration and utilization of the infrared portion of the electromagnetic spectrum was long delayed because of the lack of detectors, other than sluggish, temperature-sensitive devices, that could operate beyond the very near infrared region. Some typical detector responses are shown in Fig. 3. It is notable that infrared film, phototubes, and vidicons all cut off in the near infrared region. Much developmental work has been devoted to improving the useful range and response speed of infrared detectors.

A basic means of detecting infrared radiation is through the temperature rise that it causes. A device based on this principle is the thermocouple, in which a voltage is generated at the junction of certain dissimilar metals when the temperature is raised. These devices tend to be slow, however, and although they are widely used in laboratory instruments, such as infrared spectrophotometers, they are not suitable for applications where speed is essential.

More sensitive thermal detectors are thermistor bolometers, whose active elements are thin films composed of oxides of manganese, nickel, and cobalt. They are usually blackened to increase absorption. Thermistor bolometers have a high negative temperature coefficient and are thus quite sensitive. However, their time constant of response to infrared depends on how rapidly the incoming radiation can bring about a rise in their temperature, so care is exercised to make the devices as small as possible. Some are only $0.2 \text{ mm} \times 0.2 \text{ mm}$. Equally important is the speed at which temperature equilibrium is reached when the stimulus is removed. Speed is promoted by mounting the sensitive element on a heat sink which rapidly conducts heat away from the detector. Most current research on thermistor bolometers is devoted to improving their time constant by reducing their size and improving the thermal conductance of their heat sinks. The effort is worthwhile, because thermal detectors are the only kind that provide flat response to 14μ without cooling. However, it has not been practical to manufacture such devices with time constants much shorter than 1 millisecond.

In practice, it is customary to employ two identical thermistor bolometers in a bridge circuit. One is the active element on which the infrared radiation from the target

impinges. The other is shielded and serves to compensate for changes in the ambient temperature.

Where greater speed is essential, photodetectors are used. These devices are either polycrystalline films or single-crystal semiconductors in which a carrier is produced by a photon of incoming radiation. The amount of energy in a photon decreases as wavelength increases, and each detector material has a limit beyond which the photons are too weak to produce carriers. This fact accounts for the abrupt changes in sensitivity that characterizes photodetectors at certain wavelengths. Despite this limitation, they are widely used because of their high sensitivity and short time constants.

For the near and middle infrared regions, polycrystalline films of lead sulfide, lead selenide, and lead telluride are often used. They operate satisfactorily at room temperature, but undergo useful changes when subjected to cooling. Lead sulfide cells do not exhibit significantly greater range when cooled, but their point of peak sensitivity shifts to a longer wavelength. The spectral range of lead selenide and lead telluride can be extended somewhat by cooling to dry ice or liquid nitrogen temperature. This advantage is offset by the fact that the cooled detector exhibit longer time constants than when not cooled—10 to 30 microseconds, as compared to 1 to 10 microseconds. Cooling has the added advantage of reducing noise level and is universally used for detecting the weaker signals characteristic of the longer infrared wavelengths.

Indium antimonide (*InSb*) is an excellent semiconductor photon detector. To prevent the electrical carriers generated by thermal agitation within the detector itself from obscuring the incoming signal, cooling to liquid nitrogen temperature (77° K) is necessary. Such detectors are extremely sensitive and have time constants of about $0.4 \mu\text{sec}$.

For targets at moderate temperatures, a thermistor bolometer may exhibit sensitivity equal to that of an *InSb* detector and may be the best choice where fast response is not an important factor. As shown in Fig. 3, an *InSb* detector is sensitive to only a small portion of the radiation from a body at 300° K, whereas the thermistor bolometer absorbs radiation across the entire band. Since the total radiation the bolometer absorbs is greater, its effective

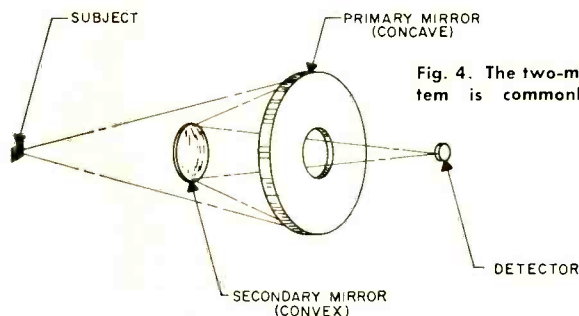

Fig. 4. The two-mirror system is commonly used.

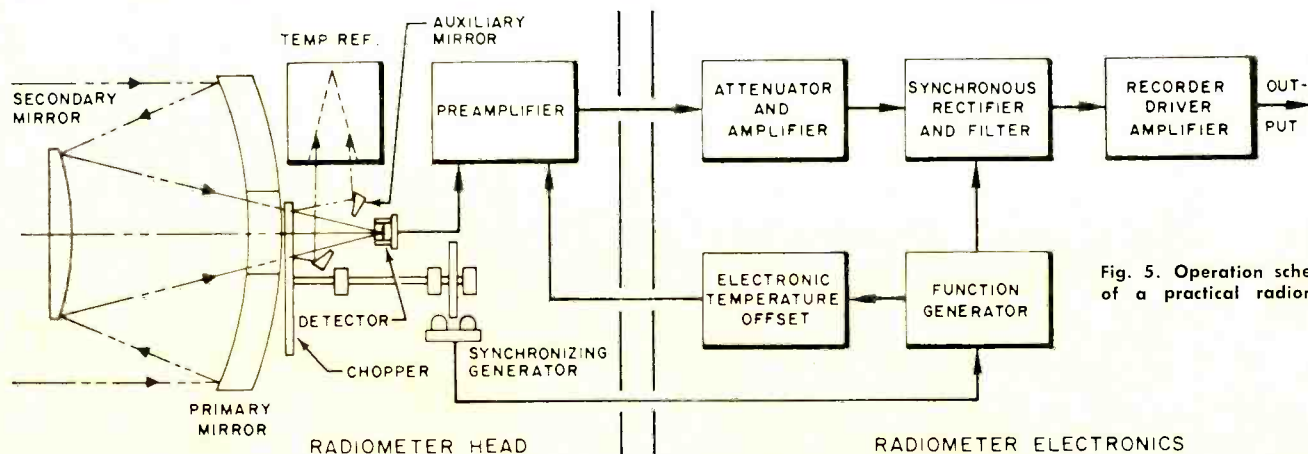

Fig. 5. Operation schematic of a practical radiometer.

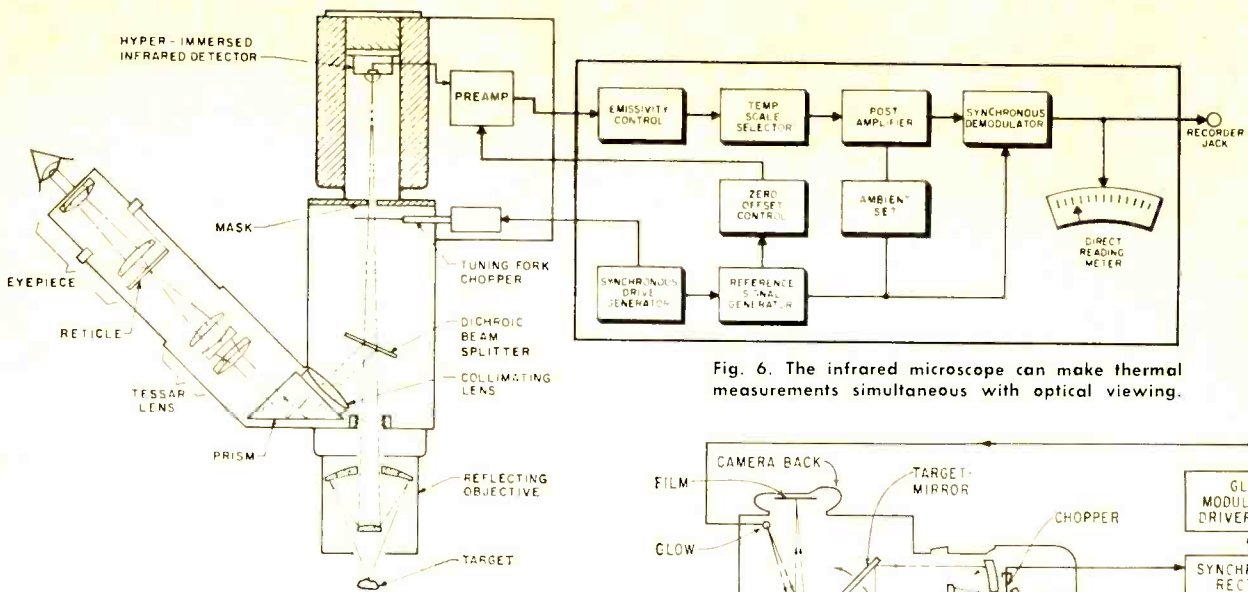

Fig. 6. The infrared microscope can make thermal measurements simultaneous with optical viewing.

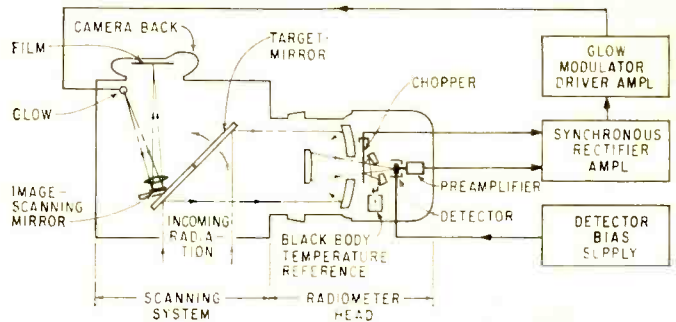

Fig. 7. Infrared camera creates TV-like scan pattern on film by the mechanical motion imparted to target mirror.

sensitivity approximates that of the *InSb* infrared detector.

Where both fast response and high sensitivity at long wavelengths are required, germanium devices doped with gold, zinc, or certain other metals are used. Typical response curves for these devices are also shown in Fig. 3. Doped germanium devices require cooling to liquid helium temperature—about 4° K. Detectors of this kind have been developed with time constants smaller than 0.01 μ sec.

Radiometers

An infrared detector is of little value, of course, unless a means is provided to focus on it only the radiation from the selected target. This is done by mounting the detector in an enclosure which is provided with an optical system to collect the radiation from the target and concentrate it on the detector. A two-mirror system of the Cassegrainian type (Fig. 4) is commonly used in radiometers because of the high efficiencies provided by mirrors over a wide spectral range. If the detector is surrounded by an enclosure having an opening just large enough so that it can see the lens, then the output of the detector will apply only to the radiation from the target. There will also be a d.c. component in the detector output due to the radiation from the enclosure itself, but this can be subtracted in the signal processing.

A practical radiometer is shown in Fig. 5. An optical system such as that just described collects radiation from the target and focuses it on the detector. The resulting electrical signal from the detector is amplified and conveyed to an electronic chassis for further processing. The radiation converging on the detector is periodically interrupted by a rotating chopper blade consisting of alternate reflecting and open sectors. When an open sector is in the optical path, the detector sees out through the optical collecting system to the subject. When a reflecting sector is in the path, the detector sees reflected in the chopper a reference source or black-body cavity. The temperature of the cavity is carefully controlled and provides a standard to which the radiation from the target is compared during each cycle of the chopper. The chopping action has the additional advantage that it provides an a.c. output signal that is easier to amplify. An optical system of this kind can be focused over a range from 30 inches to infinity by moving the secondary mirror along the optical axis. Usually, however, radiometers are specially modified for optimum performance at the working distance for which they are intended.

Many kinds of single-spot radiometers have been devised, differing chiefly in their optical systems which, in turn,

affects spot size, resolution, and working distance; their type of detector, which affects their useful spectral range and speed; and their degree of ruggedness and portability. Fixed-spot radiometers are used industrially in such applications as measuring the temperature of paper, textiles, or metal sheets continuously on a process line, or the temperature of articles on a conveyor belt. The output may be used to regulate the temperature of a furnace or some other parameter in the process. Similar instruments are used for meteorological studies, where valuable data for weather analysis and prediction is obtained by measuring temperature distributions over surfaces of water bodies, clouds, and terrain. Commercial fisheries use radiometers to trace thermal currents of the sea, since many fish are attracted to the warmer waters. Information on water temperature is also useful in determining the propagation of underwater sound waves for sonar studies. Sanitary engineers find the mapping of rivers and lakes beneficial in tracing the dissipation of wastes. In forestry, the instruments aid in the early detection of fires that are otherwise invisible. Portable instruments can readily be carried on ship or aircraft to facilitate measurements in otherwise inaccessible areas.

Radiometric Microscope

At its shortest range, about 30 inches, the instrument described in the previous section has a spot size of about 0.030 inch. Because of the increased interest in microcircuits and semiconductors, radiometers capable of resolving targets as small as 0.001 inch have been developed. These instruments use the same operating principles as other types of radiometers but have an optical system identical to that of a reflecting microscope (Fig. 6). The microscope unit makes a thermal measurement of small areas simultaneously with the viewing of the subject by the operator. The control unit contains the necessary temperature adjustments and meter scales to give direct temperature readout. A germanium dichroic beam splitter reflects visible light into the visual channel while passing infrared energy upward to the infrared detector. A tuning fork chopper is used to present target radiation and ambient reference energy alternately to the detector. The radiation microscope may be obtained

with an uncooled thermistor bolometer, a liquid-nitrogen cooled *InSb* detector, or a helium-cooled doped-germanium detector (the latter two in dewar vessels), depending on the speed and spectral range required.

As a design tool, the radiometric microscope provides a means to plot thermal contours of prototype microcircuits to determine whether the circuit elements are properly oriented to insure optimum heat dissipation. Components that are overstressed experience a rise in temperature and are readily detectable by infrared techniques. Geometry and layout can thus be chosen to avoid hot spots resulting from non-uniform power dissipation. The microscope is also valuable as a production inspection tool to spot improper connections, bondings, and adhesions of circuit elements by detecting irregular thermal patterns across the IC substrate.

Infrared Cameras

Perhaps the most interesting and useful aspect of infrared radiometry is the production of pictorial displays, called thermograms. Unlike conventional photographs that show gradations of light and shadow, thermograms show gradations of temperature in the object viewed. They resemble photographs made on infrared film, with the difference that they are not limited to the very near infrared. Being capable of presenting the weak radiation in the middle and far infrared, modern infrared cameras add a new dimension to our view of the physical world.

An infrared camera, capable of automatically producing pictorial displays of temperature patterns, is shown in Fig. 7. The radiometer head looks into a diagonal target-scanning mirror which deflects its small field of view through a television-like scan pattern. This scanning mirror is driven through a small horizontal angular excursion by a motor and cam, and the radiometer thus sees successive points on the target along a horizontal line of scan. A second cam drives the scanning mirror in rotation about a horizontal axis so that the scanned line moves slowly in a vertical direction. These two scan motions produce, on the target, a rectangular line pattern similar to a television raster. At every point in this scanning pattern, the radiometer generates an electrical signal proportional to the infrared radiation. This electrical signal, after amplification, modulates a glow lamp. The light from the glow lamp is focused in a spot on a *Polaroid* film after being reflected from an image-scanning mirror.

Since the image-scanning mirror is rigidly attached to the target-scanning mirror, the spot of light focused on the *Polaroid* film represents the infrared radiance of the corresponding point on the target. A thermal image or thermogram is thus produced on the film.

The target area may be several inches in the case of a nearby object or several miles for distant views. A thermogram of this kind provides about 60,000 individual temperature readings, giving a very detailed picture of the subject.

The use of thermography to detect malfunctioning of a circuit is illustrated in Fig. 8.

The shaded squares in the upper part of the thermogram is a gray scale showing the actual temperatures of areas corresponding to each level of gray in the picture. This information is not needed for production testing, since for that purpose it is only necessary to establish whether there is a deviation from the normal. However, a design engineer would be interested in the actual temperature to determine whether it is within the desired limits.

Applications of thermography are quite extensive and involve many fields. Probably the largest user is still the military establishment, for reconnaissance and surveillance. However, industrial uses are increasing rapidly. In addition to the inspection of electronic circuits, thermograms are used to detect faulty insulation and erosion in the walls of boilers, steel furnaces, and pipes that carry hot liquids

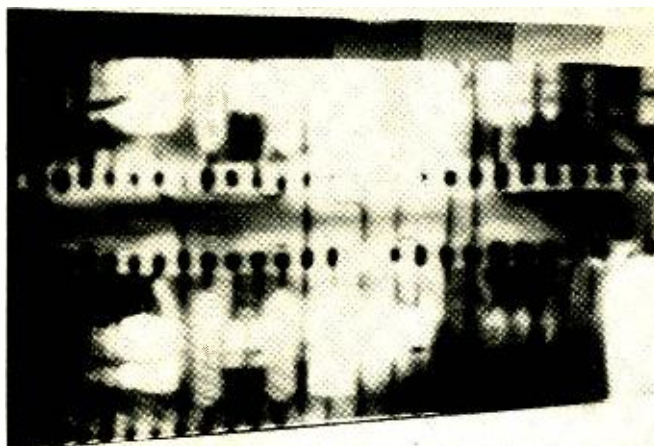
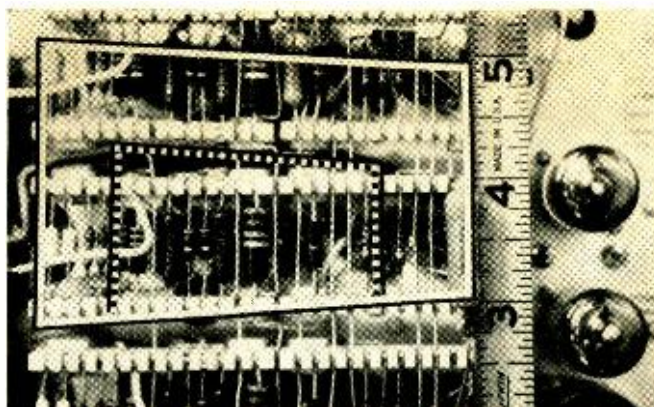

Fig. 8. (Top) Amplifier subassembly. (Center) Thermograph of solid-line portion. (Bottom) Thermograph of dotted-line portion. Note how the heat-generating components show up very clearly in photo.

or corrosive chemicals. Early detection of faults can avoid expensive breakdowns. Surveys of generators in power stations by thermograms locate failing bearings and worn brushes and commutators in high-power rotating equipment. Worn contacts in power switches are detected from thermal patterns showing a hot region in the contact area. In the medical field, thermograms have been helpful in detecting cancer from the heat generated by cancerous growths. Circulatory anomalies have also been detected and their correction observed by thermography, since an inadequate supply of blood to any part of the body shows up as an abnormally dark area on the thermogram.

It is difficult to overstate the importance of thermography as a basic tool for research in a great number of fields, since it permits non-contact measurements of the temperature of objects that are otherwise difficult to observe because they are too far away, or are in motion, or are too small or delicate, or present hazards because of power levels, or are biologically (Continued on page 69)



RECENT DEVELOPMENTS IN ELECTRONICS

Two-Pound TV Camera for Space. (Top left) A tiny television camera about the size of a home movie camera and weighing about two pounds has been developed for potential use in space exploration missions. The device, which with its lens measures under 7 in by 3 in by 1½ in, is the smallest TV camera ever built by RCA, which has produced more than 150 TV cameras for American space programs. Working in conjunction with a signal converter, the camera could relay live pictures from space to home TV audiences. It could function equally well unattended by humans. On unmanned programs, for example, it could "watch" experiments and spacecraft elements requiring visual observation by scientists on the ground. Extensive use of integrated circuits and improvements in the design of the deflection and focus coils make possible the compact size and reduced weight. A half-inch vidicon imaging tube is used. Resolution of the camera is 600 lines, slightly better than commercial TV standards. The camera operates on slow-scan; each frame requires 1½ seconds.

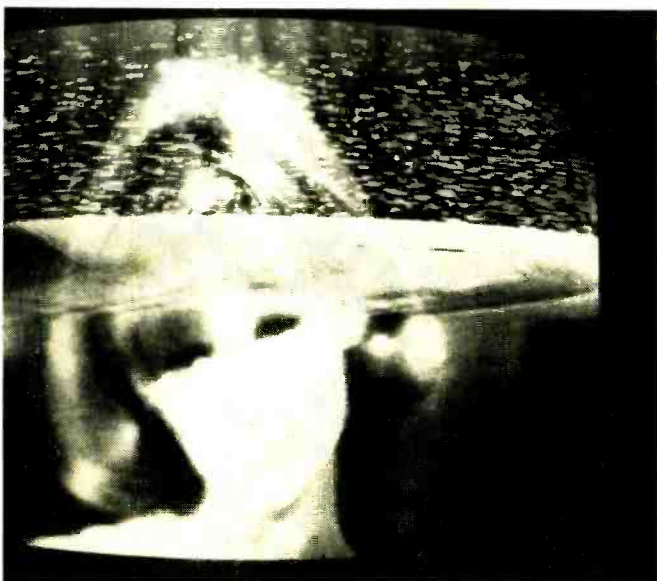

Chromium Dioxide Video Tape. (Center) A new, high-performance magnetic recording tape using chromium dioxide rather than the usual iron oxide as the magnetic medium has been introduced for video recording, instrumentation, and computer use. The new tape, made by DuPont, has higher output at a given resolution or better resolution at a given signal output level. These advantages result from the greater magnetic strength of chromium dioxide along with more precise control of particle size and shape. The new tape, called "Crolyn", makes possible the recording of narrower tracks or a reduction of head-to-tape speeds. For example, the recording speed of a commercial helical-scan video tape recorder was cut in half to make the video recording shown in the photo. The image at the top half of the pattern was produced by iron oxide video tape, while the bottom half was produced by chromium dioxide tape. Note the improved signal-to-noise ratio of the newer tape along with the improved resolution. The splice in the tape resulted in the sync loss at the image center.



Color-TV Camera in a Blimp. (Bottom left) A lighter-in-weight live color-TV camera, along with converter, rack equipment, and microwave gear (total weight 500 pounds) has been installed in the Goodyear blimps "Columbia" and "Mayflower". The camera, manufactured by G-E, is used to take aerial views of important sporting and news events for transmission over nationwide TV. A special rack made of aluminum rather than steel is used to cut the weight of the equipment. Camera system can be installed or removed in about one hour.

Wireless Extension Telephone. (Top right) An experimental lineless extension telephone, a battery-operated portable unit that performs the major functions of a regular telephone set, is being developed at Bell Telephone Labs. The unit uses a radio link to a fixed station which, in turn, is connected to regular telephone lines. Unlike push-to-talk walkie-talkies, the cordless telephone provides simultaneous two-way conversation, connecting and disconnecting, dialing, and ringing. The phone operates in the 35-43 MHz mobile highway band and has a range of 100 to 1500 feet from the fixed station. The telephone unit weighs 31 ounces, is 9 inches long, and is designed into a one-piece, dial-in-handset telephone case.

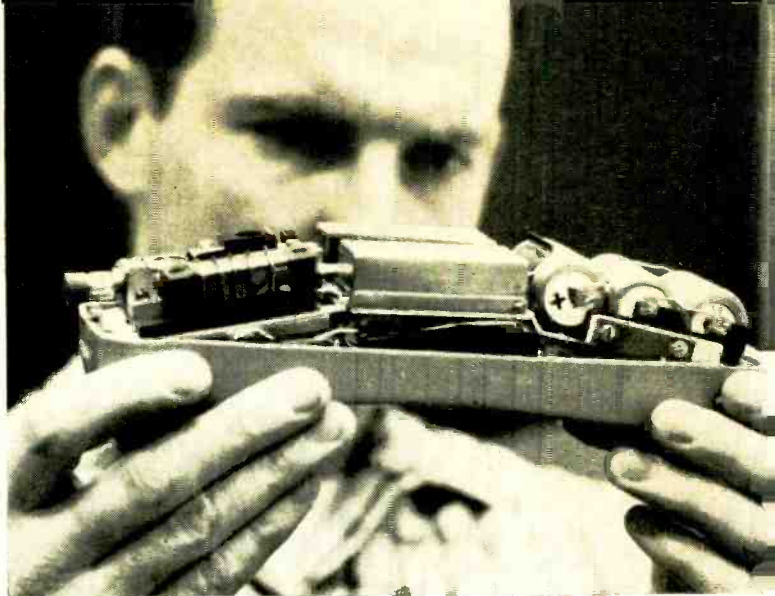

Over-Water Glide-Slope Antenna. (Center) One of LaGuardia's (New York City) airport runways has an approach that is mainly over water. Because of the normal rise and fall of the tide, the radiation pattern from the usual instrument landing system glide-slope antenna would also rise and fall, thus making ILS landings on the runway impractical. The new antenna shown here, developed by Airborne Instruments Lab, produces an unvarying pattern that does not depend on ground or water reflections for its operation. This antenna, now in full operational use, has as its radiator a 60-foot length of slotted waveguide erected at an angle of 3° from vertical.

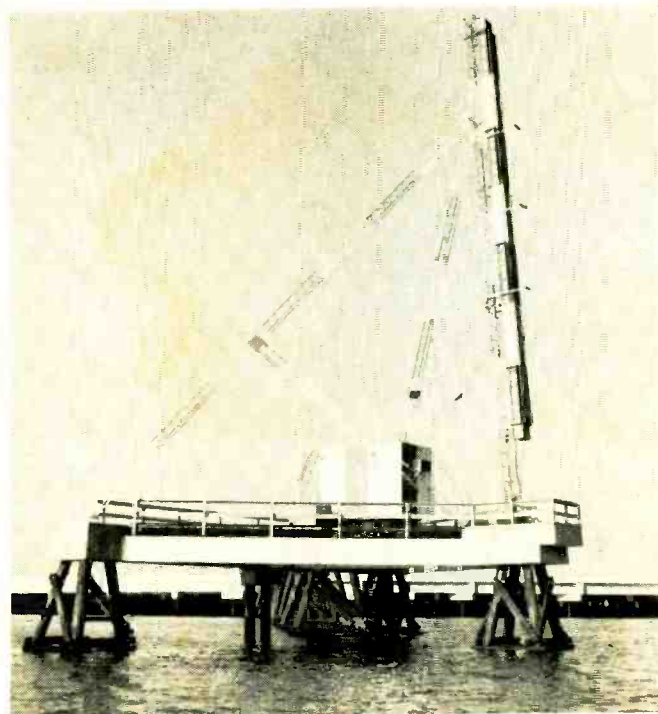

Industrial Robot Operates Lathe. (Below right) An electro-mechanical, electronically controlled industrial robot is shown here working as a lathe operator in a factory of the future. The demonstration is set up in a mirrored room at Expo 67's "Man the Producer" pavilion. The robot, now in production by Unimation Inc., is an all-purpose automated machine that can lift an article weighing up to 75 lbs and move it to another location within a 350-cubic-foot working area with an accuracy of 0.050 in in any direction. Up to two hundred sequential commands can be recorded and stored in the robot's magnetic memory. It can also be interfaced with separate computer.



Computerized World-Wide Legal Library. (Below left) The split-second capabilities of a data computer and international communications have been teamed up to place the world's legal archives at the fingertips of attorneys any place on the globe. In a recent 3-day demonstration for the World Peace Through Law Conference, the computer at the New York headquarters of Law Research Service supplied upon request neatly typed lists of legal references in the language of the country from which the request was made. An international ITT telex link carried the signals from New York City to Geneva.



USING THE NEW CONSTANT-CURRENT DIODES

By DONALD E. LANCASTER

These semiconductors maintain a constant current over a wide range of terminal voltage and appear as very high circuit impedances. Uses include over-current protection, transistor biasing, linear ramp generators, and linear ohmmeters.

A NEW type of diode is now available which works exactly the opposite of a zener diode. It is called a *constant-current diode* or *field-effect current-regulator diode*. Unlike a zener, such a diode presents a constant current regardless of the terminal voltage over a wide operating range and appears as a very high circuit impedance. These new devices are quite useful for a number of electronic applications, including overcurrent protection, transistor biasing, linear ramp and stairstep generators, differential amplifiers, precision reference voltage sources, and linear-scale ohmmeters, to name a few.

Operating Principles

The constant-current diode is basically a field-effect transistor that has its gate and source electrodes shorted together. As Fig. 1 shows, an FET connected this way generates a nearly constant current over a wide voltage range.

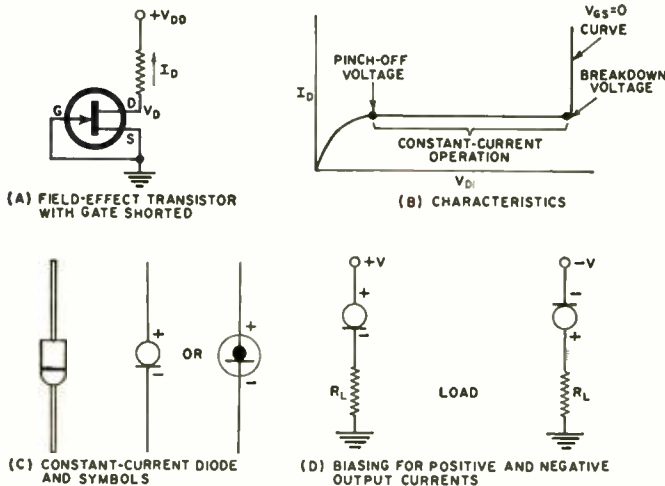
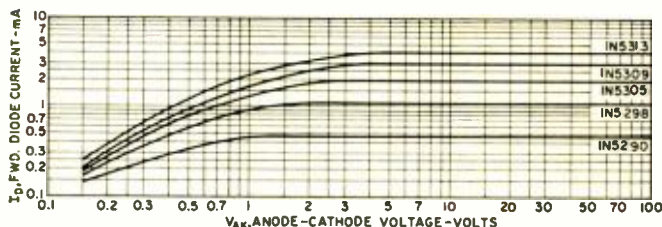

Fig. 1. Constant-current diodes behave like the conventional field-effect transistor but with gate-to-source short circuit.

Fig. 2. The characteristics of Motorola constant-current diodes.



This constant-current region extends from the pinch-off voltage to the forward break-over (breakdown) voltage. In this region, the supply or circuit voltage can vary widely with little or no change in the current the FET allows to pass. Thus, to use a field-effect transistor as a constant-current source, we bias it in the *forward* direction between the pinch-off voltage (usually 1 to 8 volts) and the forward breakdown voltage (25 to 100 volts). Any circuit voltage in this range will result in a constant drain current.

The constant-current diodes are simply field-effect transistors which have been optimized for constant-current service by making the pinch-off voltage very low, the breakdown voltage very high, and the dynamic impedance between these limits as high as possible.

The symbol and polarity of a constant-current diode are shown in Fig. 1C, while Fig. 1D shows the normal biasing and polarity for both positive and negative power supplies. Note that we use the diode in the *forward* direction, unlike a zener diode, which is normally reverse-biased. The diode will provide a constant current *only* when it is properly biased in the forward direction between the pinch-off and breakdown voltages. The constant-current diode should not be connected or biased in the reverse direction.

Available Types & Applications

The IN5283 through IN5314 diodes are a family of constant-current field-effect diodes that cover a 220-microampere to 4.70-milliamperere range in 32 different currents. Performance of several selected diodes is shown in Fig. 2. These 10% tolerance units operate over a -55 to $+200^{\circ}$ C range and have a moderate temperature coefficient that must be taken into account in precision circuitry which must operate over a wide temperature range. Maximum diode dissipation is a healthy 600 milliwatts. The pinch-off voltage ranges from 1 to 3 volts, while the forward breakdown is specified at 100 volts, giving a 97- to 99-volt range of constant-current operation.

Being fairly new, these devices are still expensive (about \$9 each in single quantities), but since an experimenter can come up with a workable substitute by shorting the gate-to-source leads of a far cheaper FET, it is almost certain that these devices will soon be priced in the \$1 to \$2 range, comparable to ordinary zener diodes.

One source of the IN5283 series is *Motorola Semiconductor*, Box 955, Phoenix, Arizona 85001. Data sheets and distributor lists are available. Another source for diodes of this particular type is *Siliconix Inc.* located at 1140 West Evelyn Ave., Sunnyvale, California 94086.

A transistor tester which uses a constant-current diode to

establish a constant, known base current independent of supply voltage variations and transistor voltage drops is shown in Fig 3A. The milliammeter then measures the collector current, directly indicating the d.c. current gain of the transistor. For *p-n-p* operation, the supply, the meter, and the constant-current diode must be reversed in polarity. A switch readily accomplishes this in a practical circuit.

Extension of this simple technique allows the current-limiting diode to be used for constant-current biasing of conventional transistor and FET amplifiers. Fig. 3B shows how a constant-current diode saves parts while biasing a transistor differential amplifier. A single diode replaces the transistor, zener, and two resistors normally used to provide a constant total emitter current.

Another important circuit application is as "active loads" for an amplifier where a substantial increase in voltage gain may be obtained. For instance, the gain of an FET amplifier is proportional to the transconductance and the load resistance. Suppose we bias an FET from a 6-V supply with 1-mA current. If we use a resistor, the load impedance will be 6000 ohms or so. If we use a constant-current diode, the load impedance will equal the *dynamic* impedance of the diode (the *slope* of the constant-current portion of the curve), or around 800,000 ohms for a 1-mA diode such as the 1N5297. This allows us to achieve 800/6 or 133 times the gain from the same circuit by simply substituting a constant-current diode for a resistor. To reach the maximum benefits of this voltage amplification, the input impedance to the next stage must be very high.

Turning to other circuit applications, the field-effect diode is ideally suited as a limiter or noise eliminator. In the circuit of Fig. 3C, any input signal between 4 and 100 volts, regardless of the noise and complexity of the waveform, will produce a 1-volt output gate for the duration of the external input signal. This is especially useful for input signal conditioning in electronic counter circuitry.

The same diode serves well as a precision millivolt reference source, where it is desirable to generate a stable and accurate voltage reference at a lower voltage than zener diodes offer. The constant-current diode simply drives a known resistor, producing an output reference voltage whose value is determined by Ohm's law (Fig. 3D).

As an example, a 1N5305 diode (2 mA) and a 250-ohm load will produce a 500-millivolt reference for an input supply voltage from 3 to 100 volts. Diodes in the 400-micro-ampere region can be selected with zero temperature drift and are preferred for wide temperature applications.

A linear-scale ohmmeter may be obtained by a similar technique. Here (Fig. 3E) the resistance is an unknown and the output voltage is measured with a high-impedance voltmeter. If a 1-mA diode is used, the output voltage will equal the resistance in thousands of ohms. A 0 to 10,000 ohm range may be obtained with a 0-10 volt meter range. The scale is linear instead of extremely cramped at one end as in an ordinary ohmmeter, allowing much easier selection of matched resistors, and more uniform accuracy of measurement.

A current-limiting diode may be combined with a zener diode to obtain much better voltage and temperature performance than a zener could provide by itself. The circuit connection is shown in Fig. 3F and may be used whenever a precision, temperature-stable reference voltage is required.

Capacitor Charging and Linear Ramps

The constant-current diode may be combined with a capacitor to produce a highly linear saw-tooth or sweep waveform, according to the formula $C = It/V$, where C is in microfarads, I is in milliamperes, t is in milliseconds, and V is the voltage. For instance, a 1-mA diode will charge a 0.5-microfarad capacitor to 10 volts in 5 milliseconds. The basic charging circuit is shown in Fig. 4A.

In a conventional RC charging (*Continued on page 78*)

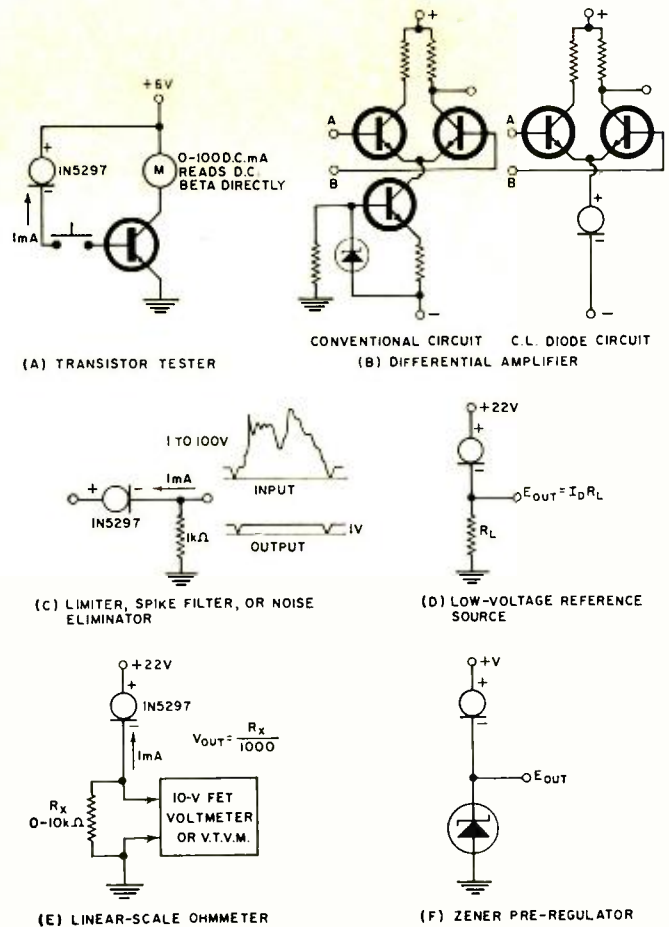
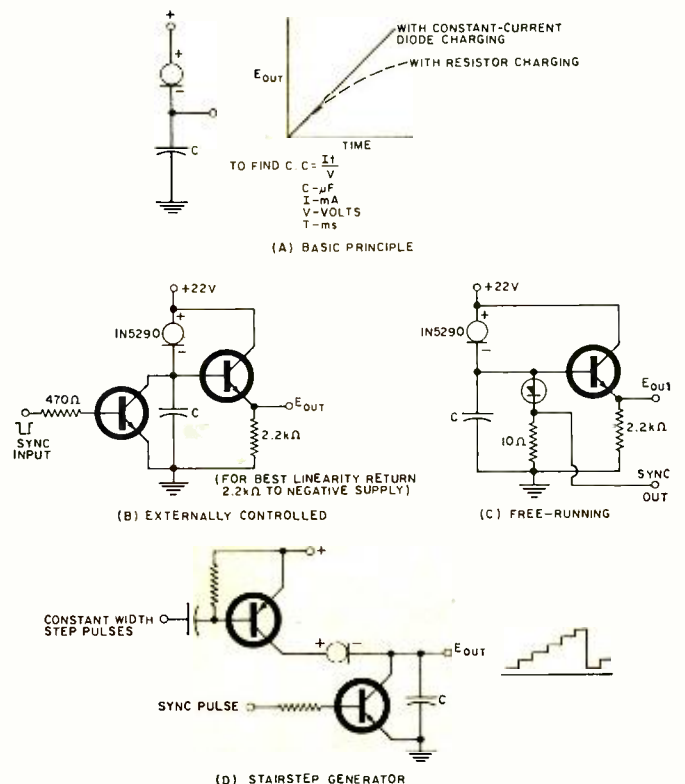

Fig. 3. A number of useful applications for the new diodes including transistor tester; differential amplifier; limiter, spike filter, or noise eliminator; low-voltage reference; linear-scale ohmmeter; or zener pre-regulator. Refer to article.

Fig. 4. Ramps and saw-tooth circuits employing the diodes: (A) The basic operating principle, (B) externally controlled, (C) free-running, and (D) stairstep generator. Operation of each of these circuits is discussed in detail in the text.





The Sun and Space Solar Measurements

Orbiting solar observatory weighs 600 pounds with about 250 pounds used for experiments. Orbit altitude is about 350 miles.

By JOSEPH H. WUJEK, Jr.

All life on earth depends on the radiation emitted by the sun. What types of radiation and what levels reach the earth are being measured by the OSO series of advanced space explorers.

FROM the beginning of life on earth, the sun has played a prominent role in the sustenance of our planet. Indeed, the sun is the prime source of energy for the animal and plant processes which must occur if life is to go on. We should not be surprised, then, to learn that man has always exhibited interest in this nearest star. From pre-historic man's worship of the sun as a deity, through the studies of the ancient Egyptians, Copernicus, and Galileo to the present, the sun remains an object of keen scientific curiosity. With the development of space technology, scientists have greatly extended our knowledge of the sun, though many questions are still unanswered. In this article, we shall examine some of the methods employed in gathering data from the sun and present some findings of this research.

Why Study the Sun?

Beyond the broad scientific and perhaps philosophical reasons for our interest in the sun, several distinct scientific reasons may be pointed out. Since the sun is a star and is an average star in mass, brightness, and temperature, knowledge of this body will give us more insight into the nature of other stars in the universe. And since the sun is the nearest star, it is much more easily observed than the much more distant bodies.

The sun had much to do with the shaping of the earth's crust and with the evolution of animal life. The action of the sun during the age of the great glaciers probably led to the migration of these massive ice sheets and the subsequent shaping of mountains, valleys, and land masses as a whole. It is well known that changes in the earth's climate led to the extinction of certain animal species, the classic example being the passing, in time, of the dinosaur.

As pointed out in earlier articles in this series ("Magnetic Measurements in Space," January, 1966; "Radiation Measurements in Space," August, 1966; "Weather Surveillance

by Satellite," March, 1967; and "Radio Measurements in Space," May, 1967), the sun strongly influences space phenomena and our weather. Magnetic storms, the aurora borealis ("northern lights") and companion aurora australis, radio wave propagation, and radio noise are all subject to the energy processes which occur in or near the sun or as a result of these intense solar reactions.

Properties of the Sun

Before examining the electronic methods used in gathering space data and some of the information obtained by space experiments, it would be well to examine the sun in relation to the earth.

The sun is at an *average* distance of about 93 million miles from the earth and is by far the nearest star. Light from the sun takes a little over eight minutes to reach the earth; put another way, the sun is about eight *light-minutes* distant from the earth. The next nearest stars, Alpha and Proxima Centauri, are 4.3 *light-years* distant.

The circumference of the earth at the equator is about 25 thousand miles, while the sun's circumference is about 2.7 million miles, a factor of about one hundred. The sun is composed entirely of light elements in the gaseous state and hence, on the average, is only about one-fourth as dense as the earth. The sun's elements are chiefly hydrogen and helium, while the earth is composed of iron and silicon for the most part. The surface temperature of the sun is estimated at 10,000° Fahrenheit, with the center under extremely high pressure. The high pressure acting on these gases yields a density in the center of fantastic proportions. For some perspective, if one were able to fill a gallon bucket with the very dense and hot gases found in the sun's center, the bucket would weigh about 900 pounds, that is, 900 pounds on the earth. But on the sun, the pull of gravity is much stronger so that 900 pounds on the earth's surface would be equivalent to over 12 tons on the surface of the

sun. To complete our mental picture of the sun, its mass is estimated at about 2×10^{30} kilograms, which means that if we could somehow weigh this enormous mass on earth, the "scale" would register more than 2×10^{27} tons.

Solar Instrumentation

Some of the instrumentation used in space solar experiments has been discussed in previous articles. Since the sun is essentially a continuously exploding, enormous hydrogen bomb or fusion reaction, swarms of charged particles and other radiations emanate from it. In addition, magnetic flux and radio waves are generated and may be measured by previously described methods. In this article, we shall be concerned only with measurement of the *solar plasma*.

The solar plasma, or solar wind, is primarily a stream of low-energy electrons and protons, with some ions and *alpha* particles, given off by the sun. In the absence of solar flares, these particles move at a speed on the order of 250 miles per hour. These swarms of particles interact with the earth's magnetic field so as to distort this field. In particular, the field on the side of the earth away from the sun is elongated, as shown in Fig. 1. With increased solar flare activity, the earth's field is further distorted, with attendant changes in magnetic-related phenomena on the earth.

In order to measure the type (electron or proton) and number of these particles, plasma probes have been developed. Because of the very low energies involved (100 electron-volts to 20 keV), the detectors described in "Radiation Measurements in Space" (August, 1966) are not sufficiently sensitive.

Fig. 2 shows the basic principles of a Faraday cup plasma probe. A fine mesh or grid is maintained at ground potential, while a collector plate is kept at some high voltage, typically 100 V to several kV (+ for electrons, - for protons). Only particles with a charge opposite to that of the collector potential will be attracted by the collector. The number of particles striking the collector will be proportional to the current flow, as in a vacuum tube. Hence we have a measure of the type and number of particles found in a region of space. A second cup may be used with the collector at a polarity (say, negative) that is opposite to that of the first cup to gather particles of the other polarity (protons)

The Faraday cup in this form is simple to construct and operate but suffers from several disadvantages. No means exist for sorting the particles by energy; thus, we cannot obtain an energy spectrum. Also, photoemission at the collector caused by sunlight and/or the particles to be measured can lead to significant errors. The usefulness of the device may be improved by employing several grids before the collector at different potentials, much as the grids of a vacuum tube are used to control electron flow. By raising or lowering the potential of at least one grid, some energy sorting is possible. This is so because only particles of the proper charge and of sufficient energy can sweep past the grids and ultimately strike the collector. These grid voltages may be varied so that only particles of a given minimum energy may be collected at any instant in time. The result is energy discrimination of the particles, and thus an energy spectrum may be deduced.

Another type of plasma probe or sensor is the curved-surface electrostatic analyzer. The principle involved here is that of altering a particle's trajectory by means of an electrostatic field, as is done in electrostatic-focused cathode-ray tubes. Electrons, protons, ions, and *alpha* particles will have their trajectories altered according to the charge as well as the mass of the particle. Collection of these particles is then similar to the Faraday cup technique.

The remainder of the instrument system is straightforward and consists of amplifiers and a means of routing signals to the telemetry. It is important that stray electric and magnetic fields be kept to a minimum in the region near the entrance to the probe so as not to distort the

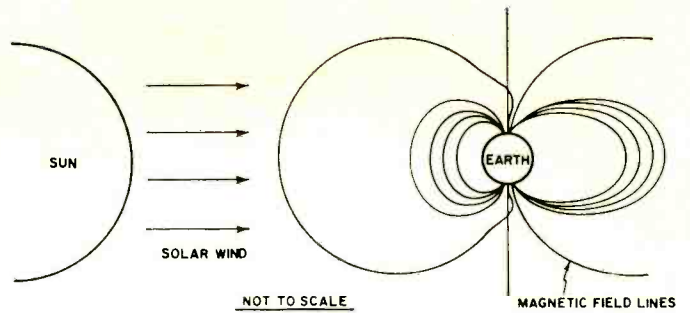

Fig. 1. How the earth's magnetic field is affected by the solar winds (low-energy electrons and protons) from sun.

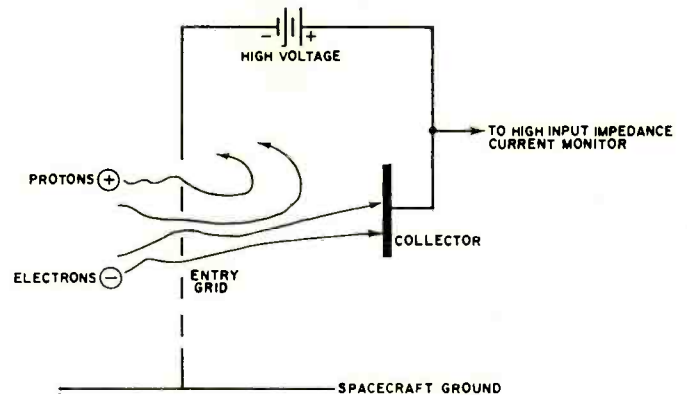

Fig. 2. Basic operation of the Faraday cup plasma probe.

plasma flow. Calibration procedures and/or data reduction methods can correct for small effects caused by the presence of these unwanted electric and magnetic fields.

Orbiting Solar Observatories

To measure some of the important parameters on the sun, NASA has embarked on a satellite program. The vehicles used, the Orbiting Solar Observatories (OSO), will be launched over a span of several years to monitor the sun in both "quiet" and "active" periods. Eight satellites are to be launched, and at this writing two of the three launches that have already taken place have been successful. OSO-I was sent into space from Cape Kennedy on March 7, 1962, carrying 13 scientific experiments which provided more than 2000 hours of scientific data. OSO-II, launched on February 3, 1965 with eight experiments, was similarly successful. OSO-C, launched in the late summer of 1965, failed shortly after lift-off when a malfunction occurred in the launch vehicle.

In addition to solar plasma experiments, an OSO satellite will typically carry magnetometers, radiation-detecting equipment, and radiometers for measurement of ultraviolet light. Also of interest is the *earth albedo*, the amount of light reflected from the earth's surface.

As more satellites are launched, and more data is gathered by the experiments, scientists hope to gain a much better understanding of the nature of the sun itself, and its role with respect to our solar system and the universe.

While enormous amounts of data have been gathered in the many experimental missions so far performed, there still remain numerous unanswered questions regarding the interactions of the solar plasma with the earth as well as the rest of the solar system.

As has historically been the case, Nature has been very slow to reveal her secrets to man as we continue to measure, theorize, and test these theories.

Continued solar plasma experiments, coupled with the measurements that were described in the other articles previously mentioned, will continue to provide mankind with new knowledge of his environment. ▲

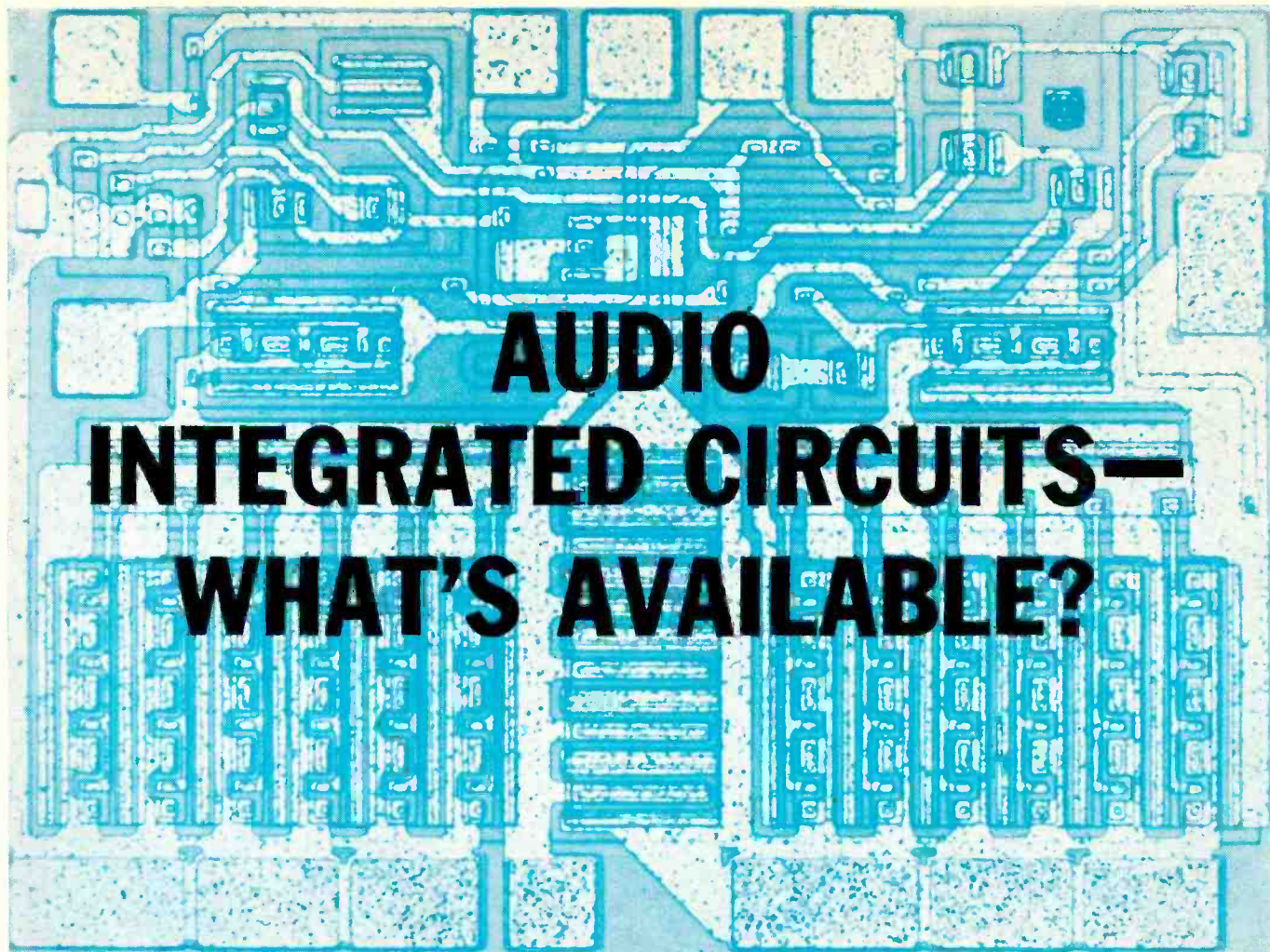

AUDIO INTEGRATED CIRCUITS— WHAT'S AVAILABLE?

Photomicrograph of circuitry used in Motorola MC1554G is fairly typical of the complexity found in the other IC's.

By DONALD E. LANCASTER

A wide range of low-cost IC's is now readily obtainable for use in low-power audio circuits. Here is a rundown on what's available with new ones coming out almost daily.

WITH the recent introduction of a dozen new integrated circuits, the audio designer now has at his command a wide range of low-cost linear IC's. He can buy a half-watt audio amplifier for under \$3; a one-watt unit for under \$4; in single quantities. He can obtain a pre-amplifier IC with a gain and input impedance considerably higher than most vacuum tubes for about \$2, and make use of other integrations whose replacement would require three or more stages of complex conventional circuitry. He can also get broadcast-quality performance to the one-watt power level in two premium units priced in the \$15 to \$25 range. Also available are subminiature audio IC's and special circuits whose gain is easily controlled electronically. (Prices for production quantities of any of these items is, of course, substantially lower than the single-unit prices given above, and further price cuts are imminent.—Editor)

Let's take a closer look at some of the audio integrated circuits that are available and see who makes them and just how they might be put to use. All those we'll talk about are available from distributor stock and the prices mentioned are the approximate single-quantity ones. Complete data and a list of distributors are available; see Table 1.

Anaperex is one of the latest entries in the field of linear

IC manufacturing. They have recently introduced five very moderately priced, high-performance, low-level audio IC's specifically aimed at consumer audio and hi-fi markets.

Their "Bifet," the TAA320 (\$2.25), is most interesting. This IC consists of a MOS transistor followed by a bipolar transistor emitter-follower and a biasing resistor, all packaged in a three-lead TO-18 can. The device combines an input impedance of 10^{12} ohms or so, a transconductance of 40,000 micromhos minimum, and a voltage gain of 40 to 100 under typical bias conditions. With external circuit impedances at the megohm level, response approaches d.c. to 1 MHz.

This is the first major low-cost integrated circuit with an input impedance comparable to or better than most vacuum tubes. Total audio noise voltage is on the order of 25 microvolts, meaning that even fractional millivolt signals may be readily amplified with no noise problems.

The obvious use of the Bifet is as a high-gain, high-input-impedance microphone and phonograph preamplifier. The high circuit impedance levels allow very small input coupling capacitors, even at subaudio frequencies. Another important application is in phase-shift and Wien-bridge oscillators. The extremely high input impedance is also useful in timer

and delay circuitry, and other such types of applications.

A second unit, the TAA310 (\$4.90), is a conventional monolithic IC in a ten-lead TO-5 can. The TAA310 is a general-purpose, low-noise, low-level preamplifier ideally suited as a tape record/playback preamplifier. A 4-dB noise figure is combined with a 90-dB ($\times 32,000$) voltage gain and an uncompensated upper frequency limit of 15 kHz. The IC contains five transistors, four diodes, and five resistors. A 7-volt single-ended supply is needed. In a tape-pre-amp circuit (Fig. 1), the TAA310 provides 64 dB of tape-compensated gain, a 75-dB volume-control range, and 0.5% distortion at a 0.5-V r.m.s. output level.

This IC is useful for any low-level preamplification or tone-compensation circuit where input impedances of 50,000 ohms or less are acceptable or desirable.

Controllable-Gain Amplifier

Although not called an "audio" IC, the RCA CA3023 (\$2.95) wide-band amplifier will find a wide range of audio applications owing to its electronic gain capability. The device has a 53-dB power gain and a 16-MHz bandwidth, all combined with a 10,000 to 40,000-ohm input impedance. A single supply (4.5 to 12 volts) powers this 12-lead TO-5 style IC.

The gain may be electronically varied over a 33-dB a.g.c. range, making this IC ideal for speech compressors, blast limiters, squelch circuits, automatic level monitors, and any other applications where it might be desirable to control the circuit gain with a d.c. control voltage.

Subminiature Audio Unit

Where size and cost are of utmost importance, the *Amperex* TAA103 (\$2.55) low-level amplifier may be put to good use. This four-lead epoxy-cased IC measures only 100-mils square by 50-mils high, yet has a 60-dB gain and can put out 8 milliwatts with less than 5% distortion. Total noise figure is 12 dB. A 6-volt, 11-mA supply is required. Optimum load impedance is 150 ohms.

Hearing aids, headphone booster amplifiers, and other subminiature audio applications are top candidates for this particular IC. Input source impedance should be 1000 ohms or less. This monolithic IC contains three transistors and two resistors.

A very similar unit, the TAA236 (\$2.10) is available in a conventional TO-18 can for use where ease of handling offsets the requirements for very small size.

Low Voltage, High Gain

The *Westinghouse* WC183 (\$7.00) is a low-level audio amplifier that has some unique features. This 12-lead, TO-5 style IC may be powered from a single 1.5-volt cell, producing a gain of 60 dB, a power output of 5 milliwatts, and an efficiency of 55%. Higher supply voltages may be

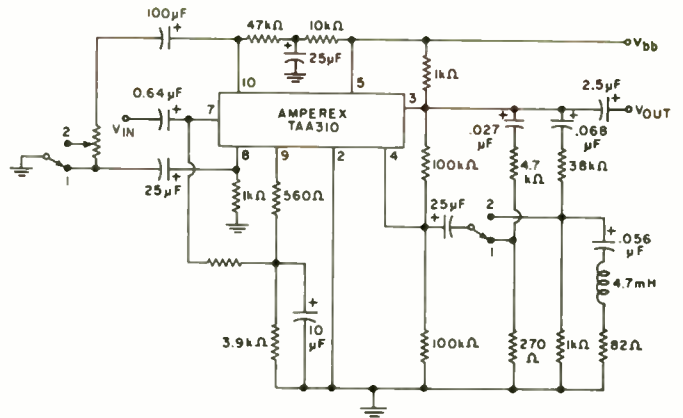
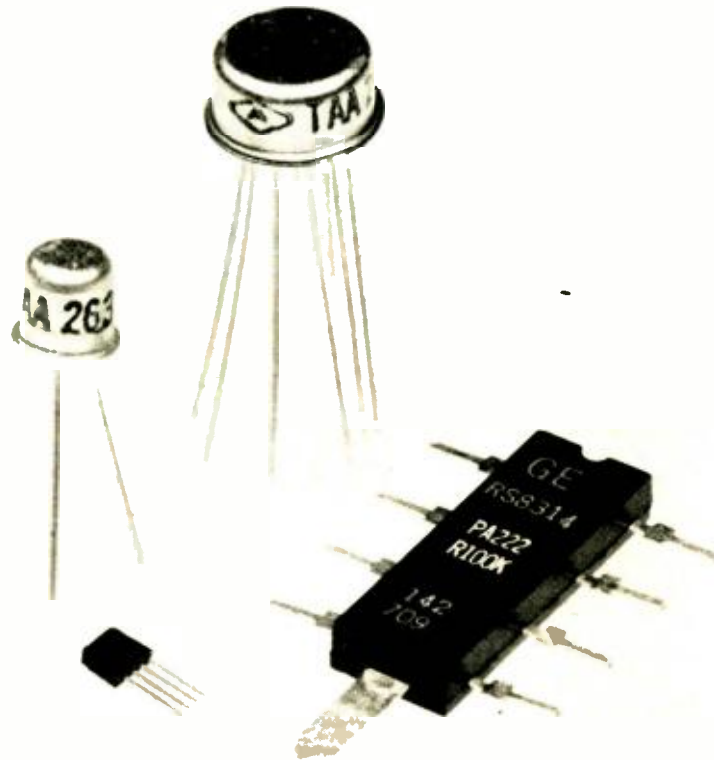

Fig. 1. Tape-recorder preamp with switch in playback position. Values for unlabeled resistors are chosen for optimum results.



The audio IC's described here come in a variety of packages. The units shown above are about two times their actual size.

TABLE 1. LISTING OF MANUFACTURERS OF AUDIO INTEGRATED CIRCUITS

Amperex Electronics Corporation
Semiconductor Division
Providence Pike
Slatersville, R.I. 02876

Fairchild Semiconductor
313 Fairchild Drive
Mountain View, California 94040

General Electric Company
Semiconductor Products Dept.
Electronics Park
Syracuse, New York 13201

Motorola Semiconductor Products
Box 955
Phoenix, Arizona 85001

Radio Corporation of America
Electronic Components and Devices
Harrison, New Jersey 07029

Westinghouse Electric Corp.
Box 7737
Elkridge, Maryland 21227

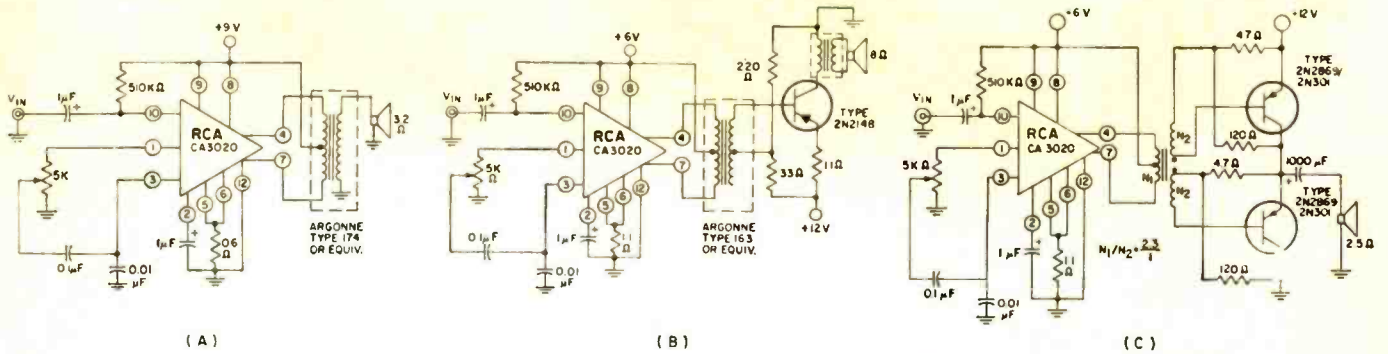

Fig. 2. Circuits using IC's in (A) half-watt audio amplifier, (B) 4-watt class-A amplifier, (C) 7-watt class-B amplifier.

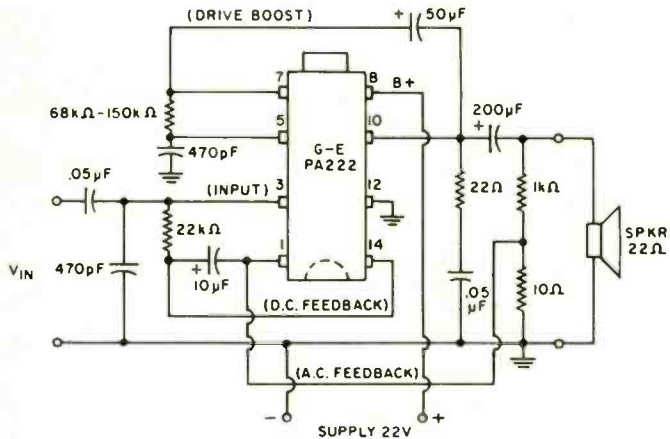

Fig. 3. Circuit diagram of the one-watt audio amplifier.

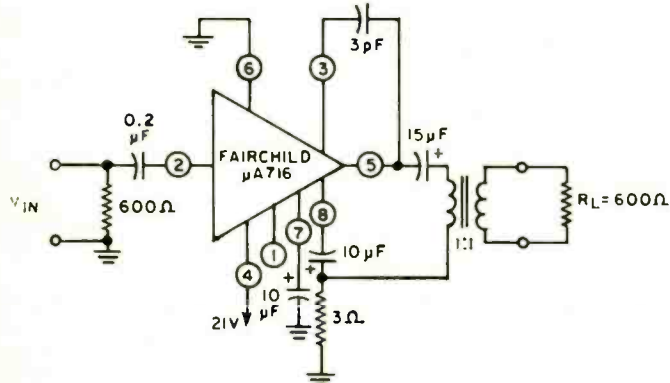

Fig. 4. Telephone system channel amplifier using an IC.

used to achieve 100-milliwatt power levels and gains as high as 94 dB. The high efficiency is obtained with class-B operation, producing distortion figures which range from 2 to 15 percent.

The WC183 is well suited to any application that requires efficient operation off a minimum supply voltage or extreme voltage gain in a compact package.

Higher-Power Audio Amplifiers

Certainly two big bargains in IC's today are the RCA and G-E integrated-circuit power amplifiers, both of which will directly drive speakers to 0.5 to 1-watt power levels.

The RCA CA3020 (\$2.80) combines a 58-dB typical power gain with a 40,000 ohm input impedance and a 550-milliwatt typical output level in a 12-lead, TO-5 style package. Harmonic distortion is 1% at the 150-milliwatt level when high-quality coupling components are used. In the absence of compensation, the frequency response extends from several hertz to 6 MHz. Nine volts at 100 milliamperes are required to handle the half-watt peak output level.

The CA3020 will directly drive a special center-tapped speaker, or else an ordinary loudspeaker and output trans-

former, such as shown in Fig. 2A, may be used. The same IC readily serves as a driver for higher power audio amplifiers. A typical 4-watt class-A and a 7-watt class-B single-ended amplifier circuits are shown in Figs. 2B and 2C.

The G-E amplifier offers higher power at a higher price tag. The PA222 (\$3.70) comes in an epoxy in-line type package with an extended heatsink tab, and will deliver 1 to 2 watts of audio power into a 22-ohm load at 10% distortion. Frequency response extends from 55 to 15,000 Hz at the 1-watt level; 75 millivolts of drive into a 40,000-ohm input are needed for this output power. A single 20-25 volt supply is employed.

This IC is susceptible to high-frequency oscillation and considerable additional circuitry is required to prevent r.f. parasitic oscillation, as the recommended amplifier circuit of Fig. 3 indicates. For high-power operation, the heatsink tab must be held at 25° C or less, through external heatsinking.

There are numerous uses for either of these two amplifiers, particularly in speaker applications where fidelity or high volume are not of prime importance. Intercoms, recorder monitors, AM radios, portable phonographs, and signal tracers are but a few of the many possible applications of these two exciting new devices. As speaker efficiency will markedly affect volume in the 0.5 to 1-watt range, high-efficiency speakers should be used wherever practical.

High-Fidelity IC's

Motorola and Fairchild both have entered the broadcast-quality audio market with two power IC's with excellent distortion figures and performance capabilities.

The Fairchild entry is the µA716 (\$15.00), which is capable of 150-milliwatts output power at 0.2% distortion over a d.c. to 10-MHz bandwidth. Gain taps are available to select one of four different values of fixed gain. Input impedance is 10,000 ohms while the output impedance is 1 ohm. The standby current is 15 mA, obtained from a single-ended 22-volt supply.

A typical application is the telephone-channel amplifier shown in Fig. 4. This circuit provides 40 dB of gain over a 50-Hz to 100-kHz bandwidth with less than 0.1% distortion and an output noise level of -75 dBm over any 4-kHz bandwidth. Gain stability over a wide temperature range is within 0.1 dB.

Motorola's candidate is the MC1554G (\$22.50), which will deliver 1 watt of output power from d.c. to 300 kHz. Distortion at the one-watt level is only 0.4%. Output impedance is 0.2 ohm, while the voltage gain is controllable from 10 to 36, with best distortion figures obtained at low gains and high load impedances. The wide bandwidth creates r.f. instability problems which may be overcome by careful circuit layout and the use of a compensating network. The circuit may be directly coupled to a speaker if split power supplies are used, or capacitor coupling may be employed if a single 16-volt single-ended supply is used. The output noise voltage is 0.3 millivolt, and the standby current drain is 11 milliamperes. This IC requires no heat-sink and comes in a 10-lead TO-5 style package. ▲

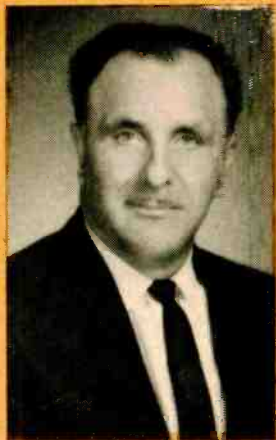

The author, president of Alcoswitch, is active in the design and engineering of new switch products for his company. He was formerly an electrical engineer at the Naval Research Laboratory.

Miniature Switches

By A.F. CONTARINO

President, Alcoswitch (Div. Alco Electronic Products, Inc.)

Occupying far less space than their standard-sized counterparts, a wide variety of these tiny switches with full-sized ratings is now available in toggle, rotary, and push-button configurations.

WITH the coming of the Space Age, factors such as weight, size, reliability, stability, and adverse operating conditions have placed an endless constraint on equipment design. As is the case with the components used in all compact equipment, design engineers have had to fit switches into exceedingly small spaces. As a result, many types of miniature switches have been created—reduced to minimum size and weight—which bear little physical resemblance to the standard switches of the 1940's and, possibly, the 1930's. These miniature switches are currently available from a number of manufacturers for laboratory, prototype, and production applications.

Miniature Toggle Switch

A miniature switch is a "reduced" version of its traditional full-size counterpart and usually performs the same functions (Table 1). Many of these new, tiny types are for applications involving printed-circuit pins rather than the standard solder-type lugs, which makes them ideal for dip soldering and PC use.

Manufacturers listed in Table 2 produce similar types of box-style miniature toggle switches, with the exception of Controls Corp. of America, which produces a line of cylindrical toggle switches. Most of these manufacturers offer miniature types which meet critical environmental requirements, making them suitable for applications in the electrical equipment and electronic fields.

Most switch users are not aware of the fact that many of the miniature toggle switches handle unusually high currents despite their small size. In many cases, these ratings are higher than those of conventional size switches.

Their high current capabilities can be attributed to the frequently closer tolerances and better grades of materials used in the design and manufacture of these switches as compared to less-expensive, full-sized switches. Most of the manufacturers of miniature switches make use of solid coin silver contacts and movable contact bars, stainless-steel bushings and hardware, and a superior grade of plastic materials in insulation and case construction to withstand high heat, high impact, and to insure low dielectric losses.

By making use of silver, gold, and other exotic materials as alloys or platings, these switches are able to handle exceptionally high currents for a smaller contact area, resulting in a much lower operating-contact resis-

tance (Table 3). By making use of inside and outside high-voltage barriers, many of the new miniature switches are capable of withstanding a much higher breakdown voltage in spite of the smaller case size.

Conventional toggle switches are usually rated at 3 A at 117 V a.c., whereas it is very common to find a typical 5 A at 117-V a.c. rating in many miniatures.

The average life of the miniature toggle switch is 100,000 cycles and this is not unusual. In most cases, the life of these devices is longer than the life of the equipment into which they are built.

Types Available

Besides making a line of commercial miniature switches, some companies also produce waterproof miniatures for the military, for marine use, and for hazardous applications, thereby meeting MIL-3950 specifications.

Industry has standardized the miniature bushing size at ¼-40. A wide variety of decorative mounting hardware is

| | TOGGLE | ROTARY | PUSH BUTTON | SLIDE | SNAP |
|---------|--------|--------|-------------|-------|------|
| Shaft | — | ⅛" | — | — | — |
| Bushing | ¼" | ¼" | ¼" | — | — |
| Case | ½" | ½" | ½" | ½" | ½" |

Maximum dimensions in each category

Table 1. The physical qualifications of miniature switches.

Table 2. Listing of major producers of miniature switches.

| MANUFACTURER | TYPES OF SWITCHES |
|---------------------------|------------------------------------|
| Alcoswitch | Toggle, rotary, push button, slide |
| Arrow-Hart & Hegeman | Toggle, push button |
| Continental Wirt | Slide |
| Controls Corp. of America | Toggle, push button |
| Cutler-Hammer | Toggle |
| Daven | Rotary |
| Grayhill | Push button, rotary |
| Janco | Rotary |
| Micro Switch | Snap, toggle |
| Oak | Rotary |
| Stackpole | Slide |
| Switchcraft | Push button |
| Unimax | Snap |

| MATERIAL | PROPERTIES | | RECOMMENDED USES |
|------------------------|-------------------------|------------|---|
| | Conductivity % IACS* | Hardness** | |
| Fine silver (Ag) | 107 | 10-30 | For applications with low contact pressures. Fine silver provides excellent low contact resistance. |
| Coin silver (AgCu) | 85 | 70-80 | Superior to fine silver in hardness. Resistant to mechanical wear. |
| Silver alloys (AgCuNi) | 60 | 75-85 | Snap contacts |
| (AgPt) | 46 | 45-75 | Sliding contacts |
| Gold (Au) | 76 | 25-65 | High resistance to tarnish and corrosion. Use is limited due to softness. |
| Gold alloy (AuAg) | 26 | 45-80 | Applications requiring stable contact resistance. |

*Standard of annealed copper at 100%. **Rockwell 15T scale.

Table 3. Comparison of materials employed for contacts.

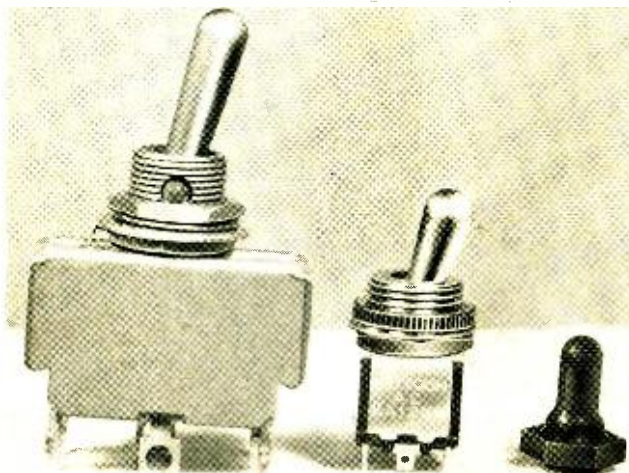

A miniature toggle switch is shown here in the center compared with its standard-size counterpart. Rubber boot is at the right.

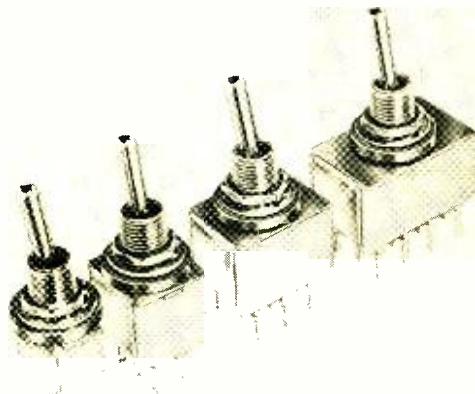

Miniature toggles are available up to 4-pole, double-throw.

available, including an unusual type of knurled nut which forms a perfect fit mounting. As a comparison, if a fixed area is available on a front panel, it is possible to have four times as many miniature toggle switches as the standard types.

These miniature switches are currently available in many styles of one-, two-, three-, and four-poles; in maintained; center-off; and momentary configurations just like standard switches. In addition, a miniature d.p.d.t. toggle with three active positions is available and can be used as a s.p. 3-position toggle switch. Prior to its introduction,

the "three active position" function could be obtained only with a rotary switch.

Some companies imprint their miniature switches with the company name, part number, indications showing "on" positions, as well as current and voltage ratings.

It is quite a feat to have this information presented in such small space—but it meets the requirements of government and industry.

To meet the ever-growing need for multiple-pole toggle switches, many manufacturers have devised means of gauging three or four snap switches to form a rather compact multi-pole switch. Now miniature switch engineers have created a much smaller version with up to four poles encased in a single body. Case size is a mere $\frac{1}{2}$ " \times 1".

The miniature switch industry has designed an unusual family of switches for engineers who prefer the "feel" of a standard $\frac{1}{32}$ " toggle but because of rear panel space limitations must use a miniature. In each case, these switches maintain the same high current rating as their standard-size counterparts.

Recently, *Cutler-Hammer* and *Alcoswitch* introduced new accident-proof "lever-lock" miniature toggle switches for use in hazardous switching operations, particularly on machinery controls and aircraft instrument panels. These lever-lock switches are currently available in a variety of single- and double-pole, maintained, or center-off configurations.

Innovations to be found in miniature toggle switches are numerous. They are designed with a variety of terminals, including lugs, turrets, and pin types that are ideal for printed-circuit applications. *Arrow-Hart & Hegeman* produces a right-angle toggle switch expressly for printed-circuit use.

Color is helpful to the operators of miniature switches. Plastic color caps (red, blue, black, white, and fluorescent tints) are available from most miniature switch makers. A new trend, started by the miniature switch industry, is the use of these colored and fluorescent caps for easier and faster identification of operational devices in test equipment and computers. This color identification scheme has now been adopted for larger switches.

Miniature Rotaries

The biggest conversion from standard to miniature in the industry has probably occurred in the rotary switch field. One of the originators is *Daven* who for many years has produced a complete line of $\frac{1}{2}$ "-diameter, MIL-grade rotary switches.

Not only have rotaries been reduced in size, but *Oak* has recently engineered a group of extremely small rotary switches measuring only 0.093" in diameter. These switches are designed expressly for direct welding to integrated circuit chips as well as for encapsulated circuits. *Alco-switch* produces a $\frac{1}{2}$ " miniature rotary with a built-in adjustable stop feature thereby allowing the user to alter stop positions to meet his requirements.

Because of the compact construction found in rotary miniatures, it is difficult to include a great number of poles with adequate contact area. For this reason, miniature rotaries are usually found to have lower current and lower voltage breakdown ratings as compared to the standard-sized rotary switches.

Potential life expectancy varies greatly in rotary switches—from 10,000 to an extreme of 100,000 operations. Many of these rotaries are sealed, usually in a single gang, and some, such as the *Janco* rotary switch, meet military specifications. However, there are many fine-grade miniature rotary switches currently being made with several gangs.

Daven provides its miniature rotaries as a "switch-in-knob" mounting where space behind the panel is at a premium. In this sort of mounting, the rotary switch requires only $\frac{3}{16}$ " behind the panel for terminals.

Miniature Push-Button Switches

There are two basic types of miniature push-button switches: *snap-action* and *silent-action*.

Grayhill probably has the most extensive line of miniature push-button switches, ranging in size from $\frac{1}{2}$ " down to $\frac{1}{4}$ " in diameter.

The snap-action type usually requires a fair actuating force, on the order of 16 ounces to as much as 60 ounces. In comparison, only 3 to 16 ounces are required for various types of silent-action switches. A current rating of 5 to 10 A at 117 volts a.c. is considered common in snap-action switches. Silent-action types have a maximum current capability of about 1 amp at 117 V a.c.

Push-button switches are produced as either normally open or normally closed. Some manufacturers are producing

1- and 2-pole double-throw versions and there is a 4-pole double-throw push-button switch on the market which will carry 6 A at 117 V a.c., using a $\frac{1}{2}$ " \times 1" case.

With the increase in computer manufacturing, the illuminated push-button switch has been created to meet the growing need for visual switching.

The tiny T-1 series bulbs with long life expectancy are now in plentiful supply and have allowed the miniature push-button switch to be installed in complicated panels.

The large variety of illuminated push-button switches makes these the fastest growing segment of the switch industry. These miniature push buttons are available in both single and ganged versions. Only the size of the human finger limits the miniaturization possibilities of the miniature push-button switch. ▲

Examples of miniature, push-button waterproof switches.

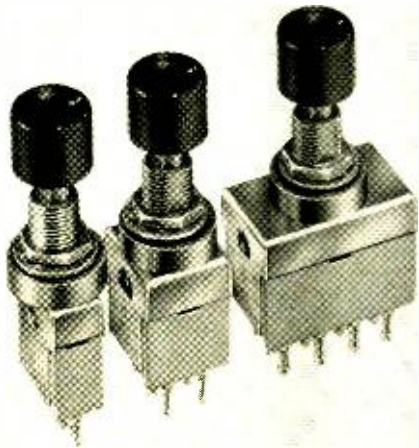

The smallest of these miniature rotary switches, shown next to the match head, is 6-position type measuring 0.093" dia.

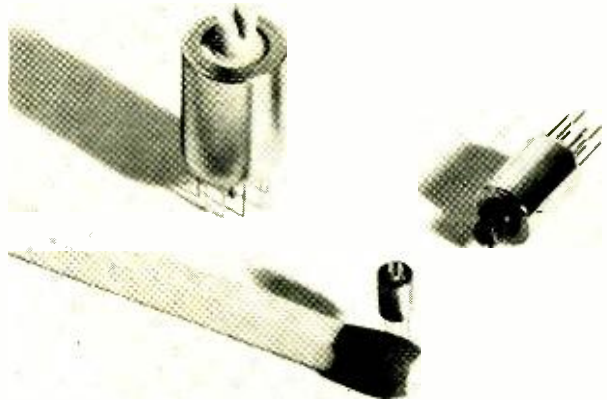

ENCLOSED ROTARY SWITCHES

By ROBERT H. TILLACK/Electro-Mechanical Products Div., Stackpole Carbon Company

THERE is an increasing awareness of the need for enclosed rotary switches in all types of applications. This is especially significant, as contamination plays a major role in determining switch reliability and life, and many atmospheres are inherently contaminating. Performance and reliability will be affected and switch life shortened if operation in such environments is required. The obvious means for protecting the switch against contamination, as has been done for other electronic components, is to isolate it with an enclosure.

In the past, there have been two major deterrents to the use of enclosed rotaries: high cost and limited versatility. The switches shown here have overcome these objections with a unique modular construction that lends itself to automated assembly and versatility. In these devices, the mode of switching has been reversed so that the stator rather than the rotor is cut in varied configurations to accomplish the required switching. The problem of handling a multitude of small parts has been eliminated by using, as a basic building block, a module that is formed by insert-molding a one-piece contact ring in impact-resistant thermo-setting plastic. These modules are then cut in varied configurations to accomplish the required switching. Two modules are needed for each deck with a silver-alloy wiper interconnecting the two. Versatility is achieved by (1) varying the cutting of the modules; (2) number of wipers and their positions; and (3) internal interconnection of decks.

The complete enclosure is maintained in the buildup of a multitude of decks, providing an environment-proof assembly. To suit the varied customer requirements, spacers and intersection shields may be incorporated to provide spacing for components and shielding of sections. Line switches and potentiometers may also be mounted on the rear. One variation even permits the inclusion of a potentiometer internally. Dual concentric shaft switches are also available particularly for use on congested panels.

Some of the areas where enclosed rotaries are finding increasing

usage are machine tools, computers, office copy machines, controls and instrumentation for paper mills and chemical factories, vending machines, self-service gasoline pumps, underwater photography and searchlights, and precision instrumentation.

The switches shown here have breakdown voltages of 1000 V a.c. from terminal to terminal and 2000 V a.c. from terminal to ground. The electrical ratings for resistive loads and silver-plated brass contacts are 0.3 A at 125 V a.c. and 0.5 A at 28 V d.c. for the $\frac{1}{8}$ -in switch, and 0.5 A at 125 V a.c. and 1 A at 28 V d.c. for the $\frac{1}{4}$ -in switch. With silver-alloy contacts, current ratings are about double these values. The standard insulation material used is phenolic, although diallyl phthalate insulation is also available for higher insulation resistance requirements. The maximum number of switch positions available for the smaller switch is 12, while the larger switch can be obtained with up to 24 positions, either shorting, non-shorting, or mixed. ▲

The enclosed rotary switches shown here have body diameters of $\frac{1}{8}$ inches (left) and $\frac{1}{4}$ inches, respectively.

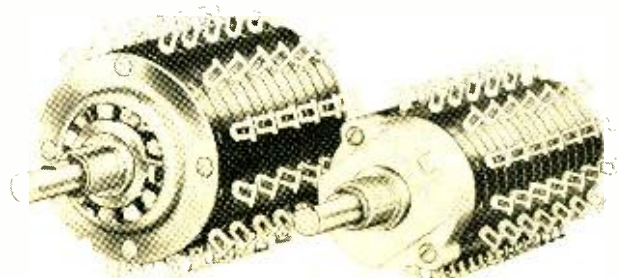

The author is a graduate of the University of Wisconsin and holds an E.E. degree. He served as a Lieutenant in the U.S. Navy during World War II, assigned to the Bureau of Ordnance. At the time proximity fuse ammunition was introduced to the fleet, he was assigned to this project. He has been at Micro Switch since 1951.



Lighted Switching Devices

By WALKER SMITH/Technical Evaluations & Support Manager
Micro Switch (Div. of Honeywell, Inc.)

Lighted devices indicate alarm or status reporting, signal command and response messages, provide verification, and pinpoint sources. Here is information on choosing the proper color, along with a check list showing factors to consider.

THE usefulness of lighted switching devices can best be demonstrated by an example. A typical check—which is routine practice at space telemetry stations—would find the Project Director at the control console in NASA Space Center, Houston. At the same time, in our hypothetical case, his back-up man is seated in front of a similar console at Cape Kennedy. The Project Director presses three lighted push buttons. One is marked "Bahama", another "Azores", the third "Canary". All three stations on the Director's and back-up man's consoles appear yellow. Then, one-by-one, the button color changes to white. Next, "Bahama" turns green, "Azores" turns

green, but "Canary" turns red. "Canary" has reported "no-go" for that station. All the Project Director sees is a display panel that he can push but, by doing so, he has asked the status of each station (yellow), while the message is verified (white) by the receiver. Reports on the same push button are then relayed in either red or green to answer his question. While this is not the most common use of lighted push buttons, it does show the need to pinpoint feedback messages from a massive array of functions.

In contrast, when an operator sees or hears feedback sights and sounds directly from the work he is controlling, lighted devices are usually unnecessary. Once the switch is actuated, the operator can see, or hear, the results.

Frequently, however, operators are physically separated from the work area, or are responsible for the control of numerous functions (often unrelated). When this is the case, the operator needs help in the following problem areas: 1. Has initiation, cycling, or completion of work occurred? 2. Are there too many sights or sounds being communicated to the operator at one time? 3. How can the operator communicate with another operator or master station? 4. How are warnings, dangerous conditions, or feedback messages conveyed?

In general, lighted devices can provide: 1. verification, 2. pinpointed sources or distinct communications from a mass without confusion, 3. command or response messages received and sent in a telegraphic form of words or colors, and 4. alarm or status reporting.

By definition, lighted devices can be simple indicating lights or, when coupled with a switch or other control, an integrally lighted push button, push-pull, selector, selector-push, or an alarm annunciator. The latter is often coupled with an audible alarm and reset mechanism.

Lighted push buttons and indicating lights range in size from the diameter of a 50-cent piece, with single-lamp circuit and heavy-duty push-button electrical ratings, down to push buttons containing four lamps in a $\frac{3}{4}$ " \times $\frac{3}{4}$ " space which can switch 5 amps resistive load at 120 volts a.c.

The size of the indicator is usually related to: size of the lamp, sealing of the unit, whether service voltage devices (such as transformers or resistors) are incorporated, and switches for controlling circuits. The features required spell out the device use areas.

For example, a push button on a computer does not require the degree of sealing necessary on an industrial machine. In an industrial application, typical voltages are 120, 240, 480, and 600 volts a.c.; oils, coolants, and lubricants are apt to disrupt the lamp or control circuits if not sealed; and excessive force in striking the push button may be a habit. This is quite a contrast to what

LIGHTED DEVICES CHECK LIST

This application check list outlines important factors in the selection of lighted devices.

| | |
|-----------------------|---|
| Need | Is there sufficient operator information without indication, or is there a need for interchanging information with feedback, memory, or command messages on the lighted device? |
| Ambient Light | Is the ambient light bright enough to allow the operator to perform the other tasks which are not lighted? Is the ambient light so bright that it overpowers the lamp's output? |
| Lighted Device | Does the lighted device provide sufficient light output for contrast between "on" and "off" states? Would an alternative lamp help? Would a change in the display color help? Would a change in the ambient light level help? |
| Display | Is the display achieved by projected or transmitted light? Is any legending required? Is sufficient legending space available on the device? |
| Lamps | What is the lamp's application voltage in relation to its design voltage? How does this affect the lamp's life? Brightness? Wattage? Heat? Will the lamp experience vibration and shock? Will the filament be allowed to cool between operations? Is there a lamp "on-time" restriction due to excessive heat to the button? Will the number of lamps being energized exceed the maximum wattage (heat-distortion point) of the device? |
| Critical Use | Is it recommended that the lamp's operation not be the sole source of information regarding human safety? Redundant lamps, secondary annunciation, timed lamp replacement, and other factors in the application must be considered for concurrent use. |
| Switch | See "Check List for Ordering Switches" in the article Requirement's "Snap-Action Switches" in this Special Section. |

the pretty young thing wants when she is changing the encoding for a computer.

Miniature Lamps

Lamps used in indicators and controls range in size from the G-3½ down to T-1—or ¼" in diameter down to ⅛" in diameter. Lamp size is usually proportionally related to its light output or brightness, for a comparable life expectancy. This can be a problem in applications which require a small device (small lamps) but the ambient light is so high that it overpowers the lamp's "on-off" contrast. Conversely, a dimly lit room with brilliant indicators can, over a long period of time, produce eye-strain from glare.

The range of lamp voltages is usually wider as the lamp size increases. As the bulb size increases, the lamp can effectively dissipate more heat for long-life operation at higher voltages.

Incandescent lamps are heat producers because the tungsten filament burns at between 2000-3000° K. Heat can distort color-coded plastic lenses if the lamp is driven above its design or rating and the heat produced exceeds the indicator's maximum temperature limit. This problem is outweighed by the efficiency of the lamp in producing high light output for its relatively small size.

When light output of a subminiature incandescent lamp is charted, the following relative energies are found when the lamp is burning at approximately 2750° K.

| Relative energy Color | 5-20 | 20-35 | 35-50 | 50-60 | 60-75 |
|-----------------------|------|-------|--------|-------|-------|
| | Blue | Green | Yellow | Amber | Red |

As the lamp generates light closer to red (and infrared) its relative energy level increases over other spectral colors. Most lighted push buttons and indicators are offered in above five colors (and white) since they provide the clearest contrast between the different colors and the "on-off" display of the unit.

Should a different color be used, such as blue-green (aquamarine), it would be difficult to pinpoint which display was green, which blue, and which aqua. As shown above, blue-colored lamps, having the lowest energy level, will be the first color washed out by high ambient light levels. Red, on the other hand, will maintain greater contrast between "on-off" states under higher ambient light conditions.

Here are six helpful hints for obtaining the greatest lamp life:

1. Voltage surges or application of voltages above the lamp's rating can shorten life. Voltage held slightly below the lamp's rated voltage decreases the light output slightly but increases lamp life considerably.

2. Continuously operated lamps last longer than lamps that are cycled on and off at a slow rate, allowing the filament to cool. Some applications provide a trickle current flow during the lamp's normally "off" state to maintain filament heat. In flasher operations, where the lamp is not allowed to cool, its life approaches that of continuous use.

3. Lamp life is generally longer when applied to surfaces that do not vibrate or receive shock. In most lighted devices care has been taken to assure a free-moving actuator and a stable lamp position. Where vibration or shock is anticipated in the application, a change to a lower lamp-design voltage is desirable since the tungsten filament is thicker and shorter on the lower voltage lamps. For example, a 6-volt lamp can withstand more vibration than a like configuration 28-volt lamp. With severe vibration, the use of neon lamps (without filaments), is recommended. However, neon light output is very low.

4. When operating lamps with resistors in the circuit, lamp life is shorter than in a comparable transformer circuit application because the lamp's voltage increases

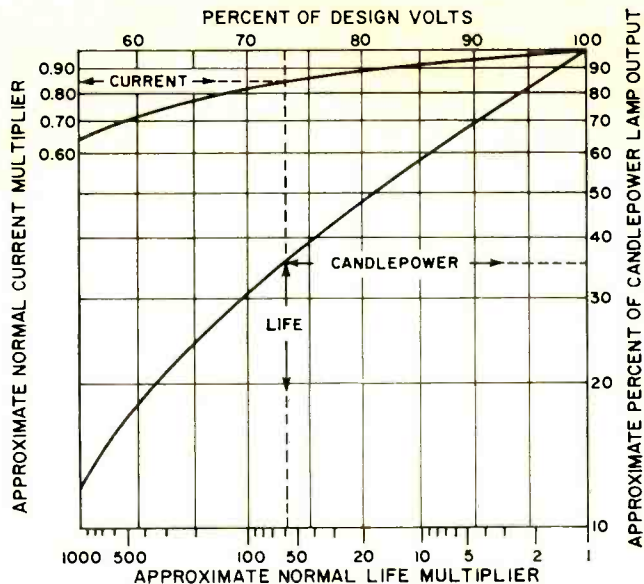

Fig. 1. Effects of lamp operation below its normal voltage.

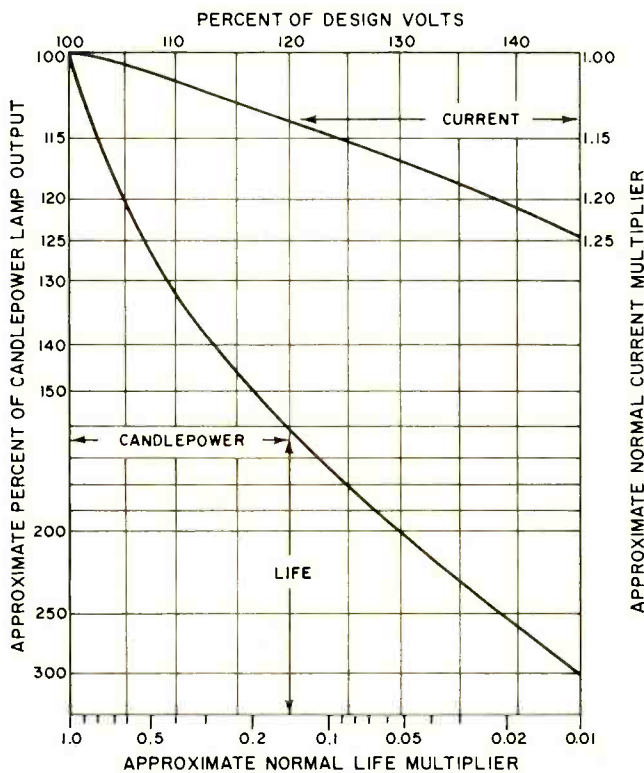

Fig. 2. Effects of lamp operation above its normal voltage.

as the filament material used in the lamp evaporates.

5. As the applied voltage is decreased, light output and filament heat decrease. This results in greatly increased lamp life. Conversely, as voltage is increased beyond the design voltage, light output and filament heat increase while lamp life decreases significantly. See Figs. 1 and 2.

6. At reduced lamp voltage, few colors are suitable. Blue and green displays, for example, have problems with brightness fall-off because of the decreased output from tungsten filament lamps and the inherent "dimness" of these colors. Amber and yellow displays, operated at reduced voltage, can appear as one color when they are separated on the panel. White and yellow also look quite similar at reduced values of voltage.

Color Display

The color display of an indicator's light is available

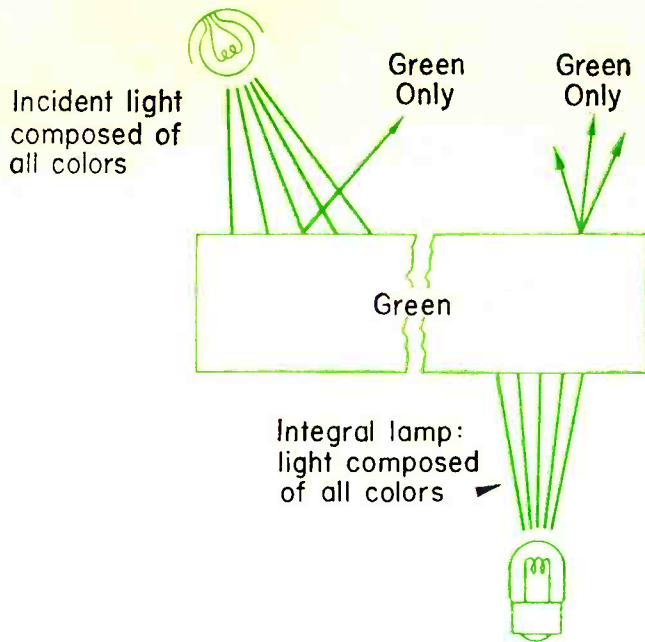

Fig. 3. Transmitted color using a green display screen.

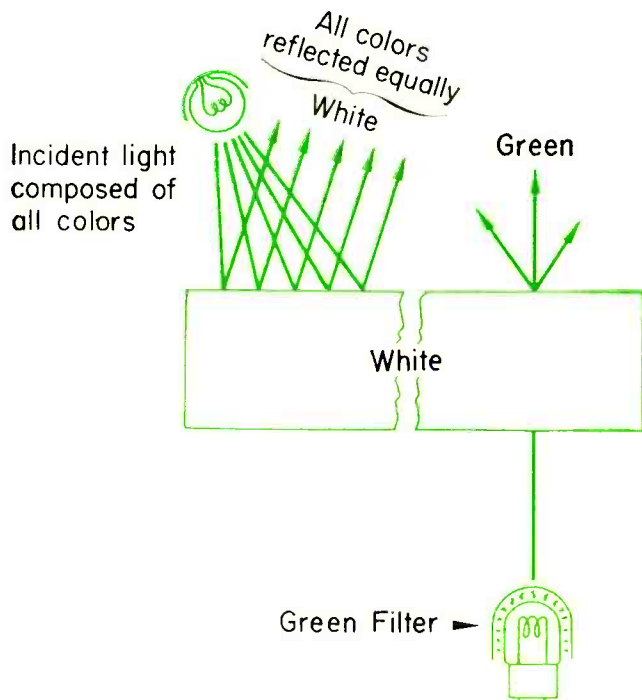

Fig. 4. Projected color using a white display screen.

with either transmitted or projected color. Transmitted color means that the lamp itself is clear and its light is transmitted through a colored display screen to achieve the desired results. For example, when incident light is reflected from a green display screen, it appears dark green in the unlighted state and brilliant green when lighted. The contrast between the lighted and unlighted state is significant because of the low reflectance of the display screen material (Fig. 3).

Projected color indicates a colored lamp or involves the use of a colored filter. The color of the lamp, or filtered light, is projected against a white screen which causes the screen to appear in color. A white display screen reflects more light than a colored screen when the lamp is not energized. In high ambient light, the reflectance of the white display screen could be intense enough to wash out all of the color from the indicator's lamp (Fig. 4).

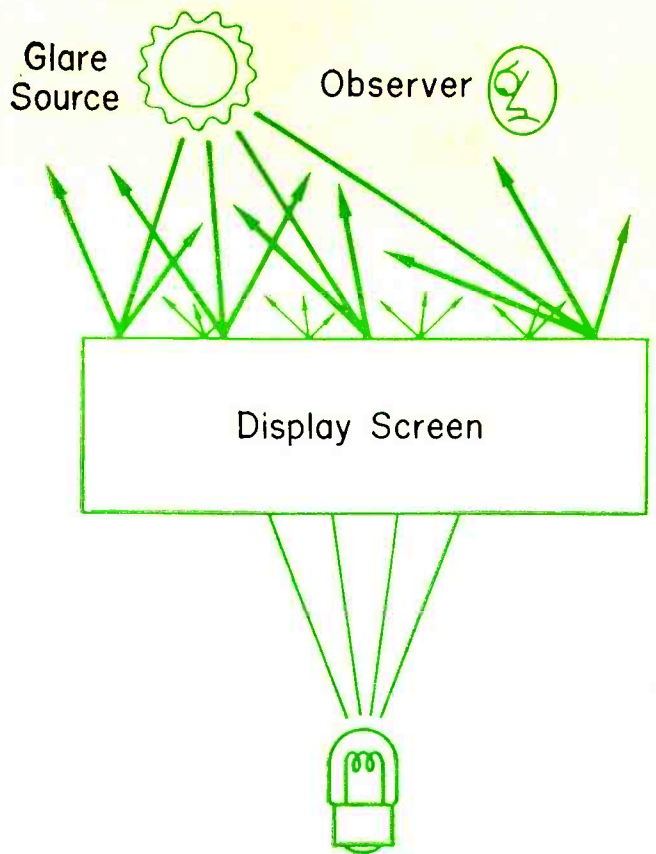

Fig. 5. High glare source, such as sun, reduces contrast.

For these reasons, the use of projected colors is not recommended at high ambient light levels because of the greatly reduced contrast between the lighted and unlighted states.

Lighted displays subjected to sunlight (approximately 5000 to 12,000 footcandles) lose desirable display contrast between the "on" and "off" states. Both transmitted and projected colors are washed out by this extremely high ambient light. Screens or covers that shield the panel from the sun can be used to increase contrast between the indicator's lighted and unlighted states (Fig. 5).

Even indoors, both transmitted and projected colors can be washed out when the angle of the display screen reflects glare to the operator. A minor change in panel angle or diffusion at the glare source reduces this problem.

Panels Containing Lighted Devices

Since panels may be responsible for operator fatigue or cause color confusion, a few simple precautions will help minimize these conditions. When smooth or highly polished panels mirror and reflect glare, a small change in the panel angle will often eliminate much of the trouble. Shielding between the light source and the panel may also be effective in eliminating glare. Textured or grained panel surfaces will also help in reducing reflected light.

A brilliant yellow panel can alter the apparent hues of any colored display and possibly cause color confusion. Vivid colors on the panel can cause operator fatigue and for this reason should be avoided. Where high ambient light reduces contrast, a darker panel color may be used to improve "on-off" recognition.

For general use, the panel should be uniformly illuminated with diffused light. Light level should be high enough to permit the operator to work on non-lighted objects, but at the same time low enough to permit easy recognition of the device's lighted state.

Available Lighted Devices

When an unlighted push button and a separate indicator

are used on a panel to actuate and indicate the same function, substantial savings are possible if the devices are combined in a single lighted push button. In these devices, the lamp circuits are usually independent of the control circuit.

Push buttons used in the electronics industry are generally equipped with snap-action switches for low operating force and to minimize the plunger travel needed for actuating the switch. These push buttons can be equipped for momentary actuation (push to actuate, spring release), alternate action (push to actuate and push to release), hold-in coil (push to actuate, held actuated by coil, release by de-energization of coil), remote pull-in and release (may be actuated by pushing or actuating coil which remains actuated until coil is released), alternate-action, electric trip (push to actuate, push to release, or push to actuate, energize coil to release). Several lighted push button lines also contain mechanical interlocking to prevent operation of two buttons at the same time, or to insure

that only one button is held actuated at a time. Each push button can accept from one to four s.p.d.t. switches, in combination with one to four lamps.

Push buttons in the industrial control field are, of necessity, more rugged and require a longer stroke to actuate a circuit and are sealed to prevent contaminants from entering the electrical contact areas. Usually these devices incorporate transformers, resistors, or other service voltage devices. These units do not accept integral hold-in, remote control, or release coils.

Some industrial control units are available as selectors and selector-push units with four lamps and four transformers in single units. These units reduce panel cost where the operator is separated from the work he is performing. The electrical loading of the contacts is usually heavy duty (high in-rush) or d.c. inductive, as well as resistive and instrumentation loads.

These mechanisms let the panel designer obtain a variety of switching objectives in minimum panel space. ▲

PRECISION ROTARY COMMUTATING SWITCHES

By PETER WAZNYS/Senior Engineer, Collectron Corp.

IN contrast with detented or snap-action switches, the precision rotary commutating switch provides a smooth accurate transition between conducting and non-conducting surfaces. Also, these switches are designed to be rotated at fairly high speeds by means of a drive motor. Standard detented rotary switches divide 360° or less into some equal multiple of "on-off" time. The rotary precision switch, on the other hand, can provide a variety of switching functions of unequal "on" time, if necessary, in accordance with some pre-arranged code. Complex logic switching sequences can be obtained by additional wipers and conductive rings.

Two basic mechanical configurations associated with precision rotary switches along with a photo of a typical switch are shown below. Both drum- and disc-type construction are used. Precious metals—gold, platinum, silver, and their alloys—are used for wiper and contact ring materials to reduce oxidation and contact resistance.

This type of switch, normally operating at low voltages and currents (below 500 milliamperes), is not considered a power-switching device but rather an information-transmitter switch to external circuitry. The amount of information that can be delivered is limited by the physical size of the switch itself. Naturally, the larger the switch diameter, the more "on-off" possibilities that are available.

Lack of detented positions in the precision rotary switch precludes manual operation. In most applications of this type of switch, electrical or mechanical drives, such as a gear train or servo motor, provide the necessary input. The switching output can be either directly or indirectly coupled to the switching circuit. Switch operations which perform within the electrical limitations of the switch can be directly coupled. Operations which require auxiliary assistance, such as with relays, are classified as indirectly coupled.

Switch versatility can best be illustrated by typical applications, which include tachometers, simulated potentiometers, incremental encoders, operation sequence controls, and machine-tool programmers.

A precision multi-speed tachometer can be developed by relating pulse

frequency ("on-off") to the speed of shaft rotation in r/min. The smooth shaft transitions inherent in this type of switch allow high-speed switching without pulsating torque, snapover, and wiper bounce. Switches of this type have exceeded 400,000,000 revolutions, at 3600 r/min, and are now being tested at 16,000 r/min.

Shunting conducting segments with external resistors together with a make-before-break wiper will simulate a stepped potentiometer output.

A uniform "on-off" switching sequence permits the switch to be used as an incremental encoder. Through appropriate mechanical drives and code pattern, the switch can divide multiples of revolutions or parts of revolutions into accurate finite values. The signal can then be sent to a pulse accumulator for a visual digital readout.

It is a delicate operation to adjust and maintain a consistent switch cycle involving time delays. A multi-gang switch with a preselected code pattern can be used in relay circuits which must operate in some desired cyclic sequence. The precision rotary switch provides not only the proper sequence but also the added versatility of changing the switching speed by simply changing the drive motor speed.

An extension of the above technique could be made in simple automatic machining of large quantities of a particular part, for example, in drilling holes at various angular positions in a flat disc. One pole would locate the turntable while the second would signal the drill spindle.

Inquiries to manufacturers of these switches should contain as many design parameters as possible. Include current, voltage, load type, contact resistance, noise allowed, switching code, number of poles, insulation resistance, size, speed, torque, life, and ambient conditions.

Precision rotary switches are usually manufactured to particular customer specifications. Depending upon quantity, switch materials, accuracy, and number of circuits required, the relative cost may vary from 3 to 10 times that of detented switches. Relative cost depends upon the parameters established by the design checklist. For military applications, precision rotary switches should meet the test requirements of MIL-Std.-202, MIL-E-5470, and MIL-E-5272. ▲

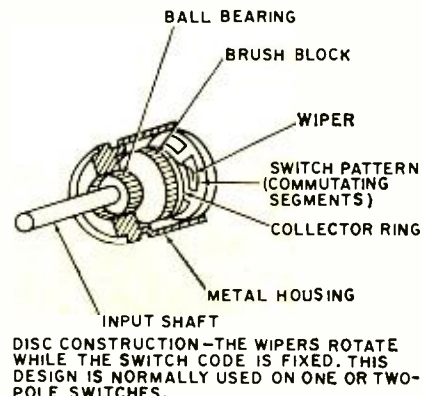
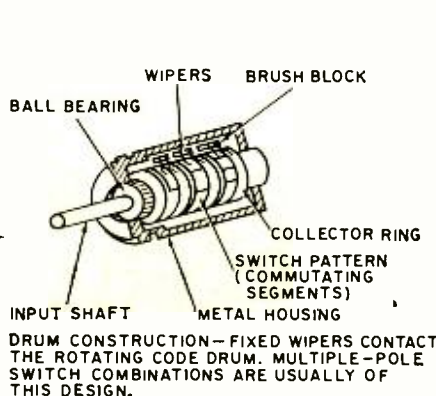
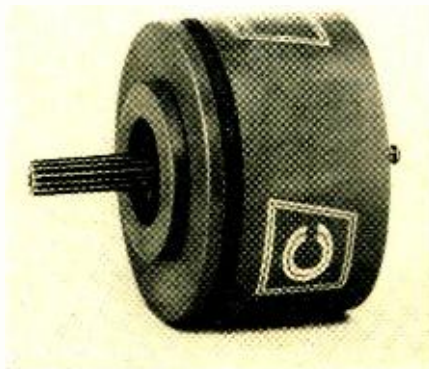

The author has a B.S. degree in Mechanical Engineering and holds 13 U.S. Patents. He joined Oak in 1959 as a project engineer and later was appointed engineering manager of switches. In his present post he is responsible for all engineering, development, and testing of switches. He is author of several published articles.



Slide Switches and their Ganged Arrays

By BERNARD J. GOLBECK/Director of Switch Engineering
Oak Mfg. Co. (Div. Oak Electro/Netics Corp.)

Knowing the mechanical options available and the factors affecting electrical performance, designers can choose the proper push-button-actuated slide switch.

SLIDE switches range all the way from a very simple button-actuated s.p.d.t. unit to a multiple push-button-actuated ganged array made up of as many as 24 separate switches. No matter what the actuating device or whether the complete switch is simple or complicated, the basic slide-switching mechanism is the same.

Actual contact making and breaking is accomplished with a sliding action. The push rod (see Fig. 1) actuates the slider which rides in a guide bracket. The slider, usually a phenolic part, contains a blade designed to make and break with a given set of contacts, depending on the switch function (s.p.s.t., d.p.d.t., etc.).

In addition to switching action, the basic electrical characteristics of most slide switches are identical. After a review of them and how they affect switch performance, we will discuss the various types of slide switches—with special emphasis on how they can be applied in ganged arrays to provide solutions to complex switching problems easily and economically.

Various electrical parameters of slide switches and the design factors which affect them should be reviewed in the light of two basic trends in switching:

1. Voltage and current requirements are becoming lower and lower. Dry circuitry (with current values less than 50 mA) is gaining favor in communications and electronic data processing.

2. Switches are becoming simpler. With the advent of integrated circuits capable of performing logic functions, switches are needed only to trigger the IC logic circuitry.

The current and voltage range of these switches is from dry circuitry up to either 1 amp at 28 V d.c. or 0.5 amp at 117 V a.c. For higher power applications—2 amps at 28 V d.c. or 1 amp at 117 V a.c.—switches with special contacts are available.

The selection of contact base material and plating should be done with several factors in mind: required switch life, type of circuit—inductive or resistive, and environment—temperature, humidity, and presence (or absence) of contaminants.

The following are the most common base material and contact plating combinations for slide switches.

Silver-plated brass with a 0.0001-inch minimum plating thickness will assure silver-to-silver contact for about 10,000 switching cycles. Silver alloy extends the usage to over 200,000 cycles. Both types stand up under 100°C temperatures.

A special spring-base material with a hard gold alloy rolled on the surface will provide gold-to-gold contact for from 50,000 to 100,000 cycles at up to 150°C constant ambient temperature.

Hard gold-plated silver alloy (0.0002-inch minimum) will give gold-to-gold contact in excess of 50,000 cycles; and after the gold has worn there will still be silver-to-silver contact with fairly low contact resistance. This combination is usable to 100°C. Another silver-alloy base with 0.00054-inch hard-gold alloy overlay gives gold-to-gold contact for up to 100,000 cycles and operates at 100°C constant ambient.

Gold plating is primarily for slide switches used very infrequently since accumulated oxide on a silver contact surface would prevent contact from being made on the first operation. Gold contacts should also be specified for switches in a corrosive atmosphere which might attack silver and for switches used in very low level circuits. Obviously, gold in-

Fig. 1. Array of push-button slide switches, showing terms.

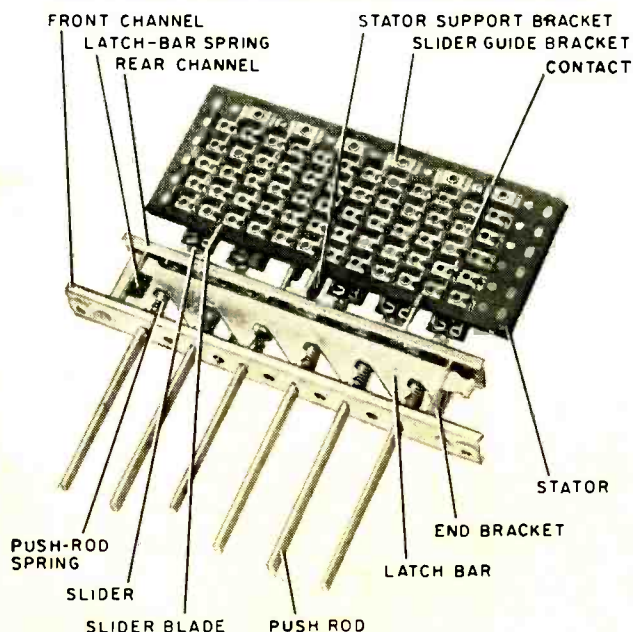

creases the cost of a switch and should be used only where absolutely necessary.

Contact resistance of most low-power slide switches ranges from 0.003 to 0.015 ohm, usually measured from one contact to the adjacent contact. Contact resistance will remain almost constant during rated switch life. However, after the rated life it may change quite significantly. For example, with silver-plated brass contacts, after 10,000 cycles when the silver wears through, brass-to-brass contact will produce increased resistance. With hard gold-plated silver-alloy contacts, resistance will increase only slightly after the rated life of 50,000 cycles.

These life ratings in cycles assume switch usage in low-power circuits. As the amount of circuit volt-amperes increases, contact life and, therefore, switch life decrease. The type of circuit also makes a difference: a low-power resistive circuit produces little, if any, arcing at the contacts, but a highly inductive circuit results in significant arcing which reduces contact life. For circuits with a total inductance of more than a few millihenrys, designers should choose contact materials with a high life rating.

Silver-plated brass contacts should be used only in low-power resistive circuits to interrupt no more than 1 amp at 28 V d.c. or 0.5 amp at 117 V a.c. Silver alloy and other high-temperature, long-life materials should be used for inductive circuits and higher power resistive circuits to interrupt up to 2 amperes at 28 volts d.c. or 1 ampere at 117 volts a.c.

The breakdown voltage rating of these switches depends primarily on the air between the contacts rather than on the dielectric material used. For the average push-button-operated slide switch, the voltage breakdown would be 2000 V between adjacent contacts.

The dielectric almost always used for slide-switch sliders and other insulated parts is high-grade phenolic conforming to MIL-P-3115 specification. Varnishing of the phenolic parts can be specified for contaminated-atmosphere applications. However, this is unnecessary for most slide switches since they are used mainly in commercial applications. In fact, designers of commercial equipment should be wary of specifying varnished phenolics since there is a chance that a bad varnishing job will degrade a good dielectric material and, in addition, destroy the moisture-recovery properties of the phenolic.

Types of Slide Switches

Starting with the simplest type of slide switch, we find it is a button-actuated unit with limited switching action. This switch, generally UL-rated for 3-amp service, is used as an "on-off" device on communications equipment, stereo and hi-fi units, and instruments.

The next type (see Fig. 2) has far more switching capacity than the simple button-actuated type. With the push-pull mechanism usually actuated by a linear solenoid, its basic application is on printed-circuit boards, since its flat construction makes for easy PC board mounting. The same basic switch can also be rotary-shaft actuated giving the user rotary switch action on the front panel and the simplicity of PC board mounting on the rear of the panel.

Push-button-actuated slide switches, usually referred to as merely "push-button" switches, are available in either single or multi-button configurations. Maximum switching is 4-pole, single-throw for the simple single-button type. Basic application for these units and their multi-button counterparts is in communications systems, stereo and hi-fi equipment, and instrumentation.

More complicated switching—up to 12-pole, single-throw per button—can be accomplished with multi-button switches employing larger (and in some cases, double-sided) stators than the single-button units previously described. These units (a typical one is shown in Fig. 1) give the designer considerable switching flexibility.

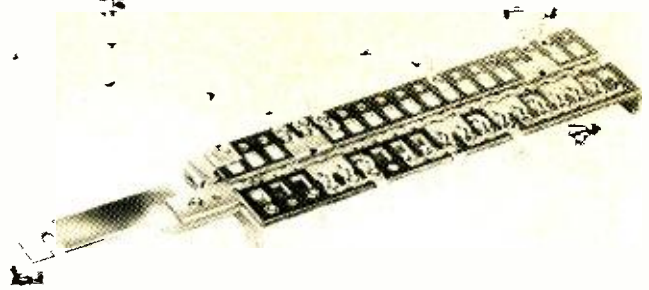

Fig. 2. A 12-pole, 4-throw slide switch for printed boards

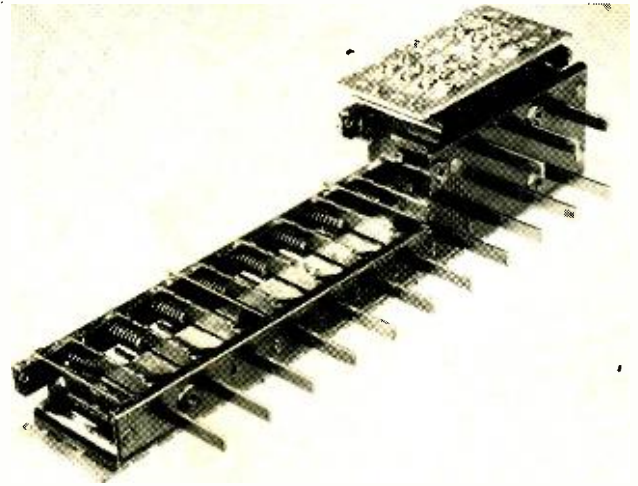

Fig. 3. A second set of buttons may be interlocked with the buttons on the main switch frame to program the operation.

Mechanical Options

The latch bar is the key to the flexibility and various operating options available in push-button/slide switches. Its design determines not only what one push rod can do by itself but also the action relationship among several push rods.

Here is a brief look at the seven basic types of switch operation.

1. *Interlock*: Probably the most often specified operating method, interlock is accomplished with a common latch bar. Depressing one button automatically releases any other depressed button. But this does not mean only one button can be pushed at a time. Any number of buttons can be depressed simultaneously. (To prevent more than one button latching at a time, block-out is used.)

2. *Release Button*: All buttons will remain down when depressed until a release button is depressed. The purpose of this arrangement is, of course, to keep several buttons down at once.

3. *Momentary*: The latching mechanism may be made inoperative on any of the buttons so that these buttons have an individual spring-return action, independent of any other button.

4. *Separate Latching*: Push rods are notched so that they hook on the mounting plate when depressed, making each button latch separately from the others. The operator presses in and down to latch the button and runs his thumb along the bottom of the buttons to unlatch them.

5. *Double Latch*: Two latch bars can operate on the same switch frame with each bar acting on a separate set of buttons. One group of buttons interlocks independently from the other. Double latch is used where maximum switching versatility must be combined with minimum space requirements.

6. *Push-Push*: Individual latches can be installed on any or all buttons. It permits holding in an "in" position when

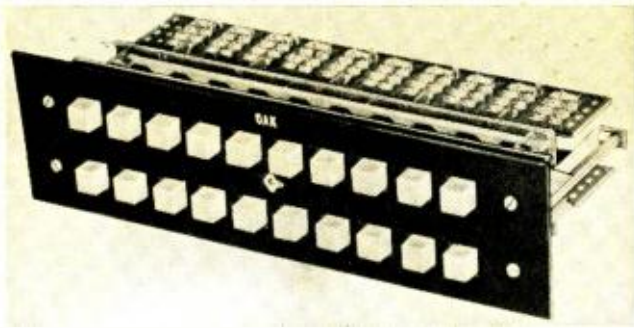

Fig. 4. In this lighted switch, single bulb is used for each group of four push buttons, reducing lighting cost.

pressed once. When the button is pressed again, it is released. The remaining buttons on the switch frame can be either interlocking or momentary.

7. *Block-out:* With this system latching of more than one button at a time is positively prevented. The principal use is in systems where pressing more than one button could cause trouble in critical circuits or, in the case of computer inputs, confuse the logic circuitry.

For a given push-button/slide switch the number of buttons with a block-out or the number of momentary action or interlock can vary depending on spacing and other design factors. It is best to check with a switch manufacturer regarding these options.

The latest development in push-button/slide switching is the use of a second set of buttons, interlocked with the button on the main switch frame (see Fig. 3). This second set does not control circuitry as the main frame buttons do, but instead programs the operating method of the circuit control buttons that are used.

Other Mechanical Considerations

After determining the number of individual buttons required and the right combination of operating options, designers should at least be familiar with the length of the stroke and the operating pressure required to actuate the switch.

Usually the stroke of a push-button/slide switch is about

$\frac{1}{4}$ inch. This length is predetermined by the basic design of the switch.

Operating pressure is dependent on the number of contacts per button. Although switch makers have been working to reduce operating pressure, there are still applications where firm pressure is required, such as coin-operated record players, business machines which handle money transactions, and rugged industrial control systems. Naturally computer input keyboards would require lighter pressure, but most users still want positive "feel" (sufficient pressure to indicate an operation has occurred).

Most push-button/slide switches will accommodate an a.c. snap switch on either side of any end button. It will turn "on" or "off" when the button is depressed. Designers should specify whether the button is to be "in" or "out" when the a.c. switch is "off". These switches, rated at 3 amp at 125 V, are usually UL and CSA approved.

Lighting and Lubrication

Lighting is not generally available for single-button slide switches but can be easily applied to multi-button arrays. One method is to use one bulb behind the panel for each four buttons. Each button has a translucent front and an opaque back so that it is lighted when depressed and dark when not. This system, used on the switch shown in Fig. 4, greatly reduces lighting cost for the switch array as compared with using a bulb for each button.

Most slide switches are lubricated for their rated life at the factory. It is not necessary for switch users to relubricate them. In fact, serious impairment of switch performance can result. Using the wrong lubrication, for example one with electrical conduction properties spilled on the phenolic, could result in a short or excessive leakage between two or more contacts. In addition, lubricating oils used by the factory have been tested over the entire rated temperature range of the switch.

With a basic knowledge of the electrical and mechanical parameters of slide switches, the wide variety available, and the tremendous flexibility ganged push-button-actuated slide switches offer, designers can choose the right one for any application. Also, help in selecting the best switch for the job is always available for any reputable manufacturer. ▲

PRESSURE-SENSITIVE SWITCHES

PRESSURE-sensitive switches perform a single and very simple function: to make or break an electrical contact when a specific pressure is reached in a gaseous or liquid system. The switches are used when specifications require changes in fluid pressure to be monitored or controlled. A variety of switches is available—ranging from those operating at over 25,000 psi to pressures in fractions of an inch of mercury.

The actuating mechanism of such switches usually uses a pressure-sensitive diaphragm that is coupled to an electrical switch, frequently of the sensitive snap-action type. The switch is usually well sealed and enclosed so that the mechanism is not affected by the fluid being controlled. When the diaphragm is actuated by pressure from a thermo-static element, then we have a temperature-sensitive switch.

Actuation of the pressure-sensitive switch, as well as deactuation, occurs within a specified range of pressures. This range included a tolerance which will vary depending on the accuracy required and the pressure range of the switch (see graph). Only the required accuracy should be specified as the tolerance, not the best available.

Other parameters specified for these switches include proof pressure and burst pressure. The proof pressure is the maximum pressure that can be applied without a calibration shift in the actuation and deactuation points. Good design requires that the proof pressure of a switch be a minimum of one and a half times the maximum system pressure.

The burst pressure of a pressure switch is the maximum pressure to which the switch can be subjected without rupture or damage. Usually, burst pressure is at least two to two and a half times the pressure in the system under normal operating conditions. Switches of this type are usually highly resistant to shock and vibration. ▲

Curve shows the maximum difference in psi that may be expected on a typical production pressure switch, in this case a Sigma-Netics Series 703, between the actuation and reset pressures under normal operation. Average values of 70°F run $\frac{1}{2}$ less.

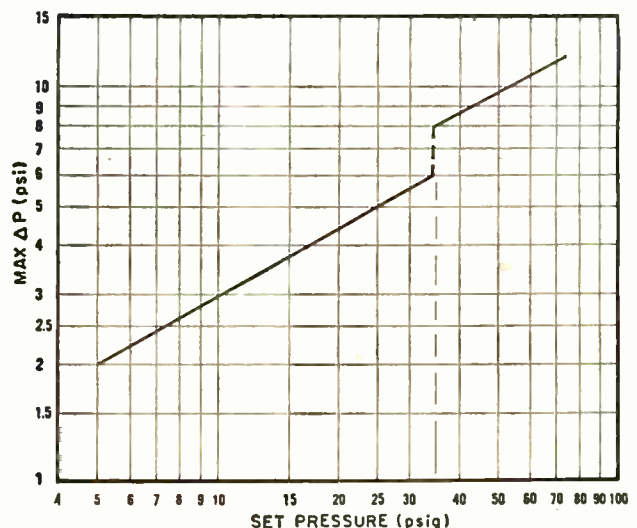



A native of Milwaukee, the author received his B.S. degree from Marquette University. In 1956, he joined the Specialty Products Division of Cutler-Hammer as a member of the Headquarters Sales group. In 1957, he was transferred to Jacksonville, Florida where he opened the company's sales office there. He returned to Milwaukee in 1960 as Headquarters Sales Supervisor and was named to his present position in 1961.

Toggle Switches

By RONALD G. REZEL/Supervisor, Commercial Switch Section
Specialty Products Div., Cutler-Hammer, Inc.

These switches are among the simplest and least expensive method of providing control. Making the proper selection requires consideration of rating, size, terminations, as well as styling and assembly costs.

SELECTION of the proper "toggle-type" switch involves not only consideration of rating, operation, size, and terminations, but factors of styling, integrating functions, and assembly costs as well. The control switch should be made a part of the finished product rather than being just an afterthought.

Standard toggle switches are undoubtedly the simplest and cheapest method of providing control. Selecting the proper switch shouldn't be difficult considering the wide variety of standard switches on the market. UL-approved switches include ratings from 60 amperes or less at 251 to 600 volts and 2 hp or less at 600 volts or less, as listed in "UL Snap Switch Specifications 20". These are basic ratings and, from these same UL-approved switches, others below the 250-volt rating and above 2 hp can be engineered.

Unfortunately, designers often leave the engineering decision regarding the switch to be used on a product until too late in the design process. This is a mistake since it usually results in a compromise which often restricts the engineer's choice to a switch that may prove less-than-ideal for the product.

Ideally, consideration of the control should be started early in the design process to provide the best possible switch for the product. For example, in a dry-circuit (low-current) requirement, the switch should have a wiping contact in order to insure a good electrical circuit. In an a.c. application, the best switch is an a.c.-de-

signed device with slow make-and-break contact operation.

Operating Mechanisms

Proper evaluation of standard switches requires an understanding of the basic operating mechanisms available. In the toggle switch area (this also includes rocker switches), the two basic mechanisms are the "teeter-totter" and "over-center spring".

The teeter-totter mechanism (Fig. 1) is basically an a.c. mechanism and is the most versatile type in that it permits a number of circuit variations. Such variations can be obtained by changing contactor shapes and contact supports. For example, a standard double-pole, double-throw switch with special contactors and a jumper can be used to provide three independent "on" circuits. Rating capabilities are generally up to 1½ hp at 125 volts or 2 hp at 250 volts in single-, double-, three-, or four-pole configurations.

Fig. 2 indicates the derating for this general category of switch in d.c. applications. At low-voltage d.c., this type of switch will outperform d.c.-designed switches in the same price category.

Due to the size of the contact area, this general type of mechanism can be modified with various precious-metal contact materials to provide additional rating capacities and adaptability to various lamp-load requirements.

Note should be made of life *versus* rating on this line of switches and Figs. 3 and 4 show the life and load curves

Fig. 1. The "teeter-totter" mechanism, designed basically for a.c. circuit operation, can also be employed at low d.c. voltages.

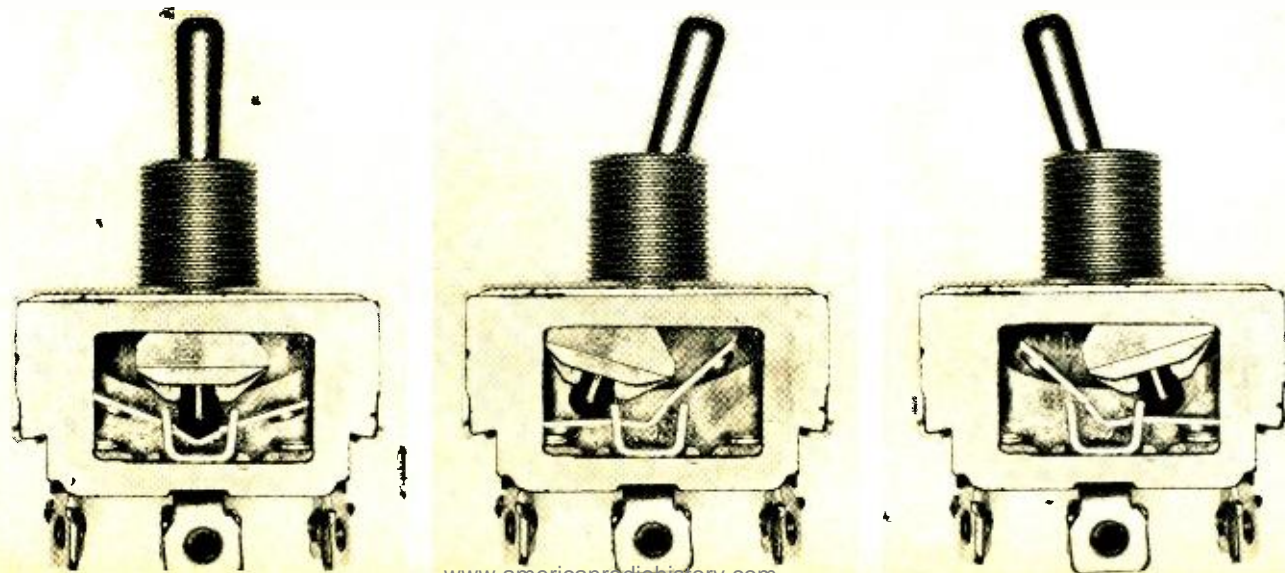

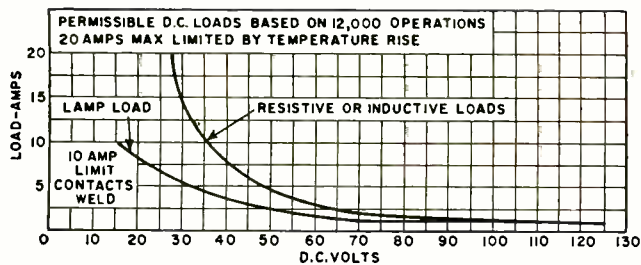

Fig. 2. Derating curves for d.c. operation for switch described.

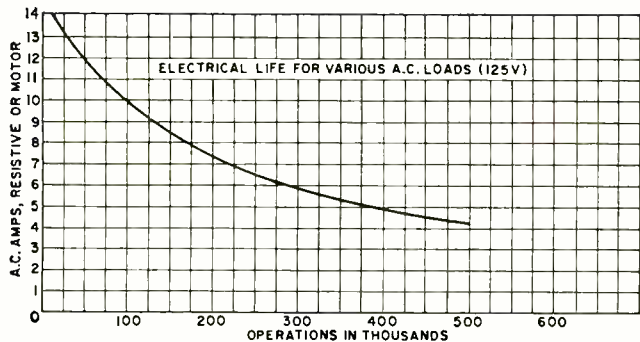

Fig. 3. At lower loads, the life of the switch is extended.

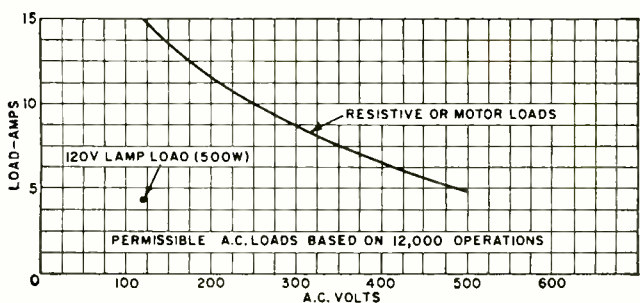
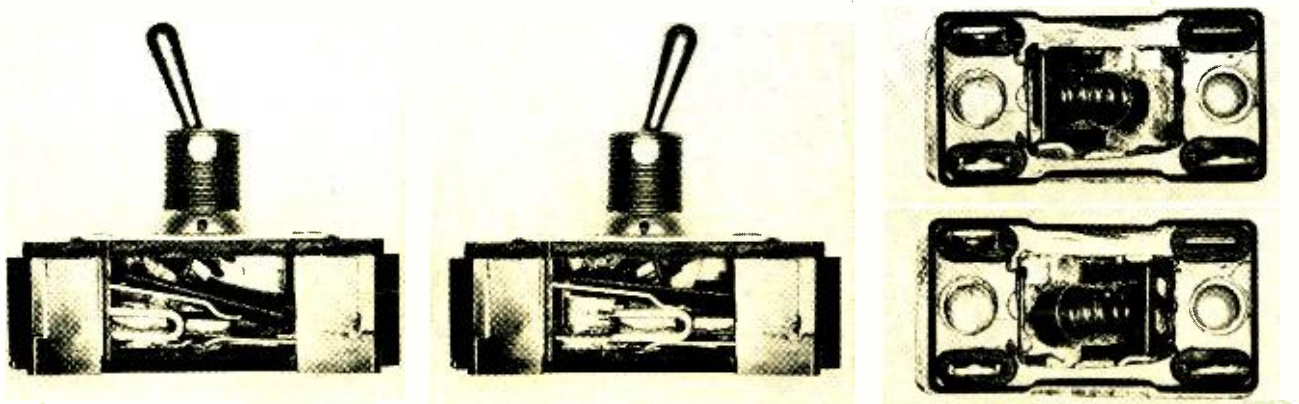

Fig. 4. Higher voltages require reduced loads for given life.

that should be considered in applying these switches. It is important in today's competitive market that the control do the job and not be over- or under-designed for the product it is to control. Life requirements must be clearly understood, based on the load the switch will control and the market life needs of the finished product.

The "over-center spring" mechanism (Fig. 5) is generally considered the basic a.c.-d.c. mechanism. Although these switches operate on both a.c. and d.c., it should be noted that the quick make-and-break mechanism will not take advantage of the natural characteristics of the a.c. sine wave to help extinguish the a.c. arc. Consequently, if all that is needed is an a.c. duty switch, it is better to use an a.c.-designed switch rather than a dual-rated unit. At best, an a.c.-d.c. rated switch is a compromise design.

Fig. 5. Two types of "over-center spring" mechanism toggle switches are shown here in cutaway photographs.



Ratings on the a.c.-d.c. mechanism go to 20 amp at 125 V on the heavy-duty mechanism and to 8 amp at 125 V on the light-duty mechanism in single- and double-pole configurations.

The light-duty mechanism is also the most common switch used on dry-circuit loads. (Dry circuits are those in which there is no arcing when opening contacts. In such circuits, voltage drop across the switch is below 50 mV and contact resistance must not exceed 200 ohms or below 10 millivolts where contact resistance must not exceed 50 ohms.) These switches, depending on the application, can be modified by plating the contacts with silver or gold or by using precious-metal inlays.

Ratings and Terminals

In all cases, the engineer must understand the ratings that apply to each type of switch. For example, on a.c.-d.c. switches, most such units have a *per-switch* rating. On a.c.-only switches, however, many are rated *per-pole*, e.g., a double-pole switch rated "3/4 hp, 125 V a.c., 10 A 120 V, 15 A, 125 V" can be listed by UL with this rating on a per-pole basis—with each pole capable of handling this rating, or it may be rated on a per-switch basis in which case the rating applies to the switch wired as a double-pole unit. There is no way an engineer can determine this by merely looking at the switch. He will have to get such information from the manufacturer or from the UL files since it is essential data when specifying switches.

Available terminals include screw, solder lug, quick-connect, wire lead, and plug-in lead. However, not all a.c. and a.c.-d.c. switches are available in all these terminations. Most switches on the market today use phenolic molding material for the base and this allows a safe operating ambient temperature between -30°F and $+160^{\circ}\text{F}$. Special molding materials and custom processing can increase the operating ambient temperature to 220°F .

Insulation and Sealing

Another factor which is getting more attention in product design these days is *double insulation*. This means:

1. An insulation system comprising both functional insulation and protective insulation. Functional insulation is the insulation necessary for proper functioning of the device. Protective insulation is an independent insulation provided in addition to the functional insulation in order to insure protection against electrical shock in case the functional insulation fails. An enclosure of insulating material may form part or the whole of the protective insulation. In such a system these two insulations, functional and protective, are mechanically separable and are so arranged that they cannot be subjected to environmental conditions simultaneously.

2. An improved functional insulation, referred to hereafter as reinforced insulation, of such mechanical and

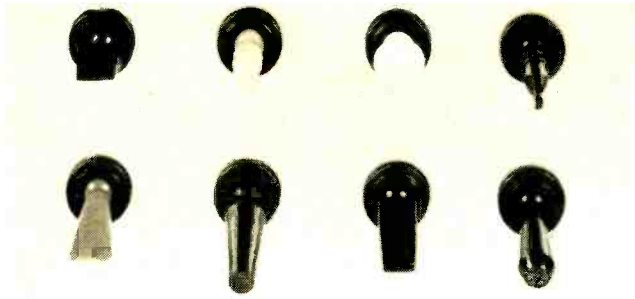

Fig. 6. Toggle switches are available with a wide variety of colored and shaped operators to meet any requirement.

electrical properties that it is acceptable in lieu of a system consisting of functional insulation and protecting insulation. An enclosure of insulating material may form a part or whole of the reinforced insulation.

At the present time there are no specifications governing double-insulated switches. However, many switches on the market can be modified to meet double-insulation standards in the finished product.

Sealed switches are generally provided by manufacturers of toggle switches by means of internal bushing seals. However, with the introduction of rocker operators (actuating mechanisms) and special styled levers, switch-sealing capability may be lost due to the inherent design of these operators. On the other hand, for certain critical operating areas complete environmental sealing can be provided.

Quite often, due to design needs, the switch manufacturers can provide added benefits to the engineer by customizing the control to the application. This is especially important in today's market where there is more and more emphasis on human engineering and space-reduction requirements.

In many industrial electronic applications it is necessary to provide controls which meet some of the requirements of aerospace switches. Consequently, there is a need to modify commercial switches to meet certain of the military specifications, such as temperature, shock, and vibration. To show how one simple modification can change operational results, examine Table 1. This shows how contact resistance changes in a standard commercial double-pole switch with different lubricants. Changing the lubrication is obviously a minor change, but a review of this table will show the importance of this one factor.

By changing contact material, contact pressures, and base material, switch characteristics can be changed dramatically to suit specific operating needs. Also the trend to miniaturization is bringing about designs for smaller switches that will meet specific rating needs, with emphasis on size rather than maximum rating. (For information on miniature switches, refer to the article on this subject on page 37 of this Special Section.—Editor)

| TYPE OF LUBRICANT | CONTACT RESISTANCE (milliohms) | | | | MEASURING CURRENT (A) |
|---|--------------------------------|------|-------------|-------|-----------------------|
| | INITIAL | | 10,000 OPS. | | |
| | MIN. | MAX. | MIN. | MAX. | |
| Dow Corning #7 Grease | 0.6 | 0.9 | — | — | 15 |
| Vaseline #634-3 | 0.7 | 1.0 | 3.2 | 14.6 | 15 |
| Low Temp. Grease #632-55 | 0.7 | 0.9 | 5.4 | 22.6 | 15 |
| Texaco Uni-Temp Grease (Blue) | 0.4 | 1.3 | 9.5 | 16.0 | 15 |
| Vaseline #634-3 Diluted With Carbon Tetrachloride | 0.8 | 1.0 | 4.9 | 10.5 | 15 |
| White Vaseline (Stanolene) | 0.7 | 1.1 | 5.9 | 11.3 | 15 |
| Vaseline #634-3 | 0.9 | 1.1 | 3.8 | 10.5 | 15 |
| Standard Oil Co. Grease #G-3 | 0.6 | 1.2 | 3.7 | 21.0 | 10 |
| Wadham's Gg #480 Grease | 0.6 | 1.4 | 1.8 | 20.5 | 10 |
| Lubriplate #130A Grease | 0.6 | 1.0 | 1.8 | 16.7 | 10 |
| Lubriplate #107 Grease | 0.6 | 0.7 | 3.7 | 25.0 | 10 |
| Mobiloil SAE 70 Ultra Heavy Oil | 0.8 | 1.1 | 4.3 | 20.0 | 10 |
| Wadham's Gg 600W Cylinder Oil | 0.7 | 1.1 | 3.0 | 17.4 | 10 |
| Wadham's MC Light Grease | 0.7 | 0.8 | 3.5 | 18.0 | 10 |
| Texaco Uni-Temp Grease #632-55 | 0.4 | 1.0 | 2.6 | 20.0 | 10 |
| Vactra Oil "2 Special" Way Lube | 0.6 | 1.0 | 4.2 | 17.3 | 10 |
| Vaseline | 0.7 | 1.3 | 3.7 | 20.0 | 10 |
| Low Temp. Grease #632-55 | 0.5 | 1.5 | 1.0 | 12.6 | 10 |
| Low Temp. Grease #632-83 | 0.6 | 1.0 | 0.9 | 5.0 | 10 |
| Texaco Stazon "B" Grease | 0.3 | 7.0 | 0.5 | 7.5 | 10 |
| Texaco SAE #30 Havoline Motor Oil | 0.4 | 0.6 | 3.0 | 9.0 | 10 |
| Cosmolube #1 | 0.7 | 1.0 | 5.0 | 11.0 | 10 |
| Cosmolube #615 | 0.6 | 0.9 | 11.0 | 30.0 | 10 |
| Low Temp. Grease #632-55 | 0.7 | 0.9 | 1.2 | 120.0 | 0.1 |
| Low Temp. Grease #632-55 | 0.7 | 0.9 | 2.4 | 24.0 | 10 |
| Mixture of Filmite #150-58 and Carnauba Wax | 0.7 | 1.0 | 1.8 | 8.0 | 0.1 |
| Mixture of Filmite #150-58 and Carnauba Wax | 0.7 | 1.0 | 1.8 | 8.0 | 10 |
| Standard ASU Super MII | 0.7 | 1.1 | — | — | .1 |

Table 1. The effect on contact resistance of changing lubricant.

Various switch mechanisms can be equipped with special operators in different styles and colors. Paddle operators, rocker operators, push operators are some of the standard operators available today. As thermoplastics become more common in the design of switch superstructures, more varieties will be made available (Fig. 6).

In the selection of switches, whether toggle, rocker, or miniature, there is a need to choose the switch as an integral part of the design rather than as a final consideration. This will provide a better, less costly, integrated control for the product. ▲

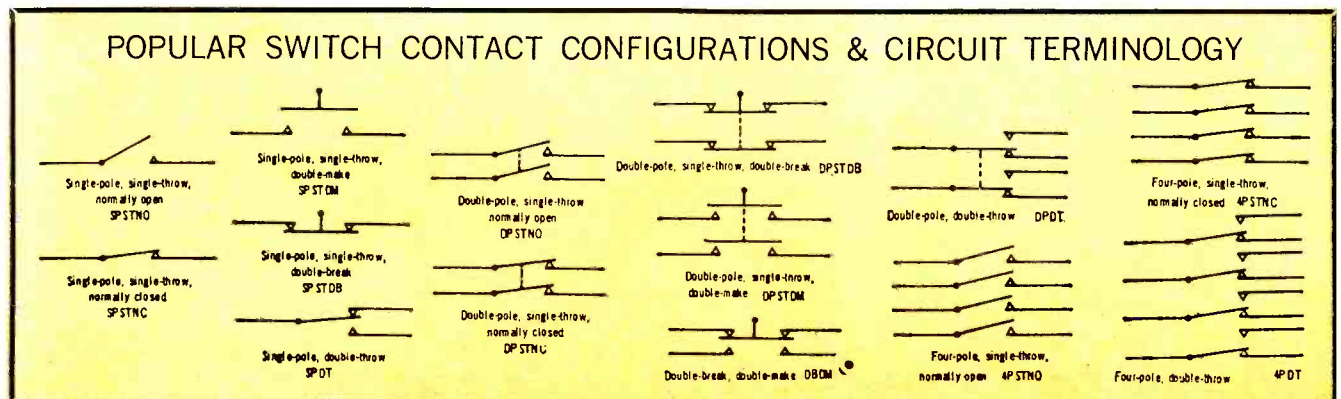

The author is a veteran of 22 years in the field of electrical development and engineering and is today recognized as one of the industry's authorities on the design and development of electro-mechanical switching devices. He joined the firm about 12 years ago as chief engineer and assumed his present position in 1962. Before coming to Switchcraft, he served as a design engineer on such varied products as hearing aids, wire and tape recorders, d.c. motors, and silver alkaline batteries used in guided missiles.



Stacked Switches and their Ganged Arrays

By JAMES BAILEY/ Director of Research & Development
Switchcraft, Inc.

These leaf-spring switches are used because of their economy, simplicity, reliability of performance, and ease of maintenance. Items to consider in choosing the proper switch are covered.

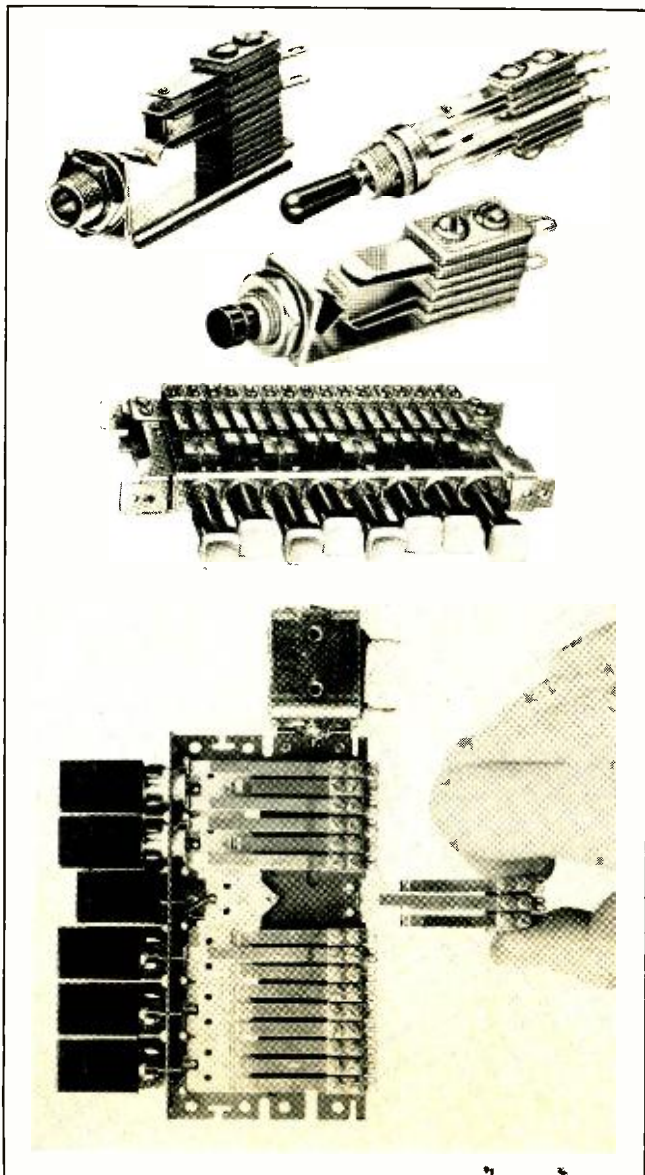

ALMOST indifferent to the more sophisticated advances in switching, the stack switch remains one of the most useful, versatile switching devices available to the circuit design engineer because of its simplicity, reliability of performance, and ease of maintenance.

Why use a stack switch? Because it may cost less per switch configuration than most other products. When properly engineered into the end product, it will provide very long life. If it has to be serviced, the technician can readily understand the mechanism and locate the trouble. Finally, its versatility is unmatched in meeting special circuit requirements in the initial design or when additional circuitry must be accommodated at a later date due to revisions in the end product.

With all its advantages, the stack switch is not recommended for high shock, anti-capacitance, high vibration, or temperature extremes.

Stack switches are included as a sub-assembly in many switching devices, such as lever keys, relays, push-button switches, and phone jacks, as shown in Fig. 1. However, many are mounted separately and actuated by various means for machine tool control, indexing, data input and retrieval, and sequence control. No matter what the application, the primary considerations in specifying a stack switch are: 1. the switching configuration desired, 2. the method of actuation to be used, 3. electrical circuit considerations, 4. environmental conditions, and 5. cost.

A stack switch consists of an actuator spring, contact springs, insulating spacers, insulating tubing, and mounting screws. (Refer to Fig. 2.)

Switching Configurations

Basic contact forms A through F (Fig. 3) may be specified on stack switches. However, caution must be exercised when specifying the total number of springs used in each stack. Attempts to use too many springs per pile-up can result in stack sway, loosened stacks, and loss of adjustment due to accumulative spacer cold flow and excessive operating forces. Also, the total number of configurations per stack will be governed by the contact size and insulators required to obtain the necessary contact clearances for proper adjust-

← Fig. 1. Stack switches may be operated by push buttons, handles, or phone plugs. They are also available in ganged arrays.

ment and operation. Where two or more stack positions are available, it is always advisable to distribute the switching configurations as evenly as possible to avoid excessively high stacks.

Ideally, each moving spring will be tensioned to result in 30 to 100 grams' contact pressure. If other design factors of the switch dictate lighter contact pressure, say 10 to 20 grams, then gold or palladium contacts may be specified. For higher contact pressures, such as for an example in the hundreds of grams or more, tungsten contacts are recommended.

An example of the versatility of stack switches is their adaptability to special contact forms or sequential operation. Late or preliminary makes or breaks may be specified for various circuit control requirements. However, some consideration must be given to the position of these special configurations in the spring stack. For instance, preliminary make or break contacts should be placed at the bottom position of the stack. Late breaks should generally be positioned at the top of the stack in order that adequate contact pressure may be maintained throughout the travel of the moving spring.

Method of Actuation

While considerable freedom as to the method of actuation is an inherent feature of stack switches, certain dimensional and force characteristics must be coordinated in the actuator design. First, the actuator spring is normally part of the switching or contact configuration, hence the actuator is usually a suitable insulator material such as fiber, plastic, or phenolic. The stack assembly requires a minimum of amount of travel to properly actuate all contact springs since too much travel will induce unnecessary spring fatigue and cause excessive contact wear. For an ideal switch, the user should design the actuator to provide an 0.010" to 0.020" contact follow after closure and a contact gap of 0.020" to 0.030" between break contacts after the switch has fully operated. See Fig. 4.

Another consideration is the speed of operation. Excessively slow operate or release timing could seriously affect contact life, especially where inductive loads are involved. Slow operate or release time is generally acceptable for a.c. circuits, but quick release is desirable for d.c. switching to achieve maximum contact life.

Mechanical switch life is practically impossible to specify without complete knowledge of all parameters involved. A good stack switch, suitably mounted and actuated, should provide 500,000 or more operations. However, this figure could be far above or below measured life for any particular application. Maximum life may be obtained by close adherence to switch travel requirements and by designing the actuator for a minimum amount of wear on the actuator spring.

Three common spring materials for stack switches are: nickel silver, phosphor bronze, and beryllium copper. Phosphor bronze is standard for many assemblies, however nickel silver has improved strength and flexure characteristics and will be furnished on quality units. Beryllium copper should be specified where exceedingly long mechanical life is required. This material is often used where severe spring forms are needed as it is highly ductile and can be tempered after forming.

Electrical Circuit Considerations

Stack switches are generally designed to accommodate switching currents from low-level dry circuits up to 5 amps, 500 watts. Contact resistance becomes a major factor in low-level circuits due to organic materials or condensates and oxides that may collect or form on the contact surfaces. Gold alloys, in combination with platinum and silver, and sufficient contact forces usually minimize oxidation and other contaminant problems.

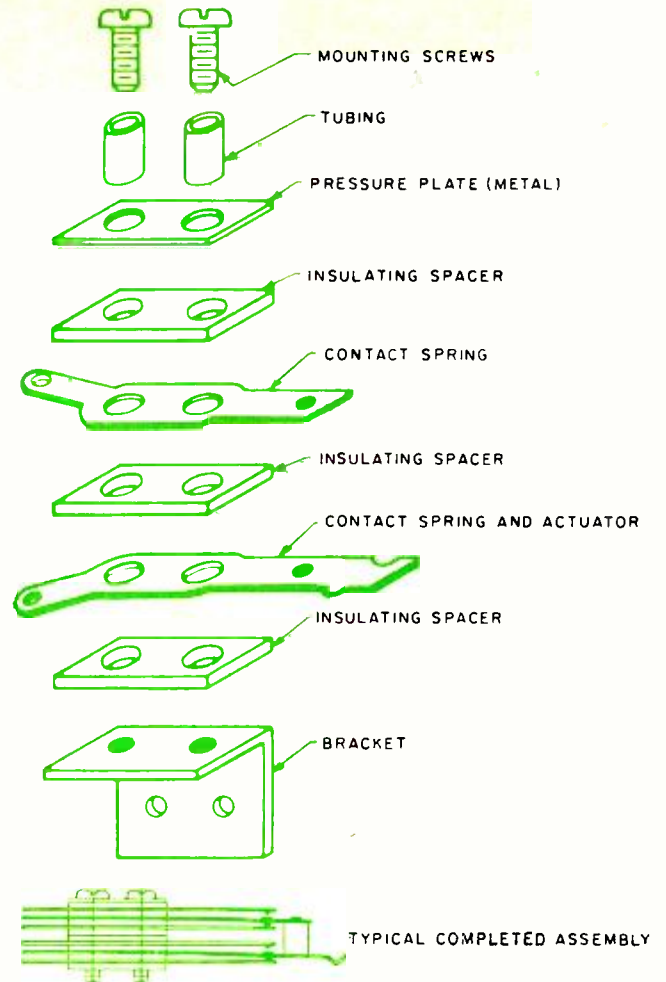

Fig. 2. An exploded view of simple stack assembly is shown here along with a more complex completed stack switch unit.

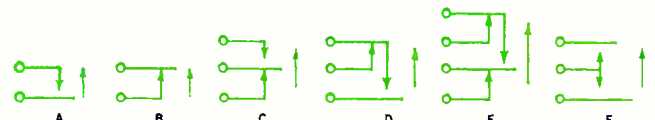

Fig. 3. The basic contact forms available in stack switches.

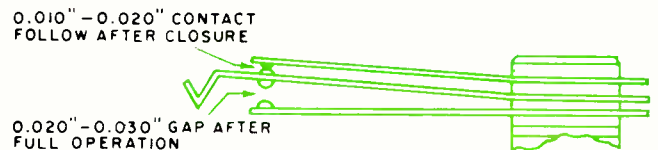

Fig. 4. Proper contact follow after closure and contact gap.

The selection of contact materials for various power levels is extremely important to the over-all performance of the stack switch.

Silver, the most economical of the noble metals, is satisfactory when used in circuits with sufficiently high current and voltage to break through any film barrier. Silver contacts are frequently suitable for wetted circuits (that is, circuits in which d.c. "breakthrough voltage" is added to the a.c. signals).

Palladium is an element of the platinum group, although harder and more resistant to mechanical wear than platinum. Most important, palladium is highly resistant to surface contamination and may be used in wet or dry circuits, making it suitable for both military and high-performance industrial applications. Palladium contacts are typically wedge shaped and opposing contacts are mounted at right angles. The vertical cantilever movement of the leaf spring produces a small but significant horizontal wiping action.

| Application | Contact Material | Contact Pressure (g) | Current Rating ($\frac{3}{32}$ " dia) |
|--|--|------------------------------|--|
| General Purpose (power circuits, solenoids, motors) | Fine silver | 30 to 100 | 3 A |
| High Power (audio amp circuits, relays, small motors) | Fine silver | 30 to 100 | 3 A |
| Low Power (audio preamps, relays, intercoms, mikes) | Fine silver or palladium | 50 to 100 30 to 100 | 3 A 2 to 3 A |
| Very Low Power (meter circuitry, intercoms, mikes) | Palladium or other precious metal alloys | 30 to 100 10 to 50 (gold) | 2 to 3 A 1 to 2 A |

Table 1. Typical contact materials and their applications.

| TYPE | ELECTRICAL LEAKAGE | HEAT RESISTANCE | MOISTURE ABSORPTION | COST |
|----------------|--------------------|-----------------|---------------------|--------|
| Phenolic | G | G | G | Low |
| Epoxy paper | VG | VG | VG | Medium |
| Silicone glass | VG | E | VG | High |
| Polystyrene | E+ | G | E+ | Medium |
| Silicone mica | VG | E+ | VG | Medium |

Code: G = good; VG = very good; E = excellent; E+ = excellent plus

Table 2. Ratings of insulating materials in stack switches.

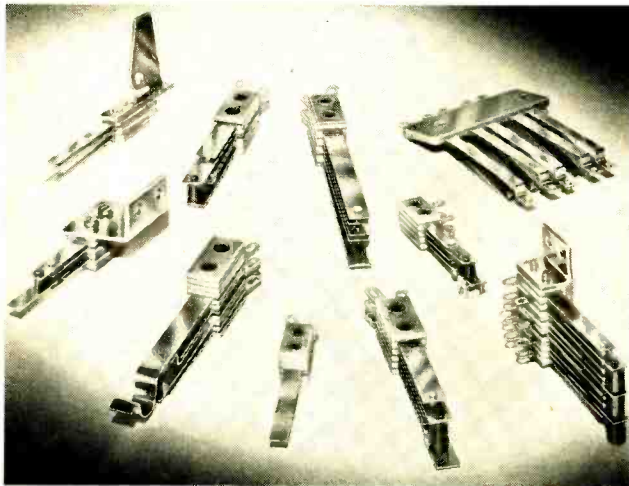

Fig. 5. Stack switches are available for variety of uses.

The advantage of using palladium is indicated by the fact that an average contact resistance of only 0.005 ohm is achieved, which is well within the limits required by MIL-J-641C for telephone jacks.

Part of the reason for such low contact resistance is that the palladium contacts are cross-bar welded to the leaf. Furthermore, bond strength uniformity can be more reliably controlled on welded contacts than with riveted attachments.

A more inert contact material than palladium, one with very high resistance to contamination, is a special gold alloy. However, this material is not only more costly than palladium but is softer and more subject to mechanical deformation. With nickel backing, gold contacts may be welded to leaf springs. Typical contact materials and their application to various power levels are shown above in Table 1.

The selection of single contacts or twin-bifurcated con-

tacts will depend upon the degree of reliability required. A substantial improvement is obtained by using parallel contacts rather than single contacts. When truly parallel, independent contacts will provide this improvement; the usual twin-bifurcated contact springs found in stack switches approximate the parallel contact arrangement. Twin or bifurcated contacts have a distinct advantage over single contacts at low energy or intermediate loads, while single contacts are usually employed for the switching of heavier loads.

Clean contacts are essential to reliable performance and the manufacturer's instructions should be followed regarding maintenance on the particular contacts furnished. Highly corrosive cleaners or highly abrasive tools can do more harm than good. Also, contacts may be protected by using diodes or RC networks for spark suppression.

The electrical insulation parameters of interest to the user are electrical leakage, heat resistance, and moisture absorption. Table 2 shows the comparative ratings of insulating materials that may be specified for stack switches. Grades XX-P and XXX-P phenolic offer excellent insulation resistance and breakdown ratings and are typically furnished on quality units. Special environmental considerations, such as high heat, would indicate the use of silicone bonded mica insulators or else polystyrene insulators for high humidity environments.

Environmental Conditions

As indicated at the beginning of this article, stack switches are not intended to be used in applications where extreme shock, vibration, humidity, or temperature ranges are involved. Some steps may be taken, however, to provide protection against these conditions. For instance, in cases where vibration is a factor, back-up springs may be added to the stack. One of the special stack insulation materials mentioned earlier may also be provided. In any case, the user should clearly detail any environmental conditions that may be encountered when specifying the stack switch in order to assist the supplier in recommending a unit to suit the requirements. UL or CSA approval cannot be provided for stack switches since they become an integral part of the device in which they are mounted so approvals must be obtained on the entire assembly, and not just on the stack switch itself.

It is highly recommended that the circuit design engineer purchase or construct prototype switches for testing under actual conditions. While switch manufacturers can simulate environmental conditions in the laboratory, there is no substitute for testing under actual operating conditions. Some manufacturers, including *Switchcraft*, offer stack switch sample kits which permit the user to construct various assemblies for test and evaluation purposes.

Cost Factors

Reduced cost is one of the major advantages of stack switches. The cost per switching configuration is less than almost any other switching device, not to mention the added savings in simplified maintenance. Stack switches will typically price out between 15 and 20 cents per s.p.d.t. combination depending upon the quantity ordered, special forming, contact material used, and type of adjustment specified.

Fig. 5 shows stack switches which were designed for various applications. The versatility of these units minimizes extra design or tooling costs to meet special switching requirements. Note the special forms in some of the switches to achieve sequential operation or to accommodate various actuator designs.

Time-tested and proven in a multitude of switching applications, the stack switch can be specified with complete confidence that it will provide superior performance at minimum cost. ▲

The author is a graduate of M.I.T. and a 15-year veteran of the Honeywell organization, having served as Project Manager on the F-104 contract of the Aeronautical Division. In 1963 he became Chief Engineer of the Residential Division in Minneapolis and in 1966 he was named to his present post. He is a member of the American Society of Mechanical Engineers (ASME) and of the American Society of Heating, Refrigeration and Airconditioning Engineers (ASHRAE).



Snap-Action Switches and their Ganged Arrays

By HARRY H. MEYER / Director of Engineering
Micro Switch (Div. of Honeywell)

These switches are characterized by positive actuation with small mechanical pressure along with small size and high electrical capacity. Included are answers to the most important questions asked concerning the proper choice of these switches as well as a checklist for ordering switches of all types.

THE five principal features of precision snap-action switches are: actuation with minute mechanical motions and forces; small size; long life; uniform travel and force characteristics; and high electrical capacity for their size. Various actuator devices, integral or accessory, are available for these switches. These provide easy adaptation to rotary or linear mechanical drive and manual operation as well as meeting the requirements of diverse uses in electronics, major appliances, machine tools, and aircraft.

A wide choice of sizes is available, without sacrificing good load-carrying ability. Units as small as 0.035 cubic inch will reliably switch 28-volt d.c. inductive loads of 4 amperes or 125/250-volt a.c. loads of as much as 7 amperes. Other snap-action switches of somewhat greater size, yet still less than 1.3 cubic inches, will control 20-ampere, 180-volt a.c. loads.

These switches can directly control: motors and other work-performing equipment; read-out devices for operator instructions or recording; and protective interlocking or detection circuitry. Their small size permits use in normally inaccessible areas. Actuation or release of the contacts occurs within a few thousandths of an inch of plunger travel which helps prolong mechanical life.

Snap-action switches must provide reliable operation for extended periods of time. In use, they serve as a substitute for human hands and eyes in controlling electrical action.

To simplify the selection of precision snap-action switches and to obtain the best service results, the following checklist is broken down into five areas: *mechanical requirements, electrical requirements, reliability, environment, and installation factors.*

Mechanical Requirements

How will the switch be operated? Linear, rotary, and multi-direction and variable motion can actuate snap-action switches. The wide variety of operating mechanisms includes push-plungers, roller-plungers, levers, roller levers, one-way roller levers, flexible wires, and coil wands (Fig. 1).

What will be the rate of motion for actuation of the switch? Micro-motion, intermediate motion, and impact motion can be handled by snap-action switches. Protective devices are available for impact actuation. An alternative switch location, or an alternative means of actuation to reduce impact motion, is desirable for optimum switch life.

What will be the frequency of switch operation? Switches can be operated from low to high frequency. In general, switch life is affected only when heavy electrical loads are driven at a high cycling rate which generates excessive internal heat. Most snap-action switches can handle their rated loads up to 150 operations per minute. As the electrical load is decreased, the frequency of operation can be increased—successfully—on the order of 1800 cycles per minute.

What operating force is available? Is a broken thread being detected or is actuation accomplished by an internal flywheel cam? Switches with operating torques as low as 4 gm/in, maximum, are available. In heavy industrial applications, operating force is usually abundant, whereas in servomechanisms the operating force is low.

What will be the length of operating travel? Excess linear or angular travel of the switch actuator can damage or greatly reduce the mechanical life of a switch. For snap-action switches, plunger pretravel, overtravel, and differential travel positions or length are specified. Plunger travel beyond the point of actuation is overtravel. Travel from the point of actuation to the point where snap-action re-

Fig. 1. Some of the actuators that are available for the basic snap-action switch, along with their applications.

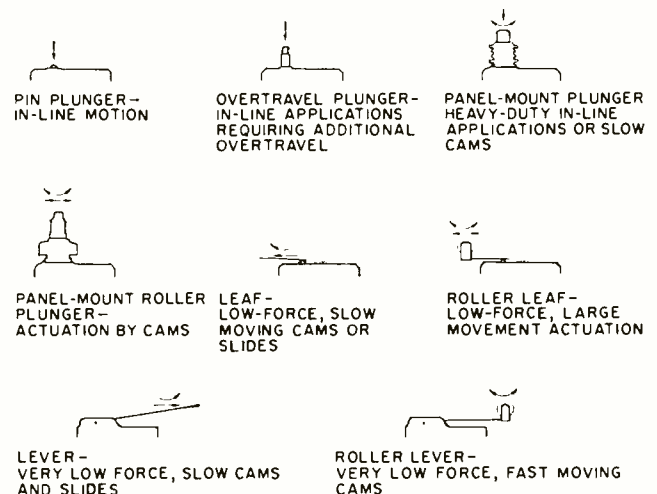

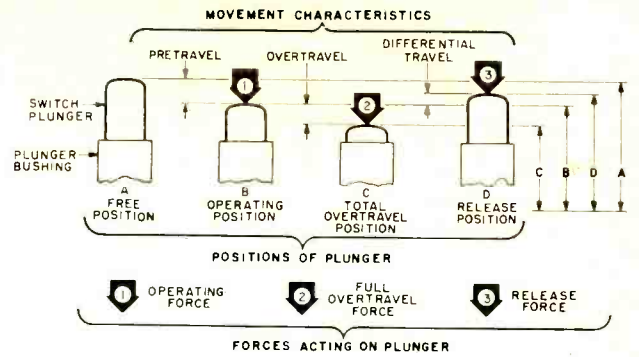
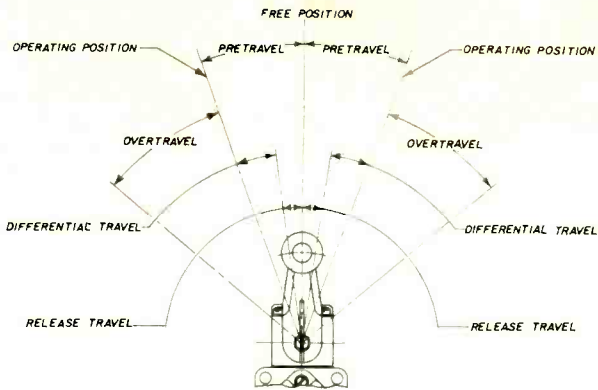
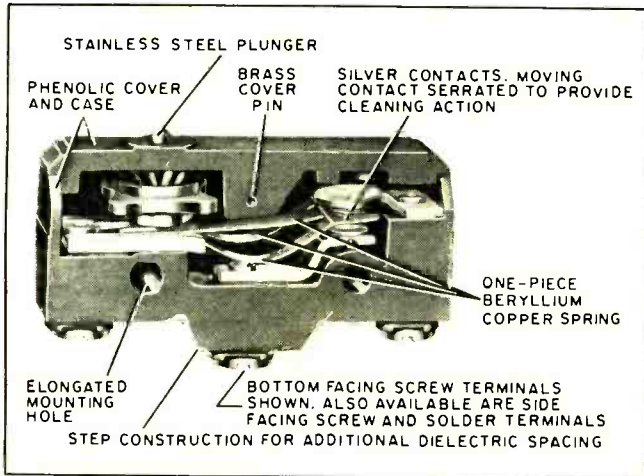
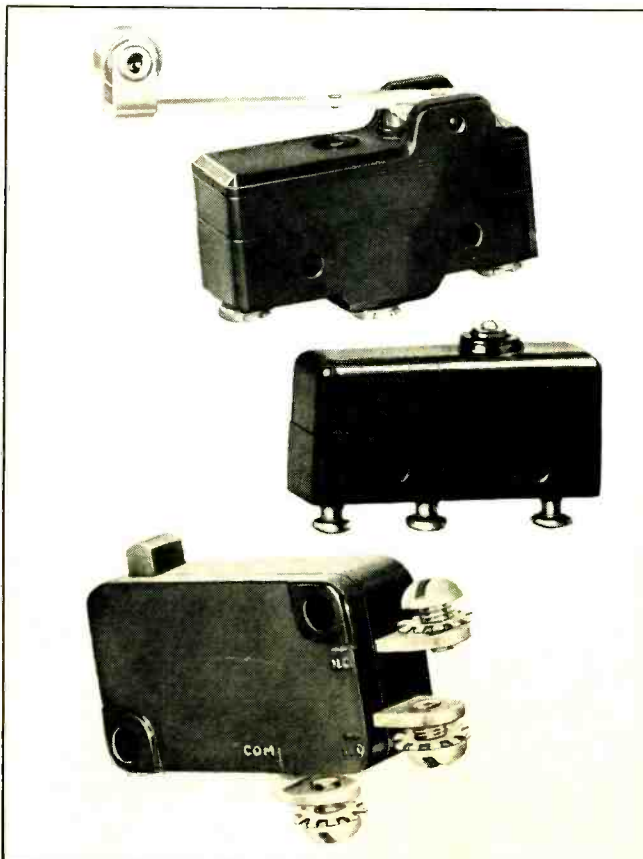

Fig. 2. Illustration of terms that are employed in describing rotary actuation (left) and in-line plunger actuation.



Internal construction details of basic snap-action switch.

Several typical examples of the basic switch. It is possible to use this mechanism with many different types of actuators including push button, toggle, and rotary (using cam) types.



lease occurs is differential travel. Optimum life is obtained when operating travel does not reach the full overtravel limit of the switch and permits full release of the plunger between cycles (Fig. 2).

Electrical Requirements

What circuitry is required? Single-pole, single-throw in normally closed or normally open configuration; single-pole, double-throw; two-circuit, double-break; or multiples thereof are available contact arrangements. Double-break switches make and break a circuit at two points, which effectively increases the contact break distance. Double-break switches allow interruption of greater d.c. and a.c. inductive loads than is possible with single-break switches.

What contact action is required? Self-returning momentary, maintained, make-before-break, and pulse action are available. Momentary switches actuate when the plunger is depressed and release when force is absent. Maintained contact switches require one operation for actuation and a second operation to reset the contacts. This type of mechanism can be used in protective interlocking to open a circuit when a fault occurs. When the fault is corrected, the contacts are reset. Make-before-break versions provide momentary overlapping when switching from one position to another and is useful where circuits must be switched with no interruption. Pulse action provides a single electrical pulse each time the actuator is depressed, but not when released. When operated by a single lobed cam, the switch provides a single pulse per revolution.

What are the electrical parameters of the load? Specify voltage and whether alternating or direct current will be passing through the switch. If a.c., specify the frequency. Specify the nature of the load: resistive, as a heater; inductive, as a coil; reactive, as a motor; or tungsten filament, as a lamp. Where applicable, specify in-rush and steady-state current requirements as well as power factor.

Keeping electrical loads within the published capability of the switch is of primary importance for long, reliable life. Snap-action switches are frequently selected on the basis of continuous current ratings of motors and solenoids without proper consideration being given to in-rush capacity. Only certain types of switches are rated by UL for control of tungsten-filament lamps.

Large amounts of alternating-current power can be reliably controlled even with small-size snap-action switches. At rated loads, difficulty with prompt interruption of a.c. loads is unknown under ground-level operating conditions. Temperature rise is seldom important, except when caused by heating of the arc on maintained high-speed cycling of heavy loads. For low-energy circuits operating in the millivolt, milliamperage range, special contact materials and designs are used to minimize and stabilize contact resistance for extended and reliable life.

Single-break snap-action switches handling direct-current loads, especially inductive loads, should be equipped with contact protective diodes or capacitor/resistor net-

works to reduce arcing and the transfer of contact materials during circuit break. Because of the small contact separation in snap-action switches, unprotected contacts handling a d.c. inductive load may not be able to extinguish the break arc that is produced.

Reliability

What constitutes failure of the switch? Reliability of switch operation depends primarily on mechanical and environmental factors, yet electrical loads can have a marked effect on switch life. Operating accuracy is one measure of reliability, life expectancy is another.

What is the permissible deviation from nominal point of actuation? As the load increases, small contact welds can occur. To compensate for this, the switch requires increased operating motion and force. Under small electrical load, usually no greater than 0.1 A, maximum repeatability can be obtained.

What switch life is expected for the application? The mechanical life to be expected from a snap-action switch depends on the type of switch and whether it is driven to the limit of its stroke at each operation. In general, mechanical life catalogue data is on the order of 10 to 20 million operations (based on full stroke). Under full rated electrical loads, contacts usually reach full useful life in less than the probable mechanical life of the spring system. In many cases, however, probable contact life up to 10 million operations may be expected. At low loads with less than full plunger travel, test switches and switches in actual applications have operated more than 150 million times.

If failure to make or break a circuit could be disastrous in critical applications, the switch should be replaced regularly as a matter of routine. The replacement cost is only of fraction of the cost of down time.

Environment

What is the ambient temperature? Standard snap-action switches perform satisfactorily in ambient temperatures from approximately -65° up to 180° F. Ceramic-metal variations are available in the market for operation down to -321° and up to $+1000^{\circ}$ F.

What is the surrounding environment? Excessive humidity, oil vapor, liquid splash, and immersion are detrimental to the switch, unless it is equipped with a protective enclosure which prevents the entrance of adverse environmental conditions into the contacts of the switch. Moisture causes electrical breakdown in a switch. Oil may be carbonized by arcing and, in this form, can lead to non-contact conditions or excessive leakage currents.

Will the switch be exposed to weather? Most snap-action switches can be protected by enclosures so that they can be used outdoors. Since a movable member is required for switch actuation, additional protection should be provided for the actuator against severe ice accumulations.

Will the switch be exposed to corrosive atmospheres? Salt fog, sulphur vapors, and acid fumes are some of the airborne contaminants that can affect unsealed switches.

Is the surrounding environment gritty or dusty? Minute dust particles can be drawn into the contact chamber of unsealed snap-action switches through changing air pressures. Dust particles can contaminate contacts and prevent reliable contact operation or cause complete failure. These particles can also contribute to mechanical failures at bearing and pivot points. Enclosures are available.

Are flammable gases or combustible dusts present? Snap-action switches can be used in flammable gas or combustible dust locations when the switch is housed in an enclosure of adequate strength and it has sufficient flame path or is of flame arrest construction. In flammable gases, the switch is allowed to "breathe" due to atmospheric pressure changes and the switch can withstand internal

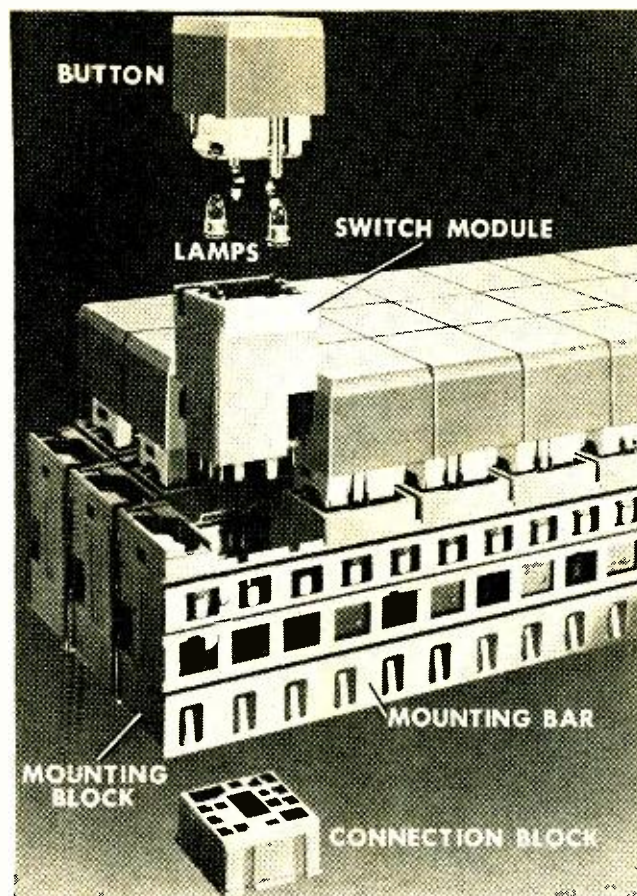

A large number of switch modules may be combined to form customized lighted or unlighted panels and keyboards.

explosions. Construction features prevent the internal explosion from triggering the surrounding gas. Also, the enclosure is not allowed to develop sufficient heat or char or cause combustion of the dust. When using snap-action switches in hazardous locations, specify the substance (gas or dust) surrounding the switch.

Will the switch be subjected to acceleration, vibration, or shock? Snap-action switches will resist false operation due to acceleration, vibration, or shock when the contact force is optimized (full overtravel and full release). Operation of the switch near the point of actuation or release, when subjected to these external forces, may cause momentary separation of contacts or false snap-over. Satisfactory performance varies with the contact break distance, for example, 0.008-in break distance withstands up to 40 g; 0.020 in up to 80 g; 0.070 up to 200 g. Locating the switch so that the snap-over spring is parallel to the direction of force increases the ability of the switch to withstand these external forces.

Will the switch be subjected to physical abuse or negligence? Snap-action switches should be protected with rugged enclosures to assure reliability of operation, long life, and live voltage protection for the operator in case the switch is subjected to physical abuse or negligence.

Will the switch be subjected to decreased air pressure or have to operate in a vacuum? Snap-action switches generally operate satisfactorily between sea level and pressures corresponding to 25,000 feet altitude. As decompression progresses, switch arc time increases, momentary flashover between terminals results, and dielectric problems arise in unsealed switches.

Snap-action switches which are hermetically sealed and which incorporate insulated lead wires can provide the best performance during and after pressure reduction. Life duration of hermetically sealed switches is derated to reflect maintenance of the seal.

Installation Factors

What termination will be required on the switch? Screw terminal, quick-connect, solder terminals, and wire-clamp type terminals are available. When soldering terminals on snap-action switches, care should be exercised to avoid excessive flux and soldering temperatures that exceed 570° F for longer than 10 seconds. Flux can create an insulating film on contacts and the movement of the flux on the terminals increases with higher soldering temperatures. Higher soldering temperatures expose the switch to a high-temperature shock so that such temperatures should be avoided.

Is switch size important in the application? Snap-action switches vary in size, depending on the electrical capacity required, whether or not an enclosure is needed, the style of the actuator, and the space available in the application.

Will a conduit connection be required? Sealed enclosures require adequate conduit sealing to maintain the integrity of the enclosure. Condensation or oil seepage can enter the switch unless it is adequately protected by its enclosure and, in addition, is well sealed at the conduit entrance.

Will the switch be at a serviceable location? In order to minimize the expense of unexpected shutdowns, machines and systems should be designed so that the control units which are subject to wear or damage are easily accessible for repair or replacement. Plug-in enclosure versions are readily available in order to reduce the down time by eliminating the need to rewire the switch.

Ganging Snap-Action Switches

In many applications basic switches are ganged or stacked to provide the necessary control functions. A gang of switches can be two or more units mounted together. This provides a multi-pole switch device which very often is operated by a single actuator. Ganged switches are usually more practical than a multi-pole single switch because the component switches are less costly and provide the designer with a greater choice of termination, actuating device, and circuitry.

Available are split-contact, double-throw, and two-pole double-throw switches in a single housing. When a designer's needs exceed these types of circuitry, two or more individual switches are used.

Snap-action switches can be ganged successfully because they are built to small gradations of movements and the "snap," or transfer of contacts, repeats (one cycle to the next), within a usual maximum variation of +0.002 to -0.003 inch.

What makes such switches ideally suited for ganging is the variety of sizes available to the designer. They are offered in a size range from basic, to miniature, subminiature, and sub-subminiature.

In placing one switch next to another (and as many as 24 switches have been ganged), the design engineer has to be sure that the tolerances of the actuator and switch travel specifications are compatible. Each switch should be mounted individually so it can be moved towards or away from the actuator to obtain the correct timing of operation with relation to the next switch. However, the usual method of ganging switches is to mount them on the same rods or screws so that they are not adjustable on an individual basis.

When switches are ganged, multi-circuit operation is required at a specific time. Without individual switch adjustment, it then becomes necessary to adjust the actuator of the switches.

Ganged switches are very often actuated by means of cams fixed to rotating shafts in such devices as timers, which are mostly motor driven, or selector switches, which are

manually operated. Timers and programmers are products in which ganging of switches is a basic part of the product design.

Ganged switches are also used in devices where the actuating means are a pivoted lever that provides nearly simultaneous operation all the way to make-before-break type sequencing. Multi-pole push button, pressure and temperature-sensitive switches, electrical coil-actuated devices, and many other electromechanical designs also employ this type of actuation.

Cams and levers, to a great degree, have built-in adjustments to insure that a switch and each subsequent switch operates at the precise time required by the circuit. One lever could operate as many as six switches in some devices.

The need to gang switches is not confined to a limited number of products. The computer, business machine, and the vending machine all use the ganging technique.

Ganging of switches is economical in the sense that the application does not require multi-operators and mechanisms just to actuate one switch. This aids in reducing the size of the control package.

Since precision snap-action switches are comparatively inexpensive—usually under \$1.00 per switch—the ganging of switches is a low-cost method of multi-circuit sequencing. ▲

CHECK LIST FOR ORDERING SWITCHES

Switches are offered in a variety of forms, sizes, and electrical ratings to fit the majority of application requirements. This check list is provided as a reminder of the areas to be considered when specifying in simple applications. However, in exotic installations, further information may be required in order to select the correct switch for reliable performance and maximum switch life.

ELECTRICAL LOAD

Voltage (a.c. or d.c., specify frequency)
Amperage
Type (resistive, motor, lamp, inductive)
Electrical life required

SWITCH ACTION

Type (snap-action, reed, double-break, mercury)
Action (momentary, pulse, maintained)

STANDARDS AND SPECIFICATIONS

MIL-Spec (specify number and sections)
UL, CSA
Other

MECHANICAL DATA

Operating force
Length of operating travel (pretravel, overtravel, differential travel)
Rate of motion
Frequency of operation
Mechanical life required

ENVIRONMENT

Temperature
Grit or dust
Humidity
Oil or sulphur
Hazardous gas or dust (specify)
Acceleration, vibration, or shock
Physical abuse or operator sabotage

INSTALLATION FACTORS

Conduit connection
Termination
Field adjustability
Switch size
Enclosure or sealing
Serviceable location



The author received his B.S.E.E. from Marquette University in Milwaukee and joined Centralab in 1956. He is presently a member of the Electronic Industries Association's P-5.5 Rotary Switch Committee.

Open-Frame Rotary Switches

By WILLIAM SEFTON /Manager, Switch Field Applications Engineering
Centralab Electronics Div. (Globe-Union Inc.)

Important factors to consider in selecting the proper rotary switch are type of contacts and insulating material, whether pile-up or non-pile-up, shorting or non-shorting characteristics are required, and type of shaft.

OPEN-frame, manually actuated rotary switches are electromechanical devices which are used primarily as circuit selectors in electronic and communications equipment. They are made up of an index or detenting mechanism, strut spacers, and screws—known collectively as the *frame*—and the electrical switching portion called *sections*. These sections have rotating insulators, or rotors; rotating current-carrying members, or contacts; stationary insulators, called stators; and stationary current-carrying members, called clips. See Fig. 1 for switch nomenclature.

Basic Operation & Construction

The indexing mechanism serves a twofold purpose. The first is to hold the contacts in proper relationship to the clips so that a complete electrical circuit is maintained even when subjected to vibration and shock. The second function is to act as a positioning device during rotation so that the switch tends to come to rest directly in switching position, not at an intermediate point. The more sharply an index positions itself, the better the "crispness" of the index and the better the "feel" of the switch itself.

The spacing on an open-frame switch usually has an

established minimum so that the solder terminals on one section won't interfere with those on an adjacent section or with the "dead metal" parts on the index. The fact that there is virtually no limit to the maximum spacing allowed is a boon to design engineers. They can place sections in areas of the chassis to optimize electrical and mechanical requirements. Of course, when a long switch is used, there is a chance that the frame will twist. This problem can be solved by rear mounting, using screw extensions or a mounting bracket.

The switch section consists of two basic parts: a rotor and a stator. The contact or rotor blade is usually fastened to the rotor by means of "legs" formed from the contact or by rivets to hold the blade firmly in place. This portion follows the movement of the index and determines the sequence of electrical switching.

The stator or stator insulator is designed to position clips so that the contact will engage the clips in proper incremental positions. The stator must also hold the clips at a proper level so that both upper and lower clip jaws will engage the contact when the blade is rotated into position.

The thickness of the rotor and stator are selected so

Fig. 1. A listing of the terms that are employed to describe the component parts making up an open-frame switch.

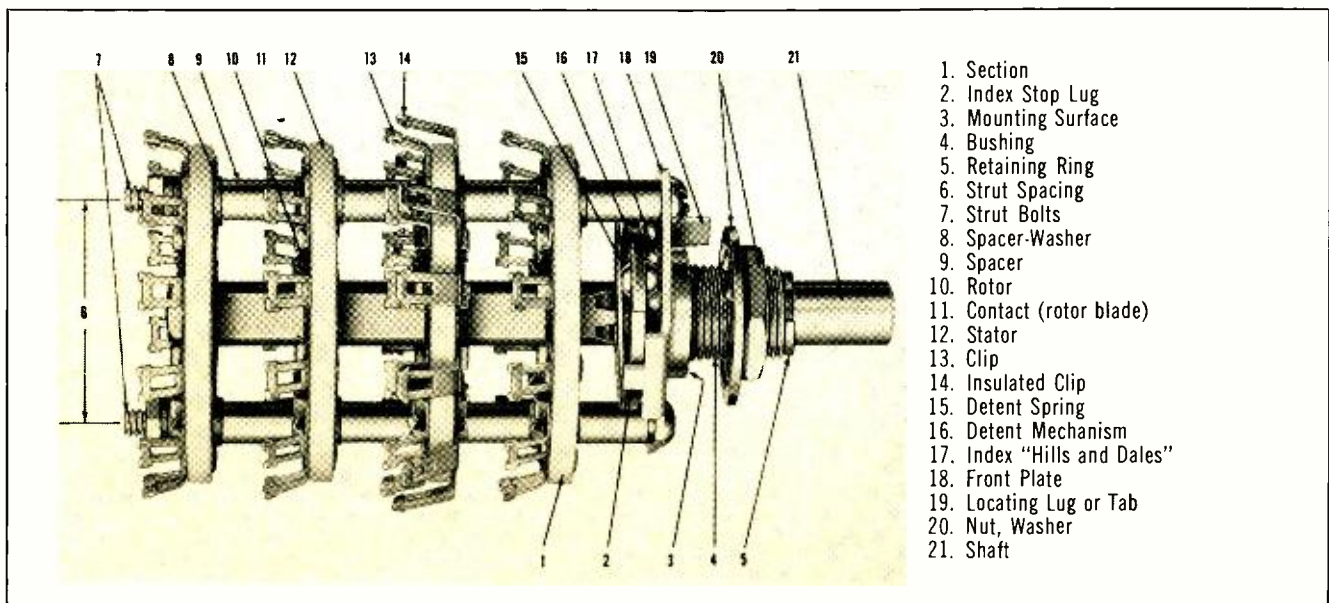

1. Section
2. Index Stop Lug
3. Mounting Surface
4. Bushing
5. Retaining Ring
6. Strut Spacing
7. Strut Bolts
8. Spacer-Washer
9. Spacer
10. Rotor
11. Contact (rotor blade)
12. Stator
13. Clip
14. Insulated Clip
15. Detent Spring
16. Detent Mechanism
17. Index "Hills and Dales"
18. Front Plate
19. Locating Lug or Tab
20. Nut, Washer
21. Shaft

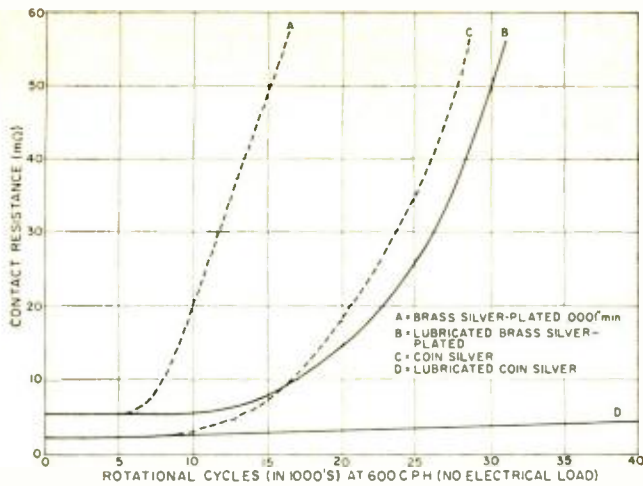

Fig. 2. Lubrication increases operational life considerably.

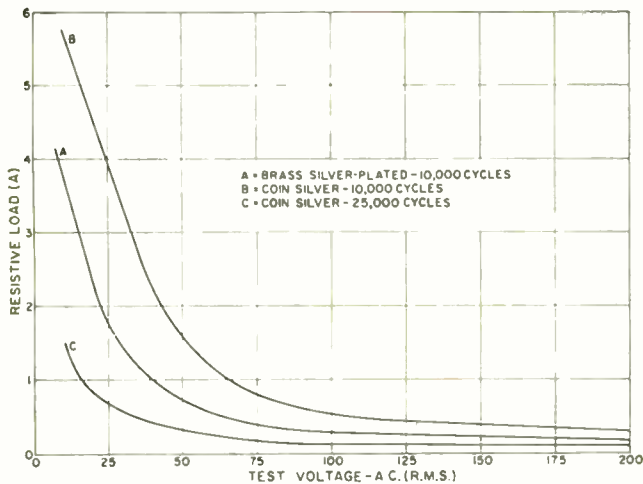
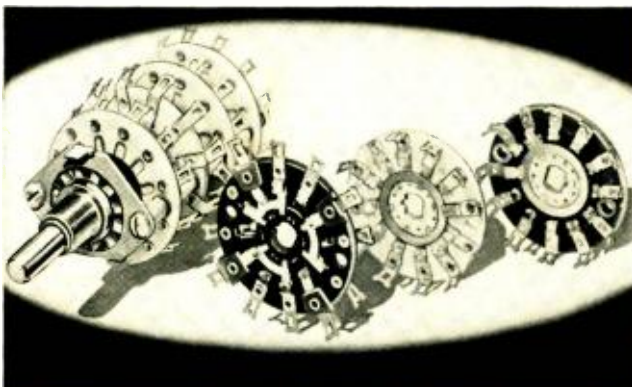
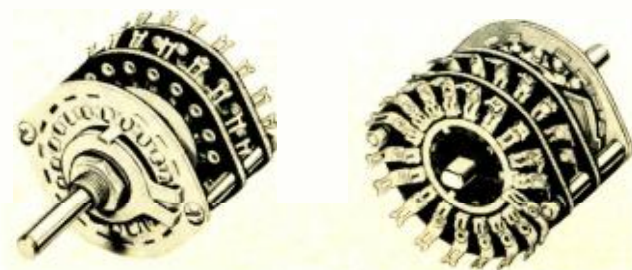

Fig. 3. Performance of various contact materials. Test sections were lubricated and run to end of life (20 m Ω).



Designed essentially as a military switch, this high-quality unit is also ideal for use in commercial equipment.

This open-frame rotary switch offers to the designer eighteen switching positions, located 20 degrees apart.



that the mid-point of the contact-blade material extends above the stator where the upper and lower clip jaws meet. This causes both jaws to wipe across the blade until the index action stops the contact. This clip action is called "double-wipe" and makes the switch section self-cleaning. Pressure of the clip jaws must be carefully balanced so that enough force is exerted to produce effective cleaning but not enough to cause excessive wear of the contact surfaces and the clip jaws.

Lubrication and Contact Life

An "end-of-life" specification can only be given as it pertains to a specific requirement for a particular piece of equipment. This is because life parameters are too numerous to be guaranteed.

For this reason, it is necessary to pick out one limiting factor that has a specific meaning to all switch users. In rotary switches, this factor is contact resistance. It is expressed as the ohmic value of a circuit as measured through one clip, the contact, and out another clip. This path is generally measured through clips on the opposite sides of the stator, providing the longest path for current to travel.

One commonly used value for "end-of-life" contact resistance is 20 milliohms. This value, when given in conjunction with the number of shaft revolutions from stop-to-stop and return (cycles), can then be used to express the life of a switch.

Since the standard contacts are brass, silver-plated to a minimum of 0.0001 inch, and the clips are spring brass, similarly plated, contact resistance will remain stable only as long as silver-to-silver contact exists. When a switch is rotated at the standard rate of 600 cycles per hour (c.p.h.), the contact resistance shows an increase over the initial value (approximately 5 milliohms) at about 5000 cycles. By 10,000 cycles, contact resistance is erratic and generally exceeds 20 milliohms.

This is the switch life that may be expected when the thin film of oil used to retard silver tarnish is the only lubricant used. When a factory-approved grease is applied to the contact surface before life testing, the sections will usually withstand 15,000 cycles before the contact resistance starts to become erratic. After 25,000 cycles of rotation, contact resistance has usually exceeded 20 milliohms on one or more clips per section.

The life of a switch section can be prolonged by the use of coin silver clips and contacts. When lubricated before life testing, coin silver clips may be expected to function for 50,000 cycles or more at very stable contact resistance. (See Fig. 2.)

Brass and silver clips and contacts are tested under "no-load" conditions, so the contact resistance values obtained are valid only for light electrical loads or for circuits that do not switch under an electrical load.

When it is necessary to switch under load, switch life will vary depending on the open-circuit voltage switched and the load the clips and contacts encounter upon closure.

Tests have been run to determine just what loads lubricated sections can switch and still maintain an end-of-life contact resistance of 20 milliohms. The graph of Fig. 3 shows a typical "load-life" curve. Note that curves A and B are capable of breaking a considerably higher ampere load for a specified voltage than the switch represented by curve C. While a load-life curve doesn't mean the physical end-of-life of the switch section, it does indicate how the load affects the physical performance of the section. The higher the load that the section must break at a particular voltage, the shorter the switch life.

Detailed information on how load requirements will affect the life of a specific switch in a particular circuit is available from the switch manufacturer and his highly trained application engineering staff.

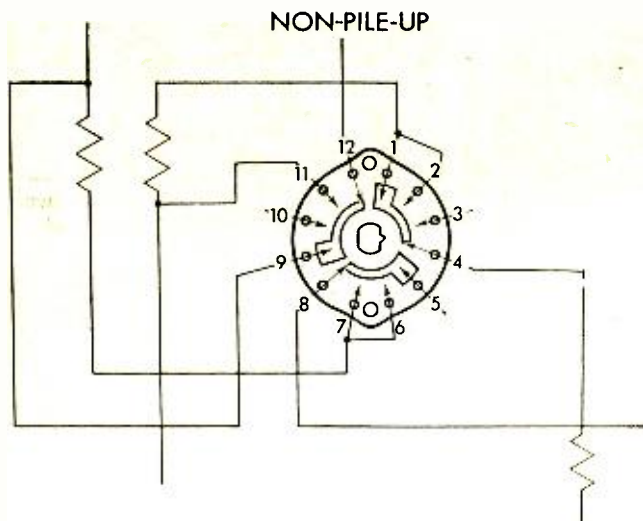

Fig. 4. With non-pile-up switching extra cross wiring is required and there are several unused clips as shown here.

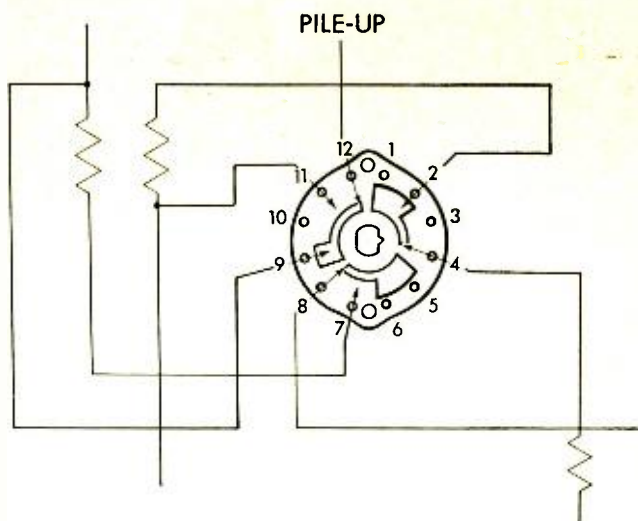

Fig. 5. Note the design of the rotor on this switch to provide pile-up switching. Wiring to switch is now simplified.

Pile-Up and Non-Pile-Up Switching

Pile-up switching is defined as "the engagement of a contact with a clip or clips in such a manner that circuits may be maintained through more than one index position, more than one circuit may be established, or a combination of both may occur".

Non-pile-up switching results "where the function of the contact is to engage clips sequentially and provide one circuit path when in a detent position". The action may be either shorting or non-shorting. Shorting action occurs when the engaged clip is not released until after the next clip has engaged (make-before-break). Non-shorting action therefore occurs when a clip which is engaged is released before the next clip is engaged (break-before-make).

The contacts of open-frame switches are usually capable of performing both non-pile-up and pile-up functions. The advantages of pile-up switching are numerous but the principal ones include: the possibility of reducing the number of switch sections required, lower cost because fewer clips are required, and a reduction in user assembly time and materials because there is less cross wiring.

A typical section using non-pile-up switching is shown in Fig. 4. Note the cross wiring from terminals 1 to 2 and from 6 to 7. There are unused clips at terminals 3, 5, and 10. When a pile-up-type switch (Fig. 5) is used instead, the pile-up clips provide the same action that the cross-wiring provided. As a bonus, the non-standard section eliminated the unused clips, for a total savings of five clips and two cross-wiring operations.

Materials Available

The standard material used in commercial and military switches is laminated phenolic NEMA grade XXXP, military grade MIL-P-3115B, type PBEP. This is a high-grade phenolic which because of its excellent loss factor and low moisture absorption performs well in electronic circuits. (See Table 1.)

When a stronger, more moisture-resistant material is required, laminated glass materials are used, among them NEMA grade G-10, military grade MIL-P-18117, type GEE epoxy. Glass silicone, NEMA G-7, military grade MIL-P-997B, type GSG, is used less often because of its higher price and difficulty in working the material.

When better loss factor and moisture absorption are needed, ceramic stators and rotors can be used for most types of sections. Ceramic has the highest surface resistivity of all the materials offered as standard by the open-frame switch industry.

Standard frame materials are steel and brass, cadmium-

| CRL STANDARD INSULATION MATERIAL | TEMP. RANGE (deg. C) | SURFACE RESIS-TIVITY (megohms) | AVAILABLE IMPREG-NATION * | RELA-TIVE COST | TYPE DESIGNATION |
|----------------------------------|----------------------|--------------------------------|---------------------------|----------------|--|
| Phenolic (paper base) | -65 to +85 | 500,000 | any | 1/3 | Standard, NEMA XXXP, MIL-P-3115P (type PBEP) |
| Glass silicone | -65 to +125 | 650,000 | any | 1 1/2 | NEMA G-7, MIL-P-997B (type GSG) |
| Glass epoxy | -65 to +125 | 750,000 | any | 1 1/2 | NEMA G-10, MIL-P-18117 (type GEE) |
| Ceramic (CRL Steatite) | -65 to +175 | 1,000,000 | any | 1 | MIL-1-10A (Grade L-422) |
| Mycalex | -65 to +175 | 900,000 | any | 3 1/2 | MIL-1-10A (Grade L-411) |
| KEL-F | -65 to +100 | 1,000,000 | none | 3 | KEL-F 500 |
| Durez (glass fiber filled) | -65 to +100 | 900,000 | any | 4 | Durez 16221 |

* Fungicidal varnish (MIL-V-173), wax moisture sealant, Dow Corning DC-200 moisture sealant fluid.

Table 1. Insulation specifications chart. Note that not all insulations are available in every rotary switch type.

plated to resist corrosion. If needed, these parts may be cadmium plated and dichromate treated to withstand 50- and 96-hour salt-spray tests. When an even more stringent finish requirement—200 hour salt-spray resistance, for example—is needed, frame parts can be made from nickel-plated brass or stainless steel.

Although the maximum operating temperature for phenolic is 85°C, glass laminates will operate at 125°C, while ceramic may be used at even higher temperatures. Both brass and silver operate well up through 125°C, but for higher temperatures special clip and contact materials must be used. These materials, when used with ceramic stators and rotors, are capable of functioning as an effective switch section at temperatures up to 175°C. Any of these materials can be plated with 23-karat gold in thicknesses ranging from 0.000030" (minimum for effective shelf life) to 0.0005" (maximum for retention of clip function).

Shaft Options

Rotary switches offer the design engineer a wide range of options. The drive shaft may be made several inches

long so the switch can be mounted inside the chassis with external operation by means of any one of a number of different knob ends. These include single- and double-flats in a wide range of lengths and thicknesses; drilled and tapped axial mounting holes; cross drilled holes, screwdriver slots; knurls; and plain round ends. Shafts can be supplied in dual concentric combinations that include 0.250" and 0.1875" diameters as well as 0.265" and 0.187" diameters for dual switches or switch-potentiometer combinations.

Since section material requirements may be more demanding in one circuit than another, it is possible to specify less expensive materials for the latter while using ceramic insulation and coin silver contacts and clips in the former. Mixing materials used on the sections is no problem and can yield a worthwhile cost improvement through value engineering.

Since most switch manufacturers are thoroughly familiar with the techniques of value engineering, their trained engineers can suggest the best materials for specific appli-

cations, simplify switching configurations, and generally reduce the cost of the switch to a minimum.

Reliability and Military Specifications

Reliable operation is a characteristic of rotary switches. When operated within their rated loads, field replacements are usually confined to switches rotated excessively or to sections which have been broken or damaged when other circuit components have been serviced.

The standard military specification for open-frame rotary switches is MIL-S-3786B. The hand-actuated rotary switches which meet this exacting specification are basically the same designs used in commercial equipment. This factor is important to all commercial users of switches.

The "know-how" acquired in designing and building switches to meet MIL-S-3786B specs is passed along to the users of commercial units. This product upgrading has allowed manufacturers to more than double the life expectancy of some rotary switches. ▲

SWITCH KITS FOR DESIGNERS

MOST switch manufacturers offer designers assortments or kits of their products for use in prototype equipment and for breadboarding. Such kits help the engineer design new equipment by providing him with a large number of switches from which to choose for incorporation into his product. The kits also help the switch manufacturer by showing the designer what standard products are available. If a choice is made from standard rather than from custom-designed switches, then costs can be kept lower.

Sampler kits are usually fairly complete, and a reasonable price is generally charged by the switch manufacturer for the assortments.

There are two main types of these kits. One type is merely a grouping or assortment of a number of samples of a manufacturer's complete line. Each switch in the assortment is a complete ready-to-use device. Another type of switch kit, apt to be more complete and more expensive, actually permits the designer to assemble his own switch from separate contacts, rotors, stators, shafts, and hardware. Tools are often included in such a kit. Following are some examples of switch kits available from several manufacturers.

Centralab has a new switch kit that provides all necessary components for complete assembly of a line of modular push-button switches. Included are mounting brackets, latch bars, and switch modules that will furnish interlocking, momentary, or push-push switching action. Six each of 30 basic brackets are included along with 60 two-pole, double-throw modules; 60 four-pole, double-throw modules; 45 six-pole, double-throw modules; and 20 eight-pole, double-throw modules. Hardware and tools are included along with a complete set of instructions. Cost of the entire kit, which is housed in a five-drawer metal cabinet, is \$150.

Stackpole Carbon Co. (Electro-Mechanical Div.) is offering a kit to facilitate the design and development of prototype enclosed rotary switches. The kit contains a full complement of parts to construct up-

wards of twelve complete rotary switches of varying electrical configurations. Complete and easy-to-follow instructions are included. Parts are readily available for restocking the kit. Complete kits are available for less than \$100 from this manufacturer.

Oak Manufacturing Co. has a number of switch kits available to aid users in developing prototypes. As a matter of fact, most of the company's rotary switches are available in kit form for this purpose. As an example of how elaborate one such kit is, among many other parts it includes 40 switch shafts, 400 index springs, hundreds of various spacers, about 2000 contact clips, hundreds of rotors and stators for both phenolic and ceramic rotary switches, plus a large assortment of hardware. Some of the special hand tools included are a file fixture for rotor blades, rotor-blade cutting pliers, eyeletting pliers, and an index spring insertion tool. The cabinet containing the kit is almost two feet square by 4½ inches deep. Shipping weight is between 50 and 75 pounds. Additional parts may be ordered to maintain a complete kit. Incidentally, these kits are not intended to be used to make switches for production runs but rather for developing prototypes.

Alco Electronic Products has available ten sampler switch kits for engineering use. These kits consist mainly of miniature toggle, push-button, and rotary types. They give the designer a variety of complete switches and do away with special inventories and small-quantity purchase order requests. One typical sampler assortment consists of six miniature toggle switches, ranging from a single-pole, double-throw unit to a four-pole, double-throw switch. These six switches would ordinarily cost over \$17 separately, but they are available as an assortment in a plastic box for \$14.

For additional information on any of these products, circle the appropriate number on the Reader Service Card as follows:

Centralab (145), Stackpole (146), Oak (147), Alco (148)



Five-drawer metal cabinet (left) contains all necessary parts for assembly of line of modular push-button switches. Modules contained in this convenient Centralab kit can be assembled in more than 1½ million combinations to produce an extremely broad range of switching devices. The photo below shows many of the miniature Alco switches that are available in kit form. Each kit is selected to offer engineer or technician most-wanted types.

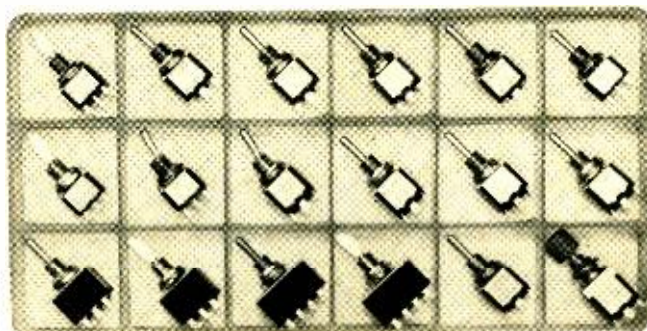



JOHN FRYE

Locating a leaking water pipe beneath a concrete floor—without digging—can present a real challenge to anyone.

PIPE AND LEAK LOCATING

Mac's face wrinkled into a smile of satisfaction as he finished reading a letter from his brother. "Must be good news," observed Barney, the second banana of the service shop.

"It is," Mac said with a nod. "It relates the successful conclusion to a long and frustrating joint effort. About a year and a half ago my brother bought a nearly new house in a Chicago suburb. It's basically brick-on-concrete-slab construction with hardwood floors laid on 2 x 4's set on edge in the concrete so there's a couple of inches of dead air space between the floor and the concrete. Keep all this detail in mind because it will make sense later.

"A trench formed in the concrete slab carries a duct around the perimeter of the house, and hot air from a gas furnace is forced into this duct and comes out registers along the outside walls in the various rooms. Cooling room air is pulled into registers near the ceiling and returns to the furnace through ducts in the attic.

"When my brother started the furnace last fall, he immediately noticed a lot of moisture in the house. Windows sweated badly; drawers stuck; the whole house had a 'hot house' feeling. At first he thought perhaps this was because the house had been standing empty for several months and had accumulated moisture that would soon dry out; but actually the condition worsened. Water stood in puddles on the window ledges and actually beaded on some of the walls. The climax came when water started dripping through a bedroom ceiling.

"When he went into the attic to investigate, he found water was condensing in the cold air ducts and was leaking out joints onto the ceiling. He called in heating experts, had the gas company investigate, and talked over the problem with his friends and neighbors. The gas company found nothing wrong with the furnace and no obstruction in the chimney. Their only suggestion was that he might leave the furnace room door open to insure plenty of oxygen for combustion. He did, but this made no difference.

"One suggestion was to give the attic more ventilation; so he opened the gable ventilators as far as possible. No difference. Then someone said the attic was too cold; so he closed the ventilators. Someone suggested the warm air striking the cold duct was possibly causing the trouble; so he laboriously insulated all the cold-air ducting. The water still kept on dripping. Every expert, after he had looked over the situation and had exhausted his ideas would shake his head and say, 'Brother, you've got a problem!' He knew that.

"By then it was Thanksgiving, and I went up to visit him. We had been talking the problem over on the telephone; and he had, at my suggestion, bought a relative-humidity gage. The little rascal went right up to 70% as soon as he took it home. I was more and more convinced *something* had to be pumping a lot of excess moisture into the house. Since the trouble started when the heat was turned on, I felt the furnace was in some way connected with the problem. We placed the humidity gage on a hot air register and watched it when the furnace blower started. The humidity indication

increased sharply for the first two or three minutes and then started to decrease slowly.

"That was the clue I was looking for. Somehow or other, I reasoned, water must be getting into the hot-air duct; and the over-running hot air from the furnace was picking this up and pushing it into the house. After the furnace ran a few minutes, the accumulated moisture was all licked up and the humidity indication at the register started to fall. But when the blower quit, the moisture started accumulating in the duct again, ready for the next moisture-grabbing push of hot air from the furnace.

"My brother had guests for Thanksgiving dinner; so we had no opportunity to make more tests; but I suggested he check for a water pipe leak beneath that concrete slab. A few days later he called and told me he had shut off everything in the house and discovered he was losing eight gallons of water in six hours. Furthermore, by shutting off first the cold water and then the hot, he had discovered the leak was somewhere in the hot-water lines. When the hot water was shut off, the water meter didn't budge and the humidity in the house fell rapidly. Obviously, water from the leaking line was finding its way into the hot air duct. That's why, even with two dehumidifiers running full-tilt twenty-four hours a day, it was impossible to lower the humidity in the house much below 70%."

"Well, his problem was solved," Barney remarked.

"Not by a long shot! Not unless my brother and his wife were willing to turn their fine home into a cold-water flat. Remember all the plumbing was buried beneath that concrete slab, and there was no practical way to get at it except by cutting a hole through the hardwood floor and through the slab. The problem resolved itself into locating and repairing the leak without cutting any more or any larger holes than absolutely necessary. And there were many hot-water lines feeding from the tank in the furnace room. One went to the kitchen sink; another, to the automatic washer; two more went to a bar-sink in the den and to a half-bath off the den; still another ran almost the length of the house to the main bathroom.

"The first blow was when my brother discovered there was no plan of the plumbing available; and a plumber told him that even if there had been it would be of little help in locating the position of the pipes. In practice, a plumber ran the lines the easiest way and not as the architect drew them. This same plumber came over with his dipping needle—which of course was useless in locating the copper tubing—and with his other pipe-locating gear. None of it, including the mine-detector type, gave any sort of a reliable indication; but he and my brother finally cut a hole in the furnace-room floor hoping they would find a leak there. They didn't find a leak, but steam seeping up through the opening confirmed there *was* a hot-water leak.

"Next we tried an idea of mine. I sent up my audio generator, my signal tracer, and a tape-recorder telephone pickup. My idea was to put the audio signal into the hot water line and use the pickup and the amplifier of the signal tracer to follow each line out from the tank. This didn't work.

problem solving microphones

by

SHURE



PROBLEM:
overload & "pop"

SOLUTION:
adjustable-volume
Unisphere® A

MODEL 585SAV

One of the most ingenious microphones ever designed. The volume control is right on the microphone case. Enables the user to reduce output if audio-break-up due to overload occurs. Also, enables a speaker or singer to control his own volume for dramatic effects. Ideal where amplifier controls are inaccessible. Model 585SAV \$72.50 list.

vibration a problem?



SHOCK-MOUNTED
SHURE
UNISPHERE® I
Model 566

All the superb feedback and pop-control characteristics of the famed Unisphere I, plus built-in vibration isolation shock-mount which prevents pickup of mechanical vibrations and handling noise. Model 566 \$140.00 list.

write for data sheets:

SHURE BROTHERS, INC.
222 Hartrey Ave.
Evanston, Ill. 60204

© 1967 Shure Brothers, Inc.

The hot and cold lines both radiated the signal and rendered it impossible to get a meaningful indication.

"Then my brother borrowed air-leak-detecting equipment from a bus company for which he used to work. This consists of a microphone, amplifier, and output meter. With it you can easily trace the high-pitched sound of escaping air right to its source. But the equipment proved useless in locating the sound of the escaping water, which by now could be faintly heard. By the time the sound got through the concrete and spread out beneath the floor, it seemed to come from everywhere in the house.

"I remembered our city had hired a firm out of Chicago to locate leaks in our water mains; so I got the address from our local superintendent of utilities and wrote about my brother's problem. I got a prompt reply explaining how a leak such as my brother had could be located. The method was most interesting.

"The suspected piping is disconnected and valved off from tanks, etc. Then a radioactive sodium hydroxide solution with a fifteen hour half-life is mixed in a truck-mounted tank under the supervision of a representative of the AEC. This solution is pumped through the leaking system back into the truck tank and is taken to a safe place for storage until it is no longer even mildly dangerous. Some of it escapes from the pipes wherever there is a leak and saturates the ground. This radioactive area is pinpointed by means of a *beta-gamma* ionization chamber, an analytical count-rate meter, or an aural-rate meter. This, of course, is a greatly simplified explanation of the technique. There was only one catch. A normal residential leak-locating job in the metropolitan Chicago area was said to price out from \$550 to \$650, and you still had to have the located leak repaired. As explained in the promotional material, "While some pipe tracing and leak detection has been done by the company in big mansions, the expense of obtaining the radioisotope and taking the time and manpower to follow the rigorous method of detection makes the technique nonfeasible for residential use."

"Anyway it was a bit salty for my brother—except as a last resort—so we fell back on our own resources. Employing a dodge learned as an automobile mechanic, he placed a yardstick from his ear to various exposed parts of the plumbing and listened to the conducted sound of the escaping water. The loudest sound was picked off the hot-water line going up to the sink. Confirming suspicion this pipe had the leak was the fact water from the cold sink faucet ran warm when first turned on. My brother suspected escaping hot

water from the hot sink line was probably surrounding the adjacent cold-water line and automatically heating the water in it.

"Now what he needed to know was the precise path of the hot-water line from the water tank to the sink, and I finally came up with the solution to that one. I sent up my battery eliminator, the telephone pickup, my a.c. v.t.v.m., and instructions. He fastened one lead from the eliminator to the disconnected hot-water main and the other lead to the hot-water sink faucet. Current through the pipe was adjusted to about six amperes. The pickup was connected to the v.t.v.m. set for a full-scale reading of .01 volt. I had thought it would be necessary to keep swinging the pickup back and forth through the static lines of force of the d.c. field surrounding the pipe in order to get a reading on the a.c. meter, but this didn't prove to be necessary. There was just enough ripple in the d.c. output of the eliminator to give an unmistakable peak reading on the v.t.v.m. when the pickup was directly over the buried pipe. Moving the pickup a couple of inches either way made the reading fall off. This arrangement was used to chart the exact path of the pipe, and its course was marked on the kitchen floor with chalk."

"I still don't see how he located the leak itself," Barney interrupted.

"He didn't have to," Mac answered. "All his tests convinced him the leak was close to the sink where it would be difficult to cut a hole or to work, so he simply cut a hole down through the floor and the slab a couple of yards away and exposed the hot water line, which, incidentally, was precisely under his chalk mark. He cut the line and bent the tank end of it up and connected a new length of copper tubing to it. This tubing was run on top the slab but beneath the floor to the wall behind the sink. Here the old hot water line was cut again and the new line was connected to the end going up to the faucet. Tests revealed the leak was gone. It was in the disconnected portion still beneath the slab.

"All that remained to do was to pour fresh concrete in the holes in the slab, repair the floor with plywood, and then cover the whole thing with some of that new kitchen carpeting. The house is so nice and dry that he probably will have to use a humidifier this winter to keep the humidity up to where it should be. He's delighted and writes it just goes to show what can be done when logic, electronics, and perseverance team up on a tough problem."

"Yeah, and I'll bet a lot of other home owners could profit by his experience," Barney said. "You can bet he's not the only guy with a problem like that." ▲

Join the PHOTOFACT[®]-OF-THE-MONTH Club

and receive each and every month

THE WORLD'S FINEST TV-RADIO SERVICE DATA

Complete up-to-the-minute coverage • Save over \$60 per year!

Howard W. Sams now offers this great new monthly package exclusively for P.O.M. members!

You get your 6 new PHOTOFACT Sets every month in sturdy new file folders sealed in factory carton to insure perfect condition and completeness—easier-than-ever to file and use. Now—only \$10 per month and you get 20% MORE COVERAGE!

NOW! more current model coverage each month to keep you ahead earning more—
AND YOU SAVE OVER \$60 PER YEAR!

As a PHOTOFACT-OF-THE-MONTH CLUB member, you get 6 new PHOTOFACT Sets every month—the world's finest TV-radio service data—with all the time-saving, profit-boosting help you want!

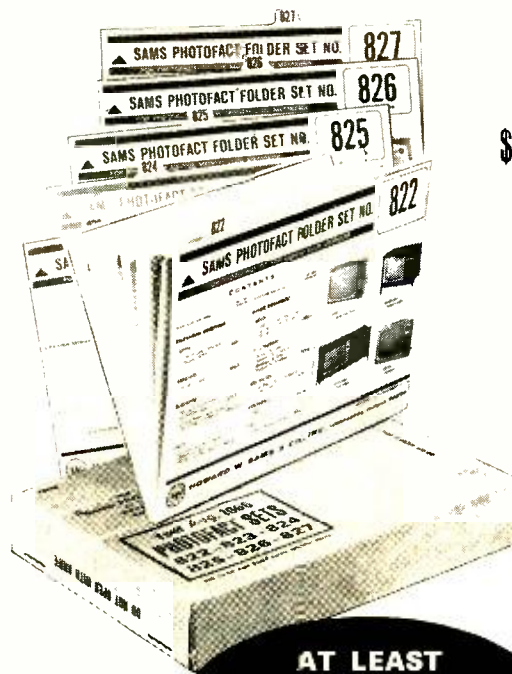

**AT LEAST
6 COLOR TV
FOLDERS MONTHLY**

**NOW! ONLY
\$10 PER MONTH
brings you
20% MORE
PHOTOFACT[®]
coverage!**

*complete current coverage of
at least 50 chassis each and
every month for less than*

20¢ per chassis model!

To stay ahead, to save money (individually purchased sets now sell for \$2.50 each)—join the PHOTOFACT-OF-THE-MONTH CLUB now!

see how PHOTOFACT boosts your earning power!

**SUBSCRIBE TODAY THROUGH
YOUR SAMS DISTRIBUTOR OR
USE THIS HANDY ORDER FORM**

TRY A THREE-MONTH P.O.M. SUBSCRIPTION

HOWARD W. SAMS & CO., INC. Dept. EWF-10
4300 W. 62nd St., Indianapolis, Ind. 46268

Enroll me for a 3-month membership in the Photofact-of-the-Month Club. I agree to pay \$10 per month, and understand I will receive 6 current Photofact Sets monthly for 3 months to be delivered by my Sams Distributor (named below).

Name _____

Shop Name _____

Address _____

City _____ State _____ Zip _____

My Sams Distributor is: _____

Signed _____

BOOK REVIEWS



"INTRODUCTION TO RADAR AND RADAR TECHNIQUES" by Denis Taylor. Published by *Philosophical Library Inc.*, 15 East 40th St., New York, N.Y. 10016. 123 pages. Price \$4.75.

This is a layman's handbook which the author has based on his earlier and more comprehensive engineering text "Principles of Radar". In deference to his audience, the author has managed to present his subject matter without relying on a pre-knowledge of mathematics and radio theory on the part of his readers.

Despite this seeming handicap, the author provides a fairly complete account of the development and use of radar in World War II and its subsequent application—within the limits of security, of course. Since the author is British and his experience is with British radar equipment exclusively, very little mention is made of developments or equipment other than those emerging from English establishments. He does cover all the different types of radar developed during the war and since, but those who work on U.S.-built equipment will find little information of immediate interest.

But, as a background text for over-all general data on the subject, this slim volume should be helpful.

"101 WAYS TO USE YOUR HI-FI TEST EQUIPMENT" by Robert G. Middleton. Published by *Howard W. Sams & Co., Inc.*, Indianapolis, Ind. 141 pages. Price \$2.95. Soft cover.

Like the publisher's other "101 Ways" books, this is a practical handbook for the professional audio technician, engineer, or serious audiophile. It concentrates on basic audio tests of hi-fi amplifiers and associated equipment and emphasizes the correct use of specialized audio test gear.

The text is divided into four main sections covering equipment checks, amplifier tests, component tests, and system checks. Each item included in the "101 Ways" lists the problem or technique, the equipment needed to perform the operation, the connections required, procedure to be followed, and an evaluation of the results. In most cases the correct connections are indicated for the test setup and the correct scope pattern is shown.

By using the complete index, the technician can quickly locate the material which applies to his particular servicing problem. The clear, concise instructions provided should permit rapid correction of the equipment fault.

"TRANSISTORS FOR AUDIOFREQUENCY" by Guy Fontaine. Published by *Hayden Book Company, Inc.*, New York. 458 pages. Price \$7.95.

This is a translation from the French edition originally published by *N.V. Philips of The Netherlands* which probably accounts for the use of "audiofrequency" and "radiofrequency" as single qualifying adjectives.

The text, which is based on courses the author has given in France, is divided into two main sections: definitions and operation of the transistor in the audio frequency range, the latter section divided into two chapters covering the response of the transistor to small signals and to large signals.

One interesting and unique feature of this book is the lavish use of multi-colored diagrams to indicate various operating parameters and transistor constructions. This feature makes it very easy for the student to understand circuit operation or trace currents and signals through the various parts of a component or circuit.

The student will need to have his mathematical skills well honed and wits about him to derive maximum benefit from this text.

"HANDBOOK OF TELEMETRY AND REMOTE CONTROL" edited by Elliot L. Guenberg. Published by *McGraw-Hill Book Company*, New York. 1298 pages. Price \$35.

This is a *cade mecum* for the telemetry engineer or graduate engineering student working in the field. With its comprehensive index and elaborate mathematical appendix, the volume provides a wealth of information in thoroughly usable and readily accessible form.

The editor-in-chief, who is manager of *IBM's Radiation Systems Research Center for Exploratory Studies*, has called upon the services of an impressive array of specialists to deal with specific topics. The text has been divided into 16 chapters covering fun-

damentals, sampling and handling of information, sensing of information, radio-telemetry systems, standards for telemetry, FM-FM telemetry systems, PDM telemetry systems, PCM telemetry system, PAM and advanced systems, telemetry-system component design, data-handling equipment, industrial telemetry and remote control, space systems and telemetry, remote control, and satellite-relay communications.

From this listing of topics, it should be obvious that there is "something for everyone" in this volume. With the proper technical background and mathematical experience, readers should find this an invaluable reference source.

"THE COMPUTER AND INVASION OF PRIVACY". A reprint of a U.S. Printing Office Document, No. 66-62406. Published by *Arno Press*, 4 E. 43rd St., New York. 311 pages. Price \$4.95.

This is a transcript of the Hearings before a Subcommittee of the Committee on Government Operations held July 26, 27, and 28, 1966 before the House.

Since the publishers of this volume felt that too few citizens were aware of the scope of the proposed National Data Center at which would be gathered comprehensive data on every man, woman, and child in the country, they have reprinted the hearing transcript to provide wider distribution and a more enlightened electorate. After reading the statements of their elected representatives some constituents will undoubtedly be moved to "take pen in hand".

"MOST-OFTEN-NEEDED 1967 TELEVISION SERVICING INFORMATION" compiled by M.N. Beitman. Published by *Supreme Publications*, 1760 Balsam Road, Highland Park, Ill. 192 pages. Price \$4.00. Soft cover.

This new edition of this publisher's schematics and service notes (Vol. TV-26) covers sets from *Admiral, DuMont, Emerson, General Electric, Magnacox, Montgomery Ward, Motorola, Philco, RCA Victor, Sears Roebuck, Sharp, Sylvania, Westinghouse and Zenith*.

Each chassis is represented by a full schematic, alignment notes, scope patterns, top and bottom chassis views, and various service hints and technical data supplied by the manufacturers.

"ELECTRONIC ENGINEERING MEASUREMENTS FILEBOOK" compiled by EEE Staff. Published by *TAB Books*, Thurmont, Maryland. 248 pages.

This is a "how-to" book with a vengeance with every single item preceded by the phrase "How to Measure.....". The material originally appeared in one of the magazine's regular departments and dealt with the measurement of specific parameters using special techniques. Some 60 items are included with almost as many authors. ▲

Special Introductory Offer to new members of the electronics and control engineers' book club

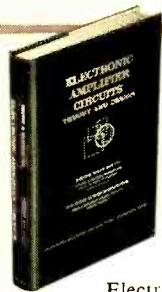

Pub. Price
\$11.50
Club Price
\$9.80

Electronic Amplifier Circuits by J. M. Pettit and M. M. McWhorter. Code #723



Pub. Price
\$16.75
Club Price
\$14.25

Electronic and Radio Engineering by F. E. Terman. Code #509

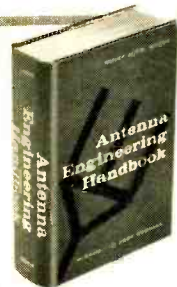

Pub. Price
\$26.50
Club Price
\$18.95

Antenna Engineering Handbook by Henry Jasik. Code #290

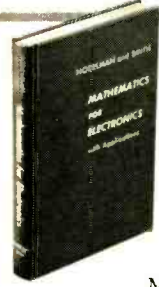

Pub. Price
\$7.00
Club Price
\$5.95

Mathematics for Electronics with Applications by H. M. Nodelman. Code #850

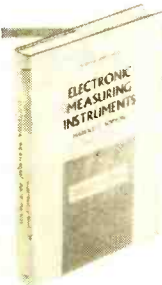

Pub. Price
\$7.50
Club Price
\$6.40

Electronic Measuring Instruments by H. E. Soisson. Code #565



Pub. Price
\$15.00
Club Price
\$12.75

Transistor Circuit Design by the Engineering Staff of Texas Instruments, Inc. Code #737

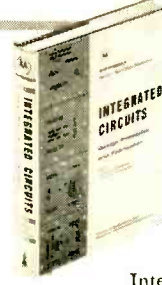

Pub. Price
\$12.50
Club Price
\$10.65

Integrated Circuits by the Engineering Staff of Motorola, Inc. Code #525

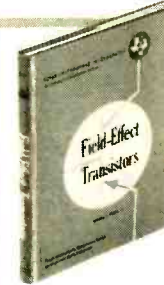

Pub. Price
\$10.00
Club Price
\$8.50

Field-Effect Transistors by L. J. Sevin. Code #355



Special \$1.00 bonus book comes to you with your first club selection

SAVE TIME AND MONEY BY JOINING THE electronics and control engineers' book club

Here is a professional club designed specifically to meet your day-to-day engineering needs by providing practical books in your field on a regular basis at below publisher prices.

HOW THE CLUB OPERATES. Basic to the Club's service is its publication, the *Electronics and Control Engineers' Book Club Bulletin*, which brings you news of books in your field. Sent to members without cost, it announces and describes in detail the Club's featured book of the month as well as alternate selections which are available at special members' prices.

When you want to examine the Club's feature of the month, you do nothing. The book will be mailed to you as a regular part of your Club service. If you prefer one of the alternate selections — or if you want no book at all for that month — you notify the Club by returning the convenient card enclosed with each *Bulletin*.

As a Club member, you agree only to the purchase of four books over a two-year period. Considering the many books published annually in your field, there will surely be at least four that you would want to own anyway. By joining the Club, you save both money and the trouble of searching for the best books.

MAIL THIS COUPON TODAY

electronics and control engineers' book club
582 PRINCETON ROAD
HIGHTSTOWN, N. J. 08520

Please enroll me as a member of the Electronics and Control Engineers' Book Club and send me the two books indicated below. You will bill me for my first selection at the special Club price and \$1 for my new membership book, plus local tax where applicable, and a few additional cents for delivery costs. These books are to be shipped on approval, and I may return them both without cost or further obligation. If I decide to keep the books, I agree to purchase as few as four additional books during the next two years at special Club prices (approximately 15% below list).

Write Code # of your \$1 bonus book

Write Code # of your first selection

NAME _____

ADDRESS _____

CITY _____

STATE _____ ZIP _____

COMPANY _____

(This offer good in United States only)

E33033

RADIO & TV NEWS

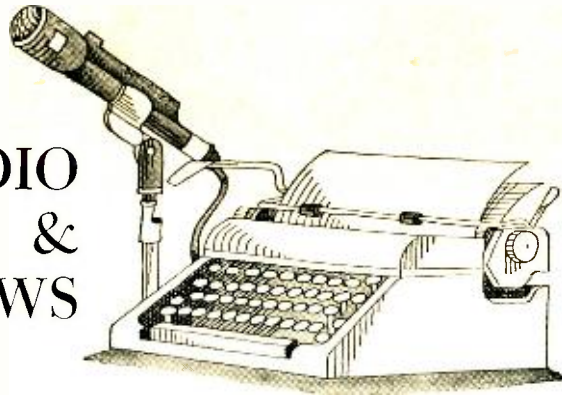

COLOR-TV made its German debut during the 25th Great German Radio Exhibition in Berlin when "The Golden Shot", a variety show, went out over the air at 8 p.m. on August 25th. While color sets are still in limited supply, 30 models are being marketed and test patterns have been available to technicians and retailers between 7:45 and 9:45 a.m. daily since July 1st, and on Second German TV from 2:30 to 4:30 each afternoon.

Programming PC Boards

A highly automated process at G-E's Communications Products Dept. in Lynchburg, Va., is meeting advanced communications manufacturing requirements by providing more circuit density on smaller printed-circuit boards. Because more conducting paths have

to be placed in a very small space on each circuit, there is a need for closer patterns and tighter circuit board hole-location tolerances.

By means of tape programming, G-E now keeps the center of each hole to the board pattern within $\pm 0.0035"$. Previously $\pm 0.015"$ hole-location tolerance accuracy was considered adequate. Now new engineering criteria make it necessary to place numerous conductors on PC boards as small as $0.4" \times 0.9"$.

Pumping a Gaseous Ion Laser

A new way to pump a gaseous ion laser using an inexpensive power supply and with virtually any gas as the active medium has been developed by IBM scientists. The device is of unusual interest because it is capable of produc-

ing a near-continuous, wide-diameter laser beam of a wide variety of colors with ordinary low-frequency power. These features make it potentially attractive for such applications as large-screen projection TV, non-impact printing processes, laser scanners, and beam-addressable type memory.

Computerized Box Office

How a nationwide network of electronic box offices will offer actual tickets to Broadway shows and other N.Y. entertainment attractions was demonstrated recently for the press.

Developed by *Ticket Reservation Systems, Inc.*, the service involves a computer which "memorizes" all available seats for the show events offered. This inventory of tickets can be tapped by any TRS remote unit hooked into the system's computer.

The prospective ticket buyer can inquire about the availability of seats for any of the listed events and indicate the general location and price range of the tickets desired. If the computer indicates that such tickets are available, the operator pushes the "buy" key and the actual tickets are printed on the spot. These seats are then removed from the computer memory.

A similar system, "Computicket" by *Computer Sciences Corporation*, is scheduled to go into operation in Southern California in 1968. ▲

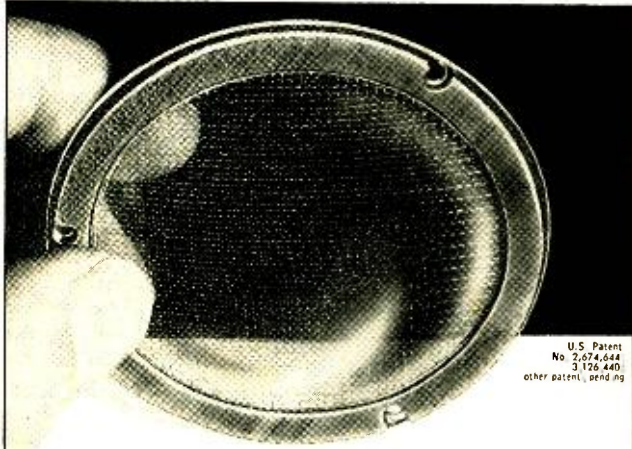

U.S. Patent
No. 2,974,644
3,126,440
other patent pending

Metex Shield-Vu™

cuts the interference but not the view

An effective, economical shield, Metex Shield-Vu is available in your choice of mesh (monel, low carbon steel, or an etched metal such as nickel) imbedded in plexiglass. The glass itself can be anti-reflection,

frosted or clear; in any color, size and shape, depending on your requirements. Ask for our assistance, or write for free samples, prices and literature.

METEX Corporation

970 New Durham Road, Edison, N.J. 08817
(201) 287-0800 • TWX 710-898-0578

West Coast: Cal. Metex Corp., 509 Hindry Ave., Inglewood, Calif.



CIRCLE NO. 198 ON READER SERVICE CARD

FREE!



BRAND NEW FALL AND WINTER RADIO-TV ELECTRONICS CATALOG



YOUR BUYING GUIDE FOR:

- Stereo & Hi-Fi Systems & Components
- Tape Recorders
- Electronic Parts, Tubes, Tools
- Phonos & Records
- Ham Gear
- Test Instruments & Kits
- Cameras & Film
- PA, Citizens Band
- Radio & TV Sets
- Musical Instruments

MAIL TODAY TO:

BURSTEIN-APPLEBEE

Dept. EWJ 1012 McGee, Kansas City, Mo. 64106

Name _____
Address _____
City _____
State _____ Zip Code _____

CIRCLE NO. 122 ON READER SERVICE CARD

Infrared Radiometry

(Continued from page 27)

unsuited for investigation by contact measurements.

Design Considerations

The most fundamental measure of the performance of a radiometer is its thermal sensitivity. This is customarily expressed as noise equivalent temperature difference (NETD), and is defined as the temperature increment necessary in a black-body target to make an output signal increment equal to the system noise. This value may typically range from 0.05° C to several degrees, depending on the total range of temperatures that the instrument must cover.

Other parameters are important in the case of infrared cameras, such as the degree of pictorial resolution and the time needed to produce a picture. The most widely used infrared cameras have a picture-element spot size of 1 milliradian, and a picture format 10 degrees high and 20 degrees wide, which gives a 180-line picture. Higher or lower pictorial resolutions may be used; it is not unusual to encounter pictures composed of 360 or 60 lines.

As would be expected, various parameters are interrelated and it is possible to trade off one against the other. The frame time may be reduced to a fraction of a second, for instance, but only at the expense of the number of picture elements. Spot size can be reduced at the expense of thermal sensitivity; thermal sensitivity may be increased at the expense of speed and pictorial resolution. The relationships among these elements are not simple and also vary according to the kind of detector, since photon detectors as a class have much shorter time constants than thermistor bolometers, and doped germanium detectors at liquid helium temperature are especially fast.

The most widely used infrared cameras produce thermograms in from 3 to 13 minutes. Where high speed is essential, however, and other elements can be sacrificed, thermograms can be produced in a fraction of a second. For example, an infrared camera might be set to scan a portion of the sky for the appearance of jet aircraft or missiles. High resolution would not be important for such an application, nor would sensitivity, since such targets would offer good contrast against the cold background of sky. Readout in such an instance would more likely be to an oscilloscope rather than film.

The optical system of an infrared radiometer must be sealed to protect it from the elements but must incorporate a window that is transparent to infrared radiation. In addition, filters are sometimes used to screen out infrared radiation of unwanted wavelengths in order to reduce the level of background noise. Since the infrared spectrum is far more extensive than the visible spectrum, the problems are much greater. Materials that will serve as windows in the near infrared region are often opaque to radiation at longer wavelengths. The transmission properties of many materials vary with temperature. Some materials that are otherwise suitable are fragile or hygroscopic.

From the visible range to 3 μ , fused silica is most widely used for windows, although some optical glasses are also satisfactory. In the middle region, from 3 μ to 6 μ , optical elements may be manufactured from germanium, silicon, rutile, sapphire, and calcium aluminate glass. Beyond 6 μ , it is hard to find a material that is entirely satisfactory. Silver chloride can be used if properly coated, but is rather soft, making it difficult to achieve uniformity of composition. Arsenic trisulfide loses transmission significantly at about 10 μ and softens at a temperature of 210° C. Crystalline germanium and silicon are suitable, although the transmission of germanium at the longer wavelengths drops rapidly with increasing temperatures, and silicon absorbs part of the radiation at some wavelengths. ▲

IBM needs technicians for systems development

Our requirements are tough. But if you can meet them, it will really pay you to write to Mr. Nerone at IBM Kingston.

ELECTRON TUBE TECHNICIAN

The candidate should have worked in a research lab or for a manufacturer doing electron tube or semi-conductor developing. He should have a strong background in materials technology. He should also have experience in, or a good understanding of, glass technology, atmosphere brazing and processing, electron tube assembly and exhaust, ceramic-metal seals, and vacuum equipment. By his experience, he should demonstrate the ability to carry on a program (at technician level) with a minimum of supervision. He should also be able to show originality in thinking. The candidate should have three years' experience, at least two years of college study in physics or electrical engineering. In lieu of education, we will accept five or more years of the right kind of experience.

CHEMICAL TECHNICIAN

Experience of three to five years in high-purity inorganic materials such as phosphors and semi-conductors. Familiarity with high-temperature furnaces, high-vacuum techniques, phosphor settling and burn in cathode ray tubes. *Note:* We also need another chemical technician with one year's minimum experience in quantitative analysis. Experience with photo-resists, plating and etching processes preferred but not necessary. Education: minimum of two years' college chemistry.

GRAPHICS TECHNICIAN

Knowledge of graphic devices, cathode ray tubes, storage tubes, and scan converters. Working knowledge of their associated components and circuits. Position involves design and troubleshooting graphic systems using both analog and digital circuits.

Company-paid benefits include insurance, hospitalization, retirement, and tuition refund. Attractive stock purchase plan. Relocation expense paid. Kingston is a small, prosperous city in the Mid-Hudson Valley about 90 miles north of New York City.

Please write, outlining your qualifications and experience, to:

**Mr. J. D. Nerone,
Department QC4-K,
IBM Corporation,
Neighborhood Road,
Kingston, New York 12401**

IBM

An equal opportunity employer.

**“Get more
education
or
get out of
electronics
...that’s my advice.”**



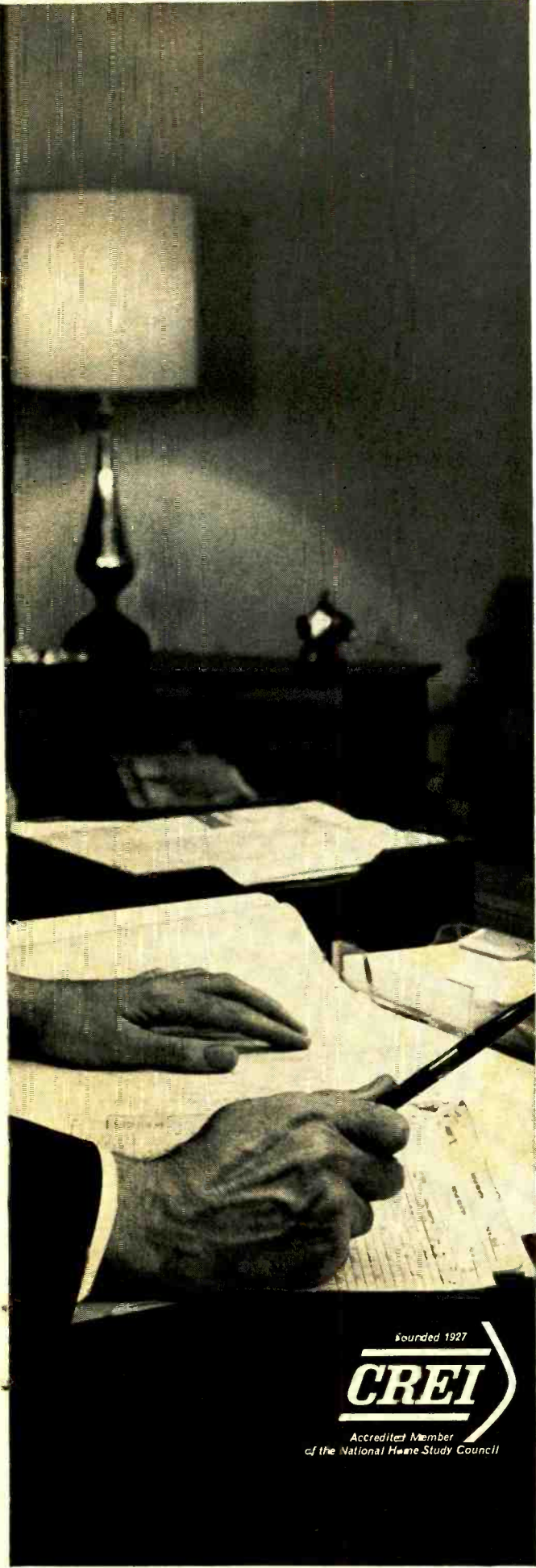

Founded 1927
CREI
 Accredited Member
 of the National Home Study Council

Ask any man who really knows the electronics industry.

Opportunities are few for men without advanced technical education. If you stay on that level, you'll never make much money. And you'll be among the first to go in a layoff.

But, if you supplement your experience with more education in electronics, you can become a specialist. You'll enjoy good income and excellent security. You won't have to worry about automation or advances in technology putting you out of a job.

How can you get the additional education you must have to protect your future—and the future of those who depend on you? Going back to school isn't easy for a man with a job and family obligations.

CREI Home Study Programs offer you a practical way to get more education without going back to school. You study at home, at your own pace, on your own schedule. And you study with the assurance that what you learn can be applied on the job immediately to make you worth more money to your employer.

You're eligible for a CREI Program if you work in electronics and have a high school education. Our FREE book gives complete information. Air-mail postpaid card for your copy. If card is detached, use coupon below or write: CREI, Dept. 1110E, 3224 Sixteenth Street, N.W., Washington, D.C. 20010.



The Capitol Radio Engineering Institute
 A Division of McGraw-Hill, Inc.
 Dept. 1110E, 3224 Sixteenth Street, N.W.
 Washington, D.C. 20010

Please send me FREE book describing CREI Programs. I am employed in electronics and have a high school education.

NAME _____ AGE _____

ADDRESS _____

CITY _____ STATE _____ ZIP CODE _____

EMPLOYED BY _____

TYPE OF PRESENT WORK _____ G.I. BILL

I am interested in Electronic Engineering Technology
 Space Electronics Nuclear Engineering Technology
 Industrial Electronics for Automation
 Computer Systems Technology

APPROVED FOR TRAINING UNDER NEW G.I. BILL

TEST EQUIPMENT

PRODUCT REPORT

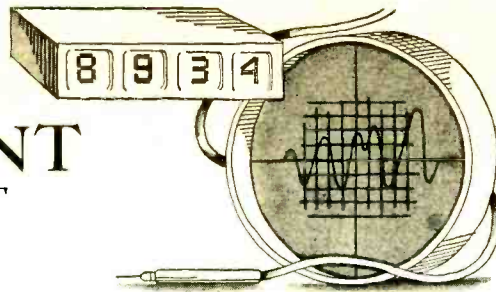

Hewlett-Packard Models 6215A and 6217A D.C. Power Supplies

For copy of manufacturer's brochure, circle No. 38 on Reader Service Card.



TWO extremely compact, well-regulated, small d.c. laboratory power supplies, selling for \$90, have recently been added to the *Hewlett-Packard* (Harrison Div.) power-supply line. These are Models 6215A and 6217A, rated at 25 V, 400 mA and 50 V, 200 mA, respectively. Reliable yet low-cost, these "hand-size" battery substitutes have performance features ideal for circuit development, component evaluation, and other laboratory applications. The power ratings are well suited for breadboarding, where the circuit designer most often needs a sizable number of power sources with higher output ratings. An interlocking feature for stacking several units vertically has been incorporated into the molded, impact-resistant case, thus minimizing the bench space required.

Underlying the new supplies is a design philosophy of achieving a low selling price while omitting only a few of the less often used operating features, such as remote sensing and remote programming. Like the higher priced, higher wattage supplies in the manufacturer's line, the 6215A and the 6217A employ all silicon circuitry. They are capable of 0.01% line regulation and load regulation, have less than 200 μ V r.m.s. ripple, and feature an output voltage fully adjustable down to zero. Selection of voltage or current metering is provided by means of a front-panel slide switch.

Low output impedance is the hallmark of high-quality power-supply design; these supplies exhibit less than 0.03 ohm from d.c. to 1 kHz. An output impedance of less than 3 ohms for

frequencies as high as 1 MHz assures satisfactory regulation with many types of active loads such as oscillators and amplifiers. Closely allied with low output impedance is fast transient recovery time—the time required for the output voltage to return to within a level approximating the normal d.c. output following a sudden change in load current.

The simplified diagram shows the basic feedback circuit principle used. The a.c. input, after passing through a power transformer, is rectified and filtered. The series regulator, by feedback action, alters its voltage drop to keep the regulated d.c. output voltage constant in spite of changes in the load, unregulated d.c., or other disturbances. The comparison amplifier continuously monitors the difference between the voltage across the front-panel voltage control R_p and the output voltage. If these voltages are not equal, the comparison amplifier produces an amplified error signal. The error signal is of such a magnitude and polarity as to change the conduction of the series regulator, thereby changing the current through the load resistor until the output voltage equals the voltage across the voltage control.

Drift-free performance is assured by the temperature-compensated zener diode and the high-gain feedback amplifier. The total change in output voltage for eight hours (after 30 minutes warm-up) at a constant ambient is less than 0.1% plus 5 millivolts, and the temperature coefficient is less than 0.02% plus 1 millivolt output change per degree centigrade change in the ambient temperature.

Current limiting and short-circuit protection are derived by permitting the driver stage of the comparison amplifier to sense the voltage developed by the load current flowing through R_m . This resistor is an internal potentiometer which is adjusted so that at a predetermined level of load current, the series regulator will be inhibited from increasing its conduction. The output current then remains within 5% of this value for any further reductions of load resistance, including a short circuit, under which the unit may be operated for an indefinite period of time.

In addition to overload immunity, other precautionary design features include reverse-polarity diodes across the input terminals and series regulator. These diodes protect supply components from the effects of any reverse voltage accidentally applied across the output terminals and, with series or parallel connection of another power supply, permit turning on one supply before the other. To safeguard the low-level input stage against damage due to large signals associated with rapid manipulation of the output controls, clamping

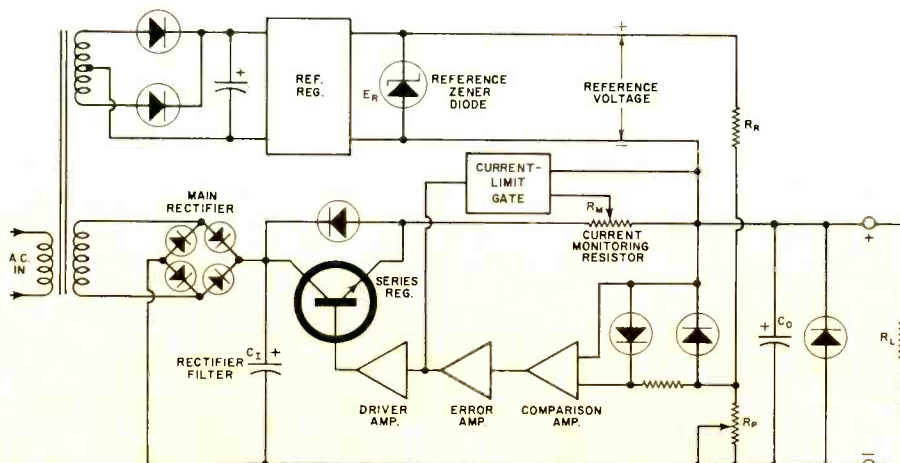

DELUXE LEATHERFLEX-COVERED EDITIONS AVAILABLE

Here is a complete selection of annuals, yearbooks, directories and handbooks available in Deluxe Leatherflex-covered editions from the world's largest publisher of special interest magazines. These are complete editions (including the original covers) which are bound in rugged leatherflex to provide long-time pro-

tection and keep them looking like new even after repeated use. The softly textured leatherflex, gold embossed for the look of elegance, makes them handsome additions to your permanent reference library. Take a moment to review the titles below. You're sure to find many of your favorites. \$3.00 each.

PHOTOGRAPHY ANNUAL
A selection of the World's finest photographs compiled by the editors of Popular Photography. 212 Pages—24 in full color.
1966.....#1
1965.....#2*
1964.....#3

ELECTRONIC EXPERIMENTER'S HANDBOOK
Many challenging projects for the electronics hobbyist.
1966 Spring Edition #36
1965 Fall Edition #9

CAR & DRIVER YEARBOOK
A complete buyers guide covering virtually every car available in the United States... Road tests... Technical specifications... Accessories and performance equipment buying guide... Guide to racing with action-packed photos.
1966.....#15

PHOTOGRAPHY DIRECTORY
World's most complete photographic buying guide.
1966.....#22

INVITATION TO PHOTOGRAPHY
A unique 116 page guide to better picture taking by the Editors of Popular Photography. Basic down-to-earth advice that helps you eliminate costly trial and error, time-consuming guess work. 20 complete, fact-and-photo packed articles in all.
1966.....#35

TAPE RECORDER ANNUAL
Everything you need to know about tape recording including a complete directory of mono and stereo recorders.
1966.....#30

COMMUNICATIONS HANDBOOK
The most complete and up-to-date guide to the exciting world of specialized radio communications.
1966.....#18

ELECTRONICS INSTALLATION AND SERVICING HANDBOOK
The only complete guide for servicemen and hobbyists to every major phase of consumer electronics servicing.
1966.....#32

FLYING TRAVELGUIDE
Here's the first really useful guide to flying vacations. Everything you need to know about: lodgings, restaurants, resorts, sightseeing, recreation, sports activities, airport facilities, childrens fun, price information, and much more.
1966.....#34

FLYING ANNUAL
The most valuable aviation yearbook ever compiled... Pilot reports... Aircraft directory... How to buy a used airplane... Navcom directory... Learn to fly section.
1966.....#27
1965.....#28

STEREO/Hi-Fi DIRECTORY
Complete buyers guide for virtually every Hi-Fi component manufactured.
1966.....#29

POLAROID LAND PHOTOGRAPHY
Complete guide and only comprehensive and up-to-date handbook on Polaroid Land Photography.
1966.....#24

SKIING INTERNATIONAL YEARBOOK
A luxuriously illustrated compendium of 1965's important events... A timely forecast of the excitement-packed 1966 season—by the editors of Skiing Magazine.
1966.....#26

Note: Deluxe Leatherflex-covered Editions are \$3.00 each, postpaid (\$3.75 for orders outside of U.S.A.). The annuals listed above are also available in regular editions at \$1.25 each plus 15c per copy for shipping and handling (\$1.75 for orders outside U.S.A.). To order your copies, check the appropriate box and circle the numbers of the annuals you wish to receive on the coupon to the right.

* Available in Deluxe Edition only.

Ziff-Davis Publishing Co., Dept. SD
One Park Ave., New York, N. Y. 10016

I am enclosing \$ _____

Send me the Deluxe Leatherflex-covered editions circled below at \$3.00 each, postpaid (\$3.75 per copy for orders outside U.S.A.).

Send me the regular editions circled below at \$1.25 each plus 15c shipping and handling (\$1.75 per copy for orders outside U.S.A.).

1 2 3 9 15 18 22 24 26 27 28 29 30 32 34 35 36

Name _____ (PLEASE PRINT) EW-107

Address _____

City _____ State _____ Zip Code _____

PAYMENT MUST BE ENCLOSED WITH ORDER

FREE!

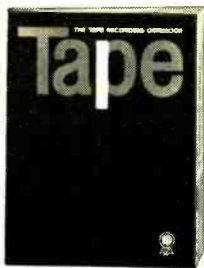

Just Published

It's a regular mini-library on the care and affection of TAPE RECORDERS (How to select. What to look for. Performance factors.); TAPE (Tips on splicing, editing and handling.); MICROPHONES (How to select and use them.); and many other provocative and useful facts. Yours FREE.

Elpa Marketing Industries Inc.
New Hyde Park, N. Y., 11040

Please send me FREE "The Tape Recording Omnibook". I'm interested in: _____
A Tape Recorder _____ Editing Systems _____
Microphones _____

Name _____

Address _____

City/State/Zip _____

CIRCLE NO. 111 ON READER SERVICE CARD

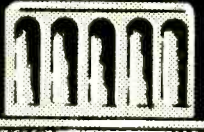

"NO NOISE"

The World's Most
Trusted Name Brand

- VOLUME CONTROL & CONTACT RESTORER
- TUNER-TONIC with PERMA-FILM
- EC-44 FOR ELECTRICAL CONTACTS
- TAPE-RECO HEAD CLEANER
- FRIGID-AIR CIRCUIT COOLER

All Guaranteed Non-Flammable, No Carbon-Tet, Non-Toxic & Won't Affect Plastics

The Only Brand Perfect For Color TV and Black & White

FREE extender assembly for pin-point application supplied with ALL NO-NOISE PRODUCTS.

Electronic Chemical Corp.

813 Communipaw Ave. / Jersey City, N. J. 07304

CIRCLE NO. 114 ON READER SERVICE CARD

diodes of opposite polarity limit the input voltage to the feedback amplifier to less than one volt.

To facilitate the use of these supplies in systems applications (for example, as offset sources for multichannel recorders), a rack-mounting kit is available for installing three supplies in a 3½" high standard 19" rack space.

High-quality components are used in these supplies. The molded case and new product techniques contribute to savings which make possible the low selling price. The result is a precision power supply which sells for about the same price as the components used if they are purchased on a small-quantity basis. ▲

Seco Model 260 Transistor Analyzer

For copy of manufacturer's brochure, circle No. 39 on Reader Service Card.

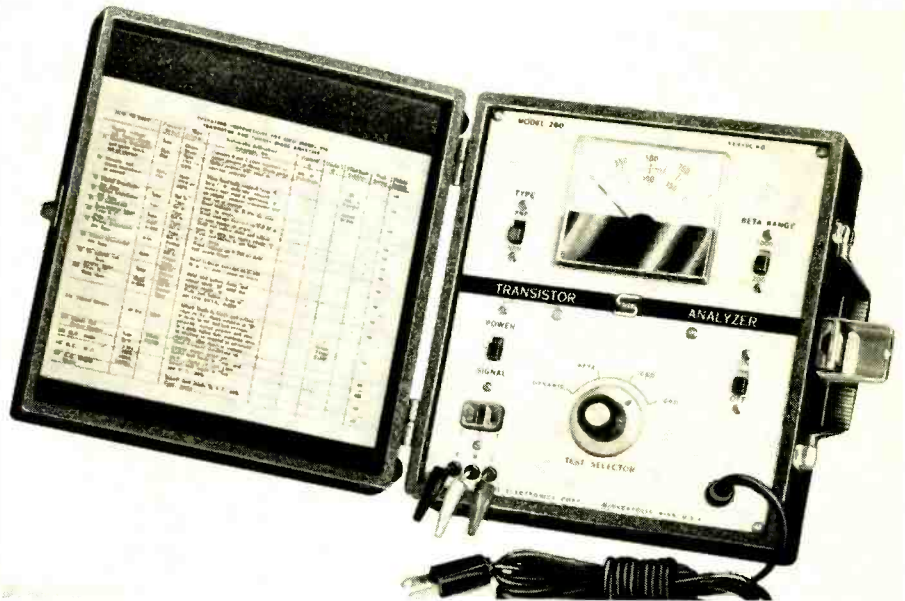

A COMPACT, solid-state transistor analyzer, designated the Model 260, is now available from Seco Electronics. Designed to provide accurate analysis of both power and signal transistors without setup, the Model 260 is fast, easy to operate, and completely safe.

Without removing the transistor under test from its original circuit and utilizing the unit's test leads, the Model 260 electrically inserts the transistor into a self-contained oscillator circuit for a fast "go/no-go" check. This dynamic test also permits immediate identification of *n-p-n* and *p-n-p* transistor types, as well as lead connections.

D.c. analysis is made out of circuit by inserting the transistor under test into a panel-mounted, universal socket. The *beta* test position provides a direct meter reading of the d.c. gain, while *I_{CEO}* and *I_{CBO}* test positions read both the collector-to-emitter and collector-to-base leakage currents.

The Model 260 transistor analyzer is priced at \$69.50. The unit, which operates from the 117-volt a.c. line, is completely self-contained, mounted in a durable vinyl-covered carrying case

Without removing the transistor under test from its original circuit and utilizing the unit's test leads, the Model 260 electrically inserts the transistor into a self-contained oscillator circuit for a fast "go/no-go" check. This dynamic test also permits immediate identification of *n-p-n* and *p-n-p* transistor types, as well as lead connections.

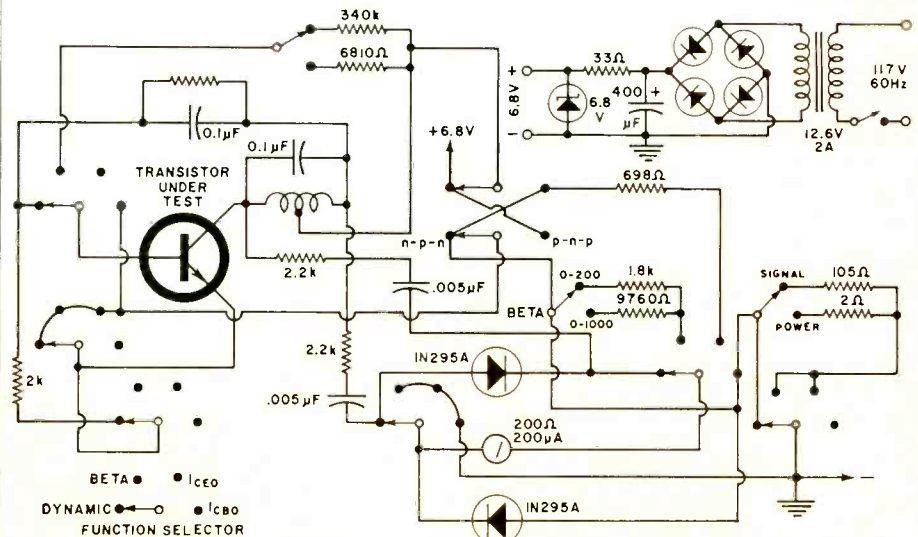

measuring 8 $\frac{1}{4}$ " high by 7 $\frac{1}{2}$ " wide by 4 $\frac{1}{4}$ " deep. It weighs only 5 pounds. ▲

Sencore Model CR143 CRT Tester and Rejuvenator

For copy of manufacturer's brochure, circle No. 40 on Reader Service Card.

A VERY rapid and accurate color-tracking test for color-TV picture tubes is an outstanding feature of the Model CR143, the CRT Champion, recently introduced by Sencore, Inc. The tester is fully automatic, eliminating the need for tedious logging and comparing of individual gun readings. With separate G2 screen-grid controls, each color gun is set up and then automatically compared with the others for tracking. This test is in accordance with CRT manufacturers' test procedures and is essential when claiming credit on factory-defective color CRT's.

A sophisticated instrument, the CRT Champion also makes all the standard color and black-and-white picture-tube tests, including shorts, emissions, and life test, using pure d.c. A line-adjust control assures accuracy when checking critical tubes.

We were especially pleased to find in the instrument setup chart booklet a listing for the type 16AVP4 tube which we have in one of our black-and-white



TV sets. This tube is not too widely used and is almost never listed in any of the catalogues for tube replacement or CRT manuals. It is listed right here, though, along with just about every other black-and-white and color picture tube, including the little 11SP22 tubes used in G-E's Portacolor set.

Rejuvenation and shorts removal are accomplished with an automatic rejuvenation circuit. Three rejuvenation positions are provided for saving faulty tubes or equalizing gun currents in color tubes.

The new tester is equipped with plug-in sockets for fast testing of all CRT's and easy updating. The unit is housed in a handsome brushed-chrome panel and rugged vinyl-clad steel case with detachable hinged cover. It measures 10" x 9" x 3 $\frac{1}{2}$ ", weighs 11 pounds, and is priced at \$99.50. ▲

modular thumbwheel switches by Amperex

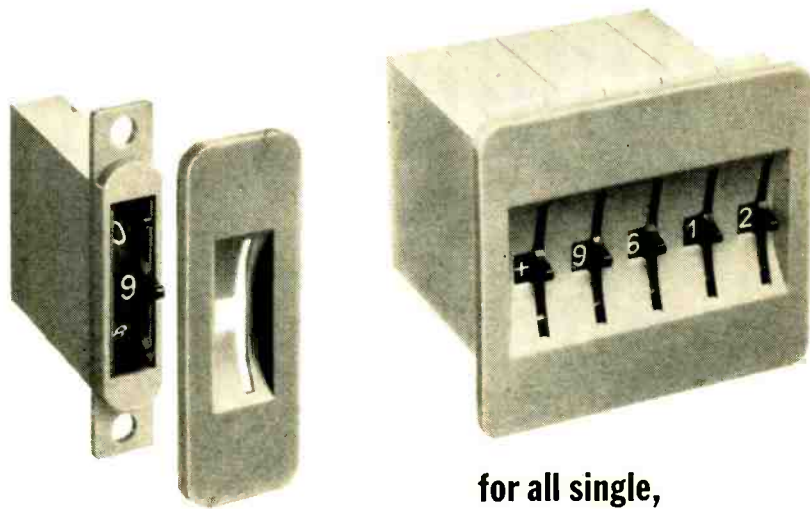

for all single,
double and
4-pole applications

easiest to mount: Individual switches mount with two screws onto the rear of the panel by means of face-plates available in lengths for one to nine switches in cascade.

easiest to wire: Uniquely designed terminals accept solder or wire wrap connections.

most versatile: 4 independent wipers provide a wide variety of decoding possibilities. The built-in diode gate in decoding switches eliminates mounting external gate and running in extra leads.

Outstanding Features

- Binary decoding and coding
- Bronze, nickel plated, glass epoxy, printed circuit board
- Lightweight, modular design

Immediately available, priced from \$3.60 per unit for the single-pole, 10-position decimal switch.

Savings are achieved through availability of multiple face-plates in various lengths to accommodate from one to nine switches in cascade on $\frac{1}{2}$ inch centers.

For complete information, write: Amperex Electronic Corporation, Components Division, Hicksville, Long Island, New York 11802.

Amperex[®]

TOMORROW'S THINKING IN TODAY'S PRODUCTS

CIRCLE NO. 124 ON READER SERVICE CARD

**ENGINEERED
FOR
EXCELLENCE:
TOP-QUALITY
TELEX
HEADSETS**

Ham operators, hi-fi fans and audio engineers all endorse famous **TELEX** headsets; known for top grade performance for more than 25 years.



MAGNA-TWIN—Typifies the quality standards which have made Telex a favorite of hams. Delivers absolute maximum intelligibility under difficult QRM conditions; equipped with super-comfort foam cushions. Rugged, moisture-proof magnetic drivers give excellent sensitivity, broad response. Made of tough, high-impact plastic for outstanding durability under hard usage.



TELESET—Lightweight, economy version of the famous Magna-Twin; designed especially for ham requirements. High performance, shock-proof Magna-Twin drivers at a low, low price.

CIRCLE NO. 83 ON READER SERVICE CARD

GET INTO ELECTRONICS



V.T.I. training leads to success as technicians, field engineers, specialists in communications, guided missiles, computers, radar and automation. Basic & advanced courses in theory & laboratory. Electronic Engineering Technology and Electronic Technology curricula both available. Assoc. degree in 29 mos. B. S. also obtainable. G.I. approved. Graduates in all branches of electronics with major companies. Start February, September. Dorms. campus. High school graduate or equivalent. Write for catalog.

VALPARAISO TECHNICAL INSTITUTE
Dept. RD, Valparaiso, Indiana



MONOSET—Feather-light 1.2 oz. weight eliminates headset fatigue. Sound from replaceable driver is fed directly into ears through adjustable tone arms.



COMBO—Brand new, high quality stereo headphones for the lively set. Big 3½" reproducers deliver deep rich bass and pure sweet highs. Exciting new styling has deluxe foam-filled vinyl earcushions. Designed for comfort, adaptability and concert-quality sound—anytime, anywhere.



SERENATA—For personal listening, these Telex Serenata headphones will reproduce high fidelity sound equal to about \$1,000 worth of speakers! Contains built-in tone control, adjustable pressure control and detachable cord add versatility, extra value.



**TELEX
acoustics**

A DIVISION OF THE
TELEX CORPORATION
3054 EXCELSIOR BOULEVARD
MINNEAPOLIS, MINN. 55416

Constant-Current Diodes

(Continued from page 31)

circuit, the voltage drop across the charging resistor changes the charging current, producing the familiar non-linear exponential waveform. This form of nonlinearity is completely eliminated in a constant-current diode charging circuit, for the charging current remains independent of the voltage across the diode. We must, of course, stop the sweep before the diode goes out of its pinch-off region, or we will obviously lose linearity.

A practical, externally controlled sweep circuit is shown in Fig. 4B. Here we have added an emitter-follower output to keep any load from disturbing the capacitor charge and have added a synchronizing transistor to discharge the ramp upon command from a sync pulse. Normally, the sync transistor is provided base current until a sweep is desired. The sync transistor is then turned off and a linear ramp is produced which is terminated either by limiting on the supply voltage or by once again providing base current to the sync transistor. The beginning of the sweep will be non-linear due to the emitter-follower not being forward-biased. This effect may be overcome by routing the 2200-ohm emitter resistor to a negative voltage.

A free-running sweep is shown in Fig. 4C. Here, the capacitor charges up to the breakdown voltage of the four-layer diode which snaps "on" and discharges the capacitor. The four-layer diode then turns "off", and a new sweep begins. There are two outputs. The emitter-follower output provides a linear, free-running saw-tooth, while the 10-ohm output provides a sharp 10-volt synchronizing spike at the end of each ramp. A constant-current diode used in this circuit must provide less current than the holding current of the four-layer diode. Otherwise, the circuit will latch "on" after one cycle. About 0.5 mA or lower current sources are recommended for operating most of these four-layer diodes.

If we turn the constant-current source "on" and "off", we can produce a staircase generator with a controllable number of equal-height steps, as in Fig. 4D. Since charge equals current multiplied by time, the longer we leave the diode "on", the higher each step will be, with the dwell time on the steps being determined by the "off" time between charging times. Such a circuit is most useful in transistor and tube type curve tracers and particularly in gray-scale generators in dot and bar service-type generators. Obviously more elegant forms of the same circuit can be used to produce accurate voltage-to-frequency converters. ▲

STEREO HI-FI DIRECTORY

STEREO/HiFi DIRECTORY

1967 — \$1.25 — #45
1966 — \$1.25 — #29

Complete buyers guide for virtually every Hi Fi component manufactured.

Order by number from
Ziff-Davis Service Division,
595 Broadway, New York, N. Y. 10012.
Enclose an additional 15¢ per copy for shipping and handling (50¢ for orders outside U.S.A.)

VARIABLE LOW-VOLTAGE POWER SUPPLY

By MURRAY S. RIFKIN / RETS Electronics Schools

Continuously variable power supply delivers up to 12 volts with a 500-milliampere load.

THIS supply will provide continuously variable voltages up to 20 volts with no load, decreasing to 12 volts with a 500-mA load. Ripple percentage over this range does not exceed 1%, and over a range of 2 to 9 volts, with load currents to 500 mA, output ripple is less than 0.5%. The power supply is fully protected against damage due to overload by a power-line fuse and a circuit breaker.

The circuit, see Fig. 1, consists of a full-wave bridge using silicon diodes and a large-value capacitor to provide a nominal 20 volts of partially filtered d.c. to the control circuit. The bridge output is applied to the load through the series power transistor Q1 operating as an emitter-follower and mounted on a heat sink.

Control of output voltage is obtained by varying the series resistance of Q1 which is, in turn, accomplished by varying the base voltage of Q2.

Final filtering without the use of additional filter capacitance is obtained by applying the load ripple voltage to the base of Q2 through coupling capacitor C1. The ripple is amplified and phase inverted by Q2 and applied to the base of Q1 where it is 180° out of phase with the original ripple appearing at the output of Q1. Cancellation of most of the ripple component results in very low ripple output, which is very difficult to achieve in a high-current supply.

Almost any low-level *p-n-p* transistor may be substituted for the 2N414. Output-voltage drift and ripple percentage may vary with the specific 2N414 selected for use and may vary with substituted transistor types.

The resistance of R1 may require adjustment of value to meet the desired minimum output voltage from the supply (with no load connected) when R2 wiper reaches the end of its rotation movement.

This voltage should be approximately 0.2 volt. If the output reduces to this voltage before full rotation of R2 is reached, the resistance of R1 should be increased. If the output is higher than 0.2 volt at full rotation, the resistance of R1 should be decreased.

The circuit breaker is the type used in TV receivers. It is important that the usual precautions be taken in mounting power transistor Q1. Silicone compound and an insulating washer must be used between transistor and heat sink. ▲

Fig. 1. Schematic of the low-voltage variable power supply.

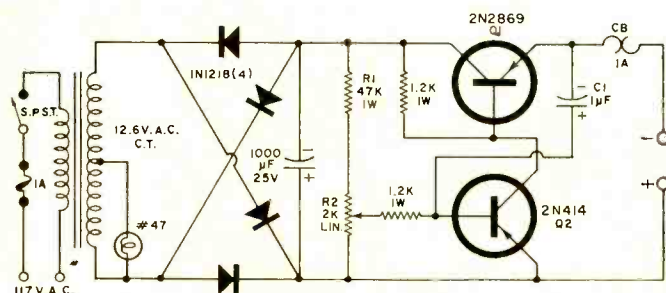

October, 1967

MAKE MONEY WITH THE CONTINUOUS-COVERAGE

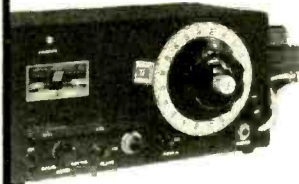

LAMPKIN TYPE 105-B

FREQUENCY METER

100 kHz to 175 MHz

ONLY \$295

Measures CB and Business Radio and marine and aviation—and others!

Don't be caught with a channel missing! Always be ready for a new customer, a channel frequency change, or band reassignment by the FCC.

- Guaranteed accuracy .001 %.
- Signal output for receiver alignment.
- Calibration correctable to WWV.

FREE BOOKLET!

"How to Make Money in Mobile-Radio Maintenance"

Name _____
Address _____
City _____ State _____ Zip _____

MAIL COUPON TODAY!

LAMPKIN LABORATORIES, INC. MFM DIVISION
BRADENTON, FLA. 33505

CIRCLE NO. 100 ON READER SERVICE CARD

A New Waterproof Series

MINIATURE

TOGGLE SWITCHES

New case design with double high voltage barriers, and low-loss, high impact, high temperature materials. Wide silver contacts. Waterproof 'O' rings and sealed terminals. Available in One, Two, Three and Four Pole configurations all in compact unitized bodies. 6 Amps @ 125 VAC.



FREE
PRODUCT
PLANNING
CATALOG

SPECIFY THE NEW "E" SERIES BY

ALCOSWITCH

DIV. OF ALCO ELECTRONIC PRODUCTS INC., LAWRENCE, MASS.

Momentary or Push On, Push Off

MINIATURE

Push Button Switches

Exceptionally high current. Positive snap-action with fast make and break contacts. SPDT, DPDT & 4PDT, useable as either a Normally Open or Normally Closed switch. Silver contacts and terminals.



FREE
12-PAGE
CATALOG
WRITE!

ALCOSWITCH

DIV. OF ALCO ELECTRONIC PRODUCTS INC., LAWRENCE, MASS.

CIRCLE NO. 200 ON READER SERVICE CARD



This important job (and its big salary) is reserved for a qualified electronics technician. It can be you!

It's a fact. There are *thousands* of jobs like this available *right now* for skilled electronics technicians. What's more, these men are going to be in even *greater* demand in the years ahead. But how about you? Where do you fit into the picture? Your opportunity will never be greater . . . so act *now* to take advantage of it. The first step? Learn electronic fundamentals . . . develop a practical understanding of transistors, troubleshooting techniques, pulse circuitry, micro-electronics, computers and many other exciting new developments. Prepare yourself now for a job with a bright future . . . unlimited

opportunity . . . lasting security . . . and a steadily-increasing salary.

Over 23,000 ambitious men are using Cleveland Institute Electronics Training Programs as a stepping stone to the good jobs in electronics. Why not join them? You will learn at home, in your spare time, and tuition is remarkably low. Read the important information on the facing page. Then fill out the postage-free reply card and drop it in the mail today. Without obligation we'll send you all the details. But act now . . . and get *your* high-paying job just that much sooner.

How You Can Succeed In Electronics

. . . Select Your Future From Five Career Programs

The "right" course for your career

Cleveland Institute offers not one, but five different and up-to-date Electronics Home Study Programs. Look them over. Pick the one that is "right" for you. Then mark your selection on the reply card and send it to us. In a few days you will have complete details . . . without obligation.

1. Electronics Technology

A comprehensive program covering Automation, Communications, Computers, Industrial Controls, Television, Transistors, and preparation for a 1st Class FCC License.



2. First Class FCC License

If you want a 1st Class FCC ticket *quickly*, this streamlined program will do the trick and enable you to maintain and service all types of transmitting equipment.

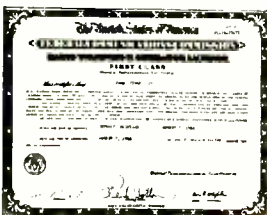

3. Broadcast Engineering

Here's an excellent studio engineering program which will get you a 1st Class FCC License and teach you all about Program Transmission and Broadcast Transmitters.



4. Electronic Communications

Mobile Radio, Microwave, and 2nd Class FCC preparation are just a few of the topics covered in this "compact" program . . . Carrier Telephony too, if you so desire.



5. Industrial Electronics & Automation

This exciting program includes many important subjects such as Computers, Electronic Heating and Welding, Industrial Controls, Servomechanisms, and Solid State Devices.



An FCC License . . . or your money back!

In addition to providing you with comprehensive training in the area indicated, programs 1, 2, 3, and 4 will prepare you for a Commercial FCC License. In fact, we're so certain of their effectiveness, we make this *exclusive offer*:

The training programs described will prepare you for the FCC License specified. Should you fail to pass the FCC examination after completing the course, we will refund *all* tuition payments. You get an FCC License . . . or your money back!

CIE's **AUTO-PROGRAMMED**™ lessons help you learn faster and easier

Cleveland Institute uses the new programmed learning approach. Our **AUTO-PROGRAMMED**™ lessons present facts and concepts in small, easy-to-understand bits . . . reinforce them with clear explanations and examples. Students learn more thoroughly and faster through this modern, simplified method. You, too, will absorb . . . retain . . . advance *at your own pace*.

Lifetime job placement service for every CIE graduate . . . at no extra cost

Once enrolled with CIE, you will get a bi-monthly listing of the many high-paying interesting jobs available with top companies throughout the country. Many Cleveland Institute students and graduates hold such jobs with leading companies like these: American Airlines, American Telephone and Telegraph, General Electric, General Telephone and Electronics, IBM, Motorola, North American Aviation, New York Central Railroad, Raytheon, RCA and Westinghouse.

CIE lessons are always up-to-date

Only CIE offers new, up-to-the-minute lessons in all of these subjects: Logical Troubleshooting, Laser Theory and Application, Microminiaturization, Single Sideband Techniques, Pulse Theory and Application, Boolean Algebra.



Full accreditation . . . your assurance of competence and integrity

Cleveland Institute of Electronics is accredited by the Accrediting Commission of the National Home Study Council. You can be assured of competent electronics training by a staff of skilled electronics instructors.

ENROLL UNDER NEW G.I. BILL. All CIE courses are available under the new G.I. Bill. If you served on active duty since January 31, 1955, or are in service now, check box on reply card for G.I. Bill Information.



Cleveland Institute of Electronics

1776 E. 17th St., Dept. EW-37, Cleveland, Ohio 44114

CIRCLE NO. 120 ON READER SERVICE CARD

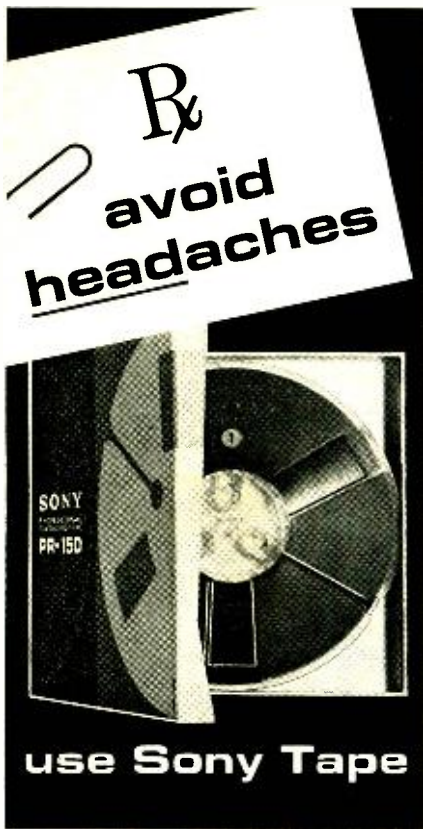

If you've been using any of the so-called bargain tapes, chances are you should have your heads examined. The odds are good that the heads are excessively worn and you're not getting the most out of your recorder. If you want to keep "factory-fresh" sound to your recorder—and avoid future "headaches" and keep it that way—Here's the prescription—buy Sony Professional-quality Recording Tape. Sony Tape is permanently lubricated by the exclusive Lubri-Cushion process. Sony's extra-heavy Oxid-Coating won't shed or sliver and is applied so evenly that recordings made on Sony Tape are not subject to sound dropouts. Sony Tape captures and reproduces the strength and delicacy of every sound—over and over again. There's a bonus, too, with every 5" and 7" reel of Sony Tape—a pair of Sony-exclusive "Easy Threader" tabs to make tape threading the easiest ever. And Sony reels are a sturdier, heavier gauge plastic for protection against possible warping. It's just what the "Doctor" ordered and yours for just pennies more than "bargain" tape.



SUN VALLEY, CALIFORNIA • 91352
CIRCLE NO. 86 ON READER SERVICE CARD

EW Lab Tested (Continued from page 16)

changing reels or any other action on the part of the listener.

The 2100 Series machines have two sets of record and playback heads, eliminating the need for interchanging supply and take-up reels after completing play in each direction. Even if the automatic reversing feature is not used, a single switch on the recorder reverses the tape travel direction and connects the appropriate heads to the amplifiers. Unlike some of the earlier *Ampex* recorders which had the ability to play back without switching reels but could not record in both directions, the 2100 is able to record in the reverse direction.

A noteworthy property of the recorders is the simplified loading procedure. The take-up reel is built in, concealed by a removable plastic cover. The tape passes below the head cover on a direct, unencumbered path and through a slot in the take-up reel cover. When the machine is started, the tape is reeled up automatically. It is also possible, if desired, to remove the special take-up reel and install a conventional spindle and reel.

The tape-transport controls of the recorders are similar to those used on other *Ampex* home machines in recent years. There are two operating levers, one for normal tape speed and one for fast speeds. The direction of tape motion, in either speed range, is set by a small switch which actually reverses the direction of rotation of the drive motor. Because of this, it is not possible to reverse direction rapidly since the motor must slow to a stop and attain full speed in the opposite direction—a process requiring about 3 seconds. Also directly on the transport panel is a lever which selects one of the three speeds (7½ in/s, 3¾ in/s, or 1⅞ in/s) and index counter with push-button reset.

On the electronic control panel to the right of the deck is a knob which serves as power switch and selects stereo operation or mono using either pair



of tracks. By using both mono positions of the selector and both directions of tape travel, one can make four-track mono recordings up to 17 hours in length on a 2400-foot reel of tape at 1⅞ in/s. Concentric with this knob is a lever for the automatic-reverse function. At the point where reversal is desired, the recorder is played in "Record" and the lever pressed to "Rev Sig" for a few seconds. This records a sub-audible (20-Hz) tone on all four tracks of the tape. With the lever in the "Auto" position and the tape motion from left to right, the recorder will reverse direction and switch to the other pair of playback heads when the 20-Hz tone is reached.

It is also possible to record the reversing signal at the other end of the tape (the normal beginning point). If the lever is set to "Repeat", the tape will again reverse at this point and repeat indefinitely. Since the tones can be recorded anywhere on the tape, one can set up the machine to repeat any desired part of a tape. Caution must be exercised when applying the signal since it erases any program previously present on track 1 (going from left to right) or track 4 (from right to left). *Ampex* recorded tapes are supplied with the reversing tone already present at the end of the tape.

The "Record/Play" knob activates the recording amplifiers, even with the tape at rest. The input levels can be set, using the twin level meters, before the recording starts. An interlocking safety button must be pressed while lifting

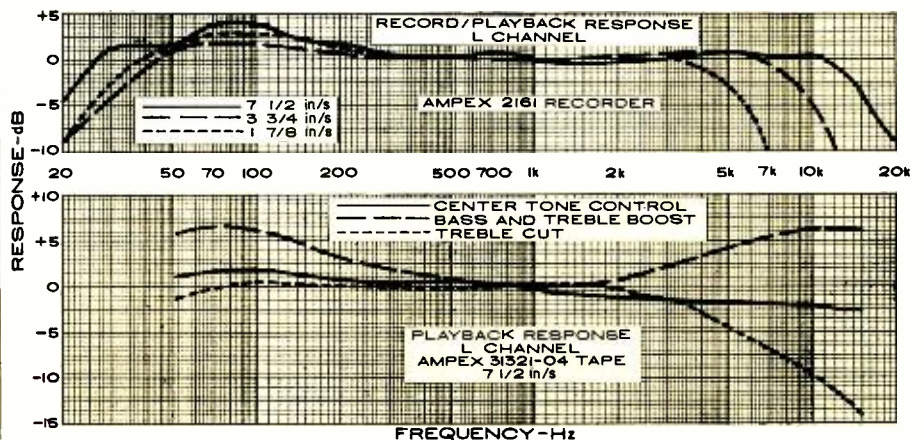

the "Play/Record" lever to make a recording.

The tone control is somewhat different from most. It controls only the treble range, supplying boost or cut. Pushing the knob in supplies a fixed bass boost. Concentric with the tone control is a lever which selects the appropriate equalization for the tape speed in use.

The last knob on the panel is a concentric dual volume control, whose slip clutch action allows differential adjustment of volume in the two channels for balancing purposes. This control affects recording level as well as playback volume. Completing the front-panel features are a pair of microphone jacks and a stereo headphone jack.

The 2100 Series recorders are available in several versions. The 2160 portable has playback power amplifiers (6 watts continuous per channel) and a dust cover. The 2165 is identical but is mounted in an oiled-walnut cabinet instead of a vinyl-covered portable case. The 2161 portable, which we tested and is shown in the photo, comes with a pair of Model 2013 speakers. These slide on to form a cover for the recorder when it is carried about. Each speaker enclosure contains a 6" woofer and a 3½" tweeter and has a self-storing 10-foot cord. Finally, the 2150 is similar to the 2160 but lacks the power amplifiers, speaker outputs, stereo phone jack, and tone control. The 2150 Series is designed for custom installation.

Recessed into the rear of the 2161 are the speaker output jacks, a three-position monitor switch which allows the speakers to be played at high or low volume while monitoring the incoming signal during recording or to be shut off entirely, and the input and line output jacks.

In our laboratory tests, the over-all record/playback frequency response of the Ampex 2161 was ± 4 dB from 20 to 16,000 Hz at 7½ in/s, ± 4 dB from 25 to 11,000 Hz at 3¾ in/s, and ± 4 dB from 25 to 6000 Hz at 1⅞ in/s. The playback response at 7½ in/s with the Ampex 31321-04 tape, was ± 2.5 dB from 50 to 15,000 Hz, with the tone control mechanically centered.

The wow and flutter were extremely low, 0.01% and 0.04%, respectively, at 7½ in/s. The tape speeds were slightly slow, but well within the specified limits of 1% at 7½ in/s. An input signal of 1.5 millivolts from a microphone or 90 millivolts through the line inputs was sufficient for a "0 vu" meter reading. Referred to this level, the signal-to-noise ratio was 47 dB at 7½ in/s. Distortion was very low, reaching 2% when the meters were driven 5 dB "into the red".

The auto-reverse system worked well and was easy to add to previously



FREE!

HOW TO IMPROVE YOUR TWO-WAY RADIO!

The right communications microphone may *double* the talk power of even the finest transmitters! Learn how unwanted noise can be eliminated—reliability improved—intelligibility increased by proper microphone selection.

Write for our helpful free booklet today!

ELECTRO-VOICE, INC., Dept. 1072N, 629 Cecil St.,
Buchanan, Michigan 49107

Please send the free E-V booklet on choosing communications microphones. I am interested in the following areas of two-way radio: Amateur Aviation CB Business.

NAME _____

COMPANY _____

ADDRESS _____

CITY _____ STATE _____

ElectroVoice
SETTING NEW STANDARDS IN SOUND

CIRCLE NO. 115 ON READER SERVICE CARD

Popular Science Top-Rates Scott's Stereo Tuner Kit

(THERE'S A SOUND REASON.)



Popular Science magazine's reviewer said, "I rate the LT-112-B as one of the finest FM tuners available — in or out of kit form." All of this fabulous tuner's critical circuitry comes pre-wired, pre-tested, and pre-aligned . . . and the full-size, full-color instruction manual makes the rest simple. In just eight hours, you'll have it completed. Again, in the reviewer's words: "Stereo performance is superb, and the set's sensitivity will cope with the deepest fringe area reception conditions . . . drift is non-existent." See your Scott dealer and review the new LT-112B-1 for yourself. Only \$199.95.



©Copyright 1967, H.H. Scott, Inc.

H.H. Scott, Inc., Dept. 160-10, Maynard, Mass. 01754. Export: Scott International, Maynard, Mass. 01754

CIRCLE NO. 91 ON READER SERVICE CARD

Solid State Circuit Boards

Featuring Professional Performance at Low-Budget Prices

Model AA-100
\$695



Model AA-300
\$1495

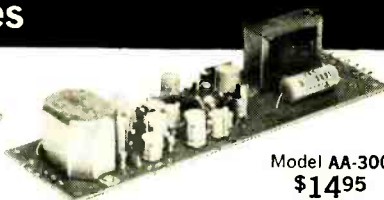

AUDIO AMPLIFIERS

Transistorized audio pre-amplifiers and amplifiers capable of delivering 200 MW of audio power, sufficient to drive a small speaker or a number of earphones. The AA-100, which includes a mounted volume control, is designed for general purpose audio applications and can also be used to modulate the TR-100 Transmitter (see below). The AA-300, a 200 MW amplifier, has excellent frequency response and low distortion characteristics which make it ideally suited for broadcast, recording, and TV applications. Either amplifier may be powered from a 9 volt source such as a battery or the PS-300 Power Supply. In applications where greater audio power is required, the AA-100 or the AA-300 may be used to drive the Model AA-400 Power Amplifier (see below).

| | Model AA-100 | Model AA-300 |
|---------------------|--|--|
| Frequency Response | ±3 db, 100 to 12K cps | ±1 db, 20 to 20K cps @ 200 MW ±2 db, 20 to 35K cps @ 100 MW |
| Harmonic Distortion | Less than 3%, 100 to 12K cps | Less than 1%, 20 to 20K cps @ 100 MW Less than 2%, 20 to 20K cps @ 200 MW |
| Input Impedance | 150, 600, and 100K ohms (shielded transformer) | 50 to 150 ohms, or 600 ohms, balanced (mu-metal shielded permalloy core transformer) 2K or 100K ohms unbalanced |
| Gain | 70 db | 80 db, 50 ohm input, 8 ohm load |
| Output Impedance | 500 ohms and 8 ohms (grain oriented transformer) | |
| Circuit | 5 transistors, 1 thermistor | 7 transistors, 1 thermistor |
| Power Supply | 9 volts DC, 50 MA | 9 volts DC, 100 MA |
| Size | 5½" L x 1¾" W x 1" H | 8" L x 2¼" W x 1½" H |
| Weight | 3½ ounces | 12 ounces |

1-WATT AUDIO POWER AMPLIFIER



Model AA-400
\$995

A transistorized audio power amplifier that can be driven to a full 1-watt output by a 1.5 volt signal. When the AA-400 is used with the Round Hill AA-100 or AA-300 Amplifier, a complete high gain, 1-watt audio system is obtained. Power can be furnished by any stable DC source delivering 14 volts at 150 MA, such as the PS-300.

Frequency Response..... ±1 db, 20 to 20K cps @ 1 watt
Harmonic Distortion..... Less than 1.5%, 20 to 20K cps @ 1 watt
Input Impedance..... 500 ohms and 2,000 ohms

Output Impedance..... 4 to 16 ohms
Circuit..... 4 transistors
Power Supply..... 14 volts DC, 150 MA
Size..... 3½" L x 2" W x 2" H
Weight..... 3 ounces

REGULATED POWER SUPPLY

The PS-300 is a zener-referenced, voltage regulated power supply which delivers a highly stable, extremely low ripple DC output of 9 volts with loads up to 200 MA and an unregulated output of 14 volts DC. The PS-300 is ideally suited for transistor circuit applications requiring a well-filtered regulated DC source, and may be used to furnish power to all Round Hill circuit boards.



Model PS-300
\$1895

Input Voltage..... 105-120 volts AC, 60 cps, 5 watts
Regulation..... Line + load 5 MV
Ripple..... Under full load 10 MV, peak-to-peak
Maximum Load Current..... 200 MA

Output Voltage..... 9 volts DC fully regulated;
14 volts DC unregulated
Size..... 4½" L x 2" W x 1½" H
Weight..... 23 ounces (with transformer)

TRANSMITTER

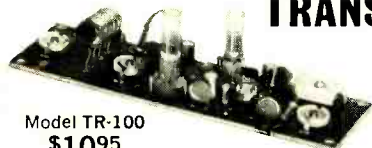

Model TR-100
\$1095

The TR-100 is a complete crystal controlled Transmitter for the Citizens' Band. It is factory pre-tuned and supplied with a channel 10 crystal. The Transmitter is capable of an RF output in excess of 100 MW and may be modulated with the Round Hill AA-100 Amplifier. Transmitter power supply requirements are 9 volts DC which can be obtained from the PS-300 Power Supply.

Circuit..... Crystal controlled, 3 transistors
Frequency Range..... Any CB channel (channel 10 crystal supplied)
Modulation..... CW or AM with external modulator such as Round Hill AA-100

RF Output..... 100 MW, 50 ohm load
Power Supply..... 9 volts DC, 50 MA
Size..... 5½" L x 1¾" W x 2" H
Weight..... 3½ ounces
Additional CB Crystals..... \$3.00 each

ROUND HILL ASSOCIATES INC. A SUBSIDIARY OF MILO ELECTRONICS
434 Avenue of the Americas, New York, N.Y. 10011

PLEASE SEND ME THE FOLLOWING CIRCUIT BOARDS:

| MODEL | QTY. | PRICE ea. | AMOUNT |
|------------------------------|------|-----------|--------|
| AA-100 AUDIO AMPLIFIER | | \$ 6.95 | \$ |
| AA-300 AUDIO AMPLIFIER | | \$14.95 | \$ |
| AA-400 AUDIO POWER AMPLIFIER | | \$ 9.95 | \$ |
| PS-300 POWER SUPPLY | | \$18.95 | \$ |
| TR-100 TRANSMITTER | | \$10.95 | \$ |
| CB CRYSTAL (channel:) | | \$ 3.00 | \$ |
| TOTAL: | | | \$ |

Send postpaid—enclosed is full payment.
 Send C.O.D.

NAME _____
ADDRESS _____
CITY _____
STATE _____ ZIP _____

recorded tapes. Combined with the ease of loading, which is probably as simple as can be achieved in a reel-to-reel recorder, this makes the unit an especially attractive choice for the average person who is not interested in extreme flexibility, yet has high standards of sonic performance. There are no provisions for special effects such as "sound-on-sound" recording or for monitoring off the tape as a recording is in progress.

The sound quality of the recorder was excellent. At 7½ in/s, the low distortion and wide frequency response produced recordings which cannot be told from the original sound sources in most cases.

The Model 2001 dynamic microphones sounded quite good, although their frequency response obviously did not match that of the recorder. The speakers, too, were pleasant to listen to, especially with the bass boost in use. Of course, external amplifiers and speakers must be employed in order to realize the full potential of the tape recorder.

The Ampex 2161 sells for \$599.95. The 2165 is \$579.95, the 2160 is \$549.95, while the model 2150 is \$479.95. ▲

A WHALE-TO-WHALE PHONE CALL

A long-distance telephone call between a lonely killer whale on exhibit in Vancouver, B.C., and the two whales that shared her pool in Seattle Public Aquarium was recently completed with the assistance of special underwater communications equipment supplied by the General Telephone & Electronics Corporation.

The 140-mile telephone call was arranged when aquarium officials became concerned about the sluggish behavior of Skana, a 3000 pound, 15-foot long female killer whale. Skana heard the high-pitched sounds of her former companions Katy and Kandu, and responded with similar shrill outbursts and swam swiftly around her tank. The "conversation" lasted about 10 minutes and was tape recorded for future study.

A study published recently by the Stanford Research Institute indicates that whales may possess a greater capability for communicating than any mammal other than man. According to SRI, "Their language appears to be more sophisticated than that of porpoises or chimpanzees".

This is not the first such communication to take place. In May 1965, a 4700-mile porpoise-to-porpoise telephone "conversation" took place between Sarasota, Florida, and Oahu, Hawaii with equipment also supplied by GT&E subsidiaries. The company also manufactures products used by humans. ▲



Why We Make the Model 211 Available Now

Although there are many stereo test records on the market today, most critical checks on existing test records have to be made with expensive test equipment.

Realizing this, HiFi STEREO REVIEW decided to produce a record that allows you to check your stereo rig, accurately and completely, just by listening! A record that would be precise enough for technicians to use in the laboratory—and versatile enough for you to use in your home.

The result: the HiFi STEREO REVIEW Model 211 Stereo Test Record!

Stereo Checks That Can Be Made With the Model 211

- ✓ Frequency response—a direct check of eighteen sections of the frequency spectrum, from 20 to 20,000 cps.
- ✓ Pickup tracking—the most sensitive tests ever available on disc for checking cartridge, stylus, and tone arm.
- ✓ Hum and rumble—foolproof tests that help you evaluate the actual audible levels of rumble and hum in your system.
- ✓ Flutter—a test to check whether your turntable's flutter is low, moderate, or high.
- ✓ Channel balance—two white-noise signals that allow you to match your system's stereo channels for level and tonal characteristics.
- ✓ Separation—an ingenious means of checking the stereo separation at seven different parts of the musical spectrum—from mid-bass to high treble.

ALSO: ✓ Stereo Spread
 ✓ Speaker Phasing
 ✓ Channel Identification

PLUS SUPER FIDELITY MUSIC!

The non-test side of this record consists of music recorded directly on the master disc, without going through the usual tape process. It's a superb demonstration of flawless recording technique. A demonstration that will amaze and entertain you and your friends.

NOW...GET THE FINEST STEREO TEST RECORD ever produced

for just...\$4.98

Featuring Tests Never Before Available Outside Of The Laboratory

UNIQUE FEATURES OF HiFi/STEREO REVIEW'S MODEL 211 STEREO TEST RECORD

- Warble tones to minimize the distorting effects of room acoustics when making frequency-response checks.

Warble tones used are recorded to the same level within ± 1 db from 40 to 20,000 cps, and within ± 3 db to 20 cps. For the first time you can measure the frequency response of a system without an anechoic chamber. The frequency limits of each warble are within 5% accuracy.

- White-noise signals to allow the stereo channels to be matched in level and in tonal characteristics.
- Four specially designed tests to check distortion in stereo cartridges.
- Open-air recording of moving snare drums to minimize reverberation when checking stereo spread.

All Tests Can Be Made By Ear

HiFi STEREO REVIEW's Model 211 Stereo Test Record will give you immediate answers to all of the questions you have about your stereo system. It's the most complete test record of its kind—contains the widest range of check-points ever included on one test disc! And you need no expensive test equipment. All checks can be made by ear!

Note to professionals: The Model 211 can be used as a highly efficient design and measurement tool. Recorded levels, frequencies, etc. have been controlled to very close tolerances—affording accurate numerical evaluation when used with test instruments.

DON'T MISS OUT—ORDER NOW

The Model 211 Stereo Test Record is a disc that has set the new standard for stereo test recording. There is an overwhelming demand for this record and orders will be filled by ELECTRONICS WORLD promptly upon receipt. At the low price of \$4.98, this is a value you won't want to miss. Make sure you fill in and mail the coupon together with your check (\$4.98 per record) today.

FILL IN AND MAIL TODAY!

Stereo Test Record
 P. O. Box 3110
 Church St. Station, New York, N.Y. 10008

Please send _____ test records at \$4.98 each, **postpaid**.
 My check (or money order) for \$_____ is enclosed.
 (Outside U.S.A. please send \$7.00 per record ordered.) N. Y. State residents please add local sales tax.

Name _____
 (PLEASE PRINT)

Address _____

City _____ EW 107

State _____ Zip Code _____

PAYMENT MUST BE ENCLOSED WITH ORDER

Dialco Sub-Miniature Illuminated PUSH BUTTON SWITCHES and matching INDICATOR LIGHTS

can solve many indication problems for you!

Dialco silent, momentary type switches—with matching (or companion) lights can offer you the switching/indication combination you require.

Check these features:

Switching capabilities: require 24 oz. (approx.) operating force. Contact arrangements are S.P.S.T., normally open or normally closed; two circuit (one normally open, one normally closed).

Switch ratings: 3 amps, 125V AC; 3 amps, 30V DC (non-inductive). Switches are completely enclosed and independent of the lamp circuit.

Mounting: units are made for single hole (keyed) mounting in panels up to 3/16" thick; mount from back in 1/2" clearance hole.

Display capabilities: 1/2" or 3/4" interchangeable push-button caps are available, with round or square shape. Caps may be had with rotatable or non-rotatable feature with a choice of 7 color combinations.

Get all the data! Write for our
new catalog today.

(illus. approx. 75% actual size)



Foremost Manufacturer of Indicator Lights

DIALIGHT CORPORATION

60 STEWART AVE., BROOKLYN, N.Y. 11237

AREA CODE 212 497-7600

CIRCLE NO. 199 ON READER SERVICE CARD



188-9730-5071-602



185-9830-1871-604

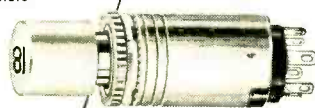

183-0301-1471-604



187-0101-1871-604

G-E Offers Bonus for H.V. Regulator Tubes

Faulty tubes emitting soft x-rays in certain color-TV receivers to be exchanged.

IN an effort to locate the last remaining color sets which have not been submitted for modification, *General Electric* is now offering a \$5.00 bonus plus a free regulator tube of the new replacement type to television technicians who seek out and replace the faulty high-voltage regulator tubes in their customers' sets.

The tubes in question are the 6EA4, 6EF4, and the 6LC6 with *white ink* printing only. If such tubes are found and replaced, the technician is asked to mail or bring the defective tube in to any *G-E* TV distributor, along with the customer's name, address, and the model and serial number of the set, to receive his free replacement tube and bonus.

The faulty tubes have been superseded by the 6EH4, 6EJ4, and 6LH6, respectively. Receivers which have been modified carry a readily identifiable red and white label pasted on the back of the set.

Technicians are asked to be on the lookout for the following models which may contain the obsolete regulator tubes: M920BWD, M930BWD, M931BMD, M932BMP, M936BWD, M938BWD, M940BWD, M941BMP, M942BCL, M950BWD, M951BMP, M952BCL, M960BWD, M961BCD, CBM961BCD, M970BWD, M971BMP, M980BWD, M258CWD, CBM258CWD, M268-CWD, M278CWD, M280CWD, M281CMP, M942CMP, M945CWD, M946CMP, M947CCL, M950CWD, M951CMP, M953CCL, M954CPN, M960CWD, M962CMP, M964CPN, M966CWD, M970CWD, M971CMP, M980CWD, M981CCD, and M984-CPN.

The modification program was instituted in May after tests indicated that certain of the company's large-screen color receivers were emitting soft x-radiation in excess of desirable levels.

The company is attempting to replace all of the obsolete regulator tubes causing the trouble with a new tube which does not require external shielding.

If you are not sure of the address of your local *General Electric* distributor, drop a note to the Consumer Electronics Division, Major Television Department, Electronics Park, Syracuse, N.Y. 13201 for such information. ▲

ELECTRONICS WORLD

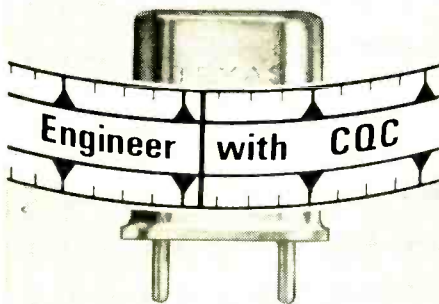

MORE CONTROL

Control of quality throughout precision manufacturing gives you crystals that assure exact frequency control.

MORE RELIABILITY

You'll stay on frequency better with CQC. And, you can rely on your CQC dealer to fill your needs promptly.

See your dealer for prices
and data on CQC



**TEXAS
CRYSTALS**

Div. of Whitehall Electronics

1000 Crystal Drive

Fort Myers, Fla. 33901

Plants in Fort Myers and Los Angeles

CIRCLE NO. 195 ON READER SERVICE CARD

Enjoy the "music-only" programs
now available on the FM broadcast
band from coast to coast.

- NO COMMERCIALS •
- NO INTERRUPTIONS •



It's easy! Just plug Music Associated's Sub Carrier Detector into multiplex jack of your FM tuner or easily wire into discriminator. Tune through your FM dial and hear programs of continuous, commercial-free music you are now missing. The Detector, self-powered and with electronic mute for quieting between selections, permits reception of popular background music programs no longer sent by wire but transmitted as hidden programs on the FM broadcast band from coast to coast. Use with any FM tuner. Size 5 1/2" x 9". Shipping weight approx. 7 lbs.

KIT \$4950

(with pre-tuned coils, no alignment necessary)

WIRED \$7500

COVER \$4.95 EXTRA

Current List of FM Broadcast Stations with SCA authorization \$1.00

MUSIC ASSOCIATED

65 Glenwood Road, Upper Montclair, New Jersey

Phone: (201)-744-3387

CIRCLE NO. 97 ON READER SERVICE CARD

Now There Are 3 Heathkit® Color TV's To Choose From

Introducing The NEW Deluxe Heathkit "227" Color TV

Exclusive Heathkit Self-Servicing Features. Like the famous Heathkit "295" and "180" color TV's, the new Heathkit "227" features a built-in dot generator plus full color photos and simple instructions so you can set-up, converge and maintain the best color pictures at all times. Add to this the detailed trouble-shooting charts in the manual, and you put an end to costly TV service calls for periodic picture convergence and minor repairs. No other brand of color TV has this money-saving self-servicing feature.

Advanced Performance Features. Boasts new RCA Perma-Chrome picture tube with 227 sq. in. rectangular viewing area for 40% brighter pictures . . . 24,000 v. regulated picture power and improved "rare earth" phosphors for more brilliant, livelier colors . . . new improved low voltage power supply with boosted B+ for best operation . . . automatic de-gaussing combined with exclusive Heath Magna-Shield that "cleans" the picture every-time you turn the set on from a "cold" start, and keeps colors pure and clean regardless of set movement or placement . . . automatic color control and gated automatic gain control to reduce color fade and insure steady, flutter-free pictures even under adverse conditions . . . preassembled & aligned 3-stage IF . . . preassembled & aligned 2-speed transistor UHF tuner and deluxe VHF turret tuner with "memory" fine tuning . . . 300 & 75 ohm VHF antenna inputs . . . two hi-fi sound outputs . . . 4" x 6" 8 ohm speaker . . . one-piece mask & control panel for simple installation in a wall, your custom cabinet or either optional Heath factory-assembled cabinets. Build in 25 hours.

GRA-227-1, Walnut cabinet **\$59.95**
GRA-227-2, Mediterranean Oak cabinet (shown above) . . . **\$94.50**



Kit GR-227
\$399⁹⁵
 (less cabinet)

Kit GRA-27
\$19⁹⁵



New Remote Control For Heathkit Color TV

Now change channels and turn your Heathkit color TV off and on from the comfort of your armchair with this new remote control kit. Use with Heathkit GR-227, GR-295 and GR-180 color TV's. Includes 20' cable.



Kit GR-295
\$479⁹⁵
 (less cabinet)

Deluxe Heathkit "295" Color TV

Has same high performance features and built-in servicing facilities as new GR-227, except for 295 sq. in. viewing area (industry's largest picture) . . . 25,000 volt picture power . . . universal main control panel for versatile in-wall installation . . . and 6" x 9" speaker.

GRA-295-1, Walnut cabinet (illust. above) **\$62.95**
GRA-295-3, Early American cabinet **\$99.95**
GRA-295-2, Deluxe walnut cabinet **\$94.50**



Kit GR-180
\$349⁹⁵
 (less cabinet)

Deluxe Heathkit "180" Color TV

Same high performance features and exclusive self-servicing facilities as new GR-227 (above) except for 180 sq. in. viewing area.

GRA-180-1, Contemporary walnut cabinet **\$49.95**
GRA-180-2, Early American cabinet **\$75.00**
GRA-180-3, Table model cabinet **\$24.95**
GRA-180-5, Table model cabinet & mobile cart (illust. above) **\$39.95**



NEW

FREE 1968 CATALOG!

Now with more kits, more color. Fully describes these along with over 300 kits for stereo/hi-fi, color TV, electronic organs, electric guitar & amplifier, amateur radio, marine, educational, CB, home & hobby. Mail coupon or write Heath Company, Benton Harbor, Michigan 49022.



HEATH COMPANY, Dept. 15-10
 Benton Harbor, Michigan 49022
 In Canada, Daystrom Ltd.

Enclosed is \$ _____, including shipping.
 Please send model (s) _____

Please send FREE Heathkit Catalog.

Name _____

Address _____

City _____ State _____ Zip _____

Prices & specifications subject to change without notice. CL-306

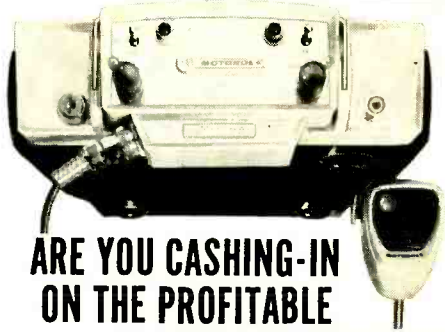

ARE YOU CASHING-IN ON THE PROFITABLE 2-WAY RADIO SERVICE BUSINESS?

- ★ Motorola will train you for this rewarding, elite profession
- ★ Send for our FREE EVALUATION EXAM. Prove to yourself that you are ready to learn FM 2-way radio servicing.

Opportunities in 2-way radio servicing are virtually unlimited. Just one of the hundreds of successful Motorola Service Stations writes, "we would be pleased to interview any graduate of your school that has received some training in 2-way radio maintenance. We are an established firm, 10 years old, with a promise of expansion governed by our ability to obtain competent technicians." Get all the facts today. There is no obligation and no salesman will call.



MOTOROLA TRAINING INSTITUTE

4545 West Augusta Blvd. • Chicago 51, Illinois • Dept. AEF 740

- Send me FREE entrance exam.
- Send full details on Home Study Course on FM 2-way Radio Servicing
- Send me details on how you can help me prepare for an FCC License.

Name _____ Occupation _____
 Address _____
 City _____ Zone _____ State _____

CIRCLE NO. 98 ON READER SERVICE CARD

A SELECTION OF ANNUALS STILL AVAILABLE

FROM THE WORLD'S LARGEST PUBLISHER OF SPECIAL INTEREST MAGAZINES

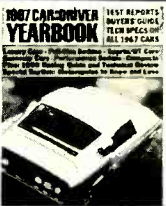

CAR & DRIVER YEARBOOK

A complete buyers guide covering virtually every car available in the United States... Road tests... Technical specifications... Accessories and performance equipment buying guide... Guide to racing with action-packed photos.

1967 — \$1.50... #40
 1966 — \$1.25... #15
 1965 — \$1.25... #17

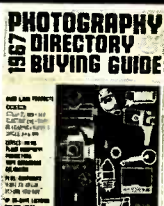

PHOTOGRAPHY DIRECTORY

World's most complete photographic buying guide.

1967 — \$1.25... #41
 1966 — \$1.25... #22



TAPE RECORDER ANNUAL

Everything you need to know about tape recording including a complete directory of mono and stereo recorders.

1967 — \$1.25... #42
 1966 — \$1.25... #30
 1965 — \$1.00... #31



STEREO/Hi Fi DIRECTORY

Complete buyers guide for virtually every Hi Fi component manufactured.

1967 — \$1.25... #45
 1966 — \$1.25... #29

Order by number from Ziff-Davis Service Division, 595 Broadway, N.Y., N.Y. 10012. Enclose add'l 15¢ per copy for shipping & handling (50¢ for orders outside U.S.A.)

ELECTRONIC CROSSWORDS

By JAMES R. KIMSEY

(Answer on page 102)

ACROSS

1. The length of time a phosphor dot glows on the screen of a cathode-ray tube before going out.
10. Conceal.
11. Perform, as work.
12. Greek letter which denotes magnetic flux, angles, scalar potential.
14. Paid public notice.
15. A circuit in which the output is continuously fed back to the input for constant comparison (2 words).
17. Tidy.
18. An external measurement (abbr.).
19. See 39 down. It produces an output whenever any one (or more) of its inputs is energized.
20. _____ back, the reproduction of a recording.
23. To destroy data stored on a magnetic tape, drum, or other storage device so that new data may be recorded on it.
25. In mathematics, the difference between the true value and a calculated or observed value.
26. _____ bias, bias produced by a spring on an electromagnet.
28. Observe.
29. Atop.
30. _____ discharger, a quenched spark gap used in early radiotelegraph transmitters employing shock excitation.
33. Organization of stations capable of direct-communications on a common channel, often on a definite schedule.
35. Ego.
37. Well known organization now merged into the IEEE (abbr.).
38. Grow old.
41. Current taken from a voltage source.
43. A unit equal to the number of coulombs (96,500) required for an electro-chemical reaction involving one electro-chemical equivalent.
45. _____ tube, a gas-filled radio-frequency switching tube used to protect the receiver in pulsed radio-frequency systems.
46. Map abbreviation.
47. Printer's measure.
48. Chemical symbol.
49. Greek letter designating the pre-

fix "micro".

50. Greek letter used to designate resistivity, density, co-ordinates.
51. A device for determining the tautness of a supporting wire or cable.

DOWN

1. Hot-cathode gas diode used as a rectifier.
2. Large duck.
3. Quantity of radioactive material that produces one million disintegrations per second (abbr.).
4. _____ horn, a horn with two parallel and two diverging sides.
5. Flanged forms serving as the foundations on which coils are wound.
6. City in Holland.
7. Clusters of oxide particles which protrude above the surface of magnetic tape.
8. An insulating plastic used for encapsulating or embedding electronics equipment (2 words).
9. The contacting part at the end of a plug or probe.
13. Exclamation.
16. A northwestern state (abbr.).
21. Exist.
22. A device used in an underwater sound system to radiate sound pulses through the water from the bottom of a ship.
23. Overhead train.
24. Affirmative vote.
27. Compass point.
31. Ratio of circumference to diameter.
32. _____ currents, those currents induced in the body of a conducting mass by a variation in magnetic flux.
34. Paying substance.
36. Given fact.
39. Circuit having one output and several inputs.
40. Home of Adam and Eve.
42. _____ compensation, a control device that compensates for voltage drop due to current flow.
43. A payment for services.
44. Process by which a constant frequency is varied in amplitude by a signal or intelligence frequency (abbr.).
46. That woman.
49. "Show Me" state (abbr.).
50. Direction (abbr.).

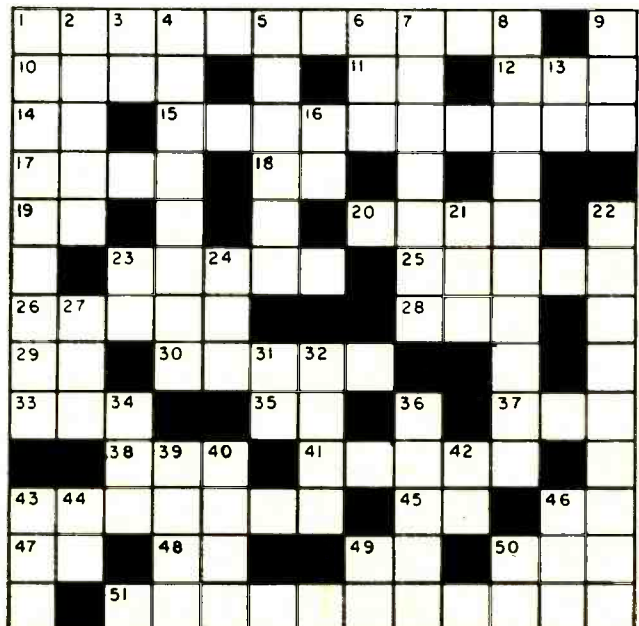

NEW PRODUCTS & LITERATURE

Additional information on the items covered in this section is available from the manufacturers. Each item is identified by a code number. To obtain further details, fill in coupon on the Reader Service Card.

COMPONENTS • TOOLS • TEST EQUIPMENT • HI-FI • AUDIO • CB • HAM • COMMUNICATIONS

RECHARGEABLE SILVER-CADMIUM CELLS

A new line of compact silver-cadmium cells and batteries of higher energy density than nickel-cadmium cells has just been introduced. Available as small sealed button cells and correspond-

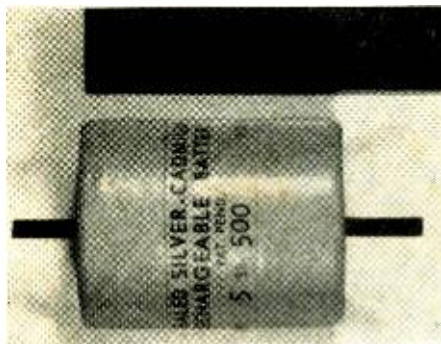

ing stacked battery assemblies, the new units are especially suited to communications, instrumentation, photographic equipment, and metal electronics applications.

The new silver-cadmium S-500 (500 mA-hr, cell which is 1.34" o.d. and 0.250" high, offers twice the capacity of a nickel-cadmium cell of the same dimensions. They can be used for micro-electronics, communications transceivers, test instruments, medical instruments, alarm systems, telemetry, paging systems, timers, and other commercial space and military applications. Electrochimica

Circle No. 126 on Reader Service Card

DIGITAL READOUT TUBE

The B-5440A series "Nixie" tube, an improved version of the low-cost B-5440 series, is electrical-ly and mechanically interchangeable with the B-5440.

The tube incorporates two important new features which makes it valuable for the latest instrument applications. The first is that the tip-off, which is at the top of the tube in the B-5440, has now been brought out in the tube base so that the over-all seated height of the B-5440A has been reduced by approximately 17%.

The optional "keep alive" is the second unique feature of the series. This feature is used when rapid ionization is required; in dark environments, in photographic applications, and in time sharing or strobe applications. It allows ionization to occur in normal ambient light in less than 100 μ s. In dark environments, for tubes with radioactive materials, ionization occurs in less than 10 ms; with a "keep alive", ionization is still less than 100 μ s.

Data sheets and detailed information are available. Burroughs

Circle No. 127 on Reader Service Card

PHOTODIODE LIGHT DETECTOR

The new Type 4207 photodiode light detector has four times the sensitive area of previous photodiodes but does not have a proportional increase in dark current, according to the manufacturer.

The larger area results in greater signal output, and the smaller increase in dark current means a better signal-to-noise ratio (detectivity) and greater dynamic range. Coupled with wide spectral response and high speed, the new detector provides a dark current of 1 nanoampere at 10 V reverse bias and at 25°C.

Because the size of the sensitive area is comparable to a slit, the sensitivity of these diodes makes them useful as radiation detectors in spectrophotometry and radiometry applications. Typical response is 0.5 μ A/ μ W into a 1-megohm load at a wavelength of 0.77 micron and reverse bias of 10 volts. Hewlett-Packard

Circle No. 128 on Reader Service Card

"N"-CHANNEL FET'S

The new JEDEC series of "n"-channel field-effect transistors, 2N5103, 2N5104, and 2N5105, feature low-noise, low-frequency characteristics.

Designed primarily for low-power d.c. and audio amplifier applications, all three FET's offer low feedback capacity, low input capacity, and low leakage. The 2N5105 is especially suited for low-frequency applications where low noise and high gain characteristics are required. It can be used in such small-signal circuits as low-noise operational amplifiers, high-impedance instrument inputs, i.f.-r.f. linear stages, and wide-band amplifiers. Amperex

Circle No. 129 on Reader Service Card

HEAVY-DUTY D.C. POWER SUPPLIES

A new line of all-solid-state regulated d.c. power supplies, designed for continuous heavy-duty use and priced in the economy range, is being introduced as the PSR-500 series.

The new units feature silicon rectifiers, SCR regulation, pi-type filters, and deliver continuously variable 500-watt outputs with continuous regulation of line or load to less than one per-



cent, no load to full load. Ripple is less than one percent at maximum rated current.

Three models, all operating from an a.c. input of 115 V, 60 Hz, are available: 2-32 V d.c., 0-15 A; 2-55 V d.c., 0-10 A; and 2-125 V d.c., 0-5 A. Electro Products

Circle No. 130 on Reader Service Card

MULTI-PURPOSE VOLTAGE TESTER

The new VT-100 "Voltprobe" incorporates a retractable probe and coil—the probes tuck right inside the case. The entire unit fits in a shirt pocket.

The unit provides fast, sure readout through illuminated windows that correspond to each voltage level, a.c. or d.c. Coverage is 115-220-227-440-550 volts a.c. and 115-220-400-600-750 volts d.c. A distinct buzz is emitted in the frequencies from 25 to 800 Hz. Amprobe

Circle No. 131 on Reader Service Card

SEMICONDUCTOR DESIGNER'S KIT

Engineers experimenting with low-cost semiconductors can cut prototyping cost by 75 percent with the new designer's kit of plastic-encapsulated economy components just released.

The kit provides 25 "n-p-n" bipolar amplifiers, 15 "p-n-p" bipolar amplifiers, 15 "n-p-n" bipolar switching transistors, 5 "p-n-p" bipolar switching transistors, 10 "n"-channel FET's, 5 "p"-channel FET's, 4 silicon controlled rectifiers, 5 unijunction transistors, 5 silicon rectifiers, 4 tab-mounted silicon power transistors, and one IC operational amplifier. Also included in the 94-semiconductor kit are full design, performance, and specification data. Texas Instruments

Circle No. 132 on Reader Service Card

TV/FM ANTENNA & WIRING SYSTEM

A non-electrical TV antenna and wiring system for u.h.f., v.h.f., FM, and FM multiplex is now available in various kits designed for specific applications. Each kit contains all necessary parts to do the complete TV wiring job whether on a new or remodeled home and includes the antenna and distribution system as well as non-electrical outlets.

The system allows wiring of up to 4 rooms for TV/audio operation and permits 4 TV/FM sets to operate simultaneously without interactions. Details on the builder's and remodeler's kits will be supplied on request. Mosley

Circle No. 1 on Reader Service Card

MINIATURE HEAT FUSE

A new type of miniaturized heat fuse designed for the protection of small electric motors, transformers, and temperature-sensitive components has just been introduced as the #270295.

The completely insulated, miniaturized thermal overload protector, having a 0.105" diameter and a length of only 0.917", can be easily mounted by crimp type connectors to 0.008" to 0.040" diameter wire leads of the protected component. In operation, the wired-in heat fuse is mounted in intimate contact with the heat generating component. The fuse, sensing an abnormal temperature rise, blows, thus eliminating heat damage and fire risk.

Normal opening temperature is 295°F, maximum operating current is 3 amps, and operating temperature range is -55°F to 225°F. Littelfuse

Circle No. 2 on Reader Service Card

PANEL INSTRUMENTS

A new line of stock panel instruments has just been introduced to the OEM market. Featuring flexibility and interchangeability, the new meters give the user a dial design that provides an area for multiple scales and other special applications. According to the company, the firm's bar-ning d.c. movements provide exact and reliable readings and inherent shielding from stray magnetic fields which permits more torque, faster response, and additional ruggedness.

The "G" Series is available in five popular sizes from the miniature, four-ounce 1½" to the 2½", 3½", 4½", and 5½" units. Each meter can be provided with a special flat insert for the masked portion of the panel meter front. The insert can be customized and painted any color desired or imprinted with the company's trademark or logo. Triplett

Circle No. 3 on Reader Service Card

SILICON CHOPPER TRANSISTORS

A complete line of "p-n-p" silicon chopper transistors with voltage capabilities up to 160 volts is now available as the SSS1001-4 series in the standard TO-5 case.

These devices offer high reliability, low saturation voltages, and can be purchased in pairs with

Start a Stereo System of Unparalleled Quality

For Solid State or Tube Amplifiers

...for less than \$40⁰⁰

FABULOUS MUSTANG M-12T

12" 3-WAY SPEAKER SYSTEM.

A new breed of high performance for whole house sound! With 35-40,000 Hz response; extra slim, thin profile; exclusive front or rear baffle mounting design; 12 15/16" dia. by 3 7/8" deep.



...for less than \$70⁰⁰

AWARD WINNING MODEL 6201

12" 2-WAY SPEAKER SYSTEM.

Updated version of the most popular true-coaxial speaker ever made! With axially mounted compression driven, wide-angle reciprocating flare horn tweeter; 28 to 18,500 Hz response; 13" dia. by 6 5/8" deep.



...for less than \$85⁰⁰

AWARD WINNING MODEL 312

12" 3-WAY DIFFAXIAL SYSTEM.

The only integrated single speaker assembly capable of response from 28 to 40,000 Hz! With high compliance woofer; Diffusicone mid-range; exclusive Sphericon tweeter; integral brilliance control; 15 1/2" dia. by 12" deep.



Listen to these and other fine University speakers at your dealers today! Ask about PSE—University's "master blue print" for goof-proof planning and building of your own speaker system. Includes many plans for speaker enclosures designed to deliver the very best in stereo sound. Address inquiries to desk 1-75



LISTEN—UNIVERSITY®SOUNDS BETTER

UNIVERSITY SOUND

A DIVISION OF LTV LING ALTEC, INC.

9500 W. Reno Oklahoma City, Oklahoma 73101

CIRCLE NO. 82 ON READER SERVICE CARD

96

offset voltages matched to 100 μ V @ $T_1 = 25^\circ\text{C}$, according to the company. A few of their many applications include modulators, servos, telemetry, and multiplexing. Complete specs will be supplied on request. Solitron

Circle No. 133 on Reader Service Card

DUAL PHOTOCELLS

Each unit of a new series (4610) of photocells has two independent, isolated photoconductors assuring close tracking of the two photoconductor elements in response to changes in illumination. By using a single enclosure, equal illuminations for the two elements is insured and both elements, being processed at the same time on a single substrate, have equal response characteristics.

The new dual photocells are designed for use in control systems in which one control input, in

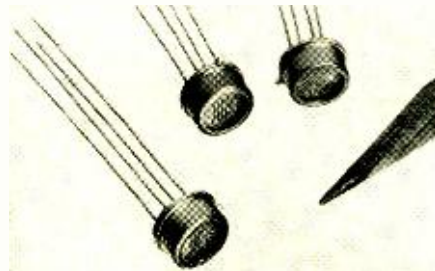

this case, the illumination on the cells, must influence two isolated signal paths.

The cells are hermetically sealed in a TO-5 transistor package with a window that is electrically shielded by a transparent conductive coating. A data sheet providing full specs and application information will be supplied on request. Hewlett-Packard

Circle No. 134 on Reader Service Card

U.H.F./V.H.F./FM ANTENNA

The recently introduced "King of the Combination" antenna line is designed for long-range u.h.f.-v.h.f. reception. The Model CPC-33G is the biggest of the four-model line which with a single downlead receives all 82 channels plus FM. The company's "Piggy-Back" power pack is featured on the CPC-24, -27, and -33 models to insure extra reception quality for both color and black-and-white even in fringe areas. A bandsplitter is included with each antenna.

All models have a special "gold coat" finish and built-in lead-in support and strain relief for durable installation. Kay-Townes

Circle No. 4 on Reader Service Card

COLOR-TV CONTROL KITS

Two new compact kits offering a comprehensive selection of exact replacement controls for color-TV sets are now being offered to service technicians.

Each kit is packaged in a sturdy, reusable metal storage tray and contains a carefully selected assortment of trimmers, convergence controls, and high-voltage controls for virtually every color-TV set on the market. Mallory

Circle No. 5 on Reader Service Card

MINIATURE WELDING TORCH

A miniature torch which welds metal smaller than 0.002" wire and up to 16 gauge steel has



been developed to meet the demands of a wide variety of welding and soldering applications in all fields.

The "Little Torch" uses oxygen and a fuel gas (acetylene, hydrogen, LP-gas, or natural gas) to produce flame temperature to 6300°F. It operates at pressures of 2 to 4 psi and uses gas at the rate of 0.23 to 2.54 cfh. It comes equipped with five different sized tips which swivel 360° for complete handling ease. Tescom

Circle No. 135 on Reader Service Card

MODULAR TV DISTRIBUTION LINE

The "Modline" is a new equipment line which includes a series of solid-state modular components: amplifiers, filters, combining networks, tapoffs, and accessories.

Designed for the ETV, ITFS markets at 2.5 GHz, and for TV distribution for apartment houses, hotels, motels, hospitals, commercial buildings, industrial plants, and the military, the company offers complete "turnkey" system capabilities including design, equipment, and construction. Jerrold

Circle No. 6 on Reader Service Card

RECHARGEABLE "D" CELL

A new rechargeable "D" cell which carries a lifetime guarantee has just been introduced as the "Life-Cell". This is a completely self-contained rechargeable cell and no charging stands or external adapters are required.

The cell is in two sections. To recharge, the top section is removed, reversed, and plugged into the bottom section again. This exposes a standard male a.c. plug on the top section which plugs into any a.c. wall outlet. After recharging, the process is reversed.

The new battery can be used in any application where conventional "D" cells are used. Waldom

Circle No. 136 on Reader Service Card

PRECISION POT

The new 2110 precision pot exceeds the requirements of MIL-R-12934E, RR1000, according to the manufacturer. The new ten-turn pot is servo-mounted, 7/8" diameter, wirewound, and offers $\pm 0.25\%$ independent linearity. It is available in resistance values from 100 ohms to 50,000 ohms and is guaranteed to give more than 20,000 cycles of rotational life.

High precision ball bearings provide maximum shaft support, extra-long life, and low torque for servo applications. The resistance element is welded directly to the gold-plated turret lugs with rugged strap terminations. A dual pickup contact prevents open circuits by continual contact pressure on the commutator. Amphenol Controls

Circle No. 137 on Reader Service Card

HI-FI—AUDIO PRODUCTS

THREE-WAY SPEAKER SYSTEM

A new 3-way, 5-speaker hi-fi system has just been introduced as the Model SP-200. The unit consists of a 12" woofer, two 5" mid-range speakers, and two 2" horn-type tweeters, all housed in a walnut enclosure with hand-carved speaker grille. The enclosure is of "pipe-ducted" construction to assist in the faithful reproduction of the bass notes.

An exclusive transformer-type crossover network permits each speaker to function in its most suitable frequency range while the specially designed level control provides three positions—natural, clear, and soft—to match various room environments.

Frequency response is 35-20,000 Hz with crossovers at 1500 and 5000 Hz. Impedance is 8 ohms. The enclosure measures 14 1/16" wide x 12 1/32" deep x 25 3/32" high. Sansui

Circle No. 7 on Reader Service Card

MICROPHONE MIXER

Four medium-input impedance channels are provided in the new solid-state portable microphone mixer being marketed as the G-300-U.

The sound level of each microphone may be adjusted separately because each channel has its

ELECTRONICS WORLD

**your
private
gallery
of the
year's most
stimulating
photographs
by the world's
most gifted
photographers**

An unforgettable photograph of a hauntingly beautiful woman . . . a heart-rending portrait of children at play in the shadows of a slum . . . the here-and-now drama of a war-torn battlefield . . . the electrifying thrills of wheels, hoofs, or sails caught in the split-second of triumph . . . the abstract images that tell there's more to life than meets the eye.

This is the kind of visual excitement that has made the PHOTOGRAPHY ANNUAL standard-bearer of photo yearbooks for nearly two decades!

And now, the 1968 edition reaches a new peak of photographic excellence. It contains over 200 pages of superb, provocative photographs gathered from around the world and selected by the editors of POPULAR PHOTOGRAPHY. All magnificently reproduced in stunning color and dramatic black and white — complete with "how it was done" technical information to help you improve **your** photographic skills.

The 1968 PHOTOGRAPHY ANNUAL is a collector's item you'll turn to again and again, month after month, year after year. Order your copy **today!** Only **\$1.50**

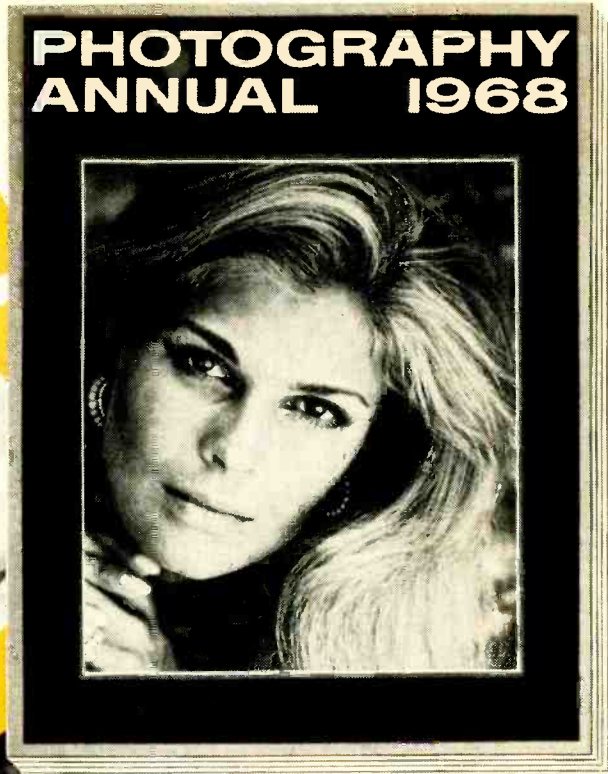

Get the Deluxe Leatherflex-Bound Edition for just \$3 Postpaid!



PHOTOGRAPHY ANNUAL is also available in a handsome deluxe edition. Rugged Leatherflex covers provide lasting protection yet are softly textured and gold-embossed for the look of elegance. A collector's item — a superb addition to your library of photo classics. And it's yours, for just \$3 postpaid, when you check the appropriate box on the order form.

Ziff-Davis Service Division, Dept. PA
595 Broadway, New York, N.Y. 10012

EW-10

Please send my copy of the 1968 PHOTOGRAPHY ANNUAL.

- I am enclosing \$1.50 plus 15c for shipping and handling for the Regular Edition. (\$2.00 for orders outside the U.S.A.)
- I am enclosing \$3.00. Please send me, postpaid, the Leatherflex-bound Deluxe Edition. (\$3.75 for orders outside U.S.A.) (Please allow 3 additional weeks for delivery of the Deluxe Edition.)

print name _____
 address _____
 city _____
 state _____ zip code _____

Our policies are your best insurance:



Sonotone has been the reliable, quality name in replacement phono cartridges since 1947. We've made and sold 20 million of them. When you service with Sonotone cartridges, you can be assured you are servicing with the best. *We'll stake our name on that.*

REPLACE WITH SONOTONE CARTRIDGES. There's a complete line for immediate replacement of virtually every cartridge in use today. Prove it to yourself — fill out and mail coupon TODAY for your free copy of Sonotone's 1967 "computer-programmed" cartridge replacement manual.

Send today for complete information:

**Sonotone Corporation, Dept. 107
Elmsford, New York 10523**

Just fill out and mail this coupon for your free copy of Sonotone's 1967 "computer-programmed" cartridge replacement manual.

YOUR NAME _____
ADDRESS _____
CITY _____
STATE _____ ZIP _____

CIRCLE NO. 87 ON READER SERVICE CARD

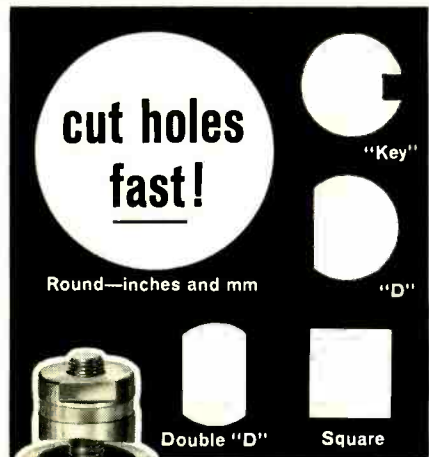

**with
Greenlee
punches**

Here's the simple speedy way to cut smooth, accurate holes in metal, hard rubber, plastics, epoxy, etc.

Save hours of hard work . . . punch clean, true holes in seconds for sockets, controls, meters, and other components. Easy to operate. Simply insert punch in a small drilled hole and turn with a wrench. For use in up to 16-gauge metal. Available at leading radio and electronic parts dealers.



GREENLEE TOOL CO
DIVISION OF GREENLEE BROS. & CO.

1866 Columbia Avenue, Rockford, Ill. 61101

CIRCLE NO. 106 ON READER SERVICE CARD



own preamp and volume control. The mixer operates on self-contained batteries or on a.c. with a built-in a.c. adapter, with automatic switching if one power source falls.

The mixer will accept low-, medium-, or high-impedance microphones with no change in performance except when the high-impedance microphones are used. In this case there is a drop of 3-4 dB in gain, which is nominal in view of the over-all gain of 55 dB. American Geloso

Circle No. 8 on Reader Service Card

SCA MULTIPLEX TUNER

A service-free modular SCA multiplex tuner, the MT-302, features a solid-state circuit, stereo filter, automatic muting with internal threshold adjustment, a syncing oscillator detector for low crosstalk and improved a.g.c., and crystal-controlled main channel.

There are color-coded test points for tuning, no controls on the front-panel—the main/sub selector switch and gain control are internally mounted for tamper-free operation, and 1 volt/600 ohm output to permit remoting the tuner and/or feeding phone lines. Dayton Electronic

Circle No. 9 on Reader Service Card

AUTOMATIC TURNTABLE

A new automatic turntable, the UA65, has been introduced to the American OEM market and offers several features of interest to component manufacturers.

The turntable has an adjustable dynamic anti-



skate control which applies a continuously corrected degree of compensation on the tonearm as required at all groove diameters to neutralize inward skating force. The control also eliminates sound distortion on both mono and stereo play caused by unequal side wall pressure on the stylus as a result of this prevailing skating force.

The unit uses a heavy deep drawn 11" cast turntable, a low-mass counterbalanced tubular tonearm with automatic lock, and a low-mass cartridge shell with finger lift. It also incorporates a cueing and pause control and automatic shut-off. BSR (USA)

Circle No. 138 on Reader Service Card

CORDLESS CASSETTE RECORDER

The Wollensak Model 4200 cordless cassette tape recorder provides a frequency response of 80-10,000 Hz ± 3 dB and output of 400 mW. The play-record, "on-off", and fast-forward

and rewind functions are controlled by a single switch. A push-button record safety lock prevents accidental erasure of recorded material. A vu meter indicates both recording level and battery condition.

The recorder comes with a dynamic microphone with remote "on-off" switch, a "Scotch" brand magnetic tape cassette, and a rugged carrying case which accommodates the recorder, microphone, and extra cassettes. 3M Company

Circle No. 10 on Reader Service Card

SOLID-STATE FM-STEREO RECEIVER

The SX-300T is a 40-watt (IHF at 4 ohms), AM-FM multiplex receiver which uses 41 transistors and 26 diodes. The multiplex section uses a time-switching demodulator with a channel separation of better than 35 dB at 1000 Hz. Stereo selection of broadcasts is automatic and is indicated by a lamp.

FM sensitivity is 3 μ V, image rejection is 52 dB



at 98 MHz, and signal-to-noise ratio is 55 dB. The amplifier section has a direct-coupled, single-ended push-pull circuit with r.m.s. rated power output of 15 watts per channel into a 4-ohm load and 12 watts per channel into 8 ohms. Over-all frequency response is 20-20,000 Hz ± 3 dB. An oiled walnut cabinet to house the receiver is available as an accessory at extra cost. Pioneer

Circle No. 11 on Reader Service Card

SLIDE PROJECTOR PROGRAMMER

"Cue Slide" projector programmers are available which record a signal on tape that is used to trip two, three, or more film projectors.

Applications for these new programmers include TV broadcast use in preparing commercials and slide presentations; in the recording studio for cueing (duration selectable between 0.1 and 0.5 second); in lecture-slide projector programs for tape-cued automatic shut-off and push-button control for instant restart; and in the classroom and for military training programs.

The unit will operate with all automatic slide projectors and may be used with any 2- or 4-track tape recorder. Suitable connectors are supplied with the unit. Meridian Enterprises

Circle No. 12 on Reader Service Card

STEREO TAPE DECKS

Two new stereo tape decks, the Models 501-D and 776-D, have just been introduced. The Model 501-D has a 3-speed, 4-track stereo capability for recording off-the-air or from phonograph records, and playback of other recorded tapes. Features include exclusive flux-field recording and playback heads, unidirectional tape transport with automatic shut-off, two vu meters, and a cue control for professional editing. Two solid-state preamplifiers are built into the unit. The deck operates at 7 1/2, 3 3/4, and 1 7/8 in/s with response 30-18,000 Hz ± 3 dB at 7 1/2 in/s.

The Model 776-D has the "Reverse-a-Track"

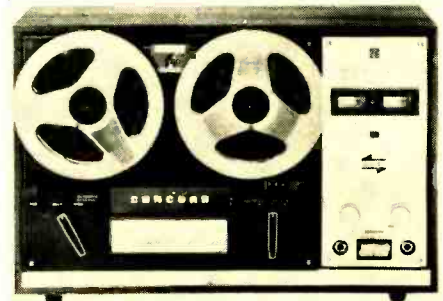

ELECTRONICS WORLD

tape transport mechanism which permits tapes to be replayed immediately without rethreading. It records and plays stereo in both directions and reel turnover and rethreading are eliminated. This deck has a two-speed, four-track stereo capability and will record sound-with-sound. Frequency response is 30-20,000 Hz \pm 3 dB. Reel capacity is up to seven inches. Concord

Circle No. 13 on Reader Service Card

STEREO PHONO CARTRIDGE

The Ortofon SL-15 stereo phono cartridge features small size, light weight (7 grams), 15° vertical tracking angle, an elliptical stylus, and the company's "Protecto Skate Glide".

Recommended stylus pressure is 1-2 grams and the elliptical diamond stylus has a tip radius of 0.007"/0.003". Compliance is 20 x 10⁻¹⁰ cm/dyne; channel separation is 20-30 dB; frequency response is 10-40,000 Hz. The cartridge is supplied either with or without external transformers. Elpa Marketing

Circle No. 14 on Reader Service Card

NEW SPEAKER SYSTEM

Five new speaker systems will make their appearance in the comprehensive "Achromatic" 1968 line that is now being introduced to the public.

Marked by a radical change in design, each model is fashioned as a fine piece of furniture with rich grille cloths and handsomely appointed cabinets. The grilles are removable so that fabrics can be changed as room decor is changed.

The top of the new line is the W90D which features a bass range divided between two 12½" woofers, each with a 9½ pound magnet assembly, on a cast aluminum speaker chassis. A pair of special 5" heavy-duty mid-range speakers and a pair of omnidirectional Mylar-dome pressure



tweeters handle the balance of the musical spectrum. All the speakers are acoustically isolated from the bass compartment and the cabinet employs the sand-filled construction principle to eliminate enclosure coloration.

The other units in the line, the W20, W30D, W40D and W60D, are designed for applications where smaller sized cabinets are required. Wharfedale

Circle No. 15 on Reader Service Card

120-MINUTE CASSETTE

A 120-minute blank cassette has been added to the company's line of 60- and 90-minute units. Manufactured according to the exacting specifications of the Norelco Standardization Agreement, the cassettes are available in two packaging configurations: in plastic, shatterproof containers or in card-stock, mailing cartons. Certron

Circle No. 16 on Reader Service Card

STEREO TAPE RECORDER

The Model A-4020 stereo tape recorder provides automatic reverse record and playback, symmetrically arranged control buttons, and newly designed outer-rotor motors which are used for reel drive in addition to a 2-speed hysteresis synchronous motor for capstan drive.

October, 1967

Now...the most enjoyable, most rewarding electronic kit project of your life



a Schober Electronic Organ!

The Schober Organ Corporation
43 West 61st Street, New York, N. Y. 10023

HAD YOUR FILL of amplifier kits, receiver kits, meter kits, all the conventional kits? Then go to work on the biggest, most fascinating kit of them all—and end up with a finer musical instrument than you could buy for twice the price. The Schober Theatre Organ at left, for example, plus Schober's self-teaching music courses, lets you participate in music, not just listen to it. This is one electronic project the wife and kids will encourage—because it's for them, too! It contains the best components available—thousands of them—plus the kind of unmistakable, step-by-step instructions you've dreamed of and Schober is famous for.

The Theatre Organ (left) costs just \$1550 if you use your own amplifier and speaker system, and you can pay as you build to spread out the cost. There are three other Schober Organ models, too, starting at \$645. Each one includes every bit and piece you need, including a magnificent walnut console—unless you want to build your own woodwork and save even more. And each model has the kind of pipelike tonal variety you don't often find in electronic organs. The free Schober color catalog has lots of pictures and data; and for 25¢ we'll send you 72 pages of schematics and tech specs so you can see just what you're buying.

FREE INFORMATION AND DEMONSTRATION RECORDING
Send today for your free copy of Schober's 16-page, full color booklet, plus 7" free recording.

The Schober Organ Corp., Dept. RN-51
43 West 61st Street, New York, N. Y. 10023

- Please send me Schober Organ Catalog and free 7-inch "sample" record.
- Enclosed please find \$1.00 for 12-inch L.P. record of Schober Organ music.
- Enclosed is 25¢ for schematics and tech specs.

NAME
ADDRESS
CITY..... STATE..... ZIP NO.....

CIRCLE NO. 92 ON READER SERVICE CARD

LEARN Electronics Engineering AT HOME

Fix TV, design automation systems, learn transistors, complete electronics. College level Home Study courses taught so you can understand them. Earn more in the highly paid electronics industry. Computers, Missiles, theory and practical. Kits furnished. Over 30,000 graduates now employed. Resident classes at our Chicago campus if desired. Founded 1944. Catalog, "Yes"—write for information about G. I. Bill Training.

American Institute of Engineering & Technology
1141 West Fullerton Parkway Chicago, Ill. 60614



Mod. Size Hwd Net Ea.
536 2x6 2x5 \$1.89
538 3x8 2x5 2.19
Other models available
free literature

EQUIPMENT CABINETS

Modern, deluxe-styled aluminum cabinets, rich leatherette covered top in black or brown with silver grey or gold panel. Rubber feet. At your dealer or order direct from:

SPECTRUM PRODUCTS CORP.
13946 Blackstone, Detroit, Mich. 48223

Low-drain Solid-state tone signal needs no amplifier

The Sonalert® Signal makes it a cinch to rig all sorts of alarm circuits for the home, shop, auto or boat. Works with just about any triggering device, operates on 6-28 VDC, draws only 3-14 ma. 110-volt AC model draws only as much current as a neon pilot lamp.

It's completely solid-state. No arcing contacts, no RF noise. Highest reliability. Tone output is either 2800 or 4500 Hz, at 68 to 80 db.

Ask your Mallory Distributor for booklet of ideas, circuits, projects. Mallory Distributor Products Company, a division of P. R. Mallory & Co. Inc., Indianapolis, Ind. 46206.

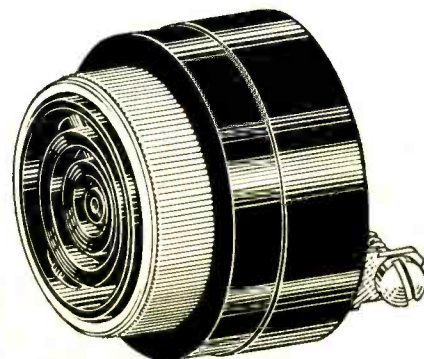

MALLORY

CIRCLE NO. 99 ON READER SERVICE CARD

OUR
1968
CATALOG
of precision quartz crystals
and electronics for
the communications industry
is now available.

It will cost you nothing.



Buy The Best



SENTRY MANUFACTURING COMPANY
1634 Linwood Boulevard - Oklahoma City, Oklahoma 73106
PHONE: 935-232-1313 - TELE: 931-3461 - TW: 918-931-3175

CIRCLE NO. 90 ON READER SERVICE CARD

You can't buy a better
recording tape
at any price



IRISH MAGNETIC RECORDING TAPE
458 Broadway, New York, N.Y. 10013

FIELD SERVICE ENGINEERS MEDICAL X-RAY

Expanding division requires several field service-
men to locate in New York, Chicago, Milwaukee,
Cleveland, Philadelphia & other metropolitan
areas. Exp in the installation, service and repair
of Medical X-Ray equipment is required.

LIBERAL STARTING SALARY - MANY COMPANY BENEFITS

Contact: MARTIN G. WOLFERT

North American Philips Co., Inc.

Norelco
An equal opportunity employer

Room 1027
100 East 42nd St.,
N.Y., N.Y. 10017



The recorder operates at 7½ and 3¾ in/s
±0.5% with wow and flutter 0.12% at 7½ in/s
and 0.15% at 3¾ in/s. Frequency response is
30-20,000 Hz (±2 dB 45-15,000 Hz) at 7½
in/s and 40-20,000 Hz (±3 dB 50-7500 Hz) at
3¾ in/s. Crosstalk is 50 dB channel-to-channel
at 1000 Hz and 40 dB between adjacent tracks
at 100 Hz. Reel size is 7 inches maximum.

A data sheet providing full electrical and
mechanical specifications will be forwarded on
request. Teac

Circle No. 17 on Reader Service Card

TAPE CASSETTES

A new line of magnetic tape cassettes which
provide 30, 60, 90, and 120 minutes' recording
time is now on the market. The line is being
offered in a variety of packages including the
"Mailer Pak", designed to meet international
postal regulations; the "Plastik Pak" which can
be used as a repeat mailer as well as a perma-
nent container; the "Twin Pak" containing two
60-minute cassettes; and a "Dispenser Pak" which
contains 12 "Plastic Paks" in a self-service dis-
penser for counter or wall mounting. Audio
Magnetics

Circle No. 18 on Reader Service Card

AUDIO COMPONENTS

In a departure from the firm's traditional role
as a supplier of tape recorders, two new audio
components have been introduced: an FM-stereo
receiver and a compact phono component system.

The Model 30 FM-stereo receiver features a
broad scale logging dial, a new concept in con-
trolled-injection a.f.c. and comes complete with
a walnut cabinet. The Model RP 2000 compact
phono system includes a 30-watt FM-stereo re-
ceiver, a precision 4-speed record changer, and
two matching air-suspension bookshelf speakers—
all housed in a walnut furniture cabinet. Roberts

Circle No. 19 on Reader Service Card

AUDIO-VISUAL RECORDER

The new Model 150 AV Wollensak audio-
visual recorder has been specifically designed
for rugged classroom and training use. It features
color-coded function push-buttons, automatic rec-
ord control, and a durable scuff- and dent-proof
cover.

Several safety features are incorporated in the
design. When the combination "on-off" and tone
control is switched off, the record or play mode
button is automatically disengaged, thereby re-
leasing the capstan pressure roller and also pre-
venting accidental erasure of tapes. When the
mechanism is switched from one function to
another, automatic disengaging occurs.

Operation is two-track monophonic at 3¾
and 7½ in/s. Frequency response is 40-15,000



Hz ±3 dB at 7½ in/s. Power output is 10 watts
EIA, 9 watts continuous at less than 5% harmo-
nic distortion. Outputs are extension speaker, head-
phones or listening center, and preamp. The
recorder measures 6½" x 10¼" x 11¾" and
weighs 17½ pounds. 3M Company

Circle No. 20 on Reader Service Card

COMPACT SPEAKER SYSTEM

The new Model 2000 speaker system has
been specifically designed for those who want
quality sound reproduction but have a limited
amount of space in which to house such a
system.

Frequency response is 35-18,000 Hz and nomi-
nal impedance is 8 ohms. The system will
handle a maximum of 60 watts of undistorted
dynamic power. The cabinet houses a 10" high-
compliance woofer with 2" voice coil and a
direct-radiator mid-range tweeter.

The system is housed in an enclosure mea-
suring 18½" high x 11⅞" deep x 11⅞" wide.
It is finished in satin walnut and comes in two
versions—with a marble top so that the cabinet
can be used as a lamp table or with a walnut

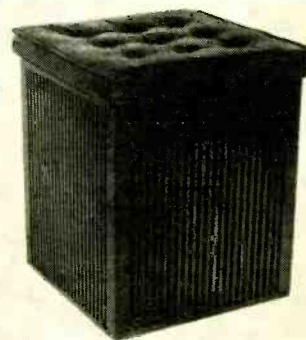

finished top which can function as an extra seat
in a small apartment with the addition of a
cushion. Empire

Circle No. 21 on Reader Service Card

CB-HAM-COMMUNICATIONS

23-CHANNEL TRANSCEIVER

A new 23-channel mobile transceiver for CB
users wishing full communications capability has
been introduced as the Model CB-24.

The new transceiver has 21 transistors, 8 di-



odes, and 4 thermistors in its transmitter/receiver
public-address circuitry. Concentric volume
and squelch controls, automatically switched
"S" meter/r.f. output indicator, illuminated chan-
nel selector and rocker-type PA/CB switch makes
the unit easy and safe to operate even while in
motion.

A special high-output audio stage cuts through
road and motor noise and increases receiving
range.

The transceiver is housed in a heavy all-metal
cabinet measuring 8" x 6" x 2½" high. The
die-cast chromed front is trimmed in black and
silver. Hallicrafters

Circle No. 22 on Reader Service Card

MARINE CB ANTENNA

A new CB marine antenna, the "Channel Cat",
has been designed to eliminate radials or other
difficult-to-install ground systems. It is salt-water
protected and is effective even on wood and fiber-
glass boats.

The antenna is 96⅜" high. The whip is con-
structed of high-grade stainless steel and loading

is through a waterproof coil in the center of the antenna and matching is via a high "Q" transformer enclosed in the waterproof base. The feed point impedance is 52 ohms. Mosley
Circle No. 23 on Reader Service Card

SELECTIVE CALL UNITS

Two new selective-call units are now available as the "Poly-Call" TC-1 and TC-7. The new units are solid-state and permit the selective contacting of any one station or stations similarly

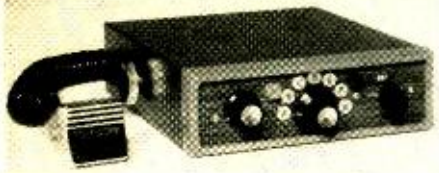

equipped. Through their use, the CB operator can avoid monitoring his transceiver at all times.

The TC-1 permits the selective calling of all stations in the network while the TC-7 is a seven-tone unit which permits the individual calling of up to seven different stations within the network. Both are equipped with tuned electronic filters for generating and selecting the audio tone, insuring operational reliability. Polytronics
Circle No. 24 on Reader Service Card

HAND-HELD TRANSCEIVERS

Low-cost, instant and dependable two-way radio communications are advantages claimed for the new Model 85 hand-held transceivers just being introduced.

These 10-transistor, one-diode, 100-mW transceivers measure 6" high x 2½" wide x 1½" deep and weigh only 21 ounces. The solid-state circuitry is housed in a die-cast case, resulting in a sturdy instrument which can withstand abuse.

Sensitivity is 3.5 µV and audio output is 75 mW with 3.5 µV input. Battery drain is 40 mA per hour on the average and an indicator enables the user to determine, at a glance, the con-

dition of the 9-V battery's life. Each unit is equipped with a 42" telescoping antenna and comes with a pair of channel-9 transmit/receive crystals already installed. Sold in pairs, the transceivers come complete with batteries and carrying straps. Amphenol
Circle No. 25 on Reader Service Card

SOLID-STATE MOBILE CB

The Model HB-525C solid-state mobile two-way radio incorporates 23 transistors, including IC's, 9 diodes, and 1 thermistor. It features dual conversion for high selectivity, a 3-position crystal delta tune for accurate fine tuning, a transmit mode indicator light, and a pi-network for optimum r.f. output.

With a full 5-watt input, the set consumes less than 1 A during transmission. Three optional power supplies permit operation on 117-volt a.c., 6-volt d.c., or as a portable shoulder-carried battery-operated transceiver. Normal mobile operation is carried out by the built-in 12-volt d.c. supply. Lafayette
Circle No. 26 on Reader Service Card

U.H.F. MOBILE ANTENNA

An ultra-high-frequency mobile antenna covering the 450-470 MHz band is now on the market. Of colinear design, the antenna exhibits a 5-dB omnidirectional gain over a quarter wavelength antenna. Both the phasing-coil housing and the feedthrough mounting base are made of high-impact plastic designed to resist weather and roughest usage.

The stainless steel whip is silver plated to increase radiation efficiency. Models are available to fit all standard mounts. Larsen
Circle No. 27 on Reader Service Card

NEW CB EQUIPMENT LINE

Two new items of CB equipment have been recently introduced: the 4101 solid-state shirt-pocket transceiver and the 4301 mobile or base-station transceiver.

The 4101, weighing only 6½ ounces, features



an automatic noise limiter, plug-in crystals, and superhet circuitry with a low-distortion transmitting amplifier. Its under 100-mW output power requires no license to operate. The 7-transistor (2 diodes) unit has a 1¼" speaker, output for earphone, built-in 28" telescoping antenna, and is powered by a standard 9-volt battery.

The 4301 features a full-power transmitter, double-modulation, modulation limiter, and a high-gain speech compressor. Other features include heat-resistant silicon transistors for use in a wide range of temperatures and a lighted push-button channel selector for the five channels. It operates from 12-volt battery systems. An a.c. adapter is available at extra cost. Craig Panorama
Circle No. 28 on Reader Service Card

MOBILE CB UNIT

The new "Director 23" two-way CB radio incorporates many features which greatly improve noise limiting, adjacent channel rejection, and cross-modulation rejection.

The unit draws less current than an ordinary car dashboard clock and will function even when the car battery is so low that it will not turn over the engine. It requires no warm-up period. The two-way unit features "HetroSync" circuitry which utilizes two frequencies instead of three, the usual method of synthesizing in a 23-channel CB circuit. The result, according to the company, is a transmit frequency of exceptional stability with maximum protection against spurious sig-

Why not sell the best

ZENITH TUBES built to the quality standards of Zenith original parts

"Royal Crest" Circuit Tubes

More than 875 tubes—a full line with the same quality as original Zenith equipment. Get Zenith tubes for greater dependability and finer performance.

Order all genuine Zenith replacement parts and accessories from your Zenith distributor.

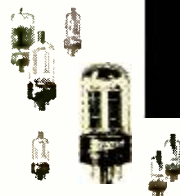

TV Picture Tubes

For color TV, B&W TV or special purposes. A complete Zenith line of more than 200 tubes built for greater reliability, longer life.

Zenith B&W replacement picture tubes are made only from new parts and materials except for the glass envelope in some tubes which, prior to reuse, is inspected and tested to the same high standard as a new envelope. Some color picture tubes contain used material which, prior to reuse, is carefully inspected to meet Zenith's high quality standards.



The quality goes in before the name goes on

CIRCLE NO. 81 ON READER SERVICE CARD

Olson



FREE

Fill in coupon for a FREE One Year Subscription to OLSON ELECTRONICS' Fantastic Value Packed Catalog—Unheard of LOW, LOW PRICES on Brand Name Speakers, Changers, Tubes, Tools, Stereo Amps, Tuners, CB, Hi-Fi's, and thousands of other Electronic Values. Credit plan available.

NAME _____
 ADDRESS _____
 CITY _____ STATE _____
 GIVE ZIP CODE _____

If you have a friend interested in electronics send his name and address for a FREE subscription also.

OLSON ELECTRONICS, INC.
 723 S. Forge Street Akron, Ohio 44308

CIRCLE NO. 96 ON READER SERVICE CARD



COMPLETE "LENS BANK" SERVICE

- "Off-the-Shelf" Delivery! From the world's largest and most diversified inventory—Finest domestic and foreign Manufacturers.
- Expert Performance Analysis!
- Satisfaction and Performance Guaranty!
- Matching or creating unusual Optics!
- Optical Services for Laser—Schlieren—Fibre Optics!
- Precision Optical Flats available!
- Modern fully equipped Optical Lab.—Lenskoting!

Lenses for Television • Audio Visual
 • Photo-Electronic • Microfilm •
 High Resolution • Research • Pro-
 jection • Near Infra Red etc.

Write for FREE Lens Performance Guide

Burke & James, Inc.
 333 W. Lake St.,
 Chicago, Ill. 60606

CIRCLE NO. 79 ON READER SERVICE CARD

nals. To further maintain stability, a zener diode is used in the input power circuit and special close-tolerance crystals are employed to provide a transmitted frequency tolerance of $\pm 0.003\%$, well below the usual $\pm 0.005\%$.

Complete specifications on this mobile unit are available on request. Pearce-Simpson
Circle No. 29 on Reader Service Card

23-CHANNEL TRANSCEIVER

The new "Royale" 23-channel CB transceiver features hand-wired, hand-soldered circuitry, tubes instead of transistors, and a big chassis with plenty of space for cooling, needed by the over-powered transformer.

The transceiver incorporates a Collins filter, cascode front end, adjustable noise limiter, an exclusive range-expander, and speech compressor. The unit comes complete with crystals for all 23 channels. Courier
Circle No. 30 on Reader Service Card

ANTENNA CHANGEVER SWITCH

The Model 381B electronic changeover switch for 52-75 coax line permits the transmitter to be continuously connected to the antenna, but blocking the antenna circuit to the receiver during transmit. There are no switch contacts to arc or burn and switching is instantaneous.

The switch is especially suited for break-in operation on c.w., SSB, and AM phone. Selectable bandswitching assures full receiver sensitivity. Barker & Williamson
Circle No. 31 on Reader Service Card

MANUFACTURERS' LITERATURE

EQUIPMENT FOR RENT

A new 28-page 1967 catalogue containing hundreds of different instruments for rent is now available. Included in the illustrated booklet are data-processing systems, tape recorders, oscillographs, d.c. amplifiers, power supplies, transducers, and frequency counters.

Listed are weekly and monthly rental rates together with manufacturers' specifications for all equipment offered by the company. Datacraft
Circle No. 32 on Reader Service Card

INDICATOR LIGHTS

Neon and incandescent two-terminal subminiature indicator lights are described and illustrated in a new 12-page catalogue (No. L-178B). Complete mounting instructions are provided for all devices listed, all of which meet or exceed the environmental and operational requirements of MIL-L-6723 and MIL-L-3661. Dialight
Circle No. 139 on Reader Service Card

REED RELAYS

A new 12-page short-form catalogue covering more than 160 relays has been released. Included are ultra-miniature, micro-miniature, and miniature reed relays, standard reed relays, and mercury-wetted reed relays.

The booklet contains detailed electrical, mechanical, and environmental specifications along with dimensional drawings and ordering instructions. Wheelock Signals
Circle No. 140 on Reader Service Card

REPLACEMENT COILS

A new 4-page cross-reference guide for 8 new color-TV sweep, linearity, and convergence coils is now available. More than 200 exact replacements are provided by the new coils. J. W. Miller
Circle No. 33 on Reader Service Card

POWER SUPPLIES

A new 22-page illustrated 1967 catalogue of power supplies, frequency converters, and multiphase adapters has been published. Entitled "Power Supplies Unlimited," the booklet contains descriptive material, tables, and complete specifications for the expanded line. NJE
Circle No. 141 on Reader Service Card

ELECTROLYTIC CAPACITORS

A new 32-page cross-reference guide that includes all electrolytic capacitors used in the color

chassis of 32 television set manufacturers has been compiled. The booklet indicates the recommended replacement by cross reference to the OEM number and also by direct reference to rating capacity voltage for single, dual, triple, and quadruple section units. Cornell-Dubilier
Circle No. 34 on Reader Service Card

TANTALUM CAPACITORS

A new 8-page Kemet brochure that compares the electrical characteristics, acceptance inspection tests, and marking requirements of MIL-C-26655B and MIL-C-39003A solid tantalum capacitor established reliability specifications is now available. Union Carbide
Circle No. 142 on Reader Service Card

ANTENNA BROCHURE

Described and illustrated in a new 6-page fold-out brochure is a complete line of Smoothline antennas and auxiliary equipment. Included are MATV and CATV antennas; head-end amplifiers; system accessories such as amplifier splitters, power supplies, and terminators; mast-mounted preamplifiers, splitters, mixers, and matching transformers; tap-offs; and coaxial cables. JFD
Circle No. 35 on Reader Service Card

TRANSFORMER CATALOGUE

A new 32-page illustrated catalogue (No. 671) that describes an expanded line of military, commercial, and industrial transformers, inductors, and toroids has been issued. Complete specifications are provided for all devices listed. Microtran
Circle No. 143 on Reader Service Card

MAGNETIC TAPE

A new 32-page illustrated booklet on tape maintenance that combines four previously published brochures is now available. Entitled "Magnetic Tape Maintenance for Computer Managers," the booklet discusses a proper tape management program, the technology of tape preventive maintenance, tape preventive maintenance and rehabilitation techniques, and the necessity for tape preventive maintenance. General Kinetics
Circle No. 144 on Reader Service Card

PHOTO CREDITS

| Page | Credit |
|------|--|
| 14 | Sherwood Electronic Labs., Inc. |
| 23 | U.S. Army Engineering Research & Development Labs., Ft. Belvoir, Va. |
| 27 | Barnes Engineering Co. |
| 32 | NASA |
| 74 | Hewlett-Packard |
| 76 | Seco Electronics |
| 77 | Sencore |
| 84 | Ampex Corp. |

Answer to Crossword Puzzle
 appearing on page 90

| | | | | | | | | | | | | |
|---|---|---|---|---|---|---|---|---|---|---|---|---|
| P | E | R | S | I | S | T | E | N | C | E | | T |
| H | I | D | E | | P | D | O | | P | H | I | |
| A | D | | C | L | O | S | E | D | | L | O | O |
| N | E | A | T | | O | D | | U | X | | | |
| O | R | | O | L | | P | L | A | Y | | P | |
| T | E | R | A | S | E | | E | R | R | O | R | |
| R | E | L | A | Y | | | S | E | E | | O | |
| O | N | | L | E | P | E | L | | S | | J | |
| N | E | T | | I | D | | D | | I | R | E | |
| | A | G | E | | D | R | A | I | N | | C | |
| F | A | R | A | D | A | Y | | T | R | | S | T |
| E | M | | T | E | | M | U | | R | H | O | |
| E | | T | E | N | S | I | O | M | E | T | E | R |

ELECTRONICS MARKET PLACE

COMMERCIAL RATE: For firms or individuals offering commercial products or services. 70¢ per word (including name and address). Minimum order \$7.00. Payment must accompany copy except when ads are placed by accredited advertising agencies. Frequency discount: 5% for 6 months; 10% for 12 months paid in advance.

READER RATE: For individuals with a personal item to buy or sell. 40¢ per word (including name and address). No Minimum! Payment must accompany copy.

GENERAL INFORMATION: First word in all ads set in bold caps at no extra charge. Additional words may be set in bold caps at 10¢ extra per word. All copy subject to publisher's approval. **Closing Date:** 1st of the 2nd preceding month (for example, March issue closes January 1st). Send order and remittance to: Hal Cymes, **ELECTRONICS WORLD**, One Park Avenue, New York, New York 10016

FOR SALE

JUST starting in TV service? Write for free 32 page catalog of service order books, invoices, job tickets, phone message books, statements and file systems. Oelrich Publication, 6556 W. Higgins Rd., Chicago, Ill. 60656.

GOVERNMENT Surplus Receivers, Transmitters, Snooperscopes, Radios, Parts, Picture Catalog 25¢. Meshna, Nahant, Mass. 01908.

METERS—Surplus, new, used, panel and portable. Send for list. Hanchett, Box 5577, Riverside, Calif. 92507.

INVESTIGATORS, FREE BROCHURE, LATEST SUBMINIATURE ELECTRONIC SURVEILLANCE EQUIPMENT. ACE ELECTRONICS, 11500-J NW 7TH AVE., MIAMI, FLA. 33168.

CONVERT any television to sensitive big-screen oscilloscope. Only minor changes required. No electronic experience necessary. Illustrated plans, \$2.00. Relco-A22, Box 10563, Houston, Texas 77018.

BIG CATALOG
World's "BEST BUYS"
in GOV'T. SURPLUS
Electronic Equipment

TCS EQUIPMENT NAVY TCS RECEIVER AM



1.5 MC to 12 MC in two (2) bands. Variable freq. oscillator & crystal control on four (4) preset channels in the entire freq. range. Audio output 1.5 watts into 500 ohm load; uses tubes 12SK7 RF A, 12SA7 converter, 2, 12SK7 IF A, 12SQ7 detector BFO, 12A6 oscillator, 12A6 audio Amp. 456 KC IF Freq. Large vernier & spin dial, audio gain, AVC, BFO and all controls on the front panel. Voltages required: 12 VDC & approx. 220 VDC 100 MA. Size: \$44.95 11 3/4 x 11 3/4 x 13 3/4". Wt.: 37 lbs. U.S.A. Checked for Operation—\$10.00 extra.

NAVY TCS TRANSMITTER AM

1.5 MC to 12 MC in three (3) bands. CW 40 watts. voice modulation 20 watts. master oscillator variable and crystal control on 4 preset channels in the entire freq. range. Uses 3, 12A6 in oscillator & buffer-doubler, 4, 1625 in modulator & power amplifier stages. 2 1/2" meters for PA Plate 0-200 DC RF meter 0-3, all tuning and operating controls on front panel. Voltages required: 12 VDC & 400-440 VDC 200 MA. W/tubes. Size: 11 3/4 x 11 3/4 x 13 3/4". Wt.: 41 lbs. USED: \$34.50 Checked for Operation—\$10.00 extra.

Antenna Loading Coil #47205 Used: \$6.95
Remote Control Box—w/Speaker #2270 Re-New: 9.95
Dual Dynamotor Power Supply
12 V. #21881 Re-New: 14.95
D-401 Transmitter Dynamotor 12 V. New: 6.95
D-402 Receiver Dynamotor 12 V. New: 4.95
CABLE—Receiver to Power Supply New: 2.75
CABLE—Transmitter to Power Supply New: 2.75
Connector Plugs 7/Remote Control Box New: 1.50
A C POWER SUPPLY—115 V. 60 cycle (Not Gov't. Surplus)

Receiver: \$20.00 — Transmitter: \$35.00
Shock Mounting for Receiver or Transmitter Used: 2.95
Noise Limiter Conversion Kit—W 6116 tubes 2.00
PARTS available for Rec. & Trans. Advise us your needs!

BIG FREE CATALOG—Send for your FREE copy now. New edition just off the press!
Address Dept. EW • Prices F.O.B. Lima, O. •
25% Deposit on C.O.D.'s

FAIR RADIO SALES
1016 E. EUREKA • Box 1105 • LIMA, OHIO • 45802

R.F. CONVERTERS World's largest selection. Also CCTV cameras, etc. Lowest factory prices. Catalog 10¢. Vanguard, 196-23 Jamaica Ave., Hollis, N.Y. 11423.

FREE ELECTRONICS (new and surplus) parts catalog. We repair multimeters. Bigelow Electronics, Bluffton, Ohio 45817.

DETECTIVES! Free brochures! Electronic Surveillance devices. **SILMAR ELECTRONICS**, 3476 N.W. 7th Street, Miami, Florida 33125.

MUSIC LOVERS, CONTINUOUS, UNINTERRUPTED BACKGROUND MUSIC FROM YOUR FM RADIO, USING NEW INEXPENSIVE ADAPTOR. FREE LITERATURE. ELECTRONICS, 11500-Z NW 7th AVE., MIAMI, FLORIDA 33168.

SURVEILLANCE EQUIPMENT—NEW HIGH PERFORMANCE SUBMINIATURE MODELS. ELECTRONIC COUNTERMEASURE DEVICES TO PROTECT PRIVACY. FREE DATA: SECURITY ELECTRONICS-EW, 15 EAST 43RD STREET, NEW YORK, N.Y. 10017.

CRYSTALS . . . largest selection in United States at lowest prices. 48 Hr. delivery. Thousands of frequencies in stock. Types include HC6/U, HC18/U, FT-241, FT-243, FT-171, etc. Send 10¢ for catalog with oscillator circuits. Refunded on first order. Jan Crystals, 2400E Crystal Dr., Fort Myers, Fla. 33901.

JAPANESE PRODUCTS CATALOG by air mail \$5. sea \$3. Intercontinental, CPO 1717, Tokyo, Japan.

TREASURE HUNTERS! Prospectors! Relco's new instruments detect buried gold, silver, coins. Kits, assembled models. Transistorized. Weighs 3 pounds. \$19.95 up. Free catalog. Relco-A22, Box 10839, Houston, Texas 77018.

ELECTRONIC PARTS! Components, transistors, diodes, kits, relays, and many special items. Guaranteed. Send 25¢ for 100 page catalog. General Sales Co., P.O. Box 2031, Freeport, Texas 77541.

MESHNA'S TRANSISTORIZED CONVERTER KIT. Converts car radio to receive police and fire. 30-50MHz and 100-200MHz. (one MHz Tuning) \$5.00 with easy to follow step instruction. Meshna, No. Reading, Mass. 01864.

ELECTRONIC Ignition. Kits, components, systems. Diagrams. Anderson Engineering, Epsom, N.H. 03239.

DIAGRAMS, service information, Radio \$1.00, Television \$1.50. **SUPREME**, 1760 Balsam, Highland Park, Illinois 60035.

100,000 PRODUCTS Wholesale! Terrific bargains! Wholesalers, 1265-PP Broadway, New York, N.Y. 10001.

INTRODUCING new line of **MORRISON** speaker systems. Introductory prices. free brochure, write: Morrison Speaker Systems, Box 6203, Coralville, Iowa 52240.

CONTINUOUS commercial-free background music from your FM radio using new transistorized SCA converter, \$49.95 complete. Simple installation. LF Labs, P.O. Box 312, Lockport, Illinois 60441.

NO telephone privacy? "Bug" on your line? Blow it off! ENGINEERING LABORATORIES, Box 1036, ANDERSON, INDIANA 46015.

POLICE RADIO. Hear all police calls, fire departments, Sheriffs, taxis, ambulances, Highway Patrol. New 5 band portable radio and direction finder. Free booklet. NovaTech, Dept. 299, Redondo Beach, Calif. 90278.

ELECTRONICS ENGINEERING AND INSTRUCTION

REI First Class Radio Telephone License in (5) weeks Guaranteed. Tuition \$295.00. Job placement free. (KANSAS CITY) R.E.I., 3123 Gillham Road, Kansas City, Missouri, Telephone WE1-5444. (SARASOTA) R.E.I., 1336 Main Street, Sarasota, Florida 33577. Telephone 955-6922.

WANTED! TV—Radiomen to learn aircraft electronics servicing. Numerous job openings everywhere. Write: **ACADEMY AVIONICS**, Reno/Stead Airport, Reno, Nevada 89500.

ASSOCIATE Degree in Electronics Engineering earned through combination correspondence-classroom educational program. Free brochure. Grantham Technical Institute, 1505 N. Western Ave., Hollywood, Calif. 90027.

HIGHLY effective home study course in Electronics Engineering Mathematics with circuit applications. Earn your Associate in Science Degree. Free literature. **COOK'S INSTITUTE OF ELECTRONICS ENGINEERING**, P.O. Box 36185, Houston, Texas 77036.

ELECTRONIC COMPONENTS Co.
715 LATHAM SQUARE BLDG.
OAKLAND, CALIFORNIA 94612
(415) 836-3180

B AMP SCR'S TO-59 CASE STYLE

100 PIV \$3.60 200 PIV \$3.90
300 PIV \$1.40 400 PIV \$1.80
FULLY TESTED AND GUARANTEED.

INTEGRATED CIRCUITS—DUAL INLINE PACKAGE

| | |
|--------------------------|--------|
| 930 DUAL 4 INPUT GATE | \$1.10 |
| 932 DUAL BUFFER | \$1.25 |
| 933 DUAL 4 EXTENDER | \$1.00 |
| 944 DUAL POWER GATE | \$1.15 |
| 945 CLOCKED FLIP-FLOP | \$1.50 |
| 946 Quad 2 INPUT GATE | \$1.10 |
| 952 DUAL 2 INVERTER | \$2.00 |
| 953 GATE-TRIPLE, 2-2-3 | \$2.00 |
| 954 GATE DUAL 4 INPUT | \$2.00 |
| 955 GATE, SINGLE 8 INPUT | \$2.00 |
| 956 BUFFER, DUAL 2 INPUT | \$2.00 |
| 957 BINARY | \$3.00 |

ALL FULLY TESTED AND GUARANTEED. COME COMPLETE WITH SCHEMATIC.

ASSORTED INTEGRATED CIRCUITS

ASSORTMENT CONTAINS BUFFERS, GATES, BINARY, INVERTERS, FLIP-FLOPS, AMPLIFIERS, ETC. COMES WITH CHART TO DETERMINE TYPE OF UNIT AND SCHEMATIC FOR A TESTER.

| | |
|--------------------------------|--------|
| 50 ASSORTED TO-5 CASE | \$5.95 |
| 50 ASSORTED FLAT PACK | \$5.95 |
| 100 ASSORTED TO-5 | \$9.95 |
| 100 ASSORTED FLAT PACK | \$9.95 |
| 100 ASSORTED MIXED TO-5 & F.P. | \$9.95 |

A GREAT BARGAIN FOR THE EXPERIMENTOR.

FLAT PACK TEST SOCKETS

| | |
|--------------------|--------|
| AUGAT 8075-1G1 | \$1.00 |
| MATCHING CONNECTOR | .95 |

TRANSISTORS

PNP—HIGH SPEED SWITCH & AMP.
SIMILAR TO 2N3962 TO-50 CASE 10/\$1.95

DUAL AMPLIFIER—NPN TO-89 CASE
SIMILAR TO SP10800 FAIRCHILD 6/\$2.95

ZENERS—400 MW

SPECIFY VOLTAGE DESIRED \$.25

ELECTRONIC COMPONENTS Co.
715 LATHAM SQUARE BLDG.
OAKLAND, CALIFORNIA 94612

CIRCLE NO. 113 ON READER SERVICE CARD
103

LEARN ELECTRONIC ORGAN SERVICING at home. All Makes including transistors. Experimental kit—troubleshooting. Accredited NHSC. Free Booklet. **NILES BRYANT SCHOOL, 3631** Stockton, Dept. A, Sacramento, Calif. 95820.

HIGHLY—effective home study review for FCC commercial phone exams. Free literature! **COOK'S SCHOOL OF ELECTRONICS, P.O. Box** 36185, Houston, Texas 77036.

FCC LICENSE training by correspondence. Low cost, pay-as-you-go plan. Free particulars. The Willard Foundation, Department EW, P.O. Box 1049, Washington, N.C. 27889.

FCC First Class License in six weeks—nation's highest success rate—approved for Veterans Training. Write Elkins Institute, 2603C Inwood Road, Dallas, Texas 75235.

ELECTRONICS! Associate degree—29 months. Technicians, field engineers, specialists in communications, missiles, computers, radar, automation. Start February, September. Valparaiso Technical Institute, Dept. N, Valparaiso, Indiana

DRAFTING (Electronic, Mechanical, Architectural, Art). Home Courses \$25.00. Send \$2.00 first lesson. **PRIOR, INC., 23-09 169 Street,** Whitestone, New York 57.

TUBES

RECEIVING & INDUSTRIAL TUBES, TRANSISTORS, All Brands—Biggest Discounts. Technicians, Hobbyists, Experimenters—Request **FREE** Giant Catalog and **SAVE! ZALYTRON 469** Jericho Turnpike, Mineola, N.Y. 11501.

TUBES, SEMICONDUCTORS, ELECTRONIC EQUIPMENT & COMPONENTS. Quality merchandise only! Serving engineers, Purchasing Agents, TV/HiFi Servicemen and Hams for 20 years. Write for Catalog or call 212-WA 5-7000. **BARRY ELECTRONICS, 512 Broadway,** New York, N.Y. 10012.

TUBES—33¢ each. Year guarantee. Tuner Cleaner \$1.09. Free catalog. Cornell, 4213-W University, San Diego, Calif. 92105.

DON'T BUY TUBES—Radio, TV-Xmitting, special-purpose types until you get our price list! Lowest prices in U.S.A. 5,000 types—Guaranteed Brand New. Send postcard for TV—Special Purpose Price List. **UNITED RADIO COMPANY, P.O. BOX 1000, NEWARK, N.J. 07101.**

FREE Catalog. Electronic parts, tubes. Wholesale. Thousands of items. Unbeatable prices. **Arcturus Electronics ZD, 502-22 St., Union City, N.J. 07087.**

WANTED

QUICKSILVER, Platinum, Silver, Gold. Ores Analyzed. Free Circular. Mercury Terminal, Norwood, Mass. 02062.

QUICK CASH . . . for Electronic Tubes, Semiconductors, Equipment (Receivers, Transmitters, Scopes, Vacuum Variables, etc.) Send lists now! Write: **BARRY ELECTRONICS, 512 Broadway,** New York, N.Y. 10012 (212-WA 5-7000).

ELECTRONIC EQUIPMENT AND COMPONENTS—Wanted agencies in **SPAIN.** Please contact **DIRECTLY ONLY** with **IN-AG, P. O. Box 19035, MADRID, SPAIN.**

WANTED IRE—IEEE Publications. Pickup service on quantities. **EPI, Box 67, Palo Alto, Calif. 94301.**

WANT TO BUY—Good used Heathkit impedance bridge, Model 1B-2A. Write: Peter Cook, 763 N. Elmwood, Wickliffe, Ohio 44092.

PLANS AND KITS

INTEGRATED CIRCUIT KITS; COMPUTER LOGIC; parts; others. Catalogue free. Kaye Engineering, Box 3932, Long Beach, California 90803.

DO-IT-YOURSELF

PROFESSIONAL ELECTRONICS PROJECTS — \$1.00 up. Catalog 25¢. **PARKS, Box 25565B, Seattle, Wash. 98125.**

PRINTING

FREE Booklet — "Secrets of Cutting Printing Cost", Dept. 1, 305 S. 4th, Springfield, Illinois 62701.

RECTIFIERS, TRANSISTORS & COMPONENTS

| | |
|--|----------|
| 6 tube Amplifier, New 4 lbs. | 2/\$1.98 |
| 1/4 Watt Resistors, asstd. | 50/1.00 |
| 1/2 Watt Resistors, asstd. | 60/1.00 |
| 2N4138 Sil. Chopper To-46 NPN | 1.50 |
| Precision Resistors, asstd. | 50/1.00 |
| Pots, 2-4 Watt, asstd. | 15/1.00 |
| 2N1724 Sil. Pow. 50 W. 80 V. Stud. | 1.50 |
| 2N1047B Sil. Pow. 80V. To-57 | .60 |
| Tantalum Capacitors, asstd. | 10/1.00 |
| 2N1722 Sil. Pow. 50W. 80V. To-53 | 1.45 |
| 2N2944 Sil. Chopper To-46 | 1.00 |
| 50W. Zeners 10 to 19 Volts | 1.00 |
| Thermistor head, 1200 ohm | 2/1.00 |
| 2N1021, Ger. Power, 7amp. 100V., To -3 | .60 |
| 2N456A, 7A. 40V. Ger. Power To -3 | .45 |
| 2N1718, Sil. Power. 10W., 60V., Heatsink | 3/1.00 |
| 70 amp Stud. 50PIV—\$2.50; 100PV | \$3.50 |

| SILICON CONTROLLED RECTIFIERS | | |
|--|---------|----------|
| AMPS. | 300PRV. | 500PRV. |
| 1A | 2.15 | 2.25 |
| 1A | 2.50 | 2.65 |
| Pots, 1W. 100K. or 1/2 W. 500K. | | 5/1.00 |
| Surprise Kit, 10 lbs. components | | 2.50 |
| Epoxy Hi-Vol diode, 200ma, 3000PIV | | .98 |
| Computer Board, TO-3 Power. Heat Sink | | 1.00 |
| I.C., To-5, untested | | 5/1.00 |
| I.C. Dual-inline, untested | | 10/1.00 |
| 2N389, 85W 60 V. TO53 | | .79 |
| 2N3707-11 Asstd. Plastic Silicon Xisters | | 20/1.00 |
| 2N3704-3706, Asstd. Plastic Sil. Xisters | | 10/1.00 |
| 2N2151, Sil. Power Xister | | .65 |
| 2N1009 Ger. Min. Xister untested | | 30/1.00 |
| 3N35 Tetrode, NPN, untested | | 5/1.00 |
| Ger. Diodes, Asstd | | 15/1.00 |
| 2N458A, 7A. 80V. Ger. Power, TO -3 | | .55 |
| Sil. Diodes, Switching, Signal, Asst. | | 15/1.00 |
| 2N118, Silicon, NPN | | 10/1.00 |
| 2N1149, Silicon, NPN, untested | | 20/1.00 |
| 2N1300, Untest. PNP & NPN, 1/4" leads | | 25/1.00 |
| 2N1714, Silicon Power 10W, 60V. | | 4/1.00 |
| Computer Boards. Parts Free, per transistor | | .05 |
| Germanium Power, 2N457A, 7A; 60V | | .50 |
| Silicon Power 40 W. 2N1047, TO-57 | | 2/1.00 |
| Tophats 750 ma., 200PIV-8¢, 400, 12¢ 600 PIV | | 18 |
| 1N34A | | 100/2.98 |
| Varicaps, 27, 47, or 100 pf | | 1.25 |
| 2N1038, Germanium 20 W. 40 V | | 4/1.00 |

With any \$10.00 Order any \$1.00 item Free. On \$25.00 order any (3) \$1.00 items Free. Catalog. Minimum order \$3.00 plus postage, C.O.D.'s 25%
ELECTRONIC COMPONENTS
 Post Office Box 2902 Baton Rouge, Louisiana 71082

CIRCLE NO. 112 ON READER SERVICE CARD

UNUSUAL BARGAINS
 . . . MANY U.S. GOV'T SURPLUS

GIANT WEATHER BALLOONS
 "Balls of fun" for kids, traffic stoppers for stores, terrific for amateur meteorologists, create a neighborhood sensation, Great backyard fun. Exciting beach attraction. Made of heavy duty neoprene. Inflate with vacuum cleaner or auto air hose; or locally available helium for high rise.
 #60, 568AK (8' diam) \$2 Ppd.
 #60, 632AK (16' diam) \$7 Ppd.

NEW, LOW-COST GEM TUMBLER
 Become a rockhound! Fascinating hobby . . . loads of fun, inexpensive, easy. Make jewelry of all kinds—decorative bookends, table tops, etc. Simply tumble-finish readily available gemstones . . . then polish to high lustre . . . brings out beautiful colors. Rugged 3-lb. capacity tumbler w/continuous duty motor compares to units selling for many times its price. Full instructions.
 Stock No. 70,874AK (10 types) \$10.75 Ppd.
 Stock No. 70,868AK (16 types) \$9.00 Ppd.

NEW SURPLUS NI-CD BATTERIES
 Save more than 50%! Long life—accept 300 charge and discharge cycles. 1.25 Volts per cell—750 milliamper hours capacity. Excess charge retention. Hermetically sealed. Indefinite storage life.
 Multiple cells welded in series—combine to form btry. 1/2" dia. x 1 1/4" high. Spec. price for 100 up. Low-cost charger separate.

| Order # | Cells | DC Volt. | Price Ppd. |
|----------|------------------------------|----------|------------|
| 40,986AK | 1 | 1.25 | \$ 1.50 |
| 40,987AK | 2 | 2.50 | 2.75 |
| 60,633AK | 3 | 3.75 | 3.60 |
| 60,634AK | 4 | 5.00 | 6.80 |
| 70,812AK | Trickle Charge (12-10 cells) | | 10.95 |

Order by Stock No.—Check or M.O.—Money-Back Guarantee
EDMUND SCIENTIFIC CO., Barrington, N. J. 08007

MAIL COUPON for FREE CATALOG

SEND FOR FREE CATALOG "AK"
 Completely new 1988 edition. New items, categories, illustrations. 148 easy-to-read pages packed with nearly 4000 unusual items. Dozens of electrical and electromagnetic parts, accessories. Enormous selection of Astronomical Telescopes, Microscopes, Binoculars, Magnifiers, Magnets, Lenses, Prisms. Many war surplus items: for hobbyists, experimenter workshop, factory. Write for catalog "AK." Please include your Zip Code.

NAME _____
 ADDRESS _____
 CITY _____ STATE _____ ZIP _____

CIRCLE NO. 116 ON READER SERVICE CARD

CLASSIFIED ADVERTISING ORDER FORM

Please refer to heading on first page of this section for complete data concerning terms, frequency discounts, closing dates, etc.

| | | | | |
|----|----|----|----|----|
| 1 | 2 | 3 | 4 | 5 |
| 6 | 7 | 8 | 9 | 10 |
| 11 | 12 | 13 | 14 | 15 |
| 16 | 17 | 18 | 19 | 20 |
| 21 | 22 | 23 | 24 | 25 |
| 26 | 27 | 28 | 29 | 30 |
| 31 | 32 | 33 | 34 | 35 |

_____ Words (@ .40 Reader Rate) = \$ _____
 (@ .70 Commercial Rate)

Insert _____ time(s) Total Enclosed \$ _____

NAME _____

ADDRESS _____

CITY _____ STATE _____ ZIP _____

SIGNATURE

WORD COUNT: Include name and address. Name of city (Des Moines) or of state (New York) counts as one word each. Zip Code numbers not counted. (Publisher reserves right to omit Zip Code if space does not permit.) Count each abbreviation, initial, single figure or group of figures or letters as a word. Symbols such as 35mm, COD, P.O., AC, etc., count as one word. Hyphenated words count as two words. EW-1067

U.S. GOV'T ELECTRONIC SURPLUS

• Nationally Known-World Famous SURPLUS CENTER offers finest, most expensive, Government Surplus electronic units and components at a fraction of their original acquisition cost.

ORDER DIRECT FROM AD or WRITE FOR CATALOGS

LABORATORY EXPERIMENTAL KIT

PERFORM 100'S OF FASCINATING ELECTRICAL EXPERIMENTS



Gov't Acquisition Cost Of Parts Over \$50.00

\$14.85

F.O.B.

• (ITEM #A222) -- Amazing Value! Valuable gift for son or husband. Hundreds of fascinating experiments. Features modern electronic theory and practice. Easy, interesting way to learn.

• Experiment with electro-plating, electro-magnetic phenomena, resonance, barium atom, relay circuits, rectification, lost circuits, excitation, motor experiments, transformer phenomena, etc.

• Kit Contains: DC motor, AC motor, electro-magnetic coils, ac and dc relays, set of lab capacitors, compass, test bulbs, plating chemicals, silicon diodes, germanium diode, barium atom actuator, carbon microphone, waxstripping, element, ac test sockets, permanent magnets, telephone handset, cords, test clips, wire, and other items. (Over 33 pieces, includes fine experimental manual with drawings, procedures, etc., written by professional engineers.)

• Also furnished with each kit our popular book Home Laboratory Bench and Experimental Procedures. (Reg. \$1.00). Shows how to build wonderful home laboratory test bench, and how to get the most out of your experimental work. (12 lbs.) Parts cost gov't over \$30.00.

AC PROGRAM TIMING CLOCK

• (ITEM #158) -- Zenith 115-VAC program timer. Use for periodic signaling, work breaks, school classes, turn-around, buzzer alarm actuator. Adjustable clips permit switching On or Off anytime during 24-hour period. Sufficient clips for multiple programming. Also has "Skip-a-Drop" feature. Controls can be turned up to 15-amps. 8 1/2" x 6 1/2" x 4 1/2". Wt. 8 lbs. Gov't Cost Over \$36.00.



Instructions Furnished. F.O.B. **\$9.49**

AUTO-PILOT GYROSCOPE



F.O.B. **\$12.47**

• (ITEM #115) -- DC motor driven, gimbal mounted gyroscopic, electro-magnetic precision unit used to "steer" large, multi-engine planes. Distal from established plane words potentiometer controlled signals to bring about change in other motors. Unit can be used as autopilot for boats, wonderful class room and to demonstrate and study gyro action. Missiles, planes, boats all use gyros. Size 9" x 8" x 10". Wt. 21 lbs. Cost gov't Over \$300.00.

STANDARD DIAL TELEPHONE

• (ITEM #115) -- Standard, commercial telephone same as used throughout U.S.A. Attractive polished black, like new condition. Use as extension phone to private systems or connect several phones together for local intercom system. Full instructions are furnished. Wt. 9 lbs. Original Cost \$24.00.



F.O.B. **\$5.95**

STEP-BY-STEP AUTOMATIC SWITCH

• (ITEM #738) -- Amazing "up-and-around" electro-magnetic telephone switch. Dial any bank pair from 1 to 100. Make your own telephone system. Can also be used to remotely control up to 100 circuits over a single pair of wires.



• One of our FOUR STAR bargains. Comes complete with date, one dial and one line bulb. Size: 5 1/2" x 7 1/2" x 15". Wt. 16 lbs. Cost gov't Over \$75.00. Complete switch, cover, dial, line bank, instructions..... F.O.B. **\$9.95**

STEP UP/DOWN TRANSFORMER



F.O.B. **\$4.99**

• (ITEM #1543) -- Step voltage up or down. Has many uses. Will step 115-volts to 230-volts or step 230-volts down to 115-volts. Will also transform 115-volts to 35-volts. Rated 1.75 amps. Output with 1.75-ohm capacity. Size: 4 1/2" x 3 1/2" x 2". Wt. 4 lbs. Gov't Cost \$12.75.

TYPICAL BUYS FROM OUR 1967 CATALOGS

- \$ 350.00 - Geared 2-hp Battery Golf Car Motor **\$24.95**
- \$ 15.00 - Westinghouse DC Ammeter, 0 to 300 **\$ 7.11**
- \$ 40.00 - Vacuum/Pressure Pump, 12-VDC **\$11.95**
- - - 80-MW Walkie-Talkies, Per Pair **\$19.60**
- - - Deluxe, Multi-Range, AC DC Tester **\$ 8.98**
- \$4000.00 - Carrier Telephone Amplifier System **\$13.91**

SPECIAL SALE

Correspondence Course in ELECTRICAL ENGINEERING



Sells For \$10.79 Postpaid, Outside U.S.A. **\$ 8.79**

• (ITEM #A181) -- Wonderful chance to obtain technical training at Amazing Low Cost! Lincoln Engineering School has suspended its Correspondence Courses because of increased operating costs. We offer a limited number of the school's complete Electrical Engineering Course but without the examination paper grading service. The course consists of 14 lesson unit books. Each book has the regular exams, and in a separate section, "Standard answers" to each exam question.

• Course is well written, easy to understand, profusely illustrated. Reader's Digest Size, easy to carry and study in spare time. Many Lincoln Engineering School students holding excellent jobs as a result of E.E.S. training. Course contains latest information on transistors, silicon diodes, etc. Additional book on how to build and operate a "Home Laboratory and Experimental Bench" furnished with each course.

SEND 25¢ COIN OR STAMPS FOR 3 MAIN CATALOGS
All Items FOB Lincoln Money Back Guarantee

SURPLUS CENTER

DEPT. EW-107 LINCOLN, NEBR. 68501

TAPE AND RECORDERS

BEFORE renting Stereo Tapes, try us. Postpaid both ways -- no deposit -- immediate delivery. Quality -- Dependability -- Service -- Satisfaction -- prevail here. If you've been dissatisfied in the past, your initial order will prove this is no idle boast. Free Catalog. Gold Coast Tape Library, Box 2262, Palm Village Station, Hialeah, Fla. 33012.

STEREO TAPES. Save up to 60% (no membership fees, postpaid anywhere USA). Free 60-page catalog. We discount batteries, recorders, tape accessories. Beware of slogans "not undersold," as the discount information you supply our competitor is usually reported to the factory. **SAXITONE**, 1776 Columbia Rd., Washington, D.C. 20009.

RENT Stereo Tapes -- Over 2,500 Different -- all major labels -- free brochure. Stereo-Parti, 1616 - E. W. Terrace Way, Santa Rosa, California 95404.

TAPE RECORDER SALE. Brand new, nationally advertised brands, \$10.00 above cost. Arkay Sales, 1028-B Commonwealth Avenue, Boston, Mass. 02215.

HI-FI Components, Tape Recorders at guaranteed "We Will Not Be Undersold" prices. 15-day money-back guarantee. Two-year warranty. No Catalog. Quotations Free. Hi-Fidelity Center, 239 (LT) East 149th Street, New York 10451.

MAGNECORD 728-44 stereo tape recorder: Perfect condition, \$495.00. With Fisher stereo control amplifier, \$545.00. Balch, 611 Livingston Rd., Linden, N. J. 07036.

RENT STEREO TAPES -- 75¢ week. Catalog. Art's, 1442 Blaze, Simi, Calif.

SCOTCH Recording Tapes. Tape Recorders. Catalog 5¢. Tower, Lafayette Hill, Pa. 19444.

CUSTOM RECORDING

L.P. Hi-Fi Records made from any speed tape. Plan sixteen minutes per side. Three identical copies \$19.95. "RECORDS", Box 206, N. Wales, Penna. 19454.

HIGH FIDELITY

FREE! Send for money saving stereo catalog -- E10W and lowest quotations on your individual component, tape recorder or system requirements. Electronic Values Inc., 200 West 20th Street, N.Y., N.Y. 10011.

HI-FI Components, Tape Recorders at guaranteed "We Will Not Be Undersold" prices. 15-day money-back guarantee. Two-year warranty. No Catalog. Quotations Free. Hi-Fidelity Center, 239 (L) East 149th Street, New York 10451.

HIFI EQUIPMENT -- Get Our "ROCK BOTTOM" prices on **NAME BRAND** amplifiers -- tuners -- tape-recorders -- speakers **FRANCHISED** -- 59 YEARS IN BUSINESS. Write for this month's specials -- NOW! Rabson's 57th St., Inc., Dept. 569, 119 W. 57th St., New York, New York 10019.

LOW, LOW quotes: all components and recorders. Hi-Fi, Roslyn, Penn. 19001.

HI-FI components, tape recorders, sleep learn equipment, tapes. Unusual Values. Free catalog. Dressner, 1523 R Jericho Turnpike, New Hyde Park, N.Y. 11040.

RECORDS

CHALLENGE YOUR SOUND SYSTEM with the most demanding music ever put on record. Theatre and classic pipe organ recorded without dynamic suppression. Write: **CONCERT RECORDING**, Lynwood, California 90262.

GOVERNMENT SURPLUS

JEEPS Typically From \$53.90. . . Trucks From \$78.40. . . Boats, Typewriters, Airplanes, Electronics Equipment, Photographic Equipment, used. 100,000 Bargains Direct From Government. Complete Sales Directory and Surplus Catalog \$1.00 (Deductible First \$10.00 Order). Surplus Service, Box 820-K, Holland, Michigan 49423.

FAIRCHILD 200 mc **PLASTIC** **Transistors** **CHOOSE ANY**

FREE OUR \$10 POLY PAK WITH \$5 EVERY ORDER FREE BARGAIN CATALOG

50-200 400 **3** for **\$1**

600 MC 2N3563 **\$1**

GUARANTEES AS ADVERTISED for 6 months

FIELD EFFECT TRANSISTORS

2N3088 **129** N-channel amplifier infrared, **2\$1 For 1** N-channel

IGFET Input **225** 10 million meg-

"MOST" 2N4353 p-channel

LOOK **FIELD-EFFECT TRANSISTORS** PHOTOCONDUCTIVE CELL **144**

CADMIUM SELENIDE "ONCE IN A LIFETIME BUY" EACH

1 AMP SILICON RECTIFIERS

| PIV | Sale | PIV | Sale | PIV | Sale |
|-----|------|------|------|------|------|
| 50 | 5¢ | 800 | 23¢ | 1800 | 99¢ |
| 100 | 7¢ | 1000 | 40¢ | 2000 | 1.50 |
| 200 | 9¢ | 1200 | 59¢ | 3000 | 1.90 |
| 400 | 11¢ | 1400 | 69¢ | 4000 | 2.50 |
| 600 | 19¢ | 1600 | 89¢ | | |

ZENER RECTIFIERS

1-WATT 49
10 WATTS 1.00

| Volts | Volts | Volts | Volts |
|-------|-------|-------|-------|
| 5.4 | 18 | 43 | 100 |
| 6.4 | 20 | 47 | 110 |
| 8.0 | 22 | 51 | 120 |
| 9.1 | 24 | 56 | 130 |
| 10 | 27 | 56 | 150 |
| 12 | 30 | 62 | 160 |
| 13 | 33 | 75 | 180 |
| 15 | 36 | 82 | 200 |
| 16 | 39 | 91 | |

1 AMP SILICON RECTIFIERS PIV Sale

MINIATURE PIV Sale
SILICON 100 9¢
RECTIFIERS 200 12¢ Glass! Epoxies!

"ONE PRICE" SCRS! check amp and PRV blocks.

PRV Sale PRV Sale

| | | | |
|-----|------|------|------|
| 50 | 55¢ | 600 | 3.35 |
| 100 | 75¢ | 800 | 4.50 |
| 200 | 1.35 | 1000 | 5.59 |
| 400 | 2.25 | | |

2 AMP SILICON RECTIFIERS

PIV Sale

| | |
|------|-----|
| 50 | 7¢ |
| 100 | 9¢ |
| 200 | 12¢ |
| 400 | 16¢ |
| 600 | 19¢ |
| 800 | 29¢ |
| 1000 | 51¢ |
| 1200 | 69¢ |

POLY PAKS TERMS: send check, money order, include postage -- avg. wt. per pak 1 lb. Rated, net 30 days. COPIES 25¢

P.O. BOX 942W
SO. LYNNFIELD, MASS.
"PAK-KING" OF THE WORLD

AUTOMOTIVE EQUIPMENT

NEW! New! Portable Electronic auto and marine engine analyzer \$24.95. Free literature. Colette Electric Co., 15024 Harper, Detroit, Michigan 48224.

AUTHORS' SERVICES

AUTHORS! Learn how to have your book published, promoted, distributed. **FREE** booklet "ZD," Vantage, 120 West 31 St., New York 10001.

POEMS WANTED For new song hits and recordings by America's most popular studio. Tin Pan Alley, 1650-ZD Broadway, New York 10019.

HYPNOTISM

FREE Hypnotism, Self-Hypnosis, Sleep Learning. Catalog! Drawer H400, Ruidoso, N.M. 88345.

FREE TRIAL!! Sensational self-hypnosis record kit improves memory, concentration, personality. Results guaranteed! Forum, 333-AA10, Michigan, Chicago 60601.

HYPNOTIZE others—unnoticed. Quietly, quickly, safely. Instruction \$1.00. Litton, 32MA, Randallstown, Maryland 21133.

EDUCATIONAL OPPORTUNITIES

LEARN While Asleep, hypnotize with your recorder, phonograph. Astonishing details, sensational catalog free! Sleep-Learning Association, Box 24-ZD, Olympia, Washington 98501.

USED Correspondence Courses and Books sold and rented. Money back guarantee. Catalog free (Courses Bought). Lee Mountain, Pisgah, Alabama 35765.

LEARN WHILE ASLEEP. Miraculously build Mind Power, achieve Self Confidence, improve Health, gain Success. Method 92% effective. Details free. ASR Foundation, Box 7021EG Henry Clay Station, Lexington, Kentucky 40502.

PHOTOGRAPHY—FILM, EQUIPMENT, SERVICES

MEDICAL FILM—Adults only—"Childbirth" one reel, 8mm \$7.50; 16mm \$14.95. International W. Greenvale, Long Island, New York 11548.

SCIENCE Bargains—Request Free Giant Catalog "CJ"—148 pages—Astronomical Telescopes, Microscopes, Lenses, Binoculars, Kits, Parts, War Surplus bargains. Edmund Scientific Co., Barrington, New Jersey 08007.

RUBBER STAMPS

RUBBER ADDRESS STAMP \$1.50. SIGNATURE \$2.88. FREE CATALOG. JACKSON PRODUCTS, 1433 WINNEMAC, CHICAGO, ILL. 60640.

INVENTIONS WANTED

INVENTORS. We will develop, help sell your idea or invention, patented or unpatented. Our national manufacturer clients are urgently seeking new items for outright cash sale or royalties. Financial assistance available. 10 years proven performance. For free information, write Dept. 42, Wall Street Invention Brokerage, 79 Wall Street, New York, N.Y. 10005.

PATENT SEARCHES, \$6.00! FREE "Invention Record"/Information. Miss Hayward, 1029HE Vermont, District of Columbia 20005.

INVENTIONS — IDEAS developed Cash/Royalty Sales. Member: United States Chamber Commerce. Raymond Lee, 230-GE Park Avenue, New York City 10017.

INVENTIONS wanted! Highest cash or royalties. Financial assistance. Free analysis. International Invention Institute, Dept. 31, 160 Broadway, New York, New York 10038.

INVENTORS! Get your "Little Piggy" to market. Highest cash or royalties. New York Invention Service, Dept. 13, 160 Broadway, New York, N.Y. 10038.

GET IT from GOODHEART!

EVERYTHING UNCONDITIONALLY GUARANTEED!

Brand new VHF revrs in original cartons! Look exactly like the familiar BC-453 Command Revrs but are 9-tube superhet 108-135 mc AM revrs and very easy to power & control without touching anything inside the unit & you can even connect an S-Meter externally! We furnish schematic and complete instructions on all pin connections and also a spline tuning knob. A.R.C. Type No. R13B. No tuning dial; use graph of freq. vs knob turns. 2 in. sensitivity. 2 RF, 3 IF stages. Ship wt. 3 lbs. For Los Angeles. **BRAND NEW... \$22.50**
R32 is same but w/adjustable squeel! \$27.50

DZ-1 Superhet revr 15-70 & 100-1500 kc. 89.50
R-23/ARC-5 Command revr 190-550 kc. 14.95
A.R.C. 12 = 22 Command revr 540-1600 kc. 17.95
APR-4Y AM/PM Revr mod. to 115 v 50/60 cy. with pwr plug, hook, tuners 38-1000 mc. 250.00
CV-253/ALR Tuner brand new 38-1000 mc. 250.00
APR-1Y with CV-253 425.00
P.U.R. for tuners 975-2200 and 2175-4000 mc.
At pwr sply good for AFT-15 w/data 49.50
RA-62-15 AC pwr sply for SCR-922, only 17.95
TDD AMR 45 W P6 A2, A3, 115-16 mc. 245.00
TDZ AMR 50 W P6 A2, A3, 225-400 mc. 395.00
LM-14 freq. meter, .01% 125 kc-20 mc. 57.50
TS-323/UR freq. meter 20-480 mc., 001% 169.50
BC-221's OK \$67.50 W/modul \$87.50

ALL-BAND SSB RCVR BARGAIN: Hallicrafters R-45/ARL-7, 550 kc to 43 mc continuous. Voice, CW, MCW, aligned, grid, w/book; 2-RF, 2-IF's, 8-meter noise limiter; 3-xtl, 3 non-xtl selectivity choices. Less pwr sply. **149.50**
60 cy pwr sply: \$30. SSB product detector: \$20

TRANSISTORIZED LV REGUL. PWR SPLIES
Univ. TQ36-1: Dual 4-50 vdc. 1A, metered 119.50
Dres-Barnes 62-143: 1/2-32 vdc. 15A, metered 129.50
Dres-Barnes 62-121: 1/2-36 vdc. 15A, metered 149.50

ATT. PHYSICS. ENGR. DEPT. PROFS. ATT. STANDARDS-LAB MANAGERS:

We have many desirable exotic things for you at budget-stretching prices. Examples: National Cesium-Beam Freq. Standard puts out 10 dbm to 50 dbm at 0.1, 5, 100 & 500 mc w/accuracy 5 parts/100 billion. Honeywell Microvolt Primat J.N. Wenner Pol. Water Calorimeters at peanut prices. E. I. For. Ph. Anale. Dynamometer Transfer Standards NBS Traceable certified. Fluke & Kintel digital pwr splies. Counters, DVM's. PLEASE ASK FOR YOUR NEEDS AS SPECIFICALLY AS POSSIBLE! We have no overall catalog.

TIME PAY PLAN: Any purchase totaling \$100.00 or more, down payment only... **10%**

Above is a small sampling of our terrific inventory. **WE ALSO BUY!** We want Tektronix scopes, Hewlett-Packard equip., aeronaut. radio-shop equip., etc., AND Military Communications of all kinds.

R. E. GOODHEART CO. INC.
Box 1220-A, Beverly Hills, Calif. 90213
Phones: Area 213, office 272-5707, messages 275-5342

CIRCLE NO. 107 ON READER SERVICE CARD

8 PIECE TOOL KIT

69¢
10 shipping
contains
4 Bristo
Wrenches
1 Hex Blade
2 Alignment
(tuning) Tools

in original mfr's bags and boxes

CORNELL TUBES

1 YR. GUARANTEED

Mutual Conductance Lab-tested, Individually Boxed, Branded and Code Dated. Tubes are new, or used and so marked.

Special!

With every \$10 Order
25¢
per tube

No Limit! from this list:
6AG5 6SN7
6AQ5 6CB6 6SA
6AU6 6J6 6W4

33¢ PER TUBE

100 TUBES OR MORE:
30¢ PER TUBE

INTERFERENCE TRAPPER

SUPPRESS PICTURE INTERFERENCE CAUSED BY:

- AUTO IGNITION
- AIRPLANES
- APPLIANCES
- OIL BURNERS
- AMATEUR RADIO TRANSMITTERS

\$1.59 + 10¢ Shipping

TUBE LIFE SAVER!

STOP TUBE BURNOUTS!

PROTECTS TV TUBES FROM BURNOUT AND CUTS DOWN ON SERVICE CALLS! SAVES YOU MONEY! ALSO USE WITH PHONOGRAPHS, TV RECORDERS, TAPE RECORDERS AND ALL TYPES OF ELECTRONIC TUBES AND HEADPHONES!

\$1.79 + 20¢ shipping

BARGAIN CORNER

| | |
|-----------------|------|
| Solder Iron | 1.49 |
| Elect Tape | .89 |
| Epoxy (pr.) | .79 |
| Diode Kit | .39 |
| Noise Filter | .89 |
| Neon Tester | .59 |
| Solder | .39 |
| Antenna Coupler | 1.89 |
| Battery Charger | 4.95 |

SILICON RECTIFIERS

all purpose **ELECTRONIC CLEANER** 89¢

1000 ml P.V. 89¢ Per Pail

TUBE SUBSTITUTES

11.000

| SIZE | FOR TUBE SIZE | PRICE PER 10 CARTRONS | PRICE PER 100 CARTRONS |
|----------|---------------|-----------------------|------------------------|
| 100 | 6A8 | .29 | 2.99 |
| BY ORDER | | .39 | 3.49 |
| BY ORDER | | .59 | 5.29 |
| BY ORDER | | .89 | 7.99 |

RADIO-TV TUBE TESTER

2.89 plus 30¢ shipping

TEST AND REPAIR TV & RADIO SETS APPLIANCES

Other tubes at low prices—send for free list.

NO SUBSTITUTIONS WITHOUT YOUR PERMISSION

CORNELL ELECTRONICS CO.

Dept EW 10 4217 University Ave., San Diego, Calif. 92105

TERMS: Add 3c per tube shipping. Orders under \$5.00 add 3c per tube shipping plus 50c handling. Canadian orders add approximate postage. Send 25¢ deposit on C.O.D. orders. No C.O.D. orders under \$5.00 or to Canada. No 24 hr. free offer on personal check orders. 3-DAY MONEY BACK OFFER.

SEND FOR **FREE CATALOG**

CIRCLE NO. 80 ON READER SERVICE CARD

OUR TRANSISTORS & RECTIFIERS ARE GUARANTEED TO WORK

Our semiconductors have full factory length leads, are American made, unused, and in good physical condition. Our technical descriptions and pictures are accurate.

All our transistors are checked for voltage & gain to insure our customers a good transistor within the category we advertise. We will stand on our reputation for quality products and service.

TRIACS

TO-66
5 AMP

| PRV | | |
|-----|------|--|
| 100 | .90 | |
| 200 | 1.40 | |
| 300 | 1.75 | |
| 400 | 2.25 | |
| 500 | 2.60 | |

10 WATT ZENERS. 3-200v State desired voltages. Ea. \$.75



POST OFFICE BOX 74B
SOMERVILLE, MASS. 02143
featuring transistors, rectifiers and components
SEND FOR OUR FALL CATALOG

- 50 WATT ZENERS. 6-200 V. State desired voltages\$1.75
- SILICON BILATERAL SWITCH. Replaces two SCR's by firing in either direction when breakdown voltage is exceeded. Used in light dimmers, etc.2/\$1.00
- 1000 PRV at 3A full wave bridge \$3.50
- NEON LIGHT OR NIXIE TUBE DRIVERS. An NPN, TO-18, S1 Transistor. With a VCBO of 120 3/\$1.00
- SIM. to 2N2875 (PNP). Silicon 20 watts with 30 MHZ cut off \$.75
- High voltage NPN 150V. VCBO at 2.5A., High HFE in TO-66 pack\$.75

Silicon Power Rectifiers

| PRV | 3A | 12A | 20A | 40A |
|------|-----|------|------|------|
| 100 | .09 | .30 | .40 | .75 |
| 200 | .16 | .50 | .60 | 1.25 |
| 400 | .20 | .70 | .80 | 1.50 |
| 600 | .30 | 1.00 | 1.20 | 1.80 |
| 800 | .40 | 1.25 | 1.50 | 2.30 |
| 1000 | .55 | 1.50 | 1.80 | 2.70 |

Terms: FOB Cambridge, Mass.

Send check or Money Order. Include Postage. Average Wt. per package 1/2 lb. Allow for C.O.D. Minimum Order \$3.00

MORE

INTEGRATED CIRCUITS



- SR Flip Flops \$.90
 - SR Clocked Flip Flops \$1.15
 - SRT Flip Flops \$1.15
 - JK Flip Flops \$1.15
 - Dual Nand Nor Gates \$1.00
 - OR Expanders \$1.00
 - Dual and Gates \$1.00
 - Quad Nand Nor Gates \$1.00
 - TO-85 flat pack with holder. Guaranteed to work.
- They come complete with schematic, elect. characteristic sheet & some typical applications.

TOP Hat & Epoxy 1 AMP

| PRV | | | |
|-----|-----|------|-----|
| 100 | .07 | 1000 | .35 |
| 200 | .09 | 1200 | .50 |
| 400 | .12 | 1400 | .65 |
| 600 | .18 | 1600 | .80 |
| 800 | .22 | 1800 | .90 |

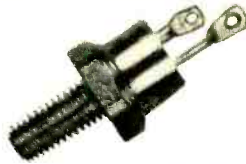

Silicon Control Rectifier #7A
Silicon Control Rectifiers

| PRV | 3A | 7A | 20A |
|------|------|------|------|
| 50 | .35 | .45 | .70 |
| 100 | .50 | .65 | 1.00 |
| 200 | .70 | .95 | 1.30 |
| 300 | .90 | 1.25 | 1.70 |
| 400 | 1.20 | 1.60 | 2.10 |
| 500 | 1.50 | 2.00 | 2.50 |
| 600 | 1.80 | 2.40 | |
| 700 | 2.20 | 2.80 | |
| 1000 | | 4.00 | |

G&G CATALOG!

NEW 24 Pages Military Electronic Gear
SEND 25¢ - Refunded with first order

AN/APR-4Y FM & AM RECEIVER "FB" FOR SATELLITE TRACKING!

High precision lab instrument, for monitoring and measuring frequency and relative signal strength. 38 to 4000 Mc, in 5 tuning ranges. For 110 V 60 cycle AC. Built-in power supply. Original circuit diagram included. Checked out, perfect. **LIKE NEW \$88.50**

All Tuning Units Available for Above
 BC-929 3-Inch Scope, with all tubes. LIKE NEW\$16.95
Conversion instructions, with diagram, for 110 V AC operation\$.65

BC-221 FREQ. METER. Accurate, reliable crystal calibrated, for 125 to 20,000 KC range. Complete with tubes, calibration book. Checked out. **\$79.50**
Exc. Used, unmodulated\$129.50
Exc. Used, Modulated\$5.50
1000 KC crystal for above

LM FREQ. METER, Modulated, 125 to 20,000 Kc. With calibration book, like new\$79.50

T-23/ARC-5 TRANSMITTER, 100 to 156 Mc. Less tubes and crystals, Used\$9.95

R-4/ARR-2 RECEIVER, 234-258 Mc, Tunable. Complete with 11 tubes, NEW\$11.95
Dynamotor (24VDC) for ARR2\$2.45

BC-645 TRANSCEIVER 435 to 500 Mc, convertible for Ham or Citizens' bands, Voice or Code. Brand new, with 15 tubes\$16.95
Dynamotor, Antenna, Plugs, All accessories available.

SCR-274-N, ARC-5 COMMAND SET HQ!



| Freq. Range | Type | Exc. Used | BRAND NEW |
|--|--------|-----------|-----------|
| RECEIVERS, Complete with Tubes | | | |
| 190-550 Kc. | BC-453 | \$18.95 | \$23.50 |
| 3-6 Mc. | BC-454 | \$16.50 | \$21.50 |
| 6-9.1 Mc. | BC-455 | \$14.95 | \$19.95 |
| 1.5-3 Mc. | R-25 | | \$21.50 |
| TRANSMITTERS, Complete with Tubes | | | |
| 4-5.3 Mc. | BC-457 | \$6.95 | \$11.95 |
| 5-3.7 Mc. | BC-458 | \$6.95 | \$12.95 |
| 7-9.1 Mc. | BC-459 | \$17.95 | \$22.50 |
| 2-1.3 Mc. | T-18 | | \$10.95 |
| 3-4 Mc. | T-19 | \$10.50 | \$14.95 |
| MODULATOR, Complete with 3 Tubes | | | |
| Voice | BC-456 | \$ 2.75 | \$ 4.95 |

All Command Set Accessories in Stock

SCR-625 MINE DETECTOR\$32.50
EE-8 FIELD PHONES, Exc. Used, Each\$16.95
BC-1206-C Beacon Recvr, 200-400 Kc. NEW\$12.95
BC-1206-C as above, used\$9.95
SCR-522 Transmitter Receiver, Like New\$39.50

TG-34A CODE KEYS
Brand New in original carton\$24.50
Exc. Used\$18.95
Practice Tapes available, with KeyerP.U.R.

CARBON HANDMIKE with push-to-talk switch, 3-ft cord and standard phone plug. Has Western Electric F-1 Unit. Brand New, each\$1.95

Please include 25% Deposit with order—Balance C.O.D., or Remittance in Full, 50¢ Handling Charges on all orders under \$5.00. All shipments F.O.B. Our Warehouse, N.Y.C. All Merchandise subject to Prior Sale and Price Change.

G & G RADIO SUPPLY COMPANY
Telephone: (212) CO 7-4605
75-77 Leonard St., New York, N.Y. 10013

MAIL SERVICES

HERMITAGE—most SECRET mail forwarding. Unique plus FREE GIFTS. \$3/month, 25¢/singles. HERMITAGE HOUSE (EW), 2783 Market, San Diego, California 92102.

MUSIC

POEM Writers beat the rush, by sending for A-1 instructions revealing how, when and where to get cash and royalties, for your poems. Act now limited amount available send \$1.00 to Artistic Writers Survey, 3531 Baronne St., New Orleans, La. 70115.

MISCELLANEOUS

WINEMAKERS: Free illustrated catalog of yeasts, equipment. Semplex, Box 7208, Minneapolis, Minn. 55412.

CIRCLE NO. 88 ON READER SERVICE CARD

Electronics World SUBSCRIBER SERVICE

Please include an address label when writing about your subscription to help us serve you promptly. Write to: Portland Place, Boulder, Colo. 80302

CHANGE OF ADDRESS:

Please let us know you are moving at least four to six weeks in advance. Affix magazine address label in space to the right and print new address below. If you have a question about your subscription, attach address label to your letter.

TO SUBSCRIBE:

- Check boxes below.
- New Renewal
- 5 years \$21
- 3 years \$15
- 1 year \$6

SPECIFY:

- Payment enclosed—You get 1 extra issue per year as a BONUS!
- Bill me later.

AFFIX LABEL

name
city
address
zip-code

please print

If you have no label handy, print OLD address here.

Add'l postage: \$1 per year outside U.S., its possessions & Canada.

name please print 0172

address

city

zip-code

EMPLOYMENT INFORMATION

FOREIGN and USA job opportunities available now. Construction, all trades. Earnings to \$2,000.00 monthly. Paid overtime, travel, bonuses. Write: Universal Employment, Woodbridge, Connecticut 06525.

BUSINESS OPPORTUNITIES

INVESTIGATE ACCIDENTS: Earn up to \$1,000 and more a month in your own business. Work spare time with average earnings of \$5 to \$8 per hour. No selling. Send for FREE booklet. No obligation. No salesman will call. Write: Universal Schools, CZ-10, 6801 Hillcrest, Dallas, Texas 75205.

FREE CATALOGS. Repair air conditioning, refrigeration. Tools, supplies, full instructions. Doolin, 2016 Canton, Dallas, Texas 75201.

I MADE \$40,000.00 YEAR by mailorder! Helped others make money! Start with \$10.00—Free proof. Torrey, Box 318-N, Ypsilanti, Michigan 48197.

FREE BOOK "990 Successful, Little-Known Businesses." Work home! Plymouth-145M, Brooklyn, New York 11218.

PROFITS to 50%, fast! No inventory, no risk! Details 25¢. Moneysaver, Box 666Z, Aptos, Calif. 95003.

STAMPS

FREE Wonderful New United States Catalog! Postage and Airmails Complete. 786 Illustrations. Special offers, Bargains Galore—Everything! Send Today. H. E. Harris, Dept. FC-1, Boston, Mass. 02117.

PRESIDENT KENNEDY Memorial Stamp First Day Cover 50¢. Artcraft, Box 66, Maplewood, New Jersey 07040.

GREGORY ELECTRONICS
Reconditioned & Used FM
2-WAY RADIO SAVINGS

Partial list—Send for New '67 Catalog



Voice Commander

132 to 172 MC, 1W 9.5" x 5.3" x 1.7" Lowest price ever, including brand New Rechargeable Nickel Cadmium Battery Pack

\$148

If crystal & tuning is desired add \$45.00
 Battery charger for these units \$16.00
 Write for Quantity Prices

VOICE COMMANDER
 Monitor Receiver only—**\$78**
 Tuned & Crystalled with dry Batteries

GE RECEIVER

4ER6 30-40 MC, 40-50 MC, 6 or 12 Volts
 3 Coil I. F. **\$28**
 4 Coil I. F. **\$34**

GENERAL ELECTRIC 4ES14A1—450-470 MC
 6/12 volts, less accessories—12 to 15 Watts. **\$38**

MOTOROLA T41GGV 30-50mc 6/12 V,
 30 watt vibrator power supply fully narrow banded complete with accessories **\$148**
 less crystals and antenna
 Add \$45.00 for tuning to desired frequency and new antenna

MOTOROLA 30-50mc 6/12 V,
 T51GGV vibrator power supply. Fully narrow banded (TX & RX) **\$198**
 Above price include accessories less crystals and antenna (less accessories, deduct \$30.00)
 To tune unit to desired frequency including new antenna add \$45.00

GE 2-Piece unit—6 volt or 12 volt 4ER6—4ET5, 30w 30-40, mc.—40-50 mc. Wide Band \$48
 Fully narrow band (TX+RX) **\$68**
 Complete Accessories
4ER6—4ET6, 60w 30-40 mc—40-50 mc. Wide Band \$68
 Fully Narrow Band **\$88**
 Complete Accessories
 Add \$45.00 for tuning and crystals to desired frequency, including new antenna.

RCA—CMCT 30 148-172 mc. transistorized power supply fully narrow banded complete with accessories \$198
 Add \$40.00 for crystals and tuning and new antenna.

G.E. PACERS—EG43SA6 150-170 mc Transistorized Power Supply 13-15 watts, 12 v Front Mount (Complete accessories, less crystals and antenna) \$108.00

We Buy Late Model Equipment for Cash
 —Write: Wire or Phone!



GREGORY ELECTRONICS CORPORATION

249 RT. 46, Saddle Brook, N.J., 07662
 Phone: (201) 489-9000

CIRCLE NO. 105 ON READER SERVICE CARD

EMPLOYMENT Resumes. Get a better job & earn more! Send only \$2.00 for expert, complete Resume Writing Instructions. J. Ross, 80-34 Kent St., Jamaica, N.Y. 11432 Dept. EW.

SPARE TIME OPPORTUNITY—MONEY. WE PAY at the rate of \$10 hr. for **NOTHING** but your opinions, written from home about our clients' products and publications, sent you free. Nothing to buy, sell, canvass, or learn. **NO SKILL. NO GIMMICKS.** Just honesty. Details from **RESEARCH, ZD-3, Box 669, Mineola, N.Y. 11501.**

STOP BURGLARS THE EASY WAY!! Affix authentic "Protected by Electronic Sentry Alarm" Decals to auto windows, doors & windows of home, retail stores; vending machines, etc. Whether you have an alarm or not—thieves stay away! Only \$1.00 for each set of two. J. Ross, 80-34 Kent St., Jamaica, N.Y. 11432. Dept. EW.

TEN Winemaking Recipes and Winemaking Supplies catalog. 10¢. Country Winemaker, Box 243EGA, Lexington, Massachusetts 02173.

ELECTRONICS WORLD OCTOBER 1967

ADVERTISERS INDEX

| READER SERVICE NO. | ADVERTISER | PAGE NO. | READER SERVICE NO. | ADVERTISER | PAGE NO. |
|--------------------|--|---------------------|--------------------|---------------------------------------|----------------|
| 200 | Alco Electronic Products Inc. | 79 | 103 | Jensen Manufacturing Division | 6 |
| 125 | Allied Radio | 91, 92 | 102 | Jerrold | 22 |
| | American Institute of Engineering & Technology | 99 | 101 | Lafayette Radio Electronics | 61, 62 |
| 124 | Amperex Electronic Corporation | 77 | 100 | Lampkin Laboratories, Inc. | 79 |
| 123 | Belden Corporation | 2 | 99 | Mallory & Co. Inc., P.R. | 99 |
| 79 | Burke & James, Inc. | 102 | 198 | Metex Corporation | 68 |
| 122 | Burstein-Applebee | 68 | 98 | Motorola Training Institute | 90 |
| | Capitol Radio Engineering Institute, The | 70, 71, 72, 73 | 97 | Music Associated | 88 |
| 121 | Cleveland Institute of Electronics | 13 | | National Radio Institute | 8, 9, 10, 11 |
| 120 | Cleveland Institute of Electronics | 80, 81, 82, 83 | 197 | Non-Linear Systems, Inc. | 7 |
| 80 | Cornell Electronics Co. | 106 | | Norelco | 100 |
| 119 | Crown International | 4 | 96 | Olson Electronics, Inc. | 99 |
| 118 | Delta Products, Inc. | 12 | 95 | Poly Paks | 105 |
| 199 | Dialight Corporation | 88 | | RCA Electronic Components and Devices | FOURTH COVER |
| 117 | EICO Electronic Instrument Co., Inc. | THIRD COVER | | RCA Institutes, Inc. | 18, 19, 20, 21 |
| 116 | Edmund Scientific Co. | 104 | | RCA Sales Corp. | 17 |
| 115 | Electro-Voice, Inc. | 85 | 94 | Radar Devices Manufacturing Corp. | 5 |
| 114 | Electronic Chemical Corp. | 76 | | Round Hill Associates, Inc. | 86 |
| 112 | Electronic Components | 104 | 93 | Sams & Co., Inc., Howard W. | 65 |
| 113 | Electronic Components Co. | 103 | 92 | Schober Organ Corp., The | 99 |
| | Electronics & Control Engineers Book Club | 67 | 91 | Scott, Inc., H.H. | 85 |
| 111 | Elpa Marketing | 76 | 90 | Sentry Manufacturing Company | 100 |
| | Fair Radio Sales | 103 | 89 | Shure Brothers, Inc. | 64 |
| 109 | Finney Company, The | 94, 95 | 88 | Solid State Sales | 107 |
| | G & G Radio Supply Company | 107 | 87 | Sonotone Corporation | 98 |
| 107 | Goodheart Co. Inc., R.E. | 106 | | Spectrum Products Corp. | 99 |
| 106 | Greenlee Tool Co. | 98 | 86 | Sony/Superscope, Inc. | 84 |
| 105 | Gregory Electronics Corporation | 108 | 85 | Surplus Center | 105 |
| 104 | Heath Company | SECOND COVER, 1, 89 | 196 | Sylvania Electronic Tube Division | 15 |
| | IBM | 69 | 83 | Telex Acoustics | 78 |
| | Irish Magnetic Recording Tape | 100 | 84 | Telex-Magnecord-Viking Stereo Stakes | 16 |
| | | | 195 | Texas Crystals | 88 |
| | | | 82 | University Sound | 96 |
| | | | | Valparaiso Technical Institute | 78 |
| | | | 81 | Zenith | 101 |

CLASSIFIED ADVERTISING 103, 104, 105, 106, 107, 108

Printed in U.S.A.

cortina®

The most exciting innovation in solid state stereo history.

Engineering excellence, 100% capability, striking esthetics — all at budget prices. We call it the industry's only **TOTAL PERFORMANCE STEREO** at lowest cost.

■ A full capability 70-watt All Silicon Solid State Stereo Amplifier for \$89.95 kit, \$129.95 wired, including cabinet. Cortina 3070.

■ An Automatic FM Stereo Tuner for \$89.95 kit, \$129.95 wired, including cabinet. Cortina 3200.

■ A 70-Watt Solid State FM Stereo Receiver for \$159.95 kit, \$239.95 wired, including cabinet. Cortina 3570.

The most electronics value for your money has been the EICO design philosophy for 22 years. Its successful expression in stereo is the new Cortina Series. In performance, specifications, circuitry, controls, decor — in everything you expect of professional quality stereo, you'll see that

nothing has been sacrificed — except high price. Let yourself in for one of the pleasant surprises in stereo history: hear Cortina, see it, examine it at your local EICO dealer. Compare and judge critically for value. We believe you'll conclude with Popular Science "The EICO Cortina Series are low-cost audio components that look, and sound, like high-cost components."

SIMPLIFIED KIT ASSEMBLY — New EICO exclusive circuitry techniques make kit building easier, faster and more enjoyable. RF, IF and Multiplex circuitry of the tuner and receiver are all supplied completely pre-assembled and pre-aligned. Each channel of the amplifier and receiver uses 3 etched printed-circuit module boards.

NEW ULTRA-COMPACT BOOKSHELF SIZE COMPONENTS

"The compact dimensions and attractive styling appealed

to us. The Cortina 3070 represents a wholesome trend away from "overblown" amplifiers which are much larger than need be. In fact, it is one of the very few we have seen which are actually suitable for bookshelf mounting." Hirsch-Houch Labs.

CORTINA TECHNICAL HIGHLIGHTS:

AMPLIFIER — Total Music Power: 70W into 4 ohms; 50W into 8 ohms. Harmonic Distortion: less than 0.8%. IM Distortion: less than 2% at full power. Hum & Noise: 72db below rated output. Frequency Response: ± 1.5 db 5Hz to 100kHz; ± 0.5 db 8Hz to 60kHz. Channel Separation: 40db. Size (HWD) 3 $\frac{1}{2}$ " x 12" x 7 $\frac{3}{4}$ ".

TUNER — Usable Sensitivity 1HF: 2.4 microvolts for 30db quieting. Channel Separation: 40db at 1kHz. Signal-to-Noise Ratio: 60 db. Capture Ratio: 4.5db. Image Rejection: 45db. Selectivity: 45 db. Audio Frequency Response: ± 1 db 20Hz to 15kHz. Size (HWD) 3 $\frac{1}{2}$ " x 12" x 7 $\frac{3}{4}$ ".

RECEIVER — Same as above Cortina Tuner and Amplifier. Size (HWD) 4 $\frac{1}{2}$ " x 16" x 9".



3570 FM Stereo Receiver



3070 70W Stereo Amplifier



3200 FM Stereo Tuner

EICO Electronic Instrument Co., Inc.
131-01 39th Avenue, Flushing, N. Y. 11352

- Tell me where I can have a free Cortina demonstration.
 Send me free 36-page catalog on EICO's 200 "best-buy" products.

Name _____

Address _____

City _____

State _____ Zip _____

CIRCLE NO. 117 ON READER SERVICE CARD

www.americanradiohistory.com



Fig. 1 - Rear Chassis View - CTC-16.

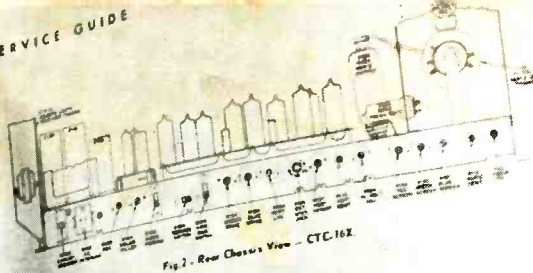

Fig. 2 - Rear Chassis View - CTC-16X.

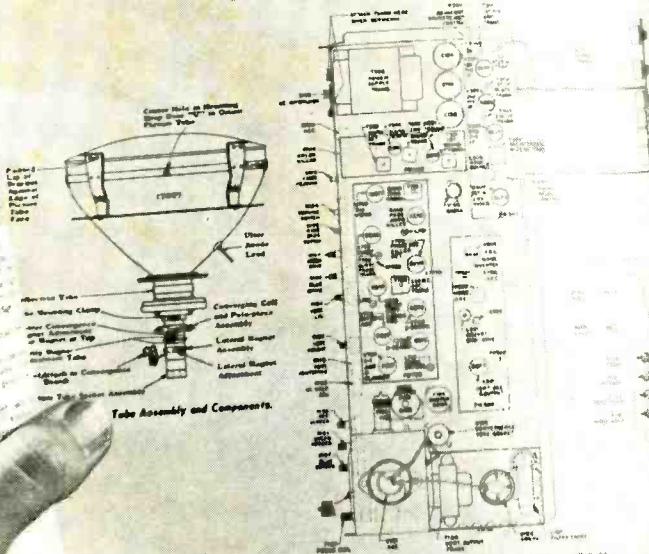

Fig. 3 - Top Chassis View - CTC-16.

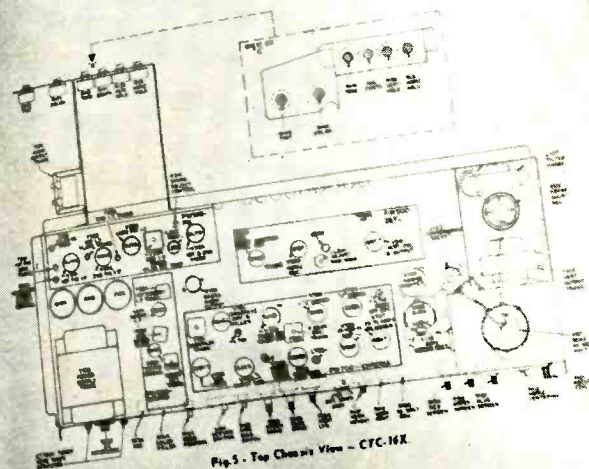
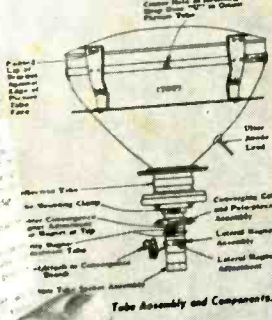

Fig. 5 - Top Chassis View - CTC-16X.



Tube Assembly and Components.

You need this guide for RCA Color Home Service Calls!

RCA'S NEW FIELD SERVICE GUIDE, ERT-200 helps you make all adjustments on all RCA color sets from 1955 to 1966 that can be performed in the home... including step-by-step procedure for replacing a color picture tube.

Three part index lets you look up the set you are working on by model number, name or chassis number. You'll find the ERT-200 Field Service Guide indispensable. There's nothing like it on house calls for RCA color sets.

WHAT THIS GUIDE CONTAINS:

- Schematics on all RCA color sets from 1955 to 1966
- Field service adjustments (AGC, linearity, centering, etc.)
- Convergence, purity and black and white setup adjustments
- Parts lists
- Wave forms keyed to test points for majority of chassis
- Top and rear chassis views
- Photos of typical receivers
- Index of models from CTC2 through CTC20
- Separate section on tuner schematics
- Separate section on remote tuner schematics

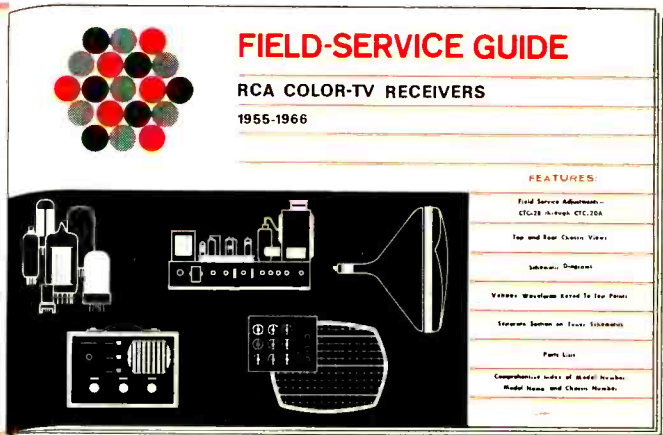

See your RCA Tube Distributor today and arrange to get your copy.

RCA Electronic Components and Devices, Harrison, N.J. 07029



The Most Trusted Name in Electronics