

# Electronics World

SEPTEMBER, 1966

60 CENTS

**USING NEW SILICON TRANSISTORS IN HI-FI AMPLIFIERS**

**NEW MOTOROLA CHROMA CIRCUITS**

**HOW TO SELECT THE PROPER SWITCH**

**TIME DOMAIN REFLECTOMETRY**

Special Features on  
**TESTING AND MEASURING**  
**RESISTORS**  
**CAPACITORS**  
**INDUCTORS**

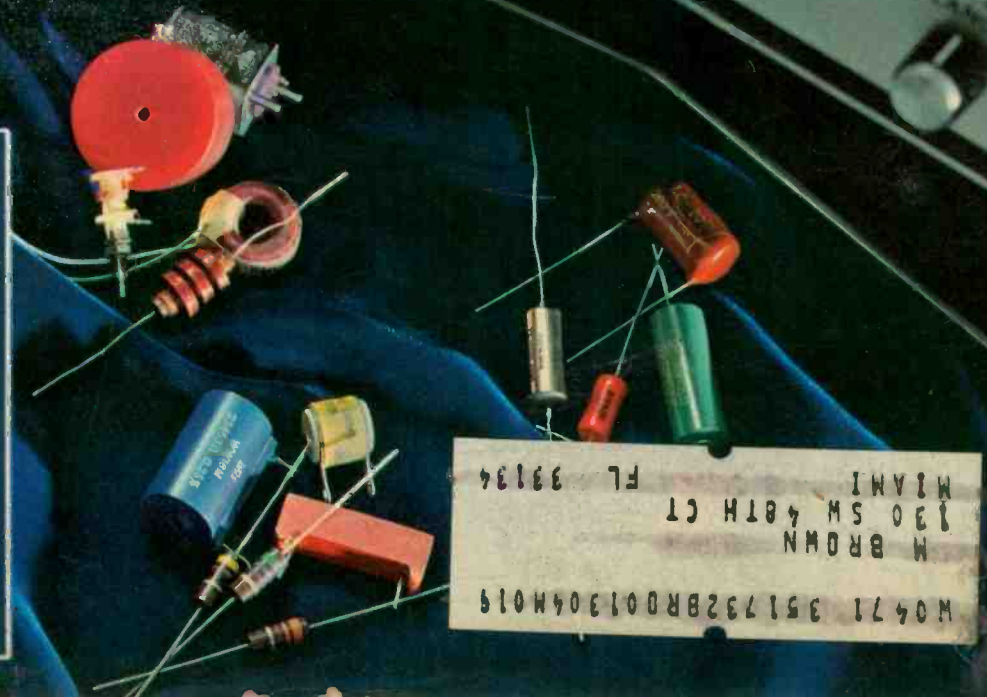

**E-V** The E-V SEVEN was born in the eerie silence of an anechoic chamber — the world's largest devoted to high fidelity design. This vast sound absorbing room let E-V engineers get right down to basic engineering. Nothing disturbed their silence — or their concentration on the subtle differences that distinguish a great speaker.

After months of experimentation, the E-V SEVEN met every design objective. Then expert listeners were invited to judge the sound — again and again — until engineers and critics were fully satisfied with E-V SEVEN performance.

But superb sound, once established, can easily slip away in the routine of mass production. We don't let it. A

completely equipped anechoic chamber — right on the production line — measures every speaker against perfection. And it's ruthless. All this may seem rather elaborate for a \$66.50 compact system... and it is. You can hear the difference!

Any fine component amplifier can display the E-V SEVEN at its best, but the new E-V 1144 stereo amplifier is uniquely suited to the purpose. Like the E-V SEVEN, the E-V 1144 is compact, handsome, and modest in cost (just \$124.50).

We threw tradition to the winds when we built the E-V 1144. Tossed out "old-hat" ideas about size and weight. Put 50 watts of stereo power in an

attractive walnut-paneled cabinet no taller than a coffee cup. It's easier when you can start from scratch — yet have years of experience in miniature solid-state electronics behind you. The young tigers in the E-V lab took it on as a personal challenge — and solved it beautifully.

So plug in any stereo phono, tape recorder, or matching E-V stereo tuner. Connect a pair of E-V SEVENS. Then turn up the volume of your E-V 1144. Natural sound? Absolutely. And that's what high fidelity is all about!

Window-shop through our complete high fidelity catalog for the answer to your high fidelity needs. It's free.

Electro-Voice, Inc., Dept. 964N, 629 Cecil Street, Buchanan, Michigan 49107

**Big sound.  
A natural for these  
compact E-V SEVENS.  
All you need is a  
very good amplifier...**



**like this one.  
The new E-V 1144.**



**Electro-Voice®**

high fidelity systems and speakers • tuners, amplifiers, receivers • public address loudspeakers • microphones • phonograph needles and cartridges • organs • space and defense electronics

CIRCLE NO. 101 ON READER SERVICE CARD

# Crime does pay!

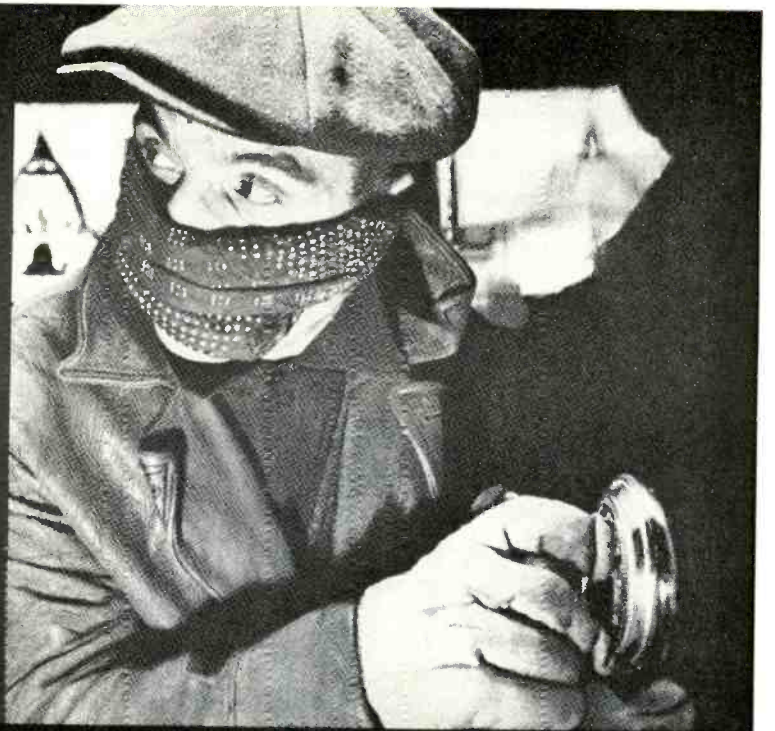

**Every 40 seconds a burglary takes place in the United States.**

#### TECHNICAL INFORMATION

The RADAR SENTRY ALARM is a complete U.H.F. Doppler Radar System which saturates the entire protected area with invisible r.f. microwaves. It provides complete wall to wall—floor to ceiling protection for an area of up to 5,000 square feet. Without human movement in the protected area, the microwave signal remains stable. Any human movement (operation is unaffected by rodents and small animals) in the area causes the doppler signal to change frequency approximately 2 to 4 cps. An ultra-stable low frequency detector senses this small frequency change, amplifies it and triggers the police type siren—which is heard up to a half mile away.

In addition, the RADAR SENTRY ALARM's protection can be extended to other areas with the use of the following optional accessories:

- remote detectors for extending coverage to over 10,000 sq. ft.
- rate of rise time detector U.L. approved for 2,500 sq. ft. of coverage each (no limit on the number of remote detectors that can be used)
- hold-up alarm
- central station or police station transmitter and receiver (used with a leased telephone line)
- relay unit for activating house lights
- battery operated horn or bell which sounds in the event of: powerline failure; equipment malfunction or tampering

At that rate, it's a multi-million dollar a year business...for burglars.

And an even better business opportunity for you.

Why? Because burglary can be stopped...with an effective alarm system.

In fact, police and insurance officials have proved that an alarm system reduces, and in many cases eliminates losses—even helps police apprehend the criminal.

Here's where you come in.

Only a small percentage of the more than 100 million buildings—stores, offices, factories, schools, churches and homes are protected by an effective alarm system.

That means virtually every home, every business is a prospect. You can sell them!

And you don't have to be a super-salesman to sell the best protection available—a Radar Sentry Alarm unit. All you have to do is demonstrate it...it sells itself.

A glance at the technical information shows why.

It's the most unique and effective alarm system ever invented.

And here's the proof.

In the past six years, thousands of RADAR SENTRY ALARM units have been sold in the Detroit, Michigan area alone—sold by men like yourself on a part-time and full-time basis.

Here are just a few customers who are protected by RADAR SENTRY ALARMS:

U.S. Government  
U.S. Air Force  
Detroit Board of Education  
Hundreds of Churches,  
Banks, Businesses and  
Homes.

Everyone is a prospect.

So take advantage of your profession. Put your technical knowledge and experience to work for you in a totally new area—an area that will make money for you!

Don't wait!

Let us prove that crime does pay.

Become a distributor.  
Write now for free details.

#### RADAR SENTRY ALARM



Mail to: RADAR DEVICES MANUFACTURING CORP.  
22003 Harper Ave., St. Clair Shores, Michigan 48080



Please tell me how I can have a business of my own distributing Radar Sentry Alarm Systems. I understand there is no obligation.

Name \_\_\_\_\_ EW-9  
Address \_\_\_\_\_  
City \_\_\_\_\_ State & Code \_\_\_\_\_



## When you need a stable capacitor...

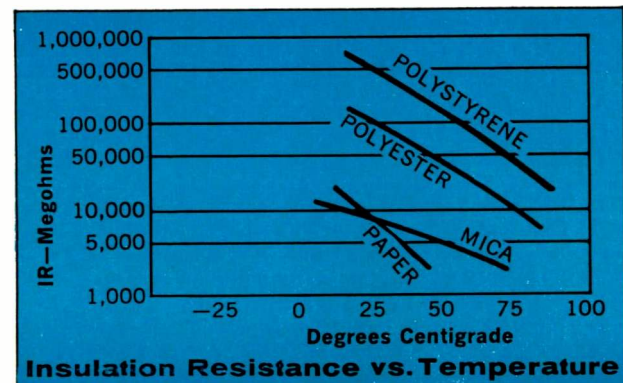
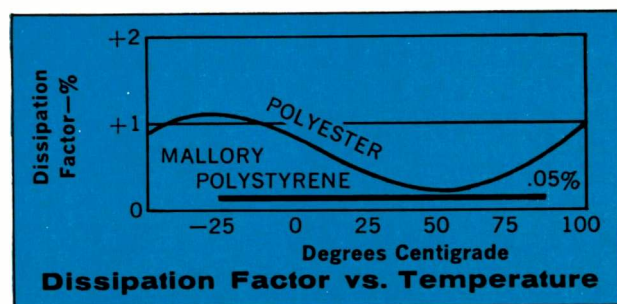
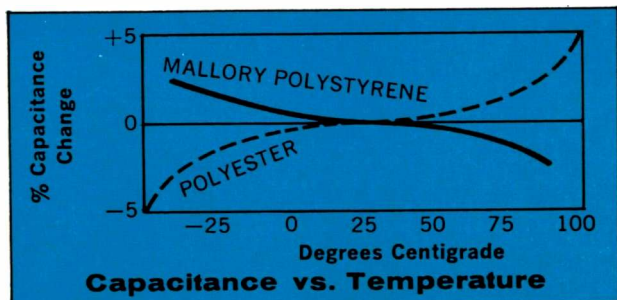
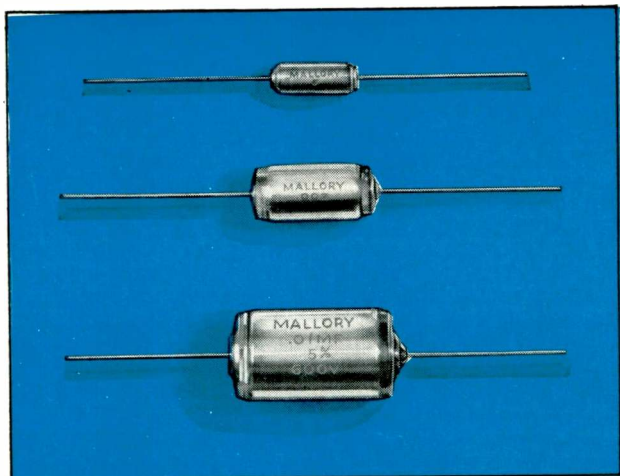

Temperature makes most capacitors wander. For electrolytics, capacitance goes down when temperature gets colder, goes up when things get hot. But this usually doesn't cause trouble, because most electrolytic applications are in filtering—and as long as you have low enough AC impedance, you get the filtering you need. Where drift can bring problems is in tuned circuits, timing and differentiator circuits; here you've got a paper, film, ceramic or mica capacitor, in the fractional-microfarad range. If it changes value due to temperature variations or just plain old age, you're going to have some headaches.

Today's tip: when you need extra stability, try the *new* Mallory polystyrene capacitors. They're the most stable you've ever seen. They look different, and they act different. They're made of a unique kind of stretched polystyrene film and high purity aluminum foil, wound up in a compact roll and then fused together in a self-sealed case of solid clear plastic.

What's extra special about these new capacitors is the way they hold their original microfarad value while temperature varies all over the lot. Temperature coefficient is considerably lower than that of polyester film capacitors—under 150 parts per million per degree C. And it's negative—which means that instead of going up with temperature, capacitance goes down. This is the direction you need to change capacitance in order to compensate for the effect of temperature on the inductive part of a tuned circuit. From  $-10^{\circ}\text{C}$  to  $+70^{\circ}\text{C}$ , their *total* capacitance change is less than 1.3%. And brother, that's *stable!*

And that's not all. These little dandies don't grow old. They hold their characteristics month after month. You just connect 'em and forget 'em.

One more thing. Mallory Polystyrene Capacitors have the lowest dielectric loss in the business. Their dissipation factor (similar to power factor, a measure of efficiency as a capacitor) is extremely low . . . only 0.05%, which is a small fraction of that of other capacitors. And it stays at this low value over the whole temperature range. This means that they're high Q capacitors, ideal for tuned circuits. And their insulation resistance is way higher than polyester, mica or paper capacitors.

In case you were wondering how much dough you would have to lay out to get such wonderful capacitors—here's the best news of all. They are really low priced. You can get them in values from 5 pF to .01 mfd, all rated 600 volts, from your Mallory Distributor. See him soon—and ask for your copy of the 1966 Mallory General Catalog. Mallory Distributor Products Company, a division of P. R. Mallory & Co. Inc., Indianapolis, Indiana 46206.

**50<sup>th</sup>**  
ANNIVERSARY

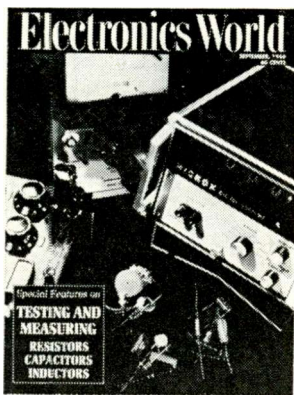

THIS MONTH'S COVER ties in with the special features we are running in this issue dealing with testing and measuring of the three basic passive components: resistors, capacitors, and inductors. Three groups of these components are shown in the foreground while three pieces of test equipment used to measure them are in the background. The unit at the left is a Yew (Yokogawa Electric Works) Model L-3C portable Wheatstone bridge for resistance measurements. The unit at the top is a Boonton Model 71A capacitance-inductance meter. The instrument at the right is a Hickok DMS-3200 digital measuring system with a capacitance meter plug-in. For further details on these three instruments refer to our Test Equipment Product Report in this issue. Photo by Bruce Pendleton.



**Publisher**  
PHILLIP T. HEFFERNAN

**Editor**  
WM. A. STOCKLIN

**Technical Editor**  
MILTON S. SNITZER

**Associate Editors**  
LESLIE SOLOMON  
P. B. HOEFER

**Assistant Editor**  
MARSHA JACOBS

**Contributing Editors**  
WALTER H. BUCHSBAUM  
Prof. ARTHUR H. SEIDMAN

**Art Editor**  
RICHARD KELLY

**Art and Drafting Dept.**  
J. A. GOLANEK

**Advertising Sales Manager**  
LAWRENCE SPORN

**Advertising Service Manager**  
ARDYS C. MORAN

September, 1966

# Electronics World

SEPTEMBER 1966

VOL. 76, No. 3

## CONTENTS

- 23** Designing Silicon-Transistor Hi-Fi Amplifiers *R.D. Gold & J.C. Sondermeyer*  
Part 1. Performance Objectives
- 27** Symmetrical Attenuator Pad Nomograms *Max H. Applebaum*
- 28** Recent Developments in Electronics
- 30** Testing and Measuring Inductors *Sam Zwass*
- 33** Chroma Circuits in Color TV: Motorola *Walter H. Buchsbaum*
- 36** Measuring Instruments for Electronic Components *Frederick Van Veen*
- 39** Testing and Measuring Capacitors *R. C. Lynds & D. Quimby*
- 42** Selecting the Proper Switch *Bernard Galbeck*
- 44** Testing and Measuring Resistors *F. Stern*
- 47** The Plumbicon: A New Approach to Camera Tubes
- 48** Time Domain Reflectometry *John D. Lenk*
- 60** Life Testing of R.F. Inductors *W. Dieter Hauser*
- 80** Army Field Calibration Technicians *Carmen J. Diodati*
- 83** Determining dB Power Ratios *Carmen J. Diodati*
- 87** Switching-Mode Power Conversion *Donald E. Lancaster*
- 93** Radio Uses IC's
- 94** Designing an Oscilloscope Vertical Attenuator *Donald R. Hicke*

- 
- 12** EW Lab Tested  
Dynaco Model 2000 Tape Recorder  
ADC Model 10/E Cartridge
  - 56** Crystal Grinding Techniques *John Frye*
  - 68** Test Equipment Product Report  
Hickok DMS-3200 Digital Measuring System  
Boonton Electronics 71A Capacitance/Inductance Meter  
Yokogawa Model L-3C Resistance Bridge

## MONTHLY FEATURES

- 4** Coming Next Month
- 6** Letters from Our Readers
- 72** Radio & TV News
- 76** Book Reviews
- 78** Electronic Crosswords
- 98** New Products & Literature

---

Electronics World: Published monthly by Ziff-Davis Publishing Company at 307 North Michigan Ave., Chicago, Illinois 60601. One year subscription \$6.00. Second Class Postage paid at Chicago, Illinois and at additional mailing offices. Subscription service: Portland Place, Boulder, Colorado 80302. Copyright © 1966 by Ziff-Davis Publishing Company. All rights reserved.

**Buy the BEST!  
Buy in KIT form!**



**MARK<sup>®</sup> TEN**  
**SCR** CAPACITIVE DISCHARGE  
IGNITION SYSTEM

ONLY \$ **29<sup>95</sup>** PPD.!

Why settle for less in motor vehicle ignition systems when you can buy the very BEST from Delta, the originators, the leaders in capacitive discharge (SCR) systems. Delta pioneered this electronic marvel. Thousands have installed this remarkable electronic system. Now YOU can purchase at low, LOW cost, and in easy-to-build kit form, the king of them all, the DELTAKIT. Low price due simply to high production levels at no sacrifice in peerless Delta quality.

**Operate Any Motor  
Vehicle More Efficiently**

Compare these proven benefits:

- ▲ Up to 20% Increase in Gasoline Mileage
- ▲ Installs in Only 10 Minutes on any Car or Boat
- ▲ Spark Plugs Last 3 to 10 Times Longer
- ▲ Instant Starts in all Weather
- ▲ Dramatic Increase in Acceleration and General Performance
- ▲ Promotes More Complete Combustion

Literature and complete technical information sent by return mail.

**BETTER YET — ORDER TODAY!**



**DELTA PRODUCTS, INC.**

P.O. Box 1147EW, Grand Junction, Colo. 81501  
Enclosed is \$\_\_\_\_\_. Ship prepaid.  
 Ship C.O.D.

Please send:

- Mark Tens (Assembled) @ \$44.95
- Mark Tens (Delta Kit) @ \$29.95

SPECIFY —  Positive Ground  Negative Ground  6 or  12 Volt

Car Year \_\_\_\_\_ Make \_\_\_\_\_

Name \_\_\_\_\_

Address \_\_\_\_\_

City/State \_\_\_\_\_ Zip \_\_\_\_\_

DP 6-2

**CIRCLE NO. 121 ON READER SERVICE CARD**

4

**COMING  
NEXT MONTH**

**SPECIAL ISSUE:  
Chokes & Coils**

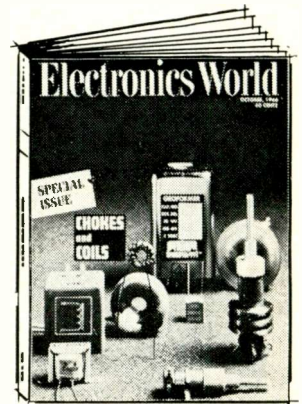

**The Inductor Industry**—Sam Zwass of Triad takes a hard look at the industry, its potentials, and the possible effects of monolithic circuit construction on component coils and inductors.

**R.F. Chokes & Coils**—William Courtney of J. W. Miller outlines the important characteristics of these inductors and suggests a number of things which will assist the user in making an intelligent selection.

**Coil Construction & Packaging**—Lack of complete standardization and overspecifying still plague the industry. A proper choice from the extremely wide variety of coil types and configurations is difficult, but must be made.

**Toroidal Inductors**—Although such units are more expensive, they are widely used because of their higher inductance in smaller sizes, their self-shielding, and high stability.

**Ferrite Beads**—By simply threading a conductor through one of these tiny beads, the circuit impedance to d.c. or audio frequencies.

**The MIL-C-30910 Spec**—W. Dieter Hauser of Jeffers outlines the MIL-Spec requirements for fixed r.f. molded coils, along with the parameters that are to be measured on such components.

**INTEGRATED CIRCUIT  
FOR CONSUMER PRODUCTS**

Larry Blaser of Fairchild describes a new circuit which can be used as a 10.7-MHz i.f. amplifier in FM receivers, a 4.5-MHz intercarrier sound i.f. amplifier in television sets, and as a 3.58-MHz

chroma reference oscillator in color-TV.

**FREQUENCY &  
FREQUENCY MEASUREMENT**

An authoritative discussion covering basic parameters, precision measuring techniques, and the equipment used.

All these and many more interesting and informative articles will be yours in the October issue of **ELECTRONICS WORLD**... on sale September 20th.

**ZIFF-DAVIS PUBLISHING COMPANY**

William B. Ziff  
Chairman of the Board (1946-1953)

William Ziff  
President

W. Bradford Briggs  
Executive Vice President

Hershel B. Sarbin  
Vice President and General Manager

Philip Sine  
Financial Vice President

Walter S. Mills, Jr.  
Vice President, Circulation

Stanley R. Greenfield  
Vice President, Marketing

Phillip T. Heffernan  
Vice President

Frank Pomerantz  
Vice President, Creative Services

Arthur W. Butzow  
Vice President, Production

Edward D. Muhlfeld  
Vice President

Editorial and Executive Offices  
One Park Avenue  
New York, New York 10016 212 679-7200

NEW YORK OFFICE 212 679-7200  
James J. Sullivan  
Joseph E. Halloran

MIDWESTERN OFFICE  
307 North Michigan Avenue  
Chicago, Illinois 60601 312 726-0892  
Midwestern Advertising Manager, Royce Richard

WESTERN OFFICE  
9025 Wilshire Boulevard  
Beverly Hills, California 90211  
213 CRestview 4-0265; BRadshaw 2-1161  
Western Advertising Manager, Bud Dean

JAPAN  
James Yagi  
c/o Sekihara  
1, Sakamachi, Shinjuku-ku  
Tokyo, Japan

CIRCULATION OFFICE  
Portland Place, Boulder, Colorado 80302



Member  
Audit Bureau of  
Circulations

Radio & TV News • Radio News • Radio-Electronic Engineering Trademarks Reg. U.S. Pat. Off.  
**SUBSCRIPTION SERVICE:** All subscription correspondence should be addressed to Electronics World, Circulation Department, Portland Place, Boulder, Colorado 80302. Please allow at least six weeks for change of address. Include your old address, as well as new—enclosing if possible an address label from a recent issue.

**EDITORIAL CONTRIBUTIONS** must be accompanied by return postage and will be handled with reasonable care; however publisher assumes no responsibility for return or safety of art work, photographs, or manuscripts.



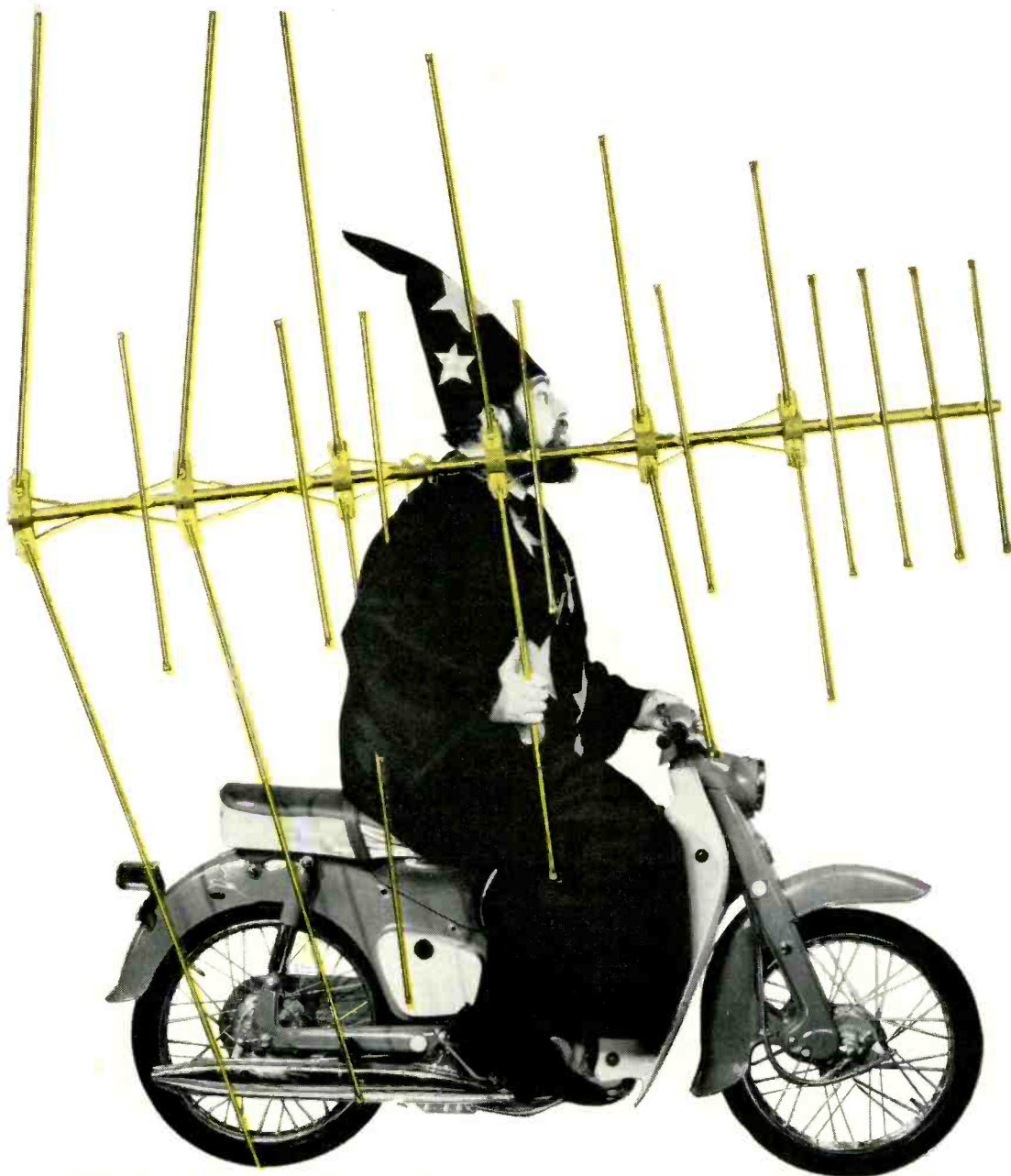

**ELECTRONICS WORLD** (September, 1966, Vol. 76, No. 3). Published monthly by Ziff-Davis Publishing Company at 307 North Michigan Avenue, Chicago, Illinois 60601. (Ziff-Davis also publishes Skiing, Flying, Business & Commercial Aviation, Boating, Car and Driver, Cycle, Popular Photography, HiFi/Stereo Review, Popular Electronics, Modern Bride, Skiing Trade News and Skiing Area News.) One year subscription rate for U.S., U.S. Possessions, and Canada, \$6.00; all other countries, \$7.00. Second Class postage paid at Chicago, Illinois and at additional mailing offices. Authorized as second class mail by the Post Office Department, Ottawa, Canada and for payment of postage in cash.

**ELECTRONICS WORLD**



## CHARGE INTO COLOR WITH GAVIN GOLD CREST

Concerned about color? Now Gavin conquers it. Captures it. With Color Antennas so new . . . so ahead of the rest . . . each bears a new, bold Gold Crest. Only Gavin tests and certifies each antenna for perfect color! For greatest gain. For best match. For lighter weight . . . with *five times* the strength. Charge into color with confidence. With the best. With new Gavin . . . Gold Crest.

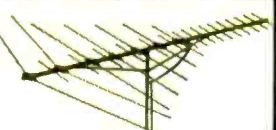
 <p>TESTED AND CERTIFIED FOR PERFECT COLOR</p>	 <p>UHF CR-5 Fringe Area</p>	 <p>UHF/VHF/FM 1113 Mid Fringe</p>	 <p>VHF/FM 1015H Mid Fringe</p>	 <p>VHF/FM 1023H Deep Fringe</p>
---	---	---	---	---

**PUT A RAINBOW ON ANY ROOF...ANYWHERE**

DISTRIBUTORS: Write for franchise information



GAVIN INSTRUMENTS, INC. SOMERVILLE, N. J.

# WHEATSTONE BRIDGE

**±0.1% ACCURACY**

**COMPACT, LIGHT WEIGHT  
GENERAL USE RESISTANCE BRIDGE**



**Model L-3C**

**Range:** .001Ω to 11.11MΩ

**Rheostat Arm:**

1Ωx10+10Ωx10+100Ω  
x10+1000Ωx10 (4 dials)

**Ratio Arm:**

x0.001, x0.01, x0.1, x1  
x10, x100, x1000

**Overall Accuracy:**

100Ω to 100kΩ	±0.1%
10Ω to 1MΩ	±0.3%
1Ω to 10MΩ	±0.6%

Accurate resistance measurement achieved with a single unit. No accessories, no power source required. Operates on three size D, 1.5V dry cells, YEW's new, rugged galvanometer, Model G-2(B) incorporated. All 5 dials make no-rubbing contact and are dust-proofed, housed in individual plastic case. The L-3C has elastic mold unbreakable housing. **Size:** 7¼" x 9" x 5" **Weight:** 5 lbs.

**Cat No. 52402 \$156.00**

shipping weight: 10 lbs.

Available for immediate delivery.

**CONFIDENCE BEGINS WITH**

**YEW®**

**YOKOGAWA  
ELECTRIC WORKS, INC.**

1995 PALMER AVE.,  
LARCHMONT, N.Y. 10538  
914-834-3550

TLX No. 710-566-1104

CIRCLE NO. 199 ON READER SERVICE CARD

## LETTERS FROM OUR READERS

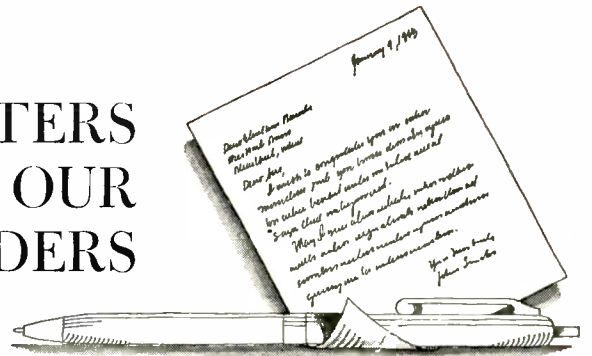

### CLASS-D AMPLIFICATION

To the Editors:

A so-called "new way to amplify signals," claiming nearly 100% efficiency for power amplifiers, has recently been described by Donald E. Lancaster in the article "Amplification Using Switching Techniques" (February issue).

To produce sinusoidal output from the rectangular-wave amplifier described, we are told that it is necessary only to pass the output through a low-pass filter—which need not be resonant nor resistive at the desired frequency. This is a fallacy. If the load is not resistive at the operating frequency, conduction pulses will not occur entirely during the minimum-voltage portion of the output cycle, and losses within the switch will be increased. In addition, the harmonic energy is not turned into fundamental-frequency energy by the filter but is stored in the filter and returned to the generator and is eventually dissipated within the generator, the filter, or connecting circuitry resistances. Even if the load is purely resistive, if the output voltage is a sine wave, voltage will still exist across the switch during its conducting time—sinusoidal, not rectangular-wave voltage. In spite of all this, a semiconductor class-C power amplifier can exceed 90% efficiency—what more can one expect?

For audio applications, "class-D" systems have been proposed which produce pulse-width modulation of a train of ultrasonic pulses, which are developed at very high efficiency. Again, we run into trouble at the filter. The pulsed energy is not simply converted into audio but is turned back by the filter, which lowers the system efficiency again. If the load is resistive to the pulses, they will join the audio in the speaker, with full efficiency maintained, but most of the output would be inaudible, except as it contributes to distortion. Ordinary meters may well show this output along with the audio, so output power measurements would require meters responding directly to r.m.s. current and voltage (such as a dynamometer movement) and filtered to remove the components other than audio. Simultaneous distortion measurements would be required to see that the audio and only the desired

audio was being measured. Proponents of "class-D" systems probably have used defective output measurements.

"Class D," like perpetual motion, is a clever method of getting something for nothing. It has been proposed by designers who understand the switch and not the load. Filters do not convert undesired components into desired ones; they simply store the undesired energy and return it to the generator. Filters make excellent load impedances for switching-type r.f. amplifiers (class B or C), but they must be resistive and designed for the narrow band of frequencies over which they maintain unity power factor. The "class-D" proposals are interesting, and study of them can lead to a better understanding of amplifier operation; however, as a practical amplifier, "D" is for "dead"!

ROBERT W. SCHOENING  
Bloomington, Minn.

*Author Lancaster's reply follows:*

To the Editors:

If we are to take Reader Schoening's conclusions at face value, we must also dismiss such something-for-nothing schemes as parametric frequency multipliers and switching-mode voltage regulators. In these devices, just as in the class-D audio systems, output power is derived at a frequency different from that of the input by using non-resonant filter techniques and converting the input frequency to the output one at very high efficiency.

If the input to an operating LC filter is suddenly short-circuited, all of the energy in the filter must eventually be delivered to and dissipated in the load. Even if the short circuit (represented in the class-D case by an "on" semiconductor) has some finite impedance, practically all of the energy in the filter still must go to the load so long as the load impedance is much higher than the impedance of the short.

If the input to the filter consists of a switch rapidly switching between ground and some low-impedance voltage source, the output of the low-pass filter will be the *time integral* of the input, given a proper choice of LC values.

(Continued on page 75)





# **NOW!** ONLY \$10 PER MONTH Brings You 20% MORE PHOTOFACT Coverage!

**JOIN THE NEW  
PHOTOFACT®  
OF-THE-MONTH CLUB!**

**MORE CURRENT MODEL COVERAGE  
EACH MONTH TO KEEP YOU AHEAD  
AND YOU SAVE OVER \$60 PER YEAR!**

As a PHOTOFACT-OF-THE-MONTH CLUB member you get 6 new PHOTOFACT Sets every month packed with the time-saving, profit-boosting servicing help you need. To stay ahead, to save money (individually purchased Sets now sell for \$2.50 each)—join the PHOTOFACT-OF-THE-MONTH CLUB now!

**HERE'S THE KIND OF PHOTOFACT COVERAGE  
YOU GET IN A TYPICAL MONTHLY "PACKAGE"**

(6-Set release, September 1966)

**20% MORE COVERAGE THAN EVER BEFORE:**

- 8** COLOR TV FOLDERS
- 13** B & W TV FOLDERS
- 31** OTHER FOLDERS

(AC-DC, FM-AM, Stereo Hi-Fi,  
Record Changers, Phonographs)

**COMPLETE CURRENT COVERAGE OF  
AT LEAST 50 CHASSIS EACH AND  
EVERY MONTH FOR ONLY**

**20¢ per folder!**

(less than 1½¢ per page of  
invaluable servicing know-how)

**TRY A THREE-MONTH SUBSCRIPTION!  
USE THIS HANDY ORDER FORM**



**A great monthly "package"  
exclusively for Photofact  
of-the-Month Club Members...**

You get your 6 new PHOTOFACT Sets every month in sturdy new file folders sealed in factory carton to ensure perfect condition and completeness—easier-than-ever to file and use. Now you get 20% more coverage and save over \$60 per year with a PHOTOFACT-OF-THE-MONTH CLUB membership!

**TRY A THREE-MONTH SUBSCRIPTION**

save on Photofact—watch it boost your earnings

See your Sams Distributor or send Membership Form below:

**HOWARD W. SAMS & CO., INC. Dept. EWF-9  
4300 W. 62nd St., Indianapolis, Ind. 46206**

Enroll me for a 3-month membership in the Photofact-of-the-Month Club. I agree to pay \$10 per month, and understand I will receive 6 current Photofact Sets monthly for 3 months to be delivered by my Sams Distributor (named below).

Name \_\_\_\_\_

Shop Name \_\_\_\_\_

Address \_\_\_\_\_

City \_\_\_\_\_ State \_\_\_\_\_ Zip \_\_\_\_\_

My Sams Distributor is: \_\_\_\_\_

Signed: \_\_\_\_\_



***Learning electronics at home is faster, easier, more interesting with new achievement kit***

Only NRI offers you this pioneering method of "3 Dimensional" home-study training in Electronics, TV-Radio . . . a remarkable teaching idea unlike anything you have ever encountered. Founded more than half a century ago—in the days of wireless—NRI pioneered the "learn-by-doing" method of home-study. Today, NRI is the oldest, largest home-study Electronics school. The NRI staff of more than 150 dedicated people has made course material entertaining and easy to grasp. NRI has simplified, organized and dramatized subject matter so that any ambitious man—regardless of his education—can effectively learn the Electronics course of his choice.

**DISCOVER THE EXCITEMENT OF NRI TRAINING**

Whatever your reason for wanting knowledge of Electronics, you'll find the NRI "3 Dimensional" method makes learning exciting, fast. You build, test, experiment, explore. Investigate NRI training plans, find out about the NRI Achievement Kit. Fill in and mail the postage-free card. No salesman will call. NATIONAL RADIO INSTITUTE, Electronics Division, Washington, D. C. 20016

**GET A FASTER START IN THE COURSE YOU CHOOSE WITH NRI'S REMARKABLE ACHIEVEMENT KIT**

When you enroll with NRI we deliver to your door everything you need to make a significant start in the Electronics field of your choice. This remarkable, new starter kit is worth many times the small down payment required to start your training. And it is only the start . . . only the first example of NRI's unique ability to apply 50 years of home-study experience to the challenges of this Electronics Age. Start your training this exciting, rewarding way. No other school has anything like it. What do you get? The NRI Achievement Kit includes: your first set of easy-to-understand "bite-size" texts; a rich, vinyl desk folder to hold your training material in orderly fashion; the valuable NRI Radio-TV Electronics Dictionary; important reference texts; classroom tools like pencils, a ball-point pen, an engineer's ruler; special printed sheets for your lesson answers—even a supply of pre-addressed envelopes and your first postage stamp.

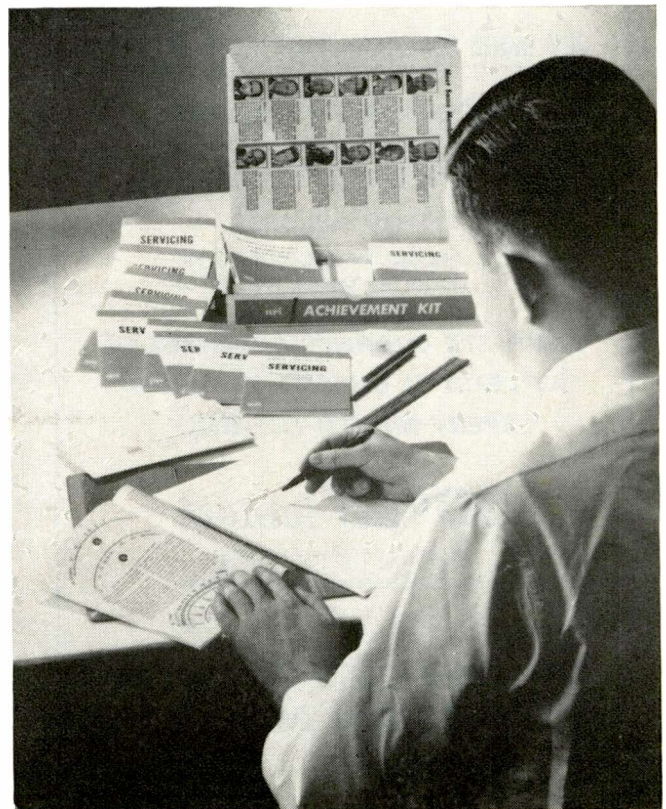

## ELECTRONICS COMES ALIVE AS YOU LEARN BY DOING WITH CUSTOM TRAINING EQUIPMENT

Nothing is as effective as learning by doing. That's why NRI puts so much emphasis on equipment, and why NRI invites comparison with equipment offered by any other school, at any price. NRI pioneered and perfected the use of special training kits to aid learning at home. You get your hands on actual parts like resistors, capacitors, tubes, condensers, wire, transistors and diodes. You build, experiment, explore, discover. You start right out building your own professional vacuum tube voltmeter with which you learn to measure voltage and current. You learn how to mount and solder parts, how to read schematic diagrams. Then, you progress to other experimental equipment until you ultimately build a TV set, an actual transmitter or a functioning computer unit (depending on the course you select). It's the practical, easy way to learn at home — the priceless "third dimension" in NRI's exclusive Electronic TV-Radio training method.

## SIMPLIFIED, WELL-ILLUSTRATED "BITE-SIZE" LESSON TEXTS PROGRAM YOUR TRAINING

Lesson texts are a necessary part of training, but only a part. NRI's "bite-size" texts are as simplified, direct and well-illustrated as half a century of teaching experience can make them. The amount of material in each text, the length and design, is precisely right for home-study. NRI texts are programmed with NRI training kits to make things you read come alive. As you learn, you'll experience all the excitement of original discovery. Texts and equipment vary with the course. Choose from major training programs in TV-Radio Servicing, Industrial Electronics and Complete Communications. Or select one of seven special courses to meet specific needs. Check the courses of most interest to you on the postage-free card and mail it today for your free catalog.

Available Under  
**NEW  
GI BILL**

If you served since  
January 31, 1955, or  
are in service, check GI  
line in postage-free card.

## *custom training kits "bite-size" texts*

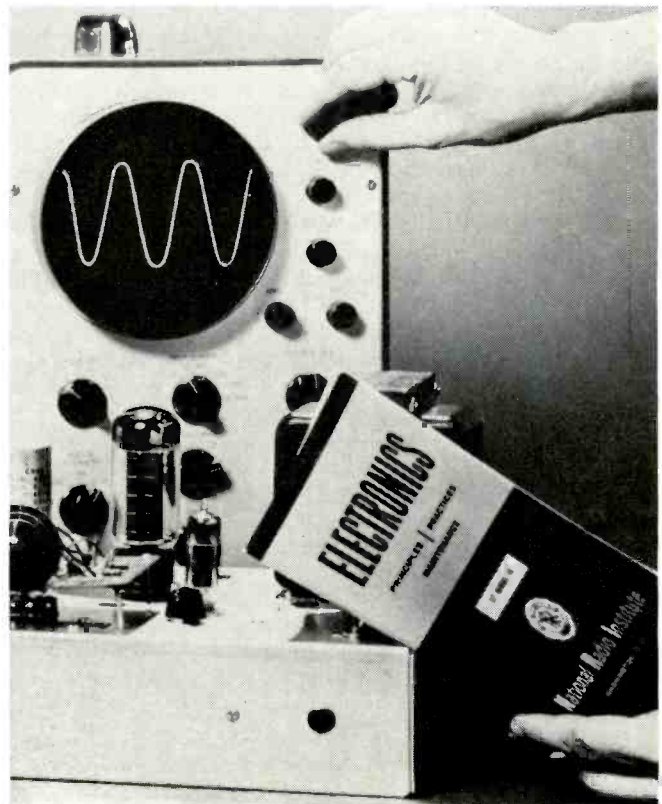
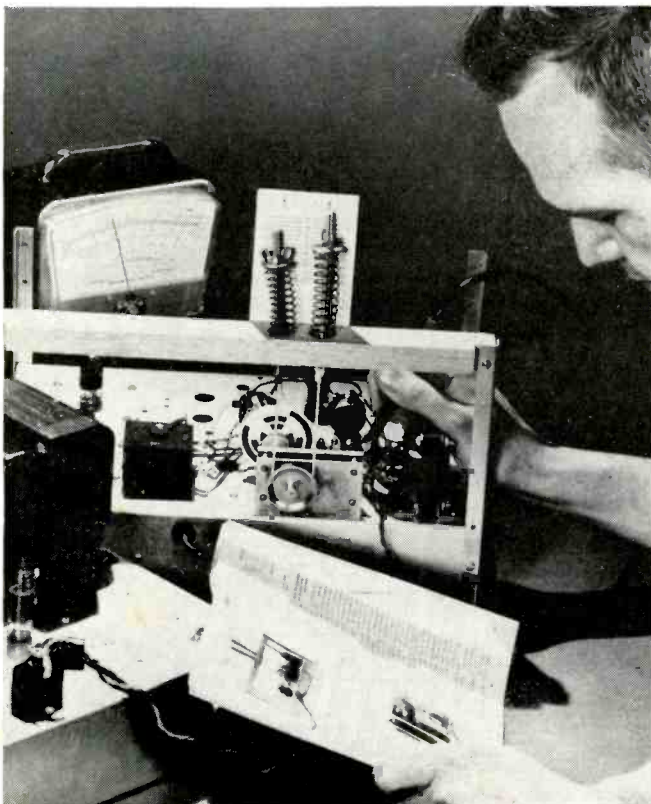

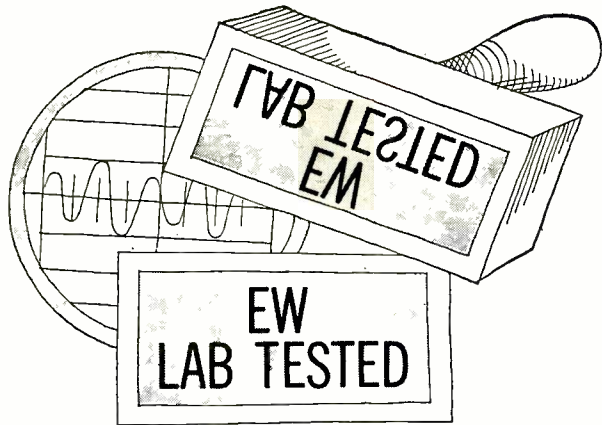

# HI-FI PRODUCT REPORT

TESTED BY HIRSCH-HOUCK LABS

**Dynaco Model 2000 Tape Recorder**  
**ADC Model 10/E Cartridge**

## Dynaco Model 2000 Tape Recorder

For copy of manufacturer's brochure, circle No. 24 on Reader Service Card.

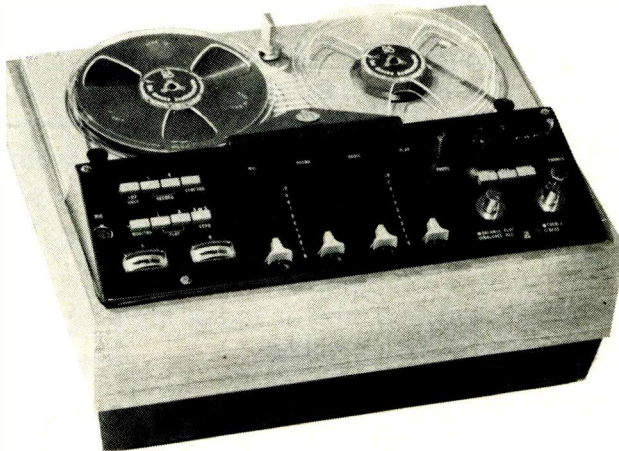

**I**N commenting on the *Dynaco Model 2000* tape recorder, space limitations prevent us from doing justice to its many unique or unusual features. This intriguing machine combines a rare simplicity of operation with an impressive capability for satisfying the most specialized requirements.

The Model 2000 is a three-speed ( $7\frac{1}{2}$ ,  $3\frac{3}{4}$ , and  $1\frac{1}{8}$  ips) machine, normally supplied with three quarter-track stereo heads, but available on special order with half-track heads. Its electronic section, which includes a pair of 8-watt playback amplifiers, is fully transistorized. It employs modular construction, which allows considerable flexibility in adapting it to unusual applications. Most of the electronic circuits are on nine plug-in printed boards. This not only allows considerable flexibility in adapting the recorder to special uses, but facilitates servicing in that repair can be as simple as plugging in a spare board and returning the defective board to *Dynaco* for replacement.

Perhaps the most distinctive feature of the recorder is its sliding level controls for microphone, phono, and radio inputs and master playback level. Each slide potentiometer is a dual-section stereo unit, with an exceptionally smooth and positive action. At a glance one can tell the relative levels of the in-

put controls, and the three inputs can be simultaneously mixed or faded as desired.

Channel balance in recording and playback is handled by a pair of concentric balance controls. Due to the excellent tracking of the stereo level potentiometers, the balance controls do not ordinarily have to be reset when changing levels. The concentric bass and treble controls, which are ganged for the two channels, are effective on playback only.

The inputs and outputs of the recorder are duplicated in both European (Hirschmann) connectors and standard American phono jacks and screw-type terminal strips. A stereo-headphone jack is on the inclined front panel. Three

push-on, push-off buttons control the two pairs of speaker outputs and add loudness compensation to the playback amplifiers. Either or both sets of speakers may be switched on independently, or both turned off for headphone listening or monitoring.

In its standard form, the recorder has an RIAA-equalized phono preamplifier module for recording directly from a magnetic cartridge. This is convenient for dubbing records onto tape, or when using the recorder as part of a low-powered music system. The high-gain microphone preamplifiers, unlike those in most home recorders, have built-in input transformers and operate with low-impedance microphones of 200 ohm to 50 ohm impedance. The radio inputs normally have a sensitivity of 0.5 volt, but when higher sensitivity is needed, an optional high-gain board can be plugged in to give 0.1-volt sensitivity. By means of a simple plug-in board replacement, the phono input can be converted to another microphone or high-level input. In fact, any combination of three inputs is obtainable in this manner.

The transport uses a single hysteresis-synchronous motor. The tape passes over two tension arms which take up any slack occurring as a result of switching from forward to reverse, or in starting and stopping the tape. A "joystick" lever puts the tape into normal motion or into fast speeds in either direction without any spillage or over-run. There is a pause lever which starts and stops the

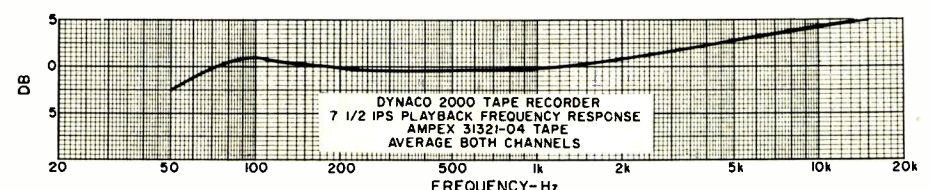
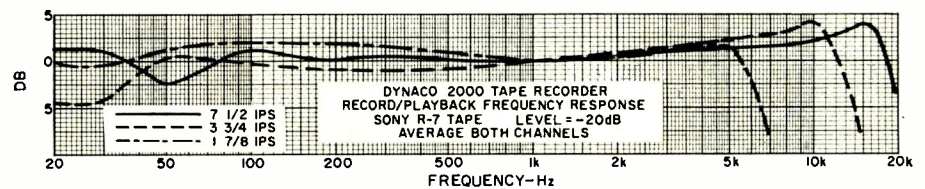

Don't just take our word for it...

# READ WHAT THE EXPERTS HAVE TO SAY ABOUT THE NEW **knight-kit** TAPE DECK



### Excerpts from Hirsch-Houck Laboratories

### Equipment Test Report in July, 1966

### HI FI/STEREO REVIEW:

"Until quite recently, it was rare to find a tape recorder selling for less than \$400 to \$500 that could record and play back an FM radio broadcast with such fidelity that it could not be distinguished from the direct broadcast. The Knight-Kit KG-415 satisfies this requirement of a true hi-fi tape recorder, yet costs only \$249.95.

Wow and flutter, 0.02 and 0.09 per cent, respectively, at 7 1/2 ips, were negligible and significantly bettered the Knight rating of 0.2 per cent. The KG-415 worked flawlessly, producing recordings which at normal listening levels could not be distinguished from the original FM program. Other recorders can do this, too, but they generally cost \$500 or more. The Knight KG-415 is, without a doubt, one of today's best values in tape recorders. It is made to order for the hobbyist on a budget who will not compromise his quality standards."

### From April, 1966 AMERICAN RECORD GUIDE:

"At \$249.95 FOB Allied Radio in Chicago, this recorder is not inexpensive. Still, I think it is remarkably cheap considering what it is and what it provides in the way of features and qualities.

It took me 14 leisurely hours to build the unit—start to finish . . .

Right off the bat, this kit performed right up to, or better than, all its specifications. I am jaded enough not to impress easily, but this got to me.

It all comes down to this in the end: the test bench indicates that this KG-415 should sound good. And it does."

### From January, 1966 AUDIO:

"This is a kit which is a perfect delight to profile for two reasons—it was a pleasure to construct it, and it performed so well after it was completed.

At the relatively low price of \$249.95 plus some 20 hours of pleasurable work, we think the KG-415 is an excellent buy."

### From March, 1966 ELECTRONICS ILLUSTRATED:

"When the job is complete the builder has a deck of unquestioned high quality with all the functions and conveniences of a professional model. A comparable factory-wired deck would cost upwards of \$400.

The instruction manual is well done, being logical and easy to follow.

Our KG-415 met or exceeded all Knight's specs."

### From March, 1966 POPULAR SCIENCE:

"Judging by the almost flawless way it records and reproduces sound, the Knight-Kit KG-415 stereo tape deck costs a full third less than it's worth."

## Knight-Kit 4-Track Stereo Tape Deck With Solid-State Stereo Record-Playback Preamp

Unmatched performance, quality and value! And so easy to build, too. You need only follow simple, illustrated, step-by-step instructions to assemble six solid-state plug-in modules. The Viking tape transport, built to Knight-Kit specs, is completely preassembled. When you complete your Knight-Kit Tape Deck you'll enjoy stereo of unsurpassed realism, plus monophonic sound of highest fidelity . . . plus many features found only on professional quality decks: Separate monitor switch with monitor-level controls, mixing facilities, exclusive low impedance stereo headphone amplifier module, bias test oscillator, switch-selected sound-on-sound and echo, push-to-reset digital counter for quick indexing of recorded selection, easy-edit head cover, studio-type VU meters for accurate control of record and playback on each channel, and more.

Complete with all parts, instructions and 7" take-up reel (less base and tape) . . . . . **\$249.95**

Read the unique money-back guarantee below . . . exclusive in the industry . . . then rush the coupon at right for full details and Special Introductory Offer.

**KNIGHT-KIT GUARANTEE**

Build a Knight-Kit in accordance with our easy-to-follow instructions. When you have completely assembled the kit, you must be satisfied or we will return your money, less transportation charges, under the Allied guarantee of satisfaction.

**ALLIED RADIO**

**ALLIED RADIO, Knight-Kit Div.**  
 Dept. 1-JJ, P.O. Box 4398  
 Chicago, Illinois 60680

Please rush Special Introductory Offer on the Knight-Kit KG-415 Tape Deck.

Name \_\_\_\_\_ PLEASE PRINT  
 Address \_\_\_\_\_  
 City \_\_\_\_\_ State \_\_\_\_\_ Zip \_\_\_\_\_

# WHY risk your reputation with "just-as-good" capacitors?

When you pay little or no attention to quality in tubular replacement capacitors, you leave yourself wide open for criticism of your work . . . you risk your reputation . . . you stand to lose customers. It just doesn't pay to take a chance on capacitors with unknown or debatable performance records when it's so easy to get guaranteed dependable tubulars from your Sprague distributor!

## There's no "maybe" with these 2 great SPRAGUE DIFILM<sup>®</sup> TUBULARS!

The ultimate in tubular capacitor construction. Dual dielectric . . . polyester film and special capacitor tissue . . . combines the best features of both. Impregnated with HCBX<sup>®</sup>, an exclusive Sprague synthetic hydrocarbon material which fills every void in the paper, every pinhole in the plastic film *before it solidifies*, resulting in a rock-hard capacitor section . . . there's no oil to leak, no wax to drip. Designed for 105°C (220°F) operation without voltage derating.

### DIFILM<sup>®</sup> ORANGE DROP<sup>®</sup> Dipped Tubular Capacitors



A "must" for applications where only radial-lead capacitors will fit . . . the perfect replacement for dipped capacitors now used in many leading TV sets. Double-dipped in rugged epoxy resin for positive protection against extreme heat and humidity. No other dipped tubular capacitor can match Sprague Orange Drops!



### DIFILM<sup>®</sup> BLACK BEAUTY<sup>®</sup> Molded Tubular Capacitors

The world's most humidity-resistant molded capacitors. Tough, protective outer case of non-flammable molded phenolic . . . cannot be damaged in handling or installation. Black Beauty Capacitors will withstand the hottest temperatures to be found in any TV or radio set, even in the most humid climates.

For complete listings, get your copy of Catalog C-616 from your Sprague distributor, or write to Sprague Products Company, 51 Marshall Street, North Adams, Massachusetts.

WORLD'S LARGEST MANUFACTURER OF CAPACITORS

**SPRAGUE<sup>®</sup>**  
THE MARK OF RELIABILITY

tape instantly without disengaging the recording interlocks. The index counter has a push-button to reset to zero. Recording and playback levels are monitored by two illuminated meters, which are red when recording. The transport shuts off automatically when the tape runs out or at any time desired when a strip of conducting foil is spliced onto the tape.

The true flexibility of the recorder lies in the eight push-button controls at the left side of the panel. One of them turns on the amplifiers independent of the transport for use as a phono- or radio-playback system. Another connects the playback amplifiers either to the incoming signal or to the playback heads for monitoring from the tape. Two others control the playback function in a simple, yet highly effective manner. With both buttons up, the mixed channels go to both speakers; with both down, each channel feeds its own speaker for stereo playback. Pushing down either one singly connects that channel to both speakers.

Two other buttons control the recording function for the two channels. One or both must be depressed while placing the tape in motion in order to record and they are released when tape motion is stopped so that accidental erasure is impossible. The "Echo" button feeds back the output of the playback heads to the recording amplifiers for an echo or reverberation effect. It is also useful for making sound-on-sound recordings (mono only) in which one channel is copied onto the other, together with a new program.

A unique feature is the synchro playback using the eighth control button. This plays back one channel into the monitor phones, using the normal record head for playback. By listening to the left channel, a program can be recorded on the right channel in exact synchronism with the left channel, since the usual delay between record and playback heads is eliminated. With an accessory, a pulse may be recorded on the right channel to operate an automatic slide-changing mechanism in synchronism with the left-channel program.

We measured the over-all 7½ ips record/playback frequency response as an excellent 20 to 20,000 Hz, ±3 dB. At 3¾ ips it was 20 to 15,000 Hz, ±5 dB and at 1½ ips it was 20 to 6000 Hz, ±2 dB. The latter response is considerably better than AM-radio quality and is well suited to background-music applications as well as speech recording.

The 7½-ips playback response, using the Ampex 31321-04 test tape, was flat from 70 to 2000 Hz, rising gradually to +5 dB at 15,000 Hz and falling to -2.5 dB at 50 Hz. Other test tapes show somewhat different playback response. Such response can be optimized by ad-

# How The New Heath DC Triggered-Sweep Oscilloscope Up-Dates The Value Standards For All Lab Oscilloscopes

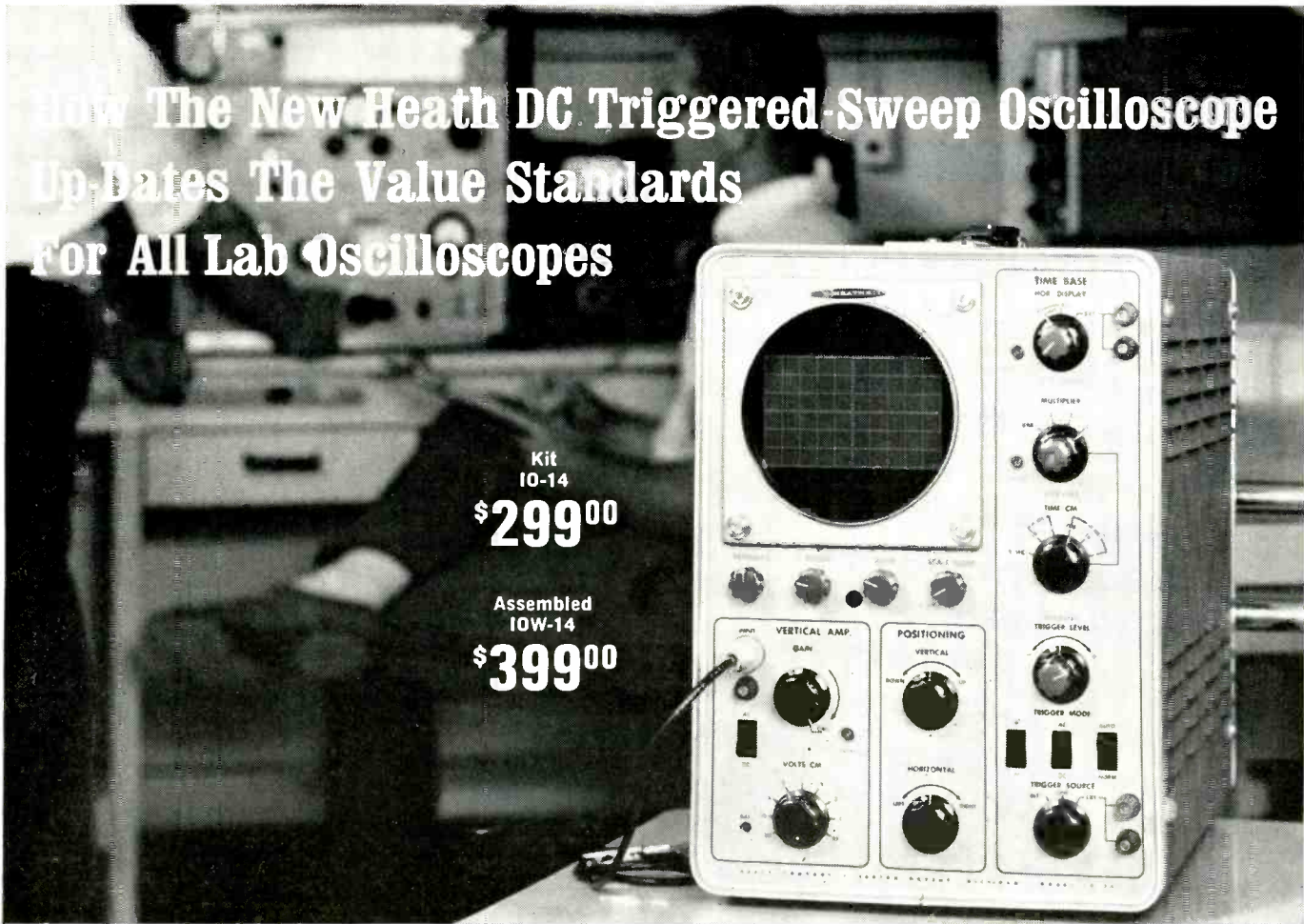

Kit  
IO-14  
**\$299<sup>00</sup>**

Assembled  
IO-14  
**\$399<sup>00</sup>**

**THE NEW HEATH IO-14 OSCILLOSCOPE OFFERS TRULY SOPHISTICATED CAPABILITIES.** It features a high-quality flat-face 5" CRT with an accurately-ruled 6 x 10 cm graticule • DC to 8 MHz bandwidth with 40 nanosecond rise time • 0.25 microsecond vertical signal delay through high-linearity delay line circuitry • 3% calibrated vertical attenuation — from 0.05 v/cm to 20 v/cm • 3% calibrated time base — from 0.2 microseconds/cm to 0.5 seconds/cm • Forced air cooling for the toughest industrial applications • Input for Z axis modulation • Input for direct access to vertical deflection plates • Highly-stable fiberglass circuit board construction • Wiring options for 115/230 volt, 50-60 hertz operation • The IO-14 is designed with modern circuitry, engineered with high-quality close-tolerance components, and capable of satisfying the most critical demands upon its performance specifications.

**THE HEATH IO-14 INCLUDES ENGINEERING FEATURES YOU EXPECT ONLY IN HIGH-PRICED OSCILLOSCOPES.** For example, switches are ball-detent type; all major control potentiometers are precision high-quality sealed components; all critical resistors are 1% precision; and vertical signal delay is provided through precision coaxial delay lines — circuitry considered by all knowledgeable electronic engineers to be the most desirable for high linearity and maximum frequency response.

**THE HEATH IO-14 PROVIDES THE ULTRA-STABLE LOW-NOISE PERFORMANCE DEMANDED FOR TRULY PROFESSIONAL INDUSTRIAL, ACADEMIC, ELECTRONICS-ENGINEERING, AND BIO-MEDICAL REQUIREMENTS.** Here's what engineer Adam L. Keller of Swiss Controls & Research Inc., Michigan City, Indiana says about the IO-14: *"May I take this opportunity to congratulate your company on the fine job you have done on your new IO-14 oscilloscope kit. In my opinion there is not a scope on the market which can compare with your fine new product, at least until you start talking 4 or 5 times the price. We are most satisfied with the instrument in every respect ... your IO-14 is probably the finest kit you have ever put on the market, bar none."* **WE AT HEATH AGREE.**

Kit IO-14 (with standard P-2 phosphor), 53 lbs. \$299.00  
Assembled IO-14 (P-2 phosphor), 47 lbs. \$399.00  
Assembled IO-14S (with long persistence P-7 phosphor for bio-medical or industrial use), 47 lbs. \$410.00  
Kit PK-1, Low-Capacitance Probe, 1 lb. \$4.95

**IO-14 SPECIFICATIONS—(Vertical) Sensitivity:** 0.05 v/cm AC or DC. **Frequency response:** DC to 5 mc, -1 db or less; DC to 8 mc, -3 db or less. **Rise time:** 40 nsec (0.04 microseconds) or less. **Input impedance:** 1 megohm shunted by 15 uuf. **Signal delay:** 0.25 microsecond. **Attenuator:** 9-position, compensated, calibrated in 1, 2, 5 sequence from 0.05 v/cm. **Accuracy:** ±3% on each step with continuously variable control (uncalibrated) between each step. **Maximum input voltage:** 600 volts peak-to-peak; 120 volts provides full 6 cm pattern in least sensitive position. **(Horizontal) Time base:** Triggered with 18 calibrated rates in 1, 2, 5 sequence from 0.5 sec/cm to 1 microsecond/cm with ±3% accuracy or continuously variable control position (uncalibrated). **Sweep magnifier:** X5, so that fastest sweep rate becomes 0.2 microseconds/cm with magnifier on. (Overall time base accuracy ±5% when magnifier is on.) **Triggering capability:** Internal, external, or line signals may be switch selected. Switch selection of + or - slope. Variable control on slope level. Either AC or DC coupling. "Auto" position. **Triggering requirements:** Internal; ½ cm to 6 cm display. External: 0.5 volts to 120 volts peak-to-peak. **Horizontal input:** 1.0 v/cm sensitivity (uncalibrated) continuous gain control. Bandwidth: DC to 200 kc ±3 db. **General:** 5ADP81 or 5ADP2 Flat Face C.R.T. interchangeable with any 5AD or 5AB series tube for different phosphor characteristics. 4250 V. accelerating potential. 6 x 10 cm edge lighted graticule with 1 cm major divisions & 2 mm minor divisions. **Power supply:** All voltages electronically regulated over range of 105-125 VAC or 210-250 VAC 50/60 cycle input. (Z Axis) Input provided. DC coupled CRT blanking for complete retrace suppression. **Power requirements:** 285 watts. 115 or 230 VAC 50-60 Hz. **Cabinet dimensions:** 15" H x 10½" W x 22" D includes clearance for handle and knobs. **Net weight:** 40 lbs.



## FREE! 1967 Heathkit Catalog

108 pages ... many in full color ... describe over 250 Heathkits for the lab, hobbyist, and industry.

**HEATH COMPANY, Dept. 15-9**  
Benton Harbor, Michigan 49022

Please send more information on \_\_\_\_\_ (product)

Name \_\_\_\_\_

Address \_\_\_\_\_

City \_\_\_\_\_ State \_\_\_\_\_ Zip \_\_\_\_\_

Prices & Specifications subject to change without notice. TE-150

# now there are 3 time & tool-saving double duty sets

New PS88 all-screwdriver set rounds out Xcelite's popular, compact convertible tool set line. Handy midgets do double duty when slipped into remarkable hollow "piggyback" torque amplifier handle which provides the grip, reach and power of standard drivers. Each set in a slim, trim, see-thru plastic pocket case, also usable as bench stand.



**PS88**

5 slot tip,  
3 Phillips screwdrivers



**PS120**

10 color  
coded nutdrivers

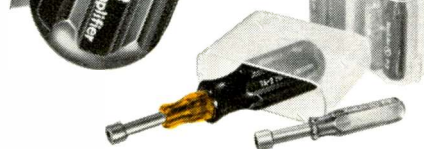

**PS7**

2 slot tip,  
2 Phillips screwdrivers,  
2 nutdrivers

WRITE FOR CATALOG SHEET N563



XCELITE, INC., 12 Bank St., Orchard Park, N.Y., U.S.A.  
Canada: Charles W. Pointon, Ltd., Toronto, Ont.

CIRCLE NO. 85 ON READER SERVICE CARD

justing the bias current, if desired, for any particular tape that will be used. The signal-to-noise ratio was 49 dB at the two faster speeds and 44 dB at 1½ ips. The noise was all hiss (and not much of that), with no audible hum. Tape speeds were exact, and the wow was literally unmeasurable, less than 0.01%. Flutter was 0.1% at 7½ ips with the Ampex 31326-04 tape.

Using the amplifier only, the frequency response was 20 to 20,000 Hz, ±3 dB. RIAA phono equalization was ±1.5 dB from 30 to 15,000 Hz. The power amplifiers delivered slightly under 5 watts per channel to 8-ohm loads at 2% distortion over most of the audio range. At lower impedances, power output would have been higher. Power bandwidth was well in excess of 20 to 20,000 Hz.

In operation, the recorder was as

smooth and easy to handle as any recorder we have used. Every function worked perfectly and the sound quality left nothing to be desired. Unlike most recorders with built-in power amplifiers, this unit can deliver really good, clean sound with any moderately efficient speaker system. If one does not try to make the rafters ring, it is hard to believe that this is such a low-powered amplifier. Dynaco does not claim that it is a "high-fidelity" audio amplifier, but it certainly does a creditable job as one, with tuner and phono inputs as well as when playing tapes.

Considering all aspects of good engineering, tasteful design and appearance, and over-all performance, the Model 2000 has few peers. It is priced at \$498 on a walnut base with plastic dust cover or \$525 in a portable case with two detachable monitor speakers. ▲

## ADC Model 10/E Cartridge

For copy of manufacturer's brochure, circle No. 25 on Reader Service Card.

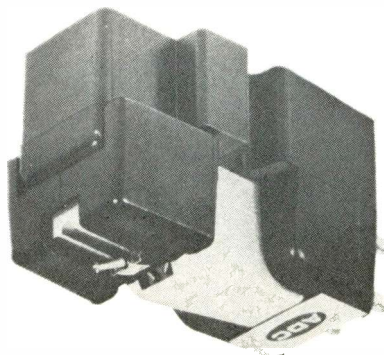

ated to a minimum effects a corresponding reduction in record wear, with attendant advantages in distortion-free reproduction of high frequencies.

The new ADC 10/E cartridge, according to its manufacturer, has one-third the moving mass of any other magnetic cartridge. This is partially due to the use of a very small elliptical diamond stylus, with radii of 0.3 and 0.7 mil, and partially to the so-called "induced magnet" design of the manufacturer's latest cartridges.

The stylus cantilever is a very small, rigid, non-ferrous tube, with the jewel at one end and a small soft iron armature at the other (pivoted) end. The magnet and coils are embedded in the plastic body of the cartridge and the armature pivoting close to the ends of the pole pieces modulates the flux to generate an electrical output.

The stylus assembly is easily removed  
(Continued on page 77)

IT is generally agreed that one of the areas in which phono cartridges are most susceptible to improvement is in the reduction of moving mass. Tiny though the jewel tip and moving system of a cartridge may be, it nevertheless must be accelerated and its motion reversed up to 20,000 times per second, with all the work required for this being supplied by the record groove wall. Reducing the mass which must be acceler-

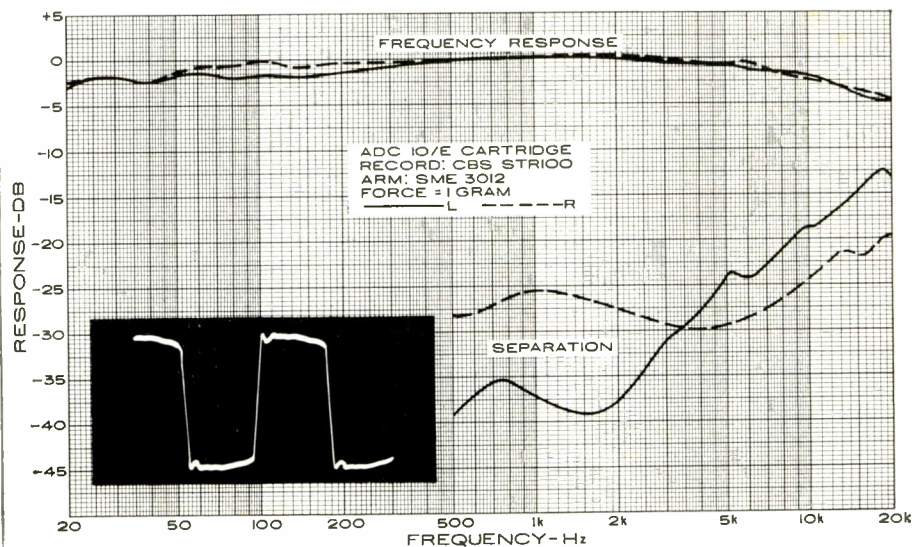





## Now instant movies in sound start at \$695.

The new Sony Videocorder deck (model CV-2000D) is both compact and versatile. It's also quite reasonably priced, \$695.

It's just like current Sony Videocorder models, but without the built-in TV monitor. Using a separate monitor or TV set, you can tape selected TV programs off-the-air. Add the optional Sony TV camera and you can tape "live" action in sight and sound. Play back your tape, and you'll see instant movies in sound.

This new deck is small enough to fit on a bookshelf, as a part of your hi-fi component system. Light enough (only 44 lbs.) to take wherever you want it to perform. Adaptable enough to use with any TV monitor, small or large screen (the new Sony 8"-inch and 22"-inch receiver/monitors are perfect mates). It can be adapted to work with most home TV sets. Handsome too, in walnut-finish cabinet.

Looking for a Videocorder with its own built-in monitor? Then meet the rest of the Sony Videocorder family. TCV-2010 complete in its own carrying case, \$995. The TCV-2020, handsome oil-finish walnut cabinet and with built-in timer to automatically tape TV programs while you're away, \$1150. For taping "live" action, there is the Video Camera Ensemble VCK-2000 (camera, elevator tripod, microphone) at \$350. For an unforgettable demonstration visit your Sony Videocorder dealer today. For free 16-page booklet write:

**SONY**® Corp. of America, 47-37 Van Dam St., Long Island City, N.Y. 11101 Dept. H

\*diagonal measurement. The Videocorder is not to be used to record copyrighted material. Sony and Videocorder are registered trademarks of the Sony Corp. All prices suggested list.

**“Get more  
education  
or  
*get out of  
electronics***

**...that's my advice.”**

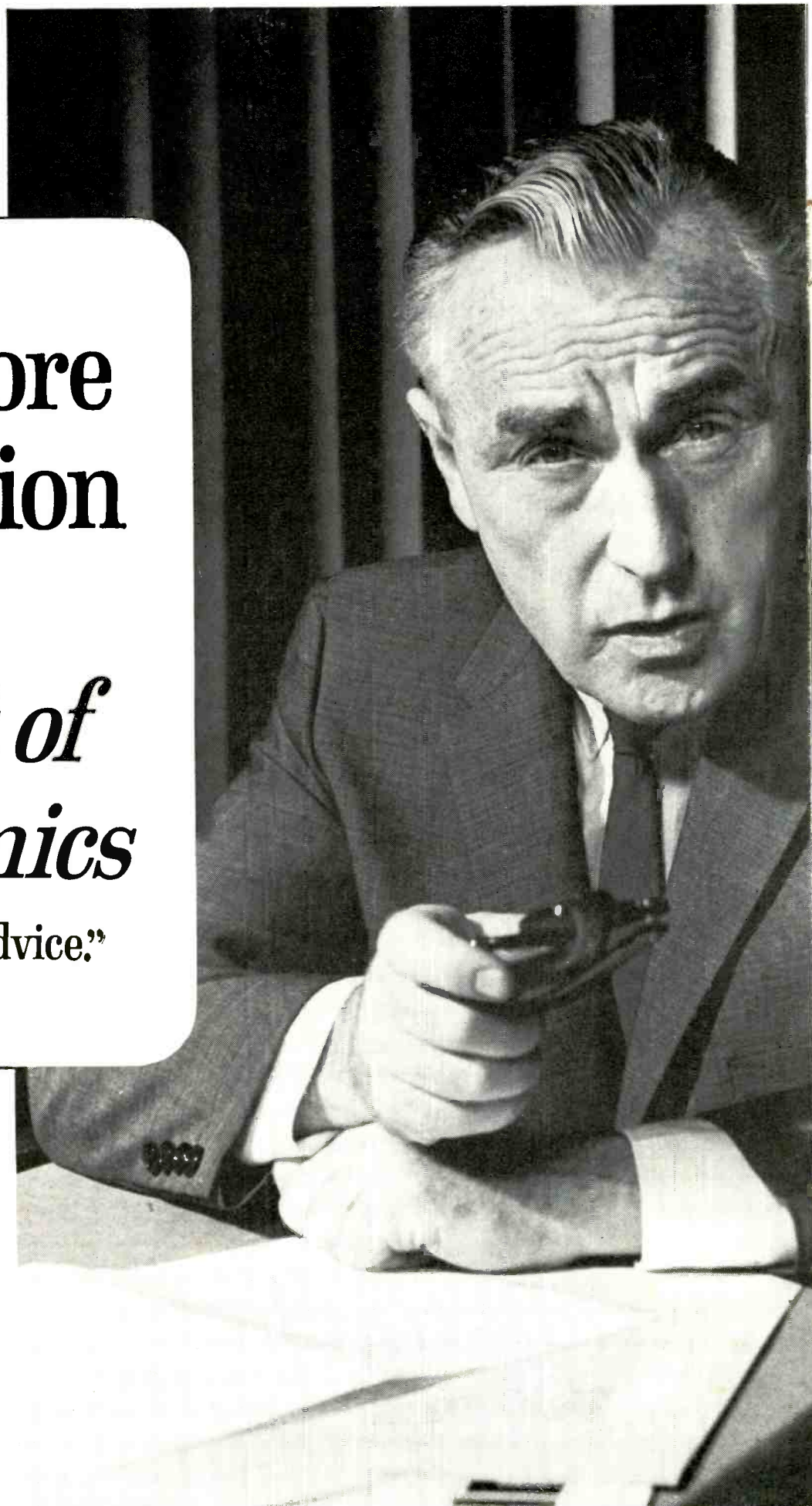



**NOW! 2 NEW PROGRAMS!**  
 ● Industrial Electronics for Automation  
 ● Computer Systems Technology

**Ask any man who really knows the electronics industry.** Opportunities are few for men without advanced technical education. If you stay on that level, you'll never make much money. And you'll be among the first to go in a layoff.

But, if you supplement your experience with more education in electronics, you can become a specialist. You'll enjoy good income and excellent security. You won't have to worry about automation or advances in technology putting you out of a job.

How can you get the additional education you must have to protect your future—and the future of those who depend on you? Going back to school isn't easy for a man with a job and family obligations.

CREI Home Study Programs offer you a practical way to get more education without going back to school. You study at home, at your own pace, on your own schedule. And you study with the assurance that what you learn can be applied on the job immediately to make you worth more money to your employer.

You're eligible for a CREI Program if you work in electronics and have a high school education. Our FREE book gives complete information. Airmail postpaid card for your copy. If card is detached, use coupon below or write: CREI, Dept. 1109D, 3224 Sixteenth Street, N.W., Washington, D.C. 20010.



**The Capitol Radio Engineering Institute**

Dept. 1109D, 3224 Sixteenth Street, N.W., Washington, D.C. 20010

Please send me FREE book describing CREI Programs. I am employed in electronics and have a high school education.

NAME \_\_\_\_\_ AGE \_\_\_\_\_

ADDRESS \_\_\_\_\_

CITY \_\_\_\_\_ STATE \_\_\_\_\_ ZIP CODE \_\_\_\_\_

EMPLOYED BY \_\_\_\_\_

TYPE OF PRESENT WORK \_\_\_\_\_  GI BILL

- I am interested in  Electronic Engineering Technology.  
 Space Electronics  Nuclear Engineering Technology  
 **NEW! Industrial Electronics for Automation**  
 **NEW! Computer Systems Technology**

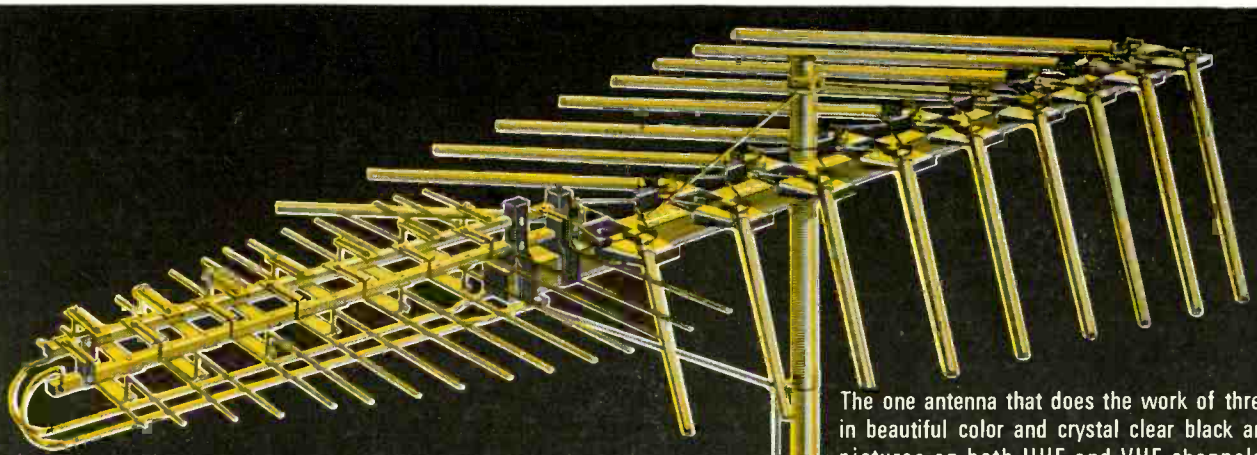

FINCO ALL-BAND UHF-VHF-FM ANTENNA  
75 OHM Model CX-UVF-24 \$72.10 List  
FINCO ALL-BAND UHF-VHF-FM ANTENNA  
300 OHM Model UVF-24 \$59.95 List

The one antenna that does the work of three! Pulls in beautiful color and crystal clear black and white pictures on both UHF and VHF channels... plus the finest stereophonic and monophonic FM sound reproduction.  
300-ohm models for normal reception areas from \$18.50 to \$59.95  
75-ohm models for poor reception areas from \$42.65 to \$72.10

# FINCO

*introduces* / 75-ohm COLOR VE-LOG ANTENNAS  
FOR UHF-VHF-FM RECEPTION

Finco's Swept-Element Antenna challenges all competition. Its unique design assures the finest color and black and white TV reception—plus superb FM and FM Stereo tone quality.  
300-ohm models for normal reception areas from \$16.95 to \$54.50  
75-ohm models for poor reception areas from \$18.55 to \$62.80

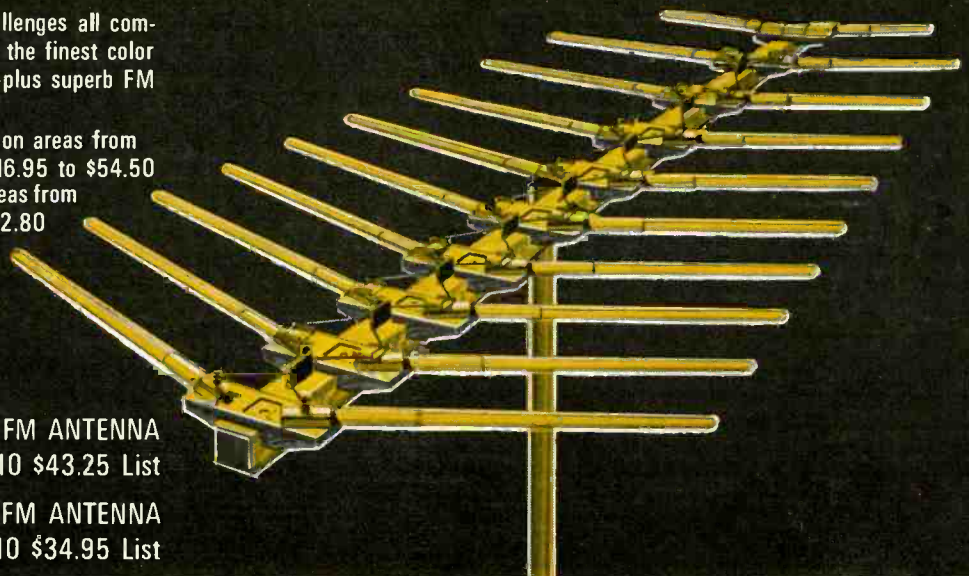

FINCO SWEPT-ELEMENT VHF-FM ANTENNA  
75 OHM Model CXVL-10 \$43.25 List  
FINCO SWEPT-ELEMENT VHF-FM ANTENNA  
300 OHM Model VL-10 \$34.95 List

**FREE!** ALL FINCO CX-VL, CX-UVF AND UVF ANTENNAS COME WITH A FREE INDOOR SET-MOUNTED TRANSFORMER, VHF-UHF TRANSFORMER SPLITTER OR VHF-UHF SPLITTER.



**THE FINNEY COMPANY**

34 WEST INTERSTATE STREET, DEPT. 410, BEDFORD, OHIO

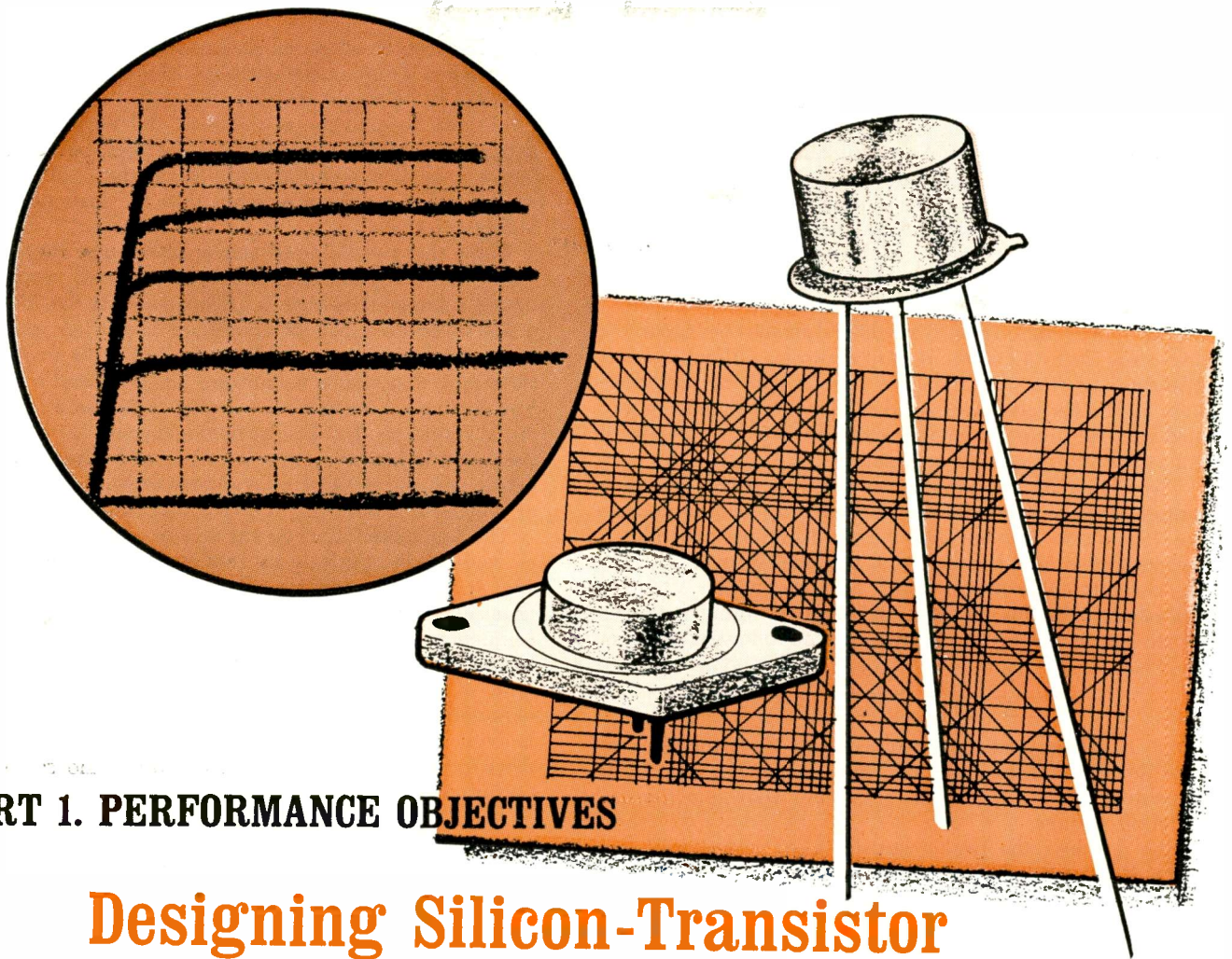

## PART 1. PERFORMANCE OBJECTIVES

# Designing Silicon-Transistor Hi-Fi Amplifiers

*Silicon power transistors now available offer a number of advantages for power output and driver stages. This series of three articles covers the considerations for conservative design and the performance of three practical hi-fi circuits.*

By R. D. GOLD and J. C. SONDERMEYER  
RCA Electronic Components & Devices

**S**ILICON power transistors that are now available offer many advantages when used in the power-output and driver stages of high-power audio amplifiers, as well as in applications such as servomechanism control systems and high-power ultrasonic generators. This three-part series explains the advantages of using such transistors in high-quality audio systems designed to deliver tens of watts of audio output power and to operate over a wide range of ambient temperatures. The discussion will deal primarily with the power-amplifier and driver stages of such systems and it is assumed that the input to these cascaded stages is obtained from a suitable voltage amplifier which provides up to 1 milliwatt of driving power, at a 1-volt level, with little distortion over the desired frequency range.

The basic design objectives for high-quality audio amplifiers are discussed in terms of power output, frequency response, distortion levels, and other major performance requirements. The characteristics and capabilities of various output and driver stage configurations are compared to determine the optimum type of circuit for a given application while consideration is given to the conservative design of high-quality audio output and driver stages. Circuit configurations and

performance data are shown for 10-watt, 25-watt, and 70-watt audio amplifiers that employ silicon power transistors.

The quality of an audio power amplifier is determined by its ability to provide high-fidelity reproduction of audio program material over the full range of audible frequencies. The amplifier is required to increase the power level of the input to a satisfactory output level with little distortion, and the sensitivity of its response to the input signals must remain essentially constant throughout the audio-frequency spectrum. Moreover, the input-impedance characteristics of the amplifier must be such that the unit does not load excessively and thus adversely affect the characteristics of the input-signal sources. The following paragraphs outline the design objectives for high-quality audio amplifiers with respect to these important performance characteristics.

### Power-Output Capability

The amount of output power that an audio amplifier is required to develop is primarily a function of the dimensions of the room in which the unit is to be used, of the size and efficiency of the loudspeaker, and of the maximum distortion that can be tolerated at high sound levels. In general, the

efficiencies of loudspeakers vary from a few percent for typical high-quality dynamic speakers down to only a few tenths of a percent for acoustic-suspension types. In typical residential-size rooms, the amplifier is required to deliver an average electrical power of several tenths of a watt to dynamic speakers at normal listening levels. Acoustic-suspension speakers, however, have a much lower transducer efficiency and may require several watts of electrical input power to produce the same sound intensity. Because high-intensity transient sounds (*e.g.*, those produced by percussion instruments) may exceed normal listening levels by a factor of ten or more, high-quality amplifiers should be capable of delivering 20 to 40 watts of output power without excessive distortion so that the transient sounds will be reproduced fully by the low-efficiency speaker. For less stringent requirements or for higher efficiency speakers, a 5- to 15-watt output capability is usually adequate.

The ability of an amplifier to supply a given amount of output power is dependent upon the loudspeaker impedance, the breakdown voltage and current-handling capability of the transistors, and the ability of the transistors to withstand the currents and voltages which may exist under all operating conditions. For all cases of practical interest, the amplifier output power,  $P_o$ , is given by the following equation:

$$P_o = \frac{I_p^2 R_L}{2} = \frac{V_p^2}{2R_L} = \frac{V_{c(max)}^2}{8R_L}$$

where  $I_p$  is the peak transistor current,  $V_p$  is the peak voltage developed across the load impedance,  $R_L$ , seen by the transistor, and  $V_{c(max)}$  is the maximum allowable transistor collector voltage.

Fig. 1 shows the peak transistor current and peak transistor load voltage required to deliver a specified output power into the load impedance seen by the transistor. The curves are idealized in that the transistor saturation voltage is neglected. The transistor breakdown voltage rating must be at least twice the peak load voltage. The vertical lines denoting 4-ohm, 8-ohm, and 16-ohm resistances are particularly useful for transformerless designs, where the transistor works directly into the loudspeaker.

It is apparent from the equation that, for a given amount of output power, a high value of load impedance will require a larger voltage capability and lower current capability than is required with a low value of load impedance. Transformer-coupled output stages are frequently used to provide an optimum impedance match between the output transistors and the speaker load impedance. However, the advent of high-current power transistors which are highly resistant to failure because of *second breakdown* has made possible the design of reliable circuits without using transformer-coupled outputs.

(Second breakdown is not a voltage breakdown, but rather an electrically and thermally regenerative process in which current is focused in a very small area. The very high current, together with the voltages across the transistor, cause a localized heating that may melt a minute hole from the collector to the emitter of the transistor and thus cause a short circuit. This regenerative process is not initiated unless certain high voltages and currents are coincident for certain finite lengths of time.)

Irrespective of how the amplifier is coupled to the load impedance, the dissipation rating of the output-stage transistors must be adequate for the maximum levels in the particular circuit configuration used. In class-A amplifiers, maximum dissipation occurs when no input signal is applied; in class-B push-pull amplifiers, however, the dissipation is maximum at 42 percent of the maximum output. In addition to an adequate thermal-dissipation capability, the transistors must be able to withstand worst-case conditions of voltage and current to avoid failure from second breakdown. The worst-case operating levels for the transistors

usually occur under conditions of high line voltage, at high volume levels, and at the extremes of the amplifier frequency range (*i.e.*, below 20 Hz and above 20 kHz). The operating conditions become more severe at the frequency extremes because the speaker impedances are then substantially different from their nominal value. Transistor load lines plotted under such conditions indicate that the load impedance is highly reactive.

From the viewpoint of power-dissipation rating, current and voltage capabilities, and freedom from second breakdown, a homotaxial-base transistor such as the 2N3055 appears to be an excellent choice for use in an audio output stage. Such transistors are constructed by a single-diffused technique that results in uniform junctions and a base structure having a homogeneous resistivity in the axial direction. As a result of the axially homogeneous (homotaxial) resistivity, the base structure is free from built-in axial electric fields, and the risks of second breakdown and other causes of electrical failure are thereby substantially reduced.

The main limitation on the use of the 2N3055 transistor in such applications is its moderate frequency capability. This transistor provides a gain-bandwidth product of 1 MHz at a collector current of 3 amperes; at high power levels, a frequency response that is flat within 1 dB at frequencies up to 25 kHz can be achieved. An increase in the upper limit of the frequencies for which a flat response can be obtained from the 2N3055 transistor requires a substantial amount of negative feedback. A significant increase in the drive power is then required to obtain the same level of output power.

### Frequency Response

The audio-frequency range is generally considered to include those frequencies between 16 Hz and 22,000 Hz. At normal listening levels, the perception range of the average listener, however, is only from about 50 to 14,000 Hz. Moreover, the frequency response of even the best quality loudspeaker systems is usually limited to about 30 to 18,000 Hz and for most typical high-fidelity speaker systems the response range is only about 60 to 12,000 Hz. These limitations indicate that an amplifier designed so that its frequency response is flat within 1 dB from 20 to 20,000 Hz is more than adequate for any high-fidelity audio system. Several advantages are obtained, however, from the use of amplifiers having a wider frequency response.

When the frequency response of the amplifier is substantially greater than the audio spectrum, the amplifier will be stable over the audio range because the phase shift of signals in this range will be negligible. It is unlikely, therefore, that the amplifier will break into audio-frequency oscillations as a result of high-level signal transients or other causes. A wide frequency response (without feedback) is also advantageous from the standpoint of transistor dissipation, because the large phase shifts that may occur when the frequency response of the output stage is poor can also lead to excessive transistor power dissipation in both the output and driver stages.

At frequencies beyond the upper limit of the flat response, the voltage gain of the output stage decreases as frequency increases. The negative feedback voltage, which is taken from the output, is also reduced. As a result, the drive signal effectively becomes larger and it is possible that the driver stages will be overloaded. For this reason, the frequency response of the output stage should be flat over the entire range of expected signal frequencies. In fact, the over-all amplifier frequency response characteristic may be deliberately rolled off at the input or driver stage to prevent such occurrences. When the output-stage transistor has a very high frequency capability, controlled roll-off at the input is still desirable to reduce the possibility of oscillation at frequencies well beyond the audio range. The effects of

amplifier frequency response on stability and dissipation are discussed in more detail in a subsequent section.

The over-all bandwidth of an audio-amplifier system is less than the bandwidth of any individual element (e.g., input transducer, preamplifier, power amplifier, or loudspeaker) in the system. The bandwidth of the power amplifier should, therefore, be substantially greater than that of any of the other components so that the effect of the amplifier on the over-all response of the system is held to a minimum. For example, if the power amplifier upper-frequency 3-dB point is 50 kHz and it is driven by a preamplifier having an upper 3-dB point of 25 kHz, the 3-dB point of the combination will occur at 22 kHz. If the 3-dB point for each stage occurs at 25 kHz, the 3-dB point for the combination will occur at 16 kHz. Moreover, the frequency response will fall off more rapidly than for either of the two amplifiers by itself. This is illustrated in Fig. 2, which shows the over-all response for a power amplifier with 3-dB frequencies at 15 Hz and 30 kHz, and a preamplifier with 3-dB points at 20 Hz and 25 kHz. The examples assume that both stages have a simple RC response characteristic (i.e., roll-off occurs at the slope of 6 dB per octave).

On the basis of the factors discussed in the preceding paragraphs, a frequency response which is flat (within 1 dB from 15 to 50,000 Hz) is a reasonable design goal for the power amplifier of a very high quality audio system. A response that is flat within 1 dB from 30 to 20,000 Hz is satisfactory for a good quality system known to be stable.

### Distortion

The principal types of distortion that must be considered in the design of high-fidelity audio power amplifiers are total harmonic distortion and intermodulation distortion. Both types result from nonlinearities in transistor characteristics and, in transformer-coupled circuits, from nonlinearities in the large-signal transformer characteristics. The amplifier does not contribute to the frequency distortion which may be introduced by other system components, such as loudspeakers, phonograph pickups, or tape pickups, provided that the frequency response of the amplifier is flat over the full audio range. Phase distortion, which may be introduced by factors such as improper placement of low- and high-frequency speakers, is not a major consideration in the design of audio power amplifiers. The ear is insensitive to the effects of the small audio-frequency phase shifts, even when the amplifier used has only moderate frequency-response characteristics.

Nonlinearities in the amplifier circuit cause harmonics of single-frequency signals to be generated. The *total harmonic distortion* is a measure of the magnitude of such harmonics in the amplifier output. If the input signal contains several frequency components, nonlinearities in the amplifier will result in mixing of the various input frequencies and of their harmonics to produce sum and difference frequencies of the mixed components. *Intermodulation distortion* is a measure of the effect of this mixing on the amplifier output.

In general, the *critical* listener can perceive a total harmonic distortion of about 0.7 percent and can tolerate about

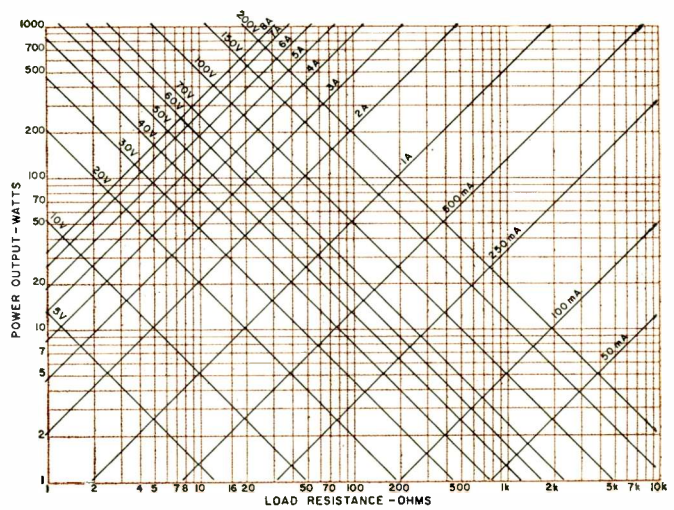

Fig. 1. Peak transistor currents and peak transistor load voltages for various output powers and load resistance values.

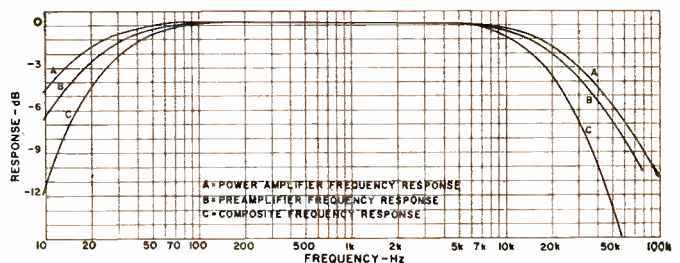

Fig. 2. The composite frequency response of the over-all audio system is poorer than the response of its poorest component.

2 percent. The levels of perception and tolerance, however, vary with the order of the harmonic, because the ear is more sensitive to the higher order harmonics. For example, it is possible that a listener may not notice 1 percent of second-harmonic distortion, but will find only 0.5 percent of fifth-harmonic distortion objectionable. Fortunately, the amplitude of the harmonic usually decreases as the order of the harmonic rises, and a total harmonic distortion of 0.5 percent is an acceptable upper limit for a class-B push-pull output stage, which suppresses even-order harmonics.

The sensitivity of the ear to intermodulation distortion is dependent upon the amplitude and the frequency of the individual signal components. A maximum of 2 percent of intermodulation distortion is satisfactory for a two-component test signal in which one component is about ten times higher in frequency and about one-quarter the amplitude of the other component (e.g., 60 and 6000 Hz mixed at an amplitude ratio of 4 to 1). The total harmonic distortion and the intermodulation distortion are both caused by amplifier nonlinearities; as a result, when one of these types of distortion is low, the other type is also low.

In common-emitter amplifiers, distortion is primarily the result of the nonlinear relationship between the base current and the base voltage (input distortion) and between the collector current and the base current (output distortion

Fig. 3. Typical transistor curves showing the nonlinearities of the input, output, and transfer characteristics.

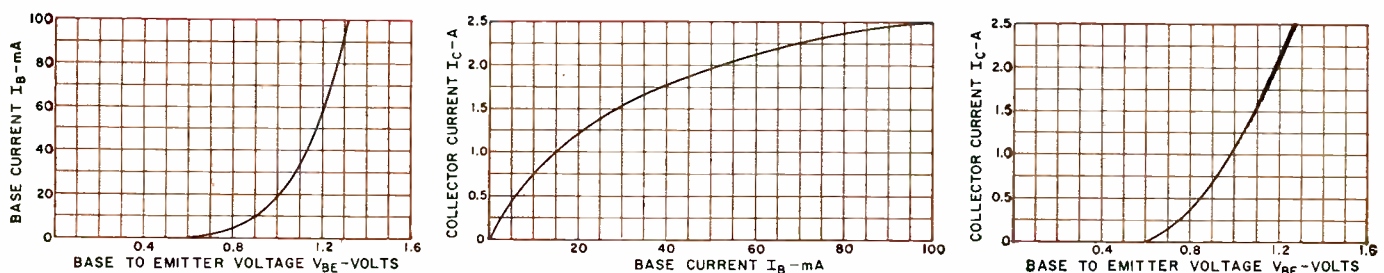

caused by nonlinear  $\beta$ ). These nonlinearities can be described in terms of the nonlinear relationship between the collector current and the base voltage (*i.e.*, nonlinear transconductance characteristics) which is useful when the driver stage has a low source impedance. Typical curves of transistor input, output, and transfer characteristics are shown in Fig. 3.

Class-B push-pull amplifiers introduce crossover distortion, which can be highly objectionable at low signal levels. This type of distortion is a result of the high degree of nonlinearity between the collector current and input voltage at low collector currents. This distortion is substantially reduced when the transistors in the push-pull stage are operated with a small quiescent current (*i.e.*, class AB).

At large signal levels, nonlinearities in transistor audio amplifiers result mainly from the dependence of the transistor  $\beta$  on both collector current and collector voltage and from signal clipping. The reduction in  $\beta$  at high collector currents is a well-known effect common to all transistors. The  $\beta$  also varies nonlinearly with collector voltage in all transistors. One advantage of the homotaxial-base family of transistors is that the dependence of  $\beta$  on collector voltage is considerably less pronounced than that in comparable diffused-base transistors. Fig. 4 compares the collector characteristics of a 2N3055 homotaxial-base transistor and a 2N3878 diffused-base transistor. The "softer" saturation characteristics of the 2N3878 transistor imply that a greater nonlinearity exists between  $\beta$  and collector voltage in diffused-base transistors than in homotaxial-base transistors.

Signal clipping occurs whenever the transistor in an am-

Fig. 4. Collector characteristics of (A) 2N3055 homotaxial transistor compared with (B) 2N3878 diffused-based transistor. In both traces the vertical scale is collector current (0.5 A/div.), the horizontal scale is collector-to-emitter voltage (1 V/div.), with four different base currents (20 mA/step).

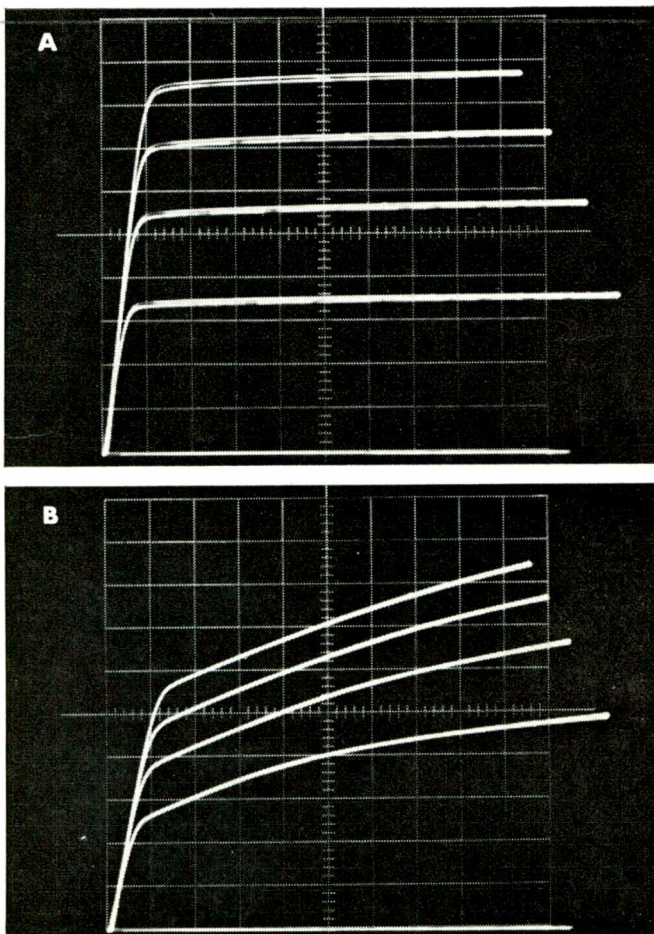

plifier stage is driven into saturation or, for class-A stages, below cut-off. In addition, distortion may be introduced in low-cost transformer-coupled amplifiers at large signal levels because of magnetic saturation of the transformer core material.

The nonlinear input and output characteristics of a transistor tend to compensate for each other over a range of collector current, as can be seen in Fig. 3. This compensatory effect results from the fact that the base current increases exponentially with base voltage and the  $\beta$  decreases rapidly at high current levels. Optimum compensation can be achieved by the addition of a resistance in series with the base to obtain maximum linearity for the output current-input voltage transfer characteristics. The disadvantage of this technique is that a larger drive voltage is required to obtain the maximum output current and that because of variations in the characteristics of transistors, even in those from the same production run, it is difficult to determine the optimum conditions for all transistors of any given type.

Negative feedback is the most common method used to reduce distortion in audio amplifiers. In general, the feedback is taken from the output and returned to the input stage. In addition, local feedback may be employed in each stage. The amount of over-all feedback required is determined by the performance and stability objective for the amplifier. With negative feedback, the distortion can be reduced, under some conditions, to 0.1 percent or lower. An additional advantage of the negative feedback is that the output impedance of the amplifier can be reduced to a fraction of an ohm to obtain a high loudspeaker damping factor (*i.e.*, ratio of loudspeaker impedance to amplifier source impedance).

A disadvantage of the feedback is that a larger input signal is required to obtain the rated output. Moreover, when local feedback is used in a stage, steps must be taken to insure that the reduction in distortion in this stage is not offset by increased distortion in the stage that drives it because of the larger signal that the driving stage is required to supply. The feedback also either increases or decreases the input impedance of the amplifier, depending upon whether it is returned to the emitter or to the base of the common-emitter input stage that is used.

#### Input Impedance

In general, the input impedance of an audio power amplifier must be high enough so that the characteristics of the preamplifier in the system are not adversely affected. If the input impedance of the power amplifier is too low, the output coupling capacitor of the preamplifier (for resistance-capacitance-coupled stages) may have to be excessively large so that the low-frequency response of the system will not be degraded. Moreover, for the same input voltage, the input current of the power amplifier will be larger because of the lower input impedance. Additional distortion may then be introduced into the preamplifier because of excessive loading by the power amplifier. For good-quality audio power amplifiers, typical values of input impedance range from approximately 5000 ohms to 100,000 ohms depending upon the capability of the signal source that is used.

#### Voltage Sensitivity

The characteristics of the preamplifier also dictate the voltage sensitivity required of the audio power amplifier. Although a few high-quality preamplifiers have been designed which provide signal outputs of several volts, output levels in the range of 0.5 to 1.0 volt are more typical. Audio power amplifiers having a sensitivity such that the rated power output is obtained for an input of 0.5 volt and having an input impedance of 10,000 ohms are, therefore, compatible with many

(Continued on page 67)



# SYMMETRICAL ATTENUATOR PAD NOMOGRAMS

By MAX H. APPLEBAUM / Warwick Electronics Inc., Pacific Mercury Div.

Resistor values to be used in T, H, Pi, and O pads with same input and output impedances for radio and audio frequencies.

**R**ESISTIVE pads are a common means of attenuating audio, video, and radio frequencies without disturbing the circuit impedances. These nomograms provide a rapid method of determining the values of resistors to make up such pads. The nomograms are for *symmetrical* pads, in which the impedances looking into the pads from both sides are equal.

Nomogram #1 is for the solution of symmetrical T and H pads, where  $Z_1 = Z_2 = Z$ .  $R_1$  and  $R_3$  are the same for both pads and are found in the following manner: (1) From the value of  $Z$  in the left-hand column draw a line to the number of dB attenuation desired on the  $N$  ( $R_3$ ) scale. Find the value of  $R_3$  where the line crosses its scale. (2) From the same value of  $Z$  draw a line to the same number of dB attenuation in the  $N$  ( $R_1$ ) scale. Find the value of  $R_1$  where the line crosses its scale.

*Example:* Design a 10-dB pad for an unbalanced 75-ohm coaxial cable terminating in its own impedance.

*Solution:* (1) Extend a line from 75 on the  $Z$  scale to 10 on the  $N$  ( $R_3$ ) scale. The line crosses the  $R_3$  scale at 52 which is the value of  $R_3$  in ohms. (2) Extend a second line from 75 on the  $Z$  scale to 10 on the  $N$  ( $R_1$ ) scale. The line crosses the  $R_1$  scale at 39 which is the value of  $R_1$  in ohms.

Nomogram #2 is for the solution of symmetrical  $\pi$  and O pads where  $Z_1 = Z_2 = Z$ .  $R_1$  and  $R_3$  are the same for both pads and found in a similar manner to Nomogram #1.

*Example:* Design a 6-dB O pad to attenuate a strong signal causing overload on all channels in a TV receiver. The wire used is 300-ohm twin-lead and connects to a balanced 300-ohm input at the antenna terminals of the tuner.

*Solution:* (1) Extend a line from 300 on the  $Z$  scale to 6 on the  $N$  ( $R_1$ ) scale. This line crosses the  $R_1$  scale at 900 which is the value of  $R_1$  in ohms. (2) Extend a second line from 300 on the  $Z$  scale to 6 on the  $N$  ( $R_3$ ) scale. This line crosses the  $R_3$  scale at 225 which is the value of  $R_3$  in ohms. ▲

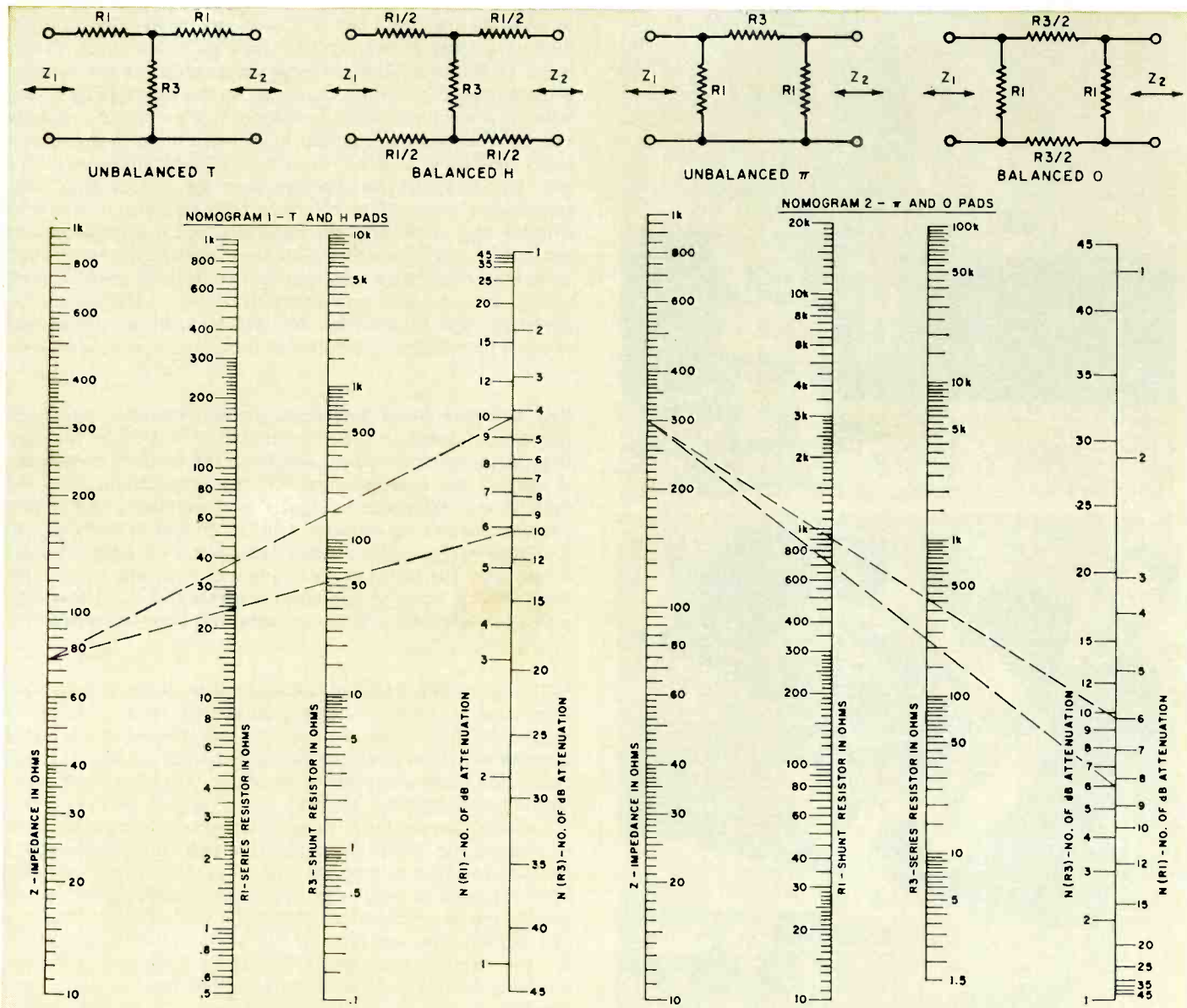



# RECENT DEVELOPMENTS IN ELECTRONICS

**Electronic Type Setter.** (Top left) By linking computer and television techniques, RCA has developed a unique electronic type composition system, called Videocomp, that sets text at speeds up to 900 lines a minute. The punched paper tape used to generate the letter "a" is shown here along with an oscilloscope display indicating the letter produced. Each of the holes in the paper tape provides information on the position of dots needed to form a character. In the new typesetter any letter that has been stored in the machine's electronic memory can be recalled and produced in thousandths of a second. An entire newspaper page can be composed in two minutes in this way. The computer memory can store up to four type fonts ranging in size from 5 to 24 points. (This type size is 8 points.) Original copy is fed into the computer, which hyphenates and justifies it and produces output tape. Under program control, up to 600 characters a second are written with an electron beam on the face of a high-resolution CRT. These characters are exposed through a precision lens directly onto sensitized film or paper for subsequent printing by offset, letterpress, or gravure.

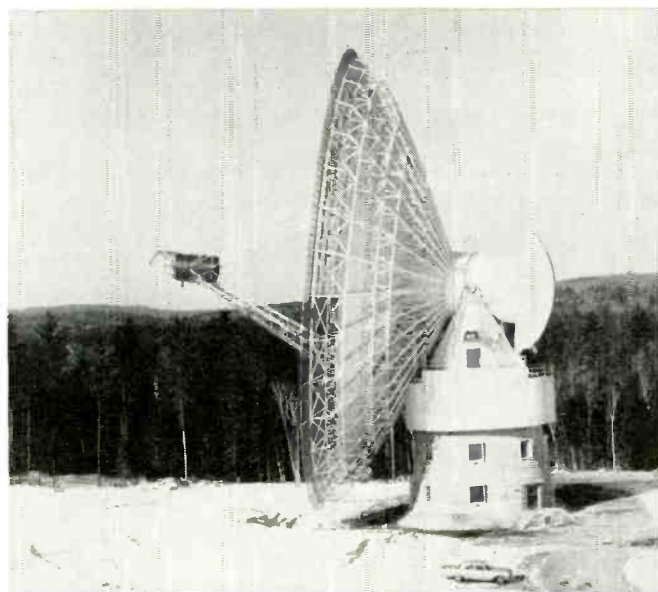

**New Canadian Radio Telescope.** (Center) Canada's new radio telescope, located in the Algonquin Park Region of Northern Ontario, is one of the most powerful in the world. It is designed to work in the microwave portion of the spectrum, observing galactic and extragalactic signals, and emissions from within the solar system. Its reflector dish is 150 feet in diameter and it is mounted on a turret which revolves on a 38-ft diameter roller track. The dish can also be tipped vertically. The conical base tower is made of reinforced concrete that is 43 feet high with 12-in thick walls. Main contractor was Dominion Bridge Co.



**First Electrically Scanned Laser Tracker.** (Bottom left) This laser tracking system is more precise than radar in following missiles during launch periods. The unit, which uses a highly concentrated light beam to locate and track its target, is capable of relocating a rocket momentarily "lost" in a cloud bank. Mechanically scanned systems simply cannot be moved rapidly enough to relocate a speeding target once it has been lost. At present, the system can pinpoint within 12 inches a rapidly moving object up to a height of 8 miles. The optical deflector used activates a horizontal and vertical scan pattern which directs the laser beam to 2000 different locations within a half second. The left tube in the photo is the beam deflector, the large center tube is a tracking telescope, while the receiving unit is in the right tube. The laser tracking system is being developed by Sylvania Electric Products for NASA.



**Acoustical Testing Dummy.** (Top left) An acoustical dummy, representing the average astronaut's upper torso and head, will be used to test and evaluate personal communications systems built into space helmets, earphones, and microphones. A special plastic "skin" is used that has the same absorption effect on sound as human skin. The dummy has an exact replica of the acoustical structure of man's outer ear along with special electronics to simulate the way we hear. Additional electronics gives the dummy a voice in excess of 100 dB sound pressure level—the equivalent of very loud speech. The dummy was developed and produced recently for NASA by CBS Laboratories.

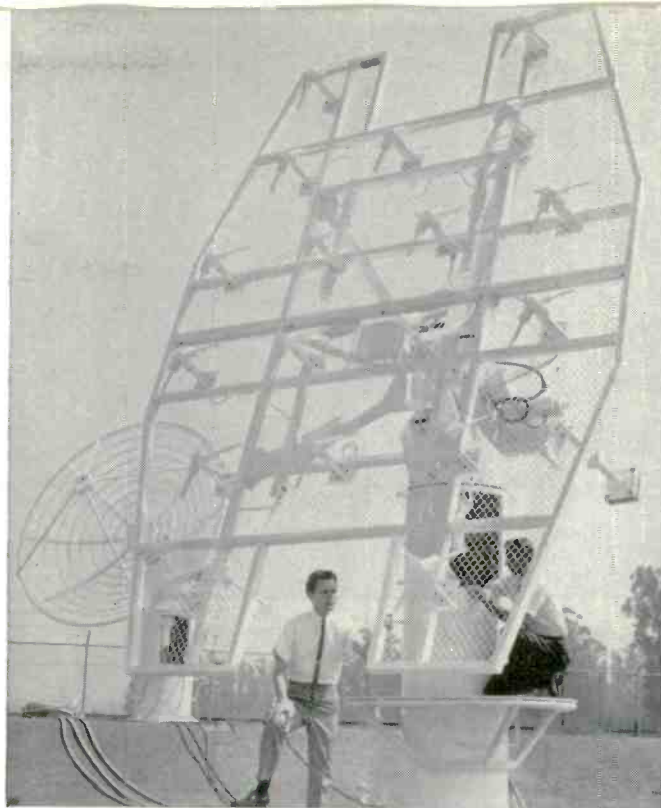

**Gemini Telemetry Tracking Antenna.** (Top right) Being readied for delivery to the Marshall Islands are these Teltrac telemetry tracking systems. They are part of four such systems being installed on Kwajalein for use in the Pacific missile test range. This equipment is used for tracking Gemini space capsules, and is being expanded for tracking Apollo manned moon shots. The tracking systems have been produced by Canoga Electronics.

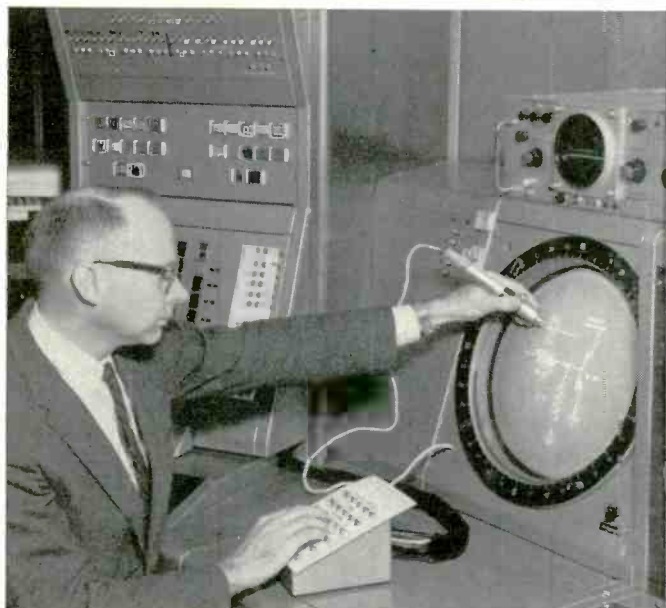

**Computer Reads Schematics.** (Center) National Bureau of Standards engineer is shown using a light pen at MAGIC (Machine for Automatic Graphics Interface to a Computer) to connect an added symbol to a schematic drawing obtained from machine memory. Machine circuitry is contained in the console at the left, while the operator sits before display and uses light pen and keyboard input to assemble graphic data. The computer system, with its unusual input-output capabilities, is being used as a research tool at the Bureau to study man-machine communication.



**TV at the Racetrack.** (Below right) The TV switching console shown here is the heart of the most sophisticated closed-circuit television system ever installed at a racetrack. From this console, an operator can control five TV cameras, video tape recorder, and a number of special effects such as split screens and lap dissolves. The control console is connected to sixty TV monitors located throughout Monmouth Park, N. J. The versatile RCA closed-circuit TV system will keep on-the-scene racing fans posted on betting odds, race results, and photo finishes.

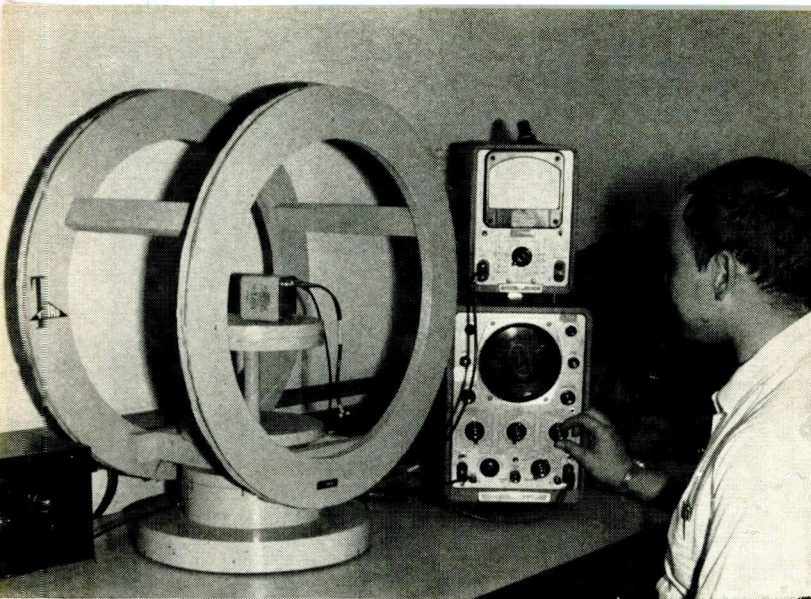

Magnetic shielding test setup using the Helmholtz structure.



Test station for checking power chokes on inductance bridge.

## Testing and Measuring INDUCTORS

*Methods and equipment used to measure inductance, self resonance, distributed capacitance, and "Q" of air-core and iron-core coils. Bridges and "Q" meters are commonly employed. Tolerances allowed and MIL-Specs are covered.*

By SAM ZWASS / Chief Engineer, Triad Transformer Corp., Div. of Litton Industries

INDUCTORS are widely used in electronic and electrical equipment. Designers of such coils generally design them for a specific application whenever the end use is known. The performance of a coil, besides being affected by its shape, size, and core material, can be drastically influenced by the mode of operation. In order to establish the performance of an inductor under actual field conditions, measurements should simulate, as closely as possible, the operating conditions of that coil.

Every inductor has associated with it spurious resistance and capacitance. Losses due to these spurious elements must be taken into account when any measurements are made and the measuring method selected accordingly. In some cases the inductance of the coil will be of primary importance and will have to be measured accurately, whereas the effective series and shunt losses need only be estimated roughly.

For other cases, however, especially if measurements are required on high-"Q" powdered-iron cores whose losses are small and difficult to measure, the determination of such losses will require much greater accuracy. Most bridges used in making measurements compare impedances to standards built into the bridge. A choice of a bridge circuit for the measurement depends entirely on the frequency, the inductance range, and the "Q" value of the coil to be measured. The bridge must have the necessary sensitivity, and its standards must cover the impedance range of the coil. The null-detecting device must have sufficient sensitivity to give visible or audible indication of balance. It may also be necessary to provide some frequency discrimination between bridge and detector to reduce erroneous balances due to harmonic distortion.

The basic bridge circuit is shown in Fig. 1. In order to achieve balance, two conditions must be met: 1. the magni-

tude  $Z_x \cdot Z_1 = Z_2 \cdot Z_3$ ; and 2. the sum of the phase angles of opposite arms must be equal:  $\theta_x + \theta_1 = \theta_2 + \theta_3$ .

Several types of bridges are used in inductance measurements. The *Maxwell bridge* permits measurements of inductance in terms of capacitance. A capacitance has many advantages over an inductor as a standard: it is small in size, easy to shield, and has practically no external field.

The Maxwell bridge (Fig. 2) is a convenient way of determining coil inductance within certain ranges. Difficulty may arise when the coil "Q" is very high. For such a case  $R_1$  is of very large value and resistance balance becomes difficult to determine. For very low values of coil "Q's" (which fall within the range of inductive resistors rather than coils),

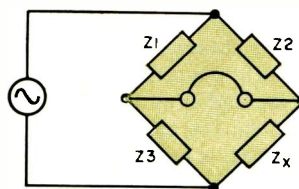

AT BALANCE  

$$Z_x \cdot Z_1 / \theta_x + \theta_1 = Z_2 \cdot Z_3 / \theta_2 + \theta_3$$

Fig. 1. Basic bridge circuit used to measure unknown impedance.

Fig. 2. The Maxwell bridge employs a capacitor as the standard.

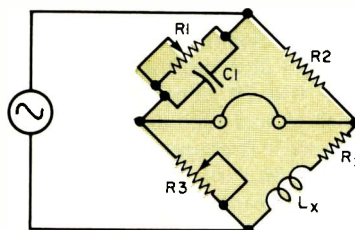

AT NULL  

$$L_x = C_1 \cdot R_2 \cdot R_3$$

$$R_x = \frac{R_2 \cdot R_3}{R_1}$$
 "Q" OF COIL = "Q" OF CAPACITOR

the Maxwell bridge exhibits very poor convergence of balance, an effect known as "sliding balance." This is caused by interaction between the controls where a new apparent balance is achieved each time the resistors in the different arms of the bridge are changed. The balance point appears to slide and settles only gradually to its final point.

For inductance measurements on coils with high "Q" values, the Hay bridge is more convenient. The Hay bridge differs from the Maxwell bridge in having resistance R1 in series with the standard capacitor, C1, instead of in parallel with it. For large phase angles this requires a low value of the series resistance and gives better balance for high "Q" coils.

The two types of bridges have a definite area of overlap. As a rough "rule of thumb," the Hay bridge would be used if the coil "Q" is above 10.

Another bridge often used is the Owen bridge shown in Fig. 3. It has the advantage of having both adjustable elements, R3 and C3, in the same arm. This makes the reactive adjustment independent of the resistive adjustment, thus avoiding the interlocking effect or "sliding balance." Another advantage of the Owen circuit is that R3 which is used to determine  $L_x$ , is a high-accuracy decade resistance, thus giving accurate determination of the inductance value. Also, if one can arrange to prevent direct current from passing through the generator, then inductance measurements with superimposed d.c. in the coil are facilitated. The disadvantage of the Owen bridge is that a decade capacitor is required. This tends to become rather large if a high-"Q" coil is measured.

As an alternative, C3 can be changed to a small value in parallel with R3. These two forms of the Owen bridge are related in the same way as the Maxwell and Hay circuits. A modified Owen bridge, with a fixed capacitor replacing decade capacitor C3, is available for inductance measurements. An adjustable resistor, R4, is added in the arm in series with the unknown coil to be measured. The unknown  $R_x$  has to be found by a difference of two readings of R4. This may seriously affect accuracy if the value of R4 is large.

Another useful circuit for inductor measurements is the resonance bridge shown in Fig. 4A. Since three arms are resistances, balance can be obtained only if the fourth arm is also purely resistive in over-all effect. This condition is met if  $|X_L| = |X_C|$ . At balance:  $R_x = R_2 R_3 / R_1$ ;  $L_x = 1 / (2\pi f)^2 C$ . This bridge can be used to determine  $L_x$  and  $R_x$  if C and the frequency are known. It can also be used to determine frequency if the values of  $L_x$  and C are known.

### Self-resonant Frequency

When an inductor is placed in a circuit or across the terminals of a bridge, it represents a complex network which includes, in addition to its inductance, resistance and capacitance. If we neglect flux leakage between turns of the winding, which in most cases is insignificant, we can simplify the coil equivalent circuit to that shown in Fig. 4B.

R1 represents the copper winding resistance and is generally independent of frequency. Only at extremely high frequencies would R1 appear to rise in value due to "skin effect." R2, representing core losses, is a combination of three frequency-dependent losses: eddy current, hysteresis, and residual losses. These losses increase with frequency and flux level. Capacitor C represents the total shunt capacitance effect of the "between turns" capacitance and the capacitance from each turn to the core or ground. This capacitance forms a parallel circuit with inductance L which resonates at the self-resonant frequency of the coil.

Due to this self-resonant effect, only those inductance measurements made far below the self-resonance of the coil will give the true inductance value of the coil. As the bridge frequency approaches the self-resonant frequency, the apparent inductance measured differs (increases) from the true

inductance according to the relationship:  $L_{(apparent)} = L_{(true)} / (1 - [f/f_0]^2)$  where f is the bridge frequency and  $f_0$  is the frequency of self-resonance.

The self-resonant frequency not only affects the apparent inductance of the coil but also adds dielectric losses to it. In addition, it limits the "useful" frequency range of the coil.

Of the several methods available for measuring self-resonant frequency of a coil, the simplest one utilizes a generator and voltmeter, as indicated in the circuit of Fig. 4C.

The generator voltage  $E_g$  is kept constant while the frequency dial is swept in search of the resonance point. Resonance occurs when the voltage across resistor R reaches a minimum (dip). The frequency at which this occurs is the self-resonant frequency of the coil. The resistor should be selected so that its value is small compared to the coil impedance at resonance. This impedance is equal to "Q"  $\times 2\pi f_0 L$ .

For any coil with a core whose permeability changes considerably with voltage level variations,  $E_g$  should be of such magnitude as to impress the same voltage across the coil as the coil will be subjected to under actual operating conditions. This method gives an accurate indication of the self-resonant frequency, particularly if the coil "Q" is of moderate value. For coils with low "Q" values, the resonance point can be difficult to establish since the impedance peak of the inductor is fairly flat.

A further difficulty arises in measuring self-resonance in coils where the inductance varies with frequency. Quite elaborate setups with phase measurements are then required.

The net effective distributed capacitance ( $C_D$ ) of the coil has a direct effect on the self-resonant frequency. This capacitance can be measured directly on some commercial bridges such as the Boonton "Q"-meter. In general, the measuring frequency should be selected far above the self-resonant frequency of the coil.

For coils whose true inductance is independent of frequency, one can calculate  $C_D$  by resonating the coil first with a capacitor, C1, to the frequency  $f_1$  then with another capacitor value, C2, to the frequency  $f_2$ .

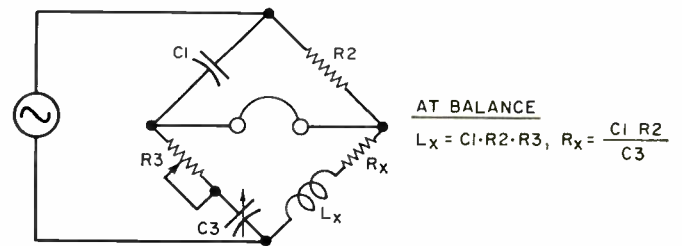
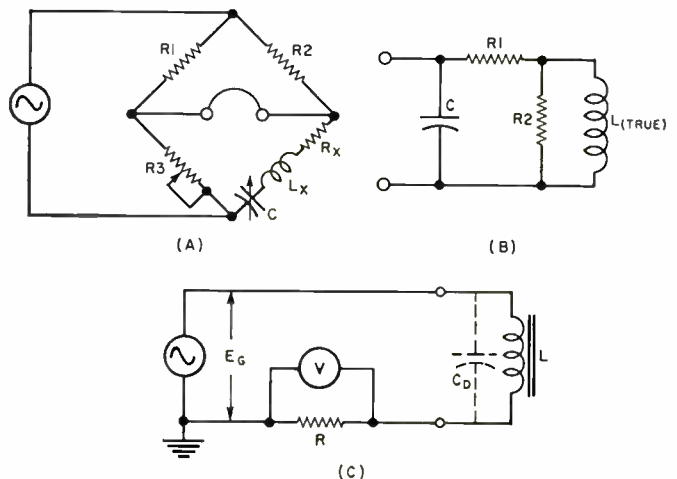

Fig. 3. Owen bridge has both adjustable elements in same arm.

Fig. 4. (A) Resonance bridge. (B) The equivalent circuit of a coil. (C) Measuring self-resonant frequency of an inductor.



## TESTS PERFORMED & TOLERANCES

Most inductors used as smoothing chokes for d.c. power supplies are required to carry a relatively large direct current in their windings. Their a.c. flux swing is generally small, consequently the  $L/\lambda$  determines the size of the unit. These chokes are generally designed on laminated core structures with gaps in their magnetic paths. The inductance requirement for this type of coil is usually a specified minimum value, while the d.c. resistance of the winding has a maximum specified limit (mostly restricted by the power dissipation in the winding and efficiency of the circuit). Core losses for this type of coil are seldom of interest. Frequently these coils will have tolerance requirements for their inductance values but, for the most part they are typically  $-20\%$  to  $+50\%$ .

Much tighter tolerances are required on inductors used as filter elements in electric-wave filters, tuning coils, transmission circuits, and in measuring apparatus. Here inductance tolerances are quite severe: from  $2\%$  or  $3\%$  to less than  $1/4\%$  are not uncommon.

Also, the "Q" requirements of the coils are limited: mostly as a minimum "Q" value but not infrequently one finds a "Q" tolerance of  $\pm 5\%$  or  $\pm 10\%$ . These types of coils, generally precision audio coils with wide frequency ranges of operation, will (and should) also have minimum self-resonant frequencies specified. Power inductors are usually tested for inductance and d.c. resistance on a  $100\%$  basis, the inductance tolerance being  $-20\%$ ,  $+50\%$ , with the d.c. resistance tolerance ranging from  $5\%$  to  $20\%$ , depending on wire size used.

Besides inductance and d.c. resistance, inductors are tested for dielectric strength (typically  $1500$  V r.m.s.), and insulation resistance (typically  $10^{10}$  ohms at  $500$  V d.c.). Many inductors are constructed to meet MIL-T-27B specifications: they are either metal encased per Grade 1 or 4 of MIL-T-27B specification, or are encapsulated per Grade 2 or 5, or open units impregnated to meet requirements of Grade 3 or 6 of MIL-T-27B. Units generally cover a maximum operating temperature range of from class R ( $105^\circ\text{C}$ ) to class T ( $170^\circ\text{C}$ ) and U (over  $170^\circ\text{C}$ ) operation.

In order to maintain close tolerances on precision toroidal coils, they are usually checked against a "standard" coil during the winding process. For that purpose toroidal winding machines may be interconnected to their own deviation bridges. This enables the operator to wind the coil to a point where the deviation bridge indicates a match. To further assure a minimum inductance shift, coils may be strain-relieved and inductance-trimmed to the required value. After processing, the coils at their final stage are again checked for compliance with their electrical and mechanical parameters.

Samples of each lot of coils are selected on a specified AQL level for additional tests consisting of: 1. Self-resonance test, 2. Electro-magnetic and electrostatic coupling between units (where applicable), 3. Electrostatic and magnetic shielding (when specified), and 4. "Q" factor.

On military items and high-reliability coils, additional tests are performed on samples selected from those units which have successfully passed the above tests. These additional tests are outlined in detail in the MIL-T-27B Spec under Group C tests. These include a series of mechanical shock and vibration tests, temperature cycling and thermal shock, temperature rise, terminal strength, immersion and moisture resistance.

Currently available are inductors which have successfully passed mechanical shocks of  $800$  g's and vibrations of  $4000$  Hz in three mutually perpendicular axes.

Inductors built for high reliability or military use are generally required to pass stringent qualification tests before qualification approval is granted. These tests are listed in Table VII of MIL-T-27B and cover complete electrical, mechanical, and environmental test requirements. Included in qualification tests, if specified, is a corona-discharge test. This test is generally performed only during qualification inspection and only if specifically called for, will it be performed as an acceptance test.

Coils which are magnetically shielded are placed in the center of an energized Helmholtz structure and a voltmeter is connected across the inductor. The inductor is then oriented until maximum voltage appears across the inductor. This voltage must generally be very low, on the order of from  $1$  or  $2 \mu\text{V}$  to less than  $100 \mu\text{V}$ .

Another test for the effectiveness of the magnetic shielding of inductors is to measure the strength of the magnetic field in the immediate vicinity of the inductor—a field caused by the flux leaving the core. For this test, the inductor is energized and a search coil is moved around the outside of the inductor. The highest voltage the search coil may register on the v.t.v.m. is specified for individual inductors ranging from several millivolts to  $0.1$  volt.

One of the most time-consuming tests performed on inductors is the moisture-resistance test. After an initial conditioning of  $24$  hours, the unit is placed in a humidity chamber maintained at  $90\%$  relative humidity. In the chamber the unit is subjected to  $10$  continuous cycles of  $24$  hours each, with alternate periods of temperature exposure, varying from  $+65^\circ\text{C}$  to  $+25^\circ\text{C}$  and from  $+25^\circ\text{C}$  to  $-10^\circ\text{C}$ . Included in five of the cycles is a period of mechanical vibration. ▲

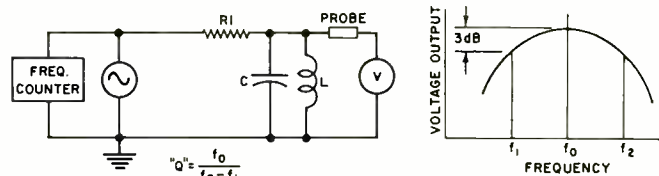

Fig. 5. The 3-dB bandwidth method of measuring coil "Q."

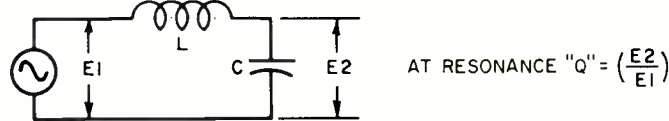

Fig. 6. The voltage-rise method of measuring coil "Q."

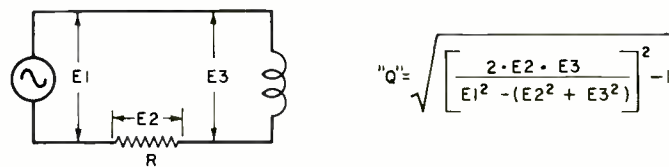

Fig. 7. Three voltage readings are required for this method.

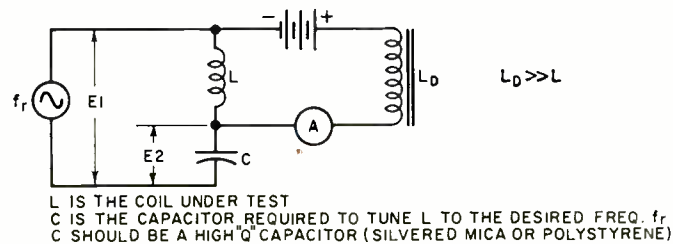

Fig. 8. Measuring inductor with a metered amount of d.c.

The distributed capacitance of the coil is then computed:

$$C_D = \frac{\left(\frac{f_1}{f_2}\right)^2 \times C_1 - C_2}{1 - \left(\frac{f_1}{f_2}\right)^2}$$

Next to the inductance of a coil, the most important parameter describing the efficiency or quality of the inductor is quality-factor or "Q." When an alternating current is flowing through a coil, energy is stored in the coil during a portion of the cycle. Most of the stored energy is fed back into the circuit later in the cycle. The difference between the stored energy and the returned energy is the energy dissipated in the coil. A perfect coil with no losses would return all the energy stored. The "Q" or figure of merit is the ratio of stored to dissipated energy per cycle. "Q" is also the quotient of the inductive reactance of the coil and the resistive losses. For a series representation,  $Q = 2\pi fL/R_{(series)}$ ; for a parallel representation,  $Q = R_{(parallel)}/2\pi fL$ .

There are several methods of measuring "Q": the most common are the damping-factor method (energy dissipation), the 3-dB bandwidth method, and the voltage-rise method. The 3-dB bandwidth method is illustrated in Fig. 5.

In all "Q" measurements, the "Q" of the entire circuit is measured. Therefore, in order to determine the coil "Q," choose capacitors of very high "Q" values (e.g., silvered mica or polystyrene) so that the "Q" of the circuit will virtually equal the coil "Q."

In the circuit of Fig. 5,  $R_1$  should be selected so it will not load the circuit. It should be at least  $100$  times the  $QX_L$  impedance. Also, the voltmeter must have high input impedance or, alternatively, a high-impedance probe should be used.

Most commercial "Q" bridges utilize the voltage-rise method for "Q" measurements (Fig. 6). Capacitor  $C$  should have a very high "Q" value and a capacitance sufficient to resonate the coil  
(Continued on page 71)

Several new circuit approaches make their appearance here. Among them are a one-tube color-difference demodulator/color oscillator, a transistorized pincushion correction circuit, and a new way to regulate the high voltage.

# Chroma Circuits in Color TV: Motorola

By WALTER H. BUCHSBAUM

THE Motorola TS-914 chassis uses 18 vacuum tubes and two transistors to drive a 23-inch color picture tube. One of the transistors is used in the u.h.f. tuner and the second acts as the vertical pincushion corrector. Horizontal pincushion correction and automatic regulation of the high voltage, plus color sync and demodulation, are the functions of new circuit approaches.

Because a radically different approach forms the basis of the color demodulator circuitry used in this set, it is first necessary to understand the principles before the circuit details can be presented for analysis.

## Demodulating Principle

In the previous chroma circuit designs of all TV manufac-

Fig. 2. Basic circuit of the Motorola demodulator and associated phase relationships. Note that the video is phase shifted rather than the color oscillator. The common cathode and control grids for the color local oscillator is shown in Fig. 3.

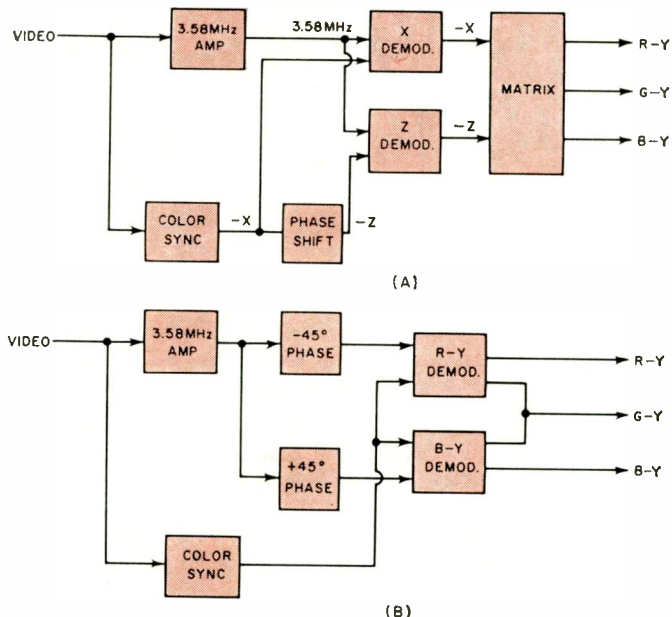
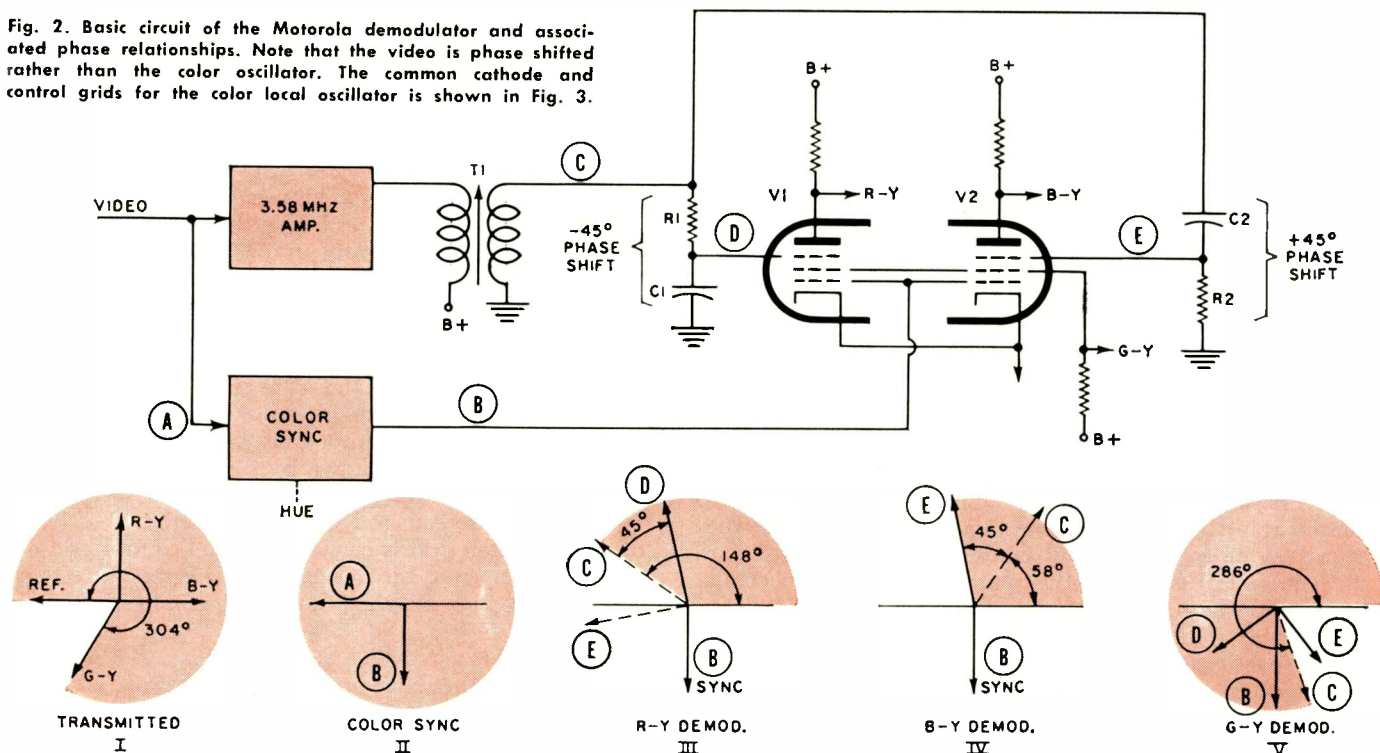

Fig. 1. (A) Typical X-Z axis demodulator. (B) The new chroma circuit phase shifts chroma rather than color oscillator signal

turers, the principle of chroma demodulation has been amplification of the color subcarrier and application of it to two demodulators. The color synchronizing signal is generated separately and synchronized with the color sync burst. The color sync signal is then split up into two signals of different phases which are then used to demodulate the color subcarrier. Fig. 1A shows a typical X and Z demodulating system. If, instead of the X and Z vectors, I and Q or R-Y and B-Y vectors are used, this merely affects the amount of phase shift between the two synchronizing signals. In the X and Z demodulating system, the two demodulated video signals, -X and -Z are supplied to three matrix amplifiers which provide the proper polarity and amplitude mixtures to generate the red, blue, and green color-difference signals.

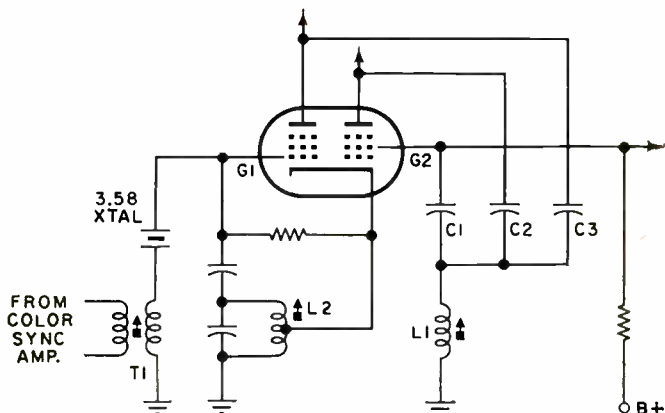

Fig. 3. Basic color oscillator is formed from the common cathode and control grids of the chroma demodulator double pentode.

In the new *Motorola* demodulating scheme, as shown in Fig. 1B, the color sync signal phase is not shifted at all. Instead, the 3.58-MHz color subcarrier is split into two different phases to provide, in effect, the same phase relationship as would exist with a color sync signal. The phase shift of the color subcarrier is accomplished in such a manner that the red and blue difference signals are demodulated directly. The green color-difference signal is obtained, as will be shown later, from the red and blue signals.

### Demodulator Operation

The demodulator circuit used in the new *Motorola* color receivers is shown in simplified form in Fig. 2. The demodulator consists of two pentodes contained in a single envelope which perform demodulation for the red and blue color-difference signals directly. After being amplified in the first video amplifier, the composite signal is brought to the 3.58-MHz amplifier that drives transformer *T1*. The composite video signal is also applied to the color sync section in which the color sync burst is converted into the constant-amplitude color sync signal. This sync signal is then applied to the control grids of both the *R-Y* and *B-Y* pentode demodulators.

From the secondary of transformer *T1* the color subcarrier is applied to the suppressor grids of the two pentodes. Before being applied to the suppressor grid of the *R-Y* demodulator (*V1*), the phase of the color subcarrier is delayed by  $45^\circ$  by means of *R1* and *C1*. Similarly, the phase is shifted forward at the grid of the *B-Y* pentode demodulator (*V2*) by *C2* and *R2*. The exact phase shift depends in each case on the values of the resistor and capacitor used as phase-shift networks. When precision resistors and capacitors are used, extremely accurate and stable phase shifts can be obtained. Each of the pentodes acts as a conventional demodulator, with one signal on the control grid, another on the suppressor grid, and the combined action of both determining the current through the tube. This is the basic mode of operation.

In trying to understand the operation of this new demodulator, it must be remembered that the phase relations and voltage conditions described here apply only for instantaneous values. As the colors change, so will the phase relations of the red and blue color demodulators.

Before describing how the green difference signal is derived, it is worthwhile to look at the phase relationships in this circuit. In Fig. 2, phase diagram I illustrates the transmitted standard phase relationships between the reference signal or the color sync, and the *R-Y*, *B-Y*, and *G-Y* signals. In diagram II, the effect of the color sync section has been diagrammed. The reference signal ("A") has been shifted by a total of  $90^\circ$  (to "B") and henceforth the color sync signal will be consistent at  $270^\circ$ . This phase angle is very important.

The phase angle of the color sync ( $270^\circ$ ) means that an *R-Y* signal would be  $180^\circ$  out of phase. In diagram III, the demodulation of a typical red signal is illustrated in phase repre-

sentation. Vector "B" represents the sync signal applied to the control grid. Vector "C" is the approximate phase angle of a red signal as it would appear at the secondary of *T1*, and vector "D" indicates the phase shift of  $-45^\circ$  due to *R1* and *C1*. It becomes apparent from looking at "B" and "D" in diagram III that the control grid and suppressor grid will be of opposite phase when a red signal is received. With the suppressor and the control grids approximately  $180^\circ$  out of phase, very little current can flow through this section of the tube, with the result that the plate voltage will be very close to the "B+" voltage. Since the plate is connected directly to the control grid of the red gun of the color picture tube, this means that the voltage there will become more positive, allowing red gun beam current to flow and producing red on the screen.

Vector diagram III also shows the phase at the suppressor grid of the *B-Y* demodulator (*V2*). This voltage, "E," is approximately  $80^\circ$  out of phase with the color sync signal which appears at the control grid of the *B-Y* demodulator. As a result, a reasonable amount of current can flow in the *B-Y* section of the demodulator. The voltage at its plate will be considerably below the "B+" value, making the grid of the blue gun, which is directly connected to the plate, less positive. This cuts off the blue electron gun.

The above explanation differs to some extent from the operation normally associated with pentode demodulators. In previous circuits, it has been shown that the color signal appearing on the CRT screen is the result of current flowing in the respective demodulators; in the *Motorola* system, the brightness or increase in a particular color is determined by the reduction of current flow.

The operation of the blue difference demodulator as illustrated by vector diagram IV is essentially the same as that for red. The only difference is that now the color subcarrier phase at "E" is in phase-opposition to the sync signal, and this does not allow any current to flow through the *B-Y* demodulator. Again, with no current flowing, the plate voltage comes close to the "B+" voltage, and this allows beam current to flow in the blue electron gun, causing blue to appear on the screen.

The green electron gun operates on the same basis as the red and blue guns, which means that the d.c. voltage on its control grid must be considerably less positive than "B+" to cut off this voltage. If green is to appear on the screen, the control grid voltage at the electron gun must approximate the "B+" voltage. Note that in Fig. 2, the *G-Y* signal is obtained from the combined screen grids of both demodulator pentodes. Although the transmitted phase for the green color-difference signal is  $304^\circ$  displaced from the color reference burst as shown in vector diagram I, for the circuit of Fig. 2 the relationships are somewhat different. At point "C," the green color-difference vector will be  $286^\circ$  from the zero point as shown in vector diagram V. This vector will appear at the suppressor grids of the red and blue difference demodulators, shifted by minus and plus  $45^\circ$ , respectively. From vector diagram V, it is apparent that the color subcarrier at the two suppressor grids and the color sync signal at the two control grids will be very close to each other in phase. This means that both pentodes will be able to draw a reasonable amount of current. The plate of the red and the plate of the blue demodulators will, therefore, be considerably below the "B+" voltage, and the red and the blue electron guns will be cut off. With considerable current being drawn by the two plates, very little current is available for the two screen grids. As a result, the voltage at the screen grid will approach the "B+" voltage. Since the screen grid is connected to the control grid of the green electron gun, this means that the green electron gun will be turned on, allowing the color green to appear on the screen.

Some readers may notice that the *R-Y* and *B-Y* signals used in the explanation above are actually  $13^\circ$  displaced from the transmitted primaries. This has become a standard practice in most recent TV receivers because the actual red and blue



colors which are now being produced by the new, improved color picture tubes are not really the same red and blue as originally specified for transmission.

To make sure that the R-Y, B-Y, and G-Y video signals are applied to the color picture tube with the correct amplitude relationships, resistance matrixing is used.

### Color Sync and Gating

Although the *Motorola* color demodulator section uses only one color sync phase, the requirement of locking in phase with the transmitted color sync burst still exists. The composite video signal must pass through the burst gate stage to separate the color burst. As will be explained in more detail, the *Motorola* circuit requires a relatively large amplitude of color sync burst and therefore two amplifying and gating stages are provided. The composite video signal is connected to the cathode of the first stage, with the horizontal flyback gating pulse applied to the control grid. A tuned coupling transformer brings the signal to the control grid of the second stage, a pentode which receives the horizontal gating pulse on the screen grid. To provide some hue control, an RLC series circuit is connected from the control grid to ground. The R is the hue control which shifts the phase of the color sync bursts. *Motorola*, at present, seems to be the only manufacturer who varies the phase of the color burst instead of the locally generated color sync signal, but the reason for this will become apparent when we analyze the color sync oscillator circuit that is used in the *Motorola* color set.

### Color Sync Oscillator

A simplified circuit of the sync oscillator is shown in Fig. 3. The oscillator consists of the common cathode and control grids of the chroma demodulator double pentode. Network C1 and L1 forms a series-resonant circuit used to remove the 3.58-MHz component from the G-Y video which is taken off at the screen grid as explained previously. The oscillations take place between grid G1 and cathode due to feedback from tapped cathode coil L2. The frequency is essentially controlled by the 3.58-MHz crystal in the control grid circuit, but the secondary of T1 is in series with the crystal and reduces its "Q" slightly. Transformer T1 is not exactly resonant at 3.58 MHz but appears as a capacitive reactance to the crystal. Depending on the tuning of T1, more or less color sync burst is coupled to the crystal, and this affects the strength as well as the phase of the oscillations. Cathode coil L2 must be tuned to the 3.58-MHz crystal frequency for proper oscillation, but, in the actual circuit, this coil is shunted by a 6800-ohm resistor and its tuning is therefore somewhat broad.

While we have spoken of this circuit as an oscillator, this only holds true when color sync bursts are received. On monochrome reception, the crystal will not be excited by the color sync burst and, if all other networks are properly tuned, the circuit will not oscillate. This operation is similar in principle to the "injection-locked" oscillator used in the RCA CTC-19 but different from the "crystal-ringing" circuit used in the G-E "Porta-color" set. In the latter, the ringing was amplified and limited to provide a continuous sine-wave signal, while here there is actual oscillation which can last for several horizontal periods without additional color sync bursts. This helps to overcome the effects of noise, but it also requires relatively high-amplitude color sync bursts. A peak-to-peak amplitude of 105 volts is specified as the secondary of T1 and that is why two burst amplifier stages are provided.

A small feedback capacitor (not shown) is wired from the primary to the secondary of T1. This helps assure that this transformer presents a capacitive reactance to the crystal. Another small capacitor connects the oscillator grid with the special feedback winding located on i.f. transformer T1 of Fig. 2. This helps stabilize the oscillator over the range of different signal amplitudes. When weak signals are received, the relationship between the color burst amplitude and the

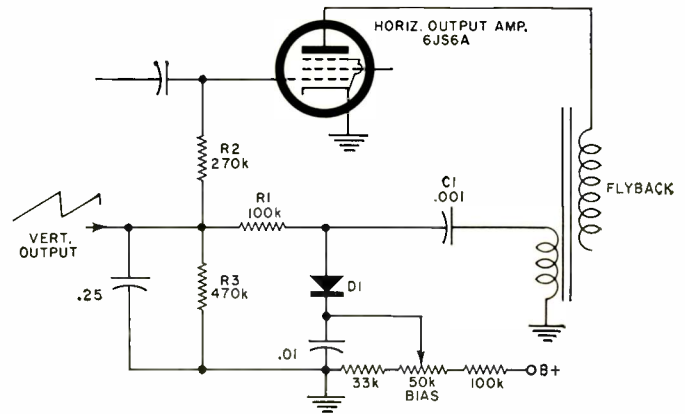

Fig. 4. As the load on the horizontal output transformer varies, the grid bias of the horizontal output stage changes to maintain a constant level of high voltage. This circuit also corrects side pincushion by introduction of vertical signal.

3.58-MHz signal at the i.f. transformer will be different because the color burst is not controlled by the color intensity control, and the signal picked up on the feedback loop helps to compensate for this.

If the preceding explanation of the principles of the new *Motorola* color demodulator and sync circuits has been understood, the actual circuit will not hold any mysteries. In addition to the basic circuit elements, a number of additional components are used in the actual circuit to provide the required decoupling, voltage division, and circuit loading, but these do not affect the principles.

Two color i.f. amplifiers, tuned to provide the right band-pass and gain for the 3.58-MHz color subcarrier are provided. Between these two stages, a potentiometer determines the amplitude of the color subcarrier and therefore the final color intensity. This is a front-panel control.

The control grid bias of the second stage is derived from the color-killer circuit, as in most color-TV receivers. Because the color sync section is so different, the color-killer operation is also unconventional. The plate of the color-killer triode receives the horizontal flyback pulse which is rectified and which provides the killer bias as in all color sets. The cathode is connected to the d.c. cathode return of the color sync oscillator and demodulator stage which is at about +22 volts. The grid potential of the color killer is obtained partly from the plate of the second color i.f. stage through a total of 25 megohms and partly from the control grid of the color oscillator. Adjustment of the color-killer control determines the bias of the color-killer stage. When a color transmission appears, the second color i.f. amplifier will draw more current, and the voltage applied to the control grid of the color killer will drop somewhat. At the same time, the color oscillator grid will go negative, and as this is also

(Continued on page 66)

Fig. 5. Transistor circuit corrects for vertical pincushion.

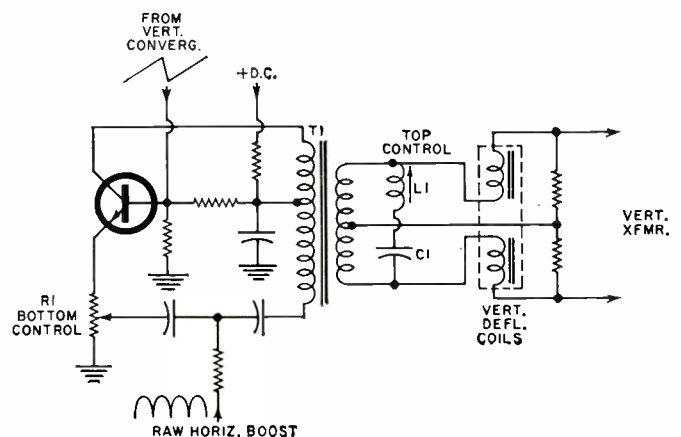

# Measuring Instruments for Electronic Components

By FREDERICK VAN VEEN / General Radio Company

*A wide variety of general-purpose and special-purpose test instruments is available for measuring resistors, capacitors, and inductors. Here are the most important factors to consider in selecting the proper instrument.*

THE technology of measurement at once leads and follows the advances of science. Today's "break-throughs" usually result from the right combination of creative genius and a laboratory well stocked with measuring instruments. The instruments themselves, on the other hand, owe their existence to creative genius. Like the chicken and the egg, invention and instrumentation spring from each other.

Today's inventor, engineer, or technician has a tremendous assortment of instruments from which to choose. If, for instance, he is interested in measuring capacitors, he no longer simply looks for a capacitance bridge. To choose the right bridge, he must consider the values and types of capacitors he wants to measure, the measurement frequencies, the desired accuracy, the desired end product (a meter reading, a chart record, a digital readout), and several other factors. Just as the specialist has come of age in the engineering profession, the special-purpose instrument has taken over much of the measurement market.

To use today's instruments effectively, you have to know exactly what you want to measure. Do you want the d.c. re-

Fig. 1. Engineer is measuring capacitance of coaxial sample (bottom right) with 0.01% General Radio capacitance bridge, said to be the most accurate available. It can intercompare two capacitors to within a part per million. Note that fingertip level switches, with associated in-line digital readout, have replaced usual rotary balance controls. The generator and the detector required are at the top of the console.

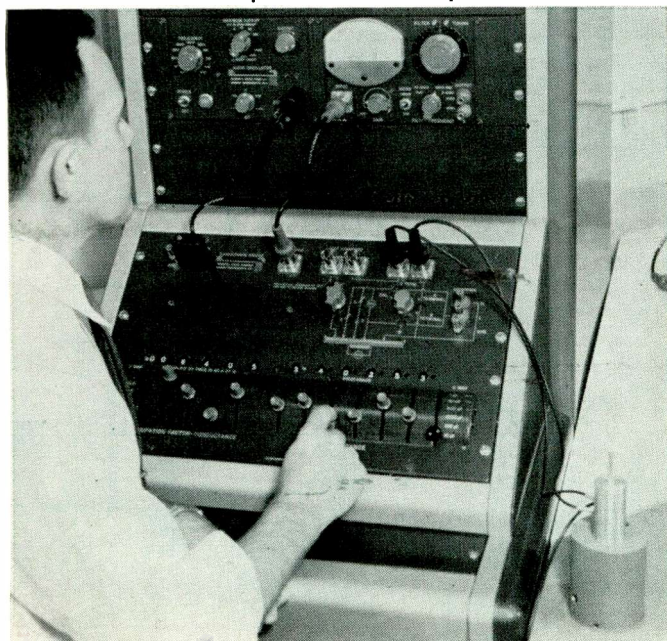

sistance or the a.c. resistance? The parallel capacitance or the series capacitance? A part-per-million resolution or a simple  $\pm 10\%$  measurement? The following may help you decide.

## Capacitor Measurements

The capacitance bridge is still the most common instrument for measuring capacitors. The operation of a capacitance bridge is covered in another article in this issue. The bridge's advantage over other capacitance-measuring techniques is that it is based on the attainment of a null, or zero-voltage, condition, which can be very precisely determined.

If you are measuring capacitors of a few hundred picofarads or less, you should be aware of the stray capacitances that exist between each terminal and ground or the case of the capacitor. To eliminate these error-causing capacitances, you should use a bridge capable of making three-terminal measurements. Such a bridge is shown in Fig. 1.

At the other end of the capacitance scale are the electrolytic types, whose capacitance may be as great as one farad. Here, the problem is not terminal capacitance, but series resistance of the leads. A 10,000- $\mu$ F capacitor has a reactance of about 0.13 ohm at 120 Hz. If the "Q" is, say, 2, the series resistance of the capacitor is only 0.065 ohm, and the lead resistance becomes important in the measurement of dissipation factor. This condition calls for a four-terminal connection, similar to that used for the precise measurement of low d.c. resistances in the Kelvin double bridge. The capacitance bridge of Fig. 2 is designed specifically for large-value capacitors. It provides the desired four-terminal connection and will also make two- and three-terminal measurements on all types of capacitors, down to a few picofarads. Adjustable d.c. bias up to 600 volts is available, a test-voltage amplitude of 0.2 V, 0.5 V, or 2 V can be selected, and d.c. leakage current can be measured on the panel meter that also serves as a null indicator.

The d.c. leakage of capacitors can also be measured by an electrometer; or, if you think in terms of insulation resistance, by a megohmmeter or teraohmmeter (a teraohm is  $10^{12}$  ohms).

All capacitance bridges measure loss, or dissipation factor, as well as capacitance; a "Q" meter will also make this measurement.

If you want to measure large quantities of capacitors quickly, you will want to consider an impedance comparator (Fig. 3), which indicates the percent difference in value between two components. With a standard capacitor at one terminal and with the panel meter set for any of several full-scale percent values, a production tester can rapidly put a batch of capacitors through a tolerance test. The instrument measures resistors or inductors as well.

For the ultimate in speed and convenience, there is the au-

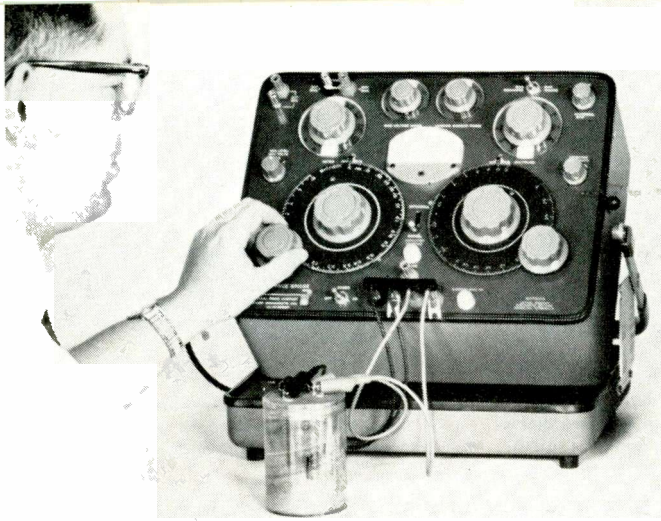

Fig. 2. Capacitance bridge, designed specially for electrolytics and other large-value capacitors, can handle units up to 1 farad or more. Capacitor under test is 16,500- $\mu$ F electrolytic.

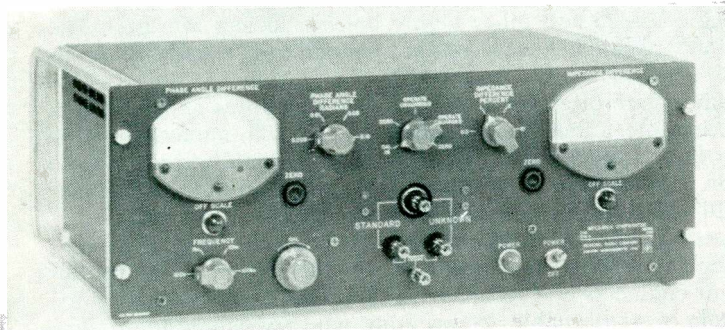

Fig. 3. This impedance comparator is used for rapid checking of components against standard. Readout is in percent difference.

automatic capacitance bridge (Fig. 4). Picture the following: Capacitors on a reel are automatically connected, at a rate of two a second, to the bridge terminals. As soon as each capacitor is connected, its capacitance and dissipation factor appear on an illuminated in-line digital readout, complete with decimal points and units. Simultaneously, the measured values are transmitted in binary-coded decimal form to a printer which records the measurements and to a sorter which automatically separates "good" and "bad" capacitors. All this is no fantasy; it is what is going on in many capacitor plants working around the clock to meet present high demand. A bridge that can automatically measure two capacitors a second (with an accuracy of  $\pm 0.1\%$ ) can quickly repay its owner his \$4850 investment.

A capacitance bridge, like any bridge, requires a signal source and a detector. Sometimes they are built in (as in the automatic bridge just described), sometimes they are not. The usual measurement frequency is 1 MHz for capacitors under 1000 pF, 120 Hz for electrolytics, and 1 kHz for most others. If you are interested in the capacitance of a component at microwave frequencies, you must forsake the conventional capacitance bridge in favor of a slotted line, admittance meter, or other instrument especially designed for work at high frequencies.

The most accurate capacitance bridges available are specified by their manufacturers to  $\pm 0.01\%$  direct-reading. A capacitor can, however, be compared against a standard unit with an intercomparison accuracy of a part per million.

#### Inductor Measurements

Air-cored inductors can easily be measured to within  $\pm 0.1\%$  or so with an inductance bridge, and can be compared against standards within a part per million. The Maxwell, Hay, and Owen bridges commonly used are described elsewhere in this issue. The "Q" of an inductor is conveniently measured with a bridge or with the well-known "Q" meter (Fig. 5). To

measure resonant frequency, one can call on a grid-dip meter or a "Q" meter.

Dielectric strength between windings or from winding to case can be measured by a dielectric test set of the type shown in Fig. 6. Protective measures must be taken to accomplish the delicate task of finding out what the breakdown voltage is while at the same time limiting the current so that the inductor isn't left a charred ruin.

Insulation resistance, as for capacitors, is measured with a megohmmeter or electrometer.

When the inductor you are measuring has an iron core, you are in the world of nonlinearity, where all the rules change. Since the coil is nonlinear, harmonics are introduced when a sinusoidal test voltage is applied. Since inductance is usually defined with respect to the fundamental component of current flowing with a sinusoidal applied voltage, for meaningful measurements the a.c. source driving the measuring instrument must have a very low impedance to harmonics, and any impedances that the measuring system places in series with the unknown impedance must be very small compared with the unknown. To minimize the effects of harmonics, the detector must be sharply tuned to the fundamental.

Because the inductance of an iron-core coil is a function of the applied voltage and d.c. bias current, the measuring instrument must be able to make the measurement with the same a.c. voltage level and d.c. bias current that will be applied in the coil's anticipated application.

The incremental-inductance bridge shown in Fig. 7 is designed for the measurement of iron-core inductors with wide range of a.c. and d.c. applied during measurement. Up to 200 volt-amperes of combined a.c. and d.c. can be applied. The high voltages (up to 1250 V) and currents (up to 50 amperes) involved warrant great respect, and the bridge panel bears several warnings which the operator must heed.

#### Resistor Measurements

The d.c. resistance is measured either by a direct-deflection instrument or a resistance bridge. The direct-reading ohmmeter, widely used for rapid testing, is often combined with a voltmeter and a milliammeter in the familiar volt-ohm-milliammeter. The megohmmeter mentioned earlier is a similar

Fig. 4. The automatic capacitance bridge in the middle of the relay rack is the nerve center of this system which measures capacitors and punches values on IBM cards. Operator can punch in supporting data. The bridge is fully automatic. As soon as the operator connects the unknown to bridge terminals (by means of jig on desk at left), the capacitance and loss are indicated, on illuminated readout, with units and decimals.



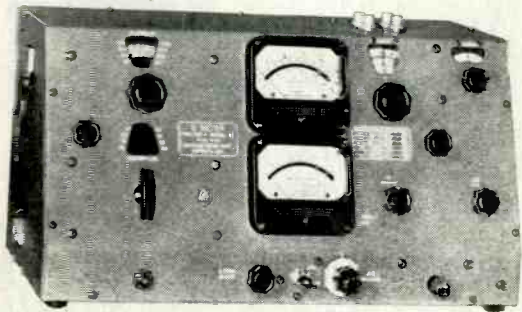

Fig. 5. Boonton Radio "Q" meter is employed to measure component "Q."



Fig. 6. Biddle 5-kV dielectric test set such as would be used to measure dielectric strength between winding or to case.



Fig. 7. This incremental-inductance bridge measures the inductance of coils over a wide range of d.c. and a.c. excitation.

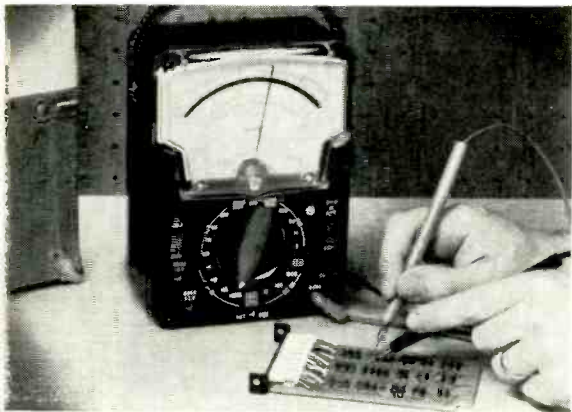
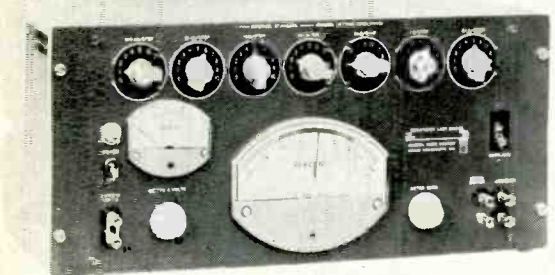

Fig. 8. Triplett v.o.m. being used to measure a number of resistors.



Fig. 9. Leeds & Northrup Wheatstone bridge for highly accurate resistance measurements can check resistors from 1 ohm to over 11,000 meg to 6 significant figures.

Fig. 10. Resistance limit bridge quickly tells whether resistors are within tolerance. Meter is calibrated in % deviation.



device, but for high resistances. Fig. 8 shows a v.o.m. used to measure resistors. Accuracy of the common ohmmeter is limited by, among other things, the nature of an analog readout. Digital ohmmeters are now available, however, with accuracies considerably better than meter-deflection types, but at much higher prices.

Wheatstone bridges for d.c. resistance measurement are available from many manufacturers; one type is shown in Fig. 9. For resistance standardization measurements, the Kelvin double bridge and other highly precise devices are used. The bridge elements and standards are held at a constant temperature, usually by means of an oil bath.

Resistors, like capacitors, are often measured in large quantities on production lines, incoming inspection, etc. Limit bridges, comparators, and automatic instruments are available for these applications. A typical resistance limit bridge is shown in Fig. 10. Deviation in percent from the standard is indicated on the meter. Color bands for the 5% and 10% parts of the scale help the user make readings quickly.

The trend toward specialization notwithstanding, there are times when a general-purpose instrument is best suited to a user's needs. A so-called "universal" bridge fills the bill for thousands of engineers and technicians who want to measure resistors, capacitors, and inductors to a reasonable accuracy but who are willing to sacrifice some performance for convenience and economy.

The impedance bridge shown in Fig. 11 is among the most popular universal bridges. It is actually five bridges in one instrument, with elements switched into the various bridge configurations by panel controls. It measures capacitance, inductance, resistance, dissipation factor, and "Q," has a built-in 1-kHz signal source and detector, operates on four flashlight batteries, and has a basic accuracy of  $\pm 1\%$ .

There are r.f. bridges available for the measurement of capacitors and inductors up to about 100 MHz. Such bridges are usually calibrated directly in ohms resistance and ohms reactance at a basic frequency such as 1 MHz or 10 MHz. Fig. 12 shows a typical r.f. bridge for frequencies to 60 MHz.

At microwave frequencies, where the dimensions of the component and its leads become comparable with a wavelength, lumped elements lose their identity and distributed-parameter methods, based on coaxial lines and waveguides, are used. Although slotted lines and admittance meters are usually thought of as being instruments for measuring the parameters of networks, antennas, and systems, they can also be employed to make simple two-terminal measurements of component impedance.

*(Continued on page 86)*

Fig. 11. One of the most popular measuring instruments is this universal impedance bridge. This instrument has its own generator and detector and measures C,R,L,D, and "Q" to 1 percent.

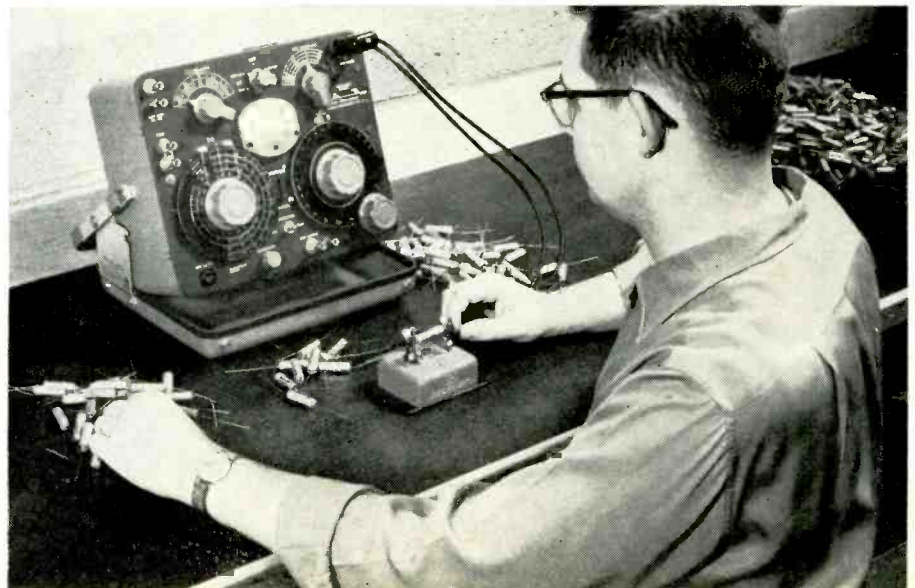

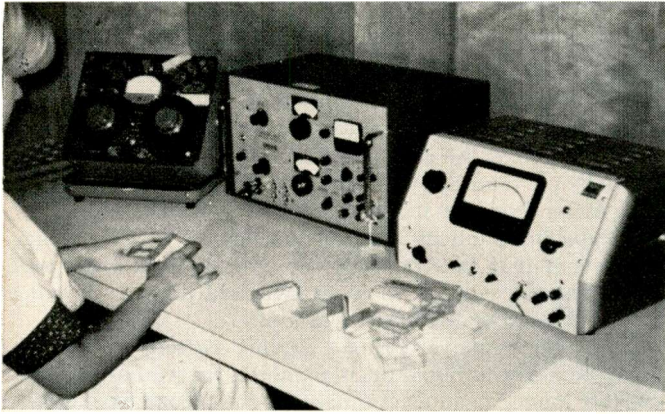

Test station showing three capacitor test instruments: 1000-Hz impedance bridge (left), 1-MHz capacitance bridge (center), and a capacitor insulation resistance test set (right).

Capacitor measurements are made at this station by means of a 1000-Hz impedance bridge which is employed in conjunction with a d.c. power supply and a filter circuit for biasing.



## Testing and Measuring CAPACITORS

*Description of techniques used to measure d.c. leakage, insulation resistance, capacitance, dissipation factor, conductance, and "Q" of all types of capacitors. Tests performed, instruments used, and tolerances are included.*

By RONALD C. LYND and DAVID QUIMBY / Cornell-Dubilier Electronics Div.

**C**APACITORS are among the most numerous discrete components in use in electronic and electrical circuitry today. The choice and use of a particular capacitor type is dependent on the circuit function for which it is intended. The extent to which the capacitor will efficiently perform in a particular circuit is a function of the individual capacitor characteristics which may affect circuit performance.

Capacitor types are categorized and defined by the dielectric materials which impart the characteristics to the capacitor, modified somewhat by configuration and form factors. Capacitor characteristics, by type and style, are well catalogued and defined for many parameters to serve as aids to design personnel in selecting the correct capacitor for a particular application. However, the knowledge of capacitor style characteristics does not ensure that each capacitor will meet these characteristics. The proof of capacitor characteristics requires actual measurement utilizing equipment and conditions which will define to the necessary degree of accuracy the actual characteristics of the individual capacitor. The measurement of capacitive characteristics becomes important even in circuits where capacitors are not present as discrete components, but exist only as distributed capacitance in coils, electrode capacitance in tubes, and other coupling and proximity effects related to physical circuit layout.

### Capacitor Characteristics

In order to provide for meaningful measurement of capacitor characteristics, it is necessary to understand the nature of these characteristics. Complete knowledge of a capacitor's many characteristics is seldom necessary or desirable, since

only those characteristics which affect the particular circuit function are pertinent.

A capacitor is basically a device for storing electrical energy. An ideal capacitor would store energy supplied from a d.c. potential in accordance with the formula:  $W = CE^2/2$  where  $W$  = energy in joules (watt-seconds),  $C$  = capacitance in farads, and  $E$  = the d.c. potential.

An ideal capacitor would store this energy indefinitely and supply all of the energy so stored to an external load when desired.

Fig. 1A shows the capacitor charge function illustrating the relationship between the charging current and voltage. It can be seen from this figure that a capacitor cannot be charged (or discharged) instantaneously, but it requires a finite time to achieve a fully charged condition. It can also be seen that since the relationship between the current and the voltage during this charge period is such that when the current is at maximum, the voltage is at a minimum, a 90° phase shift between current and voltage is obtained.

The a.c. and d.c. characteristics of a capacitor are derived from this phase-shift and energy-storage ability.

Fig. 1. (A) Relation between charging current and voltage of a capacitor. (B) Simple equivalent circuit of a capacitor.

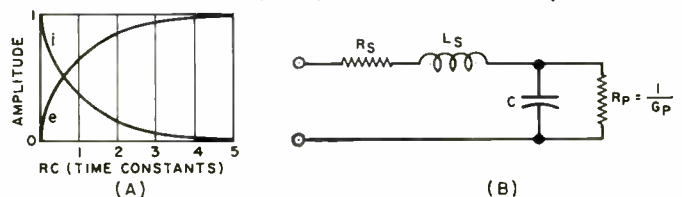

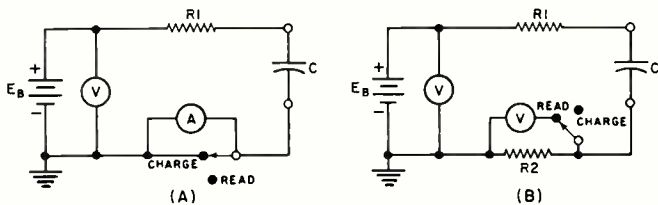

Fig. 2. Basic circuits that are employed to measure DCL and IR.

In practice, however, ideal capacitors do not exist, due in part to the resistances and inductances of leads, electrodes, and dielectrics and, in part, to the coupling effects of geometric configurations. Therefore, the evaluation of a capacitor involves not just the measurement of a pure energy-storage device, but rather the analysis of the complex impedance resulting from the assembly of the materials which make up the capacitor.

Fig. 1B represents a simple equivalent circuit of a capacitor. In this circuit:  $C$ =capacitance;  $R_S$ =resistance due to leads, electrodes, and contacts;  $R_P$ =resistance due to dielectric and case materials; and  $L_S$ =inductance of leads and electrodes.

Since all of these residual parameters exist to some degree in every capacitor, they must be considered in attempting to make accurate capacitor measurements.

### Measurement of D.C. Characteristics

The measurement of d.c. characteristics is concerned primarily with the evaluation of the dielectric material and its ability to withstand direct-current potentials and to store energy.

The simplest of all checks, employed by all technicians and engineers at one time or another, consists of a resistance check of the capacitor with the omnipresent v.o.m. Upon application of the meter to the terminals of a capacitor, a deflection toward zero will occur instantly and then approach infinity as the capacitor becomes charged.

A shorted capacitor becomes quite obvious in this check with a near-zero meter indication. A open capacitor is not as obvious since the steady reading of an open may be of the same magnitude as that of a good capacitor with high insulation resistance. For very small capacitance values and damped meters, the indication of a capacitive characteristic may be indiscernible because of the extremely fast meter deflection. Reversing the polarity of the meter after the initial check will aid in determining the existence of a small capacitance by doubling the magnitude of the applied voltage and, hence, that of the observed meter deflection.

The use of v.o.m. checks is relatively ineffective since no definitive conclusions of capacitor value or merit can be obtained. Its only value is for fast, coarse checks where other measurement equipment is not available.

As elementary as this method is, it does illustrate one of the capacitive functions and the principle of measurement of its quantitative value. This function is the energy-storage, d.c.-blocking characteristic. Equipment that is employed to make more definitive measurements of this characteristic is an extension of the ohmmeter technique.

### DCL and IR

DCL (direct-current leakage) and IR (insulation resistance) are loss parameters attributed to the equivalent shunt resistance represented by  $R_P$  in Fig. 1B.

1. DCL is the term used to define the actual amount of d.c. passing through the dielectric and is generally used for electrolytics where measurements are made at rated voltages and leakage currents are relatively high.

2. IR is the term used to define the actual d.c. resistance value of the dielectric of capacitors, other than electrolytics, under specified conditions. These conditions are the stipu-

lated voltage and time of measurement referenced to the initial voltage application.

Basic equipment used for measurement of DCL and IR may consist of a regulated power supply or battery and sensitive electrometer or microammeter as shown in Fig. 2.

In these circuits, the voltage is accurately set prior to the introduction of the capacitor into the circuit. The capacitor is initially charged through a shunt around the meter to protect the meter from the initial current surge which will occur for all capacitors and as a protection against meter damage in the event that the capacitor is shorted. When the specified time has elapsed, the meter is switched into the circuit and a direct reading of current is made.

Fig. 2A employs a direct-reading current meter, which may be a conventional microammeter, for readings which are in this range, or an electrometer in the picoampere range for smaller values of direct current.

Fig. 2B is basically the same circuit except that current is read as a function of the voltage drop across  $R_2$ . In this case the meter is removed from the circuit rather than being shorted during charging. A high-input-impedance electrometer is necessary for this reading to reduce the error caused by the shunting effect of the meter.

The critical points in making measurements in the above cases are:

1. *Power Supply.* The supply should be well regulated to provide for a steady level of d.c. potential. Voltage should be set to a calibrated meter prior to insertion of the test capacitor.

2. *Meters.* The meters used should be calibrated to a standard and afford sufficient scale resolution, usually a multi-scale meter, to enable accurate readout of the measured value. In addition, the low-potential terminal of the meter should be placed, where possible, on the low or grounded side of the circuit to establish a fixed reference point and prevent erroneous readings caused by varying circuit or ambient potentials.

Shielding of lead wires is important for measurement of extremely low values of leakage current, usually below one microampere. The effect of ambient electrical and magnetic fields on unguarded leads may cause instability, prevent accurate balancing of the meter, and give erroneous readings.

3. *Resistance.* Resistor  $R_1$  in Figs. 2A and 2B serves as a current-limiting device. Since the initial charging current of a capacitor exposed to a d.c. potential may be instantaneously very large, it is necessary to limit the maximum value of current to a safe level. Individual capacitor specifications indicate the maximum current for that particular type of capacitor. Where specifications are not available, it is good practice to limit the peak current to 50 milliamperes. Excessive currents, even though they appear as an instantaneous peak, may cause damage to certain dielectrics due to  $I^2R$  heating in the dielectric material.

Since the value of  $R_1$  is small relative to the resistance of the capacitor, negligible error in the actual measured values is introduced by  $R_1$ .

Resistor  $R_2$  in Fig. 2B is a precision unit whose value is selected to provide correlation with the meter scale. For example, if a meter with a full-scale reading of 1 millivolt and an input resistance of 10 megohms is used, a resistance of 1000 ohms would be used to indicate 1 microampere full-scale and cause negligible error in readings. A resistor of 100,000 ohms would present a full-scale reading of 10 nanoamperes ( $10^{-8}$  ampere) and introduce an error of approximately 1% in the recorded value. This is due to the shunting effect of the meter on the total circuit resistance. Determination of effects of other values of resistance may be made by computing circuit resistance as the meter-resistor parallel value. In general, if the precision resistor value does not exceed 1% of the value of the meter input resistance, no correction factor will be necessary for this measurement.

## TESTS PERFORMED & TOLERANCES

Capacitor manufacturers are faced with the problem of testing large volumes of capacitors for many attributes with accuracy and efficiency. In addition to the usual characteristics there are the many parameters required by military and other specifications. Complete evaluation of all parameters for each capacitor produced would waste both time and money. Yet, it is essential that the manufacturer establish proofs that each capacitor will meet the required specifications.

Ordinary bridge measurements are time-consuming because of the necessity to manually balance the bridge for each capacitor. Because of this, bridges are seldom used outside of laboratories or quality control areas. Since capacitors are manufactured to comply with "go, no-go" specification limits, it is unnecessary to measure each capacitor for its intrinsic value except in specific cases where sequential environmental or screening tests require recording of parameter drift characteristics. Capacitors produced for normal commercial and military use are tested for nominal ratings, utilizing automatic or semi-automatic equipment wherever possible, and high-speed manual techniques for capacitor lines which do not lend themselves to automated procedures.

To accomplish high-speed capacitance testing, automatic bridges, limit bridges, and impedance comparators in conjunction with conveyance and sorting mechanisms are used. In this manner, capacitors are tested to allowable tolerances and usually simultaneously tested for their rated dielectric withstanding voltage. Equipment accuracies for this type of operation must be such that the finished lot will contain no capacitors with actual value exceeding the nominal tolerance, which may be from  $\pm 0.5\%$  to  $\pm 20\%$ , or more.

The final proof of the capacitor's integrity is derived from testing of statistical samples from each lot. This testing is performed utilizing equipment calibrated to standards set forth by the National Bureau of Standards and encompasses all required environment, physical, and electrical requirements specified.

The many Military Specifications require that a fully equipped laboratory, approved by the Department of Defense through the Defense Electronics Supply Center (DESC), be maintained so that controlled monitoring of each lot of capacitors produced may be accomplished. In addition to these specifications are control specifications such as MIL-Q-9858, MIL-I-45208, MIL-C-45662, and others which provide for complete control of materials, procedures, equipment, and calibrations for the assurance of reproducible, high-quality products measured to accurate standards.

4. *Bias.* The magnitude of the d.c. potential is normally specified and is never greater than rated value of the capacitor. Measurements may be made at higher potentials, if desired, but the decision to test at higher potentials must be made with a knowledge of the dielectric withstanding voltage capability and only when it is anticipated that these higher potentials may be operationally encountered.

Most electrolytic capacitors are polarized and, as such, will withstand voltage in one direction only. Caution must be used to apply voltage only in the indicated polarity and never above the rated value. Damage to electrolytics may occur with reverse voltage applications, even for very brief periods of time. Reverse voltage on electrolytics may be accompanied by large magnitudes of current which cause internal heating of the capacitor and may result in the rupture of the capacitor case or seal.

A megohmmeter is the most common device for measuring the insulation resistance of all capacitors other than electrolytics. In essence, a megohmmeter is a differential device in which two currents, derived from the same d.c. power source, are placed in opposition to each other. The first current ( $I_1$ ) is controllable and is used to balance the meter to a calibrated scale. The second current ( $I_2$ ), which passes through the test capacitor, causes a deflection from the balance position by a factor which is in accordance with  $I_1$ - $I_2$ . Because both currents are derived from the same voltage source, the meter may be calibrated directly in terms of resistance, in megohms, since the difference in currents is a function of the difference in resistances.

The megohmmeter method has advantages over the DCL

circuits described previously. These advantages are that most megohmmeters contain their own power supply for d.c. voltage application and present readings directly in megohms. Some megohmmeters are available with a variable power supply for measurements over a range of voltages while others operate only from a fixed potential, which may be a battery. Individual capacitor specifications indicate at what voltage and time IR readings are made or referred to.

Electrification time is important in that sufficient time must be allowed for the capacitor to become fully charged so that the indicated value of resistance or current is attributable to the intrinsic value of the dielectric with only negligible effect from the exponential charging characteristic. The time required to charge a capacitor is based on the value of the series circuit resistance, in ohms, and the terminal capacitance of the capacitor, in farads, and is known as the time constant ( $RC$ ) in seconds.

In terms of the time constant ( $RC$ ), a capacitor will charge to 63.2% of the charging voltage ( $E_B$ ) in one time constant, 95.0% in three time constants, and become asymptotic to  $E_B$  after that point. (Refer back to Fig. 1A.) Since the charging function is exponential, a capacitor will never fully reach the charging voltage and, hence, will continue to draw current. As a practical matter, a capacitor is considered fully charged after five time constants, since at that time the capacitor has achieved greater than 99% of its possible charge; however, measurement of IR or DCL requires many more time constants since even a fraction of a percentage of charging current may be large compared to the current actually drawn by the dielectric. Where specifications are not available, standard practice is to make measurements of all capacitors, except electrolytics, at 2 minutes from time of initial charge at a voltage not to exceed the rated voltage, usually 100 to 500 volts. DCL readings of electrolytics are normally made at rated voltage after a 5-minute charge because of their much larger capacitance and, hence, time constant values, plus a time requirement for the electrochemical processes in the capacitor to become stabilized.

## C, DF, G, and "Q"

The most important characteristic of capacitors is, of course, the actual capacitance value, since this is the primary rating of the capacitor and the parameter upon which circuit designs are based. The measurement of capacitance may be accomplished through the use of bridge networks, impedance comparators, tuned circuits, and special circuits involving timing devices, phase-angle voltmeters, and other special devices.

The most common and universally employed method utilizes a capacitance bridge. There are many commercially available bridges ranging from inexpensive (under \$100) test sets to extremely accurate laboratory devices costing thousands of dollars. The choice of a measuring device is determined by the desired degree of accuracy, convenience, type of capacitor to be measured, and compatibility with shop or laboratory operations. All capacitance bridges are a.c. devices in which

(Continued on page 84)

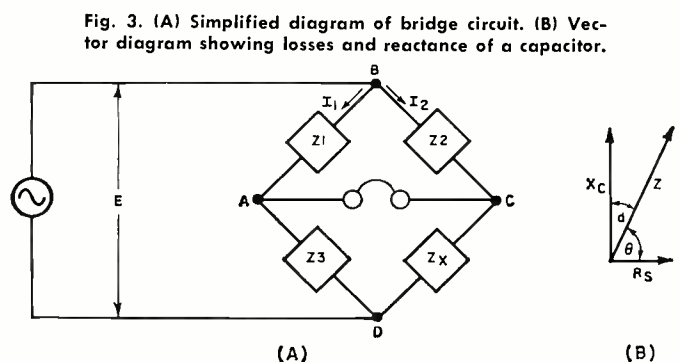

# SELECTING THE PROPER SWITCH

By BERNARD GOLBECK  
Engineering Manager, Switches  
Oak Manufacturing Co., Div. Oak Electro/Netics Corp.

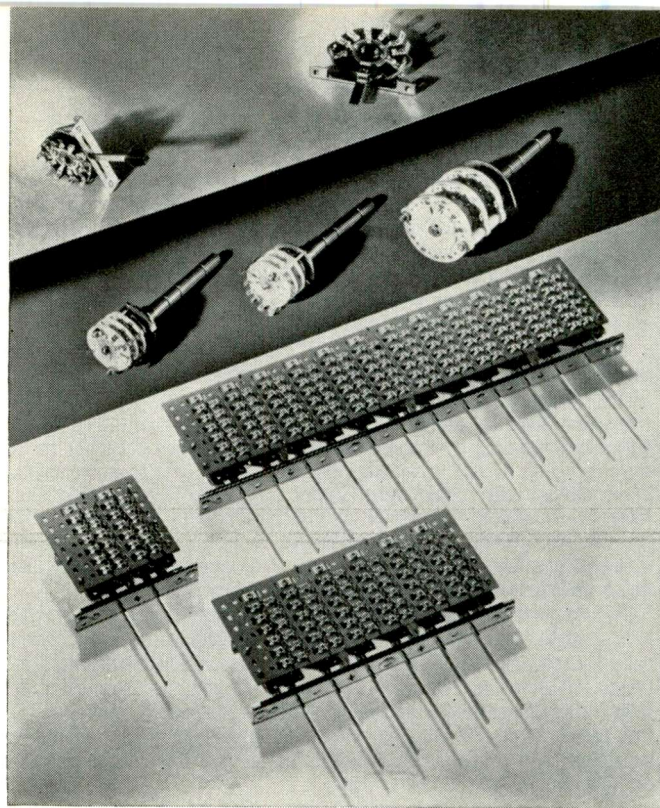

A grouping of typical lever, rotary, and push-button switches.

How materials and design affect applications and electrical performance of various switches for electronic equipment.

**P**ICKING the right resistor or capacitor for a circuit does not pose too much of a problem for design engineers and technicians. It is usually just a question of the right number of ohms or microfarads, tolerances, and type of materials. But selecting an electromechanical circuit component such as a switch, which is available in a good many different designs and types and in an extremely wide variety of materials, may be somewhat more difficult.

However, with a knowledge of basic types of switches and how materials in them affect performance, a circuit designer can usually choose a switch for his application that will perform well. This knowledge should also help designers pick a switch that is not too sophisticated—and therefore higher in price—for his circuit.

When an application calls for low-power switching functions (2 amps at 28 volts d.c. or 1 amp at 117 volts a.c.), several switch types can fill the bill: rotary, push-button, thumbwheel, and lever-actuated units.

In the past, selecting the type of switch was simple: equipment type usually dictated the choice. For example, intercoms have typically used lever switches; oscilloscopes are usually furnished with rotary units; and automatic record players have push-buttons.

Now, with increasingly sophisticated electronic equipment, the old method of switch selection no longer works. Each application should be looked at from aesthetic, cost, and space standpoints. Today's quality electronic gear must look good. This ties in closely with the amount of front-panel space available. Obviously, if front-panel space is insufficient for a push-button switch with the necessary number of stations, a less space-consuming switch should be chosen. And, of course, to place a small rotary switch in the center of a large panel with no other controls would result in poor appearance.

Space behind the panel for the switch's working parts can also limit selection of switch type and switch size.

Designers must also consider cost. In today's marketplace a specific piece of electronic equipment is invariably made

to sell at a given price. It is obvious, then, its components must conform to some kind of pricing schedule.

Cost also plays an important part in determining switch size. For the most part, transition to miniaturized versions of existing products introduces higher product costs, both in original procurement and added wiring time associated with more minute assembly. Miniaturization, for its own sake rather than being predicated on true design requirements, is certainly a waste of both time and money.

## What Switch for Which Circuit?

Strictly from a circuit standpoint, there are no hard and fast rules for saying "circuit A always uses a push-button switch; circuit B must use a rotary." In general, rotary units provide the designer with the most switching variety for the money. However, a push-button switch can be much simpler than a comparable rotary switch in applications where some circuits are "on" all the time; for example, in sports scoreboard controls.

Another factor in rotary *vs* push-button is speed of operation: does it make any difference that an operator must run through all switch positions in switching from position No. 1 to No. 8? If not, then a rotary is usable. If speed is important, obviously a push-button unit must be selected. Also, many times switching from No. 1 to No. 8 must be done without activating the circuits controlled by positions No. 2 through No. 7. Again, a push-button switch, with its inherent selectivity, must be chosen.

Push-buttons also provide greater flexibility due to the number of plunger actions available: interlock, in which depressing one button releases all the others; alternate action, in which the first depression of a button holds it down, a second releases it; momentary action, where pressure on the button is required to hold it down; blockout, which prevents more than one button from being pressed at a time; and several more.

Fortunately, however, most of the same contact designs, the same contact materials, and the same platings and di-



ELECTRICAL PROPERTIES AND CHARACTERISTICS	INSULATION MATERIAL					
	PHENOLIC	SILICONE FIBERGLASS	CERAMIC	MYCALEX	KEL-F (Clear)	DIALLYL PHTHALATE
<b>DIELECTRIC CONSTANT</b>						
Condition A 1/16" 10 <sup>6</sup> Hz	4.30	4.10	5.58	—	2.40 <sup>f</sup>	3.70
D-24/23 1/16" 10 <sup>6</sup> Hz	4.40	4.25	—	9.30	—	—
D-48/50 1/8" 10 <sup>6</sup> Hz	4.90	—	—	—	—	—
<b>DIELECTRIC LOSS FACTOR</b>						
Condition A 1/16" 10 <sup>6</sup> Hz	.120	.013	.00419	—	.034 <sup>f</sup>	.033
D-24/23 1/16" 10 <sup>6</sup> Hz	.132	.090	—	.010	—	—
D-48/50 1/8" 10 <sup>6</sup> Hz	.162	—	—	—	—	—
<b>DISSIPATION FACTOR</b>						
Condition A 1/16" 10 <sup>6</sup> Hz	.028	.003	.00075	—	.0143 <sup>f</sup>	.009
D-24/23 1/16" 10 <sup>6</sup> Hz	.030	.020	—	.0011	—	—
D-48/50 1/8" 10 <sup>6</sup> Hz	.033	—	—	—	—	—
<b>DIELECTRIC STRENGTH 1/16"</b>						
Parallel to laminations (kV Min.)						
Step by Step Condition A	80 *	60	—	—	—	—
D-48/50	80 *	40	—	—	—	60
Perpendicular to laminations (V/Mil)						
Short-Time Condition A	650	400	250 (1/4")	400 (1/8")	450 (1/8")	—
Step-by-Step Condition A	600	350	—	—	—	440+ <sup>e</sup>
<b>ARC RESISTANCE (Sec.) 1/16"</b>						
Condition A	5—8	180	—	250	360	130
<b>INSULATION RESISTANCE</b>						
Megohms 1/16"						
C-96/35/90	100,000 <sup>a</sup>	500,000	—	—	>10 <sup>9</sup>	—
<b>VOLUME RESISTIVITY</b>						
Megohm/Cm 1/16"						
C-96/35/90	1 x 10 <sup>6</sup> <sup>b</sup>	1 x 10 <sup>7</sup>	—	—	>10 <sup>10</sup>	>10 <sup>7</sup> <sup>c</sup> 50,000 <sup>d</sup>
<b>SURFACE RESISTIVITY</b>						
Megohms 1/8"						
C-96/35/90	12,000 <sup>a</sup>	400,000	—	—	>10 <sup>9</sup>	>10 <sup>7</sup> <sup>c</sup> 250,000 <sup>d</sup>
<b>WATER ABSORPTION (%)</b>						
D-24/23	.65	.15	0.02	Nil	Nil	.20 <sup>e</sup>
<b>COMPLY TO MILITARY SPECIFICATIONS</b>	MIL-P-3115C Type PBE-P	MIL-P-997B Type GSG	MIL-I-10A Grade L422	MIL-I-10A Grade L411	MIL-P-55028B	MIL-M-14F Type SDG Type SDG-F
<b>RELATIVE COST</b>	1.0	2.8	1.7	2.2	3.3	1.2

Condition A . . . . . No special conditioning; as received.  
C-96/35/90 . . . . . Humidity conditioning, 96 hrs. at 35° C and 90% rel. humidity  
D-48/50 . . . . . Immersion conditioning, 48 hrs. in distilled water at 50° C  
D-24/23 . . . . . Immersion conditioning, 24 hrs. in distilled water at 23° C  
\* . . . . . Denotes oil breakdown, not sample failure.

a . . . . . ASTM D-257 test method.  
b . . . . . 4041 Fed. L-P-406 test method.  
c . . . . . Megohms as received.  
d . . . . . Megohms 30 days at 100% rel. humidity at 158° F  
e . . . . . Immersed 48 hrs. at 122° F  
f . . . . . Test frequency 10<sup>5</sup> Hz

Table 1. Electrical characteristics of switch insulation materials based on data supplied by material manufacturers.

electric materials are used in all types of low-power switches. These design criteria greatly influence switch performance.

### Contact Material, Plating

Before arbitrarily specifying contact material, contact plating, or dielectric, designers should consider the actual environment in which the switch will operate. Temperature, vibration, humidity, and presence of contaminants are the key environmental factors.

Knowing the environment also prevents overdesigning a switch. There is no point in using a special ceramic insulation and gold-plated silver contacts for a selector switch in a low-cost table radio.

Throughout the switch industry about five different combinations of base materials and platings are used for contacts and rotors. Silver-plated brass with a 0.0001-inch minimum plating thickness will assure silver-to-silver contact for about 10,000 switching cycles. Silver alloy extends the usage to over 200,000 cycles. Both types stand up under 100°C temperatures.

A special spring-base material with a hard gold alloy rolled on the surface will provide gold-to-gold contact for from 50,000 to 100,000 cycles at up to 150°C constant ambient temperature.

Hard gold-plated silver alloy (0.0002-inch minimum) will give gold-to-gold contact in excess of 50,000 cycles; and after the gold has worn there will still be silver-to-silver contact with fairly low contact resistance. This combination is usable to 100°C. Another silver-alloy base with 0.00054-inch hard-gold alloy overlay gives gold-to-gold contact for up to 100,000 cycles and operates at 100°C constant ambient.

Gold plating is primarily for switches used very infrequently since accumulated oxide on a silver contact surface would prevent contact from being made on the first operation. Gold contacts should also be specified for switches in a corrosive atmosphere which might attack silver and for switches used in very-low-level circuits. Obviously gold increases the cost of a switch and should only be used where absolutely necessary.

Contact resistance of most (Continued on page 79)

# Testing and Measuring RESISTORS

By F. STERN/Chief Engineer, Philadelphia Div., IRC, Inc.

*The types of test equipment required and the kinds of measurements made on a wide variety of fixed resistors.*

RESISTORS are perhaps the best understood of all electronic components in terms of function; so much so that their ability to perform properly and reliably is often taken for granted in most commercial equipment. The resistor, like all other components, must operate within prescribed limits of accuracy under various environmental and circuit conditions. Standard tests have been adopted by the military, industry, and resistor manufacturers to establish a basis upon which various resistors can be evaluated. Depending upon the application, type, and requirement, test equipment for resistors can range from simple, portable meters to highly sophisticated, precise laboratory instruments. Equipment cost can range from a few dollars for a simple ohmmeter to \$20,000 or more for vibration test equipment.

## Resistor Measuring Devices

A radio and TV technician troubleshooting a circuit will

Table 1. Qualification tests for resistors from MIL-R-39008.

Examination or Test	No. of Defective Units Allowed <sup>1</sup>
<b>Group I</b>	
Visual and mechanical examination <sup>2,3</sup> .....	} 1
D.C. resistance <sup>3</sup> .....	
<b>Group II</b>	
Resistance temperature characteristic <sup>3</sup> .....	} 1
Voltage coefficient (applicable only to resistors of 1000 ohms and over) <sup>3</sup> .....	
Insulation resistance <sup>3</sup> .....	
<b>Group III</b>	
Low temperature operation .....	} 2
Temperature cycling .....	
Moisture resistance <sup>4</sup> .....	
Short-time overload .....	
<b>Group IV</b>	
Terminal strength .....	} 1
Resistance to soldering heat .....	
<b>Group V</b>	
Shock, medium impact .....	} 1
Vibration, high frequency .....	
<b>Group VI</b>	
Life (100 percent rated wattage) <sup>4</sup> .....	} 1
<b>Group VII</b>	
Solderability .....	} 1
<b>Group VIII</b>	
Life (50-percent rated wattage) .....	} 1

1. Failure of an individual resistor in one or more tests in Groups I to VI, inclusive, will be charged as a single failure. Failures for each resistance value will be permitted as specified in each group, but not more than two failures will be permitted in Groups I through VI combined.  
 2. Marking will be considered defective only if the marking is illegible.  
 3. Nondestructive examinations and tests.  
 4. When a group of resistors fails to meet the specified average percent change in resistance requirement, three failures will be charged; however, a failure will be charged for each resistor of the group which exceeds the specified maximum percent change in resistance requirement, and these resistors will not be considered in computing the average.

establish resistor failure by measuring the voltage drop across the resistor in the circuit or by measuring the resistance in or out of the circuit. Since most of the resistors in radio and TV receivers have wide purchase tolerances ( $\pm 5\%$  or wider) and broad circuit design tolerances (normally  $\pm 20\%$  or wider), the accuracy with which these measurements must be made can also be correspondingly liberal. A single instrument, such as a v.t.v.m. or v.o.m., is generally used. The accuracy of these instruments is usually  $\pm 3\%$  of full scale. After locating a faulty resistor, the technician normally replaces it with one of a like type, without performing any checks on the replacement.

Many orders of magnitude improvement in resistance-measuring accuracy are necessary for the precise, high-reliability resistors required in many of today's instrument, computer, and weapons systems. This type of resistance-measuring equipment is normally located in the laboratories of the resistor manufacturer or the military, or in commercial testing laboratories. Much of the resistance-measuring equipment is designed by the resistor manufacturer, although some very precise and accurate resistance bridges are available from test-equipment manufacturers. Automatic measuring equipment is also widely used.

Precision resistance measurements are made against NBS certified standard resistors. The certified accuracy of these standards usually ranges from 0.0004% to 0.005%. Resistance-measuring equipment is available that is accurate to better than  $\pm 25$  ppm with the ability to reproduce readings to 2 ppm. To assure measuring accuracy, these instruments and resistance standards are placed and used in an environmentally controlled room where temperature fluctuations are less than  $\pm 1^\circ\text{C}$  and relative humidity is regulated to within  $\pm 2\%$ .

## Resistor Tests

Examples of the types of tests to which resistors are subjected are shown in Table 1 (taken from MIL-R-39008). While the tests and test sequence are for the established reliability, fixed composition resistor, the tests and test equipment are similar to those used for most other types of resistors.

A review of the equipment and instrumentation employed for the more critical tests performed on resistors will give some insight into both the resistor and resistor test instrumentation requirements.

*Resistance temperature characteristic (resistance temperature coefficient)*. All known resistive materials show resistance changes with temperature. The magnitude of this change can be expressed as a single  $\% \Delta R$  between specified temperatures or as parts per million per  $^\circ\text{C}$  (ppm/ $^\circ\text{C}$ ). The temperatures at which measurements are made can range from  $-65^\circ\text{C}$  to  $+350^\circ\text{C}$ , depending upon resistor type. Most measurements are made between  $-55^\circ\text{C}$  and  $+150^\circ\text{C}$ . By determining the resistance on a standard five-dial Wheatstone bridge where the ratio arm is modified by the inclusion of a

ten-turn ultra-linear precision potentiometer, the resistance temperature coefficient value can be measured to within 2 ppm/°C of its true value. More precise instruments can provide readings with an error of less than 1 ppm/°C of the true resistance temperature coefficient value.

**Voltage coefficient.** The change in resistance due to applied voltages is normally determined by resistance measurements at full-rated voltage and at  $\frac{1}{10}$  rated voltage. We have designed a bridge that switches between two programmable voltages (full-rated and  $\frac{1}{10}$  rated). The rated voltage is applied for no more than 0.1 second with a repetition rate of one second. The bridge nulling system is so designed that the bridge reads directly in  $\% \Delta R/V$ . An alternate but highly unreliable method that is sometimes employed utilizes a voltmeter and ammeter that measure the voltage across and the current through the resistor. The major fault with this method is that it takes too long to read the two meters. This results in considerable resistor heating during the time that full-rated voltage and power are applied. Consequently, the coefficient so measured is really a composite of voltage coefficient, resistance temperature coefficient, and load.

A voltage coefficient measuring system that has been discussed by the International Electrotechnical Commission places a pure sine wave into a voltage divider that uses a zero voltage coefficient resistor (usually wirewound or metal film) in series with the resistor to be tested. The percentage of harmonic distortion in the sine wave of the voltage across the resistor under test is a function of the voltage coefficient. This system is difficult to instrument, but it offers the advantage of eliminating the resistance temperature coefficient effects.

**Low-temperature operation.** This test is a measure of the ability of a resistor to function under load conditions in sub-zero environments. There are many sub-zero boxes capable of performing this test. These boxes, such as the sub-zero, dry-ice-operated, constant-temperature cabinet manufactured by *American Instrument Co.*, can be maintained to  $\pm 0.5^\circ\text{C}$  at temperatures as low as  $-65^\circ\text{C}$ .

**Temperature cycling.** The objective of this test is to determine the ability of the resistor to withstand shocks of exposure to extremes of high and low temperatures, such as would be experienced by arctic equipment taken to and from heated shelters and rocket and missile instruments that undergo rapid temperature changes from ground to outer space. Tests are normally performed between the extremes of  $+125^\circ\text{C}$  and  $-65^\circ\text{C}$ . The low-temperature chambers used are the same as those described above. The high temperatures are obtained by forced-air ovens with temperature maintenance capability of  $\pm 1^\circ\text{C}$ .

**Moisture resistance.** This test measures in an accelerated manner the deteriorating effects of high humidity and high heat conditions found in tropical environments. It includes a low-temperature and vibration sequence to hasten the detection of faults caused by extremes in temperature, humidity, and mechanical stresses. The resistors may be tested under no load, full load, and with or without polarizing voltage. Because of the severity of this test and the differences in results that can be obtained by deviating from specified conditions, precise equipment is mandatory. A well designed test chamber will maintain the relative humidity to  $\pm 1\%$  relative humidity and  $\pm 0.5^\circ\text{C}$ . Verification of humidity is made with an electrical hygrometer that measures relative humidity to an accuracy of  $\pm 1.5\%$  and is reproducible to  $\pm 0.2\%$ .

To ensure the accuracy of measurements under high humidity conditions, extreme care must be taken with the construction of the test fixtures. High-grade materials, such as virgin electrical Teflon, should be used for insulation since surface leakage can create parallel resistances to the parts being measured. Since insulation resistance measurements are, at times, also made in the moisture chamber, the test

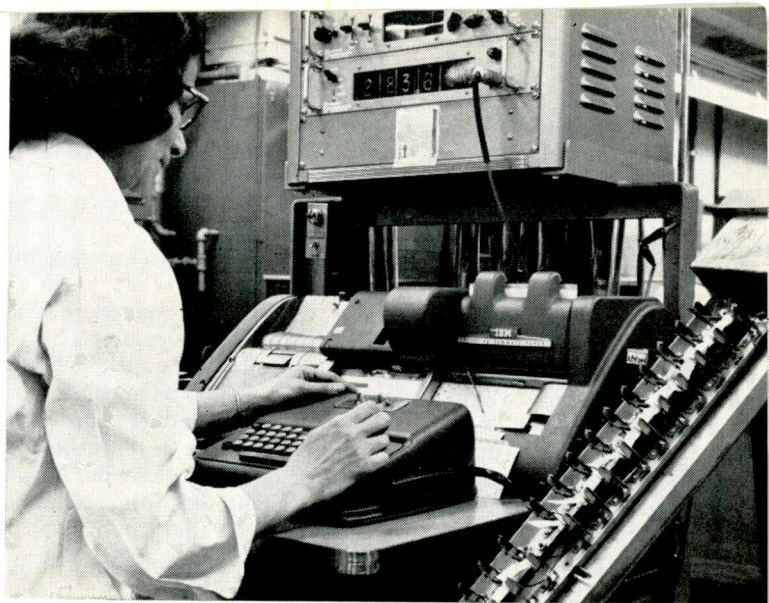

As many as 6000 resistance measurements are made daily at testing positions employing a digital ohmmeter working in conjunction with a 40-position scanner and an IBM card punch. In addition to the actual resistance measurements, the system performs a complete statistical study of the resultant resistance measurements.

racks should have guard circuits to eliminate unwanted leakage currents. Insulation resistance measurements can be made with instruments such as the teraohmmeter manufactured by *ITT*.

Conditions for this test usually require the resistors to be within specified  $\% \Delta R$ 's, have a minimum insulation resistance, and show no evidence of mechanical damage.

**Short-time overload.** A resistor's ability to withstand momentary overload surges, such as those experienced as a result of switching equipment on and off or failure of another circuit function, can be easily established in the laboratory. The test is performed by applying from four to ten times the rated load from five seconds to one hour. As noted, the test loads and times vary considerably with the type of resistor. The applied voltage, which is either a.c. or d.c., should be accurate to at least  $\pm 3\%$ . Timers with an 0.1 second accuracy are used. Considerable errors can result, however, unless the load voltage is preset with a dummy load.

The test just described is the simplest type of overload test and serves as a standard method. Overload conditions having specific pulse amplitudes, shapes, and frequencies are not as easily reproduced in the laboratory.

**Life test.** This test determines the ability of the resistor to handle various loads at temperatures ranging from room to  $225^\circ\text{C}$ . The degree of loading and ambient test temperature depend upon the type of resistor and specification. A condition of  $70^\circ\text{C}$  ambient, with full-rated load or voltage for 1000 hours, is the most frequently performed test.

**Shock.** A shock test standardizes the procedure and equipment required to measure the degree to which resistors can withstand rough handling, such as dropping and impact. Resistors are mounted by their leads and attached to a test fixture that is raised to a specified height. The fixture is then allowed to free-fall into a bed of sand or other arresting material. A *Barry* Component Shock Machine Type 20VI is typical of the equipment used to execute this test. Normally, it is performed on resistors at shocks corresponding to 50 G's. Other types of equipment, such as the *AVCO* air-operated shock machine, are capable of producing shocks of up to 5000 G's. The resistors are monitored during the shock test by thyatron trigger circuits capable of detecting intermittencies of less than 0.1 millisecond.

**Vibration.** This test is primarily designed to duplicate the vibratory conditions that can be encountered by military equipment located in aircraft, missiles, and tanks. The vibration test measures the integrity of the structure as well as

the fatigue of such parts as resistor terminals. One type of instrument employed for vibration tests is an *MB Electronics* electronic vibrator console and vibration exciter.

While most tests on resistors are performed in a frequency range of 10 to 2000 Hz and acceleration of 20 G's, or 0.06" double amplitude, tests can be made in the frequency range of 5 to 10,000 Hz and acceleration levels of up to 65 G's. Tests can also be performed at a single frequency or by a sweep through a preselected band of frequencies. The amplitude can be automatically controlled at a specified level. The force of vibration applied to the test specimens is monitored by an accelerometer mounted on either side of the specimen or, if this is impractical, on the test fixture. The accelerometer output is displayed on an oscilloscope. As with the shock test, the resistors are monitored during vibration by means of a thyatron trigger circuit that establishes any intermittency of the resistor. Intermittencies of less than 0.1 millisecond can also be detected in this test.

#### Non-Standard Tests

The following tests are more specialized than the preceding. They are intended to evaluate specific resistor types or characteristics for particular applications.

**Steady-state humidity.** These tests are designed to accelerate the effects of using and storing resistors in humid environments and are performed at a constant temperature and humidity. Normally, there is no load applied during the time of humidity exposure. Despite the fact that the moisture resistance test described previously involves a combination of humidity, temperature cycling, loading, and vibration, a severe steady-state humidity test can produce higher resistance changes than the moisture resistance test. Steady-state humidity testing provides information on the water-vapor-transmission and water-absorption property of the resistor's protective coating as well as on the sensitivity of the resistive element to moisture. One such frequently used test subjects the resistors to 98% to 100% relative humidity at  $75^{\circ}\text{C} \pm 3^{\circ}\text{C}$  for  $120 \pm 5$  hours. The equipment required is quite simple: a desiccator jar, mounting plates, distilled water, and an oven. Humidity is maintained by sealing the desiccator jar.

Other steady-state humidity tests can be performed in humidity chambers. Desiccators with supersaturated solutions of salts in water are also capable of producing various humidity conditions. This technique is often used to measure the effects of shelf life. For example, a supersaturated solu-

A portion of a load-life testing oven which has circulating oil surrounding each of the small drawers within the test chamber. Resistors within these drawers are subjected to elevated temperatures maintained within  $.5^{\circ}\text{C}$  of desired setting.

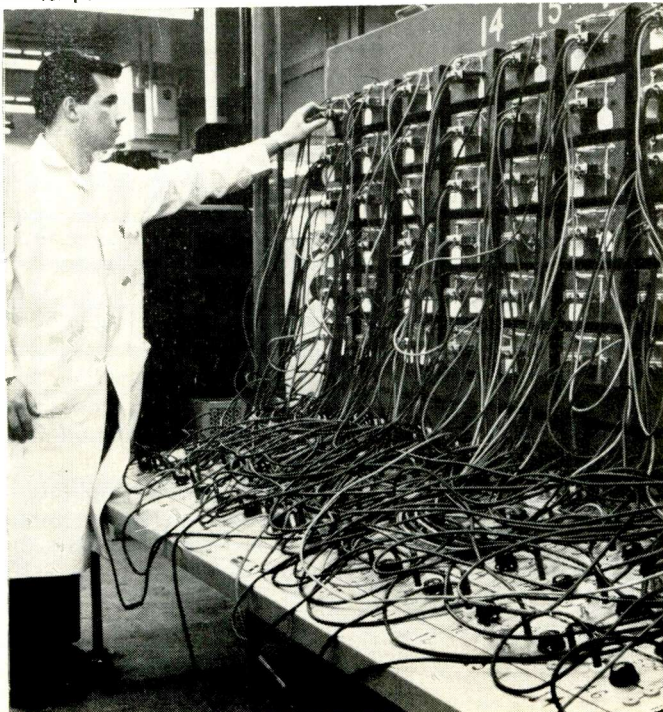

tion of magnesium chloride will produce a relative humidity of 33% at  $25^{\circ}\text{C}$ ; calcium nitrate, a relative humidity of 51% at  $24.5^{\circ}\text{C}$ ; and barium chloride, a relative humidity of 88% at  $24.5^{\circ}\text{C}$ .

**Salt-water immersion.** This test is chiefly intended to obtain evidence of seal leakage. The parts are cycled between an oven at  $85^{\circ} \pm 2^{\circ}\text{C}$ , a hot ( $85^{\circ} \pm 2^{\circ}\text{C}$ ) saturated solution of sodium chloride and water, and a cold ( $0^{\circ}\text{C} + 2^{\circ}\text{C}$ ,  $-0^{\circ}\text{C}$ ) saturated solution of sodium chloride and water. The resistors receive full-rated load in the oven during five of the eight cycles of the test.

**Salt spray.** While this test is frequently and erroneously used as a measure of the corrosion resistance of materials to seacoast environment, it is primarily a proof-of-design test. While it may not correlate to actual field conditions, the test has the ability to differentiate between materials and to determine the uniformity of materials to a standard corrosive environment. The test is performed by subjecting the specimen to an atomized spray of 5% or 20% sodium-chloride solution in water at elevated temperatures. This test is seldom used for any resistor but the variable type.

**Noise.** Noise is not normally considered a factor of resistor quality and is ignored in most applications. It has some utility in low-level audio-frequency and other low-frequency circuits followed by high amplification where the current noise of resistors may be a source of signal interference. Current noise, as opposed to thermal noise, is a function of resistor design, materials, and manufacturing process. Thermal noise is completely independent of these factors and can be determined by Nyquist's equation.

Current noise appears as a fluctuating voltage when direct current is passed through the resistive elements. Current-noise determinations can be made on such instruments as *Quan-Tech Laboratories* Model 315 Resistor-Noise Test Set. The equipment and method of measuring resistor noise is described in a report entitled "A Recommended Standard Resistor-Noise Test System" by G. T. Conrad, Jr., N. Newman, and A. P. Stansbury published in the *IRE Transactions of the Professional Group on Component Parts*, Vol. CP-7, No. 3, September, 1960.

The unit of current noise is expressed in decibels, called the current-noise index. It is a measure of the ratio of the r.m.s. value of current-noise voltage (in microvolts) to the applied d.c. voltage (in volts). The passband is one frequency decade.

**Frequency characteristic.** Resistors exhibit a change in effective resistance with frequency. This is mainly due to dielectric losses and/or skin effect. The change of resistance with frequency is a function of resistor type, construction, and material. Generally, but not exclusively, the effective resistance will decrease with frequency on all types but wirewounds, where the resistance tends to increase. The effective resistance of devices with a d.c. resistance from 15 to 50,000 ohms can be measured at frequencies from 500 kHz to 250 MHz on a *Boonton* Model 250-A RX Meter. Measuring accuracy over these resistance values is from  $\pm 2\%$  to  $\pm 13\%$ . Resistor capacitance and inductance can also be measured at these frequencies. For higher resistance values (up to one megohm) and frequencies up to 400 MHz, a cavity resonator such as described in Parts 1 and 2 of the reports on Signal Corps Contract W36-039-SC-44526 can be used. This equipment has an accuracy that is no better than  $\pm 20\%$ .

This article has briefly touched upon the many resistor tests and test instruments. Additional tests are explained in the various MIL and EIA specifications. A complete discussion of most environmental, physical, and electrical tests and test equipment can be found in MIL-STD-202.

The author wishes to acknowledge the assistance of Mr. H. M. Cassidy, Chief of Electronic Section, *IRC* and Mr. Wm. H. Morningred, Senior Test Engineer, *IRC* in the preparation of this article. ▲

# The Plumbicon:

## a new approach to camera tubes

Similar to a vidicon in both size and principle, this new camera tube uses a lead target to gain certain advantages.

MANY TV stations in the U.S. are presently using the Plumbicon type of color pickup tube in their color cameras. The name "Plumbicon" was chosen by its developers, Philips, because, as will be shown, the photoconductive target is made from lead monoxide and *plumb* is derived from *plumbum* which means lead (*Pb*) in Latin.

According to the manufacturer, compared to the vidicon the Plumbicon has higher sensitivity, slightly lower resolution, faster response, and lower dark current that results in an absence of black shading and a more accurate black level. This latter is a spurious temperature-dependent flow of charge carriers in the photoconductive layer that prevents good picture contrast under certain conditions. In size and principle of operation, the vidicon and Plumbicon are similar.

Basic operation is shown in Fig. 1. The target consists of a conducting but very thin layer of stannous oxide ( $\text{SnO}_2$ ) that has been deposited on the glass window to form the signal-collecting electrode. A very thin layer of lead monoxide ( $\text{PbO}$ ) is evaporated on top of the  $\text{SnO}_2$  to form the actual target. The target is held at about 30 volts with respect to the cathode while the inside surface of the  $\text{PbO}$  layer is scanned by the electron beam from the gun. The mesh anode screen serves to provide a uniform field between the target and the anode.

The lead monoxide layer is actually three layers thick. The center portion is almost pure  $\text{PbO}$  which is an intrinsic semiconductor. The portion being scanned by the electron beam is doped to create a *p*-type layer. The  $\text{SnO}_2$  layer is a strong *n*-type making the portion of the  $\text{PbO}$  layer adjacent to it an *n*-type region.

When the tube is in operation, the target structure makes up a reverse-biased *p-i-n* diode with an electric field and a capacitance existing across it. The overall capacitance across the target can be considered as consisting of a very large number of very small capacitors, one for each element point of the focused image.

Shunting each of these capacitors is a small current source formed by the charge carriers (electrons and holes) that have been liberated within the target material as a result of the incident illumination at that point. When the scanning electron beam contacts the face of one of these capacitors, the capacitor starts to charge from the 30-volt source. As soon as the scanning beam leaves that capacitor, it starts to discharge through the combination of resistor and current source between the target and cathode. The rate at which each capacitor discharges depends on the flow of photocurrent which is dependent on the intensity of the focused illumination at that point. Therefore, voltage developed across the series resistor is proportional to the light intensity at the target point

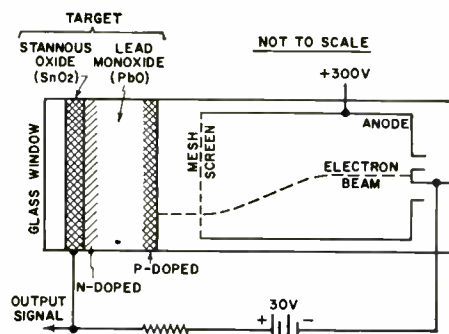
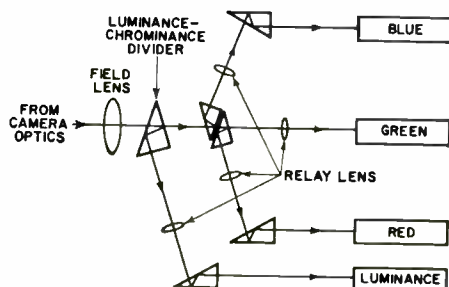

Fig. 1. Exaggerated view of a Plumbicon target shows that the lead monoxide is both "n"- and "p"-doped with center an intrinsic semiconductor. Signal pickup is from stannous oxide conducting layer.

Fig. 2. Basic four-Plumbicon color-TV camera has separate tube for luminance signal. This system uses prismatic light splitting in place of dichroic mirrors.



being scanned by the deflected beam.

The sensitivity of the Plumbicon comes from the fact that there is a high electric field across the target because the bulk of the  $\text{PbO}$  is a relatively poor conductor. Thus, almost all the charge carriers liberated in the target by the incident light are caused to drift and contribute to the photocurrent. The Plumbicon has a very small dark current because of the blocking action of the *p*-type and *n*-type layers to electrons and holes not generated by light activation.

### Color Camera Use

TV studio engineers have been using the Plumbicon in a unique four-tube color-TV camera. This camera, shown in Fig. 2, provides a separate luminance (black-and-white) output besides the three color signals.

In a conventional three-tube camera, the luminance signal is created by matrixing the signals from the three separate color pickups, and it has been claimed that registration of the three color tubes is difficult and that long-term stability of both camera and associated electronics is hard to achieve. In the four-tube camera, the luminance signal is independent of the optical registration of the three color tubes, and monochrome picture degradation caused by one of the color pickups being defective is minimized.

The optical system shown in Fig. 2 uses prismatic-type light splitting instead of the dichroic mirror system being widely used. This new system was adopted because it occupies less space than the dichroic mirror system and avoids ghost images, spurious color degradation across the picture, and unfaithful color rendition with polarized light (e.g., light reflected from hair).

The relay lenses are used to extend the light path from the input optics to the pickup tubes. These are used because it is difficult to form the input optical image directly on the pickup targets using only the camera's main lens system. This type of optical system is also useful in minimizing the influence of any stray magnetic fields that could damage color reproduction, as each of the image pickups is mounted parallel to the others and all have similarly oriented images. This system also permits the use of conventional camera lensing.

The luminance-chrominance divider prism splits the light path between the luminance and color signal pickups and can be replaced easily by a fully reflecting mirror in the event that the four-tube color camera is used for monochrome pickup. The surfaces of the remaining optical elements are treated so that each pickup tube receives the correct color image. Spectral trimming filters are inserted in each light path to make sure that the images formed at each color pickup are of the correct color quality. ▲

*Description of a useful laboratory technique for measuring transmission-line characteristics by means of a step generator and an oscilloscope.*

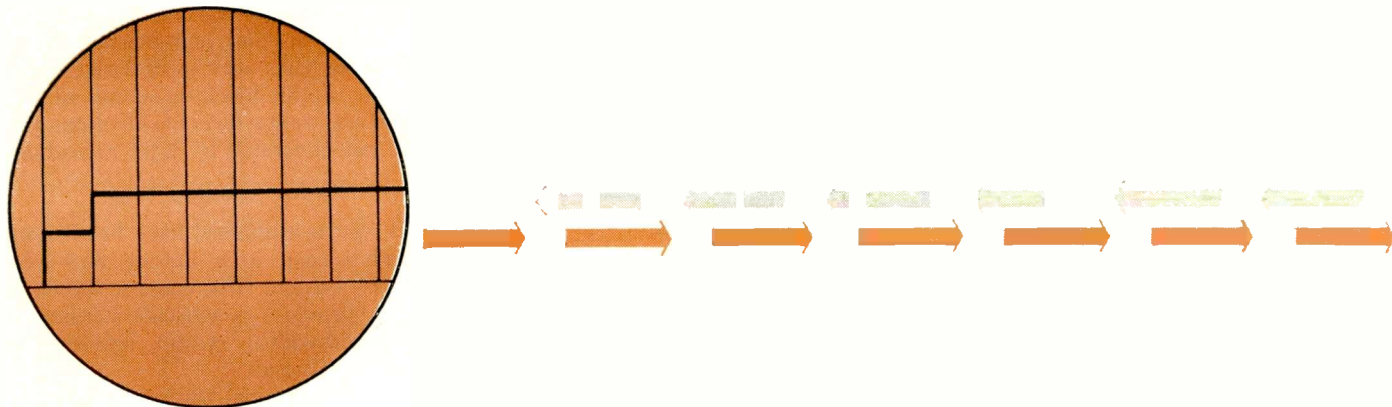

# Time Domain Reflectometry

By JOHN D. LENK

THE most common method used by industry for evaluating a transmission line and its load has traditionally involved feeding a sine wave into the system and measuring the maximum and minimum amplitudes of the standing waves resulting from discontinuities on the line. From these measurements, the standing-wave ratio is calculated and used as a figure of merit for the transmission line or system. This method involves specialized equipment and presents several problems to the technician or engineer using it.

A newer technique, *time domain reflectometry*, has recently been put into use by industry. This new method avoids the disadvantages of the s.w.r. method and can be learned quickly. TDR, as it is commonly abbreviated, uses a step or pulse generator and an oscilloscope in a system best described as a "closed-loop radar." A voltage step or pulse is sent down

the transmission line under test, and the incident and reflected waves are monitored by the oscilloscope at a particular point on the line. This echo technique reveals at a glance the characteristic impedance of the line. It also shows both the position and nature (resistive, inductive, or capacitive) of each discontinuity along the line. Time domain reflectometry also demonstrates whether losses in a transmission line are series or shunt losses. All this is done by simply observing the shape of the oscilloscope pattern.

## Typical TDR System

A typical time domain reflectometry setup is illustrated in Fig. 1. As shown, the actual test setup is quite simple, consisting only of a step or pulse generator, a bridging tee, and an oscilloscope. Any number of tee fittings can be used without modification, and there are many commercial TDR bridging-tee units available. Also, there are complete test sets known as time domain reflectometers (such as those manufactured by *Hewlett-Packard* and others) that contain an oscilloscope, pulse generator, and built-in tee.

In operation, the step or pulse generator produces a positive incident (outgoing) wave which is fed into the transmission system under test. The oscilloscope's high-impedance input effectively bridges the transmission system at its junction with the step generator. The pulse travels down the transmission line at a velocity of propagation determined by the line's characteristics. If the load impedance is equal to the characteristic impedance of the line, no wave or pulse is reflected, and all that will be seen on the oscilloscope is the incident voltage pulse or step recorded as the wave passes the point on the line monitored by the oscilloscope. The waveform would be similar to that of Fig. 2A.

If a mismatch exists at the load, part of the incident wave is reflected. The reflected voltage will appear on the oscilloscope display, algebraically added to the incident wave. This may produce a waveform similar to that of Fig. 2B.

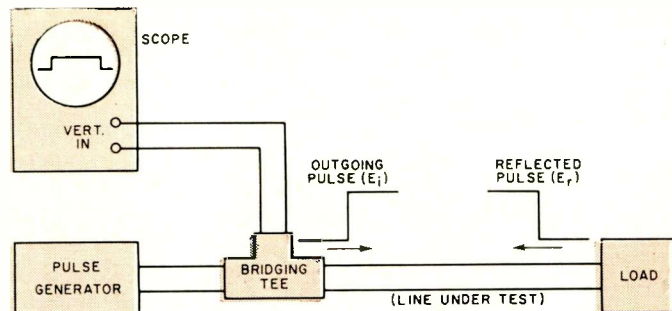
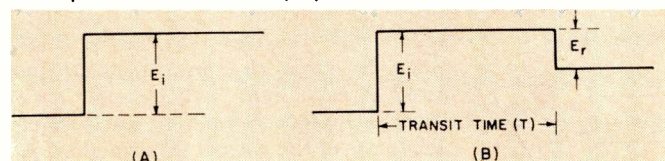

Fig. 1. The basic time domain reflectometry setup described.

Fig. 2. (A) Scope display when load equals characteristic impedance of line. (B) Display with a mismatched output load.



The actual procedures for operating a TDR setup are quite simple. In practice, operation consists of little more than adjusting the pulse generator controls until a suitable pulse is presented on the scope. From that point, actual operation is an automatic function of the system. However, the analysis and evaluation of the oscilloscope display does require some discussion. Interpretation of the scope presentation is the only real trick to learning the TDR technique.

### Locating Mismatches

Once the test connections have been made and the generator and scope controls adjusted for a suitable display, the presentation itself will show whether there is a mismatch (without a mismatch, no wave or pulse will be reflected). Locating mismatch on the line is a little more difficult.

The basic procedure for locating mismatches is to measure the travel time and speed of the pulse as it passes down the transmission line and then back to the scope. This is accomplished by measuring the distance (in time) between the incident and reflected waves. The reflected wave is easy to spot since it is separated in time from the incident wave. By measuring both the time and velocity of propagation, the distance can be calculated. The basic equation for distance is  $D = V_p \times (T/2)$  or  $D = (V_p T)/2$  where  $D$  is distance,  $V_p$  is velocity of propagation, and  $T$  is transit time for the pulse to go from monitoring point to the mismatch and back again, as measured on the scope.

The velocity of propagation can be determined from an experiment on a known length of the same type of cable being checked. For example, the time required for the incident wave to travel down to, and the reflected wave to travel back from, an open circuit termination at the end of a 120-cm length of RG-9A coaxial cable is 11.4 nanoseconds (1 nsec =  $10^{-9}$  sec). This means that the  $V_p$  is 21 cm/nsec (approximately) or  $2.1 \times 10^{10}$  cm/sec.

Transit time can be determined quickly if the scope used happens to be a precision lab model. With such scopes, the sweep length (in time) can be obtained from the specifications, and the specifications can be relied upon. On most service or shop scopes, the sweep length (in time) is not specified, only the sweep rates. Of course, the sweep length (in time) can be calculated. For example, if the sweep rate is 10 Hz, the time of each sweep is  $1/10$  second (neglecting retrace time); if the sweep rate is 1 MHz, the length is 1 microsecond; and so on. However, this is a hit-or-miss proposition on most service scopes since the sweep rate accuracy cannot be relied upon, nor can the retrace time be calculated. A more practical plan is to experiment on a known length of transmission line of the same type as will be measured. Here is the procedure.

Assume that several hundred feet of line are to be measured, or a break (or short) in a long line (say a coax in a multi-story master antenna system) is suspected. Connect the pulse generator (a low-frequency square-wave generator with a fast rise time can be used) and scope as shown in Fig. 1. Try various sweep rates until the reflected pulse is visible on the scope. Increase the sweep rate until the reflected pulse is near the incident pulse. Measure the number of scope divi-

sions between the incident and reflected pulses. Then relate this to the known length.

For example, assume that the scope has 8 major divisions, with each division broken down into 10 subdivisions. This gives a total of 80 subdivisions. If the sweep rate can be increased to a point where the 10-foot length of line produces a return pulse separated from the incident pulse by one subdivision, then the total sweep will represent 800 feet (10 subdivisions or 1 major division = 100 feet; 8 major divisions = 800 feet). (See Fig. 3.)

If very short lengths of line are being measured with a service-type scope, it may be found that sweep rates are not fast enough. In that case, an external source for the horizontal sweep can be used. Of course, the upper limit will be set by the bandwidth of the horizontal amplifier (unless horizontal plates can be driven directly with high-frequency sweep).

### Analyzing the Reflected Wave

Once a method of relating oscilloscope divisions to transmission length has been devised, there will be no trouble in locating mismatches (opens, shorts, or termination in a different impedance). The next step is to relate the reflected waveshape to the nature and magnitude of the mismatch. This can be done by studying the waveshape. Figs. 4A through 4D show four typical oscilloscope displays and the load impedance responsible for each.

In Fig. 4A, which is an open-circuit termination where the load impedance is infinity, the full voltage will be reflected back in phase and will be added to the incident voltage.

In Fig. 4B, which is a short-circuit termination where the load impedance is zero, the voltage will be reflected back in opposite phase and cancel the incident voltage.

In Fig. 4C, which is a pure resistive load where the load impedance is twice the characteristic impedance of the transmission line, one-third of the voltage will be reflected back and will be added to the incident voltage.

In Fig. 4D, which is a pure resistive load where the load impedance is one-half the impedance of the transmission line, one-third of the voltage will be reflected back and will cancel one-third of the incident voltage.

By studying these four illustrations, it will be seen that the

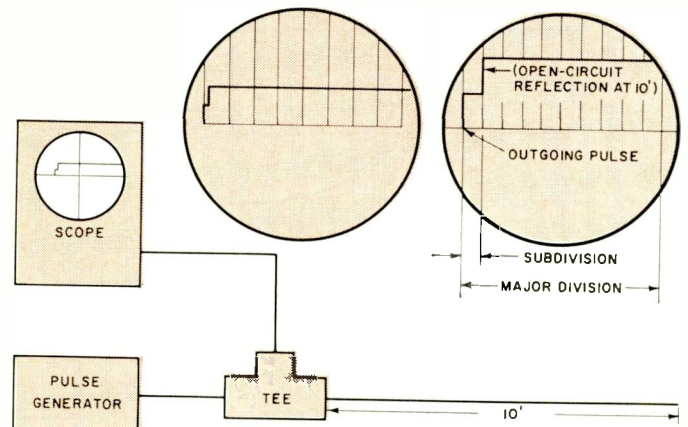
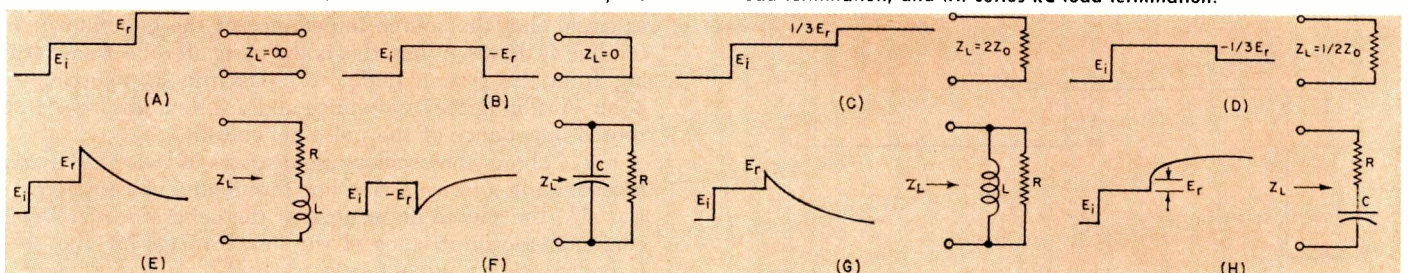

Fig. 3. Relating transit time to a fixed length of line.

Fig. 4. Scope displays with (A) open-circuit termination, (B) short-circuit termination, (C) resistive load equal to twice characteristic impedance of line, (D) resistive load equal to half the characteristic impedance, (E) series RL load termination, (F) shunt RC load termination, (G) shunt RL load termination, and (H) series RC load termination.



reflected pulses from an open, a short, or a pure resistive load will be the same shape as those of the pulse generator, and they will be added algebraically to the incident pulse on the scope display.

Unlike pure resistive loads, capacitive or inductive loads will change the shape of the reflected wave. Figs. 4E through 4H show four typical scope displays with capacitive and inductive loads and the particular load combination responsible for each.

In Fig. 4E, which is a load combination of resistance and inductance in series, the leading edge of the reflected wave is the same shape as the incident pulse and is added algebraically. With time, however, the pulse slopes off to a value below that of the incident pulse. This slope is caused by the effect of the inductance. When the pulse waveform is first applied, the inductance opposes current flow and appears as an infinite impedance. As current starts to flow, the impedance begins to drop, and the voltage slopes off in proportion. Current flow is limited only by the effect of the resistance.

In Fig. 4F, which is a load combination of capacitance and resistance in shunt, the capacitor acts like a short to the pulse waveform. Initially, the load impedance is zero, and the voltage drops to zero and cancels the incident voltage. With time, the voltage builds up across the capacitor, and current flow is reduced. The rate of capacitor charge and discharge is determined by the RC circuit values.

In Fig. 4G, which is a load combination of a high-value resistance and inductance in shunt, the leading edge of the reflected wave is the same shape as the incident pulse and is added algebraically. With time, the pulse slopes off to zero. This is a similar reaction to that of a resistance-inductance in series. However, since the inductance is in shunt, the current

flow is not limited by the resistance. Therefore, the voltage drops to zero.

In Fig. 4H, which is a load combination of capacitance and high-value resistance in series, the capacitor initially appears as a short to the pulse leading edge, leaving only the resistance as load. With time, the voltage builds up across the capacitor and is added algebraically. The rate of capacitor charge and discharge is determined by the RC circuit values.

By studying these four illustrations, it will be seen that the reflected waveshape determines the type of mismatch or load present on the transmission line under test. Once these waveshapes are learned, both the type and location of the mismatch can be determined. If the amplitude and rate of slope could be measured accurately, the actual values of resistance, inductance, and capacitance causing the particular waveshape could be calculated.

### Discontinuities on the Line

So far, we have mentioned only the effects of a mismatched load at the end of a transmission line. More often, what is happening at some point along the line, and not at the load itself, is the main concern. For example, consider that the junction of two transmission lines uses a connector of some sort as shown in Fig. 5A. Also assume that the connector adds a small inductance in series with the line. Analyzing this discontinuity on the line is not much different from analyzing a mismatched termination. In effect, everything to the right of M in Fig. 5A is an equivalent impedance in series with the small inductance, and this series combination is the effective load impedance for the system at point M. Therefore, the circuit is similar to a resistance and inductance in series (Fig. 5B), and the reflected waveform will be as shown.

One of the major advantages of TDR is its ability to handle situations involving more than one discontinuity. An example of this is shown in Fig. 6A. The scope display for this situation would be similar to that shown in Fig. 6B for the impedance values indicated. As shown, the two mismatches produce reflections that can be analyzed separately. The mismatch at the junction of the two transmission lines generates a reflected wave  $E_{r1}$ . Similarly, the mismatch at the load also creates a reflection. These two reflections interact and re-reflect pulses in both directions. This continues indefinitely, but after some time the magnitude of the reflections approaches zero.

Although TDR is useful when observing multiple discontinuities, the slight complication introduced by these discontinuities must be considered when analyzing the scope display. Fortunately, most practical measuring situations involve only small mismatches, and the effect of multiple reflections is almost nil. Even in this situation, however, it is advisable to analyze and clean up a system from the generator end. The reflection from the first of any number of discontinuities is unaffected by the presence of others. Therefore, if it is remedied first, and then the second discontinuity is checked, the complications introduced by re-reflections will not exist.

### Pulse Generator Source Impedance

When the source impedance of the step generator is not equal to the characteristic impedance of the line it drives, voltage waves returning from a mismatch or discontinuity in the system under test will be re-reflected at the generator end. This will complicate analysis of the display. Therefore, it is essential that the source impedance of the generator match the line it drives. When this is the case, all reflections returning from the system under test pass the scope monitoring point (bridging tee) only once and are then absorbed in the source impedance of the pulse generator.

Fig. 7 shows the oscilloscope displays of two TDR systems investigating a transmission line terminated in a capacitor. In Fig. 7A, the source impedance of the generator matches the characteristic impedance of the line. In Fig. 7B, the source impedance is not equal to the

(Continued on page 70)

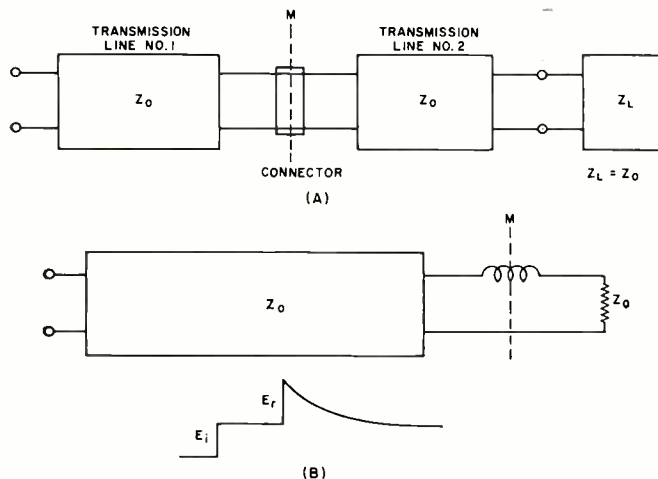
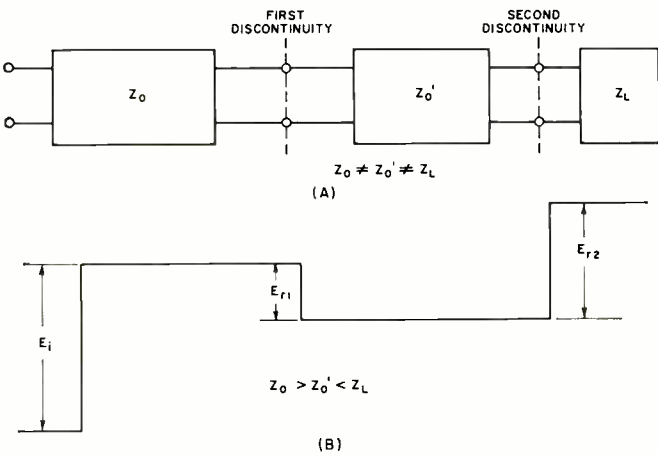

Fig. 5. Two transmission lines connected together by means of a connector that introduces inductance into the circuit.

Fig. 6. Multiple discontinuities may be determined by TDR.





# How To Get A \$570 Stereo Recorder For \$400

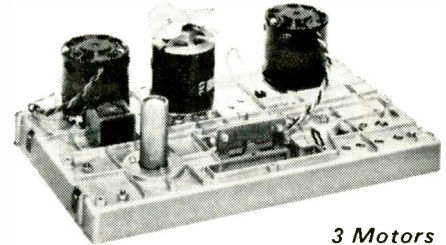
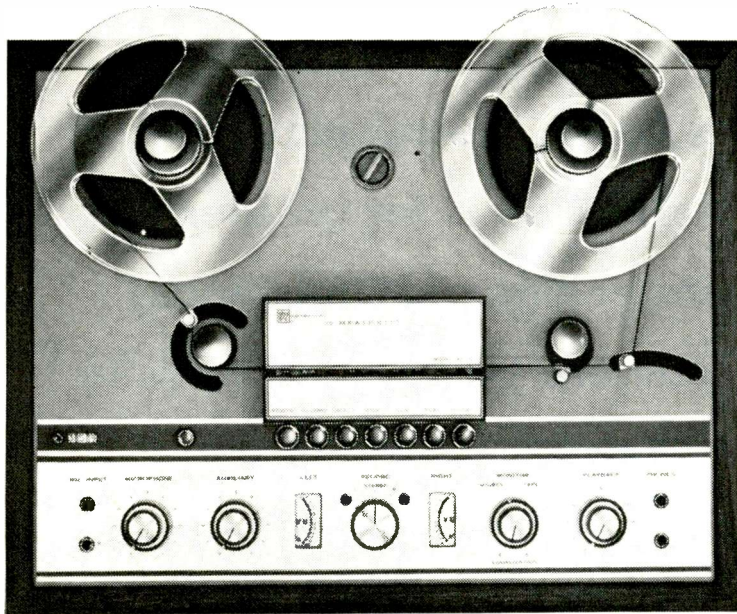

3 Motors . . .  
Solenoid Operated . . .  
Die-cast Main-plate, Flywheel  
& Capstan Shaft Housing

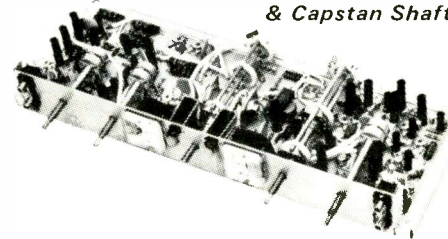

All Solid-State Electronics . . . Record  
4-Track, Stereo-Mono, Sound-On-  
Sound, Sound-With-Sound & Echo!

## Build The New Heathkit®/Magnecord® 1020!

### You Save \$170!

Thanks to Heath, you can now save \$170 on the new Magnecord 1020 4-Track Transistor Stereo Tape Recorder by building it yourself. And the only difference between this Heathkit version and the original is the \$170 you save (think of all the tape you can buy with that!).

All parts are made at the Magnecord factory . . . under a quality control system that meets the demanding requirements of the National Aeronautics & Space Administration (NASA).

Add to this Magnecord's years of pioneering and developing tape equipment for the broadcasting and recording industries, and you have a sophisticated recorder that will give you years of professional quality and reliability.

### Professional Recording Facilities

With the 1020, you can record "live" from microphones, or from auxiliary sources like tuners, phonographs, TV's, etc., and playback . . . in 4-track stereo or mono at either 7½ or 3¾ ips. And you can make sound-on-sound, or sound-with-sound (mixing) recordings, or create interesting echo effects.

### Professional Tape Transport

The tape transport is powered by 3 separate motors. The hysteresis synchronous capstan motor has a dynamically balanced flywheel and a ballbearing inertial stabilizer mount for constant, accurate speed. Two permanent split-capacitor type motors drive

the reels. With the convenient push-button controls, you can change operational modes instantly and gently with the touch of a button. Compliance arms insure correct tape tension at all times.

The military-type differential band brakes are solenoid operated for instant, gentle stops. And when the tape runs out an automatic switch shuts off all motors and retracts the tape pressure roller eliminating unnecessary motor wear and prevents deformation of rollers. The tape gate and pressure roller also are solenoid-operated for positive action.

### 3 Professional Tape Heads

Selectable ¼ track erase, record and play. Engineered and lapped to a precise hyperbolic curve for smooth low frequency response . . . made with a deep gap, deposited quartz for high frequency response and long life. Removable shields afford double protection against external magnetic fields. Protective, snap-mounted head covers provide easy access for cleaning and de-magnetizing. And for quick, accurate editing, there are center-line marks.

### Other Professional Features

All parts mount on a thick, die-cast main-plate that won't warp, reduces wear, provides rigid support and stable alignment. Two V.U. meters for visual monitoring of signal levels from either tape or source . . . allows quick comparison of source with re-

corded signal. Inputs for microphones and outputs for headphones are all front-panel mounted for easy access. Digital counter with push button reset. Low impedance emitter-follower outputs deliver 500 millivolts or more to amplifier inputs. Individual gain controls for each channel. And all solid-state circuitry . . . 21 transistors and 4 diodes . . . your assurance of cool, instant operation, long reliable life.

### Famous Heathkit Know-How Speeds Assembly

Simple step-by-step instructions with generous use of giant pictorials guide you every step of the way. You just wire two circuit boards and do the easy mechanical mounting for the transport components.

And to make construction even easier, the connecting wires and shielded cables are pre-cut, stripped, and marked . . . even the connectors are installed where necessary; just plug them in! The only soldering you do is on the circuit board! Total assembly time is around 25 hours . . . that's like getting \$7 an hour for your efforts.

Get today's best buy in a professional stereo tape recorder . . . order the Heathkit version of the Magnecord 1020 now!

- Kit AD-16, deck & electronics, 45 lbs. . . . \$399.50
- ADA-16-1, walnut base, 8 lbs. . . . \$19.95
- ADA-16-2, adapter ring for cabinet or wall mounting, 2 lbs. . . . \$4.75
- ADA-16-3, slides, (combine with walnut base for tape drawer), 7 lbs. . . . \$9.95

## FREE!

### World's Largest Kit Catalog

108 pages! Describes this and over 250 kits in stereo hi-fi, color TV, organs, ham, test, CB, marine, home and hobby. Mail coupon, or write Heath Company, Benton Harbor, Michigan 49022.



Heath Company, Dept. 15-9 Benton Harbor, Michigan 49022

Enclosed is \$ \_\_\_\_\_, plus shipping. Please send model (s) \_\_\_\_\_

Please send FREE Heathkit Catalog.

Name \_\_\_\_\_

Address \_\_\_\_\_

City \_\_\_\_\_ State \_\_\_\_\_ Zip \_\_\_\_\_

Prices and specifications subject to change without notice.

HF-194

In today's electronics boom, the demand for men with technical education is far greater than the supply of graduate engineers. Thousands of real engineering jobs are being filled by men without engineering degrees—provided they are thoroughly trained in basic electronic theory and modern application. The pay is good, the future is bright...and the training can now be acquired at home—on your own time.

# How to become a “Non-Degree Engineer”

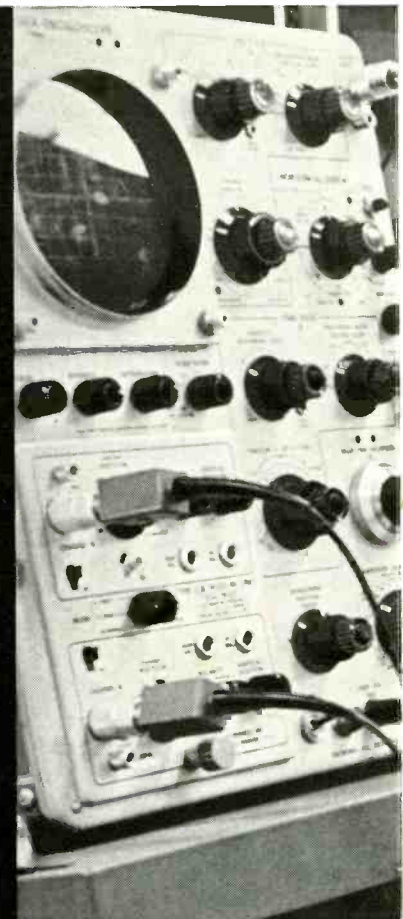

**T**HE ELECTRONICS BOOM has created a new breed of professional man—the non-degree engineer. Depending on the branch of electronics he's in, he may "ride herd" over a flock of computers, run a powerful TV transmitter, supervise a service or maintenance department, or work side by side with distinguished scientists on a new discovery.

But you do need to know more than soldering connections, testing circuits and replacing components. You need to really know the fundamentals of electronics.

How can you pick up this necessary knowledge? Many of today's non-degree engineers learned their electronics at home. In fact, some authorities feel that a home study course is the *best* way. *Popular Electronics* said:

"By its very nature, home study develops your ability to analyze and extract information as well as to strengthen your sense of responsibility and initiative."

#### Cleveland Method Makes It Easy

If you do decide to advance your career through home study, it's best to pick a school that *specializes* in the home study method. Electronics is complicated enough without trying to learn it from texts and lessons that were designed for the classroom instead of the home.

Cleveland Institute of Electronics concentrates on home study exclusively. Over the last 30 years it has developed tech-

niques that make learning at home easy, even if you once had trouble studying. Your instructor gives the lessons and questions you send in his undivided personal attention—it's like being the only student in his "class." He not only grades your work, he analyzes it. And he mails back his corrections and comments the same day he gets your lessons, so you read his notations while everything is still fresh in your mind.

Students who have taken other courses often comment on how much more they learn from CIE. Says Mark E. Newland of Santa Maria, Calif.:

"Of 11 different correspondence courses I've taken, CIE's was the best prepared, most interesting, and easiest to understand. I passed my 1st Class FCC exam after completing my course, and have increased my earnings by \$120 a month."

#### Always Up-to-Date

Because of rapid developments in electronics, CIE courses are constantly being revised. This year's courses include up-to-the-minute lessons in Microminiaturization, Laser Theory and Application, Suppressed Carrier Modulation, Single Sideband Techniques, Logical Troubleshooting, Boolean Algebra, Pulse Theory, Timebase Generators...and many more.

#### CIE Assures You an FCC License

The Cleveland method of training is so successful that better than *9 out of 10 CIE*

*men who take the FCC exam pass it—and on their first try.* This is despite the fact that, among non-CIE men, 2 out of every 3 who take the exam fail! That's why CIE can promise in writing to refund your tuition in full if you complete one of its FCC courses and fail to pass the licensing exam.

#### This Book Can Help You

Thousands who are advancing their electronics career started by reading our famous book, "How To Succeed in Electronics." It tells of many non-degree engineering jobs and other electronics careers open to men with the proper training. And it tells which courses of study best prepare you for the work you want.

If you would like to cash in on the electronics boom, let us send you this 40-page book free.

Just fill out and mail the attached card. Or, if the card is missing, write to:

### **CIE Cleveland Institute of Electronics**

1776 E. 17th St. Dept. EW-21  
Cleveland, Ohio 44114

Accredited Member National Home Study Council  
A Leader in Electronics Training... Since 1934

**NEWS FOR VETERANS:** New G.I. Bill may entitle you to Government-paid tuition for CIE courses if you had active duty in the Armed Forces after Jan. 31, 1955. Check box on reply card for details.





# J OHN FRYE

*The production of finished quartz crystals from raw mineral, whether by hand or machine, is a delicate, complex process.*

## CRYSTAL-GRINDING TECHNIQUES

**B**ARNEY came into the service department and dumped a large collection of folders, pamphlets, and mimeographed sheets on the bench in front of Mac, his employer. "There," he announced importantly, "is the harvest of umpteen letters I wrote crystal manufacturers asking for all the promotional material they had on the manufacture and application of quartz crystals. Thought you might like to browse through it."

"That I would," Mac answered. "I've had an envious interest in crystal manufacture ever since I tried grinding my own thirty-five years ago."

"Hey, you never told me about that! How'd you do it?"

"I bought rough blanks from a jeweler-ham, and they cost more than finished and mounted crystals do today. He cut them from raw quartz with his diamond saw. By today's standards, those blanks were huge affairs, averaging about an inch square and thick enough to resonate around 100 meters. Since I wanted to use them in the 80-meter band, that meant I had to take off a lot of quartz."

"How did you do it?"

"With lots of elbow grease. A fine grade of carborundum powder was mixed with water on a sheet of plate glass, and the blank was slid around in this mixture in a deliberately irregular pattern with a forefinger on the top, using a very light pressure, until you were confident one face of the blank was perfectly flat. From then on, this face was used as a reference and all grinding was done on the other side. The idea was first to grind the blank so that both flat sides were perfectly parallel to each other. Then you gradually ground away one face to raise the frequency while all four corners were kept equal in thickness and the center of the blank was 3 to 4 ten-thousandths thinner than the corners. This was tricky."

"I'd reckon. How did you manage it?"

"You ground a bit and then washed off the crystal and checked it with a good micrometer. Next you popped it into a temporary holder and connected the crystal in an oscillator circuit. A frequency meter checked the frequency of oscillation, and the oscillator grid current gave an indication of the crystal's activity. If all was well, you ground off some more. Exerting a little pressure with your finger in the center of the blank was all that was needed to cup that center slightly. Sooner or later, though, one corner would be found low, the center would be cupped too much or not enough, the crystal would oscillate weakly or stop altogether, or the cussed thing would develop two frequencies."

"What did you do then?"

"Tried to grind out any measured defects by exerting pressure on the high spots with my finger while moving the blank around in the slurry. Beveling the edges and rounding the corners would sometimes improve activity or get rid of an unwanted frequency. When I approached the target frequency, I usually switched to the finest grade of carborundum or even jeweler's rouge to slow down the frequency movement. My personal bugbear was to have the crystal oscillate beautifully right up to the desired frequency and

then go dead. It would stay dead until finally, in desperation, I ground it a bit more. Then it would oscillate vigorously again—ten to fifteen kHz above the frequency I wanted."

"What did you do about that?"

"Grabbed another blank and started all over. I could lower the frequency a kHz or so by coating the crystal with India ink or by marking all over it with a lead pencil, but the crystal frequency would gradually drift upward again as the ink or graphite wore off."

"How about a mounting?"

"I made my own crystal holder as a kind of sandwich of three 2" squares. The bottom square was of  $\frac{3}{8}$ " brass, while the middle and top squares were of  $\frac{3}{4}$ " Bakelite. The middle piece of Bakelite had a  $1\frac{1}{2}$ " square hole cut in the center. A crystal dropped into this opening rested on the brass plate, which constituted one electrode. Another 1" square brass plate was placed on top of the crystal for the other electrode, and a pigtail soldered to this plate went to the countersunk head of a binding post in the center of the top square of Bakelite. Bolts through all three layers at the four corners held the contraption together. Surfaces of the brass plates serving as crystal electrodes were lapped perfectly level. Weight of the 1" plate furnished the only pressure on the crystal. While the affair was cumbersome, would operate only in one position, and afforded the crystal no protection against shock and damage if dropped, the holder was dust-proof and worked surprisingly well. Now I've told you how I tried to do it; suppose you tell me how experts manufacture crystals today."

"Okay, but you'll see that many modern techniques simply constitute refinements and mechanization of your early methods. Quartz is a widely distributed mineral composed of silicon dioxide. Greeks called the water-clear quartz formations *crystallos*, or 'clear ice,' supposing them to be water frozen so hard by the intense cold of the Alps they would not melt.

"Complete quartz crystals have a hexagonal cross-section and pointed ends. The axis through the points is called the Z or optical axis. The three axes at right angles to the Z axis and going from one corner to the opposite corner of the crystal are called the X or electrical axes. The three perpendicular to both the Z axis and to opposite crystal faces are the Y or mechanical axes. The precise location of these axes is very important because the way the blank is cut from the crystal with regard to them determines its operating characteristics, including the mode of vibration and the temperature coefficient. Y- or X-cut crystals have their flat surfaces perpendicular, respectively, to either a Y or X axis. Other cuts, such as AT, BT, GT, etc., have precise, specified orientations with respect to these axes. X-rays and optical methods are used to detect any flaws in the crystal and the location of the axes before blanks are sawed from it with diamond saws."

"I thought synthetic quartz crystals were being grown in laboratories."

"They are, but the manufacturers I contacted all prefer natural quartz, most of which comes from Brazil. The blanks

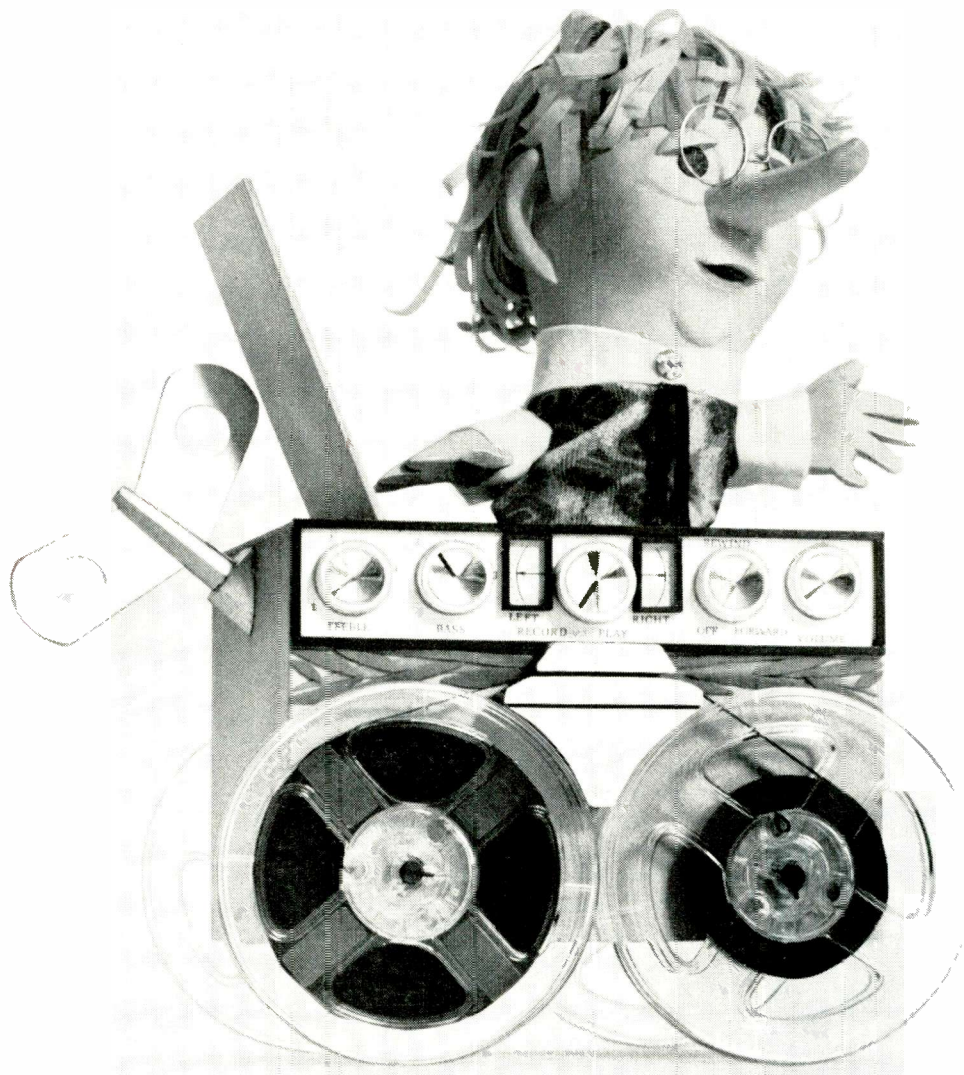

## Most tape recorders are toys:

The AMPEX 861 is a musical instrument. □ And yet, despite its technical perfection, the Ampex is one of the simplest tape recorders in the world to use. It offers uncomplicated straight line threading, versatile 3-speed operation ( $7\frac{1}{2}$ ,  $3\frac{3}{4}$ , and  $1\frac{7}{8}$  i.p.s.), and accurate record level VU meters. And, of course, our exclusive dual capstan drive insures constant tape tension for perfect flutter-free recording and playback. Two microphones and two slide-on stereo speakers are included. This neat package proves once again that when you want to record and playback sound beautifully you need something better than a plaything. You need Ampex. Only \$299.95—complete.

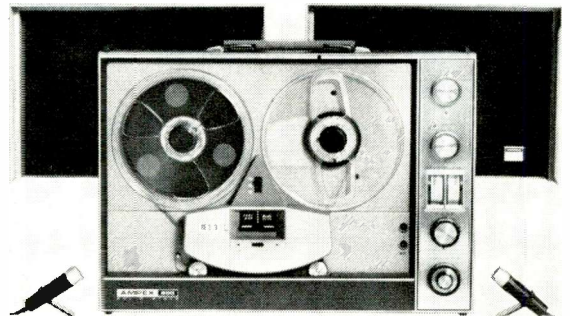

AUDIO AND VIDEO RECORDERS / SPEAKERS / MICROPHONES / VIDEO CAMERAS / TAPES / ACCESSORIES

AMPEX CORPORATION, 2201 LUNT AVENUE, ELK GROVE VILLAGE, ILLINOIS 60007

ask anyone who knows

**AMPEX**

## PERMANENT PROTECTION!



# Electronics World

Deluxe Magazine Files  
that hold a full  
year's copies!

Designed to keep your periodicals orderly and easy to refer to. These durable files guard against soiling, tearing, wear or misplacement of issues. They look, feel like leather and are washable! 23kt. gold lettering and exquisite 2-color binding make them highly-decorative additions to your bookshelves.

Shipped POSTPAID! FULLY GUARANTEED!

Only \$3.50 each—3 for \$10, 6 for \$19

Order several today—for ELECTRONICS WORLD and all your other favorite magazines.

Jesse Jones Box Corp., Box 5120, Dept. EW  
Philadelphia 41, Pa.

Enclosed is \$\_\_\_\_\_. Please send me \_\_\_\_\_  
Electronics World Magazine Files in the colors checked  
below:

- Black backing/maroon sides  
 Maroon backing/black sides

NAME \_\_\_\_\_

ADDRESS \_\_\_\_\_

CITY \_\_\_\_\_ STATE \_\_\_\_\_ ZIP CODE \_\_\_\_\_

Orders outside U.S.A. please add \$1 additional for  
each file ordered.

(Payment must accompany order)

Every No-Noise Aerosol Product

# Guaranteed

## Non-Flammable

## Non-Toxic and

## Won't Affect Plastics

# "NO NOISE"

Insist On This Trusted  
NAME BRAND

Avoid Risky "Private Labels"

"No Noise" PRODUCTS ARE  
PERFECT FOR COLOR TV

- Volume Control & Contact Restorer
- Tuner-Tonic with Perma-Film
- EC-44 For Electrical Contacts
- Tape-Reco Head Cleaner
- Frigid-Air Circuit Cooler

FREE 5" plastic extender push-but-  
ton assembly for pin-point applica-  
tion with all No-Noise products.

**ELECTRONIC CHEMICAL CORP.**  
813 Communipaw Avenue, Jersey City 4, N. J.

CIRCLE NO. 118 ON READER SERVICE CARD  
58

are carefully sorted and lapped by special machines to—in critical cases—within 10-millionths of an inch of the desired thickness. Actually, the crystal plates are ground a trifle high in frequency because the plating on of electrodes will bring the frequency back down. The plates then undergo thorough cleaning with various acid and detergent baths and sometimes ultrasonic methods. Finally, they are subjected to a chemical etching bath to prevent the crystals from 'aging,' or drifting in frequency, after they are finished.

"Most crystals now have electrodes plated directly onto their flat surfaces by means of evaporation under high vacuum, sputtering under low vacuum, or a system of furnace-firing silver or gold paints. Following this basic plating, the crystals are mounted in holders and additional metal is applied to the surface of the base plating. The weight of this additional nickel plating lowers the frequency toward the target frequency. At this point, each crystal is handled individually, with a continuous process of frequency-checking and plating going on until the oscillating frequency is within the specification limits. Finally, mounted and calibrated crystals are sealed in either metal holders filled with helium or nitrogen or in glass holders that are vacuum-sealed.

"Very recently two significant developments have transpired in the manufacture and use of quartz crystals. The first is called the 'energy-trapping theory.' Credit for work in developing the theory is shared by, among others, Wm. Shockley, Dr. G. K. Guttwein of the USAEC at Fort Monmouth, D.R. Curran of *Clevite Corp.*, Ted Lukaszek of the USAEC, and Prof. R. D. Mindlin of Columbia University.

"The theory can be explained fully only by complex mathematics, but a crude explanation goes as follows:

"In addition to the desired thickness-shear mode, a crystal for h.f. or v.h.f. vibrates in many other modes producing other resonances, the most disturbing of which are all higher than the thickness-shear mode. The presence of these unwanted modes degrades crystal-filter performance. Beveling the edges and performing other tricks to avoid this degradation are only partly successful.

"The area beneath an electrode plated onto a crystal vibrates at a lower frequency than does the remainder of the crystal because of mass loading. It has been found that increasing the electrode mass to a certain critical value will result in the area beneath the electrode vibrating at the desired frequency, while the energy produced by other modes of vibration in the crystal will leak out into the area not beneath the electrode and be absorbed. The result is that the vibration energy we want is 'trapped' beneath

the electrode—where we want it—and that other vibrational motion takes place chiefly in the rest of the crystal and does not contribute effectively to the piezoelectric current picked up by the electrodes.

"An analogy would be a waveguide feeding through a larger cavity dimensioned to propagate the desired frequency as the dominant mode. Most of the energy of the desired mode would concentrate in the resonant cavity. Higher order modes would propagate in this region, too, but most of their energy would concentrate elsewhere (where the main mode would be cut off and couldn't follow) and these higher order modes would not contribute much to the oscillations in the main mode section.

"The practical benefit of the application of energy trapping in crystal design is a cleaner, lower resistance crystal that is superior not only in filters but also in special oscillators."

"You said there were two developments."

"The second is really connected to the first since it uses the energy-trapping principle to construct two or more 'resonators' on a single quartz plate. Work in this field has been done by Roger Sykes and William Beaver of the *Bell Telephone* facility at Allentown, Pa., and by D. B. Curran, W. J. Gerber, D. J. Koneval, and K. A. Pim of *Clevite* working with the U.S. Army Electronic Components Laboratory.

"Energy trapping provides decoupling—or rather controlled coupling—between different resonators even though they are parts of the same crystal wafer. In fact, you can think of the device as consisting of mechanical resonators coupled by the elastic quality of the quartz. The result is a versatile, compact, easily constructed filter. *Bell* has a six-resonator model that compares closely with conventional filters used in point-to-point SSB use. Another model replaces a conventional filter network of two hybrid transformers, four variable capacitors, and two crystal resonator units.

"*Clevite* is marketing its filters consisting of multi-electroded thin quartz chips under the name of 'Uniwafer.' We're certain to be hearing more of these monolithic jobs."

"Where did you get all this info?"

"*International Crystals, McCoy Electronics, Texas Crystals, Bell Laboratories, and the Clevite Corporation* were especially helpful. And I owe special thanks to Mr. Arthur D. Ballato of the USAEC for trying patiently to explain to me in simple one-syllable words just what complex energy trapping was all about."

"He didn't do too badly, considering the dull pupil he had to work with," Mac said with a teasing grin. ▲

# In an age when time is of the essence, thousands of people have spent 50 to 70 hours building their own Heathkit®/Thomas Organ

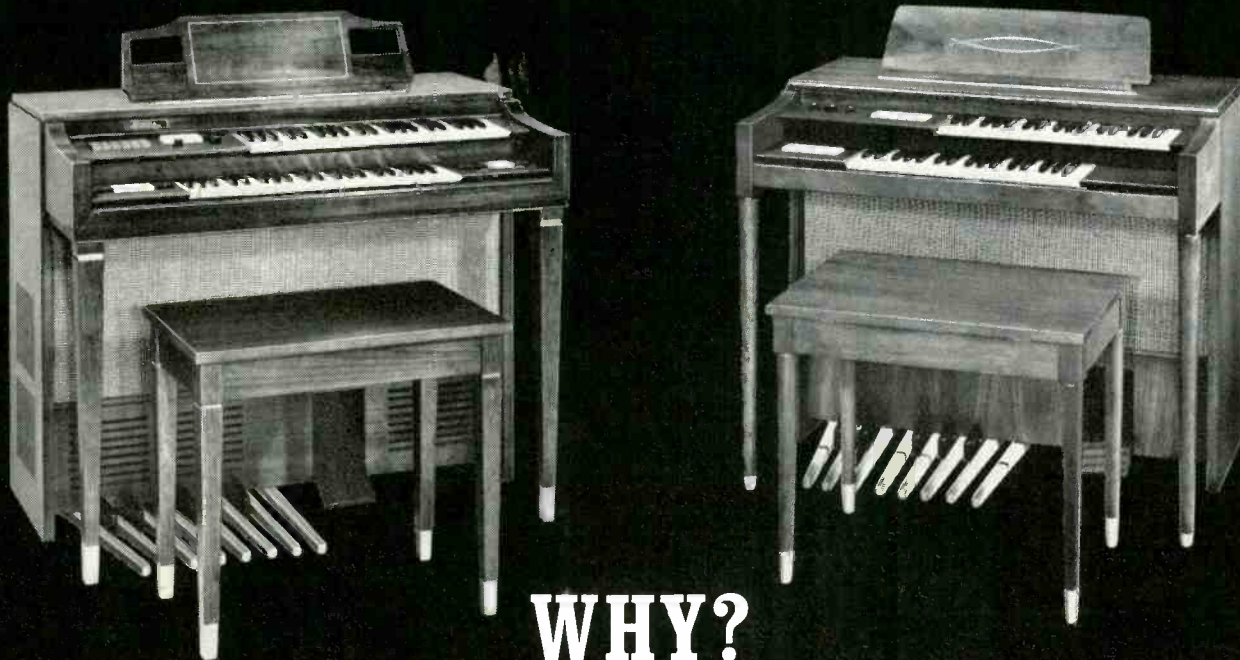

## WHY?

### Savings

It is a proven fact that significant savings can be realized. Savings amounting to several hundreds of dollars. This, indeed, is strong motivation for all.

### Superior Performance

Building your own Heathkit organ permits you to stretch your budget to afford the purchase of a superior instrument at the cost of an ordinary one. And Thomas organs are renowned for their excellent voicing, fine mechanical construction, and advanced electronic circuitry.

### Challenging Fun

If you haven't tried it, you cannot realize the exhilarating fun of constructing as complex an instrument as an organ. Yet, you need no special skills or knowledge to accomplish it. We show you how, completely. No unanswered questions, no technical jargon. Just one of the most satisfying do-it-yourself activities ever!

### Like To Hear Them Perform?

A 7", 33-1/3 rpm demonstration record is available for each organ. Use the handy coupon below, include 50¢ to cover postage and handling, and ask for record no. GDA-325-1 (GD-325B Color-Glo organ), or GDA-983-2 (GD-983 organ). You'll convince yourself.

### Deluxe Heathkit/Thomas "Coronado" ... 17 Voices, Chimes, Full Features

Just touch a tab and you create any one of 17 rich organ voices ... Saxophone 8', French Horn 8', Violin 8', English Horn 8', Oboe 8', Flute 8', Cello 8', Bass Clarinet 16', Trumpet 16', Bourdon 16', Flute D' Amour 4', Quint 5-1/3' and Diapason 16' and 8'. And you'll soon learn combinations to produce additional voices like the hawaiian guitar, vibraharp, harpsichord, zither, calliope, bagpipes, etc. It's like having an entire orchestra at your fingertips.

Its professional features also include 28 notes of chimes — worth \$500 to \$2000 as an extra on other organs; 2-speed rotating Leslie speaker plus 2-unit main speaker system; two 44-note keyboards; 13-note bass pedals; attack and repeat percussion; handcrafted walnut cabinet and bench; all-transistor circuit.

Kit assembly takes around 70 hours, and you enjoy savings up to \$350. Liberal credit terms available on both Heathkit/Thomas organs.

Kit GD-983, organ & matching bench,  
245 lbs. .... \$849.00

### Low-Cost Heathkit/Thomas "Artiste" ... Instant-Play COLOR-GLO And 10 Voices

Thanks to exclusive Color-Glo, you and every member of your family can play melody, harmony and bass notes instantly. Just match up the colors with your left hand, the letters with your right ... and you play complete songs ... even if you've never played an organ before!

And when you're finished, just flip a switch and the Color-Glo key lights disappear, leaving a beautiful spinet organ. Other features include 10 organ voices; two 37-note keyboards; 13-note bass pedals; variable repeat percussion; all-transistor circuitry; 12" speaker; plus handsome walnut cabinet and bench.

The assembly takes about 50 hours, and you save up to \$150 over a comparable factory-built model.

Discover how easy a Heathkit/Thomas organ is to build and play ... mail coupon below for FREE Heathkit catalog.

Kit GD-325B, 171 lbs. ... organ & matching bench. .... \$394.90



## FREE! World's Largest Electronic Kit Catalog!

108 pages ... many in full color ... describe these and over 250 easy-to-build kits for stereo/hi-fi, amateur radio, shortwave, color TV, test, marine, CB, educational. Mail coupon or write Heath Company, Benton Harbor, Michigan 49022

HEATH COMPANY, Dept. 15-9  
Benton Harbor, Michigan 49022

Enclosed is \$ \_\_\_\_\_, plus shipping.

Please send model \_\_\_\_\_

Please send FREE Heathkit Catalog.

Name \_\_\_\_\_

Address \_\_\_\_\_

City \_\_\_\_\_

State \_\_\_\_\_

Zip \_\_\_\_\_

Prices & specifications subject to change without notice.

CL-253



# Complete TUNER REPAIR

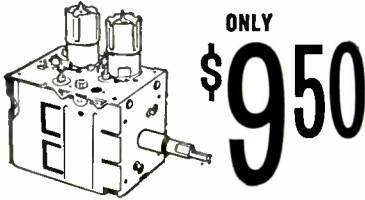

ONLY  
**\$9.50**

**Includes ALL parts (except tubes) . . . All labor on ALL makes. Fast 24-hour service with 1-year warranty**

Sarkes Tarzian, Inc., largest manufacturer of TV and FM tuners, offers unexcelled tuner overhaul and factory-supervised repair service.

Tarzian-made tuners received one day will be repaired and shipped out the next. More time may be required on other makes. Every channel checked and realigned per original specs. And, you get a full, 12-month guarantee against defective workmanship and parts failure due to normal usage. Cost, including labor and parts (except tubes) is only \$9.50 and \$15 for UV combinations. Replacements at low cost are available on tuners beyond practical repair.

Always send TV make, chassis and Model number with faulty tuner. Check with your local distributor for Sarkes Tarzian replacement tuners, parts or repair service. Or, use the address nearest you for fast, factory-supervised repair service.

TUNER SERVICE  CORPORATION

(Factory-supervised tuner service authorized by Sarkes Tarzian)

MIDWEST—817 N. Pennsylvania St.  
Indianapolis, Ind. Box 1642  
Tel: 317-632-3493

EAST—547-49 Tonnele Ave.  
Jersey City, New Jersey • Tel: 201-792-3730

SOUTH-EAST—938 Gordon St., S.W.  
Atlanta, Georgia • Tel: 404-758-2232

WEST—SARKES TARZIAN, Inc.  
Tuner Service Division  
10654 Magnolia Blvd., N. Hollywood, Calif.  
Tel: 213-769-2720

CIRCLE NO. 87 ON READER SERVICE CARD

## GET INTO ELECTRONICS



V.T.I. training leads to success as technicians, field engineers, specialists in communications, guided missiles, computers, radar and automation. Basic & advanced courses in theory & laboratory. Electronic Engineering Technology and Electronic Technology curricula both available. Assoc. degree in 29 mos. B. S. also obtainable. G.I. approved. Graduates in all branches of electronics with major companies. Start September. February. Dorms, campus. High school graduate or equivalent. Write for catalog.

**VALPARAISO TECHNICAL INSTITUTE**  
Dept. RD, Valparaiso, Indiana

# Life Testing of R.F. Inductors

*Time and temperature can affect electrical properties of coils. Here are recommendations for some testing techniques that can be used to assure reliability.*

By W. DIETER HAUSER

Manager, Electronic Technical Service  
Jeffers Electronics Div., Speer Carbon Co.  
Division of Air Reduction Co., Inc.

**M**OST fixed, molded coils are extremely rugged. They can be expected to function perfectly after being run over by a truck, dropped from an airplane, and immersed in water or most commercial solvents overnight. Yet these same coils may not function properly after only a few hundred hours of nestling in a circuit where the highest pressure is 1.0 atmosphere, the greatest shock results from slamming a door, and the strongest "solvent" is the aroma of after-shave lotion. The reason for this is thermal degradation. This is the change of the coils' electrical properties due to a combination of temperature and time.

Molded coils are not unique in this respect, as virtually all organic materials are affected by an aging process and r.f. coils contain organic materials in the form, wire insulation, and molded jacket. This process speeds up as temperature increases. A rule of thumb is this: the rate of aging doubles with every 10° C to 15° C increase in temperature above normal room ambient. Therefore, all components constructed with organic materials are subject to thermal aging.

Thermal degradation is now known to be the major factor limiting the useful life of r.f. coils in most applications. In recognition of this fact, the Tri-Service Established Reliability Specification for MIL coils (MIL-C-39010) includes a life test for determination of the extent of thermal degradation. MIL-C-15305 for general-purpose r.f. coils presently has no life-test requirements.

Life testing of coils is not a new concept. It was started as early as 1955 out of a "need to know." As more data accumulated and trends were established, it became apparent that temperature and time could permanently, and adversely, influence the electrical properties of coils. One outgrowth of this is the life test in MIL-C-39010, mentioned above. Coils qualified to this specification will have a known reliability based on accumulated life test data. This is known as "established reliability."

In almost all cases components undergoing reliability evaluations are subjected to a series of environmental stress conditions. However, of all possible en-

vironmental stress conditions and factors that can be evaluated, a life test of some sort generally constitutes the great bulk of reliability testing. In most cases a life test consists of both electrical and thermal stress for electronic components. The electrical stress condition is generally used to provide a working load and the thermal stress is used to provide some degree of severity through which the part must maintain its working capability. In the case of coils, however, the factor of electrical stress is insignificant under most applications. R.f. coils do not encounter either power dissipation or high-voltage potentials between turns which could cause an insulation breakdown. In the few cases where power dissipation is a factor, it is not coupled with electrical stresses that are severe enough to consider as a factor in coil life and can, therefore, be treated as an additional thermal stress.

A load test most useful to design engineers would require a combination of d.c. and a.c. power load. But such a test would be impractical because of the tremendous variety of frequencies, pulses, duty cycles, etc., representative of the many applications.

The above facts and observations led the industry (EIA) to select a no-load or thermal degradation test for life testing. There are significant advantages which favor this technically sound choice. (1) *Simplicity*: Less elaborate storage chambers and associated equipment. (2) *Control*: Fewer potential variables are introduced. (3) *Economics*: Capitalization costs of user or manufacturer for test facilities are greatly reduced.

In view of the fact that delays are often incurred between approval and issuance of military specifications, the following is offered. Test temperatures and definition of failures for r.f. coils have been proposed to the military as follows:

Coil-form	Materials	Phenolic	Powdered Iron and Ferrite
Test temperature		125° C	105° C
Inductance change		±3%	±10%
"Q" change		±10%	±20%
SRF change (self-resonant freq.)		±8%	±15%
DCR change (d.c. resistance)		±3%	±5% ▲



GET SUPERIOR 82-CHANNEL  
COLOR TV RECEPTION WITH

# NEW BELDEN 8290

SHIELDED PERMOHM\*  
LEAD-IN

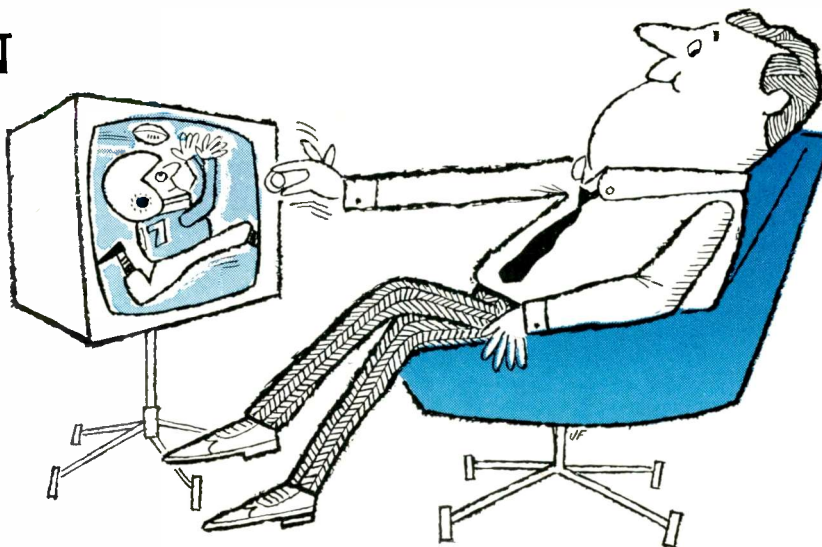

Until the introduction of Belden 8290 Shielded Permohm TV lead-in cable, there were serious limitations in the effectiveness of the various lead-in cables available, whether twin lead or coaxial.

Here Robert E. Sharp, electronic engineer of the Belden Manufacturing Company, discusses the problems and the reasons why Belden 8290 Shielded Permohm is the all-purpose answer for 82-channel and color TV reception.

**Q.** What problems have been experienced in using twin lead cables other than 8290?

**A.** Most installers have found out that using flat ribbon or tubular 300 ohm line for UHF and color installations is unsatisfactory. When these lines encounter dirt, rain, snow, salt, smog, fog, or industrial deposits, the impedance drops abruptly, the attenuation soars and the picture is lost.



To overcome this problem, Belden developed its 8285 Permohm line which encapsulates the flat twin lead in a low loss cellular polyethylene jacket. This keeps all of the surface deposits out of the critical signal areas—regardless of weather conditions.

Although this was a major improvement, there still remained the problem of electrical interference signals from automotive ignition systems, reflected TV signals and extreme electrical radiation which could be picked up by the lead-in to create ghosts and static lines in the picture.

**Q.** Then, is this why many people recommend coaxial cable as TV lead-in?

**A.** Yes. Because of the incorporation of a shield, coaxial cable has an advantage over unshielded twin lead.

**Q.** Then, why isn't coaxial the total answer?

**A.** Coaxial cable has much higher db losses per hundred feet than twin lead. Although the shield in coaxial cable does reduce lead-in pick-up of interference signals, it is not as effective as a 100% Beldfoil\* shield.

Another way to put this is that 8290 delivers approximately 50% of the antenna signal through 100 feet of transmission line at UHF while coaxial cable can deliver only 15% to 20%, frequently not enough for a good picture. Even at VHF, the higher losses of a coaxial cable may be intolerable, depending on the signal strength and the length of the lead-in.

The following chart spells this out conclusively. We have compared RG 59/U Coax to the new Belden 8290 Shielded Permohm. All 300 ohm twin leads, under ideal weather conditions, have db losses similar to 8290.



CHANNEL	MC	db LOSS/100' 8290	db LOSS/100' COAX (RG 59 Type)
2	57	1.7	2.8
6	85	2.1	3.5
7	177	3.2	5.2
13	213	3.5	5.9
14	473	5.4	9.2
47	671	6.6	11.0
83	887	7.7	13.5

Capacitance: 8290—7.8 mmf/ft. between conductors  
Coax—21 mmf/ft.  
Velocity of Propagation: 8290—69.8%  
Coax—65.9%

**Q.** Won't the use of matching transformers improve the efficiency of a coaxial cable system?

**A.** No! The efficiency is further reduced. Tests show that a pair of matching transformers typically contribute an additional loss of two db, or 20% over the band of frequency for which they are designed to operate. Incidentally, transformer losses are not considered in the chart.

**Q.** How does 8290 Shielded Permohm overcome the limitations of other lead-ins?

**A.** 8290 is a twin lead with impedance, capacitance, velocity of propagation and db losses which closely resemble the encapsulated Permohm twin lead so that a strong signal is delivered to the picture tube. At the same time, 8290 has a 100% Beldfoil shield which prevents line pick-up of spurious interference signals. In short, 8290 combines the better features of twin lead and coaxial cable into one lead-in.

**Q.** What about cost?

**A.** In most cases, 8290 is less expensive than coax since matching transformers are not required. The length of the lead-in is also a factor in the price difference. The cost of coaxial cable installations can vary tremendously, depending upon the type and quality of matching transformers used. If UHF reception is desired, very high priced transformers are required.

**Q.** Is 8290 Shielded Permohm easy to install?

**A.** Yes! Very! It can be stripped and prepared for termination in a manner similar to 300 ohm line without the use of expensive connectors. It also can be taped to masts, gutters or downspouts, thus reducing the use of standoffs. There is no need to twist 8290 as the shield eliminates interference problems. It is available from your Belden electronic distributor in 50, 75, and 100 foot lengths, already prepared for installation, or 500' spools.



BELDEN MANUFACTURING COMPANY  
P. O. Box 5070-A • Chicago, Ill. 60680  
\*Belden Trademark Reg. U.S. Pat. Off.

# RCA'S new career book can be your success story.



The Most Trusted Name in Electronics

## Home Training

Find out about...

- RCA Institutes Career Programs.  
TV Servicing • FCC License Preparation • Automation Electronics • Automatic Controls • Digital Techniques • Telecommunications • Industrial Electronics
- Nuclear Instrumentation • Solid State Electronics • Electronics Drafting.
- How RCA's "Autotext" programmed instruction teaches electronic fundamentals—the faster, easier, way to technical learning.
- RCA Institutes' liberal tuition plan—the economical way to learn electronics.
- The prime quality electronics kits students receive at no extra cost.
- How RCA Institutes Home Training has helped its students enter profitable electronics careers and continually advance in their fields.
- For your free copy of RCA Institutes 1966 Home Study Career Book, just mail the attached postage-paid card today.

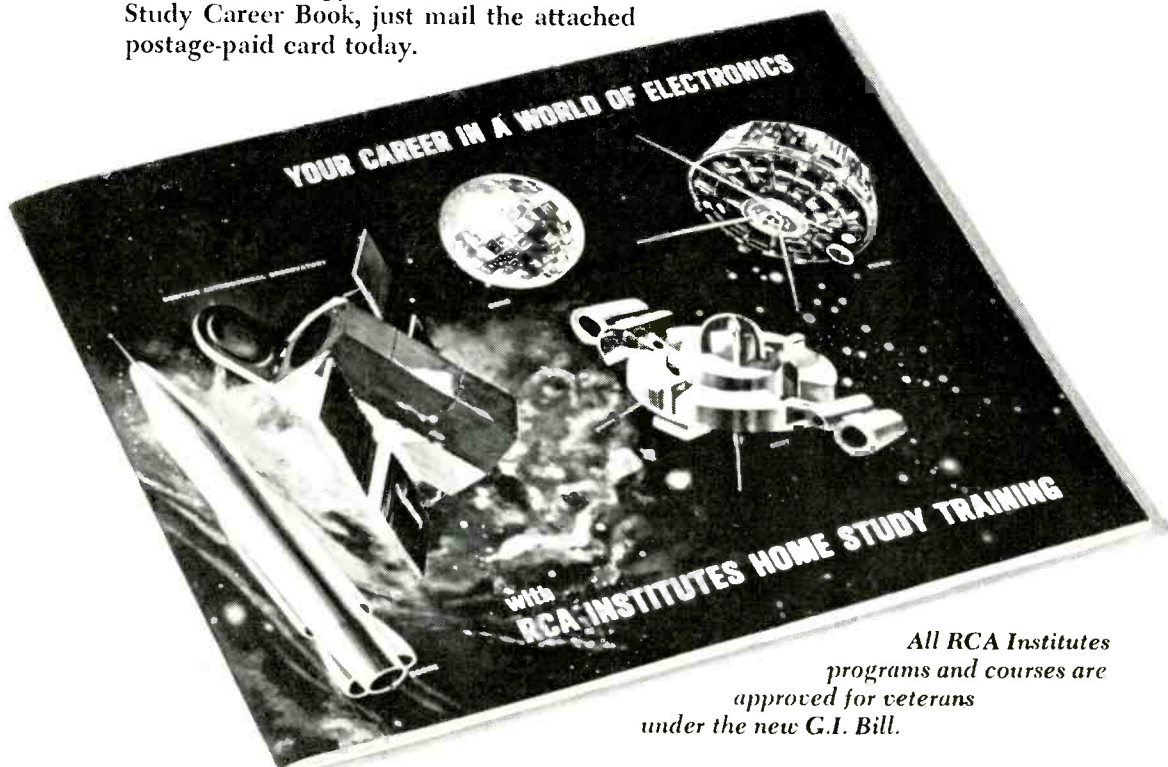

## Classroom Training

- Located in New York City, RCA Institutes is one of today's largest of its kind, and provides excellent classroom and laboratory facilities.
- Previous technical training is not required... special preparatory classes are available for students who have not completed high school.
- Day and evening coeducational programs start four times a year.
- Free placement service has in recent years placed 9 out of 10 graduating students.
- Complete descriptive catalog free on request... check classroom training on attached card.

Both Home Training and Classroom Training programs are also available in Spanish. Check Spanish on attached card and appropriate information will be rushed to you.

**RCA INSTITUTES, Inc.**, Dept. EW 96 A Service of Radio Corporation of America,  
350 West 4th Street, New York, N.Y. 10014

# You earn your FCC First Class License

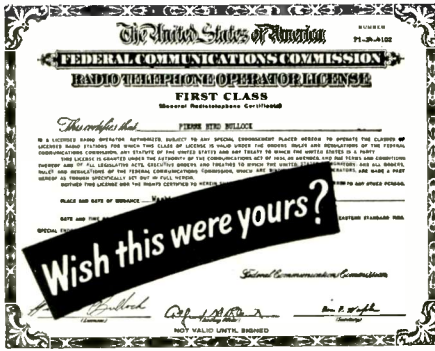

**or your money back!**

## THERE'S A WORLD OF OPPORTUNITY FOR THE MAN WITH AN FCC LICENSE

All it takes is a few spare hours a week and NRI's FCC License Course to open the way to increased opportunities in Communications. With an FCC License, you're ready to operate, service and install transmitting equipment used in aviation, broadcasting, marine, mobile and Citizens-Band communications.

What does it take? Men with absolutely no training or experience in Electronics complete the course in 10 months. A Technician or man with some background can easily cut that time in half. And because NRI has a greater enrollment than any other school of its type, training costs you less than comparable courses offered by other schools. Further, **YOU MUST PASS** your FCC exams or *NRI refunds your tuition in full.*

Get full details about NRI FCC License Course plus other home-study plans offered by NRI, oldest and largest school of its kind. Mail coupon. No obligation. No salesman will call. NATIONAL RADIO INSTITUTE, Washington, D. C. 20016.

**AVAILABLE UNDER  
NEW GI BILL.** If you served since January 31, 1955, or are in service, check GI line in coupon.

**MAIL FOR  
FREE  
CATALOG**



**NATIONAL RADIO INSTITUTE**  
Electronics Division 29-096  
Washington, D.C. 20016

Please send me complete information on FCC License Training and other NRI courses, as checked below. (No salesman will call.)

- |   |   |
|---|---|
| <input type="checkbox"/> Television-Radio Servicing     | <input type="checkbox"/> Electronics for Automation   |
| <input type="checkbox"/> Industrial Electronics         | <input type="checkbox"/> Aviation Communications      |
| <input type="checkbox"/> Complete Communications        | <input type="checkbox"/> Marine Communications        |
| <input type="checkbox"/> FCC License                    | <input type="checkbox"/> Mobile Communications        |
| <input type="checkbox"/> Math for Electronics           | <input type="checkbox"/> Electrical Appliance Repairs |
| <input type="checkbox"/> Basic Electronics              | <input type="checkbox"/> Electronics for Printers     |
| <input type="checkbox"/> CHECK FOR FACTS ON NEW GI BILL |   |

Name.....Age.....  
PLEASE PRINT

Address.....

City.....State.....Zip.....  
Code.....  
Accredited Member National Home Study Council

## Chroma Circuits: Motorola (Continued from page 35)

coupled to the color-killer grid, the grid bias on the color-killer stage will change to about 19 volts. With the grid 3 volts negative with respect to the cathode (at +22 volts), no current is drawn during the horizontal gating period and the killer bias is therefore reduced, allowing the 3.58-MHz signal to be amplified by the second color i.f. stage.

If a monochrome signal is received, the plate of the second i.f. stage will be at a higher voltage; the color oscillator grid will also be more positive, with the result that the bias on the color-killer grid will be about 21 volts. With the cathode at 22 volts, the tube can draw current during the horizontal flyback pulse, and this generates a negative bias on the control grid of the second color i.f. stage. A resistor network from the plate of the second i.f. stage to the grid of the color killer acts as a reinforcing feedback, making the color-killer action more positive.

In the plate circuit of the second color i.f. stage, there is a neon lamp, physically mounted on the front of the set, that indicates when a color signal is present. This lamp will not go on when the killer bias cuts off the color i.f. amplifier.

An important circuit detail is the d.c. return path of the two suppressor grids of the color demodulator. Each is brought to a different d.c. point on the common cathode voltage divider to provide the correct amplitude relationships between the color-difference signals. Similarly, a complex resistance network, together with video peaking coils, is used to matrix the three color-difference signals from the demodulator to the picture tube.

The 3.58-MHz subcarrier must be removed from the color-difference video signals and here again *Motorola* uses a unique circuit. As shown in the basic diagram of Fig. 3, a single coil (*L1*) together with the three capacitors, *C1*, *C2*, *C3* acts as a series trap for the 3.58 MHz subcarrier.

### High-Voltage Regulation

As shown in Fig. 4, the control grid of the horizontal output tube is returned through *R1* and *C1* to a winding on the horizontal flyback transformer. This winding also provides the dynamic convergence voltage. Diode *D1* regulates the high voltage by controlling the d.c. grid bias on the horizontal output tube. The cathode side of *D1* is connected to a positive voltage through a voltage divider network. When the horizontal bias control is properly adjusted, the cathode side of *D1* should be at approximately +155 volts. At the plate side of the diode, a positive 300-volt pulse appears

from the flyback transformer winding, causing the diode to conduct and establishing a negative voltage at the junction of *R2*, *R1*, and *R3*. This negative voltage, approximately -52 volts, is the grid bias for the horizontal output tube. If the horizontal flyback transformer is loaded down due to large ulior current in the picture tube or other factors, this will automatically reduce the amplitude of the 300-volt pulse at the plate of *D1*. In turn, this causes a reduction in the negative voltage developed at the junction of *R2*, *R1*, and *R3*, reducing the grid bias and increasing the gain of the horizontal output tube.

At the same junction, a vertical saw-tooth signal is applied from the plate of the vertical output amplifier. This saw-tooth voltage adds to or subtracts from the horizontal bias voltage in such a manner that the raster width is expanded at the center of the screen and is reduced at the top and bottom. This corrects for the pincushion error which would otherwise exist along the sides of the screen. The pincushion problem is caused by the geometry of the color picture tube and the deflection yoke. Correction of the pincushion problem is automatic for the two sides but some adjustments are required for the top and bottom pincushion arrangement.

### Vertical Pincushion Correction

In addition to the transistor used as local oscillator in the u.h.f. tuner, another transistor is used as a dynamic pincushion corrector for the vertical deflection yoke. In the simplified circuit shown in Fig. 5, the deflection coils are connected in series with a center-tapped transformer *T1*. The primary of this transformer is connected between the collector and emitter of the pincushion corrector transistor, with the base of this transistor connected to a tap on the primary. An *LC* circuit, *L1* and *C1*, tunes the transformer secondary and, by varying its resonant frequency, the pincushion correction at the top of the picture can be adjusted.

The base of the pincushion corrector transistor receives the vertical saw-tooth signal from the same source as the vertical convergence correction signals. A positive d.c. voltage from the cathode of the vertical output amplifier is connected to the tap of transformer *T1* to drive the collector and the base of the transistor. Horizontal pulses are also applied to the pincushion correction circuit from the horizontal flyback boost circuit, and these are connected to the transistor emitter through *R1*, which determines the pincushion correction at the bottom of the screen. In a typical receiver, the top and bottom pincushion adjustments are not very critical but must be set to provide a straight horizontal line at the bottom and top of the screen. ▲

if you  
snap  
with  
this...

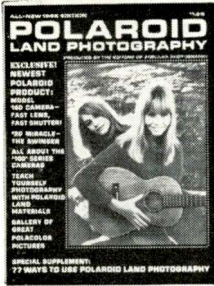
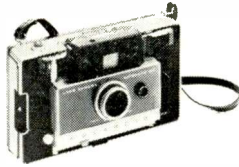

it's a  
snap  
with  
this!

## 1966 POLAROID LAND PHOTOGRAPHY

If you own a Polaroid Land camera, or are in the market for one, sign up now for the most important "excursion" of your picture-taking career. An exciting tour through the miraculous world of "instant" pictures.

Your guide is the all-new 1966 edition of POLAROID LAND PHOTOGRAPHY — the only comprehensive and up-to-date handbook on the subject. The one knowledgeable guide that delivers the skill and know-how for the most rewarding Polaroid Land photographs you've ever taken!

Your tour begins the moment you open your copy... with a detailed inspection of every Polaroid Land camera in existence, including the swingin' "Swinger" and the fabulous, new Model 180, plus the complete line of accessories and film... next, a valuable course in photography basics and technique... an important discussion on amazing Polacolor... followed by 77 fascinating uses for Polaroid Land photography.

**PLUS—gallery after gallery of masterful, enchanting Polaroid Land photographs — including 16 eye-opening pages in glorious color.**

All in all, 116 fact-and-photo-packed pages of the most extensive, authoritative, important-to-you information available. **Sign up today.** Just clip the coupon below and return it with your remittance. **\$1.25**

Also Available — **AN EXQUISITE LEATHERFLEX-BOUND EDITION... for just \$3 POSTPAID!**

Ziff-Davis Service Division • Dept. PLP  
589 Broadway • New York, N.Y. 10012

YES! Send me a copy of the 1966 POLAROID LAND PHOTOGRAPHY, as checked below:

\$1.25 enclosed, plus 15¢ for shipping and handling. Send me the regular edition. (\$1.50 for orders outside the U.S.A.)

\$3.00 enclosed. Send me the DeLuxe Leatherflex-bound edition, postpaid. (\$3.75 for orders outside the U.S.A.) Allow three additional weeks for delivery.

EW-96

name \_\_\_\_\_ please print \_\_\_\_\_

address \_\_\_\_\_

city \_\_\_\_\_ state \_\_\_\_\_ zip code \_\_\_\_\_

**PAYMENT MUST BE ENCLOSED WITH ORDER.**

## Designing Transistor Amps

(Continued from page 26)

preamplifier designs in common use.

For increased sensitivity, the power-amplifier unit will frequently contain one or two stages of voltage amplification preceding the output stage. The power amplifier may also be driven directly from a ceramic phonograph pickup (as is done in some inexpensive table-top audio systems); up to two volts of input drive may then be available at the input of the amplifier. For operation in this way, however, the input impedance of the power amplifier should be at least 100,000 ohms and is usually 1 megohm or greater.

### Hum and Noise Level

The hum level is substantially lower in transistor amplifiers than in tube amplifiers, because there is no heater supply to act as a source of the hum. Moreover, it is relatively easy to filter the ripple from transistor voltage-amplifier stages, because the current levels are low. Some precautions are necessary however to isolate the collector-supply ripple from the emitter-base terminals of each stage. Techniques used for this purpose are to be discussed in a later section.

The statistical nature of current flow through transistors, the presence of transistor and circuit resistance, and transistor surface phenomena, all result in noise sources in the amplifier. This noise is most serious in high-gain preamplifiers, where signal voltage may be only a few millivolts. The problem is much less severe for power amplifiers, because of the larger available signal voltage. It is necessary, however, to assure that the power amplifier does not contribute to the over-all system noise level. A noise level of 50 dB below 1 watt is sufficient, and levels of 60 to 70 dB below 1 watt are not difficult to achieve in a well-designed power amplifier. For example, the equivalent noise voltage for an amplifier having an input resistance of 10,000 ohms and a bandwidth of 20 kHz is less than 2 microvolts. This value is negligible compared to the input voltage required for normal, or even quiet, listening levels (i.e., about 50  $\mu$ V).

Next month's installment will cover various circuit configurations that are used while the concluding article will give some general conditions for conservative design and will include some practical circuits and show their performance. These particular circuits are for a 10-watt, for a 25-watt, and for a 70-watt audio power amplifier. These output powers are for a single channel of amplification.

(Continued Next Month)

## ASSEMBLE YOUR OWN ALL-TRANSISTOR Schober ELECTRONIC ORGAN



3 NEW MODELS  
Recital Console II \$1500  
Console II \$850  
Spinnet \$550

This is the all-new, all-transistor Schober

Recital Model... the most versatile electronic organ available today. Its 32 voices (plus amazing "Library of Stops"), 6 couplers and 5 pitch registers delight professional musicians... make learning easy for beginners. Comparable to ready-built organs selling from \$5000 to \$6000.

The pride and satisfaction of building one of these most pipe-like of electronic organs can now be yours... starting for as low as \$550. The Schober Spinnet, only 39¼ inches wide, fits into the smallest living room. The new, all-transistor Schober Console II is the aristocrat of "home-size" organs... with two full 61-note manuals, 17 pedals, 22 stops and coupler, 3 pitch registers and authentic theatre voicing.

**AND YOU SAVE 50% OR MORE BECAUSE YOU'RE BUYING DIRECTLY FROM THE MANUFACTURER AND PAYING ONLY FOR THE PARTS, NOT COSTLY LABOR.**

It's easy to assemble a Schober Organ. No special skills or experience needed. No technical or musical knowledge either. Everything you need is furnished, including the know-how. You supply only simple hand tools and the time.

You can buy the organ section by section... so you needn't spend the whole amount at once.

You can begin playing in an hour, even if you've never played before—with the ingenious Pointer System, available from Schober.

Thousands of men and women—teenagers, too—have already assembled Schober Organs. We're proud to say that many who could afford to buy any organ have chosen Schober because they preferred it musically.

Send for our free Schober Booklet, describing in detail the exciting Schober Organs and optional accessories; it includes a free 7-inch "sampler" record so you can hear before you buy.

### THE Schober Organ CORPORATION

43 West 61st Street, New York, N.Y. 10023

Also available in Canada, Australia, Hong Kong, Mexico, Puerto Rico, and the United Kingdom

THE SCHOBER ORGAN CORP., DEPT. RN-45  
43 West 61st Street, New York, N.Y. 10023

Please send me FREE Schober Booklet and free 7-inch "sampler" record.

Enclosed find \$2.00 for 10-inch quality LP record of Schober Organ music. (\$2.00 refunded with purchase of first kit.)

Name \_\_\_\_\_

Address \_\_\_\_\_

City \_\_\_\_\_ State \_\_\_\_\_ Zip No. \_\_\_\_\_

**CIRCLE NO. 91 ON READER SERVICE CARD**

# TEST EQUIPMENT PRODUCT REPORT

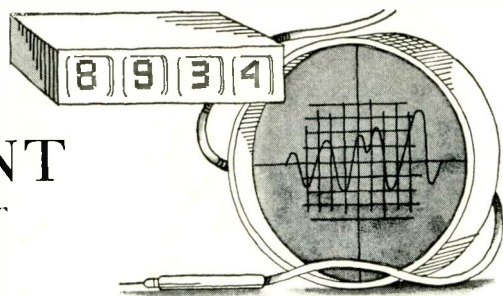

## Hickok DMS-3200 Digital Measuring System

For copy of manufacturer's brochure, circle No. 26 on Reader Service Card.



SEVERAL manufacturers of analog-type (moving-pointer) meters have recently introduced fairly inexpensive digital instruments with their attendant high accuracies and ease of reading. One of these, *Hickok*, has borrowed an idea from the lab scope manufacturers in producing a basic main-frame digital display unit along with a number of plug-ins. These plug-ins convert the main frame into a d.c. voltmeter, a counter, an ohmmeter, and a capacitance meter (shown here). The price of the main frame is \$320, while the voltmeter and counter plug-ins are \$175, and the ohmmeter and capacitance meter plug-ins are \$240.

A three-digit display is employed, with biquinary-type display tubes. Solid-state circuits are used throughout and all transistors and diodes are silicon types. All critical voltages are zener-regulated.

Heavy emphasis has been placed on mechanical ruggedness and component access. A combination of sturdy die-cast front and rear panels, along with heavy extruded aluminum side sections, provides a rugged yet lightweight housing. Both top and bottom sections can be removed for full access to all components and printed-circuit boards. Small in size, light in weight, and with front-panel carrying handles, the instrument is a readily portable, general-purpose meter.

The d.c. voltmeter plug-in has five ranges, from 99.9 millivolts to 999 volts, at an input impedance of 10 megohms. Accuracy is  $\pm 0.1\%$  of reading.

The counter plug-in is a 1-MHz unit that measures frequency and period of sine waves, square waves, pulses, or other complex waves from 0.1 Hz to 1 MHz. By using the overrange capability, the normal three-digit display can provide seven-digit resolution, with an accuracy of  $\pm 0.005\%$ . Front-panel switch selection permits readout of any three-digit sector of a seven-digit input signal.

The ohmmeter plug-in has nine ranges and is able to measure full scale from 9.99 ohms to 999 megohms, at an accuracy of  $\pm 0.2\%$  of reading up to 100 megohms and  $\pm 1.0\%$  at higher resistances. The measurement system is that of a Wheatstone bridge with internal electronic automatic null-out and resultant resistance value display. Four terminals are provided so that lead resistance does not cause inaccuracies on extremely low resistance measurements. In addition, a "guard" terminal is provided so that spurious leakages in components under test are automatically balanced out to provide high accuracies on the high-resistance ranges.

The capacitance meter plug-in has eight ranges and can measure from 999 picofarads full scale to 9990 microfarads, at an accuracy of  $\pm 0.2\%$  on most ranges. The measurement is by means of a bridge comparing the stored charge of the unknown capacitor with that of a precision internal standard capacitor. The test signal is of positive polarity only and no external polarizing voltage is needed for electrolytics. The measurement is relatively unaffected by the "Q"

of the capacitor being tested. Provision has been made for balancing out test-lead capacitance for accurate measurements of extremely low capacitance.

The over-all size of the main frame is only 9 $\frac{1}{4}$ " wide by 6 $\frac{3}{8}$ " high by 12 $\frac{3}{8}$ " deep. Additional plug-ins, including a 50-MHz counter and an a.c. voltmeter, are scheduled for production later this year. ▲

## Boonton Electronics 71A Capacitance/Inductance Meter

For copy of manufacturer's brochure, circle No. 158 on Reader Service Card.

THE Model 71A provides precise, high-resolution capacitance and inductance measurements with the speed and convenience of a v.t.v.m. In addition, the instrument produces an accurate d.c. analog voltage that is directly proportional to the capacitance or inductance being tested. This feature greatly facilitates many tests which previously could be made only by time-consuming point-by-point balancing. For example, with an oscilloscope or an X-Y plotter, curves of capacitance versus voltage of voltage-variable diodes may be rapidly displayed. Also, plots may be made of the linearity of variable capacitors or inductors, or of the tracking accuracy of a pair of voltage-variable diodes.

The instrument operates by measuring the quadrature current through the component under test, while ignoring



the in-phase current. Accuracy is  $\pm 1\%$  for "Q's" down to 3. Devices of lower "Q" (to 0.1) may be measured after proper readjustment of phase.

The instrument measures capacitors up to 1000  $\mu\text{F}$  and inductors up to 1000  $\mu\text{H}$  in seven ranges. The values are read directly from the six-inch mirrored-scale meter.

The test signal level for capacitance measurement is fixed at 15 millivolts, permitting tests on a wide variety of solid-state devices. Test level for in-

ductance measurement is less than 1 millivolt. The highly stable test signal is crystal-controlled at 1 MHz. D.c. bias up to  $\pm 200$  volts at 250 mA may be applied through rear terminals to the device under test.

The meter measures only the capacitance of the component under test. It ignores stray impedances from the "Lo" post to ground, and adjustments can render the meter insensitive to stray impedances from the "Hi" post to ground. Thus, the specimen can be connected to the terminals by coaxial cable, or a remote test fixture may be used.

The d.c. analog output mentioned above ranges in amplitude from zero to either 100 or 300 millivolts for full scale, depending on the range used. Since the response time of the d.c. output is less than 100 milliseconds, the instrument can follow rapid changes in the value of the component under test, or make a large number of individual measurements in a very short time. For example, used with a d.c. voltage comparator, it performs high-speed "go/no-go" capacitance or inductance tests, or provides facilities for automatic sorting or batching.

The Boonton Model 71A may also be used as the readout device for a wide variety of capacitive or inductive transducers. Price of the instrument is \$735. ▲

### Yokogawa Model L-3C Resistance Bridge

For copy of manufacturer's brochure circle No. 159 on Reader Service Card.

THE simplest of the bridges used for component measurements is the Wheatstone bridge. This consists of three resistance arms with the unknown resistor to be measured placed in the fourth arm. The bridge circuit is energized by a d.c. voltage source and a simple, sensitive galvanometer is used to determine when the standard resistors have been adjusted to achieve bridge



balance. Then the value of the unknown resistor is determined from the settings of the built-in resistors.

The Yokogawa Electric Works (YEW) Model L-3C is a portable Wheatstone bridge with an accuracy of up to  $\pm 0.1\%$  over most of its range. This accuracy is increased to  $\pm 0.05\%$  when the calibration chart supplied with the instrument is used. The range of the bridge is from 1 ohm to 11.11 megohms to four significant figures, the smallest increment being 0.001 ohm. The built-in galvanometer used as the null indicator is sensitive ( $0.6 \mu\text{A}$  per division) but sturdy enough not to require pointer clamping. For even more sensitivity, an external light-beam galvanometer can be used.

The five dial switches employed are of special patented design and are housed in individual dustproof, sealed, clear plastic covers to keep the contacts clean and to insure long, trouble-free life.

Power for the bridge is supplied by three conventional D-size flashlight cells. These are housed in a separate battery compartment at the bottom of the instrument and are convenient to replace.

The bridge is mounted in a heavy, plastic case measuring  $7\frac{1}{4}'' \times 9'' \times 5''$ . Price of the unit is \$156 and it is available in this country through Hallmark Standards, Inc. ▲

## ZINC-AIR-OXYGEN POWER SYSTEM

A NEW class of power system capable of delivering up to 150 watt-hours per pound at room temperature was recently shown by Leeson Moos Labs.

To form a basis for comparison, at room temperature, a LeClanché cell (similar to a flashlight cell) produces about 35 watt-hours/lb; a mercury-zinc cell produces about 25 watt-hours/lb; a silver-cadmium cell about 30 watt-hours/lb; and a sealed lead-acid cell about 14.9 watt-hours/lb.

Actually a form of fuel cell, the new 13.5-volt power source can use either an oxygen supply, or it can operate from the oxygen present in the air at atmospheric pressure.

The basic cell consists of a high-rate

oxygen cathode and a porous zinc anode in a potassium-hydroxide solution electrolyte, and the oxygen supply. The non-consumable lightweight cathode is permeable to gases but impermeable to liquids, invariant under loads, and exhibits low polarization.

In producing power, the zinc anode is converted to zinc oxide while the cathode remains unchanged, acting to form hydroxyl ions from the oxygen in combination with the electrolyte. No venting is necessary when the system is operating on a pure oxygen supply.

Recharging the system is a mechanical procedure and consists of removing the cover, releasing some clamps, and replacing the oxidized modules. ▲

## Plan and build your speaker system of tomorrow today!

### The P.S.E. Way

University's PSE — Planned Speaker Expansion is a master blueprint for better stereo speaker systems. See your University Dealer today, or write for your FREE PSE Technigrams.

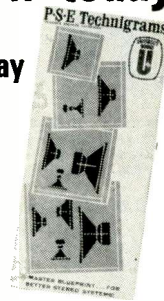

**UNIVERSITY SOUND**  
A DIVISION OF LTV LING ALTEC, INC.

Dept. P.O. Box 1056, Oklahoma City, Okla.

Name \_\_\_\_\_

Address \_\_\_\_\_

City \_\_\_\_\_

State \_\_\_\_\_ Zip \_\_\_\_\_

CIRCLE NO. 80 ON READER SERVICE CARD



MODEL 1/4 TRACK STEREO  
SX724 ONLY \$975 **DUO STATE**

**NEW!**

Modular Transport  
Low-Noise Circuitry  
Third Head Monitoring

World's Finest Recording Quality

Speed	Response	S/N
7-1/2	$\pm 2\text{db}$ 30 to 25,000	55db
3-3/4	$\pm 2\text{db}$ 30 to 15,000	50db

Crown International  
BOX 1000, DEPT. EW-9  
ELKHART, INDIANA

**MADE ONLY IN AMERICA**

CIRCLE NO. 81 ON READER SERVICE CARD

# NEW SAMS BOOKS

## 101 Ways to Use Your Oscilloscope — New Edition



by Robert G. Middleton. This popular, newly revised working handbook shows latest methods for faster, more proficient servicing using the scope. Explains how to make waveform tests and how to analyze waveforms produced by defective circuits. Includes new material on use of wide-band and triggered-sweep scopes. Covers detailed testing of various sections of both b/w and color TV sets. Describes use of square waves to evaluate circuits and components. Each test described includes information on equipment needed, proper connections, test procedure and evaluation. Heavily illustrated. 192 pages; 5½ x 8½".

Order TEM-2A, only. \$295

## Design & Operation of Regulated Power Supplies

by Irving Gottlieb. Newly revised to provide a full understanding of the design and operation of these increasingly important power supplies. Describes dozens of methods and circuits for controlling power supply outputs; details design, operating principles, uses, and variations in design parameters. Includes many diagrams of open-loop regulated supplies, closed-loop regulators, and open-loop circuits using zener diodes. 144 pages; 5½ x 8½".

Order RPS-2, only. \$325

## ABC's of Electronic Test Probes

by Rudolf F. Graf. Shows you how to get the most from your test equipment through the proper use of the many probes required for testing radio, TV, and other electronic equipment. Tells how to select the right probe to get accurate measurements for troubleshooting. Includes full information on the construction, basic function, and application of most of the common types of probes in use today.

128 pages; 5½ x 8½". Order APG-1, only. \$225

## Direct Readout Meters

by John D. Lenk. An ideal new text for student technicians and a training tool for the experienced technician who wants to enter the industrial field. Fully explains in basic terms a wide variety of digital, differential, and analog meters; provides technician-level circuit descriptions for the most widely used types. Also covers laboratory meters in logical progression, following signal sequence, wherever possible, from pickup devices, through the processing circuits, to the display functions. Provides the information required by technicians to qualify as laboratory meter specialists. 154 pages;

5½ x 8½". Order DRM-1, only. \$325

## Electronic Cable Handbook

by Engineering Staff, Belden Mfg. Co. The first comprehensive handbook on electronic cable. Explains in detail the design, construction, handling, and installation of various types of modern electronic cable. Provides full information on latest cable design, specifications, and applications. Special sections on cable for intercom, hi-fi, home entertainment systems, f-m, two-way radio, etc. Covers military and nonmilitary specifications. Includes many useful tables and a glossary. An easy-to-understand, complete guide to electronic cable.

224 pages; 5½ x 8½". Order ECH-1, only. \$395

## Applications Handbook for Electrical Connectors

by John D. Lenk. The authoritative book on connectors, their uses and selection. Discusses basic design considerations; provides detailed descriptions of connector parts, configurations, construction details, assembly methods, etc. Describes various environmental conditions to which connectors are subjected; explains tests used to check connectors under special conditions. Absolutely invaluable and much-needed data on the entire subject of connectors. 160 pages; 5½ x 8½".

Order ECL-1, only. \$325

## HOWARD W. SAMS & CO., INC.

Order from your Sams Distributor today, or mail to Howard W. Sams & Co., Inc., Dept. EW-9, 4300 W. 62nd Street, Indianapolis, Ind. 46206

Send me the following books:

- TEM-2A     APG-1     ECH-1  
 RPS-2     DRM-1     ECL-1

Send FREE Sams Booklist. \$\_\_\_\_\_ enclosed

Name \_\_\_\_\_

Address \_\_\_\_\_

City \_\_\_\_\_ State \_\_\_\_\_ Zip \_\_\_\_\_

My Distributor is \_\_\_\_\_

CIRCLE NO. 92 ON READER SERVICE CARD

70

## Time Domain Reflectometry

(Continued from page 50)

line impedance. The resulting mismatch causes the reflected wave returning from the capacitor to be re-reflected at the source, thus launching a second incident wave down the line. This second wave sends a second reflected wave from the capacitor back to the monitoring point. The second reflected wave, in turn, launches a third incident wave down the line. This process continues indefinitely but, unless the reflection coefficient at each end is equal to  $\pm 1$ , the reflections decrease in magnitude and only the first few are noticeable.

### Practical TDR Measurements

Thus far we have talked about the theory of TDR. When this theory is applied to practical measuring situations, several compromises arise. First, the best laboratory-type generators available have a rise time of about 30 picoseconds. Their output has very little overshoot, rounding, or sag. The repeti-

tion rate of these devices can be as great as 100 kHz or so, sufficient for a steady display on a sampling oscilloscope. The ideal scope would be a sampling oscilloscope with a rise time of about 90 picoseconds. A sampling oscilloscope is well suited to TDR test systems since it has a high input impedance and also a wide dynamic range to allow small reflections to be observed at high gain despite their superimposition on the relatively large incident wave.

The over-all system rise time sets the level of resolution available from a TDR system. Considering an over-all system rise time of 150 picoseconds (which is about the best that can be obtained from present-day laboratory TDR systems), when two discontinuities are spaced closer than approximately one cm, the system cannot pick out one from another. Of course, measurement of mismatches in lines over a range of a few centimeters is strictly a laboratory procedure, requiring precision lab equipment.

In theory, the reflections from small inductors and capacitors have very short time constants. However, in actual practice, the bandwidth of the TDR system becomes the limiting factor in the display. For example, assume a series combination of resistance and inductance where the resistance is 50 ohms (matching a transmission line of 50 ohms) and the inductance is approximately  $10^{-10}$  henry. In theory, the display would look like Fig. 8A. In practice, it would be closer to Fig. 8B. This is because the time constant of the reflected wave is so short.

Another point to remember is that the rise time of the test pulse tends to decrease as it travels down the line. This reduces the TDR system's ability to resolve closely spaced discontinuities on long lines or lines where there are large losses. If reflections from small series inductors or small shunt capacitors are being measured, much greater accuracy will be obtained if a good short is temporarily placed just ahead of the discontinuity in question. If this point is not accessible, place the short as close as possible (preferably on the generator side). This will at least give an estimate of the rise time of the wave actually hitting the discontinuity in question.

In well-matched systems, using good cable, the rise time may not be seriously degraded. But in transmission systems using lossy cables, or where there are several small reactive discontinuities ahead of the one in question, the rise time of the wave will be significantly degraded as it travels down the line. If certainty of the rise time of a reflected wave at any particular point on a line is desired, place a short at that point. Then compare this with the rise time of the reflected wave. ▲

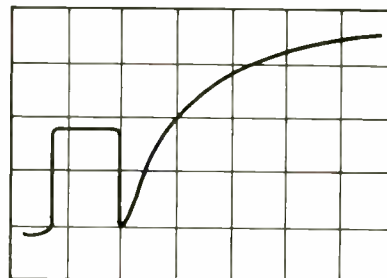

(A)

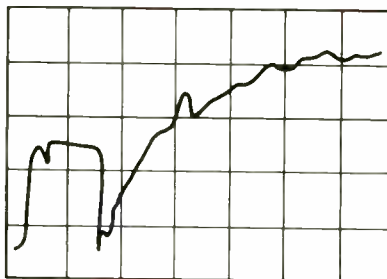

(B)

Fig. 7. Typical pulse display (A) when generator and line impedances are properly matched, (B) not properly matched.

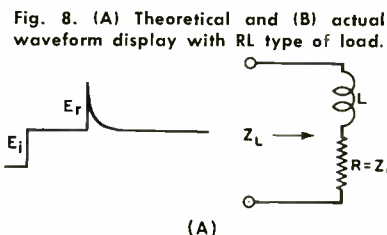

(A)

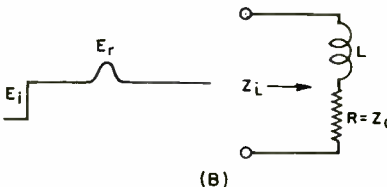

(B)

Fig. 8. (A) Theoretical and (B) actual waveform display with RL type of load.



## Testing Inductors

(Continued from page 32)

at the desired frequency. The voltmeter used for measuring  $E_2$  should have high input impedance and an input capacitance which is negligible with respect to  $C$ . At resonance, voltage  $E_1$  reaches a minimum (dip) and voltage  $E_2$  peaks.

Another method of measuring "Q," Fig. 7, is indicated in an arrangement in which three voltage readings are made.  $R$  should be a non-inductive resistor and all voltage readings must be true r.m.s.

### Coils Carrying D.C. and R.F.

When measuring coils carrying direct current in their windings, special care has to be taken: 1. to avoid providing a path which will enable d.c. to bypass the coil; 2. to keep the d.c. from passing through the generator; and 3. in some methods, the d.c. circuit impedance must be made high with respect to the coil impedance so as not to "load" the coil.

One way of meeting all three requirements is shown in Fig. 8.  $L_D$  is an inductor used to isolate the d.c. source and keep it from loading the a.c. impedance of the coil.  $L_D$  should be of such a value that its a.c. impedance under the test condition is over 50 times the coil impedance.

Basically, the circuit test procedure is the same as for the voltage-rise method of "Q" measurement. At resonance the " $Q$ " =  $E_2/E_1$  and  $L = 1/(2\pi f_r)^2 C$ .

The advantages of this method are its simplicity, accuracy, and yield of two parameters (inductance and "Q") with one set of measurements. Its limitation is the availability of an inductor for  $L_D$  which, while carrying the required d.c., maintains a sufficiently high impedance.

Radio-frequency coil measurements do not differ, in principle, from measurements made on coils at any other frequency. However, some special precautions are required for the r.f. tests.

It is especially important to use short leads when measuring coils with low inductance and low resistance. It may be necessary to subtract from the readings the bridge terminals and lead inductances.

If the inductance is of relatively large value for the frequency of measurement, the inductor may have to be shielded to prevent coupling to outside spurious fields.

If an unshielded coil is to be measured, the coil must be kept close to the terminal posts of the bridge, but kept as far away as practical from the bridge chassis and any other conductive surface. Such surfaces adjacent to the coil—even an operator's hand too close to the coil—may cause erroneous "Q" and inductance readings. ▲

**3  
more  
features  
—all  
new**



Here is RCA's new WR-50B RF Signal Generator—wired or kit. It looks just like the old WR-50A, but the resemblance ends there. It has all the features you liked in the older model...plus 3 new ones you'll find in red below:

- Wide frequency range from 85kHz to 40MHz in 6 overlapping ranges plus harmonics for higher frequencies
- Built-in crystal calibrating oscillator circuit with front panel crystal socket
- Internal 400 Hz audio oscillator
- **NEW**—Sweep output at 10.7 MHz with return trace blanking for sweep alignment of FM receivers
- **NEW**—Sweep output at 455 kHz with return trace blanking for sweep alignment of new transistorized AM radios
- Individual inductance and capacitance adjustments for each range
- Modulation level control
- Two-step RF attenuator switch plus a continuously-variable attenuator control
- **NEW**—additional switch for further attenuation of crystal oscillator output
- The Optional Distributor Resale Price is only \$65.00. Kit Form, \$45.00, includes pre-assembled range switch with pre-aligned coils and trimmers. See the RCA WR-50B at your authorized RCA Test Equipment Distributor.

RCA ELECTRONIC COMPONENTS AND DEVICES, HARRISON, N. J.



The Most Trusted Name in Electronics

# SPECIAL

FROM HIFI/STEREO REVIEW

## DELUXE DUST-PROOF RECORD AND TAPE CASES *Plus* FREE CATALOGING FORMS



**These decorative, yet sturdily constructed cases are just what you've been looking for**

to keep your records and tapes from getting tossed about and damaged, disappearing when you want them most and just generally getting the "worst of it" from constant handling. They're ideal too for those valuable old "78's" that always seem to get thrown about with no place to go.

Constructed of reinforced fiberboard and covered in rich leatherette in your choice of eight decorator colors, the HIFI/STEREO REVIEW Record and Tape Cases lend themselves handsomely to the decor of any room, whether it be your library, study, den, music room or pine-paneled garage. The leatherette back (in your color choice) is gold tooled in an exclusive design available only on HIFI/STEREO REVIEW Record and Tape Cases. The sides are in standard black leatherette to keep them looking new after constant use.

**Extra** With each Record and Tape Case you order you will receive, free of charge, a specially designed record and tape cataloging form with pressure-sensitive backing for affixing to the side of each case. It enables you to list the record names and artists and will prove an invaluable aid in helping you locate your albums. The catalog form can be removed from the side of the case at any time without damaging the leatherette.

Record Cases are available in three sizes: for 7", 10" and 12" records. Each case, with a center divider that separates your records for easy accessibility, holds an average of 20 records in their original jackets. The Recording Tape Case holds 6 tapes in their original boxes.

• The Tape Cases and the 7" Record Cases (with catalog forms) are only \$3.25 each; 3 for \$9; 6 for \$17.

• The 10" and 12" Record Cases (with catalog forms) are \$3.50 each; 3 for \$10; 6 for \$19.

Add an additional 75c per order (regardless of number of cases ordered) for shipping and handling.

Ziff-Davis Publishing Company, Dept. SD  
One Park Avenue, New York, N. Y. 10016

My remittance in the amount of \$ \_\_\_\_\_  
is enclosed for the Cases indicated below.

Quantity

\_\_\_\_\_ Tape Case at \$3.25 each; 3 for \$9; 6 for \$17.  
\_\_\_\_\_ 7" Record Case at \$3.25 each; 3 for \$9; 6 for \$17.  
\_\_\_\_\_ 10" Record Case at \$3.50 each; 3 for \$10; 6 for \$19.  
\_\_\_\_\_ 12" Record Case at \$3.50 each; 3 for \$10; 6 for \$19.

Add 75c PER ORDER for SHIPPING and HANDLING

Check color choice for back of case (sides in black only):

Midnight Blue     Red     Saddle Tan  
 Pine Green     Orange     Yellow  
 Grey     Spice Brown

Name \_\_\_\_\_

Address \_\_\_\_\_

EW-96

City \_\_\_\_\_ State \_\_\_\_\_ Zip Code \_\_\_\_\_

**PAYMENT MUST BE ENCLOSED WITH ORDER**

## RADIO & TV NEWS

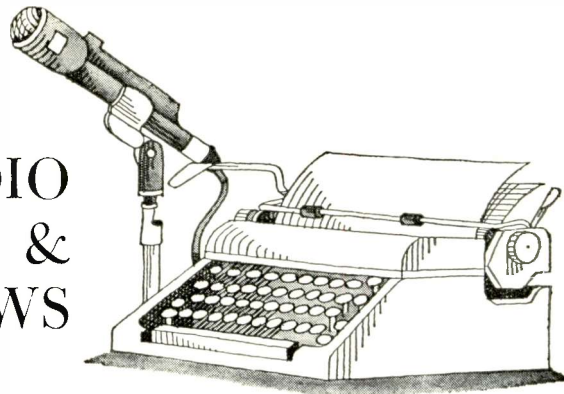

IT seems that wonders in the world of electronics will never cease. Just recently (June), we discussed the development of a "printed" battery that could be recharged. This alone seemed to be an innovation in portable power sources. Now, a release from the U.S. Dept. of Commerce takes us one step further. It seems that scientists at the Army Electronics Command have come up with a rechargeable battery that delivers an alternating current!

Although strictly a d.c. battery, the current is delivered in oscillations that are characterized by amplitude, waveform, and frequency.

The experimental battery is the size of two flashlight cells and has a power output of almost half a watt. Voltage is approximately .8 volt, and current is approximately 400 mA. Army engineers claim that further miniaturization with higher wattage and voltage may also be possible.

Thus far, the battery has successfully flashed a bulb at a rate as high as 15 cycles per second. The engineers are hoping that further research will enable them to raise the oscillation frequency to that of commercial a.c. power sources.

### Microwave Power Devices

Present-day microwave frequency generators, such as varactors and traveling-wave tubes, will be outmoded within the next few years by a new generation of microwave power generators, according to a scientist at ITT. It was pointed out that all new baseband repeated developments for low-power, line-of-sight microwave links are now on an all-solid-state basis—even much above 6 GHz.

It was further pointed out that as recently as two years ago device suppliers were pessimistic about the chances of power transistors ever exceeding 500 MHz; now even greater output-power devices are being developed at 1 GHz. Fifteen watts at 1 GHz will soon be a reality, and several watts at 2 GHz are forecast by the end of this year.

Some of the newer solid-state microwave devices that are coming are: Gunn-effect devices, silicon controlled avalanche transistors (SCAT's), and

metal-base (unipolar) transistors. With the Gunn device, watts and even kilowatts are forecast at microwave frequencies. Of the other types, it is felt that powers of five watts or more are possible at 6 GHz.

### Baby Radar

Most of us tend to think of a radar set in terms of a multi-package, bulky electronics system, a large unwieldy rotating antenna in a radome, and eyestrain from peering at a ghostly image on a CRT.

Things have changed. Recently, RCA demonstrated a two-pound, battery-powered radar that can be mounted on the barrel of a man-held firearm. It can locate moving objects smaller than a man and can distinguish between walking and running men and animals, or jeeps, trucks, and tanks from speeds of two feet per second to 45 mph, by audio tones heard through headsets.

The miniature radar uses microwave Doppler shift in its operation. A fixed horn radiates the signal, and the returning signal is mixed with a transmitted sample, the result being an audio tone that is a function of the target speed. A running man sounds like a high-pitched "crunch-crunch" while a vehicle starting up and moving away sounds like an off-pitch fire siren winding up.

RCA engineers point out that this device can be used as a rate-of-closure indicator between two vehicles or as a ground-speed indicator for light planes.

### Evaporated Tunnel Diode

Three IBM scientists have discovered that by depositing a thin layer of aluminum on a glass substrate, exposing the aluminum to oxygen to form a thin insulating oxide layer, then depositing a film of semiconductor across the top of the oxide, they could produce a new class of junction to create a room-temperature, negative-resistance device similar to a tunnel diode.

The negative-resistance effect in this new class of junction is less pronounced than that of a conventional tunnel diode; however, the IBM scientists believe that it may be strengthened by using different combinations of materials for the new device. ▲

**Letters from Our Readers**  
(Continued from page 6)

It is this integrating, *time-domain response* property of the filter that we are putting to use in the class-D theory. These relations are verified by any text on Laplace Transforms.

There are certainly losses in the semiconductors doing the switching, and these losses would be much worse if the semiconductors were operating into a resistive load. The important point is that today's semiconductors are good enough as switches so that their *total* losses when operating class D are still a very small fraction of the total output power.

Today you can buy off-the-shelf switching-mode voltage regulators or easily design one using the many published schematics. If the voltage control on one of these is varied at an audio rate, and if we capacitance-couple the output, we have a class-D audio amplifier. These are here, today, and with demonstrated efficiencies in excess of 95%. The only limit to this is the relatively low 10- to 20-kHz carrier frequency of most regulators.

Practical class-D systems have appeared in several notable journals by individuals whose competence cannot be challenged. These journals include the IEEE and NEC Proceedings, and it is upon these papers that my story was based.

DONALD E. LANCASTER  
Phoenix, Ariz. ▲

**LOUDSPEAKER ENCLOSURE  
CHART CORRECTION**

THE article "Enclosures for High-Compliance Loudspeakers" in our August, 1966 issue contained a chart in which the color plate was rotated 90° by our printer. The chart was Fig. 5 of the article, and as printed it was impossible to read off values for cabinet compliance and volume properly. A corrected version of Fig. 5 is shown below. Readers applying the design information given in the article should be sure to use the chart below rather than the original. ▲

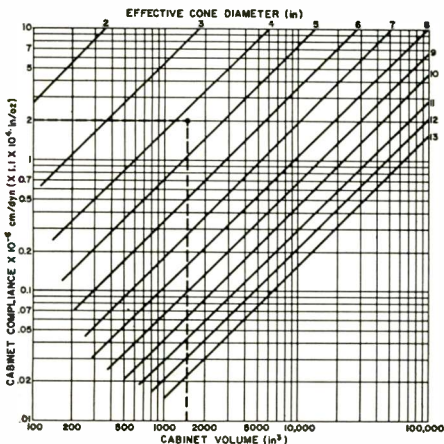

# Now, for men in electronics —“a whole new era of quick calculation”

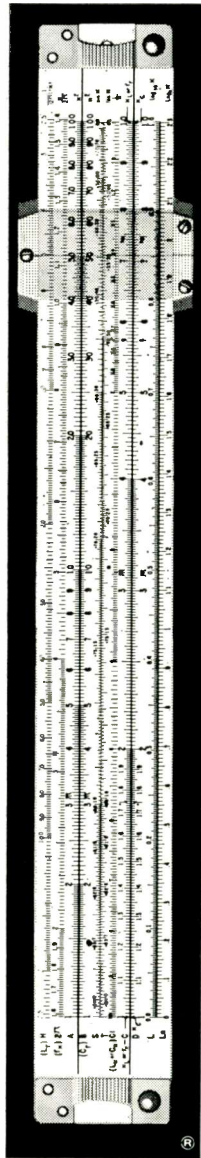

“THERE MUST BE THOUSANDS OF PEOPLE in electronics who have never had the marvelous adventure of calculating problems with a single slide rule; other thousands have had to content themselves with a slide rule not specifically designed for electronics. For both groups, the new slide rule designed and marketed by Cleveland Institute of Electronics and built for them by Pickett will open a whole new era of quick calculations.

“Even if you have never had a slide rule in your hands before, the four-lesson instruction course that is included takes you by the hand and leads you from simple calculations right through resonance and reactance problems with hardly a hitch. If you already use a slide rule, you'll find the lessons a first-rate refresher course. And it explains in detail the shortcuts built into this new rule.”

From an article in  
**Radio Electronics Magazine**

Want complete details about this time-saving new Electronics Slide Rule? Just mail coupon below...or write Cleveland Institute of Electronics, Dept. EW-127, 1776 East 17th St., Cleveland, Ohio 44114.

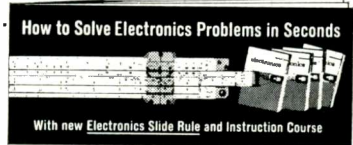

Mail this coupon for  
**FREE BOOKLET**

**CIE** Cleveland Institute of Electronics  
1776 E. 17th St., Cleveland, Ohio 44114

Please send me without charge or obligation your booklet describing the CIE Electronics Slide Rule and Instruction Course. Also FREE if I act at once: a handy pocket-size Electronics Data Guide.

Name \_\_\_\_\_ (please print)

Address \_\_\_\_\_

City \_\_\_\_\_ State \_\_\_\_\_ Zip \_\_\_\_\_

Accredited Member National Home Study Council  
A Leader in Electronics Training... Since 1934

EW-127

**CIRCLE NO. 123 ON READER SERVICE CARD**

## Electronics World SUBSCRIBER SERVICE

Please include an address label when writing about your subscription to help us serve you promptly. Write to: Portland Place, Boulder, Colorado 80302

**CHANGE OF ADDRESS:**

Please let us know you are moving at least 4 weeks in advance. Affix magazine address label in space to the right and print new address below. If you have a question about your subscription, attach address label to your letter.

**TO SUBSCRIBE:** Check boxes below.

New  Renewal  
 5 years \$21  3 years \$15  1 year \$6

**SPECIFY:**  Payment enclosed—You get 1 extra issue per year FREE!  Bill me later.

If you have no label handy, print OLD address here.

name \_\_\_\_\_ please print

address \_\_\_\_\_

city \_\_\_\_\_

state \_\_\_\_\_ zip-code \_\_\_\_\_

▲ AFFIX LABEL HERE ▲

name \_\_\_\_\_ please print 0143

address \_\_\_\_\_

city \_\_\_\_\_

state \_\_\_\_\_ zip-code \_\_\_\_\_

# BOOK REVIEWS

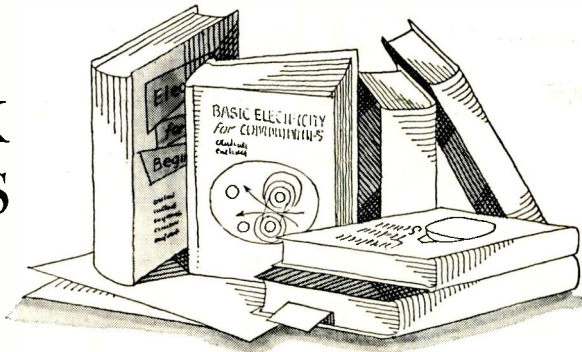

**"ELECTRONICS CONSTRUCTION TECHNIQUES"** by George L. Ritchie. Published by *Holt, Rinehart and Winston, Inc.*, New York. 227 pages. Price \$4.95. Soft cover.

This manual has been designed for junior college or technical institute courses covering the development of prototype electronics units. All of the mechanical aspects of construction receive special emphasis while the text itself deals with basic information on drafting, chassis construction and prototype development, methods of labeling, chemical processes for finishing and etching, printed-circuit development and construction, the use of photosensitive emulsions, and basic hand- and machine-tool operations.

Each lesson first outlines the project, then explains the purpose of the assignment, tools and equipment needed to perform the experiment, what is to be done, and then gives explicit instructions on how the job is to be done. Each lesson is illustrated with material appropriate to the subject under discussion and these illustrations plus the clear and concise explanations make this manual suitable for home-study as well as classroom use.

**"OPTICAL PAGE READING DEVICES"** by Robert A. Wilson. Published by *Reinhold Publishing Corporation*, New York. 189 pages. Price \$10.00.

The greatly increased demand for computer-readable information has generated a need for more people who know and understand the peculiar requirements of retrieval work. The author, a consultant in information retrieval systems, outlines the present status of optical scanners in terms of how they function, and what they are capable of doing—paper handling, optical scanning, recognition, storing the material in machine-readable form, and preparing the source material for optical reader input. He also describes the various commercially available optical readers and examines the input methods and recognition problems in depth.

He then covers the role of these reading machines in information retrieval—the uses for direct indexing, indexing for retrieval on the basis of subject content, indexes compiled by machine for human manipulation, and machine indexing for

search and retrieval. An exhaustive glossary, numerous line drawings, and photographs all help to make this volume as useful to the beginner in the field as it is to the "pro."

**"BASIC ELECTRICITY"** by Gilbert L. Rainey. Published by *Holt, Rinehart and Winston, Inc.*, New York. 179 pages. Price \$3.95. Soft cover.

This is a laboratory handbook, the first in a series prepared for a training program in Basic Industrial Electronics, and as such is designed to be used in conjunction with classroom lecture-demonstrations. The course is programmed for two sessions a week, with each session lasting three hours—two of them in laboratory work.

The text is divided into two sections, the first dealing with laboratory procedures and the second with the experiments. Thirty experiments are included in this second section. Each lesson starts off with an outline of the objectives, the equipment and supplies that will be needed, requisite background material, and the procedure to be followed in performing the experiment. There is an "Instructor Check List" and questions for the student to answer at the end of each experiment.

**"QUANTUM ELECTRONICS"** by John R. Pierce. Published by *Doubleday Anchor*, New York. 128 pages. Price \$1.25. Soft cover.

This is another volume in the excellent "Science Study Series" from this publisher and, like its companion volumes, is addressed to the general public. This particular book is a sequel to the author's 1964 "Electrons and Waves." Dr. Pierce is the executive director of the Research-Communications Sciences Division at the *Bell Telephone Laboratories* and has had a hand in many of the developments he talks about.

The book begins with a survey of the physical laws governing quantum phenomena and the principles of amplification and transmission. The bulk of the text is, however, devoted to the new devices that have been added to modern technology as a result of research in quantum and solid-state physics. The author explains how advances in quantum mechanics, spectroscopy, and mi-

crowave technology led to the development of the maser, the laser, and their applications. Finally he discusses transistor fundamentals and transistor applications ranging from portable radios to space satellites.

As is the case with all of the books in this "Science Study Series," the presentation is informal, lucid, and interesting.

**"PENGUIN TECHNOLOGY SURVEY 1966"** edited by Arthur Garratt. Published by *Penguin Books*, Baltimore. 240 pages. Price \$1.95. Soft cover.

This is a compilation of papers, each prepared by an expert in his field, dealing with the status of electrical engineering, petrochemicals, telephones, printing, metal stamping, value engineering, computers, and nuclear fission. It is a layman's compendium on what is happening in these various fields, written in non-technical language. The contributors are British so emphasis is on the research and development work done in England and Commonwealth countries or in various installations established in Britain or elsewhere by British engineers. This in no way detracts from the over-all value of the survey, but some of the institutions referred to and discussed may be unfamiliar to American readers.

The text is illustrated by a number of line drawings and there is an 8-page section containing photographs of the various products and units discussed in the text. As a bird's eye view of technology, written for the layman and in layman's language, this is an excellent and up-to-date compilation.

**"ALLIED ELECTRONICS DATA HANDBOOK"** compiled and published by *Allied Radio Corp.*, Chicago, Ill. 109 pages. Price \$0.75. Soft cover.

This is the fifth edition of a popular reference work and in this latest version represents quite a bargain for all those involved in any phase of electronics—professional or otherwise.

Fundamental mathematical data includes math constants, math symbols and algebraic formulas; squares and cubes; square and cube roots; reciprocals; common logs; natural sines, cosines, and tangents.

Radio and electronic formulas are provided for 70-volt speaker matching systems, resistance, capacitance, inductance, reactance, resonance, frequency and wavelength, "Q" factor, impedance, conductance, susceptance, admittance, transmission lines, vacuum tubes, d.c. meters, trigonometric relationships, Ohm's Law for a.c. and d.c. circuits.

A wealth of other data on a wide variety of engineering and servicing matters is also included, in handy, easy-to-use format. ▲

## EW Lab Tested

(Continued from page 16)

and replaced without tools. The fact that it weighs  $\frac{1}{4}$  gram makes setting the correct tracking force a simple matter. The arm is balanced with the stylus assembly removed and, when the stylus is inserted, the tracking force is accurately set at  $\frac{1}{4}$  gram, the recommended value.

In our laboratory measurements, the cartridge tracked our most severely modulated test records at 1 gram. For playing stereo music records,  $\frac{1}{4}$  gram should be quite sufficient. Its frequency response, with the *CBS Labs* STR100 test record, was within  $\pm 2.5$  dB from 20 to 20,000 Hz. There were no peaks in that range and the curve was exceptionally smooth. Channel separation was better than 20 dB up to 10,000 Hz, and about 15 dB at 15,000 Hz. Throughout the middle frequency range, where most of the stereo effect is created, the separation was greater than 30 dB.

Playing the *RCA* 12-5-39 intermodulation test record, with a 1-gram force, the IM distortion was under 1% (very low) up to 11.5 cm/sec velocity, reaching 4% at the very high velocity of 22.5 cm/sec.

The cartridge has a slightly lower output than most magnetic cartridges, about 3.9 millivolts at 3.54 cm/sec velocity. This is adequate for driving any modern stereo preamplifier. Its hum shielding was average in effectiveness. The response to the square-wave test signal of the *CBS Labs* STR110 record showed only a single low-amplitude cycle of ringing on the leading edge of the 1000-Hz square wave.

The listening quality of the cartridge confirmed the instrument measurements. It was totally smooth and effortless, with no detectable coloration of any part of the spectrum. A-B listening comparison with other fine cartridges did not reveal any striking audible differences, but our impression was that any such differences were generally in favor of the *ADC* 10/E. Unquestionably, it is one of the two or three finest stereo phonograph cartridges on today's market.

The *ADC* 10/E cartridge sells for \$59.50. ▲

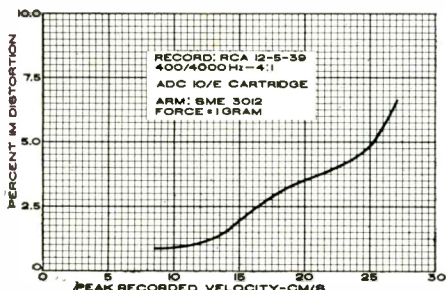

# ELECTRONIC TECHNICIANS

## GRUMMAN

Has immediate positions available in the following categories:

### ELECTRONIC TECHNICIANS

- Digital • Display Systems • Radar
- Airborne Communications • Microwave
- Inertial Systems • Test Equipment Calibration & Repair
- Ground Support Equipment • Numerical Control

### INSTRUMENTATION TECHNICIANS

- Thermal • Vacuum Calibration
- Pressure Transducer & Instruments • Physical Measurement
- Strain Gauge • Liquid Gaseous Flow

RECENT TECHNICAL SCHOOL GRADUATES ARE INVITED TO APPLY

To arrange a mutually convenient interview, send your resume to Mr. Charles W. Towers, Manager, General Employment.



# GRUMMAN

AIRCRAFT ENGINEERING CORP.

South Oyster Bay Road

BETHPAGE, LONG ISLAND, N.Y.

An Equal Opportunity Employer

### ELECTRONICS INSTALLATION AND SERVICING HANDBOOK

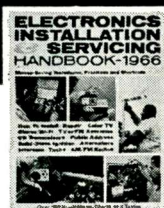

The only complete guide for servicemen and hobbyists to every major phase of consumer electronics servicing.

1966 — \$1.25.....#32

### TAPE RECORDER ANNUAL



Everything you need to know about tape recording including a complete directory of mono and stereo recorders.

1966 — \$1.25.....#30  
1965 — \$1.00.....#31

### COMMUNICATIONS HANDBOOK



The most complete and up-to-date guide to the exciting world of specialized radio communications.

1966 — \$1.25.....#18  
1965 — \$1.00.....#19  
1964 — \$1.00.....#20  
1963 — \$1.00.....#21

ORDER BY NUMBER FROM ZIFF-DAVIS SERVICE DIVISION,  
589 BROADWAY, NEW YORK, N. Y. 10012.

Enclose an additional 15¢ per copy for shipping and handling (50¢ for orders outside U.S.A.)

# GAS WELDING TORCH



Uses **OXYGEN** and **LP GAS**

- Completely self-contained.
- Produces 5000° pin-point flame.
- Welds, brazes, solders.
- Hundreds of lightweight uses.
- Suggested list — \$19.95.

GET COMPLETE DETAILS AT MOST INDUSTRIAL DISTRIBUTORS. OR WRITE TO MICROFLAME, INC.



**MICROFLAME, INC.**  
7800 COMPUTER AVENUE  
MINNEAPOLIS, MINNESOTA 55424

CIRCLE NO. 102 ON READER SERVICE CARD



# ELECTRONIC CROSSWORDS

By JAMES R. KIMSEY

(Answer on page 103)

## ACROSS

- Exterior measurement (abbr.).
- Scheme of action.
- Momentary variation in the frequency of a radio wave.
- Luminous discharges between electrodes.
- What "deci" means.
- Familiar system of radio broadcasting (abbr.).
- Pronoun.
- Possessing non-directional characteristics.
- College degree.
- Hi.....
- Abrupt change in direction between two fairly straight segments of a curve.
- Exist.
- "Can".
- Compass point.
- Authentic.
- .....area a locality at such a distance from the transmitting station that reception is likely to be weak.
- To take care of.
- Jacques' mother.
- Theater sign.
- Symbol for a coil or transformer winding.
- Greek letter used to designate amplification factor.
- A crystal cut to vibrate below 500 Hz.
- Governmental department (abbr.).
- In like manner.
- Abbreviation for an electronically controlled antenna switch.
- Back and forth rotation of the tuning control.
- Cloth worn about the neck.
- Girl's name.
- Chemical symbol for alcohol.
- Every one of two or more considered separately (abbr.).
- Ring shaped region around a transmitter within which there is no reception from the transmitter.

## DOWN

- Nameless (abbr.).
- A benign skin tumor.
- One gun in a three-gun color tube.
- Is in debt.
- Force.
- Light lunches.
- Unit of luminance.
- Region.
- Familiar schematic notation.
- Heavenly body.
- In an oscilloscope, the blanking pulse which applies voltage to the cathode or grid of the CRT to sensitize it only during the sweep time.
- Mutual conductance of a vacuum tube.
- A metal housing.
- Frequency corresponding to an audible sound wave (abbr.).
- Close.
- Prohibit.
- Anger.
- Not fluctuating.
- Long, snake-like fish.
- Not AM.
- An electrically neutral particle.
- Metal part of some vacuum tubes connected to one of the electrodes.
- Hit.
- Stamp of approval.
- Eyed.
- Perplexed.
- In television, view or display a scene.
- Specifically, that part of the general frequency spectrum between audible sound and infrared light (abbr.).
- Norse god.
- Not any.
- Abbreviation on diagrams.
- Conjunction.



## ARE YOU CASHING-IN ON THE PROFITABLE 2-WAY RADIO SERVICE BUSINESS?

- ★ Motorola will train you for this rewarding, elite profession
- ★ Send for our FREE EVALUATION EXAM. Prove to yourself that you are ready to learn FM 2-way radio servicing.

Opportunities in 2-way radio servicing are virtually unlimited. ■ Just one of the hundreds of successful Motorola Service Stations writes, "we would be pleased to interview any graduate of your school that has received some training in 2-way radio maintenance. We are an established firm, 10 years old, with a promise of expansion governed by our ability to obtain competent technicians." ■ Get all the facts today. There is no obligation and no salesman will call.



### MOTOROLA TRAINING INSTITUTE

4545 West Augusta Blvd. • Chicago 51, Illinois • Dept. AEF

- Send me FREE entrance exam.
- Send full details on Home Study Course on FM 2-way Radio Servicing
- Send me details on how you can help me prepare for an FCC License.

Name \_\_\_\_\_ Occupation \_\_\_\_\_

Address \_\_\_\_\_

City \_\_\_\_\_ Zone \_\_\_\_\_ State \_\_\_\_\_

CIRCLE NO. 100 ON READER SERVICE CARD

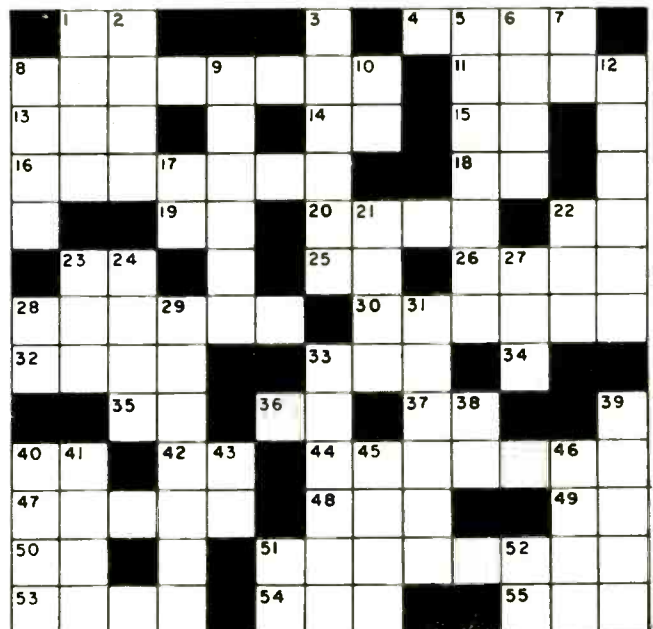

## Selecting the Proper Switch

(Continued from page 43)

standard low-power switches ranges from 0.003 to 0.015 ohm, usually measured from one contact to the adjacent contact. Contact resistance will remain almost constant during rated switch life. However, after the rated life it may change quite significantly. For example, with silver-plated brass contacts after 10,000 cycles when the silver wears through, brass-to-brass contact will produce increased resistance. With hard gold-plated, silver-alloy contacts, resistance will increase only slightly after the rated life of 50,000 cycles.

These life ratings in cycles assume switch usage in low-power circuits. As the amount of circuit volt-amperes increases, contact life and, therefore, switch life decreases. The type of circuit also makes a difference: a low-power resistive circuit produces little, if any, arcing at the contacts, but a highly inductive circuit results in significant arcing which reduces contact life. For circuits with a total inductance of more than a few millihenrys, designers should choose contact materials with a high life rating.

Silver-plated brass contacts should be used only in low-power resistive circuits to interrupt no more than 1 amp at 28 volts d.c. or 0.5 amp at 117 volts a.c. Silver alloy and other high-temperature, long-life materials should be used for inductive circuits and higher power resistive circuits, to interrupt up to 2 amperes at 28 volts d.c. or 1 ampere at 117 volts a.c.

The actual life expectancy of a switch will vary and is determined not only by the power interrupted by the contacts, but also by other factors such as ambient temperature and other environmental conditions. The rate of rotation, maximum contact resistance, minimum insulation resistance, and voltage breakdown required at end of life are also contributing factors.

Breakdown voltage rating of a switch depends primarily on the air space between contacts rather than the dielectric material used. This spacing between contacts depends upon both switch diameter and physical configuration of the switch itself which might increase the air path between adjacent contacts.

For example, compare the 2500-volt peak of a standard 1 $\frac{1}{2}$ " diameter switch with the 1800-volt peak of most 1 $\frac{1}{2}$ " diameter units. For smaller switches, breakdown voltages are even lower with typical test voltages of 750 volts r.m.s. for 1-inch switches and 500 volts r.m.s. for  $\frac{1}{2}$ -inch switches.

The next step in determining the right switch is choice of the proper dielectric from several types currently

available. Paper-based phenolic material is suitable for most standard commercial applications. It is usable to 100°C and will not support fungus growth, an important factor for high-humidity applications. Insulation resistance is about 1000 megohms.

Silicone fiberglass dielectric provides excellent resistance—about 1,000,000 megohms—but it is about two and a half times as expensive as phenolic. Polychlorotrifluoroethylene (Kel-F) can be used up to 85°C, costs more than silicone fiberglass, but has higher insulation resistance—approximately 1,250,000 megohms. Although silicone fiberglass stators can be used up to 125°C, in most cases they are paired with Kel-F rotors, limiting temperature performance of the combination to 85°C.

Ceramic stators and rotors are used in high-temperature applications, up to 150°C. Insulation resistance is excellent—1,500,000 megohms—but it costs about twice as much as phenolic.

Glass-filled mica (such as Mycalex), about equal in cost to ceramic, can be used to 150°C but insulation resistance is about 75,000 megohms. Used with a Kel-F rotor for improved bearing surface characteristics, the maximum temperature is limited to 85°C.

Diallyl phthalate can withstand operating temperature of 85°C and above and it has high insulation resistance—1,000,000 megohms. Only slightly more expensive than phenolic, it is ideal for low-temperature applications where insulation resistance must be high.

In selecting the dielectric for a particular application, criteria to be considered are insulation resistance, temperature characteristics, and cost. Table 1 presents the important electrical characteristics of the various switch insulation materials. Note that the insulation resistance values are for a block of raw material. These values do not conform to the measured values given above when materials are used in switches.

The factors discussed—contact material and plating and dielectric material—directly affect the electrical performance of a switch. Other considerations such as detent mechanism, type of shaft, and indexing mechanism vary considerably from one switch producer to another, but they do not affect electrical performance.

With a basic knowledge of these electrical factors and the ability to translate switching functions on a circuit diagram to poles and switch positions, design engineers and technicians can very often use standard switches, available locally in quantity for fast delivery. When a switching problem may be more complex than normal, the application engineering departments of major switch manufacturers can offer expert assistance. ▲

# NEW! 17TH EDITION of the world-famous RADIO HANDBOOK

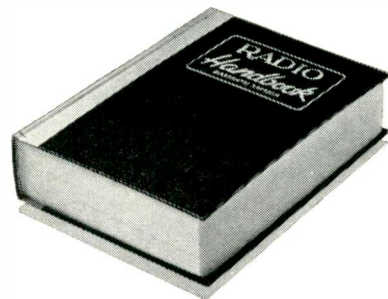

- the most comprehensive how-to-build-it source
- top problem-solver for builders of practical equipment

Completely revised and enlarged by William I. Orr, W6SAL. This is the comprehensive communications manual which is the industry standard for electronic engineers, technicians, and advanced radio amateurs. Explains in authoritative detail how to design and build all types of radio communications equipment.

### NEW HOW-TO-BUILD DATA

The new 17th Edition of the RADIO HANDBOOK presents design data on the latest amplifiers, transmitters, receivers, and transceivers. Includes greatly enlarged sections on single-sideband equipment and design, and semiconductors. Gives extended coverage to rf amplifiers, special vacuum-tube circuits, and computers. All equipment described is of modern design, free of TVI-producing problems.

### THOROUGHLY REVISED & UPDATED

Provides a complete understanding of the theory and construction of all modern circuitry, semiconductors, antennas, power supplies; full data on workshop practice, test equipment, radio math and calculations. Includes aspects of the industrial and military electronics fields of special interest to the engineer and advanced amateur. The 17th Edition of the RADIO HANDBOOK provides the broadest coverage in the field—complete information on building and operating a comprehensive variety of high-performance equipment. All data is clearly indexed. 832 pages; 6 $\frac{1}{2}$  x 9 $\frac{1}{4}$ "; hardbound. Invaluable for electronic engineers, designers, builders, amateurs, and technicians.

### SAVE SPECIAL PRE-PUBLICATION PRICE—ORDER NOW!

EE166, New 17th Edition RADIO HANDBOOK. Special Pre-Publication Price Until Sept. 30, 1966, Only... **\$10.95** (After Sept. 30, 1966, regular price will be \$12.95)

Available also in Spanish and Italian editions.

Order from your electronic parts distributor or send coupon below.

		<b>EDITORS and ENGINEERS, Ltd.</b>
P.O. Box 68003, New Augusta, Indiana, Dept. EWE-9		
<input type="checkbox"/> Ship me EE166, the new 17th Edition RADIO HANDBOOK at the special pre-publication price of \$10.95.		
\$ _____ enclosed. <input type="checkbox"/> Check <input type="checkbox"/> Money Order		
Name _____		
Address _____		
City _____ State _____ Zip _____		

CIRCLE NO. 120 ON READER SERVICE CARD

# Army Field Calibration Technicians

By CARMEN J. DIODATI/U.S. Army Metrology & Calibration Center, Frankford Arsenal

Description of program and personnel concerned with calibrating electronic test equipment used to maintain and check missiles.

TODAY'S modern and scientific Army is dependent on peak operating performance of its vast and complex equipment. In order to maintain a constant state of military preparedness, emphasis has been placed on periodic calibration of all military maintenance and test equipment. Calibration is the determining criterion in seeing that navigational equipment is functioning accurately so that combat vehicles will arrive at the proper objective and missiles will strike predetermined targets. In conventional and nuclear weapons, calibrated instrumentation assures the effectiveness of fire-control systems.

The need for standards and standardization goes back to ancient times. The cubit is the first known unit of measurement. It was established as the length of the forearm, from the elbow to the end of the middle finger—approximately eighteen inches. It was used with remarkable accuracy in building the great pyramids. In 1324 Edward of England declared that the standard inch was equal to the length of three barley corns taken from the middle of the ear and laid end to end. The foot was defined as the length of the foot

of the ruling monarch. In the sixteenth century the rod was decreed to be equal to the total length of the left feet of the first sixteen "good men and true" emerging from church on Sunday.

This standardization, although crude and approximate, was the origin from which our accurate standards, now housed at the National Bureau of Standards, evolved. The accuracy of these standards is transferred to laboratories, industry, and the users of measuring equipment, in decreasing steps of accuracy. Generally, this accuracy is mostly dependent upon the requirements of the particular user.

## Army Calibration Program

The Army Calibration Program started early in 1955. A task force was assigned to inspect and determine the tactical effectiveness of various anti-aircraft missile sites. The results of this inspection indicated that there was a serious lack of correlation of data, which was traced to inadequate calibration of the electronic test equipment used for maintaining and checking the missiles. To remedy this deficiency, an

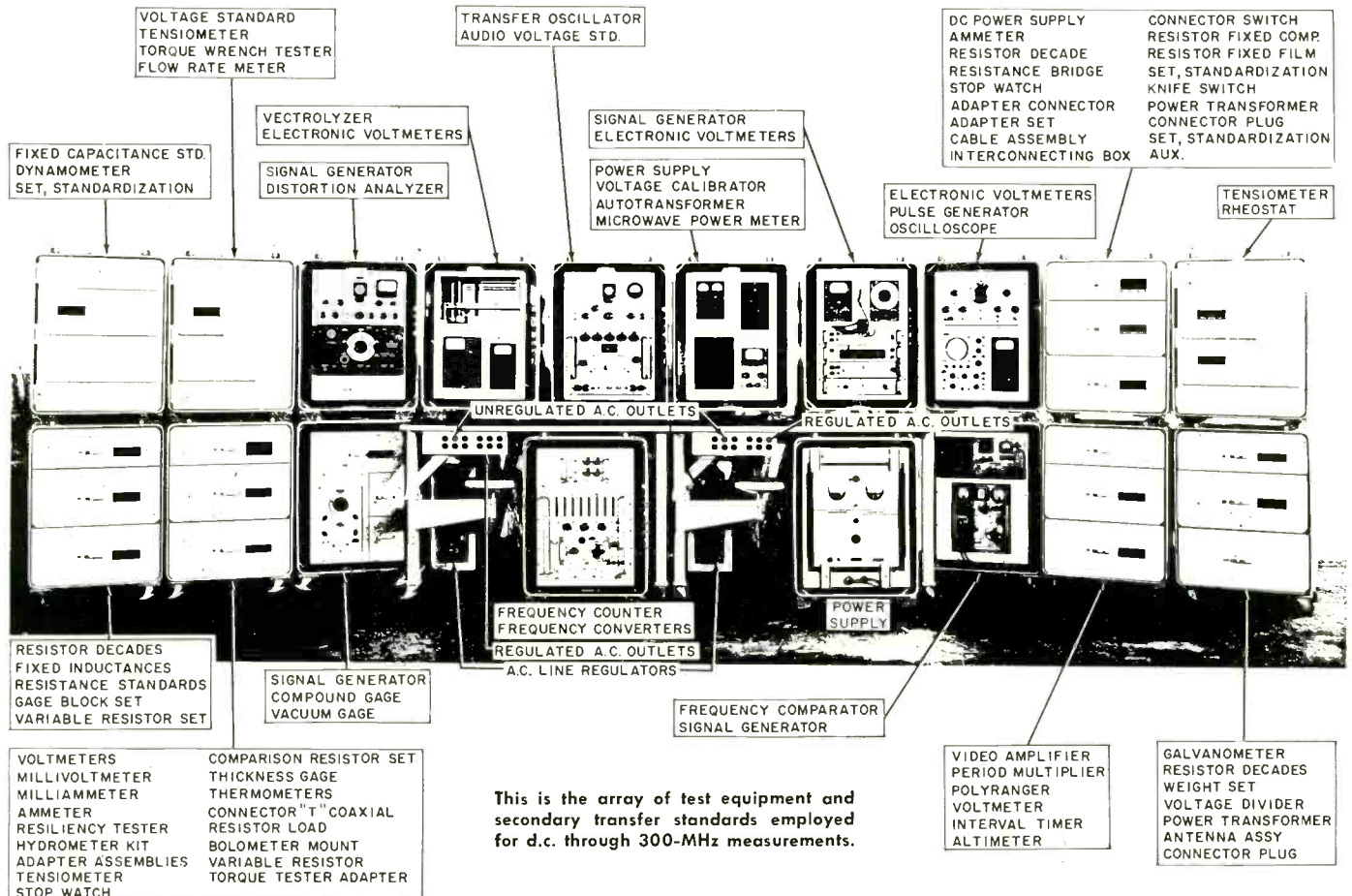

This is the array of test equipment and secondary transfer standards employed for d.c. through 300-MHz measurements.





The calibration van can be expanded by opening its sides. Hydraulic lift at rear facilitates moving heavy equipment.

interim crash program was instituted by the National Maintenance Point at Frankford Arsenal. This Arsenal, in coordination with other Arsenals, procured an interim set of equipment for calibrating the test and maintenance equipment at the missile maintenance shops.

Simultaneously, a group of electronics technicians from various Army Depots began training in the techniques of calibrating test equipment. Upon conclusion of the training, two calibration teams were formed. These teams were equipped with selected interim standards and dispatched on a predetermined itinerary to provide calibration service to all anti-aircraft missile sites within the continental limits of the United States. One team covered the east coast while the other covered the west coast. Upon completion of this mission, another team was formed, similarly equipped, and dispatched to Europe to perform calibration.

The results of this interim calibration program proved very successful. Correlation of data and equipment had been achieved. As a result, Frankford Arsenal was assigned the responsibility of directing and establishing firm calibration services. These services are now available at regularly scheduled intervals or upon request. Thus evolved the Army Field Calibration Program from approximately 20 people—now numbered in the thousands, including both military and civilian personnel. In brief, calibration has certainly become a byword for optimum performance of all types of military electronic fixed and mobile equipment.

### Equipment Employed

At the start of the program, the interim equipment did not present a transportation problem. A panel truck or station wagon sufficed. However, as time went on, the quantity and complexity of the equipment grew to such an extent that a larger vehicle was required.

The current selection is the M292 expandable van. This vehicle is approximately 17 feet long, 6 feet high, and 7 feet wide when mobile. It has expandable sides which permit the width to be increased to 13 feet to provide ample working room for personnel doing the calibrating. The van is equipped with an air conditioner and a heating system to maintain a laboratory-type temperature and humidity environment when being utilized in its calibration function; moreover, there are sufficient wiring provisions to power the equipment of the van and the units to be calibrated. The required power can be supplied by the power source at a fixed location or a transportable generator. At the rear of the van is a hydraulic lift, used for raising and lowering the equipment.

There are two types of calibration vans. The d.c./low-frequency van is used for equipment operating in the range from d.c. to 300 megaHertz. This van has a complement in excess of 100 standards, excluding accessories such as cables, connectors, and uncalibrated units used as sources. The uncalibrated units are used in conjunction with calibrated standards which monitor the required outputs. The microwave van has approximately 25 standards which cover the range from 300 to 40,000 megaHertz.

To maintain a high level of accuracy in calibration, it is

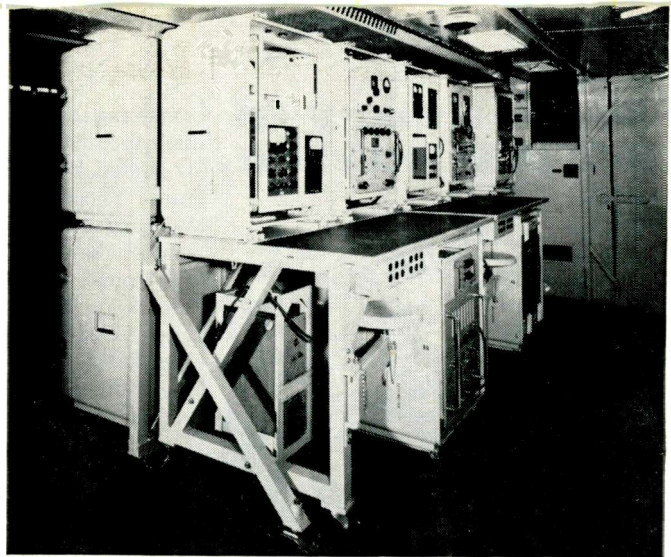

Interior view of right side of lower frequency van showing work area. When the van is in motion, the floor folds upward, the ceiling downward, and sides fold in close to workbench.

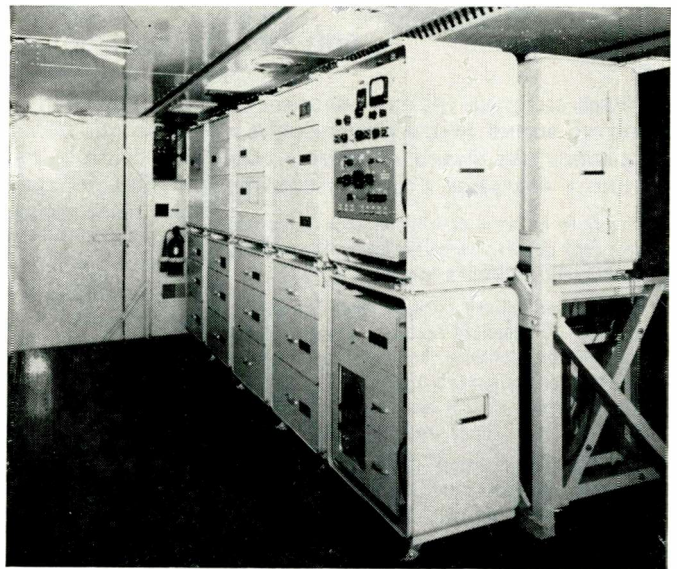

Interior view of left side of van with the workbench removed.

desirable that the standards have an accuracy of at least ten times the accuracy of the unit being calibrated. However, field requirements in some areas are so stringent that generally the best accuracy obtainable is a ratio of three to one; moreover, there are many instances where the field equipment and the standard have the same accuracy. In order to increase calibration accuracy for the most stringent requirements, these units are calibrated utilizing tolerances which are determined statistically.

The standards and equipment in the vans are mounted in carrying cases for protection in transit and to facilitate the moving of individual or groups of standards when necessary. The mobile calibration laboratory equipment is designated *transfer standards*. These standards are used to calibrate the test and measuring equipment in the field.

Transfer standards are calibrated at designated Army Depots (area support units) with reference standards which have the second highest degree of accuracy in the Army system. The reference standards are, in turn, calibrated by the primary laboratory at Frankford Arsenal with back-up support provided by the Tooele Army Depot. These primary standards have the highest accuracy within the Army system and are calibrated by the National Bureau of Standards, or with standards that have been calibrated by the Bureau.

The progression of calibration from the field to the Bureau is called *traceability*. That is, each item of equipment in the field has its accuracy specifications, certified by standards traceable to the National Bureau of Standards.

It is quite obvious that instruments alone cannot



# DETERMINING dB POWER RATIOS

By CARMEN J. DIODATI  
Army Metrology & Calibration Center, Frankfort Arsenal

Using only two tables, it becomes very easy to determine dB power ratios to six decimal places.

ONE of the problems with calculating dB power loss or gain ratios is the requirement for a dB table, and the need for extrapolating the desired conversion information. The two tables included in this article present a very easy method of determining dB power loss or gain from 1 to 60 dB, with six-place accuracy.

## Power Gain

Table 1 is used for power gain ratios with the vertical "dB" column used for units of dB's while the horizontal "dB" row is used for tens of dB's. The decimal point always follows the tens of dB's column. Some examples follow.

To determine the power gain for 5 dB, enter the vertical "dB" column and proceed down to the "5" indication. Reading horizontally from this point produces 316228. Because there are no tens of dB's, the decimal point follows the "0" column making the value 3.16228.

To determine power gain for 22 dB, enter the vertical "dB" column, proceed down to "2" and read 158489. Since 22 is between 20 and 30, the decimal point follows the "20" column making the value for 22 dB equal to 158.489.

To determine the power gain for 59 dB, enter the vertical "dB" column, proceed down to "9" and read the number 794326. Because 59 is between 50 and 60, the decimal point follows the "50" column making the number 794326.0. Sixty dB is "10" in the units column with the decimal point following the "50" column making the value 1000000.0.

Table 1. Six-place table for power gain.

dB	0	10	20	30	40	50
1	1	2	5	8	9	3
2	1	5	8	4	8	9
3	1	9	9	5	2	7
4	2	5	1	1	8	8
5	3	1	6	2	2	8
6	3	9	8	1	0	7
7	5	0	1	1	8	7
8	6	3	0	9	5	7
9	7	9	4	3	2	6
10	10	0	0	0	0	0

Table 2 is used for power loss ratio in the same fashion as previously described for power gain.

## Power Loss

Since power loss is always less than unity, the decimal point always precedes the "0" tens column for units of dB's and is moved to the left the number of places indicated by the initial digit (tens of dB's) of the amount. Some examples follow.

To determine the power loss for 1 dB, enter the vertical "dB" column and read the number 794326 alongside the "1".

Because the decimal always precedes the "0" column for units of dB's, this value is then 0.794326.

To determine the power loss for 36 dB, enter the vertical "dB" column and proceed down to "6". The number is 251188, and because the initial digit of the tens amount is 3, the decimal point moves to the left 3 places making the value 0.000251188.

Both tables can be extended to find power ratios up to 100 dB by adding the required number of zeros. For example, the figure used for 99 dB is 794326. With ten decimal places, the final value is 7943260000. Power loss for 99 dB is 125893, and with nine decimal places to the left, becomes  $0.125893 \times 10^{-9}$ .

## Voltage Ratio

Both tables can be used to determine the voltage ratio (VR) from the power ratio (PR) by applying the formula  $VR = \sqrt{PR}$ .

Table 2. Six-place table for power loss.

dB	0	10	20	30	40	50
1	7	9	4	3	2	6
2	6	3	0	9	5	7
3	5	0	1	1	8	7
4	3	9	8	1	0	7
5	3	1	6	2	2	8
6	2	5	1	1	8	8
7	1	9	9	5	2	7
8	1	5	8	4	8	9
9	1	2	5	8	9	3
10	10	0	0	0	0	0

## SELLING THAT RECORDER? BUYING A RECEIVER?



ELECTRONICS WORLD runs a Hot Line into the 197,524 electronics professionals who buy the magazine each month. And, for only 40¢ a word, a personal classified ad will help you make your connection.

ELECTRONICS WORLD has the largest audience of its kind in the world, and this creates an ideal market place for you. Actually, when you get together with your co-professionals, you may find that many are near neighbors. Yet your mutual needs may be met only through the medium of our classified columns.

Take advantage of our special personal rate of 40¢ a word (including name and address)

NO MINIMUM REQUIRED

a saving of 30¢ a word  
from our commercial  
rate of 70¢.

A small investment can bring quick results, and complete data is printed in the Classified Advertising Section. Write your ad and mail it today, with your payment to:

HAL CYMES  
Classified Advertising Manager  
ELECTRONICS WORLD  
One Park Ave., N. Y., N. Y. 10016

NOV. ISSUE CLOSSES SEPT. 5th.

3 new

**Winegard**

**Distribution Amplifiers**

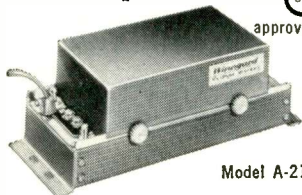

Model A-215

to run 2 sets, 200 or MORE!

- Designed for color and FM stereo—have flat frequency response, no phase distortion, full gain to top of FM band.
- Lowest Noise—use All high transconductance, low noise triodes—no pentodes.
- Easiest to Service—All jacks, controls, switches, and connections accessible from top of chassis.
- Extended Band Pass—Allows cascading without clipping the end channels.
- Fully Ventilated Top and Sides—dissipate heat for longer life.
- For complete information contact your distributor or write Winegard today.

**LIST PRICES:**

- Model A-845 (8 tube, 45 db gain, drives up to 100 sets) **\$159.95**
- Model A-430 (4 tube, 30 db gain, drives up to 52 sets) **\$84.95**
- Model A-215 (2 tube, 15 db gain, drives up to 10 sets) **\$44.95**

**Winegard Company**

3000 Kirkwood • Burlington, Iowa

CIRCLE NO. 83 ON READER SERVICE CARD

Enjoy the "music-only" programs now available on the FM broadcast band from coast to coast.

- NO COMMERCIALS •
- NO INTERRUPTIONS •

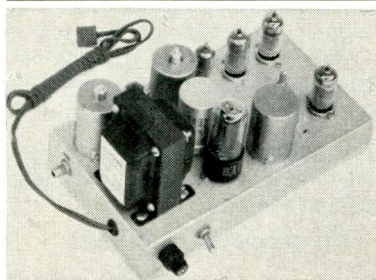

It's easy! Just plug Music Associated's Sub Carrier Detector into multiplex jack of your FM tuner or easily wire into discriminator. Tune through your FM dial and hear programs of continuous, commercial-free music you are now missing. The Detector, self-powered and with electronic mute for quieting between selections, permits reception of popular background music programs no longer sent by wire but transmitted as hidden programs on the FM broadcast band from coast to coast. Use with any FM tuner. Size: 5½" x 6". Shipping weight approx. 7 lbs.

**KIT \$49.50**  
(with pre-tuned coils, no alignment necessary)

**WIRED \$75.00**

**COVER \$4.95 EXTRA**

Current List of FM Broadcast Stations with SCA authorization ..... \$1.00

**MUSIC ASSOCIATED**

65 Glenwood Road, Upper Montclair, New Jersey  
Phone: (201)-744-3387

CIRCLE NO. 98 ON READER SERVICE CARD

**Testing Capacitors**  
(Continued from page 41)

the test capacitor's impedance is compared to known values.

The simple form of capacitance bridge bears a strong resemblance to the d.c. Wheatstone bridge. It consists of four impedance arms, an a.c. signal generator, and a balance or null detector. Fig. 3A shows a simplified diagram of the bridge circuit.

Impedance  $Z_x$  in this circuit includes the test capacitor which becomes, or alters, the fourth arm of the bridge. Two of the three impedances ( $Z_1, Z_2, Z_3$ ) are known and variable and are controlled by dials calibrated in terms of the desired parameters,  $C$  (capacitance) and  $DF$  (dissipation factor) or  $G$  (conductance). Balance is secured by adjustment of one or more of the bridge arms and is indicated by zero response of the detector which means that points A and C are at the same potential. The impedances are complex, consisting of both resistive and reactive components. The condition of zero potential difference from A to C requires that the voltage from B to A equals the voltage from B to C, both in magnitude and in time relationship, or phase. When this condition is reached, the bridge-arm impedances will satisfy the equation:  $Z_x = (Z_2Z_3)/Z_1$ .

As previously discussed, an ideal capacitor reacts to a.c. by shifting the phase of the voltage with respect to current by 90°. In this case, the capacitor appears as a pure reactance and only one variable bridge arm would be necessary to achieve balance. However, since all capacitors have internal losses (see Fig. 1B) due to lead, electrode, and dielectric resistances, a true 90° phase shift cannot be obtained. This is because the internal losses present a nonreactive element, as illustrated in the vector diagram shown in Fig. 3B.

In this diagram,  $X_C$  is the reactive element attributed to the capacitance and is computed as  $1/2\pi fC$  in ohms where  $f$  = frequency in Hz, and  $C$  = capacitance in farads.

$R_s$  is the magnitude of the internal loss, or nonreactive element, in ohms and may not be measured directly.

The bridge serves the function of separating the total impedance ( $Z$ ) into its vector parts  $X_C$  and  $R_s$  by initial balance of the bridge arm controlling reactance and a secondary balance of the bridge arm which controls phase shift. When the capacitance has been balanced and the phases of the current and voltage have been made coincident, points A and C in Fig. 3A will be at the same potential and complete impedance balance will have been obtained.

The dial indications will show under this condition the terminal capacitance and the dissipation factor or conductance of the capacitor.

Dissipation factor ( $DF$ ) is the loss factor of the capacitor and is defined as the tangent of the loss angle  $d$  (see Fig. 3B) or  $R_s/X_C$ . The  $DF$  may be displayed as a pure decimal number or in percent. Percent is used to describe the relationship between the loss and reactive components of the capacitor and, since it is a tangent function, may exceed 100%, where the real loss exceeds the reactance.

Power factor is the cosine of the angle  $\theta$ , that is,  $R_s/Z$  (see Fig. 3B) and is approximately the same as  $DF$  for values less than 10%. The reciprocal of the  $DF$  is referred to as the "Q," or figure of merit of the capacitor.

There are two common bridge methods of measuring capacitors. One measures the capacitor as a pure reactance in series with a small resistance  $R_s$ . In this case the intrinsic value of capacitance and  $DF$  are displayed by the bridge. A second method is to measure the capacitor as a reactance in parallel with a large resistance,  $R_p$ . In this case the loss vector may be displayed as conductance ( $G$ ) in micromhos ( $\mu\text{mho}$ ) which is the reciprocal of the equivalent parallel resistance. When the measured value of  $G$  is high, as in low "Q" or high  $DF$  capacitors, the displayed value of capacitance is not the same as in the series case and will require correction for correlation. The relationship between the series and parallel capacitance is defined in the formula:  $C_s/C_p = 1 + (DF)^2$ .

Normally, capacitor ratings are based on the series value of capacitance and the correction factor for parallel measurements must be applied when the  $DF$  exceeds 10%.

Measurement of capacitance and  $DF$  is normally made at a frequency of 1 MHz for values up to 100 pF (1000 pF for some capacitor types) and 1 kHz beyond this to 1.0  $\mu\text{F}$ . Above 1.0  $\mu\text{F}$ , 60 Hz is the most common measurement frequency except for electrolytics which are measured at 120 Hz for all capacitance values, unless otherwise specified.

Measurement of capacitance may be accomplished at any frequency, although the problems and inaccuracies of measurement are increased with increasing frequencies and capacitance values. This is primarily due to the effects of lead inductance and resistance in the bridge and the capacitor terminals. Quality capacitance bridges are calibrated to include their terminals to specified accuracies at specified frequencies. This calibration takes into account the resistance and inductive reactance of the internal bridge leads and connections. Since inductive reactance increases directly with frequency, its relative value

becomes a source of appreciable inaccuracy when the bridge is used at frequencies much above its calibrated value.

Because capacitive reactance decreases with increasing frequency and capacitance value, the maximum capacitance that may be measured directly on a bridge is determined by the point at which the residual bridge parameters become predominant and specified accuracies cannot be maintained.

The residual inductance,  $L_s$ , of the capacitor alters the apparent terminal capacitance to some degree due to the  $180^\circ$  phase relationship between inductance and capacitance. However, for capacitance measurements made within the specified bridge range and frequency limits, this is not consequential, since the small value of the residuals in a practical capacitor are part of the capacitor and need not be corrected or eliminated from the circuit.

The series resistance,  $R_s$ , may provide a limiting factor of bridge measurement when a combination of frequency, capacitance, and equivalent series resistance is such that the ratio of  $R_s/X_C$ , which is the  $DF$  of the capacitor, exceeds the maximum value for which the bridge has been calibrated.

This article has introduced the reader to the fundamental characteristics of capacitors and basic theories leading to their practical measurement. Equipment manuals will specify points of inaccuracies and correction factors to be utilized for that equipment. Standardized test specifications, such as MIL-STD-202 in conjunction with individual capacitor specifications, define the basic test procedures and conditions required for a test. Although specific measurement of capacitor parameters over a range of frequencies, temperatures, and environmental conditions may require sophisticated techniques, the theories of measurement remain the same. ▲



"Well, if I can't have a raise, can I have my name on the broom closet door?"

# Soliton

announces

**V<sub>CEO</sub> (SUS)**

- 325 v**
- 300 v**
- 250 v**
- 225 v**
- 200 v**



*in a 10 Amp. NPN Silicon  
Planar Power Transistor  
Plus  
50 mcs . . . . . 150 pfs*

Type Number	Pkg Size	DESIGN LIMITS						PERFORMANCE SPECIFICATIONS					
		T <sub>J</sub>	θ	P <sub>T</sub>	BV <sub>CEO</sub>	V <sub>CEO</sub> (SUS)	BV <sub>EMO</sub>	h <sub>FE</sub>	V <sub>BE</sub> (sat)	V <sub>CE</sub> (sat)	I <sub>CEO</sub>	f <sub>r</sub>	
		°C	°C/W	Watts	Volts	Volts	Volts	Min. Max.	Volts	Volts	μA	mc	
		Max.	Max.	Max.	Min.	Min.	Min.	Min. Max.	Max.	Max.	Max.	Min.	
MHT7201	TO-3	200	1.5	65	225	200	8	20	60	1.2	0.5	1.0	50
MHT7202	TO-3	200	1.5	65	250	225	8	20	60	1.2	0.5	1.0	50
MHT7203	TO-3	200	1.5	65	275	250	8	20	60	1.2	0.5	1.0	50
MHT7204	TO-3	200	1.5	65	325	300	8	20	60	1.2	0.5	1.0	50
MHT7205	TO-3	200	1.5	65	350	325	8	20	60	1.2	0.5	1.0	50

TRANSISTOR DIVISION

## Soliton DEVICES, INC.

1177 BLUE HERON BLVD. / RIVIERA BEACH, FLORIDA / (305) 848-4311 / TWX: (510) 952-6676

Leader in Germanium and Silicon Power Transistors, Cryogenic Thermometers, High Voltage Rectifiers, Hot Carrier Diodes, Temperature Compensated Zeners, Voltage Variable Capacitors, Random/White Noise Components, Microelectronic Circuits, and High-Pac Interconnection Systems.

CIRCLE NO. 200 ON READER SERVICE CARD

### LEARN Electronics Engineering AT HOME

Fix TV, design automation systems, learn transistors, complete electronics, College level Home Study courses taught so you can understand them. Earn more in the highly paid electronics industry. Computers, Missiles, theory and practical, Kits furnished. Over 30,000 graduates now employed. Resident classes at our Chicago campus if desired. Founded 1934. Catalog.

American Institute of Engineering & Technology  
1141 West Fullerton Parkway Chicago, Ill. 60614

### "HOW TO MAKE MONEY IN Mobile Radio Maintenance"

AUTHORITATIVE GUIDEBOOK ABOUT THE BOOM IN TWO-WAY MOBILE RADIO. GIVES FACTS, FIGURES, PAY RATES. WRITE TODAY! FREE

LAMPKIN LABORATORIES, INC. Mfg. Div. BRADENTON, FLA.

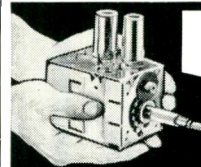

### COMPLETE TUNER OVERHAUL

ALL MAKES ALL LABOR AND PARTS (EXCEPT TUBES & TRANSISTORS) \$995

Send complete tuner now . . . or write for full information and mailing labels. Exchanges on tuners unfit for overhaul . . . . . from \$12.95

### CASTLE TV TUNER SERVICE

MAIN PLANT: 5717 N. Western Ave., Chicago 45, Illinois  
EAST: 41-94 Vernon Blvd., Long Island City 1, New York

CASTLE TV SERVICES, LTD. . . . Nation-wide service.  
CANADA: For service in Canada write to Chicago for details, Canadian address, and mailing kit.

\*Major parts are charged extra in Canada

**WORLD'S  
FINEST  
5-CORE  
SOLDER**



**ERSIN  
MULTICORE  
NEW EASY  
DISPENSER  
PAK ONLY 69¢**

BUY IT AT RADIO-TV PARTS STORES  
MULTICORE SALES CORP. WESTBURY, N.Y. 11590  
CIRCLE NO. 99 ON READER SERVICE CARD

## problem solvers by

**SHURE**



**PROBLEM:**  
Long Microphone  
Cable Runs  
**SOLUTION:**  
A95A Line Matching  
Transformer

Matching low impedance microphones to high impedance inputs? Excessive high frequency loss and hum pickup with long microphone cable runs? The A95A Line Matching Transformer solves both problems quickly—and economically. New miniature size: 3/4" diameter and 2 1/2" length. New hum shielding: superior to any other transformer. New flexibility: 35-50 and 150-210 ohms input. New ease of installation: input and output connectors furnished. Only \$17.50 List.

Shure Brothers, Inc.  
222 Hartrey Avenue  
Evanston, Illinois

CIRCLE NO. 79 ON READER SERVICE CARD

## Measuring Instruments

(Continued from page 38)

Several trends are now clearly established and are likely to accelerate. It is now well understood that the digital revolution is more than a matter of the attractive appearance of an in-line read-out and extra resolution; it is part of the massive swing to computerization and data-processing applications in all areas of business and technology.

Automatic instruments will grow in popularity, as electronic-component manufacturers, like all manufacturers in all industries, continue to look for ways to reduce labor costs. The days of manually turning balance controls and listening or watching patiently for a null are on their way out.

Microelectronics is bearing down on the instrument industry and integrated circuits are now being used in some instruments. The greatest impact of microelectronics will be in the areas of reliability and cost rather than in size; the minimum size of an instrument is often fixed, not by its circuit components, but by its panel meter or other indicators, knobs, dials, etc. However, as the function of, say, a pulse generator is performed by a few chips, and that of a pulse amplifier by a few more chips, one can expect both functions to be housed in a common package. The systems of today, in other words, will be the instruments of tomorrow.

Whatever microelectronics will do to electronic-instrument design, it is sure to have a revolutionizing effect on the whole concept of electronic components. As monolithic and hybrid chips replace millions of resistors and capacitors, they will also eliminate the need to measure these millions of components. This, in turn, will inevitably alter the instrument picture even further. Just how is not clear. One thing is certain, however: All those who now make, measure, or use passive components to any extent had better keep a close eye on the potentially explosive field of microelectronics. ▲

Fig. 12. Radio-frequency bridge for measurements at frequencies up to 60 MHz. At high frequencies, shielding becomes more important, and generator and detector are connected with coaxial cable leads.

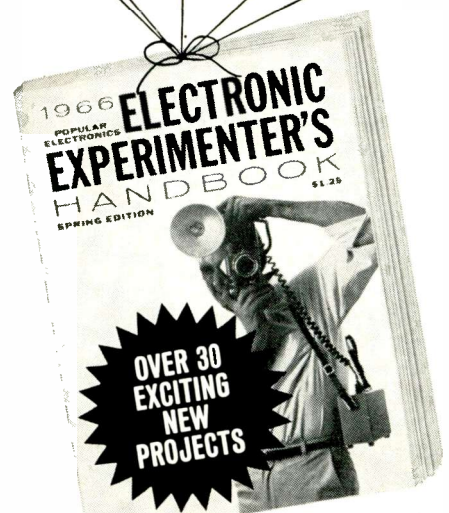
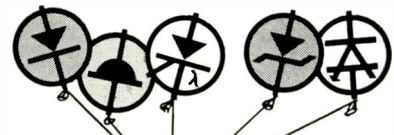

## SPRING EDITION

**Now Available**—The all-new Spring 1966 Edition of **ELECTRONIC EXPERIMENTER'S HANDBOOK!** Another big package of over 30 fascinating do-it-yourself construction projects for:

**Amateur Radio**      **Automotive Electronics**  
**Photography**      **HiFi/Stereo & Audio**  
**Test Equipment**    **Short-Wave Listening**

You'll build such valuable units as... a super photo flash... a simple auto light minder... a transistor FM multiplexer... an electric fence charger... and a self-regulating lighting controller.

Each has complete, easy-to-follow schematics, parts lists and how-to instructions that guarantee you perfect finished products! Plus—dozens of professional pointers, tips and techniques to increase your overall electronics skills and proficiency.

In all, more than 148 pages of challenging projects that will deliver hour after hour of sheer fun... and provide you with economically-built, useful items (to keep, or sell for a profit) after you've finished.

Make sure you receive your copy of this \$1.25 valuable handbook. Fill in the coupon and mail it today!

**A DELUXE, GOLD-EMBOSSED  
LEATHERFLEX-BOUND EDITION**  
...just \$3.00 postpaid



This deluxe edition is a permanent, handsomely-bound collector's item that belongs in your electronics library! Check appropriate box on coupon.

ZIFF-DAVIS SERVICE DIVISION, Dept. EEH  
589 Broadway, New York, N.Y. 10012

**COUNT ME IN**...for a copy of the Spring 1966 **ELECTRONIC EXPERIMENTER'S HANDBOOK** as I've indicated:

- \$1.25 enclosed, plus 15¢ for shipping and handling. Send me the regular edition. (\$1.50 for orders outside U.S.A.)
- \$3.00 enclosed. Send me the Deluxe Leatherflex-Bound edition, postpaid. (\$3.75 for orders outside U.S.A.) Allow three additional weeks for delivery.

name \_\_\_\_\_ please print EW-96

address \_\_\_\_\_

city \_\_\_\_\_ state \_\_\_\_\_ zip code \_\_\_\_\_

**PAYMENT MUST BE ENCLOSED WITH ORDER**

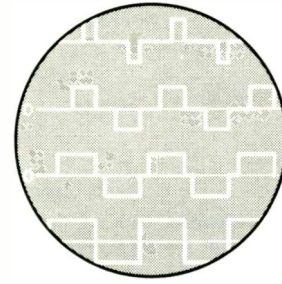

# Switching-Mode Power Conversion

*Description of new technique that can cut the size, weight, and cost of conventional power supplies and, at the same time, considerably increase efficiency.*

By DONALD E. LANCASTER

**T**HERE is an interesting paradox in present-day power supplies. While the rectifiers and regulating components are becoming almost vanishingly small, the over-all size and weight of most power supplies has stayed nearly the same. No matter how small the rectifiers become, as long as power conversion is to take place at 60 Hz, we are essentially stuck with large, heavy, iron transformers and filter chokes as well as bulky and expensive capacitors. Furthermore, as long as conventional regulation methods, such as series or shunt zeners or transistors, are used, bulky and expensive heatsinking is required to remove the heat that is produced during regulation. This heat is also reflected in very poor power-supply efficiency, requiring much more input power than is usefully converted.

The sheer bulk and weight of equipment using present power conversion techniques multiplies itself, for heavy chassis and rugged construction are required in order to support and to protect this type of supply.

## New Circuits & Techniques

Some new circuits and some significant new techniques have appeared that can drastically slash the size, weight, and cost of conventional power supplies while at the same time substantially increasing their efficiency. The size improvement attainable with these techniques is remarkable. Today's 1N4005 is about half the size of one base pin on yesterday's 5U4G. Tomorrow's power supplies will provide the same dramatic space and weight reductions when compared with present-day supplies.

These techniques are quite simple and have been known for some time. To a certain extent, they are in use in some power supplies today. Only the lack of suitable components to date has prevented the widespread use of these techniques. New components now make this transition possible.

The techniques are simply stated: (1) Go to a high frequency instead of 60 Hz for power conversion. (2) Use square waves instead of sine waves. (3) Operate all regulators in the switching mode so that they are always either off or on and thus, at least in theory, they never dissipate any power. Let us investigate the consequences of these new techniques.

## Using a Higher Frequency

Just going to a higher supply frequency is not new. Aircraft electronics systems are based upon a 400-Hz power system to reduce the amount of copper and iron required

in supplies, motors, and generators. Many automotive vibrator-type supplies also ran at this frequency. Today's transistorized power converters run at a slightly higher frequency, usually between 1 and 2.5 kHz. New techniques at present set typical operating frequencies between 50 and 200 kHz; in the near future, this will likely be upped into the megahertz region.

Fig. 1 compares two power-supply filters, one operating at a 60-Hz frequency and the other at a 60-kHz frequency. Both filters provide identical output ripple. Note that the values of all components in the 60-kHz filter are 1/1000 the size of the 60-Hz units. This means a .01- $\mu$ F, 600-volt Mylar capacitor may be used in place of a 10- $\mu$ F, 600-volt electrolytic. The size, cost, and weight savings are obvious. More subtle is the gain in reliability. All but the finest electrolytics eventually change their value and need to be replaced, but a failure in an ordinary Mylar capacitor is practically unknown. A second gain comes about when the capacitor is mounted on the supply chassis. Large brackets are required for an electrolytic, while the Mylar can safely support itself on its own leads.

The effect upon the inductance is even more marked. Instead of a 10-henry choke, we need a 10-millihenry one. One is a heavy, expensive, iron-core device, while the other is a low-cost air- or lightweight ferrite-core device. Again, the latter is self-supporting on its own leads, while the 10-henry unit requires a rugged chassis mounting. Inductance is never obtained free. There is always a copper and a core loss to contend with. The core loss is negligible in air-core and ferrite chokes but is quite significant in power-frequency iron-core units. The lower inductance value also means fewer turns of wire and thus less d.c. resistance. Because of this, the 10-millihenry choke is considerably more efficient. This reduces the input power required for the same output power and at the same time eliminates a source of heat that limits the minimum possible size of the supply.

The same dramatic reduction in size and weight is reflected in the power transformers. A 60-kHz transformer is usually a compact, lightweight toroidal unit. The toroidal

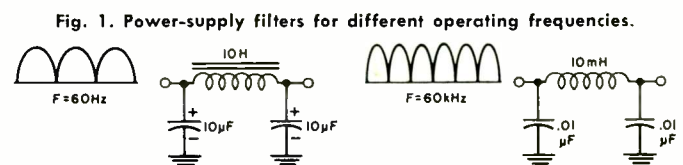

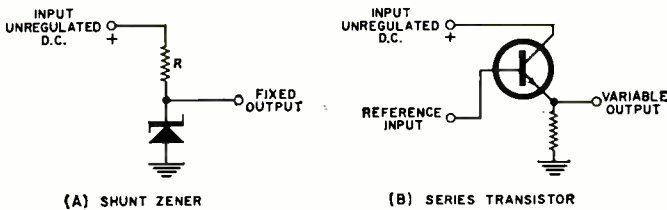

Fig. 2. Conventional regulators such as these are quite inefficient and convert much of the input power into useless heat.

design contains the field within the core, and very little shielding is required. By the same token, a toroidal transformer is relatively immune to external magnetic fields, eliminating hum and coupling problems normally encountered in conventional supplies.

In certain cases, we can go one step further and replace the 60-kHz sine wave with a 60-kHz square wave. In a full-wave rectifier that is driven by an ideal square wave, no filter at all is needed, for there is never a time when a filter would be required to store energy. Unfortunately, in the real world of finite rise times, overshoot, and transients, some filtering is required to fill in and smooth out the transitions between the cycle halves. But in a properly designed circuit, the filtering required is quite small, even when compared with that needed for 60-kHz sine-wave filtering.

By going to a high frequency, the requirements for filtering are realized with much smaller, lower cost components. By going to square-wave operation, these small components may be replaced with even smaller components.

### Regulator Circuits

Fig. 2 shows some ordinary regulators. Fig. 2A shows a zener diode connected as a shunt regulator. Constant power is always drawn from the supply, regardless of whether zero or full-load current is being drawn. The output power is proportioned between the load and zener in such a manner as to maintain constant load voltage. The efficiency of this circuit is quite low and approaches zero for small loads. In a 1-ampere, 100-volt supply, the zener employed must dissipate 100 watts of power. Resistor *R* will add at least 10 watts of dissipation. If these two dissipating components could be removed from the supply, while at the same time

retaining the same regulation, the size of the supply could be substantially reduced and operation would be considerably cooler. At the same time, supply efficiency would be markedly improved.

The series transistor circuit of Fig. 2B is somewhat more efficient and allows adjustment of the output voltage, but the transistor is still asked to dissipate considerable power. As long as the difference between the available supply power and the required power is made up by a lossy element, be it a resistor, transistor, zener, tube, or any other dissipative device, the problem of supply inefficiency and heat removal remains and must of necessity add to supply size and cost.

### Switching Circuits

Suppose, instead, that the supply were switched off and on at a 100-kHz rate by a perfect switch, perhaps as in Fig. 3. If the "on" time of the switch equalled the "off" time, one-half the available supply voltage would be present at the output, with not a watt lost as heat. Since the output is a 100-kHz square wave, it is readily filtered to obtain a smooth, low-ripple d.c. output. Diode *D1* is called a "free-wheeling diode." It automatically provides a path for filter reactive energy during the switch "off" time. The diode *D1* is essential for efficient operation. The ratio of the switch "on"

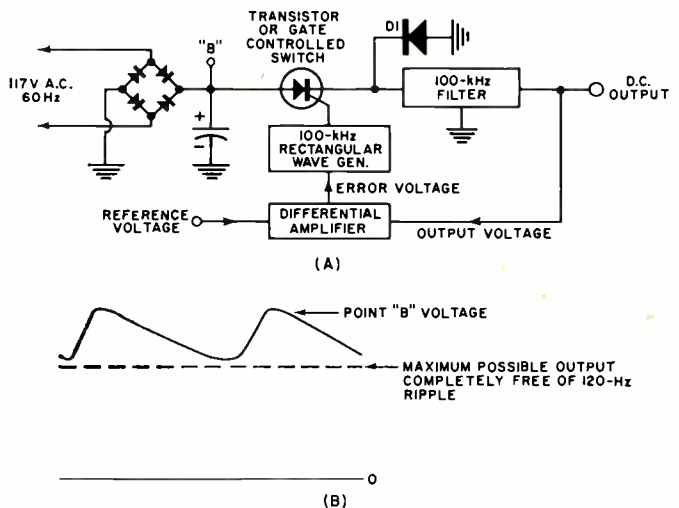
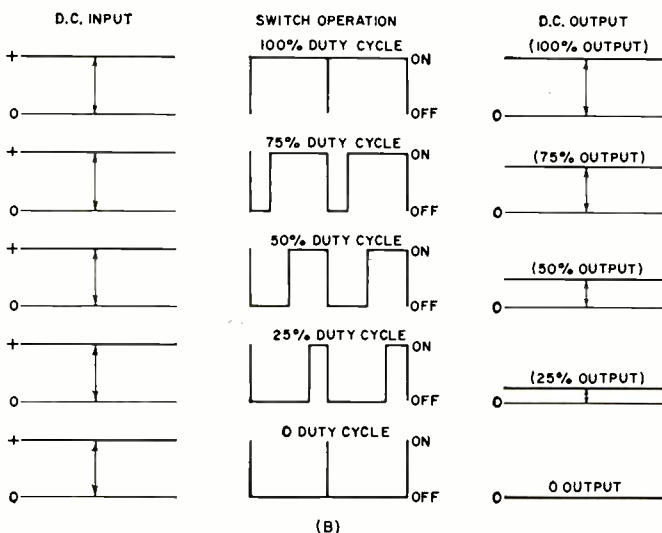
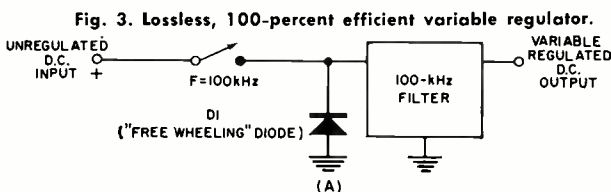

Fig. 4. Block diagram of practical switching-mode supply.

time to "off" time determines the output voltage. The greater the fraction of a period that the switch is "on," the higher will be the output voltage, and *vice versa*. This regulator is 100% efficient and requires no heatsinking and no heat removal.

A gate-controlled switch (GCS), a silicon controlled rectifier (SCR), or a power switching transistor is not quite perfect, but if it can switch much more rapidly than 100 kHz, only the small saturated forward voltage drop need be taken into account. For a silicon device, this is around .6 volt. In the 1-ampere, 100-volt supply, the semiconductor switch has to dissipate only .6 watt, and then only during the "on" time of the switch. When this .6-watt loss is compared with the 110-watt loss of a zener circuit, the advantages of switching-mode regulation become apparent.

A typical circuit operating off a.c. power is shown in Fig. 4. The a.c. line is rectified by four power diodes in a full-wave bridge configuration. The output is then crudely filtered by a single filter capacitor, perhaps to a 15 or 20% ripple level. Although a large capacitor is required, the loose tolerance on the ripple allows a substantially smaller unit than normal to be used. To perform the regulation, a precision voltage reference is compared to the output voltage by a differential amplifier. The output of this amplifier is used to alter the duty cycle of a 100-kHz rectangular-





wave generator which provides the switching pulses for the GCS regulator. The ratio of "on" to "off" time determines the output voltage. The output filter sees only a 100-kHz waveform, for the response of the differential amplifier extends well beyond 60 Hz and adjusts the duty cycle exactly to eliminate any 60-Hz ripple in the output. Any increase in output voltage is immediately converted into a shorter "on" time, which returns the output voltage to its normal value, and *vice versa*.

This circuit may be used as three distinct switching-mode power converters. As shown, it converts 60-Hz a.c. line voltage to any desired lower d.c. voltage, smoothly filtered and precisely regulated both against line and load variations. If a d.c. input is provided instead of the rectifier and first filter, the circuit serves as a nearly lossless d.c.-to-d.c. voltage down-converter. Finally, the circuit may be used as a high-efficiency regulator that automatically removes any low-frequency ripple from the output. No transformers are required.

Although more parts are required for this type of circuit than for a conventional supply, the over-all power-supply cost is actually reduced due to a lower component cost, a lighter chassis, and simplified assembly.

### New Switching Devices

The concept of switching-mode power conversion is only now possible because of the previous lack of economical high-frequency power semiconductors. Devices have recently become available that make these circuit techniques practical. Of foremost importance are new silicon power rectifiers with recovery times short enough to allow their operation into the megahertz region at average current levels between one and ten amperes. New three-terminal semiconductors are now available with high gain, fast switching time, and low cost. Where low voltages are prevalent, the power transistor may be used to advantage. Transistors have high speed as a big advantage but have no internal feedback mechanism to allow them to remain in a saturated state. Because of this, they require a continuous base drive signal. The traditional low-voltage limitations are being seriously challenged, for some newer power transistors are pushing the kilovolt level.

Silicon controlled rectifiers are low in cost and can handle quite substantial currents combined with very high breakdown voltages. SCR's may be turned on with a brief pulse and may not require continuous drive. On the debit side, the switching time is somewhat slow. Typical are turn-on times of a fraction of a microsecond and turn-off times of several microseconds. This limits SCR inverters to a maximum of 60 kHz or so at the present time. SCR's must also be turned "off" by removal or reversal of the main current. This limits the utility of the SCR in regulators.

The gate-controlled switch overcomes two objections of the SCR—it turns "off" an order of magnitude faster, and it may be turned "off" as well as "on" by a gate pulse of the proper polarity. These new devices are still rather expensive.

The choice of device depends upon the economics of the required power conversion. At present, transistors are favored for low-voltage, high-frequency operation, while the SCR's and GCS's find favor in high-current, high-voltage converters, usually operating at lower frequencies, e.g., between 20 and 60 kHz.

Addition of a transformer to the basic circuit of Fig. 4 allows voltage step-up as well as high current and voltage step-down. The transformer also isolates input from output and allows an output of reverse polarity if desired.

### Typical Switching Circuits

Typical circuits are those of Fig. 5. Fig. 5A is a conventional d.c.-to-d.c. transistorized push-pull converter, ex-

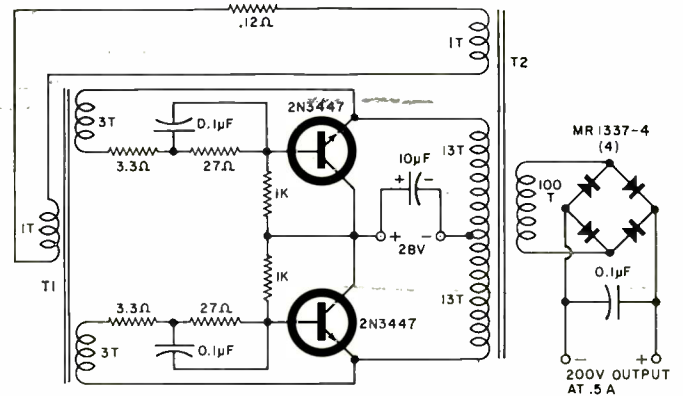

TI-FERROXCUBE 213T125 3C CORE T2-FERROXCUBE 52BT500 3C5 CORE  
(A) 100-kHz 100-W TRANSISTORIZED D.C. SUPPLY

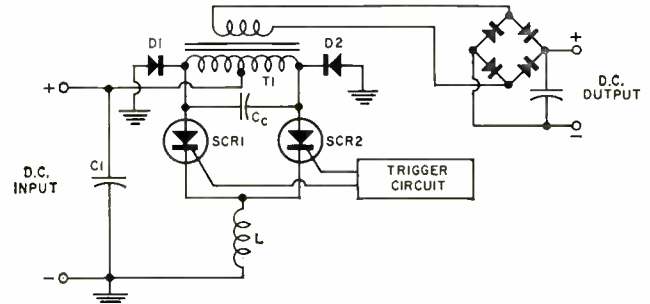

(B) SILICON CONTROLLED RECTIFIER D.C. CONVERTER

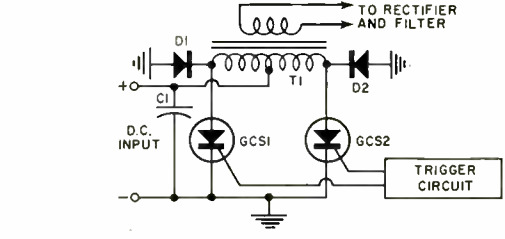

(C) ADJUSTABLE, REGULATED SUPPLY USING GATE CONTROLLED SWITCHES

Fig. 5. A number of switching-mode power supplies, converters.

cept that the choice of components gives a 100-kHz operating frequency with an over-all efficiency of nearly 85% at a 100-watt output level. The d.c. output is 200 volts at half an ampere. The second transformer (*T1*) reduces both the transients and the core loss in the main transformer (*T2*). As shown, the circuit is not self-regulating. A regulator may be added to the input or the output, or else circuit modifications may be used to make the circuit self-regulating.

Fig. 5B shows the general configuration used in an SCR inverter. This push-pull circuit operates between 20 and 50 kHz and allows supply voltages as high as 600 volts.

Every half period during circuit operation, a turn-on

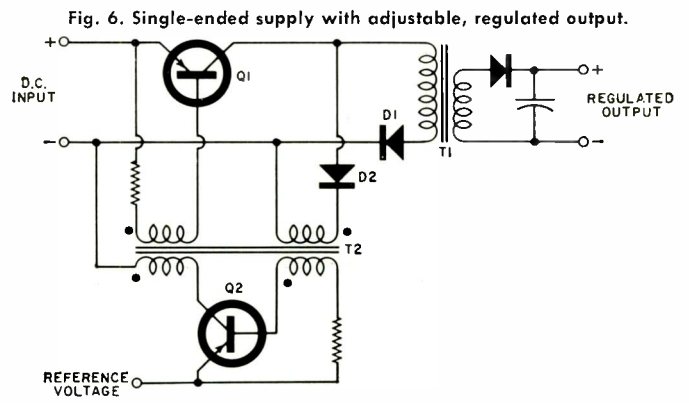

Fig. 6. Single-ended supply with adjustable, regulated output.

What most camera owners don't know about picture-taking could fill a 116 page volume ... and

here it is!



**INVITATION TO PHOTOGRAPHY**, by the editors of Popular Photography, is a unique 116 page guide to better picture taking filled with basic, down-to-earth advice that helps you eliminate costly trial and error, time-consuming guess-work.

Plagued by fuzzy pictures? Poorly exposed film? Drab color shots? Invitation To Photography is your answer. Whether you are a beginner, a hobbyist, or someone who just likes to take pictures—no matter what kind of camera you use—everything you need to know about getting the best out of your camera is now clearly defined in one concise, easy-to-understand guidebook.

Including: How to choose the right equipment ... suiting the film to the occasion ... using the correct exposure ... artificial vs. natural lighting ... getting the most from color ... creative composition ... darkroom work.

20 complete, fact-and-photo-packed articles in all! Each written by an expert for people who want to take better pictures. You'll progress quickly, easily and confidently—with pros like Rothschild, Pierce and Hattersley looking over your shoulder on every shot.

So take the first important step towards those perfect quality photos you're shooting for ... by ordering your **INVITATION TO PHOTOGRAPHY!** Use the coupon below and R.S.V.P. today! **Only \$125**

**GET THE HANDSOME LEATHERFLEX-BOUND EDITION for just \$3 POSTPAID!**



**INVITATION TO PHOTOGRAPHY** is also available in a splendid deluxe edition. Rugged Leatherflex cover provides lasting protection yet is softly textured and gold-embossed for the look of elegance. A collector's item—a superb addition to your permanent photo reference library. And it's yours, for just \$3 postpaid, when you check the appropriate box on the order form.

Ziff-Davis Service Division • Dept. IP  
589 Broadway • New York, N. Y. 10012  
**YES!** Please send my copy of Invitation To Photography as checked below:

- \$1.25 enclosed, plus 15¢ for shipping and handling. Send me the regular edition. (\$1.75 for orders outside the U.S.A.)
- \$3.00 enclosed. Send me the Deluxe Leatherflex-bound edition, postpaid. (\$3.75 for orders outside the U.S.A.) Allow three additional weeks for delivery.

NAME \_\_\_\_\_ please print  
ADDRESS \_\_\_\_\_ EW-96  
CITY \_\_\_\_\_  
STATE \_\_\_\_\_ ZIP CODE \_\_\_\_\_  
**PAYMENT MUST BE ENCLOSED WITH ORDER**

pulse is alternately routed to each SCR. Assume SCR1 has just turned on. This connects the left end of commutating capacitor  $C_c$  to ground and causes current to flow in the left half primary of T1. The right end of  $C_c$  will charge up to twice the supply voltage. When SCR2 is turned on by its gate pulse half a period later, the charge on  $C_c$  cannot instantaneously change. This forces the anode of SCR1 negative by twice the supply voltage, turning SCR1 off. The circuit has changed state, current now flows through the right half primary of T1, and  $C_c$  begins charging in the opposite direction. This happens every half period.

As a result of the above, the secondary winding produces a square wave of magnitude determined by the turns ratio. The output square wave is then full-wave rectified and filtered. Diodes D1 and D2 are transient eliminating clamps, while filter capacitor C1 and the small inductor L provide reliable transitions between the two operating states.

#### GCS Circuit

If we replace the SCR's with gate-controlled switches, we can adjust the circuit operation in such a manner that there will be times when *neither* GCS is conducting. No commutating capacitor is used and the GCS is always turned off by a properly delayed gate pulse. By varying the ratio of the conduction vs the non-conduction time, the output may be regulated and adjusted both against the line and the load variations.

At lower voltages, a transistor may be used in place of the GCS. In one ingenious single-ended circuit, the same transistor is used both for rectangular-wave generation and power switching. The circuit is shown in Fig. 6. This is not a simplified schematic, for all required parts are shown. The circuit is self-regulating against changes in input voltage and may be adjusted by simply adjusting the reference voltage. Q1 and Q2 form a rectangular output multivibrator with a variable duty cycle. It can be shown that this circuit's output voltage is determined by the reference voltage only, and *not* the input voltage, as long as the input voltage is above some minimum value. Large changes in output load will have a small effect on the output voltage because of the drops in Q1 and D1, but this change is quite small. Because of this, the circuit is also self-regulating against changes in output load.

The self-regulating characteristics of these last two circuits mean that high-ripple d.c. may be used, which allows the 60-Hz line to be rectified, crudely filtered, and used as a d.c. supply source. No 60-Hz ripple will appear at

the output because of the regulation against input-voltage variations. The amount of high-frequency ripple present can be made arbitrarily small by suitable output filtering.

#### Applications

The applications for these new techniques are numerous. With the advent of practical, economical microelectronic circuits, the bulk of the entire system size and weight is now in the power supplies. It is reasonable to assume that, as components become available, the majority of supplies for these circuits will use these high-frequency techniques, most likely at frequencies ultimately in the 1- to 10-MHz region.

The new techniques find favor in vehicular and airborne applications where weight, size, and efficiency are perpetual design headaches. This is particularly true of satellites where every ounce of payload is reflected as so many more pounds of thrust required for orbiting.

An extremely interesting application lies in television sets. If the set power conversion were to take place at 15,750 Hz, the power supply and horizontal output stage could be combined into one small, compact, low-cost circuit. This could significantly reduce the size and cost of what today are the largest and most expensive circuits in the set.

Along these lines, many all-transistor television receivers operating from a 12-volt battery, rectify a portion of the horizontal-oscillator output to provide high voltage for the video amplifiers and the cathode-ray tube.

Another natural application for switching-mode conversion lies in circuits requiring very high current at very low voltage. Fuel cells and thermoelectric cooling devices are in this category. The sizes for filters required for 60 Hz in these applications are horrendous. Furthermore, the high currents cause any inductors to be highly inefficient due to  $I^2R$  heat loss.

A present application is in portable equipment, such as transceivers, transmitters, and similar systems. There are at present gains in efficiency and output power to be made by operating r.f. and audio power stages in the 24- to 72-volt collector-supply region, but the available power is usually 12 volts from a lead-acid or nickel-cadmium battery. ▲

*Editor's Note: The circuits that have been shown and described in this article are not intended as construction projects but rather illustrate circuit operating principles. We are sorry that neither we nor the author can supply further information on the availability of the semiconductors, transformers, or any other special components that may be required for these circuits.*

## RADIO USES IC'S

WITH the advent of linear integrated circuits into TV receivers (see our June issue), the floodgates may be opening for the use of these circuits in all manner of consumer equipment.

In July, *General Electric* unveiled a miniature, rechargeable-battery radio using IC's. As shown in the photograph, the miniature radio comes with a detachable base that houses both the recharger and a clock. For portable use, the radio is removed from the base section, with the rechargeable battery useful up to 12 hours after an overnight charge.

G-E spokesmen said that because of the reliability of IC's, this radio will

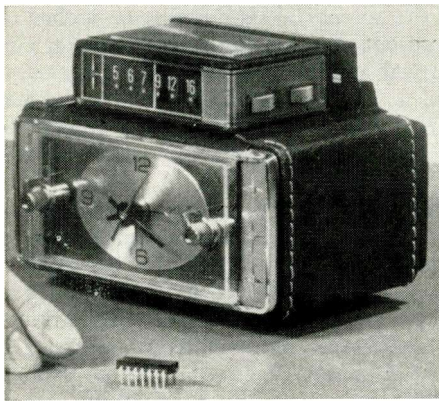

carry a three-year warranty, including the rechargeable battery.

They also pointed out that all of G-E's consumer products will use some form of microcircuits by 1970. Besides the new radio, a portable TV set and a phonograph using IC's will be available later this year. We will publish details as soon as they are available. ▲

### TINY VTR SHOWN

A PORTABLE video tape recorder, only 4½ inches high, 5½ inches wide, and 12¾ inches deep, weighing only 9½ pounds, fitting into a small over-the-shoulder case, was recently demonstrated by the Sony Corp.

Designed for operation where commercial line power is not available, the video tape recorder is powered by a light-weight 12-volt battery, also in a shoulder holster. Equipped with a special battery-powered tiny TV camera, the new machine uses conventional ½-inch-wide magnetic tape and a helical-scan recording system, operates at 7½ ips tape speed, and can record up to 30 minutes per reel. Sound is simultaneously recorded along one edge of the tape, while the unit operates by flipping a single switch.

Playback can be either on this VTR or on any other video tape recorder in the Sony line.

Availability is claimed for next year, but the price has not yet been determined. ▲



The Heart  
of your  
Radio  
is Its

TEXAS  
CRYSTALS

**INSIST ON**  
**CQC\***

*If your dealer can't supply your needs, send his name with your request for catalog to our plant nearest you.*

**TEXAS CRYSTALS**

1000 Crystal Drive  
Fort Myers, Fla. 33901  
Phone: 813-936-2109

4117 W. Jefferson Blvd.  
Los Angeles, Calif. 90016  
Phone: 213-731-2258

Division of Whitehall Electronics Corp.

\* Controlled Quality Crystals available only from Texas Crystals dealers. Extensive precision testing throughout manufacture enables Texas Crystals to unconditionally guarantee their frequency control crystals. Use of Texas Crystals in space program and by other governmental agencies is evidence of the quality you can count on.

CIRCLE NO. 88 ON READER SERVICE CARD

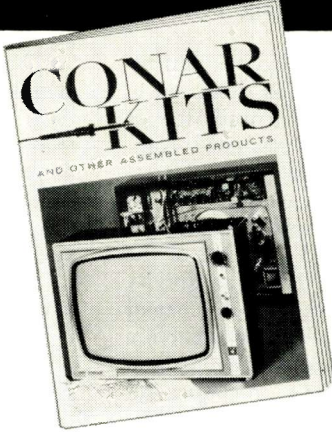

**Your new  
copy is  
waiting**

**FREE!** For fun and pride in assembly, for long years of pleasure and performance, for new adventures in creative electronics mail the coupon below and get Conar's brand new catalog of quality do-it-yourself and assembled kits and equipment. Read about items from TV set kits to transistor radios . . . from VTVM's to scopes . . . from tube testers to tools. And every item in the Conar catalog is backed by a no-nonsense, no-loopholes, money-back guarantee! See for yourself why Conar, a division of National Radio Institute, is just about the fastest growing entry in the quality kit and equipment business.

**CONAR**

**MAIL THIS COUPON NOW**

CONAR 3939 Wisconsin Ave., Washington, D.C. 20016 JB6C  
Please send me your new catalog.

Name \_\_\_\_\_

Address \_\_\_\_\_

City \_\_\_\_\_ State \_\_\_\_\_ Zip Code \_\_\_\_\_

# Designing an Oscilloscope Vertical Attenuator

By DONALD R. HICKE / Brown Engineering Co., Inc.

*Adding this calibrated 10-step attenuator to a low-priced oscilloscope will greatly enhance the scope's usefulness.*

ONE of the most annoying things about trying to use a non-laboratory oscilloscope to make exact measurements is the switching limitation of the vertical attenuator. On a typical oscilloscope, there are usually three or four positions marked "X10", "X100", and so on, with no reference to the quantity being multiplied. Apparently the manufacturer assumes that the operator has previously calibrated the vertical amplifier to some known voltage and that he remembers what this calibration is as he switches the attenuator from one range to the next.

A second problem which arises with the common three- or four-position attenuator is that the difference in scope gain between attenuator positions may be too great to be useful. To illustrate, if a voltage which is just slightly larger than the full-scale capability of a particular range is being monitored, it is necessary to reduce the display to one-tenth of its former size to view the entire waveform. Of course, the vertical gain control could be adjusted to gradually reduce the display to a convenient size for viewing, but in so doing, the calibration is lost.

A solution to both problems is the calibrated vertical attenuator switch described in this article. It was designed to replace the attenuator found in most inexpensive oscilloscopes and is constructed with readily available, standard components. It features ten full-scale ranges from .05 V/cm, the basic sensitivity of the particular scope modified, to 50 V/cm, the highest range that was anticipated to be used. It also has a calibration position to allow rapid resetting of the vertical gain control in case it is disturbed. If the sensitivity of the scope to be modified is expressed in terms of inches or "divisions" instead of centimeters, the details of construction and calibration of the attenuator will have to be changed slightly, but the theory of operation and the procedure for calculating component values remain valid for any scope.

## Theory of Operation

The vertical sensitivity of an oscilloscope is defined as the peak-to-peak or r.m.s. value of input voltage required to vertically deflect the trace on the cathode-ray tube a given

amount. Typical values are 50 mV(p-p)/cm for the *Eico* 435, 20 mV(r.m.s.)/cm for the "Knight" KG-630, and 25 mV(r.m.s.)/in for the *Heath* IO-12. This figure, when multiplied by the size of the screen in centimeters or inches as the case may be, represents the maximum voltage that can be applied to the vertical amplifier before the display overfills the screen. Thus, a 3-inch oscilloscope with a vertical sensitivity of 50 mV/cm requires a peak-to-peak voltage of (50 mV/cm) (3 in) (2.54 cm/in) or 381 mV to completely fill the screen at the center.

To view a larger voltage without a portion of it being cut off by the edge of the screen, some method must be used to reduce the input voltage before it is applied to the vertical amplifier. This is the purpose of the input attenuator. For d.c. and low-frequency a.c. signals, it requires nothing more than the resistive voltage-divider network shown in Fig. 1A. The output voltage of this circuit, that is, the voltage applied to the vertical amplifiers in the scope, is reduced by an amount called the attenuation factor,  $\alpha$ , which depends upon the values of the two resistors, R1 and R2.

The sum of resistors R1 and R2 is the load resistance ( $R_T$ ) which the attenuator presents to the signal source. It is usually desirable to keep  $R_T$  constant throughout all the ranges of the attenuator and to make it as high a value of resistance as possible to minimize adverse effects upon the circuit being monitored by the scope. A limitation of 1 megohm is usually imposed, however, by grid-current considerations of the vacuum-tube amplifier following the attenuator, and by the difficulty of purchasing precision resistors in any larger sizes. For these reasons, a value of 1 megohm for  $R_T$  is used for all calculations in this article.

The equations in Fig. 1A show how to calculate R1 and R2 for any attenuator range. For example, to design a range of 20 V/cm for an oscilloscope having a sensitivity of .05 V/cm,  $\alpha = E_{in}/E_{out} = 20/.05 = 400$ ;  $R_2 = R_T/\alpha = 10^6/400 = 2500$ ; and  $R_1 = R_T - R_2 = 10^6 - 2500 = 997,500$  ohms.

The resistive attenuator described above works fine on direct current, but as the frequency of the applied signal increases, additional attenuation results from the shunting effect of the stray capacitance which is inevitably in parallel with resistor R2. This capacitance, which is on the order of 10 to 30 pF, is affected by the construction of the attenuator switch, the dressing of leads with respect to the chassis, and the placement of components at the vertical amplifier tube socket. Unless compensated for in some way, stray capacitance across R2 will seriously limit the maximum frequency at which the attenuator is useful.

A very simple and yet effective way to compensate for this undesirable effect is to add a capacitor in parallel with R1, as shown in Fig. 1B. If C1 is chosen so that product R1C1 equals product R2C2, then the circuit may be considered as a balanced bridge. When this is the case, the voltage across resistor R2 does not fall with fre-

Fig. 1. (A) Calculations for voltage divider for d.c. or low-frequency a.c. (B) Frequency-compensated attenuator. To be effective, the product of R1C1 must equal the product R2C2.

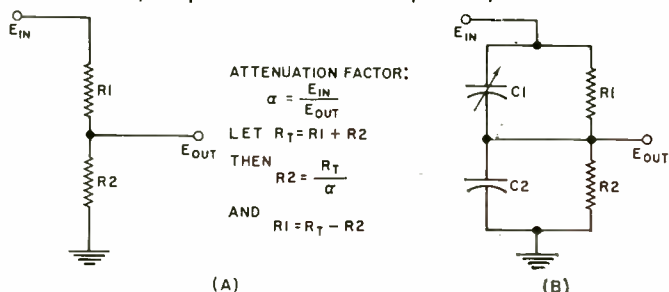

Attenuator Setting		Attenuation Factor	Calculated Component Values			Standard Value Components Available			Calculated Performance	
New	Old	$\alpha$	R1 (ohms)	R2 (ohms)	C2	R1 (ohms)	R2 (ohms)	C2	R <sub>T</sub> (ohms)	$\alpha$
.05 V/cm	X1	1	0	1M	none	0	1M	—	1 M	1
.1 V/cm		2	500 k	500 k	20 pF	499 k	499 k	20 pF	998 k	2.00
.2 V/cm	X10	4	750 k	250 k	40 pF	750 k	249 k	39 pF	999 k	4.01
.5 V/cm		10	900 k	100 k	100 pF	909 k	100 k	100 pF	1.009 M	10.09
1 V/cm		20	950 k	50 k	200 pF	953 k	49.9 k	200 pF	1.003 M	20.10
2 V/cm	X100	40	975 k	25 k	400 pF	976 k	24.9 k	390 pF	1.001 M	40.20
5 V/cm		100	990 k	10 k	.001 $\mu$ F	1 M	10.2 k	.001 $\mu$ F	1.010 M	99.02
10 V/cm		200	995 k	5 k	.002 $\mu$ F	1 M	4.99 k	.002 $\mu$ F	1.005 M	201.40
20 V/cm		400	997.5 k	2.5 k	.004 $\mu$ F	1 M	2.49 k	.004 $\mu$ F	1.002 M	402.41
50 V/cm		1000	999 k	1 k	.01 $\mu$ F	1 M	1 k	.01 $\mu$ F	1.001 M	1001

Table 1. Design calculations and component selection for the calibrated ten-step oscilloscope vertical input attenuator.

quency due to the capacitance  $C_2$  in shunt. The capacitors, therefore, have no effect upon the resistive dividing ratio of  $R_1$  and  $R_2$ , and the attenuator will work satisfactorily into the radio frequencies.

### Design

When designing a multi-position attenuator switch, several factors must be taken into consideration. First, the relationship  $R_1C_1 = R_2C_2$  must be precise, which necessitates using a trimmer capacitor for  $C_1$ . Secondly, as  $R_2$  is made smaller and smaller on successively higher voltage ranges, a point is soon reached where  $C_1$  cannot be made small enough for proper compensation. It is then necessary to deliberately add capacitance in parallel with  $R_2$  to keep product  $R_2C_2$  relatively constant on all ranges. This has the added advantage of allowing the same size trimmer to be used on all ranges, which simplifies purchasing and construction. The final design consideration is that resistors and capacitors come only in certain standard values, and this may require some compromise between the attenuation factor desired and the total input resistance obtained on some ranges.

Table 1 shows how these principles were put into practice for a typical oscilloscope attenuator, and Fig. 2 shows a schematic diagram of the circuit. The modification was performed on an *Eico* 435 scope, which originally had a four-position decade attenuator with an input resistance of 1 megohm. The values of resistors  $R_1$  and  $R_2$  were calculated to obtain each of the nine attenuation factors desired, using the equations given in Fig. 1A. The voltage sensitivities listed

were chosen in the convenient 1, 2, 5 pattern, although some other pattern such as the sequence 1, 3, 10 could have been used just as well.

When the capacitance of  $C_2$  was calculated, it was assumed that the product  $R_2C_2$  used by *Eico* in the original four ranges would be satisfactory for any new ranges added between the four. Since  $R_2C_2$  for the original "X10" range, for example, was given as  $R_2C_2 = (0.1 \text{ meg}) (100 \text{ pF}) = 10$ , the value of  $C_2$  in pF for any other range may be found by simply dividing the number 10 by the value of  $R_2$  in megohms for that range. Ordinary ceramic disc capacitors were used for  $C_2$ , primarily to keep down the cost of the modification but also because of their relatively small size. Note that the  $C_2$  capacitors used for the .2 V/cm and 2 V/cm ranges differ slightly from the ideal calculated values. This is unavoidable because capacitors are available only in certain sizes, but the trimmers were found to have sufficient adjustment to compensate for the error.

The value of trimmer capacitor  $C_1$  required, assuming that the vertical amplifier has an input capacitance of 15 pF, varies from  $C_1 = (R_2C_2)/R_1 = 10 \text{ pF}$  on the 50 V/cm range, to 35 pF on the .1 V/cm range. The miniature trimmer selected for this purpose has a range of 8 to 60 pF.

When an oscilloscope manufacturer buys resistors for an attenuator, he orders the exact values his designers have calculated and is assured of receiving them because of the large volume order. The home experimenter, however, is forced to select his resistors from a table of standard resistance values. Fortunately, it turns out that a very close match be-

Fig. 2. The schematic and parts list for over-all attenuator.

- R1, R11—499,000 ohm res.
- R2—750,000 ohm res.
- R3—909,000 ohm res.
- R4—953,000 ohm res.
- R5—976,000 ohm res.
- R6, R7, R8, R9, R10—1 megohm res.
- R12—249,000 ohm res.
- R13—100,000 ohm res.
- R14—49,900 ohm res.
- R15—24,900 ohm res.
- R16—10,200 ohm res.
- R17—4990 ohm res.
- R18—2490 ohm res.
- R19—1000 ohm res.
- All resistors  $\frac{1}{4}$  W, 1%, Dale DC- $\frac{1}{4}$  or equiv.
- C1, C2, C3, C4, C5, C6, C7, C8, C9—8-60 pF trimmer capacitor (Arco Type 404 or equiv.)
- C10—Not used
- C11—20 pF disc ceramic capacitor 10%
- C12—39 pF disc ceramic capacitor 10%
- C13—100 pF disc ceramic capacitor 10%
- C14—200 pF disc ceramic capacitor 10%
- C15—390 pF disc ceramic capacitor 10%
- C16—1000 pF disc ceramic capacitor 10%
- C17—2000 pF disc ceramic capacitor 10%
- C18—4000 pF disc ceramic capacitor 10%
- C19—0.01  $\mu$ F disc ceramic capacitor 10%
- S1—D.p., 11-position rotary switch (see text)

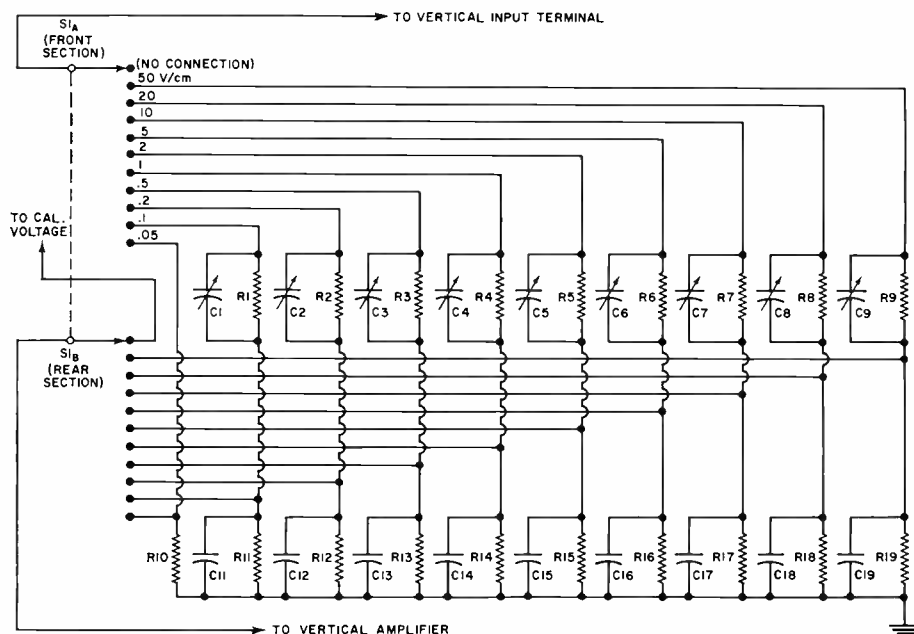

tween the calculated resistors listed in Table 1 and the standard values available occurs readily in 1% tolerance resistors.

As can be seen from Table 1, both the input resistance  $R_T$  and the attenuation factor  $\alpha$  are very close to the values desired, despite the compromises which had to be made when the resistors were selected. It should be noted that even though the resistors which came with the original attenuator were color-coded with the exact calculated values, they were 5% tolerance resistors and therefore could have caused considerable error from one range to the next.

### Construction

All of the components for the new attenuator are mounted directly on a double-pole, 11-position miniature rotary switch. If the entire switch from the old attenuator is to be replaced, use a *Centralab* Type PA-1004 phenolic switch. It will be necessary to obtain longer screws and spacers to increase the distance between the two switch sections from  $\frac{1}{2}$  inch to approximately  $\frac{3}{8}$  inch. As a slightly more expensive alternative, the three-pole Type PA-1008 switch may be purchased instead and the center section discarded, giving a spacing of one inch. The attenuator used in the *Eico* 435 oscilloscope has a concentric gain control which would have been very expensive to duplicate. Instead, the two sections of the switch were removed and *Centralab* Type PA-30 phenolic sections installed in their place.

Before starting to mount any components on the switch, be certain that the orientation of the terminals on the sections will allow all nine trimmers to be reached for adjustment after the switch is installed within the oscilloscope. It may be necessary to disassemble the switch and rotate the two sections  $180^\circ$  with respect to the indexing tab on the front. After the proper configuration is obtained, rotate the shaft

counterclockwise as far as it will go and note this as the .05 V/cm position. Connect a piece of hookup wire between the front and rear sections at this position to serve as the zero-ohm resistor listed in Table 1 for that range. Then mount the other resistors, shown in Fig. 2 as R1 through R9, moving clockwise in sequence around the switch. Bend the resistor leads so that the body of each one is recessed below the edge of the phenolic sections.

Take each of the trimmer capacitors and bend the mounting lugs up so that they are parallel to the body of the capacitor. Coat each lug with a layer of solder and then mount the trimmers directly over the resistors by soldering the lugs to the switch terminals. With a little bit of care, they will all fit with no problems. Next, mount a ground lug under each of the two nuts at the rear section. Connect resistors R10 through R19 and capacitors C11 through C19 between the proper terminals of the rear switch section and the two ground lugs. (Note that a designation of C10 is not used, so that the numbers of all components at each switch position will match.) Finally, connect the common terminal of the front switch section to the oscilloscope vertical input terminal, and connect the common terminal of the rear section to the grid lead of the vertical amplifier. If a calibration source is going to be built into the scope, connect it to the unused terminal on the rear section. Mount the switch in the scope and replace the front-panel decals to show the new ranges.

### Adjustment and Calibration

Adjustment of the attenuator is accomplished by monitoring a square wave of known characteristics with the scope and turning the set screw on each trimmer for the best-looking display, as shown in Fig. 3A. If a good square-wave generator is not available, the saw-tooth sweep voltage from the scope itself may be used instead. In this case, the trimmers are adjusted to obtain a straight line at the beginning of the trace, as shown in Fig. 3B.

Because of the 1% precision tolerance resistors used in its construction, calibration of the attenuator is not required. That is, the attenuation factor on each successive range is more exact than can be checked by eye on the oscilloscope screen. What does require calibration, however, is the gain of the vertical amplifier so that the deflection on the screen corresponds to the voltage markings on the attenuator dial. The easiest way to do this is to connect an accurately calibrated audio v.t.v.m. and an adjustable source of sine-wave voltage as shown in Fig. 4. The signal generator is adjusted for an output of 200 mV peak-to-peak, or 70.7 mV r.m.s. as read on the v.t.v.m. The oscilloscope attenuator is switched to the .05 V/cm position and the vertical gain control adjusted to give a trace exactly four centimeters high, peak-to-peak. The gain control may now be locked into position, or its setting marked in some way, because it will seldom be used.

There are times, however, when the oscilloscope vertical gain control is turned, either intentionally or otherwise, away from its calibrated position. To avoid having to use the signal generator and v.t.v.m. every time this happens, a calibrated source may be built into the scope. Fig. 5 shows the circuit used in the *Eico* Type 435 oscilloscope. A 9-volt zener diode clips the sine-wave voltage to a square wave, and the 10,000-ohm resistor and wirewound potentiometer attenuate it down to the 200-mV region. The square-wave output connects to the eleventh terminal on the rear section of the attenuator switch. When the switch is turned to that position, the oscilloscope input signal is disconnected and the calibrating voltage is applied to the vertical amplifier instead. With the gain control calibrated as explained above, adjust the wirewound potentiometer until the square wave is exactly four centimeters high. Then, any time the gain control is disturbed, the attenuator switch is simply turned to the calibration position and the gain control adjusted for a 4-cm display of the square wave. ▲

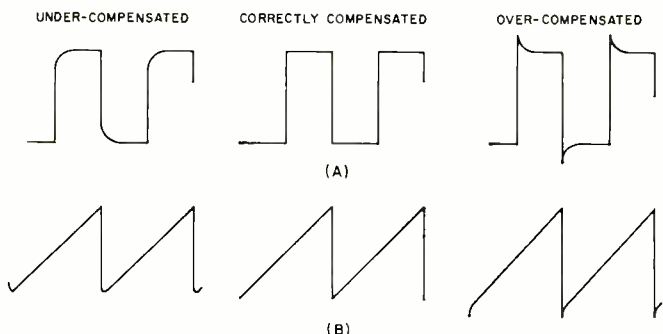

Fig. 3. Waveforms observed while adjusting the attenuator. (A) Square-wave response. (B) Response of the scope internal sweep.

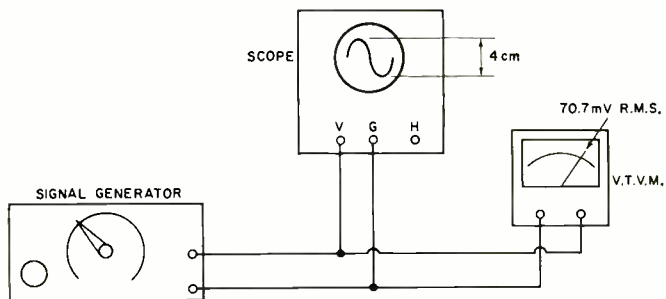
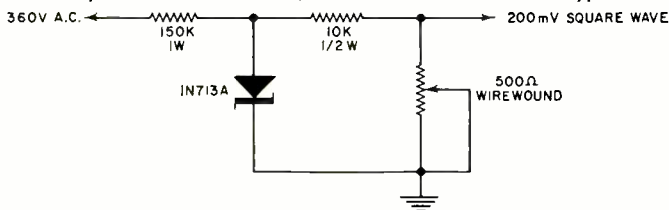

Fig. 4. Test setup for calibrating the vertical amplifier. The oscilloscope attenuator is set to 0.05 V/cm position.

Fig. 5. Square-wave calibrator can be added to any oscilloscope. The zener diode used is a conventional 9-volt type.



# DELUXE LEATHERFLEX-COVERED EDITIONS AVAILABLE

Here is a complete selection of annuals, yearbooks, directories and handbooks available in Deluxe Leatherflex-covered editions from the world's largest publisher of special interest magazines. These are complete editions (including the original covers) which are bound in rugged leatherflex to provide long-time pro-

tection and keep them looking like new even after repeated use. The softly textured leatherflex, gold embossed for the look of elegance, makes them handsome additions to your permanent reference library. Take a moment to review the titles below. You're sure to find many of your favorites. \$3.00 each.



**PHOTOGRAPHY ANNUAL**  
A selection of the World's finest photographs compiled by the editors of Popular Photography. 212 Pages—24 in full color.  
1966.....#1  
1965.....#2 \*  
1964.....#3



**ELECTRONIC EXPERIMENTER'S HANDBOOK**  
Many challenging projects for the electronics hobbyist.  
1966.....#36  
Spring Edition #36  
1965.....#9  
Fall Edition #9



**CAR & DRIVER YEARBOOK**  
A complete buyers guide covering virtually every car available in the United States... Road tests... Technical specifications... Accessories and performance equipment buying guide... Guide to racing with action-packed photos.  
1966.....#15



**INVITATION TO PHOTOGRAPHY**  
A unique 116 page guide to better picture taking by the Editors of Popular Photography. Basic down-to-earth advice that helps you eliminate costly trial and error, time-consuming guess work  
20 complete, fact-and-photo packed articles in all.  
1966.....#35



**1966 TAPE RECORDER ANNUAL**  
Everything you need to know about tape recording including a complete directory of mono and stereo recorders.  
1966.....#30



**COMMUNICATIONS HANDBOOK**  
The most complete and up-to-date guide to the exciting world of specialized radio communications.  
1966.....#18



**ELECTRONICS INSTALLATION AND SERVICING HANDBOOK**  
The only complete guide for servicemen and hobbyists to every major phase of consumer electronics servicing.  
1966.....#32



**FLYING TRAVELGUIDE**  
Here's the first really useful guide to flying vacations. Everything you need to know about: lodgings, restaurants, resorts, sightseeing, recreation, sports activities, airport facilities, childrens fun, price information, and much more.  
1966.....#34



**FLYING ANNUAL & pilots' guide**



**STEREO, Hi Fi DIRECTORY**  
Complete buyers guide for virtually every Hi-Fi component manufactured.  
1966.....#29



**POLAROID LAND PHOTOGRAPHY**  
Complete guide and only comprehensive and up-to-date handbook on Polaroid Land Photography.  
1966.....#24



**SKIING INTERNATIONAL YEARBOOK**  
A luxuriously illustrated compendium of 1965's important events... A timely forecast of the excitement-packed 1966 season—by the editors of Skiing Magazine.  
1966.....#26

**Note:** Deluxe Leatherflex-covered Editions are \$3.00 each, postpaid (\$3.75 for orders outside of U.S.A.). The annuals listed above are also available in regular editions at \$1.25 each plus 15c per copy for shipping and handling (\$1.75 for orders outside U.S.A.). To order your copies, check the appropriate box and circle the numbers of the annuals you wish to receive on the coupon to the right.

\* Available in Deluxe Edition only

Ziff-Davis Publishing Co., Dept. SD  
One Park Ave., New York, N. Y. 10016

I am enclosing \$ \_\_\_\_\_

Send me the Deluxe Leatherflex-covered editions circled below at \$3.00 each, postpaid (\$3.75 per copy for orders outside U.S.A.).

Send me the regular editions circled below at \$1.25 each plus 15c shipping and handling (\$1.75 per copy for orders outside U.S.A.)

1 2 3 9 15 18 22 24 26 27 28 29 30 32 34 35 36

Name \_\_\_\_\_

Address \_\_\_\_\_ (PLEASE PRINT) EW-96

City \_\_\_\_\_ State \_\_\_\_\_ Zip Code \_\_\_\_\_

**PAYMENT MUST BE ENCLOSED WITH ORDER**

# NEW PRODUCTS & LITERATURE

Additional information on the items covered in this section is available from the manufacturers. Each item is identified by a code number. To obtain further details, fill in coupon on the Reader Service Card.

COMPONENTS • TOOLS • TEST EQUIPMENT • HI-FI • AUDIO • CB • HAM • COMMUNICATIONS

## INDUSTRIAL TRIMMERS

A new series of rugged industrial and commercial trimming pots, Model 2, is now on the market. These units are designed with a ring of multiple contacts around the resistance element to provide smooth, light, and even contact pressure in all directions. During adjust-

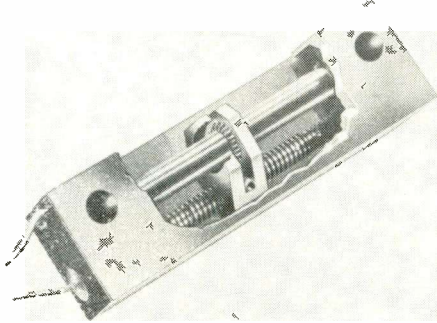

ment, the unit's spring ring makes many sequential contacts on each turn of resistance wire as the line of contact moves in a spiral motion. As a result of this concept, resolution is increased and the wiper contact noise is less than 20 ohms at vibration levels in excess of 20 G's.

Other features include resolution better than 0.2%, welded lead construction, reliable all-metal clutch, temperature range of  $-55^{\circ}\text{C}$  to  $+85^{\circ}\text{C}$ , a variety of lead and mounting configurations, 1-watt power rating, 50 ppm temperature coefficient, and 35 turn adjustment. Available resistances range from 10 ohms to 100,000 ohms. Newport Instrument

Circle No. 126 on Reader Service Card

## EPOXY EXPERIMENTAL KIT

An experimenter's epoxy kit which consists of an assortment of four different types of epoxy resin, six curing agents, five fillers, together with instructions, properties tables, and mixing and curing data is now being offered to researchers, fabricators, and designers of electronic components.

The kit is designed to simplify the selection of the most desirable epoxy-curing agent-filler combination for the formulation of special-purpose adhesives, coatings, or encapsulating mixtures. Ring Chemical

Circle No. 127 on Reader Service Card

## DISC-CERAMIC TRIMMERS

A new series of high-quality disc-ceramic trimmers, the Standard DVO1 series, is now on the market.

Designed specifically for the commercial and industrial markets, such as in BC and TV receivers, test equipment, and communications equipment, these units are offered in four styles

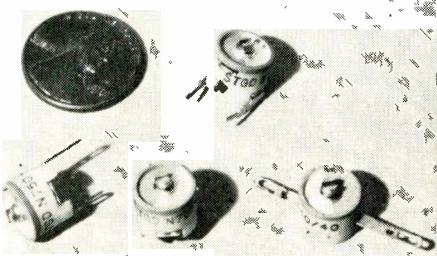

of leads: short, crimped PC board leads; flat axial leads with wire holes; flat PC board leads with wire holes; and crimped leads for right-angle mounting on PC boards.

Eight delta-C ranges are available: 2.0-8.0, 2.5-11.0, 3.0-10.0, 3.0-15.0, 5.5-18.0, 7.0-25.0, 8.0-25.0, and 9.0-35.0  $\mu\text{F}$ . This capacitance range is covered in 180 degrees and there are provisions for screwdriver adjustment from either side of the capacitor. Four temperature coefficients are available: NPO, N300, N500, and N650, each covering a capacitance range. JFD

Circle No. 128 on Reader Service Card

## CABLE SLITTERS

Three new tools, designed for slitting, stripping, and "ring" cutting inside and outside types of plastic, fabric, and rubber-covered cable, have been announced. The cable sheath slitter (No. N-62267) is for slitting most types of cable jackets, especially the outdoor heavy-duty types. The N-2878 cable sheath stripper is designed to strip the jacket from all sizes of inside types of plastic and fabric-covered cable, while the N-2060 cable tool is used for "ring" cutting the sheathing of inside type plastic, fabric, or rubber-covered cable. P. K. Neuses

Circle No. 129 on Reader Service Card

## FLASHING INDICATOR LIGHTS

Using a unique characteristic of high-brightness neon lamps in combination with solid-state components, a new line of indicator lights provides flashing operation without moving elements or contacts.

Operating from 110-125 V a.c., the miniature driving circuitry for the lights is incorporated on a tiny card enclosed within the lamp body. An extending edge of the card exposes eyeletted openings for external wire connections. Dialight

Circle No. 130 on Reader Service Card

## CIRCUIT COOLING FAN

The "Tarzan" fan measures less than 7" square and is specifically designed for cooling micro-electronic modules, compact air-to-liquid heat exchangers, PC card chassis for discrete components, computers, and communications transmitters.

Of patented aerodynamic design, the fan develops more than twice the pressure of comparably sized axial flow fans. Its shallow axial depth permits sizable reductions in the amount of package volume which must be devoted to the air-moving device.

The fan is available in both 50- and 60-Hz versions. Rotron

Circle No. 131 on Reader Service Card

## NEON PILOT-LIGHT LINE

Three new series of neon pilot lights are now on the market to meet a number of OEM requirements.

The BND miniature series permits space-saving assembly with the neon protruding beyond the panel to provide maximum light intensity. This model is available with or without a built-in series resistor for 120-volt operation. Mounting requirement is a  $\frac{3}{8}$ " hole. The BNF series is similar except that the lens system extends a greater distance beyond the panel for relatively greater illumination. A single  $\frac{5}{16}$ " hole is required.

The BNE series features a one-piece body construction and is designed for such applications

as indicating toggle switch positions or for other display configurations with space limitations. The compact lens system protrudes slightly above the panel. A single  $\frac{5}{16}$ " hole is required for mounting. Electrical specifications on all three series will be supplied on request. Alco

Circle No. 132 on Reader Service Card

## COUNTING DIAL

The Model 1350 "Microdial" features an exclusive outer vernier dial for maximum adjustment settability and readout accuracy. This dial allows the operator to set-in or read-out with increased efficiency and higher accuracy than with conventional "inner vernier" counting dials, according to the maker.

Epicyclic action accelerates the turns dial as the vernier dial passes zero. This reduces am-

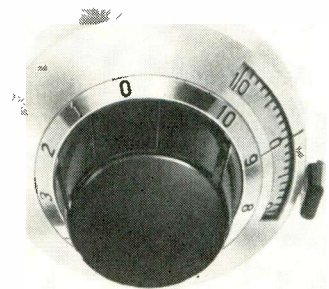

biguity for the operator so he can immediately determine on which side of the turns number the dial is set.

The vernier dial mounts directly to the shaft, eliminating backlash. A fingertip brake offers positive brake action without disturbing critical dial settings. Indexing accuracy is 1000:1. Amphenol Controls

Circle No. 133 on Reader Service Card

## PELLET RESISTOR KIT

A new experimental kit containing an assortment of microminiature solid cermet "Ceradot" pellet resistors is now being offered as an aid to designers. The resistors have an extremely high-power-to-size ratio, i.e., a minimum of 15 watts per cubic centimeter, with tolerances as low as  $\pm 1\%$ .

The resistors will not short out under any operating conditions, are stable under extreme environments, and are not affected by radiation. Resistance range is 15 ohms to 200,000 ohms. The resistors operate at  $175^{\circ}\text{C}$  hot spot without leads.

The kit contains resistors with and without leads in random resistances and in the following sizes: 0.05" dia. x 0.03"; 0.05" dia. x 0.062"; 0.1" dia. x 0.03", and 0.1" dia. x 0.062". CTS Research

Circle No. 134 on Reader Service Card

## HIGH-RELIABILITY TRANSFORMER

A subminiature transformer which measures  $\frac{1}{4}$ " x  $\frac{1}{4}$ " x  $\frac{1}{4}$ " has been developed for high-reliability military and aerospace environments. The Model 4210 exceeds the environmental requirements of MIL-T-27B and has a precision laminated core.

At 1000 Hz, insertion loss is less than 3 dB. Frequency range is 400 to 250,000 Hz with no specification degradation. In square-wave operation, droop is as low as 5%, overshoot as low



as 10%, and rise time as little as 100 nanoseconds. Maximum operating temperature is +130°C and maximum power rating is 1 watt. The primary impedance range is 100 to 200,000 ohms while the secondary impedance range is 1 to 10,000 ohms. Turns ratio is 100:1. Bourns Trimpot

Circle No. 135 on Reader Service Card

#### FREQUENCY-SENSITIVE RELAYS

Semiconductor and magnetic circuitry is combined with a ruggedized relay to provide accurate and reliable frequency sensing and a means of actuation in a single device. S.p.d.t. contacts are provided to actuate external devices such as a shut-down contactor, indicator light, or an alarm system.

Models are offered for either 60 or 400 Hz operation and the trip points can be easily varied, by a simple screwdriver adjustment, over a wide range. Extreme accuracy and temperature



stability are inherent in the basic design and no temperature-compensation circuitry is employed, thus increasing the simplicity and reliability of the device.

High-shock versions of the relay, per MIL-S-901C, are also available. Wilmar

Circle No. 136 on Reader Service Card

#### ROTATING PISTON TRIMMERS

A new design of rotating piston trimmer capacitors has been announced as the RV-RB

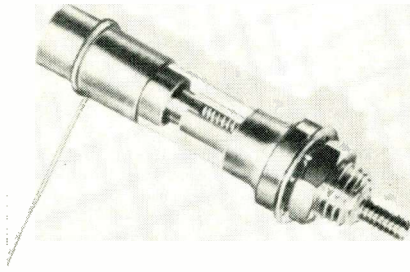

series. The new units utilize the internal arms of the bushing for a smooth sliding contact to the piston. This new approach provides a low resistance, low inductance, r.f. ground connection to the bushing, eliminating the screw as a current-carrying part. Torque is smooth and consistent. End play is eliminated by a plastic insert and life is over 10,000 cycles.

Various sizes and ranges are available in the new series. Literature covering the line is available on request. Voltronics

Circle No. 137 on Reader Service Card

#### FLEXIBLE R.F. SHIELDING

A highly flexible type of r.f. interference shielding has been developed, permitting easy and inexpensive application to cable assemblies and equipment. Available in several materials, the shielding tape's high rate of flexibility makes it easy to apply even to odd shaped cable assem-

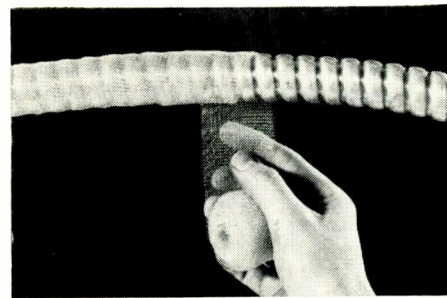

blies and equipment. The most popular materials in the line are Monel, aluminum, silver-plated brass, and tin-plated copper-clad steel.

Tapes are available in continuous lengths in widths from 1/2". Engineering assistance on specific problems is part of the company's service in connection with the shielding tapes. Metex

Circle No. 138 on Reader Service Card

## HI-FI—AUDIO PRODUCTS

#### MICROPHONE MIXER/AMP

The Model AM-5 self-powered universal mixer/amplifier is designed for use in audio-visual and electronic applications.

Up to five microphones can be used at one time through any high- or low-impedance amplifier. Five independent level adjustments provide a 30-dB attenuation range.

This solid-state unit will operate for 1000 hours on four "D" cells and is especially adaptable to the new self-contained portable p.a. systems. It is 3" h. x 8" w. x 8" d. Van San Associates.

Circle No. 1 on Reader Service Card

#### POWER TRANSISTOR FOR AUDIO

The industry's first plastic-encapsulated power transistor for consumer audio applications has

## A SELECTION OF ANNUALS STILL AVAILABLE

FROM THE WORLD'S LARGEST PUBLISHER OF SPECIAL INTEREST MAGAZINES

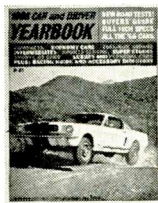

#### CAR & DRIVER YEARBOOK

A complete buyers guide covering virtually every car available in the United States . . . Road tests . . . Technical specifications . . . Accessories and performance equipment buying guide . . . Guide to racing with action-packed photos.

1966 — \$1.25.....#15  
1965 — \$1.25.....#17

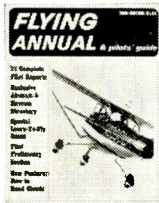

#### FLYING ANNUAL

The most valuable aviation yearbook ever compiled . . . Pilot reports . . . Aircraft directory . . . How to buy a used airplane . . . Navcom directory . . . Learn to fly section.

1966 — \$1.25.....#27  
1965 — \$1.25.....#28



#### TAPE RECORDER ANNUAL

Everything you need to know about tape recording including a complete directory of mono and stereo recorders.

1966 — \$1.25.....#30  
1965 — \$1.00.....#31

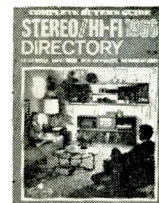

#### STEREO/Hi-Fi DIRECTORY

Complete buyers guide for virtually every Hi-Fi component manufactured.

1966 — \$1.25.....#29  
1965 — \$1.00.....#37

Order by number from Ziff-Davis Service Division, 589 Broadway, N.Y., N.Y. 10012. Enclose add'l 15¢ per copy for shipping & handling (50¢ for orders outside U.S.A.)

# Sonalert®

## New high-reliability solid-state tone signal

Produces distinctive 2800 or 4500 cps tone, draws only 3 to 14 milliamps.

**No RF noise**—no arcing contacts. Explosion-proof.

**High reliability**—solid-state oscillator drives piezoelectric sound transducer.

**High output**—68 to 80 db sound level.

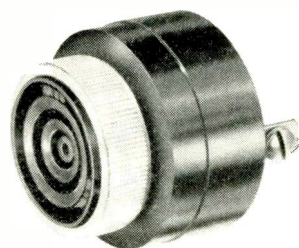

Standard models available for operation on 6 to 28 volts DC, 6 to 28 volts AC, 110 volts AC. Can be supplied with pulsed output, 3 to 5 pulses per second. For data, typical circuitry for over-voltage, under-voltage, overheat, security, and many other signalling applications, write Mallory Distributor Products Company, a division of P. R. Mallory & Co. Inc., P.O. Box 1558, Indianapolis, Indiana 46206.

50<sup>th</sup>  
ANNIVERSARY

MALLORY

CIRCLE NO. 103 ON READER SERVICE CARD

been designated the TIP21. This 2-amp epitaxial planar silicon power transistor has been specifically characterized for class-B operation up to 20 watts average power per channel. The d.c. beta brackets are utilized to provide pairs matched within 20 percent. This assures minimum distortion in class-B audio applications.

The collector of the double-ended, low-profile plastic package is in electrical contact with the special mounting tab, permitting the transistor to be mounted using only one chassis hole and one sheet-metal screw, thus reducing mounting hardware and assembly steps to a minimum. As an option, the leads and tab can be specially formed to accommodate unusual mounting requirements. Texas Instruments

Circle No. 139 on Reader Service Card

#### PORTABLE A.F. WAVE ANALYZER

A portable, audio-frequency wave analyzer which can be either line- or battery-operated, has been introduced as the Type 1568-A. The new unit has a one percent bandwidth with an attenuation of at least 75 dB at twice and at one-half center frequency. Sensitivity is from 100  $\mu$ V to 300 V full-scale.

Because of its very narrow bandwidth and consequent ability to separate closely spaced com-



ponents, the new analyzer is especially useful in electrical wave analysis as well as in sound and vibration measurements. At very low frequencies, the bandwidth is considerably narrower than that of analyzers with fixed-frequency bandwidths (at 20 Hz, bandwidth is only 0.2 Hz between 3 dB points).

Portable and rack versions of the Type 1568-A wave analyzer are available. General Radio

Circle No. 140 on Reader Service Card

#### 25-WATT SOLID-STATE MEGAPHONE

The new 25-watt solid-state "Ampli-Vox Commando" megaphone is capable of providing intelligible sound up to half a mile away. The unit is completely battery operated and includes an all-transistor 25-watt amplifier, a weatherproof horn speaker, and a noise-cancelling hand-held microphone. A hand grip and shoulder strap complete the package.

The unit weighs only 16 pounds, with batteries, and uses ordinary "D" cells. The battery pack of 10 "D" cells will normally provide a full year of service. Perma-Power

Circle No. 2 on Reader Service Card

#### FOUR-TRACK STEREO RECORDER

An all-new stereo tape recorder with automatic tape reversal has just been introduced as the Model 776. This vertically styled, four-track recorder plays and records in both directions, without reel turnover or rethreading, then shuts off automatically. Continuous recording time is thus doubled. Pre-recorded stereo tapes can be played continuously in both directions, for as long as six hours of uninterrupted music. Tapes can be replayed immediately by a touch of the control lever.

Tape speeds are 7½ and 3¾ ips and frequency response is 30-20,000 Hz  $\pm$  3 dB at 7½ ips. Wow and flutter is less than 0.15% at 7½ ips while the signal-to-noise ratio is better than 50 dB.

Also featured are two vu meters, two de-



tachable speaker systems (6" speakers in enclosures), 15 watts power output, and two dynamic cardioid microphones. The machine will handle 7" tape reels or smaller. Concord

Circle No. 3 on Reader Service Card

#### APARTMENT-HOUSE INTERCOM

A new apartment-house intercommunications system featuring two independent door-opener buttons is now available as the Model TA-2.

In addition to providing automatic privacy in each apartment, the new unit enables any apartment to selectively carry on a two-way conversation with the front or service vestibule separately, and to independently operate an electric door opener in each vestibule.

Other features include "Automatic Privacy" and a contoured communications control which disconnects the speaker within the apartment, a volume selector, a built-in fanning strip, and a custom-designed housing with stainless-steel front panel measuring 4 13/16" w. x 7 3/16" high.

Full specifications on the system and variations and accessories will be supplied on request. Talk-A-Phone

Circle No. 4 on Reader Service Card

#### UNDERWATER SPEAKER

An underwater speaker which projects high-fidelity sound both above and below the surface of a pool is being marketed as the UL-3. Since the sound transmitting efficiency of water is greater than air, the makers have taken advantage of this higher transducing efficiency by means of a unique diaphragm design which provides the wide frequency range required.

The UL-3 has a dynamic range from 50 to 20,000 Hz. It is completely operational up to a depth of 16½ feet and maintains its sound quality even in water temperatures ranging from 14°F to 140°F. Pioneer Electronics

Circle No. 5 on Reader Service Card

#### SOLID-STATE STEREO CARTRIDGE

The new "Velocitone Mark V" solid-state stereo cartridge has no coils which might cause unwanted, induced magnetic hum. Its response is 20-20,000 Hz and it tracks at less than 2 grams. Vertical stylus force ranges from 1.5 to 2.5 grams. The effective dynamic mass at the stylus is 1.8 milligrams, offering improved tracking ability. Compliance is 15 x 10<sup>-6</sup> cm/dyne and cartridge sensitivity at the 1-kHz output point (with matched networks) is 6 millivolts for either channel.

The cartridge is housed in a slim miniature

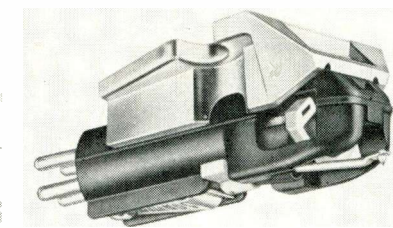

case to complement up-to-date phono equipment. It weighs 1.5 grams and has an integrated mounting bracket that fits all standard changers and professional tonearms. Sonotone

Circle No. 6 on Reader Service Card

#### "HANDS-FREE" INTERCOM

A "hands-free," 20-line intercom for small- and medium-size offices and plants is now available as the CE-20/2A. No press-to-talk switch is

required on the instrument as automatic voice switching allows conversations to take place at a distance from the sets, even from across the room.

Calls are made by touch-button and number combinations are used to interconnect individuals or areas. Both tone and lights summon the party whose station is called, thereafter the conversation is "hands-free" for both parties. Privacy provisions are included and stations can be furnished with handsets for absolutely confidential communications, if desired. Centrum

Circle No. 7 on Reader Service Card

#### CARTRIDGE TAPE DECK

A compact, easy-to-operate unit for background music and special programs in commercial and business establishments is on the market as the Model TD-101. It uses a specially designed, two-hour, no-rewind cartridge which

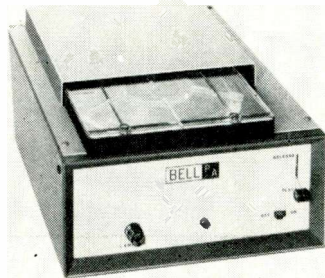

provides continuous service without tape tangles, tension loss, or tape edge fatigue.

The cartridge slides in from the front and all controls including fuse change are on the front panel so that the unit can be operated from any confined location. Response is 50-7500 Hz. There is a completely transistorized preamp and silicon-diode power supply for low heat operation and long life. A large music library is available on tape cartridges to fit this machine. Bell P/A Products

Circle No. 8 on Reader Service Card

#### SOLID-STATE PORTABLE RECORDER

The RK-142T solid-state portable tape recorder provides more than four hours recording on a long-play 0.5-mil 2400-foot reel of tape at 3¾ ips. Features include a positive-acting lever-type record/playback motor control which eliminates the possibility of accidental erasure. It also includes a pause control position for editing.

The unit operates at two speeds: 7½ and 3¾ ips. Signal-to-noise ratio is 40 dB or better at 7½ ips. Record playback response is essentially flat with tone at maximum treble. Wow and flutter is less than 0.25% r.m.s. at 7½ ips.

Controls include "on-off-tone," volume, record interlock button, and speed selector, motor shift control with pause feature. The unit measures 11¾" x 6½" x 10¼" and is powered by 120-volt, 60-cycle a.c. Lafayette

Circle No. 9 on Reader Service Card

## CB-HAM-COMMUNICATIONS

#### 6- AND 10-METER TRANSCEIVERS

Two transceivers for 6- and 10-meter operation are now available as the Model HA-460 and Model HA-410, respectively.

The receiver section is dual-conversion with crystal-controlled second converter. A sensitive nuvistor r.f. amplifier combines with an SCR controlled noise limiter to provide high sensitivity without harsh noise.

The 20-watt d.c.-plate-input transmitter features a built-in v.f.o. and effective low-pass filtering. The oscillator may be crystal-controlled with standard 8-MHz crystals. There are built-in 120 volt a.c. and 12-volt d.c. power supplies.

Frequency coverage of the HA-460 is 50 to 52 MHz while the Model HA-410 covers 28.0 to 29.7 MHz. The units measure 12½" x 5½" x 3¾" and come complete with a.c. and d.c.

power cords, a push-to-talk ceramic mike with coiled cord, and mobile mounting bracket. Lafayette

Circle No. 10 on Reader Service Card

#### SOLID-STATE CB TRANSCEIVER

The new CB-20 Citizens Band five-watt, five channel transceiver is extremely compact and features all-solid-state electronics. Sensitivity of the unit is less than 1  $\mu$ V for 10 dB signal-to-noise ratio. Output power is a minimum of 3 watts and modulation capability is exceptionally high for solid-state design, according to the manufacturer.

The CB-20 measures 7" x 6" x 2 1/8" and weighs just 4 pounds. Five crystal-controlled channels are available and transmit and receive crystals for one channel are included. The unit contains 12 transistors, 8 diodes, and 1 zener regulator. Full specifications and price will be supplied on request. Hallicrafters

Circle No. 11 on Reader Service Card

#### TWO-CHANNEL TRANSCEIVER

The "Citi-Fone II" is an inexpensive, two-channel CB transceiver designed for use in conjunction with a car radio. It contains a complete high-level transmitter section and frequency-conversion receiving section. The car radio supplies the second frequency conversion, i.f. amplification, audio, and speaker. The only connection to the broadcast receiver is through the antenna

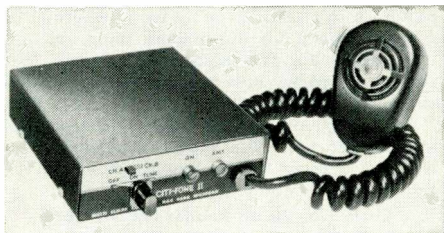

connector. Neither modification nor dismounting is required and normal car radio performance is unimpaired.

The transmitter is crystal-controlled, has 5 watts input, 3 watts output, and double "pi" r.f. output circuit.

The unit is powered by 12-volt d.c. and the entire unit measures only 4 3/8" wide x 1 1/2" high x 5 3/4" deep. It weighs 3 pounds. Multi-Elnac

Circle No. 12 on Reader Service Card

#### DUAL-CHANNEL CB TRANSCEIVER

A dual-channel CB transceiver which is designed to operate on channels 2 and 22 is now being offered as one solution to the overcrowded bands used for CB communications. Whenever interference occurs, a simple push on a slide switch tunes in a second channel at the opposite end of the band.

An a.c. adapter for this hand-held unit allows continuous line-cord operation without putting a drain on the 9-volt battery in the set. Housed in a two-tone grey high-impact cabinet, the unit comes complete with telescoping 39-inch antenna and a genuine leather carrying case. Dimensions are 4 1/8" x 2 3/4" x 1 3/4". The optional a.c. power adapter is available extra. Westinghouse

Circle No. 13 on Reader Service Card

#### MOBILE CB ANTENNA

A new mobile CB antenna, designed with a sturdy gutter clamp for semi-permanent attachment is now being marketed as the RTG-27. With a total height of only 25 inches, the new unit reputedly eliminates the extra base-matching capacitor normally required. Each antenna has a chrome-plated split ball at its base mounted on a heavy gauge chrome-plated steel gutter clamp. The latter can be secured in place without the use of a screwdriver and can be installed on any car having a rain gutter over the windows. Adjustment of the antenna

to any desired vertical position can also be accomplished.

The antennas are supplied complete with all required hardware, locking wrenches, 12 feet of 52-ohm coax with attached PL-259 connector, and an instruction sheet. The chrome-plate steel clamp is available extra. New-Tronics

Circle No. 14 on Reader Service Card

#### DIGITAL FREQUENCY METER

A new solid-state digital frequency meter for servicing two-way mobile radio equipment is now available as the Model S1078A. The new instrument not only checks frequency but also

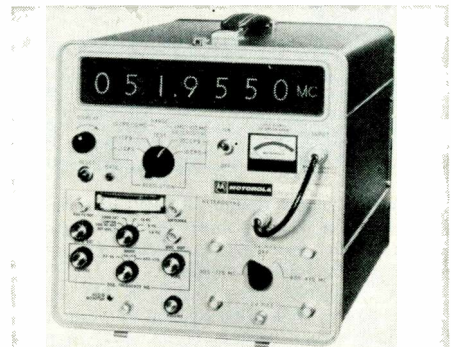

measures deviation, provides aural monitoring, and produces a highly stable signal output for setting receivers to the exact assigned frequency, in the 25-50 MHz, 136-175 MHz, and 405-475 MHz ranges.

The meter displays a seven-digit in-line readout with four automatic decimal points and indicates whether the readout is in Hz, kHz, or MHz. Simplicity of operation is ensured by the elimination of a separate time-base switch. This reduces the number of controls and operations, permitting fast and accurate frequency measurement with resolution of the readout shown on the panel switch position. The instrument also

# FAMOUS ZENITH QUALITY RECORD CHANGERS AND ACCESSORIES

## Record Changers

The world's finest automatic record changers, with such advanced features as Zenith's exclusive Micro-Touch® 2G Tone Arm with the "Free Floating" Cartridge that makes it impossible to accidentally ruin records.



"STEREO PROFESSIONAL"

"STEREO PRECISION"

## Cartridges and Needles

Large selection of cartridges, with wide choice of matching diamond or manufactured sapphire needles.

## Also, 45 rpm Spindles

Order these and all other genuine Zenith parts and accessories from your Zenith distributor.

BUILT TO THE QUALITY STANDARDS OF ZENITH ORIGINAL PARTS



The quality goes in before the name goes on

includes a memory/storage feature whereby the readout remains "fixed." If the frequency being measured should vary, only that portion of the displayed frequency that is actually changing will be affected. Motorola

Circle No. 141 on Reader Service Card

### 23-CHANNEL CB TRANSCEIVER

The "Plus 23" is an all-solid-state, 23-channel, frequency-synthesized CB transceiver which provides 5 watts input with 100% modulation. The receiver section incorporates a MOSFET in a



double-conversion design. There is a full-size "S" meter on which information is displayed on a backlighted 1½" edgewise scale, factory calibrated to read 5-9 at 100 µV.

The transceiver measures 6¾" x 2¾" x 8¾" and is housed in a vinyl-covered aluminum case equipped with a mobile mount. Snap-in power leads permit easy changeover from 12-volt mobile power to 120-volt a.c. Pace

Circle No. 15 on Reader Service Card

### ROOFTOP CB ANTENNA

A new, short, rooftop antenna for CB applications is being marketed as the "Hustler RTS-27." This streamlined 30-inch antenna can be installed easily by one person. It is factory assembled with a 12-inch length of 52-ohm coax and a utility connector which eliminates soldered connections. The unit is also supplied with 18 feet of 52-ohm coax and a PL-259 connector for hookup to the transceiver. New-Tronics

Circle No. 16 on Reader Service Card

## MANUFACTURERS' LITERATURE

### PRECISION TOOLS

A complete line of precision hand tools for microelectronic applications is described and illustrated in a new 12-page condensed catalogue (No. 423).

A wide range of tweezers, pliers, nippers, and scissors is available. Henry Mann

Circle No. 142 on Reader Service Card

### COIL CATALOGUE

A new cross-reference catalogue (No. 103) which matches coil and transformer part numbers used by all manufacturers to the company's part numbers has been compiled. Workman

Circle No. 17 on Reader Service Card

### HARDWARE

A new 2-page data sheet and catalogue (No. II-602) of standard hardware for use with connecting and switching products is now available.

Included are mechanical specifications and prices for a wide line of washers, screws and terminals, nuts, knobs, and wrenches. Switchcraft

Circle No. 143 on Reader Service Card

### SOLDERLESS TERMINALS

A new 28-page illustrated catalogue covering "Ark-Les" pre-insulated solderless terminals is now available. Complete specifications for flanged and square spade, ring, and quick-connect types are provided. Aerovox Distributor Div.

Circle No. 144 on Reader Service Card

### TEST BENCHES

Electronic test benches for laboratory, shop, and industry are described and illustrated in a new 6-page foldout brochure. Eighteen different models are offered which are available in over 100 sizes and combinations.

A wide variety of accessories, including draw-

ers and trays, shelves, and wiring tunnels, is listed. Parent Metal Products

Circle No. 18 on Reader Service Card

### POWER RELAY

Information on the new "Series 55" a.c. and d.c. heavy-duty industrial relays for two- three-, and four-pole switching is contained in a new 4-page catalogue bulletin (No. 1131). Sigma

Circle No. 145 on Reader Service Card

### DOPPLER NAVIGATORS

Complete technical information on the "Janus JN" series of marine Doppler navigators is supplied in a new 8-page illustrated booklet. Detailed explanations of the dual-beam Doppler principle, system operations, receiver, and computer are provided, along with block diagrams showing system components and functions.

Applications for the navigators include oceanographic research, geological surveying, and offshore oil-well drilling. General Applied Science Labs.

Circle No. 146 on Reader Service Card

### WIRE & CABLE

A new 44-page illustrated wire, cable, and tubing catalogue has been released. Covering military hookup, aircraft, and magnet wire; coaxial, control and instrumentation, telephone, and shielded plastic-jacketed cable; and Teflon extruded tubing, the publication also lists applicable MIL Specs and other Federal standards. Akron

Circle No. 147 on Reader Service Card

### TRIMMER CAPACITORS

A new line of miniature metallized-glass trimmer capacitors is introduced in a new 20-page brochure. The new components are available in four capacitance ranges in both panel-mount and printed-circuit styles.

Also covered in the catalogue is the company's full line of precision trimmer capacitors and inductors. Complete specifications and dimensional drawings are provided for all devices listed. LRC Electronics

Circle No. 148 on Reader Service Card

### SEMICONDUCTORS

The major parameters of a broad line of semiconductor products are covered in detail in a new 60-page illustrated catalogue (640.12). Included are silicon and germanium transistors and diodes, special silicon devices, injection lasers and light-emitting diodes, light-activated and detecting devices, and SCR's.

In addition, the publication contains a 12-page section which is devoted exclusively to outline drawings. General Electric

Circle No. 149 on Reader Service Card

### POWER SUPPLIES

"Power Supplies Unlimited," a new 26-page illustrated booklet describing the company's entire line of d.c. power supplies, is now available.

Complete specifications are provided for all-silicon, high-temperature units, transistor-driven SCR devices, bench or rack models, high-voltage types, frequency converters, and custom supplies or systems. NJE Corp.

Circle No. 150 on Reader Service Card

### PUSH-PULL SOLENOIDS

A complete line of push-pull solenoids, available in five basic sizes and in both flat-face and conical-face plunger styles, is described and illustrated in a new 24-page brochure (No. C-365).

Included in the booklet is a 6-page section containing basic information on the operation of solenoids. Lexed

Circle No. 151 on Reader Service Card

### SOLDER ALLOYS

"Choosing the Right Solder Alloy," a new 4-page illustrated technical bulletin, presents a logical method for considering all the parameters involved in the proper selection of a solder alloy.

Featured in the booklet is a detailed table of constituents, melting temperatures, and mechanical and physical properties for 20 common soldering alloys. Alpha Metals

Circle No. 152 on Reader Service Card

### TROPOSPHERIC SCATTER

A new chart and companion map showing the company's participation with its tropospheric scatter equipment in communications systems throughout the world have been made available.

Basic information such as operating frequency bands, system mileage, number of spans, and equipped channel capacity is supplied for 47 military and commercial communications projects which have been installed since 1954. Radio Engineering Labs.

Circle No. 153 on Reader Service Card

### LOUDSPEAKER CATALOGUE

A complete line of loudspeakers for use in commercial, industrial, and institutional sound systems is offered in a new 24-page illustrated catalogue (No. 1070-E).

New products described in the booklet include total-exposure, weatherproof p.a. units, coaxial loudspeakers, theater/auditorium systems, and speech master loudspeakers. Jensen

Circle No. 19 on Reader Service Card

### MOBILE TWO-WAY RADIOS

Complete information on the "PT" series of "Handie-Talkie" portable two-way FM radios is contained in a recently published brochure (TIC-2038). Designed for use in both high- and low-frequency bands, the radios feature interchangeable power packs, fully transistorized operation, and rugged construction.

Accessories and replacements, including battery charger, cable kits, headset and microphone kit, and dummy load antennas, are illustrated and described. Motorola

Circle No. 20 on Reader Service Card

### MARINE COMMUNICATIONS

A complete line of marine communications products is offered in a new 30-page fully illustrated catalogue (MAR-66). Included are integrated systems which feature amplifier, speaker, dynamic microphone, intercom station, and various plug-ins; a wide variety of transistorized megaphones and portable p.a. systems; and a broad range of speakers. Fedtro

Circle No. 21 on Reader Service Card

### MICROWAVE DEVICES

A new 120-page, fully illustrated master catalogue (C-15) of microwave components has been published. Comprehensive in scope, the book contains specifications on more than 4000 products.

Listed in the catalogue are semiconductors, power tubes, duplexers and duplexer tubes, ferrite and transmission-line devices, solid-state control devices, r.f. sources, and amplifiers, and custom-engineered subassemblies and receivers.

For easy reference, products are indexed according to subject and title as well as model number. Microwave Associates

Circle No. 154 on Reader Service Card

### POLYESTER TAPE

Information on "Scotch" polyester electrical tape is contained in a new 4-page brochure. Typical properties of ten different tapes are outlined, and additional data is provided with regard to solvent and oil resistance, toughness, bondability, dielectric strength, electrical purity, and upper temperature limits. 3M

Circle No. 155 on Reader Service Card

### RESIN CHART

A new, up-to-date selection chart for "Dolphon" resins is now available. Each resin is fully described as to method of application, reactor or catalyst, color, temperature classification, dielectric strength, hardness, shrinkage during cure, and mixing ratio. Additional technical information covers viscosity, pot life, and cure time.

# THE 1966 PHOTOGRAPHY ANNUAL

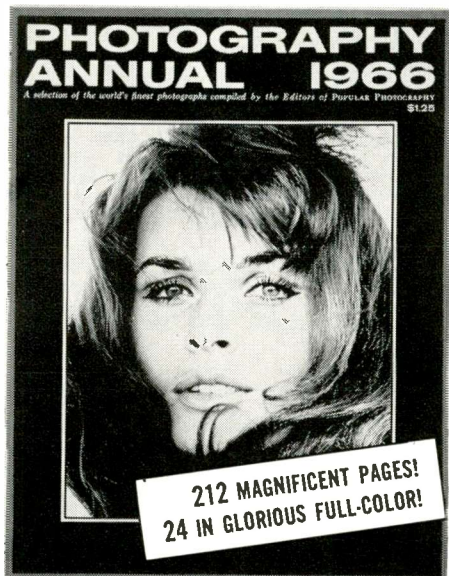

PHOTOGRAPHY ANNUAL—the favorite photographic showcase of camera enthusiasts the world over! It's an issue you'll enjoy and learn from...one you'll want to add to your collection of valuable photographic editions! To receive your copy by mail, thereby avoiding any chance of disappointment, be sure to send your order today!

### PARTIAL CONTENTS include these portfolios:

- Ralph Morse—"Biographer of the Space Age."
- Book Preview! John Rawlings' figure studies.
- Gary Winogrand's amusing "Look at the Animals."
- Story of the Year—dramatic Civil Rights photos.
- An extensive International Portfolio.
- Best News Pictures of the Year...and more!

PLUS...the full story behind each photo

Enjoy the convenience of having this year's edition delivered directly to your home!

**\$1.25**  
only

GET THE EXQUISITE LEATHERFLEX-COVERED EDITION for just \$3.00—POSTPAID!

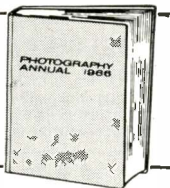

### FILL IN, DETACH & MAIL THIS FORM TODAY!

ZIFF-DAVIS SERVICE DIVISION • Dept. PA  
589 Broadway • New York, N.Y. 10012

Please send my copy of the 1966 PHOTOGRAPHY ANNUAL as I've indicated below:

- Send me the regular edition. My \$1.25, plus 15¢ for shipping and handling (25¢ outside U.S.), is enclosed.
- Send me the Deluxe Leatherflex-Covered edition, postpaid. My \$3.00 is enclosed. (Orders outside U.S. add 75¢ to partially defray postage and handling costs.) Allow three weeks additional for binding and mailing.

name \_\_\_\_\_ please print \_\_\_\_\_ EW-96

address \_\_\_\_\_

city \_\_\_\_\_ state \_\_\_\_\_ zip-code \_\_\_\_\_

(Payment must be enclosed with order.)

The 6-page foldout also includes a listing of six factors to consider when choosing a resin. John C. Dolph Company

Circle No. 156 on Reader Service Card

### TRANSISTOR REPLACEMENT

A new transistor cross-reference (1R-7018-G) has just been published which gives seven replacement numbers for the substitution of over 4000 transistor types. Also included are diodes and rectifiers. GC Electronics

Circle No. 22 on Reader Service Card

### AUDIO CATALOGUE

A complete line of audio products is described and illustrated in a new 14-page catalogue (No. 166). Included are unidirectional and omnidirectional microphones, general-purpose microphones and accessories, p.a. horns and drivers, paging speakers, curved loudspeakers, indoor and outdoor speaker systems, and p.a. transformers. Electro-Voice

Circle No. 23 on Reader Service Card

### PULSE GENERATORS

A new 12-page illustrated brochure on pulse generators and associated equipment is currently available. Prefaced by a multi-lingual introduction (English, German, French, Spanish, and Italian), the booklet covers several pulse generators, a pulse amplifier, and a tone-burst generator. General Radio

Circle No. 157 on Reader Service Card

### MICROPHONE CALIBRATION

A newly approved standard which describes the methods for performing absolute and comparison calibrations of laboratory standard microphones is now available.

The new document, "Method for the Calibration of Microphones" (No. S1.10-1966), is a revision of two earlier standards—"Method for the Calibration of Laboratory Standard Pressure Microphones" (No. Z24.4-1949) and "Method for the Free-Field Secondary Calibration of Microphones" (No. Z24.11-1954).

Copies of the new standard are available from the American Standards Association, 10 East 40th Street, New York, New York 10016 at a cost of \$6.50 each.

### PHOTO CREDITS

Page	Credit
30	Triad Transformer Corp.
36, 37, 38 (top right), 38 (bottom left & right)	
86	General Radio Company
38 (top left)	Boonton Radio Corp.
38 (top center)	James G. Biddle Co.
38 (Fig. 8)	Triplet
38 (Fig. 9)	Leeds & Northrup
39	Cornell-Dubilier Electronics Div.
42	Oak Manufacturing Co.
45, 46	IRC, Inc.

Answer to Puzzle appearing on page 78

O	D	S	P	L	A	N
S	W	I	N	G	A	R
T	E	N	A	A	M	E
A	S	T	A	T	I	C
R	F	I	K	N	E	E
F	R	I	N	S	E	R
M	E	R	E	S	R	O
M	U	C	T	P	O	L
A	S	T	R	O	C	K
S	C	A	R	F	I	D
E	A	O	S	K	I	P
A	N	O	N	W	E	N

## Get Your First Class Commercial F.C.C. LICENSE and your A.S.E.E. DEGREE

Move up. Take advantage of the good pay and security now offered by an electronics career. Grantham can train you quickly, in resident classes or by correspondence.

We offer the following courses—all of which are approved under the new G.I. Bill. Select the course you are interested in, and write or phone for free details.

- Electronics Engineering Technology** (resident course, which leads to the A.S.E.E. degree).
- Basic Electronics Engineering Technology** (correspondence course, which covers the first 1/3 of the EET course listed above, and credit for which can be applied toward the A.S.E.E. degree).
- Communications Electronics** (resident course, which leads to the FCC first class license and trains you to be a communications technician).
- F.C.C. License Course** (correspondence course, which leads to the FCC first class license).
- Radio & Television Servicing** (resident course, which trains you to be a service technician).

For complete information without obligation, write or telephone the School at any of the addresses listed below, and indicate the course you are interested in.

Dept. EW

Grantham School of Electronics

1505 N. Western Ave., Hollywood, Cal. 90027

Phone: (213) 469-7878

408 Marion Street, Seattle, Wash. 98104

Phone: (206) 622-7227

818-18th St., NW, Washington, D.C. 20006

Phone: (202) 298-7460

CIRCLE NO. 113 ON READER SERVICE CARD

## ITC

KNOWN THE WORLD OVER FOR ELECTRONIC VALUES

NORTRONICS  
**TAPE HEAD**  
LATEST TYPE  
**8 POLE — 1/4 TRACK**  
**STEREO "COMBO"**  
**RECORD — PLAY & ERASE**  
Medium-impedance  
for vacuum-tube or transistor circuits.

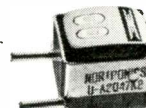

400 mhy 1 kc ind  
2500 ohm 1 kc im:  
100 kc max bias  
freq  
390 ohm dc res  
0.1 mil gap spacer  
.043 track width  
55 db 1 kc  
crosstalk rej

MODEL  
UA2Q47K2

[mfg's stock]

.136 track spacing  
center to center  
.42 ma 60 kc  
peak bias  
35 ua rec current  
1.8 mv 1 kc output  
— 3 db 10kc/1kc  
ratio  
REGULAR  
PRICE \$33.00

ITC  
SPECIAL SALE PRICE

Calif. customers  
add 4%  
sales tax.

**\$8.95**

Add 40 Cents  
for postage  
and handling

Check or M.O. must accompany order. No C.O.D.

INTERNATIONAL  
TELEVISION CORP.

2772 WEST OLYMPIC BLVD.  
LOS ANGELES, CALIF. 90006

CIRCLE NO. 108 ON READER SERVICE CARD

103

# ELECTRONICS MARKET PLACE

**COMMERCIAL RATE:** For firms or individuals offering commercial products or services. 70¢ per word (including name and address). Minimum order \$7.00. Payment must accompany copy except when ads are placed by accredited advertising agencies. Frequency discount: 5% for 6 months; 10% for 12 months paid in advance.  
**READER RATE:** For individuals with a personal item to buy or sell. 40¢ per word (including name and address). No Minimum! Payment must accompany copy.  
**GENERAL INFORMATION:** First word in all ads set in bold caps at no extra charge. Additional words may be set in bold caps at 10¢ extra per word. All copy subject to publisher's approval. Closing Date: 1st of the 2nd preceding month (for example, March issue closes January 1st.) Send order and remittance to: Hal Cymes  
 ELECTRONICS WORLD, One Park Avenue, New York, New York 10016

## FOR SALE

**JUST starting in TV service?** Write for free 32 page catalog of service order books, invoices, job tickets, phone message books, statements and file systems. Oelrich Publications, 6556 W. Higgins Rd. Chicago, Ill. 60656.

**GOVERNMENT Surplus Receivers, Transmitters, Snooperscopes, Radios, Parts, Picture Catalog 25¢.** Meshna, Nahant, Mass. 09108.

**INVESTIGATORS, FREE BROCHURE, LATEST SUBMINIATURE ELECTRONIC SURVEILLANCE EQUIPMENT.** ACE ELECTRONICS, 11500-J NW 7TH AVE., MIAMI, FLA. 33168.

**CANADIANS—Giant Surplus Bargain Packed Catalogs.** Electronics. Hi-Fi. Shortwave. Amateur. Citizens Radio. Rush \$1.00 (Refunded). ETCO. Dept. Z, Box 741, Montreal, Canada.

**JAPAN & Hong Kong Electronics Directory.** Products, components, supplies. 50 firms—just \$1.00. Ippano Kaisha Ltd., Box 6266, Spokane, Washington 99207.

**CANADIANS, transistors, all semiconductors and components.** Free catalogue contains reference data on 300 transistor types. J.&J. Electronics (Dept. EW), P.O. Box 1437 Winnipeg, Manitoba, Canada.

**TRANSISTORS—Miniature Electronic Parts.** Send for Free Catalog. Electronic Control Design Company, P. O. Box 1432M, Plainfield, N.J.

## UNUSUAL BARGAINS ... MANY U.S. GOV'T SURPLUS

"Balls of Fun" for Kids...  
Traffic Stoppers for Stores...  
Terrific for Amateur Meteorologists...  
**SURPLUS GIANT WEATHER BALLOONS**



At last... available again in big 8-ft. diameter. Create a neighborhood sensation. Great backyard fun. Exciting beach attraction. Blow up with vacuum cleaners or auto air hose. Sturdy enough for play; all other uses with reasonable care (can be punctured by sharp objects.) Filled with helium (available locally) use balloons high in the sky to attract crowds, advertise store sales, announce fair openings, etc. Amateur meteorologists use balloons to measure cloud heights, wind speeds, temperature, pressure, humidity at various heights. Photographers can utilize for low-cost aerial photos. Recent Gov't. surplus of heavy, black, neoprene rubber.  
**Stock No. 60,568-AK ..... \$2.00 Ppd.**

**Brand New, Quick-Charge, Industrial Surplus NICKEL-CADMIUM BATTERY**  
Unparalleled Value

For the first time a 6-volt light-weight nickel-cadmium battery in stainless steel, strap type casing, 4-amp. hour capacity. Almost unlimited life—thousands of discharge-charge cycles with minute deterioration—charges fully in approx. 1 hr. with Edmund charger kit. Just a few drops of water per year provide full maintenance.

Hundreds of uses: for hobbyists, amateur photographers, camera, model builders, etc. Unequaled for rechargeable lanterns, cycle scooters, and boat lights; portable fluorescent, and ultraviolet lights; electronic flash units. Battery requires minimum of electrolyte; is sealed to prevent loss; delivers nearly 100% of output at below freezing temperatures compared to 50% by lead-acid batteries. No corrosive fumes under any stage of recharge. Stud type terminals on top 1 1/8" apart, marked for polarity; 6-32 thread, nuts and lock washers. 6" x 2" x 4". Wt. 2 lbs. 12 ounces.  
**Stock No. 70,776-AK ..... \$15.00 Ppd.**

**CHARGER KIT FOR 6-VOLT BATTERY.** Charges in approx. 1 hr. Shuts off automatically, attaches to Stock No. 70,776 battery case. Includes transformer, ballast resistors, charger circuit board, mounting hardware, 8-ft. cord plug, switch, assembly instr.  
**Stock No. 70807-AK ..... \$8.00 Ppd.**

**ONE 1.2 VOLT NICKEL-CADMIUM CELL**  
**Stock No. 40,798-AK ..... \$3.95 Ppd.**

Send Check or M.O.—Money-Back Guarantee  
**EDMUND SCIENTIFIC CO., Barrington, N. J. 08007**

**SEND FOR NEW 148-PAGE FREE CATALOG—"AK"**  
 Completely new 1966 edition. New items, categories, illustrations. 148 easy-to-read pages packed with nearly 4000 unusual items. Dozens of electrical and electromagnetic parts, accessories. Enormous selection of Astronomical Telescopes, Microscopes, Binoculars, Magnifiers, Magnets, Lenses, Prisms. Many war surplus items: foil hobbyists, experimenters, workshop, factory. Write catalog—"AK".

ORDER BY STOCK NUMBER—OPEN ACCOUNT TO RATED FIRMS—SATISFACTION GUARANTEED  
**EDMUND SCIENTIFIC CO., BARRINGTON, NEW JERSEY 08007**

**CIRCLE NO. 119 ON READER SERVICE CARD**  
104

**METERS—Surplus, new, used, panel and portable.** Send for list. Hanchett, Box 5577, Riverside, Calif. 92507.

**TRANSISTORIZED Products Importers catalog.** \$1.00. Intercontinental. CPO 1717, Tokyo, Japan.

**MESHNA'S TRANSISTORIZED CONVERTER KIT \$5.00.** Two models—converts car radio to receive 30-50 mc or 100-200 mc (one mc tuning). Meshna, Lynn, Mass. 01901.

**R.F. CONVERTERS World's largest selection.** Also CCTV cameras, transmitters, etc. Lowest factory prices. Catalog 10¢. Vanguard, 196-23 Jamaica Ave., Hollis, N.Y. 11423.

**CONVERT any television to sensitive big-screen oscilloscope.** Only minor changes required. No electronic experience necessary. Illustrated plans, \$2.00. Relco-A22, Box 10563, Houston 18, Texas.

**ELECTRONIC Ignition Kits, Components Free Diagrams.** Anderson Engineering, Epsom, New Hampshire 03239.

**SURVEILLANCE EQUIPMENT—NEW HIGH PERFORMANCE SUBMINIATURE MODELS. ELECTRONIC COUNTERMEASURE DEVICES TO PROTECT PRIVACY. FREE DATA: SECURITY ELECTRONICS-EW, 15 EAST 43RD STREET, NEW YORK, N.Y. 10017.**

**WORLD'S TINIEST RADIOS.** Recorders, transceivers, AM/FM/SW portables. Free catalog. Minitorics, 1983-9623 Via Del Rio, Corona, California 91720.

**FREE ELECTRONICS (new and surplus) parts catalog.** We repair multimeters. Bigelow Electronics, Bluffton, Ohio 45817.

**DETECTIVES! Free brochures! Electronic Surveillance devices.** SILMAR ELECTRONICS, 3476 N.W. 7th Street, Miami, Florida 33125.

**"GREAT BUYS" Catalog 10¢ Multimeter 20,000 !/v \$9.95.** 1001 Bargains. Fertik's, 5249 "D" St., Phila., Pa. 19120.

**DIAGRAMS, service information, Radio \$1.00, Television \$2.** BEITMAN, 1760 Balsam, Highland Park, Illinois 60035.

**TRADE in your old CB equipment for new.** Prices? Randall's, 7035 N. 39th Street, Milwaukee, Wis. 53209.

**CRYSTALS...largest selection in United States at lowest prices.** 48 Hr. delivery. Thousands of frequencies in stock. Types include HC6/U, HC18/U, FT-241, FT-243, FT-171, etc. Send 10¢ for catalog with oscillator circuits. Refunded on first order. Jan Crystals, 2400E Crystal Dr., Fort Myers, Fla. 33901.

**HONGKONG Gifts. Catalog, 10¢.** MODERN MERCHANDISE, Box 77531-Z, Los Angeles, Calif. 90007.

**WHOLESALE: Microphones 89¢, Speakers 49¢, Amplifiers \$4.39.** Hundreds of items. Catalog 25¢. Royal, 8632 La Mesa Blvd., La Mesa, Calif.

**SOLID STATE CONVERTERS 50-54 mc input, 14-18 mc output.** Crystal controlled, 2.5 db noise figure. Wired and tested, \$25 ppd. SYNTELEX, 39 Lucille, Dumont, N.J. 07628.

**NEW supersensitive transistor locators detect buried gold, silver, coins.** Kits, assembled models. \$19.95 up. Free catalog. Relco-A22, Box 10563, Houston 18, Texas.

## ELECTRONICS ENGINEERING AND INSTRUCTION

**FCC LICENSE in six weeks.** First class radio telephone. Results guaranteed. Elkins Radio School, 2603C, Inwood, Dallas, Texas.

**ELECTRONICS! Associate degree—29 months.** Technicians, field engineers, specialists in communications, missiles, computers, radar, automation. Start September, February. Valparaiso Technical Institute, Dept. N, Valparaiso, Indiana.

**F.C.C. LICENSE (first class) in seven weeks,** Resident classes or correspondence. Grantham, 1505 N. Western, Hollywood, California 90027.

**LEARN ELECTRONIC ORGAN SERVICING at home.** All Makes including transistors. Experimental kit—trouble-shooting. Accredited NHSC. Free Booklet. NILES BRYANT SCHOOL, 3631 Stockton, Dept. A, Sacramento 20, Calif.

## GREGORY ELECTRONICS Reconditioned & Used FM 2-WAY RADIO SAVINGS

Partial list—Send for Fall '66 catalog

### Voice Commander



132 to 172 MC, 1W 9.5" x 5.3" x 1.7" Reduced price including brand New Rechargeable Nickel Cadmium Battery Pack

Lowest Price Ever!

**\$148**

If crystal & tuning is desired add \$45.00  
 Battery charger for these units \$16.00

WRITE FOR QUANTITY PRICES

### VOICE COMMANDER

Monitor Receiver only—Tuned & Crystalled with dry Batteries

**\$78**

### DELCO-RADIO TELEPHONE MODEL CVTI—Complete Accessories

Quantity Discount—20% on Quantities of Five—\$198.40 each Less Accessories Deduct \$80.00

**\$248**

### GE 4ES14—450-470 MC

6/12 Volts 12-15 Watts Less Accessories

**\$48**



### MOTOROLA T 41GGV

Fully narrow Banded, 30 Watt, LB 6/12 Volt, Complete accessories. Minus Crystals and Antenna.

**\$188**

We Buy Late Model Equipment for Cash  
 —Write: Wire or Phone!



## GREGORY ELECTRONICS CORPORATION

249 RT. 46, Saddle Brook, N.J., 07662

Phone: (201) 489-9000

**CIRCLE NO. 112 ON READER SERVICE CARD**  
ELECTRONICS WORLD

REI First Class Radio Telephone License in (5) weeks Guaranteed. Tuition \$295.00. Job placement free. Radio Engineering Institute, 1336 Main Street, Sarasota, Fla.

HIGHLY—effective home study review for FCC commercial phone exams. Free literature! **COOK'S SCHOOL OF ELECTRONICS**, P.O. Box 10634, Jackson, Miss. 39209.

ENGINEERING and Electronics—send \$1.00 for 100 page Career Opportunities. C.I.S.T., Suite 674, 263 Adelaide St., West, Toronto, Canada.

**TUBES**

BEFORE you buy receiving tubes, Transistors, Diodes, Electronic Components and Accessories... send for Giant Free Zalytron Current Catalog, featuring Standard Brand Tubes; RCA, GE, etc.—all Brand new premium quality individually boxed. One year guarantee—all at biggest discounts in America! We serve professional servicemen, hobbyists, experimenters, engineers, technicians. Why pay more? Zalytron Tube Corp., 469-W Jericho Turnpike, Mineola, N.Y. 11502.

FREE Catalog. Electronic parts, tubes, Wholesale. Thousands of items. Unbeatable prices. Arcturus Electronics ZD, 502-22 St., Union City, N.J. 07087.

TUBES, SEMICONDUCTORS, ELECTRONIC EQUIPMENT & COMPONENTS. Quality merchandise only! Serving engineers, purchasing agents TV/HiFi servicemen and hams for 16 years. Write for catalog or call WA 5-7000, **BARRY ELECTRONICS**, 512 Broadway, New York, N.Y. 10012.

TUBES—33¢ each, Year guarantee. Tuner Cleaner \$1.09. Free catalog. Cornell, 4213-W University, San Diego, Calif. 92105.

**WANTED**

QUICKSILVER. Platinum, Silver, Gold, Ores Analyzed. Free Circular. Mercury Terminal, Norwood, Mass.

CASH Paid! Sell your surplus electronic TUBES. (Want UNUSED, clean Radio/TV Receiving, Transmitting, Special Purpose, Magnetrons, Klystrons, Broadcast Types.) Want military and commercial Lab/Test Equipment. Want commercial Ham Receivers and Transmitters. For a Fair Deal Write: **BARRY Electronics**, 512 Broadway, New York, N.Y. 10012 (WA 5-7000.)

**DO-IT-YOURSELF**

PROFESSIONAL ELECTRONIC PROJECTS—\$1.00 up. Catalog 25¢ **PARKS**, Box 25565, Seattle, Wash 98125.

**TAPE AND RECORDERS**

RENT Stereo Tapes—over 2,500 Different—all major labels—free brochure. Stereo-Parti, 1616—E. W. Terrace Way, Santa Rosa, California.

BEFORE renting Stereo Tapes, try us. Postpaid both ways—no deposit—immediate delivery. Quality—Dependability—Service—Satisfaction—prevail here. If you've been dissatisfied in the past, your initial order will prove this is no idle boast. Free Catalog. Gold Coast Tape Library, Box 2262, Palm Village Station, Hialeah, Fla. 33012.

TAPE RECORDER SALE. Brand new, latest models, \$10.00 above cost. Arkay Sales, 1028-B Commonwealth Ave., Boston, Mass. 02215.

TAPE-MATES now offers ALL TAPES—ALL LABELS at TREMENDOUS SAVINGS plus FREE Tape-Mates membership. For FREE brochure write TAPE-MATES, 5280-EW W. Pico Blvd., Los Angeles 90019.

STEREO TAPES. Save up to 60% (no membership fees, postpaid anywhere USA). Free 60-page catalog. We discount batteries, recorders, tape accessories. Beware of slogans "not undersold," as the discount information you supply our competitor is usually reported to the factory. **SAXITONE**, 1776 Columbia Rd., Washington, D. C. 20009.

HI-FI components, tape recorders, sleep learn equipment, tapes. Unusual Values. Free Catalog. Dressner, 1523 Jericho Turnpike, New Hyde Park 10, N.Y.

TAPES, TAPE RECORDERS—sold, exchanged. Free catalog. Tower, Lafayette Hill, Pa. 19444.

**COINS**

50¢ CALIFORNIA Gold Pieces: 1849-1858; 75¢ Each. Seven Different \$4.00; 25 Assorted \$12.00; Plastic Holders. Metropolitan Coin Exchange, 1380-2 Penobscot Bldg., Detroit, Mich. 48226.

**BIG CATALOG**  
World's "BEST BUYS" in GOVT, SURPLUS Electronic Equipment

**BUY NOW... WHILE THEY LAST!**

- BC-453 Receiver
- BC-454 Receiver
- BC-455 Receiver
- BC-456 Modulator
- BC-457/T-20 Transmitter
- BC-458 Transmitter
- BC-696 Transmitter
- BC-603 Receiver
- BC-348 Receiver
- BC-221 Frequency Meter

And Many, Many Others!

WRITE TODAY FOR NEW LIST WITH OUR LOW, LOW PRICES

Big Variety of NEW ITEMS To Select From! Send For CATALOG!

FOR BIG CATALOG—SEND 25¢ (stamps or coin) and receive 50¢ CREDIT on your order! ADDRESS DEPT. EW

**FAIR RADIO SALES**  
1016 E. EUREKA • Box 1105 • LIMA, OHIO • 45802

**NEON AC/DC ELECTRIC TESTER**  
FOR HOME AUTO SHOP  
**Special! 59¢**

**Special!**  
With every \$10 Order  
**25¢** per tube  
(No Limit) from this list:  
6AG5 6SN7  
6AG5 6CB6 6SA  
6AU6 6J6 6WA

**CORNELL TUBES**  
1 YR. GUARANTEED  
Mutual Conductance Lab-tested. Individually Boxed, Branded and Code Dated. Tubes are new, or used and so marked.

**21" PICTURE TUBES**  
1395 1 Yr. Guar. Aluminized No C.O.D.'s on Picture Tubes

12BP4	12BP4	12BP4	12BP4
12BP4	12BP4	12BP4	12BP4
12BP4	12BP4	12BP4	12BP4
12BP4	12BP4	12BP4	12BP4
12BP4	12BP4	12BP4	12BP4
12BP4	12BP4	12BP4	12BP4
12BP4	12BP4	12BP4	12BP4
12BP4	12BP4	12BP4	12BP4
12BP4	12BP4	12BP4	12BP4
12BP4	12BP4	12BP4	12BP4

**33¢ PER TUBE**

**100 TUBES OR MORE: 30¢ PER TUBE**

**Prestige & Success are yours as an ELECTRONIC EXPERT**  
FOR CORNELL CUSTOMERS ONLY by special arrangement with the publisher, these amazing bargains are available

**COMPLETE RADIO SERVICING AND BASIC ELECTRONICS COURSE ONLY \$3.00**  
182 50 • 50 page book • 1961

**NEW PRACTICAL TV TRAINING COURSE ONLY \$3.50**  
182 50 • 50 page book • 1961

**Both above courses \$6.00**

OZ4	6A55	6CD6	6K6	6X4	12BF6
1B3	6AT6	6CF6	6K7	6X8	12BH7
1J3/1K3	6AT8	6CG7	6Q7	7A7	12BL6
1H5	6AU4	6CG8	6S4	7A8	12BY7
1L4	6AU6	6CM7	6SA7	7B6	12C5
1T4	6AU6				12CA5
1U4	6AV6				12SN7
1X2	6AW8				12SQ7
3BZ6	6AX4				25L6
3DG4	6BA6				25Z6
5U4	6BC5				35W4
5U8	6BD6	6CZ5	6SH7	7C5	35Z3
5V4	6BG6	6D6	6SJ7	7N7	50L6
5Y3	6BJ6	6DA4	6SK7	7Y4	24
6A6	6BL7	6DE6	6SL7	12AD6	27
6AB4	6BN4	6DQ6	6SN7	12AE6	77
6AC7	6BN6	6EA7	6SQ7	12AF6	78
6AG5	6BQ6	6EAS	6SR7	12AT7	84/6Z4
6AK5	6BQ7	6F6	6U7	12AU7	56B7
6AL5	6BZ6	6GH8	6U8	12AX7	6350
6AN8	6C4	6H6	6V6	12BA6	6463
6AQ5	6C6	6J5	6W4	12BD6	7044
	6CB6	6J6	6W6	12BE6	

Other tubes at low prices—send for free list

**all purpose ELECTRONIC CLEANER**  
89¢ plus 20¢ shipping

**SILICON RECTIFIERS**  
750 MA 69¢ 1000 MA 89¢  
400 P.I.V. Per Pair 800 P.I.V. Per Pair

**NO SUBSTITUTIONS WITHOUT YOUR PERMISSION**

**NEW! EASY TO USE! RADIO-TV TUBE TESTER**  
TEST and REPAIR TV & RADIO SETS APPLIANCES  
**2.89** plus 30¢ shipping

**ABC GOLOR TV \$100**  
BIG PROFITS HERE IN COLOR TV REPAIR

**PICTURE EXPANDER**  
99¢

**SOLDERING GUN**  
EASY TO HANDLE HOT SHOT  
2.99 plus 20¢ shipping

**TERMS: Add 3c per tube shipping. Orders under \$5.00 add 3c per tube shipping plus 50c handling. Canadian orders add approximate postage. Send 25¢ deposit on C.O.D. orders. No C.O.D. orders under \$5.00 or to Canada. No 24 hr. free offer on personal check orders. 5-DAY MONEY BACK OFFER!**

**CORNELL ELECTRONICS CO.**  
Dept EW 9 4217 University Ave., San Diego, Calif. 92105

### AN/APR-4Y FM & AM RECEIVER "FB" FOR SATELLITE TRACKING!



High precision lab instrument, suitable for monitoring and measuring frequency and relative signal strength of signals from 38 to 4000 Mc., in 5 tuning ranges. For 110 volt 60 cycle AC operation, built-in power supply. Original circuit diagram included. Checked out perfect. LIKE NEW ..... \$88.50

**TN-19 TUNING UNIT** for above, continuous tuning 975 to 2200 Mc., just right for 1296 Mc. Satellite Frequency and other current Ham activity. Checked out, perfect ..... \$69.50  
Other tuning units for above, TN-16, TN-17, TN-18, TN-54 in stock ..... P. U. R.

**BC-929 3-inch Scope**, with all tubes, LIKE NEW ..... \$18.95  
Conversion instructions, with diagram for 110 V AC operation ..... \$ .65

**SCR-522 2 METER TRANSMITTER-RECEIVER**  
VHF Transmitter-Receiver, 100-156 Mc. 4-channels. Xtal-controlled. Amplitude modulated voice. Complete with all 18 tubes, top rack and metal case. Exc. Cond. .... \$44.50

### FAMOUS BC-645 TRANSCEIVER

15 Tubes 435 to 500 MC

can be modified for 2-way communication, voice or code, on ham band 420-450 mc. citizens radio 400-470 mc. fixed and mobile, 450-460 mc. television experimental 470-500 mc. 15 tubes (tubes alone worth more than sale price!); 4—7F7, 4—7H7, 2—7E6, 2—6F8, 2—9A5 and 1—WE-316A. Now covers 460 to 490 mc. Brand new BC-645 with tubes, less power supply in factory carton. Shipping weight 25 lbs. SPECIAL! \$19.50

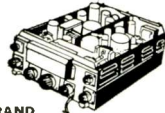

BRAND NEW

**PE-101C Dynamotor**, 12/24V input ..... \$7.95  
**UHF Antenna Assembly** ..... 2.45  
**Complete Set of 10 Plugs** ..... 5.50  
**Control Box** ..... 2.25

#### SPECIAL "PACKAGE" OFFER:

BC-645 Transceiver, Dynamotor and all accessories above, COMPLETE, BRAND NEW, While Stocks Last ..... \$29.50

**BC-221 FREQUENCY METER**  
Equipped with original calibration charts, 125Kc. to 20,000 Kc with crystal check points in all ranges. Excel. Used with original Calibration Book. Crystal, and all tubes. CHECKED OUT. Unmodulated ..... \$79.50

**BC-221 1000 Kc Crystal Brand New** ..... 5.95  
**BC221 FREQ. METER CASE**, aluminum with volt. reg. supply. Shock mounted, BRAND NEW ..... \$3.95

**LM Freq. Meter**, Modulated, 125 Kc to 20,000 Kc. With Calibration Book, Like New ..... \$79.50  
As above, less Callb. Book, exc. used ..... \$34.50

**ARR-15 Collins Receiver**, 1.5 to 18.5 Mc. Tunable, with Collins ITO and Liberator (written up in mag.) Complete with 15 tubes. LIKE NEW ..... \$79.50

**BC1206-C BEACON RECEIVER** 195 to 420 Kc. made by Satchel-Carlson. Works on 24-28 volts DC. 135 Kc. IF. Complete with 5 tubes. Size 4" x 4" x 6". Wt. 4 lbs. NEW ..... \$19.95  
USED ..... less tubes \$ 7.95

**24 V DC POWER SUPPLY** (ABC) Satchel-Carlson Model 24. INPUT: 24 VDC at 8 Amp. OUTPUT: 1.5 V at .3 A., 65 V at .010 A., and -6 V. 7"x4"x4". Wt. 4 lbs. Like New. .... \$5.95  
Checked out

#### EE-8 FIELD PHONES

Checked out, perfect working order. Complete with all parts. Excellent Condition. LIKE NEW! Each ..... \$16.50

#### SCR-274 COMMAND EQUIPMENT

ALL COMPLETE WITH TUBES

Type	Description	Used	Like New	BRAND NEW
BC-453	Receiver			
	190-550 Kc.	\$14.95	\$18.95	P.U.R.
BC-454	Receiver 3-6 Mc.	\$15.95	\$24.50	
BC-455	Receiver 6-9 Mc.	\$3.95	\$19.50	\$24.50
BC946	Receiver, 550-1500 Kc. Complete with all tubes. Brand New, in original packing		\$48.50	
	1.5 to 3 MC. Receiver Brand New		\$24.50	

**110 Volt AC Power Supply** for all 274 N and ARC-5 Receivers. Complete with metal case, instructions. Factory wired, tested, ready to operate ..... \$12.50

**SPLINED TUNING KNOB** for 274-N and ARC-5 RECEIVERS. Fits BC-453, BC-454 and others. Only ..... 49¢

**2.1 to 3 Mc. Transmitter**, Brand New ..... \$12.95  
**BC-458 TRANSMITTER**—5.3 to 7 Mc. Complete with all tubes and crystal ..... \$13.95  
BRAND NEW ..... \$8.95  
Like New ..... \$8.95

**BC-459 TRANSMITTER**—7 to 9 Mc. Complete with tubes & crystal ..... \$19.50  
Like New ..... \$16.95

**BC-696 TRANSMITTER** 3-4 Mc Complete with All Tubes & Crystal. Brand New ..... \$12.95  
Like New ..... \$5.95  
BC-456 Modulator ..... USED \$ 45 NEW \$5.95  
ALL ACCESSORIES AVAILABLE FOR ABOVE

#### SCR-625 MINE DETECTOR

Complete portable outfit in original packing, with all accessories. Excellent. Used ..... \$32.50

**AN/ARR-2 Receiver**, 234-258 Mc. Complete with 11 tubes. Brand New ..... \$11.95  
Exc. Used ..... \$ 7.95

**2-Volt Willard Storage Battery**, 20 Amp. Hr. Model 20-2. 3"x4"x5 1/2" high. Brand New ..... \$2.79  
**6-Volt Willard Midget Storage Battery**, 3 Amp. Hr. 3-5/8"x1-13/16"x2-3/8". Brand New ..... \$2.95

Please include 25% Deposit with order—Balance C.O.D., or Remittance in Full, 50¢ Handling Charges on all orders under \$5.00. All shipments F.O.B. Our Warehouse, N.Y.C. All Merchandise subject to Prior Sale and Price Change. For NEW COMPLETE CATALOG, send 25¢, refunded with first order!

### G & G RADIO SUPPLY CO.

Telephone: (212) CO 7-4605

77 Leonard St. New York, N.Y. 10013

CIRCLE NO. 115 ON READER SERVICE CARD 106

### HIGH FIDELITY

LOW, LOW quotes: all components and recorders. Hi-Fi, Roslyn 9, Penna

Hi-Fi Components, Tape Recorders, at guaranteed "We Will Not Be Undersold" prices. 15-day money-back guarantee. Two-year warranty. No Catalog. Quotations Free. Hi-Fidelity Center, 239 (L) East 149th Street, New York 10451.

FREE! Send for money saving stereo catalog #E9W and lowest quotations on your individual component, tape recorder or system requirements. Electronic Values Inc., 200 West 20th Street, N.Y. N.Y. 10011.

FREE—\$1.00 Value "Miracle" Record cleaning cloth with every quotation on HI-FI EQUIPMENT. Our "ROCK BOTTOM" prices on NAME BRAND amplifiers—tuners—taperecorders—speakers—FRANCHISED—59 YEARS IN BUSINESS. Write for this month's specials—NOW! Rabsons 57th St., Inc., Dept. 569, 119 W. 57th St., New York, New York 10019.

Hi-Fi speaker system. Small, walnut. Magnificent. \$29.95. TANG, Box 162A, Framingham Ctr., Mass. 01701.

### REPAIRS AND SERVICES

TV Tuners Rebuilt and Aligned per manufacturers specification. Only \$9.50. Any Make UHF or VHF. We ship COD Ninety day written guarantee. Ship complete with tubes or write for free mailing kit and dealer brochure. JW Electronics, Box 51B, Bloomington, Indiana.

RECONING—COMPLETE SPEAKER RECONING SERVICE ANY MAKE, ANY SIZE. MIDWEST SPEAKER SERVICE, INDIANAPOLIS, IND. 46201.

### RECORDS

REPLACE worn LP Jackets—White 20¢, Colors 25¢. Min Shipment 20, Samples 50¢, Records, Hillburn P.O., New York.

### MUSIC

POEMS wanted for songs. Send poems. Crown Music, 49-EL West 32, New York 1.

## GET IT FROM GOODHEART!

EVERYTHING UNCONDITIONALLY GUARANTEED!

**PROFESSIONAL HI-FI CONDENSER MICROPHONE**  
Brand new \$114.85 capsule only, but we include dwg of Paramount Picture's cathode-follower preamp using only 3 batteries, 3 resistors, 3 capacitors, 1 #37 18 tube. Mfr's specs: "1 db from DC to 12 1/2 kc, usable beyond 25 kc; 25 pf; -75 db across 10 meg load for 10 db signal at 180 v polarizing; will work past 170 dbm; will stand 200 G shock." Unidirectional. Size: Will fit in 3-1/16" circle; 7/8" thick O.A. WHILE THEY LAST, postpaid, only ..... 27.50

#### KEEP LINE VOLTS CONSTANT AUTOMATICALLY

These Regulators, ALL AT LOW SURPLUS BARGAIN PRICES, hold output at 115/120 v despite line changes 95-130 v and load changes 0 to full load. CV: Tuned saturating isolating transformers hold to 1% , have 14% harmonics. EM: Servo, hold to 1% , ZERO harmon. S/EI: Electronic, hold to 0.1% , 3% max. harm. Sola, Sorensen, Superior Electric.

CV: 250 VA \$ 22.50 500 VA ..... \$ 37.50  
1 KVA 69.50 2 KVA (230v) 99.50

S/EI: 500 VA 99.50 5 KVA (230v) 350.00  
2 KVA \*129.50 1 KVA ..... 129.50  
2 1/2 KVA \*199.50 2 KVA ..... 199.50

\*Items are special values 3 KVA ..... 279.50  
10KVA ..... 595.00

EM: 6 KVA, \$279.50 (Incl. Gen. Radio 1570AL)  
EMT (transistorized) 28 KVA 230V ..... 350.00

**ALL-BAND 5SB RCVR BARGAIN:** Halliercrafters R-45/ARR-7, 550 kc to 43 mc continuous. Voice, CW, MCW, aligned, grtd., w/book: 2-RF, 2-IF's. S-meter; noise imtr; 3 xtl, 3 non-xtl selectivity choices. .... 149.50  
Less pwr sply .....  
60 cy pwr sply: \$30. SSB product detector: \$20

**TIME PAY PLAN:** Any purchase totaling \$160.00 or more, down payment only ..... 10%

R-23/ARC-5 Command rcvr 190-550 kc. .... 14.95  
A.R.C. 12 #22 Command rcvr 540-1600 kc. 17.95  
ARR-5 rcvr, 60 cy, am/fm, 27-140 mc. .... 149.50  
APR-4Y AM/FM Rcvr mod. to 115 v 50/60 cy, with pwr plug, book, tuners 38-1000 mc. .... 250.00  
P.U.R. for tuners 975-2200 and 2175-4000 mc.  
RA-62-B is AC pwr sply for SCR-522, only .. 17.95  
LM-14 freq. meter, .01% 125 kc-20 mc. .. 57.50  
TS-323/UR freq. meter 20-480 mc., .001% 169.50

**OTHER MATERIAL:** Hewl-Pack & Tekt. Scopes, 30 types of Signal Generators, Gertsch material, Bridges, VLF Receivers, Noise/Field-Strength Meters, DVM's, etc. etc. WRITE! WE ALSO BUY!

### R. E. GOODHEART CO. INC.

Box 1220-A, Beverly Hills, Calif. 90213

Phones: Area 213, office 272-5707, messages 275-5342

CIRCLE NO. 114 ON READER SERVICE CARD

## CLASSIFIED ADVERTISING ORDER FORM

Please refer to heading on first page of this section for complete data concerning terms, frequency discounts, closing dates, etc.

1	2	3	4	5
6	7	8	9	10
11	12	13	14	15
16	17	18	19	20
21	22	23	24	25
26	27	28	29	30
31	32	33	34	35

Words ( @ .40 Reader Rate ) = \$ \_\_\_\_\_  
( @ .70 Commercial Rate ) = \$ \_\_\_\_\_

Insert \_\_\_\_\_ time(s) Total Enclosed \$ \_\_\_\_\_

NAME \_\_\_\_\_

ADDRESS \_\_\_\_\_

CITY \_\_\_\_\_

ZONE \_\_\_\_\_

STATE \_\_\_\_\_

#### SIGNATURE

WORD COUNT: Include name and address. Name of city (Des Moines) or of state (New York) counts as one word each. Zone or Zip Code numbers not counted. (Publisher reserves right to omit Zip Code if space does not permit.) Count each abbreviation, initial, single figure or group of figures or letters as a word. Symbols such as 35mm, COD, PO, AC, etc., count as one word. Hyphenated words count as two words. EW-966



**AUTHORS' SERVICES**

**AUTHORS!** Learn how to have your book published, promoted, distributed. FREE booklet "ZD," Vantage, 120 West 31 St., New York 1.

**SONGWRITERS WANTED.** Send songs for recordings—royalty contract. Tin Pan Alley, 1650-H Broadway, New York 10019.

**WANTED WRITERS!** Short stories, articles, books, plays, poetry. Will help place, sell your work. Write today, free particulars! Literary Agent Mead, Dept. C-45, 915 Broadway, New York 10, N.Y.

**PHOTOGRAPHS**

**PHOTOGRAPHS** and transparencies wanted, to \$500.00 each. Valuable information free—Write Intrapphoto-EW, Box 74607, Hollywood 90004.

**PHOTOGRAPHY—FILM, EQUIPMENT, SERVICES**

**MEDICAL FILM**—Adults only—"Childbirth" one reel, 8mm \$7.50; 16mm \$14.95. International W, Greenvale, Long Island, New York.

**SCIENCE Bargains**—Request Free Giant Catalog "CJ"—148 pages—Astronomical Telescopes, Microscopes, Lenses, Binoculars, Kits, Parts, War surplus bargains. Edmund Scientific Co., Barrington, New Jersey.

**RUBBER STAMPS**

**RUBBER ADDRESS STAMP** \$1.00. Signature \$2.88. Free catalog. Jackson Products, 1433 Winnemac, Chicago, Ill. 60640.

**EDUCATIONAL OPPORTUNITIES**

**LEARN** While Asleep, hypnotize with your recorder, phonograph. Astonishing details, sensational catalog free! Sleep-Learning Association, Box 24-ZD, Olympia, Washington.

**LEARN** while asleep. Remarkable, scientific. 92% effective. Details free. ASR Foundation, Box 721, Dept. e.g., Lexington, Kentucky.

**USED** Correspondence Courses and Books sold and rented. Money back guarantee. Catalog free. (Courses Bought). Lee Mountain, Pisgah, Alabama.

**INVENTIONS WANTED**

**INVENTIONS—IDEAS** developed: Cash/Royalty Sales. Member: United States Chamber Commerce. Raymond Lee, 130-G West 42nd, New York City 10036.

**INVENTORS.** We will develop, help sell your idea or invention, patented or unpatented. Our national manufacturer clients are urgently seeking new items for outright cash sale or royalties. Financial assistance available. 10 years proven performance. For free information, write Dept. 42, Wall Street Invention Brokerage, 79 Wall Street, New York 5, N.Y.

**REAL ESTATE**

**FREE FALL CATALOG!** Big NEW 180 pages! Selected Best throughout the U.S. Thousands of properties described, pictured—Land, Farms, Homes, Businesses—Waterfront, Recreation, Retirement. 66 Years' service, 490 Offices, 36 states Coast to Coast. Mailed FREE from the World's Largest! **STROUT REALTY**, 50-ZD East 42nd St., N.Y., N.Y. 10017.

**EMPLOYMENT INFORMATION**

**FOREIGN** Employment. Construction, other work projects. Good paying overseas jobs with extras, travel expenses. Write only: Foreign Service Bureau, Dept. D, Bradenton Beach, Florida.

**FOREIGN** Employment: South America, Africa, Europe, Australia, USA. Earnings to \$2,000.00 monthly. Construction, all trades, professions, occupations. Many companies pay fare, housing, benefits, bonuses. Write: Universal, Dept. B-8, Woodbridge, Conn. 06525.

**EMPLOYMENT** Resumes. Get a better job & earn more! Send only \$2.00 for expert, complete Resume Writing Instructions. J. Ross, 80-34 Kent St., Jamaica 32, N.Y. Dept. EW.

**DOUBLE BONUS**  
**\$25** WORTH OF TRANSISTORS, RECTIFIERS, RESISTORS, CONDENSERS, DIODES, ETC.  
 Add 25¢ for handling  
**BOTH FREE WITH ANY \$10 ORDER**

PLUS CHOOSE ANY \$1.00 ITEM FREE

**SALE**  
**FIELD-EFFECT TRANSISTORS** 2\$1 For TO-5  
 For experimental & shop use.  
 N-channel

**FACTORY TESTED SEMI-KON-DUCTORS**

- 2 Bidirectional Transistors 2N1641 ..... \$1
- 4 2N170 TRANSISTORS, by GE, npn for gen'l rf \$1
- 1 IGNITION SWITCHING TRANSISTORS, 10 AMP \$1
- 4 2N336 NPN SILICON transistors, Transistron \$1
- 10 ZENERS REFERENCES stud, asst types ..... \$1

**1. AMP 800 PRV**  
 SUBMINIATURE 4 for \$1 RECTIFIERS

- 25 GERMANIUM & SILICON DIODES, no test . . \$1
- 25 TOP HAT RECTIFIERS, silicon, 750ma, no test \$1
- 10 1000 MC-1N251 GERMANIUM DIODES . . . \$1
- 10 30-MC TRANSISTORS, silicon, TO18, no test \$1
- 3-2N705 MESA, 300 mc, 300 mw, pnp, TO18 \$1
- 2-800 MC, 2N709 NPN Silicon planar TO46 . \$1
- 10 NPN SWITCHING TRANSISTORS, 2N404, TO5 \$1
- 10 NPN SWITCHING TRANSISTORS, 2N338, 440 \$1
- 15 PNP TRANSISTORS, CK722, 2N335, 107 no test \$1
- 15 NPN TRANSISTORS, 2N335, 170, 440, no test \$1
- 30 TRANSISTORS, rf, if, audio osc-ifs, FO5 no test \$1

**SILICON POWER STUD RECTIFIERS**

AMPS	25 PIV	50 PIV	100 PIV	200 PIV
3	5¢	7¢	12¢	19¢
15	15¢	22¢	40¢	65¢
35	39¢	50¢	75¢	1.19
AMPS	400 PIV	600 PIV	800 PIV	1000 PIV
3	25¢	35¢	45¢	69¢
15	90¢	1.35	1.59	1.79
35	1.90	2.50	2.75	2.95

- 10 FAMOUS CK722 TRANSISTORS, pnp no test \$1
- 5 2N107 TRANS'RS, by GE, pnp, audio pak \$1
- 2 40W NPN SILICON MESA, 2N1648, 2N1048 \$1
- 25 ZENERS GLASS SILICON DIODES, no test . . \$1
- 5 SUN BATTERIES TO 1 1/2" sizes, lite sensitive \$1
- 2 2N718 NPN SILICON PLANARS, by Fairchild . \$1
- 4 2N213 TRANSISTORS, mixer-conv, TO22 . . \$1
- 10 MICRODIODE STABITORS, epoxy, silicon . \$1
- 3 2N706 500MW, 300MC NPN PLANAR, TO-18 . \$1
- 10 PHILCO MAT HI-FREQ. TR'STORS, untested. \$1
- 4 2N255 POWER TRANSISTOR EQUALS, TO3 cases \$1
- 2-500MC, 2N708 NPN Silicon planar TO46 . \$1
- 3 2N711 300MW. 300 MC, PNP MESA, TO18 . \$1
- 15 1AMP 200V epoxy rectifiers, made by Sylvania \$1
- 25 "EPOXY" SILICON DIODES, untested . . . \$1
- 4 ZENER REFERENCES, 1N429, 6-volt, silicon \$1
- 2 "TINY" 2N1613 2W, 100MC, TO-16 case, npn \$1
- 2 500MC TRANS'RS; 2N964, mesas, pnp, TO18 \$1
- 1 85W SILICON PWR TRANSR, npn, like 2N1212 \$1
- 4 2N43 OUTPUT TRANSISTORS, by GE, pnp, TO5 \$1
- 4 2N333 NPN SILICON transistors, by GE, TO5 \$1

**10¢ FOR OUR "FALL" BARGAIN CATALOG ON:**  
 Semiconductors  Poly Paks  Parts

**POLY PAKS**  
 TERMS: send check, money order, include postage—avg. wt. per pak 1 lb. Rated, net 30 days. COD's 25%  
 P.O. BOX 942 W  
 SO. LYNNFIELD, MASS.  
 "PAK-KING" OF THE WORLD

**WORLD'S MOST POPULAR \$1 PARTS PAKS**

- 3 INFRA-RED DETECTORS, with leads . . . . . \$1
- \$25 SURPRISE PAK: transistors, rect, diodes, etc. \$1
- 40 PRECISION RESISTORS, 1/2, 1, 2W; 1% values \$1
- 30 CORNING "LOW NOISE" resistors, 5% tool \$1
- 60 TUBULAR CONDENSERS, to .5mf, to 1KV, asst \$1
- 40 DISC CONDENSERS, 27mmf to .05mf to 1KV \$1
- 60 TUBE SOCKETS, receptacles, plugs, audio, etc. \$1
- 30 POWER RESISTORS, 5 to 50W, to 24 Kohms \$1
- 50 MICA CONDENSERS, to .1mf, silvers tool . \$1
- 10 VOLUME CONTROLS, to 1 meg, switch tool . \$1
- 10 ELECTROLYTICS, to 500mf, asst FP & tubular \$1
- 50 RADIO & TV KNOBS, asst. colors & styles . \$1
- 10 TRANSISTOR ELECTROLYTICS: 10mf to 500mf \$1
- 50 COILS & CHOKES, if, rf, ant, osc, & more . . \$1
- 35 TWO WATTERS, asst incl: A.B., 5% tool . . . \$1
- 75 HALF WATTERS, asst incl: A.B., 5% tool . . . \$1
- 60 HI-O RESISTORS, 1/2, 1, 2W, 1% & 5% values \$1
- 10 PHONO PLUG & JACK SETS, tuners, amps . . \$1

**ZENER VOLTAGE REGULATORS 1 WATT**  
 3 For \$1

Volts	Volts	Volts	Volts	Volts	Volts	Volts
<input type="checkbox"/> 10	<input type="checkbox"/> 15	<input type="checkbox"/> 22	<input type="checkbox"/> 33	<input type="checkbox"/> 47	<input type="checkbox"/> 68	<input type="checkbox"/> 100
<input type="checkbox"/> 11	<input type="checkbox"/> 16	<input type="checkbox"/> 24	<input type="checkbox"/> 36	<input type="checkbox"/> 51	<input type="checkbox"/> 75	<input type="checkbox"/> 110
<input type="checkbox"/> 12	<input type="checkbox"/> 18	<input type="checkbox"/> 27	<input type="checkbox"/> 39	<input type="checkbox"/> 56	<input type="checkbox"/> 82	<input type="checkbox"/> 120
<input type="checkbox"/> 13	<input type="checkbox"/> 20	<input type="checkbox"/> 30	<input type="checkbox"/> 43	<input type="checkbox"/> 62	<input type="checkbox"/> 91	<input type="checkbox"/> 130

- 10 TUBULAR ELECTROLYTICS, to 500 mf . . \$1
- INFRA-RED PHOTO DETECTOR TRANSDUCER . . \$1
- INFRA-RED PARABOLIC REFLECTOR & FILTER . \$1
- 40 WORLD'S SMALLEST COND., to .05mf . . . \$1
- 4 TRANSISTOR TRANSFORMERS, asst, worth \$25 \$1
- 2 CLAIREX PHOTO ELECTRIC CELL, CL607 . . . \$1
- 60 CERAMIC CONDENSERS, discs, npn's, to .05 \$1
- 40 "TINY" RESISTORS, 1/10W, 5% tool . . . \$1
- 10 TRANSISTOR SOCKETS for pnp-npn transistors \$1
- 30 MOLDED COND'S, mylar, pore, black beauty \$1

**FIRST TIME IN U.S.A.!**  
**"ONE PRICE" SCRS!**  
 Imagine 7-amp, 16-amp and 25-amp at one price! Just check the proper amp and PRV blocks.

7-Amps  16-Amps  25-Amps

PRV	Sale	PRV	Sale	PRV	Sale
<input type="checkbox"/> 200	1.35	<input type="checkbox"/> 600	3.50	<input type="checkbox"/> 1000	5.75
<input type="checkbox"/> 400	2.50	<input type="checkbox"/> 800	4.50		

**750 MIL TOP HAT AND EPOXIES**

PIV	Sale	PIV	Sale	PIV	Sale
50	5¢	600	19¢	1400	95¢
100	7¢	800	29¢	1600	1.10
200	9¢	1000	51¢	1800	1.35
400	13¢	1200	69¢	2000	1.50

CIRCLE NO. 96 ON READER SERVICE CARD

**BUSINESS OPPORTUNITIES**

**INVESTIGATE** Accidents—Earn \$750 to \$1,400 monthly. Men urgently needed. Car furnished. Business expenses paid. No selling. No college education necessary. Pick own job location. Investigate full time. Or earn \$6.44 hour spare time. Write for Free Literature. No obligation. Universal, CZ-9, 6801 Hillcrest, Dallas, Texas 75205.

**FREE BOOK** "990 Successful, Little-Known Businesses." Work home! Plymouth-945J, Brooklyn, New York 11218.

**MADE \$40,000.00 YEAR** by mailorder! Helped others make money! Start with \$10.00—Free proof. Torrey, Box 63566-N, Oklahoma City, Oklahoma 73106.

**CITIZENS BAND** Radio Dealerships Available. Sell Full or Part Time. Knox Electronic, Dept. 274, Galesburg, Ill. 61401.

**IT'S FUN** to sell by Mailorder! Free catalogue. Methods, 1405-FD, Lafayette Hill, Pa. 19444.

**SIX MAGIC WORDS** for financial success. 25¢ Litton, Randallstown, Maryland.

**PHOTOGRAPHY ANNUAL** 1966

1966... #1  
 1964... #3

A selection of the World's finest photographs compiled by the editors of Popular Photography. All editions \$1.25 each:

Order by number from Ziff-Davis Service Div., 589 Broadway, New York, N. Y. 10012. Enclose add'l 15¢ per copy for shipping and handling (50¢ for orders outside U.S.A.)

## RECTIFIERS & TRANSISTORS

### Silicon Diodes

Amps	100 PIV	200 PIV	400 PIV	600 PIV
.75*	.07	.10	.14	.21
3	.14	.22	.28	.40
15	—	.75	1.20	1.55
35	—	1.30	2.00	2.70

Amps	700 PIV	800 PIV	900 PIV	1000 PIV
.75*	.25	.32	.40	.55
3	.49	.58	.67	.78
15	1.70	1.85	2.25	4.80
35	3.15	3.60	4.50	—

\*TopHat. or Flangeless

10 Watt Sil. Zener Stud 20%, 12-200V. .95¢ ea.  
 1 Watt Zener, axial 20%, 8-200V. .50¢ ea.  
 Sil. diode Stud, 1500 piv, 300 ma. .50¢ ea.  
 Hoffman Sil. Epoxy diodes, 200 ma. .50¢ ea.  
 3000 PIV. .98¢ 6000 PIV. \$2.49  
 Thermistor bead, 900 or 1200 ohm, 600°F. .2/\$1.00

### Silicon Power Transistors

4W, 2n498, TO-5	.50¢
15W, 2n2989, TO-5	.75¢
30W, 2n2151, TO-60	\$1.25
40W, 2n1947, TO-57	\$1.40
50W, 2n1722, TO-53	\$1.50
50W, 2n1724, TO-61	\$1.50

2n1300 series, NPN or PNP. .6/\$1.00  
 Sil. Junction diodes, 1N200 series. .15/\$1.00  
 70 amp. stud, 50 PIV—\$2.50, 100 PIV. \$3.50  
 Amplifier, 6 Tubes, new, 3 lbs. \$1.49  
 Nickel Cadmium Battery, 9 1/2 oz. 8 amp hr. \$2.50  
 10 Lbs. Power Resistors, 5-60W. \$1.98  
 10 Lbs. Paper Capacitors, assorted. \$1.98  
 Radio Knobs for 1/4" shafts. 150/\$1.98  
 2 Watt Pots, assorted. 12/\$1.00  
 Mercury Batteries, 5.4V, 5/8"x1" 4/\$1.00  
 200—1/2 w resistors, assorted. \$1.98  
 50 W. Zeners 12, 13, 14, 15, 16, 17, 18, 19v. \$2.00 ea.  
 Computer Boards, parts free—Transistors. 8¢ ea.

### Varicap-Voltage Variable Capacitor

27, 47, or 100 pf at 4v., 4:1. \$1.25

### 150 W Germanium Power (Diamond Case)

2n1021. \$1.00 2n1022. \$1.25 2n511. \$1.50  
 20 W Germanium Power (internal heat sink)  
 2n1038 4/\$1.00 2n1039 3/\$1.00 2n1040 2/\$1.00  
 2n1041 60¢ Add 10¢ ea. for external heat sink

### SILICON CONTROLLED RECTIFIERS

PRV	.75A*	7A	16A.	PRV	.75A	7A	16A.
25	—	—	.48	300	1.20	1.80	2.20
50	—	.45	.70	400	1.70	2.20	2.70
100	—	.70	1.20	500	1.95	3.00	3.30
200	.80	1.15	1.70	600	2.30	3.20	3.90

\*Top Hat, others Stud  
 Money back guarantee. \$2.00 min. order. include postage. Write For Free Catalog. C.O.D. 25%

### Electronic Components Co.

Box 2902, Baton Rouge, La. 70821

CIRCLE NO. 117 ON READER SERVICE CARD

## HYPNOTISM

FREE Hypnotism, Self-Hypnosis, Sleep Learning Catalog! Drawer H400. Ruidoso. New Mexico 88345.

## MUSICAL INSTRUMENTS

SWISS Musical Movements. Electrical-mechanical. Spielman, 131 West 42nd, New York 10036.

## GOVERNMENT SURPLUS

JEEPS Typically From \$53.90... Trucks From \$78.40... Boats, Typewriters, Airplanes, Electronics Equipment, Photographic Equipment, used. 100,000 Bargains Direct From Government. Complete Sales Directory and Surplus Catalog \$1.00 (Deductible First \$10.00 Order). Surplus Service, Box 820-K, Holland, Mich. 49424.

## MISCELLANEOUS

WINEMAKERS: Free illustrated catalog of yeasts, equipment. Semplex, Box 7208, Minneapolis, Minn. 55412.

JUST THINK—as you scan these columns, more than 196,000 monthly buyers of ELECTRONICS WORLD are doing the same. These men are all Electronics Professionals—individuals involved actively in electronics from a business or hobby viewpoint. These readers look to the pages of the ELECTRONICS MARKET PLACE for prime sources of products and services of interest to them. Are they buying from you? They will, you know, if your advertising appears regularly in their favorite magazine. Use the handy order form printed in this section or write today to: Hal Cymes, Classified Advertising Manager, ELECTRONICS WORLD, One Park Avenue, New York, New York 10016. REMEMBER: November issue, on sale October 20th, closes September 1st.

## ELECTRONICS WORLD SEPTEMBER 1966

### ADVERTISERS INDEX

READER SERVICE NO.	ADVERTISER	PAGE NO.	READER SERVICE NO.	ADVERTISER	PAGE NO.
125	Allied Radio	73, 74	105	Lafayette Radio Electronics	91, 92
107	Ampex Corporation	57		Lampkin Laboratories, Inc.	85
	American Institute of Engineering & Technology	85	104	Mallory & Co. Inc., P. R.	2
124	Belden Manufacturing Company	61	103	Mallory & Co. Inc., P. R.	99
	Castle TV Tuner Service	85	102	Microflame, Inc.	78
	Capitol Radio Engineering Institute, The	18, 19, 20, 21	100	Motorola Training Institute	78
	Cleveland Institute of Electronics	52, 53, 54, 55	99	Multicore Sales Corp.	86
123	Cleveland Institute of Electronics	75	98	Music Associated	84
	Conar	93		National Radio Institute	8, 9, 10, 11, 66
122	Cornell Electronics Co.	105	96	Poly Paks	107
81	Crown International	69		RCA Electronic Components and Devices	FOURTH COVER
121	Delta Products, Inc.	4	95	RCA Electronic Components and Devices	71
	Editors and Engineers, Ltd.	79		RCA Institutes, Inc.	62, 63, 64, 65
119	Edmund Scientific Co.	104	94	Radar Devices Manufacturing Corp.	1
101	Electro-Voice, Inc.	SECOND COVER	93	Sams & Co., Inc., Howard W.	7
118	Electronic Chemical Corp.	58	92	Sams & Co., Inc., Howard W.	70
117	Electronic Components Co.	108	91	Schober Organ Corporation, The	67
	Fair Radio Sales	105	80	Shure Brothers, Inc.	86
116	Finney Company, The	22	200	Solitron Devices, Inc.	85
	G & G Radio Supply Co.	106	90	Sony Corp. of America	17
82	Gavin Instruments	5	89	Sprague Products Co.	14
114	Goodheart Co. Inc., R. E.	106	88	Texas Crystals	93
113	Grantham School of Electronics	103	97	Triplett Electrical Instrument Company	THIRD COVER
112	Gregory Electronics Corporation	104	87	Tuner Service Corporation	60
	Grumman Aircraft Engineering Corp.	77	79	University Sound	69
111	Heath Company	15		Valparaiso Technical Institute	60
110	Heath Company	51	83	Winegard Company	84
109	Heath Company	59	85	Xcelite, Inc.	16
108	International Television Corp.	103	199	Yokogawa Electric Works, Inc.	6
106	Knight-Kits Div., Allied Radio	13	84	Zenith	101

CLASSIFIED ADVERTISING 104, 105, 106, 107, 108

# ONE MILLION OHMS PER VOLT



## V-O-M

**Model 630-M**  
**VOLT-OHM-MICROAMMETER**

**\$200.00**

Suggested U.S.A. user net



Triplet Model 630-M features the input impedance of a VTVM with the convenience of a V-O-M. The 630-M's sensitivity is derived from the singular achievement of its basic 0-1 D.C. microampere movement. The 630-M incorporates no amplifiers, no warm-up, and no power requirements. Model 630-M is a true V-O-M whose engineering excellence is based on 60 years of instrument manufacturing, and contains the top quality associated only with Triplet.

- 1** 1,000,000 ohms per volt D.C. for greater accuracy on high resistance circuits. 20,000 ohms per volt A.C.
- 2** 1 ua Suspension Meter Movement. No pivots, bearings, or rolling friction. Extremely rugged. Greater sensitivity and repeatability.
- 3** 61 ranges, usable with frequencies through 100KC. Temperature compensated. 1½% D.C. accuracy, 3% A.C. in horizontal position.

**TRIPLET ELECTRICAL INSTRUMENT COMPANY, BLUFFTON, OHIO**

CIRCLE NO. 97 ON READER SERVICE CARD



MANUFACTURERS OF PANEL AND PORTABLE INSTRUMENTS; ELECTRICAL AND ELECTRONIC TEST EQUIPMENT

Are you ready for *today's color?*



**HI-LITE**

**ALL-NEW COLOR TV**

**PICTURE TUBE**

**HR/21FBP22A**



# RCA offers you a replacement color picture tube that meets OEM specs

RCA Hi-Lite picture tubes are all-new... glass, gun, the works! They're RCA's best... the same quality... the same tubes... that go into original equipment sets. And because they incorporate the latest technological advances of the world's largest color picture tube manufacturer, you literally "up-date" your customer's color set each time you install one. Here is picture brightness and color fidelity at its finest, available for the service trade in 19-inch and 25-inch rectangular and 21-inch round tube types.



RCA Electronic Components and Devices, Harrison, N. J.

**The Most Trusted Name in Electronics**