

ELECTRONICS WORLD

OCTOBER, 1960

50 CENTS

Complete Directory — INTEGRATED STEREO AMPLIFIERS

NEW "MUSIC-POWER" RATING FOR HI-FI
BUILD A HAND-HELD CB TRANSCEIVER
SERVICING R.F. PROXIMITY CONTROLS

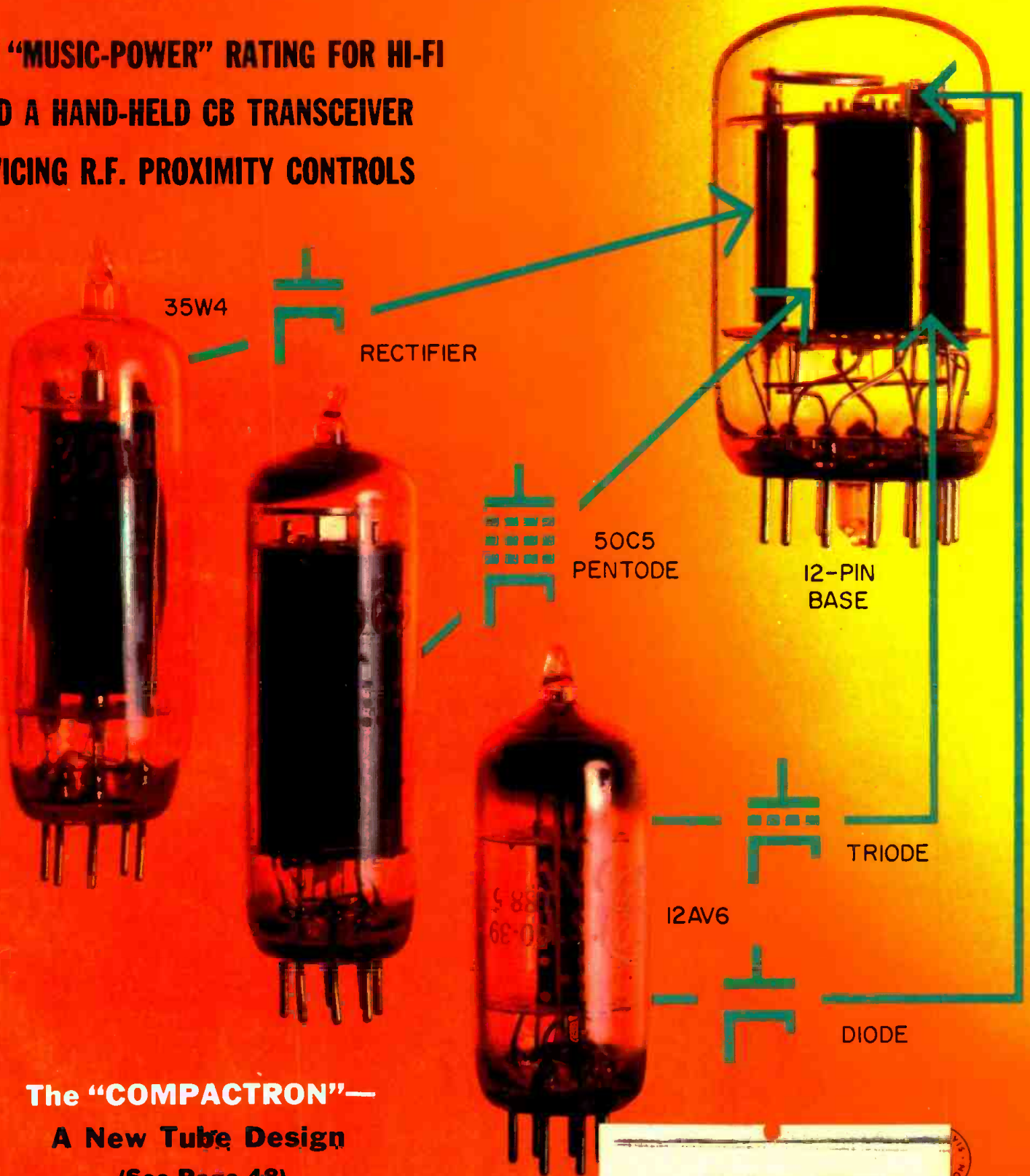

The "COMPACTRON"—
A New Tube Design
(See Page 48)

W101224923
L O GERLACH ST
6612 N 54TH ST
MILWAUKEE 23 WISC



SYLVANIA-6AU4-GTA
WITH
SARONG CATHODE
HELPS YOU
"WRAP-UP" PROFITS!

NEW life-giving, profit-building features are built into every SYLVANIA-6AU4-GTATV-damper tube. Consider, for one feature, the SYLVANIA SARONG CATHODE and how it adds dependability to tube life. SARONG provides uniform spacing between cathode and plate—reduces possibility of plate-to-cathode arc-over. SARONG prevents the build-up of “whiskers” inside the cathode sleeve that can develop during other types of coating processes—reduces possibilities of cathode-to-heater arc-over.

Consider, too, the “pigtail” heater in SYLVANIA-6AU4-GTA. Welded securely to the stem-lead, it reduces heater “hot spots” and the possibilities of heater burnout. More . . . rectangular top and bottom micas with exceptionally wide slots increase the resistance of dc leakage paths, further reduce the possibilities of internal arc-over and breakdown.

There's extra profit assurance, too, with SYLVANIA-6AU4-GTA. Every one of them is tested for shorts, emission and the ability to withstand arc-over at 5000-volts peak inverse on the anode.

So, “wrap up” the profits you make by putting a “damper” on call-backs. When you ask your distributor for 6AU4-GTA's, always specify SYLVANIA.

Electronic Tubes Division, Sylvania Electric Products Inc., 1740 Broadway, New York 19, New York.



SYLVANIA

Subsidiary of **GENERAL TELEPHONE & ELECTRONICS** 

ANOTHER FACTOR IN
"INTEGRITY IN MUSIC"

does your
turntable
CHANGE
the
music?



FOR INTEGRITY IN MUSIC...



PR-500 Single-Speed Turntable

Even a minute addition or subtraction of sound can spoil a musical performance. Only when the turntable does not change the music in the slightest, do you enjoy "Integrity in Music." To demonstrate this we suggest you hear the new Stromberg-Carlson PR-500.

The extremely low flutter and rumble of the single-speed PR-500 invite comparison with turntables at several times the price. High compliance belt drive (at 33 1/2 rpm) from two vibration-free hysteresis-synchronous motors assures constant speed. Viscous damped arm, riding on a single friction-free needlepoint bearing, tracks perfectly down to less than one gram. Wow: 0.14% rms; Flutter: 0.08% rms; Rumble: -50 db re 7 cm/sec. Complete with arm and cables, ready to play, at just \$69.95.*

The other popular Stromberg-Carlson turntable is the "Perfectempo." It incorporates every valid, time-proven design feature: belt drive; continuously variable cone drive (14 to 80 rpm); stroboscopic speed indicator; dynamically balanced, weighted table; precision motor; plus Stromberg-Carlson's original double-acting motor and table suspension system that effectively eliminates unwanted noise. Performance proves it: Wow: 0.14% rms; Flutter: 0.09% rms; Rumble: -55 db re 20 cm/sec. at 1 kc. Model PR-499, "Perfectempo," morocco red with aluminum trim \$99.95.*

Stromberg-Carlson now offers 16 equipment cabinets in a wide variety of styles and finishes. They are designed to house complete Stromberg-Carlson stereo component systems and are factory assembled. They reproduce as faithfully as separately mounted components because of a unique mounting method that isolates the speaker systems from the other sensitive components.

See your dealer (in Yellow Pages) or write for a complete component and cabinet catalog to: 1477-010 North Goodman Street, Rochester 3, New York.

*Prices audiophile net, Zone 1, less base, subject to change.

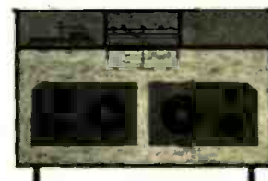

"There is nothing finer than a Stromberg-Carlson"

STROMBERG-CARLSON

A DIVISION OF **GENERAL DYNAMICS**

ELECTRONICS WORLD is published monthly by Ziff-Davis Publishing Company, William B. Ziff, Chairman of the Board (1946-1953), at 434 S. Wabash Ave., Chicago 5, Ill. Second class postage at Chicago, Illinois. Authorized by Post Office Department, Ottawa, Canada, as second-class matter. SUBSCRIPTION RATES: one year U. S. and possessions, and Canada \$5.00; Pan American Union Countries \$5.50; all other foreign countries \$6.00.

October, 1960

Editor
WM. A. STOCKLIN, B. S.

Technical Editor
MILTON S. SNITZER, W2QY1

Service Editor
SIDNEY C. SILVER

Associate Editor
P. B. HOEPER

Editorial Consultant
OLIVER READ, D. Sc., W1FT1

Industrial Consultant
WALTER H. BUCHSBAUM

Art Editor
MILTON BERWIN

Art and Drafting Dept.
J. A. GOLANEK
K. W. PAUL, JR.

Advertising Director
JOHN A. RONAN, JR.

Advertising Manager
GEORGE E. MORRISSEY

Midwest Adv. Manager
GILBERT J. JORGENSEN

Western Adv. Manager
ADRIAN WHITED



ZIFF-DAVIS PUBLISHING COMPANY
William Ziff, President; W. Bradford Briggs, Executive Vice-President; Michael Michaelson, Vice-President and Circulation Director; Hershel B. Sarbin, Vice-President; J. L. O'Donnell, Treasurer.

Editorial and Executive Offices
One Park Avenue
New York 16, N. Y. OR. 9-7200



Member
Audit Bureau of
Circulations



BRANCH OFFICES: Midwestern Office, 434 S. Wabash Ave., Chicago 5, Ill.; Western Office, 9025 Wilshire Blvd., Beverly Hills, Calif.; James R. Pierce, manager.

FOREIGN ADVERTISING REPRESENTATIVES: D. A. Goodall Ltd., London; Albert Milhado & Co., Antwerp and Düsseldorf.

First in radio-television-audio-electronics

CONTENTS

GENERAL ELECTRONICS AND INDUSTRIAL

The Soaring Sixties (Editorial).....	W. A. Stocklin	6
Spot News.....	Washington Correspondent	20
Recent Developments in Electronics.....		40
Technicians' Guide to Pneumatic Controls.....	Robert Gary	59
Servicing R.F. Proximity Controls.....	Dellroye D. Darling	62
Calendar of Events.....		93
Electronic Terminology Crossword Puzzle.....	John J. Gill	98
Engineering Schools Spend \$71-Million for R & D.....		106

HIGH FIDELITY AND AUDIO

British Stereo Broadcasts.....	Patrick Halliday	22
Music-Power Rating—Help or Hindrance?.....	Norman H. Crowhurst	35
Low-Distortion 3-Watt Audio Amplifier.....	E. William Blum	46
Integrated Stereo Preamp-Amplifiers.....	Warren DeMotte	51
Class A Transistor Power-Output Circuits.....	Walter H. Buchsbaum	55
Hi-Fi—Audio Product Review.....		74
Certified Record Revue.....	Bert Whyte	88
Sound on Tape.....	Bert Whyte	92
New Audio Test Report (Heath Model AA-50, Shure M232 Tone Arm) EW Lab Tested.....		122
Bulk Eraser for Magnetic Tape.....	William Q. Wolfson, M.D.	130

TELEVISION-RADIO

Troubleshoot with Basic Theory.....	David R. Anderson	45
Compactrons: Advance in Tube Design (Cover Story).....		48
Mac's Service Shop.....	John T. Frye	50
Keeping Step in Business.....	Ernest W. Fair	58
Intermittent Vertical Sync Problems.....	Sol Heller	72
Handy Dust Remover.....	Richard E. Shafer	81
Service Industry News.....		104
Wayward Capacitor Woes.....	Allan F. Kinckiner	134
Fuses Are Not for Confusion.....	George D. Philpott	140

TEST EQUIPMENT

"Reverse" GDO.....	John Potter Shields	85
--------------------	---------------------	----

COMMUNICATIONS AND AMATEUR

Hand-Held Citizens Band Transceiver.....	Donald L. Stoner, 11W1507	42
Stable Transistor V.F.O.....	Donald L. Stoner, W6TNS	64
Ham Radio Earth-Moon-Earth Contact.....		94

ELECTRONIC CONSTRUCTION

Audio-Ultrasonic Pickup Circuit.....	Harold Reed	38
Electronic Metronome.....	Hal Wittlinger	39
Build This Capacitance Relay.....	Rufus P. Turner	86

DEPARTMENTS

Letters from Our Readers.....	8	Manufacturers' Literature.....	118
Within the Industry.....	30	Technical Books.....	126
What's New in Radio.....	142		

Circulation (Jan.-June) 251,750 (Publisher's Estimate)

Radio & TV News • Television News Trademarks Reg. U. S. Pat. Off.
Copyright © 1960 by Ziff-Davis Publishing Company. All rights reserved.

SUBSCRIPTION SERVICE: Forms 3579 and all subscription correspondence should be addressed to Circulation Department, 434 South Wabash Avenue, Chicago 5, Illinois. Please allow at least four weeks for change of address. Include your old address as well as new—enclosing if possible an address label from a recent issue.

CONTRIBUTIONS: Contributors are advised to retain a copy of their manuscripts and illustrations. Contributions should be mailed to the New York Editorial Office and must be accompanied by return postage. Contributions will be handled with reasonable care, but this magazine assumes no responsibility for their safety. Any copy accepted is subject to whatever adaptations and revisions are necessary to meet the requirements of this publication. Payment covers all author's, con- tributor's, and contestant's rights, title, and interest in and to the material accepted and will be made at our current rates upon acceptance. All photos and drawings will be considered as part of the material purchased.

**NOW...GET
EVERYTHING
YOU NEED TO
PREPARE TO EARN
REAL MONEY IN**

ELECTRONICS

**From RADIO • TELEVISION • RADAR
To GUIDED MISSILE CONTROL, etc.**

One of
Today's
BRIGHTEST
Opportunity Fields!



Today's great Electronics field offers you a chance of a lifetime to prepare for highly interesting work and a wonderfully promising future! With so many new developments coming up in Electronics, opportunities for trained men were never brighter. Send coupon for details.

Right in your own home you may now get one of today's most interesting . . . **PRACTICAL WAYS** to prepare for a good job or your own business in Electronics. No previous technical experience or advanced education are needed! DeVry Tech brings you a unique **3-WAY COMBINATION** of texts, home movies and real equipment—the same type of basic equipment as found in our well-equipped Chicago and Toronto Laboratories.

EMPLOYMENT SERVICE
. . . helps you get started toward a good job, or toward advancement in the company you now work for. **FREE** to all graduates.

EARN WHILE YOU LEARN
DeVry Tech's practical program helps you to earn **EXTRA MONEY** in your spare time, servicing Radio and TV sets.

Your Guide

to PROFITABLE JOB OPPORTUNITIES

See how **YOU** may get ready for Jobs as:

- TV-Radio Broadcast Technician
- Color Television Specialist
- Radar Operator • Laboratory Technician
- Airline Radio Man • Computer Specialist
- Quality Control Manager

Your Own Sales & Service Shop...**PLUS MANY OTHERS**

SEND FOR FREE BOOKLET!

"One of North America's Foremost Electronics Training Centers"



Accredited Member of
National Home
Study Council

DeVRY TECHNICAL INSTITUTE

CHICAGO 41, ILLINOIS

300 EXPERIMENTS

Build over 300 practical projects from many shipments of Radio-Electronic parts. You build and operate TV-Radio circuits . . . wireless microphone . . . and many other major projects—all designed to provide outstanding practical experience at home.

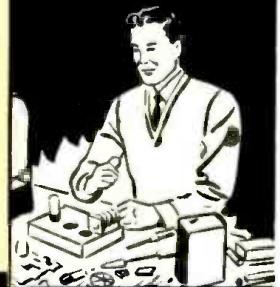

HOME MOVIES

Thanks to this exclusive home training aid, many important fundamentals quickly become "movie clear." Now you can actually see electrons on the march and other "hidden actions"—a wonderful advantage that is almost like having a teacher at your side.

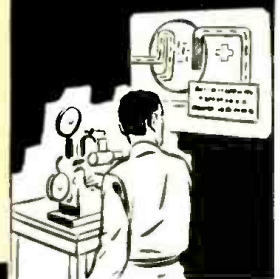

BUILD YOUR OWN TEST EQUIPMENT

As part of your home laboratory projects, you **BUILD** and **KEEP** a fine quality 5-inch **COLOR OSCILLOSCOPE** and a Jewel Bearing **VACUUM TUBE VOLTMETER**. You will find this equipment ideal for helping you earn in your spare time while a student—and later when working full time in the field.



BUILD AND KEEP A BIG 21-INCH TV SET

For added practical experience, you can also build and keep this quality 21-inch **TV SET** that provides TV reception at its finest (DeVry Tech also offers another home training without the TV set).

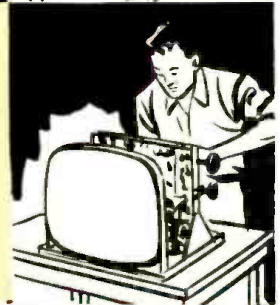

MAIL COUPON TODAY!

DeVRY TECHNICAL INSTITUTE
4141 Belmont Avenue, Chicago 41, Ill., Dept. EW-10-Q

Please give me your **FREE** booklet, "Electronics in Space Travel," and tell me how I may prepare to enter one or more branches of Electronics.

Name _____ Age _____

Street _____ PLEASE PRINT Apt. _____

City _____ Zone _____ State _____

2046

Canadian residents address: DeVry Tech of Canada, Ltd.
970 Lawrence Avenue West, Toronto 19, Ontario

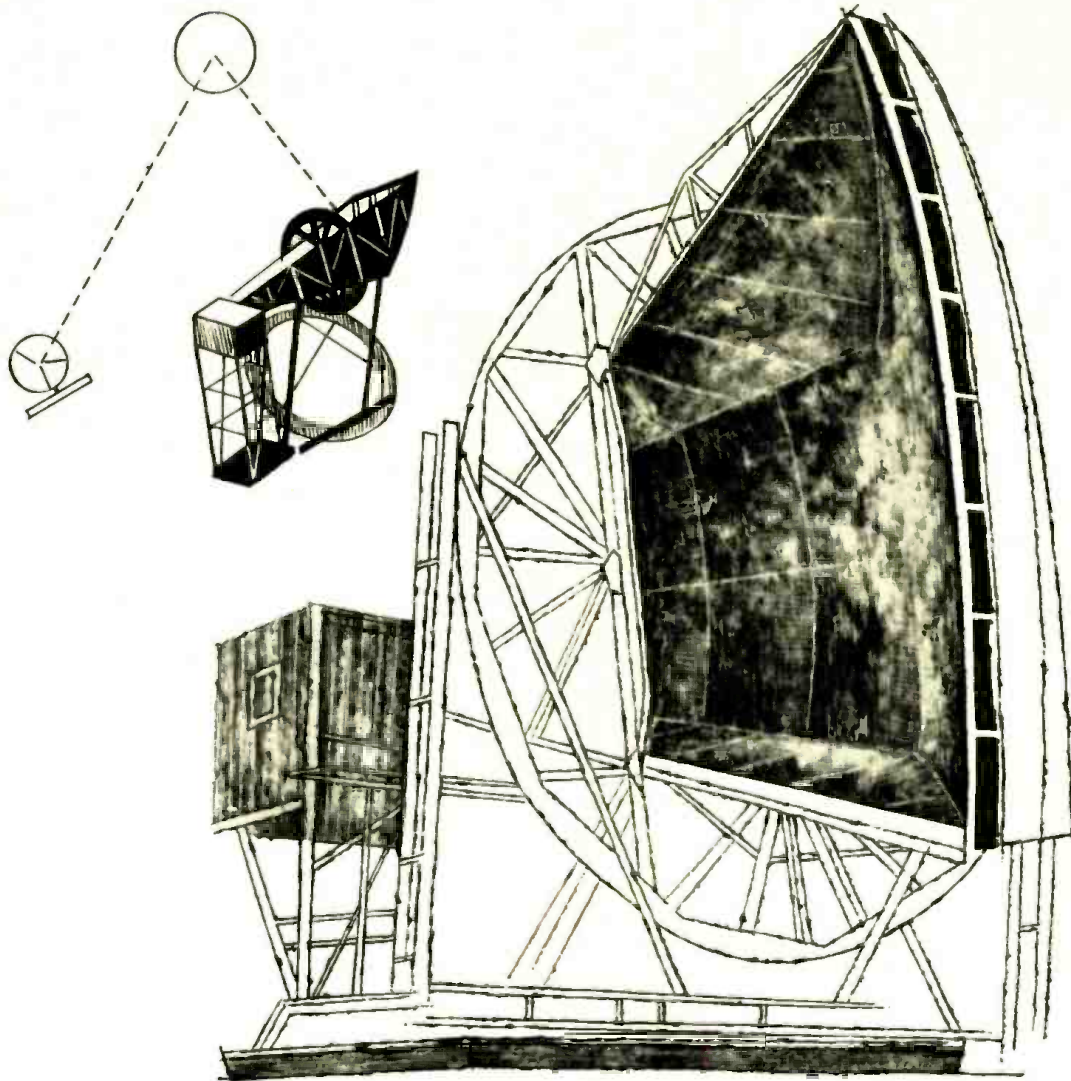

SOMEDAY... WORLD-WIDE TV AND PHONE CALLS VIA SATELLITE!

A revolutionary means of telephone transmission was unveiled by the Bell Telephone Laboratories on the morning of August 11, 1960—when a telephone call was bounced from coast to coast by using a 100-foot orbiting balloon satellite as a back-board.

A remarkable "sugar-scoop" antenna and the incredible maser were the key elements in this development.

November **ELECTRONICS WORLD** takes you behind the scenes—shows you how these devices work, what they can and can't do, what can be expected from them in the future.

Here are more pertinent features you'll find in November **ELECTRONICS WORLD**:

- **BUILD A DUAL 14 WATT STEREO AMPLIFIER**

Construction details on a medium power hi-fi amplifier using common cathode bias for improved regulation.

- **ANTENNAS FOR CITIZENS RADIO**

Increase the operating range of Citizens Radio equipment by using the right kind of antenna and transmission line in your installation.

- **INFRARED CAMERA CONTROL FOR NATURE PHOTOGRAPHERS**

ELECTRONICS WORLD

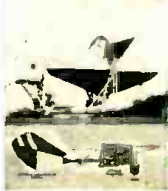

Here are complete construction details on building a simple compact unit that will help wild-life photographers get some unusual night-time shots.

**DON'T MISS NOVEMBER ELECTRONICS WORLD—
AUTHORITATIVE... INFORMATIVE... IMPORTANT!**

"I Teach MATH a Funny Way"

— says DR. AARON BAKST, distinguished mathematician and lecturer at New York University.

An Amazing New Way To Master Every Phase of Mathematics—The Key To a Better Job, Higher Pay, Security In Today's Technical Age

PARTIAL CONTENTS of this 791-Page Book

Short Turns in Long Division
Fractions Without Denominators
The Game of 999
Properties of Numbers
Repeated-Digit Bafflers
The Other Side of Zero
Secret Codes with Numbers
The Great Pyramid Mystery
Simple Calculating Devices
A Home-Made Abacus
Multiplication Made Painless
Remember that Phone Number
The Number Magician's Secret
Algebra Magic
Why the Rich Get Richer
Arithmetic Sequences for Rabbits
Logarithm Declares a Dividend
Streamlining Everyday Computations
How to Figure the Odds
Unsquaring the Square
The Triangle —
 Servant and Master
Measuring Heights with a Mirror
The Secret of the Sphinx
Trig without Tables
Squashing the Rectangle
How-to Wrap a Circle
Cutting Corners From a Triangle
The Shortest Route on Earth
Cork-screw Geometry
Mathematics on the Rifle Range
Systems of Numeration
Number Giants
The Gogolplex
Sherlock Holmes Arithmetic
The Math-Minded
 Mother-in-Law
Algebra and Common Sense
How to Buy on Installments
Fun with Lady Luck
Passport for Geometric Figures
200 Men and an Egg
Math — Key to the Universe
Math and Magic

**A WHOLE LIBRARY IN ONE
GIANT 791-PAGE VOLUME**

DR. BAKST'S "funny way to teach math" cuts out the learning and memorizing of rules and formulas. In 791 fascinating pages his book *Mathematics: Its Magic and Mastery*, uses entertaining puzzles, games and tricks to simplify and humanize math for the average person.

Even if you never finished high school math, you'll find this book easy to follow. It explains every basic step in mathematics; shows how to solve all sorts of problems, from adding up everyday bills to short-cut ways of operating giant electronic calculators. And even Einstein's theory of relativity is explained so simply that any layman can readily understand it.

**Unsquaring the Square;
How to Figure the Odds;
The Great Pyramid Mystery;
The Game of 999**

These and scores of other intriguing solutions to problems (see partial table of contents at left) quickly give you a good grasp of advanced arithmetic, algebra, geometry, and trigonometry.

You learn by *doing*, not by studying. And what you do is made so absorbing that you'll thoroughly enjoy each single "treasure hunt" episode with this

gifted mathematician and writer.

Today's Stress on Math

In today's world of science, automation, engineering, and automatic computing, a good knowledge of all phases of mathematics will help *anyone* to advance himself faster and farther. In fact, it is an absolute essential in many fields, for reaching the top positions.

Dr. Bakst's book assures that your new knowledge of math will be of *practical* value to you — because he applies its principles to home life, insurance, business, finance, scientific and managerial problems.

**SEND NO MONEY
Examine it FREE for 10 days**

There is no need to send any money now. The coupon will bring you this 791-page book for 10 days' free trial. If not convinced that it brings you an interesting and practical way to gain a knowledge of mathematics which will be of great value to you, return it and owe nothing. Otherwise you may keep it by sending us only \$1.50 down and the balance in easy payments. Mail the coupon NOW.

**D. Van Nostrand Company, Inc.,
Dept. 3710, Princeton, N. J.
(Established 1848)**

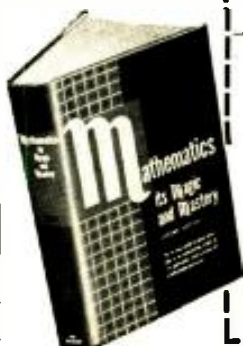

FREE EXAMINATION COUPON

**D. VAN NOSTRAND COMPANY, INC., DEPT. 3710,
120 ALEXANDER STREET, PRINCETON, N. J.**

Please send—for ten days' free examination Dr. Aaron Bakst's **MATHEMATICS: ITS MAGIC AND MASTERY**. Within ten days I will either return the book or send you \$1.50 as first payment and only \$2.00 per month for three months until the total price of \$7.50, plus a small shipping cost, is paid.

PRINT NAME

ADDRESS

CITY ZONE STATE

SAVE: Check here if you are enclosing \$7.50 WITH this coupon. Then WE will pay all shipping costs. Same return privilege; refund guaranteed.
(In Canada: Address 25 Hollinger Road, Toronto 16, Canada. Price slightly higher.)
Foreign and A.P.O.—Please send \$7.50 with order.

ANNOUNCEMENT!

FA-4 frequency adjusted

...the unique Formulation for increased dynamic range recording...is a Soundcraft exclusive.

FA-4 frequency adjusted

cannot be incorporated in any tapes other than those with the Soundcraft Trademark!

Since the introduction of the new Soundcraft Tapes with FA-4 frequency adjusted formulation, thousands of recordists have indicated their preference for this new magnetic medium. Their reasons are plain to hear in every reel! More of the dynamic range of music is captured on the sensitive FA-4 oxide formulation—resulting in recordings that sparkle with new true-to-life dimension. You've never enjoyed the full capabilities of your tape recorder until you try Soundcraft Tapes with FA-4 Frequency Adjusted Formulation. Buy Soundcraft Tapes today! They cost no more than conventional tapes!

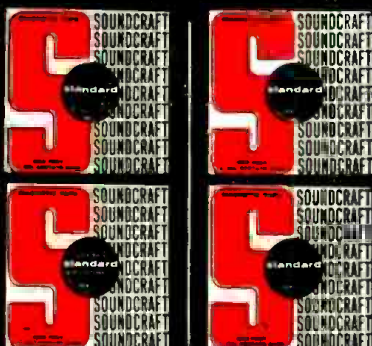

There's a Soundcraft Tape for every recording need. Write for literature.

REEVES SOUND CRAFT CORP.

Great Pasture Rd. Danbury Connecticut ■
Chicago: 28 E. Jackson Blvd. ■ Los Angeles:
342 N. LaBrea ■ Toronto: 700 Weston Rd.

...for the Record

By **W. A. STOCKLIN**
Editor



THE SOARING SIXTIES

AT the beginning of each new decade, much thought is given as to what the coming era holds in store for us. Despite the comments we have heard and the "educated guesses" which have appeared in print, we believe that one of the most thought-provoking analyses we have yet encountered is one presented by Hiram L. Fong, Senior U. S. Senator from Hawaii, in his talk before the graduating class at Tufts University.

We feel that Mr. Fong's comments deserve wider dissemination and we would like to quote, in part, from his commencement address.

"Educationally comprising the upper 5% of our population, college graduates will have a decided advantage in potential earning power over non-college workers. The job outlook for college graduates is excellent, with starting salaries higher by some 4 to 8 per-cent over a year ago. Long-range prospects are likewise auspicious. It is anticipated that within a few years if we do not have new methods and new machinery, there will be a shortage of manpower to produce the goods and services needed to sustain the American standard of living.

"The economic indicators of the next 15 years show that we will be a nation of 240 million people, 60 million more than today, with a labor force of about 95 million producing goods and services totaling 900-billion dollars.

"Translated into other tangibles, these vital statistics mean that we will build millions of dwelling units, thousands of miles of roads, and many, many bridges, dams, and flood-control projects. We will need some 77,000 more doctors, 34,000 more dentists, and a third of a million more nurses than we have today.

"Not only are there jobs for everyone, but there is also a wide choice of careers. A few years ago, there were no electronics industries, no atomic energy projects, no missiles or rockets or space vehicles. New vocations, created in the past ten or fifteen years, run the full spectrum of man's pursuits and offer careers undreamed of only a few decades ago.

"You are on the threshold of a very interesting, fascinating, and rewarding era, witnessing what promises to be the birth of a new 'Golden Age'.

"All around you life's pace has quickened. From sails to steamboats and from pushcarts to motor vehicles embraced thousands of years. Today, speed and power change within decades or less. In the first six decades of this

century in America, changes have been greater than in all the thousands of years of mankind's history. It was only 18 years ago, in 1942, that Enrico Fermi discovered the principle of atomic chain reaction that launched us into the Atomic Age. Scarcely had this era dawned when 15 years later, in 1957, we found ourselves in the Space Age with the first Sputnik.

"Fifteen years from now, supersonic airplanes will bring Paris within two hours of New York and Geneva about three hours from Los Angeles. Space travel will approach reality. In 1961 we hope to launch our first man into space with safe return; about 1970, to transport an American astronaut to the moon; and perhaps by 1975, to other places. . . .

"Men of wisdom and learning throughout the ages have cautioned that the use of leisure time wholly for fun, pleasure, and comfort renders life narrow and empty. Gratifying only material wants does not satisfy the soul. Lasting satisfaction, contributing to the fullness of life, comes from cultivating in one's heart a spirit of charity and service toward all men and from devoting a portion of one's life to benefit mankind.

"Therefore each of you ought to ponder how, with your particular talents and in your particular circumstance, you can serve family, friends, community, nation, and mankind."

Senator Fong was one of the most interesting persons we have met and his presentation was both thoughtful and dynamic. After analyzing his comments, it is almost impossible not to be optimistic about the coming decade. One fact stands out—the population growth in the next ten years will be unprecedented in our history and with this growth will come tremendous opportunities.

An increase in our working force—whether in the fields of medicine, construction, etc.—means an increasingly important role for electronics. Electronics, in many ways, is like an octopus with its tentacles reaching into every other industry and profession. An increase in population means more TV sets, radios, and hi-fi equipment. Increased demands by the medical profession will generate many new types of electronic equipment. Expansion of the construction and related industries means more electronic equipment for communications and automation. Thus it seems that no matter what career one chooses, electronics will play a vital role in the Soaring Sixties. —30—

ALLIED value-packed 1961

444-PAGE ELECTRONICS CATALOG

including products available only from Allied

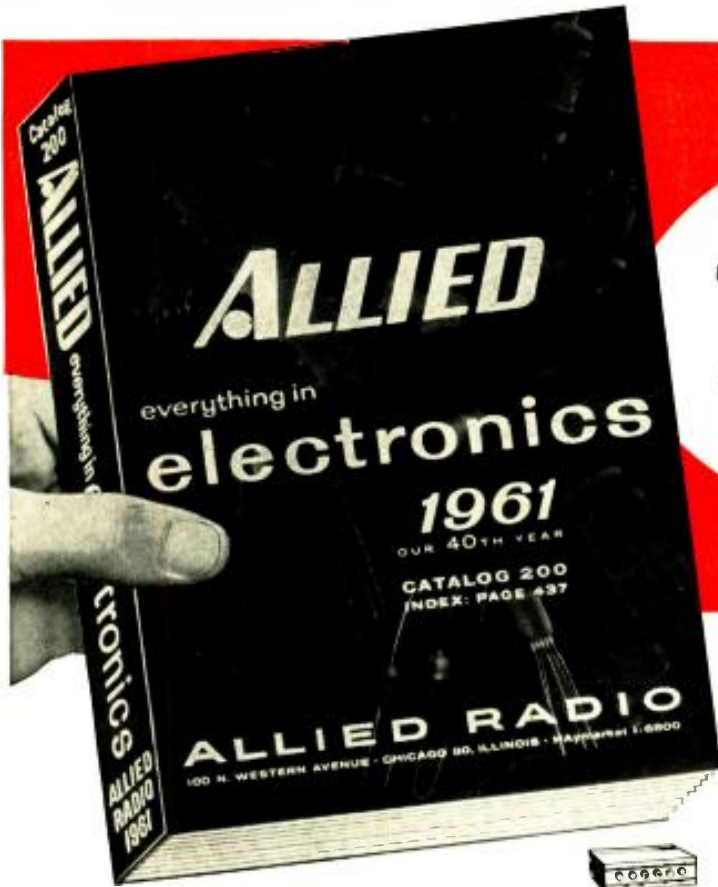

complete
up-to-date

free

send for it today!

SAVE MOST ON EVERYTHING IN ELECTRONICS

- Newest Stereo Hi-Fi Systems— Everything in Hi-Fi Components
- Money-Saving, Build-Your-Own KNIGHT-KITS® for Every Need
- Best Buys in Recorders & Supplies
- Newest Public Address Systems, Paging and Intercom Equipment
- Amateur Receivers, Transmitters, and Station Gear
- Citizen's Band 2-Way Radio
- Test and Laboratory Instruments
- TV Tubes, Antennas, Accessories
- Huge Listings of Parts, Tubes, Transistors, Tools, Books

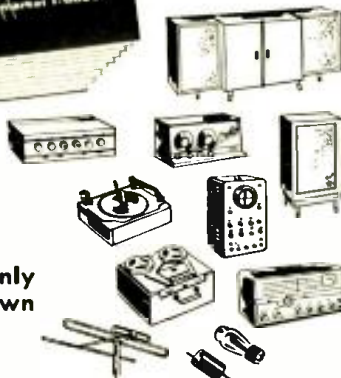

**BUY ON EASIEST TERMS
ONLY \$2 DOWN**

Yes, only \$2 down on orders up to \$50; only \$5 down on orders up to \$200; only \$10 down over \$200. Up to 24 months to pay.

ALLIED Exclusives:

MONEY-SAVING KNIGHT-KITS®—truly the very best in build-your-own electronic equipment—designed to save you money, easiest to assemble—the only kits offered with Free Inspection Privilege. See the complete selection of Stereo hi-fi kits, Hobbyist kits, Test Instrument and Amateur kits. KNIGHT-KITS are an exclusive ALLIED product.

KNIGHT® STEREO HI-FI—comparable to the best in quality and performance, yet priced far lower in cost. Select super-value KNIGHT components or complete systems and save most. Also see the largest selection of famous-name hi-fi components and money-saving ALLIED-recommended hi-fi systems.

Get every buying advantage at ALLIED: lowest money-saving prices, fastest shipment, expert personal help, easiest-pay terms, satisfaction guaranteed or your money back.

free

the most complete
electronics catalog!



ALLIED RADIO, Dept. 1-K
100 N. Western Ave., Chicago 80, Ill.

Send FREE 1961 ALLIED Catalog.

Name _____

Address _____

City _____ Zone _____ State _____

ALLIED RADIO

our 40th year **SATISFACTION GUARANTEED
OR YOUR MONEY BACK**

World's Largest Electronic Supply House

PLASTIC

PTT-PWE

CASED

PTT-PWE

'LYTICS

PTT-PWE

BY

AEROVOX

Small in Size!

Big in Performance!

Designed especially for wide applications in transistorized circuitry and cramped electronic assemblies, here is a truly miniature electrolytic tubular that will handle full sized loads.

Aerovox Type PTT-PWE units feature "Polycap" plastic cases that are the next best thing to metal cans for maximum protection against humidity. Advanced construction techniques assure long capacitor life.

Available in voltage ratings of 3, 6, 10, 12, 15, 25 and 50 VDCW in a wide range of capacitance values from 1 to 500 mfd. Units are rated for operation at temperatures from -30°C to +65°C.

Available for "off-the-shelf" delivery from your local Authorized Aerovox Distributor. See your distributor today for all your Aerovox capacitor requirements.

AEROVOX CORPORATION

DISTRIBUTOR DIVISION

NEW BEDFORD MASSACHUSETTS



AUDIO DISTORTION METER

To the Editors:

The article "Simple Audio Distortion Meter" by Richard Graham on page 57 of the April, 1960 issue of *ELECTRONICS WORLD* has some interesting ideas, but there is one point that seems doubtful. I believe that the author's choice of a 6AS6 multigrid mixer in his circuit was

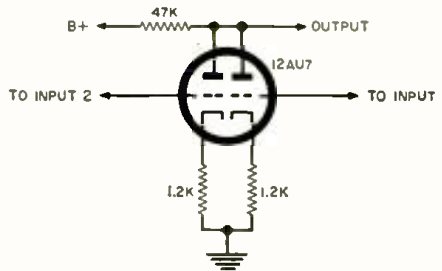

unfortunate. This type of mixer has a multiplicative type of action, and will not give the true additive mixing which the device needs. It might be better to replace the stage with a double-triode common-plate mixer such as shown in the above figure.

CHARLES ERWIN COHN
Chicago, Illinois

We are glad to pass along Reader Cohn's suggestion for improving our distortion meter.—Editors.

RADAR SPEED TRAPS

To the Editors:

I have read with particular interest your article "Radar Speed Meters and Traffic Controls" in the June issue of *ELECTRONICS WORLD*. It gives me some concern that you omitted any suggestion that speed meters as now used by the traffic officers are decidedly not infallible.

Like yourself and all good citizens, I recognize the urgent need for traffic laws and their proper enforcement, and I appreciate the great boon the "radar" speed meters have been to the embattled police. But I believe that the car riders, the police, and the courts should be advised that the reliability of the evidence provided by these instruments is by no means 100 percent.

Because none of those parties involved in a "radar arrest" and trial has, in general, any technical knowledge of electronics, the defendant finds himself in court bearing the burden of presumed guilt and of proving himself innocent. This is contrary to the basic principles of American jurisprudence. In order to even attempt to prove his innocence, the accused must engage the services of an attorney and an ex-

pert. This is a very considerable expense in order to avoid what is usually a very paltry fine. Even then he is not usually likely to win acquittal because of the "aura of infallibility" which has been built up, undeservedly, about the device.

"Radar" speed meters are not only *not radar*, but may provide unreliable evidence due to errors falling in any one or in all of the following four categories: (1) system limitations, (2) equipment limitations, (3) improper use of equipment, (4) incorrect interpretation of results.

Even if the device were as reliable, say, as the chase car's speedometer, which is certainly not the case, there are so many possibilities of error in the other three categories that neither the courts, the police, nor the arrested party should assume the speed-meter data to be accurate without specific proof and corroborative evidence, beyond a reasonable doubt, and this must be furnished by the prosecution.

I feel that it would be a disservice to the multitude of honest citizens who, in spite of veracious assertions of their innocence, have been or may be arrested and convicted on the mechanical "evidence" of this fallible device if you did not publish some statement calling attention to the facts which I have pointed out in this letter.

J. KELLY JOHNSON, E. E.
Fellow, IRE
Licensed Professional
Eng. in N. Y. and Ill.
New Canaan, Connecticut

The following is an excerpt from Author Buchsbaum's reply to the above reader's comments.—Editors.

Dear Mr. Johnson:

This is in reply to your letter concerning speed control radar. When considering this topic originally, I realized that its several aspects could each merit a full-length article. Since our magazine is primarily a technical journal, I have concentrated on the technical aspects rather than the legal or utilitarian considerations.

The problem of speeding obviously cannot be solved by the apprehension and punishment of the violators, but this approach does at least reduce the size of the problem. Any method of apprehension and punishment of a law violator—speeder, burglar, or adulterer—depends on the virtues and failings of police and judges. These human characteristics greatly outweigh any inaccuracies of the police tools.

You are quite correct in your list of
(Continued on page 12)

How to Get a Commercial FCC License

do you know what an FCC license really can do for you in Electronics?



Automation



Microwave and Mobile Radio



Guided Missiles



Radio & TV Broadcasting



Aeronautical Electronics

- 1 More income for you every week
- 2 A more interesting job in electronics

Chances are if you are reading this magazine, you can qualify for the really good jobs in electronics, like those shown at left . . . and it won't take long to do it. Your past training and experience in radio & TV repair, armed forces electronics, ham operator, etc. can be your foundation for a profitable career as an electronics technician. Send for the Career Information Material shown below today.

Cleveland Institute Announces an EXCLUSIVE Technician Training Program

in Computers, Servo Mechanisms, Magnetic Amplifiers and others

Other advanced fields covered include Basic Math, A. C. Circuit Analysis, Pulse Circuitry, Color TV, Radar, Advanced Measuring Techniques, Industrial Electronics, Instrumentation, Automation, Radio Telemetry. Send for information today.

CLEVELAND INSTITUTE OF ELECTRONICS

Desk RN-45
4900 Euclid Ave.
Cleveland 3, Ohio

1. Raytheon Manufacturing Company
2. Radio Corporation of America
3. Jupiter IRBM, Army Ordnance Missile Command
4. Collins Radio Company
5. Radio Corporation of America

GET THIS HANDY POCKET ELECTRONICS DATA GUIDE

Free . . .

Puts all the commonly used conversion factors, formulas, tables, and color codes at your fingertips. Yours absolutely free if you mail the coupon in 30 days. No further obligation!

TO GET THIS FREE GIFT, MAIL COUPON Within 30 Days!



CLEVELAND INSTITUTE OF ELECTRONICS

Desk RN-46, 4900 Euclid Ave., Cleveland 3, Ohio

Please send FREE Career Information Material prepared to help me get ahead in Electronics. I have had training or experience in Electronics as indicated below:

- | | |
|---|---|
| <input type="checkbox"/> Military | <input type="checkbox"/> Broadcasting |
| <input type="checkbox"/> Radio-TV Servicing | <input type="checkbox"/> Home Experimenting |
| <input type="checkbox"/> Manufacturing | <input type="checkbox"/> Telephone Company |
| <input type="checkbox"/> Amateur Radio | <input type="checkbox"/> Other |

In what kind of work are you now engaged? _____

In what branch of Electronics are you interested? _____

Name _____ Age _____

Address _____

City _____ Zone _____ State _____

Free!



FIND OUT HOW:

1. The new electronic devices can be handled by you
2. To solve the problems that will stump your fellow technicians
3. Training Is Job Insurance when employment is tough to find . . . and more money for you when times are good

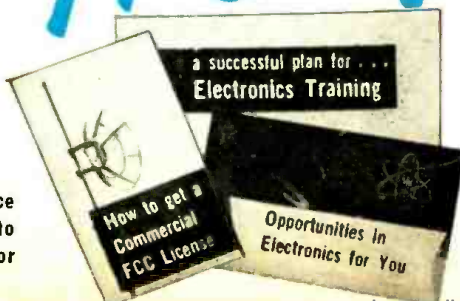



Harry Greenberg, distinguished antenna authority, and Chief Engineer of Channel Master's Electronic Development Laboratories.

Mr. G., take a bow!

You've put more power into the most powerful of all fringe area antennas!

New 10-Element T-W Ingeniously combines 6 of Channel Master's famous T-W hairpin dipoles with 4 parasitic low band and co-linear high band elements. Reaches new highs in gain and front-to-back ratios.

Strongest Mechanical Construction Hundreds of thousands of installations over a four year period prove conclusively that the T-W is the strongest antenna ever made.

New Low Band Director and Reflector System Increases gain up to $2\frac{1}{2}$ db more than a 7-element T-W—a 78% power increase!

New High Band Co-Linear Elements Add 20% to the T-W's high band gain. The co-linear reflector and director are each actually 3 half-wave elements placed end to end.

Heavy-duty Weatherproof Harness Won't let rain or salt air impede reception.

NEW 10-ELEMENT CHANNEL MASTER[®] SUPER T-W

MODEL NO. 358

The new fringe area record-holder.

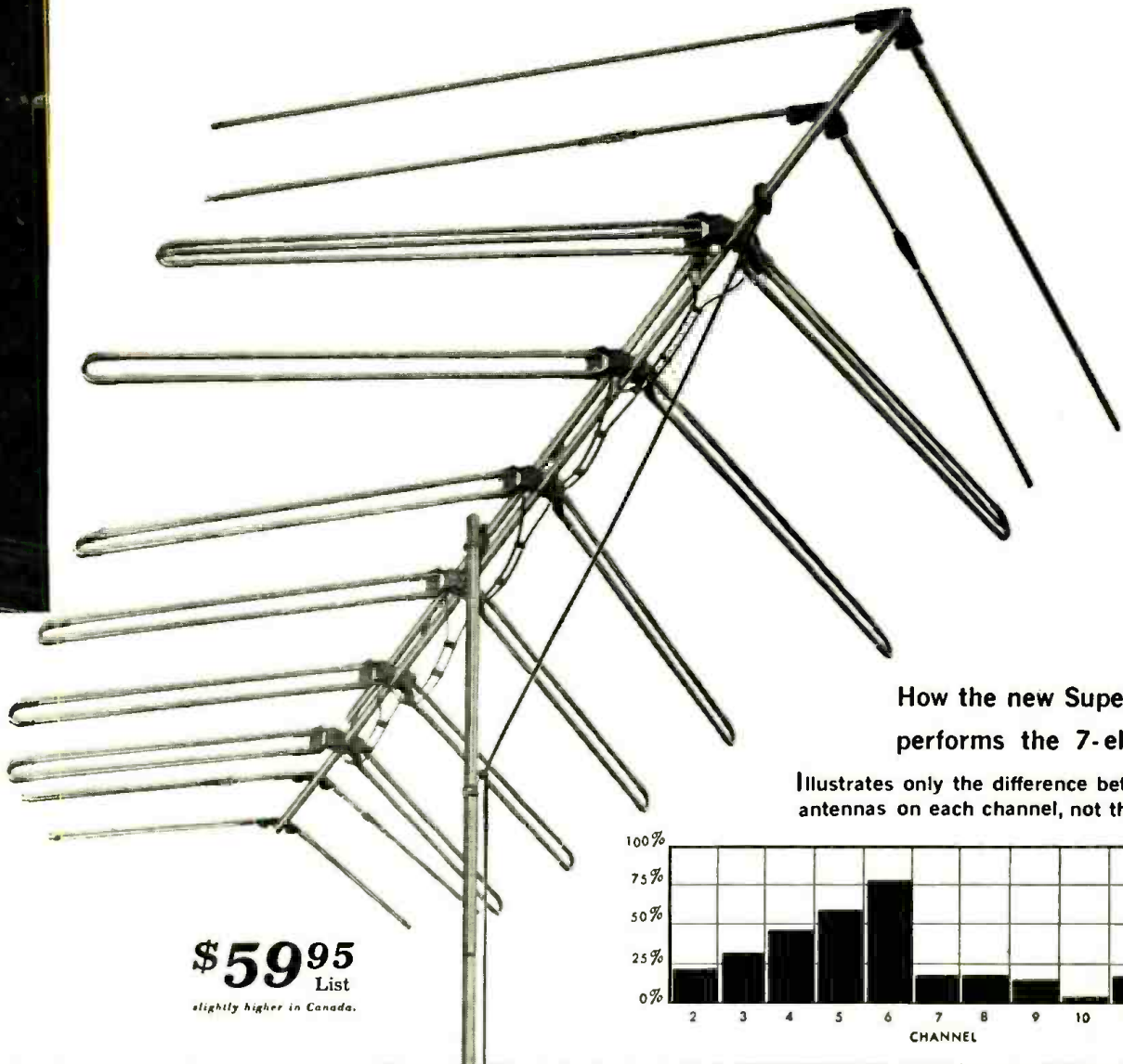

\$59⁹⁵
List
slightly higher in Canada.

How the new Super T-W out-
performs the 7-element T-W

Illustrates only the difference between the two
antennas on each channel, not their total gain.

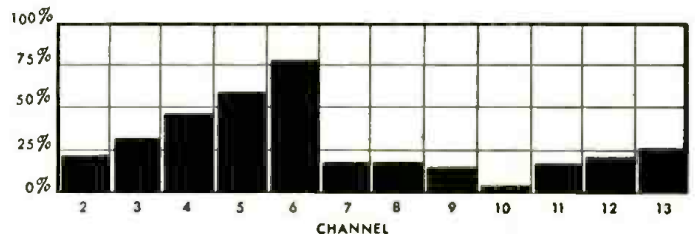

NOW THERE ARE 4
For every problem...for every area...PICK A T-W!



3-Element T-W
Model No. 352

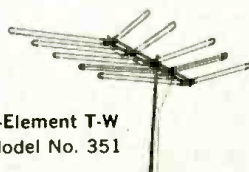

5-Element T-W
Model No. 351

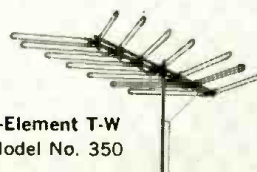

7-Element T-W
Model No. 350

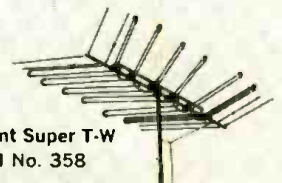

10-Element Super T-W
Model No. 358

See your Channel Master distributor for details on spectacular new promotion!



BRIGHT NEW VIEW

for Multi-set TV-FM
Home Operation ...



...and a

Bright Profit Outlook for YOU with

NEW

JERROLD

HSA-43

Amplified 3 SET COUPLER

Here's a new precision-perfected amplifier that provides *5 DB min. gain across all TV-FM channels* on two outputs and no loss in the third output. Housed in a rugged, compact and handsome case. The HSA-43 features single tube operation (6DJ8), A.C. interlock and no-strip twin lead terminals. Its excellent isolation and match prevents set interaction and ghosting. IDEAL FOR FEEDING ONE FM AND TWO TV SETS FROM THE SAME ANTENNA.

\$29.95 list

Write Jerrold today for full details on this new Profit Outlook!

JERROLD

ELECTRONICS CORPORATION, Distributor Sales Division

Dept. IDS-80 Philadelphia 32, Pa.

Jerrold Electronics (Canada) Limited, Toronto

Export Representative: CBS International, New York 22, N.Y.

LEADER AND LARGEST MANUFACTURER OF TV DISTRIBUTION SYSTEM EQUIPMENT

TYPICAL APPLICATIONS

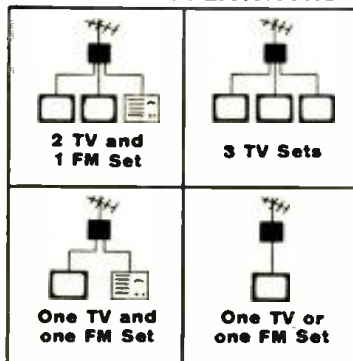

equipment limitations, but the main purpose of using speed control radar is to deter speeders. It is not expected to guarantee absolute justice. There is far less likelihood of an unjust speeding ticket with a properly set up electronics system than there is with the previous method of the chase by the patrolman.

Justice can never be assured by the electronic or by any other device, nor can injustice be prevented. You will surely agree that the entire system of traffic courts is hardly conducive to a fulfillment of the principles of American jurisprudence. The idea that one can pay a traffic ticket at a smaller cost than a court hearing is certainly unjust, but it is practiced widely. As concerns the outcome of so-called "radar arrests," the records of the New York State and City police show that in 95 per-cent of such arrests, the offender pleads guilty. In 3 per-cent, doubt or confusion as to the identity of the offender is the main reason for a trial. In the remaining 2 per-cent, the offender challenges either the radar equipment or the veracity of the operating patrolman.

When used with warning signals and sufficient publicity, electronic speed control certainly can reduce speeding considerably. The police have ample statistics to prove their contention that speed control radar cuts the accident rate substantially, and that alone seems to warrant its use.

WALTER H. BUCHSBAUM
Bellerose Manor, New York

MORE ON THE FM BOOSTER

To the Editors:

The FM amplifier that Francis A. Gicca describes in your April, 1960 issue may be fun to build and less expensive than a "store-bought" amplifier, but it certainly lacks many of the features which a commercial antenna-mounted FM amplifier possesses.

We agree with the author when he says that "low noise is of paramount importance." After this statement, however, we hear nothing more on the subject and the author gives no figures on the noise performance of the finished unit. Using available data, we can calculate that an amplifier of the 6AK5 triode-connected cascode type would have a theoretical noise figure of 4 db in the FM band. In actual practice, a realizable set performance of about 5.0 db could be obtained. However, the author's design has thrown away some gain in the input circuit by mismatching a balanced 300-ohm antenna by simply connecting one side to ground. We can safely estimate then, that the over-all noise figure is probably between 7 and 9 db.

This is only the beginning of the story, though. In a weak-signal area, the antenna is almost always located at as great a height above ground as practicable. The signal must then travel between 50 and 150 feet before it reaches the FM receiver. This attenuates the signal (but not the noise)

(Continued on page 16)

where others fizzle...this one
SIZZLES!

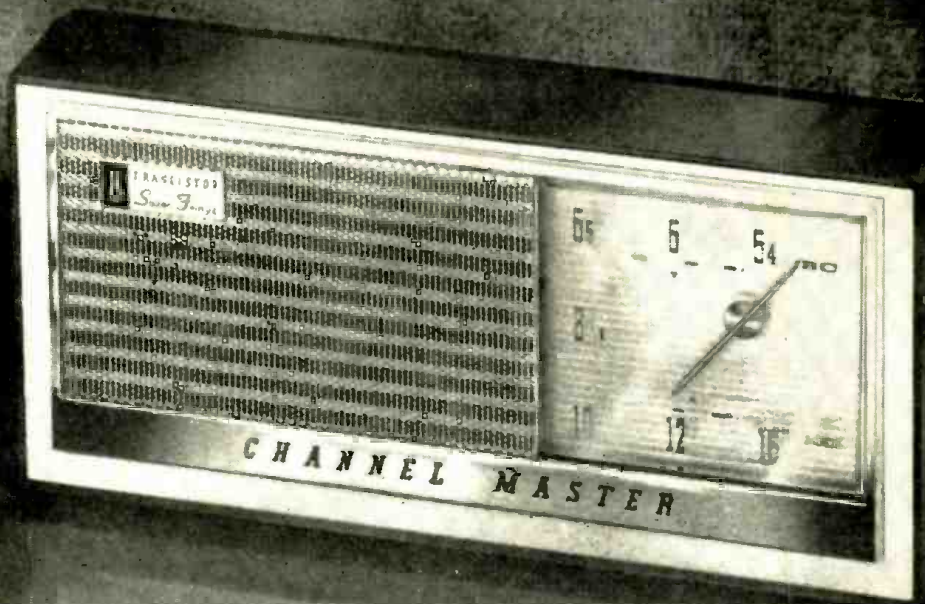

model 6515



It's a 2-in-1 radio:

- Trim portable in smart "sling" case
- Home table model

new **CHANNEL MASTER** 8 transistor "super fringe"

The most sensitive transistor radio ever made!

- RF amplification stage • 3-gang tuning condenser
- New fringe area circuit • Extra long built-in ferrite antenna
- Highest signal-to-noise ratio • Easy, precise vernier tuning
- King-size 3½" speaker • Plays for almost one year on a set of ordinary flashlight batteries (Based on average daily use)

The astonishing performance of this new radio is another reason why the dealer who features Channel Master gets ahead—and stays ahead—of his competition.

\$59⁹⁵
List

slightly higher in Canada.

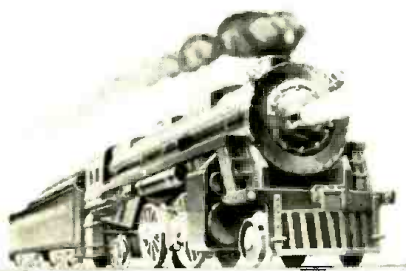

FREE Lionel Electric Train Set

Dealers:

Get a big 42-piece LIONEL Electric Train Set (worth \$75.00) with your order for only 10 assorted Channel Master radios at regular price. A fabulous pre-Christmas deal. Ask your Channel Master Distributor for full details about the "Main Line" promotion. Limited time only.

CHANNEL MASTER works wonders in sight and sound



YOU WILL SCORE G-E WORLD SERIES

Spotlights you for quality TV service right when demand hits its peak! The year's top business, profit-builder for technicians!

All 55 million TV owners will want their sets to be in first-class condition when the umpire calls "Play ball!" The neighborhood technician whom owners know best will be the one to benefit. Don't miss this profit opportunity! General Electric is going all-out to help you—by telling World Series fans whom to call, where to go for fast, reliable TV check-up. *To the technician who installs G-E tubes! He's the best! And just around the corner!*

Long before the first day's pitchers have been named, G-E displays and promotions will be pulling customers into your shop. Once play starts, fans in most large cities will receive frequent radio reminders that you are ready to serve them fast and well. Go World Series with General Electric! Get ready for a B-I-G two weeks of business! See your G-E tube distributor! *Distributor Sales, Electronic Components Div., General Electric Company, Owensboro, Ky.*



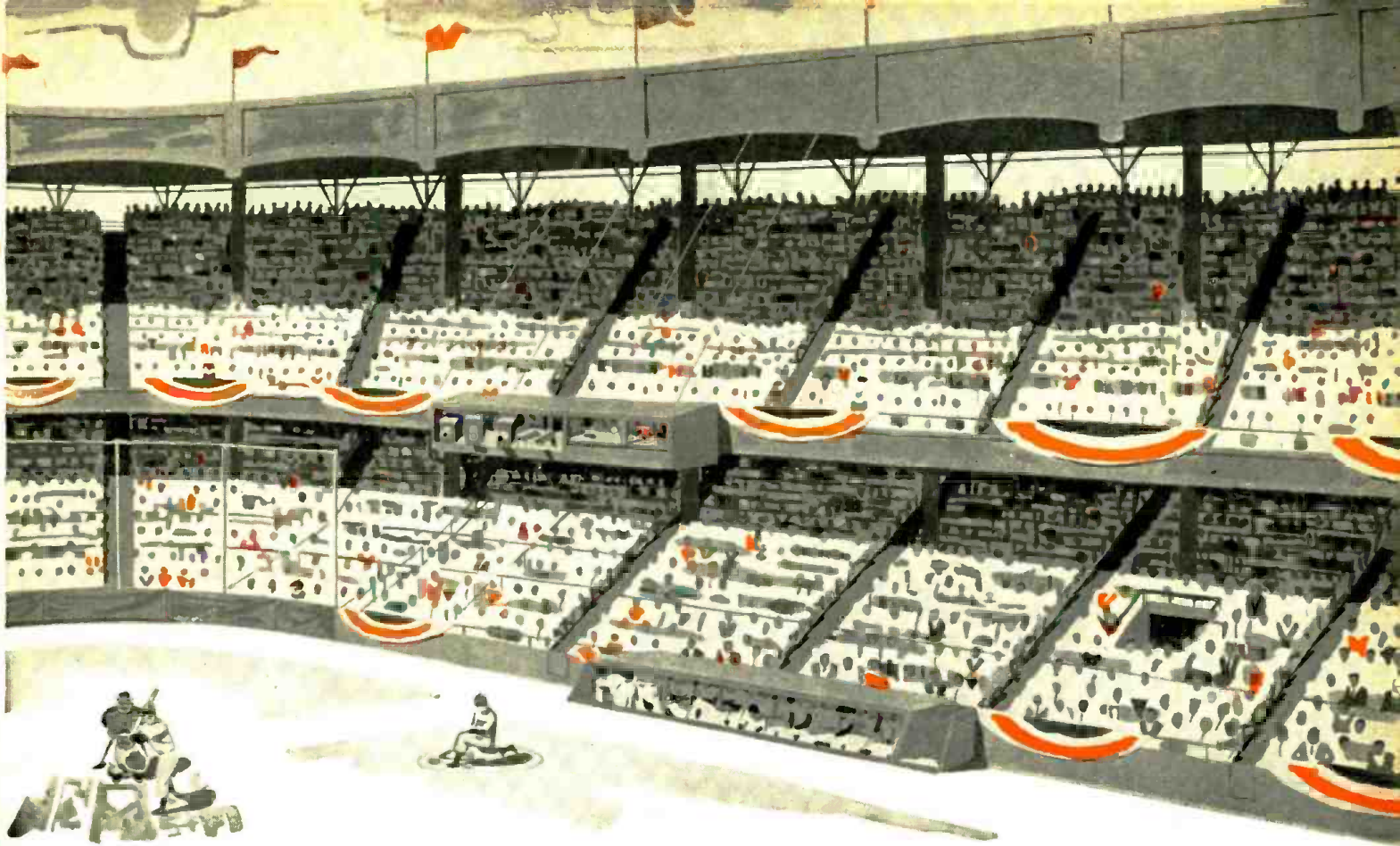

IN EVERY INNING WITH PROGRAM!

GO WORLD SERIES
to ring up
service dollars!

Timely, high-impact display items like these will draw more customers to your shop, pay off in stepped-up income. General Electric has ready for you many other World Series displays, advertising helps, and novelties, all new and exciting. See them today at your General Electric tube distributor's!

Don't miss
a play
in the

**WORLD
SERIES**

call us for our *SPECIAL WORLD SERIES TUNE-UP*

use **GE** tubes

with **GE** tubes

Progress Is Our Most Important Product

GENERAL  ELECTRIC

311-403

Biggest Soldering Gun Value on the market!

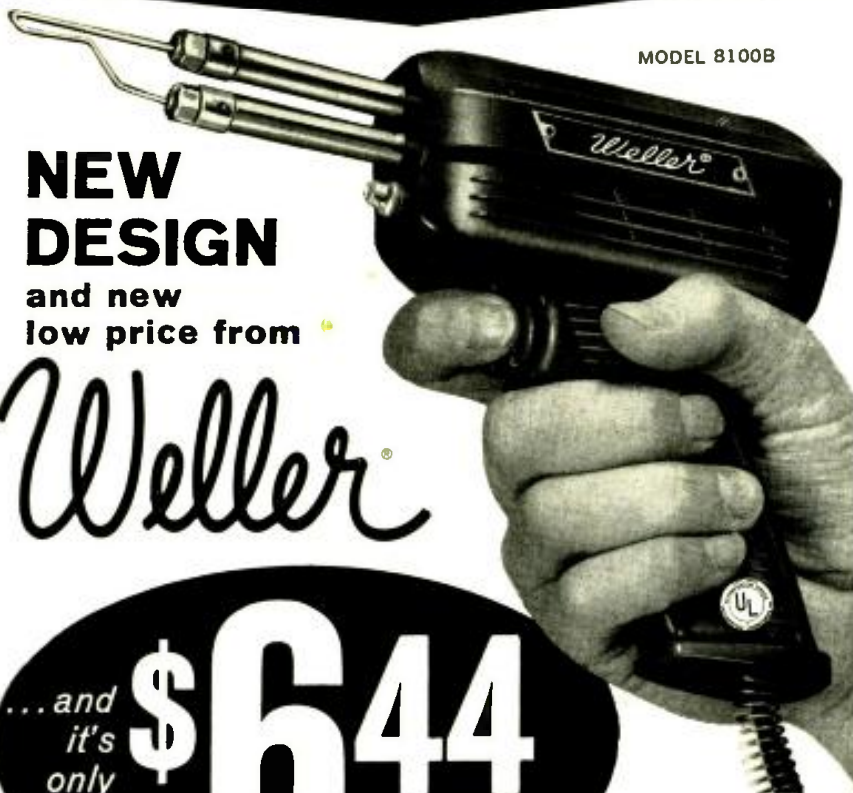

**NEW
DESIGN**
and new
low price from

Weller

... and
it's
only **\$644**
LIST PRICE

Check these advanced features:

- ✓ **New Long-Life Wellertip**—Utilizes copper for superior heat transfer, plus iron-plating for rigidity and long life. Copper conducts heat 5 times faster than steel, permits operation at lower temperature, prevents damage to components. Long reach for easier use in difficult places.
- ✓ **100 watts—single heat**
- ✓ **Tip heats instantly when trigger is pulled—no waiting**
- ✓ **Prefocused spotlight illuminates work, eliminates shadows**
- ✓ **New compact, streamlined design with rugged housing**
- ✓ **Perfect balance for greatest soldering accuracy**
- ✓ **Guaranteed for 1 year—UL approved**



On sale now at your Electronic Parts Distributor

Send for Weller Gun Bulletin

WELLER ELECTRIC CORP. 601 Stone's Crossing Rd.
Easton, Pa.

by another 1.5 db approximately. The resulting noise figure of the entire installation is then made poorer by 1.5 db. (This loss goes up by six times when the transmission line is wet.) The resulting system noise figure can then be estimated to be between 8 and 10 db.

An amplifier mounted at the antenna avoids this difficulty by "fixing" the signal-to-noise ratio by amplifying at the antenna. Incidentally, there is no problem of supplying power to the amplifier because 24 volts a.c. go up the same twin-lead through which the amplified r.f. comes down.

DONALD DWORIN
Project Engineer
Blonder-Tongue Labs., Inc.
Newark, New Jersey

Here is a portion of Author Gicca's reply to the foregoing letter.—Editors.

Dear Mr. Dworkin:

I certainly agree with your general comments concerning the importance of low-noise performance in an FM amplifier. However, I must still defend the approach taken in the circuit used for this article.

A low-noise figure in an r.f. amplifier is obtained by careful circuit choice and design and by careful circuit construction. The former is a science, the latter an art. As much noise improvement can be obtained with careful construction as with careful design. As a result, optimum noise performance with a given circuit can be obtained only after several versions are constructed using varied configurations.

It is, therefore, not unusual to expect a commercial FM booster to exceed the noise performance of a home-made unit. My unit attempted specifically to compete with an FM antenna within the same price range. This it does. It cannot compete with a commercial unit in the important area of noise performance. However, my unit's performance is adequate to pull in nearly all marginal stations.

For example, assume that the user's FM receiver has a noise figure of 5 db and that the booster has a noise figure as high as 10 db. Incidentally, the noise figure of the booster was not measured due to the unavailability of a reliable thermal noise generator in the FM band. If a signal is received which is 10 db below the receiver's limiting level, the detected signal will be quite noisy. However, with the booster, the signal level is increased by 20 db, or ten times, while the noise level is only doubled. This is sufficient to cause the receiver to limit effectively allowing the station to be received without noise.

FRANCIS A. GICCA
Senior Engineer
Raytheon Co.
Bedford, Massachusetts

Our thanks to Author Gicca for providing this additional explanatory material regarding his FM booster. We hope this clears up all the questions in our reader's minds.—Editors. —30—

ELECTRONICS WORLD

Learn RADIO, TELEVISION AND ELECTRONICS by Practicing at Home in Your Spare Time

At No Extra Cost you get specially developed Electronic Training Kits for practical experience. Shop and laboratory practice at home make learning easier, interesting, faster. You do not need a high school diploma or previous experience.

Increasing Demand for Trained Men

This is the Electronics age. Men with Electronic know-how are in demand. They enjoy high pay and growing opportunities for advancement. Satellites, Radar, Automation in Industry, Missiles, Rockets, Planes, Stereo, TV, Radio, Two



Way Communications for transportation are a few of the fantastic developments in the fast growing Electronics industry. If you are not completely satisfied with your work; if you are doubtful about your future, investigate Electronics.

High Pay, Prestige, Bright Future

What branch of Electronics interests you? Thousands of successful NRI graduates prove that NRI's learn-by-practice method is the way to success. You start in your chosen career 'way ahead of the man who only learns from books. You do not need to give up your job. You do not need to go away to school. You learn at home, get practical knowledge from training kits NRI provides.



Train With the Leader

NRI is the world's oldest and largest home study Electronics school. You benefit from the experience NRI has gained from training men for 45 years. NRI offers you proven courses of home study in Electronics; Principles, Practices and Maintenance—Radio Television Communications—Radio Television Servicing.

Start Soon to Earn More

Soon after enrolling NRI shows you how to apply your knowledge to earn extra money doing Electronics repairs or servicing Radio and Television sets for friends and neighbors. Take the first step toward success now. Find out what NRI offers you. Mail the postage-free card. No obligation. Cost of NRI training is low. Monthly payment plan available. NATIONAL RADIO INSTITUTE, Washington 16, D.C.

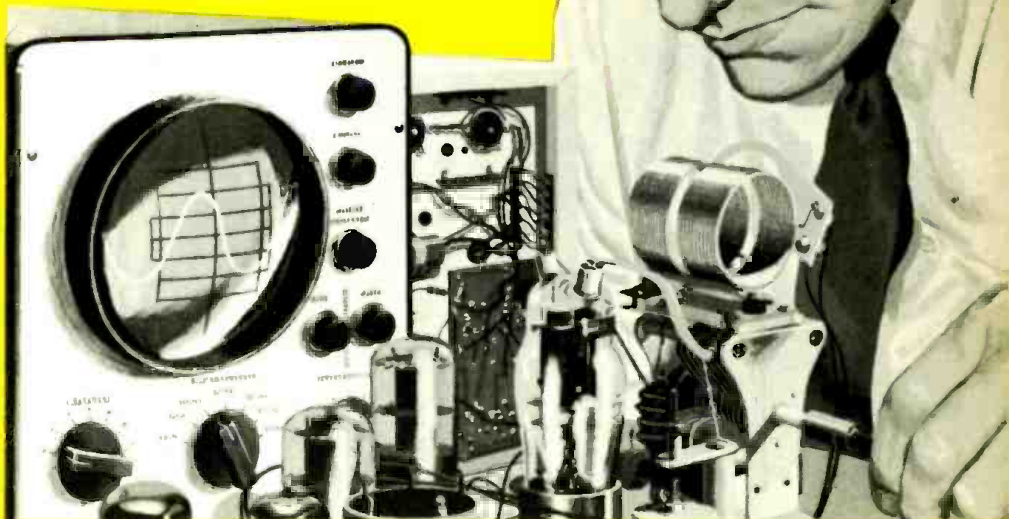

NRI Has Trained Thousands for Success



"I get over twice the salary I made before enrolling. NRI training gave me a thorough understanding." H. ATKINSON, Austin, Tex.

"I started with station CJIC, now in charge of sound effects for CBC. NRI opened doors to greater opportunity for me." F. TUDOR, Toronto, Ontario

"Averaged \$150 a month spare time before I graduated. Now have my own full time business and employ 2 men." F. W. COX, Hollywood, Cal.

NEW COURSE IN ELECTRONICS TURN PAGE

Cut Out and Mail—No Stamp Needed

64-PAGE CATALOG FREE

No Salesman will call. (Please PRINT) YZ

Name _____ Age _____

Address _____

City _____ Zone _____ State _____

National Radio Institute
WASHINGTON 16, D. C.
ACCREDITED MEMBER NATIONAL HOME STUDY COUNCIL

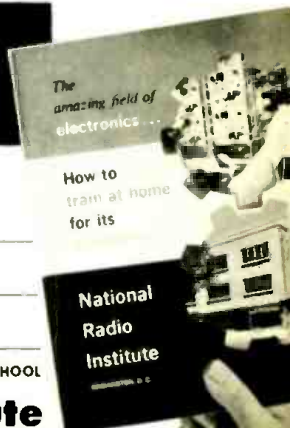



JOB COUNSELORS ADVISE LEARN ELECTRONICS



SPECIAL TRAINING KITS NO EXTRA COST

NEW Home Study Course in **ELECTRONICS** Principles-Practices-Maintenance **NOW READY**

This is the Electronic Age. Electronic equipment is already being used to count and control flow of liquids, solids, gases. Electronics is employed to search for oil, make surveys, control traffic, machine complex parts and in atomic installations. Military uses of Electronics are great and expanding rapidly. In business, Automation with Electronics plays an important part, prepares payrolls, calculates engineering formulas.

Learn More to Earn More
Now, to meet the growing demand for trained Electronic Technicians NRI has developed a comprehensive, complete course in Electronics Principles, Practices, Maintenance. This training stresses fundamentals. It is a course specially prepared for beginners and for Technicians. You get both theory and practical experience in an interesting, exciting way.

Ten Special Training Kits Give Practical Experience

You get practical experience with Thyatron Tube circuits, Multivibrators, build a D'Arsonval type Vacuum Tube Voltmeter (Kit 2); work and experiment with pentode tubes, selenium resistors, oscillators, transistors, magnetic amplifiers; and get practical experience in telemetry circuits as used in earth satellites, digital and analog computers (Kit 9).

NRI—Oldest and Largest School

Wishing for success won't bring success. You must act. Get FREE 64-page Catalog from America's oldest and largest home study Electronic-Radio-Television school. It gives facts, opportunities in Industrial and Military Electronics careers, also shows what you learn, tells about NRI's other courses in Radio Television Servicing and Radio Television Communications. Monthly payments plan. Mail Postage Free Card for 64-page Catalog.
NATIONAL RADIO INSTITUTE, Washington 16, D.C.



← **SEE OTHER SIDE** →

FIRST CLASS
Permit No. 20-R
(Sec. 34.9, P. L. & R.)
Washington, D.C.

BUSINESS REPLY CARD
No Postage Stamp Necessary if Mailed in the United States

POSTAGE WILL BE PAID BY

National Radio Institute
3939 Wisconsin Avenue
Washington 16, D.C.

**POSTAGE FREE CARD
MAIL NOW**



They're so good, we bring them to
you on a **Silver Platter** (a real one!)

Good News:

**Channel Master more than *DOUBLES*
its line of replacement tube types**

How would *you* best describe Channel Master tubes? Most dealers use the word "dependable". Dependable uniformity, dependable performance, dependable long life.

And now, with the addition of many new tube types, you can make Channel Master your first choice in *over 75% of all service calls!* Find out for yourself why Channel Master Premium Quality tubes have become America's fastest growing line.



**FREE! Genuine Wm. Rogers
Holloware Service**

Luxurious, beautiful Silverplate... made by International Silver Company.

**Well & Tree Platter • 16" Round Tray
Chip 'N Dip Dish • Double Vegetable Dish**

Get the piece of your choice with surprisingly small purchases of Channel Master tubes. Tell your Channel Master distributor how many holloware sets you'd like before Christmas.



**Latest Information
on the Electronic Industry**

Spot News

By **ELECTRONICS WORLD'S
WASHINGTON EDITOR**

ELECTRONICS CITED AS VITAL TO NEW OCEANOGRAPHIC STUDY PROGRAM—Electronics will play a key role in the recently announced expanding oceanographic research projects, according to a report by the House Committee on Science and Astronautics. Vacuum-tube and transistorized equipment not only offers the means of resolving the problem of "seeing without being seen", the report noted, but permits the measurement of temperature gradients, layers of plankton which scatter sound and noise of the sea itself. Electronics, it was stressed, can make the ocean transparent via underwater surveillance systems. It will not be too long, the Committee's review added, before we will have the counterpart of surface radars serving as crisscrossed networks of the sea—submarine beacons radiating sound beams for the guidance of underwater craft.

ELECTRONIC SCOUTING SYSTEM USING UNMANNED JET DRONE DEVELOPED—A push-button electronic scouting system, using a turbo-jet drone, which will enable battlefield commanders to learn instantly—without risking a single soldier—what is going on in enemy territory, has been unveiled by the Department of the Army. The system, designated AN/USD-5, consists of advanced ground and airborne equipment and an unmanned, combat surveillance drone which sends back information while in flight. It will operate day or night, under all weather conditions, fly at low altitudes and at high speeds, and cannot be fooled by camouflage. According to Lt. Gen. Arthur G. Trudeau, Army Chief of Research and Development, this new electronic scout is the "greatest single advance in the surveillance art...as modern as the Army missiles for which it will search out targets".

TV BOOSTERS AUTHORIZED FOR THE ULTRA-HIGHS—TV boosters—which amplify and retransmit signals of the parent station on the same channel—have received the official blessing of the FCC. According to a recently issued report and order, the new TV booster licenses will be granted to licensees of u.h.f. stations to fill in shadows which might extend out to 68 miles. Such stations will be allowed to operate with a maximum effective radiated power of 5 kilowatts.

COMPATIBLE DISTANCE-MEASURING EQUIPMENT TO BE INSTALLED BY FAA—A number of compatible distance-measuring equipment systems (DME) to provide distance capability will soon be in operation in many airports, according to the Federal Aviation Agency. DME will be combined with VOR navigation equipment to enable pilots to locate aircraft positions accurately as they fly across the country in good weather or bad.

WEATHER RADAR FENCE NOW IN OPERATION—To cover more territory and accelerate early warnings, a 3000-mile weather radar fence has been placed in operation along the coastline from Portland, Maine to Brownsville, Texas. Commenting on this advanced-type of weather reporting system, Secretary of Commerce Frederick H. Mueller said that surveillance of dangerous storms will now be better than ever before in the history of the Weather Bureau's warning service. High-powered radar, developed for this acute detecting purpose, are capable of scanning a 200,000-square-mile area. The radar and reconnaissance reports, resulting from such scanning, reveal where the storm is, its intensity, and speed and direction.

OVER \$40-MILLION MILITARY-ELECTRONICS CONTRACTS ISSUED—Various branches of the military have released over \$40-million contract awards recently. In one instance, involving an expenditure of nearly \$3-million, the Rome Air Development Center has blueprinted an advanced target data processing system. It is expected that the program will result in the design of a photogrammetric (photo-mapping) technique which will accept various types of intelligence data and supply topographic charts of the area covered by the intelligence data. Elsewhere, twelve radio-communications central systems, costing nearly \$11-million, were ordered by the Army. The system, designed to provide switched radio service to battle areas, similar to conventional telephone service, will include a radio central with v.h.f. transmitters mounted in a weapons carrier on a three-quarter ton truck, while subscriber stations, transmitters, and receivers will be used to provide more channels of information and more communications systems in a given zone.

—50—

**AT
LAST!**

RADIO-TV and ELECTRONICS TRAINING AT A PRICE YOU CAN AFFORD!

***21 INCH**
Receiver Kit included

Yes, this great course costs far less than any training of its kind given by other major schools! Radio-Television Training School will train you for a good job in Television or Industrial Electronics — AT HOME IN YOUR SPARE TIME.

Think of It—a complete training program including over 120 lessons, Fourteen Big Radio-Television Kits, Complete Color-TV Instruction, Unlimited Consultation Service . . . ALL at a really big saving to you. How can we do this? Write to us today . . . and find out!

And what's more — you can (if you wish)

OPEN YOUR OWN RTS-APPROVED AND FINANCED RADIO-TV SERVICE SHOP

We Want Many More Shops This Year

This 38 year old training organization — called RTS, that's Radio-Television Training School — wants to establish a string of Radio-TV Repair Shops in principal cities throughout the U. S. So far, a great many such shops are NOW IN BUSINESS AND PROSPERING. We are helping and training ambitious men to become future owners and operators of these shops in all areas.

FOR UNSKILLED INEXPERIENCED MEN ONLY — WE TRAIN YOU OUR WAY!

We must insist that the men we sign up be trained in Radio-TV Repair, Merchandising and Sales by our training methods—because WE KNOW the requirements of the industry. Therefore, we will TRAIN YOU . . . we will show you how to earn EXTRA CASH, during the first month or two of your training period. YOU KEEP YOUR PRESENT JOB. TRAINING TAKES PLACE IN YOUR OWN HOME, IN YOUR SPARE TIME!

ACT NOW!

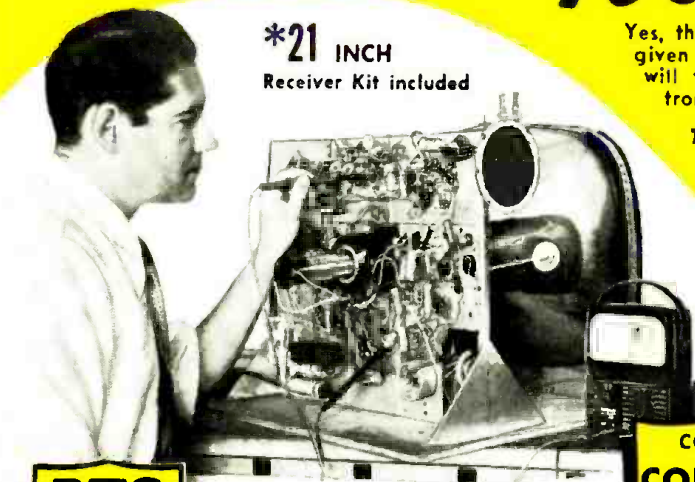

**COMPLETE
COLOR TV
INSTRUCTION
INCLUDED**

**YOU BUILD THESE
AND OTHER UNITS!**

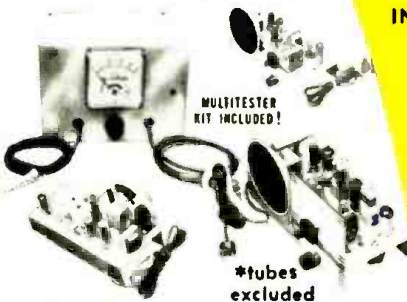

MULTITESTER
KIT INCLUDED!

*tubes
excluded

**RADIO-TELEVISION
TRAINING SCHOOL**

815 E ROSECRANS AVENUE
LOS ANGELES 59, CALIFORNIA

Est. 1922

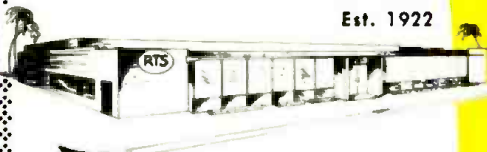

Get your free book on the
FAMOUS RTS BUSINESS PLAN
find out how you can open
A REPAIR SHOP OF YOUR OWN

We supply and finance your equipment

When you are ready and qualified to operate one of our RTS-Approved TV Repair Shops WE WILL SUPPLY AND FINANCE EVERY BIT OF EQUIPMENT YOU NEED TO GET STARTED plus an inventory of parts and supplies. In other words we will stake you . . . AN OFFER NEVER MADE BEFORE BY ANY TRAINING ORGANIZATION. Under the RTS Business Plan you receive:

1. An electric sign for the shop front.
2. Complete laboratory of test equipment.
3. Letterheads, calling cards, repair tickets, etc.
4. Basic inventory of tubes, parts, supplies.
5. Complete advertising and promotional material.
6. Plans for shop arrangement.
7. Instructions on how to go into business.
8. Continuous consultation and help.
9. The right to use RTS Seal of Approval, and the RTS Credo.
10. The right to use the Famous Trade Mark.

ACCREDITED MEMBER

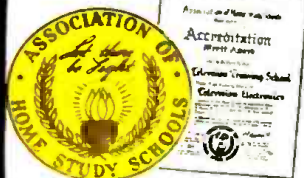

RTS' Membership in the Association of Home Study Schools is your assurance of Reliability, Integrity, and Quality of Training.

**ALL
THESE
FREE!**



CUT OUT AND MAIL — TODAY!

RADIO-TELEVISION TRAINING SCHOOL
815 EAST ROSECRANS AVENUE Dept. EW-100
LOS ANGELES 59, CALIFORNIA

SEND ME FREE — all of these big opportunity books — "Good Jobs in TV-Electronics," "A Repair Shop of Your Own" and "Sample Lesson." I am interested in:

- Radio-Television Industrial Electronics (Automation)

Name _____ Age _____

Address _____

City & State _____

302

Mail This Coupon Now — No Salesman Will Call

Coverage in depth

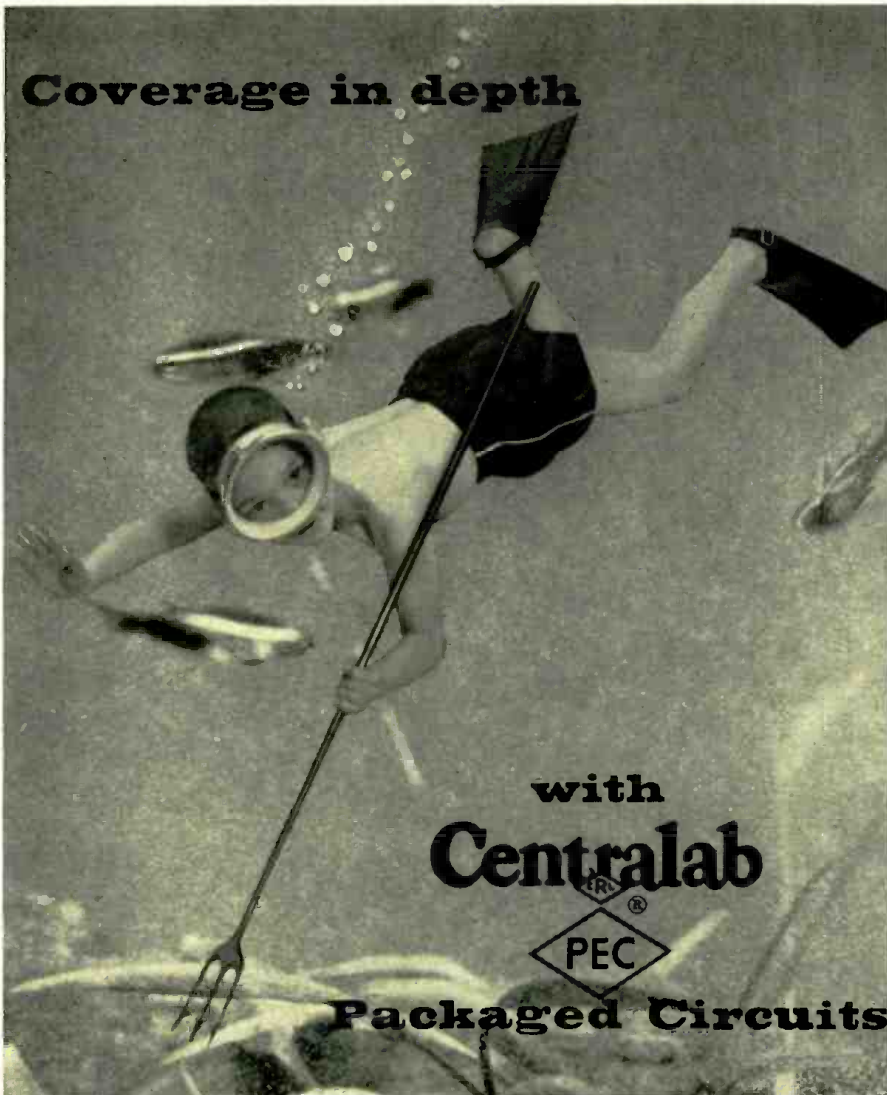

with
Centralab



Packaged Circuits

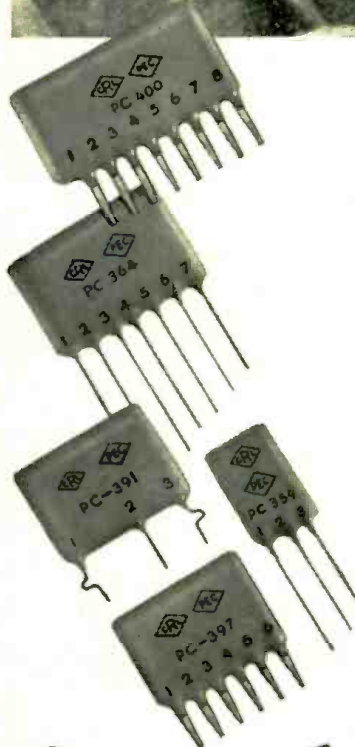

You're in the swim with CENTRALAB **PEC**'s —the packaged electronic circuits from the first company to dive in and originate, develop, and manufacture them.

With the electronics industry submerged in packaged circuits (well over one hundred million CENTRALAB units are already in the field), you'll have lots of calls for replacement units —and CENTRALAB has them available . . . well over 150 different circuits, with new ones being added all the time.

The new CENTRALAB **PEC** Guide #6 tells you how to select, and replace packaged circuits—and it's available free from your distributor or by writing direct to CENTRALAB. Spear yourself a copy right away!

Centralab
Y-6029

THE ELECTRONICS DIVISION OF GLOBE-UNION INC.
910K EAST KEEFE AVENUE • MILWAUKEE 1, WISCONSIN
CENTRALAB CANADA LIMITED—AJAX, ONTARIO

British Stereo Broadcasts

By PATRICK HALLIDAY

Two compatible systems are currently being investigated.

ALTHOUGH experimental stereo programs with national coverage are transmitted in Britain for an hour on alternate Saturday mornings by using two separate stations (one of which is normally the television sound channel), the *British Broadcasting Corporation* is moving cautiously on initiating a regular stereo service.

BBC men have pointed out that a full stereo service would pose serious economic problems because of extra studio and transmitting equipment which would be needed and also because a radical change would be necessary in the line distribution of programs on which the British networks depend heavily.

Meanwhile two systems, requiring only a single transmitter, are under investigation. The *EMI* "Percival" system in which a narrow-band signal providing directional information only is derived from the original left- and right-hand channels and carried on a subcarrier at about 22 kc. At the receiver, the left-hand channel is obtained by multiplying the single audio signal by the directional information (by means of a Hall multiplier) while the right-hand channel consists of the audio signal with the left-hand channel subtracted from it. A big advantage claimed for this system is that the effective loss of transmitter range is equal to a transmitter power loss of only about 2 db.

An alternative system, which is being actively promoted in the United Kingdom, uses time multiplexing and has been developed by G. D. Browne of *Mullard*. In this system the two channels remain independent but are radiated alternately for half-cycle periods at a frequency of 32.5 kc.—the resulting complex signals being used to frequency modulate a single transmitter. At the receiver, the output from the discriminator, at the 32.5-kc. sampling frequency, is used to phase-lock a local oscillator at this frequency. By 90-degree phase shifting the output from the oscillator, two sine waves are obtained in-phase with the sampled signal. The original stereo channels can then be recovered by a mixing process. Thus the receiver decoder stages comprise only an oscillator and two mixers. It is claimed that the theoretic crosstalk between channels is as low as -45 db, permitting the system to be used, if required, for simultaneous radiation of bi-lingual or other independent transmissions.

Both the *EMI* and the *Mullard* systems are compatible.

F.C.C. COMMERCIAL OPERATOR LICENSE

Training... for Jobs in Electronics

F. C. C. LICENSE — THE KEY TO BETTER JOBS

An F.C.C. *commercial* (not amateur) license is your ticket to higher pay and more interesting employment. This license is Federal Government evidence of your qualifications in electronics. Employers are eager to hire *licensed* technicians.

WHICH LICENSE FOR WHICH JOB?

The **THIRD CLASS** radiotelephone license is of value primarily in that it qualifies you to take the second class examination. The scope of authority covered by a third class license is extremely limited.

The **SECOND CLASS** radiotelephone license qualifies you to install, maintain and operate most all radiotelephone equipment except commercial broadcast station equipment.

The **FIRST CLASS** radiotelephone license qualifies you to install, maintain and operate every type of radiotelephone equipment (except amateur) including all radio and television stations in the United States, its territories and possessions. This is the highest class of radiotelephone license available.

GRANTHAM TRAINING PREPARES YOU

The Grantham Communications Electronics Course prepares you for a **FIRST CLASS F.C.C.** license, and it does this by **TEACHING** you electronics. Each point is covered simply and in detail, with emphasis on making the subject easy to understand. The organization of the subject matter is such that you progress, step-by-step, to your specific objective — a first class F.C.C. license.

HOME STUDY or RESIDENT CLASSES

Home Study Training: The Grantham home study course teaches you the principles of electronics in a simple "easy to grasp" manner. You learn and remember, because we emphasize *understanding* rather than memorizing. The course *teaches* electronics and specifically prepares you to *pass* FCC examinations. Lesson by lesson, you move through the course to your goal under the watchful direction of an instructor who is especially qualified in this particular field.

Home study training is conducted from the Hollywood Division of the School. To get details concerning *how* we can prepare you by correspondence for your FCC license and *how* that license can help you advance in electronics, check "home study" in the coupon below and mail it to our Hollywood address.

Resident Classes: Grantham resident schools are located in four major cities — Hollywood, Seattle, Kansas City, and Washington, D. C. Regularly scheduled classes in FCC license preparation are offered at all locations. In **DAY** classes, you prepare for your first class license in 12 weeks. In **EVENING** classes, you prepare in 20 weeks. For free details, check "resident classes" in the coupon and mail it to the School nearest you.

Get your First Class Commercial F.C.C. License in 12 weeks by training at

Grantham School OF ELECTRONICS

for **FREE** Booklet **CLIP COUPON** and mail
in envelope or paste on postal card.

HOLLYWOOD
CALIF.

1505 N. Western Ave.
Hollywood 27, Calif.
(Phone: HO 7-7277)

SEATTLE
WASH.

408 Marion Street
Seattle 4, Wash.
(Phone: MA 2-7227)

KANSAS CITY
MO.

3123 Gillham Road
Kansas City 9, Mo.
(Phone: JE 1-6320)

WASHINGTON
D. C.

821-19th Street, N. W.
Washington 6, D. C.
(Phone: ST 3-3614)



To: **GRANTHAM SCHOOL OF ELECTRONICS**

1505 N. Western Hollywood • 408 Marion Seattle • 3123 Gillham Rd. Kansas City • 821-19th, NW Washington

Please send me your free booklet telling how I can get my commercial F. C. C. license quickly. I understand there is no obligation and no salesman will call.

Name _____ Age _____

Address _____

City _____ State _____

I am interested in: Home Study, Resident Classes

06-R

MAIL COUPON NOW

see the exciting **1961**

knight-kits[®]

A PRODUCT OF ALLIED RADIO

in this value-packed **ALLIED** catalog

free

**444 pages
most complete**

send for it!

use coupon
on next page

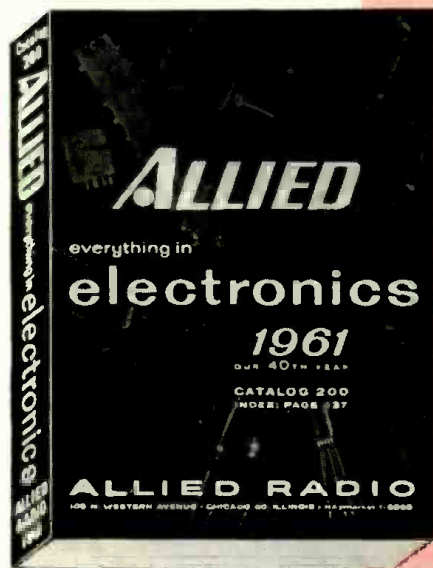

knight-kits—Best by Design

FUN TO BUILD Building it yourself is always satisfying fun—it's fun at its best when you build Knight-Kits—they're so beautifully engineered, so much easier, more pleasurable to work with...

YOU SAVE You save substantially because you buy direct from Allied at our money-saving big-volume-production prices—and because you do the easy building yourself...

YOU OWN THE BEST You'll be glad you built a Knight-Kit, because you'll own and enjoy with pride a true custom-built product, professionally engineered and styled—designed for superior performance...

EASIEST TO BUY only \$2 down on orders up to \$50; \$5 down up to \$200; \$10 down over \$200—up to twenty-four months to pay...

exclusive knight-kit

MONEY BACK GUARANTEE

Every Knight-Kit is unconditionally guaranteed to meet our published specifications for performance or your purchase price is refunded in full.

**Buy Any Knight-Kit!
... Build and Use It!
It Must Perform
Exactly as Claimed!**

Your Satisfaction is Guaranteed

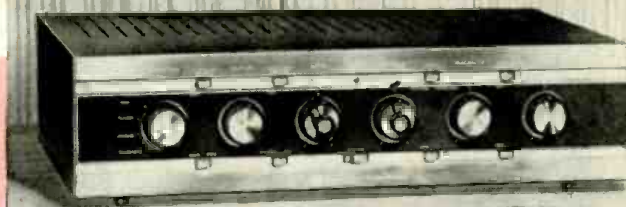

**70-Watt
Super-Power
Stereo!**

DELUXE 70-WATT STEREO AMPLIFIER

Super-power to drive any of today's speakers; the ultimate in control flexibility and functions. 83 YU 934 **\$119.95** only **\$5** down

see many more great **HI-FI KITS**

- | | |
|--------------------------|-------------------|
| Stereo Preamp | 18-Watt Amplifier |
| 60-Watt Stereo Amplifier | 12-Watt Amplifier |
| Stereo Control | FM Tuner |
| 25-Watt Amplifier | Speaker Systems |

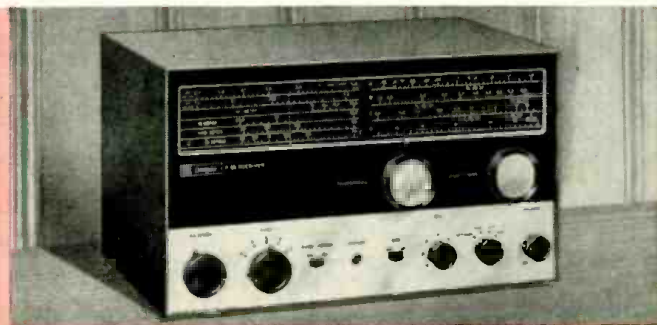

ALL-BAND SUPERHET RECEIVER

Covers 540 kc to 36 mc, plus 6 meters; general coverage tuning and calibrated Amateur bandsread tuning. 83 YU 935 **\$67.50** only **\$5** down

see many other **HOBBYIST KITS**

- | | |
|---------------------------------------|------------------------|
| "Space Spanner" [®] Receiver | Transistor Radios |
| "Ocean Hopper" Radio | Intercom Systems |
| Radio-Intercom | Electronic Lab Kits |
| Clock-Radio | Photoelectronic System |



BEST VTVM VALUE

High sensitivity general-purpose VTVM; 11 meg input resistance; balanced-bridge circuit; 4 1/2" meter. 83 Y 125 **\$25.75**

only **\$2** down



only **\$2** down

From original concept to final design, each Knight-Kit is produced by and comes directly to you from ALLIED

**sold exclusively by
ALLIED**

knight-kits: best in build-your-own electronic equipment



STEREO TAPE RECORD/PLAY PREAMP

Professional quality; permits tape monitoring, sound-on-sound and echo effect; use with any tape transport. 83 YX 929 (less case) \$79.95

only \$5 down



DELUXE 40-WATT STEREO AMPLIFIER

Full frequency center channel. Finest amplifier available anywhere in this price range. 83 YU 774.....\$76.95

only \$5 down



Only \$39.95 For Full 20 Watts Stereo!

SUPER-VALUE STEREO HI-FI AMPLIFIER

20-Watt Stereo Hi-Fi Amplifier, with special clutch-type dual-concentric level control; biggest bargain in Stereo hi-fi. 83 YX 927.....\$39.95

only \$2 down

DELUXE FM-AM STEREO HI-FI TUNER

Dynamic Sideband Regulation, variable AFC, "Magic Eye" slide-tuning, multiplex add-in. 83 YU 731.....\$87.50

only \$5 down



FM-AM HI-FI TUNER BUY

Outstanding FM-AM Hi-Fi Tuner; with AFC and tuned RF stage on FM; includes multiplex jack. 83 YX 928.....\$49.95

only \$2 down



SUPERHET CITIZENS BAND TRANSCEIVER

Dual-conversion receiver for highest sensitivity and selectivity; 2-channel crystal-controlled 5-watt transmitter. 83 YX 712-2.....\$79.95

only \$5 down



only \$2 down

\$39.95 For This Citizen's Band Transceiver

TOP VALUE CITIZENS BAND TRANSCEIVER

Lowest-priced complete Citizens Band Transceiver. Tunable 22-channel super-regenerative receiver; 5-watt transmitter. 83 Y 713-2.....\$39.95



32-WATT STEREO AMPLIFIER VALUE

Money-saving 32-Watt Stereo Hi-Fi Amplifier; high power at low cost; full frequency center channel. 83 YU 933.....\$59.95

only \$5 down

SENSATIONAL 4-BAND "SPANMASTER" RECEIVER

For thrilling world-wide reception; exciting Short-wave and Broadcast; band-switching, 540 KC to 80 MC. With cabinet. 83 YX 258.....\$25.95



only \$2 down



only \$2 down

"600" TUBE CHECKER

Checks over 700 types; illuminated roll-chart; obsolescence-proof design. 83 YX 143.....\$32.95

RF SIGNAL GENERATOR

Output to 112 mc on fundamentals; 400-cycle modulation. 83 Y 145.....\$19.75

full selection of INSTRUMENT KITS

- 5" Oscilloscopes
- AC VTVM
- Tube Checkers
- Signal Tracer
- Audio Generator
- Sweep Generator
- Battery Eliminator
- Capacity Checker
- Transistor Checker
- R/C Tester,
- plus many others

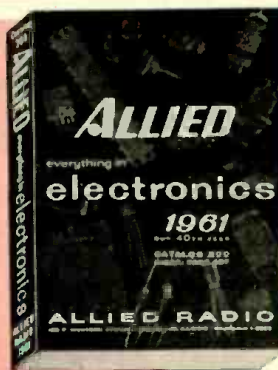

free

SEND FOR THE 444-PAGE 1961 ALLIED CATALOG

Write today for the world's biggest electronics catalog, featuring the complete KNIGHT-KIT line. See the big news in quality electronic kits—save on everything in Electronics. Send for your FREE copy.

send for it today!

ALLIED RADIO, Dept. 161-K
100 N. Western Ave., Chicago 80, Ill.

Send FREE 1961 ALLIED Catalog

Name _____

Address _____

City _____ Zone _____ State _____

RADIO

Pioneer in electronic kit development

"BEST OF ALL CONTACT SPRAYS"

AS REPORTED BY INDEPENDENT PRODUCT-TESTING LABORATORY

	Shield	A	B	C	D	E	F	G	H	I
Lubrication After Rubbing For 90 Sec.	GOOD	Fair	Very Poor	Poor	Good	Poor	Very Poor	Good	Poor	Fair
Cleaning After Rubbing For 90 Sec.	GOOD	Good	Good	Good	Good	Fair	Poor	Good	Fair	Poor
Protection After 30 Sec. Exposure to H ₂ S Gas	GOOD	Fair	Fair	Good	Good	Fair	Very Poor	Good	Very Poor	Good
Protection After 2 Hours Exposure to H ₂ S Gas	BEST	—*	—*	2nd Best	5th Best	—*	—*	3rd Best	—*	4th Best
Flash Characteristics	None at 200°F.	—*	—*	Greatest tendency	Boils at 70°F. Tendency to ignite	—*	—*	Tendency to ignite	—*	Slight tendency to ignite
Attack On Plastic Material	NO	—*	—*	Yes**	Yes**	—*	—*	Yes**	—*	Yes**

*Not tested further following sub-standard performance in 30-second exposure test.

**Presence of solvents and chlorinated hydrocarbons.

Channel Master introduces the first triple-action spray!

Channel Master set out to provide a superior cleaner, lubricant, and protector for electrical contacts. Contact Shield was the result.

To verify our own estimates of the product's effectiveness, Contact Shield was submitted to a nationally known independent testing laboratory.

This famous testing organization made a thorough study of Contact Shield, as well as of nine similar products on the market. The above findings demonstrate conclusively that this new Channel Master product is the most reliable contact spray you can buy!



Here's why Contact Shield is best:

- provides the most long-lasting protection
- eliminates background and resistance noises
- is safer. Will not ignite, flash, or cause short circuits... propellant is actually a fire extinguisher
- contains no solvents to attack plastics
- performs at temperatures from -95°F. to +320°F.

CHANNEL MASTER works wonders in sight and sound
Ellenville, New York

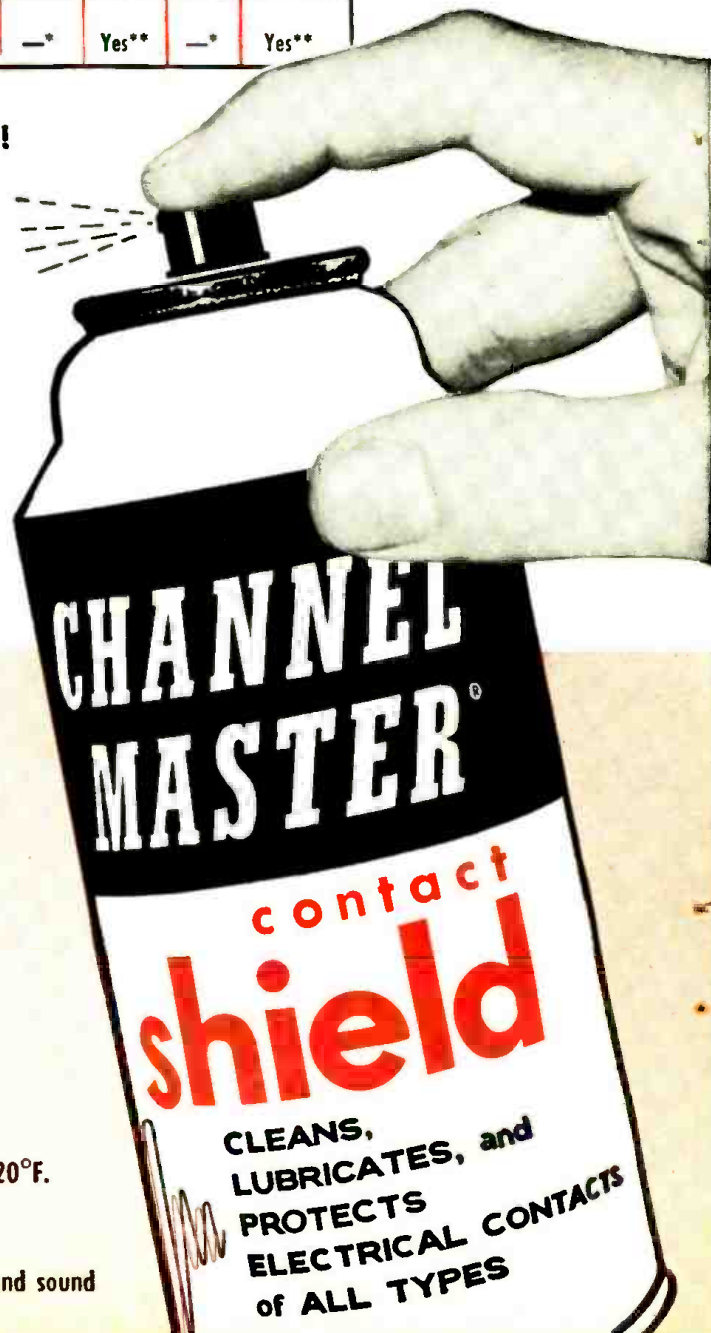

BREAK THROUGH TO HIGHER PAY

in ELECTRONICS

TV-RADIO

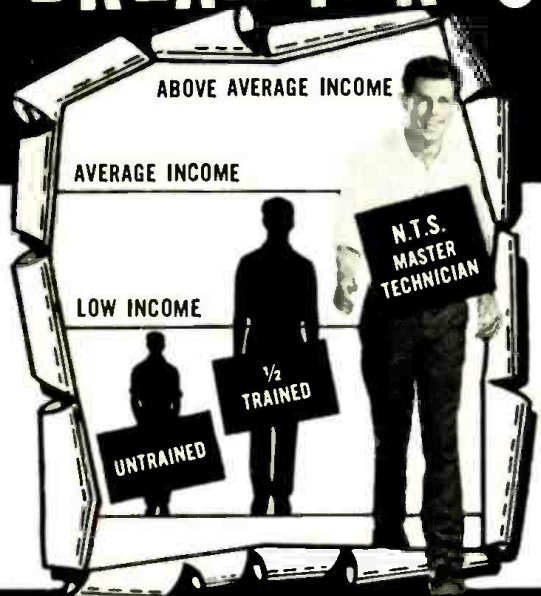

START NOW! Break through the Earning Barrier that stops half-trained men. N.T.S. "All-Phase" training prepares you — at home in spare time — for a high-paying CAREER in Electronics — TV — Radio as a MASTER TECHNICIAN. One Master Course at One Low Tuition trains you for unlimited opportunities in All Phases: Servicing, Communications, Preparation F.C.C. License, Broadcasting, Manufacturing, Automation, Radar and Micro-Waves, Missile and Rocket Projects.

A more rewarding job... a secure future... a richer, fuller life can be yours! As an N.T.S. MASTER TECHNICIAN you can go straight to the top in industry... or in your own profitable business.

You work on actual job projects

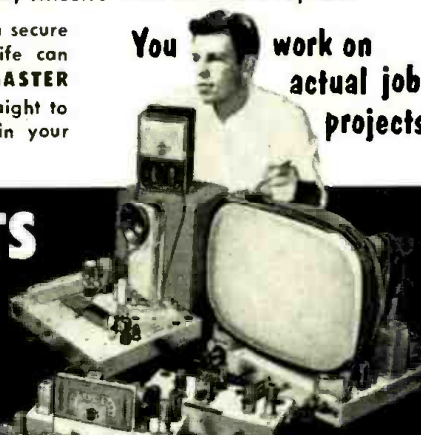

SUCCEED IN MANY HIGH-PAYING JOBS LIKE THESE...

- TV-Radio Sales, Service and Repair
- Profitable Business of Your Own
- Communications Technician — F.C.C. License
- Hi-Fi, Stereo & Sound Recording Specialist
- TV-Radio Broadcasting Operator
- Technician in Computers & Missiles
- Electronics Field Engineer
- Specialist in Microwaves & Servomechanisms
- Expert Trouble Shooter
- All-Phase Master Technician

19 BIG KITS YOURS TO KEEP

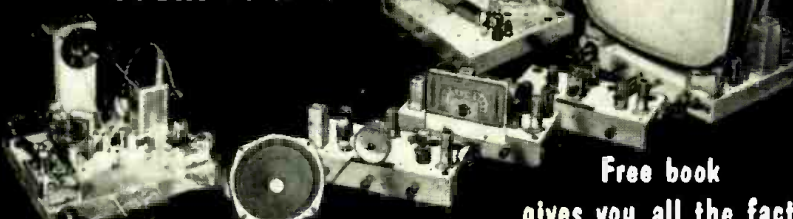

Free book gives you all the facts

NATIONAL TECHNICAL SCHOOLS

WORLD-WIDE TRAINING SINCE 1905
4000 SO. FIGUEROA ST., LOS ANGELES 37, CALIF., U. S. A.

Write Dept.
RH-100



RESIDENT TRAINING AT LOS ANGELES
If you wish to take your training in our Resident School at Los Angeles, start NOW in our big, modern Shops and Labs. Work with the latest Auto and Diesel engines — all types — fuel injection, automatic transmissions, all power equipment — most of complete facilities offered by any school. Expert, friendly instructors. Graduate Employment Service. Help in finding home near school and part time job while you learn.
WRITE FOR SPECIAL RESIDENT SCHOOL CATALOG AND INFORMATION



ACCREDITED MEMBER
... the only nationally recognized accrediting agency for private home study schools.

N.T.S. Shop-Tested HOME TRAINING is **Better, More Complete, Lower Cost**... and it is your key to the most fascinating, opportunity-filled industry today!

YOU LEARN QUICKLY AND EASILY THE N.T.S. SHOP-TESTED WAY

You get lessons, manuals, job projects, unlimited consultation, graduate advisory service. You build a Short Wave-Long Wave Superhet Receiver, plus a large-screen TV set from the ground up, with parts we send you at no addi-

tional cost. You also get a Professional Multimeter for your practical job projects.

EARN AS YOU LEARN... WE SHOW YOU HOW!

Many students pay for entire tuition — and earn much more — with spare time work they perform while training. You can do the same... we show you how.

SEND FOR INFORMATION NOW... TODAY! IT COSTS YOU NOTHING TO INVESTIGATE.

N.T.S. HOME TRAINING is

- Classroom Developed
- Lab-Studio Planned
- Shop-Tested
- Industry-Approved
- Specifically Designed for Home Study



MAIL COUPON NOW for FREE BOOK and ACTUAL LESSON

NO OBLIGATION! NO SALESMAN WILL CALL

NATIONAL TECHNICAL SCHOOLS

WORLD-WIDE TRAINING SINCE 1905

Mail Now To
National Technical Schools, Dept. RH-100
4000 S. Figueroa St., Los Angeles 37, Calif.

Please rush FREE Electronics-TV-Radio "Opportunity" Book and Actual Lesson. No Salesman will call.

Name _____ Age _____
Address _____
City _____ Zone _____ State _____
 Check here if interested ONLY in Resident Training at Los Angeles.
VETERANS: Give date of discharge _____



America's Most Popular, Most Authoritative Books on High Fidelity, Stereo and Tape

Here are some of the world's greatest hi-fi books... chosen carefully by Ziff-Davis Electronics Book Service as among the best in their field.

Right now, one or more of these great books will be sent to you for 7 days FREE! Simply write your choices on the

coupon below and mail it today. When your books arrive, read and enjoy them for seven full days. If, after that, you don't agree that they are everything you need and want, return them and owe nothing.



2751. HI-FI GUIDE-STEREOPHONIC SOUND, Hoefler

A "how-to" book on hi-fi, written in simple language. Will help you buy the right equipment and see that you get the most out of your stereo or monaural investment. \$2.50



2752. HIGH QUALITY SOUND REPRODUCTION, Meli

The perfect manual for both the professional engineer and the serious amateur interested in high fidelity. The "why" and "how" of sound reproduction is covered in complete detail. \$15.00



2753. LOW-COST HI-FI, Hoefler

Hundreds of hints for budget hi-fi will be found in these fourteen chapters with over 300 detailed photographs, drawings and diagrams. Will save you money in starting or improving your system. \$2.50



2755. THE PRACTICAL HI-FI HANDBOOK, King

A guide to high fidelity sound reproduction for the service engineer and amateur. Chapters on amplifiers, loudspeakers, pickups, microphones, record players, disc, tape and stereo. \$5.95



2756. REPAIRING RECORD CHANGERS, Ecklund

A practical manual on repair of mechanical elements of record changers, including pickups, needles, changer actions, motors, drives, tripping, dropping and shut-offs. Also magnetic recorder repairs. \$5.95



2760. HI-FI STEREO FOR YOUR HOME, Whitman

Tells what stereo is, how it differs from hi-fi, how it works, how it affects home listening habits, and how to install and maintain it. Complete list of terms defined. Generously illustrated. \$3.50



42. REVERE TAPE RECORDER GUIDE, Tydings

The first non-technical book to provide useful information on the Revere Tape Recorder. Also a basic guide to the entire field of tape. Will show you new uses and add to your enjoyment. \$1.95



49. TAPE RECORDING GUIDE, Marshall

Designed to help you get the most out of your tape recorder, whether for business, pleasure or professional use. A handy guide to have around, no matter what equipment you own. \$1.95



2750. ELEMENTS OF MAGNETIC TAPE RECORDING, Haynes

Here's how to get professional results with tape the way the experts do. Complete nomenclature, basic techniques, how to splice and edit, how to repair and maintain your recording equipment. \$7.95



2754. MAGNETIC TAPE RECORDING, Spratt

Designed to give principles of magnetic recording and to enumerate characteristics of both the medium and the machines. Excellent for adapting magnetic recording to special needs and wider applications. \$8.95



2757. RIBBONS OF SOUND, Barleben

A handbook on the fundamentals of magnetic tape recording simply and interestingly presented. Factual information you can use no matter what type or make of recorder you own. Paper, \$2.50. 2772. Cloth, \$3.50



2758. TAPE RECORDERS AND TAPE RECORDING, Weller

An ideal sourcebook of information on all aspects of tape recording. Covers all fundamentals necessary to realize full potential of your tape equipment. Special sections on accessories. \$2.95



2000. STEREO HI-FI GUIDE, 1960, Ziff-Davis

1960 edition features 60-page exclusive by Joseph Marshall on components and how they work. Includes "what you should know before buying stereo". Complete, interesting, invaluable! \$1.00



2002. ELECTRONIC KITS DIRECTORY, 1960, Ziff-Davis

New 1960 edition lists over 750 kits, latest models, prices and features for hi-fi kits—preamps, amplifiers, tuners, speakers—ham radio, SWL, Citizens Band, Fun and education. \$1.00



2004. HI-FI ANNUAL & AUDIO HANDBOOK, Ziff-Davis

1960 edition. Prepared by the editors of Electronics World. An excellent advanced guide to theory, construction and circuitry. Over 40 pages on stereo amplifiers and equipment. \$1.00



2005. HI-FI DIRECTORY & BUYERS' GUIDE, Ziff-Davis

1960 edition. World's only complete listing of all hi-fi and stereo equipment, components and accessories. Five big sections, data on more than 1200 components, over 1,000 illustrations! \$1.00



2006. ELECTRONIC EXPERIMENTER'S MANUAL, Findlay

With a few dollars worth of basic tools and this book to guide you, you can explore the wonderful world of electronics experimentation more completely than ever before. 10 big sections. \$4.95



2769. THE ELECTRONIC MUSICAL INSTRUMENT MANUAL, Douglas

Covers every design phase of the modern electronic musical instrument—including theory, schematics of organ circuits, the science of sound as well as the art of music. \$7.50

Yours For a 7-Day Free Examination from **ELECTRONICS** Book Service!

Each volume is designed to help you get more use and pleasure from your high fidelity equipment. Whether you're planning to buy or ready to improve your system—whether you now enjoy stereo or plan to convert to stereo

—whether you're a music-lover or a hi-fi do-it-yourselfer—you'll find one or more books of interest below! For yourself or for gift-giving—use the coupon below today!



2762. FROM MICROPHONE TO EAR, Slot

A complete survey of the technique of sound recording and reproduction, discussing the entire chain from microphone to loudspeaker. A practical book for music-lovers as well as sound technicians. \$4.95

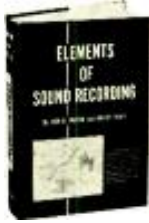

2764. ELEMENTS OF SOUND RECORDING, Frayne and Wolfe

A discussion of basic problems in sound recording and reproducing for the designer, engineer, technician and student. Covers acoustics, vacuum tubes, audio amplifiers, etc. 686 pages. 483 illustrations. \$12.00



2766. HIGH FIDELITY HOME MUSIC SYSTEMS, Wellman

Authoritative advice on choosing the right type of system for your needs with practical information on the functions of each unit—selection, assembly and installation. \$4.50



2767. HIGH FIDELITY TECHNIQUES, Newitt

A comprehensive treatment of both the principles and practice of modern high fidelity sound systems—how to plan a new system, how to improve an existing one. A goldmine of hi-fi information. \$7.50



2771. HI-FI HANDBOOK, Kendall

How to plan your home music system, choose the best components, install your system easily and maintain it by yourself. All these, and ways to save money, are presented in this basic book. \$3.50



2759. TECHNIQUES OF MAGNETIC RECORDING, Taii

Translates the complexities of a science into practical, easy-to-follow techniques. New ideas, new standards, especially for the amateur who wants a good working knowledge of magnetic recording. \$8.50



2763. MAGNETIC RECORDING TECHNIQUES, Stewart

Covers the technology of magnetic recording methods and devices for engineers and technicians concerned with their application in audio, TV, communications, computers and other fields. \$8.50



2765. YOUR TAPE RECORDER, Marshall

Based on 2500 experiments with almost every type of recorder, this book helps to eliminate trial and error under all conditions. Includes illustrations of 55 magnetic recorders with specifications. \$4.95



2768. MAGNETIC RECORDING, Bekun

Thoroughly covers the theory of magnetic recording, various types and makes of recorders, their applications and performance measurements. Includes chapter on important research problems. \$5.00



2770. HOW TO USE A TAPE RECORDER, Hodgson and Bullen

Written to help business and home recorder owners to learn how to get full value from their machines. Explains basic working of tape recorders and accessories as modern tools of communication. \$4.95

*See Your
Hi-Fi Dealer
Or Use This
Coupon Today!*

Leading hi-fi dealers and salons and radio and electronics parts jobbers are making their stores headquarters for books on every electronics subject. You can take this list to your favorite dealer for immediate purchase.

If your local dealer does not carry books, use the coupon for prompt delivery from ELECTRONICS BOOK SERVICE, on a 7-day free trial basis.

ELECTRONICS BOOK SERVICE, One Park Avenue, New York 16, N. Y.

Please send me the book(s) I have listed below for a FREE 7-day Trial Examination. I understand that if I am not completely satisfied, I may return my selection(s) and I'll owe you nothing. Otherwise, I will send you payment for the book(s) of my choice, plus postage and handling. 514

NUMBER	TITLE	PRICE
(If you need more space to list additional titles, attach a sheet of paper with additional list.)		*TOTAL

SAVE MONEY! Enclose payment in full for the book(s) of your choice and we will pay shipping charges. Same return privileges and prompt refund guaranteed.

Please send me **FREE CATALOG**, when published.

**New York City Residents, please add 3% sales tax.*

NAME _____

ADDRESS _____

CITY _____ ZONE _____ STATE _____

PLEASE PRINT CLEARLY

TUBES YOUR CUSTOMERS CAN TRUST

Give your customers tubes they can trust. Give them Sonotone miniaturized electronic tubes. Produced under the highest quality-control standards...rigorously tested to assure superior performance even under extreme conditions. In fact, Sonotone reliable tubes are being used right now in space and military vehicles. Over 150 different types available...for commercial, entertainment and military purposes. Sonotone, for quality tubes you can rely on.

Sonotone PROG

Electronic Applications Division, Dept. TI-100
ELMSFORD, NEW YORK

Leading makers of rechargeable batteries, phono cartridges, speakers, microphones, tape heads and electronic tubes.

In Canada, contact Atlas Radio Corp., Ltd., Toronto

Within the Industry

IRA KAMEN, space technology expert and authority on electronics systems, has been elected president of *Portland Industries* of South Portland, Maine.

Upon accepting his appointment, Mr. Kamen unveiled far-reaching plans to convert the huge Portland facility into an advanced scientific center for the production of complex products in space technology and the sonar and nuclear fields. The company recently completed fabrication and installation of a Bomarc Missile base at Bangor, Maine.

Mr. Kamen's more than twenty years experience in the electronics industry includes development patents in TV; vice-president of *General Bronze Corporation*; consultant to *RCA*, *Paramount Pictures Corporation*, the U. S. Navy, *Temco*, and other organizations. He is also the author of five textbooks and 150 technical papers.



the school, was named special assistant to the president, **J. MORRISON SMITH**.

STANDARD COIL PRODUCTS CO. INC. has changed its name to **STANDARD KOLLSMAN INDUSTRIES INC.** as the result of majority action by the company's stockholders... **CAVALIER AND COMPANY**, 922 King Street, Wilmington, Del., has established a custom optical lens and quartz-crystal grinding and polishing division geared especially to the requirements of electronic and research-development laboratories... The formation of a new company to manufacture silicon solar cells, silicon photocells, and related items has been announced. The company, **SOLAR SYSTEMS, INC.**, is occupying a modern, air-conditioned building at 8241 N. Kimball Ave., Skokie, Ill. Jerome Kalman, formerly with the *Hoffman Semiconductor Division*, is general manager of the new firm... The stockholders of **FAIRCHILD CAMERA AND INSTRUMENT CORPORATION** and **ALLEN B. DU MONT LABORATORIES, INC.** have approved a merger of the two corporations, with *Fairchild* the surviving company.

RAY W. LUNSTEAD has been appointed manager of *Ward Leonard Electric Company's* electronic distributor division. Formerly assistant manager, he joined the company in 1941... **JEF-FREY J. BOWE** has been named department head at *Sperry Rand Corporation's* semiconductor division; while **ROBERT B. WRIGHT** has been appointed director of industrial relations for the division... **BURTON R. COHN** has been named general manager of *General Transistor Corporation's* systematics division. Prior to joining the company in 1958, Mr. Cohn was production manager of *Radio Receptor Co.*... **J. A. MILLING**, president of the Photofact division of *Howard W. Sams and Co.*, has been re-appointed chairman of the distributor relations committee of the Electronic Industries Association... **FRED W. EDWARDS** has been elected to the new position of vice-president-engineering of *Standard Kollsman Industries, Inc.* He had been the company's chief engineer, having joined the firm in 1946... **GEORGE A. SCHUPP** has been appointed director of engineering for the consumer products division of *Magnavox*. He comes to this company from *General Electric*... **EDWARD L. DEGENER**, general manager of *National Radio Institute*, has retired after 42 years with the school. At the same time **HAROLD E. LUBER** was upped to the post of executive vice-president and **EVERETT A. COREY**, who recently joined

WALTER E. PEEK has been named vice-president, marketing, of *Centralab*, the Electronics Division of *Globe-Union, Inc.*

The position is a new one created in keeping with an administrative re-organization of the parent company to give each product division greater operating autonomy than in the past.

Mr. Peek was formerly the division's general sales manager. He has been with the firm since 1953 and active in the electronic industry since 1930.

At the same time the company announced that Bruce E. Vinkmulder, formerly assistant general sales manager, has been named marketing manager of the division.

SYLVANIA ELECTRIC PRODUCTS INC.'s Advanced Device Research Laboratory has been moved from Northlake, Ill. to Waltham, Mass. It is anticipated that the laboratory will then be moved from Waltham to Woburn, Mass. early in 1961... **LAMART CORP.** of Clifton, N. J., has moved to a new location at 16 Richmond St., also in Clifton. The company expects to double its production output as a result of the move... **VITRO CORP. OF AMERICA** has announced the opening of a West Coast



ELECTRONICS WORLD



THIS IS PHOTOFACT SET NO. 500

truly a milestone in the history of the Electronic Servicing Industry

over **20,000,000** PHOTOFACT Sets are now in use the world over
 over **50,000** listings of TV, Radio and allied equipment are covered
 over **23,000** Service Technicians subscribe to every new PHOTOFACT Set
 over **75,000** Service Technicians refer to PHOTOFACT daily

PLAIN FACTS: PHOTOFACT owes its universal acceptance and success to its unquestioned ability to help *earn more money for any Service Technician*. The man

who owns a PHOTOFACT Service Data Library knows his customers' sets best. **HE EARNS MORE... HE RATES with the public because he's PHOTOFACT-EQUIPPED.**



BE AMONG THE FIRST IN YOUR COMMUNITY TO DISPLAY THIS POWERFUL SYMBOL

If you now own a PHOTOFACT Library or plan to own one, you can apply for membership in "PEET"—the first industry program to build truly effective public acceptance for the Service Technician who qualifies. Membership helps you win public respect and confidence, builds more business for you. Benefits cost you absolutely nothing if you qualify. Ask your Sams Distributor for the "PEET" details, or mail coupon today.

HOWARD W. SAMS & CO., INC.

October, 1960

WRITE TODAY FOR VALUABLE INFORMATION

HOWARD W. SAMS & CO., INC.
 1724 E. 38th St., Indianapolis 6, Ind.

Send me full details on how I can qualify for membership in the "PEET" Program. Include details of Easy-Buy Plan and Free File Cabinet offer.
 I'm a Service Technician full-time; part-time

My distributor is _____

Shop Name _____

Attn.: _____

Address _____

City _____ Zone _____ State _____



from stand



to hand . . . instantly



introducing the
world's smallest
cardioid dynamic
microphone

UNIDYNE III
by
SHURE

EVERYTHING YOU WANT IN A
QUALITY CARDIOD MICROPHONE
. . . AND THEN SOME!

Compact size . . . modern design . . .
wide response . . . superior feedback
suppression . . . uniform cardioid pat-
tern . . . ruggedness . . . reliability; you
name it, SHURE has designed it into
the dramatic new Unidyne III.

50% SMALLER — Less than 6" x 1 1/4",
0.6 lb.!

PERFECTION IN PERFORMANCE — moving
coil design with truly uniform cardioid
pick-up pattern. Response: 50 to 15,000
cps. Up to 75% greater distances from
sound source. Impressive feedback sup-
pression.

MAXIMUM VERSATILITY — unobtrusive
size, dual impedance, light weight, in-
stant change from stand to hand, and
wide-range response make it ideal for
faithful reproduction of voice or music,
indoors or out, for P.A., tape recording
. . . anywhere fine quality is required.

RUGGED AND RELIABLE — Famous
SHURE quality. Takes 6-foot drop-
tests and still performs according to
specifications!

Literature available:

SHURE BROTHERS, INC.
222 Hartrey Ave., Evanston, Ill.

\$51⁰⁰

Professional Net

facility in Los Angeles. The organiza-
tion provides design, engineering, and
construction management services for
industrial and defense facilities . . .

BRADLEY SEMICONDUCTOR CORP. has
announced a move into modern facili-
ties at 275 Welton St., Hamden, Conn.
for more efficient production, research,
and testing of electronic components
in the semiconductor field . . . **LEL, INC.**
has moved into a new plant at 75 Ak-
ron St., Copiague, Long Island, N. Y.

JOHN R. MEAGHER has been appointed
manager of electronic instruments
merchandising for
the Distributor
Products Depart-
ment, RCA Electron
Tube Division.



An authority on
radio and televis-
ion servicing, Mr.
Meagher has lec-
tured before service
groups in virtually
every state in the
nation. In the 1920's, he edited *Wire-
less Age*. Later Mr. Meagher went into
research laboratory work. In 1936 he
joined RCA and has since served as
technical editor, field engineer, author,
and lecturer on test equipment.

He developed the TV dynamic dem-
onstrator, an outgrowth of the original
radio demonstrator which he devised in
1936. In 1946 he compiled the RCA
"Pict-O-Guide" as a TV servicing aid.
His color "Pict-O-Guide" was pub-
lished in 1957.

THOMPSON-RAMO-WOOLDRIDGE INC.
of Canoga Park, Calif., will manufac-
ture and sell its RW-300 digital control
computer in the European Common
Market through a newly formed sub-
sidiary with headquarters in Paris.
The new organization, called *Com-
pagnie Europeenne d'Automatisme
Electronique*, is part of the firm's in-
ternational division and is capitalized
at \$1,500,000 . . . **TEXTRON, INC.** has es-
tablished **BELL AEROSPACE CORP.** as a
wholly owned subsidiary for the manu-
facture of rocket engines, electronics,
helicopters, and servo-mechanical sys-
tems.

WALTER L. SCHOTT has been named
manager of the distributor sales divi-
sion of *International
Rectifier Corpora-
tion*, El Segundo,
Calif.



Mr. Schott, who
founded *Walsco*, and
later headed the *Au-
diotex* division of
*General Cement-
Textron*, will now
direct all activities of the *International
Rectifier* distributor network, which
includes 90 authorized industrial dis-
tributors and over 600 parts jobbers.

DR. SORAB K. GHANDHI has been ap-
pointed manager of solid-state circuit
research for *Philco Corporation's* re-
(Continued on page 114)



QUIETROLE

LUBRI-CLEANER

The first of its kind and still best for
silencing noisy controls and switches in
TV, Radio & all Electronic Equipment.

Spray it or Drop it

Just Press and
whoosh . . . aera-
sol QUIETROLE
quickly and easily
cleans as it lubri-
cates.

• Or, if you prefer, use
• this handy eye-drop-
• per and just a drop
• or two of quality
• QUIETROLE does the
• job perfectly.

Either way, make sure it's QUIETROLE

QUIETROLE Company, Inc.

Spartanburg, South Carolina



In Canada:
CROSS CANADA ELECTRONICS
67 Ontario St., S., Kitchener, Ont.

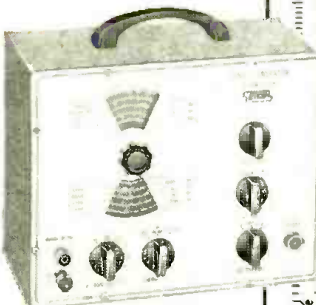

RF SIGNAL GENERATOR #324
KIT \$26.95 WIRED \$39.95
Turn Page For More EICO Values

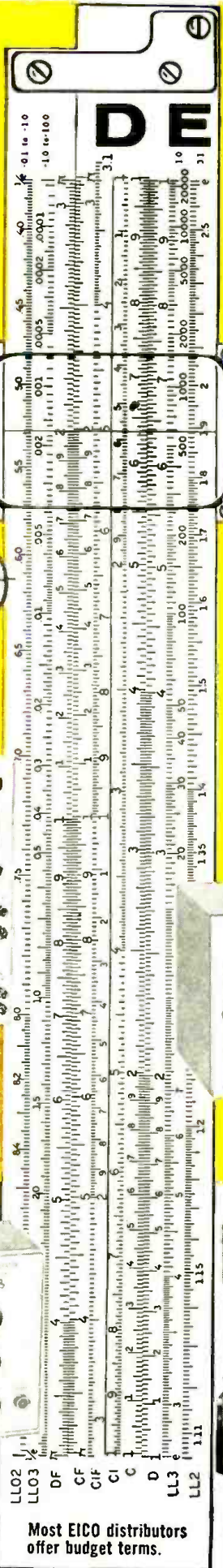

DESIGNED

AS YOU WOULD DESIGN IF YOU WERE AN ELECTRONICS ENGINEER...

Praised by the experts as Best Buys... **EICO**

A PEAK-TO-PEAK VTVM #232 & UNI-PROBE KIT \$29.95 WIRED \$49.95

B COLOR & MONOCHROME DC TO 5 MC LAB & TV 5" OSCILLOSCOPE #460 KIT \$79.95 WIRED \$129.50

Also available:
5" Push-Pull Oscilloscope #425
Kit \$44.95 WIRED \$79.95

A By far the best professional VTVM value in electronics; nobody but EICO brings you such outstanding instrument performance for so low a price! Calibration without removing from cabinet. Measure directly p-p voltage of complex & sine waves: 0-4, 14, 42, 140, 420, 1400, 4200. DC/RMS sine volts: 0-1.5, 5, 15, 50, 150, 500, 1500 (up to 30,000 volts with HVP probe, & 250 mc with PRF probe). Ohms: 0.2 ohms to 1000 megs. 4 1/2" meter, can't-burn-out circuit. 7 non-skip ranges on every function. Zero center. Features EICO's exclusive UNI-PROBE: your terrific time-saver, performs all functions: a half turn of probe-tip selects DC or AC-Ohms!

B An engineering achievement unmatched in the industry! EICO-designed for laboratory precision and EICO-priced for lowest cost. Features DC amplifiers. Flat from DC to 4.5 mc, usable to 10 mc. Vert. Sens.: 25 mv/in.; input Z 3 megs; direct-coupled & push-pull throughout. 4-step frequency-compensated attenuator up to 1000:1. Sweep: perfectly linear 10 cps - 100 kc (ext. cap. for range to 1 cps). Pre-set TV V & H positions. Auto sync limiter & amplifier Direct or C coupling; balanced or unbalanced inputs; edge-lit engraved lucite screen with dimmer control.

C More features and versatility, more range and accuracy than in generators costing three to four times as much. 150 kc to 435 mc. with ONE generator in 6 fundamental bands and 1 harmonic band! $\pm 1.5\%$ frequency accuracy. Colpitts RF oscillator directly plate-modulated by K-follower for improved modulation. Variable

depth of internal modulation 0-50% by 400 cps Colpitts oscillator. Variable gain external modulation amplifier: only 3 volts needed for 30% mod. Turret-mounted, slug-tuned coils for max. accuracy. Fine & Coarse (3-step) RF attenuators. RF output 100,000 uv, AF output to 10 v.

D Provides more ranges, greater ease and accuracy, and better performance than any competitive unit. Entirely electronic sweep circuit with accurately-biased inductor for excellent linearity. Extremely flat RF output. Exceptional tuning accuracy. Hum & leakage eliminated. 5 fundamental sweep ranges: 3-216 mc. Variable marker range: 2-75 mc in 3 fund. bands, 60-225 mc on harmonic band. 4.5 mc crystal marker osc., crystal supplied. Ext. marker provision. Attenuators: Marker Size, RF Fine, RF Coarse (4-step decade). Narrow range phasing control for accurate alignment.

E Speedy, simple operation, unexcelled sensitivity and accuracy; superb electrical and mechanical design. Tests all receiving tubes (picture tubes with adapter), n-p-n and p-n-p transistors. Composite indication of Gm, Gp & peak emission. Simultaneous selection of any one of 4 combinations of 3 plate voltages, 3 screen voltages, 3 ranges of continuously variable grid voltage (with 5% accuracy pot.). Sensitive 200 ua meter. 10 six-position lever switches; freepoint connection of each tube pin. 10 push-buttons: rapid insert of any tube element in leakage test circuit. Direct reading of inter-element leakage in ohms. New gear-driven rollchart. CRA Adapter \$4.50.



D TV-FM SWEEP GENERATOR & MARKER #368 KIT \$69.95 WIRED \$119.95



E DYNAMIC CONDUCTANCE TUBE & TRANSISTOR TESTER #666 KIT \$69.95 WIRED \$109.95
Complete with steel cover and handle



All Transistor Portable RA-6 Kit \$29.95
Wired \$49.95
less battery



Power & Bias Supply for Transistorized Eqpt. #1020 Kit \$19.95
Wired \$27.95



DeLux Multi-Signal Tracer #147 Kit \$24.95
Wired \$39.95



Tube Tester #625 Kit \$34.95
Wired \$49.95
Pix Tube Test Adapter #4.50



6 & 12V Battery Eliminator & Charger #1050 Kit \$29.95
Wired \$38.95
#1060 Kit \$38.95
Wired \$47.95



V-O-M #565 Kit \$24.95
Wired \$29.95
V-O-M #536 Kit \$12.90
Wired \$14.90



R-C Bridge & R-C-L Comparator #950B Kit \$19.95
Wired \$29.95

Most EICO distributors offer budget terms.

SEE YOUR OTHER ADVERTISEMENT ON PAGE 146

EICO 33-00 Westchen Blvd., L. I. C. 1, N. Y. EW-10
Show me HOW TO SAVE 50% on Test Instruments
 Hi-Fi Xam Gear Send free Stereo Hi-Fi Guide. Send me FREE Catalog, name of neighborhood dealer Send free Short Course for Novice License.

Name _____
Address _____
City _____ Zone _____ State _____

© 1960 EICO 33-00 N Blvd., L. I. C. 1, N. Y. Add 5% in the West

Over 2 MILLION EICO instruments in use throughout the world. Add 5% in the West.



IF YOU LOVE TO CREATE... BUILD **EICO** KITS

In **STEREO** and

Mono Hi-Fi...
the experts say
your Best Buy
Is EICO



Stereo Amplifier-Preamp HF81†



Stereo Preamp HF85††



FM Tuner HFT90††
AM Tuner HFT94††
FM/AM Tuner HFT92††



100W Stereo Power Amplifier HF89
70W Stereo Power Amplifier HF87
28W Stereo Power Amplifier HF86



Stereo Integrated Amplifier AF4††



3-Way Speaker System HFS3
2-Way Bookshelf Speaker Systems
HFSS and HFS1



NEW!
Stereo Automatic Changer/
Player 1007



- Exclusive advanced systematized engineering
 - Latest and finest quality parts
 - Exclusive "Beginner-Tested" easy step-by-step instructions
 - Exclusive TRIPLE quality control
 - Exclusive LIFETIME guarantee at nominal cost
- IN STOCK** — Compare, then take home any EICO equipment — right "off the shelf" — from 1500 neighborhood EICO dealers throughout the U. S. & Canada, most of whom offer budget terms.
- HF81 Stereo Amplifier-Preamp** selects, amplifies, controls any stereo source & feeds it thru self-contained dual 14W amplifiers to a pair of speakers. Provides 28W monophonically. Ganged level controls, separate balance control, independent bass and treble controls for each channel. Identical Williamson-type, push-pull EL84 power amplifiers. "Excellent" — SATURDAY REVIEW. "Outstanding... extremely versatile." — ELECTRONICS WORLD. Kit \$69.95. Wired \$109.95. Incl. cover.
- HF85 Stereo Preamp**: Complete master stereo preamp/control unit, self-powered. Distortion borders on unmeasurable. Level, bass, & treble controls independent for each channel or ganged for both channels. Inputs for phono, tape head, mike, AM, FM, & FM-multiplex. One each auxiliary A & B input in each channel. "Extreme flexibility... a bargain." — HI-FI REVIEW. Kit \$39.95. Wired \$64.95. Incl. cover.
- New HF89 100-Watt Stereo Power Amplifier**: Dual 50W highest quality power amplifiers. 200W peak power output. Uses superlative ultralinear connected output transformers for undistorted response across the entire audio range at full power, assuring utmost clarity on full orchestra & organ. 60 db channel separation. IM distortion 0.5% at 100W; harmonic distortion less than 1% from 20-20,000 cps within 1 db of 100W. Kit \$99.50. Wired \$139.50.
- HF87 70-Watt Stereo Power Amplifier**. Dual 35W power amplifiers identical circuit-wise to the superb HF89, differing only in rating of the output transformers. IM distortion 1% at 70W; harmonic distortion less than 1% from 20-20,000 cps within 1 db of 70W. Kit \$74.95. Wired \$114.95.
- HF86 28-Watt Stereo Power Amp**. Flawless reproduction at modest price. Kit \$43.95. Wired \$74.95.

- FM Tuner HFT90**: Prewired, prealigned, temperature-compensated "front end" is drift-free. Prewired exclusive precision eye-tronic® traveling tuning indicator. Sensitivity: 1.5 uv for 20 db quieting; 2.5 uv for 30 db quieting, full limiting from 25 uv. IF bandwidth 260 kc at 6 db points. Both cathode follower & FM-multiplex stereo outputs, prevent obsolescence. Very low distortion. "One of the best buys in high fidelity kits." — AUDIOCRAFT. Kit \$39.95. Wired \$65.95. Cover \$3.95. "Less cover, F.E.T. incl."
- AM Tuner HFT94**: Matches HFT 90. Selects "hi-fi" wide (20-9000 cps @ -3 db) or weak-station narrow (20-5000 cps @ -3 db) bandpass. Tuned RF stage for high selectivity & sensitivity. Precision eye-tronic® tuning. "One of the best available." — HI-FI SYSTEMS. Kit \$39.95. Wired \$65.95. Incl. cover & F.E.T.
- FM/AM Tuner HFT92** combines renowned EICO HFT90 FM Tuner with excellent AM tuning facilities. Kit \$59.95. Wired \$94.95. Incl. cover & F.E.T.
- AF4 Economy Stereo Integrated Amplifier** provides clean 4W per channel or 8W total output. Kit \$38.95. Wired \$64.95. Incl. cover & F.E.T.
- HF12 Mono Integrated Amplifier** (not illus.): Complete "front end" facilities & true hi-fi performance. 12W continuous, 25W peak. Kit \$34.95. Wired \$57.95. Incl. cover.
- HFS3 3-Way Speaker System Semi-Kit** complete with factory-built 3/4" veneered plywood (4 sides) cabinet. Bellows-suspension, full-inch excursion 12" woofer (22 cps res.) 8" mid-range speaker with high internal damping cone for smooth response, 3 1/2" cone tweeter. 2 1/4 cu. ft. ducted-port enclosure. System Q of 1/2 for smoothest frequency & best transient response. 32-14,000 cps clean, useful response. 16 ohms impedance. HWD: 26 3/8" x 13 7/8" x 14 5/8". Unfinished birch. Kit \$72.50. Wired \$84.50. Walnut or mahogany. Kit \$87.50. Wired \$99.50.
- HFS5 2-Way Speaker System Semi-Kit** complete with factory-built 3/4" veneered plywood (4 sides) cabinet. Bellows-suspension, 5/8" excursion. 8" woofer (45 cps. res.), & 3 1/2" cone tweeter. 1 1/4" cu. ft. ducted-port enclosure. System Q of 1/2 for smoothest freq. & best transient resp. 45-14,000 cps clean, useful resp. 16 ohms.

- HWD: 24" x 12 1/2" x 10 1/2". Unfinished birch. Kit \$47.50. Wired \$56.50. Walnut or mahogany. Kit \$59.50. Wired \$69.50.
- HFS1 Bookshelf Speaker System** complete with factory-built cabinet. Jensen 8" woofer, matching Jensen compression-driver exponential horn tweeter. Smooth clean bass; crisp extended highs. 70-12,000 cps range. 8 ohms. HWD: 23" x 11" x 9". Kit \$39.95. Wired \$47.95.
- HFS2 Omni-Directional Speaker System** (not illus.) HWD: 36" x 15 1/4" x 11 1/2". "Fine for stereo" — MODERN HI-FI. Completely factory-built. Mahogany or walnut \$139.95. Blond \$144.95.
- New Stereo/Mono Automatic Changer/Player**: Jam-proof 4-speed, all record sizes, automatic changer and auto/manual player. New extremely smooth, low distortion moisture-proof crystal cartridge designed integrally with tonearm to eliminate mid-range resonances. Constant 4 1/2 grams stylus force is optimum to prevent groove flutter distortion. No hum, turntable attractions, acoustic feedback, center-hole enlargement. Only 10 3/4" x 13". 1007S: 0.7 mil, 3 mil sapphire, \$49.75. Incl. F.E.T. and "Magnadaptor."
- †Shown in optional Furniture Wood Cabinet
WE71: Unfinished Birch, \$9.95; Walnut or Mahogany, \$13.95.
- ††Shown in optional Furniture Wood Cabinet
WE70: Unfinished Birch, \$8.95; Walnut or Mahogany, \$12.50.

EICO, 33-00 N. Blvd., L.I.C. 1, N. Y. EW-10
Show me how to SAVE 50% on easy-to-build top-quality Hi-Fi. Send FREE catalog, Stereo Hi-Fi Guide plus name of neighborhood EICO dealer.

Name _____
Address _____
City _____ Zone _____ State _____

Listen to the EICO Hour. WABC-FM, N. Y. 95.5 MC, Mon.-Fri., 7:15-8 PM.
© 1960 by EICO, 33-00 N. Blvd., L. I. C. 1, N. Y.

This author's provocative view is that this amplifier rating is a step in the right direction, however it may not tell the whole story about hi-fi performance.

By **NORMAN H. CROWHURST**

THE question that triggered this article is, "Does the new Music Power Rating help tell the quality of an amplifier? If so, how?" The answer to this question will be covered later, but mainly some concepts, notions, and viewpoints need clarifying first. There will be some explaining to do—why the particular Music Power Output definition, as used by the IHFM (Institute of High Fidelity Manufacturers) standard for rating amplifiers, was chosen, as well as what it can tell us.

For a long while, the accepted methods of rating or specifying amplifier performance have been recognized as inadequate for assessing the relative merit of different products. This has been correctly related to the fact that music, or other program material, is different in many respects from the pure-tone sine waves used for testing amplifiers.

These two standards differ in two respects: all test tones, whether one or two sine waves, or a square wave, are applied steadily, while the tones in music are constantly changing, often rapidly. Apart from their transient nature, musical waveforms are much

more complicated than anything used for testing, even when the tones are steady.

Some Viewpoints

Engineers in the high-fidelity industry have, for some time, been concerned by this discrepancy. Some have tried to do something about it and some have even dared to try and make an amplifier whose first job was to sound good, even if its specifications didn't read quite as impressively! But these engineers soon ran into opposition.

Some people either are not able to listen critically or else don't believe their ears. They want something in print that they can show around, proving that the product they have is better. We have no argument with this attitude. The difficulty is, what figures can we provide that really prove something? The notion of music power output originated with engineers: it should be a way of rating amplifiers which will more nearly evaluate how "loud" they will sound, than does the conventional power output rating.

One problem is that steady power tests force the amplifier to deliver its

maximum power continuously. Musical program material calls for maximum power for only short periods of time. Why not see what an amplifier will produce when the demand is not continuous?

If you put just one or two cycles of a frequency through an amplifier you can see its performance during such a short burst but you cannot measure it because the meters won't have time to "get up to" whatever the reading is. To overcome this, the method specified by the IHFM involves the maintenance (artificially), from an external source, of the voltages that sag under continuous power for long enough to get the reading.

This sounds good, when it is explained to you, otherwise it might appear to be "cheating a bit." Next, you want to know what the "answers" mean. And that is a good question. Until most audiophiles and hi-fi equipment makers use the music power rating, the more familiar continuous output power will also be given. So your question is: which is better, an amplifier that has both ratings the same, or nearly the same, or one for which the

Music-Power Rating

Help or Hindrance?

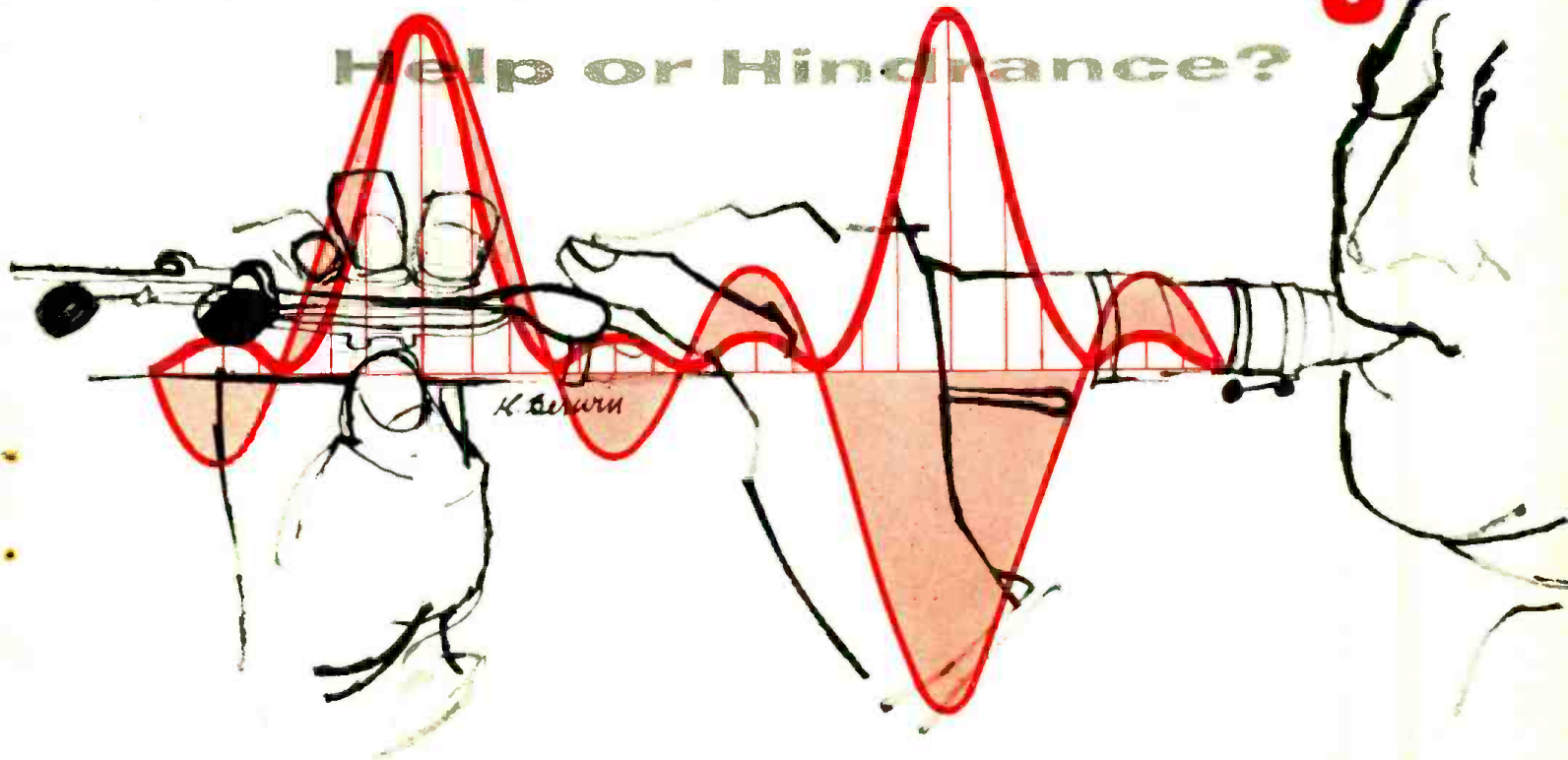

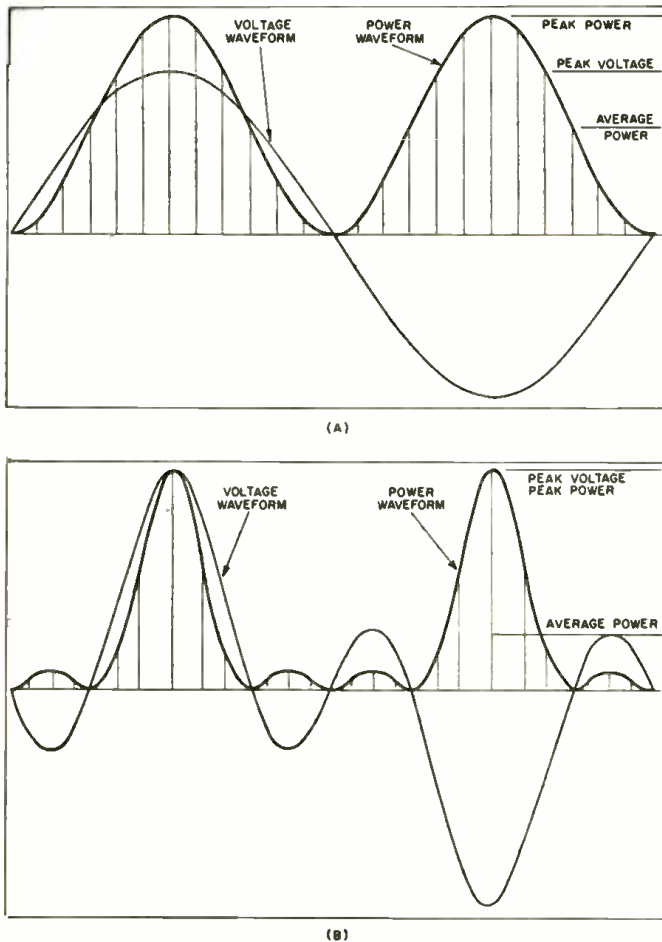

Fig. 1. Comparison of voltage and power waveforms for (A) simple sine wave and (B) musical tone consisting of a fundamental with considerable third harmonic.

music power is appreciably higher than the continuous power?

Pursuing this question reveals the fact that an amplifier with good power-supply regulation will have ratings which are closer together while one whose power supply provides poorer regulation will show a greater difference between continuous and music power ratings. Surely the amplifier with the better regulated power supply is the better amplifier? Put it this way: do you want quality watts per dollar or are you looking for the highest power irrespective of cost?

One amplifier may have both ratings at 25 watts. Another unit, by spending part of what the first spent on the power supply on other features, may give 25 watts continuous but also manages 35 watts music power as well. The second amplifier will undoubtedly provide greater clean music volume—other things being equal—than the first unit.

But we have no objection to a third amplifier that gives 35 watts measured both ways, if the manufacturer can make it competitively. It is an even better amplifier than the second one, but whether it is worth paying the 30% to 40% higher price is up to the buyer to decide.

This is, roughly, the way the new music power rating works out. It is a step forward, but some engineers are still not satisfied. While it does come

nearer to some aspects of how an amplifier performs on music, it still misses some points.

Another Look at Waveforms

What is the true relationship between the power in a musical program and the maximum power as measured by a single tone? This is the question the new music power rating does not really touch because both ratings, by definition, measure *average* power. Average *music* power can have a number of different connotations, while the average power of a sine-wave output is unambiguous.

It was the transient nature of music power that dictated the new rating. But even a steady tone, such as that played by a single instrument, can have quite a different average power from that of a sine wave, in terms of what an amplifier can handle. See Fig. 1.

The limitation to the handling capacity of an amplifier is the instantaneous *peak* power it can deliver. The peak power of a 10-watt sine wave is 20 watts. But a musical tone with 20 watts peak may very well have an average power of less than 5 watts—even as a single continuous tone. That is really the first basis for differences.

It affects the rating question in two ways. First, the lower "waveform factor" means the regulation will not hurt even a sustained tone's power as much as with the test sine waves (*unless the*

Fig. 2. The effect of combining two tones of different frequency on the relationship between the peak and average power.

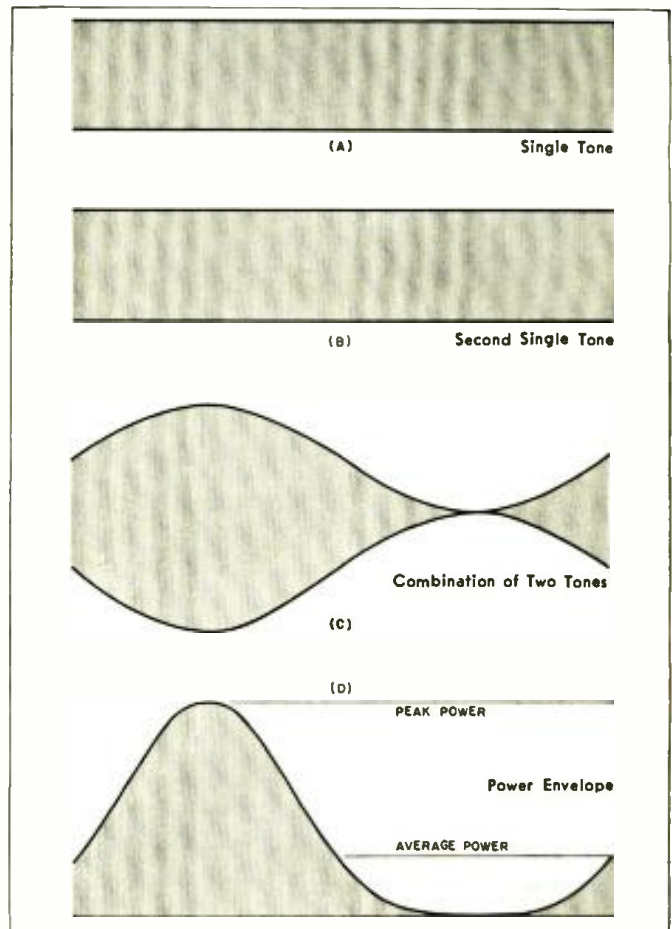

sustained tone is sinusoidal, approaches a square shape, or has a "waveform factor" such that its average value is higher than a sine wave—Editor.) Second, it alters the picture as to what "average power" itself really means.

Next point: music consists of many tones played at any single instant—most of the time. Each tone has a different frequency. At a frequency corresponding to this difference, the peaks of two tones will coincide. At each such coincidence, it is the voltage, not the power, that adds to determine the total peak. If peak voltage doubles, peak power is quadrupled, as shown in Fig. 2.

Suppose each of three tones has an average power of .5 watt and a peak power of 2 watts. If the impedance is 8 ohms, each peak will be 4 volts. Three of them will reach occasional "spikes" of 12 volts (Fig. 3). This is a power of 18 watts, although the average is only 1.5 watts. If a pedal tone is also present, it may need a further 5-watts average with perhaps 18-watts peak, also 12 volts. Now we need 24 volts, which is 72-watts peak, for just a pedal tone and trichord, totalling an average power of 6.5 watts. See Fig. 4.

The more complex the music, the greater the basic factor between average and peak power. You may have noticed that orchestral music at a certain nominal output power does not seem as loud as, say, a jazz combo.

This is because the ear recognizes the sum of all the average powers. To make the reckoning easy, let's assume each instrument contributes 0.5 watt average power and needs 2 watts or 4 volts peak.

A four-piece combo will give 2 watts average, but needs 16 volts or 32 watts peak power. A 40-piece orchestra will give 20 watts average, but needs 160 volts or 3200 watts peak power! Nobody has that kind of power, so assume we play with the same margin of safety against possible distortion: the four-piece combo can be played at a realistic level of 2 watts average from a 16-watt amplifier (32 watts peak); but the orchestra will have to be turned down to only one-fifth of a watt *total average*, to stay within 32 watts peak.

This explains why a much bigger amplifier is needed to handle good orchestra music, even though the sound doesn't seem any louder—if as loud. It also explains why no single music power rating, based on an average, can ever be completely practical.

With so many variables, the only point of common reference between amplifiers and the music they handle is *peak* power. This is what determines when the amplifier starts to distort the music. The average power that corresponds to this peak power depends entirely on the music, not the amplifier. The "waveform factor" may react on the power-supply regulation to modify the peak capability according to what

the average power is. But even the worst power-supply regulation usually makes little difference on this, with most kinds of *music*.

There was a move, some years ago, to rate amplifiers by peak power. Proposed with honest intentions, it was based on similar reasoning but the simple two-to-one relationship for test sine waves led to its serious misuse.

Give a Dog a Bad Name!

The intention was not to just double the number already on the amplifier nameplate, but this is what many companies did. The peak power intended was what the amplifier could handle on peaks, representative of the relative duration encountered in music. But insufficient explanation, plus the urge by some just to use bigger numbers, led to confusion.

Some firms measured peak power the way the IHFM now defines music power. It was really a short-term average power. Others double the number they already had, based on the mathematical sine-wave relationship. Yet others doubled the short-term average power, giving the instantaneous peak value of such a wave—and the highest number of all.

This last figure was really the most logical and, if everyone used it, would be the most informative regarding amplifier performance because it does relate directly to the musical program the amplifier can handle.

But the fact that so many methods of rating were used, led many to believe that the "good old standard" watts were "honest watts", with the obvious implication that the others were cheating — "just doubling the numbers to make the amplifier look bigger!"

This was understandable. If the new number really told something extra about the amplifier's performance, it was useful. But most often it was obtained by the arithmetical operation of multiplying by two. This had no value, except to further confuse the already confused consumer.

Experiences like this are difficult to live down. On the committee that discussed the new IHFM music power rating, several engineers favored the use of a *peak* music power rating. This would double the figure as presently defined. But they remembered the hangover of adverse criticism from the last attempt and compromised by using the present definition.

Pots and Kettles

This compromise is not unreasonable when you consider some other factors. Most important among these: what does the power rating of a loudspeaker mean? It is intended to be the electrical input power the speaker can handle, as delivered by the amplifier. A 10-watt speaker with 10% efficiency (and that's high) should be able to
(Continued on page 108)

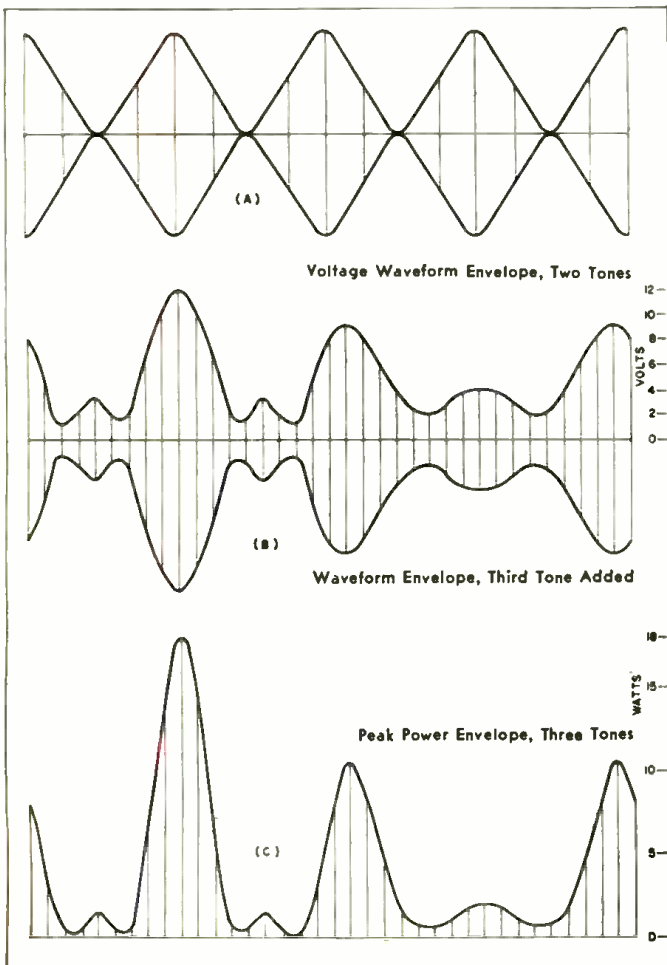
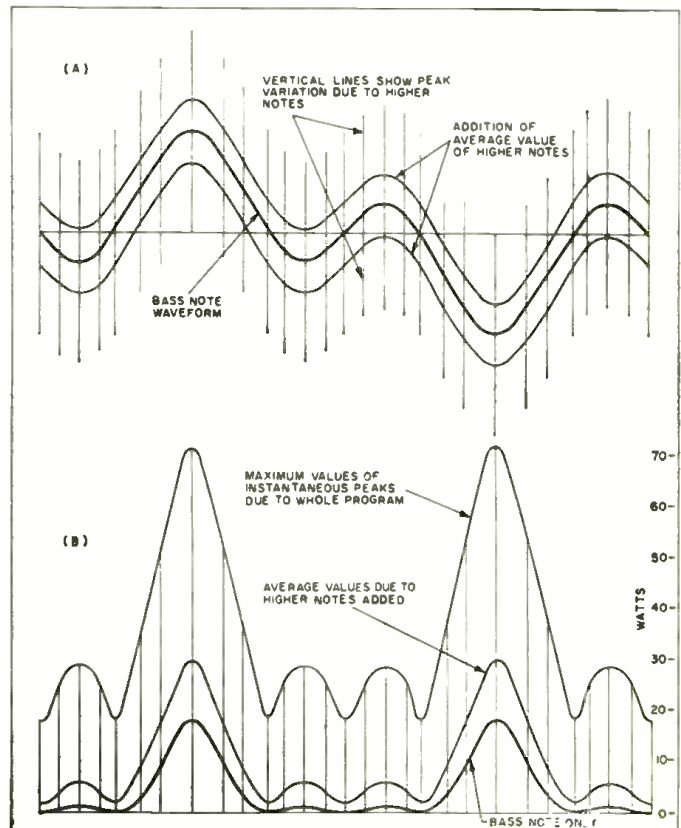

Fig. 3. Voltage and power relations that exist in an audio amplifier when three different tones are combined.

Fig. 4. Voltage and power levels that exist in musical phrase in which there are 1 bass and 3 mid-range notes.



Audio-Ultrasonic Pickup Circuit

By HAROLD REED

Simple, sensitive circuit operates relay when placed near signal-carrying circuits. May be used as sound-operated relay from 20 cps to 500 kc. at inputs as low as 3 mv.

THE author required a simple circuit that could be used for inductive pickup service over a wide frequency range with very low signal input voltages and with a total parts cost of under \$10.00. In addition, since a circuit was wanted that would energize a relay from the minute 25-cycle a.c. field of a telephone ringer coil, it was decided to "breadboard" a circuit to see what could be done. Since the cost had to be kept low, an extremely sensitive, expensive relay was taboo. The final circuit, for which all parts are readily available, is shown in Fig. 1.

Circuit Description

Any induced a.c. signal picked up by the pickup coil, L_1 , is amplified by the first transistor stage, V_1 . The output from this stage is rectified by the shunt-type diode rectifier circuit—a circuit using two crystal diodes CR_1 and CR_2 . A transistor d.c. amplifier, V_2 , follows the rectifier with the control relay in the collector circuit.

The relay is a 4000-ohm unit. Other 4000- to 8000-ohm relays may be used. The *Cardwell* BK-7-B, shown in the diagram, has adjustable sensitivity and has been available on the surplus market at a low price (\$1.50) for quite a while.

The experimenter may use other general-purpose transistors but the crystal-diode rectifiers should be of the high-conduction type as shown. Capacitor values may be changed if wide-frequency-range operation is not required.

If a different relay is used, it may be necessary to change the value of capac-

itor C_1 . If this is too large, the relay pickup and drop-out may be delayed due to the charge-discharge time of the capacitor. If it is too small, relay chatter may occur at lower frequencies.

Measured Data

Total current drain of the circuit with no input signal is 1.8 ma. Under this condition the d.c. current through the collector-relay leg of transistor V_2 is 0.2 ma. With an input signal of 3 millivolts at 1000 cycles, the V_2 collector current increases to 1.5 ma. A compilation of required input voltages over various frequency ranges for closure of the relay is given in Table 1. The signal source used for these measurements was an audio signal generator. The upper frequency limit was not checked since the generator on hand only went to 500 kc.

Tested Applications

To use the circuit as a telephone ringer pickup, the telephone pickup coil is placed under the telephone cradle. Many audiophiles and experimenters use these pickup inductors for recording telephone conversations. By employing a plug and jack arrangement, the same pickup coil may be used for either purpose. When the telephone pickup coil is in place, relay RL_1 will pull in when the telephone bell rings. The induced a.f. voltage peak at the input to C_1 measured 15 millivolts with the circuit set up 50 feet from the phone. The relay contacts complete the battery circuit to a miniature bell or buzzer and lamp, or both. Tests were not made to check maxi-

mum distance the circuit could be used from the phone but it worked up to 50 feet, using twisted-pair telephone wire run to the coil L_1 . Thus, wire leads can be run to various locations, such as outdoors, to the ham shack, etc. where the telephone bell may be inaudible, and the circuit plugged in at any of these points. It is handy, too, for the hard of hearing. Many persons can

FREQUENCY (cps)	INPUT SIGNAL VOLTS TO CLOSE RELAY
20-30	.006
30-50	.005
50-200,000	.003
200,000-400,000	.004
400,000-500,000	.005

Table 1. Signal voltage required to operate the relay at various signal frequencies.

hear on the phone but cannot hear the bell beyond certain distances from the phone.

The circuit may be used as a voice-operated relay. If the pickup coil is placed near the output transformer of an audio amplifier, the relay will operate when an audio signal passes through the amplifier. Thus the operator may speak into a microphone connected to the amplifier to close relay RL_1 , whose contacts would energize another relay to start a tape recorder mechanism or other device. This second relay can be set up to lock in and released when desired by means of a push switch. The author found that the relay would pull in when speaking into a microphone with the pickup coil placed near the loudspeaker voice coil and the gain control of the amplifier set for normal listening level.

Another useful application is in connection with motor-operated devices. The relay will close and open as a motor starts and stops. The relay contacts can then be used to operate other relays or devices for safety purposes, "fail-safe" applications, etc. The telephone pickup coil is not absolutely essential for this service. A coil from a discarded magnetic phono cartridge or plate-circuit relay will suffice as the pickup probe. Using a phono-cartridge coil probe the relay operated positively from the induced a.c. signal of the motor of an electric razor when the probe was held one inch from the razor case.

The circuit can be employed to measure relative a.c. field intensity levels.

(Continued on page 133)

Fig. 1. Telephone pickup coil L_1 is placed in the vicinity of signal-carrying wires.

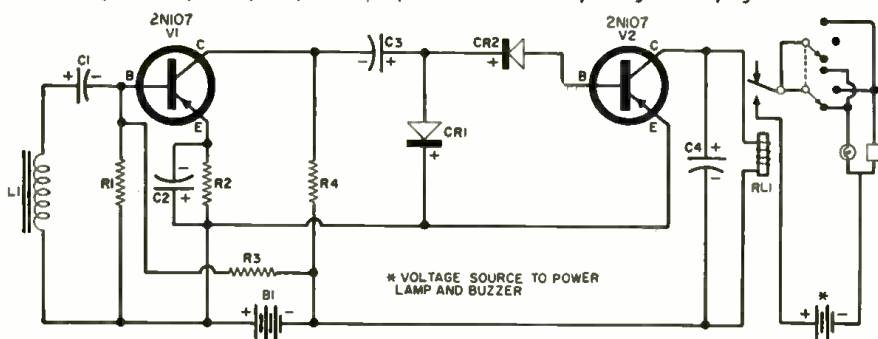

R_1 —2200 ohm, $\frac{1}{2}$ w. res.
 R_2 —1000 ohm, $\frac{1}{2}$ w. res.
 R_3 —39,000 ohm, $\frac{1}{2}$ w. res.
 R_4 —7500 ohm, $\frac{1}{2}$ w. res.
 C_1 —500 μ f., 3 v. elec. capacitor
 C_2 —25 μ f., 25 v. elec. capacitor
 C_3 —2 μ f., 25 v. elec. capacitor

C_4 —1 μ f., 15 v. elec. capacitor (see text)
 CR_1, CR_2 —Crystal diode (*Sylvania* 1N56A)
 RL_1 —4000-ohm relay (*Cardwell* BK-7-B or equiv.)
 L_1 —Telephone pickup coil (*Argonne* AR-20)
 B_1 —22 $\frac{1}{2}$ -volt battery (*Burgess* U15 or equiv.)
 V_1, V_2 —"p-n-p" transistor (*G-E* 2N107)

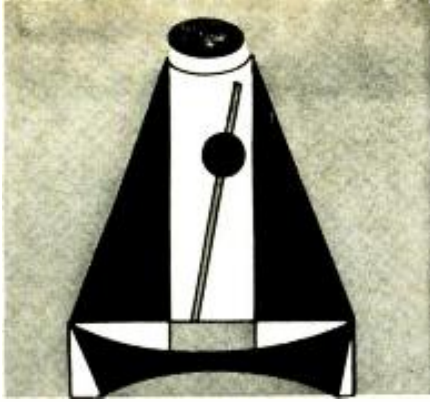

Electronic Metronome

By HAL WITTLINGER/RCA Electron Tube Div.

Easy-to-build one-transistor circuit produces loud ticks and blinking light indication over range 40-220 beats/min.

THE metronome, that venerable mechanical timer of the musician, can now be replaced by a simple, compact, and inexpensive single-transistor device. The electronic "beat-keeper" to be described not only generates the typical loud, crisp metronome tick, but also provides visual beat indication. Power is supplied by a 9-volt battery.

Circuit Description

The schematic diagram for the electronic metronome is given in Fig. 1. An RCA 2N109 transistor is used as a blocking oscillator and a resistor-capacitor network (R_1 , R_2 , and C_1) provides the necessary oscillator timing. Transformer T_1 couples a pulse of the correct polarity to charge capacitor C_1 and to bias the transistor beyond cut-off. In addition to charging C_1 , T_1 also couples this pulse to the speaker.

Discharge of C_1 takes place through resistors R_1 , R_2 , and R_3 . When the resistance of R_1 and R_2 is raised, the time required to discharge C_1 is increased. A decrease in the values of R_1 and R_2 has the opposite effect. The range covered by the "rate" potentiometer, R_2 , goes beyond the 40 to 208-beats-per-minute range found on most mechanical metronomes. This extended-range feature insures complete coverage with the normal distribution of components. The relatively high voltage gener-

ated during the pulse period is applied to another transformer which steps up this pulse voltage to light the NE-51

neon lamp. A 120- μ f. capacitor is placed across the lamp to "tune" the circuit for a symmetrical pulse. This arrangement insures maximum brightness for both electrodes of the lamp.

Construction

The entire unit is built on a small aluminum chassis which is then mounted in a Lafayette MS-315 speaker baffle. A piece of $\frac{1}{16}$ " aluminum is cut and bent to fit snugly around the speaker within the case. The "rate" potentiometer holds the chassis in place.

The jack is removed from the top of the case and two holes are cut to accommodate the rate control and neon lamp. A piece of No. 18 wire wrapped around and soldered to the base of the lamp permits easy mounting.

Operation

After the metronome is wired, connect the battery and turn the unit on. One tick should be heard immediately. A decrease in the resistance of R_2 should cause the number of ticks to increase. Coincident with each tick the neon lamp should flash.

Both electrodes in the lamp should glow with equal brilliance. If one electrode glows brighter than the other, C_2 is probably not optimized for the (Continued on page 82)

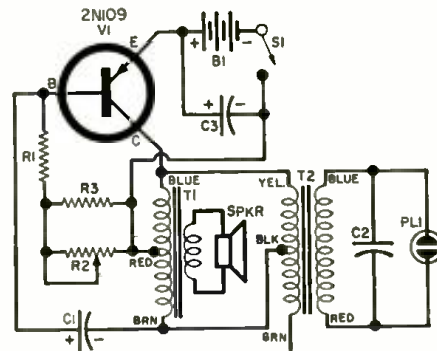

- R_1 —68,000 ohm, $\frac{1}{2}$ w. res.
- R_2 —1 megohm miniature volume control (Lafayette VS-40 or equiv.)
- R_3 —1 megohm, $\frac{1}{2}$ w. res.
- C_1 —4 μ f., 6 v. elec. capacitor
- C_2 —120 μ f. disc capacitor
- C_3 —50 μ f., 15 v. elec. capacitor
- PL1—NE-51 neon lamp
- T_1 —Miniature output trans. 500 ohms c.t. to 3.2 ohms, 100 mw. (Lafayette TR-95 or equiv.)
- T_2 —Miniature driver trans. 10,000 ohms to 2000 ohms c.t. (Lafayette TR-96 or equiv.)
- Spkr.—2 $\frac{1}{2}$ " speaker with 10 ohm v.c. (Lafayette SK-66)
- Case—3" x 2 $\frac{3}{8}$ " x 1 $\frac{3}{8}$ " baffle case (Lafayette MS-315)
- VI—"p-n-p" transistor (RCA 2N109)

Fig. 1. Circuit diagram of metronome.

Metronome is built into small plastic speaker baffle. Note how beats-per-minute calibrations are on rate-control knob.



The home-built chassis plate is cut and shaped to fit the cabinet. An aluminum "case" may be used to surround speaker.

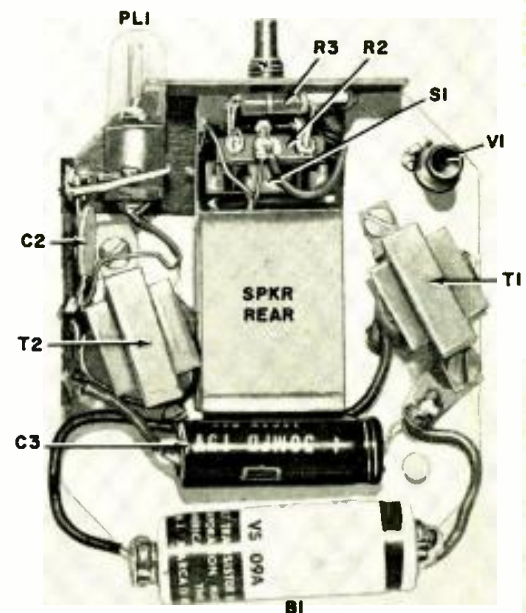



◀ Largest Microwave Radio Installation

What is believed to be the largest microwave radio installation in the world is being completed by *Collins Radio Co.* in California. There are 33 microwave transmitters and 33 microwave receivers at the Santa Cruz Island junction repeater station serving the Pacific Missile Range, headquartered at the Naval Missile Center, Point Mugu, Calif. The microwave relay connects to Pt. Mugu, 31 miles away; to San Nicolas Island, 53 miles away; and to a repeater station at Point Arguello, 69 miles away. The system provides radar video channels, carrier channels for communication and data between sites, and teletypewriter channels. Channels are also provided for transmission of azimuth and angle-mark information used in a radar surveillance system as well as signals for synchronizing 10 precision tracking radars located at the several major operating points.

High-Reliability Resistors for Missiles

A new approach to the problem of reliability achievement in resistors has been developed by *International Resistance Co.* in connection with a contract for work on high-stability, metal-film resistors for use in the Air Force "Minuteman" ICBM. The resistors, now being turned out in pilot production, are permitted only one failure in one-quarter billion unit hours. Each of the components delivered by the company will have its personal history attached. Complete records on all raw materials and process characteristics will be maintained and individual punch cards or tabulations of individual resistor values will be available. Workers coming in contact with the high-reliability parts wear over-clothing which aids in keeping the manufacturing area ultra-clean and free of dust. Humidity and temperature are also carefully controlled during the manufacture.

Recent Developments in Electronics

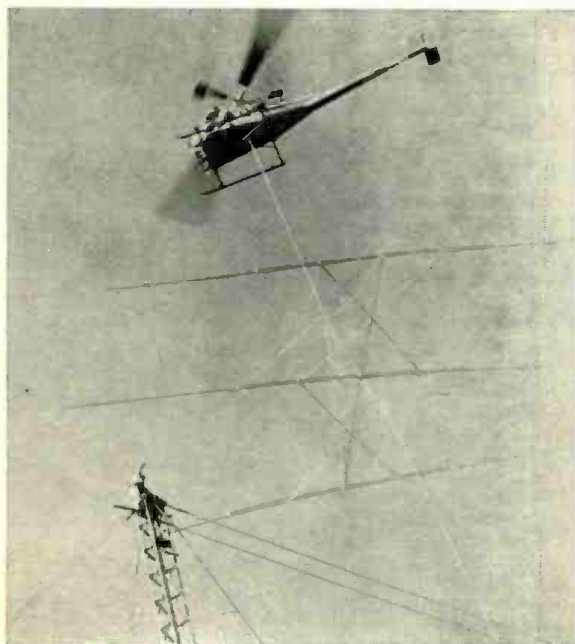

◀ Antennas Installed by Helicopter

Two antennas were recently installed atop 112-foot towers for Stanford University Radioscience Laboratory in only 16 minutes by means of a *Hiller* helicopter. Using a quick-release cargo hook under the belly of the copter, the pilot picked each antenna off the ground, flew it to an awaiting tower and, hovering almost motionless in the air, lowered each gently into a socket where it was clamped into place by a technician. The antennas will be used to receive signals bounced off the ionosphere from a station 5000 miles distant.

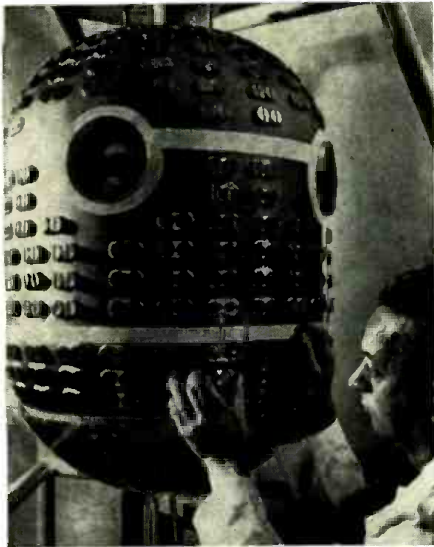

▶ Thermoelectric Generator

SNAP 1-A, "big brother" of the grapefruit-sized SNAP-3 generator which was unveiled by President Eisenhower last year, is prepared for electrical tests at the *Martin Co.* in Baltimore. Heat from tightly sealed pellets of an atomic waste material, Cerium-144, will be converted directly and continuously into 125 watts of electrical power by hundreds of thermocouples which dot the outer skin of the device. The complete System for Nuclear Auxiliary Power weighs 175 pounds and uses no moving parts. The new system promises more power than any energy unit launched into space so far. Some systems combine solar cells with chemical batteries for high wattages, but these operate intermittently. Also, SNAP can generate power while in the sun's shadow.



▲ Bridge-Installed Radar

Service engineer is shown above checking out a new radar installed atop the control room of vertical lift bridge in Duluth, Minn. The radar looks 32 miles out into Lake Superior in one direction and across the harbor in the other to warn bridge-tenders when ships are approaching in heavy weather. The new *Raytheon* radar will speed traffic of cars and ships while protecting the draw from ships which might approach too fast in heavy weather. The radar is a conventional shipboard type with a 10-inch scope and six range scales from 1 mile to 32 miles.

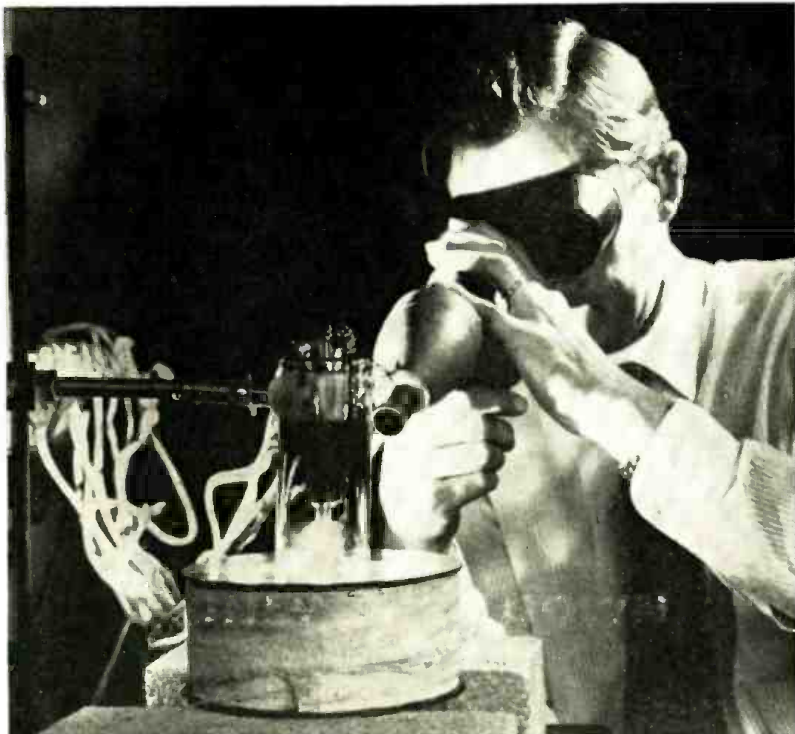

▲ New Thermionic Converter Tube

Elements of a new type of thermionic converter tube, suspended over a circular magnet, are examined with a pyrometer at the *RCA Laboratories*. The new tube, capable of converting heat directly to electric power, is under development for space vehicles and as a possible low-cost, mass-production power source for earth-bound uses. The tube functions within range of temperatures produced by burning ordinary fuels, such as gasoline and natural gas, as well as solar heat in space.

▶ Computer-Controlled Chemical Plant

The *B. F. Goodrich Chemical Co.* plant at Calvert City, Kentucky uses a *Ramo-Wooldridge* digital control computer to control and monitor two distinct chemical processes. On-line computer control of an industrial manufacturing process requires a special type of computer which can read information directly from process instruments, compute guides for optimizing process performance from the data it receives and from equations stored in its memory, and send signals directly to control devices in the process plants, thereby eliminating the human operator from the control loop.



Complete construction details on a transistorized transceiver that may be operated without any license. Unit weighs less than 2 pounds and has a 1-mile range.

By DONALD L. STONER, 11W1507*

Hand-Held Citizens Band Transceiver

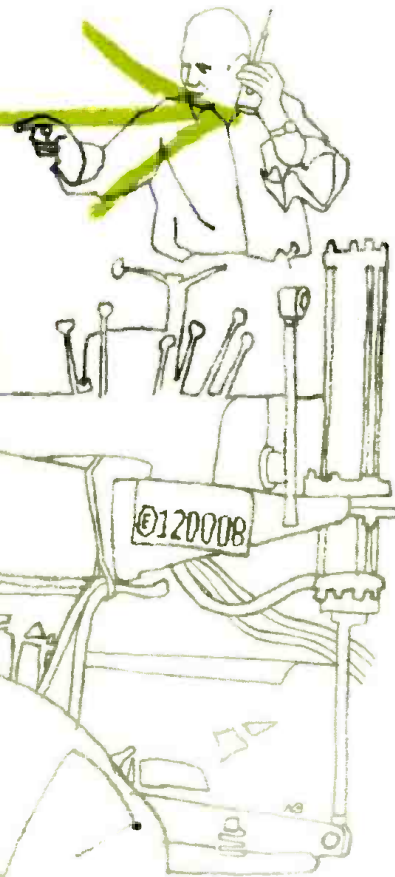

THE author has long been fascinated by "walkie-talkies" and the novelty of "pedestrian portable" operation. One of his earliest units was a raspy, single-tube, two-meter transceiver built in a cigar box about the time the 958A "acorn" tubes appeared on the surplus market. The author's hybrid transistor/tube version for the six-meter band appeared in the July 1959 issue of this magazine.

The latest project, a completely transistorized 11-meter Citizens Band transceiver, represents more "fun on the hoof" than all the other portables combined. One important reason is that this miniature two-way radio station needs *no license* when used in conjunction with other similar portables. Thus, the neighbor or wife can use the transceiver without making a license application.

Recently the unit was "worth its weight in gold" while checking out a television interference complaint. The unlicensed neighbor replied over the air to such questions as "Does that improve the picture?" or "Do you see the interference now?", while adjustments were made at the offending transmitter. The troublesome condition was quickly corrected with the aid of this little transceiver. Obviously, there are many other uses that will occur to the reader, such as antenna orientation and testing, Civil Defense exercises, and various applications that require you to be in two places at the same time.

The Circuit

This transistor transceiver is built around three printed circuit subassem-

blies, made by *International Crystal Mfg. Co., Inc.* and shown in Fig. 1.

The receiver is a one-transistor superregenerative detector connected in a common-base configuration. Feedback is provided by C_1 and the stage is biased by R_1 and stabilized by R_2 . The frequency of the receiver is determined by the tuning of coil L_1 in conjunction with the circuit capacity.

Audio output from this subassembly is coupled to transformer T_1 on the audio amplifier/modulator chassis. This assembly uses a *Texas Instruments* 2N185 (V_1) voltage amplifier and a *TI* 2N238 (V_2) audio power amplifier. Transformer T_1 provides the impedance stepdown and the voltage dividers R_{11} and R_{12} supply forward bias for V_1 . The stage is stabilized by R_{13} . Audio output is coupled to the power stage (V_2) by T_2 and forward bias appears at the junction of R_{11} and R_{12} . Resistor R_{14} (100 ohms) provides d.c. degeneration for stability. In the "receive" position, audio output is coupled through T_3 to the speaker via section *B* of switch S_1 .

On "transmit," the speaker is coupled to the input of the amplifier (the speaker is used as a microphone on "transmit"), through the "pad" composed of R_9 and R_{10} . This drops the audio voltage generated by the "mike" to prevent overmodulation and, at the same time, damps out resonant peaks in the speaker response. The amplified mike voltage appears at the collector of V_3 and serves to modulate the collector of V_3 , the power amplifier.

The transmitter board uses an *RCA*

"drift" transistor (V_3 , a 2N371) as a common-base oscillator. The crystal is impedance-matched by capacitive divider C_7 and C_8 , which are 5% components for maximum frequency stability. Forward bias is applied to the base of the oscillator through voltage divider R_4 and R_5 . The r.f. output is coupled to the power amplifier stage from a low-impedance tap on the oscillator coil, L_2 . Bias for the amplifier appears at the junction of R_6 and R_7 . The d.c. degeneration of V_2 and V_3 is obtained across R_1 and R_3 , respectively. The amplified r.f. energy appears across L_3 as a modulated envelope. The signal is coupled to the antenna from a low-impedance point on L_3 .

The antenna system consists of a 36-inch length of "piano wire" which is sold at model airplane supply stores. A base-loading coil (L_4) resonates the whip and case at 27 mc. and is shown in the photo on the next page.

The combined battery and antenna switching circuit may be confusing to some and should be explained at this point. There are three functions which must be switched in the transceiver. On "receive," the antenna must be connected to L_1 (through C_1), the battery supply (-9 volts) is connected to the bias resistor (R_1), and the speaker is connected to the amplifier output. On "transmit," the antenna is connected to L_3 (through C_{11}), the battery is applied to the oscillator, and the speaker is connected to the input of the amplifier. Since double-pole switches are inexpensive and compact, these were selected for use in the transceiver. The antenna and battery changeover func-

* "Electronic Publications," Box 137, Ontario, California.

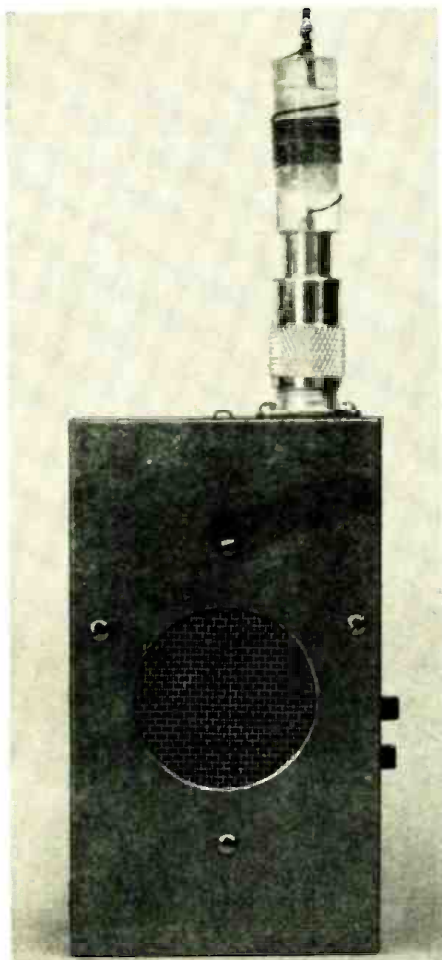

The transceiver uses five transistors and is a self-contained two-way radio station.

If you don't care to use circuit boards, the components could be mounted on the metal cabinet in regular chassis style. Place the transformers in about the same position as shown in the photos. Mount suitable terminal strips between the transformers and secure the components (including the transistor leads) to the terminal lugs. The receiver coil (L_1) slug could project through the side of the case for external tuning.

To aid the "home-brew artist," the



Back view of front panel before chassis is mounted. Note felt covering speaker frame.

56X (T_1) would go to eyelet B , the red wire to eyelet C , the black wire would connect to the junction of R_{11} and C_{15} , one green lead would go to the base of V_1 , and the other green lead would be taped up and not used. The TY-56X can also be used for T_2 , however the yellow lead shown in Fig. 1 would be black and the other green lead would be unused. The TY-44X is a perfect substitute for T_3 , and the black and white wires are left disconnected. Of course, any similar transformers can be used if the correct connections are made. Reasonable substitutions can be made for the other components as well.

The transmitter section *must* be pre-assembled and aligned to comply with Part 19.17 (d) (Citizens Radio Service) of the Commission Rules, dated effective November, 1959. However, if you intend to use the device under the provisions of Part 15 (Low-Power Communications Device) it would appear that the entire unit could be "home grown."

Getting down to the mechanical details, the transceiver is constructed in a $5\frac{1}{4} \times 3 \times 2\frac{1}{8}$ LMB chassis box. The audio and receiver sections are mounted on the bottom with 4/40 hardware. The transmitter board is mounted vertically at the end of the box on four "L" brackets. All adjustments are accessible without drilling holes in the case. The speaker, grille, antenna connector, and battery are mounted on the other half of the chassis box. The connector is mounted with two 4/40 bolts and a ground lug is placed under one of the nuts. Three wires (speaker, antenna, and battery negative) and chassis ground connect the two halves of the box.

The lettered terminals shown in Fig. 1 were arbitrarily assigned by the author to make construction easier. They correspond to eyelet terminals on the printed-circuit boards. There is no need to connect the ground terminals E , F , and J , since they are automatically grounded when the chassis boards are mounted. However, ground eyelet E was used to ground one black T_1 lead and the positive end of C_{22} . The yellow lead of transformer T_3 was conveniently grounded to eyelet F .

When laying out the transceiver, the author had difficulty finding a spot for resistors R_6 and R_{10} . To avoid having

tion is accomplished in one section while the other section switches the speaker. Choke RFC_2 serves to isolate the antenna signal from the transmitter "B-" while RFC_3 isolates the battery. Connected in this manner, the switch section handles both the r.f. and battery potential with no apparent losses.

On "receive," the oscillator and final amplifier cannot conduct for they have no forward bias. The final, or power amplifier, will not conduct even though collector voltage is applied.

The detector "B-" circuit must be decoupled from the audio to prevent motorboating and oscillation. Decoupling resistor R_8 also serves as an r.f. choke as explained earlier. Capacitor C_{22} filters the voltage and prevents audio oscillation. No regeneration control is used, but the receiver performs very well with battery voltages ranging between 6 and 10 volts.

Construction

As mentioned earlier, the "heart" of the transceiver is three subassemblies manufactured by *International Crystal*. However, if you are inclined to "home-brew" this equipment, it may be accomplished in one of several ways. The circuit boards may be purchased separately from *International* or you can make them yourself. Actually there is nothing magic about the circuit boards, except they save a little wiring time.

components specified in the parts list have been tested in the unit and performance is identical to that obtained with the *International* components. The transformer lead color codes are different, however. In addition, there is no commercial equivalent for T_3 and it is necessary to modify the transformer specified in the parts list in the following manner: Clean out the glue between the winding and the frame with a sharp, thin blade. In this space wind 50 turns of #38 enamel wire, around the core and through each gap in the core "window." The ends of this winding replace the two black wires of T_3 in Fig. 1. The blue lead of the TY-

Transceiver may be built from these three subassemblies, which are available with all parts mounted. The unit may also be built "from the ground up" if desired.

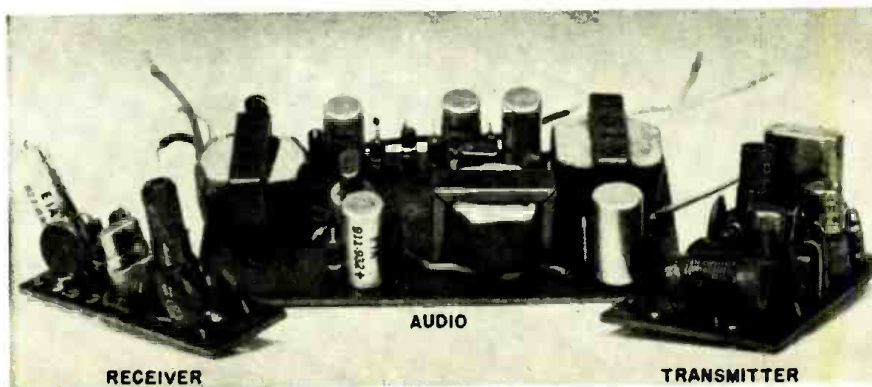

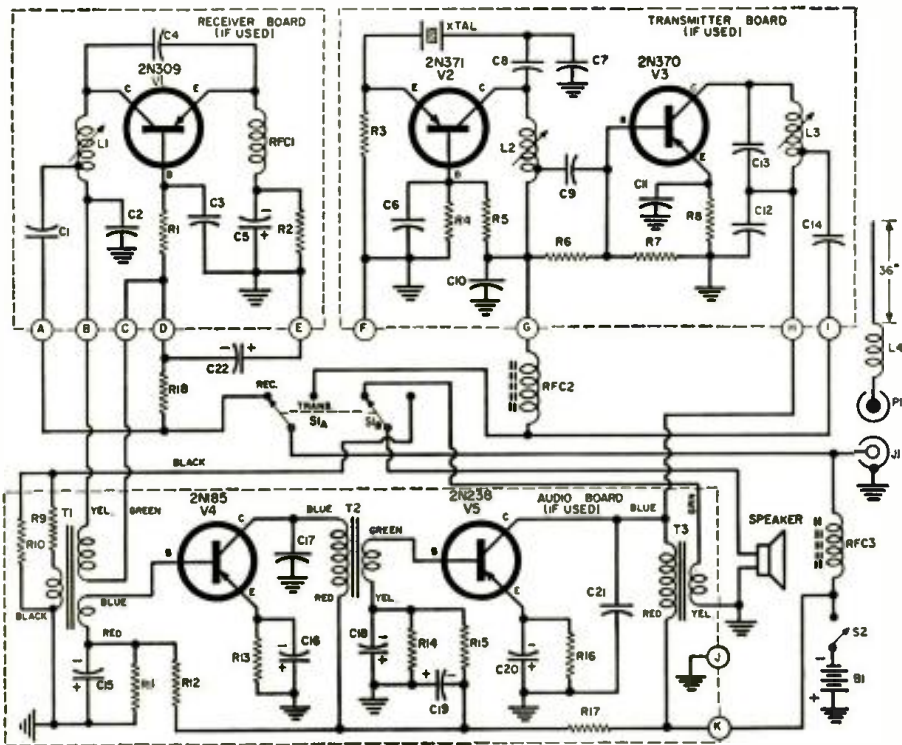

- R_1 —220,000 ohm, $\frac{1}{2}$ w. res.
 R_2, R_3 —1000 ohm, $\frac{1}{2}$ w. res.
 R_4, R_5 —470 ohm, $\frac{1}{2}$ w. res.
 R_6, R_7, R_8 —2200 ohm, $\frac{1}{2}$ w. res.
 R_9, R_{10}, R_{11} —18,000 ohm, $\frac{1}{2}$ w. res.
 R_{12} —33 ohm, $\frac{1}{2}$ w. res.
 R_{13} —3.3 ohm, $\frac{1}{2}$ w. res.
 R_{14} —1500 ohm, $\frac{1}{2}$ w. res.
 R_{15} —8200 ohm, $\frac{1}{2}$ w. res.
 R_{16}, R_{17} —100 ohm, $\frac{1}{2}$ w. res.
 R_{18} —3300 ohm, $\frac{1}{2}$ w. res.
 C_1 —220 μ f. disc capacitor
 $C_2, C_3, C_4, C_5, C_6, C_7, C_8, C_9, C_{10}, C_{11}, C_{12}$ —0.01 μ f. disc capacitor
 C_{13} —0.001 μ f. disc capacitor
 C_{14} —22 μ f. disc capacitor
 C_{15} —20 μ f., 25 v. elec. capacitor
 C_{16} —150 μ f., 5% NPO disc capacitor
 C_{17}, C_{18} —15 μ f., 5% NPO disc capacitor
 C_{19} —470 μ f. disc capacitor
 C_{20}, C_{21}, C_{22} —100 μ f., 3 v. elec. capacitor
 C_{23} —0.005 μ f. disc capacitor
 C_{24} —50 μ f., 15 v. elec. capacitor
 C_{25} —0.0068 μ f. disc capacitor
 C_{26} —10 μ f., 10 v. elec. capacitor
 Xtal.—Third overtone crystal (International F-609)
 J_1 —U.h.f. antenna jack
 J_2 —U.h.f. antenna connector
 RFC_1 —54 t. #36 en. scramble wound on 1 neg., 1 w. res. (self-resonant at 27 mc.)
 RFC_2, RFC_3 —39 μ hy. choke, self resonant at 27 mc. (J. W. Miller #4628)
 L_1 —15 t. #24 en. closewound on $\frac{1}{4}$ " slug-tuned form, tapped at 1 t. (J. W. Miller #4500 or equiv.)

- L_2 —15 t. #24 en., closewound on $\frac{1}{4}$ " slug-tuned form, tapped at 2 t. (J. W. Miller #4500 or equiv.)
 L_3 —15 t. #20 en., closewound on $\frac{3}{8}$ " slug-tuned form, tapped at 2 t. (J. W. Miller #4400 or equiv.)
 L_4 —17 $\frac{1}{2}$ t. #22 en., closewound on $\frac{3}{8}$ " polystyrene rod. Do not cement in place until adjusted.
 T_1 —Input trans. 10,000 ohms to 2000 ohms with 8-ohm winding (Triad TY-56X modified and color coded per text)
 T_2 —Interstage trans. 10,000 ohms to 2000 ohms (Triad TY-56X modified and color coded per text)
 T_3 —Output trans. 2000 ohms to 8 ohms, 10 ma. primary current (Triad TY-44X, color coded per text)
 S_1 —D.p.d.t. slide switch
 S_2 —S.p.s.t. slide switch
 Spkr.—8-ohm, $2\frac{1}{4}$ " speaker
 B_1 —9-volt mercury battery (RCA VS312 or equiv.)
 I — $5\frac{1}{8}$ " x 3 " x $2\frac{1}{8}$ " chassis box (LMB J880)
 V_1 —2N309 transistor (Texas Instruments)
 V_2 —2N371 transistor (RCA)
 V_3 —2N370 transistor (RCA)
 V_4 —2N185 transistor (Texas Instruments)
 V_5 —2N238 transistor (Texas Instruments)

Printed circuit assemblies available from International Crystal Mfg. Co., Inc., 18 N. Lee St., Oklahoma City, Okla. The receiver and audio circuit boards (boards only) may be obtained from Irving Electronics Co., Box 9222, San Antonio, Texas.

Fig. 1. Transceiver may be put together using commercially available subassemblies, already prepared printed boards, or it may be entirely "home-brewed" by builder.

to add another terminal strip, these two components were mounted on the audio board near T_1 and C_{15} . Five tiny holes were drilled in the clear area and one black T_1 lead clipped short. The resistor leads were pushed through the holes and the wires soldered together under the chassis. The mounting seems to be quite secure. If you whip up your own board, it might be advisable to add eyelets for these components.

Start the construction by mounting the boards (or components, as the case may be) in the approximate positions shown in the photographs. Locate a clear space for the switches and remove the boards before drilling these holes. Install the two slide switches (space at least $\frac{1}{8}$ inch), the two-lug

terminal strip (cut the tops to clear the transmitter board), and the two r.f. chokes. These components must be wired before the boards are permanently installed. It is suggested that an additional $4/40$ hole be drilled in the space between V_2 and V_1 . This point should be supported as the board might fracture if the set is dropped.

Resistor R_{10} is mounted on the receiver chassis between eyelets A and D, along with capacitor C_{22} between eyelets D and E.

The battery is mounted with a small aluminum bracket and $4/40$ hardware. The speaker grille is a $2\frac{1}{2}$ " x $2\frac{1}{2}$ " piece of aluminum screening. Before installing the speaker, cover the holes in the basket (frame) by gluing on felt strips

as shown in the photograph. Leave only the terminals exposed. This minimizes the "barrel" or tinny sound when the speaker is used as a microphone.

Testing

When wiring is completed and the switches are labeled, connect a milliammeter (0-25 ma.) in series with the battery. The unit, when energized, should draw approximately 10 ma. and typical superregenerative "hiss" should be heard. Tuning coil L_1 should bring in Citizens Band stations, when connected to an antenna. If the receiver does not "take off," check the detector current by inserting a 0-1 ma. meter at eyelet B. The current should be 1 ma. or less. If it is not, adjust the value of R_2 to give a reading of approximately 200-500 microamperes.

Switching to "transmit" should increase the battery current approximately 4 ma., which shows the oscillator and power amplifier are working.

Before testing the transmitter, check the resonant frequency of the antenna loading coil while holding the transceiver in a normal manner. You must be holding the transceiver when this test is made as your body is part of the antenna ground-plane system. Hold the grid-dip meter coil near the loading coil (L_1) and check for resonance. You should see a noticeable dip near 27 mc. If it is high, compress the coil turns; if low, spread them apart until the dip occurs at exactly 27 mc.

Next connect a milliammeter in series with the lead to eyelet H and apply power to the transmitter. The current may be between 4 and 6 ma., indicating a power input between 28 and 42 mw. Remember that current in milliamps times collector voltage equals milliwatts. Any reading less than 100 mw. input is satisfactory. It is difficult to exceed 100-mw. input because of the resistance of T_3 's primary.

You are required to have a radio-telephone license to adjust the transmitter if this unit is to be used in Class D service. The following information is given on the assumption that you hold the pertinent ticket. To check performance, adjust the oscillator coil (L_2) for the highest V_3 collector current con-
(Continued on page 112)

Fig. 2. Test setup used by author to check for overmodulation and distortion.

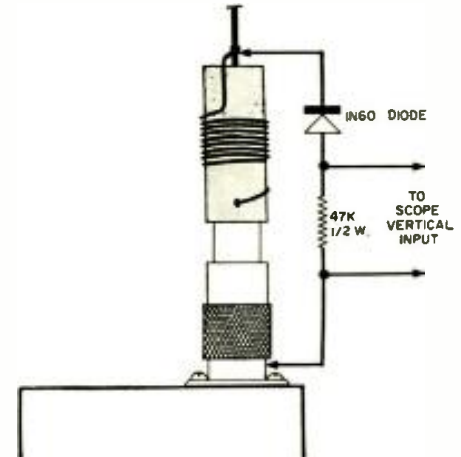

Troubleshoot with Basic Theory

By DAVID R. ANDERSON

Thinking takes much less time than unsoldering and routine checking, also yields better results.

EDITOR'S NOTE: *Troubleshooting via section analysis, based on logic and theoretical knowledge, is nothing new to most experienced hands. However, even amongst these, how many abandon logic in favor of random checking when it comes to pinpointing the exact defect? Is it to "save time" or is it due to mental laziness? Actually you can think faster than you can work with your hands. This article is worth the attention of the experienced as well as the beginner.*

EVERY electronic circuit is an entity that can be broken down into the components it contains, such as tubes, resistors, capacitors, and coils. The theory behind the operation of these components and their characteristics, as well as the theory behind operation of the circuits, is the basis of every course in electronics. It is no secret that a service technician, whether he is a beginner or a professional with many years of experience, can save a good deal of time and effort by applying this theory in his work.

Taken as a whole, a unit of electronic equipment is quite a complex affair. One of the first things an application of basic theory does is to allow the technician to simplify analysis and troubleshooting procedure by dividing the unit into individual sections or circuits. With theory, he can narrow things down even more, but this is less often done than the common technique of section division. However, before getting into theoretical analysis of specific component defects, a review of the initial sectioning off is worthwhile.

Each circuit may be considered an individual unit with an input and an output. In some cases, there may be more than one input or output. In other cases, such as the i.f. amplifier of a TV receiver, it is more convenient at first to consider the group of circuits (stages) contained therein as a single section.

Keeping to the TV receiver as an example, it may be divided into several portions, or blocks in a hypothetical block diagram, each of which has a particular function in either delivering a

satisfactory picture to the screen or sound to the speaker. The tuner, i.f. amplifier, detector-video amplifier, sync amplifier-separator, horizontal-sweep—high-voltage system, vertical-sweep system, audio section, and power supply would be included in a typical breakdown of sections. There may be some interaction between sections with certain faults, but systematic checking will show this up. This procedure, of course, is not confined to TV sets. A division into functional sections is possible with test equipment, ham gear, hi-fi units, or any electronic equipment.

Even after this approach is followed until the fault is localized to a specific section, the possibilities of the technique have not been fully exhausted. Similar logical elimination can be applied to location of the specific fault.

Let us assume, to start, that we have a TV receiver in which there is no picture, although a full raster and sound are present. The technician reasons along these lines: since the sound must pass through the tuner, i.f. amplifiers (in an intercarrier receiver), and audio sections to reach the speaker, and sound is present, these sections are at least operating. Also since the circuits mentioned depend on the power supply, the latter must also be functioning. Since the intercarrier audio i.f. signal



no picture, it does not matter at this time whether the sync section is working or not. The technician is ready to concentrate his efforts on the video amplifier, and he is ready to bring his equipment into play.

Assume that the video amplifier in question is the single-tube, two-stage circuit of Fig. 1. The next step may vary depending on the technician's preference or the nature of the circuit. With a good oscilloscope or other equipment for observing the presence or absence of signal, the technician may resort to signal tracing for further localization before he undertakes voltage and resistance measurements. In a circuit that is reasonably uncluttered he may go directly to these measurements. In either case, he can reduce the number of tests required by logical use of theory.

This theory tells us that each component has its own normal effect on circuit action depending on how it is used; and also that it will have certain effects when it become defective. Thus in any circuit there will be a number of components that may be eliminated from suspicion because they could not cause the symptom for which the equipment is being serviced.

With reference to Fig. 1, components such as R_5 and C_3 would not be responsible for the symptom of no picture even if they were defective, because of the way they are used. They help determine frequency response of the video amplifier, but do not essentially couple signal or block d.c. If R_5 shorts, the path from the V_{1A} plate to the V_{1B} grid for d.c. and signal voltage already existed through L_1 , L_2 , and C_3 . If R_6 be-

(Continued on page 138)

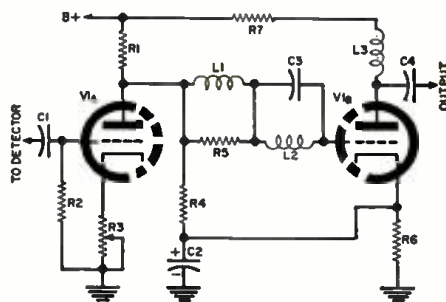
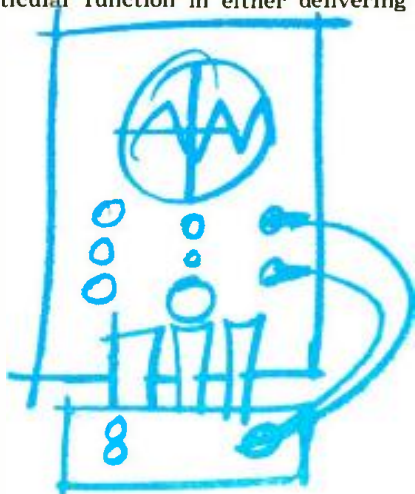

Fig. 1. This two-stage video amplifier can be analyzed before measurement.

originates in the video detector, the latter is also operating.

Already a large portion of the receiver circuitry has been eliminated from primary suspicion. Other sections can also be set aside. Because a raster is present, the electron beam of the CRT is moving, and is being deflected across the screen both vertically and horizontally. Therefore, the sweep circuits are operating, as well as the picture tube's associated circuits. For example, the presence of the raster indicates that high voltage is being developed.

At this point, without using a single test instrument or making a single measurement, only the sync and video-amplifier sections remain open to suspicion. Since the complaint is that of



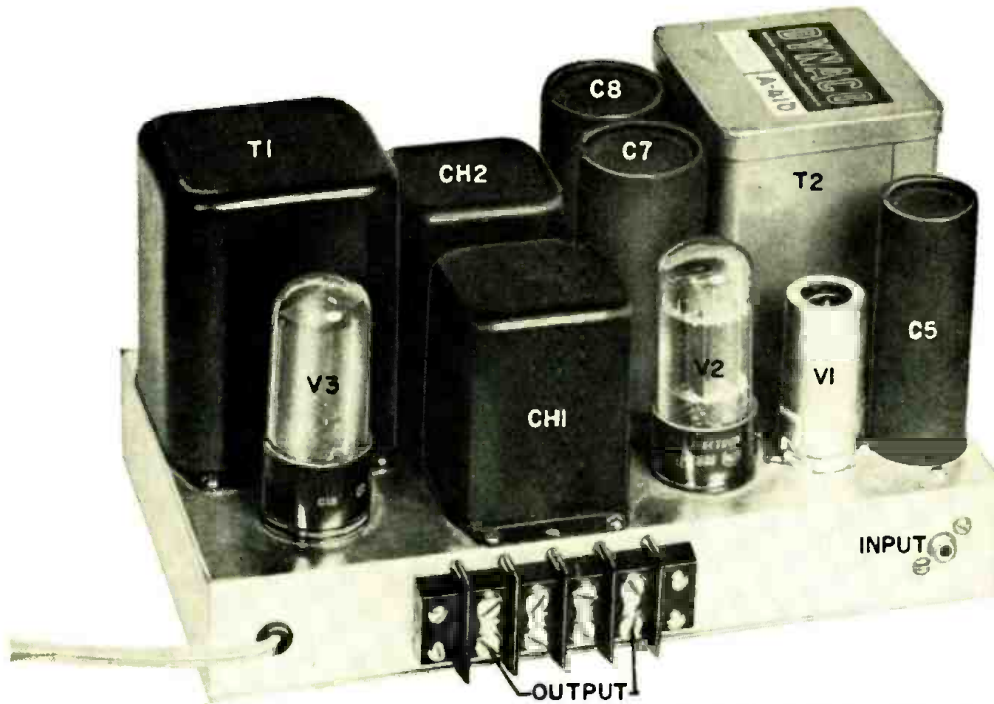

Amplifier with its built-in power supply is constructed on 9 1/2" x 5 1/2" x 1 1/2" chassis.

Low-Distortion 3-Watt Audio Amplifier

By **E. WILLIAM BLUM**
Engineer, WLDS/WLDS-FM

Complete construction details on a low-power high-fidelity audio amplifier that has almost vanishing distortion. Circuit employs a single 6BX7 twin-triode tube in the unit's output stage.

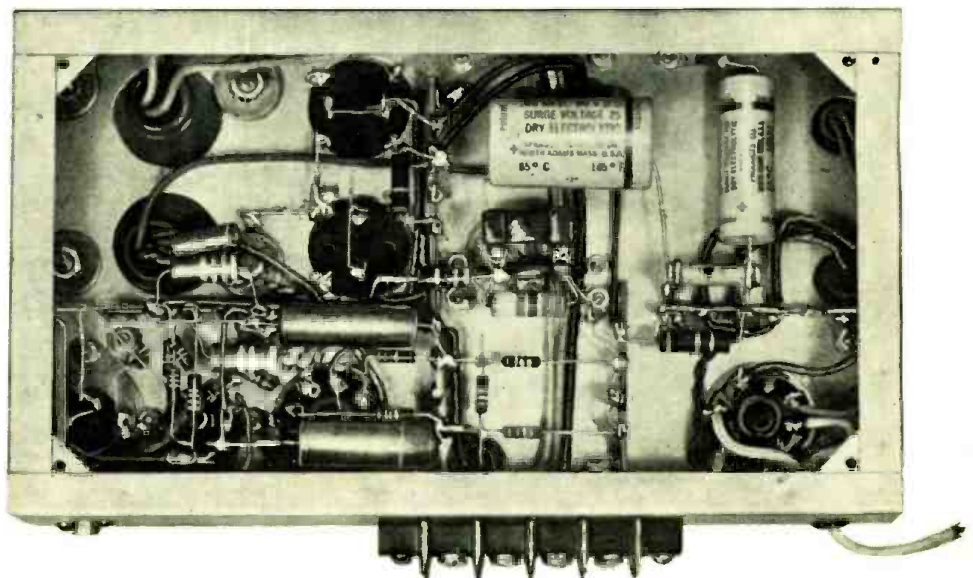

Bottom view of amplifier which author constructed directly from schematic diagram.

THERE have been many low-power audio amplifier designs offered during the past few years but almost all of them lacked some quality or feature that was desired by the true audio enthusiast.

If you have an efficient speaker set-up, the use of a high-power amplifier running at low level may not be the proper approach for several reasons. Although running a 20- or 40-watt amplifier at a half watt may result in low distortion, the residual hum may leave much to be desired—to say nothing of the waste of power and the danger

of damaging a very expensive speaker. For these reasons, the amplifier to be described should meet the needs of the audiophile who uses efficient speakers and has a relatively small listening room.

First of all, the author wishes to give credit to Paul Popenoe, Jr., who originally described the circuit.¹ His amplifier was built and used for two and a half years with excellent results. Mr. Popenoe's amplifier was the inspiration for the circuit to be described. The author's amplifier incorporates several worthwhile improvements which make

distortion and hum practically nonexistent.

The amplifier to be described was the result of three months' intensive research into the design of the best possible low-power, high-fidelity amplifier—without consideration being given to cost or complexity. It is interesting to note that the result was a fairly low-priced unit and one that is extremely simple circuit-wise—again proving that high quality and complexity need not go hand-in-hand.

This unit will deliver 3 watts with less than .25% harmonic distortion and

less than .1% under 2.5 watts. Since most commercial audio oscillators and distortion meters have a combined threshold level of around .1% distortion, it was impossible to determine the exact low-level distortion. What makes this so remarkable is that this is accomplished with only 8.5 db of over-all negative feedback. This makes the amplifier sound absolutely clean with no coloration being added to the sound. Over-all negative feedback is not a cure-all for distortion and large amounts of it invariably cause some coloration of the signal. This is because the harmonics which are fed back pass through the non-linear stages causing more harmonics and more beats to appear in the output. True, these are very low in amplitude but can, nevertheless, be heard in the form of harshness, "unrealness", or coloration.

Cathode Linearization

By using only a small amount of over-all negative feedback, maximum stability can be achieved with an extreme frequency coverage so that "presence" is assured. The only real problem, then, is how to achieve low harmonic and IM distortion and this can be realized by the use of triodes. The 6BX7-GT is the best power triode available for this service. Not only does this tube have low plate impedance, drive easily, and exhibit above-average plate efficiency, but its grid-voltage/plate-current parameter is such that it responds amazingly well to a cathode-linearizing resistor (R_{13} on the schematic). The use of such a resistor is not too well known among audio men, but it can be extremely effective in reducing distortion in some cases. It is so effective in this amplifier that 2.25 watts output can be obtained with less than .2% harmonic distortion with no over-all feedback. This resistor does not decrease sensitivity so it is virtually an example of receiving "something for nothing".

Resistor R_{13} reduces distortion for the following reason: The amount of current rise in one tube may be larger than the amount of current fall in the other (the main cause of distortion in all tubes). This will cause the voltage across R_{13} to rise slightly which, in turn, increases the cathode bias on both sections by the same amount. This, then, causes a decrease in current in both sections and, if the correct value for R_{13} is chosen, the up-swing current and down-swing current become practically equal, greatly reducing distortion.

As might be suspected, the value of this resistor is extremely critical. It is also not the same value for all power levels and a compromise must be reached; 7 of maximum output power is about the right power at which to adjust this resistor. With this circuit, 2.25 watts proved to be the best point (6 volts across a 16-ohm load resistor). If this circuit is not duplicated exactly, the author recommends the use of a 50-ohm potentiometer, adjusting it for

minimum distortion at 2.25 watts to determine the right value, then substituting a fixed resistor of the same value for the sake of stability and reliability. Because the distortion is so low at the dip, make this adjustment with the negative feedback loop disconnected.

If the circuit oscillates when connecting the feedback loop, positive feedback is taking place; simply reverse the primary leads of the output connections going to the 6BX7-GT plates.

Other Circuit Features

The 240,000 grid-to-grid resistor helps to further reduce distortion, while the 1800-ohm resistors in the grids help to prevent ringing on sharp transients.

The Dynaco output transformer gives this amplifier low distortion at both ends of the audio spectrum plus extremely good transient response.

Most of the various phase-inverter circuits were tried but the split-load type was found to give the best performance. In addition, it is not critical as to tube condition and is simple. Because the phase inverter drives the 6BX7-GT directly, the amplifier will maintain its very low distortion month after month with no adjustments. Only the tubes require replacement and that is a once-a-year or longer proposition.

This makes the amplifier practical for many applications. The 12AX7 works very well as a voltage-amplifier/phase-inverter and makes it possible to keep the tube line-up down to only three tubes, including the rectifier.

Filtering is employed lavishly in the power supply in addition to 40 volts d.c. on the heaters, but this pays off in extra low hum and IM distortion. Hum and noise checked out to 85 db below -.25 watt. With the input lead disconnected and your ear just a few inches from the speaker cone, no hum is discernible.

This amplifier checked out absolutely flat from 30 to 30,000 cps at 3.5 watts (clipping point) which were the extremes of the audio oscillator used for the tests. Since a 15-watt Dynaco output transformer plus .1- μ f. coupling capacitors are used, the frequency response of this amplifier must exceed these figures by a wide margin.

The damping factor is 8, which is completely adequate when used with a good speaker and enclosure.

This amplifier is sure to please even the most critical hi-fi fan and, if you build it, you will probably find that it has the lowest distortion of any component in your setup. It will provide a new listening experience for many.

REFERENCE

1. Popenoe, Paul, Jr.: "Small Fi," Hi-Fi GUIDE AND YEARBOOK, 1957 Edition. —30—

Cathode-linearization resistor R_{13} is effective in reducing amplifier distortion.

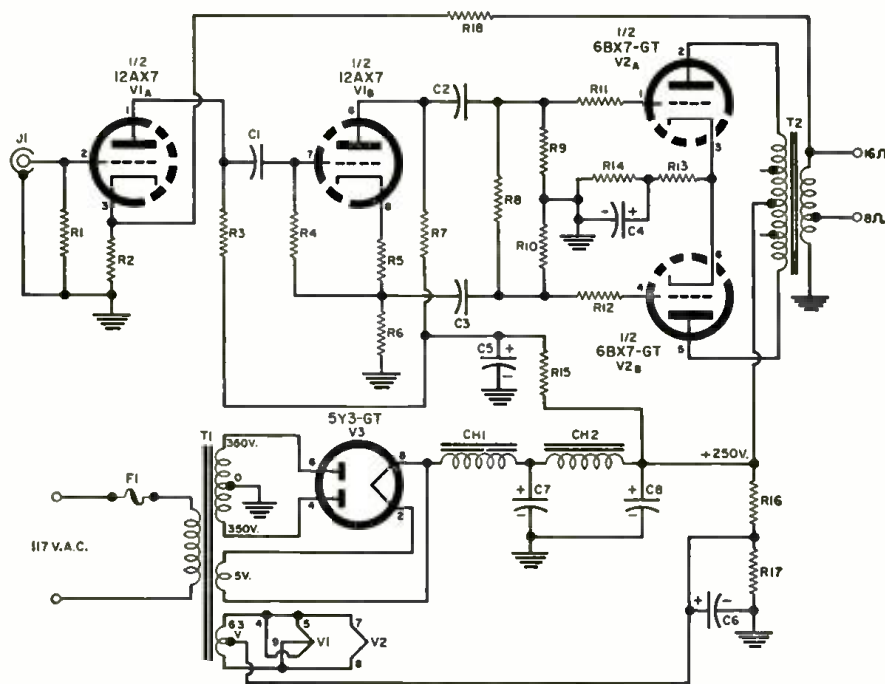

- R_1, R_2 —220,000 ohm, 1 w. res.
- R_1 —3300 ohm, 1 w. res.
- R_2 —470,000 ohm, 1 w. res.
- R_3, R_{11}, R_{12} —1800 ohm, 1 w. res.
- R_4, R_7 —47,000 ohm, 1 w. res. $\pm 1\%$
- R_5 —240,000 ohm, 1 w. res.
- R_8, R_{10} —220,000 ohm, 1 w. res. $\pm 5\%$
- R_{13} —27 ohm, 2 w. res. $\pm 5\%$ (see text)
- R_{14} —430 ohm, 10 w. wirewound res. $\pm 5\%$
- R_{15} —20,000 ohm, 2 w. res.
- R_{16} —270,000 ohm, 2 w. res.
- R_{17} —47,000 ohm, 2 w. res.
- R_{18} —27,000 ohm, 1 w. res.
- C_1, C_2, C_3 —1 μ f., 400 v. capacitor
- C_4 —250 μ f., 50 v. elec. capacitor
- C_5, C_6 —60 μ f., 350 v. elec. capacitor (Two 30- μ f. sections in parallel)
- C_7 —80 μ f., 350 v. elec. capacitor (Each two 40- μ f. sections in parallel)
- T_1 —Power trans. 350-0-350 v. @ 55 ma.; 6.3 v. c.t. @ 2 amps; 5 v. @ 2 amps (Chicago PCR-55)
- T_2 —Output trans. 15-watt 8000 ohms to v.c. (Dynaco A-410)
- CH_1, CH_2 —15 hy., 55 ma. filter choke (Chicago RC-1553)
- F_1 —1 amp. fuse
- V_1 —12AX7 tube
- V_2 —6BX7GT tube
- V_3 —5Y3GT tube
- J_1 —Phono jack
- L —9 1/2" x 5 1/2" x 1 1/2" steel chassis

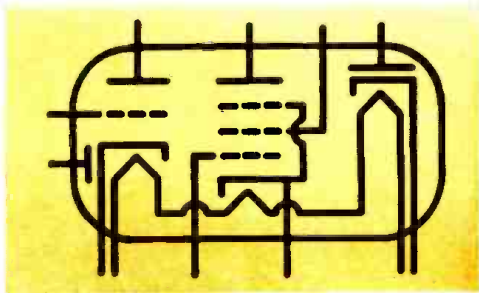

Compactrons:

Advance in Tube Design

Refinement of multi-function techniques results in advantages in cost, reliability, and equipment size.

PROMISES that semiconductor devices would eventually replace all vacuum tubes have been heard since the demonstration of the first operational transistor. To tube design engineers with the *General Electric Co.*, however, such forecasts have seemed arbitrary. These men saw certain advantages in tubes, actual and potential, that presaged a continuingly important role.

Acting on this faith, they embarked on a re-appraisal of the factors involved in tube design, to see whether they could not exploit possibilities to a greater extent than had heretofore been realized. Their success has been such that they are reluctant to call the new devices tubes. Thus the vacuum devices now emerging in this separate category are being called "compactrons."

What is a compactron? How does it differ from its vacuum-tube predecessors? Part of the answer appears on this month's cover, which features one of the first compactrons to be developed flanked by the three, conventional, miniature tubes (four tube functions) it replaces. Designed for use in a.c.-d.c. table radios, this sin-

gle envelope houses a power-supply rectifier, an audio-output pentode, a detector diode, and a first-audio voltage-amplifying triode (providing the combined functions of the 35W4, 50C5, and 12AV6 found in many radios).

Combining it with one more compactron that comprises a pentagrid section (converter) and an r.f. pentode (i.f. amplifier), we can put together a tiny, two-compactron radio. In fact, *G-E* engineers have done just this. The two compactrons, shown to the right in Fig. 1, do the work of five conventional miniatures shown to the left in the same photograph. Equivalent diagrams for these units appear just below the tubes and compactrons themselves. A developmental model of the radio, beside its cabinet, appears in Fig. 3.

The manufacturer believes that the advantages which will make compactrons attractive include the following: they will be smaller than tubes, will outperform tubes and transistors, will feature high reliability and life, and will be less expensive than either tubes or transistors. In a stereo hi-fi amplifier, 7 compactrons will do the work of 10 tubes or 26 transistors. In the home radio mentioned, 2 compactrons

are equivalent to 5 tubes or 7 transistors. In a black-and-white TV receiver, 10 compactrons will match 15 tubes and 3 diodes or 24 transistors and 11 diodes.

From the foregoing, a compactron simply would appear to be a single-envelope device in which the technique of housing as many tube functions as possible has been advanced to an exceptional degree. Yet this definition does not take into account all the distinguishing features that make compactron design possible. It also fails to account for the fact that some single-function units are included in the compactron line. To understand this advance in vacuum-tube technology broadly, we must explore specific characteristics one at a time.

Beginning at the bottom, we find that the all-glass envelope is designed around a 12-pin circle whose diameter is $\frac{3}{4}$ of an inch, larger than that of any conventional tube type. The number of pins, of course, is to take care of multi-function types, but the circle offers advantages even where single-function units are involved. The device will be solidly seated, and it adapts well to printed wiring in that there is adequate space to make connections to all pins. By assigning heater connections to pins 1 and 12, there is space to bring heavier printed wiring to these points if it should be necessary to carry higher current.

The wide, 12-pin circle also provides a good foundation for supporting internal structures. For the most part, points of support fall directly under the electrodes to which they are attached. In addition, the extra spacing between pins makes welding of internal connections easier, therefore more reliable. Simplified fabrication will be passed on to compactron users in the form of reduced costs. The development of interelectrode shorting or microphonism during use would appear to be reduced.

The compactrons thus far developed use a T-9 bulb with a diameter of $1\frac{1}{2}$ inch, allowing space for multi-function structures. While bulb height will vary, it will be kept down by reason of

Fig. 1. All functions of the "All-American Five" used in a.c.-d.c. radios (left) are included in the envelopes of just two compactrons, at the extreme right.

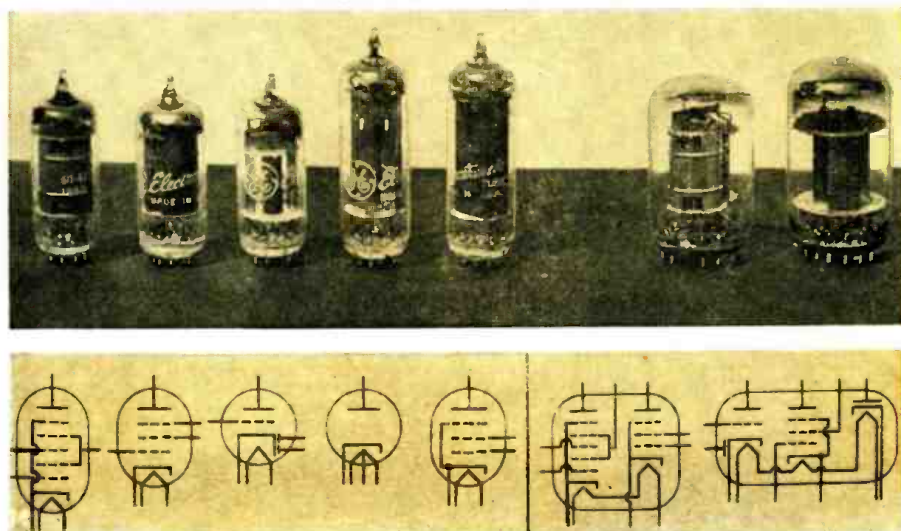

the fact that the exhaust tip, which usually extends about $\frac{5}{16}$ inch above the top of a standard miniature, is placed at the bottom of the compactron between the pins, where it is not wasting space. Thus a receiver designer would have to allow considerably less height, for the most part, than he would for conventional tubes. Compare the height of the compactrons in Fig. 1 with that of the tubes they replace. With a shorter unit, the space occupied will approximate a compact cube.

In some cases, like that of a single-function, horizontal-deflection amplifier now being developed, an envelope with a wider diameter (1½ inch, in this case) may be used. However, the pin circle will be unchanged. The wider bulb permits higher power dissipation. Even with the standard diameter, the width permits an interesting possibility. Flexibility in design and other manufacturing advantages may sometimes be obtained by disposing internal structures horizontally, as in Fig. 2, instead of using the vertical mounting common to most tubes. Horizontal mounting also often retains the desirable feature of low tube height.

The advantages of the generous pin circle are not exclusively structural. By connecting a plate (or other high-

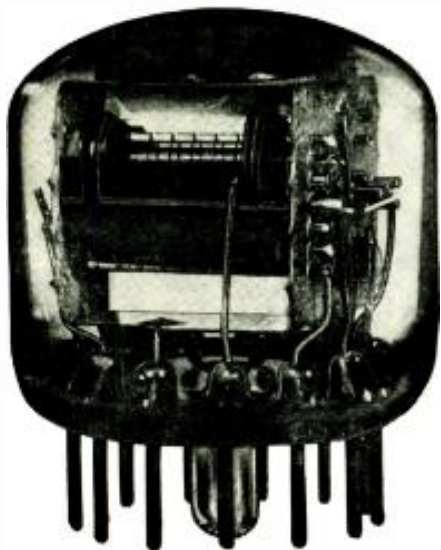

Fig. 2. Horizontal mounting of internal structures facilitates low seated height in this multi-function device.

voltage electrode) to one pin and leaving two unused pins on either side, a voltage isolation in the order of 10,000 volts can be achieved. This will permit the economy of removing the top cap in many designs (such as a horizontal amplifier, for example), since the relatively simple connection to the base can be made with safety.

Thus, even with compactrons limited to a single function because of the high voltages or power dissipation involved, there will be advantages. Improved reliability with reduced cost and size are anticipated.

However, most compactrons will be multi-functional devices, which means

lower cost per function will be obtained by the elimination of extra bulbs, extra stems, and extra evacuation procedures. Not the least significant cost-reducing factor is the use of a single heater to activate all of the cathodes (as many as three) in a single envelope. This not only reduces initial cost to the equipment designer but, by keeping heater power requirements and heat dissipation down in use, will further improve reliability.

Take the case of the two-compactron radio. The unit shown on this month's cover has a tentative heater rating of 70 volts at 100 milliamperes. Its companion in the a.c.-d.c. radio (the pentode-heptode) is tentatively rated at 40 volts and 100 milliamperes, with the heaters of both compactrons in series across the line. The standard five-tube complement which the pair replaces draws 150 milliamperes—a 50 per-cent increase in total heater power.

In part, this reduction in required heater power is made possible by the use of a copper-base, aluminum-clad, iron plate material in compactron design. The copper layer efficiently reflects heat from the plate back to the cathode, where it is needed. Also, the use of new alloys in making the cathodes increases heat transfer from heater to cathode, improving efficiency further and cutting warm-up time.

So much for the features that characterize the compactron type. To what extent have results already been achieved? With many types in various stages of development, G-E has already announced pilot production of six units, available to equipment manufacturers on a sampling basis. In addition to the two for the radio, there is a compactron with two triodes and two diodes. It is intended for TV use as a combined horizontal oscillator, phase detector, and a.f.c. unit.

A compact beam-power pentode, for use as a horizontal-deflection amplifier in TV, is one of the few single-function types. Here are some of its characteristics: plate dissipation, 12.5 watts;

perveance, 320 ma. at 60 volts; maximum plate voltage, 6500 volts; heater voltage, 6.3 volts; and heater current, 1.2 amperes. A companion "single" type is a damper diode, for use in television, with an average damper current of 165 ma. and a maximum heater-cathode voltage rating of 5000 volts. Last of the six initial units is a combined vertical oscillator and deflection amplifier (two dissimilar triodes) for TV.

Now in the works are many other types. These include an alternate unit for use as the TV horizontal oscillator, phase detector, and a.f.c. correction circuit that will consist of two diodes, a triode, and a pentode. Nor are equipments other than TV receivers being neglected. Compactrons especially designed to meet the requirements of auto-radio design are being developed. All of these are expected to be in production within the next year. And this may simply be the beginning.

With growing technical expertise, it is hoped that the advantages already established will be enhanced even further as new designs come out. One possibility that design engineers are actively evaluating is that of including within the glass envelopes circuit elements that are usually added (resistors, capacitors) externally in the case of tubes. If this is in fact done, it can further enhance miniaturization and cost savings. Inclusion of such elements inside the vacuum may also pay noteworthy dividends in the form of improved reliability.

A possible disadvantage is the replacement cost when a multi-function compactron, instead of a single tube, becomes defective. However, G-E engineers feel that other savings may at least cancel this out. Lower initial equipment cost, cost per function, and reliability will be factors.

Ultimate success of the line is probably in the hands of equipment manufacturers, whose use of compactrons in less expensive, more efficient designs will be a key factor.

-30-

Fig. 3. An engineer experiments with layout of prototype for two-compactron radio. Cabinet is to the right. A working model has since been demonstrated.

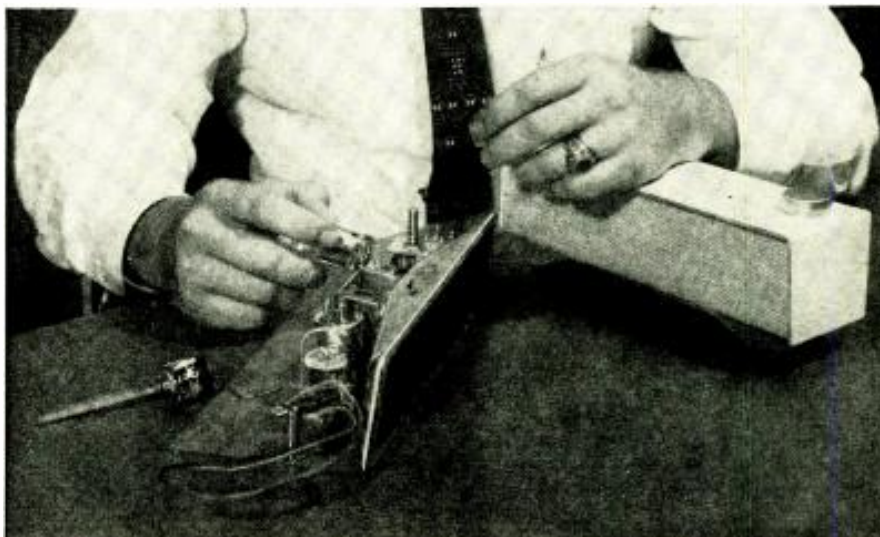

By JOHN T. FRYE

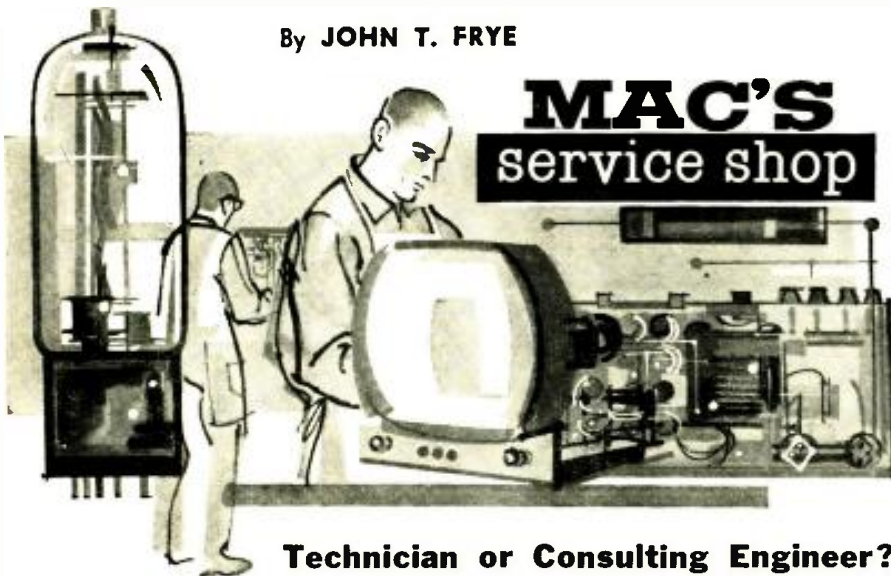

Technician or Consulting Engineer?

BARNEY, returning to the service shop after his lunch hour, stepped aside just in time to keep from being run over by a vigorous middle-aged man dashing out the front door. Cautiously the young technician opened the door and stepped inside. As he entered the service department, his eyes swept the receiving bench quickly; then he turned to Mac, his employer, already busy at the bench.

"What did those last two jokers want?" he demanded. "I saw two guys come out of here while I was parking the truck. Neither one was carrying anything, and apparently neither one brought anything, either. That last one was a competitor. What was he doing? Spying?"

"Not exactly," Mac said with a chuckle; "so you can let your hackles down. I should warn you, though, you may have to start calling me 'mister.' I'm getting up in the world. Those two sought my services as a consulting engineer."

"OK, Mr. McGregor, don't stop there," Barney insisted.

"The first man who came out was Mr. Harkle, an engineer with the spring factory on the north side of town. Right after you left on that last service call before lunch, he telephoned to say he wanted to talk to me about a problem. I agreed, and he came right away with a bunch of blueprints under his arm.

"First he showed me a print of a large metal disc about seven feet in diameter with holes bored through it all around the rim. At the factory springs are loaded in these holes, and the rim of the big disc rotates slowly between two high-speed emery wheels that are properly spaced to grind both ends of each spring simultaneously. The rotating mechanism of the big disc is indexed so that at regular intervals it stops while finished springs are removed from a section or while unfinished springs are loaded into empty holes.

"The problem is that now and then a shaft breaks or a key shears on the

shaft that rotates the big disc, and then the latter starts free-wheeling under the friction drive from the emery wheels. You can imagine the damage to the spring loading and unloading mechanism and the real danger to persons nearby which results when that big disc tries to turn as fast as those emery wheels. What was wanted was a device that would shut off the emery wheels the instant the big disc accelerated beyond its normal slow rotation. To be effective, the device had to detect acceleration that took place over a very small portion of a complete revolution."

"That rules out anything based on centrifugal force," Barney observed.

"Right. Mr. Harkle had a hazy notion the problem might be solved somehow by electronics, and I agreed it could. For example, a light could be arranged to shine through the holes in the centers of the springs onto a photocell. This cell could work into an amplifier designed to cut off at low frequencies such as those produced by the slow lighting and darkening of the cell as the disc rotated at normal speed. When the disc started to spin, this 'interruption' frequency would go up, pass through the amplifier, be rectified, and operate a relay to cut power off the grinding wheels. Another possible solution would be to mount little PM magnets around the rim of the disc so they passed close to the soft iron core of a coil. Voltage induced in this coil by the passage of each magnet would depend, among other things, on the speed of the magnet past the coil. Voltage thus produced could be amplified and used to operate a cut-off relay when it exceeded a certain value—such as that resulting when the disc started to rotate more rapidly.

"But I kept thinking of all the things that could go wrong with such arrangements: dirt could cut down the light received by the photocell; the exciting lamp could burn out; amplifier tubes could go bad; the magnets could weaken; the pickup coil could be jarred out of position; and so on. Suddenly I

remembered the 'velocity trip' arrangement used on record changers that permits the tone arm to move in toward the spindle the diameter of one groove per revolution without tripping; but when the needle strikes the tripping groove and the tone arm swings in rapidly, the change mechanism is set in motion. In an instant I had what seemed to me a simple and nearly fool-proof solution.

"I suggested a small synchronous motor and cam arrangement be used to press the end of a rubber-tipped rod firmly against the rim of the wheel once every second. The rod would be mounted so its tip could be carried sideways a small amount by the normal motion of the disc during the fraction of a second the two were in contact; but when the rod pulled back each time, it would return to its original position. When the wheel started to spin, however, the end of the rod would be carried sideways much farther during the contact period. This increased lateral motion could easily be arranged to operate a micro-switch that would remove power from the grinding wheels. I pointed out to Mr. Harker that the arrangement would be very quick acting and positive; it used only a few parts; and it could be visually inspected at any time for proper operation. He gathered up his blueprints and took off in a happy frame of mind.

"Just before Mr. Harker left, Tony Klinck dropped in to report a solution I had worked out for one of his problems was a great success. Tony is a good TV service technician, but he got into the repair game since the advent of TV and lacks the broad background of general electronic experience that comes from growing up with the business since the early days of radio. He never hesitates to yell for help when he needs it, however; and a couple of weeks back he came to me with quite an interesting little problem.

"A drive-in eating place over on the west side has installed a whole new intercom system with speakers on posts in the parking area to relay orders to the kitchen. When a button on a parking lot speaker is pushed, this turns on a light above a switch in the kitchen. The order-taker throws this switch down, steps on a foot switch that operates a relay performing the push-to-talk function of the intercom system, and says, 'May I take your order?' Releasing the foot switch transfers the kitchen speaker transformer back to the output of the intercom amplifier and the post speaker transformer to the input of the amplifier so the customer can place his order.

"An added feature is the playing of music through post speakers not being used for talking. A tuner or record player working into a forty-watt amplifier accomplishes this. When all the switches in the kitchen are in the 'up' position, all post speaker transformer primaries are connected in parallel across the output of the music ampli-

(Continued on page 132)

Integrated Stereo Preamp-Amplifiers

By WARREN DeMOTTE / By knowing what functions you require and referring to our chart, you can determine which model best fits your needs.

IN this third year of the stereo disc, a very practical method of achieving high-fidelity stereo reproduction is still through the use of an integrated preamp-amplifier as the heart of the audio system. This versatile instrument has two distinct virtues that endear it to the experienced audiophile and the neophyte alike: it is convenient and it is inexpensive.

These terms must be understood in context and the context is "component high-fidelity." The integrated amplifier is easier to hook into a system than an equivalent preamplifier plus power amplifiers, and it also is inclined to be less expensive.

Cost has taken a curious turn in the high-fidelity field during these past years. While prices in other fields have been rising, prices in hi-fi have generally remained stable, and in some instances have even been reduced. More remarkably, the audiophile also gets more value for his dollar, as technical improvements have been made and passed on to the consumer.

Today, a high-fidelity stereo preamp-amplifier can be bought at prices ranging from \$54.95 to \$289.50, and these are not too far removed from prices that prevailed a few years ago for equivalent quality monophonic preamp-amplifiers. Considering the greater complexity of the stereo unit, with its doubling of parts and functions, it is evident that the audio industry has accomplished something in the nature of a minor economic miracle.

There are over fifty different integrated stereo amplifiers currently being marketed which can claim to be "high-fidelity." They all do a good job of amplifying the program material fed into them so that it comes out satisfactorily from the loudspeakers. Some of the amplifiers do a better job than others; some do a superlatively fine job. Some operate with more flexibility; some are more suited to specific conditions than others.

What makes one amplifier more desirable than another may be the subjective matter of sounding better with given associated equipment. The amplifier itself does not produce sound and, ideally, it should not color sound, but it is a reality that in combination with the same transducers (pickups or tape heads and speakers), one amplifier may give more pleasing results than another in an actual listening test. Yet, they both may check out equally well in the usual laboratory tests, and on paper, the second may even disclose superior electronic measurements.

It is axiomatic that a thirty-watt amplifier will drive an inefficient speaker more effectively than a fifteen-watt



Bell Model 2420



Bogen Model DB 212



DeWald N-1200B "Concerto"



Eico Model ST40



Grommes Model 59PGA

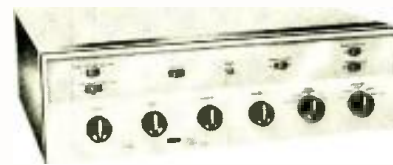

Harman-Kardon A260 "Chorale"



Heath Model AA-100

amplifier, and the difference will probably be readily apparent even to the relatively uneducated ear. But it may take much concentration and require special test material to establish the aural superiority of a forty-watt amplifier over a thirty, especially if both are operated at less than maximum ratings.

In selecting a stereo amplifier, the speakers with which it will be used must be taken into consideration. If they are high-efficiency speakers, then any amplifier on the accompanying chart will drive them without difficulty. It is something to remark that the lowest power rating among these amplifiers is higher than the ten watts which were considered entirely adequate only a short while ago.

If you plan to use low-efficiency speakers, it is wiser to buy an amplifier with high wattage. It will not have to strain to drive the speakers and the latter will function under more favorable conditions. The result will be more pleasing sound at all volume levels.

Any amplifier you purchase should have enough input facilities for any program sources you will want to use with it. Generally considered necessary are inputs for magnetic stereo cartridge, stereo tuner, and stereo tape recorder. This last is for tape machines that have their own preamplifiers for play-back, as most do. However, if you plan to incorporate a tape deck in your audio system for playing back pre-recorded tapes, separate preamplifiers are not necessary if your preamp-amplifier has a tape-head input.

A word of caution: hooking tape-heads into an amplifier may set up hum if the leads are not well shielded and kept short, or if the hum level in the amplifier itself is not low. This is a qualitative factor that must be put to the test. If it is your intention to use the amplifier's tape-head input facility, it will be wise to have the salesman demonstrate the ability of the unit to handle tape without objectionable hum before buying it.

With adequate operating space, a record changer in addition to the turntable can be an appreciated convenience. If you want to use magnetic cartridges in both and hook both of them in permanently, the amplifier should have two stereo magnetic inputs. Otherwise, you may use a ceramic or crystal cartridge in the changer and a magnetic with the turntable.

More than one pair of speakers can be used in the system if you want to pipe stereo sound into another room or

(Continued on page 54)

Integrated Stereo Preamp-Amplifier Check List

Name	Model	Price (without case)	Size (inches)	Weight (pounds net)	Power Output Per Channel	Third Channel Output	Ceramic-Crystal Cartridge Input	Magnetic Cartridge Inputs	Stereo Tape Head Inputs	Stereo Auxiliary Inputs	Stereo Tuner Inputs	Individual Channel Tone Controls	Individual Channel Volume Controls	Master Volume Control	Loudness Control	Stereo Balance Control	Blend Control	Channel Reversing	Speaker Phasing	Extra Speakers Switch	Tape Recorder Output	Channel Balance Indicator	Rumble Filter	Scratch Filter
Altec Lansing	353A	\$229.00 ¹	5 7/8" h x 15" w x 11 1/4" d	35	25 ²	Yes	Yes	Yes	Yes	Yes	Yes	No	No	Yes	Yes	Yes	No	No	No	No	Yes	No	Yes	No
Arkay	CS-28	99.95 ^{1,14}	5h x 16w x 9d	29	14 ⁵	Yes	Yes	Yes	Yes	Yes	Yes	No	No	Yes	Yes	Yes	No	No	No	No	Yes	No	Yes	No
Bell	2410	109.95	5 7/8" h x 14 1/2" w x 10 3/4" d	17	15 ⁴	No	No ¹⁰	Yes	No	Yes	Yes	No	No	Yes	No	Yes	No	No	No	No	Yes	No	No	No
Bell	2420	129.95	5 7/8" h x 17 3/8" w x 10 3/4" d	20	17 ⁴	No	Yes	Yes	Yes	Yes	Yes	Yes	No	Yes	Yes	Yes	No	Yes	No	No	Yes	No	Yes	Yes
Bell	2440	179.95	5 7/8" h x 17 3/8" w x 10 3/4" d	26	22 ⁴	No	Yes	Yes	Yes	Yes	Yes	Yes	No	Yes	Yes	Yes	No	Yes	No	No	Yes	No	Yes	Yes
Bogen	DB-712	119.95	4 3/4" h x 15" w x 11 3/4" d	18	12 ⁵	No	Yes	Yes	No	Yes	Yes	No	No	Yes	No	Yes	No	Yes	Yes	No	Yes	No	Yes	Yes
Bogen	AP-40	199.50	6h x 16w x 13 1/2" d	30	20 ⁵	Yes	Yes	Yes	Yes	Yes	Yes	Yes	Yes	Yes	Yes	Yes	Yes	Yes	No	Yes	Yes	No	Yes	Yes
Channel Master	6800	119.95	5h x 14 3/4" w x 11 1/4" d	16	16 ⁵	No	Yes	Yes	Yes	Yes	Yes	No	No	Yes	Yes	Yes	No	Yes	Yes	No	Yes	No	Yes	No
De Wald	H-1200-B	99.95 ¹	4 1/2" h x 14 3/4" w x 9d	19	15 ⁵	No	Yes	Yes	Yes	Yes	Yes	Yes	Yes ³	Yes	Yes	Yes ⁷	No	Yes	Yes	No	Yes	No	Yes	No
EMI	555	267.50	4h x 14w x 13 3/4" d	25	20 ⁵	Yes	Yes	Yes	Yes	Yes	Yes	Yes	Yes	Yes	Yes	Yes ⁷	No	Yes	Yes	No	Yes	No	Yes	Yes
Eico	HF-01	109.95 ^{1,13}	4 3/4" h x 15" w x 10 1/2" d	24	14 ²	No	Yes	Yes	Yes	Yes	Yes	Yes	No	Yes	No	Yes	No	Yes	No	No	Yes	No	Yes	No
Eico	ST-40	124.95 ^{1,11}	5h x 15 3/4" w x 14d	27	20 ³	Yes	Yes	Yes	Yes	Yes	Yes	Yes	Yes	Yes	Yes	Yes ⁷	No	Yes	No	No	Yes	No	Yes	Yes
Eico	ST-70	144.95 ^{1,12}	5h x 15 7/8" w x 16d	35	35 ³	Yes	Yes	Yes	Yes	Yes	Yes	Yes	Yes	Yes	Yes	Yes ⁷	No	Yes	Yes	No	Yes	No	Yes	Yes
Eico	2180	103.75	4 1/2" h x 12 1/4" w x 10 1/2" d	14	20 ⁵	No	Yes	Yes	No	Yes	Yes	Yes	No	Yes	No	Yes	No	Yes	No	No	No	No	No	No
Fisher	X-100	159.50	4 1/2" h x 15 1/8" w x 11 7/8" d	21 1/2	18 ⁴	Yes	Yes	Yes	Yes	Yes	Yes	Yes	Yes	Yes	Yes	Yes	No	Yes	No	No	Yes	No	Yes	Yes
Fisher	X-202	229.50	4 1/2" h x 15 1/8" w x 12 1/2" d	32	25 ⁴	Yes	Yes	Yes	Yes	Yes	Yes	Yes	No	Yes	Yes	Yes	Yes	Yes	Yes	No	Yes	No	Yes	Yes
General Electric	G-7600	139.95 ¹	5 1/8" h x 15" w x 12d	27	20 ⁴	No	No ¹⁰	Yes	Yes	Yes	Yes	Yes	No	Yes	Yes	Yes	No	Yes	No	No	Yes	No	Yes	No
General Electric	G-7700	189.95 ¹	5 1/8" h x 15" w x 12d	28	28 ⁴	No	No ¹⁰	Yes	Yes	Yes	Yes	Yes	No	Yes	Yes	Yes	No	Yes	No	No	Yes	No	Yes	Yes
Grommes	241J	99.95	4 1/2" h x 14" w x 9d	20	12 ⁴	No	Yes	Yes	Yes	Yes	Yes	No	No	Yes	Yes	Yes	No	Yes	No	No	Yes	No	No	No
Grommes	36PG	169.95	4 1/2" h x 14" w x 11d	22	20 ⁴	Yes	Yes	Yes	Yes	Yes	Yes	Yes	No	Yes	Yes	Yes	No	Yes	No	No	Yes	No	Yes	Yes
Grommes	50PGA	189.95	4 1/2" h x 14" w x 11d	26	25 ⁴	Yes	Yes	Yes	Yes	Yes	Yes	Yes	No	Yes	Yes	Yes	No	Yes	No	No	Yes	No	Yes	Yes
Harman-Kardon	A230	109.95	4 5/8" h x 13 1/2" w x 11 1/2" d	15	15 ⁵	Yes	Yes	Yes	Yes	Yes	Yes	Yes	No	Yes	Yes	Yes	No	Yes	Yes	Yes	Yes	No	Yes	No
Harman-Kardon	A260	199.95	4 7/8" h x 15 1/4" w x 13 3/4" d	32	30 ⁵	Yes	Yes	Yes	Yes	Yes	Yes	Yes	No	Yes	Yes	Yes	No	Yes	Yes	Yes	Yes	No	Yes	Yes
Health	WSA-2	99.95 ^{1,19}	4 1/2" h x 15" w x 8d	20	14 ⁴	No	Yes	Yes	No	Yes	Yes	Yes	Yes	Yes ⁴	No	Yes ⁷	No	Yes	Yes	No	No	No	No	No
Health	WAA-100	144.95 ^{1,20}	5 1/2" h x 15 3/4" w x 13 1/2" d	27	30 ⁴	Yes	Yes	Yes	Yes	Yes	Yes	Yes	No	Yes	Yes	Yes	Yes	Yes	Yes	No	Yes	No	No	No



Lafayette Model 250



Madison Fielding Series 360



Olson Model AM-147



Webster Electric Model GL20-20

two. This can be done by wiring auxiliary speakers in parallel with the main speakers and adding a switch or two for selecting which speakers should operate. However, this extra wiring is obviated in the amplifier which makes provision for additional pairs of speakers.

The problem of the "hole in the middle," which plagued early stereophiles, has been pretty well eliminated at its source by improved techniques in recording. Where the condition exists due to speaker placement or listening room acoustics, two remedies are available. One is the employment of a third speaker, and several amplifiers have built-in center-channel facilities. The center channel is essentially a blend of the signals from both regular channels which is fed through the third speaker.

Other amplifiers have a blend or separation control which takes some of the signal from each of the two channels and adds it to the other. This has the effect of narrowing the spread of the stereo sound and, carried out fully, transforms it into monophonic sound.

Not every stereophile has identical speakers for both channels, and even with identical speakers, their placement may cause one to sound entirely

different from its fellow. Also, one of the dual amplifiers in the unit may have slightly different characteristics than its mate. These possibilities make individual-channel tone controls desirable. To avoid clumsiness in operation, the tone control knobs are usually paired concentrically and employ a friction or clutch design. This gangs both treble knobs or both bass knobs at will. Thus, the treble and bass of each channel can be adjusted individually for most pleasing sound, and then further adjustments can be made of both channels simultaneously so that they remain in the original optimum relationship to each other.

The volume of sound that emanates from the two speakers must be kept in proper balance for proper fidelity. If the amplifier has individual-channel volume controls, this can be accomplished by increasing or decreasing the volume of one channel to match the other. If the two controls are on one shaft, they can also be turned together to raise or lower the volume of both channels simultaneously. Thus, they remain in proper aural relationship, and a friction or clutch design is convenient here.

An essentially simpler operating design is more commonly utilized. This consists of a permanently ganged volume control with a separate balance control. Once the latter is set, the former can usually be operated without fear of disturbing the balance.

As bass and treble have a tendency to vanish beyond the range of hearing when playing volume is lowered, provision is usually made to boost them when necessary without disturbing the normal tone settings. This is the function of the "loudness" control. When it is switched into the circuit, it adds bass and sometimes treble in accordance with certain formulas, thus re-establishing the proper balance of sound. However, leaving the loudness control on while playing at normal and

high volume levels can make a high-fidelity system sound like a veritable juke box.

When instruments exhibit a tendency to wander between the speakers and the bass sounds thin and fluttery, a disparity in phasing of the speakers is indicated. This means that one speaker is pushing air while the other is pulling it. The effect is one of cancellation instead of support and this can be un-

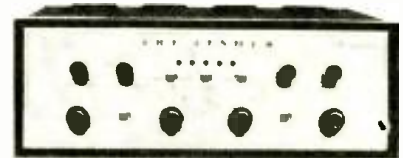

Fisher Model X-202



Knight Model 740B



Scott 299B "Stereomaster"

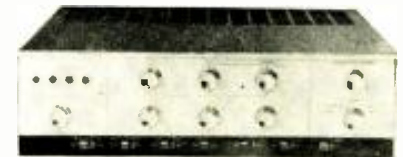

Stromberg-Carlson Model ASR-8-80



Transis-tronics Model S-25

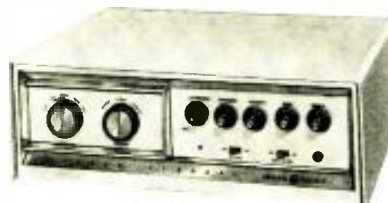

General Electric 7700 "Stereo Classic"



Paco Model SA-40



Pilot Model 248

pleasant, in addition to being unnatural. To correct this and put the speakers in phase with each other, the terminals of one speaker must be reversed. This is, of course, easily done, but some amplifiers simplify the task with a phase-reversing switch. A flip or two of this switch quickly establishes the proper phasing of the speakers.

Once channels are correctly determined with a stereo test record or a stereo record "with the violins on the left," they may be safely forgotten, until a record or a tape shows up "with the violins on the right." Then the "channel reverse" or "stereo reverse" or just plain "reverse" position of the mode switch must be turned to. This rarely happens, but switching from the normal stereo position to the reverse and back can aid in balancing the volume of the speakers. Utilize a mono

(Continued on page 124)

Class

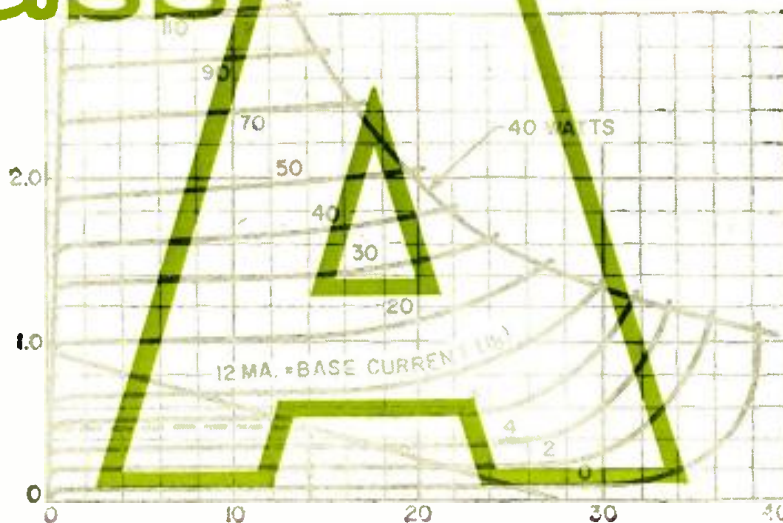

Transistor Power-Output Circuits

By WALTER H. BUCHSBAUM / Industrial Consultant, ELECTRONICS WORLD

Some simple, as well as useful, basic circuit-design information that will help to understand class A transistor output circuits.

AMONG the many possible transistor power-amplifier circuits two basic types are certain to be included in any list of preferred or standard circuits. One is the class A single-stage output amplifier and the second is the class B push-pull circuit. These two circuits can be used with practically any power transistor on the market and can be designed for almost any amount of output power, linearity, frequency response, etc.

This article will consider the operation of class A transistor power amplifiers and will present sufficient engineering detail to permit the reader to design an amplifier, tailor-made to his own special requirements. Commercially available amplifiers are designed by the same process and an understanding of the technique will be of help in repairing such equipment.

Transistor Characteristics

Just as tube characteristics are important in the design or troubleshooting of vacuum-tube circuits, transistor characteristics must similarly be understood first. We assume that our readers are somewhat familiar with vacuum-tube characteristic curves and therefore we proceed to compare them to transistor characteristics.

The first factor which must be considered in selecting a transistor as a power amplifier is its power handling ability. Vacuum tubes are rated according to maximum plate dissipation, without any reference to operating temperatures. Transistors, however, are rated according to maximum collector dissipation at a certain temperature, usually 25°C, which corresponds to approximately 75°F or room temperature. If the maximum power is

dissipated in the transistor, the temperature of the transistor itself will rise and this will limit its power handling ability. A transistor capable of handling 10 watts at 25°C sometimes can handle only 3 watts at 50°C. This brings us to the first important transistor characteristic which is different from its vacuum-tube counterpart. This is the power derating curve, a typical example of which is shown in Fig. 1. On the vertical axis we read the maximum collector dissipation in watts and on the horizontal axis the mounting base temperature is plotted. Fig. 1 applies to the type 2N235A which is a 25-watt transistor, similar to the 2N301 and a number of others. Note that up to 40°C of mounting base temperature the maximum collector dissipation of 25 watts is permissible, but as the mounting temperature goes up less power can be handled by the collector. At 90°C, with zero collector dissipation, the mounting temperature and the transistor junction temperature are the same. The solid line of Fig. 1 is based on the worst conditions, while the dotted line is representative of average transistor variations. To be on

the safe side the designer should stay within the left portion of the solid line. More detail on temperature control is given in a later paragraph.

The other important transistor characteristics can be compared to their vacuum-tube equivalents. First comes the output characteristic which shows collector current *versus* collector voltage and, as apparent from the example of Fig. 2, this is equivalent to the plate characteristics of tubes. Instead of grid voltage, base current is used here as parameter but, the load line and other design features are obtained just as for vacuum-tube amplifiers. The constant dissipation contour shown in Fig. 2, is similar to maximum plate-dissipation curves supplied for power-output tubes.

Transistor input characteristics are comparable to the grid curves supplied for vacuum tubes, except that the base-current *versus* base-voltage curves are not usually as linear as grid curves. A third type of characteristic, which is usually supplied with transistor data, is the transfer characteristic which shows collector-current output *versus* base-current input at a fixed collector voltage. This curve is very useful in determining linearity and bias.

Having convinced ourselves that transistor characteristic curves are no more complex than those which we have used for vacuum-tube circuits, we can now examine the operation of a class A transistor output amplifier.

Operating Features

Class A operation means that the output waveform will be a facsimile of the input signal and this means that the transistor will conduct during the entire cycle. To obtain proper linearity, the collector voltage and current

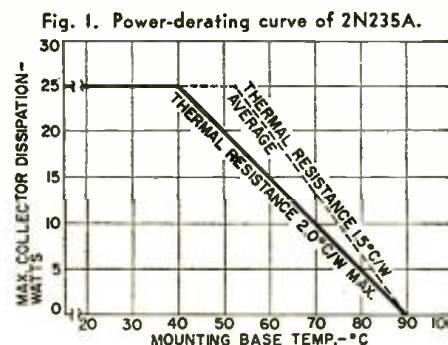

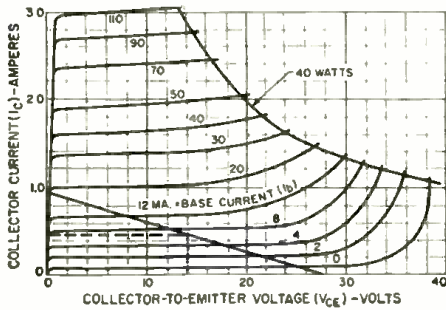

Fig. 2. Collector characteristics of 2N176.

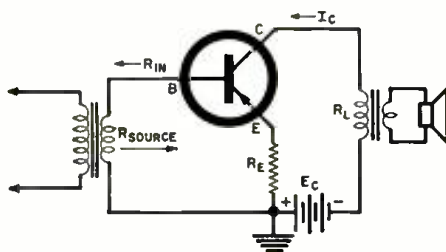

Fig. 3. Grounded-emitter output amplifier.

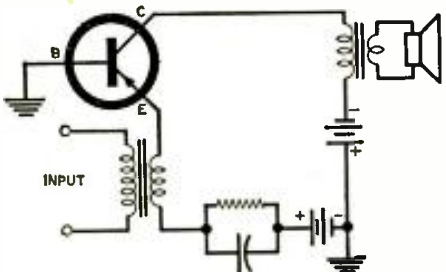

Fig. 4. A grounded base output amplifier.

must vary over a linear portion of the output characteristics. In transistor amplifier design it is possible to ground the base, the collector, or the emitter, with each connection having certain advantages and drawbacks. For audio power amplifiers the most frequently used connection is the one shown in Fig. 3 in which the emitter is effectively grounded. This provides the greatest amount of power gain while still giving reasonable linearity. Fig. 4 shows the connection for grounded-base amplifier, a circuit which gives excellent linearity but less power gain than the grounded-emitter scheme. The third connection has the collector grounded for a.c. and is called an emitter-follower. Like the cathode-follower this third circuit has high input and low output impedance, but is not really an amplifier. It is not usually used as class A single-stage and will therefore not be considered here.

One of the features of any class A power stage, tube or transistor, is the fact that considerable power is dissipated during zero-signal conditions. In a transistor this means that the quiescent point must be chosen well below the maximum collector dissipation and therefore the full power handling ability of the transistor cannot be used. The battery or power supply must deliver considerable power during zero-signal conditions. For these reasons class A amplifiers are not usually used for large power output stages, but are limited to applications below 5 watts. When two transistors are used

in class A push-pull, the standby power requirement remains, but each transistor can be driven harder and all even-harmonic distortions are cancelled out. Considerable second- and third-harmonic distortion can be encountered in single-stage class A amplifiers, but careful design and certain precautions can keep distortion below 5%.

Class A Amplifier Design

Some texts treat transistor circuit design in great detail and involve the use of accurate mathematical expressions. In this article, however, only simple arithmetic is required to design certain basic amplifier circuits from manufacturers' data. Approximations, simplifications, and certain basic assumptions are made about the transformers and other parts, which are available from jobbers' shelves. The design procedures may not be accurate enough for servo amplifiers used in missile guidance systems, but they will do for practical audio amplifiers, that our technically minded readers can design, build, and work with.

A practical approach to the design of a typical class A power amplifier must start with the known requirements. How much audio power should be produced? What battery or power-supply voltage is available? In this example the desired output power might be 2 watts. Assuming that the output transformer efficiency is 75% we can see at once that the amplifier itself must deliver 2.67 watts in order to drive the

speaker with 2 watts. Next we must provide for some overload capacity, say 25%, and this increases the power output capability of the transistor stage to 3.35 watts. Adding at least 3.35 watts for d.c. dissipation we can see that the collector dissipation must be at least 6.7 watts. If we choose a nominal battery voltage of 14 volts, the collector current can be calculated from Ohm's Law as:

$$I_c = \frac{6.7 \text{ watts}}{14 \text{ volts}} = 0.48 \text{ amp.}$$

Similarly, the load resistance is:

$$R_L = \frac{14 \text{ volts}}{0.48 \text{ amp.}} = 29 \text{ ohms (approx.)}$$

Now we can select a transistor by knowing that it must have a collector dissipation of over 6.7 watts and be able to stand a peak-inverse voltage swing of at least 2 times 14 or 28 volts. One such transistor is the 2N176, available from most jobbers and manufactured by RCA, Sylvania, Motorola, among others. The 2N176 collector can dissipate 10 watts and has a peak-inverse voltage rating of 40 volts, a safe margin for our requirements. The manufacturer's data for the type 2N176 transistor includes the collector characteristics which are shown in Fig. 2. We locate the intersection of 14 volts and 0.48 amp., which is then the quiescent point, just as in vacuum-tube circuits. The load line is drawn by connecting the quiescent point with the 28-volt point on the base line or the 0.96-amp. point on the vertical axis.

A look at the load-line drawing of Fig. 2 will indicate some of the reasons for non-linearity in the output signals. The quiescent point is here set for a base current of approximately 6 ma. A swing from 0 to 12 ma. would result in an output voltage swing from 25 to 8 volts, and this would produce a sine wave in which one portion is compressed as compared with the other. The base current is, of course, determined by the base voltage and by the signal source impedance. By making the source impedance much smaller than the base input impedance and by providing some bias on the base itself this non-linearity can be compensated for to some extent.

We see from Fig. 2 that the maximum base current will be approximately 20 ma. Next we refer to the input characteristic curve of Fig. 5 which shows that approximately 0.5 volt of base signal would be required to produce 20 ma. of base current. Multiplying these two figures we obtain the required maximum input power which is 10 mw. The input impedance can be approximated, using Ohm's Law:

$$\frac{0.5 \text{ volt}}{0.020 \text{ amp.}} = 25 \text{ ohms}$$

To reduce distortion we can choose a source impedance of 10 ohms.

The power gain of the stage can be calculated from the ratio of output power to input power, which, in this example, is 267. This corresponds to a power gain of approximately 24 db.

To get an approximate idea of the value of the emitter resistor, we must

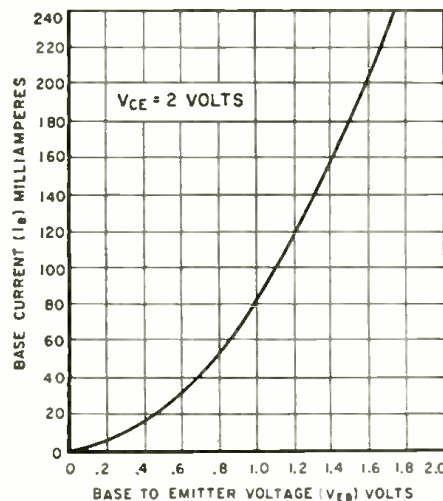
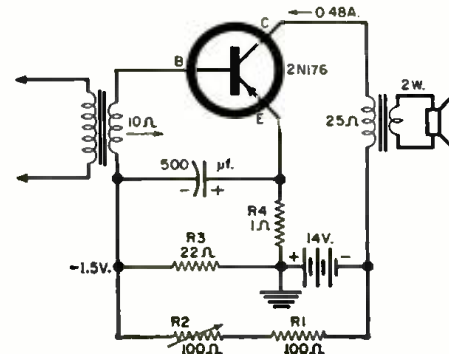

Fig. 5. Input characteristics of 2N176.

Fig. 6. A practical class A circuit.



determine the base voltage at the quiescent point which is approximately 0.25 volt. Using Ohm's Law again we know that the quiescent collector current of 0.48 amp. must pass through this emitter resistor and we then obtain a value for it as follows:

$$\frac{0.25 \text{ volt}}{0.48 \text{ amp.}} = \frac{1}{2} \text{ ohm}$$

It is a safe assumption that a 1-ohm resistor in the emitter circuit will be approximately correct.

If we want to determine the circuit efficiency of our class A amplifier we divide the audio output power, 2.67 watts, by the total input power, 6.7 watts, and multiply the results by 100 to obtain approximately 40%.

We have now established all of the values for the circuit of Fig. 3 and from this we can go to the practical circuit which is shown in Fig. 6. Note that in this circuit we have added a forward bias of approximately 1.5 volts which is applied to the base through the voltage divider R_1 , R_2 and R_3 . Some circuits use a separate battery, usually located in the emitter lead, but for simplicity's sake a voltage divider has been used in Fig. 6. The adjustable resistor is set for best output linearity. A 500- μ f. bypass capacitor is used between the emitter and the input transformer winding to keep a.c. out of the bias circuit. The 1-ohm emitter resistor limits the emitter current and therefore the base bias can effectively shift the quiescent point on the load line to obtain more linear output without causing excessive collector current to flow. It is possible to obtain 2 watts of audio power with a maximum of 3% distortion over a frequency range from 60 cps to 10 kc. with this circuit. Some of the loss at the higher frequencies is compensated by the increased efficiency of both transformers.

The circuit shown in Fig. 6 and the design procedure described above is applicable to other transistor types as well. In many instances manufacturing data includes some of the values calculated here and occasionally a complete circuit diagram for a class A audio amplifier is provided as part of the data sheets.

Controlling Temperature

As pointed out earlier, one of the limitations of any transistor is its sensitivity to changes in temperature. When the transistor gets warmer, more collector current can flow, which, in turn, tends to make it warmer still. This is often called "thermal runaway" and is the prime transistor killer in experimental work. Sometimes a circuit works perfectly until a hot day comes along and then things seem to go haywire.

There are several safeguards against thermal runaway and one of them has already been included in the design just discussed. This safeguard is the emitter resistor which at least limits the collector current and provides a back bias as the collector current increases. Another safeguard is the

original circuit design which centers around a power range well below the maximum for that particular transistor. In Fig. 2 we can see that the load line chosen is well removed from the 40-watt maximum dissipation curve. Actually the collector temperature at the maximum design power level of 6.7 watts could go up beyond the room temperature of 25°C, but to play it safe we have designed for that temperature. If we were to operate this circuit at, say, 60°C, then we would have to provide some temperature compensation such as a thermistor, connected across the 22-ohm leg of the base-biasing circuit. As temperature increases, resistance of the thermistor drops and this also reduces the forward bias and therefore tends to limit collector current.

Aside from the problems introduced by thermal runaway and possible higher ambient temperatures, collector dissipation must be considered. All power transistors have the collector connected directly to the outside body and depend on dissipating collector power through the body. For this reason it is usually necessary to mount a power transistor on some kind of heat sink. In our previous example, over 3 watts

of d.c. power is dissipated in the collector. If no heat sink is provided this power will quickly heat up the transistor body, raise the internal temperature, and thereby increase the collector current. Even with a suitable emitter resistor, the thermal runaway effect could take over. It is absolutely necessary that the collector power be dissipated into the surrounding air and, in most instances, the transistor case itself cannot radiate heat fast enough.

There are many different ways of helping the transistor dissipate heat. Some power transistors are available with tight fitting copper radiating bodies and fins. Others can be mounted on specially designed heat sinks. Almost all power transistors are sold with a mica or alumina oxide mounting washer which permits mounting the transistor on the chassis for heat dissipation while obtaining electrical insulation. A typical arrangement is shown in Fig. 7. Ordinary insulators cannot be used since they do a poor job of transmitting heat.

In locating power transistors on a chassis we must make certain that the heat they contribute does not injure other transistors and that the chassis is reasonably cool to begin with. In addition to radiating the heat on the chassis itself, some home-made auxiliary heat sinks can be used. A simple fuse clip or capacitor mounting clip can be used, especially on smaller power transistors, as shown in Fig. 8. The clip should make contact with the transistor body in as many places as possible to allow heat transfer to the clip. While the illustration shows the clip mounted against the chassis through a mica washer arrangement, in low-power applications the clip can be insulated by regular Bakelite or cardboard and then only the clip radiates the heat.

For larger power transistors the arrangement of Fig. 9 is quite useful. A rectangular sheet of aluminum, copper, or brass is used and, to add radiating surface, two angle pieces are bolted on each end. The entire structure can be mounted on Bakelite or ceramic stand-offs which provide electrical insulation from the chassis. To further increase heat radiation, any of the heat sinks can be painted black, but care must be taken that the heat transfer points between the transistor and the heat sink are not covered with paint.

One frequent mistake made by people unfamiliar with transistors is that they forget to make an electrical connection to the body of the transistor which is the collector. Never solder to the transistor body since this is equivalent

(Continued on page 121)

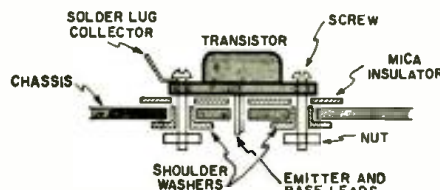

Fig. 7. Chassis mounting of transistor.

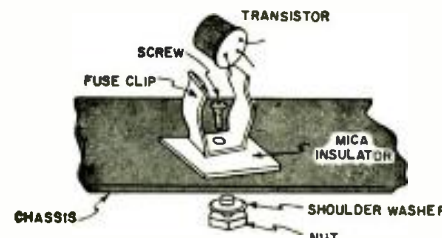

Fig. 8. The fuse-clip heat sink.

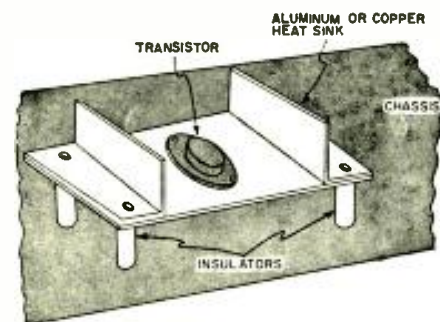

Fig. 9. Elaborate insulated heat sink.

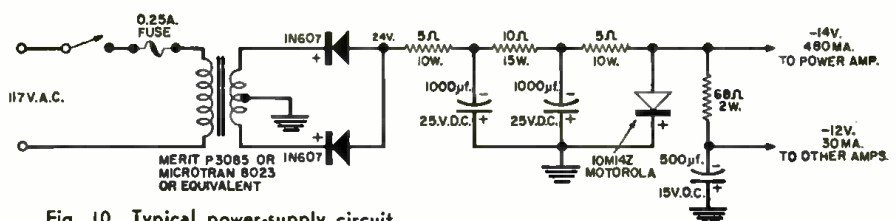

Fig. 10. Typical power-supply circuit.

Keeping Step in Business



By ERNEST W. FAIR

Technical ability alone is not enough to make up for everything else the competition may offer.

THAT wonderful day when a man could set up an electronics service business and keep it alive solely because he happened to be highly skilled has passed. In today's ever-changing business environment, technical capability alone is not enough.

Staying in business depends on many things. Many important ones come under the broad heading of keeping step with the changes going on around us—in the electronics business, in particular, and also in the general business atmosphere. There are many respects in which one must keep pace, and many ways of accomplishing this objective.

We can keep pace on the local level, and we must. To do this we must, first of all, look at our competitors. Are they offering any features or services that we do not provide? Does a competitor or his technician drive up to the set owner's house in a well-kept truck that advertises his business favorably and wear a neat uniform that also creates a good impression? Do we? The impressions made by such techniques are not always easily counteracted by the top-quality work we may offer. How does your promotion stack up against what competitors are doing?

We must also keep in step nationally. Even if the local competition, as a group, is so uninspired as to lag behind what is being done successfully in other areas, this is no reason for coasting. Take such an opportunity to pull ahead of the competition. If you don't, there is an element of risk: wherever local operators in one type of business in a given area tend to be similarly lax, some alert individual eventually spots the ripe situation. He can enter the field on an "impact" basis, providing what existing competition does not offer. At best, you have one more rival to buck. At worst, he can turn the whole situation upside

down. On the other hand, where the local situation is considered "live," a shrewd outsider is likely to pass up such a locality for one that may be easier to crack.

Do you "skip read" the trade journals and other publications that cover electronics? Sometimes a small item tucked away in the corner of a page may give you an idea that you can exploit. If you read half-heartedly, out of a sense of obligation to get it over with, you will overlook much useful information altogether and miss the possible significance even of what you do look at.

Printed matter is your best way of keeping up with things that concern you which are not happening in your immediate locality. Surveys consistently show a high correlation between successful shops and those whose owners thoroughly read and study their technical and business periodicals.

Periodicals are not the only printed matter to keep up with. Get on the mailing list of every manufacturer who will list you, whether it be for service data, new products, or new information on old products—and give honest attention to every mailing piece you get. Many of us consider such material "junk mail" and automatically relegate a great part of it to the "round file." True, some of it may merit no better treatment than this, but make sure you screen it carefully first. Manufacturers invest impressive sums of money in preparing such literature, and they consider it important. If you pass it up too hastily, you may be sacrificing good business and promotion ideas along with worthwhile technical data.

Be active in local business groups. If there is a local service association with whose program you are in agreement, be active in it. Give it the strength it needs to solve those problems of the

electronic service business that none of us can handle alone. If it isn't "your kind" of association, it may pay to get in and fight to make it your kind. From another viewpoint, this type of activity will give you a chance to meet others in the business and to exchange views and ideas to mutual advantage.

Take a good look at neighboring cities and communities. You may be surprised at what you can learn from other service shops in nearby arcas. Not your own, on only a two-day field trip. Although operators in these adjacent areas may not be direct competitors, anything they offer that is not available in your locality will eventually be picked up by someone to obtain an advantage. It might as well be you, first.

Listen to your customers. Since they do not know a great deal of what is involved in your business, or what is and is not possible to do, many customers may have suggestions or make demands that are impractical or even ridiculous. Nevertheless, it costs nothing to listen. The average customer gets around much more than any shop owner, who is generally restricted to his own business. In fact, whether you like to acknowledge the fact or not, your customers have probably seen much more of your competitors' shops than you have.

Above all, it is the customer and his expectations that you must satisfy to stay in business. He is the best source for his own viewpoint. Find out what he thinks other people are offering him that he would like to get from you. Find out what he wants that no one gives him.

Keep your eye on other lines of business, not just on radio-TV service dealers. The patterns that customers prefer in answering calls, establishing charges, or billing may show up in

(Continued on page 109)

ELECTRONICS WORLD

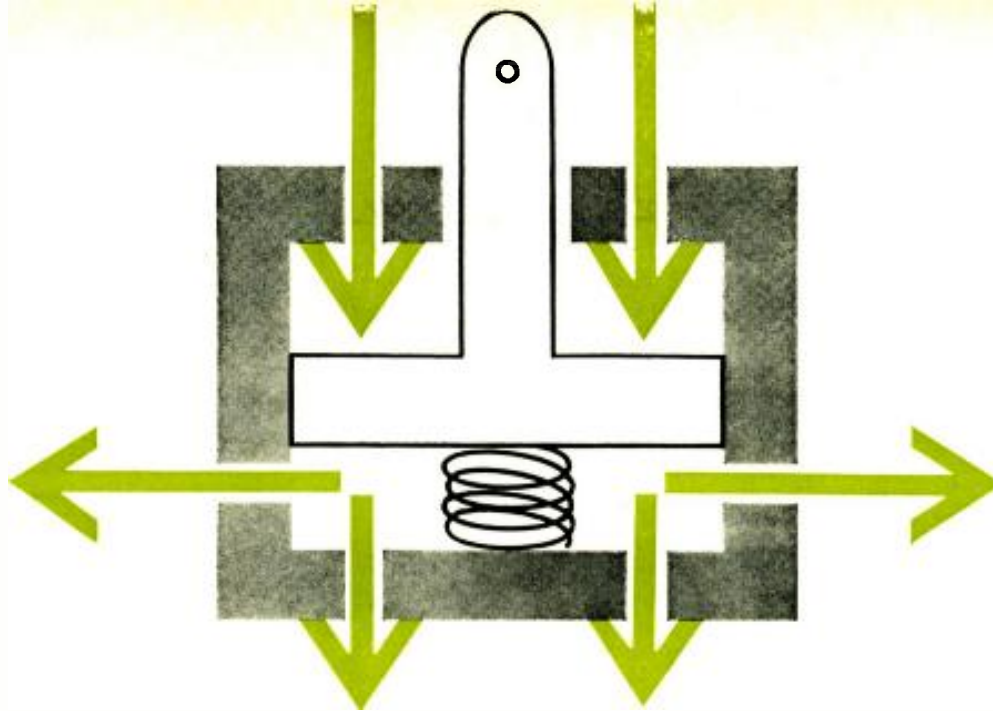

Technicians' Guide to Pneumatic Controls

By **ROBERT GARY**

Compressed air in valves and cylinders does work automatically at bidding of electrical controls.

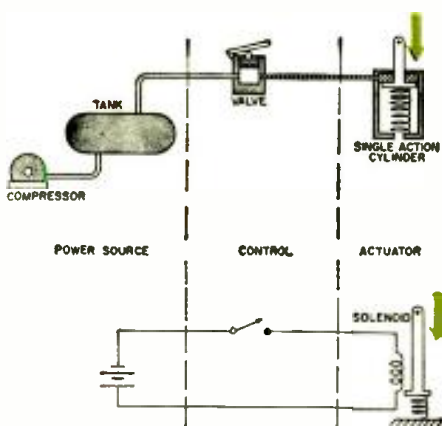

Fig. 1. The operation of a single-action, pneumatic cylinder (above) may be compared to that of solenoid below.

MANY discussions of automation tend to concentrate on the control mechanism and skip over the actuating device. Yet this part provides the muscle of the system: it carries out the decision of the automatic control and actually moves something. In a photoelectric conveyer-belt inspection system, the actuator pushes the rejected units to the side, just as in a simple, automatic door opener there must be some "muscle" to actually push the door open and hold it there. This power device, a vital part of the complete system, must be considered in any industrial servicing work.

As a rule the electronic technician will not be expected to service the mechanical, actuating portion of the system but, in order to troubleshoot the electronic portion accurately, he must know at least some of the fundamentals of such devices. This knowledge

need not be too detailed, but he should be able to read diagrams and get a general grasp of the entire operation.

The three systems most frequently used "muscle" systems involve hydraulic, electric, and pneumatic power. Pneumatic systems, used very widely in connection with electronic controls, are especially adaptable to rapidly operating machines which do not require very great power. The reader will be familiar with the pneumatic hammer and riveter used in construction work and, if he has ever worked in a factory, with the air-powered drill and screwdriver. Compressed air is also used to blow chips or scraps out of the

way and for spraying paint. All of these pneumatic tools are powered by compressed air stored in a tank and released by valves as needed.

One of the features of all of these tools is that the air is piped to the device in a single hose and, when it has done its work, is released into the surrounding atmosphere. There is no need for a return line to the compressor: air, of course, is free; one merely has to pay for compressing it. This is one of the great advantages which compressed air has over hydraulic systems. It has certain disadvantages too, but these are not important in many applications.

Fig. 2. The two possible positions of a simple, double-action cylinder, with direction of air flow in each position.

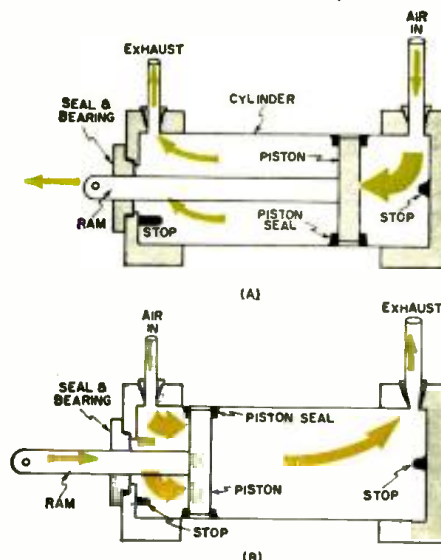

Pneumatic "Circuitry"

A familiarity with fundamental electric circuits can be used as a starting point in understanding pneumatic circuits, since analogies are possible. A simplified pneumatic system and its electrical counterparts are shown in Fig. 1. The compressor and tank are the "power source" that can be compared with the battery or power supply, while the similarity between the valve and the switch is obvious.

As actuator we show a cylinder to be roughly equivalent to a solenoid: in each case a piston or ram is pushed upward by a spring, unless power is applied to pull it down. The piston in the single-action cylinder is forced down when compressed air enters the chamber; and the armature is attracted to the solenoid when current sets up a magnetic field. Actually, each system shown is incomplete because, both in the pneumatic and in the electric system, there is no way for the energy stored in the coil or cylinder to

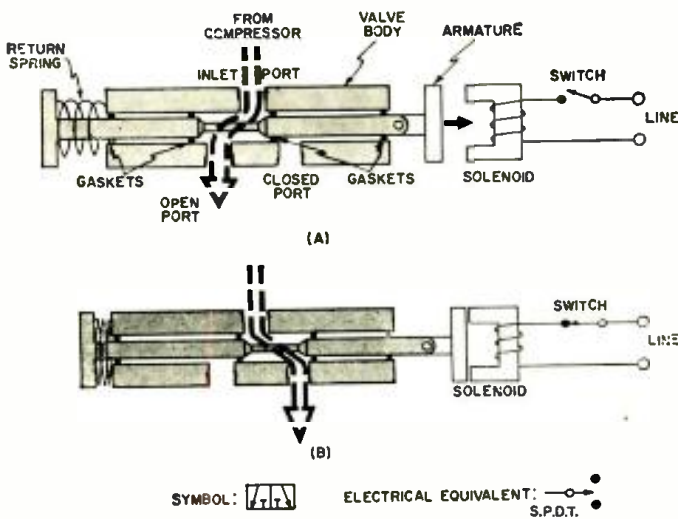

Fig. 3. The two positions of a 3-way, solenoid-operated valve. It is represented by the functional symbol below.

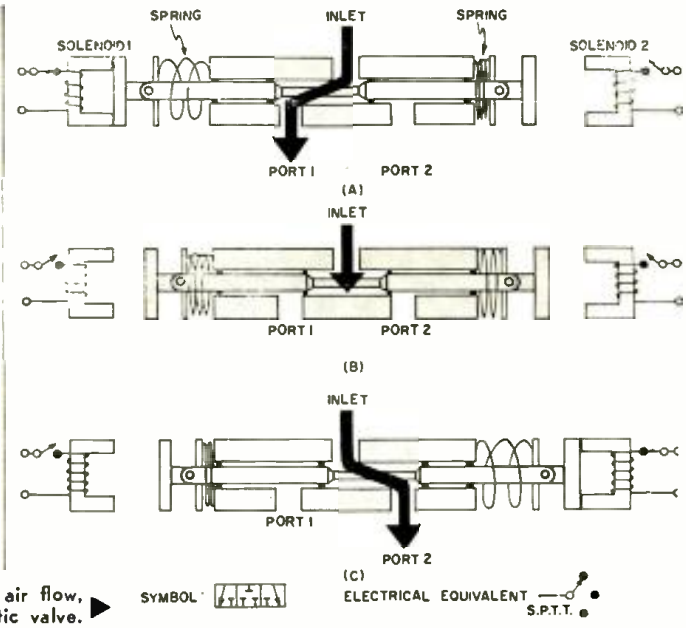

Fig. 4. The positions, including directions of air flow, for a 3-way, center-closed, 2-solenoid pneumatic valve.

dissipate when the switch is opened. However, experience teaches us that there will be an arc when the solenoid switch is opened; similarly, the valve or the cylinder will have an exhaust port to allow the spring to do its work.

To carry the analogy further, we learn that, in pneumatics, many other features of electrical systems also prevail. Comparable to meters and voltage regulators, there are special instruments—pressure gauges—which measure pressure and automatically regulate it at a fixed amount. Most pressure gauges are built into the air lines, usually near regulating valves or near the air tank. A typical air-pressure gauge may have a range from 0 to 20 or up to 120 psi in 5-lb. steps. Practically all ratings are given in psi (pounds-per-square-inch); and this means that such factors as the diameters or areas of the line, valve ports, and actuating surfaces must be known to determine the force at any given point.

A cylinder having a piston surface of 3 square inches can exert a force of 300 lbs. if a 100-psi power source is used. If the air-line diameter is small, it will take longer to push the piston out than if a lot of air can enter quickly. In a sense, we can compare the line diameter and the volume of air required to the wire diameter and the current through it in an electrical system. Losses due to leakage or high resistance due to air obstructions are also comparable troubles.

To avoid obstructions due to dirt and also to keep water away from the moving parts of valves and cylinders, special air filters are placed between the tank and the control portions of the pneumatic system. These filters must occasionally be cleaned out. Most of them use the action of the moving air itself to spin dust and dirt to the side and bottom of a bowl which also traps excess moisture. To clean out such a filter, merely open the drain cock—but keep well away from it, since the air

will blow the dirt out with considerable force.

When a single air tank has to supply several, different, pneumatic devices, there may be times when all are demanding air at once, causing air pressure to drop. Conversely, back pressure may develop when none of these tools is in use. This situation is analogous to power-supply problems that occur when the load varies over a wide range.

A pneumatic regulator usually comes complete with a dial and valve which is set for the desired pressure. The valve then regulates the volume of air through the line. Some types of regulators also bleed off back pressure automatically. This regulator should not be confused with the pressure cut-off switch that turns the compressor on and off to maintain a certain pressure within the tank.

Other special-purpose devices used in air lines include lubricators to supply a thin film of oil to the valves and other wearing parts.

Some Pneumatic Components

Probably the most important type of actuator used in pneumatic systems is the cylinder. There are quite a few rotary air tools that use instead simple turbines, or paddle wheels, but in automation systems air is used mostly to provide linear motion. This is accomplished most efficiently by cylinders. The single-action cylinder shown as an example in Fig. 1 is used only for installations involving very low power. Practically all operations requiring a controlled stroke and return use the double-action cylinder of Fig. 2. This device does not rely on a spring; its motion in each direction is accurately controlled by the air entering and leaving, as shown in Figs. 2A and 2B.

Fig. 2 shows the basic elements found in any double-action cylinder, but leaves out many of the construction details. The seal and bearing which hold the moving ram, for example, is

usually an elaborate combination of precision-machined parts and nylon, teflon, or special rubber gaskets. In some cases, cloth or rubber bellows extend from the bearing to the external end of the ram to prevent grit from collecting and wearing down the seal. The construction of the end stops varies greatly with cylinder design. There are also different means of connecting air lines to the cylinder, different adjustments, and different methods for lubricating the inner walls and the bearing.

One reason why double-action air cylinders are so widely used is that the length, the force, and even the speed of the stroke can be controlled carefully. In an automatic forming process, for example, it may be desired to move the ram rapidly for one inch; and then slowly, but with greater force, push it another half inch. The return stroke may have to be very rapid to start the next operation. This program can be achieved either by a combination of limit switches and solenoid-operated valves, or else by pneumatic time-controlled valves.

Pneumatic Valves

The cross-section of a simple three-way valve appears in Fig. 3. It consists of two main parts, both of which are round and usually machined of brass or a similar metal. The outer part is a cylinder which has three holes drilled in it, the inlet port (top) and the two outlet ports (at the bottom). These holes usually have threading so that the air-line fittings can be screwed in tight.

The inner part of the valve is a simple rod that has been turned down at one portion near its center. This permits air to pass from the inlet port to either of the two outlets, depending on the position of the rod. In a few special valves, the rod fits so tightly in the cylinder that gasket rings are not necessary, but usually such rubber or nylon rings are located as shown in

the diagram to seal the valve against leakage.

A simple, single-action, solenoid-operated valve is shown in Fig. 3. When no power is applied to the solenoid, the return spring holds the inner rod in the position shown in Fig. 3A and allows air to pass from the compressor to the port on the left. As soon as the switch is closed (Fig. 3B), current passes through the solenoid. This attracts the armature, which moves the valve rod to the right, against the force of the spring. In this condition, air pressure is switched to the lower exhaust port on the right, while the lower left port is sealed off. In effect, the pneumatic power is switched much as the electrical power is switched in a single-pole, double-throw switch, the electrical equivalent of this type of valve. At the bottom of Fig. 3, we have also shown the standard pneumatic symbol for this valve. It consists of two sections, corresponding to the two possible valve positions. In each position, the arrow indicates the direction of air flow, while the "T" symbolizes a closed port.

An elaboration of the unit shown in Fig. 3 is a valve with three possible positions, as illustrated in Fig. 4. This type, actuated by two solenoids, can deliver air to either of two ports and can also close either of them or both simultaneously. Two springs are used here, to hold the inner rod in a center position when neither solenoid is actuated.

In Fig. 4A, we see the switch for solenoid 1 closed and the rod thus pulled to the left, allowing air to pass from the air line to port 1. In Fig. 4B, we show the condition where neither solenoid is actuated and the inlet opening as well as both ports are closed. In Fig. 4C, solenoid 2 is actuated and air flows from the inlet to port 2. The electrical equivalent of such a valve would be a single-pole, triple-throw switch. Its pneumatic symbol shows three sections, one for each possible position. The unit is a three-way, center-closed, two-solenoid valve.

A little reflection will show that the left and right solenoid switches should not both be closed at the same time but, by properly programming the closing and opening of the two switches, the flow of air can be arranged in a number of different sequences. All that is necessary is an electrical control circuit, possibly using a set of micro-switches, actuated by a timing motor.

In addition to three-way valves such as that shown in Fig. 4, a similar arrangement of valve body and a moving center rod can be used for 4- and 5-way valves providing all sorts of combinations of positions. It is merely necessary to turn down the inner rod in several places, locate the various ports accordingly, and fit gasket rings into the proper places.

To give just one more illustration, let us consider a four-way valve that could be used directly with the double-action cylinder of Fig. 2. In one position, the valve must connect the com-

pressor to one end of the cylinder while allowing exhausted air to leave at the other end. For the return stroke of the cylinder, these connections must be reversed. These two conditions for the cylinder, the valve, and the solenoids that control them are symbolically represented in Figs. 5A and 5B.

Now let us look at the valve itself, which is shown in Fig. 6 without the actuating solenoids. Port 5 is connected to the air compressor. Ports 3 and 4 are attached to the two openings at the top of the cylinder of Fig. 2. When one solenoid pulls the valve rod to the left (Fig. 6A), air from the compressor passes through port 3 and on into the right-hand opening of the cylinder ("air in" in Fig. 2A). At the same time, air is forced out of the "exhaust" opening in Fig. 2A, and released through ports 4 and 2 of the valve (Fig. 6A).

When the other solenoid pulls the valve rod to the right (Fig. 6B), air from the compressor passes through port 4 and enters the cylinder as shown in Fig. 2B. Meanwhile the cylinder exhausts air through ports 3 and 1 of the valve.

The electrical equivalent of such a four-way valve is a double-pole, double-throw switch, and the electrical

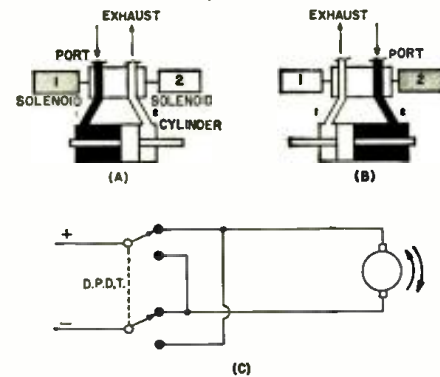
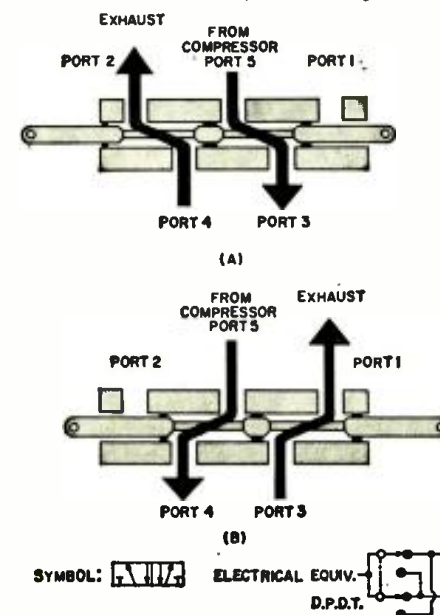

Fig. 5. Four-way valve (A, B) used with cylinder of Fig. 2. Electrical equivalent (C) of function performed.

Fig. 6. Operation of 4-way valve of Fig. 5. It controls strokes, in both directions, of the cylinder in Fig. 2.



analogue of this entire pneumatic circuit, including the cylinder, can be represented as the polarity-reversing circuit for a d.c. motor, shown in Fig. 5C.

Although solenoids have been shown moving the rods of valves, the same principles of operation hold true when other means are used. This motion may be controlled by human beings, as by the hand or foot of an operator. The rod may also be moved by a small amount of air pressure.

The latter scheme is used in so-called "pilot valves." These resemble the valves already described except that, in place of the solenoids, another, small, air cylinder actuates the valve rod. This air cylinder, in turn, is controlled by still another valve, which is located remotely. Such a system may seem like an unnecessarily involved and indirect way of obtaining the action desired, but an electrical analogy again comes to the rescue by pointing up the logic involved. Often a small, manual switch is used to control current through a heavy-duty, power relay. The latter, in turn, controls power machinery. In each case, regulation of large amounts of power from a remote point is achieved by using relatively small wires (or air lines).

There are many specialized valves available, some of which use a rotary motion to perform the same actions as the cylinder-and-rod arrangement described above. Such configurations are sometimes used to allow a controlled amount of air leakage, which serves to slow down the valve action and thereby provide some time delay. Other special valves provide a controlled exhaust pressure, while still others combine pressure-regulating and indicating instruments with the regular valve elements.

Conclusion

Once the basic operation of pneumatic valves and cylinders is understood, the difficulty in tackling the more specialized types of pneumatic components is largely overcome. Compressed air furnishes muscle power for many automated installations, especially where controlled linear motion is required. Pneumatic cylinders are very useful, for example, in operations that involve hammering, riveting, or die punching, since these cylinders can be controlled closely by a variety of pneumatic valves.

Pneumatic circuitry has many features which are analogous to electrical circuitry. The electronic technician will therefore find that he may facilitate his understanding by analyzing the unknown in terms of the known. It helps to remember that valves generally correspond to switches or relays, and the variety of different valves is almost as great as that of switch combinations. Where solenoid-operated valves are concerned, the timing and sequencing of the pneumatic-circuit operation is usually determined by the electrical circuitry that controls the solenoid valves.

By **DELLROYE D. DARLING**
Radio Electronic Television Schools

This device, which senses the presence of metals and other conductors, has many uses in automation.

Servicing

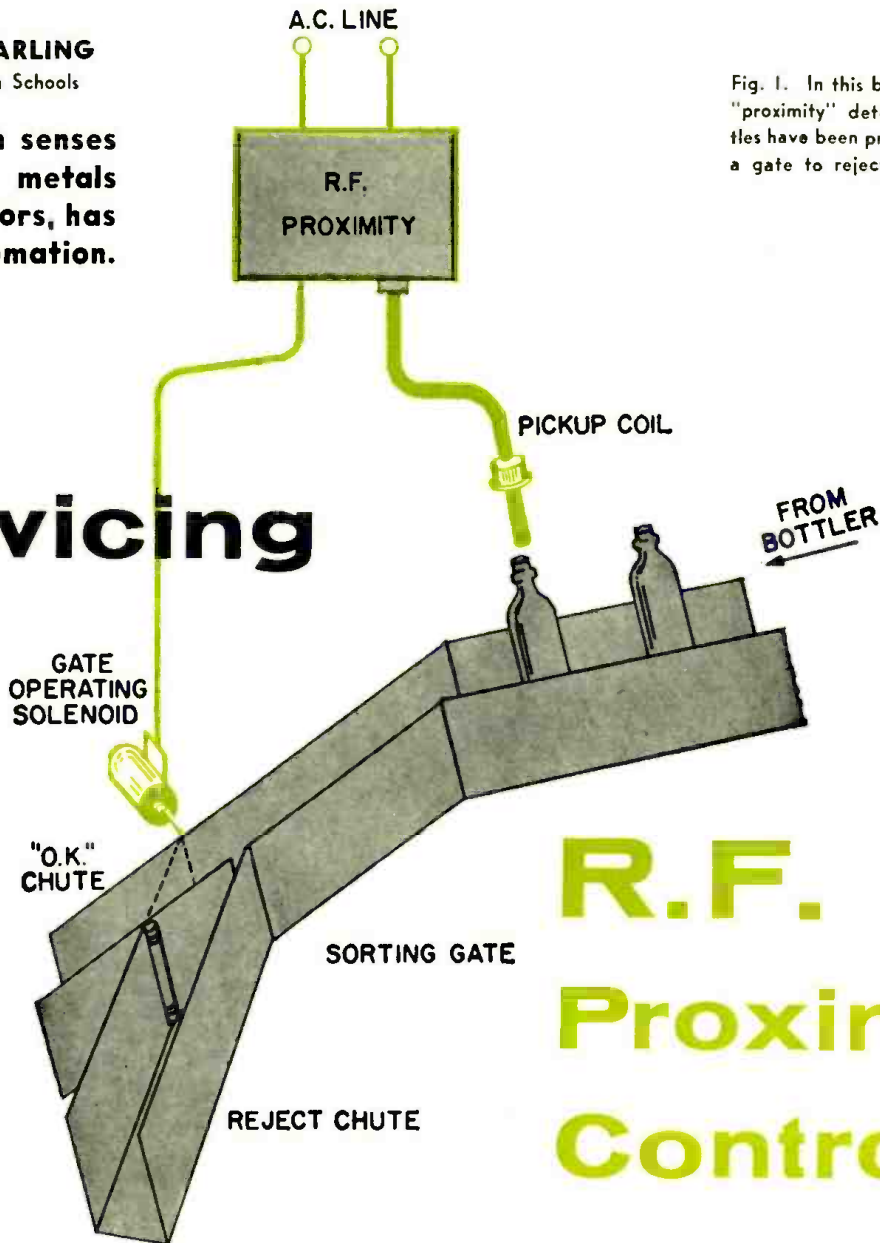

Fig. 1. In this bottling operation, the "proximity" determines whether bottles have been properly capped, opens a gate to reject those without caps.

R.F. Proximity Controls.

AUTOMATION is the operation of machines without direct human control. A human operator has the wonderful ability to see, hear, or feel various parts of his machine or product; to tell when things are positioned right for the next operation; to know whether a new piece of work has been inserted. An automatic machine must have these senses built into it, in the form of limit switches, photocells—or proximity controls.

One very popular type of sensing device is the "r.f. proximity," which is capable of sensing the presence of almost any type of conducting material (such as metals and conductive liquids). Anyone going out to do industrial electronic servicing is bound to come across these units. A good understanding of their operation and possible troubles will be a big help.

Although there are several brands on the market, the basic principles of

all are similar, so let's take as an example the Model 4905, made by *Electro Products Laboratories*. This unit (Fig. 3) is housed in a JIC (Joint Industrial Committee) approved steel case, about 6¼" x 8" x 3½" which can be sealed up tight against gas and liquid for protection.

The case is opened by loosening one clamp bolt, and the entire chassis (Fig.

Fig. 2. Various types of external sensing coils may be fitted to the control.



4) can be removed by taking out four corner screws. Although the chassis is fairly simple, you are impressed with the care that has gone into making it. All parts are first quality, and the wiring is neatly, carefully, and completely color-coded. (Industrial purchasers are more interested in quality and reliability than they are in price.)

The only part of the control not housed in the box is the pickup coil, which is on a cable to allow it to be mounted in the best position for sensing. Various types that may be used, to suit the particular job, are shown in Fig. 2.

How It Works

Take a look at the schematic diagram (Fig. 5) or "print," as an industrial technician would call it. The pickup coil is the tank of a conventional, fairly simple r.f. oscillator, using one-half of a 6SN7 tube, V_{1A} . Sig-

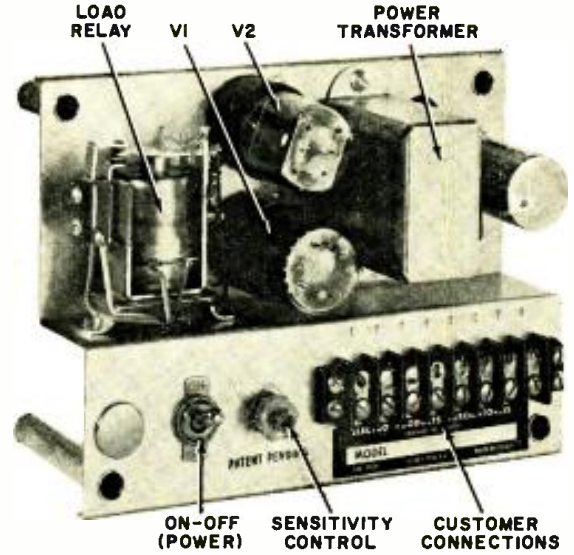
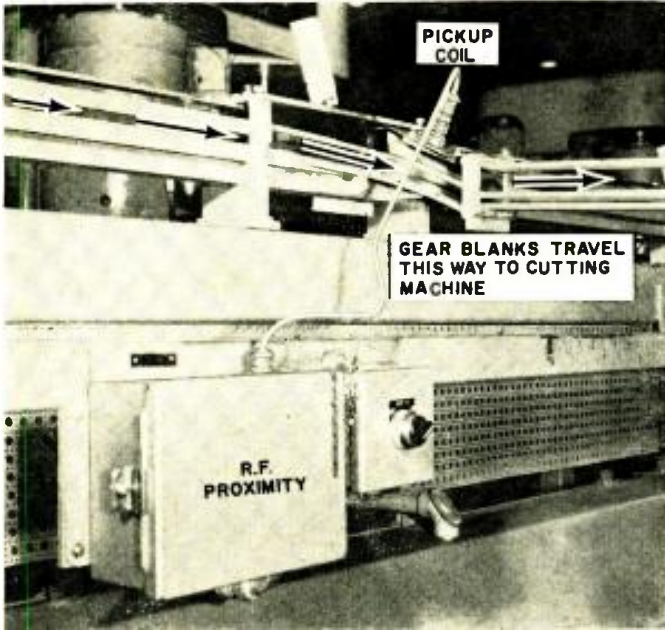

Fig. 4. The Electro Products Model 4905 with cover removed.

Fig. 3. In a Ford Motor Co. plant, the Model 4905 checks gear blanks as they are being fed to a gear-cutting machine.

nal from this oscillator is fed from the cathode into the grid of V_{1a} , which operates as a resistance-coupled r.f. amplifier.

From V_{1a} , the r.f. signal is passed to V_{2a} , where it is amplified again and fed to a rectifier circuit (1N34A), which charges a .002- μ f. capacitor to provide negative bias for the grid of V_{2b} . V_{2b} has a relay in its plate circuit, with contacts to switch the load on or off.

Normally, r.f. signal from the oscillator, amplified and rectified, keeps a negative bias on V_{2b} large enough to cut it off and leave the relay de-energized. When conducting material comes near the pickup coil, however, the latter absorbs enough energy from the coil to lower its "Q" to the degree that oscillation stops. When this happens, no r.f. will reach the 1N34A diode, and the cut-off bias will be removed from V_{2b} . This permits V_{2b} to conduct and operate the relay. This tube keeps on drawing current until the conducting material moves away from the pickup coil and permits the oscillator to come back into operation.

Sensitivity is controlled by varying the plate voltage on the oscillator tube with a 10,000-ohm pot, screwdriver-adjusted from the front of the chassis. (This adjustment has a lock-nut on it, which must be loosened and then re-tightened when an adjustment is made.)

Applications

There is almost no limit to the number of jobs that can be done by a unit of this type. With an external, electro-mechanical counter connected to the relay contacts, the proximity will count passing objects at rates up to 600 per minute. (With an all-electronic counter, using no relays, rates up to 1000 per second are possible!)

One or more r.f. proximities can be used to sense the position of a piece of work in an automatic machine, to control the sequence of machining operations. Tolerances in a setup like this

are often small, and the pickup coils may have to be positioned to within thousandths of an inch for satisfactory operation.

An r.f. proximity control can be used to inspect packages or to check bottles, among other things. In the case of bottles, it could make sure that there is a cap on each or that there is *not* a metal object inside the bottle. After all, a nail in a bottle of beer doesn't exactly improve customer relations. A possible arrangement for a bottle-capping system is shown in Fig. 1. The control itself is mounted away from the moving line of bottles and the sensing coil, on an extension cable, is placed just above the moving line of bottles.

The load relay, instead of going to an

external counter, is connected to a solenoid that operates the sorting gate, whose position determines into which of two chutes the moving bottles will be passed. When an uncapped bottle passes the pickup coil, the solenoid swings the gate to close off the "OK" chute, and the bottle is rejected.

A complete list of applications would fill volumes. Nevertheless, some are mentioned here because the job the proximity is doing often has a direct bearing on the troubles it can be expected to develop.

Troubleshooting

Although these controls are basically simple and very reliable, trouble, quite (Continued on page 129)

Fig. 5. Simplicity characterizes the circuit for the proximity device of Fig. 4.

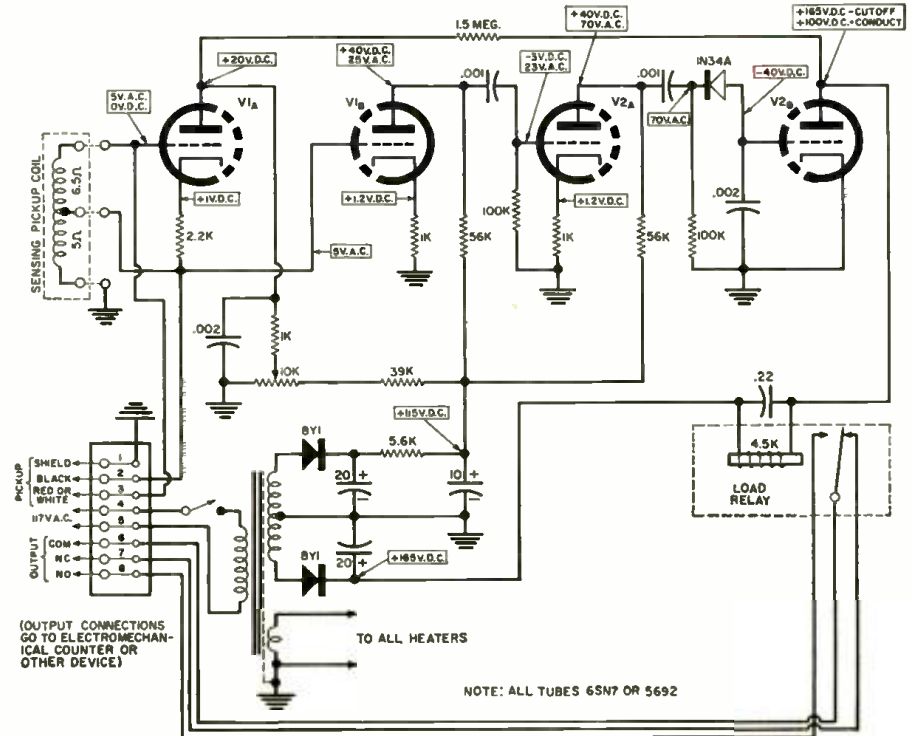

STABLE TRANSISTOR V.F.O.

TRANSISTORS can be used to good advantage in almost every circuit—with the possible exception of high-power, high-frequency applications. Another exception is the transistor variable frequency oscillator. Until recently, it has been difficult to obtain stability with useful power output and at a usable frequency.

Several problems of v.f.o. design are peculiar to the transistor alone. As an example, it is somewhat easier to temperature-compensate a vacuum-tube v.f.o. since the tubes and associated equipment bring the components up to an elevated and reasonably steady temperature. Transistor circuitry operates at (or near) room temperature and is, therefore, affected by external conditions.

Another problem arises from the changes in junction temperature. When the transistor is energized, current passes through the junction resistance and generates heat. The junction heat

changes the collector capacity which, in turn, shifts the oscillator frequency. This tiny amount of heat is not radiated to the tank circuit components and temperature-compensation tricks are not possible.

Still another problem rears its ugly head—this time one rather intriguing. Initial experiments (Fig. 3), using low-cost transistors, brought to light a rather startling effect. The transistor oscillator signal appeared to have modulation impressed on the carrier whenever it was compared to an equivalent vacuum-tube v.f.o. signal. The sound can only be described as a "gurgle." The level was low, to be sure, but was still very noticeable when the signal was detected with a selective receiver. Such a v.f.o. would be unsatisfactory for SSB or frequency-standard applications. The reason for this effect is still clouded but it would appear to result from the random arrival of carriers at the collector. This effect has not been

noted with crystal-control transistor oscillators or when the v.f.o. is detected on a broad receiver. It is therefore assumed that the random nature of the carriers produces a frequency-modulation component due to rapid variations in collector capacity.

When compared to a vacuum tube, the transistor is a rather low-impedance device. The v.f.o. tank circuit, which should be high "Q" for best stability, is not exactly compatible. Unless the transistor elements are tapped down on the tank coil (to match impedances), the transistor will load the coil and reduce the stability. Buffer-amplifier circuits can also affect the oscillator since they have poor input-output isolation, much the same as a triode.

The author was about to "throw in the towel" when a circuit appeared in a West Coast publication (*Western Radio Amateur*, "Sidelights on Sideband" by Lester A. Earnshaw, ZL1AAX) covering a stable v.f.o.

Inside view of the v.f.o. showing mounting of the toroidal coil. ▶

Another inside view showing output tuning coil (L₂) employed.

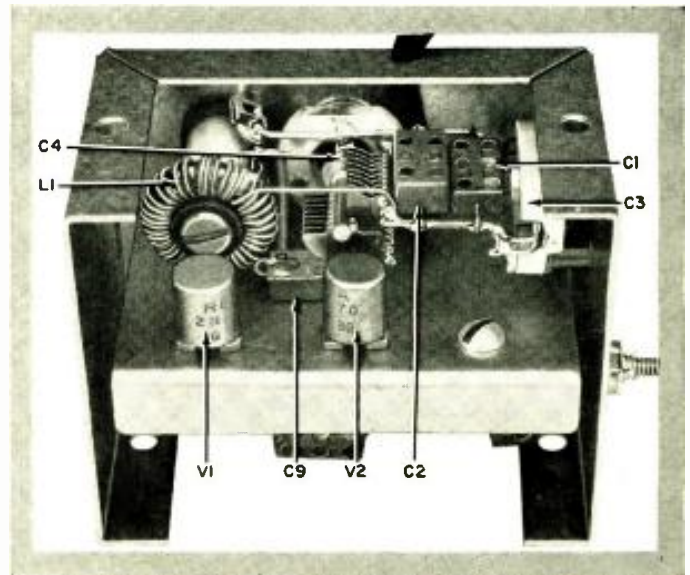
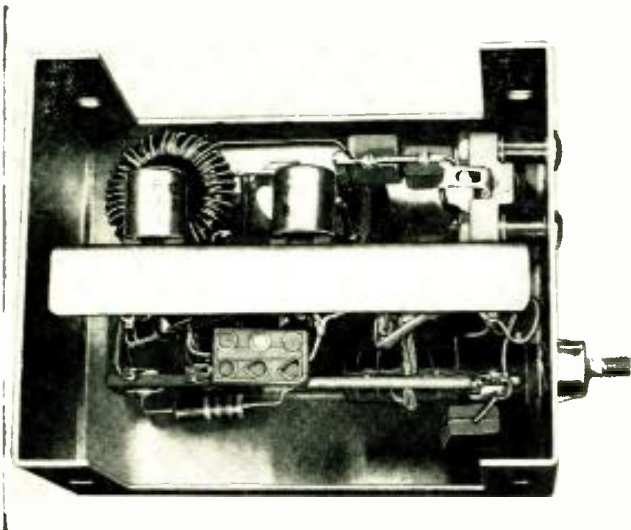

By **DONALD L. STONER, W6TNS**

Construction of compact oscillator for ham who wants to experiment with very stable unit that will drive most SSB exciters and frequency standards.

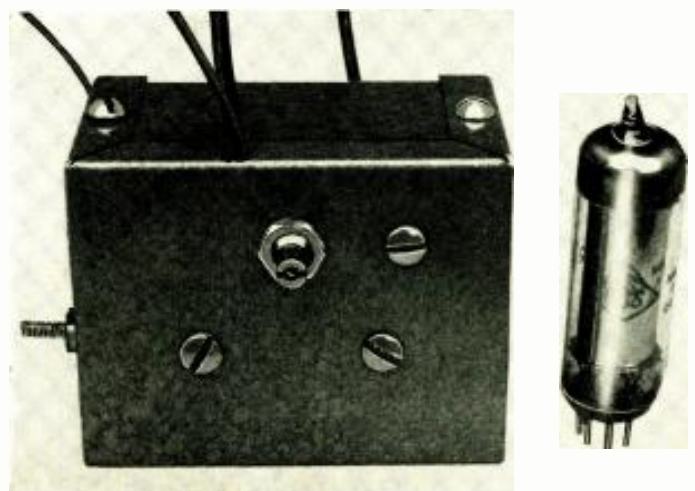

Over-all view of transistorized unit compared to miniature tube. ▶

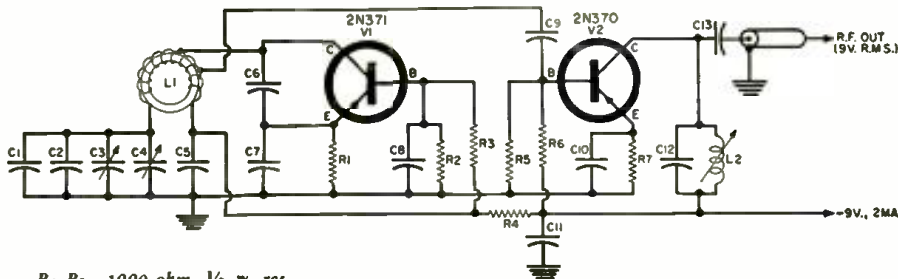

- R_1, R_7 —1000 ohm, $\frac{1}{2}$ w. res.
 R_2 —3900 ohm, $\frac{1}{2}$ w. res.
 R_3, R_6 —47,000 ohm, $\frac{1}{2}$ w. res.
 R_4 —470 ohm, $\frac{1}{2}$ w. res.
 R_5 —3300 ohm, $\frac{1}{2}$ w. res.
 C_1 —100 μ f. silver mica capacitor (Arco CM-15-J-100)
 C_2 —50 μ f. silver mica capacitor (Arco CM-15-J-50)
 C_3 —4.5–25 μ f. rotary trimmer (Centralab 822-CN)
 C_4 —20 μ f. var. capacitor (E. F. Johnson 30MB, modified per text)
 C_5, C_6, C_{10}, C_{11} —0.05 μ f. disc ceramic capacitor
 C_7, C_8, C_{12} —24 μ f. silver mica capacitor (Arco CM-15-J-24)
 C_7 —510 μ f. silver mica capacitor (Arco CM-15-J-511)
 C_9 —30 μ f. silver mica capacitor (Arco CM-15-J-30)
 C_{15} —470 μ f. disc ceramic capacitor
 L_1 —Toroid coil, 41 t. $\#24$ en., closewound on 0.68" powdered iron toroid form. Tap at 16 t. for V_1 and at 10 t. from "cold" end for V_2 . (Miller No. 7501 may be used, see text)
 L_2 —36 t. $\#36$ en. scramble-wound on 5/16" slug-tuned form (Miller No. 7502 may be used, see text)
 1 —Aluminum chassis box $2\frac{1}{8} \times 2\frac{1}{8} \times 1\frac{1}{8}$ "
 V_1 —"p-n-p" drift transistor (RCA 2N371)
 V_2 —"p-n-p" drift transistor (RCA 2N370)

Fig. 1. The highly stable transistorized v.f.o. employed by the author.

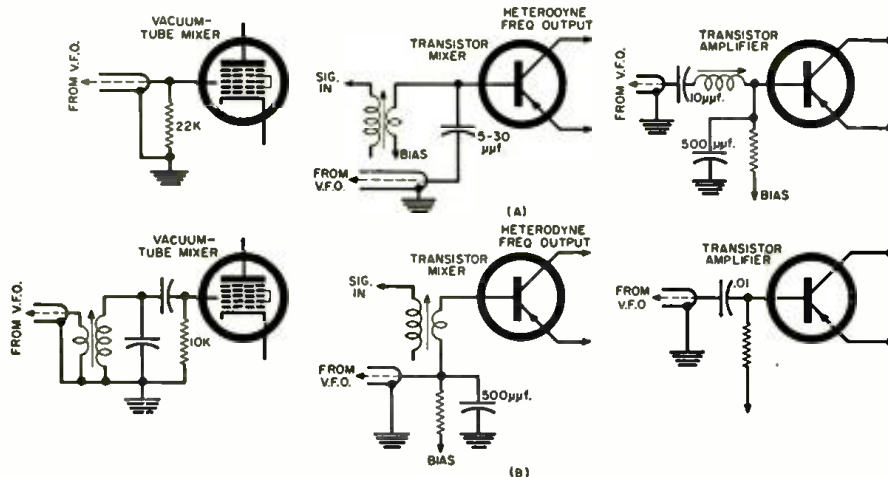

Fig. 2. Coupling circuits for use with v.f.o. (A) Circuits using short, high-impedance lines; (B) circuits using long lines along with link-coupling arrangement.

The circuit shown in Fig. 1 is a variation of Mr. Earnshaw's circuit and has been optimized for American components. In addition, the volume of the v.f.o. has been reduced by about 400% with the miniature components available in this country. In every respect, the performance of this v.f.o. exceeds its vacuum-tube counterpart, except for power output.

Junction heating was found to be in direct proportion to the oscillator current and, therefore, the amplitude of the oscillation. Since the junction heating problem could not be overcome, it was necessary to "live with it" and minimize its effect. For this reason, the design concept of using a very low power oscillator in conjunction with a class A amplifier/buffer would seem to be the most logical. A tank circuit of higher-than-normal "Q" was used and the collector was tapped near the cold end of the coil. Less than 50 cycles of drift can be attributed to junction capacity change.

The collector-capacity modulation described earlier exists but is not audible since the collector (and its capacity changes) are tapped at a low impedance point on the coil. It would appear

that the excellent high-frequency characteristics of the "drift" type of transistor contribute to the over-all stability.

Circuit Details

Coil L_1 is wound on a ferrite toroid and the unloaded "Q" is in the vicinity of 400. The highest tap is at the 16th turn out of a total of 41 turns. The use of a toroid (which has little or no external field) allows the v.f.o. to be physically compact, since the coil is less than one inch in diameter and can be mounted within $\frac{1}{8}$ " of the metal chassis. If this were attempted with a customary coil, the metal in proximity would reduce the "Q" and cause drift due to heating of the chassis.

Capacitors C_1 and C_3 are silver micas, while C_5 is the calibration trimmer and C_7 the tuning capacitor. The ratio between C_1 and the other capacitors determines the bandspeed.

Feedback occurs between collector and emitter through capacitor C_6 . A low emitter impedance is established by C_7 . The d.c. stabilization is provided by the large emitter resistor, R_1 . Forward bias for the oscillator is obtained from the voltage divider R_2 - R_3 .

Drive for the class A amplifier, V_2 , is taken from a low-impedance point on the oscillator coil and is coupled through capacitor C_5 . The low-impedance tap and the small-size coupling capacitor (30 μ f.) effectively isolate the buffer output from the oscillator tank. Additional isolation is gained by using a decoupling resistor, R_4 , in the "B" circuit. Forward bias for the amplifier/buffer is obtained through another voltage divider made up of R_5 - R_6 . Resistor R_7 is used for d.c. degeneration of the output stage. The output tank circuit consists of coil L_2 , capacitors C_{12} and C_{15} , plus the capacity of the coaxial cable. Approximately 9 volts of r.f. (r.m.s.) is available, which is more than adequate for vacuum-tube or transistor amplifiers and mixers.

Each transistor draws approximately 1 ma., making the v.f.o. suitable for battery operation, even when used in conjunction with non-portable equipment.

The voltage stability is quite amazing. A variation in the source voltage between 7 and 11 volts will cause a frequency shift of 700 cycles. A zener voltage regulator should be unnecessary, even in mobile installations. A battery lead can be keyed and no "chirp" or drift occurs.

The mechanical stability, which is a function of the construction style, is excellent. A 5G shock produces no noticeable frequency shift. The unit was demonstrated at a radio club recently. The frequency was zero-beat with WWV, then held by the wire leads and banged on the table. Not so much as a warble was heard and the frequency never came out of zero-beat! Thus, the v.f.o. should be ideal for mobile operation and could be mounted on the steer-

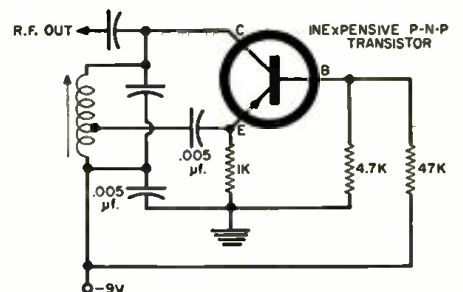

Fig. 3. Simple transistor v.f.o. which has all the faults mentioned in the text.



Fig. 4. R.f. detector probe employed.

Table 1. Voltage chart. Upper figures are probe-measured r.f. voltages. Lower figures are —d.c. with a 9-volt battery.

	C	B	E
V_1 (Osc.)	3.5*	0	.03
	8.7	.64	.53
V_2 (Amp.)	9.4	.12	0
	9.0	.54	.48

Coil L_1 : Top end—4.5 volts* r.f.; V_2 tap—2.2 volts* r.f.
 * Actually higher, but reduced due to probe loading.

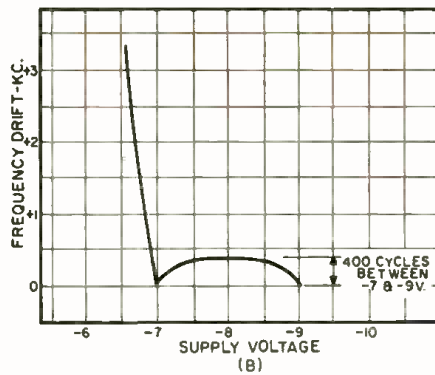
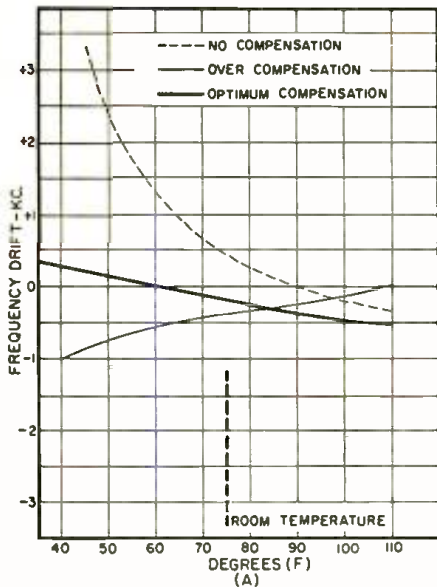

Fig. 5. Graphs showing the measured frequency stability versus temperature and supply voltage. The compensation methods used are described in the text. By the addition of the proper amount of negative temperature coefficient capacitors, the frequency shift that exists can be almost completely neutralized.

ing column (for remote frequency control) without ill effects.

This little v.f.o. is currently being used in conjunction with a single-side-band exciter on the 75 and 20 meter bands. It provides adequate drive and yet occupies less than 1/2 the volume of the BC-458 v.f.o. that it replaces. Future applications include an all-band transistor exciter and transceiver.

Construction & Testing

As can be seen from the photographs, the v.f.o. is extremely compact and is certainly no project for a beginner. The exact layout dimensions are not given since one usually winds up "playing checkers" with the components anyway. Elaborate circuit details are given and between these and the photographs, the constructor should have no trouble duplicating the unit.

The v.f.o. is constructed in a 2 3/8" x 2 1/8" x 1 1/8" aluminum chassis box. The size is approximately the same as two packs of regular cigarettes. A small aluminum chassis measuring 2 3/8" x 1 1/8" (exclusive of the 1/4" lips) is mounted on the center line of the chassis box and is secured with two 1/16" screws. This divider serves as a shield to isolate the oscillator and buffer tuned circuits. The toroid sets on a 3/4" porcelain stand-off insulator, mounted to the right of the tuning capacitor. The coil is positioned so that the oscillator tap lines up with a hole in the divider below V₁, for the collector lead. This also lines up the tap for C₆ so its lead passes through a hole below the buffer V₂. The trimmer capacitor, C₅, is mounted on the side apron. A common ground wire runs from a ground lug under the porcelain insulator, to the rotor of C₁, on to the rotor of C₃. Disc capacitor C₃ is connected between this ground lug and the cold end of L₁, with very short leads. Another common wire runs from the hot end of L₁, to the stator of C₁, and onto the stator of C₃. Fixed capacitors C₁ and C₂ are connected between these two common wires. Sockets for V₁ and V₂ are mounted on the divider, directly above the tank circuit components.

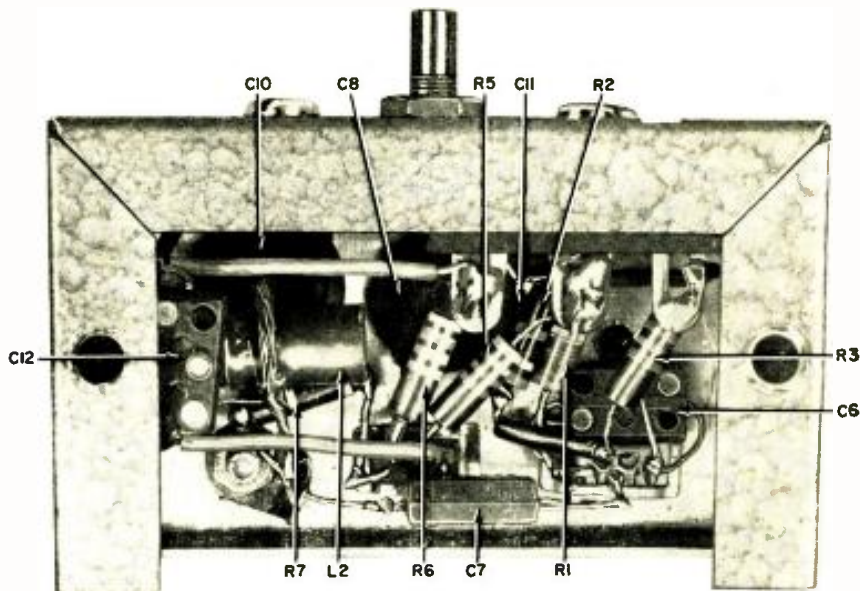

Amplifier-buffer side of chassis box. Most parts are soldered to 3-lug strip.

Looking at the amplifier side of the divider, you will see the majority of the capacitors and resistors. A three-lug terminal strip (center lug ground) is secured under the left 1/16" nut. Resistor R₁ is soldered in the eyelets, between the end terminals. The left lug secures resistors R₃, R₁₁, and the wire through the divider to the junction of C₂ and L₁. Tied to the center terminal (ground) you will find R₁, R₂, R₃, C₇, and C₁₁. The right terminal is used to secure R₆, C₁₁, and the lead to L₂. Capacitor C₁₀ is connected between the emitter and collector pins of the transistor socket. Capacitor C₇ connects to the emitter pin and the solder lug adjacent to V₂. R₇ and C₁₀ are connected between the emitter of V₂ and the adjacent ground lug, which also terminates the coaxial cable shield. Capacitor C₁₂ is secured to the coil terminals. Capacitor C₁₂ connects to the coax center lead with a "space tie point". The coax and the "B-" lead pass through a hole in the divider and another hole in the chassis

box lip. These two holes are just big enough to accept the leads, preventing them from flopping around and disturbing the oscillator circuit. The "B+" return is to the metal case.

The coaxial cable is worthy of special mention since it is part of the output tuned circuit. A 10" length of Amphe-nol #21-598 "Subminax" was used in the model. If substitutions are made, remember that the impedance (50 ohms) is not as important as the capacity-per-foot figure. If more than 20 inches of cable is required, a link should be used on output coil L₂. Coupling the cable to various circuits is shown in Fig. 2. In all cases, coil L₂ should resonate at the operating frequency.

An r.f. probe will be very useful for testing the operation of this v.f.o. The circuit shown in Fig. 4 was used by the author in conjunction with a Heath V7-A vacuum-tube voltmeter. The meter will indicate r.m.s. radio-frequency

voltage due to circuit losses. The frequency response is fairly good up to about 60 mc. The voltage chart, Table 1, gives both the r.f. (upper) and d.c. (lower) voltages that should be found in the v.f.o.

With the values shown in the parts list, the v.f.o. should cover any 0.3 mc. between 4.5 and 5.5 mc. Plates were removed from C₃ (originally 30 μmf.) to limit the v.f.o. to this range. Lower frequency ranges can be covered by adding more turns to L₁ and L₂ and moving the taps up a turn or two. If more or less frequency coverage is desired, you can increase or decrease the size of C₁. Capacitors C₁ and C₂ should be decreased or increased also (if a great change is made in the size of C₁) to keep the total circuit capacity at 200 μmf. It is recommended that a minimum of component substitutions be made. As it often happens, the temperature coefficient of one component may compensate for the drift in an-

(Continued on page 107)

DOUBLES YOUR EFFECTIVE MANPOWER

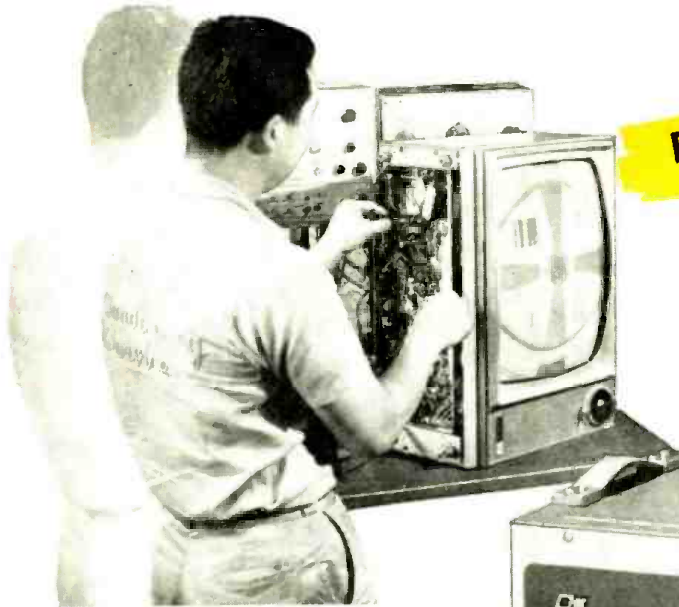

Fix "Tough Dogs" Fast!

Save Half Your Time!

Step Up Your Profit!

B&K NEW
MODEL 1076

TELEVISION ANALYST

for Black & White and Color



Check all circuits—Pinpoint any TV trouble...in minutes

**By Easy Point-to-Point Signal Injection,
You See the Trouble on the TV Screen and
Correct it—Twice as Fast and Easy!**

There's no longer any need to "lose your shirt" (and customers)—and worry about the lost hours you never recover—on "tough dogs" or even intermittents. *The remarkable B&K Analyst* enables you to inject your own TV signal at any point and watch the resulting test pattern on the picture tube itself. *Makes it quick and easy to isolate, pinpoint, and correct TV trouble in any stage* throughout the video, audio, r.f., i.f., sync, and sweep sections of black & white and color television sets—including *intermittents*. Makes external scope or wave-form interpretation unnecessary. Most useful instrument in TV servicing! Its basic technique has been proved by thousands of successful servicemen the world over.

The Analyst enables any serviceman to cut servicing time in half, service more TV sets in less time, really satisfy more customers, and *make more money*.

Model 1076. Net, \$29995

All these signals are instantaneously available on the front panel:

- | | |
|--|--------------------------------------|
| COMPLETE R.F. and I.F. | HI-VOLT INDICATOR |
| VIDEO TEST PATTERN | YOKE and HI-VOLTAGE TRANSFORMER TEST |
| COMPOSITE SYNC | |
| FM MODULATED AUDIO | Also Now Provides: |
| COLOR PATTERNS | SWITCH-TYPE TUNER |
| HORIZONTAL and VERTICAL PLATE and GRID DRIVE | NEGATIVE BIAS SUPPLY |
| B+ BOOST INDICATOR | AGC KEYING PULSE |
| | PICTURE TUBE MODULATION |



B & K MANUFACTURING CO.
1801 W. BELLE PLAINE AVE • CHICAGO 13, ILL.
Canada: Atlas Radio Corp., 50 Wingold, Toronto 19, Ont.
Export: Empire Exporters, 277 Broadway, New York 7, U.S.A.

See Your B&K Distributor or Write for Bulletin API6-T

HEATH
PRESENTS

18

NEW

ITEMS

for
your

summertime
enjoyment

A subsidiary of
DAYSTROM, INCORPORATED



"ECONOMY" STEREO AM/FM TUNER KIT (AJ-10)

Full fidelity AM and FM reception, plus up-to-the-minute design features are yours at minimum cost with this new Heathkit stereo tuner. Features include: 2.5uv sensitivity for 20 db quieting; individual flywheel tuning; separate magic-eye tuning indicators for AM and FM; AM bandwidth switch; 3-position (off-half-full) automatic frequency control (AFC); FM multiplex adapter output. 14 lbs.

AJ-10 \$59⁹⁵

\$6.00 dn., \$6.00 mo.

HI-FI RATED 25/25 WATT STEREO AMPLIFIER (AA-50)

In one handsome package, you get both stereo power and control, with a host of deluxe features. Hi-fi rated at 25 watts per stereo channel (50 watts mono), this new Heathkit design includes channel separation control; new mixed center speaker output; stereo reverse and balance controls; separate tone controls for each channel with ganged volume controls; five switch-selected inputs for each channel (stereo "mag. phono," tape head, 3 hi-level). Extra input for mono "mag. phono." Special outputs for tape recording. Ease of assembly assured by two circuit boards. 30 lbs.

AA-50 \$79⁹⁵

\$8.00 dn., \$8.00 mo.

**MIXED LOWS
STEREO CROSSOVER KIT (AN-10)**

Permits using one bass woofer and more economical "wing" speakers for stereo. Delivers non-directional bass of both channels below 250 cps to one woofer; passes higher frequencies to wing speaker. Takes 25 watts per channel; 8, 16 ohm woofers; 8 ohm high freq. speakers. 10 lbs.

AN-10 \$19⁹⁵

**Player Kit by Heath—
Mechanism by Garrard**

**MANUAL
STEREO RECORD PLAYER KIT (AD-10)**

Rubber matted heavy turntable is shock mounted, and idler wheels retract to prevent flat spots. 4-pole motor; 16, 33 1/3, 45 and 78 RPM; Sonatone 8TA 4-SD ceramic stereo turnover cartridge with diamond and sapphire styli; preassembled mechanism and base. 10 lbs.

AD-10 \$33⁹⁵



**Quality Stereo at
Minimum Cost**

**ECONOMY STEREO PREAMPLIFIER KIT
(AA-20)**

A low-cost, versatile stereo preamp-control center. Four inputs each channel accept magnetic cartridge, crystal or ceramic cartridge, and tuner, tape, TV, etc. Six position function switch gives flexible stereo or monophonic use. Features cathode follower outputs plus hi-level outputs for tape recorder drive, calibrated Baxandall-type tone controls for each channel, clutch-type volume controls, filament balance controls, and accessory AC sockets. Self-powered. Styled in black and gold. 8 lbs.

AA-20 **\$34.95**

**PROFESSIONAL RATED 35/35
WATT BASIC AMPLIFIER KIT (AA-40)**

Doubles as a superb dual 35 watt stereo amplifier or a full-fledged 70 watt monophonic amplifier. Features a mixed-channels center speaker output for fill-in sound, and individual level controls for stereo. "Stereo-Mono" switch ties both amplifiers to one level control for monophonic use. Dual outputs for 4, 8, 16, and 32 ohm speakers. Paralleling outputs for 70 watt monophonic use matches 2, 4, 8, and 16 ohm speakers. 41 lbs.

AA-40 **\$79.95**
\$8.00 dn., \$8.00 mo.

**HI-FI RATED 14/14 WATT BASIC
STEREO AMPLIFIER KIT (AA-30)
(not illustrated)**

14 watts per channel, separate level controls, local remote power switch, circuit board. Styled like AA-40 above. 21 lbs.

AA-30 **\$45.95**

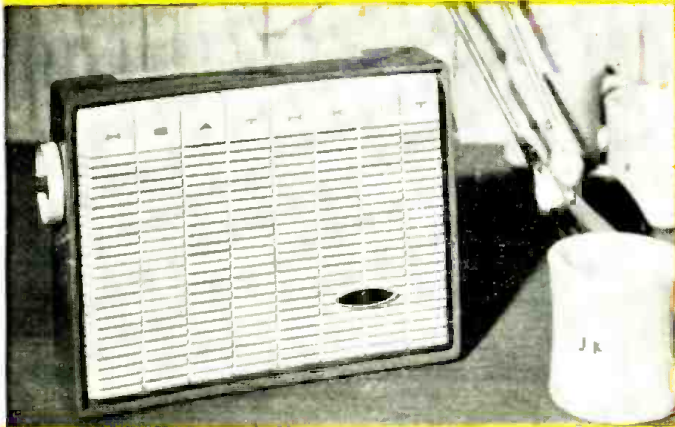

MOBILE PA SOUND EQUIPMENT

Perfect for political campaigns, advertising, sporting events... hundreds of PA applications. The 10 watt amplifier operates from any 12 to 15 volt battery. Features an all-transistor circuit for rugged, dependable performance and long life. No warm-up time required. Mounts easily under auto dash. Inputs for microphone and music source. Two channel mixing circuit "fades" auxiliary input when used with microphone supplied... lets you override music with voice without changing control settings. Outputs for 8 and 16 ohm speakers.

MOBILE PA AMPLIFIER KIT (AA-80) 7 lbs. \$39.95

COMMERCIAL SOUND SYSTEM (CSS-1) consists of AA-80 Amplifier, microphone, car-top carrier, one 16 ohm, 15 watt outdoor speaker. 19 lbs. **\$84.95**

COMMERCIAL SOUND SYSTEM (CSS-2) same as above except with 2 speakers. 25 lbs. **\$99.95**

EXTRA HORN SPEAKERS (401-38): \$19.95
As described above. 6 lbs.

Perfect for Summer Sun and Fun!
6-TRANSISTOR PORTABLE RADIO KITS (XR-2 Series)
Assembled in only a few hours, both of these models incorporate superior design features that will give you portable-listening enjoyment day after day. Vernier tuning control gives smooth, easily-separated station tuning. Large 4" x 6" PM speaker with heavy magnet provides "big set" richness of tone. Operates on standard size "D" flashlight batteries. Six Texas Instrument transistors. **\$29.95**
XR-2P (plastic) 6 lbs.
XR-2L (simulated leather) 7 lbs. **\$34.95**

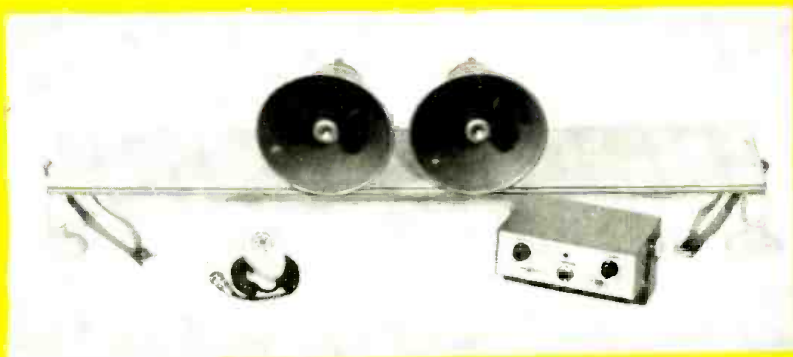

FREE CATALOG
Send for your free Heathkit catalog today... describes over 150 hi-fi, ham, test, marine, and general kits.

NEW! Citizens Band Transceiver...

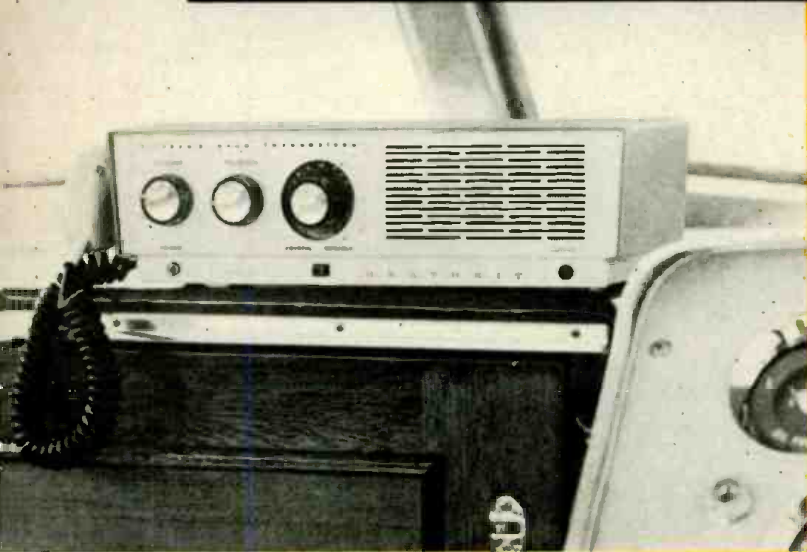

CITIZENS BAND TRANSCEIVER KIT (GW-10)

Now, from Heath, a new 2-way Citizens Band Transceiver with every modern improvement for clear, noise-free operation. The superheterodyne receiver section may be either crystal controlled on any one predetermined channel, or all 23 channels may be continuously tuned by the front panel tuning knob; a front panel switch selects either crystal or variable control. An automatic "series gate" noise limiter minimizes impulse-type noises (ignition interference, etc.). Adjustable squelch control silences the receiver during "stand-by." Press-to-talk microphone features a coil-cord connection to the transceiver. Transmitter is crystal controlled on any one of 23 assigned channel frequencies chosen. Order model GW-10A for 117v AC operation; order GW-10D for 6 and 12v DC operation, both with self-contained power supply. 11 lbs.

GW-10A or GW-10D **\$62⁹⁵** each

\$6.30 dn., \$6.00 mo.



3 band "Mariner" TRANSISTOR DIRECTION FINDER KIT (DF-3)

Features nine-transistor circuit, flashlight battery power supply, pre-assembled, pre-aligned tuning section, three bands (beacon-aeronautical, broadcast and marine-telephone), and a new "sense" antenna system that eliminates 180° ambiguity in bearings. Splash resistant. 13 lbs.

DF-3 **\$99⁹⁵**

\$10.00 dn., \$9.00 mo.



For Boating, Fishing, Skindiving

TRANSISTOR DEPTH SOUNDER KIT (DS-1)

Completely transistorized. Indicates depth, type of bottom, and submerged objects, from 0 to 100 feet. Powered by 6 flashlight batteries for complete portability. Transducer included may be mounted through hull, or temporarily outboard. Rugged, splash-resistant cabinet. Adjustable mounting bracket. 10 lbs.

DS-1 **\$69⁹⁵**

\$7.00 dn., \$7.00 mo.



Ten-transistor "Mohican" GENERAL COVERAGE RECEIVER KIT (GC-1)

First kit of its kind to use ceramic IF "Transfilters." Covers 550 to 30 mc on 5 bands, with 5 separately calibrated bands to cover amateur frequencies (including 11 meter citizens band). Powered by 8 flashlight batteries. Built-in 54" whip antenna, tuning meter, headphone jack. 20 lbs.

GC-1 **\$109⁹⁵**

(Less Batteries)

\$11.00 dn., \$10.00 mo.

First of a Series

EDUCATIONAL KIT (EK-1)

Teaches, as you build, the basic "yardsticks" of electronics... opens up fascinating areas of study for youngsters and adults alike. The combination kit and text-workbook gives you a practical demonstration of the principles of voltage, current and resistance, the theory and construction of direct current series and parallel circuits, voltmeter, ammeter and ohmmeter circuits and the application of ohms law to these circuits. The completed meter is used to verify ohms law and the maximum power transfer theorem, one of the most important theorems in electronics. The finished kit, a practical volt-ohm-milliammeter, may be used in a variety of applications. Procedures for checking home appliances and automobile circuits included with the kit. The EK-1 will serve as a prerequisite to following Heathkit Educational kits; get started NOW in this "learn-by-doing" series. 4 lbs.

EK-1 **\$19⁹⁵**



Outstanding Professional Quality...

**MUTUAL CONDUCTANCE
TUBE TESTER KIT (TT-1)**

An impressive list of electronic and mechanical features make this tube tester one of the finest values in the electronics industry. Test Gm (amplifiers) from 0 to 24,000 micromhos, Emission, Leakage, Grid Current (1/4 microampere sensitivity), Voltage Regulators (built-in variable DC power supply), low power Thyatron and Eye tubes. Features 300, 450 and 600 ma constant current heater supplies, Life test, Hybrid tube test, built-in switch-operated calibration circuit. Large, easy-to-read meter. Constant tension, free rolling illuminated chart. Kit includes 7 wiring harnesses. Assembly skill of technician or higher recommended; assembly time, 40 hours average. Black leatherette case with white trim, nylon feet, removable top. A specialized tool of unusual value that will pay for itself many times over. 27 lbs.

TT-1 **\$134⁹⁵**
\$13.50 dn., \$12.00 mo.



**New Improved Design
TRANSISTOR MOBILE
POWER SUPPLY (HP-10)**

All transistor circuit! Operates from 11 to 15VDC input; at 12VDC provides 600 VDC @ 200ma. or 600VDC @ 150ma & 300VDC @ 100ma simultaneously. at 120 watts. Negative 125V @ 30 ma also provided. Max. ambient temp. 150° @ 120 watts ICAS. Input required: 2 amps idling; 13 amps full output. Includes heavy filtering, remote relay primary control, silicon rectifiers, aluminum heat sinks. 10 lbs.

HP-10 **\$44⁹⁵**



**NEW Six and Ten Meter
TRANSCIVER KITS
(HW-19 and HW-29)**

Combination crystal controlled transmitters and variable tuned receivers operating fixed or mobile on the 6 and 10 meter amateur bands (50-54 mc for HW-29 and 28-29.7 mc for HW-19). Superregenerative receiver pulls in signals of 1 microvolt; transmitter input approximately 5 watts. Built-in 117 VAC power supply, metering jack, press-to-talk switch. 10 lbs.

HW-19 (10 meters) **\$39⁹⁵**
HW-29 (6 meters) **ea.**

Less crystal



**send today for Your
FREE HEATHKIT® CATALOG**

*Over 150 items of hi-fi,
marine, amateur, test and general
equipment are illustrated
and described in the complete
Heathkit catalog.*



**Heathkit® gives you more
in these 10 ways**

1. BUILDING A HEATHKIT IS EASY—Check-by-step instruction manuals make it virtually impossible for you to fail.
2. BUILDING A HEATHKIT IS QUICK—No complicated, technical jargon for you to decipher; at most, a Heathkit takes only a few evenings to assemble.
3. BUILDING A HEATHKIT IS ECONOMICAL—Mass production and purchasing economies are passed directly along to you, our customers.
4. BUILDING A HEATHKIT IS EDUCATIONAL—As you build, you learn . . . more about electronics, more about the component units and when and where to add them.
5. BUILDING A HEATHKIT IS FUN—Nothing quite equals the sense of achievement you receive when you successfully complete a Heathkit unit and "tune-in" for the first time.
6. YOUR HEATHKIT IS GUARANTEED—Every Heathkit unit is guaranteed to meet advertised performance specifications . . . or your money will be cheerfully refunded.
7. YOUR HEATHKIT IS AVAILABLE ON CONVENIENT CREDIT—Our time payment plan makes it possible for you to order now . . . pay later.
8. YOUR HEATHKIT IS TOPS IN QUALITY—The very finest in electronic equipment comes to you in kit form from the Heath Company.
9. HEATHKIT DEALERS CAN SERVE YOU LOCALLY—Carefully selected Heathkit representatives are available in many localities. The convenience of local Heathkit sales and service costs but a few dollars more.
10. HEATHKIT SERVICE IS CUSTOMER SERVICE—Our staff of technical experts is always ready to answer your questions or help you if you have any difficulty.

A



a subsidiary of
DAYSTROM, INCORPORATED

ORDERING INSTRUCTIONS

Fill out the order blank below. Include charges for parcel post according to weights shown. Express orders shipped delivery charges collect. All prices F.O.B. Benton Harbor, Mich. A 20% deposit is required on all C.O.D. orders. Prices subject to change without notice.

HEATH COMPANY, Benton Harbor 15, Michigan

Please send the following HEATHKITS:

ITEM	MODEL NO.	PRICE

Ship via () Parcel Post () Express () COD () Best Way

() SEND MY FREE COPY OF YOUR COMPLETE CATALOG

Name _____

Address _____

City _____ Zone _____ State _____

Dealer and export prices slightly higher.

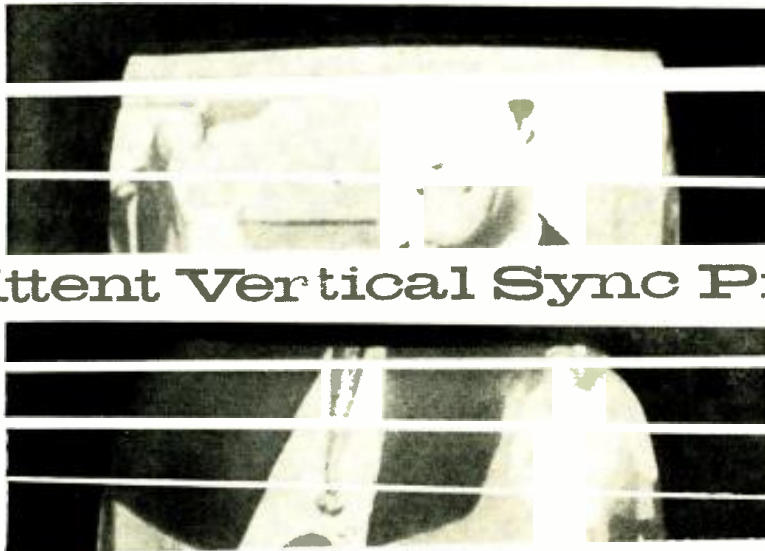

Intermittent Vertical Sync Problems

By SOL HELLER / Erratic behavior, always hard to pin down, is doubly complicated with vertical-sync symptoms.

THE CAUSE of an intermittent defect is particularly difficult to determine in any case and, when vertical synchronization in a TV receiver is involved, the difficulty is increased. The reason for this lies in the fact that almost any section of the receiver may be responsible for a vertical-sync problem—not to mention such elements outside the TV set as the antenna system, the power line, and external interference.

The possibilities are so numerous that they cannot all be dealt with in an article of reasonable length. Accordingly we will consider only those defects in the vertical system itself that may produce intermittent synchronization problems. Even within this limitation, faults that result in jitter or impairment of interlace will not be covered.

When the technician is confronted with a fault that suggests vertical-circuit involvement, he immediately

faces two questions. The first one is, do the symptoms actually represent a loss of vertical synchronization? The second one is, if they do, how can it be ascertained that their cause is in the vertical section itself? In most cases, the second question will be the important one, with the answer to the first being obvious. However, there are cases that will be hard to recognize.

Occasional frame slipping, roll, or picture lock-in at the wrong phase in the vertical direction unmistakably represent a loss in vertical synchronization. However, there may be a problem when the frequency of the vertical oscillator has become higher than normal. In this type of defect, one field of receiver scanning takes place before one field of transmitted information has come and gone.

Assume, for instance, that the defect has produced a range of possible oscillator operation between 70 and 140 cps, and the technician has succeeded in adjusting the picture steady by synchronizing at 120 cps. When the electron beam in the CRT has completed one sequence of vertical scan, the picture is actually at the midpoint of the true, transmitted field, and has reproduced alternate scanning lines representing the top half of the transmitted picture only. The receiver beam now retraces back to the top of the screen. However, a small amount of picture information, which is still being applied to the CRT, is reproduced in reverse (upside-down) during this retrace period. The electron beam then starts a second cycle of vertical scan, reproducing what remains of the transmitted field, which is essentially the alternate lines for the bottom half of the transmitted field.

The result of the action just described is that the top and bottom halves of the picture are superimposed

over each other on the receiver screen. Total vertical deflection is also reduced by about 50 per-cent, due to the higher frequency at which the vertical oscillator operates; since the saw-tooth-forming capacitor does not charge as much, sweep-signal output is reduced.

An inspection of the screen will reveal the two (top and bottom) superimposed halves of the picture. Picture information scanned in reverse during retrace will comprise a third, faint, superimposed layer. A further aid to identification of the condition is the loss in vertical deflection that is associated with the other symptoms.

When the vertical hold setting is not near 120 cps, the symptoms will not be as recognizable; however, adjustment of the control to the setting where the most recognizable picture is seen will bring the oscillator to 120 cps, facilitating the diagnosis.

If the defect causes the vertical oscillator to rise to a much higher frequency of operation—say, 400 cps—an unrecognizable, chaotic mass of picture information will be seen that suggests a total loss of horizontal synchronization. One clue to the real nature of the condition in this case, is the severe loss of vertical deflection present. Another is the greater-than-normal, uneven spacing of the horizontal scanning lines; this is the result of the vertically faster, non-linear travel of the scanning beam. A frequency check of the vertical oscillator will confirm a diagnosis of the above-normal frequency. A representative frequency range, when the hold control is rotated, is 40 to 80 cps if oscillator operation is normal.

We now come to the second question: How can we tell if the cause of the intermittent vertical synchronization lies in the vertical section?

Trouble in the vertical section is indicated if, assuming roll is the com-

Fig. 1. Vertical blocking oscillator used in DuMont sets. Capacitors C₂₈₅ and C₂₈₇ have most effect on frequency.

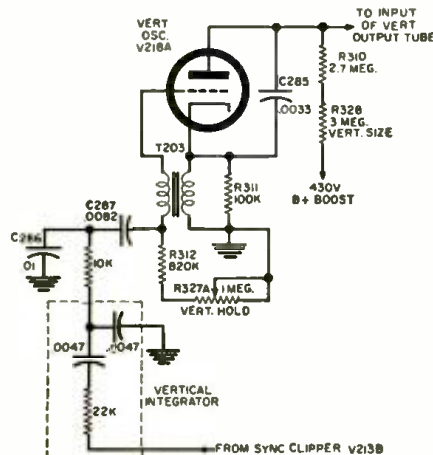

plaint, adjustment of the vertical hold control is unable to lock in a single picture even momentarily during the time roll is present. To make the test more conclusive, remove a sync stage tube (or open the coupling capacitor between the sync section and the vertical oscillator) before performing it.

Even if a single picture can be momentarily locked in, it doesn't necessarily mean the vertical section is OK; if lock-in is obtained too close to one end of the vertical hold control range, inadequate range may be present when sync signals are coming in. Therefore the test definitely clears the vertical section only if lock-in is obtained at or near the center of the control's range.

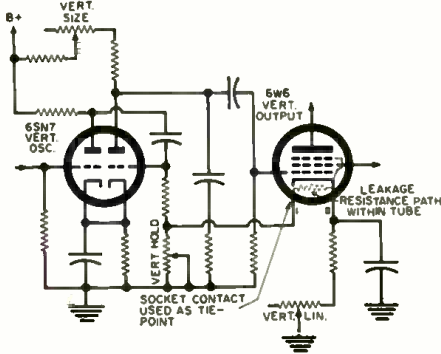

Fig. 2. Leakage between output-tube pins affected oscillator's stability.

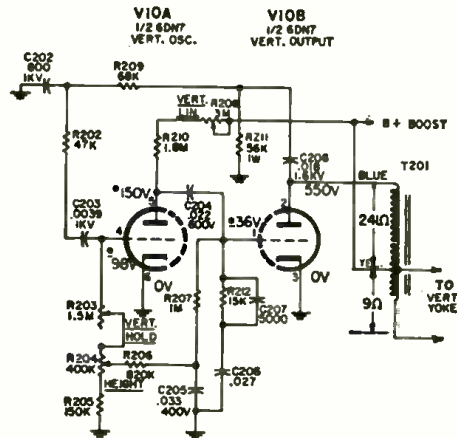

Fig. 3. Vertical circuit in G-E M5 chassis. H-v capacitors break down.

Trouble in the vertical section is indicated if—assuming occasional frame-slipping is the complaint—a scope check of the sync pulse at the input to the vertical oscillator shows no change in the amplitude or shape of the sync signal during an interval of time long enough for the symptoms to develop. The vertical oscillator tube should be removed or disabled during this test to prevent the oscillator "kickback" signal from being superimposed over the sync signal. It is assumed the receiver is tuned to a station and control settings are normal.

When occasional loss of vertical synchronization is the complaint, and symptoms have not manifested themselves, a preliminary check for insufficient vertical hold control range may prove helpful. To make the test, rotate

the vertical hold control from one extreme setting to the opposite one. If the action of the control is correct, the picture should roll upward at one extreme and downward at the other during this rotation. If roll in one direction only can be obtained, insufficient control range is present, and may be a cause, or at least a contributing cause, of the trouble.

Oscillator Defects

Tube Defects. When occasional roll or critical vertical hold is the complaint, and a 6BL7 is used as the vertical oscillator, the tube itself is a logical suspect. This is particularly true if the tube is one that was manufactured several years ago. An estimate by a manufacturing source is that about 50% of early 6BL7 tubes may cause vertical instability. A tendency to grid emission is present in the tubes. The grid emission causes bias to decrease progressively, and the frequency of oscillator operation changes in step with the decrease, causing vertical drift or roll. Tapping the tube is likely to bring on the instability symptoms, if the tube is to blame, and may be used as a test.

A number of new tubes, including several different makes of tubes, may have to be tried in some cases when a 6BL7 is being checked by substitution as the possible cause of vertical instability. A 6BL7 may be replaced by the more stable 6SN7GT in many instances; sometimes, particularly when the line voltage is relatively low, the substitution will not provide proper height, linearity, or both. A 6SN7GTA can dissipate more power than a 6SN7GT, and may be more stable; thus it is more desirable as a substitute. (Overheating of an oscillator promotes instability.)

Dirty tube pins are a possible source of intermittent instability and should be checked.

A noisy oscillator tube may be responsible for intermittent vertical synchronization losses. If gently tapping the tube brings on (or eliminates) symptoms, the tube should be replaced and results noted.

Grid Capacitor. The grid coupling capacitor is a common cause of vertical

drift trouble, particularly drift during warm-up. Heat-caused changes in capacitance are responsible. Other capacitors in the frequency-determining circuit may also be the cause of the symptoms. Holding a soldering iron near suspect capacitors, in turn, and noting whether symptoms develop is one way to test for the condition.

Capacitor substitution offers the best check when suspicion has fallen on one particular unit. The best capacitor to use as a test replacement (or a permanent replacement) is a silver mica unit. This type undergoes a very small change in capacitance in the presence of heat, and recommends itself for this reason.

Sometimes undue heating of a grid capacitor is due to the presence of a hot resistor nearby. Physical relocation of the capacitor or resistor in question will serve as a test, as well as a remedy for the condition.

When a grid or frequency-determining capacitor is located in warm surroundings and nothing else can be done about the matter, use of a silver mica capacitor with a voltage rating that is considerably higher than required will minimize the heating effects on the capacitor.

Intermittent vertical instability may be due to a leaky or intermittently open capacitor in the frequency-determining circuit. In a typical blocking oscillator like that of Fig. 1, capacitors C_{osc} and C_{sync} have the greatest effect on frequency. One way to test for such trouble is to scope-check the amplitude of the voltage waveform present at either side of suspect capacitors first, when the set is performing normally, and again later, when it isn't. The defective capacitor will show a considerable change in the relative amplitudes of the waveform voltages between its terminals and ground.

Grid Resistor. Heat-caused changes in the value of a resistor in series with the vertical hold control may be the cause of vertical instability. Checking the resistance of the suspect unit before and immediately after symptoms have manifested themselves will serve as a test for such trouble. Use of

(Continued on page 80)

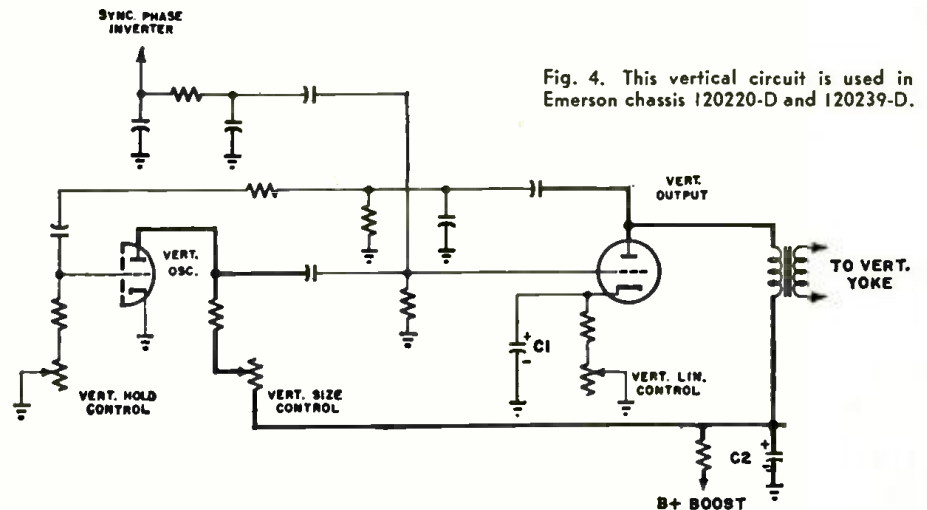

Fig. 4. This vertical circuit is used in Emerson chassis 120220-D and 120239-D.

Forge ahead... learn FM 2-way radio servicing



MOTOROLA TRAINING INSTITUTE

Radio Technicians... here's the opportunity you've been waiting for... a chance to learn 2-way FM radio servicing through the only home-study course devoted exclusively to this dynamic field.

The MOTOROLA TRAINING INSTITUTE trains you for a professional career with unlimited potential. The 2-way radio market is booming now... may triple in the next 10 years. Qualified servicemen are in high demand!

The 38 lessons, extensive texts, special articles and reference library included in the course have been compiled by a professional staff of instructors who are intimately acquainted with 2-way radio.

The MTI course is not intended for beginners. It is directed at the technician with a background in electronics or at the prospective student who can pass an examination in basic electronics.

Here is what the course offers:

- Theory of Circuit Operations
- Advanced Trouble-Shooting Techniques
- Systems Analysis and Circuitry
- Transistorized Equipment

Cost of the course is only \$95.00... you can save \$5.00 by pre-payment. Write today for complete information, including an illustrated booklet and supplementary materials.

MOTOROLA TRAINING INSTITUTE
4501 Augusta Blvd. • Chicago 51, Illinois

Please send me complete information on the
MOTOROLA TRAINING INSTITUTE, A-145
(Please Print)

NAME _____

ADDRESS _____

CITY _____ ZONE _____ STATE _____



RECORDING ECHO AID

Ecco-Fonic, Inc., 905 S. Vermont St., Los Angeles, Calif. has introduced a device that provides pre-set amounts of echo, sound delay, and reverberation during a recording session. The "Accompanist" is an amplifying and rever-



beration unit which may be used to enhance certain acoustic effects in one's own recording, as well as to overcome problems of poor room acoustics.

A portable model is designed for use by musicians and singers. Additionally, it can be used with existing stereo or mono reproducing equipment. The console model includes a built-in 15-ips tape recorder with a repeating "memory" tape cartridge.

SONY TAPE RECORDERS

Superscope, Inc., Audio Electronics Div., 8150 Vineland Ave., Sun Valley, Calif., has introduced three new "economy priced" tape recorders. The *Sony* 101 is an a.c.-operated, bantam, transistorized dual-track monophonic recorder. It comes complete with carry case, built-in speaker, and dynamic microphone.

The *Sony* 262-SL is a 4-track monophonic recorder with 4- and 2-track stereo playback. It includes a built-in monophonic preamplifier, recording amplifier, and monitor power amplifier. A second-channel playback preamplifier is also provided. It features sound-with-sound recording, and is supplied



with portable case, earphone, monitor speaker, dynamic microphone, and connecting leads for stereo playback.

The *Sony* 262-D incorporates the transport mechanism of the model 262-SL, without electronics, but with a 4-track stereo erase head and 4-track stereo record/playback head. The heads

are wired to six output and input facilities for connecting to external electronics.

P.A. AMPLIFIER

Fanon Electronic Industries, Inc., 98 Berriman St., Brooklyn 8, N. Y. has added the Model 3310 public-address amplifier to its line of audio equipment.

Power output is 10 watts at less than 5% distortion with peak power output (music waveform rating) of 14 watts. Frequency response is 30 to 20,000 cps ± 2 db. The circuit provides one microphone input and two phono inputs with fader control. Gain is 120 db on microphone and 85 db on phono. The amplifier is especially designed to accommodate a phono top which is offered as an accessory, the Model 3604.

A data sheet providing complete electrical and physical specifications on this unit is available on request.

FM CAR RADIO

Granco Products, Inc., 83-30 Kew Gardens Road, Kew Gardens, N. Y. has announced a low-cost FM receiver, to be produced for 1961 car models. Ac-

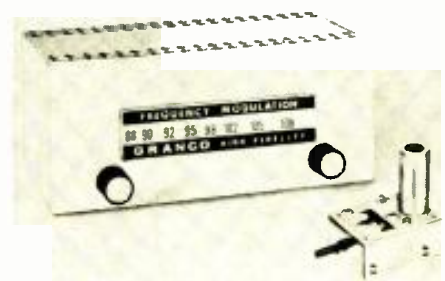

ording to the manufacturer, the front end of this 8-stage set will utilize transistors and an a.f.c. device that eliminates the need for fine tuning. Reportedly, the set will lock the FM station into perfect tune as soon as sound is picked up.

Designed for installation in cars using a 12-volt ignition system, the set is supplied less antenna and loud-speaker.

SHERWOOD FM TUNER

Sherwood Electronic Laboratories, Inc., 4300 N. California Ave., Chicago 18, Ill. has introduced its Model S-3000 III FM tuner. This unit is a basic FM tuner, with space internally to plug in the same manufacturer's Model AMX multiplex adapter, which then makes it possible to receive stereo via FM multiplex.

The tuner itself uses a "corrective" inverse feedback circuit for improved response and lower distortion. In the S-3000 III, 3 db of inverse feedback is applied from the discriminator to the

a.f.c. tube. Its effect is to increase the discriminator equivalent to 1100 kc. and the i.f. equivalent bandwidth to 290 kc., without sacrificing selectivity.

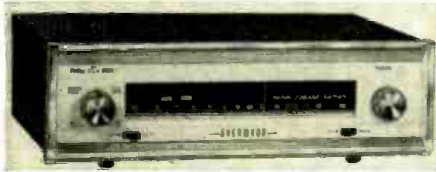

This technique also is said to improve long distance reception.

Other features include an FM inter-channel muting control; tuning eye; 7-inch expanded slide-rule tuning scale; a.f.c., and local-distant switch. Sensitivity is stated as 0.95 microvolt for 20 db quieting, and 1.8 mv. for the IHFM standard of 30 db noise and distortion below 100% modulation. IM with corrective feedback is given as 1/4% at 100% modulation. Hum and noise are specified at -60 db; frequency response, 20 to 20,000 cps $\pm 1/2$ db.

FAIRCHILD TURNTABLE

Fairchild Recording Equipment Corporation, 10-40 45th Avenue, Long Island City 1, N. Y. has announced the availability of a high-fidelity turntable, the Model 440.

The new turntable provides two-speed operation (33 1/3 and 45 rpm), single-belt drive, a "Speed Sentinel" control that varies turntable speed by $\pm 1 1/2$ %, and a precision turntable platter. The entire assembly is supplied on a channel for easy mounting. Rotational speed is controlled by applying d.c. to the motor windings. This is controlled from the top of the unit. A strobe disc is supplied with each turntable as is a graph of the unit showing performance over a 24-hour testing period.

The mounting board and base (in walnut or unfinished) are available as accessories.

THREE-WAY SPEAKER

Lafayette Radio, 165-08 Liberty Ave., Jamaica 33, N. Y. has introduced a new 10-inch, 3-way loudspeaker designed expressly for bookshelf enclosures.

Known as the "Trihelix," the new speaker utilizes three mechanically and electrically independent speakers mounted within a 10-inch frame. A built-in electrical network provides crossover from woofer to mid-range at 1500 cps, and from mid-range to tweeter at 5000 cps. Over-all response is said to be 20 to 20,000 cps ± 3 db. To minimize interaction among the three speaker cones, the mid-range and tweeter units are mounted eccentrically off center in relation to the woofer. Additionally, mid-range and tweeter are completely enclosed by specially designed baffles.



October, 1960

\$89.95*

NOW... BUILD AN FM KIT THAT WORKS AS WELL AS FACTORY ALIGNED TUNERS

NEW! Kit-Pak Container®

Opens to a self-contained work area you can use anywhere.

NEW! Part-Chart®

Speeds your work. All parts are mounted on Kit-Pak cover in numerical sequence. And every part meets H.H. Scott's tough test standards.

NEW! Ez-A-Lign System®

Requires no extra equipment. You align this tuner using the meter on the tuner itself! All needed alignment tools are included.

NEW! Pre-Stripped, Pre-Cut Wire

Every piece of wire is included. And each piece is pre-cut to proper length, stripped and tinned.

LT-10 Laboratory Tuner Specifications

- Usable (IHFM) sensitivity 2.5 μ v
- Signal: noise ratio 60 db below 100% mod. • Harmonic distortion 0.8% • Drift 0.02% • Frequency response 30 cps—15Kc ± 1 db. (IHFM measurements are made only in the range 30-15,000 cps. The LT-10 actually has far wider frequency range than shown here.)

The new LT-10 Tuner Kit will work as well as factory units, yet it can be aligned without expensive equipment. You align this tuner using the meter on the tuner itself. All needed alignment tools are included. This is the first kit to use H. H. Scott's Wide-Band circuitry. This results in greater selectivity and sensitivity than possible with any other kit on the market.

The exclusive H. H. Scott silver plated front end is completely pre-assembled and pre-aligned. All parts are mounted in sequence of assembly. All wires are pre-cut to proper length and stripped. Parts such as tube sockets and terminal strips are already riveted to the chassis. Here's a kit that's fun to build, and that you'll be proud to own.

* Prices slightly higher west of Rockies. Accessory case extra.



WORLD'S LEADING COMPONENT MANUFACTURER

H.H. SCOTT INC., 111 Powdermill Rd., Maynard, Mass.

Please send me FREE the following booklets: EW-10

Colorful new 1961 catalog and hi fi guide.

Complete technical specification sheets on your new products, including your new LT-10 Tuner Kit.

Name _____

Address _____

City _____ Zone _____ State _____

Export: Telesco International Corporation, 36 West 40th Street, N. Y. C.



A new standard of broadcast performance from UNIVERSITY NO OTHER PROFESSIONAL MICROPHONE AT ANY PRICE CAN DO WHAT THIS ONE CAN!

Never before has there been a microphone like this . . . and it's just one of *six* professional models that herald the entrance of University into the field of microphones. Each sets a new standard of wide-range, distortion-free performance . . . with frequency response available as low as 30 cps, as high as 20,000 cps. Each offers the years-ahead-of-its-time concept of modular flexibility. Each is styled with clean, uncluttered lines totally adaptable to every environment.

To accomplish all this, University drew upon its more than two decades of leadership in sound, and applied all this vast experience to the challenge of producing a better microphone than had ever been known before. University — the leading manufacturer of speakers — now sets the pace in microphones.

MODULAR FLEXIBILITY . . . a major breakthrough in microphone design . . . gives you total interchangeability between all microphones and all accessories at all times. Need a microphone with a switch and another without . . . or for slide-on and screw-on stands . . . or for cables with and without cannon plugs? Buy just one University microphone plus only the adapters you need, and you've got them all! You don't pay for features you don't need . . . you don't compromise to meet a price. That's *true* modular flexibility, and you get it only from University.

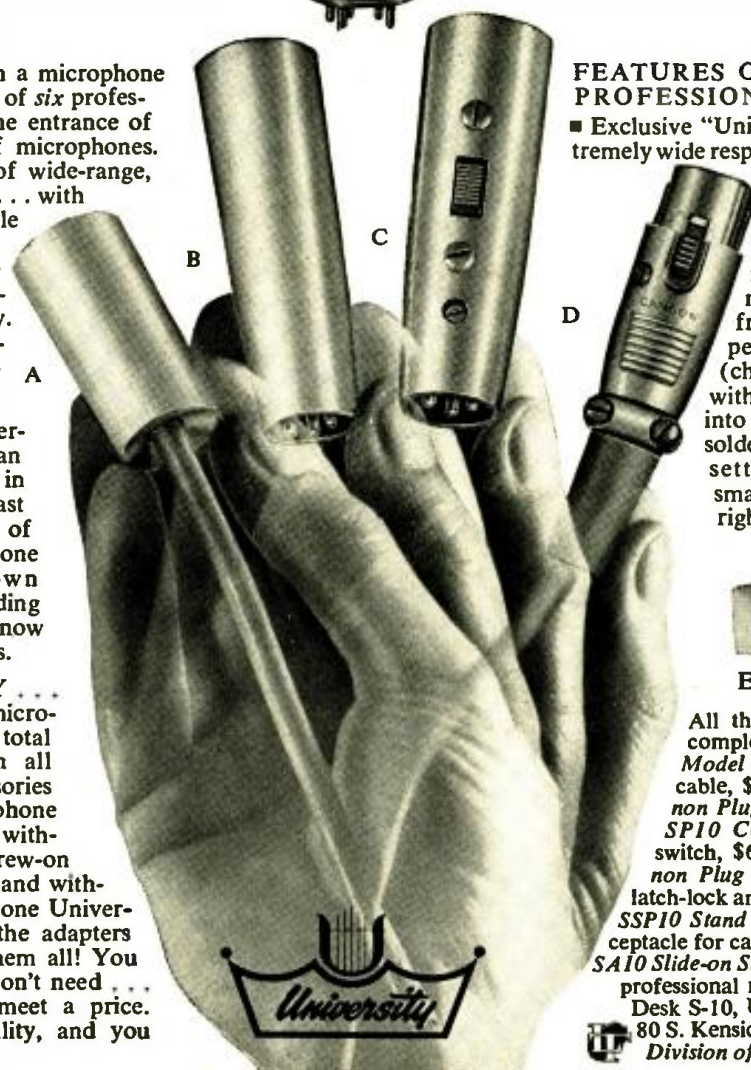

FEATURES OF THE UNIVERSITY PROFESSIONAL MICROPHONES

- Exclusive "Unilar" diaphragm assures extremely wide response range . . . from as low as 30 cps to as high as 20,000 cps.
- Rugged generating element is indestructible in normal use. Internal elements of shock-mounted models float in vibration-free foam insulations.
- Impedance matching simplicity (choice of two low, one high) with press-on connectors built into every accessory. No tools, soldering, or rewiring.
- Trend-setting exterior design with smart modern finishes . . . just right for every application.

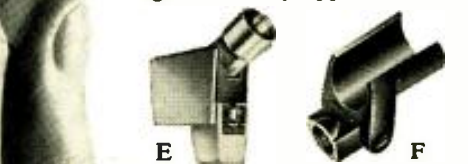

All these accessories available for complete modular flexibility: [A] Model CC10 Cable Adapter with 18' cable, \$6.00. [B] Model PA10 Cannon Plug Adapter, \$6.30. [C] Model SP10 Cannon Plug Adapter with switch, \$6.90. [D] Model CA10 Cannon Plug and Cable with push/action latch-lock and 18' cable, \$6.00. [E] Model SSP10 Stand Adapter with switch and receptacle for cannon plug, \$11.10. [F] Model SA10 Slide-on Stand Adapter \$4.20. All prices professional net. For further details, write Desk S-10, University Loudspeakers, Inc. 80 S. Kensico Ave., White Plains, N. Y. A Division of Ling-Temco Electronics, Inc.

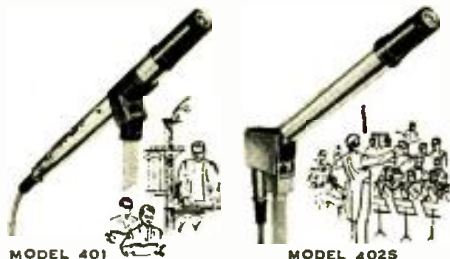

MODEL 401 OMNI-DIRECTIONAL DYNAMIC Professional broadcast microphone for diversified broadcast applications. Also ideally suited for every quality sound system: night club, church, school, commercial and industrial p.a. Exclusive "Unilar" diaphragm. Response: 40-20,000 cps. \$43.50 professional net.*

MODEL 402S OMNI-DIRECTIONAL DYNAMIC (SHOCK MOUNTED) Deluxe version of Model 401, shock-mounted to prevent mechanical feedback and pickup of spurious noise. Response: 35-20,000 cps. Otherwise identical in performance to Model 401. Exclusive "Unilar" diaphragm. \$47.70 professional net.*

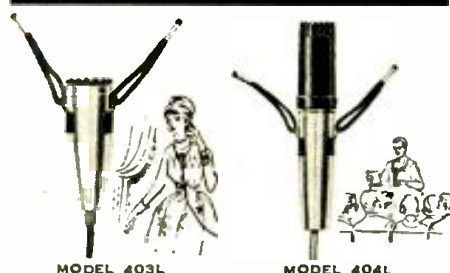

MODEL 403L TELEVISION LAVALIER Extremely rugged professional lavalier only 3 1/2" long . . . for telecasting, broadcasting and recording where uncompromised quality reproduction, minimum weight and unobtrusiveness are required. Performance factors exceed previous lavalier microphone standards. Exclusive "Unilar" diaphragm. Over-all response: 60-20,000 cps. \$52.50 professional net.

MODEL 404L BROADCAST LAVALIER Designed for exacting broadcast applications requiring specifications of the large omnidirectional microphones. For the first time, a lavalier microphone that exceeds performance of full-size units, yet is only 4 1/4" long, 1-3/32" in diameter. Exclusive "Unilar" diaphragm. Over-all response: 50-20,000 cps. \$57.00 professional net.

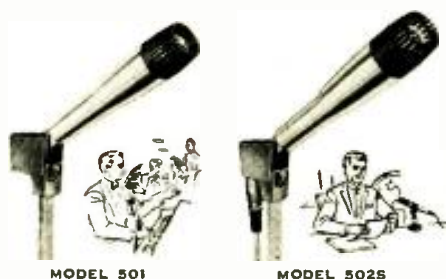

MODEL 501 PROFESSIONAL DYNAMIC CARDIOID Finest quality full-range reproduction under diverse acoustic conditions. Cardioid pattern rejects unwanted background noises and room reverberations, allowing non-critical placement of microphone. Exclusive "Unilar" diaphragm. Response: 35-15,000 cps. \$75.00 professional net.*

MODEL 502S PROFESSIONAL DYNAMIC CARDIOID (SHOCK MOUNTED) A deluxe shock-mounted microphone designed to prevent mechanical feedback and pick-up of spurious noise. Response: 30-16,000 cps. Otherwise identical in performance to Model 501. Exclusive "Unilar" diaphragm. \$87.00 professional net.*

*microphone only.



A Division of Ling-Temco Electronics, Inc.

The woofer employs a "conical stiffener" at its apex to improve piston action. Designated by stock number SK-180, the "Trihelix" has an impedance of 8 ohms, and free air resonance of 35-55 cps. Power rating is 20 watts for average program material.

REVERBERATION DEVICE

Fisher Radio Corp., 21-21 44th Drive, Long Island City 1, N. Y. has announced a new device for enhancing the reverberation characteristic in reproduced sound. Designated as Model K-10, and called the "Dynamic Spacex-pander," the new unit is said to enhance both stereo and mono playback by providing the reverberation that is heard in the concert hall, but which is usually absent in recording studios and the average listening room.



The Model K-10 can be used with virtually all Fisher units, both components and consoles, now being manufactured. Additionally, it can be used with high-fidelity systems using separate preamplifiers or having tape monitoring facilities.

LOW-COST CARTRIDGE

Shure Bros, Inc., 222 Hartrey Ave., Evanston, Ill. has brought out a new low-cost magnetic stereo cartridge. Especially designed for use with record changers, the new pickup, model M8D, is known as the "Stereo Standard Dynamic." Claimed response is 30 to 15,000 cps; channel separation is given as more than 20 db at 1000 cps. Tracking force is 5 to 8 grams.

The M8D uses the moving magnet principle. Compliance is listed as 3 x



10⁻⁶ cm./dyne. Output voltage is 5 mv. per channel at 1000 cps. Recommended load impedance is 47,000 ohms. The cartridge has four terminals but is adaptable to three-terminal arms.

ORGAN TUNING KIT

Schober Organ Corp., 43 West 61 St., New York 23, N. Y., has introduced its "Autotuner" which permits fine-tuning of electronic organs in a matter of minutes without the need for technical skill or musical knowledge.

The "Autotuner" is a strobe device that provides accurate pitch to within 1/100 semitone, said to be finer than

the human ear can hear. Small enough to be carried in the pocket, it is available fully assembled or in assemble-it-yourself kit form.

V-M STEREO RECORDERS

V-M Corporation, Benton Harbor, Mich. has added a new stereo recorder to its 1960-61 line. The new portable is Model 722 and records stereophonically on 4 tracks. It offers monophonic as well as 2-track and 4-track stereo playback. Included are two microphones and a dual tuning eye. Model 722 also incorporates the "Add-A-Track" feature which permits recording on one track, rewinding the tape, and recording again on a second track while listening to the first. Then, on playback, both tracks can be heard together.

To complete the stereo playback mode, using the 722, the company also offers its Model 168 auxiliary amplifier-



speaker as a separate unit. Other models in the new line include stereo and mono equipment in table models and consolettes.

STEREO MATRIXING XFORMER

Microtran Company, Inc., 145 E. Mineola Ave., Valley Stream, N. Y. is in production on a new stereo matrixing transformer which permits the audiophile to convert his monophonic system to stereo or enlarge and modify his existing stereo setup.

The new transformer provides for the use of "left" and "right" amplifiers to provide "sum and difference" speaker outputs. Two of these units (one for each channel) used with "left" and "right" amplifiers enables virtually any kind of stereo system to be built with simple components.

Specifications include a 30-watt power rating, 100 watts peak; frequency response from 40 to 20,000 cps; and impedance range of +16, +8, +4, 0, -4, -8, and -16 ohms. The transformers measure 3 3/4" x 2 1/2" x 2 5/16" with 3/8" mounting centers.

CRYSTAL STEREO CARTRIDGES

Sonotone Corp., Elmsford, N. Y. is offering a new Series "12" line of crystal stereo cartridges. These low cost pickups feature high output, easily replaced stylus, and simple installation. Model 12TH has an output of 2.5 volts; Model 12TL, an output of 1 volt.

Both models use 0.7-mil and 3-mil sapphire stylus tips. Both are of the turnover type. Tracking pressure for

NINE SECONDS TO STEREO



From the moment you place your stereo record on the LESA changer . . . until nine seconds later when the needle gently nestles down on the record groove . . . you can be sure that behind the classical, smart appearance of the CD2/21 every modern record changer design engineered by Italian craftsmen is working to perfection. Novice or pro . . . compare—you'll find that LESA has everything . . .

- Fully automatic, 4-speeds • pre-wired for monaural and stereo • Minimum rumble, flutter and wow • Constant speed-change cycle—only 9 seconds • Absolutely jam-proof • Automatic size intermix • Heavy duty four-pole motor • Gentle record handling • Universal plug-in head • No background noise • Stop without rejecting • Automatic click suppressor • Finished most attractively in smart continental styling.

\$44.50

slightly higher in the West

CD2/21 High-Fidelity Stereo Record Changer

ELECTROPHONO & PARTS CORP. 530 CANAL STREET, NEW YORK 13, N. Y.
Exclusive U.S. distributors for Lesa Hi-Fi components

TUNE ELECTRONIC ORGANS ACCURATELY-QUICKLY WITH A NEW Schober AUTOTUNER

Every organ owner and service technician requires this valuable aid to precision organ tuning. This instrument enables anyone to quickly tune any electronic-oscillator organ (except Thomas) without previous knowledge or skill.

An automatic stroboscopic indicator visually shows true pitch to an accuracy of 1/100 of a semitone (more accurate than human hearing), yet you pay about 1/3 the price of other tuning devices of similar precision.

Black plastic case with etched satin aluminum front panel. So lightweight it may be carried in your pocket. Size 6 1/4" x 5 1/4" x 2 1/4". Detailed instructions included.

\$69.50

(completely assembled)



\$49.50 (in assemble-it-yourself kit)

(N.Y.C. Residents add 3% Sales Tax)

MAIL ORDERS FILLED PROMPTLY • FULLY GUARANTEED
THE SCHOBEL ORGAN CORPORATION, Dept. RN
43 West 61st Street, New York 23, N. Y.
Manufacturers of the World-Famous Schobel Organ Kits,



CROWN

Professional Tape Recorder

Model A-51
CROWN-O-MATIC

An automatic tape player for background music systems and industrial uses where ruggedness and durability (with quality) are essential.



\$695

Accommodates 14" Reels

- Heavy Anodized Aluminum Construction
- Full Tape Handling and Braking Facilities
- Plug-in Enclosed Relays and Pre-Amps
- Automatic Photo Electric Reversing
- Safety Devices to Protect Tape
- Hysteresis Synchronous Motor
- Straight-line Threading
- Forced Air Cooling



Sold Mainly Thru
"SOUND SYSTEM"
DEALERS

CROWN INTERNATIONAL
Division of
INTERNATIONAL RADIO & ELECTRONICS CORP.
ELKHART, INDIANA



the 12TH is recommended at 9 to 11 grams; for the 12TL, 6 to 8 grams. Recommended load for either type is 1 megohm. Channel isolation is said to be 15 db. Each is supplied with a mounting bracket.

PROFESSIONAL RECORDERS

Crown International, So. 17 St. & Mishawaka Rd., Elkhart, Indiana, has announced its new "Supra professional" 800 series of tape equipment. Featured are: all-electric controls; a third head monitor with A-B and echo switch; "advance micro cueing;" photocell automatic stop. The 800 uses three motors with a synchronous capstan motor. It is a three-speed unit, accepts 10-inch reels, with 14-inch reel capacity available.

Performance claims are: at 15 ips, ± 2 db, 30 to 30,000 cps, with flutter and wow 0.06%, and noise ratio 58 db; at 7 1/2 ips, ± 2 db, 20 to 22,000 cps, with flutter and wow 0.09%, and noise ratio 55 db; at 3 3/4 ips, ± 3 db, 30 to 15,000 cps, with flutter and wow 0.18%, and noise ratio 51 db. Harmonic distortion is stated as below 3%, measured by NAB standards.

TAPE CUEING TABS

W. H. Brady Co., 727 W. Glendale Ave., Milwaukee 9, Wis., has introduced "Quik-Cue Contact Tabs," thin aluminum-foil tabs which are applied to recording tape for automatic stop-start-repeat operation with tape equipment that incorporates automatic switching. Tabs are applied to the tape wherever switching or cueing is desired. When the tab reaches the contact points on the machine, it actuates the mechanism.

Tabs are furnished 42 to a dispenser card. When applied to a section of tape, the tab effectively becomes a part of the tape. For further information, write direct to the manufacturer, Dept. 173.

AUDIO CATALOGUES PHONO STYLI

Astatic Corp., Conneaut, Ohio, has published a 40-page catalogue giving detailed information on the company's complete line. Included is a needle replacement and a cross-reference guide.

Illustrations and the use of two-tone printing facilitate the use of the catalogue. Also included are listing of the

ELECTRONICS WORLD

company's phono accessories, cartridges, and microphones.

REPLACEMENT DRIVES

Robins Industries, Flushing 54, N.Y. has issued a new 16-page reference guide designed to help distributors and service technicians select the right replacement drives for nearly 95% of phono and tape recorders.

The guide lists manufacturers, model numbers, and the *Robins* replacement drive for servicing each unit. A supply of new guides will be given free with the company's new phono and recorder parts deal DD-10RP. The guide carries a list price of 50 cents.

BOGEN-PRESTO BOOKLETS

Bogen-Presto Company, Box 500, Paramus, N. J. has issued three new booklets of interest to audiophiles.

The first publication, #520, describes three stereo receivers and the five tuners and amplifier which the company is offering in a new gold panel cabinet as well as in grey. Performance data, photographs, and prices are shown for each model.

Publication #521 covers the company's line of turntables for home hi-fi systems while the third publication is an 8-page catalogue of the "Presto 800 Series Professional Tape Recorders." This publication, #910, covers models for a full range of recording applications.

EICO "STEREO GUIDE"

Electronic Instrument Co., Inc., 33-00 Northern Blvd., Long Island City 1, N. Y. is now offering free a four-page booklet entitled "Stereo and High Fidelity."

The booklet covers a definition of stereo sound, discusses stereo sound sources, and provides data on various stereo and mono sound systems, complete with diagrams.

NEEDLE DISPLAYS

Jensen Industries, Forest Park, Ill. has announced a new catalogue of attractive counter card displays plus a full listing of its phono needle kits for dealers.

Divided into separate sections for dealers, distributors, and service technicians, the new booklet provides detailed data and illustrations of four different kinds of needle kits, and ten different types of point-of-sales display cards.

FM ANTENNA INFORMATION

Apparatus Development Company, Inc., Wethersfield 9, Conn., has published a 38-page booklet dealing with the installation and operation of FM antennas.

Titled "Theme and Variation," the booklet discusses in non-technical language the function of an antenna and the basic types for FM reception.

Neatly printed and bound, and amply illustrated, the publication will be mailed by the manufacturer upon receipt of 30 cents in coin.

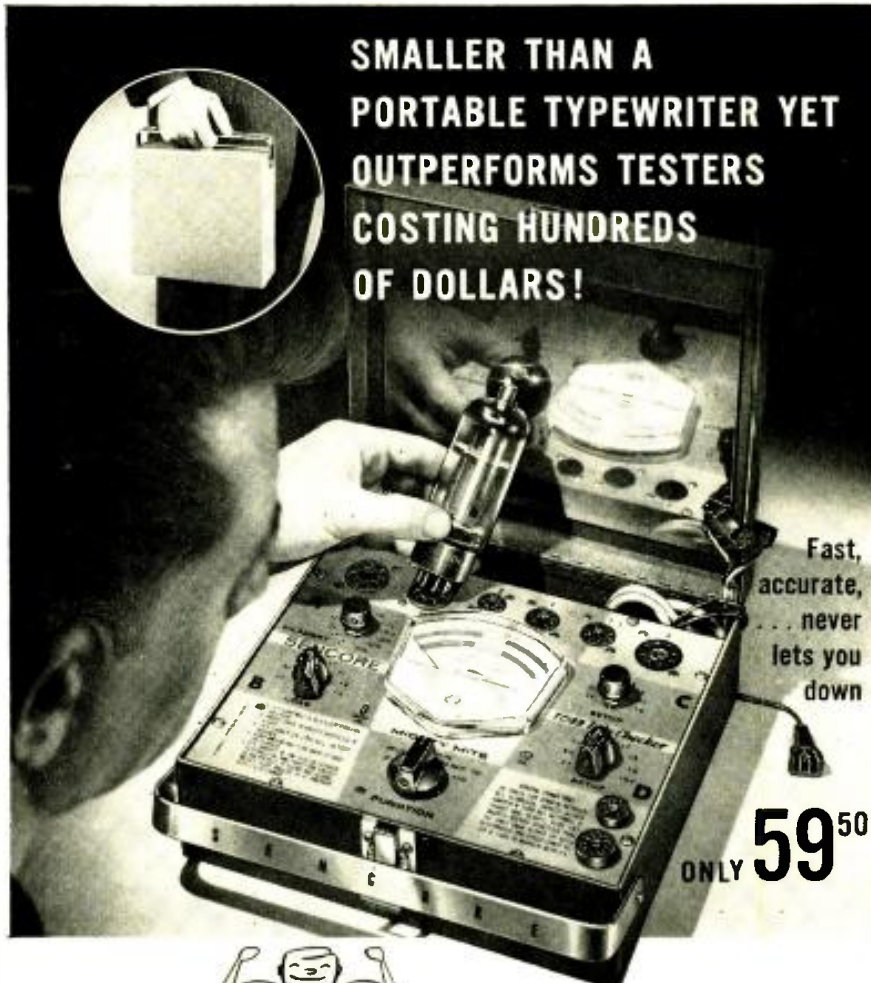

The MIGHTY MITE by SENCORE

The TC109 Tube Checker is a real money maker for the serviceman and a trusty companion for engineers, maintenance men and experimenters. Even students and hobbyists can afford the Mighty Mite for their own use or to service an occasional Radio or TV set. This small complete tester is a tremendous performer that spots bad tubes missed by costly mutual conductance testers.

New unique "stethoscope" approach tests for grid emission and leakage as high as 100 megohms, yet checks cathode current at operating levels. Special short test checks for shorts between all elements. The MIGHTY MITE will test every radio and TV tube that you encounter (over 1300!) plus picture tubes, foreign, five star and auto radio tubes (without damage). As easy to set up as a "speedy tester" from easy to follow tube booklet, New tube charts free of charge. Simple operating instructions are screened on the front panel.

Check these plus Sencore features • Meter glows in dark for easy reading behind TV set • Stainless steel mirror in cover for TV adjustment • Rugged, all steel carrying case and easy grip handle • Smallest complete tester made • Inner chassis can be easily transferred to tube caddy, bench or counter. • Only 9" x 8" x 2½". • Wt. 8 lbs.



SENCORE, ADDISON 8, ILLINOIS

Dear Pat: Will you please ...

Send me _____ Mighty Mite

Check or M.O. enclosed (PP Prepaid.) Send C.O.D.

Distributor's Name (if any) _____

Your Name _____

Street _____

City _____ Zone _____ State _____

ALL UNITS FULLY GUARANTEED OR MONEY BACK WITHIN 10 DAYS

COLUMBIA ELECTRONICS MOVES!

- New, Larger Quarters!
- Bigger Inventory!
- Better Service—Ample Parking!
- Top Values—Lower Prices!

We're at 4365 WEST PICO BLVD.
LOS ANGELES 19, CALIFORNIA!

PRS-3 MINE DETECTOR Latest model. Light Weight. More sensitive than previous models. Waterproof. Complete with case. Excellent.	\$34.95
RA-94 AC POWER SUPPLY 110 V. For Super-Pro Receiver. New condition.	\$9.95
AIRCRAFT & 2-METER RECEIVER SPECIAL! Commercial—but surplus! Mfg. by Aircraft Radio Corp. Model R-19. 28 V. Tuner variably 118-148 Mc. Has 2 HF amplifiers and 4 1-F. amp. 9 tubes. Dim.: 5½ x 4¾ x 10½ in. 5½ lbs. Good cond.	\$29.95
RECEIVER-TRANSMITTER COMBO! LINK HIGH BAND TRANSMITTER: 150-170 Mc. FM. 50W. Built-in 6 V. dynamotor. Model 2240. Terrific tube lineup: 7AG7, 7P7, 7W7, 3-2226, 821-B. 3-channel. Excellent.	\$19.95
ONLY LINK HIGH BAND RECEIVER: Model 1905. Contains 7B7, 7C7, 7AG7 PLCS (OTHERS!) Built-in 6 V. vib. supply. Companion to above. Excellent.	\$19.95
SPECIAL COMBO DEAL! BOTH FOR ONLY \$29.95	
EE-8 FIELD TELEPHONE Operates up to 10 miles with use of 2-conductor wire! BUILT-IN RINGER! Works like a charm on 2 flashlight batteries. Excellent.	\$12.50
U.H.F. MOBILE RECEIVER Navy model 10R. Mfg. by RCA. Freq.: 225-300 MC. 10 channel. Crystal controlled. Compact size: 2 1/8x10x9 in. Ready to install in 12 VDC car. Like new. With instruction book. Only	\$19.95
T-208 FM SIGNAL GENERATOR 20-30 Mc. ASD. 1.5-4.5 Mc. Built-in 110 VAC supply. 12 V. dynamotor. Excellent.	\$49.50
CITIZENS BAND SPECIALS! BC-620 TRANSCEIVER: With spare tubes. Govt. reconditioned. Includes 6 or 12 V. power supply. Makes F.B. Citizens' Band! Freq.: 20-27.0 Mc. This month ONLY.	\$19.95
BC-604 TRANSMITTER 20-28 Mc. 30 W. condition.	\$4.95
DM-35 DYNAMOTOR: 12 V. for above BC-604. New condition.	7.95
VRC-2 FM TRANSMITTER-RECEIVER COMBO! 30-40 Mc. A terrific 6 Volt installation! Consists of 30 W. transmitter and dual conversion receiver, both crystal controlled! This is the Army equivalent to Motorola Model FM-30. Excellent.	\$39.95
ALL PURPOSE ARB COMMUNICATION RECEIVER 155-9,000 kc. 4 bands. Built-in, directly calibrated tuning control. Ideal for home, mobile or marine. Excellent cond.	\$17.50
CONTROL BOX & PLUGS: For above. Only.	
\$4.95	
APR-1 RECEIVER SPECIAL! 30 Mc. IF. 1-F. 50 W. Like new cond.	\$24.50
Plug-in Units For Above	
TN-1: 38-90 Mc.	\$14.95
TN-2: 90-300 Mc.	4.95
TN-3: 300-1000 Mc.	14.95
APR-4 TUNERS—WILL WORK WITH ABOVE REC'R	
TN-16: 38-90 Mc.	\$14.95
TN-17: 90-300 Mc.	14.95
TN-18: 300-1000 Mc.	19.95
TN-19: 1000-3300 Mc.	49.95
COMBO DEAL!	
TN-16, TN-17, TN-18, TN-19	\$95.00
SCR-625 MINE DETECTOR BARGAIN Locate that hidden pipe, metal, treasure! Use for parts! With case. Excellent.	\$22.50
ART-13 XMT'R: Model 1-47. Freq.: 2-18 Mc. Excellent. Only.	\$34.50
APT-1 TRANSMITTER: 100-200 Mc. 10 TUBES in all including 832A driver, 8291 final and 931 photo tube. New cond.	\$9.95
VHF SPECIALS! R-19/TRC RECEIVER 70-100 Mc. Crystal controlled. Dual conversion. FM. Built-in speaker and 10 VAC 60 cps power supply. Self-contained table-top model which may be rack mounted. Companion to T-14/TRC Transmitter below. Excellent condition.	\$24.50
T-14/TRC TRANSMITTER JUST REDUCED! For action this month! 70-100 Mc. 50 W. input power on phone. Single channel. Built-in 110 V. 60 cps power supply. Table top size. Easily converted to 6 meters. Complete. Good condition, excellent buy!	\$19.95
COMBO DEAL! Both units for only	
\$39.50	
BC-375 100 W. TRANSMITTER Ideal for domestic use, as well as export marine and mobile! Freq.: 1.5-500 kc. with proper tuning unit. CW or MCW. Like new condition. Only.	\$14.95
ABOVE, but in speaker and 12 VAC 60 cps power supply. Self-contained table-top model which may be rack mounted. Companion to T-14/TRC Transmitter below. Excellent condition.	\$29.95
PE-73 DYNAMOTOR FOR ABOVE: Input 24 V. Output, 1000 V. @ 300 mls. W/Filter-ling base. Excel. cond. \$7.95. Good cond.	\$4.95
BC-306 ANTENNA: For above.	\$1.95
Excel. Ea.	\$1.95
TUNING UNITS TO COVER ABOVE FREQS: TU-5, TU-6, TU-7, TU-8, TU-9, TU-10.	\$1.95
Excel. Ea.	\$1.95
PLUGS: For any of above. Each only.	\$0.50
RACKS: For any of above. Each	1.50
BC-191 TRANSMITTER Same as above BC-375 but uses 12 VAC or 110 VAC power supply. Excellent.	\$14.95
BD-77 12 V. POWER SUPPLY: for BC-191. New, boxed.	\$12.95

ELECTRONICS
Columbia
4365 WEST PICO BLVD.
LOS ANGELES 19, CALIF.

Intermittent Vertical Sync

(Continued from page 73)

a resistor of the same value as the original one, but of a higher wattage rating, will generally remedy the trouble.

Oscillator Transformer. In some instances, a blocking oscillator transformer with too high a "Q" may be responsible for vertical instability. A white, horizontal area at the top of the picture is likely to be an associated symptom. The abnormally large "Q" tends to cause ringing from time to time, and the ringing voltages may trigger the vertical oscillator at the wrong times. A test as well as a remedy for the condition, in many cases, is to connect a 1-megohm resistor across the grid winding, or a 10,000-ohm resistor across the plate (or cathode) winding, and note results.

Removing the capacitor connected across the primary or secondary of the vertical blocking oscillator transformer, or reducing its value 50%, will eliminate a tendency to vertical sync instability in some receivers. The procedure is worth a try when troubleshooting has revealed no clear defect.

Hold Control. When insufficient vertical hold control range is associated with vertical instability, check in which direction roll occurs. If the picture rolls up, the vertical oscillator frequency is too far below 60 cps; an increase in grid circuit resistance is indicated. If the picture rolls down, the frequency of the oscillator is above 60 cps; look for a decrease in grid resistance (or capacitance) in this case.

When the vertical hold control has to be turned very slowly to reach a setting at which lock-in is obtained, an increase in the resistance of the control itself may have developed. Try shunting a 1-megohm resistor across the control when symptoms manifest themselves. If lock-in is now much more easily obtained, a defect in the control probably exists. A resistance check of the control may or may not indicate such a defect; substitution of a new control is often necessary as a test.

Miscellaneous Oscillator Stage Troubles. An unusual trouble that some service technicians have found hard to locate is leakage between binding posts to which an oscillator grid component is connected. See Fig. 2, in which a tube pin that normally has no internal connection is used as such a tie point. The leakage may be due to heat. A resistance measurement may or may not indicate the leakage. Disconnecting the grid components from binding posts and noting results will serve as a test for such trouble.

In a plate-coupled multivibrator circuit in which one tube serves as both output stage and part of the multivibrator, leakage in a feedback capacitor (see Fig. 3) can be responsible for intermittent vertical instability. Vertical linearity and size will often be affected by such trouble. Vertical deflection

may even momentarily disappear altogether. A resistance check (preferably on the 1000-megohm range of a v.t.v.m.) will often reveal the capacitor defect. The high pulse voltage developed across the capacitor is responsible for its tendency to break down. In Fig. 3, C_{200} , C_{201} , and C_{202} are particularly subject to this trouble. Note their voltage ratings.

Amplifier Stage Defects

Vertical instability may be due to parasitic oscillation in the vertical amplifier stage. The trouble is particularly likely when a triode is being used as the output tube. A check for the presence of such oscillation is to remove the vertical oscillator tube or disable it. If some vertical deflection is still present, parasitic oscillation is probably causing it. The placement of components in the vertical output stage is sometimes responsible for the condition. Make sure the ground returns of components are as close to the cathode ground of the stage as possible. Insertion of a 68- or 100-ohm anti-parasitic resistor in series with the grid of the output tube is often an effective remedy.

An unsuspected but possible source of trouble is a loss of capacitance in the decoupling capacitor of the vertical output stage (C_2 , Fig. 4). The defect may cause a 60-cycle deflection signal ripple to get into the "B" supply and appear in the sync stages. The ripple signal output of the sync stages will at some times be strong enough to fire the vertical oscillator. Since the phase of the ripple signal is shifted during its travels, it may be out-of-phase with the vertical sync signal, and will trigger the vertical oscillator at the wrong times.

To check for the defect, try bridging the suspected capacitor with another one of the same value and note results. Another way to test for the condition is to make a scope check on high side of the decoupling capacitor. Very little or no vertical sweep signal should be seen here.

In the plate-coupled multivibrator circuit shown in Fig. 3, certain slight defects in the vertical output transformer may cause intermittent vertical instability. (The "Q" of the transformer determines, in part, the size of the feedback signal; any defect that changes the transformer "Q" may therefore affect vertical stability.) Replacement of the transformer will serve as a test as well as a remedy for the condition. The original transformer may work normally in some other receiver, and need not be discarded.

The cathode bypass capacitor of the vertical output stage is normally not a logical suspect when intermittent vertical instability exists, but in some circuits it can cause such trouble. In Fig. 4, for instance, degeneration produced by an intermittent reduction in the capacitance of the cathode capacitor (C_1) can attenuate the vertical sync pulse and cause vertical instability. —30—

Handy Dust Remover

By

RICHARD E. SHAFER

Vacuum-cleaner extension uses suction for cleaning.

HIGH-VOLTAGE arcing, overheating, and general malfunctioning of TV sets, radios, electric clocks, fans, and other small appliances can be caused by dust and lint. Microscopic dust is plentiful, even in apparently "clean" air.

Since most appliances operate at temperatures above ambient, this causes an increase in convection air circulation, with additional dust deposited. The dust adheres to oily surfaces and is also strongly attracted by high-voltage charges found in TV sets.

It is essential to remove such dust from inside these appliances. Before beginning such a periodic cleaning operation the unit must be disconnected and the high voltages of the type found in TV sets must be discharged.

Cloths or brushes may sometimes be used for dust removal from parts but this generally stirs up the dust which may fog into more critical areas. This method also tends to force dust into small holes or gaps where it may cause trouble. A cloth and window cleaning compound can usually be used to clean the face of the picture tube and the safety glass.

Ordinary vacuum-cleaner hoses are too large to fit into such congested areas as TV chassis. A good solution to the problem is to use a short length of windshield wiper hose, as shown in the diagram. It is desirable to use the shortest practical length of hose since the suction loss is directly proportional to the length of the hose. It is also advisable to use the largest practical diameter because the pressure loss is directly proportional to the square of the velocity.

The arrangement shown has proven satisfactory and does not abrade parts or wiring. After removal of the dust, high-voltage insulators, tube supports, and other critical parts can be wiped with a cloth.

The bristles shown in the diagram can be cut from an old toothbrush or from plastic strands. A thin layer of bristles is installed around the tube, none should be placed in front of the tube opening.

Accessory plugs into vacuum-cleaner hose.

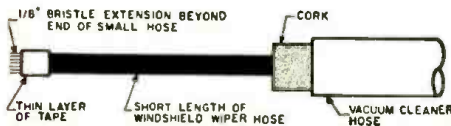

Let's clear the air...

WITH VOCALINE 4-CHANNEL COMMAIRE ED-27M CITIZENS BAND RADIO

Ranked first for dependability distance • clarity



Also available in single channel model — Commaire ED-27M — proven as the world's finest-performing class D Citizens Band Radio! Only \$179.50 each, list.

\$189.50 each, list.

Citizens band radio can be no more effective than the equipment you use! In fact, no judgment on the subject can be valid until one has heard the type of performance possible when properly engineered; truly superior equipment is utilized. Example: the Vocaline Commaire ED-27M, the finest citizens band radio available anywhere today! The difference between Vocaline Commaire ED-27M and ordinary Citizens band radios can be as substantial as the difference between the two photos above. For distance, reliability, flexibility and uniform clarity on the entire 22 channel citizens band . . . you have only to hear the Commaire to convince yourself that this is the

one unit that is unmatched by any other in its class.

Specifications and features: Finished to pass U.S. Navy 500 hour salt spray test! "Silent-Aire" squelch with exclusive noise suppression. Double conversion superheterodyne single crystal receiver—accepted as the finest. Transistorized power supply. 5 watts input — 3 watts output. 6 and 12 VDC — 115 VAC. Only 5 1/4" x 9 1/4" x 8 1/4".

VOCALINE
COMPANY OF AMERICA
122 Coultter Street
Old Saybrook, Conn.



Send complete literature to:

Name _____
Address _____
City _____ Zone _____ State _____

LEARN ELECTRONICS EASIER, FASTER THAN YOU EVER IMAGINED ... AT LOW COST!

BASIC AREAS OF ELECTRONICS

BASIC ELECTRICITY ('Pictured-Text' Course), Van Valkenburgh, Nooger & Neville, 5 vols., soft covers, \$10.00 cloth, \$11.50
BASIC ELECTRONICS ('Pictured-Text' Course), Van Valkenburgh, Nooger & Neville, 5 vols., \$10.00 cloth, \$11.50
VOL. 6. BASIC ELECTRONICS ('Pictured-Text' Course), Van Valkenburgh, Nooger & Neville, soft cover, \$2.90; cloth, \$3.60
BASIC TELEVISION ('Pictured-Text' Course), Alex Schure, Ph.D., 5 vols., soft covers, \$10.00; cloth, \$11.50
BASICS OF FRACTIONAL HORSEPOWER MOTORS & REPAIR ('Pictured-Text' Course), G. Schweitzer, soft cover, \$3.90; cloth, \$4.90
HOW TO READ SCHEMATIC DIAGRAMS, D. Mark, \$3.50
BASIC VACUUM TUBES & THEIR USES, J. F. Rider & H. Jacobowitz, \$3.00; cloth, \$4.50
R-L-C COMPONENTS HANDBOOK, D. Mark, \$3.50
VIDEO TAPE RECORDING, Julian Bernstein, cloth \$8.95
MAGNETIC AMPLIFIERS — Principles & Applications, Paul Mali, \$2.45

SPACE AGE & NUCLEAR FUNDAMENTALS

BASICS OF GYROSCOPES ('Pictured-Text' Course), Carl Machover, E. E., 2 vols., soft cover, \$6.60; cloth, \$7.75
BASICS OF MISSILE GUIDANCE & SPACE TECHNIQUES ('Pictured-Text' Course), M. Hobbs, P. E., 2 vols., soft covers, \$7.80; cloth, \$9.00
FUNDAMENTALS OF RADIO TELEMETRY, M. Tepper, \$2.95
FUNDAMENTALS OF NUCLEAR ENERGY & POWER REACTORS, H. Jacobowitz, \$2.95
INTRODUCTION TO ATOMIC ENERGY, Wm. G. Atkinson, \$1.35

INDUSTRIAL ELECTRONICS

BASICS OF INDUCTION HEATING ('Pictured-Text' Course), C. Tudbury, M.S., 2 vols. soft covers, \$7.80; cloth, \$8.90
BASIC CARRIER TELEPHONY ('Pictured-Text' Course), D. Talley, E.E., soft cover, \$4.25; cloth, \$5.75
BASIC ULTRASONICS ('Pictured-Text' Course), C. Glickstein, soft covers, \$3.50; cloth \$4.60

COMPUTERS

BASICS OF DIGITAL COMPUTERS ('Pictured-Text' Course), John S. Murray, 3 vols. soft cover, \$8.40; cloth, \$9.50
DESIGN OF TRANSISTORIZED CIRCUITS FOR DIGITAL COMPUTERS, A. I. Pressman, cloth, \$9.95

TRANSISTORS

FUNDAMENTALS OF TRANSISTORS (2nd ed.), Leonard M. Krugman, P.E., \$3.50
PRINCIPLES OF TRANSISTOR CIRCUITS, S. W. Amos, B.Sc., \$3.90
FUNDAMENTALS OF TRANSISTOR PHYSICS, I. Gottlieb, P. E., \$3.90

These and many other Rider titles are available at bookstores, electronic parts distributors, dept. stores or direct. Send for new catalog. EW-10

Buy these books today—No matter where you buy these books, we guarantee satisfaction, or your money back within 30 days of purchase.



JOHN F. RIDER PUBLISHER, INC. 116 West 14th Street, New York 11, N. Y.

Canada: Chas. W. Pointon, Ltd., 66 Racine Rd., Rexdale, Ont.

Europe & British Isles: Chapman & Hall Ltd., 37 Essex St., London India: Asia Publishing House, Bombay and other cities

GET INTO ELECTRONICS

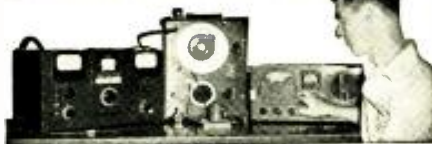

V.T.I. training leads to success as technicians, field engineers, specialists in communications, guided missiles, computers, radar and automation. Basic and advanced courses in theory and laboratory. Associate degree in electronics in 29 months. B.S. in electronic engineering obtainable. ECPD accredited. G.I. approved. Graduates in all branches of electronics with major companies. Start February, September, Durms, campus. High school graduate or equivalent. Catalog.

VALPARAISO TECHNICAL INSTITUTE
Dept. RD Valparaiso, Indiana

TAPE RECORDERS



HI-FI COMPONENTS SLEEP LEARN KITS

MERITAPE UNUSUAL VALUES
Low cost, high quality recording tape, in boxes FREE 1961 Catalog or cans. DRESSNER, 69-02 RA, 174 St., Flushing 65, N.Y.



BARGAIN HUNTING? TV SERVICEMEN!
Write for SENSATIONAL CATALOG
HENSHAW RADIO SUPPLY
3619 TROOST KANSAS CITY, MO.

Electronic Metronome (Continued from page 39)

transformers and transistor. C_2 should be varied from about 100 to 150 μf . until the optimum value is found. The brilliance of the lamp does not affect operation of the metronome and need not be adjusted unless maximum light output is desired. Several transistors were tried in the circuit with no change in C_2 being required.

Battery drain is low and varies from about 200 μa . to 1 ma. at the higher rates. Battery life is in excess of several hundred hours.

Before beginning calibration, check the range of ticks to make sure it exceeds 40 to 208 counts per minute. If this range is not covered, a slight variation in R_1 will change the upper limit as described earlier. However, during the design of the circuit, it was noted that some capacitors used for C_1 showed a leakage resistance which prevented the metronome from approaching the 40-beat lower limit. If you experience this difficulty, try different capacitors of the same value.

The extremely wide range covered by the rate potentiometer, R_2 , is reduced by shunting the control with a 1-megohm resistance, R_3 . Depending on the condition of capacitor C_1 and the actual value of R_2 , some variation in R_3 may be necessary to cover the slower rate adequately. Once you determine this resistance, the metronome is ready to calibrate.

Calibration

Calibrate the metronome by counting the number of ticks over a given period of time. For the slower rates, better accuracy can be obtained if the ticks are counted for several minutes. One easy method of calibration consists of temporarily mounting a card on the metronome and marking off the beats-per-minute for various settings of the control. Calibrations can be transferred to a disc which is then glued to the bottom side of the control knob, as shown in the photo.

View showing how chassis plate is mounted within the speaker case.



**Courses in Radio and
Electronic Fundamentals –
TV Servicing – Color TV –
Electronics for
Automation –
Transistors**



SEND FOR THIS **FREE**
64 PAGE BOOK TODAY!

Check Home Study!

RCA Institutes Home Study School offers a complete program of integrated courses for beginners and advanced students . . . all designed to prepare you for a rewarding career in the rapidly expanding world of electronics. Practical work with your very first lesson. And you get top recognition as an RCA Institutes graduate!

CANADIANS — take advantage of these same RCA courses at no additional cost. No postage, no customs, no delay. Send coupon to:
RCA Victor Company, Ltd., 5581
Royalmount Ave., Montreal 9, Que.

SEE OTHER SIDE

CUT OUT AND MAIL THIS POSTAGE-FREE CARD TODAY!

RCA INSTITUTES, INC., DEPT. EW-XO

350 W. Fourth St. • New York 14, N. Y.

Please rush me your FREE illustrated 64-page book describing your electronic training programs. No obligation. No salesman will call.

Home Study Book

Resident School Book

Name _____ Age _____

Address _____

City _____ Zone _____ State _____

Korean Vets: Enter Discharge Date _____



START YOUR CAREER IN ELECTRONICS NOW AT RCA INSTITUTES in Los Angeles-New York City

CHOOSE FROM THIS LIST...

RCA TRAINING CAN BE THE SMARTEST INVEST- MENT YOU EVER MAKE

With RCA Institutes Home Study training you set your own pace in keeping with your own ability, finances and time. You get prime quality equipment as a regular part of the course . . . and you never have to take apart one piece to build another. Perhaps most important, RCA's liberal Pay-As-You-Learn Plan is the most economical home study method *because you pay only for lessons as you order them . . . one study group at a time!* If you drop out at *any* time, for *any* reason, you do not owe RCA one penny! No other obligations! No monthly installment payments! Licensed by New York State Education Department.

	Course	Qualifications	Length of Course
A	Advanced Electronic Technology (T-3)	High School grad, with Algebra, Physics or Science	Day 2¼ yrs. Eve. 6¼ yrs.
B	TV and General Electronics (V-7)	2 yrs. High School, with Algebra, Physics or Science	Day 1½ yrs. Eve. 4½ yrs.
C	Radio & TV Servicing (V-3)	2 yrs. High School	Day 9 mos. Eve. 2¼ yrs.
D	Transistors*	V-3 or equivalent	Eve. 3 mos.
E	Electronic Drafting (V-9)*	2 yrs. High School, with Algebra, Physics or Science	Eve. 3 yrs.
F	Color TV	V-3 or equivalent	Day 3 mos. Eve. 3 mos.
G	Audio-Hi Fidelity*	V-3 or equivalent	Eve. 3 mos.
H	Video Tape*	V-3 or equivalent	Eve. 3 mos.
I	Technical Writing (V-10)	V-3 or equivalent	Eve. 3-18 mos.
J	Radio Telegraph Operating (V-5)*	2 yrs. High School, with Algebra, Physics or Science	Day 9 mos. Eve. 2¼ yrs.
K	Radio Code (V-4)*	8th Grade	Eve. as desired
L	Preparatory Math & Physics (P-0)	1 yr. High School	Day 3 mos.
M	Preparatory Mathematics (P-0A)	1 yr. High School	Eve. 3 mos.

*Courses to be added to Los Angeles Curriculum

SEE OTHER SIDE

First Class

Permit No. 10662
New York, N. Y.

BUSINESS REPLY CARD

No Postage Stamp Necessary if Mailed in U. S.

Postage will be paid by—

RCA INSTITUTES, INC., DEPT. EW-XO

350 West Fourth Street

New York 14, N. Y.

RCA Institutes is one of the largest technical institutes in the United States devoted exclusively to electronics. Co-educational Day and Evening classes. Free Placement Service. Applications now being accepted.

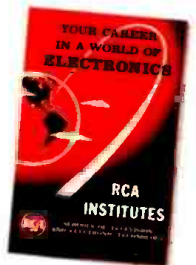

SEND FOR THIS FREE ILLUSTRATED BOOK TODAY. Fill in the other side of the postage-free card and check Resident School.

RCA INSTITUTES, INC. A Service of Radio Corporation of America • 350 W. 4th St., New York 14, N.Y. • 610 S. Main St., Los Angeles 14, Calif.



The Most Trusted Name
in Electronics

"Reverse" GDO

By JOHN POTTER SHIELDS

HERE'S a little trick that has proved handy for calibrating various receivers, r.f. oscillators, etc. All that is required is a fairly accurate signal generator and a v.t.v.m. or high-impedance v.o.m. The calibration accuracy is limited only by the accuracy of the signal generator or other calibrating source, and the procedure is simplicity itself.

Fig. 1. shows the basic idea. A coil, consisting of a few turns of hookup wire, is connected to the output of the signal generator and placed over the oscillator coil of the oscillator to be calibrated. The v.t.v.m. or high-impedance v.o.m. is used to measure the oscillator's grid voltage by connecting it across the oscillator's grid resistor.

In operation, power is applied only to the oscillator and its grid voltage is noted. Next, the signal generator is turned on and adjusted for maximum output. Slowly vary the signal generator's output frequency over the expected range of the oscillator under calibration. At some point, the oscillator's grid voltage will "jump," indicating resonance with the signal generator's output frequency. The signal generator should now be carefully adjusted for maximum oscillator grid voltage; at which point, the oscillator's operating frequency can be read on the signal generator's dial. It's that simple.

The whole idea is based on the fact that the coil placed over the oscillator coil absorbs energy from the oscillating circuit; lowering its grid voltage when its frequency is not the same as that of the signal generator. When the signal generator and oscillator are operating at the same frequency, the coil no longer absorbs energy from the oscillating circuit and the oscillator's grid voltage rises.

As in the case of a standard grid-dip oscillator setup, the coupling between the oscillator coil and pickup coil should be as loose as possible in order to obtain the sharpest reading. Also, any source of r.f. of a known frequency can be used in place of the signal generator with equally good results.

Well, that's the story on the "reverse" grid-dip oscillator. The author recommends it as a simple, inexpensive, and accurate means of r.f. calibration.

—50—

Fig. 1. Handy calibrator for receivers.

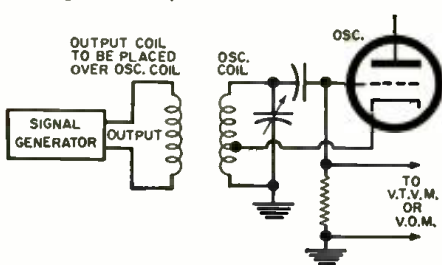

Build This Superb *Schober* Organ From Simple Kits and SAVE OVER 50%!

The Beautiful *Schober* CONSOLETTA

— the only small organ with two full 61-note keyboards and 22 stops. Requires only 2' x 3 1/2' floor space! Commercial value approximately \$1600 or more — yet you save over 50% when you build this thrilling instrument!

LET US SEND YOU FREE DETAILS HOW TO ASSEMBLE A *Schober* ELECTRONIC ORGAN IN SPARE TIME!

Give Your Family A Lifetime of Musical Joy With A Magnificent Schober ELECTRONIC Organ!

Now you can build the brilliant, full-range Schober CONSOLETTA or the larger CONCERT MODEL with simple hand tools. No skills are necessary to construct an instrument with one of the finest reputations among electronic organs. No woodworking necessary — consoles come completely assembled and finished. All you do is assemble clearly marked electronic parts guided by clear illustrations and detailed step-by-step instructions. Even teen-agers can assemble the Schober! You build from kits, as fast or as slowly as you please... at home, in spare time — with a small table serving as your entire work shop!

Send For Complete Details On Schober Organs and For Hi-Fi Demonstration Record

The coupon will bring you a handsome 16-page booklet in full color describing Schober organs in detail, plus articles on how easy and rewarding it is to build your own organ and how pleasant and quick it is to learn to play the organ. In addition, we have prepared an exciting 10" hi-fi LP record demonstrating the full range of tones and voices available on the Schober, which you may have for only \$2.00 (refunded when you order a kit). Literature on the Schober is FREE! There is no obligation; no salesman will call.

THE GREAT CONCERT MODEL meets specifications of American Guild of Organists

Pay As You Build Your Organ; Start With As Little As \$18.94!

You may start building your Schober at once with an investment of as little as \$18.94. The musical instrument you assemble is as fine, and technically perfect, as a commercial organ built in a factory — yet you save over 50% on top-quality electronic parts, on high-priced labor, on usual retail store markup! In your own home, with your own hands you build an organ with genuine pipe organ tones in an infinite variety of tone colors to bring into your home the full grandeur of the Emperor of Instruments. You may build the CONSOLETTA for your home, or you may want to build the great CONCERT MODEL for home, church, school or theatre. You save 50% and more in either case.



Mail This Coupon For FREE Literature and Hi-Fi Record Today!

The Schober Organ Corp., Dept. RN-8
43 West 61st St., New York 23, N. Y.

- Please send me FREE full-color booklet and other literature on the Schober organs.
- Please send me the 10" hi-fi Schober demonstration record. I enclose \$2.00 (refundable on receipt of my first kit order).

Name.....
Address.....
City..... Zone... State.....

Build This Capacitance Relay

By
RUFUS P. TURNER

Construction details and operating theory for a simple two-tube capacity operated relay circuit. Standard components are employed throughout.

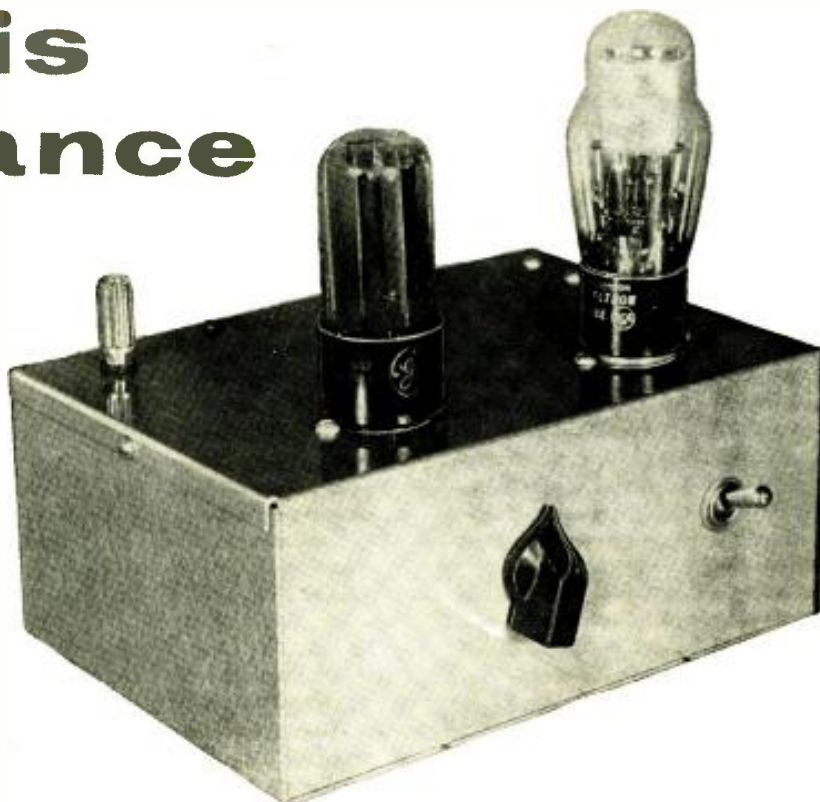

Front view of the capacitance-operated relay. Unit is built on a 7" x 5" x 3" chassis. The 117N7 tube is on the left, the 2050 is on the right. The antenna terminal is at the left rear corner atop the chassis. The knob is for pot R_2 .

A CAPACITANCE-OPERATED relay is both useful and entertaining. It can be used to turn electrical devices on and off and it has the interesting ability to go into action whenever the human body, hand, or some metallic object comes near its antenna. It makes a reliable intrusion alarm when its antenna wire is concealed around a door frame or window frame or hidden under a rug. It is an interesting crowd-stopper when used to activate exhibits in a store window when the window is touched by passers-by!

The basis of the capacitance-operated relay circuit is a simple r. f. oscillator connected to a short wire or metal plate as an antenna. Oscillator tube current is made to actuate a relay, either directly or through a second tube. The circuit is so adjusted that the current normally is insufficient to operate the relay. But the presence of a hand or body near the antenna will introduce enough extra capacitance to detune the oscillator, change the current, and operate the relay.

Rugged Circuit

The oscillator in the capacitance-operated relay shown here is built around an inexpensive, commercial capacity relay coil—Miller No. 695. This manufactured coil unit is complete and well-built and will save the experimenter a great deal of time and bother in making his own. The coil unit includes in one assembly the oscillator coil L_1 (see Fig. 1), radio-frequency choke RFC_1 , and screwdriver-adjusted trimmer capacitor C_3 . Five terminal lugs (numbered in Fig. 1) permit sim-

ple connections to other components in the oscillator circuit.

Fig. 1 shows the complete circuit which has been adapted from the hookup recommended by the coil manufacturer. The oscillator includes a 117N7-GT tube. The pentode section of this tube is the oscillator, and the rectifier section furnishes d.c. to the pentode.

The relay is a 110-volt a.c. unit. The Leach Type 1157 relay shown here was available surplus, however, any other available 110- or 115-volt a.c. relay will work in the circuit. The Leach unit has two pairs of contacts which can be connected in parallel to control heavy loads. The relay is actuated by a 2050 gaseous tube. The control grid of this tube is actuated by oscillator grid current changes in resistor R_5 . The 2050 filament is operated from the 6.3-volt output winding of filament transformer T_1 .

The capacitance-operated relay circuit has two controls which do not often need re-adjustment in permanent installations; they are potentiometer R_2 and trimmer capacitor C_3 . The latter is part of the coil assembly. The potentiometer is adjusted by means of a front-panel knob (see photo), while C_3 is adjusted with a long screwdriver blade inserted through a hole in the rear of the chassis.

The antenna may be 3 feet or more of insulated wire connected to the "Ant." terminal. The free end of this wire may be connected to a metal plate (2 inches square, or larger) when increased "pickup" is desired. The device to be controlled and its power source

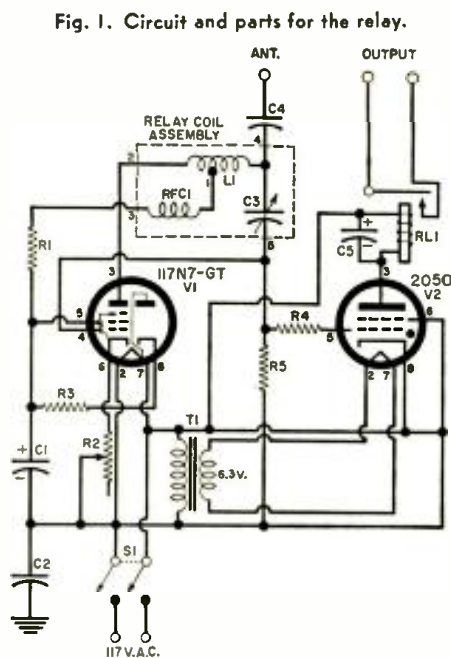

- R_1 —3300 ohm, 1 w. carbon res.
- R_2 —1000 ohm wirewound pot.
- R_3 —150 ohm, $\frac{1}{2}$ w. carbon res.
- R_4 —2.2 megohm, $\frac{1}{2}$ w. carbon res.
- R_5 —680,000 ohm, $\frac{1}{2}$ w. carbon res.
- C_1 —30 μ f., 150 v. elec. capacitor
- C_2 —1 μ f., 600 v. capacitor
- C_3 —Mica trimmer (part of L_1)
- C_4 —8 μ f., 150 v. elec. capacitor
- L_1 —Oscillator coil (Miller No. 695 capacity relay coil, see text)
- RFC_1 —R.F. choke (Part of L_1)
- RL_1 —110 or 115 volt a.c. relay (Leach Type 1157 or equiv.)
- S_1 —D.p.s.t. toggle switch
- T_1 —Fil. trans. 6.3 v. @ 1 amp. (Merit P-2944 or equiv.)
- V_1 —117N7-GT tube
- V_2 —2050 tube

are connected to the "Output" terminals.

Construction

The circuit is not critical and the reader can suit himself pretty much regarding the layout of parts. However, the arrangement shown in the photographs seems the most compact obtainable with the parts used. A 7" x 5" x 3" enamelled aluminum chassis box was used for the assembly shown in the photographs.

Each of the tubes requires an 8-contact octal socket, and these are mounted in 1 1/4" holes cut with a socket punch or fly-cutter.

The oscillator coil, potentiometer R_2 , and switch S_1 are mounted along the front lip of the chassis. The potentiometer requires a 3/8" hole, and the switch a 1/2" hole. The coil has two mounting feet which are held with 6-32 screws. Transformer T_1 and relay RL_1 are "slung" under the top of the box. The "Ant." and "Output" binding posts are mounted with insulating washers to prevent their making contact with the metal box, and the "Output" posts are placed close to the relay. The "Ant." post is mounted through the top of the box, and the "Output" posts on the rear lip.

Be careful to observe the correct polarity of the electrolytic capacitors (C_1 and C_2), as shown in Fig. 1.

The screwdriver clearance hole on the rear lip of the box should be at least 3/8" in diameter and should be directly in line with the coil (mounted on the front lip). The hole for the power cord (center of rear lip) should be lined with a rubber grommet to prevent cutting of the cord.

Operation

After checking to be sure the wiring is correct, connect about 3 feet of insulated hookup wire to the "Ant." terminal, set potentiometer R_2 to its

maximum-resistance setting, insert the power plug into a 117-volt a.c. outlet and throw switch S_1 "on."

Now allow about 3 minutes for warm-up; then bring your hand within 1 inch of the antenna wire. If the relay does not close—you should hear it click—advance the setting of the potentiometer R_2 carefully while continuing to hold your hand near the antenna. Also adjust trimmer C_5 with a long-bladed screwdriver (preferably insulated) through the hole in the back of the chassis. A point will be found in the adjustment of C_5 and R_2 where the relay clicks-in readily when your hand is brought near the antenna wire and clicks-out when it is withdrawn.

The correct adjustment with any particular antenna is the point at which the unit is sensitive to approach at the distance you wish, but is not so unstable as to set itself into operation when no object is nearby. Make the adjustments so that the relay operates under the influence of objects at the distance you wish.

Better sensitivity and stability will be obtained with the power plug inserted into the a.c. outlet one way than the other. Experiment to find which way is best. The unit must be re-adjusted whenever changing to a different type of antenna. In general, keep the antenna as short as possible to reduce radio interference.

After adjustment, connect an electric bell and battery in series with the "Output" terminals. Bring your hand near the antenna or walk by, and the bell will signal your approach. Withdraw, and the bell will stop ringing. A lamp and power source likewise can be connected in series and to the "Output" terminals as an alarm device. So can a motor be operated.

How It Works

The oscillator frequency is approximately 2 megacycles. In the simple,

self-excited circuit, there is no tank capacitor other than the distributed capacitance of the coil plus stray and tube input capacitances. This, of course, makes it easy for external capacitances to affect the circuit. Despite the low- C tank, the frequency stability is good enough for this application.

The trimmer capacitor, C_5 , which is part of the manufactured coil assembly, controls r. f. excitation to the oscillator tube grid, maximum feedback and excitation voltage occurring when this capacitor is set for maximum capacitance (screwed tightly). Rheostat R_2 being the cathode resistor of the oscillator tube, sets the static d.c. grid-bias level. At maximum resistance of R_2 , negative bias is highest, and C_5 must be set for high capacitance in order to obtain enough r.f. grid voltage for oscillation. The circuit appears to have least capacitance-sensitivity in this condition. Capacitor C_1 is an isolating unit which prevents plate voltage from reaching the antenna and thus protects against shock and particularly short-circuit.

When the unit is placed in operation, trimmer capacitor C_5 and bias rheostat R_2 are adjusted for oscillation. (Actually, the circuit is most sensitive when adjusted just to the threshold of oscillation.) An object brought near the antenna then will add capacitance to ground, thereby reducing the excitation applied through the capacitance of C_5 . This causes oscillation to cease. You might say that the nearby object robs the grid of the excitation necessary for oscillation.

Oscillator grid current is high during oscillation and low in the absence of oscillation. Grid current flows through resistor R_2 , producing a comparatively high voltage drop across this resistor during oscillation and a low voltage drop when there is no oscillation.

Since the top of R_2 is connected

(Continued on page 148)

Inside view of the capacitance-operated relay showing location of parts. Tuned circuit used is a pre-assembled, available unit. ▶

Rear view of the relay. The two output terminals are at left. Hole at right is for insertion of screwdriver to adjust C_5 . ▼

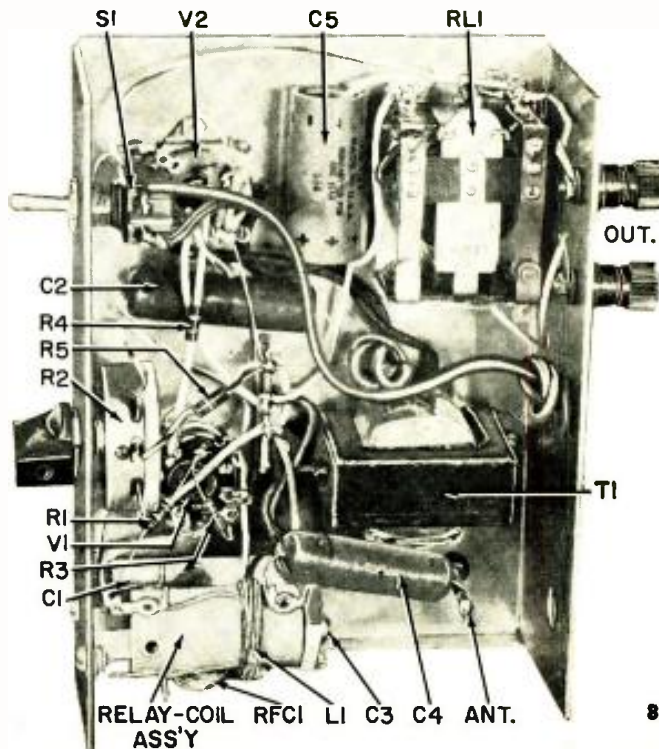
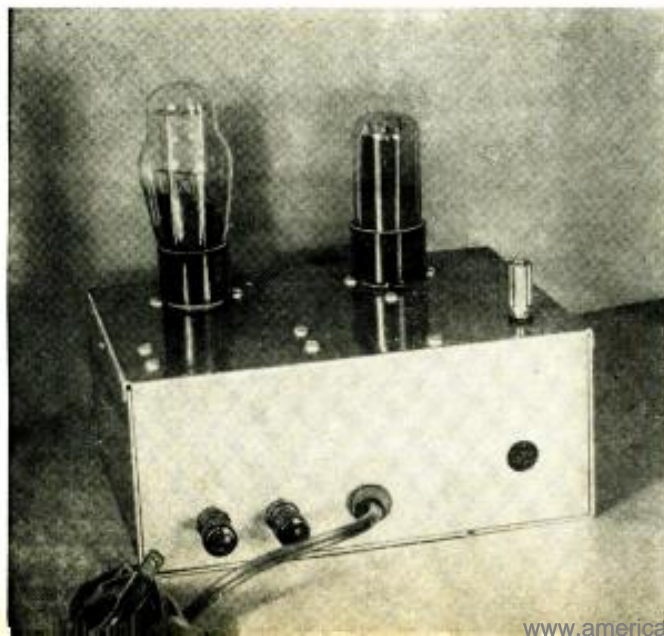

**PROTECT COSTLY
HIGH FIDELITY
EQUIPMENT!**

**Mullard
GZ34/5AR4**



The Mullard GZ34 is a low impedance, indirectly heated, full-wave rectifier. Compactness and unique characteristics make the GZ34 an excellent replacement for high power rectifiers such as the 5U4G, 5U4GA, 5V4G, etc. in most amplifiers.

CHECK THESE ADVANTAGES

- Better voltage regulation due to lowered power supply impedance.
- Higher output voltage and cooler operation with lower voltage drop.
- Protection of costly filter condensers and power output tubes due to delayed warm-up and reduced ripple.



OTHER Mullard TUBES
designed specifically for High Fidelity:

EB91/6AL5	Double Diode
ECC81/12AU7	Low-noise medium μ dual triode
ECC82/12AU7	Low-noise low μ dual triode
ECC83/12AX7	Low-noise high μ dual triode
ECC85/6AQ8	RF Double triode
ECC88/6AQ8	Frame grid RF Double triode
ECF82/6U8	RF triode pentode
ECL82/6BM8	Triode with Output Pentode
EF86/6Z67	Low-noise input-pentode
EF94/6AU6	RF AF pentode
EL34/6CA7	High-power pentode, 100 W PP
EL37	High-power pentode, 69 W PP
EL84/6BQ5	Miniature output pentode 20 W PP
EM84/6FG6	Miniature tuning indicator
EZ80/6V4	Miniature rectifier cathode type, 90 ma.
EZ81/6CA4	Miniature rectifier cathode type, 150 ma.
7025	AF Double Triode
7189	Miniature output pentode 20W PP

Available at all leading distributors.



NOW AVAILABLE: "Mullard Circuits for Audio Amplifiers"—136 pages of Stereophonic and Monophonic Audio Amplifiers, AM Tuners, Preamplifiers—only \$2.50 from your dealer or by mail.

For detailed technical data and application information write:

**INTERNATIONAL
ELECTRONICS CORP.**
81 Spring Street, New York 12, N. Y.

By
BERT WHYTE



**CERTIFIED
RECORD REVUE**

AS I write this column, Labor Day is still in the offing and the record industry is still in the throes of its mid-summer slump. Sales are far lower than those of past summers and I think that continuing public confusion regarding stereo is one of the prime factors contributing to this situation. Perhaps the story I am about to relate will offer a little insight into this very serious problem confronting the record industry.

I have been traveling a great deal in the past few months, so a few weeks ago when I was home to roost for a while, I threw a little party for some friends I hadn't seen in some time. There were eight people besides my wife and myself, all of widely varying backgrounds. Only one was connected with the electronics field—and his connection with audio was no more than casual.

The others were in the construction game, in-urance, and stock brokerage. Only one was a real "music lover," the rest professing to "enjoy music," especially, as they said, "when we hear your system." In other words, they could be properly classified as the "lay public" in terms of their knowledge of music and audio.

Now keep in mind that I had not seen these people in some time and their exposure to stereo had followed the normal pattern. They had read the propaganda barrages touting stereo as being "all things to all men," that music had "broken through the sound barrier," and that "concert hall sound was now a reality," etc., etc. They had visited the establishments selling this new miracle—the department and appliance stores. All of them felt that they had been grossly over-sold since the demonstrations they had heard didn't live up to the glowing claims of the advertisements.

All of them, having visited my home in past years, felt that my "hi-fi" sounded much better than this newfangled stereo thing. And all of them confessed that they were given such incredible gobbledegook as an explanation and sales talk that, coupled with the sound they heard, they were just plain confused about the whole thing.

Having thus elicited this information from my friends *via* the relaxation of some tall, cool glasses with interesting contents, . . . I proceeded to play some stereo discs for them. I ranged from jazz and other "pop" fare to some of the more familiar classics. In doing so I came up with some very interesting comments and perhaps a few clues as to why John Q. Public reacts as he does to the "commercial demonstration."

I hardly need tell you that my friends "flipped" when they heard my stereo system. Their enthusiasm was boundless and, at the same time, was alloyed with indignation at what had been represented to them as stereo. I hastened to point out that, in all fairness, they must remember that in hearing my stereo

they were listening to an "all-out," very expensive *component* system, very precisely positioned for maximum stereo effect, in a room that had been given special acoustic treatment for still further enhancement.

Sobered somewhat by this, I then pointed out to them that a selection of very modest *components*, set up with reasonable regard for the rules governing good stereo reproduction, could be quite satisfactory and would enable them to enjoy the musical treasures in the ever-growing stereo catalogue. At this point, as you might expect, one of the women present said, "I can see your point, Bert, but what about the problems of decor . . . you know our home is furnished in period style and I don't think I could fit components into our setup. Why can't we get the same sort of stereo sound from the consoles you see advertised? There is a lovely Queen Anne unit in X's window that would just fit perfectly in my living room."

Somewhat wearily and I confess a bit peevishly, I said to her, "You will have to make up your mind which is more important to you . . . good sound or decor." And she threw the ball right back to me and surprised me a little by proclaiming that *both* were important to her and wasn't there any way in which her desires could be fulfilled?

So there is clue No. 1. The "woman of the house," always a formidable factor in purchases which involve decor, is not wholly intractable and is pliable to the extent that *once having heard what good stereo is really like*, wants to have it in her home but wants it housed in something that will be in reasonable harmony with her furnishings.

For our lady friend and the others assembled I went into the anatomy of a stereo sound system and pointed out that no matter where or in what the other components of a stereo sound system were housed, it was desirable, in fact almost mandatory, that the speakers be housed each in its own separate enclosure. I showed the lady some pictures of currently available speaker enclosures or systems of the smallish "bookcase" size and she came out with the not-unexpected comment that they were not far removed in looks from packing cases and that while their simple lines might fit into modern decor, they certainly would be out of the question in her period living room.

Pressed a bit further, she admitted that she would make the concession of using two separate speaker systems in order to obtain good stereo but was adamant on the point that it surely must be possible to get these speaker enclosures in some reasonable approximation of the style she desired. Are you listening manufacturers?

Now to the startling part of this evening! As I played various types of music I gave everybody a chance to sit in "the best seat in the house." I think my system has as good

"off-axis" stereo perception as any I have heard, but I freely admit that until we have three-channel stereo and its enhancement of off-axis effects, the choice listening in stereo is at an optimum position between the speakers. Thus seated, my guests made some observations which should lift a few eyebrows. When "big band" type of "pop" ballad material was being played, they commented on the clarity of the instrumentation and, as with most newcomers to stereo, got quite a kick out of the directional changes in the orchestra, especially in the more "ping-pong" type of recording.

They commented that in the "appliance-store" demonstrations they had heard, directionality was talked about, but they failed to perceive it altogether or only on a very marginal basis. I played various classical pieces for my friends and was quite surprised when the consensus (by now they were all stereo experts) was that something must have gone wrong with my system and that it wasn't balanced! Needless to say, I very quickly checked and, as I suspected, nothing was wrong with the balance but my friends were manifesting a condition which never fails to astonish me.

Now, these people were all fairly well-to-do, certainly above average in intelligence and, while not all avid concert-goers, had nonetheless been to more than a few concerts. Thus you would think they had some familiarity with the way a symphony orchestra is set up and the way it sounds. Despite this, my friends were complaining that the sound was erratic . . . it was too much on either the left or the right and the two speakers were not playing together *as they were supposed to do!*

They all pointed out that in the store demonstrations, the two speakers were always working together. This is the fallacy and lack of understanding that is confusing more people and losing more stereo sales than anything else! Very patiently I played certain classical recordings for them and showed them that far from being out of balance, the system was operating at maximum efficiency and that what they were hearing was the true essence of stereo. I explained that according to the way the orchestra is disposed for stereo recording, the manner in which the engineers handle their microphones and, above all, the way in which the music is scored, will vary the effect and amount of directionality and depth in a recording. Thus I played a passage for them in which the scoring called for trumpets and trombones alone . . . explained that these instruments were positioned to the right and hence in a good system in the proper room the sound would appear to come mainly from the right speaker, although if they went right up to the left speaker they would hear the same instruments at a much lower level.

I explained this was an example of directional effects due to sound intensity differences. I then played a passage from another recording in which the first and second violins were positioned to the left and in which the score called for them alone; thus, again, apparently only the left speaker was responding. I then played a work in which a solo flute appears to come right between the two speakers and went on to describe the operation of a ghost channel in an original three-channel recording.

To prove home the point, I played full ensemble passages in which both speakers responded equally, then played M/S (mid-side) type European recordings for them. (Refer to "Stereo Microphone Techniques" by Herman Burstein in our March 1960 issue—Ed.) Having now become indoctrinated to the American style of stereo, the M/S seemed flat to them. I also pointed out and played for them various recordings on different labels, showing that some companies carried out directional effects to unrealistic extremes, some went too

2 for the money

circuit by
Pilot

tubes by
Amperex*

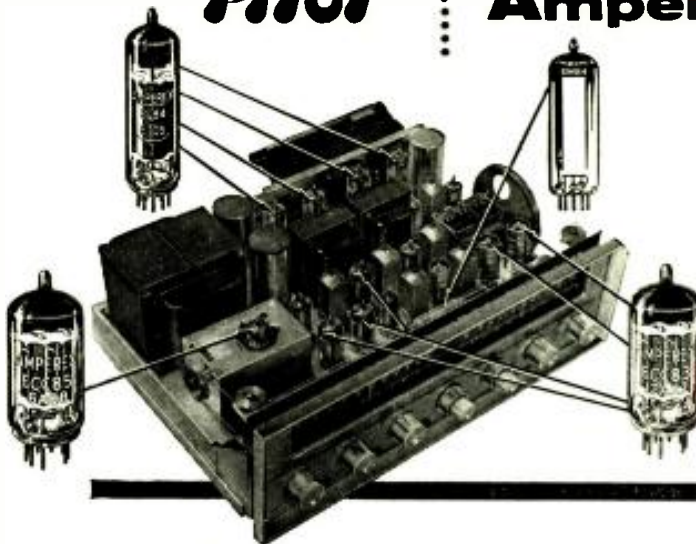

For the discriminating audio enthusiast who has been searching for high quality at a moderate cost, the new PILOT "602" Stereo FM/AM Tuner-Preamp-Amplifier is a most logical choice. Here is extreme FM sensitivity—assured by the Amperex 6AQ8/ECC85 dual-triode. To reduce hum and noise to complete inaudibility (and to prevent microphonics)—5-12AX7/ECC83's. For precise and effortless tuning—the 6F66/EM84. For distortion-free power—4-6BQ5/EL84's. For absolute dependability—Amperex throughout!

These and many other Amperex 'preferred' tube types have proven their reliability and unique design advantages in the world's finest audio components.

Applications engineering assistance and detailed data are always available to equipment manufacturers. Write: Amperex Electronic Corp., Special Purpose Tube Division, 230 Duffy Ave., Hicksville, Long Island, New York.



about hi-fi tubes
for hi-fi circuitry

AMPEREX TUBES FOR QUALITY HIGH-FIDELITY AUDIO APPLICATIONS

POWER AMPLIFIERS

6CA7/EL34: 60 w. distributed load
7189: 20 w., push-pull
6BQ5/EL84: 17 w., push-pull
6CW5/EL86: 25 w., high current, low voltage
6BM8/ECL82: Triode-pentode, 8 w., push-pull

VOLTAGE AMPLIFIERS

6Z67/EF86: Pentode for pre-amps
12AT7/ECC81: Twin triodes, low
12AU7/ECC82: hum, noise and
12AX7/ECC83: microphonics
6BL8/ECF80: High gain, triode-pentode, low hum, noise and microphonics

RF AMPLIFIERS

6ES8: Frame grid twin triode
6ER5: Frame grid shielded triode
6EN7/EF183: Frame grid pentode for IF, remote cut-off
6EJ7/EF184: Frame grid pentode for IF, sharp cut-off
6AQ8/ECC85: Dual triode for FM tuners
6DC8/EBF89: Duo-diode pentode

RECTIFIERS

6V4/EZ80: Indirectly heated, 90 mA
6CA4/EZ81: Indirectly heated, 150 mA
5AR4/GZ34: Indirectly heated, 250 mA

INDICATORS

6FG6/EM84: Bar pattern
1M3/DM70: Subminiature "exclamation" pattern

SEMICONDUCTORS

2N1517: RF transistor, 70 mc
2N1516: RF transistor, 70 mc
2N1515: RF transistor, 70 mc
1N542: Matched pair discriminator diodes
1N87A: AM detector diode, subminiature

LEADER TEST INSTRUMENTS

Lag-55 Audio Generator Sine Square

A multi-purpose generator for measurements on audio equipment—amplifiers, speakers, networks. Three waveforms: sine, square and complex for all types of measurements including response, distortion, transient and FM distortion phases. Full range is from 20 to 200,000 cps, output 5 volts with minimum amplitude variation throughout whole range.

new "LEADER" test instrument



OHMATSU ELECTRIC CO. LTD.

2596, 5-Chome, Kamimeguro, Meguro-Ku
Tokyo, Japan
Cable Address "OHMATSUELEC" TOKYO

These men are getting practical training in...

ELECTRICITY ELECTRONICS

ON REAL

Motors • Generators
Switchboards • Controls
Modern Appliances
Automatic Electronic
Control Units



TELEVISION RADIO ELECTRONICS

ON REAL

TV Receivers
Black & White and Color
AM-FM and Auto Radios
Transistors • Printed
Circuits • Test Equipment



Train in NEW Shop-Labs of COYNE

In Chicago—Electrical and Electronic Center of the World. Prepare for a better job and a successful future in a TOP OPPORTUNITY FIELD. Train on real full size equipment at COYNE where thousands of successful men have trained for 60 years—largest, oldest, best equipped school of its kind. Professional and experienced instructors show you how, then do practical jobs yourself on more than a quarter of a million dollars worth of equipment. No previous experience or advanced education needed. Employment Service to Graduates.

Start Now—Pay Later—Liberal Finance and Payment Plans. Pay most of tuition after graduation. Part-time employment help for students. Choose from nine yearly Starting Dates.

Mail Coupon or Write to Address Below for Free Book—"Guide to Careers." Whether you prefer ELECTRICITY, TELEVISION-RADIO or COMBINED ELECTRONICS, which includes both fields, this book describes all training offered.

Information comes by mail. No obligation and NO SALESMAN WILL CALL.

B. W. Cooke, Jr., Pres. Founded 1899
COYNE ELECTRICAL SCHOOL
 Chartered as an Educational Institution Not For Profit
 1501 W. Congress Pkwy., Chicago 7, Ill., Dept. 70-6C

MAIL COUPON OR WRITE TO ADDRESS BELOW

COYNE ELECTRICAL SCHOOL
 New Coyne Building Dept. 70-6C
 1501 W. Congress Pkwy., Chicago 7, Ill.

Send BIG FREE book and details of all the training you offer. I am especially interested in,

Electricity Television Both Fields

Name.....
 Address.....
 City..... State.....

(I understand no Salesman will call)

far the other way, and how a few achieved the ideal of directivity that was definite and present, but not too obtrusive and blended with the right amount of depth and instrumental density. This was the clincher with the ladies... who now realized why separate speaker enclosures, placed the proper distance apart, was a prime necessity if they were to enjoy true stereo sound.

The message for the manufacturer and retailer is implicit. If they are going to sell stereo to Mr. Average Man, they will have to return to the concepts of separate enclosures. But, in addition, they are going to have to dress up those separate enclosures, in styles and periods as acceptable as those used in the consoles, and then spend some of that advertising dollar to impress the idea on the public. They will also have to spend some more money on the sales personnel at the retail level so that when Mr. Average Man comes in, an educated sales person can give an honest and informative demonstration that can only result in increased sales.

WAGNER
DIE MEISTERSINGER OVERTURE
FLYING DUTCHMAN OVERTURE
PRELUDE AND GOOD FRIDAY
SPELL (Parsifal)

Columbia Symphony Orchestra conducted by Bruno Walter. Columbia Mono ML5482. Price \$4.98.

These are vintage Wagnerian works done to a turn by Bruno Walter. His readings are vital and purposeful and, fortunately, not too heavy-handed. Lovely string sound here and excellent brass of great weight.

In the "Parsifal" excerpts, Dr. Walter creates a wonderfully reverent mood, but doesn't quite match the passionate fervor that distinguishes the manner of Stokowski with this work. Superb playing of the orchestra must be noted here, and a nod of the head to the exceptional monophonic balance and good acoustic employment.

DANCES BY BRAHMS AND DVORAK
 Berlin Philharmonic Orchestra conducted by Herbert von Karajan. Deutsche Grammophon Stereo 138080. Price \$5.98.

That is the way the title reads on this recording. Actually famed Maestro von Karajan has excerpted eight of the Brahms "Hungarian Dances" and five of the Dvorak "Slavonic Dances" and teams up with the Berlin Philharmonic to give us a recording which cannot be called definitive, but which is a very pleasant and personal view of these staples.

His tempi, in general, are on the fast side but this is of small moment. He elicits some wondrous playing from the Berliners and gives us a recording which can find support from those who do not wish to bother with all the Brahms and Dvorak "Dances."

This is an M/S stereo recording, miked much closer than is usual, with better directivity and more orchestral detail. A very lovely clean sound, with the strings positively luscious.

GRIEG
CONCERTO FOR PIANO AND ORCHESTRA
SCHUMANN
CONCERTO FOR PIANO AND ORCHESTRA

Leon Fleischer, pianist, with Cleveland Orchestra conducted by George Szell. Epic Mono LC3689. Price \$4.98.

A pair of summery warhorses, this is a curiously lightweight version, especially with Szell at the helm. Fleischer is an excellent technician and many of his readings have had considerable warmth. Here is the lyricism and warmth but not in the degree which lifts the record above many competing versions. As noted, the Szell accompaniment is entirely

RENT stereo tapes

• OVER 1500 DIFFERENT ALBUMS
 • POSTPAID TO AND FROM YOUR HOME

SEND FOR
 FREE BROCHURE | stereo-parti 
 811-BC CENTINELA AVE., INGLEWOOD 3, CALIF.

OUT OF SPACE?

You bet we'd be... if we were to tell you all about AUDION'S "Out of this World Hi-Fi Values"

Write for
free
Catalog

audion
 25-W Oxford Road
 Massapequa, New York

ORDER YOUR ENCLOSURE KITS FROM HOMEWOOD

Bring out the best in your speakers... save dollars in assembly and finishing costs... get the fun of "doing-it-yourself"!



ONLY
\$11.95

MODEL 6

Factory assembled, ready for finishing. Makes your 8" speaker sound like a million! Made of 1/2" hardwood ply, beautifully grained and smoothly sanded. 10" h. x 16" w. x 9" d. 9 lbs. Order two for matched stereo performance.



MODEL 1

4 1/2 cubic feet of baffle space assures you crisp, cleanest bass response from any 12" speaker system. Full-grained white birch ply, with pre-attached bracing cleats for easy assembly. Kit includes everything you need for assembly. 29" h. x 20" w. x 12 1/2" d. (5" legs). 25 lbs. \$18.95



MODEL 2

Clear-grained on four sides for bookshelf or floor use. Acoustically accurate for 12" systems, with adapter board for 8" speakers. Sturdy, 3/4" ply eliminates unwanted resonances, improves bass response. 14" h. x 21" w. x 11 3/4" d. 20 lbs.
 In Birch, \$14.50
 In Walnut, \$19.95

MODEL 13. Finishing kit; includes generous quantities of everything you need to do a professional, long-lasting finishing job, plus brush, sandpaper and easy-to-follow instructions. Specify: Mahogany, Walnut, Blonde, Oak, Fruitwood, Maple, Cherry, Ebony, Natural. \$3.88

Ten-day money-back guarantee. All items shipped freight collect. Please send check or M.O. (No C.O.D.'s)

HOMWOOD INDUSTRIES, Inc.
 26M Court Street, Brooklyn 1, N.Y.

Please send me:

Model 6 Model 1 Model 2 (Birch) (Walnut)
 Model 13 _____
 Homewood catalog _____

I enclose remittance in the amount of \$ _____

Name _____
 Address _____
 City _____ Zone _____ State _____

sympathetic, but seems oddly devoid of any large sonority. The sound is clean and open but it, too, is on the thin side and could be considerably more robust.

WIENERWALZER PAPRIKA
Philharmonia Hungarica conducted by Antal Dorati. Mercury Stereo SR90190. Price \$5.98.

Some more beergarten schmaltz, but when served up so tastily by Dorati and company, is quite a good item for dancing und quaffing. Dorati follows more of a strong balletic impulse with an excellent rhythmic sense, rather than the usual "oompah-umph" treatment.

The orchestra, formed of Hungarian refugees, is playing far better than when we first heard them and turns in a spirited performance. Dorati has chosen such items as the well-known "Merry Widow Waltz," "The Gypsy Princess Waltz," and the "Village Swallows Waltz," along with the lesser known Dohnanyi "Wedding Waltz" and "Die Schonbrunner Waltz." The stereo sound has plenty of power and superb clarity, with depth treatment very effective as it was recorded in the great Grosse Saal with its wonderful reverber characteristics.

BALLET FOR BAND
Eastman Rochester Wind Ensemble conducted by Frederick Fennell. Mercury Stereo SR90256. Price \$5.98.

Versatile Fred Fennell departs from the usual thing he has been recording for Mercury these past eight years and leaves the field of original works as Rossini's "La Boutique Fantasque," Gounod's ballet music from "Faust," and Arthur Sullivan's "Pineapple Poll." They seem a mite strange at first in their new orchestral garb, but the orchestra plays with such verve and spirit, that one soon is caught up in the swirling stereo sound and begins to enjoy this new experience.

To those to whom the Fennell recordings have always been the signal for a new onslaught of brass and percussion, this may seem a little tame . . . nonetheless this is stereo sound of equally surpassing quality as in others of this series. Good directivity and depth effects throughout.

RACHMANINOFF
CONCERTO #2 FOR PIANO AND ORCHESTRA
PRELUDES FOR PIANO (#3, #6, #2)

Philippe Entremont, pianist, with New York Philharmonic Orchestra conducted by Leonard Bernstein. Columbia Mono ML5481. Price \$4.98.

It never fails . . . one company decides that it is time for a new version of this Rachmaninoff staple and all the other companies seem to get the same idea at the same time.

This is the second Entremont record of this work in the Schwann catalogue. He did this some years ago for *Concert Hall* and the recording was subsequently sold to *Urania*. By no means can any comparison be made between this and his older recording. The artist has matured in every department and this reading is miles ahead.

In the sound department it is simply "no contest" as this far surpasses what was not a particularly good recording even in its day. Entremont's most endearing quality is his rich expressive warmth. But he fails to match several other versions in the delineation of this work's power and the tone of his piano is not as big as one could want.

Bernstein gives a knowing accompaniment, but I feel he is almost trying to urge the pianist to a little faster tempo. The sound is clean and the piano transients particularly so but, as noted, more sonority would have been welcome. I say let us wait for the other entries in this concerto sweepstakes. There are some giants yet to be heard from!

more

...so much more for everyone...for every application...in the complete line of Stanton Stereo Fluxvalves*.

Here is responsible performance...in four superb models...for all who can hear the difference. From a gentle pianissimo to a resounding crescendo—every movement of the stylus reflects a quality touch possessed only by the Stereo Fluxvalve.



STANTON Calibration Standard: Model 381—

An ultra-linear professional pickup for recording channel calibration, radio stations and record evaluation by engineers and critics. From \$48.00



Collectors Series: Model 380—A precision pickup for the discriminating record collector. From \$39.85



Pro-Standard Series: MK II—A professional pickup outstanding for quality control. From \$24.00



StereoPlayer Series: Stereo 90—A fine quality stereo magnetic pickup for the audiophile...\$16.50

LISTEN!...and you will agree Pickering has more for the best of everything in record reproduction—mono or Stereo. More Output—More Channel Separation—More in Response—More in Record Life! In short...more to enjoy...because, there's more quality for more listening pleasure. * U.S. Patent No. 2,917,590

FOR THOSE WHO CAN HEAR THE DIFFERENCE

Pickering
 PICKERING & CO., INC., PLAINVIEW, NEW YORK

LISTEN!—Ask for a Stereo FLUXVALVE demonstration at your Hi-Fi Dealer today!
 Send for Pickering Tech-Specs—a handy guide for planning a stereo high fidelity system...address Dept. F100

PURCHASING A HI-FI SYSTEM?

Send Us Your List of Components For A Package Quotation

WE WON'T BE UNDERSOLD!

All merchandise is brand new, factory fresh & guaranteed.

AIREX RADIO

CORPORATION
 64-R Cortlandt St., N. Y. 7, CO 7-2137

PARTIAL LIST OF BRANDS IN STOCK

Jim Lansing*
 Altec Lansing
 Electrovoice
 Jensen
 Hartley
 University
 Acoustic Research
 Janszen
 Wharfedale
 USL Citizen Band
 Gonseth Mallicrafter
 Texas Crystals
 Concertone • Viking
 Bell • G.E.
 Weathers
 Harman—Kardon
 Eico • Pilot
 Sherwood*
 Acrosound
 Quad Ampl-Spkrs*
 Dual Changer
 Bogen • Leak
 Dynakit • Fisher
 H. H. Scott
 Thorens*
 Pentron • Revere
 Ampex • DeWald
 Sony • Roberts
 Challenger
 Wallensak
 Garrard • Norelco
 Miracord
 Glaser-Steers
 Rek-O-Kut
 Components
 Tandberg*
 Fairchild
 Pickering • Gray
 Audio Tape
 Magnecord*
 Rockford Cabinets
 Artizan Cabinets
 *Fair Traded

Special Offer 25¢

Hear these authentic recordings of dramatic events from



"The Amazing World of Short Wave Listening"

narrated by Alex Dreier, Radio-TV "Man on the Go"

- President's voice from outer space!
- Actual capture of a desperate criminal!
- Radio amateur at Little America!
- Ships at sea . . . aircraft in action!



S-38E receiver \$59.95

3 short wave bands plus standard broadcast. Built-in speaker, head-set output.

MAIL COUPON TODAY!

 **hallicrafters**
 DEPT. 20, CHICAGO 11, ILL.

Gentlemen: Please rush by return mail my recording, "The Amazing World of Short Wave Listening." I enclose 25¢.

NAME _____
 ADDRESS _____
 CITY _____ STATE _____

YOUR NEEDLE IS RUINING YOUR VALUABLE LP RECORDS

(if it isn't a Fidelitone Pyramid Diamond)

Ordinary ball point needles rise and fall sporadically; ride bumpily in high frequency grooves, bridge crests of modulation, and chip away delicate sound impressions. Your LP records are permanently impaired.

A Fidelitone Pyramid Diamond smoothly follows the intricate contours and sudden transitions from high to low tones, and gently glides along the centerline of your microgroove records. It actually prevents groove deformation and preserves all sound impressions.

HERE'S WHY...



Recording Stylus Ordinary Needle Pyramid Diamond

Fidelitone's new Pyramid Diamond is shaped similar to the stylus that recorded the original sound. It perfectly follows every contour created by the recording stylus.



In an unmodulated, or low frequency groove, the recording stylus (A) cuts a groove (W-1) wide enough to let an ordinary ball point needle (B) track the centerline of the groove accurately, and contact all recorded sound impressions.

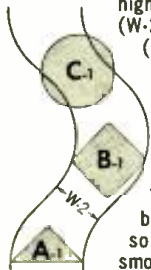

As the groove is modulated by high tones, the groove width (W-2) cut by the recording stylus (A-1) narrows. This causes the ordinary ball needle (C-1) to rise and "pinch out" of the record groove. It bridges modulation crests, mistracks centerline and distorts sound impressions. The Pyramid Diamond (B-1), because of its new shape, stays solidly in the record groove, smoothly glides along the centerline positively driven by the groove walls.



BALL POINT DIAMOND PYRAMID DIAMOND

And the new shape of the Pyramid Diamond allows more surface contact between needle and record, substantially reducing contact pressure. This greatly increases needle and record life.

See your record dealer or hi-fi specialist today. Demand the Fidelitone Pyramid Point. You owe it to your records and your listening pleasure.

For the complete story on the revolutionary new Pyramid Diamond, or the name of your nearest dealer, write Fidelitone, Chicago 26, Illinois.

Fidelitone

"Newest shape on records"

Sound on Tape

By BERT WHYTE

WHAT'S new in the tape world? That is a good question. The 4-track tapes continue to gain ground and, as might be expected, the cartridge boys are playing things real cool since RCA gave up on its entry. But no further word is forthcoming on the status of the CBS tape and if any marketing plans are afoot, it won't be this fall nor possibly next, either.

I ran across a funny analogy the other day... I was in the market for a new movie camera and, if you know anything about this field, you are aware that automation has really taken hold. There are electric-eye automatic jobs and electric zooms and drives and gosh knows what else. The fancier jobs just about think for you. Well, in my innocence I asked the salesman about magazine loading in several models. He looked at me like I must have been in the Mongolian desert for the past ten years. "Don't you know, Mac, that the magazine jobs are all passé?"

This rather surprised me, for at their introduction some years ago, this was supposed to rid the amateur movie man of the odious task of threading up his camera, and was supposed to be the gimmick that would boom movie sales to new heights. Well, it didn't and it hasn't. For some time there has been a slow retreat back to the plain old fashioned roll film, and in today's streamlined cameras, the magazine loader is dead as the dodo.

What caused the demise of such a promising gimmick? From what I was able to learn, the principal reason was that the darn thing would develop mechanical troubles... they wouldn't seal properly, or failed to engage the sprocket gears, etc. And the cost was higher than that of the plain and unglamorous roll of movie film. Add these two together plus other reasons and poof!, no more magazines.

Similarly the cartridge for tape held a promise of great things and was supposed to be a tremendous spur to business. Thus far it has led a pretty chequered career. Perhaps the CBS or some other scheme will prove workable. Only time will tell and all I can say is that movie magazine bit hit awfully and uncomfortably close to home.

The promised re-entry of RCA and Capitol has thus far failed to result in my finding any of their tapes, reel-to-reel style, in my mailbox. In the mean-

while other tapes are coming in if not in droves, in at least enough quantity to keep the pot boiling.

BEETHOVEN

PIANO CONCERTOS #3, #4

Wilhelm Backhaus, pianist, with Vienna Philharmonic Orchestra conducted by Hans Schmidt-Isserstedt. London 4-track "twin-pak" LCK80007. Price \$11.95.

This is a new idea that Ampex's UST division has come up with. It is called "twin-pak" and what it means is that whenever tape length and time permits, you get an extra-long playing tape, which contains two works instead of one. Thus here we have the Beethoven 3rd and 4th piano concertos, and there are other similar couplings such as "Le Sacre du Printemps" and "Petrouchka". You get a lot of music and you save money to boot.

Needless to say this package is for the dyed-in-the-wool Beethoven enthusiast. As noted in the review of the disc, this is Beethoven in the grand manner, with one of our pianistic giants fully in charge. He thunders his way through these works in the most supremely confident fashion, aided by the redoubtable Schmidt-Isserstedt and the Vienna Philharmonic.

The stereo is gorgeous—big, sonorous, and full blown. The piano was recorded close-up and yet its transients betray no harsh ringing and the spacious acoustics softens the contours. The sound was recorded at quite a high level and so this tape is at full comfortable listening levels, very quiet and free from hiss. All the stereo virtues are offered in profusion and, this is one of the prime 4-track stereo tapes on today's market.

BASIE

The Count Basie Orchestra. Roulette 4-track RTC502. Price \$7.95.

I have been a Basie fan from way back and therefore it pains me to give this tape a bad mark. The arrangements are clever... by that ole master Neal Hefti, but the material is rather sparse and not overly distinguished. The playing of the orchestra is good, but I have heard them better, but most of all, whatever musical worth the tape contained is drowned in a sea of distortion. The tape is noisy and full of hiss and darn near every other phrase, and especially in the higher dynamics, is atrociously overloaded. I may have gotten a badly dubbed copy, but I

rather suspect it is just a poor recording job. Too bad!

ALL AMERICAN SHOWCASE
Mantovani and his Orchestra, London 4-track LPK70001. Price \$7.95.

Well, one thing is for sure about this tape . . . you will either love it or hate it, depending on whether or not you are a Mantovani fan. I profess no mad passion for him, but don't mind if he flits quietly around my head at cocktail time.

On this tape he gives his unique treatment to the works of Rudolph Friml, Victor Herbert, Irving Berlin, and Sigmund Romberg. You name it . . . it is sure to be here . . . "Lover Come Back to Me", "The Girl That I Marry", "Kiss Me Again", "Donkey Serenade", etc., etc.

Highly artificial recording of course but expertly done, and this is what it is supposed to be . . . very much overblown and larger than life. All is very clean and the sugary string sound will delight the avid Mantovani fan. —30—

Sun	Mon	Tue	Wed	Thu	Fri	Sat
			2	3	4	5
					12	
					19	
					26	

CALENDAR of EVENTS

SEPTEMBER 26-30

Fifteenth Annual Meeting and Conference. Sponsored by Instrument Society of America. The Coliseum, New York City. Further information from ISA Headquarters, 313 Sixth Ave., Pittsburgh 22, Pa.

SEPTEMBER 27-30

Space Power Systems Conference. Sponsored by National Aeronautics and Space Administration, Air Force, AEC, Advanced Research Projects Agency with IRE and AIEE. Miramar Hotel, Santa Monica, Calif. Additional information on program from J. L. Bogdanoff or F. Kozin, Div. of Engr. Science, Purdue University, Lafayette, Ind.

OCTOBER 10-12

National Electronics Conference. Sponsored by IRE, AIEE, EIA, SMPTE. Hotel Sherman, Chicago. Details from NEC, 228 N. LaSalle St., Chicago.

OCTOBER 13-14

Symposium on Engineering Writing & Speech. Sponsored by PGEWS & Chicago Section. Bismark Hotel, Chicago. Program information from Melvin Whitmer, Admiral Corp., 3800 W. Cortland St., Chicago.

OCTOBER 11-14

1960 Convention. Sponsored by the Audio Engineering Society. Hotel New Yorker, New York City. Program details from AES, P. O. Box 12, Old Chelsea Station, New York 11, N. Y.

OCTOBER 15

HARC Convention. Sponsored by Hudson Amateur Radio Council, Inc. Statler-Hilton Hotel, New York. Tickets for event from HARC Convention, Box 971, New Rochelle, N. Y.

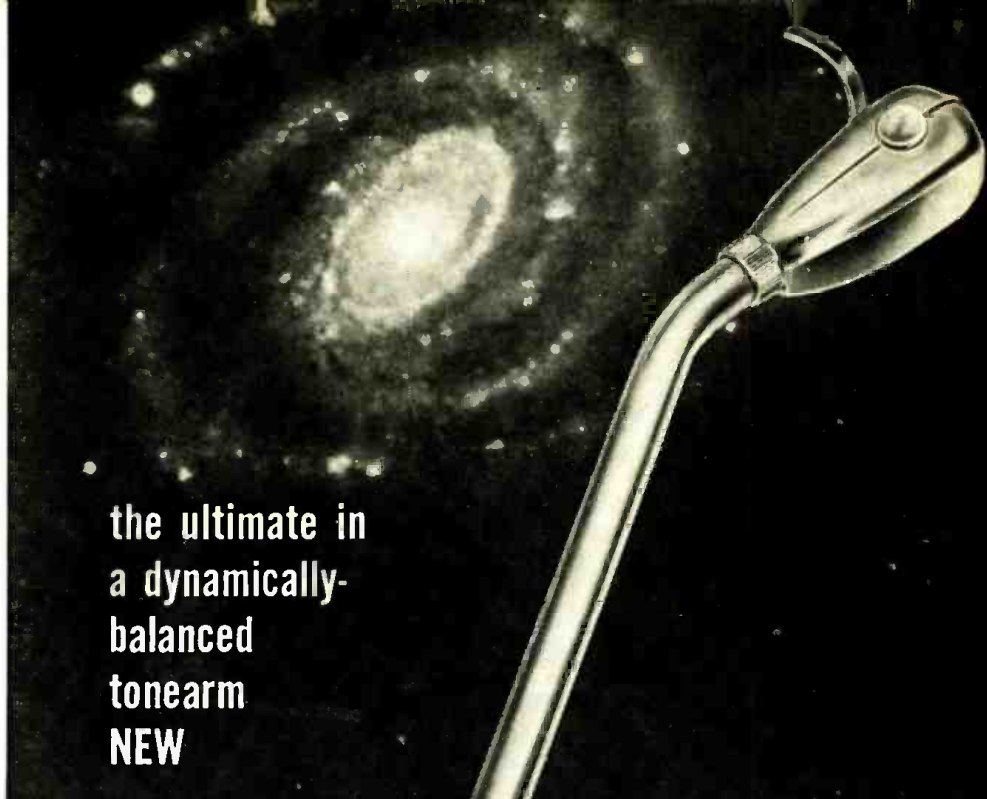

the ultimate in
a dynamically-
balanced
tonearm
NEW

REK-O-KUT
Micropoise™
STEREO TONEARM

with superb new features for higher playback quality and installation ease:

Model S-220
12" arm
\$29.95 net

PLUS THESE EXTRA FEATURES...

- Acoustically isolated counterweight.
 - Exclusive precision low friction Silicone damped horizontal bearing — eliminates horizontal oscillation.
 - Exclusive gimbal assembly incorporates individual double sets of 5 ball, 1 mm. bearings — provides freest lateral and vertical motion and assures perfect tracking.
 - Plus many other exclusive Rek-O-Kut features.
- Model S-260.....16" arm.....34.95 net
Extra Stereo Shell—
Model PS-20L..... 5.95
Still available—
Model S-120.12" arm...Now 24.95 Net
Model S-160.16" arm...Now 27.95 net

MICROPOISE DYNAMIC BALANCE CONTROL—By dialing the cushioned, spring-tension Microscope Balance Control, the arm is dynamically balanced and set for accurate stylus pressure:

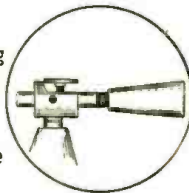

PERMANENTLY ATTACHED PLUG-IN CABLE—fully shielded single-jacket cable is anchored to the arm—includes two color-coded plug-in leads, 2 shields and a ground wire. No soldering! No hum problem! Fast, correct installation assured!

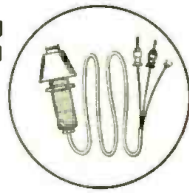

FAST SINGLE-HOLE MOUNTING: Arm base mounts through single hole by tightening of single locknut.

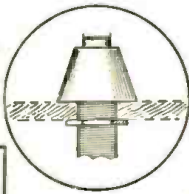

Revolutionary automatic control accommodating the S-220 will soon be announced!

Rek-O-Kut Company, Inc., Dept. ew-10
38-19 108th St., Corona 68, N. Y.

Please send me free brochure:

Name _____

Address _____

City _____ Zone _____ State _____

Export: Morhan Exporting Corp. 458 Broadway, N. Y. 13.
Canada: Atlas Radio, 50 Wingold Ave., Toronto 19.



SURPLUS
Prices are Low Here!



A



B



C

UNITS OF TBW-4

(Less tank coil wire)

100 WATTS, CW AND ICW
25 WATTS, PHONE

(A) HIGH FREQUENCY TRANSMITTER

Type CAY-52239. Frequency range 3 to 18.1 Megacycles. Input volts D-C 12, 500, 2000. Amperes 5.0, 0.2, 0.175. 3- Two inch meters on panel, 0-5 Amps. R.F., 0-15 and 0-100 Milliamps D.C. Mfr. Westinghouse Electric & Mfg. Co. Wgt. 50 lbs. Dim. 10 1/4" x 13" x 28 1/2". Ex. cond. **\$12.95**

(B) LOW FREQUENCY TRANSMITTER

Type CAY-52238. Frequency range 350 KC to 1400 KC. Input volts D.C. 12, 500, 2000. Amperes 5.0, 0.2, 0.175. 2- Two inch meters on panel, 0-9 Amps. R.F., 0-100 Milliamps D.C., Wgt. 44 lbs. Dim. 10 1/4" x 13" x 28 1/2". Ex. Cond. **\$9.95**

(C) POWER SUPPLY FOR ABOVE TRANSMITTERS

Rectifier Modulator unit type CAY 20084 2- Two inch meters on panel, 0-150 Volts A.C., 0-300 Milliamps D.C. operates on 115 Volts, 800 cycle A.C. line. Dim. 7 1/2" x 13" x 28 1/2". Ex. Cond. **\$7.95**

Inner-connecting cables for above units Ea. **\$1.00**

AC VARIACS

1 Ampere Variacs \$ 5.95
5 Ampere Variacs 9.95
7 Ampere Variacs 22.50
15 Ampere Variacs 45.00

LOW VOLTAGE TRANSFORMER

115 Volt, 60 Cycle PRI, 6 Volt secondary KVA 0.100. Ea. **\$2.95**

RECORDING BLANKS

16" Recording Blanks. Make your own Recordings. Aluminum base. Lacquered both sides. Professional quality. All New Stock.

Package of 10 **\$3.00**

Package of 100 **\$30.00**

DIAL TELEPHONES

French type phone made by Conn. Tel. & Tel. Can be used for standard extension phone. With Dial. Excellent Cond. **\$4.95**

Wgt. 7 lbs. Ea.

RESET COUNTERS

Unit Counter, changes by one digit. Reset: 000 to 999. Ideal for counting turns when winding Coils. Transmitters and General counting **\$1.50**

Work. Size is small. 1 1/4" x 3/4" x 1". Ea.

REVERSIBLE MOTOR

1/40 H. P. Ball-bearing 3450 RPM in Blast-proof case. Needs only a capacitor for starting. All Brand New. 110 V., 60 Cy Special Low Price. Ea. **\$2.95**
Starting Capacitor \$0.48 Ea. WGT. Approx. 8 lbs.

RG 59 COAXIAL CABLE

5c per foot, minimum length 100 feet. 500 Foot Rolls. **\$20.00**

See our previous ad for Special Surplus Items. All prices F.O.B. S. F., Calif. Call. orders add 3% Tax. No COD's. Remit Full Amount with All Orders.

STANDARD SURPLUS

1230 Market St., San Francisco 3, Calif.
Telephone HEmlock 1-3106

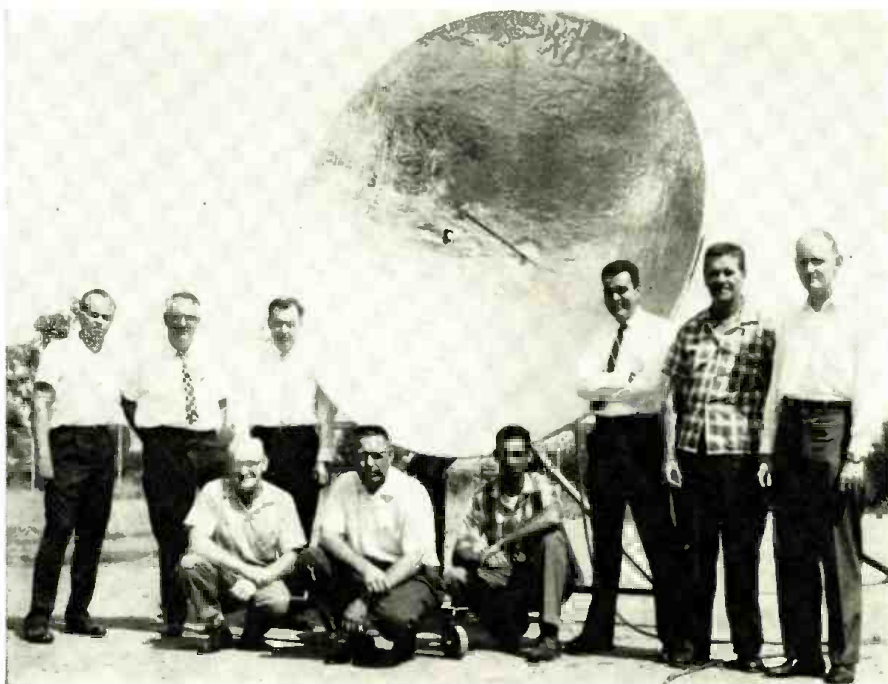

Some members of the Eimac Radio Club in San Carlos, California, who participated in the moon-bounce circuit are shown here with their make-shift parabolic dish.

Ham Radio Earth-Moon-Earth Contact

Details on the first amateur radio moon-bounce two-way microwave contact between California and Massachusetts.

THE FIRST amateur radio moon-bounce two-way microwave communication took place on Sunday, July 17 between two distant points. This contact marks an important milestone in the development of amateur radio. The historic contact was between the members of the *Eimac* Radio Club in San Carlos, California and Mr. Sam Harris, Rhododendron Swamp VHF Society in Medfield, Mass.

After months of personal effort by the radio amateurs concerned with this project, signals were transmitted in both directions on 1296 mc. The equipment was then refined and the first successful two-way communication was made. The first transmission was from West (W6HB) to East (W1-BU). The pattern was then reversed and the first amateur coast-to-coast communication *via* the moon completed. At each end of the circuit, a 1000-watt klystron was used in the transmitter and a very sensitive parametric amplifier in the receiver.

This successful reception and transmission using the moon as a signal reflector will stimulate efforts to improve amateur-built equipment for further moon-bounce communications. The only other moon-bounce communications equipment in existence is military or experimental in nature; the principal installation is the Naval link between Washington and Hawaii.

Members of the *Eimac* Radio Club who participated in the moon-bounce circuit are: Bill Orr, W6SAI; Hank Brown, W6HB; Bill Eitel, W6UF; Ray Rinaudo, W6KEV; Bob Morwood, K6-GJF; Bob Sutherland, W6UOV; Hugh MacDonald, W6CDT; George Badger, W6RXW; Allan Beer, K6GSO; Al Clark, W6MUC; Mike Krivohlavek, K6AXN, and Charlie Anderson, W6-IVZ.

Path of the 1296-mc. microwave signals.

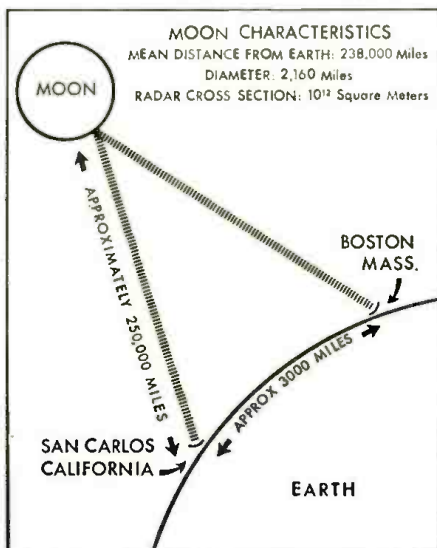



FREE!

Lafayette Radio's 324 PAGE 1961 Catalog

America's "Electronics & Hi-Fi Shopping Center"

40 years of service to Audiophiles, Experimenters, Hobbyists, Engineers, Technicians, Students, Servicemen and Dealers. **HERE IT IS** — the biggest, best and most comprehensive catalog you can ask for. Choose from thousands of items, all available for immediate delivery at the lowest, money-saving prices. And, as always, **SATISFACTION GUARANTEED OR MONEY REFUNDED.**

"The Best Buys In The Business"

- Stereophonic Hi-Fi Equipment
- Public Address Systems
- Tape Recorders
- Radio and TV Tubes and Parts
- Citizen Band Equipment
- Amateur Equipment
- Industrial Supplies

Exclusive at Lafayette. Lafayette Kits: Build a path to a new world of entertainment. Created, designed and engineered for top quality at top performance — there's more fun in doing it yourself, especially when it's so easy. An exclusive product of Lafayette Electronics — easily the best value for your money any day.

PLUS Hundreds of "specials" you'll find **only** at Lafayette.

Easy Pay Plan. The simplest, and quickest way to get what you want, when you want it. As little as \$2 down . . . up to 24 months to pay.

Mail the coupon today for your **FREE** copy of Lafayette Radio's 1961 catalog.



KT-650 FM Tuner Kit
54.50



TE-15 Tube Checker
19.95

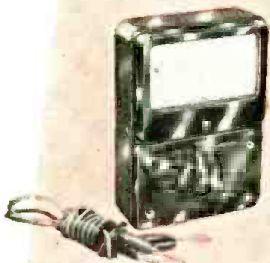

RW-60 20,000 Ohms Per Volt Multitester
13.50



RK-400 2-Speed Portable Tape Recorder
49.50

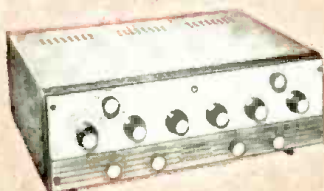

Stereo Control Center
KT-600, Kit
79.50
LA-600, Wired
134.50



Communications Receiver
KT-200, Kit HE-10, Wired
64.50 79.95



Lafayette Radio Electronics Corp.
Dept. RJ-6, P.O. Box 190
Jamaica 31, N. Y.

Send me the FREE Lafayette 324 page
1961 catalog 610

Name.....

Address.....

City..... Zone..... State.....

**Emergency
Industry
Farming
Pleasure**

NEW! LAFAYETTE HE-15A 2-WAY SUPERHET CITIZENS BAND TRANSCEIVER!

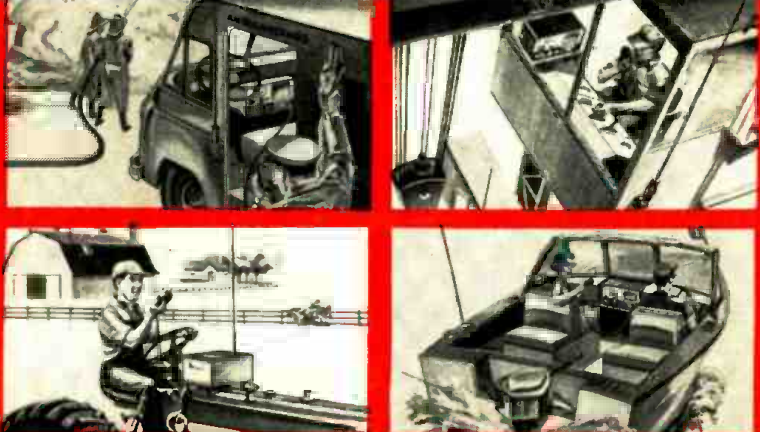

**Completely
Wired -
NOT A KIT!**

Made in U.S.A.

Not Superregenerative but SUPERHET!

COMPLETE 2-WAY COMMUNICATIONS FOR
BUSINESS, HOME, FARM, BOAT, AND SPORTS
NOW WITH ADDED FEATURES

- Effective Full-Wave Variable Noise Limiter • Five Prong Microphone Jack For Easy Relay Addition • RF Jack on Front Panel
- 5 Transmitting Positions • Tuneable Receiver Over Full 23 Channels • Planetary Vernier Tuning • Complete with Transmitting Crystal for Channel 9

57⁵⁰
Only
5.00 Down

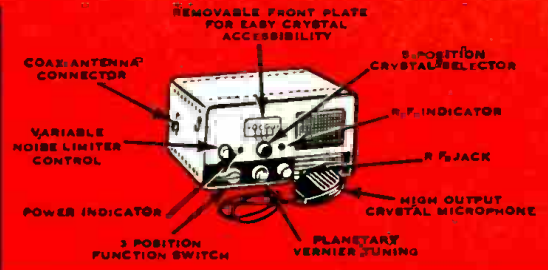

CITIZENS BAND — The New Two-Way Personal Communications Method for Everyone — Fill out the FCC form enclosed with each Lafayette Transceiver. No examination or technical knowledge required — Any Citizen 18 years or older is eligible for a license.

THE GREATEST VALUE in the CITIZENS BAND FIELD
Just think . . . now you can have economical, efficient 2-way radio communication from your home, office, store, auto, truck or boat . . . literally hundreds of uses. The Lafayette HE-15A Superheterodyne Transceiver is both a compact precision transmitter and receiver designed to operate on the new class D "Citizens Band." Two or more of these units furnish your own communications system covering up to a 20 mile or more radius depending on antenna height and terrain. The Lafayette HE-15A meets all FCC requirements and operates in much the same manner as police and other short-wave communications systems. The Transceiver features 5 crystal controlled transmitting channels operating at a maximum legal power input of 5 watts fully modulated, RF stage in both transmitter and receiver. The 5 position crystal selector on the front panel selects any one of 5 transmitting frequencies. These 5 crystals are readily accessible by means of a removable front plate. The superheterodyne receiver is tuneable over the full 23 channel band with 3 watts audio output, AVC, and an amazingly effective Full-Wave Variable Noise Limiter. The noise limiter is continuously variable from the front panel for diminishing ignition and other unwanted noise pickup. A new 5 prong microphone jack makes

conversion to a push-to-talk relay a cinch. RF jack on the front panel may be used to monitor the current in the final tube using external meter.

Controls include a 3 position function switch (transmit, receive, and transmit with spring return), planetary vernier tuning plus variable noise limiter. Output impedance matches 52 and 72 ohm antenna with Amphenol type coax connector. Has large 4" PM speaker; input jack for crystal or ceramic microphone; power receptacle in rear for AC line and 6 or 12 volt external power supply. Supplied with single transmitting crystal for channel 9, high output crystal microphone, and brackets for easy mounting of units in auto, boat, etc. Operates on 115 volts AC. Addition of 6 or 12 volt power supply (separately supplied) adapts transceiver, for mobile operation. Size 10 1/4" W x 5 1/2" H x 6 3/8" D. Tube complement: 2-6U8A/6EA8, 1-6AL5, 16V6, 1-12AX7, 1-6AW8. Shpg. wt., 11 lbs.

HE-15A 5.00 Down Net 57.50

POWER SUPPLY: Adapts HE-15A for mobile operation. Complete with cable, 6 or 12 volt vibrator and mounting flanges. Completely enclosed. Size 4 1/4" D x 6 W x 4 1/4" H. Shpg. wt., 4 lbs.

HE-16 For 12 Volts Net 10.95

HE-18 For 6 Volts Net 10.95

TRANSMITTING CRYSTALS: For any of the 23 channels. Specify channel or frequency. HE-830 Net 1.95

6.95

SENSATIONAL LAFAYETTE CITIZEN BAND MOBILE ANTENNA

THE SCOOP BUY FOR CITIZENS BAND MOBILES

- CHROME SWIVEL BASE
- PLUS STAINLESS STEEL SPRING
- PLUS 102 1/2" STAINLESS STEEL WHIP FOR OPTIMUM 11 METER PERFORMANCE

Chrome swivel ball mount base designed to be mounted on any surface. Stainless steel spring holds rod in properly adjusted position and prevents rod damage from shocks and blows. Stainless steel whip for maximum resiliency and strength. Shpg. wt., 4 lbs.

HE-800WX Net 6.95

NEW! LAFAYETTE TELESCOPIC CITIZENS BAND WHIP ANTENNA

- Chrome Plated
- Telescopes From 16 1/2 to 40"
- Mounts Vertically or Right Angle

3.95

An outstanding antenna value. This high quality three section telescoping antenna is designed for attachment directly to your citizens band transceiver. Ideal for point to point service over short distances. Molded base loading coil has a threaded stud with a PL-259 plug—connector for vertical or right angle mounting. Shpg. wt.; 1 lb. HE-19 Net 3.95

NEW! 10,000 OHMS PER VOLT MULTITESTER

Outperforms Instruments Many Times Its Size

9.95

- Completely Wired and Tested
- All Accessories Included

A convenient, pocket-sized instrument with an unusually sensitive 14,000 ohms-per-volt AC-DC meter, 1% resistors, single range selector switch. First capacity range requires 120V AC, second range requires 6V AC. Durable Bakelite case and panel; probes and flexible leads are plastic coated and color coded. Complete with battery. 4 1/2" x 3 1/2" x 1 1/8". Shpg. wt., 1 1/2 lbs.

TE-10 Net 9.95
TE-14 Pigskin Carrying Case, shpg. wt., 8 oz. Net 1.95

NEW! LAFAYETTE RADIO FIELD INDICATOR

- Provides a Continuous Indication of Transmitter Output
- Rugged 200 ua Meter Movement
- Completely Portable

7.95

With this rugged, new radio field indicator you can check performance of your marine, mobile or fixed transmitter . . . actually measures the RF field generated by any transmitter between 100KC and 250MC regardless of power. Features a 200 ua meter movement with a variable sensitivity control. Phone jack at rear of indicator accepts earphones thus providing an aural check of transmitter output. Antenna extends from 3/4 to 10 3/4". Powerful magnet on bottom plate allows easy mounting on car dashboard or metal surfaces. Use anywhere . . . requires no electricity or batteries. Dimensions: (less antenna) 3 1/8" W x 2 1/4" H x 2" D.

TM-14 Net 7.95

PLEASE INCLUDE SHIPPING CHARGES WITH ORDER

LAFAYETTE RADIO

165-08 LIBERTY AVENUE JAMAICA 33, NEW YORK

NEW YORK, N. Y.
100 6th Avenue

NEWARK, N. J.
24 Central Avenue

BRONX, N. Y.
542 E. Fordham Rd.

PARAMUS, N. J.
182 Route 17
(1 Mi. North Garden State Plaza)

BOSTON, MASS.
110 Federal Street

PLAINFIELD, N. J.
139 W. 2nd Street

LAFAYETTE
HI-FI KITS

Build A Path to A New World of Entertainment

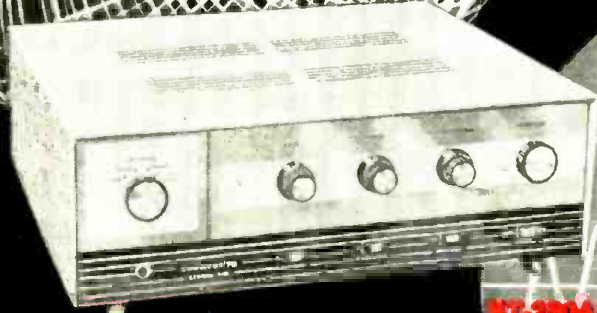
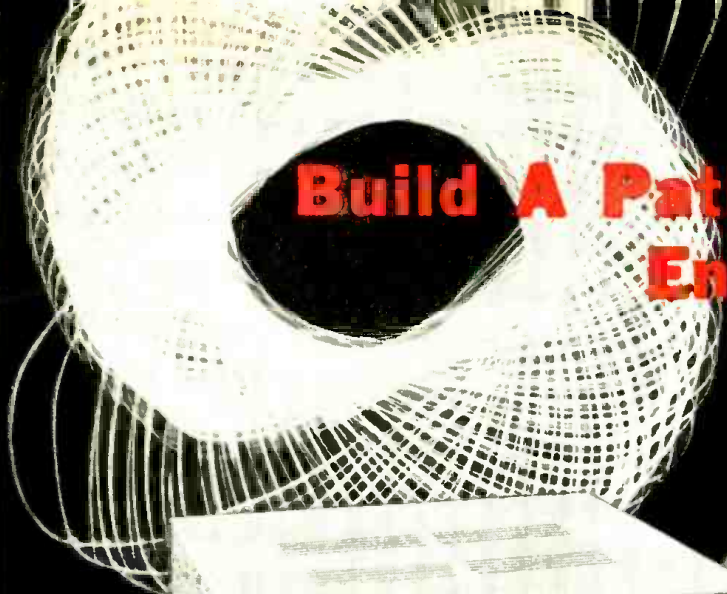

KT-280A
50-WATT STEREO AMPLIFIER... 74.80

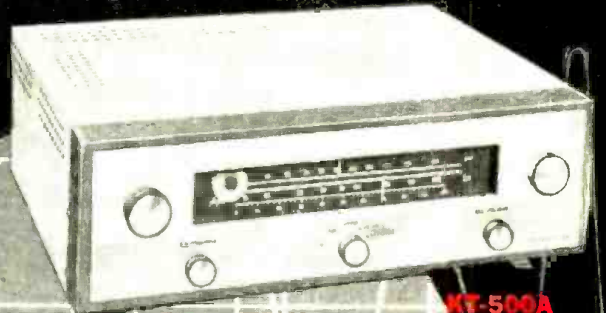

KT-500A
FM-AM STEREO TUNER... 74.50



KT-600A
STEREO PRE-AMPLIFIER... 79.50



KT-600 FM TUNER... 54.90



KT-236A
36-WATT STEREO AMPLIFIER... 59.50



KT-550 100-WATT
BASIC STEREO AMPLIFIER... 134.50

MONEY-BACK GUARANTEE
Lafayette Kits are exclusive products of Lafayette Electronics. Each Lafayette Kit must meet or exceed its published specifications, or your money is refunded in full.

ENGINEERING:

Created with the non-technical builder in mind. There's much more fun in assembling your own kit... and it's so easy.

DESIGN:

Each kit has the fine professional-looking touch. Styled to blend with every decor.

VALUE:

You can't get better units at these money-saving prices.

QUALITY:

Top performance due to high quality parts and engineering.



All Lafayette Kits are Available on the Easy Pay Plan.

CUT OUT AND PASTE ON POST CARD

Lafayette Radio Dept. RJ-6
P.O. Box 190 Jamaica 31, N. Y.

Send me the **FREE** 324-Page
1961 Catalog No. 610

Name _____
Address _____
City _____ Zone _____ State _____

SAVE MORE with

SONAR TUBES

You can't afford to pass up this golden opportunity to save on used tubes!

- Tested for mutual conductance in our own labs!
- One year free replacement guarantee!
- Prompt refunds on defective merchandise!

SPECIAL PURPOSE TRANSMITTING TUBES AND INDUSTRIAL TUBES

TYPE	PRICE	TYPE	PRICE	TYPE	PRICE	TYPE	PRICE	TYPE	PRICE
0A2	.60	4X150A	8.50	811	8.50	957	.30	5751	.90
0A3	.70	5R4GY	1.00	815	1.70	2050	.90	5763	.80
0A4	.75	C6J	6.50	829B	7.00	2051	.75	5813A	.75
0B2	.45	604	1.50	832	3.00	2625W	1.15	5879	.90
0B3	.65	6X4W	1.00	832A	5.50	5654	.75	6080	2.75
0C3	.50	6J4WA	1.15	843	.30	5686	1.50	6082	3.75
0D3	.40	218	8.00	866A	1.05	5687	.75	6135	1.00
2C44	.75	304TL	35.00	872A	1.05	5702	1.50	6146	2.45
2021	.55	313C	1.25	884	.80	5703	1.50	6159	2.75
2E24	1.95	5J29	.50	885	.75	5725	.90	6189	1.00
2E26	1.95	750TL	32.00	954	.20	5726	.40	6201	1.00
3A4	.45	807	1.00	955	.30	5749	.70		

JAN SURPLUS TUBES

TYPE	PRICE	TYPE	PRICE	TYPE	PRICE	TYPE	PRICE	TYPE	PRICE
0Z4	.42	6AG7	.44	6CL6	.59	7C4	.39	14A7/12B7	
1A7GT	.45	6AH4GT	.55	6CM6	.59	7C5	.44		.48
1B3GT	.52	6AH6	.42	6CM7	.40	7C6	.46	14B6	.48
1H4G	.39	6AK5	.43	6CN7	.40	7C7	.48	14Q7	.48
1H5GT	.45	6AL7	.45	6CS6	.42	7E6	.46	19	.48
1L4	.39	6AM8	.49	6DE6	.44	7E7	.44	19AU4GT	.49
1L6	.42	6AN8	.54	6DQ6	.79	7F7	.42	19BC6G	1.00
1NSGT	.52	6AR5	.44	6F6	.69	7F8	.42	1916	.48
1Q5GT	.44	6AR6	.42	6H6	.37	7H7	.40	19T8	.58
1R5	.41	6AQ7GT	.48	6J4	1.00	7N7	.48	24A	.48
1S5	.39	6AR5	.48	6J5	.44	7Q7	.48	25AV5	.75
1T4	.41	6AS5	.42	6J7	.59	7X7/XXFM		25BQ6	.99
1U4	.41	6AT6	.42	6K6GT	.33	7Y4	.44	25ON6	.40
1U5	.42	6AT8	.48	6K7	.48	7Z4	.39	25L6GT	.40
1V2	.49	6AU4GT	.40	6K3	.56	7Z4	.38	25W4GT	.41
1X2	.52	6AU5GT	.50	6L7	.49	12A8	.42	25Z5	.44
2A3	.95	6AU6	.40	6M7	.59	12AQ5	.52	25Z6	.44
2AF4	.88	6AU8	.49	6Q7	.59	12AT6	.42	26	.40
3BC3	.48	6AV5GT	.49	6S4	.40	12AT7	.61	35A5	.45
3BN6	.80	6AV6	.42	6S8GT	.40	12AU6	.40	35B5	.44
3BZ6	.40	6AW8	.40	6SA7	.40	12AU7	.44	35C5	.48
3CB6	.41	6AX4GT	.50	6SC7	.44	12AV6	.42	35L6GT	.46
3CF6	.42	6AX5GT	.49	6SF5	.49	12AV7	.63	35W4	.43
3C56	.42	6B8	.44	6SF7	.55	12AX4GT	.50	35Y4	.49
3LF4	.49	6BA6	.46	6SJ7	.55	12AX7	.51	35Z5GT	.47
3Q4	.44	6BC5	.44	6SK7	.40	12AZ7	.55	37	.48
3S4	.44	6BC8	.49	6SL7GT	.50	12B4	.42	39/44	.35
3V4	.44	6BQ6	.40	6SN7GT	.40	12BA6	.44	42	.45
4BQ7A	.65	6BE6	.44	6SQ7	.40	12BA7	.69	43	.45
4BZ7	.65	6BF5	.45	6SS7	.62	12BE6	.44	45	.47
5AS8	.52	6BF6	.40	6T4	.62	12BF6	.44	50A5	.45
5AT8	.44	6BG6G	.99	6T8	.61	12BH7	.51	50B5	.48
5AV8	.44	6BH6	.41	6U8	.66	12BQ6	.53	50C5	.48
5AW4	.49	6BJ6	.41	6V6	.44	12BR7	.48	50L6GT	.48
5BK7	.58	6BK5	.65	6W4GT	.39	12BY7	.55	50X6	.51
5J6	.51	6BK7	.68	6W6GT	.43	12CA5	.46	56	.43
5T8	.49	6BL7GT	.68	6X4	.37	12J5	.45	57	.43
5U4G	.39	6BN6	.70	6X5	.40	12K7	.40	58	.43
5U8	.49	6BQ6GT	.73	6X8	.65	12L6	.40	71A	.59
5V4G	.49	6BQ7	.68	6Y6G	.69	12Q7	.45	75	.60
5V6GT	.45	6BY5	.60	7A4/XXL	.44	12SA7	.44	76	.45
5X8	.45	6BZ6	.42	7A5	.42	12SG7	.48	77	.45
5Y3GT	.42	6BZ7	.68	7A6	.44	12SJ7	.48	78	.60
5Y4G	.55	6C4	.39	7A7	.42	12SK7	.44	80	.52
6A7	.60	6C5	.60	7A8	.45	12SN7GT	.46	84/6Z4	.48
6A8	.60	6C6	.60	7B4	.42	12SQ7	.44	117Z3	.44
6AB4	.40	6CB6	.44	7B5	.41	12V6GT	.40	117Z6	.90
6AC7	.55	6CD6G	.99	7B6	.46	12W6GT	.40	117L7	1.95
6AF4	.82	6CF6	.42	7B7	.48	12X4	.46	117M7	1.95
6AG5	.40	6CG7	.40	7B8	.44	12Z3	.46	117P7	1.95

6-12 VIBRATORS.....89¢ each

Write Dept. EW-1060 for complete list of tubes and special purpose tubes.

All advertised tubes not necessarily new but may be electrically perfect factory seconds or used tubes. Each is clearly marked. All tubes

postage paid. Include 25¢ handling for orders under \$5. Include 25% deposit on C.O.D.'s. Send approx. postage on Canadian and foreign orders.

SONAR ELECTRONIC TUBE CO.

112 MARTIN ST., PATERSON 3, N. J.

ELECTRONIC TERMINOLOGY

CROSSWORD PUZZLE

By JOHN J. GILL

(Answer on page 148)

ACROSS

- Reciprocal of impedance.
- Protective device.
- Greek "N".
- Used in house wiring.
- Chemical element (symbol).
- Pilot light (abbr.).
- Doughnut-shaped coil.
- Amount of force that causes rotation.
- Measurements.
- One who goes forth.
- Type of circuit.
- A "collector" of electromagnetic waves (abbr.).
- Vase.
- Frequency used in superhets (abbr.).
- 102 (Roman numeral).
- A news service (abbr.).
- E = —.
- Scotch hat.
- Equipment used in servicing electronic devices.
- Relay type (abbr.).
- high frequency.
- Tool for making holes.
- "For each".
- Falshoods.
- Tonnage (abbr.).
- Type of modulation.
- Amplification factor.
- Negative reply.
- Useful energy delivered.
- Number (abbr.).
- Part of "to be".
- Beneath.
- Inductive reactance (symbol).
- Ratio of output to input.
- Plate current (symbol).
- And so on.
- College degree (abbr.).
- Network (abbr.).
- Whip.
- TV blanking pulse.
- Memory tube used in computers.

DOWN

- Radiator of r.f. energy.
- diode.
- Values used in matching colors.
- An English unit of weight.
- Broadcast radio (abbr.).
- Pilot light symbol (abbr.).
- Capacitor of unknown value (schematic symbol).
- Iron compound used in transformer construction.
- Goad.
- Type of capacitor.
- Pedal digit.
- Coil.
- All (Latin).
- Cask.
- Quality rating of a coil.
- Above the range of human hearing.
- Power supply component (abbr.).
- Network for introducing a variable transmission loss.
- Neighboring continent (abbr.).
- Type of reactor.
- Transformers and coils are sometimes —.
- Remote TV or radio broadcast.
- Lithium (abbr.).
- Moving a TV camera to scan a field of view.
- Sorrow.
- Unit of wire size.
- Dental corpsman (USN, abbr.).
- Mother of Uranus.
- Our "aerial umbrella" (abbr.).
- Unit of 1 Across.
- By.
- Exist.
- Not down.
- Quiet!

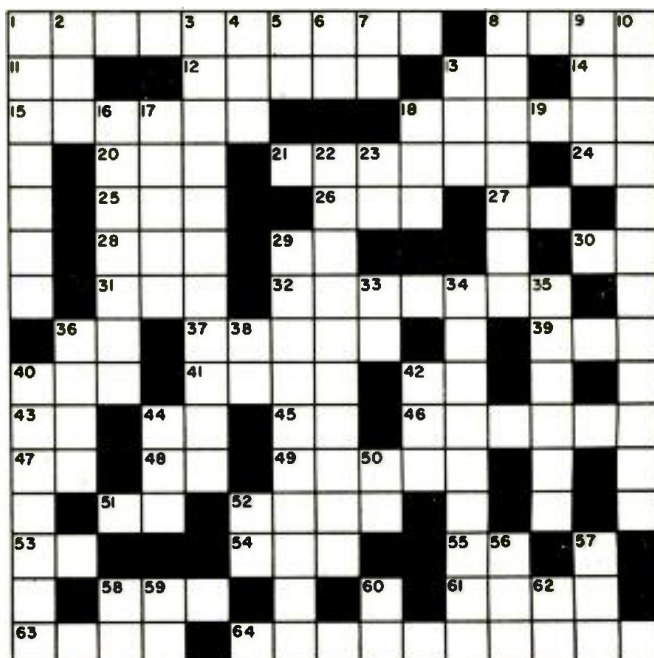

Don't miss it! A million have sent for it already! Send for your copy of **Radio Shack's new 1961 Electronics CATALOG**



FREE

Plus a full year's FREE SUBSCRIPTION to all other Radio Shack Catalogs as issued

Save up to 50% all year long on the latest and best items in the whole fascinating field of Electronics.

See the world's biggest line of Stereo, Hi-Fi, Ham Radio, Transistors, Test Equipment, Kits and Parts, scores more.

You get fast, accurate service!
 Every order processed the same day received. No delays!

You can pay as you earn on Radio Shack's Easy Budget Plan. Low as \$2.00 down.

You can open a convenient Monthly Charge Account. "Add-on" orders are easy.

GUARANTEE: Radio Shack guarantees you must be satisfied with any item you order or your money back. 15-day no-risk home trial on any item!



RADIO SHACK
 Corporation

730 Commonwealth Avenue
 Boston 17, Massachusetts

MAIL COUPON TODAY

RADIO SHACK CORPORATION DEPT. 60K6
 730 Commonwealth Ave., Boston 17, Massachusetts

Without obligation, please send me FREE AND POST-PAID, your latest Electronics Catalog packed with best sellers plus every new issue for one full year.

Name: _____

Address: _____

Post Office or City: _____ Zone: _____ State: _____

**CREI's Extension Division offers Engineering Technicians and Engineers a combination of courses in advanced electronic engineering technology.*

**The program is designed to meet your present and future employment requirements and to increase your professional status and earning power.*

-this CREI College-level Home Study Program in Electronics is Comparable in Technological Content to Advanced Residence Courses!!!!

The CREI home study program is the culmination of 33 years of working closely with leading companies and Government agencies in the critical field of electronics. This accredited program is designed for men already employed in a technical capacity in the electronics industry.

This CREI college-level program is comparable in technological content to advanced residence courses. You may complete the program in 2 to 4 years, depending on the amount of free time you can devote to study, and the courses you choose.

For several years the electronics industry has suffered a serious shortage of technical personnel with

modern advanced education, and there is every indication that this shortage will increase in the years ahead. New jobs are being created daily through the application of electronic developments in missiles, space exploration, automation, instrumentation, computers, telemetering and many other fields. These positions must be filled by men with modern advanced education, which fact is evidenced by the experience of the CREI Placement Bureau, where the demand for graduates and advanced students far exceeds the supply. It is of interest to note that Help Wanted ads frequently specify "CREI education or equivalent."

CREI is recognized by industry and government

Another reason why CREI men are respected and eagerly sought by industry and Government agencies alike is the accreditation and enthusiastic approval accorded the CREI home study program in advanced electronics. We co-founded the National Council of Technical Schools, and we were among the first three technical institutes whose curricula were accredited by the Engineers' Council for Professional Development. Further, the U.S. Office of Education lists CREI as "an institution of higher education."

Of equal importance, we believe, is the appreciation expressed by industry and government for the CREI programs. Dozens of major electronics organizations, ranging from industrial giants to the Government's Voice of America, have agreements with CREI for enrollment of students under company sponsorship. U.S. Navy electronic personnel in the number of 5,240 are enrolled in CREI extension programs. The British Royal Air Force, Army and Navy have approved CREI courses under their tuition assistance plan. The following companies comprise only a partial list of the organizations which not only recommend CREI study but actually, in many cases, pay all or part of the tuition for employees taking CREI courses:

National Broadcasting Company
Jerrold Electronics Corporation
Pan American Airways
Radio Corporation of America
Canadian Aviation and Electronics
Federal Electric Corporation
The Martin Company
Voice of America
Canadian Broadcasting Corporation
Northwest Telephone Company
Commercial Cable, Incorporated
Canadair Limited
Columbia Broadcasting System
All America Cable and Radio
Canadian Marconi
Mackay Radio
United Air Lines
Gates Radio Company
Mohawk Airlines
Florida Power and Light Company

RESIDENCE SCHOOL

... in Washington, D.C., for those who can attend classes. Day and evening classes start at regular intervals. Graduates earn AAS degree in 27 months. Electronics experience is not required for admission.

QUALIFICATIONS FOR CREI ENROLLMENT FACTS ABOUT TUITION, REGISTRATION

If you have a high school diploma or equivalent, basic electronic training and practical experience in electronics, you meet the minimum requirements for enrollment. Tuition is reasonable and may be paid monthly, if you wish. Veterans qualify for this program under the GI bill.

Over 20,500 CREI students find home study convenient and profitable

You can pursue the CREI program while you continue your regular full-time job. You study at home during hours chosen by you. You are not rushed and you have plenty of time to do your best.

The courses are prepared in easy-to-understand format, and the CREI staff of experienced instructors guides your progress all along the way. These instructors stand ready to assist you whenever you need help. You will find our personal assistance and guidance efficient and helpful, because 33 years of experience in home study teaching enables us to anticipate questions in our lesson material.

Many CREI students have learned that they do not have to wait until they have completed the program to realize significant improvement in their status and income. The very fact that you are ambitious enough to pursue this college-level program enhances your opportunities for rapid promotion. Project leaders and supervisors recognize the value of CREI education.

How you benefit from CREI program of home study

CREI students are electronic engineers and technicians engaged in every phase of electronics. They are in research laboratories and manufacturing plants. They work on the design, development and production of the latest computers; on the latest military and civilian aircraft; on the electronic equipment associated with the Nation's missiles and space exploration efforts; on communications equipment of all kinds; they maintain electronic equipment for the air lines, the Government and private corporations. You will find CREI students in all 50 States and in most foreign countries of the free world.

To the serious-minded and ambitious CREI student our home study program offers a series of important benefits:

1. You gain a solid college-level education in advanced electronic engineering technology; you keep abreast of continuous new developments in the field.
2. You can gain higher status and enjoy the increased respect of your associates.
3. You facilitate more rapid professional advancement with corresponding significant increases in pay.
4. You gain the personal satisfaction that comes from working and communicating intelligently with your technical colleagues and superiors.

WRITE FOR DETAILED 44-PAGE BOOK of curricula and other information about CREI, entitled "Insurance for Your Future in the New World of Electronics." USE POSTAGE-PAID CARD ATTACHED, or write to Dept.1110-G.

The Capitol Radio Engineering Institute

*ECPD Accredited Technical
Institute Curricula
FOUNDED 1927*

3224 16th Street, N.W.
Washington 10, D.C.
Dept. 1110-G

NEW and VITAL SAMS BOOKS

101 Key Troubleshooting Waveforms for Horizontal AFC— Oscillator Circuits

by Robert G. Middleton

First in a brand-new series by the author of the best-selling "101 Ways" books. Shows 101 abnormal waveforms (obtained when various circuit components become defective), accompanied by circuit symptoms, tests and evaluations of results. Supplementary notes provide background information. Covers the three most popular horizontal AFC-oscillator configurations: the multivibrator and blocking oscillator with pulse-width AFC, and the multivibrator with duo-diode AFC. With this book by your side you need never be puzzled by an abnormal waveform! 150 illustrations; 128 pages; 5½ x 8½". Only... **\$2.00**

Servicing Transistor TV Receivers

by Milton S. Kiver
and Charles R. Gray

Only book of its kind on this subject, timed with the appearance of the first transistor TV models. The authors introduce you to the transistor and to basic transistor circuits. Then, you are shown, one by one, how transistors are used in the tuner, video-IF amplifier, video-detector, video-amplifier, AGC, sound, sync-separator, and horizontal and vertical deflection sections. Includes data on the application of tube-set techniques; servicing differences between tube and transistor TV's; handling, testing and replacement of transistors; checking operating points, shorted and open transistors; plus special servicing pointers on specific sections, emphasizing horizontal-deflection systems. Illustrated; 272 pages; 5½ x 8½". Only... **\$4.50**

Experiments In Industrial Electronics

by Melvin Whitmer

You learn how more than a dozen industrial devices work by actually sitting down and building them—the best way to learn a new skill. Projects are simple enough to appeal to the beginner, yet meaty enough to satisfy the most bench-hardened veteran. You'll build a photoelectric doorbell ringer, garage-door opener, burglar alarm, electronic time-welder control, electronic oven, flame detector and strain gauge, proximity detector (burglar alarm, store window novelty, thickness tester, etc.), that harnesses capacitance, DC motor control (including one for a portable turntable steady enough to satisfy even the wildest hi-fi fan) and a servo system. This valuable book can be your gateway to a profitable future in the fast-growing field of industrial electronics. 5½ x 8½". Only... **\$7.95**

JUST OUT

HOWARD W. SAMS REPLACEMENT GUIDE FOR TV & AUTO RADIO CONTROLS

Vol. 3. Greatly expanded—covers 27,000 TV and over 1,000 auto radio models. Lists recommended replacement controls of Centralab, Clarostat, IRC and Mallory. **\$1.00**
8½ x 11". Only... **\$1.00**



HOWARD W. SAMS & CO., INC.

Order from your Sams Distributor today, or mail to Howard W. Sams & Co., Inc., Dept. K-10 1720 E. 38th St., Indianapolis 6, Ind.

Send me the following books:

- "101 Key Troubleshooting Waveforms" (WFM-1)
 - "Experiments In Industrial Electronics" (IEW-1)
 - "Servicing Transistor TV Receivers" (KST-1)
 - "Replacement Control Guide" (RCG-3)
- \$.....enclosed. Send Free Book List

Name _____

Address _____

City _____ Zone _____ State _____

(Outside U.S.A. priced slightly higher)



A SIGNIFICANT example of cooperation between service and another, related segment of the broad electronics industry is a matter of record in Iowa. During station breaks, WOI-TV (channel 5) of Ames, Iowa has begun to display the official emblem of the state association along with prepared material suggesting that viewers who need service call on member shops for reliable work.

This can scarcely be claimed as a "first." Over the years, there have been other stations in various parts of the nation that have undertaken similar projects. However, the scale on which this activity is being carried out in Iowa is impressive. WOI-TV is the first broadcaster to adopt this policy in the central portion of the state, but makes a total of five Hawkeye stations engaged in such activity. This is the sort of broad coverage that can give members of TESA of Iowa the type of identification with the public that many associations have sought, but few have been able to achieve.

The principals involved report that the program helps everyone. Viewers benefit in that they have some assurance of reliable service and of maintaining their sets in working condition. The broadcasters feel that this service to their viewing public assists them in maintaining their audience. As for member service shops, they report definite improvement in business.

The state group has adopted the NATESA emblem officially and is using it in this broadcast campaign. Members feel that this will provide residual benefits for NATESA members outside the state whose potential customers receive Hawkeye stations. Along with the adoption of the emblem, the state group, formerly TSA of Iowa, has officially become TESA of Iowa. A recent issue of "NATESA Scope," commenting on this effort, urges other associations everywhere to try to put over similar programs. At that, blanketing the nation with this sort of promotion would be quite a boost to the service industry.

Impact of "Tube Jockeys"

Although most of us like to be masters of our own fate, much of what we do is inevitably influenced by the behavior of others. If such influence constitutes an undesirable infringement, we consider that we have some rights in restricting the behavior of those responsible for the infringement.

An editorial in "TSA DV News" (Television Service Association of the

Delaware Valley) deals with the manner in which an "outside" influence is bringing about a basic change in the nature of established, full-scale service businesses. For many years, it has been the practice in service shops everywhere to avoid large bills on difficult repairs although the work involved may justify such high fees. The technician thus avoids antagonizing his customers and expects to compensate for these "dogs" with the greater number of routine jobs on which he can average out a reasonable profit margin.

However, the editorial takes note of a change in the ratio between routine and difficult cases that may upset this line of reasoning. "Have you given some thought to the kind of jobs you are getting?" asks the editor. "Have you noticed the absence of the gravv jobs? Where are the repairs we used to sail right through? Are we losing our touch? No, of course not. The run-of-the-mill, easy jobs are skimmed off by the incompetent shysters who are not equipped in their shops or in their heads to handle the harder jobs. These are the characters your customers and mine call in to repair their TV sets at cut prices. Then when they fail to do so, we get called in to pick the chestnuts out of the fire."

The writer proceeds to the case of a competent dealer who had to make extensive, costly repairs on a damaged set. "What can I tell my customer?" muses the dealer. "He will think I'm trying to fleece him. All of this was made necessary because the set owner had called a neighborhood tube jockey in to repair his set and this idiot had put some tubes in the wrong sockets in his endeavor to repair the set for a couple of fast bucks. Why must I be on the defensive to justify a *bona fide* repair bill?"

The editorial goes on to propound licensing as a solution because it will weed out the incompetents. Without becoming embroiled in the oft-repeated pros and cons on legislative supervision, we think this instance is worth attention simply because it highlights one of the many ways in which all members of the industry affect one another whether they wish to or not. Another point: licensing could never be the complete solution to this problem. The unrealistic notions held by the public relative to service fees—in part encouraged by dealers—must change: charge enough and don't apologize!

Answer to a Customer

Speaking of positive action in con-

sumer education, the "Guild News" (Radio and Television Guild of Long Island, New York) suggests an answer to a common problem in public relations. The problem arises when the customer says, "You just fixed the set; why should it stop working again? Didn't you check everything?"

While we would suggest a more moderate tone to avoid antagonizing clients, the essence of the recommended reply is useful: "How much did this set cost you when new? The manufacturer guaranteed the parts for only ninety days. Do you expect me to give a better guarantee when the set is old than the manufacturer did when the set was new, for a repair price that is one fourth (or fifth, or whatever the case may be) of the original cost?"

The Guild also suggests an antidote for customer moaning about the cost of repairs: "Do you use your telephone as many hours as your TV set?" (The viewer is a safe bet to answer in the negative, unless he's a bookie.) How much does your phone cost per year? Must be at least \$100. (Use your own figure, if that doesn't suit you.) Do you spend \$100 a year on your TV set? And you do own your TV set but you don't own your telephone!"

Are Shops Merging?

"TESA Miami News" reports that the local *Bell Radio & TV Service* has combined forces with *Radio Doctors of South Miami*, once more raising the point as to whether the pattern of the next few years will not be one of fewer, larger shops, many of them growing out of such business marriages. While there have been other cases of mergers here and there recently, we think it is too early to identify a trend.

Actually the optimum, efficient size of any business varies greatly depending on the type of activity. Even with such giant corporations as the larger automobile manufacturers, economists tell us there is a point beyond which increased growth actually results in reduced efficiency and economy. In short, there is such a thing as growing too big in any field.

Experience suggests that most types of service and repair operations are at their best when relatively small. The notion of large service establishments or chains is not new, but most of those that have been attempted on an independent basis, not supported by other activities, have not survived. The neighborhood service shops today far outnumber the giant ones and account for most of the repair business.

Manufacturer Jottings

Both *CBS-Electronics* and *Raytheon* have been recent recipients of NATESA "Friends of Service" Awards for "outstanding service in creating better customer relations" . . . *Philco* is offering "Trace," which consists of plastic circuit panels to be placed over parts of their transistor radios. These indicate where and how tests should be made and pinpoint possible defects. The notion has merit.

"I've never been without PHOTOFACT.."

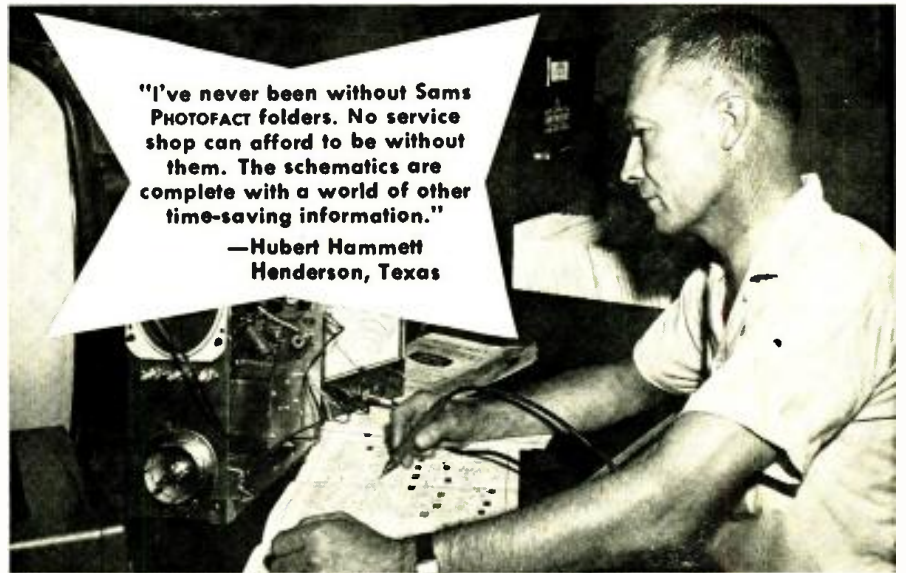

"I've never been without Sams PHOTOFACT folders. No service shop can afford to be without them. The schematics are complete with a world of other time-saving information."

—Hubert Hammett Henderson, Texas

Service Technicians! YOU EARN MORE... YOU RATE with the public when you own the PHOTOFACT® service data library!

You enjoy maximum earnings as the owner of a complete PHOTOFACT Service Data Library! It's inevitable, because no matter how expert you are, you can always *save more time on any job, get more jobs done daily*—EARN MORE, DAY IN AND DAY OUT...

What's more—as the owner of a complete PHOTOFACT Library, you know your customers' sets *best*. You can actually show each customer you have the PHOTOFACT Folder covering his very own set. Result: You command public respect and acceptance which paves the way to more business and earnings for you.

HOW TO STAY AHEAD...

Yes, the truly successful Service Technicians are those who own the complete PHOTOFACT Library, who can meet and solve any repair problem—faster and more profitably. And these men *keep ahead* because they're on a Standing Order Subscription with their Distributors to receive all new PHOTOFACTS as they are released monthly. (They're eligible for the benefits of membership in PEET, too—see below!)

ONLY \$10 DOWN puts the complete PHOTOFACT Library in your shop—and you have up to 30 months to pay. See your Sams Distributor today, or write to Howard W. Sams

NOW IS THE TIME TO JOIN

"PEET"

THE POWERFUL NEW PROGRAM FOR QUALIFIED TECHNICIANS

If you now own a PHOTOFACT Library or plan to own one, you can apply for membership in "PEET." It's the first industry program really designed to build powerful public acceptance for the Service Technician who qualifies. Builds enviable prestige and business for its members. Benefits cost you absolutely nothing if you qualify. Ask your Sams Distributor for the "PEET" details, or mail coupon today.

HOWARD W. SAMS & CO., INC.

1724 E. 38th St., Indianapolis 6, Ind.

- Send me full details on the new "PEET" Program.
- Send full information on the Easy-Buy Plan and Free File Cabinet deal.
- I'm interested in a Standing Order Subscription.
 - I'm a Service Technician full-time; part-time

My distributor is _____

Shop Name _____

Attn: _____

Address _____

City _____ Zone _____ State _____

TS 36 WE X BAND POWER METER	\$14.95
TS 45 X BAND SIGNAL SOURCE	\$14.95
TS 76 TEST METER	\$9.95
TS 102A CALIBRATOR	\$14.95
TS 173 FREQUENCY METER	\$124.50
TS 196 BRIDGE	\$24.95
TS 247 WAVE METER	\$14.95
STANDARD LABORATORY RECEIVER APR-4 with 3 Tuning Units, Frequency 38-1000 MC. Checked out	\$159.50
MEASUREMENTS CORP. 79-B PULSE GENERATOR—Checked out	\$39.50
GEN. ELECT. COMPUTER TESTER. New	\$29.95
MD 7 MODULATOR with Tubes	\$5.95
BC 442 ANTENNA RELAY with Condenser	\$2.95
Less Condenser	\$1.49
ARC 3 RECEIVER 100-156 MC	\$14.95
ARC 3 TRANSMITTER 100-156 MC with 2-82A's	\$16.95
WEST. ELECT. SOUND POWER TRANS. New	\$1.29
BC 620 TRANSCEIVER—Citizens Band FM-20-28 MC	\$16.95
MEYER—3 $\frac{1}{2}$ 0.5 MA. 270° indication By-Pass Shunt and add scale. Excellent condition	\$1.29
TELEGRAPH KEY—J 17. New	\$1.29
ART-13 TRANSMITTER with tubes and meters	\$29.95

Send M.O. or check with order
Write for Bargain Flyer

R W ELECTRONICS

2430 S. MICHIGAN AVE. DEPT. N
Phone: CAIumet 5-1281 Chicago 16, Ill.

LEARN THE SHORT-CUTS

Professional TELEVISION All-Practice TRAINING

Jump your earnings fixing black-and-white and color sets. Get into the top-pay bracket. NRI's concentrated spare time, low-cost training can do it for you. You'll fix sets faster, easier. Special course for Radio and TV servicemen — not for beginners. Full information free. Mail coupon now: NATIONAL RADIO INSTITUTE, Dept. OKET, Wash. 16, D.C.

NATIONAL RADIO INSTITUTE
Dept. OKET, Washington 16, D. C.
Without cost or obligation send me facts about your Professional All-Practice TV Course.

Name.....Age.....
Address.....
City.....Zone.....State.....

ACCREDITED MEMBER NATIONAL HOME STUDY COUNCIL

CITIZENS BAND EQUIPMENT

Check Power Output, Standing Waves — 1000 Transistor. Gives true indication of power output, VSWR. Ideal for transmitter tuning. Speedy auto scale or PL 250 10 to 1000 indicator. **\$20.95** Postpaid

Eliminate Generator Whine — On Generator Filter. Eliminates generator whine in mobile installations. Tunable for maximum attenuation. Most effective generator noise filter made. Also available for other frequencies.

Duopole Groundplane Base Antenna — Rugged, tuned CB antenna with 1 to 1 VSWR. High gain, non-directional. All elements at DC ground potential for maximum lightning protection. Also available for other frequencies. **\$29.95** Shipped Express Collect

Send check or M.O. Ohio residents add 3% Sales Tax.

THE STOTTS-FRIEDMAN CO. Dept. E
108 North Jefferson Street, Dayton 2, Ohio

Engineering Schools Spend \$71-Million for R & D

Extent of research and development expenditure that has been reported by 129 schools for the 1958 fiscal year.

ENGINEERING schools in the United States reported that they spent \$71-million for "earmarked," or sponsored, research and development in fiscal year 1958, according to information released by the National Science Foundation.

Engineering schools received \$48.6-million of this total from the Federal Government and \$10.3-million from industrial sources. Direct support of R & D from their own funds was \$10.5-million, plus an additional \$3.5-million to cover the indirect costs of outside-sponsored grants and contracts.

The 129 engineering schools, either independent institutions or affiliated with colleges and universities, were part of a comprehensive survey of expenditures and manpower for research and development in colleges and universities. In analyzing trends of R & D expenditures in engineering schools, it should be pointed out that there has been a decreasing trend in the enrollment of undergraduate students and a rapidly increasing enrollment of graduate students in engineering schools. These factors may tend to increase both the faculty time available to conduct research and development because of reduced teaching loads and the number of graduate students available to conduct research and development under faculty supervision.

Twenty schools reported expenditures of \$1-million or above for research and development, eighty-five reported between \$25,000 and \$1-million, and twenty-four reported expenditures of less than \$25,000.

Of the \$71-million total, 57 per-cent was reported as going for basic research, in contrast to the 45 per-cent reported in a comparable previous study covering fiscal year 1954.

Fig. 1 shows the percentage of support borne by each major source. Fig. 2 shows each Government agency's percentage of total Federal funds. The specific sources and amounts of sup-

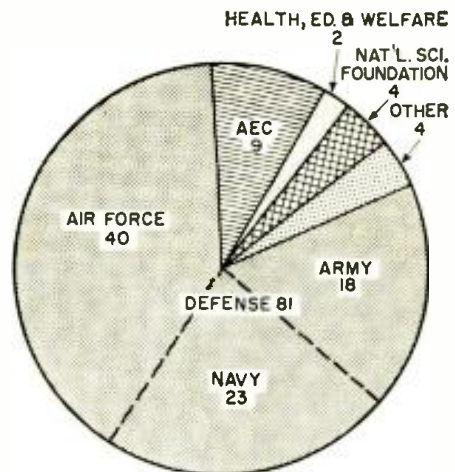

Fig. 2. Per-cent distribution of Federal expenditures for separately budgeted research and development in engineering schools, by agency involved, for the fiscal year 1958.

port for separately budgeted research and development for fiscal year 1958 are shown below:

	(thousands of dollars)
GRAND TOTAL	\$70,882
Total, Federal Government	48,626
Dept. of Defense	39,438
Dept. of the Army	8,882
Dept. of the Navy	11,193
Dept. of the Air Force	19,256
All Other	107
Dept. of Health, Education, and Welfare	929
Atomic Energy Commission	4,239
National Science Foundation	1,937
Other Agencies	2,080
Total, Other Sources	22,256
Institutions' Own Funds	10,540
Foundations	957
Industry	10,363
Other Sources	396

These and other preliminary data from the Foundation survey were issued in "Reviews of Data on Research & Development," No. 21 ("Funds for Research and Development in Engineering Schools, Fiscal Year 1958"). This publication is available for 10 cents from the Supt. of Documents, U. S. Government Printing Office, Washington 25, D. C.

Fig. 1. Per-cent distribution of expenditures for separately budgeted research and development in engineering schools, by the source of support, for the fiscal year 1958.

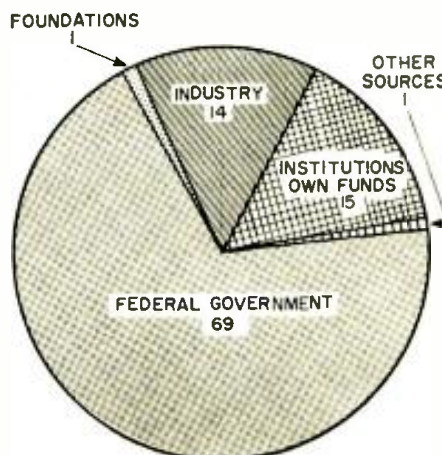

Stable Transistor V.F.O.

(Continued from page 66)

other component used in the circuit.

Oscillator Coil Notes

There is really nothing magic about the toroid coil (L_1). The fact that the lines of force are more contained in the core will allow you to build a more compact unit. However, if you do not care about the size, it is possible to use more "standard" components. A coil was constructed for 5.0-5.2 mc. by winding 18 turns of #22 enamel closewound on a 1" diameter solid polystyrene rod, with the tap at 7 turns. Using this coil, it was possible to connect the oscillator collector and the amplifier capacitor (C_2) to the same tap. The v.f.o., using this coil, was contained in a 4" x 5" x 6" aluminum box, with the oscillator coil as near the center of the box as possible.

The oscillator can also be used on 3.8-4.0 mc. Another coil was constructed with 28 turns of #22 enamel, closewound on the same form, but with the tap located at the 10th turn from the bypassed end. It was necessary to connect a 100 μf . capacitor across L_2 to pad it down to 4 mc.

The constructor may have difficulty locating the powdered iron toroid form. It must be purchased in large quantities and would be considered a "non-

standard" item. Anticipating this difficulty, the author had planned to make pre-wound and properly tapped toroid coils available directly. However, this proved to be unnecessary as the J. W. Miller Co. is making the coil available at their local distributors as part No. 7501. The Miller version of coil L_2 is also readily available as part No. 7502.

You may have noticed that there are no temperature-compensating components in this v.f.o. The performance graphs of Fig. 5 show that the drift can be reduced with the proper choice of compensating capacitors.

As the v.f.o. warms up, it will drift lower in frequency. By adding the proper amount of negative-temperature-coefficient capacitors, the frequency shift can be almost completely counteracted.

Tests were made by placing the v.f.o. in the frozen food compartment of the refrigerator and then letting it come up to room temperature. The uncompensated curve was obtained with the values shown in Fig. 1. The compensated curve was the result when a silver mica 82- μf . capacitor was substituted for C_1 , and a 68- μf . N750 compensating capacitor was used in place of C_2 . By using the N750, 82- μf . capacitor and the 68- μf . silver mica, the v.f.o. was "overcompensated." Somewhere between these two values it will be possible to compensate the v.f.o. perfectly to cover the range from 32 to 100 degrees.

SAVE on everything in **stereo hi-fi** and **electronics**



send for the 1961

ALLIED CATALOG

free

444-PAGES • VALUE PACKED. Write today for the leading Electronics Catalog. World's largest selection, including products and values available only from ALLIED. **SAVE ON:**

- Everything in Hi-Fi Music Systems & Components • Biggest Selection of Hi-Fi Cabinetry
- Exclusive Knight® Super-value Stereo • Knight-Kits®—Best in Build-Your-Own Hi-Fi • Tape Recorders and Phono Equipment
- Everything in Electronic Parts, Tubes, Transistors, Test Equipment, Amateur Gear, P.A. Systems, TV Accessories, Tools, Books.

only \$2 down on orders up to \$50

Save most at ALLIED. Write for FREE 1961 Catalog today!

ALLIED RADIO

free catalog

ALLIED RADIO, Dept. 101-K
100 N. Western Ave., Chicago 80, Ill.

Send FREE 1961 ALLIED Catalog.

Name _____

Address _____

City _____ Zone _____ State _____

Higher accuracy, bigger scale than any comparable V-O-M!



1/2 actual size

ONLY WESTON MARK II ANALYZER OFFERS THESE OUTSTANDING FEATURES

Accuracy: $\pm 2\%$ full scale DC; $\pm 3\%$ AC.

Scale Length: 4.63" long for easy reading.

Ranges: Resistance — up to 10 megohms in five steps (with protection fuse).

AC Voltage in six ranges to 1,600 (at 1,000 Ω/V). DC Voltage in seven ranges to 4,000 (at 20,000 Ω/V). DC ma — 1.6, 8, 80, 800. DC μa — 80. DC amperes — 8. DB — -15 to +54 in six ranges.

Simplified Operation: Single dial for range and function switching.

Small Size: Rugged case of crackproof plastic, 6.25" x 7.50" x 3.25" for maximum handling convenience.

Other Features: Exclusive Weston CORMAG® mechanism for magnetic shielding, electrostatic shielding provided by housing; etched circuit; spring-backed jewels for shock and vibration resistance.

Order from your local Weston distributor. For information, write to: Weston Instruments Division, Daystrom, Incorporated, Newark 12, N. J. In Canada: Daystrom Ltd., 840 Caledonia Rd., Toronto 19, Ont. Export: Daystrom's International Sales Division, 100 Empire St., Newark 12, N. J.

DAYSTROM, INCORPORATED

WESTON INSTRUMENTS DIVISION

Weston for Dependable Accuracy

COMPLETE TRAINING FOR BETTER RADIO-TV SERVICE JOBS

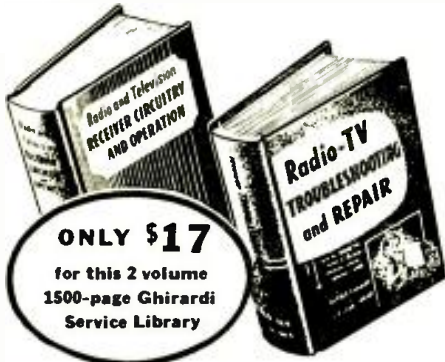

FIX ANY TV OR RADIO ever made!

These two giant Ghirardi home training manuals make it easy for you to be an expert on ALL types of TV-AM-FM service . . . at only a fraction of the price you might expect to pay for such complete training. Almost 1500 pages, over 800 clear illustrations and dozens of procedure charts explain each detail of every service job as clearly as A-B-C. Each book contains up to the minute data. Each is based on approved professional methods. You learn time-saving shortcuts. You learn to work better, more profitably. Ideal as complete training for beginners or as a handy reference library for experienced servicemen who want to look up puzzling jobs or develop new and faster methods.

A complete guide to TROUBLESHOOTING & REPAIR

① This 820-page **RADIO & TV TROUBLESHOOTING AND REPAIR MANUAL** guides you through each service procedure . . . from locating troubles to making repairs fast and right. Step-by-step charts cover practically every type of troubleshooting from Television problems to AM and FM realignment to IF and Detector Sections, car radios, record players, communications receivers, etc. 417 illustrations. Price \$10 separately. (Outside U.S.A. \$10.50.)

The complete "know how" of SET CIRCUITS & OPERATION

② Learn all about circuits and their peculiarities and watch your service "headaches" disappear! This 669-page **RADIO & TV RECEIVER CIRCUITRY AND OPERATION** manual covers all basic circuits and circuit variations used in modern home equipment; explains their likely trouble spots; teaches you to go right to the seat of trouble without useless "testing"; helps you develop fast, truly professional service techniques. Price \$9 separately. (Outside U.S.A. \$9.50.)

SAVE \$2.00—Pay As You Learn!

If sold as a course and sent to you in lesson form, you'd regard these two famous manuals as a bargain at \$100 or more. Instead you buy them complete in handy book form for only \$17 for the two (regular price \$19.00). You save \$2.00 . . . and you have 3 months to pay if desired. No lessons to wait for! Everything is at your finger tips. You learn fast . . . and you learn right! **OUR MONEY-BACK GUARANTEE PROTECTS YOU FULLY!**

STUDY 10 DAYS FREE!

Dept. RN-100, Technical Division,
HOLT, RINEHART & WINSTON, Inc.,
383 Madison Ave., New York 17, N. Y.

Send books below for 10-day FREE EXAMINATION. In 10 days I will either remit price indicated (plus postage) or return books postpaid and owe you nothing:

Radio & TV TROUBLESHOOTING & REPAIR (\$10 separately)

Radio & TV CIRCUITRY & OPERATION (\$9 separately)

MONEY-SAVING COMBINATION OFFER . . . save \$2.00! Send both big books at special price of only \$17 for the two (regular price \$19.00) . . . you save \$2.00! Payable at rate of \$8 after 10 days if you decide to keep books and \$3 a month for 3 months until \$17 plus postage has been paid.

Save! Send cash with order and we pay postage. Same 10-day return privilege with money refunded.

Name

Address

City, Zone, State

Outside U.S.A.—TROUBLESHOOTING & REPAIR \$10.50; CIRCUITRY & OPERATION \$9.50; both books \$18. Cash with order, but 10-day return privilege with money refunded.

Music-Power Rating

(Continued from page 37)

take in 10 electrical watts and deliver 1 acoustic watt—maximum. But it is called a 10-watt speaker.

That's not all. Few loudspeakers, rated at 10 watts, will handle this much input power at a single sinusoidal frequency, through the range for which they are designed—which most good amplifiers do with ease. But the same loudspeakers are quite happy handling the maximum musical power a 10-watt amplifier can deliver, which is a mixture of many frequencies, with a low waveform factor.

Taken in conjunction with this fact, and other inconsistencies we haven't space to explain here, it is not so illogical to rate amplifiers according to the new IHFM music power definition. So let's take another look at that question, "Does the new Music Power Rating help tell the quality of an amplifier?"

What Good is MPR?

If you want to use all the figures you can get hold of about every available amplifier, you will probably try to make some deductions for which the published information was never intended. In introducing music power rating, the intention is to bring into use a figure for comparison that is more realistic than the one now used.

During a transitional period, progressive manufacturers will have to use both ratings, not to provide more information about their own product, but so that comparison can still be made with other products that do not yet use the new rating. It is hoped that all firms will ultimately use music power rating—at least as the main figure.

For simplicity, most people do not want to digest a whole catalogue of specifications about each product. From this standpoint, music power rating is a more informative single figure than continuous power rating. If you are sufficiently interested, continuous power rating, as a second figure, will convey an additional measure of merit.

We should not compare amplifiers with the same continuous power ratings and different music power ratings. When both figures are given, we would compare amplifiers first by music power rating; if two amplifiers have the same music power, we may then compare continuous power ratings.

This is important. Viewing music power rating as the secondary figure, we are tempted to conclude that a bigger difference between the two numbers represents a better amplifier. Our intuition favors the amplifier with better power-supply regulation, so we suspect the whole notion of music power rating.

But starting on the other foot, with music power rating as the primary figure and continuous power rating secondary, our intuition supports the rating inference. It is legitimate, to get

reasonable quality at low cost, to put music power ahead of continuous power, by using an inexpensive power supply. But using a better power supply results in an amplifier with "more solid" quality.

We would not say music power rating completely solves the problem of providing a relative evaluation of an amplifier, though. Properly used, it is a good step forward but there are still many things the present method of specifying performance doesn't tell. Let's put it this way:

Provided the amplifier does not handle musical transients in some peculiar fashion the specification does not show, and provided you always work it so musical peaks never exceed twice the rated music power output, this rating does give a relative indication of how much power amplifiers will deliver.

We can still have amplifiers that do strange things on certain kinds of musical sound. None of the figures currently published shows what is likely to happen if a momentary peak overshoots the peak music power (twice the music power rating). One amplifier may handle these things without "batting an eyelid," while another has electronic convulsions. That the specs do not tell us even now. This difference can often account for one amplifier seeming to give a lot more undistorted power than another of the same or similar rating, even when both the ratings are fully supported by tests.

We still have the effect that loudspeaker loads can have on an amplifier, as compared with the "dummy" resistance load, used for testing. The low distortion figures are always obtained with the dummy load. Nobody publishes, even if he measures, distortion with a loudspeaker load, because this depends, in an amplifier, on how much reactance the loudspeaker has—and no two loudspeakers are alike.

A good amplifier may give up to twice the test distortion when a loudspeaker is connected. A poor one may give many times as much distortion as soon as a little reactance enters the picture.

It should be possible, for the benefit of those who really care, to find a standard means of evaluating these various differences. It would be good to see the manufacturers make a move, possibly through the IHFM, in this direction. Meanwhile, it remains true that the specifications are a good starting point in judging an amplifier; but the real test is how it performs in your system.

REFERENCES

1. Crouchurst, Norman H.: "Why Do Amplifiers Sound Different?" *RADIO & TELEVISION NEWS*, March, 1957.
2. Crouchurst, Norman H.: "Some Defects in Amplifier Performance Not Covered by Standard Specifications," *Journal of the Audio Engineering Society*, October, 1957.
3. Von Recklinghausen, D. R.: "Mismatch Between Power Amplifiers and Loudspeaker Loads," *Journal of the Audio Engineering Society*, October, 1958.
4. Crouchurst, Norman H.: "The Amplifier Distortion Story," *Audio*, April and May, 1959.

Keeping Step

(Continued from page 58)

other types of service businesses. The people who repair washing machines, air conditioners, or refrigerators may be more favorably regarded in your particular locality than TV service technicians. It might pay to find out why. For all you know, the local bake shop may be using an idea that can help you. Most of the ways of doing business that are characteristic of our era and distinct from the methods of an earlier day originated in one, single field. After they won acceptance, they spread to other fields by change and adaptation. The idea of self-service may have started with the cafeteria. Eventually the modern supermarket replaced the small grocery with the same basic notion. Today a do-it-yourself trend that has affected nearly every type of endeavor may be traced to the same principle.

Be prepared to pay the price, literally, for keeping up with the times. Of course, it is never wise to squander money without knowing why, but nickel-nursing, as distinguished from thrift or good management, never built a solid business. A study was made not so long ago of firms that had once been well-established, but were found to be losing out to competition gradually over the years. The most obvious pat-

tern of similarity among these was found to be the fact that the owners were standing pat financially. "Creeping death" was due to the fact that these people had no arrangement for allocating a regular percentage of funds out of profits for making necessary changes to keep up with the world around them.

Look for new sources of revenue. Don't just speculate about new items to sell or to service. Take action. The chances are that you are letting opportunities go by right now, some of which you may even recognize to some extent, because they do not fit into your present operation conveniently. There is a close relationship between rigidity and rigor mortis. There are shops that will let a ripe local market for service of non-entertainment receivers go to someone else by default, for want of the addition of just one more piece of test equipment.

Don't forget advertising. The word-of-mouth type is fine. It doesn't make any difference which of the many other possible types—phone-book, mailing pieces, door-to-door leaflets—do or do not work best for you, as long as you keep up the ones that have proved themselves. Advertising is just as important in keeping old customers as it is in getting new ones.

Finally, stay profitable. You must make a certain minimum profit on every dollar you turn over. This too is part of keeping step.

ELECTRONIC SURPLUS

KAY MODEL RFP "MARKA-SWEEP". Used. Electronic, hand-switched, sweeping oscillators with narrow pulse type marker. Designed for rapid production testing of TV receivers and tuners. Complete with separate power supply and tubes. Needs repairs, but sells new at \$795.00.

\$69.50

DYNAMIC PRESS-TO-TALK MICROPHONE. Made by American Microphone Co. Hand held, polished chrome case, 4 wire lead. These are rugged, high performance mikes, guaranteed worth twice our closeout price. List price \$62.50. Choice of high or low impedance. **\$14.95**

WEBCOR STEREO CHANGER. Deluxe four speed WEBCOR Changer for hi-fi, replacement, or mono conversion. "Magic-Mind" intermix, stereo-mono switch, Sonotone 8T4S ceramic cartridge. Includes cables and mounting hardware.

ea. \$23.95
Lots of 3 or more **22.00**
Walnut or blonde Base **4.50**

TEST LEAD SET. Heavy 6" prods on one end, alligator clips on other end of 36" red rubber test lead. Prods alone more than worth the price. **49c**

PICT TUBE BRITENERS. Parallel six wire type. Famous brand closeout. Individually boxed, ten to a master case. Get a years supply at this fabulous price. Lots of 10 (min.) ea. **69c**
Lots of 100 ea. **55c**

RG11/U COAXIAL CABLE. Famous brand 72 ohm, regularly sells at \$11.00 per 100 feet. Quantity limited . . . Hurry. Per 100 ft. **\$ 6.95**
Per 1000 ft. **\$59.50**

JAN 6SH7 & 6H6 TUBES. Brand new gov't. surplus; higher quality than commercial grade. Manufacturers and experimenters, note!
For 10 (min) **\$2.95**
For 100 **24.95**

CROSS-OVER CONDENSER. Non-polarized 4 mfd. @ 25V wax impregnated. Excellent for cross-over networks. **39c**

FM-AM VARIABLE CONDENSER. Standard 3 gang tuning condenser, for replacement or building. **\$1.10**

POWER TRANSFORMER. For radio or amplifier use. Upright mounting style. Primary 117VAC Sec. 1-540V @ 86MA. Sec. 2-12.6V CT @ 1.4A. **99c**

All shipments FOB Chicago, Ill. 25% deposit on CO orders. Min. order, \$3.00. All items subject to prior sale.

IRVING JOSEPH, INC.

5959 W. Fullerton Ave.
National 2-3914 Chicago 39, Ill.

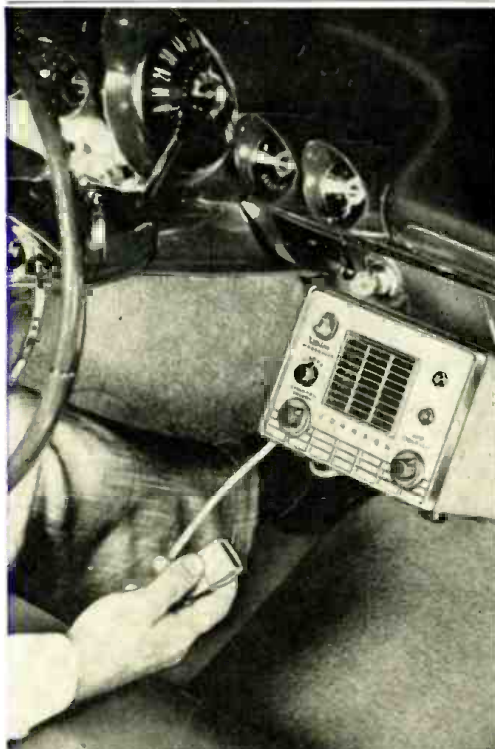

"More than Citizens' Radio"...

a complete, fully engineered "industrial-type" transceiver!

VIKING *Messenger*

Anyone can operate—license issued by the FCC on request

from

\$134⁹⁵

- Complete 23 channel Citizens' Band coverage—choose 1 of any 5 channels by the flip of a switch.
- Maximum legal power—excellent range—meets all FCC requirements.
- Excellent receiver sensitivity and selectivity—full fidelity voice reproduction.

"More than just 2-way Citizens' Radio equipment"—the Viking "Messenger" will deliver the finest performance of any equipment available in the field. Designed throughout for 10 watt power level—limited to 5 watts for Citizens' Radio. Easy to install anywhere in your home, business location, car, truck or boat . . . offers many unique features found only on more expensive communications systems. Built-in Squelch, Automatic Volume Control, and Automatic Noise Limiter. Compact, modern styling—only 5 3/4" high, 7" wide, and 1 1/2" deep. Complete with tubes, push-to-talk microphone, and crystals for one channel.



Available from authorized Johnson Electronic or Marine Distributors. Installation and service coast-to-coast at all General Electric Communications Service Stations.



E. F. JOHNSON COMPANY

103 Second Ave. S. W. • Waseca, Minnesota
• Please rush me your full color brochure describing the Viking "Messenger" Citizens' Transceiver.

NAME _____
ADDRESS _____
CITY _____ STATE _____

Manufacturers of the world's most widely used personal communications transmitters

TUBE TESTER



Model 85—Trans-Conductance Tube Tester.
Total Price—\$52.50. Terms: \$12.50 after 10 day trial, then \$8.00 monthly for 5 months if satisfactory. Otherwise return, no explanation necessary.

● Employs latest improved TRANS-CONDUCTANCE circuit. Tests tubes under "dynamic" (simulated) operating conditions. An in-phase signal is impressed on the input section of a tube and the resultant plate current change is measured as a function of tube quality. This provides the most suitable method of simulating the manner in which tubes actually operate in radio, TV receivers, amplifiers and other circuits. Amplification factor, plate resistance and cathode emission are all correlated in one meter reading.

● **SYMBOL REFERENCES:** For the first time ever in a trans-conductance tube tester, Model 85 employs time-saving symbols (★, +, ●, ▲, ■) in place of difficult-to-remember letters previously used. Repeated time studies proved to us that use of these scientifically selected symbols speeded up the element switching step. As the tube manufacturers increase the release of new tube types, this time-saving feature becomes more necessary and advantageous.

● **THE "FREE-POINT" LEVER TYPE ELEMENT SWITCH ASSEMBLY** marked according to RETMA basing, permits application of test voltages to any of the elements of a tube. The addition of an extra switch position permits the application of the necessary grid voltage needed for dynamic testing and insures against possible obsolescence due to changes in basing design.

● **NEW IMPROVED TYPE METER** with sealed air-damping chamber provides accurate, vibrationless readings.

● **FREE FIVE (5) YEAR CHART DATA SERVICE.** The chart provided with Model 85 includes easy-to-read listings for over 1,000 modern tube types. Revised up-to-date subsequent charts will be mailed to all Model 85 purchasers at no charge for a period of five years after date of purchase.

● **SPRING RETURN SAFETY SWITCH** guards Model 85 against burn-out if tube under test is "shorted."

● **7 AND 9 PIN TUBE STRAIGHTENERS** have been included on the front panel to eliminate possibility of damaging tubes with bent or out-of-line pins.

● **AN ULTRA-SENSITIVE CIRCUIT** is used to test for shorts and leakages up to 5 megohms between all tube elements.

Model 85 comes complete, housed in a handsome portable cabinet with slip-on cover. Only.....

\$52⁵⁰

SUPERIOR'S
NEW MODEL 77

VACUUM TUBE VOLTMETER

WITH NEW 6" FULL-VIEW METER



Model 77—VACUUM TUBE VOLTMETER
Total Price \$42.50—Terms: \$12.50 after 10 day trial, then \$6.00 monthly for 5 months if satisfactory. Otherwise return, no explanation necessary!

Compare it to any peak-to-peak V. T. V. M. made by any other manufacturer at any price

- ✓ Model 77 completely wired and calibrated with accessories (including probe, test leads and portable carrying case) sells for only \$42.50.
- ✓ Model 77 employs a sensitive six inch meter. Extra large meter scale enables us to print all calibrations in large easy-to-read type.
- ✓ Model 77 uses new improved SICO printed circuitry.
- ✓ Model 77 employs a 12AU7 as D.C. amplifier and two 9006's as peak-to-peak voltage rectifiers to assure maximum stability.

- ✓ Model 77 uses a selenium-rectified power supply resulting in less heat and thus reducing possibility of damage or value changes of delicate components.
- ✓ Model 77 meter is virtually burn-out proof. The sensitive 400 microampere meter is isolated from the measuring circuit by a balanced push-pull amplifier.
- ✓ Model 77 uses selected 1% zero temperature coefficient resistors as multipliers. This assures unchanging accurate readings on all ranges.

AS A DC VOLTMETER: The Model 77 is indispensable in Hi-Fi Amplifier servicing and a must for Black and White and color TV Receiver servicing where circuit loading cannot be tolerated.

AS AN AC VOLTMETER: Measures RMS values if sine wave, and peak-to-peak value if complex wave. Pedestal voltages that determine the "black" level in TV receivers are easily read.

AS AN ELECTRONIC OHMMETER: Because of its wide range of measurement leaky capacitors show up glaringly. Because of its sensitivity and low loading, intermittents are easily found, isolated and repaired.

SPECIFICATIONS

● DC VOLTS—0 to 3/15/75/150/300/750 1,500 volts at 11 megohms input resistance. ● AC VOLTS (RMS)—0 to 3/15/75/150/300/750/1,500 volts. ● AC VOLTS (Peak to Peak)—0 to 8/40/200/400/800/2,000 volts. ● ELECTRONIC OHMMETER—0 to 1,000 ohms/10,000 ohms/100,000 ohms/1 megohm/10 megohms/100 megohms/1,000 megohms. ● DECIBELS—10 db to +18 db, +10 db to +38 db +30 db to +58 db. All based on 0 db = .006 watts (6 mw) into a 500 ohm line (1.75v). ● ZERO CENTER METER—For discriminator alignment with full scale range of 0 to 1.5/7.5/37.5/75/150/375/750 volts at 11 megohms input resistance.

Model 77 comes complete with operating instructions, probe and test leads. Use it on the bench—use it on calls. A streamlined carrying case, included at no extra charge, accommodates the tester, instruction book, probe and leads. Operates on 110-120 volt 60 cycle. Only.....

\$42⁵⁰ NET

GENOMETER

7 Signal Generators in One!

- ✓ R.F. Signal Generator for A.M.
- ✓ R.F. Signal Generator for F.M.
- ✓ Audio Frequency Generator
- ✓ Bar Generator
- ✓ Cross Hatch Generator
- ✓ Color Dot Pattern Generator
- ✓ Marker Generator

A versatile all-inclusive GENERATOR which provides ALL the outputs for servicing:

A.M. Radio • F.M. Radio • Amplifiers • Black and White TV • Color TV



Model TV-50A—Genometer
Total Price\$47.50
Terms: \$11.50 after 10 day trial, then \$6.00 monthly for 6 months if satisfactory. Otherwise return, no explanation necessary.

R. F. SIGNAL GENERATOR: The Model TV-50A Genometer provides complete coverage for A.M. and F.M. alignment. Generates Radio Frequencies from 100 Kilocycles to 60 Megacycles on fundamentals and from 60 Megacycles to 180 Megacycles on powerful harmonics.

VARIABLE AUDIO FREQUENCY GENERATOR: In addition to a fixed 400 cycle sine-wave audio, the Model TV-50A Genometer provides a variable 300 cycle to 20,000 cycle peak wave audio signal.

BAR GENERATOR: The Model TV-50A projects an actual Bar Pattern on any TV Receiver Screen. Pattern will consist of 4 to 16 horizontal bars or 7 to 20 vertical bars.

THE MODEL TV-50A comes absolutely complete with shielded leads and operating instructions.

CROSS HATCH GENERATOR: The Model TV-50A Genometer will project a cross-hatch pattern on any TV picture tube. The pattern will consist of non-shifting, horizontal and vertical lines interlaced to provide a stable cross-hatch effect.

DOT PATTERN GENERATOR (FOR COLOR TV): Although you will be able to use most of your regular standard equipment for servicing Color TV, the one addition which is a "must" is a Dot Pattern Generator. The Dot Pattern projected on any color TV Receiver tube by the Model TV-50A will enable you to adjust for proper color convergence.

MARKER GENERATOR: The Model TV-50A includes all the most frequently needed marker points. The following markers are provided: 188 Kc., 262.5 Kc., 456 Kc., 600 Kc., 1000 Kc., 1400 Kc., 1600 Kc., 2000 Kc., 2500 Kc., 3579 Kc., 4.5 Mc., 5 Mc., 10.7 Mc., (3579 Kc. is the color burst frequency)

\$47⁵⁰ NET

EXAMINE BEFORE YOU BUY!
USE APPROVAL FORM ON NEXT PAGE

The Model 88.... A New Combination TRANSISTOR RADIO TESTER and DYNAMIC TRANSISTOR TESTER



The Model 88 is perhaps as important a development as was the invention of the transistor itself, for during the past 5 years, millions of transistor radios and other transistor operated devices have been imported and produced in this country with no adequate provision for servicing this ever increasing output.

The Model 88 was designed specifically to test all transistors, transistor radios, transistor recorders, and other transistor devices under dynamic conditions.

AS A TRANSISTOR RADIO TESTER

We feel sure all servicemen will agree that the instruments and methods previously employed for servicing conventional tube radios and TV have proven to be impractical and time consuming when used for transistor radio servicing. The Model 88 provides a new simplified rapid procedure — a technique developed specifically for transistor radios and other transistor devices.

An R.F. signal source, modulated by an audio tone is injected into the transistor receiver from the antenna through the R.F. stage, past the mixer into the I.F. Amplifier and detector stages and on to the audio amplifier. This injected signal is then followed and traced through

the receiver by means of a built-in High Gain Transistorized Signal Tracer until the cause of trouble whether it be a transistor, some other component or even a break in the printed circuit is located and pinpointed. The injected signal is heard on the front panel speaker as it is followed through the various stages. Provision has also been made on the front panel for plugging in a V.O.M. for quantitative measurement of signal strength.

The Signal Tracing section may also be used less the signal injector for listening to the "quality" of the broadcast signal in the various stages.

AS A TRANSISTOR TESTER

The Model 88 will test all transistors including NPN and PNP, silicon, germanium and the new gallium arsenide types, without referring to characteristic data sheets. The time-saving advantage of this technique

is self-evident. A further benefit of this service is that it will enable you to test new transistors as they are released!

SPECIFICATIONS:

✓ Model 88 operates on a self-contained 4½ volt battery and is always ready for instant use on the bench or in the field.

✓ Signal Injector:

The signal injector used in the Model 88 is a new departure in signal source design. Previously, signal sources were provided by signal generators operating on a single frequency and requiring retuning. The Signal Injector of the Model 88 employs a transistor in a grounded emitter self-modulating blocking oscillator generating a low R.F. frequency providing stable harmonics to 30 megacycles. A power output of over 2.5 volts peak to peak is provided. An attenuator prevents overload of the receiver or the amplifier under test.

✓ Signal Tracer:

Two high-gain grounded emitter transistors are utilized in a high gain amplifier with sufficient output to operate the built-in 4½" Alnico V Speaker. A diode is used as a "clamp" to prevent overloading of the output stage. A volume control permits attenuation of strong signals. Provision is also made on the front panel for the addition of a meter or an oscilloscope for quantitative evaluation of the signal strength.

✓ Transistor Tester:

The transistor tester used in the Model 88 measures the two most important transistor characteristics needed for transistor servicing; leakage and gain (beta).

The leakage test measures the collector-emitter current with the base connection open circuited. A range from 50 ohms to 100,000 ohms covers all the leakage values usually found in both high and low power transistor types.

The gain test (beta) translates the change in collector current divided by the base current. Inasmuch as the base current is held to a fixed value of 50 microamperes, the collector current calibrated in relative gain (beta), is read directly on the meter scale.

The Model 88 will test all transistor types, including NPN or PNP, germanium, silicon, gallium arsenide and the newer diffused junction and mesa types.

Model 88 comes housed in a handsome portable case. Complete with a set of Clip-On Cables for Transistor Testing, an R.F. Diode Probe for R.F. and I.F. Tracing, an Audio Probe for Amplifier Tracing and a Signal Injector Cable. Complete—nothing else to buy! Only

\$38⁵⁰

SHIPPED ON APPROVAL NO MONEY WITH ORDER — NO C.O.D.

Try any of the instruments on this or the facing page for 10 days before you buy. If completely satisfied then send down payment and pay balance as indicated on coupon. **No Interest or Finance Charges Added!** If not completely satisfied return unit to us, no explanation necessary.

MOSS ELECTRONIC, INC.

Dept. D-812 3849 Tenth Ave., New York 34, N. Y.

Please send me the units checked on approval. If completely satisfied I will pay on the terms specified with no interest or finance charges added. Otherwise, I will return after a 10 day trial positively cancelling all further obligations.

Model 85..... Total Price \$52.50
\$12.50 within 10 days. Balance \$8.00
monthly for 5 months.

Model 77..... Total Price \$42.50
\$12.50 within 10 days. Balance \$6.00
monthly for 5 months.

Model TV-50A..... Total Price \$47.50
\$11.50 within 10 days. Balance \$6.00
monthly for 6 months.

Model 88..... Total Price \$38.50
\$8.50 within 10 days. Balance \$6.00
monthly for 5 months.

Name

Address

City Zone..... State.....

All prices net, F.O.B., N. Y. C.

Export Division: **Rocke International Corp.**
13 East 40th Street, New York 16, N. Y.

SPECIAL MICROAMMETERS 4 inch sq.

50-0-50 Microamps, each \$6.95
0-50 Microamps, each \$7.95

EIMAC TRANSMITTING TUBE

450T—Brand New—Fully Guaranteed. \$39.50
Each.....

DYNAMOTOR SPECIAL

12 Volts Input-Output 440V, @ 200Ma. 12 Volts
Input-Output 225V, @ 100Ma. All in
one Dynamotor. BRAND NEW. Ea. \$7.95

BRAND NEW CARTER DYNAMOTOR

INPUT 5.9 VOLTS, OUTPUT 405 V. @
270 MA. SMALL SIZE Ea. \$4.95

COAX CABLE

RG8U—52 Ohm Impedance—Fresh Stock—500
feet on sealed wooden spools \$32.50
Each.....
RG62A/U—92 ohm impedance—Fresh Stock—500
Foot Spools..... \$38.50
Smaller quantities 7 1/2¢ per ft. Min. order 25 ft.

NEW VACUUM CAPACITORS

50 MMF-5KV95
25 MMF-10KV 2.25
EIMAC VC 600 MMF-32KV ea. \$4.95
EIMAC VC 25 MMF-32KV ea. 7.95
EIMAC VC 50 MMF-32KV ea. 6.95
JENNINGS 100 MMF-50KV ea. 24.95
JENNINGS JHC-150 MMF-50KV ea. 24.95

POWER TRANSFORMER

Primary 110V, 60 cy., Sec 445-0-445V, @ 150
Ma, 6.3V, @ 6 Amps, 5V, @ 3 Amps.
Fully shielded. \$3.95
Write for quantity prices

CHOKE—FULLY CASED

5 HENRY @ 200 Ma 1.95
5 HENRY @ 250 Ma 2.25
4-12 HY (Swinging) @ 300 Ma 3.95
12 HENRY 400 Mil 3.95
12 HENRY 500 Mil 6.95
4 HENRY 800 Mil 6.95
6 HENRY 800 Mil 6.95

BRAND NEW OIL CONDENSERS

3 MFD 800 VDC .60	4 MFD 2000 VDC 3.50
4 MFD 600 VDC .75	6 MFD 2000 VDC 4.95
5 MFD 600 VDC .80	8 MFD 2000 VDC 6.95
6 MFD 800 VDC .85	2 MFD 2000 VDC 1.50
8 MFD 800 VDC .95	2 MFD 1000 VDC 1.65
10 MFD 800 VDC 1.19	2 MFD 1000 VDC 3.50
12 MFD 800 VDC 1.50	1 MFD 4000 VDC 6.25
15 MFD 800 VDC 1.70	2 MFD 600 VDC 1.95
3x8 (24 MFD) 600 VDC 2.50	3 MFD 4000 VDC 8.95
1 MFD 1000 VDC 1.10	4 MFD 4000 VDC 13.95
2 MFD 1000 VDC .70	15 MFD 1500 VDC 2.95
4 MFD 1000 VDC 1.35	1 MFD 7500 VDC 6.95
8 MFD 1000 VDC 1.95	2 MFD 12,500 VDC 17.95
10 MFD 1000 VDC 2.50	2 MFD 18,000 VDC 29.95
12 MFD 1000 VDC 2.95	1 MFD 12,500 VDC 19.95
15 MFD 1000 VDC 3.50	1 MFD 12,500 VDC 34.95
1 MFD 1200 VDC .45	1 MFD 15,000 VDC 42.50
1 MFD 1500 VDC .75	5 MFD 25,000 VDC 34.95
2 MFD 1500 VDC 1.10	1 MFD 600 AC 1.95
4 MFD 1500 VDC 1.95	10 MFD 330 AC 1.95
8 MFD 1500 VDC 2.95	20 MFD 330 AC 2.95
1 MFD 2000 VDC 1.50	5 MFD 600 AC 1.95
2 MFD 2000 VDC 1.50	2 MFD 600 VDC .50

RELAYS

GUARDIAN 110V AC, 2 Pole Single Throw
(1 N.O. & 1 N.C.) Repl. SC-61D \$2.50
Potter-Brumfield SMSLS 5000 ohm,
4 Ma. Sens \$2.25
Hermetically Sealed Relay Coil 110V AC,
60 cy SPDT Contacts 5 Amps \$1.50
6 Volt DC DPDT H.S. 99c
12 Volt DPDT DC Relay \$1.35
SIGMA type 22RJC 6,000 ohm
SPDT, small sealed relay \$2.49
Sealed Relay, SPDT, 6,000 ohm
coil \$1.95
G.E. Relay control, contains 8000 ohm
relay, sensitivity 2 mils. 10 for \$9.25, ea. \$1.10
SIGMA 5F-16,000 ohm SPDT, operates
on 500 Microamperes or less \$3.95

PANEL METERS

STANDARD BRANDS	3" METERS
1 1/2" METERS	100-0-100 Micro Amps
0-1 Mil 2.95	DC 5.95
0-100 Micro 3.95	0-1 Mil DC 3.95
	0-10 Mils DC 3.95
	0-100 Mils DC 3.95
	0-150 Mils DC 3.95
2" METERS	0-500 V. DC 3.95
100-0-100 Micro 3.95	D-1 Amp RF 4.50
0-50 Micro (0-5 scale) 4.95	0-15 Amps RF 4.50
0-10 Amps DC 2.95	0-12 Volts AC 3.95
0-20 Volts DC 2.95	0-15 Volts AC 3.95
18-36 Volts DC 1.99	REED Freq. Meter
0-150 V. AC 3.49	-110V. AC, 37- 63 cy 9.95

MISCELLANEOUS SPECIALS

JOHNSON Var. Cond. 250 MMF \$2.50
3500 V.
SPERTI Vacuum Switch used in ART13 ea. \$1.50
36 OHM 50 Watt Globar Non-Ind. Res. 2 for \$1.00
3-12 MMF Erie Ceramic Trimmers 21c
FULL WAVE SELENIUM RECTIFIERS—20 Plates
per section—Output 320V. @ 4 Amps.
Ea. \$4.95
MAGNETIC PICK-UP TOOL gets Nuts, Bolts, Tacks,
etc. out of difficult places. 79c
Each.....
CUTLER-HAMMER TOGGLE SWITCH 29c
SPDT (ST42D) 4 for \$1.00 ea.
WILLARD STORAGE CELL—2V, 28 Amps
hrs. Clear plastic case. Shipped dry. ea. \$2.50
Write for quantity prices on all special items

All merchandise sold on a 10 day money back guarantee
Min. Order \$3.00—25% with Order—F.O.B. New York

PEAK

ELECTRONICS COMPANY
66 W. Broadway, New York 7, N. Y., WO-2-2370

Hand-Held CB Transceiver

(Continued from page 44)

sistent with stable oscillator performance. Then adjust coil L_2 for maximum r.f. output as indicated by a grid-dip meter coupled near coil L_1 . All adjustments should be made with someone holding the case to represent a ground-plane for the antenna. The whip should be clear of all metal objects. Tuned in this manner, the transceiver should be well within the specified frequency tolerance of 0.005% (1.3 kc.). However, the actual frequency should be checked accurately. (See "What's Your Citizens Band Frequency?" in the August, 1960 issue of this magazine.)

You can observe the modulation waveform by constructing the test set-up shown in Fig. 2. If you talk loudly, you may note a flattening at the top and bottom of the speech waveform as seen on the oscilloscope. However, speaking in a normal voice about 12 inches from the microphone should produce clear, crisp audio at approximately 85% modulation. You cannot over-modulate the device, but you can distort the audio by speaking too loudly or working too close to the microphone.

"No License" Operation

Special provision is made in Part 15 of the Commission Rules relating to low-power transmitters. No license is required for this unit if the following requirements are met:

1. The power input to the final amplifier must not exceed 100 mw. (11 ma. at 9 volts). This transceiver cannot be overpowered when wired as shown.
2. An antenna no longer than 60 inches, attached to the case, may be used. The antenna on this unit is 36 inches.
3. The carrier must be maintained within the band 26.97-27.27 mc. For

class D operation, a frequency tolerance of 0.005% (about 1.3 kc.) must be observed. This circuit uses a 0.005% crystal and the circuit will maintain this stability. The manufacturer of the transmitter subassembly has certified the unit at the factory.

4. Spurious radiation is at least 20 db below the fundamental frequency. The second harmonic of this transceiver is 38 db below the fundamental. Other spurious signals are too weak to be measured.

It is suggested that a typewritten sheet containing the following information be attached to the back of the case: "This device is intended for low power, short range, two-way voice communication in compliance with Part 15.205 of Commission Rules and shall be used only with the single wire antenna supplied. Said antenna does not exceed 36 inches. Frequency control is by means of quartz crystal and is certified to 0.005% specifications."

Whenever the transceiver is used in conjunction with the usual 5-watt class D Citizens Band station, or is used with an outside antenna, it assumes the call numbers and becomes a unit of the station. A card giving the call numbers, owner, and frequency should be attached to the unit in compliance with FCC Citizens Band Rules (Part 19).

Conclusion

This Citizens Band portable has proven invaluable on numerous occasions. Even though it is used and loaned quite often, it is still on the first battery indicating long life. The dependable range is in excess of 2000 yards on a line-of-sight basis. The power is so low it cannot possibly "skip out" and interfere with other stations. Since the unit is completely portable and interference is eliminated, the transistor transceiver is useful in many places where the "high power" 5-watt units would not be applicable.

Inside view of the completed transceiver. Audio board with its three transformers occupies most of the space. Receiver board is at the top left in this photo; the transmitter board is at the right side. Two slide switches, employed for on-off and transmit-receive functions are mounted along the top edge in this illustration.

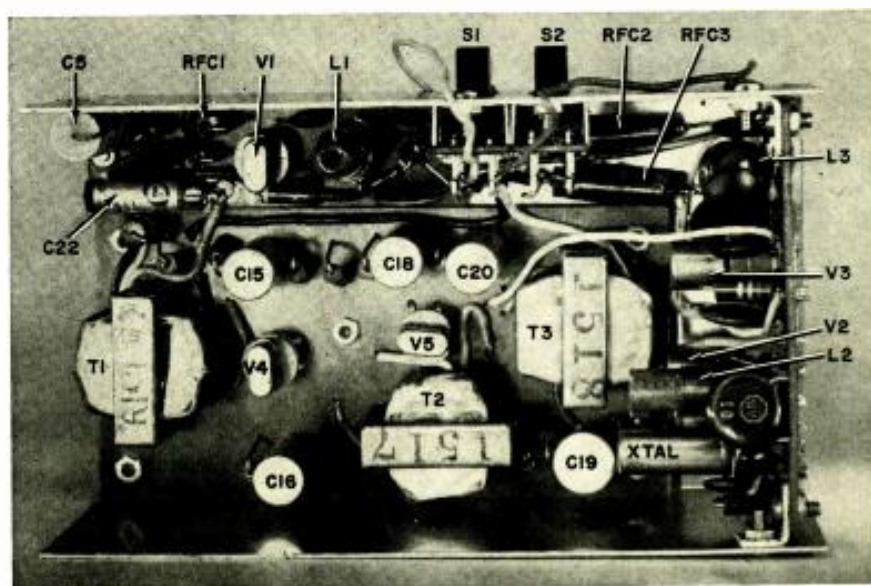



... symbol of
RAD-TEL
FIRST
QUALITY

INSIST ON RAD-TEL FOR EVERY
 TELEVISION AND RADIO TUBE NEED

Super-Special!

KIT OF 100
Bi-Pass
CONDENSERS

Over 50% Are 600V
 Others 400V And 200V

at
LESS
THAN
 4¢ each

\$3.95

Goodall
Semi-Molded
Paper
and
MYLAR

Values .001 to 1 mf

Up to 75% OFF on BRAND NEW TUBES

GUARANTEED ONE FULL YEAR!

You Can Rely On Rad-Tel's Speedy One Day Service!

Not Used — Not Pulled Out Of Old Sets • Each Tube Individually and Attractively Boxed!

Qty.	Type	Price	Qty.	Type	Price	Qty.	Type	Price	Qty.	Type	Price	Qty.	Type	Price	Qty.	Type	Price
—	0Z4M	.79	—	3DT6	.50	—	6AB4	.46	—	6B16	.62	—	6E08	.79	—	12A4	.60
—	1AX2	.62	—	3Q5	.80	—	6AC7	.96	—	6BK7	.85	—	6E88	.79	—	12AB5	.55
—	1B3GT	.79	—	3S4	.61	—	6AF3	.73	—	6BL7	1.00	—	6H6GT	.58	—	12AC6	.49
—	1DN5	.55	—	3V4	.58	—	6AF4	.97	—	6BN4	.57	—	6J5GT	.51	—	12AD6	.57
—	1G3	.73	—	4BC5	.56	—	6AG5	.65	—	6BN6	.65	—	6J6	.67	—	12AE6	.43
—	1I3	.73	—	4BC8	.96	—	6AH6	.99	—	6BQ5	.74	—	6K6	.63	—	12AF3	.73
—	1K3	.73	—	4BN6	.75	—	6AK5	.95	—	6BQ6GT	1.05	—	6S4	.48	—	12AF6	.49
—	1L6	1.05	—	4BQ7	.96	—	6AL5	.47	—	6BQ7	.95	—	6SA7GT	.76	—	12A16	.46
—	1LN5	.59	—	4BS8	.98	—	6AM8	.78	—	6BR8	.78	—	6SK7	.74	—	12A15	.45
—	1R5	.62	—	4BU8	.71	—	6AN4	.95	—	6BU8	.70	—	6SL7	.80	—	12A18	.95
—	1S5	.51	—	4BZ6	.58	—	6AN8	.85	—	6BY6	.54	—	6SN7	.65	—	12AQ5	.52
—	1T4	.58	—	4BZ7	.96	—	6A05	.50	—	6BZ6	.54	—	6SQ7	.73	—	12AT6	.43
—	1U4	.57	—	4CS6	.61	—	6AR5	.55	—	6BZ7	.97	—	6T4	.99	—	12AT7	.76
—	1U5	.50	—	4DE6	.62	—	6AS5	.60	—	6C4	.43	—	6U8	.78	—	12A06	.50
—	1X2B	.82	—	4DK6	.60	—	6AT6	.43	—	6CB6	.54	—	6V6GT	.54	—	12A07	.60
—	2AF4	.96	—	4DT6	.55	—	6AT8	.79	—	6CD6	1.42	—	6W4	.57	—	12AV5	.97
—			—	5AM8	.79	—	6AU4	.82	—	6CF6	.64	—	6W6	.69	—	12AV6	.41
—	3AL5	.42	—	5AN8	.86	—	6A06	.50	—	6CG7	.60	—	6X4	.39	—	12AV7	.75
—	3AU6	.51	—	5AQ5	.52	—	6AU7	.61	—	6CG8	.77	—	6X5GT	.53	—	12AX4	.67
—	3AV6	.41	—	5AT8	.80	—	6AU8	.87	—	6CM7	.66	—	6X8	.77	—	12AX7	.63
—	3BA6	.51	—	5BK7A	.82	—	6AV6	.40	—	6CN7	.65	—	7AU7	.61	—	12A27	.86
—	3BC5	.54	—	5BQ7	.97	—	6AW8	.89	—	6CR6	.51	—	7A8	.68	—	12B4	.63
—	3BE6	.52	—	5BR8	.79	—	6AX4	.65	—	6CS6	.57	—	7B6	.69	—	12BA6	.50
—	3BN6	.76	—	5C6G	.76	—	6AX7	.64	—	6CU5	.58	—	7Y4	.69	—		
—	3BU8	.78	—	5CL8	.76	—	6BA6	.49	—	6C06	1.08	—	8AU8	.83	—		
—	3BY6	.55	—	5EA8	.80	—	6BC5	.54	—	6CY5	.70	—	8AV8	.93	—		
—	3BZ6	.55	—	5E08	.80	—	6BC7	.94	—	6CY7	.71	—	8BQ5	.60	—		
—	3CB6	.54	—	5I6	.68	—	6BC8	.97	—	6DA4	.68	—	8CG7	.62	—		
—	3CF6	.60	—	5T8	.81	—	6BD6	.58	—	6DB5	.69	—	8CM7	.68	—		
—	3CS6	.52	—	5U4	.60	—	6BE6	.55	—	6DE6	.58	—	8CN7	.97	—		
—	3CY5	.71	—	5U8	.81	—	6BF6	.44	—	6DG6	.59	—	8CX8	.93	—		
—	3DK6	.60	—	5V6	.56	—	6BG6	1.66	—	6DQ6	1.10	—	8E88	.94	—		
—			—	5X8	.78	—	6BH6	.65	—	6DT5	.66	—	10DA7	.71	—		
—			—	5Y3	.46	—	6BH8	.87	—	6DT6	.53	—	11CY7	.75	—		

Not a Kit, but Completely Wired
STEREO AMPLIFIER
CHASSIS \$4.95

- Single, \$5.95 ea.
- Set of tubes: 2-35C5; 1-12AX7, 1-35W4 \$1.15
- Set of 3 grey 1/2" knobs 30c



SEND FOR FREE TROUBLE SHOOTER GUIDE AND
 NEW TUBE & PARTS CATALOG.

NOT AFFILIATED WITH ANY OTHER MAIL ORDER TUBE COMPANY.

RAD-TEL TUBE CO.

55 Chambers St
 Newark 5, N. J.

TERMS: 25% deposit must accompany all orders — balance C. O. D.
 \$1 HANDLING CHARGE FOR ORDERS UNDER \$5. Subject to prior sale.
 Please add postage. No C. O. D.'s outside continental U. S. A.

EW 1060

3 OUTSTANDING

ORDER TODAY

Hy-gain

CITIZENS BAND

BASE STATION ANTENNAS

The Hy-Gain base station Citizens Band antennas are designed for high efficiency point-to-point or base station to mobile operation. Complete instructions; easy to assemble; precision tuned and matched for 52 ohm coax; will ship parcel post. All construction in accordance with military specifications for maximum weather ability.

Standard

GROUND PLANE

Highest quality, lowest cost ground plane delivering maximum efficiency. Radiator and radials constructed of heavy wall $\frac{3}{8}$ " OD aluminum tubing. Unbreakable cycloac plastic and iridite-treated steel base assembly accepts masts up to 1 $\frac{1}{2}$ " OD.

Model SGP

\$2695

List

Heavy Duty

GROUND PLANE

For long, trouble-free commercial duty, withstanding wind velocities up to 100 mph. Radiator & radials use heavy wall $\frac{3}{8}$ " to $\frac{1}{2}$ " OD telescoping aluminum tubing. Departure angle of ground plane radials adjusted for perfect 50 ohm match. Unbreakable cycloac plastic and iridite-treated steel base assembly accepts all masts up to 1 $\frac{1}{2}$ " OD.

Model GP-1 \$4375 List

Coaxial ANTENNA

A coaxial half-wave sleeve antenna (equal to ground plane in efficiency) designed for inconspicuous rooftop or side mounting. The CXL is constructed of heavy wall $\frac{3}{8}$ " OD aluminum tubing radiator and 2" OD aluminum sleeve. Easy, rapid mounting on standard 1 $\frac{1}{4}$ " OD masting or 1" ID plumbers pipe. No threading. Sleeve length adjustable for proper decoupling action.

Model CXL \$3325 List

FREE
Antenna
Catalog

Complete Line
of
Citizens Band
Antennas



EW-10

Hy-gain antenna products

1135 NO. 22ND ST. LINCOLN, NEBRASKA

PLEASE SEND:

- FREE CITIZENS BAND CATALOG
 COMPLETE DEALER INFORMATION

Name: _____

Firm: _____

Address: _____

City & State: _____

Within the Industry

(Continued from page 32)

search division in Philadelphia. Dr. Ghandhi is chairman of the AIEE-IRE semiconductor devices subcommittee, and was staff member of the G-E electronics laboratories for nine years before joining *Philco*. He is a graduate of the Benares Hindu University of Benares, India, where he earned his Ph.D. in electronics in 1951 . . . **DONALD E. GARRETT** has been named manager of advanced development engineering for *General Electric's* television receiver department. He has been with the company since 1950 . . . **THOMAS C. PRIDMORE** is the new chief engineer for *Bradley Semiconductor Corp.* . . . **CYRIL J. STATT** has been appointed manager of *General Electric's* Schenectady tube plant. He joined the company in 1940, originally in testing work . . . **IRA S. FRENCH** has been named director of public relations for the Instrument Society of America. He was previously in PR work as well as the newspaper field . . . **ARTHUR S. DAVIS** has been appointed customer relations manager of *Elgin Micronics*, a division of *Elgin National Watch Co.* Prior to joining the firm, Mr. Davis was sales manager, Gearing division of *Westinghouse* . . . **HERMAN FIALKOV**, president of *General Transistor Corp.*, is the new chairman of the Long Island, N. Y. chapter of the Young Presidents Organization . . . **EDWARD S. MAURY** has been appointed vice-president in charge of engineering for *Marion Instrument Division of Minneapolis-Honeywell*. Since 1955 he had been the division's sales vice-president . . . **BERNARD B. MASKET** has been named vice-president and controller of *BSR (USA) Limited* . . . **BOYD B. BARRICK** has been promoted to general sales manager for *Raytheon's* distributor products division. He was formerly central zone manager for the division . . . **GEORGE D. BUTLER** has been elected a vice-president of *International Resistance Co.* For the past two years he had been director of marketing for the company . . . **JOHN D. VICKREY** has been named sales manager for the selenium products division of *International Rectifier Corp.* He was formerly sales manager of the distributor division . . . **C. DONALD PRICE** has been appointed advertising and sales promotion manager of *Sylvania Home Electronics Corp.* Since 1958, he had been district advertising manager of the Hotpoint Appliance Division of *General Electric* . . . **JOHN C. SCHMIDT** has been named customer liaison engineer for the military products division of *Tempo Instrument Inc.* Before joining the company he was a sales engineer for *Airborne Instruments Laboratory* . . . **EUGENE JOHN FREEMAN** has been appointed vice-president and general manager of *Roberts Electronics*. He was formerly general manager of *Pacific Mercury's* marketing division . . . **WILLIAM S. AIKEN** has been named di-

rector of engineering at the *Thompson-Ramo-Wooldridge Products Co.* He was formerly manager of the computer firm's product engineering department.

EDWARD E. BAUER is the new vice-president and general manager of the New Bedford Division of *Aerovox Corporation*.



He comes to the job from the *General Electric Company* where he was general manager of the Irmo, South Carolina capacitor plant, manufacturing tantalum, Mylar, and electrolytic capacitors. Previously, he was employed in various capacities with other divisions of G-E.

Mr. Bauer received his B.S. in Mechanical Engineering from the University of Wisconsin and his Master's Degree from the University of Pennsylvania. He holds an LL.B. from LaSalle University in Chicago.

BRITISH BROADCASTING CORPORATION has opened the first of its new White City studios in Britain. According to **ENGLISH ELECTRIC VALVE COMPANY, LTD.**, whose image orthicon tube will be used by *BBC*, the new studios are expected to give Britain the lead over any other European country enjoying TV services . . . **PAM ASSOCIATES, INC.**, specialist in noise control and acoustic and vibration equipment, has moved to larger quarters in Baltimore . . . **ULTRASONIC INDUSTRIES, INC.** is building a new plant at Engineers Hill, Plainview, N. Y. . . **CHICAGO AERIAL INDUSTRIES, INC.**, Melrose Park, Ill., has moved its executive offices and industries division to new facilities in Barrington, Ill. The kintronic and aerial survey divisions will maintain their own quarters in Franklin Park, Ill. . . **COOKE ENGINEERING CO.** has announced the opening of new offices at 735 N. St. Asaph St., Alexandria, Va. The organization specializes in telecommunications from a systems design viewpoint and is also active in radar air traffic control . . . **KENTUCKY ELECTRONICS, INC.** is the new name of the firm previously known as **ERSKINE PRECISION WIRE CORP.** Its entire facilities and offices have been moved from Emporium, Pa. to Owensboro, Ky. . . **ATLEE CORP.** is constructing a new manufacturing plant in Rockland, Mass.

JAY CARVER, advertising and merchandising manager of *University Loudspeakers*, was killed in an automobile accident while returning home from his company's stereo demonstration at Grossinger's. He was associated with a number of well-known firms in the industry, most recently with *Electro-Voice*. He was a contributor of numerous audio articles to this and other publications in the electronics field.

FAMOUS BC-645 TRANSCEIVER

15 Tubes 435 to 500 MC

Can be modified for 2-way communication. Voltage on coil on high band 420-450 mc. circuit and modified 400-430 mc. circuit. Includes export metal 470-500 mc. 15 tubes. Tubes, about 100% more than set listed. 4-7F7, 4-7HT, 1-7F1, 1-6Y6, 2-6X5, and 1-6W6. 110V. Now comes 480 mc. 450 mc. Brand new BC-645 with tubes, less power supply in factory carton. **\$19.50**

Shipping weight 2 1/2 lbs. **SPECIAL!**
 PE-101C Dynamotor, 12/24V unit \$7.95
 UHF Antenna Assembly 2.45
 Complete Set of 10 Plugs 5.50
 Control Box 2.25

SPECIAL "PACKAGE" OFFER:
 BC-645 Transceiver, Dynamotor and all accessories above. COMPLETE, BRAND NEW. **\$29.50**
 White Stocks Last

BC-929 3-INCH SCOPE

Low cost station monitor and air bench scope. Has Horiz., focus, sweep, intensity controls. Tubes: 2-6SN7, 2-6H6, 1-6X5, 1-6G8, 1-2X2, 3HP CR Tube. Voltage req. 115V 400 cy. and 24 VDC. Complete with tubes, exc. **\$9.95**

used **BRAND NEW** \$12.95
 Conversion instructions for 110V 60 cy. AC **65c**

LORAN R-65/APN-9 RECEIVER & INDICATOR

Used in ships and aircraft. Determines position by radio signals from known transmitters. Accurate to within 10% of distance. Complete with tubes and crystal. Exc. used **\$19.50**

Value \$1200.00
 Our Price **\$19.50**

Used, less tubes, crystal and visor, but with 3HP1 C.R. tube for above. **\$29.50**
 12 Volt Inverter Power supply for above. **\$32.50**
 NEW **\$32.50**
 28 Volt Inverter Power Supply, exc. cond. **\$49.50**
 Shock Mount for above. **\$2.95**
 Circuit diagram and connecting plugs available.

LORAN APN-4 FINE QUALITY NAVIGATIONAL EQUIPMENT

Determine exact geographic position of your boat or plane. Indicator and receiver complete with all tubes and crystal.

INDICATOR ID-6B/APN-4, and RECEIVER R-9B/APN-4, complete with tubes. Exc. used \$49.50
 Receiver-Indicator as above. **BRAND NEW \$88.50**

12V Inverter Power Supply. **BRAND NEW \$32.50**
 28V Inverter Power Supply, exc. cond. **\$49.50**
 Shock Mount for above. **\$2.95**

ARC-5/R28 RECEIVER

2-meter Superhet. 100 to 156 Mc in 4 crystal channels. Complete **\$24.45**
 with 10 Tubes. **BRAND NEW \$49.75**
 110V AC Power Sup. Kit for above **\$9.75**

ARC-5/T-23 TRANSMITTER

100-150 Mc Includes 2-832A, 2-1825 Tubes. **BRAND NEW \$21.50**
SPECIAL! Limited quantity ARC-5/T23 transmitters. OFFER! Excellent Used, less tubes. **\$5.95**
 MD-7 MODULATOR for T-23, complete with **\$9.95**
 4 tubes, 1-LIKE NEW

ARC-5 MARINE RECEIVER-TRANSMITTER

Navy Type Comm. Receiver 1.5 to 3 Mc **BRAND NEW with 6 tubes. \$16.95**

Navy Type Comm. Transmitter 2.1-3 Mc **BRAND NEW with 4 tubes and Xtal \$12.45**
 MODULATOR for above, new with tubes. **\$5.95**

SCR-274 COMMAND EQUIPMENT

ALL COMPLETE WITH TUBES

Type	Description	Used	Like NEW
BC-453	Receiver 110-550 KC.	\$12.95	\$14.95
BC-454	Receiver 6-9 Mc.	9.45	12.45
BC-455	Receiver 6-9 Mc.	11.50	13.95
BC-450	3-Receiver Control Box.	1.29	1.75

110 Volt AC Power Supply Kit, for all 274-N and ARC-5 Receivers. Complete with metal case, instructions (tested, ready to operate). **\$7.95**

Factory wired, tested, ready to operate. **\$11.50**

SPLINED TUNING KNOBS for 274-N and ARC-5 RECEIVERS. Fits BC-453, BC-454 and others. Only \$49c

BC-457 TRANSMITTER—4-5.3 Mc. Complete with all tubes and crystal. \$8.95

BC-458 TRANSMITTER—3.3 to 7 Mc. Complete with all tubes and crystal. \$9.75

BRAND NEW

BC-459 TRANSMITTER—7-9.1 Mc. complete with all tubes and crystal. \$13.95

BC-456 Modulator. USED 3.45 NEW 5.95

BC-451 Transmitter Control Box 1.25 NEW 1.49

ALL ACCESSORIES AVAILABLE FOR COMMAND EQUIPMENT.

234-258 MC RECEIVER

AN/ARR-2
 BRAND NEW 11-tube UHF Tunable Receiver with schematic. Only a few at this low price!
 Complete with tubes **\$8.88**

Send Name, Address on Post Card for FREE CATALOG of Wonderful Surplus Buys!

ARC-3 RECEIVER!

Crystal controlled 17-tube superhet. tunes 100 to 156 Mc AM on any 8 pre-selected channels. 28V DC Power input. Complete with all tubes. Exc. used. **\$16.95**

ARC-3 TRANSMITTER

Companion unit for above, tunes 100 to 156 MC on any 8 pre-selected channels. 9 tubes, crystal controlled, provides tune and voice modulation. 28V DC Power input. Complete with all tubes. Exc. Used. **\$16.95**

5-TUBE AMPLIFIER

Made by Pioneer Instruments Co. Uses 6-6SN7, 1-6X5, 2-6H6 tubes **VERY SPECIAL \$2.95**
 BRAND NEW

AN/ART-13 100-WATT XMTR

11 CHANNELS
 200-1500 Kc
 2 to 18.1 Mc
\$48.50

Complete with Tubes
 Famous Collins Autotune Aircraft Transmitter, AM, CW, MCW. Quick change to any of ten preset channels or manual tuning. Speech amplifier/clipping circuit or magnetic mike. Highly stable, highly accurate VFO. Built in Xtal controlled calibrator. PPM 1 to modulate 813 in final up to 90% class. A Real "HOT" Ham buy at our low price! **\$48.50**
 Orig. cost \$1800. Exc. Used **\$48.50**
 0-16 Low Freq. Osc. Coil for ART-13. **7.95**
 24V Dynamotor for ART-13. **11.95**
 Same as above less meter. **39.50**

POWER SUPPLY for BC-620, 659, available for 6, 12 or 24 Volts DC. Specify. **\$8.95**

BC-659 TRANSMITTER & RECEIVER

27 to 39.9 Mc. F.M. Two preselected channels, crystal controlled. 5 watts. Complete with speaker. **\$10.95**
 tubes. Used. **\$5.95**
 Less tubes, used. **\$2.95**
 Antenna for BC-659. Telescoping 20' to 8-Ft. **\$2.95**

NAVY AIRCRAFT RADIO RECEIVER

ARR/CRV 46151-190 to 9050 Kc in 4 bands. 6 Tube Superhet communications receiver, with local and remote tuning, band change, sharp and broad tuning. AVC. CW. Illuminated dial. Complete with tubes and dynamotor. **BRAND NEW. \$36.50**
 Like New. **\$36.50**
 Power Supply 110 V. AC. Wired **\$8.50**

BC-906 FREQ. METER—SPECIAL

Cavity type, 145 to 235 Mc. **BRAND NEW**, complete with antenna. Manual included.
OUR LOW PRICE. \$10.88

SCR-625 MINE DETECTOR

Complete portable outfit in original packing, with all accessories. **Brand New \$22.50**

DYNAMOTOR ASSEMBLY

Very fine unit, made by Collins Radio. Consists of TWO dynamotors mounted on filter base.

Dynamotor #1— INPUT OUTPUT
 12VDC @ 3.8A 220V/100 Ma.

Dynamotor #2— INPUT OUTPUT
 12VDC @ 9.9A 40V/100 Ma.

Like **BRAND NEW**, in original packing. **\$10.95**
 SHIP WT 29 lbs.
OUR LOW PRICE.

MOBILE-MARINE DYNAMOTOR

Model DM35
 Input 12V DC. Output: 625 V DC @ 225 Ma. for pre-selector intermittent operation. Ship. wt. 14 lbs. **OUR LOW PRICE. BRAND NEW \$8.45**

OTHER DYNAMOTOR VALUES: Excellent BRAND

Type	Input	Output	Used	NEW
DM-25	12V 2.2A	250V .050A		\$4.50
DA-1A	28V 1.6A	230V 1.00A		3.25
DM-28	28V	224V .07A	2.75	4.75
DM-32A	28V 1.1A	250V .05A	2.45	4.45
DM-33A	28V 5A	54V .15A		
DM-34	28V	250V .25A	1.95	3.75
DM-34D	12V 2A	220V .080A	4.15	5.50
DM-53A	28V 1.4A	220V .080A	3.75	5.45
DM-64A	12V 5.1A	275V .150A		7.95
PE-73C	28V 20A	1000V .350A	7.95	P.U.R.
PE-86	28V 1.25A	250V .050A	2.75	3.85

SD-77 DYNAMOTOR Input 14V @ 39A. Output 100V @ 350A with starting solenoid. Filter Box and Mounting Base. **Like New \$14.95**

SCHEMATIC DIAGRAMS

For any equipment on this page, each. **65c**

Please include 25% Deposit with order—Balance C.O.D. or Remittance in Full. 50c Handling Charges on all orders under \$5.00. All shipments F.O.B. Our Warehouse, N.Y.C. All Merchandise subject to Prior Sale and Price Change.

G & G Radio Supply Co.

Telephone: CO 7-4605
 51 Vesey St., New York 7, N. Y.

BC-603 FM RECEIVER

20 TO 27.9 MC. **\$14.95**
 Excellent Used **\$17.95**
BRAND NEW **\$17.95**

10 Channel, pushbutton tuning or continuous tuning. Complete with speaker, tubes, switch.

12 or 24V Dynamotor for Above. **Brand New \$5.50**
 Exc. Used \$4.25

BC-604 TRANSMITTER—Companion unit for BC-603 Rcvr above. With all tubes. BRAND NEW. \$10.95
 With Tubes, Used. **\$4.95**

SPECIAL! BC-603 FM RCVR CONVERTED FOR ANY FREQUENCY FROM 30 TO 50 MEGACYCLES!

BRAND NEW! Checked out, perfect working condition, ready for operation. Specify Frequency desired (between 30-50 Mc) when ordering. **\$27.50**

AC POWER SUPPLY for BC603, 683
 Interchangeable, replaces dynamotor. Has On-Off Switch. NO POWER CHANGE NEEDED. Provides 220 VAC @ 80 Ma. 24VAC @ 2 Amps. **\$10.49**
 Complete 240-page Technical Manual for BC-603, 684. **\$3.15**

BC-605 INTERPHONE AMPLIFIER

BRAND NEW Special, each **\$4.95**

AN/APR-4 RECEIVER only. 38 to 4000 Mc in 5 tuning unit ranges. High precision laboratory instrument used to monitor or indicate frequency of any signals within its range. Includes wide and narrow band IF strip selected from panel. Outputs provided for attachments to pulse analyzer, panelizer. **\$69.50**
 Exc. Input 115 V 60 cy. 1-1/2" NEW

Tuning Units: TU16, TU17, TU18. **each \$39.50**
 TU19 **each \$89.50**

RECEIVER SPECIALS!

BC-312 MOBILE RECEIVER 6 Bands. 1500 Kc to 18 Mc. With Tubes and 14V Dynamotor. \$59.50
 Exc. Used

BC-342 RECEIVER 1.5 to 18 Mc. AC only. Exc. Used \$69.50

BC-348 SUPERHET Receiver 200 to 300 Kc and 1.5 to 1800 Mc. Voice, tone, CW. Self-contained dynamotor for 24 VDC. Like NEW \$69.50

BC1206-C BEACON RECEIVER

195 to 420 Kc. made by Satchel - Carlson. Works on 24-28 volt DC. 135 Kc. IF. Complete with 5 tubes. Size 4" x 4" x 6". Wt. 4 lbs. **BRAND NEW \$9.99**
 Brand New, less tubes. **\$5.95**
 USED, with tubes. **3.95**
 USED, less tubes. **2.95**

SCR-522 2-METER RIG!

Test the buy! VHF Transmitter-receiver. 100-156 Mc 2 channels. Xtal controlled. Amplitude modulated voice. They're going fast! Excellent condition. **SCR-522 Transmitter-Receiver, complete with all 18 tubes, top rack and metal case. \$29.50**
 COMBINATION. Exc. Used

MICROPHONES

Model	Description	Excellent BRAND Used NEW
T-17	Carbon Hand Mike.	\$5.45
T-10	Carbon Throat Mike.	\$ 34. 2.45
T-45	Army and Navy Lip Mike.	1.25
TS-9	Handset	3.88
TS-10	Handset	4.68
TS-13	Handset	4.25
RS-38	Navy Type	4.75

HEADPHONES

Model	Description	Excellent BRAND Used NEW
HS-23	High Impedance	\$2.19 \$4.65
HS-13	Low Impedance	2.89 4.65
HS-30	Low Imp. (featherwt.)	.90 1.65
H-18 U	High Imp. (2 units)	3.75 7.95

TELEPHONE CORDS—0-000 ohm Low Impedance HEAD-SETS, BRAND NEW, PER PAIR **\$3.25**
 CD-307A Cords, with PL55 plug and JK26 Jack **.95**
 Earphone Cushions for above—Pair. **\$1.50**

TG-34A CODE KEYS

Self-contained automatic unit, reproduces code practice signals recorded on paper tape. By use of built-in speaker, provides code-practice signals to one or more persons at speeds from 5 to 25 WPM. Checked out, exc. used. **\$18.95**
 Signal Reels of Tape, Each. **\$1.85**

BRAND NEW \$22.50

BC-221 FREQUENCY METER

SPECIAL BUY! This excellent frequency standard is equipped with original calibration charts, and has ranges from 125 Kc to 20,000 Kc with crystal check points in all ranges. Excel. Used with original Calibration Book, Crystal. **\$59.50**

STANDARD TUBES

Removed from Brand New Gov't Equipment

RECEIVING	Model	Price	Model	Price	
6AG5	35	6J5	65	813	6.95
12AT7	45	6H6	55	814	2.25
6AK5	45	6X5	45	815	3.15
6C4	25	12A6	45	826	4.4
6AL5	38			1625	2.9
6AV6	38	2C39	3.50	4X150	5.5
6J6	32	3E29	4.25	6072	2.50
6V6	65			1P25A	7.95

WILLARD 6-VOLT MIDGET STORAGE BATTERY

3 Amp. Hour. **BRAND NEW 35% x 1-13/16" x 2 3/4". Uses Standard Electrolyte. Only \$2.95**

2 VOLT BATTERY "PACKAGE"

1-2V. 20 Amp. Hr. Willard Storage Battery, Model #20-2. 3" x 4" x 3 3/4" high. **\$2.79**

1-2V. 7 prong Synchronous Plug-in vibrator. Bottle Electrolyte (for 2 cells). **1.49**

ALL BRAND NEW!
 Combination Price **\$5.45**

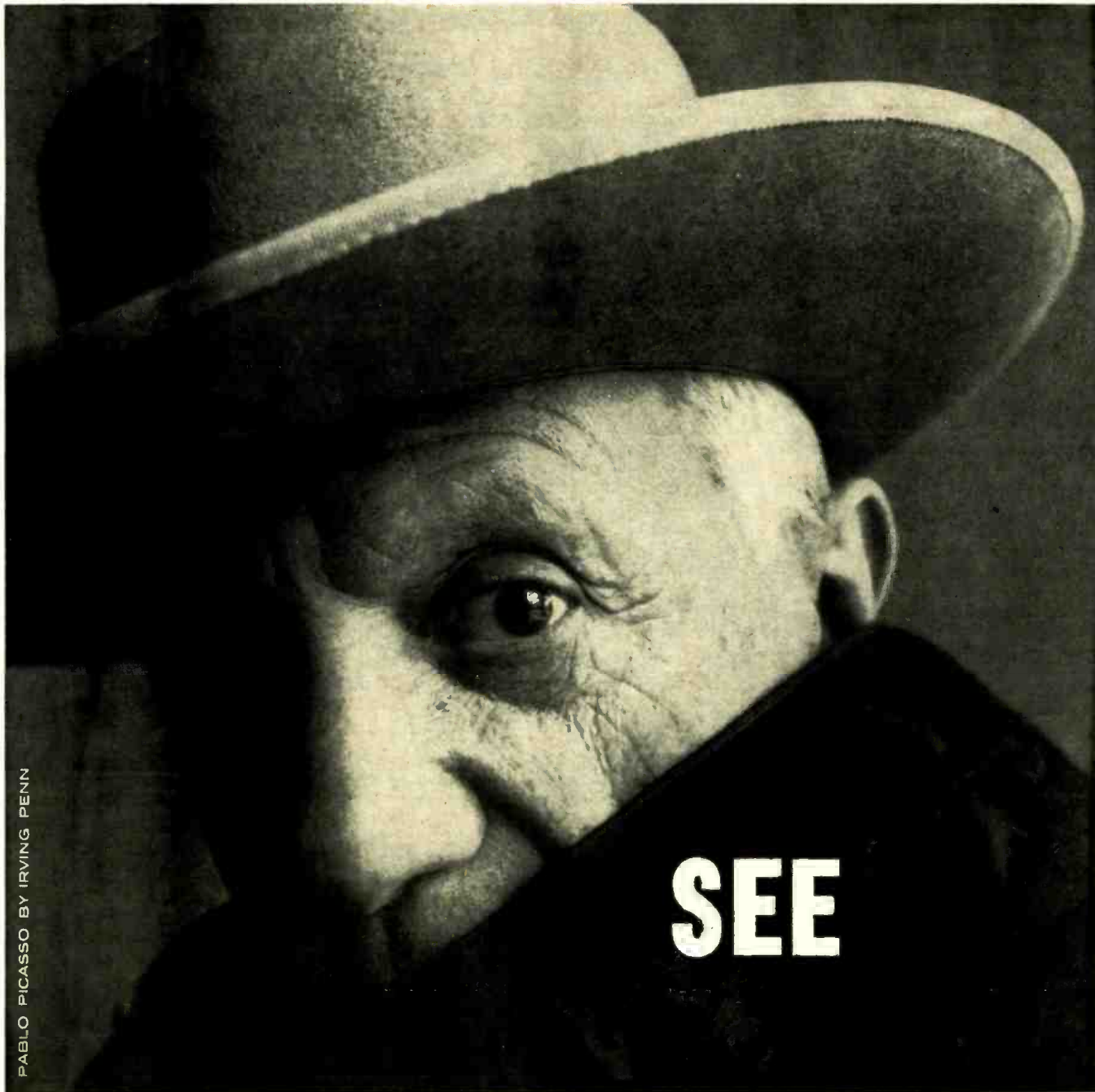

PABLO PICASSO BY IRVING PENN

SEE

the 1961 PHOTOGRAPHY ANNUAL

- Photojournalism
- Glamor
- Abstraction
- Nudes from Japan
- International Portfolio
- Industrial Advertising
- Plus the Work of
- Cartier-Bresson
- Davidson
- Halsman
- Haas
- Heyman
- Nakamura
- Penn
- Winquist
- And Many Others

all in the world's greatest show.
case of fine photographs.

Ziff-Davis Publishing Company
 Department EW-106
 434 S. Wabash Avenue
 Chicago 5, Illinois

Please send me a copy of the 1961 PHOTOGRAPHY ANNUAL. I enclose \$1.25, the cost of PHOTOGRAPHY ANNUAL, plus 10¢ to cover mailing and handling charges.

NAME _____

ADDRESS _____

CITY _____ ZONE _____ STATE _____



The 1961 PHOTOGRAPHY ANNUAL is now on sale at newsstands and camera stores—or you can use this handy coupon to order today.

ONLY \$1.25

ELECTRONICS WORLD

IF

If you're in a weak signal area where all channels are not sharp and clear, or in a big city where buildings interfere with reception ■ If your TV set is growing old and doesn't perform the way it used to ■ If you're operating 2, 3 or more TV sets from a single antenna, and reception is not quite up to par ■ If your FM radio is not bringing in all stations in your area

ADD

NEW BLONDER-TONGUE TV/FM POWER BOOSTER* MODEL BTA...ONLY \$18.95

**TV
PICTURES
WILL
SPARKLE**

and FM will
come through
crisp and
static-free



All of the engineering know-how responsible for the nation's finest TV products has been incorporated in the remarkable new Blonder-Tongue BTA. The result — a product that:

- offers more gain than ever before possible, at such a low price . . . \$18.95
- improves TV (black & white or color) and FM reception by boosting signal strength. (7 to 9 db, channels 2-13; 4-8 db, FM)
- installs in seconds with only a screwdriver
- features stripless 300 ohm terminals and "on/off" switch
- employs latest low-noise, frame-grid tube
- works with indoor or outdoor antennas
- improves 2, 3 & 4 set installations.

engineered and manufactured by

BLONDER-TONGUE, 9 Alling Street, Newark 2, N. J.
Export: Morhan Export Corporation, New York 3, New York



prepare for your career in

ELECTRICAL ENGINEERING ELECTRONICS COMPUTERS RADIO-TV

At MSOE, you can equip yourself for a career in many exciting, growing fields: **MISSILES**
RADAR • AUTOMATION
RESEARCH • DEVELOPMENT
ELECTRICAL POWER
AVIONICS • ROCKETRY

When you graduate from the Milwaukee School of Engineering, you are prepared for a dynamic career as an Electrical Engineer or Engineering Technician. Under a faculty of specialists, you gain a sound technical education in modern, completely equipped laboratories and classrooms. As a result, MSOE graduates are in great demand and highly accepted by industries nationally.

At MSOE you will meet men from all walks of life and all parts of the country — some fresh out of high school or prep school, others in their twenties — veterans and non-veterans.

You can start school in any one of four quarters and begin specializing immediately. Engineering technicians graduate in 2 years with an Associate in Applied Science degree. For a Bachelor of Science degree in Engineering, you attend 4 years. A 3-month preparatory course also is available.



FREE CAREER BOOKLET!
If you're interested in any phase of electronics, radio or television, be sure to look into the programs of study offered by the Milwaukee School of Engineering. Just mail the coupon.

MILWAUKEE SCHOOL OF ENGINEERING

Dept. EW-1060, 1025 N. Milwaukee St.
Milwaukee, Wisconsin

Please send FREE Career Booklet. I'm interested in Electrical Engineering;
 Electronics Computers
 Electrical Power Radio-TV
 Mechanical Engineering

Name _____ Age _____
PLEASE PRINT

Address _____

City _____ Zone _____ State _____

I'm eligible for veterans education benefits.
MS-123



Manufacturers' Literature

RCA TUBE MANUAL

Radio Corporation of America, Electron Tube Division has published a new edition of its Receiving Tube Manual, RC-20.

The new edition contains 432 pages and maintains its traditional format. Contents have been up-dated, revised, and augmented. More than 760 tubes are covered, including types for TV, series-string applications, a.c.-d.c. equipment, 12-volt car radio receivers, and stereo and mono hi-fi. Data is also provided for more than 173 picture tubes, including color types.

Basic tube theory and application information are covered in the same style as used in previous editions. The circuits section features new diagrams for hi-fi circuits. The Manual may be obtained from distributors or by sending \$1.00 to Commercial Engineering, Electron Tube Division, Harrison, N. J.

SAMS INDUSTRIAL BROCHURE

Howard W. Sams & Co., Inc., Indianapolis 6, Ind., has issued a brochure titled "Special Services and Products."

Intended as an aid for the industry, the new booklet describes Sams' services in testing, marketing help, product analysis, compilation, technical writing and editing, drafting, technical art and photography, printing and direct mail services.

ANTENNA CATALOGUES

Hy-Gain Antenna Products, 1135 North 22 St., Lincoln, Nebraska has issued two new antenna catalogues. One covers a complete line of beams, verticals, tri-banders, halos, monobanders, ground planes, doublets, mobile and portable types, and the rotobrake for ham use.

The other includes antennas for Citizens Band use.

Catalogues are available from distributors or by writing direct to the manufacturer.

LAFAYETTE 1961 CATALOGUE

Lafayette Radio Electronics Corp., 165-08 Liberty Ave., Jamaica 33, N. Y. announces its 1961 catalogue. Containing over 320 pages, this volume is the largest and most comprehensive yet issued by the firm. Items offered include the company's own lines of kit and ready-made equipment, as well as the latest equipment offered by major manufacturers.

Among the equipment described are stereo and mono hi-fi components, radio and TV components and accessories, Citizens Band gear, tools, books, optical units, cameras, p.a. systems and parts, and a host of products of inter-

est to hobbyists, students, hams, experimenters, and industrial personnel.

Listed as Catalogue No. 610, the new volume is available free on request to the company.

KNOB REPLACEMENT GUIDE

GC Electronics Co., Division of Textron Electronics, Inc., 400 South Wyman St., Rockford, Ill., has announced a comprehensive, fully illustrated wall chart on exact replacement TV knobs.

The new chart pictures 235 knobs that are claimed to take care of 98 percent of all replacements.

Charts are free at distributors or by writing direct to the manufacturer at the above address.

BRITISH TUBE BULLETINS

English Electric Valve Co. Ltd., Chelmsford, England has issued three booklets describing some of its new tubes.

The contents of each are self-explanatory from the respective titles: "Voltage Stabilisers and Reference Tubes," "V.H.F. Transmitting Tetrode for FM and Television Service," and "Valve Replacement Index." The first two booklets contain tube data, illustrations and dimensional drawings.

G-E RECTIFIER MANUAL

A new design manual for applying silicon controlled rectifiers in electronic and electrical equipment has been published by the Semiconductor Products Department, General Electric Company, Charles Building, Liverpool, New York.

The 13-chapter, 255-page "Controlled Rectifier Manual" was prepared by five members of the Department's application engineering organization. It contains information on voltage transients in SCR circuits, test circuits, turn-off characteristics of the device and methods, firing characteristics and firing circuits, and series and parallel operation of SCR's. Charts, nomographs, oscilloscope traces, and 224 circuit diagrams are also included.

Copies are priced at \$1.00 each, obtainable from the firm's authorized semiconductor distributors, or from the department direct.

TOROIDAL INDUCTORS

Burnell & Co., Inc., 10 Pelham Parkway, Pelham Manor, N. Y. has published a unique and comprehensive ready-reference wall chart on toroidal and variable inductors which it is offering to design engineers.

The three-color chart measures 24"x36" and has a metal edging top and

bottom to insure its hanging flat against the wall. Twenty graphs provide "Q" versus frequency curves for several ranges of voltage or inductance. Also shown is a table of the electrical characteristics and physical dimensions of 25 toroidal inductors with diagrams and sizes of a number of commonly used hermetic and epoxy-potted metal cases.

The reference chart is available on letterhead request addressed to Mr. Leo Schwartz, vice-president, sales.

PERMANENT MAGNET ALLOY

Hoskins Mfg. Co., 4445 Lawton Ave., Detroit 8, Mich. has published a new illustrated brochure describing the properties and applications of a new copper-nickel-iron ductile permanent magnet alloy of the generic "Cunife" type.

Properties listed include high coercive force and energy product values, plus excellent ductility, malleability, and machinability. The material can be stamped, machined, or otherwise fabricated in a wide variety of shapes and sizes.

Full details on this new product are included in the brochure which is available without charge upon request.

TV ANTENNA REPLACEMENTS

JFD Electronics Corp., 6101 Sixteenth Ave., Brooklyn 4, N. Y. has just issued a second edition of its "Exact Replacement Antenna Guide," covering portable and "Tote-Able" TV sets marketed since 1947.

The 16-page guide lists the manufacturer, receiver model number, year manufactured, picture tube size, manufacturer's antenna part number, and JFD replacement antenna number.

Copies of this guide are available without charge to service technicians and dealers who write on their company's letterhead.

NEW A.S.A. STANDARD

The American Standards Association, 10 East 40 St., N. Y. 16, N. Y. has issued "American Standard, Preferred Frequencies for Acoustical Measurements, S1.6-1959."

This standard has been approved by the Association in order to reduce to a minimum the number of frequencies at which acoustical measurements need to be tabulated. It refers all frequency-series to a single reference frequency, and selects others in such a way as to afford a maximum number of frequencies common to the various series.

Copies of the new Standard are available at 35 cents each from Dept. PR 140, care of the Association.

PRECISION METER DATA

Greibach Instruments Corp., 315 North Ave., New Rochelle, N. Y. has issued a single-page, two-color data sheet covering its patented "Bifilar" meter movement which is applicable to a wide range of single and multi-range current, voltage, and resistance meters in bench, panel, and portable models.

Exploded views illustrate how the "Bifilar" design is applied in the construction of measuring equipment for transistors, semiconductors, amplifiers, and ionization.

Copies of this bulletin, as well as the company's complete 20-page catalogue, are available on request.

"COMPUTERESE"

The Industrial Division, Minneapolis-Honeywell Regulator Co., Philadelphia, Pa. has issued a new booklet entitled "Do You Talk 'Computerese'?"

This pocket-sized 22-page glossary is intended to make computer language more intelligible to the layman by defining some 82 terms which crop up in both professional and consumer publications.

"EICO" DEALER AID

Electronic Instrument Co., Inc., 33-00 Northern Blvd., Long Island City 1, N. Y. has announced two attractive red-white-and-black neon and clock-neon signs for window and interior display by dealers. Each sign calls attention to the Eico line of stereo and mono hi-fi test in-

HOW TO BECOME A RADIO TECHNICIAN FOR ONLY \$26.95

Reg. U.S. Pat. Off.



Build 20 Radio and Electronic Circuits At Home—ALL Guaranteed to Work
Progressive Radio "EDU-KIT"

NOW INCLUDES

- ★ 12 RECEIVERS
- ★ 3 TRANSMITTERS
- ★ SQ. WAVE GENERATOR
- ★ SIGNAL TRACER
- ★ AMPLIFIER
- ★ SIGNAL INJECTOR
- ★ CODE OSCILLATOR

- ★ No Knowledge of Radio Necessary
- ★ No Additional Parts or Tools Needed
- ★ Excellent Background for TV
- ★ School Inquiries Invited
- ★ Attractively Gift Packed

FREE EXTRAS

- SET OF TOOLS • RADIO & ELECTRONICS TESTER • ELECTRIC SOLDERING IRON • TESTER INSTRUCTION MANUAL • MEMBERSHIP IN RADIO-TV CLUB • CONSULTATION SERVICE • HI-FI GUIDE • QUIZZES • TV BOOK • FCC AMATEUR LICENSE TRAINING • RADIO BOOK • PRINTED CIRCUITRY • PLIERS-CUTTERS • ALIGNMENT TOOL • WRENCH SET • CERTIFICATE OF MERIT • VALUABLE DISCOUNT CARD

WHAT THE "EDU-KIT" OFFERS YOU

The "Edu-Kit" offers you an outstanding PRACTICAL HOME RADIO COURSE at a rock-bottom price. Our kit is designed to train Radio & Electronics Technicians, making use of the most modern methods of home training. You will learn radio theory, construction, servicing, basic Hi-Fi and TV repairs, code, FCC amateur license requirements.

You will learn how to identify radio symbols, how to read and interpret schematics, how to mount and layout radio parts, how to wire and solder, how to operate electronic equipment, how to build radios. Today it is no longer necessary to spend hundreds of dollars in a radio course. You will receive a basic education in radio, worth many times the small price you pay, only \$26.95 complete.

THE KIT FOR EVERYONE

The Progressive Radio "Edu-Kit" was specifically prepared for any person who has a desire to learn Radio. The "Edu-Kit" has been used successfully by young and old in all parts of the world, by many Radio Schools and Clubs in this country and abroad. It is used for training and rehabilitation of Armed Forces Personnel and Veterans throughout the world.

The Progressive Radio "Edu-Kit" requires no instructor. All instructions are included. Every step is carefully explained. You cannot make a mistake.

PROGRESSIVE TEACHING METHOD

The Progressive Radio "Edu-Kit" is the foremost educational radio kit in the world, and is universally accepted as the standard in the field of electronics training. The "Edu-Kit" uses the modern educational principle of "Learn by Doing." Therefore, you will construct radio circuits, perform jobs and conduct experiments to illustrate the principles which you learn.

You begin by examining the various radio parts included in the "Edu-Kit." You then learn the function, theory and wiring of these parts. Then you build a simple radio. With this first set, you will enjoy listening to regular broadcast stations, learn theory, practice testing and troubleshooting. Then you build a more advanced radio, learn more advanced theory and techniques. Gradually, in a progressive manner, and at your own rate, you will find yourself constructing more advanced multi-tube radio circuits, and doing work like a professional Radio Technician.

Included in the "Edu-Kit" course are twenty Receiver, Transmitter, Code Oscillator, Signal Tracer, Square Wave Generator, Amplifier and Signal Injector circuits. These are not unprofessional "breadboard" experiments, but genuine radio circuits, constructed by means of professional wiring and soldering on metal chassis, plus the new method of radio construction known as "Printed Circuitry." These circuits operate on your regular AC or DC house current.

In order to provide a thorough, well-integrated and easily-learned radio course, the "Edu-Kit" includes practical work as well as theory; troubleshooting in addition to construction; training for all, whether your purpose in learning radio be for hobby, business or job; progressively-arranged material, ranging from simple circuits to well-advanced topics in Hi-Fi and TV. Your studies will be further aided by Quiz materials and our well-known FREE Consultation Service.

THE "EDU-KIT" IS COMPLETE

You will receive all parts and instructions necessary to build 20 different radio and electronics circuits, each guaranteed to operate. Our Kits contain tubes, tube sockets, variable, electrolytic, mica, ceramic and paper dielectric condensers, resistors, the strips, coils, hardware, tubing, punched metal chassis, Instruction Manuals, hook-up wire, solder, selenium rectifiers, volume controls, switches, knobs, etc.

In addition, you receive Printed Circuit materials, including Printed Circuit chassis, special tube sockets, hardware and instructions. You also receive a useful set of tools, a professional electric soldering iron, and a self-powered Dynamic Radio & Electronics Tester. The "Edu-Kit" also includes Code Instructions and the Progressive Code Oscillator, in addition to the F.C.C.-type Questions and Answers for the Radio Amateur License training. You will also receive lessons for servicing with the Progressive Signal Tracer and the Progressive Signal Injector, and a High Fidelity Guide and Quiz Book. Everything is yours to keep.

J. Statats, of 25 Poplar Pl., Waterbury, Conn., writes: "I have repaired several sets for my friends, and made money. The 'Edu-Kit' paid for itself. I was ready to spend \$240 for a Course, but I found your ad and sent for your Kit."

UNCONDITIONAL MONEY-BACK GUARANTEE

The progressive Radio "Edu-Kit" has been sold to many thousands of individuals, schools and organizations, public and private, throughout the world. It is recognized internationally as the ideal radio course.

By popular demand, the Progressive Radio "Edu-Kit" is now available in Spanish as well as English.

It is understood and agreed that should the Progressive Radio "Edu-Kit" be returned to Progressive "Edu-Kits" Inc. for any reason whatever, the purchase price will be refunded in full, without quibble or question, and without delay.

The high recognition which Progressive "Edu-Kits" Inc. has earned through its many years of service to the public is due to its unconditional insistence upon the maintenance of perfect engineering, the highest instructional standards, and 100% adherence to its Unconditional Money-Back Guarantee. As a result, we do not have a single dissatisfied customer throughout the entire world.

ORDER FROM AD—RECEIVE FREE BONUS RESISTOR AND CONDENSER KITS WORTH \$7.00

- Send "Edu-Kit" Postpaid. I enclose full payment of \$26.95.
- Send "Edu-Kit" C.O.D. I will pay \$26.95 plus postage.
- Send me FREE additional information describing "Edu-Kit."

Name
Address

Progressive "EDU-KITS" Inc., 1186 Broadway, Dept. 89E
Hewlett, New York

GET IT FROM GOODHEART!

0.1% SORENSEN Line Voltage Regulator

—5000s. Brand new at low surplus price! Input 95-130 V, 1 ph., with taps for 50 or 60 cy. Output for any power up to 5000 watts. Output adjustable 110-120 V and holds to $\pm 0.1\%$ at line frequency, or to $\pm 0.25\%$ if line frequency drifts 5%. Regulates against line changes of 95-130 V and against load changes from 0 to 5 KVA. Maximum harmonics less than 3%. Recovery time 0.15 seconds. Input to the control section can be moved to the point where you will use the power, thus compensating for line drop. In rack cabinet 28" h, 22" wd, 15" dp. Net wt 190 lbs. Shpg wt 285 lbs FOB Utica, N. Y. In original factory pack suitable for export under PARL-PA-8753. Sorensen catalog net price is \$695.00 less spares. Our price, WITH SPARES... **\$349.50**



It is smart planning to buy this 5 KVA capability even if your present need is for lower power, because: 1. It works as well at lower power. 2. Price is as low as a 1 KVA unit! (Sorensen's prices, LESS SPARES, are \$320.00 for 1 KVA, \$460.00 for 2 KVA, \$520.00 for 3 KVA, and \$695.00 for 5 KVA.)

WRITE FOR DETAILS ON OTHER C-V UNITS

Raytheon unit has harm. filter, output 115 V $\pm 1/2\%$ at 7.1 A and 1 other fixed load. \$49.50. Following units regulate for any load within ratings: Superior servo-driven Powerstat, 1.2 KVA, \$125.00, and 2.5 KVA \$150.00; no harmonics in either. Sola 1 KVA at \$79.50, 2 KVA w/ dual input \$147.50, 3 KVA w/ dual input and output \$167.50. G.E. 2.3 KVA \$49.50.

130 DC AMPS AT LESS THAN \$1.00/AMP!

Complete DC power supply ready to plug in and use. Outputs 15 and 30 volts DC at 130 and 60 amps continuous, or 600 and 300 amps intermittent for 100 seconds with 16 sch int. operations per hour permissible. Meters for V and A, input 240 V, 3 ph, 60 cy. Brand new! 550 lbs fob Topeka, Kansas... **\$129.50**

SURPLUS BARGAINS IN TEST EQUIPMENT:

Gen. Radio 715-AM combination DC Amplifier and VTVM with 1% accuracy. Output 5 ma into 1000 ohms with inputs 0-100 mv and X2, X5, X10. Has 9 calibrated input res. so can be used as mv, uA, or power meter. Input current less than .002 uA. Brand new, w instr. book. G.R. price \$340.00. Our low price only... **\$97.50**

Brush BL-320 Universal Analyzer is an AC Wheatstone Bridge and DC amplifier widely used with Strain Gauges. Converts 10 uV varying DC to 15 v rms at 20 ma to drive penmotors. Brush price \$610.00. Certified, with book... **\$199.50**

Brush BL-905, -913, -932 DC Amplifiers, your choice, certified... **\$79.50**

Brush Piezo-Electric-drive 2-pen recorder complete with two tailor-made DC amplifiers, certified and ready to use, the set... **\$375.00**

Brush BL-206 6-pen recorder is part of Fairchild REAC Mod. R-01, mounted eye-high on rack cabinet on roller dolly, with all power supplies and differential DC amplifiers, gain-control switches, etc. Certified as new, Fairchild price is \$7350.00. Our low price only... **\$1500.00**

Gen. Elect. 0-100 Microamp Recorder uses self-contained optical servo amplifier, certified, \$295.00 perfect. 1 5 G.E. Price... **\$295.00**

Write for bargains in other G.E. West., Est. Angus recording DC and AC volt and current meters.

Hewlett-Packard 100-D Low Freq. Standard gives sine waves at 10, 100, 1 K, 10 K, & 100 K cy; rect. waves at 10, 100, 1 K & 10 K cy, w harm. to 5 mc; and marker dips spaced 100, 1 K, and 10 K u-secs. Accuracy 2 millionths week. Built in scope, see listings to check out from the 100 KC crystal in oven. Certified. H.P. price \$750.00. Our low price only... **\$349.50**

See Interpolation Osc. 1107-A in Gen. Radio's latest catalog, 0-10 KC. We have R-117-K, which is same except 0-5 KC. Certified condition... **\$199.50**

Gen. Rad. 620-A Met. Freq. Meter, w harmonics, range is 300 kc-300 mc, $\pm 0.1\%$. Old cat. price \$625.00. Our price, certified... **\$199.50**

Gen. Rad. 561-D Vacuum-tube Bridge measures every tube and transistor parameter. G.R. price \$850.00. Our price, like new, but less cords and small accessories is only... **\$199.50**

Meas. Corp. Mod. 31 Intermodulation Analyzer, excellent cond. only... **\$99.50**

Stoddard NMA-5A (TS-5B7 U) Radio Interference and Field Intensity Meter, 15-420 mc, with tripod, 2 dipoles, cords, coupler, 2 cases, and 2 RE heads, an apparently excellent condition... **\$499.50**

Test Oscilloscope OS-4B USM-25B has freq. response ± 3 db, 10 cy-8 mc; Pulse rise time less than 0.1 us. 2 sync marker crystals, 10 us or counted to 50 us; and 12.2 us (2 K yards) or counted to 61 us (10 K yds), w accuracy $\pm 0.3\%$. Calibrated range step, internal sweep 82-820,000 cy or sync w ext. sine source 20 cy to 1 mc. Certified. **\$349.50**

SEE OUR AD IN ELECTRONICS WORLD, Sept. 1960, page 111, for 2 columns of other desirable bargains in electronic surplus. See description of AN APR-4 Receiver at only... **\$49.50**
Now add to it: Complete with all tuning units, 3B-4000 mc, certified... **\$299.50**

SCHEMATICS/CONVERSIONS, SURPLUS GEAR

List G. NEW! Send long stamped addressed envelope. Includes many Tech Manuals. Add 25c for chart explaining AN Nomenclature. Example of new listings: 20-page book on 1-177, with diagram of MX-949 U socket adapter & tube data compiled March 1957 \$5.00. RT-18 ARC-1 schem. & tune-up instr. \$2.00. MAR. 22 pages & 5 large pullout schematics, \$5.00.

Calif. buyers please add 4% when remitting.

R. E. GOODHEART CO.

P. O. Box 1220-A Beverly Hills, Calif.

struments, ham gear, and receivers in both kit and wired form.

The clock neon sign is 14 inches high by 37 inches wide; the standard neon sign, 10 inches by 25 inches. For further information, dealers and distributors should contact their local *Eico* representative.

METER-RELAY BULLETIN

Assembly Products, Inc., 75 Wilson Mills Rd., Chesterland, Ohio has issued a 4-page bulletin which describes a new kind of meter-relay which combines continuous signal indication with reliable control action and instantaneous reset.

Entitled "The Picture Story of the CRMR," Bulletin S-2-1 features diagrams showing how various circuit components are affected during operation.

ULTRASONIC APPLICATIONS

Acoustica Associates, Inc., 10400 Aviation Blvd., Los Angeles 45, California is offering actual case history reports describing twelve standardized ultrasonic cleaning applications in everyday industrial use.

How such equipment is used by firms like *Bell Labs*, *Texas Instruments*, *Fairchild Controls*, *Reeves Instrument*, etc. is presented along with process data for cleaning an additional 48 specialized items.

DIRECT-WIRE TV

Argus Cameras, Inc., 405 Fourth St.,

Ann Arbor, Mich. has published a brochure that describes how a business may use direct-wire (or closed-circuit) television with a minimum investment of \$595.

The new booklet, titled "How to Use Direct-Wire TV as a Tool of Business and Industry," presents ideas for the use of this form of TV by many organizations.

To obtain a copy, write to the A-V Systems Dept. at the company address.

CB EQUIPMENT CATALOGUE

GC Electronics Co., 400 S. Wyman Street, Rockford, Ill. is now offering a new illustrated 8-page catalogue covering its line of Citizens Band equipment.

Included in the listing are specially designed antennas for fixed station and mobile applications; antenna mounting devices for mobile installations; wall, chimney, and tower mounts; adapters, capacitors, and suppressors.

Copies of catalogue No. AN-61 are available without charge upon request.

INSULATED CABLES

Sequoia Wire & Cable Co., 2201 Bay Road, Redwood City, Calif. has issued a four-page brochure giving specification details on Teflon-insulated hook-up wire for the internal wiring of meters, panels, electrical and electronic equipment, and data on Teflon cables for high-frequency equipment and r.f. transmission lines of the type employed in radar and communications.

ADDING BASS RESPONSE TO A.C.-D.C. RECEIVERS

By MARSHALL HARRY

SOME of the methods for improving the bass response of small a.c.-d.c. radio receivers involve adding a few parts or changing the output transformer. The output transformers of these little sets are usually small, not only because of the lack of space on the chassis but for reasons of cost.

Fig. 1 shows one method of connecting a small push-pull output transformer in place of the single-ended type usually found in all a.c.-d.c. receivers. As most such radios have a little extra space, either back of the speaker or on the speaker itself for mounting this new transformer, this is no problem.

A 10-watt output will work wonders with these little sets since most of them have an output of 2 watts or less—even the better varieties.

Fig. 2 shows how by adding an RC network across the primary of the output transformer, an increase in effective

bass response can be obtained without too much loss of volume. If the bass isn't low enough after the network has been installed, try a somewhat larger resistor, that is, add 5000 ohms or so, making the resistor 20,000 ohms.

Fig. 3 is a variation of Fig. 2 but with a control provided. Here, again, one can do a little juggling of resistor and capacitor values to provide optimum results.

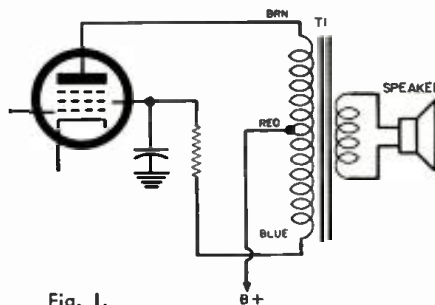

Fig. 1.

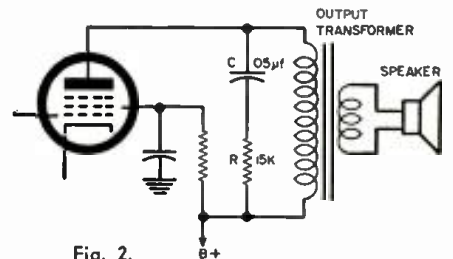

Fig. 2.

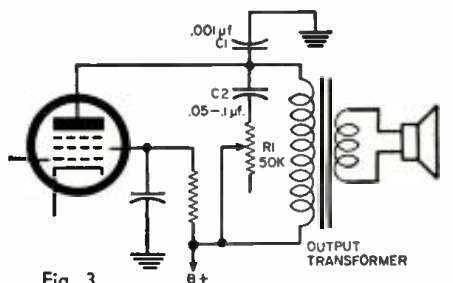

Fig. 3.

Transistor Output Circuits (Continued from page 57)

to heating the entire unit. A solder lug should be screwed on to the unpainted mounting flange and the wire should, preferably, be soldered to the lug beforehand.

Power Supply or Battery

Our readers may justly wonder about a suitable source of 14 volts at half an ampere. Batteries that can deliver such power are rather large, and smaller units don't last very long. The ordinary laboratory type power supplies can deliver the power but not at the voltage and current required. For this reason special power supplies are usually designed to work with transistor circuits. While there is not enough space in this article for a complete description of such supplies, we do want to give the reader some idea of what is required.

The circuit shown in Fig. 10 is typical of those used with transistor audio amplifiers and has certain features which make it somewhat different from vacuum-tube type supplies. The power transformer is available from jobber's stock and is widely used for selenium-rectifier, low-voltage supplies. Although two 1N607 rectifiers are shown, any unit capable of 500-ma., 50-volt peak inverse operation will do. The reason for not using a choke is that chokes having low enough d.c. resistance are not always available. Capacitors of the values shown are readily available and the power resistors are also carried in jobber's stock.

One luxury accessory in the power supply of Fig. 10 is the zener diode, type 10M14Z. It is not absolutely necessary but will help to reduce a.c. ripple, voltage variations with load changes, and will also present a low output impedance for the power supply. The author has found that the addition of a zener diode greatly improves over-all amplifier performance and is well worth the extra expense.

Conclusion

The basic method for designing a class A transistor power amplifier has been explained and a typical design has been illustrated. Class A operation, especially with transistors, is not very efficient for larger power ranges, and a number of precautions must be observed. Distortion can be reduced by proper circuit design and selection of a very low signal-source impedance. The heat generated by the collector current must be dissipated to avoid overheating of the transistor. To supply the low voltage and relatively high current, a fairly simple power supply can be constructed and a circuit for such a unit is shown here. Despite some of the disadvantages of using a class A power output amplifier, the circuit simplicity and reliable operation make this circuit useful in many low-power applications.

-30-

October, 1960



GCT-9W
GCT-9S

NEW!
Only
Grid Circuit
Tube Tester
with Full TV
tube coverage!



GRID CIRCUIT TUBE TESTER

Introducing the new Seco GCT-9—the first and only Grid Circuit Tester that offers you complete coverage of all TV tube types—including voltage amplifiers, power output and heater-type diodes, hundreds of Foreign and Industrial types as well as types with Grid, Plate or Cathode caps. Quickly lets you test for Grid Emission, Leakage, Shorts and Gas in one operation—indicates results instantly, visually on a 6AF6 "Eye" Indicator. In addition to conventional tests, the GCT-9 also offers two exclusive new testing features not found on any other tester: 1. Cathode Continuity Check; and 2. Complete Inter-Element Short Test, with shorts identified to pin numbers.

The new Seco GCT-9 is available in a sturdy metal case with exposed panel (GCT-9S); or mounted in a compact, portable carrying case (GCT-9W)—complete with easy to read tube set-up data.

MODEL GCT-9S
Wired and Factory Tested . . . \$3295 NET

MODEL GCT-9W
Wired and Factory Tested . . . \$3495 NET



Cut servicing and installation time on crystal-controlled 2-way radio equipment!

New 2-way radio test set—combination Crystal Checker, RF Signal and Field Strength Meter, plus dozens of other time-saving uses.
MODEL 500 \$29.95



Most complete tester available!

Finest, fastest tester at a popular price. Won't be obsoleted—offers every important test you need for a wide range of tube types.
MODEL 107 \$139.50



NEW!

PIGGY-BACK ADAPTER for tube caddies!

Developed by Seco to save you steps! Free with Seco tube testers or by enclosing 25¢ with coupon.

SECO ELECTRONICS, INC. W-7
5015 Penn. Ave. So.—Minneapolis 19, Minn.
Please send free literature on all Seco Test Equipment.

I have enclosed _____ Please send _____
Seco "Piggy-Back" Adapters. (25¢ each.)

NAME _____
ADDRESS _____
CITY _____ ZONE _____ STATE _____

EAST CANADA: Davaco Agencies, Ltd., Montreal, Quebec WEST CANADA: Ron Merritt Co., Vancouver 1, B. C.

TV TUNERS OVERHAULED

ALL MAKES AND MODELS **\$995 NET** 90 DAYS WARRANTY UHF/VHF \$19.90

SAME DAY SERVICE

ON POPULAR TYPES—48 HOURS MOST OTHERS

Overhaul charge includes labor and minor parts; tubes and major parts are extra at net prices. Tuner to be overhauled should be shipped complete; include tubes, shield cover and any damaged parts. Quote model and state complaint. Pack well and insure.
WE WILL SHIP C.O.D.—F.O.B. CHICAGO OR TORONTO

Castle TV Tuner Service

5710 N. WESTERN CHICAGO 45, ILL. U.S.A. • TORONTO 13 CANADA

THE SECRET OF A GOOD BUY IS

KNOWING EXACTLY

WHAT YOU'RE LOOKING FOR!

And when it comes to photo equipment, there's one sure source for the facts and figures that will help you make a decision before you buy!

THE NEW

1961 PHOTOGRAPHY DIRECTORY

& BUYING GUIDE
PRICE \$1.00



Complete listings on over 5,000 pieces of photo equipment... data, prices, illustrations and comparisons of:

- Still Cameras • Accessories • Movie Cameras & Projectors • Lenses • Underwater Gear • Lighting Equipment • Darkroom Supplies • Stereo • Films and Papers
- plus new Comparison Charts on Tape Recorders, Slide Projectors, Filters, and Electronic Flash.

PLUS:

GIANT 16 PAGE BONUS INSERT ON:

HOW TO BUY PHOTOGRAPHIC EQUIPMENT—a complete handbook on how to buy wisely—what to look for—how to check out quality, prices, models—compare features—eight chapters covering every type of photo equipment!

The 1961 PHOTOGRAPHY DIRECTORY AND BUYING GUIDE is on sale October 25th at your favorite newsstand—or order by handy coupon below today.

ONLY \$1.00

Ziff-Davis Publishing Co., Dept. EW106
434 South Wabash Ave., Chicago 5, Ill.

Please send me a copy of the 1961 PHOTOGRAPHY DIRECTORY AND BUYING GUIDE. I enclose \$1.00, the cost of the DIRECTORY, plus 10¢ to cover mailing and handling charges. (Canada and Foreign \$3.25 plus 10¢ postage)

NAME _____

ADDRESS _____

CITY _____ ZONE _____ STATE _____

New Audio Test Report

LAB TESTED
ELECTRONICS WORLD

Heath Model AA-50 Integrated Stereo Amplifier Kit
Shure Model M232 Stereo Tone Arm



Heath Stereo Amplifier Kit

THE first impression one gets of Heath's Model AA-50 integrated stereo amplifier is that it is compact, reasonably priced, neat in appearance, and that it incorporates all the necessary functional controls. Actually, it is more than this in that their engineers have utilized a circuit design that provides hi-fi performance with exceptionally low distortion for an integrated system. If we were to judge by the performance characteristics at its maximum power output (25 watts per channel), we would have to say that it is the best unit of its type that we have tested to date. The reason is that Heath has underrated the power output of the unit. If they followed standard industry procedures, they could have rated the amplifier at approximately 33 watts per channel, which would be 66 watts for monophonic operation.

The harmonic-distortion figures that we obtained are as follows: At 1000 cps: .36% at 25 w., .41% at 30 w., .49% at 32 w., and 2% at 33.2 w. At 30 cps and 15,000 cps: the power output for 2% harmonic distortion was slightly less. These figures were taken with one channel in operation. When we loaded both channels equally, we were able to obtain 28.5 watts at 1000 cps with 2% harmonic distortion.

The IM distortion (60 and 7000 cps, 4:1 ratio) was .08% at 2 watts, .24% at 10 watts, .67% at 20 watts, and .81% at 25 watts. Again, this is for single-channel operation. When both channels were loaded equally, the IM distortion per channel was 1.1% at 25 watts. We had to change our method of taking IM distortion measurements since the 4-ohm output tap in this design is grounded. We loaded the amplifier and took our power-output measurements in the normal manner across the 8-ohm tap. The IM tests were made at the 4-ohm tap.

The number of operating controls was held to a minimum, and only the essential ones have been incorporated. They are as follows: 4-position "function switch" (stereo, reverse stereo, and either channel A or B through both speakers); an input selector switch (tuner, 2 auxiliaries, tape head, and separate magnetic phono inputs for stereo and mono); balance, channel separation, level, and individual bass and treble controls; and a separate power switch. In addition, an output phasing switch is incorporated on the rear apron.

The tone controls provide normal (approximately 18 db) boost and attenuation at 30 and 15,000 cps.

The RIAA magnetic equalization curve proved to be within ± 1.2 db of the standard curve over the entire range.

Frequency response at a 2-watt level was within $\pm .85$ db from 30 to 15,000 cps.

Damping factor at 1000 cps with 2-watt output was slightly over 11.

Sensitivity of the amplifier at 1000 cps was .178 v. on all high-level inputs, and .0016 v. for low-level inputs for 25-watt output.

Hum and noise was measured at -55 db on magnetic phono input (volume control adjusted for 2-watt output with 6 mv. input) and -70 db on auxiliary input at the same volume setting with respect to 2 watts output. The inputs were shorted for this test.

The channel separation control, which is sometimes referred to as a blend control, permits adjustment of the channel separation from its maximum of 39.1 db at 1000 cps to 0. The purpose of this control is to eliminate the so-called "hole-in-the-middle" effect. If your speakers are too far apart or are not placed ideally in your room, it is possible to adjust the control to blend the two channels together so that the

sound emanates from a broad front and not just from the left and right. We personally dislike this approach, and feel that every attempt should be made to place the speakers properly or, if necessary, to add a third, center speaker. This amplifier has separate output connections for such a center speaker.

One additional feature, which we find quite convenient, is that the amplifier incorporates individual level controls on all inputs, with the exception of tape. These controls can be adjusted so that, for example, when switching from tuner to phono, re-adjustment of the front-panel master level control will not be necessary. Additional level controls are connected at the inputs to the power amplifier sections of both channels. With these two controls it is

possible to adjust the individual gains of the two channels to correct for differences in speaker efficiency.

The construction of the unit is such that any novice could assemble the amplifier. It is time-consuming, as for all integrated stereo systems, but two printed circuit boards do help in reducing the time required. If one follows the instruction manual exactly, the amplifier should operate as intended. In performance, all of its characteristics come extremely close to the manufacturer's published specifications. In our opinion, this integrated stereo amplifier (available in kit form at a price of \$79.95) is an exceptionally good unit, and can be classed among many of the best available, even some of those at a much higher price. —30—

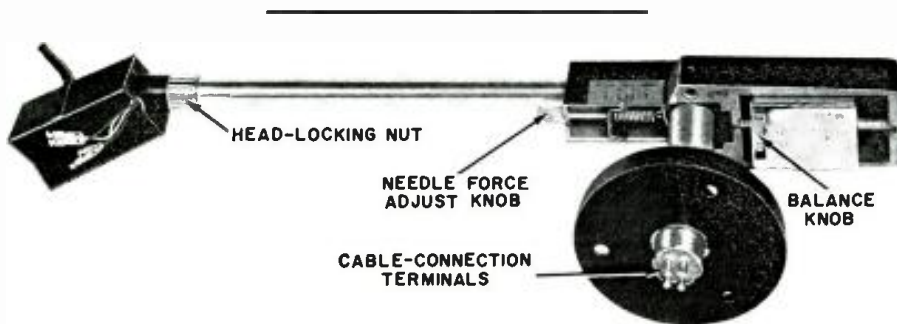

Shure Stereo Tone Arm

THE essential characteristics of a tone arm are mainly mechanical. The arm must permit the convenient mounting of any one of a large number of phono cartridges with ease. It must allow perfectly free vertical and lateral motion so that the cartridge is able to track any record with a minimum of tracking pressure. Any resonance it has must either be completely damped out or well outside of the audible range. It would also be convenient to be able to adjust the stylus force to the correct value, and it would be helpful to be able to read the value of the force directly on a scale on the tone arm without recourse to a stylus-pressure gauge (except for occasional checking). And finally, the arm should be convenient to use, easy to mount, and attractive in appearance. We are glad to report that the *Shure Model M232* stereo tone arm meets all these requirements admirably.

Complete instructions, along with all the necessary hardware and mounting plates, are supplied to mount just about any available cartridge. Conveniently, the arm is designed so that it may be completely installed from the top of the motorboard. After mounting has been completed, the adjustable counterweight is moved by means of a thumbscrew until the arm is perfectly balanced. Then, the stylus-force spring thumbscrew is put in place and adjusted for the proper stylus force, as indicated by the 0 to 8-gram scale printed directly on the side of the arm near the pivot. Precision ball bearings are used throughout on all pivot sur-

faces so that the arm moves perfectly free. The plug-in type black plastic shell that mounts the cartridge is offset from the tubular metal arm to provide minimum tracking error over the entire record.

The pivot post, which fits in the mounting base, has a four-pin plug at its end for the connecting leads. A four-foot cable, supplied with the arm, has a matching receptacle to fit this plug and phono plugs at the other end of the prefabricated cable make it unnecessary to take your soldering iron out of your tool box when installing this arm. The four-foot cable uses special low-capacity shielded cable—an important consideration when working into high-impedance inputs of preamps. These may have input impedances of up to 100,000 ohms when they are to be used with some phono cartridges.

Along these lines, we recently had occasion to measure the capacity of some plastic-covered shielded cable that we wanted to use between our phono cartridge and our preamp. We were dismayed to find that the cable we planned to use had a capacity of 65 μf . per foot, making it quite unsuitable for this use. Low-capacitance shielded cable or even coax is a must.

The Model M232, designed to play records up to 12 inches in diameter, can be adjusted up to 2 $\frac{1}{4}$ inches above the level of the motorboard. The tone arm, complete with plug-in shell, mounting base, and 4-foot cable, is available for \$29.95. The manufacturer also has the longer Model M236 available for records up to 16 inches in diameter. —30—

COYNE'S New Complete
Pin-Point
TROUBLE SHOOTING
Series
See All 4 Books On 7-Day FREE TRIAL!
Takes Headaches Out Of All Servicing Problems!



Pin-Point
TRANSISTOR TROUBLES
IN 12 MINUTES!

Trouble-shoot every type of circuit in ALL transistorized equipment! 525 pages; hundreds of illustrations; 120 check charts! \$5.95



Pin-Point
RECORD CHANGER
TROUBLES IN 5 MINUTES!

Locate mechanical and electronics troubles fast. Covers all makes. 320 pages; 450 photos; 58 check charts! \$3.95



Pin-Point
TV TROUBLES
IN 10 MINUTES!

Find the exact sound or picture trouble in any TV set from 700 possibilities! 300 pages; 300 diagrams, check charts! \$4.95



Pin-Point
COLOR TV TROUBLES
IN 15 MINUTES!

Covers every type of color TV and picture tube! 550 pages; 362 check charts, diagrams, picture patterns! \$5.95

Simple Check Chart System Saves Time

These amazing practical handbooks with an ENTIRELY NEW METHOD, show you how to find the trouble in ANY tv, record changer or transistor circuit FAST! Index tells you where to look; famous Check-Charts help you pin-point the exact trouble in minutes! These on-the-job books quickly pay for themselves in profitable new business and valuable time saved!

SEND NO MONEY!

Just mail coupon for free trial. After 7 days, send only low price or return books and pay nothing! If you keep all 4 books, send only \$4 after 7 days. Pay \$18.35 balance plus postage at \$4 per month.

VALUABLE FREE GIFT!
Send for FREE TRIAL OFFER of all 4 Pin-Point books and get FREE book "Bigger Profits in TV" whether you keep series or not!

FREE TRIAL OFFER...Mail Coupon Now!

- Educational Book Publishing Div.
COYNE ELECTRICAL SCHOOL, Dept. AD-RT
1455 W. Congress Pkwy., Chicago 7, Ill.
- Rush 4 book PIN-POINT Series for 7-day FREE TRIAL per offer. For individual books, check below.
 - RECORD CHANGER (\$3.95 plus postage)
 - TRANSISTORS (\$5.95 plus postage)
 - TV (\$4.95 plus postage)
 - COLOR TV (\$5.95 plus postage)

NameAge.....

Address

CityZone.....State.....

- \$19.95 Cash Price enclosed; Coyne pays postage.
- Send C.O.D. for \$19.95 plus M.O. fee; Coyne pays postage. 7 Day money-back guarantee in Cash or C.O.D. orders.



FREE Catalog Of The WORLD'S FINEST GOV'T SURPLUS ELECTRONIC BARGAINS

AUTOMATIC CONTROL UNIT

• INDUSTRIAL • ELECTRONIC AUTOTUNE
• RAILROADING
115 Volt 60 cycle 1/100 HP Capacitor type Motor with automatic gear and ratchet assembly that enables you to pre-set motor stops any 10 positions within 360 degrees. Unit is geared to a two deck 12 position ceramic wafer switch that terminates into a plug-in socket. Local control panel has channel position selector, light dimmer control and local remote switch that enables unit to be operated local or remote control. Part of RDZ-1 Transmitter Autotune Assy. Collins #596A-1. Size: 9 x 4 x 6".
Stock No. EW-23491—Price—NEW

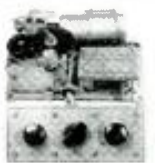

\$14.95

Coaxial Cable LESS THAN 3¢ PER FOOT

RG-54 A/U CABLE—Designed for long life and constant attenuation. with polyethylene jacket, 58 ohms .250 00—370 FOOT ROLL. \$10.95

RECEIVERS:

NAVY ARB/CRV 46151—190 to 9050 KC... U: \$18.95
ARC-3 AM Rec. 100 to 156 MC... Used: 24.95
BC-733—Localizer Rec.—108.3 to 110.3 MC... Used: 4.95
R-23/BC-453 Rec.—190 to 950 KC... Used: 14.95
R-4/ARR-2 Rec.—540-830 KC: 230-258 MC... R-N: 8.95
BC-1206 Beacon Receiver—200 to 400 KC... R-N: 9.95
BC-652 Receiver—2 to 6 MC—Less Dyn... Used: 19.95
BC-344 Rec.—150 to 1500 KC—For AC op. Used: 49.50

BC-603 • \$16.95 • RE-NEW

BC-603 FM RECEIVER—20 to 27.9 Mc... Re-New: \$16.95
BC-604 FM TRNSMTR—20 to 27.9 MC. U: \$4.95—Re-N: 7.95
BC-684 FM TRNSMTR—27 to 39.1 MC. U: \$7.95—New: 12.95
FT-237 MOUNTING for Rec.—Trans. Price... Re-New: 7.95
FT-346 MOUNTING—for Receiver only... Re-New: 4.95
DM-34 DYN. 12 V 1/BC-603-683... U: \$2.95—R-N: \$4.95
DM-35 DYN. 12 V 1/BC-604-684... U: \$6.95—R-N: 9.95
AC POWER SUPPLY—F/BC-603-683—Output: 220 VDC 80 MA & 24 VAC 2 Amps. Transformer & Tube type. Chassis not hot. Mounts on rear Plug of BC-603-683. Can be adapted to other Receivers. \$14.95
KIT: \$10.00 WIRED:



TELEPHONES, HEADSETS, MICS., Etc.:

TS-9 Handset... Used: \$2.95—New: \$3.95
TS-13 Handset, w/PL-55 & PL-68... U: \$2.95—N: 3.95
T-17 Microphone... New: 6.95
EE-8 Field Telephone... Used: \$12.95—Recond.: 16.95
BD-71 Switchboard—6 Line... U: \$14.95—New: 24.95
RM-29 Control Unit... New: \$6.95—W/Handset: 8.95
RM-52 Control Unit (Patch Found.) U: \$1.95—N: 2.95
H-16/U Headset—8000 ohm... U: \$1.95—New: 2.95
HS-33 Headset—300 ohm... U: \$4.95—New: 7.95

T-67/ARC-3 AIRCRAFT TRANSMITTER AM 100—156 MC. Crystal Control. 8 channel. electric band change. With tubes: 2/B32, 2/6L6, 3/6V6, 1/12SH7, & 1/6J5... Used: \$24.95

SEND FOR FREE CATALOG!

Address Dept. EW • All Prices F.O.B., Lima, Ohio. \$5.00 Minimum Order, 25% Deposit on all C.O.D.'s.

FAIR RADIO SALES
2133 ELIDA RD. • P.O. Box 1105 • LIMA, OHIO

PREVIOUSLY ADVERTISED ITEMS STILL AVAILABLE:

TCK-7 TRANSMITTER—Navy Type... New: 150.00
TS-10B/APN TEST SET—w/lease... Used: 15.00
I-166 VOLTOHMETER... New: 18.95
I-176 VOLTOHMETER... Used: 19.95

Stereo Preamp-Amplifiers

(Continued from page 54)

record with all controls set for stereo operation. Adjust the balance control until the volume is the same in either speaker when the switch is flipped back and forth from "stereo" to "reverse."

A few amplifiers make balancing even more simple. They provide methods of balancing that range from induced a.c. hum to a cathode ray tube on the front panel. The latter shows visually that the system is in balance—up to the speakers. If these are not matched or their individual acoustic environments differ, more balancing has to be done. The sound's the thing, not the electronic patterns.

If you plan to use a good turntable,



Altec Model 353-A



Arkay Model CS-28



Channel Master Model 6600

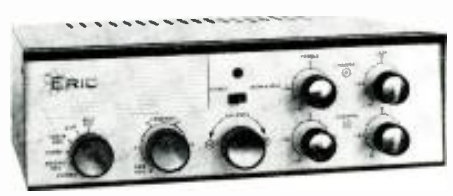

Eric Model 2160



Sargent-Raymont SR-2051

KRECO

SUPERIOR QUALITY

CITIZEN BAND

CO-AXIAL

ANTENNA

The Best Construction Available in Citizen Band Antennas

Lightweight—5 lbs.
6061 Tempered Aluminum
Non Corroding
Quality Alsimag Insulator
Will Not Absorb Water

"IT PAYS TO BUY THE BEST"
MODEL CO-CB \$33.00
TRADE PRICE

See Your Distributor or Write

HERB KRECKMAN COMPANY • CRESCO, PA.



JUST STARTING IN TV SERVICE? -- then you need us!

GET STARTED RIGHT by writing for FREE 8 page catalog illustrating over 30 business forms and systems designed specifically for TV-Radio Service.

ON SALE AT YOUR PARTS JOBBER

Oelrich Publications • 4308 N. Milwaukee • Chicago 41, Ill.

BARRY'S GREENSHEET VALUES ARE OUT OF THIS WORLD...

*A complete catalog of specialized Industrial Electronic TUBES and COMPONENTS... featuring Barry Electronics savings to Industry, Home & Experimenters. Prove these values to yourself! Complete and mail the coupon below for your copy of the *Greensheet. We'll also purchase your equipment and unused tubes. Send details: BARRY ELECTRONICS CORP., 512 Broadway, New York 12, N. Y. Dept. EW10. Please send me a copy of the *Greensheet and add my name to your mailing list. (EW10)

Name Title.....
Company
Address
City State.....



Shell Stereo Amplifier



Sherwood Model S-5000



EMI 555 "Steroscope"

you will have no need for a rumble filter. However, if you use a turntable that is somewhat the worse for wear or a record changer that is not specifically designed for high-fidelity stereo operation, you will have to use a rumble filter or suffer the annoyance of a continuous low-pitched growl in your system.

A scratch filter is not nearly as necessary. Most modern records have pretty decent surfaces, and even when they don't, a little surface noise is usually preferable to the loss of the high frequencies and consequent dulling of sound that ensue from employing the scratch filter.

All in all, there is such a great variety of integrated stereo preamplifiers on the market today, and from a large number of reputable manufacturers, that it should not be too difficult to make a choice that will please your ear, your eye, as well as your pocketbook. These manufacturers have done their best to please you, so that it is up to you to choose a product that will make stereo convenient and enjoyable, with all the features you could possibly want.

Unless you are an audio technician, you cannot delve into the electronic and electrical characteristics of an amplifier. However, by knowing what functions you require of an amplifier and referring to the accompanying chart, you are well on your way to determining which model will best suit your needs. Add to this a few minutes of physical inspection and listening, and you will know if the workmanship employed in the manufacture of the amplifier is of good quality and if its sound is the type you prefer. When you reach the last point, you are one-up on the experts, for it is your taste that the amplifier—and almost every other piece of audio equipment—has to please.

FREE

GIANT 1961 204 PAGE CATALOG



BA 1961
ANNUAL CATALOG #71
SINCE 1927

A Complete Buying Guide for Everything in
**RADIO TV
ELECTRONICS**

for DEALERS, SERVICE MEN, SCHOOLS,
BROADCASTERS, INDUSTRIALS, THEATRE
MANUFACTURERS, CHURCHES, HOTELS, PUBLIC
UTILITIES, LABORATORIES, ENGINEERS,
EXPERIMENTERS, AMATEURS

INDEX PAGE 201-202 PHONE BARNHART 1-1593

BURSTEIN-APPLEBEE 1012-14 McGEE ST., KANSAS CITY 6, MO.

SAVE UP TO 50% ON B-A SELECTED KITS

TOP VALUES IN POWER AND HAND TOOLS

HI-FI AND STEREO SYSTEMS & COMPONENTS

30 PAGES OF BARGAINS NOT IN ANY OTHER CATALOG

100'S OF NEW ITEMS LISTED HERE FOR 1ST TIME

Guarantee

Our guarantee covers the full range of products in this catalog. It is the best in the industry. It is backed by the reputation of Burstein-Applebee. It is the only guarantee in the industry that is backed by the full resources of a major corporation.

RUSH COUPON TODAY!

Send Free 1961 B-A Catalog No. 611

NAME _____

ADDRESS _____

CITY _____ STATE _____

WE CAN FINANCE THIS OUTSTANDING INVESTMENT OPPORTUNITY

Your investment dollars will be returned 3-5 times annually if you can sell 100 or more picture tubes weekly. Windsor franchised TV Tube rebuilding enables you to produce custom built, highest quality tubes. Costs are low. Local distribution eliminates freight charges.

We train your men and while so doing produce 100 or more tubes you can sell. Our engineers are at your service for duration of lease.

WINDSOR ELECTRONICS
999 N. Main Glen Ellyn, Ill.

ENGINEERING DEGREE IN SCIENCE 27 or 36 MOS. MATH



Accelerated year-round program prepares for early employment in fields of Science and Engineering. Regular 4-year program for B.S. Degree completed in 36 months, special engineering degree program in 27. Classes start quarterly—January, March, June, September. Quality education. Graduates employed from coast to coast. Government approved for veteran training. Students from 50 states, 40 countries. 20 buildings; dorms, gym. Campus. Save time and money. Earn board while studying. Write for catalog and complete information.

9100 E. Washington Blvd., Fort Wayne 2, Indiana

INDIANA TECHNICAL COLLEGE

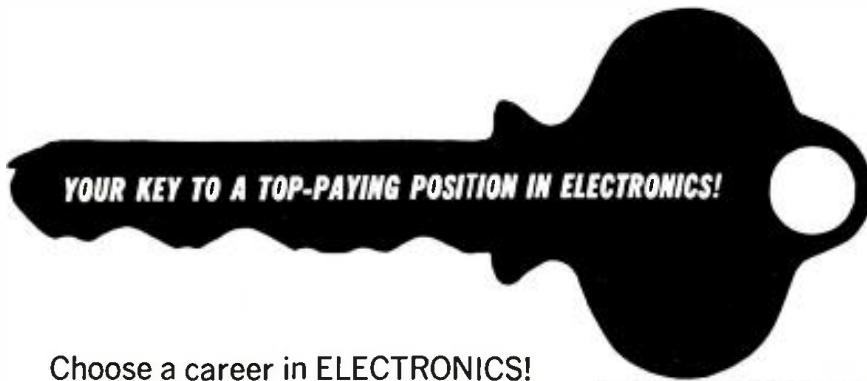

Choose a career in ELECTRONICS! It's wide open...with interesting jobs for engineers, technicians, technical writers. And the all-new 1961 edition of JOBS AND CAREERS IN ELECTRONICS is your perfect guide to this big, exciting field!



Five Giant Sections Covering:

• **OPPORTUNITIES IN ELECTRONICS**

Where are the jobs in electronics today? This section pinpoints the best areas in the country in which to look for a job!

• **CASE HISTORIES OF CAREERS IN ELECTRONICS**

What kind of jobs are available in electronics? Here are 11 accounts of people at work in various branches of electronics!

• **HOW TO PLAN A CAREER IN ELECTRONICS**

How do you start out in electronics? This section is devoted to training—includes information on the military, correspondence schools, courses to study, much more!

• **TESTING YOUR ELECTRONICS APTITUDE**

Do you qualify for an electronics career? This special testing section gives you an accurate picture of your ability to qualify for a technical job.

• **SPARE TIME ELECTRONICS**

Want to earn money in your spare time? Here's a rundown on spare time radio repair, complete with a listing of the tube types you'll need.

Buy your copy at your favorite newsstand or electronics parts store—or order by handy coupon below.

NOW ON SALE—ONLY \$1.00

Ziff-Davis Publishing Company
 Department EW-106
 434 S. Wabash Avenue, Chicago 5, Illinois

Please send me a copy of the 1961 JOBS AND CAREERS IN ELECTRONICS. I enclose \$1.00, the cost of JOBS AND CAREERS IN ELECTRONICS, plus 10¢ to cover mailing and handling charges. (Canada and Foreign, \$1.25 plus 10¢ postage.)

NAME _____

ADDRESS _____

CITY _____ ZONE _____ STATE _____



"MATHEMATICS FOR ENGINEERS" by W. N. Rose. Published by *John F. Rider Publisher, Inc.*, N.Y. 2 vols. Vol. 1, 548 pages; Vol. 2, 420 pages. Price per vol. \$6.60.

Each volume in this set is devoted to certain areas of engineering mathematics, going from fundamental rules and processes through calculus and its applications. More than a thousand examples are given and worked out.

"ELECTROMAGNETIC ENERGY TRANSMISSION AND RADIATION" by Richard B. Adler, Lan Jen Chu, and Robert M. Fano. Published by *John Wiley & Sons, Inc.*, N.Y. 621 pages. Price \$14.50.

In this volume, the three M.I.T. professors treat electromagnetic waves and oscillations in one, two, and three space dimensions, using time-domain, complex-frequency domain, and energy points of view.

"MATHEMATICAL METHODS FOR DIGITAL COMPUTERS" by Anthony Ralston and Herbert S. Wilf. Published by *John Wiley & Sons, Inc.*, N.Y. 293 pages. Price \$9.00.

This book deals with the interrelation among problem analysis, computer capabilities and limitations, and coding procedures. It offers mathematical analyses and derivations of commonly used techniques of digital computation, and detailed, step-by-step discussion of the processing of problems.

"ELECTRONIC CIRCUIT THEORY" by Henry J. Zimmerman and Samuel J. Mason. Published by *John Wiley & Sons, Inc.*, N.Y. 564 pages. Price \$10.75.

This book deals primarily with methods of analysis of electronic circuits, stressing the "model concept". Basic circuit functions are classified as: rectification and detection, waveshaping and amplification, and waveform generation.

"DIRECT CONVERSION OF HEAT TO ELECTRICITY" edited by Joseph Kaye and John A. Welsh. Published by *John Wiley & Sons, Inc.*, N.Y. 369 pages. Price \$8.75.

Recent developments in efforts to convert thermal energy directly into electrical energy are here discussed in a number of edited papers contributed by various researchers in this field.

"THE DYNAMIC BEHAVIOR OF THERMO-ELECTRIC DEVICES" by Paul E. Gray. Published by *John Wiley & Sons, Inc.*, N.Y. 136 pages. Price \$3.50.

This is a report that investigates the small-signal dynamic behavior of ther-

moelectric devices, such as heat pumps and generators. The text is based on mathematical analyses of linear models.

"ELECTRONIC CIRCUITS, SIGNALS, AND SYSTEMS" by Samuel J. Mason and Henry J. Zimmerman. Published by *John Wiley & Sons, Inc.*, N.Y. 616 pages. Price \$12.50.

This book presents matrix, topological, and signal-flow graph methods of circuit and system analyses. In each case the formulation and solution of electronic circuit problems is stressed, but the methods used are applicable to many other fields.

"PHOTOCONDUCTIVITY OF SOLIDS" by Richard H. Bube. Published by *John Wiley & Sons, Inc.*, N.Y. 461 pages. Price \$14.75.

A unified physical description and interpretation of photoconductivity is provided in this volume, with examples drawn from different kinds of material. Additionally, the correlation between photoconductivity and related phenomena in insulators and conductors is given.

"ELECTRONIC SWITCHING, TIMING, AND PULSE CIRCUITS" by Joseph M. Pettit. Published by *McGraw-Hill Book Co., Inc.*, N.Y. 267 pages. Price \$7.50.

This book integrates the numerous circuits devised during the 1940's in connection with radar, nuclear instrumentation, and TV into a unified analytical framework for understanding

the use of tubes and transistors as switching devices.

"INTRODUCTION TO MODERN NETWORK SYNTHESIS" by M. E. Van Valkenburg. Published by *John Wiley & Sons, Inc.*, N.Y. 498 pages. Price \$11.75.

For readers already familiar with network analysis, here is an intensive study of network synthesis, which attempts to provide a scientific and mathematical basis for circuit design. This subject is regarded with increasing importance in modern electronics, along with information theory, automatic control theory, and automatic computation.

"TUBE SUBSTITUTION HANDBOOK" by the Sams Staff. Published by *Howard W. Sams & Co., Inc.*, Indianapolis, Ind. 96 pages. Price \$1.50. Soft cover.

To facilitate the work of the technician who comes across different tube types, this volume serves as a reference work on tube substitutions. Included is a cross-reference of American receiving tubes; a list of industrial substitutes for receiving tubes; European substitutes for American types; American substitutes for European types; and a section on picture-tube substitutes.

"TRANSISTORS" by Saedi Staff. Published by *Saedi Unlimited*, 626 S. Federal St., Chicago 5, Ill. 30 pages. Price \$1.25. Soft cover.

This is an elementary treatment of the subject, presented in the form of

Ask By Name For **GENUINE** your assurance of brand name quality

"NO NOISE" PRODUCTS



NO-NOISE TUNER-TONIC
With PERMA-FILM

- Cleans, lubricates, restores all tuners, including wafer type.
- Non-toxic, non-inflammable.
- For TV, radio and FM use.
- Economical — a little does a lot.

6 Oz. Aerosol Can

\$3.25
Net to Servicemen

NO-NOISE VOLUME CONTROL and CONTACT RESTORER

- Lubricates
- Cleans
- Protects
- Not a Carbon Tet Solution

2 Oz. Bottle 6 Oz. Spray Can

\$1.00 \$2.25
Net to Servicemen Net to Servicemen



FREE At Your Jobbers

5" PLASTIC EXTENDER

- Push Button Assembly
- For Pin-Point Applications
- Does Not Cause Shorts

ELECTRONIC CHEMICAL CORP.
813 Communipaw Avenue Jersey City 4, N. J.

P.S. Be Sure to Ask for **NO-NOISE RUBBER COAT** 6 Oz. Spray Can **\$3.25**

LESA
MADE IN ITALY



**POTENTIOMETERS • POTENZIOMETRI • POTENTIOMETER
POTENTIOMETRES • POTENTIOMETROS**

▼
Choose from hundreds of factory models

▼
Custom made to your specifications

World Renowned Reliability

LESA COSTRUZIONI ELETTROMECCANICHE S. P. A. - VIA BERGAMO, 21 - MILANO ITALY
LESA OF AMERICA 11 WEST 42ND STREET - NEW YORK, 36 - N. Y. - U. S. A.

OVER 1300 HI-FI COMPONENTS

at your fingertips in the

1961 STEREO & HI-FI DIRECTORY

The world's most comprehensive hi-fi reference gives you facts, data, prices, illustrations, performance analysis on virtually every piece of hi-fi equipment manufactured. Entire sections on:

TUNERS • RECORD PLAYERS • TAPE RECORDERS • CARTRIDGES • TONE ARMS • TURNTABLES • AMPLIFIERS • PRE-AMPS • LOUDSPEAKER SYSTEMS • RECORD CHANGERS
ENCLOSURES AND CABINETS

*On sale at your
newsstand or electronics
parts store October
4th, or order by
coupon today.*

ONLY \$1.00

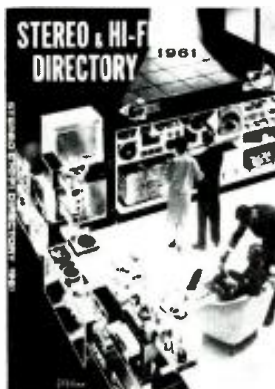

five "Lessons", which are equally adaptable to home-study or classroom use. The text is well enough illustrated and clear enough in its presentation so that those without prior semiconductor experience should have no trouble handling the material. The fifth lesson covers servicing procedures, the balance is theoretical.

"STEREO HIGH FIDELITY HANDBOOK" by Norman H. Crowhurst. Published by Crown Publishers, Inc., New York. 183 pages. Price \$5.95.

This is another in the growing roster of popularly written books on this subject that have appeared in the past three years. Written in non-technical language and profusely illustrated with photos and drawings, the book attempts an explanation of stereo, how it relates to high-fidelity, and offers advice on equipment for new and converted-from-mono systems.

"PRACTICAL TRANSISTOR SERVICING" by William C. Caldwell. Published by Howard W. Sams & Co., Inc., Indianapolis, Ind. 191 pages. Price \$2.95. Soft cover.

Avoiding some of the more complex theory of transistors, the author here devotes much of this book to showing how the transistor works, to explaining circuit components, and mostly to isolating and curing troubles in equipment using transistors. One whole chapter contains "case histories" of troubleshooting auto and portable transistor receivers.

"TELEVISION EXPLAINED" by W. E. Miller, revised by E. A. W. Spreadbury. Published by Iliffe & Sons, Ltd., London, England. 192 pages. Price 12s. 6d., plus postage.

Written simply, and in non-mathematical language, this book explains the technical fundamentals of television, with emphasis on receivers. As the seventh edition of a work originally published in 1947, the present volume has been generally revised and updated to keep pace with new developments. A new chapter deals with combined TV and FM receivers. The book assumes no previous knowledge of TV circuits by the reader, but it does assume an acquaintance with ordinary radio receivers.

"RADIO SERVICING" by Abraham Marcus. Published by Prentice-Hall, Inc., Englewood Cliffs, N. J. 649 pages. Price \$7.95.

This is the third edition of a reputable staple in the technical library that first appeared back in 1948. Its purpose, briefly, is to teach the theory of the radio receiver and how to service it. It presumes some previous technical training, at least in electronic fundamentals, and then builds on that to delve into tubes and their uses, typical circuits, test and servicing instruments, and servicing procedures. Serious students will find the book valuable; older hands may welcome it as a general refresher course.

-30-

ELECTRONICS WORLD

Ziff-Davis Publishing Company

Department EW 106
434 S. Wabash Avenue, Chicago 5, Illinois

Please send me a copy of the 1961 STEREO AND HI-FI DIRECTORY. I enclose \$1.00, the cost of the DIRECTORY, plus 10¢ to cover mailing and handling charges. (Canada and foreign, \$1.25 plus 10¢ postage.)

NAME _____

ADDRESS _____

CITY _____ ZONE _____ STATE _____

R. F. Proximity Controls
(Continued from page 63)

naturally, is always possible. When it does occur, it must be found in a hurry. A machine out of operation may cost thousands of dollars per hour in lost production.

Since almost no current flows in the pickup coil, about the only thing that can go wrong with the latter is physical damage. A quick check with an ohmmeter at the control end of the cable will usually tell whether the coil is still in good condition.

Unlike most radio and TV oscillator circuits, the d.c. bias on the grid will not tell if the oscillator is working, since no grid resistor or capacitor is used. However, an ordinary multimeter, switched to the output function, can be used to trace the oscillator signal right through the control.

Naturally, if you find the r.f. signal present at the plate of V_{1B} but not at the grid of V_{2A} , you would suspect that the .001- μ f. coupling capacitor between these triodes is open. As you can see, there is nothing mysterious about fault-detection methods. The exact signal voltages will vary with the adjustment of the sensitivity control, and also according to the presence of conducting material near the pickup coil; but signal tracing should still show an increase in signal strength at each amplifier.

If r.f. is present right up to the cathode of the 1N34A diode, a simple d.c. voltage check between grid and cathode of V_{2B} will show whether the diode circuit is working or not.

Tube changing hasn't been mentioned here, because any electronic service technician who doesn't change tubes first is not a realist!

Because of the quality construction, the chance of serious trouble other than tubes in the control chassis is very small. Most cases of faulty operation can be traced to external causes, such as the following:

A careless installation may have resulted in location of the pickup coil too near masses of metal or metal objects other than the ones that are supposed to be sensed. Small pieces of metal (or other conducting material) may have become stuck on the pickup coil or are near it. The coil itself may have become physically damaged.

Erratic operation can also sometimes be traced to the manner in which the control box is mounted, without regard to the nearness of conducting matter. It may be that the box is subjected to considerable vibration. This can shorten tube life. It can also sometimes cause the load relay to make momentary contact when it should be open.

A system using an r.f. proximity control is actually a simple one. The only "special equipment" a technician really needs when breakdown occurs is an understanding of how this device works.

FREE \$25 WORTH OF RADIO-TV PARTS PLUS POLY PAK LISTED BELOW

BOTH FREE with every \$10 ORDER

- | | | | |
|--|---|--|---|
| <p>60 TERMINAL STRIPS
1 to 10 tie points. Used in every type of job. Worth \$5.</p> <p>10 ELECTROLYTICS
Incl. can & paper types. Leads lead. To 1000 mfd to 450V. Worth \$12.</p> <p>3 TRANS'N RECTIF'RS
Selenium; designed for submini. eqts. Only 5/16 x 1/4 1/2 wave. plugs in.</p> <p>70 MICA CONDENSERS
Incl. silver lead, mfg'd to .01 to .001V. Worth \$20.</p> <p>2 500-MIL RECTIFIERS
Silicon, hi-hat, with long axial leads.</p> <p>30 MOLDED CONDENSERS
Only tool lasts for life. Worth \$8.</p> <p>SOLDERING IRON
115V AC, with cord & plug. Nice job-by-unit. Worth \$3.</p> <p>4 TRANSITION DIODES
Power! At long axial leads. For submini. & transistor semi-cond. eqts.</p> <p>6 SPOOLS OF SOLDER
Rosin core type. Handy shop pack.</p> <p>40 TRANS'N RES'TRS
Asst. to 3 megs. 1/2 watt rating. Color coded. Worth \$8.</p> <p>10 VOLUME CONTROLS
Asst. to 1 meg. Some with switch. Worth \$15.</p> <p>TRANS'N RADIO BASIC
Incl. transistor socket, base, diode. Worth \$3.</p> <p>13-IN-1 PAK
Diodes, carbon, W.W., precision, hi-Q resistors; disc, ceramic, molded, oil, paper, mica condensers; socket, coils. Worth \$15.</p> <p>60 PLUGS & RECEPT'LS
Incl. power, audio, battery, etc. Worth \$8.</p> <p>50-PC. COBALT MAGNET
Set! 100's of uses for schools, tool shops, for the experimenter of magnetic properties.</p> <p>20-PC. TWIST DRILL SET
In case, 1/16 thru 3/4". For all types of drills.</p> <p>60 RESISTOR SPECIAL
Carbon, precision, hi-Q, W.W. carbon films, to 50W, 1% too. Worth \$10.</p> | <p>60 CONDENSER SPECIAL
Incl. discs, ceramics, molded, mica, papers, oils, etc. Worth \$12.</p> <p>60 RADIO 'N' TV KNOBS
Asst. colors, sizes. Shaped some \$1 ea.</p> <p>300-FT. HOOKUP WIRE
Asst. colors, insul. (10 sizes) Worth \$5</p> <p>8 SIL & XTAL DIODES
1N21, 1N34, etc. Some worth \$10.</p> <p>100 1/2-WATT RES'TRS
Asst. values. Some 1%. Worth \$18.</p> | <p>35 POWER RESISTORS
Asst. 1/2 to 50W to 10,000 ohms. Vitroous types too. Worth \$12.</p> <p>8-PC. NUTDRIVER SET
Plastic handle, 7 1/4 thru 7/16, children's in handy case. Worth \$1</p> <p>6 115VAC SWITCHES
Panel; Toggle type. SPST, DPDT, Etc. A shop must.</p> <p>40 TUBE SOCKETS
Filled tool & nut types. Worth \$8.</p> | <p>8 NEON INDICATORS
For 110 VAC; mount. bay types.</p> <p>24 ARTISTS BRUSHES
100% pure bristles. Sizes 1 to 5.</p> <p>\$25 SURPRISE PAK
Wide variety of usable radio-TV, hobby parts.</p> <p>3 FERRITE LOOPSTICKS
Adjustable; 5-in to 14-in long. Worth \$2.</p> <p>10 INSTRUMENT KNOBS
Pointer types, black, brass insert & set screws.</p> <p>50 PRECISION RES'TRS
1% resist. values. 1/2W to 2W.</p> <p>\$30 RELAY SURPRISE
Popular lab and shop asset.</p> <p>4 PILOT LITES
Assorted, with 1/2" green jewel. Fits mini bay bulbs. Druco type. Worth \$1.50.</p> <p>40 TINIEST RESISTORS
Only 4/16" long; with long axial leads. For transistor eqts. color-coded. World's smallest!</p> <p>70 1-WATT RESISTORS
Incl. fractions, W.W., carbon films, 1% & 5%.</p> <p>3 TRANSISTOR CHOKES
For making mini transistor power supplies. Only 5/8 x 7/8 x 7/8". Open frame. Leads. Worth \$3.</p> <p>4 AC & DC CHOKES
Power & radio types; to 300 mhs. Open frame types. Worth \$10.</p> <p>4 TRANS'N OSC. COILS
For 456 kc superhet eqts; found in trans. radios. Mini size.</p> <p>CRYSTAL MIKE
Sensitive 110 to 7,000 cps. Worth \$2.98.</p> <p>5 MICRO-SWITCHES
Ultra-sensitive; for burglar alarms, photoelectric, etc. For 115VAC, SPST. Worth \$1 \$1.50 ea.</p> <p>70 COILS & CHOKES
RF, ant. one, slug-tuned, I.F. Wonderful shop \$1 ea.</p> |
|--|---|--|---|
- \$1 POLY PAK HEADLINERS**

 - 2000-ohm PHONE, cord & plug.....\$1
 - XTAL PHONE, cord & plug.....\$1
 - CRYSTAL RADIO SET.....\$1
 - 10-3-sec. TIM'G DEVICES.....\$1
 - 40 ASST. SILVER MICAS.....\$1
 - 50 ASST. DISC CONDENSERS.....\$1
 - 5 1N34 CRYSTAL DIODES.....\$1
 - 30 PANEL LITE BULBS.....\$1
 - 3 HOBBY TRANSISTORS.....\$1
 - 15 "POLY" BOXES to 1".....\$1
 - 125 CERAMIC CONDENSERS.....\$1
 - 12 GERMANIUM DIODES.....\$1
 - 7 SIL. DIODES, 1N21, 1N22.....\$1
 - 15 ROTARY SWITCHES, asst.....\$1
 - \$15-Radiation DETECTORS.....\$1
 - 125 ASST. RESISTORS.....\$1

OVER 1000 SOLD THE 1st MONTH — Not one returned to date!

JUMBO PAKS! RADIO-TV PARTS by the Pound

500-1000 pcs. per pound

BUY 4* the 5th FREE

3 per pound

MONEY BACK GUARANTEE

- ONE POUND Precision Resistors Worth \$100, NOW \$75
- ONE POUND Disc Condensers Worth \$50, NOW \$35
- ONE POUND Ceramic Condensers Worth \$85, NOW \$60
- ONE POUND Discs and Ceramics Worth \$75, NOW \$55
- ONE POUND Diacs, Ceramics, Precision Worth \$70, NOW \$50
- ONE POUND Carbon Resistors Worth \$60, NOW \$45
- ONE POUND "Tiny" Paper Condensers Worth \$60, NOW \$45

LEKTRON 133 Everett Ave. CHELSEA 50, MASS.

MINIMUM ORDER \$2.00—Avg. wt. 1 lb. per pak

HOW TO ORDER Check items. Return ad w check or M.O., including sufficient postage; excess returned. C.O.D. orders 25% down; rated, net 30 days. Print name, address WITH POSTAL ZONE in margin.

ADD TO YOUR INCOME

Learn at Home to Fix APPLIANCES

FREE SAMPLE LESSON

Tester Furnished—No Extra Charge. National Radio Institute trains you at home. Every service customer is worth more when you can fix his electrical appliances. Mail coupon for Lesson and Catalog.

National Radio Inst., Dept. EKO Washington 16, D.C.
Please send me Electrical Appliance Sample Lesson and Catalog FREE (No salesman will call).

Name.....Age.....
Address.....
City.....Zone.....State.....
ACCREDITED MEMBER NATIONAL HOME STUDY COUNCIL

RECORDING TAPE

*Outside guaranteed not to rub off or squeak or mangle! Look for more care with other "Bargain" tape. You'll find it's more than just "bargain" when you deal with us. We are original inventors in the tape recorder business and our reputation has grown every day!

600' acetate, 1/2".....	1.75
900' MYLAR Polyester, 7/8".....	1.95
1200' MYLAR, 1" and 1 1/2" reel.....	1.25
1200' Acetate, 1".....	1.25
1200' MYLAR 1 1/2" (stereo).....	1.95
1500' acetate (stereo).....	1.75
1800' MYLAR 1 1/2" not 1/4".....	1.75
2400' MYLAR, unswitched, 7".....	2.69
3000' MYLAR, unswitched, 7".....	3.49

SEND FOR CATALOG

NORELCO SPEAKERS

5" mm 970M, twin cone 8" speaker, original list \$9.95, now \$4.97. NOW, while they last 1/2 off net.

11.98 plus postage, (discontinued model). Frequency 40 to 20,000 Hz. Other SPEAKERS: 3" Speaker reduction on a hot come, first served basis. SEND FOR SPEAKER SPECIFICATION SHEET.

COMMISSIONED ELECTRONICS CO.
1776 Columbia Road Washington, D. C.



FREE!

Olson Radio Catalogs FOR ONE YEAR

- ★ 8 Different Issues
- ★ All Bargain Packed



FREE One Year Subscription to OLSON RADIO'S Fantastic Bargain Packed Catalog—Unheard of LOW, LOW WHOLESALE PRICES on Brand Name Speakers, Changers, Tubes, Tools, Hi-Fi's, Stereo Amps, Tuners and other Bargains.

Another **OLSON** Bargain!

CEILING SPEAKER

- ★ Mounts Flush Without Cutting Hole



NEW!

No. S-394
3 for
\$15.00

\$5.49

Mounts on wall or ceiling. Perfect for built-in systems, built-in Hi-Fi systems, and adding extensions to your present system. For the Hi-Fi music enthusiasts who enjoy their music in the air. Specially designed to handle up to 15 watts. Response: 60 to 13,000 CPS. Voice coil 8 ohms. Overall depth is only 3". 6" speaker factory mounted. Finished in dull gold to blend with any surroundings.

MAIL COUPON TODAY

Fill in coupon below for your FREE one year subscription to Olson's Bargain Packed Catalog. To order Ceiling Speaker, simply check quantity desired and send remittance along with coupon. (Include enough for postage or parcel post shipment. Send \$2.00 deposit for C. O. D. orders.)

- FREE Olson Catalogs for One Year
- 1-S-394 Ceiling Speaker.....\$5.49
- 3-S-394 Ceiling Speakers.....\$15.00

NAME _____
ADDRESS _____
CITY _____ ZONE _____ STATE _____

OLSON RADIO CORPORATION

612 S. Forge St., Akron 8, Ohio

Bulk Eraser for Magnetic Tape

By WILLIAM QUITMAN WOLFSON, M.D.

*Make this high-performance eraser for tape
in 15 minutes at a cost of only a few dollars.*

FEW scientific fields remain a stranger to magnetic recording tape. In medicine, for example, its uses are countless and varied, including such different applications as data recording in physiologic laboratory experiments, continuous monitoring of the vocal behavior of psychiatric patients, the registration of heart sounds illustrated on the cover of the November 1957 issue of this magazine and even, for the past few years, a complex system of recorded tape summaries for practicing physicians which permits them to absorb the well-abstracted meat of the newest developments in medical science while they are driving from call to call.

For at least some of these applications, such as the accurate recording of heart sounds, it is desirable to have as low a level of background as possible. With most inexpensive recorders, even when the instrument is new, it is difficult to erase completely earlier recordings from previously recorded tape, yet it is essential to do so for optimum results in certain problems. Even very slight background will markedly impair a recording of heart sounds. If the recording apparatus has been used much, the erase efficiency is generally not maximal because of worn pressure pads or inexact alignment of the head horizontally or with respect to azimuth, defects not so obvious as if they had occurred with the record or playback head. However, even if these factors are carefully controlled, poor erase may ruin a critically important tape if the line voltage happens to be low when the recording is made or if the tape happens to be from a lot which is intrinsically difficult to erase. During 1954, the writer purchased some 1-mil Mylar tape which was not notably reduced in intensity by one passage across the erase heads of any of a half-dozen different American and European home-type recorders.

The solution to these problems is the use of a so-called "bulk eraser" before the recording is made. A properly designed bulk eraser will, in a matter of seconds, completely remove previous recordings from a reel of tape and leave it with a background level less than that which it had when new. Unfortunately, many commercially avail-

able erasers are expensive enough to discourage their wide use by amateur home recordists. Fortunately, however, home construction of an adequate bulk eraser is almost ridiculously simple and inexpensive, providing the right starting material is used. The unit to be described is not the first "do-it-yourself" bulk eraser to be suggested but it is far simpler even than the eraser suggested by Driscoll¹ which is made by a somewhat tedious process from surplus power transformers.

Construction

Purchase a receiver or transmitter power supply filter choke of the commonly used 5 to 25 henrys inductance, rated at 75 to 200 ma. capacity. If bought surplus, such chokes may cost as little as 70 cents and, in any case, should not cost more than a few dollars. Remove the case of the choke. Examine the laminations. These will be found to consist of two groups: (a) a series of E-shaped laminations with a coil wound on the center bar of the E and (b) a series of straight laminations which close the open parts of the E. The latter are generally held against the E only by varnish. Using a screwdriver to direct the force properly, knock off the straight laminations and discard them. There now remains the coil wound on the center bar of the E-shaped laminations. Fasten these E-shaped laminations together tightly with two nuts and bolts; most chokes already have holes which permit this to be done without drilling. Tape the coil down securely with electrical insulating tape and attach its two leads to an ordinary line cord and 117-volt male plug. A convenient additional feature is to mount a press-to-make switch on the unit. It is connected in one side of the 117-volt line and permits the unit to remain plugged in continuously with current flowing only when the switch is pushed.

Erasing Technique

The effective erasing field is located at the open ends of the E and, like any electromagnetic field, it falls off in intensity in proportion to the square of the distance from this region. This means that, while being used, the unit should be closely applied to the reel of

tape being erased. In practice, the eraser is plugged into the 117-volt socket and passed slowly over the reel so that every area on the reel passes directly under one of the two open gaps in the E. A simple extra precaution against failure to erase some small area is to pass the eraser successively over both faces of the tape reel, although this is unnecessary if the first face is covered carefully. After this process is completed, slowly withdraw the eraser to about two feet from the reel before turning it off; this is a precaution against recording the self-induction current surge which occurs after the current is turned off. The coil is carrying considerably more current than its rated continuous capacity and therefore the unit should be operated only intermittently. With the prototypes, up to ten reels were erased without excessive heating. Ample warning against excessively prolonged use is given by the obvious rise in coil temperature if the unit is used for a long period.

The only parts needed are the choke, two nuts and bolts, one 117-volt male plug and cord and some insulating tape; all at a cost of only a few dollars. The only tools needed are a hammer and screwdriver. Any interested person with no mechanical experience or special electrical training can make this unit in less than 15 minutes. It has been found, in the case of the prototypes, that all tapes studied have been completely erased by passing the unit over one surface of the tape reel in the manner described. Samples of tape studied have included the 1954 material which is virtually unaffected by the erasing fields of the erase heads of a number of representative U.S. and foreign recorders. This performance is comparable to that of the commercially available bulk erasers and is obtained at a cost much less than that of the commercial units.

REFERENCE

L. Driscoll, R. M.: Hi-Fi Tape Recording, November 1957.

M. C. Anderson of Arlington, Va., suggests that plastic cabinet repairs are easier to make than most people suspect. Most plastics can be readily repaired with plastic cement (available at radio supply houses and dime stores). Since the cement will mark finished surfaces, use it sparingly to avoid smears. Even a badly broken cabinet can be repaired if cloth reinforcing patches are used on the inside. Soak patches in cement and smooth them over the break. Allow 24 hours for "setting."

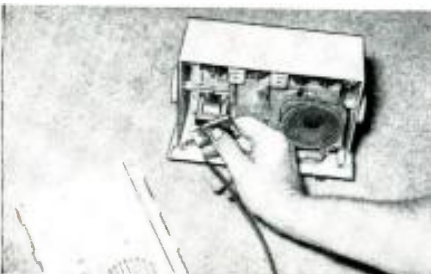

October, 1960

WE TRADE HIGHER!



Howdoody...

They're lettin' me out Monday . . . so's I can go ahead and give you my extra stupid high trade-ins on your old ham gear.* Got a new catalog too—want it?

Write your lonesom fren,

Jack S.

* only amateur receivers and transmitters made since 1945

DO YOU HAVE OUR NEW CATALOG? IT'S FREE!

All prices f. o. b. St. Louis • Phone Chestnut 1-1125



WALTER ASHE RADIO COMPANY 1125 Pine Street, St. Louis, Mo.	OUR 38TH YEAR
Rush "Surprise" Trade-in Offer on my _____	
for _____ (sh. = make and model of new equipment desired)	
Send me a FREE Walter Ashe catalog. R-114-6H	
Name _____	Address _____
City _____	Zone _____ State _____

**SEND
ELECTRONICS WORLD
EVERY
MONTH**



name _____
address _____
city _____ zone _____ state _____

Check one:

- 3 years for \$12
- 2 years for \$9
- 1 year for \$5

In the U. S., its possessions, and Canada
 Payment enclosed Bill me

Foreign rates: Pan American Union countries, add .50 per year; all other foreign countries, add \$1.00 per year.

Mail to: **ELECTRONICS WORLD**
Dept. EW 106, 434 S. Wabash Ave., Chicago 5, Ill.

"TAB" Tubes Tested, Inspected, Boxed
Six Months Guarantee! No Rejects!
NEW & Used Gov't & Mfrs. Surplus!

Orders \$10 or more. Receiving types only. 3rd. U.S. States

0A2	.80	6BJ6	.69	12AT6	.59	4X1500	\$15
0B2	.65	6BK7	.99	12AT7	.84	1172A	1.10
0C3	.69	6BL7	1.25	12AU6	.89	4X5A	13.00
0D3	.35	6BM6	.98	12AU7	.89	2D21	2/31
0Z4	.59	6BQ6	1.19	12AX7	.79	3D23	3.85
1A7	.89	6BZ7	1.25	12BA6	.65	717A	5/81
1B3	.74	6CA4	.74	12BF6	.59	4B21	2/10.00
1N5	.78	6CS	.69	12BD6	.59	4250	35.00
1N4	.78	6CB6	.69	12BE6	.59	4B22	7.00
1T4	.78	6CD6	1.49	12BF6	.59	4FR60	29.50

Send \$1 for Catalog!

1U4	3/81	6H6	3/81	12BH7	.99	4X1500	\$15
1U5	.73	6J5	.52	12BY7	.98	4X250	\$35
1X2A	.68	6J6	.48	12BZ7	.99	4X500	\$38
3Q4	.88	6K6	.59	12C6	1.45	5B1	4.98
3Q5	.86	6K7	.74	12SA7	.94	5B4	4.98
3Q4	.68	6L6	1.19	12SQ7	.89	35T	4.00
3V4	.83	6S4	.59	12SH7	.89	100T	7.00
5R4	.83	6S8	.99	12SJ7	.75	316A	5/81
5U4	.59	6SA7	.99	12SK7	.94	388A	3/81
5V4	.89	6SB7	1.19	12SL6	.84	15B	16.00

Partial Surplus Electronics from schools & 7

5Y3	.59	6SC7	.89	19G6	2.15	450T	42.00
6A4	.59	6SG7	.79	19T8	1.16	607	1.00
6AC7	.70	6SM7	.69	25R6	1.39	809	3.00
6A7	.89	6J7	.69	25T6	1.29	811	1.40
6AG6	.99	6SK7	.72	25W4	.97	812	3.00
6AK5	.69	6SL7	.89	25Z5	.63	813	9.00
6AL5	2/81	6SN7	2/81	25L5	3.79	814	1.45
6AQ5	.89	6SR7	.79	EL37	3.49	815	2.75
6A7	3.00	6SR7	.79	EL37	2.49	826	.59
6AT6	.49	6T8	.98	35L6	.69	829B	8.00

Wanted 30TL tubes! Top \$ \$ \$ Paid

6AU4	1.10	6UB	.89	35U4	.69	822A	7.00
6AU6	1.10	6V6GT	.70	35V4	.69	866A	2.75
6AUG	.69	6W4	.79	35Z5	.63	1625	5/81
6A4	.70	6W6	.89	50A5	.09	814	4.00
6A6	1.00	6X4	2/81	50B5	.09	879	.98
6B7	.49	6X5	.49	50C5	.69	8881	2.70
6BD6	.89	6Y8	.97	50L6	.69	8550	3.90
6BE6	.59	6Y7	.79	50P6	3.89	8886	1.00
6BG6	1.50	12AL5	.59	75	.59	8894	12.00
6BH6	.72	12AQ5	.75	80	.59	7193	10/81

TUBES WANTED! WE BUY! SELL & TRADE!

NEW SILICON 750MA* DIODES TOP

GENERAL PURPOSE 400 PIV at 25 MA
SPECIAL 39c HATS 25 FOR \$8

rms/piv	rms/piv	rms/piv	rms/piv
35/50	70/100	140/200	210/300
19c	29c	34c	43c
rms/piv	rms/piv	rms/piv	rms/piv
280/400	350/500	420/600	490/700
80c	89c	99c	95c
rms/piv	rms/piv	rms/piv	rms/piv
560/800	630/1000	700/1200	770/1100
\$1.05	\$1.25	\$1.70	\$2.00

*CAPACITOR INPUT DERATE 20%
(\$5 or more we pay postage 48 states!)

"TAB" KITS! "TAB" THE BEST KITS! "TAB"

- All Kits Contain Most Popular Values & Sizes
- Kit 2 Eng. Parallel Rules
 - Kit 35 Precision Resistors
 - Kit 10 Switches
 - Kit 75 Resistors 1/2 1/2W
 - Kit 150 Carbon Resistors
 - Kit 25 Panel Lamp
 - Kit 12 Electrolytic Cond's
 - Kit 56 Tube Sockets
 - Kit 65 Tubular Condensers
 - Kit 500 Lug & Eyelets
 - Kit 10 Bathub Oil Cond's
 - Kit 5 lbs. Surprise Pckg.
 - Kit 10 Xmitr. Mica Cond.
 - Kit 3 Phone Patch Ximrs
 - Kit 3 Searchlights
 - Kit Circular Slide Rule
 - Kit 12 Algr. Clip Ass't'd.
 - Kit 5 Sub-Win Tubes
 - Kit 40 Standoff Insulators
 - Kit 100 Power Resistors
 - Kit 75 Mica Condensers
 - Kit 5 Crystal Diodes
 - Kit 100 Ceramic Cond'r.
 - Kit 10 Germanium Diodes
 - Kit FT243 Xtal Holders
 - Kit 8 Silicon Diodes
 - Kit 5 Microswitches
 - Kit 4 Ass'd Rectifiers
 - Kit FT243 Xtal Filters
 - Kit 4x50 FT Hookup Wire
 - Kit 2 Vee'dr. Counters
 - Kit 5000 Transistors
 - Kit High Gain XTAL Mike

BUY 10 KITS—GET ONE FREE EACH KIT 99c

"SUNTAB" BATTERY-SELENIUM PHOTOCELL

5AP—Round 1 1/2" Dia.	\$1.00
10AP—ROUND 1 1/2" Dia.	1.75
360 ua	1.75
15AP—ROUND 2" Dia.	3.00
75 ua	3.00
28P—RECT. 3/4 x 7/16	.70
75 ua	.70
SBP—RECT. 1-7/16	1.35
7/8-200 ua	1.35
10BP—RECT. 1-11/16 x 7/8-360 ua	1.80
Kit ALL SIX ONE EACH KIT 99c	7.00

ORDER QTY'S. TEN OR MORE DEDUCT 20%

This Item Shipped Postpaid Orders \$5 Up

TRANSISTORS & ACCESSORIES

2N441	\$3.	2N442	\$4.50	2N472	\$5.
2N155	\$1.39	2N176	\$1.80	2N177	\$1.
2N178	\$1.75	2N247	\$1.50	2N255	\$1.20
2N270	\$1.20	2N408	\$1.25	2N409	\$1.20
2N410	\$1.50	2N570	\$2.20	2N581	\$1.25
2N582	\$2.10	2N174	\$8.50	2N443	\$6.50
DIAMOND BASE MICA MOUNTING KIT	\$.30				
DELCO ROUND BASE MICA MOUNTING KIT	\$.30				
DELCO POWER HEAT SINK WITH FINS	\$.75				

★ NEW "TEKSEL" SELENIUM RECTIFIERS

FULL WAVE BRIDGE RECTIFIERS ONE YEAR GTD!				
AMP.	18VDC	36VDC	72VDC	144VDC
CONT.	14VDC	28VDC	56VDC	118VDC
1AMP	\$ 1.30	\$ 2.00	\$ 4.90	\$ 6.50
2AMP	2.15	3.00	6.25	12.30
3AMP	2.90	4.00	8.40	16.75
6AMP	4.15	5.80	11.75	23.15
10AMP	6.10	12.15	26.30	46.90

Write for Complete Rectifier Catalog

NEW Selenium Radio & TV Rectifiers! GTD.

65Ma 45c.	@ 6 for \$2.	100Ma 45c.	@ 12/\$5.
250Ma 55c.	@ 10/\$5.	300Ma 85c.	@ 10/\$9.
500Ma \$1.	@ 10/\$8.	25/518	

Orders this item \$10 or more, Postpaid 48 States!

SNOOPERSCOPE TUBE 2" \$5 @ 2 for \$9

AN-ARR2 RCVR GOOD COND. Tubes .20. \$1.59

BUY BTY 115V/60 CY SELSYNS TWO for \$9

NEW POWER CONVERTER

12VDC to 500VDC up to 200MA: 100 Watts: Tap at 250VDC Type C1250E \$35. Hi efficiency, low ripple, low idle current—Silicon rectifiers! Formulated HIFIT! Mag-metal tape wound transformer, fused & short circuit proof, small in size! Quiet! Light weight! C1250E built, ready to go. Conservatively Rated! Delco Transistors Heavy Copper-Heatsink. 12VDC to 250VDC up to 150MA Type C1225A \$30.

TERMS: Money Back Guarantee! Out 15th year. \$2 min. order F.O.B. N.Y.C. Add ship charges or for C.O.D. 25% Dep. Prices shown subject to change.

111-WN LIBERTY ST., N. Y. C.

Send 25c for Catalog PHONE: RECTOR 2-6245

Mac's Service Shop
(Continued from page 50)

fier. Throwing any one switch down removes the attendant speaker transformer from the music bus and connects it to the intercom circuit. The rub was that music was heard through post and kitchen speakers, even when they were switched to the intercom circuit, interfering with orders.

"A couple of things complicated the situation: first, I could not make my own tests. It was Tony's job; so it simply would not do for me to go nosing around. I had to depend on him to do the testing. Second, the system had been struck by lightning shortly after being installed, and the owner could not be sure if the trouble had been present before then or not.

"Tony had checked over all the wiring carefully to make sure it was correct and that there were no short-circuits feeding the music into the intercom circuits. I suggested several tests aimed at isolating the part of the circuit where this transfer was taking place, and he soon reported that it was happening somewhere in the banks of switches that transferred each post speaker from the music bus to the intercom circuit, and vice versa. Remembering the lightning, I thought possibly an arc had carbonized a path across the insulation of one or more switches; so I suggested the switch banks be disconnected and individually checked for leakage with an ohmmeter. This test revealed no degradation of switch insulation, and that left just one possibility: the music was being transferred across open switch contacts through the capacity between them. Capacity between contacts on one switch would be quite small; but when dozens of switches were wired in parallel, the total would be high.

"I could think of no practicable way of reducing this capacity appreciably; so I decided to try to 'buck out' the music in the same way a transmitting tube is neutralized; that is, supply a bucking signal equal in amplitude but 180° out-of-phase with the signal being transferred through the switch capacities. I worked out a circuit to do this and tested it here on the bench. I let the audio generator represent the music amplifier. One half the primary of a small output transformer was connected across the output of the generator, the center-tap being grounded. The output of the generator was fed through a 20- μ f. capacitor to the a.c. v.t.v.m.; and the output of the generator, operating at 1000 cycles, was adjusted for a 10 millivolt reading. A 35- μ f. variable capacitor was connected between the loose end of the transformer primary winding and the hot terminal of the v.t.v.m. The 20- μ f. capacitor represented the capacity between switch contacts through which the unwanted signal—10 millivolts in this case—was feeding. I knew any signal appearing at the hot end of the

portion of the transformer winding across the signal generator would produce another signal equal in amplitude but 180° out-of-phase at the other end of the winding. This phase-shifted signal would be transferred through the variable capacitor to the v.t.v.m., representing the intercom bus in our test setup. When the variable capacitor was adjusted to 20 μ f., the two signals should cancel—and they did! With the capacitor adjusted for maximum attenuation, the reading could be dropped 35 or 40 db; and since the two signal paths were identical, this attenuation would hold all the way from 50 to 5000 cycles.

"All Tony had to do was connect one end of a center-tapped output transformer winding to the music bus, ground the center-tap, and connect the other end of the winding through a small variable capacitor to the intercom bus. He stopped by to tell me that when he set the variable capacitor equal to the capacity between switch contacts, the music dropped out of the intercom as if by magic, and stayed out."

"How about pay, Mr. Consulting Engineer?" Barney inquired.

"In Tony's case, when he asked for my bill I suggested he could pay me by doing some antenna tower work out at the house. He is a crackerjack at this and well equipped. As for the spring company, I'll send them a bill for consultation and advice. The point I want to make, though, is that the radio and TV service technician has acquired a wealth of knowledge, not necessarily restricted to repairing ailing radio and TV sets, that others are willing and eager to buy—if he is alert to this fact.

"On the other hand, the technician must be careful not to get in over his head. For example, yesterday I had a long distance call from the director of the hospital over in Carlston. He wanted to install a two-way radio system at the hospital and in ambulances so that the emergency ward and doctors could be alerted and ready to handle accident patients when they arrived. He had received some quotations from people manufacturing and selling this type of equipment, but he did not like the prices. He had heard of the fabulous 'bargains' to be had in surplus electronic equipment, and he wanted me to go with him to a war surplus depot, pick out suitable equipment, convert it, and install it in the hospital at a big fat saving to the hospital. I politely declined after pointing out several of the many pitfalls involved in converting war surplus, getting the equipment licensed, maintaining it, etc."

"I don't blame you," Barney remarked. "Dependability would be very important in such a setup. He had better wait until he can afford commercial equipment. That's a case where you probably gave away advice worth several hundred dollars to the hospital director."

"Oh well, it's a good cause," Mac said with a grin.

Audio Pickup Circuit

(Continued from page 38)

For this service a 0-1 ma. meter, in series with a 10,000-ohm resistor, can be connected in the collector circuit of transistor V_2 in place of the relay. A phono-cartridge coil probe works fine for this purpose.

Many other applications will undoubtedly occur to the experimenter—such as picking up the field from a tape recorder bias oscillator coil to operate an indicator light or to control the a.c. power to the tape transport mechanism to prevent recording without proper bias current should the oscillator fail.

Satisfactory tests were also made with a simple crystal-diode power supply in place of the 22½-volt battery.

Since there is nothing critical about wiring or assembly, layout and construction into a compact unit can be arranged to suit the builder and according to the application for which the circuit is to be used.

-30-

GROMMET GADGETRY

By JOHN A. COMSTOCK

IF YOU have extra pilot lamps lying around in your spare-parts box, you might try slipping a rubber grommet over the envelope of each one to eliminate the chance of breakage.

It doesn't take much of a jar to loosen the inside filament mountings, either, and the rubber grommet "bumpers" serve as all-around protection for the lamps.

Another handy use for grommets is as pilot-lamp pullers whenever your regular rubber pilot lamp remover happens to turn up missing. An ordinary rubber grommet, pressed firmly against the lamp's envelope, does a neat job of removal and can also be used in installing the new lamp as well.

-30-



(Above) Using grommets as "bumpers" to protect pilot lights. (Below) In emergencies, grommets make good pilot-light pullers.



The Perfect
Workshop
Companion For
The Advanced
Audiophile

THE 1961 AUDIO YEARBOOK

Over 25 projects and features covering stereo, hi-fi, components, acoustics—every phase of audio! Advanced discussions and instructions on:

- CONSTRUCTING THE BI-PHONIC COUPLER
- STEREO MICROPHONE TECHNIQUES
- FINDING FAULTS IN HI-FI SYSTEMS
- WIDE SPACE STEREO
- MULTIPLEXING MUSIC ON ONE RECORDER
- ROOM ACOUSTICS FOR STEREO
- Plus many other authoritative articles

Now on sale at your newsstand or electronics parts store or order by coupon today.



ONLY
\$1.00

Ziff-Davis Publishing Company, Dept. EW-106
434 S. Wabash Avenue
Chicago 5, Illinois

Please send me a copy of the 1961 AUDIO YEARBOOK. I enclose \$1.00 plus 10¢ to cover mailing and handling charges. (Canada and Foreign \$1.25 plus 10¢ postage.)

NAME _____

ADDRESS _____

CITY _____ ZONE _____ STATE _____

EVERY technician is confronted at one time or another by tubes that pass every test on the very best tube checkers but simply will not work properly in certain circuits, although a substituted tube will. After a number of such experiences, the technician adopts the following credo: If a tube is suspected, don't rely on a check—substitute.

Another electronic component that often presents the same baffling condition of causing circuit malfunction while passing every test is our friend the capacitor. A look at what tests these components are subjected to in the better capacitor analyzers reveals the following: capacitance measurement (generally quite accurate) and leakage (the amount of direct current the component will pass). In the latter check, a substantial d.c. voltage is fed into one terminal of the component, which is in series with a voltage-reading meter. Some analyzers use eye tubes or neon bulbs in place of the meter.

A more efficient leakage test is to use a source of several hundred volts (depending on the component's rating) applied to one terminal of the capacitor, which is series-connected to a

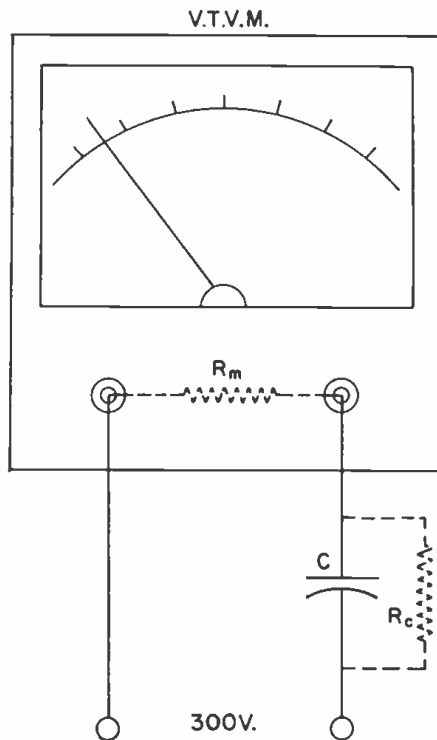

Fig. 1. Sensitive leakage measurement.

will not always be possible to determine exactly what defect has occurred, although malfunction disappears when a substitution is made. Following are several accounts of skirmishes with capacitors, to prove the points made.

Before going into the case histories, we should like to point out another parallel between tubes and capacitors. The baffling defects are most likely to occur in more critical electronic circuits, such as low-level amplifiers, discriminating or limiting networks (such as the sync stages), sine and other waveform generators (such as TV deflection generators), and in other pulse-handling or pulse-forming circuits.

The Sizzling Ceramic

A V-M model 711 tape recorder came in for service with the complaint of being noisy. Inspection revealed that, with no tape threaded on and with the "play" button depressed, a constant sizzling noise could be heard. The latter could be attenuated by adjusting the volume control, indicating that the trouble was in a preceding stage (or perhaps in a later stage, but was being detected by the sensitive preamplifier). A scope check quickly eliminated the alternate possibility in this instance.

Wayward Capacitor Woes

By ALLAN F. KINCKINER

Look out for "perfectly good" capacitors that pass all tests but produce strange and confusing faults.

v.t.v.m., as in Fig. 1. Leakage resistance may then be determined from the following relationship: $R_c/R_m = E_c/E_m$; where R_c is the leakage resistance of the capacitor, R_m the input d.c. resistance of the v.t.v.m. (usually 11 megohms), E_c is the voltage across the capacitor, and E_m is the voltage read on the meter.

In the example shown, the meter reading (E_m) is .1 volt, which leaves 299.9 volts as E_c . Solving for R_c , we have a leakage resistance of almost 33,000 megohms. The leakage current, determined by Ohm's Law, would come to less than a hundredth of a microampere. Insignificant as these leakage figures seem, there are circuits in which capacitor replacement would be warranted.

The advantages of checking leakage in this way are twofold. First, the sensitivity is greater than in the test provided by most analyzers. In the second place, leakage is more easily read. A man could get eyestrain trying to judge the opening or closing of an eye tube or the lighting of a neon lamp. However, just as the tube checker should be neither condemned nor scrapped because it doesn't bat one thousand, the capacitor analyzer should not be demoted for its less-

than-perfect score on the leakage test.

It is true that the substitution of a suspected capacitor is not so easily accomplished as that of a tube. Yet this will often be the quickest path to a repair. However, the substitution should only be considered after thorough circuit testing has left the capacitor as the prime suspect, although on circumstantial evidence. The capacitor fault may be so elusive that it

Fig. 2. Preamp in which noise was generated by a "good" ceramic capacitor.

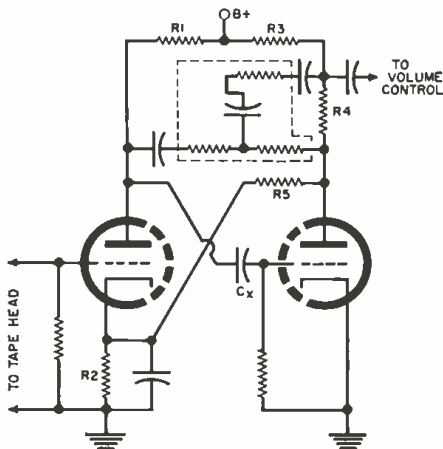

The preamplifier consisted of a 12AX7 with the triodes in cascade (see Fig. 2.) Further troubleshooting revealed that grounding the second grid killed the noise, but grounding the first grid had no effect. The sizzling noise sounded precisely like a noisy resistor, so the resistors were substituted after resistance and voltage checks in the order numbered, but without any result.

Capacitor C_x was disconnected at the second grid and checked with an analyzer, which passed it as being faultless. C_x was also checked as per the technique discussed in connection with Fig. 1; not the slightest leakage was indicated. Since every other component in the circuit had been substituted, C_x was now temporarily replaced with a tacked-in unit, and dawg-gone if that didn't cure the trouble.

This capacitor, a black .01- μ f. disc ceramic, subjected to all types of further testing on our brand X capacitor analyzer, was also checked on a fellow service technician's brand Y analyzer. It passed without even the slightest indication of fault.

Shifting Height

A TV set came in with the complaint that raster height was insufficient, with the compression occurring on the bot-

tom. The condition occurred only after the receiver had been operating an hour or more, and would get progressively worse. After the saw-tooth forming capacitor in the vertical circuit had been replaced, the bottom of the raster was easily stretched out to fill the bottom of the CRT screen with normal linearity. Furthermore, the raster remained constant in vertical size, without needing later re-adjustment.

The capacitors that produce the not uncommon defect noted here are generally of the waxed paper type. Their capacitance may tend to increase as their temperature goes up. While a capacitor analyzer is quite capable of indicating an increase in capacitance, it can do so only if the suspected component is heated to the temperature at which it works in the receiver. Thus, tacking in a replacement is the quickest way to make a satisfactory check.

Sneaky Plastics

The horizontal Synchronizer circuit

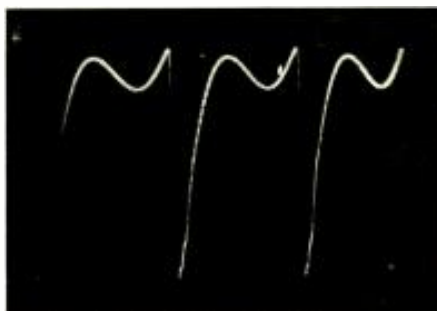
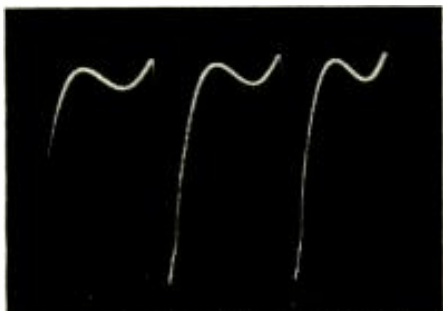

Fig. 3. Low (A, left) and proper (B) sine-wave height in Synchronizer waveform.

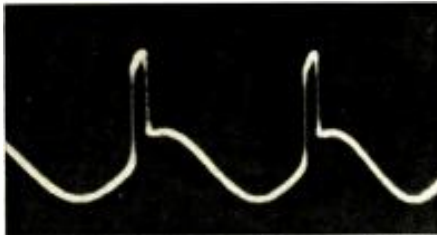
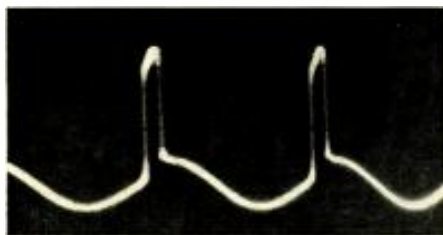

Fig. 4. Low (A, left) and proper (B) sine-wave height in multivibrator waveform.

is one of those where capacitors can really raise havoc. For example:

The fellow service technician previously referred to as the owner of the brand Y analyzer sought help on a tough dog. It was an RCA KCS34B that would not hold horizontal sync for more than twenty minutes. In answer to questioning, he insisted that he had disconnected and tested all the capacitors in the circuit and that all read up to par on his analyzer. Knowing him to be a thorough technician who normally makes the necessary resistance, voltage, and scope checks when he has trouble, we advised him to tack-solder capacitor substitutions.

About one hour later he phoned with the information that, "after replacing the .002 μ f. that feeds the sync and sampling pulses to the grid of the a.f.c. triode (C_1 in Fig. 5), the trouble was corrected." While he was happy that he had repaired the set, he was also extremely unhappy because his ex-

pensive analyzer would not indicate anything wrong with the replaced unit. The .002- μ f. unit was one of those black, plastic-encased capacitors.

In line with this experience involving Synchronizers, one set, an RCA KCS-84F, operated relatively normally except that the horizontal sync was critical. It was noticed during troubleshooting that the frequency slug of the oscillator transformer adjusted at an extremely withdrawn position. Component and voltage-checking tests revealed nothing, so the various frequency-determining capacitors were temporarily replaced. When C_2 in Fig. 5 was replaced, not only did the frequency slug adjust to a more orthodox position, but the horizontal saw-tooth waveform increased from 130 to over 160 volts, peak-to-peak, as a scope check showed. As a result other improvements occurred; the width increased, as did the high voltage, with improved focusing.

C_2 was also a black, plastic-encased

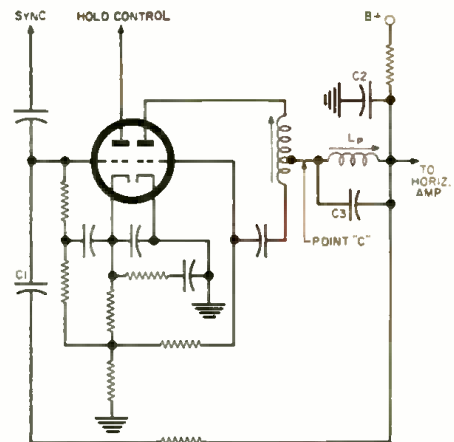

Fig. 5. Synchronizer oscillator with sine-wave generating tank (L_p and C_2).

shunted by L_p , with the latter being known as the phasing coil. Stabilizing efficiency is affected by the over-all "Q" of the tank, which is affected by the "Q" of C_2 specifically. This factor may decrease over a period of time, reducing sine-wave amplitude.

Analysts will not indicate this lowered "Q" factor, but it can be determined with the scope. The waveform of Fig. 3A was noted at point C of a Synchronizer used in a '53 Philco. Note that, while the phasing coil is adjusted properly, the sine-wave amplitude is about 15 per-cent of the composite waveform's total amplitude. The waveform of Fig. 3B was noted at the same point after C_2 was changed. Note now that the sine-wave amplitude is nearly 25 per-cent of the composite amplitude. This change improved horizontal synchronization in this particular receiver considerably.

In multivibrator-type horizontal oscillators, the stabilizing tank again consists of an adjustable coil (usually called the ringing coil) shunted by a

Fig. 6. The pointer indicates stain on capacitor case from electrolyte leakage.



tubular; it too passed all tests, including leakage, and its measured capacitance was within ten per-cent of nominal value although it was only rated at twenty per-cent. We are not exactly sure what the elusive fault is that occurs in units of this type, but suspect that the pulsed nature of the voltage to which they are subjected causes them to react erratically in a way that does not show up on static tests.

Watch That "Q"

On to case 4: The stabilizing network in the Synchronizer circuit is a tank that generates a sine wave at approximately the horizontal sync frequency. This plays an important role in maintaining synchronization in the presence of random pulses that might otherwise trigger the oscillator falsely. The network consists of an adjustable coil shunted by a capacitor.

In Fig. 5, this network consists of C_2

PERFORMANCE THAT SPEAKS FOR ITSELF



Precision Crafted

CITIZENS BAND RADIOS

5 watts input, low current drain (3.2 amps at 12 volts standby), automatic noise limiter, squelch, built-in transistor power supply. Compact, easily movable.

CBD-1: Single channel, 12 volt DC or 115 AC complete with crystal, microphone, both power supply cables, universal mounting bracket \$159.50

CBD-5: Five channel set, 12 volt DC or 115 AC complete with crystals for one channel, microphone, both power supply cables, universal mounting bracket \$170.00

CBD-5: Same as above but 6 volt only \$170.00

DEALER INQUIRIES INVITED. Dealer efforts backed by strong national advertising campaign. Write today for details.

For free brochure write to:

PEARCE-SIMPSON, INC.

A Leader in Creative Electronics

Dept. E, 2295 N.W. 14th St., Miami 35, Fla.

engineering degree in 27 mos.

Become an Electronics Engineer. Share rewards awaiting college men . . . higher income, rapid advancement. Important firms visit Tri-State to interview seniors. *Bachelor of Science Degree in 27 months* in Electrical (Electronics or Power major), Mechanical, Civil, Aeronautical, Chemical Engineering. *In 36 months* a B.S. in Business Administration (General Business, Accounting, Motor Transport Management majors). For earnest, capable students. Small classes. More professional class hours. Well-equipped labs. Dorms. Campus. Modest costs. Year-round operation. Enter Jan., Mar., July, Sept. Founded 1884. Write J. H. McCarthy, Director of Admissions, for Catalog and "Your Career" Book.



TRI-STATE COLLEGE

16100 College Ave., Angola, Indiana

capacitor. The coil's action parallels that of the phasing coil in that it generates a sine wave each time the oscillator plate switches on to draw current. The tank is invariably in series with a resistor in the plate lead of the multivibrator's controlling (first) triode. The stabilizing efficiency of this network is similar to that of the one in Fig. 5, and similar problems may occur.

The relative "Q" factor of the tank in these circuits can also be determined with the scope. Fig. 4A was taken at the plate of the first triode of a horizontal multivibrator in a *Motorola*. Note that the amplitude of the sine wave is about 30 per cent of the composite waveform's amplitude. Fig. 4B was taken at the same point after the tank's capacitor was changed. Now the sine wave scopes better than 50 per cent of the total waveform height. The replacement cleared up a complaint that setting of the horizontal hold control was too critical.

The ratios given here for sine-wave amplitude to over-all waveform height are those most often used in original design for Synchroguide and multivibrator circuits, although they are not universal. In general, where marginal horizontal-hold is the problem and no other defects exist, approximating these ratios will produce enough improvement to satisfy an unhappy customer.

The change in the capacitor, over a period of time, that produces this reduction in sine-wave amplitude sheds light on the tendency of older sets to develop more critical sync.

Capacitor or Rectifier?

A *Philco* TV about nine years old was benched for drifting vertical lock. The hold control had to be re-adjusted every ten minutes until it reached the end of its rotation, after which rolling could not be stopped. Trouble of this nature is due to gradual changes in such frequency-determining oscillator components as resistors (including the control), the blocking oscillator transformer, and, of course, the coupling and timing capacitors. In this case, replacing a capacitor corrected the trouble.

Suspected of leakage, the capacitor had been checked on an analyzer but no leakage had been found. When it was checked again after the replacement had worked, there was considerable leakage. Further checking showed that, when the capacitor was connected to the tester in one way, there was still no leakage. However, when the capacitor leads were reversed, leakage was clearly indicated! Evidently the component had begun to act like a semiconductor, passing current in one direction only. It was weird but it happened. The unit was a .01- μ f. capacitor encased in plastic.

An Eccentric Electrolytic

The villain in case 6, unlike the smaller units involved with the other histories noted so far, was the big brother of the capacitor family, an

CITIZEN BAND

CLASS "D"

CRYSTALS



3rd Overtone—Hermetically Sealed .005% tolerance—Meet F C C requirements, 1/2" pin spacing—.030 pin diameters, (.093 pins available, add 15c per crystal.) **\$2.95 EACH**

ALL 22 Frequencies in Stock!
(add 5c per crystal for postage and handling)

The following Class "D" Citizen Band frequencies in stock (frequencies listed in megacycles): 26.965, 26.975, 26.985, 27.005, 27.015, 27.025, 27.035, 27.055, 27.065, 27.075, 27.085, 27.105, 27.115, 27.125, 27.135, 27.155, 27.165, 27.175, 27.185, 27.205, 27.215, 27.225.

Matched crystal sets for Globe, Gunset, Citi-Pone and Hallcrafters Units . . . \$5.90 per set. Specify equipment make.

RADIO CONTROL CRYSTALS

In stock for immediate delivery (frequencies listed in megacycles); tolerance .005%—.14" pin spacing, .050 pin diameter, (.093 pins available, add 15c per crystal.) Specify frequency desired.

26.995, 27.045, 27.095, 27.145, 27.195, 27.255 . . . **\$2.95 EACH**
(add 5c per crystal for postage and handling)

Send for **FREE CRYSTAL CATALOG #860 WITH OSCILLATOR CIRCUITS**

ASK YOUR PARTS DEALER FOR TEXAS CRYSTALS See big red display . . . if he doesn't stock them, send us his name and order direct from factory.

ALL ORDERS SHIPPED 1st CLASS MAIL FROM OUR NEW FLORIDA PLANT

Rush your order to:
TEXAS CRYSTALS
Dept. R-100—1000 Crystal Drive, Fort Myers, Fla.
For even faster service phone WE. 6-2100

SAY YOU SAW IT IN

ELECTRONICS WORLD



A NOTE TO THE HI-FI BUYER

AIR MAIL us your requirements for an IMMEDIATE LOWEST PRICE QUOTATION

Components, Tapes and Records SHIPPED PROMPTLY AT LOWEST PRICES

WRITE TODAY FOR FREE CATALOG

AUDIO UNLIMITED 714-W Lexington Ave. New York 22, N. Y.

LEARN TO DRAW; READ BLUEPRINTS, SCHEMATICS, WIRING DIAGRAMS; and to render any Mechanical, Electronics, Architectural & Art Drawing or Painting

SELF STUDY COURSES & Drafting Room Essentials available in simplified form. Plan 1: Send \$2.25 for any one of the above desired "individual" chapter. Plan 2: Send \$9.00 for the "Special Main Chapters" of our book entitled, "Encyclopedia of Drawing & Design" (for Home Study or School Text).

Publisher: (Author's experience: Chief Draftsman, Art Director, Engineer). **LOUIS D. PRIOR, INC.**, 23-09 169th Street, Whitestone 57, New York, N. Y.

MAIL ORDER HI-FI

You can now purchase all your Hi-Fi from one reliable source and be assured of perfect delivery. Carston makes delivery from NY stock on most Hi-Fi, Records and Tapes within 24 hours. **SEND US A LIST OF YOUR HI-FI REQUIREMENTS FOR OUR WHOLESALE QUOTATION and our FREE wholesale catalogue.**

CARSTON STUDIOS
125-TD East 88 St. New York 28, N. Y.

PACKAGE HI FI or SINGLE COMPONENTS

You'll find our prices low and service fast.

Write for our quotation.

CENTER INDUSTRIAL ELECTRONICS, Inc.
74-L Cortlandt Street, New York 7, N. Y.

ELECTRONICS WORLD

electrolytic. A *Sylvania* TV (Model 540) came in with the complaint that it was erratically blowing a 2.5-ampere fuse. One fuse might last several days; but the next might only survive for one hour.

In a bench check, line current was metered at about 1.5 amperes. Receiver operation was entirely normal, with good picture and sound. Instrument checks revealed no unusual conditions. However a visual check showed a suspicious chemical staining at the metal band used to mount a 150- μ f., 200-volt electrolytic filter to the chassis. Unfastening the metal band by removing the self-tapping screw that held it to the chassis caused the line current to fall to about 1 ampere.

Fig. 6 shows the staining on the cardboard case of this unit, with the metal band removed to render the symptom more visible. This type of electrolyte leak-through on cardboard-cased units was more common in pre-war radios, where it often led to puzzling hum problems. Service technicians can be grateful that the difficulty doesn't arise so often these days, but they should keep in mind the fact that it can occur. One end of this capacitor was connected directly to one side of the a.c. line in a voltage doubler using two selenium rectifiers, which is why the leakage blew fuses. However, an analyzer would not have indicated abnormal leakage.

Thus we close the file on wayward capacitors. In each of the cases described here, the defects were of the kind that would escape detection with capacitor analyzers or other direct instrument checks. In each, secondary evidence was the only indication that the capacitor might be at fault. In closing, a few words of commendation might be said for that old stand-by, the oscilloscope. As in several instances recounted here its role in revealing the secondary conditions that lead to apprehension of guilty capacitors with off-beat defects is important. -30-

TIGHTENING INTERLOCKS

By ROBERT HERTZBERG

INTERMITTENT operation of a TV set was traced to poor contacts in the interlock line connector on the back of the chassis. This was fixed in a jiffy by the addition of a rough layer of solder on each of the male pins.

It is difficult to fix the female connectors, to which the cord is attached, because the contacts here are sunk in a molded head. -30-

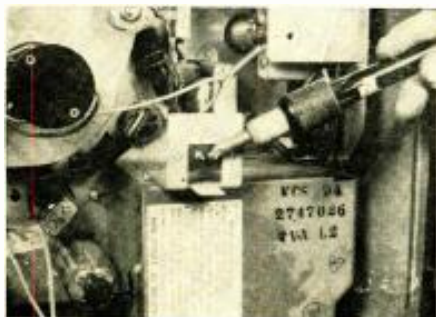

We'd like to send you these important new books for a 7-day free trial examination

Class D CITIZENS RADIO by Leo G. Sands

Here is the first complete book on Citizens Radio Operation. Ever since the initial use of 2-way radiotelephone by police departments, this field has been growing in importance and application. Now, with more than a million vehicles equipped for its use, Citizens Radio is a major phase of the electronics field. This important new volume covers every aspect of the field—its history, rules, and everything about how it works—in seven big chapters with one hundred major sections. You'll learn exactly what Citizens Radio is, its applications, what equipment you need, the full story on receiver circuits and transmitters, antennas, installation, and maintenance, full FCC rulings, how to apply for licenses, etc. Many illustrations. **\$4.95**

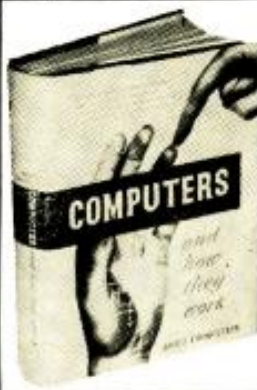
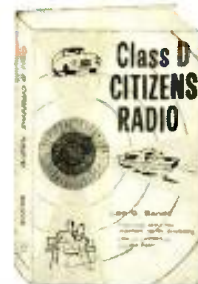

COMPUTERS AND HOW THEY WORK by James D. Fahnstock

Here is a fact-filled exciting guidebook to the wonderworld of electronic computers, with more than 110 illustrations and easy-to-follow tables in 10 big chapters. Step by step, you'll see and understand the workings of many types of computing machines. This important new book illustrates the basic principles of computers in methods that require no knowledge of electronics. You'll learn all about computer memories, flip-flops and the binary counting system. You'll learn the mathematical language of computers where $1 + 1 = 10$. Other chapters show you how computers use tubes and transistors to make complex logical decisions in thousandths of a second. **COMPUTERS AND HOW THEY WORK** is must reading for career minded students and for electronics pros who want a more complete knowledge of this field. **\$4.95**

THE ELECTRONIC EXPERIMENTER'S MANUAL by David A. Findlay

With a few dollars worth of basic tools, and this book to guide you, you can explore the magic of electronics experimentation more completely than ever before. In a few short hours, you'll start your first project. You'll learn about every component used in experimentation, every tool, its function and why it is used. There are 8 big sections, each covering a specific phase of construction. There is a giant section of projects you can build, test equipment you'll construct and use in your future work. **THE ELECTRONIC EXPERIMENTER'S MANUAL** will give you the professional know-how you must have no matter what phase of electronics is your specialty. **\$4.95**

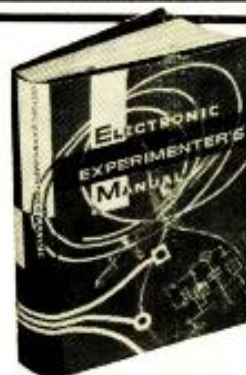

7-DAY FREE EXAMINATION

When your books arrive, read and enjoy their diversity of contents, their thoroughness of coverage. Then after seven days examination, if you decide that they are not everything you want, send them back and receive a complete refund of the purchase price.

USE THIS CERTIFICATE FOR 7-DAY FREE EXAMINATION

ELECTRONICS BOOK SERVICE One Park Avenue, New York 16, N. Y.

Please send me _____ copies of **CITIZENS RADIO** and bill me at only \$4.95 a copy plus postage and handling.

Please send me _____ copies of **COMPUTERS AND HOW THEY WORK**, and bill me at only \$4.95 a copy plus postage and handling.

Please send me _____ copies of **THE ELECTRONIC EXPERIMENTER'S MANUAL** and bill me at only \$4.95 a copy plus postage and handling.

If I don't agree that this is one of the best electronics investments I've ever made, I may return the book(s) within seven days and get a full refund.

\$ _____ enclosed. (SAVE MONEY! Enclose payment with your order and we'll pay the postage.)

Name _____

Address _____

City _____

Zone _____

State _____



EF-513

• Maximum range reproducer — 30 cps to well beyond audibility

• Only 18" x 24" x 4½" thin

a dream from every angle...

THE "440" BI-PHONIC COUPLER

The first complete full range reproducer, so radically different that it is classed as a musical instrument. Like a precious violin, the Bi-Phonic Coupler is hand-crafted of selected woods — with the panel structure radiating bi-directionally (unlike the usual restricted "boxed-in" speakers) — reproducing the full realm of sound with acoustic depth, fundamental tonal purity and realism. The wafer-thin Bi-Phonic Coupler beautifully blends into any decor arrangement.

ADVANCED ACOUSTICS CORPORATION
391 Lakeside Avenue, Orange, New Jersey
A subsidiary of Electronic Research Associates, Inc.

In mahogany, oiled or lacquer walnut \$134.40
Ebony base (optional) \$7.50

Troubleshoot with Theory

(Continued from page 45)

comes open, the alternate path just mentioned still exists. Similarly, a shorted or open C_3 will not affect d.c. voltage or the signal path appreciably. Picture quality might be seriously affected, but the picture would not be lost altogether. Thus—still without measurements—reason has removed two components from serious consideration. Similar reasoning eliminates L_1 and L_2 , making the total four.

Assume that the first reading, at the plate of V_{1A} , indicates noticeably low "B+" voltage here although a check shows that the power supply is operating normally. The schematic reveals eight components that still might be involved with this condition: V_{1A} , R_{11} , R_{21} , R_{22} , R_{23} , R_{24} , C_1 , and C_2 . But we can eliminate two of these from suspicion.

Low plate voltage may be present because R_{11} has increased in value or because the tube is drawing too much current. If the latter is true, then the grid is too positive or the cathode resistor is shorted. However, the grid components, R_{21} and C_1 , do not seem to be involved. If R_{21} were open, the charge on C_1 , caused by grid-current flow, could not leak off. Thus, the negative voltage on the grid would increase, tube current would decrease, and plate voltage might rise somewhat, but would not drop. But what if R_{21} were shorted? We would still have the cathode bias resistor, R_{22} , which would keep plate current down and plate voltage up. So much for R_{21} .

As for C_1 , it would have little effect on the operating bias if it were open, so it would have little effect on plate voltage. Suppose that C_1 is shorted or leaking. If this component was intended to block d.c., some positive voltage would now pass through it to affect operating bias of V_{1A} , and plate voltage would go down. However, there is no positive voltage available at the output of the detector to do this. C_1 may now join R_{21} as being exonerated.

With a single measurement and the application of theory, the defect has not only been narrowed down to a single stage, but six of the twelve possibly defective components in Fig. 1 have been set aside. The few minutes spent in studying the schematic to make these conclusions involve less time than it would take to make checks on the several parts that are not likely to be involved.

Even with components that may be involved, it is not necessary to perform all checks on each. The various ways in which a component may become defective, and the effect of these various abnormalities on the circuit, may also be taken into account. For example, resistors may become open, change in value, or possibly (though not usually) short. Capacitors may short, open, leak, or change capacitance. Coils may have shorted turns, which will change inductance, or they may develop an open

NEW!

INDUCTANCE QUALITY TESTER

As the name implies, this instrument determines the quality of an inductance such as found in flybacks, audio output transformers, vertical output transformers, chokes, yokes, etc. It has the remarkable property of high sensitivity combined with adequate energy level to provide actual operating voltages. For example, the instrument will detect a single shorted turn in a flyback transformer and yet deliver approximately 1500 volts peak-to-peak across the primary of an average transformer! Design engineers and technicians alike should find this instrument extremely useful.

For complete information and name of local distributor write: **TELSON ELECTRONIC PRODUCTS, INC.**
PO Box 183 Rapid City, S. D.

QUICKLY CUT HOLES

in metal, plastics, hard rubber...

ROUND SQUARE KEY "D"

GREENLEE CHASSIS PUNCHES

Make smooth, accurate openings in 1½ minutes or less... for sockets, plugs, controls, meters, panel lights, etc. Easy to use... simply turn with wrench. Many sizes and models. Write for literature.

GREENLEE

GREENLEE TOOL CO.
1916 Columbia Ave., Rockford, Illinois

winding. Tubes are subject to open filaments, shorted elements, open elements, and changes in characteristics.

Each type of defect for any given component will affect the circuit in which it is used in a specific way. Therefore, a suspected component need only be checked for the type of defect that could cause the complaint being serviced. For example, it would be unnecessary to disconnect one end of a capacitor for a leakage test if the symptom observed could not be caused by leakage. Conversely, with low plate voltage on V_{1A} , of Fig. 1, C_2 would be checked for leakage or shorting, but it would not be necessary to place this capacitor on a bridge to find out whether it had lost capacitance or was effectively open.

The samples chosen here illustrate the method but certainly do not exhaust all possibilities. In any event, they indicate that the systematic application of theoretical analysis does more than provide mental exercise. It can save much valuable time. -30-

SIMPLE CRYSTAL CALIBRATOR

By STEPHEN MAYBAR, K2IBQ

A CRYSTAL calibrator is a necessary item for all ham shacks. Many an amateur has shied away from building a calibrator because of the numerous parts which had to be purchased. With this deterrent in mind, the following circuit was dreamed up. It uses no r.f. chokes, coils, or variable capacitors. None of the parts is critical and most, if not all, of the parts can be found in the average spare-parts box.

The circuit has been in use at the author's station for a while now and results have been very satisfactory. Any crystal can be used but at this station we use a 3525-ke. crystal which gives us spots on all amateur bands with which to line up the receiver.

A relaxation oscillator was used to modulate the buffer stage so that the signal could be spotted easily on a crowded band. A d.p.d.t switch with a center "off" position was used. This turns on the "B+" to the oscillator and cuts the modulation in or out.

The circuit functions quite well with voltages of from 90 to more than 150. In our receiver, the power is taken from the VR tube. Since the unit draws about 0.8 ma. in operation, it is not necessary to worry about the drain on the receiver supply. With this circuit strong signals are provided on all amateur bands up to 31 mc., which is as high as the receiver goes. -30-

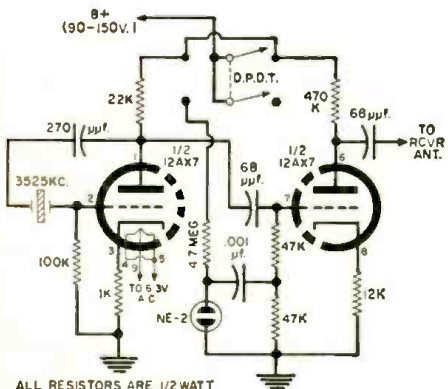

ALL RESISTORS ARE 1/2 WATT

DOES YOUR BUSINESS SLUMP AS TEMPERATURES SOAR?

DIVERSIFY WITH 2-WAY MOBILE-RADIO MAINTENANCE!

Hundreds of progressive radio servicemen are filling the summer slump in entertainment radio—by adding mobile-radio maintenance! Actually, mobile-radio service is business 12 months out of the year—often on contract basis—paid for by going organizations. So rise above competition—and end that summer slump—send coupon below for "How to Make Money in Mobile-Radio Maintenance". It's free!

THIS BOOKLET IS BASED UPON A CAREFUL SURVEY OF THE ACTUAL OPERATING PRACTICES OF SUCCESSFUL MOBILE-RADIO ENGINEERS. IT SHOWS TYPICAL CONTRACT PROVISIONS . . . MONTHLY FEES . . . INSTALLATION CHARGES . . . LABOR RATES . . . ETC.

Lampkin instruments are the most popular mobile-maintenance meters.

MAIL COUPON TODAY →

LAMPKIN LABORATORIES, INC.
BRADENTON, FLA.



LAMPKIN 105-B
FREQUENCY METER
RANGE 0.1 TO 175 MC AND UP
PRICE \$260.00 NET



LAMPKIN 205-A
FM MODULATION METER
RANGE 25 TO 500 MC
PRICE \$270.00 NET

LAMPKIN LABORATORIES, INC.
MFM Division, Bradenton, Florida
At no obligation to me, please send
 Free booklet Data on Lampkin meters
Name _____
Address _____
City _____ State _____

A "brass-tacks" guide to TIME-SAVING TEST PROCEDURES!



BASIC ELECTRONIC TEST PROCEDURES is a big new 316-page manual with the kind of "brass tacks" training that helps you locate TV, AM and FM troubles in a jiffy. Teaches you exactly what instruments to use and exactly where and how to use each type. Tells how to substitute one instrument for another and how to develop time-saving, money-making test methods all along the line.

Complete—Easy to Understand!

Here are some of the subjects it covers: Current Checks; making measurements of Power, Capacitance, Inductance, Resistance, AF, RF, Phase, Distortion & Modulation; checking Sensitivity, RF Gain, Fidelity, AVC Voltage, Operating Voltages, etc. Includes handy VISUAL ALIGNMENT TECHNIQUES. Even covers transmitter and industrial electronic test procedures. 190 how-to-do-it pictures and dozens of step-by-step troubleshooting procedures charts make things doubly easy. Price only \$8.00. Money-back guarantee.

PRACTICE 10 DAYS FREE!

Dept. RN-100, Technical Division
HOLT, RINEHART & WINSTON, INC.
383 Madison Ave., New York 17, N. Y.
Send BASIC ELECTRONIC TEST PROCEDURES Manual for 10-day free examination. If I like book, I will then send \$8.00 (plus postage) in full payment. Otherwise, I will return manual and owe you nothing. (SAVE! Send \$8.00 with order and we pay postage. Same 10-day return privilege with money refunded promptly.)
Name _____
Address _____
City, Zone, State _____
OUTSIDE U.S.A.—\$8.50 cash—10-day money-back guarantee.

PICTURE TUBES at New Low Prices!

108P4	\$ 7.95	20HP4	\$13.95
12LP4	8.95	21AP4	18.95
14B/CP4	10.75	21AMP4	13.95
16GP4	13.95	21ALP4	14.95
16KP4	9.95	21AUP4	14.95
17AVP4	12.95	218TP4	14.95
178P4	10.95	21C8P4	14.95
17CP4	15.95	21EP4	13.95
17GP4	16.95	21FP4	14.95
17HP4	12.95	21MP4	19.95
17LP4	12.95	21YP4	14.95
17QP4	12.95	21ZP4	13.95
19AP4	15.95	24CP4	24.95
20CP4	12.95	24DP4	25.95

SPECIAL! SPECIAL!

ALL 17" 110° TUBES.....\$14.95
ALL 21" 110° TUBES..... 16.95
(Only \$2 Extra for Alum. Types)
8XP4 110° TEST TUBE..... 22.95

1 YEAR WARRANTY! Performance GUARANTEED equal to any other brand on the market! Prices include return of an acceptable similar tube under vacuum. These tubes manufactured from reprocessed glass bulbs. All parts and materials including electron gun are brand new. ALL PRICES FOB ALBANY, N. Y. Deposit required when old tube is not returned, refundable at time of return. 25% deposit required on COD shipments. Old tubes must be returned prepaid.

ALL OTHER TYPES IN STOCK!
WRITE FOR COMPLETE LIST!

GREYLOCK Electronics

438 Central Ave.
Albany, N. Y. IV 9-5411

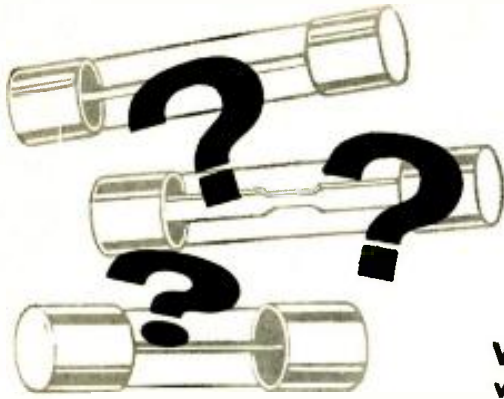

Fuses Are Not for Confusion

By GEORGE D. PHILPOTT

Wrong replacements cause annoyance—or harm. Know which types to use, when, and how to identify them.

IN RECENT years, manufacturers of TV receivers and of fuses as well have done much to alleviate a set of common complaints made by set owners and service technicians. "It's that fuse again," is heard less often than in the past. So is the wail of woe over a burned-out part that was not adequately protected. Special requirements have been analyzed and met. New fuses and fuse holders have been developed. However, one ominous factor remains to becloud an otherwise clearing fuse picture—correct fuse replacement.

An undo-it-yourself set owner—sometimes even a service technician—doesn't happen to have a satisfactory replacement for a blown fuse or cannot identify it properly because the brand he happens to have on hand uses a method of coding that differs from that of the original. The replacement used is one thought to be a reasonably acceptable equivalent. The result may be annoying and unnecessary repeated fuse failure or the burn-out of an expensive component while the fuse remains intact. Sometimes, on the other hand, a replacement with slightly different characteristics is desirable. In any case, the operator should know what he is doing. This means he must know something about fuses and their applications.

Blowing Speed

The speed with which a fuse blows is important. Broadly, there are three general categories, the quick-acting,

medium-lag, and slow-acting (or "Slo-Blo," as *Littelfuse* calls these types). Actually there are more shades of difference than these three types would indicate. High-speed instrument fuses, like those used to protect meter movements, generally act faster than the more commonly encountered fast-acting types. They are used because some types of instantaneous overloads could damage a meter.

Medium-lag fuses are the most popular, being widely used in aircraft

applications, amplifiers, car radios, TV receivers, and other equipment. According to brand, these are found in the AGC types (*Bussmann*) and the 3AG or 5AG types (*Littelfuse*).

Slow-blowing fuses are most useful where harmless transient currents or voltage surges are likely to occur that would ordinarily cause quicker acting fuses to blow unnecessarily. Most fuses, whatever delay they may show under partial overload, will blow rather quickly under heavy overload.

Slow-blowing types often find specific applications in TV receivers. The transient surges caused by the action of certain LC networks in the horizontal section of a TV set might cause even a medium-lag fuse to open unnecessarily. The inductances used in many TV circuits (yokes, flyback transformers, peaking coils, others) often create reverse e.m.f.'s for short periods during set warm-up that may double the current drain in a circuit.

A common example of apparent fuse unreliability occurs in the horizontal output stage. Low drive voltage from the horizontal oscillator to the grid of the output tube, especially during warm-up, may permit the latter tube to overload.

Voltage Ratings

A frequently asked question is, "What does the fuse's voltage rating mean?" Some sets come from the factory with 125-volt fuses installed. Others may use fuses with a maximum rating of 250 volts. Furthermore, the latter may appear in 500-volt circuits. Does the excess voltage make the fuse blow?

Essentially, fuses respond to changes in current without respect to the applied voltage, within certain limits. The maximum voltage rating, according to *Littelfuse*, is that voltage up to which a fuse, when subjected to a current overload (defined as a 10,000-ampere d.c. short circuit), will interrupt safely, without shattering or burning up. The most severe short likely to occur, say, in a TV receiver will produce a current that is only a small fraction of this test rating. Thus fuses rated at 125 or 250 volts can safely be used at much higher voltages. However current ratings must be considered very carefully, taking into account the normal current range likely to be found in the protected circuit and

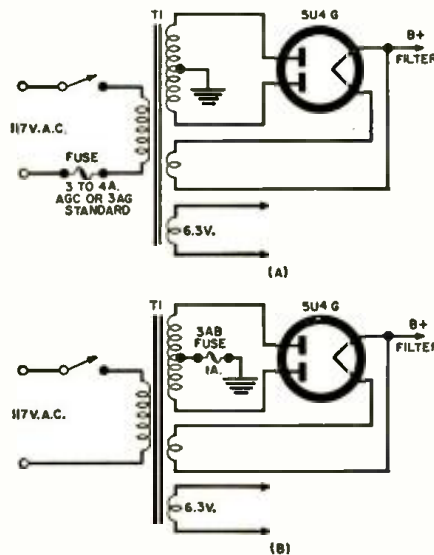

Fig. 1. Fuse in xformer primary (A) protects more than (B) in secondary.

Table 1. Common TV and other fuses in the lines of two leading manufacturers. Note that code designations assigned to various fuse types relate to such differences as physical size and blowing characteristics, but not to current rating.

BLOWING CHARACTERISTICS	FUSE TYPE (Bussmann)	FUSE TYPE (Littelfuse)	SIZE	RATING (Amps.)	MAXIMUM VOLT-AGE RATINGS*
High Speed	AGX	8AG	1" x 1/4"	1/500-5	32, 125, 250
			1" x 1/4"	1/500-2	125, 250
Medium Lag	3AG		1/4" x 1/4"	1/16-20	32, 125, 250
		5AG	1/2" x 1/32"	1-50	32, 250
	AGC		1/4" x 1/4"	3-30	32, 250
	MTH		1/4" x 1/4"	4-6	250
	GLH		1/4" x 1/4"	8 or 10	125
Slow Acting	4AGU		1/2" x 1/32"	1 to 60	32, 250
		3AG	1/4" x 1/4"	1/100-5	32, 125
		5AG	1/2" x 1/32"	1-30	32, 125
	MDL		1/4" x 1/4"	1/100-30	32, 125, 250
	MDX		1/4" x 1/4"	1/4 to 7	125, 250
AGU		1/2" x 1/32"	1 to 60	32, 250	

Types N and C, especially suited to television receiver protection, irrespective of voltage rating or manufacturer, are directly interchangeable.
* The ampere rating applying to individual voltage ratings may be determined from manufacturer's literature.

Cat. #	DESCRIPTION
311005	5 amp. 3AG fuse, 32 v.
311010	10 amp. 3AG fuse, 32 v.
311015	15 amp. 3AG fuse, 32 v.
311020	20 amp. 3AG fuse, 32 v.
311030	30 amp. 3AG fuse, 32 v.
307009	9 amp. SFE fuse
307014	14 amp. SFE fuse
307020	20 amp. SFE fuse
312001	1 amp. 3AG fuse, 250 v.
312002	2 amp. 3AG fuse, 250 v.
312003	3 amp. 3AG fuse, 250 v.
312005	5 amp. 3AG fuse, 250 v.
31201.5	1/2 amp. 3AG fuse, 250 v.
312.250	1/4 amp. 3AG fuse, 250 v.
312.500	1/2 amp. 3AG fuse, 250 v.
313001	1 amp. 3AG "Slo-Blo" fuse
313.250	1/4 amp. 3AG "Slo-Blo" fuse
313.500	1/2 amp. 3AG "Slo-Blo" fuse
361.010	1/100 8AG instrument fuse
361.031	1/32 8AG instrument fuse
361.250	1/4 amp. 8AG instrument fuse
318.250	1/4 amp. 3AG pigtail fuse
342001	3AG fuse extractor post
341001	3AG fuse extractor post
357001	1 pole 3AG m'nt'g (Type S)
357002	2 pole 3AG m'nt'g (Type S)
383002	8AG mounting
150027	Fuse retainer; 19" lead, 14 amp.
150028	Fuse retainer; 19" lead, 9 amp.

Table 2. Contents of service-maintenance fuse kit recommended by Littelfuse.

the possible magnitude of harmful overloads.

Fatigue

Occasionally a technician wonders why a fuse of any type may, for no reason that can be found, fail during operation. He may say facetiously that the fuse just got tired. He may also be correct. In circuits where a constantly interrupted current is flowing through the fuse (vibrator applications, TV horizontal sections, frequency choppers, high-current multivibrators, and the like), such cycling may produce constant expansion and contraction of the fuse element, eventually wearing out this slender, metal strand. This "cyclic fatigue" is just one of many problems confronting a fuse manufacturer endeavoring to supply a reliable product to users. The slow-blowing fuses usually stand up better under cyclic fatigue.

Interchangeability

One of the problems likely to confuse a technician attempting replacement is the fact that different manufacturers do not code identical or similar fuses in the same way. Table 1 is a handy cross-listing of fuses manufactured by Littelfuse and Bussmann. The boxes in which fuses by the latter manufacturer are packed usually carry cross-identification, although the fuses themselves are not so marked. For example, a pack of Bussmann AGC fuses may carry such information as "formerly called 3AG." For some similar types, there may be slight differences in certain characteristics between one manufacturer and another. While these do not usually affect use much, it is a good idea to learn what they are and what effect they might have in specific applications.

Some TV Applications

The problem of fuse failure and replacement are of above-average concern in the case of TV receivers, where more than one fuse is likely to be used, where there may be conflicts between

over-all and single-section protection, and where the fuses used on a single set may be quite different from each other. A brief examination of common configurations will help show how and where fusing is provided and help in choosing replacements to meet special problems.

The partial schematic of Fig. 1A is of a commonly encountered full-wave rectifier circuit. The fuse, in the primary lead of the transformer, gives over-all protection. A disadvantage, if no other fusing is used, lies in the fact that it takes a rather healthy overload to pop the unit. Thus, if no other protection is used, excess current due to a short in a particular circuit may be enough to cause circuit damage but under the amount required to blow the fuse. An advantage is that the expensive power transformer is fully safeguarded.

Suppose that the envelope on a rec-

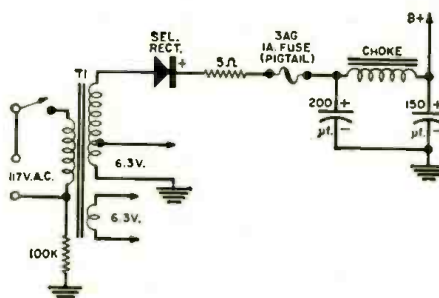

Fig. 2. Half-wave rectifier supply, fused in d.c. line going to filter.

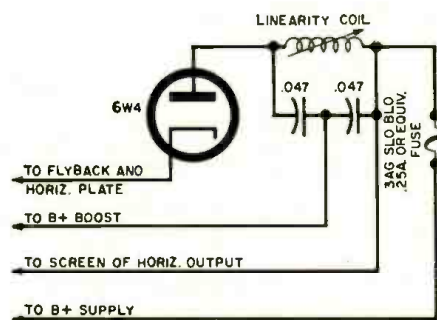

Fig. 3. Separate fusing for "B+" supply in TV's horizontal-sweep section.

tifier tube should crack. When it does—and every technician has probably seen this happen several times—the filament of a heavy-duty rectifier like the 5U4 may, in the process of melting as it is exposed to air, form a dead short across the 5-volt winding. This could cook a transformer to death. Standard cartridge fuses, rated at a few amperes, are used here.

An alternate method of fusing the low-voltage section is shown in Fig. 1B. Here the center-tap on the transformer's high-voltage secondary is fused to ground or "B-." The transformer is protected except in the case of filament-circuit overloads. Since the receiver's many tubes consume quite a bit of filament power in relation to total drain, and current for the filaments does not pass through the fused winding, the current rating of the fuse

is substantially reduced. The type 3AB shown is a special, arc-quenching variety often found here. It prevents element flashing, a condition related to the inductance of the transformer. The fuse is a medium-lag type.

Fig. 2 shows a common half-wave rectifier using a semiconductor. Sometimes a voltage doubler is used without the transformer. Here a standard pigtail fuse is likely to be found wired into the circuit, but it will be the slow-blowing type too. A surge resistor is necessary to protect the rectifier from the heavy initial surges that would otherwise charge the filter capacitors. Because of these surges, a faster acting fuse might open needlessly.

Fig. 3 shows the damper portion of a horizontal-output and high-voltage circuit. Again a slow-acting fuse, but at a reduced current rating, is used. Although the location of the fuse in the horizontal-output circuit may vary, the fuse characteristics are likely to remain the same.

Many recently made TV receivers use other protective devices, such as resettable, thermal-overload cut-outs, fusible resistors, and thermistors, instead of fuses. These do not act rapidly, as a rule. Where fuses are used instead, they correspondingly tend to be slow-blowing. Radios and amplifiers usually have medium-acting fuses. Instruments and aircraft equipment tend to use fast-acting fuses, although many aircraft applications call for medium-speed types.

Bayonet-type fuses, becoming increasingly popular, were originally designed for the TV industry. These are made in different sizes depending on current rating, as are the corresponding fuse holders. Thus only the right fuse can be inserted and locked into the fuse holder. These type C and N fuses are made by both leading manufacturers, but the two brands may be interchangeable.

If your fuse kit happens to be short of some types when you need them, you might check your supply against the list of most frequently used types for service dealers and maintenance engineers in Table 2. Some common holders and mountings are listed as well. Also helpful is Table 3, which is a short list of fuse sizes generally used to protect insulated copper wiring of various sizes.

Just one more thought before closing. Fuses are used for good reasons—protection and safety, both to equipment and personnel. This good purpose should not be thrown away with a thoughtless or indifferent replacement.

—30—

Table 3. Ratings of fuses generally used with popular sizes of copper wire.

WIRE SIZE (B & S)	FUSE RATING (Amps.)
No. 16	10
No. 14	15
No. 12	20-30
No. 10	40
No. 8	50

TELTRON

Leading VALUES in
TUBES



All Tubes Individually Boxed
1-YEAR UNCONDITIONAL GUARANTEE
Send For Free Complete Tube List & Order Blank

FREE EICO TUBE TESTER
With every receiving tube order of \$199 or more within 60 days. Tests all new tubes and six tubes. May be purchased from Teltron for \$34.95.

FREE BONUS

ONE YEAR FREE subscription to ELECTRONICS WORLD PLUS ONE SCHEMATIC DIAGRAM of Your Choice With Every Receiving Tube Order of \$30 or More!
NOTE: If you are a subscriber, one year will be added FREE!

TELTRON ELECTRIC CO.
428 Harrison Ave., Harrison, N. J.

Send me one year FREE subscription to Electronics World PLUS one FREE schematic diagram (state model # of radio or TV)

Name _____
Address _____
City _____ State _____

Mail this Coupon Today

SAVE ON ALL TUBES Here's a Partial List of Most Often Used Tubes

Quan.	Type	Price	Quan.	Type	Price
10	0Z4	.45	10	6BG6	1.18
10	1B3	.62	10	6BM6	.51
10	1R5	.51	10	6BJ6	.51
10	1T4	.51	10	6BK5	.75
10	1U4	.51	10	6BK7	.78
10	1U5	.43	10	6BL7	.78
10	1X2	.62	10	6BN6	.90
10	2AF4	1.02	10	6BQ6	.83
10	30C5	.58	10	6BQ7	.83
10	3B6	.90	10	6BY5	.75
10	3BZ6	.45	10	6BZ6	.45
10	3CB6	.51	10	6BZ7	.95
10	3V4	.48	10	6C4	.41
10	4BQ7	.75	10	6CB6	.51
10	5U4	.43	10	6CD6	1.63
10	5U5	.59	10	6CG6	.58
10	5V4	.49	10	6CF6	.45
10	5X8	.55	10	6CG7	.44
10	5Y3	.30	10	6CM7	.44
10	6AB4	.43	10	6CQ8	.59
10	6AC5	.52	10	6CU6	.95
10	6AH6	.47	10	6DA1	.59
10	6AL5	.43	10	6CQ6	.89
10	6AM8	.59	10	6J5	.49
10	6AN6	.64	10	6K6	.39
10	6AQ5	.48	10	6K6	.39
10	6A55	.52	10	6L7	.41
10	6AU4	.50	10	6L7	.41
10	6AU6	.43	10	6S7	.45
10	6AV6	.37	10	6SL7	.60
10	6AW8	.50	10	6SN7	.60
10	6AX4	.48	10	6SQ7	.38
10	6BA6	.56	10	6T8	.71
10	6BC5	.48	10	6U8	.76
10	6BE6	.46	10	6V6	.48
10			10	6W4	.41
10			10	6X6	.50

Send for FREE complete list of most often used tube types

New Price Schedule of Television Picture Tubes

PICTURE GUARANTEED FOR ONE (1) YEAR

10BP4	7.95	17CP4	17.25	21AP4	18.75
12LP4	10.75	17GP4	17.95	21AP4	21.25
14BP4	11.75	17HP4	18.49	21AP4	19.25
14CP4	11.95	17JP4	16.49	21AUP4	19.25
14QP4	13.25	17LP4	17.45	21AUP4	19.25
16AP4	16.45	17OP4	15.75	21AWP4	18.75
16CP4	12.49	17TP4	16.49	21EP4	17.25
16GP4	15.99	17YP4	16.49	21FP4	19.25
16KP4	11.95	20CP4	15.75	21MP4	21.25
16RP4	11.95	20HP4	17.75	21WP4	17.25
17AP4	16.75	21ACP4	21.95	21XP4	18.75
17AVP4	15.75	21ALP4	18.75	21YP4	18.75

Aluminized on any tube, \$4 extra. All six tube receive dep. on dcd. Add additional \$5 on tube sizes to 17". Add \$7 on sizes 19", 20", 21", 24". Cash dep. refund on receipt of dcd paid. Fla. tubes shipped from our warehouse (DB Cont. & Canada only).

NEW LIBERAL TERMS: No min. order. Free postage on all tubes & parts orders over \$5 in U.S.A., A.P.O. & Territories. 25% disc. required on C.O.D. Please send approx. postage on Canadian & foreign shipments... excess refunded. All six tube & outdoor antennas shipped FOB Harrison, N.J.

25c Handling Charge on Orders under \$5
Tubes may be factory seconds or used tubes and are clearly marked.

Humboldt
4-9848

TELTRON ELECTRIC CO.
428 HARRISON AVE. HARRISON, N. J.

New Isotronic Training Method

LEARN TV REPAIR IN ONE SHORT WEEK!

Now, after 5 year's research—a streamlined training system that *obsoletes all others!* In just 7 days you may earn \$150 weekly, without paying up to \$250 for training, studying long months! Developed by electronic scientists in cooperation with major TV mfr's., the new Isotronic method is the most practical ever devised! For conclusive proof, write for details and FREE SAMPLE LESSON. Use it on your own set or a friend's—repair it—convince yourself you can make big money immediately in your own TV business! Hurry—Free Lesson supply limited. Write: TV Servicing Systems, Dept. D-76A, 1038 So. La Brea Ave., Los Angeles 19, Calif.

What's

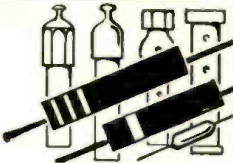

New in Radio

SPRAGUE ASSORTMENT

Sprague Products Co., North Adams, Mass. is offering a specially selected assortment of its "Littl-Lytic" capacitors for transistorized equipment.

Known as the EK-4 assortment, the package consists of 15 miniature metal-



encased capacitors (one each of the 15 most frequently used ratings), boxed in a case. Individually identified compartments keep each capacitor in place and permit easy selection.

PORTABLE DF RECEIVER

ALCO Electronics, 3 Wolcott Ave., Lawrence, Mass., has introduced a portable, transistorized superheterodyne radio direction finder. Designed for marine craft or personal use, the set uses four standard flashlight batteries for its power source. The printed circuit uses seven transistors plus a diode and thermistor for low power consumption. Other features include: a high-gain ferrite-rod antenna, aluminum case, convenient illuminated dial, and sensitivity control. Also included is a built-in marine compass that works simultaneously with marine radio signals.

The direction finder measures 7" x 5" x 5 1/2" and is light enough to be worn from the shoulder with the strap furnished. The company invites further inquiries.

TRANSISTOR CHECKER

Dynatron Laboratories, 71 Glenn Drive, Camarillo, Calif. has introduced its Model 1003 transistor checker, for checking all important transistor d.c. parameters, including those in the inverted condition. A remote connector permits checking a transistor while it is in an environmental chamber.

The meter's 50 microampere movement enhances its capability to read



I_{co} and I_{eo} . Because the *beta* of many transistors exceeds 100, a *beta* times ten scale has been provided for accurate indications up to 1000.

The Model 1003 is said to be accurate to ± 3 per-cent on all scales. Its dimensions are 5 5/8 inches wide, 6 7/8 inches long, and 3 inches high.

SSB POWER SUPPLY

The Amateur Division of Tel-Instruments Electronics Corp., 728 Garden St., Carlstadt, N. J. is now offering a compact high-voltage power supply which has been expressly designed for SSB ham use.

The entire unit measures 17"x17 1/2" x10" and is capable of delivering 4200 volts d.c. at 500 ma., continuous duty. The power supply is currently available in two models, the 65A, rated at 4.2 kv. at 500 ma. and the 65B providing 3.5 kv. at 500 ma. Both models provide, simultaneously, any screen voltage (in 350-volt steps) up to 1050 volts. Overload trip relays and remote control operation is provided in both models.

Dept. U-2 will supply complete descriptive literature, including prices, on request.

CB TRANSCEIVER

Utica Communications Corp., 1834 W. Foster Ave., Chicago 40, Ill. has brought out its Model MC 27 "Town and Country" radiotelephone for Citizens Band operation.

The transceiver incorporates a new noise-eliminator circuit that clips

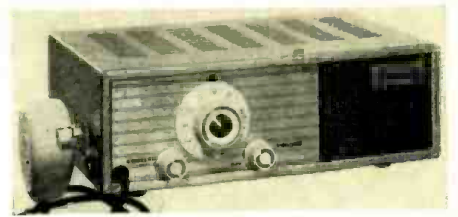

peaks without distorting the audio portion of the incoming signal. Equipped for six-channel operation, the MC 27 will operate on 6, 12, or 117 volts.

REGULATED POWER SUPPLY

Freed Transformer Co., Inc., 1718 Weirfield St., Brooklyn 27, N. Y. has introduced a regulated supply containing a reactor and a hermetically sealed constant-voltage transformer.

This tubeless power supply is said to eliminate the periodic replacement of tubes as well as the maintenance problems of supplies that use tubes.

Input of the unit is 95 to 130 volts a.c. at 60 cps; output is 155 volts d.c. at 150 milliamperes, regulated to ± 1 per-cent. Ripple is less than 10 mv.

Also built in is a 6.3 volt a.c., 60 cps supply, regulated to ± 1 per-cent against line variations of 95 to 130 volts. For further information, write to the manufacturer.

CENTRALAB PEC'S

Centralab, Division of Globe-Union, Inc., 900 E. Keefe Ave., Milwaukee 1, Wis., has added 27 new packaged electronic circuits to its line of replacement PEC's.

In addition to replacements in TV sets, part of this new group is for use in high-fidelity equipment. The new group, numbered from PC-344 to PC-370, includes loudness contour networks, a diode-triode "Couplate," a

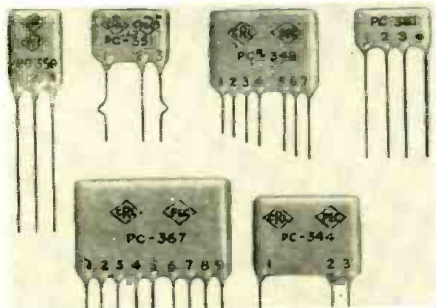

balanced dual capacitor, a horizontal oscillator and phase detector, and other specialized units.

POCKET-SIZE RECEIVER

Tokyo Shibaura Electric Company of Japan has introduced a new transis-

tor receiver, of shirt-pocket dimensions, and covering the 1.6-4.50 mc. marine band as well as the 540-1600 kc. broadcast band. The set features two antennas: a 10-section telescoping type for marine reception and a ferrite core type for standard broadcasts.

Seven transistors are used. Included with the set is a leather case, an earphone, and a mounting bracket. For additional information, contact the American distributor, Transistor World Corp., 52 Broadway, New York 4, N. Y.

CAPACITOR KIT

Cornell-Dubilier Electric Corp., South Plainfield, N. J. is offering a compact kit of molded Mylar capacitors. Called the "Hit Kit," the package reportedly is the company's answer to distributor and technician requests for a smaller sized version of an earlier larger service-shop size kit.

The new kit contains 35 popular "PM" capacitors, in seven widely used values, packed in a plastic box. As part of this "Hit Kit" promotion, the company is conducting a contest for jobber salesmen and professional technicians. Details and entry card are included in the kit.

NEW TV YOKE

F. W. Sickles Division of General Instrument Corp., Chicopee, Mass., has announced a new type of "super-sensitive" yoke for controlling the beam in a TV picture tube. The new yoke is (Continued on page 144)

TUBE REPLACEMENT GUIDE

EVERYONE who uses vacuum tubes NEEDS this new 1960 Expanded Edition TUBE GUIDE!

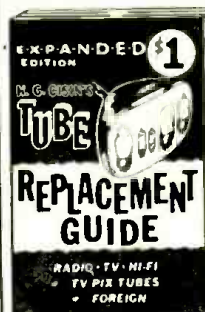

Contains over 4600 DIRECT SUBSTITUTIONS, including radio and TV receiving tubes, tubes used in Hi-Fi & Stereo, picture tubes and TV picture tubes.

All tubes suggested for substitution have characteristics similar to those they are to replace. FIT INTO SAME SOCKET & NEED NO WIRING CHANGE.

Two chapters cover complete listing of 738 TV Pict tube replacements including newest 110° tubes.

Substitutes given for over 414 foreign tubes, also lists 415 transistor substitutes. The only complete GUIDE featuring all receiving tube SUBSTITUTIONS WITHOUT SOCKET CHANGES OR REWIRING.

This valuable book will save you TIME & MONEY and permit operation even though original tubes are unavailable.

Guaranteed Money Back in 5 days if Not Satisfied. Order from your Parts Jobber or RUSH COUPON NOW!

\$1 Post-paid

SUPERIOR INSTRUMENTS CO., Dept. 103
2435 White Plains Road, New York 67, N. Y.

Enclosed find \$1. Rush TUBE REPLACEMENT GUIDE.

Name

Address

City Zone..... State.....

TRU-VAC 1-YEAR GUARANTEED RADIO and TV TUBES

Factory Used or Factory Second Tubes! TRU-VAC will replace FREE any tube that becomes defective in use within 1 year from date of purchase!

ALL TUBES INDIVIDUALLY BOXED! CODE DATED & BRANDED "TRU-VAC"

Partial Listing Only . . . Thousands More Tubes in Stock!

SPECIAL! 6SN7GT 30¢ 6W4GT 30¢

0Y4	3CB6	6A6	6AX4GT	6C8B	6H6	6T8	7E6	12AZ7	12L6	25Z6GT
0Z4	3Q4	6AB4	6AX5GT	6C8E	6J4	6U5	7E7	12B4	12Q7	27
1A7GT	354	6AC7	6BB	6C0GC	6J5	6U8	7E7	12BA6	12R5	35A5
1B3GT	3V4	6AF4	6BA6	6CF6	6J6	6V6GT	7F8	12BA7	12SA7	35B5
1N5GT	48Q7A	6AG5	6BC5	6CC7	6J7	6W6GT	7G7	12BD6	12S7	35C5
1L4	48S8	6AH4GT	6BC8	6CG6	6K4	6X4	7H7	12BE6	12SK7	35D4
1L6	4B27	6AM6	6BD6	6CH8	6K7	6X5GT	7N7	12BF6	12SN7GT	35Z5
1N5GT	4CB6	6AK5	6BE6	6CL6	6N7	6X8	7Q7	12BH7	12SQ7	36
1R5	5AR8	6AL5	6BF5	6CM6	6O7	6Y6G	7S7	12C6S	12V6GT	38
1S5	5AN8	6AM8	6BGG	6CM7	6S4	7A4	XXL 7X6	12BR7	12W6GT	39, 44
1T4	5AT8	6AN8	6BH6	6CN7	6S7	7A5	7X7	12BY7	12X4	41
1U4	5AV8	6AO8	6BJ6	6CG6	7A6	7Y4	12CA5	14A7	12B7	42
1U5	5AZ8	6AQ8	6BK5	6CR6	6S47	7A7	7Z4	12CN5	14B6	43
1V2	5BR8	6AQ7	6BK7	6CS6	6SD7GT	7A8	12AB	12D4	14Q7	50A5
1X2	5CC8	6AR5	6BL7GT	6CS5	6SF5	7B4	12AB5	12E5	19AU4GT	50B5
2AF4	5J6	6A5S	6BN6	6CU2	6SF7	7B5	12AQ5	12F8	19B6G	50C5
2BN4	5R4	6AT6	6BQ6GT	6CU6	6SG7	7B6	12AT6	12K5	19J6	50L6
2CY5	5T8	6AU6	6BQ7	6D6	6SH7	7B7	12AT7	12K7	19T8	56
3A5	5U4	6AUGT	6BR8	6DE6	6SJ7	7B8	12A6G	12A7	84	6Z4
3AL5	5U8	6AUSGT	6BS8	6DGGT	6SK7	7C4	12AU7	12A8	117Z3	
3AU6	5V4C	6AUB	6BYS6	6DQ6	6SL7	7C5	12AV6			
3BC5	5V6GT	6AV5GT	6BZ6	6E5	6SQ7	7C6	12AV7			
3BN6	5X8	6AV6	6BZ7	6F5	6SR7	7C7	12AX4GT			
3BZ6	5Y3	6AW8	6C4	6F6	6T4	7E5	12AX7			

Any Tube Not Listed Also Available at 35¢ Each! BRAND NEW 1-YEAR GUARANTEED TV PICTURE TUBES

Below Listed prices do not include duty Add Additional \$5.00 Deposit on tube sizes to 20" on 21" and 24" tubes - \$7.50. Deposit refunded immediately when dud is returned prepaid.

Picture tubes shipped only to continental USA and Canada - All tubes F.O.B. Harrison, N. J. 10B7A 7.99 16N7 11.99 17H7A 16.99 20H7A 17.89 21AW7A 17.49 21X7A 17.49 12L7A 10.49 16L7A 12.19 17L7A 16.99 21A7A 21.49 21E7A 17.29 21Y7A 18.39 12B7CP4 11.99 16H7CP4 11.99 17C7A 13.89 21AL7A 18.79 21FP4 18.39 21Z7A 17.49 16A7D4 16.09 17AV7A 13.49 17P7A 16.99 21A7FP4 18.79 21K7A 18.39 24CP4 22.79 16DP4 12.19 17BP4 13.49 19A7A 18.39 21A1P4 17.99 21M7A 22.39 24CP4 27.79 16G7A 16.09 17C7CP4 16.99 20CP4 15.89 21AU7A 18.79 21Y7A 18.39 24DP4 29.79 16U7A 17.19 17C7A 17.99 20DP4 15.89 21V7A 18.79 21W7A 17.49

ATTENTION QUANTITY USERS! Big Discounts Are Yours... Call or Write For Our 1960 Tube "Private Label" Special Attention Branding Dept. MGR. Money cheerfully refunded within Five (5) Days, if Not Completely Satisfied! TRU-VAC PAYS YOUR POSTAGE - On orders of \$5 or more in U.S.A. and Territories. Send approximate postage on Canadian and foreign orders. Any order less than \$5 requires 25¢ handling charge. Send 25¢ on C.O.D.'s. All orders subject to prior sale. Complying with Federal regulations, the following statement appears in all Tru-Vac advertisements: Tubes appearing in this ad may be FACTORY SECONDS or USED tubes and are clearly marked.

LOOK! 1,000 USED TV'S

Costly, famous make console models with little or no tube replacement! Perfect for resale, or as your own second set! 16", 17" and 19" screens... none smaller! Sets shipped F.O.B. Harrison, N.J. \$16.95

TRU-VAC

Harrison Avenue • Box 107 • Harrison, N. J. HUmboldt 4-9770

Sensational Offer! "Self Service" TUBE CHECKERS \$37.95 FOB Our Warehouse

Let your customers test their own tubes! These reliable, reconditioned 22-socket tube checkers will return your investment in one week or less with little or no effort on your part! Handsome, fluid-tested console models COMPLETE WITH KEY FOR BOTTOM DOOR AND NEON-LIGHTED HEAD!

fications are contained in a special potentiometer and rheostat bulletin which the company will supply on request.

TWO-ELEMENT ANTENNA

Herb Kreckman Co., Cresco, Pa., is now offering its two-element co-plane "Kreco" communication antenna in an all-aluminum construction.

The new Model CP-105A weighs only 2 pounds at 150 megacycles. A gain of 3 db is guaranteed. This antenna can be ordered cut to any frequency from 108 to 470 megacycles. The all brass Model CP-150B is still available.

The same type antenna is made for the 25-50, and the 72-76 mc. bands in both the all-brass and all-aluminum constructions.

INDUSTRIAL THYRATRON

National Electronics, Inc., Geneva, Ill. has introduced its type NL-710A inert-gas and mercury vapor high-voltage thyatron.

The tube, designed especially for the higher voltages encountered in the new spike welding applications, is rated at 2.5 amps., 2500 peak inverse and forward voltage. According to the manufacturer, this rating enables the new thyatron to be used as an ignitor firing tube in the new welding operations as well as in many other applications requiring such high voltages. For additional data, contact the manufacturer.

CB-BC POCKET PORTABLE

American Japan Trading Co., Inc., No. 2, 3-Chrome Ginza, Chuo-Ku, Tokyo, Japan is now offering a pocket-sized combination CB transceiver and broadcast receiver.



The "Dauphin Model CB-1" is transistorized and weighs less than a pound, including battery. It measures 3 1/16" wide, 5 3/4" high, and 1 1/2" deep and is powered by a single 9-volt battery.

The CB transceiver is a single-channel, fixed-tuned crystal-controlled superhet using nine transistors, one diode, one thermistor, and two crystal oscillators. The broadcast band is covered by a seven-transistor superhet. Since the transmitter output power is 50 mw., no license is needed to operate this equipment. Communication range is said to be 1 to 1 1/2 miles between similar units. There is a built-in ferrite bar antenna in addition to a base-loaded telescopic whip which extends to 59".

The unit comes complete with cowhide carrying case, whip antenna, magnetic earphone, and battery.

"TWINWELD" EPOXY

Fybgilas Industries, 3010 W. Montrose Ave., Chicago 18, Ill. has recently

BRAND NEW
UNITED'S FIRST QUALITY
TUBES DISCOUNTS up to **80% OFF**
GUARANTEED ONE FULL YEAR! NOT USED! NO PULLS! WHY PAY MORE?

Qty.	Tube #	Price	Qty.	Tube #	Price	Qty.	Tube #	Price	Qty.	Tube #	Price	Qty.	Tube #	Price
024	.75	1C3Y5	.70	6AC7	.75	6BU8	.69	608	.77	12CUG/		17L6	.57	
1A5	.80	1DK6	.59	6AM4	.82	6BX7	1.02	6V6	.53	GA	1.00	18A5	.90	
1A7	.94	1DT6	.48	6AM6	.96	6BY6	.56	6WA	.80	12B7	.70	18FW6	.45	
1AX2	.70	1Q4	.68	6AK5	3/1.00	6BZ6	.54	6W6	.68	12BV7	.80	18FX6	.52	
1B3	.73	1Q5	.89	6AL5	.46	6BZ7	.96	6X4	.38	12B7V	.73	18FY6	.40	
1C5	1.07	1S4	.60	6AL7	1.25	6BZ8	1.05	6X5	.51	12B7V	.74	18G6	1.30	
1G3	.73	1V4	.57	6AM8	.77	6C4	.42	6X8	.75	12C5	.55	18H6	.80	
1G4	.60	4AU6	.54	6AM8	.84	6CB6	.53	7AD7	.80	12C5	.55	19G6	1.30	
1M5	.75	4BA6	.54	6AQ5	.49	6CD6	1.20	7AF7	.70	12C6	.55	19H6	1.40	
1J3	.72	4BC5	.55	6AQ6	.60	6CD6G	1.40	7AU7	.60	12CR6	.53	19K6	.78	
1K3	.72	4BC8	.95	6AR5	.54	6CF6	.63	7EY6	.75	12CT8	.90	25A4	1.00	
1L4	.60	4BN6	.75	6AS5	.59	6CG7	.64	8A8	.92	12D5	.55	25B6	.52	
1L4A	.99	4BQ7	.95	6AS6	2.25	6CG8	.76	8AW8	.92	12DB5	.68	GTB	1.00	
1L6A	.99	4BS4	.97	6AS8	.85	6CM7	.65	8Q5	.59	12DE8	.74	25C6	.52	
1L6A	.99	4BU8	.70	6AT6	.42	6CN7	.64	8C7	.61	12DL8	.84	25C6/		
1L6C	.99	4BZ6	.57	6AU4	.81	6CQ8	.83	8CM7	.67	12DQ6	1.00	25C6/		
1LD5	.99	4BS7	.95	6AU5	1.05	6CR6	.50	8CN7	.65	12D57	.78	25C6/		
1LE3	.99	4CB6	.57	6AU6	.49	6CS6	.56	8CX8	.90	12D75	.72	25C6/		
1LG5	.99	4CS6	.60	6AU7	.60	6CS7	.70	8EB8	.93	12DZ6	.55	25C6/		
1LM4	.99	4CY5	.70	6AU8	.86	6CU5	.57	9CL8	.75	12E6	.53	25L6	.56	
1LM5	.99	4DE6	.61	6AV5	.97	6CV7	.59	10B	.95	12E6	.53	25W4	.67	
1N2	.75	4DT6	.54	6AV6	.39	6CY5	.70	11C7	.74	12E6	.53	25Z6	.65	
1S6	1.10	5AM8	.78	6AW8	.88	6CY7	.70	12A5	.54	12E6	.52	32E5	.52	
1R5	.61	5AN8	.85	6AX4	.64	6DE6	.57	12AC6	.48	12F5	.75	32L7	.89	
1S4	.75	5AQ5	.51	6AX5	.75	6DM6	.55	12AD6	.56	12F8	.65	38B5	.65	
1S5	.50	5AT8	.79	6BA6	.48	6DN6	1.40	12AE6	.42	12FA6	.49	38D5	.50	
1T4	.57	5AV8	1.00	6BA7	.92	6DN7	.85	12AF3	.72	12FM6	.44	35L6C	.35	
1U4	.56	5B8	.36	6BA8	.91	6DM6	1.00	12AG6	.48	12FR6	.91	35L6C	.56	
1U5	.49	5BK7	.81	6BC5	.54	6D55	.65	12AJ6	.45	12FX8	.85	35L6C	.56	
1V2	.99	5BQ7	.96	6BC7	.93	6DT6	.52	12AL5	.44	12GC6	1.05	36AM3	.49	
1X2	.75	5BT6	.78	6BC8	.96	6E8	.78	12AF3	.72	12G6	.53	40B2	1.50	
2AF4	.95	5CG8	.75	6BD6	.50	6E88	.90	12AQ5	.51	12L6	.61	50B5	.59	
2B3	1.00	5EA8	.79	6BE6	.54	6E8	.78	12AT6	.42	12SA7	.85	50C5	.52	
2BN4	.63	5EU8	.79	6BF5	.88	6E86	.95	12AT7	.75	12SC7	.75	50H5	.54	
2CY5	.70	5J6	.67	6BF6	.43	6F6	.85	12AUG	.49	12SF5	.75	50L6	.75	
3A3	.84	5T8	.80	6BGG6	1.40	6G6	.55	12AUI	.59	12SJ7	.75	50L6	.75	
3A4	.55	5U4	.59	6BG6A	1.60	6J5C	.35	12AV5	.40	12SK7	.75	50L7	.85	
3AF4	1.02	5U8	.80	6BM6	.64	6J5GT	.50	12AV7	.74	12SL7	.88	50L7	.85	
3AL5	.41	5V4	.82	6BM8	.86	6J6	.66	12AW6	.75	12SN7	.66	50L7	.85	
3AU6	.50	5V6	.55	6B56	.63	6J7	.85	12AX7	.62	12SW6	.68	117L7	2.50	
3AV6	1.40	5W4	.95	6BK5	.85	6K6	.58	12AX7	1.44	12T6	.52	117Z6	1.00	
3BA6	.60	5X4	.78	6BK7	.84	6L6	1.10	12AZ7	.62	12W6	.68			
3BC5	.53	5Y7	.45	6BN4	.56	6SA7	.75	12B4	.62	12X4	.62			
3BE6	.51	5V4	.77	6BN6	.73	6C7	.75	12BA6	.49	14H7	.80			
3BN4	.53	6A7	1.30	6BQ5	.59	6SF5	.75	12B4	.49	14K7	.80			
3BN6	.75	6A8	1.15	6BQ6	.55	6SM7	.75	12B6	.49	17AX4	.66			
3BU8	.70	6AB4	.45	6C78	1.00	6SJ7	.75	12BE6	.52	17BQ6	1.00			
3BY6	.54	6AC7	.85	6C8	1.00	6SK7	3/1.00	12BF3	.43	GTB	1.00			
3BZ6	.54	6AD3	.72	GA	1.00	6SL7	.79	12BM7	.72	17CUG/				
3CB6	.53	6AF4	.96	6BQ7	.64	6SN7	.64	12BL6	.55	17C5	.57			
3CF6	.59	6AF4A	.96	6BR8	.77	6SQ7	.72	12BQ6	1.00	17DQ6	1.00			
3CS6	.51	6AG5	.64	6BS8	.93	6T8	.84	GTB	1.00	17H3	.50			

SEND FOR COMPLETE PARTS CATALOG WITHOUT COST USE THIS AD AS ORDER BLANK

UNITED RADIO CO.
 ESTABLISHED 1920
 BOX 1000 A
 NEWARK, N. J.

TERMS: remit full price plus postage with order. No COD. Mail to Dept. RE. Excess postage will be refunded. Subject to Prior Sale \$5 MINIMUM ORDER

ELECTRONIC TECHNICIANS!

Raise your professional standing and prepare for promotion! Win your diploma in **ENGINEERING MATHEMATICS, or ADVANCED ENGINEERING MATHEMATICS,** from the **Indiana Home Study Institute**

We are proud to announce two great new courses in Engineering Mathematics for the electronics industry. These unusual courses are the result of many years of study and thought by the President of Indiana Home Study, who has personally lectured in the classroom to thousands of men, from all walks of life, on mathematics, and electrical and electronic engineering. You will have to see the lessons to appreciate them!

NOW you can master engineering mathematics, and actually enjoy doing it!

WE ARE THIS SURE: you sign no contracts—you pay only AFTER you have completed each Unit of your course.

In plain language, if you aren't satisfied you don't pay, and there are no strings attached.

Write today (a postcard will be fine), for more information and your outline of courses.

You have nothing to lose, and everything to gain!

The INDIANA Home Study Institute
 924 E. Columbia Avenue, Fort Wayne, Indiana

PACO WANTS YOUR NAME...

... for their permanent mailing-list to receive advance information on all new electronic kit developments—

TEST and MEASURING INSTRUMENTS
HI-FI STEREO COMPONENTS
HI-FI SPEAKER SYSTEMS
MARINE INSTRUMENTS
AUTOMOTIVE EQUIPMENT

When you want **PRECISION**-made electronic equipment (kits or wired), you want **PACO!** For your personal copy of the NEW 1961 **PACO Catalog.** WRITE:

PACO ELECTRONICS CO., INC.
 70-31 84th Street, Glendale 27, L. I., New York
 Kit Division of **PRECISION Apparatus Co., Inc.**
 a subsidiary of **Pacotronics, Inc.**

from **EICO**
... a completely new
CITIZENS BAND TRANSCEIVER

that meets
FCC regulations*

Model 760: 117 VAC
Kit \$59.95 Wired \$89.95
Model 761: 117 VAC & 6 VDC
Model 762: 117 VAC & 12 VDC
incl. mounting bracket: Kit \$69.95, Wired \$99.95

*EICO premounts, prewires, pretunes, and seals the ENTIRE transmitter oscillator circuit to conform with FCC regulations (Section 19.71 subdivision d). EICO thus gives you the transceiver in kit form that you can build and put on the air without the supervision of a Commercial Radio-Telephone Licensee!

Highly sensitive, selective SUPERHET (not regenerative) receiver with 5 1/2 dual function tubes and RF stage. Continuous tuning over all 23 bands. Exclusive Super-Hush® noise limiter. AVC 3" x 5" PM speaker. Detachable ceramic mike. 5-Watt crystal-controlled transmitter. Variable "pi" network matches most popular antennas. 12-position Posi-Lock® mounting bracket. 7 tubes and 1 crystal (extra xtals available). Covers up to 20 miles. License available to any citizen over 18—no exams or special skills required, application form supplied free. Antennas optional.

TOPS IN DESIGN... QUALITY



All-Transistor Portable RA-6
Kit \$29.95 Wired \$49.95
High sensitivity & selectivity. New type plug-in transistors. 4"x6" speaker; push-pull audio. Prealigned RF & IF transformers. Less battery, incl. FET.



New! 60-Watt CW Transmitter #723
Kit \$49.95 Wired \$79.95
Ideal for novice or advanced ham needing low-power, stand-by rig. 60W CW, 50W external plate modulation. 80 through 10 meters.



90-Watt CW Transmitter #720
Kit \$79.95 Wired \$119.95
"Top quality"—ELECTRONIC KITS GUIDE. Ideal for veteran or novice. 90W CW, 65W external plate modulation. 80 through 10 meters.
*U.S. Pat. No. D-184,776



High-Level Univ. Mod.-Driver #730
Kit \$49.95 Wired \$79.95
Delivers 50W undistorted audio. Modulates transmitters having RF inputs up to 100W. Unique over-modulation indicator. Cover E-5 \$4.50.



Grid Dip Meter #710
Kit \$29.95 Wired \$49.95
Includes complete set of coils for full band coverage. Continuous coverage 400 kc to 250 mc. 500 ua meter.

Compare — judge for yourself — at your neighborhood EICO distributor. For FREE catalog on over 70 models of easy-to-build professional test instruments, hi-fi and ham gear, fill out coupon on Page 33

Most EICO distributors offer budget terms.



3300 N. Blvd., L.I.C. 1, N. Y.
Add 5% in the West

introduced a new "TwinWeld" epoxy adhesive which has been engineered for permanent adhesive use for metal, glass, ceramic, concrete, hard rubber, wood, fiber glass, and other materials for the aircraft, electronics, tooling, etc. industries.

The new material is said not to expand or contract and is resistant to acids, alkalis, grease, and solvents. In order that prospective users can test this new product the company is offering a free sampling kit that contains equal 50/50 quantities of epoxy resin and hardener.

The test kit and additional information on the product are available direct from the manufacturer.

MIKE FOR MOBILE USE

Lafayette Radio, 165-08 Liberty Ave., Jamaica 33, N. Y. has introduced a new high-impedance dynamic microphone designed expressly for mobile and industrial applications (CB and ham radio, police, ship-to-shore, public address, and aircraft).

Designated as Model PA-77, the unit features a slide switch which operates microphone and relay circuits for "transmit" and "receive" switching. Frequency response is said to be 100 to 9000 cps. Impedance is 50,000 ohms. The PA-77 comes with mounting bracket and a 5-foot single-conductor shielded cable plus two color-coded switching conductors in one plastic jacket. Size is 3" x 1 3/4" x 1".

D.C. POWER SUPPLY

Sorensen & Co., South Norwalk, Conn. (a subsidiary of Raytheon), is offering seven new, completely transistorized

d.c. power supplies, ranging in output from 6.3 to 36 volts. These units are component-type supplies, completely contained in a military-type can.

Supplementing the 36 existing models in the company's "QM" series, the new units have a maximum output rating of 30 watts with voltage regulated to ± 0.05 per-cent against line and load variations.

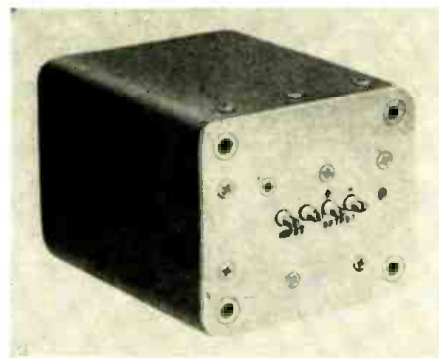

HAM AFFAIRS SCHEDULED FOR OCTOBER

THE SSB Amateur Radio Assn. is joining forces with the Quarter Century Wireless Assn. to honor Dr. George W. Bailey, W2KH, secretary of the IRE and former president of the ARRL, with a testimonial dinner October 14th. The affair will be the opening event of the Hudson Division ARRL Convention which will be held at the Statler-Hilton in New York.

An SSB Forum will be held from 2 to 5 p.m. on the 15th with Ed Piller, W2KPQ, president of the SSB Amateur Radio Assn. presiding.

INVITATION TO AUTHORS

Just as a reminder, the Editors of ELECTRONICS WORLD are always interested in obtaining outstanding manuscripts, for publication in this magazine, covering the fields of audio and high-fidelity and radio-TV-industrial servicing. Articles in manuscript form may be submitted for immediate decision or projected articles can be outlined in a letter in which case the writer will be advised promptly as to the suitability of the topic. We can also use short "filler" items outlining worthwhile shortcuts that have made your servicing chores easier. This magazine pays for articles on acceptance. Send all manuscripts or your letters of suggestion to the Editor, ELECTRONICS WORLD, One Park Avenue, New York City 16, New York.

SAVE! CHECK THESE PLATT BARGAINS... EVERY ONE IS A SPECIAL!

***** SENSATIONAL SAVINGS ON MOBILE RADIO EQUIPMENT! *****

Platt Electronics has available a complete inventory of all LINK past and present equipment. Its technical staff, with considerable experience in the 2-way FM Communications field, is in a position to give Link product users excellent service. Inquiries are invited.

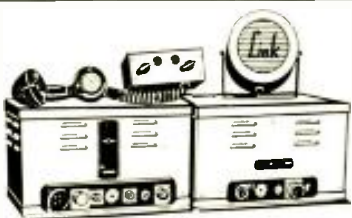

2-PIECE MODEL FMTR 30-50 MC ED. 7 FM MOBILE TRANS. & REC.—6 OR 12 VOLTS

Unit complete with Peak Modulation control head, mike, antenna, cables & crystals ground to your specific frequency. Modified.

6 Volt—\$109.95 12 Volt—\$149.95

2-PIECE MODEL FMTR 152-174 MC ED. 7, 25 W. FM MOBILE TRANS. & REC.—6 OR 12 VOLTS

Supplied as illustrated above.

6 Volt—\$134.95 12 Volt—\$174.95

MOBILE RADIO EQUIPT. 450-470 MCS MODEL 2975-15VR-D2b

For 150-460 mcs. 6 1/2 volts. Single unit construction. Power output 15 to 20 watts. Featuring noise-free, trouble-free operation, peak modulation control, excellent split-channel selectivity. Unit complete with accessories.

NEW... \$395.00

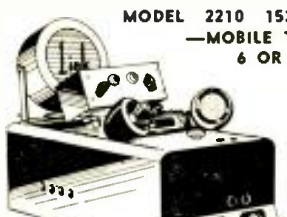

MODEL 2210 152-162 MC FM MOBILE TRANS. & REC. 6 OR 12 VOLTS

Antenna, cables, control head, mike, crystals, complete for immediate installation. Specially priced.

6 Volt \$139.50
12 Volt \$162.50

MODEL 2365 25-40 OR 30-50 MC FM MOBILE TRANS. & REC.—6 OR 12 VOLTS

Supplied as illustrated above. Complete for immediate installation.

6 Volt—\$119.50 12 Volt—\$149.50

FEDERAL PORTABLE MOBILE SIGNAL GENERATOR 110 V AC POWER—TYPE 104A

Designed to facilitate alignment of FM mobile and land station receivers in the field. Provides a continuous source of frequency modulated carrier, the frequency of which is determined by the multiplier-type crystal that is used in the unit. It will, by the proper selection of crystals, provide a signal suitable for the alignment of FM mobile receivers in both the 25-50 MC band and the 148-174 MC band. In addition to these frequencies, the type 104A Mobile Signal Generator provides a 1000 cycle signal that may be used to check audio circuits. Unit has external power facilities.



\$49.50

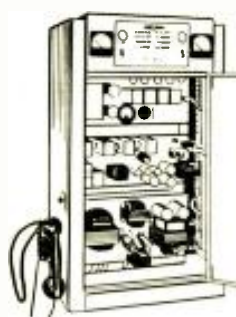

MODEL 50 UFS 60 WATT 30-50 MC BASE STATION

Housed in a 34" upright cabinet. Operates on 110 AC. Reconditioned, checked out, complete with accessories.

\$249.50

MODEL 1907 60 WATT FOR HIGH FREQ. OPERATION 152-174 MC—110 V.

Reconditioned, checked out, complete with all accessories.

\$299.50

REMOTE CONTROL UNITS

Model 1890 for operation in the 25-50 megacycle band. Used for Link Base Station operation & can be adapted for any other type.



Brand New \$169.50

7 TUBE FM TRANSMITTER

- 6 Volt Dynastor Power Supply.
- Instructions for connecting and for converting to 110 or 6 meters.

A 7C7 is used in a resistance coupled crystal controlled oscillator circuit. The output freq. is between 30 & 40 MC. The crystal freq. is between 337.5 KC and 1250 KC. Two 7A8's are used as balanced modulators. Two 7C7's are used as freq. doublers, and a 7C5 as a freq. doubler. An 807 is used as a power amplifier. Also included are a schematic diagram of the transmitter, a hook-up diagram and instructions for converting to 6 or 10 meters. Transmitter housed in louvered grey enamel case 8"x8"x10" W. Link Radio Mobile FM Transmitter Model 35-CMF as described. Reg. \$325.00.

Less tubes—SPECIAL... \$11.95

AC MOTOR

1/4 H.P., RPM 2100. Shaded Pole MOTORS for continuous duty. Full load ratings are 10 amps, 10.75 W., 2400 RPM's. 0015 horse power. Exc. for chassis, cond. inc. NEW... \$9c

FREQUENCY METERS

For the maintenance shop and field service. BC-221 Frequency Meters complete with original calibration book. Available in modulated and unmodulated types as well as ac operated models. Factory tested, checked for frequency alignment and GUARANTEED.

Unmodulated Type..... \$119.50
Modulated Type..... \$139.50
Modulated Type with AC power Supply..... \$159.50

NEW! Our own version of the famous BC-221 with built-in magic eye zero-beat indicator. Add \$25.00 to any model.

SPECIAL! 17 LBS. of ASSORTED RADIO PARTS

Now at low-away price of only... \$1.59

AMAZING KIT SALE!

Kit of 25 Assorted 10 & 20 watt RESISTORS, Popular Sizes..... \$1.97
Kit of 25 CONDENSERS—both tubs, Electrolytics & high voltage Mica..... \$1.89
Kit of 15 Assorted Popular WAFER SWITCHES..... \$1.59
Kit of 20 AIR PATHER VARIABLE CONDENSERS, 1/4" dia. sizes..... \$1.89

NEW CHICAGO PLATE TRANSFORMER TR-1040

115 VAC Primary, 2500 VDC @ 250 MA AC secondary, 9" high, 8 1/2" wide, 7" deep. Weight 60 lbs. \$39.95

MINIMUM ORDER \$5.00
Immediate Delivery. Include 20% deposit with order—balance C.O.D. All shipments F.O.B. our warehouse, N. Y. C. (N. Y. C. residents add sales tax to your remittance.)

RADIO SET SCR-694

We maintain a complete replacement stock for this type equipment. We invite all inquiries and offer free technical assistance. Platt Electronics participated in the original design and manufacture of this equipment.

BC-1306 TRANSMITTER RECEIVER

For MARS application, 3800 to 6500 KC, MO or Crystal Control. Includes Crystal Calibration and Net Controls. NEW UNITS, with all tubes. Each... \$29.50

PE-237 POWER SUPPLY

For BC-1306. Supplies all necessary voltages and current for both transmitter & receiver sections. Operates from 6, 12 or 24 Volts DC. NEW UNITS Each... \$24.95

BRAND NEW SIMPSON METERS 3 1/2" SQUARE

0—250 mill. \$4.95
0—750 Mill. \$5.95
0—150 AC Volts. \$4.95

SPECIAL! UNIVERSAL 6/12 VOLT VIBRATOR POWER SUPPLY

Wired, Mfd. by D. MONT. Rating 300 V. @ 100 mill. Ideal for all types of mobile applications. Chassis measures 5 1/2" x 8". Brand New \$11.95
Vibration for above... \$2.95

FIELD TELEPHONES

Army surplus, completely reconditioned and electrically tested, using 2 flashlight cells and a pair of interconnecting wires. GUARANTEED. NEW. \$19.95 each, \$35.00 pair

SPECIAL!

Current Westinghouse 832-A Tube, boxed. Sensationally priced at only... \$4.95

BRAND NEW CARTER GENEMOTOR

Input 26.1 VDC @ 7 amps. Output 405 VDC @ .270 amps. \$7.95

TS-9 HANDSET HAS BUTTERFLY-TYPE PRESS-TO-TALK SWITCH

Standard Signal Corps handset has 50 75 ohm carbon button, 135 1000 ohm & 1 ke magnetic reverb capsule, press-to-talk switch and 3-conductor cord. NEW... \$3.95

Terrific Buy! TRANSMITTING KEY

1-42 with metal knees. \$2.45

While They Last! T-17 HAND-HELD CARBON MIKE

For use in voice communication. Effectively covers the audio frequency range from 300 to 2000 cps. 200 ohms. with piezoelectric switch, 5 ft. rubber cord & plug. NEW... \$3.95

HEADSET H-16/U

8000 ohms. Rubber insert similar to headset H-33D, with ear cups to exclude noise. Cord 12' terminating into PL-51 short phone plug. (CD-307 extension cord used with this item.) BRAND NEW — ONLY \$2.95
CD-307 CORD — \$1.25

HEADSETS

H5-23 high impedance, brand-new \$4.95
H5-33 low impedance, brand new with cord and PL-24 PLUG... \$4.65
Navy-type H 63-U 600 ohm impedance \$6.95
6 ft. Extension Cord with jack & PLUG for above headset... \$1.15
High Impedance Matching Transformer from low to high... \$1.79c

PLATT ELECTRONICS CORP.
20 MURRAY ST., NEW YORK 7, N. Y.
Telephone: CORland 7-2575

Full Color Giant Fold-Out Charts Still Available!

Here's a complete series of colorful, authoritative fold-out wall-charts (originally appearing in the pages of **ELECTRONICS WORLD**)—yours for only 15¢ each. All in full-color—each suitable for framing.

- V.H.F. TV Spectrum and Interference Chart:** Servicing aid for TV technicians and hams—saves hours by tracking down interference.
- Hi-Fi Crossover Network Design Charts:** Tells how to build speaker nets for any crossover frequency. Complete coil-winding data, capacitor values given.
- Color Codes Chart:** Gives you coding for capacitors, resistors, transformers, resistance control tapers—all in easy-to-use form.
- Bass-Reflex Design Charts:** Complete data on building own bass-reflex enclosures for any speaker, including ducted-port enclosures.
- Radio Amateur Great Circle Chart:** For Hams and short-wave listeners—gives complete listing and map of amateur prefixes by calls and countries.
- Sound:** Fundamental data on all phases of Sound: frequency ranges, sound levels, equal loudness curves. A must for all audiophiles.

ALSO AVAILABLE:

Reprints of:

- "Build a Citizens Band Transceiver"**—complete details on building an 11-meter transceiver for Citizens Band service.
- "Electrical Shock: Fact and Fiction"**—must reading for everyone whose work or hobby involves electricity. Ideal for utility companies . . . service associations.

IMPORTANT: ORDER BY NUMBER! OUR SUPPLY OF ALL GATEFOLDS AND REPRINTS IS LIMITED. OFFERED ONLY ON A FIRST COME, FIRST SERVED BASIS.

Send 15¢ per selection to

ELECTRONICS WORLD, Dept. N 1060

Box 378, Church Street Station

New York 8, New York

McGEE SPECIAL PURCHASE SALE
SAVE \$60.00
 MODEL G-7600
40 WATT GENERAL ELECTRIC STEREO AMPLIFIER

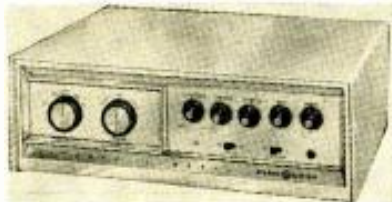

Regular \$139.50 General Electric model G7600, 40 watt (20 watts per channel) high fidelity stereo audio amplifier on sale at McGee for only \$79.95. Limited quantities. McGee offers this money saving value on new factory cartoned genuine General Electric Hi-Fi amplifiers, 11 tubes, push pull audio on each channel, dual bass and treble tone controls. Inputs for all phono cartridge plus a radio tuner. Regular \$139.50 McGee sale price \$79.95.

Regular \$129.50 General Electric model FA-17 FM/AM tuner, matches and made for use with the model 7600 amplifier. Offered at a \$60.00 saving. McGee's sale price only \$69.95. Limited quantity available.

Send your remittance with your order. COD orders shipped when you send a 25% deposit. Prices F.O.B. Kansas City, Mo.

WRITE FOR OUR 1961 160-PAGE CATALOG BARGAINS in Hi-Fi—T.V. Parts — Tubes — Speakers — Electronic Material

McGEE RADIO COMPANY
 1901-47 McGee Street Kansas City 8, Missouri

SEND 1961 McGEE 160-PAGE CATALOG

Name

Address

City Zone State

DEWALD 35 YEARS OF KNOW-HOW
 MF'D BY ...



Leads Again With
 Citizens Band "RADIO-PHONE" TR-800 TRANSCEIVER



ONLY 99.95 LIST

Furnished with Ceramic Microphone and one Transmitting Crystal

For Communication on the move!

- Superhet Trans-Receiver
- 5 Channel Transmit
- 22 Channel Vernier Tuned Receiving
- 5 Watts Input-Plate Modulated
- R. F. Amplifier
- On-Off & R. F. Indicators
- Noise-Limiter Control
- Mobile Mounting Brackets Included
- Power Supply Available for 6 and 12 Volt Operation

Write for Brochure and Name of Your Nearest Dealer

UNITED SCIENTIFIC LABORATORIES, INC.
 35-05 37th AVE., LONG ISLAND CITY 1, N. Y.
 Also Mfr's of DeWald Hi-Fi Stereo Components and FM Radio

Capacitance Relay (Continued from page 87)

(through current-limiting resistor R_1) to the 2050 grid, this grid is quite negative during oscillation of the 117N7-GT and somewhat less negative when oscillation ceases (object near antenna). The positive-going swing fires the 2050 and energizes the relay. If the 2050 anode were supplied from d.c., the tube would then remain fired indefinitely. But since it is a.c.-supplied, the tube is self-restoring (that is, it is extinguished each time the a.c. supply cycle goes through zero). Relay chatter due to this action is prevented both by using an a.c. relay and by including the large shunting capacitor, C_2 . When the object withdraws from the vicinity of the antenna, grid current and the voltage drop across R_2 increase, the 2050 is extinguished, and the relay opens.

Sensitivity of the circuit is such that the operator's fingertip 1 inch from a 2-foot length of insulated wire connected to the antenna terminal will actuate the relay. Good action is obtained from the whole body when walking past a 5-foot vertical antenna 1 foot away. A 4-inch metal disc connected to the antenna terminal allows the relay to be operated by the fingertip 6 inches away, or the palm of the hand about 8 inches away.

-30-

Answer to Puzzle
 Appearing on page 98



PHOTO CREDITS

Page	Credit
39, 41 (center), 82	RCA
40 (top)	Collins Radio Co.
40 (center)	International Resistance Co.
40 (bottom)	Hiller Co.
41 (top left)	Martin Co.
41 (top right)	Raytheon Co.
41 (bottom)	Thompson-Ramo-Wooldrige
48, 49	General Electric Co.
62, 63	Electro Products Laboratories
94	Elmac Radio Club
122	Heath Company
123	Shure Brothers, Inc.

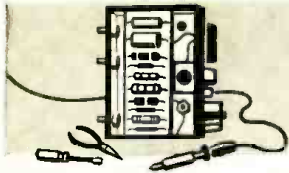

ELECTRONICS MARKET PLACE

RATE: 60c per word. Minimum 10 words. December issue closes October 13th. Send order and remittance to ELECTRONICS WORLD, One Park Ave., N. Y. C. 16, N. Y.

RADIO ENGINEERING & INSTRUCTION

USED Correspondence Courses and Books sold and rented. Money back guarantee. Catalog Free. (Courses bought.) Lee Mountain, Plsgh, Alabama.

LEARN Code. Qualify for Amateur or Commercial License. Free Book. Candler System, Dept. EW-10, Box 9226, Denver 20, Colorado.

ENGINEERING and Art Degrees earned through home study. Electronics, Electrical, Mechanical, Civil, Physics, Business Administration, Accounting, Liberal Arts. When writing, specify courses desired. Pacific International College of Arts & Science, primarily a correspondence school. Resident classes also carried. 5719-C Santa Monica Boulevard, Hollywood 38, California.

COMPLETE study horizontal output systems—new technique of servicing—\$3.00 C.O.D. E. F. Schwarz, 512 Roslyn Avenue, Colonial Heights, Virginia.

FOR SALE

TUBES—TV and Radio tubes. Guaranteed—Save up to 80%—Write: Emkay Electronics, P.O. Box 142, Blythebourne Station, Brooklyn 19, N. Y.

GOVERNMENT Sells: Surplus Electronics; Test Equipment; Oscilloscopes; Transceivers; Jeeps; Boats; Aircrafts; Misc. Send For U.S. Depot Directory & Procedure \$1.25—Brody Surplus, Box 425 RT, Nanuet, N. Y.

GOVERNMENT Surplus Receivers, Transmitters, Snooperscopes, Parabolic Reflectors, Picture Catalog 10c. Meshna, Malden 48, Mass.

TUBES—TV, Radio, Transmitting And Industrial Types At Sensibly Low Prices. New, Guaranteed. 1st Quality. Top Name Brands Only. Write For Free Catalog or Call Walker 5-7000, Barry Electronics Corp., 512 Broadway, New York 12N, N. Y.

SOMETHING for sale? Place a classified ad in this section. Low-cost fast results. It's easy.

DIAGRAMS for repairing radios \$1.00. Television \$2.00. Give make, model. Diagram Service, Box 672-RN, Hartford 1, Conn.

AUTO Radio Distributor. Selling, Servicing. Becker Blaupunkt, FM-AM, other European, American Sets. Save 30%+. Square Electronics, 150-60 Northern Blvd., Flushing, N. Y.

RADIO & TV Tubes at Manufacturer's prices! 100% Guaranteed! Brand New! No re-brands or pulls! United Radio, Box 1000-W, Newark, N. J.

RADIO and television tubes, brand new, 1st quality, original boxed name brands only. Discounts up to 66 2/3% off list. Positively no seconds. Send for free price schedule. Edison Tube Co., Menlo Park, N. J.

YOUR Call Letter, embossed enamelled steel, 7"x2 1/2" —\$2. Sho-Plates, 5364 Wingohocking, Philadelphia 44.

EXPERIMENTERS, Modelers, Hobbyists: Power your model craft with sun light. Full details, schematic and materials source list, price \$7.00. Write today. Smithfield Enterprises, Box 230, Warren, Ark.

OUR Remote Control attachment operates your Citizen Band equipment from any remote location. Frontier Electronics, Orr, Minnesota.

TWO-meter FM Industrial Radio Company Packsets \$30 ea. Motorola 33D 2 way radio mobile units \$125 ea. W. Vogel 1760 Pine Tree Rd., Winter Park, Fla.

SURPLUS electronics, optics, free catalog. APS 4 radar, manual \$40.00. Thermolectric Devices, 302 Massachusetts Avenue, Cambridge, Mass.

TRANSISTOR portable radio kits, \$6.95. TV's, console models, 16", 17", 19", used, \$14.95. Heavy duty solder gun, free extra tip, solder, \$5.95. Channel Master conical antenna, \$6.95. Switch-type indoor antenna, \$2.99, 6 for \$2.49 ea. Parallel picture tube brightener, 99c; series type, \$1.39. Auto vibrators, 6V 4 prong Universal, \$1.59, 12V 3 prong Standard, \$1.79, 12V 4 prong Standard, \$1.99. Fiber fuse clips, 15c ea., 12 for \$1.65. RCA cheater cords, 39c ea., 6 for \$1.95. Write for free catalog of tubes, parts. All postpaid except used TV and channel master antenna, FOB Harrison, N. J. Teltron Electric Co., Dept. EW10, 428 Harrison Ave., Harrison, N. J.

TV & Radio Tubes—All top Name Brands—R.C.A., etc.—60-10-5%. Full replacements—regular boxed—no jobslots or closeouts. (Representatives wanted for all states.) Radio Tube Specialists, 397—7th Ave., Brooklyn 15, N. Y.

TV Tuners—Rebuilt or Exchanged \$9.95 complete—all types—fast, guaranteed service. Send tuner with all parts to: L. A. Tuner Exchange, 4611 West Jefferson Blvd., Los Angeles 16, California.

WANTED

CASH paid for short-wave ham receivers and transmitters. Tregler, W91VJ—2023C N. Harlem Ave., Chicago 35, TUXedo 9-6429.

WANT to buy good equipment and accessories? Place a low-cost classified ad in this space.

CASH Paid! Sell your surplus electronic tubes. Want unused, Clean radio and TV receiving, transmitting special purpose, Magnetrons, Klystrons, broadcast types. Want military and commercial lab/test equipment such as G.R.H.P., AN/UPM prefix. Also want commercial Ham Receivers and Transmitters. For a Fair Deal write: Barry Electronics Corp., 512 Broadway, New York 12, N. Y. (Walker 5-7000).

SURPLUS measurement model 78 or 80 signal generators. Also federal 804 or I-122 or used Motorola two-way equipment. State quantity, price, and condition. Communications Service, Inc., 3209 Canton Street, Dallas, Texas.

TAPE & RECORDERS.

HI-FI Components—Tape Recorders. All brands in stock at "We Will Not Be Undersold Prices." Quotations. Free Wholesale Catalog return mail. Hi-Fidelity Center, 1797NC First Avenue, New York 28, N. Y.

AMPEX, Concertone, Magnecord, Presto, Bogen, Tandberg, Pentron, Sherwood, Rek-O-Kut, Scott, Shure, Dynakit, others. Trades. Boynton Studio, Dept. RT, 10 Pennsylvania Ave., Tuckahoe, N. Y.

RECORDING Tape 1800' Mylar \$1.89 10 for \$18.00, 2400' Mylar \$2.95 10 for \$27.50. First quality, splice-free, brand new, manufactured by one of the top four U.S. tape companies. Absolutely uniform frequency response. G.E. VR 11 3-ply diamond cartridges \$9.95 (reg. \$19.95). ESL arms \$26.75 (reg. \$34.95). Wollensak 1515-4's \$159.95. Free stereo cartridge (your choice to \$25.00) with the purchase of any changer and base. Many more bargains, write for catalog. All items unconditionally guaranteed. The Sound Room, 7959 Melrose Ave., Los Angeles 46, California.

OVER 245,000 buyers and sellers will read your ad when placed in this space. It costs only 60c per word; minimum of 10 words including your name and address.

SELF-Hypnosis tape. New! Free literature. McKinley-Smith Co., Dept. T6, Box 3038, San Bernardino, Calif. RENT Stereo Tapes—over 1,500 different—all major labels—free catalog. Stereo-Parti, 811-L, Centinela Ave., Inglewood 3, California.

HIGH-FIDELITY



INDUCTORS for Crossover Networks. 118 types in stock. Send for brochure. C & M Coils, 3016 Holmes Ave. N.W., Huntsville, Ala.

DISGUSTED with "Hi-Fi" Prices? Unusual Discounts On Your High Fidelity Requirements. Write. Key Electronics, 120 Liberty St., New York 6, N. Y. Cloverdale 8-4288.

RECORDERS, Components. Free wholesale catalogue. Carston 125-R, East 88, N.Y.C. 28.

COMPONENTS—Best Quotation—Sale Items. Bayla Co., Box 131-E, Wantagh, N. Y.

PRICES? The Best! Factory-sealed Hi-Fi Components! Yes! Send for free catalog. Audion, 25T Oxford Road, Massapequa, N. Y.

PICKERING #371-7D Stereo Cartridges. Factory Boxed and Guaranteed. \$12.00 ea. Music Box, 1325 Derry St., Harrisburg, Pa.

BUSINESS OPPORTUNITIES

EARN big money. Self service tube checkers, console model, 22 sockets. Customers test own tubes. Includes neon light head, key for bottom door. \$39.95, FOB warehouse. Teltron Electric Co., Dept. EW10, 428 Harrison Ave., Harrison, N. J.

SHOPPING GUIDE Classified

A HANDY GUIDE TO PRODUCTS. NOT NECESSARILY ELECTRONIC. BUT OF WIDE GENERAL INTEREST.

PHOTOGRAPHY—FILM, EQUIPMENT, SERVICES

GUARANTEED quality processing, 35mm, 8mm Kodachrome \$1.00. Send for free mailers, photographic discount catalogue. Carterchrome, Box 645, Utica 1, New York.

OPTICAL—Science—Math Bargains—Request Free Giant Catalog "CJ"—128 pages—Astronomical Telescopes, Microscopes, Lenses, Binoculars, Kits, Parts. Amazing war surplus bargains. Edmund Scientific Co., Barrington, New Jersey.

MUSIC

SONGS into Dollars! Share \$33 million dollars yearly for New Songwriters, Songpoets. Any subject, songs composed. Published, promoted by largest firm. Information appraisal free. Send Noryke Music Publishers. 6000 Sunset, Hollywood 283, California.

WRITE Martin Lincoln, Electronics World, 1 Park Avenue, New York 16, N. Y. for information on how to place a classified ad in this section.

MAGNETS

ALNICO Permanent Magnets. Hobbyist Surprise Assortments. \$2 (refundable). Postpaid. Magnetics, 7777 Sunset, Dept. PA, Los Angeles 46.

HELP WANTED

DETECTIVES—Experience unnecessary. Detective particulars. Wagoner, 125-Z West 86th, N. Y.

OVERSEAS Employment. American Firms and United States Government. Comprehensive job information \$2.00. Foreign Opportunities, Box 172, Columbus 16, Ohio.

EARN Extra money selling advertising book matches. Free Samples furnished. Matchcorp, Dept. MD-100, Chicago 32, Ill.

HAVE you read "How To Get A Good Job?" Secrets heretofore highly guarded now revealed. Free Literature. Write: Employment Informallon, Box 10634, Jackson 9, Miss.

EDUCATIONAL OPPORTUNITIES

COMPLETE Your High School at home in spare time with 63-year-old school. Texts furnished. No classes. Diploma. Information booklet free. American School. Dept. X736. Drexel at 58th, Chicago 37, Illinois.

LEARN while asleep (methods 92% effective). Develop with power and dynamic personality, control weight and tension through electronically proven transitional sleep techniques. Details free. A.S.R. Foundation, Box 21-eg., Henry Clay Station, Lexington, Kentucky.

LEARN While Asleep, Hypnotize with your recorder. Phonograph. Astonishing details, unusual catalog free! Sleep-Learning Association, Box 24-ZD, Olympia, Washington.

BUSINESS OPPORTUNITIES

RADIO Parts Stores & Hi-Fi Salons! Someone "borrowing" your personal copy of Electronics World each month? You ought to be taking advantage of Electronics World convenient re-sale plan. Sell copies in your store . . . perform a good service for your customers . . . with no risk involved. For details, write: Direct Sales Department, Electronics World, One Park Avenue, New York 16, N. Y.

MAKE \$25-\$50 Week, clipping newspaper items for publishers. Some clippings worth \$5.00 each. Particulars free. National, 81-DG, Knickerbocker Station, New York.

MISCELLANEOUS

FREE! New 1960 catalog of all photographic books available. For your copy, send postcard with name and address to Catalog Popular Photography Book Service, One Park Ave., New York 16, N. Y.

LOANS By Mail—\$50 to \$600 for any purpose. Employed men, women eligible. Confidential. 2 years to repay. Write for free loan application, American Loan Plan, City National Bldg., Dept. 2D 8-9220, Omaha 2, Neb.

SKYSCRAPER-Heel Shoes, Wasp-Waisted Corsets! Photo catalogs, \$2.00. Finecraft, Box 442-P, Hollywood 28, Calif.

BIZARRE Fashions! Illustrated Catalogue, \$1.00. Renne, Box 2804-P, Hollywood 28, Calif.

"WINEMAKING," "Beer, Ale Brewing." Highest powered methods. Illustrated. \$2.20. Eaton Bookstore, Box 1242-X, Santa Rosa, California.

RUBBER stamps for home or office. 3 lines personalized stamps \$1.65. Special rates on stock stamps. Precision Industries, 262 Farmers Ave., Lindenhurst, N. Y.

FREE Illustrated, Hypnotism Catalogue. Write: Powers, 8721 Sunset, Hollywood 46, California.



ELECTRONICS WORLD HAS

A BUYER FOR YOUR USED EQUIPMENT OR COMPONENTS!

The 245,000 purchasers of ELECTRONICS WORLD are always in the market for good used equipment or components. So if you have something to sell, let EW readers know about it through our classified columns. It costs very little: just 60¢ a word, including name and address. Minimum message: 10 words.

For further information write:

Martin Lincoln
ELECTRONICS WORLD
One Park Avenue
New York 16, N. Y.

INDEX OF Advertisers

OCTOBER 1960

ADVERTISER	PAGE NO.	ADVERTISER	PAGE NO.
Advance Electronics	144	McGee Radio Company	148
Advanced Acoustics Corporation	138	Milwaukee School of Engineering	118
Aerovox Corporation	8	Moss Electronic, Inc.	110, 111
Airex Radio Corporation	91	Motorola Training Institute	74
Allied Radio	7, 24, 25, 107	National Radio Institute	17, 18, 106, 129
Amperex Electronic Corp.	89	National Technical Schools	27
Ashe Radio Co., Walter	131	Oelrich Publications	124
Audio Unlimited	136	Ohmatsu Electric Co., Ltd.	89
Audion	90	Olson Radio Corporation	130
B & K Manufacturing Co.	67	Paco Electronics Co., Inc.	145
Baltimore Technical Institute	144	Peak Electronics Company	112
Barry Electronics Corp.	124	Pearce-Simpson, Inc.	136
Blonder-Tongue	117	Pickering & Co., Inc.	91
Burstein-Applebee Co.	125	Picture Tube Outlet	144
Capitol Radio Engineering Institute, The	100, 101, 102, 103	Platt Electronics Corp.	147
Carston Studios	136	Prior, Inc., Louis D.	136
Castle TV Tuner Service	121	Progressive "Edu-Kits" Inc.	119
Center Industrial Electronics, Inc.	136	Quietrol Company, Inc.	32
Centralab	22	RCA Institute, Inc.	83, 84
Channel Master	10, 11, 13, 19, 26	R W Electronics	106
Cleveland Institute of Electronics	9	Rad-Tel Tube Co.	113
Columbia Electronics	80	Radio Corporation of America	FOURTH COVER
Commissioned Electronics Co.	129	Radio Shack Corporation	99
Coyne Electrical School	90, 123	Radio-Television Training School	21
DeVry Technical Institute	3	Reeves Soundcraft Corp.	6
Dressner	82	Rek-O-Kut Company, Inc.	93
EICO	33, 34, 146	Rider Publisher, Inc., John F.	82
Electronic Chemical Corp.	127	Sams & Co., Inc., Howard W.	31, 104, 105
Electronics Book Service	28, 29, 137	Schober Organ Corporation, The	78, 85
Electrophono & Parts Corp.	78, 127	Scott Inc., H. H.	75
Fair Radio Sales	124	Seco Electronics, Inc.	121
Fidelitone	92	Sencore	79
G & G Radio Supply Co.	115	Shure Brothers, Inc.	32
General Electric Company	14, 15	Sonar Electronic Tube Co.	98
Goodheart Co., R. E.	120	Sonotone Corp.	30
Grantham School of Electronics	23	Standard Coil Products Co., Inc.	THIRD COVER
Greenlee Tool Co.	138	Standard Surplus	94
Greylock Electronics	139	Stereo-Parti	90
Hallicrafters	91	Stotts-Friedman Co., The	106
Heath Company	68, 69, 70, 71	Stromberg-Carlson	1
Henshaw Radio Supply	82	Superior Instruments Co.	143
Holt, Rinehart and Winston, Inc.	108, 139	Sylvania Electric Products, Inc.	SECOND COVER
Homewood Industries, Inc.	90	TV Servicing Systems	142
Hy-gain Antenna Products	114	TAB	132
Indiana Home Study Institute, The	145	Telson Electronic Products, Inc.	138
Indiana Technical College	125	Teltron Electric Co.	142
International Electronics Corp.	88	Texas Crystals	136
International Radio & Electronics Corp.	78	Tri-State College	136
Jerrold Electronics Corporation	12	Tru-Vac	143
Johnson Company, E. F.	109	United Radio Co.	145
Joseph, Inc., Irving	109	United Scientific Laboratories, Inc.	148
Key Electronics Co.	144	University Loudspeakers, Inc.	76, 77
Kreckman Company, Herb	124	Valparaiso Technical Institute	82
Kuhn Electronics	144	Van Nostrand Company, Inc., D.	5
Lafayette Radio	95, 96, 97	Vocaline Company of America	81
Lampkin Laboratories, Inc.	139	Weller Electric Corp.	16
Lektron	129	Weston Instruments Division	107
Lesa of America	127	Windsor Electronics	125



Here is the new Standard Coil Tuner Replacement and Repair Program that enables you to offer better service to your customers at greater profit. Now Standard Coil Products provides the tools that will enable you to cash in on the profitable tuner repair and replacement market.

TUNER REPLACEMENT LISTING IN SAM'S PHOTOFAC

Starting in January, Standard Coil tuner replacement listings will appear in all Sams TV Photofact. Tuner replacement information will be right at your finger tips. Standard Coil is the *only* manufacturer ever to provide this service.

NEW TV TUNER REPLACEMENT GUIDE

Lists original equipment TV tuners with the Standard Coil equivalent replacement for each. Also includes major mechanical replacement parts for all Standard Coil Tuners—those used in original equipment as well as the universal replacement. Eliminates all guesswork—minimizes your tuner repair and replacement problems.

48 HOUR FACTORY GUARANTEED REPAIR SERVICE

Standard Coil's special service department set-up assures factory guaranteed repairs—*on a 48 hour in-plant cycle!*

All repaired tuners carry a *six month warranty* on defective workmanship and parts failure (excluding tubes). Gives you more time for additional service calls—promptly returns your customer's set to like new operating condition.

DEFECTIVE TUNER TRADE-IN ALLOWANCE

Tuners which can *not* be repaired can be traded in against a new replacement tuner which carries a *full twelve month factory guarantee*. See your Standard Coil Distributor for complete details on how trade-ins can increase your tuner sales and profits—create greater customer satisfaction.

JUMP ON THE STANDARD COIL PROFIT WAGON TODAY!

For additional details, see your authorized Standard Coil Distributor or write to:

Standard

Coil Products Co., Inc.

2085 North Hawthorne Avenue, Melrose Park, Illinois

FACTS



to help you sell more
RCA Silverama Picture Tubes

... the All-New replacement picture tubes that command premium price and profits.

Here are the facts—proof that RCA Silverama is your customers' best picture tube buy.

1 FREE OF GLASS DEFECTS. Glass cord lines, scratches, chips, or buffed faceplates are common defects found in many brands of tubes made with used glass. Surest way to avoid these defects and also obtain the latest optical advances in faceplate engineering: an All-New RCA Silverama!

2 ALL-NEW. Of the three largest-selling brands of replacement TV picture tubes, only RCA Silverama is guaranteed 100% all-new—new glass, new gun, new phosphor, new everything! You'll get written proof—right on the warranty card.

3 FINEST SCREEN QUALITY. Advanced screen coating and bonding processes combined with RCA's giant vibration-free screen settling machines assure the maximum in picture screen quality and uniformity.

4 RCA "KNOW-HOW". RCA's continuous product research and advanced design engineering have resulted in RCA Silverama picture tubes being steps ahead of all other brands.

5 WORLD'S FINEST. RCA Silverama is manufactured in the world's most modern manufacturing plant using all-new premium-quality materials. Result? RCA Silverama is the world's finest picture tube.

© Silverama



The Most Trusted Name in Electronics
RADIO CORPORATION OF AMERICA
Electron Tube Division

Harrison, N. J.