

# ELECTRONICS ILLUSTRATED®

By the Publishers of MECHANIX ILLUSTRATED

Special  
Section:  
Amateur  
Radio

**FULL COVERAGE—NOVICES TO ADVANCED HAMS!**

**60 PAGES OF SPECIAL FEATURES & PROJECTS!**

How to Get a Ham License

Tips on Learning Theory & Code

Build a Unique Mainmast Antenna

Antenna & Transmission-Line Theory

Plans for 250-Watt Antenna Tuner

Add a Low-Cost RF Output Meter

A Modulated Crystal Calibrator

How to Use a Grid-Dip Oscillator

Power Supply for Surplus Receivers

Build Your Own Electronic Keyer

Specialized Hamming: SSB and RTTY

**BUILD THIS 2-BAND HAM STATION!**

Complete plans in this issue:

40-watt CW transmitter,

superhet receiver.



# Where You Train Is As Important As Your Decision To Train



Electronics is a growing and expanding industry. That's why so many ambitious men are deciding to train for careers in this exciting field. They recognize the opportunities to advance and prosper. But, where a man trains and how the school of his choice teaches Electronics

... how it encourages him to reach his goals and realize his ambitions ... is most important to his success.

This is a fast changing world. A school offering Electronics courses must keep pace. That's why NRI—with nearly 50 years of specialized experience—now offers eight choices of training within the one field of Electronics. Select the course of most interest to you and receive the kind of home-study training that prepares you for a specialized career. NRI's large staff of specialists is always on the job keeping course material up-to-date ... helping you earn your way while training ... assisting you with job placement when ready. In short, whatever branch of Electronics you select, NRI is qualified through knowledge and experience to help you grow.



## SPECIAL TRAINING EQUIPMENT INCLUDED

NRI "learn by practice" method is the time-proved way to learn easier, faster, better. Most NRI courses include—at no extra cost—special training equipment to give shop and laboratory experience in your own home. All equipment is yours to keep.



Projects you build, experiments you perform, make NRI lessons come to life. Complex subjects become interesting, easy to grasp. Your first projects are measuring voltage and current in circuits you build yourself. You use a Vacuum Tube Voltmeter which you construct. Later on, you progress into more involved experiments. If you like working with your hands, you'll enjoy learning Electronics with NRI.

## THE PROVEN WAY TO BETTER PAY

Best of all, NRI provides training right in your own home and in your spare time. No time wasted getting to school. You fit study hours to your own schedule. You go as fast or as slow as you like. Check the training of most interest to you; cut out and mail the postage-free card now. Read about Electronics opportunities, NRI courses, the NRI trial plan, convenient terms.

# Pick the **ELECTRONICS** CAREER You Want

## 1 INDUSTRIAL ELECTRONICS

Learn Principles, Practices, Maintenance of Electronic equipment used today in business, industry, defense. Covers Electronic controls and measurement, computers, servos, telemetry, multiplexing, many other subjects.

## 2 RADIO-TELEVISION SERVICING

Learn to service AM-FM Radios, black and white and color TV sets, Stereo Hi-Fi, PA systems, etc. A profitable, interesting field for part-time or full-time business of your own.

## 3 COMPLETE COMMUNICATIONS

A comprehensive training course for men seeking careers operating and maintaining transmitting equipment in Radio-TV Broadcasting or mobile, marine, aviation communications. Prepares you for FCC License.

## 4 FCC LICENSE

Prepares you quickly for First Class License exams. Every communications station must have one or more FCC-licensed operators. Also valuable for Service Technicians. You train at home.

## 5 MOBILE COMMUNICATIONS

Training in installation and maintenance of mobile equipment and associated base stations like those used by fire and police, taxi companies, etc. Prepares you for First Class FCC License exams.

## 6 MARINE COMMUNICATIONS

Shipboard transmitting equipment, direction finders, depth indicators, radar are all covered in this course. You prepare for your First Class Radiotelephone License with Radar Endorsement.

## 7 AVIATION COMMUNICATIONS

For men who want careers working with and around planes. Covers direction finders, ranges, markers, loran, shoran, radar, landing systems, transmitters. Prepares you for FCC License exams.

## 8 MATH FOR ELECTRONICS

From basic arithmetic review to graphs and electronic formulas in one complete "short course" package of five carefully prepared texts. Quick, complete and low in cost.

**nri**

America's Oldest and Largest Radio-TV  
Electronics Home-Study School

MAIL POSTAGE-FREE CARD NOW



**“Well worthy of the Fisher name, both in performance and in ease of construction... Beautifully packaged and ‘instructed’... Excellent specifications, and the performance equals or exceeds the specs.”**

**—AUDIO MAGAZINE**

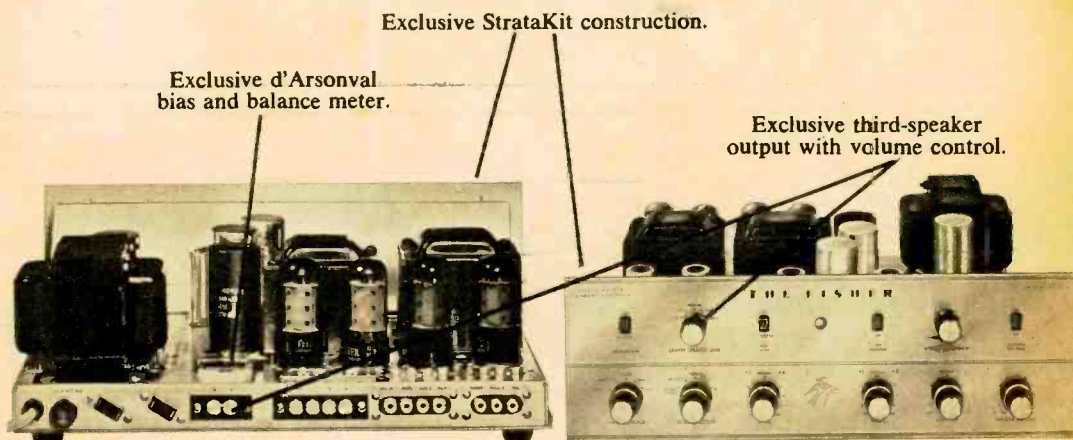

**The Fisher KX-200 StrataKit, the 80-watt stereo control-amplifier kit, \$169.50\***

This is the most powerful and in every way the most advanced single-chassis stereo control-amplifier kit you can buy — and by far the easiest you can build.

The 80-watt music power output (IHFM Standard, both channels) assures peak performance with even the most inefficient speakers. Engineering features never before offered in an integrated control-amplifier kit result in unequalled versatility. And the exclusive Fisher StrataKit method of kit construction makes the technical skill or previous experience of the builder completely unimportant and immaterial.

But the most exclusive thing about the KX-200 is the Fisher name — your guarantee of a head start in kit building before you even pick up your screwdriver!

**FREE! \$1.00 VALUE!** The Kit Builder's Manual: a new, illustrated guide to high-fidelity kit construction.

**The  
Kit Builder's  
Manual**

**FISHER RADIO CORPORATION**  
21-55 44th Drive  
Long Island City 1, N. Y.

Please send me without charge The Kit Builder's Manual, complete with detailed information on all Fisher StrataKits.

Name \_\_\_\_\_

Address \_\_\_\_\_

City \_\_\_\_\_ Zone \_\_\_\_\_ State \_\_\_\_\_

21911

\* WALNUT OR HANOGANY CABINET, \$24.99. METAL CABINET, \$19.99. PRICES SLIGHTLY HIGHER IN THE FAR WEST. EXPORT: FISHER RADIO INTERNATIONAL, INC., LONG ISLAND CITY 1, N. Y. CANADA: TRI-TEL ASSOCIATES, LTD., WILLOWDALE, ONT.

# ELECTRONICS ILLUSTRATED

September 1963

A Fawcett Publication

Vol. 6, No. 5

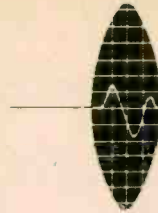

## Special Ham Features

Ham Marketplace .....	14
The Wonderful World of Amateur Radio .....	29
Why Be a Ham?..... John Huntoon, W1LVQ	30
The Code .....	32
The Theory .....	34
The Test .....	36
Using a GDO..... Herb Cenan	38
The 10 Most Useful Ham Accessories.....	41
How to Choose the Right Transmission Line..... Al Toler	45
What You Should Know About SSB..... Robert Smith, W1LLF	53
Ham Shack..... Robert Hertzberg, W2DJJ	56
Ham Antenna Facts..... Herb Friedman, W2ZLF	72
A Ham's Library..... Len Buckwalter, K1ODH	80
The League That Maxim Built..... Robert Hertzberg	93
The Radio Teletype Hams..... Byron H. Kretzman, W2JTP	96

## Special Ham Projects

250-Watt Antenna Tuner..... Bert Mann	48
Kit Report: Hybrid Phone Patch.....	50
Build a 2-Band Ham Station..... Harry Kolbe	57
A Modulated Crystal Calibrator..... Herb Cenan	75
Add-On RF Output Meter..... Russ Cogan	78
Build Your Own Electronic Keyer..... Herb Friedman	82
Low-Cost Sideswiper for EI's Electronic Keyer..... Gerald Wainwright	85
3-Band Mainmast Antenna..... Edward M. Noll, W3FQJ	90
Command Control Center..... Chet Stephens	100
Kit Report: 150-Watt AM-CW Transmitter.....	104
Stop That (RF) Leak!.....	113

## Audio & Hi-Fi

Hi-Fi Record Guide..... Warren DeMotte	99
Let's Look at Cartridges..... Hans Fantel	106

## Regular Departments

Feedback from Our Readers.....	6
Electronics in the News.....	10
Broadside.....	12
CB Corner: Putting the Bite On..... Len Buckwalter, KBA4480	44
The Listener..... C. M. Stanbury II	68
Beginner's Page: How to Make a Mike..... H. B. Morris	89
Good Reading..... John Milder	103

Audit Bureau of Circulations



MEMBERSHIPS



Magazine Publishers Association, Inc.



COVER — Ektachrome by  
Grayson Tewksbury, EI  
Studios.





**Has shop in basement — gets  
"more and more work all along"**

"I HAD PRACTICALLY no knowledge of any kind of repair work. One day I saw the ad of NRI in a magazine and thought it would be a good way to make money in my spare time. Now I am busy almost all my spare time and my day off — and have more and more repair work coming in all along. I have my shop in the basement of my home."

—JOHN D. PETTIS,  
172 N. Felton, Bradley, Illinois

# IF YOU'VE BEEN WANTING TO START "A LITTLE BUSINESS OF YOUR OWN" IN YOUR BASEMENT OR GARAGE

**CHECK the advantages of NRI training in Servicing Electrical Appliances**

- STEADY DEMAND** for your services. Over 400 million appliances in U.S. — 6 million sold last year alone — mean shortage of trained appliance service men.
- NO ELABORATE EQUIPMENT NEEDED** — just simple hand tools, and Appliance Tester which we provide at no extra charge.
- START SMALL — GROW BIG.** You can start out in your own basement or garage, in spare time. Gradually expand until you open your own shop.
- NO NEED TO RISK YOUR SAVINGS.** Many businesses require a sizable investment. But here you can build up a following of customers *first*, then open a full-time shop if you wish to.
- EARN \$3 TO \$5 PER HOUR.** Fixing appliances is a high-paying skill because the demand for trained men is so great.
- ENJOY SEMI-RETIREMENT ON A GOOD INCOME.** When you're ready to retire, you can devote a few hours a day to this work. Live and work anywhere you please.
- NO PREVIOUS EXPERIENCE OR TRAINING NEEDED.** We tell you what you need to know, in plain English and clear pictures.

If you're like so many men today, you've been "hankering" to start "a little home business of your own." In spare time at first, then maybe full-time later on. Something you'd enjoy — and that pays well. Something that fills an existing need in your neighborhood or town — that "sells itself," without any high pressure arguments — that doesn't take a big investment or elaborate equipment.

This is it — Servicing Electrical Appliances! Now is the perfect time to get into it. Sales of electrical appliances have skyrocketed. Look how YEARLY SALES have risen since 1950: Coffee Makers — from 900,000 to 4,750,000. Room Air Conditioners — from 200,000 to 1,800,000. Clothes Dryers — from 318,000 to 1,425,000. Floor Polishers — from 240,000 to 1,090,000. No wonder that men who know how to service appliances properly are making \$3 to \$5 an hour — in spare time or full time!

**Your Skill Always in Demand  
— "Set Up Shop" Anywhere**

People need their appliances fixed in good times or bad. Once word gets around that you are trained to service them, you'll have plenty of work.

Your training costs less than 20¢ a day. And you need only the few basic tools you may already have — and an Appliance

Tester which we provide at no extra charge. You can work anywhere — in a corner of your basement or garage, even on the kitchen table. If you like, you can open up your own shop, have others work for you. And you can save money by fixing your own appliances.

**FREE BOOK  
and Sample Lesson**

Our 24-page Free Book tells how you can "cash in" on America's "Electrical Appliance Boom" — the money our students are making, what they say about us.

Free Sample Lesson shows how simple and clearly illustrated our instruction is — how it can quickly prepare you for a profitable future in this big field. Mail coupon, letter, or postcard to: National Radio Institute, Dept. K13, Washington 16, D.C. (No obligation — and no salesman will call on you.)



**EARN WHILE YOU LEARN**

with this  
**APPLIANCE  
TESTER**  
— Yours  
at No Extra  
Charge



Your NRI Course comes complete with all the parts to assemble a sturdy, portable Appliance Tester that helps you earn while you learn. Easy-to-follow manual tells how to assemble and use the Tester right away. Locate faulty cords, short circuits, poor connections, etc. in a jiffy; find defects in house wiring; measure electricity used by appliances; many other uses.

With this Tester you save time and make money by doing jobs quicker, making sure appliances operate correctly after repairs.

**NATIONAL RADIO INSTITUTE  
Dept. K13, Washington 16, D.C.**

Please send me Free Book about your Electrical Appliance Repair Course and a free Sample Lesson. I am particularly interested in:

- Spare Time Earnings     Business of My Own     Better Job  
I understand there is no obligation on my part, and no salesman will call.

Name .....

Address .....

City ..... Zone ..... State .....

Accredited Member National Home Study Council

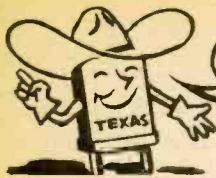

Send for NEW  
FREE CATALOG #962  
with oscillator  
circuits

## Citizen Band Class "D" Crystals

### CITIZEN BAND CLASS "D" CRYSTALS

3rd overtone — .005% tolerance — to meet all FCC requirements. Hermetically sealed HC6/U holders. 1/2" pin spacing. .050 pins. (Add 15c per crystal for .093 pins).

**\$2.95**  
EACH

All 23 channels in stock: 26.965, 26.975, 26.985, 27.005, 27.015, 27.025, 27.035, 27.055, 27.065, 27.075, 27.085, 27.105, 27.115, 27.125, 27.135, 27.155, 27.165, 27.175, 27.185, 27.205, 27.215, 27.225, 27.255.

Matched crystal sets for ALL CB units (Specify equipment make and model numbers) **\$5.90 per set**

### CRYSTALS IN HC6/U HOLDERS

<b>SEALED OVERTONE</b>	.486 pin spacing — .050 diameter — .005% tolerance	
	15 to 30 MC	\$3.85 ea.
	30 to 40 MC	\$4.10 ea.
	40 to 65 MC	\$4.50 ea.
<b>FUNDAMENTAL FREQ. SEALED</b>	From 1400 KC to 2000 KC .005% tolerance	\$5.00 ea.
	From 2000 KC to 10,000 KC, any frequency, .005% tolerance	\$3.50 ea.
<b>RADIO CONTROL</b>	Specify frequency. .05 pins spaced 1/2" (Add 15c for .093 pins).	\$2.95 ea.

### QUARTZ CRYSTALS FOR EVERY SERVICE

All crystals made from Grade "A" imported quartz—ground and etched to exact frequencies. Unconditionally guaranteed! Supplied in:

<b>FT-243 holders</b> Pin spacing 1/2" Pin diameter .093	<b>MC-7 holders</b> Pin spacing 3/4" Pin diameter .125
<b>CRIA/AR holders</b> Pin spacing 1/2" Pin diameter .125	<b>FT-171 holders</b> Pin spacing 3/4" Banana pins

<b>MADE TO ORDER CRYSTALS</b>	Specify holder wanted
1001 KC to 1600 KC: .005% tolerance	\$4.50 ea.
1601 KC to 2500 KC: .005% tolerance	\$2.75 ea.
2501 KC to 9000 KC: .005% tolerance	\$2.50 ea.
9001 KC to 11,000 KC: .005% tolerance	\$3.00 ea.

### Amateur, Novice, Technician Band Crystals

.01% Tolerance \$1.50 ea. — 80 meters (3701-3749 KC) 40 meters (7152-7198 KC), 15 meters (7034-7082 KC), 6 meters (8335-8650 KC) within 1 KC  
FT-241 Lattice Crystals in all frequencies from 370 KC to 540 KC (all except 455 KC and 500 KC) 50c ea.  
Pin spacing 1/2" Pin diameter .093

Matched pairs — 15 cycles \$2.50 per pair  
200 KC Crystals, \$2.00 ea.; 455 KC Crystals, \$1.25 ea.; 500 KC Crystals, \$1.25 ea.; 100 KC Frequency Standard Crystals in HC6/U holders \$4.50 ea.; Socket for FT-243 Crystal 15c ea.; Dual Socket for FT-243 Crystals, 15c ea.; Sockets for MC-7 and FT-171 Crystals 25c ea.; Ceramic Socket for HC6/U Crystals 20c ea.

ENGINEERING SAMPLES and small quantities for prototypes now made at either Chicago or Fort Myers plants with 24 hour service. IN CHICAGO, PHONE GLadstone 3-3555

IF YOUR PARTS DEALER DOESN'T STOCK Texas Crystals, order direct and send us his name.

TERMS: All items subject to prior sale and change of price without notice. All crystal orders must be accompanied by check, money order or cash with payment in full.

RUSH YOUR ORDER NOW TO

# TEXAS CRYSTALS

Div. of Whitehall Electronics Corp., Dept. E-93  
1000 Crystal Drive, Fort Myers, Florida Phone WE 6-2100

FOR SHIPMENT VIA FIRST CLASS MAIL AT NO EXTRA COST ATTACH THIS ADVT. TO YOUR ORDER!

# ELECTRONICS ILLUSTRATED

By the Publishers of MECHANIX ILLUSTRATED

editor **ROBERT G. BEASON**  
feature editor **Richard A. Flanagan**  
technical editor **Robert D. Freed**  
art editor **Lou Rubsamen**  
editorial assistant **Linda R. Grossman**  
production editor **Rosanne Walsh**  
advertising mgr. **John F. Webster**

### CONTRIBUTING EDITORS

amateur radio **Robert Hertzberg, W2DJJ**  
citizens band **Len Buckwalter, KBA4480**  
swl-dx **C. M. Stanbury II**  
special projects **Herb Friedman, W2ZLF/2W6045**  
medical electronics **R. A. Markoff, M.D.**  
audio **Harry Kolbe**  
audio **John Milder**  
audio **David Muirhead**

### EXECUTIVE STAFF

editorial director **Ralph Daigh**  
advertising director **James B. Boynton**  
art director **Al Allard**  
associate art director **Ralph Mattison**  
production director **George H. Carl**

### ADDRESSES

Editorial and Advertising Offices: 67 West 44th St., New York 36, N.Y. Subscriptions: Change of address Form 3579 to Subscription Dept., Fawcett Bldg., Greenwich, Conn.

ELECTRONICS ILLUSTRATED is published bi-monthly by Fawcett Publications, Inc., Fawcett Place, Greenwich, Conn. W. H. Fawcett, Jr., President; Gordon Fawcett, Secretary and Treasurer; Roger Fawcett, General Manager; Roscoe K. Fawcett, Circulation Director; Donald P. Hanson, Assistant General Manager.

Second-class postage paid at Greenwich, Conn., and at additional mailing offices.

Subscription price \$4 for 12 issues in U.S. and possessions and Canada. All other countries \$6 for 12 issues. Foreign subscriptions and sales should be remitted by International Money Order in U.S. funds payable at Greenwich, Conn.

Printed in U.S.A. Copyright 1963 by Fawcett Publications, Inc. Permission hereby granted to quote from this issue of this magazine on radio or television provided a total of not more than 1,000 words is quoted and credit is given to the title of the magazine and issue, as well as the statement, copyright 1963 by Fawcett Publications, Inc.



# PICK YOUR OWN SUCCESS STORY FROM THIS PAGE

These are the true stories of people who seemed trapped in routine, low-pay shaky jobs. Handicapped by lack of proper training, they couldn't get the things they wanted out of life—more money, a job they liked, security and happiness.

They are a small sample of the thousands of men and women—young and old—who turn to I. C. S. for help. Their will-to-learn plus I. C. S. training have changed the course of their lives.

Are you discouraged with your job and pay and feel you can't improve yourself because of lack of specialized education? Well, these men and women were in the same boat. With I. C. S. training, one of these success stories could be about you.

I. C. S. is the oldest and largest correspondence school. 250 courses. Business, industrial, engineering, academic, high school. One for you. Direct, job-related. Bedrock facts and theory plus practical application. Complete lesson and answer service. No skimping. Diploma to graduates.

Clip coupon here—and take your first big step to real success! I.C.S., Scranton 15, Penna.



**Wins \$3000 contest**—"After my I. C. S. courses I secured a new position," says Mr. Cecil Rhodes. "My income has more than doubled and I recently won a \$3000 sales contest."



**From clerk to Assistant Estimator**, thanks to I.C.S. "Any way you look at it," writes Mrs. Edna James, "the time and money one spends for I. C. S. Courses will be repaid a thousandfold."



**As a college graduate**, I found I. C. S. very valuable." Robert Lee took the I. C. S. Course in Advertising, is now Promotion Manager for a large corporation. "I. C. S. got me started on the way up," he says.



**Reports 20% increase in salary!** Gregory C. Johns says. "I. C. S. training gave me unlimited opportunity! I have completed one course, and am now enrolled in Practical Plumbing."

**3 FREE BOOKLETS**—a 36-page pocket-size guide to advancement, a gold mine of tips on "How to Succeed." Also a big catalog outlining opportunities in your field of interest and a sample I. C. S. lesson.

Accredited Member  
National Home Study Council

## INTERNATIONAL CORRESPONDENCE SCHOOLS I C S

Box J3723G, Scranton 15, Penna.

(In Hawaii: P. O. Box 418, Honolulu. In Canada: I. C. S. Canadian, Ltd., Montreal.)

Without cost or obligation, rush me FREE Success Kit, with 3 valuable booklets: (1) How to Succeed; (2) opportunity booklet about the field I've checked below; (3) Sample I. C. S. Lesson.

### ARCHITECTURE and BUILDING TRADES

- Air Conditioning
- Architecture
- Arch. Drawing
- Building Contracting and Estimating
- Carpentry & Millwork
- Heating
- House Planning
- Painting
- Plumbing

### ART and DESIGN

- Commercial Art
- Fashion Illustrating
- Interior Decorating
- Magazine Illustrating
- Show Card & Sign
- Painting
- Sketching and Painting

### AUTOMOTIVE

- Auto Body Rebuilding
- Auto Electric Technician
- Automobile Mechanic
- Engine (Gas & Diesel)
- Engine Tune-Up

### TRANSMISSION Specialist

- AVIATION
- Aero Engineering
- Aircraft Drafting
- Aircraft Mechanic

### BUSINESS

- Accounting
- Cost Accounting
- Public Accounting
- Bus. Administration
- Executive Training
- Marketing
- Personnel-Labor Relations
- Programming for Digital Computers
- Purchasing Agent
- Real Estate
- Salesmanship
- Sales Mgmt.
- Small Business Mgmt.
- Traffic Mgmt.

### CHEMICAL

- Analytical Chemistry
- Chem. Engineering
- General Chemistry

- Lab. Technician
- Nuclear Energy
- Plastics
- Pulp, Paper

### CIVIL ENGINEERING

- Civil Engineering
- Construction Engrg.
- Highway Engineering
- Reading Structural Blueprints
- Sanitary Engineering
- Structural Engineering
- Surveying & Mapping

### DRAFTING

- Architectural
- Electrical and Electronic
- Mechanical
- Sheet Metal

### ELECTRICAL

- Elec. Appliance Servicing
- Electrical Engineering
- Elec. Eng. Technician
- Elec. Motor Repairman
- Industrial Electronic Technician

- Industrial Telemetering
- Instrument Technician
- Practical Electrician
- Practical Lineman

### ELECTRONICS

- Automation
- Basic Electronics
- Electronic Computers
- Electronics Technician
- Hi-Fi Stereo and Sound Systems
- Industrial Electronics
- Ultrasonics

### ENGINEERING (Professional)

- Chemical
- Civil
- Electrical
- Mechanical

### ENGLISH and WRITING

- Better Business Writing
- Introductory Technical Writing
- Short Story Writing

### Practical English

- HIGH SCHOOL (Diploma)
- High School General
- High School Math
- High School Secretarial
- High School Vocational
- College Preparatory

### MECHANICAL and SHOP

- Gas and Electric welding
- Industrial Engineering
- Industrial Instrumentation
- Machine Design
- Machine Shop Practice
- Mechanical Engineering
- Reading Shop Blueprints
- Tool Design
- Toolmaking
- Safety Engineering

### SECRETARIAL

- Clerk-Typist
- Professional Secretary

### Shorthand

- Stenographic
- Typist

### STEAM and DIESEL POWER

- Boiler Inspector
- Power Plant Engineering
- Stationary Diesel Engineering
- Steam Engineering

### SUPERVISION

- Foremanship-Suprv'n
- Personnel-Lab. Rel'n's

### TV-RADIO

- Radio and TV Servicing
- Radio-Telephone License
- TV Technician
- Practical Radio-TV Engineering

### MISCELLANEOUS

- Railroad Textile
- Other (please specify)

Name \_\_\_\_\_ Age \_\_\_\_\_ Sex \_\_\_\_\_  
 Home Address \_\_\_\_\_  
 City \_\_\_\_\_ Zone \_\_\_\_\_ State \_\_\_\_\_  
 Occupation \_\_\_\_\_  
 Employed by \_\_\_\_\_ Working Hours \_\_\_\_\_ Special low rates to members of U. S. Armed Forces!

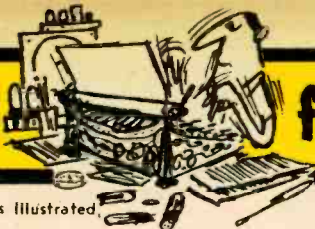

Write to: Letters Editor, Electronics Illustrated,

67 West 44th Street, New York 36, New York

## ● Idea Man

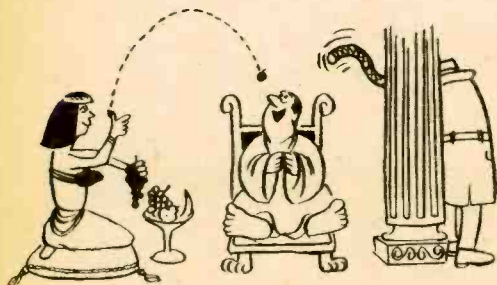

How come you didn't think of the perfect tie-in between three articles in your July issue—**FASCINATING FIBER OPTICS, CINEMA SOUND, and WANT TO BE A COUNTERSPY?** Here's how I would have done it: You get a full-fledged counterspy equipped with the latest model fiberscope sneaking around the set when Cleopatra was being filmed to find out if what they've been saying really is true. Can't imagine how you happened to miss this one!

Robert Harris  
Jackson Heights, N. Y.

## ● Biter Truth

Your statement in **A RADIO PROPAGANDA HANDBOOK** (May EI) that France hasn't recovered from the divisive effects of Hitler's propaganda is harsh. I'd rather think it not true, but I'm afraid it is. Look what has happened there of late, even with the Large Eminence at the helm.

Jean Barton  
Portland, Ore.

## ● Involved

I have a suggestion to clean up CB: log books. What do you think?

George C. Loud  
Eastport, Me.

*Billie Sol Estes proved what you can do with books, George.*

## ● Resolved

I'm not a CBER, but I've spent some time trying to figure a way to clean up the band. Here's my solution: Buy all your CB friends casting rods for Christmas and a sign for the shack: **Gone Fishing.**

Lloyd F. Vickery  
Winfield, Kan.

## ● Dual Purpose

The **ROBOT GUNSLINGER** (July EI) is for me. Now I can practice in private and show off in public.

Gregg Hanson  
Scarsdale, N. Y.

*You sound mighty confident, Gregg. But if things don't go quite your way, you can always stand the ugly critter at your front door to ward off burglars.*

## ● Caveman Espionage



In **WANT TO BE A COUNTERSPY?** (July EI) you trace our electronic-age cloak-and-dagger boys way back to the caveman. Since I have a thing on reconstructed dinosaurs and whatnot, I keep wondering what those prehistoric sleuths might have looked like.

Jack Masters  
Los Angeles, Calif.

*It's anyone's guess, but here's what our cartoonist came up with.*

[Continued on page 8]



# You Have Aptitude for Electronics

## ... Why Not Make It Your Career?

Get the Training You Need at COYNE then Step into High Salary Position in the Branch of Electronics You Like Best!



No matter what branch of electronics you prefer, you'll have no trouble landing just the job you want—provided you get the right kind of training.

Without this training you'll not get far. With it most of our graduates start right out with a beginner's salary of \$100 a week or more. Once you've started, you can move ahead fast to more important jobs that pay as much as \$14,000 a year.

### AIRLINES NEED MEN

Who pays this kind of money to beginners? You'd be surprised at how many fine openings there are for Coyne trained men—in small towns and big cities everywhere all year 'round. For example, the airlines are always on the lookout for men who can fill jobs as radio mechanics, aircraft electricians and electronic systems technicians, to mention only a few. From a good starting salary, a trained man can quickly boost his income to \$8,000 a year. And that is by no means the limit.



And the same thing can be said of salaries. These radio and TV manufacturers are expanding into new fields and are growing at an unheard of rate. Any man with ability and ambition can grow with them, earn promotion after promotion. With these promotions come frequent pay raises as he continues to step from one important job to one still more important.

### OR, YOUR OWN BUSINESS

Hundreds of graduates have gone to work for former graduates, servicing TVs and Radios, Air Conditioners, Refrigerators, other household appliances—then, after learning business methods have branched out and started their own shops. Others have started their own shops immediately upon graduating. Profits as independent business men, after taxes and other business expenses, are as high as \$10,000 to \$20,000 a year.

These are not dreams. They are realities. But don't try to break into Electronics "on your own." You can save years of struggle and disappointment by first getting the necessary training at the great shop-laboratories of the Coyne School in Chicago.



### THE MISSILE INDUSTRY

Another field where employers are clamoring for trained men is the missile industry—an industry growing so fast as to be almost unbelievable. Here there is a constantly increasing need for trained men. Every day these companies are hiring electronic technicians, laboratory technicians, electronic assembly inspectors and field service engineers. A field service engineer with minimum experience can easily demand and get \$8,000 a year—plus extra compensation in the form of living expenses and incentive pay.

### COMPUTERS—Data Processing

A tremendous field. Men with basic electronic training are welcomed by manufacturers to receive further training—while on salary in—the operation and maintenance of their specialized equipment. Opportunities unlimited. No ceiling on salaries.

### TV and RADIO Manufacturers

Perhaps the biggest opportunities of all are to be found with the large electronic manufacturers. With these giants, job opportunities are practically without limit.

### CHICAGO—THE NATION'S ELECTRONICS CENTER

Don't get the idea that coming to Chicago to learn with Coyne is a costly or complicated undertaking. Nothing could be further from the truth. With modern transportation, Chicago is "close by" no matter where you live. High living costs? Not at all. We find a place for you to live—a place where, in many cases, your room and board cost no more than you would pay at home. And don't forget that you have every opportunity to earn money while you learn. Our employment department helps you get a part time job if you need extra money.

And think of the training you will get! Coyne is the oldest, largest and most completely equipped Resident School of its kind. And it is right in the heart of America's electronics center! Best of all, you can start your training with only a small down payment. Then take care of the balance after you graduate!

### FREE CATALOG

You've just read a bare outline of what Coyne offers to men who want to get into electronics.

You'll find the complete, fascinating story in our big 48-page book which will be mailed free of charge when you return the coupon below or send your name in on a postcard today.



### Coyne Electrical School

Chartered as an Educational Institution not for Profit  
Dept. 63-A Chicago 7, Illinois

Clip OUT AND MAIL NOW!

COYNE ELECTRICAL SCHOOL, Dept. 63-A  
1501 W. Congress Parkway, Chicago 7, Ill.

Send me your big 48 page Book "Your Opportunities in Electronics" and complete information about getting training for a high paying position in electronics.

Name..... Age.....

Address..... Phone.....

City..... RR No. or Zone..... State.....



FREE!

Interested in Amateur / Shortwave Radio?

# NEW RECEIVER GUIDE

## FREE from National

Just out! National's complete receiver guide. All the facts and specs you need to choose the very best in amateur / shortwave equipment. Describes, in complete detail all of the superb equipment built by National — including:



NC-190

Double-conversion receiver with National's exclusive Dial Selector! Product detector and ferrite filter selectivity, special AVC, 60:1 Dial Vernier for unequalled tuning ease. \$219.95.



NC-105

New all-band receiver designed exclusively for the shortwave listener, novice, and Hi-Fi fan. S meter Q multiplier. Exclusive tuner output for use with your Hi-Fi system. \$119.95. NC-105W in handsome walnut case. \$139.95.



NC-60

Perfect choice for the beginning shortwave listener. This superhelodyne all-band receiver with giant electrical bandspread and built-in speaker. Thousands in use throughout the world. \$59.95.



NC-140

Brand new! Double-conversion all-band receiver with National's famous Dial Selector and Q multiplier selectivity. RF Stage and S meter. No other receiver compares in value. \$189.95.



Rush, **Me** **Free** **Your** **Complete** **Guide** **To** **National** **Receivers!**

**NATIONAL RADIO COMPANY, INC.**  
Dept. EI-9

A Wholly Owned Subsidiary of National Company, Inc.  
Melrose 76, Massachusetts

Name

Address

City  State

For speed or for show  
**BUILDING AND RACING HOT RODS**  
for top information

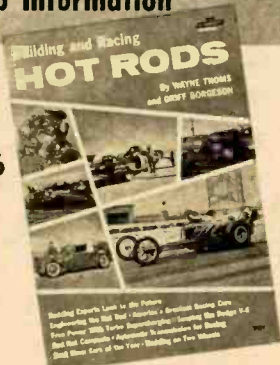

No. 526

75¢ at your newsstand—  
or send 75¢ plus 10¢ postage to Fawcett Publications, Greenwich, Conn. Specify book by title and number.

# FEEDBACK

Continued from page 6

## ● Transformers

MEET THE AUDIO TRANSFORMER in the May issue contains a lot of good information, but puts too much emphasis on the size of the audio transformer saying, in effect, "the larger the better." We have seen equipment with oversized, low-grade transformers which tries to take advantage of the prevalent belief that size denotes quality. Large cans sometimes enclose small transformers for the same reason. In actual fact, a transformer should be judged by its performance rather than its size.

David Hafler  
President  
Dynaco, Inc.

## ● Appreciation



YAK-YAK-YAK

Thanks for the AUTOMATIC SLIDE PROGRAMMER (July EI), although it nearly upset our family applectart. My wife wanted to buy a dishwasher; I wanted a slide projector and a tape recorder. I suspect she really didn't mind losing—she stars in all the productions.

Harry Mills  
Jacksonville, Fla.

## ● Variety

Keep the *all-ham*, SWL or CB issues. Give me ones like the July EI—all good.  
Scott Burns  
Cleveland, Ohio



# 3 More Big Training Advantages



## DeVRY TECH Exclusive!

WITH TRANSISTORIZED  
METER . . . PLUS NEW "MODULAR  
CIRCUITS" TO BUILD  
AT HOME!

Now Prepare for GOOD  
JOB OPPORTUNITIES IN  
ELECTRONICS Faster—with

1. **METER** — Transistorized, Portable, AC-DC Multimeter
2. **SCOPE** — 5-inch New Streamlined Commercial-Type Oscilloscope
3. **ELECTRO-LAB\*** — For 3-Dimension Circuit Building

To help you get ready F-A-S-T-E-R . . . and THOROUGHLY . . . for good-paying job opportunities in the fast growing Electronics field, DeVry Technical Institute now presents the newest and finest training advantages in its over 30 years of experience. Now . . . AT HOME . . . in your spare time, you prepare with "industry-type" home laboratory equipment. To provide real PRACTICAL EXPERIENCE, you build a quality Transistorized Meter and a 5-inch industrial-type Oscilloscope . . . work with small, 3-dimensional circuits on DeVry's new Design Console . . . use highly instructive home training movies . . . and follow up-to-date lessons with many time-saving fold-out diagram sheets.

Little wonder DeVry men qualify for such fine opportunities in Space-Missile Electronics, Automation, Computer Work, Radio-TV, Industrial Controls, and other fields.

You learn PRACTICAL techniques important in today's Space Age industry, because you build many compact circuits with the streamlined Electro-Lab, using exclusive solderless "modular connectors." You perform over 300 construction and test procedures in all! Your self-built test equipment has function-grouped controls, meter scales color-keyed to the panel markings—much like instruments used on today's jobs. What's so important, the home laboratory and the test equipment are YOURS TO KEEP!



OSCILLOSCOPE

DESIGN  
CONSOLE



METER

### INDUSTRY NEEDS TRAINED MEN

Through this remarkable 3-way method, DeVry Tech has helped thousands of ambitious men prepare for good jobs or their own profitable full-time or part-time service shops. It is the newest in a long series of PRACTICAL training aids that we have pioneered and developed in more than three decades of experience. Sound interesting? Then see how DeVry Tech may help YOU. Mail the coupon today.

### From RADIO TO SPACE- MISSILE ELECTRONICS

DeVry's training goes all the way from radio repair . . . to space-missile electronics. That's the range of subjects covered in its programs AT HOME or in its well-equipped training centers in Chicago and Toronto. You learn up-to-date techniques, working with new equipment, modern texts, movies—one of today's finest combinations of training equipment . . . geared for RESULTS!

### EMPLOYMENT SERVICE

When you complete the program, DeVry's efficient Employment Service is ready to help you get started. There is no extra charge—ever—for this aid. ACCREDITED MEMBER, NATIONAL HOME STUDY COUNCIL

**DeVRY** TECHNICAL  
INSTITUTE  
CHICAGO • TORONTO

\*Trademark ©

### MAIL COUPON FOR FREE FACTS

DEVRY TECHNICAL INSTITUTE  
4141 Belmont Ave., Chicago 41, Ill., Dept. E1-9-T 2082

Please give me your two free booklets, "Pocket Guide to Real Earnings" and "Electronics in Space Travel"; also include details on how to prepare for a career in Electronics. I am interested in the following opportunity fields (check one or more):

- |  |   |
|--|---|
| <input type="checkbox"/> Space & Missile Electronics | <input type="checkbox"/> Communications         |
| <input type="checkbox"/> Television and Radio        | <input type="checkbox"/> Computers              |
| <input type="checkbox"/> Microwaves                  | <input type="checkbox"/> Broadcasting           |
| <input type="checkbox"/> Radar                       | <input type="checkbox"/> Industrial Electronics |
| <input type="checkbox"/> Automation Electronics      |   |

Name \_\_\_\_\_ Age \_\_\_\_\_

Address \_\_\_\_\_ Apt. \_\_\_\_\_

City \_\_\_\_\_ Zone \_\_\_\_\_ State \_\_\_\_\_

Check here if you face military service.

Canadian residents: Write DeVry Tech of Canada, Ltd.  
970 Lawrence Avenue West, Toronto 19, Ontario

**PIE PLATE** . . . An aluminum umbrella atop one of the world's most powerful electron diffraction cameras plays watchdog to the 250,000 volts of electricity that powers the device. Used for studying the atomic make-up of matter, the camera generates electrons, accelerates them to 90 per cent of the speed of light, then beams them onto the sample to be studied. As the electrons pass through the material, they spread

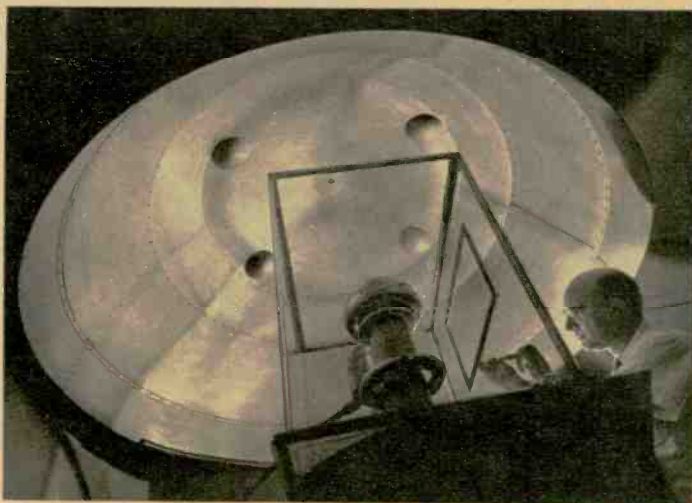

apart slightly from their straight paths and show up as spots or circles of light. The patterns they produce on a film or fluorescent screen are as characteristic of a particular material as the individual fingerprints of a human being. Designed and constructed by engineers at Westinghouse, the new instrument is some five times more powerful than the usual electron diffraction camera. It is expected to be particularly valuable in the company's research on oxidation and corrosion—both surface phenomena and ideal for study with electron diffraction techniques.

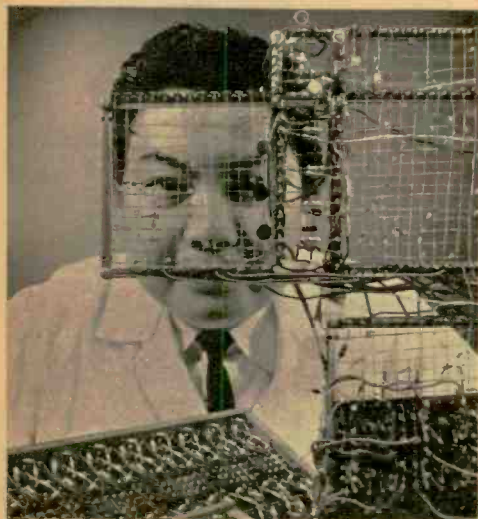

**Moon Bound** . . . This network of wires and components is part of a computer that may guide Uncle Sam straight to his man—in the moon, that is. Developed by Republic Aviation, the computer will automatically fire course-correcting rockets should a moon-bound spaceship accidentally stray off course.



**Lasers** . . . it seems, are in the news as much as the Russians these days. This overgrown eyecup by RCA isn't a laser, but it does detect laser light beams and convert them into electrical energy. Called a lasecon, it already has sorted out several hundred different TV signals carried on a single laser beam.



# BUILD 20 RADIO

Reg. U.S.  
Pat. Off.

## CIRCUITS AT HOME

with the New  
**PROGRESSIVE RADIO "EDU-KIT"**®

only  
**\$26.95**



**A Practical Home Radio Course**

**Now Includes**

- ★ 12 RECEIVERS
- ★ 3 TRANSMITTERS
- ★ SQ. WAVE GENERATOR
- ★ SIGNAL TRACER
- ★ AMPLIFIER
- ★ SIGNAL INJECTOR
- ★ CODE OSCILLATOR

- ★ No Knowledge of Radio Necessary
- ★ No Additional Parts or Tools Needed
- ★ EXCELLENT BACKGROUND FOR TV
- ★ SCHOOL INQUIRIES INVITED
- ★ Sold in 79 Countries

**YOU DON'T HAVE TO SPEND  
HUNDREDS OF DOLLARS FOR A RADIO COURSE**

The "Edu-Kit" offers you an outstanding PRACTICAL HOME RADIO COURSE at a rock-bottom price. Our Kit is designed to train Radio & Electronics Technicians, making use of the most modern methods of home training. You will learn radio theory, construction practice and servicing. THIS IS A COMPLETE RADIO COURSE IN EVERY DETAIL.

You will learn how to build radios, using regular schematics; how to wire and solder in a professional manner; how to service radios. You will work with the standard type of punched metal chassis as well as the latest development of Printed Circuit chassis.

You will learn the basic principles of radio. You will construct, study and work with RF and AF amplifiers and oscillators, detectors, rectifiers, test equipment. You will learn and practice code, using the Progressive Code Oscillator. You will learn and practice trouble-shooting, using the Progressive Signal Tracer, Progressive Signal Injector, Progressive Dynamic Radio & Electronics Tester, Square Wave Generator and the accompanying instructional material.

You will receive training for the Novice, Technician and General Classes of F.C.C. Radio Amateur Licenses. You will build 20 Receiver, Transmitter, Square Wave Generator, Code Oscillator, Signal Tracer and Signal Injector circuits, and learn how to operate them. You will receive an excellent background for television, Hi-Fi and Electronics.

"Edu-Kit" is the product of modern educational principle of "Learn by Doing." Therefore you construct, learn schematics, study theory, practice trouble-shooting—all in a closely integrated program designed to provide an easily-learned, thorough and interesting background in radio.

You begin by examining the various radio parts of the "Edu-Kit." You then learn the function, theory and wiring of these parts. Then you build a simple radio. With this first set you will enjoy listening to regular broadcast stations, learn theory, practice testing and trouble-shooting. Then you build a more advanced radio, learn more advanced theory and techniques. Gradually, in a progressive manner, and at your own rate, you will find yourself constructing more advanced multi-tube radio circuits, and doing work like a professional Radio Technician.

Included in the "Edu-Kit" course are twenty Receiver, Transmitter, Code Oscillator, Signal Tracer, Square Wave Generator and Signal Injector circuits. These are not unprofessional "breadboard" experiments, but genuine radio circuits, constructed by means of professional wiring and soldering on metal chassis, plus the new method of radio construction known as "Printed Circuitry." These circuits operate on your regular AC or DC house current.

You will receive all parts and instructions necessary to build 20 different radio and electronics circuits, each guaranteed to operate. Our Kits contain tubes, tube sockets, variable, electrolytic, mica, ceramic and paper dielectric condensers, resistors, tie strips, hardware, tubing, punched metal chassis, Instruction Manuals, hookup wire, solder, selenium rectifiers, coils, volume controls and switches, etc.

In addition, you receive Printed Circuit materials, including Printed Circuit chassis, special tube sockets, hardware and instructions. You also receive a useful set of tools, a professional electric soldering iron, and a self-powered Dynamic Radio and Electronics Tester. The "Edu-Kit" also includes Code Instructions and the Progressive Code Oscillator, in addition to F.C.C.-type Questions and Answers for Radio Amateur License training. You will also receive lessons for servicing with the Progressive Signal Tracer and the Progressive Signal Injector, a High Fidelity Guide and a Quiz Book. You receive Membership in Radio-TV Club, Free Consultation Service, Certificate of Merit and Discount Privileges. You receive all parts, tools, instructions, etc. Everything is yours to keep.

The "Edu-Kit" is the foremost educational radio kit in the world, and is universally accepted as the standard in the field of electronics training. The "Edu-Kit" uses the modern educational principle of "Learn by Doing." Therefore you construct, learn schematics, study theory, practice trouble-shooting—all in a closely integrated program designed to provide an easily-learned, thorough and interesting background in radio.

You begin by examining the various radio parts of the "Edu-Kit." You then learn the function, theory and wiring of these parts. Then you build a simple radio. With this first set you will enjoy listening to regular broadcast stations, learn theory, practice testing and trouble-shooting. Then you build a more advanced radio, learn more advanced theory and techniques. Gradually, in a progressive manner, and at your own rate, you will find yourself constructing more advanced multi-tube radio circuits, and doing work like a professional Radio Technician.

Included in the "Edu-Kit" course are twenty Receiver, Transmitter, Code Oscillator, Signal Tracer, Square Wave Generator and Signal Injector circuits. These are not unprofessional "breadboard" experiments, but genuine radio circuits, constructed by means of professional wiring and soldering on metal chassis, plus the new method of radio construction known as "Printed Circuitry." These circuits operate on your regular AC or DC house current.

You will receive all parts and instructions necessary to build 20 different radio and electronics circuits, each guaranteed to operate. Our Kits contain tubes, tube sockets, variable, electrolytic, mica, ceramic and paper dielectric condensers, resistors, tie strips, hardware, tubing, punched metal chassis, Instruction Manuals, hookup wire, solder, selenium rectifiers, coils, volume controls and switches, etc.

In addition, you receive Printed Circuit materials, including Printed Circuit chassis, special tube sockets, hardware and instructions. You also receive a useful set of tools, a professional electric soldering iron, and a self-powered Dynamic Radio and Electronics Tester. The "Edu-Kit" also includes Code Instructions and the Progressive Code Oscillator, in addition to F.C.C.-type Questions and Answers for Radio Amateur License training. You will also receive lessons for servicing with the Progressive Signal Tracer and the Progressive Signal Injector, a High Fidelity Guide and a Quiz Book. You receive Membership in Radio-TV Club, Free Consultation Service, Certificate of Merit and Discount Privileges. You receive all parts, tools, instructions, etc. Everything is yours to keep.

### PRINTED CIRCUITRY

At no increase in price, the "Edu-Kit" now includes Printed Circuitry. You build a Printed Circuit Signal Injector, a unique servicing instrument that can detect many Radio and TV troubles.

This revolutionary new technique of radio construction is now becoming popular in commercial radio and TV sets.

A Printed Circuit is a special insulated chassis on which has been deposited a conducting material which takes the place of wiring. The various parts are merely plugged in and soldered to terminals.

Printed Circuitry is the basis of modern Automation Electronics. A knowledge of this subject is a necessity today for anyone interested in Electronics.

### UNCONDITIONAL MONEY-BACK GUARANTEE

#### ORDER DIRECT FROM AD—RECEIVE FREE BONUS RESISTOR AND CONDENSER KITS WORTH \$7

- Send "Edu-Kit" postpaid. I enclose full payment of \$26.95.
- Send "Edu-Kit" C.O.D. I will pay \$26.95 plus postage.
- Rush me FREE descriptive literature concerning "Edu-Kit."

Name .....

Address .....

### PROGRESSIVE "EDU-KITS" INC.

1186 Broadway, Dept. 549AE, Hewlett, N. Y.

Training Electronics Technicians Since 1946

### FREE EXTRAS

- SET OF TOOLS
- SOLDERING IRON
- ELECTRONICS TESTER
- PLIERS-CUTTERS
- ALIGNMENT TOOL
- WRENCH SET
- VALUABLE DISCOUNT CARD
- CERTIFICATE OF MERIT
- TESTER INSTRUCTION MANUAL
- HIGH FIDELITY GUIDE & QUIZZES
- TELEVISION BOOK & RADIO
- TROUBLE-SHOOTING BOOK
- MEMBERSHIP IN RADIO-TV CLUB:
- CONSULTATION SERVICE & FCC
- AMATEUR LICENSE TRAINING
- PRINTED CIRCUITRY

### SERVICING LESSONS

You will learn trouble-shooting and servicing in a progressive manner. You will practice repairs on the sets that you construct. You will learn symptoms and causes of trouble in home, portable and car radios. You will learn how to use the professional Signal Tracer, the unique Signal Injector and the dynamic Radio & Electronics Tester. While you are learning in this practical way, you will be able to do many a repair job for your friends and neighbors, and charge fees which will far exceed the price of the "Edu-Kit." Our Consultation Service will help you with any technical problems you may have.

### FROM OUR MAIL BAG

J. Stataitis, of 25 Poplar Pl., Waterbury, Conn., writes: "I have repaired several sets for my friends, and made money. The 'Edu-Kit' paid for itself. I was ready to spend \$240 for a course, but I found your ad and sent for your Kit."

Ben Valerio, P. O. Box 21, Magna, Utah: "The Edu-Kits are wonderful. Here I am sending you the questions and also the answers for them. I have been in Radio for the last seven years, but like to work with Radio Kits, and like to build Radio Testing Equipment. I enjoyed every minute I worked with the different kits; the Signal Tracer works fine. Also like to let you know that I feel proud of becoming a member of your Radio-TV Club."

Robert L. Shuff, 1534 Monroe Ave., Huntington, W. Va.: "Thought I would drop you a few lines to say that I received my Edu-Kit, and was really amazed that such a bargain can be had at such a low price. I have already started repairing radios and phonographs. My friends were really surprised to see me get into the swing of it so quickly. The Troubleshooting Tester that comes with the Kit is really swell, and finds the trouble, if there is any to be found."



Pamphlets, booklets, flyers, application notes and bulletins available free or at low cost.

**The Box With No Bottom** suggests the tube carton, which has contained an endless variety of tubes through the years. This booklet discusses recent developments in the field—those in receiving tubes and photoconductive cells, among others. It's free from the General Electric Co., Owensboro, Ky.

A series of **lessons in binary logic**—the reasoning of digital computers—is available without cost to people in electronics. Requests, which must be on company letterhead, go to Mr. Randy Walthers, Frontier Electronics Div., International Resistance Co., 4600 Memphis Ave., Cleveland 9, Ohio.

Want to **Lower the Cost of Fun With Tape Recording?** A little pamphlet by Sarkes Tarzian might show you the

way. It includes tips on how to care for tapes and points out the many uses of a tape recorder. The booklet is free from the company's Magnetic Tape Div., East Hillside Dr., Bloomington, Ind.

**All About High Fidelity and Stereo** explains the principles of monaural and stereophonic hi-fi, then goes on to suggest ways of setting up a sound system. Each component is discussed separately with a special section devoted entirely to kits. The booklet is available for 50 cents postpaid from Allied Radio Corp., 100 N. Western Ave., Chicago 80, Ill.

The hobbyist may not have time for a **microwave tube booklet** in his workshop, but it should be an enlightening piece of armchair reading. This pamphlet by Varian Associates gives specifications on klystrons, traveling-wave tubes and magnetrons—all used in radar operations. For a free copy write the company's Tube Div. Advertising Dept., 611 Hansen Way, Palo Alto, Calif.

Over 200 manufacturers are represented in Arrow Electronic's new **buyer's guide** free at Arrow distributors.

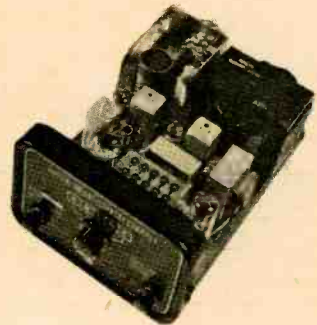

*General's*  
RUGGED  
DEPENDABLE

VS2

- \* Quality
- \* Performance
- \* Dependability

Write for complete technical manual and brochures or see your dealer.

**GENERAL RADIOTELEPHONE COMPANY**

15 Watt Construction

Under present rules part 19.32 the FCC does not provide for more than five (5) watt input in the Citizens Radio Service (26,965-27,225 MC Band)

Dept. 4 3501 West Burbank Boulevard, Burbank, California

Phone: 849-6891 Area Code: 213



# Get Your First Class Commercial F.C.C. License In a Hurry — Or at Your Own Pace!

## Is the Course Proven?

A high percentage of Grantham resident students get their 1st class FCC licenses in the short period of 12 or even 8 weeks from the time they start the course. Many others choose *home study*, completing the course and getting their licenses at their own convenience.

## Is the Course Complete?

Not only does the Grantham course cover all required subject matter completely; it grows and changes and expands in phase with change and expansion in the electronics field generally. With the Grantham course, you are assured of modern, up-to-the-minute instruction.

## Is the Course "Padded"?

The streamlined Grantham course is designed specifically to prepare you to pass FCC examinations and examinations given by electronics firms. What you need to know to achieve these goals, you are taught completely and in detail. The course is not "padded" with information you will not need.

## Is It a "Coaching Service"?

The weakness of the "coaching service" or "Q & A" method employed by some schools and individuals is that it presumes the student already has a knowledge of basic electronics.

The Grantham course is presented from the viewpoint that you have no prior knowledge of the subject; nothing is taken for granted where your training is concerned. We "begin at the beginning" and progress in a logical, step-by-step manner from one point to another, with the necessary math taught as an integral part of the course. Every subject is covered simply and in detail; the emphasis is on making the subject easy to understand.

With each lesson you receive an FCC-type test so that you can discover after each lesson just which points you do not understand and clear them up as you go along. In addition to the lesson tests, ten comprehensive Review Exams are given throughout the course.

For further details concerning F.C.C. licenses and our training, send for our FREE booklet



## GRANTHAM

## SCHOOL OF ELECTRONICS



Train through home study or at one of our four convenient resident locations shown below:

1505 N. Western Ave.  
Los Angeles 27, Calif.  
(Phone: HO 7-7727)

408 Marion Street  
Seattle 4, Wash.  
(Phone: MA 2-7227)

3123 Gillham Road  
Kansas City 9, Mo.  
(Phone: JE 1-6320)

821 - 19th Street, N.W.  
Washington 6, D. C.  
(Phone: ST 3-3614)

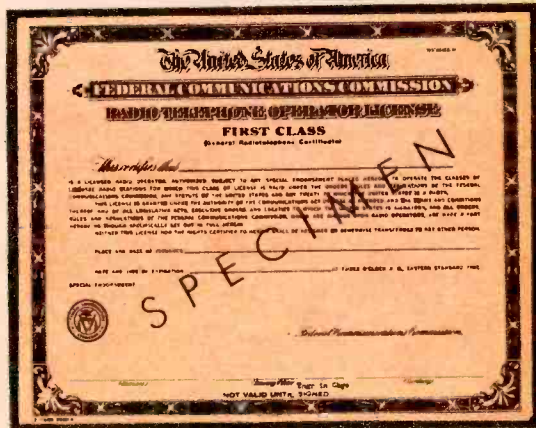

## Is the School Accredited?

Grantham School of Electronics is accredited by the Accrediting Commission of the National Home Study Council.

## Is It a "Memory Course"?

Grantham School has never endorsed the "memory" or "learn by rote" approach to preparing for FCC license exams. This approach may have worked in the early days of broadcasting, to the extent that a man could get his license that way; but, Heaven help the employer who expected this man to be able to demonstrate abilities implied by possession of the license!

Fortunately for all concerned, it is no longer possible for a man to pass FCC exams by spilling out memorized information which is essentially meaningless to him. Advances in the field of electronics—and the desire of the FCC to have the license really mean something — have caused upgrading of the exams to the point where only the man who is able to *understand and reason* electronics can acquire the 1st class FCC license.

Learn to thoroughly understand basic electronics from the school whose graduates are successfully employed by virtually every major electronics firm in the United States. Why not join them through Grantham training?

(Mail in envelope or paste on postal card)

TO: GRANTHAM SCHOOL OF ELECTRONICS  
NATIONAL HEADQUARTERS OFFICE  
1505 N. Western Ave., Hollywood 27, Calif.

Gentlemen:

Please send me your free booklet telling how I can get my commercial F.C.C. license quickly. I understand there is no obligation

Name \_\_\_\_\_ Age \_\_\_\_\_

Address \_\_\_\_\_

City \_\_\_\_\_ State \_\_\_\_\_

I am interested in:

Home Study,  Resident Classes 38-P



# AMATEUR MARKETPLACE



The KT-200 general-purpose communications receiver covers 550 kc through 31 mc. This AM/CW superhet is in semi-kit form, has 5-meter and BFO. Semi-kit, \$64.50; wired (HE-10), \$79.95. Lafayette Radio, Syosset, N. Y.



The SW-240 is a 3-band SSB/AM/CW transceiver for AC or battery operation. Transmits lower sideband SSB on 80 and 40 meters, upper-sideband SSB on 20. Peak input is 240 watts on SSB. Swan, Oceanside, Calif.



Collins' 755-3 is an SSB/CW/RTTY ham receiver. Bands are covered in spread-out 200-kc segments. Crystal filter for CW. \$680. Collins Radio, Cedar Rapids, Iowa.



Lafayette's HE-50A 10-meter transceiver has a dual power supply for 117 VAC and 12 VDC. The 12-watt unit features PTT ceramic mike, noise limiter, choice of 3 crystals. \$114.95. Lafayette Radio, Syosset, N. Y.

# MICRO

ELECTRON TUBE

FABULOUS LOW PRICES!

LARGE, SELECT STOCKS!

DEPENDABLE, FAST SERVICE!

# 37¢ ea.

# \$35 PER HUNDRED ASSTD

## FOR ANY TUBE LISTED

See Selection Tubestol

ALL TUBES SENT POSTAGE PAID

Please send 35¢ handling for orders under \$5. Send 75¢ deposit on C.O.D. orders. Send approximate postage on Canadian and foreign orders.

# MICRO

ELECTRON TUBE CO. Dept. EI-9 P. O. Box 55 Park Sta., Paterson 3, N. J.

- Each and every tube is tested in our own laboratory for mutual conductance and life test.
- We guarantee FREE replacement for one year of any tube purchased from us which fails to function efficiently under any or all operating conditions. Prompt refunds are made on any defective merchandise.
- The advertised tubes are not necessarily new, but may be electrically perfect factory seconds or used tubes—each is clearly so marked.

6A2	6X2	6D9G	6SF5	724	10000C
6AV7	6Y30T	6E4	6SF7	12A5	1076
6B7	6Y30T	6E5	6S7	12A5S	1076
6C1	6Y30T	6E6	6S7	12A7	244
6C2	6Y30T	6E7	6S7	12A7T	244
6C3	6Y30T	6E8	6S7	12A8	244
6C4	6Y30T	6E9	6S7	12A9	244
6C5	6Y30T	6E10	6S7	12A10	244
6C6	6Y30T	6E11	6S7	12A11	244
6C7	6Y30T	6E12	6S7	12A12	244
6C8	6Y30T	6E13	6S7	12A13	244
6C9	6Y30T	6E14	6S7	12A14	244
6C10	6Y30T	6E15	6S7	12A15	244
6C11	6Y30T	6E16	6S7	12A16	244
6C12	6Y30T	6E17	6S7	12A17	244
6C13	6Y30T	6E18	6S7	12A18	244
6C14	6Y30T	6E19	6S7	12A19	244
6C15	6Y30T	6E20	6S7	12A20	244
6C16	6Y30T	6E21	6S7	12A21	244
6C17	6Y30T	6E22	6S7	12A22	244
6C18	6Y30T	6E23	6S7	12A23	244
6C19	6Y30T	6E24	6S7	12A24	244
6C20	6Y30T	6E25	6S7	12A25	244
6C21	6Y30T	6E26	6S7	12A26	244
6C22	6Y30T	6E27	6S7	12A27	244
6C23	6Y30T	6E28	6S7	12A28	244
6C24	6Y30T	6E29	6S7	12A29	244
6C25	6Y30T	6E30	6S7	12A30	244
6C26	6Y30T	6E31	6S7	12A31	244
6C27	6Y30T	6E32	6S7	12A32	244
6C28	6Y30T	6E33	6S7	12A33	244
6C29	6Y30T	6E34	6S7	12A34	244
6C30	6Y30T	6E35	6S7	12A35	244
6C31	6Y30T	6E36	6S7	12A36	244
6C32	6Y30T	6E37	6S7	12A37	244
6C33	6Y30T	6E38	6S7	12A38	244
6C34	6Y30T	6E39	6S7	12A39	244
6C35	6Y30T	6E40	6S7	12A40	244
6C36	6Y30T	6E41	6S7	12A41	244
6C37	6Y30T	6E42	6S7	12A42	244
6C38	6Y30T	6E43	6S7	12A43	244
6C39	6Y30T	6E44	6S7	12A44	244
6C40	6Y30T	6E45	6S7	12A45	244
6C41	6Y30T	6E46	6S7	12A46	244
6C42	6Y30T	6E47	6S7	12A47	244
6C43	6Y30T	6E48	6S7	12A48	244
6C44	6Y30T	6E49	6S7	12A49	244
6C45	6Y30T	6E50	6S7	12A50	244
6C46	6Y30T	6E51	6S7	12A51	244
6C47	6Y30T	6E52	6S7	12A52	244
6C48	6Y30T	6E53	6S7	12A53	244
6C49	6Y30T	6E54	6S7	12A54	244
6C50	6Y30T	6E55	6S7	12A55	244
6C51	6Y30T	6E56	6S7	12A56	244
6C52	6Y30T	6E57	6S7	12A57	244
6C53	6Y30T	6E58	6S7	12A58	244
6C54	6Y30T	6E59	6S7	12A59	244
6C55	6Y30T	6E60	6S7	12A60	244
6C56	6Y30T	6E61	6S7	12A61	244
6C57	6Y30T	6E62	6S7	12A62	244
6C58	6Y30T	6E63	6S7	12A63	244
6C59	6Y30T	6E64	6S7	12A64	244
6C60	6Y30T	6E65	6S7	12A65	244
6C61	6Y30T	6E66	6S7	12A66	244
6C62	6Y30T	6E67	6S7	12A67	244
6C63	6Y30T	6E68	6S7	12A68	244
6C64	6Y30T	6E69	6S7	12A69	244
6C65	6Y30T	6E70	6S7	12A70	244
6C66	6Y30T	6E71	6S7	12A71	244
6C67	6Y30T	6E72	6S7	12A72	244
6C68	6Y30T	6E73	6S7	12A73	244
6C69	6Y30T	6E74	6S7	12A74	244
6C70	6Y30T	6E75	6S7	12A75	244
6C71	6Y30T	6E76	6S7	12A76	244
6C72	6Y30T	6E77	6S7	12A77	244
6C73	6Y30T	6E78	6S7	12A78	244
6C74	6Y30T	6E79	6S7	12A79	244
6C75	6Y30T	6E80	6S7	12A80	244
6C76	6Y30T	6E81	6S7	12A81	244
6C77	6Y30T	6E82	6S7	12A82	244
6C78	6Y30T	6E83	6S7	12A83	244
6C79	6Y30T	6E84	6S7	12A84	244
6C80	6Y30T	6E85	6S7	12A85	244
6C81	6Y30T	6E86	6S7	12A86	244
6C82	6Y30T	6E87	6S7	12A87	244
6C83	6Y30T	6E88	6S7	12A88	244
6C84	6Y30T	6E89	6S7	12A89	244
6C85	6Y30T	6E90	6S7	12A90	244
6C86	6Y30T	6E91	6S7	12A91	244
6C87	6Y30T	6E92	6S7	12A92	244
6C88	6Y30T	6E93	6S7	12A93	244
6C89	6Y30T	6E94	6S7	12A94	244
6C90	6Y30T	6E95	6S7	12A95	244
6C91	6Y30T	6E96	6S7	12A96	244
6C92	6Y30T	6E97	6S7	12A97	244
6C93	6Y30T	6E98	6S7	12A98	244
6C94	6Y30T	6E99	6S7	12A99	244
6C95	6Y30T	6E100	6S7	12A100	244
6C96	6Y30T	6E101	6S7	12A101	244
6C97	6Y30T	6E102	6S7	12A102	244
6C98	6Y30T	6E103	6S7	12A103	244
6C99	6Y30T	6E104	6S7	12A104	244
6C100	6Y30T	6E105	6S7	12A105	244
6C101	6Y30T	6E106	6S7	12A106	244
6C102	6Y30T	6E107	6S7	12A107	244
6C103	6Y30T	6E108	6S7	12A108	244
6C104	6Y30T	6E109	6S7	12A109	244
6C105	6Y30T	6E110	6S7	12A110	244
6C106	6Y30T	6E111	6S7	12A111	244
6C107	6Y30T	6E112	6S7	12A112	244
6C108	6Y30T	6E113	6S7	12A113	244
6C109	6Y30T	6E114	6S7	12A114	244
6C110	6Y30T	6E115	6S7	12A115	244
6C111	6Y30T	6E116	6S7	12A116	244
6C112	6Y30T	6E117	6S7	12A117	244
6C113	6Y30T	6E118	6S7	12A118	244
6C114	6Y30T	6E119	6S7	12A119	244
6C115	6Y30T	6E120	6S7	12A120	244
6C116	6Y30T	6E121	6S7	12A121	244
6C117	6Y30T	6E122	6S7	12A122	244
6C118	6Y30T	6E123	6S7	12A123	244
6C119	6Y30T	6E124	6S7	12A124	244
6C120	6Y30T	6E125	6S7	12A125	244
6C121	6Y30T	6E126	6S7	12A126	244
6C122	6Y30T	6E127	6S7	12A127	244
6C123	6Y30T	6E128	6S7	12A128	244
6C124	6Y30T	6E129	6S7	12A129	244
6C125	6Y30T	6E130	6S7	12A130	244
6C126	6Y30T	6E131	6S7	12A131	244
6C127	6Y30T	6E132	6S7	12A132	244
6C128	6Y30T	6E133	6S7	12A133	244
6C129	6Y30T	6E134	6S7	12A134	244
6C130	6Y30T	6E135	6S7	12A135	244
6C131	6Y30T	6E136	6S7	12A136	244
6C132	6Y30T	6E137	6S7	12A137	244
6C133	6Y30T	6E138	6S7	12A138	244
6C134	6Y30T	6E139	6S7	12A139	244
6C135	6Y30T	6E140	6S7	12A140	244
6C136	6Y30T	6E141	6S7	12A141	244
6C137	6Y30T	6E142	6S7	12A142	244
6C138	6Y30T	6E143	6S7	12A143	244
6C139	6Y30T	6E144	6S7	12A144	244
6C140	6Y30T	6E145	6S7	12A145	244
6C141	6Y30T	6E146	6S7	12A146	244
6C142	6Y30T	6E147	6S7	12A147	244
6C143	6Y30T	6E148	6S7	12A148	244
6C144	6Y30T	6E149	6S7	12A149	244
6C145	6Y30T	6E150	6S7	12A150	244
6C146	6Y30T	6E151	6S7	12A151	244
6C147	6Y30T	6E152	6S7	12A152	244
6C148	6Y30T	6E153	6S7	12A153	244
6C149	6Y30T	6E154	6S7	12A154	244
6C150	6Y30T	6E155	6S7	12A155	244
6C151	6Y30T	6E156	6S7	12A156	244
6C152	6Y30T	6E157	6S7	12A157	244
6C153	6Y30T	6E158	6S7	12A158	244
6C154	6Y30T	6E159	6S7	12A159	244
6C155	6Y30T	6E160	6S7	12A160	244
6C156	6Y30T	6E161	6S7	12A161	244
6C157	6Y30T	6E162	6S7	12A162	244
6C158	6Y30T	6E163	6S7	12A163	244
6C159	6Y30T	6E164	6S7	12A164	244
6C160	6Y30T	6E165	6S7	12A165	244
6C161	6Y30T	6E166	6S7	12A166	244
6C162	6Y30T	6E167	6S7	12A167	244
6C163	6Y30T	6E168	6S7	12A168	244
6C164	6Y30T	6E169	6S7	12A169	244
6C165	6Y30T	6E170	6S7	12A170	244
6C166	6Y30T	6E171	6S7	12A171	244
6C167	6Y30T	6E172	6S7	12A172	244
6C168	6Y30T	6E173	6S7	12A173	244
6C169	6Y30T	6E174	6S7	12A174	244
6C170	6Y30T	6E175	6S7	12A175	244
6C171	6Y30T	6E176	6S7	12A176	244
6C172	6Y30T	6E177	6S7	12A177	244
6C173	6Y30T	6E178	6S7	12A178	244
6C174	6Y30T	6E179	6S7	12A179	244
6C175	6Y30T	6E180	6S7	12A180	244
6C176	6Y30T	6E181	6S7	12A181	244
6C177	6Y30T	6E182	6S7	12A182	244
6C178	6Y30T	6E183	6S7	12A183	244
6C179	6Y30T	6E184	6S7	12A	



# What Job Do You Want In Electronics?

Whatever it is, Cleveland Institute can help you get it!

Yes, whatever your goal is in Electronics, there's a Cleveland Institute program to help you reach it quickly and economically. Here's how: Each CIE program concentrates on electronics theory as applied to the solution of practical, everyday problems. Result . . . as a Cleveland Institute student you will not only learn electronics but *develop the ability to*

*use it!* This ability makes you eligible for any of the thousands of challenging, high-paying jobs in Electronics. Before you turn this page, select a program to suit your career objective. Then, mark your selection on the coupon below and mail it to us *today*. We will send you the complete details . . . without obligation . . . if you will act **NOW!**

## Electronics Technology



A comprehensive program covering Automation, Communications, Computers, Industrial Controls, Television, Transistors, and preparation for a 1st Class FCC License.

## First Class FCC License



If you want a 1st Class FCC ticket quickly, this streamlined program will do the trick and enable you to maintain and service all types of transmitting equipment.

## Industrial Electronics & Automation

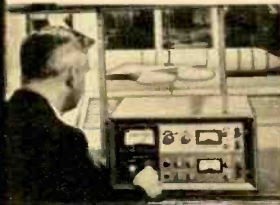

This exciting program includes many important subjects as Computers, Electronic Heating and Welding, Industrial Controls, Servomechanisms, and Solid State Devices.

## Electronic Communications



Mobile Radio, Microwave, and 2nd Class FCC preparation are just a few of the topics covered in this "compact" program . . . Carrier Telephone too, if you so desire.

## Broadcast Engineering



Here's an excellent studio engineering program which will get you a 1st Class FCC License and teach you all about Program Transmission and Broadcast Transmitters.

## Mail Coupon TODAY For FREE Catalog

### Cleveland Institute of Electronics

1776 E. 17th St., Dept. EI-47  
Cleveland 14, Ohio

Please send **FREE** Career Information prepared to help me get ahead in Electronics, without further obligation.

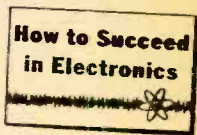

#### CHECK AREA OF MOST INTEREST—

- |   |  |
|---|--|
| <input type="checkbox"/> Electronics Technology | <input type="checkbox"/> First Class FCC License   |
| <input type="checkbox"/> Industrial Electronics | <input type="checkbox"/> Electronic Communications |
| <input type="checkbox"/> Broadcast Engineering  | <input type="checkbox"/> _____                     |
- other \_\_\_\_\_

Your present occupation \_\_\_\_\_

Name \_\_\_\_\_ Age \_\_\_\_\_  
(please print)

Address \_\_\_\_\_

City \_\_\_\_\_ Zone \_\_\_\_\_ State \_\_\_\_\_

Approved for Veteran's Training under Korean GI Bill. EI-47

## Cleveland Institute of Electronics



1776 E. 17th St., Dept. EI-47  
Cleveland 14, Ohio

Accredited Member

September, 1963

from Scott . . .

# FREE STEREO KIT CATALOG

Have fun . . . save money . . . build the best! Now world-famous Scott stereo components come in easy-to-build kit form. You can build an FM Multiplex tuner, your choice of an 80 watt or 48 watt stereo amplifier, a preamp, power amplifier, and a speaker. Write for complete details.



**SCOTT** Dept. 130-9  
H. H. Scott, Inc. 111 Powdermill Road, Maynard, Mass.

Rush me complete information on Scottkits.

Name \_\_\_\_\_

Address \_\_\_\_\_

City \_\_\_\_\_ State \_\_\_\_\_

Export: Morhan Exporting Corp., 458 Broadway, N.Y.C.

Canada: Atlas Radio Corp., 50 Wingold Ave., Toronto

## AMATEUR MARKETPLACE



The Shawnee HW-10 VHF transceiver works on 6 meters with built-in power supply for 117 VAC and 6- or 12-volt battery operation. Comes with PTT ceramic mike, speaker. Its mate, Pawnee HW-20, works on 2 meters. Kits are \$199.95. Heath Co., Benton Harbor, Mich.



The SX-115 triple-conversion receiver covers 80-10 meters in nine 500-ke segments. Has separate noise limiters for SSB, CW and AM, built-in S-meter, 100-ke crystal calibrator, crystal-controlled first and third oscillators. \$599.95. Hallicrafters Co., Chicago, Ill.



The HQ-110A is a double-conversion SSB/AM/CW receiver that covers seven bands (160-6 meters). It includes built-in  $\Phi$ -multiplier, 100-ke crystal calibrator, noise limiter, BFO. The second oscillator is crystal-controlled. \$249. Hammarlund Mfg. Co., New York, N. Y.

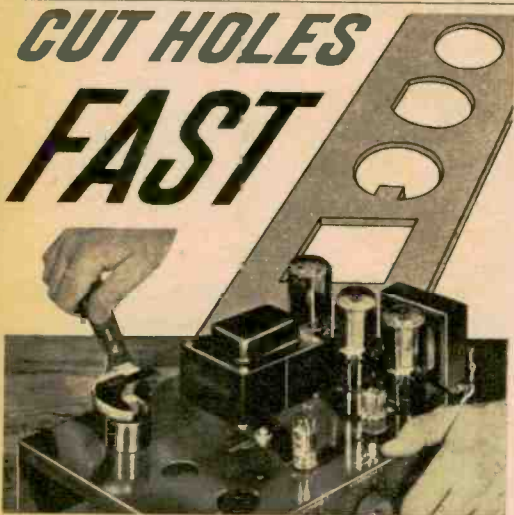

## CUT HOLES FAST GREENLEE CHASSIS PUNCHES

Make accurate, finished holes in 1½ minutes or less in metal, hard rubber and plastics. No tedious sawing or filing — a few turns of the wrench does the job. All standard sizes . . . round, square, key, or "D" shapes for sockets, switches, meters, etc. At your electronic parts dealer. Literature on request.

**GREENLEE TOOL CO.**   
2028 Columbia Ave., Rockford, Illinois



**faster than a  
telephone...  
more convenient  
than a booth**



**Heathkit deluxe "Master Station" CB transceiver...ideal for mobile or fixed business or personal communications**

The most complete, most versatile CB Transceiver ever offered! Provides instant 2-way radio at the touch of a button for every communication need. Compare these high-performance features with any other . . . you'll agree the Heathkit GW-42 is an outstanding value! 1. Built-In 4-tone selective call circuitry. 2. Five crystal-controlled transmit & receive channels. 3. Illuminated channel selector. 4. PTT microphone with coiled cord. 5. Illuminated tuning meter. 6. Illuminated slide-rule dial. 7. Variable receiver tuning. 8. Volume on/off. 9. Microphone clip/tone call defeat switch. 10. Superhet. receiver with RF stage, 1/4 microvolt sensitivity. 11. Built-in power supply for 117 v. AC, 6 or 12 v. DC (switch-selected). 12. Adjustable squelch control. 13. Automatic noise limiter (on/off switch on rear apron). 14. Three circuit boards and wiring harness for fast, easy assembly. 15. Handsome modern styling in two-tone brown color. Order your GW-42 today for the ultimate in CB performance at lowest cost! 22 lbs.

Kit GW-42 . . . no money down, \$11 mo. . . . . **\$119.95**  
Assembled GWW-42 . . . no money down, \$18 mo. . . . . **\$189.95**

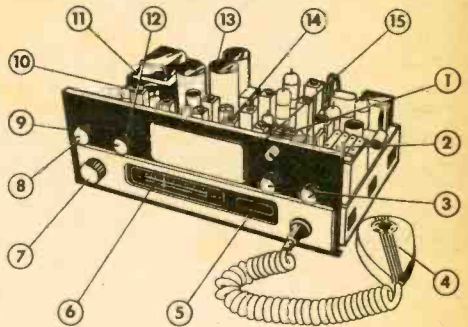

**SEND FOR FREE 1963 CATALOG**  
Full descriptions on the world's most complete line of Citizen's Band Transceivers and Walkie Talkie's . . . from \$19.95 up! Also the world's biggest selection of kits in Hi-Fi, Test, Amateur Radio, Marine, Educational and General Hobby fields of interest.



**HEATH COMPANY**  
Benton Harbor 39, Michigan

Please send me FREE 1963 Catalog

Name \_\_\_\_\_

Address \_\_\_\_\_

City \_\_\_\_\_ Zone \_\_\_\_\_ State \_\_\_\_\_



# AMATEUR MARKETPLACE



An unusually small SSB transceiver, the SB-33 uses 20 transistors, covers 80-15 meters. Built-in power supply. \$389.50. Sideband Engineers, Rancho Santa Fe, Calif.



The Poly-Comm 6 is a complete fixed or mobile 6-meter station for AC or car-battery operation. It's rated at 10 watts RF output and features a built-in speaker, hand-held mike. \$319.50. Polytronics Lab., Clifton, N. J.



Lafayette's HE-30 receiver tunes 80-10 meters with full coverage from 550 kc to 30 mc. Wired, \$99.95; semi-kit (KT-320), \$79.95. Lafayette Radio, Syosset, N. Y.



The Drake TR-3 SSB/AM/CW transceiver covers 5 bands, 80-10 meters. Has a 300-watt peak input on SSB. Includes VFO. \$495. 117 VAC power supply, \$79.95; 12-volt DC supply, \$129.95. Drake, Miamisburg, Ohio.

**ELECTRONICS**  
**ELECTRONICS**  
**ELECTRONICS**  
**ELECTRONICS**  
**ELECTRONICS**  
**ELECTRONICS**  
**ELECTRONICS**  
**ILLUSTRATED**

Get the best magazine for all hobby electronics: Citizens Band radio, ham radio, audio & hi-fi, short-wave listening, kits, theory, test equipment . . . Subscribe now and make sure you get every issue! Special get-acquainted offer:

**6 issues for only \$1.98**

**YES!** I want to take advantage of your special get-acquainted offer. Please enter my subscription right away.

- I enclose \$1.98
- Bill me
- New order
- Re-order

NAME.....

ADDRESS.....

CITY.....ZONE.....STATE.....

Mail to: Electronics Illustrated  
Circulation Department  
Fawcett Bldg., Greenwich, Conn.

9-63



# AMATEUR MARKETPLACE



A crystal-controlled CW-only transmitter for the beginner is the EICO 723. Input is 60 watts peak. Kit, \$49.95; wired, \$79.95. EICO, Long Island City, N. Y.



An AM/CW transmitter in kit form, the Knight T-60 has a 60-watt peak input, jacks for VFO or crystals. Price, \$49.95 less crystals. Allied Radio, Chicago, Ill.



The Starlite AM/CW transmitter works 80-10 meters with provisions for 5 crystals or external VFO. 90 watts. Kit is \$79.50. Lafayette Radio, Syosset, N. Y.



The SX-117 triple-conversion receiver tunes SSB, CW, AM with first and third oscillators crystal-controlled. Includes crystals, variable 3-step selectivity control and BFO. \$379.95. Hallicrafters Co., Chicago, Ill.

## FREE CAREER BOOKLET

To guide you to a successful future in

## ELECTRONICS RADIO-TV COMPUTERS ELECTRICAL ENGINEERING

This interesting pictorial booklet tells you how you can prepare for a dynamic career as an Electrical Engineer or Engineering Technician in many exciting, growing fields:

**MISSILES • AVIONICS • AUTOMATION  
SALES • DEVELOPMENT  
ELECTRICAL POWER • ROCKETRY  
RADAR • RESEARCH**

Get all the facts about job opportunities, length of study, courses offered, degrees you can earn, scholarships, part-time work — as well as pictures of the Milwaukee School of Engineering's educational and recreational facilities. No obligation — it's yours free.

### MILWAUKEE SCHOOL OF ENGINEERING

#### MAIL COUPON TODAY!

Milwaukee School of Engineering  
 Dept. E1963, 1025 N. Milwaukee St., Milwaukee, Wis.  
 Please send FREE "Your Career" booklet  
 I'm interested in  
 Electronics     Radio-TV     Computers  
 Electrical Engineering     Mechanical Engineering

Name \_\_\_\_\_ Age \_\_\_\_\_

PLEASE PRINT

Address \_\_\_\_\_

City \_\_\_\_\_ Zone \_\_\_\_\_ State \_\_\_\_\_

I'm eligible for veterans education benefits.

Discharge date \_\_\_\_\_ MS-117



studying antenna system in Tri-State's electronics lab

## become electronics engineer in 27 months

College graduates enjoy higher income . . . advancement. Become a graduate Engineer. Industry likes Tri-State graduates. Major corporations visit us regularly to interview and employ seniors. **BACHELOR OF SCIENCE DEGREE IN 27 MONTHS** in Electrical (Electronics or Power major), Mechanical, Aeronautical, Chemical, Civil Engineering. **IN 36 MONTHS** a B. S. degree in Business Administration. One-year Drafting-Design Certificate Program. Enrollment limited. Small classes. Campus. Well-equipped labs. Modern dorms. New library. Founded 1884. Moderate costs. Enter January, March, June, September. Write **J. A. McCarthy** for Catalog and "Your Career in Engineering and Commerce" Book.



# TRI-STATE COLLEGE

4893 College Avenue • Angola, Indiana

## FOR SPEEDY SERVICE

1102171 647 98 24 0664  
 T M BROWN  
 1625 CONGRESS ST., N.W.  
 WASHINGTON 6, D. C.

## WE'RE LOST WITHOUT THIS LABEL

Well, not really lost — but we can do things faster for you if you send along the **ADDRESS LABEL** from your magazine any time you write to us about your subscription.

### CHANGE OF ADDRESS

If you're moving, please let us know six weeks before changing your address. Better still, attach the magazine address label to this form, and print your new address here.

name \_\_\_\_\_  
 street \_\_\_\_\_  
 city \_\_\_\_\_ zone state \_\_\_\_\_

attach  
label  
here

ELECTRONICS ILLUSTRATED Subscription Dept., Greenwich, Conn.



## AMATEUR MARKETPLACE



The Call-Ident Tymeter is a direct-reading 24-hour clock with a buzzer signal that reminds you to give call letters. \$22.50. Peanwood Numechron, Pittsburgh, Pa.



A TV camera in semi-kit form should bring new adventures to the ham-video experimenter. \$225, less tube and lens. Craftsmen Instrument Labs, Woodside, N. Y.



P&H transmitting converters come in 2- and 6-meter models for use with any 20-meter exciter/transmitter. Peak input is 175 watts on SSB. Model 2-150, \$329.95; 6-150 \$299.95. P&H Electronics, Lafayette, Ind.



The EICO 730 is a 50-watt modulator especially designed to work with EICO models 720 and 723 CW transmitters. Features an over-modulation indicator. Kit, \$59.95; wired, \$89.95. EICO, Long Island City, N. Y.



TV-RADIO Servicemen or Beginners...

# Send for Coyne's 7-Volume Job-Training Set on 7-Day **FREE TRIAL!**



The First  
Practical  
TV-RADIO-  
ELECTRONICS  
Shop  
Library!

## Answers ALL Servicing Problems QUICKLY... Makes You Worth More On The Job!

Put money-making, time-saving TV-RADIO-ELECTRONICS know-how at your fingertips—examine Coyne's all-new 7-Volume TV-RADIO-ELECTRONICS Reference Set for 7 days at our expense! Shows you the way to easier TV-Radio repair—time saving, practical working knowledge that helps you get the BIG money! How to install, service and align ALL radio and TV sets, even color-TV, UHF, FM and transistorized equipment. New photo-instruction shows you what makes equipment "tick." No complicated math or theory—just practical facts you can put to use immediately right in the shop, or for ready reference at home. Over 3000 pages; 1200 diagrams; 10,000 facts!

**SEND NO MONEY!** Just mail coupon for 7-Volume TV-Radio Set on 7-Day **FREE TRIAL!** We'll include the **FREE BOOK** below. If you keep the set, pay only \$3 in 7 days and \$3 per month until \$27.25 plus postage is paid. Cash price only \$24.95. Or return set at our expense in 7 days and owe nothing. Either way, the **FREE BOOK** is yours to keep. Offer limited, so act NOW!

### "LEARNED MORE FROM THEM THAN FROM 5 YEARS WORK!"

"Learned more from your first two volumes than from 5 years work."  
—Guy Bliss, New York

"Swell set for either the serviceman or the beginner. Every service man should have one!" —Melvin Masbruch, Iowa

### FREE DIAGRAM BOOK!

We'll send you this big book, "150 Radio-Television Picture Patterns and Diagrams Explained" **ABSOLUTELY FREE** just for examining Coyne's 7-Volume Shop Library on 7-Day **FREE TRIAL!** Shows how to cut servicing time by reading picture-patterns, plus schematic diagrams for many TV and radio sets. Yours **FREE** whether you keep the 7-Volume Set or not! Mail coupon TODAY!



## Like Having An Electronics Expert Right At Your Side!

**VOL. 1—EVERYTHING ON TV-RADIO PRINCIPLES!** 300 pages of practical explanations; hundreds of illustrations.

**VOL. 2—EVERYTHING ON TV-RADIO-FM RECEIVERS!** 403 pages; fully illustrated.

**VOL. 3—EVERYTHING ON TV-RADIO CIRCUITS!** 336 pages; hundreds of illustrations, circuit diagrams.

**VOL. 4—EVERYTHING ON SERVICING INSTRUMENTS!** How they work, how to use them, 368 pages; illustrated.

**VOL. 5—EVERYTHING ON TV TROUBLESHOOTING!** Covers all types of sets. 437 pages; illustrations, diagrams.

**VOL. 6—TV CYCLOPEDIA!** Quick and concise answers to TV problems in alphabetical order, including UHF, Color TV and Transistors; 868 pages.

**VOL. 7—TRANSISTOR CIRCUIT HANDBOOK!** Practical Reference covering Transistor Applications; over 200 Circuit Diagrams; 410 pages.

BOOKS HAVE BRIGHT, VINYL CLOTH WASHABLE COVERS

## FREE BOOK—FREE TRIAL COUPON!

Educational Book Publishing Division  
**COYNE ELECTRICAL SCHOOL**  
1455 W. Congress Parkway, Dept. 93-E1, Chicago 7, Ill.

Yes! Send me COYNE'S 7-Volume App'ed Practical TV-RADIO-ELECTRONICS Set for 7-Days **FREE TRIAL** per offer. Include "Patterns & Diagrams" book **FREE!**

Name ..... Age .....

Address .....

City ..... Zone ..... State .....

Check here if you want Set sent C.O.D. Coyne pays postage on C.O.D. and cash orders. 7-Day Money-Back Guarantee.

**Coyne**

Educational Book Publishing Division  
**ELECTRICAL SCHOOL**  
1455 W. Congress Parkway Dept. 93-E1, Chicago 7, Illinois

# AMATEUR MARKETPLACE



Heath's DX-60 is a 90-watt peak AM/CW transmitter, a good bet for the new ham. The rig is crystal-controlled with provision for external VFO. Mates with the HR-10. Kit, \$79.95. Heath Co., Benton Harbor, Mich.



The HQ-170A triple-conversion receiver tunes SSB, AM, CW on 160, 80, 40, 20, 15, 10, 6 meters. Built-in calibrator. \$369. Hammarlund Mfg. Co., New York, N. Y.



The Poly-Comm 62 transceiver works fixed or mobile on the 6- and 2-meter bands. Dual power supply, S-meter, VFO and squelch are some of the features of the 18-watt rig. Ceramic mike. \$379.50. Polytronics, Clifton, N. J.



R-100A receiver tunes 540 kc through 30 mc; band-spread on 80-10 meters. Built-in Q-multiplier. Printed circuit bandswitch. Kit, \$99.95. Allied, Chicago, Ill.

# AMATEUR MARKETPLACE



The Galaxy 300 SSB/AM transceiver tunes 80, 40, 20 meters. Mobile or fixed operation. \$299.95, less power supplies. World Radio Labs, Council Bluffs, Iowa.



National's NCX-3 is an SSB transceiver for mobile or fixed use. Built-in VFO, 200-watt peak SSB input. \$369, less speaker. National Radio Co., Melrose, Mass.



A 6-band, general-coverage transistor portable, the WR-3000 receiver tunes AM, SSB and CW on 185-400 kc, 535-1.625 kc and 2-23 mc. It weighs about 12 lbs. \$199.50. Hallicrafters Co., Chicago, Ill.



The SR-150 SSB/CW ham-band transceiver has a special control for adjusting receiver tuning 2 kc independent of transmitter. \$650. Hallicrafters Co., Chicago, Ill.

## NOW IN PAPERBACK THESE FAMOUS BEST SELLERS BY KENNETH ROBERTS

America's Greatest Historical Novelist

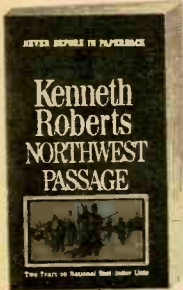

### NORTHWEST PASSAGE

"An enormous tale in every sense of the word ... a tremendous story."

—Chicago Tribune

M610

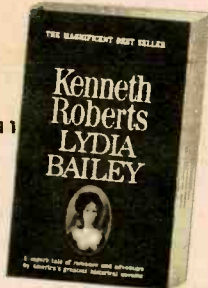

M611



### LYDIA BAILEY

"As superb entertainment as can be found."

—Boston Herald



ON SALE WHEREVER PAPERBACKS ARE SOLD only 95c each

FAWCETT WORLD LIBRARY

Buy this Crest Book from your local newsdealer. If your dealer is sold out, send only 95c plus 10c for postage and handling to Crest Books, Fawcett Publications, Inc., Greenwich, Conn. If order is for five or more books, no postage or handling charge is necessary. Please order by number and title. No Canadian orders.

## THE FAMOUS BEST-SELLING GUIDE TO HAPPIER, HEALTHIER LIVING

NOW ONLY 50¢ IN THIS SPECIAL NEW CREST EDITION

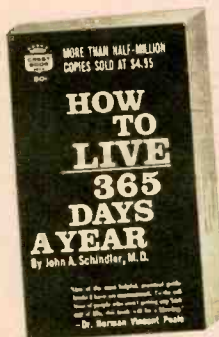

d613

### HOW TO LIVE 365 DAYS A YEAR

by JOHN A. SCHINDLER, M.D.

"To the millions of people who aren't getting any 'kick' out of life, this book will be a blessing."

—Dr. Norman Vincent Peale

ON SALE WHEREVER PAPERBACKS ARE SOLD

FAWCETT WORLD LIBRARY

Buy this Crest Book from your local newsdealer. If your dealer is sold out, send only 50¢ plus 10c for postage and handling to Crest Books, Fawcett Publications, Inc., Greenwich, Conn. If order is for five or more books, no postage or handling charge is necessary. Please order by number and title. No Canadian orders.



**NOW!**  
at a price  
you can afford!

# MAKE MORE MONEY in ELECTRONICS TELEVISION-RADIO

**BETTER...MORE COMPLETE...LOWER COST...  
WITH NATIONAL SCHOOLS SHOP-METHOD  
HOME TRAINING!**

**BETTER...** Training that is proved and tested in Resident School shops and laboratories, by a School that is the **OLDEST** and **LARGEST** of its kind in the world.

**MORE COMPLETE...** You learn **ALL PHASES** of *Television-Radio-Electronics*.

**LOWER COST...** Other schools make several courses out of the material in our **ONE MASTER COURSE** . . . and you pay more for less training than you get in our course at **ONE LOW TUITION!**



Prepare  
for your  
**F.C.C. LICENSE**

Be prepared for secure future in

- INDUSTRIAL ELECTRONICS
- COMPUTERS
- GUIDED MISSILE SYSTEMS
- ELECTRONIC CONTROLS
- or go into . . .
- COLOR TV REPAIR
- HI-FI AND SOUND SYSTEMS
- BROADCASTING STUDIOS
- INSTALLATION

## TOP PAY... UNLIMITED OPPORTUNITIES LIFETIME SECURITY CAN BE YOURS!

You are needed in the Television, Radio, and Electronics industry! Trained technicians are in growing demand at excellent pay—in **ALL PHASES**, including Servicing, Manufacturing, Broadcasting and Communications, Automation, Radar, Government Missile Projects.

**NATIONAL SCHOOLS SHOP-METHOD HOME TRAINING**, with newly added lessons and equipment, trains you in your spare time at home, for these unlimited opportunities, including many technical jobs leading to supervisory positions.

**YOU LEARN BY BUILDING EQUIPMENT WITH KITS AND PARTS WE SEND YOU.** Your National Schools course includes thorough Practical training—**YOU LEARN BY DOING!** We send you complete standard equipment of professional quality for building various experimental and test units. You advance step by step, perform more than 100 experiments, and you build a complete TV set from the ground up that is yours to keep! A big, new TV picture tube is included at no extra charge.

**EARN AS YOU LEARN.** We'll show you how. Many students pay for their course—and more, while studying.

**GET THE BENEFIT OF OUR  
OVER 55 YEARS EXPERIENCE**

APPROVED FOR  
GI TRAINING



ACCREDITED  
MEMBER



**NATIONAL SCHOOLS**

World Wide Training Since 1905  
Write to Dept. R4Y-83  
4000 So. Figueroa Street  
Los Angeles 37, California

## YOU GET...

- 19 Big Kits—**YOURS TO KEEP!**
- Friendly Instruction and Guidance
- Job Placement Service
- Unlimited Consultation
- Diploma—Recognized by Industry
- **EVERYTHING YOU NEED FOR SUCCESS!**

**IMPORTANT  
SEE OTHER SIDE**

## THESE TWO FREE BOOKS TELL HOW

**SEND FOR FREE FULLY-  
ILLUSTRATED BOOK AND  
ACTUAL LESSON TODAY.**

Your own copy of "Your Future In Electronics-Television-Radio" will be mailed to you at once. No salesman will call; there is no obligation. Cut out card along dotted lines, fill in and mail today!  
**NO POSTAGE NECESSARY.**

## CUT OUT AND MAIL THIS CARD TODAY

Yes, I want to make more money in Electronics-TV-Radio. Send me your **FREE Fully-Illustrated Opportunity Book** and **Actual Lesson** today.

**RUSH TODAY—NO POSTAGE NECESSARY**



Name \_\_\_\_\_ Age \_\_\_\_\_

Address \_\_\_\_\_

City \_\_\_\_\_ Zone \_\_\_\_\_ State \_\_\_\_\_

Check here if interested only in Resident Training at Los Angeles. R4Y-83  
Veterans: Give date of discharge \_\_\_\_\_

**NO SALESMAN WILL CALL; NO OBLIGATION ON YOUR PART**

# DON'T BE HALF-TRAINED

Be a **MASTER TECHNICIAN** in

# ELECTRONICS-TV-RADIO

Only **N.T.S.** offers you **ALL 8 PHASES** in **ONE MASTER COURSE**



**SUCCESS IS THEIRS;  
IT CAN BE YOURS TOO!**



I cannot praise N.T.S. enough. I've just graduated and already I have started repairing radios and servicing TV's ... At 53, I'm starting a new life and my diploma from National Technical Schools is my proudest possession.

William E. Eckenroed

As field director of Berean Mission Inc., I have complete charge of our radio work.

With the expert advice and training I am receiving from you I can do my own repairs on our recorders and P.A. systems, besides keeping our radios going. My training from N.T.S. helps keep us on the air. I feel privileged to be a member of such a fine institution.

Rev. Enoch P. Sanford



Thanks to N.T.S. I have a business of my own right in my home. I have paid for all my equipment with money earned servicing TV sets. Yes, N.T.S. gave me my start in television.

Louis A. Tabat

I have a TV-Radio shop in Yorkville, Illinois, about 4 miles from my home, and it has been going real good. I started part-time but I got so much work that I am doing it full-time. Thanks to National Technical Schools.

Alvin Spera



## ALL 8 PHASES IN ONE MASTER COURSE

**PHASE 1  
TELEVISION  
INCLUDING COLOR TV**  
90% of homes have at least one set. Color TV is becoming more popular daily. TV Stations grow in number, need technicians. Maintenance and repair offer big opportunities.

**PHASE 5  
FCC LICENSE  
PREPARATION**  
FCC License holders have a wide range of top jobs open to them. FCC License now a requirement for most Communication jobs.

**PHASE 2  
RADIO—AM & FM**  
Radios in homes, cars, schools, all need expert upkeep. Stations expand as FM becomes popular. Now transistors boom entire field.

**PHASE 6  
RADAR AND  
MICROWAVES**  
These are the communications systems of the future, already used in tracking and contacting satellites.

**PHASE 3  
INDUSTRIAL  
ELECTRONICS**  
Computers, Data-Processing machines, Electronic Controls, Guided Missile Systems are new fields where Electronics play a vital role.

**PHASE 7  
AUTOMATION  
& COMPUTERS**  
Automation and Computer electronics are the new tools of industry and commerce. Skilled Technicians in these fields are in great demand at top pay.

**PHASE 4  
SOUND SYSTEMS**  
New popularity of Hi-Fi Stereo, as well as industrial sound systems and business intercoms make this a highly specialized and important field.

**PHASE 8  
BROADCASTING &  
COMMUNICATIONS**  
In the entertainment industry, or in commerce, communications and broadcasting have great importance. Installation and maintenance of equipment requires trained technician know-how.

**SEE OTHER SIDE**

**FIRST CLASS**

Permit No. 3087

Los Angeles, Calif.

**BUSINESS REPLY MAIL**  
NO POSTAGE STAMP NECESSARY IF MAILED IN THE UNITED STATES

— POSTAGE WILL BE PAID BY —

**NATIONAL TECHNICAL SCHOOLS**

WORLD-WIDE TRAINING SINCE 1905

4000 So. Figueroa Street

Los Angeles 37, California

RESIDENT TRAINING  
AT LOS ANGELES

If you wish to take your training in our famous Resident School in Los Angeles—the oldest and largest school of its kind in the world—check special box in coupon.



Approved for GI Training

**NATIONAL TECHNICAL SCHOOLS**

WORLD-WIDE TRAINING SINCE 1905

Address correspondence to Dept. R4Y-83

4000 So. Figueroa Street  
Los Angeles 37, California

National Technical Schools also offers Complete Home Study Training Programs in Auto Mechanics & Diesel, Air Conditioning, Refrigeration-Electrical Appliances, and Home Appliances Repair. For information and FREE BOOK write the School, Dept. RDC, stating course desired.



# AMATEUR MARKETPLACE



The Knight R-55 receives 530 kc to 36 mc plus 47-54 mc. Tunes 80- through 6-meter ham bands. Built-in speaker, power supply. Kit, \$59.95. Allied Radio, Chicago, Ill.



Mosley's CM-1 double-conversion receiver tunes 80-10 meters. It has a crystal-controlled first oscillator, 5-meter. Price, \$182.70. Mosley Electronics, Bridgeton, Mo.



Collins 325-3 SSB/CW transmitter-exciter has a peak power rating of 175 watts on SSB and 160 watts on CW. Price, \$750. Collins Radio, Cedar Rapids, Iowa.



The Communicator IV triple-conversion AM transceiver comes in 2- and 6-meter models for mobile or fixed use. Built-in speaker. \$389.95. Gonset, Burbank, Calif.

## NEW HOME BUSINESS...

# Install BURGLAR ALARM SYSTEMS

### ...MAKES YOU BIG MONEY

I reveal how corner of garage, other extra space can be alarm workshop. No costly equipment or large stock needed.

All materials & tools for NAS burglar alarm systems can be carried in car trunk.

To men of good character. I bare my web method of protecting against one of underworld's most successful methods of entry... skylights.

I give you business building kit in Guide - plans to help you cash in on need for installers.

I show you how to apply thin foil strips that turn windows into silent barr rfs.

**GO AFTER PROFITS LIKE THIS...**

Protection for Men's Shop  
**GROSS PROFIT \$188.50**

Protection for Auto Parts Store  
**GROSS PROFIT \$225.00**

Protection for Floor Covering Co.  
**GROSS PROFIT \$411.00**

Profits on burglar alarm service business need more explanation to give you full profit picture... like 100 clients pay \$6,000 to \$12,000.00 a year. Rush coupon for free details.

Tiny magnetic signal you fasten with screw driver protects better than door lock.

I reveal how estimating system helps you price jobs.

Open envelopes with money that comes in like clock-work from your monthly contracts.

Protect walls, ceilings against undetected entry using secrets of electronic vibrators.

**New Plan Unlocks Mysteries of Big Pay Burglar Alarm Business**— opens door to small home operators for first time. Start now full or spare time. Expert discloses industry's "inside secrets" guarded for years by nation's top burglar alarm specialists. With step-by-step plans, so clearly explained, you'll find even if you've never held a screwdriver, you'll make "practical" installations few short hours after you receive complete plan.

**Big Opportunity for Men from All Walks of Life.** Office workers, salesmen, mechanics, factory workers—now big profit burglar alarm opportunities for you. Clerks, repairmen, farmers—NASC0 Plan opens big earnings to all.

**Millions of Buildings Not Protected** Shocking national crime wave that sees burglary committed every 40 seconds creates need for protection in stores, offices, warehouses, homes. Plan shows how to cash in on this huge need. Install Nasco web of protection that guards windows, doors, walls... sounds alarm when an illegal entry is attempted.

RUSH COUPON for

## FREE DETAILS!

**NASCO, Dept. K639**  
11071 Massachusetts Ave., Los Angeles 25, Calif.

**ALARM SECRETS COUPON**

Rush full details showing how I can gain prestige, profit and financial security in the booming burglar alarm business. **ALL FREE!**

Name .....

Address .....

City..... Zone..... State.....

## BEST BUYS IN STEREO AND MONO HI-FI

Transistorized Stereo/Mono 4-Track Tape Deck RP100 Semikit (electronics in kit form) \$299.95 Wired \$399.95



New Stereo FM Multiplex Tuner ST97 Kit \$99.95\* Wired \$149.95\*



FM-AM Stereo Tuner ST96 Kit \$89.95\* Wired \$129.95\* \*Incl. FET

FM Tuner HFT90 Kit \$39.95 Wired \$65.95 Incl. FET Metal Cover \$3.95



AM Tuner HFT94 Incl. FET Kit \$39.95 Wired \$65.95

70-Watt Integrated Stereo Amplifier ST70 Kit \$99.95 Wired \$149.95



40-Watt Integrated Stereo Amplifier ST40 Kit \$79.95 Wired \$129.95



Stereophonic Dual Preampifier ST84 Kit \$59.95 Wired \$89.95



28W Integrated Stereo Amplifier HF81 Kit \$69.95 Wired \$109.95

Stereo Power Amplifiers



	Kit	Wired
70W HF87A:	\$74.95	\$114.95
100W HF89A:	\$99.50	\$139.50
28W HF86:	\$43.95	\$ 74.95



FM-Multiplex Autodaptor MX99 Kit \$39.95 Wired \$64.95 Cover Optional, \$2.95 (Patents Pending)



Bookshelf Speaker System HFS1 Kit \$39.95 Wired \$47.95

## BEST BUYS IN CITIZENS TRANSCEIVERS, HAM GEAR, RADIOS

Citizens Band Transceivers 770 Series from Kit \$79.95 Wired \$109.95



U. S. Pat.



60W CW Transmitter #723 Kit \$49.95 Wired \$79.95

Walkie-Talkie Citizens Band Transceiver #740 Kit \$54.95. Wired \$79.95. Complete with rechargeable battery & charger.



## BEST BUYS IN TEST EQUIPMENT

Metered Variable Auto-Transformer AC Bench Supplies



Model 1073 (3 amps) Kit \$35.95 Wired \$47.95

Model 1078 (7½ amps) Kit \$42.95 Wired \$54.95

Peak-To-Peak VTVM #232 & Uni-Probe® (U.S. Pat.) Kit \$29.95 Wired \$49.95



VTVM #221 Kit \$25.95 Wired \$39.95

DC-5 MC 5" Scope #460 Kit \$89.95 Wired \$129.50



General Purpose 5" Scope #427 Kit \$69.95 Wired \$109.95

Tube Tester #625 Kit \$34.95 Wired \$49.95



RF Signal Generator #324 Kit \$28.95 Wired \$39.95



1000 Ohms/Volt V-O-M #536 Kit \$14.95 Wired \$18.95



6- & 12V Battery Eliminator & Charger #1050 Kit \$29.95 Wired \$38.95



Extra-filtered for transistor eqmpt. #1060 Kit \$39.95 Wired \$49.95

AC Volt-Watt Meter #261\* Kit \$49.95 Wired \$79.95



\*Formerly called #260

Multi-Signal Tracer #145A Kit \$23.95 Wired \$32.95



**EICO**  
EXCELLENCE  
IN  
CREATIVE  
ELECTRONICS

Over 2 MILLION EICO instruments in use throughout the world. Compare, take them home — right "off the shelf" — from 2000 neighborhood dealers, most of whom offer budget terms.



EICO, 3300 N. Blvd., L.I.C., N.Y. E1-9  
 Send free Catalog describing over 106 top-quality products, free Stereo Hi-Fi Guide, free Short Course for Novice License, name of nearest EICO dealer.  Send new 36-page GUIDEBOOK TO HI-FI for which I enclose 25¢ for postage & handling.

Name.....  
 Address.....  
 City..... Zone..... State.....  
 Add 5% in the West





# THE WONDERFUL WORLD OF AMATEUR RADIO

**A** MATEUR RADIO is somewhat like electricity. It's difficult to define but the effects are observable. To various people, hamming may represent a meeting of a social klatch, a sizable market for electronic products, a means of keeping in contact with distant relatives or the basis for scientific experiment and development. But, more than anything else, operating an amateur station is merely a pleasant and engrossing hobby. The average licensee never takes part in a dramatic rescue and formulates no new laws of radio propagation. His only reward is hours and years of pleasure. That hamming is a fascinating hobby is attested to dramatically by the increase in number of licensees. Three hundred and fifty thousand hams can't be wrong. EI in this issue presents a Special Section on Amateur Radio to advise and encourage those who are interested but do not yet have a license, and to offer good reading and good projects to Novices, beginning General licensees and veteran hams. Our material begins with articles on studying code and theory and on taking the test—representing our advice on "how to get a ham license"—and progresses up the scale to discussions on specialized types of operation for advanced hams—radio-teletype and single sideband. Whatever your level of achievement—neophyte to advanced ham—we hope you find our Special Section enjoyable, informative—and useful. ●

# WHY BE A HAM?



By JOHN HUNTOON, WILVQ  
General Manager, The American Radio Relay League

**A**BOUT THREE years ago, a young priest named Father Raphael de la Berra called on a friend at the Osorno Volcano resort in Chile to help with a problem. On this occasion, the problem was not one of deep spiritual significance. For Father de la Berra is one of the world's 350,000 radio amateurs, and the problem concerned his friend's radio equipment.

Repairs completed, Father de la Berra, known to other amateurs as CE7BN, put the station on the air just to assure himself that the equipment was working properly. When he did, he heard disturbing news: the town of Valdivia, 70 miles north of the volcano, had just been struck by an earthquake! Checking further, he found that Puerto Varas, 70 miles to the south, also had been hit.

Quickly the young priest spread the word to the 40 people at the resort. And, since a volcano is no place to be during an earthquake, most of the vacationers immediately started down the mountain with the priest. But nine were skeptical and remained on the volcano. The resort was still visible to the fleeing group when an avalanche buried it and the scoffers under fifteen feet of rock.

Such a gripping drama seldom happens to the ordinary man—even in the exciting world of amateur radio. But the hobby does offer unique opportunities for public service, for technical investigations, for communications on a person-to-person basis crossing political and language barriers the world over.

The amateur's opportunity for public service stems partly from the fact that

there are hams almost wherever there are people. Thus, when a flood, hurricane, forest fire or other disaster rips out normal power and telephone lines, there is bound to be an amateur nearby, ready to take over the task of communicating with the outside world.

And the amateur has the ability to do a good job. He knows the International Morse Code, and he can use it with even the simplest of transmitters. Chances are that he's sharpened his operating skills in radio contests. Or perhaps he's handled messages from servicemen on the Pacific islands or scientists at the Poles.

Another part of the amateur's fitness to serve stems from the basic technical knowledge he has had to acquire in order to secure his license from the Federal Communications Commission. If his equipment breaks down during an emergency, he knows how to repair it. On a few occasions, amateurs have even used parts from broadcast sets to build make-shift emergency transmitters.

But amateurs do far more than help out during disasters. They participate in community affairs, using their car radios to speed up parades; to coordinate sports-car rallies and road races; to help in the fund drives of such organizations as the American Red Cross, health foundations, the united funds and so forth.

Amateurs also use their skills to advance the cause of world friendship. By just being themselves and chatting with people all over the globe, they project an image of the American as a friendly person, really interested in others.

Language barriers don't intrude too



much. Hams have their own international slang of Q-signals (groups of three letters starting with Q which stand for entire sentences). They also use English-language abbreviations which have been translated and memorized by the amateurs of other nations.

Thus, QRV? means "Who is calling me?" in English and "Qui m'appel?" in French. Again the letters YL, from "young lady," clearly indicate "Une jeune fille" to a French ham.

Even the Iron Curtain is punctured nightly by hams. Amateurs in Russia and Soviet-bloc countries don't seem to have nearly the same freedom as our hams. Even so, they are permitted to carry on short, non-controversial technical conversations with hams here.

The workbench is often a lure to radio amateurs. The opportunity to develop new equipment has been a magnet drawing many youngsters to lifelong careers in engineering and related sciences.

Several of the top men in the electronics industry got their start as radio amateurs. Similarly, many of the largest manufacturing companies in the electronics field began as basement workshops turning out ham gear.

How to start? The U.S. hams' national organization, the American Radio Relay League, offers a series of books to teach the necessary technical background. Of greatest interest to the newcomer are the four booklets grouped together as "The Gateway to Amateur Radio"—How to Become a Radio Amateur, The Radio Amateur's License Manual, Learning the Radiotelegraph Code, and Operating an Amateur Radio Station. The complete set of four booklets can be obtained in electronics parts stores or direct from the League (225 Main Street, Newington 11, Conn.) for \$1.50.

A 300-page book which discusses radio theory and amateur technical practices in simple and readable terms is also available from parts houses or the League headquarters. Called Understanding Amateur Radio, it sells for \$2.

Prospective amateurs who already have their short-wave receivers can

tune in nightly to code practice sessions transmitted by the League as a public service. These broadcasts emanate from W1AW, the League's own station.

The ARRL also helps local radio clubs conduct their own training courses for interested newcomers. For a code practice schedule or the name of the radio club nearest you, send a brief note with a stamped, self-addressed envelope to the League at the above address.

A satisfying hobby, a public-service opportunity, a self-training ground in electronics, a means for making friends around the world—amateur radio is all these things. Care to come aboard? —

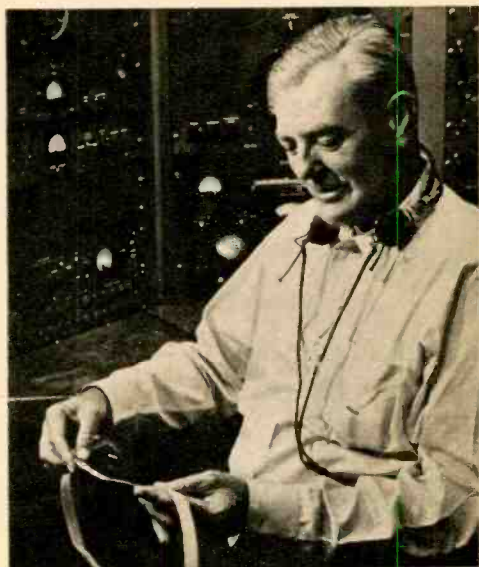

Amateur radio has been my hobby more than 40 years. Not only has it been a wonderful way to relax and let off steam, but it has helped steer me into a most interesting and satisfying career in engineering. The accompanying article by John Huntoon helps explain the thrills and opportunities opened up through amateur radio.

**Herbert Hoover, Jr., W6ZH**  
**President, The American**  
**Radio Relay League**

# THE CODE



**All you need to learn the dit-dah language is persistence.**

**T**HERE are as many ways to learn International Morse code as there are to sharpen a pencil. And if you stacked together all the advice ever given on the subject you'd have a pile higher than any radio tower yet built.

Some people say code is a snap; others say it requires a great deal of study. Fact is, anyone who can learn to speak a language also can learn code—enough of it to pass the 13-words-per-minute test given for a General ham license. But some can pick up the dit-dah language in less than 30 days. For others, it's a months-long ordeal. The biggest variable is the learner himself.

In almost any code-learning method you can find attractive features that might make it appear to be the best way. But for the real code bug, any approach is like stealing second after the pitcher swallows the ball.

At the other extreme is the guy who aches for that magic 13-wpm level but can never remember whether didahdah is w or g and didahdah keeps on sounding like something he's never heard before.

Most of us fall somewhere between the extremes. The choice of a learning method may depend largely on personal preference, circumstances or what the ham across the road has at hand. Several good approaches are available. And, given a good approach, you *will* get there. How soon will depend on how persistently you practice. Once you know the code, building up speed is almost purely a matter of persistency and regularity of practice. You usually read that code is an *aural* art rather than a *visual* one and should be learned as such. We couldn't argue with that, but for those who just can't learn the characters via their ears (and there are many), flash cards are the only alternative left. Having to shift later from eyes to ears is better than having no gearshift at all.

Though nearly every method of learning code offers some attractive feature, we hold that there is one best method. That is a code class taught by an experienced hand. Hundreds of such classes are formed each year, sponsored by local ham organizations, Citizens Band



clubs, radio manufacturing companies and other groups. Where interest remains high and the instructor knows what he's about virtually all members of a code class make the grade.

To find a code class a-forming in your area, contact such organizations as those mentioned above. The American Radio Relay League can put you onto the nearest ham club if you are unable to locate one.

Group-study in itself seems to represent some kind of catalyst between man and code and a regular, tried-and-proven progression assuredly does make learning easier. Next best to a code class probably is study by two or three friends who get together regularly. But here much obviously depends on the people involved.

Barring class or small-group study, you have only one approach left to Mr. Morse's language—individual study. Tens of thousands of people have learned code this way. Obviously, it can be done. But here again much depends on the self-discipline of the student and his regularity of study. Most popular among current methods of self-teaching is the code course offered on 33½- or 45-rpm records. One attractive feature of record courses is the cost, which begins as low as \$3.50 and doesn't go much beyond \$10. All large electronic supply houses stock them.

Record courses start off with bands that teach you the characters. Subsequent bands increase your speed to as much as 25 wpm. All include printed instruction books and a few have spoken instructions on the discs. One drawback with records lies in the fact that most phonograph and hi-fi setups have no earphone outlet. Your study sessions via a loud-speaker may drive the rest of your family to dire ends, and the student himself sometimes

is distracted by outside noises. Code courses also can be found on magnetic tape, though they're pretty scarce.

One of the oldest standard methods of learning code is with punched tapes and a rented code machine, such as the Instructograph. This setup includes (besides the tape-reading mechanism) a booklet, headphones, a key, an oscillator and a set of ten tapes. You make a \$15 deposit on the machine and then pay a monthly rental of \$4.75. Or, you can buy the equipment outright for \$61.

The Instructograph, like any other good course, first teaches you the code and then builds your speed. But it also has a couple of valuable special features. The phones mean that you are shut away from the rest of the world, which is the best way to learn. Secondly, the slightly raucous tone of the code is the very type you are most likely to get thrown at you at the FCC office.

Another type of code machine is typified by the Accentronome Corp.'s Codome. It consists of a buzzer keyed by code characters etched in a rotating printed circuit board. Many people learn code this way, but the machine is pretty fast for a rank beginner.

Those are the major methods of learning code, and any one of them *can* be successful for you. But that, as we said, will depend more on you than on the method. ●

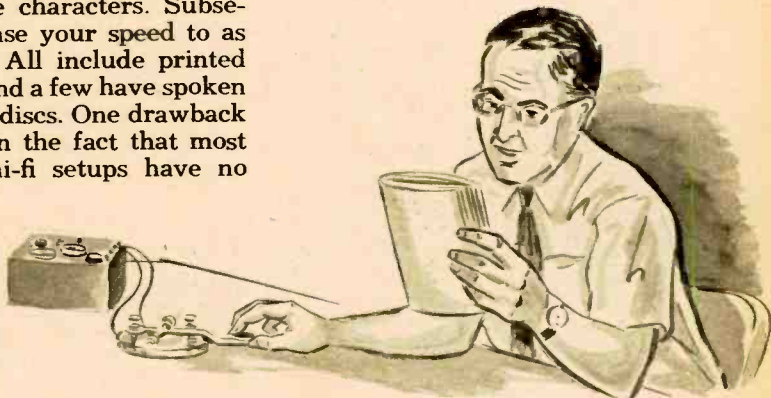

# THE THEORY

**Learning electronic theory is easy—if you know how. One month of the right kind of study and a ham ticket can be yours.**

**I**F YOU CAN give yourself an hour a day for 30 days, you can digest enough electronic theory to get an amateur license. Boning up on theory isn't the grind you might think it is. In fact, unless your interest in electronics is newer than the latest compactron, you're already off to a good start.

As you know, there are three principal classes of ham licenses—Novice, Technician and General. Each class requires an examination in both electronic theory and Morse code. In addition, you'll also have to prove that you're familiar with the regulations governing ham radio.

The scope of the exam naturally differs with the class of license you're after,

but how you prepare for that exam is going to be much the same in each case.

While you'll have to work for your ticket, an amateur license is most decidedly worth working for. Furthermore, neither the theory (nor the code, for that matter) need be an insurmountable barrier. If you consider that you're cramming for an exam rather than learning electronics, you're on your way to your own call letters.

An amateur exam can be compared to any other kind of exam—that for a driver's license, for instance. You aren't born knowing how to drive. First, you're taught the principles of driving; then you do some practicing. Next, you take the driving test and then—after you've received your driver's license—you really learn what driving's all about!

In other words, the real learning comes from the doing. It's almost the same with ham radio. Cram to pass the test. You'll learn plenty about electronics after you get your ticket!

Regardless of which ticket you go after, it's important to establish a definite study routine, preferably the same amount of time, at the same time, every day. Don't start out with a big bang and

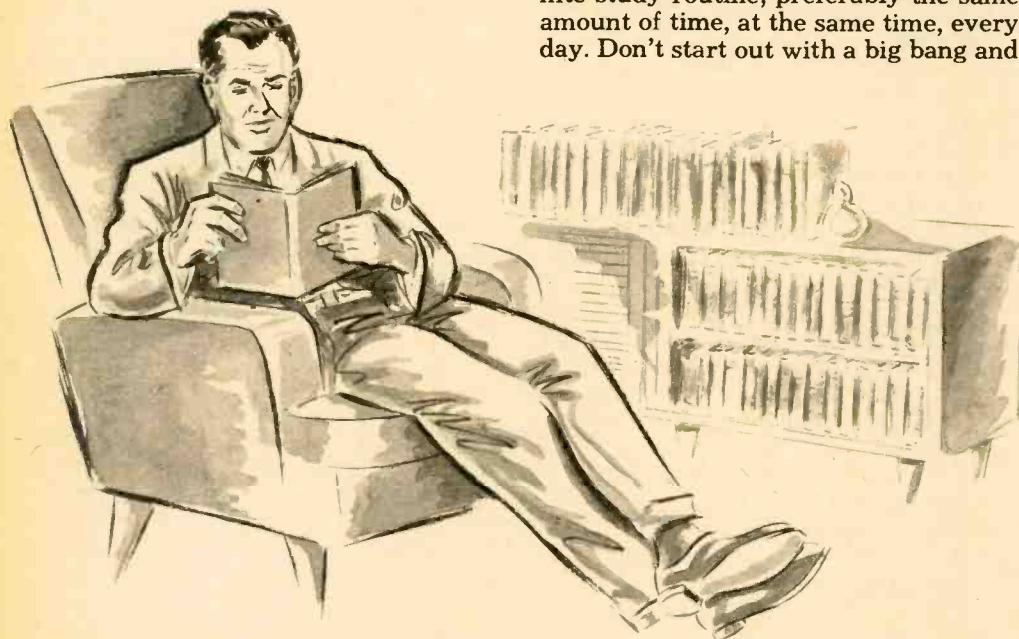



put in several hours of study the first few evenings. You're likely to run out of wind and enthusiasm, then give up in despair.

Divide each study period into half—say 30 minutes for theory and 30 minutes for code. This way, you'll be quitting at your peak each evening, looking forward to another session later on.

If you're working for your Novice ticket, take out the ARRL License Manual and digest the chapter on the Novice license. It contains questions and answers similar to those you'll get on the exam. In the rear of the Manual are all the rules and regulations applicable to the amateur. Read them a few times, memorize the sample questions (and answers), and then go down and take the exam.

The Technician and General exams require far more study. And you'll need two ARRL books—the

License Manual mentioned above and the Radio Amateur's Handbook. Pull out the Handbook first and flip to the chapters devoted to basic theory (about 70 pages).

Take at least a week to read this section. After all, you can digest small amounts much more easily than you can one big gulp. And, while you're still on theory, devote some time to reading up on ham regulations.

Cramming out of the way, give another week to testing yourself on the sample questions in the License Manual. As you go along, cross off those questions which you understand completely (you'll be amazed at how much

you know!). Each day, select several questions you can't answer and look up the information in the Handbook.

You'll find that searching for the answer to one question often uncovers the answers to many others. In time, the number of sample questions you're in doubt about will get smaller and smaller. When you have about ten questions left, you're ready to wrap it up.

Spend the last five days reviewing every sample question in the book. Your object is to read and re-read those samples until they're practically memorized.

When the exam day comes, go down and take it! Don't spend any of that day trying to learn a little extra. That little extra has been the downfall of many potential hams.

In short, at this stage of the game you should forget about what you don't know and

concentrate on the things you're sure of. Your cramming behind you, all you need worry about at exam time are your jitters and that little bit of luck.

Incidentally, the books in the chart above are all but indispensable to the would-be ham who's studying electronic theory. There's no point in buying all of them, of course, but the first two (which we've already mentioned) belong on your bookshelf anyway. Or perhaps we should say "belong in your shack," since it doesn't take an Einstein to figure out that you won't learn much theory with the books on the shelf!

See you on the band! —

#### CHOICE BOOKS ON THEORY

The Radio Amateur's Handbook (ARRL)  
728 pages, \$3.50

The Radio Amateur's License Manual (ARRL)  
132 pages, 50 cents

A Course in Radio Fundamentals (ARRL)  
103 pages, \$1

Amateur Radio Theory Course (Ameco)  
300 pages, \$3.95

Radio Electronics Made Simple (Ameco)  
192 pages, \$1.95

Radio Amateur Question and Answer License  
Guide (Ameco)  
32 pages, 50 cents

Basic Radio Course (Gernsback)  
224 pages, \$4.10

ABC's of Ham Radio (Sams)  
112 pages, \$1.50

# THE TEST

With both code and theory tucked firmly under your belt, you're ready to face the FCC. Here's what the test is like.



Hand in pocket, another ham-to-be musters courage enough to enter the FCC examining office.



As in any government office, forms come first. They tell the FCC who you are and why you came.

**A**T THIS moment thousands of potential hams are growing groggy from practicing code, cramming on electronic theory and wrestling with schematic symbols and diagrams. Are they headed for adventure on the DX bands? Not necessarily. Their immediate objective is a day in the hot-seat at a local FCC office.

Here's why. To win the durable General Class license and all the privileges accorded the full-fledged amateur, a personal appearance for a code and theory test is the rule. Novices face it after their one-year ticket expires. Technicians must bow in, too, if they want to work the choice bands below 50 mc.

What happens within the walls of an FCC Field Engineering Office on ham exam day?

As you enter you'll probably be pegged as a ham applicant, even before you say a word. Your shaky knees usually are a dead giveaway—at least in the opinion of Charles Finkelman. And he should know. As an FCC examiner for 16 years, Mr. Finkelman has greeted and tested applicants at the Commission's busy New York City examining



Prove that you can copy code at the required 13 wpm, and you're over the big hurdle of the day.



office at the rate of about 2,000 a year.

Highlight of the exam is a test to determine whether you can receive code at the required 13 words per minute. As you might expect, it is here that the mortality rate is highest. Whether you're Phi Beta Kappa or sport an IQ in the low tens, there's about a 50-50 chance of passing. Failure to copy one solid minute of code out of a possible five washes out the applicant for the rest of the test.

Some luckless candidates might argue that the code was sent too fast. The examiner could reply by pointing to the infernal machine that transmits, with deadly accuracy, 13 wpm.

How can you improve your chances? Actually, it is nervousness that cramps most applicants in their ability to receive code. And, in the unfamiliar atmosphere of an FCC office you must allow some margin for butterflies in the stomach. Best advice comes from the examiner himself. "Be able to copy 15 at home before attempting the test," says he.

Maybe the fear of flunking can be eased by these tidbits: there is no limit on the number of times you can take

the test, but you must wait at least a month between tries. Failures have absolutely no bearing on your future chances of getting a ticket. In fact, such information isn't even sent to FCC headquarters, where all Licenses are issued.

When you come right down to it, no one (except you) cares whether you flunk or not, and test failures are cast into a mute file. Of course, you might attract attention if you break the standing record for the office. One applicant we know of doggedly took the code test no less than 12 times before he passed!

Before you sit at the code-test position, consider these opportunities for improving your chances. In the five-minute test run, about 325 Morse characters are sent. You need copy only 65 error-free characters in a row to pass (numbers count as two characters).

This system of grading has major advantages to exploit. Since the machine-like precision of the code may sound different from what you normally hear on the air or at a home session, it's often helpful to spend the first few seconds of the test transmission just listening.

[Continued on page 116]



Sending code is a snap—once you've passed the receiving test. Examiner listens in on phones.



Written portion of exam can be graded while you wait. If you score 74 per cent, you are a ham!

# how to use the GRID DIP OSCILLATOR



By Herb Cenani

**W**HENEVER an amateur or Citizens Bander compiles a list of equipment he wants to add to his test bench, a grid-dip oscillator usually ends up somewhere near the bottom of the page. Actually, a GDO is among the most valuable instruments you can put in your shack. Don't agree? Well, take a look at all the things it can do.

- Measure the resonant frequency of cold circuits—filters, traps, antennas, feedlines and so forth.
- Measure relative field strength.
- Serve as an oscillating detector for frequency measurements.
- Function as a local oscillator for receiver troubleshooting.
- Act as a signal generator.

● Operate as a modulation monitor.  
To understand exactly how a GDO can perform all these functions, let's take a minute to understand how it works. As you can see from the simplified schematic below, the GDO is a variable-frequency oscillator (VFO) with a built-in meter to indicate RF power. Meter M1 indicates grid current flowing in oscillator tube V1. Naturally, the more RF power developed, the higher the grid current and the higher the meter reading.

If an L-C circuit tuned to the VFO frequency is placed near VFO inductor L2, this L-C combination absorbs some of the RF power. Since VFO power is reduced, the grid current also is reduced

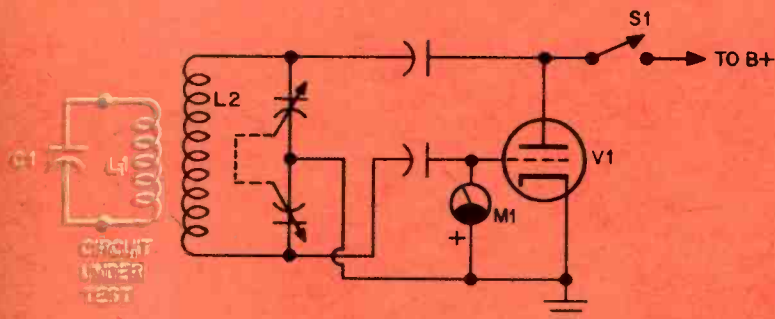

Grid-dip oscillators come in a wide variety of shapes and sizes, but all have two things in common—a tube or transistor connected as an oscillator, and a microammeter to indicate grid or base current. Simplified vacuum-tube version shown here is basically a Colpitts oscillator.



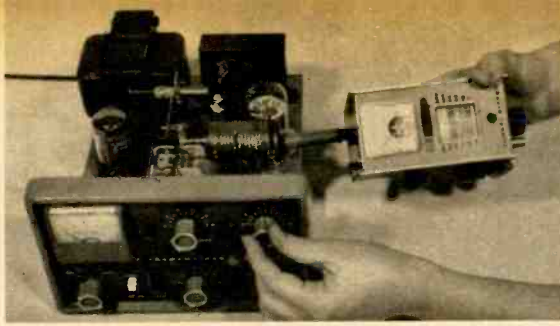

Considered from a cost vs. performance standpoint, a grid-dip oscillator scores so high that no ham or CBER can afford to be without one. The versatile GDO can be used to tune a transmitter (left), determine the value of an unmarked capacitor, and align receivers, converters and RF preamps (below).

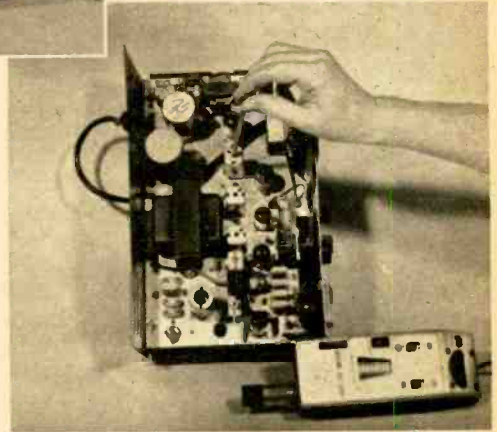
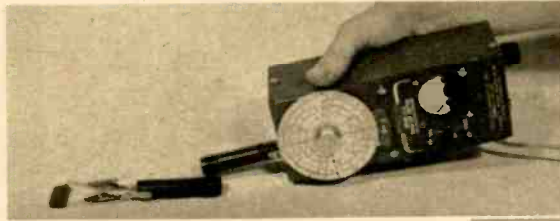

and M1 dips—hence the name grid-dip oscillator. Inductor L1 and capacitor C1 form the external L-C circuit in the diagram at left.

Similarly, if an unknown tuned circuit is placed near the VFO inductor, its resonant frequency can be determined by sweeping the VFO. As in the previous examples, the grid current dips at the resonant frequency of the tuned circuit.

Cut off the B+ to the VFO (by opening switch S1) and V1 becomes a detector. The circuit now performs as a standard wavemeter, with meter M1 indicating relative field strength.

Most GDO's utilize a tube for the oscillator and are powered by an internal AC supply. They are reasonably stable and their dials can be calibrated accurately. Although their nominal frequency range is from 1 to 260 megacycles, some GDO's are supplied with inductors which extend the range down to the neighborhood of 350 kilocycles.

Until recently, the vacuum-tube GDO was the standard type for experimenters. However, because the tube GDO requires an AC power supply, it's often impossible to use such an instrument at remote locations. Not so with the semiconductor GDO that utilizes a transistor or tunnel diode for the oscillator and batteries for power. It can operate practically anywhere.

While the term GDO is not really ap-

plicable to the semiconductor versions (where there is no grid to be dipped), these devices still are tagged with the name. The limiting factor of the more inexpensive solid-state GDO's is that they do not have the required stability for precise dial calibration. A minor disadvantage with *all* solid-state GDO's is their restricted frequency range; the lower limit usually falls somewhere around 3 mc. On the other side of the ledger, the semiconductor GDO does have its advantages—portability, for example, which can be a major consideration.

Possibly the greatest asset of any GDO is its ability to indicate resonance. Let's say it's time to try out that high-power linear you've worked on for weeks. Do you hang back for fear those expensive tubes will light up the moon before you can dip the final? Do you twist the tuning controls frantically,

# GRID DIP OSCILLATOR

hoping to hit resonance before the tubes become shooting stars? Not if you have a GDO.

With transmitter power off, you set your GDO to the operating frequency, place it near the grid tank and tune the grid capacitor for dip. Repeat the procedure with the plate tank, and you will have tuned both circuits before touching the power switch. Now when you apply power to the transmitter, it will take just a little trimming to get the rig tuned on the button.

If you roll your own coils—including traps and filters—you'll find the GDO especially handy. Instead of laboriously calculating each coil, you simply wind one that looks good. This done, you connect it across the required capacitor and measure with your GDO. Your first attempt may be considerably off-frequency, but it takes only a few seconds to trim off some turns.

For checking out antennas and feedlines, the GDO shines. Is that new antenna really resonant at your operating frequency, or have end effects, miscalculations or some nearby metal objects changed everything? Stop guessing (or hoping). Put a GDO next to the antenna, give a quick spin of the dial, and you'll know for certain whether you'll get out. How about your resonant feedlines? Are they resonant where they're supposed to be? Again, spin the GDO dial and you will know for certain.

A GDO is almost indispensable when you discover that you're producing parasitics (spurious signals). Just switch off the GDO's B+ (converting it to a wavemeter), and place the GDO near the transmitter's output. Sweep the dial until the meter indicates output at some frequency other than the one you are supposed to be on, and you've found the parasitic. Using the GDO as a probe, you now can trace the circuits to determine the origin of the spurious signal. Try doing this without a GDO!

Having outlined the major uses of the GDO, let's run through the many little

## Grid-Dip Oscillators

Model	Freq. Range (Mc)	Tube or Semi-Conductor	Kit	Wired
Barker & Williamson 600	1.75-260	T		\$45.72
EICO 710	0.4-250	T	\$29.95	49.95
Heath HM-10A	3-260	S	34.95	49.95
Knight G-30	1.5-300	T	22.95	
Lafayette TE-18	0.36-220	T		29.50
Millen 90651	1.7-300	T		68.85
PEL DM201	3.1-230	S	29.90	39.90

kinks that it can iron out for you. For example, if you set the GDO to wavemeter and plug in a headset, you can monitor your own signals.

Many GDO's come with interpolation charts which allow easy measurement of unknown capacitors. You connect the capacitor across a specified inductor, then measure the frequency of the inductor-capacitor combination. Compare the resonant frequency against the charts, and you can read off the capacitor value as easy as 1, 2, 3. In much the same way you can measure unknown inductors which are connected across known capacitors.

Since AC-powered GDO's have excellent calibration, they can be used as signal generators for aligning budget-price receivers, converters and RF preamps. Of course, there is no easy means to control the signal level, as there is with a standard signal generator. But since you wouldn't attempt to align a \$400 receiver with a GDO anyway, this is hardly a handicap.

Connect a headset to the GDO while the B+ is on and the instrument becomes a heterodyne frequency meter. When the GDO is placed near a radiated signal of unknown frequency, a tone (heterodyne) will be heard in the headset as the GDO's frequency approaches the one you're trying to determine. Naturally, the pitch of the tone becomes lower as the frequency of the GDO approaches the unknown frequency. When the GDO is set precisely at the unknown frequency, the tone disappears. This is the zero-beat condition, and the unknown frequency is the same as the GDO reading. ●



# The 10 Most Useful Ham Accessories

**I**N THIS AGE of amateur equipment with astronomical specifications, and sometimes equally elevated prices, many hams plug along with equipment that's best described as rock-bottom. But some of them knock out solid contacts and win awards as handily as a fellow with a \$3,000 rig.

What's the secret? Well, no one's going to deny that it's nice to own a shack-full of top-notch gear. But this often is just plain wishful thinking. Fortunately, there are ways to get more out of a basic, run-of-the-mill-rig without spending a small fortune. The answer is accessories.

Here are ten low-cost accessories—most of them priced at less than \$15—which can give your operations a big boost. Naturally, no one needs all ten. But you're going to find a few items that will prove invaluable.



At the top of the list is a first-rate headset. Weak signals can get lost easily in the QRM and QRN between a speaker and your ear, but a headset isolates you from your surroundings—directing your attention solely to the received signal. Furthermore, by bringing the sound directly to your ear, a headset adds definition to the sound (it's easier to separate two CW signals or distinguish a voice in a headset than in a speaker). And, because of its high sensitivity, a headset can give you that little extra gain you need to hear those weak DX stations. Even if you already have a headset, it may not be doing all it should for you. Perhaps it's an ancient model, loaded with distortion and producing masking due to ear fatigue. Is a new set in order?

How about your key? Do you still have that budget model you purchased when you were learning code? Such keys never were designed for day-in, day-out use. Worn bearings and poor spring tension may be causing your fist to sound like a beginner's. Why not check into a modern, high-quality key with a full range of adjustments—a sideswiper for high speed, an electronic key for flawless characters? Even a good straight key can be a decided asset, and the Army J-38 still is available for less than a dollar from some supply houses. Or let's look at a good key from another angle. A CW contact with a pipsqueak DX station can get that original ham enthusiasm going all over again—and there's lots of CW DX virtually begging for a call. Even if you consider yourself a phone man, why not get that key ready?

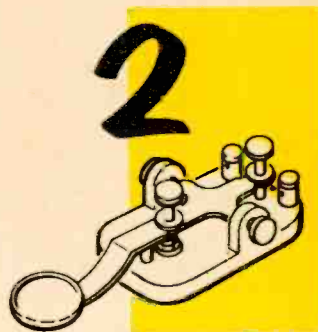

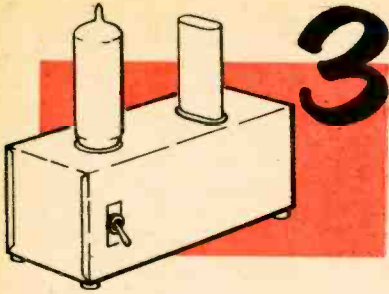

Another item that's mighty useful around any shack is a crystal calibrator. Transistorized or tube-operated, all incorporate a 100-kc crystal to serve as an inexpensive frequency standard. By zero-beating the calibrator with one of the WWV transmissions, it's possible to insure that the calibrator is on frequency. This done, you can use the calibrator to check the dial calibration of your receiver, using the harmonics (multiples of 100 kc) throughout the spectrum. Furthermore, since the edges of most ham bands are also exact multiples of 100 kc, a crystal calibrator makes it very easy to pinpoint the precise limits of practically any ham band.

Getting back to keys, are you confident that your keying is really good? Do you just hope that it is, or depend on biased reports from friendly contacts? Or do you try to transmit only on the receiving frequency so you can monitor on your receiver? One sure way to eliminate such makeshift arrangements is to buy or build a keying monitor—an inexpensive device which reproduces your signal independently of your receiver. Most can be connected easily to your transmitter, and a monitor such as EI's model (Jan. '63) will work with no connections to the transmitter. Once you have a keying monitor, you can install key-to-transmit circuits and work on any frequency you chose. Above all, you'll know exactly how your fist sounds to others.

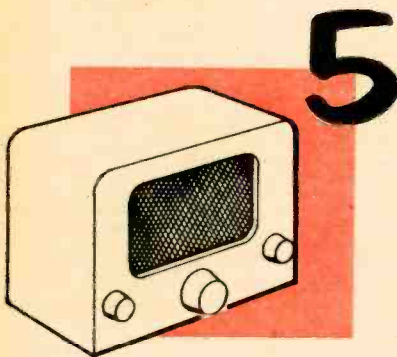
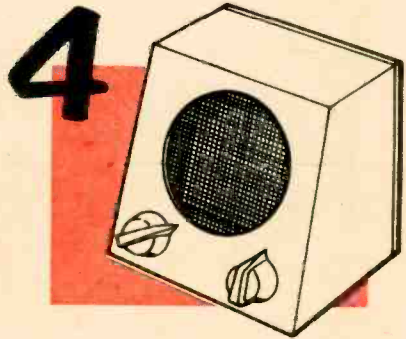

A modulation monitor is to the phone man what a keying monitor is to the CW operator. Commercial models are basically demodulators which permit you to monitor an AM signal and listen for hum, noise or distortion. You also can feed the monitor's output to a tape recorder for critical signal analysis. If you experiment with different microphones, or if you have a tendency to weave in and out when you're at the mike, you can use a modulation monitor to help maintain a high modulation level—simply connect a VU meter across the monitor's output. Of course, if you want a device which indicates modulation percentage directly, you can build EI's Monitor Meter (Nov. '62). An oscilloscope also can be used as a modulation monitor, giving you constant visual indication of just what your signal actually looks like.

An antenna coupler is a gadget which can match almost any antenna to any transmitter. Hams often assume that a pi-network output will load into anything, but this isn't necessarily true. Further, some of the transmitter circuits for Novices have the simplest of output circuits and can load into only a narrow range of impedances. If you keep in mind that maximum transmitter power output is obtained only when the transmitter is matched to the antenna system, you'll see the value of an antenna coupler. Since this is one item where it pays to purchase the best, it's wise to plan ahead for future requirements. Some deluxe couplers have built-in SWR bridges and a range of adjustments to match almost anything to anything.

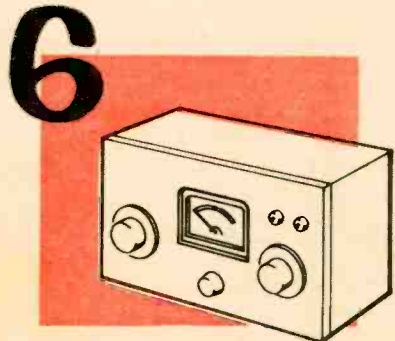



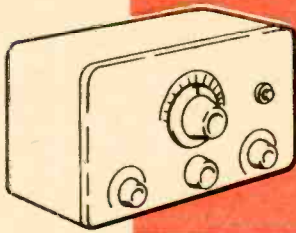

# 7

An old standby that belongs in every shack is a Q-multiplier, a device which can take that budget receiver's broad selectivity and make it razor sharp. A Q-multiplier can be connected easily to your receiver—in some instances, only a single connection is required. Once installed, a Q-multiplier can simulate either extremely sharp bandpass or rejection. Adjacent signals which usually pass through the IF amplifier and cause interference can be removed. In fact by proper adjustment of a Q-multiplier, your receiver's selectivity can be narrowed to the point where it is just about impossible to understand human speech.

Some accessories aren't restricted only to phone or CW men—those which improve a signal have universal value. Heading the list is a standing-wave ratio (SWR) bridge, a device which indicates when your transmitter is tuned for maximum output and how much of the output your antenna will accept. By way of explanation, the amount of power an antenna will accept is determined by the impedance match between the transmission line and the antenna; the SWR is nothing more than the ratio between the antenna impedance and the line impedance. To insure that maximum power is transferred to the antenna system, the SWR must be maintained as close to 1:1 as possible. An SWR bridge is the only low-cost, convenient means of measuring SWR. In addition, it can be left permanently in the transmission line, providing a continuous check on the condition of the antenna system and showing how well it's matched to your rig.

# 8

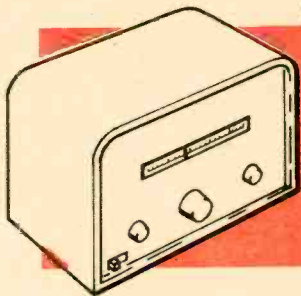
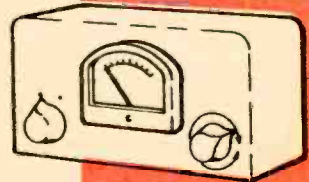

# 9

Unless you're a Novice, why tie yourself down to a few crystal frequencies? A variable-frequency oscillator (VFO) will deliver an RF signal on any frequency you choose. In this day of high-pressure operation, most hams monitor their calling frequency first. If you have to wait your turn while a CQer tunes to your frequency, you're certain to miss many contacts. With a VFO, you can get on or near the calling station's frequency almost immediately. A VFO also comes in handy when a whole neighborhood seems to have chosen crystals of the same frequency—with the result that there seem to be 50 stations on a single frequency. With a VFO, you're free to pick the quietest frequency you can find and work other stations as you choose.

Still another handy accessory is a field-strength meter (FSM), a device which indicates relative RF power. An FSM's major use is adjusting or checking an antenna's radiation. For example, an FSM is indispensable when adjusting a directional beam for maximum front-to-back ratio or maximum forward gain (the twain don't meet). Obviously, something has to receive your signal in order for you to know whether your adjustments are correct. Since an FSM indicates relative field strength, this is the device for the job. Similarly, an FSM can be used to check for maximum radiation node on a long-wire or a multi-band antenna. Most FSMs handle anything from 80 through 2 meters.

# 10

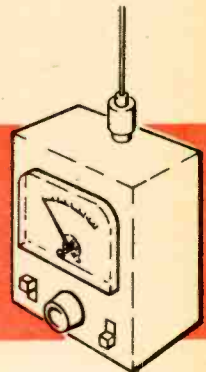



## CB CORNER

BY LEN  
BUCKWALTER  
KBA4480

# Putting The Bite On

**FIRST FINE . . .** For some time the FCC has been doing quite a bit of barking. Now it has a bite as well as a bark.

Just a scant two months after the FCC announced there would be cash fines for some dozen offenses it lowered the boom by imposing a walloping \$300 fine on Vincent R. Banville of Ft. Lauderdale, Fla. This was the first such action taken by the Commission since Congress gave it the teeth to levy cash forfeitures against CB violators.

Mr. Banville, licensee of CB station KDH1734, was accused of repeated or willful (in the words of the FCC) violations in three categories—unauthorized communications, improper identification, and false call sign. He was given 30 days to respond to the notice.

The second such action by the FCC occurred two weeks later. Morris J. Green of Mabelton, Ga., was slapped with a \$100 fine for repeated or willful violations of rule 19.6(a)—unauthorized communications.

News of the FCC's actions is enough to send a bolt of panic through the most conservative, law-abiding CBer. But take heart: the swift flexing of the Commission's newly-found muscle apparently has deeper meaning. It's likely that these cases were triggered, not by the offenses listed above in themselves, but rather by the lack of response to earlier letters of warning.

Key words in the fine actions are "repeated" and "willful." The point is obvious: the Commission is not bent on filling its coffers by fining Cbers who may commit an inadvertent or accidental offense—off-frequency operation, say. But it's likely that fines will continue to be levied against hard-core offenders who toss official communiques into the round file. Our advice: answer your mail!

Hash . . . from your car's voltage regulator frequently can produce noisy reception in a mobile rig. While many Cbers install spark-plug suppressors, the regulator often is overlooked. Interference from this source can be identified by a crackling sound that doesn't vary with engine speed and is intermittent in nature. A good remedy is the



addition of a 0.1-mf coaxial capacitor (see photo).

To install the capacitor, remove the lead(s) from the regulator terminal marked *B* or *Batt* and connect them to one end of the capacitor. Then add a short wire between the other end of the capacitor and the *B* terminal on the regulator. Complete the installation by grounding the mounting lip of the capacitor to a nearby bolt.

If some noise persists, add a similar capacitor to the regulator's *A* or *Arm* terminal. The remaining regulator terminal (*F*) should not be touched.



# HOW TO CHOOSE THE RIGHT

# TRANSMISSION LINE

By Al Toler

**W**ELL, your ticket finally arrived! Now you can plug in the transmitter. Everything's legal. But hold off a second. How are you planning to connect it to that dipole you strung up last spring? Lamp wire or that old TV lead-in are out of the question. You've got a small problem, OM, in getting your signal from the transmitter to the antenna without losing half your power along the way.

A special transmission line is the answer, and the type you use can make or break your station's performance. Actually, you could use ordinary lamp cord, but there would be big losses. Your 200 watts at the transmitter might become 10 watts at the antenna.

When you look for transmission lines in a parts catalog you may be surprised by the many types and specifications: twinlead, coaxial cable, 72 ohms, 300 ohms, 52 ohms. Where do you start? The situation assuredly can be confusing, but if you're armed with the advice in this article you should have little trouble deciding which line is best for your station.

Those readings in ohms represent the most important piece of information to consider when you're looking for a feedline. They refer to a line's characteristic impedance, also called surge impedance. (Impedance is to an AC circuit what resistance is to a DC circuit.)

**Characteristic Impedance.** To find out what the term means, let's take an extremely short piece of twinlead like that attached to your TV set and examine its electrical properties. First, think of the two little pieces of stranded wire as the two plates of a capacitor, between which there is a measurable capacitance. In Fig. 1 this capacitance is represented by the capacitor symbols. Each wire has inductance, too, and this is represented by the circles of arrows. When radio-frequency (RF) power is fed into this minute section of line (Fig. 2) each wire appears as a series impedance to the RF. Knowing the voltage and current of the RF, we can compute the impedance the signal sees when looking into A and B.

To this short section of line let's add a few more sections of like length—in fact, let's add an infinite number of sections as in Fig. 3. Each section we add is in parallel with the one before it and, therefore, it lowers the impedance at A and B. But each section adds a smaller and smaller amount of impedance.

In an infinitely long line the impedance doesn't continue to fall

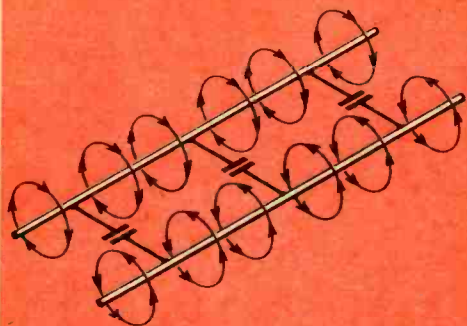

Fig. 1—Parallel wires act as capacitor. Wires have inductance, too, so current creates magnetic lines of force (arrows).

but, rather, eventually assumes a definite value and stays there. To a transmitter connected to A and B in Fig. 3, the infinite number of little feedline sections looks like a pure resistance. This impedance value is known as the characteristic or surge impedance of the line. It is stated in ohms. (The symbol for impedance is Z while the standard symbol for resistance is R.) Characteristic impedance so far as open line is concerned is a function of the diameter of the wires and the space between them. Engineering handbooks give formulas if you want to calculate it.

What we've been talking about is the impedance that a feedline presents to an RF signal. But after the signal finally fights its way through, it faces still another impedance—that represented by the antenna, which in this context is referred to as the *load*. A transmission line's input impedance is the same as its characteristic impedance only when the characteristic impedance and the *load* impedance are equal. Take a piece of

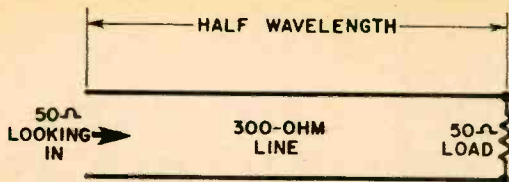

Fig. 4—If a line is half-wavelength long, impedance looking in always equals load impedance regardless of line's characteristic impedance.

300-ohm twinlead, put a 300-ohm resistor across the far end to represent the antenna, and the transmitter will see exactly 300 ohms. Only under this condition will all the power fed into a line be absorbed by the load (this neglects other line losses, which we'll discuss in a moment).

If the load impedance is not the same as the line's characteristic impedance, some of the power is reflected back down the line and is dissipated as heat. The greater the mismatch, the less RF will get to the load.

The mismatch is expressed by the term standing-wave ratio, or SWR (see *WHAT SWR MEANS TO YOU*, July '63 EI).

SWR is the ratio of the line's characteristic impedance to the load impedance compared to 1. If the line's characteristic impedance is 300 ohms and the load impedance is 50 ohms, the SWR is 300/50 or 6 (it is written as 6:1).

The power reflected back because of a mismatch sets up what are called standing waves on the line. Standing waves will make the line's input impedance a different value from its characteristic impedance. We won't go into the reasons for it here, but the thing to remember is that the input impedance of a random

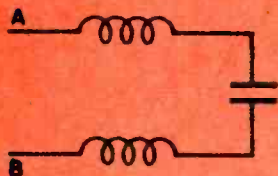

Fig. 2—Inductance and capacitance combined in a very small section of two-wire line.

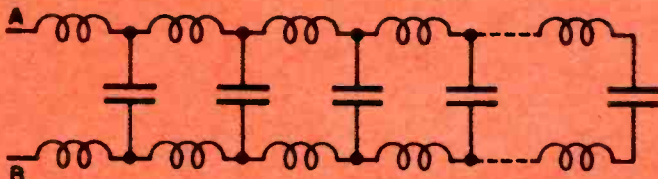

Fig. 3—Infinite number of sections in Fig. 2 are connected in parallel here. Voltage applied at A and B causes current flow through network. Characteristic impedance equals  $E/I$ .



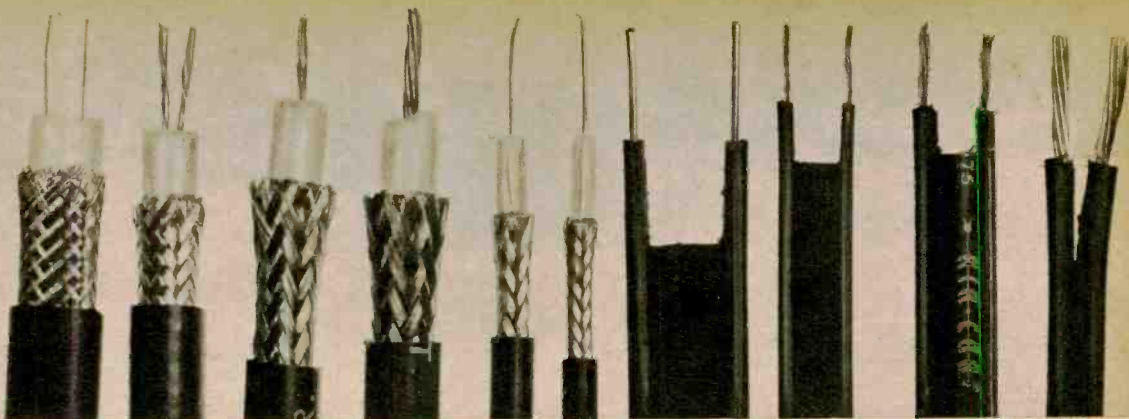

Fig. 5—Actual size of transmission lines. L to R: K-111, 300-ohm shielded twinlead; RG22/U, 95-ohm shielded twinlead; RG11/U, 75 ohms; RG8/U, 52 ohms; RG59/U, 73 ohms; RG58/U, 53.5 ohms; Amphenol 214-022, 300 ohms, TV 300 ohms; Amphenol 214-076, 300-ohm air-core; Amphenol 214-023, 75 ohms.

length of line that is *not* matched to its load may be considerably higher or lower than its characteristic impedance at the point where it is connected to the transmitter. Under this condition, the transmitter will not be able to transfer all its power into the line.

Let's see what happens if we use 300-ohm line to connect a transmitter to a 50-ohm antenna. The 50-600 output impedance of many transmitters would be matched to the line in theory. However, because of the mismatch between transmission line and antenna, the line may appear to the transmitter as, say, 1,000 ohms. So only part of the transmitter's power would ever be coupled into the transmission line. This would be indicated by a failure to load to rated input current. So in addition to the loss caused by the line/antenna mismatch, we have added a transmitter power-transfer loss.

**How to Match Impedances.** For maximum power transfer to the antenna, impedances must match everywhere. This isn't difficult to achieve since most ama-

teur transmitters have an output impedance that corresponds to common antennas.

If the antenna impedance differs from the transmitter impedance, matching devices such as an antenna coupler or balun are available. Whenever possible, match the antenna to the line and then use a matching device to couple the transmitter to the line rather than the other way around. Even with a severe line/load mismatch there are ways to get the transmitter's power into the antenna efficiently. Take a look at Fig. 4. If you use a line that is exactly a half-wavelength or a multiple of a half-wavelength long, the input impedance of the line will be exactly the same as the impedance at the load, regardless of the SWR. For example, if we connect a 50-ohm antenna to a half-wave 300-ohm line, the input to the line will appear to the transmitter as 50 ohms. So far as the transmitter is concerned, it is working into 50 ohms. The entire system is

[Continued on page 110]

Fig. 6—Transmission lines used as impedance inverters can match 28-ohm antenna to 50-ohm transmitter. Input to quarter-wavelength of 53-ohm line connected to 28-ohm antenna is 100 ohms. Input to quarter-wavelength of 73-ohm line connected to first section is 53 ohms, which is close enough to the transmitter's 50-ohm output impedance.

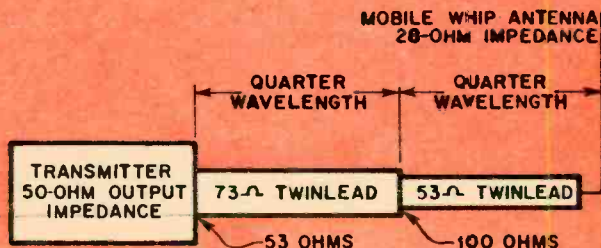

# 250-Watt ANTENNA TUNER



By Bert Mann

**M**ANY amateurs working 40 or 80 meters don't have enough room for a half-wave antenna and must settle for a random length of wire. While a random-length job will radiate some RF, the full get-out ability of the transmitter rarely is realized.

Our handy Antenna Tuner can match your transmitter to practically anything, even an innerspring mattress.

The Tuner will handle up to 250 watts of power from 10 to 80 meters. If you use a capacitor with wider spacing between the plates than that of the capacitor specified, the Tuner will handle up to 350 watts. To simplify Tuner adjustment, an RF indicator lamp is included.

**Construction.** The author built his Tuner in a 4x5x6-inch Minibox. Mount C1 and S1 1½ inches above the bottom of the box. To mount C1 on the front panel, remove its front mounting foot. After it is mounted, place a spacer or a stack of washers under the rear mounting foot and secure with a screw. C1 must be supported from the rear as it is long and heavy and may be deformed if held only with its shaft bushing.

Every other turn of L1 is indented to make soldering to it easier. Orient L1 so these indents face up and toward the front. L1 is mounted ½ inch from the rear and bottom of the box and is supported by its own leads. One lead is

connected to J1, the other to the feed-through insulator.

S1 is a progressive-shorting type rotary switch assembled from a Centralab PISD steatite section and a P-270 index assembly. Mount S1 so the three contacts closest to the front panel face C1. The wiper contact should face the bottom of the cabinet. Connect the lugs on S1 to C1 and J1 before wiring to L1.

When wiring to the taps on L1, start at the end closest to C1. (It will be almost impossible to avoid shorts if you start at the other end.) Use No. 18 wire and solder to the taps as shown on the schematic, starting at the fifteenth raised tap and working back to the third tap.

If your transmitter's power exceeds 150 watts, use an NE-2J or NE-96 neon lamp instead of an NE-51. Note that you make a connection to only one terminal on NL1. Put rubber feet on the bottom of the tuner.

The final detail is labeling the positions on S1 and C1 on the front panel. Mark C1's minimum capacity 0 and, mark 0 also at the position of S1 when all contacts are shorted (full counterclockwise). When C1 and L1 are set to 0, the tuner is out of the circuit and the transmitter sees the antenna as if the Tuner didn't exist.

**Operation.** Connect the output of your transmitter to J1 and your antenna



to the feed-through insulator. (For optimum results the antenna should be at least a multiple of a half-wavelength at the lowest operating frequency.)

Set C1 and L1 to 0 and tune the transmitter in the normal manner. Then adjust S1 for maximum RF output, as indicated by NL1's glow, or for a peak-loading indication on the transmitter. Now adjust C1 for peak output. After C1 is adjusted try the next position on S1; two or three tries usually are required for optimum adjustment. You can try the Tuner out on all bands and mark the settings on the front panel so the Tuner can be reset quickly later.

*A word of caution:* Occasionally you find the Tuner gives such a solid match the transmitter can be overloaded.

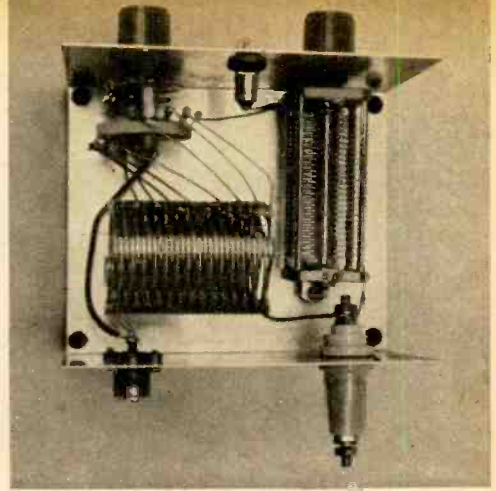

NL1 is mounted so only the glass bulb, not the metal base, is in the grommet. Taps indicated on schematic are the raised turns on the coil.

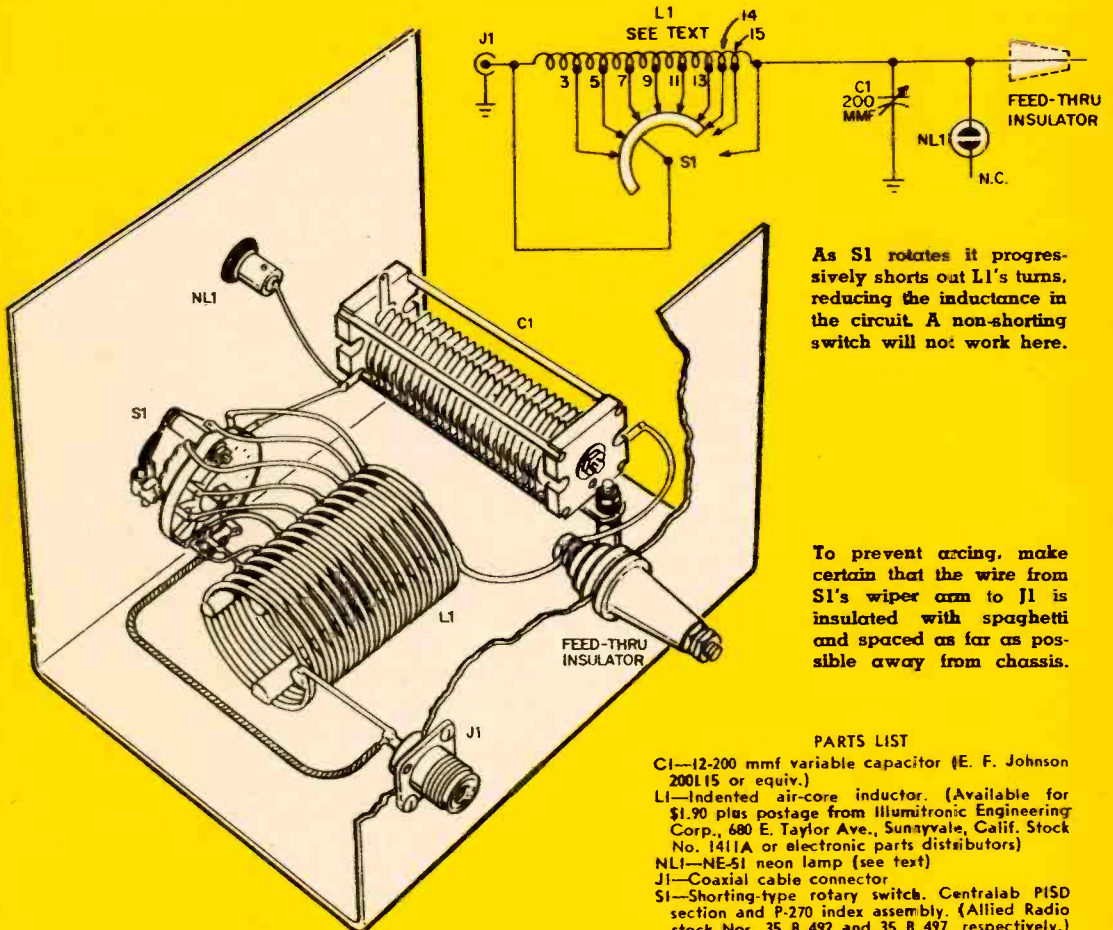

As S1 rotates it progressively shorts out L1's turns, reducing the inductance in the circuit. A non-shorting switch will not work here.

To prevent arcing, make certain that the wire from S1's wiper arm to J1 is insulated with spaghetti and spaced as far as possible away from chassis.

**PARTS LIST**

- C1—12-200 mmf variable capacitor (E. F. Johnson 200L15 or equiv.)
- L1—Indented air-core inductor. (Available for \$1.90 plus postage from Illumitronic Engineering Corp., 680 E. Taylor Ave., Sunnyvale, Calif. Stock No. 1411A or electronic parts distributors)
- NL1—NE-51 neon lamp (see text)
- J1—Coaxial cable connector
- S1—Shorting-type rotary switch. Centralab P1SD section and P-270 index assembly. (Allied Radio stock Nos. 35 B 492 and 35 B 497, respectively.)

KIT

EI

REPORT

# HYBRID PHONE PATCH



## Heathkit HD-19

ONE of the most satisfying activities of ham radio is running a phone patch. Here's how it works. If a serviceman on Okinawa or other remote location wants to talk to his family in, say, Oregon he looks up an amateur on or near his base. That ham then contacts a ham in Oregon who is able to run a phone patch. On the Oregon end the serviceman's voice is fed from the radio receiver directly into the phone line and is carried by long-distance (or local) wires to the family telephone. The voices of the family, coming over the same wires, are used to modulate the transmitter.

The telephone company has a rule about tampering with its equipment but it conveniently ignores phone-patching by hams. After all, patches represent extra income in the form of long-distance charges. If you don't overload the line with a strong signal from your receiver, causing crosstalk, and if your transmitter's RF is kept out of the phone lines you have nothing to worry about.

The Heath HD-19 phone patch, which sells for \$29.95 in kit form, is known as a hybrid patch. It gets its name from a special hybrid mixing transformer which makes it unnecessary to throw a switch when going from *receive* to *transmit*. Switching is done electronically. The HD-19 has a calibrated VU meter to warn you when the maximum permissible signal is being fed into the phone line. The circuit also includes an effective RF filter.

In addition, there is a nulling device which prevents the receiver signal from tripping the transmitter if VOX (voice-

operated transmit) is used. The VOX turns the transmitter on as soon as the party on your end of the conversation starts talking. When he stops, the receiver comes on automatically and the voice from afar is fed to the line.

The telephone line normally is connected to the patch-in terminals. When the mode switch is set to *off*, the patch is disconnected from the line and the station mike is connected directly to the transmitter. When the mode switch is set to *on*, the patch is connected to the line and the speaker and the mike are disabled. You use your telephone handset to talk and listen if you want to get in on the patch conversation.

Separate gain controls are provided to adjust the phone-line level into the transmitter and the receiver-output level into the phone line. The calibrated VU meter insures you that *enough* signal is getting into the line but not so much as to cause crosstalk.

It was a snap to assemble the kit. There aren't many components and even a beginner should be able to finish it in an evening. None of the wiring is critical nor are there tight corners.

The instruction manual is up to Heath's high standards and fold-out pictorials make it unnecessary to keep flipping back and forth. However, the manual assumes an experienced ham is building the patch so it doesn't go into detail about lead lengths, etc. There also is an excellent explanation on how to connect the patch and how to use it.

The same night you open the box you should be able to run a patch like an expert. ●



# What You Should Know About SINGLE SIDEBAND

By Robert Smith, WILLF

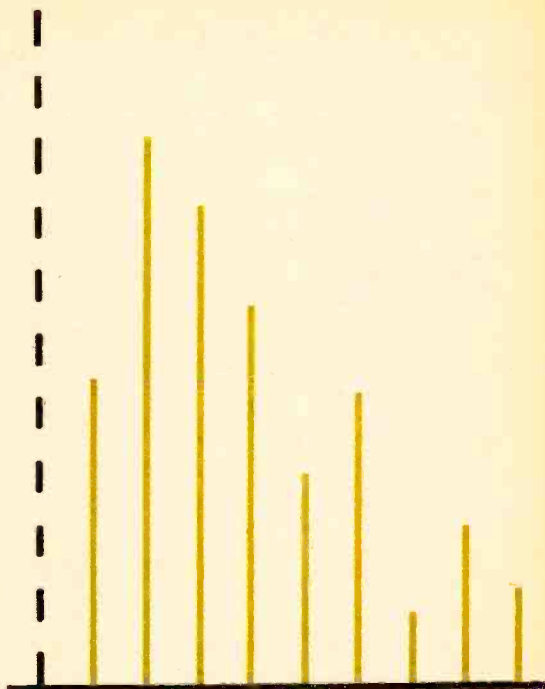

**A little theory shows you why SSB has many advantages over AM.**

**S**INGLE SIDEBAND (SSB) is becoming a big thing with amateurs these days. And Citizens Band operators are interested in it, too, because it offers a solution to the problems of crowded channels and limited range for a 5-watt signal.

Why the growing interest in SSB? In a nutshell, these are the advantages it offers: first, more of an SSB transmitter's power is used for producing an effective signal at the receiver than is the case with regular AM radio. In CB, for example, SSB will turn 5 watts of input power into roughly 20 watts of effective power. Looking at it another way, if you take the power of your AM rig and go single sideband you'll get a much greater transmission range. Furthermore, power isn't wasted in transmitting a carrier that, as we'll see later, is entirely expendable.

Secondly, a sideband signal occupies much less space in the radio spectrum—exactly half the space required by a regular AM signal. This is important on crowded bands.

Thirdly, in long-distance AM com-

munications, the distortion caused by fading is reduced considerably if the transmission is SSB.

Fourthly, annoying whistles on a crowded band caused by the heterodyning of carriers are eliminated since SSB has no carrier on the air.

SSB really is not new. Hams started experimenting with it in the early 1930's. But since more and more new hams and CBers are getting on the bandwagon, we'll start at the beginning to explain what it's all about. You'll find it

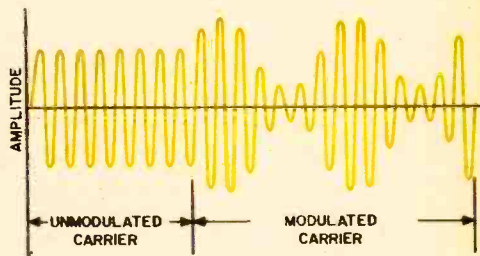

Fig. 1—Conventional AM waveform pattern is composite picture of the carrier and two sidebands.

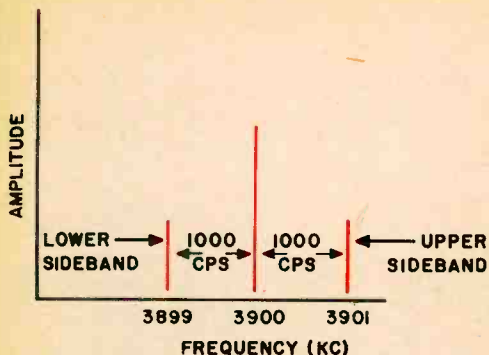

Fig. 2—Spectrum diagram shows amplitude and frequency relationships of carrier and sidebands when the modulation is a 1,000-cps audio tone.

easier to understand SSB by reviewing amplitude modulation (AM) theory. (See ALL ABOUT MODULATION, March '63 EI.)

**Visualizing the Signal.** Most explanations of AM are illustrated with waveform or envelope patterns that you see when monitoring your transmitter's output on an oscilloscope. The pattern in Fig. 1 of an unmodulated and a modulated RF carrier is shown this way. (For further illustrations of this type, see BUILD THE EI CITIZENSCOPE, March '63 EI.) The shortcoming of this pattern is that it doesn't show the relationship to the carrier of what are called side frequencies, or sidebands.

When you apply an RF and an AF signal to the final stage of a transmitter, you'll end up with four signals—the original RF carrier, the carrier frequency plus the audio-modulating frequency, the RF carrier minus the audio modulating frequency, and the audio frequency itself. (But the audio gets lost

in the shuffle, so forget about it.)

The side frequencies (RF plus audio and RF minus audio) change in amplitude in step with the amplitude changes of the audio signal. But, believe it or not, the amplitude of the carrier doesn't change a bit! You can see this easily on the S-meter of a receiver sufficiently selective to tune through each side frequency and the carrier of a signal.

Assume your carrier is 3,900 kc. If you whistled a 1,000-cps tone into your mike, two side frequencies—one at 3,899 and another at 3,901 kc—would appear at your transmitter's output, in addition to the 3,900-kc carrier. This is shown in Fig. 2, a spectrum picture of the complete signal. Here you see amplitude vs. frequency. Figure 1 showed only amplitude vs. time. The amplitude of the side frequencies is determined by how loudly you whistle.

If two people whistled different tones at the same time, there would be two vertical lines on either side of the carrier, as shown in Fig. 4A.

Therefore, a complete radio signal of a 1,000-cps audio tone consists of the 3,900-kc carrier and two side frequencies. In other words, three RF signals are transmitted. Forget about the old notion of the carrier carrying the modulation; it does no such thing. The carrier is just something that the audio beats against to produce two new signals. And it is these side frequencies *only* that carry—or, shall we say, represent—the modulation. At the receiver, the carrier is needed only by the second detector to convert the side frequencies back to audio.

Between the transmitter and the re-

Fig. 3—SSB transmitter. RF and AF are mixed in balanced modulator, whose output is sidebands only—with no carrier. One sideband is removed by the filter, whose output is converted up to the transmitting frequency, is amplified, and then fed to the antenna.

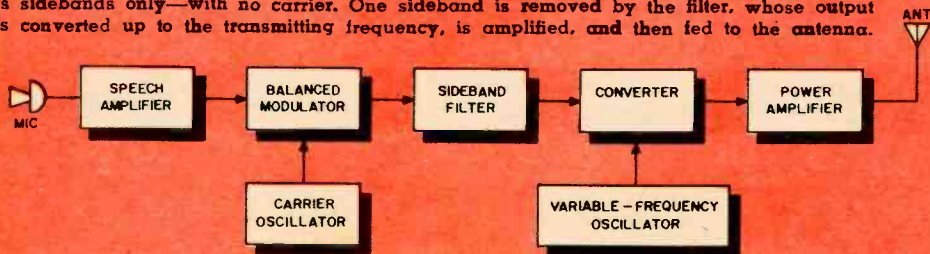



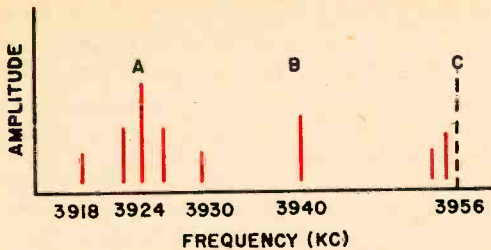

Fig. 4—Spectrum view of part of 80-meter band shows AM signal at A, a CW signal at B, a lower-sideband signal (carrying two audio tones) at C.

ceiver the carrier does nothing. But it requires a lot of the transmitter's power just to be there for the ride.

In an SSB transmitter, there still is a carrier but after it does its job of forming side frequencies it is suppressed and not transmitted. The two side frequencies are mirror-images of each other, so we can eliminate either the upper or lower one. After all, the difference between 3,900 kc and 3,901 kc is 1,000 cps, and so is the difference between 3,900 kc and 3,899 kc.

At the receiver we substitute a homebrew carrier from the BFO and beat it against the side frequency in the second detector. The side frequency won't know the difference and will give us back the 1,000-cps audio just the same.

For example, when you tune a receiver to 3,901 kc, the first detector or mixer is fed a 4,356-kc signal from the local oscillator. This brings the incoming signal down to the 455-kc IF. If the BFO is adjusted so its frequency is 454 kc, mixing it with the 455-kc IF in the second detector will give us back the 1,000-cps audio signal.

For CW reception, it doesn't matter too much what the BFO frequency is. One operator may like a 700-cps tone, while another prefers 1,000 cycles. But for SSB reception, if the BFO frequency is set too far from or too close to the sideband the original signal will have too high or too low a pitch.

**Power Advantages.** The amateur power limit is based on the DC input power to the transmitter's final stage. A CW transmitter running a kilowatt input power delivers about 700 watts to the antenna and all of the 700 watts is a usable signal that contributes to the output at the receiver. A fully modulated AM transmitter running a 1-kw input on phone delivers 700 watts (average power) of carrier to the antenna. But this is just carrier and does not contribute to receiver output (though it does move the S-meter). The maximum average sideband power which would contribute to receiver output is 350 watts, half the carrier power. This is divided into two sidebands (only one of which is needed) of 175 watts each. So, with 1 kw input power on regular AM, you get only 175 watts of usable power. That's quite a waste—approximately 82%.

But with an SSB transmitter, 1 kw average power input will get you 700 watts average power output—and all of it is useful power at the receiver. And 700 watts compared to 175 watts is a 6db gain. Another way of stating this is to say that a 1-kw SSB transmitter would do as much for you as a 4-kw AM transmitter.

**Tuning an SSB Signal.** One way to  
[Continued on page 114]

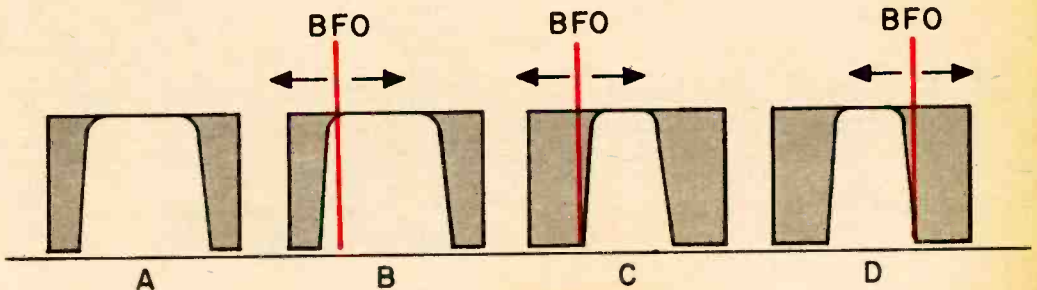

Fig. 5—Tuning a receiver is like moving a window, whose width corresponds to IF selectivity, across band. BFO frequency (red line) is moved within the window by BFO pitch control. Tuning knob moves window and BFO line. BFO line must be set directly above carrier line in Fig. 4C for perfect SSB reception.



ROME

**WE'RE OFF!** . . . As you can gather from the date-line, our European trip came off and we're writing from Rome. With the stateside ham shack padlocked behind us, the XYL and I hopped the Atlantic—she to try out her linguistics, yours truly to engage in

some QRM-free eyeball QSO's with familiar European contacts. Needless to say, our meanderings up the Rhine, through Switzerland and on to Rome already have given us so many ideas that we could fill EI cover to cover—and then some!

**Cologne, Germany . . .** The first major stop on this long-awaited journey found us the owners of a new Volkswagen which we had ordered back in the States. Before we took to the road I slapped one of my QSL cards on the side window and it did the trick. At least once a day we'd come out of our hotel to find a "pleasant trip" note on our windshield, and sometimes invitations to visit with local hams. We took advantage of these whenever we could and, as a result, met some interesting people and saw some mighty nifty shacks.

My first contact was DL6AW, manned by Horst Rohmann (see photo). DL6AW operates from Braunschweig, a West German city that practically hangs on the Iron Curtain. Believe it or not, Horst's gear is entirely home-made—there's not a kit in the setup. Since his installation makes my own pretty expensive outfit look almost breadboard I decided not to swap shack photos with him.

Horst works SSB on 80 through 10 meters and AM on 2 meters. He's always glad to QSL contacts, either direct from his home QTH (Hermann-Von-Vechelde Strasse 12) or through the Deutsche Amateur Radio Club (DARC) in Munich.

**Geneva, Switzerland . . .** Of all the stations we've seen in Europe, probably the busiest is 4U1ITU. The station is operated by the International Amateur Radio Club of the International Telecommunications Union, an agency of the United Nations. I'd say the bulging shack has one each of everything Hallicrafters ever made—all donated by company president Bill Halligan, W9AC.

Since the ITU essentially is a technical body it is loaded with hams of all nationalities who do their relaxing by pounding brass or addressing a mike. The secretary-general of the 400-man club is Gerald Gross, W3GG, a ham since the early 1920's.

The day I visited 4U1ITU the 20-meter band was noisy with generally poor conditions. But a few CQ's brought replies from UQ2AS in Latvia and two from my native land: WA2HVR in Seaford, N.Y., and W7MPZ/4 working portable in Virginia. A few minutes after I signed with W7MPZ/4 he raised Latvia's UQ2AS, but the skip had changed so quickly that I could no longer hear Latvia at all.

Incidentally, 4U1ITU QSL's 100%. Just be sure your cards are addressed to the club at Geneva 20, Switzerland.

**Milan, Italy . . .** In Milan, as in most of Europe, heavy import duties, transportation costs, insurance, etc., make  
[Continued on page 119]



This shack in West Germany is as tidy as they come and 100% home-brew to boot. All the gear is the work of the OM in the photo, DL6AW.



*build this*

# TWO BAND HAM STATION

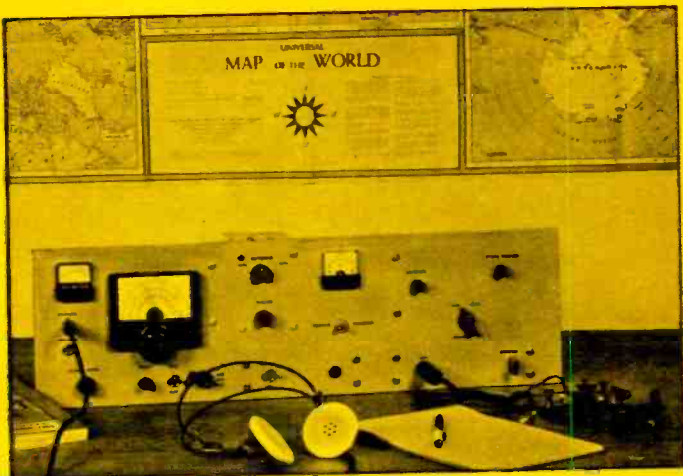

- *Superhet Receiver*
- *Regulated Power Supply*
- *40-Watt Transmitter*

By Harry Kolbe

**I**N the good old days, hamming was a real adventure. That was back when kits were still a thing of the future and half the challenge of going on the air was in building your own equipment. The equipment may have lacked all the spit and polish that kits now have, but the real spirit of hamming came through to those who cut, drilled, added a turn or rolled a coil with their own hands.

The ambitious Novice or General amateur who would like to see what it once was like can now build a complete ham station with components. EI's rig consists of a hot four-tube superhet receiver; a one-tube, 40-watt CW transmitter and a power supply. The station provides complete coverage of the 40 and 80 meter ham bands and the cost runs to about \$50.

At first glance you may wonder why the station is built on three chassis. The answer—versatility. The station actually is three projects and may be built as such. For example, if you wish to build only the receiver, use a 12-inch panel instead of a 24-inch panel. A smaller power supply can be built on the receiver chassis. On the other hand, if you own a receiver, you may only want a transmitter and power supply. Or you may only want a good regulated power supply for experimental work.

## The Receiver

Although the receiver has only four tubes, its sensitivity and selec-

TO TS14-1  
TO TS14-2  
TO TS14-3

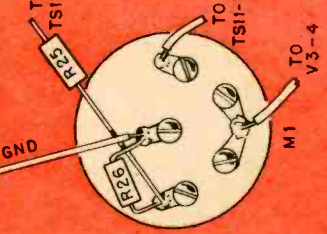
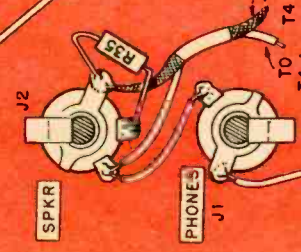
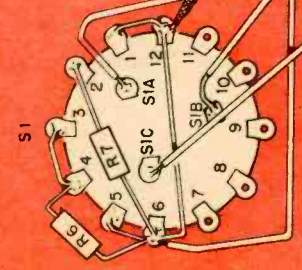
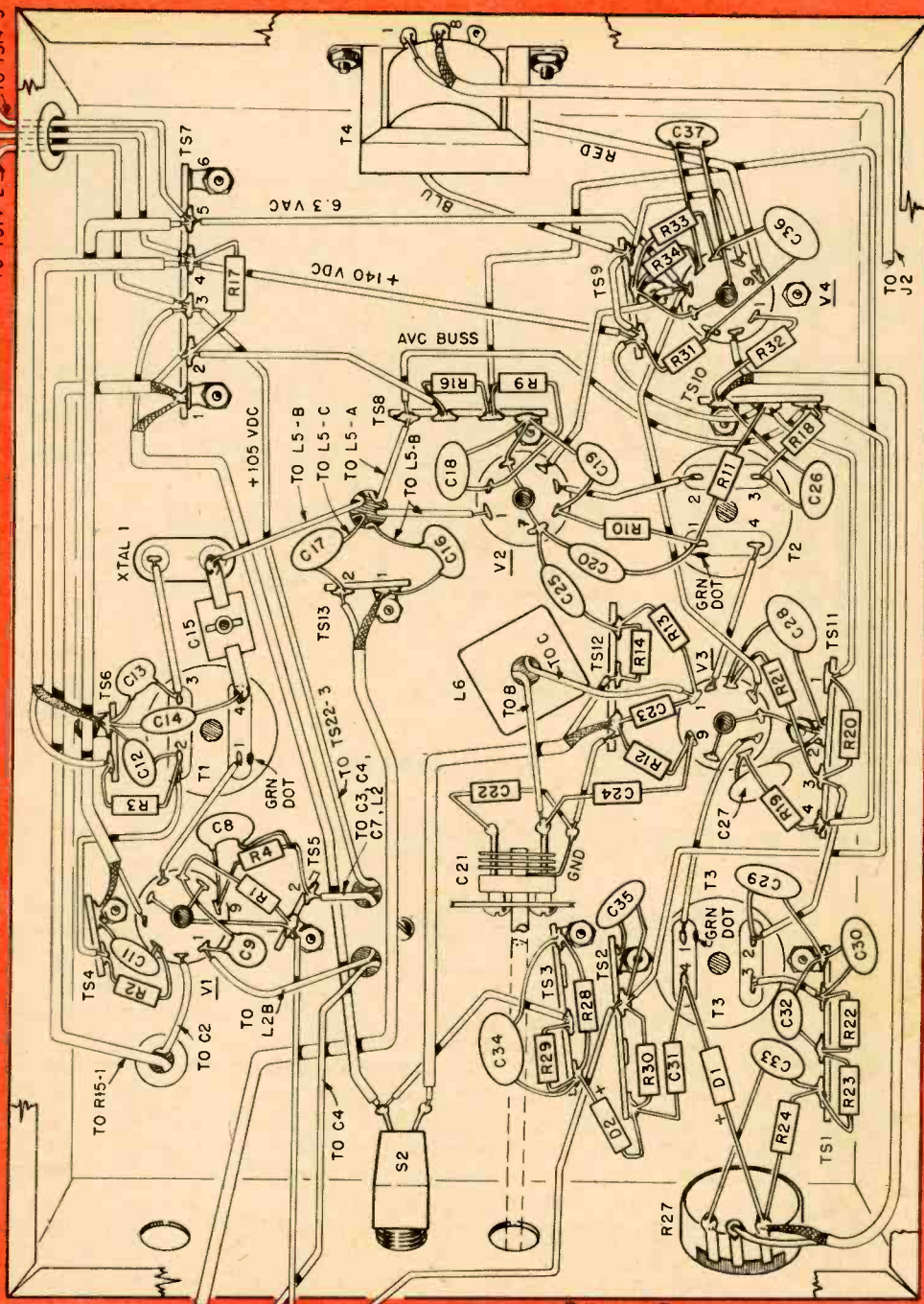



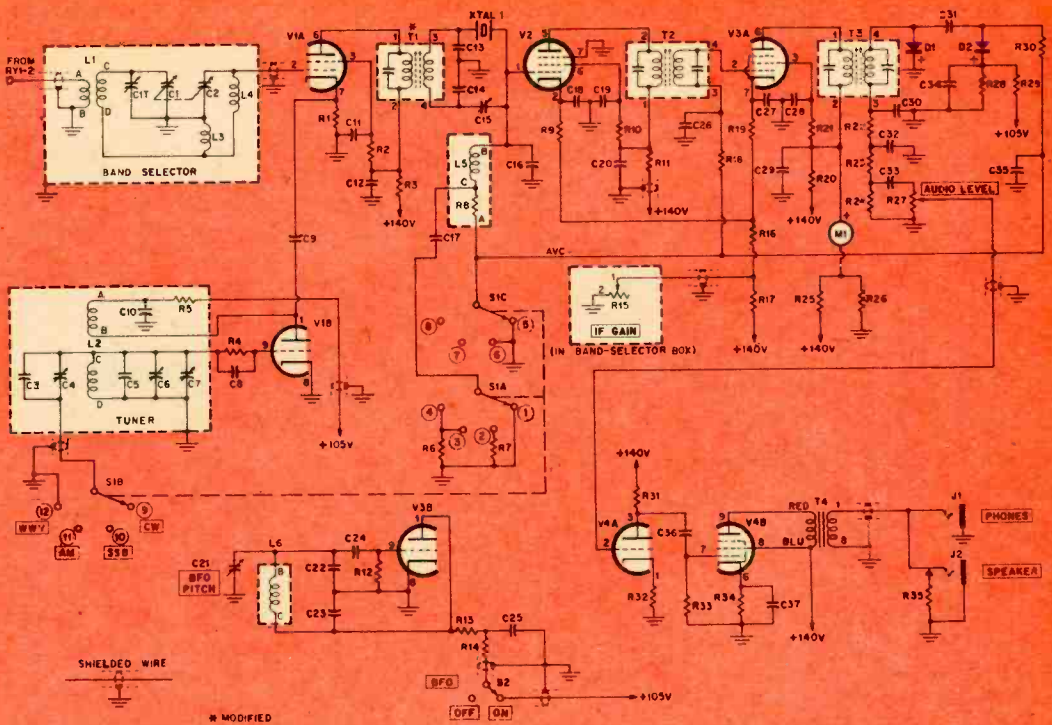

Fig. 1—Receiver schematic. Switching mode-selector switch S1 to the WWV position adds an additional capacitance (C3, C4) across oscillator coil L2 so that 5-mc signal can be received without tuning C7.

Fig. 2—Receiver pictorial (left). C21 should be mounted where shown to keep connections to it short. The control knob on front of chassis is connected to it with extension shaft and coupler (not shown).

tivity are excellent. After careful alignment we measured a sensitivity of about 1/2 to 1 microvolt for a 10db signal-to-noise ratio. Many features are incorporated in the receiver's design which usually are found only in high-priced communications receivers.

● **Construction.** The receiver can be built on a 7x9x2-inch aluminum chassis without crowding. Follow closely the layout of the components shown in Figs. 2 and 14. The front panel is a 7x24-inch rack panel (Premier Metal Products ARP-724). The receiver chassis is held to the panel by R27, S1 and S2.

It is necessary to modify IF transformer T1 and antenna-tuning capacitor C1/C2. T1 is a standard IF transformer with built-in fixed capacitors across both the primary and secondary windings. To provide the correct feed to the crystal filter (XTAL 1, C15, C16 and L5) the capacitor across T1's sec-

ondary must be removed (C13 and C14 mounted outside T1 are used instead of the removed capacitor).

Refer to Fig. 7. Bend back the two tabs that hold the transformer in its can then pull off the can. The secondary winding is connected to the lugs marked 3 and 4. These lugs are bent 90 degrees where they enter the plastic base. As they overlap each other and are separated by a mica dielectric, they form a fixed capacitor.

Carefully break off one corner piece of the plastic base with a pair of diagonals. Pull either lug out sideways, taking great care not to break the fine wire attached to it. Cut off the horizontal part of the lug, which forms one half of the capacitor. Now return the lug to its original position and cement it in place with Duco cement. Allow the cement to dry several hours, then replace the transformer in its shield can.

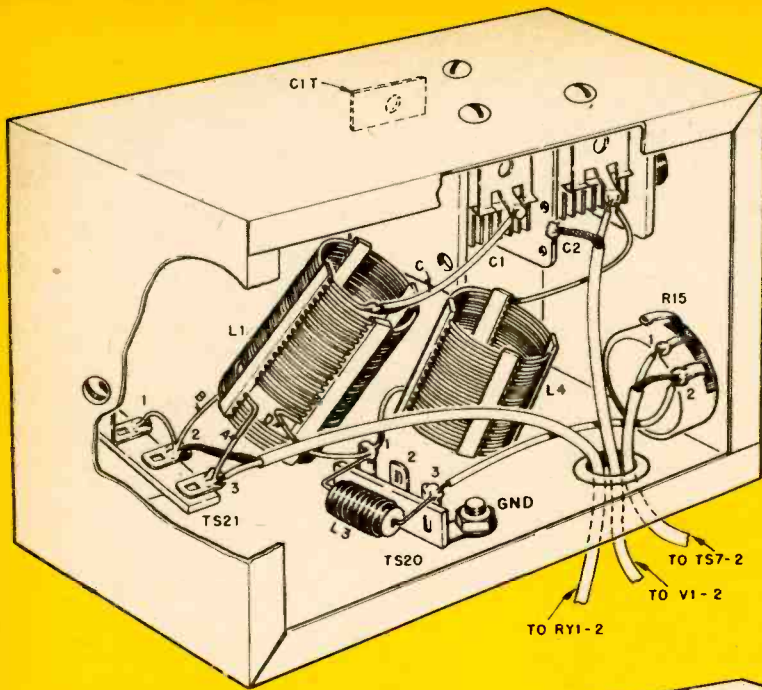
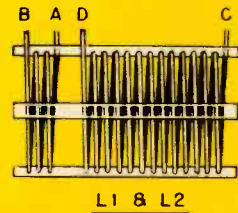

Fig. 3—Band-selector box (above). C1T is a trimmer capacitor on the other side of C1. L1 and L4 are supported by their own leads, which should be kept as short and direct as possible.



L2 AB 4 TURNS  
CD 14 TURNS  
L1 AB 3 TURNS  
CD 43 TURNS

Fig. 6—L1 and L2 details. Letters correspond to connections in pictorials and schematic.

Fig. 4—Tuner (right). Wiring in size Minibox specified is tight, so watch out for shorts. Keep L2's leads short. If they're too long, L2 may flop around and the receiver oscillator will be unstable.

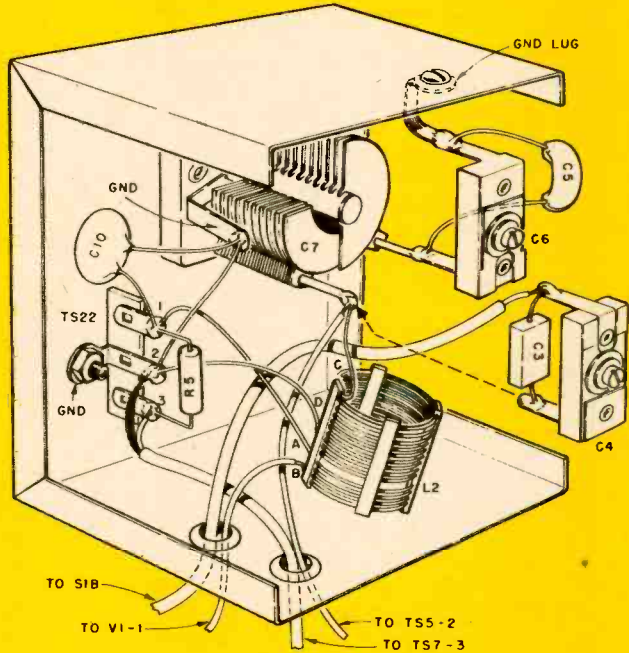
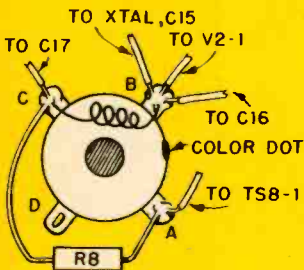

Fig. 5—R8 (below) must be connected directly to coil terminals. Orient lugs with the color dot.



L5

BOTTOM VIEW

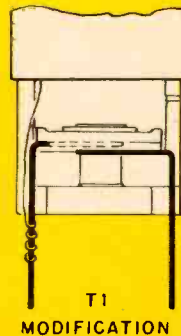

Fig. 7—Cutaway view of base of T1. Lugs overlap in base, forming capacitor. Dotted line is part that must be cut off to remove the built-in capacitor.



### RECEIVER PARTS LIST

Resistors: 1/2 watt, 10% unless otherwise indicated

R1—2,200 ohms  
 R2, R8, R12, R13, R14, R18, R23—100,000 ohms  
 R3, R11, R20—1,000 ohms  
 R4, R22—47,000 ohms R5—3,300 ohms  
 R6—27 ohms R7—10 ohms  
 R9, R19—330 ohms  
 R10, R21—15,000 ohms  
 R15—2,500-ohm linear-taper potentiometer  
 R16—1,200 ohms  
 R17—39,000 ohms, 2 watts  
 R24—56,000 ohms R25—390 ohms  
 R26—33,000 ohms  
 R27—500,000-ohm audio-taper potentiometer  
 R28—220 ohms, 5%  
 R29—82,000 ohms, 5%  
 R30—270,000 ohms  
 R31—68,000 ohms R32—1,000 ohms  
 R33—470,000 ohms  
 R34—470 ohms, 1 watt R35—47 ohms  
 Capacitors: 500 V ceramic disc unless otherwise indicated  
 C1, C2—2-gang variable capacitor, 365 mmf per gang (Allied 60 L

725 or equiv. Modified, see text)  
 C3—240 mmf mica  
 C4—55-300 mmf trimmer (ARCO 427 or equiv.)  
 C5—150 mmf mica  
 C6—7-100 mmf trimmer (ARCO 423 or equiv.)  
 C7—3.2-50 mmf variable (Hammarlund MAPC-50 or equiv.)  
 C8—100 mmf mica  
 C9—.001 mf  
 C10, C11, C12, C17, C18, C19, C20, C26, C27, C28, C29, C33, C34, C36, C37—01 mf  
 C13, C14—120 mmf mica  
 C15—3-35 mmf trimmer (ARCO 403 or equiv.)  
 C16—47 mmf mica  
 C21—2.3-15 mmf variable (Hammarlund MAPC-15 or equiv.)  
 C22, C23—330 mmf mica  
 C24—200 mmf mica C25, C35—.05 mf  
 C30, C31—100 mmf C32—100 mmf  
 S1A, B, C—3-pole, 4-position switch (Mallory 3243J or equiv.)  
 S2—SPST toggle switch  
 T1, T2, T3—1,750 kc IF transformer (Lafayette HP-226 or equiv.)

T4—Universal output transformer (Lafayette TR-12 or equiv.)  
 L1—Antenna transformer (see text)  
 L2—Oscillator transformer (see text)  
 L3, L4—Choke (see text)  
 L5—105-200 microhenry coil (North Hills Electronics S-120-H and S-120 can.)  
 L6—36-64 microhenry coil (North Hills Electronics S-120-F and S-120 can.)  
 J1—Phone jack  
 J2—Shorting-type phone jack  
 D1, D2—1N54 diode  
 M1—Illuminated S-Meter (Lafayette TM-11 or equiv.)  
 XTAL—1,750 kc crystal  
 V1—6E8 tube V3—6U8A tube  
 V2—6B6 tube V4—6CX8 tube  
 Misc.—2 3/4 x 2 1/8 x 1 1/2-inch Minibox (tuning); 5 x 4 x 3-inch Minibox (band selector); crystal socket; Millen No. 10039 dial; 9 x 7 x 2-inch chassis; shaft coupler (Lafayette MS-917); knobs; brackets (Bud MD-458 or equiv.); 7- and 9-pin tube sockets

Now modify variable capacitor C1/C2 by removing all but four rotor plates in each section. Open the capacitor fully, hold a plate with a pair of long-nose pliers and then pull, wiggling it at the same time.

Coils L1, L2 and L4 are made from Barker and Williamson No. 3012 Miniductors. Fig. 6 tells you the number of turns for each winding. (The separation between the windings is one turn.) After counting off the total number of turns (plus one turn), the coil stock must be cut. Push in a turn, cut it inside the coil, and then push the newly cut ends through to the outside of the coil. Peel the wires back with pliers. The plastic support bars can be cut with a fine-tooth jeweler's saw. L3 is 18 turns of No. 22 enamel wire closewound on a 100,000-ohm, 1-watt resistor.

To build the filter assembly consisting of L5 and R8, remove L5 from the can and line the inside of the can at the bottom with tape. Note the color dot and orient the coil as shown in Fig. 5. Solder R8, a 100,000-ohm, 1/2-watt resistor to lugs A and C. (These letters do not appear on the coil. We have designated the lugs A, B, C, D with respect to the color dot to facilitate wiring.) The lug designations for coil L6 are the same. However, there isn't a resistor on L6.

Oscillator tuning capaci-

tor C7 and the following parts are mounted in a 2 3/4 x 2 1/8 x 1 5/8-inch Minibox as shown in Fig. 4: C3, C4, C5, C6, L2, C10 and R5. A 1/4-inch diameter shaft and shaft coupler connect C7 to the front-panel dial assembly. First mount the parts in the Minibox to determine where the dial should be mounted so it can be coupled to C7.

The antenna tuner/band selector consists of L1, L3, L4, C1 and C2. Trimmer C1T is part of C1. These parts are mounted in a 5x4x3-inch aluminum box for shielding as shown in Fig. 3. The box is mounted in the center section of the panel over the power-supply chassis as shown in Fig. 15.

The rest of the receiver construction and wiring is straightforward. Terminal-strips are used generously in the receiver for mounting components and

Fig. 8—Paste scale on paper, insert in dial.

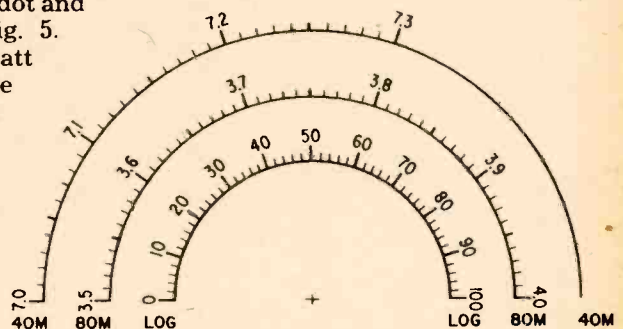

**TRANSMITTER PARTS LIST**

- R36—33,000-ohm, 1/2-watt, 10% resistor
- R37—100-ohm, 2-watt, 10% resistor
- R38—100-ohm, 1-watt, 10% resistor
- C38—3-35 mmf trimmer capacitor (ARCO 403 or equiv.)
- C39—100 mmf, 500 V mica capacitor
- C40, C42, C43—.001 mmf, 500 V disc capacitor
- C41—.01 mf, 500 V disc capacitor
- C44, C45—.001 mf, 1.6 kv disc capacitor
- C46—365 mmf variable capacitor

- (Lafayette M5-214 or equiv.)
- C47—1,000 mmf, 500 V mica capacitor
- C48—Dual 365 mmf variable capacitor (Lafayette M5-142 or equiv.)
- L7, L9, L11—2.5-millihenry, 125 ma RF choke (National R-50 or equiv.)
- L8—10 turns No. 18 wire closewound on R38
- L10—Inductor (see text)
- J3—Phone jack
- J4—Coaxial cable connector type SO-239
- M2—0-100 ma meter (Lafayette

- TM-403 or equiv.)
- RY1—DPDT relay, 117 VAC coil (Potter and Brumfield GP11 contacts and GPA 115 VAC coil)
- S5—SPDT rotary switch (Centralab 1460 or equiv.)
- V5—6DQ6B tube
- Misc.—Feed-thru insulators (Johnson 135-44 or equiv.); plate cap (Millen 36004 or equiv.); ceramic octal tube socket; 5x4x4-inch Minibox; 7x7x2-inch chassis; terminal strips; crystal socket; 40- or 80-meter crystal

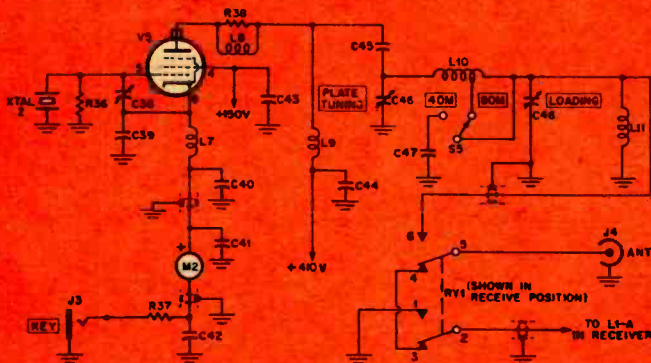
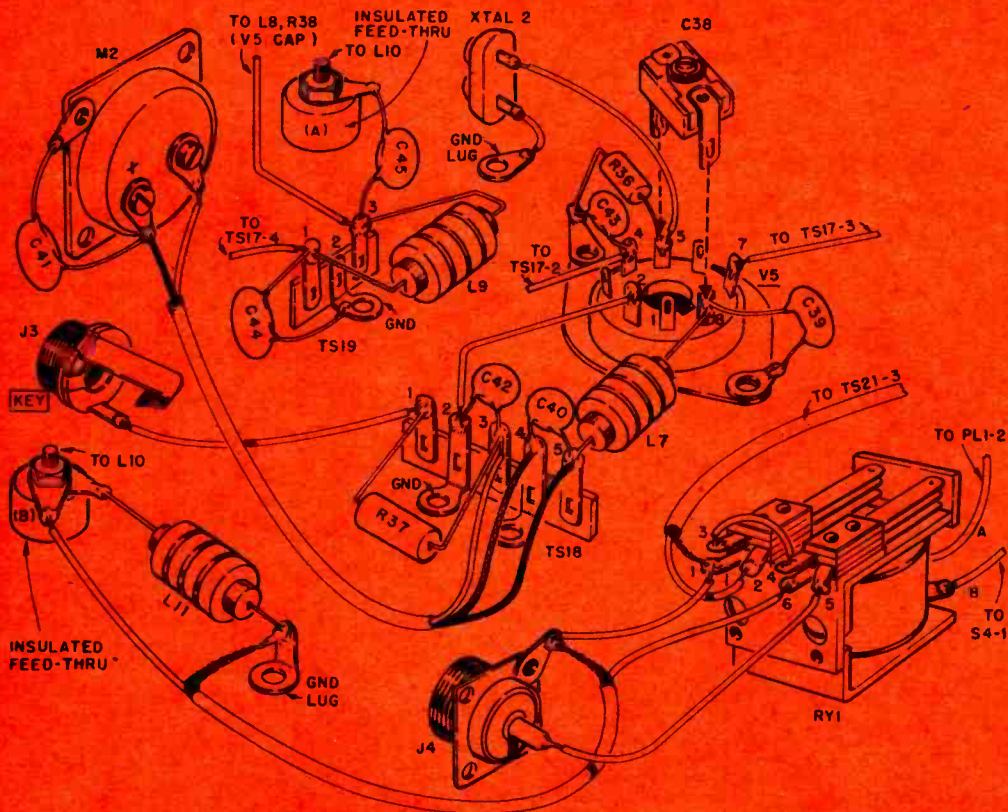

Fig. 9—Transmitter schematic. Two 365 mmf sections of loading capacitor C48 are connected in parallel for total capacitance of 730 mmf. Range of 0-730 mmf is sufficient to couple transmitter output to 50-75-ohm transmission line on the 40-meter band.

Fig. 10—Transmitter pictorial. Parts appear in perspective to show all connections more clearly. Try to follow the layout that was used by the author and which can be seen in the left chassis in Fig. 14.





inter-connecting wiring. On the pictorials the terminal strips are designated, for example, TS12-2. The last number refers to the lug. In several places the receiver is wired with RG174/U coaxial cable to minimize hum and radiation, especially around the crystal filter. The places where the coax is used are shown on the schematic.

Now build the power supply and then proceed to the receiver alignment.

● **Alignment.** After turning on the power, you should hear a hum when R27 is advanced fully clockwise. If you don't hear hum, touching a screwdriver to pin 3 on T3 should produce a loud hum and click. This means the *audio* section is working. If you still don't hear anything, check over the wiring.

Set the front-panel controls to the following positions: *IF gain* (R15) full clockwise; S1 to CW; and BFO switch S2 to on. The next step is to peak T1, T2, T3, L5 and L6 to 1,750 kc, the crystal and IF transformers' frequency. If you own or can borrow an RF signal generator, feed a 1,750 kc signal from it to pin 2 of V1A. Lacking a signal generator, you can use an ordinary broadcast-band receiver tuned to 1,295 kc. Since most broadcast receivers have a 455 kc IF, the set's local oscillator will be operating on 1,750 kc when the receiver is tuned to 1,295 kc. But don't de-

pend on the broadcast receiver's calibration. Verify its dial calibration first by checking it with stations whose frequency you know. The oscillator of the broadcast receiver can supply the 1,750 kc signal, which can be picked up by the Station's receiver. Run a wire from pin 2 of V1A to a point near the antenna of the broadcast receiver.

With the plates of C21 (*BFO pitch*) half open, adjust the slug of L6 until you hear the beat note resulting from the broadcast receiver's 1,750 kc signal and the BFO oscillator's signal. Now adjust the slugs on the top and bottom of T1, T2, T3, and the slug of L5 for the loudest sound. If the Station's receiver overloads, reduce the strength of the 1,750 kc signal from the broadcast receiver by moving the antenna wire away from the broadcast receiver until you are just able to hear the beat note. Turn S2 off and slowly change the frequency of the broadcast receiver by tuning it back and forth. You should notice a spot where the noise increases, then falls off quickly. The crystal frequency is at that point where the noise is maximum. Repeat T1, T2, T3 and L5 for loudest noise, regardless of the broadcast receiver's dial setting.

You should now hear a few signals with an antenna connected to the receiver. When C1/C2 is almost unmeshed, the receiver will tune the 40-

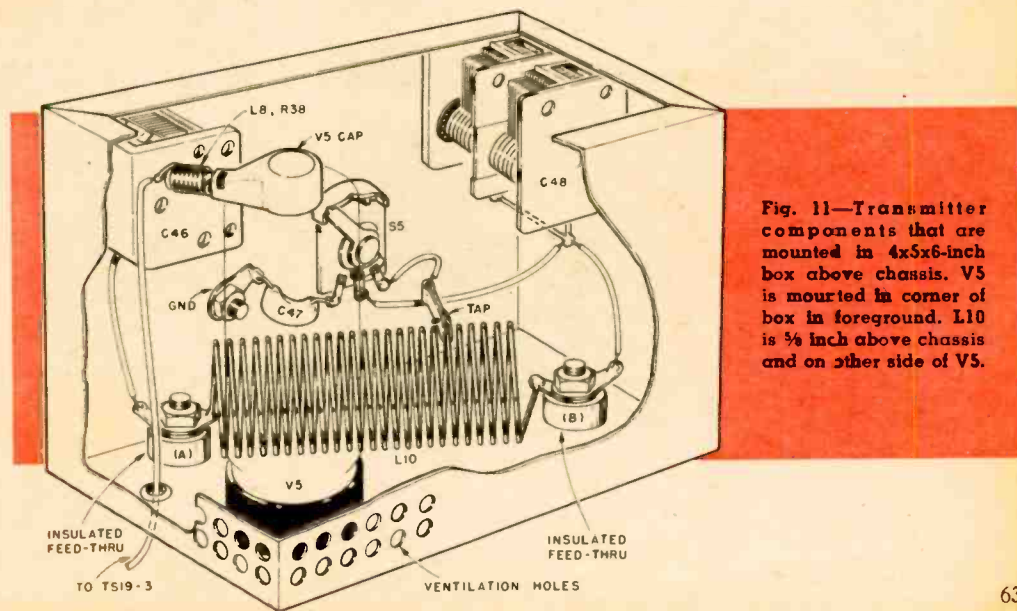

Fig. 11—Transmitter components that are mounted in 4x6x6-inch box above chassis. V5 is mounted in corner of box in foreground. L10 is 3/4 inch above chassis and on other side of V5.

**POWER SUPPLY PARTS LIST**

R39—2,400-ohm, 2-watt, 10% resistor  
 R40—4,500-ohm, 20-watt 10% resistor  
 R41—20,000-ohm, 5-watt, 10% resistor  
 C49—.05 mf, 500 V disc capacitor  
 C50A, B, C—40-40-40 mf, 450 V electrolytic capacitor  
 S3, S4—SPST toggle switch

F1—2-amp fuse and holder  
 PL1—3-watt, 117 V pilot lamp  
 PL2—Pilot lamps in M1  
 SR1-SR4—750 ma, 400 PIV silicon rectifiers  
 V6—0B2 tube V7—0A2 tube  
 RY1—See transmitter parts list  
 CH1, T5 — Available from Mike Kranz, 80 Cortlandt St., N. Y. 7,

N. Y. Specify Berkshire power transformer, \$2.45, and Philco 150 ma cased choke, \$1.40. Add 75¢ postage for both. T5's secondaries are: 700 V center-tapped @ 120 ma, 6.3 V @ 5 A (Allied 62 G 044 or equiv.). Choke: 150 ma, 100 ohms (Allied 61 G 483 or equiv.). Misc.—Tube sockets; terminal strips

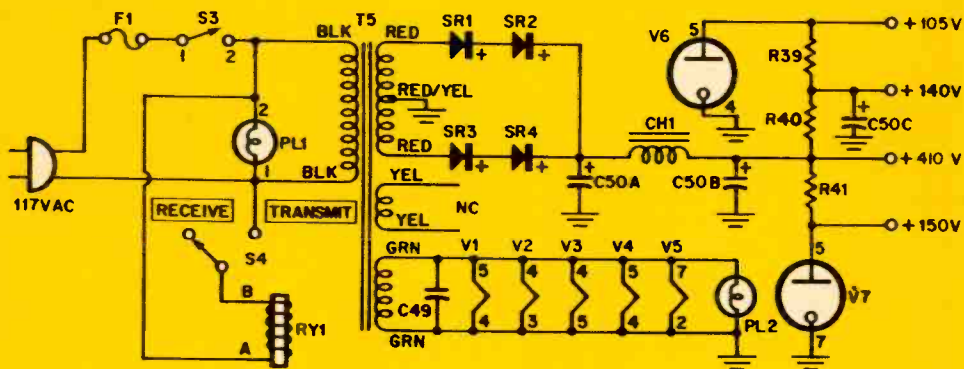

Fig. 12—Power supply. Four 400 PIV silicon rectifiers provide full-wave rectification. Filtering is provided by the pi-network filter consisting of C50A, CH1 and C50B. V6 and V7 supply regulated 105-volt and 150-volt outputs. Resistor R40 and C50C furnish 140 V at 40 ma for the receiver. PL2 is in M1.

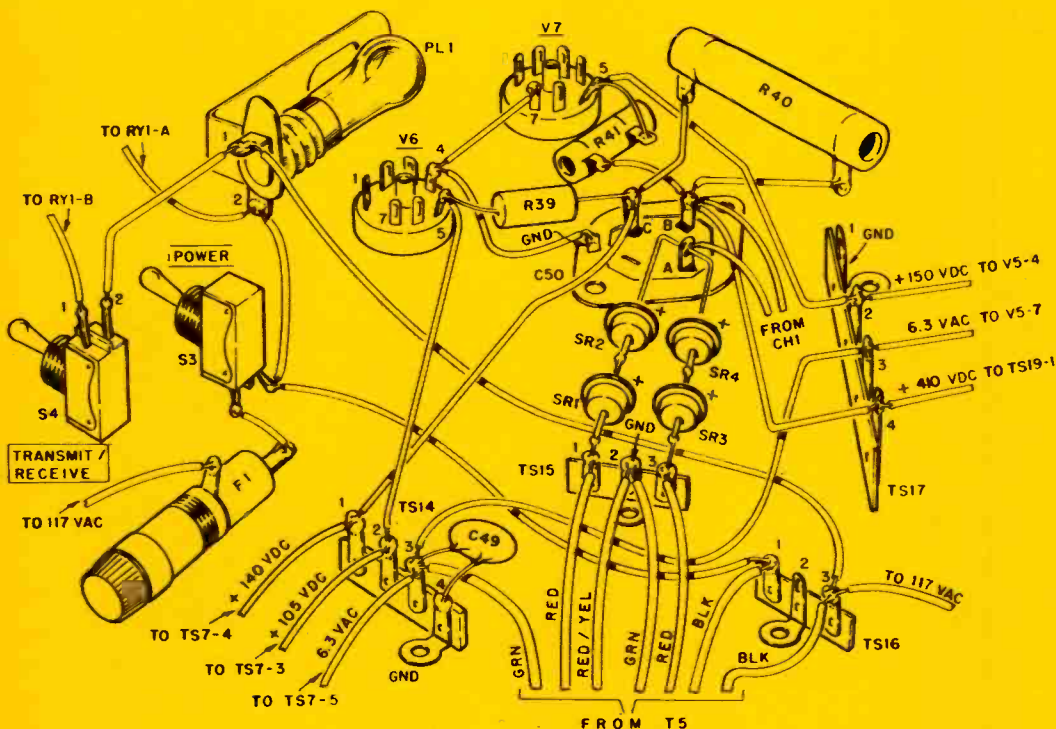

Fig. 13—Power supply. Parts have been shown in perspective to show all connections clearly. Follow layout shown in center chassis in Fig. 14. If you plan to build the receiver only, you can omit V7 and R41.



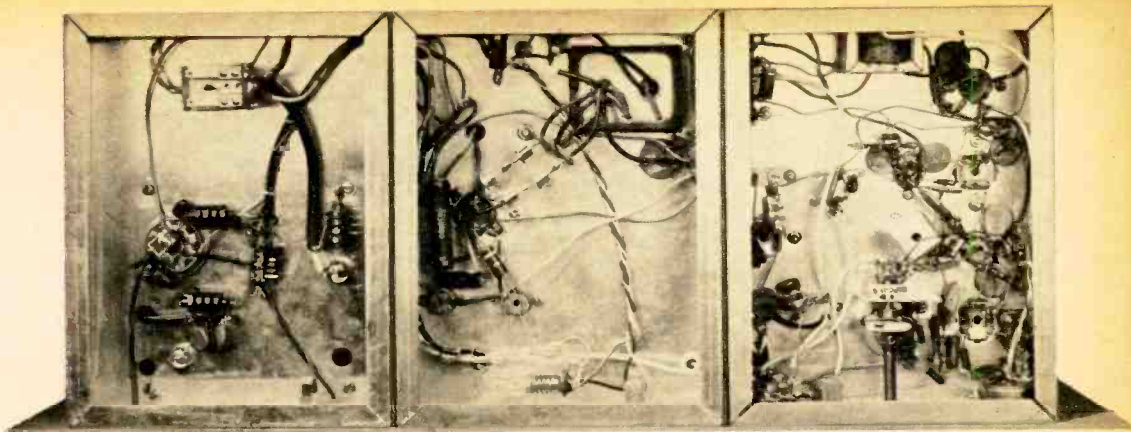

Fig. 14—Underside view of station chassis: transmitter (left), power supply (center), receiver (right).

meter band. When C1/C2 is almost meshed, the receiver tunes the 80-meter band. Tune in a signal of known frequency with the main tuning knob (a signal generator or the station's transmitter may be used as the signal source). Now adjust trimmer C6 until the signal comes in at maximum strength. Adjust C1T (trimmer on the opposite side of C1) for maximum volume.

You may notice that tuning C1/C2 and C1T changes the location of the signal on the dial. In other words, C1/C2 or C1T pull the oscillator slightly. To remedy this would have made the receiver more complicated. The simple solution is first to peak C1/C2 on noise on the desired band, then tune with C7.

Turn the BFO back on and tune in a CW signal. When tuning through the signal, note that it is louder on one side of zero beat than on the other. Experiment with the setting of C21 until what's called the maximum single-signal effect (signal louder on one side of zero beat than the other) is obtained. It may be necessary to adjust C15 and to retune T1 and L5 to achieve this effect. After a little adjustment, the single-signal effect should be quite apparent.

If T1, T2, T3 and the crystal filter (XTAL 1, C15, C16 and L5) have been aligned correctly, the dial calibration for 40 and 80 meters should coincide. If alignment is incorrect, the calibration will be offset on the two bands.

To align for WWV at 5 mc, set S1 to the WWV position, set C1/C2 to 80 me-

ters, and adjust C4 to bring in WWV at any quiet spot on the dial. Mark that spot on the dial. To tune in WWV later, reset C1/C2, set S1 to WWV and set the dial to the mark.

● **How it Works.** Refer to the schematic in Fig. 1. The receiver is a superheterodyne with a 1,750 kc IF. The pentode section (V1A) of the 6EA8 is used as a mixer and the triode section (V1B) is the local oscillator. The receiver is tuned by changing the frequency of the local oscillator, which tunes from 5.25 to 5.75 mc. With this range, both the 3.5-to-4-mc and 7-to-7.3-mc bands may be tuned. Here's how. If the local oscillator is set by C7 so its output is 5.25 mc, the difference between 5.25 mc and 3.5 mc is 1,750 kc, the IF. And the difference between 5.25 mc and 7 mc also is 1,750 kc. Although you might expect to hear a 3.5 mc and 7 mc signal at the same setting of the tuning dial, the two signals never reach the mixer because of the double-tuned rejection filter, consisting of L1, L3, L4 and C1/C2, between the antenna and mixer grid.

This double-tuned filter is extremely selective and provides close to 70db rejection of the band to which it is tuned.

The advantage of this design is that by eliminating coil switching it is easy to build a stable high-frequency oscillator, which results in a stable receiver. Additional stability is obtained by using regulated 105-VDC power for V1B.

The high degree of selectivity is obtained by using a crystal filter and two IF stages. The frequency of the crystal

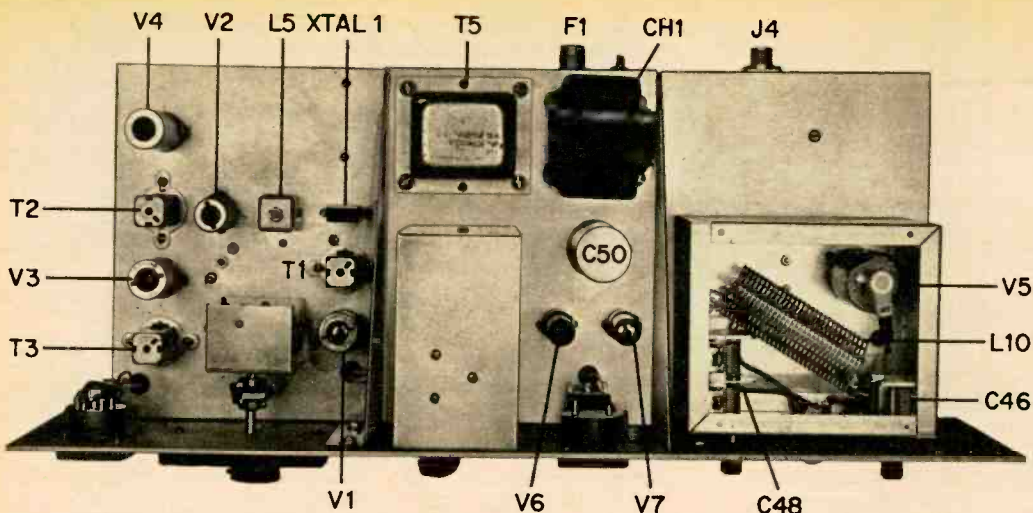

Fig. 15—Top view of station. Receiver (left), power supply (center), transmitter (right). Tuning unit is in box in front center of receiver. Band selector is over power supply chassis in front of T5.

is 1,750 kc, the same as the IF transformers. In combination with the resonant circuit consisting of L5, C15, C16 and the tuned secondary of T1, XTAL 1 forms a filter that sharply attenuates all signals on both sides of the IF frequency.

For CW reception set S1 to CW. This is the narrowest IF passband and results in sharp tuning and a clean signal. When S1 is in the SSB or AM position, R7 or R6, respectively, is inserted between L5 and ground. Placing either resistor in series with L5 broadens the response of the filter.

The crystal filter is followed by two stages of IF—a 6BA6 (V2) and the pentode section of the 6U8 (V3A). The gain of the IF stages is controlled by R15. However, when S1 is set to AM, S1 inserts an AVC loop. Voltage for the AVC loop is rectified by D2. This AVC is delayed—that is, the AVC is not effective at low signal levels. This is achieved by back-biasing (R28, R29) AVC diode D2 with a small positive voltage so it does not conduct until the IF voltage reaches the same level as the back-bias voltage. This occurs when the signal at the antenna is 4 microvolts or greater.

D1 is the audio detector. The audio signal across R27 is applied to triode voltage amplifier V4A and then to pentode power amplifier V4B. The output of V4B is sufficient to drive a speaker

or low-impedance headphones.

The BFO, V3B, is a triode Colpitts oscillator whose frequency is set close to the IF frequency by adjusting the slug of L6. Fine-frequency or pitch adjustment control is provided by C21. Stray coupling to V3A at its socket and within the tube envelope provides adequate BFO signal injection.

### The Transmitter

● **Construction.** All transmitter components except C46, C47, C48 and S5 are mounted on a 9x7x2-inch aluminum chassis. The aforementioned parts are mounted on a 5x6x4-inch aluminum Minibox which acts as a shield to reduce BCI. You can reduce radiation further by putting a bottom plate on the transmitter chassis, but you *must* put a plate on the top of the Minibox. Don't forget the ventilation holes at the bottom and top of the Minibox or V5 will overheat.

Tank coil L10 is 29 turns of a Barker and Williamson No. 3018 Miniductor, tapped six turns (with a Barker and Williamson No. 3942 clip) from the end marked B in Fig. 11. It is mounted  $\frac{5}{8}$  inch above the chassis on ceramic or polystyrene feed-through insulators. Mount C46, C48 and S5 on the front of the Minibox first.

The transmitter chassis is held to the front panel by key jack J3, the crystal



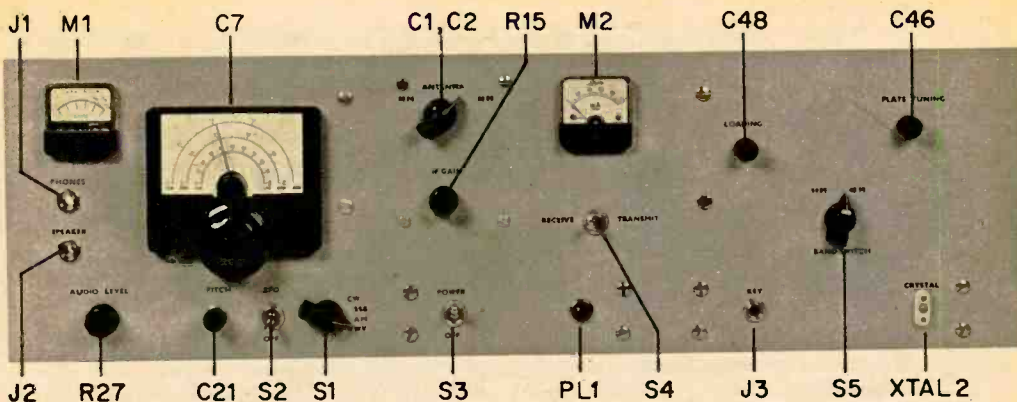

Fig. 16—Front view of station shows control locations and can be used as guide in laying out panel.

socket and four heavy bolts and nuts.

If you're going to build only the transmitter, the power supply easily will fit in a corner of the transmitter chassis and you'll be able to get away with a 7x19-inch rack panel.

● **Transmitter Tune-up.** Connect a 15- or 25-watt lamp bulb between the output at J4 and chassis ground. Plug in a 40- or 80-meter crystal and a key. Set S5 to the same band as the crystal, turn on the power and set transmit-receive switch S4 to *transmit*.

Set C48 to maximum capacitance (plates closed) and hold the key closed. Tune C46 quickly to resonance, which will be indicated on M2 by a dip in current. Gradually open the plates of C48 while readjusting the tuning of C46 as loading increases. Increasing lamp brilliance means increased loading. M2 also should indicate a higher current. The cathode current should be between 85 and 100 ma when the transmitter is fully loaded. To determine actual input power, multiply the current indicated by M2 by 410, the plate voltage of V5.

Adjust C38 for the best keying characteristic. To do this, listen to the transmitter keying through the receiver (there is a small amount of signal leakage from the transmitter to the receiver) while adjusting C38.

Don't adjust C38 with a lamp dummy load as the lamp resistance changes during keying. Use a regular antenna and load the transmitter with the same technique as is used with the dummy load. Maximum loading is now indicated by

peak current on M2 rather than maximum lamp brilliance.

● **Transmitter Operation.** V5 functions as both a crystal-controlled Colpitts oscillator (the screen grid acts as the oscillator plate) and an RF amplifier. V5's input power is 40 watts on the 40-meter band and about 34 watts on the 80-meter band. Regulated voltage (+150 V) on V5's screen grid minimizes key chirp or frequency skip.

Power output is taken from a pi-network tank circuit consisting of L10 and C46. C46 tunes the tank. At the pi-network output, antenna and transmission-line loading are controlled by C48.

Operation on 80-meters requires that C47 be paralleled with C48. S5 takes care of this. When RY1 (S4) is in the *transmit* position, the antenna input of the receiver is grounded and the transmitter is connected to the antenna. When S4 (RY1) is set to *receive*, the antenna is disconnected from the transmitter and is connected to the receiver.

### The Power Supply

The power supply also is built on a 7x9x2-inch aluminum chassis. Follow the layout shown in Figs. 13 and 14. The chassis is held to the front panel by PL1, S3 and four bolts. Because of the weight of T5 and CH1, 8-inch chassis mounting brackets must be used on both sides of the chassis for mechanical rigidity. For additional support, put bolts through the sides of the transmitter and receiver chassis and the support brackets into the power supply chassis. ●



# THE LISTENER

SWL-DX NOTES

BY C. M. STANBURY II

**FRENCH LESSON** . . . The best news is local news—news direct from where and when it happens. With this in mind, did you ever stop to think that Americans don't have to own a short-wave receiver to hear Canadian news? Most Americans can tune in on Canada in the same way that Canadians do—by listening to any one of a number of big (50-kilo-watt) stations on the broadcast band.

The stars on the map at right show the locations of seven 50-kw stations operated by the Canadian Broadcasting Corp. (CBC).

Readers who live right along the border probably will be able to hear at least one of these during daylight hours. Farther away, reception will be possible only after dark.

Frequencies of the stations shown are: CBK (Watrous, Sask.), 540 kc; CBW (Winnipeg, Man.), 990 kc; CBL and CJBC (both Toronto, Ont.), 740 and 860 kc, respectively; CBF and CBM (both Montreal, Que.), 690 and 940 kc, respectively; CBA (Sackville, N. B.), 1070 kc. Best resurrect your high school French for CBF. It's one of four basic stations in the CBC's French network.

For readers who prefer the SW bands, Canada also has five privately owned short-wave transmitters which bring news to the nation's more sparsely populated areas. The most widely received are CFRX, a 6070-kc outlet in Toronto, Ont., relaying CFRB on 1010 kc; and CHNX, a 6130-kc station in Halifax, N. S., in parallel with CHNS on 960 kc.

**Anti-Red Russians** . . . An SWL usually forms concrete opinions of short-wave broadcast stations, first by listen-

ing to them, and later by looking over their replies to his reception reports. Depending on his own beliefs and prejudices, he is either for them, against them, or perhaps somewhere in the middle. But every so often an SWL comes up against a broadcaster which stops him cold, no matter what his own political concepts may be.

Such an organization is *Narodno Trudovoi Soyuz*, or National Alliance of Russian Solidarists. Popularly known as the NTS, the group is comprised of Russian anti-Communists and operates Radio Free Russia

from Western Europe (DXers on that continent believe the stations to be in West Germany).

Because it is directly connected with the underground, Radio Free Russia is considered a real threat by the Reds. It has been jammed ever since it first came on the air—in December, 1950, with a mere 38 watts. But NTS differs from other European anti-Communist organizations (such as Radio Free Europe and Radio Liberty) in three important aspects.

First, its stations are not licensed. It operates two transmitters in roving trucks on approximately 6400 and 11550 kc. The trucks are moved from place to place to avoid detection and Communist sabotage. Worse yet, while NTS operations obviously are winked at by local authorities, the group is not afforded much protection.

Secondly, NTS has a history. The organization was founded back in the summer of 1930 at Belgrade, Yugoslavia, by a group of young Soviet refugees. During World War II, they worked intermit-

[Continued on page 113]





# RCA introduces a new easy way to learn electronics at home

Learn faster, remember more with this revolutionary new "learning method!" And RCA Institutes, Inc. is first to bring it to you!

Forget all your old ideas about learning! The newest method, RCA "Autotext", uses the latest scientific development in the field of home training! RCA "Autotext" is a system of programmed instruction, accurately planned so that as you read a series of statements, questions, and answers, you learn almost without realizing it! It's fun to learn this new RCA way!

We'll prove it to you now! RCA Institutes now offers you a complete Home Training Course using RCA "Autotext" called "Introduction to Electronics." In addition, you get a complete set of experiment lessons, service practice lessons, and all the kits you need. You learn electronics theory faster with less effort.

## FREE OFFER!

We'll send you complete information on the amazing new RCA "Autotext", along with a FREE SAMPLE of a Home Training lesson to prove to you how easy it is to learn this new way. Check "Autotext", and information will be rushed to you.

**WIDE CHOICE OF HOME TRAINING COURSES IN ELECTRONICS:** In addition to Introduction to Electronics, RCA Institutes offers this complete selection of Home Training Courses:

- Electronics Fundamentals\*
- TV Servicing
- Color TV
- Transistors
- Electronic Drafting
- Communications Electronics
- FCC License Preparation
- Mobile Communications
- Automation Electronics
- Computer Programming

*\*Available in Spanish*

All RCA Institutes Home Training Courses are complete step by step easy-to-understand units. You get prime quality equipment in the kits furnished to you to keep and use on the job. In addition, RCA's liberal tuition plan affords you the most economical possible method of home study training. You pay for lessons only as you order them. If you should wish to interrupt your training for any reason, you do not owe one cent. Licensed by the N. Y. State Department of Education. Approved for Veterans.

CLASSROOM TRAINING AVAILABLE IN NEW YORK CITY, LOS ANGELES, AND CHERRY HILL (NEAR CAMDEN) NEW JERSEY. Check "Classroom Training" and information will be rushed to you.

**Send postcard for free illustrated book today! Specify home training or classroom training!**

**RCA INSTITUTES, INC.,** Dept. EI-93  
A Service of Radio Corporation of America  
350 West 4th St., New York 14, N. Y.  
Pacific Electric Bldg., 610 S. Main St., Los Angeles 14, Calif.



**THE MOST TRUSTED NAME  
IN ELECTRONICS**

By Herb Friedman, W2ZLF

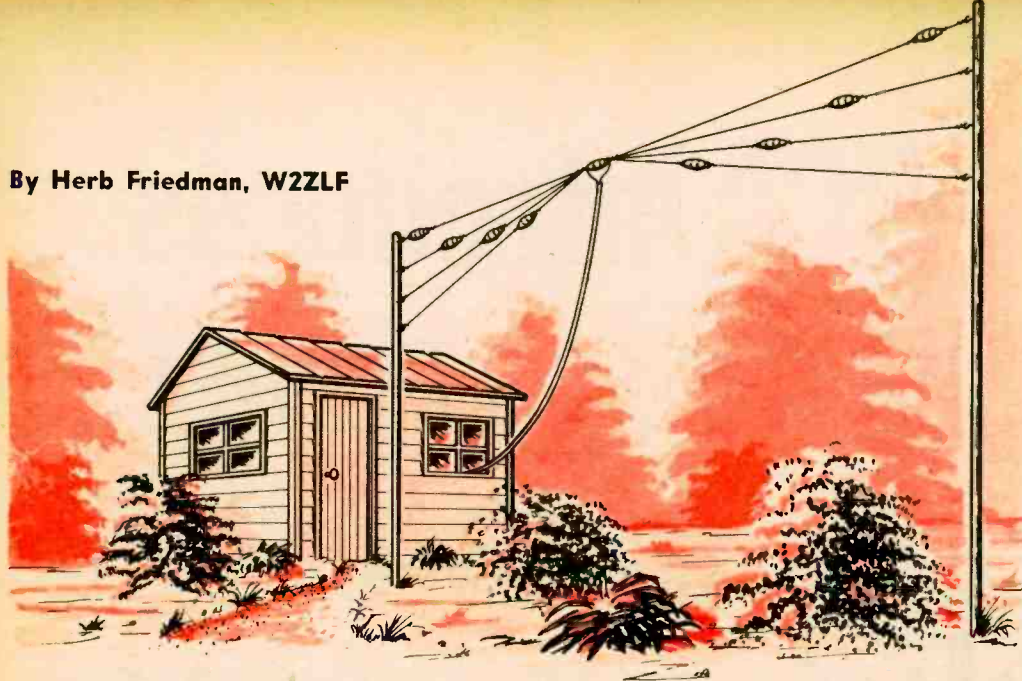

# HAM ANTENNA FACTS

**Building or buying an antenna is easy, once you know the score.**

**A**LL TOO OFTEN the newcomer to the amateur ranks grinds along month after month with a hastily erected skyhook. And, though his thoughts may be on that super-duper work-all-countries antenna he plans to erect, he may pump out less signal than if he shouted from a window.

Much of this is understandable, of course. In his first burst of enthusiasm to get on the air, a ham is willing to use anything for an antenna. But there's no reason to settle for inadequacy. Many inexpensive, easily erected antennas—both home-brew and ready-made—can give quite satisfactory performance until you get around to your all-out antenna-raising party.

## The Long Wire

The easiest antenna to install is the long-wire, which can be of any length. While it's not the most desirable antenna by a long shot, a long-wire is sometimes a necessity when you're faced with space or a landlord's restrictions.

Figure 1 shows a typical arrangement: the antenna, as high and as free from obstructions as possible, is supported by two poles and is electrically isolated from the poles by means of insulators. An antenna coupler is almost mandatory with a long-wire, and therein lies one of its many weaknesses. All in all, if you're not forced into using a long-wire, you'd do better with one of the antennas which follow.

## The Dipole

The simple dipole is capable of giving results which can satisfy you for years. Basically, it's a wire which is one-half wavelength long at the operating frequency, broken at the center to permit connection of a transmission line (see Fig. 2). The impedance at the feed-point is matched easily with standard 52- or 72-ohm coaxial cable or with twin-lead.

For best results, a dipole must be used at the frequency for which it has been cut. However, it also will give good per-



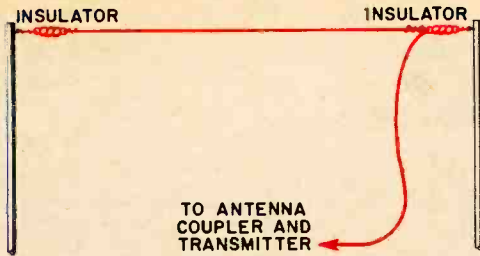

Fig. 1—Long-wire antenna is old as the hills but has one advantage: it can be of any length.

formance on its third harmonic, so a 40-meter dipole will perform efficiently on 15 meters. This feature is particularly handy for the Novice who can work the States on 40 and DX on 15 with only one antenna.

While a dipole is one-half wavelength electrically, it isn't precisely a half-wavelength physically. The insulators at each end contribute a shortening effect of about 5 per cent, and the length (L) is determined from the corrected formula,  $L$  (in feet) =  $468/F$  (frequency in megacycles).

### The Multi-Band Dipole

One way to work several bands without erecting an antenna farm in your back yard is through the use of the multi-band dipole shown in Fig. 3. Such an antenna actually is a number of dipoles all tied to a common feedpoint.

As with the standard dipole, the 40-meter section also can be used on 15 meters. Therefore, a multi-band dipole need consist only of 80-, 40-, 20- and 10-meter sections (or any combination of

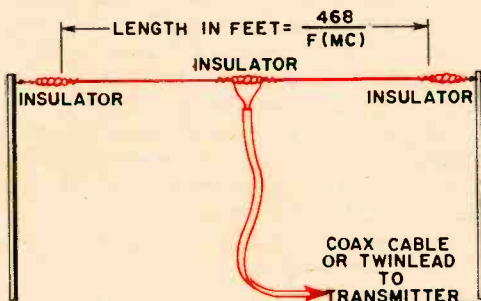

Fig. 2—Half-wave dipole must be cut to a specific frequency. It has an impedance of 72 ohms.

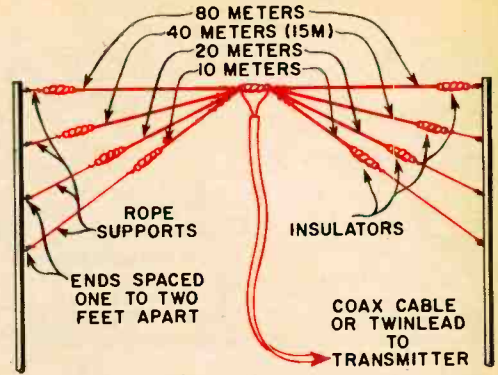

Fig. 3—Multi-band dipole consists of several dipoles connected to a single transmission line.

two or more). The dipole for the lowest frequency can be at the top, with dipoles for successive bands spaced at the ends one to two feet apart. Any non-metallic material can be used for the supports, but wire is *verboten!*

If the multi-band dipole looks like your cup of tea, keep in mind that your transmitter has to be clean. Multi-band antennas radiate harmonics just as well as they do fundamentals. Therefore, if your rig is loaded with harmonics the multi is going to do a great job of pushing them out into space. Only if you are certain your transmitter meets good engineering standards is the multi-band dipole recommended.

### The Folded Dipole

The dipole can be modified easily into what is probably the most convenient antenna around—the folded dipole (see Fig. 4). If a second wire is stretched a given distance above the dipole and connected to the ends of the dipole, the ra-

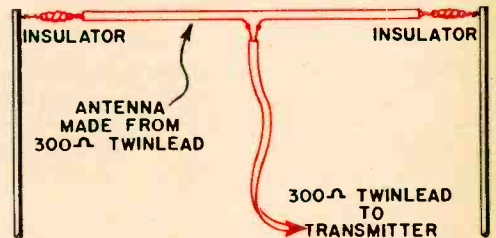

Fig. 4—Folded dipole offers broader response than simple dipole. Its impedance is 300 ohms.

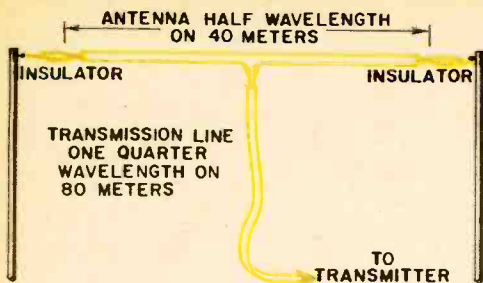

Fig. 5—Resonant folded dipole works on both 40 and 80 meters because of special feedline.

radiation resistance is increased approximately four times, to about 300 ohms—a value easily matched with low-cost TV twinlead.

In contrast to a simple dipole, which gives maximum performance at its resonant frequency with a sharp drop on either side, a folded dipole gives good performance over a relatively broad range of frequencies. Cut for the center of the ham band, a folded dipole will give efficient performance over all of that band. To determine the proper length for a folded dipole, use the formula shown in Fig. 2.

### Resonant Folded Dipole

For 80-meter enthusiasts with 40-meter space, the resonant folded dipole shown in Fig. 5 may be the answer. It is cut for 40 meters and can be made conveniently from 300-ohm twinlead.

Naturally, if used on 80 meters, its radiation resistance would be too high to match with commercial twinlead. However, when the transmission line is an exact quarter-wavelength of 80 meters, the feeder acts as an impedance-matching transformer between transmitter and antenna. As a result, good performance can be expected.

When determining the length of the transmission line, it's important to take into account the *velocity factor*—a characteristic which shortens the line electrically. The velocity factor for common twinlead is 0.82, and the length in feet for a quarter-wave section is  $246 / F$  (mc)  $\times 0.82$ . If you want to save yourself a little time, you can buy an 80-meter folded dipole made from

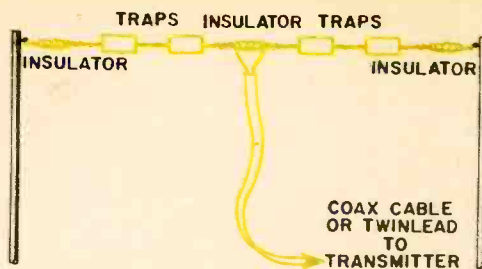

Fig. 6—Trap antenna makes use of resonant L-C circuits for operation on two or more ham bands.

300-ohm twinlead and trim it down to size.

### The Trap Antenna

Still another popular ham antenna is the multi-band trap shown in Fig. 6. Whereas a dipole is useful only on the frequency for which it is cut—or the third harmonic of that frequency—trap antennas can cover two, three or all bands, 80 through 10 meters.

To effect multi-band operation, traps (resonant L-C circuits) are installed in both legs of the antenna. These traps alter the length of the antenna electrically so it is resonant at the signal frequency. Since the traps are automatic in operation, all you have to do to change bands is change the transmitter's frequency.

Trap antennas have another important advantage: they can be made physically shorter than an equivalent dipole. Whereas you might not have sufficient space for an 80-meter dipole (or long-wire), you may have room for a short trap antenna.

The same precaution which applies to a multi-band dipole applies to a trap. Since a trap antenna also does a great job of radiating harmonics, it's imperative that your transmitter be clean.

While there are many other types of antennas, the ones we've discussed offer the hard-to-beat advantages of easy installation and good performance. At least one of them is bound to meet your specific requirements. Take a little extra care with the installation, and a good, efficient antenna system can be yours.



# A MODULATED

By Herb Cenon

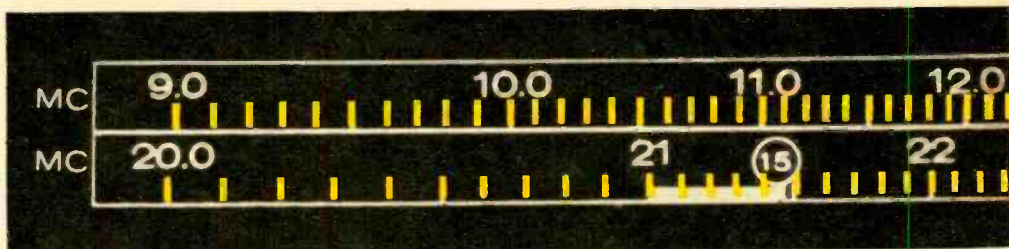

## CRYSTAL CALIBRATOR

... for 100-kc markers that really stand out.

ANY ham or SWL will tell you that you can't beat a 100-kc crystal calibrator to determine exactly where you are when checking the calibration of communications receivers, converters and oscillators. And they'll also tell you that it is often virtually impossible to spot the output of most calibrators in the all-too-common messes of noise on a crowded band.

But EI's crystal calibrator is different from the others—its output can be modulated to produce the most raucous of sounds. Its markers will stand out like your howl when you put your thumb on a hot soldering iron. What's more, you can adjust the Calibrator's output frequency slightly to zero-beat it with WWV. This will get the markers exactly where they should be.

The Calibrator, which uses two transistors and costs less than \$15, produces markers every 100 kc from 100 kc to 30 mc. Since the markers are harmonics of 100 kc, they naturally will be weaker at higher frequencies.

Most of the Calibrator's components are mounted on a small piece of perforated board, which could be mounted permanently inside a receiver.

### Construction

The unit shown is built on a  $2\frac{5}{8} \times 3\frac{5}{8}$ -inch piece of perforated board which is mounted in the main section of a  $5\frac{1}{4} \times 3 \times 2\frac{1}{8}$ -inch Minibox. Make certain the board does not exceed the specified dimensions or the Minibox cover will not fit in place.

Follow the pictorial closely and do not substitute different values for any of the frequency-determining components—C2, C5 and L1. Plug the crystal in its socket and mount it near the edge of the board

Author's model is in  $5\frac{1}{4} \times 3 \times 2\frac{1}{8}$ -inch Minibox. Switch selects modulated or unmodulated outputs.

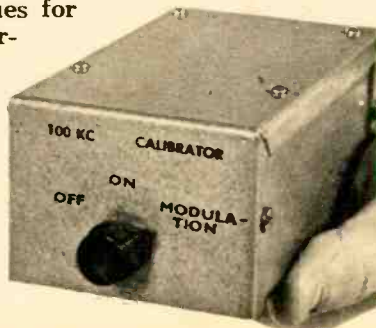

by strapping it down with a piece of hook-up wire. Twist the wire ends together under the board and apply a drop of solder.

T1 should be mounted by soldering a flea clip to each of its mounting tabs and then jamming the clips into the perforated board. The tabs are so spaced that the clips should line up exactly with the holes. Cut off T1's green and yellow leads near the frame. L1 is held in place by two flea clips near the crystal socket. If possible, position L1 so one terminal touches the lug on the crystal socket near the center of the board. Put a short length of wire through the crystal socket terminal and through the flea clip to which one side of L1 is soldered.

Solder one lug of C5, the trimmer capacitor, to a flea clip in the board and connect the other lug to the outside lug on the crystal socket. Solder the remaining parts to flea clips but do not install C3 yet.

Diode D1 is required only if you want markers up to 30 mc. If you do not need markers above 20 mc, don't install D1. Cut Q1's and Q2's leads as short as possible and hold them with pliers to prevent heat damage when soldering.

A miniature switch was chosen for S1 to save space and to allow room for the batteries. The first set of contacts on S1 is the *off* position and should not be used.

After all parts are mounted on the perforated board, place a ¼-inch spacer

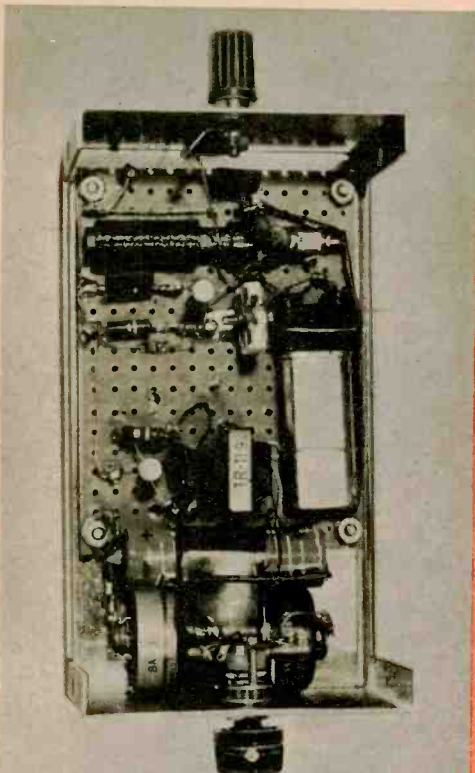

Wire the circuit board completely before mounting it in the cabinet. Keep the leads in the RF section (C2, C3, C4, C6, L1, R2, Q2) of the circuit as short and direct as possible. To prevent D1, Q1 and Q2 from being damaged, hold the leads with a pair of pliers when soldering in place.

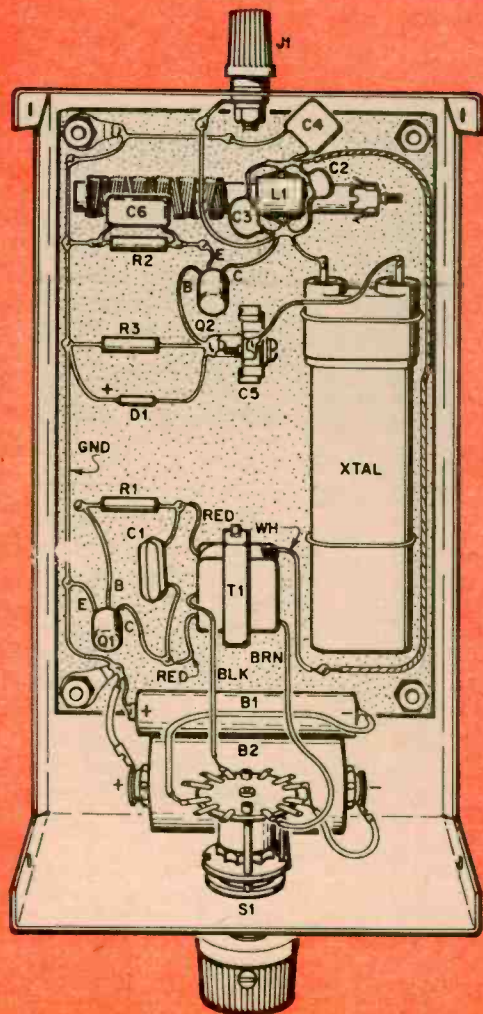



**PARTS LIST**

Resistors: 1/2 watt, 10%  
 R1—15,000 ohms R2—1,000 ohms  
 R3—100,000 ohms  
 Capacitors: Ceramic disc, 75 V or  
 higher  
 C1—.1 mf C2—500 mmf  
 C3—250 mmf (see text)

C4,C6—.05 mf  
 C5—180 mmf trimmer Capacitor  
 (ARCO 463 or equiv.)  
 T1—Audio-output transformer  
 (Lafayette TR-119)  
 D1—1N34A diode (see text)  
 Q1,Q2—2N217 transistor  
 J1—5-way binding post  
 L1—2-18 mh TV width coil (Miller  
 No. 6314)

S1—2-pole, 3-position rotary switch  
 (Lafayette SW-78 or equiv.)  
 B1—1.5-volt battery  
 B2—9-volt battery  
 XTAL—100 kc Crystal, 0.093-inch  
 diameter pins (Texas Crystals,  
 1000 Crystal Drive, Ft. Myers, Fla.  
 Type TX-100, \$4.80 postpaid)  
 Misc.—Perforated board, flea clips,  
 crystal socket, Minibox



Output of RF oscillator, consisting of L1, C2, Q2, XTAL and C5, is modulated by audio oscillator Q1. In on position, S1 applies power to RF oscillator. In modulation position, S1 applies power to Q1 also.

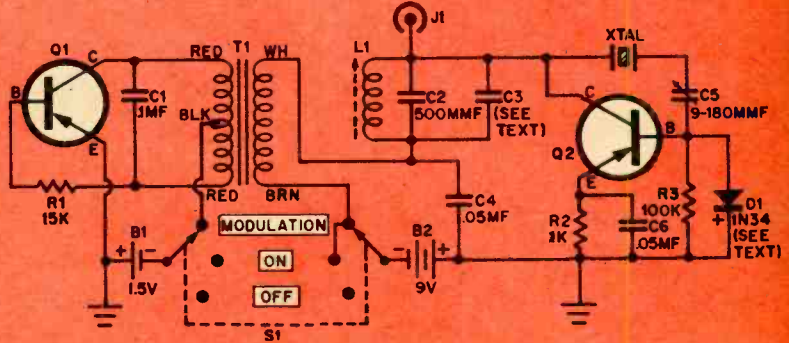

or stack of washers between the board and the Minibox to prevent the protruding flea clips from being shorted by the Minibox.

Since the current drawn by the circuit is very low, you can expect to get the full shelf life out of B1 and B2. They, therefore, can be soldered in the circuit. Don't solder the negative leads yet.

**Checkout and Tune-up**

Adjust L1's slug so it is halfway in. Connect a 0-5 (or higher range) ma meter in series with B2's negative lead and set S1 to on (no modulation). The meter should indicate slightly less than 1.5 ma. If the meter indicates considerably less current (say, 100 microamperes), the circuit is not oscillating. Rotate L1's slug clockwise—as you do, the current should climb to the range of 1.5 to 2 ma. If you cannot obtain this current even with the slug all the way in, connect C3, a 250 mmf capacitor across C2. L1's range of adjustment is very broad so you probably won't get a peak setting with the slug. Consider the adjustment complete if the current is more than 1.5 ma and the slug is in enough for you to get the cover in place. Remove the meter and solder B2's negative lead to S1.

Now connect the meter between B1's negative lead and S1. When S1 is set to

*modulation*, the meter should indicate approximately 5 ma. If the current is greater, there is a wiring error.

If you don't need accurate 100 kc markers, tighten C5's screw completely and the Calibrator is ready for use. For accurate markers, it will be necessary to beat the Calibrator's output with one of WWV's stronger frequencies (2.5 or 5 mc).

Connect a short wire to J1 and put the other end near your radio's antenna terminals. Turn the Calibrator on but *do not* set S1 to modulation. Tune the receiver so you hear WWV at 2.5 or 5 mc. You should hear a whistle caused by the heterodyning of the Calibrator's signal and WWV's signal. Adjust C5 with an insulated alignment screwdriver. The pitch of the whistle should fall, become inaudible, then rise again. At the point where the whistle is inaudible, the output is 100 kc.

To find the Calibrator's signals quickly on a receiver, set S1 to *modulation*. The markers will be raucous and can't be missed. Make adjustments to the receiver for either maximum volume or maximum S-meter indication. For the final precision adjustment of the receiver, turn the modulation off. If the Calibrator's signal overloads the receiver, merely place its output lead near the receiver's antenna terminals.



## Peak Your Final with EI's Add-On

# RF OUTPUT METER

By Russ Cogan

**H**AVING trouble tuning your transmitter's final? Sure, it sounded easy when you read about how it should be done. You were told just to dip the plate current, then load to rated current. Unfortunately, this method won't always work. Many rigs, particularly on 6 and 10 meters, deliver maximum power when the RF final is tuned slightly off-dip (off-resonance). And if the transmitter is overcoupled to the antenna power output decreases, even though plate current remains at a high value.

EI's \$5 Output Meter will simplify the tuning procedure. It is connected between the transmitter output and the antenna and gives a constant indication of relative RF output power up to 1 kw. All you have to do for a fast, accurate tune-up is peak the transmitter for maximum meter indication. (Naturally, don't exceed the final's maximum input power.) As an added feature, a phone jack is provided to enable you to listen to your own modulation.

The Meter can be left in the line permanently since it has no effect on SWR. It's a natural for portable transceivers which lack built-in metering. This meter differs from the output meter in the March '63 EI (DIRECT-READING POWER OUTPUT METER FOR CB)

in that it indicates power going to the antenna. The previous meter acted as a dummy load for CB transmitters and was limited to 5 watts.

**Construction.** You can build the Output Meter on the main section of a 5¼x3x3½-inch Minibox. The unit shown has connectors that match unbalanced coax line. Circuit grounds can, therefore, be made directly to the cabinet.

But if you use balanced 300-ohm line, replace J1 and J2 with screw-type connectors and use a common-ground buss. Do not connect the buss to the cabinet and be sure J3 is insulated from the cabinet with a shoulder washer. Sensitivity control R3 does not have to be insulated when you use balanced line, but the ground strap from R3's mounting bushing to the ground terminal must be eliminated. If you use an unbalanced 300-ohm transmission line you may make ground connections to the cabinet.

R1 will handle power up to 100 watts. It can handle higher power but this will cause R3 to "bunch up" near full rotation. For higher power, select R1 from the values in the table.

**How to Use It.** Connect your transmitter output to either J1 or J2 and attach the antenna to the other jack. Ro-



tate R3 full counterclockwise. Turn on the transmitter and rotate R3 slowly for a half- to two-thirds-scale meter indication. (If the meter deflects to the left, reverse the connections.)

Plugging a pair of phones into J3 automatically disconnects the meter and permits you to hear your own modulation. In this mode of operation, R3 is a volume control. Because of the circuit, it is important that you use magnetic phones for monitoring.

Cabinet is ground in author's model, which is used with unbalanced coax. For balanced line, add a ground buss and omit the ground strap from R3's mounting bushing to its grounded lug.

The Output Meter is especially handy when adjusting pi-network couplers. The pi-net is overcoupled easily, and output power can decrease even though final plate current is high.

Overcoupling starts at the point where an increase in loading fails to increase plate current. For optimum output, tune the transmitter in the normal manner until you approach the recommended loading, then increase loading until the Output Meter peaks.

Input Power (watts)	R1 (ohms)	R2 (ohms)
1.5-100	4.7K	2.2K
100-250	39K	2.2K
250-500	56K	2.2K
500-1,000	100K	2.2K

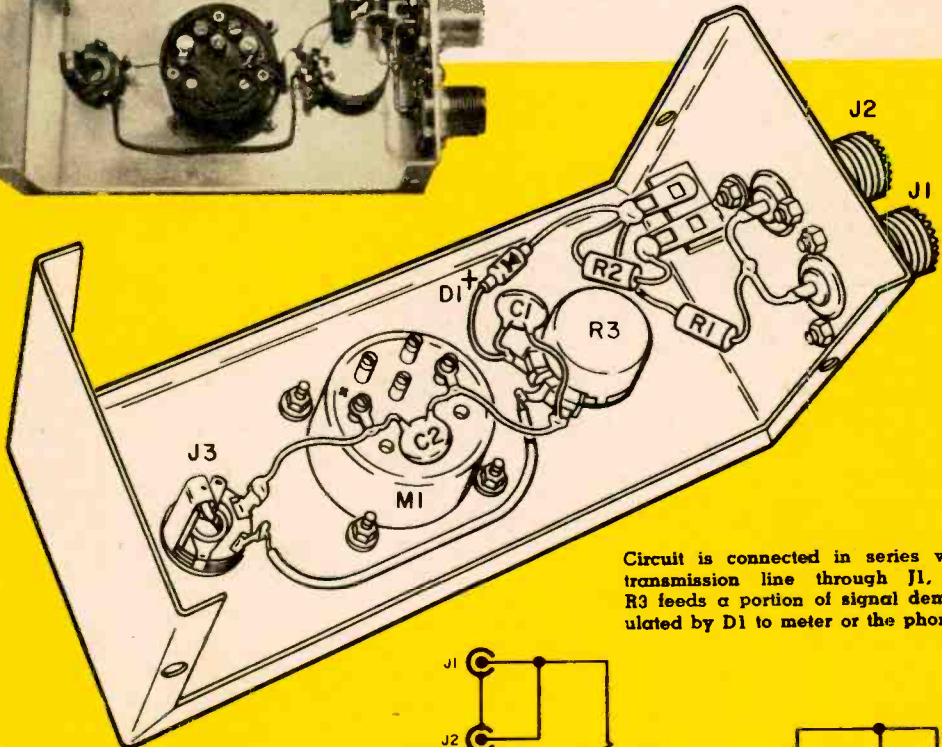
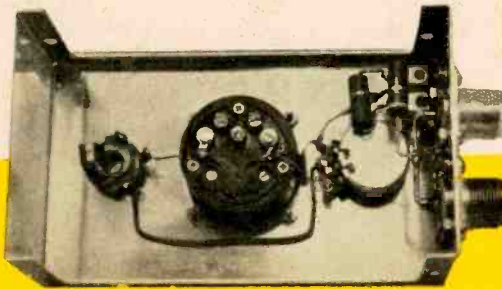

Circuit is connected in series with transmission line through J1, J2. R3 feeds a portion of signal demodulated by D1 to meter or the phones.

- PARTS LIST**
- R1—4,700-ohm, 1-watt, 10% resistor (see text)
  - R2—2,200-ohm, 1-watt, 10% resistor
  - R3—100,000-ohm potentiometer (log. taper)
  - C1, C2—0.001 mf, 1 kv disc capacitor
  - D1—1N34A diode
  - M1—0-1 ma meter (Lafayette TM-11 or equiv.)
  - J1, J2—Coax connectors (see text)
  - J3—Closed-circuit phone jack
  - Misc.—Minibox, terminal strip, buss wire

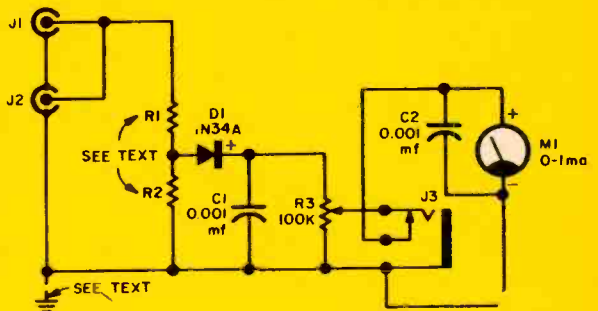





# LIBRARY



published material to ease the beginner smoothly over this hurdle.

A dynamic approach is used in the four-volume Basic Electronic Series (Sams, \$2.95 each). Since schematics are printed in four colors, circuit operation can be readily visualized and easily discussed.

Another fine source of explanatory material on circuits is a five-volume series called Basic Electronics (Rider, \$2.25 each). Dry theory springs to life with a picture-text approach that reinforces every concept with an active drawing. Gernsback, too, distributes a basic series with principles presented in a simple, clearly-written style.

The highly specialized aspects of ham radio have prompted publication of numerous special-interest books. Chances are that one has been written on your pet project or favorite field.

Want to modify cheap Army surplus equipment for ham use? The three-volume Surplus Radio Conversion Manual (Editors and Engineers, \$3 per volume) contains all the necessary in-

structions and diagrams. Interested in radio-teletype? Ham-RTTY (73, Inc., \$2) gives all the dope in detail.

Don Stoner removes the mystery from SSB in his New Sideband Handbook (Cowan, \$3). VHF enthusiasts will find that the Orr and Johnson VHF Handbook (Radio Publications, \$2.95) contains a rich lode of data.

Books are only one part of a ham's library. Magazines complement them with a continuing source of fresh new circuits and projects. Three significant periodicals are edited expressly for the ham—QST (American Radio Relay League), CQ (Cowan) and 73 (73, Inc.). Their content ranges over all aspects and levels of hamdom.

One or more of these publications is a necessity for the beginning ham's library. Not only will you get information of immediate value, but you'll be introduced to new and different ways to exploit and enjoy your hobby.

Less prominent ham magazines are either regional in nature or devote their contents to special interests. Electronics Journal (formerly titled Western Radio Amateur), for example, specializes in ham DX, VHF, SSB, etc. It has its offices on the West Coast and is published on a bi-monthly schedule.

Many of the general electronics magazines devote a good deal of space to amateur radio (this issue of EI is given almost exclusively to the subject). Magazines in this category, besides ELECTRONICS ILLUSTRATED, include Electronics World, Popular Electronics and Radio-Electronics. (EI offers a six-issue trial subscription for only \$1.98. If you'd like to subscribe send your check or money order to the EI Circulation Department, Fawcett Bldg., Greenwich, Conn.)

We've only sampled the vast flow of literature that's currently available. Whatever you select as a starter, keep building—information at your fingertips is easily as important as your soldering gun.

And the next time you visit an electronic parts store, look for those two absolutely free gems for your library—RCA Ham Tips and GE Ham News.

—Len Buckwalter, K1ODH. 

# build your own ELECTRONIC KEYS

... for cleaner keying and to increase your speed.

By Herb Friedman, W2ZLF

**Y**OU think speed is all that counts when sending code? Not by a long shot! Sure, it may seem important when you're a rank beginner and have trouble sending 20 wpm, but other things count, too. Your keying must be clean and even, and there must be a consistent relationship between the length of a dot, a dash, and a space. One way of achieving all this is with an electronic keyer. But commercial ones are expensive.

EI's Electronic Keyer produces dots and dashes at the rate of about 20 wpm. When you move the paddle of its special key, called a sideswiper, to the left and hold it there the keyer produces a continuous string of dashes. Hold the paddle to the right and you get dots.

Though slower than commercial keyers, our Keyer's big advantage is that for less than \$10 (special key included; see **LOW-COST SIDESWIPER KEY FOR EI'S ELECTRONIC KEYS** in this issue) you will be able to get valuable practice at learning an entirely new keying technique. Later you'll be ready to move up to a faster commercial electronic keyer. Meanwhile, EI's Keyer will give you a clean fist from slow to moderately fast speeds and will take the work out of those long QSO's.

Our Keyer is easy to build and uses standard components. It includes speed (wpm) and ratio controls. The latter determines the duration of the dots and spaces compared to the dashes—the correct relationship being three dots to one dash. Operation is stable since the Keyer does not use a multivibrator circuit.





**Construction.** The author built his Keyer in a 3x4x5-inch Minibox. All components except the relay are mounted on the front panel as shown in the pictorial. The battery holder is mounted on the other half of the Minibox as shown in the photo.

Diode D1 should be connected directly across RY1's coil lugs. Take care that D1's polarity is correct. If it is connected in reverse, it will act as a low-resistance path in parallel with RY1's coil and will conduct a heavy current, preventing RY1 from closing.

#### PARTS LIST

- R1—10,000-ohm linear-taper potentiometer
- R2—50,000-ohm linear-taper potentiometer
- R3—470-ohm, 1/2 watt, 10% resistor
- R4—1,200-ohm, 1/2 watt, 10% resistor
- C1—3 mf, 15 V electrolytic capacitor
- C2—10 mf, 15 V electrolytic capacitor
- C3—300 mf, 15 V electrolytic capacitor
- D1—1N34A diode
- D2—Silicon rectifier, 25 ma, 25 PIV
- Q1—2N581 transistor
- RY1—SPDT relay, Potter and Brumfield RS5D-12.
- (Allied Radio No. 75 P 504)
- J1—J5—5-way binding posts
- S1, S2—SPST slide switch
- T1—Filament transformer: 117 V primary, two 6.3 V center-tapped secondaries (Stancor P-6545 or two Allied Radio 61 G 416 transformers.)
- B1, B2—4-volt battery (Burgess Z4 or equiv.)
- Misc.—Minibox, terminal strips, battery holder

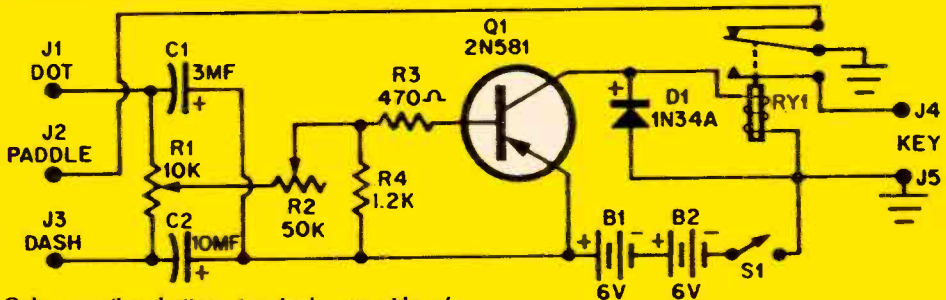

Only negative battery terminal, one side of RY1's coil and one side of D1 are connected to cabinet. Do not ground any other parts.

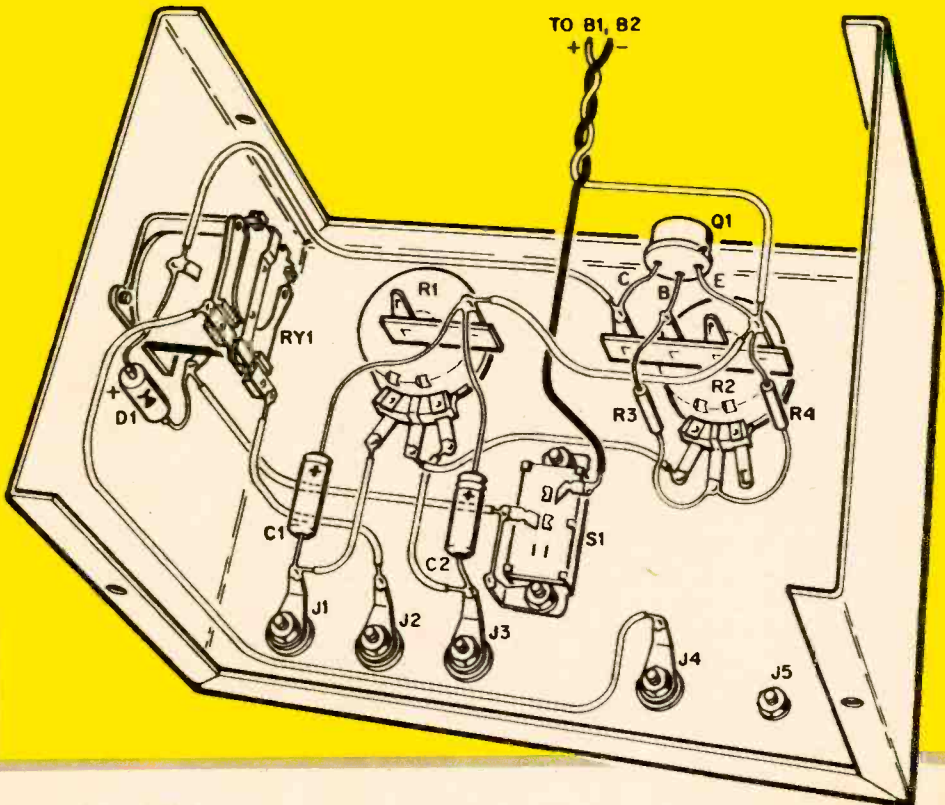

# ELECTRONIC KEYS

RY1's wiper arm is connected to the relay frame and is grounded. RY1 is standard but may not be stocked by all parts distributors. Allied Radio carries it under stock No. 75 P 504.

When soldering the terminal strips to the covers of R1 and R2, avoid prolonged heating. With the exception of J5, all binding posts must be insulated from the Minibox with shoulder washers. If you use a key-click filter across your standard key, transfer it to

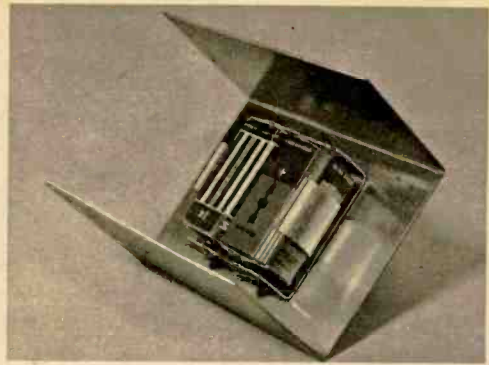

Two 6-volt batteries fit in a Keystone No. 176 battery holder mounted on back of the Minibox.

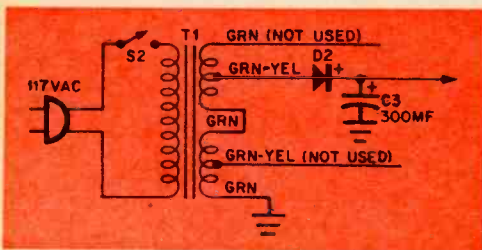

Power supply schematic. Separate transformers may be used with their primaries in parallel.

output connectors J4 and J5.

If you want to eliminate the batteries, the power supply shown in the small schematic can be built into the keyer or used as an external unit. Notice that the 6.3 V secondaries of T1 are connected so that one full 6.3 V winding and half the other 6.3 V winding are in series. The combined voltage of the two windings is about 9.4 volts. If you get only 3.2 volts, reverse the connection of only one winding. D2's rating should be at least 25 ma at 25 PIV or higher.

**Operation.** Set both R1 and R2 to mid-position, connect the sideswiper key and turn on the power. When the key paddle is moved so as to connect J2 and J3, the keyer's output should be a series of dashes. When the key connects J1 and J2, the output should be dots. If you get dashes instead of dots, reverse the leads to J1 and J3. If the relay doesn't operate when the key is closed, advance R2 to  $\frac{3}{4}$  rotation.

R1, the ratio control, should be ad-

justed so the dash length is approximately equal to the length of three dots. However, R1 may be set for any ratio you want. R2 controls the number of wpm the keyer can send. There is a slight interaction between R1 and R2 so it may be necessary to readjust the ratio control when the speed is changed.

When the key is completed, don't be in a rush to get on the air with it. It takes several hours of practice to become proficient with an electronic keyer. Also, take care that your speed doesn't run away. Because a sideswiper is easier to use than a hand key, it is possible to send much faster than you can receive. Try to keep your send speed down to your receive speed. If you prefer the rhythm of high-speed code characters, send at a high speed but leave plenty of space between characters. Remember, if someone hears you calling CQ at machine-gun speed he probably will answer you at a like pace.

**How It Works.** Assume J1 and J2 are connected by the key. C1 charges, Q1 conducts and RY1 is energized. RY1's contacts transfer, removing the ground from Q1's base and grounding J4. But Q1 continues to conduct until C1 discharges through R1, R2 and R4. When C1 discharges, RY1 is de-energized, J4 is ungrounded and the base of Q1 is grounded through R1, R3 and RY1's closed contacts. The cycle repeats itself as long as the key is held in either position. The length of time RY1 remains closed is determined by C1 or C2 and R1 and R2.



# low-cost SIDESWIPER for EI's ELECTRONIC KEYER

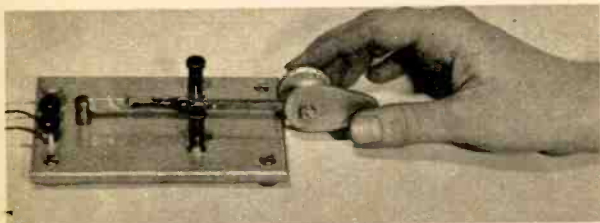

You can build this key in one hour by modifying a surplus J-38.

**T**O operate the Electronic Keyer described elsewhere in this issue, you'll need a special key called a sideswiper. A sideswiper's paddle moves left or right from a neutral center position. This motion controls two independent circuits. A conventional key whose paddle moves up and down affects only one circuit.

Commercial sideswipers are relatively expensive, but you can make this home-brew for less than \$2—the cost of a J-38 telegraph key on the surplus market. An hour or so of modifications to the J-38 and you're ready to go.

## Construction

First, disassemble the J-38. The sideswiper uses only those parts of the J-38 shown at the left in Fig. 2. With a hammer or vise, straighten the J-38's paddle, then cut off its end and sides as shown at the right in Fig. 3. A file will remove the rough edges. Using a fine-tooth hacksaw blade, cut a section out of the J-38's shorting-lever spring shown at

the left in Fig. 3. Mount the flattened paddle in a vise again and cut a 1/2-inch-deep slot through its widest dimension in the end without a hole.

Remove the screw from one of the J-38's three terminal posts and cut a 1/2-inch-deep slot in the top. Run a 6-32 screw into the post from the bottom to protect the threads, put the spring in the slot and apply solder.

Look through your junk box for three terminal posts and mount them at the end of a piece of bakelite or the old J-38 base. Mount the J-38 terminal post, to which the paddle is attached, with a 6-32 screw, solder lug and lockwasher from beneath the base. Mount the remaining J-38 terminal posts on either side of the paddle as shown in Fig. 3. Again, fasten each with a solder lug and lockwasher from beneath.

Insert a metal rod or nail through the dot and dash terminal posts and slide it in until it just touches the paddle. If the two nails are below the paddle, place a stack of washers be-

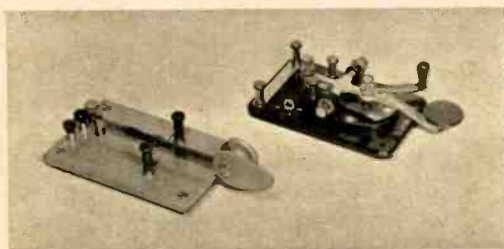

Fig. 1—J-38 key before disassembly is at right. Sideswiper built from its parts is at the left.

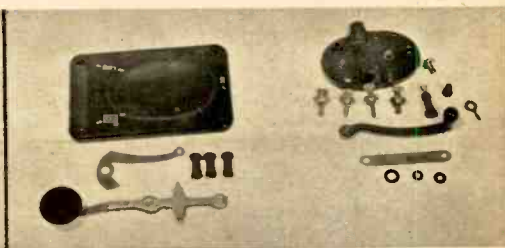

Fig. 2—Use six parts at left from J-38: base, shorting-lever spring, terminal posts, paddle.

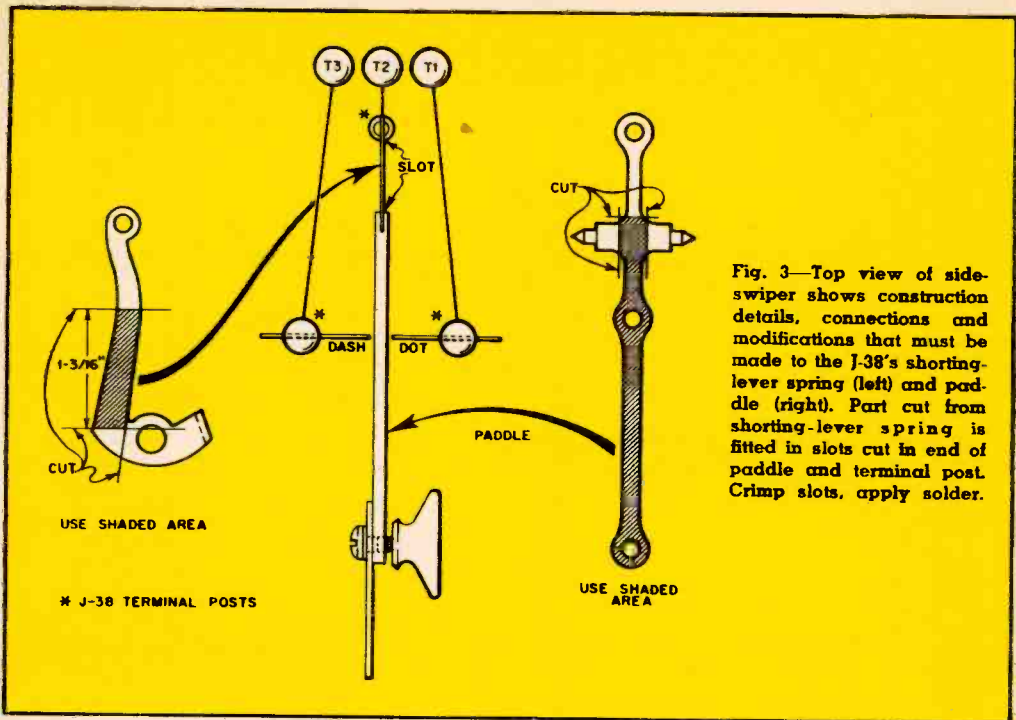

Fig. 3—Top view of side-swiper shows construction details, connections that must be made to the J-38's shorting-lever spring (left) and paddle (right). Part cut from shorting-lever spring is fitted in slots cut in end of paddle and terminal post. Crimp slots, apply solder.

tween the post and the base. Connect wires from the paddle and the dot and dash terminal lugs to terminal posts T1, T2 and T3.

The original paddle knob from the J-38 key can be used for the sideswiper finger-knob. The thumb-plate is made from a piece of Bakelite or plastic, cut in the shape of a teardrop. Drill a hole in the thumb-plate and secure it to the paddle with an 8-32 screw and lock-washer, then screw on the finger-knob.

Mount rubber feet on the Bakelite base and the job is done. For a professional appearance, spray the base and knobs with grey hammertone paint before final assembly.

Fig. 4—Underside view shows connections of dot, dash and paddle terminal posts to T1, T2, T3.

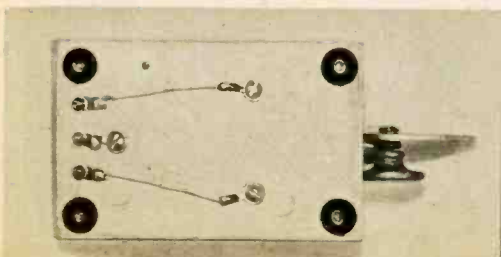

## Adjustment

Move the nails about 1/32-inch back from the paddle. If the feel is not quite right, increase the nail spacing slightly. When sending, don't slam the paddle from side to side. Push it gently. The softer the touch, the cleaner the keying. If the paddle has too much spring-return or bounce, apply a small amount of solder to one (preferably the dash) side of the paddle spring.

It takes practice to get used to the sideswiper since your fingers and not your wrist are used to operate the key. Keep a loose wrist and brush the paddle with your thumb and forefinger.

—Gerald Wainwright

Fig. 5—If paddle has too much bounce, apply a light coat of solder to the dash side of spring.

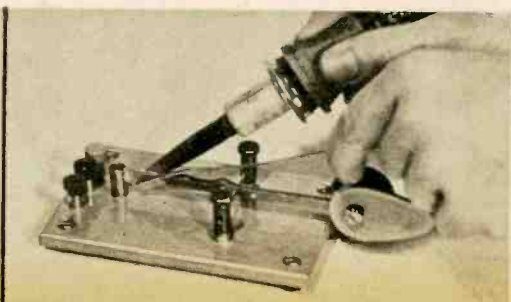



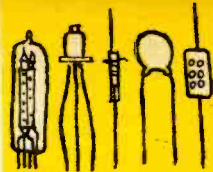

# BEGINNERS PAGE

# how to make a MIKE

IT'S easy to make your own microphone, especially if it's a carbon mike—the simplest type and the least difficult to adjust.

The carbon mike's operation is based on the ability of carbon to conduct an electric current. If a battery is connected across a piece of carbon a current will flow. The magnitude of the current depends on how tightly the carbon particles are packed together. The tighter the particles, the greater the current.

Let's replace the carbon rod with a container of loosely packed carbon granules and connect the battery leads to opposite sides of the container. The pressures generated by the sound waves of your voice will compress the granules to varying degrees in step with your speech. This will vary the current flow. If the mike is connected to an amplifier through a battery and transformer, your voice will be reproduced at the amplifier's output.

Start building the mike by removing the carbon rod from a dead flashlight battery. Saw off the flat end of the battery case, scoop out the stuffing and pull out the carbon rod. Crush the rod with a pair of pliers and grind up the particles by using a round file or a metal rod as a rolling pin. Place the

granules in a small plastic (don't use metal) bottle cap and connect as shown.

The transformer may be a table-radio audio-output type with a 3.2- or 8-ohm secondary (used here as the primary) and a primary (used here as a secondary) of several thousand ohms. Or an old power transformer will do. Use the filament winding

as the primary and the plate winding as the secondary. Connect a plug to the secondary to match your amplifier's input connector. When you connect the alligator clips make sure they're well surrounded by the carbon granules.

Since it would be inefficient to speak directly into the mike element, you must use a paper tube to concentrate your voice. Make the tube from a sheet of 8½x11-inch paper rolled into a tube 2 or 3 inches in diameter.

Scotch tape will hold the paper together.

Flatten the tube slightly so the mike element will stay in place on the top. Plug the transformer into the magnetic-cartridge input of your amplifier, get close to the open end of the tube and start talking. Your voice is coupled by the tube to the granules. While talking, slide the mike back and forth for best sound. If the sound is weak, use two batteries.—H. B. Morris

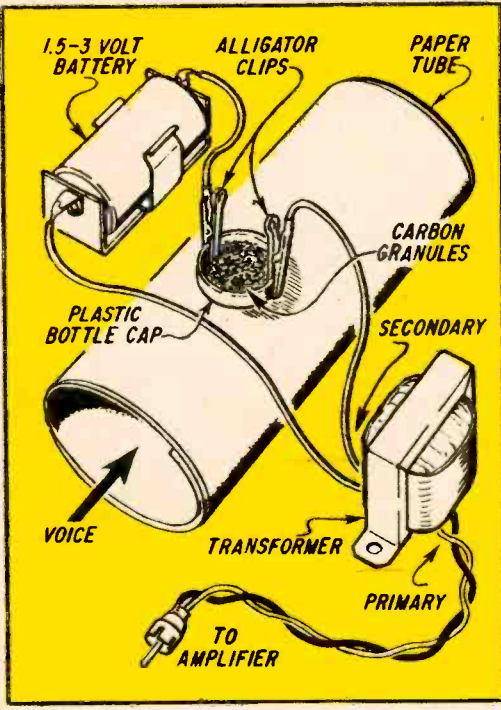

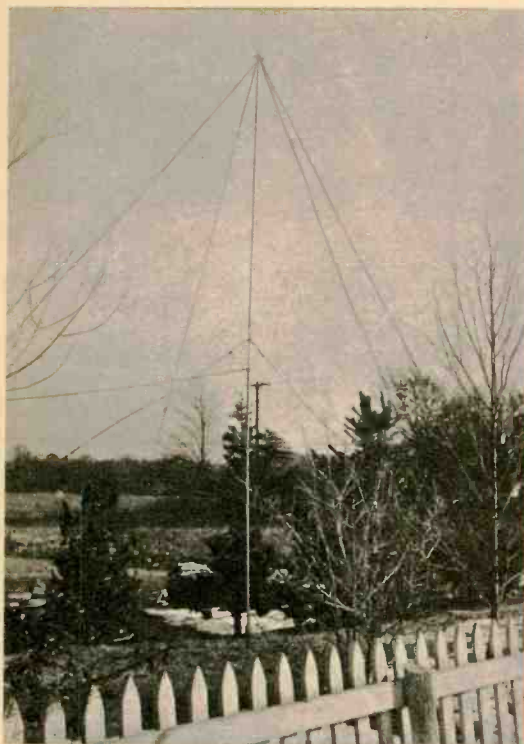

# 3-BAND MAINMAST

**Little work and less space  
are required to build this  
antenna for the low bands.**

**By Edward M. Noll, W3FQJ**

**O**NE of the biggest problems faced by the ham who wants to operate on the lower-frequency (ergo, longer-wavelength) bands is the space required for a decent antenna. For a Novice, it's a real headache because he is restricted to certain sections of 80, 40 and 15 meters if he wants to go in for anything other than purely local contacts.

If you happen to have a small ranch, you can indulge in that old favorite of hamdom, the half-wave dipole, since one cut for 80 meters runs a mere 126 feet from end to end. But when your open range is a city lot, life on 80 is a bit hectic.

Our 3-Band Mainmast Antenna, operating efficiently on 80, 40 and 15 meters, is designed to give you a decent skyhook in minimum space. It can be put up in a back or side yard, or mounted on the house or garage.

The Mainmast's unique feature lies in the fact that the four guy wires serve as parts of the antenna's radiator. They are attached electrically at the top of the mast and are insulated from the ground stakes. There also is an insula-

tor at the bottom of the mast itself.

The mast of the antenna is made up of two 10-foot lengths of half-inch steel electrical conduit (or  $\frac{3}{4}$ -inch aluminum conduit). A standard coupling is used to join the two sections. A TV-type guy ring is dropped down the mast and is held at the center by the larger diameter of the coupling. A clamp-on type guy assembly is fastened to the top of the mast.

A good ground is important. For yard erection, use a 10-foot pipe driven into the ground. For roof mounting, such as on the chimney, run a large-diameter ground wire to the vent pipe or the cold-water system. The antenna can even be mounted on the vent pipe.

For an insulator between mast and ground, use a 6-inch length of  $\frac{7}{8}$ -inch inside-diameter phenolic tubing with quarter-inch walls to provide rigid support. Four bolts hold the tubing in place between ground and mast. Attach solder lugs to one upper and one lower bolt to provide connecting points for the coaxial transmission line.

The guys, which we'll discuss in more



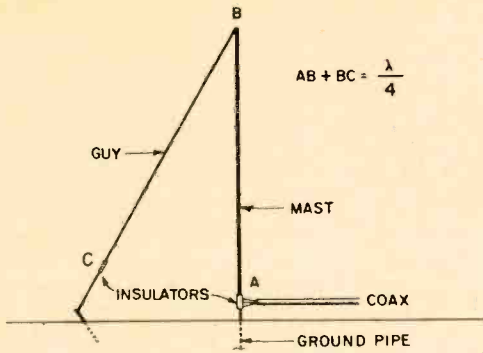

Fig. 1—Single guy wire (BC) is connected to 20-foot mast (AB) to form quarter-wave arm of antenna; second arm improves bandwidth, guying.

detail in a moment, should be about 14-gauge wire. Be sure to space them roughly 90 degrees apart around the mast. The directional letters (N, S, E, W) in Figs. 2 and 4 are merely to remind you of the 90-degree spacing.

With a  $\frac{1}{4}$ -wave cut to frequency, the base feed point displays a low impedance for matching to the transmission line and the low-impedance output of the transmitter. It so happens that any  $\frac{1}{4}$ -wave job cut for 40 meters can be used efficiently on 15 meters, too, because 15 meters falls approxi-

mately on the third harmonic of 40 meters.

Each of the Mainmast's guys, when added to the length of the vertical, represents a quarter-wave antenna. Thus in Fig. 1, we would add the 20-foot length of the vertical (AB) to the length of the single guy (BC) to find its electrical wavelength. The mast length also would be added to the guy on the opposite side. In other words, the mast forms part of each quarter-wave arm of the antenna.

Figure 4 shows how the longer 80-meter guys are accommodated by running each wire to a ground stake and then bringing the end back up to a guy ring at the center of the mast. Depending on your installation, you may want to tape the transmission line to the mast up to the height at which the line can be run into the shack.

The inner conductor of the coaxial transmission line is connected to the bottom of the mast and the outer shield of the coax goes to the ground pipe.

The lengths of the four guys are shown in Fig. 2. To arrive at the proper length for a  $\frac{1}{4}$ -wave against ground, divide your operating frequency in megacycles into 234 (using what is called the 234 Formula). Just for the record, the complete formula we're dealing with

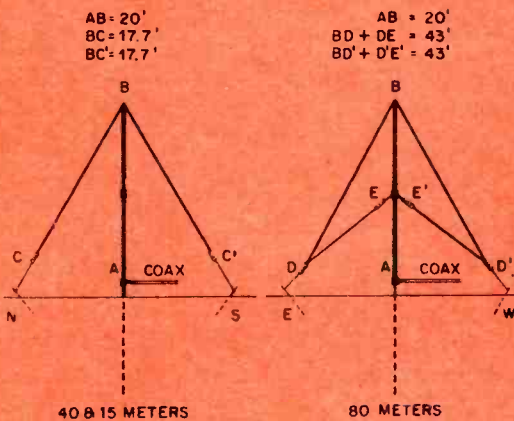

Fig. 2—Diagrams show approximate lengths for all sections. Guys BC and BC' operate on 40-15 meters; guys BDE and BD'E' are for 80 meters.

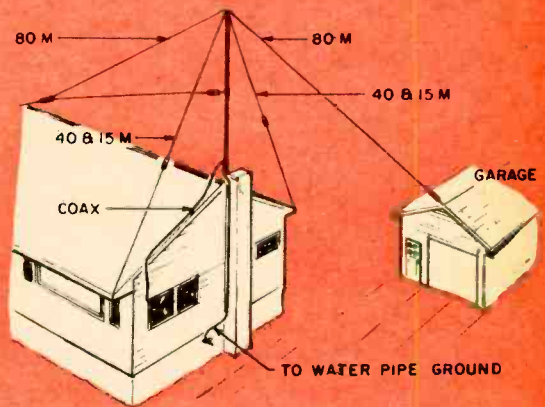

Fig. 3—Mainmast can be built in yard or mounted on building and, if there is space, one 80-meter guy can be stretched out, as in this drawing.

reads as follows:

$$\frac{\lambda}{4} = \frac{234}{F(\text{mc})}$$

where  $\lambda$  is the combined length (in feet) for the vertical (AB) and the guy (BC), and F is your operating frequency in megacycles.

The diagram at the right in Fig. 2 indicates that two of the guys should be 43 feet long. When you add the length of the guy (43) to the height of the mast (20), you get 63 feet, which is exactly what the formula gives you as the length of a  $\frac{1}{4}$ -wave element cut for the center frequency of the 80-meter Novice band.

But the Mainmast, like any other antenna, is subject to some cutting-and-trying. The formula length for the 40-meter arms of the antenna simply did not operate efficiently for the author, who then went to the cut-and-try method. For resonance on both 40 and 15 meters, it was found that the shorter guys should be approximately 17.7 feet in length. We recommend that you try this length first. If you have trouble, start your own cut-and-try experiments.

In Fig. 3 we show how the Mainmast can be mounted on a chimney and, if space is available in one direction, one of the 80-meter guys can be strung out full-length to the garage or a pole.

Fig. 4—How the Mainmast is rigged. Dimensions for the guy wires may be found in Fig. 2. Note that the 40-15 meter guys run straight to ground stakes, 80-meter guys double back to guy ring.

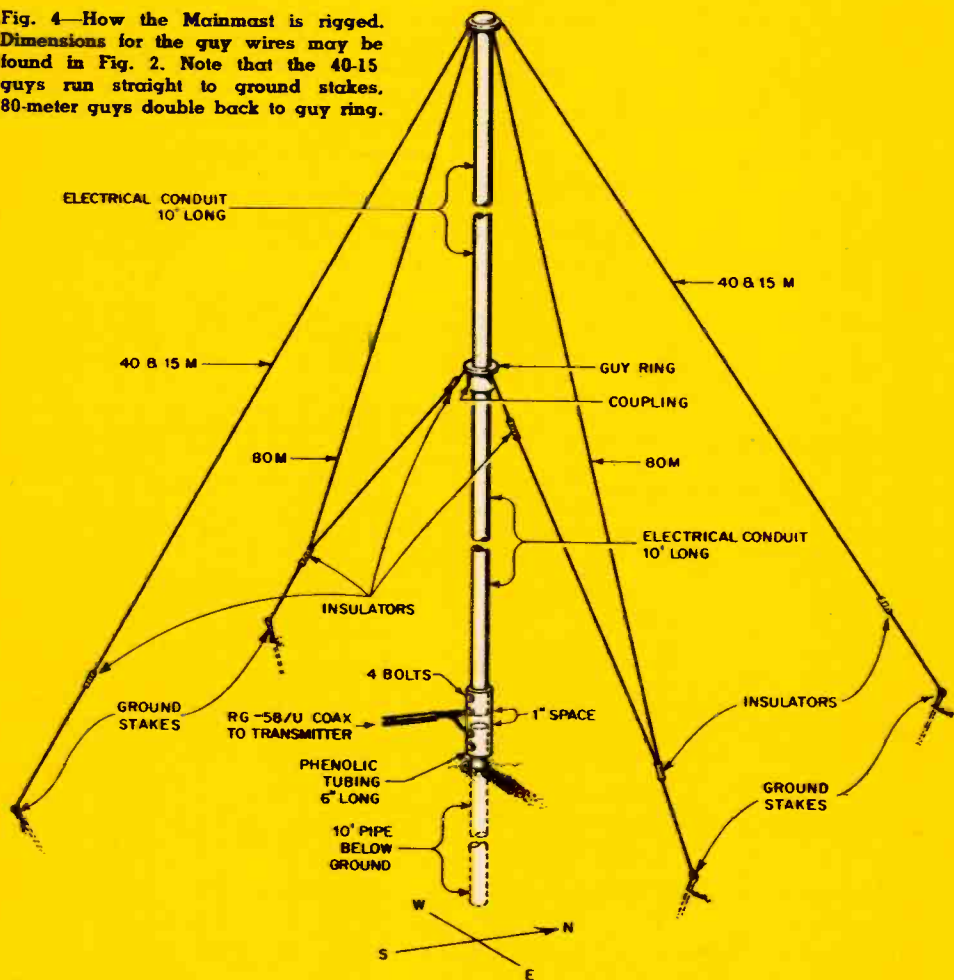



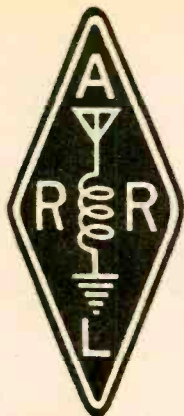

# The League That Maxim Built

The American Radio Relay League, world's largest organization "of, by and for the radio amateur," looks ahead to another half-century of progress.

By Robert Hertzberg, W2DJJ

**A**MATEUR RADIO today owes its stature and popularity almost entirely to the efforts of one man and the organization that man formed. The man was Hiram Percy Maxim, W1AW. The organization, now known and respected around the world, is the American Radio Relay League. How did Maxim give lifeblood to his prized hobby?

World War I was over. The ARRL, the tiny organization with the big name, lay dormant. Ham operations had been suspended during the war and hadn't been allowed to resume. And, for reasons never disclosed, certain members of Congress were planning legislation that would have made the suspension permanent.

In short, World War I not only signaled the end of one phase of amateur

radio; it also came dangerously close to signaling its end for all time. It was Maxim, founder and president of the American Radio Relay League, who led the fight to get amateurs back on the air.

More than devotion to amateur radio took Maxim to Washington after the war. Not only was the proposed legislation a death threat to the hobby he loved, but a suspension of ham operations seemed morally wrong. After all, some 4,000 hams had proved in the Army and Navy during the war that their self-acquired, sorely needed skills constituted more than just a pastime. They deserved to be heard.

And so the Old Man, an outspoken, rugged individualist, badgered Congress into seeing the error of its ways.

More than any other individual Hiram Percy Maxim was the George Washington of amateur radio. From his earliest interest in the hobby until his death in 1936, he gave amateur radio his all. This famed photo shows the OM, pipe in hand, seated at the controls of the ARRL headquarters station.





The ban was lifted on October 1, 1919. And almost immediately ham radio exploded into a frenzy of activity that continues unabated to this day.

It is a matter of historical fact that league-sponsored two-way communications tests between the U.S. and Europe were sensationally successful and

opened up the short-wave era as we now know it. And this bent toward experimenting with the new and "impractical" has never stopped. Recently, league members have participated in several phases of the International Geophysical Year, have cooperated with the Air Force in studying little-understood methods of transmission, such as meteor and auroral reflections, and even have helped in tracking earth satellites.

But how did a group of amateurs come to call themselves a "radio relay league?" The explanation lies in the fact that the name, like the league, dates from the early days of ham radio, when all long-distance messages had to be relayed. And, in a time when relaying meant life or death to a radio message, it seemed only natural that an organization of "radio relayers" be called the American Radio Relay League.

From its humble beginnings in the radio shacks of a handful of hams in West Hartford, Conn., the league that Maxim founded has grown over the years into the world's largest organization for radio amateurs. It has but one function: to protect and promote amateur radio. Its monthly magazine, QST, and its annual publication, The Radio Amateur's Handbook, are the acknowledged bibles of the hobby, read eagerly by beginners and old-timers alike.

Although its business staff is paid, its elected directors and leading officers are not. The current president is Herbert Hoover, Jr., W6ZH, an electronics engineer and a ham from way back.

The league has had only three paid general managers in its almost half-century of existence—Kenneth B. Warner, W1EH, now deceased; A. L. Budlong, W1BUD, in retirement after 30 years of



The league's own station, W1AW, can be heard throughout the States and around the world.

ARRL service; and John Huntoon, W1LVQ, the incumbent.

Mr. Huntoon heads a salaried, full-time staff of 65 who are responsible for the everyday administration of the league's activities, now a big business running into seven figures annually. Some 24 staff members, including three girls, are licensed hams.

The league's membership list is a cross-section of American society and shows the universal appeal of ham radio: corporation presidents and bus drivers; doctors and dance instructors; schoolboys and great-grandfathers; generals and corporals; admirals and seamen; blind men and polio victims in iron lungs.

Paid-up membership in the League is well over 100,000. It has grown steadily since the end of World War II when, following a four-year suspension of ham broadcasting, it stood at about 45,000. The sole requirement for membership is an interest in amateur radio, but only licensed members are eligible to vote in elections. Dues are \$5 a year, including a subscription to QST.

By joining, hams and would-be hams strengthen the league, assure the continuation of ham operating privileges and benefit from high-grade technical data published month after month in QST—now the oldest radio magazine in print.

Although equipment engineering is not a league function, some notable





Projects for QST and the Handbook are built and tested in the league's well-equipped laboratory.

technical developments have come out of the league's old basement lab in West Hartford. When James J. Lamb was active there in the 1930's, he conceived the single-signal superheterodyne and the noise-silencer. Like many other hams, Lamb went on to bigger things—he's presently scientific adviser and director of the Army's huge electronic research and development activity at Fort Huachuca, Ariz.

Also during the pre-World War II period, another league member, Ross A. Hull disproved the old theory that signals of extremely high frequency are limited to line-of-sight applications. The practical use of his new theory has enabled hams to cover unprecedented distances with low power on frequencies once considered useful only for line-of-sight work.

Lab projects at the league originate in several different ways. Often, there's a call for a modernized version of a unit that already has been built and described in an old edition of the Handbook. Or a member of the technical staff may see an item in some electronics publication and become convinced that it has some value from the amateur's standpoint. At other times, suggestions from league members result in lab projects for later publication in QST or the Handbook.

The lab crew generally tries to use parts which are available in the large mail-order catalogs so that members

will have no difficulty in obtaining them. Some of the men build the final version the first time; others do a breadboard version first, then rebuild after all the bugs have been ironed out.

The Hiram Percy Maxim Memorial Station, W1AW, is a model amateur station maintained by the league in Newington, Conn. Its call letters were used by Mr. Maxim until his death, and special government action later transferred them to the ARRL. W1AW transmits news bulletins for amateurs, conducts code-practice sessions, and works hams around the world.

The league's present status as the voice of ham radio is recognized by practically every government in the world. In fact, league representatives participate actively in telecommunications regulatory conferences whenever and wherever they are held.

In this role, the league has been highly successful in maintaining the ham's position in the frequency spectrum against the demands of the less democratic countries—most of which consider radio primarily as a medium for propaganda. Strongly backed by high-ranking U.S. civilian and military officials (many of whom are hams themselves), the league's men have been to meetings in Madrid, Cairo, Moscow, Geneva, Havana, Santiago, Rio de Janeiro, Washington and Atlantic City.

In fact, whenever the radio amateur needs a spokesman, he has one—in an organization that has proved itself time and time again to be "of, by and for the radio amateur."



New ARRL headquarters building will be completed about the time this issue of EI appears.

# THE RADIOTELETYPE HAMS

**EVERYONE** is familiar with the standard brand of radio amateur who communicates with others via microphone or key. But amateurs run to rarer strains, too. Among them is the radioteletype ham, who does his communicating with a Teletype machine.

Called RTTYers for short, radioteletypers use machines similar to those you see in Western Union offices, news rooms and in introductions to newscasts on television. The RTTYer can read his own message as he transmits it, and the other chap's reply appears right before his eyes in more or less permanent record form.

The requirements for becoming a radioteletype ham are not as extensive as you might think. A regular ham license gives you the only permission you need from the FCC. In the way of equipment, you use the normal transmitter and receiver found in ham shacks. To these the RTTYer adds three other pieces of equipment. First, of course, is the Teletype machine. The other pieces are a converter, hooked up to the receiver. Its job is to convert received radioteletype signals into DC pulses that make a Teletype machine print a message. The other piece of equipment, the frequency-shift keyer, has the task of keying the transmitter with Teletype code characters that come from the machine when the keyboard is operated.

As you already may know, RTTY is much like CW, although there are some significant differences. For one thing, instead of communicating in a code each operator can recognize, RTTYers talk with one another in a special kind of code that only a Teletype machine can understand. A key actually turns the carrier on and off in a CW transmission but the carrier is on all the time in an

RTTY QSO. Depending on the type of RTTY setup, the carrier either undergoes an 850-cycle shift in frequency, or it is modulated by two audio tones 850 cycles apart.

The main difference between CW and RTTY is that a whole string of pulses (not just a dot or a dash) is sent every time a key is pressed on the keyboard. These pulses, represented by the shifts in frequency noted above, identify the character in much the same manner that various combinations of dots and dashes identify letters and numbers in Morse. If you press the A key on a Teletype machine on the transmitting end, for example, the transmitter sends out a certain series of pulses. On the receiving end these pulses, when decoded, cause the A matrix of the receiving Teletype machine to strike.

In the way of skill, knowing how to touch-type is a help, of course, but it isn't necessary. Even the hunt-and-peck RTTYer can build up a manual sending speed of over 30 words per minute on the keyboard. With additional automatic tape perforating and tape transmitting equipment, the RTTYer can type up what he wants to send ahead of time. The procedure is to make a tape while the other fellow is still transmitting. By the time he stands by, all the answers, reports, etc., are on tape, ready for automatic transmission at a speed of 60 words per minute.

DX chasing is not a major activity of amateur RTTY, although contacts from coast to coast on 20 meters are just as common as those made on phone and CW. Foreign contacts are possible if the RTTY DXer uses a teleprinter machine synchronized at the amateur radio-teletype speed specified by the Federal Communications Commission. Ameri-



BY BYRON H. KRETZMAN, W2JTP

A Teletype machine does work of a mike or key in the shack of the RTTYer, and tapes (above) produced on auxiliary equipment enable him to transmit messages at speeds up to 60 wpm. Here, RTTYer Otto Pollei, Jr., K4FPW, is seated at his Teletype, ready to talk to fellow RTTYers.



can military bases overseas frequently have amateur RTTY installations for handling the large volume of GI traffic. Even the U. S. Navy now permits amateur RTTY operation from some ships at sea.

On the 80- through 15-meter bands, the RTTYer frequency-shifts his carrier. The actual shift in frequency generally is 850 cycles. On the 6- and 2-meter bands audio-frequency-shift keying (AFSK) is used. An audio oscillator is frequency-shifted between 2125 and 2975 cycles. It, instead of a microphone, is plugged into the modulator of the transmitter.

Electrically, the wire-line circuit between two Teletype machines, or between a radioteletype converter and a machine, is nothing startling. In fact, it's much like the old series Morse telegraph circuit that used sounders and telegraph keys with circuit-closing switches. In the Teletype circuit, key-down is called *mark*, since current flows to the receiving selector magnets of the machine. Similarly, key-up is called *space*, since no current flows.

At the 60-wpm speed, every character is made up of a *space* start pulse 22 milli-seconds (ms) long; five information pulses, each also 22 ms long, which may be either *mark* or *space*, depending on the character selected; and a stop pulse, always a *mark* 31 ms long. Timing, of course, is provided by the Teletype motor.

When receiving, the machine scans

each entire character of 163 ms length, performs the printing function, then resets the selecting mechanism to await the next start pulse. This is why Teletype frequently is called a start-stop system of information transmission.

To receive RTTY, the beat frequency oscillator (BFO) is turned on, and the receiver is tuned to produce the 2125 and 2975 cycle tones when an FSK signal is tuned in. These audio tones are then fed to a converter which provides the direct current needed to operate the selector magnets on *mark* pulses and no current on *space* pulses.

To receive AFSK, the VHF receiver simply is tuned to the station. No BFO is necessary, as the tones are detected as modulation and fed directly to the converter.

Transmission of RTTY is accomplished by electronically switching a small value of capacitance across the variable-frequency oscillator. (Crystals seldom can be shifted far enough.) This is done from the keyboard by means of a dual diode tube—a 6AL5, for example. Only a few parts are needed besides the tube.

To transmit AFSK on the VHF bands, an audio oscillator is frequency-shifted from the keyboard by means of a pair of inexpensive germanium diodes. Component values are selected so when the keyboard circuit is closed (*mark*), a 2125-cycle tone is fed to the modulator; and when the keyboard circuit is open (*space*), a 2975-cycle tone is trans-

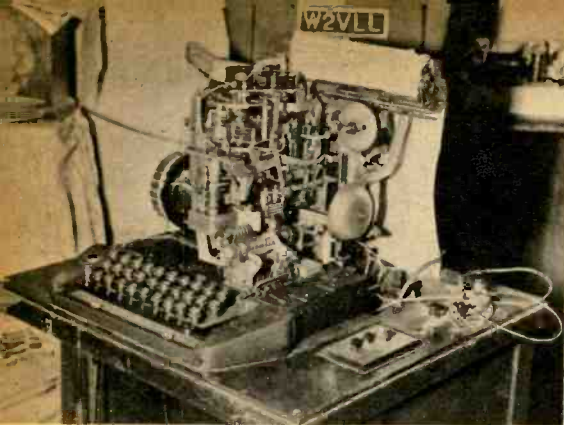

Teletype machines used by RTTYers are models which have been discontinued by the Teletype Corp., such as the Nos. 26 and 15 pictured above. A few hams have purchased surplus Kleinschmidt teleprinters.

mitted (see block diagram below).

The greatest attraction of this facet of amateur radio is to the fellow who likes to build his own equipment. There is little available commercially in the way of converters, and most of those you can get are in the \$300-and-above class. But a simple converter can be built for around \$35. Parts needed to FSK a transmitter should cost less than \$3. Hams with well-stocked junk boxes may have only to buy the machine.

Teletype page printers run from about \$50 to \$125, depending on model and availability at a particular time. These are used machines, such as the Models 26 and 15, which have been discontinued by the Teletype Corp. and are being replaced with newer models.

Don't try to obtain a machine from either Teletype or your local telephone company. Machines, for the most part, are obtainable only through organized RTTY societies. They are made available to such groups on the proviso that

they be used by the radio amateur solely for non-commercial experimental use. In fact, the purchaser is required to sign a statement to that effect.

Operationally, RTTY can be just as interesting as building the necessary converters and frequency-shifters. On the HF bands, contact is established by CW or Morse frequency-shift keying (the FCC requires that call letters be given in Morse during every transmission, or at least once every ten minutes if break-in is used).

Message traffic can be handled at a 60 words-per-minute clip if the RTTYer has tape equipment. Tape in this case means the 11/16-inch-wide perforated paper tape of the type used by the wire services. This is prepared by operating the keyboard of a reperforator or a perforator.

Such tapes are transmitted by a motor-driven transmitter-distributor, which is then connected to the fre-

[Continued on page 111]

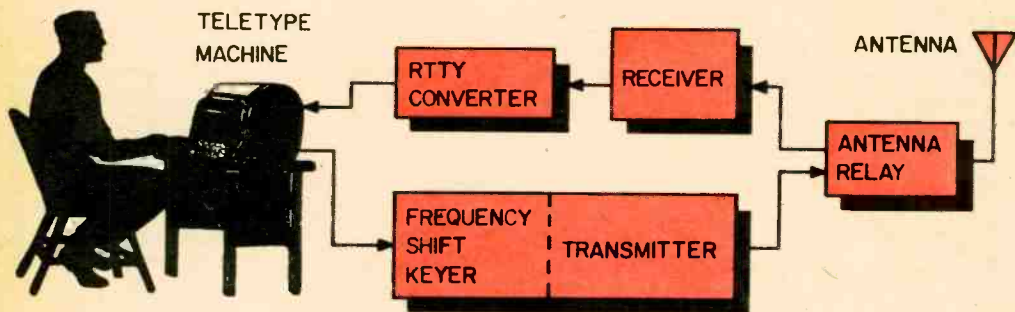

In an RTTY ham station, a converter changes the received signals into DC pulses for the Teletype machine, while a frequency-shift keyer keys transmitter. Tape equipment can increase speed to 60 wpm.



# HI-FI RECORD GUIDE

by Warren DeMotte

**EAST AND WEST** meet harmoniously and colorfully in Koto and Flute (see cut). Kimio Eto plays the 13-string Japanese koto, with intermittent assistance from Bud Shank's silvery-voiced flute. The music is lyrical and rhythmic, with enough Western influence to make it accessible. And the koto is attractively varied in tonal quality,



sounding variously like a guitar, a mandolin and a banjo.

More subtle in timbre and rhythm is the music of India played by Ravi Shankar in Improvisations. He is both a remarkable virtuoso on the guitar-like sitar and an imaginative composer who brilliantly blends the improvisatory character of his native oriental music and occidental jazz. He is assisted by a responsive ensemble of Indian and American musicians. The recording has excellent fidelity.

Paul Paray leads the Detroit Symphony Orchestra in sensuous performances of Maurice Ravel's vividly colored music. Included are the French master's La Valse, Rapsodie Espagnole and a couple of smaller pieces, with Jacques Ibert's luscious Escales tossed in for good measure. A 35-mm magnetic film recording, this disc provides sound that

is opulent and beautifully balanced.

An economy disc that offers a full measure of quality in music, performance and engineering is Sir Adrian Boult's recording of the Beethoven Eroica Symphony. Boult's rendition of the mighty music is sturdy and expressive and the sound is clean and bright. The Coriolan Overture is added as a valuable bonus.

Gustav Mahler's First Symphony receives a powerful reading from Erich Leinsdorf and the Boston Symphony. There is little Viennese flavor in the performance of this expansive work, but the recording has unusual instrumental definition—due, perhaps, to the new Dynagroove recording process. Extraneous noises are virtually non-existent.

David Oistrakh possesses the ability to unravel the knottiest of musical problems, supplied in this instance by Paul Hindemith's Violin Concerto. The great Russian violinist makes its spikey measures almost lyrical in a triumph of sensitive phrasing, purity of tone and architectural insight. The collaborating London Symphony Orchestra is capably led by the composer. Overseas, Oistrakh and the same orchestra, here conducted by Jascha Horenstein, do an appealing rendition of Max Bruch's Scottish Fantasy.

Everybody loves a parade, and The Big 18 offers a dozen and a half of the most popular marches in the repertoire. Paul Lavalley leads his Band of America in peppy renditions that bring back a host of memories.

Big Noise from Winnetka has been a Bob Crosby specialty since Bob Haggart wrote it 20 or so years ago. Now it is a feature of the composer's own orchestra, and it heads a program played with verve and recorded with sonics that have stunning impact.

Smooth and stylish is Warren Covington  
[Continued on page 116]

# COMMAND

By Chet Stephens

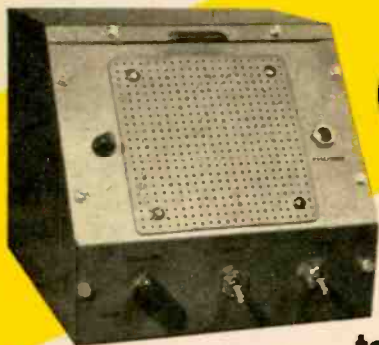
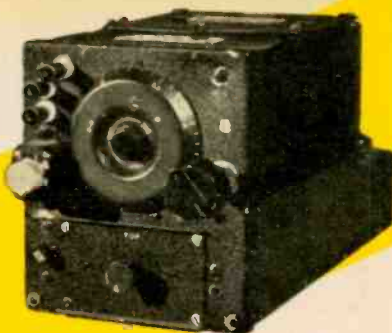

## CONTROL CENTER

Try this easy, inexpensive way  
to get a hot receiver on the ham bands!

ONE of the great buys in surplus electronic equipment after World War II was (and still is) the Command series of Army/Navy receivers. There's a reason for the popularity of the sets. For about \$15 you get a receiver of outstanding design that is built like the Rock of Gibraltar.

Originally, the rigs were used in aircraft communications systems. Several models are available, which makes it possible to tune from weather stations down around 190 kc right up to 9 mc. Three complete ham bands are covered by different Command jobs. The BC-455 model tunes 40 meters, BC-454 tunes 80 and R-25 tunes 160 meters. The table below lists the models by military designations and gives tuning ranges.

Popular as these receivers were, many people shied away from them because of the modifications and additions thought necessary to get them working. Most of the conversion plans now available show you the hard way to do it and require rewiring of the filaments and addition of a power supply and audio amplifier.

However, EI's Command Control Center (CCC) will enable you to get one of these receivers going with a mini-

mum of effort and cost. Modifications to the receiver are *not* necessary.

Our CCC provides B+ and 24 volts for the receiver filament circuit. A BFO on/off switch is provided, as well as a volume control (actually an RF gain control). The receivers originally were designed to drive headphones but the CCC contains an output transformer for speaker operation (phones still can be used). Some special parts are required but our parts list tells you where to get them.

While the CCC has only one receiver connector, a second or third switched connector can be added easily if you want to use two or more receivers without having to change the connecting cable.

**Construction.** The CCC is built on a 2x6x7-inch chassis which is mounted in a sloping-panel cabinet by the volume, BFO and standby controls. Only the

COMMAND RECEIVERS		
Model		Tuning Range
Army	Navy	
BC-453	R-23	190-550 kc
BC-946	R-24	520-1500 kc
—	R-25	1.5-3 mc
BC-454	R-26	3-6 mc
BC-455	R-27	6-9.1 mc





# COMMAND

## CONTROL CENTER

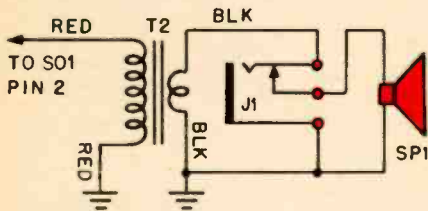

If your phones are low-impedance, connect a shorting-type jack across T2's secondary as shown.

four-inch speaker, power indicator NL1 and phone jack J2 are mounted on the panel itself. A piece of copper screen or perforated phenolic board should be placed in front of the speaker.

R1 is included in the specified neon-lamp assembly. If you use a neon lamp other than the type specified (without an accompanying resistor), be sure to add R1. R3's ground connection is made with the ground strap supplied with the control. It may appear to be connected to the wrong side of R3, but this is correct in this application. Try to obtain a speaker with a bracket for T2.

T2's wiring as shown permits high-impedance phones (2,000 ohms or more) to be connected directly to the receiver output. If you want to use low-impedance phones, J2 must be wired as shown in the separate schematic.

Power transformer T1 is a special type made for Command Receiver conversions. No instructions are supplied with it so follow the color coding shown in the pictorial and schematic. The CCC uses silicon power rectifiers, so tape the unused 5-volt white leads.

**Operation.** Command Receivers are designed to have a dynamotor mounted on the rear apron, and they have three banana plugs (to carry B+ and filament power) to connect to the dynamotor. Since the CCC is connected to the accessory socket on the rear of the receiver, the exposed hot banana plugs must be taped as a safety precaution.

Connect P1 to the CCC, P2 to the

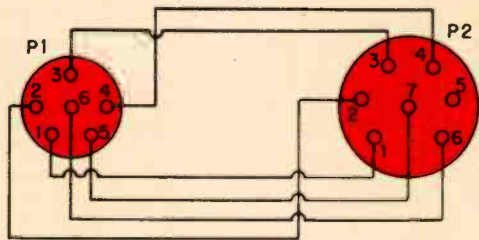

POWER CABLE: P2 PLUGS INTO SOCKET ON REAR APRON OF RECEIVER

A 6-pole rotary switch can be used to connect several Command receivers (P2) to a CCC (P1).

receiver and set BFO switch S3 and standby switch S2 to *off*. Turn on power with the switch on R3. After warmup, set S2 to *on*. As you advance R3 there should be a rushing sound. If there isn't, check the power cable connections.

Command receivers require a long-wire antenna. On the front panel of the receiver is a control marked *align input*. Adjust the setting of this control for maximum signal or noise. If you want to copy code, set S3 to *on*. Though the BFO's frequency is preset, it can be changed. On the right side of the receiver there is a small hole behind which is a screwdriver-adjust control which changes the BFO's frequency. Tune in a signal and use a thin-blade screwdriver (it need not be insulated) to turn the screw.

Command receivers can be converted easily to operate at other frequencies and one model, the BC-453 makes a fine Q5er. A Q5er can give a budget receiver the selectivity of a receiver costing several hundred dollars. After you have used the Command Receivers and experimented with them, you may want to make some other conversions or soups-ups. The CCC will make the job much easier. Since you already have the receiver working, you'll be digging into something you're familiar with. Both the schematic for the Command Receivers and descriptions of virtually every use and conversion for them can be found in the Surplus Conversion Manuals, Volumes 1, 2 and 3.





# GOOD READING

By John Milder

**TROUBLESHOOTING HIGH-FIDELITY AMPLIFIERS.** By Mannie Horowitz. Radio Magazines, Inc., Mineola, N. Y. 127 pages. \$2.95

If the average radio-TV repairman feels unprepared to service modern hi-fi equipment, one good reason is that most how-to books on the subject are about as up to date as a Model T Ford. Among the many faults of the usual primer on audio servicing is the author's casual, part-time attitude toward his subject. Having taken time out from preparing a book, say on transistor radios, he may not have let the reader know that an amplifier employs something called push-pull output and phase inversion, or that a thing called stereo has arrived on the hi-fi scene.

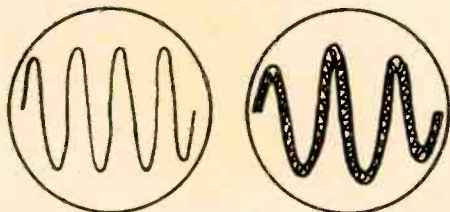

All this happily is not the case with Mr. Horowitz's book. A full-time designer of hi-fi equipment, this author has included facts that are practical, pertinent and up to date. He begins with a section on the equipment necessary for hi-fi servicing, then outlines the circuitry of modern hi-fi amplifiers (from output stage back to preamp) and shows how to track down and cope with common and uncommon problems.

The illustrations above, taken from the book, both show how second harmonic distortion looks on an oscilloscope. But the one on the right also reveals an unhealthy amount of hum.

**OVER 11,000 DIRECT TUBE SUBSTITUTES.** Compiled and published by Harry G. Cisin, Amagansett, N. Y. 73 pages. \$1.25

One of our pet peeves in the book

world is the tube substitution guide that doesn't really tell you which tubes are direct substitutes for which. This book, we're happy to say, is not in that category. Like previous editions, it's thorough, well organized and easy to use, with particularly complete information on TV picture tubes.

**BASIC SERVOMECHANISMS.** By Ed Bukstein. Holt, Rinehart, and Winston, New York. 190 pages. \$5.25

If we have doubts that this is a world we never made, books like the one at hand (and those on computer theory) confirm them. But no matter how awesome, machines that oversee their own operation—and perhaps, someday, yours and mine—employ the workaday components of electronics. What's more, they operate in a way that's straightforward enough to be understood by anyone who can recognize a feedback circuit. If you're a fan of our brave new world, Mr. Bukstein's volume will provide you with its schematic.

**FM AND MULTIPLEX MODULATION SYSTEMS.** By Edward M. Noll. Howard W. Sams & Bobbs-Merrill, New York & Indianapolis. 222 pages. \$4.95

Be warned that this book, third volume in Sams' Modern Communications Course, is *not* about something we call stereo FM. In fact, that's about the only aspect of multiplexing that *isn't* covered. What the book does tackle is every practical aspect of FM for non-entertainment purposes, from relatively simple two-way radio to space communications.

And make note of . . .

**HALL-EFFECT INSTRUMENTATION.** By Barron Kemp. Sams. 128 pages. \$4.95

**REPAIRING TV REMOTE CONTROLS.** By L. Cantor and H. Horstmann. Rider. 122 pages. \$2.50

KIT

EI

REPORT

## Knight-Kit T-150



# 150-WATT AM-CW TRANSMITTER

**T**HE beginning ham—be he newly minted General, Novice or Technician—often settles for a low-power rig as his first transmitter. Trouble is, he usually wastes his money because he soon wants something better and that first job ends up in the attic.

A sensible alternative is the purchase right at the start of a higher-power set with added features—something you can keep on using until you scratch up enough for sideband or a kilowatt amplifier. The Knight-Kit T-150 is one of the transmitters capable of filling this role. It is a six-band AM-CW job, rated at 150 watts input on 80 through 10 meters and 100 watts on 6 meters. Its attractive features include a \$119.95 price tag, built-in VFO and full metering of all RF circuits, including output (the meter samples your signal and tells you when you're tuned on the button). Either crystal control or VFO can be

used on all of the T-150's bands.

There is nothing tricky about assembling the T-150. The instructions are straightforward and quite adequate. Our kit was one of the first off the line. Our builder, a neophyte, got it together in about 22 hours, then spent another three hours with a modification kit which Knight had sent along. The average builder should be on the air in under 20 hours, and those modifications and some others now have been incorporated into the kit. If you happen to have one of the early T-150's and have not obtained the modification kit, ask Allied Radio (Knight's parent) for one.

The only trouble our builder had in the wiring was a jam-up of components at a couple of tube bases. A Novice need have no fear of tackling the T-150, but he should have built one or two other kits previously. In number of components alone, the T-150 would be a large

T-150's underchassis has fair component density at a point or two but isn't difficult to wire. Photo below shows final tank coil in center and parallel 6146's near it. VFO at the upper left.

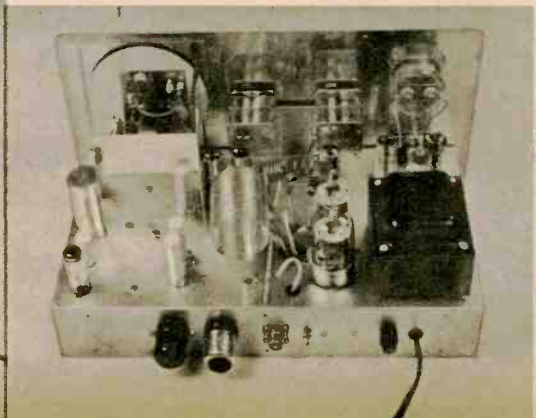
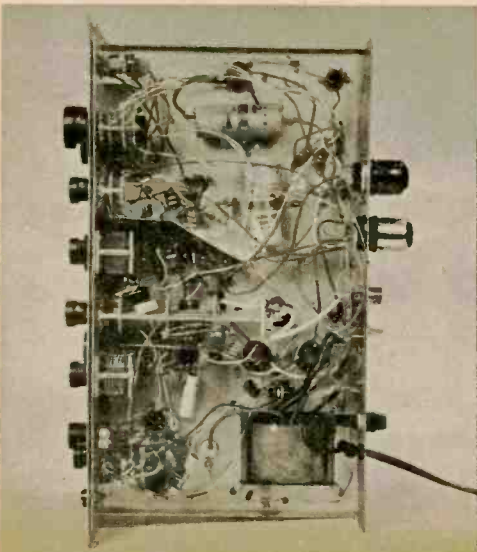



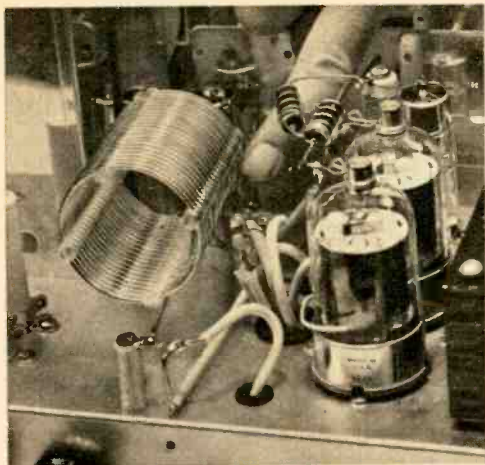

Tank coil and output tubes; the finger points to taps, which are soldered on soldering lugs.

first bite to chew. Since you have circuits carrying a fair amount of power, use a hefty soldering iron (up to 100 watts) and more solder than you would with a receiver or hi-fi amplifier. Keep leads as short and direct as possible.

As might be surmised from the modification kit mentioned above, Knight has made some design changes since introducing the T-150, and continues to make additional ones. However, new kits incorporate all changes to date, including alterations in the instruction manual. The tuning instructions in our manual would have led to early demise of the output tubes but corrected information was supplied by Knight and now appears in the revised manual.

A Novice with a T-150 finds he has many features he can't use. Besides a 75-watt power limitation, he is restricted by law to CW on 80, 40 and 15 meters and he must stick with crystal control. There is one school of thought that says the chap won't be able to spurn the temptation of cranking up the power and going to VFO, but we don't subscribe. A 1-cent sale on hypodermic needles doesn't make dope addicts; neither does availability of equipment make outlaw Novices. And when that General ticket does come, the ex-Novice finds himself with a quite acceptable transmitter for general hamming.

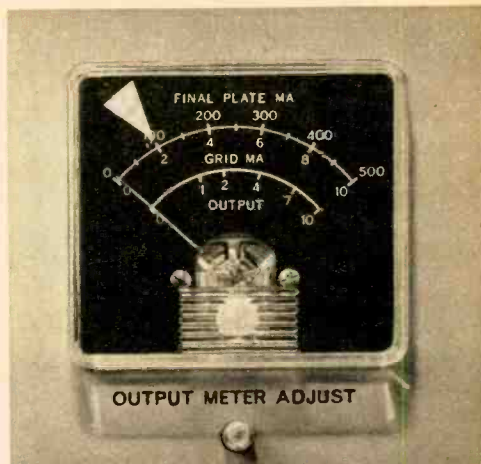

Output meter with pasted-on marker indicating maximum plate current (about 100 ma) for Novice.

It is impossible, of course, to measure (with a wattmeter) the actual power input to the final of a transmitter, so a Novice would turn to other means to hold the T-150 to 75 watts. The formula at hand is  $P=EI$ , where  $P$  is power in watts,  $E$  is voltage and  $I$  is current. To arrive at the input power of the T-150, then, you multiply the B+ on the final plates by the final plate current indicated on the front-panel meter. The manual lists the T-150's B+ as 800 volts but the actual figure is 700 volts. By dividing this into 75 watts, we get .107, or 107 milliamperes, as the plate current that will give us 75 watts input. The Novice should put some kind of indicator on the *Final Plate MA* scale just over the 100 mark (see photo). This then represents his power limit.

The T-150's circuits are about as straightforward as you can get. The rig has the usual lineup of crystal oscillator, buffer-multiplier and final, the latter consisting of parallel 6146's, which are known for dependability and efficiency. To insure maximum RF output, the final operates straight-through on all bands.

When the voltage-regulated VFO is selected the crystal oscillator functions as a straight-through or multiplier amplifier. Whether crystal or VFO control, there is plenty of grid drive to the final,

[Continued on page 112]

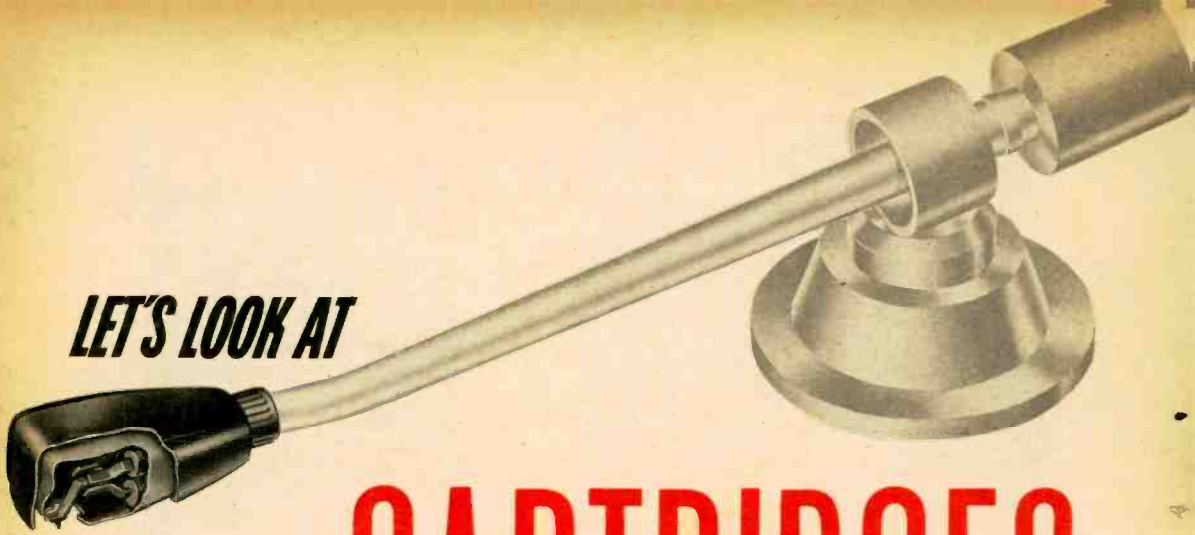

**LET'S LOOK AT**

# CARTRIDGES

By  
**Hans Fantel**

**I**T'S THE SMALLEST component in your stereo system, and it's tucked away so neatly that your visitors are hard-put to give it even an admiring glance. Chances are, you've devoted little—if any—thought to it since the day it was installed.

Yet your phono cartridge is one of the most important links in your sound-reproducing chain. Why? Because your amplifier and speakers—no matter how good they are—have only one thing to

work with. And that (when you're playing records, at least) is the signal your cartridge delivers.

If your cartridge fails to read out all the music from the record groove—if it clips off highs, swallows up bass or throws in distortion—there are no corrective measures later on. That's why your cartridge is so important in determining what kind of sound you get from your records.

Within the last year or so, stereo

One of three types of magnetic cartridges, the moving-coil gets its name from the fact that the coils themselves move within the cartridge. A typical cartridge of the moving-coil variety is the Grado Classic which is pictured below. It has a frequency response  $\pm 1$ db from 15-28,000 cps. It carries a price tag of \$37.50.

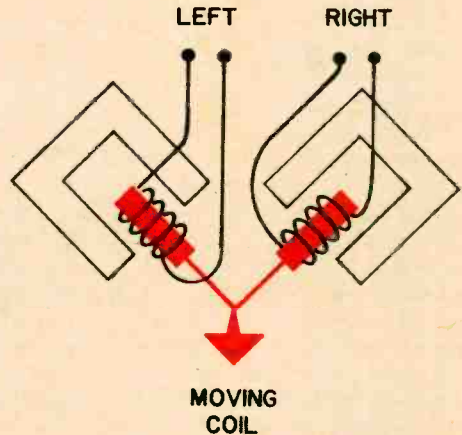
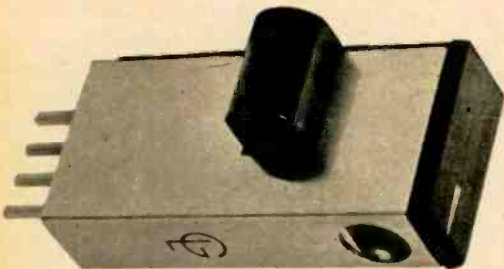



cartridges have been improved significantly all across the board. Therefore, if your amplifier and speakers are in good shape, you probably can upgrade the performance of your system by installing a late-model cartridge. To guide your choice, here's a brief brush-up on the basic principles of cartridge design.

A cartridge has the job of translating the twists and turns of a record groove into electrical voltages. But this isn't an easy task. Imagine the wild zig-zag ride of the stylus in the groove of a spinning record. The poor stylus is tossed back and forth thousands of times as it follows the audio-frequency wiggles up to 20,000 cps.

You may hear a smooth trumpet note. But to the stylus that note is a grueling stretch of hairpin turns on a bumpy road where it can't slow down. And in stereo the stylus isn't just swinging from side to side. It goes up and down, as well, in a sort of combination roller coaster ride and snake dance.

All along this course, the stylus must hug the road. In engineering terms, the stylus must *track*. Any skidding or cutting of curves means distortion—that grating roughness of sound you often notice in loud passages or near the end of a record.

### Compliance

But can you tell how a cartridge will behave in the groove before you buy it? Fortunately, if you know how to interpret it, there's one good clue: the com-

pliance rating. This indicates how well the stylus will yield to guidance from the record groove. And that in itself is one way of determining how accurately it will follow the twists and turns.

Let's get down to cases. Suppose you come across a specification reading: compliance =  $8 \times 10^{-6}$  cm/dyne. Granted, it looks complicated; but the meaning is simple. If you want to be technical about it, the statement means that if a force of 1 dyne pushes on the stylus, the stylus has enough give to move a distance of 8-millionths of a centimeter.

What really matters here is the first figure—the one before the multiplication sign, which, in our case, happens to be 8. The higher that figure, the more compliant the cartridge and the more easily it tracks. As a rough guide, remember that  $4 \times 10^{-6}$  is quite good, and anything beyond that is even better. The most compliant cartridges made today have ratings as high as  $30 \times 10^{-6}$ .

### Tracking

High compliance has an added advantage: less weight is needed to bear down on the stylus to make it track. Indirectly, therefore, the recommended tracking pressure for a given cartridge also is an index of its compliance. For a high-compliance cartridge, the tracking pressure may be less than a gram—so light that a puff of air could blow the tone arm off the record.

Record wear virtually vanishes at

Another type of magnetic cartridge is the moving-iron or variable-reluctance. The stylus is coupled to two pieces of iron, which move within electromagnets to produce electrical output. The Dynaco Stereodyne II pictured here is manufactured by Denmark's Bang and Olufsen. It has a frequency response  $\pm 2$ db from 30-15,000 cps. The Stereodyne II cartridge sells for \$29.95.

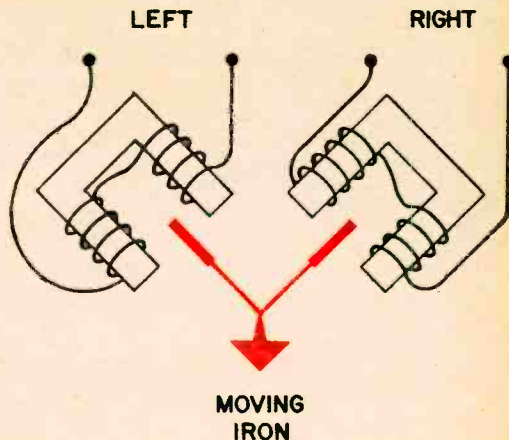
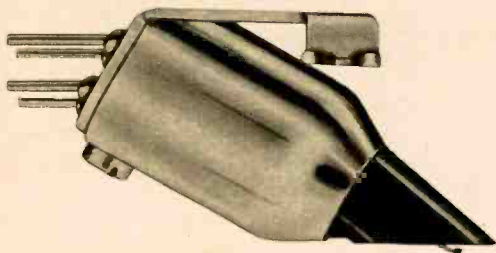

# CARTRIDGES



such featherweight pressures. Assuming you keep your records reasonably dust-free, they'll last almost indefinitely. In addition, the stylus (it always should be a diamond), having less friction to sustain, should last for years with normal use.

But there's one catch. Only professional-type tone arms will operate under such nearly weightless conditions. The ordinary kind of tone arm used on most changers and inexpensive record players has too much frictional drag and would jump grooves.

In addition, such arms usually are counterbalanced by springs that cannot be adjusted accurately to such light tracking pressures. So unless you have a first-rate arm (with counterweights or calibrated pressure adjustments), you had better stick with cartridges that are designed to track at pressures between 3 and 6 grams.

In picking the right cartridge for your sound system, you have a choice between two basic types: (1) crystal and

ceramic cartridges, and (2) magnetic cartridges.

## Crystals and Ceramics

If a record player plugs into an ordinary radio or TV set, your selection is pretty much predetermined: unless you want to add an external preamplifier, you must use a crystal or ceramic type. Only these cartridges match the high impedance of the phono input jacks on radios and TV sets. Also, these inputs require a high signal level (0.5 volt or more) that only a crystal or ceramic can provide.

Such cartridges are simple in principle. When subjected to mechanical stress, certain crystals (usually Rochelle salt) and some ceramic materials generate an electrical voltage due to a phenomenon known as the piezoelectric effect. In a stereo cartridge, two small slabs of such materials (one for each channel) are linked to the stylus. As the stylus twists in the groove, the slabs produce a voltage proportional to the stylus motion. This signal is fed directly into the audio stages of your radio or TV set.

This attractively simple method has one drawback—a fair amount of sheer physical energy is needed to do the twisting in order to squeeze the signal out of the crystal slabs. Because the stylus acts as a lever to do this work,

Still a third type of magnetic cartridge is the moving-magnet, which is shown in simplified form in the diagram at the right. The stylus in this case moves a magnet suspended within four coils, and thus produces an electrical voltage. Typical of moving-magnet cartridges is the Stanton 481AA, pictured below. It tracks at pressures as low as ¼ gram and has a \$49.50 price tag.

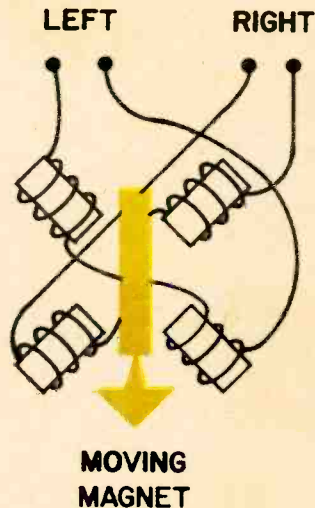
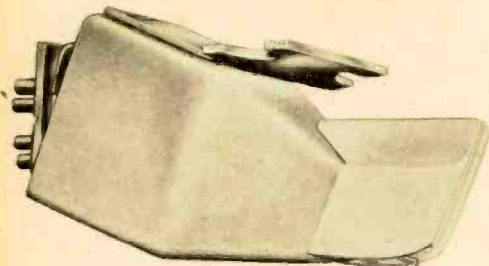



it must push quite hard against the record groove. This limits the compliance attainable in cartridges of this type. In fact, for many crystal and ceramic cartridges, compliance isn't even specified.

Thanks to their simplicity, crystals and ceramics are considerably cheaper than magnetics. Though most of them can't equal the magnetics in fidelity and low record wear, they have their place in inexpensive phonographs where fidelity is limited in any case by cheap speakers and mediocre amplifiers.

### Magnetics

If you have a component-type sound system, your best bet is one of the many magnetic cartridges now available. Nearly all current amplifiers have provisions for magnetic cartridges—which means that they have built-in preamplifiers. (Naturally, you also can use a separate preamplifier and power amplifier.)

Magnetic cartridges, which have an output measured in millivolts, need the extra gain from the preamp. In turn, the preamp provides the necessary corrective networks to match the recording characteristic used for today's records.

To some extent, a magnetic cartridge works like a miniscule power plant. In some, small magnets linked to the stylus move inside tiny coils, generating volt-

ages proportional to the stylus motion. These are known as moving-magnet cartridges. In others, the process is reversed—the coils move and the magnets remain fixed. Logically enough, they are called moving-coil cartridges.

In still another variant, called a moving-iron cartridge, the iron stylus shank wiggles between electromagnet poles and sets up the signal that way. Electrically, the result is much the same in all three cases; only mechanical detail differs.

The great advantage of magnetic cartridges is that their moving parts are light and have little resistance to motion. That's what makes the high compliance possible. With resistance and inertia at a minimum, the cartridges can follow the contours of the record groove more easily and accurately. There's actually no need to bear down heavily on the stylus.

What's more, the lightness and smallness of the moving parts shift their natural resonance beyond audible limits—usually above 20,000 cps. Consequently, no harsh-sounding resonance peaks occur within the frequency range of the cartridge.

### Frequency Response

The frequency specifications of the better cartridges of this kind tell you  
[Continued on page 119]

The ceramic or crystal cartridge makes use of the piezoelectric effect to convert a stylus's vibrations into electrical energy. This is the ability of certain types of rock and ceramic materials to produce a voltage when placed under mechanical stress. Typical of these is the Electro-Voice Magn ceramic 31. This is a ceramic cartridge that tracks at pressures from 2-4 grams. It's priced at \$24.

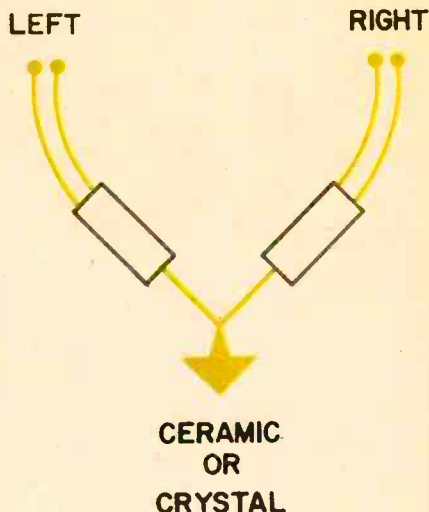
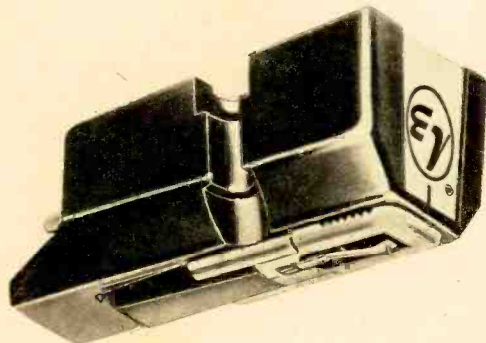

## Transmission Line

Continued from page 47

matched and the SWR is 1:1. Even when the line is matched to the load, as a safety measure, cut the line to a half-wavelength or multiple thereof to minimize line-impedance variations and SWR losses.

We just showed how the half-wavelength line is an impedance matching device—a 1:1 transformer. But a quarter-wavelength line is an *impedance inverter*. That is, if the output end of the quarter-wave line is connected to a low-impedance load, the input to the line appears as a high impedance. This property is useful when matching transmitters and antennas whose impedances differ from the impedance of common transmission lines. Here's a practical example:

A quarter-wave mobile whip antenna (Fig. 6) may have an impedance of 28 ohms. If the transmitter has an output impedance of 50 ohms, you have a matching problem. Here's how you solve it. If a quarter-wave section of 53-ohm line is connected to the 28-ohm antenna, the impedance at the input of the line will be 100 ohms. We can now consider this 100 ohms to be the load and use another quarter-wave section to match into the transmitter. If we connect a quarter-wavelength section of 73-ohm line to the 100-ohm input of the 53-ohm line the input of the 73-ohm line will ap-

pear as 53 ohms, a close match to the 50-ohm transmitter output impedance. For really difficult matching problems, consult an antenna manual, such as the ARRL Antenna Book.

**Line Losses.** A further factor you must consider when selecting a transmission line is the loss or signal attenuation caused by the dielectric between the leads. The thing that makes a special transmission line superior to lamp wire is its lower losses. Typical lamp wire can have a characteristic impedance of about 72 ohms. For many years it was used as transmission line. The problem was that the rubber insulation cracked and when it got wet the characteristic impedance changed, increasing SWR losses. But today transmission lines can withstand weather deterioration for many years.

**Open Line.** Open line is exactly what the name implies—two wires held apart by a low-loss insulator spaced every few inches. It looks like the line shown on the first page of this story. Notice in the table that the losses are low for open line, even at 144 mc. Open line, then, might appear to be an ideal choice, but it is difficult to work with. If spacing between wires is changed during installation an impedance bump appears at that point and the SWR increases. Therefore, the line has to be installed on insulators and with great care. If possible, avoid open line. It's a pain in the neck to handle.

**Twinlead.** Twinlead is just modified open line imbedded in polyethylene to insure constant spacing. You can bend and twist twinlead without worrying about impedance changes. Of course, using a plastic dielectric increases line losses. Considering how easy it is to handle, its lower losses and low cost, 300-ohm transmitting twinlead generally is the best deal for the newcomer to ham radio. But the important thing to remember is not to use light twinlead, such as is used for TV, to handle high RF power. Most modern transmitter outputs will match the line's 300-ohm impedance, and 300-ohm antennas for use below 30 mc can be made easily. (See HAM ANTENNA FACTS elsewhere in this issue.)

**ATTENUATION CHART**

TYPE	MAXIMUM RATING	CHARACTERISTIC IMPEDANCE (OHMS)	ATTENUATION db per 100 feet (SWR=1:1)							
			Frequency (mc)							
			3.5	7	14	21	28	50	144	
Open wire		200-800	.03	.05	.07	.08	.10	.13	.25	
Coaxial										
RG8/U	1 kw	52	.28	.42	.64	.81	1.0	1.4	2.6	
RG11/U	1 kw	75	.26	.41	.61	.75	.92	1.3	2.4	
RG58/U*		53.5	.53	.8	1.2	1.6	1.9	2.7	5.1	
RG59/U*		73	.55	.81	1.2	1.6	1.8	2.5	4.6	
Twinlead										
214-076**	1 kw	300	.16	.23	.34	.41	.51	.69	1.3	
214-022**	1 kw	300	.13	.19	.28	.33	.41	.54	.90	
214-023**	1 kw	75	.28	.50	.88	1.1	1.5	2.3	5.0	

\*Receiving types; suitable for low-power transmitters.  
\*\*Amphenol numbers.



Continued from page 98

As a general rule, it is better to use twinlead than coaxial cable if your antenna is a dipole. The dipole and the folded dipole are balanced antennas and perform best when fed by a *balanced line*, such as twinlead. Depending on your transmitter, you may have to use an antenna coupler or a balun to feed an unbalanced transmitter into a balanced line. Coax, unless the shield is not grounded (and then there's no advantage to using it), is unbalanced with respect to ground and the performance from a balanced antenna will not be as good as with twinlead.

**Coaxial Cable.** Coaxial cable is easier to install. It can be buried underground or snaked through a wall without producing extra losses as would twinlead if it is near metallic objects. The usual coaxial cable has a life of two or three years. It may look satisfactory to the eye, but if it's over three years old, replace it. For this reason, always buy new coax at the outset. War-surplus coax may be selling at rock-bottom prices but its performance may be just as low. Coax is available for both receiving (RG58/U, RG59/U) and transmitting (RG8/U, RG11/U) applications. While either type can be used below 200 watts, the line losses (due to the dielectric capacitance between the inner lead and outer shield) are greater than for twinlead. At the higher amateur frequencies, the line loss becomes appreciable, particularly for receiving-type coax.

Since coax frequently is used above 30 mc, and since losses in any coax above 30 mc become appreciable, you have to consider carefully whether the lower cost and greater attenuation of the receiving type will be worth the power sacrifice.

If you really want to keep attenuation losses down, specify Polyfoam dielectric when ordering RG8/U or RG59/U. It costs more but you will suffer only about half the loss of the usual coax line.

As you can see, choosing the correct transmission line involves more than buying merely the least expensive type. The difference between an efficient installation and one that turns your signal into a peanut whistle is a few dollars at most.

quency-shifter instead of the keyboard. In some installations, a typing reperforator is connected to the receiving converter. Since this device prints the message right on the tape, as well as punching holes in it, tapes of messages received can be made for retransmission at a later time on another net or frequency.

One of the more fascinating aspects of RTTY operation on VHF is *auto-start*. Briefly, fixed-frequency receivers parked on a previously agreed-on channel are turned on, with an associated receiving converter, by a time clock at a certain preselected time. If a steady *mark* tone of 2125 cycles is detected, a relay turns on the machine motor. After a reasonable time (to make sure that the motor has started) the machine copies any message sent.

These are the things, then, that make RTTY one of the last frontiers of amateur radio. For the world of RTTY has a place for the radio amateur tired of the inane yak-yak of the phone bands, just as it affords a place for the fellow who would like to create and use the somewhat different equipment required to work this particular mode of emission.

If you fall in this class and want to obtain a machine, try contacting one of the more active RTTYers in your own FCC District—W1AFN, W2ZKV, W3CRO, W4EHU, W5KXD, W6AEE, W7HRC, W8DLT, W9GRW, or W0ATM, are all good bets. Canadians should try VE2ATC. One of these fellows should be able to advise you of current availability and can tell you of those societies or other sources which might be close.

For those interested in pursuing Teletype and radioteletype circuitry further, the following publications are available:

**The New RTTY Handbook.** By Byron H. Kretzman, W2JTP. Cowan Publishing Corp., 300 West 43rd St., New York 36, N. Y. \$3.95

**The ABC's of Teletype Equipment.** Teletype Corp., Skokie, Ill.

**The RTTY Bulletin.** By Merrill W. Swan, W6AEE. RTTY Society of Southern California, Inc., 372 West Warren Way, Arcadia, Calif. \$3 per year.

## AM-CW Transmitter

Continued from page 105

even when you're running on 6 meters.

The output circuit is a pi-network which, like many others, is designed to match anything from 40 to 600 ohms. However, the efficiency drops in any wide-range match. As any pi-net student could guess, the T-150 will not load into one antenna efficiently on all its six bands. We could not load it with any efficiency into a 50-ohm load on 80 meters, and improvement was nominal on 40 meters (to improve loading here Allied now recommends cutting two turns off the cold end of the final tank coil and moving the 40-meter tap two turns backward). On 20, 15 and 10 meters the transmitter loads properly into 50 ohms. The 100-watt input was obtained easily on 6 meters with a 50-ohm load.

The T-150, like any comparable rig, balks at loading into a random-length antenna (unless, says Knight, it just happens to be an odd quarter-wavelength at the operating frequency). If you plan to use a long-wire we recommend an antenna coupler (such as the one described elsewhere in this issue). With a coupler the transmitter can be loaded to full rated input. With a commercial matchbox, it could be loaded into *anything*, including a rusty screen door being climbed by a one-eyed tomcat.

The VFO is well designed but take care to install the upper and lower shields properly (with lockwashers). When on 80 and 40 meters the entire transmitter is operating straight-through and the VFO would be susceptible to instability with improperly installed shields. The shields prevent the buffer and final signal from feeding back to the VFO.

VFO dial calibration is particularly good. When the band edges are aligned carefully an entire band falls into place with excellent accuracy. Use extra care when installing the dial on the shaft since it can work loose easily. We suggest cementing it in place after the 80-meter alignment. When the cement is

dry, move on to 40-10 and 6 meters. These latter calibrations are delicate and should be made in the shack; handle the rig gently and try not to move it thereafter.

Plenty of mike gain is provided by the modulator, making it easy to overdrive. Contrary to what the instruction manual says, we suggest loading the transmitter into a 150-watt light bulb on 40 meters to adjust mike gain. Work for rated CW input first, then switch to AM and advance the mike gain as you speak. The bulb, flashing at the audio rate, will glow more brilliantly as you increase gain. At some point, more gain *decreases* brilliance. Stop here, back off the gain control a few degrees and your modulation will be clean and at maximum.

For those who may want to add high-level plate modulation later (though the T-150's screen modulation is good) Knight provides a jumper plug on the apron with which to connect a plate modulator. It disconnects the screen modulator automatically.

An accessory plug provides 6.3 VAC and 300 and 700 VDC for accessories you might want to add. The plug also delivers 117 VAC for an antenna relay. An unusual feature of this plug is that it's wired so the transmitter can be controlled from other equipment, such as a send-receive switch on the receiver or auxiliary contacts on an antenna relay operated off a master station switch.

Knight now is contemplating a few more changes in the oscillator coils for improved stability. If the changes come off they will appear in all new T-150's coming off the line.

Working mainly on 80 meters at W2ZLF, we made a good number of successful contacts with a long-wire and coupler. We switched to 6 meters and a beam and our first contact covered 110 miles—a startlingly good hop.

In summary, the T-150 gives you a lot of power and attractive features for your money. It is to be recommended for general hamming but, more to the point in our story, the T-150 also represents an excellent first transmitter that *won't* wind up in the attic. 



Continued from page 68

tently with factions within the German military. Even in view of this, NTS could not possibly have been a Nazi organization in the strict sense, since the Nazis always considered the Slavic people "subhuman."

Third, and most important, NTS has a political philosophy all its own, and a highly controversial one. Consider these quotes (from the NTS's own fact book):

"The supreme authority is simply qualified as being a 'central' power dedicated to service of the values represented in the ideology and situated above the strife of political parties . . . . The supreme authority must guard the country's unity and insure the proper functioning of the legislative and executive powers."

Radio Free Russia seldom is heard in North America. Although the operating schedule is comparatively extensive, transmitters may be forced to move as much as 50 kc off listed frequencies to avoid jamming. When something is heard, it's usually these jammers. But 15-minute NTS programs now are carried by two Latin American stations for Russian troops in Cuba.

One of these stations is HIUA, Radio Caribe, at Santo Domingo, Dominican Republic. Its broadcasts can be monitored at 2245 EST every night except Sunday on 3322 kc, 9505 kc and, with a little luck, 860 kc on the broadcast band.

The second station is Radio Libertad, La Voz Anticomunista de America, a clandestine outlet on 9325 kc which does not announce its location.

Radio Libertad's NTS transmission is on Saturday nights only and begins sometime between 2230 and 2300 EST, varying from week to week. In addition to 9325 kc, Radio Libertad announces a variety of frequencies, including 4005 (heard on 3997), 5065 and 7315 kc, all at night. They also use 15050 kc, primarily in a morning transmission.

Incidentally, Radio Libertad does not verify reception reports, but NTS does. Address your reports to 125 bis rue Blomet, Paris 15(e), France.

## STOP THAT (RF) LEAK!

IT WAS ONLY recently that shielded meters became standard equipment in small transmitters and other gear. You might put in hours of labor TVI-proofing your equipment, only to have RF escape out the meter holes. (Aha! That's how the RF is getting around your low-pass filter!)

What to do about it? Simply shield your meters with aluminum foil. Coil dope, household cement, "Scotch" tape, etc., will hold the foil in place. Carefully cut holes in the foil to pass the terminals, of course. And in your final wrapping of the body of the meter leave enough of a "skirt" to line the back of the meter bezel. And be sure some corner or tab of the foil is left over to go under one of the mounting screws (and a washer). To insure good grounding to the front panel sand off a patch of paint where the meter mounting screws come through. Sand or steel-wool the inside of the meter hole to remove rust.—Nicholas Rosa, W1NOA



## Single Sideband

Continued from page 55

get a better idea of what we've been talking about is to imagine we're tuning an SSB signal. At some time when things aren't too hectic, a spectrum view of part of the 80-meter band might look like Fig. 4. The signal at A is an AM signal, identified by the large carrier in the center and the flanking side frequencies. The signal at B is an unmodulated carrier or code (CW) signal at the moment the sender's key is held down. The signal at C is an SSB signal and the dashed line represents the spot where the carrier once was. (The lower sideband is being transmitted.)

Now consider the tuning knob on your receiver a device that can move a window from one end of the 80-meter band to the other. The purpose of the window is to enable you to look at only a small portion of the band at a time. How much of the band the window sees depends on its width, which corresponds to the receiver's selectivity curve. Let's tune across the signals of Fig. 4.

In tuning, we might set the dial to 3,924 kc. That frequency then would be centered in the window shown in Fig. 5A. Now let's move the window all the way to the left in Fig. 4—to just below 3,918 kc—and then start moving it back to the right. As the sidebands below 3,924 kc fall within the window, we hear one side frequency beating against the other (the two marks to the left of the carrier) and the sound will be gibberish. As the window moves farther right, enough of the carrier will be admitted to beat against the side frequencies, and you have intelligible sound. As the window continues to move to the right it admits the two lower sidebands, the two upper sidebands and the carrier (five signals altogether) and the audio is clean. As we tune to a still higher frequency, we reach a point where only the upper side frequencies are visible and again the sound becomes distorted.

Continuing our tuning, we hear nothing until we approach the signal at B. When it appears in the window, we hear a change in the normal hiss of the receiver, indicating a CW signal. Switch

on the BFO (red line in Fig. 5B) and we hear code. Moving the BFO pitch control changes the pitch. The relationship between the BFO line and the window is changed by the BFO pitch control. When we tune the receiver, we move the window *and* the BFO line together without changing the relationship between the two. If the BFO is on and centered in the window and we tune from the left across the signal at 4B, we first hear a high-pitched signal, and then gradually a lower-pitched signal, as the BFO line and the spot where the carrier was (dashed line) get closer together.

Let's approach the signal in Fig. 4C from the left with the narrower window in Fig. 5C. When the left sidebands first appear in the window, audio output will be produced by the beating between the side frequencies. Moving the BFO line to the right toward where the carrier should be will cause the sound to go from a low pitch to normal. Now move the BFO line to the right side of the window (5D) and adjust the control so the BFO frequency approaches the point where the carrier should be (dashed line, Fig. 4C). At first, the sound will be high-pitched. When the BFO line is directly over the carrier line, the BFO will be in the correct frequency relationship with the sidebands and speech reproduction will be normal.

You can now see that in order to receive an SSB signal without having to constantly readjust the BFO pitch on your receiver, the BFO oscillator must be extremely stable.

Inexpensive communications receivers may have an unstable BFO. This means that you may have to keep your hand on the BFO pitch control constantly. One way of solving the problem is to add a voltage regulator tube to the receiver to supply regulated DC to the BFO.

If you want to learn more about SSB theory and equipment, refer to these books: *Single Sideband for the Radio Amateur*, published by the ARRL; *New Sideband Handbook*, by Don Stoner, published by Cowan Publishing Co., and the *Single Sideband Communications Handbook*, by Harry Hooton, published by Howard W. Sams, Inc.



Is this where  
your job in electronics  
is taking you?



That's up to you. Everyone knows education is what pays off in electronics. Keep learning and your job is a starting point—stop and it's the end of the road. Sure, going to school may be impossible. But you can continue your education and put yourself in line for a better job through a CREI Home Study Program in Electronic Engineering Technology. You're eligible if you work in electronics and have a high school education. If your knowledge of fundamentals is rusty, CREI's refresher course

will take care of that problem. Our free book gives all the facts—mail coupon or write: CREI, Dept. 1709 A, 3224 Sixteenth St., N.W., Washington 10, D.C.

**SEND FOR FREE BOOK**

The Capitol Radio Engineering Institute.  
Dept. 1709A, 3224 Sixteenth St., N.W.  
Washington 10, D.C.



Please send me FREE book describing CREI Programs in Electronics and Nuclear Engineering Technology. I am employed in electronics and have a high school education.

Name \_\_\_\_\_ Age \_\_\_\_\_

Address \_\_\_\_\_

City \_\_\_\_\_ Zone \_\_\_\_\_ State \_\_\_\_\_

Employed by \_\_\_\_\_

Type of Present Work \_\_\_\_\_

Check:  Home Study  Residence School  G.I. Bill

PE-11

ACCREDITED MEMBER OF THE NATIONAL HOME STUDY COUNCIL



Continued from page 99

ton's Dancing Trombones, a program that is reminiscent of the halcyon days of Tommy Dorsey. The tunes are standards that range from then till now.

Even more distant days are evoked by the New Christy Minstrels, a folk-song group which hearkens back to the old-time minstrel show for the format of its presentations. Ten strong, the New Christy Minstrels alternate solo pieces with ensemble numbers. In Tall Tales, they have themselves a ball with songs of Legends and Nonsense. The performances suggest tremendous exuberance, with everybody obviously having a wonderful time.

It is amazing how zestful some religious music can be. In Makin' a Joyful Noise, the Limelitters perform a program of folk hymns and prove that not all good tunes belong to the devil. They make a joyful noise unto the Lord with enthusiasm, conviction and vibrant sonics.

Judy Henske derives some of her inspiration from gospel hymns and a lot of it from the salty old blues that have their genesis in a world remote from religion. She brings to her material an incredible amount of vitality and an inexhaustible fountain of good humor and sheer animal spirit. All of which makes her an exciting and magnetic performer, one eminently worth hearing.

Records discussed in this column, with monaural discs listed first and stereo versions following:

Koto & Flute Eto, Shank World Pacific 1424; S-1424  
 Improvisations Ravi Shankar World Pacific 1416; S-1416  
 Ravel: La Valse Paray, Detroit Sym. Orch. Mercury MG-50313; SR-90313  
 Beethoven: Eroica Symphony Boulton, Philharmonic Promenade Orch. Vanguard SRV-127; SRV-1275D  
 Mahler: Symphony No. 1 Leinsdorf, Boston Sym. Orch. RCA Victor LM-2642; LSC-2642  
 Hindemith: Violin Concerto Oistrakh, Hindemith London CM-9337; CS-6337  
 The Big 18 Lavalley, Band of America MGM E-4114; SE-4114  
 Big Noise from Winnetka Bob Haggart Command 849; RS-849SD  
 Dancing Trombones Warren Covington Decca DL-4352; DL-74352  
 Tall Tales New Christy Minstrels Columbia CL-2017; CS-8817  
 Makin' a Joyful Noise Limelitters RCA Victor LPM-2588; LSP-2588  
 Judy Henske Elektra EKL-231; EKS-7231

Continued from page 37

As five or ten characters go by, you'll become accustomed to the speed, rhythm and tone in the earphones. A slight delay before you start to copy also gives you a chance to adjust the phones. If volume is too loud, just push them forward an inch or two.

Once you've begun to copy, don't try to fill in characters you may have missed. Instead, keep going and avoid backtracking. Just remember there are dozens of chances—right up to the last minute—to copy the required span of 65 characters.

At the end of the receiving run, you'll be asked to transmit with a straight key on the table. If anyone has ever failed the sending test, it's a well-kept secret. We're not trying to suggest that the sending test is a snap. But if you can receive 13 wpm, sending 13 should be easier than reciting Ohm's Law.

The second part of the exam is a written test. The number of failures here drops to a piddling 5 or 10 per cent. Although there is no time limit, most applicants take about an hour to complete the 50 test questions. All are of the multiple-choice type, except for several schematic diagrams. (Schematics, incidentally, cause the most trouble on the written exam.)

One last word of advice: don't make the mistake of showing up at the FCC office too late. One applicant appeared recently at the New York office just an hour before closing time. "How long does it take to complete the test?" he asked. Examiner Finkelman's reply: "Just a few minutes—but I know the answers."

You'll know moments after taking the test whether you've passed. The examiner usually checks answers on the spot and utters the verdict. Passing grade is 74 per cent, which means you can err on 13 questions without affecting the final result.

That result is worth a day at the FCC. Success is greeted with a call sign and station license in two to six weeks. Or you can try again next month.



# WHY BUY A TRANSISTOR AMPLIFIER?

## IT MAKES MUSIC SOUND BETTER!



Shimmering cymbals, thundering tympani, blaring trumpets, abrupt, bursting piano . . . each with its characteristic sound, unmodified . . . this is the sound of realism . . . the quick, natural sound of transistor amplifiers. "Transient Response" . . . the ability of an amplifier to provide instantaneous bursts of power as the music demands . . . an ability so superior in transistor equipment that it has already created the term, "transistor sound". To this greater realism, add Longer Life, Lower Power Consumption, Cooler, Faster Operation . . . these are the reasons why you should move up to a Transistor Amplifier!

## WHY BUY A HEATHKIT TRANSISTOR STEREO AMPLIFIER? • IT IS BETTER!

The first of the high power transistor stereo amplifiers to live up to its specifications! A full 70 watts continuous power, 100 watts music power, plus or minus one db at all frequencies from 13 to 25,000 cycles! No faltering, no compromising, just the most satisfying, solid stereo sound you've ever heard. You choose the latest in electronic circuitry with the Heathkit AA-21 . . . 28 transistors, 10 diodes, and complete controls. Easy to build, too, with circuit boards and encapsulated component modules. Order it now; kit or assembled, it's better!

Kit AA-21, 28 lbs., \$13 mo. . . . . **\$139.95**  
 Assembled AAW-21, \$16 mo. . . . . **\$167.95**



**FREE HEATHKIT CATALOG**  
 100 pages of the world's most famous do-it-yourself electronic kits . . . over 250 in all . . . for stereo/hi-fi, marine, amateur radio, test and lab., automotive, electronic organ, television, home and hobby . . . easy to build equipment which requires no special skills and saves you up to 50%.

**HEATH COMPANY**, Benton Harbor 39, Michigan

Enclosed is \$\_\_\_\_\_ plus postage, please send Heathkit Model \_\_\_\_\_ Transistor Amplifier.

Please send FREE Heathkit Catalog.

NAME \_\_\_\_\_

ADDRESS \_\_\_\_\_

CITY \_\_\_\_\_

ZONE \_\_\_\_\_

STATE \_\_\_\_\_

Prices and specifications subject to change without notice. Dealer and export prices slightly higher.

# ELECTRONICS ILLUSTRATED

# Classified Ads

Your advertisement can reach this mail-buying audience for only 50¢ per word . . . payable in advance (Check or M.O. please) . . . minimum 10 words. Closing dates are the 20th of 4th preceding month i.e. copy for the January issue must be in our office by September 20th. Mail to ELECTRONICS ILLUSTRATED, 67 West 44th St., New York 36, N. Y. Word count: Zone number free. Figure one word: Name of state (New Jersey), name of city (New York); sets of characters as in key (14-D); also abbreviations as 35MM, 8x10, D.C., A.C.

## SAVE MONEY • ORDER BY MAIL

### • • • FOR SALE

**FREE LITERATURE** keeping you informed on the latest work-saving, money-making test equipment. Learn how Easy Budget Payment Plan lets you pay out of increased earnings. Top engineered test instruments are priced for tremendous value. Write today. Century Electronics, 352 Maple Ave., Westbury, N. Y.

**"LISTEN-IN-COIL"** PICKS up any telephone conversation in vicinity. No connection to telephone necessary. Easily concealed. \$2.98 complete. Consolidated Acoustics, 1302-C Washington St., Hoboken, New Jersey.

**EXCELLENT BUYS** on Tubes and equipment all listed in the "Green Sheet." Send .25¢ for your copy today. Cash paid for unused tubes. Write: Barry Electronics Corp., 512 Broadway, Dept. EI, NYC 12, NY.

**GOVERNMENT SURPLUS.** How and Where to Buy in Your Area. Send \$1.00. E.I. Surplus Information, Headquarters Bldg., Washington 6, D. C.

**CANADIANS—GIANT** Surplus Bargain Packed Catalogs. Electronics, Hi-Fi Shortwave Amateur Citizens Radio. Rush \$1.00 (Refunded). ETCO, Dept. EI, Box 741, Montreal.

**MYLAR TAPE** 1½ mil (strong) 7" reel 1200' \$1.75 postpaid. A.D.B., 200 Rose, Alamogordo, New Mexico.

**INEXPENSIVE BUSINESS** Cards, Labels, Rubber Stamps. Prices, Samples—Postcard. Hubbard, Box 1281-P, Berkeley 1, Calif.

**INVESTIGATORS, WRITE** for free brochure on latest subminiature electronic listening devices. Dept.-5X, Ace Electronics, 11500 NW 7th Ave., Miami 50, Florida.

**CONVERT ANY** television to sensitive, big-screen oscilloscope. No electronic experience necessary. Only minor changes required. Illustrated plans, \$2.00. Relco, Box 10563, Houston 18, Texas.

**MAILORDER COURSES.** Fantastic Discounts. Selmar Scientific, 14808 N. 30th Drive, Phoenix 23, Arizona.

### • • • BUSINESS OPPORTUNITIES

**VENDING MACHINES—**No selling. Operate a route of coin machines and earn high profits. 32-page catalog free! Parkway Machine Corp., 715E1 Ensor St., Baltimore 2, Md.

**MAKE \$25-\$50 WEEK** clipping newspaper items for publishers. Some clippings worth \$5.00 each. Particulars free. National, 81 Knickerbocker Station, New York City.

**\$100 WEEKLY POSSIBLE.** Compile mailing lists and address envelopes for advertisers. Home — spare time. Particulars free. National Service, 81 Knickerbocker Station, New York City.

### • • • EMPLOYMENT OPPORTUNITIES

**PRINTING - ADVERTISING SALESMEN.** Excellent moneymaking sideline selling Decalcomania Name Plates. Advertising Specialties. Sign letters, Automobile initials. Free Samples. "Ralco" EI, Box L, Boston 19, Mass.

### • • • EDUCATION & INSTRUCTION

**DIGITAL COMPUTER Simplified:** Basic, concept level introductions, clearly illustrated. Advent Editions, P. O. Box 124C, Sarasota, Florida. \$3.00, 25¢ postage.

**HIGHLY-EFFECTIVE HOME** Study Review for FCC Commercial Phone Exams. Free Literature! Wallace Cook, Box 10634, Jackson 9, Miss.

**BASIC MATHEMATICS.** Algebra, Calculus, Trial first 4 easy lessons \$1. Mathco, Cincinnati 17, Ohio.

### • • • BUILD-IT-YOURSELF

**RADIO TROUBLESHOOTER** \$5.95. With Isoprobe, information, and parts, you now can make any radio a complete Signal Tracer-Injector to pinpoint trouble in radios or amplifiers. Easy—Only 2 connections required. Safe—Isoprobe carries only the signal—No voltage. Timesaver—For Hobbyist or Pro. Complete instructions. All parts. Order Isoprobe AM #141 \$5.95, AM/FM #241 \$7.95. Waltronic, 1814 N. 84th, Milwaukee 13, Wisconsin.

**PROFESSIONAL ELECTRONIC** Projects—Organs, Timers, Computers, etc.—\$1 each. List free. Parks, Box 1665, Lake City, Seattle 55, Wash.

### • • • HI-FI & STEREO

**4/TR Stereo Tapes—**bought, sold, rented, traded! Bargain closeouts! Catalog Columbia, 9651 Foxbury, Rivera, California.

### • • • TAPE RECORDERS

**LEARN WHILE Asleep** with your recorder, phonograph or amazing new "Electronic Educator" endless tape recorder. Details free. Sleep-Learning Research Association, Box 24-EI, Olympia, Washington.

**TAPE RECORDERS** Hi-Fi Components. Sleep Learning Equipment, tapes. Unusual values. Free Catalog. Dressner, 1523 Jericho Tpke., New Hyde Park-4, N. Y.

**RENT STEREO** Tapes—over 2500 different—all major labels—free catalog. Stereo-Parti, 811-AY Centinela Ave., Inglewood 3, California.

**SALE ITEMS—**Tapes—Recorders—Component Quotations. Bayta, Box 131E, Waukegan, N. Y.

### • • • RADIO & TV

**BEFORE YOU Buy** Receiving Tubes, Test Equipment, Hi-fi Components, Kits, Parts, etc. . . send for your Giant Free Zalytron Current Catalog, featuring Standard Brand Tubes: RCA, GE, etc.—all Brand New Premium Quality Individually Boxed, One Year Guarantee—all at Biggest Discounts in America! We serve professional servicemen, hobbyists, experimenters, engineers, technicians. Why Pay More? Zalytron Tube Corp., 461 Jericho Turnpike, Mineola, N. Y.

**I HAVE** Over 500 Types Radio And T.V. Tubes On Hand. Some Used But All Good, \$1.00 Each, 3 For \$2.00, 50 For \$20.00. Money Back Guarantee: Marion's T.V., Box 16, Parma, Ida.

**15 DISTANCE ONE-TUBE** plans—25¢; One-tube Handbook—50¢. Includes Transistor experiments, catalog. Laboratories, 1131-K Valota, Redwood City, California.

### • • • PLASTICS

**NEW LIQUID Casting** Plastic, clear, colors. Embed real flowers, butterflies, photos, coins. Send 25¢ for two handbooks, "How to Cast Liquid Plastics" and "How to Make Extra Money at Home." Castolite, Dept. K-107, Woodstock, Illinois.

### • • • INVENTIONS & INVENTORS

**PATENT SEARCHES,** \$6.00! Free "Invention Record"/information. Miss Hayward, 1029 Vermont, Washington 5, D. C.

### • • • DETECTIVES

**DETECTIVE PROFESSION.** Easy home study plan. Lapel pin, certificate, future. Free information. Professional Investigators, Box 41197-CC, Los Angeles 41, Calif.

### • • • PERSONAL

**INDEPENDENT THINKERS—**investigate Humanism, the scientific personal philosophy! Free literature. American Humanist Association, Dept. EI-2, Yellow Springs, Ohio.

**PERSONAL DATA** Record Book \$1.79. Rosen, Box 3920, Chicago 54.

### • • • MISCELLANEOUS

**"WINEMAKING," "BEER, Ale,"** Strongest methods. Illustrated. \$2.20. (Supplies, hydrometer headquarters.) Eaton, Box 1242-EL, Santa Rosa, California.

**TRANSISTOR IGNITION.** 260/1 coil, manual Special \$8.50. Kits, parts, available. Anderson Engineering, Wrentham, Massachusetts.

**HYPNOTIZE UNNOTICED,** quickly, effortlessly, or refund! Thousands delighted! \$2.00. Minter, Box 244-P, Cedarburg, Wisconsin.



*Continued from page 56*

American ham gear a luxury. This is especially true of SSB equipment, which carries a sizable tag even before it's exported from the United States. When an Italian or German ham boasts of running the full Collins S line, you aren't at all surprised to find a Maserati in the driveway and a squad of servants in the house.

What do the average Joes do for receivers, transmitters and the countless components needed for construction purposes? Well, they have Geloso, an electronics firm noted throughout the Continent, Africa and South America for its extensive line of popular-price gear ranging from hi-fi systems to set screws.

John Geloso, head of the outfit, has a special interest in the ham market which dates back to pre-World War II days when he was a young radio engineer with Pilot Radio in—of all places—Brooklyn, N. Y. His call by the way, is IJGM—John Geloso, Milan. Obviously, letter combinations of this kind are not hard to arrange here.

**Fiesole, Italy . . .** On our way again, we stopped in this picturesque town just outside Florence for a bit of picture-taking. Through my finder I eyed a tall young man examining the QSL on my car window. The lad introduced himself as Alexander Demcenko, I1ALX. He's a student attending a university in Florence and had all his gear in temporary quarters nearby. Would we like to see it? We didn't resist.

Alex's breadboard station represented little money but much typical ham make-do. It consisted of a surplus U.S. Signal Corps BC-342 receiver (circa 1940), a home-made 25-watt AM/CW transmitter and two simple half-wave dipole antennas for 40 and 15 meters. Breadboard or no, the log book showed QSO's from all over the world.

After Rome, our itinerary reads: Israel, France, the Low Countries, Scandinavia and, finally, England. We hope to report it all in the next issue. ●

*Continued from page 109*

more than their overall response—30 to 18,000 cps, for instance. They also spell out the maximum deviation from flat response within that range—say, 30 to 18,000 cps,  $\pm 2$ db.

Whenever you see a frequency response statement qualified with this  $\pm$  figure, you can take it for granted that the manufacturer has devoted special care to eliminate unwanted resonances that might cause harshness of sound. (Crystal and ceramic cartridges, because of the tricky linkage between stylus and slabs, sometimes are troubled by such resonances.)

Comparing magnetic and crystal cartridges purely in terms of sound, you notice a characteristic difference. The magnetics, as a rule, have greater transparency. You can see through the orchestra more clearly. Instruments remain more defined, even when they are playing together. You can tell more easily a cello from a trombone or a clarinet from a flute.

Another difference is that the magnetics usually put more bite in percussive attacks—a sharper, more incisive sound on staccato, tutti passages; more snarl in the snare drum. Of course, your amplifier and speakers must be capable of showing up such subtle differences.

In one respect, cartridges are much like speakers. Even the most carefully stated specifications can't tell you exactly how a cartridge sounds. Obviously, there are differences in tonal coloration that can be expressed only subjectively.

Most audio fans, for instance, agree that some cartridges have a warm and silky sound with the bass sounding round and full. Others tend toward brightness and brilliance. Which you like better is strictly a matter of personal preference.

Let your hi-fi dealer play the same record for you with various cartridges so you can hear the difference yourself. Then, after weighing the facts, let your ears make the final choice. ●

# RAD-TEL'S

# 1 for 1 TUBE SALE!

Your Choice

# 29¢

each

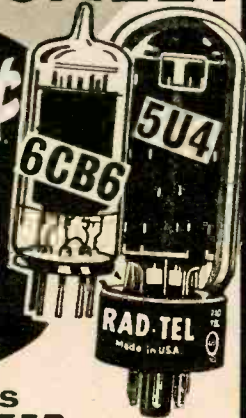

## \*RAD-TEL'S SPECIAL OFFER

For every Rad-Tel quality Brand New Tube you buy, as advertised—Rad-Tel will give you your choice of a Brand New 5U4 or 6CB6 tube for only 29¢ each!!

THIS OFFER EXPIRES AUG. 31, 1963

LIMITED TIME OFFER—ORDER NOW!

## ONE YEAR GUARANTEE

ONE DAY SERVICE—OVER 500 TYPES IN STOCK

up to **75% OFF\*\*** Rad-Tel's Quality BRAND NEW TUBES  
\*\*Manufacturers Suggested List Price

**FREE!** Send For New Tube & Parts Catalog  
Send For Trouble Shooting Guide

Be your own TELEVISION REPAIRMAN

The Original NOW YOU CAN  
FIX YOUR OWN TV SET BOOK

You can fix your own TV if you have TV First Book... because 80% of troubles are caused by tubes. This book explains, illustrates trouble and what tubes cause this trouble. Pinpoints in over 3000 layouts by model number, position and type tube causing trouble.

**\$1.00**

No. 170... **CHEATER CORD** Easy to work on set while panel is off. 6 ft., No. 154... **29¢ ea.** Lots of 3—25¢ ea.



## RAD-TEL TUBE CO.

TV, RADIO AND HI-FI

DEPT. EI-9 55 CHAMBERS STREET, NEWARK 5, NEW JERSEY

TERMS: 25% deposit must accompany all orders. balance C.O.D. Orders under \$5: add \$1 handling charge plus postage. Orders over \$5: plus postage. Approx. 8 tubes per 1 lb. Subject to prior sale. No C.O.D.'s outside continental U.S.A.

### EACH TUBE ATTRACTIVELY BOXED & BRANDED RAD-TEL

Qty.	Type	Price	Qty.	Type	Price	Qty.	Type	Price	Qty.	Type	Price
—	0Z4	.79	—	6AU8	.87	—	6K6	.63	—	12CU5	.58
—	1AX2	.62	—	6AV6	.41	—	6S4	.52	—	12CU6	1.08
—	1B3	.79	—	6AW8	.90	—	6SA7GT	.99	—	12CX6	.54
—	1DN5	.55	—	6AX4	.66	—	6SH7	1.02	—	12D4	.69
—	1G3	.79	—	6AX5	.74	—	6SJ7	.88	—	12DE8	.83
—	1J3	.79	—	6BA6	.50	—	6SK7GT	.95	—	12DL8	.88
—	1K3	.79	—	6BC5	.61	—	6SL7GT	.84	—	12DQ6	1.04
—	1R5	.77	—	6BC8	1.04	—	6SN7	.65	—	12DS7	.84
—	1S5	.75	—	6BE6	.55	—	6SQ7GT	.94	—	12DT5	.76
—	1T4	.72	—	6BF5	.90	—	6T4	.99	—	12DT7	.79
—	1U5	.65	—	6BF6	.44	—	6T8	.85	—	12DT8	.78
—	1X2B	.82	—	6BG6	1.70	—	6U8	.83	—	12DW8	.85
—	2AF4	.96	—	6BH8	.98	—	6V6GT	.54	—	12DZ6	.62
—	3AL5	.46	—	6BJ6	.65	—	6W4	.61	—	12ED5	.62
—	3AU6	.54	—	6BJ7	.79	—	6W6	.71	—	12EQ6	.62
—	3AV6	.42	—	6BK7	.85	—	6X4	.41	—	12EK6	.62
—	3BC5	.63	—	6BL7	1.09	—	6X8	.80	—	12EL6	.50
—	3BN6	.75	—	6BN6	1.74	—	7A8	.68	—	12EZ6	.57
—	3BU8	.78	—	6BQ6	1.12	—	7AU7	.65	—	12F8	.66
—	3BY6	.58	—	6BQ7	1.00	—	7EY6	.75	—	12FA6	.79
—	3BZ6	.56	—	6BU8	.70	—	7Y4	.69	—	12FM6	.50
—	3CB6	.56	—	6BX7	1.11	—	8AU8	.90	—	12FR8	.97
—	3C56	.58	—	6BZ6	.55	—	8AW8	.93	—	12FX8	.90
—	3DG4	.85	—	6BZ7	1.03	—	8BQ5	.60	—	12G6	1.06
—	3DK6	.80	—	6C4	.45	—	8C67	.63	—	12J8	.84
—	3DT6	.54	—	6CB6	.55	—	8CM7	.70	—	12K5	.75
—	3GK5	.99	—	6CD6	1.51	—	8CN7	.97	—	12L6	.73
—	3Q4	.63	—	6CG7	.61	—	8CS7	.74	—	12SF7	.69
—	3S4	.63	—	6C8	.80	—	8EB8	.94	—	12SK7GT	.95
—	3V4	.75	—	6C8L	.79	—	8F07	.56	—	12SL7	.80
—	4BQ7	1.01	—	6CM7	.69	—	9CL8	.75	—	12SN7	.67
—	4C56	.61	—	6CN7	.70	—	11CY7	.75	—	12SQ7GT	.91
—	4DT6	.55	—	6CQ8	.92	—	12A4	.60	—	12U7	.63
—	4GM6	.60	—	6CR6	.60	—	12AB5	.60	—	12V6	.62
—	5AN8	.79	—	6CS6	.57	—	12AC6	.55	—	12W6	.71
—	5AN8	.90	—	6CS7	.69	—	12AD6	.57	—	12X4	.47

### RAD-TEL TUBE CO. NOT AFFILIATED WITH ANY OTHER MAIL ORDER TUBE COMPANY

—	5AQ5	.54	—	6CU5	.58	—	12AE6	.50	—	17AX4	.67
—	5AT8	.83	—	6CU6	1.08	—	12AE7	.94	—	17DQ6	1.06
—	5BK7	.86	—	6CYS	.70	—	12AF3	.73	—	18FW6	.59
—	5BQ7	1.01	—	6CV7	.71	—	12AF6	.67	—	18FX6	.43
—	5BR8	.83	—	6DA4	.68	—	12AJ6	.62	—	18FY6	.50
—	5CG8	.81	—	6DE6	.61	—	12AL5	.47	—	19AU4	.87
—	5CL8	.76	—	6DG6	.62	—	12AL8	.95	—	19BG6	1.39
—	5CQ8	.84	—	6DJ8	1.21	—	12AQ5	.60	—	19EA8	.79
—	5EA8	.80	—	6DK6	.59	—	12AT6	.50	—	19T8	.85
—	5EU8	.80	—	6DN6	1.55	—	12AT7	.76	—	21EX6	1.49
—	5J8	.72	—	6DQ6	1.10	—	12AU6	.51	—	25AX4	.70
—	5J8	.86	—	6DT5	.81	—	12AU7	.61	—	25C5	.53
—	5U4	.60	—	6DT6	.53	—	12AV6	.41	—	25CA5	.59
—	5U8	.84	—	6DT8	.94	—	12AV7	.82	—	25CD6	1.52
—	5V6	.56	—	6EA8	.79	—	12AX4	.67	—	25CU6	1.11
—	5X8	.82	—	6EB5	.73	—	12AX7	.63	—	25DN6	1.42
—	5Y3	.46	—	6EB8	.94	—	12AY7	1.44	—	25EH5	.55
—	6AB4	.46	—	6EM5	.77	—	12AZ7	.86	—	25L6	.57
—	6AC7	.96	—	6EM7	.82	—	12B4	.68	—	25W4	.68
—	6AF4	1.01	—	6EU8	.79	—	12BD6	.50	—	32ET5	.55
—	6AG5	.70	—	6EV5	.75	—	12BE6	.53	—	35C5	.51
—	6AH4	.81	—	6EW6	.57	—	12BF6	.60	—	35L6	.60
—	6AH6	1.10	—	6EY6	.75	—	12BH7	.77	—	35W4	.42
—	6AK5	.95	—	6FG7	.69	—	12BK5	1.00	—	35Z5	.60
—	6AL5	.47	—	6FV8	.79	—	12BL6	.56	—	36AM3	.36
—	6AM8	.78	—	6GH8	.80	—	12BQ6	1.16	—	50B5	.69
—	6AQ5	.53	—	6GK5	.61	—	12BR7	.74	—	50C5	.53
—	6AS5	.60	—	6GK6	.79	—	12BV7	.76	—	50EH5	.55
—	6AT6	.49	—	6GN8	.94	—	12BY7	.77	—	50L6	.61
—	6AT8	.86	—	6H6	.58	—	12BZ7	.86	—	70L7	.97
—	6AU4	.85	—	6J5GT	.51	—	12CN5	.56	—	11Z73	.85
—	6AU6	.52	—	6J6	.71	—	12CR6	.67	—	807	.75

### ORDER FORM • MAIL TODAY

RAD-TEL Tube Co.

Dept. EI-9

55 Chambers Street  
Newark 5, New Jersey

ENCLOSED IS \$ \_\_\_\_\_

SEND: \_\_\_\_\_ Book(s) Be Your Own TV Repairman @ \$1.00 ea. #170  
Cheater Cord 29¢ ea. Lots of 3 - 25¢ ea. #154  
Orders under \$5.00 - Add \$1.00 handling charge - plus postage.

**FREE!**

Send FREE Tube and Parts Catalog  
 Send FREE Trouble Shooting Guide

NAME \_\_\_\_\_

ADDRESS \_\_\_\_\_

CITY \_\_\_\_\_

ZONE \_\_\_\_\_ STATE \_\_\_\_\_

Total Tubes \$ \_\_\_\_\_

Total Part(s) \$ \_\_\_\_\_

Postage \$ \_\_\_\_\_

Grand Total \$ \_\_\_\_\_

Please rush order.





# **COURIER 1-M**

---

**NOW!**

# **QUIETEST**

---

**MOST POWERFUL**

# **MOBILE**

# **C.B. UNIT!**

**HEAR IT TO BELIEVE IT!**

*Write for Free Brochure . . . . . \$229.50 list, slightly higher west of Rockies.*

 **e.c.i. electronics communications, inc.** 325 no. macquesten pkwy, mt. vernon, n. y.



# AMERICAN BASIC SCIENCE CLUB'S **ELECTRONICS LAB and RADIO COURSE**

All the Equipment for 65 Exciting Projects, Including  
3 Tube Short Wave Radio, DC Power Supply,  
Microphone and Audio Amplifier, Signal Tracer.... only

**\$17.80**  
COMPLETE  
LAB AND  
COURSE

**Get it All in One Complete Shipment —  
or Divided into these 4 Monthly Kits**

**TROUBLE SHOOTING WITH THE SIGNAL TRACER**

**YOU GET A VALUABLE  
ELECTRONICS LAB**

Containing parts by RCA, MALLORY, PYRAMID,  
GE, CENTRALAB, STACKPOLE, TRIM, CINCH and  
other reliable manufacturers. Retail value of  
parts alone is MORE THAN **25 DOLLARS**

**PLUS A COMPLETE  
ELECTRONICS COURSE**

You REALLY LEARN ELECTRONICS. The  
progressive "learn by doing" American Basic  
Science Club system is the EASIEST, MOST  
THOROUGH and MOST EXCITING way to a  
solid background in electronics.

**NO EXPERIENCE NECESSARY**

Basic enough for beginners.  
Rewarding enough for experts.  
NOWHERE ELSE is a course of this  
scope available at this LOW PRICE!

**ENTHUSIASTIC MEMBERS WRITE:**

"basic principles unforgettably  
learned" . . .

It is only after having completed the experi-  
ments in your kits that I can say I have truly  
and unforgettably learned the basic principles  
of electronics. JOHN R. KANIA, 2 Berkeley  
Ave., Yonkers 5, N. Y.

"your kits are interesting and  
rewarding" . . .

I am an electronics student in the Air Force  
and find your kits interesting and rewarding.  
We have not covered anything in the school  
that you have not covered in the kits. JOHN  
G. DILL, Keesler Air Force Base, Biloxi,  
Miss.

"far ahead of friend taking  
another course" . . .

A friend of mine is taking a correspondence  
course in electronics, and I have learned more  
from your first two kits than he has in  
twenty lessons. RAY P. BILODEAU, 139  
Exchange St., Leominster, Mass.

"the number of concepts presented  
is amazing" . . .

Your kits offer a range of experiments  
usually performed only in the better high  
school and college laboratories. The number  
of concepts presented, and the clarity and  
concreteness of their development is amazing.  
R. M. HELM, Professor of Physics, East  
Carolina College, Greenville, N. C.

## 1st KIT — DC AND AC CIRCUITS

Equipment for 26 Projects Including:  
• Electroscopes • Electromagnetic Relay • Galvanometer  
• AC Buzzer • Magnetizer and Demagnetizer • Solenoid  
Coin Tosses • Safety AC Power Supply with Isolation  
Transformer.

Subjects Covered:  
• Electron Theory  
• DC and AC  
• Inductance  
• Transformer  
Principles  
• Electro-Chemistry

FREE with 1st Kit — "Mystery Shock Box"

## 2nd Kit — RESISTANCE, CAPACITANCE AND RECTIFICATION

Equipment for 18 Projects Including:  
• Strobe Light - variable pulse Neon Lamp "freezes" the  
motion of vibrating or rotating objects and checks RPM  
• Thermocouple • Wheatstone Bridge (measures resistance)  
• Extinction Voltmeter • DC Power Supply (Transformer,  
Vacuum Tube Rectifier and 20-20 mfd. Capacitor Filter  
Circuit.) Provides safe power for electronics.

Subjects Covered:  
• Ohm's Law  
• Rectification  
• Resistance  
• Neon Glow Tubes  
• Capacitance  
• Filter Circuits

FREE with 2nd Kit — Electric Soldering Iron

## 3rd KIT — AMPLIFIERS AND OSCILLATORS

Equipment for 14 Projects Including:  
• Two Stage Amplifier • Capacitance Burglar Alarm  
• Proximity Detector • Variable Frequency Ripple Tank  
Wave Generator (Produces standing waves, nodal lines,  
etc. Invaluable in understanding wave theory) • Code Prac-  
tice Oscillator.

Subjects Covered:  
• Vacuum Tube  
Amplifiers  
• Frequency and  
Wave Length  
• Wave Theory  
• Oscillator Circuits

FREE with 3rd Kit — "Steps to a Ham License" Manual

## 4th KIT — AUDIO AMPLIFICATION AND RADIO

Equipment for 7 Projects Including:  
• Short Wave and Broadcast Radios (3-tube regenerative.  
Uses 115V AC house current. Complete with Headset) • Car-  
bon Microphone and Two Stage Audio Amplifier • Radio  
Transmitter • Signal Tracer and Continuity Tester (valuable  
trouble-shooting tools).

Subjects Covered:  
• Audio Amplifiers  
• Radio Theory  
• Regen. Circuits  
• Tuning Circuits  
• Signal Tracing

FREE with 4th Kit — Radio-TV Service Manual

**ALL FOUR KITS IN ONE SHIPMENT ONLY \$17.80 POSTPAID**  
**OR—YOU CAN GET THE FOUR KITS, ONE A MONTH**

SEND **\$2.00** WITH PAY **\$3.95** PLUS COD POSTAGE  
ONLY COUPON ONLY ON RECEIPT OF EACH KIT

**ALL SHIPMENTS ON 10 DAY APPROVAL.  
YOUR SATISFACTION OR YOUR MONEY BACK.  
WE KNOW YOU WILL BE AMAZED AND DELIGHTED.**

USE THIS "NO RISK" COUPON FOR EITHER PAID IN FULL OR MONTHLY PLAN

AMERICAN BASIC SCIENCE CLUB, Inc., 501 E. Crockett, San Antonio 6, Texas

- Send me ABSClub's Electronics Lab in four kits — one a month. I enclose \$2.00 and will pay \$3.95 plus COD Postage on arrival of each kit. I understand that all kits will be on 10 day approval with full refund guaranteed and also that I may cancel unshipped kits at any time without obligation.
- Send me ABSClub's Electronics Lab (all four kits) in one shipment. I enclose \$17.80 full payment POSTAGE PAID to me. I understand that this will be on a 10 day approval with full refund guaranteed.

NAME \_\_\_\_\_

ADDRESS \_\_\_\_\_

CITY and STATE \_\_\_\_\_