

July

BROADCAST
WRNY
STATION

25 Cents

Science and Invention

OVER 300 ILLUSTRATIONS

A CATAPULT
FOR DIVERS

See Page 206

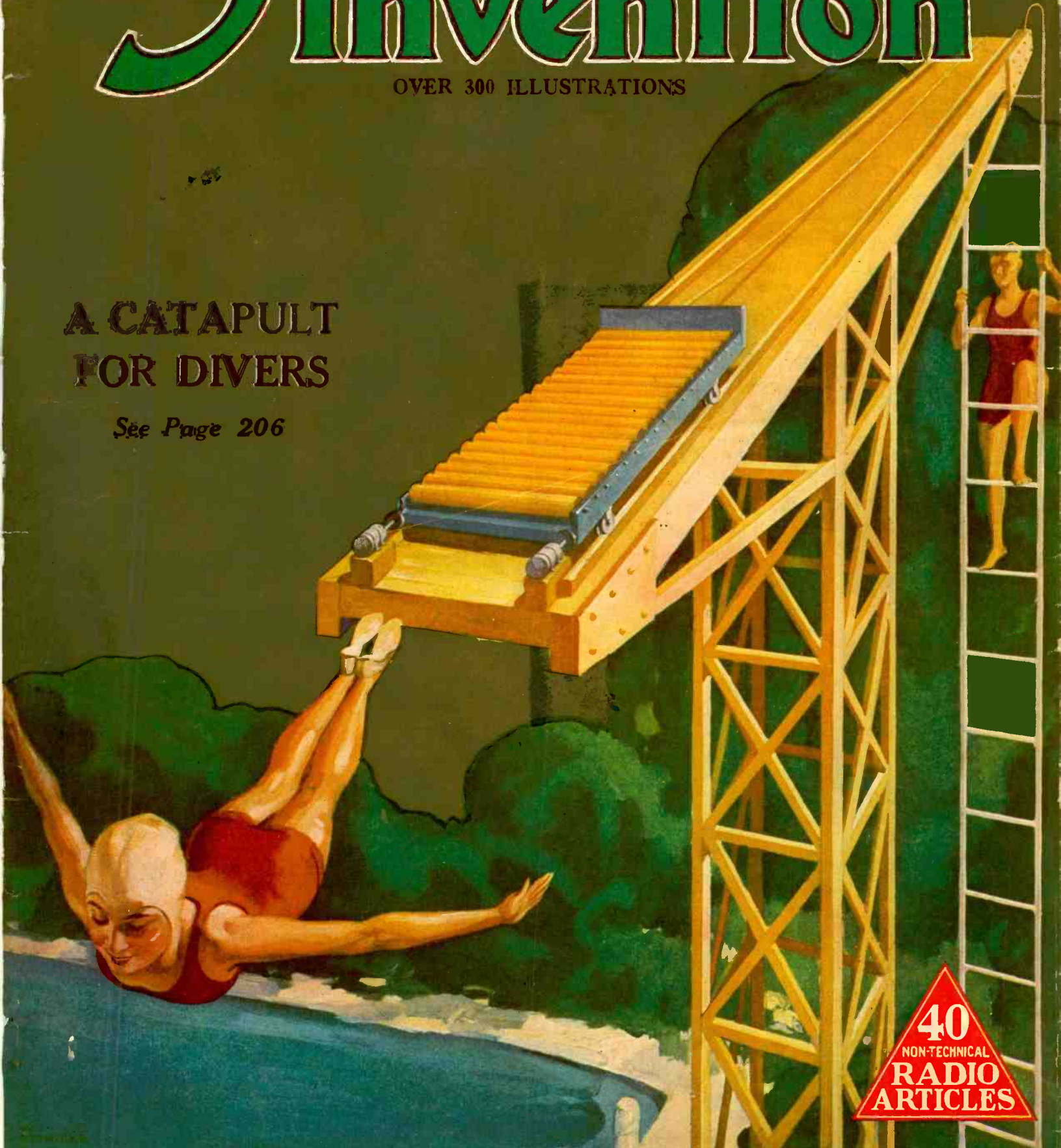

40
NON-TECHNICAL
RADIO
ARTICLES

EXPERIMENTER PUBLISHING COMPANY, NEW YORK, PUBLISHERS OF
RADIO NEWS - SCIENCE & INVENTION - RADIO LISTENERS' GUIDE - AMAZING STORIES - MONEY MAKING - RADIO INTERNACIONAL

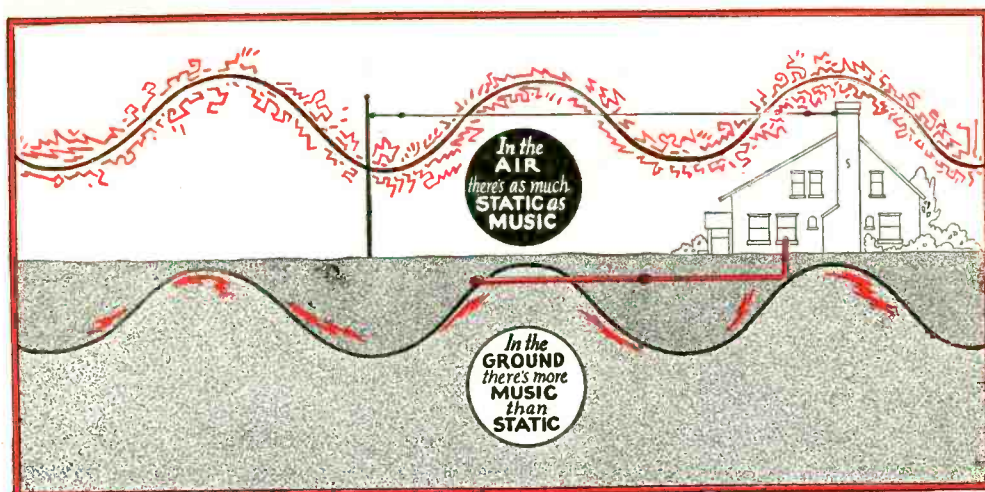

Use **STATIC-FREE** Ground Waves Get Distance Loud and Clear all Summer

SUBANTENNA—new underground Antenna System astounds listeners and laboratories with loud clear DX on hot summer nights when old style aerial gets nothing but unwanted noise

Imagine the intense pleasure of bringing in your favorite distant station loud and crystal clear—right through summer's curtain of static and noise! But, you don't have to be content with merely imagining it. Real DX in summertime—real big volume—amazing clarity—much better selectivity—all these are now available to you—and, with your present set. Simply connect your set to **SUBANTENNA**—the marvelous new underground antenna system that uses filtered ground waves instead of noisy air waves.

Read PROOF that SUBANTENNA is the Greatest New Thing in Radio

Says Static Is No More

"I have received the Subantenna. My grandson installed it. **STATIC IS NO MORE.** Am well satisfied. I can tune in stations I never could coax out of the air even though I had a long aerial."—A. E. F., Kans.

Better Selectivity—No Static

"It has always been impossible for me to eliminate the Drake Hotel. I was told that Subantenna would enable me to do this. Although skeptical, in view of many similar claims made by other manufacturers of radio accessories, I had one of the Subantennas installed. The results have been most satisfactory, in that I have not only been able

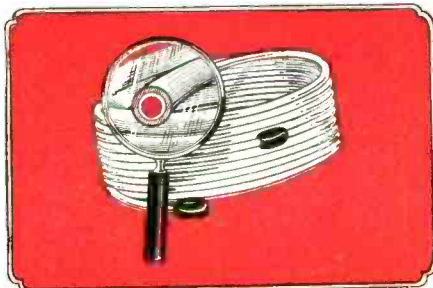

to get every station in Chicago of any consequence, when the Drake was on the air, but out-of-town stations as well. In addition I am able to report that static, which was a source of much annoyance before, has been entirely eliminated so far as I am able to observe."—R. L. P., Chicago.

Michigan Gets California

"I have had KFI, California, several times and go all over U. S. A. to Portland, Maine. You have the goods. It is far better for volume and tone on loud speaker than outside aerial."—C. J. S., Mich.

Why SUBANTENNA Makes Every Night a Good Radio Night

In summer air, the ratio of static strength to signal strength favors static. The "noise" is so much greater

than the broadcast signal that it hides the music you wish to hear. That's why you don't get distance in the summertime. But, when you use **SUBANTENNA**, the situation is just reversed. For, in the ground, the ratio of static strength to signal strength favors the latter. In fact, there is so little static in the ground that the broadcast signal easily dominates it, with the result that you hardly hear the static, even on the most distant stations. Radio research men have long known this fact, but no device had ever been perfected by which ground waves could be used. Now, however, you have **SUBANTENNA**—a great new device which makes radio, for the first time, an all year 'round pleasure.

Eliminates Lightning Risk

Not only will **SUBANTENNA** give you loud, clear DX in summer—not only will this remarkable invention better the selectivity of your set—but it also completely eliminates the lightning hazard. With **SUBANTENNA** you can go right on listening-in during the most severe electrical storm without noise, fear of attracting lightning or damaging your set.

FREE TRIAL

Make This Convincing Test

Install **SUBANTENNA**. Leave your old aerial up. Select a bad night when DX is almost impossible with the ordinary aerial. Make a comparison station for station, connecting first your aerial, then **SUBANTENNA**. If, from stations that are just a mess of jumbled noise with the old aerial, you don't get reception that rivals local in sweetness and clarity the instant you switch to **SUBANTENNA**, this test won't cost you even a single penny. Send coupon at once for scientific explanation of **SUBANTENNA** and for particulars of **GUARANTEE** and **FREE TRIAL OFFER**. Send **COUPON NOW!**

SUBANTENNA

Underground Antenna System

CLOVERLEAF MANUFACTURING CO.

2715C CANAL STREET

CHICAGO, ILLINOIS

CLIP AND MAIL AT ONCE

CLOVERLEAF MFG. CO.,
2715C Canal Street, Chicago, Illinois
Tell me all about SUBANTENNA, your unqualified, unconditional guarantee and your FREE TRIAL OFFER.

Name

Address

Listen to Subantenna Static Eliminators over KYW, Chicago, 536 meters, every Wednesday, 7:30 to 8 P.M., Central daylight saving time.

GO INTO

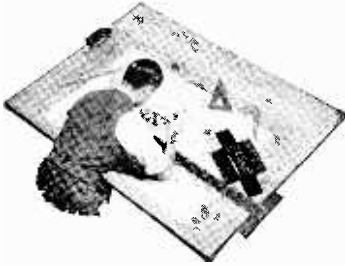

DRAFTING

YOU men who are earning *less than \$40 a week*, who have neither school education nor specialized training—have you noticed how hard it's getting to find, or *keep* a good job? Have you watched the spread of **UNEMPLOYMENT**, and do you know that it's *your class* which are first to be fired when the high pitch of prosperity lets down a bit? Do you realize that **BIG CHANGES** have taken place in all business and industry in the past five years, and that unless you learn to know and face these dangers, you're **SUNK**? The American School presents these facts in a friendly spirit, to help you realize how these **NEW CONDITIONS** strike at your very existence.

Every year worse "Luck"

Ten years ago men could "get by" with neither school nor training. Then it was still possible to learn by "practical experience" alone. Today, there are millions of high school and college graduates to compete with you for jobs and advancement. Each June *half a million more* come into the battlefield armed with **DIPLOMAS**. They are elbowing uneducated, untrained men out of the way. They are pushing into the factories and offices and drafting rooms. *What chance have YOU to win against this "June" army of better educated men?*



There's One Way Out!

Now you see the danger which you must face sooner or later. What are you going to do about it? You can't quit your job and go away to school, but *the school can come to you*. You can get **SPECIALIZED TRAINING**, right in your own home, in spare time, the best sort of education for your needs,



EVERY JUNE

they say "Go back half a million places, to the end of the line!"

general school subjects, the kind of equipment which employers are seeking these days of highly-organized industry. We have equipped 250,000 men to meet the new dangers, we have prepared them for better jobs and bigger pay. We have placed many in fine positions.

You have only to follow their example. You can afford the cost and the terms. And you take no risk. We take all the risk that you will succeed. You must master the training, you must be placed in a well-paid position, *or the service will not cost you a penny.*

Last Call!

What are you going to do about it? You must face the new dangers **RIGHT NOW**. You dare not put off decision. It will be much harder to meet the enemy **WHEN HE IS UPON YOU**. You won't find it as convenient to *start*, after you're out of a job, as today. Snap into it then. Mail the coupon. Get all the facts about the new conditions in our booklet "The June Terror." Look into the opportunities open to you when you're an expert Draftsman. Find out how easily you can learn, at home. *Get our guarantee to train you and help you get placed.* **DO IT NOW!**

Go Into Drafting

Expert Draftsmen are urgently needed in all building, manufacturing and engineering lines. Salaries of \$60 to \$125 a week are offered to men who can draw original plans, who can calculate and design machinery, buildings and products. A knowledge of Drafting is the entering wedge to success in the Electrical, Automotive, Structural, Architectural and all Mechanical industries. A

good Draftsman is always sure of employment at a fine salary, and he is in line for promotion to still better, executive positions. Drafting is fascinating work, and you'll like the fine bunch of fellows and the good-natured atmosphere of the Drafting room.



First--We Train You

We have developed a simplified, one-step-at-a-time method for teaching Drafting. Any man with only common schooling can learn, quickly and easily, at home in spare time. We start you off doing actual Drafting room jobs, the way it's done in the big Architectural and engineering offices. We give you the kind of training employers specify. In fact our instruction has been prepared by noted Engineers who are themselves big employers of Draftsmen. Mail coupon for 3 Drafting lessons, actually free, to prove that you can learn at home, in your spare time.

Then We Help You Get PLACED!

Coupon also brings amazing combination training and employment service offer, which says, unless this instruction leads directly to a better job and increased salary, it will not cost you a penny. **Outfit GIVEN!**

We include without extra charge, as a part of this training, imported instruments, board, T-square, triangles, paper, ink and supplies. These are full size and professional quality—the kind that you will keep and use in your job after you finish.

O. C. MILLER, Director Extension Work



Dept. DB-26, Drexel Avenue and 58th Street, Chicago

3 DRAFTING Lessons FREE!

O. C. Miller, Director Extension Work,
The American School, Dept. DB-26,
Drexel Ave. and 58th St., Chicago.

Please send free booklet "The June Terror."
 Please send 3 Free Drafting lessons to prove I can learn at home, in spare time.

Name

Address

Age Occupation



Vol. XV
Whole No.
171

July
1927
No. 3

Formerly **ELECTRICAL EXPERIMENTER**
COMBINED WITH "THE EXPERIMENTER"
Member Audit Bureau of Circulations

EDITORIAL, ADVERTISING & GENERAL
OFFICES:
230 Fifth Avenue, New York City

Published by Experimenter Publishing Company, Inc. (H. Gernsback, Pres.; S. Gernsback, Treas.; R. W. DeMott, Sec'y.)
Publishers of **SCIENCE & INVENTION**, **RADIO NEWS**, **RADIO LISTENERS' GUIDE**, **AMAZING STORIES**,
SPARE-TIME MONEY MAKING and **RADIO PROGRAM WEEKLY**.

Editorial Staff

HUGO GERNSBACK, Editor-in-Chief.
H. WINFIELD SECOR, Managing Editor
T. O'CONNOR SLOANE, Ph. D.
Associate Editor
JOSEPH H. KRAUS, Field Editor.
PAUL WELKER, Radio Editor.
S. GERNSBACK, Wrinkles Editor.
W. J. ROMAINE, Art Director.

Contributing Editors

Astronomy—
Dr. Donald H. Menzel, Ph.D., W. J. Luyten, of the
Harvard College Observatory.
Entomology and Allied Subjects—
Dr. Ernest Bade, Ph.D.
Physics—
Dr. Harold F. Richards, Ph.D., Ernest K. Chapin,
M.A., Dr. Donald H. Menzel, Ph.D.
Chemistry—
Raymond B. Wailes, Dr. Ernest Bade, Ph.D.

Automotive Subjects— George A. Luers
Radio— A. P. Peck, Herbert Hayden.
Magic and Psychic Phenomena—
Joseph Dunninger, Joseph F. Rinn, Edward Merlin.
Foreign Correspondents—
Dr. Alfred Gradenwitz, Germany; Dr. H. Becher,
Germany; C. A. Oldroyd, England; S. Leonard Bas-
tin, England; Count A. N. Mirzoeff, France; Hubert
Stouka, (Czecho-Slovakia); P. C. van Petegem, Hol-
land; Richard Neumann, Austria.

IN AUGUST ISSUE

Traceless Poisons!

A remarkable article, in which the old adage that "dead men tell no tales" is reversed to read "dead men tell too many tales."

What Chances Has Your Baby to Live?

A very interesting article containing the latest statistics on the "life-chances" of babies of different ages.

An All-Metal Dirigible

A brand new design of lighter-than-air machine, which is propelled in an unusual way.

New Picture Transmitter

Full details of marvelous new picture transmission apparatus which greatly enlarges photo in the process of transmission and reception.

CONTENTS OF THIS NUMBER

Editorial	201	What Is Matter?	225
By Hugo Gernsback		By Dr. Donald H. Menzel	
Mississippi Flood Prevention	202	Island Universes	226
Sun Spots and the Flow of Rivers	203	By W. J. Luyten, of the Harvard Col- lege Observatory	
By Carrington Wolf, Ph.D.		How Telescopes Work	227
New French Television Scheme	204	By Dr. Donald H. Menzel	
By Lucien Fournier		The Astrology Humbug	228
Catapult for Divers and Other Aquatic Amusement Devices	206	By Joseph H. Kraus	
By Joseph H. Kraus		Tales from the Scientific Club	229
Wonders of the Universe	209	By Ray Cummings	
Huge Movie Furniture	210	Magic—A Monthly Feature	230
Rejuvenation by Concentrated Sleep	211	By "Dunninger"	
The Evolution of Speed	212	Home Mechanics—Building a Martha Washington Sewing Cabinet	231
Infra-red "Eye" Sees in the Dark	213	By William Butterfield	
Can I Study Engineering at Home?	214	\$3,000 Wirecraft Contest	232
Part II. By H. Winfield Secor		Matchcraft—\$100.00 in Prizes Monthly	234
Ultra Audible Sound Waves	215	Motor Hints	235
By Raymond B. Wailes		By George A. Luers	
Aerial Fire Fighters of Tomorrow	216	Model Department—This Month's "Cup Winner"	236
The Month's Scientific News Illustrated	217	Experimental Chemistry	238
By George Wall		Everyday Chemistry	240
Effects of X-Rays on Fruit Flies	218	By Raymond B. Wailes	
By Dr. James W. Mavor		Experimental Electrics	241
Home Magic Tricks for You	219	Constructor Department	243
By Sam Brown		Garden Pottery	244
New Devices of the Month	220	Hints for the Mechanic	245
The Sun House	221	How-to-Make-It Department	246
Have You a Model Ship in Your Home?	222	Wrinkles, Recipes and Formulas	247
By Paul Welker		Edited by S. Gernsback	
Do You Know How to Use a Microscope?	223	Readers' Forum	248
Secrets of the Flower	224		
By Dr. Ernest Bade			

HOW TO SUBSCRIBE FOR "SCIENCE AND INVENTION." Send your name, address and remittance to Experimenter Publishing Co., 230 Fifth Ave., New York City. Checks and money orders should be made payable to Experimenter Publishing Co., Inc. Mention magazine desired, inasmuch as we also publish **RADIO NEWS**, **AMAZING STORIES**, **RADIO LISTENERS' GUIDE**, **SPARE-TIME MONEY MAKING** and **RADIO PROGRAM WEEKLY**. Subscriptions may be made in combination with the other publications just mentioned at special reduced club rates. Send postal for club rate card. Subscriptions start with the current issue unless otherwise ordered.

ON EXPIRATION of your subscription we enclose a renewal blank in our last number to you, and notify you by mail. Then unless we receive your order and remittance for a renewal, delivery of the magazine is stopped.

SCIENCE AND INVENTION is published on the 10th of each month. There are 12 numbers per year. Subscription price is \$2.50 a year in U. S. and possessions. Canada and foreign countries \$3.00 a year. U. S. Coin as well as U. S. stamps accepted (no foreign coin or stamps). Single copies 25c each. All communications and contributions to this journal should be addressed to Editor, **SCIENCE AND INVENTION**, 230 Fifth Avenue, New York.

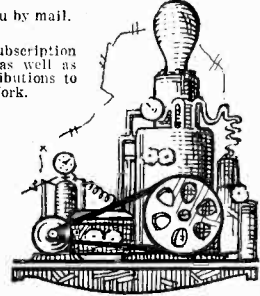
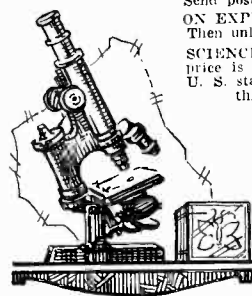

City, N. Y. Unaccepted contributions cannot be returned unless full postage has been included. ALL accepted contributions are paid for on publication. **SCIENCE AND INVENTION** Monthly. Entered as second class matter May 10, 1921, at the Post Office at New York, N. Y., under the act of March 3, 1879. Additional entry at Long Island City, N. Y., and San Francisco, Calif. Title Registered at the Patent Office. Copyright, 1927, by E. P. Co., Inc., New York. The contents of this Magazine are copyrighted and must not be reproduced without giving full credit to the publication. **SCIENCE AND INVENTION** is for sale at all newsstands in the United States and Canada. European Agents, S. J. Wise Et Cie, 40, Place Verte, Antwerp, Belgium.

ADVERTISING REPRESENTATIVES—L. F. McCLURE, 720 Cass St., Chicago, Ill.; DAVIES, DILLON & KELLY, 15 West 10th St., Kansas City, Mo.; T. F. MAGRANE, Park Square Bldg., Boston, Mass.; HARRY E. HYDE, 548 Drexel Bldg., Philadelphia, Pa.; A. J. NORRIS HILL CO., 5 Third St., San Francisco, Calif.; 412 West 6th St., Los Angeles, Cal.

A HANDY RULE FOR YOU





An actual photo of a small part of one of our nine departments

Where 1000 Young Men Are Learning Electricity By Actual Work...in 90 Days

COYNE can and does make men electrical experts in 90 days. Coyne students learn without books or lessons. They learn by doing... by actually performing every conceivable step on every type of electrical apparatus.

They learn the theory, operation and repair of storage batteries, not by looking at charts, but by actually building one complete, testing it and operating it. They learn house-wiring by actually wiring a house. Step by step, Coyne training takes you from the simplest first principles to the most complicated switch boards, great motors and power stations—always on real full-sized equipment in full operation.

In the great Coyne Shops are mammoth control boards... there are automobile chassis... here a whole roomful of illumination equipment... here farm power plants... dynamos... motors... a two-story transmitting station... and

other machinery too numerous to mention.

And here, working on the greatest outlay of electrical apparatus ever assembled, are 1,000 students from every state and province of Canada.

You learn from men who know—men who are themselves masters of electricity. Here in this great school, every student gets individual attention. Training is intensely practical. No time is wasted and no student is ever hurried. In each department you may stay as long as you like.

The Amazing Opportunities

These are some of the reasons why Coyne men are in demand all over the country... why our Employment Department secures dozens of positions weekly and why many

graduates are earning up to \$800 a month.

The whole world of electricity is open to the Coyne trained man. He is trained completely. He can make big money as Power Plant Operator, Superintendent, Construction Worker, auto, truck or tractor electrician, battery man, radio expert, or he can go into business for himself as electrical contractor, dealer, auto ignition or battery expert and make \$3,000 to \$20,000 a year.

FREE R.R. Fare to Chicago

Coyne training requires 12 weeks, and you may enter at any time. Age, lack of experience or advanced education bars no one. Don't let lack of money hold you back. Our Employment Department assists many fellows to part time positions where they can earn while learning. And right now our special offer pays your railroad fare to Chicago as soon as you enroll.

Get The Facts, FREE

Find out now what Coyne training can mean to you in money and future. Simply mail the coupon below for FREE Coyne catalog—56 pages of photographs... facts... jobs... salaries... opportunities in the electrical industry. This step does not obligate you. So act at once.

\$100 a week

Many of our graduates have achieved spectacular success. One month after graduation Clyde F. Hart accepted a position with the Great Western R. R. at \$100 a week.

Clarence Ackland, living in the little town of West Brooklyn, Ill., writes: "Today I am making more money than ever before in my life. Some days I have made as high as \$75 clear."

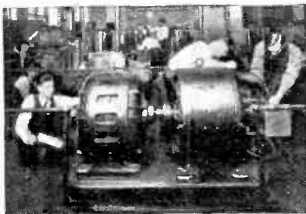

56 Page CATALOG FREE 150 Photographs

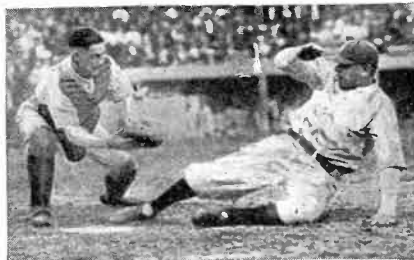

COYNE

ELECTRICAL SCHOOL
H. C. LEWIS, Pres., Dept. B7-83
1300 W. Harrison St., Chicago, Ill.
Founded 1899

Mr. H. C. Lewis, Pres.,
COYNE ELECTRICAL SCHOOL, Dept. B7-83
1300 W. Harrison St., Chicago, Ill.

Dear Mr. Lewis:
Without obligation send me your big free catalog and all details of FREE Railroad Fare to Chicago, Free Employment Service, Free Radio and Free Automotive Courses. I understand I will not be bothered by any salesmen.

Name.....
Address.....
City..... State.....

INDEX TO ADVERTISERS

Page	Page	Page	Page
A	E	Mc	R
American Business Builders Back Cover	Dryer, Prof. J. A.274	Lancaster & Allwine262	Radio Association of America...285
American School of Correspondence193	E	Law Morris & Co.265	Radio Specialty197
American School of Music268	Elto Outboard Motor Co.276	La Salle Extension University268, 269, 270	Randolph & Co.262
American School of Photography270	Engineers Service Co.272	Long Eakin Co., The278	Rosenberg, Manuel260
American Telephone & Telegraph Co.267	Evans, Victor J.265		Ross-Gould Co.266
Andre & Co.267	Experimenter Publishing Co.268, 277, 282, 284, 285	M	S
Anita Co.278	F	McGraw-Hill Book Co.261	Scientific Apparatus Corp.260
Arveo Co.274	Fawcett Publications, Inc.198		Seaver Williams Co.268
Associated Industries Corp.271	Federal Mail Order Corp.270	M	Sherman Corp., The264
Audel & Co., Theo.Third Cover	Ferry & Co.272	Maxon, F. P.274	Sherman & Johnson283
Automatic Rubber Co.278	Fisher Mfg. Co., Adam264	Michigan State Auto School....272	Sherms270
B	Franklin Institute269, 272	Miller, Monroe265	Shields Engineering & Pub. Co.278
Balda Art Service271	G	Miniature Ship Models259	Shipman Ward Mfg. Co.274
Bernard & Heller262	Gernsback, S.280	Motion Picture Operators' School270	School of Engineering of Milwaukee275, 277, 281
Blancke Auto Devices Co.200	Gilson Glide Rule Co.278	Munn & Co.264	Sinclair, Jas.272
Blandin, Ernest W.264	Givens Chemical Co.278		Snyder Publishing Co., R.278
Bliss Electrical School269	H	N	Spors & Co., F.267
Bogue Institute for Stammerers 270	Hardin & Lavin274	Nassau Hotel266	Sterling Stop-Watch Co.285
B. Sc. Chemical Co.283	Haywood Tire & Equipment Co.274	National Can Co.272	Strongfort, Lionel279
Bureau of Inventive Science....265	Hobart Bros. Co., The269	National Candy Machine Co.272	T
C	Hydro United Tire Corp.272	Nestler Rubber Fusing Co.274	Tamblin, F. W.267
C. & G. Sales Co.269	I	New Method Mfg. Co.264	Tarbell System, Inc.271
Chemical Institute199	Ideal Aeroplane & Supply Co.274	New York Electrical School....260	Townsend Radio274
Clock Co.285	The Inkograph Co.269	Novelty House269	
Cloverleaf Mfg. Co.First Front Cover	Irwin Aircraft Co.268	N. Y. Institute of Photography 274	U
Coleman, Watson E.264	J	O	United Electric Motor Co.272
Cumer Mfg. Co., The266	Jaroszk Jewelry Dealer278	O'Brien, Clarence A.263	
Commonwealth Tire Co.278	Johnson Smith Co.288	Owen, Richard B.262	V
Conn. C. C., Ltd.271	K	Ozment, C. J.283	Weeks Super Carburetor Co.285
Conrad Co., Inc., The270, 273, 276, 279, 281, 283	Karol & Sons Co., B.267	P	Van Deventer, H. R.263
Coyne Electrical School195	Kelsey Co., The278	Parker, C. L.264	W
Critchlow, Walter278	L	Parks Woodworking Machine Co.272	Washington School of Art266
Dynamo Timer Co.273	Laboratory Materials Co.271	Plymouth Rock Squab Co.270	Whirlwind Co.285
D	Lacey & Lacey265	Polachek, Z. H.264	Wilrite Fountain Pen Co.276
DeForrest, Jimmy Boxing Course278		Polk, R. L.283	Wollensack Optical Co.270
De Hol268		Press Guild275	Wonder Magic283
Douglas, Lyle278			

TELEVISION!!!

The Newest and Greatest Development of this 20th Century

**JUST OUT
116 PAGE
BOOK
ON
TELEVISION**

by the combined staffs of
**SCIENCE & INVENTION
and
RADIO NEWS**

4 special chapters of many pages on how to make your own television apparatus. Profusely illustrated.

You Can Build Your Own Television Apparatus—At Home

The marvel of Radio Broadcasting, the transmission of the voice and music over the air is no longer the greatest achievement of this precocious 20th century.

We now have TELEVISION — the transmission of events over land wires or by radio. A tremendous step ahead of even Radio.

For many years experiments on television have been diligently made by many famous inventors and engineers. Step by step machines have been corrected, improved and simplified—until today—practical machines are in constant operation,

annihilating distances in picturing events to the eager public.

Here is the first and only book in print that gives you the complete story of television from earliest experiments to the present day machines.

And further this book gives you complete instructions on how to build your own apparatus at home—the real workable television set. The field is new and more wonderful than anything you have ever tried.

BUY YOUR COPY NOW!

PRICE 50c—SOLD EVERYWHERE

If your dealer cannot supply you write direct

EXPERIMENTER PUBLISHING CO., Inc.

230 Fifth Avenue

New York, N. Y.

READY

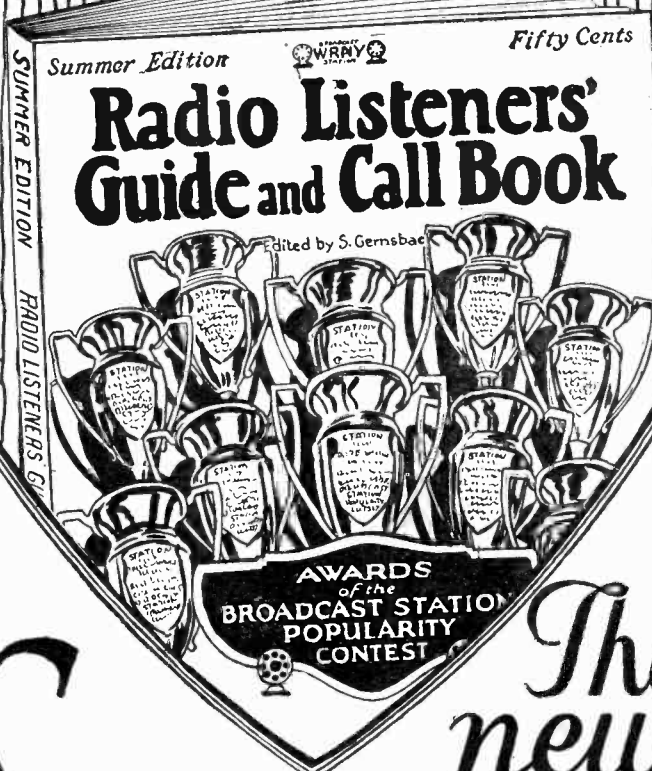

—for every set owner or set user

for Set builders, Amateurs and Engineers



LIST OF CONTENTS

LIST OF CONTENTS

- Radio Broadcast Stations of the U.S. by Call Letters
- Radio Broadcast Stations of the U.S. by Wavelengths
- Radio Broadcast Stations of the U.S. by States and Cities
- Radio Broadcast Stations of Canada by Call Letters
- Radio Broadcast Stations of Canada by Provinces and Cities
- Foreign Broadcast Stations, including U.S. Possessions
- Cup Winners 1927 Broadcast Station Popularity Contest
- Prizes Awarded in Radio Set Contest
- How to Build the Transoceanic "New Phantom" Model
- How to Build Sir Oliver Lodge's "N" Circuit Receiver
- The Phasatrol Receiver

- The Phono-Radio Combination Set
- The Keystone Five-Tube T.R.F. Set
- How to Build the S-C II
- How to Build the Standard Brown-Ing-Drake Receiver
- Building the Loftin-White Constant-Coupling Receiver
- A 13 to 735 Meter Universal Receiver
- A Constant Voltage "B" Eliminator
- How to Install Power Tubes
- Some Interesting Experiments with Large Cone Reproducers
- When You Take Your Radio Vacationing
- The Listeners' Accessory Guide.

The new Summer-EDITION

SUMMER is here—with the big outdoor features on your radio —baseball, fights, stadium and band concerts.

You'll want all you can get of course. But to get them all you'll need a brand new up-to-date call book.

The new "Summer Edition" of Radio Listeners Guide and Call Book is as new as the season. Bright and fresh from the press.

It gives the very latest revised list of all broadcast stations of the United States, Canada and foreign stations. Arranged with spaces for writing in your dial readings.

And don't forget—there are a dozen or more brand new circuits written up for home construction. See the list of contents on this page.

It's one great edition for each and every radio set user. Contains 176 pages, 100 illustrations on the large magazine size, 9 x 12 inches—and with a beautiful two-color cover.

Buy your copy today

50¢ the Copy

ON SALE EVERYWHERE

50c. THE COPY

50¢ the Copy

If your dealer cannot supply you, order direct
The Consrad Co., Inc. 230 Fifth Avenue, New York

Ruth Foils the Timber Thieves in this thrilling tale of the North Woods—



Scene from
"God's Finger,"
L. Paul's north woods
novelette in the July
TRIPLE-X

GOD'S FINGER *By* L. Paul

Buck Blodgett and his villainous crew would have smiled at murder, even, in their attempt to steal a priceless stand of virgin timber from Old Man McNab—but along came Ruth, his daughter, and her fighting sweetheart, Bill Hall, and then things began to happen! Folks, here's an adventure story that will have you gasping for breath. "GOD'S FINGER" appears in the

Out
Today

25
Cents

JULY
Fawcett's
Triple-X
Western-Adventure
MAGAZINE

Watch
for
←
this
title

INCLUDED FOR JULY ARE THESE THRILLERS:

J. R. JOHNSTON'S
GUNMAN'S PARADISE

Cattle rustling in the old Southwest

LOUIS E. LEGNER'S
HOT LEAD and STEEL

A stirring western railroad novelette

RICHARD MARTINSEN'S
GUN PALS

Story of the Mexican border

Also stories by JAY LUCAS, GLENN
CONNER, BILL SMITH and others

H. BEDFORD-JONES'S
FOR VALOR

Adventure on the high seas



LOOK FOR THIS COVER!

Fawcett Publications, Inc., S.I.
Robbinsdale, Minn.
Enclosed find \$1 (bill or stamps) for which
mail me Triple-X Magazine for the next five
months. Or, enclosed find 25c for one copy of
the July issue.
Name
Address.....
City.....State.....

SUCCESS

from

CHEMICAL INSTITUTE OF NEW YORK,
16 East 30th Street, New York City.

Mountoursville, Pa.

Gentlemen: I must tell you the success I have had since taking your chemistry course. My salary has been increased several times, and different industrial plants are coming to me for a little advice on different things, netting me a fair side income.

I am only sorry that I did not make My whole life study of the wonderful science.

(signed) M. E. Van Sickle.

CHEMISTRY

NOW
is the Time to Study
Chemistry

Not only are there boundless opportunities for amassing wealth in Chemistry, but the profession affords congenial employment at good salaries to hundreds of thousands who merely follow out its present applications. These applications are innumerable, touching intimately every business and every product in the world. The work of the chemist can hardly be called work at all. It is the keenest and most enjoyable kind of pleasure. The days in a chemical laboratory are filled with thrilling and delightful experimentation, with the alluring prospect of a discovery that may spell Fortune always at hand to spur your enthusiasm.

Easy Monthly Payments

You don't have to have even the small price of the course to start. You can pay for it in small monthly amounts—so small that you won't feel them. The cost of our course is very low, and includes everything, even the chemistry outfit—there are no extras to buy with our course. Our plan of monthly payments places a chemical education within the reach of everyone. Write us and let us explain our plan in full—give us the opportunity of showing you how you can qualify for a highly trained technical position without even giving up your present employment.

CHEMISTRY has no equal as a profession in the modern world. There is mystery, romance and fortune awaiting the man in the laboratory.

Millions have been made by the discoverers of the chemical formula of dynamite, bakelite and many other world known chemical products.

Opportunities in the chemical profession abound on every hand—and as modern business and competition progresses the chemist will play an important part.

Profit by the experience of Mr. Van Sickle and many others, resolve to study chemistry NOW.

YOU CAN LEARN AT HOME

To qualify for this remarkable calling requires elaborate specialized training. Formerly it was necessary to attend a university for several years to acquire that training, but thanks to our highly perfected and thorough system of instruction, you can now stay at home, keep your position, and let us educate you in Chemistry during your spare time. Even with only common schooling you can take our course and equip yourself for immediate practical work in a chemical laboratory. Dr. Sloane gives every one of his students the same careful, personal supervision that made him celebrated throughout his long career as a college professor. Your instruction from the very beginning is made interesting and practical, and we supply you with apparatus and chemicals for performing the fascinating analyses and experimental work that plays such a large part in our method of teaching, and you are awarded the Institute's official diploma after you have satisfactorily completed the course.



T. O'CONOR SLOANE,
A.B., A.M., LL.D., Ph.D.

Noted Instructor, Lecturer and Author. Formerly Treasurer American Chemical Society and a practical chemist with many well known achievements to his credit. Not only has Dr. Sloane taught chemistry for years but he was for many years engaged in commercial chemistry work.

Special 30 Day Offer

Besides furnishing the student with his Experimental Equipment, we are making an additional special offer for a short while only. You owe it to yourself to find out about it. Write today for full information and free book "Opportunities for Chemists." Send the coupon right now while it is fresh in your mind. Or just write your name and address on a postal and mail it to us. But whatever you do, act today before this offer is withdrawn.

DON'T WAIT—MAIL COUPON NOW!



EXPERIMENTAL EQUIPMENT FURNISHED TO EVERY STUDENT

We give to every student without additional charge this chemical equipment, including forty-nine pieces of laboratory apparatus and supplies, and forty different chemicals and reagents. These comprise the apparatus and chemicals used for the experimental work of the course. The fitted heavy wooden box serves not only as a case for the outfit but also as a useful laboratory accessory for performing countless experiments.

**Chemical
Institute
of
New York**
Home Extension
Division 7
16 East 30th St.
New York, N. Y.

CHEMICAL INSTITUTE OF NEW YORK
Home Extension, Division 7
16 East 30th Street, New York City.

S. I. July

Please send me at once, without any obligation on my part, your free Book "Opportunities for Chemists," and full particulars about the Experimental Equipment given to every student. Also please tell me about your plan of payment and your special 30 day offer.

NAME

ADDRESS

CITY STATE

LIGHTING MATCHES WILL MAKE YOU



Strongest Guarantee In Automotive History

backs sale of Blancke Controls. Guaranteed to give over 30 miles per gallon on Fords—to practically eliminate carbon formation and its troublesome consequences—to save half oil—to relieve battery strain—make motor run smoother—give better acceleration—allow slower speeds in high gear. Starts motor immediately in any weather without use of choke—and saves half repair bills. No holes to drill; no bolts to remove. Anyone can attach it in 3 minutes. Ford owners everywhere delighted with it and their boosting promotes sales.

Amazing Sure-Fire Demonstration

sells by thousands new automatic attachment that sworn public tests prove makes Fords run

43.8 to 68 Miles on 1 Gallon of Gas

Agents everywhere report astounding results. R. K. Waite ordered 1,000 Blancke devices in one month. (Profit \$3,000.00). Wires, "Get ready another 2,000." Clyde B. Jones sold 63 devices in one day. (Profit \$189.00). You don't need experience—thrilling demonstration sells for you!

What Is This Sensational Demonstration?

The instant heat touches the Blancke Thermostatic Carburetor Control, the needle valve on the carburetor slowly turns before the fascinated eyes of spectators. As it cools, the needle valve turns back again. It is easy to understand why immensely superior results can be obtained with this accurately adjusted automatic instrument—to see why Blancke Thermostatic Carburetor Control in official public and private tests showed 43.8 to 68 miles per gallon of gas. 250,000 tests averaged 32 miles per gallon. Guaranteed to give over 30 miles per gallon on Fords.

Starts Motor Instantly In Any Weather

without use of choke. Guaranteed results combined with amazing demonstration make Blancke Control greatest agent's selling success of recent years.

Get 1 Free to Introduce

Also Blancke Plan that starts you without capital in a real business that pays you \$300.00 to \$2,500.00 and up, each month. Exclusive territory. Sales guaranteed. Start to make big money—beginning NOW! Send coupon today for sample Blancke Control and great Distributor's Plan.

SALES Guaranteed

BLANCHE AUTO DEVICES CO.

157 E. Erie St.
Dept. 863-K, CHICAGO, ILL.

Cadillac, the new La Salle and Delco Light now use a standard equipment Thermostatic Carburetor Control under Blancke License. You can get no better proof of merit than this.

\$15.00
**A Day Guaranteed
To Distributors**
Blancke Plan and Guarantee gives every user Agent new Ford car FREE by time his present one is worn out.

Blancke Auto Devices Co.,
Dept. 863-K, 157 E. Erie St.,
Chicago, Ill.

Gentlemen:—I should like to get a Blancke Control Free to introduce in my community. Also send details of amazing new Guarantee Plan by which I can make from \$300.00 to \$2,500.00 a month profit and get a new Ford Free by time my present one is worn out.

Name
Address
City State

Science and Invention

HUGO GERNSBACK, *Editor-in-Chief*
H. WINFIELD SECOR, *Managing Editor*
DR. T. O'CONNOR SLOANE, Ph.D., *Associate Editor*

Editorial and General Offices, - - - 230 Fifth Avenue, New York

"Those Who Refuse to Go Beyond Fact Rarely Get As Far As Fact" - - HUXLEY

MODERN ILLUSIONS

By HUGO GERNSBACK



As time goes on it becomes apparent that our senses are becoming more and more involved directly due to scientific progress. From the very first day, when fire originally was made use of by savages, up to the present time, our senses have become increasingly used to various and variegated illusions. When the first torch was placed in a cave of our ancestors, it was done to simulate daylight during the normal night. Heretofore human beings, if such they might be called, as well as much of the animal world, slept practically during the entire dark night, except those animals of the roving kind who could see in the dark.

As artificial light became known the illusion that it was daylight at once went abroad, and immediately human progress took a great impetus. Of course, there was moonlight, but the moon did not always shine into the depths of the caves, particularly when the entrance of the cave had to be closed up, barricaded, or hung with skins to keep out the cold.

In modern times, however, many new illusions have come about, all illusions, by the way, that strangely enough tend to aid progress and help in many cases to further elevate the human race. For instance, you pick up a telephone receiver and listen to your friend talk. Most people have an idea that they hear the voice of their friend. The engineer knows better and will tell you that you hear no such thing. You do not hear the voice of your friend at all. It is simply an auto-illusion. What you do hear is the vibration of a thin iron disc, as it vibrates to and fro in the telephone receiver which you hold to your ear. No sound reaches you from your friend, as sound does not travel through the wire. Your friend, when he speaks, creates sound-waves, which strike the microphone in front of him. The vibrations set up by the sound waves when striking the microphone are translated into electrical vibrations, which are then fed through the wires to the other end, where the electrical vibrations in turn set up mechanical vibrations in a thin iron diaphragm. These vibrations set up corresponding vibrations in the air, which now result in sound waves which you can hear. But I wish to make it plain that you are simply the victim of an illusion. Your hearing senses are fooled into believing that you hear your friend speak.

The same thing happens when you hear a great artist perform over the radio. You do not hear the artist at all in any way. It is again an illusion and the processes involved here are similar to the one just mentioned with the telephone. The sound is translated into electrical vibrations which are then sent out through space and afterwards translated again from electrical vibrations into sound vibrations by your loud speaker; which latter, by the way, is nothing but an overgrown telephone receiver.

The radio illusion is the same as the telephone illusion, and the more carefully the illusions are carried out, the more will your senses be fooled into believing that you are actually listening to certain voices or certain sounds.

Of late you have seen a good deal of the so-called moving electric signs. You see blazing names being written out in the night sky. You see all sort of figures in motion. You see entire words and sentences rushing from the right to the left of a huge sky sign, to appear from nowhere on the right and jump off into dark space at the left.

Most people will be surprised to learn that *on such signs nothing at all actually moves*. It is a pretty optical illusion, commercialized to the nth degree. The letters which you see moving are not letters at all, nor do they move. The figure which you see jumping back and forth on an electric light sign stands still. It does not move. What happens is that in all of these cases electric lights are switched on and off so rapidly that they seem to move. The simplest example of such electrical signs is the moving garland as it seems to circle around a row of stationary letters. The illusion is produced by having first one electric light switched on, then another, then the first one extinguished, then the next one lit up and extinguished, and so on. This gives the illusion of motion, but the lamps, of course, are stationary and do not move at all. In the moving word sign, where the letters and whole words seem to rush from the right to the left, a similar process is used. Down in the switching room there is a perforated cardboard or similar device, which is fed by motors over an elaborate system of electric contacts. These contacts switch the lamps of the electric sign on and off with great rapidity, and so fast does this lighting and extinguishing occur that the illusion is produced that you see the letters in motion.

Modern illusions do not stop at mystifying simply our senses of hearing and sight. The modern scientists, for instance, go further by giving us illusions of scent. The majority of perfumes today, except the most expensive ones, are not what they seem to be. You smell the exquisite perfume of a violet, or a lily of the valley, although such perfumes, likely as not, are made chemically from coal tar. Your sense of smell is fooled completely and the illusion in most cases is complete.

The same can be said of your taste, where many illusions prevail. When you think you are tasting real cane sugar, it may be only glucose or saccharine, which are not cane sugar at all, but given to keep up the illusion that it is cane sugar. You can make glucose from a shirt or piece of paper.

If the French *chef* is clever at all, he will be able to create almost any sort of illusion by mixing his condiments in such a way that certain tastes and flavors are produced, which in no case are what they seem to be.

It is even possible to fool a number of our senses simultaneously. Not so many years ago, at certain fairs and resorts, you and your companion took seats in a swing and an attendant entered and started it swinging. It was an agreeable sensation. In a few seconds the attendant left the room, when suddenly the swing seemed to gain momentum, and before you knew it you were holding on desperately to your seat with both hands, because evidently the swing was beginning to make a complete turn. The illusion for your senses was perfect, in that the swing did not swing at all—as a matter of fact, it had stopped. But the room itself, which swung on an axis, had started to turn around you, giving a perfect illusion to most of your senses that you were about to be thrown out when the swing had apparently reached its top position, with your head pointing downwards.

The physiological effects were quite severe and made many people actually sick. In this case, the reaction was both psychical and physiological. All of which shows that we should never trust our senses too much in these latter days of scientific progress.

**THE GOLDEN AGE OF
SCIENCE**
is symbolized by the golden cover
OF SCIENCE & INVENTION.
LOOK FOR THE GOLD COVER
every month!

Mr. Hugo Gernsback speaks every Monday at 9 P. M. from Station WRNY on various scientific and radio subjects.

Mississippi Flood Prevention

A Number of Schemes Having More or Less Merit Are Here Described

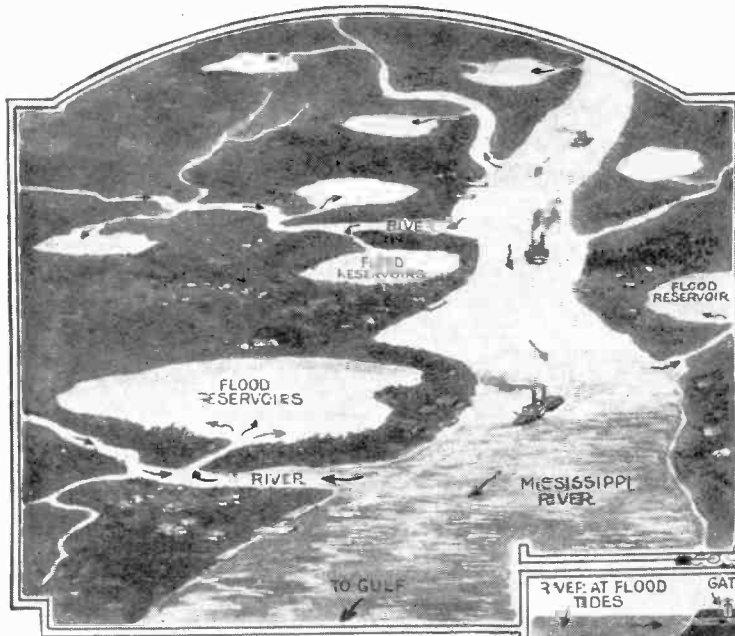

The above illustration shows the Mississippi River connected, by canals, to flood reservoirs. When the river is high the overflow runs into these reservoirs and this is kept at the natural level. As soon as the river runs below the level the water again runs back from these reservoirs.

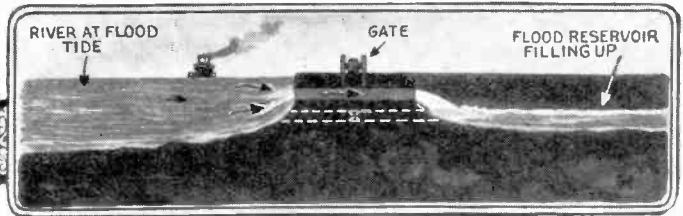

One of the methods suggested for the prevention of further floods is shown in the illustrations appearing above and below. A reservoir with a gate is provided so that the flood waters may run off and the reservoir again emptied when the river is low.

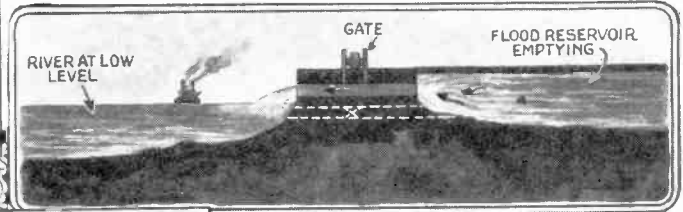

At the left we have two large concrete wells or tanks; these tanks serve the same purpose as do the reservoirs, but do not take up the area which would be required for them. The flood waters seep away or are pumped off.

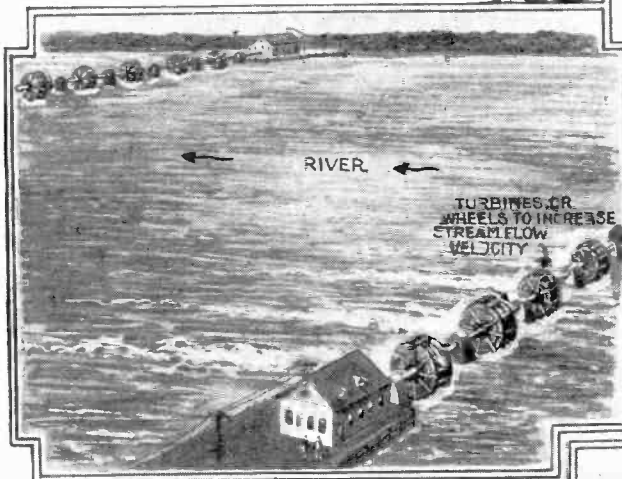
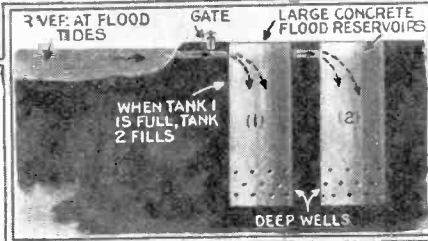

A French engineer, J. Archer, has suggested that the Mississippi flood might have been prevented by installing turbines or wheels to increase the velocity of the flow of the water. These wheels are to extend across the river. According to the inventor, the whole cost of installation would not equal the losses in one big flood.

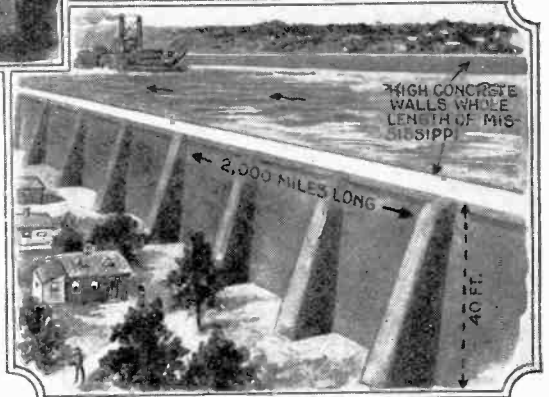

A suggestion has also been advanced whereby concrete walls, 40 feet high and extending some 2,000 miles from the mouth of the Mississippi River, should be built as a means for controlling future floods. The cost of this construction would be entirely prohibitive and amounts to approximately \$64,000,000,000,000.

Below we have an ingenious flood prevention method advanced by one of our "master minds." This consists of building a river under a river in emulation of our present-day subway system. The overflow is to run through this culvert and thus the surplus water is passed on to the mouth of the river.

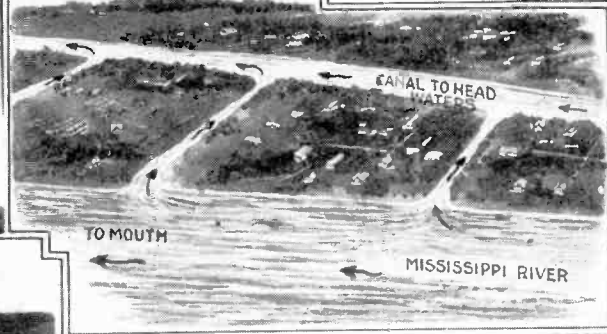
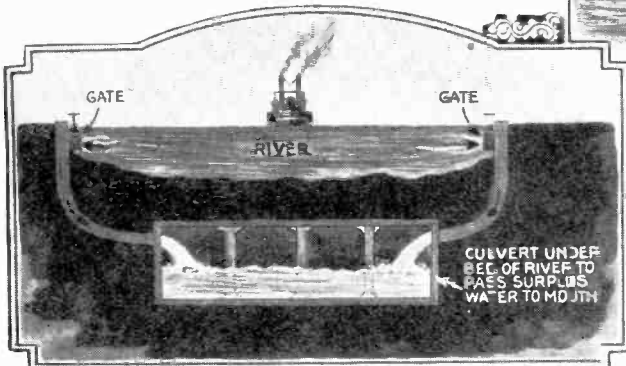

Probably the most fantastic and deceiving plan for preventing the flood is shown at the left. This consists of constructing a canal parallel to the Mississippi River, or, in other words, it amounts to the making of another Mississippi. The flood waters run through canal to the mouth.

THE Mississippi flood could have been prevented, according to the inventors who have advanced the various ideas appearing on this page. Probably the most feasible of these is to provide overflow tanks or reservoirs which will take care of the excess water in the time of flood. All of the ideas illustrated on this page would undoubtedly work, but are not practical, the main drawback being the excessive cost. It is certain that within a relatively short time a worth-while flood prevention method will be adopted. The cost of building and maintaining such a system would probably not cost more than the loss incurred during one large flood.

Sun Spots and the Flow of Rivers

By CARRINGTON WOLF, Ph. D.

IN a recent issue of SCIENCE AND INVENTION, some of the phenomena observed to vary in the sun spot cycle of eleven years were discussed. Among the more interesting are displays of the aurora, or northern lights, and earth current disturbances to telephone and telegraph lines, both of which are more frequent and pronounced in years of sun spot activity. It has been found by careful measurement that the heat given off by the sun, and the percentage of ultra-violet light in its rays are both greater in the same years. In spite of the fact that the sun is emitting more heat in these years, investigators are agreed that most of the United States and Europe have cooler weather. This perhaps accounts for the Iowa corn crop being poorer in this period, since corn is a warm weather crop. On the other hand, measurements of several groups of trees, including the big trees of California, indicate that trees in general do bet-

sun spots are numerous.

A partial explanation of this variation depends on the fact that about four-fifths of the water which falls as rain and snow in Iowa is evaporated, leaving one-fifth to go down the rivers. The rainfall does not follow the sun spot curve appreciably, but the temperature follows the curve inverted, that is, the temperature is higher in years of few sun spots. Presumably the evaporation is higher in the warmer years,

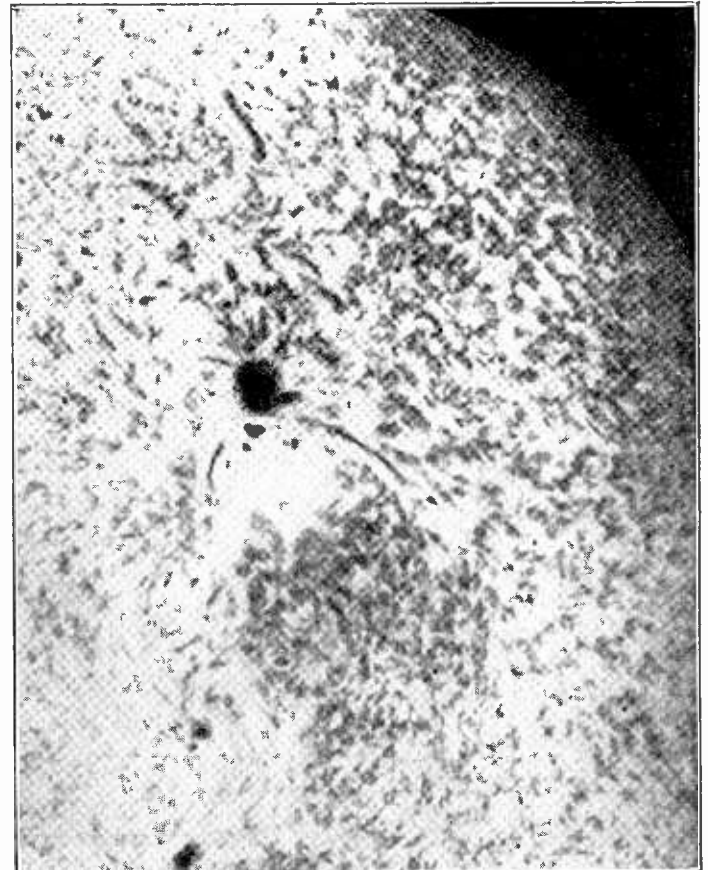

The photograph above shows the spectacular appearance of a large sun spot as actually seen through one of the largest astronomical telescopes. Sun spots have a great deal to do, scientists now believe, with our weather, flow of rivers, radio transmission and many other earthly conditions.

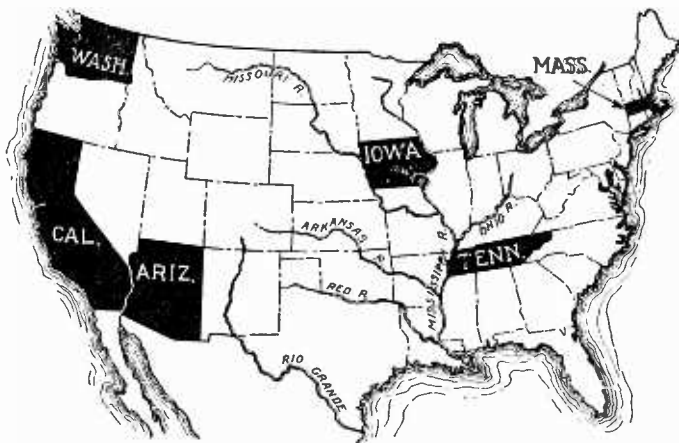

ably the rivers are lower in years of many sun spots. In Iowa the rivers are higher in years of many sun spots, which condition holds true also for Arizona and California. For Washington the results are uncertain; probably some rivers are higher in years of many sun spots.

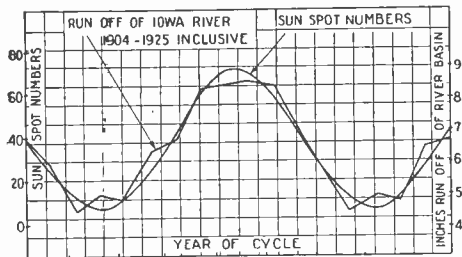

Graph above shows run-off of the Iowa River based on measurements taken at Iowa City, Iowa. The results for 22 years, 2 sun spot cycles, are averaged on one cycle to make this graph.

ter in the years of sun spot activity. The growth rings average thicker.

Several other investigations have been made. For instance De Lury examined a French record of the arrival of birds in spring, extending over seventy-five years, and found that the birds came later in years of many sun spots. Since these are the cooler years, this would be expected, but it should be born in mind that all of these are general results of little or no value for individual predictions.

A similar investigation has just been made of the sun spot cycle in the flow of rivers. The accompanying plot shows the average run off of the Iowa river compared with the average sun spot numbers throughout the cycle of eleven years. It will be seen that the correspondence is surprisingly close, the most water going down the river when

leaving more water to go down the rivers in the cooler years of many sun spots.

Several other rivers for which records of twenty or more years were available were studied at the same time. It was found that the Colorado River, the Cedar River in Iowa, and the San Gabriel and Kern Rivers in California behaved as the Iowa River. For the Columbia River in the Pacific northwest the result was uncertain,

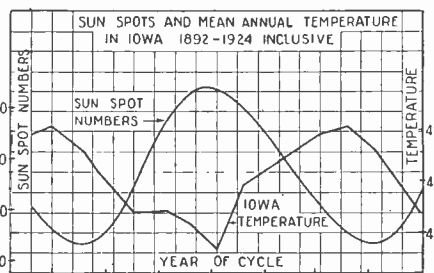

The curves above showing the variation of the Iowa temperature is from means of the Weather Bureau figures for the mean annual temperature of Iowa for the 33 years, 1892 to 1924, inclusive. The 33 years, 3 sun spot cycles, were averaged on one cycle of 11 years.

as other variations obscured the sun spot cycle effect, but over most of the west the rivers average higher in years of sun spot activity.

East of the Mississippi, good records for the Tennessee River gave another indefinite result, but the records for two New Eng-

land rivers gave a perfectly definite result directly opposite to that of the western rivers. The accompanying plot of the average flow of the Merrimac River throughout the sun spot cycle of eleven years shows this. By inverting the sun spot curve a good correspondence with the flow of the river can be obtained.

This opposite behavior of rivers in different parts of the country is something most of us would not have guessed, and for a complete explanation we must no doubt wait for a careful study by experts in meteorology. The following has been suggested as a partial explanation:

In Iowa, most of the precipitation is in the spring and early summer. The weather is warm so the evaporation is relatively high. Further, Iowa is largely an agricultural state. The water drains from the comparatively level fields of corn rather slowly, giving considerable opportunity for evaporation before it reaches the streams. As was pointed out previously, evaporation is probably the chief factor in producing the sun spot cycle variation in the west.

In New England, much of the precipitation is in the winter. With the cool weather of that season, there is very little evaporation. (Continued on page 281)

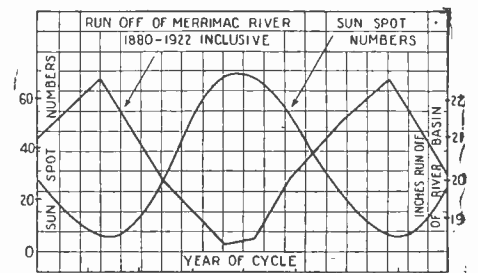

Curves above show run-off of Merrimac River from measurements taken at Lawrence, Mass., over a period of 43 years, averaged on one cycle of 11 years.

New Televisor of M. Valensi

New European

By LUCIEN

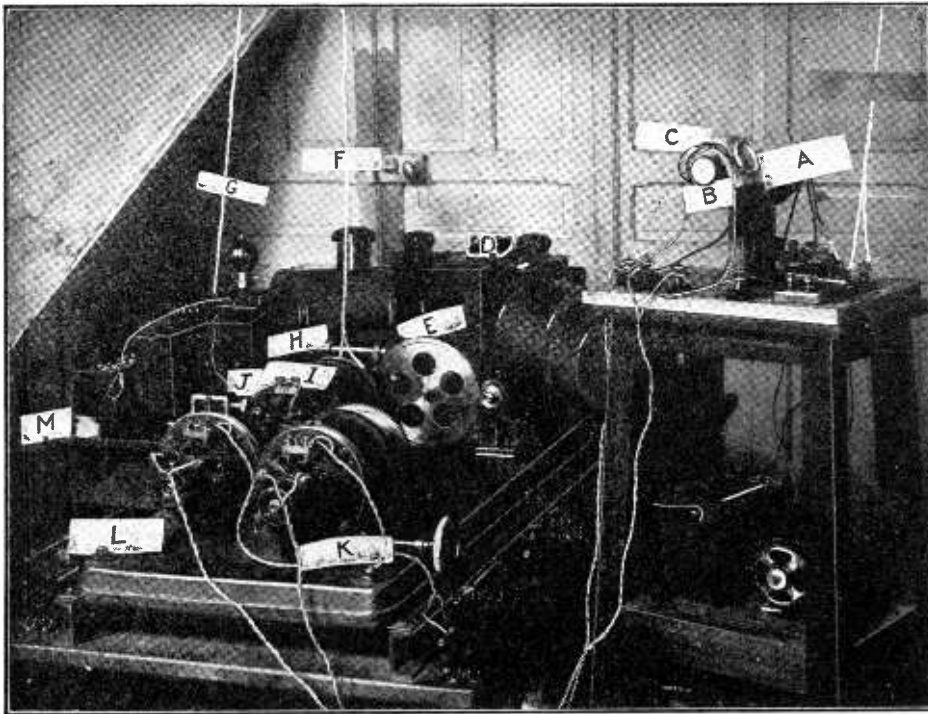

The television apparatus used by Monsieur Valensi, chief engineer of French Post Office, is shown above. The apparatus used is labelled as follows: A, receiving lamp; B, fluorescent screen; C, coils of the magnetic field; D, reflection apparatus; E, explorer disks; F, synchronizing circuit; G, receiving circuit; H, collimator; I, synchronized motor; J, photo-electric cell; K, 8-cycle alternator; L, 800-cycle alternator; M, amplifier. Monsieur Valensi is much more ambitious in his desires and achievements than most of his contemporaries, looking farther into the future.

M. VALENSI, chief engineer of the French Post Office, is one of the first inventors who had the idea of utilizing the cathodic ray for television apparatus. His first patents go back to December 29, 1922 for reception, and January 3, 1923 for transmission; they have been completed since these dates by numerous additions. We will only allude to the principles of these experiments carried out in 1923 and 1924. Since then he has gone far beyond the early conception. Especially does he suppress in his latter experiments fluorescent light, whose luminous intensity seems too feeble to him.

In the laboratory of the French Post Office, installed under his supervision, M. Valensi constructed and experimented with his apparatus. A theorist and technician in the science of electric communication, the inventor constructed not only a receiving apparatus and a transmitting apparatus, but a complete transmission and a receiving office, such as each correspondent should have at his service. More than this, he looks forward to the simultaneous utilization of apparatus for television and telephoning, using both ether waves and the telephone circuit, so that one of the two subscribers talking can cause an object in motion or an explanatory diagram to be seen by his correspondent. Telephotography and teletcinematography will be *a fortiori* solved, if the problem thus put has received a solution which is practically satisfying.

Here again the two essential principles are exploration and synchronism.

EXPLORATION OF THE IMAGE

The image to be transmitted may be a lantern slide in a lantern, or an opaque subject, drawing, postal card, watch, etc., placed in an "opaque object" lantern. There is nothing special about the projecting lantern. It contains two arc lamps which can be made as powerful as desired, casting the greater

part of their light on the object whose image is to be transmitted, and this image strongly illuminated is formed at an exact place between two stroboscopic disks.

These disks are shown in Fig. 1-A. It will be seen that one carries a wave line made up of arcs of spirals of special form, while the other carries one single line eccentric to the disk. The two are connected by means of gears which give to the first disk a rate of rotation of 2,400 turns a minute, and to the second a rate of 480 turns. As our diagram shows the two disks are so placed with relation to each other, that any point on one of the disks is always opposite one point of the second disc. A ray of light can then constantly pass through a point of intersection of the two curves.

Under these conditions the image is not explored or traced over by a double sine curve, but by a series of straight lines uniformly switching over it from left to right, and from right to left; not parallel but at an extremely acute angle with each other. The following advantages are incident to this arrangement. In the tracing by double sine curve, the ray of light reduces its transverse velocity as it approaches the extremities of the image it is tracing, so that these parts are better lighted than is the central part. To understand this phenomenon it is enough to think of a pendulum in oscillation, its speed is greater at the central part of the oscillation than at the extremities. M. Valensi on the contrary, gets a uniform tracing or exploration of constant speed represented in a diagram by the figure shown, it being clearly understood, that each of the lines which form it, is to connect in some way with the preceding one.

The same result can be obtained by using two identical disks with openings like the teeth of a gear following the arcs of spirals, but turning in opposite directions around the same shaft and with velocities nearly identical.

Before speaking of synchronism we will go on with the description of the transmitting system.

The image being placed between the two disks these only permit one point of light to pass at a time. This point is received in an angular collimator which reflects it upon a photo-electric tube, where the phenomena which we have described, and which it is useless to repeat, are reproduced. In our diagram it will be seen that the modulated currents coming from the photo-electric tubes are directed into a first amplifying vacuum tube, which transmits them into a second three electrode tube connected to batteries and resistance coils, which finally acts upon the radio transmitter; here the modulated currents are transmitted by radio.

EMISSION OF SYNCHRONIC CURRENTS

The shaft of the toothed disk turning 2,400 times per minute is the prolongation of the shaft of the central motor and of an 800 cycle alternator. It will be seen that by reducing gear, this shaft controls that of the disk of 480 turns per minute, which is connected also to an alternator of eight cycles. The central motor is driven by a direct current at 110 volts potential. It has two Gramme armatures with two points of their winding connected, producing a synchronic current, which is carried to the receiving station over the telephonic circuit, and which is super-imposed on the talking current. By simply moving a switch, the two correspondents can put their line "on vision," after they have finished their preliminary telephoning.

The synchronic current or the position current, as we may call it, is received by the central motor of the receiving station, which is of course an alternating current motor with a monophasic commutator. The two elements thus put in electric connection turn at the same speed; if one of them starts to turn faster, it draws upon the other so as to re-establish synchronism. This process, utilized by M. Poirson during the war, for secret telephony, made it possible

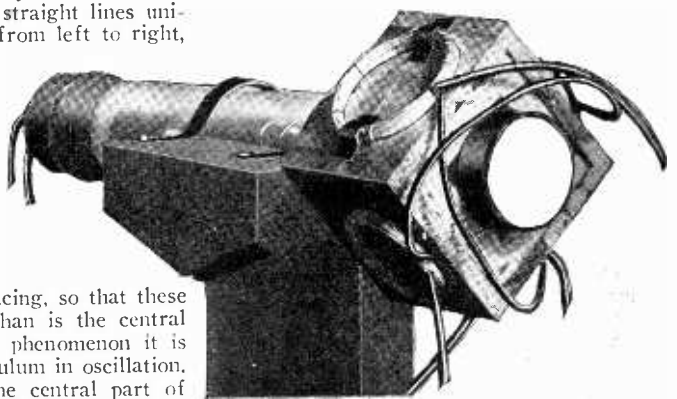

This illustration shows the Cathode-Ray Tube, fluorescent screen, and the four coils which surround the extremity of the tube very near to the fluorescent screen. This unit comprises the apparatus used for projecting the received signal. The currents coming from the radio receiver, act upon the cathode emission of the tube.

Television Scheme

French Engineer's
Clever Device

FOURNIER

to obtain very close synchronism between two shafts.

It now appears that each station, transmitting or receiving, depends directly on an alternating current motor, in central position, which governs on one hand by means of the stroboscopic disks the transmission of photo-electric currents; and on the other hand by means of alternators, one of 800 and one of eight cycles, the magnetic fields of deviation of the luminous point of varying brightness upon the receiving screen.

It is important to understand this feature. Each station has the transmitting and the receiving apparatus mechanically coupled on a single shaft of the central motor; a single synchronic current carried by the telephone line completely synchronizes the two corresponding television stations.

THE RECEIVING APPARATUS

Mr. Johannes of a Paris instrument firm has constructed for M. Valensi, a Braun tube characterized by this feature; that with a very feeble modulation energy factor, (a few micro-amperes at about 12 volts), it was possible to light and extinguish a brilliant luminous point on a fluorescent screen. The concentration of the electrons is there produced in a very simple way by means of traces of a neutral gas acting by their positive ions. The electrons formed by the incandescence of a filament (Wahnel's cathode) are put in motion by a perforated plate anode facing the filament. Between filament and anode is found a group of small auxiliary electrodes acting as the grid of a triode tube.

It will be seen on the diagram that the currents coming from the radio receiver act upon the cathodic emission between grid and filament; a grid battery keeps said grid always negative as referred to the filament. These two elements can be very near together, without the filament being in danger of change by positive ions precipitating themselves upon it. The cathodic emission is then greatly influenced by currents acting upon the grid and coming from the radio receiver, and which it will be remembered are due to waves emitted by the photo-electric current at the transmitting station.

The perforated plate of the Braun tube, the anode, is supplied by a continuous current generator at 800 volts potential; the beam of electrons passes out through the canal tube belonging to this plate and impinges upon the fluorescent screen. On the other hand, the eight cycle and 800 cycle currents generated by the two alternators are passed through four coils, situated on a core of square sections, which surround the extremity of the Braun tube very near to the fluorescent screen. The wave profiles of these alternators is made up of isosceles triangles; the intensity and phase of the eight cycle and 800 cycle circuits can be governed by rheostats and other appliances acting on the fields of the alternators.

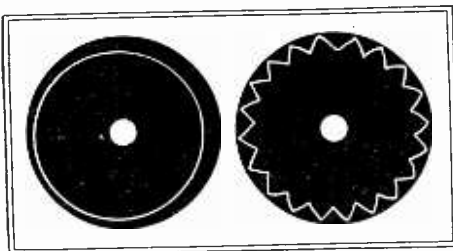

This illustration shows the two disks of the stroboscope. One of them carries a wave line of special form, while the other carries a single line.

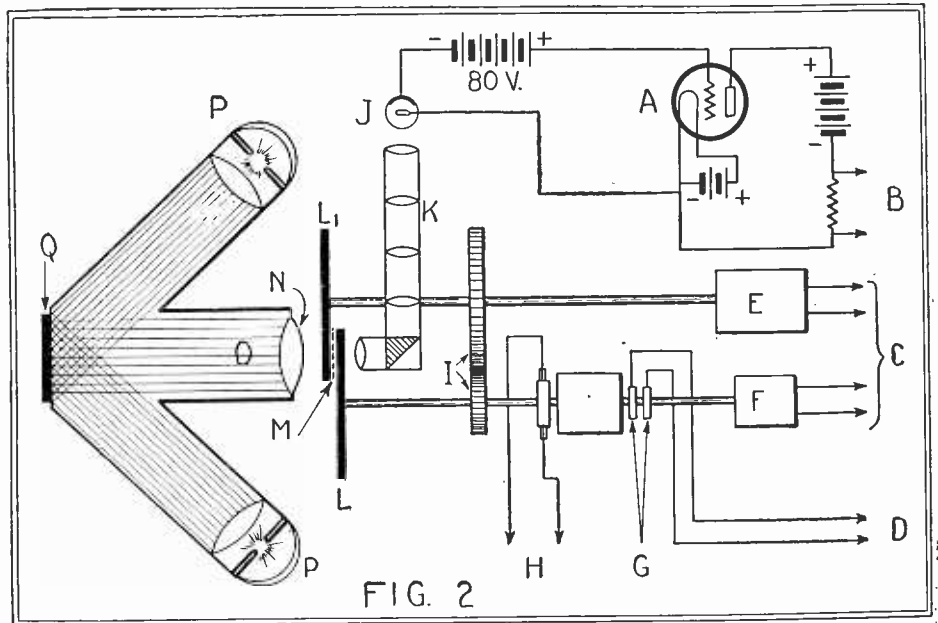

The diagram of the televisor is shown here. The various components of the circuit are as follows: A, amplifying tube; B, circuit to the amplifying battery; C, circuit of the coils of the magnetic reflecting fields; D, lines to the telephone circuit; E, 8-cycle alternator; F, 800-cycle alternator; G, rings connecting to the two points of the motor field coil; H, 110-volt circuit; I, gearing; J, photo-electric tube; collimator; LL1, disks; N, lens; O, beam of parallel light rays; P, arc light; Q, object to be transmitted.

The diagram of the receiving instrument shows how the coils of the magnetic fields are associated to give very regular fields of force, which produce the same phenomenon

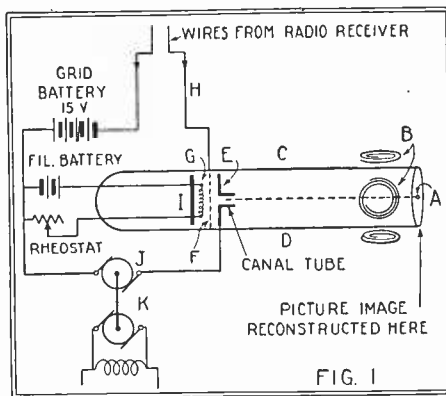

The cathode-ray tube apparatus is shown here. A, cathodic point; B, deflecting magnetic fields; C, path of the gas; D, cathodic emission; E, plate; F, grid; G, filament; J, 800-volt D.C. generator; K, motor.

which we have already explained; that is to say a deviation or movement of a cathodic ray in perfect synchronism with the photo-electric emission currents, and having exactly the same form as that of the explorer or image tracer, and operated at a uniform rate.

ALTHOUGH not perfected so that it is of great practical value yet, television is in that early and quick-moving stage that the radio and telephone were forty years ago. It will take a few years to develop the television apparatus so that it will be practical for every-day use, but if the strides taken in the last few years continue, we will soon have apparatus for sight, attached to our radios and telephones and so forth. The recent experiments of the Bell Telephone Laboratories, which were described in the June, 1927, issue of this magazine, show the results ob-

tained with a slightly different method of operation. Perfectly synchronized motors drive revolving disks, both at the transmitter and receiver, at identical speeds. These disks are rotated eighteen times per second, or 1080 times per minute. They contain fifty small perforations, through which a beam of light can pass, as it passes the lens of an arc light. As each hole comes in place before the light, a pencil of light leaps out on to the object to be transmitted. At each revolution of the disk, fifty pencils of light flash across the image, and as the disk rotates eighteen times a second, each target of light moves across the face eighteen times a second also. As each light beam coming from the disk impinges on the object, there is a reflecting beam which falls on one of three large photo-electric cells.

These photo-electric cells convert variations of light into very minute electric currents, which are used in transmitting. Photo-electric cells have practically no inertia and respond instantly to every variation in a light beam thrown upon them. The holes in the disk are so arranged that they sweep across the object, completely covering its surface at every revolution of the disk. Sixty-cycle synchronous motors were found to be slightly unstable in operation, and thus unsuitable for television work, so the engineers of the Bell Telephone Laboratories devised a system of compensation by mounting a 2000-cycle synchronous motor on the same shaft as the sixty-cycle motor.

This system was recently demonstrated by means of radio transmission and reception over a distance of about thirty miles between Whippany, N. J., and New York City. Full details of the radio transmission are given in an article, appearing in the June issue of *Radio News* Magazine.

The experiments of Monsieur Valensi bring to light again the cathode-ray tube. Recent experimenters have somewhat neglected this tube, and the developments of Monsieur Valensi seem to indicate that in this tube probably lies the solution of the television problem, with regard to a cheap, compact and light-weight apparatus.

A CATAPULT

and other
Aquatic Amusement Devices

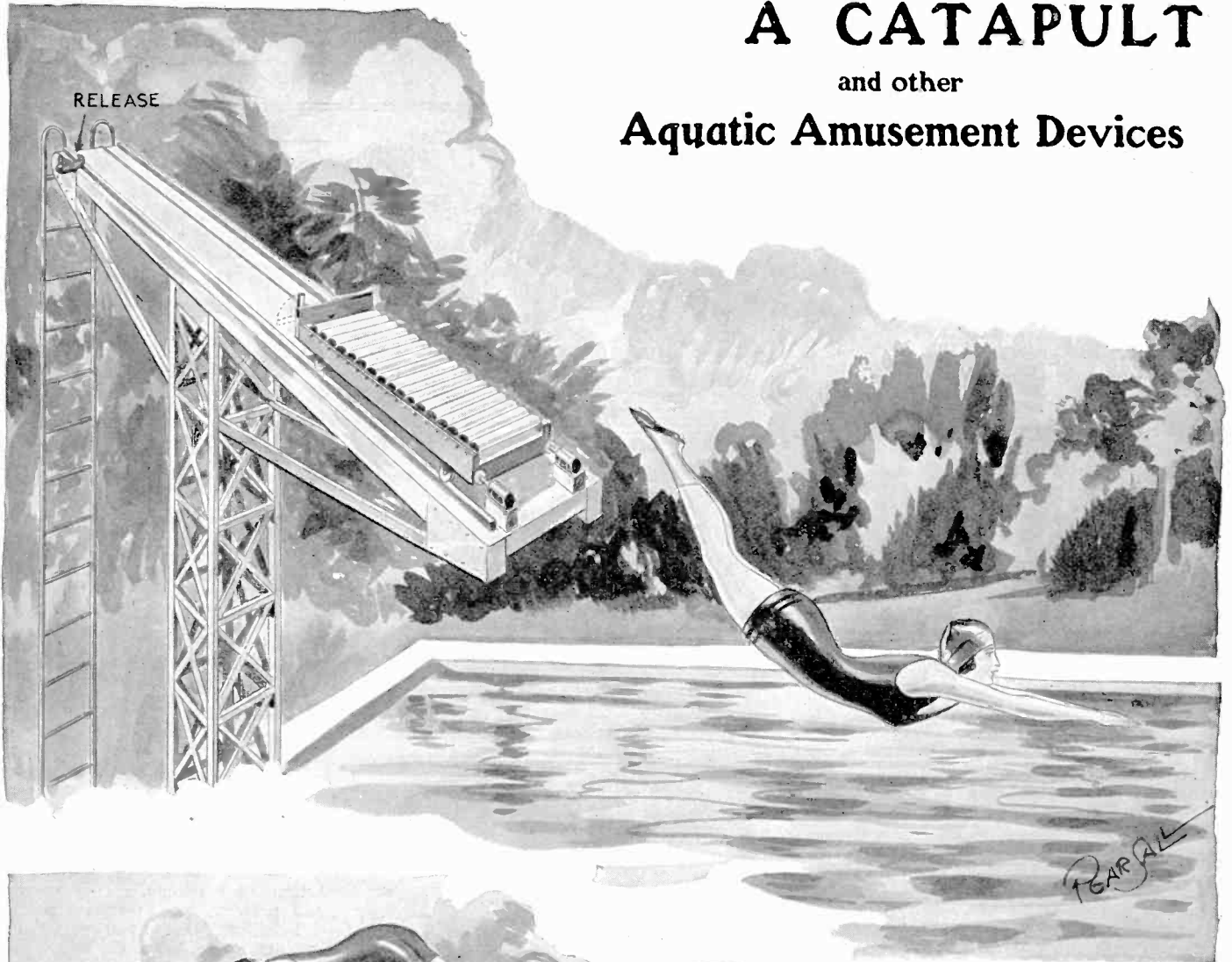

PEARALL

In the catapault for divers indicated in the above illustration, there is a small truck running on rails, the platform of which is made up of rollers. As it proceeds down the incline, gaining speed, the diver assumes the position she is to take as she is hurled into the air. The bumpers suddenly check the carriage, hurling the diver forward.

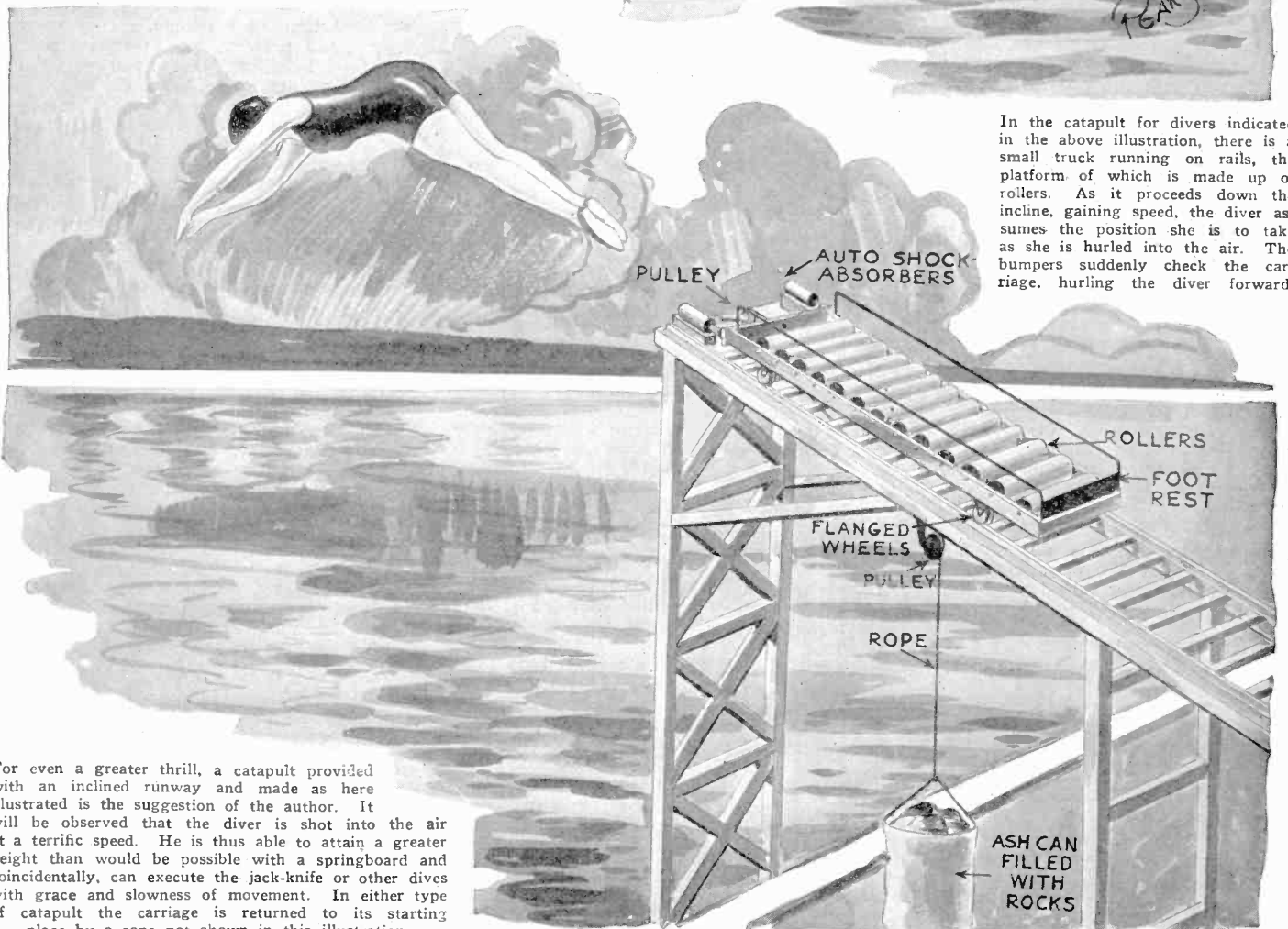

For even a greater thrill, a catapault provided with an inclined runway and made as here illustrated is the suggestion of the author. It will be observed that the diver is shot into the air at a terrific speed. He is thus able to attain a greater height than would be possible with a springboard and coincidentally, can execute the jack-knife or other dives with grace and slowness of movement. In either type of catapault the carriage is returned to its starting place by a rope not shown in this illustration.

FOR DIVERS

By JOSEPH H. KRAUS

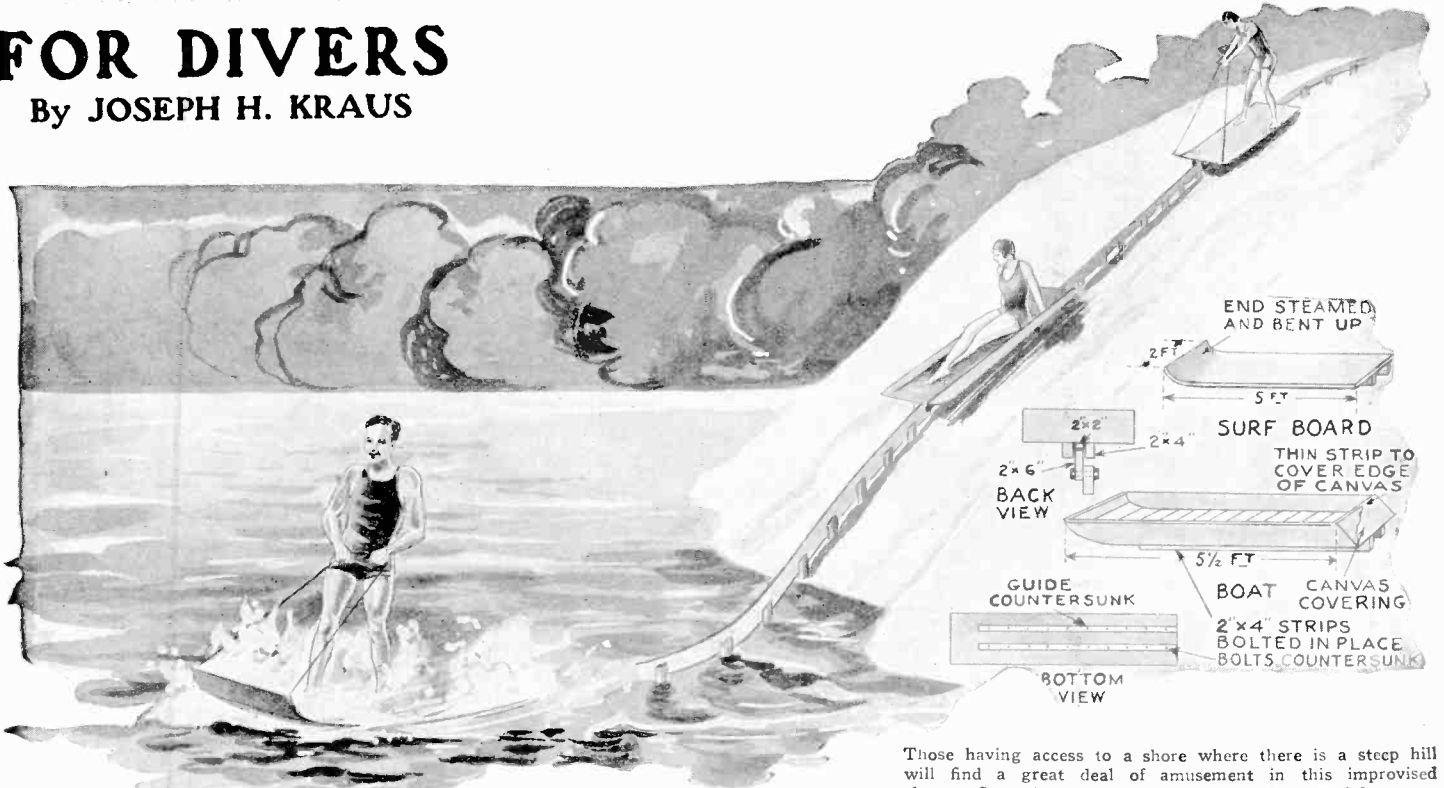

Those having access to a shore where there is a steep hill will find a great deal of amusement in this improvised chute. Several 2x6-in. beams are nailed to upright posts. At the bottom of the hill the track terminates just below the surface of the water with a slight upward curve. Details of the boat and aquaplane are given above.

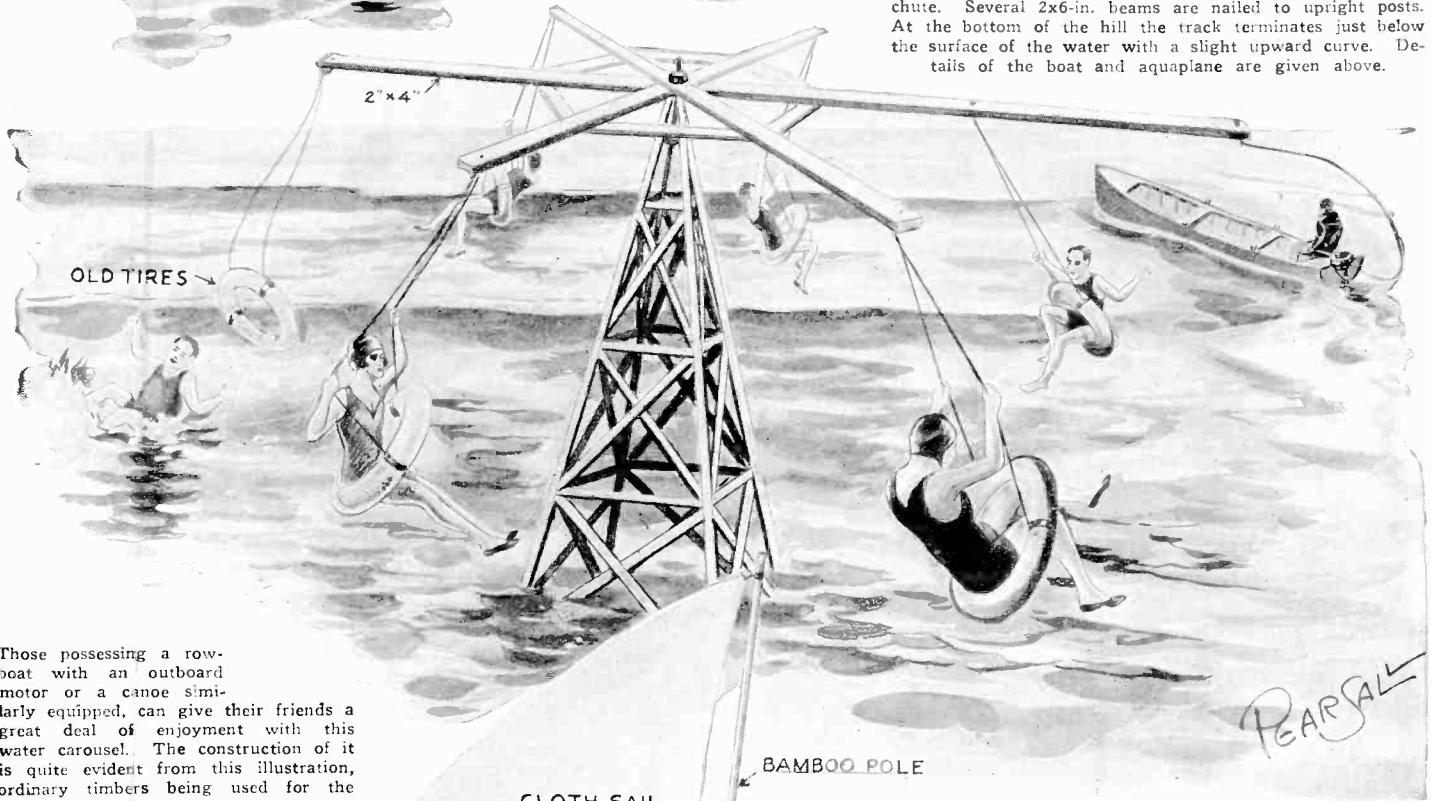

Those possessing a row-boat with an outboard motor or a canoe similarly equipped, can give their friends a great deal of enjoyment with this water carousel. The construction of it is quite evident from this illustration, ordinary timbers being used for the tower and cross-beams.

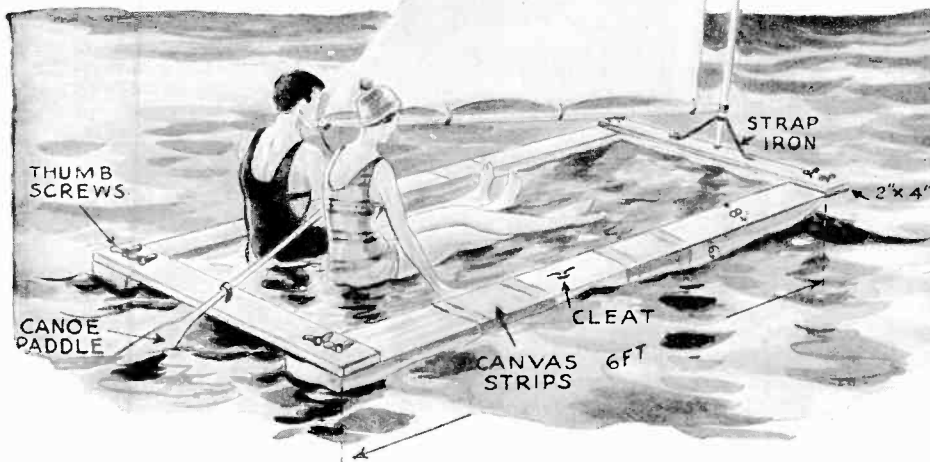

A swimmer's sail-boat is illustrated at the left. This is made so as to be entirely collapsible. When taken apart, it can be placed on the running board of a car or can be stored in a locker. The swimmers are seated on two canvas strips, running from beam to beam. The canvas strips help to bind the beams together when the vessel is figuratively rolled up. A slight upward curve at the forward end of the beam will speed up the vessel and if the bathers do not object to being immersed in the water further than the illustration indicates, the length of the vessel can be cut down.

Aquatic Amusement Devices

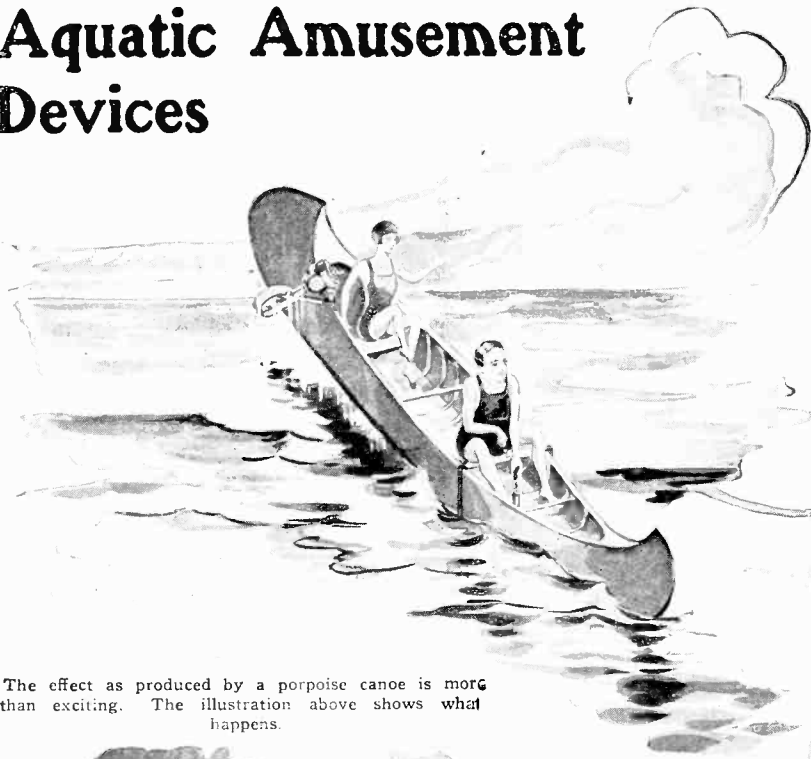

The effect as produced by a porpoise canoe is more than exciting. The illustration above shows what happens.

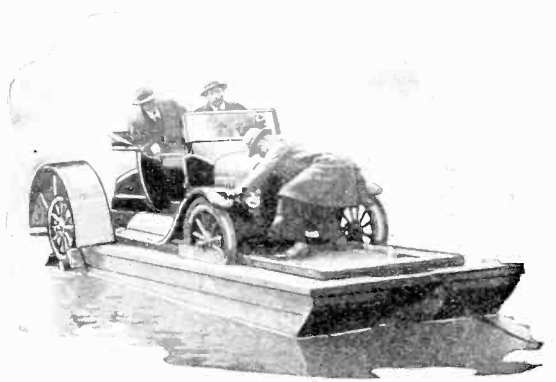

Attaching paddle wheels to the rear axle of a Ford enables Mr. Arthur H. Smith, of Winthrop, Mass., to send this heavy craft through the water at a speed of four miles per hour.

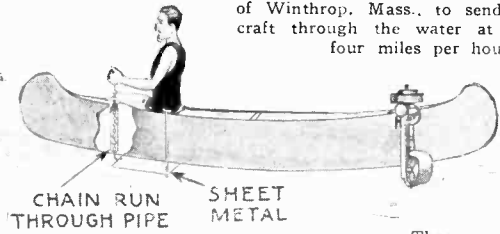

The porpoise canoe is operated by an outboard motor. At the forward end of the canoe there is a sheet of metal affixed immediately below the body on two pivots. A chain running through a pipe communicates with the flat metal sheet which, when lifted or lowered, causes the vessel to bounce along.



These strange craft in the form of fish and propelled by pedalling are the latest novelty in boats on the lake at Clapham Common, England. Illustration at the right shows their construction.

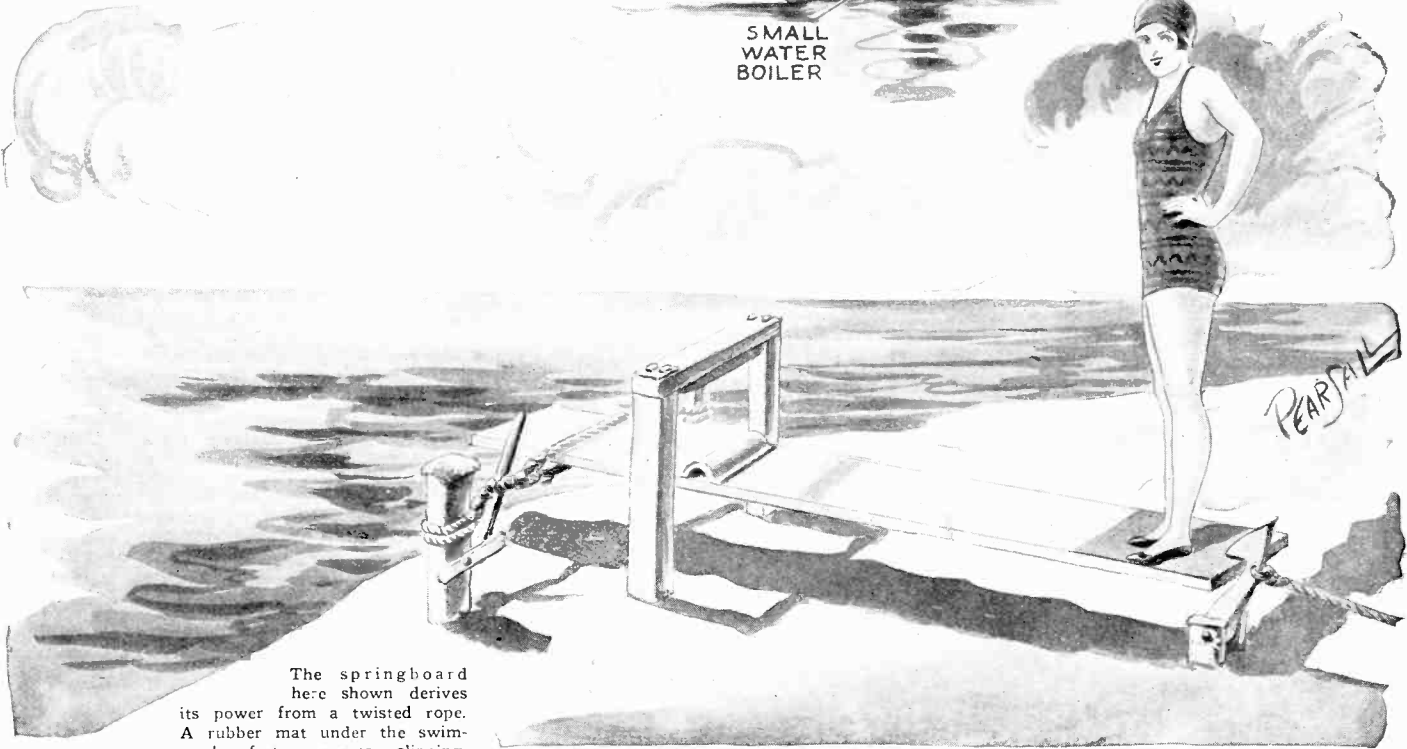
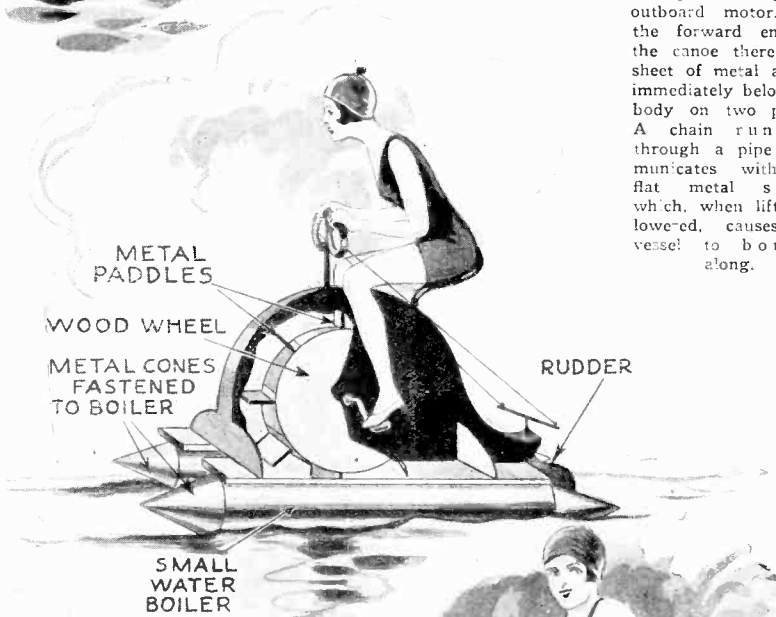

The springboard here shown derives its power from a twisted rope. A rubber mat under the swimmer's feet prevents slipping. The higher the stop, the further will it hurl the diver.

PEARSON

Movie Shows Wonders of the Universe

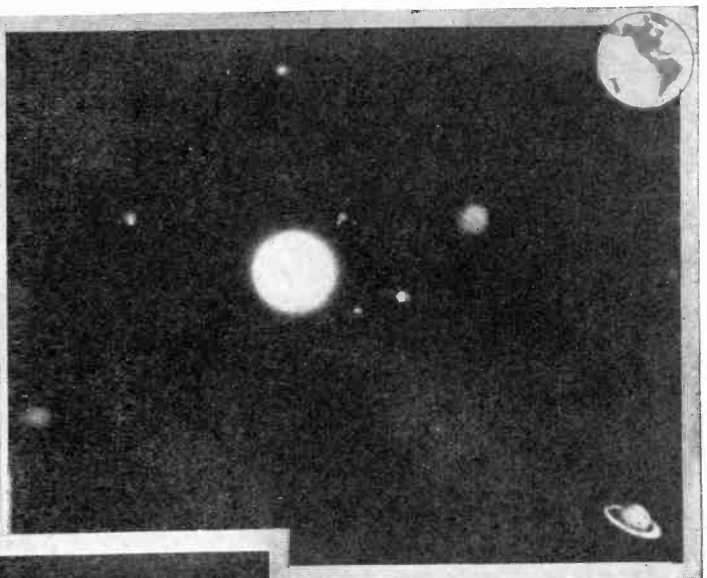
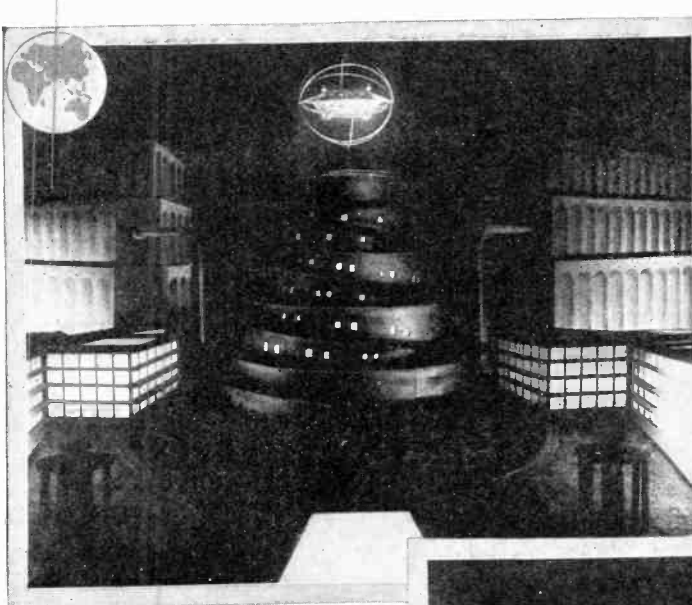

A view of the phantastic ether-ship which carried the "Earthlings" through boundless space into the realm of the stars.

A glimpse of our universe as seen by the occupants of the space-flyer.

The earth as seen from the planet "Jupiter." Note the irregular surface on this planet.

SEVEN long reels, in which the mysteries and beauties of the star covered sky pass before our admiring eyes, is one of the latest productions, called, "Our Heavenly Bodies," which comes to us from Germany. Theoretical speculations are brought to life, based on profound studies and technical experiments. The feeling of highest dramatic suspense and excitement occurs when we enter the ether-ship, and then, equipped with all the latest technical efficiencies and scientific knowledge of a highly cultured age, sail out into the realm of the stars. Solid bodies, yet floating in space, they glide by in alarming monotony. We halt at "Jupiter," at "Mars," at one of the innumerable small stars, seeking the fabulous giants and dwarfs so often heard of. When we reach the fixed stars and when the power of gravitation and attraction ceases, we see

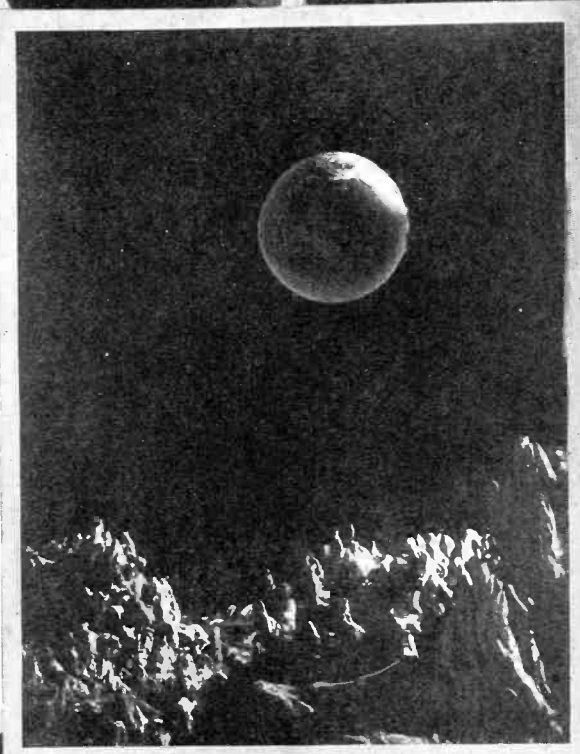

strange phenomena. The model trick-scenes are superb from a filmic point of view. They made it possible to show each planet and each planet-moon in its rotation around its axis as well as in its rotation around the sun as a center. The total number of star and planet rotations represented in this one trick-scene amount to nearly 40,000. The climax is attained in the seventh reel. In gripping mass-scenes we witness the death of the earth, first through a period of ice, and then through fire. Fire actually falls from the sky, smashing the panic-stricken crowds of human beings and dissolving the entire earth into a mass of smoke and flame.

On this page are illustrated some of the most spectacular outstanding and novel scenes which appear in this remarkable picture.

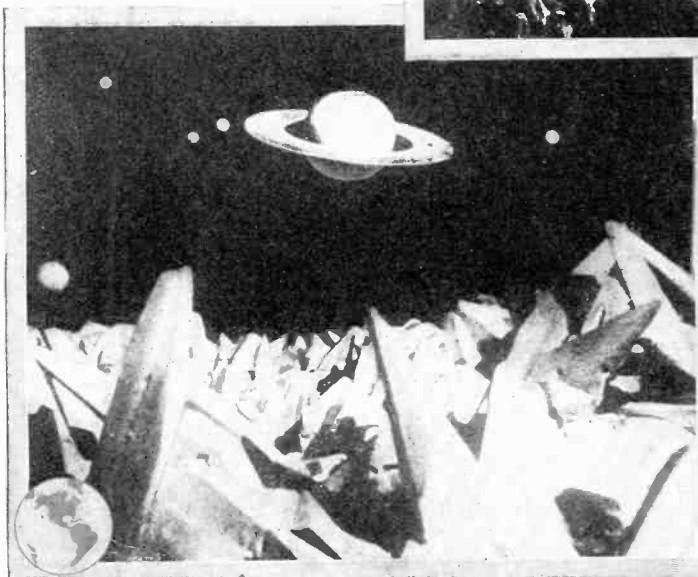

"Saturn" with his concentric rings as seen from the planet "Mars." The arid surface of "Mars" may be seen with its pencil-like, sharply pointed rocks. The shadows cast on the planet "Mars" are very sharp and well defined. Other bodies of our universe may be seen in the background.

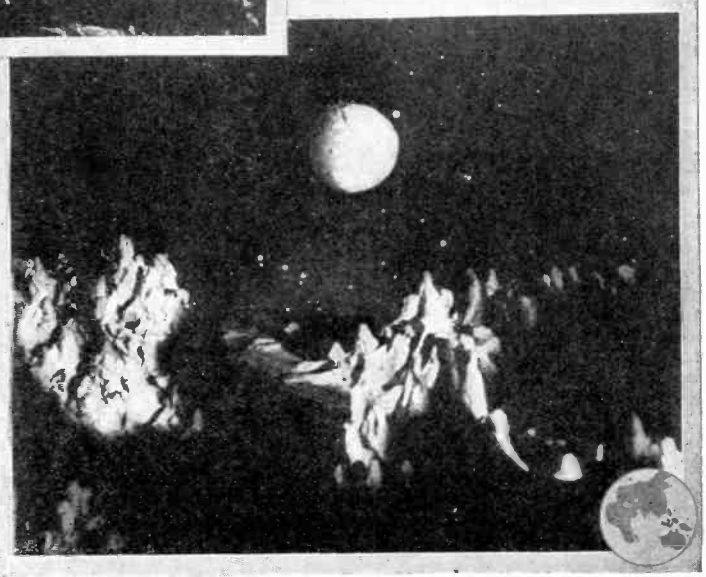

Another view of the earth from its neighboring planet "Venus." The surface of "Venus" is more regular than that of the other planets and the visitors from the earth traversed it with ease. Again other planets and various stars may be seen.

Huge Movie Furniture Makes Pygmies of Actors

By EDWIN SCHALLERT

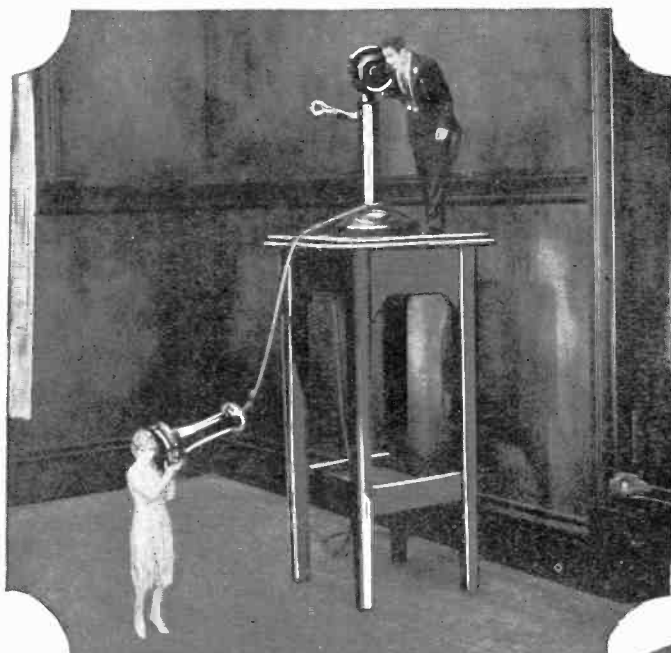

At the left we have a view of the set used to produce the strange effects which were seen in the picture "Wolf's Clothing." Note the relative size of the actors.

In the photograph to the left and below we see Monte Blue helping Patsy Ruth Miller to climb the huge chair. Note the size of the actors as compared with the articles used in this mammoth

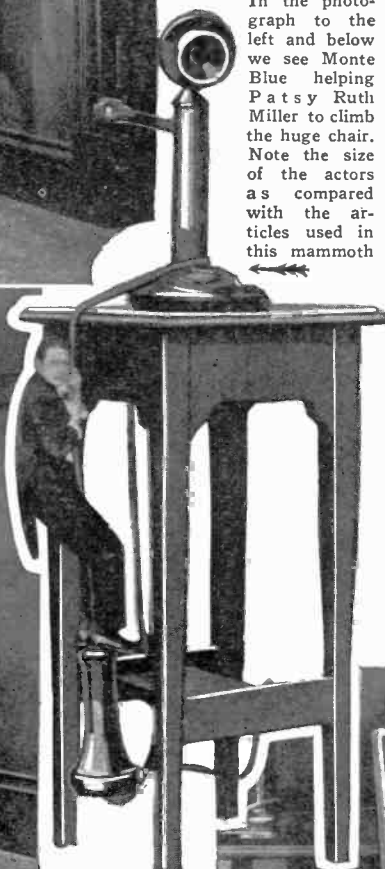
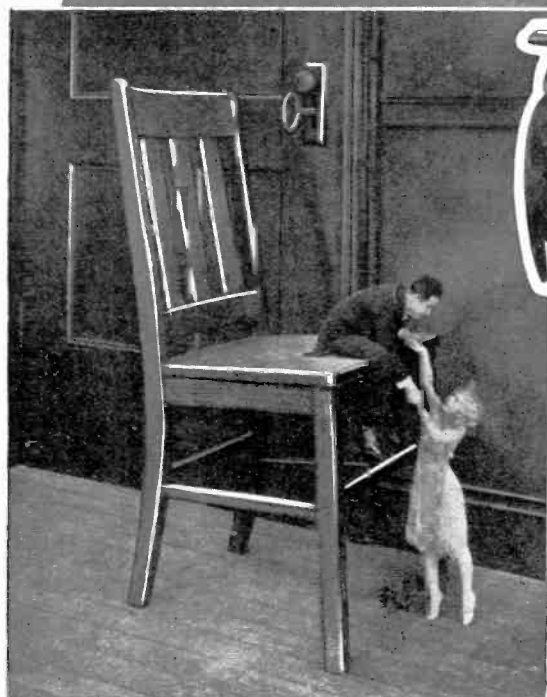

A BED more than 30 feet long and 20 feet wide; a door merely 30 feet high, a telephone 4 feet tall and a telephone stand in proportion were among the "props" required for the filming of "Wolf's Clothing," a Warner Brothers picture, starring Monte Blue and Patsy Ruth Miller. The production is what may be called glorified comedy. The picture portrays an exciting series of adventures, involving a wild New Year's party, and ending with a kidnaping. It is during this kidnaping episode that the huge set shown in the photographs was used. When the hero wakes up in a daze everything appears to him to be distorted. This effect was obtained by a refraction through a detachable camera lens which was tilted in order to obtain the required distortion. Further peculiar effects were obtained by the use of a "slow motion" camera. In the final subway sequence the train appears to be running away while the hero climbs along the top. To give the impression of the great speed at which the train is supposed to be traveling, some pictures were taken on the front platform of a real subway train in New York, the camera being ground slowly in order to increase the apparent motion.

The size of the "props" used in this film can easily be seen in the accompanying photographs. Imagine trying to use a telephone as tall as one's self or climbing on to a chair 8 or 9 feet tall. The effect certainly would be astonishing.

Here we have a picture of Monte Blue climbing up the telephone receiver cord. When somebody hands you a strong line of conversation, think of the predicament of this actor who dreamed that he had to climb 15 feet to use the phone.

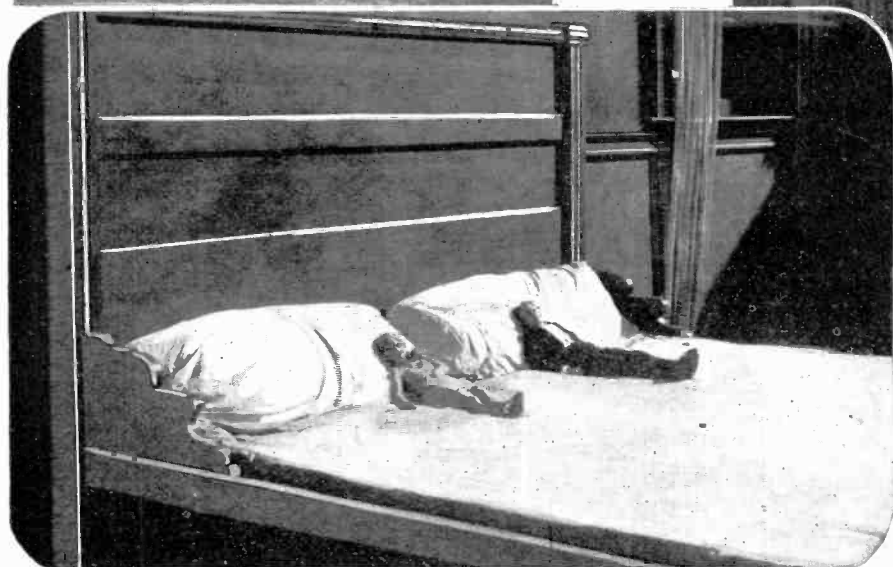

Here the actors are completely lost in the gigantic bed, which was used in the picture. The bed was more than 30 feet long and 20 feet wide. The window and other articles of furniture were built in proportion. Thus the startling effect of the "dwarfed" actors was produced. These were only some of the many "props" required for the filming of this startling picture, which depicts a fantastic series of adventures.

Above we see the hero trying to extract the key from a huge door. Slowly and laboriously he draws up the massive chair, climbs into position and tries to turn the key. His weird movements were intensified by the use of a "slow motion" camera effect.

Rejuvenation by Concentrated Sleep

AN eminent American engineer has recently proposed a method which permits the concentration of eight hours sleep into one hour of perfect relaxation. The apparatus utilized has been used for years in similar processes, but this is the first time to our knowledge that as satisfactory and ingenious appliance has been formulated. The illustration at the right shows the complete assembly. The gaze ball, sustained at the eye level just in front of the patient, induces sleep through self-hypnosis. A modified alarm clock is provided to awaken the sleeper at the termination of any desired period. A low voltage high frequency current is provided which passes current to electrodes placed in various positions. In the drawing, electrodes are provided for the patient's hands, a cap electrode for the head, and the metal plate itself is also connected to the circuit. The passage of the high frequency current through the body causes a rejuvenation of the tissues, which is greatly accelerated over that produced by normal sleep. An ultra-violet ray generator supplements the d'Arsonval currents produced by the generators. Proper regulation of the electrical currents is important, and care must be taken to insure that the voltage does not reach a dangerous level. There can be no possible ill effects resulting from the careful use of this device, and we have every reason to believe that the idea presents a subject well suited to experimentation and that its practical development is imminent.

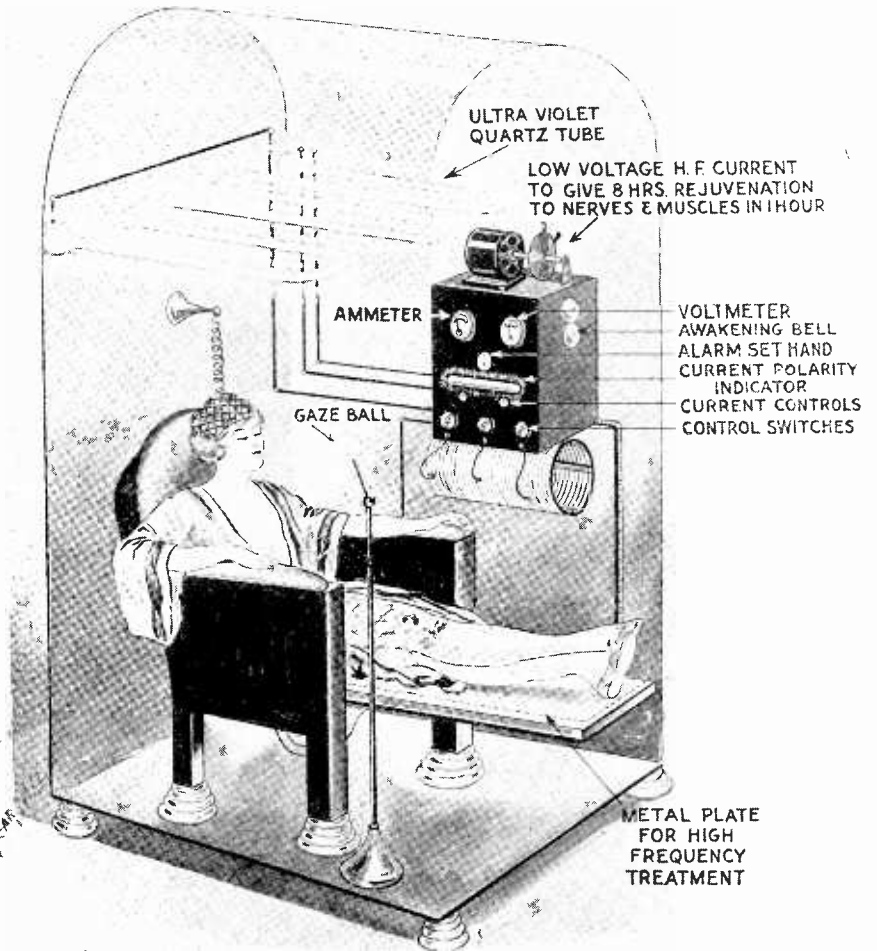

A drawing of the rejuvenation apparatus as recently proposed.

World's Distribution of Telephones

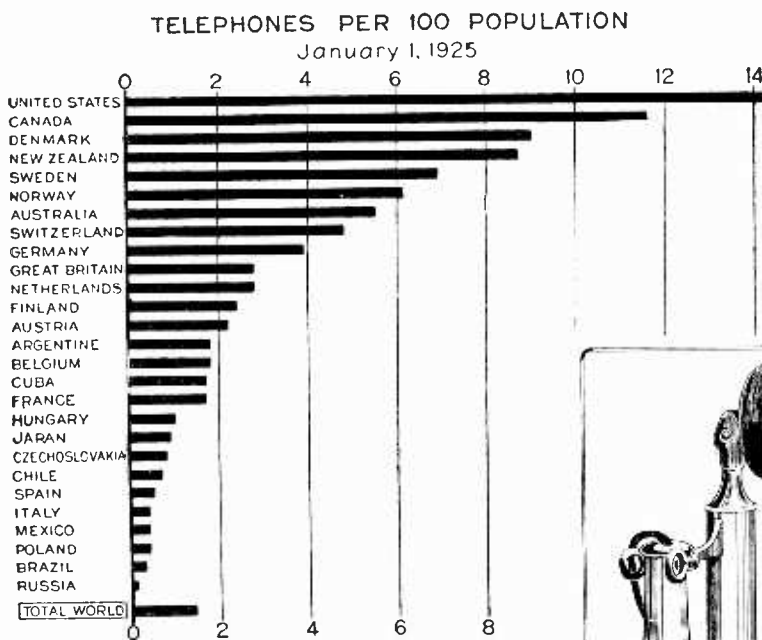

The above chart shows that the telephone development of foreign countries is very much less than that in the United States. The United States is still far ahead of all other countries both in the absolute number of telephones and in the number of telephones in proportion to the population. On January 1, 1925, there were in this country 14.2 telephones for each 100 inhabitants. In Europe as a whole, with 1.4 telephones per 100 population, there was only one-tenth of the telephone density of the United States. Canada ranks second to the United States.

At the right we have a graphic representation of the telephone density in the various countries. In the United States, 62% of the world's telephones are located, in Europe, 26% and 12% in all other countries. On January 1, 1925, the total number of telephones in the world was 26,038,508.

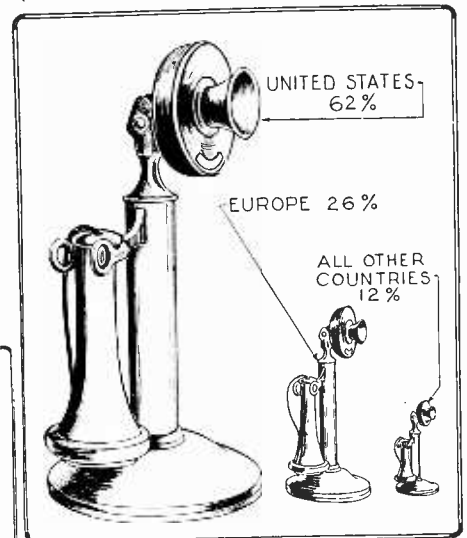

Of all the telephones in the world, the various governments own only 29%, the remaining 71% being owned and operated by private companies. In Spain, where the government telephone service was transferred to a private company a few years ago, the gain in telephones was comparatively large. In both Canada and Denmark, which are next in rank to the United States in the extent of telephone facilities in proportion to population, the great majority of the service is operated by private enterprise. The figures given here are taken from the annual telephone and telegraph statistics of the world, prepared by the Chief Statistician's Division of the American Telephone and Telegraph Co.

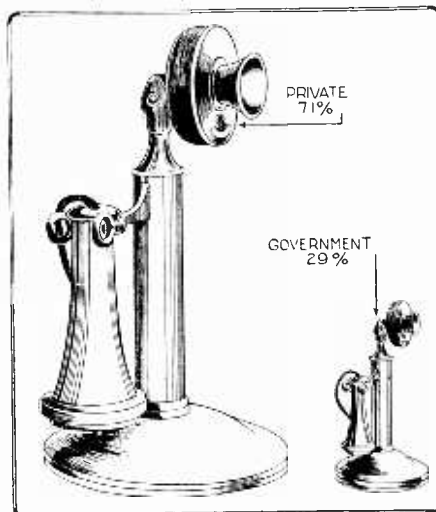

The Evolution of Speed

The rate of land travel is fast approaching the speed records made in the air. The drawing below compares the various land speeds.

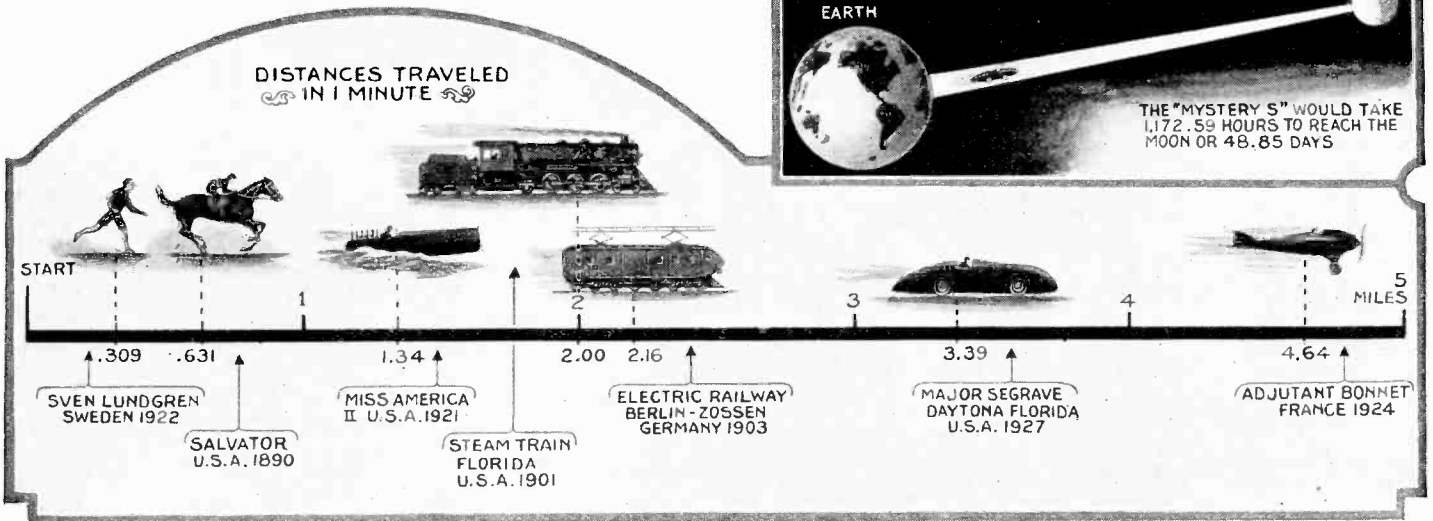

Man, whose natural talents place him far above the slow-going animals, has again demonstrated his ability to outspeed anything that moves on the earth. With the aid of an automobile he has reached and passed the 200-mile-an-hour mark, relegating to the background the horse, whippet, ostrich, and all other swiftly moving animals.

Major Segrave's "Mystery S" has set the record for land speed, having covered one mile at the rate of 203.79 miles per hour. Above, the various speeds are compared showing the distance traveled in one minute, in each case. It would take the "Mystery S" 1,172.59 hours to reach the moon. Who will be the next record breaker?

New Floating Break-Water

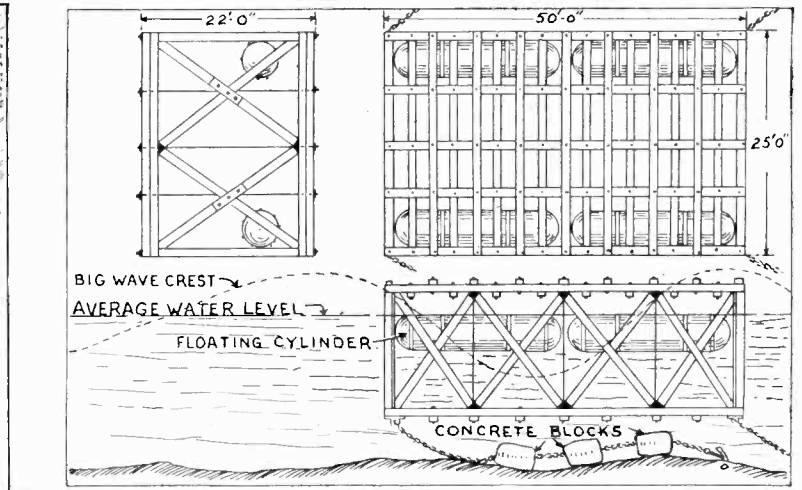
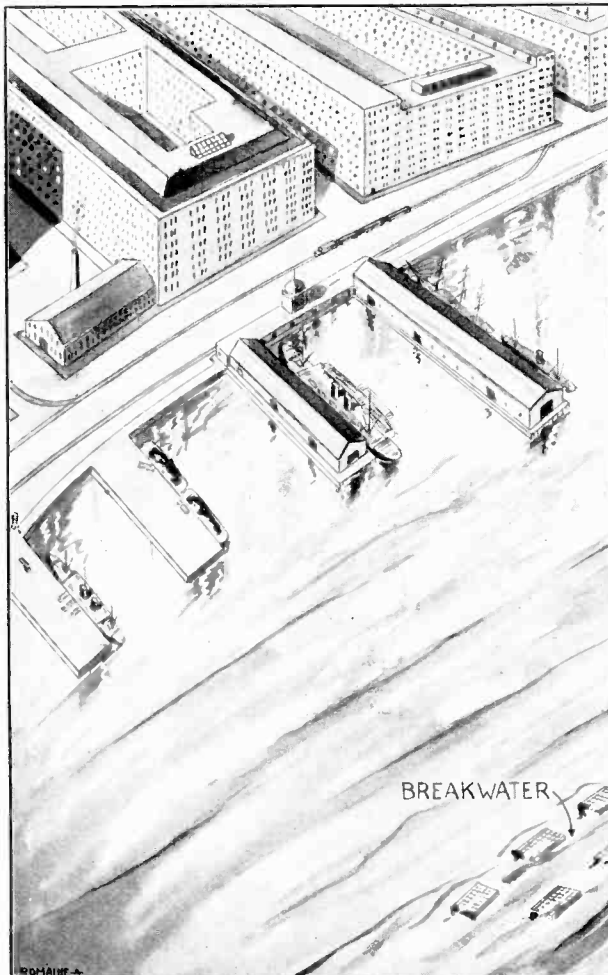

The floating break-water illustrated above has been invented by Mr. G. W. Chance and possesses special advantages when time and cost are vital elements. It can be of service especially in new harbors where it may be installed in a small fraction of the time required to build a stone break-water. A crib-work floating on, or a little above the surface of the water, is at-

tached to concrete blocks on the bottom. The whole structure is anchored between suitable moorings. The upper grillage perforates the rising waves and the lower one retards the mounting action of the upper, holding it back and crushing the wave structure. This device should be of great interest to all those having such problems in hand.

Infra-Red "Eye" Sees at Night

How J. L. Baird, Television Investigator, Utilizes Infra-Red Beam and Photo-Electric Cell to See Through Darkness or Fog

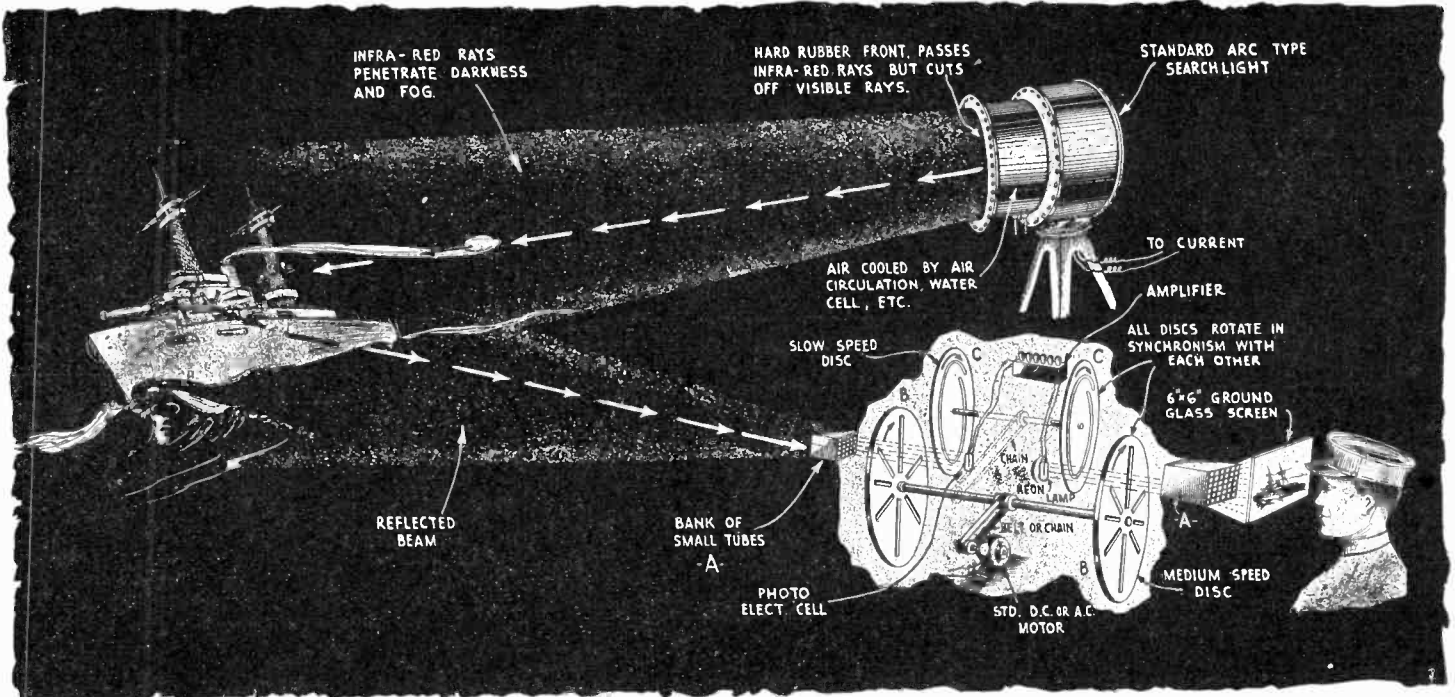

The apparatus used to receive the view illuminated by the invisible beam of the infra-red searchlight and render it visible to the eye of the operator, is shown in the above illustration. The infra-red rays have the property of penetrating darkness and fog and thus lend themselves to use during war time and also in locating ships lost at sea during a storm.

The infra-red rays, striking the invisible object are reflected back to the receiving apparatus. As the angle of incidence equals the angle of reflection, it is possible to determine beforehand the exact position which the receiver must occupy. The details of the invisible ray projector and the receiving mechanism are further described in the accompanying text.

VISION in total darkness and fog is now made possible through the recent invention of J. L. Baird, of London, England, who has completed the "Noctovisor," which is the name given to his new device. The apparatus makes use of infra-red rays, those invisible heat rays which are found beyond the red end of the spectrum. Recently heat rays have been measured which have a wavelength of .0107 centimeters, or 160 times as long as the wavelength of the red end of the spectrum, and from this limit there is an unbroken series all the way to the end of the visible spectrum.

What might be termed the transmitting portion of this device consists of an infra-red ray projector. A standard arc type search light is used with a hard rubber front which cuts off the visible rays but allows the invisible ones to pass. A special type of filter glass, which serves the same purpose as the hard rubber, may also be used. The rays emanating from the projector strike upon some invisible object and are reflected back to the receiving apparatus. The receiving portion of the "Eye" consists of first an analyzer, a bank of small tubes which subdivides the scene or

picture into minute areas and transmits it to the light sensitive cell. Directly in back of this analyzer is a rotating disk, which is slotted and at regular intervals varies the amount of the ray which is received by the photo-electric cell. The photo-electric cell itself is placed behind a disk revolving at a relatively low speed, which is spirally slotted, thus the cell receives different portions of the reflected beam at a set time. The photo-electric cell

converts the energy received into an electric current which is amplified by means of a bank of vacuum tubes. A neon lamp is connected to the output of the amplifying unit and two other disks, as previously described, are placed in front of the lamp. In front of the last disk another analyzer is arranged with a ground glass screen, upon which the image appears. The rapid movement of the spot of light builds up and makes visible to the naked eye the scene revealed by the infra-red searchlight.

All the disks are rotated in synchronism with each other, the two sets being joined by a chain or gear drive.

The "invisible searchlight" has 200 to 300 times the penetrating power of ordinary light through darkness, fog or smoke and consequently will find many uses in our present day existence. Two-thirds of the energy in the searchlight beam resides in the infra-red component.

The applications of this invisible searchlight will readily be seen both for use in war and peace times. Because of its penetrating features and invisibility it is especially useful as a war implement. Another important use is as a safety device for ships at sea.

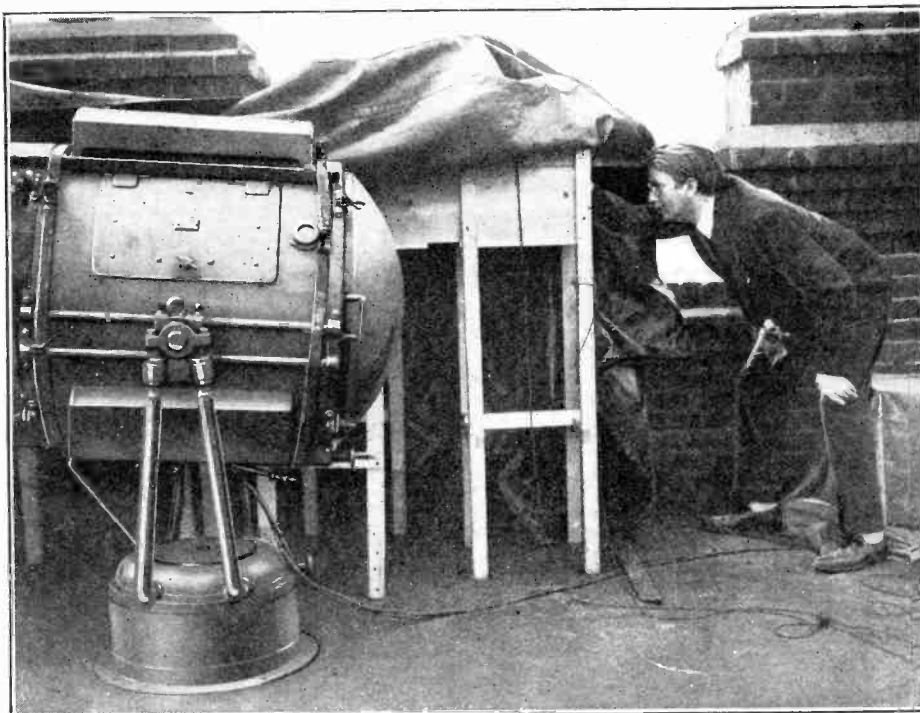

The photograph above shows Mr. J. L. Baird, the inventor of the "Noctovisor," the instrument which makes sight in total darkness or fog possible.

Can I Study Engineering at Home?

By H. WINFIELD SECOR
Part II

IN a radio talk which the writer gave some time ago at WRNY under the above title, and which was published in the May issue of this journal, the pros and cons of studying engineering at home were discussed at length. As pointed out in the previous article one of the fundamental factors in the success attained by any engineering student lies in his application of theory to practice. The college trained engineer invariably has enjoyed the facilities of a very good laboratory, and also the benefit of visits

to nearby power plants and industrial plants, where he gets a first hand acquaintance with various forms of electrical and mechanical machines. Some correspondence courses in engineering are supposed to be studied in connection with plenty of practical work, and several of the schools giving correspondence instruction in engineering either supply with the course, or at a slight extra cost, an experimental chemistry outfit as well as an electrical testing set, such as those illustrated herewith.

The student, or prospective student, of engineering who for various reasons cannot

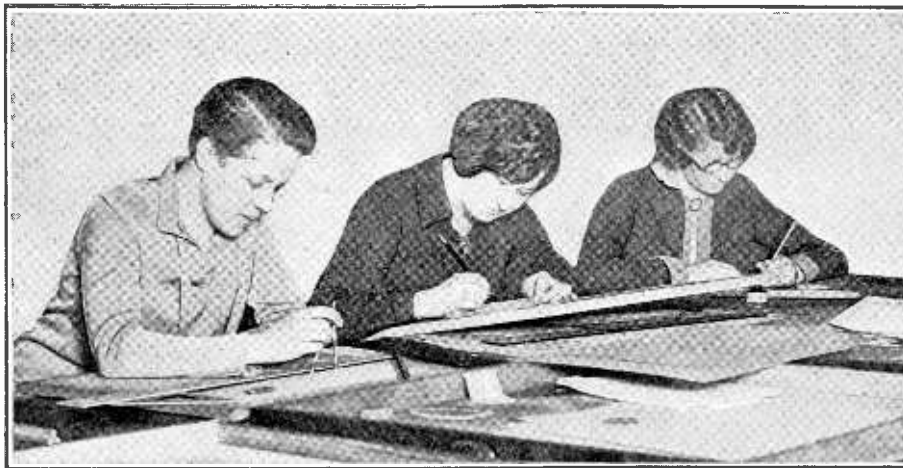

In the above photo will be seen several young women working at drafting boards in the course of studying the methods used in engineering practice.

tends to follow his chosen branch of engineering as a life work.

The writer would very strongly recommend that every engineering student taking a correspondence course obtain one of the chemical outfits sold by some schools, or else its equivalent; also the home electrical laboratory outfit, including the Wheatstone bridge and galvanometer, as shown in one of the pictures herewith. The student will do well to purchase a good quality voltmeter and ammeter, and for the mechanical tests encountered in the study of physics and machine design, you will be surprised how much

takes some post graduate work, after which some colleges confer the additional degree of R. E. (radio engineer) upon completion of the one year post graduate work. On the other hand, it is possible to follow the studies qualifying one for a position in the radio engineering field in a specialized shorter course, wherein the studies are arranged so as to concentrate the student's activities on radio subjects, together with the necessary mathematics, mechanical drawing, etc.

In other words, as you will doubtless begin to perceive, it is a very good idea to first

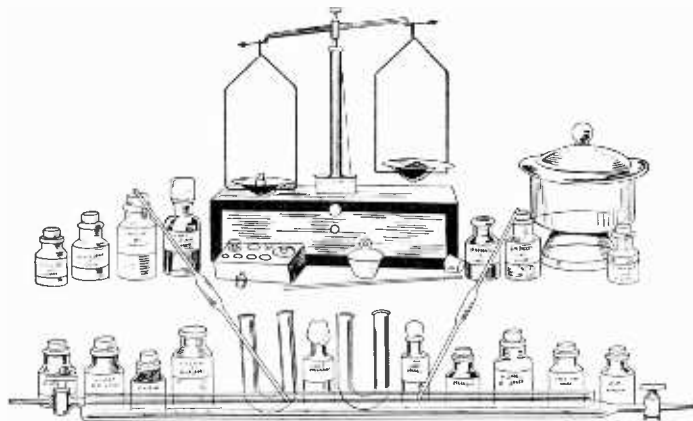

The outfit used by the students of one of our large correspondence schools in quantitative chemical analysis is shown above.

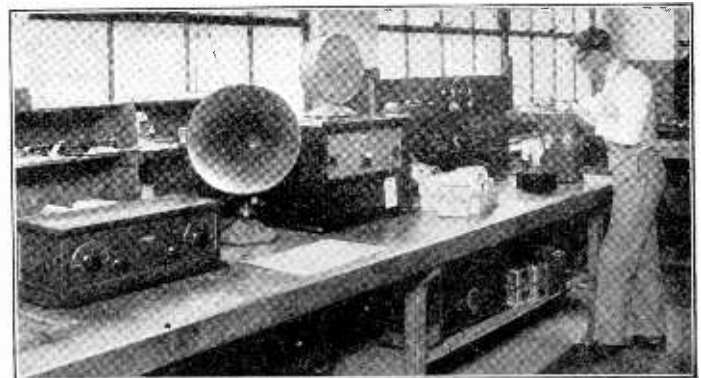

A graduate of a well-known radio school is shown above working in the laboratories of a large radio manufacturer. Photo courtesy National Radio Institute.

enjoy the advantages of a regular collegiate course at a resident institution, will find that he can derive very worthwhile results from an engineering course as given by some of our leading correspondence schools, as well as the extension departments of several of our universities.

As the writer has stressed particularly in the previous article, the person taking up a correspondence engineering course should endeavor to obtain a position with some company engaged in this sort of work; so that he can learn as much of the practical work as possible. If this practical first hand experience with electrical and mechanical machinery is not obtained at the same time that the theory is being studied, it is quite likely to leave the student very one-sided, and many times he is liable to be not absolutely sure of himself. Especially is it important that the student obtain plenty of practical experience along with his home study of theory and other lessons, if he in-

you can learn by experimenting with a few pulleys, cords and spring scales. You can obtain fairly accurate scales, pulleys, springs, et cetera, from one of a number of companies supplying college laboratory apparatus.

WHO IS A RADIO ENGINEER?

The question is frequently asked as to

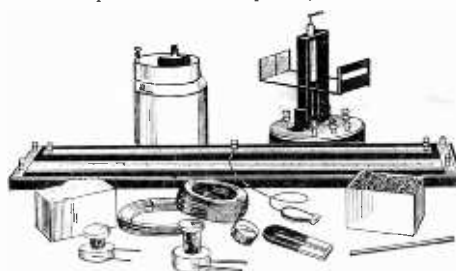

The electrical apparatus supplied by one of the correspondence schools is shown above. Courtesy Technical Supply Co.

take an electrical engineering course, and then follow this with some specialized course of study in radio engineering. A practical radio engineer, as a matter of fact, may be an electrical engineering course graduate who has taken a liking to radio and done sufficient experimenting and reading up on the matter to fit him for radio engineering work. It is interesting to note that many different classifications of electrical engineering branch out from the basic "E.E." course of study given in many colleges, such as telephone engineering, et cetera.

At this juncture it will doubtless be very interesting to look over the course of study in a typical electrical engineering course, as given by one of our leading correspondence schools.

SUBJECTS TAUGHT

- Mathematics
 - The Slide Radio (Optional)
 - Mechanics and Machine Elements
- (Continued on page 276)

Super Sound Waves

Some Experiments With Inaudible Oscillations

By RAYMOND B. WAILES

Below is a hook-up of the apparatus used as the wave producer. The quartz plate vibrates with the same frequency as the current supplied. Three hundred thousand vibrations per second were obtained.

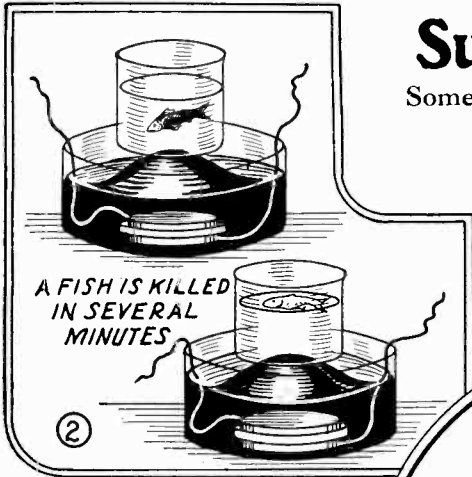

A FISH IS KILLED IN SEVERAL MINUTES

The quartz crystal, covered with a layer of oil, vibrates and causes the oil to "mound up" in the center. A beaker containing a fish is held against the peak of this mound and the fish is killed after some minutes. The mound of oil reached a height of four inches when measured from the peak to the surface of the surrounding liquid.

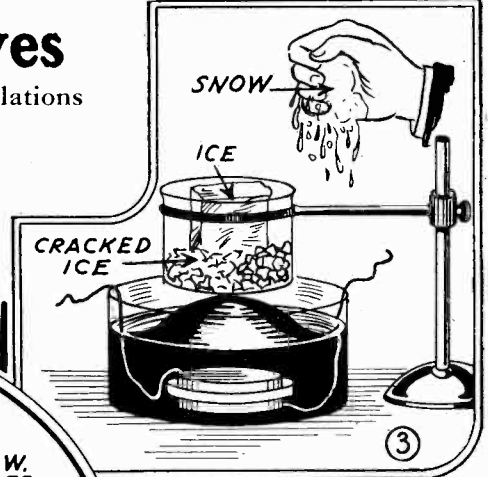

A block of ice, is placed in a beaker and kept cold by placing cracked ice around it. The high frequency sound waves, produced by the quartz crystal, are transmitted through the mound of oil to the ice and cause the ice to vibrate so rapidly that it is torn to pieces and may be crushed in the hand like snow.

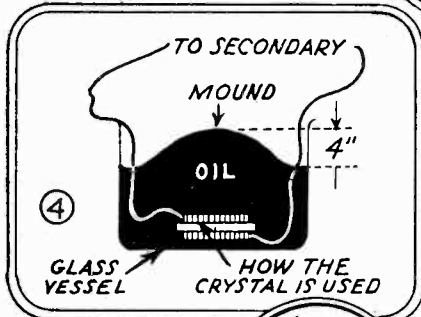
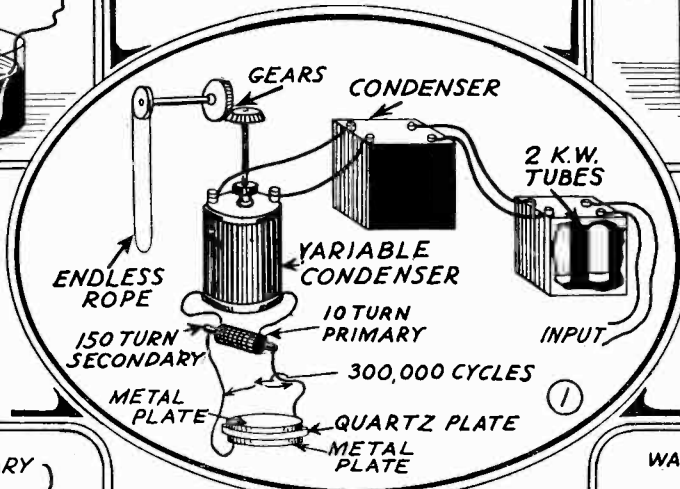

At the left, in Fig. 4, is shown how the quartz crystal is used. The dissolved air in water is displaced as shown from the solution but does not escape in Fig. 5.

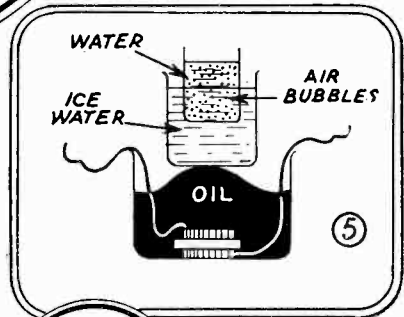

A thermometer, or glass rod, held above the oscillating crystal vibrates so rapidly that the fingers are burned; because at this point it is held rigidly and resists the energy of the vibrations. The thermometer does not get hot as evidenced by its reading.

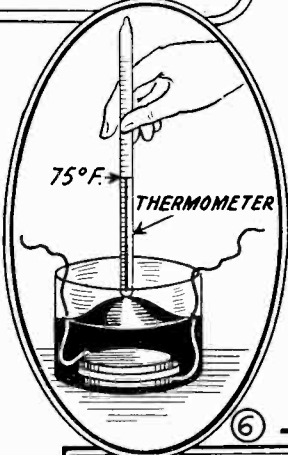

A glass of dirty water held on the oil mound is caused to vibrate. The particles of dirt are shaken into rhythmic bands which are evenly placed about the vessel. The beaker containing the dirty water is held upon the peak of the oil mound.

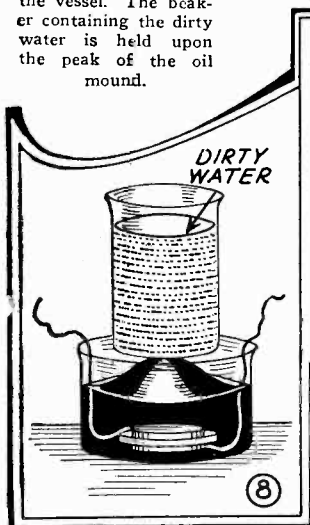

ULTRA-SHORT waves, those high frequency vibrations which are inaudible to the human ear, offer some means for interesting experimentation, which may be carried out at a nominal cost. On this page are illustrated some of the experiments which proved successful and there is no reason why anyone cannot duplicate them with the same results. In a new field such as this, there are endless experiments which may be performed, some of them will probably lead to practical applications. The experiments and their applications have been demonstrated before the National Academy of Sciences by Prof. R. W. Wood of Johns Hopkins University.

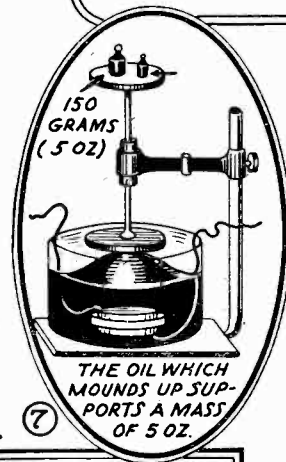

The oil which rises up will support a mass of 150 grams or 5 ounces. The weights are placed upon a pan which rests upon the mound of oil. The whole arrangement is held in position by means of a single guide-bearing as shown in Fig. 7.

A champagne glass held upon the mound, is lightly covered with cork dust and soon becomes striated with concentric cork-dust rings. The vibrations are transmitted from the mound of oil through the stem of the glass to the top of the glass.

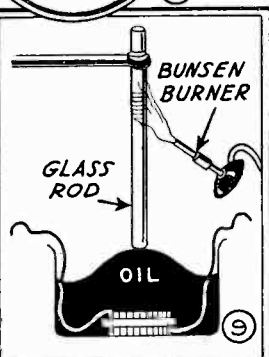
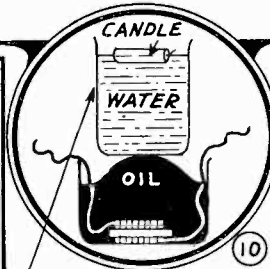

If a glass rod is held over the oil and then heated with a Bunsen burner, it will soon become covered with permanent wave-lines which are visible to the naked eye.

"Eskimo milk" can be made as shown in Fig. 10. The candle is torn into powder which becomes suspended in the water. A drop of mercury added to it forms a black colloidal solution.

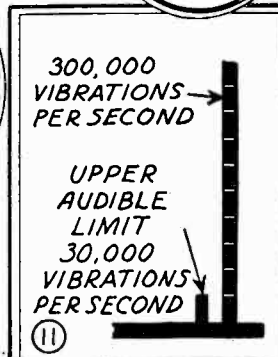

The quartz plate vibrates with a frequency of 300,000 per second. The human ear can hear up to 30,000. The quartz plate oscillates ten times faster than the highest pitched audible sounds.

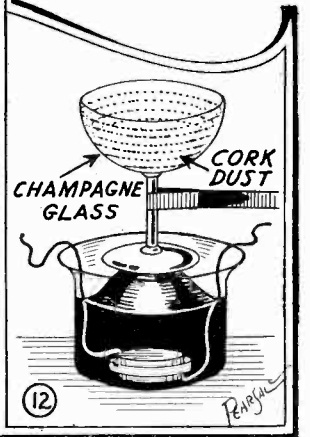

Aerial Fire-Fighting Methods

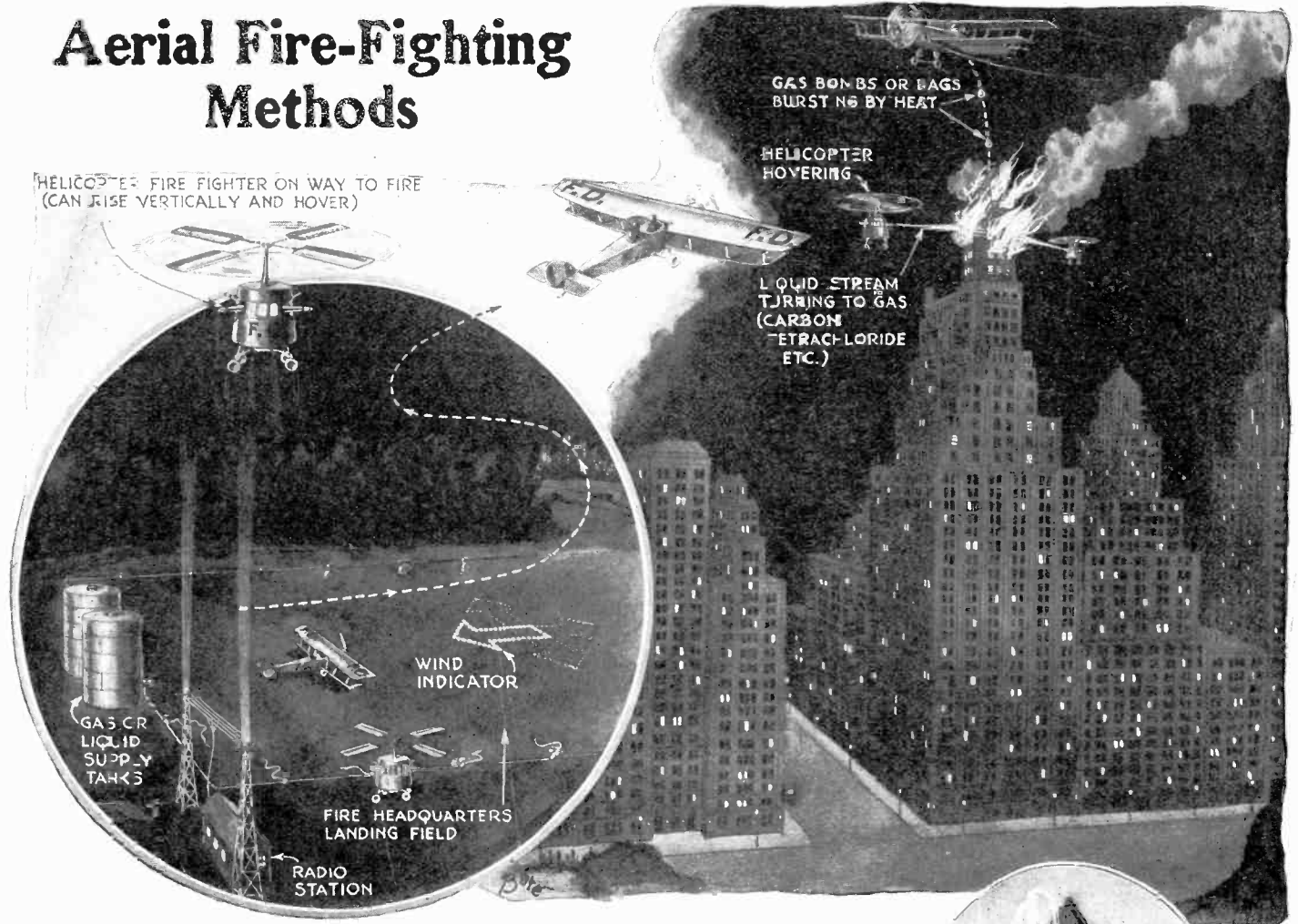

It is suggested that fires can be extinguished from the air by means of airplanes and helicopters. The airplanes would carry gas bombs or bags which burst from the heat of the flames. The helicopters could project a stream of fire extinguishing liquid upon the burning structure.

WITH the growth of our modern buildings, daily reaching higher and higher into the air the present day fire apparatus is rapidly becoming antiquated, and we have to cast about for some means of success-

fully coping with conflagrations in these huge structures. On this page are illustrated some of the methods which have been advanced. One of the most efficient ideas is pictured at the top of the page. In this case the fires are fought entirely from the air, by dropping bombs of fire-quenching materials upon the fire or by projecting upon it a stream of liquid which will turn to a gas upon hitting the flames. Carbon tetrachloride and liquids of similar nature are suggested. The fire alarm is received by a radio station located at the fire headquarters flying field, and at a moment's notice the fire-fighting planes are on their way. Storage tanks containing the fire-fighting gas or liquid are located on the field so that the supply may be replenished quickly.



A high pressure test was carried out on the Custom House tower in Boston by the fire department. The hose projected a stream of water 500 feet above the street level under a pressure of 280 pounds.



At the left we have another fire-fighting device. The small V-shaped cars are held aloft by water motors driving propellers.

One of the worst conflagrations of the season was the fire which broke out in the new Sherry-Netherland Hotel in N. Y. City. The blazing beacon may be seen at the right.



An extremely ingenious device for fire-fighting has been invented by Edward P. Conlin of Girard, Ohio. The pressure of the water is caused to operate two lifting propellers, the purpose of which is to carry the hose to great heights so that the water may be projected into the burning building with a much greater degree of accuracy than heretofore possible with the present day hose-towers. The fire-fighting structures are permitted to rise by their own power to a height greater than the floor level which the water is to reach. The stream of water or chemical can be further directed by the aid of a grip at the base. Even though the water may not pour out of the nozzle at a high pressure, it is evident that the floor space could be completely drenched.

The Month's Scientific News Illustrated

By GEORGE WALL

Elsie Keller, expert typist, of New York City, recently started on an experiment conducted by the Colgate University Psychological Laboratory, in order to determine what an effect office noises have on typists' outputs. The tests were made under the direction of Professor Donald C. Laird. Miss Keller first used a noiseless typewriter for two hours in a sound-proof room. Then the "noise machine," which is an invention of Dr. Laird's, was put in full blast. Gongs were rung, automobile sirens shrieked, whistles were blown and a radio set added to the general bedlam. →

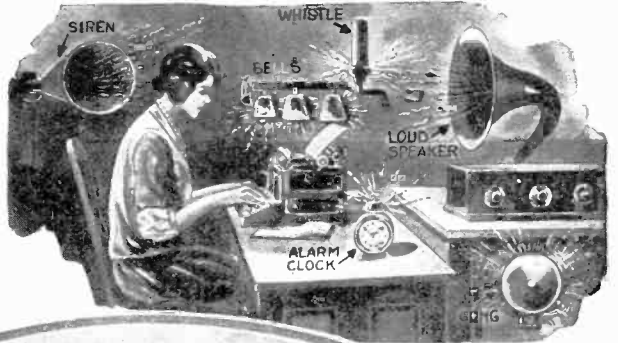

Little hope is entertained for Mrs. N. A. George of Portland, New York; a short time ago both eyes were blinded by a trolley flash. She was sewing at a window when a car passed; a brilliant flash from the overhead trolley was reflected from the shining needle and she found herself sightless. Physicians succeeded in restoring sight to one eye, but they fear that she will lose the use of the other. The flash from the trolley striking upon the needle evidently was reflected as a concentrated beam of light which struck the optic nerves and produced blindness.



Mathew W. Stirling, assistant curator of the National Institute, has returned from an expedition into the remote jungles of Dutch New Guinea, where no white man has ever trod before. The expedition brought back 7,000 specimens of wearing apparel, tools, and weapons of not only the Papuan natives, but also of five tribes of Negroid pigmies who were found living on a plateau of the Nassau Mountains. They also took 25,000 feet of motion picture films of native life and 50 phonograph records of a half dozen dialects, including those of the pigmies. The pigmy men averaged about 4 feet in height, the women were slightly smaller and the children dwindled down in proportion.

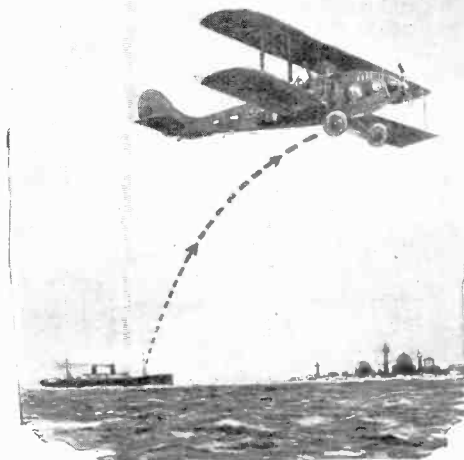

Seaplanes are the latest luxury which will be placed at the disposal of passengers of ships on pleasure cruises, thus enabling tourists to enjoy the beauties of scenery within flying radius of the various ports of call, without the disadvantages of bothersome customs officials and slow land transportation. The North German Lloyd has arranged to carry a 25-passenger plane aboard the "Lutzow," scheduled for Mediterranean and Oriental cruises. It is also contemplated using the plane to transport passengers to port while the ship is still from 100 to 200 miles at sea.



One of the most cunningly created, yet wicked weapons, which has ever been wrung from criminals is the key-hole fume-gun. The gas-fume gun can be inserted into a key-hole and its vapor-containing ball made to burst at a certain time, thus overcoming the inmates of the room without causing their death. This and other devices were shown at a hearing to a group of Baumes Crime Commissioners.



The long hours of posing by models will soon be eliminated. The possibility of sculpturing without the usual hours of posing is seen through this recent invention.

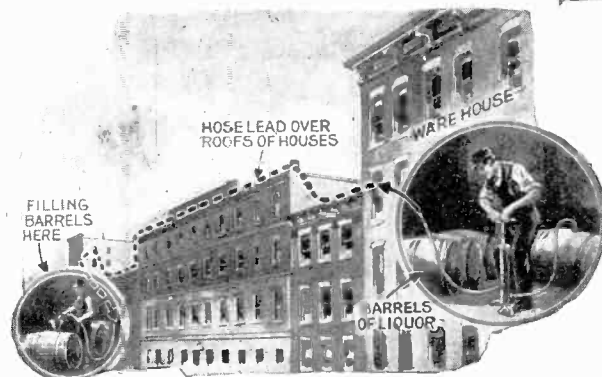

The most elaborate plan for shipping whiskey from a government warehouse was interrupted recently by a raid. The warehouse was surrounded while the whiskey thieves were at work. They had a pump near the barrels, forcing the whiskey through a hose, which led out of a fourth story window, over the roofs of ten houses, to a vacant house situated about a block away. The government agents said that the total barreled stock was valued at \$1,200,000 and that it could have been pumped out of the warehouse in less than a week. Within the warehouse 35,000 cases and 500 barrels of old whiskey were stored.

The invention of two Chicagoans, consisting of a stereoscopic motion picture camera, now makes sculpturing a pleasure, at least as far as the model is concerned. After five years of hard work C. L. Parish and William Englemann have completed a camera which revolves about the subject's head, and in 30 seconds takes 450 pictures. This gives a picture from every angle desired. These pictures are projected in the studio, thus enabling the sculptors to complete their task, without forcing the subject to endure the long hours of posing which were previously necessary. The moving picture camera is fastened to a circular strip of metal which is turned at high speed by a geared arrangement driven by an electric motor, thus making it possible for a great number of pictures to be taken in a few moments' time. The stereoscopic camera will do away with long posing.

Effects of X-Ray on Fruit Flies

By DR. JAMES W. MAVOR,
Dept. of Biology, Union College, Schenectady, N. Y.

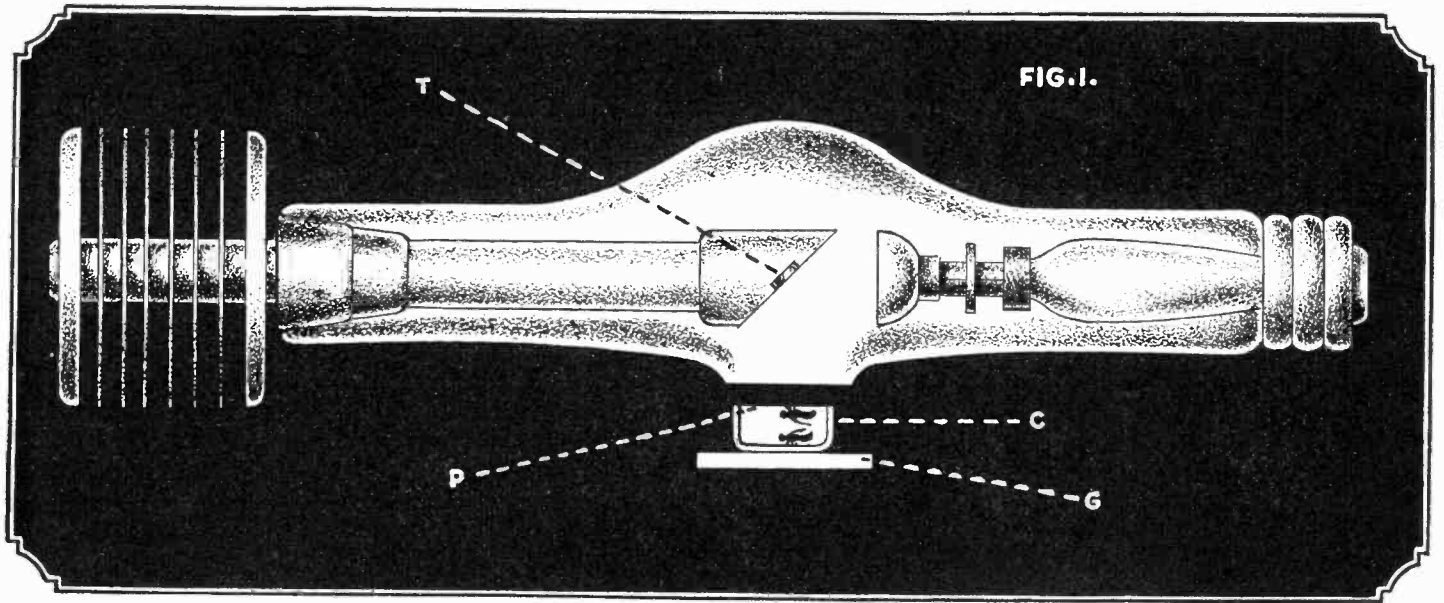

The method of exposing the flies to the X-rays is shown above. T is the target, C small glass cup, P paper cup and G a glass plate.

IT is with a sense of fear and dread that we think of X-rays when applied to living things. Well should we. If there is any radiation to which we can apply the term death ray, it is certainly this mysterious invisible and death-dealing form of light. For X-rays are, as most of us know, very short ether waves. So short and of such high frequency are these ether waves that they are able to penetrate not only within the atom but even to its inner electrons. It is this quality of penetration which makes them so mysterious and it is undoubtedly this same quality which makes them so deadly.

X-rays, let me tell you, are no things for the careless to play with. Lead and yet more lead, is the motto of those who stay in the business, for lead and other heavy substances, in proportion to their density, provide protection against them by absorbing the radiation. Our bodies are composed of relatively light materials, so that X-rays easily penetrate our tissues and, when of sufficiently short wavelength, "hard" as the roentgenologist says, go into the deeper and

more vital organs. However, "soft" X-rays, that is those of longer wavelength, cause serious burns, and through the mysterious power of X-ray ulcers to bud off malignant cells, cause death.

It has been the province of science to turn to good uses the forces of Nature. So it has been with X-rays. In the skillful hands of those who have devoted themselves to the careful study and application of these rays in medicine, wonderful results have been and are being obtained in the cure of malignant diseases. In any application of scientific progress, there is always a theoretical and a practical side. The best results can be expected from the use of X-rays in medicine only when their effect on living cells is accurately and thoroughly known. This is the reason for experimenting on the lower animals.

One is inclined to think that a small animal, like a fruit fly, would be extremely sensitive to X-rays; indeed one might think

that the smaller the animal, the more sensitive it would be. As a matter of fact practically the reverse is the case, if one considers only adult animals. "Adult animals," because it has been found that, of all the organs and cells in the body, the reproductive cells are the most sensitive to X-rays, and that embryos or extremely young animals are much more sensitive than adults. For example, in the fruit fly the eggs, before they are hatched, are about one hundred times as sensitive to X-rays as adult fruit flies. To kill the adults with X-rays requires a dose about one hundred times as large as that required to kill the embryo in the egg and many times the dose which would lead to death in a human being.

Probably the most interesting thing about the effects of X-rays on fruit flies is what is actually done to the cells. To explain this, it is necessary to go into certain details concerning the biology of the fly and the structure of its cells. As everybody knows, all animals, even tiny flies, are made up of cells; millions of cells in a fly. Now these cells

(Continued on page 279)

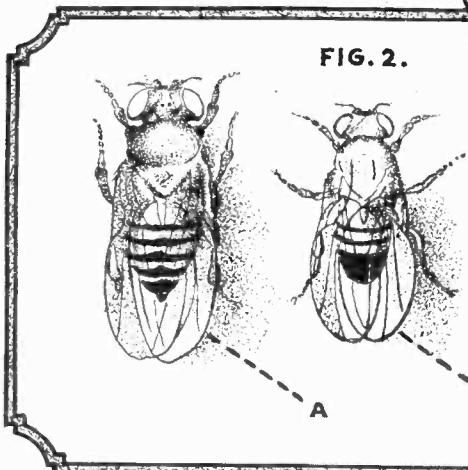

The male and female fruit flies are shown in Fig. 2. A is the female and B is the male fly.—By permission of Henry Holt and Co.

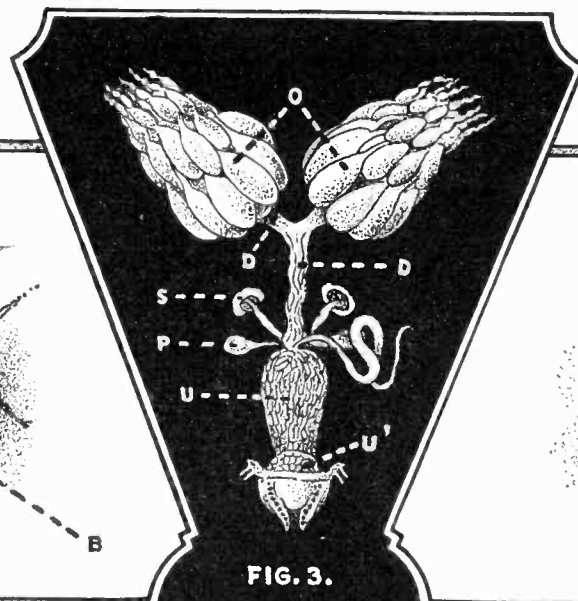

The reproductive organs of the female fruit fly may be seen in Fig. 3. O are the ovaries with the eggs and U the uterus where the eggs are fertilized.—By permission of Marine Biological Laboratory.

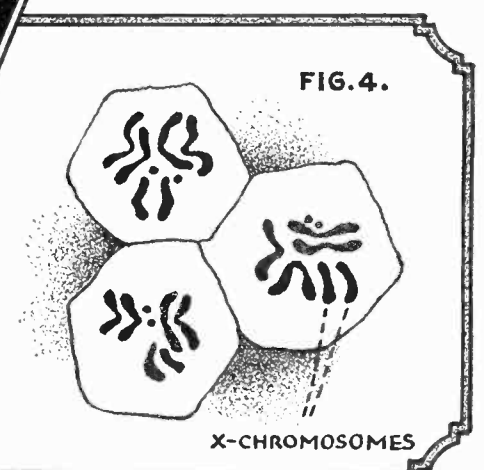

In the above figure the cells of the female fruit fly have been stained in order to show the chromosomes clearly. The eggs of the fruit fly are much more sensitive to X-rays than are the adult flies.

Home Magic Tricks For You

By SAM BROWN

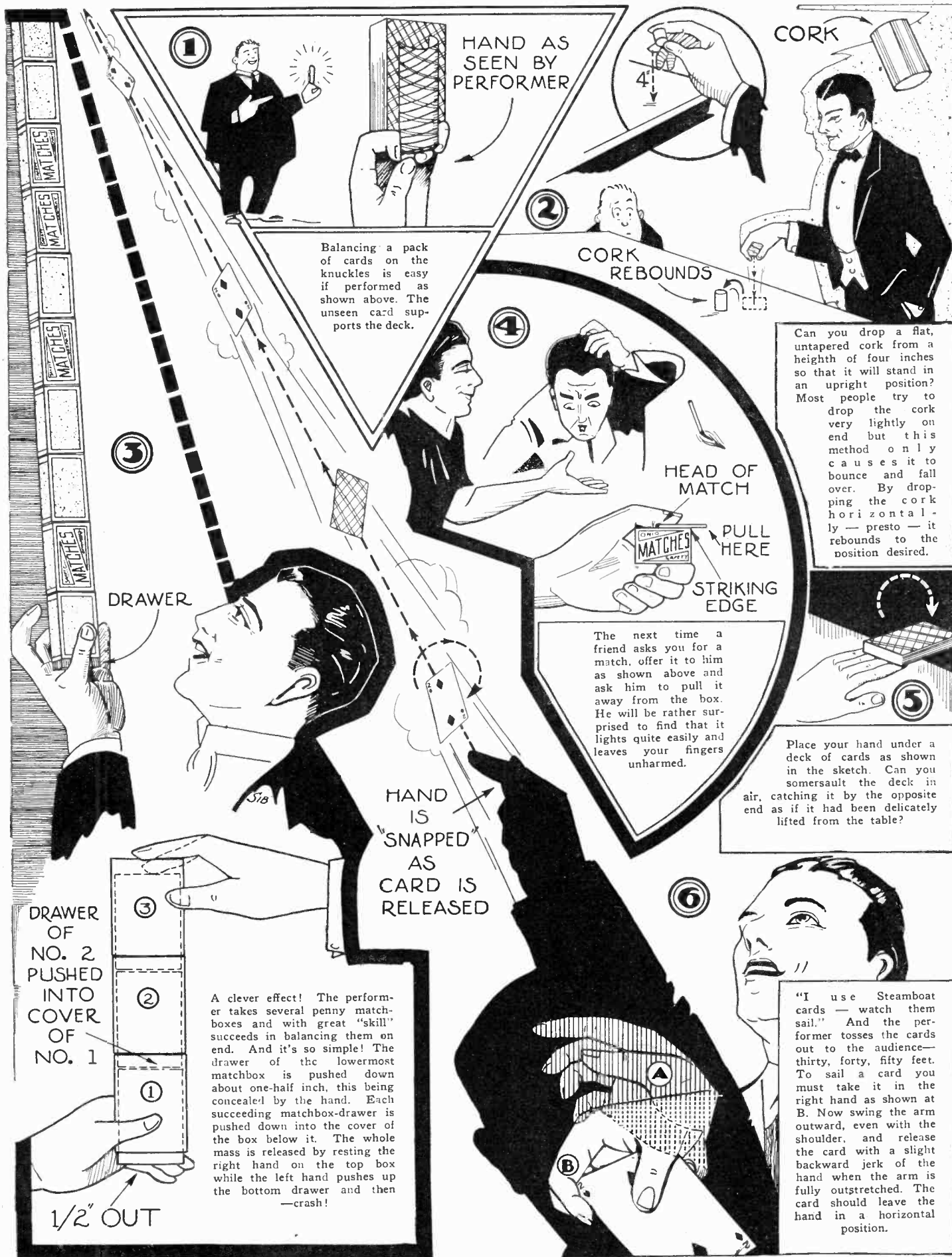

1

HAND AS SEEN BY PERFORMER

CORK

2

CORK REBOUNDS

4

HEAD OF MATCH

PULL HERE

STRIKING EDGE

The next time a friend asks you for a match, offer it to him as shown above and ask him to pull it away from the box. He will be rather surprised to find that it lights quite easily and leaves your fingers unharmed.

Can you drop a flat, untapered cork from a height of four inches so that it will stand in an upright position? Most people try to drop the cork very lightly on end but this method only causes it to bounce and fall over. By dropping the cork horizontally — presto — it rebounds to the position desired.

5

Place your hand under a deck of cards as shown in the sketch. Can you somersault the deck in air, catching it by the opposite end as if it had been delicately lifted from the table?

Balancing a pack of cards on the knuckles is easy if performed as shown above. The unseen card supports the deck.

HAND IS "SNAPPED" AS CARD IS RELEASED

6

"I use Steamboat cards — watch them sail." And the performer tosses the cards out to the audience—thirty, forty, fifty feet. To sail a card you must take it in the right hand as shown at B. Now swing the arm outward, even with the shoulder, and release the card with a slight backward jerk of the hand when the arm is fully outstretched. The card should leave the hand in a horizontal position.

DRAWER OF NO. 2 PUSHED INTO COVER OF NO. 1

1/2" OUT

A clever effect! The performer takes several penny matchboxes and with great "skill" succeeds in balancing them on end. And it's so simple! The drawer of the lowermost matchbox is pushed down about one-half inch, this being concealed by the hand. Each succeeding matchbox-drawer is pushed down into the cover of the box below it. The whole mass is released by resting the right hand on the top box while the left hand pushes up the bottom drawer and then —crash!

New Devices of the Month

LIQUID BOTTLE COOLER

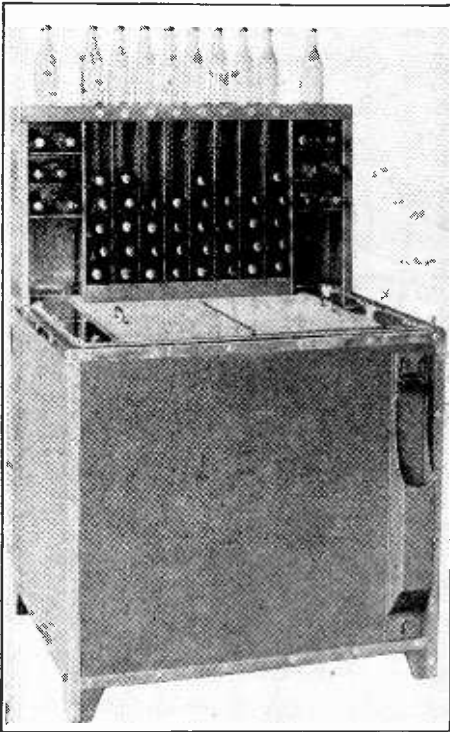

Above we have a view of the bottle servitor or liquid bottle cooler. The cabinet remains entirely closed on the top except for a small opening on either side. The bottles are inserted in the opening at the right and are ejected from the opening at the left.

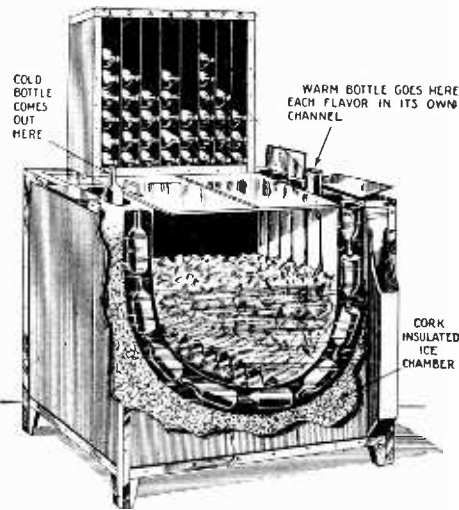

Above is a sectional view of the bottle cooler. Each flavor has its own channel which will accommodate a number of bottles at a time. The ice is placed in the center of the cabinet. The ice chamber itself is insulated with cork. At the back of the cabinet is a space which provides for the storage of additional bottles. —Liquid Carbonic Co.

GRINDING ATTACHMENT

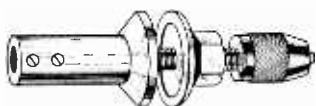

This small attachment can be used with any small motor and has a chuck which will accommodate wood or metal drills. It also has a mounting for any circular grind stone or buffer which is held in place by the two metal flanges. This makes it of great use to the machinist and especially to the radio fan. —United Electric Motor Co.

CANNED MILK CONTAINER



The container shown here accommodates a can of either condensed or evaporated milk. The container is made of metal and is nickel or silver plated. A large base is provided so that it cannot be easily tipped over. The cover can be tightly screwed in place thus preventing dust from entering.

An article of this nature should prove to be a boon to any housewife. Two holes can be punched in the can the can inserted in the container, the lid screwed on tightly and the milk ready to serve within a few moments time.

An article of this nature presents an attractive appearance at the table, and can be easily cleaned. If convenient the can and container can be placed in the ice-box until they are to be used again. This container keeps the milk free from dirt and dust and ready for use at a moment's notice.



A view of the handy container showing the cover in place. In this position the can has been inserted and the container is now ready for use. A large finger grip is provided to facilitate matters in pouring. The spout is attached to the outer rim of the cover.

CANDY FLOSS MACHINE

This handy device enables any one to make excellent candy at a small cost. A metal grid heated from the 110-volt line is spun at a high speed by a motor concealed in the base. The sugar, flavoring and coloring matter is added at the opening in the top, melted by the metal grid, forced between the apertures in the grid and emerges in the form of a fluffy and tasty candy. The candy is caught in a sanitary bowl which surrounds the spinner head. —National Candy Machine Co.



A view of the candy machine completely assembled. Note the neatness and simplicity of the construction of this novel candy-making machine.

TURF EDGER



This simple invention consists of a pair of shears mounted on a long handle and operated by means of two levers at the top. The clipper is indispensable for trimming the lawn bordering sidewalks, bushes, and the like. It converts a back-breaking and tedious task into a pleasant job.

PENCIL SHARPENER

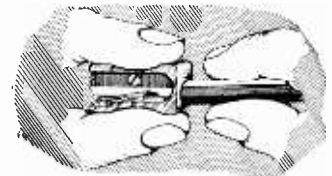

The new pencil sharpener illustrated above should make many friends. It is an ideal pocket pencil sharpener, with a very sharp-edged blade, making the breaking of the pencil point impossible. It also has a file attached whereby a flat edge can be given to the point. —A. W. Herbert.

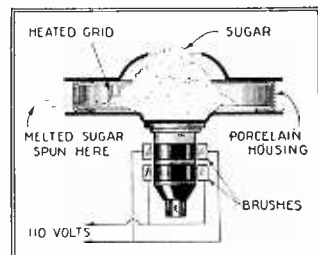

Above is a photo of the spinner head showing the various parts used in its construction. Note the relatively few parts.

A diagrammatical view of the machine showing the sugar container and wiring to the 110-volt circuit.

The Sun House

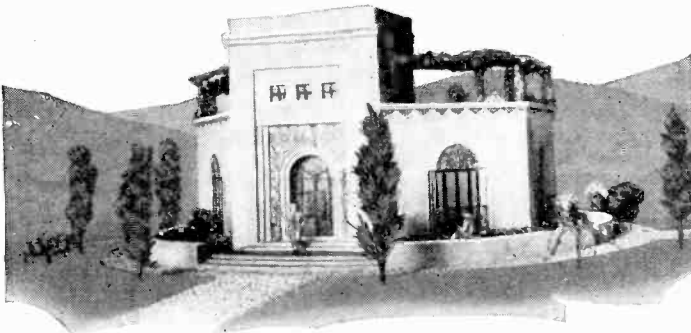

The Sun House designed by M. Lecuyer, a French architect, is shown in the above photograph. The house is erected upon a circular turntable, so that it may be revolved at will. Any one of the rooms can be made to face the sun at the whim of the owner, by merely pressing a button which starts an electric motor.

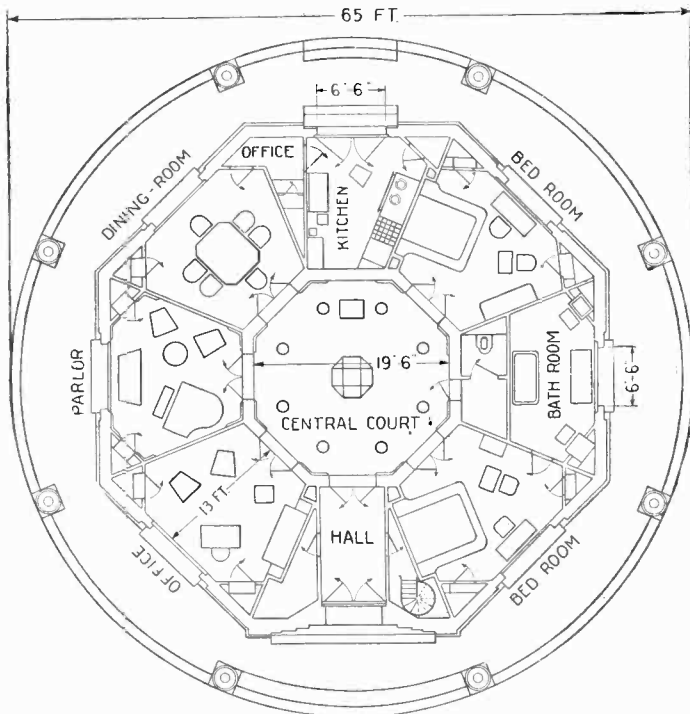

Above we have the plan of the house showing the arrangement of the rooms.

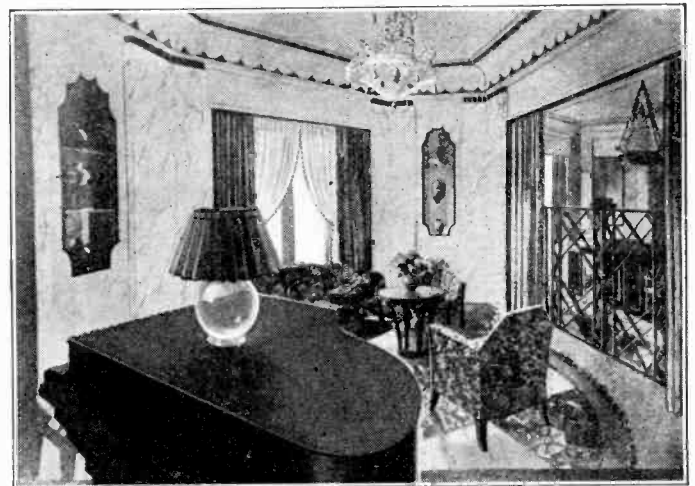

The living room of this strange house is shown above. In the center of the house there is a central court which admits the light through the rear windows of the rooms. Below is a side plan of the revolving house showing the position of the control switch and electric motor. The house turns upon a tubular pivot placed in the center.

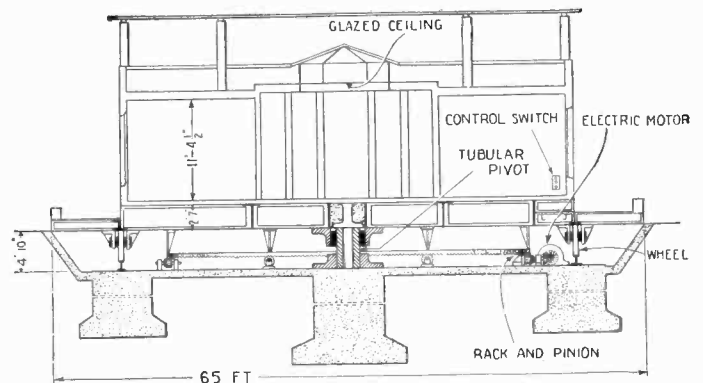

The Electrical Sherlock Holmes

By S. R.

WINTERS

A MECHANICAL detective proved to be a more uncanny sleuth than Sherlock Holmes at a recent meeting of the New York Electrical Society, when a robbery was planned, committed and solved, all within the space of an hour. Three students volunteered to commit the "crime." All three "suspects" were then given the third degree and their heart beats were made as audible as the beatings of tom-toms by means of the electrical stethoscope. By other apparatus the action of the sweat glands in the palms of the hands was shown by the flickering of a tiny light on the wall. Each of the "defendants" was given a series of crucial words. The two innocent defendants responded quickly with

The electrical sleuthing apparatus may be seen in the photograph below. The detective in this case was the electrical stethoscope, an instrument developed by the engineers of the Bell Telephone Laboratories, which amplifies the heart beats.



The three "suspects" may be seen seated on one side of the table. The heart beat amplifier and the sweat gland gauge-light are also visible.

a steady heart beat, but the third was detected instantly when the word "policeman" was given. His heart beats increased to a war dance cadence and his sweat gland gauge-light flickered across the wall.

The new instrument is expected to bring a tremendous advance in the knowledge of heart trouble. The amplification of heart beats by means of vacuum tubes makes it possible to detect defects more readily and it is possible to concentrate on the sounds of significance in diagnosis by eliminating sounds not wanted. It means that physicians in the most remote country towns can put records of all kinds of heart vagaries on an ordinary phonograph for comparison with the heart beats of their patients.

Have You a Model Ship in Your Home?

By PAUL WELKER

Below we have a view of one of the completed products of the model ship workshop, a masterpiece of wood and canvas.

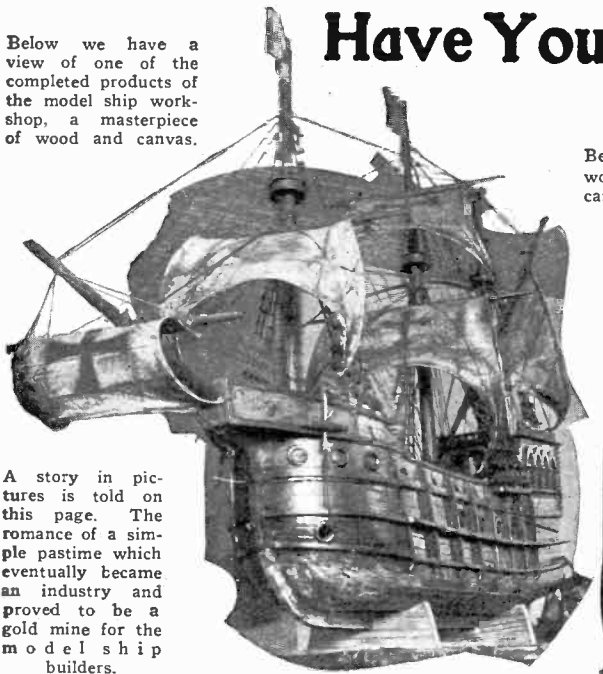

A story in pictures is told on this page. The romance of a simple pastime which eventually became an industry and proved to be a gold mine for the model ship builders.

Below is a view of the model ship workshop. Here a number of wood carvers are shown at work putting the finishing touches on a group of unfinished models. Each model is carefully carved by hand before it leaves the shop. Note the size of the wood used and the amount of work that is required to fashion each ship.



At the left we have another view of the carving bench. Alphonse M. Greis is shown working at the left-hand side of the bench. Each model is roughly shaped by hand and the small and delicate portions such as railings and windows are carefully shaped and finished by expert carvers, each an artist in his own line.

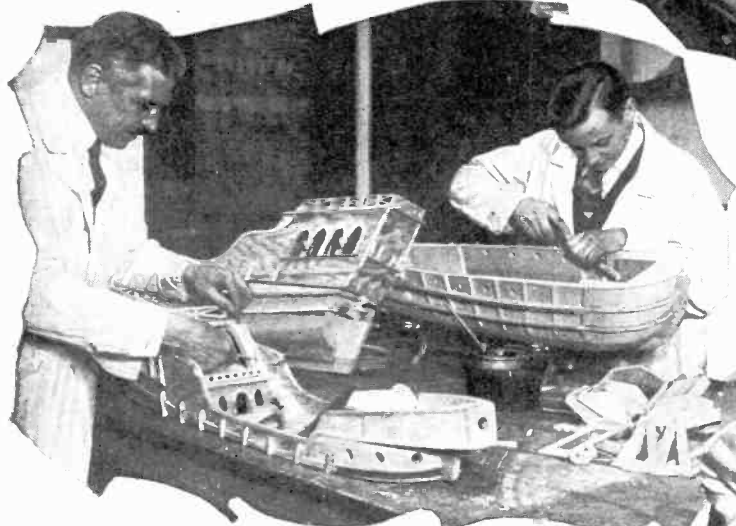

In the photo below we have another view of the model workshop. In this particular picture we see one of the workmen carving a hull for one of the models. Note that each hull is shaped by hand with a broad chisel. In the background we catch a glimpse of several finished models. Resting on the table adjacent to the workmen are numerous finished hulls.

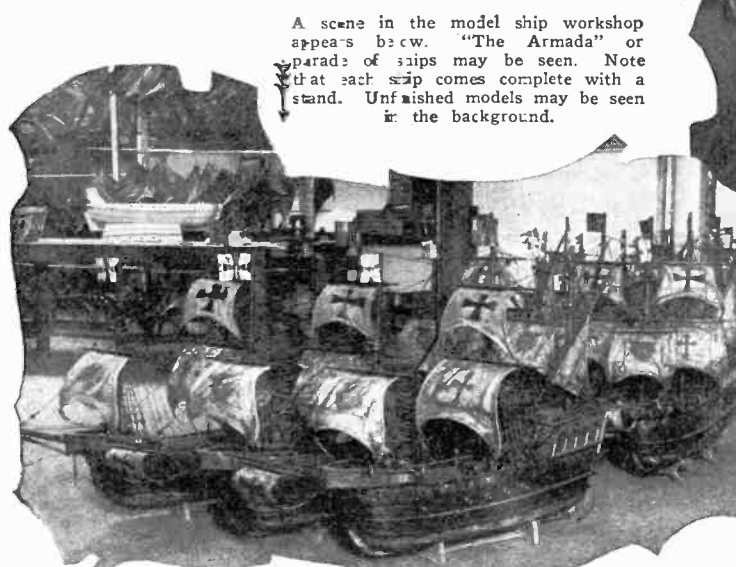

A scene in the model ship workshop appears below. "The Armada" or parade of ships may be seen. Note that at each ship comes complete with a stand. Unfinished models may be seen in the background.

increasing demand. Their small work shop was enlarged, extra workmen employed, new benches installed and production largely increased. Both men are artists, and the ships they turn out certainly give evidence of this fact. The models are made entirely from wood with the exception of the sails, which are constructed from genuine canvas. A great deal of hand work is necessary before the finished products are turned out. Expert carvers are employed for this portion of the work, but the partners put the finishing touches on each ship before it leaves their work-shop. Each model is artistically finished in several different colors and the sails are hand painted in replica of the ancient Spanish galleons. The rigging and lines of each ship are a faithful reproduction of the original, and the models actually float. However, it is doubtful whether many people buy them for this purpose. The illustrations on this page show only a few of the successive steps which the model has to pass through before it is completed and ready for sale. The artistic and pleasing outlines of these models may be seen by glancing at the photos.

IN a little work shop, in the Bronx, New York, two men, Alphonse M. Greis and Karl Bauer, with several assistants, are engaged in a unique industry, the making of model ships. A few years ago these two men began making the ships for a pastime in their spare moments, but the American public suddenly became interested in ship models and the fad grew so fast that a real demand for them was created. The model builders now have all they can do to make them quickly enough in order to supply the ever-

Do You Know How To Use a Microscope?

Surprising Sights Revealed by Small Students' Instrument

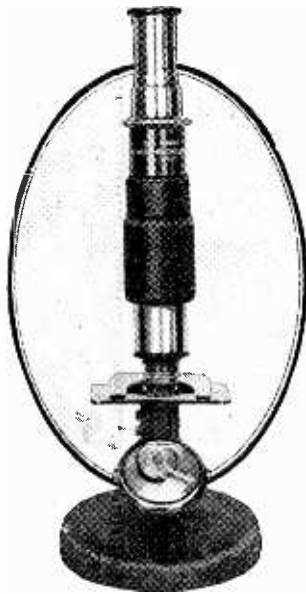

At the left is shown a small microscope which can be purchased at a nominal cost and will provide many interesting hours of entertainment for the adult as well as the growing boy and girl. A microscope is a splendid means of education and enjoyment.
Photo courtesy Wollensak Optical Co.



Mr. Andrew Barbieri is shown above demonstrating the use of the microscope. The reflecting mirror at the base of the microscope is tilted at such an angle so that the object is well lighted.

One of the most spectacular and entertaining demonstrations which can be carried out with the use of the microscope is shown in the illustration at the right. A live goldfish is held in the hand and the tail, placed under a glass slide, is put under the lens. The circulation of blood in the tail may then be seen.

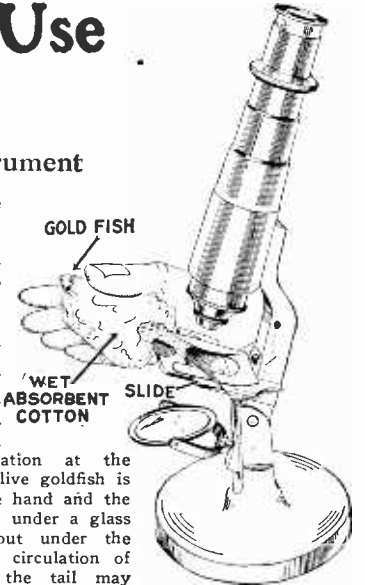

taining demonstration can be carried out with the aid of a spark coil and some iron or copper filings, the whole being arranged as shown in the illustration.

Those who possess a microscope have, no doubt, at one time or another wished to permanently record what they saw with the instrument. Many imagine that to photo-

A MICROSCOPE is a splendid means of education and enjoyment. It familiarizes the adult and growing boy and girl with the minute life that is all about us. Tiny insects are seen as queer fantastic creatures; bits of plant life reveal new beauties of color and structure; and particles of vegetable, mineral and animal

light thus striking the mirror will give a daylight effect.

Of course, slides can be purchased for use with the microscope but there are many interesting experiments which can be carried out otherwise. A human hair when viewed under the microscope appears irregular and bears small bumps, a pin point has a blunt edge and an irregular surface, which is caused by rust and corrosion. In

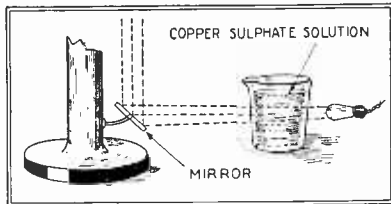

When using a microscope at night, a light comparable with the north light may be obtained with the arrangement shown above.

matter assume striking appearances when viewed in comparatively colossal proportions.

The simplest and cheapest "magic tube" will reveal many hidden and novel wonders to the amateur. On this page are illustrated some of the easiest and simplest demonstrations which can be carried out with the aid of a microscope. If one is forced to use the microscope at night, it is well to place

A pin-point and a human hair magnified 250 times appear as shown. This is one of the simplest experiments which can be performed.

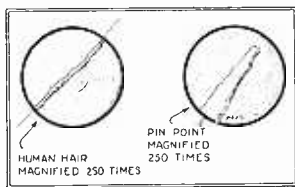

an electric lamp behind a beaker containing a copper sulphate solution. The rays of

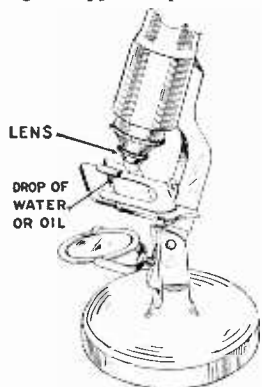

The magnifying power of an ordinary microscope can be greatly increased by placing a drop of water or oil upon the lens. Many hidden wonders, otherwise invisible or indistinct, are thus revealed. In focusing the object it may be necessary to turn the lens down until it touches the slide; if this is the case, the drop of oil may be placed upon the slide directly.

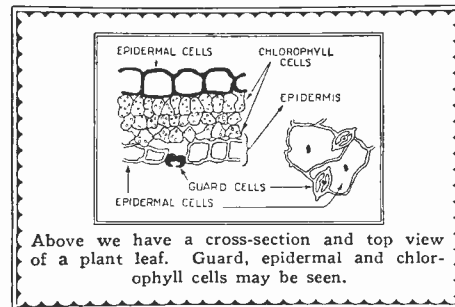

Above we have a cross-section and top view of a plant leaf. Guard, epidermal and chlorophyll cells may be seen.

order to obtain small creatures for microscope examination, a hay infusion may be prepared. A small quantity of hay is placed in a beaker of water and left to stand, in a warm room, for three or four days. A drop of this water, placed under a microscope, will be veritably teeming with animal life, otherwise invisible to the naked eye. As these small objects move rapidly and often pass out of the range of vision, it is well to electrocute them when in the desired position. A small wax ring is fastened to the microscope slide and a drop of water placed in the center. Two wires, connected with a battery, are then placed on either side of the ring, a switch is also provided so that the small animals may be electrocuted at the desired moment. The circulation of blood may be seen in a gold-fish by placing the tail under the microscope. The same demonstration can be also carried out with the webbed foot of a frog. The more experienced amateur may cut a thin section of a leaf or plant stem and place this under the microscope. This is a delicate procedure and special knives may be bought for the cutting process. Another enter-

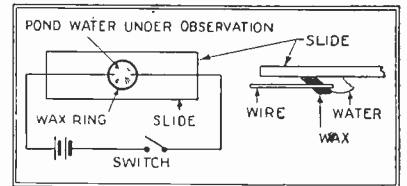

The small infusoria found in pond water sometimes pass out of the range of vision. By electrocuting them, this may be avoided.

graph what they see under the microscope entails costly and accurately working apparatus. This may be true with an oil immersion lens, but the photomicrographs may be easily produced with the ordinary type of microscope. The camera lens can be dispensed with, as for this kind of work, the microscope becomes the lens unit. The eyepiece of the microscope should fit tightly into the lens hole in the front of the camera,

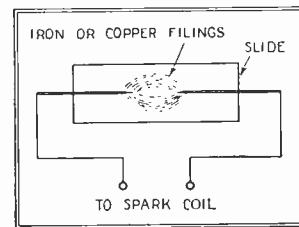

The characteristics of an electric current can be made visible by bringing two wires from a spark coil and placing some iron or copper filings on gap.

so that no stray beams of light are allowed to enter. The camera bellows should be extended as far as possible until a sharp image is seen upon the ground glass plate. The exposure may vary from a few minutes to one-half hour, depending on the light intensity.

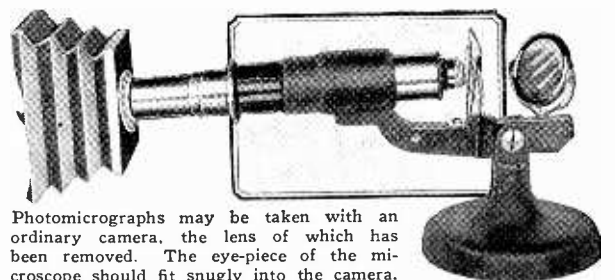

Photomicrographs may be taken with an ordinary camera, the lens of which has been removed. The eye-piece of the microscope should fit snugly into the camera.

Secrets of the Flowers

By DR. ERNEST BADE

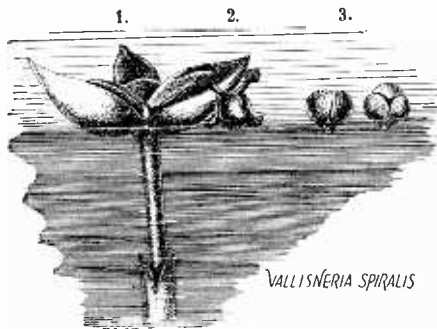

Vallisneria spiralis. 1 is female flower at surface of the water. 2 is male flower swimming freely at the surface ready to fertilize the female flower. 3, two closed free swimming male flowers.

Seed formation can only take place after fertilization with the pollen has occurred. This seems to be a simple process with assured success in all those types of flowers having both pistil and anther, the latter being the sack holding the pollen on thin filaments within the flower and surrounding the pistil. But things are not quite what they seem, for the pollen is ripe at an earlier period than the pistil, only in very rare cases are both ripe at the same time. This means that the pollen of one flower can not be used to fertilize the same flower, it must be transferred to the pistil of another flower of the same species. Then, too, the pollen of a flower, transferred to the pistil of the same flower is not only often without effect, but may, at times, act upon it like a poison. The devices which nature has evolved to circumvent self-pollination are manifold in the extreme.

THE perfect charm of the flower with all its innumerable tints and shades is not made for man, for he is unable to offer any special advantages to the plant for its propagation. The flowers are primarily made for the insects, and the insects for the flower. Both have adapted themselves to each other throughout the eons and not only have they developed, but they have perfected themselves in the mighty struggle for life which is known as the battle for existence.

Flower and insect are each dependent upon the other and specialization has been carried out to such an extent that often a flower relies entirely upon one particular type of insect for the transferring of the pollen grains. Should this special insect be absent while the flower is open, the plant is unable to produce its seeds. Certain types of flowers are adapted for flies, others for wasps, still others for bees while still others are so constructed that they depend entirely on butterflies. Even the color of the flower is a lure for the various kinds of insects for the eye of the insect reacts differently, in its different species, to the various colors.

The visiting insect is quite willingly provided with the nectar of the flower for the insect is a necessary means of transferring the pollen of one flower to the pistil of another flower of the same species. But the flower is so constructed, that the insect, without knowing anything about it, must give up the pollen which is attached to its body from other flower visits, and deposit it on the stigma, the gluey part of the pistil, which is capable of receiving the pollen, before the creature can reach the nectar.

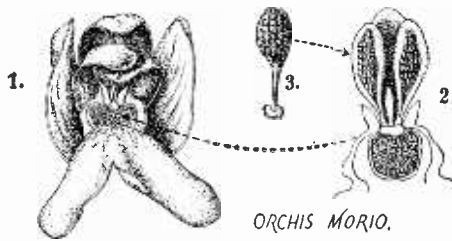

1, *Orchis morio*, flower from the front, showing pistil and two anthers. 4, cross-section through the flower with bee. 5, head of bee to which it attached the anthers.

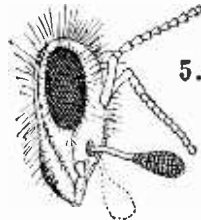
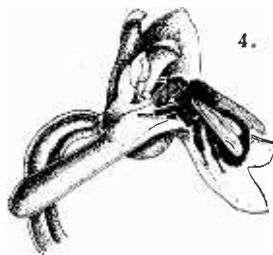

1, *Orchis morio*, flower from the front, showing pistil and two anthers. 4, cross-section through the flower with bee. 5, head of bee to which it attached the anthers.

To grasp the idea behind the wonderful adaptability of the insects to the flowers in the process of fertilization, it must be remembered that inbreeding is harmful while an occasional crossing or cross-fertilization, leading to a more or less distinct hybridization, is, at least, a necessity for the continual adaptation to environment, thus helping to keep the species alive.

Far to one side the orchids are flowering. They are not only a peculiar plant group,—just like their exotic sisters,—of our own plant flora,—but also a valuable addition to our wild plant life. A honey bee alights upon the lip of the flower which is so invitingly placed as if to lure it on. The creature begins to suck up the nectar and during the course of this agreeable occupation, the bee arrives to the middle of the flower. Deeply the proboscis of the bee is dipt into the sweet repast provided and while this is going on, two anthers which contain the pollen of the flower, are lowered and attach themselves to the head of the bee by means of glue covered disks. These do not disturb the bee in the least,

Section through ¹*Yucca filamentosa* showing *Yucca* moth placing pollen into the pistil. 2, head of *Yucca* moth with pollen held with the specially adapted palps.

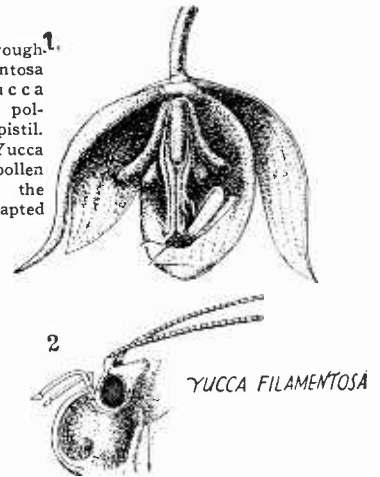

and when it has finished its repast, it flies to another flower. In the mean time something has happened to the two horns of the bee. They were originally erect, but now they are bent towards the front. This was caused by air currents drying the front of the filaments carrying the pollen sack so that they shrunk, pulling the tips forward so they lie just above the glue disks.

This movement is of great importance, for when the been visits the next flower of this species, the stigma or tip of the pistil is in line with the anthers and a few of the pollen grains which it contains are inadvertently stuck to the stigma. This fertilizes the flower. But the larger part of the pollen grains are still in the pollen sack on the bee's head and the sack is gradually emptied as the busy worker goes from flower to flower, thus fertilizing all that are visited.

Another peculiar flower mechanism is found in the forms of *Salvia* (Sage). Here the lower lip of the flower also gives the honey seeking bumble-bee an easy approach. The creature alights and goes forward into the flower. But before it can reach the nectar it must push upon a short lever-like arm which is hung in such a way that it is free to move towards the back of the flower. The other end of the lever arm carries the anthers within which the pollen grains are found. As soon as the bumble-bee presses the lever backwards to reach the nectar, the upper end of the arm carrying the anther is pressed downwards on the hairy back of the insect upon which the pollen is scattered.

(To be continued)

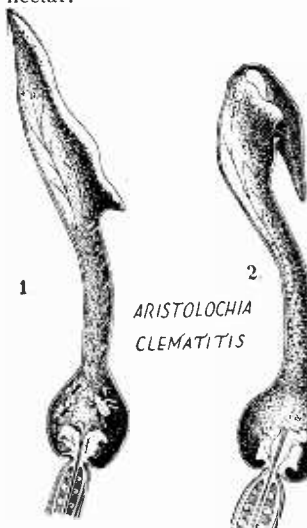

Aristolochia clematitis, section through flower. 1, the downward pointing hairs permit the entrance of insects but do not let them leave the trap. After the insects have been covered with pollen, the hairs of the trap die and fall off, permitting the escape of the creatures.

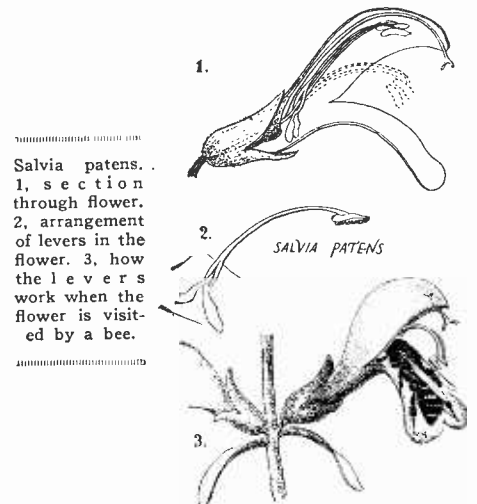

Salvia patens. 1, section through flower. 2, arrangement of levers in the flower. 3, how the levers work when the flower is visited by a bee.

What Is Matter?

The Wonders of a Piece of Iron

By DR. DONALD H. MENZEL

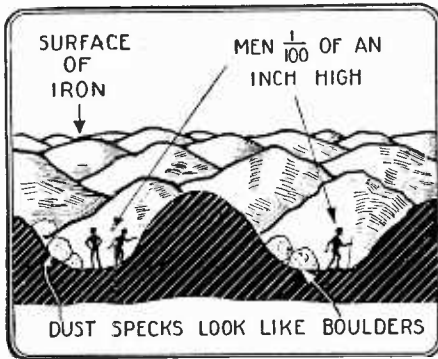

Imagine yourself reduced to the height of one one-hundredth of an inch. The dents and incrustations of cast iron would be formidable hills.

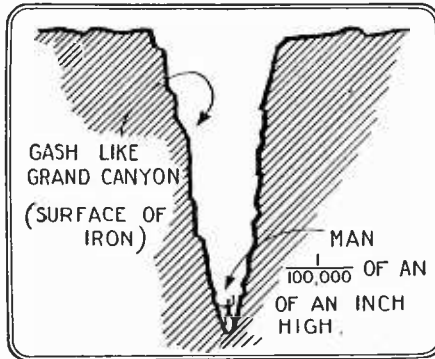

Then try to think of yourself one thousand times smaller than that. Look what would happen if you fell into a pin-scratch.

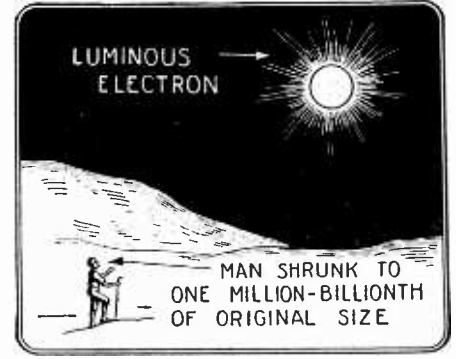

If you were finally shrunk ten thousand times more, an electron would appear as a baby sun about the same size as yourself.

HOLD at this moment a piece of iron in my hand. It possesses certain properties by which I recognize it—for example color and weight. I wonder, for a moment, whether or not these properties are not as much a part of my own mind as part of the iron itself. If I were a billion times larger or smaller, would I recognize iron by the same properties? Lewis Carroll, the famous mathematician, wrote a book which brought him more fame than all his works on logic and pure theory numbers. At one point in this book—Alice in Wonderland—the heroine controlled her size by

the iron appears to shrink to microscopic size and then vanishes. Let us journey in the other direction. Notice that the surface of the metal is polished and seemingly quite smooth.

But yet, as we decrease in size, the small imperfections in it become very evident. When we are 1/100th of an inch high, we find the surface very rough—yet remember that we are all unconscious of our own change in size. The scratches have become large gulleys. Large holes and pits surround us on every side.

The shrinking process continues or, as it seems to us, the universe seems to expand still further, until we have reached the ultra-microscopic size of a hundred-thousandth of an inch. We now stand in the midst of a mountainous country! a gash as deep as the Grand Canyon lies before us. The mountains are of peculiar shape—roughly indicating the crystalline structure of the iron—sharp, jagged, and broken.

The scene rapidly shifts. The mountains tower into the sky. Chasms yawn and open at our feet until suddenly we are engulfed and find ourselves falling—no, floating in space. The piece of iron was made up of molecules and these of atoms and we have slipped in between them, our size but a billionth of an inch. The solid surface beneath our feet became a void and now what a different aspect greets us! In fact it can scarcely be called an aspect, for the material universe appears to have vanished and we exist in a world where *matter has become nothing!* We are too small to see matter in its more familiar condition and too large to see the electrons and protons which compose it.

As we shrink ten thousand times more until we are but *one million-billionth* (one quadrillionth) of our original size we see a ball floating up to us, its apparent diameter just equalling our own height and casting a faint glow of a peculiar shade which heightens the effect of the darkness beyond. There is no certainty that either electrons or nuclei would be luminous in the ordinary sense of the word. In fact, their sizes are so minute compared to the length of light waves that the colors emitted by them would indeed be different. While science has undoubtedly proved the existence of electrons and nuclei, the latter made up of protons and electrons, and while the account of the wonders of a piece of iron is rigidly accurate to this point, we shall have to call upon our imagination to deduce the further aspects of the iron atom.

We wait until we are of a size small enough to crawl upon this minute planet. Now, as we look into the distance, we see other moving electrons and, at a distance measured by about 100,000 times the diame-

ter of the electron, is a somewhat larger object which is obviously nothing more than the nucleus about which the electrons are circling.

Let your imagination bridge the gulf! You have now become so small that the electron appears to your senses as large as the earth. As it whirls about its nucleus it is a miniature counterpart of a planet of our solar system. What will the surface of the electron be like? Who knows, or whose imagination is great enough to conceive it? It will not be material, for we have just seen that the well-known properties of matter are

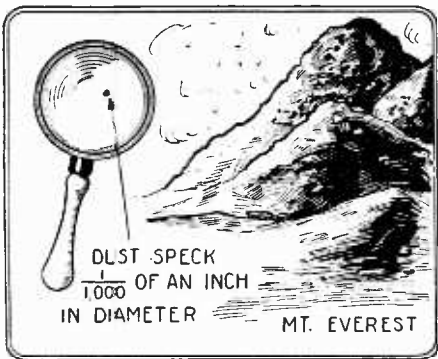

Fig. 1. If the atoms of a small dust-speck were enlarged to the size of bricks, the resulting pile would be as large as Mt. Everest.

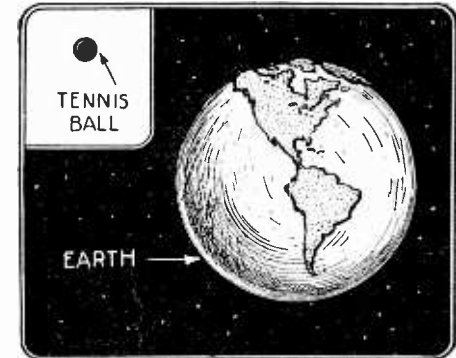

Fig. 2. If the air molecules in a tennis ball were each as large as the ball, they would form a tennis ball as large as the earth.

eating a bit of mushroom. The effect was astonishing. While she was decreasing in size the world seemed to grow larger—she being unconscious of her own state. When Carroll wrote the passage he had in mind the physical interpretation which I am about to suggest. Is not our conception of a material world a product of our own mind?

The physicist answers the question. Imagine, for the moment, that we possess in common with Alice the power of controlling our size. The first possibility I have mentioned is not very interesting, for as we grow larger

to be attributed to atoms and huge aggregations of electrons. In fact, the present trend of science is to ascribe the slight mass of the electron to the energy it contains and a ball of concentrated energy is so entirely outside of our experience that we cannot picture it.

Philosophical and pseudo-scientific deductions point to the similarity between the atomic and solar systems and suggest that just as the former is an integral part of the (Continued on page 260)

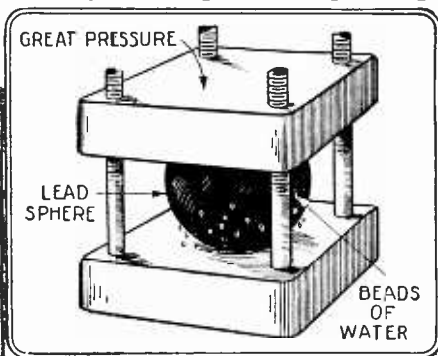

Fig. 3. Bacon, attempting to compress water, forced it through solid lead.

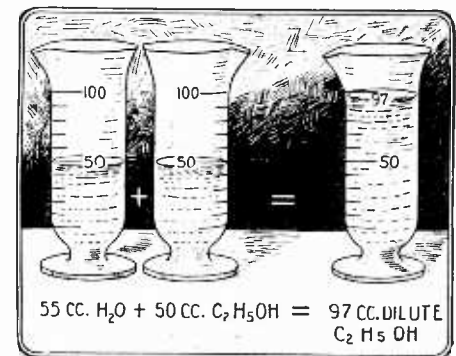
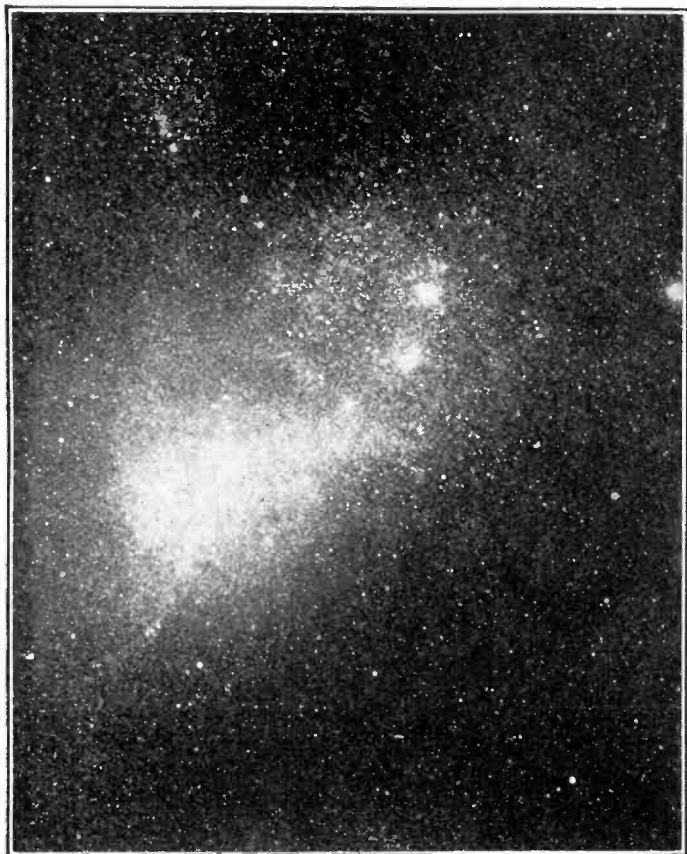

Fig. 4. Some molecules interpenetrate as in the case of water and alcohol above.

Island Universes

By W. J. LUYTEN
Of the Harvard College Observatory



The small Magellanic Cloud, 100,000 lightyears distant, 10,080 years in size, and containing several millions of stars.



The great Spiral Nebula, in the constellation Canes Venatici, called the "whirlpool." This "island universe" is at a distance of several million lightyears.

IT may sometimes seem as if the chief task of the astronomer were to enlarge the size of the universe. Scarcely have we become accustomed to accepting the distance of the Milky Way system as a hundred thousand light years, when new discoveries come along and inform us of the existence of "other universes," vast conglomerations of stars at distances of millions, tens of millions and even hundreds of millions of lightyears. And the further out we get the easier it seems to go still further. It took thousands of years to increase the size of the universe from our own earth, or rather from a small portion of our own earth, to the limits of the solar system, no more than a billion miles, all told. Now it has taken us only a decade to extend our milestones from one hundred thousand light years, or almost one million, million, million miles to one thousand times that distance. Naturally enough, such a step was not taken without due preparation, and the foundations for it were laid more than a century ago. Let us follow the course of progress, and see how by painstaking observation, and logical thinking astronomers came to the conclusion that the Cosmos is really so much larger than we thought it to be.

INTER-STELLAR YARDSTICK

But before we embark upon our celestial voyage to make the acquaintance of these far-off universes, we must devise a new yardstick, so that we may always know where we are. On Earth we measure in inches, feet and miles. In their laboratory the physicist and chemist come down to billionths of an inch, and when they deal with individual electrons and protons they conjure with quadrillionths of an inch. The

astronomer needs all of these units, the smallest ones to make his calculations on the inside of a star, the larger ones to tell us how high the mountains on the moon are. But he needs more. When it comes to expressing distances in the universe a mile is a mere nothing. The nearest of all objects, the moon is no less than 240,000 miles away. The sun is a "mere" 92 million miles from us and as for the nearest star: it is quite meaningless to express the distance of even Alpha Centauri, our nearest neighbor in space, in miles. Even an astronomer does not like to juggle with numbers when the very smallest of them is 25 trillion (25,000,000,000,000). So, naturally, we look for something else, and since we owe our very existence as astronomers to light, we turn again to light for help. And we take, as a new unit of distance in the universe, the distance traveled by a ray of light in one year. Light, as you know, travels at the rate of 186,000 miles a second; and there are more than 30,000,000 seconds in a year. Multiply those two numbers and you have a lightyear, our new yardstick, equal to almost six trillion miles. Now that we have completed our celestial surveyor's outfit let us begin our exploring.

One second to the Moon, eight minutes to the Sun, four and one-half years to the nearest star, 200 years to the Pole Star, 600 years to the Orion Nebula, twenty-five thousand lightyears to the remotest stars in our system. To the remotest single stars we should say perhaps, for we have not yet reached the limits of the Milky Way. The globular clusters and Milky Way Clouds are still beyond. But two hundred thousand lightyears will include even those, and beyond that we are really and truly in the

Ocean of Space, in the great void of Creation, the cold and shelterless deserts of astronomical space, boundless and silent, stretching in all directions. But as the oceans on earth, the celestial ocean too, contains islands: island universes, spiral nebulae to be more exact, vast conglomerations of stars, millions of lightyears distant from us.

ISLAND UNIVERSES

Of course we have not always known that they were *island universes*; in the very beginning we knew no more than that they were nebulae, faint nebulous spots of light in the sky. Even Sir William Herschel, the greatest astronomer of the eighteenth century, who spent his life gauging the heavens and who discovered many nebulae, was unable to see any detailed structure in them. Nevertheless, he ventured to make the statement that possibly some of them were systems of stars comparable to our own, but so far away that we could not see the individual stars, and he even applied the term *island universe* to them.

It remained for Lord Rosse, however, to usher in the new era, for it was he who first recognized the spiral structure of some nebulae, particularly of that in the constellation Canes Venatici, which he aptly called the whirlpool nebula. Controversy as to whether his observations were correct raged for some time, but the introduction of greater telescopes and especially the application of photography established beyond doubt the complicated spiral structure of these objects. And at present the spirals form a well recognized and very numerous class of objects; some astronomers have estimated that there are several hundreds of thousands of them within the reach of our present telescopes.

(Continued on page 274)

How Telescopes Work

By DONALD H. MENZEL
Of the Lick Observatory, Mt. Hamilton, Calif.

ON this page, a number of illustrations are found which tell us the story of the telescope. Fig. 1 indicates how a simple lens forms a true image and Fig. 2 indicates a very simple telescope using a magnifying glass and the camera as the principal components. If the magnifying glass is powerful enough, the image may appear larger and nearer than it actually is. This same principle is employed in the telescope, a simplified form of which is indicated in Fig. 3.

But every simple lens may be considered as being composed of a series of prisms,

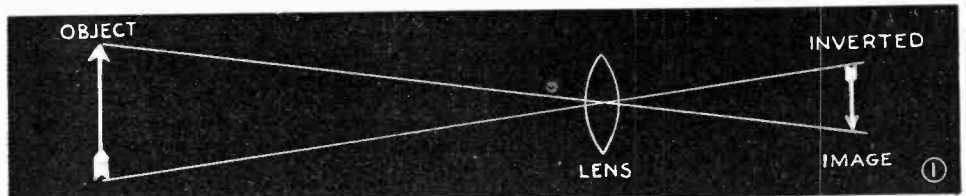

In the above diagram the principle of the camera is illustrated. The simple lines show how an image is formed and how the lines of light are refracted through the lens to form this image. The object is at the left. This same principle is employed in the refracting telescopes in a manner described further on this page.

The diagram below illustrates the formation of an image in a camera. The same principle is here employed as depicted in the diagram above, namely, that a simple lens will produce an inverted image. In the camera, the image may be brought to a focus on a ground glass plate and may thus be seen with the naked eye. Obviously, it exists whether the ground glass is there or not.

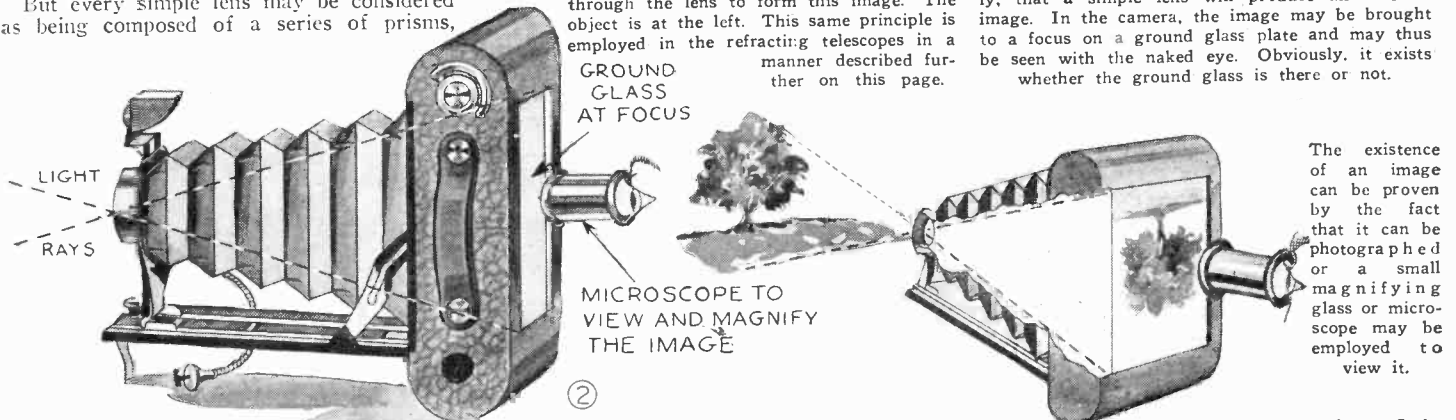

If the magnifying glass or microscope used to view the image is powerful enough, the image may appear larger and nearer than it actually is. The im-

age itself is viewed directly and no ground glass is required at the focus. It is upon this principle that the telescope is based.

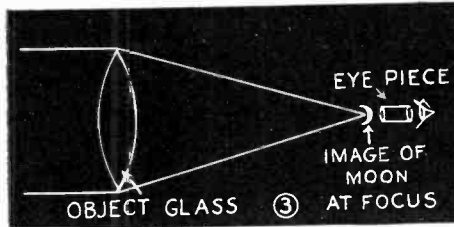

The simple refracting telescope is explained in the diagram above. It employs a long focus lens called an object glass to form the image and an eye-piece to magnify it.

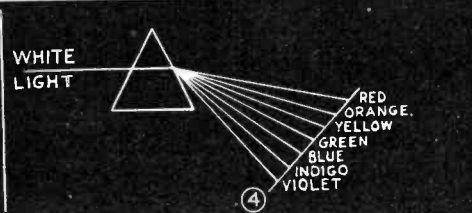

The above diagram depicts a property of a glass prism or other simple transparent in breaking-up light into its component rainbow colors. This property is well known. Red is bent the least and violet, the most.

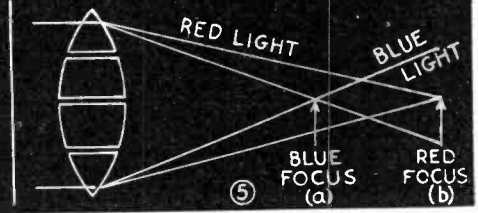

This property of prisms breaking up light into component colors, introduces serious difficulties into the problems of telescope making. A simple lens may be considered to be made up of a series of prisms.

each acting to split the light into the component colors. This is illustrated in Fig. 5. The result would be that red light would be brought to one focus, yellow to another and blue to still another, the last being nearest the lens as shown. This effect would not be serious if the star being examined sent out only one color, *e. g.*, blue; but all colors are present. If we examine the image at *a* (blue focus) we will see a fringe of red or if it be at *b* a fringe of blue surrounding it. The image will be blurred and colored—chromatic, as the astronomers call it. In order to eliminate this a double lens is necessary.

The double lens arrangement is indicated in Fig. 6. The refractor there shows as an achromatic (without color) object glass. The part *a* is made of crown glass and *b* of flint glass. The largest refractor in existence today is the one at Yerkes Observatory, Williams Bay, Wis.—the lens being 40 inches in diameter.

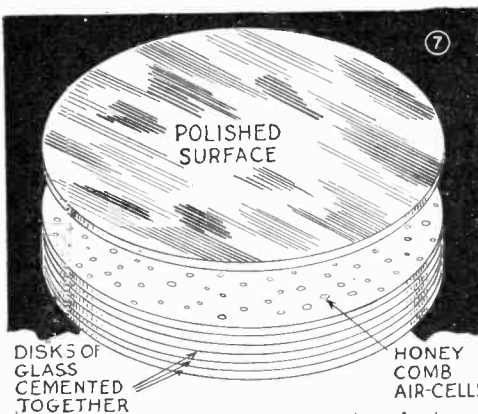

The new process for the construction of mirrors is indicated in this diagram. The mirror is cast in sections and then cemented together, the inside of the mirror is honey-combed with air cells.

The reflecting telescope has the advantage of being perfectly achromatic since all colors are reflected by the concave mirror at the same angle. The largest reflector is at Mt. Wilson Observatory, Pasadena, Calif., the mirror being 100 inches in diameter.

One wonders whether or not larger telescopes than these are possible. Grave difficulties lie in the way of their manufacture. First a flawless disk of glass of the required diameter and thickness must be procured. In the case of the reflecting telescope, slight imperfections will cause no great trouble as long as a smooth reflecting surface is obtained. For the lens of a refractor, however, high quality of glass is required for the light rays pass through it. Owing to this, it does not seem likely that the size of refractors will be materially increased for some time to come.

The manufacturing of the huge reflecting disks is no simple task.

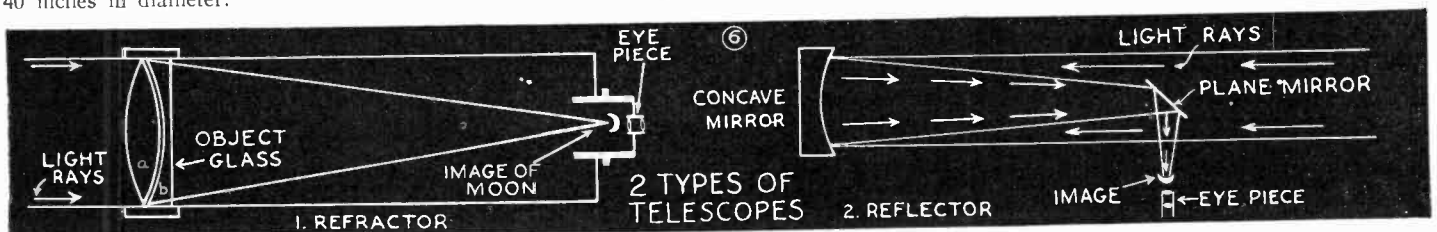

The two diagrams show the principles of refracting and reflecting telescopes. In the former (left), light passes through the lens, in the latter (right) light is reflected.

Improves Acoustics of Halls

By CORA DEFOREST GRANT



Emile Berliner, the inventor of the acoustic plaster, is shown above, with a tuning fork, demonstrating the characteristics of his latest invention.

plished more easily when the walls are under construction. The panels of acoustic cells can be painted to harmonize with the room or can be molded in an ornamental pattern, if so desired, without detracting from their efficiency in the slightest degree.

These new cement cells combine the necessary resonance of wood with the appearance and solidity of stone, brick or marble, and solve the age-old problem of acoustics. This invention by Emile Berliner adds one more

scientific achievement to a life abundantly rich in the science and art of sound reproduction. In 1877, Dr. Berliner invented the continuous current transformer, the telephone transmitter, the microphone, and the lateral cut disk record.

ACOUSTIC cement cells, a new device for perfecting acoustics in assembly halls, has just been successfully demonstrated by Emile Berliner, inventor of the microphone. The unique device clarifies the sound waves by destroying echoes and reverberations, and by amplifying projected tones. It consists of concave circular cells made of interlaced plate wire filled with a composition of porous cement. Each cell then becomes a vibratory diaphragm and the sections formed of these cells are as resonant as panels of pine, spruce or maple wood. The finished wall presents a flat surface of reinforced cement, disguising hundreds of diaphragms which are as responsive to sounds as the diaphragm of the microphone.

This new invention can be easily installed after a building is erected, but it is accom-

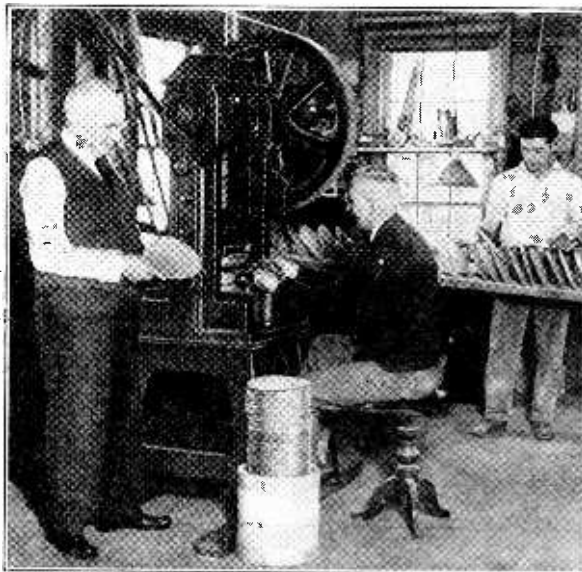

In the photograph below we see the inventor in the work shop.

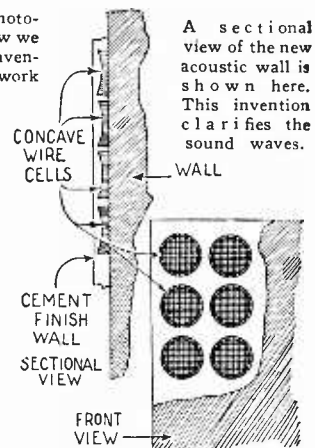

A sectional view of the new acoustic wall is shown here. This invention clarifies the sound waves.

By installing these new Clarifiers in broadcasting studios and concert halls, the reproduction of music for radio broadcasting will be improved to a remarkable degree. Another application of this device is in the studios of Phonograph Record manufacturers.

The Astrology Humbug

By JOSEPH H. KRAUS

Further Letters From Our Readers and Our Answers

A COLLEGE OF ASTROLOGY

In the *Astrological Bulletin*—quarterly, a publication primarily intended for astrologers and boasting of 30,000 readers (although it is difficult to see how it could have that many when its circulation is by no means as great), and edited by Llewellyn George, who is also the Managing Editor, Business Manager and owner of the publication and who runs the Llewellyn College of Astrology; we find several articles expounding the cause of astrology. One of these is written by Sidney Kimball Bennett and another by Llewellyn George himself. Mr. George accuses this publication of having invented a trick for free advertising amongst the 30,000 readers of his bulletin. In view of the fact that the net paid circulation of *SCIENCE AND INVENTION* Magazine at the present date is approximately ten times the assumed number of the *Bulletin*, we will return the compliment and advise Mr. George that the publicity he is now getting is worth ten times the questionable publicity which *SCIENCE AND INVENTION* Magazine is getting through his readers. Let us continue.

In an article by Mr. Bennett we find a reprint of the quotation from Huxley and then the following: "It is nothing short of purest irony that editor Gernsback should write his personal opinions—merely personal opinions—under such a quotation as that!" Why not, we ask? In view of the fact that the first page in *SCIENCE AND INVENTION* Magazine is an editorial page, and in view of the fact that every editor, writing an editorial, always writes his personal opinions, why is not Mr. Gernsback entitled to the same privileges?

Further in the article we find: "Together with this article is printed an offer which has all the earmarks of a fake offer, in which *SCIENCE AND INVENTION* claims it will pay certain amounts of money on certain conditions which are but remotely related to Astrology as a science. . . . It is apparently a fake offer because there is no evidence of intent on the part of *SCIENCE AND INVENTION* to ever pay that money to anyone. They do not state who is to be the judge of the merits of the data submitted. If they themselves are to judge, the judges are prejudiced by their own admissions in this number of their magazine. . . . It will continue to look like a fake offer until such time as they name such a board or committee to act as judges in the contest. . . . "If *SCIENCE AND INVENTION* does do as is suggested here and do give their offer the semblance

\$6,000.00

For Proofs of Astrology

SCIENCE AND INVENTION Magazine holds that there is nothing scientific in Astrology, that Astrology is not a science and that statements made by astrologers unless very general cannot be entertained seriously.

Accordingly, this publication has decided to award an Astrology Prize of \$6,000 for the following:

\$5,000 will be paid to the astrologer or forecaster who will foretell three major events of such a nature that he will have no control over the outcome of the same. He must describe in advance each event in detail, giving the location and result or the casualties if the event is an accident.

\$1,000 will be paid to the astrologer or forecaster who will produce three accurate, detailed and perfect horoscopes, free of contradictions on the lives of three people whose initials will be given him when he requests the same and the birth dates and place of birth will also be supplied by this office.

This contest closes October 1st, 1927, and all entries must reach us by that time. In event of a tie, prizes of an identical nature will be given those so tying.

Address all entries to Editor, *ASTROLOGY*, care of *SCIENCE AND INVENTION* Magazine, 230 Fifth Avenue, New York, N. Y.

of being fair and open, it will still resemble a fake offer unless they print a new set of conditions—conditions which will accord with the claims of Astrology—(What are the claims?—Editor). It is not fair to ask a science (?) (question-mark ours.—Editor) to demonstrate more than it claims. . . .

"Just to be funny for a moment . . . some ten-year-old boy will describe in advance three events in detail, giving the location, etc., by predicting that the Sun will set in the West on January 1st, 1927, the Moon will rise in the East on January 21st, 1927, and that the Sun will cross the Equator on March 21, 1927. (We wonder whether it was necessary for an astrologer to figure this out?—Editor). . . ."

"I suppose," writes Mr. Bennett, "they are looking for the forecast of a railroad wreck, or some such 'accident,' and would refuse to award their prize if the location mentioned was two miles away from where it happened, or if it happened fifteen minutes later than predicted, or if the names and addresses of everybody on board the train were not accurately given." Evidently the author has not sent a prediction.—Editor.

"The only investigation they have made . . . was to send a few birth dates, one of which carried admittedly false data (the author, Joseph H. Kraus, giving his sex as female) to an astrological practitioner." This statement is false, as mentioned many times in these columns.—Editor.

"Perhaps their idea of science includes the furnishing of false data such as the outright and malicious lie about the sex of the author of the article referred to. Sex is a principle of Nature and is found throughout all the sciences as a tremendous factor. It is the Positive and Negative of Electricity (Whatever that is.—Editor) and Scribbler Kraus has no more right to expect satisfactory results when he lies about his sex (sic.) to an astrologer, than he would if he were to lie about the positive and negative connections of a wiring diagram to a student of electricity."

And then follow several other paragraphs bearing this publication and its editors, which are not intended to be complimentary. We never like to cast reflections upon a person's ability until he has proven his incapability of doing the work assigned. We could say that if Mr. Bennett's ability "to read the English language was commensurate with his ability to cast horoscopes or teach astrology", we would sympathize with his followers, but we won't say this, because we

(Continued on page 264)

Tales from the Scientific Club

A Bar of Poisoned Licorice

By RAY CUMMINGS

"A CASE, gentlemen, of attempted murder," said the Doctor. "Most of you have heard, no doubt, of Jonathan J. Blake, octogenarian philanthropist. Some one of his family has attempted to murder him."

"I shouldn't say we could be certain of that," the Lawyer interposed.

"No, but it is fairly obvious." The Doctor gazed at the group of men gathered in the private clubroom. "The idea, gentlemen, is this: Mr. Blake narrowly escaped taking poison. It may have been an accident; or it may have been a deliberate at-

This will be merely a question of fact—our attempt to identify the criminal, if there is one, and obtain a confession.

"Mr. Blake has given freely to charity, but there remains an estate of several million dollars, all of which he has divided among five people. He is a curious old man. Kindly at heart, but very dogmatic. Difficult, I'm sure, to live with. He rules his household with a rod of iron. He lives unpretentiously—almost plainly. He has an obsession that it is wrong to spend money for luxuries—he keeps his family upon a basis of strict economy. And he is always

"Of the household there is, besides the twins, the chauffeur, Robert Thorpe; the secretary, one William Fontaine, a man about thirty-five; and the middle-aged housekeeper, Mrs. Green. Thus, five of them, gentlemen, any one of whom had opportunity and motive for the crime. The housekeeper, chauffeur and secretary are all of some years' service. All know the terms of Mr. Blake's will—the bulk of his estate divided equally between the twins, but very handsome legacies for each of the other three.

"The circumstances are these: I must

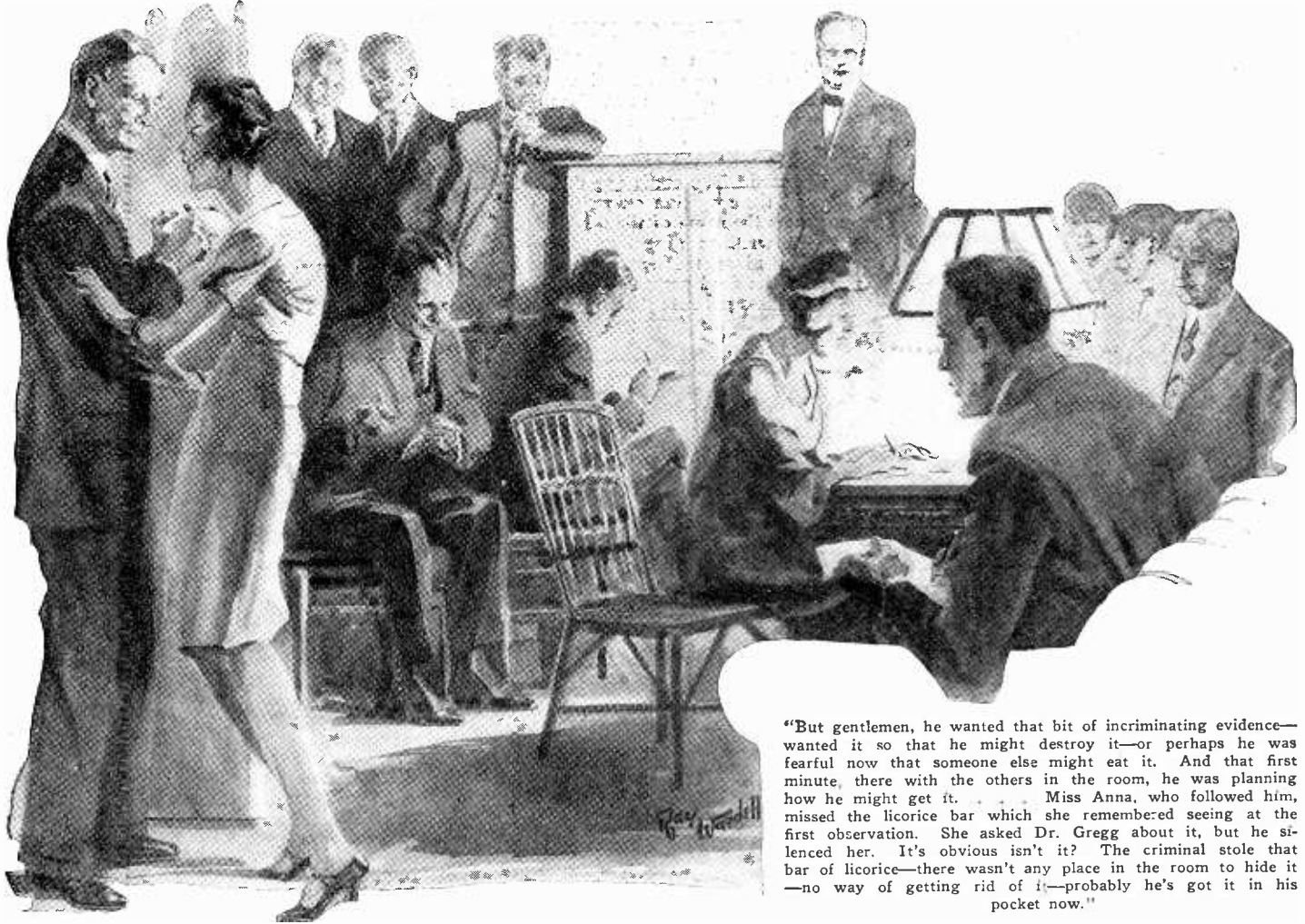

"But gentlemen, he wanted that bit of incriminating evidence—wanted it so that he might destroy it—or perhaps he was fearful now that someone else might eat it. And that first minute, there with the others in the room, he was planning how he might get it. Miss Anna, who followed him, missed the licorice bar which she remembered seeing at the first observation. She asked Dr. Gregg about it, but he silenced her. It's obvious isn't it? The criminal stole that bar of licorice—there wasn't any place in the room to hide it—no way of getting rid of it—probably he's got it in his pocket now."

tempt by one of his household. There is no evidence, except the poison itself. We felt that to give the matter to the police would avail nothing, and I suggested that perhaps we of the Scientific Club could handle it by our different method. There may have been no attempted crime at all, in which case no harm will have been done by our experiment. Mr. Blake said nothing to his family; he told only myself, his physician."

The Banker said, "Give us the details, Frank."

"I will," agreed the Doctor. "Briefly, then: Jonathan J. Blake is now eighty-two years old. Hale and hearty—a man who might conceivably have another ten years of life remaining. A bachelor—a very wealthy man, and all his heirs chance to be members of his present household. Call that the motive, if you like—a desire to hasten the inheritance. The motive is immaterial; as I say, there is no evidence.

looking for worthy charities to which he can donate, so that his wealth is steadily dwindling."

The Chemist said dryly, "I can understand why the heirs would have a motive."

"Quite so. Well, as I was saying—"

"Let's get down to it, Frank," the Banker interrupted. "Who are the heirs? Are you going to have them here tonight?"

"Yes. Mr. Blake is bringing them." The Doctor glanced at his watch. "He said they would be here punctually at nine o'clock. I will be brief. Twenty years ago, Jonathan Blake adopted a boy and girl—twins. They are twenty-five years old now—George and Anna. The boy is inclined to be wild and postpones going to work; and the girl has recently shown a predilection for the handsome family chauffeur. I give you Blake's version of it—but aside from that I imagine his adopted children are decent enough.

tell you first—though Mr. Blake is perfectly well—compatible with his advanced years—he is always experimenting with remedies to improve his physical condition. So long as they are harmless, I have let him go ahead." The Doctor smiled. "Perhaps I couldn't stop him anyway—he's very eccentric—and very obstinate. At any rate, he nibbles often at soda mints; or little peppermint sticks. He chews pepsin gum inordinately; and lately he has taken to nibbling at licorice bars. A variety of such things, and a few of the milder household drugs. He keeps them all in his bath-room medicine cabinet—to which any one of the household has easy access.

"A week ago he took a bite from a new bar of licorice. He thought it tasted peculiarly—at all events he didn't eat it. Then he seemed to remember that of the bar he had last replaced in the cabinet, he had sucked on one end. This one did not show

(Continued on page 265)



MAGIC "DUNNINGER" By



THE MAN WHO MYSTIFIED
 Pres. Coolidge
 Prince of Wales, Ex-President
 Harding, Tatt, Roosevelt,
 and other celebrities
 Writes Exclusively for
SCIENCE AND INVENTION



NO. 52 OF A SERIES

NEW CARD MYSTERY

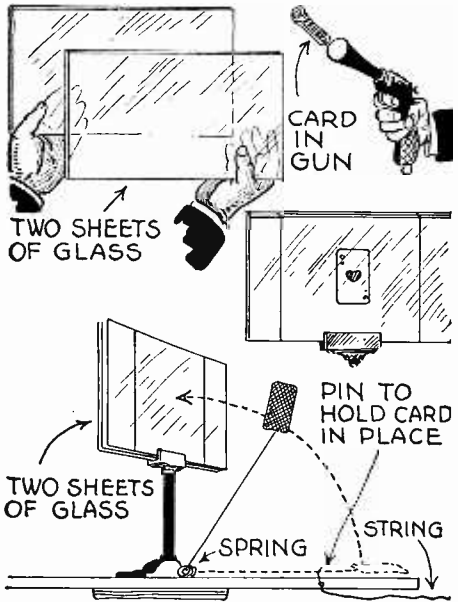

Two sheets of glass mounted on a stand are later found to frame a playing card fired at them from a pistol.

TWO sheets of glass are held together with two elastic bands and then placed in a stand. A selected playing card is then loaded into the barrel of the magician's pistol who, firing at the glass, causes the card to mysteriously appear, apparently between the glasses. Actually the card is carried up in back of the glass and held there by a spring arm. Manipulating the glasses makes it appear that the card is removed from between them.

LIVING OR DEAD

THE magician supplies his spectators with eight or nine small visiting cards. He requests all of them to write the name of living persons whom he does not know upon the cards, except one spectator who is requested to write the name of a dead person on the card. The cards are dropped into a hat, and the magician on picking them out, announces the name of the dead person. The penciled writings give him the clue. The magician gives the spectator writing the name of the dead person a hard lead pencil; all the others get soft pencils.



The nature of the pencil is the clue to this trick.

A SPONGE TRICK

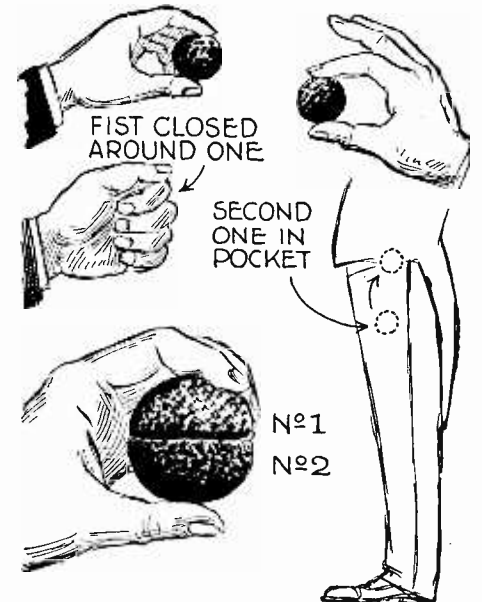

A sponge ball is put in the pocket, another is held in the hand, and a moment later, the one in the hand becomes two, whereas the one in the pocket has disappeared.

IN performing the trick illustrated above, three balls are actually used. Two of them are held between the forefinger and thumb as illustrated. These appear as one. A third is pushed into the pocket and by the aid of the thumb, secretly moved upward in the corner of the pocket toward the waistband. Turning the pocket inside-out will not reveal the third ball.

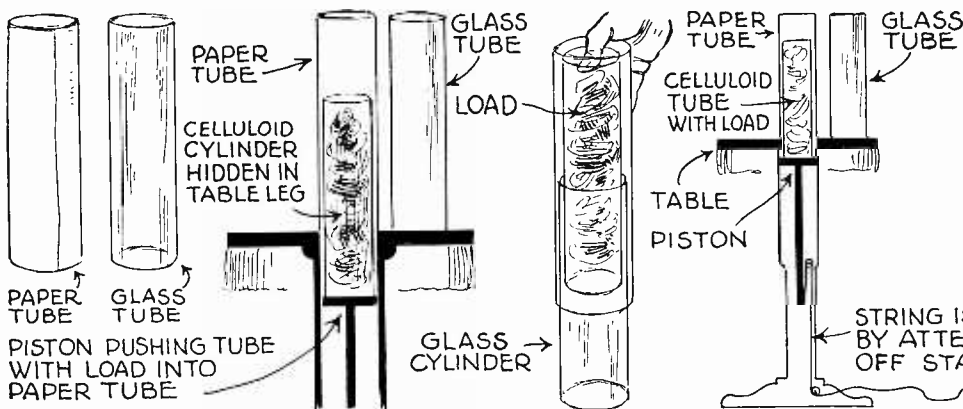

The conjurer presents a glass chimney and a paper tube for examination. They are returned to the table, meanwhile the conjurer bares his arms. Nesting the glass cylinder within the paper cover, he proceeds to draw yards of silks and ribbons from the glass chimney. The load in this effect is placed

in a container made of celluloid, and concealed in the leg of the magician's side stand. While baring his sleeves, an attendant pulls on a string, operating the piston which pushes the load into the cardboard tube. Both the paper tube and load are then placed around the glass cylinder as illustrated.



Home Mechanics

Building a Martha Washington Sewing Cabinet

By WILLIAM BUTTERFIELD

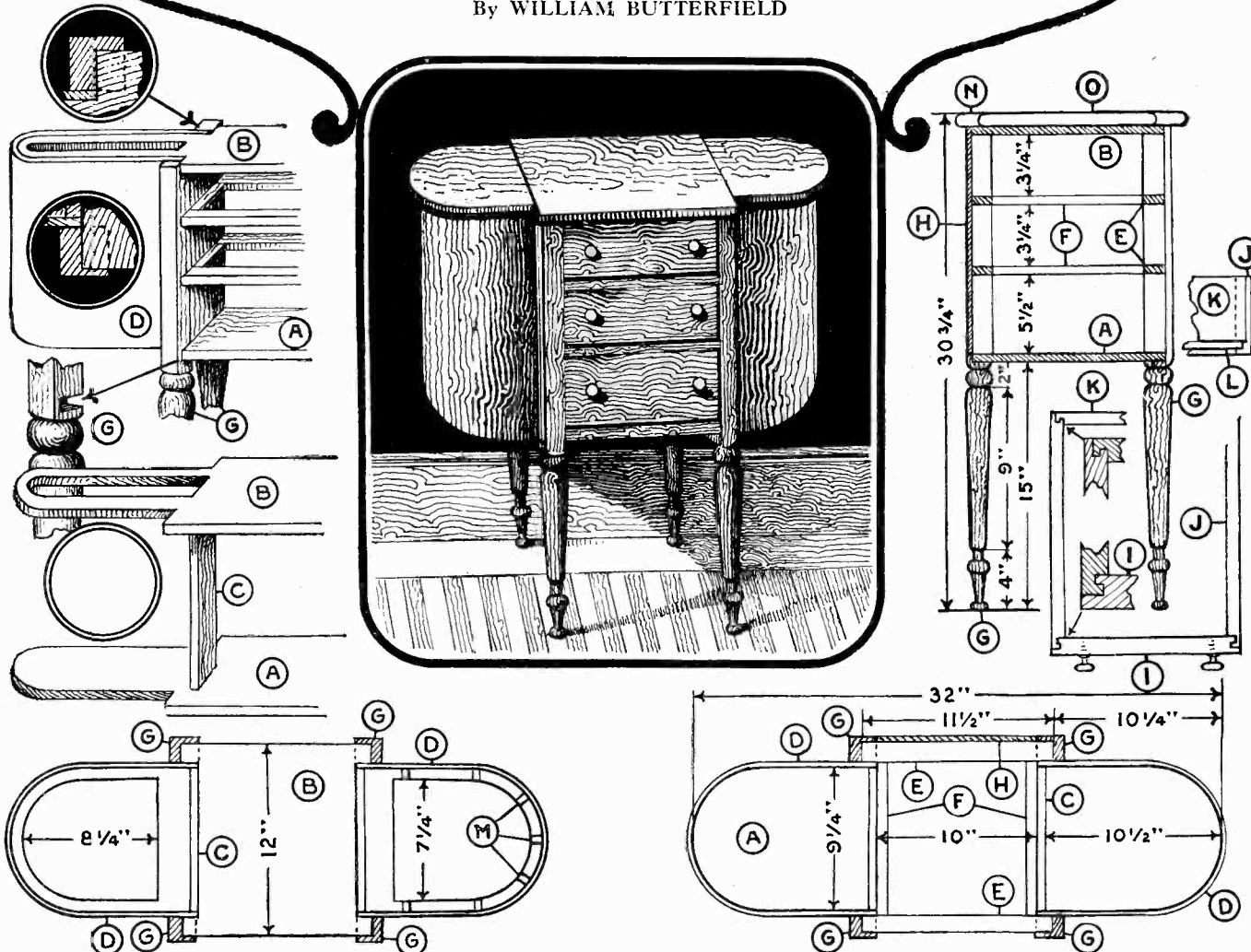

The constructional plan of the body of the sewing cabinet is shown above together with an end view.

Above is a horizontal section and above that a side view of the cabinet, showing the details; the letters in all views are referred to in the text.

THE Martha Washington Sewing Cabinet is an American production, as the name implies, but it is difficult to say who were the first to make the piece. It seems to have been an American copy of what is called the "Old Bonaparte Work-Table," made in France, and imported into this country during the later Colonial Days, which accounts for its having been added to our rather extensive list of American "Early Period" Furniture. The name is modern, it would seem, and has a great deal to do with the popularity awarded this attractive reproduction.

Made in the "Home-mechanic" way it will be found to give a very interesting furniture job, particularly, as there have been invented several novel features for use in constructing the cabinet. Walnut, Mahogany, and Maple are the woods that have been used by the cabinet-makers, but we introduce a plan wherein soft wood is used for a frame, and hard wood is only used for legs, top, drawer-fronts, and ends; thus producing a cabinet that is light, and, at the same time, lower in cost.

The materials used in making the cabinet are as follows:

- Four 1 1/2" Legs, 30" long (turned as shown), Walnut or Mahogany.
- One 3/4" Board, 14 1/2" x 13 3/4" (for top), Walnut or Mahogany.
- One 3/4" Board, 10 1/2" x 21" (for top), Walnut or Mahogany.
- One 3/4" Board, 6" x 21" (for drawer fronts), Walnut or Mahogany.
- One 1/8" Veneer-board (suitable for steaming and bending), 15" x 70" (for ends), Walnut or Mahogany.
- One 3/4" Board, 12 1/2" x 65" (for frame), Whitewood or Pine.
- One 1/2" Board, 10" x 30" (for partitions), Whitewood or Pine.
- One 1/2" Board, 6" x 102" (for drawer frames), Whitewood or Pine.
- One 1/4" Ply-board, 10" x 37" (for drawer bottoms), Whitewood or Pine.
- One 3/4" Board, 1 1/2" x 93" (for drawer slides), Whitewood or Pine.
- One 1/2" Board, 1" x 86" (for braces at round ends), Whitewood or Pine.
- Four 3/4" Brass-hinges, with screws (for top end-lids).
- Six 1" Glass Drawer-pulls (for drawers).
- Fig. A—This pieces is 32" long, 12" wide, and 1/2" thick; with two end parts

- 10 1/4" long, and 9 1/4" wide—having round ends; the center is 11 1/2" wide, and 12" long—the four corners forming tenons to fit into notches in the four legs (see Fig. G).
 - Fig. B—This piece is identical in size and shape with Fig. B, but has holes 7 1/4" wide, and 9 1/4" long, cut in each end to form openings for the work-pockets.
 - Fig. C—Partitions of 1/2" lumber, 9 1/4" wide, and 13 1/2" long, are used to divide the work-pockets and drawer frame, these partitions form, with the square post of the legs, the sides of the drawer frame.
 - Fig. D—Veneer-board is used to form a casing for the sides and ends of the work-pockets; it is 1/8" thick, and 15" wide. The wood is steamed or soaked in boiling water, then bent or shaped and allowed to dry. It is glued to A, B, and C in the manner illustrated, forming the work-pockets.
 - Fig. E—Drawer divisions or slides are used with tenon and notch joints in the front and rear legs; they are 3/4" thick, 1 1/4" wide, and 11 1/2" long. They form
- (Continued on page 280)

WIREKRAFT CONTEST

\$3,000.00 In Prizes

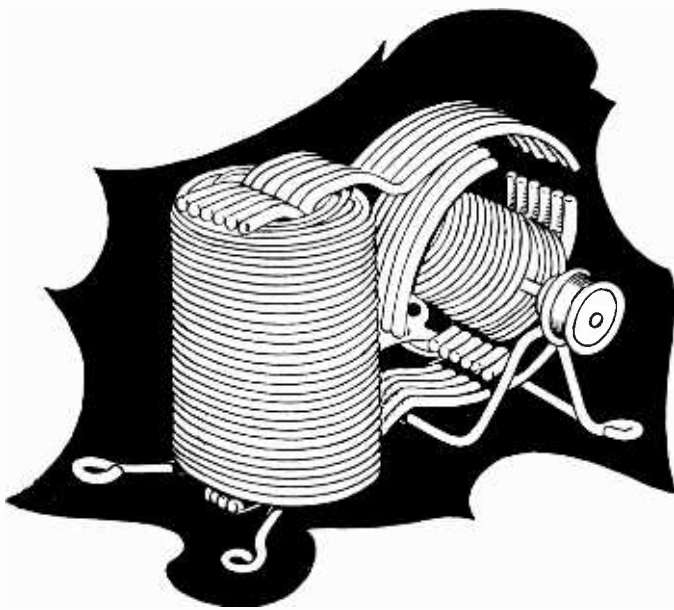

FIRST PRIZE—\$100.
The first prize winner for this month's Wirekraft Contest submitted the model shown in the illustrations on either side of this caption. This is a 6-volt battery motor made entirely of wire. The armature, field as well as the core, are made of wire as the illustrations clearly depict. This motor arrived untagged.

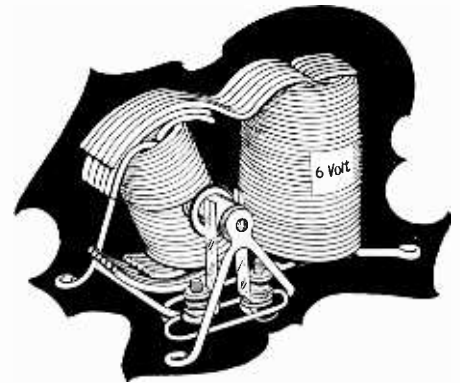

SECOND PRIZE—\$50.

The two book ends illustrated at the right were built by John Taylor of Chicago, Ill. These are made of wire as the diagram indicates and then drops of solder were permitted to flow on the outside of the ends and this solder was splattered as indicated. Note the ship design on the upright portion of the book ends. They are surprisingly heavy for their size and will easily hold heavy books.

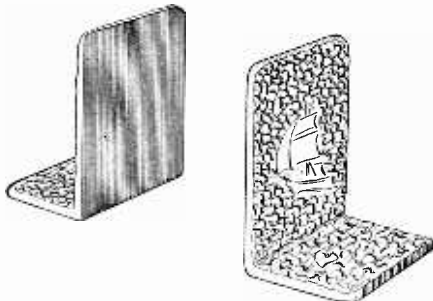

Anyone could duplicate the book racks indicated above, but in order to make an artistic job, patience and care will have to be exercised.

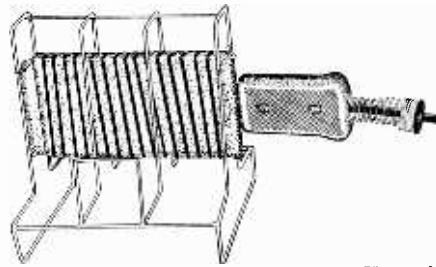

Third prize—\$25.00 was awarded to Harry A. Hirschfield of Philadelphia, Pa., for a wirekraft toaster made entirely of wire with the exception of the insulating asbestos plate. Its simplicity is quite striking. A projecting shelf prevents the toast from dropping off.

The motor which won the first prize in this month's contest develops considerable power when operated from a 6-volt storage battery. Due to the fact that it has only a double-pole armature, a dead center will be found. When once up to speed, it is stopped with difficulty.

Fourth prize—\$20.00 was won by the chemistry teacher of the St. Stephen High School at Newport, Ky., who did not sign his name to the prize entry. This article is a very clever ring stand made entirely of wire and fitted with gauze likewise wired in place.

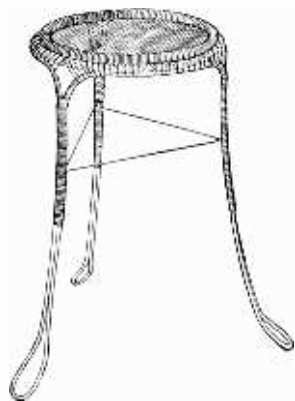

In the ring stand above the legs are made of galvanized iron wire. There is a double circle at the top to which the gauze is affixed. Surrounding this there is a copper coil for further radiating the heat.

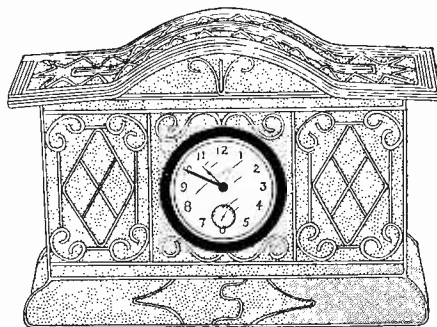

Fifth prize—\$15.00. The clock and frame here shown was made by Bertrand Schwartz of East Mauch Chunk, Pa. Both round and square bus-bar wire is used in the construction and this is backed by pink rayon. This is a nice way to fix up your old clock. The tinned bus-bar wire will not tarnish.

Seventh prize—\$7.50. And now we have a watch holder also made of bus-bar wire carefully cut out as indicated.

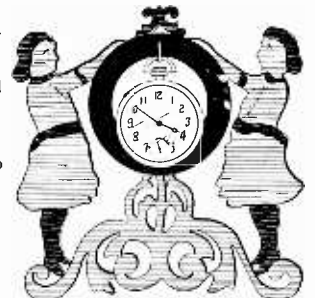

The watch holder here shown was made by John Zeleznik of Bridgeport, O., who was a frequent contender in the Matchcraft Contest held by this publication.

Eighth prize—\$5.00 was won by William Aleda, Vauxhall, N. J., for his construction of a fountain pen indicated in the diagram at the left. Although a little too heavy for use, the pen is serviceable.

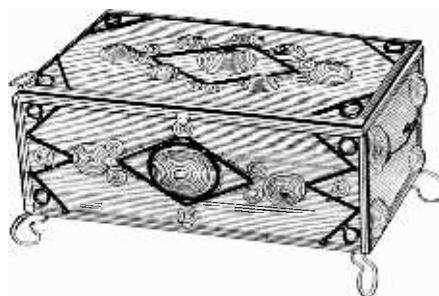
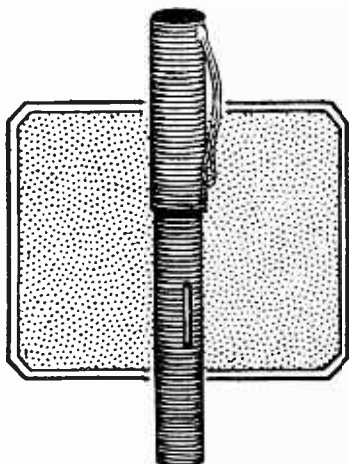

Sixth prize—\$10.00. Here is a jewelry box made of round bus-bar wire with brass filigree or rather bus-bar wire painted with bronze paint. The corners and decorations are lacquered black, and the box is lined befittingly. There is a handle on either side of this jewel chest. This was made by John Ertim, Jr., of Cleveland, O.

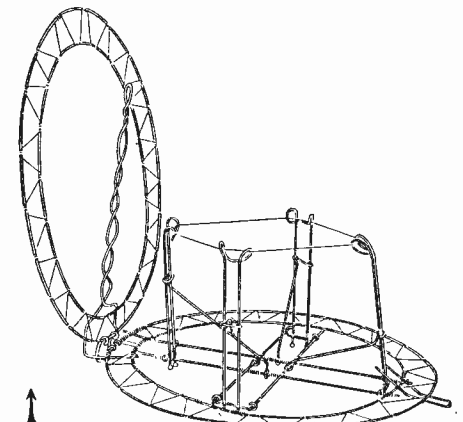

Ninth prize—\$3.50 was won by Vern Greiveldinger of Hanover, Kansas, for a collapsible hat rack for straw hats and the like. This illustration shows the rack in an open position. The ring fits down over the brim of the hat.

\$3,000.00 IN PRIZES

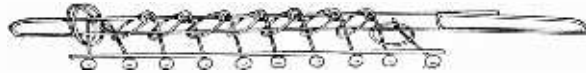

Twelfth prize—\$2.00. An extremely interesting puzzle made of wire by Mr. W. A. Gelschichter of Wilkesbarre, Pa.

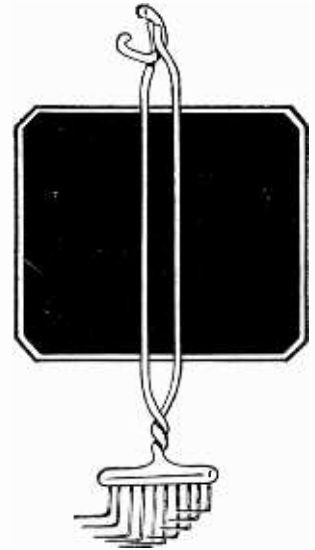

Eleventh prize—\$2.00 was awarded this grapefruit seeder.

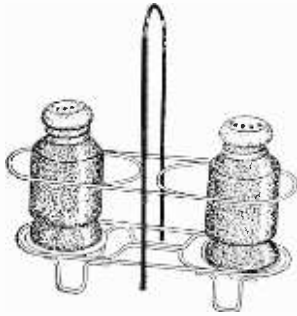

Tenth prize—\$2.00. The picture here shows a salt and pepper shaker holder which was made by Mr. M. Falkenheim of Newark, N. J.



Thirteenth prize—\$2.00. Here is a marshmallow toaster or bread toaster in the form of a fork. One single piece of wire, twisted as shown and pointed at the ends, finish the fork. This device was made by Burl Knutson of Bismark, N. D.



Fourteenth prize—\$2.00. The watch chain here illustrated was constructed by Leslie Carpenter of Burlington, Vt.

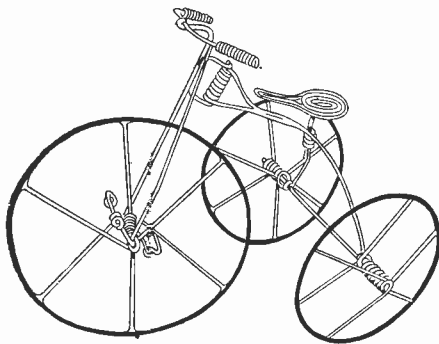

Fifteenth prize—\$2.00. Here is a miniature bicycle built by Harold Jackson of Kanakee, Ill. The bicycle is approximately 4 inches long.

The Wirekraft Contest is a very interesting and fascinating pastime and arduous many contestants have walked away with some of the very valuable prizes which are awarded monthly. The rules for the contest are given in the box below. These suggestions which were prize-winning ideas can be surpassed by other Wirekrafters. The first thing is to get the idea and the second, to work it up and ship the model in. Perhaps the greatest difficulty will be in striking upon a successful thought. The construction is quite simple. The eleventh and sixteenth prizes indicated in the right-hand column of this page were made respectively by Grant S. Martin of Ann Arbor, Mich., and Carl R. Klein of Jersey City, N. J. Both received \$2.00 prizes.

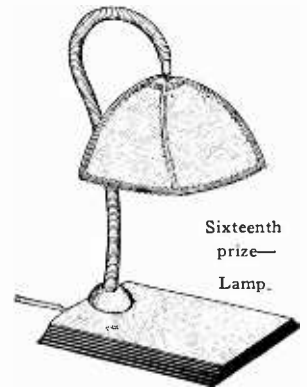

Sixteenth prize—Lamp.

RULES OF WIREKRAFT CONTEST

THIS is a wirekraft contest. Hence wire is to be used in the construction of all of the models entered in this contest.

The size of the wire to be employed is limited. The heaviest wire must not be larger than No. 8 American or B and S gauge, and the smallest no smaller than No. 30 B and S gauge—or (for foreign countries not having these exact sizes), the nearest available equivalent.

No. 8 B and S gauge is .12849 inches in diameter or 3.264 millimeters. Its nearest equivalent in the Birmingham or Stubbs iron wire gauge is No. 18. In the British Imperial Standard it is No. 10. The nearest wire to No. 30 B and S gauge which is .01002 inches or .2546 millimeters in diameter is No. 31 in the Birmingham or Stubbs iron wire gauge. In the Stubbs steel wire gauge it is No. 80; in the British Standard it is No. 33.

The builder may avail himself of the opportunity of using any intermediate sizes of wires between No. 8 and No. 30, B and S gauge.

The wire may be copper, brass, iron, steel, or these materials coppered, tinned, nickel-plated, or galvanized, or the wire may consist of an alloy. Any kind of wire available on the market may be employed.

It is preferable to use non-rusting wires. The publishers will not be responsible for the rusting of any model. To protect wire which rusts easily or for color effects, the models may be painted, lacquered, varnished or otherwise covered.

Any additional decorations or accessories may be employed to enhance the effect. (Example: Silk on a lamp shade; glass in decorative fixtures; electric motors for operating mechanisms, etc.)

Only those portions actually constructed of wire will be judged.

(Example: A reed basket is suspended from a wire chain. The basket not being made of wire is NOT considered. On the

merits of the chain only will the prize be awarded.)

Wires may be twisted, spliced, soldered, welded or bound together. Wire may be used to bind other wires together. If soldered a non-corrosive soldering flux should be employed.

There is no limit to the size of the models which may be entered nor to the number of entries which any maker may submit during any calendar month.

In every case the model must be forwarded express prepaid to SCIENCE AND IN-

vention Magazine. It should be tagged with name and address of the maker, who will prepay charges if model is to be returned.

The first prize will always be awarded to a model possessing the greatest utilitarian merits. This must be an object NOT found on the market today.

The second prize will always be awarded to an object possessing the best decorative, artistic or constructive effect. It may be a replica of an existing object or a model of an imaginative object or effect.

The remaining prizes will be judged from either one or the other viewpoints at the discretion of the judges.

All models may remain at the office of this publication until the close of the contest at the discretion of the editors.

This contest starts January 1st, 1927, and will terminate January 1st, 1928.

This is a monthly contest lasting for twelve months, each monthly contest closing on the first of the month following dates of issue. Thus the contest for the month of June, 1927, will close July 1st, 1927. Winners for June will be announced in the September Issue.

\$3,000.00 In Prizes Arranged in Monthly Awards

First Prize	\$100.00
For Utility Only	
Second Prize	50.00
For Artistic, Decorative or Constructive Effect—may be a replica or model of some imaginative or existing object.	
Third Prize	25.00
Fourth Prize	20.00
Fifth Prize	15.00
Sixth Prize	10.00
Seventh Prize	7.50
Eighth Prize	5.00
Ninth Prize	3.50
10th to 16th Prizes of \$2.00 each ..	14.00
Total	\$250.00

Tools Required

THE tools required for the construction of Wirekraft articles may be found in the Dec. issue of this publication, a reprint of which will be sent free upon request. The following tools may be used advantageously:

1 pair flat-nosed pliers, 1 pair round-nosed pliers, 1 wire cutter, 1 hacksaw, 1 small vise, 1 soldering iron.

The materials which are necessary are: Solder, soldering paste or flux, nails, one piece of wood, and most important of all, wire of the sizes specified in the contest rules and regulations.

If the builder decided to weld his wires together, a small welding transformer or a storage battery may be used for this purpose. For the formation of long cylinders, a coil winding machine or a lathe may be advantageously employed. Toy motors for the operation of any devices constructed of wire could of course be procured and added to the model and the addition of miniature sockets and bulbs to illuminate the interior of any buildings constructed of wire might also find a place in some of the constructions.

Address all entries to
Editor Wirekraft

SCIENCE & INVENTION MAGAZINE
230 Fifth Avenue, New York City

MATCHCRAFT . . . \$100 Awarded Monthly

Humidor Wins First Prize, Army Tank Carries Second

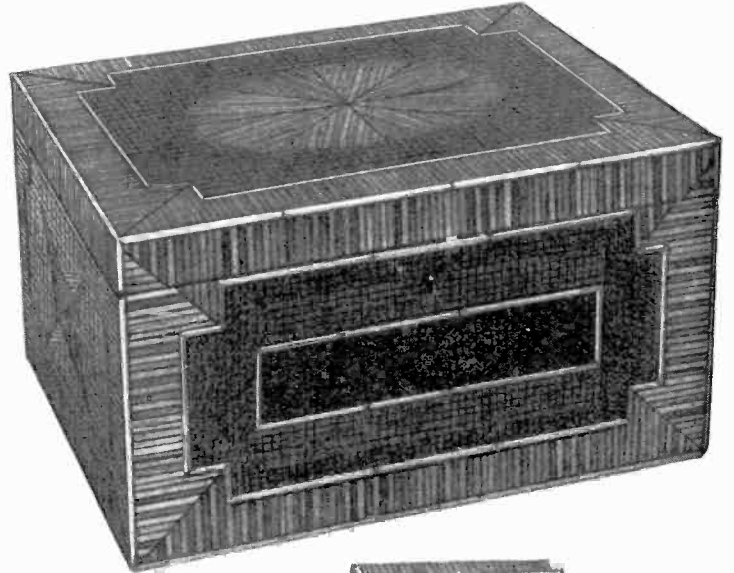
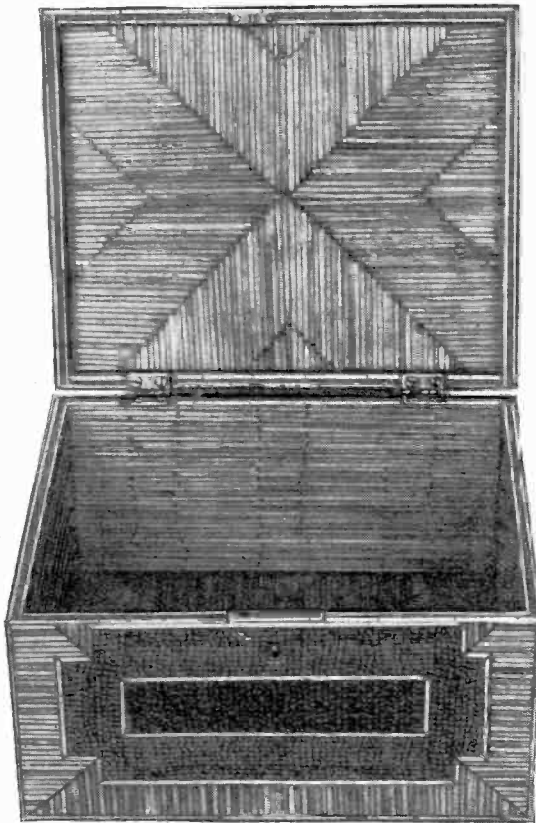

First Prize—\$50.00 was won by C. Horte of Altamont, N. Y. The two views here show the construction of this humidor which was polished to a glass-like finish.

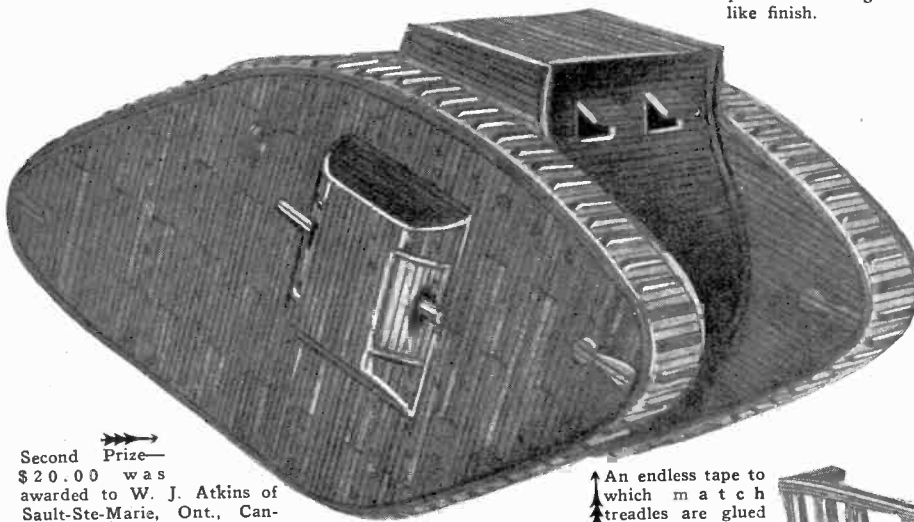
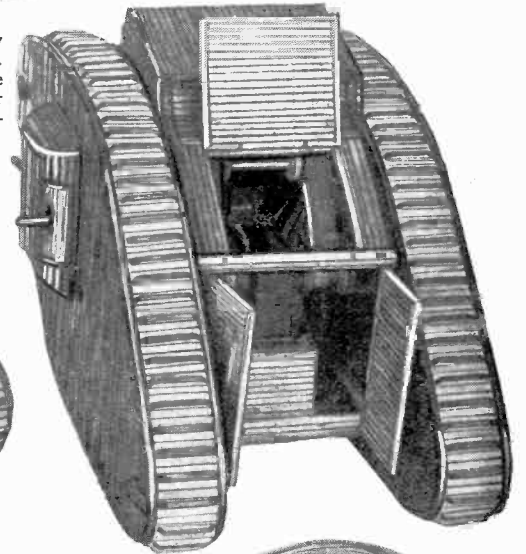

Second Prize—\$20.00 was awarded to W. J. Atkins of Sault-Ste-Marie, Ont., Canada, for the army tank here shown. This is operated by a spring motor.

An endless tape to which match treads are glued causes the tank to move. The gun turrets are rotatable.



Fourth Prize—\$10.00 was the award decided upon by the judges for the tete-a-tete chair made by Fred Spinden of Abingdon, Ill., and illustrated above.

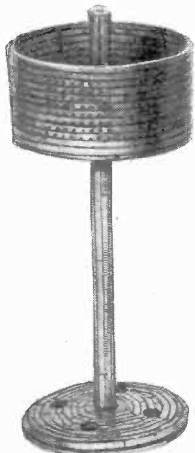

Third Prize—\$15.00 was won by E. J. Raible of Louisville, Ky., by his construction of a coffee percolator. Note how the matches were steamed and bent to conform with the shape of the actual article.



Fifth Prize—\$5.00 was given to Risdon Moore of Galesburg, Ill., for his matchcraft wrench. This monkey wrench actually works, the jaw sliding back and forward by action of the thumb screw.

Rules for the Matchcraft Contest appear in this issue on page 285



MOTOR HINTS

Conducted by GEORGE A. LUERS

DO YOU KNOW—
continued high speed driving causes erratic engine missing? The heat warps valves and weakens the springs, making it necessary to renew these parts.

SOLDERED PATCH FOR DENT IN BODY OF THE CLOSED AUTOMOBILE

Where the closed car body is dented, in locations especially where the rear is covered by the upholstery inside, an exterior repair to hide the dent is most desirable. In a dented Buick, that was recently put into our paint shop, the painter filled a dent with a putty made from whitening and white lead and painted over this, hiding the dent perfectly. The fear of this owner, however, is that the putty will eventually drop out, leaving an ugly spot.

One of the best forms of repair to a dent or body defect, is that shown in the sketch, which means was used some months ago to repair a Cadillac body.

The dented area was simply fitted with a piece of sheet tin, cut out to exactly cover

SOLDERED PATCH FOR DENT IN BODY OF CLOSED CAR

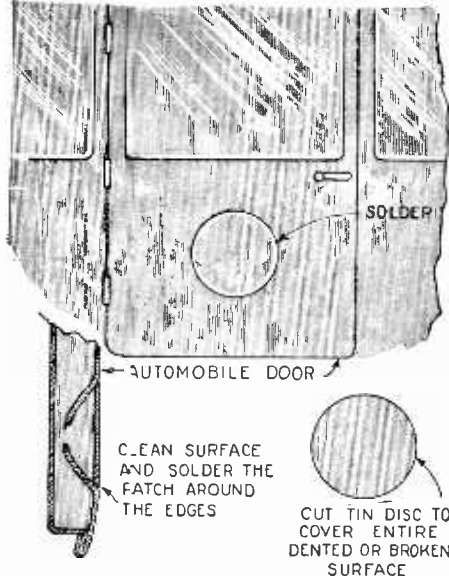

The above illustration shows clearly the method pursued in repairing a closed car body with an exterior patch.

a jagged hole. The edges of the patch were soldered directly to the body, after cleaning away the old paint to insure a clean soldering surface.

With this patch the owner will not have need to concern himself, as it will not drop off and is practically as permanent a repair as could be made with welding, and is a far simpler and less expensive a repair.

SCREEN WIRE BRUSHES FOR REMOVAL OF CARBON AND OLD PAINT

For the removal of paint from the body of the automobile, previous to renewing it, advantageous and inexpensive scraping tools will be seen in the illustration.

Similar scraping work is required in the removal of carbon from the cylinders of the engine. Hand tools, or even small circular scratch brushes, which can be used in the electric drill, are an assurance of doing the proper kind of a carbon scraping job.

These forms of brushes are also shown in the attached sketch.

Additional to the brushes shown in the sketch, various other kinds of brushes are available made up from ordinary screen

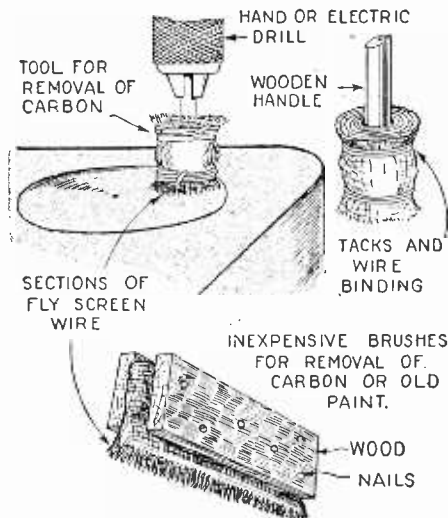

The various forms of brushes used for the removal of carbon and old paint are shown in the above illustration.

wire. This material is easily handled, inexpensive and a brush of the required shape and size is easily put together without loss of time or expense.

SAFETY WHEN WORKING ON HIGH TENSION IGNITION OR SPARK PLUGS

The jolt that contact with the high tension circuit as used for engine ignition gives the repairer, will often lead to other injury.

Recently one repairman, feeling the shock, withdrew his hand only to thrust it into a fast revolving fan which nearly severed two fingers.

When working on high tension circuits it is possible to have the pliers insulated with two pieces of rubber hose slipped over the handle as shown. Similarly the wrench

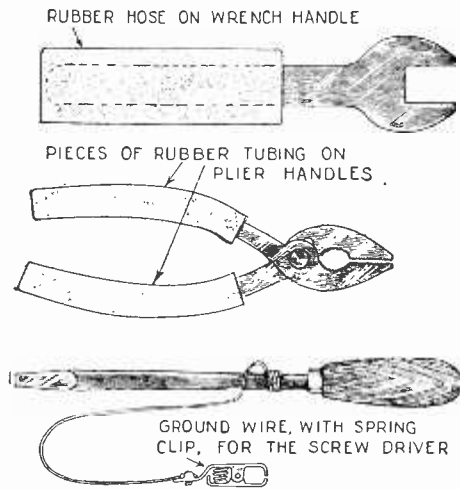

SAFE TOOLS FOR USE AROUND HIGH TENSION CURRENT AS IGNITION CIRCUIT TO SPARK PLUGS

When working on high tension current, it is well to have the pliers insulated with rubber hose slipped over the handle as shown.

can be insulated with a piece of hose slipped over the handle.

When testing plugs with the screw driver, one of the best guards the writer has come in contact with is a piece of wire with a clip at one end, the other end wound around the blade of the screw driver. To work with this tool, the spring clip is snapped to a stray rod or other part of the engine, leading any current to ground.

PREVENTION OF EXCESSIVE CRANKCASE DILUTION

Crankcase dilution has been the reason for much recent consideration and addition of devices on engines for ventilation and for rectifying the engine oil. While oil rectifiers are attached to a large number of this year's models, much can be done with the car not so equipped to avoid excess crankcase dilution.

It will be understood that crankcase dilution is a thinning of the engine oil on account of the gasoline leaking by the piston rings into the reservoir. The seriousness of this condition is illustrated by the sketches, showing a full body oil keeping the moving surfaces apart, while the diluted oil lacks body and allows for metallic contact, with its consequent wear.

The following five rules for operation, while they are not the equal of an oil rectifier or ventilator for the crankcase, represent good practice.

ENLARGED SECTIONS THROUGH CYLINDERS

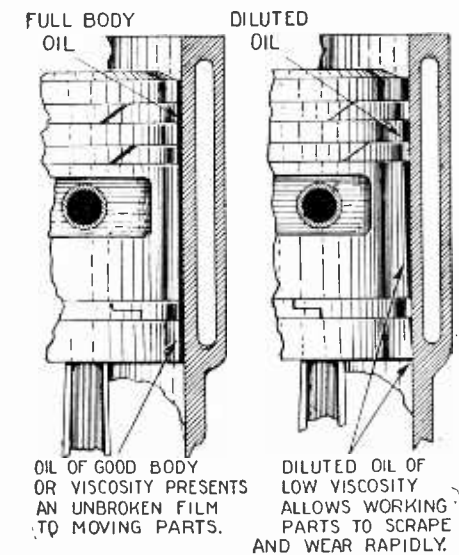

Excessive crankcase dilution causes the parts to wear rapidly.

(1) Do not use the choke longer than is actually necessary to start the engine running. Do not warm up with the choke out.

(2) Avoid as far as possible idling the engine and do not indulge in excessive slow driving, especially during cool nights.

(3) Keep engine in good mechanical condition, particularly the piston rings. The compression of the engine is indicative of the fit of the rings.

(4) Use a radiator cover or shutters and a radiator thermometer to keep the motor temperature up to or above 180 degrees.

(5) Drain the oil, preferably each 500 miles, never over 1,000 miles. Do not use kerosene or flushing oil, because of the amount that remains to dilute the fresh oil.



MODEL DEPARTMENT



The photograph at the right shows the trophy cup compared with the prize-winning model in the monthly Model Department Contest. Both objects were photographed at the same focus, giving us a good idea of the size of this trophy cup. The cup is nearly nineteen inches high.



CUP WINNER FOR THIS MONTH'S CONTEST

Is H. W. DARR, Jr.
OF MINNEAPOLIS, MINN.

Model Steam Engine Carries Away the Honors in the Model Department Cup Contest

This photo shows winning model and the prize cup.

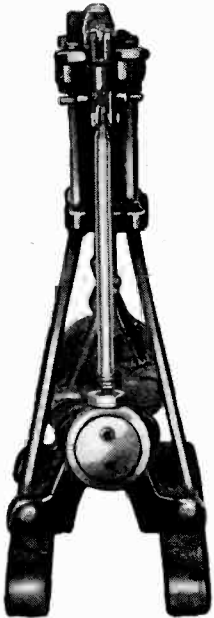

End view of the prize-winning engine model.

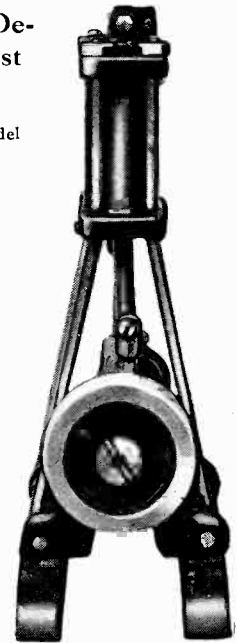
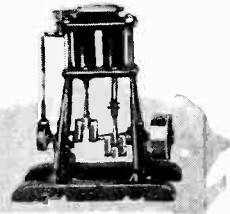

The photograph above shows the front end of the model steam engine. This type of engine can be used to propel small power boats.

BECAUSE of the popularity of the Model Department, the publishers of this magazine have decided to continue this section for another year. A trophy cup will be awarded monthly for the best model submitted in this contest during any month. The rules of the contest are easily complied with, the only requisite being that the model be shipped to the offices of SCIENCE AND INVENTION Magazine. Our own draughtsmen will take care of the drawings and our photographers will make the necessary photographs for illustrating the article. Of course, any assistance in the nature of drawings which the builder may care to send will be of inestimable value and might even be deciding factors in awarding the cup.

In this contest any type of a model may be submitted, be that a model of a generator, a motor, an airplane, a submarine, a battle cruiser, a yacht, or in fact any conceivable type of a model of some existing or for that matter, futuristic object.

The prize-winner in this month's contest built the steam engine in as simple a manner as possible. The drawings for the same appear on the following page.

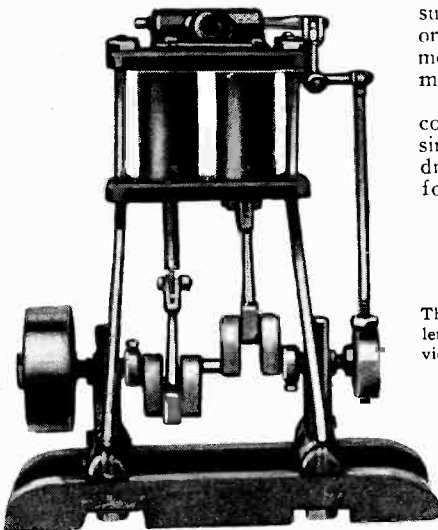

These two photographs give us excellent side views of the engine. The device is not double-acting but there is practically no dead center due to the double-piston arrangement. Steam is exhausted on either side of the slide valve. The direction of rotation can be changed by shifting the eccentric. This is locked in position by a nut.

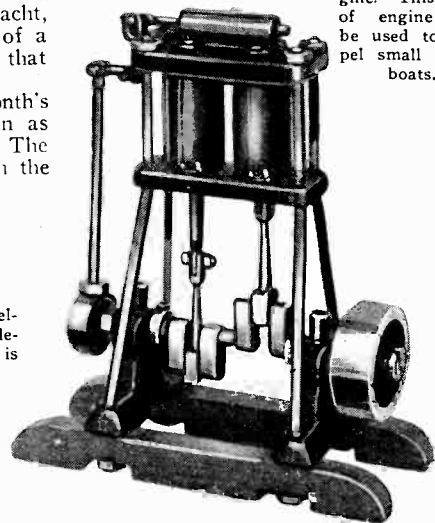

Blueprints of model steam engine are available from the Model Department.

CUP WINNER—Twin Cylinder Marine Engine Details

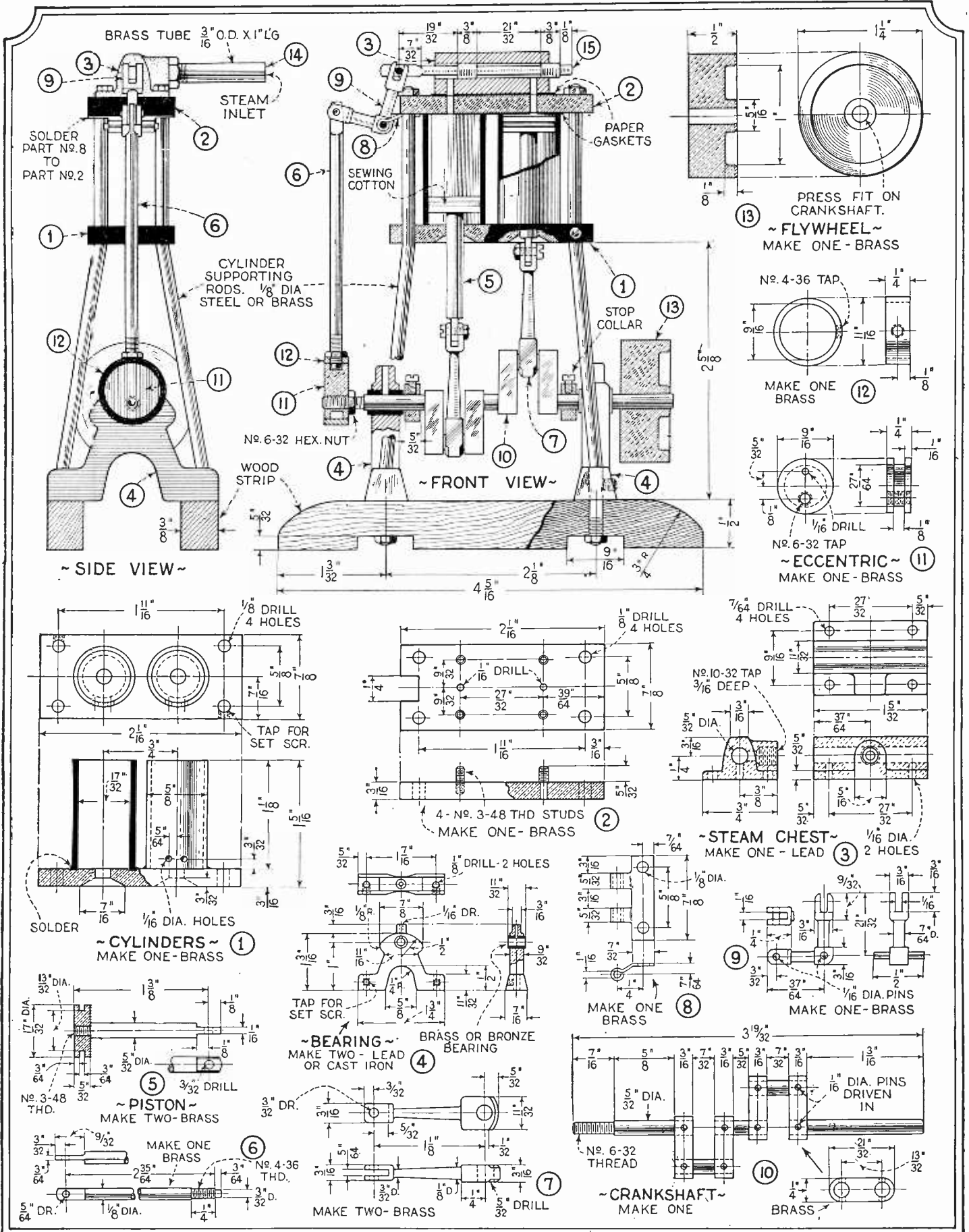

The diagrams above show the complete details for the construction of the prize-winning model in this month's Model Contest. It will be observed that the steam exhausts from the cylinder past the slide valve 15 in the center diagram above. Meanwhile, steam is flowing into the cylinder at the right. Also note that the crankshaft instead of being constructed of

one piece is made of several pieces pinned together. This manner of construction enables the builder to dispense with much of the fine work on the lathe. A great saving in material is also had by this means. The fly-wheel itself is fitted to the shaft by a friction-tight fit. To change direction of rotation, shift the eccentric through 180 degrees.

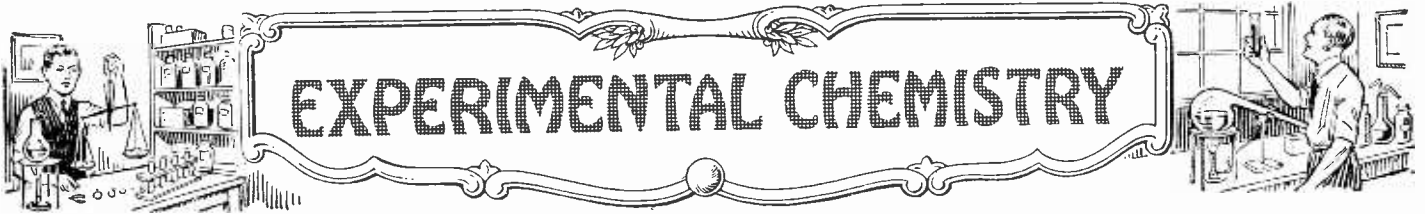

EXPERIMENTAL CHEMISTRY

Electroplating Made Simple

By RAYMOND B. WAILES
PART ONE

IF you have a radio using storage battery tubes you have the essential requirement for electroplating objects about the house and shop. That one essential is a good source of current, which can be derived from a storage battery. A rheostat such as is used for controlling filament brilliancy, a glass or earthenware jar, sheets of copper and nickel and about a dollar's worth of chemicals are all that are required for plating those brassy handles of your car, that old clock, the dingy handles of a dresser, handles of drawers, headlight rims, tools, instruments, medals, and many other things.

Electroplating itself is not complicated or difficult to perform. The most difficult part of electroplating is in preparing the work to be coated. This consists of cleaning it free from all paint, dirt and grease.

For the beginner it is best to nickel plate brass objects. Such, for instance, would be nickel plating the handles of the family car, assuming that they are brass and badly need attention.

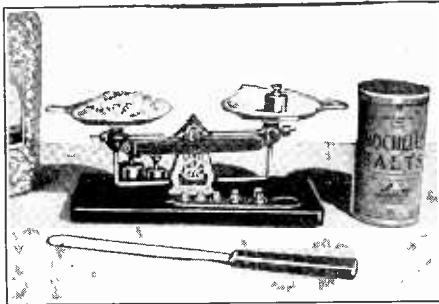

In electro-plating the chemicals used should be carefully weighed out. Accidental results count for nothing. While many use the American or English weights, the chemists will always adhere to the metric system, the gram and the milligram.

First remove the remains of the old nickel coating which is upon them by immersing the handles in a solution made by mixing four parts sulphuric acid and one part of water, with stirring and then one part of nitric acid, all parts being by volume. Let it cool before using. Allow the brass handles to remain in this stripping solution until the old nickel plate has been eaten off, then wash in water, scrub with soapy water and then immerse in lye water made by dissolving 1 lb. caustic lye in a gallon of water or about 125 grams in a liter. This caustic solution will remove the grease and after the work has been removed from it, the metal should not be touched with the fingers. A stick with a cloth wound on the end will make a good scraper for use with the lye solution. Attach a wire to the work so that it can be connected with the negative terminal of the battery and it is ready for the plating bath, after rinsing in water. Use clean pincers for twisting the wire and holding the articles. Do not touch with the fingers.

For nicked plating copper or brass articles, dissolve 50 grams of nickel sulphate in a liter (1000cc) of water and then dissolve 25 grams of ammonium chloride in this solution. Other solutions giving good results are:

- No. 1
Nickel ammonium sulphate, 14 ounces
Boric (Boracic) acid, 2 ounces
Water, 1 gallon.
- No. 2
Nickel sulphate, 34 grams
Nickel ammonium sulphate, 7 grams
Magnesium sulphate (Epsom salts), 2 grams
Boric acid (boracic acid), 2 grams
Water, 200 cc.
- Either of the above solutions work well.

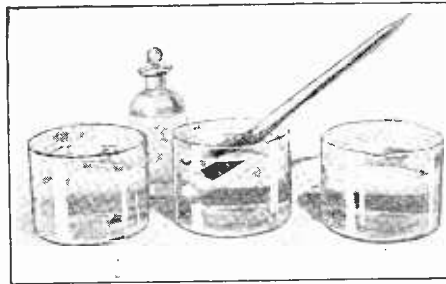

Three baths are required in electro-plating; one is an acid bath, another a bath of caustic soda or lye, and finally a rinsing water bath is needed, but this may be supplied, of course, by the faucet.

It is best to procure CP (chemically pure) chemicals and distilled water. If either of the two is to be impure it is best to have impure water. Keep the solutions in glass bottles. Vinegar jugs make good containers.

To plate the brass handles with nickel two sheets of pure nickel to serve as anode are needed. The writer has had good results with ordinary sheet nickel such as sold in

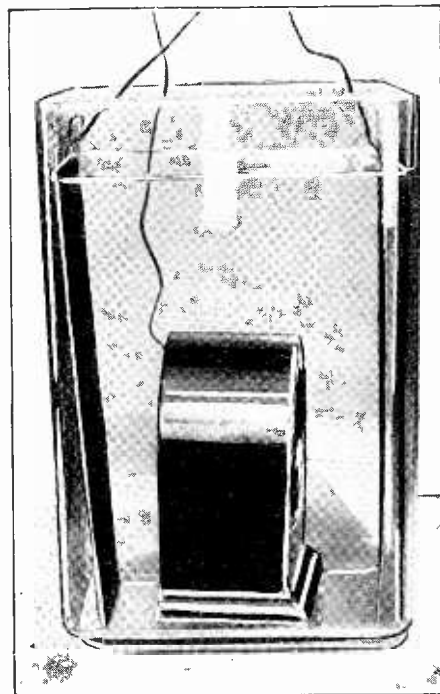

Here the use of two anode plates is shown, the idea being to reduce the resistance of the bath and get a more even deposition of metal.

metal supply stores. This should be cleaned with emery cloth, washed and connected by means of a wire to a rheostat such as is used for radio purposes. Two rheostats can be put in series if desired. The free terminal of the rheostat is connected to the positive terminal of the storage battery. The wire connecting the work to be plated is always connected to the negative terminal, which means to the positive plate of the storage battery. An ammeter can be used in the circuit if desired.

Place the two nickel plates in either of the three above solutions contained in a glass or earthenware jar, one on each side of the work, as shown in the illustration. The work to be plated shown here is a badly scarred clock. Turn on the current through the rheostat and adjust the rheostat so that a somewhat small stream of bubbles is seen coming off of the object to be plated. You will have to experiment a bit here to estimate just what "a somewhat small stream" of bubbles is. The bubbles should not be gushing from the object. If this happens, it means that too much current is being passed

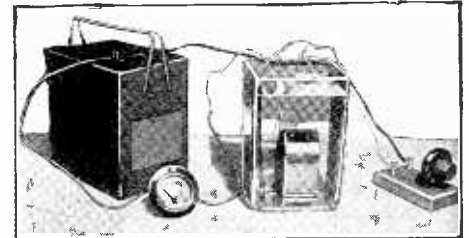

This shows on a small scale the apparatus set up for electro-plating; an ammeter is one of the parts specified. You can omit the ammeter if you keep sufficient resistance in the circuit.

and the rheostat will have to be adjusted so that more resistance is in the circuit. If too much current is used the nickel will be deposited in a fluffy, worthless film upon the work. You can continue plating or allowing the current to pass for several hours so that a good film will be deposited. After this time, remove the work, wash in water and then buff on a motor-driven buffing wheel or polish with a prepared silver cleaning paste to bring out the good qualities of the nickel.

The object of using two nickel plates in the solution is to evenly coat the object with nickel. If one plate is used, the side of the object away from the plate will only receive a poor coat.

The two essentials of good plating, it must be remembered, are thorough cleaning and removal of grease and correct passage of current.

To copper plate most of the common metals, and also carbon, but not iron, a simple solution of copper sulphate and sulphuric acid can be used for the plating bath. 200 grams of copper sulphate, 30 grams of sulphuric acid and 1000 cc of water make a good acid copper plating solution. A copper wire can be soldered to a carbon rod such as an arc lamp carbon by first plating the carbon rod with copper, using the above solution, and then soldering the copper wire to the coating of copper. This is a good method to use in making wet batteries where a carbon electrode is used.

Iron and steel objects cannot be copper plated with the acid copper plating solution just described, for the acid in it attacks the iron. Iron or steel articles can be plated with copper or nickel by using an alkaline copper solution to plate them with copper and then, if it is desired to plate with nickel, it can be done directly on top of this copper coat. Nickel cannot be plated directly upon

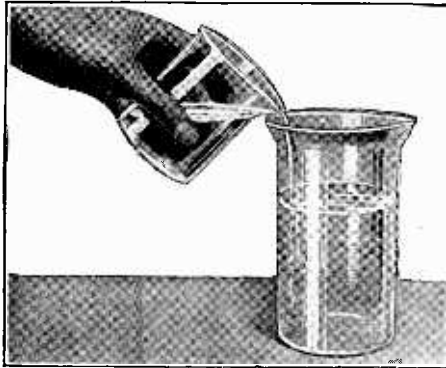

A solution for the electro-plater for silver plating can be made by the use of silver chloride, a precipitate produced by adding hydrochloric acid, or a solution of salt to a solution of silver nitrate.

iron by a simple means. For the alkaline copper plating solution use the following:

SULPHURETTED HYDROGEN APPARATUS

An apparatus for generating sulphuretted hydrogen is illustrated here. Two Erlenmeyer flasks or other vessels of the same character are mounted as shown and are supplied with India rubber corks. The left-hand bottle contains iron sulphide; the right-hand bottle contains dilute sulphuric acid. If the

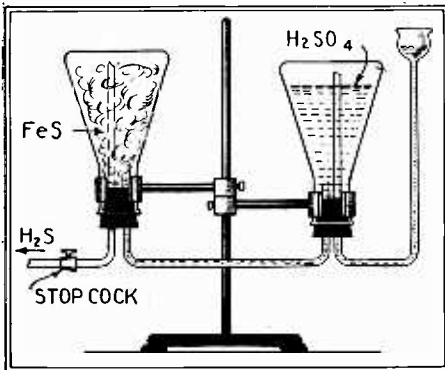

This useful sulphuretted hydrogen apparatus will be found far superior to the ordinary common bottle and funnel tube arrangement, for this is really automatic. Too much acid should not be put in the right-hand bottle.

stop-cock is open, acid will enter the left-hand flask and sulphuretted hydrogen will be delivered to the stop-cock and tube connected thereto. Now if the stop-cock is closed, the gas will generate for a few seconds and the pressure will force the acid away, although if it still continues to generate, some will escape into the acid flask on the right and if there is sufficient, it may bubble out through the thistle tube. For this reason the capacity of the funnel of the thistle tube should be sufficient to hold all the acid that can fill the tube.—Homer S. Pooley.

MOLTEN LEAD WHICH WILL NOT POUR OR RUN
By RAYMOND B. WAILES

This seemingly impossibility can be demonstrated very clearly if one has a toy step down transformer, or in its place, a source of current and a rheostat, and some lead wire. The lead wire used by the writer was sold for the purpose of packing joints in gas

Dissolve 5 ounces of Rochelle salts in one pint of water. Dissolve in another container, 1 ounce of copper sulphate in a pint of water. Mix the two solutions and then add sodium hydroxide (caustic soda) until the precipitate, or cloud, which forms when the two solutions are mixed, dissolves. After the caustic is added, the solution is dark blue. The work to be plated is thoroughly cleaned and then hung in the solution on copper wires connecting it to the negative side of the battery. You can adjust the rheostat so that about 1 ampere passes through the solution when plating small tools, etc. After the work has been plated, remove it from the solution at once and wash well with warm water, then dry and polish. Sometimes results can be had by using 75 grams of nickel ammonium sulphate dissolved in 1000 cc of water for plating directly on iron or steel. Use about 0.3 amperes when plating with this solution.

For silver plating a silver cyanide solution is used. The previous solutions all have been free from this deadly poison, but it seems that it cannot be excluded from silver plating baths. This plating solution consists of 10 grams of silver chloride dissolved in a solution of 20 grams of potassium cyanide dissolved in 1000 cc of water. The silver chloride can be purchased as such or can be made by adding a solution of common salt to a solution of silver nitrate.

Silver chloride can be made from silver coins by dissolving the coins in nitric acid

mains, and is sold under the name of lead wool.

It can be said that when substances are at about the temperature of 600 degrees they are red in color—dull red hot. Now if lead reaches this color, it can be assumed that it is at least 500 or 600 degrees in temperature. Now lead melts at 324 degrees, so it can be seen that if the lead wire used in the experiment becomes red hot it is molten, and is at a temperature far above its melting point.

Take several strands of the lead wire and connect them to the output side of a toy transformer, using the low voltage terminals. Apply the current through the primary, or, turn on the current and then use the lowest voltage possible by setting the switch arm at the correct position. The wire will become red hot and retain its looped form, or will melt, or will suffer no change. If it becomes red hot and holds its form the apparent fact that lead does not flow when it is above its melting point is demonstrated. If either of the two other conditions occur, reduce or use more current. A rheostat can be put in series with the wire.

The experiment is best performed in a dark room. Of course, like all "easily performed" experiments, the conditions have to be right before it will work. The thickness of the wire, number of strands and their length, the source of voltage have to be just right, but the range is somewhat wide.

The explanation for this red hot lead which will not run or flow probably lies in the fact that the outer layer of lead is oxidized, forming a coating or layer of lead oxide, which does not melt at the red hot temperature and supports the liquid lead within it in the form of a loop, like a tube of lead oxide filled with metal.

A FEW CHEMICAL EXPERIMENTS A SILVER TREE

Fill a test tube with a strong solution of nitrate of silver, then attach a piece of zinc to a piece of cotton and suspend in solution and set it by where it may be quite undisturbed; in a short time, brilliant plates of silver will be seen to collect around the zinc, assuming more or less a crystalline form. This is a case of elective affinity; the acid with which the silver was united prefers the zinc to the silver. Mercury may be used instead of zinc.

(one part acid to two parts of water). This will attack the coin, dissolving the copper and the silver. Now if a solution of table salt or better, potassium chloride, is added to the resulting blue "coin solution," a white precipitate or cloud of silver chloride will form. Shake or stir violently, allow the silver chloride to settle and then add more salt or chloride solution to the clear liquid. Stop if no more precipitate forms; keep on

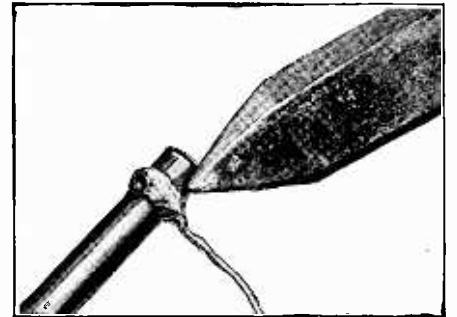

Soldering of wire to a battery carbon is done by first electro-plating the carbon with copper. This makes a very good joint.

adding if a precipitate does form. Filter off the precipitate, wash well with water and use in the above formula. Keep it in an amber bottle, excluding light.

(To be continued)

EXTRACTION APPARATUS

This very ingenious apparatus uses the same solvent over and over again. The solvent is contained in the Erlenmeyer flask and is heated therein. The substance to be

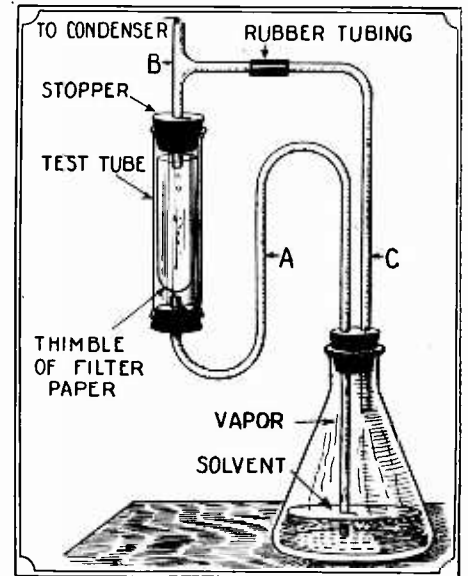

In this apparatus the solvent is evaporated, condenses and falls upon the substance contained in the cut-off test tube. When it fills it to the top the tube A is filled to its upper bend and acts like a siphon and draws all the solution back into the flask when the solvent is evaporated again.

extracted is placed in a filter paper thimble or it may be in a little bag of cheese cloth or fine muslin. The tube rising from B goes to a condenser. The action of the apparatus is as follows: The vapor passing up through C into the condenser as the Erlenmeyer tube is heated, condenses and drops down upon this substance to be extracted; it gradually fills the test tube and when the test tube is filled to the level of the top of the bend of the tube A, it siphons off, returning to the vessel whence it came. This action is repeated over and over again and the siphoning makes it particularly efficacious. The tube marked as a test tube is one with the bottom cut off and the edges of the glass rounded.—Darwin Harris.

Everyday Chemistry

By RAYMOND B. WAILES



WANT A GOOD STRAW HAT CLEANER?

A good straw-hat cleaner such as sold at drug-stores consists of sodium bisulphite, 5 oz.; tartaric acid, 1 oz.; borax, 1/2 oz. Apply with a tooth brush.

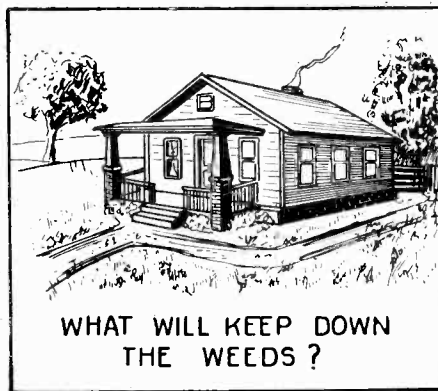

WHAT WILL KEEP DOWN THE WEEDS?

By sprinkling ammonium sulphate on the lawn, it is kept in an acid condition which is favorable to the greens, and unfavorable to weeds.

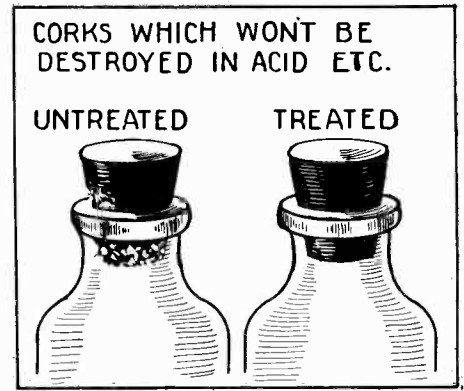

CORKS WHICH WONT BE DESTROYED IN ACID ETC.

UNTREATED TREATED

Collodion or water-proof court plaster applied to corks used in iodine and acid bottles will protect them from the corrosive vapors.

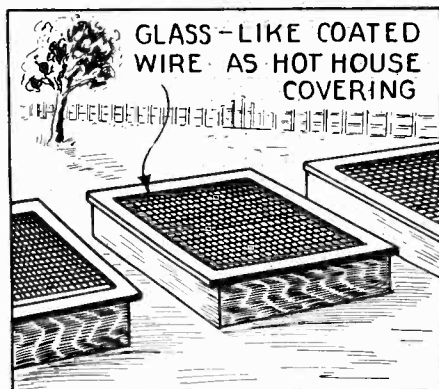

GLASS-LIKE COATED WIRE AS HOT HOUSE COVERING

The "glass cloth" used is wire screening which has been dipped in cellulose acetate, or a celluloid-like solution, and dried.

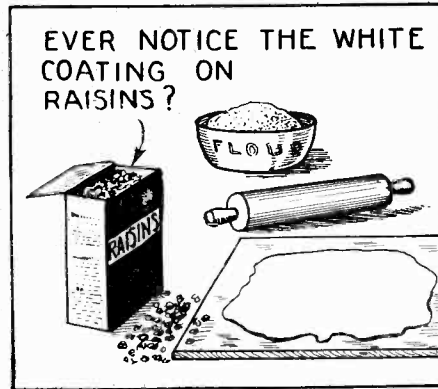

EVER NOTICE THE WHITE COATING ON RAISINS?

The white coating on dry raisins is not mildew, but a layer of fruit sugar which has crystallized from the sweet juices within.

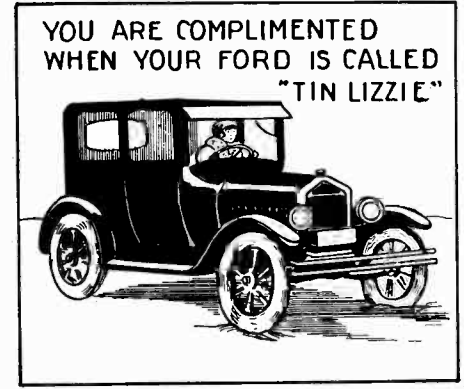

YOU ARE COMPLIMENTED WHEN YOUR FORD IS CALLED "TIN LIZZIE"

Sure you are. Tin is rather an expensive metal and a Ford car would cost about \$1,500.00 if it were made of real tin.

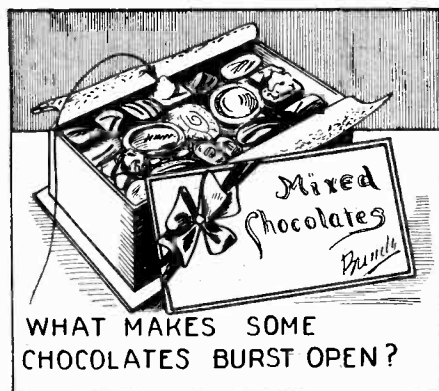

WHAT MAKES SOME CHOCOLATES BURST OPEN?

The bursting of cream-centered chocolates is due to yeasts which produce gases that literally blow open the chocolate.

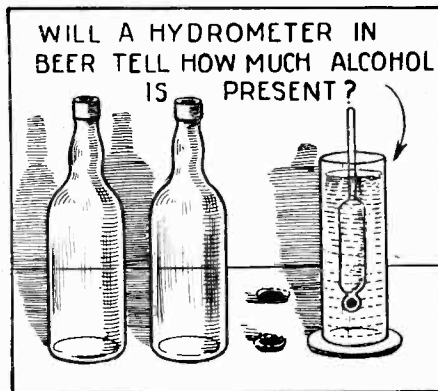

WILL A HYDROMETER IN BEER TELL HOW MUCH ALCOHOL IS PRESENT?

The presence of sugars and other solids in the beer will alter the specific gravity, making a test of this sort worthless.

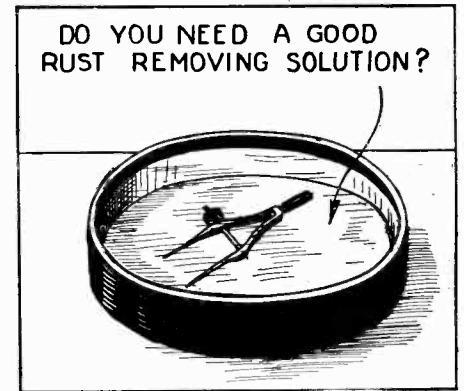

DO YOU NEED A GOOD RUST REMOVING SOLUTION?

By dissolving about a teaspoonful of ammonium citrate in half a glass of warm water, and immersing the rusted articles over night, they can be cleaned.

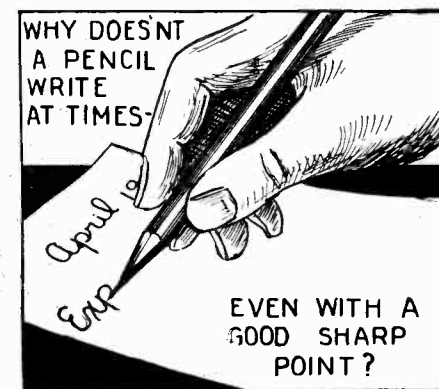

WHY DOESNT A PENCIL WRITE AT TIMES?

EVEN WITH A GOOD SHARP POINT?

The lead in pencils is a mixture of graphite and clay. When the pencil does not write, a little particle of clay and not graphite is touching the paper.

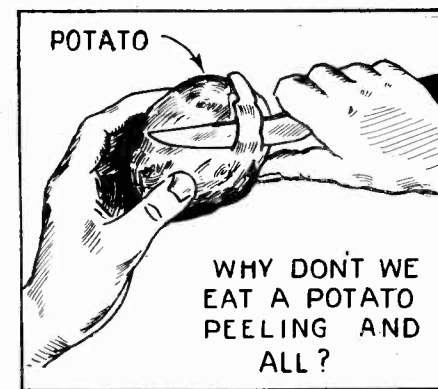

POTATO

WHY DONT WE EAT A POTATO PEELING AND ALL?

Our digestive organs are not designed to assimilate cork, for that is the substance of which potato skins are composed.

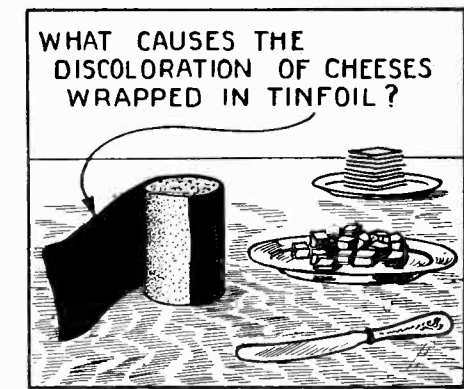

WHAT CAUSES THE DISCOLORATION OF CHEESES WRAPPED IN TINFOIL?

Impurities in the tin-foil such as iron, lead and copper, together with the sulphur compounds in the cheese, cause the dark discolorations sometimes found.



Experiments in Magnetism

By RAYMOND B. WAILES

A PIECE of unmagnetized iron or steel has millions of little magnets in it. The little magnets are all jumbled around pointing this way and that, so that they neutralize one another; and the iron as a whole does not show magnetic properties.

If the piece of iron is rubbed on a magnet, the little magnets which it contains are lined up so that the north-seeking ends point one way and the south-seeking poles point

Shaking up the tube mixes the filings, or stirs up or unlines the little magnets and the iron is no longer magnetized.

A little known method of lining up the little magnets, or in everyday language,



A hack-saw blade is magnetized and on being broken up it becomes a number of small magnets. Take care that you do not get consequent poles.

magnetizing a piece of iron is by twisting it. This can be shown by twisting a strip of galvanized iron in a vise with a pair of pliers. After twisting, the iron will affect a compass needle, showing that it has become a magnet. Be sure that the pliers are unmagnetized or the magnetism produced will not probably be that of the twisting effect.

Magnetize an old worn hack saw blade or similar strip of iron or steel by rubbing a magnet over it. One end will be a north-seeking pole and attract the south end of a magnetic compass and the other end will be a south-seeking pole and attract the north

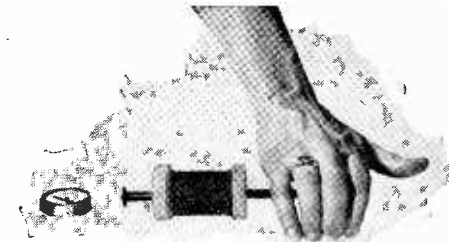

Illustrating what is called the right-hand rule for the induction of current by electro-magnetic action.

pole of a compass. If the magnet were broken in half would one piece contain the north pole and the other the south pole? By snapping the blade in as many parts as desired, it will be found that each broken piece will have a north-seeking and a south-seeking pole.

The right-hand rule for currents and magnetism is a very handy one to learn. Place the hand as shown, next to or over a coil of wire so that the fingers point in the direction of the winding of the wire. If an electric current flows in this same direction, then the thumb will point toward the north

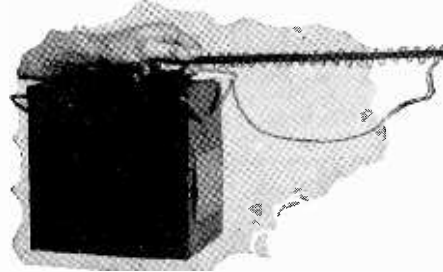

Passing a current through a loosely wound coil, as shown above, which is slipped over an iron rod, the turns will be drawn together by induction.

pole of a piece of iron inside of the coil. A compass placed at the other end will have its black half or north pole attracted to the south pole, or little finger end of the iron nail, as opposite kinds or unlike kinds of magnetism attract one another.

Wind about 35 turns of wire rather loosely on a broom handle and then slip the coil formed over an iron rod and connect the ends of the wire to a battery. A sudden jumping together of the coils will be seen



A version of jack-straws. Here a magnet is used to withdraw letters from a little heap, each letter having a bit of iron secured to it as a paper clip or two pieces of paper may be pasted together with a little bit of iron between them.

as soon as the current is passed through it. This is due to the coils becoming magnetized alike and attracting each other. Do not leave the wire on the battery over a few seconds.

A good game akin to magnetic jack straws can be made in a very few minutes' time. Cut out letters about one-half inch high from advertisements and paste them on pieces of cardboard. Slide a paper clip over each letter, or you can omit the paste and

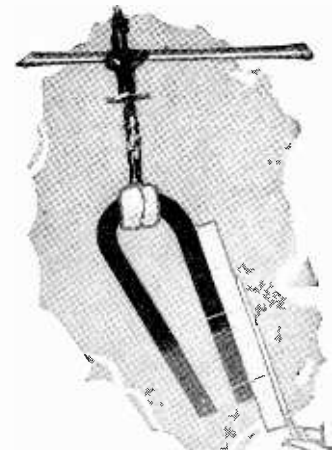

A nail is attached to a strip of wood, which wood is tied to a magnet as shown. The nail will have enough magnetism induced to pick up small objects.

Magnet filings in a test tube are made to illustrate the action of lines of force and of the action of magnetism upon a bar of iron.

the other, thus the piece of iron becomes a magnet. Erroneously believed by many, the magnetizing magnet does not put magnetism into the iron, but simply lines up the little inactive magnets of which every piece of iron and steel is composed.

A simple experiment with iron filings in a glass vial or test tube will serve to make this point. Imagine the individual filings as little magnets in the piece of iron. The tube of filings will not have a bit of effect upon a

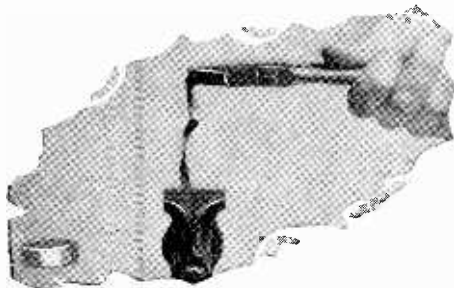

Twisting a piece of sheet-iron imparts to it a slight magnetic force, but quite sufficient to be detectable. A compass needle will show the effect.

compass needle. Lay the tube on the end of a horseshoe magnet as shown and tap the tube with the finger. This will serve to line up the little magnets in the filings, or if you will think of the filings themselves as representing the little magnets and that they themselves are lined up, you will have a better idea of just what happens in the piece of iron. Now after the tapping, if the tube is not shaken, it will attract or repel a compass needle like any other magnet.

Let the clip hold the letter to the cardboard. Mix up a pile of the prepared letters and let each player take turns with a magnet, trying to pick out letters without moving other letters, as in jack straws. The one who spells a word with letters which he has extracted from the pile without moving other letters, wins the game.

Pieces of iron or steel can be magnetized by induction, i.e., without having the excit-

ing or magnetizing magnet come into contact with them. One can show this by fastening a half-inch strip of wood to one pole or leg of a horseshoe magnet and then attaching a nail to the strip. The nail will be found to lift or attract iron tacks, although the horseshoe magnet is not touching the nail.

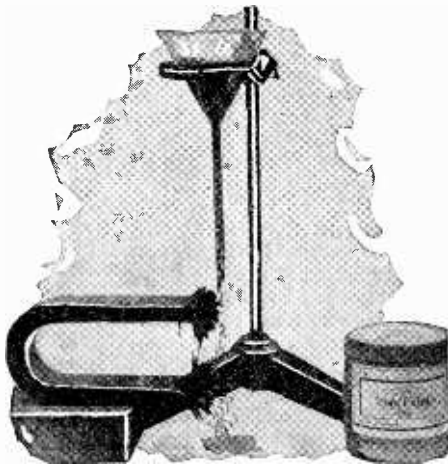

Iron filings mixed with sand or other foreign material are caused to drop past the poles of a magnet. This attracts the iron filings, effecting their separation from non-magnetic material.

The nail is said to be magnetized by induction.

Many industries employ electromagnets for removing "tramp" iron and steel from the raw materials which go to make up their products. A simple experiment which illustrates a device of this character is shown in one of the photographs. A mixture of sand and iron filings are used. Bird gravel is very satisfactory. The mixture is placed in a funnel and the issuing stream of iron and sand is allowed to fall near the poles of a magnet, which attracts the iron and allows the sand to pass by the poles so that it can be collected.

Magnetic shielding can be illustrated by sparsely covering an iron washer with iron filings holding a magnet to one side of the washer. The filings will arrange themselves in the usual magnetic patterns but



Magnetic shielding is shown; an iron washer projects or shields iron filings within its opening from the action of a magnet.

those inside the ring of iron will not be affected in the least. The iron walls here act as a shielding agent.

A magnet can cause electricity to flow through a wire and the current produced can be made to magnetize a piece of iron, as a nail for instance, and produce effects on a compass as shown in one of the photographs. Two spools of wire such as sold for radio use are connected together and through each spool a nail is thrust. If a magnet is brought near one nail, it will cause magnetization, which will cause a current to be formed in the coil of wire around it. This current will flow through the second coil or spool of wire also, the nail inside will become a magnet and cause the needle of the compass to swing.

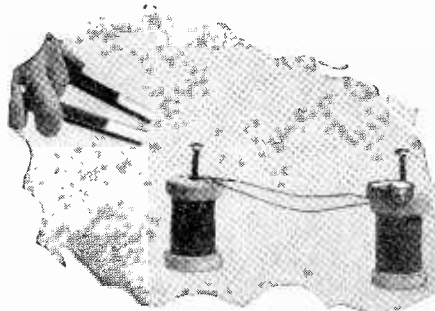

Connecting two coils as shown, an ordinary compass will show the production of a current, when a magnet is brought near a heavy nail which stands in the center of the coil. The action is intensified by the action of a second nail in the other coil.

VOLT OR AMMETER By DALY SCHURR

A VERY simple and delicate form of electric meter, which may be used for measuring either potential difference or current, in other words, which may be a voltmeter or an ammeter, is shown in the illustration. The numerous titles on the illustration make it practically self-explanatory.

For the base a block of wood about five inches long and one inch or 2 inches wide is used, and it may be one-half inch thick. The coil is mounted on one of its ends as shown. The coil must be exactly perpendicular as regards its central opening, and the essence of the instrument requires that it should be accurately leveled. The wire used for winding the coil will be of a size adapted to the work it is to do. If it is to be used as an ammeter, heavy wire must be used and with a current carrying capacity equal to the capacity for the amperes which have to pass. The coarse wire also will have the effect of introducing a minimum of resistance in the circuit. The theoretically perfect ammeter would have, of course, zero resistance. If it is to be used as a voltmeter, fine wire must be used and enough turns of it given to protect it by its own resistance from melting.

An armature of soft iron or soft steel, a round bar, 3 inches long and a 1/4-inch diameter, and perfectly straight, plays up and down through the central opening in the coil. A brass tube in which this bar is a very easy fit, is driven down in the center of the coil. It is a good plan to have it enter a hole in the base.

Through a transverse hole drilled near the top of the armature bar, a brass pin is driven, whose ends are filed to a wedge shape.

The index needle whose details are clear from the cut, has a notch filed about one inch from its end across the forked pieces and exactly at right angles to them. On top of the spool on which the coil is wound, a bent bit of brass is screwed so as to stand up about an inch above the top of the spool and its upper end is filed to an edge. This is a fulcrum for the index needle and the illustration shows clearly the disposition of the parts.

A vertical piece, which may be of brass or wood, rises vertically from the end of the base opposite to the coil and to this is screwed the arc-shaped scale, which carries two stop-pins, top and bottom. The long end of the needle, may be made so heavy as to normally rest on the bottom pin, or it may be made so light, that the armature would pull it up by its own weight, so that it would strike the upper pin. Of course, the latter arrangement would make it inoperative, and the first arrangement would allow it to work, but not conveniently as it would not start from zero. So to give it a zero position, it is made so light that the weight of the armature over-balances it and an extremely delicate spring, shown in the drawing to the right of the fulcrum support holds it in a horizontal position, so that the zero

of the scale is in the center. It would be a simple matter to attach a thread to the end of the spring, so as to be able to adjust it, or the scale may be made to shift up and down.

It may be calibrated by putting it in series with a standard instrument.

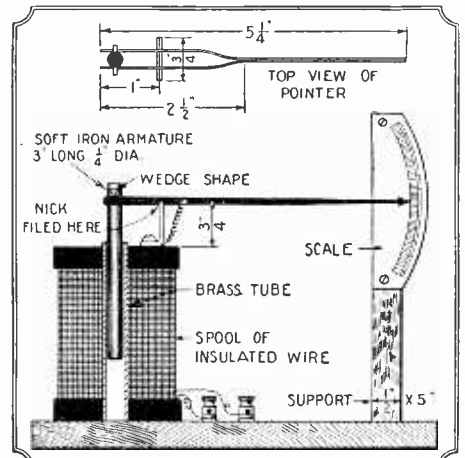

A very sensitive electric meter is shown here, which according to its winding, will act either as a voltmeter or an ammeter. The illustration shows very accurately the different parts and a very sensitive instrument can be constructed on the lines indicated.

MAGIC SHIPS By G. L. ASHMAN

Every electrical experimenter remembers the experiments devised to show the interaction between current-carrying conductors and magnetic field, but it is not so well known that a liquid conductor can be made to rotate.

The diagram will explain the action of this interesting electrical experiment. A glass dish (6 or 7 inches in diameter) is placed on a wooden block, the centre of the dish being just over a magnet pole in the block. A strip of copper foil is fitted closely round the inside of the dish, and a wire or copper rod makes contact with the liquid at its centre; the liquid may be acidulated water so as to conduct the current. A second wire connects to the copper foil.

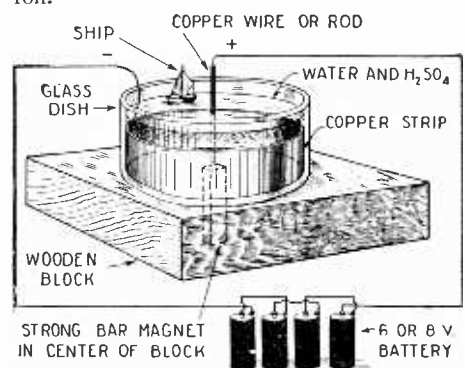

A modification of one of Faraday's classic experiments adapted to a window display, keeping a little ship in motion around the vessel of water in which it floats.

When a battery of 6 to 8 volts is connected to the centre rod and foil, with the polarity indicated, the liquid will rotate around the magnet pole, and reversing the current will reverse the direction of rotation. But remember that reversing the current will cause the copper foil to dissolve.

Small ships made of cork or any light material may be floated in the liquid and would make a good window display. This is a modification of the experiment known as "Faraday's Rotations."

A solution of sodium or of potassium hydroxide with an iron foil may be used.



THE CONSTRUCTOR

Making a Portable Picnic Table

By WARREN BULMAN

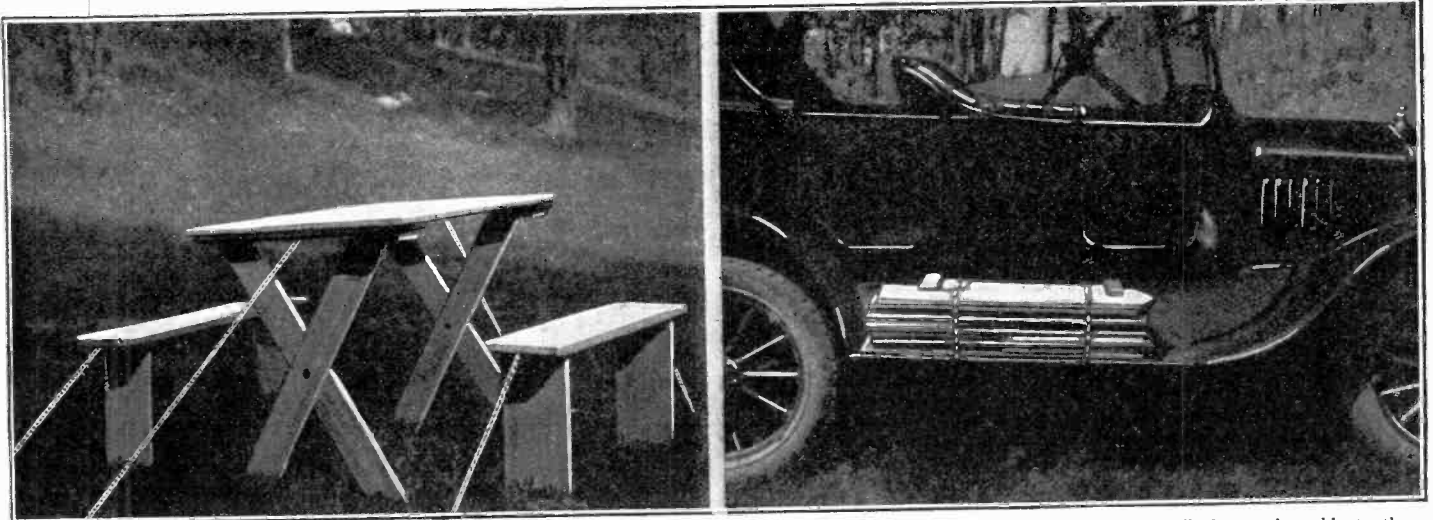

The portable picnic table and benches set up ready for use.

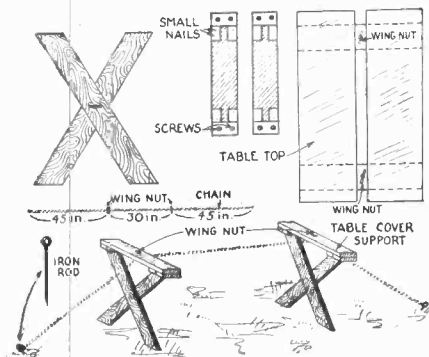

The constructional details of the table and supports are given above. The supporting chain is held secure by two iron rods.

A sketch of the marionette show appears below. Note the position of the operators and the puppets.

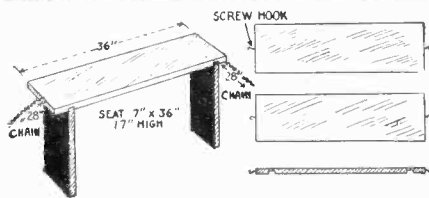

The wise motorist will fasten the table to the running board of his car where it will be out of the way. Two holes are drilled in the running board and chains are passed around the table and seats and through this hole.

At the left we have the details of the picnic benches. Note that the benches, when set up for use, are also supported by chains. An old packing case will provide the necessary lumber for the table and benches.

New Marionette Operation

A PATENT, recently granted to an American inventor, provides an ingenious method for the operation of marionettes. A marionette is attached to each of the operator's legs leaving the hands free for the manipulation of the head and arms. The operator's leg is thus hidden by the figure and yet an excellent movement is obtained. With practice it is possible to produce life-like movement with ease and by further adjustment of the chords a perfect movement may be obtained.

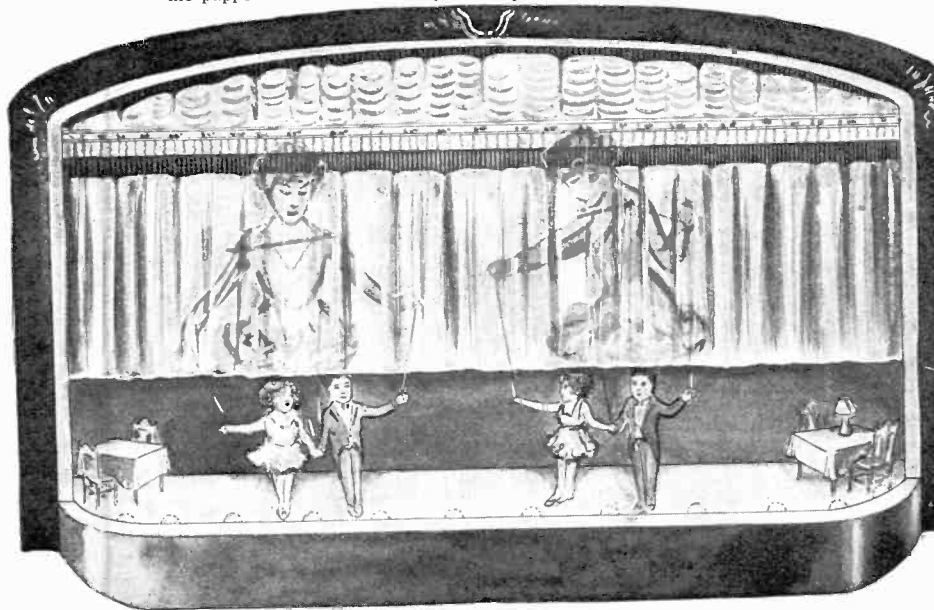

Making Garden Pottery

By ALBERT FORSTON

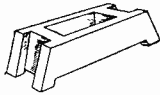

Here we have a sketch showing two useful articles which may be made from the cement as described, one is an artistic pottery vase and the other a novel flower box which may also be used as a bird bath if made small enough.

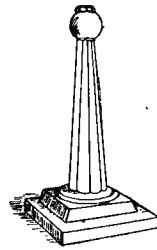

The pottery lamp stand should find many uses in the modern home and may be colored to suit the individual taste. The jar should also prove useful and ornamental.

The box shown here is useful in many ways, the most obvious being as a flower box. A large box can be made and divided into several sections so that different species of plants may be accommodated and yet remain separate. As a finishing touch it should be painted red or green.

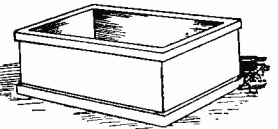

SOLID MOLD MADE FROM CLAY

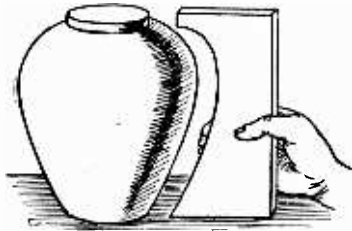

1

STRINGS PLACED OVER MOULD

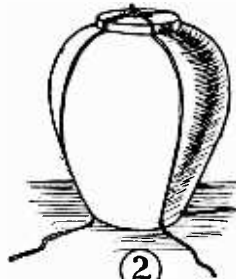

2

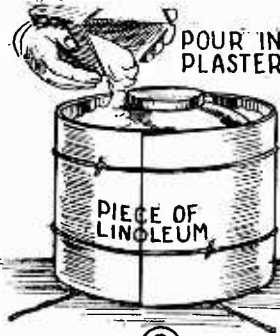

3

CUT MOLD IN THREE PIECES

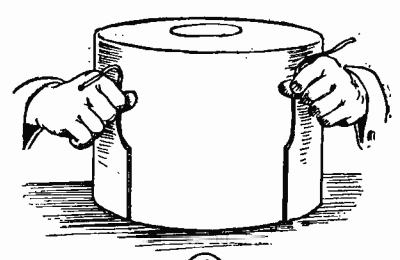

4

The first step in the making of the cement pottery is to form a solid pattern from clay. The clay should be formed around a vase to get the correct shape, or an old vase may be used. After the pattern has dried three threads are placed over it as shown in Fig. 2.

The surface of the pattern is next thoroughly oiled, and the piece is surrounded by a sheet of linoleum, which is held in shape with cord. A mixture of plaster of Paris and water is then poured around the mold, the linoleum keeping it in place.

While the plaster of Paris is stiff but still soft, cut it into three pieces by pulling the threads as shown in Fig. 4. If done correctly this will sever the mold neatly into three separate parts.

MOLD IN THREE PIECES

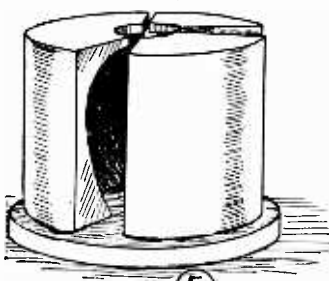

5

POUR IN CEMENT

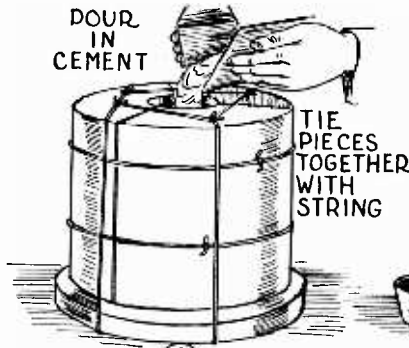

6

POUR AND ROTATE



7

PAINT THE VASE

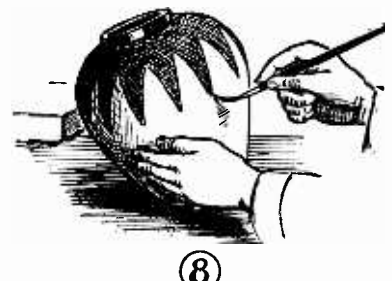

8

In the figure above we have a sketch showing the mold after it has been cut. The inside of the three pieces should then be oiled and all tied together with strong cord. After this has been done the mold is ready for use.

Next pour in a mixture made of equal parts of fine sand and cement until the form is full. Let it stand for half an hour and then pour out some of the cement. This process should be repeated three times.

After all the loose cement has been poured out the whole is allowed to dry for several days, after which the covering is removed and the finished product is given a coat of paint.

COAT HANGER CANDELABRA

By L. B. ROBBINS

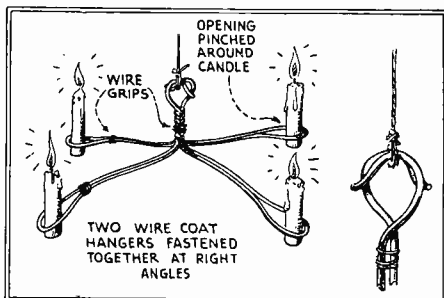

Two coat hangers bound together with wire, their arms crossed at right angles, makes an excellent candelabra. The open spaces at the ends of hangers should be closed far enough so that a candle can be held in the opening without slipping. This will serve to hold the candles securely in a vertical position. The finished candelabra may be suspended with a piece of fancy cord or wire.

CLOWN ASH TRAY

By R. BEROTT

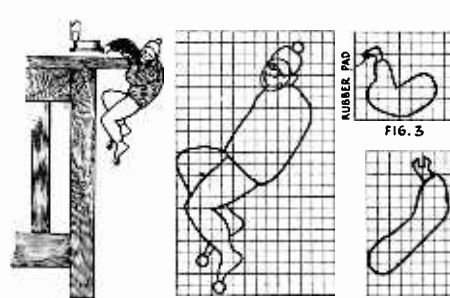

In the figures above we have the details of the clown ash tray. The feet are weighted down with lead balls, the weight keeping the balance on one hand which is covered with a small piece of rubber in order to keep it from slipping. Fig. 1 is on linear scale of 1 to 4.

BIRD CAGE STAND

By L. B. ROBBINS

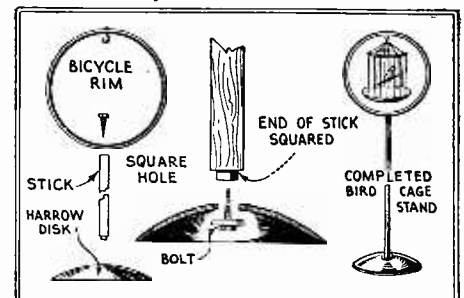

The bird cage stand shown above is made entirely from odds and ends found about the house. The base is made from a harrow disk turned hollow side down. A four-foot length of old curtain pole is then fitted securely in the hole and held in place with a lag bolt and washer. The cage support is fashioned from the rim of an old bicycle wheel.

Home-Made Breakfast Nook

By HAROLD JACKSON

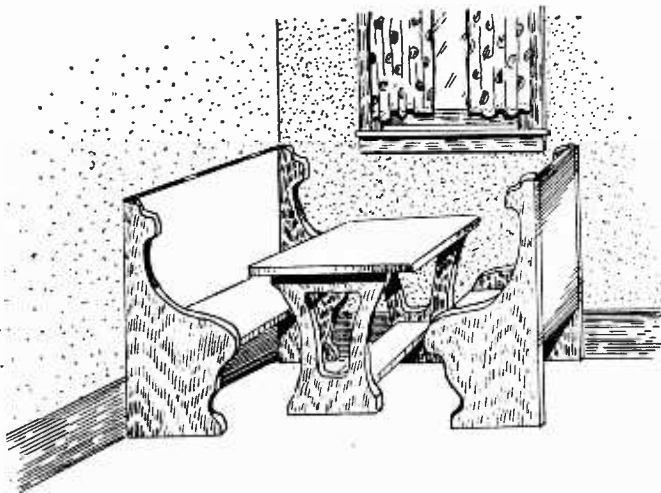

The breakfast alcove shown here does not require a special alcove or room. It may be set in one corner of the kitchen and presents an attractive and pleasing appearance. The breakfast set is best made from hard wood and can be artistically decorated in bright colors or finished in the natural grain. The design and style can be varied to suit the individual taste and also to harmonize with the rest of the room.

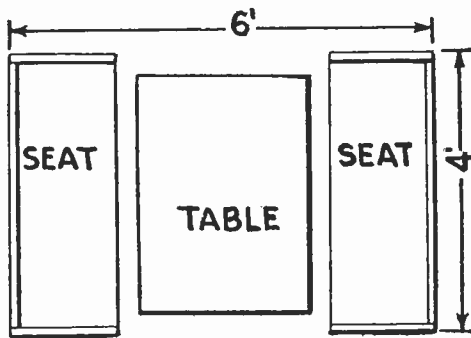
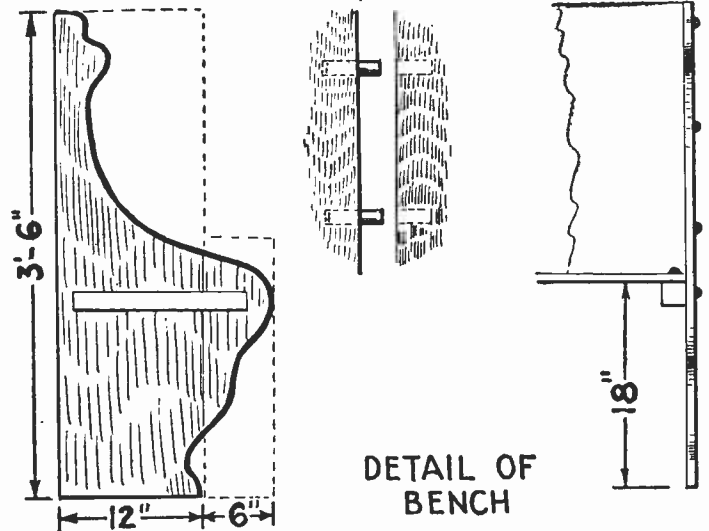

FIG. 1

The placement and spacing of the various members of the breakfast set are shown above. There is a distance of 6 feet from the back of each seat with the table placed in the center. The seats are 4 feet wide. The whole set fits within a space 6 feet long and 4 feet wide thus adapting itself to the average size kitchen without consuming too much space.



The constructional details of the benches are given above. Full width boards should be used but if not obtainable two narrower boards can be joined with dowels and glue as shown.

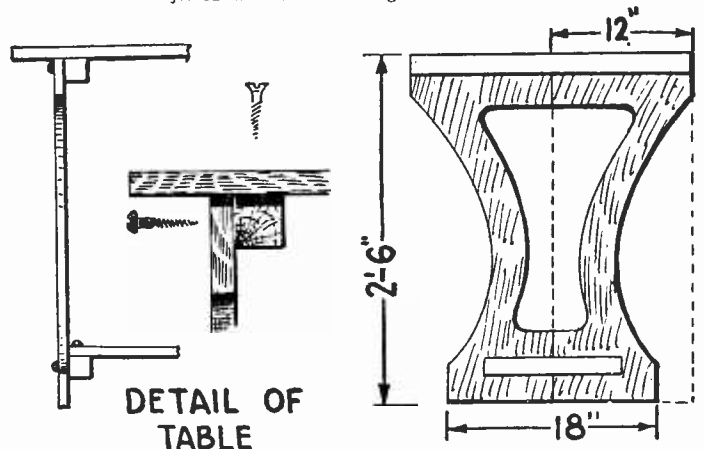

FIG. 2

The breakfast table is constructed according to the details given in the figure above. The table is joined together with round-head blue screws. The design given here need not be followed exactly and the constructor may build the table to suit his own fancy. It is well to finish the set in some color which will be in harmony with the general color scheme of the room.

Hints for the Mechanic

BELT TIGHTENER AWARDED \$10.00 PRIZE

A novel method for decreasing the slippage of a belt without burning out the shaft bearings is shown in the sketch. Two springs are made fast to the belt with rivets, in some cases where the belt is a large one it will be found necessary to use three springs. The springs stretched across the belt in this manner take up any slack and keep the belt from slipping. It will be found when using this method of tightening that the burning out of shaft bearings will be eliminated, and that the belt will be kept tight at all times.—Charles Rugler.

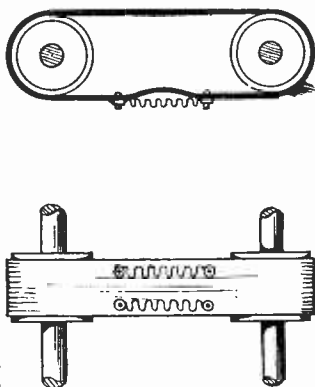

A New Department!
BEGINNING with the May number we started this new department—"Hints For the Mechanic," in which we intend to publish wrinkles useful to mechanics in general. You can help us with this department by writing a brief description of your favorite shop wrinkle and sending this to the editor of this department, together with a pencil or pen and ink sketch of the wrinkle. The ideas published herewith will give you some idea of what we want. Our draughtsmen will make the necessary mechanical drawings, so you need not send us finished drawings. We will pay \$10.00 each month for the best Wrinkle or Hint sent in; others published will be paid for at space rates. Address all letters to Editor, Hints For the Mechanic Dept., in care of this magazine.

HINGE DOOR STOP

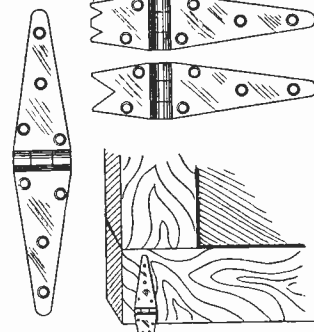

By cutting a V-shaped notch in one side of a strap-hinge and fastening the uncut side to a heavy door a practical door stop can be made. This will do much to hold the door in place, either opened or closed, as required. The single V cut proves the best

for gripping in soil or gravel, whereas the double cut offers a larger gripping surface for wood or cement. Hinges used as described here make very efficient door stops for swinging doors, at the same time take up little space and rarely ever slip. For heavy door heavier hinges should be used than for light doors but all hinges should be provided either with a deep V or double V notch.—Howard C. Kramer.

(Continued on page 273)



HOW TO MAKE IT



FASTENING PIPES

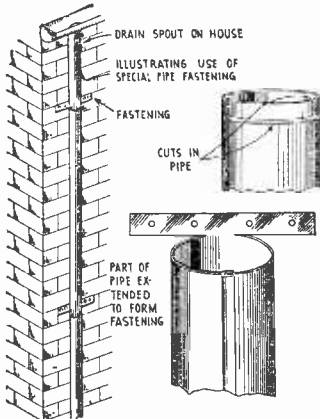

Galvanized pipe and ducts for heating plants, stoves or drain spouts can be held in position without stay wires or other fastenings, by adopting the means shown in the sketch. A narrow band of metal is cut from the pipe and the two ends extended to form brackets. These are nailed or otherwise secured to the wall, ceiling or adjacent surfaces along which the pipes are to run. The hanger is made at the end of the pipe which is straight and the crimped end of the connecting pipe slips into the opening below the hanger. This method of fastening may be adapted to any size of pipe, is easily and quickly made and is neat appearing. The old method of fastening pipes with stay wires or special clamps is inefficient inasmuch as the clamps become loosened or wires break or sag resulting in a displeasing appearance.—G. A. Luers.

erwise secured to the wall, ceiling or adjacent surfaces along which the pipes are to run. The hanger is made at the end of the pipe which is straight and the crimped end of the connecting pipe slips into the opening below the hanger. This method of fastening may be adapted to any size of pipe, is easily and quickly made and is neat appearing. The old method of fastening pipes with stay wires or special clamps is inefficient inasmuch as the clamps become loosened or wires break or sag resulting in a displeasing appearance.—G. A. Luers.

FLOWER BASKET HINT



It is often troublesome to water flower baskets and if these are allowed to become dry the plants will soon suffer. A saucer placed in the bottom of the basket before the soil is put in will retain a certain amount of the water and the basket is not so likely to go dry. A great deal of trouble is thus saved and the plants as a whole grow much better and keep in a better condition.—S. Leonard Bast'n.

PEBBLE GUN

A pebble gun can be made in a few minutes from an old umbrella rib and a cover of a tin can which are arranged according to the sketch.—L. B. Robbins.

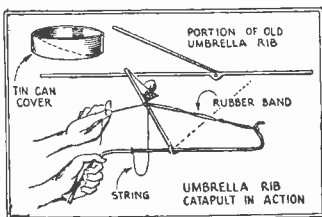

HOME-MADE HOOKAH

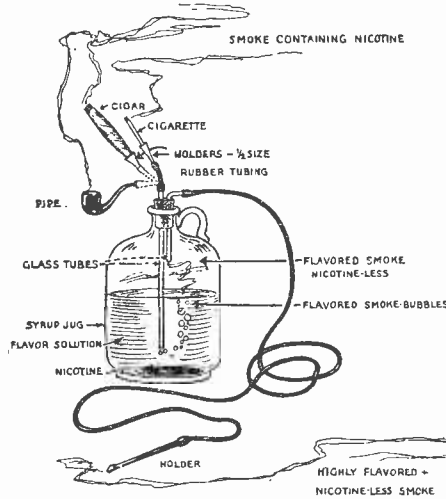

A Hookah or turkish smoking pipe filters out the nicotine and provides a cool smoke. A glass jug is fitted with a two-hole stopper and two glass tubes inserted as shown. The shorter tube is connected to the mouth piece, which is a cigarette holder, by means of a piece of rubber tubing. The longer tube projects into a flavored solution. The cigarette or cigar is placed at the upper end of the long tube, which is fitted with a small size holder.—G. P. Johnson, Rep. No. 16,995.

PHOTOGRAPH LAMP SHADE

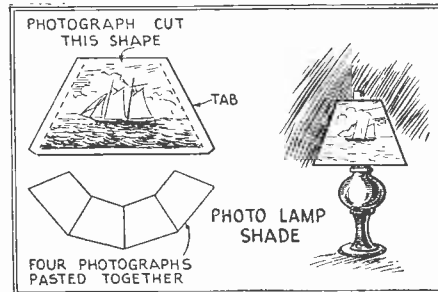

A distinct novelty for the living room is a lamp shade made of your favorite photographs. The photos should be at least 5 x 7" in size and good contrast pictures should be chosen with a variety of subjects. Cut each print so it is about the shape indicated and leave a margin at each angle. Then paste or glue the four prints together to form a strip as shown in the bottom of the sketch. Now bend these at each joint and fasten the first and last prints together. This will form a square shade smaller at the top than at the bottom with a different picture exhibited on each face. A wire frame is made to hold the shade in place.—L. B. Robbins.

DELICATE KNIFE

A small, delicate knife useful in microscopy may be made from the edge of a razor blade. The blade is inserted between a toothpick and wrapped in place.—L. G. Shinn.

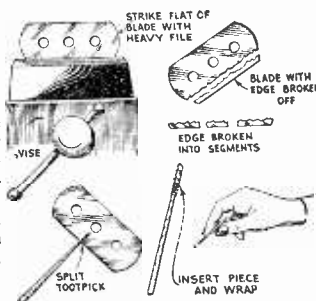

PRESSURE EQUALIZER

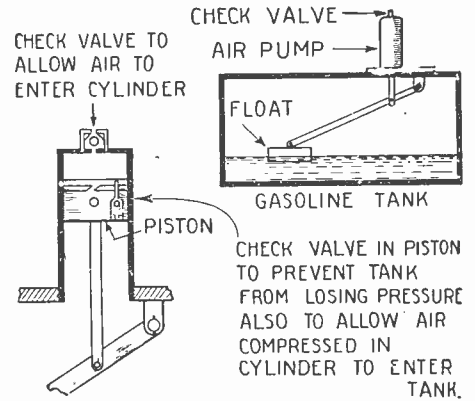

Trouble is sometimes encountered when the gasoline supply runs low as this creates a partial vacuum within the tank. By fitting the inlet of the gasoline tank with a piston and a check valve this trouble can be eliminated.—Thomas McCartie.

BLOWN-OUT FUSE INDICATOR

A small red or green electric light connected in parallel with the fuse will light when the fuse is blown out. The signal lights should be numbered to correspond with the fuses, so that no signal time will be lost in locating the blown fuse. The signal lights must be of the same rated voltage as the line to which they are connected.—Charles F. Felstead.

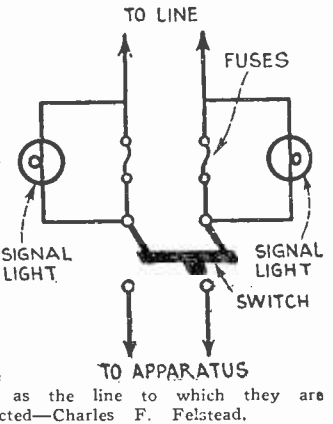

CONVENIENT HOSE REEL

An old tire rim, fastened to the house with metal brackets placed in the position indicated in the drawing, will make an excellent hose reel. The hose can remain attached to the faucet and thus be ready for use at any time. This does away with the necessity of rolling the hose on the reel.—Wilson G. Walters.

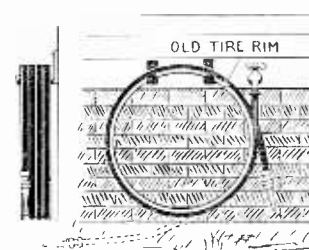

LABEL PROTECTORS

A section of the transparent window of an open faced envelope makes an excellent protector for the labels on medicine bottles.—Wilson G. Walters.

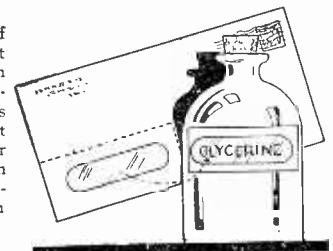



WRINKLES RECIPES & FORMULAS



Edited by S. Gernsback

TIRE SPREADER

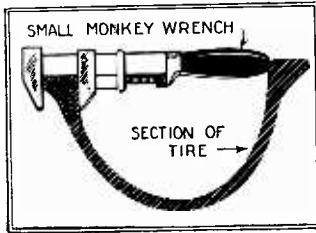

The small monkey wrench proves useful in holding a tire open when one wants to remove dirt or nails, or when putting in a plug or patch. The end of the handle is braced against the inside of the tire and movable part fits against the other edge.—Arthur Flinner.

PROTECTING AUTO WIRING

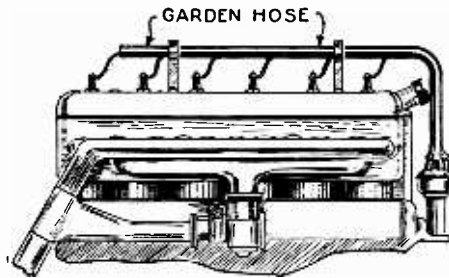

The high tension wires leading from the distributor to the various spark plugs may be effectively protected with a piece of garden hose. Contributor kindly send name and address.

AUTOMATIC LIGHT SWITCH

A switch which can be made to turn off the light at any desired time may be constructed from an old alarm clock and a spool. The spool is placed over the alarm winding arm. A piece of string is then connected from the chain on the light to the spool.—Peter D. Adams.

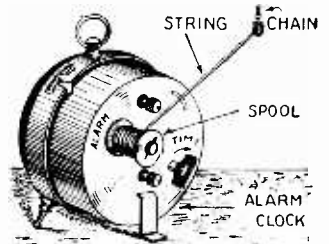

connected from the chain on the light to the spool.—Peter D. Adams.

CLEANING BATTERY CLAMPS

Battery terminals have a tendency to become heavily corroded. This greatly handicaps perfect contact and electrical connections. The clamps may be cleaned quickly and effectively by immersing them in a solution of either dilute or concentrated ammonia.—F. R. Moore, Reporter No. 1993.

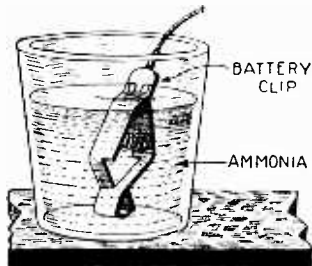

REPAIRING BROKEN PEN POINTS

A broken pen point, if made of gold, may be fixed very easily. The tips of the point are made even with a piece of emery cloth and the underside bevelled slightly. Next, the end of the point is dipped into a very small globule of mercury which should be removed in a few seconds.—Charles S. Bassin.

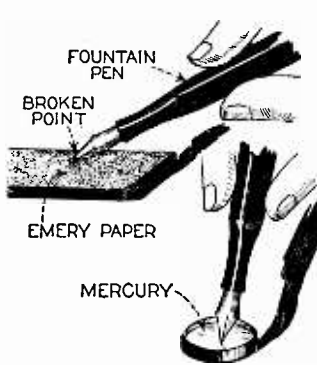

SAVING FILE SPACE

Space in letter files may be saved by the following ingenious method: A number of copy sheets are "staggered" and a brush dipped in glue is run along the upper left hand corner. The glue is then allowed to dry and the sheets put away for use. The original letter and the answer may then be stuck together with ease.—W. Leslie Todd, Reporter No. 7791.



SALVAGING A BROKEN FLASK

A distilling flask, when broken, is usually thrown out as being of no further service. This, however, is extravagant and the economical chemist or experimenter will repair the broken flask as shown here. A serviceable side-arm test tube may be made from the glass by sealing the bottom of the neck in a Bunsen or alcohol burner. If the repairing is neatly done a satisfactory and useful piece of apparatus will be produced.—Richard Bannerot.

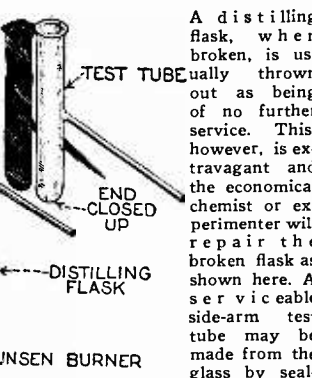

ing the bottom of the neck in a Bunsen or alcohol burner. If the repairing is neatly done a satisfactory and useful piece of apparatus will be produced.—Richard Bannerot.

SAW RACK

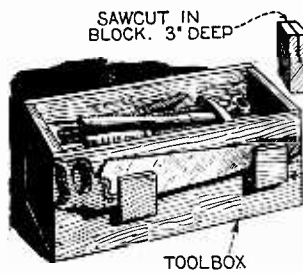

If the saw is supported on the side of the tool chest by means of blocks of wood it will keep its keen edge longer than if other heavy tools were placed in the tool chest with it.—F. W. Kinard.

KEY HOLE PROTECTOR

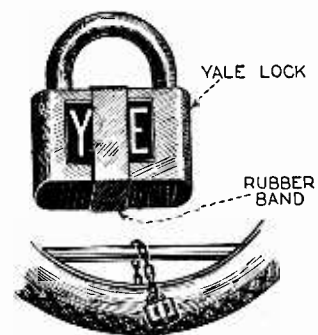

Much annoyance and sometimes expense, caused by mud plugging up the key hole of the spare tire lock, may be avoided by placing a wide rubber band around the lock and over the key hole before the shackle is snapped shut.

This inexpensive protection will prove a great help to the motorist.—Waldo Archer.

SIMPLE TWEEZERS

A pair of tweezers may be hastily made from a cotten-pin the end of which has been filed off. Large splinters may be easily removed with these tweezers.—D. S. Jenkins.

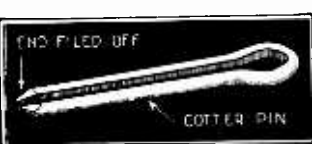

DRILL CONTAINER

An old renewable fuse may be employed as a handy container for small metal and wood drills. The drills are thus kept from being lost and are always handy at a moment's notice. Different sizes of renewable fuses may be utilized to accommodate various sizes of drills.—Thos. F. Johnson.

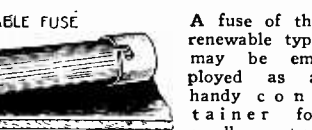

RUBBER HANDLES

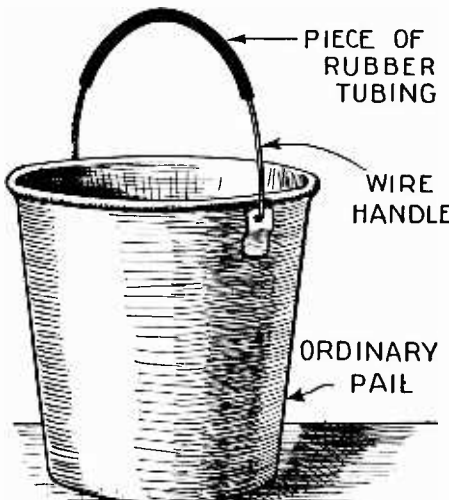

A piece of ordinary rubber tubing placed over the handle of a bucket or pail provides an excellent grip.—Ivy M. Howard, Reporter No. 19,697.

FLASK FROM LIGHT BULB

A neat flask can be made from a burnt-out, tipless electric bulb. The top of the flask is filed off so that the screw base and filament support may be removed. A lip is formed by heating the glass and pressing the edges outward with a file or with a round battery carbon. The bottom of the bulb is next heated until it is soft and is then pressed flat against a block of wood. The finished flask will find many uses in the experimenter's laboratory. By using different sizes of bulbs various sizes of flasks can be made.—Jack Riffin.

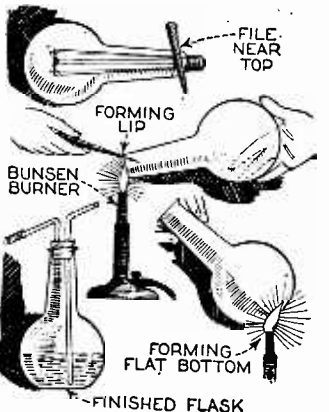

TRUE PSYCHICAL PHENOMENA

Editor, SCIENCE AND INVENTION:

I have just seen an advance copy of SCIENCE AND INVENTION.

Page 25—May issue—Dunninger says, "Any psychical manifestation in so-called spiritualism, that he will not explain."

To my mind this conveys the idea that he wishes to impress the ignorant public with the idea that there are no true psychical phenomena and a most sinful assumption, as a man of his intelligence must know that there are plenty of true psychic demonstrations or he has been most unfortunate in his contacts.

I have had too much of it with those I have contacted with—no money consideration involved—to have any doubt.

To be sure that I have contacted with fakirs but because there are those who resort to that sort of stuff is no argument that there is no true evidence.

The exposition of fakirs is a good work—I've done quite a bit of it myself, although I think its hardly worth the trouble in my case as I've only done it privately—but its certainly wrong to convey the idea that the entire business has been faked.

I've known mediums to be the instrument of producing true phenomena and, because they thought they could make some extra fees, I suppose, have caught the same mediums faking.

"that he will not explain"—If he means that he can explain true psychical phenomena, that's another thing. I can explain nearly every phenomenon I've experienced. I've seen eighteen different forms materialize in one evening and each and every one of them speak in a different voice—heard nine different voices sing, each in succession and in four different languages—got hundreds of forms in photographs of which there was never an original in the same position, from which copies could have been made, etc., etc.

I don't suppose you would care to print any reports of true phenomena, but if you care for anything in that line, let me know what compensation you are ready to pay and if sufficient, I may take the trouble to prepare something for submission, with no obligation on your part to accept.

In my work I've been able to expose a certain public entertainer who bragged about having spent \$40,000 in exposing mediums. Do you know where he got the \$50,000 that he received for that work.

The greatest sin, in my mind, is to mislead the ignorant, when one knows he is doing it, and as there is a "Great God Force" in this universe that is governed by certain fixed laws, that everything operates according to nature and that psychical phenomena are as simple as radio. I know that there is no money in the world sufficient to compensate for the agony he will suffer when he realizes the enormity of such deception.

If Dunninger, Rinn and others of that stamp are truly ignorant of such phenomena, I'm sorry for them—they'll miss a lot when they get out of the material body.

D. M. HOUGHT,
Chicago, Ill.

(While SCIENCE AND INVENTION Magazine does not state that psychical manifestations might not at some time be produced, we do believe that up to the present time no authentic phenomenon, capable of being demonstrated, has been presented. We have read of many cases of phenomena occurring to different individuals. These, however, can be discounted as being hearsay evidence or as being attributed to an association of ideas. For instance, were one to wear an opal ring, and were that person to entertain the belief that the opal was unfortunate, and while wearing the ring, were he to meet with a serious accident, he might attribute it to the ring.)

Some card players will even tell you that they must put their hats on backward in order to be "lucky" at cards and that they have no success whatever if they do not wear their hats or when wearing them, they put them on in the approved fashion. It is quite evident that the hat has nothing to do with the way the cards lay or with the skill of the player.

Some time, however, a psychological effect might be produced on the contesting player. Chess games have been known to have been lost, particularly because the opponent wore a loud necktie or because in one instance, the player was congratulated before the game. The same reasoning applies to psychical manifestations of the seemingly true type.

Perhaps while day-dreaming, you might think what a terrible thing it would be for Mrs. Smith and her children if Mr. Smith were suddenly killed in a railroad accident. If perchance such an accident occurred, then checking back on your day-dream, you might believe that you were spiritually gifted.

SCIENCE AND INVENTION Magazine has \$21,000 which it is prepared to spend, either wholly or in part, to those demonstrating exactly the type of phenomena which you list in your letter, namely, materializations, photographs and independent voices.—EDITOR.)

S. & I. RESEARCH LABORATORY?

Editor, SCIENCE AND INVENTION:

It has been a habit of mine to browse over the



SCIENCE AND INVENTION desires to hear from its readers. It solicits comments of general scientific interest, and will appreciate opinions on science subjects. The arguments pro and con will be aired on this page. This magazine also relishes criticisms, and will present them in both palatable and unpalatable forms. So if you have anything to say, this is the place to say it. Please limit your letters to 500 words and address your letters to Editor.—The Readers Forum, c/o Science and Invention Magazine, 230 Fifth Avenue, New York City.

AMAZING STORIES

IN THE JULY ISSUE:

THE ETHER SHIP OF OLTOR, by S. Maxwell Coder, the first honorable mention cover contest story, which deals with Venus and a war there. A fine, spontaneous and original story, and it follows the illustration conscientiously.

THE VOICE FROM THE INNER WORLD, by A. Hyatt Verrill. This story has won second honorable mention and the writer, who is by this time well known to our readers, treats these strange people as ferocious female cannibals—making it a somewhat gruesome narrative.

THE LOST CONTINENT, by Cecil B. White. Third honorable mention story. Some thoughts on the fourth-dimension and a trip centuries back on time are very cleverly worked into the subject of the illustration. A clever, original story, well told.

THE GRAVITOMOBILE, by D. B. McRae, awarded the fourth honorable mention, again treats the subject of the illustration in a quite individual manner. It starts in Mexico, goes to Mars, and ends—well, very unexpectedly.

THE MOON POOL, by A. Merritt (Conclusion). The third and final instalment carries you into the realms of the mysterious Three and the Shining One. The author very ingeniously depicts a war, effectively fought, between the two underground factions, with weapons entirely new and astounding. The story becomes more and more exciting and interesting chapter by chapter.

RADIO MATES, by Benjamin Witwer. Every time an X-ray picture is taken, many particles—bits of actual matter—pass from the machine to your body. The author of this story very cleverly weaves a fascinating romance around the possibilities of sending solids and then living beings through the air to be "received" at distant points. An unusual story, excellently told.

THE PLATTNER STORY, by H. G. Wells, probably constitutes the forerunner of all his other dealings with a fourth or higher plane, sends its hero, in a unique fashion, into the fourth dimension and mysterious "Other World." Somehow, astounding internal bodily changes are effected. A fine story told in Wells' best manner.

Readers Forum after reading and digesting the facts, theories, and news contained in SCIENCE AND INVENTION. Some of these letters interest me more than your humor page; others are very plausible. It is impossible for a magazine to cater to the wants of every individual reader, it must please the masses, although I am inclined to agree with Mr. Blaine Hollimon (Feb. issue) that there is Radio News for those interested in radio.

I also wish to comment on his paragraph referring to a Geographic Expedition. Very good, but do you think that could come under the heading of Science and Invention? I feel that if a vote was taken, it would be found that it would not interest 5% of the readers.

Such suggestions are no doubt helpful to the editors when acted upon by the readers. The above is my opinion of Mr. Hollimon's Geographic Expedition. In accordance, I wish to make a suggestion.

Magazines devoted to the care of the home, have proving plants, laboratories and other workshops that are owned and operated by the publishers in their respective magazines.

Why not a Science and Invention Research and Experimental laboratory; owned by the readers of SCIENCE AND INVENTION; business management to be operated by candidates elected by the readers; business manager to secure the services of scientists, professors, or young men who are enthused and capable to carry on such work.

It is not for me to suggest what kind of work may be carried on, but I might say color photography improvements, perfection of printing, printing inks, radio television, and you know how many other subjects that are profitable to man, such as "Why does a man digest food?"

The equipment for such a laboratory to be purchased by funds secured by the sale of stock, to the readers of SCIENCE AND INVENTION; stock to cost about five dollars a share so that at least one share is within the reach of the young fellows, who are interested. This could also be arranged so that when 20 shares of stock are purchased, say \$25.00 is paid down, the balance on time a little each month. My reason for this is to give everybody a chance.

It is my opinion that such a laboratory, with capable management, could start to pay dividends in a short time, for the sale of patents, or manufacture of objects invented therein.

You are aware, no doubt, that I am very enthused, now let us see if it will not go over.

I believe it was Raymond Wailes who said "the Germans form a group when they have an idea to push it to those who do not know they are interested."

Write to SCIENCE AND INVENTION, a group is what is necessary, to bring this out of the air down to a fact. I am sure that our magazine will give it plenty of advertising and help, if it pleases the masses. Raymond B. Wailes and H. Winfield Secor are two men who could do a pile of good in putting it across.

You—Everyone of you who read this, if you are interested, act. Do not let the next man act first, you do it.

GEORGE H. BOESKEN,
Lakewood, Ohio.

(A research laboratory of the type suggested by you requires a heavy capitalization and entails a terrific expense. It may be that the laboratory would continue to operate for a period of several years before a worth-while invention were actually patented. It is equally possible that after the invention has been patented, it would be difficult to commercialize the idea. Of course, we will admit that a factor sadly lacking in America is some form of a patent finance bureau which will enable the poor inventor to place his suggestion on the market, or which would assist him in the sale of his idea. The average poor inventor has a difficult uphill road to climb, but if his suggestion is really worth-while, it eventually meets with success, the amount of such success being dependent entirely on the contract of sale and on the usefulness of the suggestion. We will of course, be interested in what the readers have to say about this suggestion.—EDITOR.)

TRAPPED AIR POWER

Editor, SCIENCE AND INVENTION:

I have been a constant reader of your magazine ever since it changed from the Electrical Experimenter and a month seems kind of empty if I don't get the magazine. Last fall I heard a story on how a miner, back in the hills, away from any source of power, (except wood) worked his mine and I'd like to hear your opinion of it. There was a fair sized stream running close to the mine and a small falls. Up the stream, he put in a bunch of riffles to get the water charged with air.

Suspended beneath the falls where it would get the full force of the water, was a bell-shaped affair, (resembling the bell on a door bell.) This was drilled full of small holes. I don't know the size or the manner of arrangement. The bell was suspended by an iron pipe, the pipe running to a storage tank on the bank. The tank was about half the size of the tank cars that the railroad uses. The water going over the riffles was supposed to charge the water with air. Going down over the falls the water hit this bell, forming a suction. The bell was then supposed to separate the air from the water and draw it back into the tank. He then piped the air to his mine and ran it on compressed air.

BURTON A. RUBECK,
Spokane, Wash.

(This particular scheme is not entirely new and while the air confined in a large enough bell-shaped trap might be put to useful work, the efficiency of the mechanism is extremely slight. It is far better to use the power of the water-falls to turn a wheel, generate electric current and then use motors or to use the wheel to operate the air pump directly; that one wonders why a miner should have erected the bell in place of the wheel. The air pressure will depend entirely upon the depth of the bell beneath the surface of the stream. Many of the air bubbles will not be trapped in the bell affair and there are losses along the entire system.—EDITOR.)



RADIO

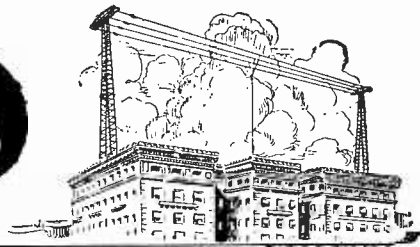

The Radio "Power Plant"

Transmission of Power Over the Air Actually Accomplished

RADIO power, encasing the globe similar to a blanket of energy, will, in the future, provide the means for operating our electrical appliances and furnish us with unlimited light, heat and energy. The transmission of this power over the air was recently demonstrated, on a small scale, by Dr. Phillips Thomas, research engineer of the Westinghouse Electric & Mfg. Co. Using radio waves like those used in broadcasting, except of a shorter wavelength, Dr. Thomas actually lighted small flashlight bulbs connected with a short antenna, from this invisible source of power.

A transmitting tube having an output of 35 watts was suspended from a wooden stand; directly underneath this the short-wave antenna was placed. The transmitting aerial itself consisted of a loop of copper tubing to each end of which a small plate was attached, separated by an air gap, which acted as a condenser. From this short-wave oscillator, waves 240 centimeters or 8 feet long were radiated, which is only about one one-hundredth of the wavelength of the shortest waves ordinarily used in broadcasting. The receiving antenna consisted of a piece of copper rod, 120 centimeters in length, which corresponded to one-half wavelength. An ordinary flashlight bulb connected at the mid-point of the receiving antenna, lighted when brought in a vertical position adjacent to the transmitter. By referring to the diagram it will be seen that the bulb lighted only when placed at the point of minimum voltage and maximum amperage, and that a neon tube, held in the hand, glowed when brought to the position of maximum voltage and minimum amperage. These points, of course, are invisible and cannot be determined beforehand, so that the bulb had

to be moved experimentally in different positions, in order to determine where the point of maximum amperage and minimum voltage was located. This also had to be done in the case of the neon tube which was not connected to an antenna, but simply held in the hand. Two aluminum strips, receiving the power inductively from the transmitter, were stretched across the platform. A flashlight bulb connected across these strips lighted at the successive points of minimum voltage and maximum amperage, when moved along by hand. This same demonstration was also carried out with the neon tube, which was placed close to the strips.

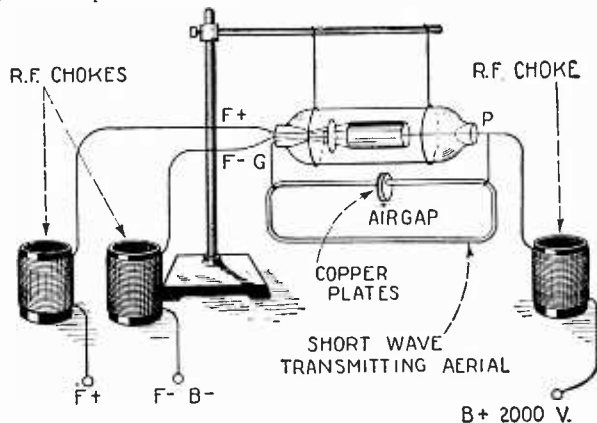

Above Miss Adele Frank is shown with the small antenna which is used in exploring the radio field for power. Note the size of the antenna and the position of the flashlight bulb. The simple apparatus used for the transmission of the radio power is shown at the left. A tube with an output of 35 watts was used. Note the size and novel construction of the short-wave transmitting aerial.

Beams of radio power, criss-crossing a city like a searchlight ray and carrying light and power as wires do now, were discussed as future scientific possibilities. These beams could be produced by reflect-

ing short waves from metal mirrors to make narrow beams or rays, like those produced from automobile headlights. Short waves of less than one meter in length would be used. We may visualize a parallel beam of radiation ten centimeters or four inches across, along which is being sent ten kilowatts of energy. What sort of effects shall we find? Will this be a means of delivering energy for heat and light to individual homes? Nikola Tesla had a similar idea many years ago. Later improvements in the radio art make it interesting to consider such a possibility once more. We may imagine each house furnished with a half wave receiver in line with a parallel beam from a sending station, so that heat and light may be obtained very much as at present, by simply turning a switch, but without the costly transmission wire equipment now required. If these short wave beams ionize the atmosphere, it may also be possible to send an ordinary 60-cycle 110-volt alternating current across them as a carrying medium. The beam could also be directed to any desired spot, with dire results to the target. It would constitute the so-called "heat ray" employed with such deadly effect by the Martians in H. G. Wells' story of their descent upon the earth.

Experiments of this nature, while not practical as yet, offer the stepping stones or foundation for the future transmission

Dr. Phillips Thomas is shown at the left explaining the operation of his short-wave "power plant." In a spectacular demonstration of present power transmission, small flashlight lamps held in empty air, lighted brightly, although not connected to any source of power. A neon tube held in the hand glowed with the characteristic orange-pink color when carried across different points of the platform.

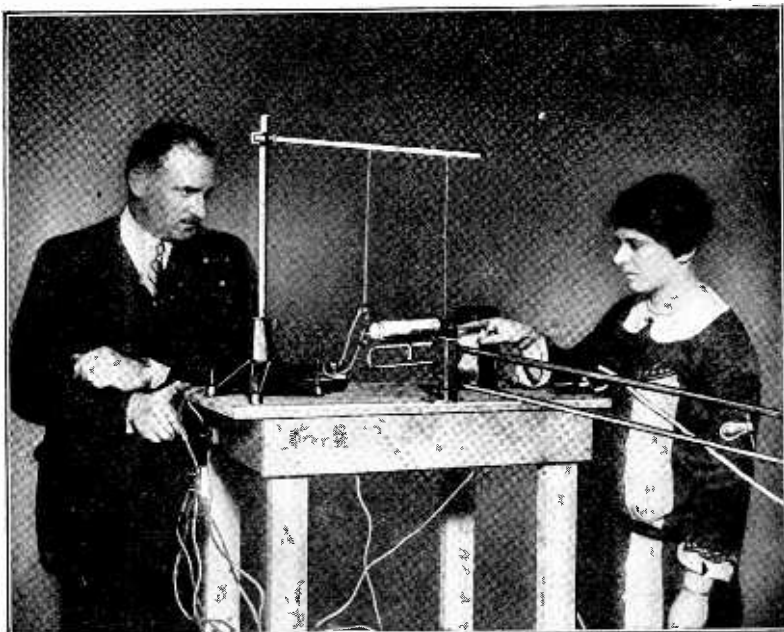

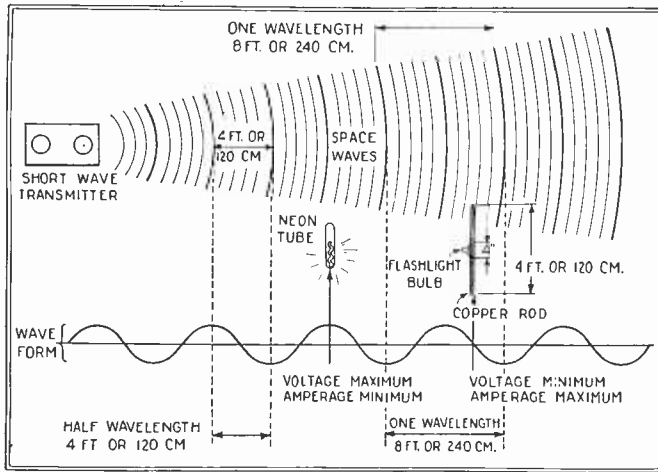

At the left we have a simple sketch illustrating clearly how the transmission of radio power was accomplished. The wave form at the bottom is a graphic representation of the radio power waves and shows the nodes and loops or points of maximum and minimum voltage and amperage.

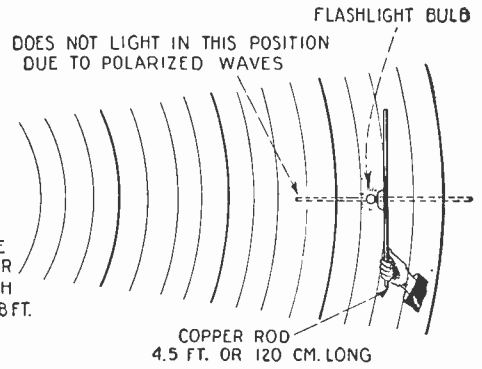

In the illustration above we see that the flashlight bulb lighted when held in a vertical position at the point of minimum voltage and maximum amperage. If the receiving antenna was turned in a horizontal position the bulb went out showing that the transmitted waves were polarized.

of power through the air. The radio city of the future is brought a trifle nearer to our vision. These radio-power beams of

special variety are mentioned not as a fantastic dream of some modern Jules Verne, but as a sober, scientific possibility, which

will enable future generations to live with a greater ease and comfort than is possible at present.

The Radio Hotel

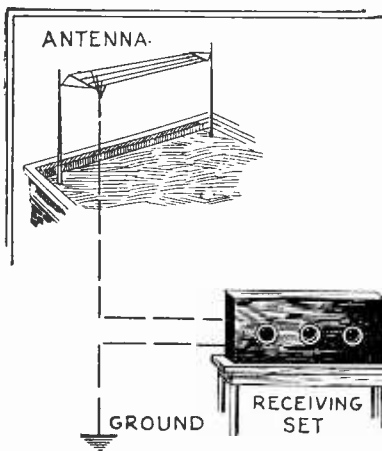

Radio circulates like water in the new Jacksonville Hotel. Below we see the various uses to which it is put. A switchboard is provided whereby the hotel orchestra can be heard in the different rooms or radio programs can be relayed at will. A paging system is also connected to the board.

THE success of the George Washington Hotel in Jacksonville, Florida in furnishing radio programs to each of its three hundred guest rooms has set an example, it is believed, which will be followed by many large hotels in the future. Each room is wired, so that the guests can listen-in on programs from WJAX, the municipal radio station of the city, outside programs and the hotel orchestra concerts. Each room has wall outlets for the connection of loud speakers, which in turn are connected with a powerful super-heterodyne receiver, coupled up with a power amplifier. The receiving set is similar to that used by all large broadcasting stations.

Installation of radio was considered when the hotel was first planned. One of the problems confronting the builders was the annoyance to guests in the adjoining rooms. This was solved by constructing the walls of a combination of gypsum and hollow tile, making the rooms soundproof. The complete cost of the equipment and installation was only \$10,000. This includes 20 loud speakers operating from a central switch board whereby guests may be paged in all parts of the hotel, receiving set, amplifiers and microphones.

When the hotel was opened the program was broadcast and listeners were requested to write or wire, with five listeners to be



Three public address systems are used, one for paging guests, one for bringing programs within the hotel to each room and a third for the reception of outside programs.

chosen from each state as guests of the hotel for three days. That the program was heard throughout the country was evidenced by the fact that more than 2,000 telegrams, letters and post cards were received from 30 states and 4 provinces in Canada.

Three public address systems are used—one for bringing programs within the hotel to each room, one for paging guests and a third for bringing the programs from outside stations, both local and distant, to

the guest rooms. Cone speakers are provided for all the guests and a convenient wall outlet is placed in each room so that the speaker may be plugged in at will.

The idea of wiring a house or a building for radio is not a new one and has been carried out on a small scale many times but the wiring of the Jacksonville Hotel has been a new departure along this line. Never before has this been carried out to such a great extent or to such perfection. In the future private houses will be equipped so that programs may be received in every room. The installation of the radio wiring system will be made when the house is being built. The radio equipped hotel has met with unanimous approval of all the guests and has done much to keep them home nights while in Jacksonville.

Vacuum Relay Operates on 1/40 Fly-Power

A TUBE, so sensitive that the energy from one ounce of coal will operate it 17,000,000,000 times, has been developed by Mr. D. D. Knowles, research engineer, of the Westinghouse Electric and Manufacturing Company. This device, an extremely sensitive grid tube, operates on approximately one-billionth of

If a voltage is applied between the positive and negative electrodes, particles of electricity called "free electrons" attach themselves to the grid. When this grid is thoroughly insulated these minute charges of electricity cannot escape, thus the tube is prevented from passing any current. However, if this grid charge can be removed, the blockade is lifted, and a current then flows between the cathode and the anode and operates whatever device is connected in the circuit. In operation the tube is connected to a transformer which will deliver

Mr. Knowles is shown here demonstrating his new invention, the "grid-glow relay."

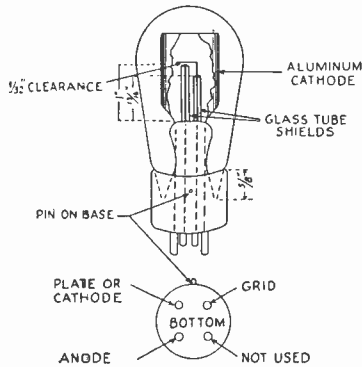

A sectional view of the new relay tube, showing the placement of the elements. Note the small clearance between the grid and the anode.

an ampere. This unit of current comes very close to being "next to nothing," or zero. To make comparison in terms of muscular energy, a house fly walking one inch vertically in one second expends enough energy to operate 40 of these devices simultaneously. To light the ordinary 60-watt lamp requires 60-million times the amount of electricity needed to operate the new relay tube.



A photograph of the new "grid-glow relay," which is of about the same size as the ordinary radio vacuum tube.

amount of power, except when actually operating, and suffers practically no deterioration. It can be set up and kept ready for operation indefinitely without expense; and after it operates it returns to its original state prepared for the next occasion. Its operating speed is 1/120 second on ordinary 60-cycle alternating current, and it can be operated continuously for several years without wearing out.

The power expended by a fly walking vertically one inch in one second, energy of about one-billionth of a watt-second, is sufficient to cause the new tube to operate. This infinitesimally small amount of energy is sufficient to start a current of as high a value as 25 milliamperes flowing through the tube. The marvelous relay has an amplifying power of approximately 100,000,000.

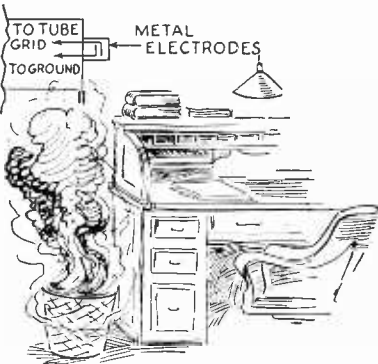
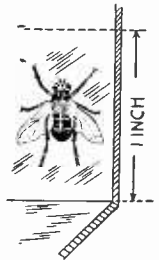

One of the many uses of the new tube finds practical application in a fire alarm system.

Analyzed briefly, the tube consists of three electrodes, a negative electrode and a positive electrode, the latter being surrounded by a plate which constitutes the third electrode. Differing from the ordinary vacuum tube, the glow tube has no heated

440 volts, which in turn is impressed on the anode and cathode. Now, when the grid charge is removed, the voltage gradient is shifted in such a way that the tube will pass current at a fairly low voltage, for instance, about 200 volts.

A hook-up of the new relay tube showing how it is possible to operate a mechanical relay, electric bell or any similar device. Note the various ways in which the grid may be discharged.

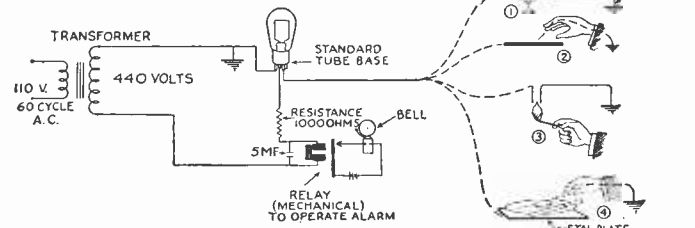

The grid charge can be removed through a resistance or a capacity. The resistance may take the form of a photo-electric cell, a flame or any substance which has any degree of conductivity and which will allow the flow of electrons from the grid to leak off to the ground.

One of the interesting features of this device is that it consumes no measurable

Its chief application will be in electrical engineering, because the tendency is now in the direction of automatic, semi-automatic, and supervisory control for electrical circuits. In addition, however, it can be used to protect valuable exhibits in stores, museums, and picture galleries; turn lights

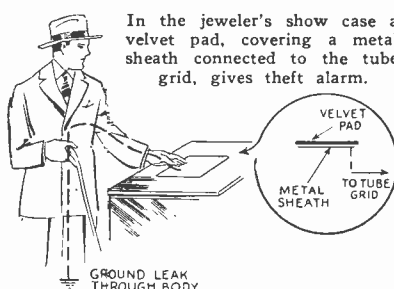

filament and, therefore, does not consume any energy when not operating. It is filled with neon, an extremely rare gas taken from the air. This gas is inert to chemical action and, therefore, feasible for use in the tube.

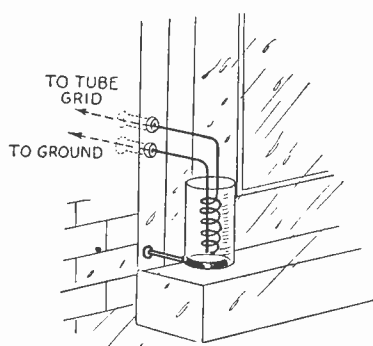

A drop of rain falling between the two wires offers a high resistance path for the grid charge to leak off to the ground.

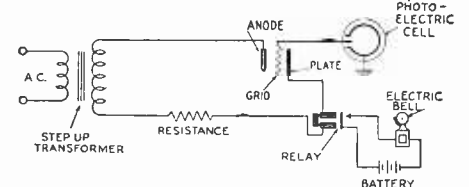

An ordinary photo-electric cell connected between the grid and the ground if exposed to light, will cause the tube to operate.

off at daybreak; give advanced warning of thunderstorms, guard gas and oil stoves and furnaces by turning off the fuel supply in case the flame is accidentally extinguished. It can also be used to count people, automobiles, or products passing given points; send out alarms in case of burglary and provide a very delicate temperature regulator.

A Set for the Experimenters Power Pack

In Which Is Described a Very Selective Receiver to Be Used With the Eliminator—Amplifier Detailed Previously

By A. P. PECK

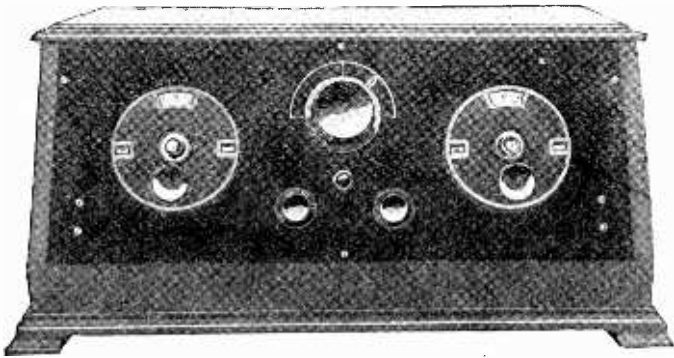

Fig. 1. The cabinet of the Power Pack Receiver are shown in this illustration. Note the neat appearance of the panel with its two tuning dials, at the extreme left and right, the regeneration control in the vertical center, and the pilot light and rheostats below. This arrangement gives a perfectly balanced layout and keeps reaction at a minimum. A sloping panel is used, giving a neat appearance to the set.

IN the May issue of this magazine the writer described the design and construction of a complete power pack consisting of a 3-stage audio-frequency amplifier combined with a "B" and "C" battery eliminator. This eliminator and amplifier was so designed as to permit its use with almost any type of 2-, 3- or 4-tube receiver employing radio-frequency amplification and a detector circuit. The layout described formerly was so wired that only four leads were necessary to connect it to the receiver. Inasmuch as no tuner was described or illustrated to be used with this unit, the writer is now giving here complete data for such a receiver. This set is now in use in his home and is giving excellent results. Because of the simplicity of construction and the ease with which the set can be tuned, even by one unfamiliar with the operation of radio receivers, the author feels sure that many of the readers of this magazine will be greatly interested in the receiver itself.

The type of circuit that was decided upon for this particular set is a combination of tuned radio-frequency amplification and a sharply tuned regenerative detector circuit, controlled by the well known Weagant "X" System. By using comparatively loose coupling between the radio-frequency and the detector circuits, it is possible to increase selectivity to an enormous degree and to render the circuit so sharp in tuning that little or no trouble is experienced even in the present congested state of radio broadcasting.

The photographs give an excellent idea of the appearance of the receiver itself, and when in use with the eliminator and amplifier previously described.

Below is shown the receiver completely assembled and placed in position on the top of the console table which houses the eliminator, amplifier and "A" battery

To the left of the receiver I place the cone speaker used for reproduction. Located on the top of the receiver cabinet is a small electric light, which is very handy when tuning or logging new stations.

Fig. 1 shows a panel view of the set. By placing the tuning dials at the extreme left and right, the regeneration control in the vertical center, and the pilot light and rheostats below, a perfectly balanced layout is obtained.

In Fig. 2 is illustrated a top view of the receiver removed from the cabinet. Here are shown the relative positions of all the

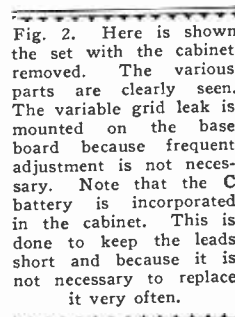

Fig. 2. Here is shown the set with the cabinet removed. The various parts are clearly seen. The variable grid leak is mounted on the base board because frequent adjustment is not necessary. Note that the C battery is incorporated in the cabinet. This is done to keep the leads short and because it is not necessary to replace it very often.

various parts. It will be noted that the variable grid leak is mounted on the baseboard. This is done because it need not be frequently adjusted, but when once set can be left in that position. Notice in particular the "C" battery placed under the left-hand tuning condenser. This battery was incorporated in the cabinet because it need not be changed for probably 18 or 20 months, and, therefore, can best be placed out of the way in the place shown.

Fig. 3 shows a rear view of the receiver. This gives an excellent idea of the construction of the celluloid-supported coils and of the position of the three variable condensers in relation to each other. It also serves to depict the loose coupling between the radio-frequency plate coil and the grid

coil in the detector circuit. Fig. 5 shows a rear view of the two cabinets. It will be noted that six flexible leads enter the set cabinet. Two of these are connected directly to antenna and ground binding posts mounted on the small terminal strip placed on the rear of the console table. The other four enter the table through holes drilled in the top, and serve to connect the terminal strip of the set with the correct terminals on the eliminator-amplifier placed within the console table.

APPARATUS USED

In Fig. 5 the circuit diagram of the receiver employed is shown. The various components of the circuit, many of which will be mentioned in more detail further on, are as follows:

- C—4½-volt "C" battery.
- C1—.0001-mf. fixed condenser.
- C2 and C4—.0005-mf. variable condensers.
- C3—.0002-mf. regeneration control condenser.
- C5—.00025-mf. grid condenser.
- RF—Radio-frequency tube—UX-201-A type.
- Det—Detector tube—UX-200-A or UX-201-A type.
- R and R1—Bradleystats.
- R2—Bradleyleak.

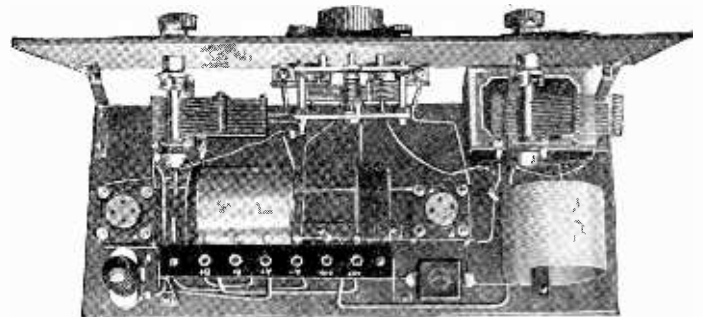

- L—Antenna coil.
- L1—Radio-frequency plate coil.
- L2—Detector grid coil.
- L3—Feed-back coil.
- P—Pilot light.

CONSTRUCTION OF COILS

The method of constructing the coils used in this receiver is worthy of particular notice. It has generally been conceded that the best type of inductance for use in a broadcast radio receiver, is a single layer solenoid with little or no supporting material and with the turns spaced a slight distance from each other. Coils of this type when properly used are found to give excellent results and to be efficient. Therefore, this type of coil was selected for the receiver.

While the best method of constructing such coils is on a machine designed especially for the purpose, still this work is not beyond the average experimenter who will take the time to do the job correctly. Probably the best procedure to follow is that outlined below.

A fairly heavy cardboard tube of the desired diameter and somewhat longer than the longest coil to be wound is first obtained. Two discs of wood are cut, these to be of such a diameter as to fit snugly within the ends of the cardboard tube. A strip about 1/8 inch wide is then cut lengthwise from the tube. The wooden blocks are then placed in the ends of the tube, the slot closed as far as possible, and four tacks, placed

Fig. 4 shows how the set is mounted to be used with a console cabinet. The B eliminator and power amplifier are enclosed in the console cabinet. Six wires are connected between the upper cabinet and the lower one. The antenna and ground terminals may be seen in the center.

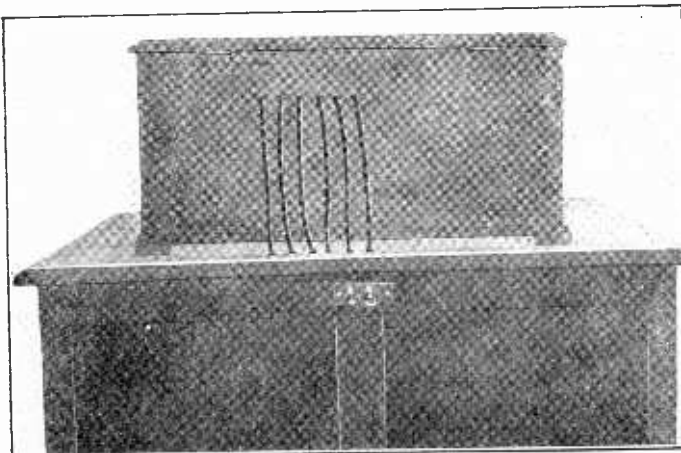

to hold the cardboard in position. Some thin sheet celluloid is then obtained and a strip slightly wider than the length of the finished coil is wound around the cardboard form. One and one-quarter turns of the celluloid will be ample. The overlapping ends are pulled tight and cemented in place with "dope," a solution of amyl acetate and celluloid. Be careful not to get any of this on the cardboard form, for if you do it will be almost impossible to remove the same after the winding is completed.

The antenna and detector grid coils are wound with No. 20 bare copper wire. This wire can be silver plated if the very highest efficiency and best appearance is desired. The wire is wound on the form side by side with small cord whose diameter is about $\frac{3}{4}$ of that of the wire. After the winding is completed, but before the thread is removed, a light coat of amyl acetate-celluloid solution is given to the coil. While this is still moist—you will have to work fast—the cord separating the turns of wire is carefully removed. The coil is then examined for any touching turns of wire, and if found to be perfect is given another coat of the amyl acetate dope. When this has thoroughly dried, the tacks are removed from the cardboard form, the wooden discs taken out, the cardboard form collapsed and removed from the coil.

DATA FOR COILS

The data for the various coils are as follows: The antenna coil, which is also the grid coil of the radio-frequency circuit, is wound on a form $3\frac{1}{8}$ inches in diameter. Forty-eight turns of No. 20 bare wire are required. The R.F. plate coil is wound on the same size form, but here cotton-covered wire wound without spacing thread can be employed without any loss of efficiency. Twenty-four turns are used. The detector grid-coil and the feed-back or regeneration coil are wound on the same form, but in opposite directions from each other. The grid coil consists of 46 turns of No. 20 bare copper wire, while the detector plate coil, wound in the opposite direction, consists of 18 turns of No. 30 D.C.C. wire. These two windings are separated by about $\frac{1}{8}$ inch.

In mounting the coils, thin, hard-rubber strips about $\frac{1}{4}$ inch wide and $\frac{1}{2}$ inch longer than the coils are employed. Holes drilled in each end of these strips allows screws to be placed through them. One strip is placed within the coil and one on the outside. One pair of strips is to hold down the antenna coil and another pair to hold the radio-frequency plate coil and the detector grid and plate coils. This is sufficiently long to allow 2-inch coupling between the radio-frequency plate coil and the detector grid.

It should be mentioned here that the regeneration coil is to be wound at the grid end of the detector grid coil, while the radio-frequency plate coil is to be coupled to the filament end of the detector grid coil. This will all be made plain by reference to the photographs.

In the construction of the receiver illustrated, the writer decided upon the use of a sloping panel. If the constructor does not

Fig. 3. Celluloid-supported coils and the position of the three variable condensers are clearly shown in this photograph. Note also, the arrangement of the panel to leave room for the variable condensers. The terminal strip is also shown in this photograph.

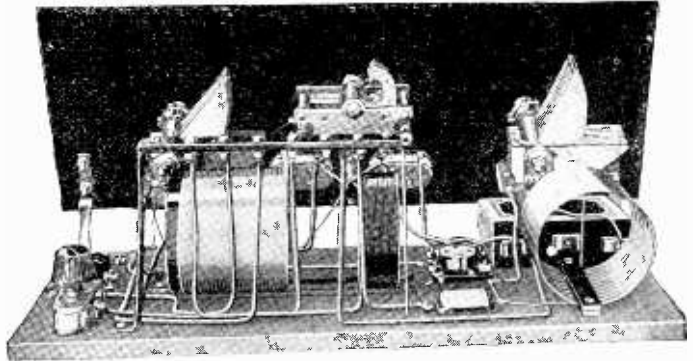

carefully plan his receiver when using a sloping panel of this type, trouble will be encountered. In order to provide sufficient room for the variable condensers and the cylindrical inductances, the writer had to resort to the mounting method shown in Figs. 2 and 3. Here special angle brackets had to be employed so that the sub-panel could rest on the base of the panel, yet the panel could be put in its proper position in the front of the cabinet. However, the use of such brackets is no hardship, and, in fact, it makes the wiring of the set easier.

In Figs. 2 and 3 the terminal strip used is illustrated. This strip, instead of having the usual binding posts placed upon it, has six cord-tip jacks mounted on it. These are connected as shown in the diagram in Fig. 5. The reason for using these jacks in place of binding posts is readily apparent when we remember the purpose for which the eliminator-amplifier was built. Look up the article entitled "Dressing Up Experimental Work" and you will see for yourself. By using flexible rubber-covered wire to connect from the eliminator-amplifier to the receiver proper and equipping the ends of these cords with regular phone cord tips, the receiver can be quickly plugged into and out of the circuit, and any other receiver substituted. This will be especially valuable if the builder of this layout also constructs a breadboard affair equipped with cord-tip jack terminals. A new circuit can then be wired up on this breadboard and quickly substituted for the regular receiver. You will undoubtedly hear more of this in an early issue.

In wiring this receiver the writer used a type of wire that is a great favorite with him. This is rubber covered material, the wire itself being No. 18 in size. It is almost impossible to create a short-circuit in the set when this wire is used.

PRELIMINARY TESTING

After the set has been completely hooked up, it should be carefully tested before con-

necting it to the eliminator-amplifier unit. The following procedure is to be recommended. Tubes are plugged into the sockets and the rheostats are turned on. An "A" battery is then connected across the two "A" posts on the terminal strip, whereupon the tubes should light. Then, leaving one battery terminal on the "A" negative post, touch it to the first "B" positive post. If the tubes light there is a wrong connection or possibly the variable condenser "C₃" is short-circuited. If nothing happens, remove the terminal from the first "B" positive post and connect it to the other "B" positive post. Here again nothing should happen if the circuit is correct. If, when the "A" battery is connected to the plus "A" and the first plus "B" post, a spark occurs, this again indicates a wrong connection or a short-circuited condenser.

After a thorough test and examination of the wiring has shown everything to be in perfect accord with the diagram, the set is hooked to the eliminator-amplifier. It will now be necessary to adjust the two "C" bias controls for the audio amplifier and the plate voltage control for the detector and radio-frequency amplifier. The exact setting for these can only be determined by experimenting. However, it is recommended that both the radio-frequency and the detector tubes be worked at as low a potential as is consistent with good results. Then the "C" bias controls may be adjusted for clarity of reproduction. The proper "C" bias can also be determined by the action of the milliammeter as described in the previous article in the May issue.

TUNING THE SET

The tuning of this receiver is quite simple. The two tuning controls, however, will not quite match each other. The radio-frequency or antenna tuning control will usually lag somewhat behind the detector control. This can be remedied to a limited extent by increasing the number of turns on the antenna coil by one or two, but it has not been found worthwhile, as this procedure disturbs the tuning on the short waves. Stations can be tuned in "on the squeal," in the manner of ordinary regenerative receivers, but because of the blocking action of the radio-frequency tube and the effective aperiodic antenna circuit, there will be practically no radiation from the oscillating circuit other than that emanating from the inductance "L₂."

Because of the amplification effect of the regenerative detector circuit, it has been found that the receiver is easily equivalent both in volume or reproduced signals and in its ability to pull in DX stations, to any two-stage radio-frequency receiver in which

(Continued on page 277)

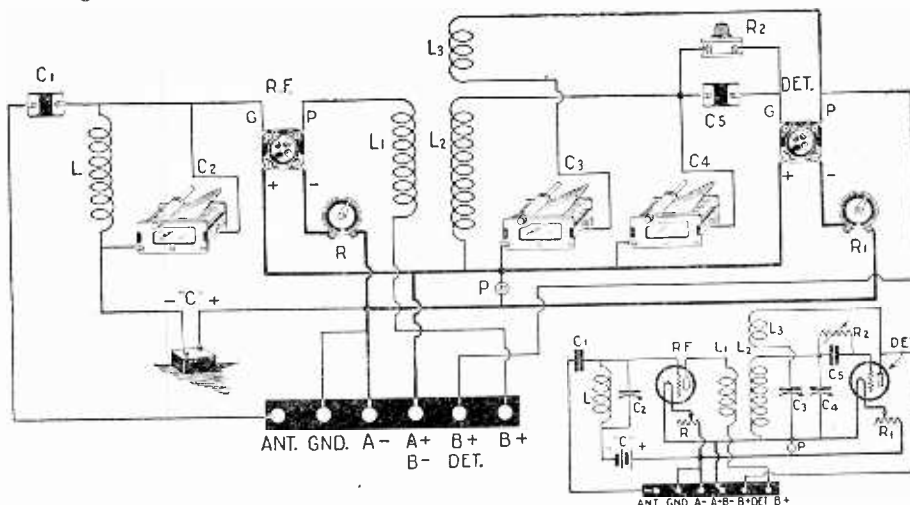
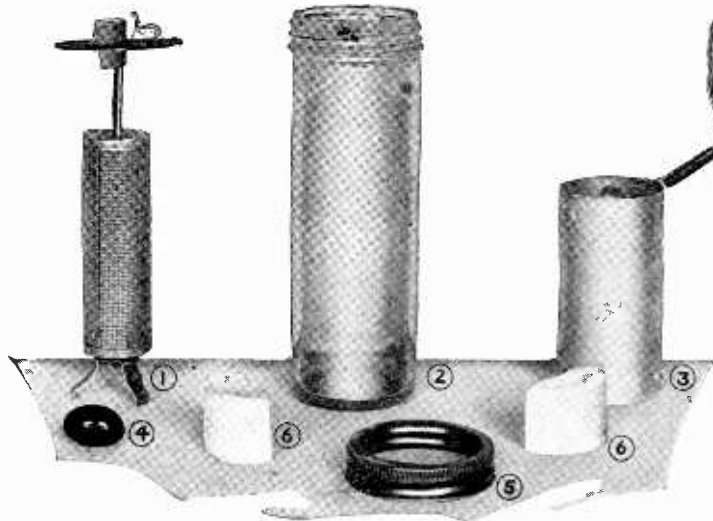
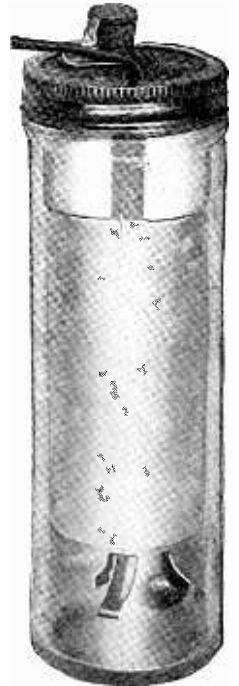
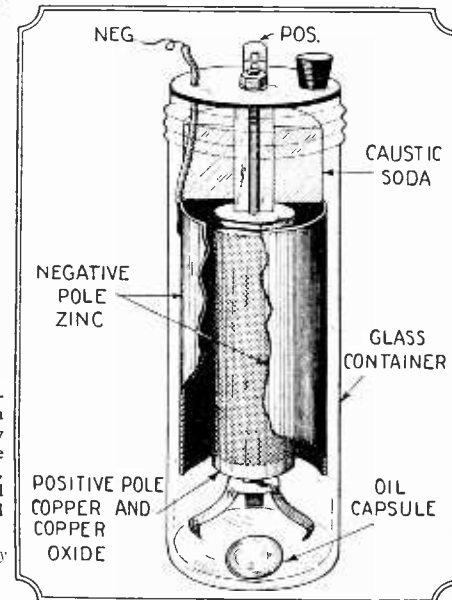

Fig. 5. The circuit diagram of the receiver is illustrated above. The schematic diagram is also shown. The Weagant "X" circuit is used, because of the sharp tuning that it is possible to get with this type of receiver.

A "Dry," Wet Battery



self-contained, compact unit, but slightly larger than the ordinary dry cell. When water is added the cakes of caustic soda, at the top of the cell, dissolve, form the electrolyte and generate enough heat to re-



A view of the cell completely assembled is shown above. Note placement of caustic soda.

At the left we have a sectional view of this unique cell, showing the disposition of parts.

THE "Telecell" is a dry, wet battery designed to fill the need of a cell that can be absolutely depended upon to deliver relatively large amounts of current intermittently or continuously, as required in radio service as an "A" battery for dry cell tubes, that would not dry out or lose capacity in stock or in service and that would be flexible in its applications. All elements are sealed in an air-tight glass jar, making a

Above is a photograph showing the various parts used in the construction of the new battery. 1 is the copper oxide positive pole, 2 the container, 3 the zinc pole, 4 the oil capsule, 5 the screw cap and 6 the caustic soda.

Photo courtesy Waterbury Battery Co.

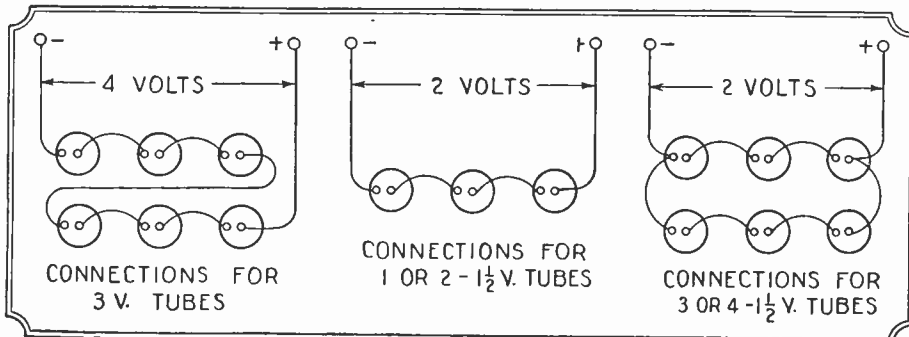

The dry, wet battery makes an ideal A battery for two types of radio receiving tubes, the 1.5-volt tubes such as WD11, WX12 or similar tubes and the three-volt tubes such as UX199, UX120 or any tubes of that type. The connections for the cells when used with the respective tubes mentioned are given above. For use with three-volt tubes 6 cells are connected in series.

lease a special oil placed in a small capsule, which covers the liquid electrolyte and prevents it from evaporating.

The cell will handle continuous discharges up to 1/4 amperes. For light, intermittent discharge work the voltage is about 8/10 volt and in continuous closed circuit operation it is about 2/3 volt per cell. Each cell has a capacity of 75 ampere hours. The positive pole is composed of copper oxide, which prevents the cell from becoming polarized; the negative electrode is composed of rolled zinc which contains small bars by means of which the life remaining may be estimated. The cell is exhausted when one or more bars have been eaten away. When the cell has become dead and no longer fit for use the worn out elements are thrown away and replaced with new ones.

The Universal Trouble Shooter

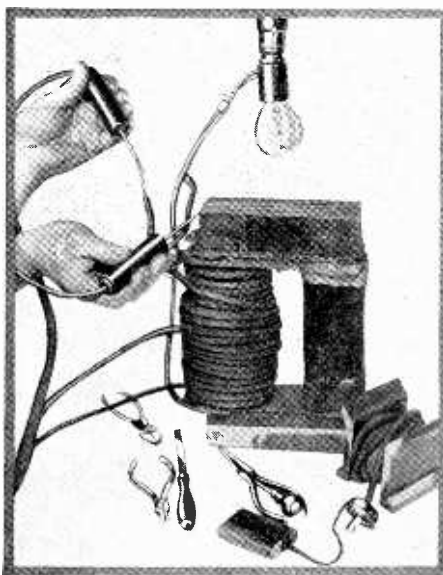

Testing the windings of a high voltage transformer for short, open and ground with the universal trouble shooter, is shown above.



The thermoplex handle of the trouble shooter is shown above. The test handle is heat-proof, shock proof, moisture proof and will not warp.

THE universal trouble-shooter described here has a socket which will fit into any standard socket or receptacle. It has a separable plug so that it may be used in either. An electric lamp of about 40 watts is inserted in this socket, the current turned on and the test points touched together, the lamp will then light. The test points are then placed on conductors in various parts of the circuit which is to be tested. If the lamp lights, it indicates that the circuit is not broken. Failure of the lamp to light shows conclusively that the circuit is broken. A special socket is provided with the trouble shooter, which insures against fuse blow-outs, except in certain cases where one or both test points come in contact with a radiator, water pipe or conduit. The trouble shooter is especially designed to locate short circuits, open and grounded circuits. This instrument is designed to operate with either A.C. or D.C. circuits and will be found invaluable for testing the

continuity of transformers, coils and the like in radio sets.

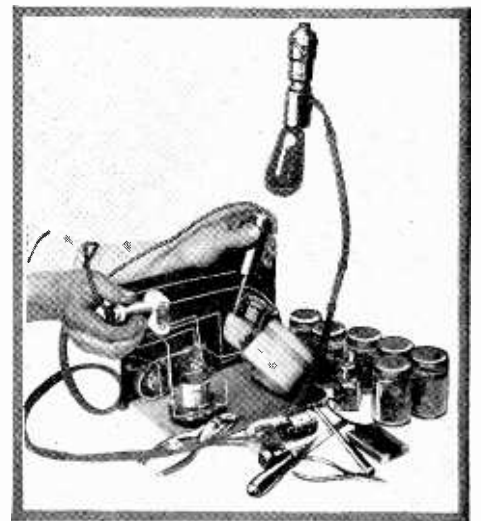

One of the many uses of the trouble shooter is in the testing of radio circuits.

Photo courtesy Universal Test Equipment Co.

RADIO ORACLE

In this department we publish questions and answers which we feel are of interest to the novice and amateur. Letters addressed to this department cannot be answered free. A charge of 50c. is made for all questions where a personal answer is desired.

IMPEDANCE COUPLING

(552) E. Anderson, Hornell, New York,

writes
Q. 1. Will you please illustrate in your department the correct hook-up for a combination two-stage double impedance coupled and one

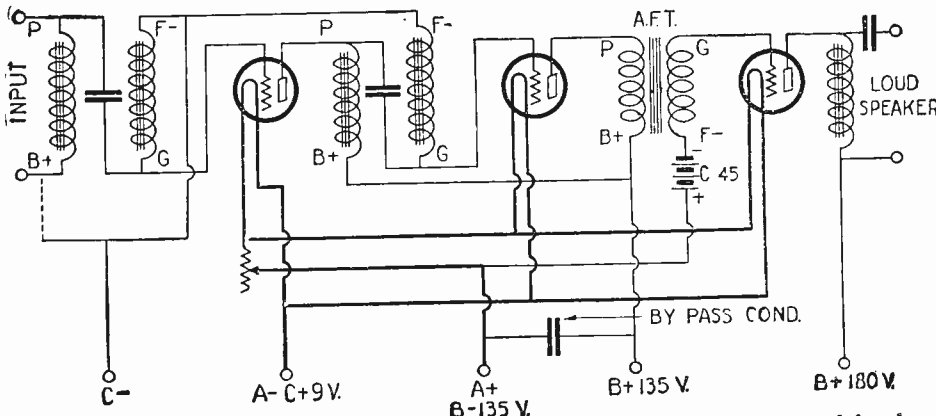

552. Above is given the hook-up for a combination two stage double impedance coupled and one stage transformer coupled amplifier with a speaker filter using a UX201A, UX112 and UX171. This type of amplifier eliminates the "blocking" which often occurs in the usual impedance coupled amplifier. The B-180V lead is connected to the A+.

stage transformer coupled amplifier with speaker filter using a UX201A, UX112 and UX171? What are the advantages of double impedance coupling over the usual impedance system?

A. 1. You will find illustrated on this page the schematic diagram for the impedance coupled amplifier. Double impedance coupling differs radically from the usual impedance coupled amplifier. "Blocking" frequently occurs particularly in the last stage tube of the ordinary impedance coupled amplifier. This is probably due to the fact that, in spite of precautions taken to adjust the grid bias properly, an occasional signal causes the grid to charge. Unless this charge has leaked off before the next impulse reaches the grid, "blocking" occurs. The high resistance leak used in the usual impedance coupled amplifier does not permit the charge to leak off rapidly enough. If the resistance is reduced to the point where "blocking" no longer occurs, signal strength suffers. The reactance type of leak of the double impedance coupler, on the other hand, combines a high impedance to alternating current with a low direct current resistance and the tendency to "block" is overcome.

"B" ELIMINATOR TROUBLE

(553) A. Zach, Brooklyn, N. Y., writes:

Q. 1. I am building several AC operated power supply devices ("B" Eliminators) and would appreciate some general rules on trouble shooting.

A. 1. Briefly the possible sources of trouble in line supply devices are given herewith. Quite frequently it is found that a hum is audible in the output of the receiver when it is operated from a power device. This hum need not necessarily indicate poor design and may be due entirely to mechanical vibration. It can be eliminated by moving the device further from the receiver or by placing the receiver on sponge rubber or on several layers of soft cloth. Trouble in the power-supply unit may be the result of breakdown of one of the filter condensers, the break-down of one of the resistances controlling the intermediate voltage taps, a defective rectifier, or open connections. In testing the device a voltmeter is essential. It should be connected between the negative post and the various taps, and if the taps give no reading, the trouble is probably due to a defect in the resistance unit supplying that tap. This is not an uncommon cause of trouble and therefore, good resistances, capable of carrying the required current without excess heating, must be used. Defective resistances are also capable of creating "home-made" static. If reception is accompanied by considerable noise when using the power-supply device, the antenna should be disconnected, and, if the noise persists, all of the connections should be carefully examined. Be sure that the "A" battery terminals are not corroded. If possible, substitute for the power unit good dry B batteries, and if there is no noise, it is a good indication that the line power supply device is causing the trouble. If no voltage readings can be obtained on any terminals, the rectifier tube should be examined. Make sure that the filament has not burned out, or, if the rectifier is of the electrolytic type, be sure that it contains sufficient solution. The filter condensers should be tested with phones and "B" battery to make sure that they have not broken down. The same test may also be made on the choke coils. If all the connections appear to be complete and the apparatus in good condition, it will be best to try a new rectifier tube. The fact that the tube lights does

not necessarily indicate that it is functioning in a satisfactory manner.

SIMPLE VOLUME CONTROL

(554) John Prince, Adams, Ala., writes:

Q. 1. I have a three-tube receiver with a de-

torator and two transformer-coupled audio frequency stages, and I find that when the three tubes are used my loud speaker is overloaded, whilst signals are not quite loud enough when two tubes are used. Can you suggest a suitable form of volume control, so that the strength when using three tubes is cut down to a more agreeable value?

A. 1. The distortion to which you refer is due to overloading the third valve as well as to overloading the loud speaker and results will be much more pleasant if an adjustable volume control is fitted to enable you to reduce the volume to the desired strength. A simple but effective volume control consists of a variable high resistance shunted across the secondary of the first audio transformer. If this has a maximum value of about 500,000 ohms a very fine control of volume is obtained without impairing the quality in any way.

B-POWER SUPPLY UNIT

(555) H. Moriarity, Antioch, Michigan, writes:

Q. 1. Can you give me the hook-up of a B-power supply unit, employing two Raytheon tubes and two transformers which will have an output of about 400 volts?

A. 1. You will find illustrated on this page the correct hook-up for the B-supply unit. Two Raytheon tubes are connected in series to furnish plate voltages up to 435 volts D.C. at 20 milliamperes, when using the type B, and at 35 milliamperes, when using the type BH. Standard designs of approved transformers and choke coils are employed, the same as are found in the usual B-power unit employing a single tube. The condensers C1 and C2 have a capacity of 2 microfarads; C3, 8 microfarads; C4, C5, C6 and C7, 0.1 microfarad. However, the condensers should be designed for a working voltage of 750. If the plate supply is to be furnished to the usual four or five tube receiver using 201 type tubes, a variable resistor should be used for R1, allowing a range of 0 to 20,000 ohms, and fixed resistors of 10,000 ohms each for R2 and R3, and 18,000 ohms for R4, with by-pass condensers C of 1 microfarad in each case, as indicated. While the C or grid bias can be obtained for the power tube by means of a suitable resist-

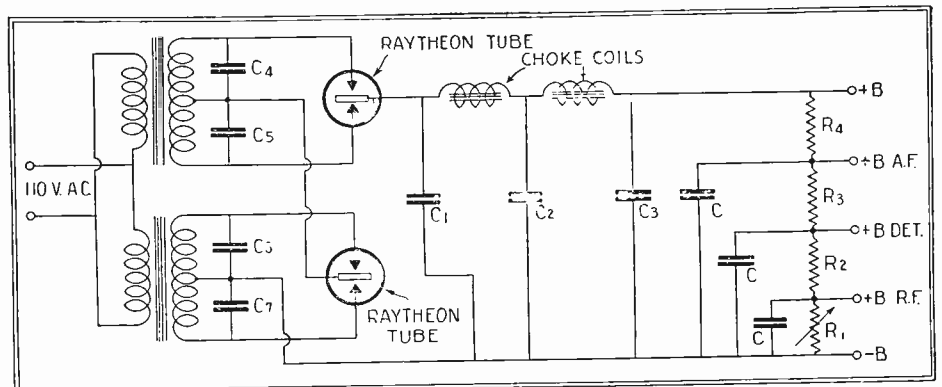

555. The connections for a B-power supply unit, employing two Raytheon tubes and two transformers having an output of about 435 volts D.C., are shown above. Using the type B Raytheon tube 20 milliamperes of current will be delivered and with the type BH 35 milliamperes.

tance drop, it is advisable to employ a tapped B battery. The full voltage when applied to the power tube will be approximately 425 volts.

POTASSIUM HYDRATE BATTERIES

(556) Newman Stern, New York, N. Y., writes:

Q. 1. Kindly give me the specific gravity necessary in mixing a new solution of potassium hydrate for Todd storage "B" batteries. Is the distilled water poured upon the potassium hydrate or the hydrate dropped into the water?

A. 1. The electrolyte solution consists of one part of potassium hydrate to four parts of distilled water. This is approximately one pound of hydrate to a quart of water. The specific gravity will be from 1.200 to 1.250. The condition of this type of cell is tested by a voltmeter, and not by a hydrometer, as is the case with an acid battery. When fully charged each cell has a potential of 1.4 volts and drops during its use to 1.2 volts. The 100-volt battery uses two quarts of water and the 140-volt battery three quarts of water. Put the hydrate into the water very slowly and use an earthen jar as the container, because great heat is evolved and other containers might crack.

UNDERGROUND ANTENNAE

(557) B. F. Mills, Waco, Texas, writes:

Q. 1. How can I construct an underground or underwater antenna to the best advantage? Does an antenna of this nature compare favorably with the usual type of receiving antenna?

A. 1. Ground antennae usually consist of a single wire lying on the surface or a short distance under the surface of the ground. They operate more efficiently when the soil is wet rather than dry and with an insulated rather than with a bare wire. They may also be used under the surface of fresh or salt water. In salt water they should be submerged only a short distance below the surface. The best results are usually obtained with wires well insulated with moisture-proof material. The amount of power received by ground antennae is considerably less than that received by the usual elevated antennae. The ground antennae, however, have a number of compensating advantages as they are directional receiving devices, the strongest signals being received when the wire extends along the line of propagation of the waves. Also they do not develop the usual troubles during local thunderstorms which make elevated antennae dangerous to the operator. The ground antennae as sometimes employed, have a somewhat greater ratio of signal strength to strays than the usual elevated antenna. The length of wire which should be used as a ground antenna depends upon the wave length of the signals to be received. Thus for a long wave length longer wires should be used than for short wave lengths. The length of the ground or underwater antenna which should be used for the reception of a particular wave length depends upon the diameter of the conductor itself and also upon the nature of the dielectric material adjacent to the conductor. If it is desired that a wire buried in the ground should remain in effective operation more than a few months it is usually necessary to use wire insulated with at least 3/4 inch of good live rubber. For temporary work an insulated wire is sometimes laid upon the surface of the ground. In earth of the average range of moisture content a ground antenna 75 feet long may be expected to give satisfactory reception from 150 to 500 meters. Under average conditions it will be advisable to use stranded or solid conductors, about No. 14 B & S, with good rubber insulation, buried in a shallow trench 6 to 12 inches below the surface of the ground. Under some conditions it may be advisable to bury a wire as deep as 24 inches. It should be noted that a ground antenna can not be expected to give good results unless several stages of amplification are used. At a small receiving station with the usual equipment it will usually be found more satisfactory to use the ordinary elevated antenna.

Scientific Humor

BY NO STRETCH OF IMAGINATION

EBONIZER: Say, Hezikiah, you all know that Mister Gernsback that publishes this here SCIENCE AND INVENTION Magazine; he's pretty long-headed, ain't he?

HEZIKIAH: How's that, what you mean, long-headed?

EBONIZER: Because he stretches his imagination so much.

NOT A VIVISECTIONIST

NED: "My father's a doctor, and yours is only a butcher."

TED: "Well, my father doesn't cut 'em up till they're dead, anyway."—*Henry Vanderholt.*

THEN HE BURNED



PATIENT: The size of your bill makes my blood boil.

DOCTOR: That will be twenty dollars more for sterilizing your system.—*John W. Harris.*

THE BLOW THAT KILLED FATHER

Hotel clerk to Farmer who had spent his first night in a hotel: "Well, how did you sleep last night?"

FARMER: I didn't sleep at all; the light was burning.

CLERK: Why didn't you turn it out?

FARMER: I blew on it for an hour, but the darn thing had glass around it.—*Robert Layman.*

IMPOSSIBLE

TEACHER (to one of the boys who was cutting up in school): "James, sit down in front."

JAMES: "I can't, I'm not made that way."—*Harold Dawson.*

MEDICAL MAGIC



SPEED DEMON: Judge, I'm deaf.

JUDGE: You may be deaf now, but you'll get your hearing in the morning.—*Clifford N. Harthill.*

HIGHER MATHEMATICS

"Have you heard of my latest discovery?"

"No, what is it?"

"I've found how to tell the number of pieces of macaroni on a plate."

"How?"

"Why, you add up the ends and divide by two."—*Clifford N. Harthill.*

First Prize \$3.00

FRECKLED SUN

YOUNG MISS: Prof., I hear you are an authority on sun spots.

PROF: Well, I made a study of them.

YOUNG MISS: That's fine. Then which would you suggest, lemon juice or cold cream.—*Steve H. Bugar.*

CALLING THE WARDEN AN OSMOTICIAN

FIRST STUDENT: Why is a jail warden like osmosis?

SECOND STUDENT: I'll bite, why?

FIRST STUDENT: Because they both pass from cell to cell.—*Howard Boroughs.*

WE receive daily from one to two hundred contributions to this department. Of these only one or two are available. We desire to publish only scientific humor and all contributions should be original if possible. Do not copy jokes from old books or other publications as they have little or no chance here. By scientific humor we mean only such jokes as contain something of a scientific nature. Note our prize winners. Write each joke on a separate sheet and sign your name and address to it. Write only on one side of sheet. We cannot return unaccepted jokes. Please do not enclose return postage.

All jokes published here are paid for at the rate of one dollar each, besides the first prize of three dollars for the best joke submitted each month. In the event that two people send in the same joke so as to tie for the prize, then the sum of three dollars in cash will be paid to each one.

LOOKING AT IT FROM A-CUTE ANGLE



STUDENT: I call my girl "Geometry."

DUDE: Why for?

STUDENT: Because she's so plane and solid.—*Henry Fischer.*

MIGHT STILL HAVE 4,800 TEETH LEFT

PROF. (in Biology class): Now, children, it is hard to realize, but the whale shark has 24,000 teeth set in eighty rows of three hundred teeth each.

VOICE FROM THE REAR: Oh, my goodness, wouldn't it be awful if he had pyorrhea?

NO SPIKA DA LANGWICH

STUDENT: What's a corpuscle?

PROFESSOR: An oosphere in a gymnospermous archegonium.

STUDENT: Excuse me, sir. I'll ask somebody who speaks English.—*Paul S. Powers.*

TIGHTLY STRETCHING THINGS

"Building operations certainly are queer."

"Why?"

"If for some reason a man wants to expand his building, he calls in a contractor."—*Clifton Ask.*



CHEMICAL LOVE

He has found out by recent experiment that potassium iodide (KI) unites with sulphur (S) under pressure with the following reaction:



Care should be taken to perform this experiment in the dark, as the material is explosive and the reaction usually violent.—*Mrs. Violet Urwin.*

AN EAT-O-MOLOGIST

PROFESSOR: Can you tell me how to prevent diseases caused by biting insects?

STUDENT: Yes, sir. Don't bite the insects.—*Clifton Ask.*

FROM ALL OVER

Alas for the chemist

For—

He was calm as he mixed them

But—

Collected after it happened.—*Martin C. Burns, Jr., Rep. No. 22857.*



GRAVITY'S FORCE

AIRMAN (who survived after his plane had crashed): What are you crying about? You should be glad I'm safe and sound.

WIFE (sobbing): I was thinking about the gravity of the situation.—*N. Schmitt.*

SCIENTY SIMON, SCIENTIST

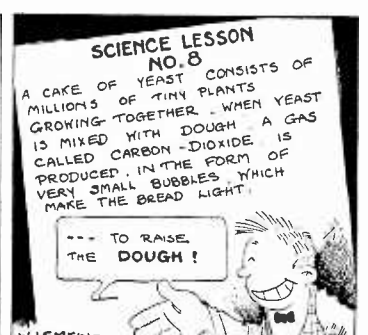
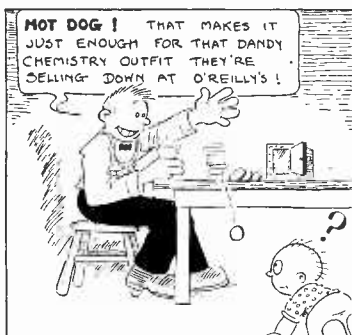



LATEST PATENTS

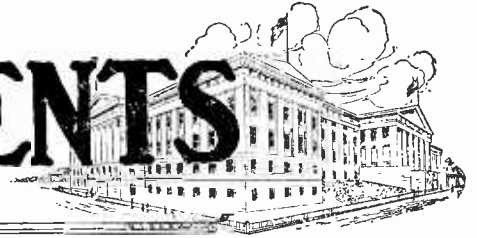

TALKING DOLL

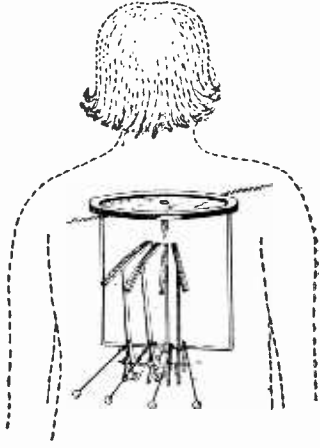

No. 1,622,441, issued to Oscar A. Garland. The talking doll shown above has a phonographic diaphragm operated by a button whereby a short record may be brought into engagement with the diaphragm and caused to move across the stylus, producing the utterance of a sound or word.

HAND SAW

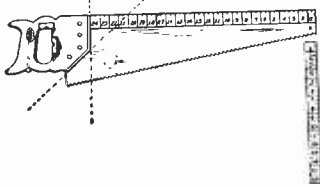

No. 1,622,466, issued to Carl Patterson. The tool shown above may be employed as a saw, a square, a gauge or ruler, a level, or as a compass.

ELECTRIC CLOCK SYSTEM

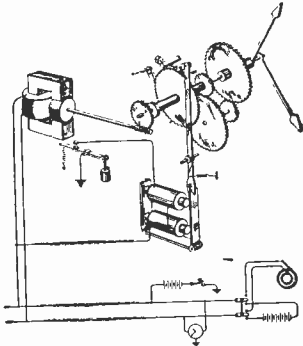

No. 1,622,588, issued to Charles A. Hoxie. This electric clock system provides for the operation of one or more secondary clocks, which are controlled by a master clock, in such a way, that they will indicate correct time.

FLY CATCHER

No. 1,623,006, issued to Edward Hamborg and Victor T. Lobdel. This novel device is held in the hand of the operator and wielded through the air in order to catch flies in flight, whereby any insect coming in contact with the device is sure to be caught. In appearance it resembles the common fly swatter.



ELECTRIC BED WARMER

No. 1,622,326, issued to Anson T. Lister. The bed warmer shown below is provided with an electric heating mechanism having a thermostat control. It is housed in a tubular cylinder which is perforated.

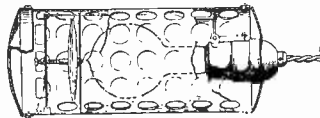

DENTAL COMPACT

No. 1,626,310, issued to Edna Sibley Tipton. The compact shown below provides a small, neatly arranged case containing a number of dental accessories, such as a tooth brush, dental floss and tooth paste, and may easily be carried in the vest pocket.

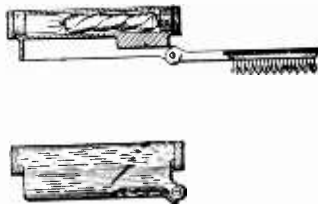

MEDICAL APPLIANCE

HOT WATER INLET COLD WATER INLET

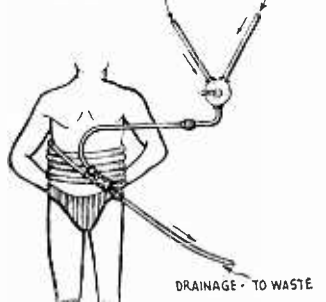

No. 1,622,903, issued to John L. Cox. The object of this invention is to provide a device for use upon the human form whereby the latter may be subjected to the beneficial effects of hot or cold water or any other liquid.

WINDOW CLEANER

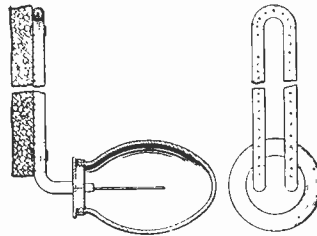

No. 1,623,004, issued to Raul Greenberg. This window washer or cleaner is primarily adapted for use in connection with apartment windows. A soft rubber bulb is provided, which contains the water, and when this is compressed, the liquid is forced out against the surface to be cleaned. For drying the window, a piece of chamois is provided which fits over the cleaner.

SWIMMING INSTRUCTING MACHINE

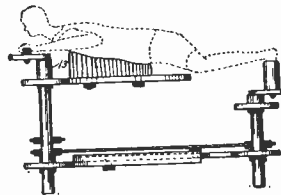

No. 1,620,146, issued to Thomas A. Walton. The machine shown above teaches the pupil the correct movement of the limbs utilized in swimming and at the same time exercises and strengthens the desired muscles. Arm-exercising cranks are mounted at the forward end and leg exercising cranks are mounted on the rear supporting member. The apparatus is adjustable.

AUTOMATIC EGG BOILER

No. 1,623,093, issued to Philip P. Chapin and William J. Kupec. With the egg boiler shown below it is possible to automatically cook eggs to the desired state. The egg carrier is raised or lowered by means of a thermostatic bar. A spring is provided to keep the carrier submerged.

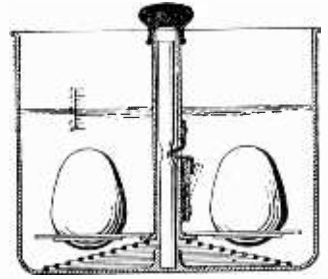

WAVE AND TIDE MOTOR

No. 1,620,258, issued to Nishan Hoshafian. This invention relates to devices for utilizing the surface motion of bodies of water. It may also be used for converting the tide and wave motion into mechanical or electrical energy. The latter mechanism preferably takes the form of a dynamo or storage battery.



COMBINATION BRUSH, COMB AND MIRROR

No. 1,626,415, issued to Mike Koske. The device shown below consists of a combination brush, comb and mirror arranged in a novel manner. The combs may be swung outwardly and be used as a fine or coarse comb. On the back of the same a brush is attached. The back and handle are made of wood or hard rubber.

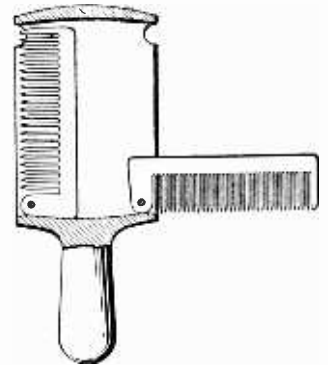

NOTICE TO READERS. The above illustrated and described devices have recently been issued patent protection but are not as yet to our knowledge available on the market. We regret to advise that it is impossible to supply the names and addresses of inventors of the above devices to any of our readers. The only records available, and they are at

the Patent Office at Washington, D. C., give only the addresses of the inventors at the time of application for a patent. Many months have elapsed since that time, and those records are necessarily inaccurate. Therefore, kindly do not request such information as it is practically impossible to obtain up-to-date addresses.

—EDITOR.



THE ORACLE



The "Oracle" is for the sole benefit of all scientific students. Questions will be answered here for the benefit of all but only matter of sufficient interest will be published. Rules under which questions will be answered:

1. Only three questions can be submitted to be answered.
2. Only one side of sheet to be written on; matter must be typewritten or else written in ink; no penciled matter considered.

3. Sketches, diagrams, etc., must be on separate sheets. Questions addressed to this department cannot be answered by mail free of charge.
4. If a quick answer is desired by mail, a nominal charge of 50 cents is made for each question. If the questions entail considerable research work or intricate calculations, a special rate will be charged. Correspondents will be informed as to the fee before such questions are answered.

TELESCOPE MAGNIFYING POWER

(2178) Q. I. H. R. Coursey, Friendship, Maine, asks for information regarding the magnifying power of large telescopes when focused on Mars. A. 1. Our largest telescopes would magnify Mars to 40 times the diameter of the moon, or 1,600 times larger in surface area.

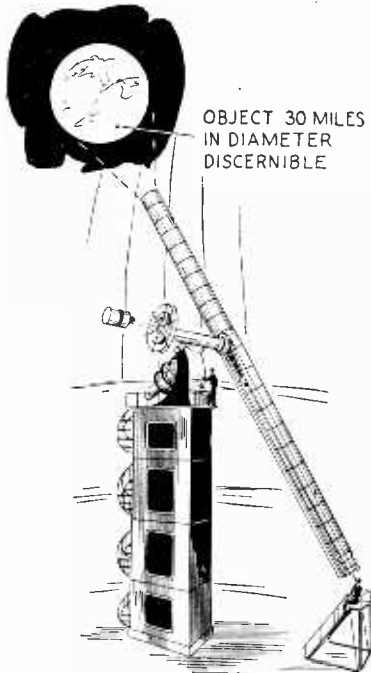

2178. Above is a sketch of one of our modern telescopes by means of which objects at least 30 miles in diameter are made discernible.

PHOTO FINISHING

(2179) Q. 1. Mr. Wallace Aley, Kenusha, Wis., asks our advice as to the commercial possibilities of a one-hour photo finishing process.

A. 1. Frankly, as an all year round proposition, we do not believe that your one hour photographic finishing plant would meet with much success. At seashore resorts it might be profitable if correctly advertised. The average eight-hour finishing for photographs seems quite satisfactory to the public. However, we give you below as much information as we have on hand on the subject of quick drying of photographic negatives and prints.

Let us first discuss the drying of negatives. The system outlined below was described to the writer by the Eastman Kodak Co. We believe it to be superior to the alcohol method. One way of using it would be to deliver the prints to the aniatuer within an hour, but to retain the films for further washing as described below.

To an amount of water necessary to properly immerse the film, add potassium carbonate until no more will dissolve. Then carefully filter the solution which should not have an oily appearance. After the film negative has been thoroughly fixed in the acid fixing and hardening bath, it should be rinsed thoroughly for several minutes and the surplus water removed from both sides with a soft rubber squeegee. If the fixing and hardening has been thorough and the squeegee is clean, there will be no danger of scratching the negative.

The negative is now immersed in the saturated solution of potassium carbonate for two or three minutes, drained, and the excess carbonate solution removed in the same way as the excess water in the previous operation. The negative, which now feels quite hard and dry but seems to have a greasy surface, is laid on a perfectly clean surface and both sides are polished with a soft cloth.

The negative is now ready for printing and the entire operation of drying has not required more than four minutes.

After the required number of prints have been made, the negative should be washed thoroughly

Science and Invention

CORRESPONDENT REPORTER'S IDENTIFICATION NO. 10000

THE BEARER OF THIS CARD IS AN AUTHORIZED CORRESPONDENT-REPORTER OF SCIENCE AND INVENTION MAGAZINE THE PUBLISHERS OF SCIENCE AND INVENTION WILL APPRECIATE ANY COURTESY EXTENDED THEIR REPRESENTATIVE.

EXPERIMENTER PUBLISHING CO.

(over) *Harold Ball*

IN ORDER to present to the public the very latest scientific details, SCIENCE AND INVENTION maintains a large staff of field reporters. Any one of our readers is eligible to join this staff and, upon request, a reporter's card will be forwarded, together with complete instructions for gathering material. The reporter's card is illustrated above, and its use will gain admittance to many places that would otherwise be closed to the ordinary person. You need not have any special ability to obtain one of these cards other than a desire to help others to gain knowledge.

Address Field Editor, SCIENCE AND INVENTION. Submitted manuscripts cannot be returned unless accompanied by postage.

for at least fifteen minutes in water at a temperature below 70° Fahrenheit, in order to thoroughly remove the potassium carbonate from the film. If the water is over 70° in temperature the gelatin is very likely to reticulate during washing. No trouble need be feared from reticulation if the film is hardened in a 5% formalin bath, following the acid fixing bath. This quick drying method is not practical for use with plates because in the subsequent washing the gelatin film is most likely to strip from the glass and the negative is ruined. This does not occur with film because of the nature of the film and the greater adhesion of the gelatin to the surface.

As to the quick drying of positives, we would suggest the so-called squeegee method of employing heat. The prints are placed on the squeegee plates in the standard manner and suspended in a draft of warm air which may be supplied by a fan and a small electric or gas heater, the fan blowing over the heater and directing the warmth against the prints on the plates. Prints can be dried by this method in ten to fifteen minutes.

GAS MANTLES

(2180) Q. 1. Ralph F. Spencer, Seattle, Wash., asks for a description of the process of manufacture of gas-illuminating mantles.

A. 1. These are prepared after processes differing slightly from one another, but all based on the original formula of Welsbach—the impregnation of vegetable fibers with certain mineral oxides in solution, drying out, and arranging on platinum wire.

- Lanthanum oxide30 parts.
- Yttrium oxide20 parts.
- Burnt magnesia50 parts.
- Acetic acid50 parts.
- Water, distilled100 parts.

The salts are dissolved in the water, and to the solution another 150 parts of distilled water are added and the whole filtered. The vegetable fiber (in its knitted or woven form) is impregnated with this solution, dried, and arranged on platinum wire. In the formula the acetic acid may be replaced with dilute nitric acid. The latter seems to have some advantage over the former, among which is the fact that the residual ash where acetic acid is used has a tendency to ball up and make a vitreous residue, while that of the nitric acid remains in powdery form.

FILTERS

(2181) Q. 1. Mrs. Davis Garrick, Leavensworth, Kansas, asks several questions relating to filters for purifying liquids.

A. 1. We regret to say that we do not have any information regarding a filter such as the one you mention. We do not believe that it is physically possible to construct a filter which will not need periodical cleaning. Furthermore, we do not be-

lieve that one can be made which will operate as you suggest.

We would advise that most hardware supply houses carry what is known as filter clay which will undoubtedly suit your purposes. If you can obtain some of this clay which, by the way is a natural product, and not manufactured, a filter made up as you suggest would probably work. However, we believe that it would become clogged on the inside and cause trouble.

Our experience in dealing with liquid such as you mention is that by far the best way to obtain a clear liquid is to allow the solid matter to settle and decant and siphon off the clear remaining liquid. This is faster and seems to be more satisfactory than the average filter. A little alum followed by sodium carbonate may accelerate the process.

RAINPROOFING WINDSHIELDS

(2182) Q. 1. Thomas Calvert, Buchanan, Miss., is interested in the possibility of making a dry compound to make windshields rainproof, and asks our advice on the technical data.

A. 1. Probably the simplest procedure for you to follow in order to make use of your solution would be to make up the mixture of glycerin and alcohol and soak pads of woven material therein. These pads can be wrung out quite dry and then used by merely rubbing over the surface of the glass. A coating of glycerin will thus be applied to the glass and will undoubtedly accomplish the work you mention for a short time. This is the same method as is used by various companies in manufacturing pads for use in keeping windshields of automobiles clear of moisture during rain storms. We are of the opinion that such a method would be far superior to that of attempting to make up a paste to accomplish the same purpose.

TESTING ARMATURE FOR GROUNDS

(2183) R. Sullivan, Liverpool, England, inquires: Q. 1. Can you give me a simple method which may be used for testing the armature of an automobile for grounds?

A. 1. The method for testing the armature is shown in the diagram appearing on this page. All intentional ground connections to the motor are disconnected. The brushes are lifted off the commutator and the field is disconnected from the armature. The negative terminal of a dry cell is connected to the commutator segment and the positive terminal to the binding post of the voltmeter. The circuit is completed from the three volt binding post on the voltmeter to the armature shaft or motor frame. If an indication or deflection is obtained, the armature is grounded. The cause of the ground is very likely due to damaged insulation on the armature conductors. The armature should be carefully examined for this. On one-way systems of the two-unit type, a grounded coil will result in slow cranking and a materially reduced charging rate. In some starting and lighting outfits using motor generators, two windings are placed on a single armature, each being brought out to a separate commutator. One winding is for the motor and the other for the generator. A ground may be developed between these windings. To test for such a ground the terminal of the voltmeter which was attached to the shaft is touched to the second commutator.

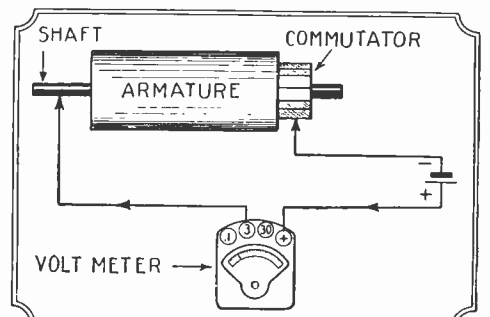

2183. For testing an armature for grounds the connections shown above should be followed. All ground connections should be removed beforehand.

SHIPS OF MELODY

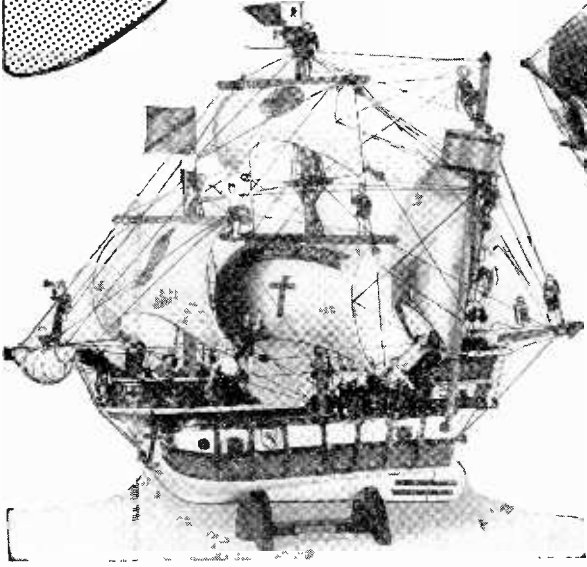

SANTA MARIA

THE FLAG SHIP OF COLUMBUS IN THE DISCOVERY OF AMERICA IN 1492.

Size: Height, 25 in. Width, 11 in. Length, 27 in.



LA PINTA

A picturesque Merchant Ship of the Fifteenth Century.

Size, Height 25 inches.
Width 13 inches.
Length 27 inches.

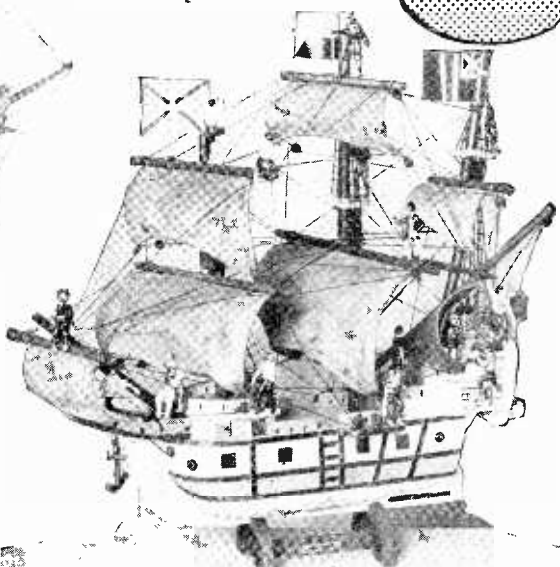

MAYFLOWER

THE SHIP THAT BROUGHT THE PILGRIMS TO AMERICA.

Size: Height, 25 in. Width, 9 in. Length, 27 in.

BUILD A BEAUTIFUL SHIP MODEL LOUDSPEAKER---in a few hours
No tool needed but a tackhammer—Any schoolboy can put it together.

PERFECT TONE - PLENTY OF VOLUME - NO DISTORTION

Do you want a Loud Speaker that is different and worth \$100.00?
Do you want a beautiful Ship Model?

Do you want perfect tone? Of course you do. All of these are to be found in the Melody Ship, and it will not cost you as much for both, combined in one, as the ordinary Ship Model or Loud Speaker would alone. The Ship Model when complete is the most beautiful of its kind on the market today. The Loud Speaker combination is unsurpassed for beauty of tone and undistorted volume that brings out all the low musical notes faithfully reproducing the zoom of the base viol, the drums and tuba, as well as the higher alto and soprano. There is nothing like it on the market today anywhere. It is absolutely new. This is not an experiment, but a real proven fact, sold on a money-back guarantee to assure satisfaction.

THE WORLD'S LARGEST BUILDERS OF SHIP MODELS will supply you with all the parts to build a Melody Ship. You may choose either the La Pinta, Santa Maria or Mayflower Models. The parts for the Ship Models are made of wood. This is not a cheap cardboard imitation, but a real Ship Model. Putting this Model together is as simple as A, B, C. The instructions read like this: put No. 49 on top of No. 48 and tap lightly with a small hammer, etc. A schoolboy can put it together in a few hours.

The Loud-Speaker Unit is of the Electro-Magnet type. Power amplification is not needed to force the low tones through. They come through with perfect ease and do not interfere with the higher notes. Giving you faithful reproduction at all frequencies. The Unit is placed on the Main Mast, which is firmly seated two inches deep in a three and one-half pound hull. Making it impossible for counter vibrations to effect the perfect reproduction of the Melody Sail. The driving pin is attached to our super-vibrating, especially prepared, Melody Sail. It does not change the appearance of the Ship Model. Instructions for installing come with each Melody Ship.

Those who own a Ship Model and wish to install the Melody Sail and Unit can easily do so by forwarding us an out-line drawing of your main sail. We will then forward to you a Melody Sail and unit to fit your Model, via parcel post C. O. D., nine dollars (\$9.00), plus postage.

The un-assembled parts for either the La Pinta, Santa Maria or Mayflower Models (without the Melody Sail attachment) can be had for four dollars and ninety-eight cents (\$4.98) plus postage. Full detailed diagram and instruction sheet, showing and explaining every operation, for completing the Model supplied with each. If you want the un-assembled parts for either the Santa Maria or Mayflower Model, together with the Melody Sail attachment, for making the Melody Ship complete, send us your order—NO MONEY—pay postman \$12.50, plus postage.

CANADIAN AND FOREIGN ORDERS MUST BE ACCOMPANIED BY MONEY ORDER

If, after assembling the Melody Ship, you do not think it worth many times the purchase price, return it to us in good condition and we will gladly refund your Money. What can be fairer than this?

WRITE FOR OUR CATALOGUE

Complete Melody Ship Orders Include Metal Figures Illustrated Above. If Figures are Ordered Separately Same Will Be Furnished For 25c Each Figure.

MINIATURE SHIP MODELS

3818-20-22-24 Baring Street
Philadelphia, Pa.

MINIATURE SHIP MODELS S.I. July
DEPARTMENT L16.
3818-20-22-24 Baring St., Philadelphia, Penna.

Please send me the complete parts cut to fit and ready to put together for the MELODY SHIP Complete. For which I agree to pay postman \$12.50 plus postage. For the SHIP MODEL only. For which I agree to pay \$4.98, plus postage. For MELODY SAIL & UNIT only for ship model. for which I agree to pay postman \$9.00, plus postage.

PLEASE PRINT NAME AND ADDRESS

NAME
STREET OR R. F. D.
CITY OR TOWN
STATE

Be An Electrical Expert

Come to New York
See this wonderful city while learning a high pay profession,

ACTUAL EXPERIENCE

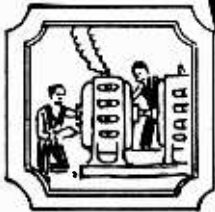

PRACTICAL LESSONS



Enjoy the Wonders of New York the modern Bagdad while learning Electricity

OUR GRADUATES IN DEMAND.

Graduates of the NEW YORK ELECTRICAL SCHOOL are in demand by all the big electrical companies. Or, if you prefer the independence of a business of your own, there are thousands of opportunities for efficient, dependable men to become electrical contractors. When you are your own boss the money you can make is limited only by your own energy and ability.

PERSONAL INSTRUCTION.

The NEW YORK ELECTRICAL SCHOOL is not a correspondence school. You learn by doing—by personal instruction on full size standard electrical equipment under the personal supervision of trained instructors.

At N. Y. E. S. you train your hands and mind at the same time. You learn the theories of electricity—and then you are shown how to put the theories into actual practice by solving the problems with your own hands.

The man who has learned electricity by actually doing electrical work under intelligent personal instructors can go to any part of the world and be sure of a good living. There are N. Y. E. S. graduates in all the countries of the world.

Write today for the 48-page booklet giving full information about the N. Y. E. S. Course and showing pictures of the equipment available for your personal use in our two seven-story buildings. IT IS ABSOLUTELY FREE TO YOU.

The NEW YORK ELECTRICAL SCHOOL
29 W. 17th St., New York

MAIL TODAY

The New York Electrical School
29 W. 17th Street, New York.

Please send me FREE your 48-page booklet. It is understood that this request puts me under no obligation.

Name

Address

Easy Way To Learn CARTOONING

Make \$150 a Week as a Cartoonist
Get into the most fascinating money-making profession in the world. The Chief Cartoonist for Cincinnati Post and 25 other big newspapers will teach you quickly. My amazingly easy method, based upon 15 years' experience, teaches you both Drawing and Cartooning, to your profit.
Complete Course Only \$5.00
100 Lessons—300 Illustrations

Superior to any correspondence course. Tips on how to earn while you learn, how and where to sell your work, everything you should know to become a high-salaried famous cartoonist, are in this big 100 lesson course. Send \$5.00 or order C.O.D. Pay postman on delivery. **Satisfaction Guaranteed or Money Refunded.** Be another of my successful students—send for this money making course NOW.
Manual Rosenberg, Studio 27, Artists' Bldg., Cincinnati, O.

Magnified 225 Diameters

This is what the tip of a fly's leg is like when seen through the

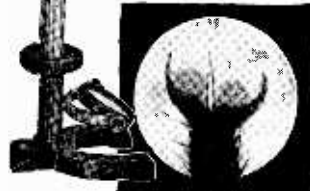

\$7.50 for Complete Outfit Prepaid

ULTRALENS MICROSCOPE

At last a high powered microscope is within the means of all who wish to study, observe and experiment with the vast world of minute objects invisible to the naked eye. Such fun it is, as well as educational. No technical training required, yet hundreds of scientists and teachers are using this instrument. Gives enormous magnification and perfect definition. Send \$7.50 for complete outfit. Send for descriptive literature.

Scientific Apparatus Corp., Dept. 263, Milton, Pa

What Is Matter?

By DR. DONALD H. MENZEL
(Continued from page 225)

latter, may not our sun with its planets also be an atom in a still greater macro cosm? Or, if we were able to examine the surface of the electron, would we not find it covered with groups of living organisms? As fascinating as these speculations are, they are

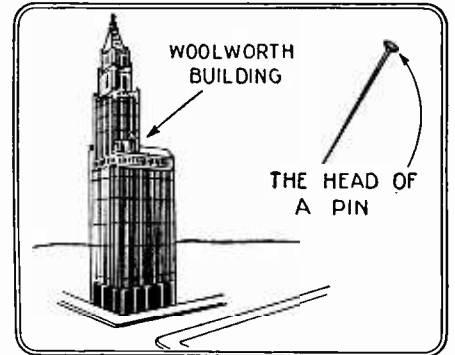

Fig. 5. Matter of apparent solidity is composed of widely spaced particles. The electrons of all the atoms contained in the Woolworth Building, if closely packed together would be the size of a pinhead.

of little value for they can never be proved. The more conservative scientists, however, point out that, while there is a superficial resemblance of an atom to the solar system, the similarity stops very soon, and tell us that there are many difficulties in the way of believing in such a complex universe. But is not matter itself intricate enough without going any farther? We have resolved it into electrons and nuclei—from matter to electricity and from electricity to energy, and yet, there is no one who can answer the question definitely "What is Matter" for who knows what energy is!

When the average person tries to visualize the fact that he has heard repeated so often, that the universe is built up of atoms—he finds great difficulty in getting any tangible conception. Perhaps he may get to the point where he regards the atom as a tiny brick which goes to make up any solid in the same way as bricks go to make up a dwelling. But even then he has no conception of the magnitude of the ultimate particle. If the "atomic bricks" which form a small dust-speck one-thousandth of an inch in diameter (past the limit of naked-eye visibility) were to be enlarged to the size of regular bricks, the resultant pile would be as large as Mt. Everest. (Fig. 1). If a super-microscope could be turned on the air molecules in a tennis ball, magnifying each so that it appeared as large

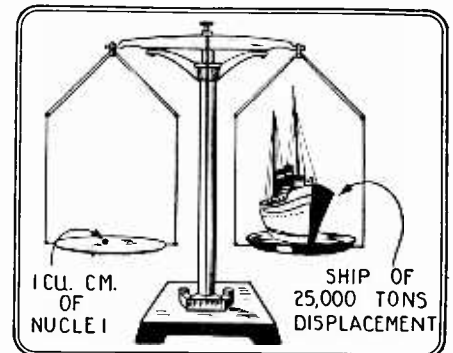

Fig. 5a. The nuclei contained in one cubic centimeter would weigh twenty-five-thousand-tons.

as the ball itself, the original ball, in proportion, would seem as large as the earth. (Fig. 2).

Insure your copy reaching you each month. Subscribe to Science & Invention, \$2.50 a year. Experimenter Publishing Co., 230 Fifth Avenue, New York City

Our first glimpse of the way in which atoms are arranged in a solid—that they form a sort of lattice-work instead of a perfectly continuous medium—came from the famous experiment of Bacon, who attempted to compress water in a lead sphere. (Fig. 3). Instead of being compressed into a smaller volume, the water passed completely through the solid lead and formed beads on the outside surface.

That molecules interpenetrate to a certain extent may be proved by anyone. When 50 cc. of water are mixed with 50 cc. of grain alcohol, the resulting volume will not be 100 cc. but 97 cc. (Fig. 4).

We now know the atom to be composed of a nucleus of positive and negative electricity, about which the electrons revolve much as the planets do about the sun. The kind of element is determined by the excess of positive electricity in the nucleus and the number of encircling electrons. Hydrogen, the lightest element, has but one of the latter, helium two, lithium three, and so on up to uranium, the heaviest element, which has ninety-two electrons outside of the nucleus.

The diameters of the atoms which we have previously mentioned refer to the diam-

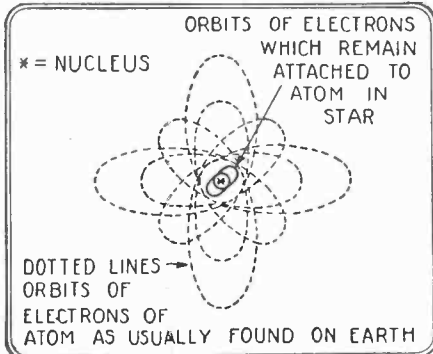

Fig. 6. It is said that the electrons of the atoms of the star Sirius have been dispersed by terrific temperatures, and that the star itself is composed mainly of detached nuclei.

eters of the outside orbit of the electrons. The particles of electricity which form the atom are about a hundred thousand times smaller. All in all, the actual space occupied by the electricity is so small in comparison to the space occupied by the atom that if the electricity which goes to make up all the atoms of the Woolworth Building were tightly compressed, in other words, if all the electrons could be removed from their orbits and nuclei and massed together, they could be contained in a space no larger than the head of a common pin. (Fig. 5). In answer to the question "What is Matter?" one could truly state, to a very high degree of approximation, "Matter is a vacuum."

In spite of its apparent solidity, science has proved a piece of iron to be mostly empty space. Whence, then, is the natural query, comes its heaviness. A little thought will show that this must be due to the extreme density of the ultimate particles. A little mathematical calculation shows that the nuclei are about twenty-five billion times as dense as water. That is, one cubic centimeter of them would weigh 25,000 tons.

A number of years ago the astronomers discovered a star (the companion to the bright star Sirius) whose measured density was 50,000 times that of water—a cubic inch would weigh a ton. Loth to believe this, they seldom discussed this anomalous object. In the light of the atomic theory this does not, however, appear so unreasonable. Within the hot interiors of these stars, the atoms will be moving in such violent agitation that the outer electrons will be torn from them, leaving bare nuclei, or at any rate only the small inner orbits. The atoms will, therefore, not take up so much room and may easily be compressed to the above density and still remain a gas. (Fig. 6).



Go after the Big-Pay Job!

"Know electricity as experts know it and get an expert's pay"

DON'T be satisfied to worry along in little jobs with little pay. Master the finer points of electrical practice and bring the big-pay job within your reach. Croft will show you how. Through his famous books he will teach you electricity as experts know it and put you in line for an expert's pay. Forty thousand men are using these books to step ahead—WHY NOT YOU?

The Croft Library of Practical Electricity

A Combined Home Study Course and Reference Library
8 volumes—3000 pages—2100 illustrations—flexible Keratol binding
Now \$19.50—Soon \$23.50

Last Chance

Act Now

No method of teaching electricity offers a quicker, surer way to success than the Croft books.

Starting right in with the ABC's of modern electrical practice, Croft takes you through his books in easy steps. He gives you the secrets of success in electricity in plain words, figures and illustrations.

Croft teaches you electrical practice complete—inside and outside work—central stations and the whole subject. He takes you in quick, easy steps from the simplest principles to the complete and economical operation of a great central station.

He tells you things you need to know about motors, generators, armatures, commutators, transformers, circuits, currents, switchboards, distribution systems—electrical machinery of every type, installation, operation and repair—wiring for light and power—how to do it mechanically perfect, in accordance with the National Electrical Code—wiring of finished buildings—underwriters' and municipal requirements—how to do a complete job, from estimating it to completion—illumination in its every phase—the latest and most improved method of lighting—lamps and lighting effects, etc.

The Sure Way to Bigger Pay

Big salaries are paid in the electrical field for expert knowledge. The man who knows electricity in all its many phases—the man who has completely mastered the subject from A to Z—can pick his own job and name his own salary. The only way you can earn more is to learn more. Small knowledge means small pay. Learn the way to bigger pay. Become an expert.

FREE TRIAL

The proof of all we have said is in the books themselves, and it costs you **N-O-T H-I-N-G** to examine them. There are no charges of any kind to pay. We pay everything. We send the books to you for 10 days' examination and let you be the sole judge as to their value.

EASY PAYMENTS

If you decide to take this sure road to promotion, you need send only \$1.50 in ten days and pay the balance at the rate of \$2 a month. You do not have to send any money to see the books. You do not have to buy them unless you feel that they actually will mean more money to you.

This is the last chance you will have to get your Croft LIBRARY OF PRACTICAL ELECTRICITY at its present low price.

This is a great set of books. Get it now and save \$4.00. Send for the LIBRARY for free examination NOW.

It means your electrical success. It means more money for you. And that's worth going after immediately. Act now in your own interest. Do this for yourself today.

YOU SAVE \$4.00 AND HAVE 10 MONTHS TO PAY

FREE EXAMINATION

NO MONEY IN ADVANCE

SEND YOUR COUPON NOW

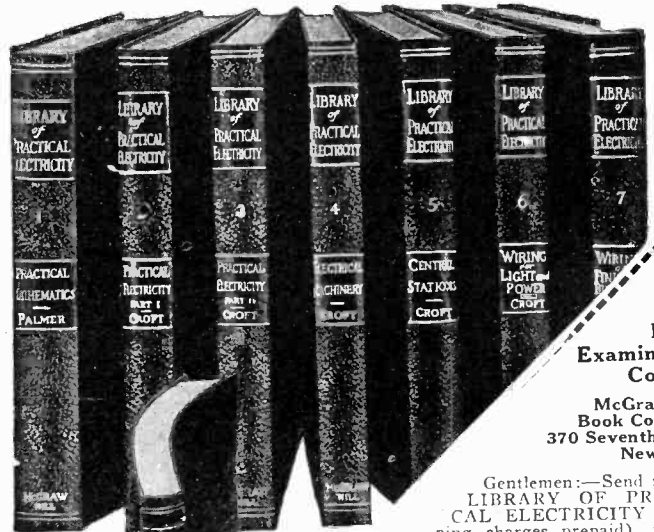

FREE Examination Coupon

McGraw-Hill Book Co., Inc., 370 Seventh Ave., New York

Gentlemen:—Send me the LIBRARY OF PRACTICAL ELECTRICITY (shipping charges prepaid), for 10 days' free examination. If satisfactory, I will send \$1.50 in ten days and \$2 per month until the special price of \$19.50 has been paid. If not wanted, I will write you for return shipping instructions.

Name

Home Address

City and State

Employed by

Occupation S. I. 7-1-27

U.S. PATENTS



SEND FOR THIS FORM

Don't Lose Your Rights

Before disclosing your invention to anyone send for blank form "Evidence of Conception" to be signed and witnessed. A sample form together with printed instructions will show you just how to work up your evidence and establish your rights before filing application for patent. As registered patent attorneys we represent hundreds of inventors all over the U. S. and Canada in the advancement of inventions. Our schedule of fees will be found reasonable. The form "Evidence of Conception" sample, instructions relating to obtaining of patent and schedule of fees sent upon request. Ask for them,—a post card will do.



Registered Patent Attorneys in U.S. and Canada
255 Ouray Bldg., Washington, D. C.
"Originators of form Evidence of Conception"

PATENTS

TO THE MAN WITH AN IDEA

I offer a comprehensive, experienced, efficient service for his prompt, legal protection and the development of his proposition.

Send sketch, or model and description, for advice as to cost, search through prior United States patents, etc. Preliminary advice gladly furnished without charge.

My experience and familiarity with various arts frequently enable me to accurately advise clients as to probable patentability before they go to any expense.

Booklet of valuable information and form for properly disclosing your idea, free on request. Write today.

RICHARD B. OWEN, Patent Lawyer
164 Owen Building, Washington, D. C.
41V Park Row, New York City

TRADE-MARKS REGISTERED



INVENTORS

IDEAS DEVELOPED AND PERFECTED

Models, Experimental work; labor-saving machinery for manufacturers. 20 years' experience.

Bernard & Heller, 275-B Water St., N.Y.C.

INVENTORS PROTECT YOUR IDEAS

Send for our Guide Book, **HOW TO GET A PATENT**, and Evidence of Invention Blank, sent Free on request. Tells our terms, methods, etc. Send model or sketch and description of your invention for **INSPECTION AND INSTRUCTIONS FREE. TERMS REASONABLE. BEST REFERENCES.**

Name

Street

City

RANDOLPH & CO.

Dept. 172, WASHINGTON, D. C.

Patent Advice

Edited By **Joseph H. Kraus**

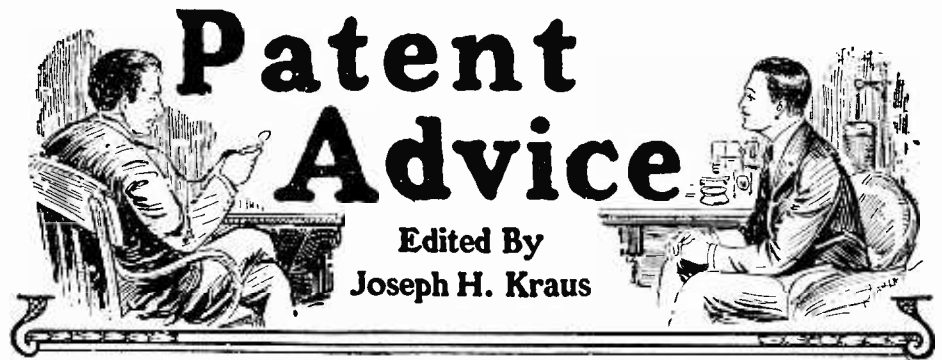

In this Department we publish such matter as is of interest to inventors and particularly to those who are in doubt as to certain patent phases. Regular inquiries addressed to "Patent Advice" cannot be answered by mail free of charge. Such inquiries are published here for the benefit of all readers. If the idea is thought to be of importance, we make it a rule not to divulge all details, in order to protect the inventor as far as it is possible to do so.

Should advice be desired by mail a nominal charge of \$1.00 is made for each question. Sketches and descriptions must be clear and explicit. Only one side of sheet should be written on.

NOTE:—Before mailing your letter to this department, see to it that your name and address are upon the letter and envelope as well. Many letters are returned to us because either the name of the inquirer or his address is incorrectly given.

EXERCISER—AND LAW SUIT

(1027) G. R. Foster, Detroit, Mich., has designed an exerciser using rubber instead of springs and asks whether he will be reasonably safe to manufacture this exerciser, giving the user instructions for its assembly; or whether he would be liable to suit in event that one of the rubbers snapped and caused more or less serious injury. He intends to warn the user.

A. It is very difficult for us to give you information from a legal standpoint because each and every case when presented to the courts will be considered on its own merits. Even courts have been known to disagree with each other, so how could we be expected to give you an answer which would hold in every case? It seems, however, that you have given the purchaser of your exerciser due warning that the use of poor rubber might cause injury; also the exerciser, when sent, is perfectly safe. It, therefore, follows that any injury would be due directly to negligence on the part of the purchaser and not on the part of the manufacturer.

Why not complete the exerciser and furnish it with the proper cotton covered rubber? In this style the danger is considerably lessened.

AUTO VALVES

(1028) Charles Hennan, Queens Village, L. I., submits an idea for a valve mechanism for automobiles which is similar to the sliding valve in the steam engine. He asks our opinion on the same.

A. The sliding valve which you have designed is in no way superior to the poppet valve in everyday use and we would strongly advocate against applying for a patent on your construction. The sliding valve has many disadvantages. While it does not carbonize as easily as the poppet valve, the ports do not open quickly enough to permit of high speed nor are they opened fully except for a fraction of the time. In the Willys-Knight sleeve valve motor, due to the peculiar construction of the valve, many of these faults are eliminated. We consider your particular style much inferior to the afore-mentioned motor and would, therefore, not advise any further procedure with the suggestion.

FLASHER SWITCH

(1029) William Schmidt, Lakewood, Ohio, asks us what our opinion is of a series flasher signal switch to be used in connection with an automobile direction lamp.

A. Inasmuch as you have enclosed no specifications or drawings of your switch, it would be impossible for us to comment on the same. We would like to have some further information on the subject.

TUBE CRIMPER

(1030) George E. Thornton, Kansas City, Mo., submits a sketch for a tube crimper to be used in the automobile industry.

A. We think that the idea advanced by you is quite clever and we would certainly advocate that you proceed with the suggestion to the extent at least of having a patent search made for the purpose of discovering if there are any other similar articles patented. As a result of the search you could determine whether or not you should proceed further with patenting the suggestion. We advocate that before you proceed further in patenting the article, that you have several of these devices made and have them tested out by some friends in some public garage. If they do what is claimed for them, we would advocate further action.

IDEAS VS. EMPLOYERS

(1031) Victor D. Clark, Chicago, Ill., asks whether his employers have any right to his ideas or patents. He suggests a partnership arrangement to protect the patent.

A. 1. Your employers have no right to your ideas, provided, of course, that you were not hired for the express purpose of developing ideas or if you are not being paid by your concern for development work.

If you should happen to be a bookkeeper in a concern and you see some improvements which could be made on their machinery, there is no reason why you could not patent your suggestions and then attempt to sell them to the organization with which you are connected. Only in event of a contract with your employers, to the contrary, would they be able to make use of your suggestions without purchasing them.

While the partnership game advised by you is frequently attempted, unless the partner actually was responsible for enough of the development of the patent for him to swear to developing the idea, an act of this nature would be perjury. The patent could be assigned to a partner and then other contracts could eliminate him from possessive rights.

PROTECTING AND MARKETING A SUGGESTION

(1032) Dorothy Urfer, Muncie, Ind., asks several questions made clear in the answers.

A. 1. There is a vast difference between marketing a houndoir or novelty doll and protecting the idea. The ideal way to market a novelty doll or any other novelty is to manufacture it yourself or have it manufactured for you and then sell it through your own sales agencies, through your own solicitors or through various houses that deal primarily in novelties.

The novelty may be either "design" patented or "letters" patented. If the novelty presents some new idea, other than its shape, you should get a "letters" patent on it. For instance, if you had a doll which moved its eyes constantly or which danced, or was capable of some other movement or some other peculiarity of construction, then you should get a letters patent on the idea. If the doll was just an ordinary bisque, papier mache or combination doll with nothing startling about it, except its form (a diving girl or a nymph-like figure), even though this doll might be capable of the ordinary arm, leg, head, and eye movements, you need only get a "design" patent. We advocate that you let your attorney decide on this matter.

You cannot copyright anything except printed or published material, diagrams, illustrations, paintings and the like. A diagram for a doll construction might be copyrighted, but it would afford little protection.

At the right is a view of my drafting and specification offices where a large staff of experienced experts are in my constant employ.



All drawings and specifications are prepared under my personal supervision.

PATENTS

My Patent Law Offices
Just Across Street From U.S. Pat. Office



Protect Your Ideas

Take the First Step Today—Action Counts

If you have a useful, practical, novel idea for any new article or for an improvement on an old one, you should communicate with a competent Registered Patent Attorney AT ONCE. Every year thousands of applications for patents are filed in the U. S. Patent Office. Frequently two or more applications are made for the same or substantially the same idea (even though the inventors may live in different sections of the country and be entirely unknown to one another). In such a case, the burden of proof rests upon the last application filed. Delays of even a few days in filing the application sometimes mean the loss of a patent. So lose no time. Get in touch with me at once by mailing the coupon below.

Prompt, Careful, Efficient Service

This large, experienced organization devotes its entire time and attention to patent and trademark cases. Our offices are directly across the street from the U. S. Patent Office. We understand the technicalities of patent law. We know the rules and requirements of the Patent Office. We can proceed in the quickest, safest and best ways in preparing an application for a patent covering your idea. Our success has been built on the strength of careful, efficient, satisfactory service to inventors and trademark owners located in every state in the Union.

Strict Secrecy Preserved—Write Me in Confidence

All communications, sketches, drawings, etc., are held in strictest confidence in strong, steel, fireproof files, which are accessible only to authorized members of my staff. Feel free to write me fully and frankly. Your case will have my personal attention. It is probable that I can help you. Highest references. But FIRST—clip the coupon and get my free book. Do THAT right now.

No Charge for Information On How to Proceed

The booklet shown here contains valuable information relating to patent procedure that every inventor should have. And with it I will send you my "Record of Invention" form, on which you can sketch your idea and establish its date before a witness. Such evidence may later prove valuable to you. Simply mail the coupon and I will send you the booklet, and the "Record of Invention" form, together with detailed information on how to proceed and the costs involved. Do this NOW. No need to lose a minute's time. The coupon will bring you complete information entirely without charge or obligation.

Clarence A. O'Brien

Registered Patent Attorney

Member of Bar of: Supreme Court of the United States; Court of Appeals, District of Columbia; Supreme Court, District of Columbia; United States Court of Claims.

PRACTICE CONFINED EXCLUSIVELY TO PATENTS, TRADEMARKS AND COPYRIGHTS

Inventors Write for these Free Books



Mail this Coupon Now

CLARENCE A. O'BRIEN

Registered Patent Attorney

53-Z Security Savings & Commercial Bank Bldg., Washington, D. C.

Please send me your free book, "How to Obtain a Patent," and your "Record of Invention" form without any cost or obligation on my part.

Name

Address

(Important; Print or Write name clearly)



"The Boss Didn't Even Know My Name"

"He said my face was more or less familiar and he remembered seeing me around, but he didn't even know my name until the I. C. S. wrote him that George Jackson had enrolled for a course of home study and was doing fine work.

"Who's George Jackson?" he asked. Then he looked me up. Told me he was glad to see I was ambitious. Said he'd keep his eye on me.

"He did too. Gave me my chance when Frank Jordan was sent out on the road. I was promoted over older men who had been with the firm for years.

"My spare-time studying helped me to get that job and to keep it after I got it. It certainly was a lucky day for me when I signed that I. C. S. coupon."

How much longer are you going to wait before you take the step that will bring you advancement and more money?

It takes only a moment to mark and mail this coupon and send it to the International Correspondence Schools at Scranton. Isn't it better to do this today than to wait a year or five years and then wish you had?

Mail the Coupon for Free Booklet

INTERNATIONAL CORRESPONDENCE SCHOOLS Box 6194-E Scranton, Penna.

Without cost or obligation, please send me a copy of your booklet, "Who Wins and Why," and full particulars about the course before which I have marked X:

BUSINESS TRAINING COURSES

- | | |
|---|---|
| <input type="checkbox"/> Business Management | <input type="checkbox"/> Salesmanship |
| <input type="checkbox"/> Industrial Management | <input type="checkbox"/> Advertising |
| <input type="checkbox"/> Personnel Organization | <input type="checkbox"/> Better Letters |
| <input type="checkbox"/> Traffic Management | <input type="checkbox"/> Show Card Lettering |
| <input type="checkbox"/> Business Law | <input type="checkbox"/> Stenography and Typing |
| <input type="checkbox"/> Banking and Banking Law | <input type="checkbox"/> English |
| <input type="checkbox"/> Accountancy (including C.P.A.) | <input type="checkbox"/> Civil Service |
| <input type="checkbox"/> Nicholson Cost Accounting | <input type="checkbox"/> Railway Mail Clerk |
| <input type="checkbox"/> Bookkeeping | <input type="checkbox"/> Common School Subjects |
| <input type="checkbox"/> Private Secretary | <input type="checkbox"/> High School Subjects |
| <input type="checkbox"/> Spanish | <input type="checkbox"/> Illustrating |
| <input type="checkbox"/> French | <input type="checkbox"/> Cartooning |

TECHNICAL AND INDUSTRIAL COURSES

- | | |
|---|--|
| <input type="checkbox"/> Electrical Engineering | <input type="checkbox"/> Architect |
| <input type="checkbox"/> Electrical Lighting | <input type="checkbox"/> Architects' Blueprints |
| <input type="checkbox"/> Mechanical Engineer | <input type="checkbox"/> Contractor and Builder |
| <input type="checkbox"/> Mechanical Draftsman | <input type="checkbox"/> Architectural Draftsman |
| <input type="checkbox"/> Machine Shop Practice | <input type="checkbox"/> Concrete Builder |
| <input type="checkbox"/> Railroad Positions | <input type="checkbox"/> Structural Engineer |
| <input type="checkbox"/> Gas Engine Operating | <input type="checkbox"/> Chemistry <input type="checkbox"/> Pharmacy |
| <input type="checkbox"/> Civil Engineer | <input type="checkbox"/> Automobile Work |
| <input type="checkbox"/> Surveying and Mapping | <input type="checkbox"/> Airplane Engines |
| <input type="checkbox"/> Metallurgy <input type="checkbox"/> Mining | <input type="checkbox"/> Agriculture and Poultry |
| <input type="checkbox"/> Steam Engineering <input type="checkbox"/> Radio | <input type="checkbox"/> Mathematics |

Name.....
Street Address.....
City..... State.....
Occupation.....

If you reside in Canada, send this coupon to the International Correspondence Schools Canadian Limited, Montreal

NEW PRODUCTS WANTED

Many of our clients have unused plant and facilities for manufacture and sale of new products. They will consider new products and those which are now being manufactured unsatisfactorily. Among products wanted are: Electrical devices and those using small motors; products for machine shops or foundries, especially malleable or grey iron; scales; refrigerating devices; agricultural or other implements; railroad equipment; household products. Opportunities also for products not in the foregoing classification.

Write Division of New Products

THE SHERMAN CORPORATION
ENGINEERS
31 MILK ST., BOSTON

Insure your copy reaching you each month. Subscribe to SCIENCE AND INVENTION—\$2.50 a year. Experimentor Pub. Co. 230 Fifth Ave., N.Y.C.

The Astrology Humbug

By JOSEPH H. KRAUS

(Continued from page 228)

feel that we respect Mr. Bennett for his views even as he must respect us for ours. We do not know why our gentle readers likewise have to suffer by reading all this, but, believing that they perhaps are interested in both sides of this controversy, we are placing our cards on the table and inviting the astrologers to do likewise. Perhaps it will eventually result in a Civil War, but we hope not. Perhaps the astrologers can tell what the ultimate outcome of our contest will be. Unfortunately, we do not know the exact second when the idea for a contest of this nature was given birth, but we can approximate it to within a few minutes.

Concerning the monetary argument advanced by the aforementioned Bennett, we would say that SCIENCE AND INVENTION Magazine, during the past year has paid \$5,000.00 in actual cash for Matchcraft models alone. These comprise only three pages in any individual issue of this publication and consequently are but very small items in the payments expended by this publication. Mr. Bennett and other astrologers know this and must have foresight enough to know that if SCIENCE AND INVENTION Magazine ever discovered an astrologer capable of casting a horoscope or producing a prediction which would be accurate, and which would come under the classification of astrology, that the attendant publicity which this publication would get, as well as the publicity which the astrologer would get could not be compensated for by the \$6,000.00 investment. The advertising bill of this publication is many times the \$6,000.00 every month.

Referring to the further statements made by Mr. Bennett and with particular regard to the "false data such as the outright and malicious lie about the sex of the author of the article referred to", we must merely request that the aforesaid gentleman read the previous articles in SCIENCE AND INVENTION Magazine again and also note the facts which have been repeated at least one-half dozen times. For the benefit of Mr. Bennett, we would advise that a young lady, Florence B., was born and died at the times and dates specified. These are facts and, as facts, are indisputable. The young lady was a female personage of the genus homo, and had she been married, she might have been the mother of a proud family. Please note that we say mother, not father, thus reiterating that the woman belonged to the fairer sex. These are facts and these were known to us. They were delivered to the astrologer, but in view of the impossibility of having a letter delivered to the young lady, who had crossed into the Great Beyond; and due to the impossibility of securing the answer if it were delivered to that land, and in view further of the fact that it is impossible to get the spirits to write letters to astrologers, this writer (or as Mr. Bennett prefers to call him), "Scribbler Kraus," impersonated the young lady. He gave the astrologer Florence B.'s birth date and he signed his own name to the communication for the purpose of side-tracking the letter and making it arrive at his own home instead of the present spiritual residence of the aforesaid Florence B. This lengthy explanation was absolutely necessary as Mr. Bennett has proven.

Further comments by Mr. Bennett being irrelevant, inconsequential and not bearing on the issue, we need waste no more more valuable space.

It may be a good idea also for Mr. George, editor, owner, managing editor, etc., of the Astrological Bulletin, to likewise read the above script and to refer to past articles in this publication. In an article entitled, "The Science and Invention of Humbug," written by this all-around director, he states, "In fact, one 'Science Magazine' immediately condemns all astrologers because they 'fell' for a cheap so-called horoscope from an unauthoritative source (yet they purposely deceived about the data)." Yet in the Astrological Bulletin we find an article written by this same astrologer.

Does drawing up a horoscope for us make it unauthoritative, while an article by the same astrologer for the Bulletin is authoritative?—EDITOR.

Mr. George follows further, "In the following issue of their magazine, the editors went to even more elaborate methods of deception in a so-called investigation of astrology. Before applying to an astrologer for a horoscope under a fictitious name, it seems that they even went so far as to have a letterhead especially printed with that name on it, for the express purpose of deceiving the astrologer into believing that the delineations were for a business man of this country who is just about to take a journey. But the fact was concealed that the data given was in reality that of the Kaiser and that the delineation should be considered as for one in his conditions.

"But, did the astrologer give a delineation for the Kaiser because it was the date of his birth that had been deceptively given here? Not at all. She properly fulfilled the requirements of the science by giving a delineation for that date suited to a person in America in the business sphere of life. In doing this, she conformed to the rules of astrology as laid down by Ptolemy, the great

(Continued on page 272)

PATENTS

TRADE-MARKS—DESIGNS
FOREIGN PATENTS

MUNN & CO. PATENT ATTORNEYS

Associated since 1846 with the
Scientific American

1583 SCIENTIFIC AMERICAN
BUILDING
24 West 40th Street
New York City

522 SCIENTIFIC AMERICAN
BUILDING
Washington, D. C.

1311 TOWER BUILDING
Chicago, Ill.

664 HOBART BUILDING
San Francisco, Cal.

519 VAN NUYS BUILDING
Los Angeles, Cal.

Books and Information on Patents and
Trade-Marks By Request

Associates in all Foreign Countries

PATENTS

BOOKLET FREE HIGHEST REFERENCES
PROMPTNESS ASSURED BEST RESULTS

Send drawing or model for examination
and advice.

WATSON E. COLEMAN, Patent Lawyer
724 9th Street, N.W., Washington, D. C.

C. L. PARKER

Ex-Examiner U. S. Patent Office

Attorney-at-Law and Solicitor of Patents

McGill Building, Washington, D. C.

Patents, Trade Mark and Copyright Law

INVENTIONS Commercialized

ON A CASH OR ROYALTY BASIS
PATENTED OR UNPATENTED

In Business 25 Years. Complete Facilities-References.

Write ADAM FISHER MFG. Co.,
205D Enright Ave. St. Louis, Mo.

NEW YEAR - NEW IDEA

PATENT YOUR IDEAS

Call or send me a sketch of

your invention. Phone LONgacre 3088

FREE Inventors Recording Blank
Confidential Advice

U. S. and Foreign Patents secured by

Z.H. POLACHEK Reg. Patent Attorney
Consult. Engineer

1234 Broadway, New York

REFLECTING TELESCOPES SUPPLIES

ERNEST W. BLANDIN

1207 Columbia Terrace, Peoria, Ill.

Mysterious!

Winner for Agents

New Pocket Lighter! What Makes it Light?
Why can't a Blizzard Blow it out? No flint—
No Friction—No Troublesome Parts. Why fool
with matches NOW? Instant—Infallible—Guar-
anteed. Send 50c for Sample and Selling Plans.

NEW METHOD MFG. CO.
Box S-1-5 Bradford, Pa.

Tales from the Scientific Club

By RAY CUMMINGS

(Continued from page 229)

that. He said nothing of his suspicions, but at once brought the licorice to me. I have had it analyzed. It contains a deadly poison, gentlemen. Enough in one little bite, to have killed him!"

Before the Doctor could continue, the door opened and an attendant announced, "Mr. Jonathan J. Blake and party to see Dr. Adams."

"Bring them up," the Doctor ordered. "Gentlemen, those are all the facts—all the evidence we have. It will not take long—if we can find this criminal at all. You just say nothing—just listen and watch. . . . Are you all ready, Jack?"

"Yes," said the Very Young Man nervously. "Everything's all ready. Dr. Gregg has the paper and pencils—and I've got the stuff all ready in the other room."

Articles In July "Radio News"

The Service Area of a Broadcast Station.
\$250 Prize Title Contest.

The Time Chime at WRNY.

Loud-Speaker Coupling Devices.

Some Aspects of High-Quality Reproduction.

The Stroboddyne, a New Frequency-Changer.

What Can You Do With Burnt-Out Tubes?—\$100 Prize Contest.

Light-Sensitive Crystals.

An 18- to 1500-Meter Receiver.

The Acme "D"-Coil Receiver.

The "Ham's Own" Short-Wave Receiver.

A Traveler's Set.

Building a Remote-Control Loud-Speaker Cabinet.

The Effects of Shielding.

By Harold A. Zahl

The Doctor nodded, and turned to the Alienist. "Dr. Gregg, as you advised, we'll take them all into the other room together at first. Give them—say sixty seconds?"

"Yes," agreed the Alienist. "That's long enough."

"And then—sixty seconds each, as they go in singly? You keep the time, Jack—but don't even go into the room, except at first when they are all there together. Be with them then—watch them closely."

The hall door opened; Jonathan J. Blake and the five members of his family were ushered in. The room was in confusion for a moment as the Doctor introduced them to the club members. The twins sat together on a leather settee. They were a good looking youth and girl—this George and Anna Blake; but plainly not of the patrician blood of their foster-father. Old Blake was obviously an aristocrat to his finger-tips—a stern, fine old face surmounted by a shock of snow-white hair.

Robert Thorpe, the chauffeur, was a muscular, handsome man of about thirty. He drew his chair close to Anna; began whispering to her. The secretary, William Fontaine, sat apart—a thin, pale-faced man who looked thirty-five or forty. The housekeeper, Mrs. Green, was a middle-aged woman of matronly aspect, dressed in black sateen, in the style of a by-gone age. She was plainly flustered by the number of men

1000 NEEDED INVENTIONS

Here is the most remarkable book ever offered to inventors. One Thousand needed inventions listed and described. Arranged as follows: General Problems; Automotive; Mechanical; Electrical; Chemical; Radio; Marine. Separate chapter on the Ten Most Needed Inventions. This book may give you one idea that will win you a fortune. Nothing else like it has ever been published. Compiled at enormous expense. Edited by Raymond Francis Yates, formerly Managing Editor of a leading scientific magazine. Over 100 pages durably bound. Send no money. Pay postman only \$1.00, plus postage on arrival. (Outside U. S. \$1.20, cash with order). Money back after 10 days' examination if desired. Limited edition. Write NOW.

BUREAU OF INVENTIVE SCIENCE
Dept. 77 Rochester, New York

PATENTS

As one of the oldest patent firms in America we give inventors at lowest consistent charge, a service noted for results, evidenced by many well known Patents of extra ordinary value. Book, Patent-Sense, free. Lacey & Lacey, 644 F St., Washington, D. C. Estab. 1869

For Indian Patents Write to:—

LAW MORRIS & COMPANY

Patent & Trade Marks Agents

Post Box 377

Calcutta, India

A Personal Service for INVENTORS

I maintain an unexcelled organization and thoroughly equipped laboratories, to render the following services.

I PREPARE APPLICATIONS for patents for filing in the United States and foreign countries.

I PLACE INVENTIONS with responsible manufacturers, with whom I am acquainted, under arrangements that are made profitable to the inventor.

I SPECIALIZE in Electrical, Mechanical, Chemical, and Radio Devices.

I INVITE CORRESPONDENCE with reputable inventors, Scientists, Chemists and Physicists, regarding their inventions and uncompleted experiments.

H. R. VAN DEVENTER

Licensed Professional Engineer
Registered Patent Attorney

342 Madison Avenue, New York City

BLUE BOOK ON PATENTS

and Priority Record blank gratis.

MONROE E. MILLER, PATENT LAWYER,
411-6 Ouray Building, WASHINGTON, D. C.
ELECTRICAL AND MECHANICAL EXPERT

PATENTS TRADE-MARKS AND COPYRIGHTS

OUR OFFER: FOR THE PROTECTION OF YOUR INVENTION

YOUR FIRST STEP. The inventor should write for our blank form—"RECORD OF INVENTION." This should be signed, witnessed and returned to us together with model or sketch and description of the invention for INSPECTION and INSTRUCTIONS FREE!

Our Four Books Mailed Free to Inventors

Our Illustrated Guide Book

HOW TO OBTAIN A PATENT

Contains full instructions regarding U. S. Patents. Our Methods, Terms, and 100 Mechanical Movements illustrated and described.

OUR TRADE-MARK BOOK

Shows value and necessity of Trade-Mark Protection. Information regarding Trade-Marks and unfair competition in trade.

OUR FOREIGN BOOK

We have Direct Agencies in Foreign Countries and secure Foreign Patents in shortest time and lowest cost.

PROGRESS OF INVENTION

Description of World's Most Pressing Problems by Leading Scientists and Inventors

All Communications and Data Strictly Confidential. Interference and Infringement Suits Prosecuted.

IMPORTANT

TO MAKE YOUR CASE SPECIAL AND AVOID DELAY YOU SHOULD HAVE YOUR CASE MADE SPECIAL IN OUR OFFICE to secure protection, save correspondence and obtain early filing date in Patent Office. To secure special preparation of your case send \$25.00 on account with model or sketch and description of your invention.

Highest References—Prompt Attention—Reasonable Terms

WRITE TODAY

FREE COUPON

VICTOR J. EVANS & CO.

Registered Patent Attorneys

MAIN OFFICES: 779 Ninth St., Washington, D. C.

New York Offices, 1007 Woolworth Bldg.; Philadelphia Offices, 518-519 Liberty Bldg.; Pittsburgh Offices, 514 Empire Bldg.; Chicago Offices, 1114 Tacoma Bldg.; San Francisco Offices 1010 Hobart Bldg.

Gentlemen: Please send me FREE OF CHARGE your books as described above.

Name
Address

Insure your copy reaching you each month. Subscribe to Science & Invention—\$2.50 a year. Experimenter Publishing Co., 230 Fifth Avenue, N. Y. C.



**Come Now to
the Nassau
at Long Beach L.I.**

Just 40 minutes from New York by train
THE BOARDWALK IS GLORIOUS
THE AIR IS LADEN WITH HEALTH
THE HOTEL IS A PLEASANT TREAT

**Sea Baths ♪ Music ♪ Dancing
Festive Week-Ends**

Room Plus Food - Only \$ 8⁰⁰ per Day

OPEN ALL YEAR
TELEPHONE - LONG BEACH 100
Henry H. Gerard - *Managing Director*

in the room; she sat on the edge of her chair nervously twisting her fingers. But the others were all seemingly at ease, though plainly curious to know what new eccentricity of old Blake had brought them here. The twins said something to that effect.

"You're all here because I told you to come," Blake exclaimed testily. "I've a purpose, which is not for you to criticize." He had seated himself beside the Doctor; he glared at his household.

The secretary said, in a soft almost effeminate voice, "They meant no offense, Mr. Blake."

The chauffeur said nothing; the housekeeper murmured volubly that she was always ready and willing to do anything she was told; but no one heeded her.

The Doctor said quickly, "I'm sure Mr. Blake doesn't really mind being called eccentric. You of course are all wondering why we asked you here. Call it an eccentricity of Mr. Blake's, if you like." His glance to the old man flung a swift warning; then he smiled and added, "I'm one person

**\$21,000.00
for Spirits**

Dunninger, who writes exclusively for SCIENCE AND INVENTION Magazine and who is the Chairman of our PSYCHICAL INVESTIGATION Committee will personally pay \$10,000.00 to any medium or spiritualist who can present any psychical manifestation in so-called spiritualism, that he will not explain or that he cannot reproduce by natural means.

More than two years ago SCIENCE AND INVENTION Magazine offered a prize of \$11,000.00 to anyone who could demonstrate his or her ability to communicate with the spirits or to give some definite form of a psychical demonstration which in itself was not tricky.

The result has been that mediums and spiritual organizations have been afraid to place proofs before us. Those weak attempts which have been made to demonstrate psychical phenomena were almost instantly proven fraudulent, and no medium has dared to contradict our findings.

In view of these facts, should we not consider all mediums fraudulent?

To the \$10,000.00 which has been offered by Joseph F. Rinn through this publication for Spiritual proofs and the \$1,000.00 in addition offered by SCIENCE AND INVENTION Magazine we now add Dunninger's \$10,000.00.

So now we have a total of \$21,000.00 offered for proofs of Psychical Manifestations. Spiritualists—get busy.

you cannot bully, can you, Mr. Blake? . . . Of course you cannot, and so I'm going to tell them plainly why they are here. . . . Mr. Blake, my friends, has recently become interested in psychology. Dr. Gregg here is an alienist, as you perhaps know, of national fame. These other gentlemen are all interested in the subject—but they are here merely as spectators.

"In a word, Mr. Blake a week or so ago, suggested that Dr. Gregg put him through the various tests to determine the condition of his mentality. We were surprised; and I know Mr. Blake was gratified to have us tell him that his mental powers, at eighty-two, far surpass the average of any age. Perhaps he is vain about it; at any rate he is eccentric enough to demand that those of his family and household go through the same tests—"

Old man Blake said, "There isn't one of them can make any showing at all."

The Doctor laughed. "Perhaps not, Mr. Blake—though don't be too sure. They may not be as stupid as you think they are."

It put the affair upon a basis of lightness and jocularity, which was the Doctor's purpose. There was a confusion of questions, explanations and argument. None of the vis-

**SHEETS OF CARDS
make Speedy Visible Records**

Handifax -- A Wonderful Invention -- Helps Business



Visualizes recorded facts to executives. 50 Card-sheets show 1000 cards. Visible space on each card 1/2 or 1 inch. Easy to analyze graphic chart "picture." Color signals "flag" your attention. Cuts record-keeping costs 40%. Quick for use in reference or posting. As handy to use as a sheet of paper. Sheets of cards can be typewritten. Good for all kinds of records. Any size, 100, 1,000, 10,000, 1,000,000. Your present system can be used. Very low cost—very compact.

Sales Agents Wanted

Send for
**FREE
Samples**

Ross-Gould Co.
404 N. Tenth Street, St. Louis, Mo.

Handifax

**I Offer You
\$8.00 a Day
and a**

Write quick for new proposition. We offer \$8.00 a day and a new Chevrolet Coach for demonstrating and taking orders for Comer All-Weather Topcoats and Raincoats. Spare time. No experience required. Sample Outfit Free. Write now.

Comer Mfg. Co., Dept. U-73, Dayton, O.



Become an Artist

LEARN AT HOME

You can learn to draw pictures that sell through a remarkable simple home-study method. Earn money while learning and secure a well-paying position after completing course. Good artists are always in demand and earn from \$100 to \$250 a week.

Write today for free book. No obligation.

WASHINGTON SCHOOL OF ART Room 267-E
1115-15th St., N. W. Washington, D. C.



itors displayed any opposition to the experiment: they seemed not to take it seriously; George Blake declared that he would probably fail ignominiously; but that he was sure Anna was dumber than himself. They were all smiling except Mrs. Green. The housekeeper was plainly frightened; she didn't understand what they were talking about; she was willing to go through with it only out of loyalty to her employer.

The Doctor said, "It won't hurt you, Mrs. Green—I promise you that. The first test is merely to demonstrate accuracy of memory." The smile left his face as he added, "I want you all to pay careful attention. The first is an observation test for memory. In the adjoining room we have a table with a number of small articles on it. They are all articles taken from Mr. Blake's home. Perfectly familiar to you—you have seen them all many times. You are each going in twice to observe the table—all together first, to look at the articles sixty seconds. Then one at a time for another sixty seconds. We will supply you with paper and pencil. . . . Jack, get them from Dr. Gregg and pass them around. . . . You are to write from memory when you come out a list of as many of the articles as you can remember. That's simple enough, isn't it?"

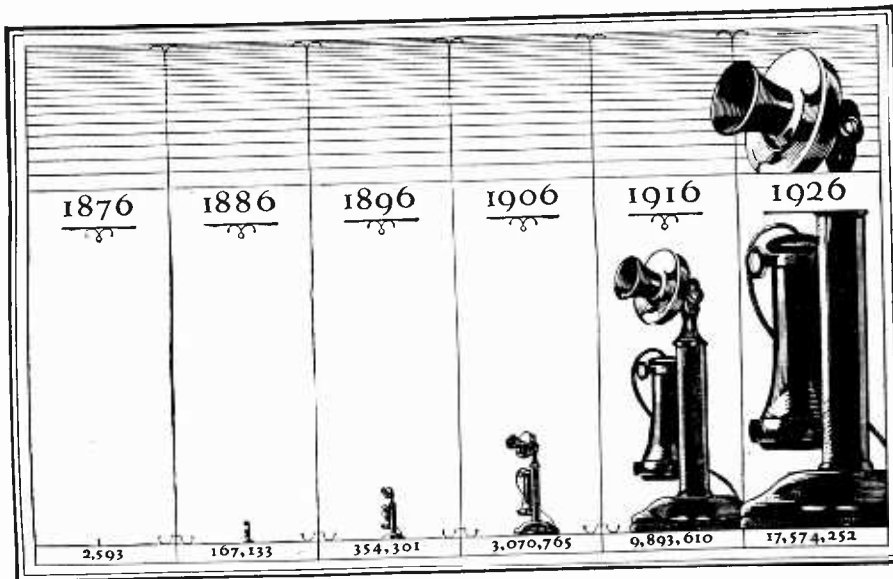

Milestones in National Service

An Advertisement of
the American Telephone and Telegraph Company



THERE are twenty-five Bell companies but only one Bell System—and one Bell aim and ideal, stated by President Walter S. Gifford as:

"A telephone service for this nation, so far as humanly possible free from imperfections, errors or delays, and enabling anyone anywhere at any time to pick up a telephone and talk to anyone else anywhere else in this country, clearly, quickly and at a reasonable cost."

The year 1926 brought the service of the Bell Telephone System measurably nearer that goal. Seven hundred and eighty-one thousand telephones were added to the System—bringing the total number interconnected in and with the Bell to more than seventeen and a half million.

The number of applications waiting for service, including those in new and outlying sections, was reduced fifty per cent.

A third transcontinental telephone line was completed to the Pacific coast.

The largest number of miles of toll wire for one year was added to the System—more than 664,000 miles.

The average length of time for completing toll calls throughout the System was lowered by thirty-five seconds.

A seven per cent improvement over the previous year was made in the quality of voice transmission in toll calls. An adjustment was made in long distance rates amounting to a reduction of about \$3,000,000 annually.

IMPORTANT

TO NEWSSTAND READERS

IN order to eliminate all waste and unsold copies it has become necessary to supply newsstand dealers only with the actual number of copies for which they have orders. This makes it advisable to place an order with your newsdealer, asking him to reserve a copy for you every month. Otherwise he will not be able to supply your copy. For your convenience, we are appending herewith a blank which we ask you to be good enough to fill in and hand to your newsdealer. He will then be in a position to supply copies to you regularly every month. If you are interested in receiving your copy every month, do not fail to sign this blank. It costs you nothing to do so.

To Newsdealer:

Address

Please reserve for me copies of SCIENCE & INVENTION every month until I notify you otherwise, and greatly oblige,

Name

Address

It was; and as soon as Mrs. Green had thoroughly understood it, they were ready. The Very Young Man had handed out the slips of paper and lead pencils. The Doctor said:

"You are not to use the paper and pencil while in the room. Understand? But the moment you come out you may start your list. No talking or laughing now. Anyone who makes a comment, or glances at any list besides his own is disqualified. Keep your mind firmly on remembering what you see. If you do that you'll have no time for anything else. Write your name now at the top of your list."

A hush fell upon the room. Silently the Very Young Man led them through the inner doorway. The Detective, who had not been introduced and who had been sitting in a secluded corner of the main room, rose and whispered to the Alienist. The adjoining room was about twenty feet square. It had no windows; no other door. It was wholly bare save for a single large table which stood in the center of the room with a shaded electric globe directly over it. The articles on the table were in the full glare of the light, but the room itself was in shadow. There were about two dozen of the articles. A pair of scissors; an ash tray; a package of cigarettes; a spool of thread; a single needle; a pin; a lead pencil; and six or eight articles from old Blake's medicine cabinet—a bar of licorice; a package of chew-

New Invention SPORS Fountain Pen. 60 Day Trial. Money back if not pleased.

AGENTS **65c** SELLS FOR \$1.25. Writes Like a \$7 Pen
SAMPLE **65c** Make \$10 Daily Easily

Comes in Red or Green
GUARANTEED
2 YEARS
Improved Point



MADE \$20.25 IN 1 DAY'S SPARE TIME
Rush 6 dozen pens, sold 27 pens yesterday. James S. White, Ala
Write for free wholesale specialty catalog.
F. SPORS & CO., 527 Agate St., Lesueur Center, Minn.

SKIN-TROUBLES

ANDRE'S ACNE CREAM is Guaranteed for all Skin Troubles no matter how severe or chronic. Pimples, Black-heads, Eruptions on face or body. Eczema, Barbers' Itch, Scales, Crusts, Pustules, Enlarged Pores, Oily, Shiny or Itching Skin. Lightens Freckles, softens and whitens the skin. Immediate results. Write for full particulars.

Andre & Co., 4029 Cottage Grove Ave., Suite 457 Chicago, Ill.

Insure your copy reaching you each month. Subscribe to SCIENCE AND INVENTION—\$2.50 a year. Experimenter Publishing Co., Inc., 230 Fifth Avenue, New York City.

PLUMBING - HEATING WATER SYSTEMS

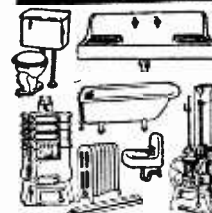

SAVE UP TO 40%

Wonderful bargains—everything guaranteed. Full line of plumbing and heating supplies. Hot water, steam heating plants and fixtures and water systems at big savings. Install Them Yourself. Finest materials all brand new and perfect. Tell us your wants and mail us a rough sketch of your rooms.

SEND FOR PRICE LIST
B. KAROL & SONS CO. 800 S. MEDZIE AVE. Dept. 27 CHICAGO

“STRONGER, CLEARER, BETTER BINOCULARS



than those costing double.”—
E. F. D., Annapolis, Md.
“Didn't need 10-day trial—
10 minutes was enough.”
L. H. K., Katispee, Mon.

8 POWER PRISMS
IMPORTED French and German makes; 8-POWER magnification, genuine prism, famous PEREIRE QUALITY, brilliant illumination, exquisite definition. WIDER field of vision. Individual eye-strength and width adjustments. Leather case, neck and shoulder straps.

Tested by the GOVERNMENT

TESTED by Bureau of Standards at Washington
See miles away! Conquer distance! Bring people, ships, game, scenes—right to your feet! Explore vistas of nature! Double the thrill of dashing sports! You'll find these Binoculars a never-ending pleasure—a life-time treasure! Usually sell from \$10.00 to \$50.00. As leading Importers, selling “Direct-by-Mail,” our price is ONLY \$23.50. We are selling thousands to Army, Navy Officers, Explorers, Motorists, Tourists, Yachtsmen, Big Game Hunters, Globe-Trotters, Naturalists, Men and Women all over \$23.50 the World, at this Bargain Price

10 Days' Trial Absolutely FREE!

Our Plan is Different! It is arousing nation-wide comment. We ask for NO money in advance! NOTHING on Delivery. BINOCULARS are sent to responsible persons for 10-Days' Trial ABSOLUTELY FREE.

If pleased you may pay on budget plan:
\$5.00 MONTHLY **\$21.75**
or if you prefer to pay cash at end of 10 DAYS deduct \$1.75 and send Check or Money Order for \$21.75 in FULL SETTLEMENT. Otherwise return them. Order NOW at this Bargain Price! Send NO Money! Pay NOTHING on Delivery!

SEAVER-WILLIAMS CO.

Importers, Exporters, International Mail-Order Co.—“2 Generations of Honorable Dealings.”
365 WASHINGTON ST., BOSTON, MASS.
Largest Retailers of Binoculars in the World
Gentlemen:—Send me the 8-POWER BINOCULARS for 10 days' FREE TRIAL on the above plan.
Name
Address
Clip and mail this Adv. NOW. If a new customer, please tell us something about yourself. We will appreciate and respect the information.
THANK YOU. S. I. 7-27

LAW STUDY AT HOME
Become a lawyer. Legally trained men win high positions and big success in business and public life. Be independent. Greater opportunities now than ever before. Big corporations are headed by men with legal training. Earn **\$5,000 to \$10,000 Annually**. Build this classy plane and learn to construct and operate aircraft. Use your motorcycle engine or the IRWIN 20 h.p. motor. We furnish parts very reasonable to build this wonderful little “Meteorplane” the World's first successful LIGHT PLANE. Send \$3.50 for complete set of blue prints and parts price list of this latest Model M-T-2 IRWIN AIRCRAFT COMPANY Sacramento, California.

We guide you step by step. You can train at home during spare time. Degree of L.L.B. conferred. LaSalle students found among practicing attorneys of every state. We furnish all text material, including fourteen-volume Law Library. Low cost, easy terms. Get our valuable 100-page “Law Guide” and “Evidence” books free. Send for them NOW.
LaSalle Extension University, Dept. 7384L, Chicago
The World's Largest Business Training Institution

FLY Young man, learn aviation. Build this classy plane and learn to construct and operate aircraft. Use your motorcycle engine or the IRWIN 20 h.p. motor. We furnish parts very reasonable to build this wonderful little “Meteorplane” the World's first successful LIGHT PLANE. Send \$3.50 for complete set of blue prints and parts price list of this latest Model M-T-2 IRWIN AIRCRAFT COMPANY Sacramento, California.

MUSIC LESSONS IN YOUR HOME

You can read music like this quickly
Write today for our **FREE BOOKLET**. It tells how to learn to play Piano, Organ, Violin, Mandolin, Guitar, Banjo, etc. Beginners or advanced players. Your only expense about 2c per day for music and postage used.
AMERICAN SCHOOL OF MUSIC, 67 Manhattan Building, CHICAGO,

\$2000 IN 3 MONTHS
80c PROFIT on \$1 order; started with ad costing \$21, sold over 2000 orders in 8 months. Let me send you copy of ad and tell you how I did it.
QUINCY CO., 708 QUINCY BLDG., CHICAGO

ing gum; tooth paste; a tooth brush and others. All small articles each in plain sight, ranged in orderly rows.

The five subjects of the experiment gathered about the table, eyeing its contents. The Very Young Man stood at one end of the table, watch in hand. At the open door, unseen by them all, the Detective was peering in, with the Alienist standing beside him.

“Time's up,” the Very Young Man announced peremptorily. “All out, please. Hurry, there!”

With a last reluctant look, they filed out—Mrs. Green was muttering to herself; Anna Blake laughed. George Blake said, “I'm mixed up already—can you remember any of 'em, Anna?”

“Stay apart now,” commanded the Alienist. “Write down what you remember. Next time you go in I want you to count the total number of articles on the table. Remember that number, and when you come out put it on the top of your list.”

There was another short silence—a minute or two—while they started their lists. Every eye in the room was upon them.

“Now,” said the Alienist, “you are going

\$5,000 for Perpetual Motion

When SCIENCE AND INVENTION Magazine was still in its infancy, the editors denied the possibility of constructing a perpetual motion machine using those forces of nature as we now know them.

Since that time the editors have received thousands of different designs for perpetual motion devices, and have received hundreds of circular letters soliciting finances for the building of perpetual motion machines.

The editors know that if they receive these letters, there are thousands of others in this country who get similar letters and who fall for the claims made in the numerous prospectuses giving the earning capacities of the various machines.

Most of the shares of stock for these perpetual motion machines are being sold at a rate of \$1.00 per share, although some inventors are trying to sell shares of stock at \$100.00 per share.

Therefore the editors of this publication say, “Just come in and show us—merely SHOW us—a working model of a perpetual motion machine and we will give you \$5,000.00. But the machine must not be made to operate by tides, winds, water-power, natural evaporation or humidity. It must be perpetual motion.”

in again one by one. Then you can add to your list when you come out. . . . Be sure now to count the total number of articles and put that number on the top of your list. . . . Mrs. Green, first. Let me have your pencil and paper please—I'll give it to you when you come out.”

The housekeeper handed them over as she passed the Alienist at the doorway. The Very Young Man was there, still with his watch in hand.

“I'll rap on the door in sixty seconds, Mrs. Green. Come out promptly, please.”

He closed the door upon her. While she was within the Alienist scanned her partial list, and on a slip of his own made an entry.

The Very Young Man rapped; then opened the door. “Come out, Mrs. Green. Take your list from Dr. Gregg. . . . Did you count the articles? Good. Write it down. . . . Who's next?”

“George Blake,” called the Alienist.

The performance was repeated with each of them in turn. George Blake; the chauffeur; Anna Blake; and then the secretary. As Anna Blake came out she whispered to Dr. Gregg a question, but he silenced her vehemently. They were presently all in the main room busy with the lists. The Alienist went in to examine the table; when he came out he glanced at the Very Young Man's watch.

Spare Time IS Your Time

to make every hour pay dividends in Gold!

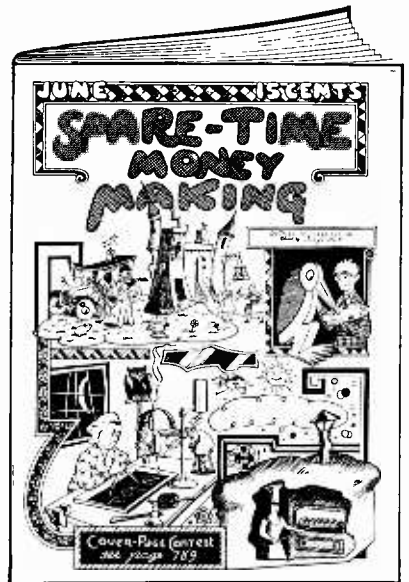

YOUR time—the few minutes or hours before and after your daily work—is opportunity land. The chance to establish a paying business or merely to sell your time or services to reap an additional income.

The extra income will bring within your means the luxuries of life.

It will ease your worries, your financial troubles and give you a new interest in life.

Make a start today to utilize your time. There are hundreds of ways to develop a steady, additional income that will bring to your home the many little things that make life more enjoyable.

SPARE-TIME MONEY MAKING tells you how, each issue takes various ways and means and explains them in such a way that you can immediately apply them to your own benefit. Some plans require no initial outlay, while others for a small first cost, return many dollars a year to your pocket.

Begin now—let today be the starting point for you into a bigger income and a thorough enjoyment of the luxuries of this life.

Copies 15c On All Newsstands

Subscriptions \$1.50 the Year—If your newsdealer cannot supply you, write.

The Conrard Co., Inc. 230 5th Ave., New York

"How long, Jack?"
 "Time's up now. Did—"
 "Sh!"

The Alienist called, "Time's up. Let me have your lists please."

The Very Young Man collected them. At a table apart, the Alienist and the Doctor examined them; and examined the notes the Alienist had made. It only took a moment; but in that moment a suppressed air of excitement had spread about the room. An unnatural, strained silence, which everyone instinctively seemed to avoid breaking. It may have originated with the club members who knew the real import of what was transpiring; and it spread so that abruptly everyone felt the tension. Old man Blake was sitting grim and silent; his face gone pale, his thin lips pressed tightly together, his eyes black and ominous, roaming from one to the other of the suspected members of his household. George Blake regarded him. "What's the matter? What is—"

The Doctor leaped to his feet. "You've a right to know, all of you. And it won't take me a minute to tell you. An attempt was made a few days ago to murder Mr. Blake. . . . Silence, please. . . . Yes, this has been more than an innocent psychological test—a psychological test to find a murderer! And we've found him!"

The Doctor turned to address the room in general. . . . "Gentlemen, as I told you a while ago, one of the members of Mr. Blake's home substituted a poisoned bar of licorice for the one in his bath room cabinet. This criminal had easy access to it—put it there and waited for Mr. Blake to eat some of it, and die. The criminal was frightened—a guilty person always is, after he has committed a crime. Wondered if Mr. Blake had found out it was poison—haunted by the fear that he would be discovered. But he didn't dare show his fear. Tried to get the licorice bar back again—but it was gone from the cabinet. That frightened him still more. He wanted that incriminating evidence destroyed—he was sorry, perhaps, that he ever attempted murder. And he came here tonight with guilt in his heart.

Mrs. Green's teeth were chattering; the others sat white faced and silent. One of them was guilty but he held himself quiet.

The Doctor went on vehemently, "What I have said of the murderer's feelings, gentlemen, is pure assumption—but it's a very easy guess that I'm right. And we have proof of the crime—and the criminal identified—here in his own writing on his list!

"I'll follow is mental processes. He was suspicious of this test—he thought doubtless we had had the bar of licorice analyzed—as in fact we did—and that this was some scheme to trap him. He was wary. He went into that little room over there with his companions. On the table he saw the bar of licorice. He thought it was the poisoned bar—it looks identically like it. He was relieved. His attempted crime had not yet been discovered, he thought; and the licorice had disappeared from Mr. Blake's cabinet because we had taken it for this innocent test. And his suspicions of our motive were lulled—he forgot to be wary.

"But gentlemen, he wanted that bit of incriminating evidence—wanted it so that he might destroy it—or perhaps he was fearful now that someone else might eat it. And that first minute, there with the others in the room, he was planning how he might get it.

"We were fairly sure then of his identity. When he handed his list to Dr. Gregg—as he went in for the second time—he had only been able to write three articles on it, and one of them was wrongly named. His mind was too busy with his crime for him to think of anything else."

The Doctor took the lists from the Alienist. "The table, gentlemen, held twenty-four articles. These lists, after the first observation, all contained from six to twelve

EQUIP YOUR CAR WITH A

NOLL SPARK INTENSIFIER

IT MAKES

A Sick Car Well
 An Old Car New
 A New Car More Efficient

Price—Model No. 1, \$5.00 each
 Model No. 2, \$7.50 each



Model No. 1 Noll Spark Intensifier Facts Model No. 2

It increases the spark 100% to 500%—therefore it overcomes almost all starting troubles and keeps the plugs from fouling—100% efficient, making quicker combustion—more power, quicker and more complete combustion means more speed and more mileage from a leaner mixture. It is the only intensifier marketed today that DOES NOT put a gap in the wire. It gives a regular, easy flow of current without harm to the system.

Good for the life of your car and pays for itself in gas in time.

AGENTS WANTED
 Exclusive Territory—Attractive Proposition—Write for Particulars.

C. & G. SALES COMPANY **1026 CHESTNUT ST.**
 National Distributors—Philadelphia, Pa.

BLISS ELECTRICAL SCHOOL

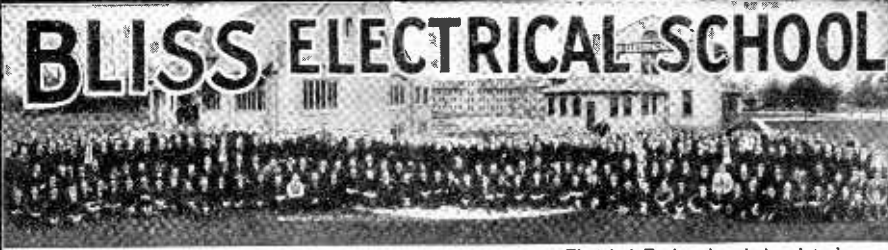

A special technical school with concise but comprehensive course in Electrical Engineering designed to be completed in ONE COLLEGE YEAR. Non-essentials eliminated. Thorough knowledge of underlying principles emphasized. Theory and practice are closely interwoven in class-room and laboratory

ELECTRICAL ENGINEERING

The course is designed for earnest, ambitious young men of limited time and means. Curriculum includes mathematics, mechanical drawing and intensive shop work. Students construct motors, install wiring, test electrical machines. Graduates are qualified to enter the electrical field at once.

Bliss men hold responsible positions throughout the world. Thoroughly equipped fire-proof dormitories, dining hall, laboratories and shops. Prepare for your profession in the most interesting city in the world. School established 1893. Catalog on request. Address

BLISS ELECTRICAL SCHOOL, 147 Takoma Avenue **Washington, D. C.**

Travel on "Uncle Sam's" Payroll

RAILWAY POSTAL CLERKS

MAIL CARRIERS

\$1700 to \$3000 Year Many U. S. Government Jobs Obtainable

MEN--BOYS, 17 UP SHOULD MAIL COUPON IMMEDIATELY

Steady Work. No Layoffs. Paid Vacations.

COUPON → **FRANKLIN INSTITUTE, Dept. L178, Rochester, N.Y.**
 Sirs: Rush to me without charge:
 (1) Specimen Railway Postal Clerk Coaching; (2) FREE 32-page book describing U. S. Government positions open to men and women and full particulars telling how to get them.

Name _____
 Address _____

10 DAYS FREE TRIAL — MONEY BACK IF NOT SATISFIED

THE NEW IMPROVED **INKOGRAPH** SELF FILLER
 GREATEST VALUE EVER OFFERED

The Perfect Writing Instrument \$1.50

Writes with ink easy as a lead pencil. Won't skip, blot, scratch, leak or soil hands. Inready uniform flow of ink improves handwriting.

Makes three carbon copies with original in ink. Guaranteed — Send No Money. Pay postman \$1.50 plus postage.

INKOGRAPH, CO., Inc.
 197-37 Centre St., New York City

AGENTS Send for an Inkograph or sales plan book which shows how to make big money.

BECOME AN EXPERT ACCOUNTANT

Executive Accountants and C. P. A.'s earn \$3,000 to \$10,000 a year. Thousands of firms need them. Only 9,000 Certified Public Accountants in the United States. We train you thoroughly at home in spare time for C. P. A. examinations or executive accounting positions. Previous experience unnecessary. Training under the personal supervision of William B. Castenholz, A. M., C. P. A., and a large staff of C. P. A.'s, including members of the American Institute of Accountants. Write for free book, "Accountancy, the Profession that Pays."

LaSalle Extension University, Dept. 7384-H Chicago
 The World's Largest Business Training Institution

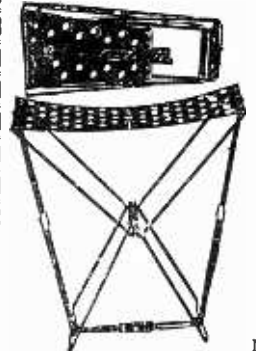

Folding Metal Chair

all metal, strongly built, fits pocket when folded, most useful article when fishing, hunting, camping, motoring, etc.

Send M. O. for \$1.95 for one of them prepaid insured P.P. all U. S. A.

Free Novelty Catalog to All

NOVELTY HOUSE
 39 W. 97th St., New York, N. Y.

Insure your copy reaching you each month. Subscribe to Science & Invention — \$2.50 a year. Experimenter Pub. Co., 230 Fifth Ave., N. Y. C.



Three Years Ago \$40 a Month

—now heads his own business

In 1922 J. H. Bryson, now head of the Bryson Novelty Manufacturing Company, Fayetteville, Tenn., was clerking in a grocery store at \$40 a month. Today he is president and proprietor of the firm which bears his name, doing a nation-wide business. "Had it not been for LaSalle and the self-confidence and inspiration which came from the knowledge secured from you," writes Mr. Bryson, "I would still be working as a grocery clerk or somewhere in this same channel. . . Nothing I could say would express the gratitude I feel toward LaSalle for my training."

Without cost, would you like to learn what your future can be with LaSalle's help? The true facts about your opportunities, together with information and data of the utmost value, are contained in a 64-page book which LaSalle will send you if you are sufficiently interested in your future to ask for it. With it you will receive a copy of "Ten Years' Promotion in One," the inspiring story of how one man, after many wanderings, found the shorter path to responsibility and power. Action today means a bigger job and better pay in the months to come. Fill in, clip and mail the coupon NOW!

— Find Yourself Thru LaSalle! —

LA SALLE EXTENSION UNIVERSITY

The World's Largest Business Training Institution
Dept. 7384-R Chicago

I should be glad to learn about your salary-increasing plan as applied to my advancement in the business field checked below. Send also copy of "Ten Years' Promotion in One," all without obligation.

- | | |
|---|--|
| <input type="checkbox"/> Modern Salesmanship | <input type="checkbox"/> Modern Business Correspondence and Practice |
| <input type="checkbox"/> Business Management | <input type="checkbox"/> Modern Foremanship |
| <input type="checkbox"/> Higher Accountancy | <input type="checkbox"/> Personnel and Employment Management |
| <input type="checkbox"/> Traffic Management | <input type="checkbox"/> Expert Bookkeeping |
| <input type="checkbox"/> Railway Station Management | <input type="checkbox"/> C. P. A. Coaching |
| <input type="checkbox"/> Law—Degree of LL.B. | <input type="checkbox"/> Business English |
| <input type="checkbox"/> Commercial Law | <input type="checkbox"/> Commercial Spanish |
| <input type="checkbox"/> Industrial Management | <input type="checkbox"/> Effective Speaking |
| <input type="checkbox"/> Factory Management | <input type="checkbox"/> Stenotypy |
| <input type="checkbox"/> Banking and Finance | |

Name _____
Present Position _____
Address _____

250 POWER MICROSCOPE

MADE IN U.S.A.

Educational and entertaining, this fine instrument familiarizes young and old with life around us that is invisible to the unaided eye. Tiny insects appear as monsters. Plant and mineral life reveal new beauties in form and color. Ideal for students, home, office, dentists, physicians, scientists and laboratory. Precise optical qualities, giving variable magnification from 100 to 250 diameters. Tilting stand. Black finish, nickel trim. Complete with plush lined case, prepared slide and instructions. 100 Power Model \$8.50. At your dealer or direct, postpaid. Money back guarantee.



\$16.50

Models as low as \$2.50

Further information free upon request.

Wollensak Optical Company
961 Hudson Avenue : Rochester, N. Y.

You can be quickly cured, if you

STAMMER

Send 10 cents for 288-page book on Stammering and Stuttering, "Its Cause and Cure." It tells how I cured myself after stammering 20 yrs. B. N. Bogue, 8142 Bogue Bldg., 1147 N. 111. St., Indianapolis

SQUAB BOOK FREE
Breed squabs and make money. Sold by millions. Write at once for free 40-page book beautifully printed in colors telling how to do it. You will be surprised. PLYMOUTH ROCK SQUAB CO. 506 H St., Melrose Highlands, Mass.

articles correctly named—except the guilty list. That named three—one wrongly. The bar of licorice was the most prominently displayed article on the table. Every list at once bore it—except the guilty one. He didn't dare name it—he had planned what he was going to do. He went back for the second time—counted the articles and put on his list a total count of twenty-three instead of twenty-four. Those who went into the room ahead of him counted twenty-four; those who followed him counted twenty-three. Miss Anna, who followed him, missed the licorice bar which she remembered seeing at the first observation. She asked Dr. Gregg about it, but he silenced her. It's obvious isn't it? The criminal stole that bar of licorice—there wasn't any place in the room to hide it—no way of getting rid of it—probably he's got it in his pocket now. . . Marberry! Hold him!"

The detective was on his feet; the Detective chaffeur for him; with the muscular Very Young Man they overpowered him—found the bar of licorice in his pocket. He confessed. He was in love with Anna Blake; secretly she had agreed to marry him. They would inherit a fortune, and he wanted it. If they married while Mr. Blake was alive, he knew Anna would be disinherited. His brother worked in the licorice factory; had prepared the poisoned bar upon a promise of later money payment. He told it freely, brokenly. And ended, "That's all—take me away—arrest me—let's have done with it—I tell you I've been frightened as hell—I'm glad it's over."

For the first time in half an hour old man Blake spoke. "I don't care to prosecute him—have I the right to let him go, Mr. Marberry?"

The Detective nodded dubiously. "Well then—send him away—I'll give him a ticket to the coast—anywhere away from Anna. I guess he's been punished enough by his own guilty conscience. . . Anna! Forget him, child—you made a mistake, that's all."

The girl was crying.
THE END.

MODEL DEPARTMENT BLUEPRINTS

Correct—Easy to Follow

- 1 Horizontal Steam Engine
- 2 Engine detailsset \$1.00
- 3 Boiler construction for
- 4 aboveset \$1.00
- 5 880 Ton Bark..... 50c
- 6 Twin Cylinder Steam engine and Boiler.....set \$1.00
- 7 Gasoline Fired Locomotiveset \$2.00
- 8 U. S. S. Constitution,
- 9 "Old Ironsides".....set \$1.00
- 10 13th Century Man-of-War, 50c
- 11 Chinese Junk, set 50c
- 12 Electrically driven auto-mobile.....set \$1.00
- 13 Roman Ballista..... 50c
- 14 Simple Steam Engine, set 50c
- 15 "Santa Maria"complete 50c
- 16 23-24 Model U. S. S. Ports-mouthset 1.00
- 17 Building a Model Tug-boat 50c
- 18 How to Build a Reflecting Telescope 1.00

Send Orders to
MODEL DEPARTMENT
SCIENCE AND INVENTION
230 Fifth Avenue
New York City



Make Money in Photography!

We train you quickly at home. No experience necessary. Spare time or full time. Photographs in big demand by magazines, newspapers, advertisers, etc. Portrait Photographers make more money today than ever before. Commercial Photography also pays big money. New plan. Nothing else like it. Write today for details and new FREE book, "Opportunities in Modern Photography."

American School of Photography
3601 Michigan Ave., Dept. 142-B., Chicago, Ill.

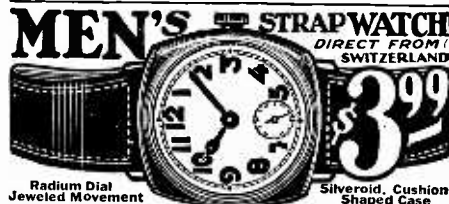

MEN'S STRAPWATCH
DIRECT FROM SWITZERLAND
\$3.99
Radium Dial Jeweled Movement Silveroid, Cushion Shaped Case
This fully guaranteed watch cannot be manufactured in America for less than \$12. Genuine leather strap. Accurate—durable—handsome. SEND NO MONEY. Pay on delivery \$3.99 plus postage. "FEDERAL." U. S. Swiss Agents, 561 Broadway, New York City, Dept. W-17

LEARN TO ENTERTAIN WITH
Master Magic
The World's Largest Manufacturers OF TRICKS AND PUZZLES.
Send 10cents for new illustrated catalogue. HUNDREDS OF TRICKS YOU CAN DO.
Dept. A. "SHERMS" BRIDGEPORT, CONN.

MEN WANTED TO LEARN

Motion Picture Projection

\$2,000 to \$4,000 a Year

Quickly learned. Short hours, big pay. Best equipped school in Michigan. Projectionists for Movie Houses and Road Shows.

MOVIE OPERATORS SCHOOL
51 Sproat Street, Dept. 4, DETROIT, MICHIGAN

WHEN stations crowd the air & spoil your programs

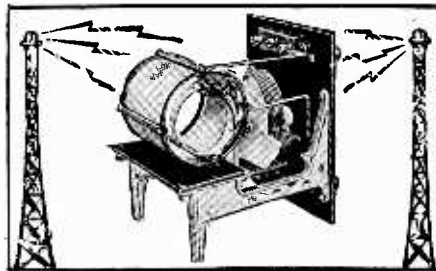

use a wave trap!

Improve your Reception—build a wave-trap with a Consrad Pattern

NO matter how large or small, how expensive or inexpensive a Radio Set may be, it can be decidedly improved with a good WAVE-TRAP.

The new Consrad pattern contains a gigantic blueprint, 27 1/4 inches by 20 1/2 inches, containing simplified Panel layout, Front View, Top View, Side View and Picture Wiring diagram. All measurements are shown actual size. A complete illustrated Pamphlet is enclosed that shows exactly how to proceed throughout the entire construction; these are enclosed in a heavy folder envelope size 9 1/4 x 9 1/2 inches.

ONLY 25c—EVERYWHERE

If your dealer cannot supply you, write direct
The Consrad Co., Inc., 230 5th Ave., N.Y.



THEFT INSURANCE

The ECLIPSE Nut Lock for disc wheels protects valuable automobile equipment from theft—for less than the cost of a new tube. The ECLIPSE is rust-proof, fool-proof and tamper-proof.

\$3.00 each postpaid—specify make and size of wheel.

At your dealers— or if he cannot supply you send his name and we will supply you direct.

ASSOCIATED INDUSTRIES CORPORATION
Pomona, Calif.



Easy

A FEW weeks of pleasurable practice gives you command of the Conn saxophone which enables you to entertain yourself and friends. Be popular, increase your income if you wish! Start now with an easy playing Conn. Choice of world's foremost artists—and costs no more. Free Trial, Easy Payments on any Conn. Write for Free Book, details. C. G. Conn, Ltd., 756 Conn Bldg. Elkhart, Ind.

CONN BAND INSTRUMENTS



CHEMISTS

Our new catalog listing 5000 Chemicals, 2500 illustrations. Laboratory Apparatus and 1000 books, sent on receipt of 50c. Radio catalog (100 pages) liberal discounts 10c.

Laboratory Materials Company
635 East 71st St., Chicago, U.S.A.

MAGIC Earn \$250 to \$1000 Monthly

New! Different! Teaches you Big Tricks, Illusions, Stage Stunts, "Pattee" and the Principles of Magic. Learn at home. Earn \$250 to \$1,000 a month. Write today for special offer. **TARBELL SYSTEM, INC.** 1925 Sunnyside Ave., Studio B-142 Chicago, Ill.

"BECOME A LIGHTNING TRICK CARTONIST"

Send \$1.00 for Beginners Instructions with Laugh Producing Program of 25 Comic Trick Drawings. Catalog of Chalk Talk Supplies Free. **BALDA ART SERVICE, Dept. 4, Oshkosh, Wisconsin.**

TELEVISION!

the greatest marvel of the 20th Century

Completely explained in new 116-page book which also gives full constructional information on how to build your own television apparatus at home. See page 196.

AUTO SPARK INTENSIFIER



For single coil ignition For Ford ignition system

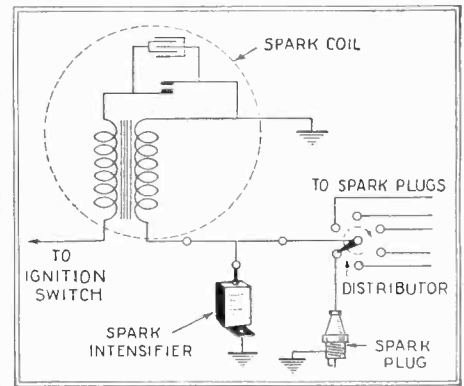

THE intensifier shown here, differs in principle and operation from the usual type of spark intensifier. It consists of a condenser of the proper capacity, built to withstand high voltages. It is connected in parallel with the secondary or high tension circuit of the ignition coil or transformer of your automobile. A single condenser is required for most cars, but Ford ignition systems require a specially built one, having four terminal wires that connect directly to the top of the spark plugs is used.—*Courtesy C. & G. Sales Co.*

AUTO LOCKING DEVICES

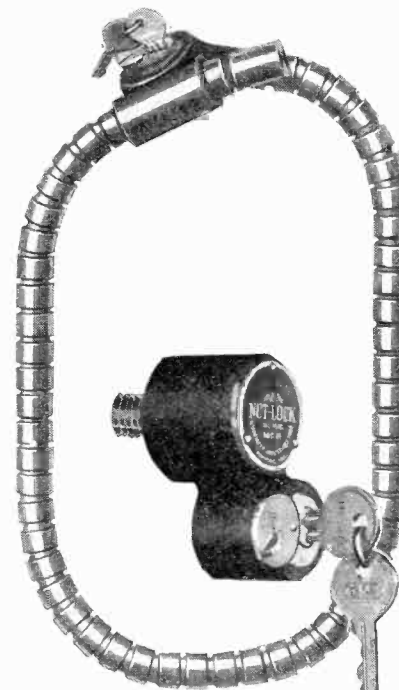

Two automobile spare-tire locks are shown in this illustration. They are both made entirely of tool steel, simple, good looking, rust-proof and they are said to be positive proof against tampering with all ordinary forms of jimmying tools. The one shown in the center is slipped on in place of one of the nuts on the carrier. The other, is placed around the spare-tire and the car frame.

Courtesy Associated Industries Corp.

Here's Work That is Almost ROMANCE!



EARN BIG MONEY in RADIO

Get into the great new BIG-Pay Industry—Radio. If you're earning a penny less than \$50 a week clip coupon now. Send for 61-page FREE BOOK. Be a Radio Expert, and draw down big money for this easy, fascinating work. Positions everywhere. Need for Radio Experts in every community. Short hours. BIG PAY. Free book gives all the facts.

Learn Quickly and Easily at Home

Skilled Radio Engineers will show you how to qualify quickly and easily at home, for Radio's fine jobs. We train you completely and thoroughly. Hundreds of N.R.I. trained men are today holding down good, big jobs in the Radio field. Hundreds of opportunities now awaiting the trained man. **FREE EMPLOYMENT SERVICE.** Many other big features. Get the facts—CLIP COUPON.

Get This Free Book!

Send coupon below for FREE BOOK "Rich Rewards in Radio." Read for yourself. No previous experience needed. Common schooling enough. **WRITE NOW!**



Big Receiving Outfit Furnished

Materials for building up-to-date receiving sets, and to construct 50 well-known Radio circuits included to help you learn. An UNEQUALLED OFFER. Other special features now being offered. so Act Quick!

NATIONAL RADIO INSTITUTE
Dept. GD-6, Washington, D. C.

MAIL COUPON

National Radio Institute, Dept. GD-6, Washington, D. C.

Without obligating me in any way, please send me your free book, "Rich Rewards in Radio," also complete information on your practical, home-study Radio course.

Name

Address

Town State

a Better Job! NOW!

Why take small pay from uncertain jobs? Why be bounced around from this to that, and not know whether you are going to have a job tomorrow or not? You can change all that. Learn a trade. Know Autos—how to repair them, and take advantage of the countless opportunities to make money. **Pave the way for a business of your own—a business that can make you independent for life.** You can do it with a few weeks training at the Michigan State Automobile School—the great auto-trade school in the heart of the auto industry. **Be a Trained Man—Successful!** More than 18 million cars in use, thousands more made daily. All need service by trained men. More men needed for good jobs. More garages, electric service stations, tire, battery and welding shops needed. This means amazing opportunities for men who start now. Small capital needed, no experience. **Fit yourself now to make big money.**

COME TO THE AUTO CENTER
Learn by Factory Endorsed Methods

Here you have wonderful advantages. Study autos, trucks, engines, auto electricity, tractors. All on best equipment, up-to-date. Many new cars; expert instructors; a thorough course that slighting nothing. Inspect the great auto plants. These great companies approve this school. Get factory endorsed training at Detroit, the Auto Center. Good positions open. Here's your chance to be independent. Write today for full information about Detroit training to make the most money.

Michigan State Automobile School
3707 Auto Building Detroit, Michigan



TRAVEL
for "Uncle Sam"



New Bandit Proof Railway Mail Car

U. S. Government Jobs

\$1140 to \$3000 Year

MEN--WOMEN, 18 Up

Steady Work. Paid Vacations. Common education Sufficient.

Franklin Institute, Dept. K-181, Rochester, N. Y. Gentlemen: Rush to me without charge 32-page book with list of U. S. Government big paid positions obtainable. Advise me regarding the salaries, hours, duties, vacations and send me full particulars.

Mail coupon today—**SURE**

Name: _____ Address: _____

Oh Boy! See All!

People and objects miles away seem close. New pleasures for home, farm, travel, sport. See Sun, Moon, Stars as never before! P. Brush writes: "Watched submarine 8 miles off coast."

Free C. Scribner's "See light-houses 18 miles away."

Send No Money On delivery of Telescope, free Case and Eye Piece, pay Postman only \$1.85 plus postage. (2 outfits \$3.50.) Satisfaction guaranteed or money refunded. Send today!

FERRY & CO., Dept. 125A Chicago, U.S.A.

3 1/2 Foot Telescope 5 Sections 8 Power Measures 12 inches closed, opens out 3 1/4 ft. Brass board, powerful lenses protected by dust caps. Carrying Case with Shoulder Strap. Also Solar Eye Piece to view Sun—a feature found only on expensive instruments.

CLIP THIS AD

On the Beach

MAKES A COMPLETE MACHINE SHOP \$7.95

ELECTRIC MOTOR ATTACHMENT
Fastened on shaft of small motor in a jiffy. Holds Grindingstones, Buffs, Circular Saws, Drills, Etc.

GRINDS—POLISHES—SAWS AND DRILLS

We Supply **ELECTRIC MOTORS** AT REDUCED PRICES. WRITE US YOUR REQUIREMENTS

UNITED ELECTRIC MOTOR CO.
176 Centre St., New York, N. Y.

Insure your copy reaching you each month. Subscribe to **SCIENCE AND INVENTION**—\$2.50 a year. Experimenter Publishing Co., Inc., 230 Fifth Avenue, New York City.

The Astrology Humbug

(Continued from page 264)

Astronomer-Astrologer, whose 'Tetrabillos' has been used from generation down to succeeding generations for the past 1600 years. In giving a delineation of the birth data suitable to the character and position of the man making application for the chart in this country, she was absolutely correct and had she given a delineation for the Kaiser, she would have violated the first canon of the 'Centiloquoy' or 100 Aphorisms by Caludius (Claudius?—Editor) Ptolemy in the 'Tetrabillos,' and because she did not violate this first principle of delineation, the horoscope was criticized by the editors of the magazine, for they read the interpretation as for the Kaiser, although they ordered it under the pretense of an American business man. They did not read the delineation as they ordered it, they read it for an entirely different person and then criticized it because it did not fit that different person, namely the ex-Kaiser, for whom the astrologer never intended it. Such methods of so-called investigation are, to say the least, capable of being termed the Science and Invention of humbug. . . .

"Well, here you are, folks, tell the astrologer what you are, who you are, what you do and what you don't do, and he will immediately tell you your chances of future happiness. But whatever you do, don't try to deceive him because you admittedly will succeed. Don't give any astrologer the Kaiser's birth date and claim it as your own, because he will not give you the same horoscope that the Kaiser will get. Your chances of living as long as the Kaiser, of being as happy or as unhappy as he is are not the same. The stars impel different things for royalty than they do for those in the middle stations of life, even though we may have all been born in the same hospital at the same second. This statement only goes to prove what we have contended right along, namely, that there can be nothing in astrology. If the planetary bodies have any effect on any human being on this earth, it is evident that another person born at the same instant, regardless of his station or position in life, should be similarly influenced by the planets. The constitution of these United States reads that all men are born free and equal, but the astrologers would not desire to be held to such a statement.

Our own contention has always been that environment and position have a tremendous influence on the future history of a person's life, and that the stars themselves tell us absolutely nothing nor do they convey any directive influence whatsoever. For example, in this same publication we find mention made of two predictions that Dempsey, former heavy-weight champion, would win the fight. One of these predictions was made from the birth horoscope and the other from Dempsey's parental chart. However, on the morning of the fight, a certain group predicted that Tunney would be the victor after drawing up a chart for the day on which the fight took place. Had the first two astrologers been correct, then one would never have heard from the second group; but in view of the fact that the astrologers were wrong, some one must naturally come to the rescue and find the loop-hole somewhere. It seems that we have read statements made by several astrologers to the effect that the dates given them were incorrect. This, of course, is a usual excuse employed by nearly every astrologer when the facts result differently than the predictions.

Not knowing the circumstances of the three persons whose names are not being given, but whose birth dates are being supplied to any astrologers working for our prizes, it would, therefore (following this line of reasoning), be impossible for any astrologer to give us a delineation of the three unknown characters, for does not Mr. George, editor and publisher of the Astrological Bulletin, say that we did not order the delineation as for the Kaiser, but we ordered it for an American business man and that we have no right to interpret it as for the Kaiser?

Perhaps there are other astrologers who do not hold views identical with those expressed in the Bulletin. We know that there are a great many who do not entirely agree as to the limitation in astrology as pointed out by the above writers.

Will some one please put us on the right track and guide us as to what the astrologer should be able to do and what he cannot do?

We are beginning to realize more and more every day that when the astrologer makes a claim such as "have regard for health rules, avoid anxieties and attend to routine duties or a great deal of money will be appropriated for huge developments in shipping, transportation, etc.," that the astrologer was not supposed to make these predictions and if he did make them, we are not to believe them, and if we do believe them, we should only do so after they are interpreted to fit their own particular stations in life.

WANTED

Copies July 1926, Science and Invention. Write I. S. Manheimer, c/o S. & I., 230 Fifth Avenue, New York City.

PARKS
Manual Trainer
\$35.00



For your home shop! Combination 11-inch band saw and 11-inch wood-lathe. If you have a knack for wood-working you can turn out first-class bridge lamps, cabinets, furniture, ship models, etc. in fast time. Get one! Write for specification circular.

THE PARKS WOODWORKING MACHINE CO.
1553 Knowlton Street Cincinnati, Ohio
Canadian Factory: 208 Notre Dame, E. Montreal, Can.

Auto Owners Wanted to sell **HYDRO** Insured TIRES—the only tires in America Insured for One Year against all road hazards regardless of mileage. Insurance Policy with every tire. Made by the only tire factory in America selling its product through authorized Salesmen-Agents. We offer opportunity of life-time to establish profitable tire business of your own. No capital required. Sales Kit and advertising helps furnished. Exclusive territory granted. Write today for catalog and complete information about the Hydro Agency Plan.

HYDRO Insured TIRES
"The Most Beautiful Tire in America"

ADDRESS NEAREST BRANCH.
Dept. 47 HYDRO-UNITED TIRE CORPORATION
POTTSTOWN, PA. CHICAGO, ILL.

WORLD'S FINEST
(3 FT. CONE) LOUD SPEAKER
"ENSCO" KITS—\$10.00



The choice of leading engineers. Write for booklet on how to make this in less than an hour.

ENGINEERS SERVICE COMPANY
25 Church St., Desk 10 New York

COPPER CANS

Airtight Screw Top

3 Gal.	\$ 4.75
5 Gal.	5.50
8 Gal.	7.80
10 Gal.	10.50
12 Gal.	12.50
15 Gal.	13.50
20 Gal.	18.50

1/2 Inch or 3/4 Inch Unions Postage and Insurance Extra

Prices on Large and Special Made Cans and Boilers by Request

COPPER TUBING
3/8-inch soft copper tubing, 1 1/2, 2, 2 1/2, 3-inch tubing, 25¢ per foot. Deposit required on all C. O. D. orders

CATALOG FREE

NATIONAL CAN CO.
44-SC, North 4th St., Philadelphia, Pa.

WHY NOT spend Spring, Summer, Fall gathering butterflies, insects. Buy hundreds of kinds for collections. Some worth \$1 to \$7. Simple work with my Instructions, pictures, price list. Send 10¢ (NOT STAMPS) for my Prospectus before sending butterflies. Mr. Sinclair, Dealer in Insects, Dept. 41 Box 1424, San Diego, Calif.



Candy Floss Machines
\$100 Dally, Parks and Pairs. 1 lb. sugar brings \$2. Elec. or hand, \$150. Catalog Free.

Nat'l Candy Machine Co.
163B E. 35th St., N.Y.C.



Insure your copy reaching you each month. Subscribe to **SCIENCE & INVENTION**—\$2.50 a year. Experimenter Pub. Co., 230 Fifth Ave., N. Y.



—do YOU have to be shown—

YOU have most certainly read many reports of men and women who have built up, in their sparetime, solid, substantial and big income businesses. Perhaps you are skeptical, but these stories are far from being the "bunk"—Sparetime businesses are *real*—and often bring amazing incomes. If you are one of those who have to be shown the means to make a success from a Sparetime business, spend 50c (only) for the book displayed above.

67 PLANS TO MAKE MONEY

It contains no less than 67 definite, practical and workable money making plans—selected as the best for the average man.

Each plan consists: First—of an item that can be retailed by people of limited means and have only a few spare minutes a day to utilize. Second—the best method of production is outlined carefully with suggestions as to what to avoid. Third—Avenues of distribution or selling are given—such methods of selling by mail as are applicable and all similar details are discussed, and Fourth—information of importance in carrying on to reap large, generous profits is discussed.

Sparetime Money Handbook contains 100 Pages, of the Jarge magazine, 9 x 12 inches—with handsome colored covers, over 100 illustrations.

NEW EDITION JUST OFF THE PRESSES

Price 50c

If your dealer cannot supply you use Coupon below

THE CONSRAD CO., Inc.,
230 Fifth Ave., N. Y.
Gentlemen: I enclose 50c for one copy of "Sparetime Money Handbook,"

Name

Address

City, State

Hints for the Mechanic

(Continued from page 245)

CEMENT CONSTRUCTION

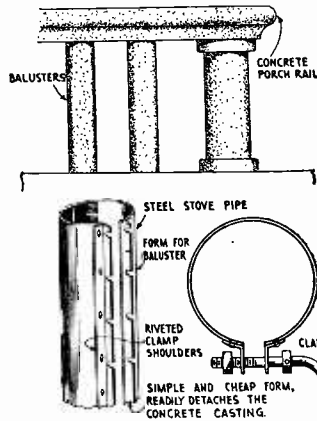

Iron stove-pipes can be effectively used as molds in making concrete porch balusters and other cement work. Iron shoulders are riveted on the stove-pipe, to form clamps. The cement is poured into the moulds

SPLICING LEATHER BELTS

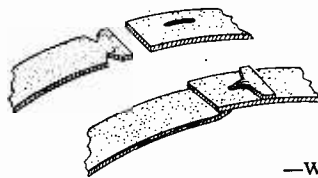

By cutting the ends of leather belts as shown, they may be easily spliced.

—Wilbur S. Stump.

HANDY SAW HOLDER

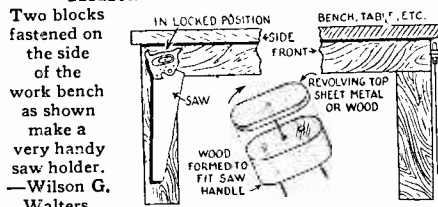

Two blocks fastened on the side of the work bench as shown make a very handy saw holder. —Wilson G. Walters.

AUTOMOBILE GASOLINE SAVER



A patent has been applied for by an automobile engineer, on a device designed to cut gasoline consumption of automobiles. The theory of his invention is that of adding large quantities of air to the gasoline, in such a way as to create perfect combustion. The device produces a whirlwind of air to break the particles of gasoline before they reach the cylinders, not only saving gasoline, but giving more power and making it more possible to start motors quickly. —Weeks Whirlwind Carburetor Co.

NEW FORD TIMER

In this Ford Timer the brushes rotate, travelling on the outside of the commutator, assuring a powerful, steady spark. —Weeks Dynamo Timer Co.

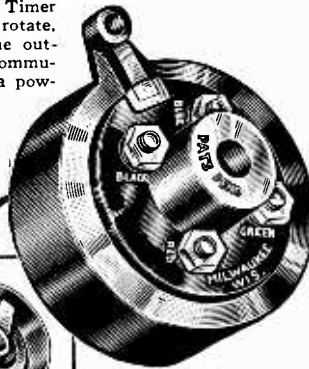

CORRECTION NOTICE

In the June issue of SCIENCE AND INVENTION Magazine, on page 154 there appeared an article entitled "Secret Radio Communication" by S. R. Winters. No credit to the inventor was given and this inventor should have credit: Dr. James Harris Rogers, the famous inventor of underground radio.

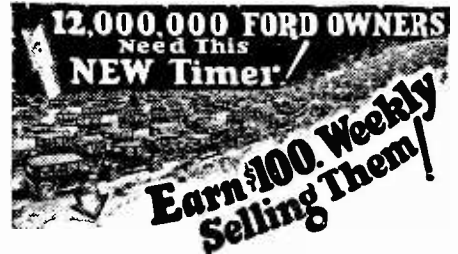

You will never again find such an opportunity to make big money as the DYNAMO TIMER offers you now—the Timer is the weak spot of the Ford car. Expert automotive engineers claim that the average Ford wears out from 8 to 10 ordinary Timers. Think of the tremendous sales possibilities, when you offer the Dynamo Timer with a guarantee for the life of the car. You don't have to be a salesman—this amazing Dynamo Timer sells itself on sight—millions of Ford owners need it. 200 per cent profit for you on every sale.

MAKES OLD FORDS RUN LIKE NEW

Once a Ford car is equipped with the "DYNAMO," the Timer can be forgotten—the only thing that will prevent forgetting it will be the noticeable improvement in the running of the car. More power, more mileage, instant starting, amazing pick-up, are only a few of the features that will make any Ford owner a "DYNAMO" booster after he once uses this new Timer.

GUARANTEED FOR THE LIFE OF FORD CAR

Remember, every Ford owner in your territory sooner or later is going to have to buy a new Timer. Why not be the one to sell him a Dynamo Timer backed with our actual guarantee for the life of the car?

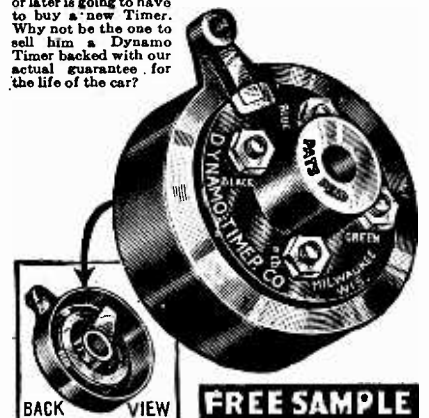

To aid our agents we have arranged a plan that provides them with a Free Sample so they can equip their own car or carry it for demonstration purposes. The unique principles of this wonderful Timer will make themselves apparent to any Ford owner after a minute's examination. Send this card today for this Free Sample Offer and particulars of our big money making proposition.

BIG MONEY FOR YOU

The money-making possibilities of a DYNAMO TIMER agent are absolutely unlimited, especially with the sales help and backing we give our men. JOHN KABLE made \$200 in less than 10 days. Many others are making big profits also. There is no reason why you, too, cannot get into the big-money class the same as John Kable and these others.

EASY TO SELL

Ryan, from Washington, says: "I wouldn't take \$25.00 for my Timer if I couldn't get another. I sold three in ten minutes." "I am having good success in selling Timers," writes Berton, of Iowa. "I sold 10 Timers in three hours and am sending you an order for more, but they won't last!"

There is no sales resistance for the Dynamo Timer agent. Our agents everywhere are meeting with the same ease in selling as Ryan and Berton. You, too, will find it easy to sell the Dynamo Timer. Send the coupon now.

GET TERRITORY QUICK!

Territory is going fast. Our agents can easily make \$5,000, \$8,000 and even \$10,000 a year. Spare time workers make \$20 to \$30 a day. If you want to get in on this big money, investigate NOW.

NOW IS THE TIME TO ACT!

Don't let some friend or neighbor in your territory beat you to it. Send in the coupon TODAY for FREE SAMPLE offer and particulars of our big money-making proposition.

DYNAMO TIMER CO.

MILWAUKEE 426-1142 Eleventh St. WISCONSIN

RUSH COUPON TODAY

DYNAMO TIMER CO., 426-1142 Eleventh St., Milwaukee, Wis.

Gentlemen: I want to get in on the big money to be made with your new DYNAMO TIMER. Without obligation, send me particulars of your territory plan and FREE SAMPLE offer.

Name.....

Local Address.....

City.....

State.....

Marvelous Townsend "B" Socket Power Unit

Complete---NOW
\$6.85
 \$1 Down
 Balance C.O.D.



London, Ont., Can. "Am very well pleased with your Eliminator. Since using it I have had many more stations and greater distance."
 C. E. BOND.

Dewey, Okla. "I am more pleased with your Eliminator than I was with batteries."
 B. E. DOURETON.

Renova, Penn. "I have received the Townsend Eliminator and it works fine."
 CLARENCE WITCHEY.

Replaces "B" Batteries

Enjoy greatly improved reception and forget unreliable "B" battery nuisance. Every part in the Townsend "B" Socket Power Unit is made and assembled in our own factory. That is why we can give you a high grade instrument at a startlingly low price, with a real guarantee of money back if not satisfied. Delivers up to 100 volts on any set, on direct or alternating current—any cycle. Full tone, clarity and volume.

ORDER TODAY

Just put your name and address on a piece of paper, pin a \$1.00 bill to it and mail today. Your "B" Socket Power Unit will be sent promptly. Deposit only \$5.85, plus postage, with the postman. Try out for ten days—then if not delighted by improvement in reception, return it to us and purchase price will be refunded. Send today.

TOWNSEND LABORATORIES
 Dept. 35
 713 Townsend St. Chicago, Ill.

10 Days FREE TRIAL
 You are the Judge!

OWN A TYPEWRITER!



Prices CUT!



A GENUINE UNDERWOOD!

Clip and mail this, if you want a real rebuilt UNDERWOOD—price of all typewriters. Remanufactured and guaranteed FIVE years. Price and terms you'll NEVER see equalled. **FREE BOOK** with this BARGAIN and other models in FULL COLORS! Typist's Manual, touch typewriting course offer, etc. Write at ONCE to Shipman-Ward Mfg. Co. 5216 Shipman Bldg., Chicago.

Name.....
 Address.....

BIG PROFITS in a NEW BUSINESS of your own —No Competition!

Send for the little book of Big Opportunities—"The Nestler Plan." It tells, in a few words and with actual photographs, how any ambitious man can become a Nestler Operator, and build up a flourishing, money-making business of his own. There is a big demand for Nestler service from automobile owners everywhere. The Nestler Rubber Fusing Process is the first and only satisfactory method of servicing tires. You convert an old, worn tire into one as good as new at one-half the cost. Little capital required; previous tire or garage experience unnecessary; exclusive territory; full-time or spare-time, as you prefer.

This book describes the amazing Nestler Method. Shows how to build up profits in your own exclusive Nestler business.

Send TODAY for free book, "The Nestler Plan"



NESTLER RUBBER FUSING CO. INC.
 Dept. 27, 245 West 55th St., New York, N.Y.

MEN INTERESTED IN RADIO

Big money for your spare or full time. Give a service to radio owners and autoists. No machines, no equipment. Something all need once a month anyhow. **EVENINGS ALONE PAY YOU SEVERAL DOLLARS EACH**—full time much better. No technical knowledge required—we teach everything. Enclose 25¢ for sample to try and full details. **ARVEO INDUSTRIES, Dept. 13, Grosse Ile, Mich.**

Island Universes

By W. J. LUYTEN

(Continued from page 226)

SPIRALS COMPOSED OF STARS

After the structure of the spirals had been settled, the next question that came up was to explain their constitution. Were they great masses of gas, like the Orion nebula, or were they great aggregations of stars, only appearing nebulous on account of their enormous distances? The spectroscope soon settled this controversy for it proved conclusively that the Orion nebula is composed of incandescent gas, but that the spirals are tremendous collections of stars not unlike the sun. Long before we had any definite knowledge of the distance or the size of these objects, long before we could distinguish the individual stars in them, the spectroscope had proved to us that the behavior of atoms and electrons was exactly the same at those distances as it is here on earth—a good illustration of the power of the spectroscope. At these vast distances all we could really be sure of was the way in which the smallest of all things, the atoms and electrons behaved themselves.

After we knew that spirals were composed of stars, the question arose as to how large they were. Was a spiral simply a star cluster, perhaps a large one, or was it an enormous condensation of stars, comparable in size to our Milky Way system? Easton of Holland, a supporter of the latter theory, even went so far as to suppose that the Milky Way system itself had a spiral form. On the other hand Van Maanen at Mt. Wilson had measured some photographs of spirals and arrived at the conclusion that the whole nebula was in rotation in these cases; that the whole vast mass of stars was turning round in a very short time. Very short, astronomically speaking of course, 80,000 years or less. Now this rotation was a serious obstacle to the *island universe* theory, for it limited the size of the spiral nebula very considerably. For suppose that such a spiral has a diameter of one thousand light-years; then, if it rotates in 80,000 years, the particles on the outside of the spiral will travel all along the circumference of a circle with a radius of 1,000 lightyears, in 80,000 years, that is to say they will cover a distance of 3,000 lightyears in 80,000 years, or go about 26 times slower than light, or roughly, 7,000 miles a second. But imagine on the other hand that the spiral has a diameter of 50,000 lightyears, then the stars on the outer edge of it would travel the circumference of a circle with this radius in eighty thousand years; they would cover a distance of 150,000 lightyears in 80,000 years. Now if we recall what a lightyear is, viz., the distance traveled by a ray of light in one year, then we see that in the last case where the particles on the outer edge of the spiral nebula are covering 150,000 lightyears in 80,000 years, against a ray of light only 80,000 lightyears in the same time, the outer portions of the spiral are going faster than light. Here of course the theory of relativity steps in and vetoes whatever assumptions we have made, for it is absolutely prohibited for any material thing to attain a velocity greater than that of light. We are left with the choice either to disbelieve that spirals rotate or to reduce their size, down to reasonable limits, say not larger than a thousand lightyears.

In the meantime the supporters of the *island universe* theory had not remained idle. During many years past we had seen new stars flash up in our Milky Way system, as well as in these spirals, stars which shine only temporarily, which come up out of nothing in a day or so, reign supreme as the brightest star in the sky for a while, and

PLUMBING-HEATING

Install Your Own—Save Half

Lowest wholesale prices on highest quality Grade A goods. Any Handy Man can install his own Plumbing and Heating BY OUR NEW EASY METHOD. Get the best and pay only a little each month.

Send for FREE Book.

New bargain catalog just issued. With our cut-to-fit systems you save waste material and high labor cost. 50 years of economical service to home owners, farmers, builders and mechanics. Million Dollar Plans back up our bonded Guarantee. FREE Book gives you the whole story. Write for your copy today.

OVER 50 YRS. **HARDIN-LAVIN Co. EST. 1876**
 104-114 West Pershing Road, Chicago, Ill.



REG. U.S. PAT. OFFICE F.P.M. Helps You Win CONTESTS! Cuts Wood & Iron

The F.P.M. saw cuts wood, iron and bakelite at any angle. Used and recommended by experts in every line. Unequaled for sturdy, lasting construction and fine workmanship. Blades of finest tempered steel. Get the F.P.M. Saw at any hardware store or order direct.

1 F.P.M. Saw and 7 Blades sent prepaid \$1.00

DEALERS Write for Discounts JOBBERS

F. P. MAXSON, 3722 N. Ashland Ave. Chicago

Whole World in the Workshop Professional Photographers

\$50. to \$250. a Week in Photography

FREE BOOK Tells How

You can quickly qualify for big-paying position in Motion Picture, Portrait, Commercial or News Photography or start your own business. No experience needed.

CAMERA FREE Learn at home or in our great New York Studios. Earn while learning. Write today for Free Book, Job Chart and Free Camera offer.

NEW YORK INSTITUTE OF PHOTOGRAPHY
 Dept. 82 10 West 33rd St. New York

BUILD and FLY a Model Aeroplane

Learn the principles of Aviation with an accurate model of a real plane. Ideal Scale Drawings and Building-Flying Instructions show you how. Drawings and Instructions for any one of the following planes sent postpaid for 25 cents; Fokker North Pole Plane; Curtiss JN1D-2 Training Plane; DeHavilland Plane; No. 4 Seaplane; Bleriot, Nieuport or Taube Monoplane; or Cecil Peoli Racer. 48-pp Catalog of Parts and Supplies—5c postpaid.

IDEAL AEROPLANE & SUPPLY CO.
 165-169 Spring Street New York City

Tire Repair Business is good now!

\$500 a month

Nation-wide chain of Tire Surgery Shops now being extended to every town and city. Men handy with tools and willing to work are needed. We train you, furnish everything and establish you in a shop of your own. Small investment required. Write for interesting book.

HAYWOOD TIRE EQUIPMENT CO.
 1312 S. Oakley Ave. Chicago

Free Book GIVES DETAILS

I Positively Guarantee

to increase your arms one-half inch in size, chest one full inch, strength 25%, health, 100% in one week's time, by following my instructions and using my exerciser 10 minutes mornings and at night. Send \$1 for complete course and exerciser. Satisfaction guaranteed or \$1 refunded.

PROF. J. A. DRYER
 Box 1850-X Chicago, Ill.

Thousands Use These Ingenious TRANSMITTER UNITS

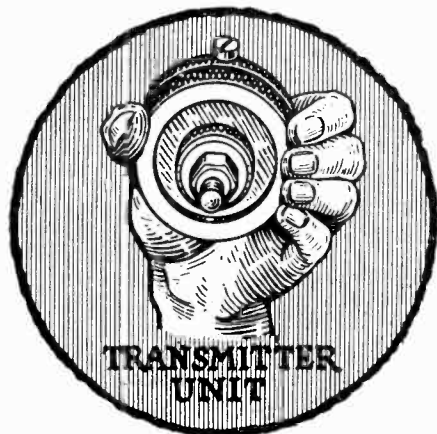

Here's a marvel of Engineering design—a practical miniature transmitter, used by thousands of radio fans and experimenters for amplification purposes. It is a most novel unit, having hundreds of uses. Every amateur should have two or three of these amplifiers in his laboratory.

A FEW USES FOR THESE UNITS

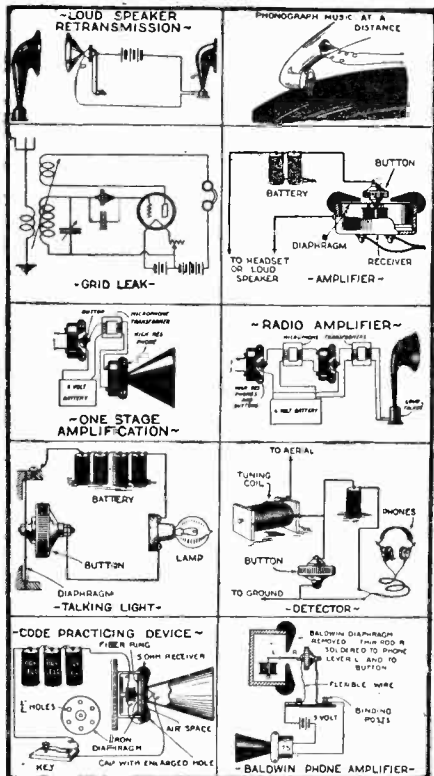

With each unit is mailed an eight-page instruction pamphlet containing suggestions for innumerable uses. Our supply is limited; avoid disappointment by ordering today. The coupon below is for your special convenience.

SPECIALLY PRICED
AT— 95c
 (or two for \$1.75) per unit

THE PRESS GUILD
 16 East 30th Street, New York, N. Y.
 Enclosed find 95c/\$1.75 for which send me postpaid one/two amplifier units as advertised.
 Name.....
 Address.....
 City, State.....

sink away into oblivion again. We know more or less what the candlepower is of the new stars in our Milky Way system, and we have every reason to suppose that it is the same in these far-off spirals. But since the new star in spirals appear to us much fainter than those in the Milky Way they must be very far off. And a precise calculation performed by Lundmark and Curtis yielded about one million lightyears for the nearest of all spirals.

So there we were: contradictory evidence and no way out. The battle raged merrily for several years until two years ago Hubble at Mt. Wilson discovered variable stars in the spirals, so-called Cepheids. These Cepheids are stars whose light varies perfectly regularly and in such a way that they are always recognizable, in addition to this we know exactly what their total light output is, their candlepower. And since we can easily measure their apparent brilliance in the spiral nebula they give us an immediate and very accurate clew to the distance of the spiral. So great is the belief in the validity of this method, that when the answer came out one million lightyears it was universally accepted, and the rapid rotation found before immediately regarded as an optical illusion, as a result of defects in the photographic plates on which it was measured.

So at last we know again where we are at. The new edition of the *social register* of the Cosmos therefore contained all spirals as full-fledged *island universes*, all having equal standing. They are not of course all alike. There are great differences among them. Some are still in a very early stage of evolution, appearing to us as very condensed objects, where the stars are still very closely packed together. Such spirals or rather such nebulous objects are generally called globular nebulae, they show no form or shape otherwise. As the spiral grows older however, it begins to reveal its real structure, two spiral arms begin to show and as time advances these arms in turn begin to unwind and pour out streams and streams of stars, star clusters and like objects.

BEST KNOWN SPIRAL NEBULA

Probably the best known of all spiral nebulae is the great nebula in Andromeda, the only spiral visible to the unaided eye. It is just one million lightyears distant from us and about fifty thousand lightyears in diameter. It contains millions and possibly billions of stars, the vast majority being too faint to be seen individually. The only stars we can see are thousands of times brighter than our sun, indeed at a distance of a million lightyears our sun would appear more than one hundred million times fainter than the faintest star the human eye can see.

During the time we have had the Andromeda nebula under observation, we have seen several novae flash up in it. The brightest of all was the new star of 1885 which to us appeared of the seventh magnitude, *i. e.* just too faint to be seen with the unaided eye. Yet in reality this star was more than a hundred million times brighter than the sun. During the few days of its reign in the Andromeda nebula, while it was at its maximum splendor, this gigantic star poured out so much light and energy into space, that it was thereby losing more than two hundred trillion tons of matter every second, according to the theory of relativity. On the average, the Andromeda nebula seems to produce about two new stars a year. This is far too many, and it makes us worry about the cause of these new stars. We have no reason to suppose that the past fifty billion years were any "leaner" for the Andromeda nebula than the past ten, so it would seem that during the past fifty billion years, which is a mere instant in the history of a spiral, there have appeared a hundred billion new stars in the nebula, *i. e.*, more than there are ordinary stars there now. Do all stars eventually become novae, or is the nova stage some-

Jobs for Home Trained Men in ELECTRICAL ENGINEERING

\$65 a WEEK AND UP!

Get into a field that's not crowded. Draw real pay! If you can be reached by mail, we can train you for success in electricity.



A few Happy Hours a week in work with a "kick" in it.

ELECTRICAL EXPERTS are needed now as never before. Even electrical trades are making record money. But men with expert electrical training such as we give you, are earning \$3250 a year and up by the thousands. And the big modern electrical "boom" has only started. Jobs by the hundreds are opening up. Electrical refrigeration, power plants, battery stations. A profitable business for yourself. The kind of job you've always wanted. Where you do the bossing and let the other fellow do the \$25 a week hard work.



Charles F. Steinmetz, A. M. Ph. D. "Electric wizard of General Electric was for the last six years of his life on the Advisory Board of School of Engineering."

FREE EMPLOYMENT SERVICE

Thousands of firms look to us for men. Nordberg, Harnischfeger Corp'n., Commonwealth Edison are only a few places where S. of E. men get rapid advancement. Hundreds have been helped by us in selecting the right place to go into business for themselves. Coupon brings you big FREE book with all details.

WHATEVER YOUR AGE OR EXPERIENCE

we can train you for success and big pay in electrical work. Hundreds of our most successful students are not even high school graduates. You don't need to know a single fact about electricity. In 23 years of teaching men to be a success we have found just what you should know and how to teach it to you to insure the quickest success when you go on the job. Earn \$65 a week and up. It's "in the cards" for you if you act and send the coupon.

IN BUSINESS FOR YOURSELF



Hundreds of S. of E. men locate in business for themselves. With our help it's easy to get started.

SATISFACTION GUARANTEED OR MONEY BACK is the way we stand behind S. of E. training. We can afford to because S. of E. men make good. They have the prestige for some of the biggest electrical men in America are S. of E. men. A signed money-back guarantee bond is yours the minute you enroll. Your training must satisfy you or every penny is returned.

GET STARTED—MAIL THE COUPON NOW. A big 64 page book in colors and illustrated with pictures of successful S. of E. men and their jobs will be rushed postpaid. Full details on S. of E. home training and the big opportunities that await you. **Mail Coupon Right Now.**

\$50 Outfit FREE

An electrical expert's outfit complete, of finest materials when you enroll.

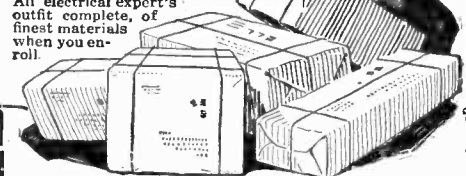

SCHOOL OF ENGINEERING OF MILWAUKEE
 Dept. 727 Box 351 Milwaukee, Wisconsin

Send me FREE and postpaid without obligation your big 64-page book telling about S. of E. training and opportunities for me in electrical work. Also details of your employment service and money back guaranty.

Name.....
 Address.....
 City..... State.....

Now the New Fashioned desk Sets at a popular price

\$ 2 98
Postpaid

WILRITE fountain PEN DESK SET

Genuine Russian Iridium tipped points—Barrel of hard rubber with gold trimmings—Ends in 4 beautiful colors, jade, amber, black or red casein.



Base beautifully beveled and heavily weighted in colors to match pens.

25 Years or More of Fine Writing Service

Throw away your old pens and fountain pens. Your trouble and worry over a satisfactory, smooth writing pen whenever you want it, are no longer!

This beautiful, handsome Gold point, Iridium tipped fountain pen and desk stand will last a lifetime and more. It can be handed down from father to son, giving perfect, smooth writing for many years.

It is handsome, serviceable, with beautifully tapered casein ends, made in 4 colors, Red, Black, Amber or Jade. Base in colors to match.

—and its price only \$2.98, is within everyone's means. Buy one for yourself, or for your friends as a gift—there is none better.

Order direct, delivery made immediately.

WILWRITE FOUNTAIN PEN CORP.
312-314 Lafayette St. New York



A Motor Boat -for half the cost!

The Super Elto clamps on any open boat — gives all motor boating pleasures at amazingly small cost. Powerful, speedy, reliable. Light and portable. Write today for intensely interesting catalog! ELTO OUTBOARD MOTOR CO., Ole Evinrude, President, Mason St., Dept. 48, Milwaukee Wis.



Insure your copy reaching you each month. Subscribe to SCIENCE AND INVENTION—\$2.50 a year. Experimenter Pub. Co., 230 Fifth Ave., N. Y. C.

thing like a disease which, once it has struck a star, is apt to recur very often? What is the answer? We do not know but we hope to clear it up in the near future.

The Andromeda nebula, although the largest and best known, is not the nearest of all island universes. As near as 100,000 lightyears we find two very small islands, the Magellanic Clouds visible only in the southern hemisphere, and resembling patches of the Milky Way torn off, and thrown away in empty space. At greater distances we find many more island universes, the great spirals in the constellations Triangulum Canes Venaticae and the Big Dipper. All over the sky do we find them, large and small, in early stages of evolution, or far advanced, as open spirals or even as "old" as the Magellanic Clouds, where even the spiral structure has been broken up, to give away to a complete star-cloud effect. By means of the spectroscopy we have been able to measure the velocities of a great many, and we know that the Andromeda nebula, e. g., is approaching us at a speed of almost 200 miles a second. Others are receding from us, some even as fast as 1,000 miles a second. So we see, that, after all, these islands in the ocean of cosmic space are not stationary, but that they more closely resemble ships in transcosmical traffic, each and everyone of them bound for its own destiny, voyaging through infinite space, through all eternity; the flying Dutchmen of the universe!

Can I Study Engineering at Home?

By H. WINFIELD SECOR
(Continued from page 214)

- Electricity and Magnetism (2 Parts)
- Theory of Direct-Current Generators and Motors
- Direct-Current Generators
- Direct-Current Motors
- Resistance Measurements
- Direct-Current Measuring Instruments
- Alternating Currents (2 Parts)
- Alternators
- Transformers
- Alternating-Current Rectifiers
- Alternating-Current Motors and Synchronous Converters
- Industrial Motor Applications
- Alternating-Current Measuring Instruments
- Watt-Hour Meters
- Voltage Regulation of Alternating-Current Circuits
- Storage Batteries
- Electric Lamps (2 Parts) (Part 2 Optional)
- Electric Heating (Optional)
- Local Distribution of Electrical Energy
- Long-Distance Transmission of Electrical Energy
- Line Calculations
- Interior Wiring (2 Parts)
- Sign Wiring (Optional)
- Switchgear
- Electric Stations
- Electric Substations
- Operation of Electrical Machinery (2 Parts)
- Efficiency Tests
- Electric Railway Systems
- Electric-Railway Line Construction
- Track Construction
- Electric-Railway Calculations
- Railway Motors
- Electric-Car Equipment
- Speed Control
- Design of Direct-Current Machines (3 Parts)
- Design of Transformers
- Design of Alternating-Current Machines (3 Parts)
- Geometrical Drawing (2 Parts)
- Mechanical Drawing

RADIO SUBJECTS

One of the well known radio engineering schools provides, besides the regular home lessons sent to the students, a set of work sheets which are outlined below:

Work Sheet No. 1.—Testing A, B and C radio dry batteries; chart of battery voltages required for all tubes; method of procedure; how to use instruments.

Work Sheet No. 2.—Correcting common tube troubles; sockets; replacements; test sets; how to make tests; checking characteristics.

Work Sheet No. 3.—Installation of the antenna system; five points to consider; types of aerials; position; interference; lead-in; directional qualities; methods of



The first and only complete manufacturers directory of all Standard Radio Receivers.

We all want to know what kind of a set is best to buy. Here is a book that describes all standard manufactured sets from authentic descriptions furnished by the manufacturers themselves.

It gives you all the information you need to make your choice, saves you from "blind" buying, and vain regrets.

GIVES PRICES, TECHNICAL DESCRIPTIONS—ILLUSTRATIONS

Receivers are illustrated, prices are given, manufacturers' names and addresses supplied. General characteristics of sets are described, number of tubes, "Electrified" Receivers, etc., etc.

All you need know—Just like a permanent "Show."

The only book of its kind—absolutely unprejudiced. 40 pages—size 6 x 9 inches, profusely illustrated.

DON'T BUY IN THE DARK—AVOID MAKING THE WRONG CHOICE.

USE "The Directory of Standard Radio Sets"

ONLY 25c Sold Everywhere

If your dealer cannot supply you Write direct

The Consrad Company, Inc.
230 Fifth Ave. New York, N. Y.

SECRETS of your Hands.

[PALMISTRY]

A Revelation of Character, Fortune and Natural Span of Life.

FINGERPRINTS are used throughout the world as a means of apprehending criminals—but fingerprints are but a small portion of the secrets of your character that your fingers, your palm, even your handshake reveals.

Every inch of your hand has been charted by the experts of this highly developed science, and so simply and accurately that anyone can learn the telltale signs by heart.

Here is a brand new book with all the latest information—written in such a way that you can quickly master "Palmistry."

Price 50c

IT'S BRAND NEW

**96
Page
Book**

Hundreds
of illustrations

Size
9 x 12
inches

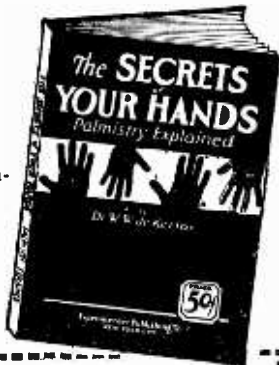

EXPERIMENTER PUB. CO., Inc.
230 Fifth Avenue, New York, N. Y.
Gentlemen—I enclose 50c for one copy of "SECRETS OF YOUR HANDS."

Name

Address

City, State

procedure; indoor antenna; testing the antenna system.

Work Sheet No. 4.—Storage batteries and rechargers; general types; how to make; charging; testing the charge; trouble-shooting on batteries; how rectifiers work; general types.

Work Sheet No. 5.—Loud speakers and how to use them; factors in good tone quality; rôle of the power tube; how to make tests; proper selection of speaker; installing the speaker; trouble-shooting.

Work Sheet No. 6.—Building radio receivers; selection of circuit; selecting parts; how to examine and test all parts; mounting receiver components; drilling panel; wiring; the art of soldering.

Work Sheet No. 7.—Power tubes; what they are and how they are used; some causes of distortion; power tube vs. standard tube; applying the power tube to any receiver; methods of procedure.

Work Sheet No. 8.—Putting new life in radio tubes; equipment necessary; how to make rejuvenator; methods of procedure; chart of characteristics of all tubes.

Work Sheet No. 9.—Winding coils; how to make a coil winder; low-loss solenoid coils; methods of procedure; basket weave and diamond weave coils; data on specimen coils.

Work Sheet No. 10.—Designing coils for receivers; how to determine inductances; easy methods of selecting a coil; single layer coils; multi-layer coils; low-loss coils; losses in coils and condensers.

The radio parts listed below, applied with the lessons given in the home study radio engineering course, will enable the student to build any type of receiving set known, except the super-heterodyne, and this he can try out with a few coils wound by himself from information given in the course.

LIST OF RADIO PARTS

- 1 Panel, Hd. Rub., 7x18x3/16.
- 3 Condensers, var., .00035.
- 1 Midget Condenser.
- 1 Grid Condenser Mounting.
- 1 Grid Condenser, .00025.
- 1 Grid Leak, Variable.
- 3 Sockets, Vacuum Tube UX201A.
- 1 Interchangeable Coil Mounting.
- 1 Transformer, Audio, 3-1 Ratio.
- 2 Rheostats, 30 ohm.
- 12 Binding Posts.
- 1 Terminal Strip.
- 2 Fibre Tubes, 2 1/2 x 1 1/2.
- 2 Fibre Tubes, 2 1/2 x 3 3/8.
- Spaghetti.
- 3 Dials.
- 1 Mounting Board, 10x17x5/8.
- 4 Angle Brackets.
- 1 Binding Post Strip.
- Miscellaneous Screws.
- 1 Crystal Detector.
- 1 Galena Crystal.
- 1 Spool of Wire.

A Set for the Experimenter's Power Pack

By A. P. PECK

(Continued from page 253)

regeneration is not employed. The writer is located only a few miles from the super-power station WJZ, yet has no trouble in bringing in more or less distant stations at any time of the day or night. Frequently Chicago and other mid-west stations have been tuned in and held consistently.

- Pliers, several kinds.
- Screw drivers, several sizes.
- Hammer, hacksaw and blades.
- Hand drill.
- Twist drills, several sizes.
- Scriber.
- Center-punch.
- Soldering iron, electric or other type.
- Wire solder, self-fluxing or plain solder and non-corrosive flux.
- Rule, steel or wood.
- Center finder for dials.
- 1 three- or four-cornered reamer and handle for expanding panel holes for shafts, jacks, etc.
- Small tool andawl handle very useful.
- Volt and ammeters for testing set, batteries, etc.
- 1 countersink.

ELECTRICAL REFRIGERATION

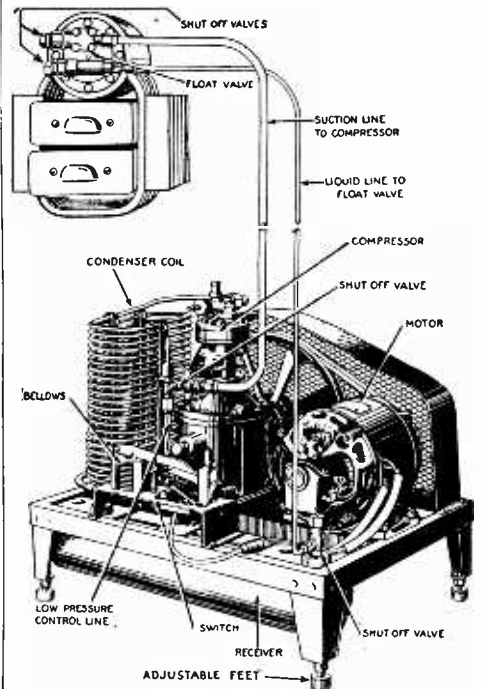

Offers You a
Brilliant Future

Learn in **3 MONTHS**

In 3 months, only—just 90 days you can be one of the new group of trained experts who will guide and develop the most lucrative and newest of America's gigantic industries.

Experts Needed

Electrical refrigeration needs men, men and more men—with positions—big, responsible, well-paid positions open—waiting for them.

Special Training Essential

Trained mechanics cannot service these new machines—they need refrigeration experts of which there are but a pitiful few.

Let us prove what we say. Let us send you our literature. It's free—no obligation—the coupon will bring it to you—no fuss—no trouble.

New Classes Now Organizing
Act At Once

SCHOOL OF ENGINEERING
of Milwaukee
FOUNDED 1905

SI-727R, 163 E. Wells St., Milwaukee, Wis.

SCHOOL OF ENGINEERING
SI-727R, 163 E. Wells St., Milwaukee, Wis.

Send me FREE, with no obligations, more details on your three-month course in Electrical Refrigeration.

Name Age

Address

City State

\$35100 CLEARED ~ IN ONE DAY

So writes W. H. Adams of Ohio. Letter from V. A. Marini of California reports \$11275 sales in three months. Jacob Gordon of New Jersey \$4000 profits in two months." Alexander of Pennsylvania "33000 profits in four months." Ira Shook \$365 sales in one day. Bram bought one outfit April 5 and 7 more by August 28. Ivata bought one outfit and 10 more within a year. Mrs. Lane of Pittsburg says "sold 4000 packages in one day. J. R. Bert says "only thing I ever bought that equaled advertisement." John Culp says:



WE START YOU IN BUSINESS
Furnish secret formulas, raw material, and equipment. Little capital required; no experience needed.

Build a Business of Your Own
No limit to the sale of Crispettes. Everybody likes them. It's a delicious food confection. Write for facts about a business that will make you independent. Start now, in your own town.

Profits \$1000 a Month Easily Possible
Send postal for illustrated book of facts. It contains enthusiastic letters from others—shows their places of business, tells how and when to start, and all information needed. Free. Write now!

LONG-EAKINS COMPANY
753 High Street Springfield, Ohio

IMPORTANT TO YOU!
Auto Owners, Auto Mechanics, Electricians, Machinists, Draftsmen, Etc. We are offering you the greatest handbook ever published for the money. It contains 156 practical tables and formulas on Changing Gears, Motor Knocks, Engine troubles, Ignition troubles, Carburetor and Spark Plug troubles, Storage Battery, Piston and Piston Rings, Decimals, S. A. E. Tables, Bolts, Gears, Capers, Angles, Lettering, Shop Mathematics, Pipe Fitting, Horsepowers of Steam, Gasoline Engines and Motors, Weights and Strength of Metals and numerous other tables The Universal Machinists' and Auto Handbook is written so anyone can understand it and is not misrepresented. Price 35 cents, prepaid. Send stamps to Dept. B—SHIELDS ENG. & PUB. CO., 3962 Delmar Ave., St. Louis, Mo.

THE MIDGET SLIDE RULE
Instantly adds, subtracts, multiplies, divides, solves proportion, gives all roots and powers. Logarithms, Sines, Cosines, Tangents, Cotangents, Etc. Also gives decimal equivalents, lettered and numbered drill and tap sizes. More than 110,000 sold, more than 2000 unsolicited testimonials. The Engine-divided scales are on white finished aluminum and are grease and waterproof. Diameter 4". Price with Instruction Book, \$1.50. Pocket Carrying Case, 50c extra. Cash or C. O. D. Catalogue free. Your money back if you are not satisfied. **GILSON SLIDE RULE COMPANY, Stuart, Florida**

ZIP-ZIP SHOOTER
CAMPERS AND TOURISTS:
Here is the very thing for you. Campers tell us that this is the greatest weapon to be had where firearms are prohibited. Zip-Zip Shooter is noiseless, powerful and effective and is used by a great number of tourists and campers. Thousands of boys are made happy with this wonderful Zip-Zip Shooter. If your dealer happens not to have them order from us. Zip-Zip Shooter, 35c or three for \$1.00. **AUTOMATIC RUBBER CO., Dept. BB, Columbia, S. C.**

Fifty Dollars a Week With Car and Camera—By Paul Glenn Holt
With 100 pages and 14 illustrations the author fully describes an independent living he makes with an amateur camera, out-of-doors. Workable by anybody, anywhere. Sent postpaid \$1.50, Or C.O.D. plus postal charges. Address Drawer 5, R. Snyder Publishing Company, Guilford, Connecticut

500 MAGIC BOOK 10c
Latest 1927 Edition—100 Pages Profusely Illustrated. Over 500 Tricks described and explained. Reduced Price Catalog of Magic—Illusions—Escapes—Jokes—Puzzles—Books and European Novelties included. Amaze and mystify your Friends—It's easy! Send 10c today. Lytle Douglas, Station A-3, Dallas, Texas.

Book Review

THE INHERITANCE OF ACQUIRED CHARACTERISTICS, by Dr. Paul Kammerer, stiff cloth covers, 6"x9", 410 pages. Published by Boni & Liveright, New York City. Price \$4.50.

This is a truly remarkable book which unfortunately does not go quite far enough. The experiments outlined as having been performed by Dr. Kammerer with animals and the photographs and tables which he gives prove that characteristics can be acquired. The work itself is scientifically very remarkable. Dr. Kammerer points out that environment changes have a great influence upon our children and it is suggested that many parents would benefit by reading this work. The lessons pointed out and the inferences when applied to the human race are of vast importance and should lead to material improvement. The work, while written for the layman, is useful to the student, the biologist and to the members of the medical profession. It is of special value because of its extreme thoroughness.

PRACTICAL PHYSICS, by T. G. Bedford, stiff cloth covers, 5 1/2"x8 3/4", 426 pages. Published by Longmans, Green & Co., New York City. Price \$3.50.

While this work has a short introduction divided into the mechanics and properties of matter, heat, light, sound, magnetism and electricity, those experiments commonly found in elementary text

Station WRNY
NEW YORK
309.1 Meters—970 Kilocycles
is owned and operated by the publishers of this magazine
Our Editors will talk to you several times every week—
See your Newspaper for details
TUNE IN ON WRNY

books have been omitted in even the introduction and only the more advanced experiments are described. It is not intended to be an elementary work in physics and the author has approached the subject in just such a direction. It is written for students who desire to enter the more advanced classes in physics, for students who are already familiar with simple measuring instruments and with the determination of specific gravities and the more simple physical experiments. From this point the work advances rapidly and with extending thoroughness. Well illustrated and containing formulas and instructions for the carrying on of the various experiments, we have several steps in advance of the ordinary general practical physics. After the student completes the experiments in a work of this nature, he will have no further difficulty in proceeding further on his own initiative. The work can certainly be recommended to the college student or advanced physicist.

FIFTY DOLLARS A WEEK WITH CAR AND CAMERA, by Paul Glenn Holt. Stiff cloth covers, 5"x7 1/2", 100 pages. Published by R. Snyder, 18 Derne St., Boston, Mass. Price \$1.50.

This book is written by one who snapped his camera shutter over 10,000 times in one and a half years, which it will be observed represents the using up of considerable film. He gives the typical expense account for one of those days, when his work cost him \$4.60, and he sold \$16.50 worth of pictures, which shows a profit only ten cents short of \$12.00 a day. The book is an exhortation to get out in a car and to photograph things which will give selling merchantable pictures. He appeals to the great middle class as his market. He says he is willing to make a large bet, that he can go into any field and make from \$15.00 a day upward. He says that experience and caution are both necessary, so the proposition seems to be a very attractive one. He recommends a roll-film camera, with a 3 1/2"x5 inches field, which gives postal card size of prints. The book is written quite charmingly and he is clearly a lover of the great outdoors.

REDUCE YOUR TIRE COST!
Compare our Prices with others. Chicago's largest tire shop offers the following on tires such as Goodyear, Goodrich, Firestone, highest grade strictly used tires. **Absolutely Lowest Prices Ever Offered**

Size	Our Price	Trade Name
30x3	\$2.65	\$1.15
30x3 1-2	2.75	1.35
32x3 1-2	3.25	1.45
31x4 ss	3.45	1.60
32x4	3.65	1.65
33x4	4.00	1.75
34x4	4.00	1.75
32x4 1-2	4.50	1.95
33x4 1-2	4.65	2.15
34x4 1-2	4.75	2.25
30x5	5.00	2.45
32x5	5.00	2.45
33x5	5.50	2.75
34x5	5.50	2.75
30x5-77	5.00	2.75
31x5-25	5.00	2.75
31x6-00	5.50	3.00

COMMONWEALTH TIRE CO.
1154 So. Canal Street
Dept. 16 CHICAGO
Fine Shipping Charge

RESHAPE YOUR NOSE
to beautiful proportions—while you sleep!

ANITA NOSE ADJUSTER
is SAFE, painless, comfortable. Speedy, permanent results guaranteed. Doctors praise it. No metal to harm you. Small cost.

Gold Medal Won 1928
Write for FREE BOOKLET BEFORE AFTER

ANITA CO., Dept. G-73 ANITA Bldg., NEWARK, N. J.

50¢ A WEEK 50¢

This Beautiful Tonneau-shaped Ladies' Wrist Watch. Genuine solid 18kt. white gold engraved case, with fancy white gold dial. A beautiful velvet gift box given free. Send no money. Pay postman only \$2.85 and postage and 50c weekly after that (\$10.85 in all).

THE JAROSZK JEWELRY DEALER
Dept. M J.
1470 Gallagher St. Hamtramck, Mich.

Learn How to BOX

in 20 weeks, the System of Jimmy DeForest, World's Greatest Trainer and Maker of Champions, teaches you all there is to learn about boxing and professional training. Every 6 months 20 are selected from all classes and recommended to leading promoters for engagements. Send for famous book "The Golden Age of Boxing," full of valuable information, photos of great boxers and pupils who became successes overnight. Enclose 10c to cover cost of mailing, etc.

JIMMY DEFOREST BOXING COURSE, Box 3019
347 Madison Avenue New York City

PIMPLES
Cleared Up—often in 24 hours. To prove you can be rid of Pimples, Blackheads, Acne Eruptions on the face or body, Barbers' Itch, Eczema, Enlarged Pores, Oily or Shiny Skin, simply send me your name and address today—no cost—no obligation. **CLEAR-TONE** tried and tested in over 100,000 cases—used like toilet water—is simply magical in prompt results. You can repay the favor by telling your friends: if not, the loss is mine. **WRITE TODAY.**
E. S. GIVENS, 468 Chemical Bldg., Kansas City, Mo.

66 Miles on 1 Gallon
Amazing New Auto Gas Saver
All Make Cars. Spare or Full Time Agencies Wanted Everywhere

1 FREE TO ADVERTISE
BIG PROFITS to any MAN WITH CAR
CRITCHLOW, Inventor, A-863, Wheaton, Ill.

Do Your PRINTING
Cards, Stationery, Circulars, Paper, etc. Save money. Print for others, big profit. Complete outfits, \$3.85. Job press \$11.89. Rotary \$149. All easy, rules sent. Write for catalog presses type etc. **THE KELSEY CO., T-47, Morden, Gonn.**

Insure your copy reaching you each month. Subscribe to **SCIENCE AND INVENTION**—\$2.50 a year. Experiment Publishing Co., Inc., 230 Fifth Avenue, New York City.



12 P.M. Gives up in disgust!

The man who forgot to buy

THE RADIO TROUBLE FINDER

FROM 8 o'clock to 12 he was frantically trying to tune in on the big anniversary program, but his radio set positively would not work.

He had a dozen books on the care of his car but not one for his Radio.

Radio Sets rarely need an expert's attention, if you have a copy of "The Radio Trouble Finder" handy.

It's a 68-page, simplified manual for trouble correcting—written expressly for home users.

Common Radio faults are charted and remedies are given in language as devoid of technical expressions as is possible.

ORDER YOUR COPY TODAY

25c Every Where

If your dealer has no copies available write direct.

The Conrad Co. Inc.,
230 Fifth Ave.
New York



Effects of X-Ray on Fruit Flies

By DR. JAMES W. MAVOR
(Continued from page 218)

are not at all simple things, mere lumps of jelly; but each of them is almost a little creature in itself.

In our figure three of these cells are drawn at a magnification of 5,000 diameters, which is about the highest magnification which can be realized today when ordinary light is used in the microscope. These cells were killed and stained with a dye so as to bring into contrast their structure. The conspicuous and somewhat irregular black bodies are the chromosomes. It will be noticed that these occur in pairs. One of these pairs, marked X-chromosomes in the diagram, is concerned with the determination of sex. In the fly there is no doubt after an egg has been fertilized what it is going to turn into. Its sex is determined then and there by the male cell or spermatozoon which enters it.

When the eggs are formed they are all alike and each one contains only one of each of the chromosomes of a pair. So that, in this particular species of fly, each egg would contain just four chromosomes, one of which would be one of the x-chromosomes. The spermatozoon, when it fertilizes the egg, contributes another single set of chromosomes. The chromosomes which are in the egg and come from the mother, become associated with those which the spermatozoon brings with it at the time of fertilization. In this way the embryo, which develops from the egg, has a complete set of pairs of chromosomes; in the case of the fruit fly, four pairs.

How then does the male cell or spermatozoon determine the sex of the offspring? There are two kinds of spermatozoa. The two chromosomes, which correspond in the male to the pair of x-chromosomes in the female, are not exactly alike. One of them is exactly like the x-chromosomes of the female, but the other is bent into the shape of a hook and is otherwise different. Since each male cell or spermatozoon contains only one of the two different chromosomes, there are two different kinds of spermatozoa. The spermatozoa which contain the x-chromosome produce females, those with the hooked chromosome, or as it is called y-chromosome, produce males.

Now one of the peculiar things which X-rays do to egg cells, while they are still in the body of the mother and are not yet fertilized, is to cause the destruction or elimination of the x-chromosome, leaving the rest intact and so far as can be determined entirely normal. Or, which is still more peculiar, they may cause an egg to be formed which has two x-chromosomes, instead of the single one which it normally has. In each case, when such an egg is fertilized, it develops into an abnormal fly, abnormal both in its bodily structure and in the way it reproduces.

When an egg having no x-chromosome, as the result of X-ray treatment of the mother, is fertilized by a male cell carrying an x-chromosome it becomes a male; but, having no y-chromosome in its cells, it is sterile and unable to reproduce its kind. Such an offspring is peculiar also in its hereditary characters. When an egg, which as a result of X-ray treatment has two x-chromosomes in place of one, is fertilized by a y-chromosome, instead of giving rise to a male offspring as it normally would, it gives rise to a female with the two x-chromosomes and one y-chromosome. Such females are also peculiar in their inherited characters and when they produce offspring, as they do, some of these offspring have the same inherited peculiarities which their mother had.

Oh You Skinny!

ARE YOU LAUGHED AT ON THE BEACH?



STRONGFORT
Builder of Men

Are you a puny, boney, skinny outfit at whom everybody laughs? Are you a curiosity on the beach, inviting all sorts of ridicule? Do girls titter as you pass them? Do they shun your society? If this is your sorry plight, young fellow, just take a hunch from me—snap out of your skinniness—put on flesh and muscle, build up strength and straighten up your back. **YOU CAN DO IT.** You can be a duplicate of that bronzed and much admired life-guard over whom the girls rave. You can develop a symmetrical form, rounded out chest, rippling muscles on your arms and legs. You can be a powerful swimmer, a graceful dancer, a peppy boxer, a swift runner—just what you'd like to be.

Let STRONGFORT Make a Man of You

I've taken thousands of young fellows, skinny as a lath, and built them up into strapping, powerful men who commanded respect and admiration wherever they went. Some of these chaps had set too fast a pace for themselves, others had wasted their vitality and broken down their manhood, others had gone stale from neglect of their bodies or other abuses and excesses. No matter how despondent their state of mind or how physically broken they were, they quickly came back when they adopted

STRONGFORTISM

The Science of Health and Strength

STRONGFORTISM works wonders with run-down, weakly, skinny men. It builds them up to health through internal muscular development, then rounds them out into robust physical specimens, by bringing into play every muscle and making every muscle do its work as Nature intended. You'll be astonished how quickly you'll feel the benefits of this best of all health and strength Courses. You'll feel like a new man almost from the first day you start under my instructions. You'll be surprised at the lazy muscles you wake-up when you begin, and they'll wake you up in turn. You'll quickly realize that a new day has dawned for you as you feel the red blood coursing through your whole body like a bounding mountain stream. That old, stupid, sluggish feeling will disappear like magic. That gloomy outlook will vanish as though a heavenly hand had brushed it away. Oh, it's a great feeling! Great to feel like a man! And you surely will when you adopt Strongfort as your instructor and guide—Strongfort, "the builder of men."

I Want to Send You MY FREE BOOK

This book of many pages and dozens of pictures tells of my wonderful experience—how I became the outstanding athlete of the world, performing feats others dared not attempt; how I turned the knowledge gained through developing my own body to the benefit of others, and then how STRONGFORTISM was evolved. It tells what I have done for others, what I can do for you. It doesn't mince words. It tells plain truths. "Promotion and Conservation of Health, Strength and Mental Energy," points the way from disease and weakness to health and strength. It is priceless. I'll send it to you on request—FREE. Write for your copy today.

STRONGFORT INSTITUTE

LIONEL STRONGFORT, DIRECTOR
Physical and Health Specialist
DEPT. 355 NEWARK, NEW JERSEY, U. S. A.

SEND THIS FREE CONSULTATION COUPON ABSOLUTELY CONFIDENTIAL

Mr. Lionel Strongfort, Strongfort Institute, Dept. 355, Newark, N. J.

Please send me absolutely free my copy of your book, "Promotion and Conservation of Health, Strength and Mental Energy." I have marked (x) along the subjects in which I am most interested.

.. Catarrh	.. Constipation	.. Lung Troubles
.. Colds	.. Weak Back	.. Round Shoulders
.. Asthma	.. Weak Eyes	.. Youthful Errors
.. Headache	.. Rheumatism	.. Manhood Restored
.. Rupture	.. Nervousness	.. Stomach
.. Thinness	.. Night Losses	.. Disorders
.. Pimples	.. Short Breath	.. Increased Height
.. Insomnia	.. Weak Heart	.. Muscular
.. Impotency	.. Great Strength	.. Development
.. Overweight	.. Vital Losses	

Private Ailments.....

Name

Age..... Occupation.....

Street

City..... State.....

116 pages of MODERN MAGIC by Dunninger



The greatest living magician of today

Tricks by the thousands

SECOND PRINTING "POPULAR MAGIC"

First completely sold out

EVERYBODY'S buying this book. The first time "Dunninger" has revealed his tremendous store of marvelous parlor and professional tricks and magic in one volume. Second big edition of 100 pages, crammed full of mystery. Illustrated—large size 9 x 12 inches.

They are going faster and faster. Orders are pouring in. We believe there never was a magic book like this. It may never be reprinted—so order now. Delivery within 24 hours.

THERE'S NOVELTIES — FUN — MYSTERY IN "POPULAR MAGIC"

ONLY 50c

If your dealer cannot supply you, write direct

EXPERIMENTER PUB. CO., Inc.
230 Fifth Ave. New York

The whole COUNTRY

is praising

AMERICA'S FIRST RADIO ENCYCLOPEDIA



\$2

A place in every home, every library, every laboratory

S. GERNSBACK'S RADIO ENCYCLOPEDIA is the only standard work ever published in America attempting to classify alphabetically the countless words used in the highly specialized science of RADIO. The ENCYCLOPEDIA is written in plain English so that everybody can understand the definitions and descriptions.

No expense has been spared, covering over two years in compilation, to make it worthy a place in your library.

It is published in one volume—168 pages—size 9x12 inches, nearly an inch thick and nicely accommodates the beautiful illustrations and the large, easy to read type.

Every page is replete with illustrations—to make the text easily understandable.

REMEMBER THIS IS A REAL ENCYCLOPEDIA—NOT A DICTIONARY—and very few of the things described and illustrated in this volume can be found in any dictionary, or any other encyclopedia.

The book contains as a supplement a classified cross-index designed to bring together radio references under one heading having relations in common.

All circuits new and old are described by word and picture and every part and apparatus used in Radio is explained and made understandable by means of photographs and drawings.

The work contains 1,930 definitions, 549 photographs, drawings and diagrams.

Order Direct from
S. GERNSBACK
230 Fifth Ave., New York

NEW YORK, N. Y. . . . It is the best work of the kind we have ever seen and shows considerable painstaking and laborious effort.—*Telegram*.

NEW YORK, N. Y. . . . The volume amounts to practically a compact review of all that has been done in radio up to this date.—*Examiner*.

WASHINGTON, D. C. . . . It presents a complete classification of the latest authoritative data in radio.—*Evening Star*.

SAN FRANCISCO, CAL. . . . A book that will be of value to all that are interested in practical radio work.—*Examiner*.

PITTSBURGH, PA. . . . Many radio fans will be interested in the new Radio Encyclopedia by Sidney Gernsback.—*Sunday Post*.

PITTSBURGH, PA. . . . It will be of great interest to all engineers.—*Examiner*.

PHILADELPHIA, PA. . . . It is a masterpiece of engineering.—*Examiner*.

PHILADELPHIA, PA. . . . It is a complete classification of the latest available data in radio.—*Day Tribune*.

NEW YORK, N. Y. . . . Mr. Gernsback is author of other volumes on radio and his encyclopedia may be recommended as authoritative.—*Daily Press*.

CHICAGO, ILL. . . . S. Gernsback has aimed to provide not merely a dictionary of radio terms but an actual ready reference.—*Herald and Examiner*.

ST. LOUIS, MO. . . . S. Gernsback's new radio encyclopedia holds all needed facts.—*St. Louis Star*.

ST. LOUIS, MO. . . . This book of radio information is S. Gernsback's radio encyclopedia.—*Globe Democrat*.

MACON, GA. . . . Gernsback's radio encyclopedia fills a demand that has been made by every radio fan as well as technical expert since the industry has started.—*Telegraph*.

DALLAS, TEXAS. . . . This encyclopedia is readily understandable to anyone who reads English and is thorough and readable.—*Sunday News*.

LOS ANGELES, CAL. . . . Its references cover every item of importance relative to the radio industry.—*Sunday Times*.

OTTAWA, CANADA. . . . It is an encyclopedia in the true sense of the meaning and not a mere dictionary.—*Journal*.

S. GERNSBACK 230 FIFTH AVE., N. Y.
I enclose \$2.00 for one copy of your encyclopedia.
Name
Address
City
State

Home Mechanics

By WILLIAM BUTTERFIELD

(Continued from page 231)

three drawer slides 10" wide, 12" long, and 5½" high for one drawer, and 3¼" high for two others.

Fig. F—These pieces complete the drawer slide frames, and are merely glued to the pieces E and the sides of the partitions C. They are ¾" thick, 1¼" wide, and 9¼" long.

Fig. G—The legs are 30" long, 1½" square, with a square post section 15" long, and a turned end 15" long. Four notches are cut in each post ¾" high, ¾" long, and 1¼" deep, as indicated. The top notches are merely depressions, only taking the tenons of the piece B in flush with the top of the leg. There is a right and left leg for both front and back. Care must be taken in cutting the notches to make each for a right or left leg respectively.

Fig. H—This piece is a back for the drawer frame; it is ⅝" thick, 10" wide, and 15" long, and is glued to the pieces A, B, and the drawer slide pieces C. It is a piece of the veneer-board.

Fig. I—Two widths of drawer fronts are made, one 5½" and two 3¼" wide, all are ¾" thick, and 10" long. The soft wood sides are joined to the fronts as illustrated.

Fig. J—The drawer sides are grooved ¼" from the bottom with a ¼" groove to hold the drawer-bottom, as shown; they are ½" thick, 5½" and 3¼" wide, and 11⅞" long. They are joined to the drawer fronts and to the backs as illustrated.

Fig. K—Drawer backs are ½" thick, 5" and 2¾" wide, and 9½" long. The drawer-bottom slips into the side grooves below the level of the lower edge of the drawer-back.

Fig. L—The ¼" ply-board is used for the drawer-bottoms, it is 9½" wide, and 11⅞" long; the bottoms are not glued but slide into the grooves in the sides of the drawers.

Fig. M—To keep the thin casing forming the work-pockets from buckling seven 1" by ½" vertical braces, 13½" long, are glued round the work-pocket openings—to the casing and to the pieces A and B, in the manner illustrated.

Fig. N—The hard wood top is ¾" thick, 14½" wide, and 15½" long; it is glued to the top of the legs and the center part of the piece B. The work-pocket lids are hinged to this piece.

Fig. O—Two work-pocket lids are provided, each is ¾" thick, 10½" long, and 9⅞" wide; they fit over the openings in the piece B.

It will be seen from the two top-view diagrams that the legs are glued on the inside face of the post to the casing D, they are also glued to the tenons on the pieces A and B and the tenons on the drawer slides E. This gives a strong support both to the legs and to the frame. The braces M also strengthen the outer ends of the frame, making, altogether, a very strong and a very rigid piece of furniture. The hard wood top, with its work-pocket lids, and the hard wood legs and hard wood ends, make it appear as though the piece is made entirely of one kind of wood.

If one cares to give a little more time and attention to the job, the hard wood deception can be carried a bit farther, by gluing ¼" strips of Mahogany or Walnut to the front edges of the pieces A, B, and E, where these pieces show between the hard wood drawer fronts; this can be done before the pieces are glued to the legs. Another thing can be done with the piece A at the front lower edge of the drawer case, there can be a bit more thickness shown

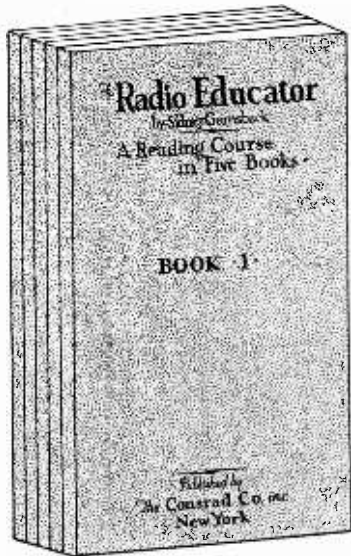

Price \$1.97

A RADIO EDUCATION

IN 5 VOLUMES

Theory, Design, Construction,
Operation and Maintenance

LEARN AT HOME

THESE five component parts of a complete Radio Instruction Course are outlined in five volumes that contain not merely the essentials as so many books do, but more, they contain all that any modern up-to-the-minute textbook on any subject would cover. They are in themselves a COMPLETE radio education teaching every possible portion of Radio science.

Size of each book 6 by 9 inches, handsomely bound and illustrated with charts, diagrams, descriptions of equipment, etc. Each volume 52 pages.

SEND NO MONEY for these books. Just forward your name and address. We send you the books at once. On receipt of same you pay the postman \$1.97 plus a few cents postage and then they are yours.

Distributed by

The Conrad Co.

Incorporated

230 Fifth Ave., New York, N. Y.

than the $\frac{3}{4}$ " in that bottom piece, and this will improve the appearance of that part of the frame. An extra $\frac{3}{4}$ " can be glued to the under side of A making it look $1\frac{1}{2}$ " instead of $\frac{3}{4}$ " that it would be without the addition.

Staining—Most antique furniture is very dark in color, and it is advisable in imitating the old styles, to keep the imitation as near the color of the genuine as possible. This is true of walnut as well as mahogany, and it is also easier to polish a dark piece where the color is uniform in all parts, than a lighter stained piece where the grain of the wood obtrudes in spots of dark and light shading. It is presumable therefore that a dark stain is wanted. It should be dark red mahogany for mahogany, and dark brown umber for walnut. It may be necessary to double stain to obtain the required depth of color.

Finishing—After the staining process, the piece is lightly sandpapered to smooth the rough spots formed by staining; crack-filler tinted with the stain is then used if necessary. This is followed by a coat of finish or varnish. Whatever the finish is to be, glossy or dull, it is quite important to follow the instructions given with the finishing preparation that is being used, be it oil-finish or varnish. Most of the makers have some little kink or other in their instructions which does not seem important, but it usually is, and which it is safer to follow than not to follow. A dull or glossy, finish is purely a matter of taste, some fine old pieces are beautiful in a glossy, high finish, while other pieces are just as beautiful in a dull finish.

Sun Spots and the Flow of Rivers

(Continued from page 203)

tion. The summer rains are drained off much more rapidly than on the western prairies, and as a result about half of the annual precipitation goes down the rivers, instead of only a fifth as in Iowa. Evaporation is therefore of less importance, and as the records indicate more rain in the warmer years of few sun spots, it is not surprising that the rivers of that section average higher in those years.

Rules for Model Contest

1. A handsome trophy cup engraved with your name, will be awarded as the prize for the best model submitted during the month. The decision of the judges will be final and will be based upon, A—novelty of construction; B—workmanship; C—operating efficiency of the model as related to the efficiency of the device which the model simulates, and D—the care exercised in design and in submitting to us sketches and other details covering the model. See page 236.
2. Models of all kinds may be entered. They may be working models or not, according to the subject that is being handled.
3. Models may be made of any available material, preferably something that is cheap and easily obtainable. Models made of matches should not be submitted to this department but should go to our Matchcraft Contest Editor.
4. Models must be submitted in all cases. Good photographs are also highly desirable and where the maker does not desire the model to be taken apart, legible drawings with all dimensions covering parts that are not accessible must be submitted.
5. Models should be securely crated and protected against damage in shipment and sent to us by parcel post, express or freight, prepaid. Models will be returned when requested.
6. Models for entry in any particular contest must reach this office on or before the 25th of the third month preceding date of publication. For instance, models for the Sept. contest must reach us on or before the 25th of June.
7. Address all entries to Editor Model Department, c/o Science and Invention Magazine, 230 Fifth Ave., New York City.



Choose as Your Profession Electrical Engineering

Electricity offers a brilliant future to the young man who is about to choose his career. Never before has there been such wonderful opportunity in this great field. Big paying positions in electrical work the world over are open to trained men — men who possess specialized, practical knowledge. Come to the School of Engineering of Milwaukee—the largest, the best equipped electrical school of its kind in America. Here you are trained in both theory and practice by a faculty of experts. You learn in large, finely equipped laboratories. If you have 14 high school credits or equivalent, you can become an Electrical Engineer with a Bachelor of Science degree in 3 years. If you have not finished high school you can make up the credits you lack in our short intensive Junior Electrical Engineering course.

Practical Electrical Education

Learn by the thorough, approved scientific methods which our twenty-three years of specializing enable us to give you. In addition to Electrical Engineering, the following complete courses are given: A.C. and D.C. Armature Winding—Wiring and Testing—Practical Electricity—Electrotechnics—Commercial Electrical Engineering—Junior Electrical Engineering and Automotive Electricity, Electrical Refrigeration, and Radio Sales and Service.

EARN WHILE YOU LEARN

You can earn money to help defray part of your expenses while learning. Our wonderful co-operative plan brings an Electrical Career within the reach of every ambitious man. Our Free Employment Department secures positions for those students who wish to earn part or all of their expenses. In addition, the Department will help you get a good position in the Electrical industry when your training is completed. Daily Broadcasting W.S.O.E.

New Term Opens September 1st, 1927

Big Book FREE

Mail the coupon today for our big new illustrated catalog. Mention the course that interests you most and we will send you special information. Read about the school that trains men for practical and quick success. See how easy it is for you to get the training that will enable you to step to a splendid position and a handsome income. Mail the coupon right NOW. No cost or obligation.

SCHOOL of ENGINEERING of Milwaukee

Founded 1905

Dept. S.I.-727A

Jackson & E. Wells Sts., Milwaukee, Wis.

----- MAIL COUPON NOW -----

SCHOOL OF ENGINEERING OF MILWAUKEE
Dept. S.I.-727A—Jackson & E. Wells Sts.,
Milwaukee, Wis.

Please send me without any cost or obligation, full particulars of the electrical course I have checked, and your big Free Book telling about your institution and how it will fit me for a big position in the electrical field. Also tell me about your Earn-While-You-Learn Plan.

(Be sure to check courses interested in)

- Electrical Engineering, B. S. Degree in 3 Years.
- Commercial Electrical Engineering, 1 Year.
- Junior Electrical Engineering, 1 to 2 Years.
- Master Electrician, 6 Months.
- A.C. and D.C. Armature Winding, 3 Months.
- Light, Motor Wiring and Testing, 3 Months.
- Automotive Electricity, 3 Months.
- Refrigeration, 3 Months.
- Radio Sales and Service, 3 Months.
- Home Laboratory Service.
- I am interested in your "Earn-While-You-Learn" Plan.

Name Age

Address

City State

Education

Free 60-page Reference Book

POLK'S
DIRECT MAIL ADVERTISERS

Mailings List Catalog No. 55

Get Business by Mail

60 pages of vital business facts and figures. Who, where and how many your prospects are. 8,000 lines of business covered. Compiled by the Largest Directory Publishers in the world, thru information obtained by actual door-to-door canvass. Write for your FREE copy.

R. L. POLK & CO., Detroit, Mich.
880 FOLK DIRECTORY BLDG.
Branches in principal cities of U. S.



Wonderful, new device, guides your hand; corrects your writing in a few days. Big improvement in three hours.—No failures. Complete outline FREE. Write C. J. Ozment, Dept. 44 St. Louis, Mo.

CHEMISTRY MADE EASY

Saves months of study. Be POPULAR and UP-TO-DATE. Study CHEMISTRY by this new, easy, rapid method; fascinating and efficient; success guaranteed. PARENTS, get this splendid NEW INVENTION for your boy or girl; "PLAY THE GAME." Complete outfit, with full instructions, \$2 postpaid; write today.

B. Sc. CHEMICAL CO.,
West Palm Beach, Fla.

Box 2495 West Palm Beach, Fla.

SUMMER

A PORTABLE RECEIVER

fun with this powerful portable set!

MAKE THIS A RADIO SUMMER

Touring, camping, or at home, a portable Radio Receiver is a real summer enjoyment. It's convenient to carry, in your car, with your baggage or if at home from room to room or out on the lawn.

You can build your own "portable" at a small cost—from a "Consrad" pattern which gives 4-page instruction booklet of parts needed, together with full size blueprints 16 inches wide by 20 inches high, of panel and wiring diagram.

The Consrad method is the simplest ever devised—you do not have to know anything about Radio to follow it.

THIS CONSRAD PATTERN

50c—EVERYWHERE

Or send direct on receipt of 50c.

THE CONSRAD CO., Inc.

230 Fifth Ave., New York, N. Y.

Radio Wrinkles
CONVERTING UV-TYPE TUBES

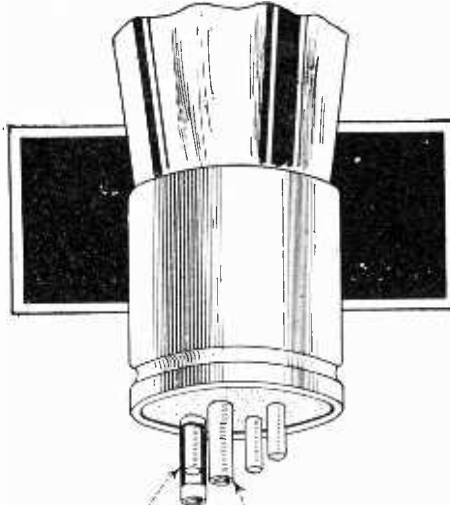

BRASS OR COPPER BUSHING
About the only difference between old UV-type tubes and the later UX-type lies in the fact that in the latter, the filament prongs are made larger than the grid and plate prongs. The UV tubes may be used in this type socket without danger if bushings are fitted on the filament prongs.—J. E. Anderson.

A SIMPLE BATTERY

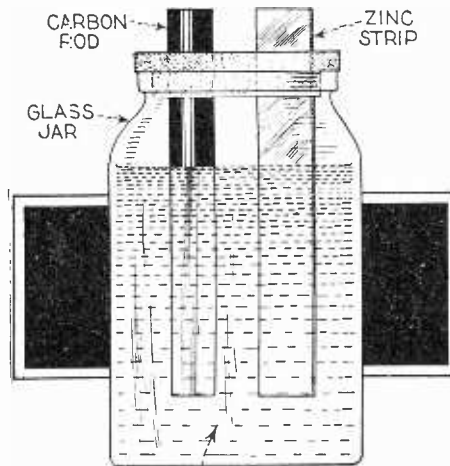

POTASSIUM BICHROMATE SOLUTION
This battery is assembled from the parts of a dry cell. The zinc casing is cut 2" wide for the negative pole, the carbon of the cell being used for the positive pole. The electrodes are mounted in a composition top. The solution is made of 1 oz. of potassium bichromate in one pint of water.—W. Lancaster. Rep. No. 22810.

INVISIBLE SET LEAD

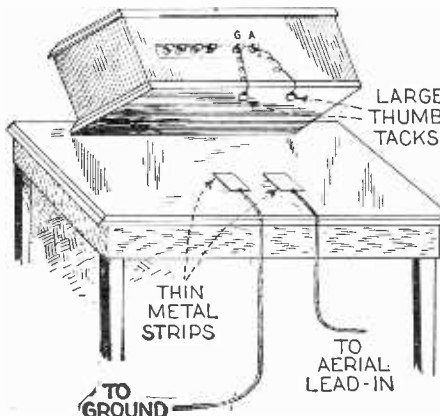

Thin metal discs connected to antenna and ground may be placed under table covers, as shown above, to which contact is made by means of thumb-tacks in the bottom of the set.—L. M. Curtis.

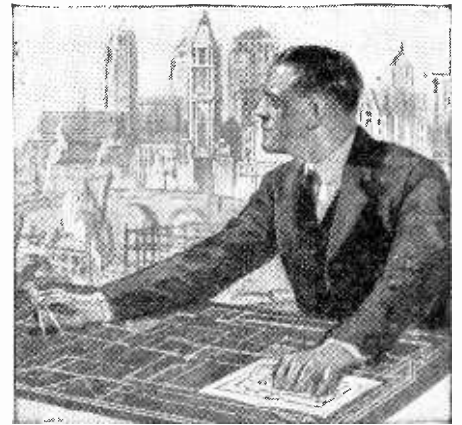

Former Plasterer Now Earning \$12,000 a Year

"When I enrolled with the International Correspondence Schools, I was a plasterer and I didn't know a thing about blueprints. Today I have my own contracting business and I am able to figure the most difficult jobs and execute them to the satisfaction of everyone concerned. My income is between \$12,000 and \$15,000 a year. It certainly was a lucky day for me when I sent in that I. C. S. coupon."

That's a true story of what just one student of the International Correspondence Schools has done. Every mail brings letters from other ambitious men and women telling of promotions and increases in salary due directly to spare-time study.

One hour a day spent with the I. C. S., in the quiet of your own home, will prepare you for success in the work you like best.

Mail Coupon for Free Booklet

TEAR OUT HERE

INTERNATIONAL CORRESPONDENCE SCHOOLS
Box 6193-E, Scranton, Penna.

Without cost or obligation, please send me a copy of your booklet, "Who Wins and Why," and full particulars about the course before which I have marked X:

- | | |
|--|---|
| <input type="checkbox"/> Architect | <input type="checkbox"/> Plumber and Steam Fitter |
| <input type="checkbox"/> Architectural Draftsman | <input type="checkbox"/> Electrical Engineer |
| <input type="checkbox"/> Architects' Blueprints | <input type="checkbox"/> Electric Lighting and Rwsys. |
| <input type="checkbox"/> Contractor and Builder | <input type="checkbox"/> Mechanical Engineer |
| <input type="checkbox"/> Building Foreman | <input type="checkbox"/> Show Card and Sign Painting |
| <input type="checkbox"/> Concrete Builder | <input type="checkbox"/> Business Management |
| <input type="checkbox"/> Structural Engineer | <input type="checkbox"/> Private Secretary |
| <input type="checkbox"/> Structural Draftsman | <input type="checkbox"/> Business Correspondent |
| <input type="checkbox"/> Heating and Ventilation | <input type="checkbox"/> Bookkeeper |
| <input type="checkbox"/> Plumbing Inspector | <input type="checkbox"/> Stenographer and Typist |
| <input type="checkbox"/> Foreman Plumber | <input type="checkbox"/> Higher Accounting |
| <input type="checkbox"/> Sheet Metal Worker | <input type="checkbox"/> Commercial Law |
| <input type="checkbox"/> Civil Engineer | <input type="checkbox"/> Common School Subjects |
| <input type="checkbox"/> Surveying and Mapping | <input type="checkbox"/> Mathematics <input type="checkbox"/> English |
| <input type="checkbox"/> Electric Wiring | <input type="checkbox"/> Illustrating |
| <input type="checkbox"/> Telegraph Engineer | <input type="checkbox"/> Railway Mail Clerk |
| <input type="checkbox"/> Telephone Work | <input type="checkbox"/> Civil Service |
| <input type="checkbox"/> Mechanical Draftsman | <input type="checkbox"/> Mining Engineer |
| <input type="checkbox"/> Toolmaker | <input type="checkbox"/> Gas Engine Operating |
| <input type="checkbox"/> Machine Shop Practice | <input type="checkbox"/> Stationary Engineer |
| <input type="checkbox"/> Chemist <input type="checkbox"/> Pharmacy | <input type="checkbox"/> Textile Overseer or Supt. |
| <input type="checkbox"/> Navigation | <input type="checkbox"/> Traffic Manager |
| <input type="checkbox"/> Salesmanship | <input type="checkbox"/> Automobiles <input type="checkbox"/> Spanish |
| <input type="checkbox"/> Advertising | <input type="checkbox"/> Agriculture <input type="checkbox"/> French |
| <input type="checkbox"/> Window Trimmer | <input type="checkbox"/> Poultry Raising <input type="checkbox"/> Radio |

Name.....

Street Address.....

City.....State.....

Occupation.....

If you reside in Canada, send this coupon to International Correspondence Schools Canadian, Limited, Montreal

Make things appear and disappear
LIKE A REAL MAGICIAN!

Tricks with Cards, Coins, etc.
Easily done by Anyone
WITHOUT PRACTICE

MAGIC TRICKS
MYSTIFY YOUR FRIENDS
with the "WONDER BOX"
of MAGIC TRICKS \$1.00
Complete with full Secret Instructions

WONDER MAGIC Co. Suite 1104A, 25 W. 45th St. New York

FIBER DOOR MATS—Always something new and better. We offer **FIBER DOOR MATS**. Last for years. Four feet wide, any length, or smaller, half-inch thick. Half square foot by mail, six cents.

SHERMAN AND JOHNSON, Wallingford, Conn.

1000 HOURS OF FUN!!
Read
SAM LOYD'S TRICKS and PUZZLES
116-page book is ready.
50c—ON ALL NEWSSTANDS

NOW—You can build your Summer portable in an INDEX CARD CASE

The Travelers Set

THE designer of this delightful, compact and light portable receiver set up for himself a number of ideal standards before attempting to build this set—this exacting bill of particulars was as follows:

It must operate on a light-socket antenna for locals; cover a radius of at least five hundred miles on a good average antenna; pick out the locals from the big ones; weigh not over three pounds exclusive of battery (battery should weigh no more than the receiver) be of small bulk; be strongly built to stand the hazards of travel; and finally, to cost not over ten dollars.

The marvel of ingenuity he has achieved is contained in a small standard wooden index card case.

RADIO NEWS, for July, gives complete instructions, written by the designer himself with a circuit diagram and illustrations of the completed receiver and special mountings.

An 18-1500 Meter Receiver

RADIO NEWS, offers a marvelously efficient combined short and long wave receiver, using standard plug-in coils for different wavelengths. This receiver is of the newest, finest type with greatly simplified wiring for those who want to build one at home—Circuit and all constructional details are given in the JULY ISSUE of RADIO NEWS.

NOW ON ALL NEWSSTANDS



The Acme D-Coil Receiver

A loop operated Receiver, that is so ingeniously designed as to permit reception from great distances, overcoming the handicap of an indoor antenna.—It is one of the best of this type receivers.

Cover Title Contest \$250 in Gold

RADIO NEWS will pay \$250 in prizes for the best title to our JULY COVER. Everyone is eligible. Get your issue now and try for a big prize.

What Can You Do With Burnt Out Vacuum Tubes?

\$100.00 in Gold will be offered by RADIO NEWS for the best uses for old burnt-out vacuum tubes—See our JULY ISSUE for details.

Theory of the Strobodyne

RADIO NEWS has exclusive rights in America for publishing the theory of the marvelous new French Radio Receiver, "The Strobodyne"—watch for it in the AUGUST ISSUE.

25c the Copy: \$2.50 the Year

BIG ONE HUNDRED PAGE JULY ISSUE

EXPERIMENTER PUBLISHING CO., Incorporated
230 Fifth Ave., New York, N. Y.

8 BIG AMAZING STORIES

--featuring--

—THE OTHERS—

The Ethership of Oltor
By S. Maxwell Coder

The Voice from the Inner World
By A. Hyatt Verrill

The Gravitomobile
By D. B. MacRae

A story of Radio phenomena with a thrill of mystery, poisonous hate and mad experimentation all enfolded before your eyes

RADIO MATES

By BENJAMIN WITWER

"Think of it! A twist of a switch and the living, breathing animal is slowly dissolved before your eyes and vanished along a pair of wires to a radio whence it is transferred as a set of waves in the ether to the receiving apparatus—there to reincarnate into the living organism once more, alive and breathing, unharmed by its extraordinary journey!"

The inventor of the above apparatus then decides to transmit his long loved mate by the same phenomenal manner as were the animals, but—why spoil the terrible climax. Read it in the big July issue of AMAZING STORIES.

The Moon Pool
By A. Merritt

The Lost Continent
By Cecil B. White

The Plattner Story
By H. G. Wells

Von Kempelen and His Discovery
By Edgar Allan Poe

Editorial
By H. Gernsback
Department for Discussions by Readers



July Issue---On Sale Everywhere

25c THE COPY—\$2.50 THE YEAR

If your dealer cannot supply you, order direct

EXPERIMENTER PUBLISHING CO., Inc.,—230 5th Ave., New York

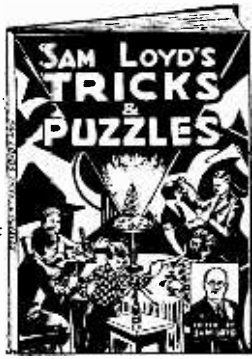

1000 HOURS OF FUN IN Sam Loyd's TRICKS & PUZZLES

THERE are more than one thousand hours of truly amazing fun and frolic—in Sam Loyd's "Tricks and Puzzles." There is only one Sam Loyd, the Puzzle King, the incomparable, a true master mind, and he has crowded in this new volume, "Tricks and Puzzles," the best work of his lifetime.

In this book are thousands of puzzles of every conceivable nature, games, tricks, conundrums. Hundreds of illustrations. Scores of real brain-teasing puzzle stories, dozens of humorous anecdotes.

With this inexhaustible gold mine of lively entertainment at hand you need never be at loss for an evening's party program or a rainy day's delight.

It's a book for young and old folks alike—Riddles for the youngsters—Brain teasers for the grown-ups.

The kind of a book every home should have in its book-rack. 116 pages, 100 or more illustrations, large size, 9 x 12 inches with beautiful 2-color cover.

50c THE COPY ON ALL NEWSSTANDS

Or use this coupon.

EXPERIMENTER PUB. CO., Inc.,
230 Fifth Ave., New York City.
Gentlemen—I enclose 50c for one copy of your book, "Tricks and Puzzles."

Name
Address
City, State

Rules for Matchcraft Contest

(Continued from page 234)

\$100.00 Monthly Prize "Matchcraft" Contest

DURING the past year SCIENCE AND INVENTION Magazine awarded \$5000.00 for articles made entirely of matches. While this \$5000.00 contest has officially expired, the publishers have decided that because of the great popularity in Matchcraft constructions, the contest would continue in force on a new prize rate basis until further notice. The list of new prizes will be found in the center box and the same rules for the first contest are to be observed in this contest.

- (1) Models submitted must contain at least 90 per cent. safety matches in their construction.
- (2) Models made of toothpicks, paper matches, or non-safety matches, are not eligible in this contest.
- (3) Models can not be built around boxes or other supporting articles. Walls, roofs, etc., must all be self-supporting and made of matches.
- (4) All liquid adhesives, such as glue, shellac, cements, etc., are permissible.
- (5) Models may be painted, gilded or silvered.
- (6) Models may be of any size.
- (7) In order to win a prize, it is necessary that either models be submitted, or, if this is not practical, owing to their size, a 5"x7" photograph of the model may be sent in lieu of the model itself. The best models submitted each month will be awarded the prizes scheduled herewith.
- (8) All models submitted to SCIENCE AND INVENTION Magazine will be promptly returned to the builder, who will prepay all charges.

PRIZE AWARDS

First Prize	\$50.00
Second Prize	20.00
Third Prize	15.00
Fourth Prize	10.00
Fifth Prize	5.00
Total	\$100.00

(9) Where SCIENCE AND INVENTION has any doubts as to the model (where photos only are submitted) complying with all the regulations, the judges may, at their discretion, require that the actual model be sent in for inspection, paying transportation charges both ways.

(10) This is a monthly contest and will continue until further notice. Each monthly contest closes on the first of the month following date of issue. Thus the contest for the month of June will close July 1st and prize-winning announcements will be made in the September, 1927 issue.

(11) Models must be shipped in a strong wooden box, never in a cardboard box, as SCIENCE AND INVENTION can not be held responsible for breakage in transit due to models having been improperly packed.

(12) When models are sent, be sure to affix tag, giving your name and address, to the model itself. In addition, put name and address on outside wrapper of package.

(13) Address all letters, packages, etc., to Editor, "Matchcraft" Contest, care SCIENCE AND INVENTION Magazine, 230 Fifth Ave., New York.

Caution—Soak or cut heads from matches before building your model so that the models may be expressed or mailed. The strike-everywhere square cut Liberty matches can be used if the heads are cut off.

Did You See "Hints for the Mechanic"?—a new monthly department.

TESTS SHOW FORD CAN RUN 60 MILES ON GALLON OF GAS

The amazing fact that a Ford can run 60 miles on a gallon of gasoline was recently brought to light through tests conducted by America's foremost engineers. Great strides have already been made in this direction by the recent invention of

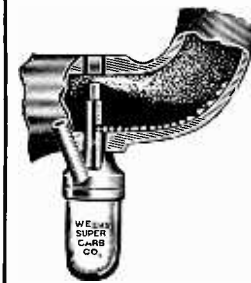

a simple attachment which can be installed in a few minutes without any alteration to the motor. A. C. Winterburn made 41.4 miles on 1 gallon of gasoline after this device was attached. E. O. Weeks, famous aviator and inventor, wants agents and will send sample for trial. Write him today at 426-1714 Eleventh St., Milwaukee, Wisc.

GASOLINE NOW 11¢

AUTO OWNERS MYSTIFIED BY NEW DEVICE Public Welcomes News

NEW INVENTION MAKES THIS POSSIBLE A mysterious whirlwind device that can be installed in a few minutes on any car makes it possible for cars to run on 7% gas. Already thousands of cars have been equipped and are showing amazing mileage tests on gas. Dona file reports show up to

60 MILES ON A GALLON OF GAS

This device not only saves gas but increases power, prevents carbon forming, produces flashy pick-up and quick starting.

\$100 a Week Territory Open



The demand for the whirlwind is spreading like wildfire. Men are needed everywhere to take care of local business. FREE SAMPLE \$100 a week is easily possible. Part time workers can earn \$5 an hour. Write today for this splendid opportunity and free sample offer.

Whirlwind Carburetor Company
1041-409 Winnebago St
Milwaukee, Wisc.

BUILD YOUR OWN GRANDFATHER'S CLOCK



We furnish blue prints, finishing material and instructions. Buy the works, dial, weights and pendulum from us at surprisingly low prices. You make a fine profit building artistic clocks for your friends.

Plain Works As Low As \$5.00. Others With Chimes At All Prices. Ask For Attractive Free Offer.

CLOCK COMPANY
1679 Ruffner St.,
Philadelphia, Pa.

Earn \$75 Weekly Building Radio Sets

Join the Association! We train you to build and repair radio sets—start you in business—enable you to earn \$3 an hour upwards. Free 5-Tube Radio Set to members. Write for special limited-time plan whereby your membership need not cost you a cent. Write today!

RADIO ASSOCIATION OF AMERICA
Dept. S.N. 7 4513 Ravenswood Ave. Chicago, Ill.

STOP WATCHES

Needed for Accurate Laboratory Timing. The "Pastor" is a guaranteed fifth-second time-piece. Unbreakable crystal. Price only \$7.50. Start, stop, flyback hand. Or a fifth-second Timer only. 30 minute register, 6 jewel. Price only \$11.25 Write today to

Sterling Stop-Watch Co., M'n'f'r.
15 East 26th St. New York, N. Y.

Opportunity Ad-lets

YOU will find many remarkable opportunities and real bargains in these columns. It will pay you to read and investigate the offerings made every month by reliable firms, dealers and amateurs from all over the country. No matter what you may be seeking, whether supplies, automobile accessories, the opportunity to make money, or anything else, you will find listed here the best and most attractive specials of the month.

Advertisements in this section twelve cents a word for each insertion. Name and address must be included at the above rate. Cash should accompany all classified advertisements unless placed by an accredited advertising agency. No advertisement for less than 10 words accepted. Ten per cent discount for 6 issues, 20 per cent discount for 12 issues. Objectionable or misleading advertisements not accepted. Advertisements for the September issue must reach us not later than July 10th.

EXPERIMENTER PUBLISHING CO., INC., 230 Fifth Avenue, New York, N. Y.

Advertisers and Distributors

Earn \$8. Distribute 400 free Samples Stopleak Rivets. Send 6c stamps for samples and secure territory. Rivetec Co., Cohoes, N. Y.

Advertising Agencies

24 Words—355 Rural Weeklies, \$14.20. Ad—Meyer, 4112-SI, Hartford, St. Louis, Mo.

Agents Wanted

Agents—Best seller; Jem Rubber Repair for tires and tubes; supercedes vulcanization at a saving of over 800 per cent; put it on cold. It vulcanizes itself in two minutes and is guaranteed to last the life of the tire or tube; sells to every auto owner and accessory dealer. For particulars how to make big money and free sample, address Amazon Rubber Co., Philadelphia, Pa., Dept. 601.

\$50—\$200 a week. Genuine Gold Letters for store windows. Easily applied. Free samples. Liberal offer to general agents. Metallic Letter Co., 441 B., North Clark, Chicago.

\$10 daily silvering mirrors, plating and refinishing lamps, reflectors, autos, beds, chandeliers by new method. Outfits furnished. Write Gummetal Co., Ave. D, Decatur, Ill.

Bankrupt and Rummage Sales. Make \$50.00 daily. We start you, furnishing everything. Distributors, Dept. 171, 609 Division, Chicago.

Make Money Silvering Mirrors, refinishing auto headlights, tableware, metal plating, bedsteads, chandeliers. Outfits furnished. International Laboratories, Dept. 69, 309 Fifth Ave., New York.

Big money and fast sales. Every owner buys gold initials for his auto. You charge \$1.50; make \$1.35. Ten orders daily easy. Write for particulars and free samples. American Monogram Co., Dept. 71, East Orange, N. J.

\$50.00 Weekly easy, applying Gold Initials on Automobiles. No experience needed. \$1.45 profit every \$1.50 job. Free Samples. "Ralco Monograms", R1043, Washington, Boston, Mass.

Polmet Polishing Cloth cleans all metals like magic! Gets enthusiastic attention. Sells fast at 25c. Sample Free. F. C. Gale Co., 93 Edinboro Street, Boston, Mass.

Mirrors Resilvered at Home. Costs less 5 cents per square foot; you charge 75 cents. Immense profits plating autouparts, reflectors, tableware, stoves, refinishing metalware, etc; outfits furnished. Details Free. Write Sprinkle, Plater, 955, Marion, Indiana.

Just Out—Patented Apron. No strings or straps; on sale; or off instantly; \$20 a day easy; every demonstration a sale; over 100% profit; commissions daily; write today for free offer. Sta-Put Co., Dept. 507, St. Louis, Mo.

Open Rummage Store. We furnish everything. \$75.00 daily. Write for free particulars. N. Young, 2549 So. Halsted, Chicago.

Hosiery Free and \$12 daily. Sell nationally known Pure Silk Hosiery. Amazing values. Experience unnecessary. Free sample outfit mailed immediately. Pure Silk Hosiery Co., 208 W. Monroe, Dept. P-131, Chicago.

Don't sell for others. Employ agents yourself. Make your own products. Toilet articles, household specialties, etc. 500% profit. We furnish everything and show you how. Valuable booklet free. Write at once. National Scientific Laboratories, 1976-W Broad, Richmond, Va.

Sell "Fixit" Rubber Repair. Big pay. Doubles mileage of tires and tubes. Self-vulcanization without heat or tools. Big season now. Marquette, GG2323 Wolfram, Chicago.

Be Independent. Make, sell your own specialties. Immense profits. Catalog, dependable formulas, special selected agents' best sellers, free. F. Lustro, 832 East Pershing, Chicago.

Our New Household Device washes and dries windows, sweeps, cleans walls, scrubs, mops. Complete outfit costs less than brooms. Over half profit. Harper Brush Works, 152-3rd St., Fairfield, Iowa.

New Camera. Regular black and white photos finished quickly inside camera. Make money selling cameras, taking photos or doing both. Crown Company, Dept. 488, Norwalk, Conn.

Agents: Build a permanently profitable business on one easily sold item. Globe Re-Atomizers, a new, patented invention has an untouched, ten-million dollar market awaiting it. Act now and obtain exclusive representation. Send \$1.00 for sample and complete information. References: Chamber of Commerce, R. G. Dun, National City Bank, Brotherhood Bank, Globe Sales & Distributing Co. 101c Spokane St., Seattle, Wash.

Agents: Make \$500.00 monthly. Pay daily. No investment. Rhinestone initial buckles and novelties. Sell easy everywhere. Exclusive territory. CHATON NOV-ELTY CO., 606 Blue Island, Chicago.

Furniture Refinishing, Polishing, painting, handyman shop; wonderful profits; start yours on nearly nothing. John Braeland, 1463 So. Ninth, Philadelphia, Pa.

\$500 Weekly assured, operating Rummage Store. Everything furnished. Lowest prices. Particulars FREE. United Bankruptcy Sales, K3819 State, Chicago.

Thaxly formulas, processes, trade-secrets produce perfect products. Make them yourself. All lines. Send for catalog, circulars free. D. Thaxly Company, Washington, D. C.

Agents Wanted (Continued)

Agents—If low prices and big profits interest you, buy and sell direct from old established manufacturer, ladies and children's dresses, rubber specialties and sanitary goods. To earnest parties we will mail new illustrated catalog and price list. Write B. & G. Mfg. Co., Dept. 229, Pittsburgh, Pa.

Wanted! Ambitious, industrious person to introduce and supply the demand for Rawleigh Household Products. Good openings near you. Make sales of \$150 to \$600 a month or more. Rawleigh methods get business everywhere. No selling experience required. We supply Products, Sales and Advertising Literature and Service Methods—everything you need. Profits increase every month. Lowest prices; best values; most complete service. W. T. Rawleigh Co., Dept. NY8363, Freeport, Ill.

A Sensational Seller, "Kleanzy," the new mop with the steel plate. Housewives delighted. Eager buyers. Will send one prepaid on approval to convince you how easily you can make \$20.00 daily. Kleanzy Mop Co., Dept. 7-M, Delphos, Ohio.

Agents: \$13.80 daily (in advance). Spare time will do. Introduce 12 months Guaranteed Hosiery, 57 styles, 39 colors, for men, women, children; including latest "Silk to the Top" Ladies' Hosiery. No capital or experience needed. We furnish samples. Silk Hosiery for your own use free. NEW PLAN. Milton Mathews, Road 6707, Cincinnati, Ohio.

Earn \$10 daily silvering mirrors, plating, refinishing metalware, headlights, chandeliers, bedsteads. Outfits furnished. N. Decie Laboratories, 1133 Broadway, New York.

Agents: Eze-Sharp Knife Sharpeners sell like hot cakes. Samples and particulars 25 cents. The Eze-Sharp Products, 840 Third Ave., N. Y. C.

\$75.00 weekly to introduce "Chieftain" 3 for \$4.95. Guaranteed Tailored Shirts. Full working outfit free. Your own shirts free. Cincinnati Shirt Company, Lane 2707, Cincinnati, Ohio.

Our Superior Proposition will net you \$100 a week, every week in the year. Equipment and car furnished. No capital or experience necessary. Immediate profits. Write today for particulars. American Products Company, 9240 Monmouth, Cincinnati, Ohio.

Artificial Stone Houses, \$100! (Patent pending) Healthful, everlasting. Scientific American says. Agents' bonanza. K. Bradley, Box 1586, Cincinnati, Ohio.

We pay \$48 a week, furnish auto and expenses to introduce our Soap and Washing Powder. Russ-Beach Company, Dept. A-185, Chippewa Falls, Wis.

Airplanes

Biggest, Best Catalog Model Airplanes, Parts, Supplies; 5c postpaid. Ideal Co., 169 1/2 Spring St., New York.

Airplanes. Send for free cut and plans of our wonderful two Place, Companion type, small, high lift wing monoplane, and information. How to build this ship, and be sure it will fly, also propeller literature. Crawford Airplane Mfg., 2225 American Ave., Long Beach, Calif.

Art

Imported Art Magazine "Galerie" brings you every month high grade reproductions of prominent European painters, printed on art paper with tissue paper inlays. \$2.00 a year sample copy, 25c six copies as introductory offer one dollar with 20 art cards gratis. Publisher, 347 East 73rd Street, New York.

Books

Free—My illustrated Circulars on Newthought, Self-culture, Healing, Yoga Philosophy, Occult, Mystic and Scientific Books. Mariens Publisher, Inc., Burlington, Iowa.

Hypnotism Wins! 25 easy lessons and 248 page illustrated reference guide, \$2.00. "Mindreading" (any distance). Wonderful, \$2.00. Science Institute, 8430 Milwaukee Ave., Chicago.

The Boy Electrician. Pocket size. 75 illustrations, 25c. J. Tillberg Proctor, Vermont.

Business Opportunities

Sell By Mail!—Books, novelties, bargains; large profits! Particulars FREE! E-Rifco, 525 South Dearborn, Chicago.

Big Money Awaits You Here. 250 signs or pictures an hour without press, type or machinery. Samples and particulars 10c. Strao, 1015 1/2 Mulberry, Springfield, O.

Amateur Photographs Profitable. Booklet describing one hundred best magazine markets, 10c. Snyder Publishing Co., Guilford, Connecticut.

Real Money for You—Our combination Aluminum Cooking Set; easy to sell. No delivering; no collecting. Make \$10 to \$15 daily. Esny-Riddle Co., Dept. 14, 2325 Carson Street, Pittsburgh, Pa.

Clever New Money-Making Scheme You Can Operate Anywhere by Mail in Spare Time. A permanent income with the least expenditure of money, time and effort. Particulars for addressed stamped envelope or \$2 for complete instructions. Not a cheap affair but a high class legitimate office business paying \$100 a week and up. Takes \$10 to operate it. Metropolitan News Bureau, Box 1038, Washington, D. C.

Cameras and Photography Supplies

Make money in Photography. Learn quickly at home. Spare or full time. New plan. Nothing like it. Experience unnecessary. American School of Photography, Dept. 5332, 3601 Michigan Avenue, Chicago.

Chemistry

Learn Chemistry at Home. Dr. T. O'Connor Sloane, noted educator and scientific authority, will teach you. Our home study correspondence course fits you to take a position as chemist. See our ad on page 199 of this issue. Chemical Institute of New York, 66 W. Broadway, New York City.

Experimenters, 20 C. P. Chemicals for \$1.00. Chemical Laboratories, 900 Belmont, Chicago, Ill.

Correspondence Courses

Used correspondence school courses sold on repurchase basis. Also rented and exchanged. Money-back guarantee. Catalog free. (Courses bought), Lee Mountain, Pisgah, Alabama.

Drawing

Amateur Cartoonists: Make money in spare time with new cartoon selling plan. Smith's Art Service, Wenatchee, Wash.

Educational

Home Study Courses. All Schools, Lowest Prices, Terms. Catalog Free. Mention subject. Fred Goetz, 440-H Sansome, San Francisco.

Educational Books; all kinds, new and used. List free. Lyle's, Pisgah, Alabama.

Electricity

Electric Fun! Seventy stunts, 110 volts, \$1. Cuttingco, Campbell, Calif.

For Boys

Interested in Science? Form Science Club in your town. Conduct experiments, field trips, etc. Instruction booklet, club plans, membership blanks, sample magazine 25c coin. Scientific Clubs America, McComb, Mississippi.

For Inventors

Inventors—Get this pamphlet, "What to Invent," No theory or guess work, but things actually asked for by manufacturers. Sent prepaid for only \$1.00. Inventor's Syndicate, 22 Paladium Bldg., St. Louis, Mo.

Unpatented Ideas Can Be Sold. I tell you how and help you make the sale. Free particulars (Copyrighted). Write W. T. Greene, 808 Jenifer Bldg., Washington, D. C.

Inventors! Use our special service for presenting your invention or patent to manufacturers. Adam Fisher Mfg. Co., 205-A Enright, St. Louis, Mo.

Inventions Commercialized. Patented or Unpatented. Write Adam Fisher Mfg. Co., 205 Enright, St. Louis, Mo. We help inventors financially to get patents. Equitable Investment Co., Box 1648, Washington, D. C.

Patents Obtained under cooperative payment plan. Write for particulars, W. E. Beck, Registered Patent Lawyer, 953 Jenifer Bldg., Washington, D. C.

Formulas

12 Honest to Goodness Money Making Formulas, \$1.00, Dorhan Co., Box 17, Woodhaven, N. Y.

Help Wanted

Be a Detective. Work home or travel. Experience unnecessary. Particulars free. George Wagner, 2190 Broadway, N. Y.

Silvering Mirrors, French plate. Easily learned, immense profits. Plans free. Wear Mirror Works, 16 W, Excelsior Springs, Mo.

Detectives Earn Big Money. Travel. Excellent opportunity. Great demand everywhere. Experience unnecessary. Write, American Detective System, 2190 Broadway, N. Y.

Firemen, Brakemen, Baggagemen, (white or colored) sleeping car, train porters (colored). \$150-\$250 monthly. Experience unnecessary. 897 Railway Bureau, East St. Louis, Ill.

If you are a man worthy of the name and not afraid to work, I'll bet you \$50.00 you can't work for us thirty days and earn less than \$200.00. Think I'm bluffing? Then answer this ad and show me up. Openings for managers. Wonder Box sells on sight. The best selling proposition in America today. Write Tom Waker, Dept. 121, Pittsburgh, Pa.

Men, get Forest Ranger job; \$125-\$200 month and home furnished; permanent; hunt, fish, trap. For details, write Norton, 271 McMann Bldg., Denver, Colo.

Help Wanted (continued)

Wanted: Men, Women. Make fortunes as Real Estate Specialists. I made \$100,000. Cooperate with me. Learn the secret of my success. Use my remarkable system. Start at home in spare time. Build wonderful business without capital or experience. Write at once for my amazing money-making offer. Address Ostrander, Room 35, 18 East 18th St., New York.

You Are Wanted. Men-women, 18 up. Government jobs. \$1.10-\$3.000 year. Common education sufficient. Sample coaching—FREE. Write immediately. Franklin Institute, Dept. L4, Rochester, N. Y.

Distributors—No canvassing, no capital. Honery, Rosoto, Pa.

U. S. Government Jobs. Men-women, 18 up. \$1,140 to \$3,000 year. Steady, pleasant work. Paid vacation. Short hours. Experience unnecessary. Common education sufficient. List positions and sample coaching with full particulars free. Write today sure. Franklin Institute, Dept. L16, Rochester, N. Y.

Insects Wanted

Cash paid for butterflies, insects. See Sinclair's Advertisement on page 272.

Instruction

Learn Chemistry at Home. Dr. T. O'Connor Sloane, noted educator and scientific authority, will teach you. Our home study correspondence course fits you to take a position as chemist. See our ad on page 199 of this issue. Chemical Institute of New York, 66 W. Broadway, New York City.

Home Study Courses by all schools on all subjects, sold complete in fine condition, at bargain prices, because slightly used. Sensational reductions on all standard drafting, engineering, automobile, radio, chemistry, electrical courses. Money back guarantee. Easy Terms. Courses bought. Write for FREE catalog. Economy Educator Service (Dept. H) 202 W. 49th St., New York.

Build the latest non-directional hexagonal aerial for better reception, tone and quality. Full instructions with blueprint, \$1.00. R. F. Williams, North Powder, Oregon.

Inventions Wanted

Inventions Commercialized. Patented or Unpatented. Write Adam Fisher Mfg. Co., 205 Enright, St. Louis, Mo. Will buy approved invention. Write W. L. Kendig, 416 N. Duke Street, Lancaster, Pa.

Machinery and Tools

Concrete Building Block Machines and Molds. Catalog free. Concrete Machine Co., 5 N. First St., St. Louis, Mo.

Magic and Games

Free with \$25 order our large die box. Send 20c for our large catalogue of tricks, puzzles, wigs, sensational escapades, Oaks Magical Co., Dept. 549, Oshkosh, Wis.

Card tricks, Coin tricks, Hypnotism, Ventriloquism, 64-page books, complete guides, 10c each. G. Fenner, 2401 Jefferson, Louisville, Ky.

Mystery Books, containing secrets of ventriloquism—Sleight of Hand—Magic—Mind Reading—Crystal Gazing—Astrology—Tricks—Puzzles—Handcuff Escapes, etc. Catalog 10c. Box 75, Washington Bridge Station, New York City.

Manuscripts—Short Stories Wanted

Earn \$25 weekly. Spare time. writing for newspapers, magazines. Experience unnecessary. Details Free. Press Syndicate, 987, St. Louis, Mo.

Make \$25 weekly at home, spare time, writing short stories for photoplays. Experience unnecessary. Outline free. Producers League, 603, St. Louis, Mo.

Miscellaneous

Forms to cast Lead Soldiers, Indians, Marines, Trappers, Animals, 151 kinds. Send 10c for illustrated Catalogue. H. C. Schlercke, 1034-72nd St., Brooklyn, N. Y.

Underground Treasures. Simple, scientific method for locating explained free. T. Santschl, Genellyn, Ill.

Goodell Pratt Lathes; practically new, cheap. Lake Mountain, Pisgah, Alabama.

Gears and Mabel Supplies of every description. Catalog 5 cents. Experimenters Supply House, Box 10, Station Y, New York City.

Wanted: Royalty Manufacturer for proven wire screen window hanger. Box 2043, Daytona Beach, Florida.

Look. Fly balloons anywhere. Inflator \$1.00 and \$6.00. Balloon Inflator Co., Box 853, Providence, R. I.

Model Supplies

Ship Model Fittings and Blueprints: Send two cent stamp for booklet. A. J. Fisher, 1002 Etowah Ave., Royal Oak, Mich.

Model and Experimental work at lowest cost. Wagar Model and Machine Works, 115 So. Clinton Street, Chicago.

Motorcycles—Bicycles

Don't buy a Bicycle Motor Attachment until you get our catalogue and prices. Shaw Mfg. Co., Dept. 6, Calesburg, Kansas

Motorcycle Bargains. Used, rebuilt. Guaranteed Shipped on approval. Catalog free. Floyd Clymer, 813 Broadway, Denver, Colo.

Musical Instruments

Violins—Deep, Mellow, Soulful—on easy credit terms. High grade, wonderful instruments of my own make. Development of many years' expertise. Write for book. Gustav A. Henning, 2124 Gaylord St., Denver, Colo.

Old Coins

California Gold, quarter size, 27c; half-dollar size, 53c. Columbian nickel and catalogue, 10c. Norman Shultz, Box 746, Salt Lake City, Utah.

Old Money Wanted

\$2 to \$500 Each paid for hundreds of Old or Odd Coins. Keep all old money, it may be very valuable. Send 10c for new illustrated Coin Value Book, 43c. Guaranteed Prices. Get Posted, We pay Cash. Clarke Coin Company, 14 Street, LeRoy, N. Y.

Partner Wanted

I Want a Partner—agent to take care of my business in your town I furnish everything, including world's finest line of 175 household products and I split the selling price with you 50-50. Beautiful sample outfit makes selling easy; food products; household necessities; things people eat; highest quality—lowest price—quick sales—permanent repeat business; \$25,000.00 bond guarantees quality. I pay largest commissions—give Chrysler closed car besides. Get my amazing offer for your locality quick. Write or wire C. W. Van de Mark, Vice Pres. Health-O Products Co., Dept. 31-E, Health-O Bldg., 117 Duane St., Cincinnati, Ohio.

Patent Attorneys

Millions spent annually for ideas! Hundreds now wanted! Patent yours and profit! Write today for free book—tells how to protect yourself, how to invent, ideas wanted, how we help you sell, etc. American Industries, Inc., 212 Victor Bldg., Washington, D. C.

Richard E. Babcock, Patent Lawyer, Washington Loan & Trust Bldg., Washington, D. C. Booklet.

Monroe E. Miller, Ouray Bldg., Washington, D. C. Patent Lawyer; Mechanical, Electrical Expert. Booklet and Priority Record blank gratis.

Patents—Send for form "Evidence of Conception" to be signed and witnessed. Form, fee schedule, information free. Lancaster and Allwine, Registered Patent Attorney in United States and Canada, 242 Ouray Bldg., Washington, D. C.

Patents Procured: Trade Marks Registered—A comprehensive, experienced, prompt service for the protection and development of your ideas. Preliminary advice gladly furnished without charge. Booklet of information and form for disclosing idea free on request. Richard B. Owen, 130 Owen Bldg., Washington, D. C., or 41-T Park Row, New York.

Patents. Send for free booklet. Highest references. Best results. Promptness assured. Send model or drawing for examination and advice. Watson E. Coleman, Patent Attorney, 724-9th Street, N. W., Washington, D. C.

Cooperative Plan for safe-guarding and commercializing inventions before patenting. Write for free booklet, Ralph Burch, Patent Lawyer, 501 Jenifer Building, Washington, D. C.

Unpatented Ideas Can Be Sold. I tell you how and help you make the sale. Free particulars (Copyrighted). Write W. T. Greene, 809 Jenifer Bldg., Washington, D. C.

Patents. Time counts in applying for patents. Don't risk delay in protecting your ideas. Send sketch or model for instructions or write for Free book, "How to Obtain a Patent" and "Record of Invention" form. No charge for information on how to proceed. Communications strictly confidential. Prompt, careful, efficient service. Clarence A. O'Brien, Registered Patent Attorney, Security Bank Building (directly across street from patent office), Washington, D. C. See page 263.

Patents: Trade-Marks. Ten years experience in Patent Office. Consultation invited. Booklet. Geo. Beeler, 9 Park Place, New York.

"Inventor's Advisor," Valuable Patentbook sent free. Labiner, 3 Park Row, New York.

Patent, Trade-Marks, Copyrights. Reliable services by an experienced practitioner devoting personal attention to each case. Inquiries invited. References furnished. B. P. Fishburne, Patent Lawyer, 525-D McGill Building, Washington, D. C.

Patents obtained under Co-operative Payment Plan. Write for particulars. W. E. Beck, Registered Patent Lawyer, 552 Jenifer Bldg., Washington, D. C.

Get your own patents. Forms, complete instructions \$1 Cuttingbros, Campbell, Calif.

Patents secured for inventors on our new financial plan assuring prompt filing of application. Equitable Investment Company, Box 1648, Washington, D. C.

Patents—Write for Instructions. Carl Miller, Registered Patent Attorney (former member examining Corps United States Patent Office) 211 McGill Bldg., Washington, D. C.

Inventors who derive largest profits know and heed certain simple but vital facts before applying for Patents. Our book Patent Sense gives those facts: free. Lacey & Lacey, 644 F St., Washington D. C. Established 1869.

"Inventors' Guide" free on request; gives valuable information and advice for all who have original ideas or improvements. Frank Ledermann, Registered Attorney and Engineer, 17th Floor, Woolworth Bldg., New York.

Patents

Inventions commercialized. Patented or unpatented. Write Adam Fisher Mfg. Co., 205 Enright, St. Louis, Mo.

Two Inventions—Two automatic inventions and a plaster paris press. Beware inventors' rights. William Haines, Habana, Cuba.

Valuable patent for sale. Children's playground equipment. Roland Follmer, Berwick, Penna.

Patents for Sale

Outright or royalty. Patent automobile tire. A double tube to be used separately. In case that one gets punctured you can inflate the other. M. Lemos, c/o Green Brook Country Club, North Caldwell, N. J.

Patents Wanted

Mr. Inventor. If you have a patent or invention for sale write Hartley, 38 Court St., Bangor, Me.

Inventions Commercialized. Patented or Unpatented. Write Adam Fisher Mfg. Co., 205 Enright, St. Louis, Mo.

Patents Wanted—Get my list of buyers and copyrighted sales plan. How and where to sell a patent, if you want results. Leroy Brown, 1311 Broadway, Baltimore, Md.

Photography

Have you a Camera? Write for free sample of our big magazine, showing how to make better pictures and earn money. American Photography, 118 Camera House, Boston, 17, Mass.

Photoplays Wanted

\$\$\$ For Photoplay Plots. Stories accepted any form, revised, criticized, copyrighted, marketed. Estab. 1917. Booklet free. Universal Scenario Co., 223 Western & Santa Monica Bldg., Hollywood, Calif.

Printing Outfits and Supplies

Print your own cards, stationery, circulars, paper, etc. Complete outfits \$8.85; Job Presses \$11; Rotary \$19. Print for others, big profit. All easy, rules sent. Write for catalog presses, type, paper, etc. Kelsey Company, F-6 Meriden, Conn.

Radio

Boys! Don't overlook this. The "Rasco" Baby Detector. Greatest detector ever brought out with molded base. Fully adjustable. See former advertisements in this publication, or our catalogue. Detector with Galena Crystal complete 50c. The same detector with Radiocite Crystal 75c prepaid. Send for yours today. Radio Specialty Company, 100 Park Place, New York City.

30H, 85MA 280 Ohm chokes, \$2.75. We estimate on kits to your specification. Write for list of specials. Radio Parts Sales Co., Orange, N. J.

S-T-A-T-I-O-N-S Radio Game Fifty Cents postpaid. Leslie Carpenter, Burlington, Vermont.

Unmounted chokes. 30H, 50MA, \$1.75. 50H, 60MA, \$2.00. C. R. L. Power Rheostats, \$1.00. Music Master Phonograph attachments, \$2.50. 5-inch 0-50 Voltmeter, Jewell, \$1.50. Write your "B" climator requirements for quotations. New list ready. Radio Parts Sales Co., Orange, N. J.

Salesmen Wanted

A Sure Fire Money Maker; 150% profit. Every woman a prospect. Special sales idea with this plan makes it a winner. Plan and full particulars, only 50 cents. The Hughes Sales Co., 501 East South St., South Bend, Ind.

Millions of business men waiting for Brand New Indispensable \$10.00 office utility saving hundreds of dollars annually. One man sold sixteen in three hours. Splendid profits. Write quick for trial offer and exclusive Virginia territory. Lightning Calculator Co., Dept. W, Grand Rapids, Mich.

Salesmen—Get exclusive selling rights of a scientific drugless health product needed in every home. Unlimited possibilities. Write Radiumed Applied Co., 1303-D Fillmore, Buffalo, N. Y.

Song Poems

Song-poem writers. Address Monarch, 236 West 53th St., New York.

Stamps and Coins

Stamps 100 All Different 3 cents. S. I. Quaker Stamp Company, Toledo, O.

206 Different Stamps. Abyssinia, Liberia, Egypt, Bulgaria, China, Chile, etc.; illustrated list and approvals, only 10 cents. W. Mikkelsen Co., 4029 Grace St., Chicago, Ill.

Typewriters

Typewriters, all standard makes, \$10 up. Fully guaranteed. Free trial. Write for complete illustrated lists. Northwestern Exchange, 121 N. Francisco Ave., Chicago.

Wanted

Detectives Earn Big Money. Work home or travel. Experience unnecessary. Write, George Wagner, 2190 Broadway, N. Y.

POWERFUL MUSIC From Only 2 Tubes



Can't be equaled. Powerful music from only 2 tubes. The famous Harkness. Circuit non-oscillating, easy to build, inexpensive to operate. Conrad Pattern No. 11 gives full instructions to build this set at home. Anyone can use them. Blue-prints of Panel layout and Wiring diagram drawn actual size—no measurements necessary. All enclosed in handsome colored folder.

Sold by All Radio Dealers or Direct Order THE CONSRAD COMPANY, INC., 230 Fifth Ave., New York City

LUMINOUS PAINT

Make Your Watches, Clocks, Etc., Visible by Night

The very latest discovery in the scientific world. Hitherto, practically unobtainable except at an exorbitant price, we have at last succeeded in producing a LUMINOUS PAINT, which, applied to the surface of any article, emits rays of white light, rendering it perfectly visible in the dark. **THE DARKER THE NIGHT, THE MORE BRILLIANT IT SHINES.** Quite simple to use. Anyone—you can tell the time by night. You can use the watch or clock without a battery. A little applied to the dial you can see the buttons or switch plates of your electric lights, match boxes, and innumerable other articles; make your own Luminous crucifixes, Luminous Rosaries, etc. Bottle containing sufficient to coat several small watches. Price 25c. Largest sizes 50c and \$1 postpaid. Johnson Smith & Co., Dept. 713 Racine, Wis.

The "Little Giant" Typewriter

A First Class Writing Machine For \$1.50

A perfect little typewriter for \$1.50. There are thousands of persons who would like to own a typewriter, but whose needs and business do not warrant the expense attached to the purchase and use of a fifty or seventy-five dollar machine. To such persons we confidently recommend our Little Giant. It is strongly made, but simple in construction, so that anyone can quickly learn to operate it, and write as rapidly as they would with pen and ink. The letters of the alphabet most frequently used are so grouped as to enable one to write rapidly, the numerals 1 to 10, and the punctuation marks being together. With this machine you can send your best girl typewritten love letters, address envelopes, make out bills, and do almost any kind of work not requiring a large, expensive machine. With each typewriter we send a tube of ink and full printed instructions for using the machine. Price complete \$1.50 by mail postpaid to any address in the world.

Every Boy His Own Toy Maker

Greatest boys' book written. Tells how to make a Pinhole Camera, a Canoe, model Railroad, a Telephone, Boomerang, Telegraph Instrument, Box Kite, Talking Machine, Microscope, Electric Motor, Electric Door Bell, Water Wheel, Fiddle, Raft, a pair of Skis, a Dog Sled, Bird House, Rabbit Yard, etc. 64 pages, 150 illustrations. PRICE, 30c postpaid; 3 for 25c.

GOLD TEETH

You know how fashionable it is to have gold crowns—if you can afford it. These gold-finished shells fasten over your real teeth and look like very wealthy things. Can be slipped on and off in an instant. Get some and surprise your friends. PRICE 25c each, 3 for 15c, or 50c for 1 doz. postpaid.

REAL PISTOL

Shoots Blank Cartridges

Exact reproduction of a real pistol; actually fires REAL BLANK CARTRIDGES of miniature size. Illustration is actual size. 1 1/2 inches long, with ring at end for attaching to watch chain. Looks like a regular pistol. Pull the trigger and it goes off with a loud bang. Pistol is break-open type; illustration shows position for loading. Made entirely of high grade steel, nickel plated, action barrel, hand made in U.S.A. Price \$1.75. Also furnished with pearl handles, \$2.50. BLANK CARTRIDGES, 50c per box of 25

BOYS! BOYS! BOYS! THROW YOUR VOICE

Into a trunk, under the bed or anywhere. Lots of fun fooling the teacher, policeman or friends.

THE VENTRILLO

a little instrument, fits in the mouth; out of sight, used with above for Bird Calls, etc. Anyone can use it.

Never Fails. A 16-page Course on ventriloquism, and the Ventrilo, ALL FOR 10c postpaid.

MIDGET BIBLE

GREAT CURIOSITY

Smallest Bible in the world. Size of a postage stamp. 200 Pages. Said to bring good luck to the owner. A genuine work of art. Must be seen to be appreciated. Make good money selling them to friends, church acquaintances, etc. PRICE 15c each, 3 for 40c, 12 for \$4.35, 100 for \$7.50. Also obtainable in Leather Binding, with gold covers. Price 50c each, 3 for \$1.25, \$4.50 per doz. Magnifying Glass for use with Midget Bible, 15c

KU KLUX KLAN

Everything about the Ku Klux Klan told in a clear, fearless manner. Book tells all how it started and was suppressed in 1871—The New Ku Klux Klan—How organized—How members are controlled—Oath of the Klan—Questions for Candidates—Cred—Objects of the Order—Obedience—Fidelity—Pledge of Loyalty—Ku Klux Klan; and the Masons—The Jews—The Masons—Real K. of C. Oath—The Negro Ku Klux Klan, etc., etc. Latest and most complete book on the Klan published. Price, 35c, postpaid.

SEX INDICATOR

Hold the MAGIC INDICATOR over a man's hand—instinctly it moves in a straight line backward and forward. Hold it over a woman's hand and it describes a complete and continuous circle. The same action can be obtained over a letter written by a man or woman, etc. It is fascinating; baffling. We have never been able to figure out how it's done—but we've never seen it fail. Many novel and entertaining tests may be performed with the Sex Indicator. For example, similar results can be obtained with animals, cats, dogs, rabbits, over birds, chickens, canaries, etc. Also used to predetermine the sex of chickens and birds, etc., in fact it is sold as a patented egg tester in Europe. Price 25c, or 3 for 65c, postpaid.

A DeLuxe Edition of our new 1927 CATALOG mailed on receipt of 25c. Handsome cloth binding. Only book of its kind, 350 pages of all the latest tricks in magic, the newest novel, riddles, puzzles, games, sporting goods, interesting books, curiosities in seeds and plants, etc., etc. See elsewhere.

STAGE MONEY

With a bunch of these bills, it is easy for each person of limited means to appear prosperous by flushing a roll of these bills at the proper time and peeling off a genuine bill or two from the outside of the roll, the effect created will be found to be all that can be desired. Prices, postpaid: 40 Bills 20c, 120 for 50c, or \$3.50 thousand postpaid.

Wonderful X-Ray Tube

A wonderful little instrument producing optical illusions both surprising and startling. With it you can see what is apparently the bones of your fingers, the lead in a lead pencil, the interior opening in a pipe stem, and many other similar illusions. A mystery that no one has been able to explain. Price 10c, 3 for 25c, 1 dozen 75c. Johnson Smith & Co.

Good Luck Ring

Quant and Novel Design

A VERY striking and uncommon ring. Silver finish, skull and crossbones design, with two brilliant, flashing gems sparkling out of the eyes. Said by many to bring Good Luck to the wearer, hence its name. Good Luck Ring. Very unique ring that you will take a pride in wearing. ONLY 25 CENTS.

Exploding Cigarettes

JUST LIKE ORDINARY CIGARETTES. BUT SUCH REAL STARTLERS! Each cigarette contains ten genuine cigarettes of excellent quality. They appear so real, but when each cigarette is about one-third smoked, the victim gets a very great surprise—BOOM! a loud BANG! A great mirth provoker yet entirely harmless. Price 25c per box.

Popular Watch Charms

ONLY 3 for 40c; \$1.35 doz.

Very pretty little curiosities and decidedly novel. Fitted with Magnifying Lenses that enlarge the pictures to a very surprising degree; in fact, it seems almost incredible that clear picture could be possible in such a small compass, and how sharp and distinct they show up when you look through. Come in assorted views—Actresses, views of Panama Canal, Lord's Prayer in type, etc.

CIGARETTE MAKER

Roll your own and save money. Makes them better and quicker besides saving more than half. Use your favorite brand of tobacco. Neat, useful and handy. Pocket size, weighs 1/2 oz. Made entirely of metal, nickel-plated. Price 25c postpaid.

MAGIC FLUTE

Wonderfully Sweet Toned and Musical

The Magic Flute, or Humanation, is a unique and novel musical instrument that is played with nose and mouth combined. There is just a little knack in playing it which, when once acquired after a little practice will enable you to produce very sweet music that somewhat resembles a flute. There is no fingering, and once you have mastered it and ease. When played as an accompaniment to a piano or any other musical instrument, the effect is as charming as it is surprising.

Novelty Badges

Kissing Permit 10c Garter Inspector 10c

Two very novel metal badges, nickel plated, that you can wear, giving you fun out of all proportion to their tiny cost. 10c, each badge, 3 for 25c, or 75c per doz. p.p.d.

BLANK CARTRIDGE PISTOL

Price \$1.00 Postpaid

This well made and effective Pistol is modeled on the pattern of the latest type of Revolver, with the appearance of which alone is enough to scare a burglar, whilst, when loaded, it will probably prove just as effective as a revolver with real bullets, without the danger to life. It takes the standard .22 Calibre Blank Cartridges, that are obtainable most everywhere. Even the most timid women can use it with perfect safety and frighten a thief with out risk to herself or anyone else. A Great Protection Against Burglars, Tramps and Dogs. You can have it lying about with out the danger attached to other revolvers. We sell large numbers around the 4th of July. Well made of solid Metal. PRICE ONLY \$1.00 Postpaid. Blank Cartridges 22-cal. shipped by express only, 50c per 100. Johnson Smith & Co., Dept. 713 Racine, Wis.

Sneezing Powder

Place a very small amount of this powder on the back of your hand and blow it into the air, and everyone in the room or car will begin to sneeze without knowing the reason why. It is most amusing to hear their remarks, as they never suspect the real source, but think they have caught it one from the other. Between the laughing and sneezing you yourself will be having the time of your life. For parties, political meetings, car rides, or any place at all where there is a gathering of people. It is the greatest joke out. Price 10c or 3 for 25c

Mystic Skeleton

10c p.d.

A jointed figure of a skeleton 14 in. in height, will dance to music and perform various gyrations and movements, while the operator may be some distance from it.

Serpent's Eggs

Box contains 12 eggs. When lit with a match, each one gradually hatches into a snake several inches long, which curls and twists about in a most lifelike manner. Price per box 10c p.p.d.

Microphone Transmitter Button

1.00 POST-PAID

You can easily make a highly sensitive detectophone by using this Transmitter Button to collect the sound waves. You can build your own outfit without buying expensive equipment. It is simple and inexpensive. You can install it in your home and use it for detecting things being held all over the house. You can connect up different rooms of a hotel. This outfit was used by secret service operatives during the war. It is being used on the street. It is ultra-sensitive and is the greatest invention in micro-phones. You can mount the Button almost anywhere—card board boxes, stove pipes, stiff calendars, on the wall behind a picture frame, etc. Button is so light and small it cannot be detected. Persons can be overheard without suspecting it. You can listen in on conversations in another room. A deaf person in the audience can hear the speaker. Connected to phonograph, piano or other musical instrument, music can be heard hundreds of feet away. Button may be used to receive telephone transmissions; often makes an old line "talk-up" when nothing else will. The ideal microphone for radio use; carries heavy current and is extremely sensitive. Amplifies radio signals. Uses will suggest themselves. Experimenters find the Button useful for hundreds of experiments also—the lines of telephones, amplifiers, loud speakers, etc. Many fascinating stunts may be devised, such as holding the button against the throat of a friend to reproduce speech without sound waves. \$5.00 is given to anyone who sends in a new suggestion for the use of the Button providing the manufacturers find it suitable for use in their literature. PRICE \$1.00 POST-PAID ANYWHERE.

ANARCHIST BOMBS

One of these glass vials dropped in a room full of people will cause more consternation than a limburger cheese. The small entirely disappears in a short time. 10c a Box, 3 Boxes for 25c

INVISIBLE INK

The most confidential messages can be written with this ink, for the writing MAKES NO MARK. Can be seen unless you know the secret. Invaluable for many reasons. Keep your notes and other private memorandums away from prying eyes. Great fun for playing practical jokes. Only 15c Bottle

ITCHING POWDER

This is another good practical joke; the intense discomfort of your victims to everyone but themselves is thoroughly enjoyable. All that is necessary to start the ball rolling is to deposit a little of the powder on a person's hand and the powder can be relied upon to do the rest. The result is a vigorous scratch, then some more scratch, and still some more. 10c box, 3 boxes for 25c or 75c per doz boxes

LOOK 35c Look

Wonderful Instrument. Greatest thing yet. Nine separate articles in one. Everybody delighted with it. Odd, curious and interesting. Lots of pleasure as well as very useful. It is a double microscope for examining the wonders of nature. It is also an Opera Glass, a Stereoscope, a Burning Lens, a Reading Glass, a Telescope, a Compass, a Pocket Mirror, and a Laryngoscope—for examining eye, ear, nose and throat. It is worth all the cost to locate even one painful cinder in the eye. Folds flat and fits the pocket. Something great you need one. Don't miss it. Sent by mail, postpaid. Price, only 35c or 3 for \$1.00 postpaid.

RESURRECTION PLANT

One of the most wonderful plants known. Possesses the strange power of turning in a few minutes from an apparently lifeless, dry herb to a BEAUTIFUL LIVING FERN-LIKE PLANT of a dark green color. Simply place the plant in saucer of water, it will open up and start to grow in 20 minutes. When taken out it will dry up and go to sleep until placed in water again. Fine house plant—summer or winter. 10 cents each or postpaid. 25c, Agents Wanted

ADDRESS ORDERS FOR ALL GOODS ON THIS PAGE TO JOHNSON SMITH & CO. DEPT. 713, RACINE, WIS. Postage Stamps Accepted

Let These Guides

Solve Your Problems

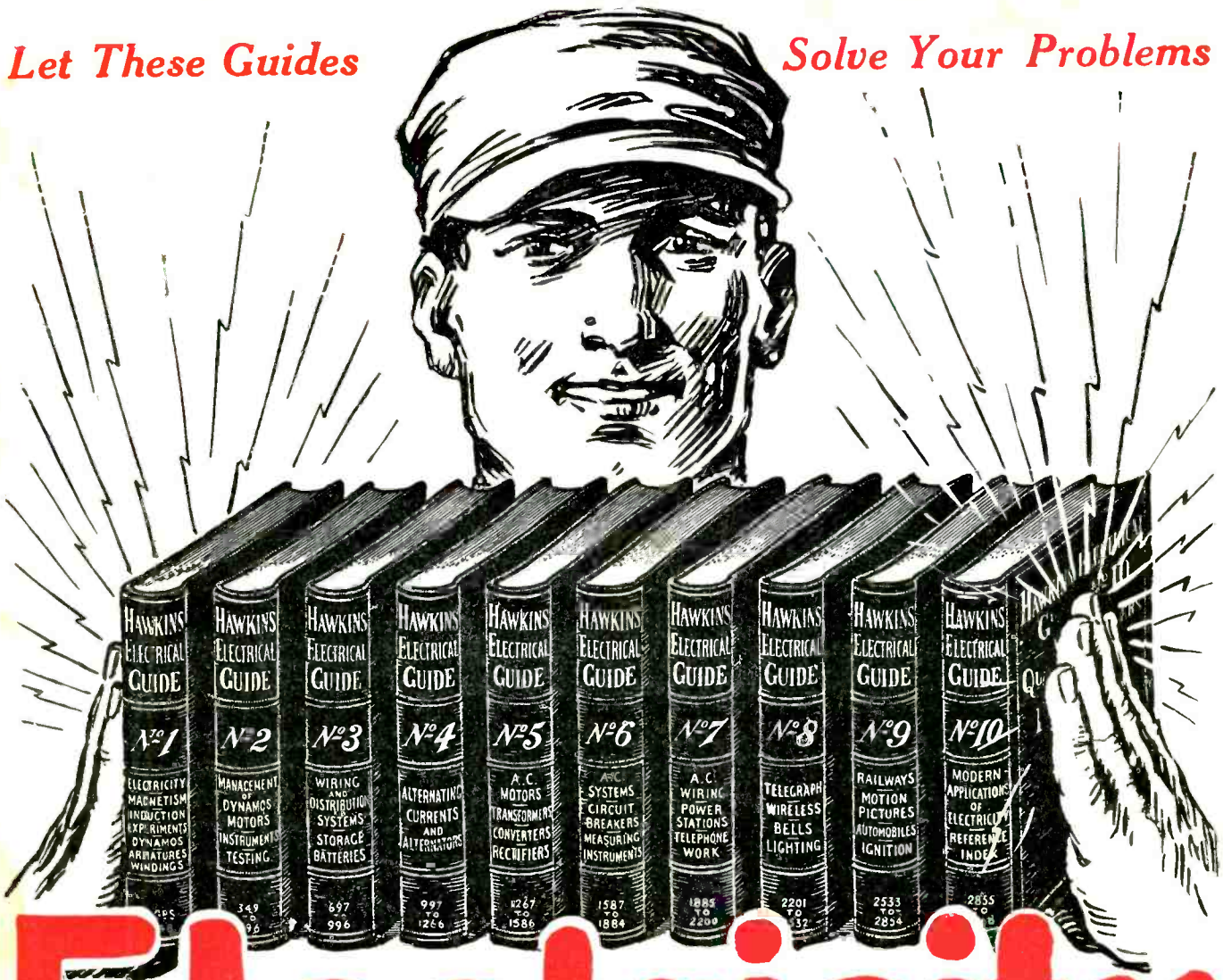

Electricity at your finger ends

HAWKINS ELECTRICAL GUIDES IN TEN VOLUMES

**3500 PAGES
4700 PICTURES**

**\$1 A VOLUME
\$1 A MONTH**

SEND NO MONEY—SEND ONLY THIS COUPON

Know the facts in Electricity. They mean more money and better position for you. Hawkins Guides tell you all you need to know about Electricity. Every important electrical subject covered so you can understand it. Easy to study and apply. A complete, practical working course, in 10 volumes. Books are pocket size; flexible covers. Order a set today to look over.

LEARN ALL ABOUT

Magnetism—Induction—Experiments—Dynamometers—Electric Machinery—Motors—Armatures—Armature Windings—Installing of Dynamometers—Electrical Instrument Testing—Practical Management of Dynamometers and Motors—Distribution Systems—Wiring—Wiring Diagrams—Sign Flashers—Storage Batteries—Principles of Alternating Currents and Alternators—Alternating Current Motors—Transformers—Converters—Rectifiers—Alternating Current Systems—Circuit Breakers—Measuring Instruments—Switchboards—Wiring—Power Stations—Installing—Telephone—Telegraph—Wireless—Bells—Lighting—Railways. Also many Modern Practical Applications of Electricity and Ready Reference Index of the ten numbers.

SHIPPED FREE

Not a cent to pay until you see the books. No obligation to buy unless you are satisfied. Send Coupon now—today—and get this great help library and see if it is not worth \$100 to you—you pay \$1.00 a month for ten months or return it.

THEO. AUDEL & CO.

65 West 23rd Street, New York City.

Please submit me for free examination, HAWKINS ELECTRICAL GUIDE (Price \$1 a number). Ship at once prepaid, the 10 numbers. If satisfactory, I agree to send you \$1 within seven days and to further mail you \$1 each month until paid.

Name

Occupation

Employed by

Home Address

Reference

S.I., July

Join This Happy Throng

Money Talks Read These Records



\$8,500

in 17 weeks! That's what Chas. F. Worthen, a Massachusetts man, made with this remarkable real estate system. Free book tells how!



\$2,700

on one deal! That's the news from Edw. A. Anderson, of Chicago, Ill., who attributes his success to this system. Free book tells how!



\$14,400

in less than four months! That's the enthusiastic report from H. G. Stewart, a Maryland user of this money-making real estate method. Free book tells how!



\$248

in one transaction! That's the first "pin-money" Mrs. J. H. Hastings made following this plan for business success. Free book tells how!

Be a Real Estate Specialist. Use this wonderful System. Make Big Money—right at home—in your spare time—without capital or experience. New Book giving full facts and amazing proof of success, now mailed free.

If you walked into your boss' office tomorrow morning and asked him to double—or triple—your salary, would he do it?

Neither would E. K. McLendon's boss. McLendon, who lives in a small city in Oregon, was getting \$35 a week, and he says, "My savings were few and my worries many."

By depending upon himself instead of his boss—by sending for this free book—by following this successful Real Estate System—McLendon has increased his income from \$35 a week to an average of \$200 per week. He is now enjoying an income nearly six times as large as his boss paid him.

If you want your pay—your salary—your income—doubled, tripled or quadrupled, you know that your boss won't do it. You know that to make really big money you will have to get started in some business of your own. You know that as long as you stay in the pay-check class you will get only what the other fellow is willing to pay you.

So, send for this free book now—today. Learn what others are doing—learn what you can do—in the biggest business there is—real estate.

Here are just a few of the great advantages and opportunities offered you in real estate:

(1) Real estate is the biggest thing you can get into. Sixty-five per cent of the wealth of the entire nation is invested in real estate. It amounts to 230 billions! (2) Users of this remarkably successful method are reporting profits of \$500—\$1,000—\$5,000—and more—on single deals—sometimes as much money in one lump as the average man in the average business gets for months and years of hard work. (3) With this amazing System you can start in

your spare time—without giving up any work—and income you now have. (4) Real estate offers you a permanent business—as permanent as the earth itself. (5) It is a healthful, interesting occupation—no dirty work or hard labor requiring unusual health or strength. (6) The business can't stop growing. It gets bigger as population increases. Last year six billion dollars was invested in new buildings. (7) It is a business suitable to both sexes of all ages from 21 to 75. One woman user of this System made her start at 77. (8) The business is practically unlimited. There are ten million properties always in the market for rent, sale or exchange.

Do you know of any other business, of any kind, that offers you such remarkable advantages and opportunities?

You know that you will never get rich working for somebody else. You know that the way to big money is through a business of your own. And you know that you cannot find a bigger business than real estate.

Why stick to a pay-envelope all your life? Why not start right now—in your spare time—use our scientifically successful System—get into the biggest money-making field there is—begin at once to build up a business for yourself—not for somebody else.

Send for this free book at once. You will find it the most fascinating book of real estate opportunity and real estate achievement that ever fell into your hands. It will show you how you can do what other wide-awake men and women are doing—build up an independent business of your own—the kind of a business you have dreamed about—the kind of a business you have longed to get into—the kind of a business you want for your business.



This Free Book Shows How



American Business Builders, Incorporated
(Authorized Capital \$500,000.00)
Dept. 35 GG, 18 East 18 St., New York, N. Y.

You may send me—without cost or obligation—your book giving full facts about your Real Estate System, and how I can use it to build up a profitable business of my own in my spare time.

Name

Address

Blame Yourself If You Don't



\$5,500

profit on first deal! So says Evalynn M. Balster, Illinois widow who was trying to raise three children and make both ends meet on a teacher's salary. Free book tells how!



\$28,000

first six months' profits! That's the record of Thos. C. Mone, Jr., a New York State insurance solicitor. Free book tells how!



\$100,000

first year's sales! This New Jersey man, H. D. VanHouten, worked for twenty-five years for a wholesale grocer until he got into real estate. Free book tells how!



\$500

average monthly profits! That's what this great real estate System is doing for W. H. Robinson, an Illinois man. Free book tells how!