

July

25 Cents

Science and Invention

IN PICTURES

\$500

IN PRIZES

WHAT CAN
YOU

DO WITH THIS
GOLD PAPER

Nationally Advertised

RICO

The mark of Guaranteed Products

EVERY STATION Is Reproduced With Clarity Tone and Volume

\$15.00

No. 120
Patented
Dec. 25, 1923



24 IN. HIGH
LARGE BELL
BLACK FINISH

THROUGH THE
MARVELOUS

GRAND OPERA
LOUD SPEAKER

No 120

THE MASTER
OF THEM ALL

Proclaimed by users to be the wonder of the age. You get so much for so little when you consider the price of this marvelous loud speaker. Tunable and adjustable by means of the VOLUMETER (Pat. Dec. 25, 1923) and no metal can touch the diaphragm.

Like the waters of the brook flowing gracefully on to the river, so does the broadcasting come to you through the throat of the RICO GRAND OPERA.

No additional batteries are required. Operates best on two stages of amplification.

Insist on the GRAND OPERA. If your dealer cannot supply you, then order direct with coupon below.

**RADIO
INDUSTRIES**
CORPORATION

131 Duane St. New York

Cable Address: Ricotrade, New York

SEND NO MONEY		S&I 7
Radio Industries Corp. 131 Duane St., New York City		
Gentlemen:—Please send me by Parcel Post 1 RICO GRAND OPERA LOUD SPEAKER No. 120 for which I will pay the postman the amount of \$15.00.		
Name
Street
City	State

VOLUMETER

WHEN A BETTER PRODUCT CAN BE MADE—RICO WILL MAKE IT!

RICO RICO RICO RICO RICO RICO RICO RICO RICO RICO



FREE! The Book That is Bringing Thousands Big Money in **ELECTRICITY!**

There is no field in the world that offers such great money making possibilities to trained men, as electricity. Thousands are qualifying the new way by actual S & H Shop Type training. A few weeks during spare time in your own home, then you are equipped to step right into jobs paying from \$50 to \$150 per week. Get this wonderful book which tells you just how you can do this. Sent free.

Train at Home for \$3,000 to \$10,000 Jobs

Don't stand back on account of education, experience, age, or location. No matter where you live, or what you are now doing, through my course you have the chance to become in a very short time a big pay "electrical expert."

Actual Shop Methods in Your Own Home

For I have devised a wonderful new system that gives you the benefit of actual shop experience in your own home. Never before has this been possible. But now, after finishing my training you will be at home in the biggest electrical plant, in a sub-sta-

tion, in a battery station, or with expert maintenance men, or on automobile and tractor starting, lighting and ignition work because you will have had actual experience, which means everything.

Backed by Lincoln Institute of Technology

This new system of teaching electricity has proved so successful that it has been highly recommended and endorsed by the great Lincoln Institute of Technology. When you enroll you know that you are backed by a great institution. You receive free, employment service and expert advisory service as long as you live.

Free Outfit

There is such a call for men now that we are giving free an electrical outfit for experimental and practical home use if you enroll now. Think what it will mean to leave forever the low pay rut to become a trained, efficient electrical technician, capable of managing and supervising ten or five hundred men on the biggest jobs; to travel, to be a man of influence—to have a salary of \$5,000 to \$10,000 per year. Find out now how

you can do this. You cannot afford to delay a day. Send right now for this wonderful free book that is pointing the way for thousands to big money in electricity. The coupon brings you this book entirely free, without obligation. Fill it out.

S & H ENGINEERING COMPANY

Affiliated with the Lincoln Institute of Technology

Dept. G-2, 1422 W. Monroe St., Chicago, Ill.

FREE BOOK — FREE OUTFIT COUPON

S & H Engineering Co.,
Division of Lincoln Institute of Technology,
Dept. G-2, 1422 W. Monroe St.,
Chicago, Ill.

Please send me at once your big book "How to Get the Better Jobs in Electricity," and full particulars of your course in practical electricity, your free outfit and your free employment service offer. I am not obligated in any way.

Name

Address

City State.....

Give age if under 16.....

Science and Invention

FORMERLY
ELECTRICAL EXPERIMENTER

Members Audit Bureau of Circulations

EDITORIAL & GENERAL OFFICES: 53 Park Place, New York City
Published by Experimenter Publishing Company, Inc. (H. Gernsback, Pres.; S. Gernsback, Treas.; R. W. DeMott, Sec'y).
Publishers of SCIENCE AND INVENTION, RADIO NEWS, PRACTICAL ELECTRICS and MOTOR CAMPER & TOURIST.

23 Table of Contents for July

POPULAR SCIENTIFIC ARTICLES		EASILY CONSTRUCTED CYCLE CAR 273
EDITORIAL.....	By H. Gernsback	237
MYSTERIES OF "GIRL SHY".....	By Tamar Lane	238
TELEPHONE WIRES CARRY PICTURES.....	By H. Winfield Secor	240
MOVIES "DEMOLISH" NEW YORK.....	By Oliver S. Arata	242
A MODERN PYRAMID.....	By W. B. Arvin	243
QUARTZ—THE WONDER SUBSTANCE.....	By H. Gernsback	244
TWENTIETH CENTURY MUMMIES.....	By H. Gernsback	246
HEARING THE STARS.....	By Ernest Brennecke	247
MAKING SINGERS OF US ALL.....	By Ernest Brennecke	248
THE GIANT IN THE ATOM.....	By Ernest Brennecke	249
DR. HACKENSAW'S SECRETS, NO. 30, THE SECRET OF THE FLYING HORSE.....	By Clement Fezandie	250
THE MAN ON THE METEOR—PART VII.....	By Ray Cummings	252
SUN'S RAYS MELT GOLD AND STEEL.....	By H. Gernsback	254
ODDITIES OF THE HUMAN BODY.....	By Tamar Lane	255
PAINTINGS AS MOVIE SETS.....	By Tamar Lane	256
DEFLATABLE PONTOONS TO SALVAGE SHIPS.....	By H. Winfield Secor	256
SCIENTIFIC BASS ANGLING.....	By John E. Hogg	257
THE OLD AND NEW IN ASTRONOMY.....	By Charles T. Dahama	258
RAILROADS OF TOMORROW.....	By George F. Murphy	260
ELECTRICAL STRESS MEASUREMENTS.....	By S. R. Winters	260
ARTIFICIAL CREATION OF LIFE.....	By Dr. Ernest Bade and J. F. Mazur, M.B.	261
A NOVEL SCENE SHIFTING METHOD.....	By Harold C. Howe	262
SEA RESCUE INVENTION.....	By Joseph H. Kraus	263
THE VERTICAL REALM OF LIFE.....	By F. W. Horton	263
HEREDITARY LAW IN FLOWERS.....	By Dr. Ernest Bade	264
REPLICA OF YOSEMITE VALLEY.....	By Robert H. Moulton	264
MAGIC FOR EVERYBODY, NO. 16 OF A SERIES.....	By Prof. Joseph Dunninger	267
GAMBLER'S TRICKS EXPOSED.....	By Mark Mellen	268
DICE TRICKS SIMPLIFIED.....	By Walter B. Gibson	269
THE HEAVENS IN JULY.....	By Isabel M. Lewis, M.A., of the U. S. Naval Observatory	270
HOME MECHANICS.....	By Wm. M. Butterfield	271
EXPERIMENTS WITH PLANTS.....	By Dr. Russell G. Harris, Harvard University	274
PRIZE CONTESTS		
GOLD COVER CONTEST—\$500.00 IN PRIZES.....		245
HOW-TO-MAKE-IT DEPT.—\$30.00 IN PRIZES.....		276
AWARDS IN \$1,000 MONTHLY CONTEST.....		288
SCIENTIFIC HUMOR—PRIZES FOR BEST JOKES..		290
AUTOMOBILES		
NOVEL DUST CAP.....		266
GASOLINE INDICATOR.....		266
RADIO ARTICLES		
BROADCAST STATIONS.....		280
PORTABLE RADIO RECEIVING SETS.....		281
THREE CIRCUIT COUPLER.....	By C. B. Kramer	282
PARABOLIC REFLECTOR AS LOUD SPEAKER.....	By C. A. Oldroyd	282
EFFICIENT LOUD SPEAKER HORN.....	By Horace Porter	283
SOLDERING IN THE RADIO LABORATORY.....	By Edward F. Staver	283
STYLES OF RADIO CABINETS.....	By William Butterfield	284
NOVEL COCKADAY SET.....	By M. A. Lurye	285
COMBINATION OF VARIOMETER AND VARIO-COUPLER.....	By Kenneth B. Murray	285
RADIO ORACLE DEPARTMENT.....		286
RADIO WRINKLES.....		319
CONSTRUCTOR ARTICLES		
BOAT STEERING APPARATUS.....	By L. B. Robbins	272
BUILDING AN ART CRAFT LAMP.....	By J. T. Garver	272
EASILY CONSTRUCTED CYCLE CAR.....	By Galen Barber	273
EXPERIMENTS WITH PLANTS.....	By Dr. Russell G. Harris	274
OIL BURNING EQUIPMENT FOR THE HOME.....	By L. K. Wright	275
CHEMISTRY ARTICLES		
TWENTIETH CENTURY MUMMIES.....	By H. Gernsback	246
ARTIFICIAL CREATION OF LIFE.....	By Dr. Ernest Bade and J. F. Mazur	261
EXPERIMENTS WITH PLANTS.....	By Dr. Russell G. Harris	274
ASTRONOMY ARTICLES		
HEARING THE STARS.....	By Charles T. Dahama	247
THE OLD AND NEW IN ASTRONOMY.....	By Charles T. Dahama	258
THE HEAVENS IN JULY.....	By Isabel M. Lewis, M. A.	270

HOW TO SUBSCRIBE FOR "SCIENCE AND INVENTION." Send your name, address and remittance to Experimenter Publishing Co., 53 Park Place, New York. Mention the name of the magazine you are ordering. We also publish RADIO NEWS, PRACTICAL ELECTRICS and MOTOR CAMPER & TOURIST.
RATES AND TERMS. The subscription rate for SCIENCE AND INVENTION is \$2.50 per year (12 numbers). When remitting do so by check, money order or registered letter, if cash is enclosed. Avoid sending cash through the mail if

SCIENCE AND INVENTION is published on the 25th of each month. There are 12 numbers per year. Subscription price is \$2.50 a year in U. S. and possessions. Canada and foreign countries \$3.00 a year. U. S. coin as well as U. S. stamps accepted (no foreign coin or stamps). Single copies, 25 cents each. A sample copy will be sent gratis on request. Checks and money orders should be drawn to order of EXPERIMENTER PUBLISHING CO., Inc. If you change your address notify us promptly, in order that copies are not misrouted or lost.

possible. Subscriptions for less than one year are not accepted. Subscriptions may be made in combination with RADIO NEWS, PRACTICAL ELECTRICS or MOTOR CAMPER & TOURIST with considerable saving. Send postal for special rates. Subscriptions start with the current issue, unless otherwise ordered.
POSTAGE. We prepay postage in all parts of the United States, Mexico and island possessions. For foreign or Canadian subscriptions we require 50 cents in addition to the subscription price for additional postage charges.

All communications and contributions to this journal should be addressed to Editor, SCIENCE AND INVENTION, 53 Park Place, New York City, N. Y. Unaccepted contributions cannot be returned unless full postage has been included. ALL accepted contributions are paid for on publication. A special rate is paid for novel experiments; good photographs accompanying them are highly desirable.
SCIENCE AND INVENTION, Monthly. Application as second class matter made at New York, N. Y. with additional entry at Long Island City, N. Y. Post

CHANGE OF ADDRESS. Notify us as far in advance as possible. It requires several weeks to make an address change on our records. Always write clearly, giving your old address as well as your new. ON EXPIRATION of your subscription we enclose a renewal blank in our last number to you and notify you otherwise. Unless we receive your order for a renewal, with your remittance, we stop our delivery to you on expiration.
COMMUNICATION to us should always bear your full name, address and when possible the number which appears on your wrapper every month.

Office, under act of Congress of March 3, 1879, formerly entered at Jamaica, N. Y. Title Registered at the Patent Office. Copyright, 1924, by E. P. Co., Inc., New York. The contents of this Magazine are copyrighted and must not be reproduced without giving full credit to the publication.

SCIENCE AND INVENTION is for sale at all newsstands in the United States and Canada; also at Brentano's, 37 Avenue de l'Opera, Paris. Member of the Audit Bureau of Circulations.

New York City
General Advertising Dept.
53 Park Place

Western Advertising Representatives
Finucan & McClure
720 Cass St., Chicago, Ill.

Pacific Coast Advertising Representatives
A. J. Norris Hill Co.
Hearst Bldg., San Francisco, Calif.

Kansas City Advertising Representatives
George F. Dillon
Republic Building, Kansas City, Mo.

I WANT 100,000 MEN AND WOMEN TO BE THE OWNERS OF A

CHECK-PROTECTOR
Security
FOUNTAIN PENS

AND
THEN
BECOME
OUR
REPRE-
SENTATIVES.
YOUR
INVESTMENT
THE PRICE OF
A PEN.
17 YEARS IN PERFECTING.

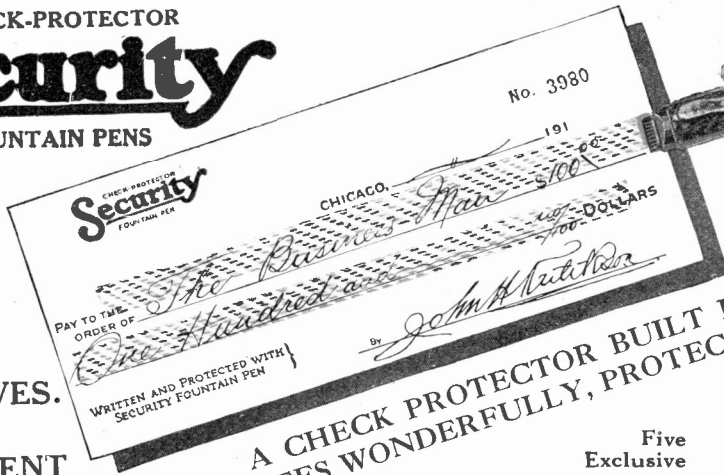

A CHECK PROTECTOR BUILT INTO A PEN.
WRITES WONDERFULLY, PROTECTS PERFECTLY.

Five
Exclusive
Patented Features

SEND for one of our big "Giant" mottled finish "masterpieces" or any of the other sizes in black finish. We will give you a complete demonstrating outfit free of charge. This wonderful combination of a perfect, smooth-writing, non-leakable, self-filling fountain pen with a unique and practical check protector, enables the writer to write and protect his checks Any Time, Any Place. After you have received the pen, given it a fair trial, sold yourself thoroughly on its merits and convinced yourself that it is the best fountain pen that money will buy, that its smooth and excellent writing qualities are far superior to any other pen on the market and that the check protector alone is worth many times the price of the pen itself, then show it to your friends and acquaintances, business and professional men, including your banker, and you will be surprised how quickly people become interested when the Security is demonstrated to them and how easily you can get their orders.

MONEY BACK GUARANTEE

If, on the other hand, you do not find the Security all that we claim it to be and are not satisfied, return it to us at our expense and the full purchase price will be refunded to you, without any "ifs" or "ands."

WONDERFUL SIDE LINE

It doesn't make a particle of difference whether you can devote one, two or three hours of your spare time each day or whether you wish to devote all of your time for the Security Pen. It doesn't make any difference whether you wish to work in a small town or big city, one county or ten counties, whether you have been accustomed to earning two thousand or ten thousand dollars a year. Our proposition is bound to interest you. Every business and professional man in every city and town is a potential prospect for a Security. Every sale cements a lasting friendship with your buyer.

UNLIMITED SALES POSSIBILITIES

(Just think! In 1900 only 500,000 pens were sold in the United States. In 1923 over 18,000,000 fountain pens were sold and the business continues to grow with leaps and bounds.) Bearing this in mind, you can readily visualize the splendid and unlimited sales possibilities of the Security, compared with the ordinary fountain pens on the market.

DISTRICT MANAGERS

We offer an exceptional opportunity for our representatives to become district managers after they have developed their territory and are qualified to handle other sales people. Write us giving a brief history of yourself, your past experience, references and territory desired; in other words, give complete details in first letter.

ALBERT G. BURNS,
Director of Sales.



No. 800 Giant, \$8.00

No. 400 Long, \$4.00

No. 300A, \$4.00

COUPON

SECURITY PEN CORPORATION, DEPT. P.S. (25)
904 W. Jackson Blvd., Chicago, Ill.

Gentlemen: I am interested in your proposition from the standpoint of District Manager agent. I wish to devote full time part time. In the following territory. Explain in full.

Enclosed find.....check.....money order, \$..... Send me one Security Pen No. Long Short Medium Fine Stub Coarse in flexible or stiff action. Also Demonstrating Outfit Free with pen. With the understanding that if I am not thoroughly satisfied with the pen you will return my money in full. Write name plainly.

NAME

ADDRESS

CITY..... STATE.....

SECURITY PEN CORPORATION, Dept. P.S. (25) 904 W. Jackson Boulevard, Chicago

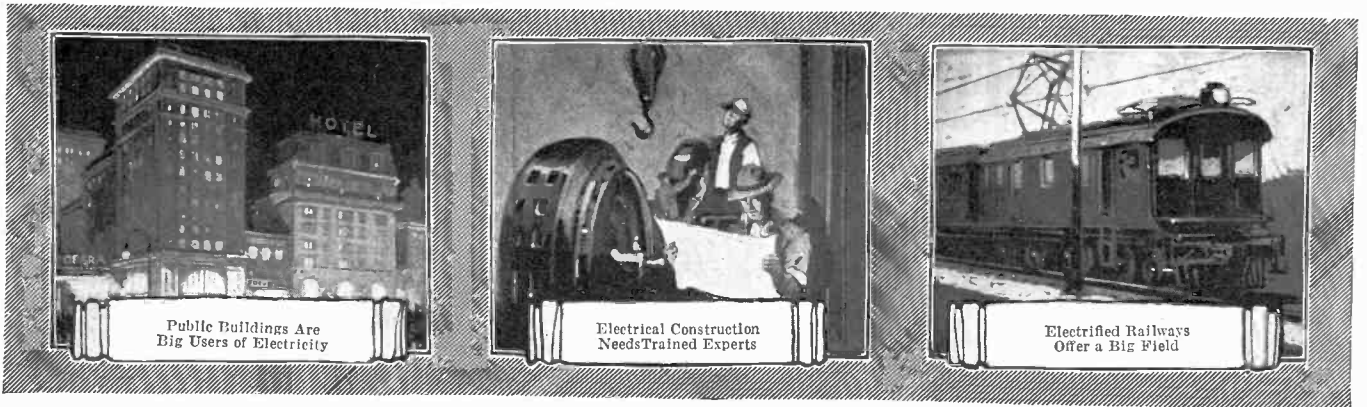

Public Buildings Are
Big Users of Electricity

Electrical Construction
Needs Trained Experts

Electrified Railways
Offer a Big Field

ELECTRICITY

Electrical Experts Earn

The Men in the Picture

Below is a picture of L. L. Cooke, Chief Engineer, and his Engineering Staff, engaged in Students' Consultation Work. Through this Free and unlimited consultation service, nine trained and competent engineers help the students of this school with the problems that come up in their work—not only while they are studying but for years afterward—just as long as they care to use it. Think what this means to you—having a group of engineers advising and helping you—without costing you one penny.

This is only one of the features of the unbeatable "Cooke" Service that backs up "Cooke" Training.

Be a COOKE Trained Electrical Expert

Now you earn \$20 or \$30 or \$40 a week. In the same six days as an Electrical Expert you can make \$70 to \$200 and make it easier—not work half so hard. Why, then, remain in the small-pay game, in a line of work that offers no chance, no big promotion, no big income? Fit yourself for a "bossing" job—Be a Cooke Trained Electrical Expert.

Today even ordinary Electricians—the "screw driver" kind—are making money—big money. But it's the trained man—the man who knows the whys and wherefores of Electricity—the "Electrical Expert"—who is picked to "boss" the ordinary Electricians—to boss the Big Jobs—the jobs that pay \$3500 to \$10,000 a year.



The "COOKE" Trained Man

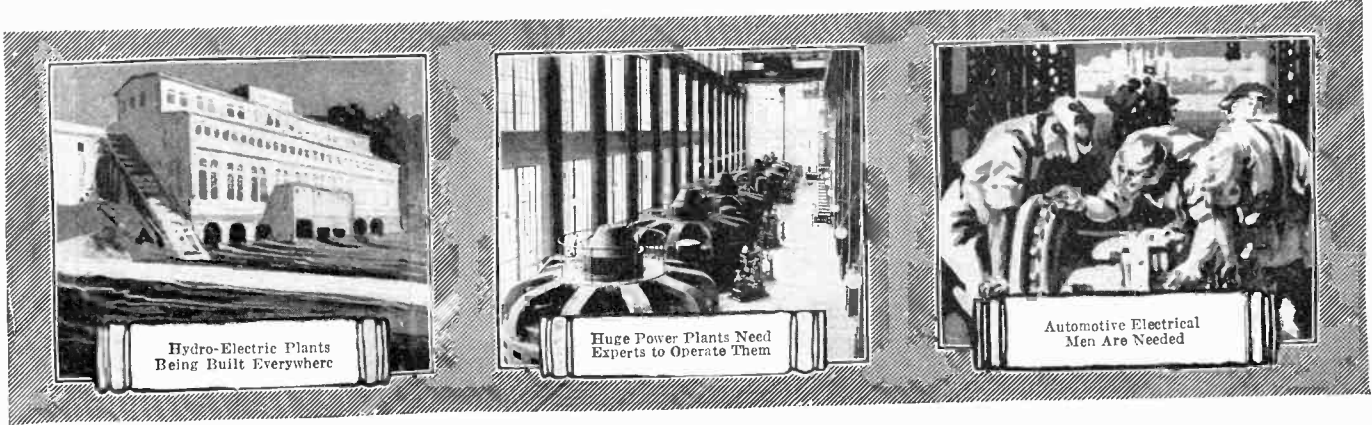

for BIG PAY

\$3500 to \$10,000 a Year

Get in line for one of these "Big-Pay Jobs" by enrolling now for my easily learned, quickly grasped, right-up-to-the-minute, Spare-Time Home-Study Course in Practical Electricity.

Age or Lack of Experience No Draw-Back

You don't have to be a High School graduate—it isn't even necessary that you should have finished the grades. As Chief Engineer of the Chicago Engineering Works, I know exactly the kind of training you need, and I will give you that training. My course in Electricity is the most simple, thorough, successful and practical in existence, and offers every man, regardless of age, education, or previous experience, the chance to become, in a few short months, an "Electrical Expert," able to make from \$70 to \$200 a week.

Earn While You Learn

With me you do practical work—at once. In my first few lessons I show you how to make money doing Electrical work in your spare time. (Over half of my students are paying for their course in this way.) I show you also how to get started in business for yourself, and then help you to get started.

FREE—Electrical Working Outfit—FREE

To do spare time work you'll need tools, etc. These I give you—Free—a whole kit including measuring instruments, a real electric motor (no toy), and other things—the greatest value ever given by any School.

Your Satisfaction Guaranteed by a Million Dollar Institution

I absolutely guarantee to return every penny paid me in tuition if, when you have finished my Course, you are not satisfied in every way with my instruction. And back of me, in my guarantee, stands the Chicago Engineering Works, a million dollar institution.

Nothing Like "Cooke" Training Anywhere

"Cooke" training is different because it's the most practical and most successful. It's best because it's backed up by the greatest Service to students ever known. It's this Service, plus "Cooke" training, that makes the "Cooke" trained man the "Big Pay" man everywhere. Become a "Cooke" Trained Man yourself, and earn \$12 to \$30 a day—\$70 to \$200 a week—\$3500 to \$10,000 a year.

Investigate! Mail Coupon

Get the Vital Facts. Let me send you free my big, new book on The Future of Electricity. Let me tell you more about the big demand for "Cooke" trained Electrical experts. Sign and send me Coupon below.

L. L. COOKE, Chief Engineer
Chicago Engineering Works, Inc.

2150 LAWRENCE AVE. Dept. 2-B CHICAGO, ILL.

Some Features of Cooke Training That Make Success Certain

1. Practical Money-Making Instruction—no useless, high-sounding theory.
2. Free Electrical Outfit—Finest outfit ever sent out for home experiment and practical use.
3. Free Unlimited Employment Service. (Helps you get a good job.)
4. Free Unlimited Consulting Service. (No chance to get stuck on anything, while studying or afterward.)
5. Free Subscription to Monthly Engineering Magazine.
6. Free use of my Big Electrical Laboratory.
7. Extra Courses Free—Radio—Electrical Drafting—Business—Automobile Electricity—Mine Electricity and Special Lessons on Health and Thrift.
8. Spare Time Work—Special earn-while-you-learn lessons.
9. Reduced prices on all Electrical Supplies.
10. Cash Refund Guarantee Bond.

These features are all explained in my big Free Book—the "Vital Facts."



L. L. COOKE,
Chief Engineer,
Chicago Engineering
Works, Dept 2-B,
2150 Lawrence Ave.,
Chicago, Ill.

Dear Sir—Send at once the "Vital Facts" containing Sample Lessons, your Big Book and full particulars of your Free Outfit and Home Study Course—all fully prepaid, without obligation on my part.

Name
Address
City and State
Occupation Age.....

is the "BIG PAY" Man

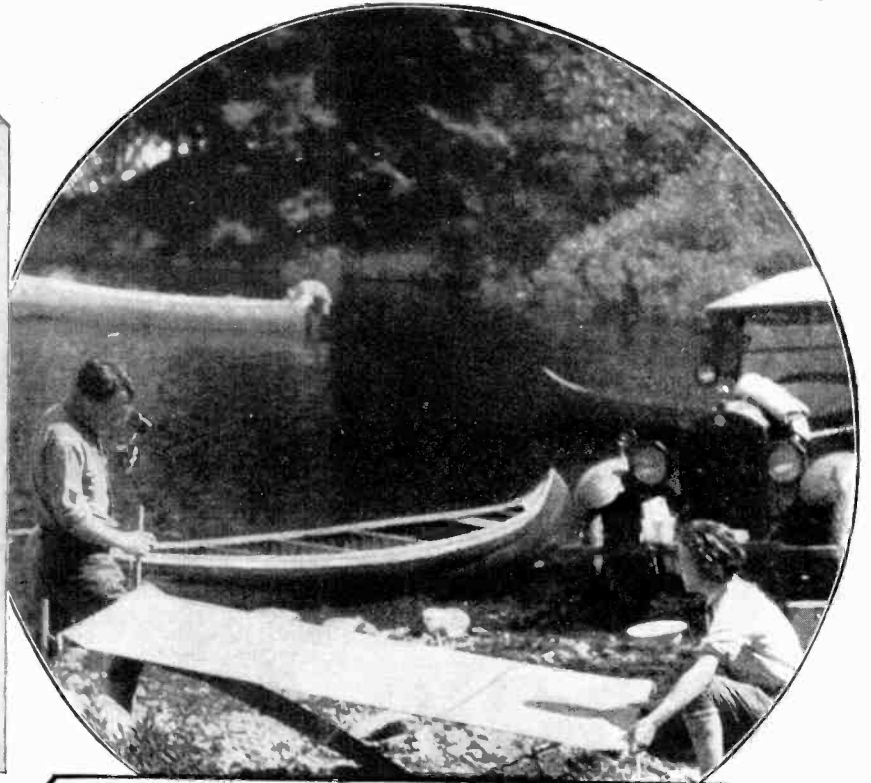

SEND FOR
FREE SAMPLE
COPY

Edited by
H. GERNSBACK,
Editor of RADIO NEWS,
SCIENCE AND INVEN-
TION and PRACTICAL
ELECTRICS.

The Signpost of the Open Road—

NOW is the time to prepare for your vacation trip in the car. Not one person in 50 knows how simply, how cheaply and how comfortably you can travel from coast to coast in your car or through the mountains of the east or west and live in the fresh, body-building out-of-doors every minute of the time.

MOTOR CAMPER & TOURIST tells you where to go, how much it will cost, when to travel and all those problems as to what to take, where to stop, etc.

The July issue is now on the newsstands. It contains 64 pages of information of value to anyone who owns a car. Printed in the finest modern process of Rotogravure. Buy your copy today or send in your subscription direct.

SUBSCRIPTIONS \$2.50 THE YEAR—FOREIGN 50c EXTRA
ON ALL NEWSSTANDS 25c THE COPY

GERMOTT PUBLISHING COMPANY, Inc.
53 Park Place New York City

Publishers of RADIO NEWS, SCIENCE and INVENTION,
PRACTICAL ELECTRICS and MOTOR CAMPER & TOURIST

MOTOR CAMPER & TOURIST

S&I 7

Germott Pub. Co., Inc.,
53 Park Place, N. Y. C.

Enclosed you will find
dollars for my subscription to
MOTOR CAMPER & TOURIST.

Name

Address

FREE!

New Book About "What and How To Invent"

Invention is the easiest way to earn a fortune. Little ideas have made millions of dollars for their inventors. A wonderful book, recently written, explains how fifteen famous inventors now teach you in your own home the secrets of successful invention known and used by every great inventor; what to invent and how to invent, what dangers to avoid, the methods that make it easier to complete inventions, hundreds of other valuable facts not obtainable elsewhere—and *why you already possess the native ability to become an inventor.*

This test shows how easily you can develop your ability to invent.

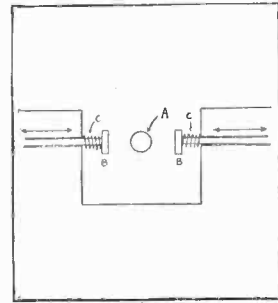

Here is an interesting little problem and its solution will be found very simple, if we really think hard.

"A" is the end of a shaft. The two members "B B" are free to move in either direction indicated by the arrows. If they are pushed back, the springs "C C" will immediately pull them forward again. Our problem is to put some kind of an attachment on the revolving shaft "A" so that the members "B B" will be pushed back both at the same instant every time the shaft "A" makes a single revolution. The device on shaft "A" must also allow the two members "B B" to come forward once in every revolution. What would you suggest putting on the shaft "A"?

This simple problem proves YOU CAN INVENT

THOUSANDS upon thousands of persons have inventive ability and do not know it, or do not develop it. Invention is open to everybody. From a farmer's 17-year-old son to the King of England—men and women of every age, class and degree of education have produced valuable money-making inventions. Your chances are as good as anybody's—because ANYBODY WHO CAN THINK CAN LEARN TO INVENT!

It is easy to prove that this statement is true. What were our greatest inventors before they invented anything? Simon Lake was a schoolboy. Bell was a teacher. Edison was a telegrapher. Gillette was a traveling salesman. Others were office clerks, mechanics, farmers, peddlers, housewives. Yet they all became inventors!

Little Ideas Worth Fortunes

One reason why most people think that they cannot invent is that they think of an invention as something like the steam-engine, the automobile, the aeroplane, the submarine. Few people think of the ice-pick, can-opener, glove-clasp, paper safety match, metal-tip shoe string and wire paper clip as inventions. Yet every one of these little inventions have enabled their inventors to reap large fortunes, to live in ease, to enjoy the comforts and pleasures of life.

Surely you have often had ideas for inventions just like these. It may be a new toy for your children. The man who invented the Kiddie-Kar, it is reported, made over \$5,000,000. It may be a new kind of soap. B. T. Babbitt is worth millions of dollars today. Even so simple a thing as a common wooden wedge to stop the wobbling of tables and chairs (which millions of people must have thought of has brought the woman who DID something with her idea, a respectable fortune!



Raymond F. Yates, who with fourteen other famous inventors, now makes it easy to learn how to invent in your spare time at home.

- How to develop your imagination.
- How to develop your ideas.
- How to get the facts you need for inventions.
- How to keep legal records of ideas.
- How to use scientific principles of mechanics.
- How to avoid wasting time on impractical inventions.
- How to apply for a patent.
- How to organize a company.
- How to protect your rights.
- How to market a patent.

and hundreds of other vitally important facts which EVERY successful inventor knows and uses.

Proof Invention Can Be Taught

Invention is not guesswork or blind luck—it is not a God-given faculty possessed by a few favorite mortals. As a matter of fact inventors themselves say that invention is based upon exact laws of thought and action which anyone can learn. Even Edison says: "Invention is a science and should be taught as a profession."

Prove to your own satisfaction, that you can learn how to invent. At the top right hand corner of this page is a simple problem in invention. See how quickly you can find its solution. A little thought will give you the answer in a few minutes.

When you have gotten your answer you will have found the fundamental idea behind the ordinary electric light switch—an idea which has earned its inventor thousands of dollars! This simple test, besides proving that you can learn to invent, also proves that you have the ability to develop ideas for any invention—because every invention was produced in exactly the same way.

Now Fifteen Famous Inventors Teach You How to Invent

Now for the first time you can profit by Edison's advice. You can actually learn invention as a profession—exactly as other people are learning electricity, mechanics, law, medicine.

Fifteen famous inventors tell you WHAT TO INVENT and HOW TO INVENT. They tell you the secrets of inventions which every successful inventor knows. They explain how to originate ideas, how to develop and perfect them, how to get patents. But they tell you even more. Thousands of inexperienced inventors have been defrauded of

their rewards because they did not know how to protect their patent rights. This great course tells you everything you want to know—how to sell your invention, how to get royalties—how to get the most money for your ideas.

The Bureau of Inventive Science offers you the first course in practical invention ever devised. It has written down the easy-to-learn principles of Inventive Science so that everybody can read them and learn to use them. It doesn't matter who you are, or what your present work is—you have the native ability to invent—which you proved you now have by solving the problem shown on this page. What you need now is to develop this ability so you can use it to produce practical inventions. All you need, to become successful, is this easy, fascinating training which will develop your ability so it will be worth real money.

New FREE Book

The most interesting part of this wonderful course is that it teaches invention by actual practice right in your own home. With each lesson you are sent at least one practical problem in invention just like the one you solved here. This absorbing exercise in solving actual inventive problems sharpens your instinct to fix things. Better than anything else it gives you an unforgettable, instinctive habit of thinking inventively, which is worth more than you realize. In fact, the lessons and exercises are so simple, so easy to understand, so interesting, that they seem more like a pleasant game than like instruction which can make you a successful inventor.

A wonderful new book, just printed, tells you more about the Bureau of Inventive Science and its simple new course in invention. It costs nothing, so send the coupon at once. This bureau is not connected with patent attorneys or manufacturers. Its only purpose is to teach you the principles of practical invention used by every successful inventor. Write for the FREE BOOK now. It may show you the way to make a fortune!

BUREAU OF INVENTIVE SCIENCE
Wisner Building, Dept. 77, Rochester, N. Y.

BUREAU OF INVENTIVE SCIENCE

Dept. 77, Wisner Building, Rochester, N. Y.

Please send me your free book, "The Science of Invention."

Name

Address

City State



RADIO NEWS

“RADIO’S GREATEST MAGAZINE.”

—with the
Stride of a Mighty Giant

List of some of the Important Articles Appearing in the July Issue of RADIO NEWS

- Radio to the Rescue
By J. Farrell
- The Importance of the Trivial
By Sir Oliver Lodge
- The Radio Tax Was Defeated
- The Loop Antenna
By R. H. Langley
- Ring Up Your Friend by Radio
By H. Diamond
- Reflex Receiver with Neutrodyne Control
By A. D. Cowper
- Distortionless Broadcast Reception
By H. J. Round
- Matching Intermediate Wave Transformers for Super-Heterodynes
By Prof. Grover Ira Mitchell

SUBSCRIPTION PRICE
 One Year, \$2.50
 Foreign, \$3.00
 Two Years, \$4.25
 Foreign, \$5.25
 Or at all newsstands
 25 cents per copy

WITH the strides of a mighty, mythical giant, Radio is progressing day by day. The story of its growth is as fascinating as the most wondrous chapters of science in which are discovered daily new things that go far beyond the dreams of the layman.

RADIO NEWS is the link between Radio, with all its marvelous research, and the public. It is the recording agent that brings to you the story of Radio as it takes form and develops in the great research laboratories of America. RADIO NEWS is the greatest Radio magazine in the United States and is read from month to month by more than 320,000 people.

You can obtain a copy today at the nearest newsstand for 25c.

By filling out the subscription blank below and mailing it to us with \$2.50 you can have RADIO NEWS delivered to your door for twelve months.

EXPERIMENTER PUBLISHING CO., INC.,
 53 Park Place,
 New York City, N. Y.

Enclosed find \$2.50 for my subscription to RADIO NEWS for one year.

Name

Address

City, State

Conrad Publications

"The Experimenter's Library" Series

- Tips for the Radio Amateur Constructor.
- How to Make a Radio-Phone Receiving Set.
- Radio Questions Answered.
- Radio Frequency Amplification.
- Loud Talkers and How to Build Them.
- How to Tune Your Radio Set.
- One Hundred Radio Hook-ups.
- All About Radio Parts History and Operation of Vacuum Tubes.
- The Neutrodyne and All About It.
- How Radio is Received.
- How to Locate Trouble in Your Radio Set.

25c Each

"The Radio Constructor" Series

- Radio Map of the U. S. on Cloth.
- How to Make the S. T. 100 Receiver.
- How to Make a Neutrodyne Receiver.
- How to Make a Reinartz Receiver.
- How to Make a Reflex Receiver.
- How to Make a Cockaday Receiver.
- How to Make a Short Wave Regenerative Receiver.
- How to Make a Radio-Phone Crystal Set.
- How to Make One or Two Stage Amplifiers.
- All About Aerials and Their Construction.
- 20 Radio Diagrams and Hook-ups.
- Radio Amateurs' Practical Design Data.
- How to Make the Ultradyne Receiver.
- How to Make a Five Tube Cockaday Receiver.
- How to Make a Portable Receiver.

50c Each

Radio Books

- Radio News Amateur Handbook\$1.00
- Radio For All 2.00
- The How and Why of Radio Apparatus75
- Wireless Course in 20 Lessons 2.00
- Experimental Electricity Course in 20 Lessons 1.25
- A Thousand and One Formulas 1.50
- Radio Reading Course in 5 Volumes..... 1.25
- The Beginners Radio Guideea. .10
- Building an Inexpensive Radio Crystal Set.....ea. .10
- Radio Log Book50
- Radio March35
- Radio Jazz35
- Listen In..... .35

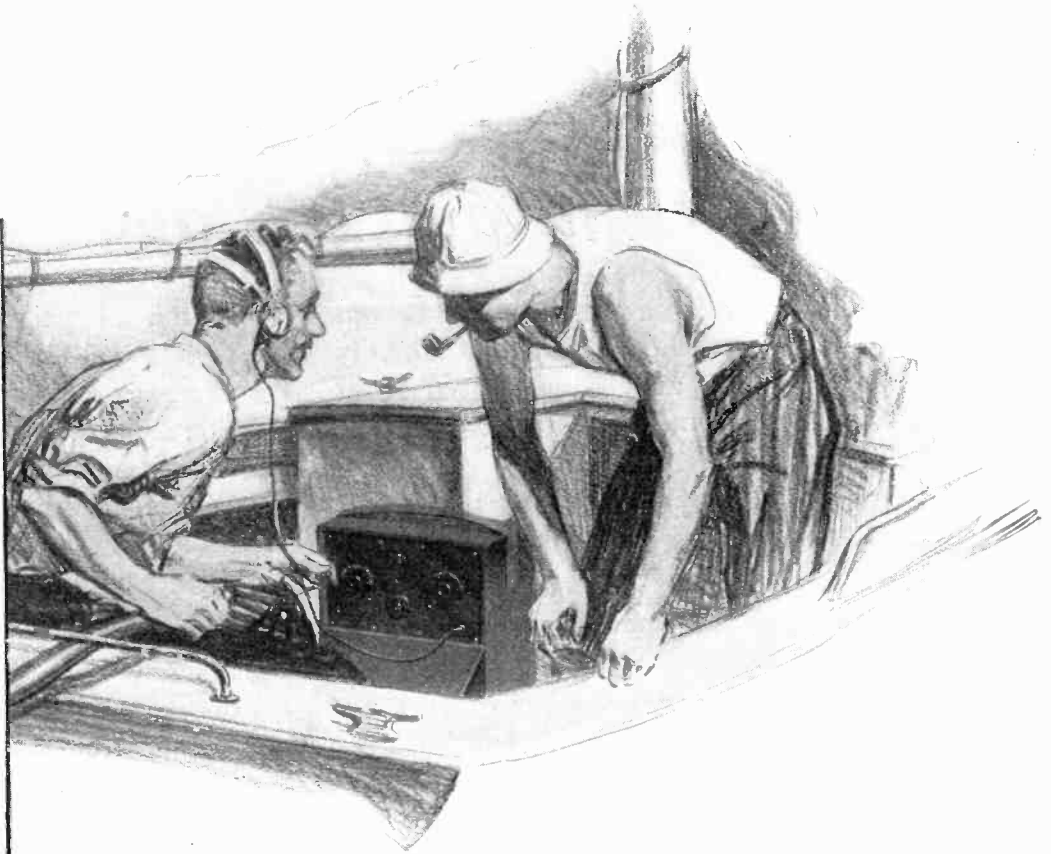

You Can Build this Portable Radio Set Quickly and Easily

The supreme gratification of work well done is the reward for the man who builds his own Radio Set. There is a definite, lasting thrill in the knowledge of the fact that the set you have built with your own hands, works sturdily and easily.

To those who want to be guided this summer in building a Portable Outfit, CONSRAD has prepared a new addition to its well known line of Radio Publications, THE PORTABLE RADIO SET PATTERN. It consists of diagrams with three full sized blueprints and complete instructions in simple everyday language so that you can follow them quickly and easily. In their complete form they show every step in the building of a complete, practical, PORTABLE Radio Outfit.

This set has been fully tested for results. It is designed by Radio Engineers who know what can be done in the way of Portable Outfits.

Pattern No. 12—"How to Make a Portable Receiver"

PRICE 50c PREPAID

At all reliable dealers or write direct

Address Department R.N.

THE CONSRAD COMPANY, Inc.
 233 FULTON STREET NEW YORK CITY

Consrad

RADIO'S FOREMOST PUBLISHERS

SCIENCE and INVENTION READERS' BUREAU

Time and Postage Saver

IN every issue of SCIENCE and INVENTION you undoubtedly see numerous articles advertised about which you would like to have further information.

To sit down and write an individual letter to each of these respective concerns, regarding the article on which you desire information, would be quite a task.

As a special service to our readers, we will write the letters for you, thus saving your time and money.

Just write the names of the products about which you want information, and to avoid error the addresses of the manufacturers, on the coupon below and mail it to us.

If the advertiser requires any money or stamps to be sent to pay the mailing charges on his catalogue or descriptive literature, please be sure to enclose the correct amount with the coupon.

We will transmit to the various advertisers your request for information on their products.

This service will appear regularly every month on this same page in SCIENCE and INVENTION.

If there is any Manufacturer not advertising in this month's issue of SCIENCE and INVENTION from whom you would like to receive literature, write his name, address and the product in the special section of the coupon below.

TEAR ALONG THIS LINE

READERS' SERVICE BUREAU,
Experimenter Publishing Co., Inc., 53 Park Place, New York, N. Y.

Please advise the firms listed below that I would like to receive detailed information on their product as advertised in the issue of SCIENCE and INVENTION.

NAME	ADDRESS	List here specific article on which you wish literature.	If Catalogue of complete line is wanted, check in this column.
.....
.....
.....
.....
.....
.....
.....
.....
.....
.....

If you desire any special information from a manufacturer whose advertisement does not appear in this month's issue, use this space.

.....
.....
.....

Your own name here.....
Address.....
City..... State



COME to MILWAUKEE

INVESTIGATE—compare—write to any big business concern in Milwaukee for information about us—or to any of the big electrical organizations in the United States—and you will surely decide to come to Milwaukee, on old Lake Michigan, for your training, at America's Greatest Institution of Electrical Education.

Built on the Corner-Stone of Personal, Individual Service to every student.

SCHOOL of ENGINEERING of Milwaukee

Learn More in Less Time at Less Cost

The only school advertising in this magazine that is authorized to confer the degree of Bachelor of Science upon graduates of its Electrical Engineering College. Our equipment is the most elaborate, complete and up-to-date of any electrical school in America, and includes wiring, testing, D. C. and A. C. motor generator, armature winding and transformer, starting, lighting and ignition, storage battery and chemical laboratories, drafting and designing rooms. Unique laboratory equipment originally designed and patented by us, housed in our most modern steel and concrete fire-proof structure. Our complete facilities afford to every student ample opportunities for actual practice.

No matter how young or old you are, no matter how little or how much general schooling you have had, no matter whether you want to master every branch of electricity and become an Electrical Engineer or desire only to become a highly skilled and well-paid shop worker at one particular kind of

electrical work—there is a place for YOU in one of our many classes of students who are learning to be Electrical Engineers, Commercial Engineers, Electrotechnicians, Practical Electricians, Motor Generator Repairman, Electrical Draftsman, Automotive Electricians, etc., etc.

We do not use our students to make secret profits for ourselves by selling the work they do and the things they produce in the shops.

Don't even think of enrolling with any other school until you have written direct to headquarters for full information about the particular kind of training you are interested in. Choose from the list below. Then mark and mail the coupon TODAY.

S. of E. graduates make big salaries everywhere in the great electrical field. Our Employment Department will help to secure profitable employment with opportunities for advancement.

Our Special Practical SHOP COURSES

These courses are intensely practical and are easily learned by any man who can read and understand common English and simple arithmetic.

Course 1.—Learn in SIX Weeks:
Complete shop course in Electric Light and Motor Wiring.

Course 2.—Learn in SIX Weeks:
Complete shop course in Armature Winding for A. C. and D. C. motors.

Course 3.—Learn in THREE Months:
Complete shop course in Electric Light, A. C. and D. C. Motor Wiring Armature Winding and Motor Generator Repairs.

The above courses are taught to day classes only—eight hours' training and practice five days each week. We guarantee every student satisfaction.

AUTOMOTIVE ELECTRICIAN—Learn in 3 Months

A complete and thoroughly practical course, including every phase of electric starting, lighting, ignition, storage battery work for automobiles, trucks, tractors, motorcycles, airplanes, etc. An invaluable training for any progressive garage man.

ARMATURE WINDING—Learn in 3 Months

The theory and actual practice of armature winding, giving you a complete mastery of this fascinating subject. One of the best paid branches of work in the electrical industry.

COMMERCIAL ELECTRICAL ENGINEERING Learn in 12 Months

This new profession demands young men with combined technical and commercial training.

ELECTRICAL DRAFTING—Learn in 9 to 12 Months

Easy, interesting, pleasant work that is earning big salaries for our graduates all over the world.

PRACTICAL AND THEORETICAL ELECTRICITY Learn in 6 Months

For the man or youth who cannot spare the time or money to enroll for more intensive and higher training, this course is ideal. We positively guarantee that as a student in one of these classes you will learn Practical Electricity in the shortest possible time—no matter how much you pay for your instruction. This course teaches you everything you need to know to go into business for yourself either as the owner of an electrical shop or as an electrical contractor.

EARN WHILE YOU LEARN

We provide for a limited number of worthy men, half-time jobs at good wages, and permanent positions with unlimited prospects to all duly qualified graduates.

ELECTROTECHNICS—Learn in 1 to 3 Years

This elaborate course prepares the student for entrance to our College Course for Electrical Engineers. Electrotechnicians are a special type of electrical experts qualified to fit electricity to the demands of modern industry and for such positions as superintendent of maintenance, director of construction, superintendent of installation and testing, electrical equipment salesman and automotive electrotechnician.

ELECTRICAL ENGINEERING—Learn in 3 Years 36 Months

Bachelor of Science degree conferred on graduates. Full provision is made for making up deficient high school credits. It is the Electrical Engineers who have given to the world the thousands of fortune making inventions in the electrical field. No man with this training can fail to realize his highest ambitions in life.

EVERY INSTRUCTOR A SPECIALIST

These are some of the experts whose teaching has supplied thousands of high-salaried men to the electrical industry through this school—many of whom in overalls and jumpers stand at your elbow teaching and explaining while you learn by doing. The only way you can fail to learn is to refuse to learn:

Oscar Werwath, E.E.
Francis A. Vaughn, B.S.
Willard C. Hartman, A.B., A.M.
Chester C. Aiken, B.S.
Asher C. Ball, B.S., LL.B.
W. H. Bleck, B.S.
W. E. Boren, A.B.
E. L. Consoliver, M.E.
J. T. Baker
I. C. Fisher, B.S.
George B. Haverson, A.B.
Elmer A. Ihrke, B.S.

Arthur A. Koch, M.S., Ph.D.
Fred W. Krotzer, A.B.
Charles Nyberg, A.B.
C. E. Pettingill, B.S.
Charles M. Ploetz
F. C. Raeth, B.S.
H. A. Rickeman, A.B.
Charles G. Simpson, M.A., Ph.B.
J. W. Smith
A. L. Sudduth
Peter C. Winther, B.S.

Next Term Opens Sept. 2

MAIL COUPON NOW

Mail the coupon today for our Free Illustrated catalog. Tell us what course interests you most and we will send you special information. Find out about the great opportunity in Electricity today. Learn how we can help you to a permanent and lasting success. Don't put it off! Mail the coupon now!

SCHOOL of ENGINEERING of Milwaukee
Dept. S. I.-724, 415 Marshall Street, Milwaukee, Wisconsin

SCHOOL OF ENGINEERING OF MILWAUKEE

Dept. S. I.-724, 415 Marshall Street, Milwaukee, Wisconsin

Please send me, without cost or obligation, your big free illustrated book and details of the course which I have indicated below.

Course

Name

Address

City..... State.....

Age..... Education.....



Master Electricity By Actual Practice

The only way you can become an expert is by doing the very work under competent instructors, which you will be called upon to do later on. In other words, *learn by doing*. That is the method of the New York Electrical School.

Five minutes of actual practice properly directed is worth more to a man than years and years of book study. Indeed, Actual Practice is the only training of value, and graduates of New York Electrical School have proved themselves to be the only men that are fully qualified to satisfy EVERY demand of the Electrical Profession.

The Only Institution of the Kind in America

At this "Learn by Doing" School a man acquires the art of Electrical Drafting; the best business methods and experience in Electrical Contracting, together with the skill to install, operate and maintain all systems for producing, transmitting and using electricity. A school for Old and Young. Individual instruction.

Over 8,000 Graduates are Successful Men in the Electrical World

No previous knowledge of electricity, mechanics or mathematics is necessary to take this electrical course. You can begin the course now and by steady application prepare yourself in a short time. You will be taught by practical electrical experts with actual apparatus, under actual conditions.

The N. Y. E. S. gives a special Automobile Ignition Course as an advanced training for Auto Mechanics, Garage Men and Car Owners. The course covers completely all Systems of Ignition, Starters, Lighting and other electrical equipment on automobiles, motor boats, airplanes, etc.

Let us explain our complete courses to you in person. If you can't call, send now for 64-page book—it's FREE to you.

New York Electrical School

29 West 17th Street, New York

New York Electrical School
29 W. 17th St., New York, N. Y.

Please send FREE and without obligation to me your 64-page book.

..... NAME
..... STREET
..... CITY STATE

Science and Invention

H. GERNSBACK, EDITOR AND PUBLISHER
H. WINFIELD SECOR, ASSOCIATE EDITOR
T. O'CONOR SLOANE, Ph.D., ASSOCIATE EDITOR

Editorial and General Offices, - - - 53 Park Place, New York

"Those Who Refuse to Go Beyond Fact Rarely Get As Far As Fact" . . . HUXLEY

Smell

By HUGO GERNSBACK

ONE of the least explored human senses, no doubt, is smell. Of the five senses man has, the sense of smell is the least developed. We all know that a dog for instance has a well developed sense of smell and can scent his quarry at a considerable distance. This is the case also with a great many of the wild animals who have had some of their senses sharpened a great deal through outdoor life. On the other hand certain human beings have their sense of smell rather well developed. This is particularly true of people who are both blind and deaf. These individuals often develop this sense to such a degree that they are able to recognize different people simply by their various odors.

I BELIEVE

¶ In 1,000 years all diseases will have been eradicated.

According to the Dutch Physiologist, Zwaardemaker, smells are classified roughly into the following classes: (1) Ethereal smells which includes most fruit odors. (2) Aromatic smells, as for instance spices, camphor, lemon, etc. (3) Fragrant smells like those of flowers. (4) Ambrosaic smells similar to those of musk. (5) Alliaceous smells as those of garlic, fish, etc. (6) Emphyreumatic smells as those of tobacco and toast. (7) Virulent smells like that of opium. (8) Nauseating smells as for instance that of decaying animal matter.

This list is possibly satisfactory from a human standpoint, but we do not know much about the effects which certain odors and scents have upon animals and insects. That which smells good to us may not smell good to certain animals and insects, and vice versa.

It is quite possible that many objects give out scents and odors, as for instance metals, which probably have strong odors to animals and insects, but which cannot be smelt by human beings. Until an instrument is discovered that can artificially respond to scents and odors, we probably will not learn very much about this important subject. Nearly all of our other senses can be checked by means of instruments, but no instrument to simulate the effects of odors has as yet been invented although it is much needed. We have instruments to accurately measure the equivalent of touch. A photographic camera and the photoelectric cells may be said to replace the human eye. The telephone may be called the electric ear. Chemical

apparatus can be used to replace taste, but smell so far stands unmeasured. Once scientists appreciate how important the science of odors and scents is, an instrument will probably be invented upon which the most minute quantities of odors can be detected. Let no one make the mistake and think that odors are not material. When you leave a piece of scented soap lying in your bathroom this piece of soap becomes a miniature broadcast station sending out scent through the entire room in a very short time. The scent particles are carried through the air in all directions the same as radio waves. If your eye were equipped with an ultra-microscope you would see floating in the air small particles which carry the odor about. Of course these particles are extraordinarily small and they are probably no larger than a molecule and maybe smaller. Thus, a piece of musk will give off a powerful scent for dozens of years, while it has so far been impossible to detect any reduction in weight of the original article, despite the fact that the piece of musk is losing perhaps millions of particles every second.

I BELIEVE

¶ Time exists only in our imagination. It does not exist in nature.

I BELIEVE

¶ During the next twenty years science will make greater discoveries and inventions than during the past 100 years.

We say a scent or odor is strong or weak. This refers simply to the dilution of the particular scent or odor in the atmosphere. Just as you can take a little coloring matter and color a glass full of water strongly and then gradually lose the color by putting the glass under a faucet; if you keep on adding more water a dilution is finally reached where it is not possible to detect any color at all.

This is exactly the case with all odors which can be diluted in the atmosphere to such an extent that they no longer are detectable.

How little a scented body loses in weight and how long the scent remains was recently shown when King Tut-ankh-Amen's tomb was opened. Some of the vases still gave off a faint odor of aromatic oils with which they were filled over 3,000 years ago.

Another interesting fact about smell—at least in human beings—is the inter-relation between taste and smell. Certain foods become tasteless to us if we cannot smell them. Everyone who has a cold realizes this truth. The nerve ends in our nose, susceptible to odors, become paralyzed when we have catarrh, hence we can no longer smell.

THE GOLDEN AGE OF SCIENCE

is now symbolized by the golden cover of SCIENCE & INVENTION. LOOK FOR THE GOLD COVER every month!

The Mysteries

Featuring
By TAMAR LANE



HAROLD LLOYD'S new comedy "Girl Shy" drew capacity houses for three weeks at the Strand Theatre, New York City. The editors have no hesitancy in saying that it is one of the greatest motion picture comedies ever filmed. In the accompanying picture story, some of the more interesting and exciting comedy action scenes are explained by our Hollywood correspondent. Mr. Lloyd has certainly distinguished himself in this production. Moreover he keeps you on edge practically every minute as he drives through city streets with horses, automobiles and trolley cars at lightning speed.

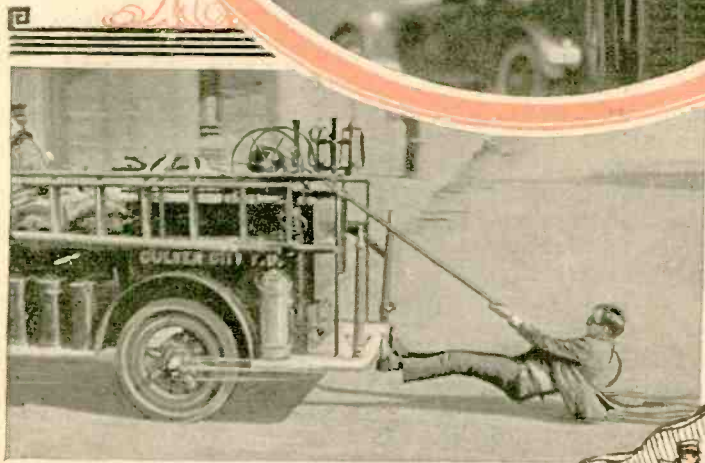

The picture above will be familiar to those who have seen "Girl Shy." This represents the moment when Lloyd drives the trolley car across the picture at lightning speed. The illusion of great speed was obtained in most of these scenes by turning the camera slowly and having the pedestrians and automobiles move at about half normal speed, and when the film was shown on the screen at normal speed, the effect of great velocity was obtained.

The photo above and diagrams at the right explain how Lloyd performed the hose cart stunt. At first he stands upright as he jumps on the tail board and keeps pulling on the hose in a wild effort to keep from falling off, but the hose continually unwinds, so that eventually he gets down to the low angle shown above, and finally lands on the street, the hose cart dashing on without him. This trick was dependent upon the alertness of the operator at A, who controlled, by means of a brake on the hose reel, the speed with which the hose unwound. The top photo shows Harold hanging on to the trolley pole adrift from the car, in another scene.

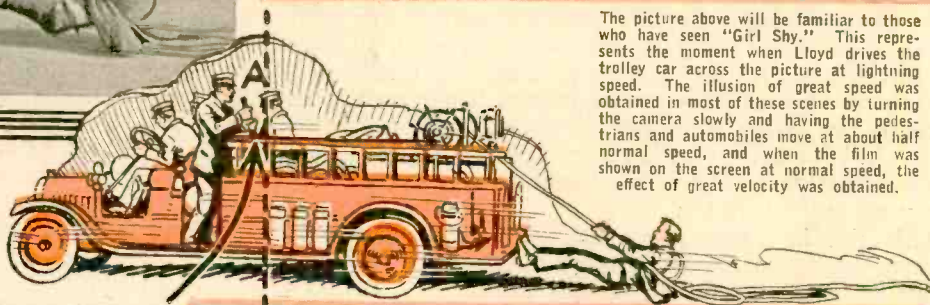

BRAKE ON HOSE-REEL CONTROLLED BY MAN AT A



The three pictures above as well as the enlargement from the film reproduced at the right explain how the bumpy automobile scene was taken. Those who have seen the picture will remember that even after Harold and his automobile leave the rough road and arrive on the nice smooth boulevard, the machine still persists in jumping up and down alarmingly. The secret lies in the fact that the property man was instructed to provide four special wheels for the automobile, the hubs of these wheels being located off center. By referring again to the three small pictures above the consequent action and resultant comedy will become evident.

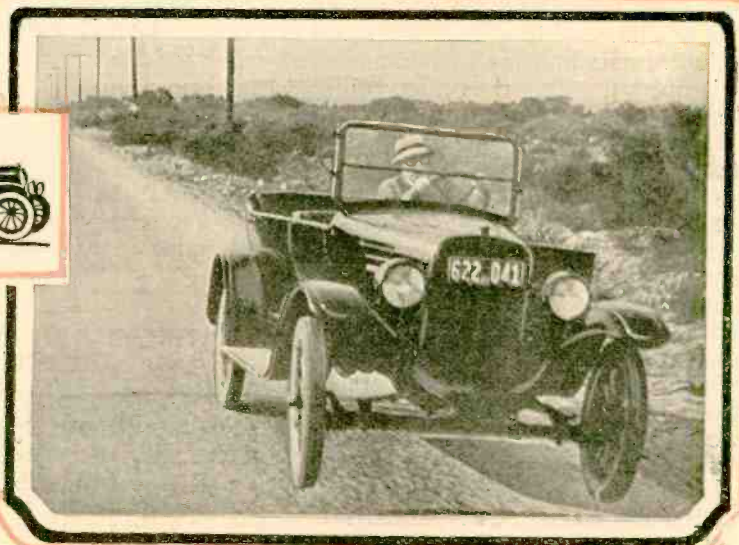

of "Girl Shy"

HAROLD LLOYD

of Hollywood, Calif.

Mr. Lloyd in his latest comedy film-play has shown us some wonderful horsemanship, the photo at the right showing him tearing down the main street in a large California city amid all kinds of traffic. It is entirely possible, as the author of this article says, that several people were injured in the taking of this picture. The action is so fast that it almost takes one's breath away. The great speed obtained in the projected picture on the screen is due to the fact that the cameras were turned slowly, while all pedestrians and vehicles on the street were under the control of the director and also moving slowly. The resultant screen speed of Harold and his horses is nothing short of astounding.

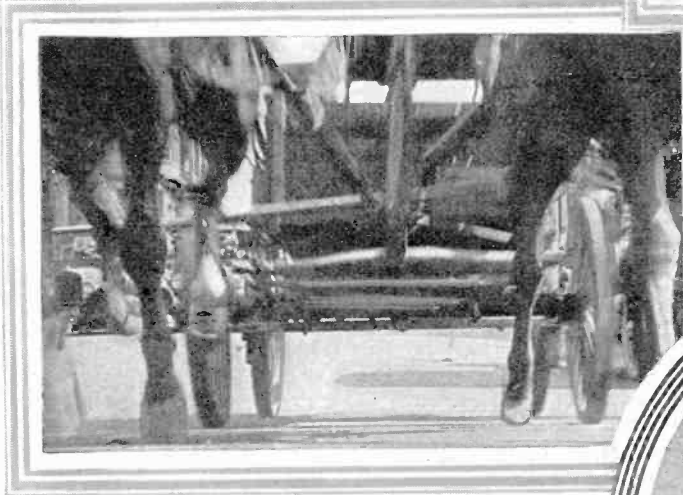

In the photo above and line drawing at the right, we learn how that part of the picture was taken where the team of horses drive over the heads of the audience. The cameraman was located in a man-hole in the street, and a most unusual and bewildering effect was obtained as the team of horses come tearing down the pavement directly at the camera and pass overhead. One sees flying horses' hoofs and the under side of the wagon as it speeds over the camera—a most unusual sight.



One of the most astounding feats of horsemanship shown in the picture is illustrated above and at the right. Here one sees Mr. Lloyd riding on the back of one of the horses, and suddenly the horses trip and fall. This picture was being filmed from an auto truck following the team and the director ran into the picture, thinking Mr. Lloyd was injured by the fall—purely accidental. The frames in the picture from 2 to 5, where the alarmed director rushed into the picture were removed in the printing process, and the audience now sees the team fall and Harold remount the horse and rise with it from the ground.

Among the thrills in "Girl Shy" is that where he snatches up the little dog of his sweetheart-to-be with his cane, just as the rear of the train speeds along past the dog. Harold catches the harness of the dog with the stick. This stunt had to be taken several times. It should be explained that the young lady, greatly excited at losing her dog, is on the train. The camera was turned slowly and the train also moved slowly, the effect of great speed being obtained when the film passed at normal speed through the projector and was projected upon the screen.



Telephone Wires

By H. WINFIELD SECOR

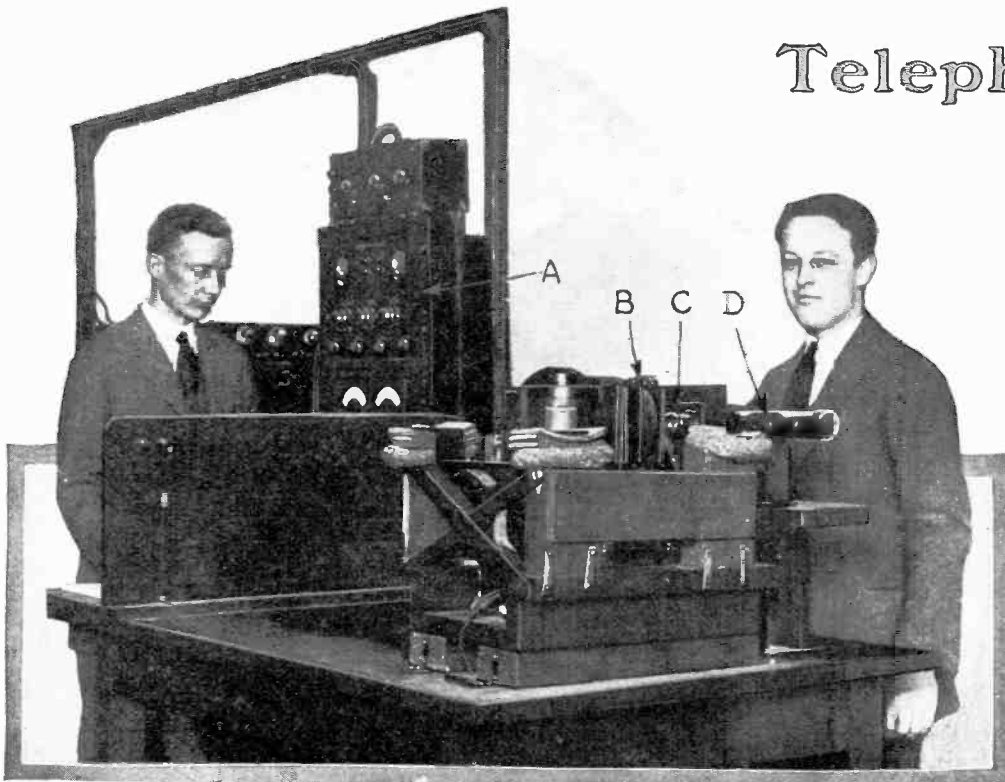

THROUGH more than 600 miles of telephone wire and dozens of switchboards, photographs have been transmitted by a new device of the American Telephone and Telegraph Co., from Cleveland, Ohio, to New York City. The detail of the reproduced pictures were so perfect that half-tones of them were made and published in the daily papers in New York. The actual wire transmission required but four minutes and thirty-six seconds. In a recent test, a picture taken on the streets of Cleveland was reproduced in New York in less than forty-four minutes after the camera man snapped his shutter. In the photograph at the left, A is the control switchboard containing the vacuum tubes, meters and other apparatus not a part of the immediate receiver; B is the light valve, C is the lens and D is the film revolving on the cylinder.

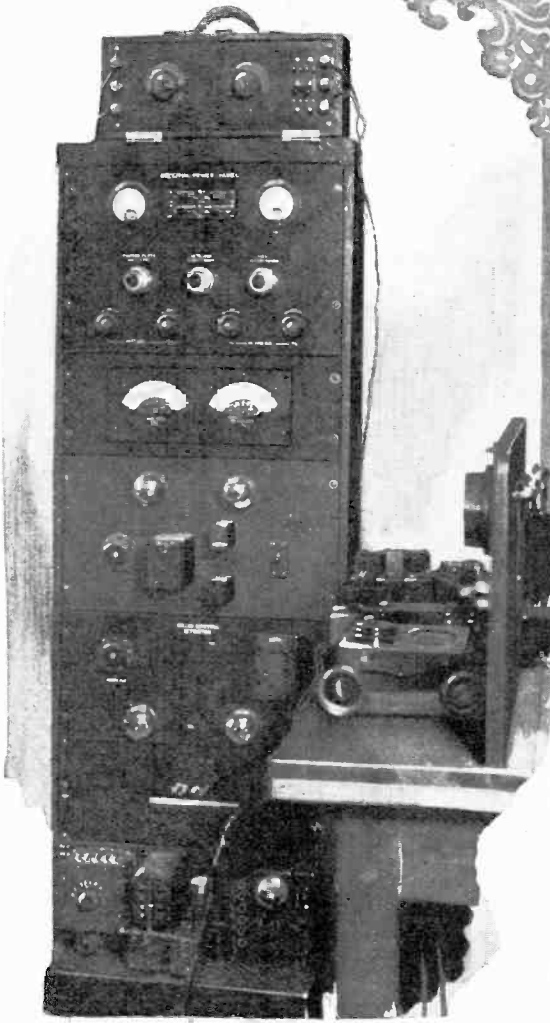

Front view of the control panel, A, at receiving station showing power vacuum tubes, meters, etc. This apparatus is seen at the left of the picture at the top of the page, the operator behind the center panel board giving the signal to Cleveland when the apparatus has had a new film placed on it, and everything is ready for reception of the picture.

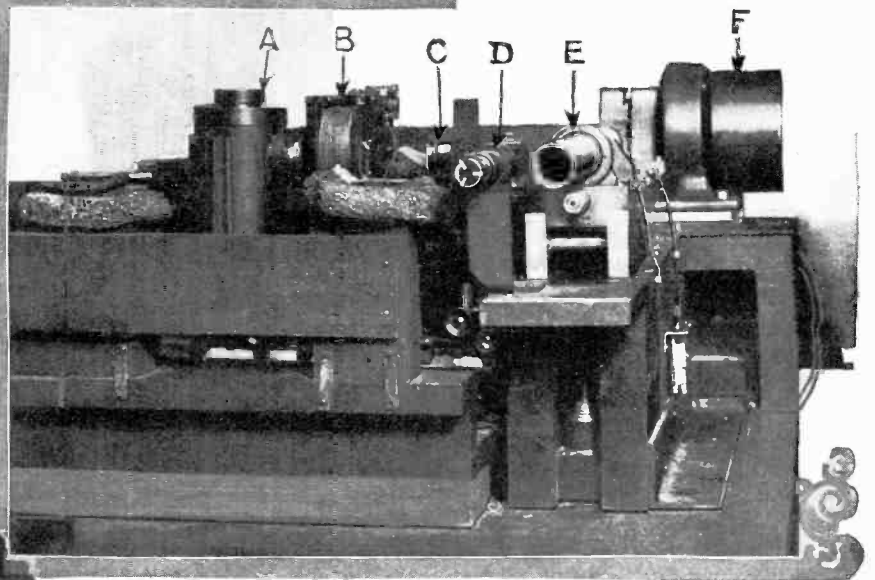
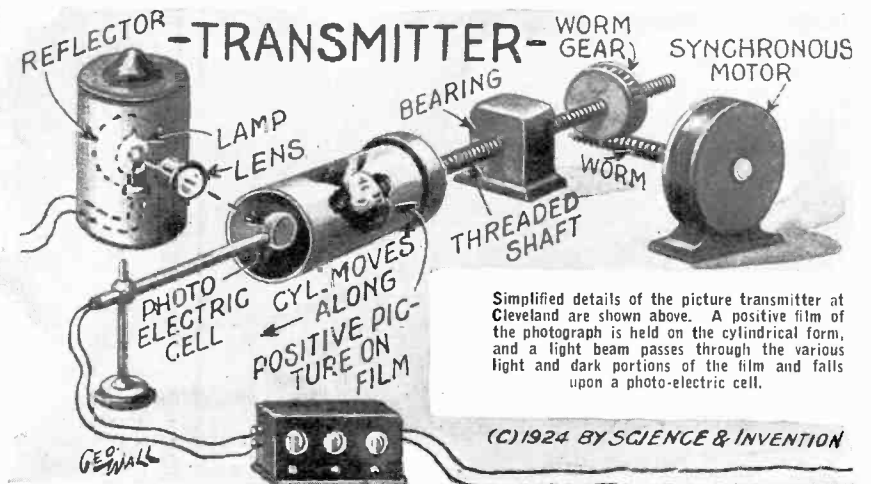

Photo above shows close-up end view of receiving cylinder, E, containing the photographic film. This cylinder, E, is driven by synchronous electric motor F. A strong light beam from housing A, passes through the light control valve B, and lens C, on to the film on revolving cylinder E. D represents prism and telescope for checking light ray form. The receiving apparatus room is lighted with red lamps.



Simplified details of the picture transmitter at Cleveland are shown above. A positive film of the photograph is held on the cylindrical form, and a light beam passes through the various light and dark portions of the film and falls upon a photo-electric cell.

Carry Pictures

Associate Member, A. I. E. E.

The picture at the right shows a close-up of a greatly enlarged view of President Coolidge's left eye, the exact area being indicated by dotted lines in his portrait at the extreme right. The uncanny manner in which the picture is traced by the constantly fluctuating beam of light at the receptor is made more evident by a close study of the two photographs shown herewith, and particularly the enlargement of the eye. The picture is made up of lines of varying width which correspond to the light and dark portions of the picture. The two photographs reproduced herewith appear in line engraving, but they may also be reproduced in half tone, using 65 screen, corresponding to the pitch of the lines on the apparatus as now set up. The print has to be turned 45 degrees in photographing it through a screen for half-tone reproduction. Try looking at the enlarged picture of the eye at a distance of six feet. The two pictures herewith are line cuts.

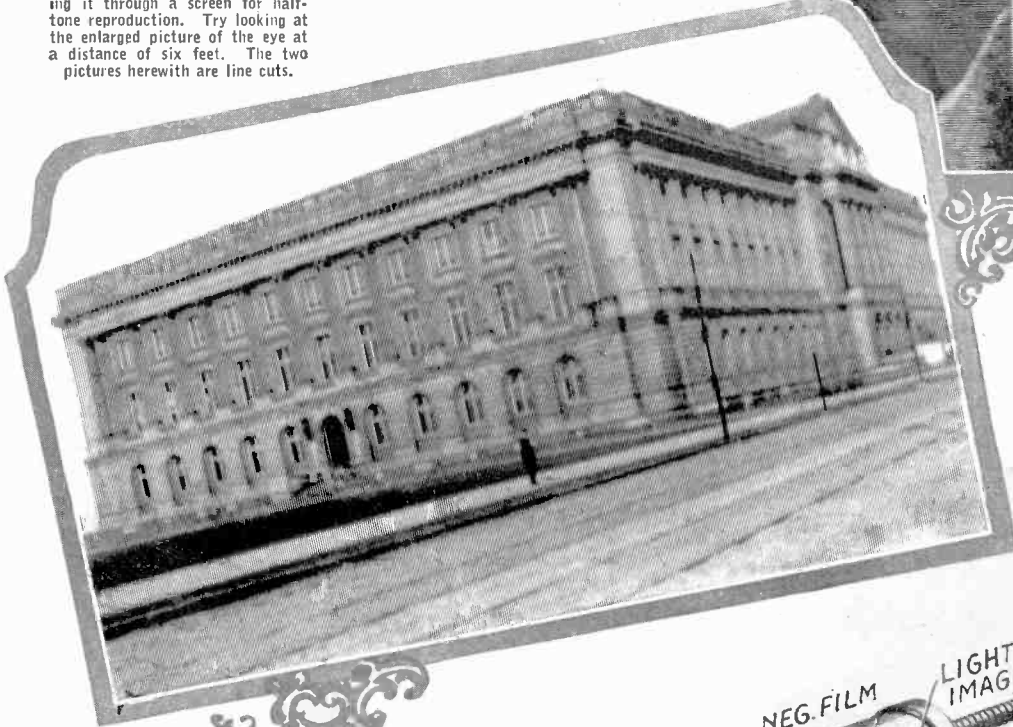
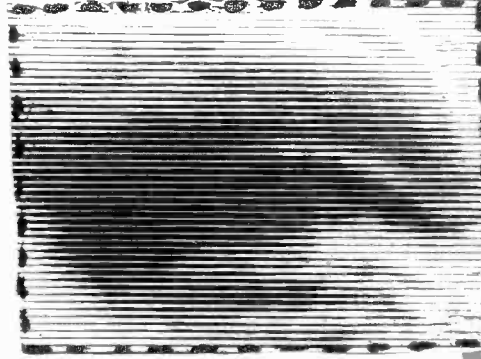

The picture above of President Coolidge and the picture of the building at the left, both of which were transmitted from Cleveland to New York City, in approximately four and one-half minutes, give a clear idea as to the excellent results obtained by this new system of transmitting pictures over an electric circuit, as developed by the engineers of the A. T. & T. Co., and the Western Electric Co. These experts succeeded in transmitting pictures a year or more ago, but it was only a short time ago that the first public demonstration was held. The commercial aspects of the new picture transmission system have not been worked out as yet, but the machines now in use will be offered for press use as soon as possible.

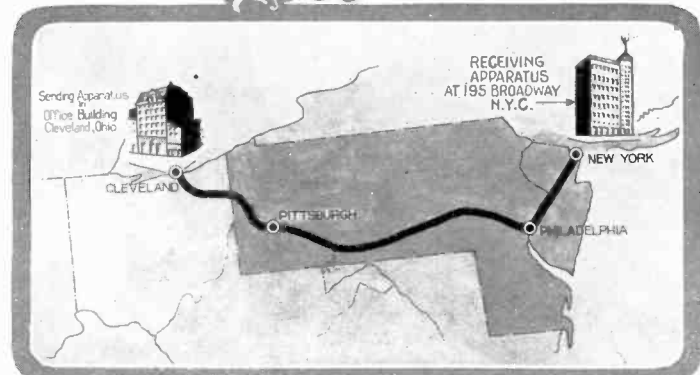

The circuit over which the picture currents traveled between Cleveland and New York City is shown in the official map above. Vacuum tube amplifiers, as shown in the diagram below, were used at certain points along the line to boost the picture currents, and the vacuum tube found another role in supplying the necessary control currents for the synchronous motors.

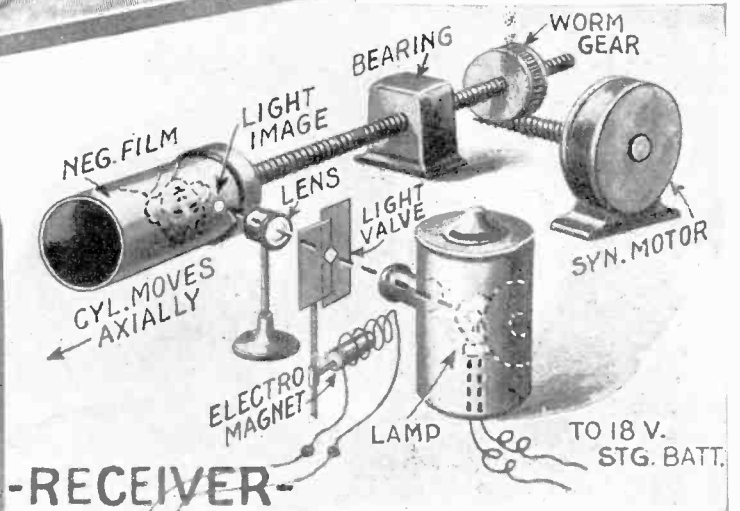

Here we are at the receiving end of the picture transmission circuit. The fluctuating electric currents passing over the circuit (radio transmitting and receiving stations may be used) act on the magnetically-controlled light valve shown above, which constantly changes the diameter of the beam of light passing through the lens on to the unexposed film rotating progressively before it, and causes lines of constantly varying constriction to be photographically formed on the sensitized film. The synchronous motor and worm gear rotate the receiving cylinder in exact step with the cylinder at the transmitter. With a positive film used at the transmitter, the received image will be in the form of a negative. As soon as this is developed, prints can be made.

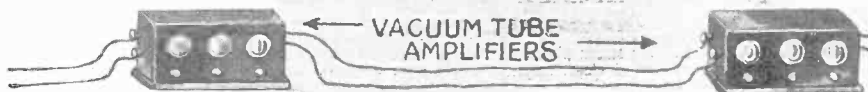

Movies "Demolish" New York

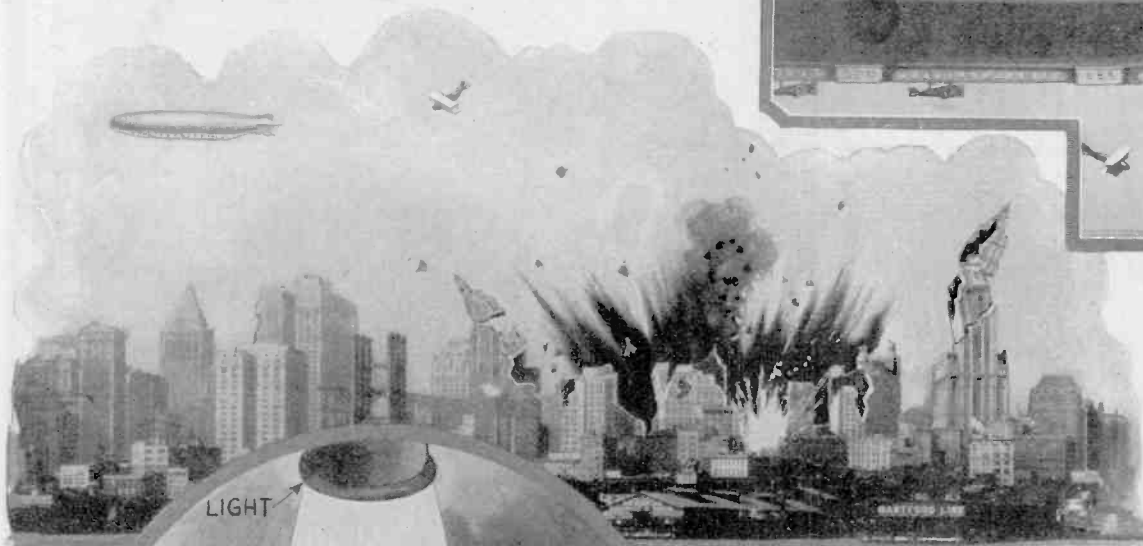
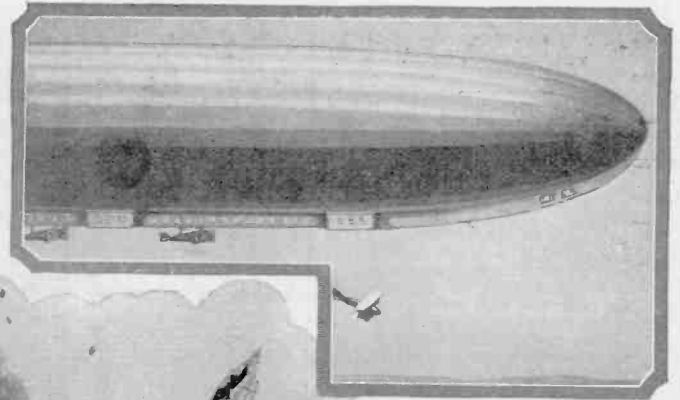

The Bray Studios have "blown up" New York City for the benefit of a national aeronautical society. The results are shown here. Above is seen the bow of a huge dirigible. It will carry small planes beneath it, releasing them for battle. Below, a huge dirigible, three times larger than any constructed at present is realistically shown moored over the busiest section of New York. All these stunts were accomplished by a simple method of double exposure.

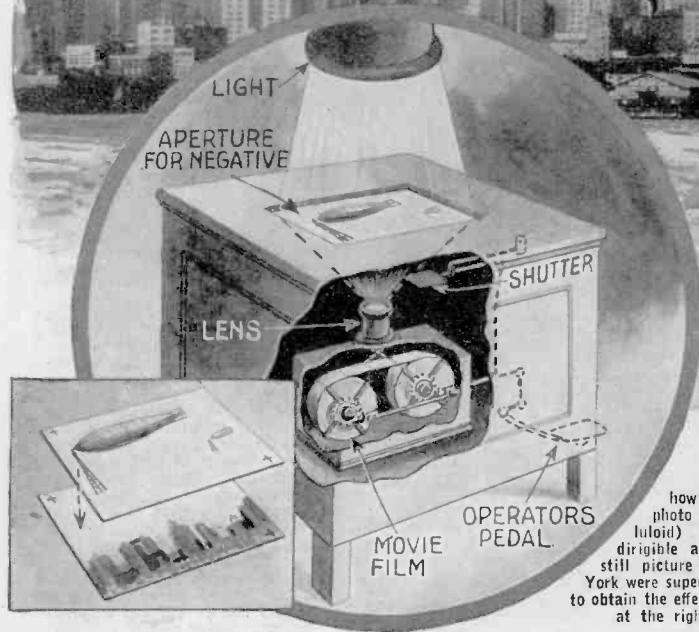

Showing how the still photo (on celluloid) of the dirigible and the still picture of New York were superimposed to obtain the effect shown at the right.

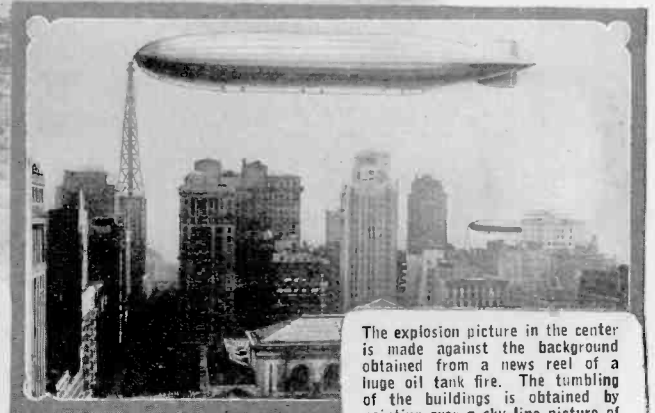

The explosion picture in the center is made against the background obtained from a news reel of a huge oil tank fire. The tumbling of the buildings is obtained by painting over a sky-line picture of the city. It was done similarly to the one above. —W. B. A.

Movies of Heartbeats Taken

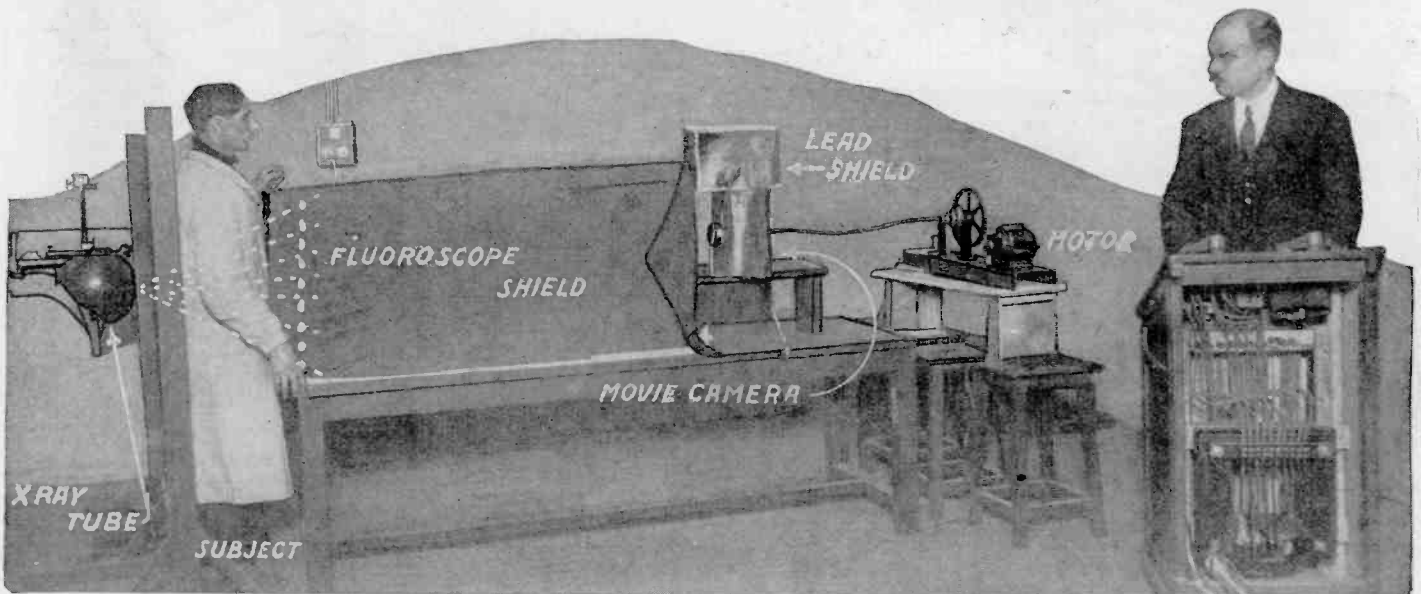

A French scientist, Dr. Lomon, of Paris, has developed a new system whereby it is possible to make motion picture studies of heart action. Photo shows a demonstration of the apparatus. The patient has his back to a tube which emits Roentgen rays. At the

end of a long screen placed against his chest is a motion picture camera, especially constructed, and shielded, sensitive to the rays, which, passing through the patient's body, record his internal action on the film. Dr. Lomon is shown manipulating his apparatus.

A Modern Pyramid

By OLIVER S. ARATA

AMERICA is to have an obelisk. It will be 130 feet high and is already being erected of concrete on a peak of the Ozark Mountains in Arkansas. The construction is being paid for by Mr. William H. Harvey, who assumes that in twenty thousand years from now this civilization will be destroyed and that a new group of nations will have been established. Mr. Harvey then advises that if you scoff at this idea, you list to the lesson taught by history. The ancient Egyptians also scoffed when a wiser man told them that their great civilization would be lost. The pyramid, the approximate cost of which will be \$25,000 when completed, is being erected at Monte Ne in Benton County, Arkansas, on solid limestone rock. The base is to be 40 feet square. In the room just above the limestone rock, which will be 16 feet square, many unique and valuable features and records will be placed. Descriptions of airplanes, circulation of blood, railroads, the phonograph, electricity and numerous other modern inventions are to be placed in one of the three airtight chambers, two of which are to be in the shaft of the pyramid itself.

Our artist's conception of the opening of the tomb 20,000 years from now is shown in the illustration herewith. Radio television will enable the world at large to see what is going on at any important place. Individual flying machines will make busy bees of us all. Even inter-planetary trips will become frequent and regular occurrences.

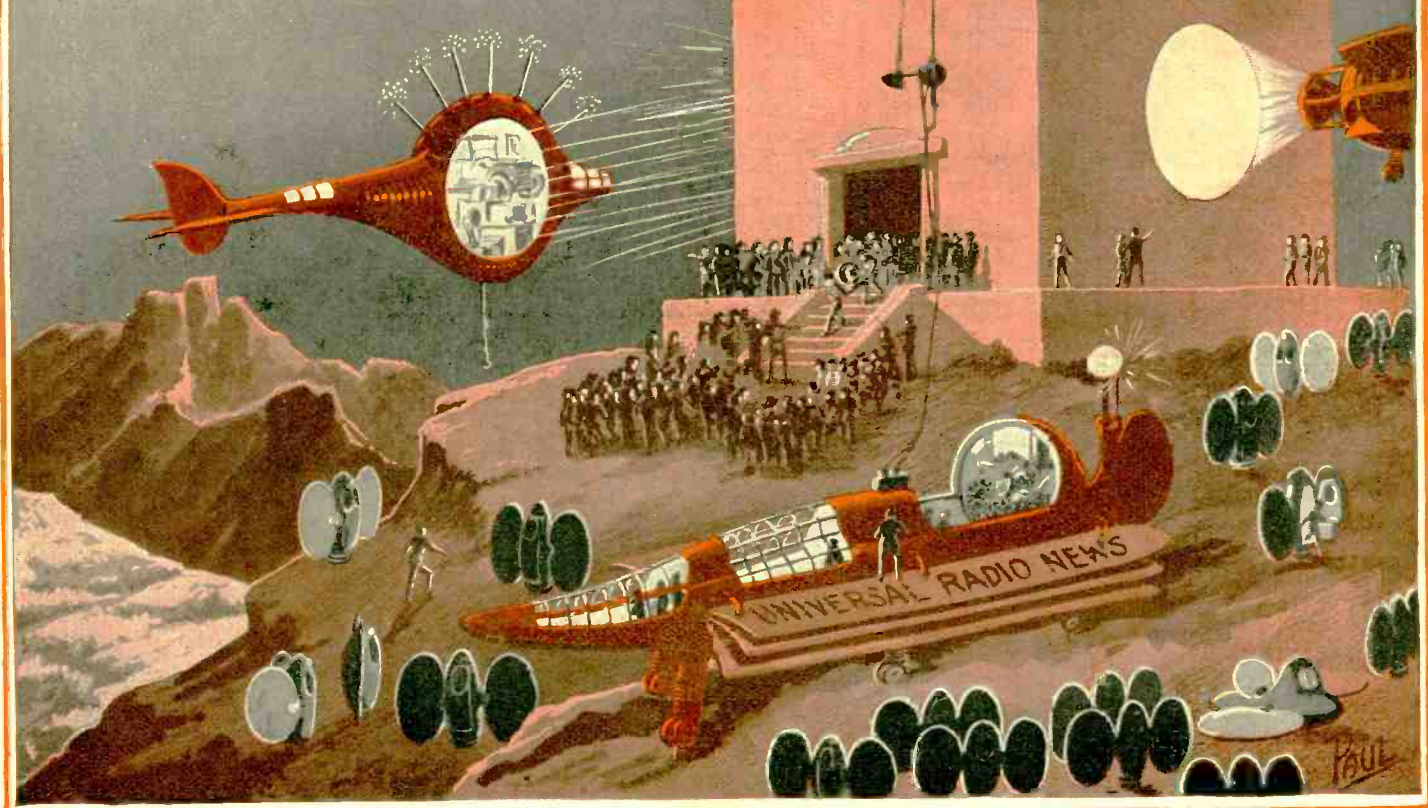

Quartz The Wonder Substance

Makes Light Turn Corners and Composes Near Perfect Lenses.

By W. B. ARVIN

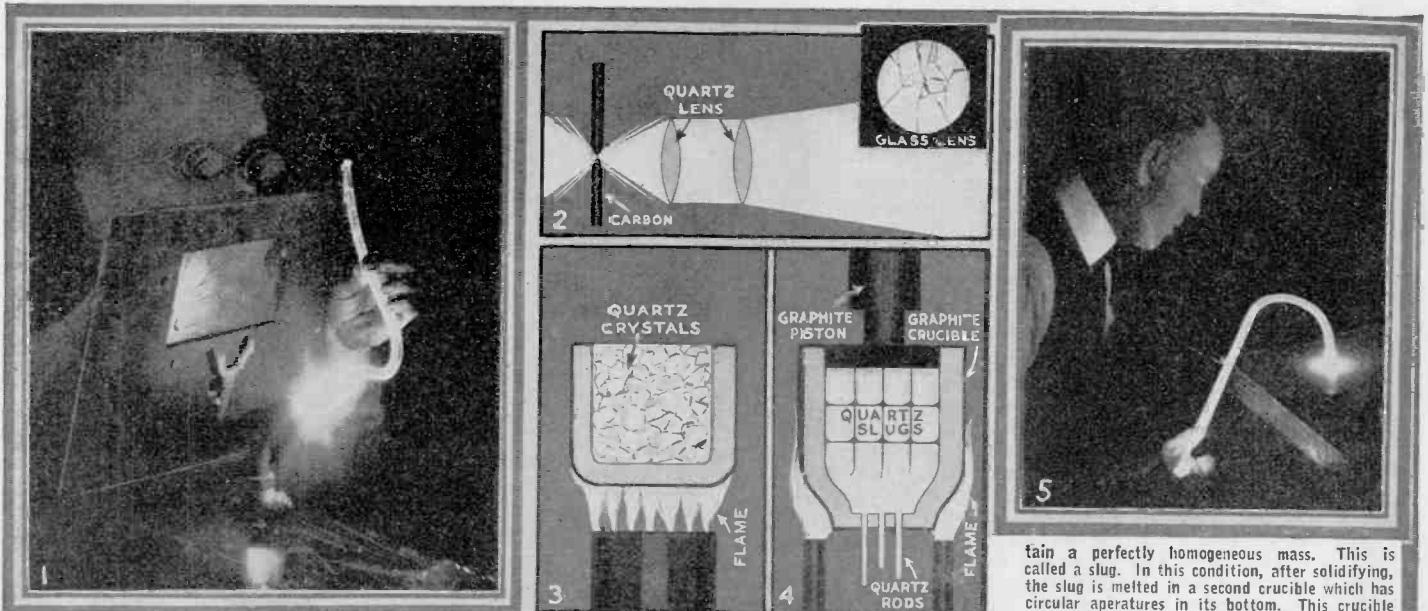

Quartz, the most perfect transmitter of light, has at last been made available for scientific and commercial use through the recent perfection of a process by the General

Electric Co., for fusing and working the material. The first picture shows one of the inventors of the process holding a quartz tube in his fingers while the heat of a oxy-hydrogen flame impinges on its end. Figs 3 and 4 show how the quartz is fused. The quartz crystals, which must be of the clearest description, are melted in a vacuum. Bubbles inevitably form all through the mass, and the purpose of the vacuum is to withdraw them and ob-

tain a perfectly homogeneous mass. This is called a slug. In this condition, after solidifying, the slug is melted in a second crucible which has circular apertures in its bottom. This crucible is of cylindrical shape for its upper portion, and a piston actuated by heavy pressure forces the quartz after a second fusion, to which it is now subjected in this new crucible, out through the apertures like so much dough. It is a variation of what is known in mechanics as die-extruding. A rod of the material bent carries light as a pipe does water. The experimenter, Fig. 5, holds a bent rod; at one end there is an electric lamp, and 93% of its light issued from the other end.

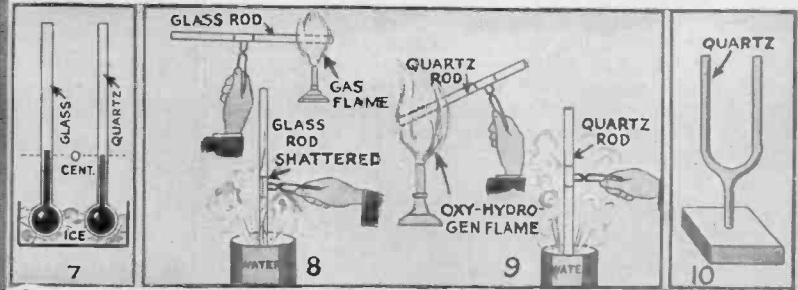

Because of its low rate of expansion with heat, quartz thermometers do not lag as do those made of glass. Fig. 7. Comparison of glass rods with quartz ones is shown in Figs. 8 and 9. Fig. 10 is a quartz tuning fork. On account of the low coefficient of expansion of quartz, this tuning fork will keep its tone much more accurately than will the ordinary variety which is constructed from metal.

Above are shown some of the forms into which the fused quartz has been worked. The large circular piece, which the gentleman at the left of the photo is holding is worked into lenses, such as those shown at illustration 2 above. The quartz, having coefficient of expansion much lower than that of glass, will not break with the quick changes of temperature inflicted upon it by such uses as condenser lenses for motion picture machines, etc., are subjected to. The other subjects in the above illustration show how the quartz may be brought from the furnace. Afterward, it is worked into desired shapes in much the same manner as glass, with the aid of a gas flame and a blow-pipe.

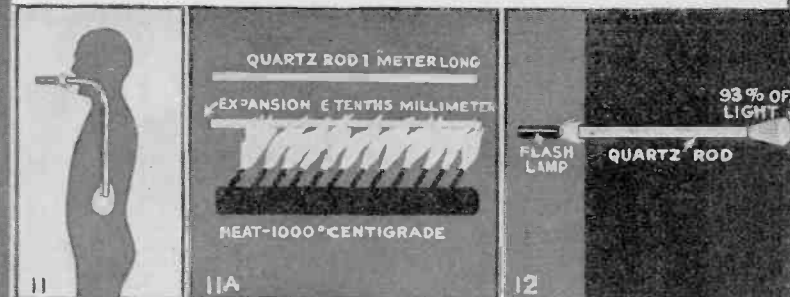
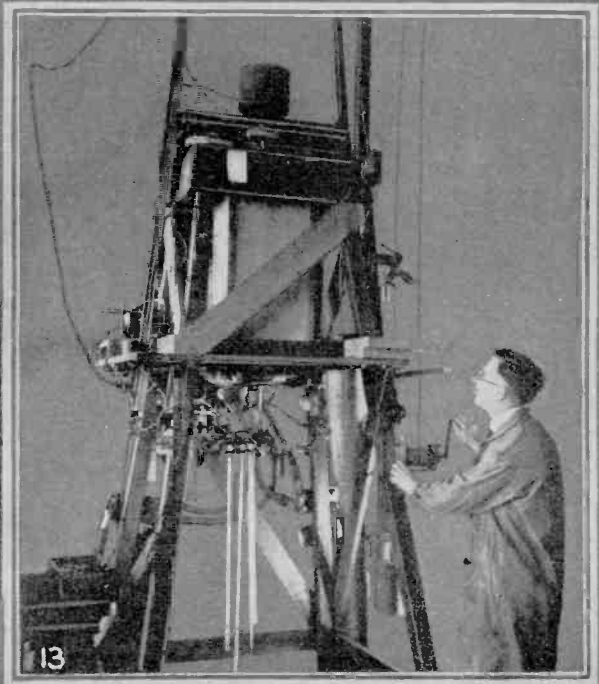

Fig. 11 shows how light may be carried around a corner with the aid of quartz rods. Fig. 5 also shows this. In the latter a flash-light is held at one end of the rod and 93 per cent. of the original light is cast on the paper at the other, shown also at Fig. 12. Fig. 11a shows quartz used as a standard measure. The quartz furnace is shown at Fig. 13.



\$500.00 PRIZE CONTEST

What Can YOU Do With Our Gold Cover?



DRY GOODS

LETTERS FOR STORE WINDOWS

WE have run many contests in the past, but the present one bids fair to outdo all the previous ones, on account of its originality and unusual appeal. Here is a contest that does not require a scientist. Any member of the family from the youngest to the oldest can join in the fun with good prospects of becoming a prize winner.

For a number of months we have been running a gold cover on our magazine and **SCIENCE AND INVENTION** is today famous for it. When looking at the cover the other day, the Editor wondered what could be done with the gold cover or similar gold paper. Immediately dozens of different uses appeared before his vision. While the above few suggestions show what can be done, there must be thousands more.

As will be noted, we have purposely withheld our cover design this month in order to give you a start in the contest.

It goes without saying that no prizes can be awarded to any of the ideas in the above illustration. If the cover of the magazine does not give you enough of the decorative paper, any other paper may be used so long as it is *exactly* the same weight, dimensions, texture, finish and gold as that of the cover. Should you desire, upon receipt of a postal card from

PRIZES	
First Prize	\$100
Second Prize	75
Third Prize	50
Fourth Prize	25
Fifth to Fifteenth, \$20 each	220
Sixteenth to Twenty-first,	
\$5 each	30
TOTAL	\$500

you, we will send you prepaid a reasonable amount of the gold paper. Before you attempt to try for a prize, be sure to read the conditions of the contest carefully.

THE CONDITIONS

- (1) Use only gold paper such as that which forms the cover of this issue of **SCIENCE AND INVENTION** or other paper of exactly the same dimensions, weight, texture, etc., as the cover of this issue.
- (2) Should you desire, upon receipt of a postal card from you, we will send prepaid to you any reasonable amount of this gold paper.
- (3) A model or sample of the idea should in all cases accompany the idea.

- (4) Drawings of the design or idea are only allowable where it becomes physically impossible to forward the article by mail.
- (5) When models or designs are submitted they should be completely assembled. The judges cannot take it upon themselves to paste or otherwise put together the prize entries.
- (6) Only the pure gold part of this cover or other paper of similar dimensions, weight, texture, etc., with no printing on it should be used.
- (7) As many designs or models as invented can be submitted by a single contestant. There is no limit to the number of entries.
- (8) The prizes will go to those who submit the most practical and useful ideas.
- (9) The contest is freely open to all, whether subscribers or not. From the contest are excluded employees of the Experimentor Publishing Co. and their families.
- (10) This contest closes at noon, August 10th, 1924, at which time all entries must be in the hands of the judges in order to qualify. Should two or more contestants submit the same idea, a prize identical to that offered will be given to each of those so tying. Address all entries and packages to Editor, Gold Cover Contest, c/o **SCIENCE AND INVENTION**, 53 Park Place, New York City.

Twentieth Century Mummies

By HUGO GERNSBACK

Member, American Physical Society

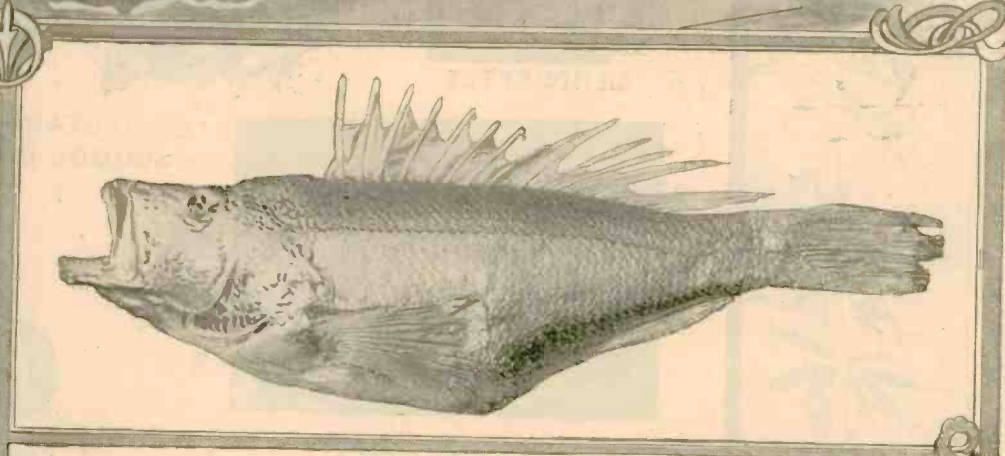
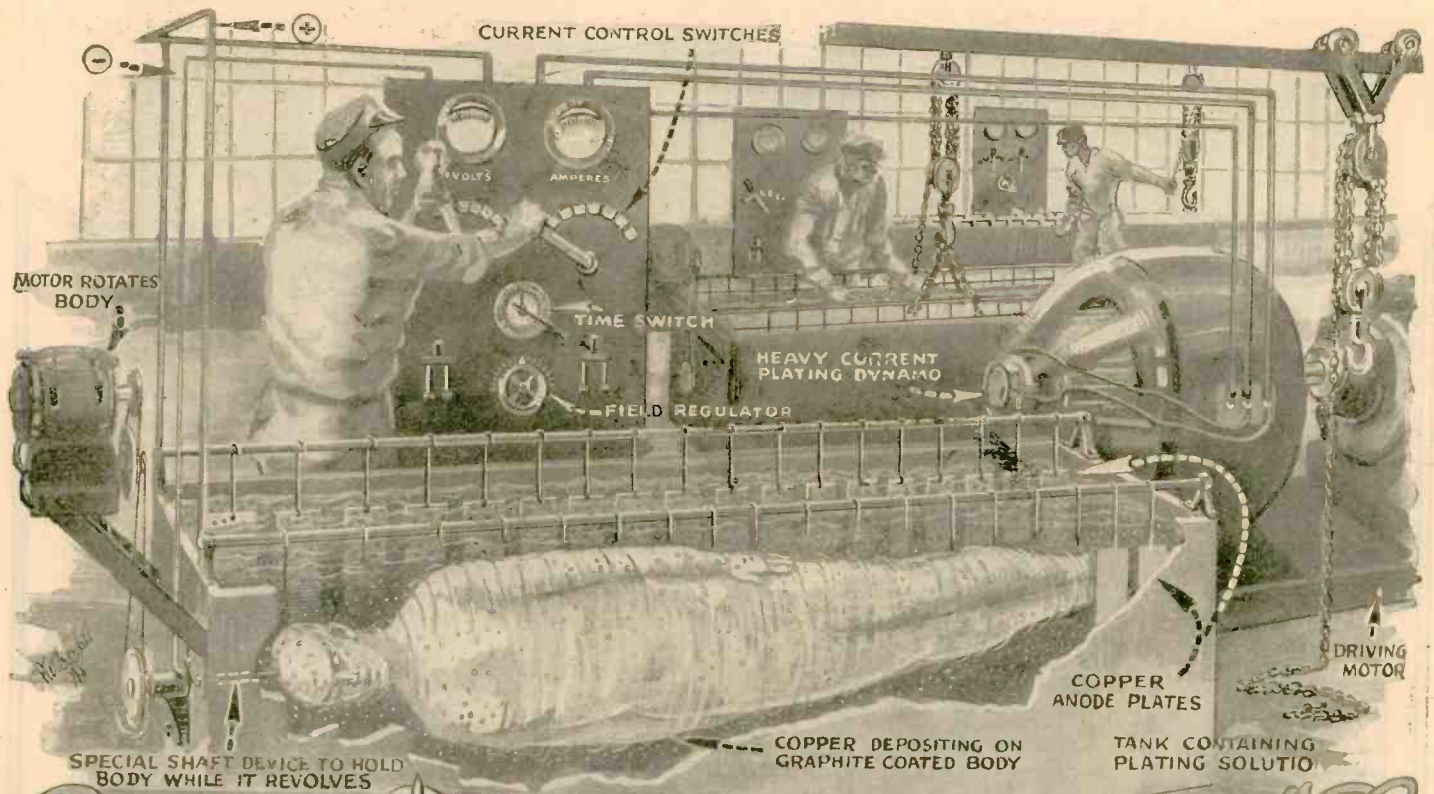

THE art of embalming was carried to a high degree by the old Egyptians as is well known. Egyptian mummies have survived the ravages of time and air for thousands of years. The method that was used by the Egyptians is briefly as follows:

An opening was made in the lower abdomen and the entrails taken out. A special tool was used whereby the entire brain was taken from the skull through the nose. After the body had been steeped for forty days in natron (solution of sulphate carbonate and chloride of sodium), it was ready for embalming. The interior of the body was filled with bitumen, spices, gums and natron, after which the mummy was ready for wrapping and for the tomb.

In our present illustrations the writer proposes a twentieth century mummy with its new means of preserving the human body for thousands of years to come. The writer resorts to electro-plating the entire body. In order to be sure of the theory, he went to the trouble to first try it out on a 1½-foot fish shown in the illustration. The insides of the fish were first taken out, the fish then filled with wax, dried and finally covered with graphite in order to make it conductive to the electric current. It was then placed in an electro-plating bath which plated it entirely with copper in such a way that every scale and fin is clearly preserved. Not a detail was lost. Afterwards the fish was silver plated over the copper.

The same process can be used for human beings without any trouble. Anyone who is fastidious and does not like to think of his body being disintegrated and wishes to preserve it in a mausoleum for thousands of years to come can now have his body electro-plated after his death at an expense that is not prohibitive. In the case of the fish it took four days to complete the electro-plating process which necessarily had to be slow in order to faithfully preserve all the details of the scales, fins, etc.

The price of electro-plating a human being will not be in excess of \$60 to \$75 for a solid coating of copper from 1/8" to 1/4" thick, the price naturally being higher for a heavier plating. In the case of a human being the process would be slightly different. After the body had been thoroughly cleaned and dried and made proof against the ravages of the air and time by certain embalming fluids and substances, the body would then be coated with a thin covering of paraffine or other impervious wax. The wax would then be covered with graphite in order to make it conductive before placing the whole in the plating bath. By means of this process the contour, facial expression and even the hair will be faithfully preserved for posterity, the entire body being covered with a solid sheathing of metal. It will therefore be impossible for air to enter into the inside of the shell and preservation of the body will be well nigh perfect.

The writer makes the suggestion that some of our great immortals should be thus preserved. They could then be enclosed in glass coffins so that people could view them and study them, thereby receiving a good idea of exactly how they appeared in life.

Copper-plating has been chosen because the process is both cheap and efficient. It goes without saying, however, that some of our more fastidious millionaires will probably have themselves gold or platinum plated, or at least have a heavy gold-plating over the copper.

Listening to the Stars

Method used by French scientists for stellar audibility.

French scientists have a new way of differentiating the stars. The method employed by them is shown in detail in the present illustration. The heart of the apparatus is the small photo-electric cell which is composed of a loop of fine wire inside a glass bulb which is coated on its inner surface with a deposit of potassium. When the light from the star falls on the filament, which has a sort of grid action, it acts as an electrode passing a minute current.

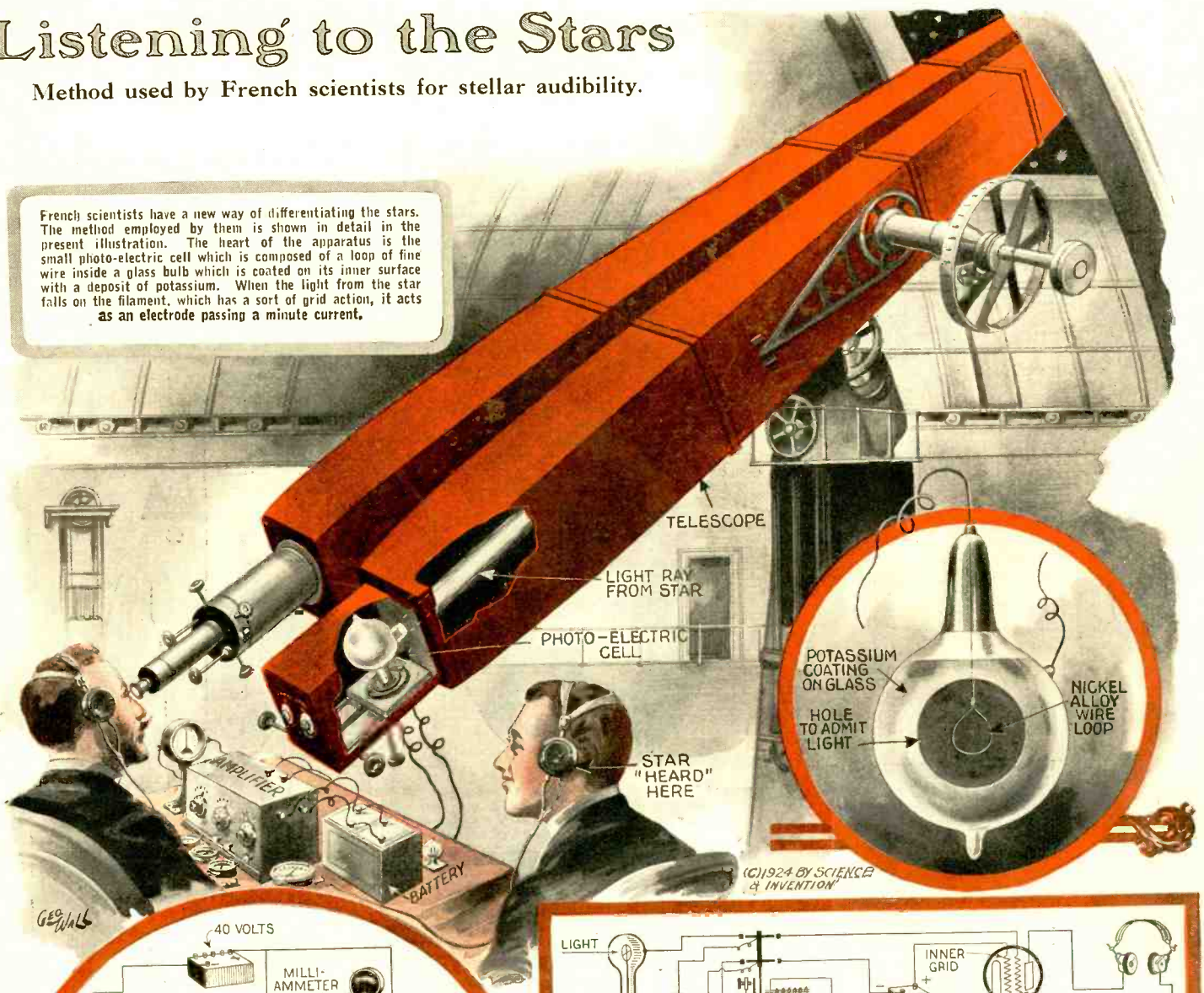

(C) 1924 BY SCIENCE & INVENTION

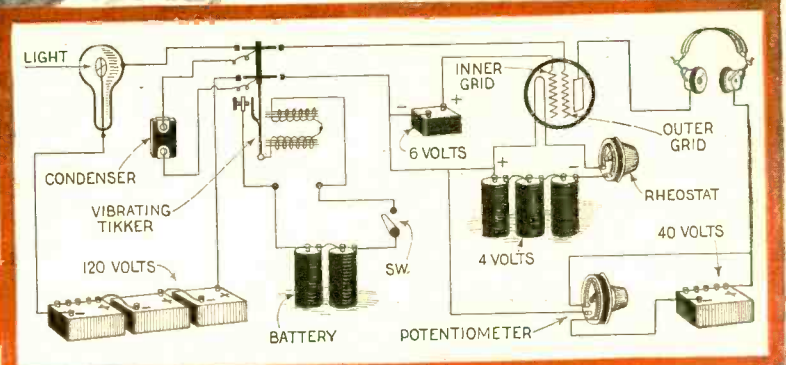
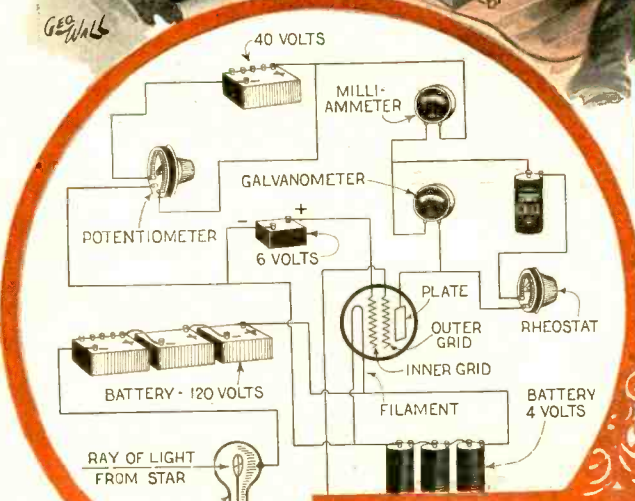

The circuit above shows how a tiker was employed to charge and discharge a condenser into a circuit connected with a special double grid vacuum tube. The sounds heard in the phones comprised a series of ticks. Different stars gave different strengths of sound.

The circuit above shows double grid audion connected with a photo-electric cell and sensitive galvanometer. With this arrangement different stars gave different deflections upon the galvanometer, depending upon the strength of the light from the star.
The circuit at the right shows how clocks may be synchronized as a star passes the Meridian. As a star passes and impresses its light upon the photo-electric cell, a current pulse passes through the galvanometer relay, closing the clock synchronizing circuit.

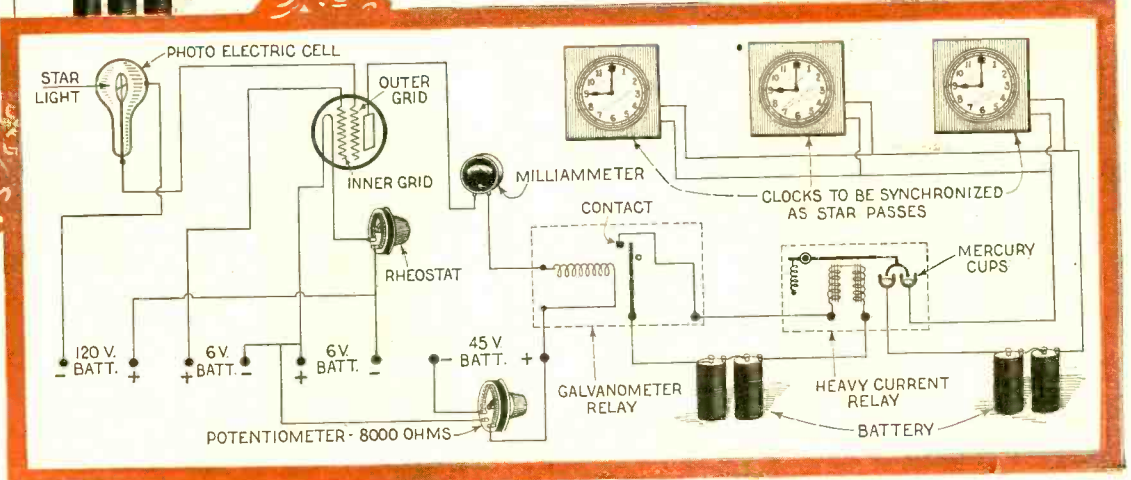

Making Singers of Us All

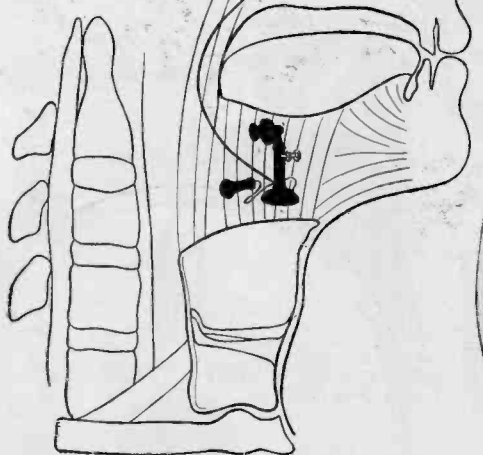

"Waken the dormant brain cell which controls the Hyo-Glossus muscle," says Prof. Eugene Feuchtinger, A.M., "and you have taken the first step toward a super-singing or speaking voice." Strange as it may seem, the first step toward developing a super voice begins in the brain instead of in the throat. First the ambitious singer must gain conscious control of that muscle. The average man does not know that such a muscle exists. Much less can he isolate and exercise it. Why? Simply because the tiny cell in the brain which controls this muscle is asleep. Not dead—simply dormant through lack of use. The brain acts as a switchboard—your 'phone being worthless unless the operator is awake. Through daily silent exercise of the Hyo-Glossus, the super voice, which lies within the reach of all of us, begins to show itself. The biceps are developed by the use of dumbbells or some such device; the Hyo-Glossus is developed by repeatedly making a groove in the tongue. This exercise in time will so develop the Hyo-Glossus that it will be able to neutralize the strain of the other muscle forces shown in the illustration below, thus adding great beauty and resonance to the natural voice. The ability to groove the tongue, as Caruso did (see photo below), is evidence that the Hyo-Glossus is attaining the strength necessary to provide such resistance to the force exerted by the other throat muscles as is required to stabilize and operate the "voice box." This groove is of itself no aid in singing, though it does open the throat. It is merely the external evidence that the singing muscles are functioning properly. Also note groove in tongue in lower left-hand photo. Prof. Feuchtinger claims to have found Hyo-Glossi with a resistance of sixty pounds.

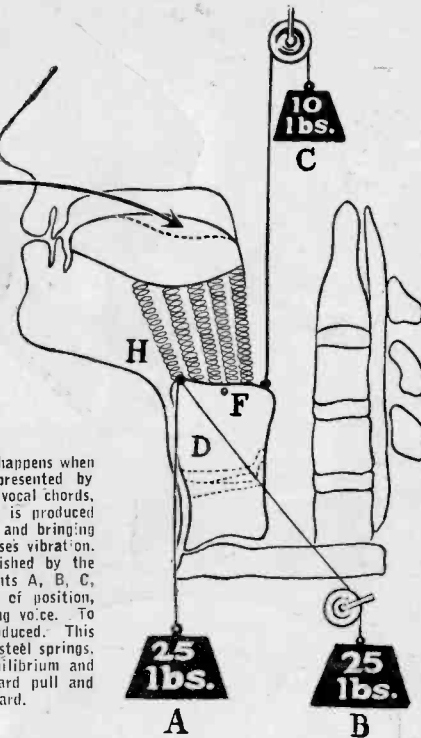

The diagram at the right shows in simplified fashion what happens when you sing properly. The main pulling muscles are represented by weights. Three cartilages, the middle one containing the vocal chords, are pulled together to form a hollow box. "D". Voice is produced by stretching the vocal chords (indicated by dotted lines) and bringing them close together so that air passing between them causes vibration. In the speaking or weak singing voice, this is accomplished by the muscles within the larynx. Forces represented by weights A, B, C, lacking resistance, would pull the whole voice box out of position, rather than tilt it, as should be done for a strong singing voice. To bring about the desired result, a new force must be introduced. This is the function of the Hyo-Glossus muscle, represented as steel springs. "H". The Hyo-Glossus must hold the voice box in equilibrium and supply a fulcrum at the point F, equalizing the downward pull and allowing the backward pull B to tilt the box forward.

WHY LEAVES FALL

The reason trees lose their foliage is due to a special formation of the leaf stalk. When the leaf is formed, a mass of cells are also developed along the layer of separation. This runs right across the base of the stalk as shown in the photos below. In the fall the cells become spongy and permit the leaves to fall, but a scar is already formed and no open wound is left.

—S. Leonard Bastin.

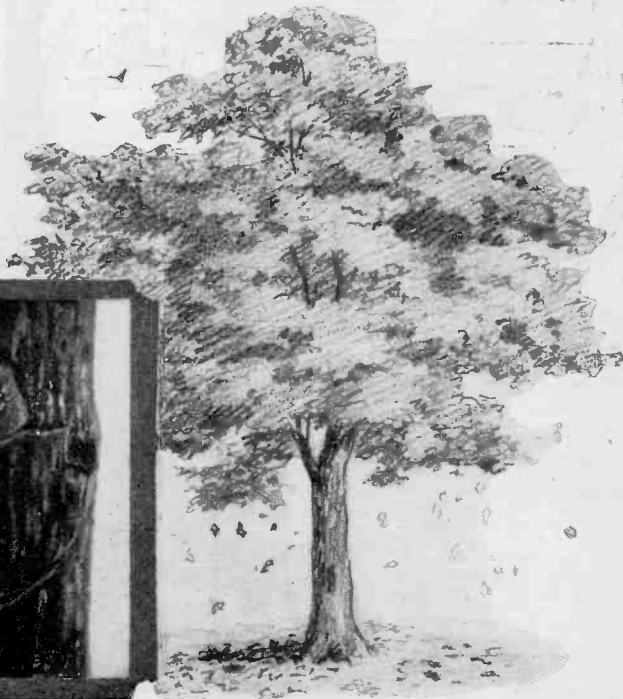
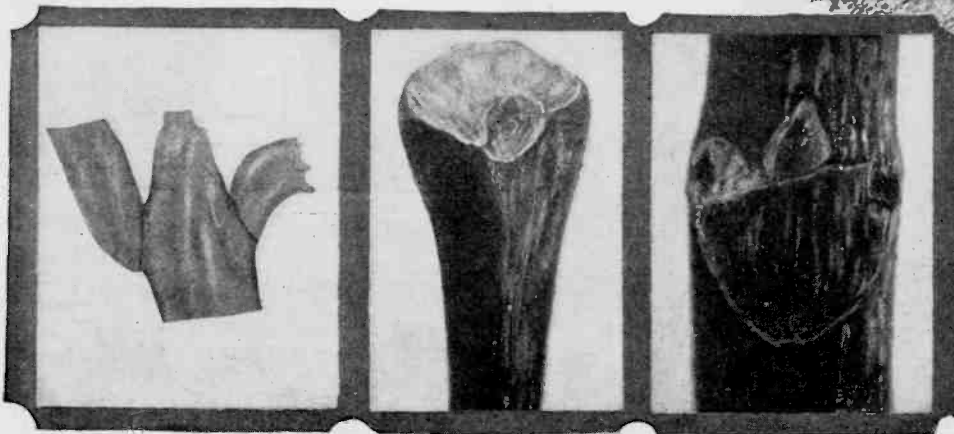

The Giant In the Atom

THE energy chained in one cigarette is great enough to demolish the Woolworth Building. This energy is locked up in the atoms that compose it. Energy is a compound of mass and velocity. The great energy in the tiny particles of matter are a result of the great speeds at which they move. In some cases this speed closely approaches that of light. Note the illustration of the formation of an atom in the illustrations below. A clear idea of the atomic energy in a number of comparatively small articles with which every one is acquainted may be gained by looking over the drawings on this page which clearly depict what the energy contained in the things will do. The horsepowers refer to one second of action.

—Ernest Brennecke.

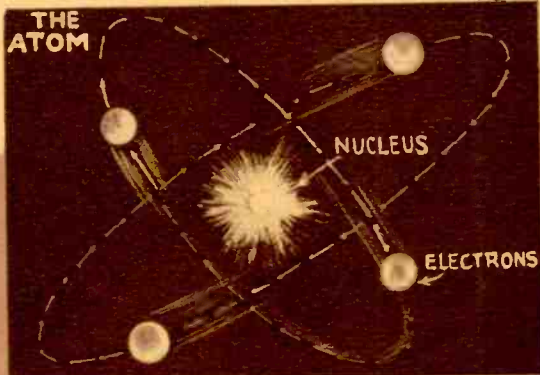

THE ENERGY IN A SINGLE CUP OF TEA (150,000,000,000 HORSE POWER) REPRESENTS A CHAINED GIANT, WHO COULD DEMOLISH A CITY IF RELEASED

MATTER WHICH SEEMS "AT REST" REALLY CONSISTS OF BILLIONS OF ATOMS, MANY PERHAPS MORE COMPLICATED THAN THIS.
SPEED OF WHIRLING ELECTRONS, 625 TO 94,000 MILES PER SECOND, MORE THAN 6,000,000,000,000,000 REVOLUTIONS PER SECOND

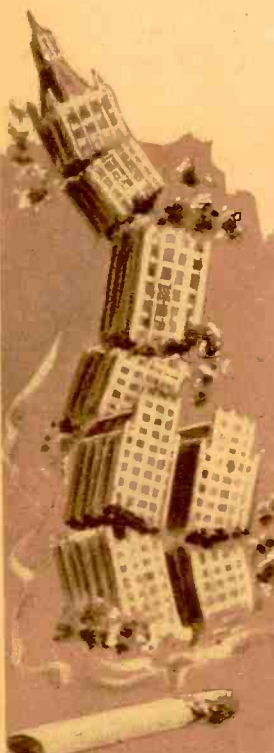

ATOMIC ENERGY IN A SINGLE CIGARETTE (360,000,000 H.P.) WOULD BE SUFFICIENT TO BLOW UP THE WOOLWORTH BUILDING.



ENOUGH ENERGY IN ONE BISCUIT TO DRIVE TRAIN FROM COAST TO COAST. 2,500,000,000 H.P.

WALL WRECKED BY 2 TON CAR AT 60 MILES PER HOUR —



ATOMIC ENERGY IN A SINGLE MATCH STICK, IF COMPLETELY EXPLODED WOULD DRIVE A MILLION 120 H.P. RACING CARS

SAME DAMAGE TO WALL (SAME AMOUNT OF ENERGY EXPENDED) BY IRON BALL 4" IN DIAMETER SHOT AT VELOCITY OF 1,100 FT. PER SECOND



Doctor Hackensaw's Secrets

By CLEMENT FEZANDIÉ

NO. 30—THE SECRET OF THE FLYING HORSE

This horse could walk, trot or gallop at will. To enable it to fly, the doctor adapted large wings to its shoulders, and the flapping of these enabled the animal to rise from the ground and soar like a bird of prey.



was looking, the angel spread her wings and flew up and around the horse, and then came down again and stood on tip-toe on its back, like the girls does in the circus!"

At this fresh addition to the story, a shout of derision went up from the crowd, who were convinced that Cooney's addition to, and apparent corroboration of, the story were intended as a satire on the tales of his predecessors.

But Cooney vehemently maintained his statement as fact.

"Say, Cooney!" cried a young fellow with a sandy goatee, "Do you know what's the difference between you and a liar?"

"No."

"Well, neither do I, but I'll bet there ain't much difference—and I'll say the same of Dave and Joe. And I'll say one thing more. If the angel had wings, what thearnation did she need a flying horse for? Why didn't she use her own wings?"

CHAPTER I

A HUMAN FLYING MACHINE

Some three months before the conversation above recorded, Miss Pep Perkins, while rummaging through the garret of Doctor Hackensaw's country house, came across a large wooden chest and tried to open it. But it was locked. At the first opportunity she inquired of the doctor what the contents might be.

Doctor Hackensaw laughed. "That," said he, "is one of my earlier attempts at a flying machine. That was long before the days of the Wright brothers, and, of course, my idea of a flying machine then was of one with wings that would flap up and down—so I built that one."

"Oh, show it to me, please," begged Pep, and the doctor obligingly opened the case and showed her the machine. Pep was delighted with it, for it was a gem, a real work of art. The wings were made of real birds' feathers, and were pure white, and of the softest and finest texture."

"What a beauty!" cried Pep, delighted. "It's a regular peach! Haven't you ever tried to make it fly?"

"What's the use? A propeller is a far more efficient motor than wings. To make a winged flying machine would be just a step backwards."

"But could you make a winged machine if you wanted to?" persisted Pep.

"Certainly," replied the doctor. "There would be no difficulty about it. Man has already beaten Nature in the field of aviation. A man can now fly faster than any winged creature that exists. It would be but child's play to beat Nature again by making a me-

(AUTHOR'S NOTE:—For centuries man has dreamed of flying. From the days of Icarus, who flew too near the sun, and from the days of the fabled flying horse Pegasus, literature is full of such flying creatures, griffins, dragons, fairies, and what not. The primitive idea, of course, was naturally that of using bird-like wings for the flying. When the airplane was invented, however, the propeller was found far more practical than wings. But flying machines with flapping wings are a possibility, and while they cannot hope to compete with airplanes in most matters, they would still fill a niche of their own. As a substitute for cavalry, in war, they would possess certain advantages. Barbed wire obstructions and trenches would offer no obstacles to their passage.)

PROLOGUE

"YOU say you seen it, Joe?"

"That's what I said. I saw that flying horse as plain as I see you."

"What had you been drinking? Some of your own apple-jack?"

A roar of laughter from the loungers in the country tavern greeted this sally, but Joe continued undaunted.

"No, sir, I hadn't touched a drop of Jersey lightning."

"Are you sure it wasn't some new kind of flying-machine?"

"Flying-machine your granny! Hain't I lived in the country long enough to know a horse when I see him? This was a sure-enough horse, with hide and tail and teeth and everything—and wings to boot!"

"I seen it, too, fellers," chimed in a second man, familiarly known as Dave. "I seen it down by the river, standing quietly in the pasture, and though it was much bigger than

an ordinary horse, I thought I'd try to catch it. So I went up close to it, but when I got within twenty feet of it, it saw me, and reared up on its hind legs and shouted to me: 'Go back! Go back!'

"Must have been a guinea-hen," suggested the man who had first spoken; "They always say 'Go back! Go back!'"

At this a fresh laugh went up, and Dave looked sheepish, for the horse's remark had really been: "Go back, you fool, go back!" But Dave had thought it advisable to present an expurgated edition.

"That's some horse!" cried a fourth man. "A horse that can fly and talk is a horse worth seeing!"

"I didn't hear the horse talk," interrupted a new speaker, who answered to the name of "Cooney." "but I heard him snort and neigh, and I saw what I never expected to see in this life! The horse when I saw him was flying up into the air, and he had an angel astraddle on his back! And while I



At sight of the flying horse, the elephant leader gave a trumpet of alarm, and the troop gathered together in a bunch, wondering whether to flee or to hold their ground.

chanical bird, depending solely on its wings for flight, yet larger than any bird that evolution has yet been able to produce."

"Doctor Hackensaw," begged Pep, "I want you to do me a great favor," and she coaxingly put an arm around the doctor's neck. "I want you to fix those lovely wings so they can be attached to my shoulders. You could arrange them so they could be worked by a light motor. I want to be able to fly like a bird. And I also want a winged horse, one that can both gallop and fly!"

Doctor Hackensaw shook his head, but, in spite of all his inventions, the worthy man had not yet invented any means of circumventing a woman with a fixed idea in her head. So Pep finally carried the day, and the doctor constructed the two machines she desired. The winged horse presented no special difficulties. Doctor Hackensaw had already perfected a mechanical horse for the use of farmers—one that worked by gasoline and that could be harnessed to a plough or cart or carriage at will, thus taking the place of an ordinary horse. One of these he had constructed with a radium-motor, and made in the exact shape of the animal, covering it with the hide of a giant Percheron horse. The body was so large that a man could comfortably lie down inside. This horse could walk, trot or gallop at will. To enable it to fly, the doctor adapted large wings to its shoulders, and the flapping of these enabled the animal to rise from the ground and soar like a bird of prey. The wings were worked by a train of revolving gear wheels, so they could vibrate, if desired, with the speed of the wings of an insect. The speed could be regulated by the use of gear-shifts. The head of the horse was hollow, of India rubber, inside the skin of the head of the real horse. By means of a tank of compressed air, kept filled by the engine, the animal could be given the most life-like movements, lifting its legs, turning or shaking its head, rolling its glass eyes and opening its mouth. A special neighing and snorting whistle had been attached, and Pep had insisted on a concealed horn opening into the animal's mouth. The horn was arranged so as to disguise her voice and change it into a deep bass. "I want a hoarse voice," said Pep, emphasizing the pun. "I want the people to think that it is really the beast that is speaking."

As to the wings for her own use, these gave the doctor more trouble. In these, too, he used his radium motor, the energy being furnished by the disintegration of radium into lead. By a special heating device, one gram of radium could be made to disintegrate rapidly enough to produce sufficient power to work the wings and enable the young lady to fly. A gasoline motor would have been too cumbersome.

"Gee! I'll make a peach of an angel!" cried Pep delightedly as she fastened the beautiful white wings, made of real bird feathers to her shoulders, and surveyed herself complacently in the looking-glass. "I'll have to have a special costume made when I really fly."

It may be well to state here that the wings were fastened, not directly to the young lady's arms, but to lugs that formed part of a light, but strong metallic frame-work—a metal combination garment, worn under her clothing. This garment was rather snug-fitting, and encircled her thighs and bust. To put it on, she stepped into the two leg openings and then buckled the garment over her shoulders and around her waist. In this way her whole weight when flying was borne by the frame-work, which, of course, was well padded to prevent chafing her skin.

Learning to control the machine was no easy task. But Pep could already drive an automobile, and she was young and determined; so she had soon mastered control of the horse. After that, it was not very difficult for her to learn to fly with her own "angel-wings," as she called them. Doctor



Before the startled girl could utter a single cry of warning, the lion had pounced on its prey as a cat pounces on a mouse, and carried him off in its jaws.

Hackensaw had ordered her not to fly beyond the bounds of his large country estate, and to fly only at night, when she was less likely to excite comment. But as Pep mastered the control of her flying steed and gained confidence, she became somewhat reckless and flew beyond the boundaries set. And that is how it happened that the three farmers had been able to catch sight of her. Nor did Pep try to hide from them. On the contrary, she took a malicious pleasure in mystifying them. Miss Pep, although eighteen years old, was still a child.

Pep was especially delighted with her angel-wings. These fastened at her shoulders to lugs on the metal frame-work, the lugs projecting through openings at the back of her dress. The machinery was entirely concealed, so that Pep, when flying, looked exactly like the conventional pictures of angels. Of course, great speed was not possible—both she and the horse flew with what the Italians call "a slow slowness." But this moderate pace had the advantage that no unsightly helmet was necessary, as on an aeroplane. You could fly with your face uncovered and enjoy the beauties of the scenes below you. There is, of course, an exhilaration in an airplane traveling at from one hundred to two hundred miles per hour, but it is entirely different from the satisfaction of gliding quietly along through the air at "angel-speed." It was like the difference

between running a race and taking a stroll. Each has an interest of its own.

CHAPTER II

A TRIP TO AFRICA

"Pep," said Doctor Hackensaw, "I'm going to take a short trip to Africa. Do you want to come along with me?"

"Do I? Well, I just guess. But what African bug is biting you?"

"I am going to study a big problem: whether it is possible to flood the desert of Sahara by letting in the Mediterranean Sea. Some people claim the thing is possible; others that it is not, that most of the desert is at a higher elevation than the sea, and hence the best that could be done would be to create a few lakes in the desert. However, even that might be worth doing, and if by irrigation I can bring fertility to large areas of this great waste of land, I will gladly undertake the work."

"When do we start?" asked Pep.

"The steamer sails Tuesday. Can you be ready in time?"

"Sure Mike!" responded Pep, gleefully. "And what's more, I'll take my flying horse along. I want to see the Desert of Sahara and go for a lion or an elephant hunt on my 'winged steed'."

CHAPTER III

THE ELEPHANT HUNT

"Now, Pep," said Doctor Hackensaw, "tomorrow we are going to have a grand hunt. The guide tells me there is a troop of wild elephants within a couple of miles from here, and a troop of lions not far off. You can have all the sport you want. But do promise to be careful. On your flying horse there is no danger so long as the mechanism works properly, and so long as you are not reckless. I have carefully overhauled the machine. It is in perfect condition, and your own wings can help you in an emergency. But do be careful!"

"All right, Pop!" answered Pep, flippantly, for it must be confessed that she was youthfully disrespectful toward the worthy doctor.

Doctor Hackensaw sighed, but said nothing further.

The morning dawned bright and fair, and the doctor, accompanied by a couple of Arab servants and a troop of negro beaters, started out for the spot where the elephants had been sighted. As for Pep, she mounted her flying steed "Pegasus" and started ahead on her own account. She soon outdistanced the hunters and came in sight of the elephants.

At sight of the flying horse, the elephant leader gave a trumpet of alarm, and the troop gathered together in a bunch, wondering whether to fly or to hold their ground.

(Continued on page 300)



She now had a good chance for a shot, she placed two bullets in the animal's head just as the infuriated animal made a leap for her horse. Down came horse, lion and rider in one heap.

The Man On the Meteor

By RAY CUMMINGS

Part VII

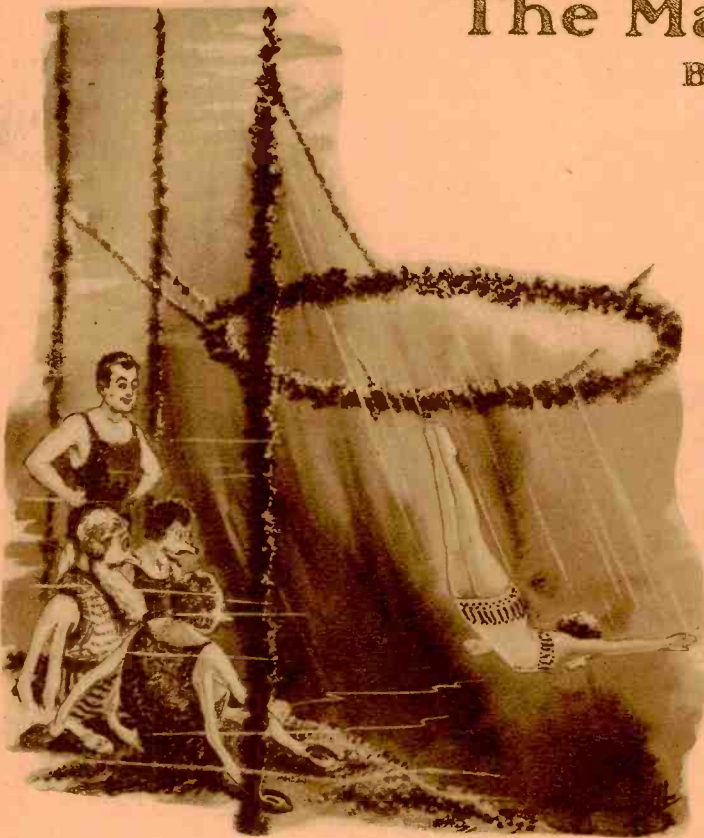

Down Nona came in a head-first dive. She hardly made a ripple as she passed through the water. Through one of the hoops she passed, then swimming zig-zag through other hoops, up and down, slowly turning over to pass a hoop feet first, then doubled up, spinning like a ball, and at last straightening out.

WITH no memory of past events, a young man suddenly comes to his senses on a meteor which is part of one of the rings of Saturn. He looks for nourishment and finds the mouth of a cave. As he looks toward the cave a girl comes into view. One day, upon returning to the cave, Nona, the girl, shows Nemo, as the man calls himself, several mollusks which make good food. To gather more of this food, they wade into a stream. Nemo sees Nona's head is completely engulfed. Soon his head goes under water and he feels the liquid rush into his lungs. However, by violent effort he is able to breathe the water.

Later they see coming toward them a party of ten people, four men and six women, who are somewhat human in form, but have four arms like the tentacles of a cuttlefish. Nemo and Nona are captured and tied by them.

They are taken by the Marinoids, as the members of the party call themselves, to the city called Rax. This city is built in the stream of underwater vegetation.

A man named Og insulted Nemo and challenged him to a fight. The fight took place in front of the palace of the ruler and Nemo was defeated because Og had a peculiar property, which was characteristic of the Marinoids, enabling him to send a charge of animal electricity into the body of Nemo, thereby rendering him unconscious.

For a year things go along peacefully, when suddenly the daughter of a Marinoid family disappears. This is repeated again and again until thirty of the young women of the city were stolen. Later Nemo saw a strange figure in the street. Suddenly all light is obliterated and Caan and Nemo, swimming through the darkness, find a woman unconscious, shocked into insensibility by animal electricity. Nemo comes to grips with the man attempting to abduct the woman and finds it to be his old enemy Og. Nemo returns to his home to find that Nona is gone.

The Water of Wild Things, an unknown stretch of sea, is the home of the tribe doing the kidnaping. An expedition is organized to bring the stolen girls back, and led by Atar, the king's son, they go into the Water of Wild Things. Atar, Nemo and Caan penetrate a barrier of vegetation, which guards the entrance, descend the side of a perpendicular cliff and soon see lights in some sort of a dwelling place. They enter the place and find it to be crowded with other people. Og is seen talking to them and on a raised platform is Nona.

Og declares his love for Nona to the people and says that he will lead them to victory over the Marinoids and that Nona will be their Queen. One of Og's lovers becomes jealous and protests. She is waved away and suddenly returns with a dagger to kill Nona. Nemo interferes and releases Nona. They start away from the Water of Wild Things.

Later in the day, through the aid of Og's jealous lover, Nemo with Nona and the remainder of the party, make their escape, after learning that Og, as leader of the tribe who call themselves the Maagogs, plan to make war on Rax and capture the city. The party on returning home tells the king of their discovery who begins preparations for war.

I HAVE said that those next three days in Rax—the three days immediately following our return from the Water of Wild Things—were critical. We did, indeed, have but little time for sleep. We were exhausted when we returned—Nona and I. We played with Boy a little; and then, with him beside us lustily practicing his newly-learned swimming strokes, we fell into deep slumber.

Atar awakened us. The city, he said, was seething with excitement. Our return was already known. Rumor of danger—nobody knew just what—was on every tongue.

Atar was pale, but composed. "Strange things are impending, Nemo. Very strange. And ominous—frightening. My father bids me bring you to him now."

He said it so ceremoniously, so solemnly, that his tone alarmed me more than the words. I sat him down and he waited impatiently while Nona hastily prepared us food. Then—with Nona and Boy—we swam past Caan's house. Nona and Boy stayed there; I would not again leave them alone.



There was music in the water! It came from a platform that dangled from the foliage overhead. There were a dozen Marinoid men. Three or four plucked at thin, vibrating lengths of fish-bone, which gave off curiously twanging, but not unmusical notes. The rest pounded shells of different sizes—thumped them with resilient little hammers in odd rhythm.

Then Atar and I went on, swimming slowly through the city streets toward the King's palace.

The city was indeed in turmoil. I wondered how the news of our return had spread so swiftly. To do anything secretly of public interest and importance is difficult. And yet how should the Marinoids know already that danger was all about us in the water? How could they know that war with the Maagogs was impending? The city knew it; rumor of it was everywhere.

The streets had almost a holiday aspect. At every intersection groups of swimmers were gathered. Passersby were hurrying to and fro, aimlessly. Women cluttered the balconies. A holiday aspect, did I say? It was not that. The crowds hung poised, talking in low tones; the swimmers gazed often behind them apprehensively; the women on the balconies stared down with solemn, frightened eyes—and hushed their children with over-stern commands. Terror, not joy, was in the water that morning—a nameless terror, born of the Unknown.

I whispered something of the kind to Atar.

"Soon they will know what the danger is," he answered. "Then will come enthusiasm, the desire to fight. The terror will be forgotten. Father's speech to them will fix that."

Patriotism! That grim fortitude, courage, reckless enthusiasm, loyalty. Call it what you will, it nerves all but the most arrant coward to face death.

"Yes," I said. "We must give them that, or we are lost."

As we swam forward through the streets, the people recognized us. Occasionally a few would cheer; but for the most part they stared at us silently. Some followed us; soon there would have been a crowd in line behind us, but Atar dispersed them imperiously.

THE HALF-BREEDS

"Atar! Look there!"

In a doorway a figure was lurking. A man. I recognized him. He had never married; and I remembered that they said no Marinoid girl would take him for mate because of his Maagog origin.

The half-breeds! I have so far mentioned them but casually. With both Marinoid and Maagog blood, they were called Marinogs—a term they resented heartily. I had never given them much thought, had never known nor cared how many of them there might be. But now, as you shall hear, we were soon to deal with them in tragic fashion.

The Marinog in the doorway stood motionless. And as we passed, I felt his inscrutable gaze upon us. Something in it made me shiver, and I turned and looked back to him. He was still staring—his face wholly expressionless.

Atar pulled me on. As we approached the King's palace, the throngs in the streets grew denser. They cheered us more frequently now. But among them, everywhere, I saw Marinogs—whiter, puffy of flesh, with larger eyes. Those were the real half-breeds. But I wondered how many there might prove to be among us with that unseen, unmarked taint of Maagog blood.

The crowds cheered—but the Marinogs were silent. They swam about furtively; or lurked in doorways; or in tangles of the street vegetation here and there. And always I felt their stolid gaze upon Atar and me.

We entered the upper palace doorway, at the threshold of which the dolphin sleigh lay waiting on the platform. In a broad low room, brightly lighted by rows of pods at its ceiling, the King greeted us. He was seated in a shell, on a throne built of smaller shells cemented together.

Save for him, the apartment was empty. He kept his seat, and we reclined on the platform at his feet. Outside we could hear the murmurs of the gathering crowd.

"You must speak to them soon, my father," said Atar.

The King nodded. He was very grave, perturbed inwardly I knew; but outwardly solemn and grim. Then, suddenly discarding his reserve, he talked to me as though I were his son. For generations, he said, this secret mingling of Marinoid and Maagog blood had been a source of concern to the Government at Rax. There were no more than a few hundred known half-breeds in each of the Marinoid cities. The Marinoid women were averse to mating with them. Yet, nevertheless, thousands perhaps of the Marinoids were tainted. There were two reasons for this. First: Some of the Maagog men who had smuggled themselves

in, looked enough like Marinoids to pass unrecognized. And secondly: There were immoral Marinoid women in all the cities.

"Why, there may be several thousand of these Marinogs—these half-breeds," I exclaimed. "But why should they all turn against us?"

RACE HATRED

Prophetic thought! We did not know then that the Marinogs would turn against us. And yet we feared it. They were looked down upon—scorned. And there is something always smouldering in the heart of an inferior race, a jealousy, a desire to prove that the servant is really the master.

Though we did not know it then, our fears were all too well founded. Og had already sent emissaries from the Water of Wild Things. One by one they had smuggled themselves through the coral barrier and into the Marinoid cities. It was they who were spreading the rumors of coming war. Their insidious talk was inciting the half-breeds. They were telling the half-breeds that this was the beginning of a new era. The Maagogs soon would rule in Rax. The despised half-breeds then would take their place as rightful, honored leaders. The Marinoid women—those beautiful women who always had scorned them—would be their slaves.

The King long had feared such conditions as these which now were coming to pass; and he told his fears to me frankly. Then he smiled.

"You have thought me unprepared, Nemo," he added. "I am—for this sudden crisis—and yet not wholly so."

Then he told me that for most of his reign—all Atar's life, in fact—he had maintained a secret cavern in Marinoid waters, where preparations for war were going forward. I had not known that. Caan even now did not know it. The strictest secrecy was maintained, for above everything the half-breeds and Maagogs had to be kept in ignorance of it. The cavern was not far from Rax. It was well guarded; and no one had ever been in it, or heard of it, save a few of those known to be of full and loyal Marinoid blood.

"Not wholly unprepared, Nemo," the King repeated. "After the next Time of Sleep I will take you to the cavern. If this Og will only delay a little—"



Another figure from near at hand dove at him. The Marinoid girl who had taunted the half-breed! Her arms went around the King's neck. . . . A flash of silver as the needle-fish came at them. . . . A choking female cry.

A noise outside the palace interrupted him. For some moments I had been conscious of a growing murmur, a confusion, which now broke out into cheers.

The King swam from his seat and we followed him across the room. Through a doorway upward, we emerged to the palace roof-top. It was empty, but in the foliage overhead figures were clinging; and I saw that the whole open cube of water before the palace was cluttered with them.

The shaded lights along the parapet were lighted, flinging their greenish beams outward and leaving the roof in shadow. A great cheer rolled out as we appeared. The King advanced to the parapet; and at his low-toned command, Atar turned several of the lights to shine full upon him. He stood there facing the throng; his figure, thrown into bold relief by the light upon it.

The cheering continued. Figures fluttered overhead, seeking places of vantage. Then silence fell; and extending his four arms outward to his people, the King spoke.

II

Atar and I crouched in the shadows at the King's feet; but between two of the illuminated pods, I could see plainly the green-glowing water before us, with its silent, expectant throng of faces.

The King spoke slowly, carefully at first. Gradually his voice rose in power; the smile faded from his face. With grim, forceful words, he told of the Maagog peril—bid all his loyal subjects hold themselves ready for his commands.

(Continued on page 294)



The outlines of the city loomed before us. A ring of hovering predatory figures surrounded it! We could see other figures launching themselves out from the streets, desperately; and the waiting figures surging upon them.

Sun's Rays Melt Gold and Steel

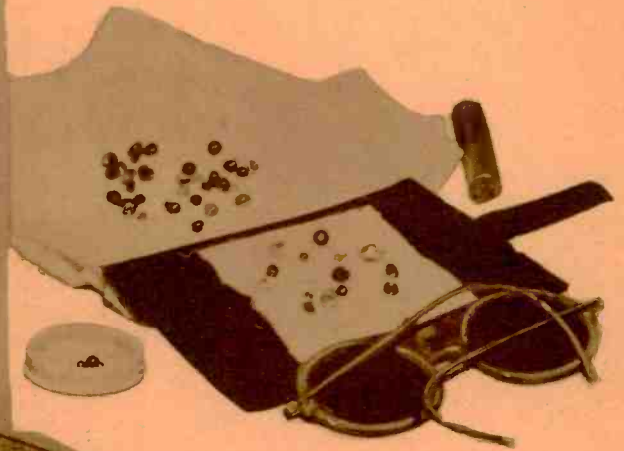
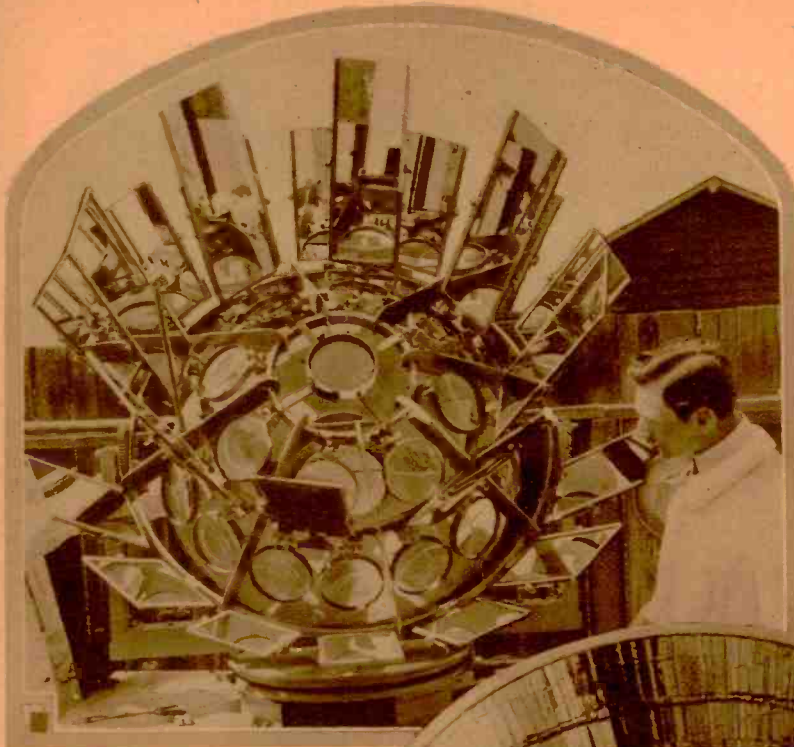

By the use of twenty-two mirrors and twenty-three magnifying glasses, Marcel Moreau, a young French inventor of San Francisco, has succeeded in obtaining heat from the sun sufficient to melt steel and manufacture artificial gems. He produces one of the most intense heats known to man. According to his claims he produces more than 7,000 degrees Centigrade. In the illustration above is shown the machine used by the inventor for the production of this temperature. The device is set on a tripod arrangement so that it may be moved to face the sun. All of the rays collected are focussed on a spot just under the central mirror where they are concentrated. The inventor is shown standing beside his machine. In preliminary tests he has cut steel, melted copper and gold and worked with the molten metals, using only the solar machine as his heat producer. That the sun's rays could be used to produce one of the world's most intense heats has long been known. The machinery usually employed, however, was so bulky that their use was hardly considered practicable. Moreau's device, however, is so small and easily operated and so simple of construction that it will probably find many commercial uses.

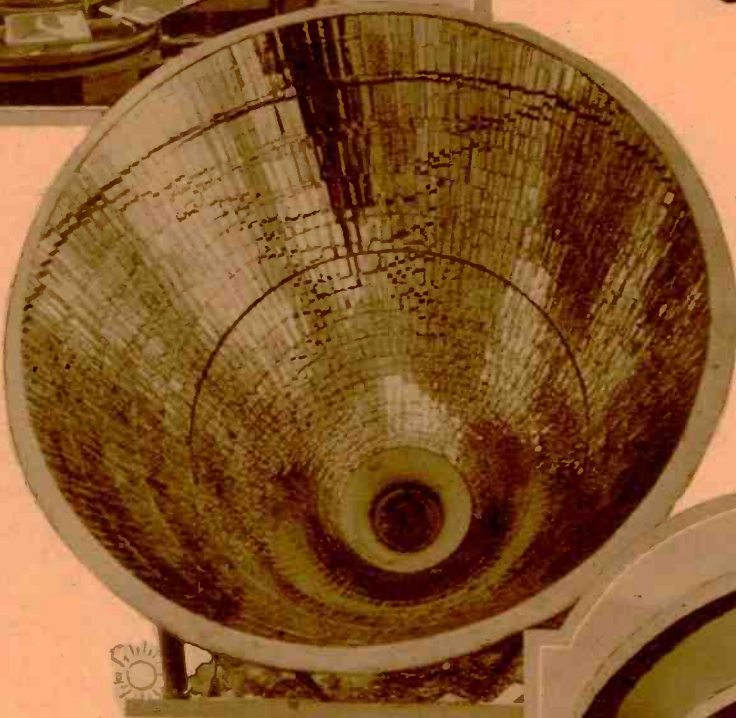

Above is shown a collection of rough artificial gems made with the use of the solar heat machine. At the left is a view of another of Moreau's solar heat concentrator. It consists simply of a large number of mirrors—more than fifteen hundred of them—placed around the inside of a cone. This form of the device does not produce so intense a heat as the one shown at the top of the page, but it has the advantage of being cheaper in construction. A chicken may be cooked in a little less than a minute with it. Below at the left is given an exterior view of the huge cone as it faces the sun. In the photo below it is seen operating a small hot-air motor which produces about one-twentieth horse-power.

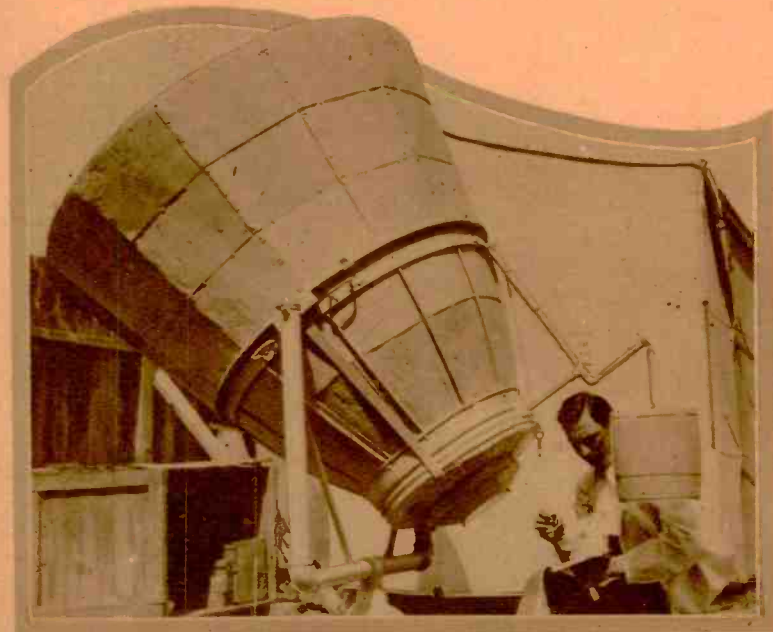

Oddities of the Human Body

Greatly Enlarged Drawings and Interesting Analogies Make Study of Body Easy.

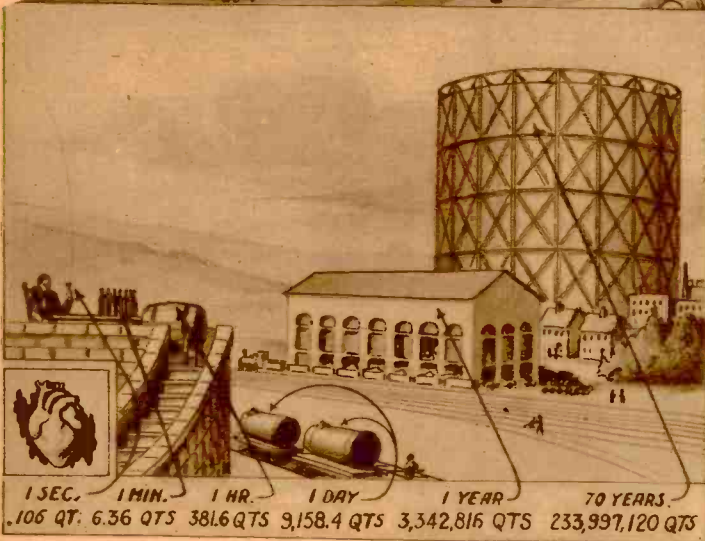
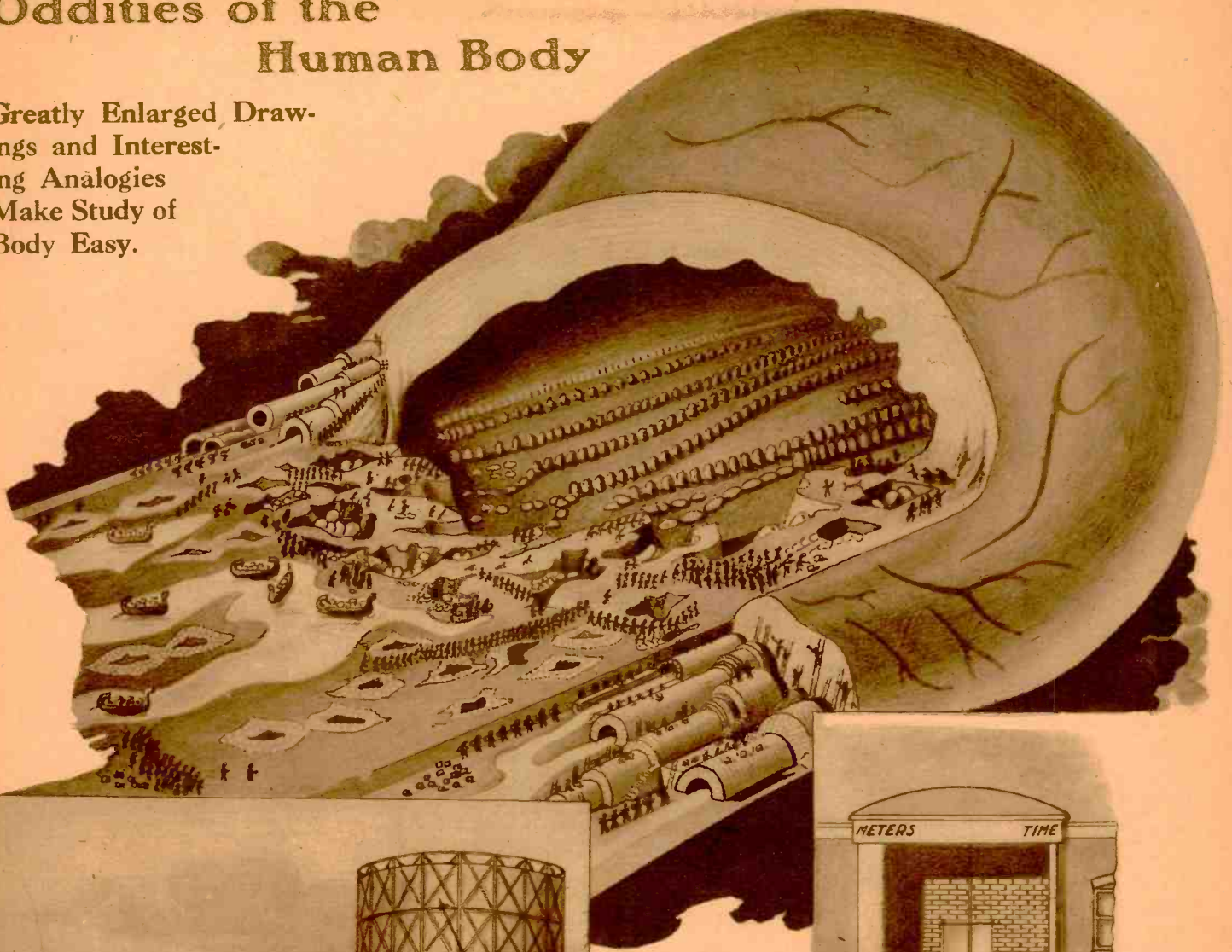

The illustration above gives a picturesque version of the terminal portion of a bone. Note the hollow structure of the bone with the boats floating around in the bone marrow. Notice the people walking around in and upon the Haversian canals of the bone. In the formation of bone the spongy network in the center is removed by osteoclasts. This leads to the formation of the marrow cavity. During the prime of life, the bone is formed more rapidly than the cavity. In old age, however, the reverse is the case, the shaft of the bone becoming thinner.

In the above analogy the volume of blood which the human heart pumps in different periods of time is clearly shown. In one second the heart pumps .106 quart of blood. This seems like a very small quantity, but after the elapse of but one minute the heart would have delivered by its pumping, 6.36 quarts of blood. If it were champagne the drinker would find it difficult to consume the quantity at one sitting. At the end of an hour a barrel of blood would have been filled by this efficient little pump. In a day the blood pump would fill two tank cars, and before the year had expired a warehouse would be well supplied with the red fluid. Assuming that the individual lived seventy years, the heart would have pumped in that period of time nearly 234,000,000 quarts, a veritable Niagara of blood.

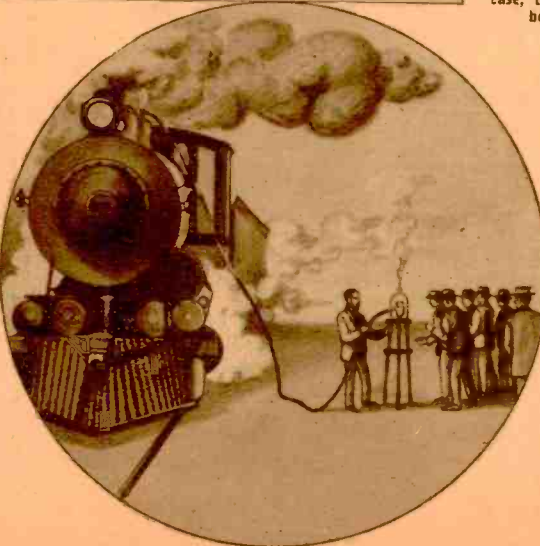

The illustration to the left gives an idea of the tremendous strength of the arterial system of the human body. Here a pipe leading from a locomotive capable of delivering steam at a pressure of ten to fifteen atmospheres is connected to the heart and the arteries. Many of the arteries in this system have an outside diameter smaller than that of a lead pencil. The walls of these arteries are particularly tough, due to the elastic nature of its walls, which contain much white fibrous tissue and circular muscle tissue.

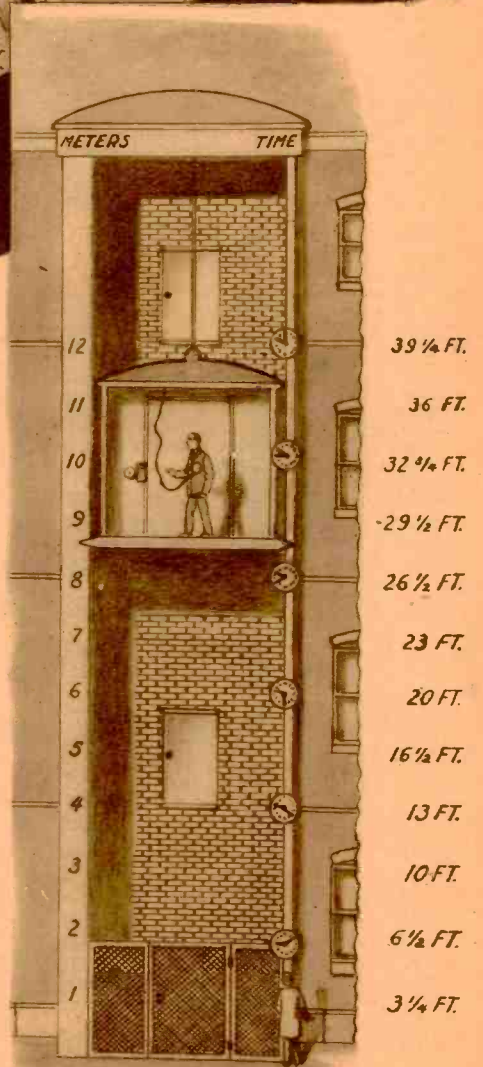

If all the power which the heart develops was converted into electricity, or were directly coupled with the lifting mechanism of an elevator, the power developed in one hour would lift a man and the elevator to a height of 39 1/4 feet.

Paintings as Movie Sets



The great orchestra of the theatre rolls out a majestic theme, making one think of ancient Thebes and dynasties long perished. The screen shows massive temples, stretches of sandy desert, great monarchs dressed in gorgeous robes taking their retinues into vast temples much larger and more magnificent than anything on earth today. The movie audience wonders at the hugeness of it all and, with awe in its eyes, at the money the director must have expended to raise such a huge edifice as scenery for only ten minutes of film. The audience is wrong. The scene itself probably cost only a few dollars. No more than a couple of hundred, if the director of the film took advantage of the latest technical method which is shown here. This new system has been used in various other forms, but the present adaptation as perfected by William P. S. Earle is the most realistic yet devised, albeit the most difficult of execution. Immediately above is shown an excerpt from one of his films using this method. The sketch in the center gives some idea as to the executionary methods and the inset at the right top of the page shows the inventor holding the "scenery" used in the massive picture shown at the left. Of course, all film made by this method must be carried through double exposure, but his method is so effective that the illusion is perfect, many times fooling old directors.



The actual system is comparatively simple. First the scene to be used for a background is painted in perfect detail on a canvas about two by three feet square. The colors of paint used, however, are not those appearing in the original scene to the eye. There is a very complicated system of choosing the colors so that when photographed they appear with the greatest reality. The canvas of the scene is then photographed on the number of feet of film to be used and then the film is rewound. Then a dull black background is set up and various points on the scene are marked on it. Through these markings the actors seem in the projection to pass in and out of the doors in the completed film. In the taking they simply move between two marked lines. Chairs and tables, placed properly, and covered with the background cloth are also used. —Tamar Lane.

Deflatable Pontoons to Salvage Ships

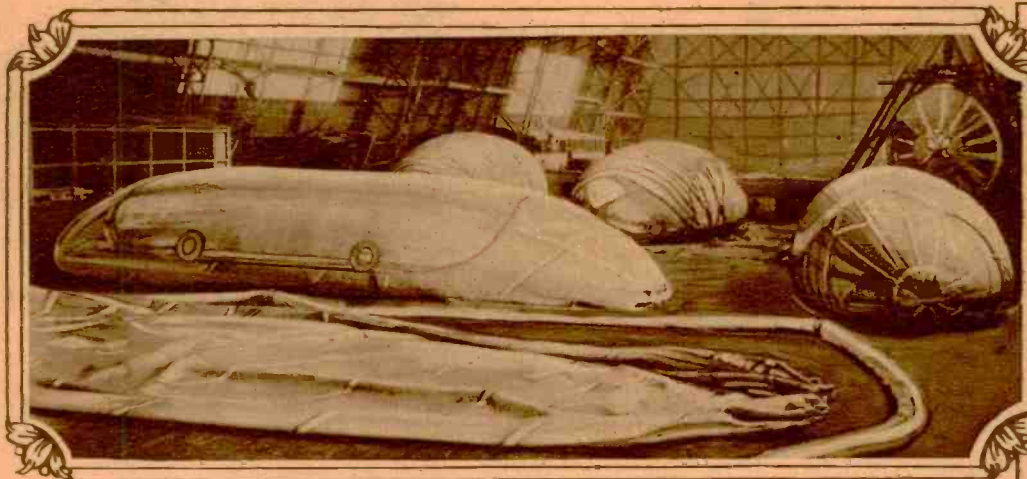

The photo above and the three diagrams at right illustrate an interesting new development in ship salvage engineering. This novelty takes the form of a deflatable pontoon made of rubberized fabric. These pontoons are easily carried about in their deflated condition to the point where the sunken vessel is to be raised. Each pontoon is said to be capable of lifting five hundred tons, and a sufficient number of the pontoons are used to raise the total tonnage of the ship. The pontoons are lowered either by weighting or else by means of a cable to the hull of the wreck, and are suitably attached by divers. There are several different ways in which the pontoons can be attached to the hull of the sunken vessel, several of which have been described in past numbers of SCIENCE AND INVENTION. One method is to drill holes in the hull, and by means of toggle eye-bolts slipped through the holes, steel cables or chains are made fast and attached to the pontoons. When all of the pontoons have been placed about the vessel, they are inflated by pumping compressed air into them through armored flexible tubes from the salvage vessel at the surface. When all are fully inflated, the vessel will rise to the surface. Once the vessel has been floated to the surface, it can be towed to the nearest drydock. In some cases such salvaged ships have proceeded to the drydock under their own power, suitable temporary repairs having been made and the water pumped out of the hull. —H. W. SECOR.

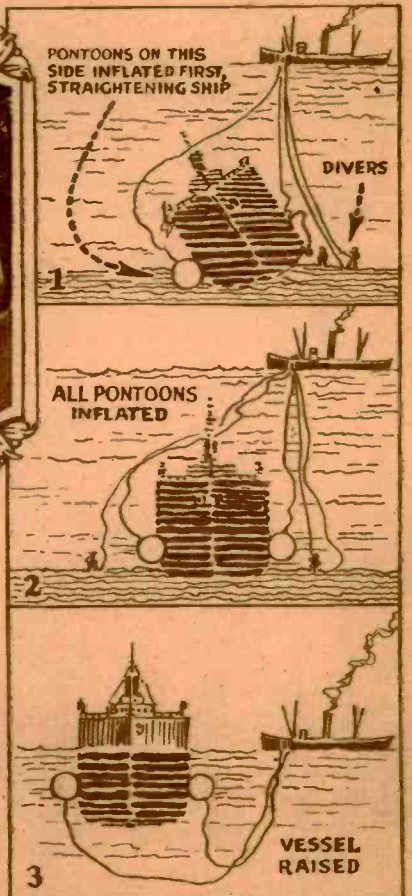

Scientific Bass Angling

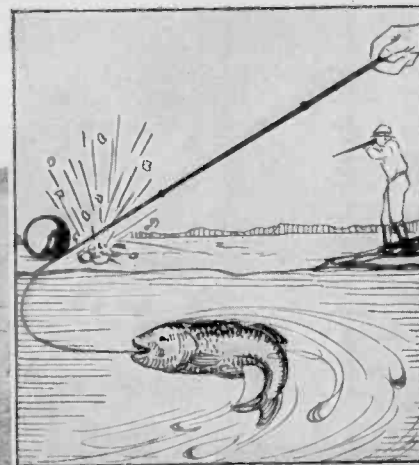
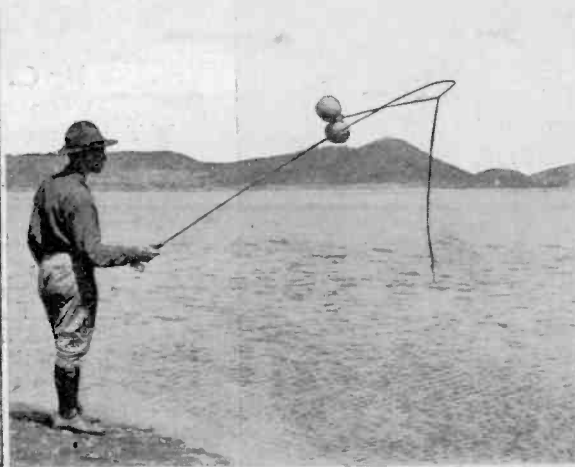
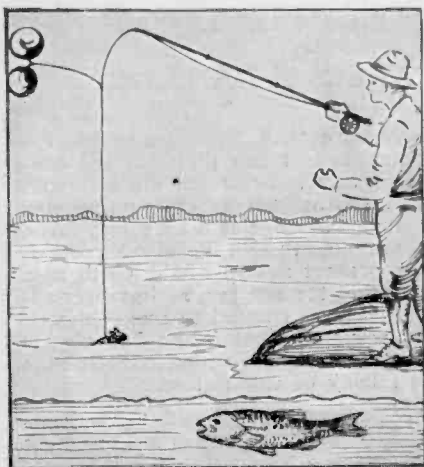

While fishing for bass where there were a large number of anglers at work Mr. John E. Hogg discovered that the fish—the large ones—failed to respond to the ordinary fly bait but that every time a mouse was run into the water it was immediately gobbled up by a fine large bass. Consequently he procured the exceptional string of bass shown in the photo simply by using mice as bait. The live mouse was harnessed into a hook arrangement and attached to a line. Air currents carry the balloons and mouse out on the water. Mr. Hogg used toy balloons filled with hydrogen as shown. The balloons were punctured with a shot-gun as soon as the fish was securely hooked.

War Instruments of Savages

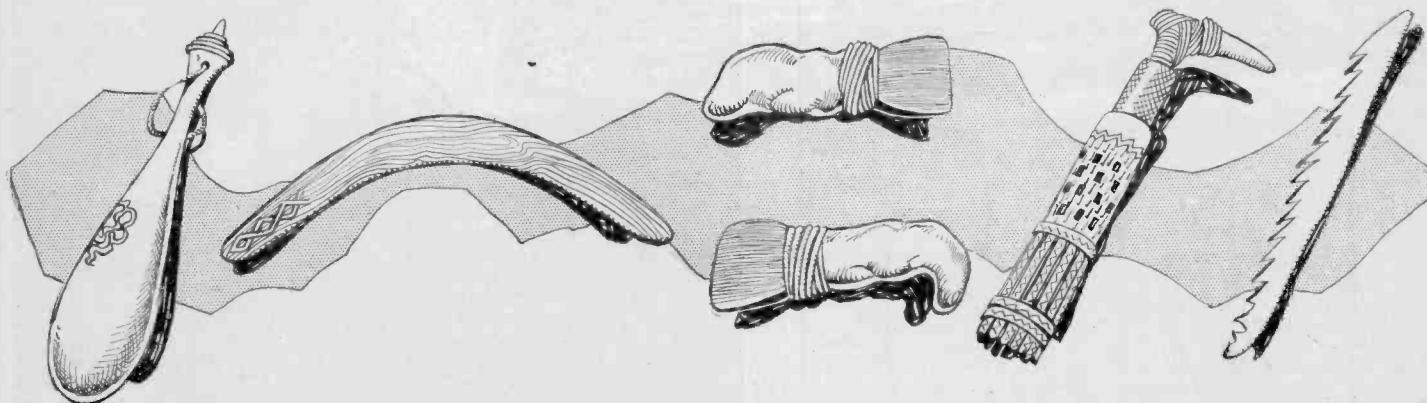

The war and hunting instruments of the savages are diversified as are those of the civilized man, but not one hundredth as effective, of course. Several of the most prominent types of death-dealing weapons used by savages are shown in this group of illustrations. The first one at the left is the Patoo-patoo of the New Zealanders. It is constructed of a very hard wood and has an attached thong which the warrior attaches to his wrist so as to have his weapon handy at all times. We have heard of the boomerang from our earliest childhood. This weapon is used by the native

Australians and some have the peculiarity of returning to the owner after having been thrown. The Esquimaux have long used knives, two of which are shown in the above illustration. They have bone handles and steel blades. The steel and iron used in their knives, however, were brought to them by Europeans. The strange looking instrument to the right of the Esquimaux knives is a South Sea Islander's idea of an axe. It has a finely carved handle. The Fuegians living on the southern point of South America, use harpoons such as shown on the right.—N. Wright, Reporter No. 7211.

The Old and New in Astronomy

By CHARLES T. DAHAMA

IT has required more than 3,000 years for the world's astronomers to reach their present conception of the universe. From the old Babylonian astrologers and soothsayers to the present day observer and his huge telescope is a long cry. And from the old idea of the earth as a flat disc surrounded by water to the present notion of the earth as a sphere revolving around the sun is a still greater advance. Man has always attempted to make himself the center of the universe—that is, he has always thought himself in that exalted position until science demonstrated the fallacy of this notion.

The first real system of astronomy—the first one worthy of the name—was that devised by Ptolemy. His system charted the earth as being the center of all things and depicted the other planets as well as the sun revolving around fixed points which points in turn revolved around the earth as a center. The sun and moon merely revolved around the earth. This system noted the constellation as groups of stars in fixed relation to each other moving around the periphery of the solar system in groups.

These latter days have brought forth an even more impressive idea. The sun is the center of the solar system around which all the planets revolve but the sun is not the center of the universe. Quite the contrary. It is very much out of center. The illustrations given on these pages will give some idea of the advances in astronomy from its entry into the field of exact science to the present time.



About forty years ago Prof. Barnard discovered a faint, hazy object in the constellation of Sagittarius. Careful examination showed that it was composed of myriads of faint stars and small clouds of gas much like the so-called Magellanic Clouds pictured above. Investigation proved that this group was more than a million light years away and far beyond the limits of the Milky Way of which our planetary system is a part.

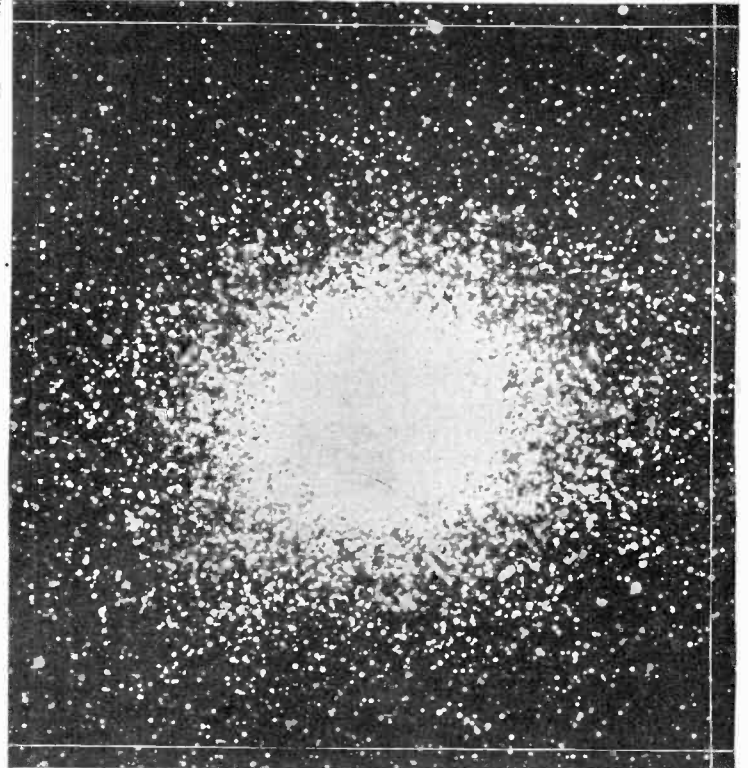
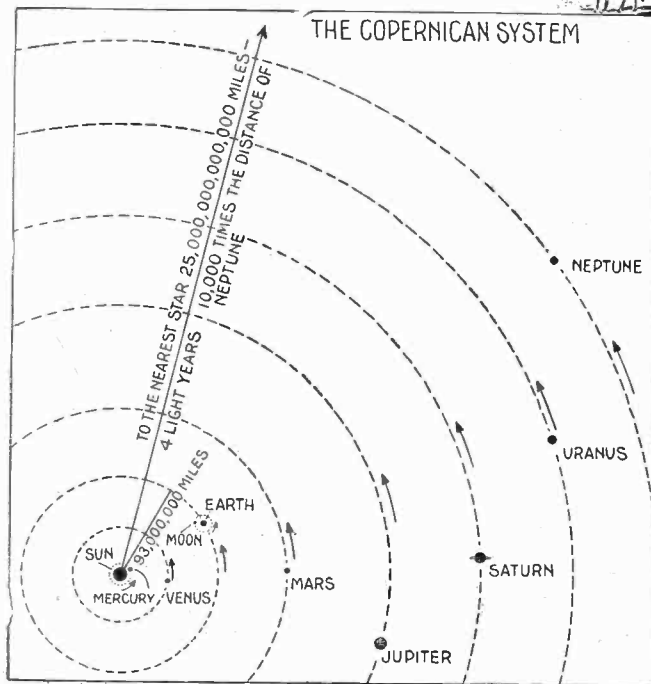
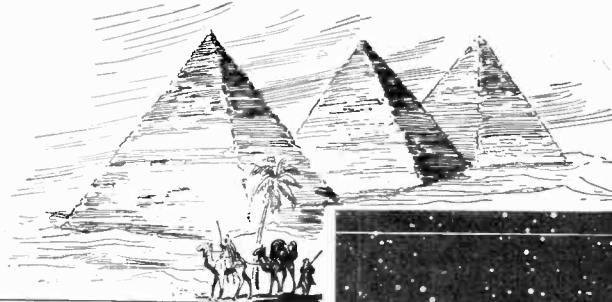

Copernicus was the best known of the early advocates of the correct theory of our planetary system. He published long ago the statement that the sun was the center, around which the planets revolved. Above, the diagram shows the placement of the various planets and their relation to the other members of the system as noted by the famous ancient mathematician and astronomer. Near the time of this discovery the first telescope was made.

While the sun is now definitely known to be the center of the solar system, another old idea, namely, that the sun is at the center of the universe, has recently been exploded by Dr. Harlow Shapely. From a study of "globular clusters," one of which is shown above, and about a hundred of which exist in the Milky Way, it has been proved that the sun is far away from the center of the system.

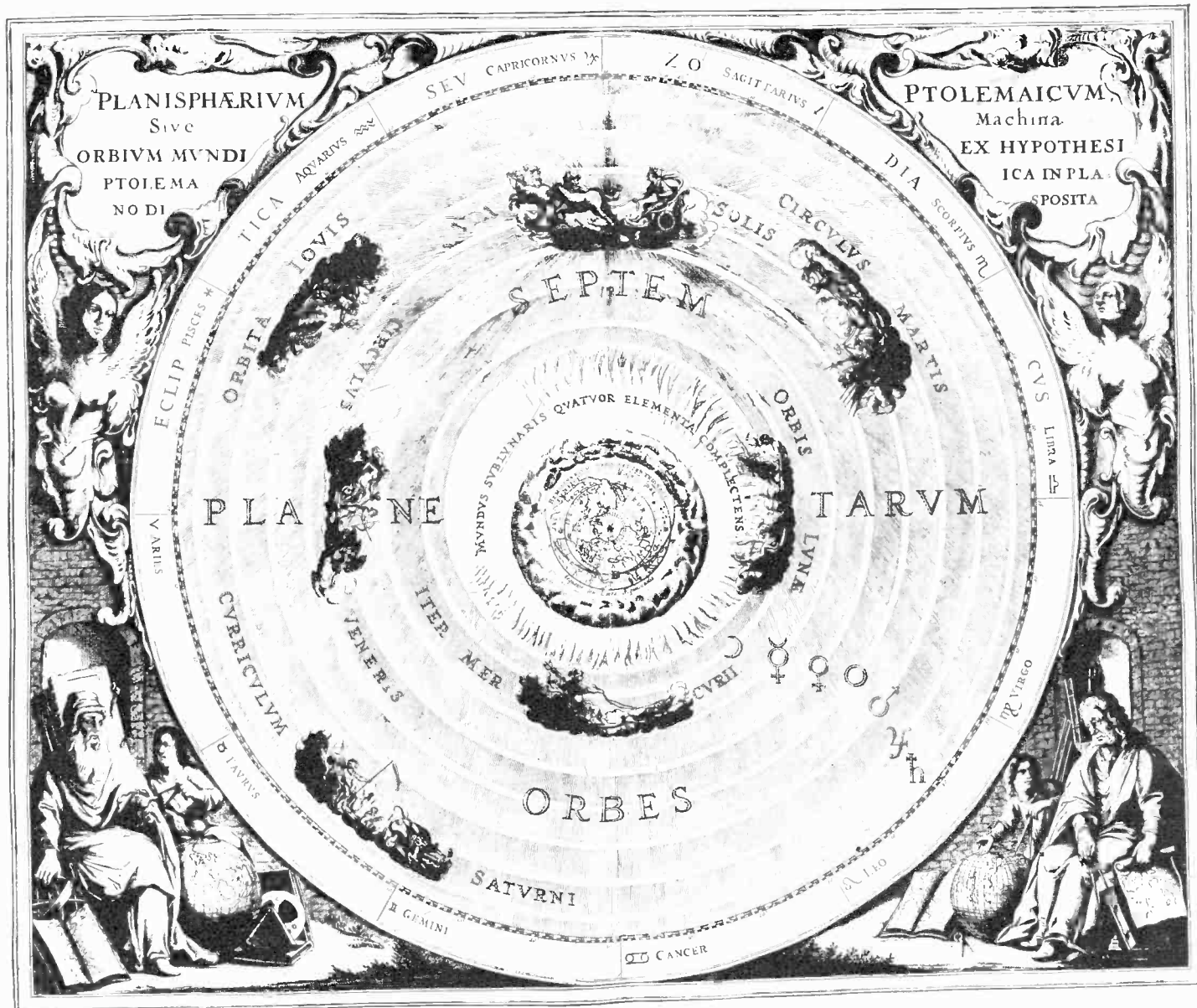

The old cut reproduced above is taken from a celestial atlas published about the time the Pilgrims landed on the coast of North America. It is a reproduction of the old Ptolemaic system and gives the earth as the center of the planetary system. If examined closely it will be seen that some of the geographical divisions of the earth itself are noted. The book from which the cut was taken is in the collection of the New York Public Library.



The very latest conception of the sun and its planets in relation of the remainder of the celestial bodies. Note that the sun is not in the center of the system by any means. The stars which compose the Milky Way lie within a disk. It takes a ray of light 200,000 years to cross this disk. There are many stars in the Milky Way ten thousand times brighter than our sun.

According to the conception of Ptolemy the planets revolved around a fixed point and the fixed point followed the orbit shown around the earth. Note that under this system the sun is the fourth large body counting from the earth. It revolved around its orbit, and not around a fixed point. The constellations passed around the outside limit of the planets in fixed groups as shown.

Railroads of Tomorrow

By GEORGE F. MURPHY

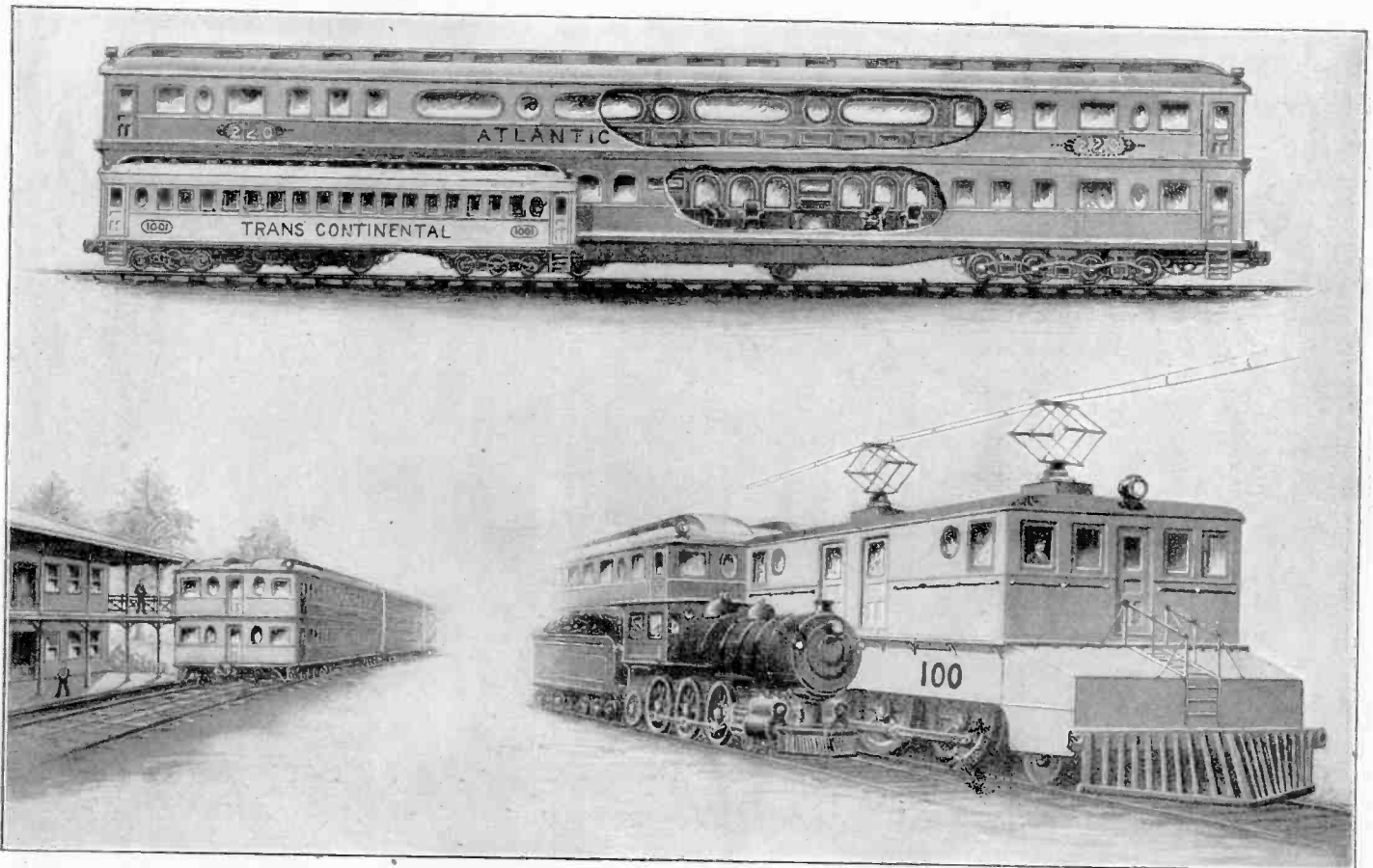

Sea transportation has long had the advantage in the use of huge units. Railroads, however, are now using only slightly larger transportation units than those which were in vogue at the inception of the industry. With the constantly increasing operating costs and the steady approach of travel to the point of saturation, particularly on eastern railroads, something must be done in the near future to increase the carrying capacity of

the railroads and at the same time decrease operation costs. The scheme given here is a logical one to perform this service. At the top of the illustration is shown the passenger car of the future for carrying at least 8 times the present number of passengers. Below is a comparison of the huge electric locomotive of the future and its present steam counterpart. The gauge of the future railroad will be 2½ or 3 times that used at present.

ELECTRICAL STRESS MEASUREMENTS

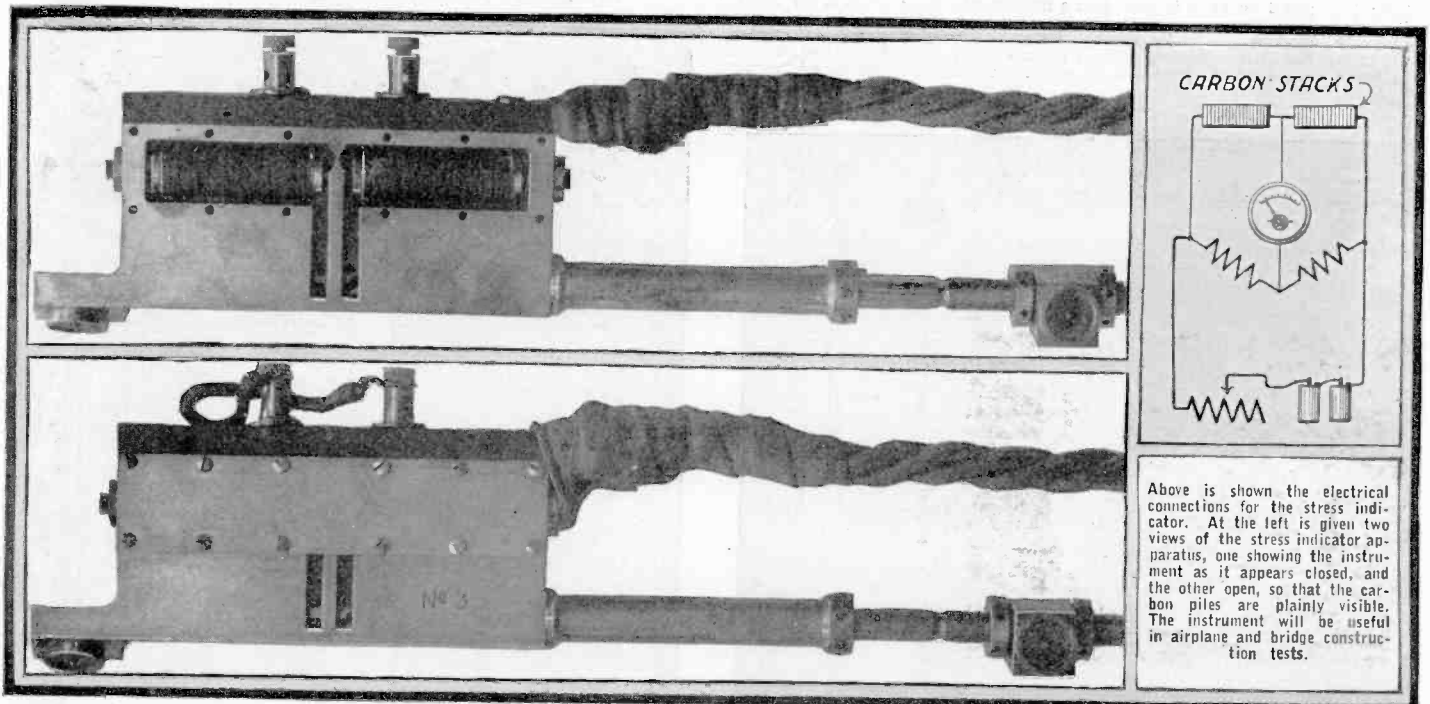

Above is shown the electrical connections for the stress indicator. At the left is given two views of the stress indicator apparatus, one showing the instrument as it appears closed, and the other open, so that the carbon piles are plainly visible. The instrument will be useful in airplane and bridge construction tests.

The Bureau of Standards recently announced the invention of a new electrical method for measuring stresses which promises to be of the utmost importance in civil engineering work. The device is comparatively simple consisting of 2 piles of carbon disks, through

which electrical currents are passed and which are measured by a differential or bridge method. The amount of current passed varies directly with the amount of pressure transmitted to the carbon piles, thus giving a proportional indication. —S. R. Winters.

Artificial Creation of Life

Man made cells that live, grow, reproduce and die.

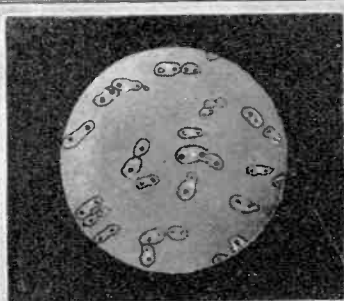

Living cells, artificially produced, undergoing mitotic division. Cells reproduce within one hour's time when provided with the proper culture media.

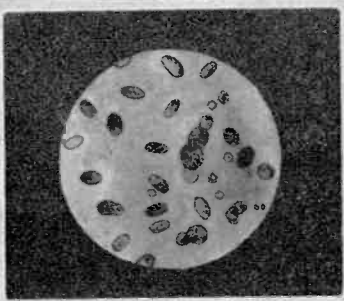

Artificial cells shown in the above photograph are transformed into living cells by adding potassium nitrate. All staining methods fail to show the nucleus.

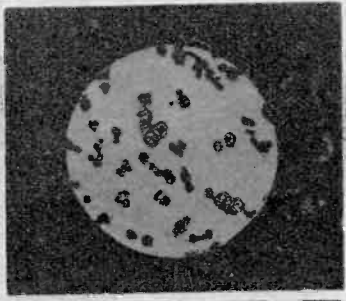

The above micro-photograph shows a group of cells that were artificially produced by man from glue and tannic acid. The cell culture processes are tedious.

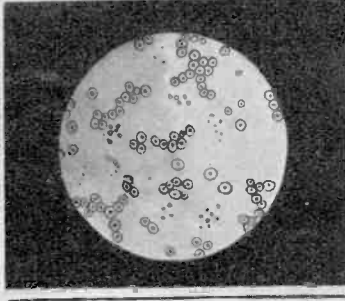

This photo-micrograph shows another group of man-made cells. An indication of a nucleus is seen in each. Reproduction is by fission division.

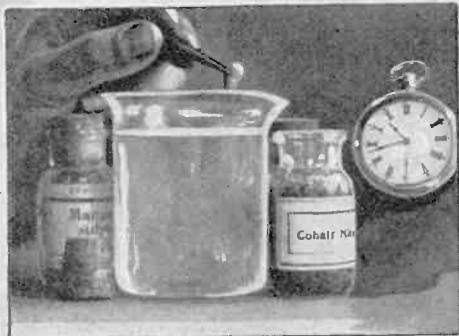

Chemical plant-like growths can be produced by the amateur by following the technique hereafter described. At 17 minutes of 11 a crystal of cobalt nitrate was dropped into the solution.

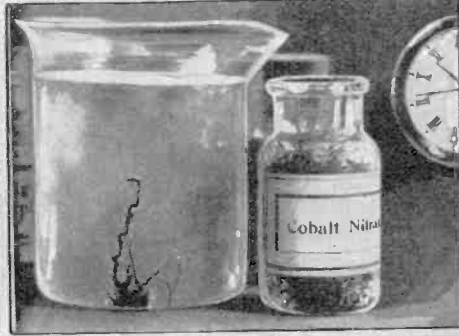

The solution consisted of a solution of sodium silicate commonly known as water glass in water. Within 3 minutes one arm of the crystal has grown and the crystal itself appears five times as large.

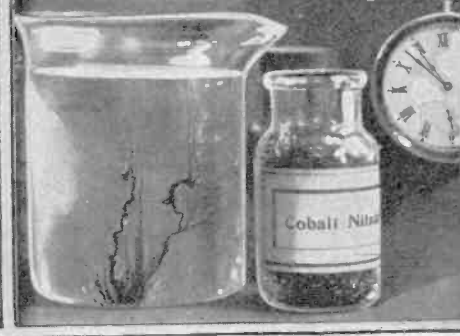

At 8 minutes of 11 the plant-like structure shown here was developed. This growth the chemist explains, is due to osmosis, the diffusion of two liquids of different densities through a thin partition.



Thirty minutes after a slide of lecithin has been prepared the growth of another peculiar chemical structure begins. These latter chemical growths are not creations of artificial life.

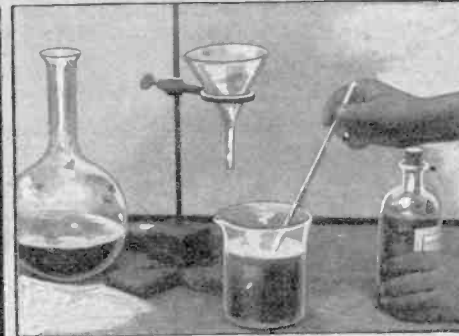

It is only the top row of photographs that actually resemble living protozoa and amoeba. For the production of growths shown at the right and left of the above photograph this photo shows the extraction process.



After 8 hours the "myelin" formation or liquid crystalline structures shown in the above micro-photograph becomes well developed. Slide enlarged approximately twenty-five times.

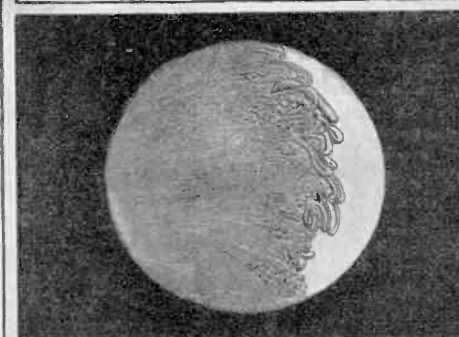

When lecithin freshly formed is placed on a microscopic slide and water and glycerine added, the glycerine retards the growth. The many bulb-like protuberances which develop may be viewed with a microscope.

IF man were actually able to produce cells, similar to amoeba, each having one or more nuclei; and if these cells had all the vital characteristics of life in that they assimilated food, lived, grew, reproduced and died, would you not say that man had actually produced life? Such was the experience of J. F. Mazur, M.B., a leading bacteriologist.

The cells were produced as follows: Tin receptacles each contain 100 C. C. of water which is boiled for five minutes and then cooled. Place one gram of common solid glue in the water and let it stand for six hours, then heat almost to boiling till dissolved. Remove from fire and immediately add three scruples of tannic acid a little at a time until the mixture assumes the appearance of milk. Place on microscopic slide and examine. The cells should appear even and uniform in size. If too large, add more tannic acid. Their appearance is shown in the second photograph at the top of this page. To change them into a living condition, take a platinum loop and place a drop of the fluid containing the cells on a slide. Add a drop of oxgall and mix with fluid on the slide. Within three minutes the cells will change, forming nuclei and if kept at room temperature, growth and multiplication of the cells will occur.

A Novel Scene Shifting Method

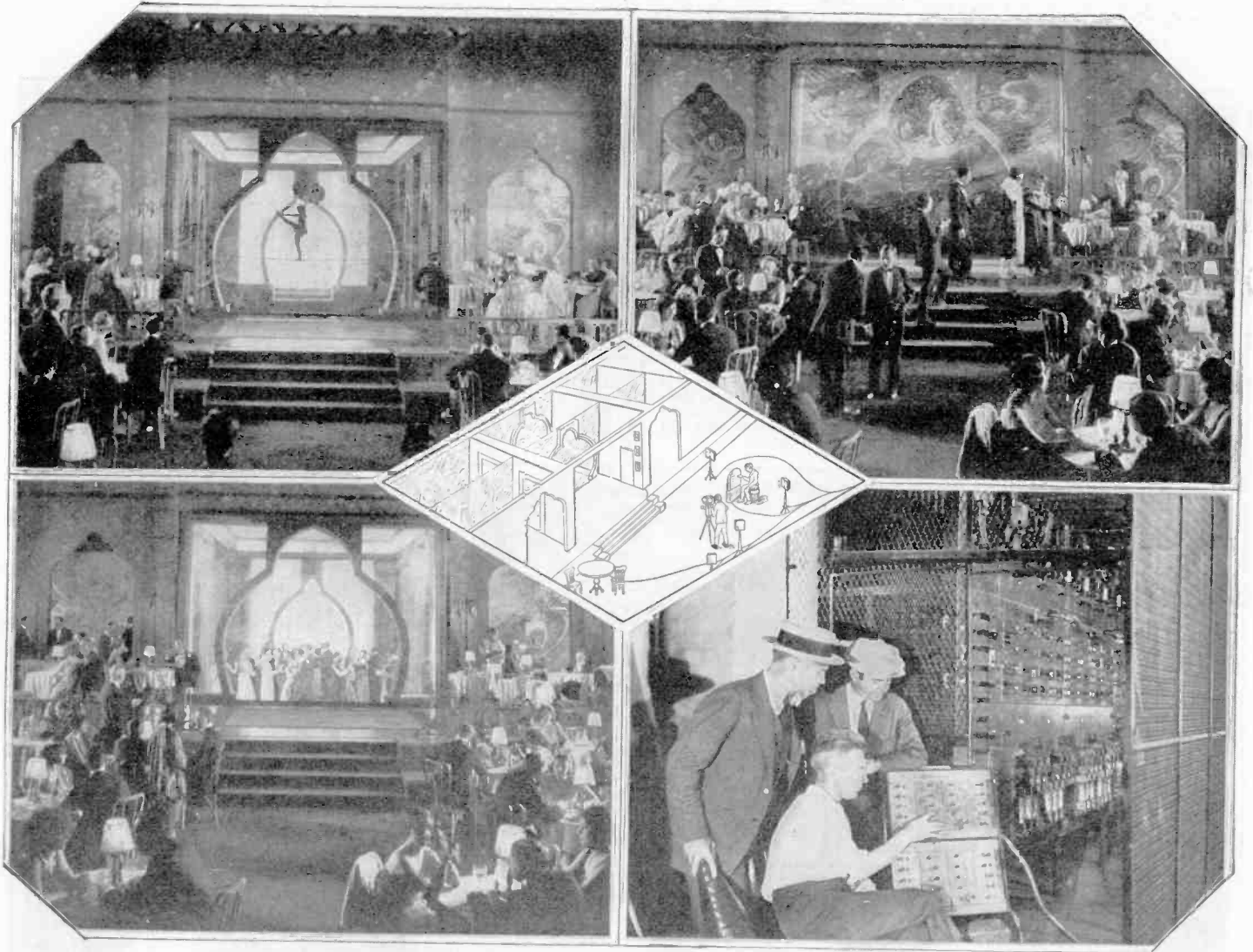

In the recent Clifton production "Six Cylinder Love", it was necessary to stage a cabaret scene with a quick shift to a second cabaret scene, and then to a group of people behind the stage. A novel method was used to obtain a quick shift from one scene to another resembling a dissolving of one set into the other. By the use of theatrical gauze and lights separating three compartments, and throwing a light on each compartment alternately, the effect

was easily obtained, since the scenery background for each of the compartments was painted on the gauze. With the light in front of the gauze the background was visible, but as soon as the light in front of the gauze was flashed out and those behind it lighted, the gauze with its painted background became transparent, and the next set with its background became visible to the audience.

Mystery Disk



Hot Air Motor

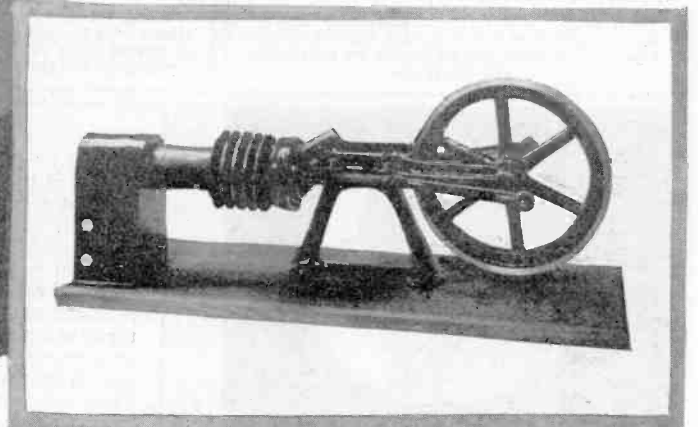

A marvellously entertaining experiment results if a cardboard disk about 4" in diameter, one-half of the surface on which is covered with black velvet, the other half with pale gray paper, and a slot approximately 60 degrees wide cut in the bottom of the gray section, is revolved at a speed of about six revolutions a second, in front of a picture of a woman painted as follows: hair blue, face green, dress red and violet. If the disk is revolved in front of this picture, as shown in the illustration at the left, the correct coloring of the picture returns in spite of the painted tints. Directly above is shown a new toy hot air engine of German manufacture.

Sea Rescue Invention

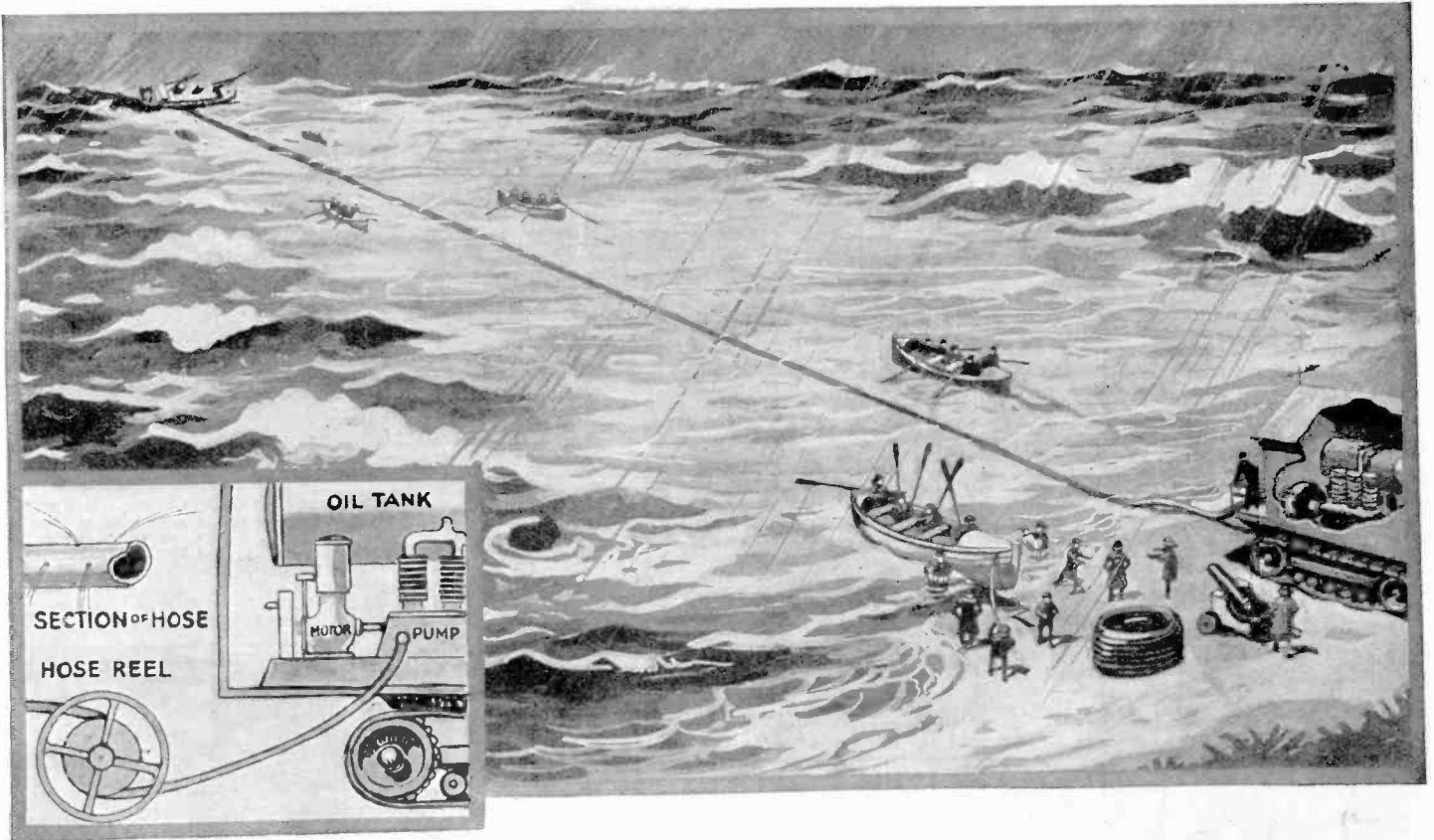

The efficacy of oil for quieting rough seas has long been known, however, in many sea disasters it is impossible to use this method since tide or wind carries the oil away from its area of usefulness. The methods shown above obviate this fault by shooting the

hose from the rescuers to the troubled ship and forcing oil into the hose which is perforated, thereby forcing a constant film of oil on the water greatly facilitating the rescue work. —Jos. H. Kraus.

THE VERTICAL REALM OF LIFE

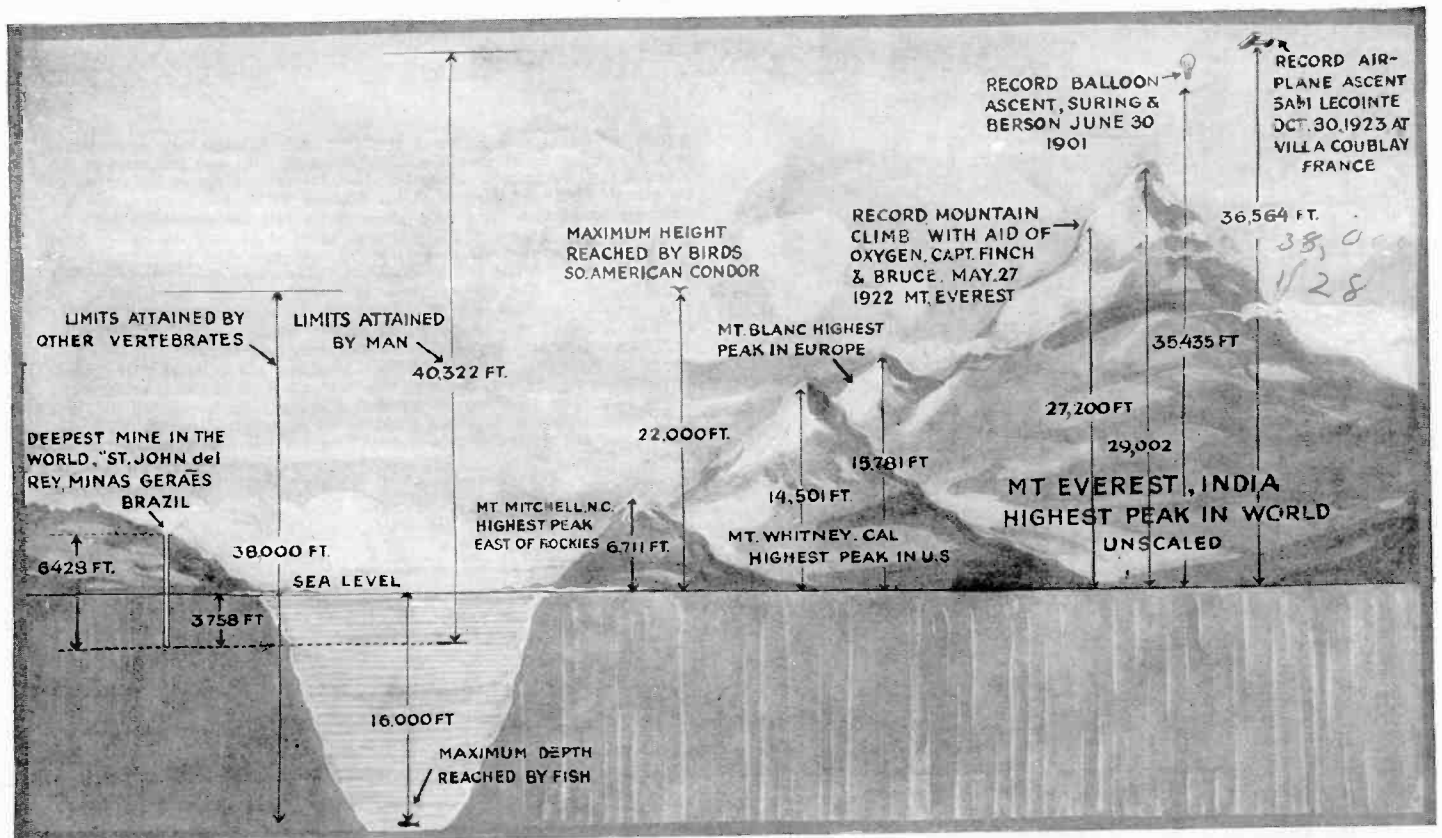

Man has conquered practically all parts of the earth's crust, at least those parts of it which are useful to him. However, his vertical domain may be considered comparatively limited since it covers a more or less restricted region compared to his lateral realm.

The illustration above gives graphically the upper and lower limits of man's explorations which may be considered practically the limits of mammalian life. Some fishes and invertebrates live beneath the limit shown. —F. W. Horton.

Hereditary Law In Flowers

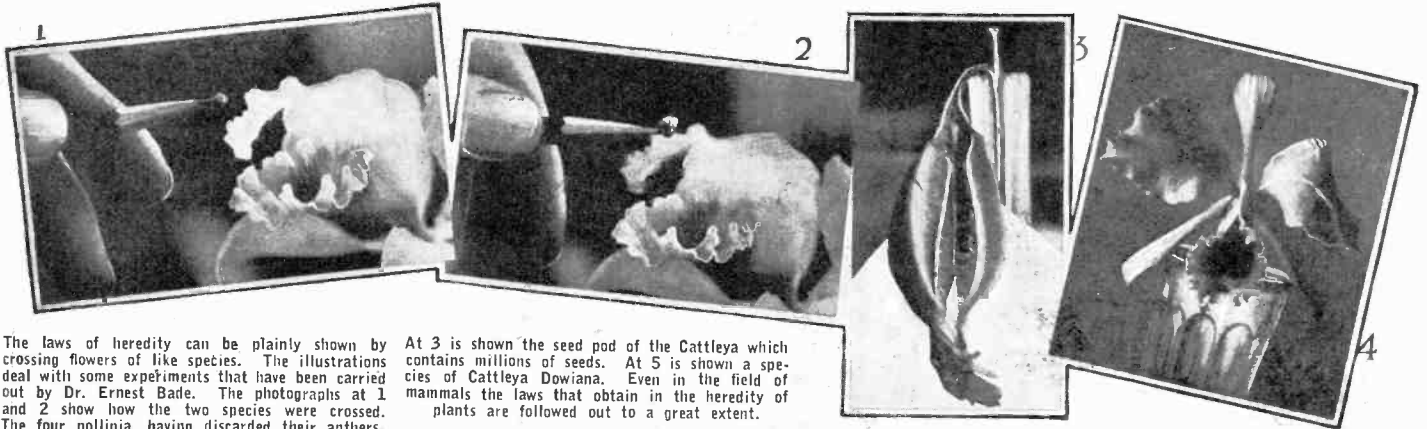

The laws of heredity can be plainly shown by crossing flowers of like species. The illustrations deal with some experiments that have been carried out by Dr. Ernest Baile. The photographs at 1 and 2 show how the two species were crossed. The four pollinia, having discarded their anthers, stick to the pencil. The pollen is then transferred to the pistil of another flower. The diagrammatic illustration at the bottom of the page shows the hybrid generations following the characteristics of the parents in coloring and type. Note that the second generation is pink, while the third generation brings back a part of the original coloring of the individual parents.

At 3 is shown the seed pod of the Cattleya which contains millions of seeds. At 5 is shown a species of Cattleya dowiana. Even in the field of mammals the laws that obtain in the heredity of plants are followed out to a great extent.

Above is shown the Cattleya labiata. In crossing species it is necessary to use plants of closely connected families. At 6 we see a hybrid of Cattleya dowiana (5) and Cattleya labiata (4). Note the striking coloring and markings.

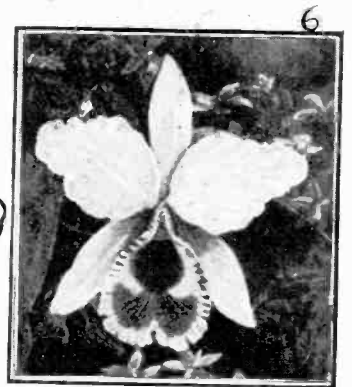
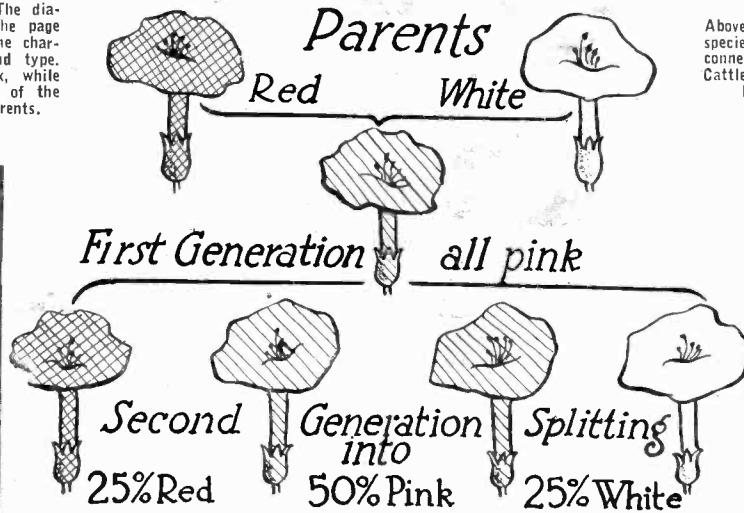

Replica of Yosemite Valley



ANSEL F. HALL, Park Naturalist of the Yosemite National Park in California, is the constructor of what is probably the finest relief map ever made in this country. In a space of ten feet by four and one-half feet he has reproduced the gigantic cliffs and waterfalls of the Yosemite Valley, with every contour and sculptural feature modeled to scale. More than a year was required to finish the job. In making this model Mr. Hall used layers of cardboard one-eighth inch in thickness in building up the contours of the map, each strip in the map representing a rise of 50 feet in the actual cliff. The pieces of cardboard were cut out on a jigsaw. The built-up pieces of cardboard formed the foundation on which prepared modeling clay was spread for surfacing. Having cut out his contours, Mr. Hall commenced building up the skeleton on a solid base. He used 38 pounds of one-inch brads in tacking alone. Approximately 31,500 square feet of cardboard were used. (See left). Below Mr. Hill is shown at the model. At the left is the completed model or relief map. A study of this is equivalent to making an airplane flight over the Yosemite Valley and the surrounding cliffs and domes, every natural feature being shown in its proper proportion and the routes of all roads and trails clearly defined, shaping the marvelous formations of the Valley.

—Rob't. H. Moulton.

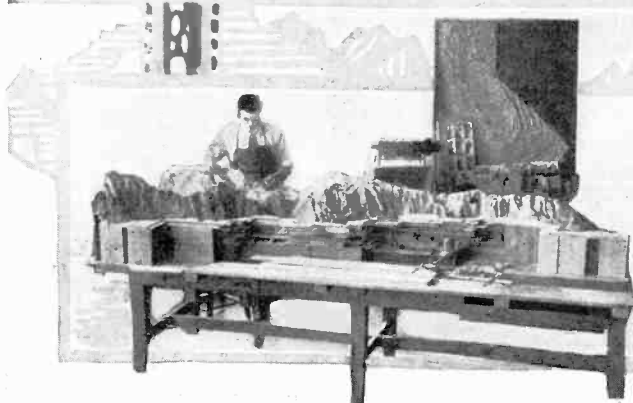

New Advertising Medium

A Monument



We have sky-writing as advertising and now we have sky-lighting for the same reason. Above is shown the advertising plane equipped by Peter LaGrosse, a New York pilot, which is used in announcing to the public the things they need. The device is simple. The letters of the sign, made just as are the letters in an ordinary terrestrial sign and lighted with small bulbs, are fastened to the bottom wing of the plane. Current to supply light to the bulbs in the letters is supplied by a small wind-driven generator installed just outside the fuselage. The letters are fastened to a framework on the wing so that they may be changed easily from one design to another. —Aviation.

A Japanese, living in San Francisco, knowing that he was to die soon, and wishing to perpetuate his memory carved the statue of himself, life size, shown above. The hair and the beard on it are his own. He placed them on the wooden statue after pulling them from his face and head. —H. Gillett.

SMALLEST ENGINE

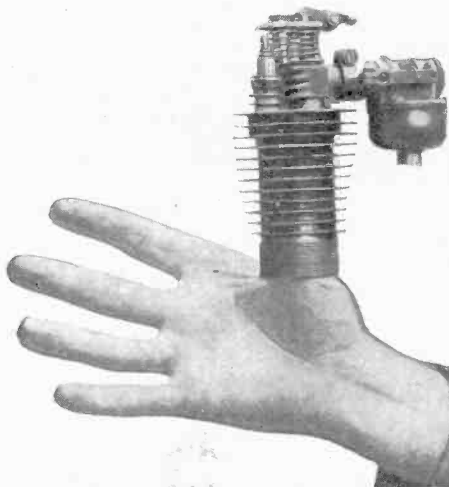

The above shown gasoline engine drives a motorcycle twenty-five miles per hour and will run 125 miles on a gallon of fuel.

In the human body in the region of the abdomen and beneath the skin and muscles is a cavity. This cavity is lined with a thin glistening membrane called peritoneum which is reflected over the organs within the cavity. This membrane prevents friction of organs upon one another to a very great extent. Thus in the covering process two portions are developed. One is called the parietal layer, and the other the visceral layer. The former is closely attached to the walls of the abdomen, except in places along the back where it extends forward in folds to invest the viscera. The drawing at the right shows the natural size of a piece of peritoneum and its enlargement showing its various coats.

THE BODY LINING

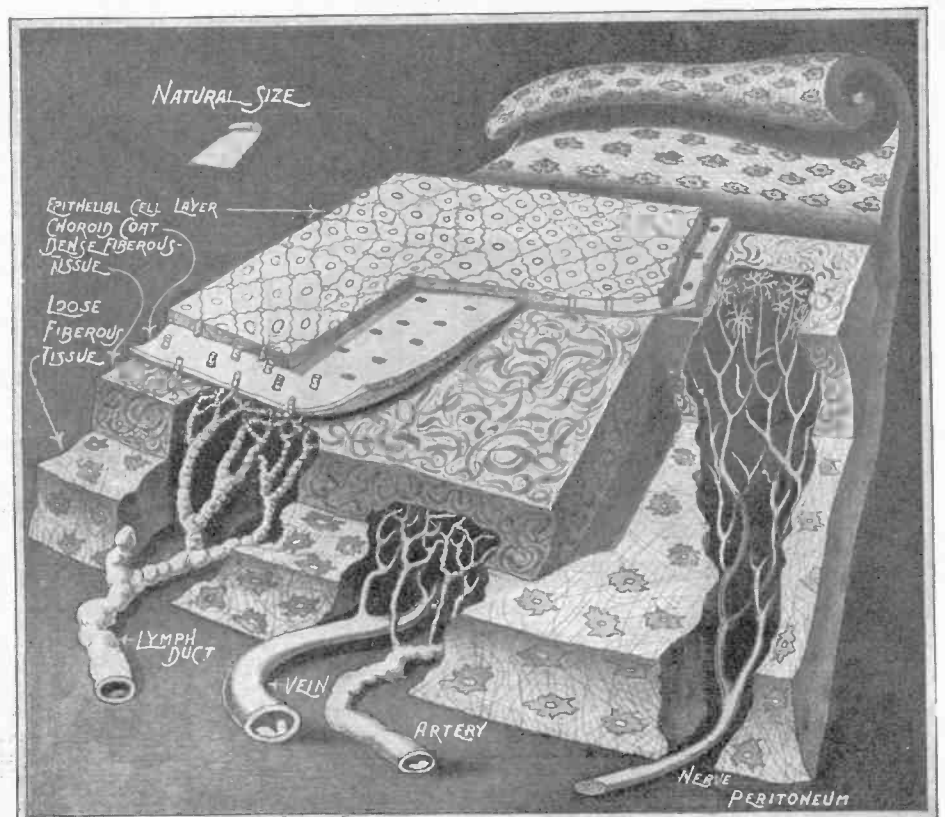

Critical Camera

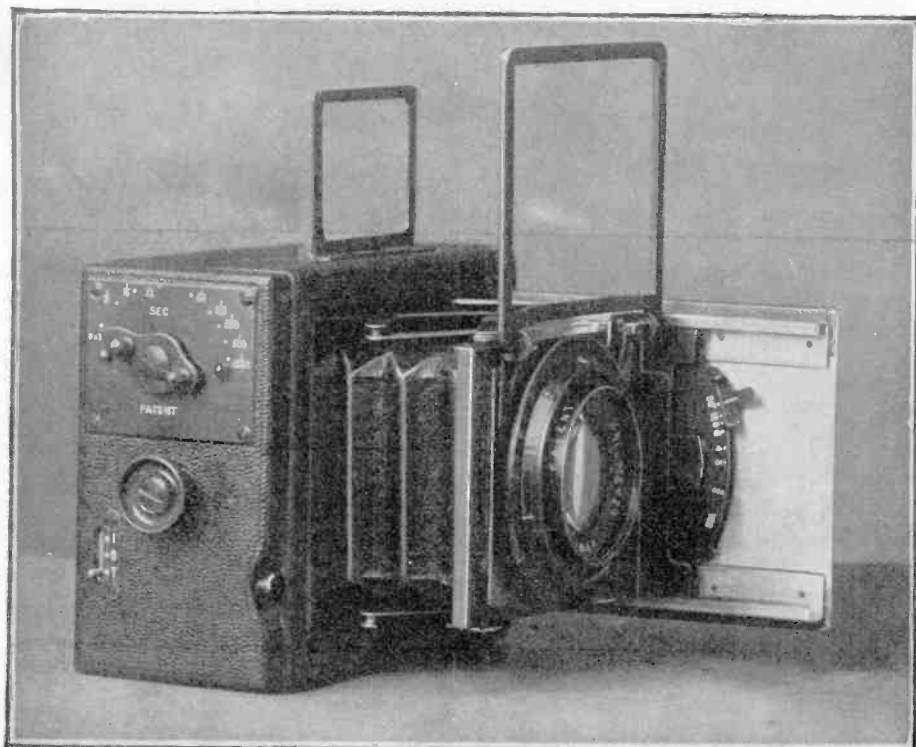

Fitted with a lens 2½ times as fast as an f.4.5 lens, the above illustrated camera can take pictures at night of street scenes and theatre scenes which are illuminated by the ordinary methods. —C. A. Oldroyd.

Shoe Kink



The Lock-tite fastener familiar on tobacco pouches has been extended to ladies' shoes and the result is shown above. This fastener is operated by pulling the ring. It cannot come undone accidentally.

Novel Dust Cap

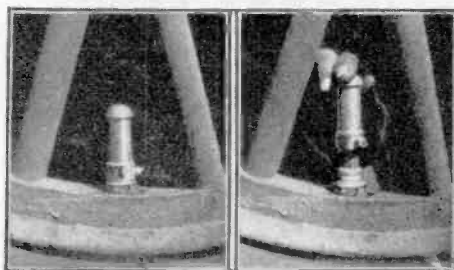

At the left is illustrated a dust cap for automobile inner tube valves which does not have to be twisted for several minutes before it can be removed from the valve stem. A specially constructed nut is first screwed down over the valve stem, whereupon the cap is pressed upon the nut. A strong spring holds the cap in place so that it cannot jar loose, but pulling on the top of the cap removes it instantly. This feature can be greatly appreciated when all four tires and the spare are to be inflated at the same time. —Allen P. Child.

Radiator Condenser

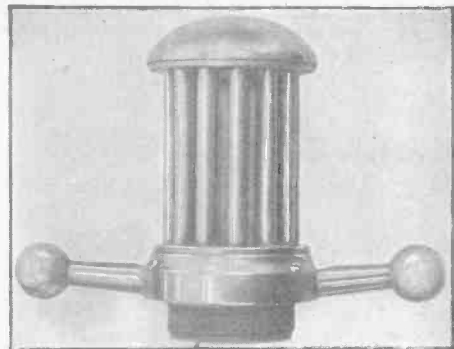

When the radiator of an automobile becomes heated, steam is given off and water is lost, thereby necessitating frequent refilling. This is eliminated by the use of the combination condenser and radiator cap shown above and to the left. The steam is condensed and the water flows back into the radiator. —Louis Jules Becker.

Gasoline Indicator

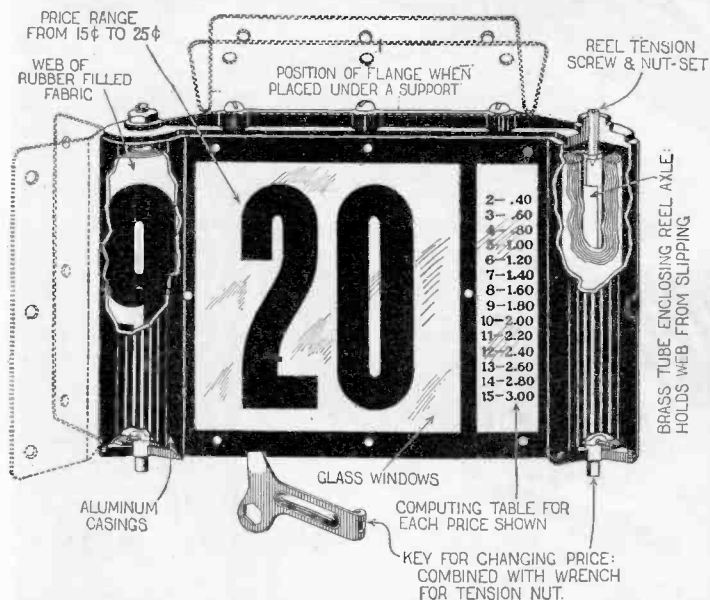

The combination instrument illustrated above performs several services when used in connection with a gasoline service station. It is to be mounted in a prominent position on the gasoline tank and the large number shows the price of gasoline. Beside this figure is shown the price of any number of gallons of gasoline from two to fifteen, at the current price.

Safe Parking Light



When the parking light illustrated here is mounted on the fender of an automobile, it shows to front and to rear. The sections can be opened for cleaning or for replacing the bulb. —Louis Jules Becker.

Magic for Everybody

By Prof. JOSEPH DUNNINGER

NO. 16 OF A SERIES

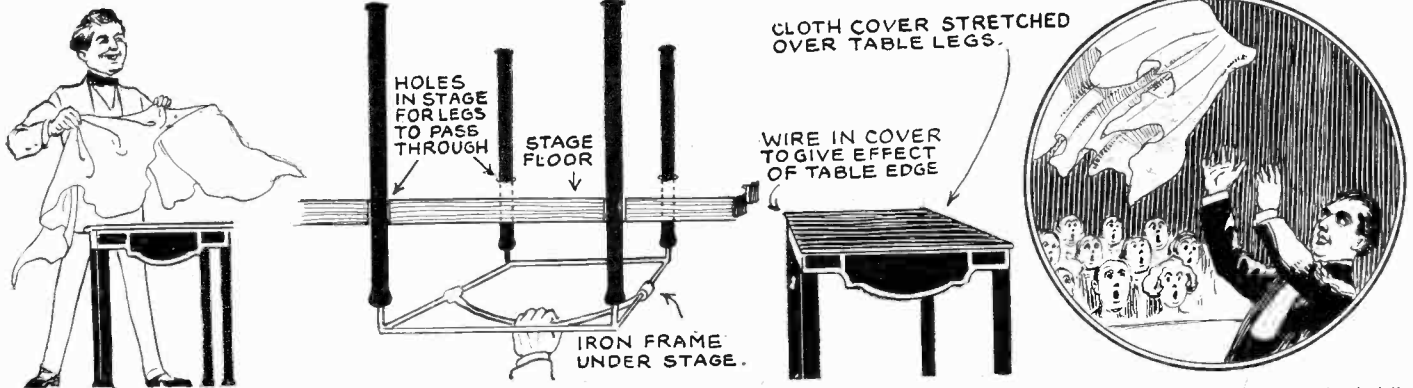

The performer covers a large table with a cloth. With considerable effort he tosses the cloth into the air and the table has completely disappeared. The legs of the table are solid and pass through holes in the floor. They are joined together by an iron frame so

that but one movement is required to lower them, as shown. The table top is of cloth with a wire frame around the edges to give the effect of solidity. The cloth is disappeared into one of the legs or remains concealed in the covering. An assistant is needed.

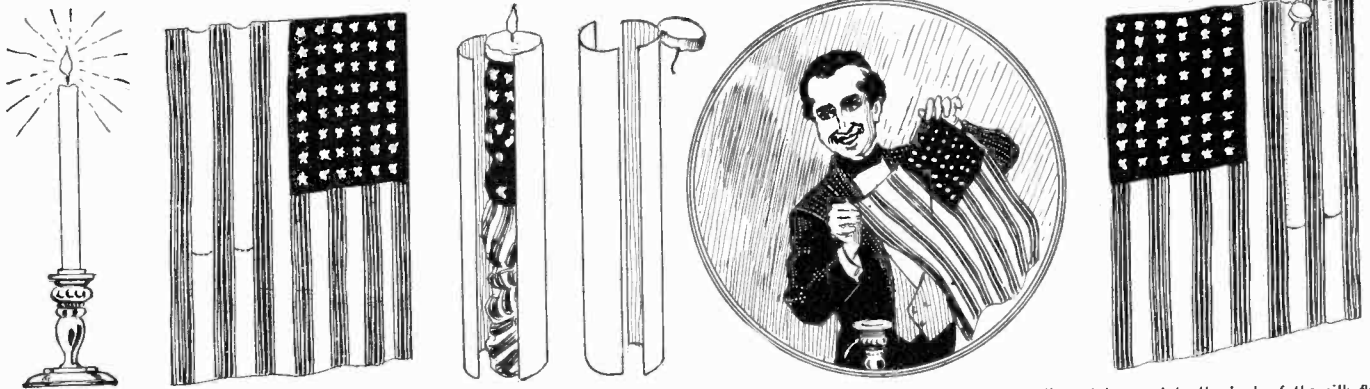

A lighted candle is taken from its holder and immediately changes into an American flag. The candle is made of two metal parts and at its upper extremity a small piece

of real candle is loosely fastened. The candle end is sewed to the back of the silk flag and is hidden by it from the audience. This trick is easily learned.

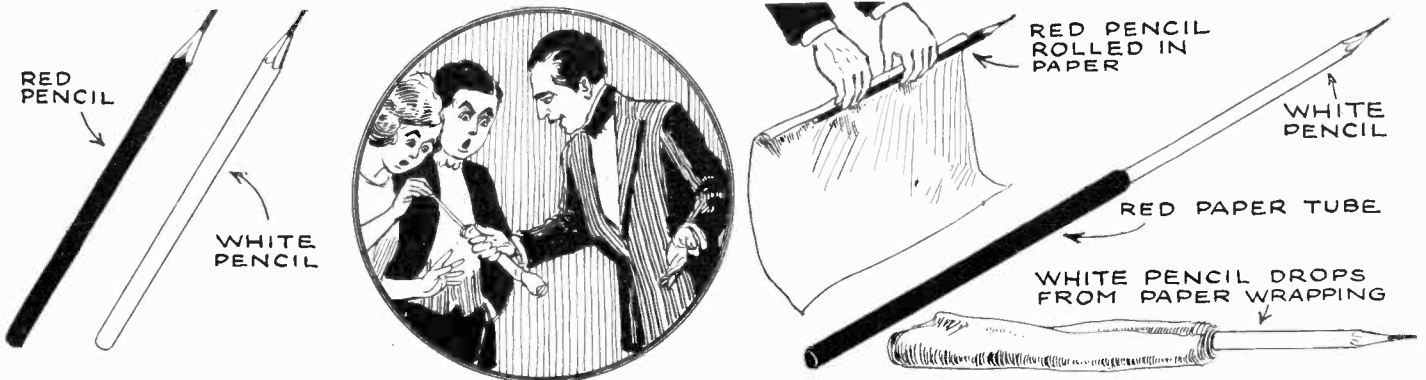

A red pencil is rolled into a sheet of paper. One of the audience is then requested to draw it out. It miraculously changes to white. The paper is crumpled and thrown

away. The secret is, that the white pencil has a red paper tube covering it which makes the audience think that the pencil is red. The red tube remains in the paper.

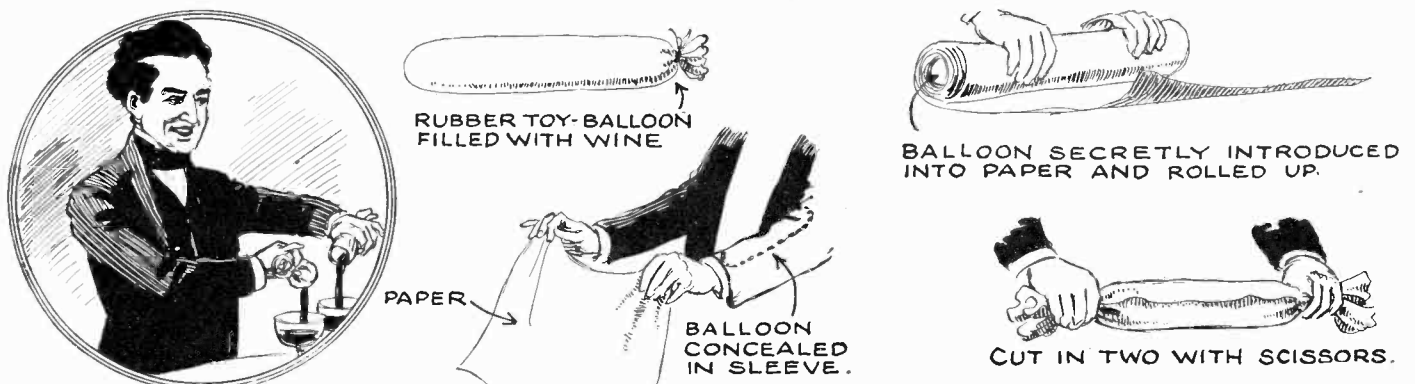

A paper is rolled into the form of a tube. Both ends are then twisted up and the tube is cut through the center with a pair of shears. Wine flows out of the tube, filling two glasses, and the paper is then crumpled and thrown away. In the sleeve of

the performer's coat, a rubber toy balloon filled with wine, either real or artificial, is to be found. This is secretly introduced into the paper roll while it is being formed. The balloon remains in the paper when it is thrown away.

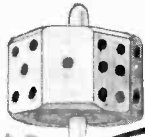

The spinning die-top at the left is manipulated by slipping the stem through from one side to the other. The dissimilar bevels at the edge do the rest.

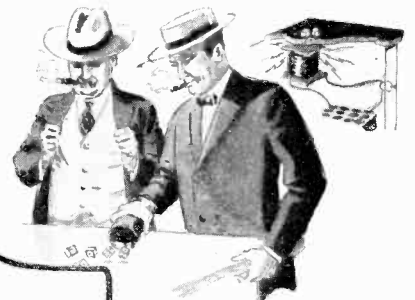

By placing electro-magnets under the counter where dice are played for cigars and other merchandise, the operator is able to hold the totals on the faces of the dices from running too high. This method of cheating the game is illustrated above. One side of each die contains steel filings which are attracted by the magnets.

A Gambler's Tricks Exposed

By MARK MELLEN
The Man Who Fooled P. T. Barnum

THE various professional devices used in roulette and dice are shown in this month's installment. Much legitimate gambling apparatus is on the market, but the professional seldom uses it. He does not care to take any more chances than necessary. The pieces of crooked paraphernalia shown on this page are more or less common and they may be found in a great many gambling houses.

During the past month several letters have been received through the magazine enclosing cards and small bits of apparatus suspected of being crooked. Every single card that was sent in by wondering players who had been fleeced was found to be marked. Some of them were very crude jobs, too. We will be glad to show such markings and tell readers whether or not cards are marked if the reader will enclose cards or apparatus and a stamped self-addressed envelope with his inquiry. This applies also to those anonymous readers who have already submitted cards and apparatus. All such communications will be considered as confidential.

When a gambler repeatedly wins large bets and allows the small ones to pass, or in other ways arouses the suspicion of the ordinary player who simply plays for the fun of it, then closes the game, there is almost always a possibility of the honest player obtaining one or more of the cards. We will be glad to uncover crookedness in players if the honest player can obtain the evidence, such as cards or apparatus.

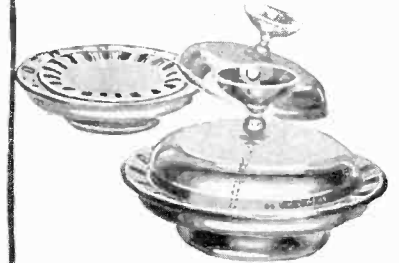

Another method of giving a great air of honesty around a gambling device and at the same time making it extremely easy to mulct the poor yokel who plays the game unknowingly is shown above. The bottom part containing the pockets is covered with a dish which is surmounted with a funnel into which the ball is dropped. A small pipe runs down carrying the ball to any number which the operator selects, causing it to win. This game is played with a "booster" employed by the house.



Above is illustrated the dice tub. The game consists in throwing a number of dice into it. An electro-magnet concealed in its base allows the operator a certain amount of control over the way the dice fall—enough control to see that the right players lose in the end.



The small roulette wheel shown in the above illustration is controlled by the operator through the aid of the collar between the spinning stem and the numbered disk. With it he is able to shift the winning number from odd to even or vice versa. Below is shown a pocket roulette wheel which may be crooked in much the same manner. The wheel is spun by winding the stem. A bit of a turn on the back of the case causes a shift in the numbers at the face which enables the operator to change from odd to even or from red to black, thus controlling the winning number.



By enclosing the dice in a cage a perfect air of honesty is created. However, by loading the dice on one side they are caused to fall as the operator of the game wishes. The roulette wheel above is equipped with a "throw off," which is nothing more or less than a movable splinter fixed in the path of the rolling ball which may be caused to rise at the operator's will, knocking the ball out of its regular course after the "winning" number passes.



Many card clubs use tables fashioned after the plan of that shown above. It spins over, hiding the evidence of the game in case the police pay an uninvited call.



Dice Tricks Simplified

By WALTER B. GIBSON



Place three dice on a transparent tray and shake them. Let someone look up through the bottom of the tray and add the pips on the bottoms of the dice. Looking down from above, you tell him his figure. Simply add the tops of the dice, and subtract the sum from 21.



Hold two dice and a tumbler as shown in the illustration. The problem is to toss the upper die and catch it in the tumbler, and then to repeat with the remaining die. The first part is simple, but when the second die is tossed, the first jumps out of the tumbler. To accomplish the feat, release the second die and bring the tumbler down rapidly, catching the second die.

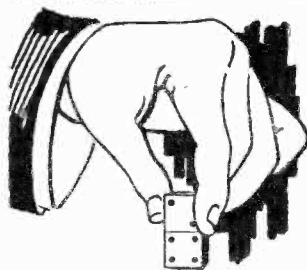

Magnetism? One die is set on top of another. When the upper one is lifted, the lower comes along. The secret lies in moistening the bottom of the upper die. When it is pressed on the lower, the two will adhere.

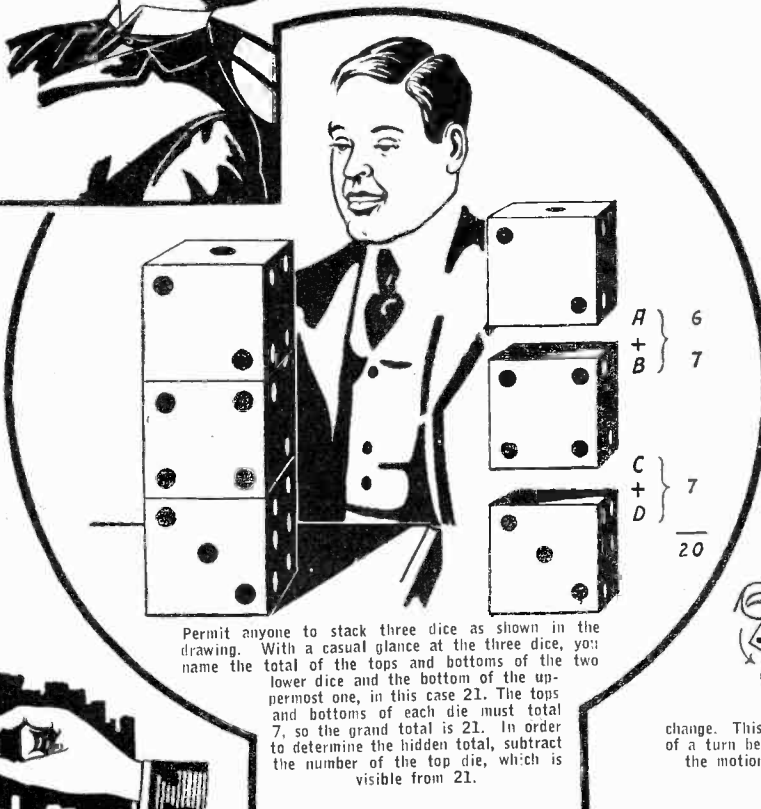

Permit anyone to stack three dice as shown in the drawing. With a casual glance at the three dice, you name the total of the tops and bottoms of the two lower dice and the bottom of the uppermost one, in this case 21. The tops and bottoms of each die must total 7, so the grand total is 21. In order to determine the hidden total, subtract the number of the top die, which is visible from 21.

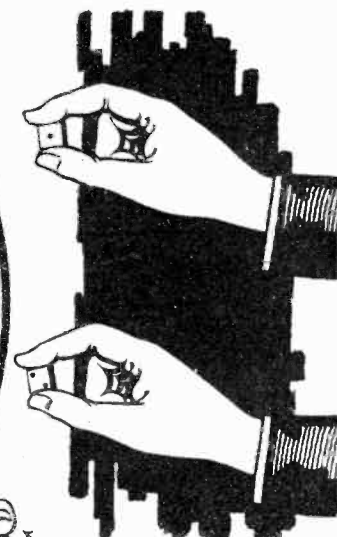

Hold a single die between the tips of your thumb and forefinger. By waving your hand slightly, you cause the number on the die to change. This is accomplished by giving the die a quarter of a turn between your fingers. With a slight movement the motion for producing the change is not noticed.

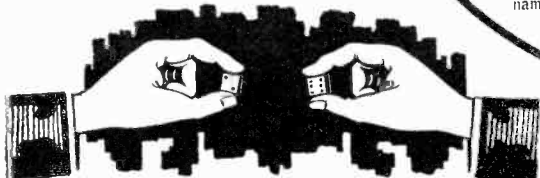

NUMBERS 1-8-15-22-29-36-43
IF OPPONENT PLAYS

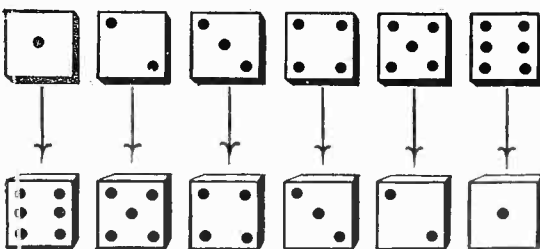

FOLLOW WITH

A race with dice. You show any side of one die—say two. Your opponent shows a side, and adds it to yours. Then you repeat. This operation continues until a total of fifty is reached. The person scoring fifty wins the race, and you always win. There are seven key numbers: 1, 8, 15, 22, 29, 36 and 43. Play to reach one of these numbers and from then on the game is yours for you can jump from one key number to another. If you begin the first play with one, it will be impossible to lose. You should always make your opponent's score and your own total 7, after the first key number has been reached.

While your back is turned or while blindfolded, tell someone to roll the dice and add their totals together. Then have him pick up one of the dice leaving the other on the table. Add its underside to the grand total. The die that was picked up is now re-rolled, and its new value added to the grand total. Supposing that 1 and 5 were the first numbers rolled, total 6, and 5 was picked up. Its opposite side 2 was added, bringing the total to 8.

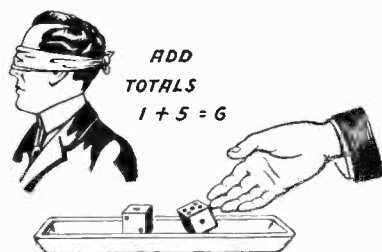

The secret is to simply add seven to the totals as they finally lie. In this case the grand total reached is 11. When you look at the dice you find the total indicated on the table as 4, and by adding 7 you reach the unknown grand total, 11.



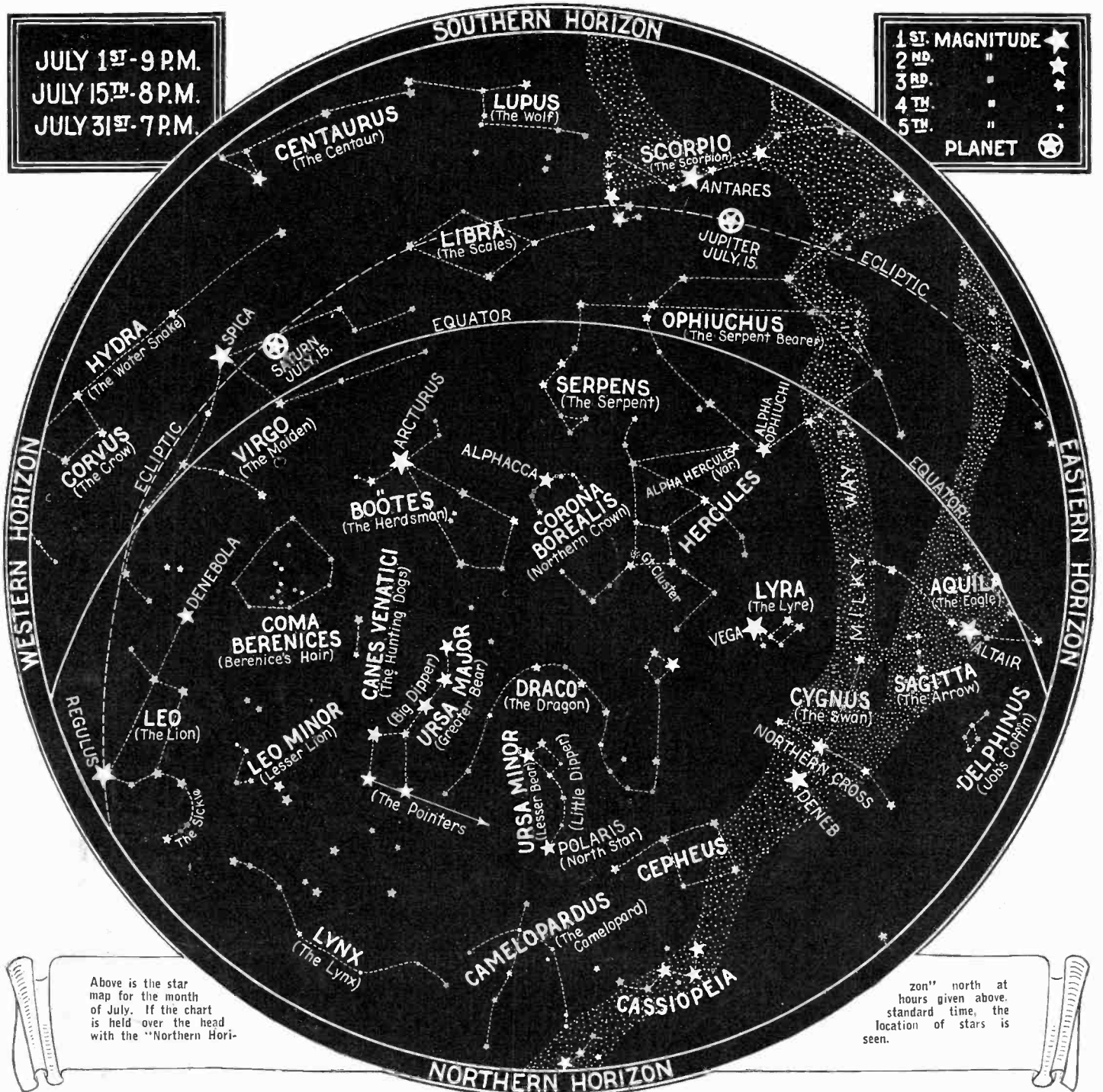

Above is the star map for the month of July. If the chart is held over the head with the "Northern Horizon" north at hours given above, standard time, the location of stars is seen.

zon" north at hours given above, standard time, the location of stars is seen.

The Heavens in July

By ISABEL M. LEWIS, M.A.
 of the U. S. Naval Observatory

A LITTLE to the east of the meridian in the early evening hours of July we find the huge constellation of Hercules which contains no first or second magnitude stars but a number of the third and fourth. Hercules represents the well-known hero of ancient mythology, son of Jupiter, famous for his marvelous strength and bravery and for the performance of the twelve labors for the accomplishment of which the Delphic oracle promised him immortality. These included, among other feats, the slaying of the Nemean lion, Hydra, the Water-snake, and Cerberus, the three-headed dog that guarded the entrance to the lower regions, and the capture of the golden apples of the Hesperides. Hercules is represented as kneeling, with one foot resting on the head of Draco to the north, as a symbol of his conquest of the serpent. In his uplifted right hand he holds a club and in

his left a branch, to represent the capture of the golden apples of the Hesperides, while over his shoulders is flung the skin of the Nemean lion. The head of Hercules is very appropriately marked by the variable giant star Alpha Hercules, which is estimated to have a diameter of nearly two hundred million miles and which is so far from the earth that its light takes over two centuries to reach us.

On the western edge of the keystone-shaped group of stars that outlines the body of Hercules, in the position shown on the chart, is a faint, hazy patch of light which is visible even to the naked eye on clear, dark nights. This is the famous globular star cluster known as the Great Hercules Cluster, one of the most beautiful objects in the

heavens when viewed with the aid of a powerful telescope. It is estimated that over thirty thousand stars appear on photographs of this cluster taken with the 100-in. reflector of the Mt. Wilson Observatory. All of these stars are probably giant suns, for stars no brighter than our own sun would be hopelessly invisible at the distance of this cluster. There are known to be about one hundred clusters in the heavens similar to the great Hercules cluster and they are estimated to be at enormous distances from the Milky Way and from our own solar system which lies in it. The Great Hercules cluster is believed to be at a distance of thirty-five thousand light years from the earth and it is one of the nearer clusters. The most distant clusters are over two hundred thousand light years from the earth. The diameter of the

(Continued on page 301)

Cloth Covered Porch Furniture

By WILLIAM BUTTERFIELD

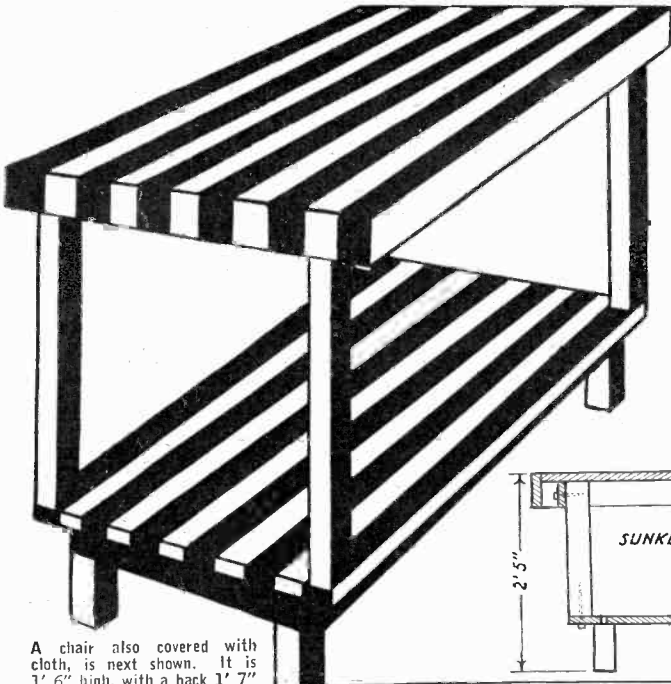

Furniture for the porch that is for the most part, if not completely, covered with cloth, is a novelty which is shown in our illustrations. A sunken leg table is the first shown. It can be of any convenient size, 2' 5" high, and with legs and posts 2"x2". The whole table can be made of soft wood. The cloth, which may be of awning canvas, is glued to the table.

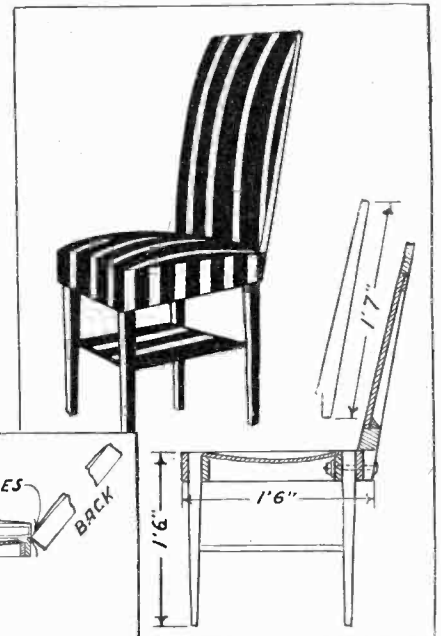

A chair also covered with cloth, is next shown. It is 1' 6" high, with a back 1' 7" high. The seat is 1' 6" x 1' 5" with two frames holding the legs in place. The inner frame supports a springy seat bottom on which the stuffing or upholstery is supported. The back is made by using a large seat bottom made to fit as shown. Bolts hold the back. The cloth is glued on this piece of furniture also.

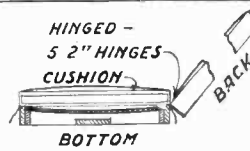
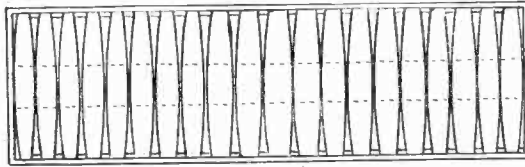

BACK AND BOTTOM FRAMES 7 X 2 FT. WITH BARREL STAVES SCREWED TO INNER FRAMES AS SPRINGS

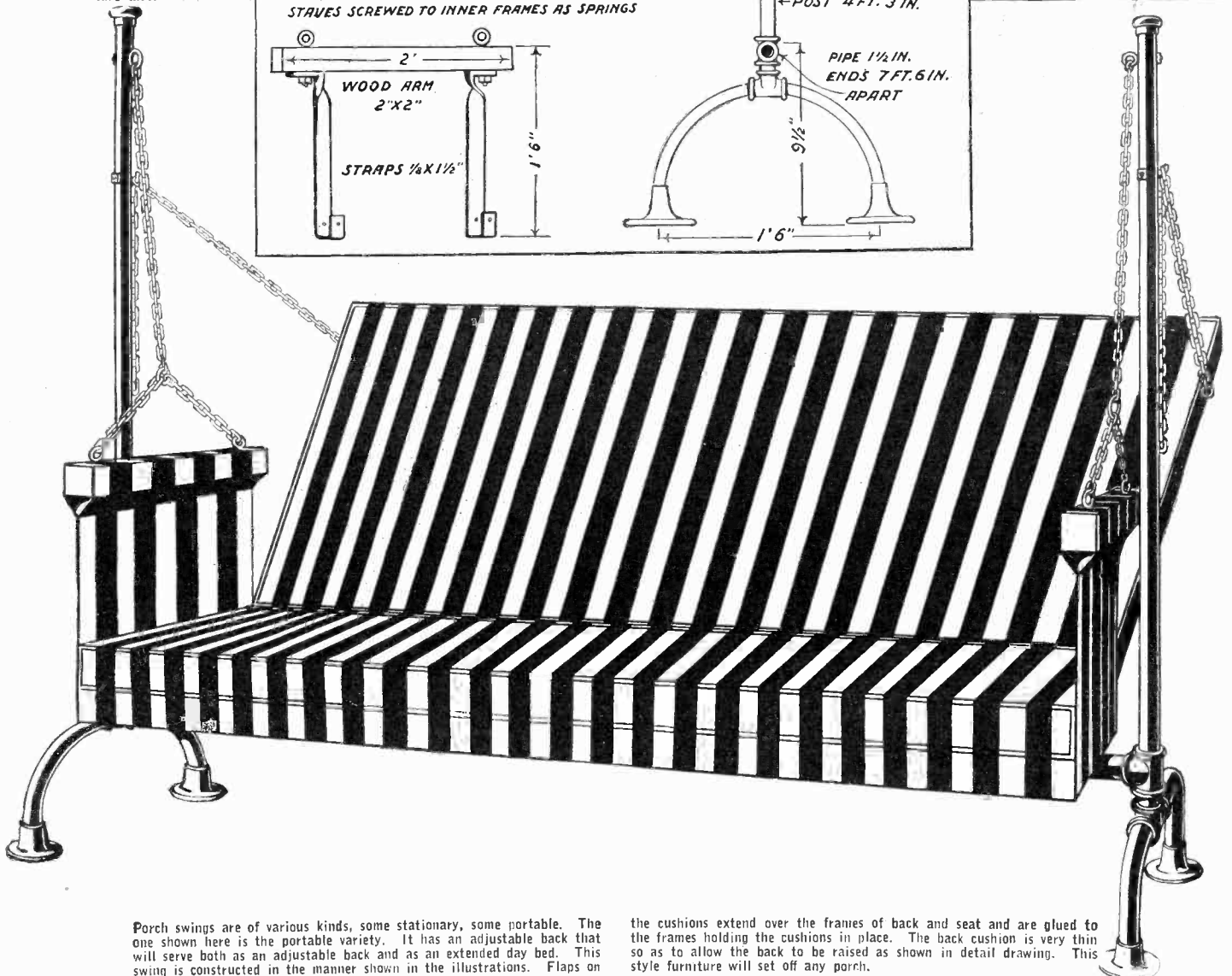
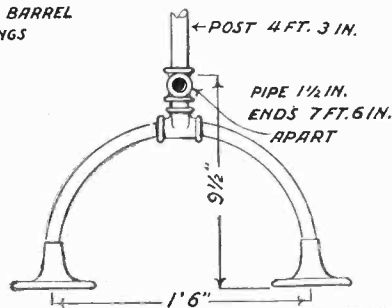
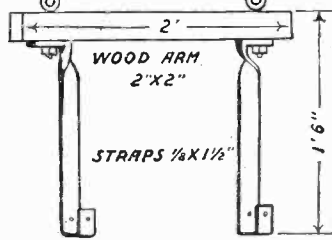

Porch swings are of various kinds, some stationary, some portable. The one shown here is the portable variety. It has an adjustable back that will serve both as an adjustable back and as an extended day bed. This swing is constructed in the manner shown in the illustrations. Flaps on

the cushions extend over the frames of back and seat and are glued to the frames holding the cushions in place. The back cushion is very thin so as to allow the back to be raised as shown in detail drawing. This style furniture will set off any porch.

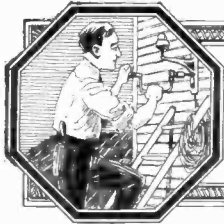

THE CONSTRUCTOR

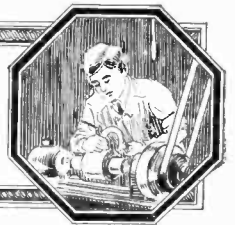

Boat Steering Apparatus

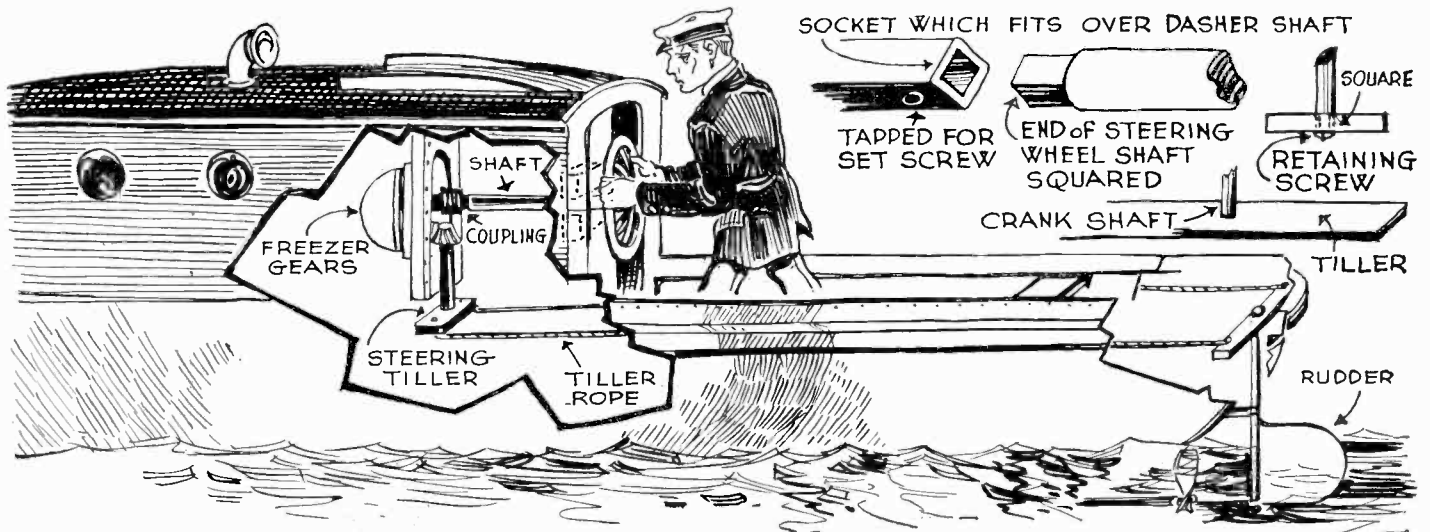

To give the small boat at least one appurtenance of a large cruiser it should be fitted with a regular steering wheel. This can be done easily and inexpensively by the method shown above in which an old ice cream freezer and an automobile steering wheel are used. The rudder is first fitted with a cross tiller to which are fastened two ropes. These pass along the gunwales into the bow. If the boat is decked forward, it is an easy matter to hide the ropes beneath the deck. Remove the

handle of the freezer from its crankshaft and replace with a second tiller yoke having the same dimensions as the one on the rudder. Make this of metal with a square hole in the center and tap the end of the shaft for a retaining screw. Then provide a round iron rod with a squared end to fit the socket in the dasher gear of the freezer. Place and secure the wheel as shown. This will give the effect of a high speed racing boat.
—L. B. Robbins.

Building An Art Craft Lamp

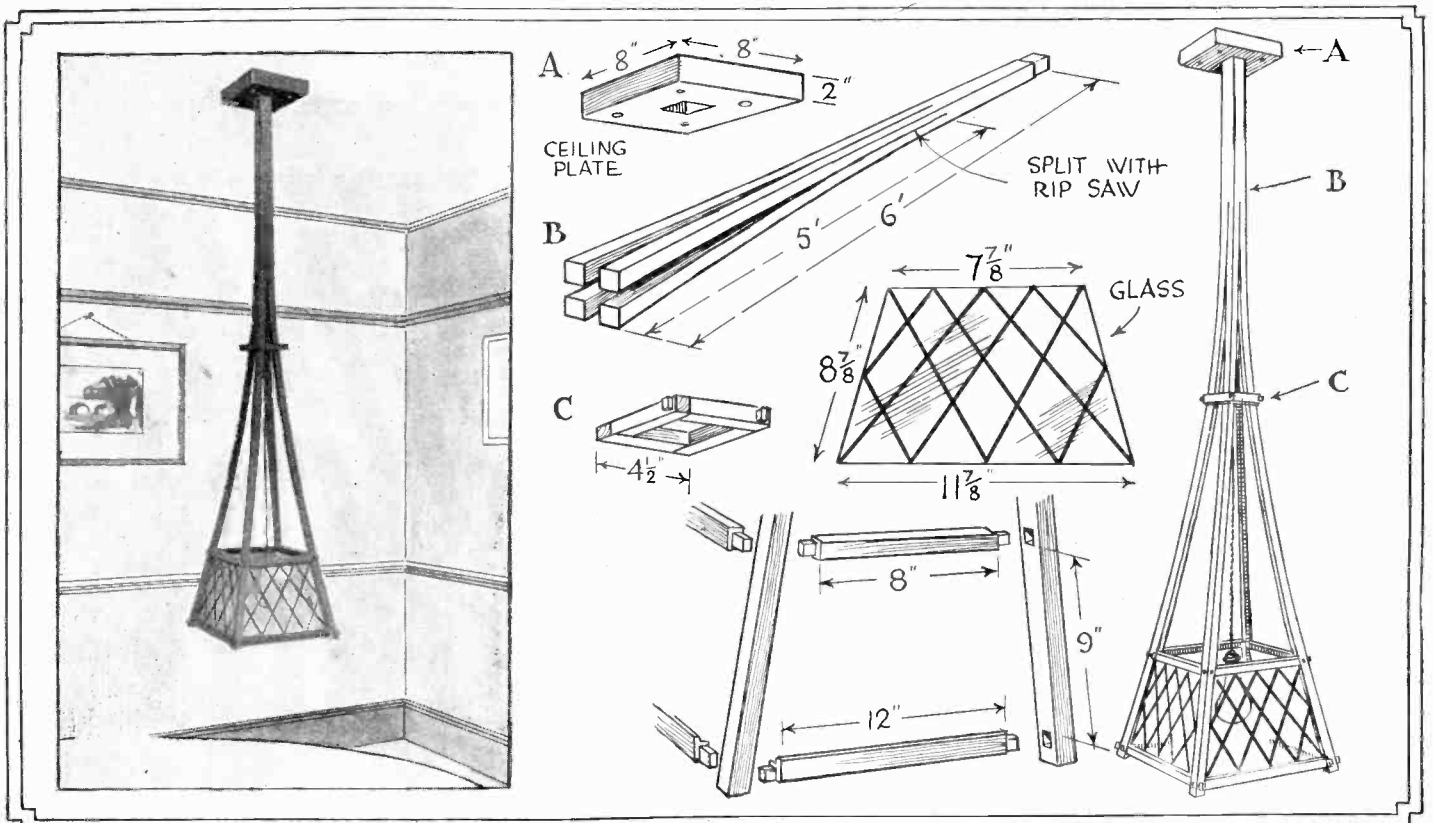

A straight grained piece of oak $1\frac{1}{2}$ inches square and 6 feet long should be ripped twice up the center with two cuts at right angles to each other for a distance of five feet. This piece forms the drop and four corner posts. The segment B, at the top is drilled down its center for the lamp cord. To hold the posts in proper relation, and in order to give the lamp its majestic curve—a binder, C, is made which is passed down on the frame. The lamp is held to the ceiling by means of

four screws and the block, A. After the wood has been cut, small blocks are placed between the strips so as to spread them apart. This facilitates the work of sand-papering the wooden pieces. The cross-pieces of the frame, eight in number are rabbeted back one-quarter inch to hold the glass. Plain or colored glass lined with drop black and japan increase the beauty of the lamp. It will harmonize well with the favorite mission type furniture.
—J. T. Garver.

Easily Constructed Cycle Car

Motorcycle engine and wheels used. No fine work necessary

By GALEN BARBER

An auto speedster that will tickle the heart of young men everywhere. The cost of building the machine is insignificant compared to the pleasure to be derived from such a car. A motorcycle engine supplies the necessary power for propelling the car. Ford parts can be used on many sections of the speedster.

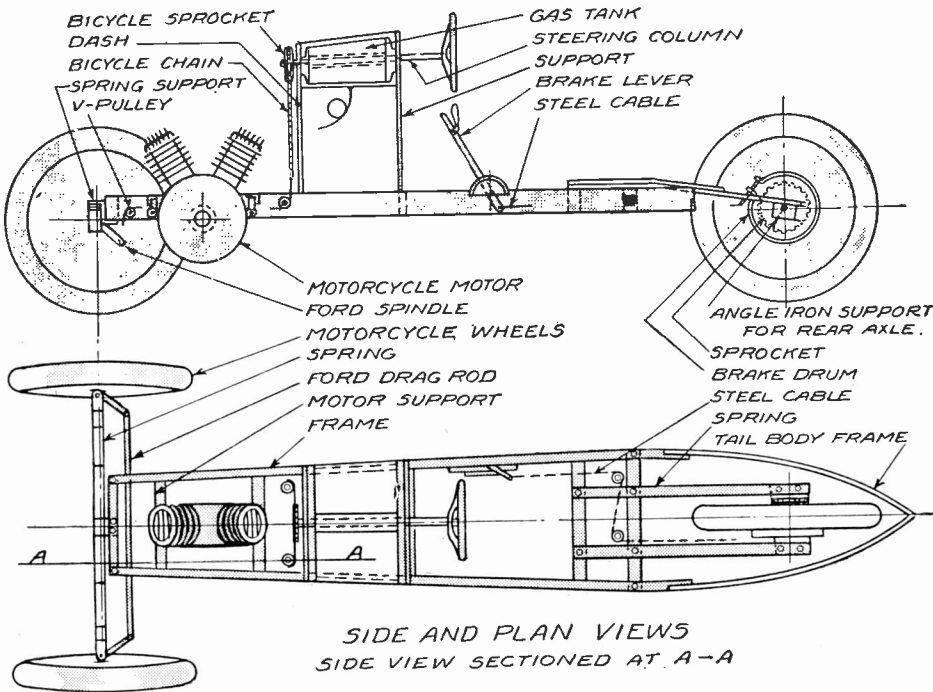
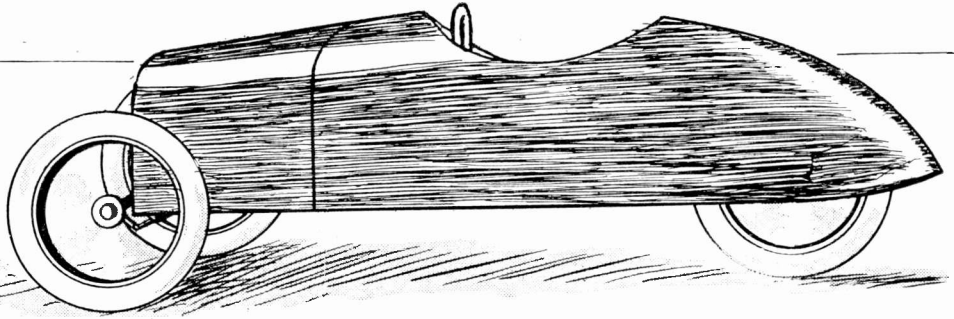

SIDE AND PLAN VIEWS
SIDE VIEW SECTIONED AT A-A

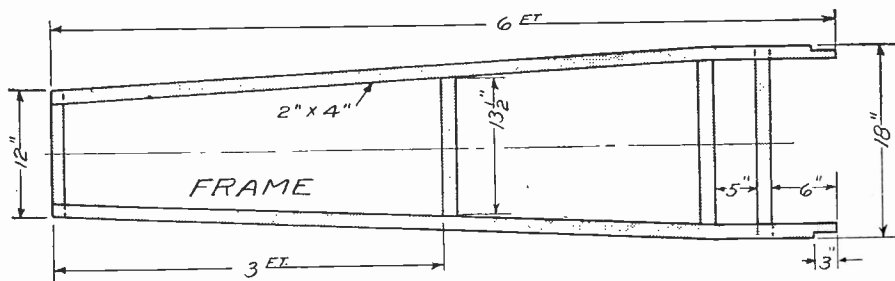

FRAME

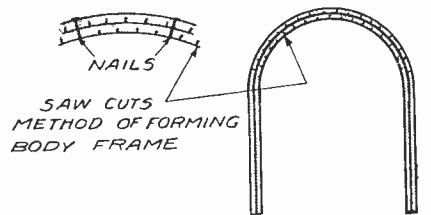
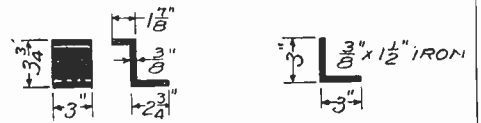
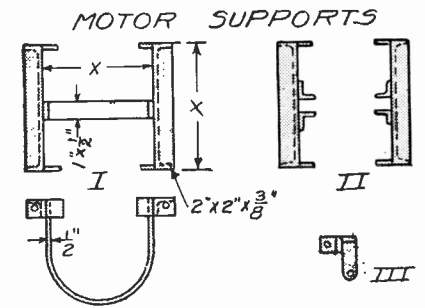
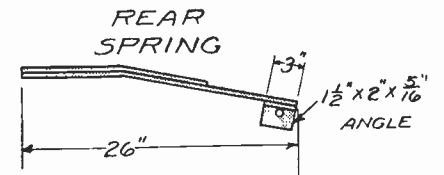
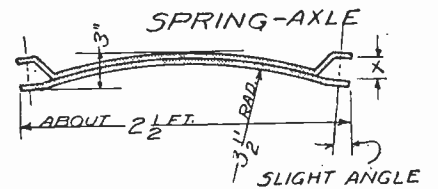
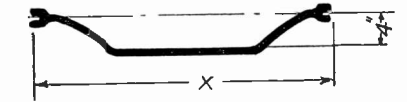
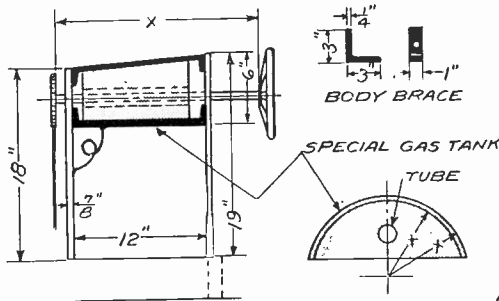
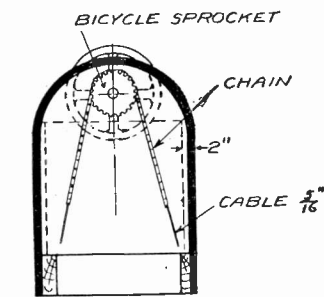

NOTE - "X" INDICATES DIMENSIONS WHICH MUST BE DETERMINED TO SUIT MATERIALS AVAILABLE.

Although the three wheeled motor car has not come into use in this country, it has achieved great popularity in Europe. The construction is so simple that any amateur craftsman may undertake the building of it. The wheels and engine are motorcycle parts. The frame is of ash or oak, well seasoned and firmly braced at the corners. The stringers and cross pieces are mortised and tenoned. The corner braces are made of malleable steel. Stock spring steel cut to shape form the springs which

are attached to the frame with bolts and yokes. The front wheel spindles are Ford parts and must be turned to suit the wheels used. The connecting or drag rod must be bent to clear the frame. The steering gear is built with a bicycle sprocket and chain with steel cable. The dimensions given in the drawings will fit for the most part. However, many changes may be made to suit the builder. The gas tank will have to be specially made. Interpose motorcycle clutch and chain drive.

Experiments With Plants

Strength of Plants Accurately Measured

By DR. RUSSELL G. HARRIS, Harvard University

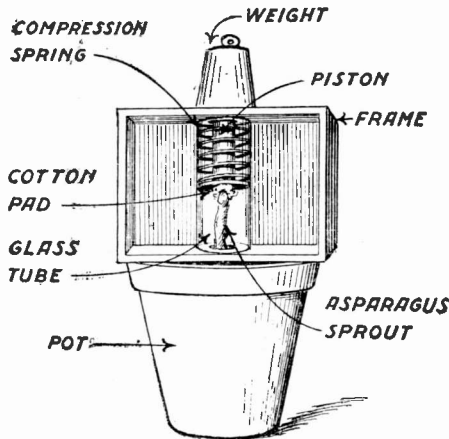

A growing plant exerts more pressure than that in a steam boiler. To prove it place a glass tube around the plant, in the tube place a plunger which is held down by a loose spring, place a piece of cotton between the plunger and the shoot and a weight on top of the spring. When the plant has forced the spring as far as it will go measure the pressure and divide it by the cross-section of the plant.

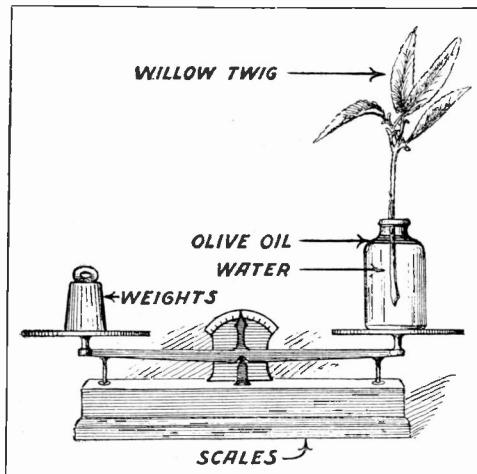

That some plants evaporate large amounts of water can be shown by placing a willow shoot in a jar of water and then carefully balancing the scale upon which it is sitting. The olive oil on top of the water prevents evaporation except through the plant. From hour to hour it will take a smaller weight to balance the water and plant in the jar. Large trees growing near water often evaporate barrelsful.

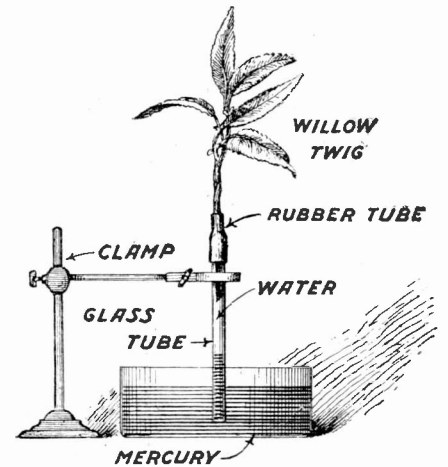

Another method of showing the large amount of water evaporated by some plants is shown above. The twig is placed in a tube filled with water. The bottom of the tube is placed in a dish of mercury as shown in the illustration and as the water is evaporated by the plant the atmospheric pressure acting on the mercury in the pan forces it up into the tube to take the place of the water ejected.

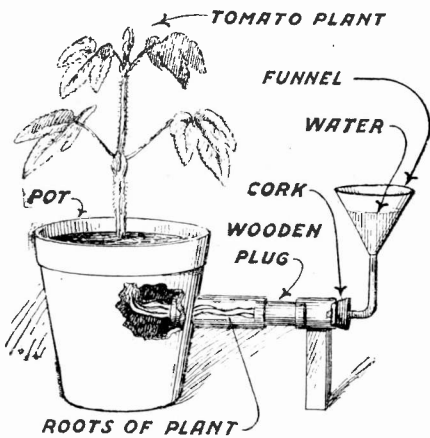

The force of plant roots is very strong. This can be graphically shown by the method above. Place a plant, in a pot with a side pipe. In the end of this side pipe place a wooden plug and keep the end of this plug constantly wet through the method shown. Water the plant sparsely. It will be found that the roots will pass through several plugs parallel with the section of the wood grain.

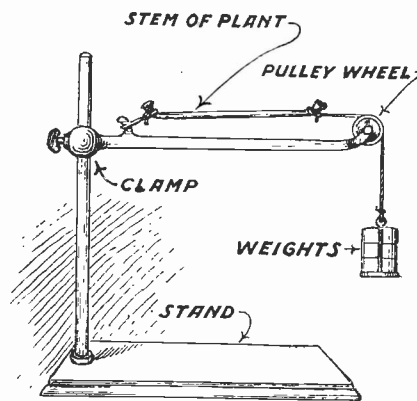

To measure the osmotic pressure of a plant stem make two India ink marks on the stem of such a plant as the geranium. Then soak the stem in a 10 per cent solution of common salt for 24 hours and again measure the distance between the marks carefully. Then with the arrangement shown above stretch the stem until the marks are separated by the first distance. Measure the force needed to do this.

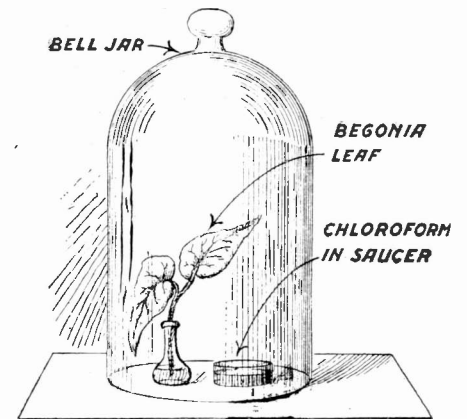

To demonstrate the effect of poisons on plants place a begonia leaf under a bell jar and with it place a pan of chloroform or ether. After a short time the leaf will be seen to discolor. If it is not removed to fresh air immediately following the discoloration the plant will die. If the dose of poison given it is restricted and it is moved to the proper surroundings immediately it may be saved.

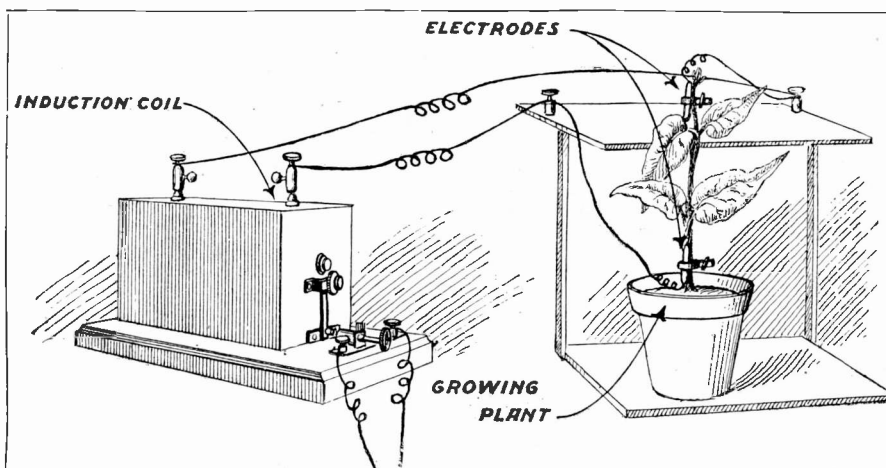

Even as electrocution kills the human animal so it does plants. An experiment to demonstrate this is illustrated above. A spark coil is used to furnish the high tension current. One of the secondary leads is attached to the plant at a point near where it enters the earth in which it is planted. A lead from the other electrode is taken to the plant near its top. The current is allowed to pass through the plant continuously. For a short time after the

beginning of the application of the current, the plant will be stimulated, but after the first flurry of stimulation it will die. The treatment with high tension current has been suggested from time to time as a method to force the growth of hot-house plants. In such cases the correct amount of current is applied and the advantages of the stimulation are gained without the death of the plant itself, presenting a real advantage.

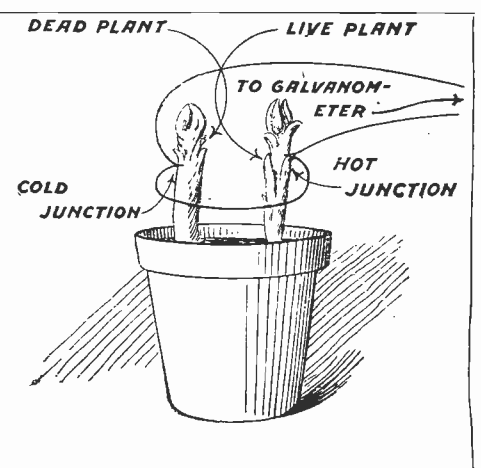

That live plants are warmer than dead ones can easily be proven by the thermocouple method. Place two like plants in a pot and kill one of them with boiling water. Attach one terminal of a thermocouple to the dead plant and the other to the live one. A short time after the death of the first plant a temperature difference of a fraction of a degree will be noted in favor of the live plant. The junction of the thermocouple should be varnished.

Oil Burning Equipment for the Home

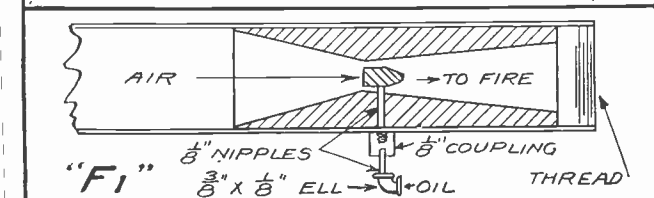
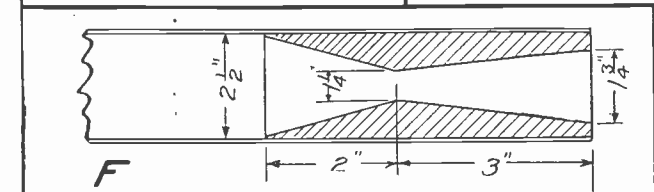
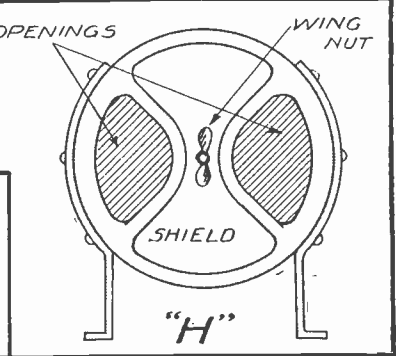
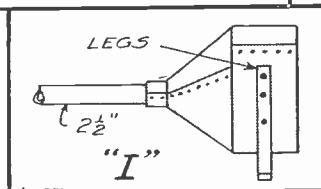
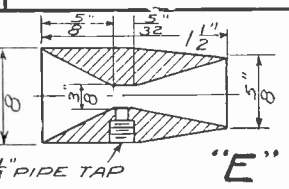
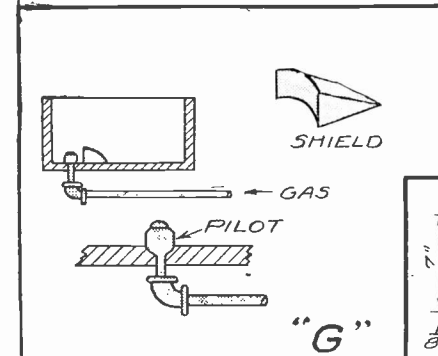
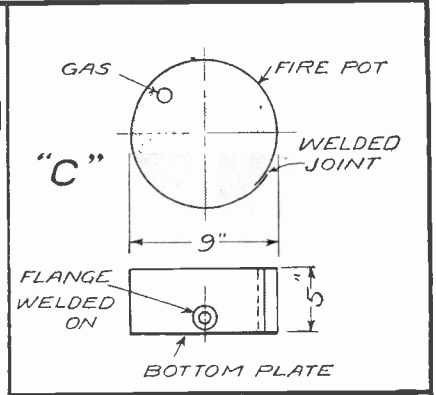
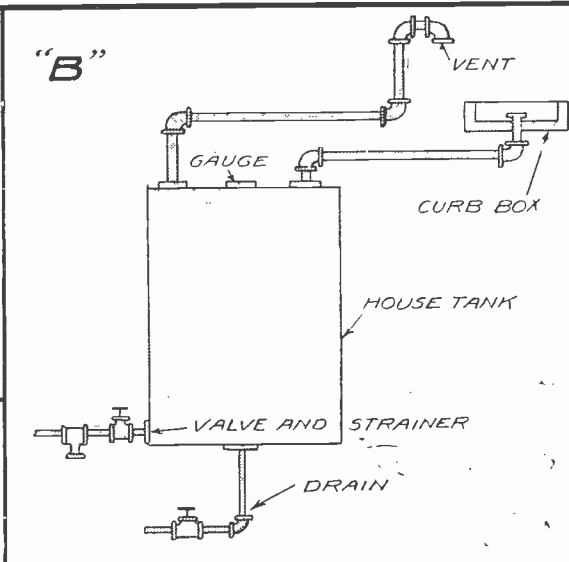
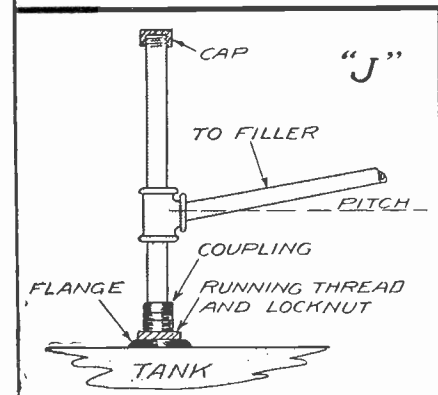
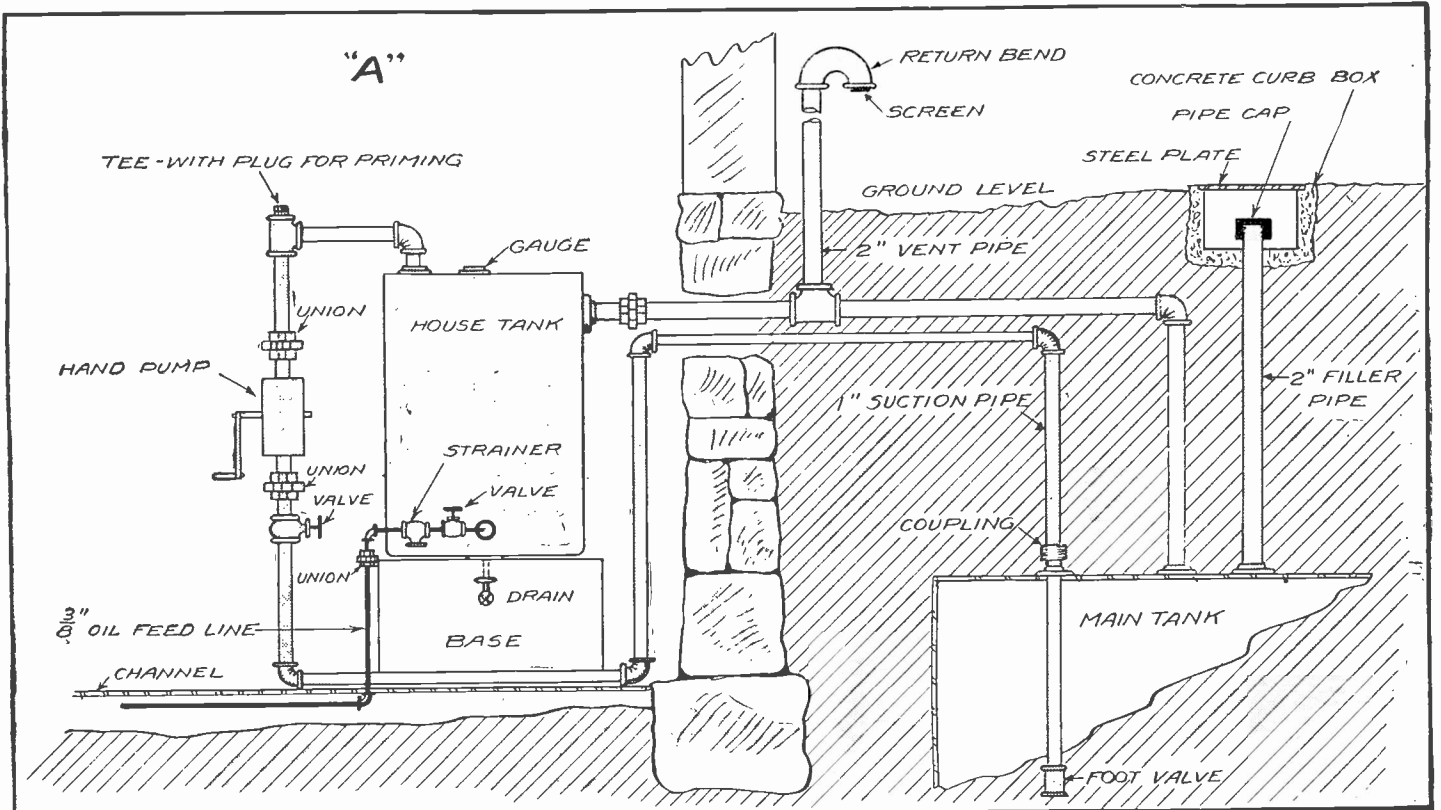

THE ever increasing cost of coal, and the occasional total inability to obtain it at any price, has caused many home owners to think of liquid fuel as a solution for forever ending heating problems. Oil fuel is no more dangerous than coal and has the advantages of no ashes and no grates to shake, and no dust or dirt of any kind to get rid of. In the comparison of fuel costs it will be found that oil can be purchased for the same price or less per heat unit. Oil delivers about one-third more heat per pound used than coal does.

The main tank buried in accordance with local ordinances, is a great convenience, but it may be eliminated if desired. Its size will vary. It may be from 100 to 2,000 gallons' capacity and should be provided with three flanges welded on the side. Before installing the tank in the pit it should be given a good coat of asphaltic or other rust resisting paint. The larger the tank the smaller the cost per gallon of oil, since there is a surprising cut in the price for large quantities.

(Continued on page 313)



HOW-TO-MAKE-IT



This department will award the following monthly prizes: First prize, \$15.00; second prize, \$10.00; third prize, \$5.00. The purpose of this department is to stimulate experimenters toward accomplishing new things with old apparatus or old material, and for the most useful, practical and original idea submitted to the Editors of this department a monthly series of prizes will be awarded. For the best idea submitted a prize of \$15.00 is awarded; for the second best idea a \$10.00 prize, and for the third best a prize of \$5.00. The article need not be very elaborate, and rough sketches are sufficient. We will make the mechanical drawings. Use only one side of sheet. Make sketches on separate sheets.

Chimney Kink

FIRST PRIZE \$15

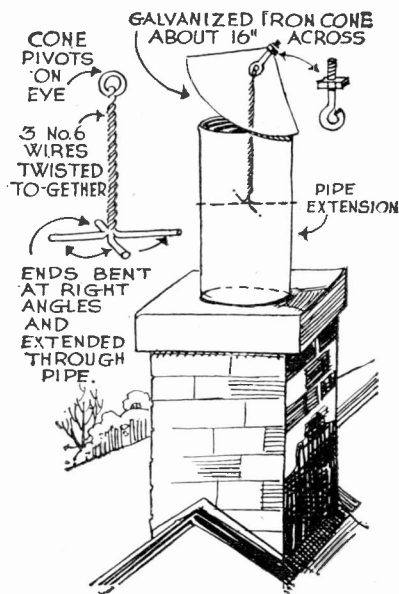

When a chimney is too short to produce sufficient draft the installation of the cone shown above supported by an eye and three suspension wires fastened in a short length of extension chimney pipe will bring the draft up to normal. The supporting wires should be at least No. 6 or larger. —Dale R. Van Horn.

Window Closer

SECOND PRIZE \$10

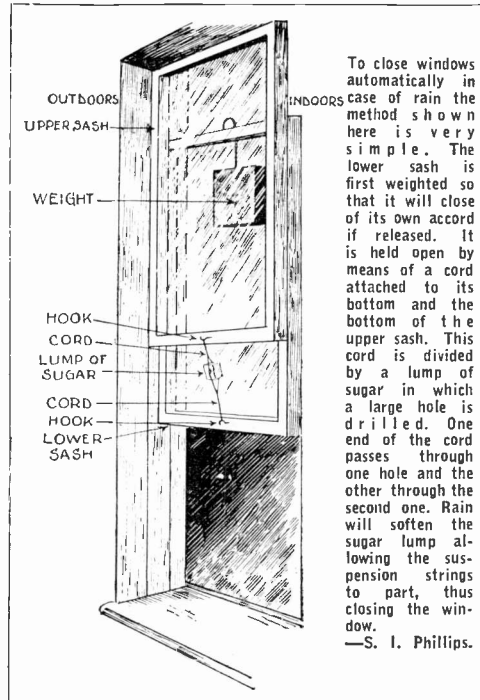

Telephone Signal

THIRD PRIZE \$5

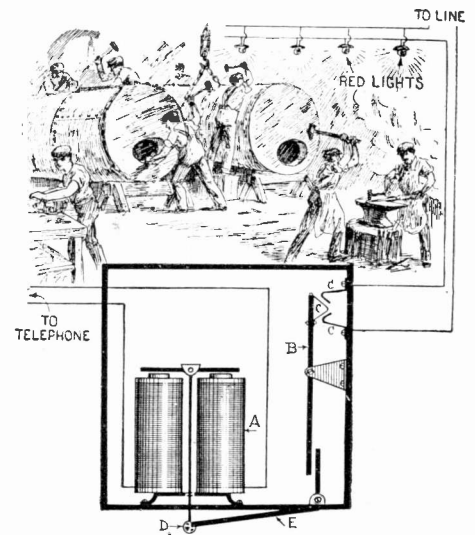

In machine and boiler shops where there is a great deal of noise a very convenient method for calling attention to the ringing of the telephone is shown above. The attachment shown in the bottom of the illustration is placed in series with the telephone ringer and flashes red lights in the shop. When the bell rings the arm E drops out of the notch in the clapper and falls against B which in turn closes the light circuit. —H. L. Anderson.

Balancing Egg

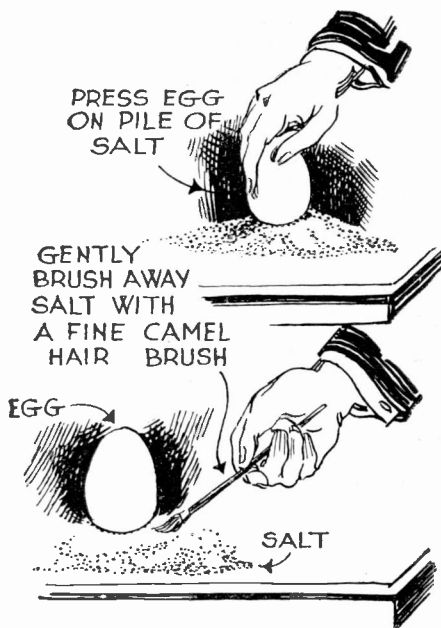

A very entertaining stunt for the dinner table is shown above. An egg is balanced in the center of a plate and stands perfectly. The method of performing the stunt is simple. Place a half teaspoon of salt in the center of the plate and press the egg lightly in the center of the salt. Then with the aid of a fine camel's hair brush slowly remove the salt from around the egg. At the completion of this operation the egg will seem to stand by itself. —C. A. Oldroyd.

Turn Pointer

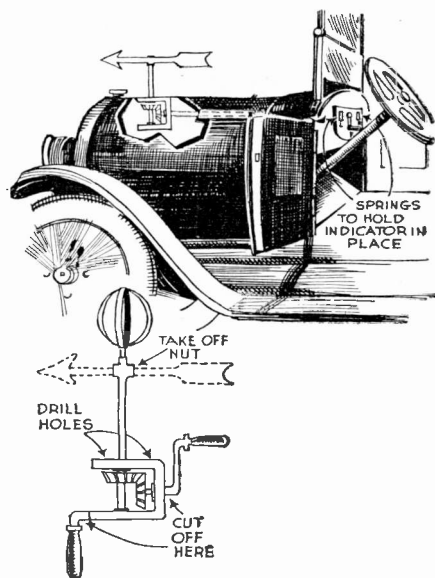

A very simple direction indicator for motorists that can be made from spare parts found around the ordinary shop is illustrated above. The gear part of the device may be taken from an old egg-beater or other similar kitchen apparatus. The beater is cut as indicated and placed under the fore part of the hood. The beater blades are cut off and an arrow substituted in their place. An extension arm is placed on the operating gear and is carried back to the dash board. A handle is placed there for the operator's use. In congested districts and heavy traffic this little device will be found of exceptional merit in saving the driver time and the wrath of traffic policemen. —W. S. Hendren.

Hydraulic Press

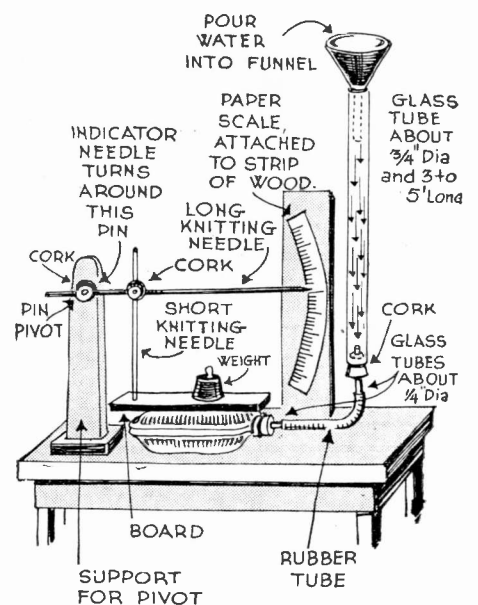

An extremely interesting model of the hydraulic press can be made as shown in the above illustration. The only pieces of apparatus needed are an old hot water bottle, some corks and a few bits of glass tubing. They are assembled as shown in the illustration. The levers and the indicating scale are for measuring the distance through which the weight is raised. To operate the device and raise the weight it is only necessary to pour water in the funnel at the top of the head tube. A fifty-pound weight can be raised. —C. A. Oldroyd.



WRINKLES

RECIPES & FORMULAS



Edited by S. GERNSBACK

Garage Light

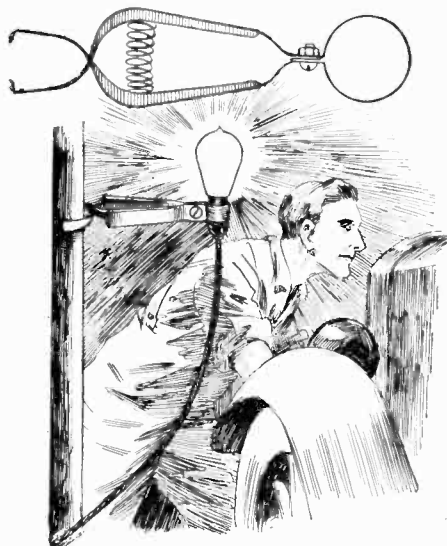

If a storage battery clip is attached to a short strip of brass and a socket with extension cord is thus attached to the clip a handy working lamp for garage results. It may be clipped anywhere.

—Axel Haglund

Paper Ladder

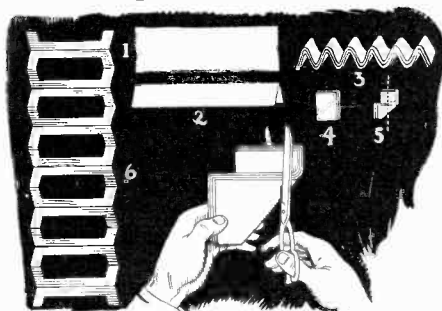

To make a beautiful paper ladder take a bit of paper and fold it according to the steps as indicated in the illustration. Then, with shears cut the paper along the line shown. The ladder will result.

—Ben Zyl

Chemical Color



Heat a coiled copper wire to whiteness and plunge it into a pan of sodium hydroxide (ordinary lye). Note the color; heat again and allow the excess chemical to drip off and dip again.

—S. Fuchs

Musical Tube

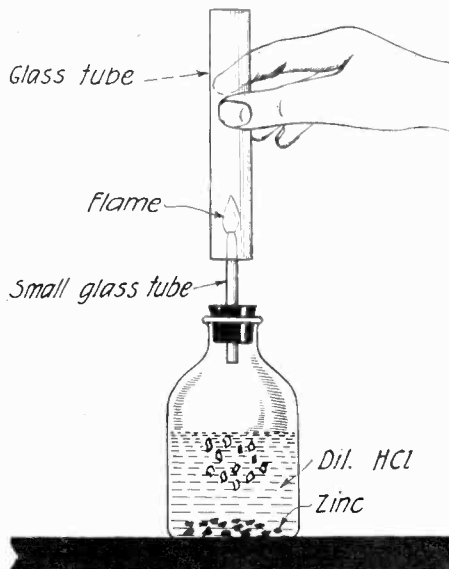

Drop a little zinc in dilute hydrochloric acid. Place a cork with a glass tube and jet passed through it into the top of the bottle. After gas has formed for five minutes light the jet—not before. Then place a glass tube over the flame as shown. A musical note will result.

—J. E. Rafferty

Glass Remover

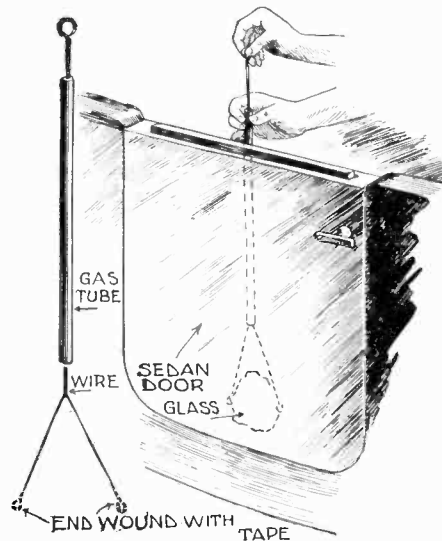

For removing glass that has fallen into a closed car door the above kink will be found exceptionally handy. A wire with taped end loops is passed through a glass tube and is used as shown in the above illustration for fishing out the broken bits of glass.

—Pol Irene

Pulse Recording

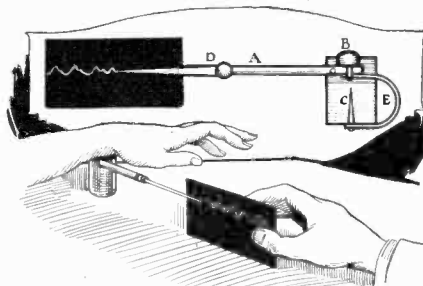

D is a flat slip of quill as is E, A is a match, C a cork and B a shoe button. The cork has a slot cut through the top and the other parts are arranged as shown. The graph is made on a piece of paper smoked in a candle flame. The hand is held as shown for operation.

—Ethel Amine

Cutting Glass

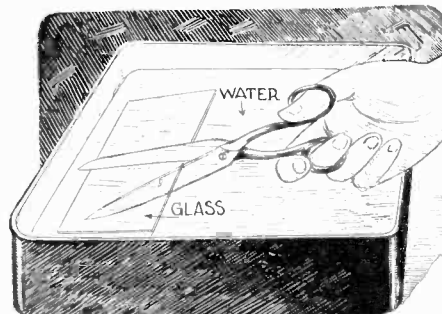

If thin sheet glass is held under water it may be shaped with scissors without cracking. The scissors should be heavy and the glass not too thick. Work around the edges and corners little by little.

—A. Blumenfeld

Windshield Cleaner

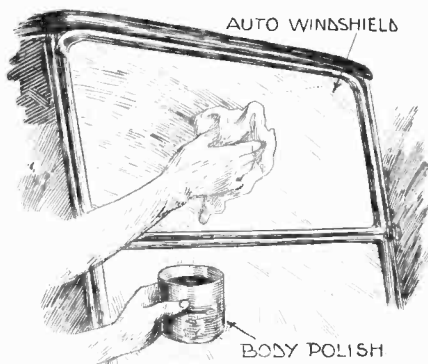

For cleaning windshields and other glass of automobiles the use of a body polish rather than the conventional soap and water is recommended for haste and a good job. Just apply the polish to a cloth and wipe off the glass. It is best to use a polish that gives a wax finish. This finish leaves a slight coating on the surface that will keep clear in rains.

—Orin Watkins

Warped Records

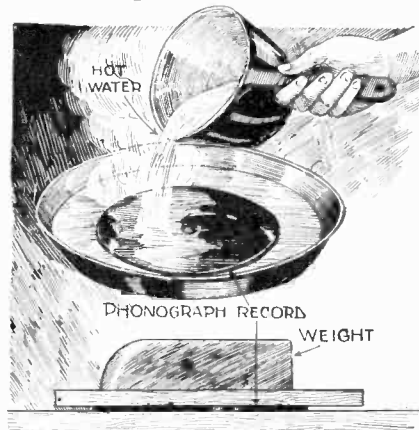

When phonograph records become warped it is only necessary to place the record in a pan, cover it with warm water and then compress it between two flat surfaces and a large weight as shown in the above illustration.

—E. D. Johnson



RADIO

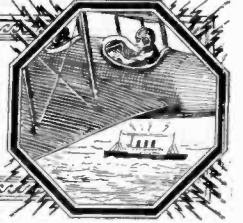

Airplane Broadcast--Radio Typewriter

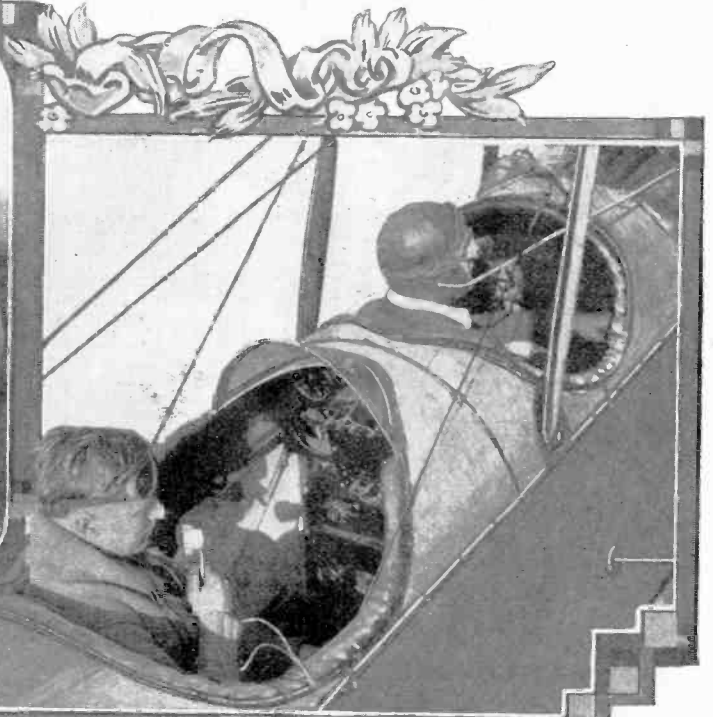

Talks on the joys of Army life have been broadcast to busy New Yorkers from an airplane flying overhead. This stunt was inaugurated as a means of increasing enlistment in the N. Y. State National Guard. Above is shown the small Army transmitter which was used in the tests.

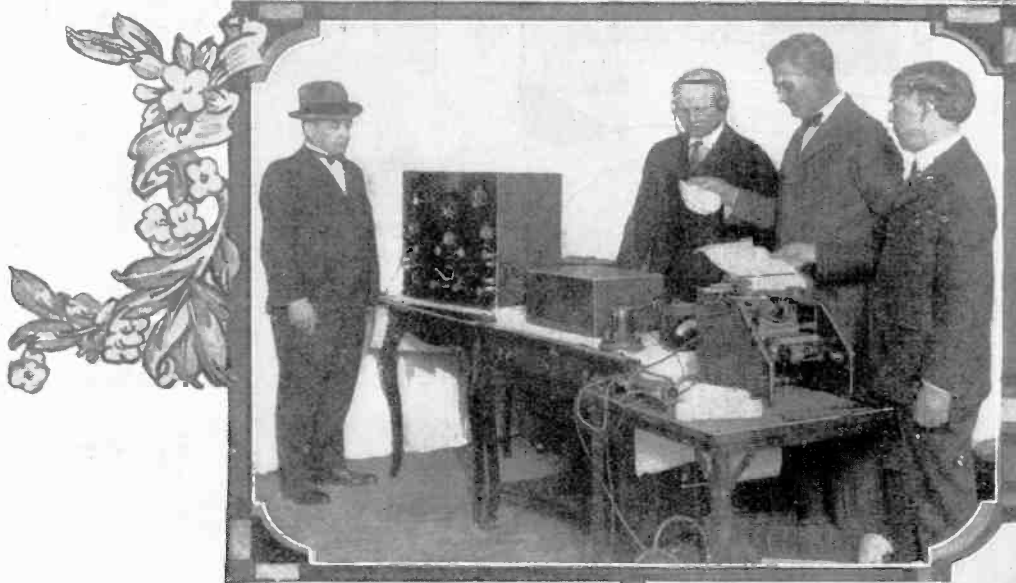

The aerial broadcasting was carried on under the direction of Major George A. Vaughn of the 27th Air Service, N. Y. N. G. He enlisted the services of several former aces of the army and placing two of them in the plane, equipped them with the five tube broadcast transmitter shown in the upper illustration and sent them forth to scatter information concerning the joys of summer camping trips and the well-being and physical fitness that comes only with army training.

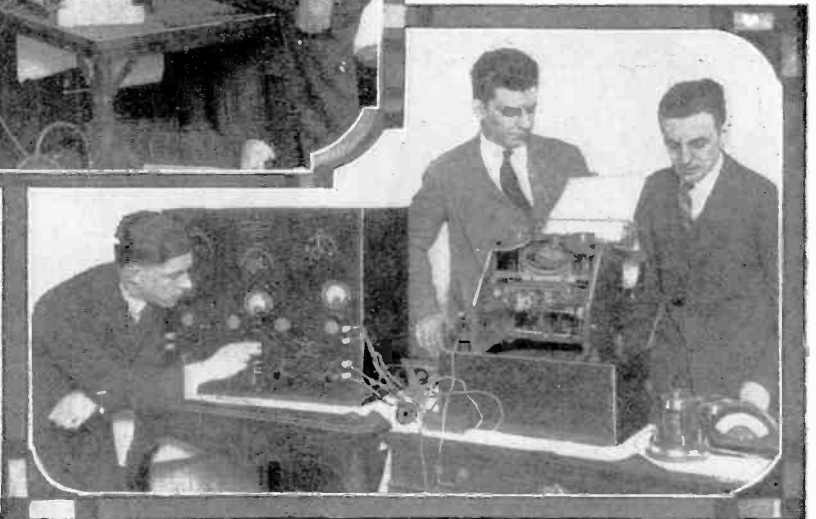

A refinement that promises to revolutionize the newspaper industry of the country is that shown in the two accompanying illustrations. A short time ago at a national editors' convention, a radio typewriter was operated at a distance of two miles with an accuracy of more than 99 1-2 per cent. The experiment was carried out before a large number of prominent editors and radiomen.

The severity of the test may be appreciated when it is known that during all the period of operation three of the largest broadcast stations in the country were running full blast within fifteen blocks of the receiving station and that they had not the slightest effect on the operation of the station.

One reason for the great success of the device is due to the fact that a filter is installed before the amplifier which tends to delete all extraneous noises and waves, enabling operation at a high rate of speed and accuracy.

Latest Developments in Radio



COURTESY OF PHILA. EVENING BULLETIN

One of the most novel radio sets developed by the recent craze for building small and bizarre radio instruments is the one shown above. It was built by a Philadelphia school boy. The construction is very simple. A flat coil is tapped to cover the broadcast range and is inserted between the pages of the book. Several pages glued together form the panel upon which the instruments are mounted. Opposite the face of the switch and the crystal detector, a hollow square is cut out as shown. This allows the book to be closed when the set is not in use.

Radio has produced a number of helps for curing deafness. Below is illustrated the latest method devised by the surgeons of a Chicago hospital. The patient is equipped with a pair of headphones which is attached to a phonograph. The phonograph, through a recording diaphragm, is connected to a radio instrument that is capable of picking up most of the broadcast stations in the United States. The incoming signals from the radio are recorded on the phonograph and retransmitted to the patient through a microphone. In preliminary tests this method of treatment has proved of exceptional merit.

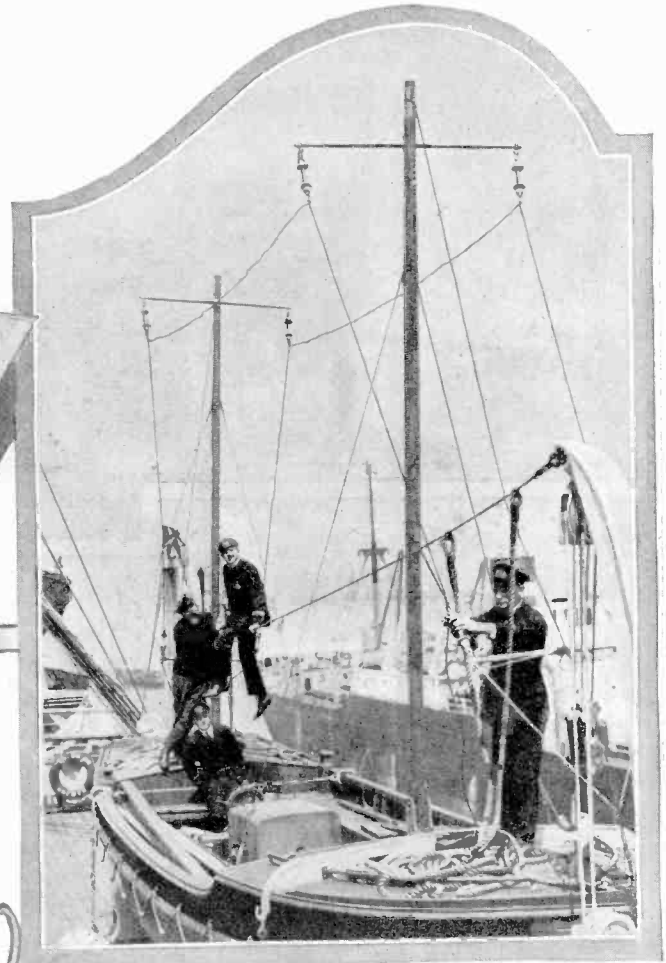

The latest method of installing radio equipment aboard the life boats of ocean liners. The illustration above shows one of the small craft belonging to the S. S. "Columbus." The transmitting and receiving apparatus is installed in the bow of the boat and is capable of communicating over a comparatively long distance. It is hoped through the means of the radio apparatus installed in each of the boats to keep them together in case of accident.

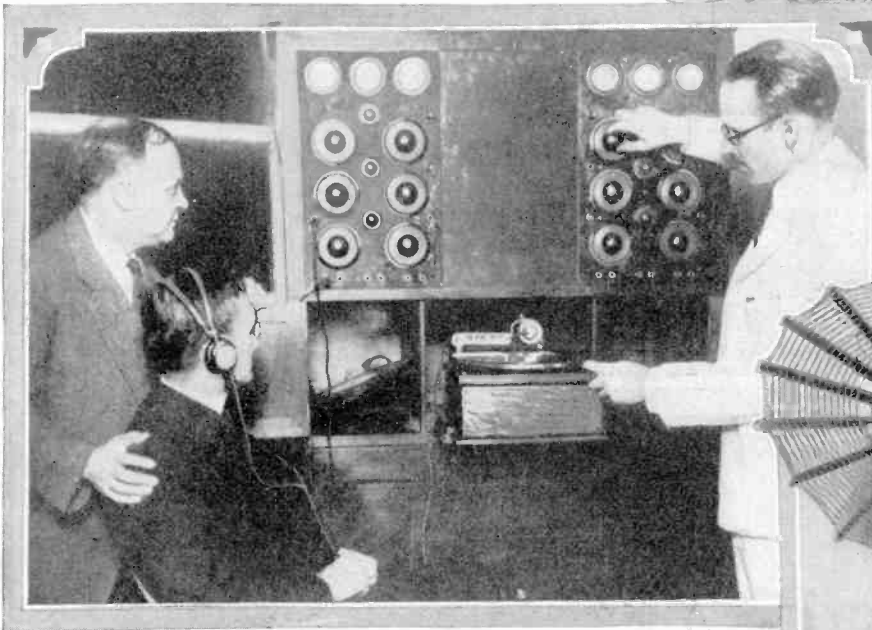

At the right is shown the new spider-web loop antenna. On account of the low distributed capacity of this form of winding, it is said that such method of building a loop is the most efficient so far devised. It is the invention of Harold Herbert, a New York radio man. According to his statement as to preliminary tests made with this antenna, surprising DX results were obtained.



BROADCAST STATIONS

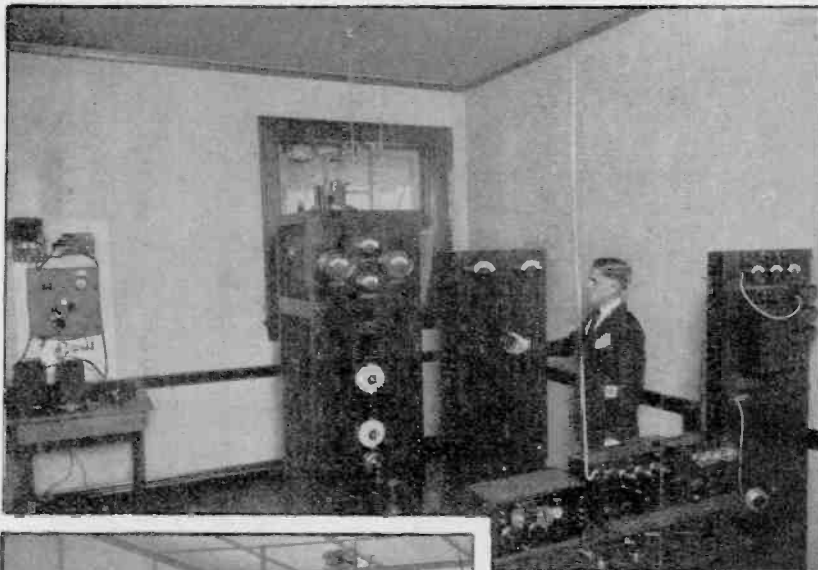

The two photos at the top of this page and that in the lower left-hand corner are of station WDAF, operated by the Kansas City Star of Kansas City, Mo. Above is Mr. Leo Fitzpatrick, broadcasting a vocal solo. In the lower left-hand corner is shown Louis Forbstein's orchestra which has broadcasted from WDAF. At the left is shown the operating room of station WBZ, located in Springfield, Mass., and Chief Operator Hiller. Below is the studio of station KDKA, showing the tubular chimes used in broadcasting and a special type of microphone suspended from a balanced arm so that its height may be regulated at will.

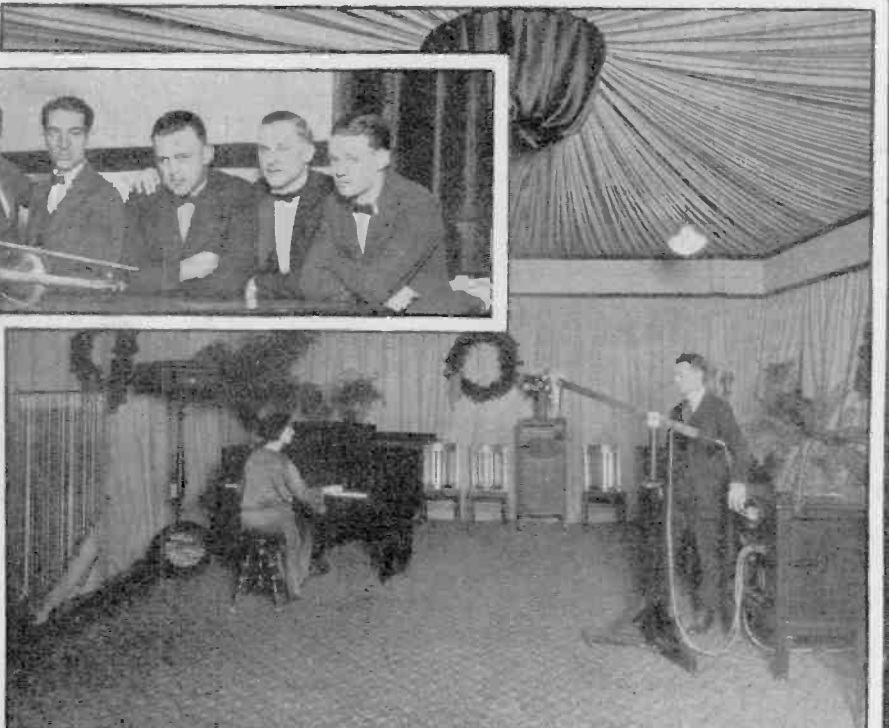
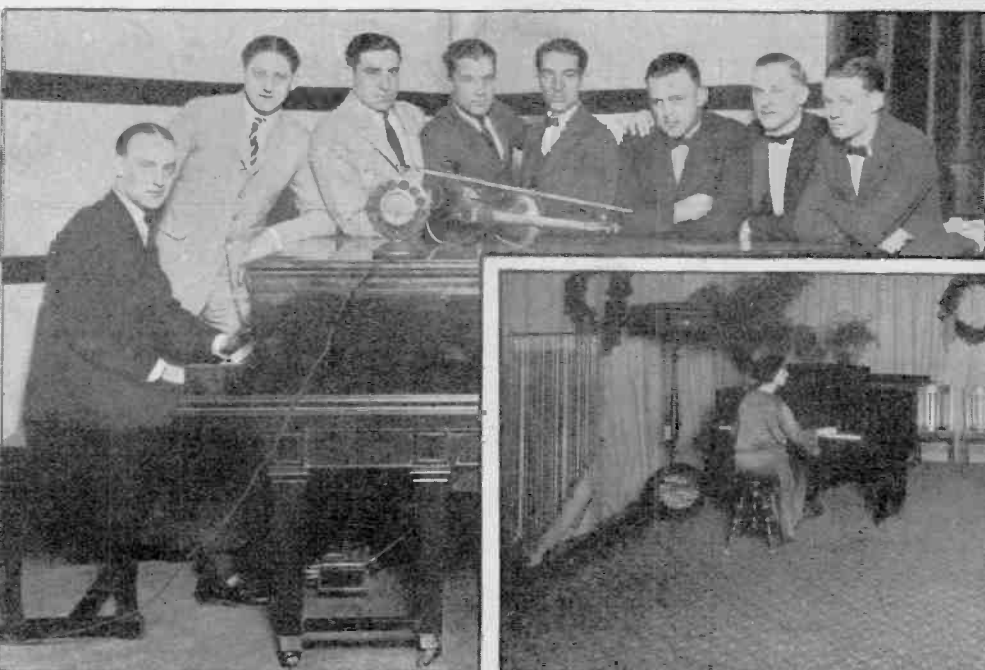

Portable Radio Receiving Sets

Photos of Sets That Will Interest All Travelers

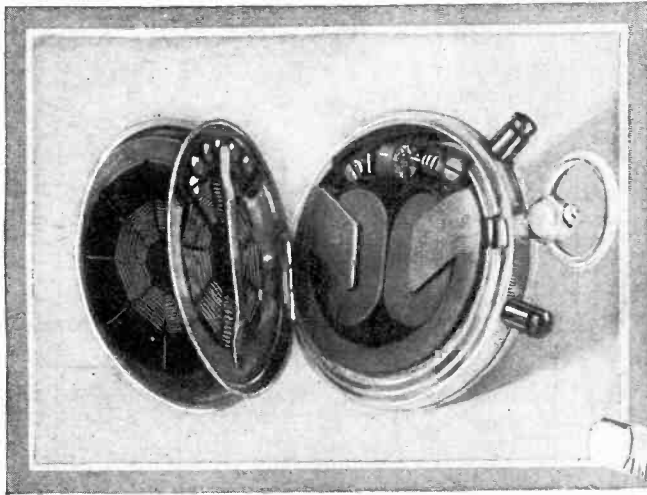

The receiving set illustrated at the left and at the right is entirely self-contained, even including the phone. This set was designed by Mr. A. Page, B. Sc. of Scotland and gives excellent results. The device includes a complete tuning unit, a crystal detector and the diaphragm and magnets which constitute the phone.

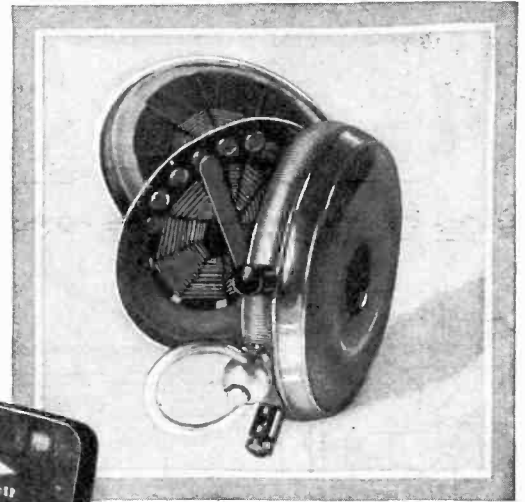

The unique receiving sets illustrated at the right were designed and constructed by Maurice L. Hunt of Canada. The smallest one is slightly larger than a postage stamp and the largest is contained in a safety razor box. Comparison with a six inch rule is given in the photo. Conventional crystal circuits are used in all the sets.

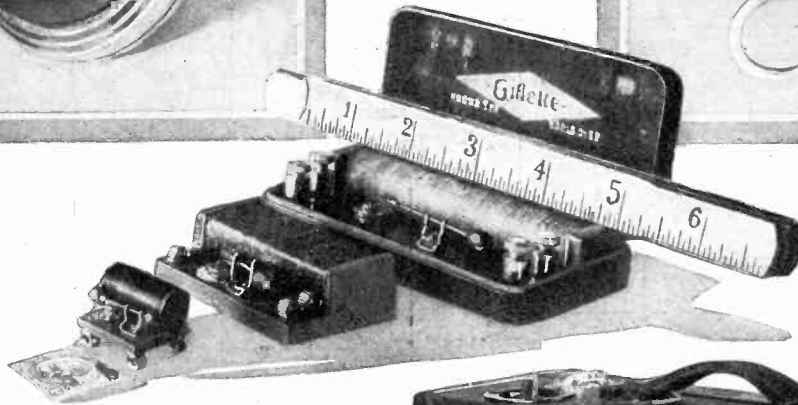

The watch case receiving set illustrated above, when used with an outdoor aerial and a good ground, has done some remarkable broadcast reception. Claims are made that broadcasting stations ten miles away were received with an umbrella as an aerial and no ground. —T. B. Marsden, Jr.

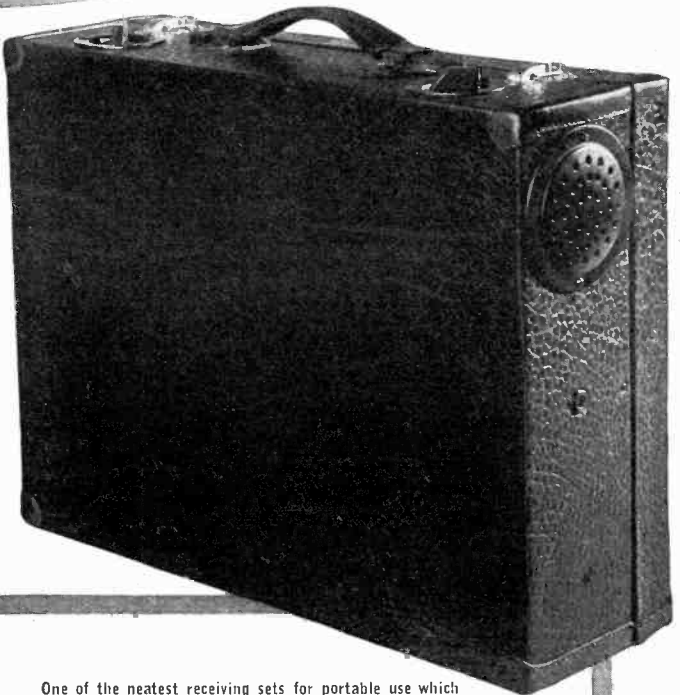
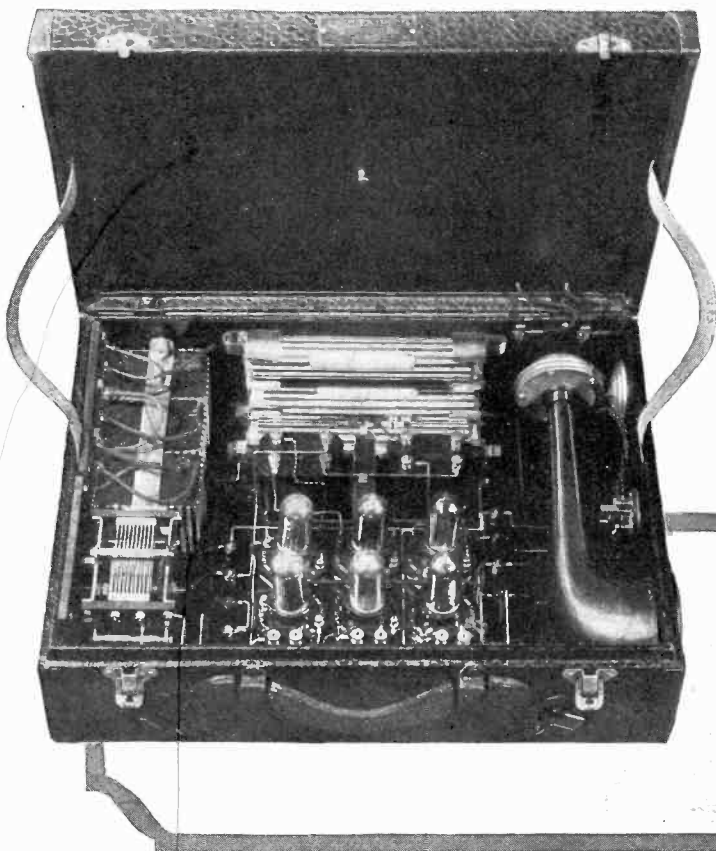

One of the neatest receiving sets for portable use which has come to our attention is illustrated at the left and above. A conventional circuit employing six vacuum tubes, three radio frequency amplifiers, a detector and two audio frequency amplifiers is used. As may be seen, the batteries and all accessories are contained in the case. The set need not be open to be operated but can be controlled from the outside. The two rheostat knobs are on the top of the suitcase and the condenser control is a sunken dial on the end. This set is known as the Westburr Six.

With the summer season at hand, the attention of the Radio Bug will most naturally turn toward portable receiving sets. Advances in radio frequency amplification and loop aerials make possible very compact self-

contained sets. An excellent illustration of this is the Westburr Six receiver illustrated above. Other suggestions are given which will undoubtedly aid the constructor in designing a set to meet his requirements. The

editor would advise against one point. Do not become too fanatical in your design. That is, do not try to get too much apparatus in a small space as, very often, failure will result from such procedure.

Three Circuit Coupler

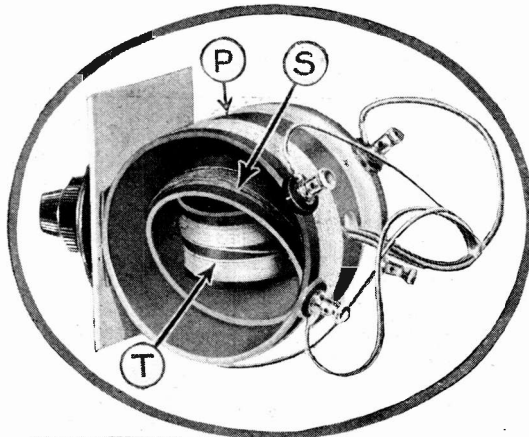

A very compact tuner which will give excellent results may be constructed by following the details given at the right. This coupler operates on the same principle as the well known three honeycomb coil circuit but it is much more compact and at the same time covers the band of broadcast wave-lengths very well. A photograph of the finished coupler is shown at the left and the circuit for connecting it with its auxiliary apparatus is shown below both in perspective and schematic form. No binding posts are shown for the primary coil although they may be added, if desired, by placing them at any convenient point. All the winding data and details of the construction are shown at the right.

—C. B. Kramer, Sr., Rep. No. 6349.

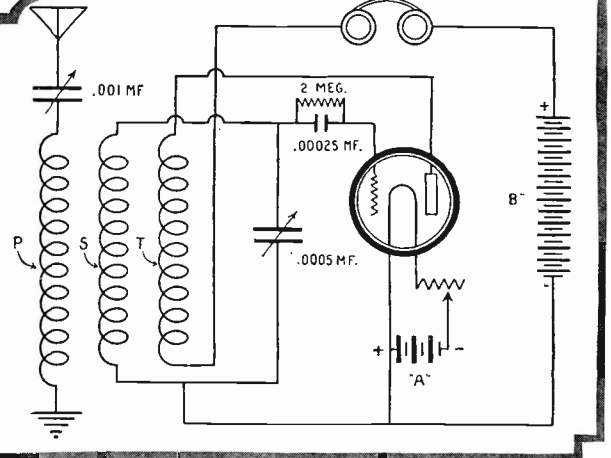
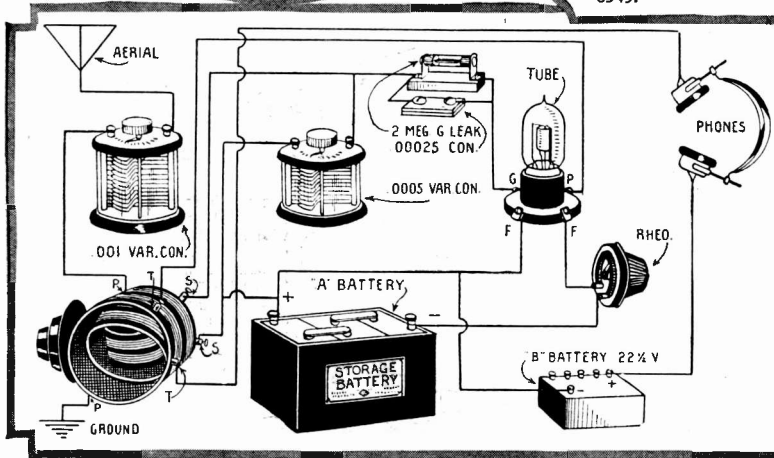
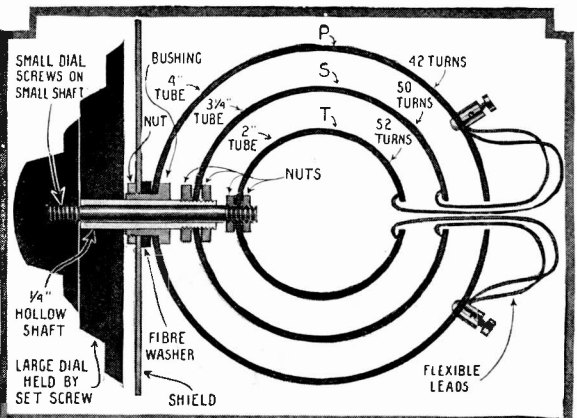

Parabolic Reflector As Loud Speaker

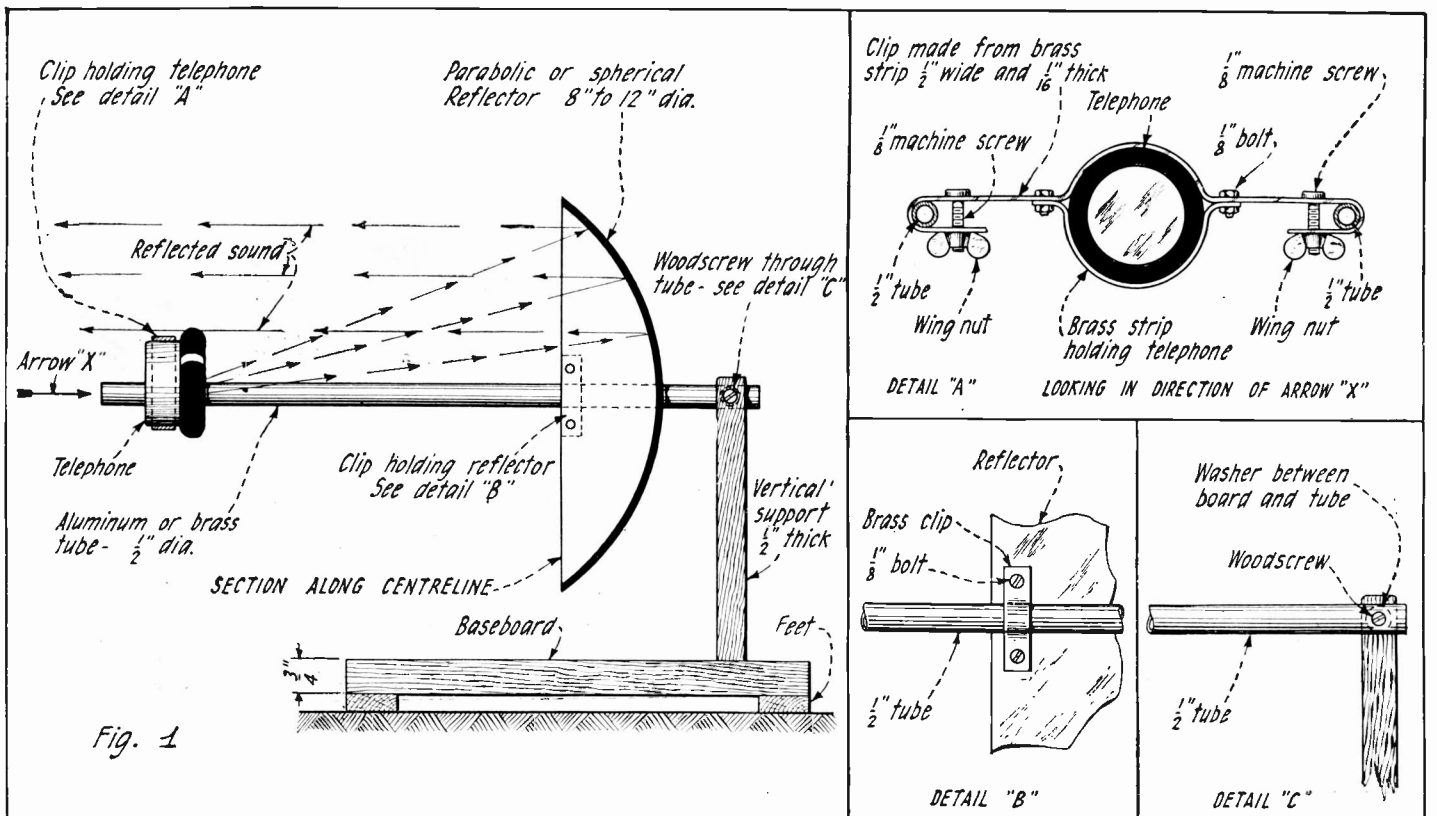

If an ordinary telephone receiver such as used in connection with a radio receiving set is placed opposite a parabolic reflector, the sound from the phone can be concentrated at any point or thrown in any desired direction so that the whole device operates as a loud speaker. Details for the construction of such a reproducer are given above. The dimen-

sions may be made to suit the material which the builder has on hand and therefore none are given in the drawing. After the entire device is assembled, the angle of support of the reflector and phone may be changed at will so that the sound may be projected in any direction.

—C. A. Oldroyd.

Efficient Loud Speaker Horn

TOP
21"

BOTTOM
3/4"

17 1/2"

TABS FOR ASSEMBLING

When a great volume of music is to be reproduced the metal horns often found on loud speakers tend to vibrate and cause distortion. When this happens with a loud speaker try the horn illustrated above and to the right and you will have no more trouble on this score. The entire horn is made of heavy cardboard such as used by draftsmen, which material can be obtained either black or white at any stationery store. At the same time the cardboard is purchased obtain some strong glue and some split paper clips. Lay out, on four sheets, the pattern shown above.

After the pattern is carefully drawn, cut out along the outside. The figures shown on the drawing above are for assistance in laying out the pattern. Connect the figure 1 on the center line with the two figures 1 on the upper edge. Do the same with the other figures. After cutting out the outline of the sides of the horn carefully, bend the tabs for assembling and place the four sides together, fastening with glue and paper clips. The horn should now have a shape as shown in the photographs at the right. The small end of the horn can then be fastened to the loud speaking unit. Paint the rough edges.

—Horace Porter.

Soldering In the Radio Laboratory

10Z ROSIN IN 10Z ALCOHOL

MELTED SOLDER

BUNSEN BURNER
GAS FLAME

COAT HOOKS

For use in connection with hooking up radio sets it is advisable to have on hand either a four ounce and a one pound soldering iron to be heated by gas, or an electric iron of about one and one-half pounds weight. The latter is the most efficient and allows much speedier work. These irons are illustrated in Fig. 1. Fig. 2 shows an excellent method of using rosin as a flux. Dissolve the rosin in the alcohol in the proportions indicated and keep in a tightly corked bottle.

A small brush may be placed in the cork of the bottle as shown. Fig. 3 shows the method of cleaning the tip of a soldering iron by means of a file. In Fig. 4 is shown how a small bowl of solder and the soldering iron may both be heated over a bunsen burner at the same time. After filing the point bright, apply a small amount of flux to the tip and dip the iron into the melted solder; then wipe it on a cloth as in Fig. 5. Fig. 6 shows heating on a gas stove.

SOLDER

WIRE

SOLDER

PLIERS

Fig. 7; a convenient rack for a soldering iron made of two coat hooks. Figs. 8A, 8B, 8C, and 8D show how to remove enamel from wires. Sandpaper may be used, or the enamel may be scraped off with a knife. Another method is to heat the wire with a match and then wipe off the end with a cloth soaked in alcohol. Tinning the iron is shown in Fig. 9 or if no melted solder is at hand, it may be accomplished as shown in Fig. 10. After applying flux to the end of a wire which

is to be soldered to another part, tin it with the solder from the end of the iron as shown in Fig. 11. Then apply flux to the other part to be soldered and tin as shown in Fig. 12. Holding the wire with a pair of pliers, join the two together as shown in Fig. 13. A little more solder may be required to make a tight joint. Hold the iron in position until the solder "sweats" into the joints. When cool remove excess flux with a cloth and alcohol as in Fig. 14.

—Edward F. Staver..

Styles of Radio Cabinets

Types of Construction That Prove Efficient

BY WILLIAM BUTTERFIELD

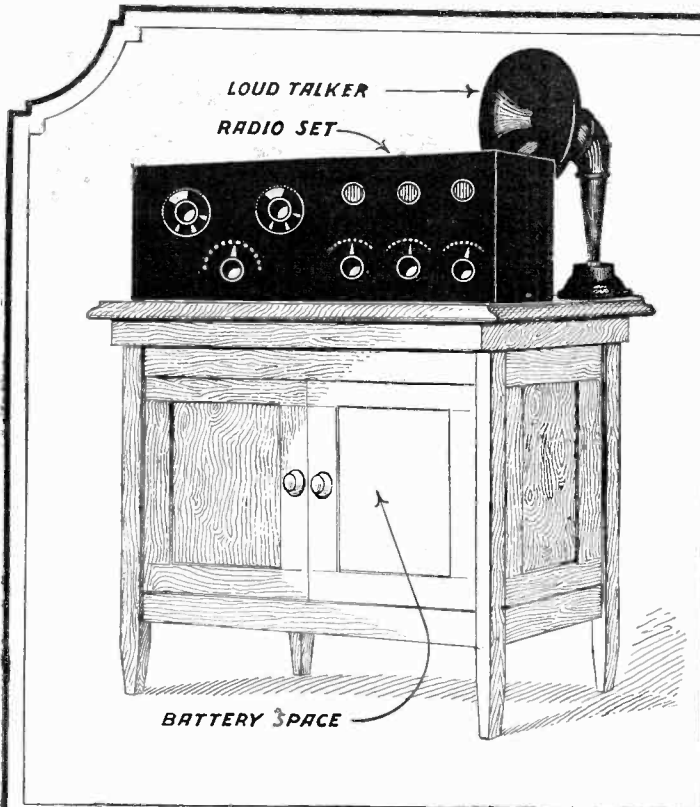

The simplest form of radio unit is the one shown above. It is a small cabinet upon which the radio set itself is placed, and in which the batteries, renewal parts and other accessories are kept. A cabinet of this type may take any one of a number of forms of construction so long as the cabinet is large enough to contain the necessary apparatus. Such a cabinet may often be found around the household.

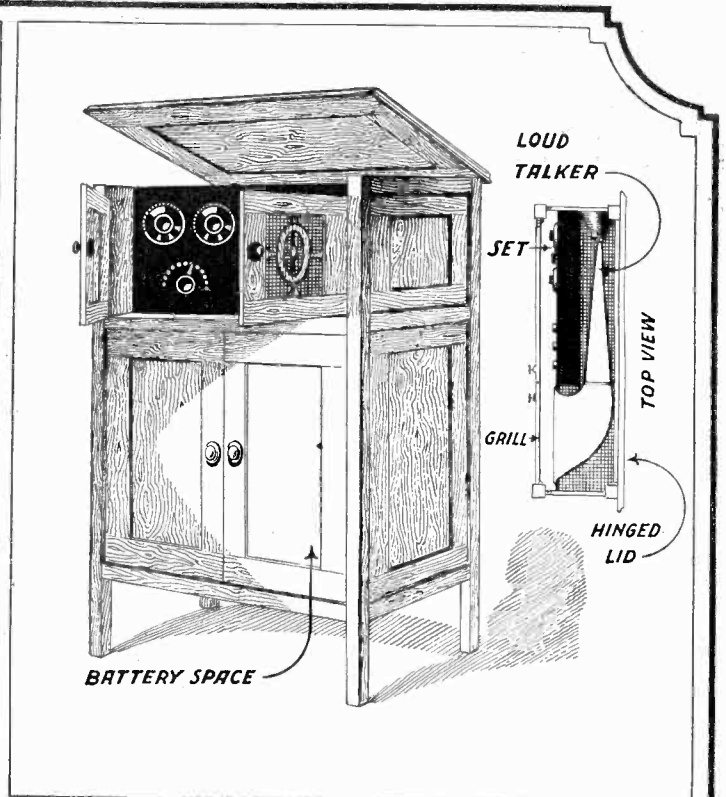

A slightly more elaborate cabinet is one constructed in the design shown above. The loudspeaker is built in the top container together with the operating cabinet. The bottom portion is given over, as in the previous case, to housing the batteries and other necessary accessories to the operation of the set. With this type of construction all parts of the set may be reached with comparative ease in case of repairs.

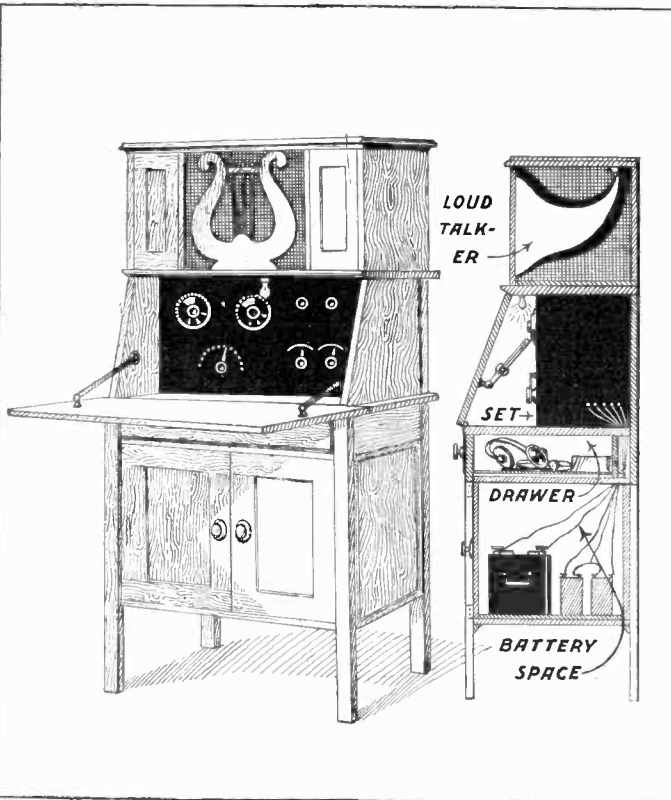

A still more elaborate case for a well confirmed "Radio Fan" is the one shown here. The cabinet takes the form of a writing desk and contains several refinements, which the arrangements previously shown do not contain. Note the small light above the operating cabinet, special drawer provided for head phones and bits of apparatus, and the ample space provided for a storage battery charger in the bottom compartment.

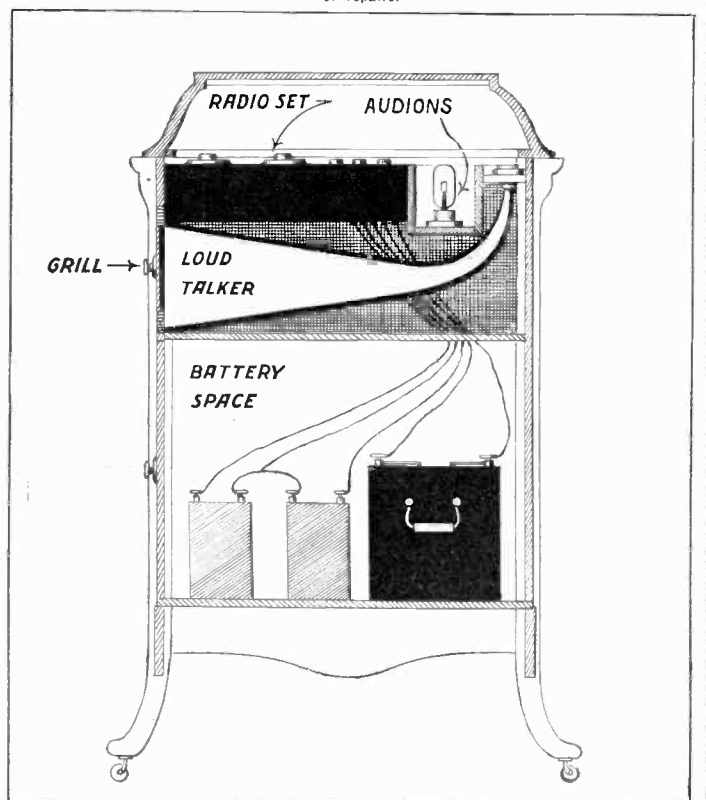

A radio set housed in a cabinet very similar to the well-known phonograph type is shown above. Some companies have commercially adopted this form and have met with no little success in selling them, tending to prove that this form of construction, aside from having exceptional acoustic properties, proves very handy to the operator. The construction is simple, and the necessary details of arrangement are shown in the sketch.

Novel Cockaday Set

By M. A. Lurye

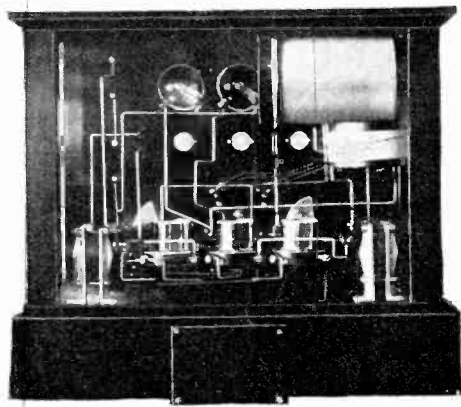

The cabinet which houses the four circuit tuner illustrated above and in the upper righthand corner was made from an old chemist's balance cabinet. Three of the glass sides were retained and the fourth one replaced with a bakelite panel. The instruments are mounted on the panel and on a baseboard. The loud speaker, which is an integral part of the set, is built into the base as shown at the right. All details of the construction are shown. Wood strips serve as the sides of the sound chamber, the sound emanating from the front of the drawer. The latter is cut away and the hole covered with cloth.

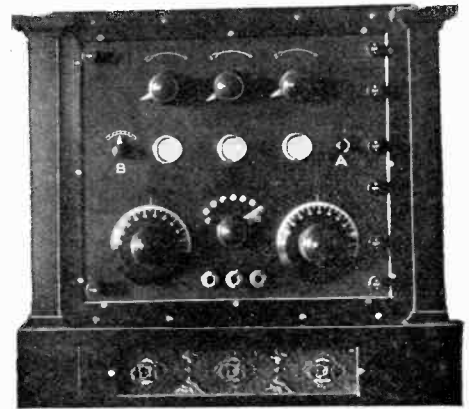
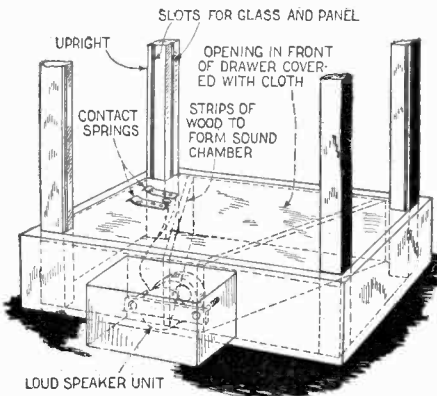

Above is a front view of the panel of this set. A designates the loud talker switch and B, the variable grid leak. Referring to the diagram of the loud speaker at the left we find that the drawer of the cabinet is utilized as the sound chamber. A loud talker unit is fastened to the back with any convenient type of bracket. The leads from this unit are connected to strips of spring brass, which in turn make contact with other strips of brass on the baseboard, thereby placing the loud speaker in the circuit, to be controlled by the switch illustrated.

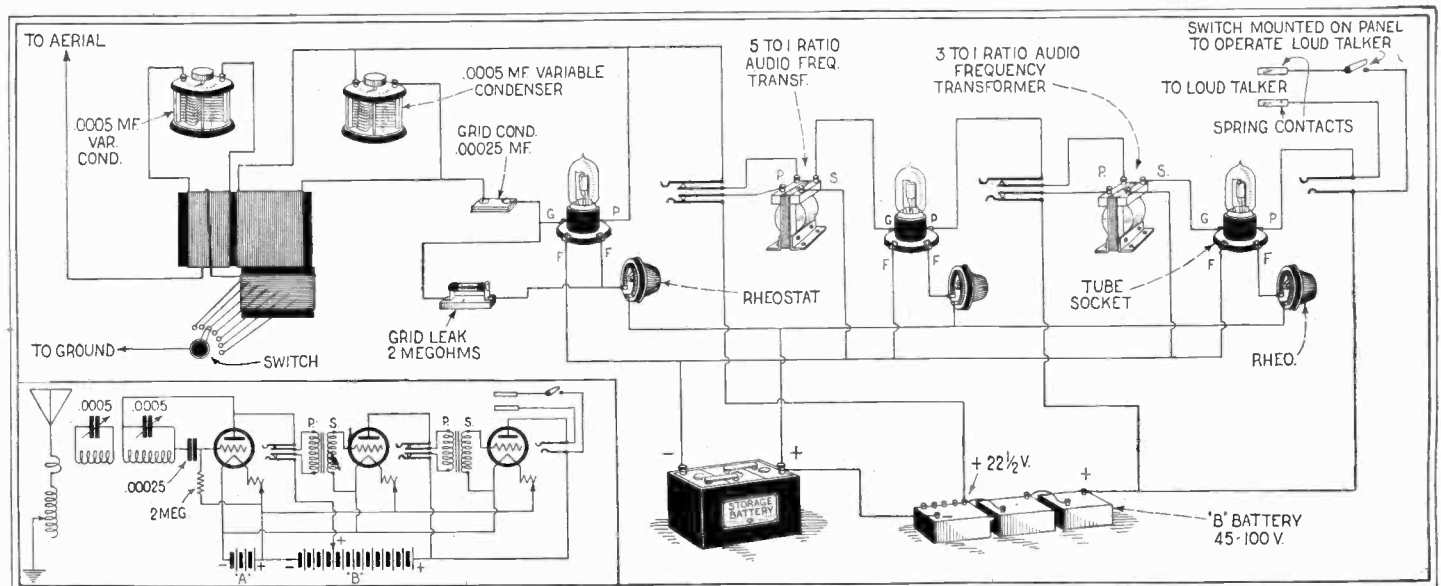

The circuit diagram for the connections of the set illustrated on the upper part of this page are given herewith. The coil is of the standard four circuit type and the construction is described in the November, 1923, issue of SCIENCE AND INVENTION. All

coils are wound on 3 1/2 inch tubes. The stabilizer which is not connected in the circuit has 35 turns of No. 18 wire. The secondary is of 65 turns and the primary at right angles to the secondary, is of 45 turns in triple layer bank winding.

Combination of Variometer and Variocoupler

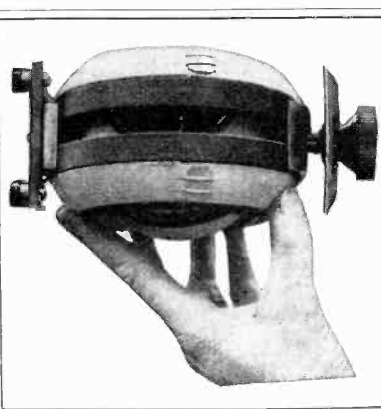
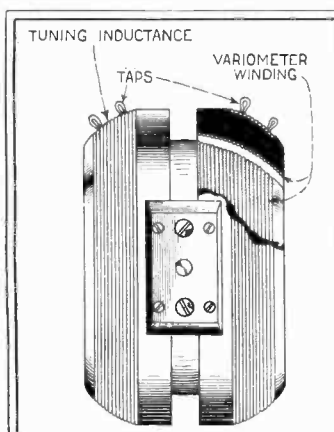

The details of the construction of this novel tuner are shown above. The primary is a single winding while a complete variometer is contained within it.

Above is shown a photograph of the completed variometer and variocoupler. Four taps are taken from the primary coil. The variometer and primary inductance are connected as shown at the right. In order to make a standard short wave regenerative set, an external variometer is used for regeneration. —Kenneth B. Murray.

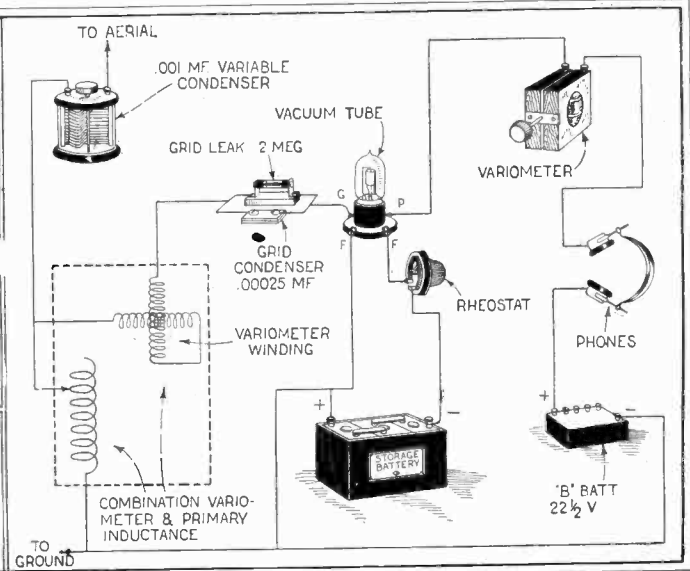

Radio Oracle

In this Department we publish questions and answers which we feel are of interest to the novice and amateur. Letters addressed to this Department cannot be answered free. A charge of 25c. is made for all questions where a personal answer is desired.

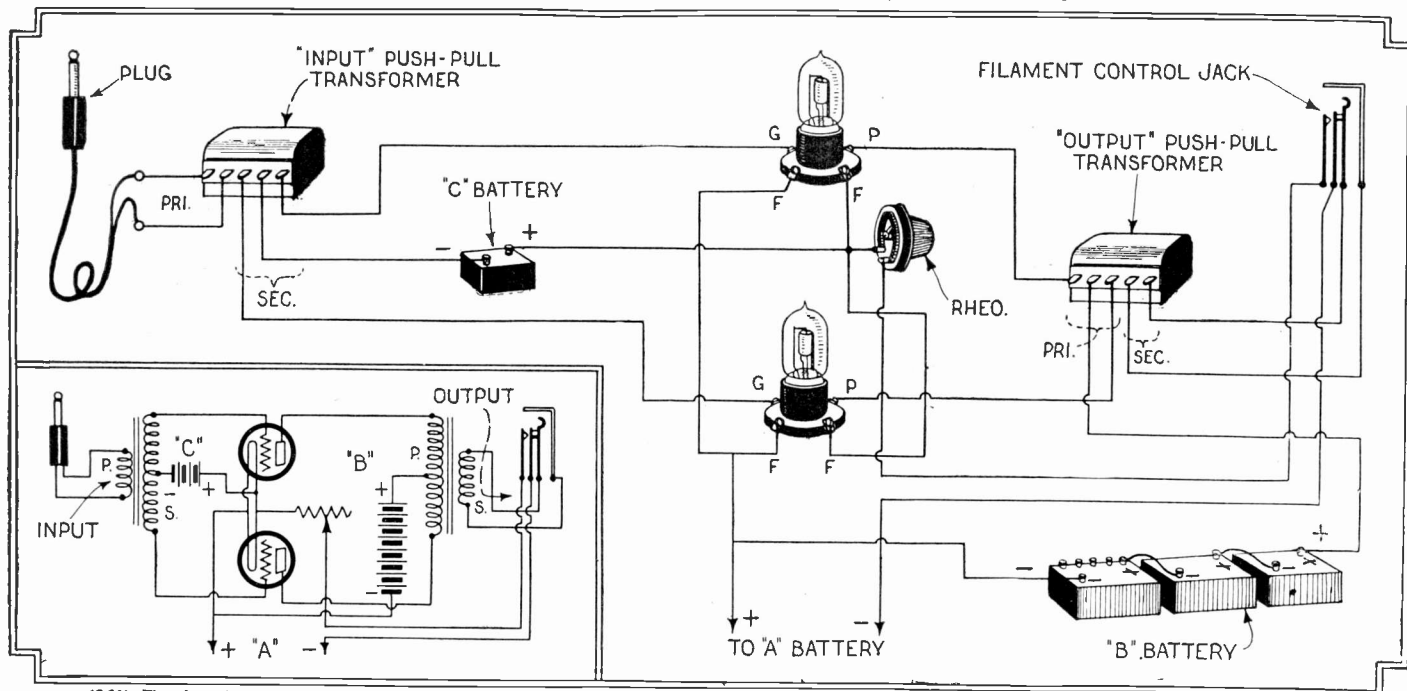

(264) The above diagram depicts a very efficient push-pull amplifier unit with filament-control jack. One rheostat handles the filament current very nicely.

PUSH-PULL AMPLIFIER CIRCUIT

(264) Frank J. Atkinson, Paducah, Ky., says that he has a radio receiving set employing filament control jacks. He asks:

Q. 1. Can you give me a circuit diagram of a push-pull amplifier to be used with my set which will enable me to use the filament control jacks and also use the same in the amplifier circuit?

A. 1. A circuit diagram of this type will be found in these columns. To use the push-pull amplifier, place the plug in the last jack on the receiving set and place the telephone plug in the filament control jack which is in the push-pull amplifier circuit. Thus all the filaments will be lighted and all the necessary connections will be made. The same "A" battery can be employed as is used for the rest of the set, but a separate "B" battery is advisable for the push-pull amplifier.

SNOW STATIC

(265) M. R. Schoff, North Stratford, N. H., states that one night as he started to use his receiving set he found that his antenna was charged with electricity. He investigated and did not find it touching any power lines. He also states that many others in the same city were troubled with the same occurrence. He asks:

Q. 1. Is there any explanation for this?

A. 1. The phenomenon you mention is very often noticed and the fact that the aerial is charged is usually due to heavy static conditions. If it was snowing at the time, this contributed to the trouble. Just how snow causes a heavy charge of static to collect on an aerial is not known, but the fact that it does has been often observed. One theory for the so-called snow static is that the particles of snow are highly charged electrically. When they strike the antenna wire they charge that body, which, of course, would cause the phenomenon you mention.

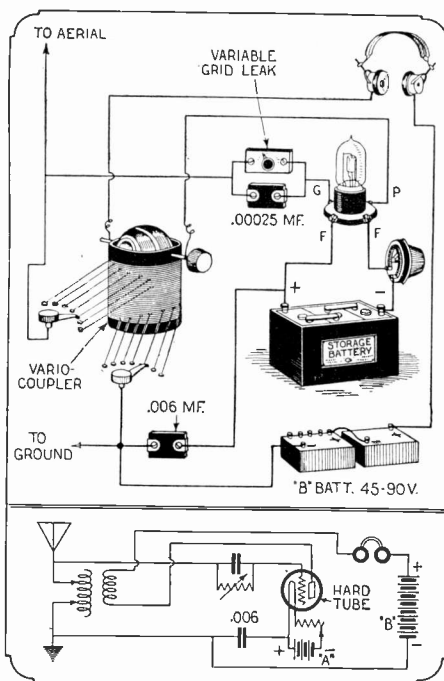

(266) Simplified Flewelling circuit, employing but one fixed condenser besides the usual grid capacity.

SIMPLIFIED FLEWELLING

(266) John J. Wilkins, Tacoma, Wash., asks:

Q. 1. Can you give me a circuit showing all the connections necessary for hooking up a single tube, improved Flewelling set, using only one fixed condenser instead of the usual three?

A. 1. You will find the necessary circuit diagram in these columns.

TROUBLE

(267) Collins Clark, Cortland, New York, says that he has constructed a set using a peanut tube which gives a faint light, but that when he turns the tube on, he only gets a roar in the phones and no signals. He asks:

Q. 1. Can you help me locate this trouble?

A. 1. It is practically impossible for us to say just what is the matter with your receiving set, without further information on the same. Since you say that your tube lights and you get a roaring sound in the phones, we would say that you are probably applying too much filament potential.

We would advise that if possible, you have someone well versed in radio go over your set and test it out thoroughly. If you care to do so, you might make a clear circuit diagram of your connections and send it to us. Upon receipt of the same we will be only too glad to check it over thoroughly and go into the matter further.

GRID RETURN CONNECTIONS

(268) Lowell Bogle, Watertown, Tenn., asks:

Q. 1. To which side of the "A" battery should the secondary of an audio frequency transformer be connected?

A. 1. In an amplifier, the secondary of the transformer should be connected to the negative side of the "A" battery.

Q. 2. Which side of the "A" battery should the negative side of the "B" battery be connected to?

A. 2. The connection from the negative side of the "B" to the "A" battery must be found by experiment. Some tubes work best with this connection made to the negative side of the "A," and some with it made to the positive side.

WANTED!!! RADIO ARTICLES

WE want descriptions of new radio ideas which you have worked out in practice. Take photographs of the important parts and make pencil or pen and ink sketches of the hook-ups or mechanical details, et cetera. We are particularly

desirous of obtaining new hook-ups and descriptions of single tube sets, reflex and other types which have proven satisfactory. We want articles on the latest single tube receptors which require a minimum current from the filament battery.—Editor.

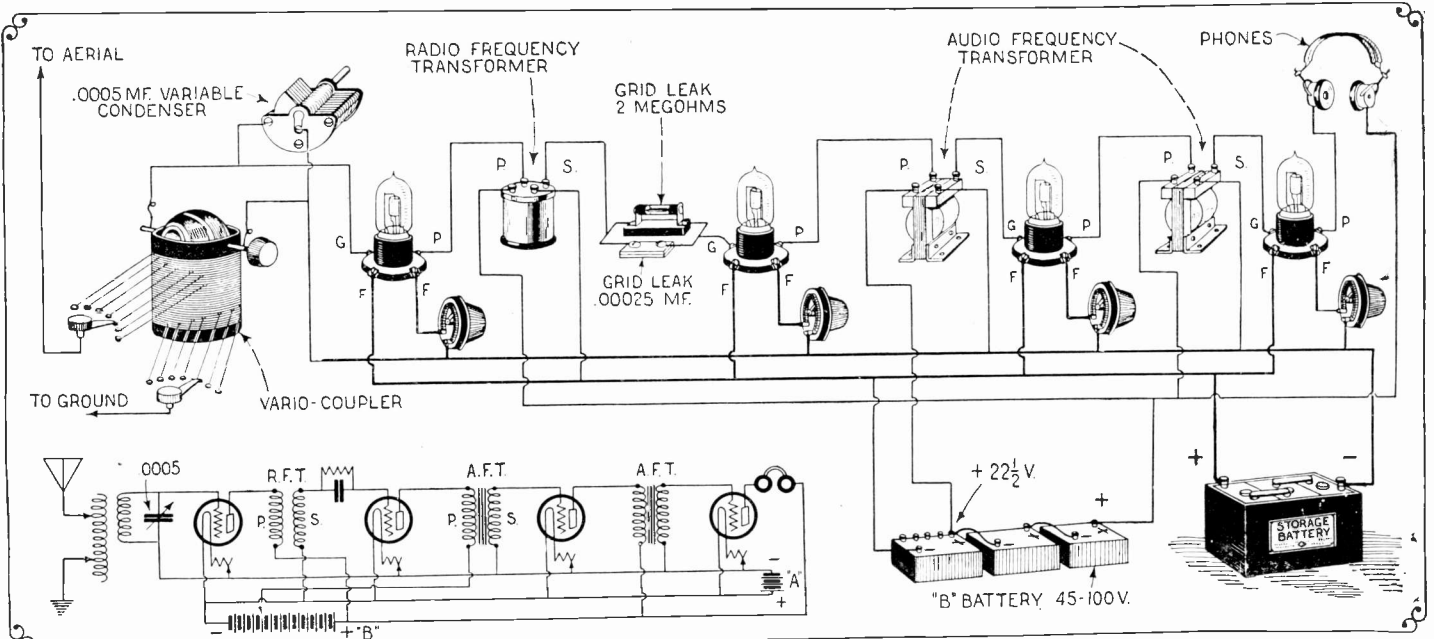

(269) Here is shown the familiar two circuit non-regenerative receiver to which has been added one stage of radio and two stages of audio frequency amplification. This set is absolutely squealless and is to be recommended for use in congested areas.

RADIO AND AUDIO AMPLIFICATION

(269) Benj. F. Fukrman, West Point, Nebraska, says that he has at present a single circuit tuner. He inquires:

Q. 1. Can you show me how to add one stage of radio frequency amplification and two stages of audio frequency amplification to this set?

A. 1. A diagram showing the requested amplification in connection with your present tuner is given in these columns. This circuit is not regenerative.

NEUTRODYNE CONSTRUCTION

(270) C. K. Maytum, Rochester, Minn., wants to know:

Q. 1. In building a Neutrodyne receiver, would you advise me to purchase a set of manufactured parts or to construct the coils and pick out the other parts myself?

A. 1. The Neutrodyne sets made by well-known concerns in knock-down form are very good and we would suggest that you buy one of these rather than purchasing parts promiscuously. If you wish to build the coils, patterns may be obtained. Name of company furnished on receipt of stamped addressed envelope.

Q. 2. Would you recommend that I build a three-tube Neutrodyne without audio frequency amplification or that I build the five-tube type with two stages of audio frequency?

A. 2. If a three-tube Neutrodyne set is built, it may readily be used with an external two-stage audio frequency amplifier as the latter has nothing whatsoever to do with the operation of the Neutrodyne set itself. In general, we believe this would be the best plan for you to follow as you could then locate any trouble in your radio frequency and

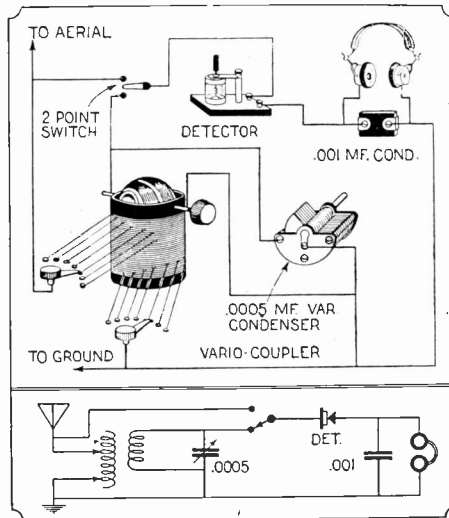

(271) A favorite of days gone by is the above combination of a single and double circuit crystal set.

detector circuits, if such should occur, without having to contend with the audio frequency amplifier also.

CRYSTAL SET

(271) J. E. Armstrong, Toronto, Ont., Canada, asks:

Q. 1. How can I hook up a vario-coupler and variable condenser with a crystal detector so that broad tuning for "stand-by" work or fine tuning can be obtained?

A. 1. The necessary diagram will be found in these columns. The switch enables you to manipulate the set as you desire.

AMPLIFYING TUBES

(272) Ruffner Thompson, Logan, W. Va., asks:

Q. 1. Can the same type of amplifying vacuum tube be used both for radio and audio frequency amplification?

A. 1. The same kind of amplifying vacuum tube may be used for both radio and audio frequency amplification.

Q. 2. Which do you consider to be the best; a detector with two stages of radio frequency and one stage of audio frequency amplification or one stage of radio frequency, a detector and two stages of audio frequency amplification?

A. 2. For long distance work two stages of radio frequency, a detector and one stage of audio frequency will be superior. For comparatively short distance work and loud reproduction, one stage of radio frequency, a detector and two stages of audio frequency will be best.

AMPLIFICATION

(273) C. F. Whittaker, Coshocton, Ohio, says that he desires to utilize a phonograph for supplying music for dancing in a large hall and requests information on the methods sometimes used by speakers for addressing large audiences.

A. 1. The method used to carry speakers' voices over a large area is generally amplification by audions. The amplified current is delivered to a loud speaker or a series of loud speakers. This method, however, is quite expensive. A device which might be used to pick up the phonograph music and relay it to the audion bulbs is that known as the Skinderviken button, which is in reality merely a very small type of telephone transmitter carbon case. See page 1144 of the March, 1924, issue of SCIENCE & INVENTION for circuits.

200 ILLUSTRATIONS—100 ARTICLES

is the average of every issue of RADIO NEWS. We doubt if there is a radio magazine in print that can show the diversity of articles and illustrations that is found in this magazine.

But above all, it is the quality of the material that is of prime importance to the man interested in radio. RADIO NEWS appeals to all factions; the Scientist, the Amateur, the Experi-

menter, the Broadcast Listener, and the Manufacturer. Each will find articles written especially for him. Every issue of RADIO NEWS is a radio education by itself. Sold on 35,000 newsstands in the United States and in every international book store in every civilized country the world over.

A LIST OF INTERESTING ARTICLES APPEARING IN THE JULY ISSUE OF RADIO NEWS

- Radio to the Rescue. By J. Farrell.
- The Loop Antenna. By R. H. Langley.
- The Importance of the Trivial. By Sir Oliver Lodge.
- Ring Up Your Friend by Radio. By H. Diamond.
- The Radio Tax Was Defeated. By A. D. Cowper.
- Distortionless Broadcast Reception. By H. I. Round.
- Matching Intermediate Wave Transformers for Super-Heterodynes. By Prof. Grover Ira Mitchell.

(Radio Department continued on page 310)

Awards in \$1000 Monthly Contest

The Regular Departments Pay Prizes of Their Own. Authors on Contract Receive Their Own Rates; Making the Total Paid for Articles in Excess of \$1500.00 Monthly.

FIRST PRIZE \$100.00

"Oil Burning Equipment for the Home," by L. K. Wright..... 275

TWO PRIZES OF \$50.00 EACH

Mysteries of "Girl Shy," by Tamar Lane.....238-239
 "The Old and New in Astronomy," by Charles T. Dahama.....258-259

TEN PRIZES OF \$25.00 EACH

"A Modern Pyramid," by Oliver S. Arata..... 243
 "The Giant in the Atom," by Ernest Brennecke..... 249
 "Scientific Bass Angling," by John E. Hogg..... 257
 "Railroads of To-morrow," by George F. Murphy..... 260
 "Artificial Creation of Life," by Dr. E. Bade..... 261
 "A Novel Scene Shifting Method," by Harold C. Howe..... 262
 "The Vertical Realm of Life," by F. W. Horton..... 263
 "Easily Constructed Cycle Car," by Galen Barber..... 273
 "Experiments with Plants," by Dr. Russell G. Harris..... 274
 "Novel Cockaday Set," by M. A. Lurye..... 285

FIVE PRIZES OF \$20.00 EACH

"Artificial Creation of Life," by J. F. Mazur, M. B..... 261
 "Hereditary Law in Flowers," by Dr. E. Bade..... 264
 "Three Circuit Coupler," by C. B. Kramer, Sr., Reporter No. 6349 282
 "Parabolic Reflector as Loud Speaker," by C. A. Oldroyd..... 282
 "Efficient Loud Speaker Horn," by Edward F. Staver..... 283

TEN PRIZES OF \$15.00 EACH

"Paintings as Movie Sets," by Tamar Lane..... 256
 "War Instruments of Savages," by N. Wright, Reporter No. 7211 257
 "Electrical Stress Measurements," by S. R. Winters..... 260
 "Mystery Disk," by Dr. Albert Neuburger..... 262
 "Replica of Yosemite Valley," by Robert H. Moulton..... 264
 "A Monument," by H. Gillett..... 265
 "Critical Camera," by C. A. Oldroyd..... 266
 "Boat Steering Apparatus," by L. B. Robbins..... 272
 "Building an Art Craft Lamp," by J. T. Garver..... 272
 "Soldering in the Radio Laboratory," by Edward F. Staver..... 283

TWENTY PRIZES OF \$10.00 EACH

"Why the Leaves Fall," by S. Leonard Bastin..... 248
 "Hot Air Motor," by Dr. Albert Neuburger..... 262
 "Radiator Condenser," by Louis Jules Becker..... 266
 "Novel Dust Cap," by Allen P. Child..... 266
 "Safe Parking Light," by Louis Jules Becker..... 266
 "Balancing Egg," by C. A. Oldroyd..... 276
 "Turn Pointer," by W. S. Hendren..... 276
 "Hydraulic Press," by C. A. Oldroyd..... 276
 "Garage Light," by Axel Haglund..... 277
 "Musical Tube," by J. E. Rafferty..... 277
 "Windshield Cleaner," by Orin Watkins..... 277
 "Warped Records"..... 277
 "Portable Radio Receiving Sets," by Maurice L. Hunt..... 281
 "Portable Radio Receiving Sets," by T. B. Marsden, Jr..... 281
 "Combination of Variometer and Variocoupler," by Kenneth B. Murray..... 285
 "Bending Bus-Bar," by Clifton Ask..... 319
 "Loop Aerial Spacers," by Harold Jackson, Reporter No. 2903... 320
 "Novel Switch Points," by Fred J. Huhn..... 321
 "Tube Protection," by Raymond B. Wailes..... 322
 "Magnetic Crystal Detector," by Arthur Blumenfeld..... 322

TEN PRIZES OF \$5.00 EACH

"Cutting Glass," by A. Blumenfeld..... 277
 "Chemical Color," by S. Fuchs..... 277
 "Rugged Detector," by Robert Toran..... 319
 "Battery Kink," by R. P. Barrows..... 320
 "Lightning Switch," by Walter T. Markowski..... 320
 "Switch Stops," by Lyndon Young..... 321
 "Detector Lamp," by C. A. Oldroyd..... 323
 "Folding Loop," by Steve Goff..... 323
 "Bank Winding Kink," by A. Leven..... 323

(Balance—1 prize \$5.00—No Entries)

TWENTY PRIZES OF \$2.00 EACH (No Entries)

TEN PRIZES \$1.00 EACH (No Entries)

Here Is How You Can Get in the Contest:

\$12,000 or More in Gold

EVERY month SCIENCE AND INVENTION pays \$1,000 or more in gold in prizes. Every text article published will receive a prize—(most of the departments have awards of their own which they give every month). Ideas are what the Editors want. The ideas must be told simply, so that your mother or your sister can understand them—in pictures or sketches or both. But the idea must be new and must have something to do with science or invention. The Editors want pictures and sketches—must have them—but what they want most

88 monthly prizes will be given as follows:

FIRST PRIZE \$100.00				
2 PRIZES of \$50.00 each				
10	"	"	25.00	"
5	"	"	20.00	"
10	"	"	15.00	"
20	"	"	10.00	"
10	"	"	5.00	"
20	"	"	2.00	"
10	"	"	1.00	"

\$12,000 or More in Gold

is IDEAS. These ideas will be handsomely paid for. We have published a pamphlet showing the rules of the contest which we shall be glad to send to anyone free on receipt of a postal card with your name and address. The pamphlet gives full details, the rules and how to submit articles. The magazine itself shows you what is wanted. Study it closely and submit your ideas. The closing date for all prize contributions is the 15th of the month preceding date of issue, i.e., the 15th of July for the Sept. issue, the 15th of Aug. for the Oct. issue, etc.

WILL YOU BE OUR REPORTER?

IN connection with our \$12,000 prize contest announced herewith, it goes without saying that you will have to do a little work in order to win a prize. The Editors do not wish to make it hard for you, quite the contrary. We want pictures and ideas and we cannot have too many of them. Herewith is reproduced our reporter's card. Up to now we have issued over 11,000 of these. Note in our awards how our reporters are winning prizes right along. We shall be glad to send the reporter's card free to anyone who makes an application for it. By means of this card you will be able to secure entry into industrial plants, business houses, motion picture studios, steamships, docks, public buildings, etc. This reporter's card will prove an open sesame to you in many instances. Every card is numbered and only one is given to a correspondent. A postal card from you and a request for this reporter's card is all that is necessary to obtain one. It will be sent to you by return mail. With it we will send you a pamphlet giving rules of the contest and how to proceed in order to get photographs, to send in sketches, and other information in order to obtain a valuable prize. Not only will this card help you to obtain material for this magazine, but it will train you to become a news gatherer, and will be the means of helping you to earn a good deal of money during your spare hours.

Address Field Editor, SCIENCE AND INVENTION, 53 Park Place, New York

REPORTER



Science and Invention

CORRESPONDENT
REPORTER'S
IDENTIFICATION

NO. 10000

L. W. Shackner

THE BEARER OF THIS CARD IS AN AUTHORIZED CORRESPONDENT-REPORTER OF SCIENCE AND INVENTION MAGAZINE. THE PUBLISHERS OF SCIENCE AND INVENTION WILL APPRECIATE ANY COURTESY EXTENDED THEIR REPRESENTATIVE.

EXPERIMENTER PUBLISHING CO.
Herbert G. Ball
PRESIDENT



LATEST PATENTS

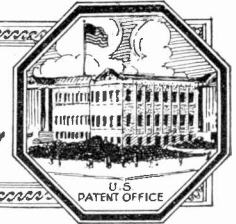

Parachute Toy

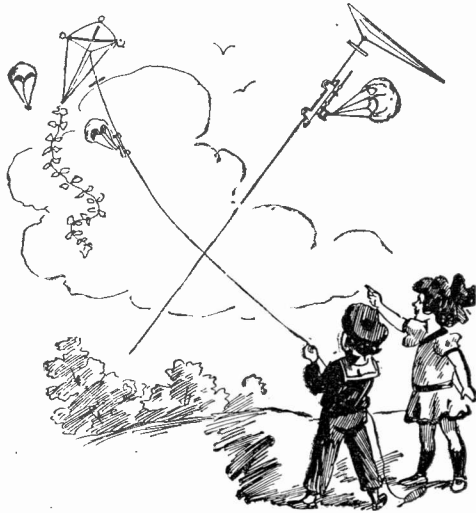

No. 1,484,775, issued to Galen A. Haight. In this system a kite is sent up into the air. A special carrier suspended from two wheels is put upon the string of the kite. This carrier has a hooked rod extending from it. A parachute is placed upon the hook. The wind opens it and forces both carrier and parachute to the kite. A stop in the string releases the parachute, which floats gracefully to the ground, while the carrier returns to the fliers.

Ship Power Generator

No. 1,491,688, issued to Charles R. Ford. This invention is designed primarily for propelling marine vessels. In the funnel-like arrangement on the top of the vessel a number of gear turbines will be found. The funnel is constantly maintained in a direction toward the wind by the vanes at the opposite end of the funnel. By means of shafts and gears, energy is transmitted to the propeller of the vessel permitting it to be driven into the wind by wind power alone. This is a good example of "perpetual motion."

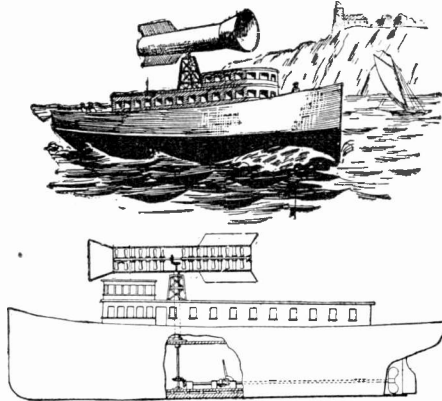

Alcohol Tester



No. 1,481,277, issued to Jacob Wershow. A complete alcohol tester corresponding in size to a fountain pen is indicated here. One of these should surely be found in everyone's home for then our private bootleggers could not fool us by selling us furniture polish instead of liquor. The bottom half of the tester unscrews. This contains an alcohol lamp. The top half is a small well into which the alcohol to be tested is placed. A coil of wire is rotated in the cap. The wire is heated and plunged into the liquor. If the mixture contains wood alcohol, fumes of formaldehyde are thrown off.

Advertising Device

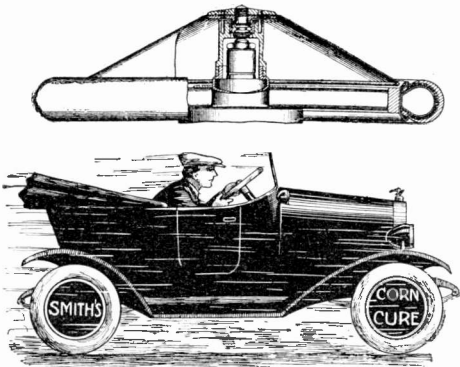

No. 1,478,475, issued to Alfred Charles Jago and Edwin Armitage Wade. This system provides for a conical disk which is mounted on the hubs of automobile wheels. The disk is weighted at the bottom so that it will remain in a relatively upright position while the center is permitted to rotate freely at the hub cap. Advertising is painted on the conical disks and when the automobile is in motion, the wheels seem to be stationary.

Camera Light Absorber

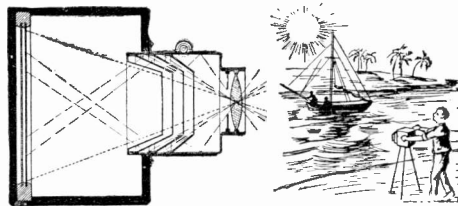

No. 1,479,112, issued to Will Sparks. Inasmuch as only the direct rays of light can convey a true image to the plate of a camera, those rays which fall outside of the area of the plate strike the box. Even though the interior of the camera is black, they are reflected onto the plate again, producing a fogged effect. In order to overcome such fogging, the inventor has designed a camera having vanes in it in the form of frustrums of cones. These prevent reflection.

Theatrical Illusion

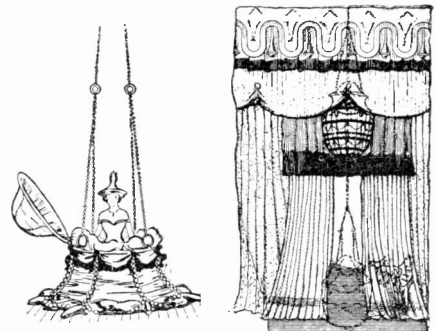

No. 1,489,839, issued to Harry Robert Law. On the stage a large vanity bag is hung near the top of the stage opening. This is lowered by any of the many well known means, but while the bag is being lowered, the performer steps from behind one of the side curtains into a position directly behind the bag. He then steps upon that portion of the bag which is collapsed upon the stage and crouches lower and lower, finally throwing back the lid and emerging to perform a dance. He disappears by reversing the process.

Boat Propelling System

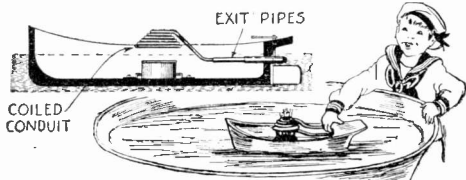

No. 1,481,270, issued to William F. Purcell. By means of heat the inventor has found that he can approximate a uniform reciprocating movement in the manner shown above. Two pipes lead to a coiled conduit placed over the heating agency. If this is partially filled with a liquid and the exits of the pipe are arranged below the water level, the water alternately enters the pipes and is forced out, causing the ship to be propelled.

Hedge Trimmer



No. 1,486,140, issued to John J. Hickey. Strapped to the body of the user is a spring motor in its casing. Leading from the central shaft, a flexible hose runs to the clippers which are held in the hand of the operator. In use, the operator steps on a stirrup and by working this up and down, transmits the movement to a drum upon which the chain is wound. This in turn winds up the spring and works the clippers.

Fly Catcher

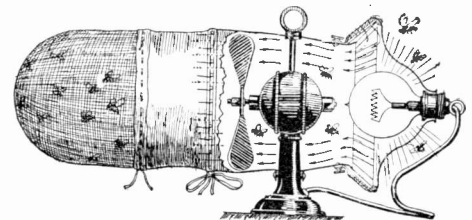

No. 1,484,369, issued to Carlo Andreucci. This fly catcher works in the following manner: The flies are lured by the light of the lamp. In attempting to reach the latter, they enter the spaces provided and are caught in the suction of air produced by the fan. They are carried in the direction of the arrows and hurled into the bag from which they may be removed from time to time.

Scientific Humor

NEEDED INVENTIONS

Noiseless Auto Horns
Cast Iron Balloons
Safe Safety Razors
Wireless Cookers
Unbreakable Mirrors
Dry Water
Square Eggs
Inexhaustible Beer Bottles
Portable Stills
Water-tight Pockets
Rubber Yardsticks
Balloon Vulcanizers.—*Leslie Carpenter, Reporter No. 8520.*
(P. S. Laughly Jokes. Editor.)



A FASHION ARTIST

VISITOR TO THE ASYLUM: "What is that man drawing?"

WARDEN: "He went crazy over radio and is trying to design hook-ups for women's dresses."—*Leslie Carpenter, Reporter No. 8520.*

dresser."—*Leslie Carpenter, Reporter No. 8520.*

OUR SET SHIPWRECKS 'EM

SMITH: "Why is a radio set like the prow of a ship?"

BROWN: "I'll bite. Why is it?"
SMITH: "Because it separates the waves."—*Clifton Ask.*

AN ILL BRED YOUTH

ORDERLY OFFICER: "Any complaints?"
MESS ORDERLY: "Yes, sir. Bread's wrong, sir."
O. O. "What's the matter with it?"
M. O. "Contradicts the laws of gravity, sir."
O. O. "Explain."
M. O. "It's as heavy as lead, and it won't go down."—*Nathaniel Gotfried.*

ONE WRENCH DESERVES ANOTHER

JIM: "Why is a wrench like a man?"
BILL: "Don't know. Why?"
JIM: "Because they both started as a monkey."—*J. C. Mello.*



Reporter No. 8520.

ALSO APPLE SAUCE

TEACHER: "What did Newton discover when the apple fell on his head?"

PUPIL: "Apple cider."—*Leslie Carpenter,*

COMPARING INVENTORIES

RICHMAN: "I made my money with inventions."
POORMAN: "Then, Sir, you are like me, an inventor."
RICHMAN: "No. I was a patent lawyer."—*J. C. Mello.*

GRAVELY SPEAKING

SCIENTIST TO FELLOW TRAVELER: "Do you think that Gravity is a universal force measured by the square of the distance and mass of matter, or whether it is an inherent property of matter itself?"

FELLOW-TRAVELER: "It's no matter; gravity ends where the laugh comes in."—*Alfred Henry.*

First Prize \$3.00



WEE-WEE-WEE-EE!

One farmer speaking to another. "Well, it's wonderful, the packing companies use everything about a pig but the squeal."

"Yes, but they're using the squeal now. How come?"
"The manufacturers are putting it in radio sets."—*Thomas Williams.*

HA-HA!!

I have spent ten years of study and research in an endeavor to originate an original joke. That my efforts have finally been crowned with success you will see from the enclosed jokes. Please send me the three dollars, for which I thank you very much. *Sic eunt fata hominum.—N. Compton.*

(Your jokes are too fresh. Send next lot in 1934. Sorry, old top, joke's on you.—*Joke Editor.*)

WE receive daily from one to two hundred contributions to this department. Of these only one or two are available. We desire to publish only scientific humor and all contributions should be original if possible. Do not copy jokes from old books or other publications as they have little or no chance here. By scientific humor we mean only such jokes as contain something of a scientific nature. Note our prize winners. Write each joke on a separate sheet and sign your name and address to it. Write only on one side of sheet. No letters acknowledged unless postage is included.

All jokes published here are paid for at the rate of one dollar each, besides the first prize of three dollars for the best jokes submitted each month. In the event that two people send in the same joke so as to "tie" for the prize, then the sum of three dollars in cash will be paid to each one.

CUT IT OUT—SAID THE SCISSORS

The hatchet suggested to his friends a game of poker. The cards were dealt out and they started to play.

"I open," said the knife.
"I'll draw one," said the magnet.
"I pass," said the escalator.
"I chip," said the hatchet.
"I'm losing, I stop," said the clock.—*A. Schusterman.*

CHESTNUT TREES ARE NOT ALL DEAD

STUDENT: "I heard you were sick last week."
PROFESSOR: "I was. I had the new disease called clothing sickness."
STUDENT: "What on earth is that?"
PROFESSOR: "I had a coat on my tongue"



and my breath came in short pants."—*Henry Nef.*

POOR ADVICE

MOTHER: "I won't let James take up machine shop practice."
FATHER: "Why?"
MOTHER: "Because I heard that machine shops are full of vises."—*J. C. Mello.*

THEY PADLOCKED THE INPUT

"The dry squad confiscated the radio set next door."
"Why was that?"
"Bootleg tubes on the bus-bar."—*Jack Bront.*

WHERE MA'S HAIRPINS GO



For ma's hair, 40; for auto repairs, 60; emergency fuses, 100; artificial glasses (Willie), 20; emergency book marks, 12; radio upkeep, 10; in teacher's desk, 125; button hooks, 105; mute for banjo, 165; burglar alarms, 40; radio lead-ins, 15; picture hangers, 25; black head removers, 15; battery connectors, 250.—*Leslie Carpenter, Reporter No. 8520.*

NON-SENSE!

WILLIE: "What's the sixth sense, Dad?"
CRABSHAW: "That's something claimed by a lot of persons who haven't much of the other kinds."—*Jas. J. O'Connell.*

UNDERGRADUATED

FRESH MAN: "Why is a college student like a thermometer?"
SENIOR: "Because he is graduated with degrees."—*Raymond A. Bailly.*

HOW ABOUT THE CAPITAL OF FRANCE?

BIOLOGY PROFESSOR to lazy student: "Name a parasite."
STUDENT: "Me?"
BIOLOGY PROFESSOR: "Yes, but name another one."—*Edward M. Carr, Reporter No. 10224.*

HE TOOK A SHORT CIRCUIT

A radio bug of the worst kind took up golf, with very disastrous results.

He would yell out "Fore, fore," while tuning in, to get rid of interference. He used vacuum tubes as golf balls, his niblick as an aerial, his caddie as a shield, his golf bag as a loud speaker, his golf trousers as a tickler coil, his golf ball as a variometer, and he "put" with ground pipe.

He got station XYZ "in one," made a "hole" at 89°, and wanted to put posts in every hole on the golf course to string his antenna on.

He was very promptly put in an asylum.—*J. Gaskins.*

BUT THEN HE COULDN'T METER

"You will have to Regulate your bedtime, Control your habits and Cut Out your loafing or I will reFuse your allowance," said the father to his wayward son.—*Ned Guffey, Reporter No. 6042.*





THE ORACLE



The "Oracle" is for the sole benefit of all scientific students. Questions will be answered here for the benefit of all but only matter of sufficient interest will be published. Rules under which questions will be answered:

1. Only three questions can be submitted to be answered.
2. Only one side of sheet to be written on; matter must be typewritten or else written in ink, no penciled matter considered.

3. Sketches, diagrams, etc., must be on separate sheets. Questions addressed to this department cannot be answered by mail free of charge.

4. If a quick answer is desired by mail, a nominal charge of 25 cents is made for each question. If the questions entail considerable research work or intricate calculations a special rate will be charged. Correspondents will be informed as to the fee before such questions are answered.

PERPETUAL MOTION

(1692) P. Termengal, Wesleyville, Pa., sends us a sketch of a proposed perpetual motion machine which is reproduced herewith and requests our comment on the same. The device, of course, is purely theoretical and in order to assume that it will work, we must assume a capillary tube and a series of floats small enough to fit within it in about the proportion shown. Our illustration is greatly exaggerated in order to set forth the idea.

A. 1. The device you have designed will not work. This is the case with many machines of the type which have been proposed by sanguine inventors. However, the device will fail to function because of the fact that the minute amount of buoyancy obtained in the capillary tube will be so very small that the losses in friction between the floats and the pulleys, and the pulleys and their axles, will be more than the power obtained. Even

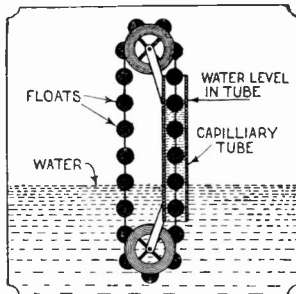

A fairly well-known form of "perpetual motion machine" is shown here comprised of floats, which are supposed to rise continuously in the capillary tube, and rotate the wheels or drums. The opinion of the editors is given in the answer to this question.

when friction is reduced to the lowest possible extent, it will be found that the power generated will not be sufficient to overcome it and allow the device to operate. The floats will have to be so small to pass within a capillary tube that they will not have any appreciable amount of buoyancy.

RESISTANCE QUERY

(1693) Robert J. Phillips, Mineola, L. I., wants to know:

Q. 1. If a resistance—for instance, a 100 watt lamp—is connected in series with a source of power—say 100 volts at 5 amperes—what will be the resulting voltage and amperage?

A. 1. In the instance you mention, the resulting voltage will be determined by the voltage drop across the lamp, but the amperage will be equal to that passed by the lamp; in this particular instance, approximately one ampere.

WATER-PROOFING SOLUTIONS

(1694) Ray Shriner, Nallpee, Wash., submits a sample of a water-proof cloth and asks us how it is made. He also requests a formula for the making of a water-proofing compound.

A. 1. The water-proof cloth of which you submitted us a sample, is merely a very tightly woven material, impregnated with some water-resisting chemical. Many different kinds of solutions could be used for water-proofing cloth and we are giving you one herewith.

Coat the material with a mixture of equal parts of the three solutions given below.

1. Gelatin 5 pounds by weight, boil in 300 parts of water free from lime.
2. Alum 10 parts, dissolved in 300 parts of water.
3. Soda soap dissolved in 200 parts of water.

THEORY OF AUTOMOBILE SPRING

(1696) Donald D. Dresser, New Bremen, Ohio, wants to know:

Q. 1. Will you kindly explain the action of the leaf springs used in automobiles for supporting the body?

A. 1. To understand this matter thoroughly, refer to the diagram herewith. Here we view one of the springs supporting the body of an automobile. In this case it is one of the rear springs. One end of the long spring is connected to the body by means of a shackle. The other end is connected to the top spring by means of another similar device. When the car is travelling along a very smooth road, the position of the spring is shown in the solid lines as at A. When the wheels strike a bump, the springs compress. If they are not flexible enough, the shock is transmitted to the

Interesting Articles in July "Practical Electrics"

- Electrocuting Whales. By H. Gernsback, Member American Physical Society.
- The Rain Maker. By J. Kay London.
- Comic Picture Projector. By Harold Jackson.
- Ohm's Law. By F. S. Yamamoto.
- Uses for Spark Plugs. By Jacob E. Raible.
- Electric Insects.
- The Gate for Your Voice Highway. By Paul B. Findlay.

ELECTRIC FLASHER

(1695) Ralph W. Johnson, Gifford, Ill., asks: Q. 1. Please give some information on how an experimental thermostat may be made that will flash a sign on and off at fairly regular intervals?

A. 1. The usual method of making a flasher such as you mention is to employ a strip of thermostat metal, a compound bar of iron and copper, in the circuit. When current passes it heats this bar; as it gradually becomes hot it bends, breaking the circuit. As it cools, it closes the circuit and the process is repeated.

The manner in which an automobile spring absorbs shocks is shown here. When the car is traveling along a smooth road, the position of the spring is shown by the solid lines at A; when the wheels strike a bump, the spring recoils as at B.

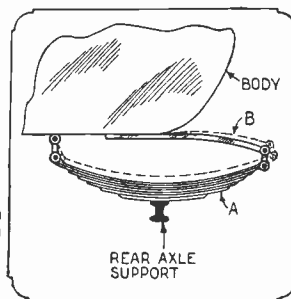

body of the car and the occupants. However, the inertia of the body of the car is so great, due to its comparatively great weight, that, if the springs are at all flexible, they compress and expand without affecting the body to any great extent. Shock absorbers operate on somewhat the same principle since they take up the shock imparted to the wheels by a rough spot in the road without allowing the body of the car to vibrate through any appreciable distance.

SKINDERVIKEN BUTTON VOLTAGE

(1697) J. J. Asselin, Co. Laval, P. Q., Canada, wants to know:

Q. 1. Can a 6-volt storage battery be used in connection with a Skinderviken button?

A. 1. A 6-volt storage battery may be used on a Skinderviken transmitter button. It is not advisable, however, to use more than 6 volts.

OUR \$12,000 PRIZE CONTEST

IT will be noted from recent issues and the present one that our prize contest has been a whale of a success. Over \$1,000 has been paid out this month for worth while contributions to SCIENCE AND INVENTION, either in pictures, suggestions, ideas or articles. We now have on our staff, close to 12,000 correspondent reporters who are scouting the world for

new material that can be written up for SCIENCE AND INVENTION. And the formula is simple—just keep your eyes open. Even if you were totally deaf or blind, you could still win a prize by simply using your head and sending us ideas of a scientific nature, or of a nature directly or indirectly attached to new inventions.

ARTICLES FOR AUGUST SCIENCE AND INVENTION

- The Diabolic Ray—Special Illustrated Article. By C. A. Oldroyd.
- The Bed-bug and Its Extermination. By Joseph H. Kraus.
- The Size of the Moon. By Howard Deem.
- German Stagecraft. By Dr. Albert Neuburger.
- A New, Sharply Tuned Receiver of Low Cost—Full Working Details. By Herbert E. Hayden.
- A "DX" Loop Receiver for the Summer. By Harold Jolliffe.
- Casein—Its Many Uses. By Raymond B. Wailes.
- Animated Electric Animals.
- Unique Clocks. By H. E. Zimmerman.
- Sundials—How They Work. By Samuel Bernard.
- Latest Devices Page.
- Patent Advice.
- Question and Answer Column—The Oracle.
- Radio Oracle.

FREE INFORMATION

IF you want additional information concerning any of the subjects illustrated and described in this number of SCIENCE AND INVENTION we shall be glad to give you other data we have at our command. To make this work as easy as possible for our editors, please be brief. Write only on one side of the paper and state exactly in a few words just what it is you desire further information on. We have the original manuscripts and drawings of many of these articles in our files and can furnish much additional data in most cases. Please do not fail to send stamped and self-addressed envelope. Make all questions concise and specific. Address all inquiries of this nature to INFORMATION EDITOR c/o Science and Invention, 53 Park Place, New York City.

IMAGE IN A CONCAVE MIRROR

(1698) Joseph R. Middleton, Birdsboro, Pa., asks:

Q. 1. Can you show by a diagram how to locate the image formed by a concave mirror?

A. 1. The illustration herewith answers your question. First the parallel lines AD and BH are drawn. Since the rays of light represented by these lines are parallel to the principal axis they will be reflected through the principal focus F. Therefore, construct the lines DX and HY. Next draw the lines AG and BE representing the rays of light passing through the axis of the reflector. This ray is reflected upon itself since it strikes the surface perpendicularly. The points of intersec-

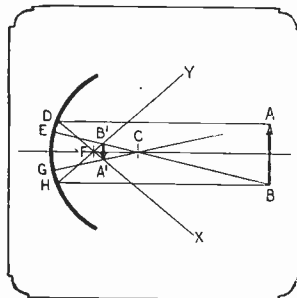

The accompanying diagram shows how an image is formed by a concave mirror. The point of intersection between the two reflected rays determines the position of the image, as shown. The image so formed is real, inverted and smaller than the object.

tion between the two reflected rays determine the position of the image as shown. The image so formed is real, inverted and smaller than the object.

INCREASING CAPACITY OF SHIPS

(1699) John Mihalko, Hazelton, Penna., asks:

Q. 1. Since almost all ships are equipped with airtight compartments, why could not these compartments be filled with hydrogen or helium gas, thereby allowing the ship to carry more cargo because of the buoyant effect of the gases?

A. 1. The air compartments in the holds of ships are not designed to buoy up the ships, nor to enable them to carry more cargo. In fact, ships equipped with airtight compartments cannot carry as much, for the simple reason that their hold space is reduced. The reason for these tanks is that if a hole is torn in the side of a vessel, the entire ship cannot fill up, and the automatic pumps will at once set to work to expel the water. Even if helium or hydrogen gas were used in these tanks, the difference in buoyancy will be inappreciable due to the relatively slight amount of gas and the large weight of the ship.

TAPERED ROLLER BEARINGS

(1700) R. H. Gooding, Cleveland, Ohio, asks:

Q. 1. What is the advantage of a tapered roller bearing?

A. 1. When a tapered roller bearing is used, there is no necessity of a separate thrust bearing such as is used when a straight roller bearing is employed. The reason for this is shown in the illustration given herewith. The radial and thrust loads are indicated. The method of compensating for each of these can be plainly seen.

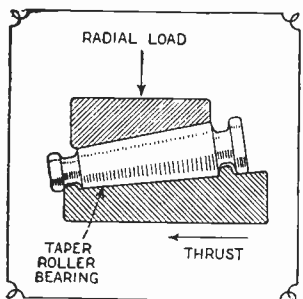

When a tapered roller bearing is used, as shown in the accompanying illustration, it is not necessary to employ a separate thrust bearing as is the case when a straight roller bearing is employed.

POSITIVE PHOTOS ON GLASS

(1701) James J. Godfried, San Diego, Calif., asks:

Q. 1. How are photographic plates made and how can I make a positive photograph on glass?

A. 1. Ordinary photographic plates can be purchased so cheaply that it is hardly worth while to try to make them yourself as the results would vary considerably and in most cases would be far from satisfactory. We would, therefore, suggest that you purchase a quantity of plates of the correct size as they can be obtained for many different speeds. If you wish to have a positive photograph on glass instead of a negative, during development, when the plate is about three-quarters developed, flash the light from an ordinary pocket lamp upon the plate for a fraction of a second. Finish development and fixing in the ordinary manner and the plate will be found to have a positive instead of a negative impression. The exact length of time for exposing the plate to the light will have to be determined by experiment. Positive prints cannot be made from a plate of this type.

RECTIFIER TROUBLE

(1702) Grover C. Shriner, Detroit, Mich., submits a diagram of an electrolytic rectifier saying he has used a solution of sodium phosphate for the same, but, that every time he uses it, the jars over-heat and he sometimes blows out fuses. He asks:

Q. 1. Can you give me any help in this matter?

A. 1. You are evidently not using any resistance in series with your A. C. line when using your electrolytic rectifier. You should use a bank of lamps for this work, the number and size of the lamps depending upon the amount of current you wish to draw from the D. C. side.

GAS MANTLES

(1703) E. J. Schmidt, Medicine Lodge, Kansas, asks:

Q. 1. Why is it that gas mantles before they are burned are rather strong, but after they have been ignited they become very fragile?

A. 1. Gas mantles are made by weaving a long cylinder of cotton in a loose net-like form. This cylindrical web is then saturated with certain chemicals, pieces of the cylinder now cut off, one end tied together, and the other end fastened to the hole. When the mantles dry, they are quite stiff and not easily broken. When they are put on the gas fixture and lighted, the cotton burns away, leaving a very fragile shell, composed of the crystallized chemical. This chemical is such that when it becomes crystallized and subjected to heat such as encountered in the gas flame, it becomes highly incandescent.

IMPORTANT

TO NEWSSTAND READERS

IN order to eliminate all waste and unsold copies it has become necessary to supply newsstand dealers only with the actual number of copies for which they have orders. This makes it advisable to place an order with your newsdealer, asking him to reserve a copy for you every month. Otherwise he will not be able to supply your copy. For your convenience, we are appending herewith a blank which we ask you to be good enough to fill in and hand to your newsdealer. He will then be in a position to supply copies to you regularly every month. If you are interested in receiving your copy every month, do not fail to sign this blank. It costs you nothing to do so.

To Newsdealer

Address

Please reserve for me copies of SCIENCE & INVENTION every month until I notify you otherwise, and greatly obliged.

Name

Address

LOCATING SUNKEN SHIPS

(1704) R. W. Peterson, Milwaukee, Wis., asks:

Q. 1. Can you give me a resumé of the various practical methods for locating sunken ships?

A. 1. There are several methods of locating a sunken vessel. The first is the induction balance method. Sound ranging is another fairly good system, but in this and the first named method you meet with many great difficulties which are hard to overcome. If the bottom of the water bed is irregular, then the sound waves reflected from the bottom may be like those which would be reflected from a sunken ship and a mistake may be made.

Another system would be to drop an insulated cable to the bottom between two vessels and drag this along until it strikes some object, measuring the distance between the surface and the electrode at the bottom. It is evident that if this contact at the bottom of the water should strike a large body, the resistance will be immediately decreased. Such is the case if the objects were of relatively large size and the contact made were quite perfect. Here again the system would have to be developed rather fully before one could look upon it with any degree of favor.

There are two remaining methods which could be employed which will give quite accurate results. The first is a device similar to a diving bell, and the second, a deep sea conveyance of either the Williamson or Lake types. Both of these devices have been described in our magazine several years ago, and they are without a doubt the only good methods of locating a ship. The submarine camera may also be effective. Sound ranging from shore stations or the Fessenden method of ore location could perhaps also be used, but none of these devices are positive in action, and much experimental work would have to be done before they could be practically employed.

EINSTEIN THEORY

(1705) Hans Skog, Detroit, Mich., asks: Q. 1. Can you tell me where I can find published accounts dealing with the Einstein theory of relativity?

A. 1. Several articles on the Einstein theory of relativity have been published in this magazine. We are giving you the dates of several of the more important ones. December 1920, April 1922, September 1921, December 1921.

GEAR TERMS

(1706) George Brody, Portland, Me., says that he has heard terms such as tee, heel, face and flank applied to gear teeth. He asks:

Q. 1. Can you show by an illustration just what these and other terms mean?

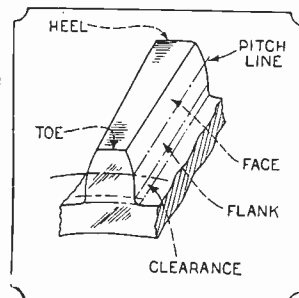

The illustration herewith shows the various technical terms and their relation to beveled gear teeth, such as the toe, heel, face and flank. The toe represents the edge of the tooth on the inner diameter of a beveled gear.

A. 1. Our illustration herewith shows the various parts of a gear tooth, every one of them being designated plainly.

SOLAR HEATER

(1707) Harry A. Palmer, Avalon, Calif., asks:

Q. 1. What is the black compound used for coating a solar heater so that light will be absorbed and heat produced?

A. 1. Almost any kind of black paint which gives a dull finished surface can be used for coating a solar heater. This paint should be applied so that the finished surface will not have a gloss or polish. If such is the case, however, any fine abrasive can be used to give a dull surface.

SIZE OF ELECTRONS

(1708) Helen L. Jones, Canutillo, Texas, asks:

Q. 1. Has matter ever been magnified to such an extent that an individual electron can actually be seen?

A. 1. If a drop of water were to be enlarged to the size of the earth, one of the atoms of the drop would be about the size of a baseball. In turn one of these atoms were enlarged to the size of the earth, each individual electron would be about the size of a medium sized peanut. It is impossible to magnify matter to such a degree that one electron can be seen.

CADMIUM TEST FOR STORAGE BATTERIES

(1709) Raymond F. Darrow, Springfield, Mass., asks:

Q. 1. How is the so-called cadmium test applied to storage batteries?

A. 1. The illustration herewith shows this test. To ascertain whether the positive plates are in good condition, connect the plain terminal indi-

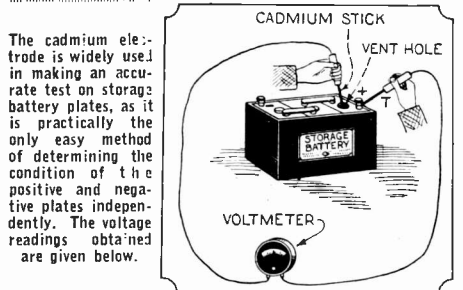

The cadmium electrode is widely used in making an accurate test on storage battery plates, as it is practically the only easy method of determining the condition of the positive and negative plates independently. The voltage readings obtained are given below.

cated by T to the positive side of one cell. Insert the cadmium stick into the vent hole of the cell to be tested, but do not allow it to touch the plates. Observe reading on zero center scale voltmeter when reading becomes constant. This should be between 2.35 and 2.45 volts if the positive plates are in good condition. If less than 2.35, it is probable that the positive plates are defective. Test the negative plates in the same manner except that the plain terminal is to be transferred to the negative terminal of the cell. The reading will be in the opposite direction on the voltmeter scale. If the negative group is in good condition, the reading will be between .1 and .2 volts to the left of the zero mark. If the reading approaches zero or the hand swings to the right of zero, the negative plates may be either defective or in a sulphated condition requiring a long charge. If the test on both positive and negative plate readings approaches zero, the battery is internally short-circuited. This test is made while the battery is on charge just as it has been brought up to full voltage and when the electrolyte is of the proper specific gravity. Connect cadmium stick to negative side of voltmeter.



Hot off the Press

THE NEW STARRETT CATALOG N^o. 23 "LE" is now ready for distribution. Shows all the new Starrett Tools which have been added since our last catalog was published, many of which are here listed for the first time. Get your copy at any Hardware Store selling Starrett Tools or write us.

for instance

- Angle Gage
- Hold Downs
- Extension V Base for Jack Screws
- Rolling Mill Gage
- Drill Point Gage
- Flexible Stainless Rule
- Cylinder Gage
- Pocket Micrometer Case
- Dial Bench Gage

and some fifty others

THE L. S. STARRETT CO.
The World's Greatest Toolmakers
 Manufacturers of Hacksaws Unexcelled
 ATHOL, MASS.

6631

Starrett Tools



Be An AUTO EXPERT
Make \$75 to \$200 A WEEK

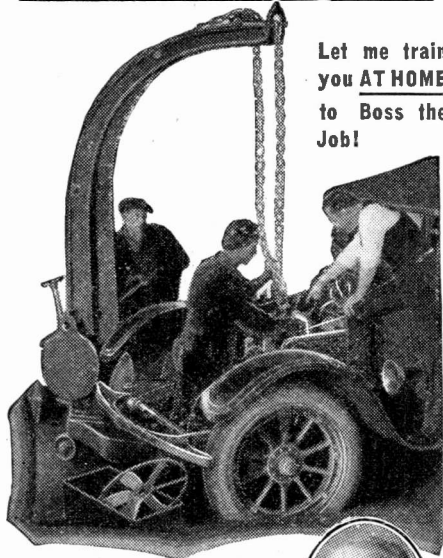

Let me train you **AT HOME** to Boss the Job!



B. W. COOKE
 Directing Engineer
 CHICAGO AUTO SHOPS

WILL MAKE you a successful AUTO EXPERT, prepare you to go into business for yourself, train you for positions paying \$3,000 to \$10,000 a year! Keep your job—stay home—loan me a part of your spare time. As Directing Engineer of the Big CHICAGO AUTO SHOPS I train you the "JOB-WAY"—not with books.

AT HOME!
 I Train You
 My home-training makes Auto EXPERTS! I prepare you to BOSS THE JOB! My "Job-Way" instruction makes you MASTER of every branch of automotive work: Mechanical, Electrical, Battery, Taxicabs, Busses, Ignition, Farm Power Plants, Welding, Brazing, Vulcanizing, etc. You can not get all this training anywhere else on earth.

FREE OUTFIT!
 Big repair and testing outfit free to my students. Use it to do my JOBS, use it to make money, use it to make this training pay for itself!

FREE JOBS!
 Employment department helps you get big pay jobs without one penny of cost!

Go into Business!
 —make \$3,500 to \$15,000 Yearly
 Biggest opportunities to go into business with small capital when you have my training. Auto Experts run their own business and make \$3,500 to \$15,000 net profits a year. The same opportunity is open to YOU thru my guaranteed "Job-Way" instruction.

START NOW!
 Inducements you cannot resist to help you START RIGHT now reach. One week's pay

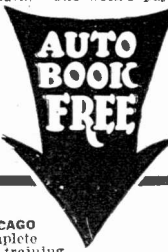

B. W. COOKE, Directing Engineer
 CHICAGO AUTO SHOPS
 Dept. B28
 1916 Sunnyside Ave., CHICAGO

B. W. COOKE, Directing Engineer
 Dept. B28, 1916 Sunnyside Ave., CHICAGO
 Please send me Free Book and complete information about your "Job-Way" training at home. Tell me about the opportunities today for Auto Experts, how to secure FREE REPAIR OUTFIT.

Name.....
 Address.....
 City..... State.....
 Occupation..... Age.....

The Man On the Meteor

By RAY CUMMINGS
 (Continued from page 253)

A burst of cheering interrupted him. The crowd waved its arms; in the confusion many of the spectators overhead lost their holds, or were crowded from their places.

Then again silence fell over the water. And in the silence a single voice shouted two words. A female voice—the shrill voice of some Marinoid girl.

"Loyal subjects!" She called it out cynically, quoting it from the King's last sentence. She was directly across the water from me; I saw her plainly—a girl who was considered one of the beauties of Rax. A half-breed man was passing near her, and obviously she was aiming the taunt at him.

"Loyal subjects!" And then she added: "That does not mean you—Marinog!"

It roused the half-breed to frenzy. He dashed at the girl, struck her in the breast with his arm.

Instantly there was confusion. A dozen swimming figures cut off my view. Out of the melee the Marinog came diving. I saw him escape in the crowd.

The King was trying to cover up the incident by going on with his speech. But they would not listen to him. From everywhere came shouts.

"Down with the Marinogs!" "Half-breeds! Tainted blood of the Maagogs!"

The King's speech had precipitated the very thing he had been trying to avoid! In a sudden fervor of patriotism against the Maagogs, the people were openly taunting all of Maagog blood among them.

There were many half-breeds in the crowd—lurking in secluded spots, eyeing the King with their huge, solemn eyes. They began slinking away; and most of the crowd let them go. Except the Marinoid girls. Perversely feminine, the girls swam around them—taunting, laughing, jeering.

THE KING COMMANDS

The King looked down anxiously at Atar and me. Then, with sudden dominance, his roaring voice stilled the confusion.

"Silence all! Your King speaks! Are you Maagogs that you defy the majesty of your King? You are unjust to the half-breeds. The half-breeds are loyal. Their Maagog blood is forgotten. Tainted they were by heritage—but their taint is washed clean by our Marinoid Waters. They are your brothers! You must love them! They are loyal to me! I trust them!"

Thus runs the art of diplomacy. There was nothing our King feared more—or trusted less—than these self-same half-breeds. They stopped at the edges of the crowd and listened to his praising words—listened with the same impassive faces and inscrutable eyes.

"Loyal!" the King repeated. "And when the war is over and we have defeated our four enemies from the Water of Wild Things—the loyal half-breeds will be honored among us!"

A crowd is easily swayed for the moment. Soon they were cheering the half-breeds—exhorting them to remain loyal. The girl whose taunting words had started the trouble was swimming toward us across the open cube of water. Some instinct at that moment caused me to glance overhead. A figure was clinging to the foliage directly above the King—a half-breed man. I saw his arms fling something downward. Something long and thin, and gleaming green-white in the glare of lights. It looked like a spear. But it came down more slowly.

And then I saw it was swimming! A needle-fish the length of a man, with a nose two feet long, pointed and stiff as a rapier! With increasing speed it was swimming downward directly at the King!

III

A second or two of confused thought too rapid for action. The needle-fish was darting downward faster now than a thrown spear. The King was unaware of it. The fish's rapier nose would run him through from back to chest!

I found myself gripping the King's legs, trying to pull him down. But another figure from near at hand dove at him. The Marinoid girl who had taunted the half-breed! Her arms went around the King's neck. . . . A flash of silver as the needle-fish came at them. . . . A choking female cry. . . . The girl's body sank to the roof-top at the feet of the startled King. On her face, inert, she lay with the fish like a sword-blade buried in her back!

The King was unhurt. He was shouting commands at the excited crowd. Overhead there was a scuffle—a scream of anguish; the half-breed's body—he who had launched the needle-fish—came slowly down to us. . . . I saw a dozen spears from the enraged crowd sticking in it.

We lifted up the girl—grotesque to my mind with her four arms—but by Marinoid standards one of their greatest beauties. She was still alive. Thoughtlessly, I pulled the fish from her wound, broke its sword-blade nose across my knee—snapped its slim body as one would snap a length of string.

A thoughtless act! From the wound, the girl's blood gushed. It spread like smoke in air; the water all around us was pink.

Atar had his arms about the girl! Then he got to his feet; and with a command to the crowd to disperse, he swam away to fetch the man of medicine.

The King and I knelt by the girl. Atar would be too late; she was dying.

"Child," said the King gently, "soon you will be healed and strong again. And never shall I forget what you did for me today." But she shook her head weakly; her lips, twisted with pain, were trying to smile at him. Her words were low, halting; the King and I bent lower to hear them.

"Loyal—subjects! I was loyal. didn't—mean to start—any trouble. You—forgive me?"

"Yes," said the King. "Don't talk now, child."

"Loyal," she repeated. "Everyone should be—loyal to his King. I'm—glad I could show—To die for—"

The blood gushing from her mouth stopped the words; but her eyes were still smiling—smiling as they glazed and the light faded from them.

And out beyond the stars—to join the self-same God who watches over the Marinoids as well as you of Earth—her soul went winging.

IV

"Nona," I said, "do you wish to go to this merry-making? . . . Caan, should I take her?"

It was two days after the attempted assassination of the King. I had not yet seen the cavern where the King was preparing for war. I was going there after this next time of sleep.

We in Rax—the King, Atar, Caan and I—were much perturbed at the turn affairs were taking. We knew now that Og's emissaries were among us. But they kept themselves hidden—talking secretly to the half-breeds, to all who sympathized with the Maagogs.

(Continued on page 296)

"BUILD YOUR OWN" WITH "RASCO" PARTS!

Buy from the Oldest and Original Exclusive Radio Parts House in the United States

We pay ALL transportation charges in U. S. ALL GOODS SENT PREPAID IN 24 HOURS

Order direct from this page.

SPECIAL PRICES FOR THIS MONTH ONLY

Money refunded if goods do not satisfy

COMPLETE SET SALE AT REDUCED PRICES

Reinartz Receiver
Exactly as shown with mahogany cabinet, panel, all necessary instruments, binding posts and pattern for assembling. This set can be put together by anyone in a few hours.
L9988 Reinartz Receiver\$13.50



Autoplex Circuit
Will bring broadcast on loud speaker on single tube. Complete as pictured here. All parts, including mahogany cabinet, panel, instruments, binding posts, etc. Can be put together with a few hours time.
L9955 Autoplex outfit\$15.00



Two Stage Amplifier
Complete as pictured including mahogany cabinet, panel, all instruments, Al audio transformers, binding posts, etc. Can be put together in a few hours' time.
L9966 Two stage amplifier\$12.25

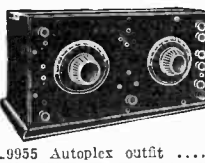

Short Wave Regenerative Receiver
Complete as pictured with mahogany cabinet and all necessary instruments and parts. Can be put together in a few hours' time.
L9977 Short wave set.\$11.50



Rheostats and Potentiometers
Come with metal dials and composition knob. Excellent merchandise despite low price.
L4210 6 ohm rheo. \$.27
L4211 30 ohm rheo. .30
L4212 200 ohm Potentiometer45



Moulded Dials
Only very best grades handled. Bushings absolutely true. Dials cannot wobble. Letters inlaid in fast white enamel. All dials for 1/4" shaft.
L3074 Dial 2"\$.20
L3075 Dial 3"\$.25
L3076 Dial 4"\$.40

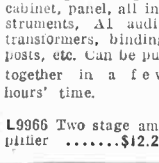

Tapped "B" Batteries
We positively guarantee these batteries to be of long life. We carry only fresh stocks. All with taps.
L2250 Sm. 22 1/2 V. \$.85
L2251 Medium Navy size, 22 1/2 volt 1.20
L4500 Large size, 45 volt 2.30



Panel Mounting Condensers
Positively no better condenser on the market. Shafts 1/4". Save from 40 to 60% by assembling condenser yourself.
L1111 11 plate.\$1.10
L1211 21 plate. 1.22
L1343 43 plate. 1.33



"Rasco" Bezels
Finest bezel on the market. Bezel comes entirely nickel plated. Can be used on 1/2" or 3/16" panel.
L1700 Rasco Bezel, 1"\$.15
L1701 Bezel, 1 1/2"\$.20



Rasco 180° Variocoupler
Sik wire wound on bakelite tubes. Six taps. Wave length, 150 to 600 meters. For panel mounting. 1/2" shaft. Your money refunded if it is not all we claim.
L3100 Variocoupler prepaid\$1.50



Dielectric Panels
Highest dielectric strength as per Bureau of Standards.
L7100 7x10x3-16"\$.70
L7120 7x12x3-16"85
L7140 7x14x3-16"95
L7180 7x18x3-16" 1.25
L7210 7x21x3-16" 1.45
L7240 7x24x3-16" 1.65



Silicon Steel
Used practically in all audio-frequency transformers. Better than iron. Extremely soft, 7/8" wide and .007" thick.
L4900 Silicon steel, per foot\$.08
10 feet lots\$0.70



Spider Web Forms
Fine forms to wind your spider webs. Made from hard, well seasoned fibre. 1-16" thick, center and side holes for wiring. Both 5" diameter.
L3200 Spider form.\$.25
L3201 Spider form.\$.25



Universal Bearing
To hold rotors. Length of bearing 2 3/4" shaft 1 1/4" thread 1 1/2" long thread sleeve 3/4" long. Each\$.25
L1550 Sockettes. Four of these take one vacuum tube. Grasp tube firmly. Best by test. Set of 4 \$2.25

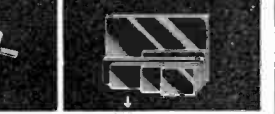

Brass Strip and Tubing
Brass strip 1-16" thick; 6 1/2" wide; L1430 Per length.\$1.10
L1431 Brass tubing, dia. 1/4"; 6" long; length \$1.15
L1432 3/8" thread \$1.08
L6032 6-32" thread .06



Alcohol Blow Torches
Best made. Give intense hot flame. Great for fine work.
L8981 5" Torch\$.85
L8982 3" Torch\$.50
L4104 Rustin Core Solder. A non-corrosive solder with flux inside. 18" length\$1.10



Monodyne Socket
This socket takes up 25% less room than any other tubes. No outside connections. Nickel plated shell. Has fiber bottom with 4 sockettes. Sockettes hold socket to panel or board.
L6502 Socket\$.25



"Rasco" Switch Points
Nickel and polished.
L301 3/4" x 1/4" 6-32" doz.\$1.10
L304 3/4" dia. 7/8" thick, 6-32" doz.18
L305 1/2" dia. 3-16" thick, 4-36" doz.10
L375 Switch stop 7/8" long, with nut, doz.18



Throw Switches
Mounted on composition block. Small enough for all radio purposes.
L4100 Single pole.\$.25
L4104 Double Throw Single Pole\$.35



Bakelite 180° Coupler De Luxe Style
Tubes of natural color bakelite, wound with green silk. Cast aluminum bracket, 1/4" shaft. Primary 1 1/2" taps. 180 to 350 meters.
L3150 Coupler\$2.35



"Rico" (Adjustable) Loud-Speaker Phone
Has rubber gasket underneath diaphragm, making phone fully adjustable. Gives amazing results as loud-talker on 1 and 2 stage of amplification.
L2525 Speaker with 5 ft. cord\$2.65

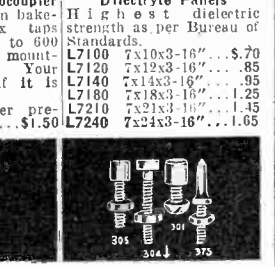

Soft Rubber Ear Cap
At last! Ear Caps that will relieve headaches, earaches, and undue pressure on the ears. Fit all receivers.
L3500 Ear caps; pair\$.50



Series Parallel Switch
Quick change from one circuit to another. Black composition knob, nickel plated fittings. Blade radius 1 1/4".
L2950 Series parallel switch\$.25



Melotone Loud Speaker
Best popular loud speaker. Fibre horn, heavy metal base, 5-ft. cord. Nickel roose neck. Greatest tuned (adjustable) talker. Horn length 1 1/2", bell 6 5/8", total height 9".
L255 Melotone Speaker\$4.75



Nickel Lugs
All lugs are nicked.
L310 Brass Lugs for No. 8 screw, doz.\$1.10
L311 Copper Lugs for Nos. 6 and 8 screws, dozen\$1.10
L309 Copper Lugs for Nos. 4, 6 and 8 screws, dozen\$1.10



Wood Cabinets
Highest grade mahogany cabinets made. Top is hinged. Made of 1/2" stock.
L710 Panel, 7x10",\$2.60
L712 Panel, 7x12", 3.00
L714 Panel, 7x14", 3.35
L718 Panel, 7x18", 3.60
L721 Panel, 7x21", 3.90
L724 Panel, 7x24", 4.40



Loop Aerial
Made entirely of well seasoned hard wood. Complete with all parts and base. Total height of loop 36". Can be put together by anyone in less than 5 minutes.
L2600 Two ft. loop aerial, complete\$1.15



Mica Diaphragms
Made of special India mica in two sizes, 2 1/2" diameter and 1-13/16" diameter. Cement iron washer in center for real results on your phones.
L2550 Diaphragm,\$.20
L2551 Diaphragm with 1-15/16"15



JUST OUT
The big "Rasco" catalogue No. 11. Contains all Armstrong circuits. Every up-to-date vacuum tube hook-up. Greatest little book printed. Free upon receipt of postal.

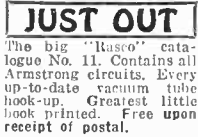

The Radiogem
The simplest radio outfit made. Includes all parts for tuning; coil, tapped switch, crystal, catwhisker.
L5353 Radiogem, no aerial or phone\$.75
L5354 Radiogem, with 1000 ohm phone and 3 ft. cord\$3.75

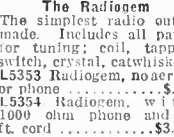

Three-Gang Socket
Aluminum shells, genuine heavy bakelite base, 3 brackets for mounting, 12 nickel binding posts. Length 7 1/4".
L5995 Three-gang socket\$1.75

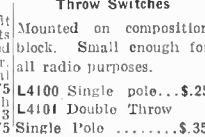

Cockaday Coil
Guaranteed best make. Three windings of No. 18 D C C Magnet wire. Has brass brackets for panel or base mounting. Results guaranteed or money back.
L2750 Cockaday coil.\$1.85



Neutralizing Condenser
Latest pattern. Genuine bakelite base. Fahnestock connectors, hard rubber composition knob, easiest to regulate. Size 5 1/2" long, 1" wide and 1" high.
L1202 Neutralizing condenser\$.40



Neuro-Transformer
Can be used for all neurodyne circuits, also for all tuned radio frequency circuits. Made for usual broadcast waves. Secondary has one center tap. Two genuine bakelite tubes. Two nickel mounting brackets.
L6969 Neuro-transformer\$1.70



Sponge-Rubber Cushions
Get rid of tube noises. Due to vibration. Softest sponge rubber made. Also used under cabinets to absorb shock and vibration. Size 2 1/2"x3", 3/8" thick.
L8989 Sponge-rubber cushions, each\$1.12

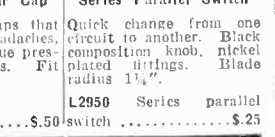

Dial Marker
The big little thing you have been waiting for. Just drill a hole in the panel and mount the marker above the dial. Very neat, nicely nickel plated and polished.
L7788 Dial Marker, each\$.05



Vacuum Tubes
Only best make tubes carried in stock. All tubes guaranteed to work or exchanged if filament lights.
L201A 5 v., 25 amp. \$3.75
L199 3 v., .06 amp. 3.75
L12 1 1/2 v., 25 amp. 3.75



Loop Aerial
Made entirely of well seasoned hard wood. Complete with all parts and base. Total height of loop 36". Can be put together by anyone in less than 5 minutes.
L2600 Two ft. loop aerial, complete\$1.15



Mica Diaphragms
Made of special India mica in two sizes, 2 1/2" diameter and 1-13/16" diameter. Cement iron washer in center for real results on your phones.
L2550 Diaphragm,\$.20
L2551 Diaphragm with 1-15/16"15



Nickel Screws
Made of brass, nickel plated. Flat and round head style. Any thread up to 10/32".
Price, 1/4", 3/8", 1/2" long, dozen\$.15
Price, sizes 3/4" and 1" long, dozen\$.30

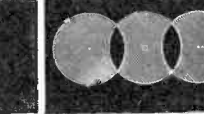

NEW! NEW!!
Push Pull Transformer for many new circuits. See any radio magazine. Made of best materials. Coils impregnated. Silicon steel laminations. Save 50 per cent by assembling yourself. Simple instructions furnished.
L1159 Transformer. Ratio 6 1/2" to 1.\$4.00

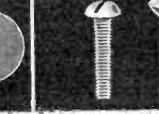

NEW! NEW!!
Push Pull Transformer for many new circuits. See any radio magazine. Made of best materials. Coils impregnated. Silicon steel laminations. Save 50 per cent by assembling yourself. Simple instructions furnished.
L1159 Transformer. Ratio 6 1/2" to 1.\$4.00



NEW THINGS FROM CATALOG No. 11

Dial Marker
The big little thing you have been waiting for. Just drill a hole in the panel and mount the marker above the dial. Very neat, nicely nickel plated and polished.
L7788 Dial Marker, each\$.05



Vacuum Tubes
Only best make tubes carried in stock. All tubes guaranteed to work or exchanged if filament lights.
L201A 5 v., 25 amp. \$3.75
L199 3 v., .06 amp. 3.75
L12 1 1/2 v., 25 amp. 3.75



Three-Gang Socket
Aluminum shells, genuine heavy bakelite base, 3 brackets for mounting, 12 nickel binding posts. Length 7 1/4".
L5995 Three-gang socket\$1.75



Cockaday Coil
Guaranteed best make. Three windings of No. 18 D C C Magnet wire. Has brass brackets for panel or base mounting. Results guaranteed or money back.
L2750 Cockaday coil.\$1.85



Neutralizing Condenser
Latest pattern. Genuine bakelite base. Fahnestock connectors, hard rubber composition knob, easiest to regulate. Size 5 1/2" long, 1" wide and 1" high.
L1202 Neutralizing condenser\$.40



Neuro-Transformer
Can be used for all neurodyne circuits, also for all tuned radio frequency circuits. Made for usual broadcast waves. Secondary has one center tap. Two genuine bakelite tubes. Two nickel mounting brackets.
L6969 Neuro-transformer\$1.70

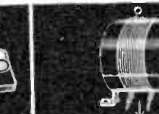

Sponge-Rubber Cushions
Get rid of tube noises. Due to vibration. Softest sponge rubber made. Also used under cabinets to absorb shock and vibration. Size 2 1/2"x3", 3/8" thick.
L8989 Sponge-rubber cushions, each\$1.12



RADIO SPECIALTY CO., 100 Park Place, New York City
Factories Brooklyn, N. Y. Elkridge, Md.

Learn Electricity

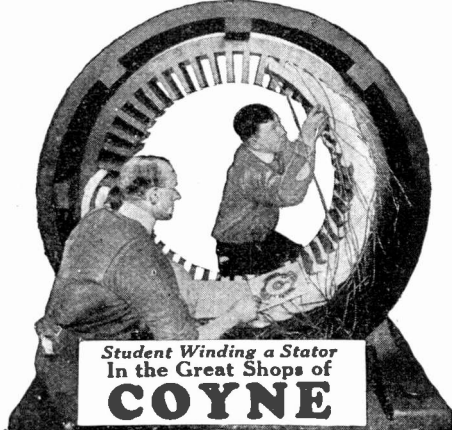

Earn \$250 to \$600 a Month!
New Enlarged Course

You work on motors, generators, house wiring, autos, batteries, radio, switch-boards, power-plants—everything to make you an expert ready to step right into a position paying from \$65 to \$150 a week. You get a complete practical training in Circuits, House wiring, D. C., A. C., Armature and Stator Winding, Drafting, Auto, Truck and Tractor Electricity, Battery Building and Repairing, and Radio. Everything to make you a thoroughly trained Electrical Expert.

Chicago
The Electrical Center of the World

The whole world of electricity is open to the Coyne trained Electrical Expert. Come to Chicago—the Electrical Center of the World. We pay your fare. Get your training at Coyne—the oldest, largest and best school of practical electricity in the country—the only school endorsed by Electrical Industry. Coyne trains you in all branches of electricity. We do not offer a number of individual courses—we give you just one Complete course so that you will be an *Electrical Expert* capable of commanding big pay. Let ordinary electricians do the small jobs. You can become an *Expert* and get the big money in any branch of electricity if you seize this chance to come to Coyne. Opportunities for *Experts* are unlimited. Get started now.

Learn in 3 Months

No books or useless theory. Not a correspondence school. You are trained on the greatest outfit of electrical apparatus of any institution in the country. We give you FREE complete Radio and Automotive courses. We also give you FREE a life Membership which enables you to stay longer if you want or to come back at any time and take up any new work which is constantly being installed to keep our school the most modern at all times.

Earn While You Learn!

We help students to secure jobs to earn a good part of their living expenses while studying.

Send Coupon Now

Don't delay a minute—send that coupon right now for our big free catalog and full particulars of special offer. Act now!

Free R. R. Fare to Chicago

Come to Chicago—the country's greatest summer resort city—and be ready for BIG MONEY in the fall!

COYNE
Electrical School

Endorsed by Electrical Industry

1200-1310 W. Harrison St., Dept. 53-3B Chicago

Coyne Electrical School, Dept. 53-3B
1300-1310 W. Harrison St., Chicago

Dear Sir: Please send me free your big catalog and full particulars of your special offer.

Name

Address

The Man on the Meteor

(Continued from page 294)

We knew all this; but we could do nothing about it. There was no police force, or army, or anything of the kind in this crude Marinoid civilization. Soon the King would organize an army—we were planning to do that almost at once—as soon as the final preparations in the cavern were complete. And meanwhile the King wished to do nothing that might precipitate further trouble with the half-breeds. An internal revolt, on the eve of foreign warfare—that was what we most dreaded.

It was at this juncture that some of the King's councillors suggested a public celebration, such as was always held at the birth of a child to the royal family, or on other festive national occasions.

A celebration! When we were at the brink of war! To me, it was a mistake. It could do nothing but humiliate—antagonize—the half-breeds. They could not take open part in it; the Marinoids would not permit that. Yet, said the King, we had our own people to think of. There is a certain human quality of mind which turns to merry-making on the eve of danger. You on Earth have seen that in your own history. The Marinoid morale would be helped. To laugh, sing, shout, and make love—and then go to battle. That was what the people wished; and against my advice, the celebration was to be held.

Now, in Caan's house—where Boy was asleep with Caan's children—we were planning to go to the cube of water before the palace where the festival was to be held.

"Take me," cried Nona. "I want to go with you, my Nemo."

Never had my Nona seen public merry-making; the woman in her was very eager to go, to take part in it.

And I took her. With Caan, we started after that next meal; and Caan's woman stayed at home with Boy and her own children.

My last moment decision to take Nona seemed somewhat superfluous, for all that day she had been getting ready to go! Clothes! My Nona was as interested in them as any woman of your own Earth.

She had made every preparation, and soon she swam before us, laughing with excitement and delight. I gasped. For the first time, I saw her usually up-flowing hair bound down to her shapely head, coiled and braided, and with a garland of tiny marine flowers in it. A new, close-fitting suit, with a girdle. And anklets of dull green, which by contrast made her smooth skin shine like polished pink marble.

"You like me, my Nemo?" she laughed. And she eyed me sidewise through lowered lashes—as though I were not her mate, but only one who wished to be.

Like her? I did indeed. And looking back on it now from my withered old age, I can say that I have seen no sophisticated beauty here on your earthly beaches who can compare with my child-like Nona.

THE MERRYMAKING

Then we started. The streets—more brightly lighted than usual—were bedecked with flowers. The light slanting down through the water from overhead lent queer grotesque shadows to the figures swimming beneath them. The crowd was all moving toward the palace. Marinoid men and girls—gaudily dressed; the girls, I noticed, all more scantily robed than upon less festive occasions. In couples and little groups, they swam along. The water rang with the gay voices of the girls. A cart passed us—a sleigh driven by a swimming animal—the equipage of one of the King's advisers. But

its owner was not in it now. It was loaded with Marinoid girls; as they swept past, one of them leaned out and tossed a garland of seaweed over my head, laughing at me provocatively.

We three—Caan, Nona and I—swam slowly onward. The eve of warfare! No one would have believed it who swam the gay streets of Rax that night! And yet—a figure lurked here and there. The Marinoid half-breeds! From doorways of houses dark, with the shades all closed, from roof-tops, tangles of street vegetation, they hovered, motionless. Or swam furtively, close along the walls of cross-streets.

I could feel their eyes upon me. At one corner we passed a giant half-breed man. He stood on the street-bottom, motionless, and he did not move to make way for us. I passed quite close to him; and I could sense that his figure stiffened, tensed. I looked back. . . . He was staring after me, grim, inscrutable, sinister.

"Nona," I said softly. "May the great God of the Marinoids be with us tonight!"

But my Nona was too excited, too flushed with pleasure, to share such solemn thoughts. We swam on, close behind Caan. . . .

The palace, and the water before it, were jammed. Glaring green water. Lights everywhere. Crowds of gaudy figures. . . . Laughing girls, alert to their sex. . . . Confusion . . . gayety everywhere. . . .

I followed Caan, keeping Nona close beside me. On the palace roof we came to rest, near a sort of throne erected at the parapet—a throne on which the King and Queen were sitting.

Atar joined us. "Will you eat now? Food is there waiting."

He smiled at my Nona, kneeling before her. And she bent down and touched his head with her cheek, Marinoid fashion.

We did not care to eat; across the palace roof I could see servants of the King handing out food to all who approached.

At the edge of the parapet, with the King and Queen above us, and Atar gallantly at Nona's side, we sat down to watch.

There was music in the water! I looked about for its source. At first I did not know what it was; how should I—since I had never heard music before? It came from a platform that dangled from the foliage overhead. On the platform were a dozen Marinoid men. Three or four plucked at thin, vibrating lengths of fish-bone, which gave off curiously twanging, but not unmusical notes. The rest pounded shells of different sizes—thumped them with resilient little hammers in odd rhythm.

MUSIC AND SPORTS

An orchestra! Perhaps you could call it that. They played it with enthusiasm, and almost continuously. On the platform also were three Marinoid girls. One of them, waving a long, filmy robe about her, was twisting her body in the music's rhythm; when she tired, the other girls took her place. And their voices, singing, joined the music.

Nona and I watched, breathless, confused, but like children at your circus, eager to see everything which simultaneously was going on.

Presently, several young men swam to different parts of the arena, and clung to the foliage. A young girl—one of the Marinoid beauties—swam to the center of the open water. She hung poised; and as the music suddenly stopped, she unbound her coiled hair and dropped the garland of sea-

(Continued on page 298)



Radio Jazz:

Irresistible foxtrot. One of the prize winners of RADIO NEWS Broadcast contest! Young feet dance—old feet tap time, to the fascinating melody of this real masterpiece of jazz.

Radio March:

Another Prize Winner of RADIO NEWS Broadcast contest. Here, music lovers, is a wonderful number! Is there anything so appealing as the stirring strains of a military march?

Listen In:

Featured in RADIO NEWS Broadcast contest, has caught the fancy of all America! Its rare swing hypnotizes—and its tuneful melody makes it simply irresistible.

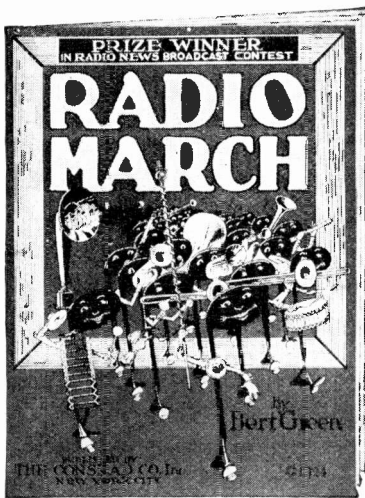

RADIO HITS!

In a recent nation-wide Musical Radio Contest three compositions were selected from the hundreds of Manuscripts submitted as prize winners. These numbers have now been published in the conventional form so that Radio Music Lovers and also Music Lovers everywhere can enjoy these distinctly new hits in Popular Music.

These prize Radio Hits will be a sensation in your dance folio. They offer you the opportunity of buying three fine melodies at the same time each better than the other. It were as if you had picked the choice numbers out of hundreds of songs at your dealer.

These Radio Song and Dance hits are exclusively Radio—To and for the Radio Public. They are being Broadcast from your local Broadcasting station. Listen in for them. Your local Radio Dealer will have copies for you. Look them over the next time you visit him or write us direct for your copies.



Published and Distributed by

The Consrad Company, Inc.
233 Fulton Street, New York City

35c
THE COPY
—
AT ALL
RELIABLE
DEALERS

Consrad

RADIO'S FOREMOST PUBLISHERS

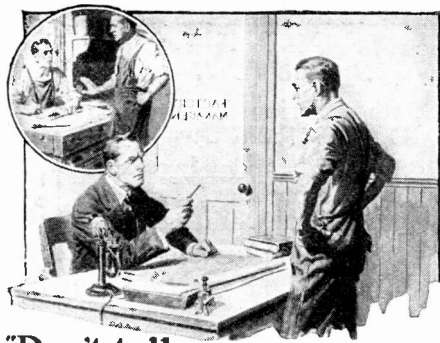

“Don't tell me you never had a chance!”

“Four years ago you and I worked at the same bench. I realized that to get ahead I needed special training, and decided to let the International Correspondence Schools help me. I wanted you to do the same, but you said, ‘Aw, forget it!’ You had the same chance I had, but you turned it down. No, Jim, you can't expect more money until you've trained yourself to handle bigger work.”

There are lots of “Jims” in the world—in stores, factories, offices, everywhere. Are you one of them? Wake up! Every time you see an I. C. S. coupon your chance is staring you in the face. Don't turn it down.

Right now over 180,000 men and women are preparing themselves for bigger jobs and better pay through I. C. S. courses.

You can join them and get in line for promotion. Mark and mail this coupon, and find out how.

INTERNATIONAL CORRESPONDENCE SCHOOLS Box 6244-C Scranton, Penna.

Without cost or obligation on my part, please tell me how I can qualify for the position or in the subject before which I have marked an X:

BUSINESS TRAINING COURSES

- | | |
|---|---|
| <input type="checkbox"/> Business Management | <input type="checkbox"/> Salesmanship |
| <input type="checkbox"/> Industrial Management | <input type="checkbox"/> Advertising |
| <input type="checkbox"/> Personnel Organization | <input type="checkbox"/> Better Letters |
| <input type="checkbox"/> Traffic Management | <input type="checkbox"/> Show Card Lettering |
| <input type="checkbox"/> Business Law | <input type="checkbox"/> Stenography and Typing |
| <input type="checkbox"/> Banking and Banking Law | <input type="checkbox"/> Business English |
| <input type="checkbox"/> Accountancy (including C.P.A.) | <input type="checkbox"/> Civil Service |
| <input type="checkbox"/> Nicholson Cost Accounting | <input type="checkbox"/> Railway Mail Clerk |
| <input type="checkbox"/> Bookkeeping | <input type="checkbox"/> Common School Subjects |
| <input type="checkbox"/> Private Secretary | <input type="checkbox"/> High School Subjects |
| <input type="checkbox"/> Spanish | <input type="checkbox"/> Illustrating |
| <input type="checkbox"/> French | |

TECHNICAL AND INDUSTRIAL COURSES

- | | |
|---|--|
| <input type="checkbox"/> Electrical Engineering | <input type="checkbox"/> Architect |
| <input type="checkbox"/> Electric Lighting | <input type="checkbox"/> Architects' Blue Prints |
| <input type="checkbox"/> Mechanical Engineer | <input type="checkbox"/> Contractor and Builder |
| <input type="checkbox"/> Mechanical Draftsman | <input type="checkbox"/> Architectural Draftsman |
| <input type="checkbox"/> Machine Shop Practice | <input type="checkbox"/> Concrete Builder |
| <input type="checkbox"/> Railroad Positions | <input type="checkbox"/> Structural Engineer |
| <input type="checkbox"/> Gas Engine Operating | <input type="checkbox"/> Chemistry |
| <input type="checkbox"/> Civil Engineer | <input type="checkbox"/> Pharmacy |
| <input type="checkbox"/> Surveying and Mapping | <input type="checkbox"/> Automobile Work |
| <input type="checkbox"/> Metallurgy | <input type="checkbox"/> Airplane Engines |
| <input type="checkbox"/> Mining | <input type="checkbox"/> Agriculture and Poultry |
| <input type="checkbox"/> Steam Engineering | <input type="checkbox"/> Mathematics |
| <input type="checkbox"/> Radio | |

Name.....
 Street..... 3-6-24
 Address.....
 City..... State.....

Occupation.....
 Persons residing in Canada should send this coupon to the International Correspondence Schools Canadian, Limited, Montreal, Canada

Write FOR BOOK ABOUT Elto

3 H.P.—The Fastest “Light Twin”
 Designed and Built by Ole Evinsrud
 Weighs less than 17 lbs., per h. p.
 Gives half more power, much more speed, yet easy to carry. Instant starting without spinning. Safe rudder steering. Trouble proof carburetor. Push button reverse, without danger of tipping boat. The ideal family motor. Fits carrying case without taking apart. Write for catalog.
ELTO OUTBOARD MOTOR COMPANY
 Manufacturers' Home Bldg., Dept. 48 Milwaukee, Wis.



The Man on the Meteor

(Continued from page 296)

weed which had been adorning it. The garland drifted downward. The girl uttered a sudden sharp command. At the signal, the young men dove for the prize. A sharp scuffle. . . . Then one, quicker, more fortunate than the rest, secured the garland and amid applause from the onlookers, swam up and restored it to the girl. Her embrace thanked him. With tenderly lingering fingers he bound up her tresses and adorned them with the garland; and together they swam off to the roof-top to eat, or to sit down and watch the performance repeated by others.

In another section of the water, the couples thus chosen were dancing. I can call it nothing else—swimming in close embrace in time to the music.

And there were other games, the details of which I could not grasp. Combats between young men—bloodless, but real enough for all that—with the maiden's favor always as the prize. Nona and I sat enthralled. I was disappointed in my Nona. She wanted to join in the games! But I would not let her, of course.

We were getting hungry. I turned to find that Atar was no longer with us. On the throne behind us the King was adorning a Marinoid girl just chosen as the most beautiful. But where was Atar?

A group of girls and a gay young man came swimming up and impertuned the King. He listened to them, and then signed for Nona and me to approach.

“Nemo,” he said. “They wish your Nona for the swimming and diving exhibitions.”

I did not know what he meant at once; but Nona seemed to understand.

“Nemo! Let me do it! Please!” Her eagerness was child-like.

And then abruptly Atar dashed up. He whispered to the King. Then he turned to me.

“Nemo, come!” Nona was still begging me.

“Let her do it,” said Atar. “We will be back shortly.”

“You will stay near her?” I said to Caan. I could not leave Nona again uncared for.

Caan nodded; and Atar pulled me away.

We swam from the gay, noisy scene—up a dim cross-street which was silent and deserted. Atar had not spoken.

“What is it?” I demanded.

THE MARINOGS LEAVE

“The half-breeds!” He increased his pace. Soon we were at the roof of the city; open water stretched above us. From the cross-streets at the side of the city, figures were issuing—the figures of men, women and children. They came out into the open water furtively, and mounted at once. Little groups, mounting upward to gather in a crowd above the city. And then streaming off in a line single-file—a swimming line of figures which already extended out of sight into the dimness of the distant water.

The half-breeds—Marinogs—all the Maa-gog sympathizers—were leaving Rax! Rats leaving a sinking ship? Was it that? Or a gathering for action somewhere else? The Water of Wild Things lay in that direction. Were they going there? Or to Gahna—sister city to Rax? Gahna also lay that way.

We watched for a time, and then Atar led me back to the festival. I need not repeat our speculations. Our questions soon were to be answered.

We reached the roof-top. The swimming and diving exhibitions were in progress—Marinoid girls of beauty and grace, diving

from the overhead foliage down across the brilliantly lighted cube of water.

I saw hoops of woven weed being held in front of the palace—a dozen of them at intervals. And Nona was just then poised, ready for her dive. I held my breath, staring up to where her slim, pink-white figure stood gracefully on the wavering end of a huge, fan-like leaf high above me. A signal, shouted by the King. Down Nona came in a head-first dive. She hardly made a ripple as she passed through the water. Through one of the hoops she passed, then swimming zig-zag through other hoops, up and down, slowly turning over to pass a hoop feet first, then doubled up, spinning like a ball, and at last straightening out again, swimming up and finishing on tip-toe before the King, graceful as a swallow alighting.

My beautiful Nona! Even the Marinoids—strange as her mermaid beauty was to them—applauded her loudly. And the King smilingly touched her radiant cheek with his. My own cheeks burned with the pleasure of it, my pride in this girl of mine. Presently she was back at my side, and I was holding her close, while still they applauded.

Then other girls dove. Then we ate. And I, with Nona only, swam in time to the music. Gayety. The pleasure of the senses. And then like a thunder-clap came a woman's shrill cry of horror. The music was stilled; silence, strange, uncanny, after all that laughter, fell over the water. A little knot of people were approaching the King. I hurried there, found a Marinoid girl of Gahna—a girl with frail body torn and bleeding.

We laid her down; and to the King she gasped out her news. The half-breeds had risen into revolt. From Rax and all the other Marinoid cities, they had gone to Gahna. The city was in terror. Bloodshed. And the Marinoid girls who resisted the half-breeds were being killed!

The half-breed revolt! It had come!

V.

Once before, I had been to Gahna. It lay to one side, but fairly close to the entrance to the Water of Wild Things. Like Rax, it was built of marine vegetation—a narrow cylinder standing on end. There was a slight current to the water here. The city sustained upright by its air-pods overhead—nevertheless leaned to one side under pressure of the current. From a distance, it looked like your leaning tower of Pisa.

It was a beautiful city—less densely populated and more beautiful than Rax. Its exterior surfaces—its sides and top—were laid out in parks and gardens. Large houses, many-balconied, with ferns and flowers. And the entire top one broad public garden.

In the King's sleigh we went there now. The water between the two cities was deserted. We passed straggling figures coming from Gahna—broken, bleeding figures—Marinoid refugees escaping for their lives. They came on, swimming slowly, painfully. We passed a girl, floundering, then sinking, inert.

Ahead lay the dim distance. The water was pale green with its glowing, inherent light. Then it began tinting red. Atar gripped me, trembling with the horror of what we knew lay ahead; and the King urged his dolphin faster.

Then, Gahna! The outlines of the city loomed before us. A ring of hovering, predatory figures surrounded it! We could

(Continued on page 300)

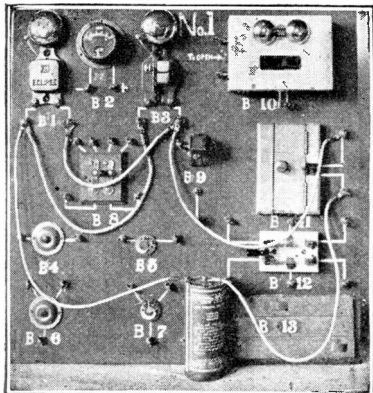

Illustrations show three of the series of electrical Home-Laboratory equipment furnished to every student. They are not just models, but

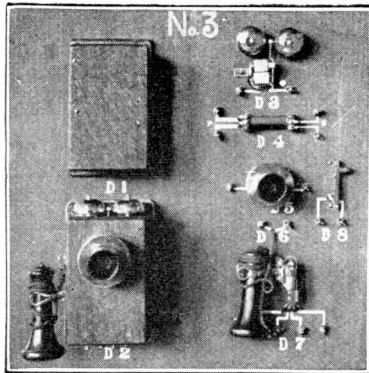

life-size, actual apparatus, the same as you meet in everyday work. Cost thousands of dollars to prepare, but sent free to students.

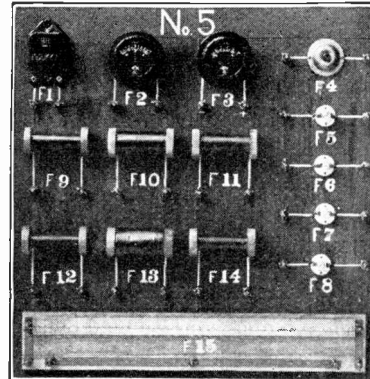

An Entirely New Way to Learn Electricity Right at Home

Fits You Quickly and Surely to Fill a \$3,000 to \$10,000 Job—No Other Training Just Like This—Don't Confuse with Other Home-Study Courses—You Do Not Pay for the Home Laboratories, They Are Furnished Free—Just Like Going to School.

Lectures by Radio Every Week

School of Engineering of Milwaukee owns and operates Radiophone Broadcasting Station WIAO, heard the country over. Each week, educational lectures are given by the President and other faculty members. These lectures are heard by our students everywhere and give personal contact with the school. You know what a big field is that of Electricity, the boundless opportunity it offers to ambitious men. Now, through this great school, you can accomplish your ambition, quickly and surely. You can, with this training behind you, hold your own with any expert anywhere.

You Do This NOW!

The gateway to certain success in the wonderful, boundless field of Electricity swings ajar for you. All you have to do is enter. The way to start is to clip and mail the coupon below. It will bring to you full proof of our claims. It will show you how within a few short weeks, you can become a full fledged expert, ready for a big-pay job.

Don't hesitate! Don't wait! Those that do are left behind! Act right now, while that impulse and ambition burns strong within you!

**EXTENSION DIVISION
SCHOOL OF ENGINEERING OF MILWAUKEE
Dept. H. 1202, 415 Marshall St., Milwaukee, Wisc.**

Extension Division, School of Engineering of Milwaukee,
Dept. H. 1202, 415 Marshall St., Milwaukee, Wisconsin.

Please send me quick and without cost or obligation on my part full particulars of your new Home Laboratory System of Teaching Electricity Right in My Own Home.

Name..... Age.....
Address.....
City..... State.....

This amazing new System of Training for success in Electricity was originated and produced by America's Greatest Institution for Electrical Education. For years, nineteen of them, we had trained boys and men from the world over, here in our great residence school to enter this big field on the right footing. We realized that many boys could not leave home to get an education, and therefore, after years of experiment and at a cost of many thousands of dollars, this special Extension Course was developed.

Only One Way to Learn Electricity Right

We knew that the only way to become an expert, a trained specialist, fitted to fill a big-pay job in the great field of Electricity, the student must have actual practice with life-size, actual electrical instruments, as well as the theory he might learn from books. And so, was born the idea of our Home Laboratory Unit System of Training. At the top of this page are shown three of the nine unit boards furnished to each student. They cost us thousands of dollars, but they are loaned to you, *absolutely free.*

No Other Home-Study Training Like This

No other home training system can be just like this, because behind this extension training is the largest Electrical School in America. You have as advisors some of the country's best known and highly regarded instructors in electricity. They are the authorities for the training and they are open to you for advice at all times. And, no other school of which we know furnishes, absolutely free, such expensive, complete equipment for *shop training.* No guess-work here—you learn by doing.

Makes good right from the start—Gives credit to this School

E. Pittsburgh, Pa., March 9, 1924.

Mr. F. C. Raeth,
Extension Director, Extension Division,
School of Engineering of Milwaukee.

Dear Sir:

In answer to your complimentary letter of March 5, 1924, I wish to thank you very much for the high standard you have accredited to my work in the Extension Course of the School of Engineering of Milwaukee. I might add that all through the course I have had no help because I wished to get the full benefit of the work by relying on my own efforts.

Before writing you my opinion of the course I decided to wait until I had nearly, or completely finished, so that I might give my opinion of the entire course. Having completed lesson 49 which finishes all of the theory and having completed most of the laboratory work, I am safe in saying that I believe your course to be the clearest, most practical and up-to-date course of its kind published. I have compared it with a number of other courses.

The outstanding feature of the course is the attention which you have given to details. Nothing is left to the imagination. A fellow can sit down and try to wade through a lot of text books and get a hazy conception of the subject he is studying, but it takes a course like yours with faculty of expert instructors—that is another important feature—it is not the knowledge of just one man, but of many which makes the course so much broader than a good many others.

After completing the course it becomes an easy matter to read most text books intelligently, for you have the fundamental knowledge and theory of electricity and can then supply whatever detail may be lacking in the text. This makes them very useful for reference.

At present I am plotting hysteresis curves of various kinds of magnet steel in the Standard House of the Westinghouse Electric & Mfg. Co. Will have an opportunity to get practical work in meter testing, electrical measurement, etc. This is where my S. of E. training will count a great deal.

On my diploma I should like my name appear: Henry De Witt Carrington.

Thanking you for the personal interest you have taken in me throughout the course and wishing you and your excellent home-study course the best of success,

Very sincerely yours,
DE WITT CARRINGTON.

DON'T STALL but go get that job Strongfortize!



STRONGFORT
The Perfect Man

YOU may have a go-getting brain, but you'll never get and hold a man-size job until you've developed a go-getting body too. In the business, mechanical and industrial world, just the same as in athletics, success is very largely a matter of muscle.

STOP FIGHTING!

If you just can't help fighting, then take a wallop at some mean looking stranger. Don't be always picking on yourself. Don't be always putting some obstacle between success and you. Stop bullying, despising and degrading the only body that you'll ever have.

The average employer will forgive a little wildness, but he never can forgive physical weakness in the men he hires. He knows that poor health spoils the morale of an organization and throws a monkey wrench into the efficiency machine. Keep on ailing and you'll keep on failing. A man is as good as the muscles on and in him—no stronger than his weakest part.

STRONGFORTISM, the science of health, strength and virility with scientific muscularity, produces great business and industrial leaders because it develops the full powers, mastery and rewards of complete manhood. STRONGFORTISM strengthens the heart, stimulates digestion and assimilation, ends constipation, makes good red blood and covers the body with a wicked coat of fighting muscles. Thousands of my pupils trace direct to STRONGFORTISM their triumphal progress from failure, futility and half-death to the supreme rewards of leadership in the world's work and utter happiness in family, social and sex life.

STRONGFORTISM IS CERTIFIED SUCCESS AND MANHOOD AND YOU'LL FIND IT SO. I'LL BE MORE THAN GLAD TO GIVE YOU THE BIG LIFT TO THE HIGH PLACES IF YOU'LL SHOW A KINDLY DISPOSITION TOWARD YOUR BEST OLD PAL—THAT'S YOU!

A Terribly Truthful Book FREE—

Years of my busy life have been spent in writing for you "Promotion and Conservation of Health, Strength and Mental Energy." It's a daringly frank exposé of the dangers and disasters, the glories and triumphs that surround every living human body every minute of the day. You'll call it the most astonishing body literature you ever read. No cost, not even postage. Just send the coupon NOW.

LIONEL STRONGFORT
Physical and Health Specialist for 25 Years
Dept. 1450 Newark, N. J., U.S.A.

CONSULTATION COUPON

----- Absolutely Confidential -----

LIONEL STRONGFORT,
Dept. 1450, Newark, N. J., U. S. A.
Send me, postpaid and without cost or obligation to me, your world-famous book of the body and its mysteries. IT MAY TELL ME SOMETHING STARTLING ABOUT ME.

Name

Address

The Man on the Meteor

(Continued from page 298)

see other figures launching themselves out from the streets, desperately; and the waiting figures surging upon them.

We halted our dolphin; and presently, still at a distance, we mounted over the city, to gaze down into its garden roof. A crowd of mermaids were huddled there—huddled in groups, trying to hide in the clumps of ferns.

But the half-breeds sought them out. Swords flashed silver, then red. Faint screams of agony floated up to us.

Slowly we passed over the city. A Marinoid girl clung to an air-pod. Three men, dead-white of flesh, saw her there. They dove at her . . . their arms entwined her, tore at her robe. Two of the men swam aside, laughing. The other persisted; and at the girl's resistance he suddenly drew a dagger and plunged it into her breast, furious because his comrades were laughing at him.

There was a balconied, terraced home. Through the red haze that now stained the water everywhere, we saw a man and woman and little child huddled in a corner of the roof. From a roof-doorway to the house below, a group of half-breed men appeared. They rushed at the Marinoid man . . . a

scuffle and the man lay dead. Two of the assailants dragged the woman away . . . she was fighting them, screaming with terror, and they cuffed her face to subdue her. . . . Two half-breeds were left with the child. One drew his sword, but the other held him back, producing from his robe a struggling white thing—a needle-fish. Then they tossed the child upward into the water, launched the fish at it. Through the child's soft body, the fish bored its way.

And everywhere it was the same. We swung upward, beyond sound of the screams. But the red in the water followed us. Figures were plunging from the city at every point; but few escaped the waiting ring of half-breeds. The water darkened with the blood that was added to it.

Slowly, sick at heart, we retraced our way to Rax. And then the crowning blow. Our guards at the entrance to the Water of Wild Things had been set upon and defeated. A few had escaped to bring the news. Og's Maagog army was advancing through the coral! With our preparations still incomplete, the Maagogs were striking!

The war had begun!

(To Be Continued)

Doctor Hackensaw's Secret's

By CLEMENT FEZANDIÉ

(Continued from page 251)

Not wishing to spoil the sport of her companions, Pep gave the animals a wide berth and circled around to see if she could spy the lions. She did not see them, but she spied something else—another camp of men, of whose proximity the doctor was unaware.

Curiosity prompted Pep to come nearer, at the risk of being shot at. She slowed up as she approached, but her presence was not noticed, for these men, too, were on a lion hunt and had just caught sight of several of the animals in a neighboring thicket, and were endeavoring to surround them.

And then Pep saw a sight that made her blood run cold. A large male lion was creeping unperceived behind one of the hunters who was kneeling by a tree, his eyes glued in the opposite direction. Before the startled girl could utter a single cry of warning, the lion had pounced on its prey as a cat pounces on a mouse, and carried him off in its jaws.

Pep almost fell from her horse at the sight, for she had seen that the man was a white man—some traveler or explorer in those wild regions. Pep had a rifle slung to her saddle, and two revolvers in her belt, but she dared not shoot, her aim from the flying horse being too uncertain. Reckless of all danger, Pep directed her course straight for the lion, and as she passed, clubbed him over the head with her rifle. The animal scarcely felt the blow, but he was startled and dropped his prey while he turned around to see what foe had assailed him. The sight of the flying horse, however, was not to his liking, so the beast turned and, picking up the senseless man again, made for a thick jungle.

But Pep was now desperate. She knew that if the beast once got into the tangled underbrush, she could do nothing. She must head him off at all costs. Pulling out her revolver, she first shot the lion in his hind-quarters, and then flying over his head, landed between him and the jungle, ready for a second shot.

Snarling with pain and rage, the lion once

more dropped his senseless burden and came at her with a roar of anger. Poor Pep was half frightened to death, but she was a girl of spirit and seeing she now had a good chance for a shot, she placed two bullets in the animal's head just as the infuriated animal made a leap for her horse. Down came horse, lion and rider in one heap, but luckily one of the shots had hit a vital spot. The beast gave one convulsive roll on the ground and died, while Pep fainted away.

Pep's shots had been heard, and when the rescuers arrived on the scene Pep was quickly revived and found to be unhurt except for a few bruises and scratches. As to the man whose life she had so miraculously saved, he had sustained no vital injuries, though his left arm was broken. He begged to be allowed to go with Doctor Hackensaw's party and Pep played the role of untrained nurse to the wounded man, who in return delighted her with the present of a lively young lion cub.

Poor Pegasus, the flying horse, had been put out of commission, so Pep had to ride a camel and was dreadfully sea-sick from the motion of the beast. She understood then that the term "ship of the desert," applied to the camel, is no mere metaphor.

But when Doctor Hackensaw playfully joked her about having gone out for a lion-hunt and captured a man, she replied seriously:

"No, doctor. I don't want to marry yet. I don't mind flirting a little—you used to scold me every day on the ship for flirting with the officers—but a husband isn't much fun. All I've captured on this trip is a fine lion's skin that will make a handsome rug!"

Doctor Hackensaw, himself, was not so fortunate. He returned to New York with his problem unsolved.

The Heavens in July

By ISABEL M. LEWIS, M.A.

(Continued from page 270)

cluster is about three hundred and fifty light years, and the distance between neighboring stars at the center of the cluster, where they are most closely packed together, is less than one-fifth of a light year or over one trillion miles. We have in our part of space nothing to match the glittering splendor of such a brilliant assemblage of suns.

Close to the star Alpha Herculis and a little to the east of it is the second-magnitude star, Alpha Ophiuchi, which marks the head of Ophiuchus the Serpent Bearer, who was reputed to be the son of Apollo and a great physician. So great was his power that it was said he could raise the dead, a fact which won the disapproval of Pluto, god of the lower regions, whose kingdom was fast becoming depopulated as a result of his skill, so he persuaded Jupiter to hurl a thunderbolt at Ophiuchus. Apollo intervened in behalf of his son, however, and as a result he was placed in the heavens where his healing powers would cause less trouble.

The head of Serpens, The Serpent, which Ophiuchus holds in his hands, is marked by a triangular-shaped group of three faint stars just south of Corona Borealis, The Northern Crown, which is now nearly overhead. From here we can trace the serpent southward in a line of faint stars, then eastward to and across the constellation of Ophiuchus to a point in the Milky Way where it turns to the northeastward. As neither Ophiuchus nor Serpens are particularly distinctive in form and contain no bright stars with the exception of Alpha Ophiuchi they are not as easily identified as some of the other groups.

The Milky Way is now coming conspicuously into view in the eastern part of the sky after lying so close to the horizon for several months that it has not been noticeable. The portion now visible is a continuation of the part visible in the western heavens in the winter months. It can be traced from Cassiopeia and Cepheus in the northeast to Cygnus, which is known familiarly as the Northern Cross and which lies directly in the path of the Milky Way. Here the Milky Way is divided sharply into two branches, which can easily be traced across the eastern heavens to the southern and southeastern horizon.

Nearly due south at this time we find the brilliant constellation of Scorpio, the Scorpion, which contains the fiery red first-magnitude star Antares, the heart of the Scorpion. The tail of the Scorpion extends in a brilliant line of stars, like the tail of a boy's kite, toward the southeastern horizon. According to the story, this was the creature that Apollo sent to sting Orion because of his presumption in falling in love with Diana, sister of Apollo. For this reason Orion disappears beneath the western horizon when Scorpio appears in the southeast. There is another story to the effect that Scorpio is the monster that caused the runaway of the steeds that drew the chariot of the sun, when Phaëthon undertook to drive them across the heavens against the wishes of his father Phoebus. Jupiter then punished the youth for his recklessness by hurling him into the Sky-River, Eridanus.

Antares is one of the super-giants of the heavens. Its diameter is estimated to be about four hundred million miles and its distance from the earth is about three hundred and fifty light years. It is attended by a small green companion star so close to the brighter star that it cannot be seen with a small telescope.

Not far to the northeast of Antares at this time we will find the huge Jupiter, largest planet of the solar system, and at present

(Continued on page 309)

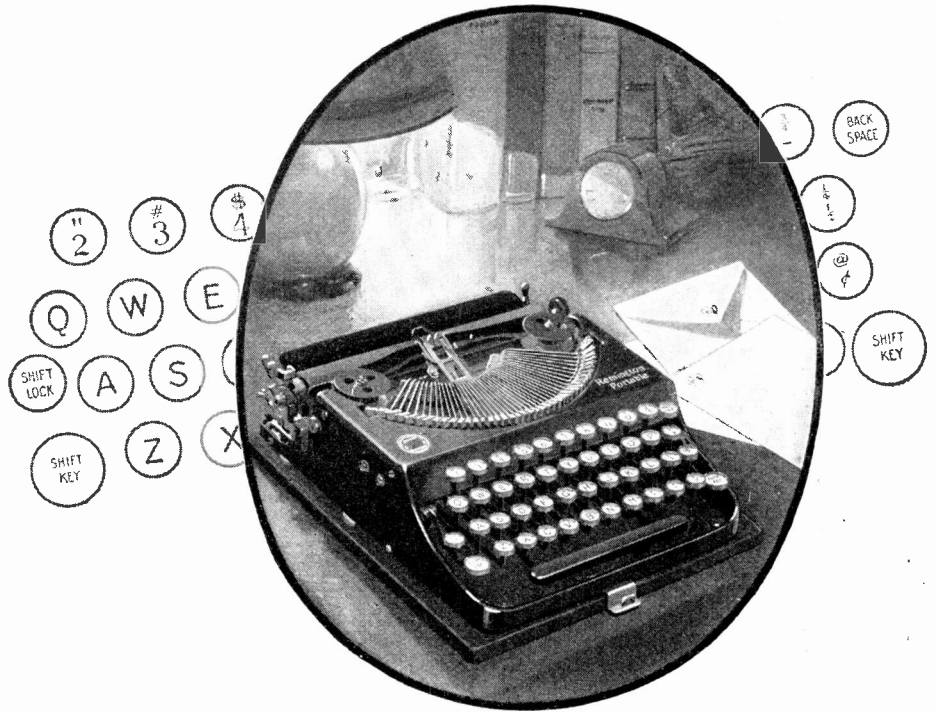

The complete keyboard makes writing easier

The Remington is *that* portable with the four-row keyboard (42 keys)—just like the big machines. No shifting for figures. Everything arranged according to the business standard. Simplest to learn and easiest to operate.

It is compact, light, and easily carried in a handy case. Then there is the baseboard already attached—that makes writing convenient in any place or position.

To countless people who write—much or little—the Remington Portable lends an indispensable aid.

Examine the Remington Portable. Sold by all Remington branches and dealers everywhere. A demonstration will prove to you its adaptability for all personal writing.

Convenient time payments, if desired. Let us send you "For You—For Everybody". Address Department 14.

We believe we make the best typewriter ribbon in the world, and its name is PARAGON

Remington Typewriter Company
374 Broadway, New York

Remington Typewriter Company of Canada, Limited;
Main Office, 68 King Street West, Toronto



REMINGTON PORTABLE

THE RECOGNIZED LEADER—IN SALES AND POPULARITY

U.S. PATENTS



SEND FOR THIS FORM

Don't Lose Your Rights

Before disclosing your invention to anyone send for blank form "Evidence of Conception" to be signed and witnessed. A sample form together with printed instructions will show you just how to work up your evidence and establish your rights before filing application for patent. As registered patent attorneys we represent hundreds of inventors all over the U. S. and Canada in the advancement of inventions. Our schedule of fees will be found reasonable. The form "Evidence of Conception" sample, instructions relating to obtaining of patent and schedule of fees sent upon request. Ask for them,—a post card will do.



255 OURAY BLDG.,
WASHINGTON, D. C.

"Originators of form Evidence of Conception"

PATENTS Patent Litigation
Trade Marks
Copyrights

Handbook of Instructions, "Inventive Knowledge"
Free on Request

R. H. FRAVEL, Patent Attorney
Formerly of the U. S. Patent Office Examining Corps
3533 McLachlen Bldg. Washington, D. C.

C. L. PARKER
Ex-Member Examining Corps, U. S. Patent Office
**Attorney-at-Law and
Solicitor of Patents**

American and Foreign Patents secured. Searches made to determine patentability, validity and infringement.
Pamphlet of Instructions sent upon request
MCGILL BUILDING WASHINGTON, D. C.

PATENTS
Trade-Marks, Copyrights and Patent Litigation
Write for advice and Instructions how to proceed, costs, etc.

Hand Book with Illustrations of 100 Mechanical Movements sent free on request.

ALBERT E. DIETERICH
Patent Lawyer and Solicitor
Successor to Fred G. Dieterich & Co.
602 OURAY BLDG. WASHINGTON, D. C.

PATENTS

BOOKLET FREE HIGHEST REFERENCES
PROMPTNESS ASSURED BEST RESULTS
Send drawing or model for examination and report as to patentability

WATSON E. COLEMAN, Patent Lawyer
644 G Street, N. W., Washington, D. C.

INVENTORS PROTECT YOUR IDEAS

Send for our Guide Book, **HOW TO GET A PATENT**, and Evidence of Invention Blank, sent Free on request. Tells our terms, methods, etc. Send model or sketch and description of your invention and we will give our opinion as to its patentable nature.

Name
Street
City

RANDOLPH & CO.
Dept. 172, WASHINGTON, D. C.



In this Department we publish such matter as is of interest to inventors and particularly to those who are in doubt as to certain Patent Phases. Regular inquiries addressed to "Patent Advice" cannot be answered by mail free of charge. Such inquiries are published here for the benefit of all readers. If the idea is thought to be of importance, we make it a rule not to divulge all details, in order to protect the inventor as far as it is possible to do so.

Should advice be desired by mail a nominal charge of \$1.00 is made for each question. Sketches and descriptions must be clear and explicit. Only one side of sheet should be written on. NOTE:—Before mailing your letter to this department, see to it that your name and address are upon the letter and envelope as well. Many letters are returned to us because either the name of the inquirer or his address is incorrectly given.
(NO QUERIES ANSWERED THIS MONTH DUE TO MR. MARSHALL'S ARTICLE).

Patents for Inventions

By CHARLES ORR MARSHALL

Patent Department, Toledo Scale Company, former Examiner, U. S. Patent Office

(CONCLUDED)

THE "MONEY CHANGERS" OF THE PATENT OFFICE

While the writer was employed as an examiner in the Patent Office a curious letter written to President Wilson by a fanatical inventor was forwarded from the White House to the Patent Office. The letter, after complaining about delay in obtaining the patent to which the inventor thought himself entitled, closed with this language:

"Down in the Patent Office stands a massive chair, all covered with cobwebs. No one has ever occupied it; no one occupies it now. It is the chair of truth, justice and honor. Oh, Mr. President, take the scourge and drive the money changers from the Patent Office."

This ridiculous epistle was a source of considerable amusement to the "money changers," who were at that time subsisting in one of the world's most expensive cities on munificent salaries of from \$125.00 to \$200.00 a month.

REQUIREMENTS OF PATENT EXAMINER

The examination for appointment to the Patent Office is probably the most difficult given by the Civil Service Commission, and, considering the meager salaries paid, the personnel of the examining corps is of very high order, most of the examiners being graduate engineers and many of them being law graduates as well. The duties performed by the examiners are comparable to those of a federal judge, and during all the years since the office was established only one case of dishonesty on the part of an examiner has occurred. Considering the nature and value of the matter handled by the office, this is a very remarkable record.

BONANZA PATENTS AND OTHERS

One of the most interesting of American inventions is the lock stitch sewing machine. About the year 1832 Walter Hunt, of New York, conceived the idea of placing the eye of a needle in the point so that the thread might be thrust through the cloth and caught by a shuttle operating on the other side. By changing the position

of the eye from the heel of the needle to the point he made it possible to do swiftly and easily by machine what had before required slow hand-work. The few machines that he built and tried out in New York and Baltimore exhibited, however, an exasperating defect. When the needle was thrust through the cloth the thread would frequently break at the eye. A few years later Elias Howe, Jr., overcame this trouble by providing the needle with grooves which extended upwardly from the eye along the sides of the needle so that when the needle was thrust through the cloth the thread would lie in the grooves and would not shear off. Howe obtained a patent which was later reissued with the following claim: "A grooved eye pointed needle constructed and adapted for rapid machine sewing, substantially as described."

This simple improvement was the inventive step which turned failure into success. It is found today in every domestic machine needle.

When Howe petitioned Congress for a second extension of his patent he admitted having received \$1,185,000 for his invention, but said that he considered it worth \$150,000,000. Had Hunt obtained a patent on his broader invention he might have participated in the profits that fell to Howe, but he neglected to make application until too late and, though he published bitter denunciation of Howe's claims, he failed to share either in Howe's fame or his pecuniary reward.

Many of the most valuable patents are characterized by extreme simplicity. The ball bearing patent No. 822,723, which is said to have brought some \$250,000 per year in royalties during the last years of its life, shows and claims only two grooved rings, a set of bearing balls, and a spacer. The Burton patent, No. 1,049,667, describing a simple process of cracking oils to increase the yield of gasoline and having only a single figure of drawings, is said to be valued by its owners at \$150,000,000. An award of approximately \$100,000 was made for infringement of the claims of patent No. 366,362,

(Continued on page 304)

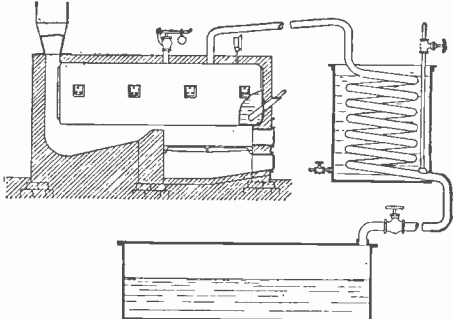

The Burton oil cracking patent. The original application contained only the drawing shown above. It is said that the owners value the patent at more than \$150,000,000.00 Patent No. 1,049,667.



EXPERIENCE **SERVICE**

CLARENCE A. O'BRIEN

PATENT ATTORNEY

REGISTERED IN UNITED STATES PATENT OFFICE
 MEMBER OF THE BAR OF
 SUPREME COURT OF UNITED STATES, COURT OF APPEALS DISTRICT OF COLUMBIA,
 SUPREME COURT DISTRICT OF COLUMBIA, UNITED STATES COURT OF CLAIMS.
 PRACTICE CONFINED TO PATENTS AND TRADE MARKS.



PATENTS

PROTECT YOUR IDEAS

ANY NEW article, machine, design or improvement thereof, or any new combination of parts or improvements in any known article which increases its efficiency or usefulness, *may be patented*, if it involves invention.



Drafting and Specification Room of Clarence A. O'Brien, Registered Patent Attorney, Washington, D. C.

IF YOU HAVE ANY NEW IDEAS

which you feel are useful, practical and novel, *take prompt action to protect your rights*. If you have invented any new machine, or new combination of parts of improvement, or any new design or process. **SEND DRAWING, MODEL OR DESCRIPTION** of it for information as to procedure to secure protection.

Write Today for Blank Form
"Record of Invention"

USE THE COUPON attached, and immediately upon its receipt I shall send you this form to be returned to me with drawing, description or model of your idea; promptly upon receiving your idea I shall write you fully as to procedure and costs.

No Charge for This Information

All communications are held in strict confidence. My personal, careful and thorough attention is given to each case. I offer you efficient, reliable and prompt service—based upon practical experience. *Highest references.*

WRITE TODAY for free book "How to Obtain a Patent." This book will give you valuable information, and it may save you much time and effort. *Send for it, NOW.*

My practice is devoted *exclusively* to United States and Foreign Patents and Trade Marks. Write me freely, frankly and with full confidence; it is very probable that I can help you. **Write TODAY.**

FREE COUPON

CLARENCE A. O'BRIEN, Registered Patent Attorney, WASHINGTON, D. C.
 534 Security Savings & Com'l Bk. Bldg., directly across street from U. S. Pat. Office.
 Please send me your free booklet, "How to Obtain a Patent" and blank form
 "Record of Invention" without any obligation on my part.

Name

Address

(IMPORTANT: WRITE OR PRINT NAME CLEARLY)



SCIENCE
INVENTION
INDUSTRY

ECONOMY
EFFICIENCY
INITIATIVE

PATENTS

TO THE MAN WITH AN IDEA

I offer a comprehensive, experienced, efficient service for his prompt, legal protection and the development of his proposition.

Send sketch, or model and description, for advice as to cost, search through prior United States patents, etc. Preliminary advice gladly furnished without charge.

My experience and familiarity with various arts frequently enable me to accurately advise clients as to probable patentability before they go to any expense.

Booklet of valuable information and form for properly disclosing your idea, free on request. Write today.

RICHARD B. OWEN, Patent Lawyer
164 Owen Building, Washington, D. C.
2276-8 Woolworth Bldg., New York City

PATENTS

Hand books on Patents, Trade Marks, etc., sent free. Our 78 years of experience, efficient service, and fair dealing assure fullest value and protection to the applicant. The Scientific American should be read by all inventors.

MUNN & CO.

618 Woolworth Building, New York

Scientific American Building, Washington, D. C.
Tower Bldg., Chicago, Ill.
Hubart Bldg., 582 Market St., San Francisco, Cal.
Van Nuys Building, Los Angeles, Cal.

PATENTS

As one of the oldest patent firms in America we give inventors at lowest consistent charge, a service noted for results, evidenced by many well known Patents of extraordinary value. *Book, Patent-Sense, Free.* Lacey & Lacey, 644 F St., Wash., D.C. Estab. 1869.

EARN MONEY AT HOME

YOU can earn \$1 to \$2 an hour in your spare time writing show cards. No canvassing or soliciting. We instruct you by our new simple Directograph System, supply you with work and pay you cash each week. Write today for full particulars and free booklet.

WEST-ANGUS SHOW CARD SERVICE LIMITED
Authorized Capital \$1,250,000.00
67 Colborne Building, Toronto, Can.

LEARN TO DRAW! \$295

Complete Course 24 Easy Lessons

Use your skill. Draw for pay or pleasure, for programs, newspapers, magazines, show-cards. One sale pays for course. **SOLD ON APPROVAL.** Send money order for \$2.95. Money back if not happy and pleased after 5 days progress.

National School of Caricature & Art
P. O. Box 1017—City Hall Station,
New York, Dept. SC.

5 Master Keys

Work like magic in emergencies or prove whether your door or padlocks are burglar-proof. Open and test thousands of different locks. Recommended by users in ten different nations. Most wonderful and only keys of their kind. Send \$1 today. Novel key chain FREE with set.

MASTER KEY CO., 78 West Water St., Milwaukee, Wis.

Insure your copy reaching you each month. Subscribe to Science and Invention—\$2.50 a year. Experimenter Publishing Co., 53 Park Place, N. Y. C.

Patents for Inventions

(Continued from page 302)

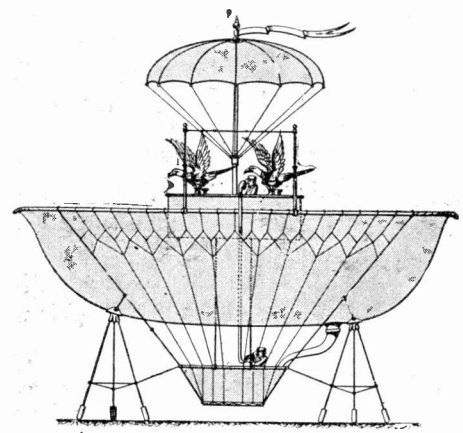

An early flying machine which contemplated using the power of birds, such as eagles or condors, to produce the power necessary to sustain and propel the machine.

covering merely the idea of leaving spaces in the cores of transformers to expedite cooling. The Supreme Court recently decreed the payment of half a million dollars on the following claim, covering merely the use of light material in an indicating cylinder for scales such as are used in grocery stores and meat markets.

"An indicator drum for weighing mechanism consisting of a spindle provided with a plurality of skeleton frames of light material and secured to said spindle, and having secured to their peripheries a sheet of paper forming a cylinder."

Scales with computing cylinders were old. All the inventor did was to make the cylinder light so that it would turn more easily.

The value of patents varies as greatly as the value of buildings. For every one that may compare in worth to a lower Manhattan office building there are a dozen or a score that are scarcely comparable to a dog house. Accurate valuation of a patent is impossible, and even approximate valuation is exceedingly difficult. Many corporations carry their patents at the nominal figure of one dollar. Others value their patents at an even figure, such as one million or five millions.

WHY SOME PATENTS ARE WORTHLESS

The reason for failure of a patent to bring pecuniary reward may be inherent in the patented device itself, or it may result from the circumstance that the invention is too far in advance of the march of progress, or it may be attributable to technical failure of the patent to protect the invention in its broad aspect, or to lack of commercial exploitation. No one who makes searches among the million and a half patents in the U. S. Patent Office can fail to be struck by the hundreds of ingenious and useful instruments that are apparently lying dormant awaiting only the enlivening breath of intelligent merchandising. The ball bearing patent spoken of elsewhere which brought such handsome royalties during the last years of its life, was such a patent. It lay unused for nearly ten years before effort was made to exploit

(Continued on page 306)

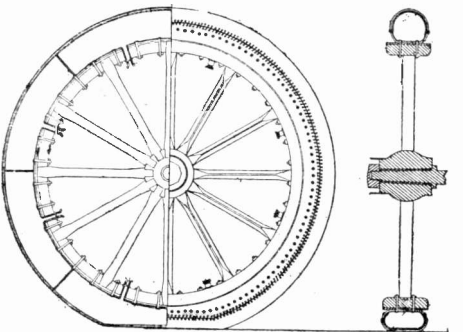

The patent illustrated in the above drawing was too far ahead of its time. It was originally taken out by Thompson in 1847. There being no great need for pneumatic tires at the time of the invention, little value accrued to the inventor. Note that the device contains all the modern tire principles, including inner tube, casing and valve.

YOU CAN LEARN NEWSPAPER WORK

Experienced Editor Will Teach You How to Become a Reporter

FASCINATING WORK--GOOD PAY

Only a Few Months' Work Required To Qualify You for a Better Position

Regular reporters earn from \$40 to \$125 a week. Good deskmen on a daily paper are paid from \$60 to \$100 a week. A "Star" Reporter can command his own salary. Hundreds of ambitious men and women enhance their income materially by corresponding for newspapers or writing for magazines in their spare time.

We Will Teach You at Home

We can develop your talent for writing and lead you into this well paying profession. Our Practical Course in Journalism was personally prepared by Henry J. Brockmeyer, for 13 years on the Editorial Staff of the N. Y. Evening Post. Mr. Brockmeyer has trained hundreds of men and women, many of whom have, under his guidance, developed into front rank reporters.

Mr. Brockmeyer's course will teach you what it would take years of actual newspaper work to learn. It consists of six comprehensive lessons just brimful of everything a reporter must learn. The following are only a few of the subjects covered.

Starting in Journalism. What is a Newspaper? What is News? Start and Finish of a News Story. Technical Terms. The Type Point System. Styles of Type, Proof Reading. Capitalization and Punctuation. A Late Fire Bulletin. Court Stories. Libel Laws, Copyright. Hints to Reporters. Personal Conduct. Re-Writing and Condensing Stories. Paragraphs and Short Items. Good and Bad Styles. Broadening the Vocabulary. Aids to Good Style. Special Stories. Suggestions for Stories. Rhetoric. Preparing Your Story. Don'ts for Writers. Office Organization. Syndicated Matter. Business Office. Mechanical Department. Hints for Headline Writers. The Make-Up. The Country Correspondent, etc., etc.

Use Coupon—Save 50%

Although the price for the entire course is \$10, entitling the students to full consulting services directed by Mr. Brockmeyer personally, we will accept enrollments, if the coupon below is used before August 20, at \$5—exactly half price.

Five Days' Trial

Just pin a check, money order or five dollar bill to the coupon below and mail. Then take five days after the course arrives to decide whether you want to keep it. If not, return it at our expense, and your money will be immediately refunded.

THE PRESS GUILD, Inc., 66-S West Broadway, N. Y.

THE PRESS GUILD, Inc. (Expires August 20, 1924)
66-S West Broadway, New York City.

Enclosed find \$5 for which you are to ship me at once, prepaid, Henry J. Brockmeyer's complete course in Practical Journalism with the distinct understanding that if I return the course in five days my full \$5 will be refunded and no questions asked.

(Name)

(Address)

(City)(State)

PATENTS TRADE-MARKS and COPYRIGHTS

OUR OFFER: No Charge for Examination and Instructions

VICTOR J. EVANS & CO.

PATENT ATTORNEYS

779 9TH ST., WASHINGTON, D. C.

Opposite

U. S. PATENT OFFICE

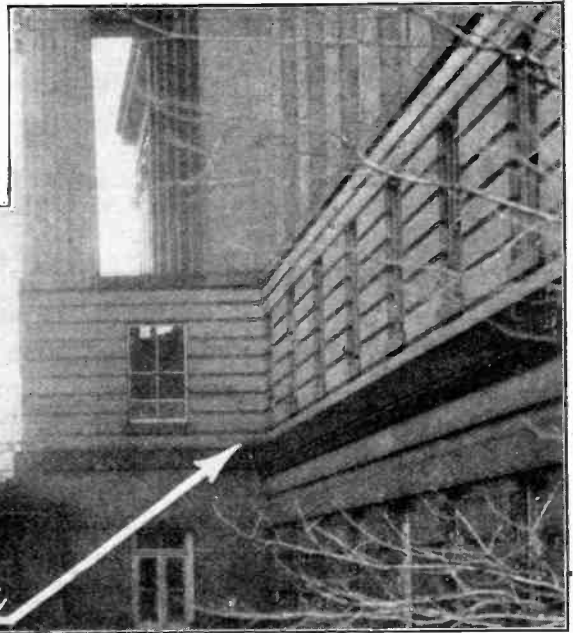

Have You An Idea?

Your First Step before disclosing an invention, the inventor should write for our blank form.

"Record of Invention"

This should be signed and witnessed and returned to us together with model or sketch and description of the invention for examination and instruction and to establish Evidence of Conception. *No charge for the above information.*

Our Three Books Mailed Free to Inventors

OUR ILLUSTRATED GUIDE BOOK How To Obtain a Patent

Contains full instructions regarding U. S. Patents. Our Methods, Terms, and 100 Mechanical Movements illustrated and described. Articles on Assignment or SALE OF PATENTS, Patent Practice and Procedure, and Law Points for inventors.

Our Trade Mark Book

Shows the value and necessity of Trade-Mark Protection and gives information regarding *Trade-Marks and unfair competition in trade.*

Our Foreign Book

We have Direct Agencies in all Foreign Countries. We secure Foreign Patents in shortest time and lowest cost.

Have Your Case Made Special

To avoid delay many inventors take the precaution of having their cases made Special. You should have your case made special in our office in order to save unnecessary correspondence and secure an early filing date in the Patent Office. In order to secure the special preparation of your case, you should send us \$25.00 with the model, sketch or description.

Our Organization Offers Personal Service

by registered and practical attorneys and draftsmen of long and varied experience, who will give your patent business special attention, the whole being under the supervision of Victor J. Evans.

Infringement and Interference Suits Prosecuted

All communications and data strictly confidential

We Regard a Satisfied Client as our best advertisement, and will furnish to anyone, upon request, lists of clients in any state for whom we have secured patents.

Highest References—Prompt Attention—Reasonable Terms

FREE COUPON

VICTOR J. EVANS & COMPANY

PATENT ATTORNEYS

NEW YORK OFFICES
1007 Woolworth Bldg.

CHICAGO OFFICES
1114 Tacoma Bldg.

PHILADELPHIA OFFICES
714-715 Liberty Bldg.

PITTSBURGH OFFICES
514 Empire Bldg.

SAN FRANCISCO OFFICES
Hobart Bldg.

MAIN OFFICES: 779 9th Street, N. W., WASHINGTON, D. C.

Gentlemen: Please send me *Free of Charge* your books as described on preceding page.

Name

Address

Link after Link

FRANKLIN plucked a zigzag of lightning out of the sky. Bell linked it with a bit of wire and gave the human voice more power than the thunder. Now scientists, discarding the wire, hurl one voice—undiminished—in countless radii across the world.

Each day the ingenuities of men are bettering, strengthening yesterday's progress. In foods, clothing, house-furnishings, inventions, minds are adding link to link—trying to lift you closer to contentment.

Records of this progress flash in advertisements before you. They are personal, timely messages of products that will please.

The advertisements suggest not only the new—but the best; spread them out honestly before you so that you can conveniently choose. They show you highest values at sensible cost. They help you to live better—and save.

Read the advertisements to learn of the latest ways you can make your life more pleasant.

Keep up with the advertisements
to keep apace with progress

Two Years' Engineering Course With Diploma and Degree

Civil Mechanical Electrical Chemical
Compact courses of essentials. Rich in higher mathematics, higher science and mechanical drawing; also shop and field work. Planned for those short in time and money, but strong in purpose. Courses distinguished alike for what is embraced and what is omitted. Adapted to

Engineers with Practical Experience desiring a Degree

No Entrance Examination or High School Diploma Required

Indispensable preliminary work provided for students with only elementary school education. Modern shops, Laboratories, Library, Apparatus and Machinery. If interested, be sure to write. Expenses low. For catalog address

TRI-STATE COLLEGE OF ENGINEERING, Box S-7 Angola, Ind.

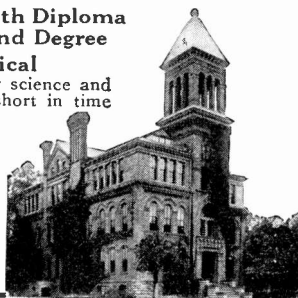

Insure your copy reaching you each month. Subscribe to Science and Invention—\$2.50 a year. Experimenter Publishing Co., 53 Park Place, N. Y. C.

Patents for Inventions

(Continued from page 304)

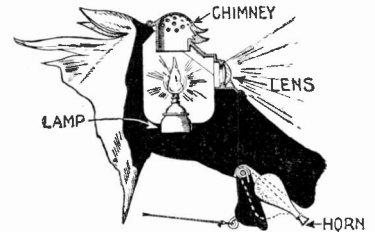
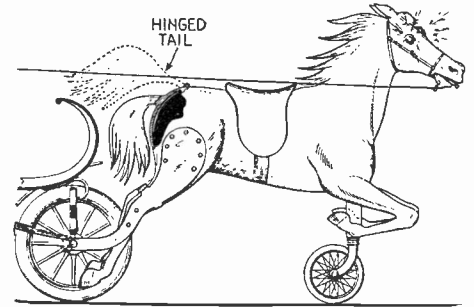

So that horses would not be frightened by automobiles in the early days, one inventor took out a patent comprising the above method of attaching a wooden horse in front of the car. Patent No. 777,369.

it. On the other hand, patents that are practically worthless *per se* are sometimes so exploited as to bring undeserved reward to the patentee. I know of a case in which the inventor of an ironing board obtained a patent with a single extremely limited claim, but, being densely ignorant so far as patents were concerned, he went through the middle west and collected over \$100,000 by the sale of county rights to his invention.

A patent that was too far ahead of its time was the pneumatic tire patent No. 5104, granted to Thompson in 1847 (see other page). Thompson, the real inventor of the pneumatic tire, realized nothing from his invention, while a patent for a minor improvement which was in force after pneumatic tires came into use brought more than a million dollars.

THE BIZARRE IN INVENTION

The Patent Office does not refuse a patent on an invention because the device is not, in the opinion of the examiner, a practicable one. If it is for a good purpose and if it will work, its utility is not further questioned, be it ever so clumsy or bizarre. The practice of the office is set forth in *ex parte* Cheesebrough (C. D. 1869, 18), in which the Commissioner said:

"Utility, in the eye of the patent law, refers rather to a utility of purpose than a utility of means. If the end which the inventor proposes to accomplish be useless, mischievous, frivolous, or immoral, he can obtain no patent, though the means which he proposes may be ingenious and for his purpose of great utility, as, for example, a burglar's tool. On the other hand, if the purpose be a good or useful one, the means need not be carefully scanned. If the means are inferior to the old way of doing the same thing or inferior to other new ways, the invention sinks into obscurity and is soon forgotten. The best test of utility is use; and in the busy competition of trade this test is soon applied, and the judgment of the inventor is affirmed or reversed by an inexorable tribunal.

The office can only see that the purpose proposed, if accomplished, would be useful, or that the plan does not show the absence of some part obviously essential. Beyond

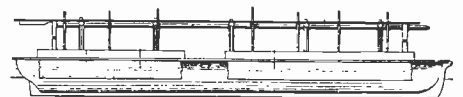

Abraham Lincoln's invention of 1849—patent No. 6469. He contemplated placing bellows along the sides of ships that might be filled with air, giving the vessel additional buoyancy to cross bars.

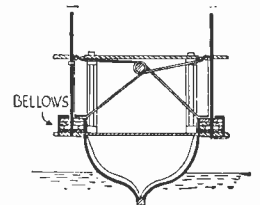

this it can only oppose the opinion of man to man—an opinion by which if all our great inventions have been tried when first presented to the office or the public, the great majority of them would have been strangled at birth by the unfriendly hand of adverse criticism."

This attitude on the part of the office sometimes results in the grant of patents for very queer inventions, as is evident from the illustrations on these pages. These are, however, only a few rare exceptions to the general rule that patents disclose very practical and prosaic structures.

An interesting case in which a patent was held not to be for a useful invention is the Twentieth Century Motor Car & Supply Co. vs. Holcomb Co., 220 Fed. 669. The patent was for a rain vision windshield in which the upper glass was swung forwardly to leave an opening through which the driver could view the road. I quote from the opinion:

"When the upper glass is swung into position away from the lower glass, the horizontal distance between them cannot exceed three inches. What the perpendicular distance through which the chauffeur must look in order to see the road would be is not stated, but manifestly it must be less than three inches. To rely upon such a narrow opening, through which to view the road ahead seems to us a highly dangerous expedient. When it is remembered that cars moving at the rate of twenty-five miles an hour, which is not generally considered excessive, are approaching each other at the rate of fifty miles an hour, it seems plain that if drivers relied upon these narrow perpendicular openings they would be in the jaws of collision before they knew of each other's approach."

There may be some doubt as to whether or not this finding of fact was right. The size of the opening that is necessary for adequate vision depends, of course, upon its distance from the eye of the driver. We know, for illustration, that a ball game may be viewed through a knot hole in a fence.

ABRAHAM LINCOLN'S PATENT

The brightest minds are often unable to foresee the extent to which an invention may prove useful. This is well illustrated by patent No. 6469, granted to Abraham Lincoln in 1849. Lincoln's invention involved the idea of equipping vessels with large bellows extending along each side and with apparatus arranged to open the bellows and push them down into the water so that the ship might be floated over sand bars. Though Lincoln's invention never brought him any return, he continued to be a staunch champion of the patent system. At the dedication of the library in Springfield some ten years after the patent issued, Lincoln said that there were certain things in the history of the race that were of pre-eminent consequence because of the extent to which they permeated civilization and directed its course, and he named as three examples: the discovery of America, the invention of printing, and the establishment of our patent system.

"PERPETUAL MOTION" PATENTS

The Patent Office will not issue a patent for a device that is inoperative. The drawing must show a machine that will work. For many years the office refused to issue patents for heavier than air flying machines, on the ground that such devices could not be made to work. It is said that in one case a patent was issued after the attorney had added to the drawing a rope which extended from the machine upwardly and added to the description the statement that the rope was intended to be attached to a balloon.

Patents are refused in cases where the invention is a perpetual motion device. In the class of vehicles, which I examined while I was a member of the examining corps, many applications are received which purport to provide a way in which the weight of the vehicle may assist in propelling it over the ground. Most of the inventors of such devices admit that the vehicle will not run about with no other means of propulsion than its own weight, but they insist that their mechanism causes the weight to help, the idea being that less fuel will be required with their devices than without, and in most such cases the inventor believes that if he were to get stuck in a bad road he could just throw a few big rocks into the machine and go ahead.

MODEL REQUIRED

When an application is filed involving a perpetual motion device the office offers to return the filing fee, and if the inventor insists on an examination he is required to furnish a working model. In response to such a requirement, an unkempt individual once appeared at my desk with a battered canvas telescope bag from which he produced a small wooden model incorporating a device intended to make a vehicle run by its own weight. The model had only two wheels, so that it was necessary for the inventor to place his hand upon it to keep it from falling over. He placed the device on the desk, pushing down with his hand—and lo! it moved forward. He then operated a trigger in the mechanism, pushing down upon it again, and it moved back. He was push-

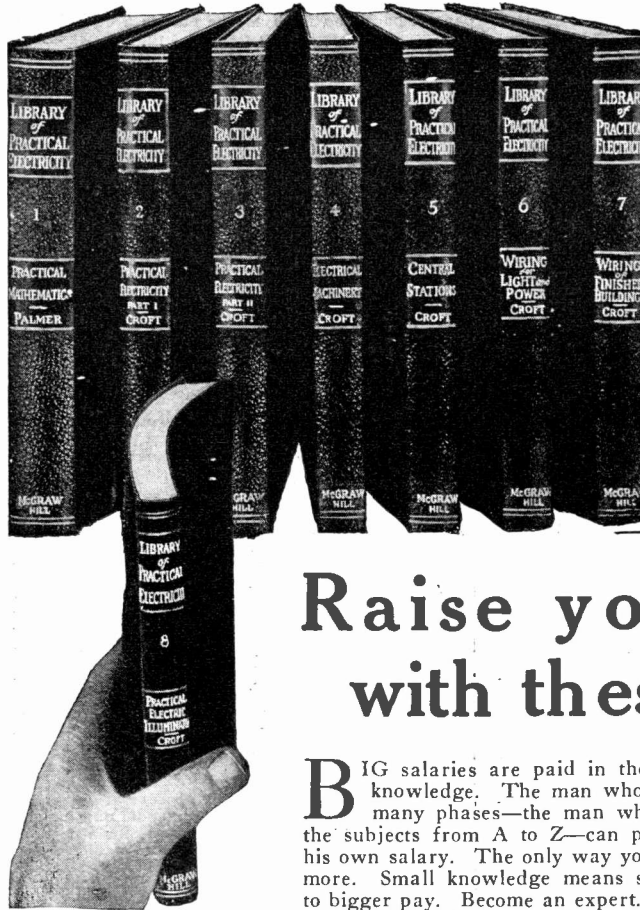

Now Only \$19.50

Recently we clipped \$8.00 off the price of this popular electrical library—made it \$19.50 instead of \$27.50. And more than that, we are offering the easiest terms we have ever made on the Croft books. You now pay \$1.50 in ten days and the balance at the rate of only \$2 a month. Think of getting this great Home Study Course and Reference Library at \$19.50—a saving of \$8.00! This is a real opportunity! No electrical worker who wants to fill a bigger job can afford to miss it.

You save \$8.00 and have 10 months to pay

Raise your pay with these books

BIG salaries are paid in the electrical field for expert knowledge. The man who knows electricity in all its many phases—the man who has completely mastered the subjects from A to Z—can pick his own job and name his own salary. The only way you can earn more is to learn more. Small knowledge means small pay. Learn the way to bigger pay. Become an expert. Croft will show you how.

Croft Library of Practical Electricity

8 volumes—3000 pages—2100 illustrations—flexible keratol

EVERYWHERE the Croft Library is acknowledged as the standard—the leader—in practical electrical training. In the Croft books you will find complete, detailed and up-to-the-minute information on all phases of electricity, motors, generators, armatures, commutators, transformers, circuits, currents, switchboards distribution systems—electrical machinery of every type—wiring for light and power—how to do it mechanically perfect, in accordance with the National Electrical Code—wiring of finished buildings—underwriters' and municipal requirements—how to do a complete wiring job, from estimating it, to completion—illumination in its every phase—the latest and most improved methods of lighting—lamps and lighting effects, etc.

Know electricity as experts know it and get an expert's pay

Fit yourself for a bigger position by knowing electrical practice complete—inside and outside work—central stations and the whole subject. Croft will teach you. He will take you in quick, easy steps from the simplest principles to the complete and economical operation of a great central station. The Croft-trained man wins because he knows the "why" and the "how" of modern electrical practice. Croft has been through the mill. His

knowledge has been gained by shirt-sleeves contact with electrical problems. He has worked his way up from the bottom to the top—from apprentice lineman to electrical engineer for one of the great electrical manufacturing companies. Now he heads his own consulting company, and his name is known in every corner of the electrical world. He is the one man above all others who can show you the way to permanent success.

EXAMINE THEM FREE!

We want you to test our statements—we want you to compare the Croft books with others. Fill in and mail the coupon attached and we will send you the entire set of eight volumes for ten days' Free Examination. We take all the risk—pay all charges. You assume no obligation—you pay nothing unless you decide to keep the books. Then \$1.50 in ten days and the balance at the rate of \$2 a month. Send the coupon NOW and see the books for yourself.

Send No Money—Just the coupon

Small Monthly Payments—No Money Down

FREE EXAMINATION COUPON

McGraw-Hill Book Co. Inc., 370 Seventh Ave., New York

Gentlemen:—Send me the LIBRARY OF PRACTICAL ELECTRICITY (shipping charges prepaid), for 10 days' free examination. If satisfactory, I will send \$1.50 in ten days and \$2 per month until the special price of \$19.50 has been paid. If not wanted, I will write you for return shipping instructions. (Write plainly and fill in all lines.)

Name

Home Address

City and State

Employed by

Occupation

S&I-7-24



Choose as Your Profession ELECTRICAL ENGINEERING

Electricity offers a brilliant future to the young man who is about to choose his career. Never before has there been such wonderful opportunity in this great field. Big paying positions in electrical

**B. S. Degree
In 3 Years**
work the world over are open to trained men — men who possess specialized, practical knowledge. Come to the School of Engineering of Milwaukee — the largest and best equipped electrical school in America. Here you are trained in both theory and practice by a faculty of experts. You learn in large, finely equipped laboratories. If you have 14 high school credits or equivalent, you can become an Electrical Engineer with a Bachelor of Science degree in 3 years. If you lack these credits they can be made up in our Institute of Electrotechnics in a short, intensive course.

Earn While You Learn
By our special system you may earn your way while learning. Our Employment Department will secure you a position to which you may devote a part of each day, spending the remainder at the school. This plan both solves the students' financial problems and provides splendid experience at the same time. Low tuition fee. Board and room reasonable. Daily Broadcasting W.I.A.O. School Orchestra. Fraternities.

Write for Free Catalog

Write today for our free, illustrated catalog. Read about this wonderful institution and the great opportunities that lie before you. Find out about our specialized method of training and the details of our "Earn While You Learn" plan.

SCHOOL of ENGINEERING of Milwaukee

Dept. E-1402, 415 Marshall St., Milwaukee, Wis.

SCHOOL OF ENGINEERING OF MILWAUKEE.
Dept. E1402, 415 Marshall St., Milwaukee, Wis.

Please send me your free illustrated catalog on Electrical Engineering and give me the details of your "Earn While You Learn" plan.

Name
Address
Town State
Age Education

Get this Wonderful Book without cost



PROF. TITUS
As he is Today

It is written by the man who has trained many of the world's greatest strong men. It tells you how to develop

Vitality, Energy, Endurance,
Nerve Strength, Muscular
Strength, Perfect Physique.

My new 54-page book, "Building Better Bodies," is just off the press. It contains the kind of clearly written information you want, including 30 halftone illustrations of my pupils now among the professional ranks. It tells you, if you are weak or underdeveloped, how to grow strong; if strong, how to grow stronger. It explains how to develop the lungs and muscles—a strong heart and vigorous digestion—in short, how to improve health and strength internally as well as externally. If you will send me 10c in coin or stamps to help pay postage and wrapping, I will mail you a copy at once. Send TODAY—NOW.

Prof. H. W. Titus 105 E. 13th St., Dept. 510
New York City

— ONE THOUSAND AGENTS WANTED —
We want one thousand agents to sell subscriptions to RADIO NEWS, SCIENCE AND INVENTION, PRACTICAL ELECTRICS and the MOTOR CAMPER & TOURIST. We will pay a generous commission for this work and help you in every way. Our three publications are leaders in their fields, ready sellers and this is an offer well worth your while. A few spare hours a day will bring you a handsome return. Write regarding our proposition at once and be the first one to get started in your vicinity.
EXPERIMENTER PUBLISHING CO.
Herbert H. Foster, Sales Manager
53 Park Place New York

ing it back and forth as one pushes a ouija board. But when I ventured to suggest that he was moving it the way he wanted it to go, he became very angry and demanded to know why it wouldn't work. Never having seen the apparatus before, I was unable to explain why it wouldn't work, and he finally agreed to produce a four-wheeled model that could be operated by a dead weight. About a month later he appeared with the four-wheeled model and I placed a heavy weight on it with some misgivings. I was afraid that it might be in some sort of unstable equilibrium in which the weight would cause it to move a few inches, but when I placed the weight upon it it did not budge. The inventor exhibited the utmost astonishment. If he had ever tried the device out at all, it must have been standing on an incline when he tried it, so that it merely rolled down hill.

THE TYPE OF INVENTION MOST LIKELY TO BRING PECUNIARY REWARD

Many of the so-called revolutionary inventions were discoveries of means for accomplishing things that had never before been accomplished. In this class are photography (1829), the telegraph (1837), vulcanization of rubber (1839), the dynamo (1867), the telephone (1876), the phonograph (1877), the X-ray machine (1895), and the airplane (1905). Such inventions require so much development that they are unlikely to bring their creators great financial returns.

Among the famous inventions which provided means for doing an old thing in a new and better way were the air brake, the reaper, the sewing machine, the linotype, the carbon filament for incandescent lamps, and the McKay shoe sewing machine, all of which brought great pecuniary rewards. This type of invention—that is, a device for doing an old thing in a new and better way is in general more likely to bring wealth to the inventor. Most inventions are of this type. They are short cuts, and the ability to make such short cuts is the chief characteristic of the inventor. It is related that a young man with several university degrees and the best of recommendations applied to one of our most prolific inventors for a position as assistant. The inventor read the young man's recommendations and then handed him an old burned-out nitrogen-filled electric light bulb, saying: "Let's see if you can measure the volume of the gas in this bulb." Now, the interior of an electric light bulb has a very odd shape, and in addition there is a peculiarly shaped post which occupies a part of the space. The shape of the space, therefore, makes it very difficult to measure. The young man took the bulb away with him and worked on the problem for three days, using all the mathematics that he could bring to bear upon it. When he submitted his solution, the inventor said: "Let's see if you're right." He punched holes through the base of the bulb and filled the bulb with water, which he then poured into a measuring glass. The young man's answer was correct. He was a scientist, but he was not an inventor.

The ages at which famous inventors made their so-called revolutionary inventions make an interesting subject of study. Some of them are listed below:

Inventor	Age	Invention	Date
Perkin	18	Aniline Dye	1856
Marconi	21	Wireless	1896
Westinghouse	22	Air Brake	1868
McCormick	22	Reaper	1831
Howe	26	Sewing Machine	1845
Whitney	27	Cotton Gin	1792
Edison	27	Quadruplex Telegraph	1874
Watt	29	Steam Engine	1765
Edison	30	Phonograph	1877
Mergenthaler	30	First Linotype	1884
Stevenson	33	First Locomotive	1814
Nobel	34	Dynamite	1867
Wright (O.)	34	Airplane	1905
Wright (W.)	38	Airplane	1905
Goodyear	39	Vulcanization of Rubber	1839
Daguerre	40	Photography	1829
Morse	46	Telegraph	1837
Daimler	50	Gasoline Engine	1884
Roentgen	50	X-Ray Machine	1895
Siemens	51	Dynamo	1867
Harvey	67	Harveyized Steel	1891

PITFALLS

The Supreme Court has said that patent specifications and claims are the most difficult of all legal instruments to prepare. The litigation over the agitation froth process of ore concentration furnishes one of the best examples of the pitfalls which lie in the path of the claim draftsman. The patent related to a process for separating metalliferous matter from crushed ore. At the date of the patent it was old to mix oil with water and agitate the mixture with crushed ore so that the metalliferous particles would adhere to the oil and float to the top, leaving the gangue or waste matter in the bottom of the tank. This process required enough oil to float the metalliferous part of the ore, which was then drawn off from the surface of the mixture. The inventor of the frothing process discovered that by using a very small quantity of frothing oil and then by agitation, beating air into the mixture of oil, water and ore, the metalliferous matter would adhere to the oil and the oil would form a froth which would rise to the surface and carry the metal with it. The froth could then be

**Magnified
225 Diameters**
This is what the tip of a fly's leg is like when seen thru the

**Wonderful New
Ultralens
MICROSCOPE**

At last the high powered microscope is within the reach of all who wish to study, observe and experiment with the vast world of minute objects that are invisible to the naked eye. A remarkable discovery enables us to manufacture the Ultralens Microscope (magnifies 225 diameters) for one-eighth the usual cost.

\$7⁵⁰
for Complete Outfit, prepaid

EASY TO USE!
Any amateur can immediately start using his Ultralens to examine the edge of a razor, the mesh of a cotton shirt, the bacteria in dirty water. No technical training required, yet hundreds of scientists and teachers are using this instrument today. It is at once interesting, instructive, and scientific. Gives enormous magnification and perfect definition.

Compact
The Ultralens Microscope comes packed in a beautiful Bakelite case with full instructions that anyone who can read can understand. Lenses of 125 x and 325 x objectives can be furnished at \$1.50 each.

ORDER TODAY
Order direct from this advertisement and get your Ultralens Microscope now. Fully guaranteed. If, however, you desire more information before purchasing we will gladly send free descriptive catalog.

SCIENTIFIC APPARATUS CORP.
Dept. 203 MILTON, PA.

*A Good Time
all the
Time*

**If You
Own a
BUESCHER**

True
Tone **SAXOPHONE**

Here is the great joy maker of all musical instruments. Unequaled in beauty of tone; the favorite instrument in band or orchestra or for home, school, church or lodge entertainment.

EASY to Play—EASY to Pay

In one hour you can play the scale—in a few weeks play popular tunes and in 90 days take your place in band or orchestra. You may order any Buescher Saxophone, Cornet, Trumpet, Trombone, etc., without paying in advance and try it six days in your own home. If satisfied, you can pay for it on any of our terms to suit your convenience. Write today, mentioning the instrument you are interested in and we will send you at once Free Catalog and illustrated literature.

Buescher Band Instrument Co.
Everything in Band and Orchestra Instruments
6049 Buescher Block Elkhart, Ind.

Buescher Band Instrument Co.
6049 Buescher Block, Elkhart, Ind.

Gentlemen:

I am interested in the instrument checked below:
Saxophone... Cornet... Trombone... Trumpet...
(Mention any other instrument interested in)

Name

Street Address

Town State

removed from the surface and the metal recovered. The patented process, instead of relying upon the lesser specific gravity of the oil in bulk, relied upon the production of a froth which formed and contained a multitude of air cells, the buoyancy of which floated the adhering particles of metal to the surface of the liquid. Only a small quantity of oil was thus required, where comparatively great quantities had been required before. In fact, the process would not work unless the quantity of frothing oil were less than one-half of one per cent. The process was of immense value and was promptly adopted in all the principal mining countries of the world. In the Minerals Separation Ltd. case, 242 U. S. 261, the Supreme Court held the patent valid and infringed and the patentees claimed royalties amounting to millions of dollars. The claims of the patent which were sustained by the Supreme Court provided for carrying out the process "with oil and water containing a fraction of one per cent. of oil on the ore." The claim draftsman had been careful not to specify any particular kind of oil because he wanted the claims broad enough to cover any kind of oil, though pine oil and other frothing oils were the oils actually used in the process. After the Supreme Court had held the patent to be valid and infringed, the Butte & Superior Mining Co. began adding about one per cent of petroleum oil to the mixture containing less than one-half of one per cent. of frothing oil so that the mixture contained more than one per cent. of oil instead of a fraction of one per cent. as specified in the claim. The petroleum oil did not in any way affect the function of the frothing oil and did not itself function as frothing oil, so that its addition had about the same effect on the process as the addition of so much more water. Nevertheless, the Supreme Court held in the case of Minerals Separation vs. Butte & Superior Mining Co., 250 U. S. 336, that the patent was not infringed. If the claims had been "narrowed" by specifying the kind of oil employed, they could not have been thus easy to get around.

Truly, patent law is, as the Supreme Court has said, "the metaphysics of the law."



Want a ride to Big Pay? Come on Get into the AUTOMOTIVE GAME!

Earn \$75 to \$200 a Week

That's the money for you! And you can have it! Why not? The jobs are open—they're calling for trained men to fill them—all you need to walk off with a \$75 to \$200 a week job is **training**. Get it! Here's how:—Give us an hour a day, spare time, and we'll quickly put you across to big success in the Automotive Game. We've done it for hundreds of fellows just like you—men with perhaps less education, brains and ability. These fellows are holding down big money jobs—running their own business—making something out of themselves—**YOU** can do it too! For the sake of your dollars and cents future, send the coupon today, and find out just what we can do for you.

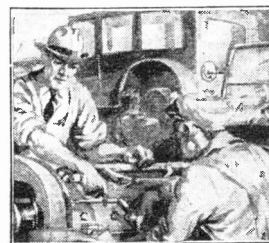

Automotive Expert



Garage Manager

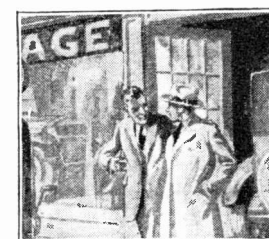

Garage Owner

Learn at Home From 20 Master Experts

Here's a course written not by one man, with the narrow, one-man viewpoint, but by 20 of the country's brainiest, most successful Automotive Experts. Fits you for a dozen big pay jobs. Shows how to start and build a successful business of your own. Learn it all at home, in spare time, under a money back guarantee of results and satisfaction.

WRITE! QUICK! Get Our FREE Auto Book

Get the facts on this great course. Read of the success of others. Learn how you too can easily earn \$3500 to \$10,000 a year. See why and how this course excels all others. Get our special free tuition offer and full information on EXTRA FEATURES found in no other school or course. Write today for big free book. No obligation whatever. Rush the coupon or a postal today.

American School

AB26 Automotive Division
Drexel Ave. and 58th St.
Chicago

© A. S. 1924



FREE Auto Book

American School

Dept. AB26 Chicago

Without a penny's expense or obligation please send me Free Book and all information on your Automotive Course.

Name.....

Address.....

Learn at Home to Boss the Job
EARN \$ 3500 to \$ 10000 a YEAR

The Heavens in July

(Continued from page 301)

the most brilliant object in the heavens. Venus, which has been such a magnificent object in the western evening sky all this winter and spring, comes into conjunction with the sun the first of July and by the end of the month will be seen in the east before sunrise. Saturn is also above the horizon now. It will be found over in the southwest a few degrees to the northeast of the white first-magnitude star Spica in Virgo. Saturn is yellowish in color and brighter than Spica though it is not a match for Arcturus to the north of it or Vega over in the northeast. These two are now the brightest stars in view though far inferior to the planet Jupiter in brightness.

Mars is not yet visible in the early evening. It is now in the constellation of Aquarius and will soon appear in the southeast. Its distance from the earth on July 1st is 49,760,000 miles, on the 15th its distance will be reduced to 43,310,000 miles and on the 31st to 37,780,000 miles. So more than a month before opposition, which occurs on August 21st, it will be as near the earth as it has been at many of its near oppositions. The brightness of Mars will increase very rapidly this month and by the end of July it will surpass Jupiter in brightness. From now on until the end of September will be the best time to view this mysterious little world which is so fascinating to us because of the possibility that some form of life may exist there.

WANTED!!! RADIO ARTICLES

WE want descriptions of new radio ideas which you have worked out in practice. Take photographs of the important parts and make pencil or pen and ink sketches of the hook-ups or mechanical details, et cetera. We are particularly desirous of obtaining new hook-ups and descriptions of single tube sets, reflex and other types which have proven satisfactory.—Editor.

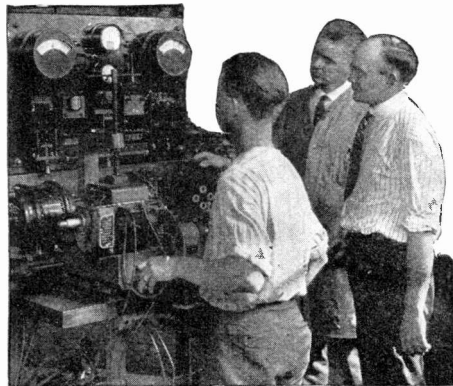

BECOME AN AUTOMOTIVE ELECTRICAL ENGINEER

A new calling of men who know the theory and practice of Electricity as it applies to the automobile. They are scientific experts who know all there is to know about automotive electrical equipment. They work with automobile and electrical equipment manufacturers in designing, making, installing, repairing and servicing automotive electrical devices of all types. Some work at factories, some travel as Service Supervisors, going about advising with dealers and distributors. Some are connected with large garages and service stations. It is a fascinating field of endeavors and commands large salaries. Some set up businesses of their own.

1 Year Intensive Training

To fill these big jobs, you must have training, the right kind of authoritative, specialized, practical training. Here you will be trained by nationally known experts whose skill and ability are widely recognized. Every step of this important subject is treated in the most thorough and intensive way. When you leave the school, you are fitted to start right into a big-pay job or set up a paying business of your own.

Automotive Electrician 3 Months' Training

A practical course in Starting, Lighting, Ignition and Storage Batteries. Fits man for good pay job in garage, service station or factory. Automotive Electricians are in demand everywhere and trained men are the only kind that are wanted. If you want a quick, but practical course, select this one.

SCHOOL OF AUTOMOTIVE ELECTRICITY INC.

Associated with the

SCHOOL OF ENGINEERING OF MILWAUKEE
Dept. A1302, 415 Marshall Street, Milwaukee, Wis.

FREE BOOK COUPON

SCHOOL OF AUTOMOTIVE ELECTRICITY, Inc.,
Dept. A1302, 415 Marshall Street, Milwaukee, Wis.
Please send me by return mail without obligation to me your book on Automotive Electricity. Am interested in courses checked below.
Automotive Electrical Engineer. Automotive Electrician.

Name..... Age.....
Address.....
City..... State.....
Education.....

YOU TOO CAN PLAY THE HAWAIIAN GUITAR JUST AS THE HAWAIIANS DO! PLAY ALL THE LATEST HITS

After your **FIRST LESSON** you will play a complete selection. We guarantee that—our method is so simple, interesting and appealing that you begin in your first lesson to learn the famous Hawaiian Folk Song "ALOHA". Think how happy you will be when you surprise your friends by playing the fascinating Hawaiian Guitar.

Only Four Motions— and You Master Them Quickly!

In a few minutes you acquire the four motions necessary to play any piece—after that a short period of practice and you will have mastered this weirdly sweet music. Complete course of 52 lessons includes FREE beautiful Hawaiian Guitar, necessary picks, steel bar, etc. No extras.

No Previous Musical Knowledge Necessary

If you never read a musical note in your life—if you haven't even the slightest knowledge of music, we can quickly and positively teach you to play this wonderfully popular instrument. Don't be just a "listener" when you can easily be the center of interest among your friends. Over 40,000 successful students.

Just Mail a Post Card for Details of our remarkable FREE Hawaiian Guitar Offer—simply write: "I am interested"—but do it today.

First Hawaiian Conservatory of Music, Inc.
Desk 40—223B Broadway (Woolworth Bldg.)
New York City



Motor Hints

Generator Troubles and Tests
BY TOM C. PLUMRIDGE
Automotive Expert

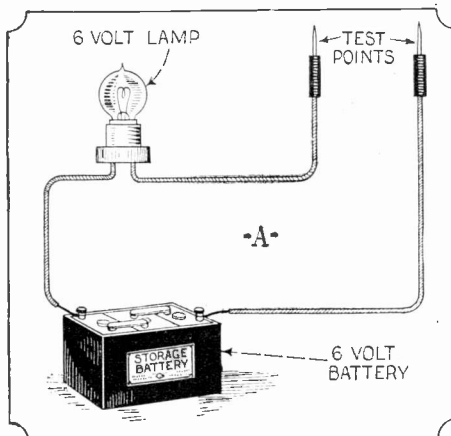

Most of the trouble experienced with motors and generators on automobiles come from short- or open-circuited coils in the devices themselves. Above is shown a particularly useful testing apparatus. It consists of a small lamp, two prod contacts and battery, as shown.

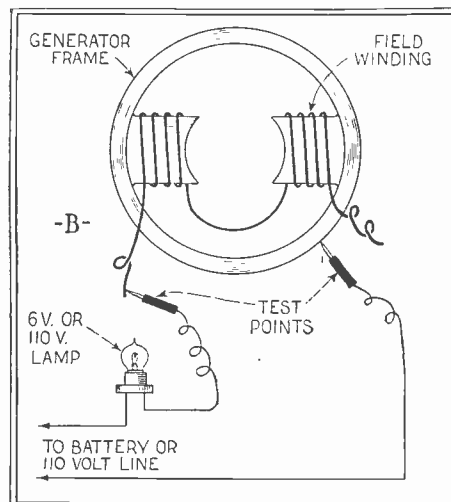

Above is illustrated the method applied for testing a grounded field winding. If the lamp lights with the contacts as shown, the coil is grounded and must be repaired or re-insulated.

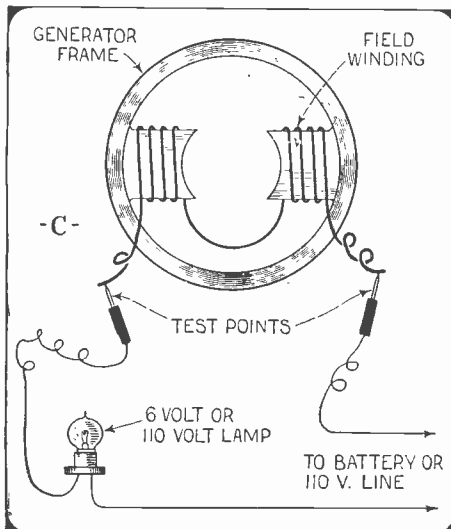

To test for an open field coil place the terminals as shown above. If the lamp lights the coil is all right and it may be dismissed as a cause of trouble, if it is proved not to be grounded in the previous test.

Personal Stationery

200 SHEETS and 100
ENVELOPES Printed
with your Name and
Address

\$1.00

Clear, white bond paper, with envelopes to match. Your name and address printed in beautiful, rich blue ink, on both paper and envelopes, and sent to you postpaid, for only \$1.00. (West of Denver and outside of U. S. \$1.10). If inconvenient to send the money, we will ship C. O. D.

*Write name and address
plainly.*

Money returned if you are not more than satisfied. Order today!

Elite Stationery Company
5030 Main Street
Smethport, Pa.

FOOTBALL FOR EVERYBODY

Every fan, old or young, likes The Gregg Football Game. A perfect representation of college football, with the new 1924 rules. Not a toy using spinners, cards or dice, but a new game of wits and strategy played on a table with a small football field and two teams. Each player is his own Quarterback and directs his team as in real football. At your dealer or post-paid for \$2.50.

Write for illustrated folder.

ALBERT A. GREGG CO.

Dept. I West Jefferson, Ohio

WANTED!

The Editor, for his private library, desires the following numbers of the ELECTRICAL EXPERIMENTER:

- July, 1913
- September, 1913
- October, 1913
- November, 1913

If you have any of these numbers and will dispose of same address EDITOR, Science & Invention, 53 Park Place, New York City.

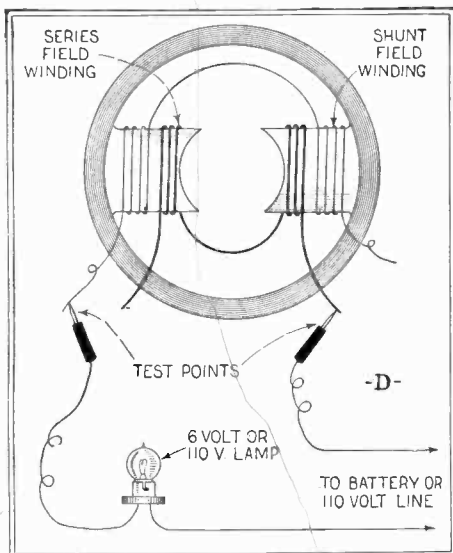

Where the generator is wound directly with the motor—as on the Buick and some other cars—the field winding will be compound. That is, there will be both a series and a shunt winding. Both windings must be tested as in the previous two cases, as well as for a short-circuit between them. The above method shows means for ascertaining if the two windings are short-circuited to each other.

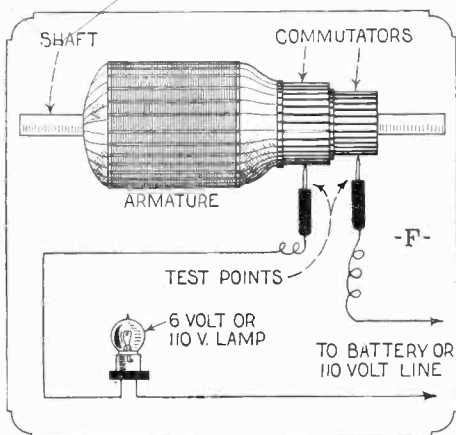

The next step is to test the armature. This is carried out as above. One test point is placed on the shaft and the other on the commutator. If the armature is grounded the lamp will light.

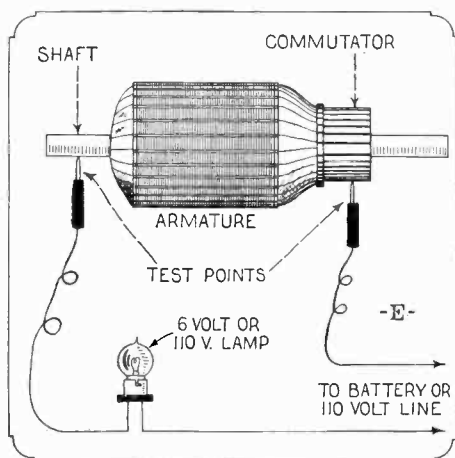

As in the case shown at the top of this page, where both motor and generator are combined in one frame it will be found that there are two commutators. Both must be tested for a ground to the frame as well as for a short-circuit between their two windings. The means of making the latter test is shown in the above illustration. Each must be tested for a ground to the frame as shown in the next preceding illustration before the test for a short between them is made. As shown in all the illustrations in this article 110 volts—or any lighting current—may be used for the tests provided the lamp of the circuit voltage is used.



THE mechanical principles of Magnavox Reproducers are as marvelous as the vocal chords of a great singer.

The Reproducer Supreme with a Human Throat

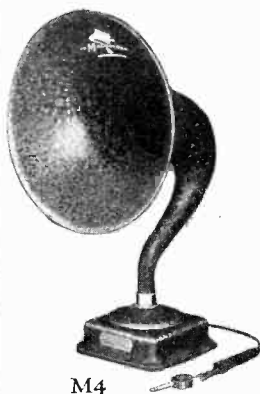

M4



R3

BETWEEN Magnavox and ordinary "loud speakers" there are certain essential differences hidden away in the base of the instrument, insuring for Magnavox utmost clearness of tone.

Reproducers

- M4—the latest Magnavox achievement: requires no battery \$25.00
- M1—also constructed on the semi-dynamic principle, requiring no battery \$35.00
- R3—famous electro-dynamic type: new model with Volume Control \$35.00
- R2—same as R3 but larger size: new model with Volume Control \$50.00

Combination Sets

- A1-R and A2-R—the only instruments combining electro-dynamic Reproducer and Power Amplifier in one unit. \$59.00, \$85.00

Power Amplifiers

- A1, AC-2-C, AC-3-C—the most efficient audio-frequency Amplifiers: one, two and three stage \$27.50 to \$60.00

To obtain the fullest enjoyment from your receiving set, equip it with the Magnavox—for sale at good dealers everywhere.

THE MAGNAVOX CO., Oakland, Calif.
 New York Office: 350 West 31st Street
 Canadian Distributors:
 Perkins Electric Limited, Toronto, Montreal, Winnipeg



7-C

Your Choice 75c a Week



No matter what your occupation, one of the home study sets listed below will quickly fit you for a better job and bigger pay. Any set you select will be sent for seven days' examination, and if you decide to buy you may pay the rock-bottom price at the rate of only 75c a week. But you must act now! The rising cost of paper and binding materials won't permit us to continue the present low prices much longer.

These books are the work of recognized authorities. They are written in plain, easily understood language, by recognized authorities, and contain hundreds of photographs, diagrams, tables, etc., that make difficult points as simple as A-B-C. Handsomely and durably bound in half or full morocco leather (except as noted), and stamped in gold.

Pay-Raising Books At Greatly Reduced Prices

Business Management, 8 vol., 2500 pages, 1000 pictures. Was \$52.50	Now \$29.80
Carpentry and Contracting, 5 volumes, 2138 pages, 1000 pictures. Was \$37.50	Now 19.80
Civil Engineering, 9 volumes, 3900 pages, 3000 pictures. Was \$67.50	Now 34.80
Electrical Engineering, 8 volumes, 3800 pages, 2600 pictures. Was \$60.00	Now 29.80
Automobile Engineering, 6 volumes, 2600 pages, 2000 pictures. Was \$45.50	Now 21.80
Machine Shop Practice, 6 volumes, 2300 pages, 2500 pictures. Was \$45.00	Now 21.80
Steam and Gas Engineering, 7 volumes, 3300 pages, 2500 pictures. Was \$52.50	Now 24.80
Law and Practice (with reading course), 13 volumes, 6000 pages, illustrated. Was \$97.50	Now 49.80
Fire Prevention and Insurance, 4 vols., 1500 pages, 600 pictures. Was \$30.00	Now 14.80
Telephony and Telegraphy, 4 volumes, 1728 pages, 2000 pictures. Was \$30.00	Now 14.80
Sanitation, Heating and Ventilating, 4 volumes, 1454 pages, 1400 pictures. Was \$30.00	Now 14.80
Drawing, 4 volumes, 1578 pages, 1000 pictures, blue prints, etc. Was \$30.00	Now 14.80

Send No Money Shipped for 7 Days' Trial

Yes, we'll gladly ship any set right to your home or office upon your simple request. Pay only shipping charges when the books arrive. Don't send a penny until after you have used them seven days, then remit only \$2.80 or return them at our expense. Pay balance at the rate of \$3.00 a month—75c a week.

Act now—while these splendid books are being offered at 20% to 50% less than regular prices. This offer is open to every person within the boundaries of the U. S. and Canada. Grasp your opportunity—fill in and mail the coupon now.

American Technical Society Dept. X-B-25, Chicago

American Technical Society, Dept. X-B-25, Chicago, U.S.A.

Please send me set of

for 7 days' examination, shipping charges collect. I will examine the books thoroughly and, if satisfied, will send \$2.80 within 7 days and \$3.00 each month, until I have paid the special price of

If I decide not to keep the books, I will notify you at once and hold them subject to your order. Title not to pass to me until the set is fully paid for.

Name

Address

Employed by

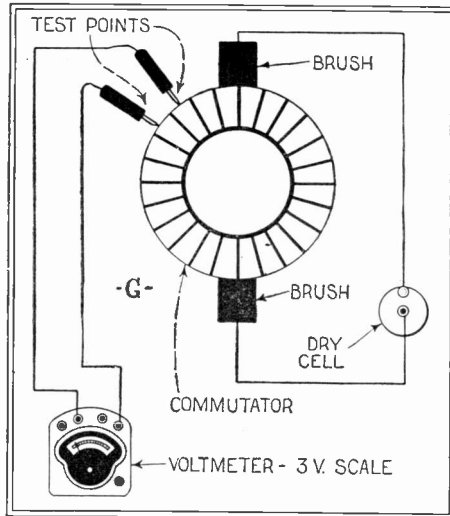

For finding the particular coil of an armature that is open-circuited the above method is used. A voltmeter with a three volt scale is used. When the test tips are on the bars to which the "open" coil is attached, the deflection will rise greatly. A "shorted" coil gives nil deflection.

SCIENCE AND INVENTION IN SCHOOL PROGRAM

Editor, SCIENCE AND INVENTION:

The General Science Department of Greensboro High School, Greensboro, North Carolina, decided at the first of this year to turn the class period of every Friday into a Science Club day. This period was to be taken up by reports of interesting inventions and of everything else in the science world, the reports to be prepared and given by the pupils. Another idea was also brought forth, that of subscribing to different scientific magazines.

The next day the students were asked to contribute to a fund, the purpose of which was to provide scientific magazines for the library. The students proved their interest by responding liberally. A treasurer was duly appointed. He was told to subscribe to some monthly scientific magazines. SCIENCE AND INVENTION was the first to find its place on the book shelf. Many others followed, but when the program is read at the first of each week, there is a general rush of the members, for they know which magazine was first and best.

JOHN THORNTON, Reporter No. 11,068.

Film Projector

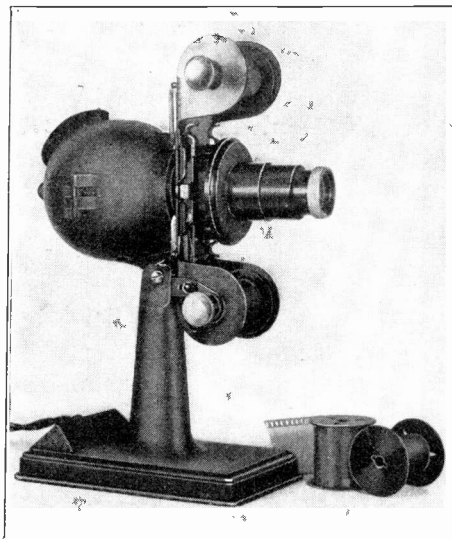

In order to save the great bulk in slides for stereopticon views, Mr. J. R. Bray, of New York City, has brought out the above device for showing still pictures. The pictures to be projected are printed on a standard movie film. The light is furnished by an ordinary automobile lamp and is lighted from standard lighting current through a fixed resistance.

WORLD BATTERY

Saves You 50%

Famous Guaranteed Quality and Service—Backed by Years of Successful Manufacture and Thousands of Satisfied Users.

Prices That Save and Satisfy

Auto Batteries	Radio Batteries
6-Volt 11 Plate, \$12.25	6-Volt 60 Amps. \$ 8.50
6-Volt 13 Plate, 14.25	6-Volt 80 Amps. 10.00
12-Volt 7 Plate, 17.00	6-Volt 100 Amps. 12.50
	6-Volt 120 Amps. 14.50
	6-Volt 140 Amps. 16.00

Special 2-Volt Storage Battery for W.D.11 and 12 tubes. Will run 200 hours on one charge. Rechargeable. \$5.00.
Special 4-Volt Storage Battery for U.V.199 tubes. Same features as 2 Volt. \$8.00.

Shipment express C.O.D. subject to examination. 5% Discount for cash in full with order.

2-Yr. Guarantee Bond in Writing With Each World Storage Battery

proves satisfactory World performance. Mail this ad with your name and address and we will ship battery day order is received; and give you a 45-Volt "B" Battery and Hydrometer Free with each battery purchased. Write today.

World Battery Company
Dept. 19, 1219 S. Wabash Ave.
CHICAGO, ILL.

FREE
45 V. B-BATTERY
and
HYDROMETER

You can be quickly cured, if you

STAMMER

Send 10 cents for 288-page book on Stammering and Stuttering, "Its Cause and Cure." It tells how I cured myself after stammering 20 yrs. B. N. Bogue, 8106 Bogue Bldg., 1147 N. Ill. St., Indianapolis

YOU CAN NOW BECOME A COMMERCIAL ELECTRICAL ENGINEER in one year

A new branch of the electrical profession in pressing need of thoroughly trained men. The Commercial Electrical Engineer knows business as well as the techniques of electricity. He is the Consulting and Efficiency Engineer, the man who knows commercial engineering problems and how to solve them. Our course specially attractive to high school graduates. You learn here by doing. Our big laboratories are filled with over a quarter of million dollars worth of actual electrical machinery and apparatus, the same as you meet in every-day work. For 18 years, we have been training ambitious men for big-pay electrical jobs.

Electrical Engineering with B.S. degree in 3 years

The top of the profession. Brilliant careers opened to the man who will dig in and fit himself for this splendid, highly paid field of endeavor. Electrotechnics training 1 to 2 years. Electrical and Mechanical Drafting taught in 9 months. Automotive Electricity 3 months. Automotive Electrical Engineer, 1 year. Armature Winding and Motor Generator Repair, 3 months. Practical Electricity, 6 months.



A place for every student, regardless of age or education. Faculty of nationally known experts. Individual instruction. Radio Broadcasting station WLAO. Boys—the finest men you'll ever meet—from all over the world come here.

Mail Coupon For Free Books and Complete Information.

SCHOOL OF ENGINEERING of Milwaukee

Founded 1905

Dept. C-1502

School of Engineering of Milwaukee, Dept. C-1502, 415 Marshall St., Milwaukee, Wisconsin. Without obligating me in any way, please mail free illustrated book and further particulars on course I have checked below.

- | | |
|---|---|
| <input type="checkbox"/> Commercial Electrical Engineering. | <input type="checkbox"/> Automotive Electricity |
| <input type="checkbox"/> Electrical Engineering. | <input type="checkbox"/> Automotive Electrical Engineering |
| <input type="checkbox"/> Practical Electricity | <input type="checkbox"/> 3 Months Armature Winding Course |
| <input type="checkbox"/> Drafting | <input type="checkbox"/> 3 Months Light and Motor Wiring Course |
| <input type="checkbox"/> Electrotechnics | |
| <input type="checkbox"/> Earn While You Learn Plan | |

Name

Address

City

Education

Oil Burning Equipment for the Home

(Continued from page 275)

The piping, preferably of galvanized stock, is clearly shown in the sketch "A." The filler pipe, of 2" size, is connected to the tank from the curb box. This box is placed in some convenient location easily accessible for the oil supply truck.

If the filler pipe is run off to some distance it is better to insert a tee in the upright pipe, the top opening in the tee being used for the insertion of a measuring stick which may be calibrated to determine the amount of oil in the tank. This pipe, using the tee, is shown in drawing "J." The filler end should be provided with a cap. The vent line may be of pipe not smaller than 1", and the riser should extend 6 to 12 feet above ground, ending in a return bend.

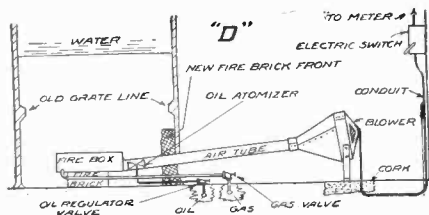

Arrangement of oil burner in fire box of boiler, also layout of blower, oil and gas valves, etc.

The suction line is of one inch pipe and should extend to the bottom of the main tank, the end being equipped with a foot valve which prevents the return of oil. A running thread with lock nuts and a coupling provide means for connecting the suction line to the tank. This line is connected to either a hand or motor driven pump by means of valves and unions. A tee is placed above the pump as shown, so that the pump may be primed. The foot valve will eliminate subsequent priming. All joints on the oil pipes are made with a thick mixture of litharge and glycerine, care being taken to carefully remove all cutting oil and dirt from the pipe and the threaded ends before applying. Mix the sealing compound only as needed, for it hardens rapidly, and once hard is useless and must be discarded. The joints on the gas pipes may be made up with red or white lead.

The small tank into which the pump discharges may be of about fifty gallons capacity and should be set upon a pipe stand or concrete base. It should be provided with the openings shown, and if a concrete gauge is desired an additional opening is necessary. The overflow pipe also acts as a vent. The tank should be given a coat of rust-resisting paint and is to be provided with a drain at the bottom, in the event of there being water in the oil.

The feed line to the burner should be of 3/8" pipe, and may be concealed by running in a channel in the basement floor. A shut off valve and strainer are to be installed near the tank as shown in drawing "A." Drawing "B" shows the hook-up if only a house tank is decided upon, the disagreeable feature of this installation being the necessity of constant refilling, unless the tank be of large size.

For the usual medium sized house heating plant, whether it be hot water, steam or air system, a nine inch "fire pot," or combustion chamber is used, although when this chamber is first installed in the ash pit the builder will feel skeptical because of the great contrast in its size to that of the original coal grate. It is best made of boiler steel 3/8" or more in thickness with a lap joint and bottom plate welded on. A hole is drilled in the bottom plate for a gas pilot light while the side has either an

No Matter What Your Vocation

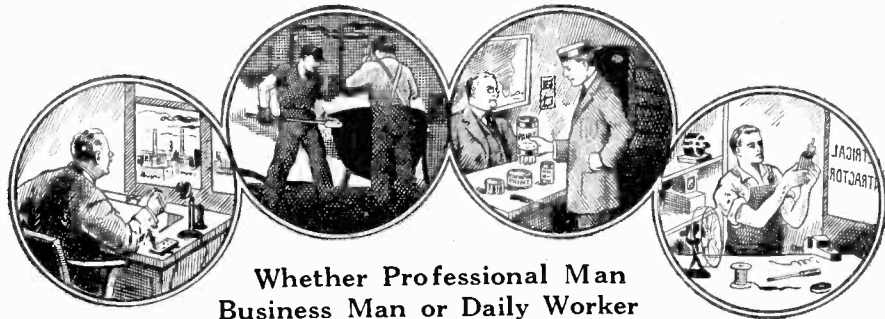

Whether Professional Man
Business Man or Daily Worker

A Thorough Training In CHEMISTRY Will Help You To Get Ahead

TO be successful today is to know Chemistry! Every line of business, every branch of industry depends upon Chemistry in some form. You may not realize it, but your own proficiency in whatever work you are doing would be increased by a knowledge of Chemistry. In many lines such knowledge is absolutely essential. In others it is a guarantee of promotion and more money.

The keen competition that exists in every commercial activity today requires that a man know all there is to know about his vocation. If you have something to sell—no matter what—Chemistry enters into its makeup. The salesman who knows the chemical composition of his article can talk about it more intelligently than the one who lacks this information, and his sales are proportionately larger. In the building trades Chemistry is of prime importance. The mason, electrician or painter who knows something about Chemistry can do better work and command more money than the one who does not. Through Chemistry a shop-keeper learns how to attract the most trade, and even in clerical positions one can capitalize his chemical skill.

Chemistry should be as much a part of your mental equipment as the ability to calculate or to write correct English. The world is paying a thousandfold more for ideas than for actual labor. The big rewards go to the man who can show how to turn out a little better product at a little lower cost. And Chemistry will give you the ideas that will save money for yourself or your firm in the very fundamentals of your business. There is nothing remarkable about this; it is going on every day. If you have not heard of it before, it is because the general public has been slow to recognize the tremendous value of chemical training. People have been content to leave Chemistry in the hands of a few trained chemists who could not possibly develop the subject to anywhere near its greatest extent.

Now we are on the eve of a great awakening. Our heritage from the World War has been an intense development of the chemical industries in the United States and a tremendous interest in all the applications of Chemistry. People are taking up the subject merely for the good it will do them in their own line of business.

It is no longer necessary to enter college in order to learn this fascinating science. Our Home Study Course trains you just as thoroughly, and with the same assurance of success, as those who took the longer way. And our methods are so simple that we can teach you no matter how little previous education you may have had. Many of our graduates now hold responsible positions or have materially increased their incomes from private enterprises as a result of taking our course. Hundreds of letters from students testifying to the benefits they have derived from our training are here for your inspection.

Remember that you do not need to study Chemistry with the idea of actually practicing as a chemist, although a great many of our students are taking our course with this object in view. If you want to know more about what Chemistry will do for you, if you want to know what our home study course offers, sign and mail the coupon today for FREE BOOK, "Opportunities for Chemists."

**Chemical Institute
of New York, Inc.**
HOME EXTENSION DIVISION 7
66-S West Broadway, New York City

DR. T. O'CONNOR SLOANE
Will Teach You Chemistry
In Your Own Home

The Chemical Institute of New York, of which Dr. T. O'Connor Sloane is Educational Director was founded to fill the need of ambitious, far-sighted men who realize and recognize the splendid future Chemistry offers them, but who cannot spare either the time or the money to attend college. Dr. Sloane, a foremost authority on Chemistry, will teach you and will give you any individual help you may require. He will personally go over your papers, correct them, point out your faults, teaching you in a practical and interesting way. No special education required other than the ability to read and write English. One student has characterized our lessons as "The course that takes the mystery out of Chemistry."

**Read What One of Our Recent
Graduates Reports**

"I thought I would let you know of my success. I finished your course about two months ago and now have a fine position as chemist at the DuPont Dye Works. I am getting along fine with my work and like it very much. It was through your course alone that I have been so successful. It is wonderful and I hope you have great success with it."

(Name and Address on request.)

Easy Monthly Payments

You do not have to have even the small price of the course to start. You can pay for it in small monthly payments—so small that you won't feel them. The cost is very moderate, and includes everything, even the Laboratory Equipment—there are no extras to buy with our course. Our plan of monthly payments places a chemical education within the reach of everyone.

**Laboratory Equipment Given
To Every Student Without
Additional Charge**

We give to every student without additional charge his chemical equipment, including forty-two pieces of laboratory apparatus and supplies and seventeen different chemicals and reagents. These comprise the apparatus and chemicals used for the experimental work of the course.

Special 30-Day Offer

For a short period we are making a special offer that will be worth your while to take advantage of. Write for particulars, using the coupon below or simply a postal card. This will not obligate you in the least. Do not wait until tomorrow. Send the coupon now while you think of it.

**Sign and Mail the Coupon for
FREE BOOK**

CHEMICAL INSTITUTE OF NEW YORK, Inc.
Home Extension Division 7,
66-S West Broadway, New York City

Please send me at once without any obligation on my part, your Free Book "Opportunities for Chemists," and full particulars about the Laboratory Equipment furnished to every student. Also please tell me about your plan of payment and your special 30 day offer.

NAME

ADDRESS

CITY

STATE

S. & I. 7-24

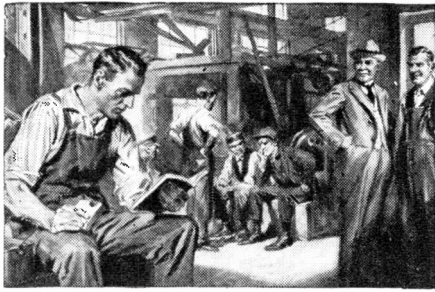

"There's One Man We're Going to Keep"

"Ed Wilson, there, is one of the most ambitious men in the plant. I notice that he never fools away his spare time. He studies his International Correspondence Schools course every chance he gets.

"It's been the making of him, too. He hasn't been here nearly so long as Tom Downey, who was laid off yesterday, but he knows ten times as much about this business.

"I'm going to give him Tom's job at a raise in salary. He's the kind of man we want around here."

HOW do you stand in your shop or office? Are you an Ed Wilson or a Tom Downey? Are you going up? Or down?

No matter where you live, the International Correspondence Schools will come to you. No matter what your handicaps or how small your means, we have a plan to meet your circumstances. No matter how limited your previous education, the simply-written, wonderfully-illustrated I. C. S. textbooks make it easy to learn.

This is all we ask: Without cost, without obligating yourself in any way, put it up to us to prove how we can help you. Just mark and mail this coupon.

INTERNATIONAL CORRESPONDENCE SCHOOLS Box 6243-C, Scranton, Penna.

Without cost or obligation on my part, please tell me how I can qualify for the position or in the subject before which I have marked an X:

BUSINESS TRAINING COURSES

- | | |
|---|---|
| <input type="checkbox"/> Business Management | <input type="checkbox"/> Salesmanship |
| <input type="checkbox"/> Industrial Management | <input type="checkbox"/> Advertising |
| <input type="checkbox"/> Personnel Organization | <input type="checkbox"/> Better Letters |
| <input type="checkbox"/> Traffic Management | <input type="checkbox"/> Show Card Lettering |
| <input type="checkbox"/> Business Law | <input type="checkbox"/> Stenography and Typing |
| <input type="checkbox"/> Banking and Banking Law | <input type="checkbox"/> Business English |
| <input type="checkbox"/> Accountancy (including C.P.A.) | <input type="checkbox"/> Civil Service |
| <input type="checkbox"/> Nicholson Cost Accounting | <input type="checkbox"/> Railway Mail Clerk |
| <input type="checkbox"/> Bookkeeping | <input type="checkbox"/> Common School Subjects |
| <input type="checkbox"/> Private Secretary | <input type="checkbox"/> High School Subjects |
| <input type="checkbox"/> Spanish | <input type="checkbox"/> French |
| <input type="checkbox"/> Illustrating | |

TECHNICAL AND INDUSTRIAL COURSES

- | | |
|---|--|
| <input type="checkbox"/> Electrical Engineering | <input type="checkbox"/> Architect |
| <input type="checkbox"/> Electric Lighting | <input type="checkbox"/> Architects' Blue Prints |
| <input type="checkbox"/> Mechanical Engineer | <input type="checkbox"/> Contractor and Builder |
| <input type="checkbox"/> Mechanical Draftsman | <input type="checkbox"/> Architectural Draftsman |
| <input type="checkbox"/> Machine Shop Practice | <input type="checkbox"/> Concrete Builder |
| <input type="checkbox"/> Railroad Positions | <input type="checkbox"/> Structural Engineer |
| <input type="checkbox"/> Gas Engine Operating | <input type="checkbox"/> Chemistry <input type="checkbox"/> Pharmacy |
| <input type="checkbox"/> Civil Engineer | <input type="checkbox"/> Automobile Work |
| <input type="checkbox"/> Surveying and Mapping | <input type="checkbox"/> Airplane Engines |
| <input type="checkbox"/> Metallurgy <input type="checkbox"/> Mining | <input type="checkbox"/> Agriculture and Poultry |
| <input type="checkbox"/> Steam Engineering <input type="checkbox"/> Radio | <input type="checkbox"/> Mathematics |

Name.....
Street..... 3-6-24
Address.....
City..... State.....

Occupation.....
Persons residing in Canada should send this coupon to the International Correspondence Schools Canadian, Limited, Montreal, Canada



Learn to Write

Begin Today—Write for My FREE BOOK. I can make a good penman of you at home during spare time. Write for my FREE BOOK, "How To Become a Good Penman." It contains specimens and tells how others mastered penmanship by the Tambllyn System. Your name will be elegantly written on a card if you enclose stamp to pay postage. Write today for book.

F.W. TAMBLYN, 424 Ridge Bldg., Kansas City, U.S.A.

Delivered to you Free

for 30 days trial on approval. Your choice of 44 Styles, colors and sizes of the famous **Ranger Bicycles**. Express prepaid. Bicycles \$21.50 and up.

\$5 a Month if desired. Many boys and girls easily make the bicycle earn the small monthly payments.

Wheels, lamps and equipment at half usual prices. Write for remarkable factory prices and marvelous offers.

Tires

MEAD CYCLE COMPANY Write us today for free catalog
DEPT. B107 CHICAGO



opening drilled for the air tube or has a suitable flange welded on. The air pipe may be threaded and lock nuts used to hold the pipe and fire-chamber together, or the pipe may be screwed directly into the flange, if one is provided. The pilot gas light consists of a lava tipped burner set into the bottom of the chamber, so that only the tip protrudes. This pilot flame must be protected from the draft of the blower by a shield made of molded fire clay, shaped somewhat like a section of an Edam cheese, but hollow at its greatest thickness, as shown in "G." The top of the shield should be about an inch above the burner tip.

The blower consists of a sheet iron funnel housing an eight inch ventilating fan, the construction of which is shown in drawing "I." This housing is provided with two openings through which the air is drawn. An adjustable shield is shaped as shown in drawing "H" and mounted upon the body of the blower, and is used to determine the proper amount of air, when it is locked into position by means of the wing nut. Two legs should be riveted to the body for support while the two and one half inch steel tube, usually about three and one half feet in length, is bolted into the funnel sleeve with two quarter inch stove bolts.

A Venturi constriction is turned from either brass or iron and made to fit the tube snugly as shown in drawing "F," which gives the dimensions. Another smaller constriction is made of brass and is used as an oil atomizer. It is shaped as shown in "E," which gives the dimensions, the centre being drilled with a 3/8-inch drill. The central cylindrical part is 5-32 inch long. A 1/8 inch drill is run through to give an oil duct and the lower part is further drilled and tapped for a 1/8" pipe. The oil atomizer is mounted upon washers and fastened in place by a 1/8" pipe nipple, which is held by a coupling or lock washer from the under side. The oil pipe is joined to the atomizer by means of a reducing ell 3/8 inch x 1/8 inch, as shown in drawing "F 1."

When all material has been checked over the apparatus is assembled as shown in "D," and after removing, the coal grates is installed upon the ash-pit floor, being raised from it by two fire bricks one on either side of the gas line. The open front space, however, is walled up with fire brick, using ground asbestos as a cement. Merely mix the asbestos with water to provide a thick clay-like mass and apply to the wetted bricks, taking care to tamp each brick into place. The legs of the blower should rest upon a two inch slab of cork lagging set into the floor. While not an absolute necessity it greatly reduces vibration and noise. The gas line should be provided with a stop cock, the oil line with a stop valve, regulator valve and strainer, while the electric line should be provided with a switch and fuse box.

Before running a test make sure that the chimney and boiler flues are clean, then open the gas cock and light the flame pilot, start the fan blowing and open the oil shut-off valve at the tank, while the oil regulator valve should be just lifted off its seat. The shield on the air openings is then adjusted so that the resulting flame in the combustion chamber is an intense white fire of great heat. Too much air and oil, or too little, constituting an unbalanced mixture of oil and air cause the fire to smoke and the builder should experiment until he has regulated the air openings and the oil valve, so that the flame is without a trace of smoke, for with perfect combustion there is no waste.

It is best to allow the gas in the pilot flame to burn in the event of there being water in the oil which may momentarily cause flame to cease, although the combustion chamber is generally hot enough to ignite the atomized oil even after a stoppage of several minutes duration.

—L. K. WRIGHT.

\$2.50
Per Day
and upward

is one reason for the rapidly growing popularity of the Hotel Martinique.

Another is the consistent economy of the entire establishment. Here you may enjoy a Club Breakfast at 45c., consisting of Fruit or Cereal, Bacon and Egg, and Rolls and Coffee — Special Luncheon and Dinners of superior quality are also served at the most moderate possible prices.

No location can be possibly more convenient than that of the Martinique. One block from the Pennsylvania Station (via enclosed subway)—Nine blocks from Grand Central—one block from the greatest and best Shops of the City—half a dozen blocks from the Opera and the leading Theatres—and directly connected with the Subway to any part of the City you wish to reach.

The BEST without extravagance!
**Hotel
Martinique**
Affiliated with Hotel McAlpin
Broadway-32nd to 33rd Sts.
NEW YORK
A.E. Singleton, *Manager.*

Be An Auto Expert

Learn the Simplex Way!

Let us prepare you at home to become an Auto Expert

Write for SPECIAL OFFER

SIMPLEX AUTO SCHOOL

2016-2024 W. Van Buren St.
Chicago, Ill.



Straightens Shoulders —Increases Pep

THE NATURAL BODY BRACE—Corrects stooping shoulders, straightens the back, gives the lungs chance for normal expansion, induces proper breathing. Brings restful relief, comfort, energy, and pep. For men and women.

Costs nothing to try it

Write for 30 days free trial offer and free book.
NATURAL BODY BRACE CO.
Howard C. Rash, Pl. 286 Rash Bldg., Salina, Kansas



B-METAL

B-METAL Loud Talking Crystals often make a good set out of a poor one. Ask your dealer to order them for you.

B-METAL REFINING CO.
11th F. 525 Woodward Ave.
Detroit, Mich.

Book Review

MEASUREMENT, COMPRESSION AND TRANSMISSION OF NATURAL GAS. By Lester Clyde Lichty. Hard covers, 5 3/4" x 9 1/4", 523 pages, profusely illustrated. Published by John Wiley & Sons, New York City. \$7.50.

We have in this book an advanced treatise on many phases of gas engineering. Of course the engineering of natural gas with its enormous pressure is a far different science, or rather is in a way a much higher branch, than the ordinary gas engineer's work of dealing with his product under a pressure of only 1" to 6". The book is written for those concerned with natural gas, but the manufacturer of illuminating and heating gas should have this book warmly recommended to him. It is in all respects exceedingly interesting and valuable, and with all its formulas is very good reading.

THE WONDERS OF THE STARS. By Joseph McCabe. Hard covers, 5" x 7 1/2", 134 pages, illustrated. Published by G. P. Putnam's Sons, New York City. \$1.50.

This is an attractive little book not only in its illustrations, but in its text. It is a good example of very clear printing and the illustrations are very well presented. It is a book to be read rather than studied. Towards the end of the book nebulas are treated, and the author shows the peculiar enthusiasm that we find in some scientists by which they can carry out the theory of the ether. That the book is up to date, is shown by the fact that it gives the diameters as far as determined, not only of Arcturus and Betelgeuse, but of Antares, the latter nearly double the diameter of Betelgeuse.

THE VAULT OF HEAVEN. By Sir Richard Gregory. Hard covers, 5" x 7 1/2", 202 pages, with numerous illustrations. Published by E. P. Dutton & Co., New York City. \$2.50.

This is an exceedingly interesting presentation of the abstruse subject of the higher astronomy. The effort, and one which has succeeded very strikingly, is to popularize the subject, and produce a book that can be read by everyone. To show its popularity of treatment, on page 117 we find the method shown of drawing an ellipse with a thread and two pins, so as to give the idea of the path followed by the celestial bodies in their orbits. The book is somewhat larger than the one we have just reviewed, and would make a good sequel thereto. Both are excellent reading.

QUALITATIVE ORGANIC ANALYSIS. By Oliver Kamm. Hard covers, 5 3/4" x 9 1/4", illustrated, 260 pages. Published by John Wiley & Sons, New York City. \$2.50.

Dr. Kamm is the Director of Chemical Research at the great Parke Davis establishment. This book covering such ground as underlies the work of commercial firms, is most interesting and in the way it is arranged really presents a novel aspect. Students who are good at inorganic analysis, are apt to be frightened at the analysis of organic compounds, but here we have a method of qualitative analysis given, essentially a scheme in the full sense of the word, and it is very interesting to note that something is said about quantitative analysis. We certainly would like to see the companion book in the quantitative aspect. A vast number of organic compounds are classified into groups and sub-groups, a large number of pages being devoted to this portion of the treatise.

JAHRESZAHLEN DER GEOGESCHICHTE. By Dr. R. Lotze. Hard covers, 5 1/4" x 8", 77 pages, illustrated. Published by Kosmos, Stuttgart, Germany.

The general theme of this book is the geologic age of the earth. In Teutonic fashion a picture of an hour glass, a clock, and a section of a tree are given as a starting off point of a treatise dealing with the measurement of time, but before long the author gets into geologic time and cycles, and clock and hourglass have to be pretty well forgotten. The book is exceedingly good, and towards the end treats of radio-activity and the decomposition or degradation of the radio-active elements varying from the millions of years of uranium I, for less than two minutes for radium X³. We recommend to our readers the study of the excellent analogy of the falling and overflowing of water to give radio-activity a picturesque presentation.

USE "RAGECO" TOOLS TO BUILD BETTER RADIO SETS

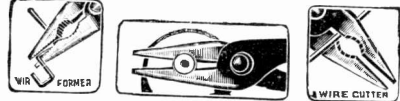

AS202. Combination Plier, Wire Cutter, Wire Former and Wrench. Drop forged, slender but exceptionally strong. 6 inches long.
Price75c

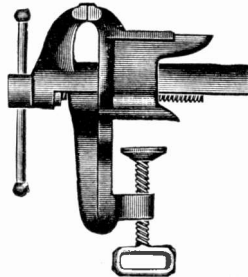

AS700. Bench Vise. This vise can be clamped to any table. Can be used for filing, sawing, drilling, soldering etc. Very

strong jaws, 1 1/2 inch face. Black japanned and finished.

Price60c

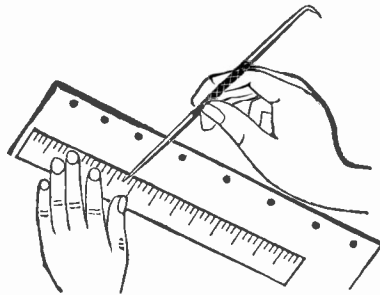

AS600. Scriber and Marker. Made of finest steel with hardened and tempered points, 8 inches long. Invaluable to the radio constructor to lay out and mark his panel. Marks on hard rubber, brass, steel, wood, etc.

Price25c

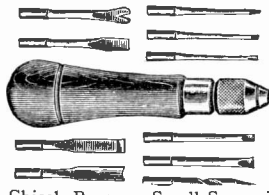

AS400. Hollow Handle Tool Set. Genuine Coco Bola handle, containing the following tools, four inches long, made of tempered steel: Chisel, Reamer, Small Screw Driver, File, Bradawl, Saw, Large Screw Driver, Scratch Awl, Gimlet, Gouge. Chuck is of the latest, most approved type, with hardened steel jaws.

Price per set\$2.25



AS301. Three-in-One Nut Wrench. Consists of handle with hollow stem 6 inches in length and three interchangeable sockets fitting popular sizes of nuts. The hexagon sockets grip the nut solidly.

Price per set65c

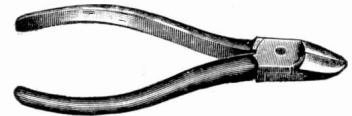

AS201. Side Cutting Nipper, Lap Joint. For cutting all kinds of wire. Jaws hardened and oil tempered. Natural steel finish with polished jaws. Length 6 inches.

Price75c

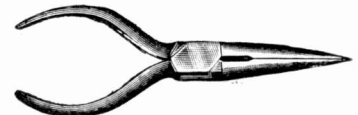

AS200. Long Sharp Nose, Side Cutting Pliers. Just the pliers for the radio constructor. Bends and cuts all kinds of soft wire. Nose 1 1/2 inches long, black body, polished jaws. Length 5 1/2 inches.

Price75c

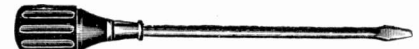
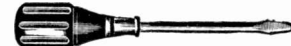
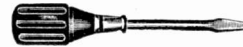

AS300. Set of Three Screw-Drivers. Specially selected for the radio constructor. Black handles, popular fluted design. Round steel blades, with flat sides of point; nickel plated ferrule; lengths, 4 3/4, 5 3/4 and 7 3/4 inches.

Price per set60c



Radiogem Complete Radio Receiving Outfit \$2.50

This outfit is absolutely complete. Nothing more to buy—no batteries or tubes needed—no upkeep of any kind. The simplest radio outfit made—you build it yourself! So simple that anyone can construct it. Complete instruction book with every outfit.

Complete Radiogem Outfit\$2.50
The Radiogem only 1.00
The Gemphone only 1.00
Aerial Outfit only50

Order by order numbers. Remit by check, money order, stamps or cash. All goods are shipped free of transportation charges to all parts of U. S. and possessions same day as order is received. If not satisfied, money will be refunded upon return of goods.

The Radiogem Corp.
66-S-West B'way, N. Y. City

ONE THOUSAND AGENTS WANTED

WE want one thousand agents to sell subscriptions to RADIO NEWS, SCIENCE AND INVENTION, PRACTICAL ELECTRICS and the MOTOR CAMPER & TOURIST. We will pay a generous commission for this work and help you in every way. Our four publications are leaders in their field, ready sellers and this is an offer well worth your while. A few spare hours a day will bring you a handsome return. Write regarding our proposition at once and be the first one to get started in your vicinity.

Experimenter Publishing Co.
HERBERT H. FOSTER, Circulation Manager

53 PARK PLACE

NEW YORK

ONLY \$3
Brings You This
Genuine Underwood
Typewriter
on 10 Days' FREE TRIAL
A perfect machine,
complete in every
detail. Read all
about this great offer



Yes, We Will Positively
Ship You

this splendid Underwood upon receipt of only \$3.00. This is by far the most liberal typewriter offer that has ever been made on so perfect a machine. Nearly two million Underwoods have been made and sold, proving conclusively that it is superior to all others in appearance, mechanical perfection and all-round excellence.

Ten Days' Free Trial

We want you to see for yourself that this is the typewriter you ought to have, and, therefore, we make our great free trial offer. You merely send us the three dollars deposit and we ship the machine for you to try for ten full days before you decide to keep it. If not satisfied, every penny of your money will be returned to you.

Rebuilt Like New

Every Underwood we sell is rebuilt just like new. It is dismantled right to the very bottom, and remanufactured to make it just like a new typewriter, with new enamel, new nickel, new platen, new key rings, new type; a complete, perfect typewriter, with two-color ribbon, back spacer, stencil device, automatic ribbon reverse, tabulator, key shift lock, etc. Impossible to tell it from a brand new Underwood, either in appearance, durability or quality of work.

Easy Monthly Payments

Our easy monthly payment plan makes it possible for YOU to own this splendid machine without having to pay out any big sum of money. You will hardly know you are paying for it. REMEMBER, you have the full use of the machine, just the same as though it was fully paid for.

Over 325,000 Sold

Over 325,000 people have purchased and been satisfied with our product. What better proof could anyone ask of the perfection of our typewriters and the integrity of this firm!

Your Money Back

Yes, you can have your money back if you want it. After you have examined the typewriter carefully, used it to write letters, if you decide for any reason whatever that you do not care for it, you may return it to us at our expense and every penny you have paid will be cheerfully and promptly refunded.

No Obligation on Your Part

When you send in the coupon for either further information about our great typewriter offer or for the typewriter itself on our free trial plan, you are under no obligation whatever until after you have tried it and have decided for yourself that you want to keep it.

Write Now for Our Big
Typewriter Book

telling all about our great big typewriter factory. In this book we illustrate and describe all of the various processes of re-enameling, retickling and assembling this splendid Underwood. It tells in an interesting way how each part is examined and tested carefully and thoroughly to insure the finished machine being one you will be proud to own.

Write Right Today
Use Coupon Below

SHIPMAN-WARD MFG. CO.

B216 Shipman Bldg., Chicago

Send me your big bargain catalog and complete details of your surprising offer, without obligation on my part.

NAME

STREET

CITY STATE.....

FALTERLEBEN. By Dr. Kurt Floericke. Hard covers, 5 1/4"x8", 77 pages, illustrated. Published by Kosmos, Stuttgart, Germany.

Insect life is, here treated in a very popular way, the Lepidoptera being its theme. Moths and butterflies, their structures, and their metamorphoses, are all described and illustrated in an exceedingly interesting and popular way. The illustrations, which are really of the nature of the old-fashioned wood cuts, are quite picturesque and adequately numerous. Although the work is of less than one hundred pages, a page and a half index of things treated, adds greatly to its value.

ALL ABOUT RADIO PARTS. By Thomas W. Benson. Illustrated, paper, 48 pages, 7 1/2"x5 1/4", price 25c. Published by the E. I. Company, New York City.

Radio parts can stand a lot of explanation and to fill a long felt want, the author of this book has put into it descriptions of all the various types of apparatus used in standard receiving sets and explained just how they operate. The first part of the book deals with antenna erection and equipment, explaining each part thoroughly. The method of selecting various stations during reception (tuning) is next dealt with and the operation of inductances and condensers set forth. Detectors receive attention next and both crystal and vacuum tubes are described in detail. Amplification is dealt with in a chapter by itself, both audio and radio frequency being described and some of their troubles pointed out. The subject of voice reproduction occupies the last chapter and many types of receivers and loud speakers are described in detail.

This book will undoubtedly prove of great assistance to the tyro when it comes to purchasing his first group of radio apparatus as it points out the faults and shortcomings of various types and the good points of other types. Sound advice is given in clear and simple form.

100 RADIO HOOKUPS. By Maurice L. Muhleman. Illustrated, paper, 48 pages, 7 1/2"x5 1/4", price 25c. Published by the E. I. Company, New York City.

This little volume of the Experimenter's Library covers the subject of circuits in a manner which will delight the heart of every radio fan. The circuit diagrams are all drawn in the standard schematic form, but in order to make them perfectly clear to everyone, a part of the book is given over to a table of symbols. The name of each instrument is given and on either side of it is placed the schematic symbol and a perspective view of the instrument. Then follow several diagrams using the perspective form so that the reader can become intimate with the reading of hook-ups. The correct method of following out hook-ups is carefully explained. The various different types of circuits are grouped together, all the crystal detector hook-ups being given first, followed by the plain and regenerative vacuum tube circuits. Amplifiers both of radio and audio frequency type are illustrated, each circuit being one that has proven itself by actual use. Miscellaneous circuits then follow and two diagrams of the Super-Heterodyne appear, one of them resistance coupled and the other transformer coupled. The miscellaneous hook-ups include such ones as combination crystal and vacuum tube and also several of the circuits lately developed. This last sub-division puts a finishing touch on one of the best collections of radio reception circuits which we have seen as yet.

HOW TO TUNE YOUR RADIO SET. By Maurice L. Muhleman. Illustrated, paper, 46 pages, 7 1/2"x5 1/4", price 25c. Published by the E. I. Company, New York City.

While no hard and fast rules can be laid down for the tuning of a certain type of radio receiving set, still there are certain principles which should be followed. These principles have been collected together and put into a simple and understandable form by the author of this book.

Fundamentals of radio reception are first dealt with and various instruments described. The hook-ups of these instruments are also given both in perspective and schematic. The theory of regeneration is dealt with and the tuning of various types of regenerative sets described. "Supers" are touched upon, the Flewelling receiver being described in detail. A standard type of loop receiver, employing radio frequency amplification is then illustrated and the fundamental methods of tuning it described.

For the first time we find described in this book a clear explanation of the actual tuning of a Neutrodyne receiver.

In his conclusion the author gives a few hints which tend to help the amateur out with his particular type of set and these hints finish off a very good and useful book.

We Teach
COMMERCIAL
ART

Meyer Both Company the largest Commercial Art Organization in the World offers you a practical training, based upon twenty-five years of success. This nationally known organization each year produces and sells to advertisers over 15,000 commercial drawings. This well paid profession equally open to men and women. Home study instruction.

Get Facts Before You Enroll in Any School
 Ask the Advertising Manager of the leading newspapers in your city about Meyer Both Company—let them tell you about us. Send four cents in stamps for illustrated book telling of the success of our students.

MEYER BOTH COMPANY

Michigan Ave. at 20th St. Dept. 64
 CHICAGO, ILL.

Note—To Art and Engraving Firms: Secure artists among our graduates. Write us.

Agents Wanted!
Salesmen—Distributors

to use and introduce attachment that makes Fords run on 94% air. THERMOSTAT on exhaust automatically turns down needle valve as engine warms, exactly as Ford Manual says do by hand.

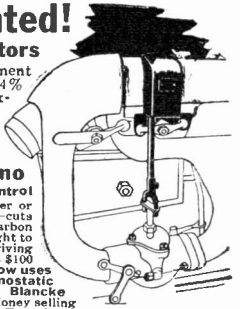

Blanche Auto Thermo

An Automatic Carburetor Control. Makes Fords start easier winter or summer—saves half gas and oil—cuts repair bills one-half—reduces carbon formation one-half. Sells on sight every Ford owner as easily as giving him a \$100 bill. Because it saves \$100 every 10,000 miles. Cadillac now uses as standard equipment thermostatic carburetor control under Blanche license. You can make Big Money selling this wonderful proven device. Experience not necessary. Blanche plan will start you without capital in a business of your own that makes you from \$250 to \$2,000 a month profit.
 Write for free circulars Now!

A. C. Blancke & Co. 602 W. Lake Street Dept. 221, Chicago

\$4.00 ADDING MACHINE



The GILSON ADDER will do your figuring easily, quickly and with absolute accuracy. It adds, subtracts, multiplies and divides and automatically carries from one column to the next. Capacity 100,999,999 or 1,099,999.99. Size 3 1/2"x6"x1 1/4". Made with aluminum case and steel operating parts. Written Two-Year Guarantee. Catalogue free.

Price, postpaid, \$4.00
 your money back
 if you are not satisfied.

GILSON SLIDE RULE CO., NILES, MICH.

"LIGHTING FIXTURES"
READY TO HANG
 Direct from manufacturer. Completely wired including glassware. Send for Catalogue No. 26 (Just off the Press)
 Special Proposition to Dealers
ERIE FIXTURE SUPPLY CO.
 Desk B Erie, Pa.

PIMPLY SKIN
 made WELL

When a few applications of this wonder working lotion has cleared faces of pimples, blackheads, acne eruptions on the face or body, enlarged pores, oily or shiny skin, you can realize why CLEAR-TONE has been tested and approved in over 100,000 Test Cases. The simplicity of the treatment. The Story of How I Cured Myself are all explained in my free booklet. Write for your copy today and learn of the results gotten by thousands of men and women.
E. S. GIVENS
 168 CHEMICAL BLDG. KANSAS CITY, MO.

HISTORY & OPERATION OF THE VACUUM TUBE. By John H. Morecroft, E. E. Illustrated, paper, 48 pages, 7½"x5¼", price 25c. Published by the E. I. Company, New York City.

The vacuum tube has often been referred to as the Aladdin's Lamp of radio and it well deserves this title. Its mode of operation is almost inconceivable and when we sit in front of our radio set, gazing at the tiny light within the glass tube, it is hard to visualize the many operations taking place therein. However, this volume explains the theory and operation of the vacuum tube in such a clear and simple manner that it makes interesting reading instead of tiresome study.

In order to get at the operation of the vacuum tube, the author of this work has presented a synopsis dealing with electricity, atoms and electrons. The action of electrons is fully discussed and various types of filaments used in vacuum tubes described.

The history of the vacuum tube from the initial Edison discovery of the "Edison Effect" up to the present day three electrode tube is given. The action of the vacuum tube both as detector and amplifier and later on as an oscillator is explained and the fundamental circuits shown. The last page of this, well written book deals with the "wired wireless" developed by Major-General G. O. Squier and explains its operation.

To everyone interested in the operation of his receiving set, this book will prove a welcome source of information and each statement put forth can be relied on as it is written by one of the foremost radio experts of today.

RADIO FREQUENCY AMPLIFIERS.

By John M. Avery. Illustrated, paper, 32 pages, 7½"x5¼", price 25c. Published by the E. I. Company, New York City.

Since the "DX" craze hit radio, radio frequency amplifiers have surged steadily to the fore. They are, however, rather ticklish sets to operate unless the radio frequency amplifier is designed by competent engineers. However, if the radio frequency amplifying transformers are correctly built, excellent distance reception can be expected. This volume deals with just this phase of radio work and covers it in a complete and authoritative manner. The construction of a two winding radio frequency amplifying transformer is very clearly explained and circuits for employing the same are shown. Various radio frequency amplifiers are discussed and their merits compared.

The subject of tuned radio frequency amplification is next taken up and both circuits and data for the same given. Radio frequency amplifiers for use with regenerative sets are discussed and a very good experimental circuit of the self-heterodyne type is given. A reflex circuit of excellent design employing two vacuum tubes and giving the effect of three is next shown and its action discussed. Data is given for the construction of the same.

If there is any possibility of your adding radio frequency amplification to your present receiving set, you cannot do without this little book.

RADIO QUESTIONS ANSWERED. By A. P. Peck. Well illustrated, 48 pages, paper, 7½"x5¼". Published by the E. I. Co., New York City. Price 25c.

This book, written by the editor of the Radio Oracle Department of SCIENCE AND INVENTION Magazine, deals with the simplest parts of radio reception from the viewpoint of the veriest beginner. The subjects for the queries were gleaned from a thorough review of the questions asked by readers of the magazine over a period of many months and includes those queries most frequently put forth. The first chapter deals with the questions coming under the head of "What Is Radio?" The general terms pertaining to the science are explained therein. The operation of radio apparatus is next dealt with and the numerous illustrations and descriptive matter cover the subject very well. Aerials and grounds are discussed as well as the protective measures which must be taken when installing a set.

The operation of the vacuum tube is explained in simple language and the various types illustrated. After a description of the operation of phones, a resumé of various fundamental circuits is given and their operation explained. Under the heading of miscellaneous queries, constructional data on various apparatus is given and several queries which usually confuse the beginner are correctly answered.

LOUD TALKERS—HOW TO BUILD THEM. By H. Winfield Secor. Illustrated, 48 pages, paper, 7½"x5¼". Published by the E. I. Company, New York City. Price 25c.

Usually the next step in the life of the radio amateur, after he masters the operation of his set is the study of reproducers in general and loud speakers in particular. A sort of a halo of mys-

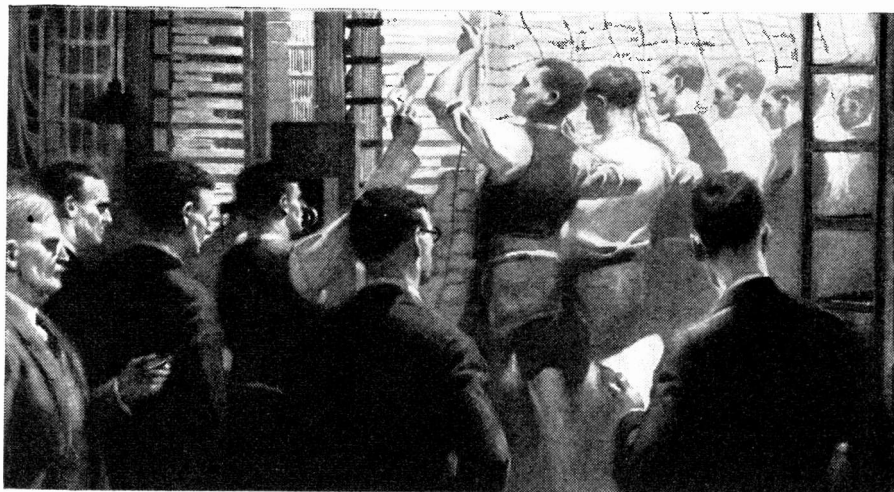

The Switchboard Comes to Life

Zero hour approaches. Wire chief and assistants are set for the "cut-over" that will bring a new central office into being.

In the room above operators sit at the new switchboard. Two years this equipment has been building. It embodies the developments of hundreds of engineers and incorporates the scientific research of several decades. Now it is ready, tested in its parts but unused as an implement of service.

In the terminal room men stand in line before frames of myriad wires, the connections broken by tiny insulators. Midnight comes. A handkerchief is waved. The insulators are ripped from the frames. In a second the new switchboard becomes a thing alive. Without their knowledge thousands of subscribers are transferred from the old switchboard to the new. Even a chance conversation begun through the old board is continued without interruption through the new. The new exchange provides for further growth.

This cut-over of a switchboard is but one example, one of many engineering achievements that have made possible a wider and prompter use of the telephone.

To-day, in maintaining a national telephone service, the American Telephone and Telegraph Company, through its engineering and research departments, continuously makes available for its Associated Companies improvements in apparatus and in methods of operation.



AMERICAN TELEPHONE AND TELEGRAPH COMPANY
AND ASSOCIATED COMPANIES
BELL SYSTEM
One Policy, One System, Universal Service



"BECOME A LIGHTNING TRICK CARTOONIST"

Make money chalk talking. Send \$1 for snappy program of trick drawings, with instructions by a professional cartoonist. Satisfaction guaranteed. Circular free. Balda Art Service, Dept. 4, Oshkosh, Wis.

BOXING, JIU-JITSU & WRESTLING \$1.67

10-Day Trial—send no money. Pay postman deposit \$1.67 plus postage. Use 10 days, money back if not satisfied. Stillman Ass'n., Dept. 1424G 247 Park Ave., New York

WANTED
RAILWAY MAIL CLERKS
\$1600 to \$2300 Year
MEN—BOYS 17 OR OVER SHOULD
MAIL COUPON IMMEDIATELY
Steady Work. No Layoffs. Paid Vacations
Common Education Sufficient:
TRAVEL—SEE YOUR COUNTRY



FRANKLIN INSTITUTE
Dept. L181, Rochester, N. Y.
Sirs: I want to travel and see my country. Send me without charge, (1) Sample Railway Mail Clerk Examination questions, (2) List of U. S. Government jobs now obtainable, (3) Send free illustrated book, "How to Get Government Jobs."
Name
Address

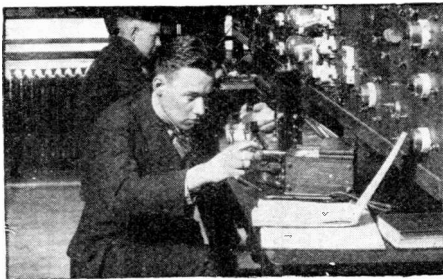

Corner of One of the Seven Laboratories

Take This Short Cut to Accomplish Your Ambition

The field of electrical engineering offers wonderful opportunities for trained men to direct and carry out great industrial and commercial projects. Get a thorough and practical training here in our course of

ELECTRICAL ENGINEERING with B. S. Degree in 3 Years

A faculty of specialists is leading hundreds of ambitious young men to sure success. Why not you? If you are lacking some preparatory studies you can make them up here as you go along. This is an exceptional opportunity to become an electrical engineer in the shortest possible time.

ELECTROTECHNICS

From 1 to 2 years in this course makes you a completely trained electrotechnician—prepared to fill such positions as general plant superintendent, director of construction, superintendent of maintenance, chief draftsman, etc. The Electrotechnician is the man between the Electrical Engineer and the Electrician—a well paid position and a stepping stone to higher executive work. A grade school diploma or equivalent admits you without examination. New term opens every 6 weeks.

COMMERCIAL ELECTRICAL ENGINEERING in 1 year

Unparalleled opportunities for brilliant, successful careers in the new field of Commercial Electrical Engineering. To meet the extraordinary present-day demands for trained electrical business men, consulting and efficiency engineers, we offer this thorough, condensed and very practical training, especially adapted to high school graduates.

PRACTICAL ELECTRICITY

In this complete 6 months' Electrical Course—8 hours daily—you can learn house, factory and theatre wiring, testing and meter work, A.C. and D.C. Armature Winding and all necessary mathematics.

A 3 months' course in A.C. and D.C. Armature Winding, or a 3 months' Course in Light and Motor Wiring and Testing is offered to those with limited time and means.

AUTOMOTIVE ELECTRICITY

Electrical specialists who instinctively diagnose and locate automotive electrical troubles command high positions and are well paid. Specialize in starting, lighting, ignition and storage batteries and command a big job at a big salary.

"EARN WHILE YOU LEARN"

We agree to provide, for a limited number of worthy young men, half-time jobs at good wages, and permanent positions with unlimited prospects to all duly qualified graduates. Here is the opportunity of your life to acquire a thorough, practical training for a big-paying profession that is in urgent need for trained men.

ESTABLISHED 18 YEARS AGO

The S. of E. stands absolutely alone in the field of thorough, practical electrical education and in commercial and electrical engineering.

NO NEED OF YOUR BEING WITHOUT AN S. OF E. TRAINING

It does not matter how old you are or what schooling you have had. Students from 16 years up to 50 are in attendance here.

Fill out the following coupon and mail it to-day.

SCHOOL of ENGINEERING of Milwaukee

Founded 1905

Dept. X1602, 415-17 Marshall St., MILWAUKEE, WIS.

SCHOOL OF ENGINEERING OF MILWAUKEE, Dept. X1602, 415-17 Marshall Street, Milwaukee, Wis.

Without obligating me in any way, please mail free 72-page illustrated book "Electricity and the One Best Way to Learn It" and particulars regarding the course I have marked with an X.

- Electrical Engineering.
- Electrotechnics.
- Commercial Electrical Engineering.
- Automotive Electricity.
- Armature Winding.
- Light, Motor Wiring and Testing.
- Practical Electricity.
- I am interested in your "Earn While You Learn" Plan.

Name..... Age.....
 Address.....
 City..... State.....
 Education.....

tery seems to surround the construction of the average so-called loud talker and this book is designed to dissipate it. The author has actually constructed several types of loud speaking receivers and from notes made during experimental work, he has compiled the data for this book. The first type of loud speaker described is that of the well known moving coil type, and full constructional data for each part of the instrument are given. The circuit diagram for a vacuum tube cascade amplifier is given and the connections between this and the loud talker are plainly shown.

In order to get more volume from a set, a third stage of audio frequency amplification* is sometimes desirable and this is given in diagrammatic form. It is shown how to use A. C. house current for replacing the storage battery required for the field coil of the loud talker.

The next described type of loud speaking receiver is the one of the original moving coil type using a bi-polar field coil. Here also full constructional details are given. The last chapter of the book deals with various types of improvised loud talkers, all of them making use of one or two standard phones. The hints given in the last chapter are well worth the price of the book alone and the data on the two types of power loud talkers is practically invaluable.

HENLEY'S 222 RADIO CIRCUIT DESIGNS. By John E. Anderson, A.B., M.A., Arthur C. C. Mills, and Elmer H. Lewis. Profusely illustrated, 271 pages, paper, 7 3/4" x 5 1/4". Published by the Norman W. Henley Publishing Company, New York City. Price \$1.00.

Instead of aching, the "hook-up bug" seems to be on the increase and biting more and more radio fans. It is seemingly with this view in mind that the publishers have put out the above mentioned book. The volume starts with a list of the various symbols used in circuit diagrams, explaining each and every one carefully. It then goes on to explain the various terms used in radio and deals with the care of various parts. Several pages of the introduction deal with the care of a storage battery, one of the most neglected parts of a radio set. Turning to page 12, the reviewer once more saw that illustration so dear to the hearts of all beginners; water waves set up by a stone. It is our sincere hope that some day some bright and enterprising author will eventually devise some analogy other than this for the setting up of radio waves in the ether by an oscillating discharge. However, this is not a "knock" and no fault can be found with this book.

The subject of tuning is explained in a simple manner and for the more advanced amateur, various calculations are given. Antennas are then dealt with both in picture and descriptive form.

The actual subject which the title indicates is then entered into and various types of coupling clearly explained. Fundamental crystal detector circuits present the subject very nicely. A chapter is devoted to the description of various commercial inductances, transformers and condensers.

The circuits given include all of the well known and some of the less known crystal detector circuits and the vacuum tube is introduced with a short description of the Fleming two element valve. Three element valves are then described and there follows a series of circuit diagrams setting forth every conceivable circuit from the simplest to the most complicated Super-Heterodyne.

A chapter on transmitting circuits, covering the subject very well from an amateur standpoint is presented. The use of vacuum tubes, operated both by batteries and from power lines is covered. A novelty in short wave "loop" transmission is presented which tends to give the book greater value to the experimenter. Filter systems, a subject on which volumes could be written, are treated in a very clear manner and diagrams of the connections of various filters are shown.

Taken as a whole, the book is well worth our commendation, as it is thoroughly up-to-date and furnishes much material for experimental work.

ATOMIC STRUCTURE AND SPECTRAL LINES. By Arnold Sommerfeld. Hard covers, 6" x 9", 616 pages, illustrated. Published by E. P. Dutton & Co., New York City. \$12.00.

This is a 600 page book translated from a work by the eminent German Professor Sommerfeld, treating on what may be fairly termed the present popular subject among the higher physicists. It treats of atomic structure, the Quantum Theory, and all the higher theories with regard to the atoms that build up the world, and their so-called planetary structure. The book has a very high aspect and is far from a popular treatise, and without hesitation the author uses higher mathematics. The book is not adapted to popular reading, but for those who wish to follow out the modern only too rapidly developing theories of the atom, cannot be too warmly recommended. Einstein and Lorentz, radio-activity, and many subjects with whose names we are more familiar than with their full scope, appear here. Atomic models are well presented with illustrations and diagrams, and it is interesting to note brought forward the doubts of the truth of theories but a few years old triumphantly produced. Relativity, as is to be expected, is accepted by the author, and in one place the spectroscopic confirmation thereof is adduced.



SEND NO MONEY 5 DAYS FREE TRIAL

"INVINCIBLE" Rebuilt GUARANTEED STANDARD No. 10 Self Starter Model **REMINGTON**

A real bargain. All late improvements—84 characters, standard type, back spacer, etc. Splendid rebuilt machines that will give years of service. Priced less than one-half the cost of new. Many other standard makes. Time payments if desired. Shipments from nearest of our conveniently located branch stores. Order NOW or write for circular. Resident salesmen wanted.

American Writing Machine Co.
 Established 1880
 Factory, 458-R Central Ave., Newark, N. J.



I OFFER YOU THE FOLLOWING:
 My Personal Attention,
 87 Lessons on Electricity,
 Slide Rule or Practical Electrical Outfit,
 Slide Rule Course,
 Radio Course,
 "Tele-Draft,"
 Drafting Course,
 Burgess "Blue Book,"
 Gold "Burgess Service" Button Consultation Service,
 Purchasing Service,
 Opportunity to Earn While You Learn,
 No Outside Studies Required,
 No Time Limit,
 Diploma,
 Membership in I. E. A.
 Employment After Graduation,
 Service to Graduates,
 Monthly Payments.
PRICE, \$60.00 FOR ALL THE ABOVE.
 No Extra Charges.
AND, START ANY TIME—STOP ANY TIME.
 Write for my catalog.
 YORKE BURGESS, President
BURGESS ELECTRICAL SCHOOL
 Dept. 7—745 E. 42nd Street, Chicago, Ill.
 Canadian Branch, 201 Crawford St., Toronto.

HANDS UP! \$1.79

GET one of these little beauties right now, and protect yourself against hold-up thugs, rowdies, etc. and at the same time it serves as the best novelty cigarette case ever invented.

Made exactly like the real thing! Just pull the trigger, back flies the lid showing a full package of your cigarettes.

Lots of fun scaring your friends and at the same time useful and a great protector.

Made of light weight metal, gun metal finish, 4 3/4 inches long. Sold exclusively by us. Order at once, supply limited. Special introductory price **\$1.75 each** PAY POSTMAN on delivery our price plus postage. Money back if not satisfied.

PATHFINDER COMPANY
 Dept. HA-1B 534 Sixth Avenue New York

The CHEAPEST SWINGOUT in the World

THE SWALLOW \$10.95

38 or 32-20 cal. 6 shot
 Accurate. Dependable and Powerful. Made of Bilbao Blue Steel. **ONLY \$10.95.**

SEND NO MONEY—Pay on Delivery Satisfaction Guaranteed or Money Back.
 New York Imp. Co., 453S. 200 B'way, N.Y.C.

Send To-day for the "Electrical Worker's Friend" **\$3.00**

An electrical book of 66 motor drawings with complete instructions for re-winding and reconnecting A. C. motors. Special at.....

Or write for full particulars of this valuable book.
SMITH & SMITH PUBLISHING CO.
 Dept. B., Valencia, Pa.

RADIO WRINKLES

EDITED BY
A. P. PECK

Associate Member Institute Radio Engrs.

UNDER this heading we are going to publish items of interest to everyone who likes to build radio instruments. In order to continue this department it is necessary for our readers to tell us about their latest experiments. Write us a short description of some time- or money-saving kink you have discovered and send it to us along with a few sketches. Our regular prizes will be paid for this material. Be brief and try to put everything in the drawing. Don't be too elaborate. Address "RADIO WRINKLES" editor care of Science and Invention.

Bending Bus-Bar

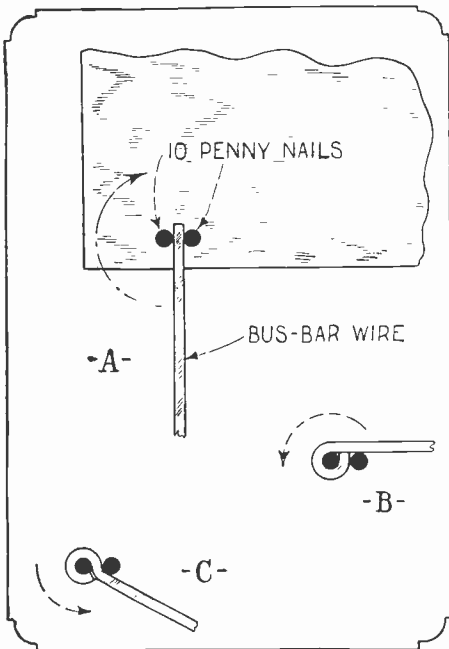

To make this bus-bar bending jig, remove the heads from two ten-penny nails, and drive them into a block just far enough apart so that the bus wire can pass between. It is very easy to form eyes on the ends of bus wire with this device. —Clifton Ask.

Rugged Detector

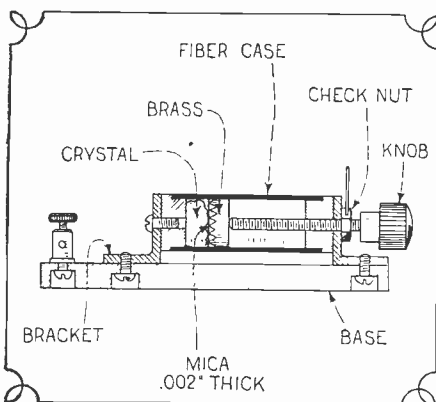

A rugged crystal detector which will withstand considerable handling, and therefore very desirable for radio camping sets, is shown above. A piece of round brass tubing has several sharp points filed around one edge, and this is pushed into contact with the crystal, through a disk of mica, as shown. The adjusting screw regulates the pressure with which this toothed ring is forced against the crystal, and a check nut enables the user to lock the adjustment. —Robert Toran.

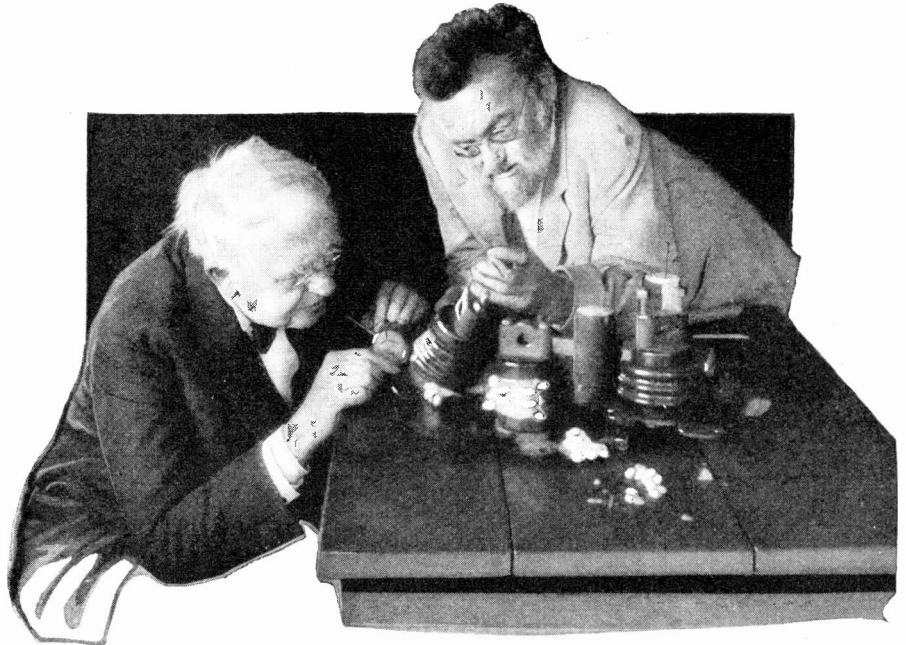

Thomas A. Edison and Charles P. Steinmetz in the Schenectady laboratories of the General Electric Company, where Dr. Steinmetz did his great work.

Steinmetz

The spirit of Dr. Steinmetz kept his frail body alive. It clothed him with surpassing power; he tamed the lightning and discharged the first artificial thunderbolt.

Great honors came to him, yet he will be remembered not for what he received, but for what he gave. Humanity will share forever in the profit of his research. This is the reward of the scientist, this is enduring glory.



Emerson tells how the mass of men worry themselves into nameless graves, while now and then a great, unselfish soul forgets himself into immortality. One of the most inspiring influences in the life of a modern corporation is the selfless work of the scientists in the laboratories, which it provides for their research.

GENERAL ELECTRIC

New ¼ H.P. 110 volt, guaranteed motors, 60 cycle A.C. Complete with cord, plug and pulley.	Gen. Elec. 1725 speed	\$14.75
Gen. Elec. ½ H.P. Rep. Ind.	Master ¾ H.P. Rep. Ind.	\$39.00
Master 1 H.P. Rep. Ind.	Master 1 H.P. Rep. Ind.	\$52.50
Master 1 ½ H.P. Rep. Ind.		\$60.00
Master 2 H.P. Rep. Ind.		\$68.00

All makes and sizes up to 100 H.P. both new and rebuilt. Motors bought, repaired, exchanged. Let us quote on your needs. Satisfaction guaranteed or money refunded. Illustrated catalog of Motors and Supplies Free.

HYRE ELECTRIC COMPANY.
631 M So. Dearborn St. Chicago, Ill.

BLANK CARTRIDGE PISTOL

Protection against Burglars, Tramps, & Dogs

PRICES
50c.
\$1.00

Well made and effective. Modeled on latest type of Revolver. Appearance alone is enough to scare a burglar. When loaded it may be as effective as a real revolver without danger to life. It takes standard .22 Cal. Blank Cartridges obtainable everywhere. Price 50c., Superior quality \$1.00 post-paid. Blank Cartridges, by express, 50c per 100.

JOHNSON SMITH & CO., Dept. 151 Racine, Wis.

Insure your copy reaching you each month. Subscribe to Science and Invention—\$2.50 a year. Experimenter Publishing Co., 53 Park Place, N. Y. C.

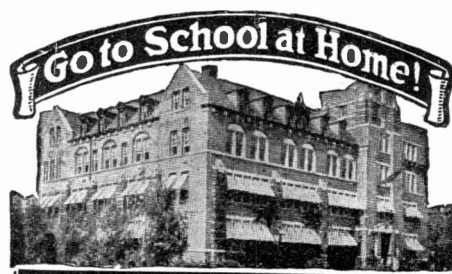

Headquarters For Home Study

There's a better job just ahead of you—in the line of work you like—at double your present salary. We'll help you get it by training you the quick, sure American School way. The lessons are simple, you study right at home in your spare time, the results are sure. The cost is low, terms easy, satisfaction guaranteed. Would you like to earn **More Money Immediately?**—then send coupon for information!

High School Course in 2 Years

You can complete this simplified High School Course at home inside 2 years. Meets all requirements for entrance to college and leading professions. Especially prepared for homestudy by leading professors.

Electrical Expert in 1 Year

Our free book "Be a Power in Electricity" will show you how to make money in your spare time—how in a few months' time you can qualify as an electrical expert or become independent in a profitable business of your own.

Law Course in 2 Years

Be a lawyer. Law trained men earn from \$5,000 to \$10,000 a year and occupy top positions in social, business and public life. Our system guides you step by step until you have passed the bar examination. We furnish everything including Complete Law Library.

Auto Expert in 1 Year

In all the world no Auto Course like this. It will quickly fit you for an expert's job at top-notch pay—in your spare time at home. Investigate. Get the facts on this great course. Learn why thousands have taken this course in preference to any other, and made good.

Business Success in 1 Year

Without specialized training in a specialized field of business you won't have even a fair chance for success. Our free book "How to Make Money in Business" points the way to success and big pay. Send for it now.

American School

Dept. GB26 Drexel Ave. and 58th St., Chicago

American School, Dept. GB26 Drexel Ave. and 58th St., Chicago
Send me full information on the subject checked and how you will help me win success.

- | | |
|--------------------------|--------------------------|
| --- Architect | --- Business Law |
| --- Building Contractor | --- Lawyer |
| --- Automobile Engineer | --- Mach. Shop Practice |
| --- Auto Repairman | --- Mechanical Engineer |
| --- Civil Engineer | --- Shop Superintendent |
| --- Structural Engineer | --- Employment Mgr. |
| --- Business Manager | --- Steam Engineer |
| --- Certified Public | --- Foremanship |
| --- Accountant | --- Sanitary Engineer |
| --- Accountant & Auditor | --- Surveyor & Mapping |
| --- Bookkeeper | --- Telephone Engineer |
| --- Draftsman & Des'ner | --- Telegraph Engineer |
| --- Electrical Engineer | --- High School Graduate |
| --- General Education | --- Wireless Radio |
| --- Personal Analysis | --- Undecided |

Name _____
Address _____

Money Back When You Finish If Not Satisfied

BATTERY KINK

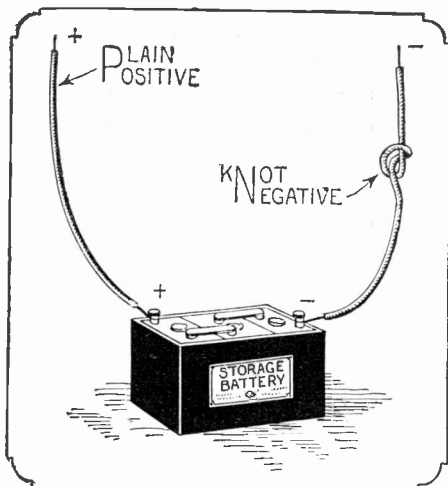

When considerable experimental work is being done and battery leads are to be changed frequently, the polarities are very often mixed up with a consequent failure of a circuit to work properly. Especially is this true when long battery leads are used and twisted together. This trouble can be done away with by following the kink illustrated above. The leads distinguish themselves and the rule is very easy to follow.
—R. P. Barrows.

LIGHTNING SWITCH

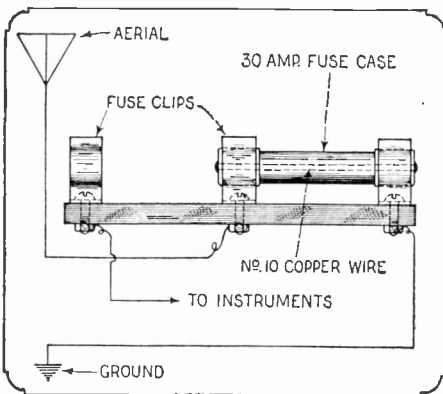

A very serviceable lightning switch may be made from a 30 ampere fuse case and three fuse clips. The fuse wire is replaced with a length of No. 10 copper wire and connections are made as shown. This switch is comparatively cheap to construct, but at the same time gives very satisfactory results.
—Walter T. Markowski.

LOOP AERIAL SPACERS

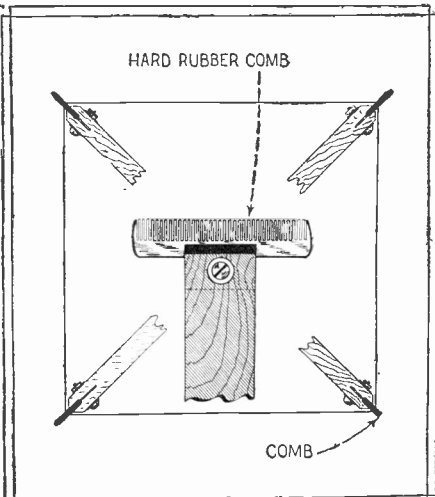

Excellent insulators that at the same time provide automatic spacing of the wires in a loop aerial may be made from four hard rubber combs as shown above. A simple clamp holds the combs in place.
—Harold Jackson. Rep. No. 2903.

ARROW BATTERY SLASHES Prices TO CONSUMERS ONLY

Prices Smashed! Quality Not Sacrificed! Here is real battery quality, guaranteed to you, at prices that will astound the entire battery-buying public. Order direct from factory. Put the Dealer's Profit in your own pocket. You actually save much more than half, and so that you can be convinced of true quality and performance, we give a **Written Two-Year Guarantee**

- Here is your protection! Noneed to take chance. Our battery is right—and the price is the lowest ever made. Convince yourself. Read the prices!
- Special 2-Volt Radio Storage Battery, \$3.75
 - Special 4-Volt Radio Storage Battery, 6.00
 - 6-Volt, 60 Amp. Radio Storage Battery, 7.00
 - 6-Volt, 80 Amp. Radio Storage Battery, 8.00
 - 6-Volt, 100 Amp. Radio Storage Battery, 9.50
 - 6-Volt, 120 Amp. Radio Storage Battery, 11.50
 - 6-Volt, 140 Amp. Radio Storage Battery, 13.00

We ask for no deposit. Simply send name and address and style wanted. Battery will be shipped the day we receive your order Express C. O. D., subject to your examination on arrival. Our guarantee accompanies each battery. We allow 5% discount for cash in full with order. You cannot lose! Act quick. Send your order today—NOW.

Arrow Battery Co.
1421 South Wabash Ave.
Dept. 9 Chicago, Ill.

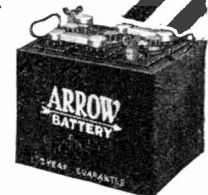

SEND FOR THE INTERNATIONAL CATALOG

Our net price list. Full line of auto bodies and accessories for Ford at Wholesale Prices. Save big money on bodies by buying Direct from Factory. FOR FORD—Prices from \$27.85 up. Consumer direct—Pay only One Profit.

International Body Works, 914 W. Ohio St., Dept. 4, Chicago, Ill.

1/6 H. P. MOTORS \$5.00
A. C. 60 cycles and D. C. 110 Volts 1750 r.p.m., used motors equipped with worm gear. In fine condition. Mostly Holtzer-Cabot make. With little ingenuity can be used to drive washing machine, drill press, grinder, small lathe, etc. Satisfaction guaranteed. Write to:
A. E. SHAW 334 73rd St., Brooklyn, New York

SEND NO MONEY Big 3 foot Telescope in 5 Sections

See people and objects miles away just like they were close, see Moon and Stars as you never did before. Brass bound, useful and entertaining. "Could tell color of aeroplane 4 miles away" — Mrs. Yarbrough. "Watch my boy arrive at school 2 miles away" — Mrs. Horn. "Read numbers on freight cars mile away, see mountains on moon" — A. C. Palmer. Thousands pleased. SPECIAL OFFER. Send just your name. On arrival pay postman \$1.85 plus few cents postage. Satisfaction Guaranteed or money back. FERRY & CO. 630 W. Jackson Blvd. Dept. B-125 Chicago, Ill.

What See This
Wonderful, new device, guides your hand; corrects your writing in few days. Big improvement in three hours. No failures. Complete outline FREE. Write C. J. Ozment, Dept. 44 St. Louis, Mo.

WHY NOT IMPROVE YOUR PERSONAL APPEARANCE?
Send for booklet showing photos of Men with and without the "PERFECT LEG FORMS" for BOW LEGS and KNOCK-KNEES. Also BRACES, for children for PERMANENT CURE. Perfect Sales Co., 140 N. Mayfield Ave., Chicago, Ill. Dent. 50

GOES DIRECT TO THE HEART OF THE SEX QUESTION
SEX
Facts other sex books don't dare discuss are plainly told in "Where Knowledge Means Happiness." Creates a new kind of married love. One reader says: It contains more real information than all other sex books put together.
From "Where Knowledge Means Happiness" Copyright 1921
Sent in plain cover, by return mail, for \$1.00 cash, money order, check or stamps
Dept. 39 COUNSEL SERVICE, 257 W. 71 St., N.Y.

NOVEL SWITCH POINTS

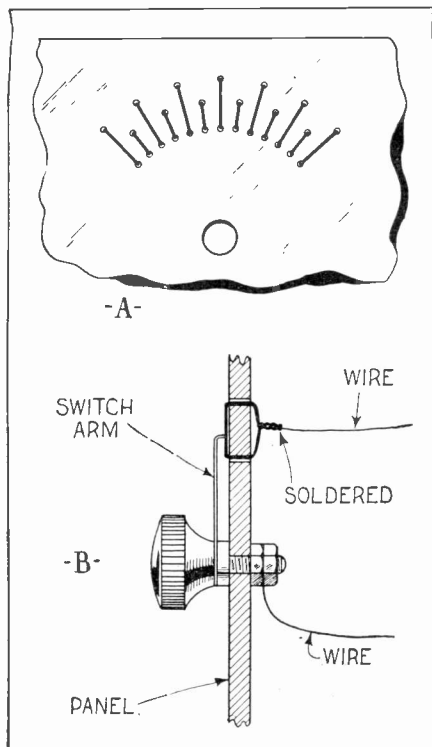

Switch points which present an exceedingly neat and novel appearance may be made as shown above. Two holes are drilled in the panel for each point. They should be made with a drill of such a size that the wire used will just pass through the holes. By spacing the holes for adjacent points as shown at A, the effect is better. B shows the sectional view of one of these switch points. No. 14 bare copper wire should be used for the contact. Hard drawn wire is best.

—Fred J. Huhn.

SWITCH STOPS

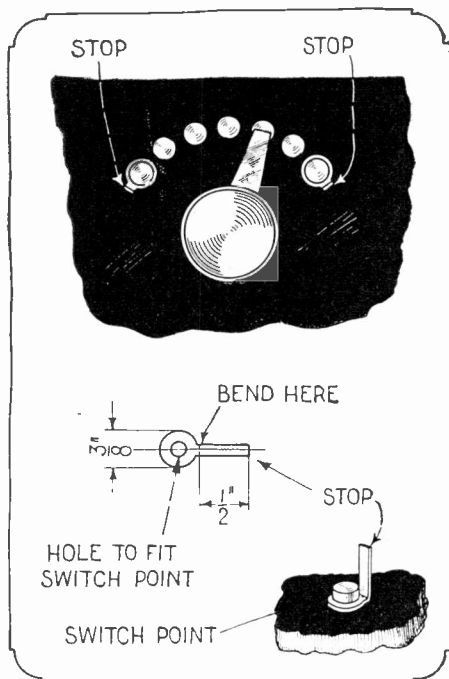

Probably one of the most annoying occurrences when tuning a radio receiving set is to have the switch blade run off the last point and hit the panel. This can be eliminated by constructing switch stops such as illustrated above. They are cut from about No. 20 gauge sheet brass as shown. The dimensions can be varied if necessary to fit different sizes of switch points. A right angle bend is made in the stop at the point illustrated and the assembly is made as shown.

—Lyndon Young.

BLISS ELECTRICAL SCHOOL

Established 1893. A special technical school with concise but comprehensive course in Electrical Engineering. Non-essentials eliminated. Thorough knowledge of underlying principles emphasized. Theory and practice are closely interwoven in class-room and laboratory.

Electrical Engineering in One Year

The course is designed for earnest, ambitious young men of limited time and means. Curriculum includes mathematics, mechanical drawing and intensive shop work. Students construct motors, install wiring, test electrical machines. Graduates are qualified to enter the electrical field at once.

Bliss men hold responsible positions throughout the world. Thoroughly equipped fire-proof dormitories, dining hall, laboratories and shops. Prepare for your profession in the most interesting city in the world. Send for catalog. Address

BLISS ELECTRICAL SCHOOL, 106 Takoma Avenue, Washington, D. C.

Make Money Taking PICTURES

Tremendous, big-paying opportunities are open for ambitious men in Modern Photography. This is the picture age. Magazine and newspaper publishers buy thousands of photographs each year. Every manufacturer sends out high priced pictures of his products. Every home wants portraits. Photography is a business running into millions of dollars each year. And there is a great shortage of trained photographers.

Got \$100 for Flood Pictures
"I took pictures of a flood and sold them for \$100. I have been able to buy my house and lot from the sale of pictures."
C. M. Cole, Washington.

Earn \$3,000 to \$10,000 a Year
Hundreds of men are earning big money and establishing their own businesses. Even during spare time, while training, you can make \$75 a week easily—no matter where you live!

Amazing New Easy Method
I show you at home, how to do the kind of work turned out by the big studios in New York and Chicago! I show you how to make big money within 30 days!
C. M. Cole bought a home with money he had made when only half way through his training. So well do I know what I can do for you that I guarantee under bond to return every cent of your tuition if you are not thoroughly satisfied.

Professional View Camera FREE!

Write at once for Free Camera Offer—I give you, free, a splendid professional view camera. You will be astonished and delighted. This offer open for short time only—so act quick! No obligation.

INTERNATIONAL STUDIOS, Inc.
Dept. B-533
3601 Michigan Ave., Chicago, U.S.A.

King of 'Em All

Means Auto Wheel

Here comes Bill and his Auto-Wheel Coaster Wagon. They are old friends—Bill and the Auto-Wheel. Bill wouldn't give up his Auto-Wheel unless he was sure that he could get another just like it, for in his choice of coaster wagons, Bill knows that "King of 'Em All" means

Auto-Wheel

Write for catalog of all models of the Auto-Wheel and the Auto-Cart (for little brother and sister). If you send names and addresses of three coaster wagon dealers in your town, telling which sell Auto-Wheel, we give you a year's subscription FREE to the "Auto-Wheel Spokes-man," our magazine.

AUTO-WHEEL COASTER CO., INC.
North Tonawanda, N. Y.

"THERE'S MONEY IN IT"

LEARN TELEGRAPHY AT HOME

MORSE AND WIRELESS

TEACH YOURSELF in half usual time, at trifling cost, with the wonderful Automatic Transmitter THE OMNIGRAPH. Sends unlimited Morse or Continental messages, at any speed, just as an expert operator would. Adopted by U. S. Government and leading Universities, Colleges and Telegraph Schools. 3 styles. Catalog free.

If you own a Radio Phone Set and don't know the Code, you are missing most of the fun.

OMNIGRAPH MFG., CO. 22 Hudson St., NEW YORK

MAKE \$150 TO \$300 MONTHLY CHARGING BATTERIES!

Start now to build your own money-making business. Charging Auto Batteries. No experience needed. Buy an HB One-Day Constant Potential Battery Charger on long easy terms, more than paid by big monthly profits. Small cash payment puts HB outfit in your shop. 30 days' free trial on money-back guarantee. Only \$20 monthly pays for your outfit. No repairs, no expensive renewals. More HB outfits in use than any other make. Write today for Bulletin 724. **HOBERT BROS. CO., Box S7, Troy, Ohio.**

Profits Easily Carry Small Monthly Payments

ONE THOUSAND AGENTS WANTED

We want one thousand agents to sell subscriptions to RADIO NEWS, SCIENCE AND INVENTION, PRACTICAL ELECTRICIAN and the MOTOR CAMPER AND TOURIST. We will pay a generous commission for this work and help you in every way. Our three publications are leaders in their fields, ready sellers and this is an offer well worth your while. A few spare hours a day will bring you a handsome return. Write regarding our proposition at once and be the first one to get started in your vicinity.

EXPERIMENTER PUBLISHING COMPANY
53 Park Place
HERBERT H. FOSTER, Circulation Manager
New York

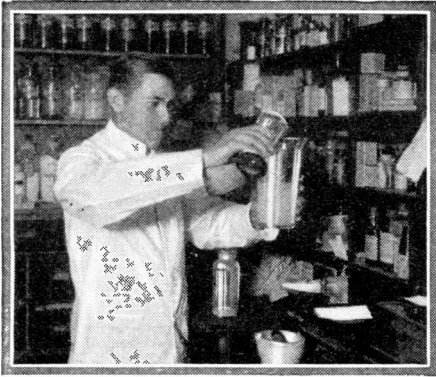

An Easy Way to Learn PHARMACY AT HOME

Graduate pharmacists are always in demand. The work is interesting and pleasant and salaries are good. Many young men open drug stores of their own and become independent.

There's an easy way to learn pharmacy right in your own home in spare time, without losing a day or a dollar from your present work.

The International Correspondence Schools course in Pharmacy supplies the knowledge which it will be necessary for you to have in order that you may pass your State Board Examination.

Just mark and mail the coupon printed below to the International Correspondence Schools, Box 6245-C, Scranton, Pa., and full particulars about the Pharmacy Course or any other work of your choice will come speeding to you by return mail.

TEAR OUT HERE

INTERNATIONAL CORRESPONDENCE SCHOOLS
Box 6245-C Scranton, Penna.

Without cost or obligation on my part, please send me full particulars about the subject before which I have marked an X in the list below:—

TECHNICAL AND INDUSTRIAL COURSES

- | | |
|--|--|
| <input type="checkbox"/> PHARMACY | <input type="checkbox"/> Civil Engineer |
| <input type="checkbox"/> Chemistry | <input type="checkbox"/> Surveying and Mapping |
| <input type="checkbox"/> Automobile Work | <input type="checkbox"/> Mine Foreman or Engineer |
| <input type="checkbox"/> Agriculture and Poultry | <input type="checkbox"/> Steam Engineering |
| <input type="checkbox"/> Mathematics | <input type="checkbox"/> Gas Engine Operating |
| <input type="checkbox"/> Electrical Engineering | <input type="checkbox"/> Airplane Engines <input type="checkbox"/> Radio |
| <input type="checkbox"/> Electrician | <input type="checkbox"/> Architect |
| <input type="checkbox"/> Mechanical Engineer | <input type="checkbox"/> Contractor and Builder |
| <input type="checkbox"/> Mechanical Draftsman | <input type="checkbox"/> Architectural Draftsman |
| <input type="checkbox"/> Machine Shop Practice | <input type="checkbox"/> Concrete Builder |
| <input type="checkbox"/> Railroad Positions | <input type="checkbox"/> Structural Engineer |

BUSINESS TRAINING COURSES

- | | |
|---|---|
| <input type="checkbox"/> Salesmanship | <input type="checkbox"/> Business Management |
| <input type="checkbox"/> Advertising | <input type="checkbox"/> Industrial Management |
| <input type="checkbox"/> Better Letters | <input type="checkbox"/> Personnel Organization |
| <input type="checkbox"/> Foreign Trade | <input type="checkbox"/> Traffic Management |
| <input type="checkbox"/> Stenography and Typing | <input type="checkbox"/> Business Law |
| <input type="checkbox"/> Business English | <input type="checkbox"/> Banking and Banking Law |
| <input type="checkbox"/> Civil Service | <input type="checkbox"/> Accountancy (including C.P.A.) |
| <input type="checkbox"/> Railway Mail Clerk | <input type="checkbox"/> Nicholson Cost Accounting |
| <input type="checkbox"/> Common School Subjects | <input type="checkbox"/> Bookkeeping |
| <input type="checkbox"/> High School Subjects | <input type="checkbox"/> Private Secretary |
| <input type="checkbox"/> Illustrating | <input type="checkbox"/> Business Spanish <input type="checkbox"/> French |

Name.....
Street Address.....
City..... State.....

Occupation.....
Persons residing in Canada should send this coupon to the International Correspondence Schools Canadian, Limited, Montreal, Canada.

Ford Runs 57 Miles on Gallon of Gasoline

A new automatic and self-regulating device has been invented by John A. Stransky, 2587 Fourth St., Pukwana, South Dakota, with which automobiles have made from 40 to 57 miles on a gallon of gasoline. It removes all carbon and prevents spark plug trouble and overheating. It can be installed by anyone in five minutes. Mr. Stransky wants agents and is willing to send a sample at his own risk. Write him today.—Adv.

TUBE PROTECTION

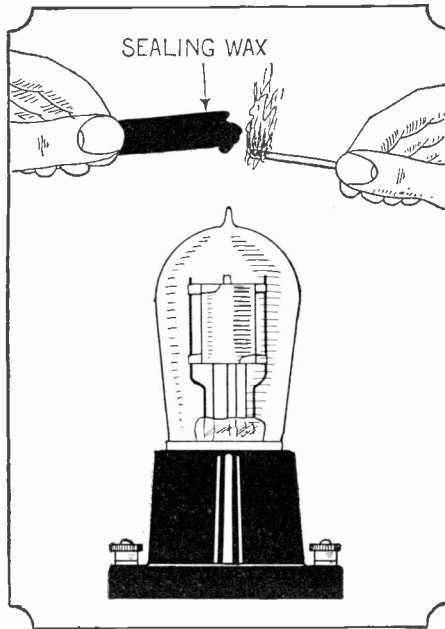

The most vulnerable point of a vacuum is the tip which is left at the top of the tube after the air has been exhausted from the tube. Very often a comparatively light shock such as touching the tip with a metallic object will cause a break or crack which will allow air to enter the tube and render it useless. A good precaution to take against this trouble is illustrated above. Cover the tip with a fairly heavy layer of sealing wax. This will increase the mechanical strength of this point and may save the price of a new tube.
—Raymond B. Wailes.

MAGNETIC CRYSTAL DETECTOR

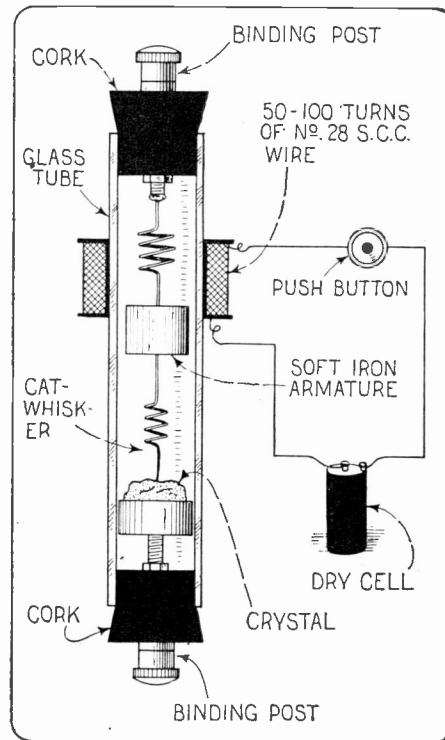

A very interesting crystal detector which gives excellent results in all types of receiving sets may be constructed as shown above. The detector itself is enclosed in a piece of glass tubing with corks at each end. Binding posts are mounted on the corks as illustrated, one of them connecting to the crystal cup and the other to the cat whisker, which is made with two spirals and between these is located a small iron armature. A solenoid is then wound around the tube as shown and connected to a battery and push button. To readjust the detector, press the button and release it. —Arthur Blumenfeld.

Free HEALTH Beauty TRIAL at Home

Latest Book for Men and Women

Free trial proves that Wonder Mist revitalizes every cell and works miracles overcoming pain and sickness. Physicians and plain folks explain how "Wonder Mist" has made them well, strong and happy, in our 64 page book. Actual photographs, scientific charts and diagrams. It's FREE.



Wonder Mist New Improved Violet Ray

"Wonder Mist" works quickly; it's scientific, goes after the cause. That's why results are quick, permanent. Dr. Duncan, Kewanee, Ill. writes "Wonder Mist" is the finest thing to relieve pain, treatments are so pleasant all my patients like it." Use it at home. Save doctor bills. Brings the natural magnetic beauty of health, no dieting, exercise or drugs.

SEND FOR FREE BOOK

Explains how Nicola Tesla discovered "Wonder Mist," how it works, why it heals. Tells how to conquer pain, disease and nervous trouble.

Reveals Marvelous Scientific Discovery. Shows charts of human body, explains where pains start, how to banish them. Offered Free for a limited time only to introduce "Wonder Mist." Send for Free copy today.

VI-REX CO. 211 S. Peoria St., Dept. 407 Chicago, Ill.

— Mail Coupon—Send No Money—

VI-REX CO., 211 S. Peoria St., Dept. 407 Chicago, Ill. Please send me without cost or obligation your free 64-page book describing your Vi-Rex "Wonder Mist" outfits, and details of your FREE Trial Offer.

Name.....
Address.....
City..... State.....

Radio Safeguards

SOLDERALL
SOLDERS ALL JOINTS PERMANENTLY 25¢

STORM KING
LIGHTNING ARRESTER
APPROVED BY THE NATIONAL BOARD OF FIRE UNDERWRITERS

\$1.00 AT ALL DEALERS

SOLDERALL CO., Newark, N.J.

FILE SAWS in 5 Minutes

Save money on your work,—make money filing saws for others, with the Foley Automatic Saw Filer and Saw Set. Get free catalog. Agents Wanted.

FOLEY SAW TOOL COMPANY
3625 Portland Ave., Minneapolis, Minn.

STAMMER NO MORE

Kill the fear of stammering. Re-education the key. The widely famed Hatfield Method fully outlined in an accurate, dependable, worthwhile book—"HOW TO STOP STAMMERING." It has inspired thousands. Free copy today.

THE HATFIELD INSTITUTE, 109 N. Dearborn, Chicago, Ill.

LEARN RADIO

Here's your opportunity. Radio needs you. Win success in this fascinating field. Trained men in demand at highest salaries. Learn at home, in your spare time.

Be a Radio Expert

I will train you, quickly and easily, to design, construct, install, operate, repair, maintain, and sell all forms of Radio apparatus. My new methods are the most successful in existence. Learn to earn **\$1,800 to \$10,000 a Year**

FREE Wonderful, home-construction, tube receiving set, of latest design. Write for "Radio Facts" free. Engineer Mohaupt. **RADIO ASSOCIATION OF AMERICA** Dept. 67 4513 Ravenwood Ave., Chicago

CATALOG

L-25-148 PAGES FREE

SUPER-HETERODYNE—NEUTRODYNE!

New Complete Branon Kit, Including Oscillator Coupler, Antenna Coupler, 3 Inter. R.F. Trans. and Special Transfer Coupler. Complete Kit Lists, \$36.50. Acme 30 Kilo Cycle R.F. Trans., \$5.00. All American 2,000 to 10,000 Meter Trans., \$6.00. Hilco Antenna Coupler, \$8.00. Oscillator Coupler, \$7.00. Gen. Pads, Neut. Parts, 5 tube, \$65.00; 4 tube, \$61.00; Kit, \$25.00.

10 HOUR SERVICE

AMERICAN RADIO MFG. CO.

WHOLESALE DISTRIBUTORS

Dept. F. 6 West 14th St. Kansas City, Mo.



MIRACO

GETS 'EM FROM COAST TO COAST

PRICE ONLY \$29.50

At rock bottom prices you get the efficiency of sets costing three times as much. Users tell us that Miraco Radio frequency receivers pick up stations from east to coast. Operate either on dry cells or storage battery. Solid mahogany cabinets—finest workmanship throughout. Order direct or send for bulletin.

Two tube outfit.....\$29.50
Four tube outfit.....\$54.50

DEALERS — AGENTS — write for proposition quickly—it's a winner

THE MIDWEST RADIO COMPANY
809 Main Street Cincinnati, Ohio

2650 Miles ON ONE TUBE

Broadcasting from Atlantic Coast, Mexico, Canada, Cuba and Hawaii, heard in California by users of CROSS-COUNTRY CIRCUIT

Atlantic Coast users hear California. Range due to simplicity of set and operation by only one tuning control. Easy and cheap to build by any novice. Dry cell tubes may be used. Complete understandable instructions, full size panel layout, assembly photo, etc. Postpaid, 25c.; Stamps accepted.

VESCO RADIO SHOP
Box S. 1. 117 OAKLAND, CALIF.



Charge Your Battery For A Nickel

The Gold Seal Homecharger charges Radio and Auto Batteries at home overnight for a nickel. Your dealer has it. Write for FREE booklet and list of broadcasting stations.

The Automatic Electrical Devices Co.
116 W. 3d St., Cincinnati, Ohio

MOTOR CAMPER & TOURIST

The only magazine that covers the entire field of Touring and Camping by Motor. Tells you where to go in your car, the best route to take and how to get the most pleasure from the trip.

Second Issue, July—Out June 15th

On all newsstands 25c the copy.
By subscription \$2.50 per year.

Germott Publishing Company

Successors to Practical Electrics Co.
53 PARK PLACE NEW YORK CITY

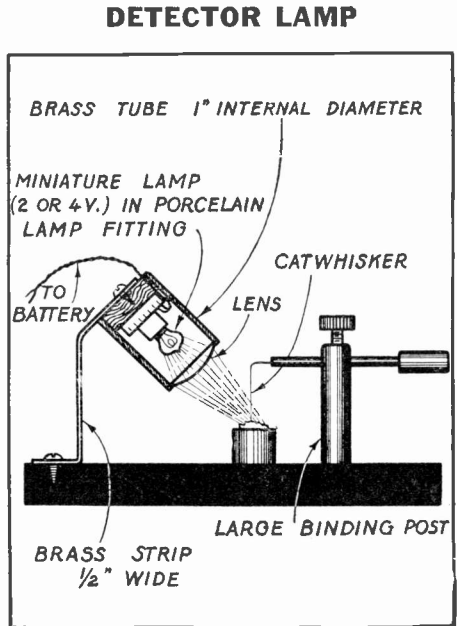

When the radio set is located in a dark corner, a lamp such as illustrated above will be of great assistance in illuminating the detector while it is being adjusted. The lamp may be lighted by means of a flashlight cell.

—C. A. Oldroyd.

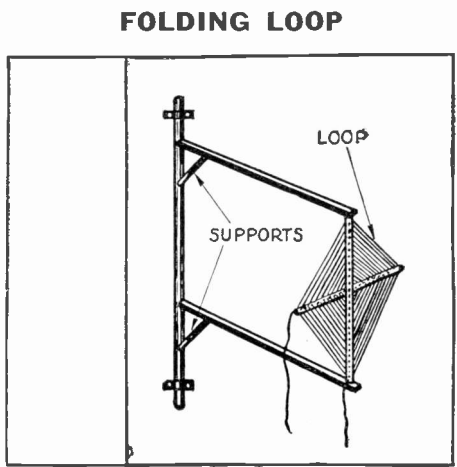

The question of room for the loop aerial is quite a serious one in most places. However, the problem can be solved as shown above. Mount the loop on two wooden arms which are in turn fastened to the wall in such a manner that they may be swung. The loop may then be placed flat against the wall when not in use.

—Steve Goff. (Kindly forward address.—Ed.)

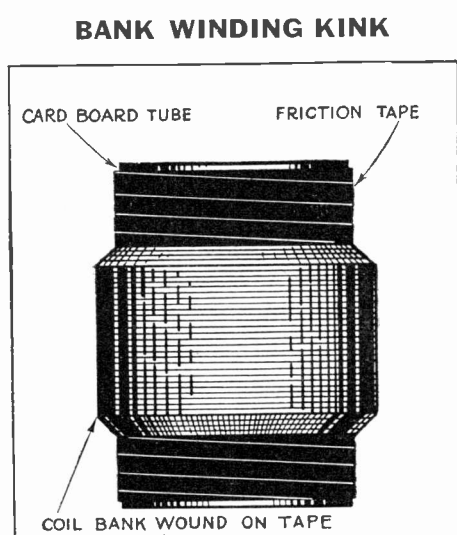

When bank winding is being done, the turns often slip out of place. This can be avoided by first covering the tube with friction tape, winding it spirally and not allowing the edges to overlap.

—A. Leven.



More Money For You in RADIO

THE amazing expansion of Radio has opened up hundreds of wonderful new positions on land and sea. Big salaries, fascinating, easy work, short hours, and a wonderful future are offered to ambitious men who get into Radio now.

Take advantage of these wonderful opportunities to step into a big paying position in this great new field. Radio offers you an opportunity to travel and see the world, with all expenses paid, and a fine salary besides. Or you can stay at home and work up to a position paying up to \$10,000 a year. One of our recent graduates secured a position one week after graduating, paying a salary of \$300 per month. Hundreds of others report equal success.

Easy to Learn Radio at Home

Hundreds of men are already earning handsome incomes in this wonder science. If you want to get into a profession where opportunities are unlimited make Radio your career—become a Certified Radio-trician.

Thousands of Certified Radio-tricians are wanted to design Radio sets; to make new Radio improvements; to manufacture Radio equipment and to install it; to maintain and operate great broadcasting stations and home Radio sets; to repair and sell Radio apparatus; to go into business for themselves; to operate aboard ship and at land stations.

You can easily and quickly qualify in your spare time at home through the help of the National Radio Institute, first school to teach radio successfully by mail, established 1914. No previous experience or training needed. Prominent Radio experts will help you. FREE, with course—circuits and parts for building latest receiving set; also, three instruments are loaned to students, making the work thoroughly practical. The same plan that has already helped hundreds of our graduates to real success and real money in Radio is open to you.

Send for BIG BOOK

No other field today offers such great opportunities as Radio. Take your choice of the many wonderful openings everywhere. Prepare now to step into the most interesting and best paid profession today. Read about the opportunities open now—the different kinds of work—the salaries paid. Write today for the 32-page book that tells how America's first and biggest Radio school can teach you to become a Certified Radio-trician in your spare time. Mail the coupon or write a letter NOW.

National Radio Institute
Dept. 14GA
Washington, D. C.

National Radio Institute, Dept. 14GA
Washington, D. C.

Without obligation send me your book, "Rich Rewards in Radio," which tells all about the opportunities in Radio, how spare time study at home will qualify me quickly as a Certified Radio-trician so I can get one of these splendid positions, and how your Employment Service helps me to secure a big pay job. (Please write plainly.)

Name Age.....
Street Occupation.....
City State.....

Practical Electrics

Keeps You In Touch
With the Progress
of Electricity the
World Over

SEND FOR
FREE
SAMPLE COPY

Every important advance or change in the world of Electricity for the Electrical Experimenter and Electrician is published in PRACTICAL ELECTRICS and explained in language that everyone can understand. PRACTICAL ELECTRICS maintains departments, or special sections, devoted especially to the important phases of electrical development. These sections appear regularly every month. Some of these departments are: *NEW THINGS ELECTRIC*, *MOTOR ELECTRICS*, *EXPERIMENTAL ELECTRICS*, *JUNIOR ELECTRICIAN*, etc.

PRACTICAL ELECTRICS is edited by H. Gernsback, Editor of *RADIO NEWS*, *SCIENCE and INVENTION*, and *MOTOR CAMPER & TOURIST*. It contains over 60 pages every issue and maintains prize contests that amount to over Five Hundred Dollars. Some of these contests are listed below.

Send in your subscription today

Subscription Price \$2.50 the Year.
On All Newsstands at 25c the Copy.

Germott Publishing Company, Inc.
53 Park Place New York City

OVER \$500—IN PRIZES

ODD ELECTRICAL EXPERIENCE CONTEST	CONTEST FOR ELECTRICAL EXPERIMENTERS	SHORT CIRCUITS	ELEC-TRICKS

Opportunity Ad-lets

YOU will find many remarkable opportunities and real bargains in these columns. It will pay you to read and investigate the offerings made every month by reliable firms, dealers and amateurs from all over the country. No matter what you may be seeking, whether supplies, automobile accessories, the opportunity to make money, or anything else, you will find listed here the best and most attractive specials of the month.

Advertisements in this section twelve cents a word for each insertion. Name and address must be included at the above rate. Cash should accompany all classified advertisements unless placed by an accredited advertising agency. No advertisement for less than 10 words accepted. Ten per cent. discount for 6 issues, 20 per cent. discount for 12 issues. Objectionable or misleading advertisements not accepted. Advertisements for the September issue must reach us not later than July 15th.

The Circulation of Science and Invention is over 177,000 and climbing every month

EXPERIMENTER PUBLISHING CO., INC., 53 Park Place, New York City, N. Y.

Agents Wanted

Agents—Best seller; Jenm Rubber Repair for tires and tubes; supersedes vulcanization at a saving of over 800 per cent; put on cold. It vulcanizes itself in two minutes and is guaranteed to last the life of the tire or tube; sells to every auto owner and accessory dealer. For particulars how to make big money and free sample, address Amazon Rubber Co., Dept. 601, Philadelphia, Pa.

Big money and fast sales. Every owner buys gold initials for his auto. You charge \$1.50; make \$1.35. Ten orders daily easy. Write for particulars and free samples. American Monogram Co. Dept. 71, East Orange, N. J.

We start you without a dollar. Soaps, Extracts, Perfumes, Toilet Goods. Experience unnecessary. Carnation Co., Dept. 232, St. Louis.

Make \$25 to \$50 week representing Clows' Famous Philadelphia Hosiery, direct from mill—for men, women, children. Every pair guaranteed. Prices that win. Free book "How to Start" tells the story. George Clows Company, Desk 27, Philadelphia, Pa.

Only one sale a day means \$200 per month. Five sales, \$1,000 per month. Marvelous new adding machine. Retail \$15. Work equals \$50 machine. Adds, subtracts, multiplies, divides automatically. Speedy, accurate, durable, handsome. Five-year guarantee. Offices, stores, factories, garages buy one to dozen. A fortune for live agents. Write quick for protected territory and free trial offer. Lightning Calculator Co., Dept. W., Grand Rapids, Mich.

Earn big money fast applying gold initials to autos. Every owner buys—\$1.35 profit on \$1.50 sale—particulars and samples free. Write quick. Lithograph Co., Dept. 19, East Orange, N. J.

Write and learn how to start profitable business without capital or experience. Silvering mirrors, refinishing auto headlights, tableware plating. Outfit furnished. International Laboratories, Dept. 25, 309 Fifth Ave., New York.

We want Salesmen and Agents, either whole or side line, to sell our low priced radio books to the trade. Excellent proposition for live wires. The E. I. Company, Publishers, 233 Fulton Street, New York City.

New Wonderful Seller. Over 100 per cent profit on every sale of Harper's Ten-Use Set. Needed in every home. Washes and dries windows, sweeps, scrubs, mops, etc. Greatest year 'round seller. Write Harper Brush Works, 152-2nd St., Fairfield, Iowa.

Earn \$10 daily silvering mirrors, plating and refinishing metalware, chandeliers, bedsteads, headlights. Outfits furnished. N. Deele Laboratories, 1153 Broadway, New York.

\$60—\$200 a week. Genuine Gold Letters for store windows. Easily applied. Free samples. Liberal offer to general agents. Metallic Letter Co., 441 B., North Clark, Chicago.

Agents—Big returns, fast office seller; particulars and samples free. One Dip Pen Co., 12 Daily Record Bldg., Baltimore, Md.

Make \$120 Weekly in Spare Time—Sell what the public wants—long distance radio receiving sets. To sales weekly pays \$120 profit. No big investment, no canvassing. Sharpe Colorado made \$955 in one month. Representatives wanted at once. This plan is sweeping the country—write today giving name of your county. Ozarka, 825 Washington Blvd., Chicago.

Big money and fast sales. Every owner buys gold initials for his auto. You charge \$1.50, make \$1.44. 10 orders daily easy. Samples and information free. World Monogram Co., Dept. 32, Newark, N. J.

Agents Wanted Full or Part Time to Sell on liberal commission new Thermostatic Automatic Carburetor control Attachment for Ford cars. Increases mileage 100%. No holes to drill. Attached in 2 minutes. Does automatically exactly what Ford Manual instructs driver do by hand. Cadillac now using Thermostatic Carburetor Control under Blanche license. Write at once. A. C. Blanche & Co., Dept. 151 E, 602 W. Lake St., Chicago.

Rummage sales make \$50.00 daily. Offer wonderful values. We start you. "Wholesale Distributors." Dept. 32, 609 Division Street, Chicago.

Agents—\$25.00 daily taking orders for Walton-Duplex Reversible Doublewear Shirts, factory to wearer. Pay advanced. We deliver. Walton-Duplex Company, 252 Brooks Bldg., Chicago.

Wonderful discovery. Charges batteries in ten minutes. Gallon free to agents. Radiolite Co., St. Paul, Minn.

Best proposition in the Specialty Field. Perry Lykold Paintings, Photo Medallions, and Novelties have no equal. Every interview means a sale. 600% profit. Write for details. Perry Photo Novelty Corporation, Sect. 817, 360 Bowery, New York.

Agents, both sexes, we manufacture and control new household article. Fast seller. Big profits. Exclusive territory. Write now. Connolly, 123 Liberty St., New York.

\$30.00 daily taking orders. Beautiful guaranteed embroidered (two colors) washable table cloth, \$2.95. Big commission. We deliver. Atlas Linen Co., 600 Blue Island Ave., Factory 14, Chicago.

Agents—Here's a sure winner. We pay \$3 an hour for your spare time taking orders for "Zanol" Pure Food Flavors. Miss Edith Haut made \$54 in one week. Write for sample case. Makes beautiful display. Shows 18 articles of best and fastest sellers of Flavors, Soaps, Perfumes, Toilet Articles, etc. Every woman buys. Big repeaters. Have a steady income. Customer must be satisfied or money back. Send for sample case today. American Products Co., 1832 American Building, Cincinnati, Ohio.

Agents Wanted—(Continued)

Succeed with your own products—Formulas, Processes, Trade-Secrets. Different, dependable, profitable. Catalog free. D. Thaxly Co., Washington, D. C.

Easy money applying Monograms, Gold Initials on Automobiles. Simple process, done while waiting, cost 6c. Get \$1.50 sample free. "Ralco," 32513 Harrison Ave., Boston, Mass.

American Made Toys

Opportunity to start Manufacturing Metal Toys and Novelties. No experience necessary. Enormous demand exceeds supply. We furnish, at cost, casting forms for production and buy entire output, also place yearly contract orders. Casting forms made to order. Catalog, advice and information free. Metal Cast Products Co., 1696 Boston Road, New York.

Automobiles

Build a Real Automobile—Weight 150 pounds. Handy men or boys build at small cost. Complete Book Easy-to-Follow Plans, 25c. Famous 2 1/2 H. P. Shaw Motor supplies power; also sold complete. Stamp brings descriptive circular. Shaw Manufacturing Company, Dept. 81-2, Galesburg, Kansas.

Battle Photos and War Relics

For Dens: Relics Collected from Europe's Battlefields. Firearms, medals, helmets, etc. Illustrated catalogue and sample War photographs 25c. Lieut. Welsh, 2117 Regent Place, Brooklyn, N. Y.

Books

Perpetual Motion, by Percy Verance. A history of the efforts to discover same from earliest days to the present, together with a scientific discussion regarding the possibility of its ultimate achievement. Profusely illustrated. 357 pages. Price postpaid, \$2.00. The Enlightenment Specialty Co., 305 Fifth St., Edwardsville, Ill.

Free—Upon request will send you my literature illustrating the following books. Astrology, Character, Clairvoyance, Concentration, Healing, Hypnotism, Magnetism, Mediumship, Personal Magnetism, Personality, Physiognomy, Salesmanship, Seership, Success, Sex, Will, Yoga, Philosophy, Gazing Crystals, etc. A. W. Martens, E. E. 6, Burlington, Iowa.

Hypnotism Astonishes, Controls. Wants gratified. 25 easy lessons \$2.75. "Mindreading" (Any distance) Wonderful. Genuine. Guaranteed \$2.75. "Book of Wonders, Mysteries and Disclosures" \$20.00 worth for \$2.00. All three \$5.00. Catalogs free. Science Institute, SV 1014 Belmont, Chicago.

Sleep Quickly Produced. Self or others. Infallible. Priceless. Guaranteed \$1.10. "How to Live Right" 10c. "Way to Win" 10c. Prof. Deprado, SV357 Oak, Chicago.

"Nature's Finer Forces"—1923 Includes Lights, Colors, Tones, Vibrations, Aurals, Odics, Electro-Magnetics, Cold-lights, Radio, Marvellous Discoveries 260 pages. Satisfaction guaranteed. Table contents Free. Stevens Research Laboratories, 212 Powell, San Francisco, Calif.

Personal Success Illustrated. Catalog 4c. Phipps Library, 1014 Belmont, Chicago.

How to Make and Use a small chemical laboratory. Book for amateurs, students—75c, postpaid. Wright Laboratory, Caldwell, New Jersey.

Business Opportunities

If you have adaptability to selling specialties, exclusive territory is available on the Hush-A-Phone. This device is generally recognized by the largest concerns in the country, as superior to a phone booth for voice privacy, office quiet, and telephoning in noisy places. Over a thousand banks have adopted it. It is without competition. Energetic men can make a life occupation of selling the Hush-A-Phone in their section. Office appliance, and telephone men particularly adapted. Write for proposition. Hush-A-Phone Corp., Room 1311, 19 Madison Avenue, New York City.

Dollars yearly in your backyard. No mushroom dope. Particulars free. Metz, 319 East 89th, New York.

You can have a business-profession of your own and earn big income in service fees. A new system of foot correction; readily learned by anyone at home in a few weeks. Easy terms for training, openings everywhere with all the trade you can attend to. No capital required or goods to buy, no agency or selling. Address Stephenson Laboratory, 18 Back Bay, Boston, Mass.

Start your own business, remunerative, interesting; little capital. Learn privilege trading. Dept. X, Paul Kaye, 119 Broadway, New York.

\$10 daily silvering mirrors, plating and refinishing lamps, reflectors, autos, beds, chandeliers by new method. Outfits furnished. Write Gunmettal Co., Ave. D, Decatur, Ill.

53 Great Money-making plans free. R. Ross, Box 57-K, Medford, Mass.

Free \$5 Book. "How to be Successful in Real Estate." Particulars. Macdonald Co-Operative Realty, San Diego, Calif.

Business Opportunities—(Continued)

I Made \$100,000 as real estate specialist. Free information tell how. American Business Builders, Dept. A-357, 1133 Broadway, New York.

Stop Plodding! Be Successful. Operate a Tire Repair Shop. Make big profits in any locality. We teach you and furnish complete equipments \$100 up. Book of Opportunity free. Haywood's, 1312 South Oakley Avenue, Chicago.

Earn \$10 to \$20 per day. Learn sign painting, auto painting, decorating paperhanging. Be an expert in a few weeks; low cost; actual work; no books. Catalog Free. Chicago Painting School, 132 West Austin Avenue, Chicago.

Make \$100 weekly. Shoe repairing business. Enormous demand. United States copyrighted Practical repairing (23 lessons) Postpaid complete \$2.00. C. Bower, Box 1234, Seattle, Wash.

Chemistry

Learn Chemistry at Home. Dr. T. O'Connor Sloane noted educator and scientific authority, will teach you. Our home study correspondence course fits you to take a position as chemist. See our ad on page 313 of this issue. Chemical Institute of New York, 66 W. Broadway, New York City.

J. O. Nesser, Analytical and Consulting Chemist, 10230 Oakland Blvd., Detroit, Mich.

Experimenters—we carry a complete supply of chemicals and glassware for your chemical laboratory. Catalogue 5c. National Scientific Supply Co., 211 Pa. Ave., Washington, D. C.

Experimenters! Six big issues "Popular Chemistry"—25c (no stamps). Wright Laboratory, (Ab), Caldwell, New Jersey.

Correspondence Courses

Used correspondence courses bought and sold. Bargain catalogue 1,000 courses free. Students' Exchange, Dept. 4, 47 West 42d St., New York.

Used correspondence courses of all schools sold, rented and exchanged. New 1924 catalogue free. (Courses bought). Lee Mountain, Piskah, Alabama.

Duplicating Devices

"Modern" Duplicators save Time, Labor and Money. Gets Business, Reproduces Typewritten or printed letters, Drawings, Lessons, Music, Menus, Bids, Notices, Specifications, Maps or anything in one or more colors. Prints two per minute. Special Sale On 30 Days' Free Trial. \$2.25 up. Booklet Free. B. J. Durkin-Keeves Co., Pittsburgh, Pa.

For Advertisers

24 words—355 Rural Weeklies \$14.20. Ad-Meyer, 4113 St. Hartford, St. Louis, Mo.

For Inventors

Cashing In—If you have a practical, useful invention to sell, write us today, stating whether patented. American Patents Corporation, Barrister Building, Washington, D. C.

We Develop your ideas into commercial shape for presentation to purchasers making working models, drawings, experiments or tests. Courtesy, efficiency, secrecy and ample equipment; 30 years' experience. Duorcon-Rich Engineering Co., 504 Pacific Mutual Bldg., Los Angeles, Cal.

Unpatented Ideas Can Be Sold. I tell you how and help you make the sale. Free particulars (Copyrighted 1923). Write W. T. Greene, 808 Jenifer Bldg., Washington, D. C.

Your Chemical problem solved and working process furnished for Five Dollars. Write me. W. Stedman Richards, Consulting Chemist, Box 2402, Boston, Mass.

Formulas

Money-making Books, Plans, Formulas. Catalogue Free. Ideal Book Shop, 5501-E, North Robey, Chicago.

Make Your Own Fireworks! Full instructions next issue. "Popular Chemistry." Six months—25c (no stamps). Wright Laboratory, Caldwell, New Jersey.

For Sale

For Sale or Trade. Concrete Culvert. Particulars on request. Smith Caldwell, Castague, Mont.

For Sale—Patent on alarm clock. Variable sound. Jack Moore, 131 Circle Drive, Wichita, Kansas.

For the Photographer

Have you a Camera? Write for free sample of our big magazine, showing how to make better pictures and earn money. American Photography, 118 Camera House, Boston, 17, Mass.

Games and Entertainment

Tricks, Puzzles, Jokes, Magical Apparatus, Plays, Stage Supplies. Mind-Reading Acts and Sensational Escapes. Send 10c for 300-page illustrated 1923 professional catalogue. Oaks Magical Co., Dept. 549, Oshkosh, Wis.

Health

Free to men—Information of a scientific nature that has brought physical vigor and happiness to thousands. No charge; no obligation. Enclose stamp for reply. C. I. Wood & Co., Colorado Springs, Colorado.

Free—Stop using tobacco. We will give free information how to conquer habit easily and permanently. Results guaranteed. Anti-Tobacco League Box M, Omaha, Neb.

Booklets on healing. Particulars for stamp. Arthur Stevens, Wauseon, O.

Help Wanted

We want Salesmen and Agents, either whole or side line to sell our low priced radio books to the trade. Excellent proposition for live wires. The E. I. Company, Publishers, 233 Fulton Street, New York City.

Detectives Needed Everywhere. Work home or travel. Experience unnecessary. Write, George Wagner, former Government Detective, 1968 Broadway, N. Y.

Silvering Mirrors, French plate. Easily learned, immense profits. Plans free. Wear Mirror Works, Excelsior Springs, Mo.

Earn \$25 Weekly, spare time, writing for newspapers, magazines. Experience unnecessary; details free. Press Syndicate, 988 St. Louis, Mo.

All men, women, boys, girls, 17 to 65, willing to accept Government positions, \$117-\$250, traveling or stationary, write Mr. Ozmert, 293 St. Louis, Mo., immediately.

Detectives Earn Big Money. Travel. Excellent opportunity. Great demand everywhere. Experience unnecessary. Particulars free. Write, American Detective System, 1974 Broadway, N. Y.

Clerks for Government Postal and other good positions, \$1,400-\$2,300 yearly. Experience unnecessary. Full particulars free, by writing G. W. Robbins, Civil Service Expert, 764 Burchell Bldg., Washington, D. C.

Detective Agency. Opportunities for ambitious men. Experience unnecessary. We train you free. Clarke System, Box 239, Providence, R. I.

Firemen, Brakemen, Baggage-men, Sleeping car, train porters (colored). \$140-\$200. Experience unnecessary. 897 Railway Bureau, East St. Louis, Ill.

Be a Detective—Exceptional opportunity; earn big money. Travel. Thousands of dollars offered in rewards. Established 1909. Particulars free. Write C. T. Ludwig, 1417 Westover Bldg., Kansas City, Mo.

Money: Silvering Mirrors, Autolights, Radiators, Tableware, Stoves, Brassbeds. Outfits, Methods Free. Sprinkle, Water, Dept. 95, Marion, Indiana.

Railway Postal Clerks—Start \$133 month. Railroad pass; expenses paid; questions free. Columbus Institute, H-4, Columbus, Ohio.

Ambitious men, 18 up. Become Railway Mail Clerks—Mail Carriers. \$140-\$2300 year. Steady work. Full particulars free. Write immediately. Franklin Institute, Dept. L 24, Rochester, N. Y.

Earn \$1.20 an hour cutting blanks at home; anywhere; spare time. Men only. Send addressed reply envelope. Goodyear Sy., 147 W. 23d St., New York.

Instruction

Learn Chemistry at Home. Dr. T. O'Connor Sloane, noted educator and scientific authority, will teach you. Our home study correspondence course fits you to take a position as chemist. See our ad on page 313 of this issue. Chemical Institute of New York, 66 W. Broadway, New York City.

Correspondence Courses sold complete; one-third usual prices because slightly used; easy terms; money back guarantee. All schools and subjects. Write for special Free catalog. Courses bought for cash. Economy Educator Service, H202, West 49th St., New York.

Machinery and Tools

Concrete Building Block Machines and Molds. Catalogue free. Concrete Machine Co., 305 South Third St., St. Louis, Mo.

Manufacturing

To order: Metal articles, simple, or complicated machinery. Models, tools, patterns. Experimenting. Parma Engineering Works, Brooklyn Station, Cleveland, Ohio.

Miscellaneous

Razor Blades Resharpener. Roseto Hanery, Roseto, Pa. Cheapest, best work.

Developing ideas and manufacturing our specialty. Absolute satisfaction, 33 years' experience, write us. The Eagle Way & Stop Signal Co., 2016 Elm St., Cincinnati, Ohio, Dept. A.

Hindu Psychology, Yogi, Personal Magnetism. The Secret Sciences, Books and Courses. Large illustrated Private Catalogue, with "How Realize Any Desire," 25c. Adaros, 116 South Michigan, Chicago.

Remanufacture Fords—most profitable business on earth—\$14,355.00 made on 300 complete jobs. \$850.00 completely equips shop with tools recommended by Ford Motor Company. Circular K. B. Wilson, Buffalo.

Automobiles. Ignition: Wiring Blue Prints for any make car. State year and model. 40c prepaid. No stamps. C. M. Labunski, 2640 Hendrie, E. Detroit, Mich.

Health, Love, Health. There is an easy road to them. Inquire Mr. Robb, 5641 Sherbrooke Street, Montreal, Canada.

Models and Model Supplies

The Modelmaker. For those interested in making working models. Send 10 cents. Address P. E., 120 Liberty Street, New York.

Novelties

Chemical Magic Tricks in Every issue of "Popular Chemistry." Six months—25c (no stamps). Wright Laboratory, (Ac), Caldwell, New Jersey.

Patent Attorneys

Patents. Send for free booklet. Highest references. Best results. Promptness assured. Send model or drawing for examination and opinion. Watson E. Coleman, Patent Attorney, 644 G Street, Washington, D. C.

Get your own patents. Application blanks, complete instructions \$1. Cutting Bros., Campbell, Calif.

Inventors write me about patents. My fees payable monthly. Booklet free. Frank Fuller, Washington, D. C.

Unpatented Ideas Can Be Sold. I tell you how and help you make the sale. Free particulars (Copyrighted 1923). Write W. T. Greene, 809 Jennifer Bldg., Washington, D. C.

Patents Procured, Trade-Marks Registered—A comprehensive, experienced, prompt service for the protection and development of your ideas. Preliminary advice gladly furnished without charge. Booklet of information and form for disclosing idea free on request. Richard B. Owen, 130 Owen Bldg., Washington, D. C., or 2278-T Woolworth Bldg., New York.

"Inventor's Advisor," the valuable Patentbook with 139 mechanical movements and illustrations, sent free upon request. M. I. Labiner, Patent Attorney, 3 Park Row, New York.

Lacey Patent-Sense. "The book the inventor keeps." Free. See page 304.

"Inventors' Guide" free on request; gives valuable information and advice for all who have original ideas or improvements. Frank Ledermann, Registered Attorney and Engineer, 15-E Park Row, New York.

Herbert Jenner, Patent Attorney and Mechanical Expert, 624 F Street, Washington, D. C. I report if patent obtainable and exact cost. Send for circular.

M. P. Laughlin, Patents. Engineer-Attorney, 47 West 42nd Street, New York.

Patents—Write for our Guide Books and "Record of Invention Blank" before disclosing inventions. Send model or sketch of your invention for examination and instructions. No charge for the above information. See advertisement on page 305. Victor J. Evans & Co., 194 Ninth, Washington, D. C.

Patents Procured. Send sketch or model today for examination, prompt report and advice. No charge for preliminary advice. Write for free Booklet and blank form on which to disclose your idea. Highest references. Promptness assured. Clarence A. O'Brien, Registered Patent Lawyer, 924 Security Bank Building, Directly across the street from Patent Office, Washington, D. C.

Monroe Miller, Ouray Bldg., Washington, D. C. Patent Attorney; Mechanical, Electrical Expert, Free Blue Book gives candid advice.

Inventors—Send for form "Evidence of Conception" to be signed and witnessed. Form, fee schedule, information free. Lancaster and Allwine, 242 Ouray Bldg., Washington, D. C.

Millions spent annually for ideas! Hundreds now wanted! Patent yours and profit! Write today for free books—tell how to protect yourself, how to invent, ideas wanted, how we help you sell, etc. American Industries, Inc., 212 Kresge Bldg., Washington, D. C.

Patentome. Interesting, Informative. Mailed on request. Explains fully how to secure patents. Anderson & Son, Patent Lawyers, Established 1865. 635 F St., Washington, D. C.

Patents

M. P. Laughlin, Patents. Engineer-Attorney, 47 West 42nd Street, New York.

Patent applications filed with drawing \$20; deferred \$15; strongest claims; foreign patents low. Inventors' Service, 11 Broadway, New York.

Patents For Sale

Outright—Pend. Pat. Pitted adjuster attachment for wooden levels, especially adapted for pipe work or where a desired grade is required, used by Plumbers, Steamfitters, etc. Makes calculating unnecessary, insures a uniform pitch at a fraction of an inch per foot, easily attached, light weight metal stamping, cost 10c retail at 75c, reasonable offer accepted. Box No. 175, Science & Invention.

Personal

Lonesome? Make new friends. Write Dolly Gray Club, Box 185K, Denver, Colorado. Stamp appreciated.

Exchange Jolly letters with new friends. Lots fun! Send stamp. Eva Moore, Box 908, Jacksonville, Fla.

Lonely Hearts, Join our Club, be happy, correspondence everywhere, many wealthy, descriptions, photos free; either sex, most successful method, 23 years' experience. Standard Corr. Club, Grayslake, Ill.

Exchange Cheery Letters with new friends. Write Betty Lee, Inc., Box 820, City Hall Station, New York City. Stamp appreciated.

Correspondence Club. Many wealthy members everywhere. Fascinating particulars free. Smith, Box 1167-Y, Denver, Colo.

Exchange interesting letters with new friends. Write Dolly Gray Club, Box 186K, Denver, Colorado. Stamp appreciated.

Phonographic Supplies

Build Your Phonograph. Quality phonoparts. Famous Serenado Motors. Also original Perfection Motors. Electric Motors, tonearms, reproducers, amplifiers, case material, accessories. Free blueprints and building instructions. Big saving. Wonderful results. Prompt delivery. Catalogue mailed for ten cents. Hoosier Mfg. & Supply Company, 321 Baldwin Block, Indianapolis, Indiana.

Photoplays, Stories, Etc.

Big money writing photoplays, stories, poems, song. Send for free copy America's greatest magazine for writers. Tells you how to write and sell. Writer's Digest, 637 Butler Bldg., Cincinnati, Ohio.

\$ \$ \$ For Ideas. Photoplay Plots Accepted any form: revised, criticized, copyrighted, marketed. Advice free. Universal Scenario Corporation, 223 Security Bldg., Santa Monica & Western, Hollywood, California.

Printing

Quality Printing 1,000 letterheads, envelopes, cards or statements, \$3.00. Your name on 200 note sheets and 100 envelopes, \$1.00. Samples Free. Howlett's, Paris, Ill.

Radio

Attention! 50 Vacuum Tube Hook-Ups. The greatest collection of Vacuum Tube Circuits ever brought under two covers at such insignificant cost. These diagrams will be found in the great "Rasco" catalogue which contains raw materials and parts in a greater profusion than any other catalogue. 15c in stamps or coin will bring the catalogue to you. Radio Specialty Company, 100 Park Place, New York City.

Boys, don't overlook this! The "Rasco" Baby Detector. Greatest detector ever brought out with molded base. Fully adjustable. See former advertisements in this publication or our catalogue. Detector with Galena Crystal complete, 50c; the same Detector with Iadictos Crystal, 75c, prepaid. Send for yours today. Radio Specialty Co., 100 Park Place, New York City.

Radio Batteries

Lambert's Reach-Out Crystals. The Kind I use on my famous DX crystal sets that reach out and bring in concerts 400 to 1000 miles away. Mounted 60c each, two for \$1.00. Unmounted, 40c each, three for \$1.00. Fixed detector, \$1.50. Mailed postpaid the day I get your order. Leon Lambert, 541 South Volusia, Wichita, Kansas.

Salesmen Wanted

Stop right here. Make real money this summer. Week's salary often made on one sale. Lose at our salesman's monthly averages—N. Y. man, \$600.00; N. Dakota man, \$500.00; Ind. man, \$750.00, and so on. You call on business men only. Introduce entirely new proposition. No competition. Rich territory open. No collections. No deliveries. You take orders—we do the rest. Write—get complete dope. National Advertising Service, Inc., P. O. Box 77, La-Grange, Ind.

A Salesman wanted in every town or city within 25 miles of a broadcasting station to sell Radiogem, the complete radio receiving set that retails for \$2.50. With Radiogem there is nothing else to buy—the outfit includes the Radiogem receiving apparatus, 1,000-ohm phone, and aerial outfit. The cheapest radio outfit on the market—yet as practical as the most expensive. Big money to the right men. Send \$2.00 for sample outfit. The Radiogem Corp., 6614 West Broadway, N. Y. City.

Short Stories, Manuscripts Wanted

Earn \$25 Weekly Spare Time writing for newspapers, magazines. Experience unnecessary; details free. Press Syndicate, 987 St. Louis, Mo.

Stories, Poems, Descriptive Articles, Plays, etc., are wanted for publication. Submit Mss. or write Literary Bureau, 165 Hannibal, Mo.

Song Poems Wanted

Write the words for a song. We compose music. Our Chief of Staff wrote many big song-hits. Submit your song-poem to us at once. New York Melody Corp., 412H Romax Bldg., New York.

Stammering

St-Stu-t-t-tering and Stammering cured at home. Instructive booklet free. Walter McDonnell, 105 Potomac Bank Bldg., Washington, D. C.

Stamps and Coins

California Gold, quarter size, 27c; half-dollar size, 53c. Columbian nickel and catalogue, 10c. Norman Shultz, Box 146, Colorado Spring, Colo.

Stamps 100 All Different 3 cents. S. I. Quaker Stamp Company, Toledo, O.

Rare Coins—Silver, gold, copper and paper money of the world. Villa Coin New Catalogue, 10c. Alexis Mengelle, Box 387, Colorado Springs, Colo.

158 Genuine Foreign Stamps. Mexico War Issues. Venezuela, Salvador and India Service, Guatemala, China, etc., only 5c. Finest approval sheets 50 to 60%. Agents Wanted. Big 72-p. Lists Free. We buy stamps. Established 20 years. Hussman Stamp Co., Dept. 156, St. Louis, Mo.

Typewriters

All standard makes, \$10 up. Fully guaranteed. Free trial. Write for complete illustrated lists. Northwestern Exchange, 121 N. Francisco Ave., Chicago.

Wanted

Detectives Earn Big Money. Work home or travel. Experience unnecessary. Particulars free. American Detective System, 1974 Broadway, N. Y.

Wanted Jewelry

Cash for old jewelry, teeth, gold, silver. Highest prices. Prompt payment. Mail to Baltic Mercantile Co., 10129 Baltic Rd., Cleveland, Ohio.



IT'S all like a fascinating game—this new home-study method of learning cartooning. You start with the basic principles of cartoon-making. Then you learn the little tricks of originating cartoon-ideas, the secrets of action, expression, and exaggeration. You progress rapidly through serious cartooning, comics, caricaturing, sport and animated cartooning until almost before you realize it you are drawing striking cartoons that SELL. Many students of this method have sold enough work while taking their courses to pay for them many times over!

Over \$100 a Week

Learn cartooning this easy way. Never has the demand for cartoonists been so great. Today magazines, newspapers, advertisers and movies use them by the thousands. No matter how poorly you draw now, you can quickly qualify for one of the attractive positions in this fast-growing business. Just think of earning \$3,000 to \$20,000 a year for this work that is play. Successful cartoonists often get \$25 to over \$100 for single cartoons. Then there is the joy of the work itself—the thrill of seeing your own cartoon-ideas in print.

Send For Free Book

Mail coupon today for our handsomely illustrated book which is crammed full of up-to-date, interesting facts about cartooning. It gives you an outline of the whole field of cartooning, describes the opportunities for you in this business, and explains in detail all about this new method which makes cartooning so pleasant to learn. Send for it today!

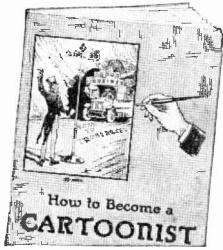

WASHINGTON SCHOOL OF CARTOONING
Room 267, 1113-15th St., N.W., Washington, D. C.

WASHINGTON SCHOOL OF CARTOONING
Room 267, 1113-15th St., N. W., Washington, D. C.

Please send me your Free Book on Cartooning, and details of your home-study method.

Name
(Please write plainly)

Address

City..... State.....

If under 16, state age.....

FREE LESSON IN DRAFTING

Send for our free lesson which shows how easily you can master Drafting by the Chicago "Tech" Method and prepare for a high salaried job. **Increase Your Income** You get this pay raising training by mail under the direction of our experts. The fees are moderate, the terms easy. Find out about this now. The lesson is free and we send our catalog with it. Write today.

CHICAGO TECHNICAL COLLEGE
745 CHICAGO "TECH" BUILDING, - CHICAGO, ILLINOIS



FREE—This Book on WOOD FINISHING

This book explains how you can easily and economically refinish and keep furniture, woodwork, floors and linoleum in perfect condition. Includes color charts, gives covering capacities, etc. We will gladly send this book free and postpaid for the name of your dealer.

S. C. JOHNSON & SON
Dept. S. 1.7 RACINE, WIS.
"The Wood Finishing Authorities"

Technical Schools

Chicago Technical College offers short, intensely practical courses in Drafting and Engineering—civil, mechanical, electrical, structural—Architecture, Building Construction, Plan Reading, etc. Courses fitted to your needs. No time wasted. Instructors are experts. Graduates in demand at big salaries. Opportunities for part-time work while studying. Day and evening classes. 21st year. Enter any time. No special preliminary training required. Low tuition—easy terms. Write for 52-page illustrated Blue Book, describing opportunities open to our graduates. Chicago Technical College, 24 Chicago Tech. Building, Chicago.

Wireless

The How and Why of Radio Apparatus, by H. W. Secor, E. E. This newest book on radio matters fulfills a distinct gap in wireless literature in that, while the treatment is made as understandable and as free from mathematics as possible, it at the same time incorporates a wealth of technique and instruction for the Radio Amateur—the Radio Operator—the Installation and Designing Expert—as well as teachers and students of the subject in general. A very broad field has been covered by the author, at the same time giving a great deal of information not found in other text books. If you are engaged in any branch of the Radio or allied arts at all you will surely need this latest contribution to radio literature which is destined to be found on every radio man's book shelf before long. A glance at the following list of chapters gives but a very scant idea of the extensive and useful radio knowledge provided in its text. The Induction Coil; The Alternating Current Transformer; Radio Transmitting Condensers; The Spark Gaps; Radio-Transmitting Inductances; Radio Receiving Tuners; Radio Receiving Condensers; Detectors; Telephone Receivers; Radio Amplifiers; Construction of a Direct Reading Wavemeter and Decimeter; Antenna Construction; The Calculation and Measurement of Inductances; Appendix containing very useful tables, covering all subjects treated in this very unusual book. This newest of Radio Works, cloth bound in Vellum de Luxe, Gold Stamped and Hand Sewed, has 160 pages. Size of book, 6x9 inches. The How and Why of Radio Apparatus, Postpaid, \$1.75. Experimenter Publishing Co., Book Dept., 53 Park Place, New York City.

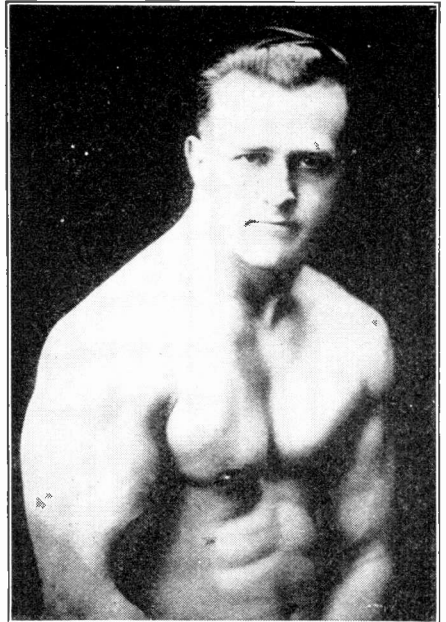

EARLE E. LIEDERMAN
The Muscle Builder

A Slap In the Face With A Cream Puff

is not a man's way of fighting. Neither can you do a man's job with balls of mush on your arms where muscle ought to be. How long are you going to drag along this way? Don't try to kid yourself by saying: "Oh, I'll start regular exercise next week." I know a lot of fellows who kept doing that until—Zowie—it was too late. They couldn't make a comeback no matter how they tried.

THIS IS A BIG DAY FOR YOU

Don't put this off another second. If you want to make the best of your life, you'll have to start right now. Come on, let's go—you and me—and you're going to bless the day you read this message. I'm going to make you work—you can bet your old shirt on that. But you'll thank me for it, 'cause—oh boy!—what a different looking chap you're going to be. Just for a starter I'm going to put one full inch on those arms of yours in exactly 30 days—and two inches on your chest in the same length of time. But that's nothing. Then comes the real works. I'm going to build out that neck of yours and put a pair of shoulders on you that will bulge right out of your old coat sleeves. I'm going to fill out your chest with a perfect pair of lungs that will pump real oxygen into your blood, shooting a thrill over your entire body and sending a quiver up your old spinal column. I'm going to put a ripple of muscle up and down your stomach instead of that roll of fat that is now hanging over your belt line. And while I'm doing this, I am also going to build muscle in and around every vital organ. You will have a spring to your step and a flash to your eye. In fact, you will say to yourself: "What a terrible oil-can I was turning out to be; why didn't I start this long ago?"

LET'S GO!

Why waste time over these things. You want muscle. You want strength. You want life. What you want, I can give you—it's yours for the asking. I don't try to kid you on with a lot of idle promises. I guarantee these things. You don't take any chance with me. Come on now and get on the job. Be the man you have always wanted to be.

Send for my new 64-page book "MUSCULAR DEVELOPMENT" IT IS FREE

It contains forty-three full-page photographs of myself and some of the many prize-winning pupils I have trained. Some of these came to me as pitiful weaklings, imploring me to help them. Look them over now and you will marvel at their present physiques. This book will prove an impetus and a real inspiration to you. It will thrill you through and through. All I ask is 10 cents to cover the cost of wrapping and mailing and it is yours to keep. This will not obligate you at all, but for the sake of your future health and happiness, do not put it off. Send today—right now before you turn this page.

EARLE E. LIEDERMAN
Dept. 207, 305 Broadway, New York City

EARLE E. LIEDERMAN,
Dept. 207, 305 Broadway, New York City

Dear Sir: I enclose herewith 10c for which you are to send me, without obligation on my part whatever, a copy of your latest book "Muscular Development."

Name
Street
City State.....
(Please write or print plainly)

One Thousand Agents Wanted

WE want one thousand agents to sell subscriptions to RADIO NEWS, SCIENCE AND INVENTION, PRACTICAL ELECTRICS, and THE MOTOR CAMPER & TOURIST. We will pay a generous commission for this work and help you in every way. Our four publications are leaders in their fields, ready sellers and this is an offer well worth your while. A few spare hours a day will bring you a handsome return. Write regarding our proposition at once and be the first one to get started in your vicinity.

Experimenter Publishing Co.
HERBERT H. FOSTER, Circulation Manager
53 Park Place, New York

ADULTS! SEX KNOWLEDGE BOOKS

instructive, authoritative, profusely illustrated in natural colors, etc. The worth-while sort. Contains everything one should know both before and after marriage to enjoy health and happiness. Large Catalog, 10c. F. SMETANA & CO. Saginaw, West Side, Mich.

Two New Additions!

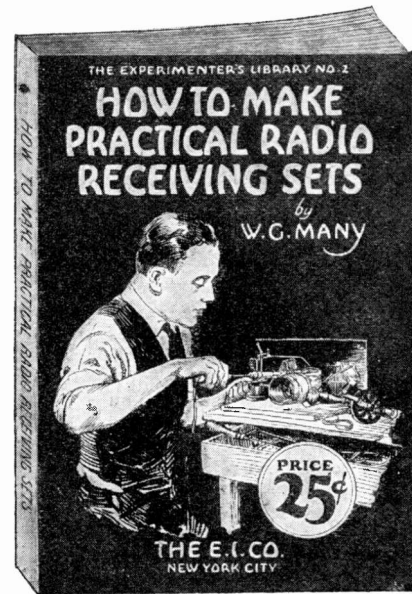
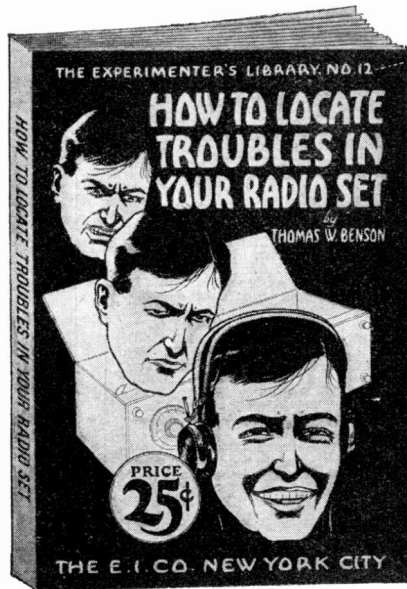
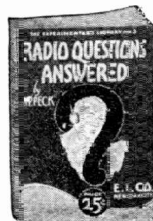
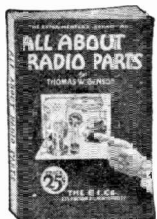
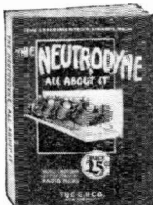
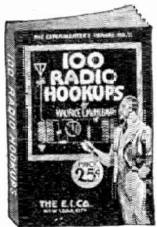
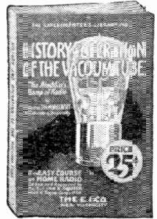
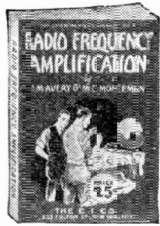

How to Locate Troubles In Your Radio Set

By THOMAS W. BENSON

The simplified method of going after the trouble in your Radio Set. A handy book that takes every detail from the Aerial to the Ground and explains what might go wrong and how troubles can be remedied at home.

It is one of the best Radio Books for instant reference that is published today being written so that all the general troubles of the Radio Set can be quickly understood by the reader.

You can obtain a copy today at your local dealer or if he cannot supply you, write direct and we will send you a copy. Price 25c prepaid.

How to Build Practical Radio Receiving Sets

By W. G. MANY

The Publishers of the Experimenter's Library, realizing an increasing demand, have published a complete book on some of the most effective standard circuits in use today.

The author has compiled in this book only those hookups that have been tested by time in the Radio Field, hookups that have and will always give complete satisfaction to the man who builds them correctly.

The book is made up in a standard, handy pocket size and is profusely illustrated with sketches and wiring diagrams that can be followed easily and quickly.

You can obtain your copy at any reliable radio dealer or write to us direct. Price 25c prepaid.

AT ALL RELIABLE RADIO DEALERS

OTHER BOOKS IN THIS LIBRARY

Tips for the Radio Amateur Constructor
Radio Questions Answered
Radio Frequency Amplification
How to Tune Your Radio Set

One Hundred Radio Hook-ups
All About Radio Parts
History and Operation of Vacuum Tubes
The Neutrodyne

The E. I. Company :: Consrad Co. Inc., Selling Agents
233 FULTON STREET, NEW YORK CITY

Let These Guides

Solve Your Problems

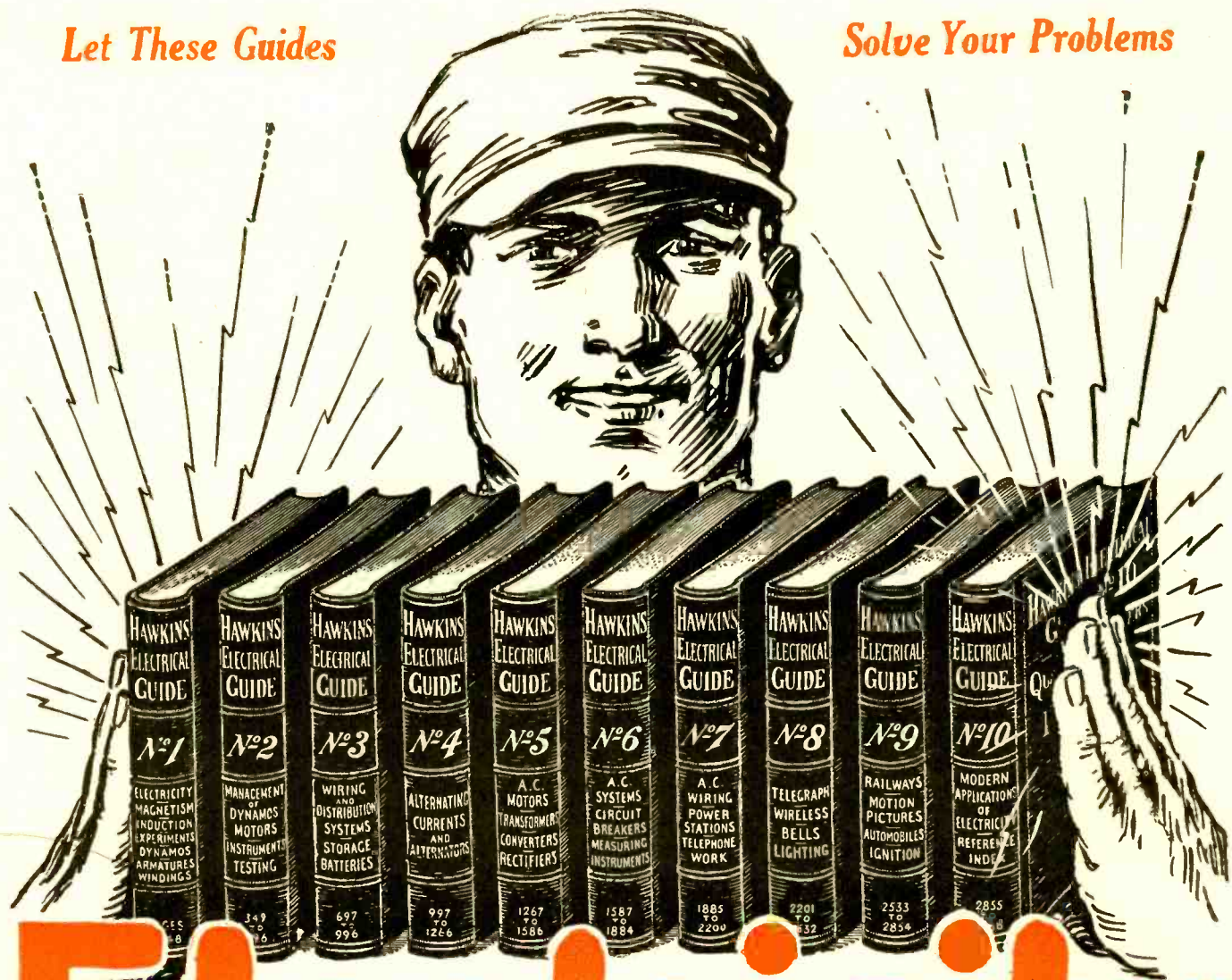

Electricity at your finger ends

HAWKINS ELECTRICAL GUIDES IN TEN VOLUMES

3500 PAGES **\$1 A VOLUME**
4700 PICTURES **\$1 A MONTH**

SEND NO MONEY—SEND ONLY THIS COUPON

Know the facts in Electricity. They mean more money and better position for you. Hawkins Guides tell you all you need to know about Electricity. Every important electrical subject covered so you can understand it. Easy to study and apply. A complete, practical working course, in 10 volumes. Books are pocket size; flexible covers. Order a set today to look over.

LEARN ALL ABOUT

Magnetism—Induction—Experiments—Dynamos—Electric Machinery—Motors—Armatures—Armature Windings—Installing of Dynamos—Electrical Instrument Testing—Practical Management of Dynamos and Motors—Distribution Systems—Wiring—Wiring Diagrams—Sign Flashers—Storage Batteries—Principles of Alternating Currents and Alternators—Alternating Current Motors—Transformers—Converters—Rectifiers—Alternating Current Systems—Circuit Breakers—Measuring Instruments—Switchboards—Wiring—Power Stations—Installing—Telephone—Telegraph—Wireless—Bells—Lighting—Railways. Also many Modern Practical Applications of Electricity and Ready Reference Index of the ten numbers.

SHIPPED FREE

Not a cent to pay until you see the books. No obligation to buy unless you are satisfied. Send Coupon now—today—and get this great help library and see if it is not worth \$100 to you—you pay \$1.00 a month for ten months or return it.

THEO. AUDEL & CO.,
72 Fifth Ave., New York City

Please submit me for free examination, HAWKINS ELECTRICAL GUIDE (Price \$1 a number). Ship at once prepaid, the 10 numbers. If satisfactory, I agree to send you \$1 within seven days and to further mail you \$1 each month until paid.

Name

Occupation

Employed by

Home Address

Reference

S. I. July

YOU TOO CAN MAKE BIG MONEY

Begin Now!

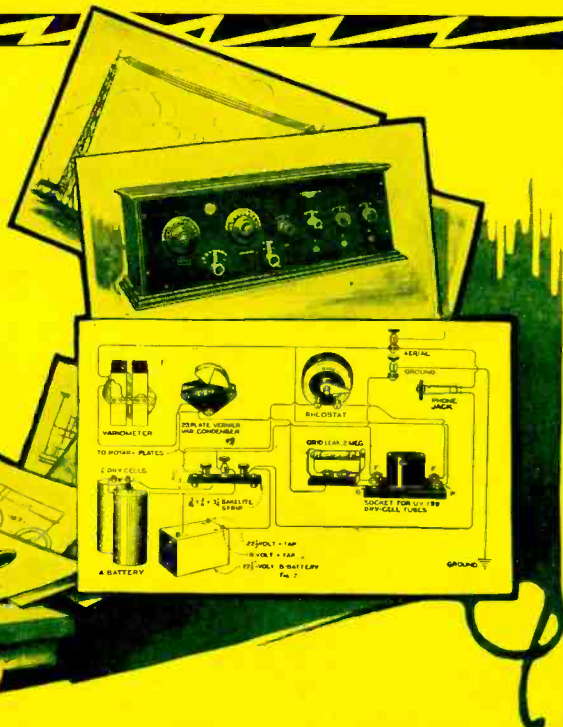

Learn RADIO DRAFTING

Free Course



ROY C. CLAFLIN
PRESIDENT

As a student of the Columbia School of Drafting you will be under the personal instruction of Roy C. Claflin, owner and President of this School. He gives you his most earnest co-operation and the tens of thousands of men who have been benefited by his highly efficient method of training are a living proof of the value of his guidance. Mr. Claflin's long years of experience as a Professional Draftsman, as well as a teacher, especially qualify him for this great work.

THE popularity of the Radio and its increasing field of usefulness have created a keen demand for men who can design and draw clear plans for Radio Equipment and layout. **GET IN ON THE GROUND FLOOR OF THIS PROFITABLE OCCUPATION.** Here is your opportunity to learn

RADIO DRAFTING FREE!

As soon as our regular course in Mechanical Drafting has been completed the graduate is entitled to take our Radio Drafting Course **FREE OF CHARGE.**

THIS OFFER IS MADE FOR A LIMITED TIME ONLY! Therefore, do not delay and run the chance of missing this unusual offer. Write us today for full particulars.

OTHER POST GRADUATE COURSES

which may be selected in place of Radio Drafting—and also taught free—are as follows:

- Electrical Drafting Machine Drafting Sheet Metal Drafting
- Aeroplane Drafting Automobile Drafting Shop Mathematics

REGULAR BASIC COURSES ARE

MECHANICAL (Machine) DRAFTING ARCHITECTURAL DRAFTING
TOPOGRAPHIC (Map) DRAFTING

Special and Complete Instructions in Lettering with All Courses.

Persons in a position to come to Washington are invited to enroll in our large local school.

GET YOU A JOB

We help you secure a satisfactory position as soon as you qualify as a draftsman, which is frequently before our course is half completed. Your ability to make good from the start is assured by our thorough and practical training.

Columbia School of Drafting

Roy C. Claflin, President
14th at T and N.W., WASHINGTON, D. C.



This Drafting Outfit is furnished Free with Course

COLUMBIA SCHOOL OF DRAFTING.
Dept. G-24, Washington, D. C.
Without obligation please send me your catalog showing opportunities for me in Drafting and particulars of your special training.

Name

Address

City

State My Age