

March

25 cents

# Science and Invention

FORMERLY  
ELECTRICAL EXPERIMENTER

## THE SLEEP ELIMINATOR

See Page 1062

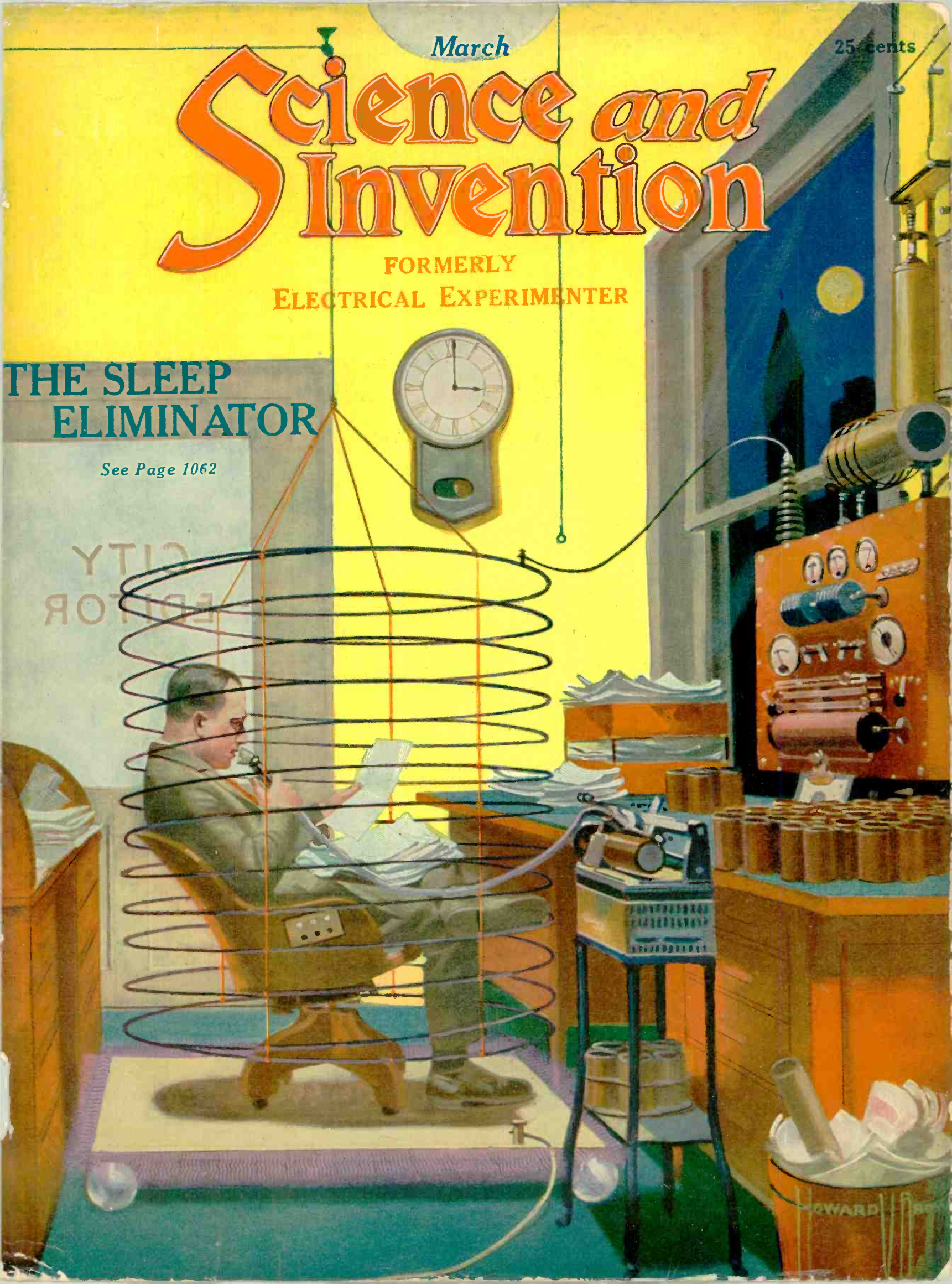



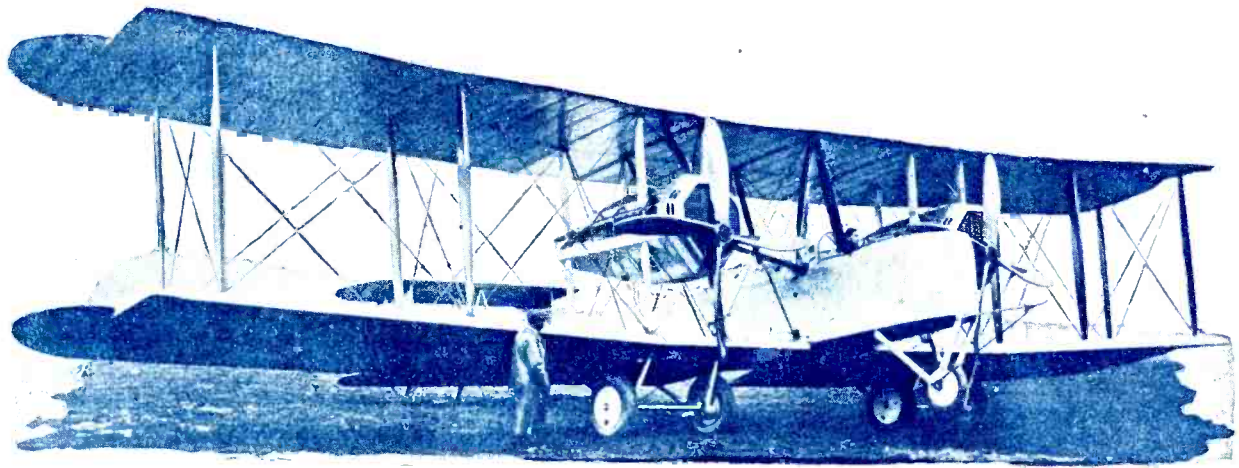

# Go as High as You Like No Limit to Salaries in Aviation

No other industry offers the wonderful chances for big money-making that the Airplane Industry offers to ambitious men. Many more trained men will be needed to fill big paying jobs. The airplane has come to stay—it will soon be a part of our everyday life. The men who get in now are the ones that will cash in big. Look at the "big fellows" in the automobile game today. They represent power and wealth because they got in early—you can do the same in Aviation and you have an advantage because you can be trained before you start.



Delivering Newspaper "Extras" by Airplane



A New Seven-Passenger Airplane

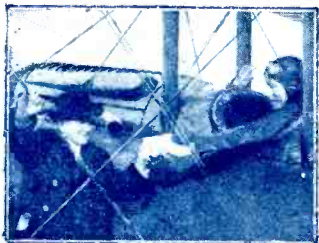

A New Job—The Aerial Postman



View in an Airplane Factory

## Thousands of Airplane Mechanics will be Needed

The airplane industry is going forward by leaps and bounds. Transportation—passenger carrying and mail carrying lines are being opened up everywhere. This means men—men—men! Trained men only are wanted—men who know what's what. Get ready now to make big money. The industry is calling for real red-blooded fellows—heed the call—*now* is the time to get started—while the industry is still in its infancy.

**Here Are a Few Jobs That Will Pay \$50.00 to \$250.00 a Week:**  
 Aeronautical Instructor    Aeronautical Engineer    Aeronautical Contractor    Airplane Repairman  
 Airplane Mechanician    Airplane Inspector    Airplane Salesman    Airplane Assembler    Airplane Builder

## Learn at Home In Your Spare Time

is simplified for home instruction and is endorsed by airplane manufacturers, aeronautical experts, aviators and the leading aero clubs. Any man who can read English can understand it. The Lessons are self-explanatory and are made plain as day with Blueprints, Diagrams, etc. Our Advisory Council and Instructors are behind you all the time giving you everything you must know. The entire field of Practical Aeronautics and Science of Aviation is laid right before your eyes. You are bound to succeed with this training. This means for you a man's size job with a man's size pay.

## Big Book of Opportunities FREE!

Send for our big free book showing just what is going on in the Airplane Industry. It also shows what other men have done in this fascinating field and what you can do, too. It gives a list of some large manufacturers and dealers in airplanes and some of the jobs that are open to trained men. With the book we will send you a special offer that you will be glad to know about. This special offer may be withdrawn at any time without notice. *Send the coupon now and take advantage of this offer.*

Keep right on with the work you are doing now. A little of your spare time is all you need. Our Special Course



**AMERICAN SCHOOL OF AVIATION**  
 Dept. 7443  
 3601 Michigan Ave.  
 Chicago

Without obligation on my part you may send me your book entitled "Opportunities in the Airplane Industry" and your SPECIAL Limited offer.

**Mail This Coupon For FREE BOOK**

 Name.....  
 Address.....  
 City..... State.....

**American School of Aviation**  
 Dept. 7443    3601 Michigan Ave., Chicago

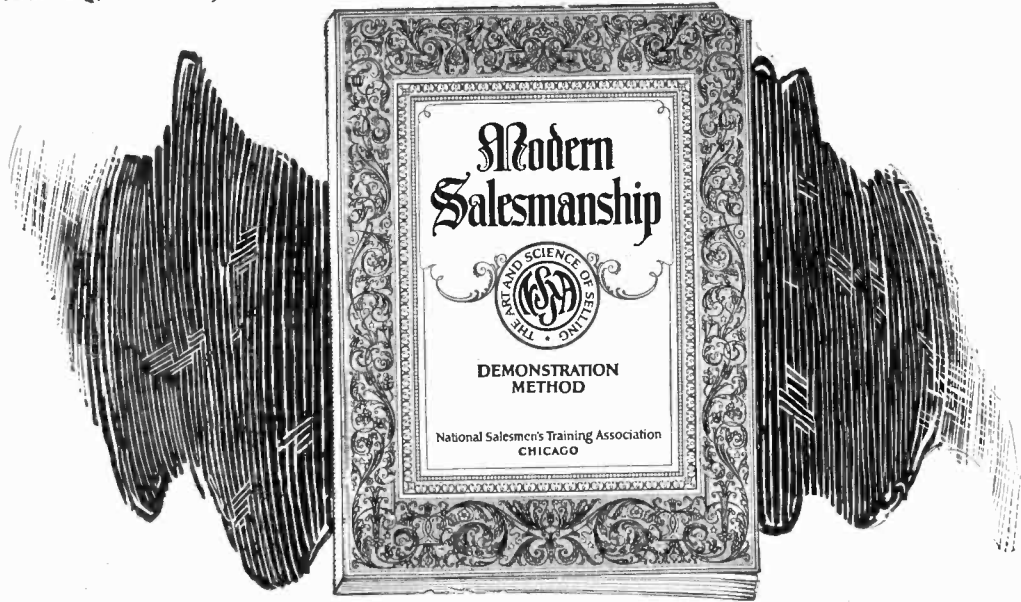

# NOW FREE!

## The Book That Has Shown Thousands the Way to Amazing Salary Increases

*Do you want to leave the rut of routine work and start right out making more money than you ever dreamed possible? We have done exactly this for thousands of men. Here is the book which gave them their start. Read how it is now offered to you—FREE!*

**T**AKE this situation: A man who had worked all his life in a routine job at low pay suddenly surprises his friends, by moving into a better neighborhood, taking a big house, buying a car and blossoming out as a well-to-do and influential citizen in his new community. How did he do it? What is the secret that he used? Simple enough. He knew that the biggest money in business is in Selling, and though he felt that he couldn't sell a thing, he suddenly learned the secrets that make Master Salesmen and then began to make big money.

If only one man had found inspiration enough in this remarkable book to jump to a sudden brilliant success in the Selling field—into a job paying him many times his former salary—then you might call it luck. But thousands have done it.

**R E A D !**  
Charles Beery of Winterset, Iowa, stepped from \$18 a week as a clerk to a position making him \$1,000 the very first month. J. P. Overstreet of Dennison, Texas, read this amazing book, left a job on the Capitol Police Force at a salary of less than \$1,000 a year and in six weeks earned \$1,800. F. Wynn, Portland, Ore., an ex-service man, earned \$554.37 in one week. Geo. W. Kearns of Oklahoma City found in this book a way to jump his earnings from \$60.00 a month to \$524.00 in two weeks, and C. W. Campbell learned from it how he could quit a clerking job on the railroad to earn \$1,632 in thirty days.

### Your One Chance to Make the Biggest Money of Your Life

Not one of the men whose names appear in the panel at left had ever sold a thing before—not a dime's worth. Yet every one of these men, through reading this book, discovered an amazingly easy way to jump suddenly from low pay to extraordinary earnings in the Selling field.

Sounds remarkable, doesn't it? Yet there is nothing remarkable about it. There are certain ways to approach different types of prospects to get their undivided attention—certain ways to stimulate keen interest—certain ways to overcome objections, batter down prejudices, outwit competition and make the prospects act.

### Simple as A B C

"Modern Salesmanship" tells exactly how the National Salesmen's Training Association will teach you these principles in your spare time at home.

As soon as you are qualified and ready, the Association's Employment Service helps you to select and secure a selling position as city or traveling salesman.

### Now Free to Every Man Who Will Act at Once

We are not making any extravagant claims about what we will do for you. We don't have to. All of the amazing proof and many important features about Salesmanship are contained in our new salary-raising book, "Modern Salesmanship." It is yours—FREE. Send the coupon for it today. It will show you how you can quickly become a Master Salesman—a big money maker. It will tell you about the National Salesmen's Training Association system of Salesmanship training—about the National Demonstration method that gives you actual experience while studying—and all about the amazing opportunities that await you in the Selling field.

This may be the one big chance of your life to leave forever behind you the low pay of a routine job for a sudden, brilliant success at a big salary.

Is it worth 2c. to find out? Then mail this coupon NOW.

**National Salesmen's Training Association**  
Dept. 42-C, Chicago, Illinois

National Salesmen's Training Association  
Dept. 42-C, Chicago, Ill., U. S. A.

Please send me, without any obligation on my part, your free book, "Modern Salesmanship," and full information about the N. S. T. A. system of Salesmanship Training and Employment Service. Also a list showing lines of business with openings for salesmen.

Name .....

Street .....

City..... State.....

Age..... Occupation.....



Vol. X  
Whole No. 119

# Science and Invention

March, 1923  
No. 11

FORMERLY  
**ELECTRICAL EXPERIMENTER**

PUBLICATION OFFICE:  
542 Jamaica Ave., Jamaica, N.Y.

EDITORIAL & GENERAL OFFICES:  
53 Park Place, New York City

Published by Experimenter Publishing Company, Inc. (H. Gernsback, Pres.; S. Gernsback, Treas.; R. W. DeMott, Sec'y).  
Publishers of SCIENCE AND INVENTION, RADIO NEWS, and PRACTICAL ELECTRICS

## Table of Contents for March

### POPULAR SCIENTIFIC ARTICLES

EDITORIAL	1047
CHICAGO-NEW YORK-BERLIN VIA THE AIR	1049
By Dr. H. Becher	
RAPID SCENE CHANGES IN "JOHANNES KREISLER"	1051
By Joseph H. Kraus	
THE SUBMARINE OF TOMORROW	1053
By Graser Schornstheimer, Naval Expert	
NEW PROCESS COLORS BLACK AND WHITE MOVIE FILMS	1054
By Lewis Yeager	
FISH THAT HANG UP THEIR YOUNG TO RIPEN	1055
By Dr. Ernest Bade	
RECOVERING SUNKEN TREASURES	1056
HOW OLD IS THE WORLD?	1057
By Harry Van Demark	
THE STAR	1058
By H. G. Wells	
BISHOP WILKIN'S MATHEMATICAL MAGIC	1061
By T. O'Conor Sloane, Ph.D., L.L.D.	
THE EVER CHANGING GULF STREAM	1061
THE SLEEP ELIMINATOR	1062
By H. Gernsback	
WATER-PROOFING AND MOTH-PROOFING BY ELECTRICITY	1063
By Ismar Ginsberg, B.Sc., Chem. Eng.	
NOVELTIES AT NEW YORK AUTO SHOW	1064
DR. HACKENSAW'S SECRETS—NO. 14—THE SECRET OF THE MOTORLESS AIRPLANE	1065
By Clement Fezandic	
HOW ENAMELED IRON TUBS ARE MADE	1066
By H. Winfield Secor	
MEASURING ONE MILLIONTH OF AN INCH	1067
MACHINE MAKES 12,000,000 KEY-LESS CODES	1068
By H. D. Hunter	
ETHER USED IN MANUFACTURING ICE CREAM	1068
THE AMATEUR MAGICIAN	1069
By Joseph H. Kraus	
SCIENTIFIC PROBLEMS AND PUZZLES	1071
By Ernest K. Chapin	
PORTRAIT PHOTOGRAPHY	1076
By Dr. Ernest Bade	

### PRIZE CONTESTS

MOTOR HINTS—\$50.00 IN PRIZES MONTHLY	1070
HOW-TO-MAKE-IT DEPARTMENT—\$30.00 IN PRIZES MONTHLY	1078
WRINKLES, RECIPES, AND FORMULAS—Edited by S. Gernsback	1079
AWARDS IN THE \$100.00 INTERFERENCE PREVENTER CONTEST	1086
ANNOUNCEMENT OF THE \$100.00 BINDING POST CONTEST	1087

### AUTOMOBILES

MOTOR HINTS—\$50.00 IN PRIZES MONTHLY	1070
NOVELTIES AT NEW YORK AUTO SHOW	1064

### ELECTRICITY

THE SLEEP ELIMINATOR	1062
By H. Gernsback	
WATER-PROOFING AND MOTH-PROOFING BY ELECTRICITY	1063
By Ismar Ginsberg, B.Sc., Chem. Eng.	
NOVELTIES AT NEW YORK AUTO SHOW	1064
THE AMATEUR MAGICIAN	1069
MOTOR HINTS—\$50.00 IN PRIZES MONTHLY	1070
EXPERIMENTAL ELECTRO-CHEMISTRY	1074
By Raymond B. Wailes	
ELECTROSTATIC A.C. TO D.C. CONVERTERS	1077
By Clyde J. Fitch	
HOW-TO-MAKE-IT DEPARTMENT	1078
LATEST PATENTS	1092
THE ORACLE—QUESTION AND ANSWER BOX	1093
PATENT ADVICE—Edited by Joseph H. Kraus	1115

### RADIO ARTICLES

TALKING ACROSS THE ATLANTIC	1080
UNDER-RIVER RADIOPHONE RECEPTION	1081
SECRECY IN RADIO AT LAST	1082
By A. P. Peck	
RADIO FOR THE BEGINNER—NO. 13—HOW TO SELECT A HEADSET	1083
By Armstrong Perry	
AN AMPLIFIER FOR YOUR PRESENT TUNER	1084
By Bert T. Bonaventure	
AWARDS IN THE \$100.00 INTERFERENCE PREVENTER CONTEST	1086
ANNOUNCEMENT OF \$100.00 BINDING POST CONTEST	1087
COMPLETE REVISED LIST OF RADIOPHONE BROADCAST STATIONS	1088
RADIO ORACLE	1091

### CHEMISTRY AND ELECTRO-CHEMISTRY

PRACTICAL CHEMICAL EXPERIMENTS	1072
By Raymond B. Wailes	
EXPERIMENTAL ELECTRO-CHEMISTRY	1074
By Raymond B. Wailes	
WRINKLES, RECIPES, AND FORMULAS—Edited by S. Gernsback	1079
THE ORACLE—QUESTION AND ANSWER BOX	1093

### CONSTRUCTOR ARTICLES

REFRIGERATION IN THE HOME	1075
By L. K. Wright, Refrigerating Engineer	
PORTRAIT PHOTOGRAPHY	1076
By Dr. Ernest Bade	
ELECTROSTATIC A.C. TO D.C. CONVERTERS	1077
By Clyde J. Fitch	
AWARDS IN THE \$100.00 RADIO INTERFERENCE CONTEST	1086

### ASTRONOMY

THE STAR	1058
By H. G. Wells	

SCIENCE AND INVENTION is published on the 25th of each month. There are 12 numbers per year. Subscription price is \$2.50 a year in U. S. and possessions. Canada and foreign countries \$3.00 a year. U. S. coin as well as U. S. stamps accepted (no foreign coin or stamps). Single copies, 25 cents each. A sample copy will be sent gratis on request. Checks and money orders should be drawn to order of EXPERIMENTER PUBLISHING CO., Inc. If you change your address notify us promptly, in order that copies are not misdirected or lost.

All communications and contributions to this journal should be addressed to Editor, SCIENCE AND INVENTION, 542 Jamaica Avenue, Jamaica, New York, or 53 Park Place, New York City, N. Y. Unaccepted

contributions cannot be returned unless full postage has been included. All accepted contributions are paid for on publication. A special rate is paid for novel experiments; good photographs accompanying them are highly desirable.

SCIENCE AND INVENTION, Monthly. Entered as second-class matter at Jamaica, N. Y., Post Office, under act of Congress of March 3, 1879. Title Registered at the Patent Office. Copyright, 1923, by E. P. Co., Inc., New York. The Contents of this Magazine are copyrighted and must not be reproduced without giving full credit to the publication.

SCIENCE AND INVENTION is for sale at all newsstands in the United States and Canada; also at Brentano's, 37 Avenue de l'Opera, Paris. Member of the Audit Bureau of Circulation.

General Advertising Dept.,  
53 Park Place,  
New York City.

Western Advertising Representatives,  
Finucan & McClure,  
720 Cass St., Chicago, Ill.

Pacific Coast Advertising Representatives,  
A. J. Norris Hill Co.,  
Hearst Bldg., San Francisco, Calif.

Kansas City Advertising Representative,  
George F. Dillon,  
Republic Building, Kansas City, Mo.



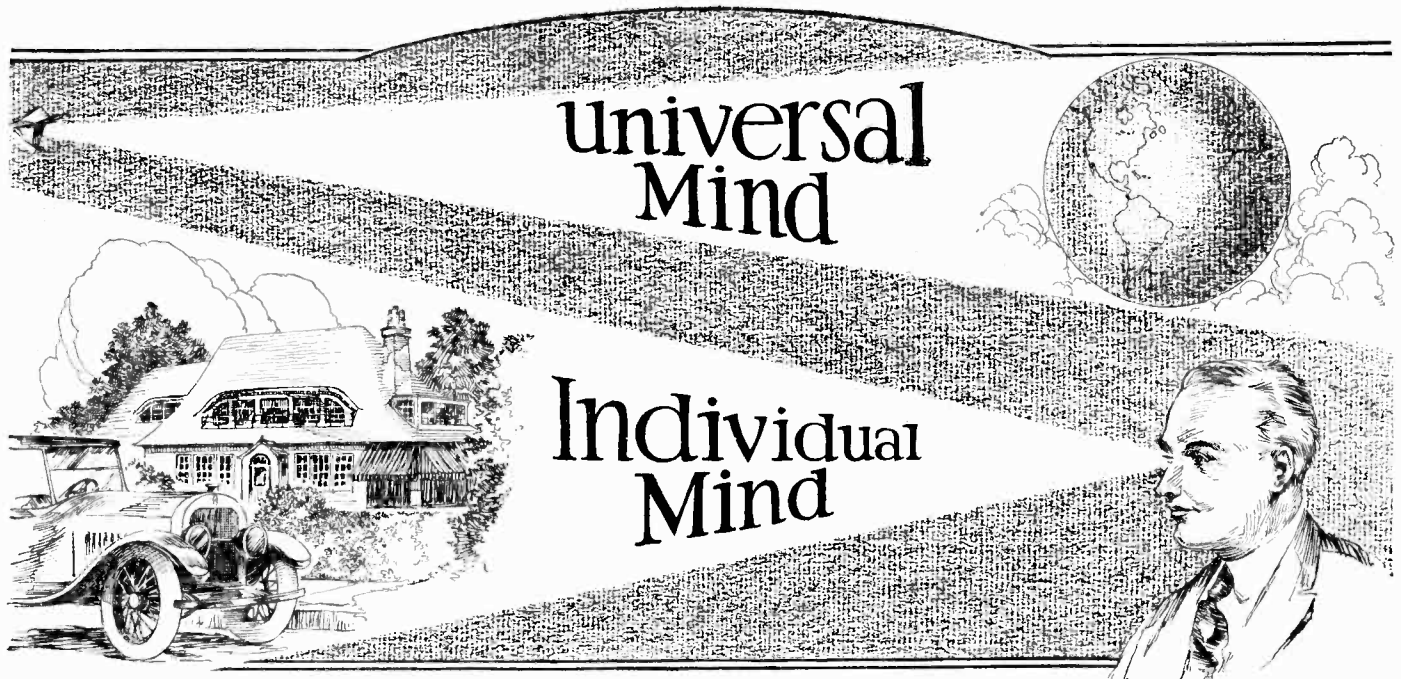

## The Creative Power of Mind in Action You Can Create the Things You Desire

**M**IND is the real motive power behind all creation, both natural and artificial. The Universal Creative Mind projects into the formless mass of uncreated substance a mental picture of a world, with continents, and oceans, and islands, and mountains, and valleys, and teeming life; and in due course the uncreated substance takes the form of the mental picture.

The individual human mind, under proper conditions, projects into its environment a mental picture of a splendid home, and forthwith the materials for that home and the money to pay for them begin to move together. The same is true of any other specific thing the individual may desire.

### What One Thing Do You Desire Above Everything Else in the World ?

That desire can be realized. You can have not only that one thing, but what things soever else may be necessary for your happiness. You have within you the creative ability to bring these things into existence and into your possession. The Universal Creative Mind exclusively occupies at least four-fifths of your brain and nerve-substance, and its manifestation in you is called your subconscious mind. It is infinitely wise. It is infinitely powerful. It is all-creative. It created your body from its very beginning, and still repairs, renews and sustains it. It is your Greater Self, your God-Self, your Real Self. Once the individual comes to know his marvelous indwelling Self, and takes it into partnership in his life and affairs, he becomes the architect of his own fortune, the reins of his destiny come into his own hand, and he makes his life just what he wants it to be.

It is remarkably easy to get acquainted with your Real Self, and taking it into partnership puts real life into living. Judge Daniel A. Simmons, one of the best known and most successful practical psychologists in the world, has introduced a great many men and women to their real Selves, and as a result of that introduction they have acquired splendid homes, fine jewels, vastly increased incomes, coveted promotions, business and professional successes, literary and dramatic achievements, and many other such like things. Many of them who were sick have healed themselves of nearly every kind of stubborn disease, and some of these healings have been truly miraculous. We have their reports of these things—a great mass of them—in our files, and since we have used the picture of a home at the top of this page, we here quote from just one of these reports which tells about the acquirement of a home.

"It seems that lately everything is coming my way, just as though I were being carried forward by some unseen power. Only this week a business deal came to me which placed myself and family in a most beau-

tiful home valued at Ten Thousand Dollars. This home is just like what I have been visualizing, even to the steam-heated, electric-lighted garage."

Look again at the picture at the top of this page, and see if you can determine how this man got his splendid home. He says he had been "visualizing" it. Can you get things by "visualizing" them? It is easy, if you know how.

Judge Simmons has written a plain and simple personal message entitled, "REALIZATION," which will actually introduce you to your greater, creating, conquering Self, and set you on the way to the attainment of the things you desire. It has transformed thousands of lives. It is free to anyone who will ask for it. If you will merely fill out and send to us the coupon at the lower right hand corner of this page, we will send you a copy of "Realization" full postpaid and

#### Absolutely Free of Charge

We suggest that you fill out the coupon now, before it gets away from you, or something else crowds the matter out of your mind.

#### The Realization System of Practical Psychology

##### THE REALIZATION SYSTEM,

Law Exchange Building, Jacksonville, Florida.

I accept your offer to send me free and postpaid a copy of Judge Simmons' personal message entitled "REALIZATION," with the understanding that I thereby incur no obligation of any kind whatsoever.

NAME .....  
STREET, or R. F. D. ....  
CITY..... STATE.....

**50c EACH**

**THE BIGGEST SUCCESS IN RADIO:  
CONSOLIDATED RADIO CALL BOOK CO.'S.  
PATTERNS and DIAGRAMS**

**EACH 50c**

**Complete Patterns, Diagrams and Instructions  
How to Make Your Own  
SHORT WAVE REGENERATIVE  
RADIOPHONE SET**

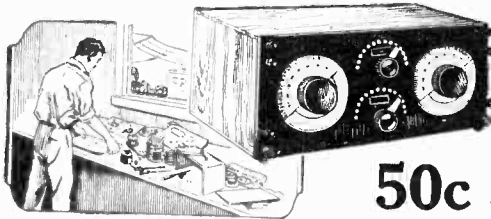

**50c**

One of the foremost Radio engineers constructed this set for us: it's simple to follow our patterns and assemble the parts comprising this set with which spark, C. W. signals and Radiotelephony may be received. We don't only give you pictures of how the apparatus looks, but each pattern is full size and printed on heavy blue print paper. Only standard parts are used.

**PATTERN No. 1**

Consisting of a Five-Page Illustrated Direction Pamphlet, size  $8\frac{1}{2} \times 11\frac{1}{2}$  inches. One Blue-Print pattern, size  $16 \times 22$  inches and One Blue-Print pattern, size  $17\frac{1}{2} \times 22$  inches, all contained in a heavy Two-Color printed Envelope,  $9 \times 11$  inches.

SENT POST-PAID

**DETECTOR and AMPLIFIER  
RADIO UNITS**

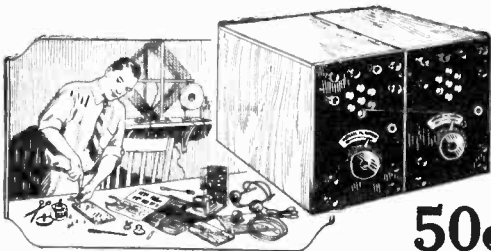

**50c**

You can build this detector and the amplifier units anywhere in your house; no machine shop is needed. When built they may be used with any type of Regenerative Receiver or short wave set, with which spark, C. W. Signals and Radiotelephony may be received. We've tested these patterns by actually building the outfit—they're perfect! Only standard parts are used in making the outfit.

**PATTERN No. 2**

Consisting of a Four-Page Illustrated Direction Pamphlet, size  $8\frac{1}{2} \times 11\frac{1}{2}$  inches. One Blue-Print pattern, size  $16 \times 18$  inches, and One Blue-Print pattern, size  $13\frac{1}{2} \times 15$  inches, all contained in heavy, Two-Color Printed Envelope, size  $9 \times 12$  inches.

SENT POST-PAID

**RADIOPHONE CRYSTAL SET**

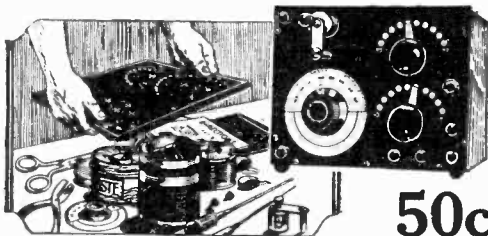

**50c**

We designed these patterns especially for those who are without technical knowledge but who are sufficiently abreast of the times to desire a radio receiving set in their homes. An instruction pamphlet comes along with the blue prints and all you have to do is follow the simple instructions. This radio set can be tuned in from stations within 50 miles. Standard materials only are used.

**PATTERN No. 3**

Consisting of 4-page illustrated Direction pamphlet, size  $8\frac{1}{2} \times 11\frac{1}{2}$  inches, one Blue-Print pattern size  $16 \times 22$  inches. All contained in two-color printed envelope,  $9 \times 12$  inches.

SENT POST-PAID

**14 RADIO FORMULAE  
AND DIAGRAMS**



Usefulness!

Economy!

Pleasure!

**50c**

With this packet of radio knowledge you need never worry about schematic wiring diagrams, measurements and radio tables. All formulas and diagrams are printed on heavy paper in black and blue; and contained in two-color printed envelope,  $9 \times 12$  inches.  
SENT POST-PAID

**ALL ABOUT AERIALS**

**12 Diagrams How to Construct and Erect  
All Types of Aerials**



RECEPTION

and

TRANSMISSION

ALL FOR

**50c**

THESE ARE DIAGRAMS THAT EVERYONE with a radio set wants and needs. These blue prints were made after practical erection of each aerial, and point out to you how simple it is to erect not only the proper aerial for your particular need, but how to erect this aerial in the most practical manner and at the least expense.

Consists of 12 blue prints  $8\frac{1}{2} \times 11$  inches and one four-page instruction pamphlet  $8\frac{1}{2} \times 11$  inches. All contained in a heavy two-color printed envelope  $9 \times 12$  inches.

SENT POST-PAID

**20 Radiophone Diagrams and  
Hook-Ups of**

**Crystal and Audion Receiving Circuits, Amplifier Circuits,  
Regenerative Circuits, Sending Circuits**

with

**Key Chart of Symbols and Pamphlet  
"How to Read Diagrams"**

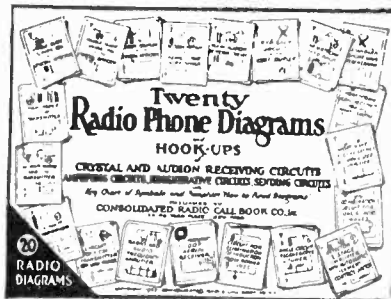

**50c**

These diagrams show how to get the best possible efficiency from the instruments you make or purchase. They cover hook-ups from the simplest to the most complicated, in a way that any amateur can understand and follow without difficulty. Get this set, and hook up right.

All 20 diagrams are printed on heavy paper, each sheet size  $8\frac{1}{2} \times 11\frac{1}{2}$  inches, and together with KEY CHART OF SYMBOLS and pamphlet "HOW TO READ DIAGRAMS" are contained in a heavy two-color printed envelope, size  $9 \times 12$  inches.

SENT POST-PAID

ORDER FROM YOUR DEALER—or direct from us

**CONSOLIDATED RADIO CALL BOOK CO., Inc.**

98 Park Place

PUBLISHERS

NEW YORK CITY



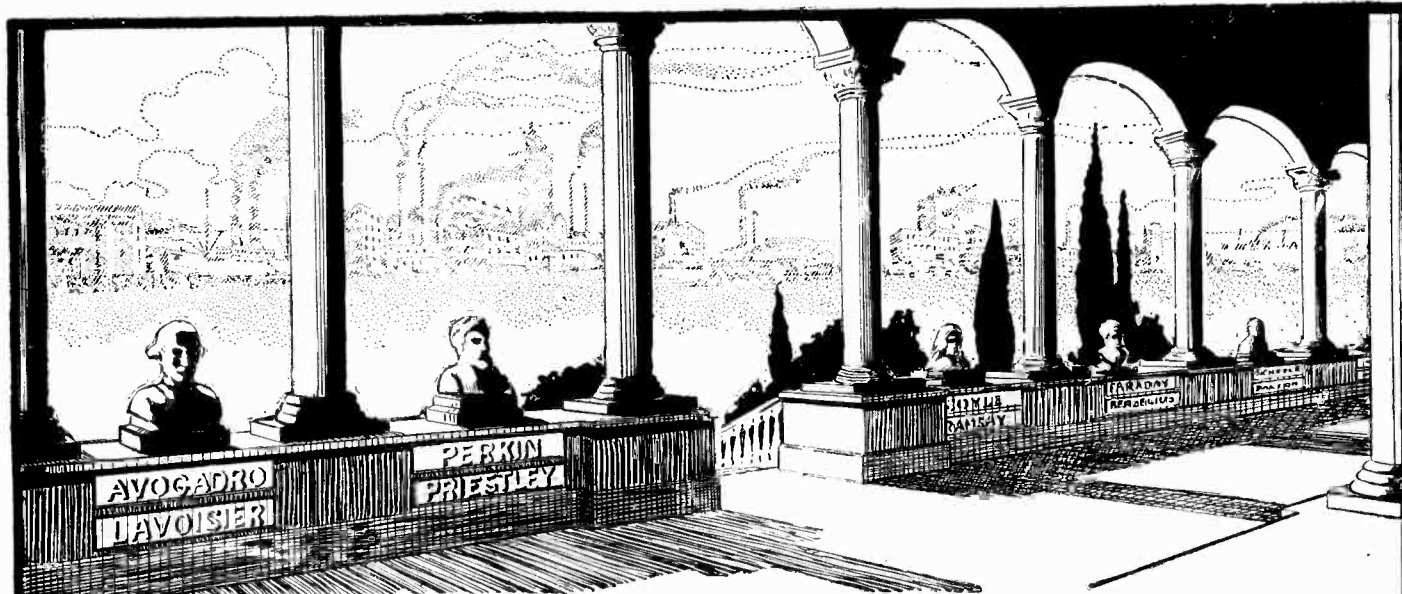

# THE HALL OF FAME

*Will There Be A Niche For You ?*

NO man knows what is in store for him. Men now famous in business and scientific worlds were obscure only yesterday. Men today unknown may leave their names in the HALL OF FAME. Great discoveries have been born over night—marvelous scientific deeds sometimes were the results of decades of labor, other times the outcomes of a scant week's research. Truly, no man can tell what the future holds for him. But it is within the power of each and everyone of us to control our own destinies, by self-training and diligent study to fit ourselves to render a lasting service to the world—a service that will bring reward, perhaps in fame, perhaps in riches. You control your own future.

## Great Growth of Chemistry

*What It Means to YOU*

It is the growth of chemistry that has made the past century the most wonderful period in man's history. In a few years the chemist has changed the industrial customs of the world. In a little more than one century he has advanced civilization by ten centuries. Do you know you can learn chemistry at home in your leisure hours? You can—hundreds of others are learning now!

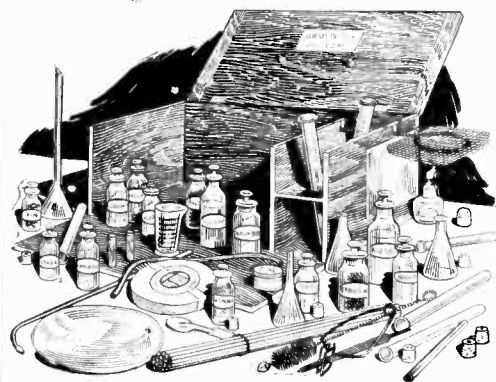

**Experimental Equipment Furnished to Every Student**

We give to every student without additional charge this chemical equipment, including forty-two pieces of laboratory apparatus and supplies, and seventeen different chemicals and reagents. These comprise the apparatus and chemicals used for the experimental work of the course. The fitted heavy wooden box serves not only as a case for the outfit but also as a useful laboratory accessory for performing countless experiments. Full particulars about this special feature of our course are contained in our free book, "Opportunities for Chemists."

## Dr. T. O'Connor Sloane Will Teach You Chemistry in Your Own Home

The Chemical Institute of New York, of which Dr. T. O'Connor Sloane is Educational Director, was founded to fill the need of ambitious, far-sighted men who realize and recognize the splendid future chemistry offers them, but who cannot spare the time nor the money to attend college. Dr. Sloane, a foremost authority on chemistry, will teach you and will give you any individual help you may require. He will personally go over your papers, correct them, point out your faults, and place you on the path which bears foot-prints of many who have trod it on to the HALL OF FAME.

## Easy Monthly Payments

You don't have to have even the small price of the course to start. You can pay for it in small monthly payments—so small that you won't feel them. The cost of our course is very low, and includes everything, even the Experimental Equipment—there are no extras to buy with our course. Our plan of monthly payments places a chemical education within the reach of everyone.

## Industries Need Chemists---

**Pay Them Good Salaries**

Industrial plants of all kinds have awakened to the need of skilled, trained chemists. Good salaries are paid them. There is no reason why you, too, cannot join this small army of trained men who are reaping material benefits from their knowledge that guards and advances civilization!

## ---and Special 30-Day Offer!

Besides furnishing the student with his Experimental Equipment, we are making an additional special offer for a short while only. You owe it to yourself to find out about it. Write today for full information and free book, "Opportunities for Chemists." Send the coupon right now while it is fresh in your mind. Or just write your name and address on a postal and mail it to us. But whatever you do, act today. Signing the coupon may prove the most important event in your life—mail it at once and let our book give you the facts.

# Act Now!

CHEMICAL INSTITUTE OF NEW YORK  
Home Extension Division 3  
140-D Liberty St., New York City

Please send me at once without any obligation on my part, your free Book, "Opportunities for Chemists," and full particulars about the Experimental Equipment given to every student. Also tell me about your plan of payment and special 30-day offer.

NAME .....

ADDRESS .....

CITY .....

## Chemical Institute of New York, Inc.

Home Extension Division 3. 140-D Liberty Street, New York City

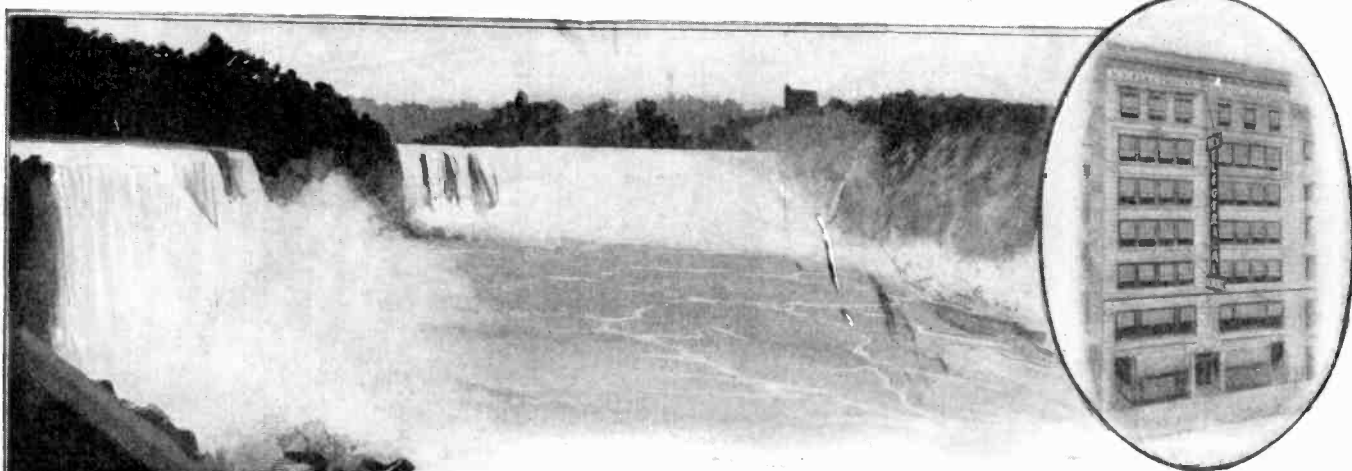

# Master Electricity By Actual Practice

The only way you can become an expert is by doing the very work under competent instructors, which you will be called upon to do later on. In other words, *learn by doing*. That is the method of the New York Electrical School.

Five minutes of actual practice properly directed is worth more to a man than years and years of book study. Indeed, Actual Practice is the only training of value, and graduates of New York Electrical School have proved themselves to be the only men that are fully qualified to satisfy EVERY demand of the Electrical Profession.

## The Only Institution of the Kind in America

At this "Learn by Doing" School a man acquires the art of Electrical Drafting; the best business methods and experience in Electrical Contracting, together with the skill to install, operate and maintain all systems for producing, transmitting and using electricity. A school for Old and Young. Individual instruction.

## Over 8,000 Graduates are Successful Men in the Electrical World

No previous knowledge of electricity, mechanics or mathematics is necessary to take this electrical course. You can begin the course now and by steady application prepare yourself in a short time. You will be taught by practical electrical experts with actual apparatus, under actual conditions.

The N. Y. E. S. gives a special Automobile Ignition Course as an advanced training for Auto Mechanics, Garage Men and Car Owners. The course covers completely all Systems of Ignition, Starters, Lighting and other electrical equipment on automobiles, motor boats, airplanes, etc.

*Let us explain our complete courses to you in person. If you can't call, send now for 64-page book—it's FREE to you.*

# New York Electrical School

29 West 17th Street, New York

New York Electrical School  
29 W. 17th St., New York, N. Y.

Please send FREE and without obligation to me your 64-page book.

..... NAME  
 ..... STREET  
 ..... CITY ..... STATE

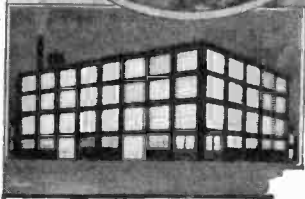
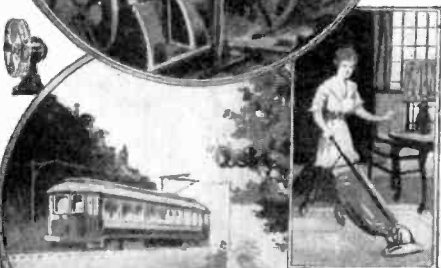
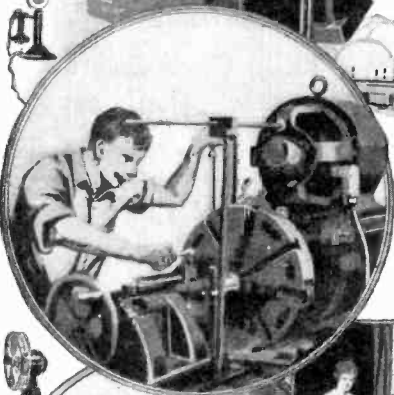
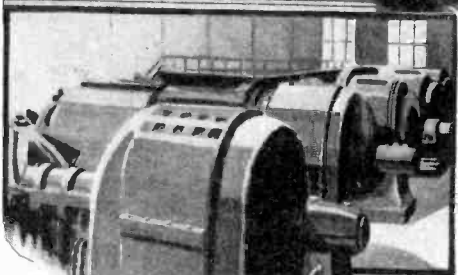



Volume X  
Whole No. 119

# Science and Invention

MARCH  
1923  
No. 11

H. GERNSBACK, EDITOR AND PUBLISHER

H. WINFIELD SECOR, ASSOCIATE EDITOR

T. O'CONNOR SLOANE, Ph.D., ASSOCIATE EDITOR

Editorial and General Offices, - - - 53 Park Place, New York

*"Those Who Refuse to Go Beyond Fact Rarely Get As Far As Fact"--HUXLEY*

## How Empty Is Space?

WE often hear the remark, "as empty as space," which we utter frequently, quite unthinkingly, having accepted the theory that space indeed is empty. But is it really? When we sum up the evidence, and there is a good deal of it, we find that space is not at all empty, but on the contrary is filled up with a great quantity of matter. When we say that space has no atmosphere or gases, we must take this with a large grain of salt. To be sure, let us say, halfway between the earth and Mars, or between the earth and Venus, if we could "sample" a bit of this "vacuum," we probably would be surprised to find that it was not so nearly complete as we once thought it was. As a matter of fact, scientists tell us that there is no such thing as a 100 per cent vacuum anywhere.

To prove this, we know, as a fact, that the earth is gradually losing a good deal of atmosphere as the years pass by. Thus, for instance, the moon once upon a time had an atmosphere the same as the earth, but due to the fact that its gravitational pull is so much lower than that of the earth its atmosphere passed out into space more quickly. Physics teaches us that nothing is lost in nature. Where, then, did all this atmosphere of the moon go, and where does the atmosphere that the earth loses in the course of centuries go? We also know that Mars is losing its atmosphere and has lost the greater part of it already, so that there is only a fraction left of what there was before. All of this air or gas of countless celestial bodies, be they stars or planets, has spread through all space, where it can still be found, although, of course, in a very attenuated condition.

We venture to say that average space contains a vacuum somewhat better than that in our ordinary electric light bulb, which, as we know, is only a poor one, technically called "a soft vacuum." This vacuum is not to be compared at all with, for instance, that found in a high grade amplifier tube used for radio purposes. The rarefaction in the latter is far greater than that of the ordinary incandescent lamp. So we see that the outer space probably contains a good deal of gases which, while very tenuous, are not at all to be compared with the next-to-impossible absolute vacuum.

Besides this tenuous atmosphere or gas, the outer space contains a tremendous amount of floating matter, as can be proven readily by anyone. There is not a single night when, if you watch long enough, you will not see one or more shooting stars illuminating the sky. And if you see such shooting stars, it is safe to say that other millions of observers who are watching for them, can see them as well every night. We know what these shooting stars are. They are meteorites, usually composed of metallic iron, that drive into our atmosphere, there to be reduced to metallic dust, which, after the meteorite has exploded, falls down harmlessly to the earth. Once in a while a big meteorite crashes down and specimens as large as a small house have been found. Some of the larger pieces are preserved in our museums. But we do not see, by any means, all of these meteorites. There is a tremendous amount of meteoric dust floating about in space, aimlessly, which, if it strikes the earth, has not sufficient speed and mass to make any great pyrotechnic display. Such meteoric matter settles down slowly upon the surface of our planet.

It has been calculated that the sun alone attracts enough of such meteoric matter in the course of a century to amount to a mass that is as great as our moon—a tremendous amount. If the earth is between 20 and 35 millions of years old—that is, if it has formed a crust for this length of time as our geologists assure us—and if only 100 tons of such meteoritic material falls down upon the earth each day (this is a conservative estimate), you can figure out for yourself the tremendous amount of material that must be floating in space.

And we must not forget that at certain times of the year, when we pass through one of the large meteorite swarms—which meteorites are the remnants of destroyed planets—the amount of matter that is thus deposited not only upon the earth but upon the moon as well as upon other planets, amounts to a colossal figure.

It is safe to say that when man finally perfects his "stellar express" the greatest problem will be, not how to get from one planet to another, but how to safeguard the flyer from the impact of meteorites traveling at a speed anywhere from 5 to 30 miles per second.

H. GERNSBACK.

# BERLIN - NEW YORK - CHICAGO VIA THE AIR

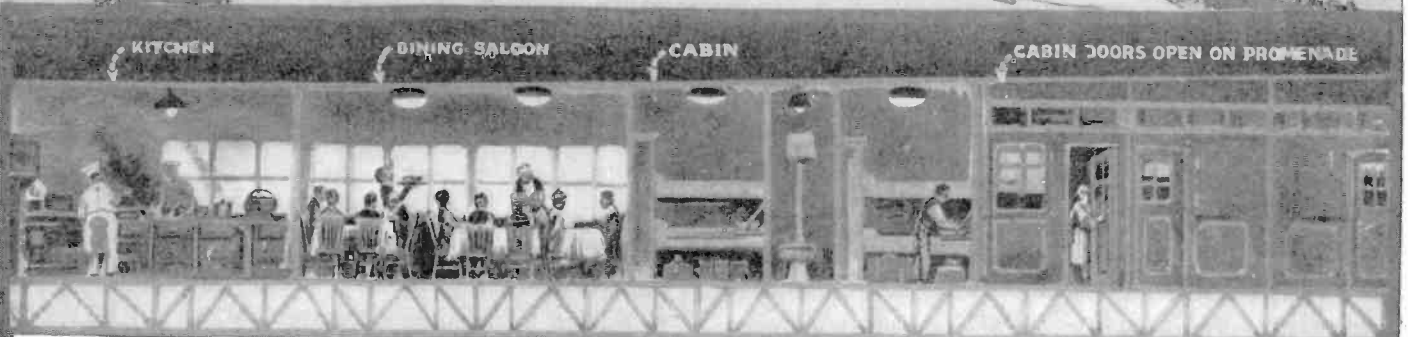

The longitudinal view showing the various compartments along the promenade deck of the new giant dirigibles, being built for the Berlin—New York—Chicago air traffic. Note how comfortable the passengers will be while flying through the air at an altitude of several thousand feet. Meals will, of course, be served en route, and as the other pictures on this page show, the passenger compartment is of different design than that followed in previous aircraft of this type, in that the cabins are all arranged in one continuous section in the forward part of the ship. One can sleep in perfect comfort on these giant airships, minus the noises encountered in railroad sleeping cars.



View along the promenade deck of the huge trans-Atlantic dirigible. These decks will be lighted by electricity and glass panels in the rail shelf will permit the passenger to look directly downward.

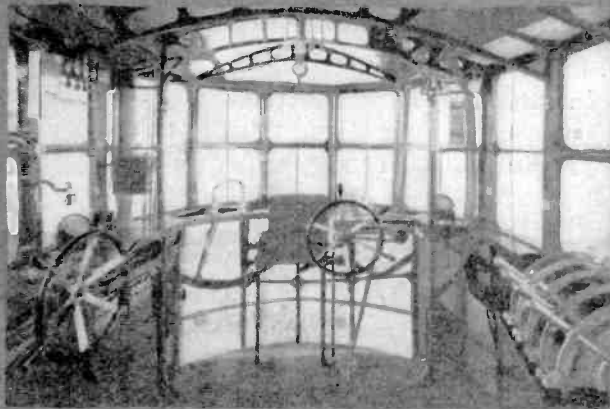

This view shows the interior of the airship Commander's cab, the horizontal and vertical rudders being operated by means of the wheels shown, while the handles at the right control the various engines driving the propellers. The front of the cab, as will be noted, is made of glass all the way down.



The Schutte-Lanz airship in the course of construction in German factory, less the external skin.

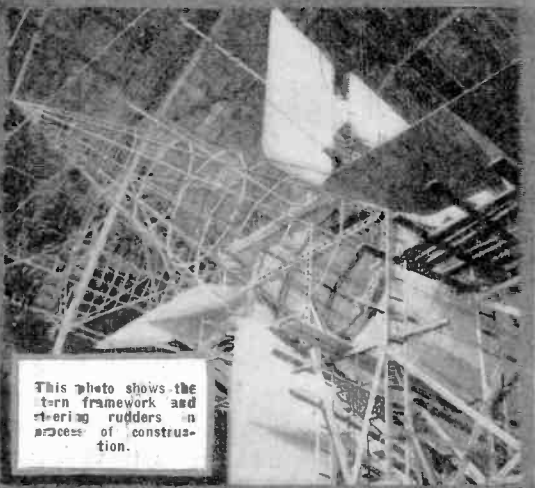
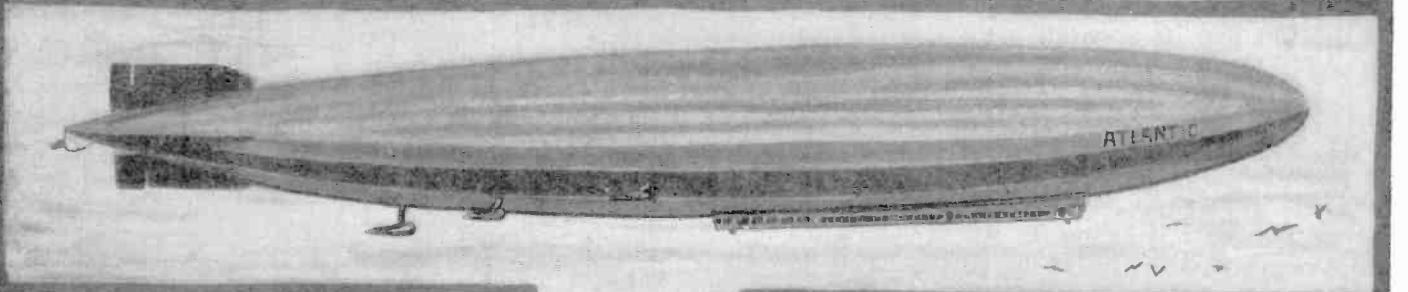

This photo shows the stern framework and steering rudders in process of construction.

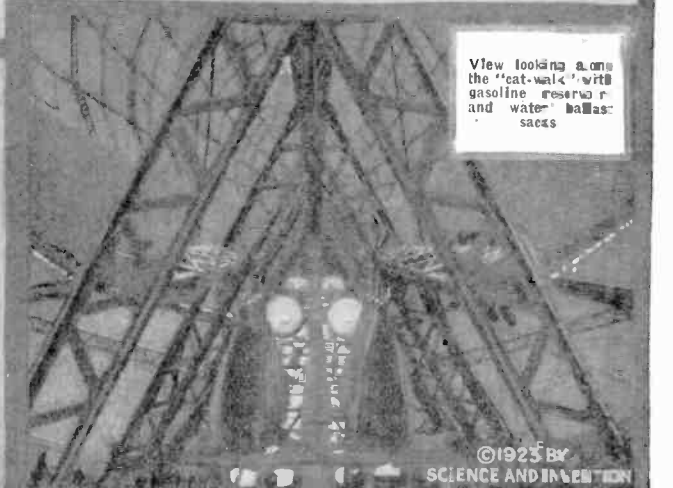

View looking along the "cat-walk" with gasoline reservoir and water ballast sacs.

©1925 BY  
SCIENCE AND INVENTION



# Chicago-New York-Berlin Via the Air

By Dr. H. BECHER

"WE learn by making mistakes," runs an old saying. We learn to overcome and to avoid dangers as soon as we have but once come into contact with them.

Germany has undergone this experience during the war with regard to her aerostats when necessity forced her in these four years of war to run through a period of development of thirty years as far as devising and constructing aerostats is concerned. The final product of endeavors had been an excellent model of inflexible aerostat, the *Schütte-Lanz*. Fully appreciating the merits of this, leading American concerns of commerce and industry established in connection with Dr. Schütte, the General Air Service, a branch affiliated to the American Investigation Corporation, who in the near future will call into existence a regular aeronautic commercial traffic first of all in America. The project is to raise in America a preliminary share-capital of 50 million dollars which is to be increased afterwards and to build three large Schütte-Lanz dirigible balloons or aerostats of about 110,000 cubic metres capacity. Setting these going a regular traffic will be opened up on the line New York-Chicago to begin with; a second line, New York-Berlin, is to follow soon after.

Of course, a few single aerostats only will not answer the purpose. There will have to be created besides large ports, well provided with gas-works and hangars to house the aerostats and the hangars must include stable ones and some capable of being turned. There must be set up *masts for anchoring*, provisions made for affording refuge, etc.; wireless telegraphy and the meteorologic service will have to be adapted to the necessities of aerial traffic. The different countries will have to work together for which purpose international agreements will have to be made and all progress of technic must carefully and continually be studied so that the necessary development will neither be stopped nor retarded.

And besides, the whole project must be carried out in a manner so it will turn out to be *profitable*. If you mention to an outsider the approximate sums necessary for constructing one single aerostat of large size or for creating a well equipped port, he will in turn doubtfully shake his head and express his opinion that to his mind it would seem impossible to find any subscribers to a project like this. And yet he is wrong! Comparison will show better than figures and counts could do, where the fault lies in the reasoning of this critic. If you travel today on board of one of those huge modern steamers from New York to Hamburg, you do not think for one moment—and surely no one else does—that this steamer might just as well go back and forth doing her service without properly built ports containing docks and quays and all requirements for proper landing, discharging and re-loading. On the contrary, everybody knows that in the harbors of all large seaports millions of dollars are invested. Everybody knows further that compared with these sums the cost of building the steamer herself counts almost as a mere trifle. As a matter of course extensive measures have to be taken for securing navigation on the ocean as well as on rivers, exact sea-charts must necessarily be drawn up and constantly controlled, the navigable road must be regulated, dangerous spots marked by light-houses, light-ships, and buoys; and last but not least a regular and well organized meteorological service, encircling all parts of

the world, must be maintained. In short, high working expenses are incurred constantly which in some way have to be reimbursed.

In the aeronautic service matters are quite the same; here also we need ships and ports. But there is one profit compared with the navigation service, i. e., that in the free atmospheric ocean we need no light-ships, no charting of channels, etc., and that thus a considerable part of the running expenses connected with the ocean service does not come into existence.

In the present article by Dr. H. Becher, one of our Berlin contributors, we are told of the newest plans for a trans-Atlantic air service in which the latest aeronautical developments are to be applied in building huge gas-filled airships, which are intended to link Berlin with New York and Chicago. The financial and other arrangements have, it is said, already been completed, and the present plans call for the building of three large dirigibles, of the type shown in the photographs on the opposite page. The dirigibles are of the Schütte-Lanz type, and every precaution is to be taken in the pleasure machines to guard against explosions or fire. It is intended to fill the balloon compartments with non-inflammable helium gas, and the builders are planning to replace the benzine motors with those to be operated with heavy oil. The engines are, moreover, to be placed in separate gas-tight compartments of their own.

Careful and thorough calculations of the profit have thus far shown that in an aeronautic service suitable to all modern requirements passenger prices will suffice which are but little above first class passenger prices of our modern saloon-steamers. In fact, taking here into account the saving of time, the *air service will really be cheaper than a steamship- or railroad-service*, for "time is money"; this proverb being to-day more valid than ever before in every business project. For instance: The highly paid correspondent of one of the large newspapers has to be travelling constantly all over the world; he must be everywhere where there is "something going on". If this correspondent, in using the air-service, has to be idle but one month a year in all, instead of three months as by using the steamship- and railroad-service, the profit for himself and his newspaper will most probably be some hundreds of times larger than the somewhat higher price for using the air-service would amount to.

Another example: If a representative of finance, of commerce or diplomacy, or the reporter of a newspaper of world-renown, has to go from New York to Berlin, it will take him at least 8 days to travel by steamer and by railroad. If the air-service on this route were a fact to-day, it would not take him more than about 2 to 2½ days. The great saving of time is obvious.

A means of traffic for multitudes the air-service will never be, because the carrying capacity of an aerostat is too small as compared with the running expenses of the whole service. An aerostat like that which Schütte-Lanz intend to put into service between New York and Germany, can take about one hundred passengers only, but these will certainly enjoy all the comfort which the travelling public is accustomed to on board of the modern fast steamers.

As a second important factor in the profit of air-service we must mention the mail-service. Cablegrams and radio-telegrams are very expensive and the secrecy

of business is nowadays no longer guaranteed. Over-sea letters go too slowly by steamer. This obvious deficiency is done away with by means of the air-service which at a comparatively low charge and in a very short time carries most important news from one part of the earth to another. A letter weighs very little, the charge for forwarding it can therefore be small. It does not at all appear utopian to think that in future times on certain routes mere *post-aerostats* may be in service which do not take any passengers at all but forward exclusively mail and matters or goods of high value. The American Mail-Service, for instance, has already had excellent results in forwarding letters from New York to San Francisco and back again by airplane. This service is arranged in such a manner that an airplane carries the mail during the first light-day period after having started. In the evening of that day the mail is delivered to a fast-train going in the desired direction which again in the morning gives the whole matter to another airplane for delivery at destination. Forwarding at night by means of airplanes is not possible as yet, because flying and landing at night for a vehicle like this is still too dangerous.

A few words may here be allowed on the relation of aerostat to airplane. It would be wrong to believe that they should exclude one another or be in competition with each other. On the contrary, they must both be considered *necessary supplements* to one another, the aerostat representing a fast-communication for large distances, while the airplane with its greater rapidity but its present still much smaller radius of action, comes preferably into question for small distances.

If we should sketch out upon a globe an air-service comprising all parts of the world, as we might expect for the future, we could limit ourselves to a few, say about a dozen lines, representing all routes from one country to another and beyond it. At the ends of these routes a fine net-work of lines would represent the short-distance routes of the airplanes within the different countries themselves.

Finally a few words on the security of the aerostat.

The gas-filling is generally considered to be very dangerous. The hydrogen contained in the balloonets mixed with the atmosphere, forms, it is known, an explosive mixture. Consequently, on board the aerostat every possibility of an explosion must be avoided and there must be no possibility of conflagration. This aim has been attained in practical manner in which there is of special importance the discharge of gas which Schütte-Lanz has adopted in his system in the shape of gaspits. A second danger which is also connected with the airplane, is the benzine motor which nowadays is still necessary for driving the aerostat. Benzine-vapors are easily set ablaze, but even this danger is not to be taken in earnest on board of a modern aerostat. The *motor plant*, for instance, is put into special tightly closed gondolas which hang at quite a distance from the main body of the aerostat, there being thus always a strong current of air passing between the gondola, the source of danger, and the balloonets in their casing. In consequence of this arrangement there would be, even if a little fire should occur inside of the gondola, no harm whatever done to the ship itself, as experience has shown.

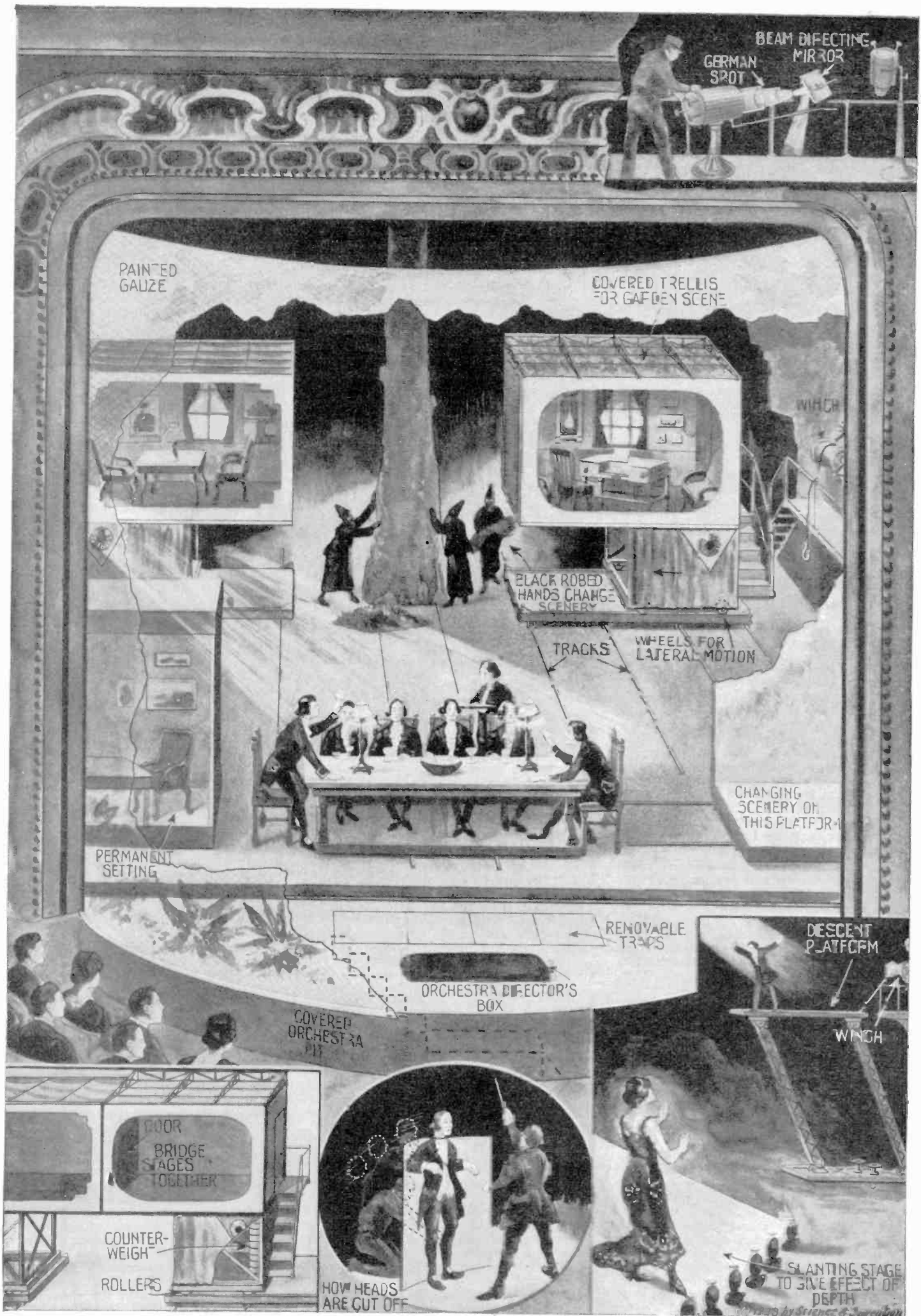

In "Johannes Kreisler," the latest New York theatrical sensation, there are forty-one scenes, which are changed right before the audience without dropping the curtain. These marvelous scene changes are effected by switching off the lights, the stage attaches being garbed in black; these rapid transformations being aided by a number of clever moving scenic structures, as shown above.

# Rapid Scene Changes in "Johannes Kreisler"

By JOSEPH H. KRAUS

ONE of the most spectacular productions on the American stage today is now being viewed by thousands of theatre-goers daily at the Apollo Theatre, New York. This production was imported from Germany, where it was first shown under the name of "Die Wunderlichen Geschichten des Kapellmeisters Kreisler." Svend Gade, a Danish inventor, was also brought over to construct the stage and produce the scenic effects, he being the inventor of the system of rapid scenery changing used. In the play, forty-one scenes are to be counted; there are twenty-one in the first act, ten in the second act, and ten in the third act, all of which pass before the eyes of the audience within the prescribed period of two and one-half hours. There is no intermission at all between scenes.

Just a few words with regard to the story of the play itself, will be given and then we will continue with the description. Part 1.—Johannes Kreisler has written an opera in which Undine is to star, Undine being a character in the opera. Kreisler is befriended by Julia, a girl whom he meets, and is invited to her house by Julia's parents, where he subsequently teaches her to sing. A Padre tries to persuade Julia's mother to have her take the veil, and warns her against the musician. A rich man also enters and proposes for Julia's hand. On a subsequent visit, Kreisler is told that the Padre has taken Julia to mass, which creates in him, maddening visions. He sees Julia tied to a whipping post, with the Padre scourging her unmercifully. As Kreisler cries out, the scene rapidly changes, and the whipping post becomes the convent cross, before which Julia is praying. They return to Julia's room and the rich man enters. Again Kreisler has a vision in which the rich man is seen offering hoards of gold to Julia. Kreisler enters upon this scene, where the money bags turn into skulls, skeletons, and spooks. Again the scene changes to Julia's room, where she and Kreisler have an understanding. She informs him that she doesn't want riches, but wants him. Just then, as they embrace, the Padre enters, and Kreisler is ordered away.

Part 2.—Kreisler, now musical director of the Royal Opera, is commanded to appear at the Grand Duke's Palace, to play music for a dance. He refuses, but Euphemia, the Duke's niece, coaxes him to play for her pleasure, which he does. Kreisler's rivals and enemies mock him. The Lord Chamberlain, having proposed to Euphemia, adds to the Grand Duke's worry over her growing intimacy with Kreisler, but she assures him she will do what is right. Kreisler seated at his desk writing in the following scene, is tortured by oppressive imaginings, his enemies standing about him, laugh at him, and with his baton he cuts their heads off. This beheading scene is shown in detail in the insert in our illustration. The scene changes to one at the stage door of the Court Theatre, where Kreisler, mastering himself, says that he will direct the ballet in the opera, which ballet he has been instructed to introduce. The next scene is in front of the curtain of the theatre, where the rehearsal of Kreisler's opera *Undine* is to take place. After violent words with the director, Kreisler throws his baton down and leaves the theatre. Outside he meets Euphemia, who gives him her hand and says farewell. For the second time he has lost all.

Part 3.—Kreisler still telling the story to his friend, states that he has entered a thea-

tre to steep himself in Mozart's music. He explains that Donna Anna, Julia, and Euphemia are all one and the same—his Undine. He adds that although Donna Anna was at the moment on the stage, he felt her presence behind him, the scene changing to indicate this. The bell rings, and Donna Anna must return to the stage. While singing, she stretches her arms alluringly toward Kreisler, who drawn by a super-natural force, floats from his box through empty space, down to her on the stage. This takes place supposedly at two o'clock in the morning, after Kreisler had fallen asleep in the theatre box. They embrace, and a moment later she lies lifeless in his arms. The scene

upon a mirror, which reflects the light making it possible to rapidly change the location of the beam, in much the same manner as a boy with a mirror can reflect sunlight, directing it very easily toward any spot desired. These lights instead of employing large colored screens, use a strip of colored gelatine only one inch wide, and about six inches long, blending colors from a vivid violet to the other or red extreme of the spectrum. Sliding this back and forth just a little out of the focus of the beam of light, where the rays concentrate before being thrown upon the mirror, it is possible to rapidly change the color. An iris diaphragm slightly larger than a silver dollar, controls the amount of light. These spot-lights are located upon a special gallery erected just back of the proscenium arch.

The orchestra pit is entirely covered, the director observing the scene through an elongated prompter's box. A flight of stairs leading from the roof above the orchestra and extending below the stage, permits Kreisler to go down to a platform later in the play, to direct the musicians in the scene when the opera is being staged. This flight of stairs is covered by removable traps. Extending from the forward edge of the orchestra box (for the pit now is a sector of a circular box, the orchestra being completely covered), an immense gauze curtain rises upwardly, being attached at the upper end to an iron supporting rail. The gauze curtain itself is painted. This provides for a change of scenery behind it, when one of the smaller stages is illuminated, without the necessity of lowering the regular drop. The audience can see through the gauze curtain when the stage is illuminated, but when the stage is in total darkness it appears as though the curtain itself was absolutely opaque. Strange to say, the actors never see the audience.

In order to facilitate the changing of the scenes rapidly, the stage has been divided up into six smaller stages, which may be almost completely drawn out of the way. There are three sets of longitudinal tracks, upon which flat platform-like cars roll, which may be drawn forward or pushed back whenever desired. On the center platform smaller settings are mounted and on the two platforms on either side running parallel with this, some of the larger scenes are erected. Each of these platforms contains a double story structure, the upper story of which extends considerably beyond the lower one. This particular construction may be shifted at right angles to the platform upon which it rests, as it also moves on rollers. Thus it is possible to construct a bridge with one of these on either side. Either a complete scene or a half scene may be erected on the half bridges.

Each bridge is equipped with its own supply cable and electric lights, and at no time are the usual footlights of the stage or the lights in the flies, lit up, except in the settings when the space of the entire stage is employed. In order to make it appear that a person is walking off into the distance, the main platform of one of these double-deck structures is gradually pushed toward the rear of the stage by figures draped in black, and hooded like members of the Ku Klux Klan. The other movement of the double-decked structure is also utilized, so that at the same time that the main platform is being moved toward the rear, the bridge section is pushed laterally or toward the

(Continued on page 1099)

## April Feature Articles in Science and Invention

*Measuring the Heat From the Planets.* By Donald H. Menzel, M.A.

*The Thing From—Outside.* By George Allan England.

*Producing Burning Ship Scene on Stage.*

*The Birth of a Clay Pitcher.* By Jay B. Elliott.

*Talking Over 70,000 Volt Transmission Line* By "Wired Wireless."

*Utilization of Tidal Power—Latest European Development.*

*Wave Traps and Interference Preventers.* By A. P. Peck.

*How to Build an Ultra-Selective Short Wave Tuner.*

*What Will Be the Future of Radio Broadcasting?* By H. Winfield Secor.

*Producing Helium From the Carbon Arc.*

*Pipe, Cigars or Cigarettes—Which?* By Ismar Ginsberg, B.Sc. Chem. Eng.

*All the Earth's Atmosphere in One Tank.* By Charles Nevers Holmes.

changes to the room where he is telling the story, where Kreisler is informed that the opera would not be played because Donna Anna died at two o'clock that morning. Kreisler closes his eyes, and falls into a slumber from which no one can arouse him, his soul passing to meet his Undine, or otherwise Euphemia, Donna Anna and Julia.

\* \* \*

The scenic effects in this production are remarkable because of the extreme rapidity, with which they flit before the eyes of the audience. The ordinary footlights are not employed, colored spot-lights taking their place. Here we find amongst the innovations, several new German spot-lights, which instead of requiring their entire body to be shifted in order to change the position of the spot, are fixed and stationary with regard to their carbon housings, lenses, color screens and diaphragms. The beam from these machine gun-like spot-lights is thrown



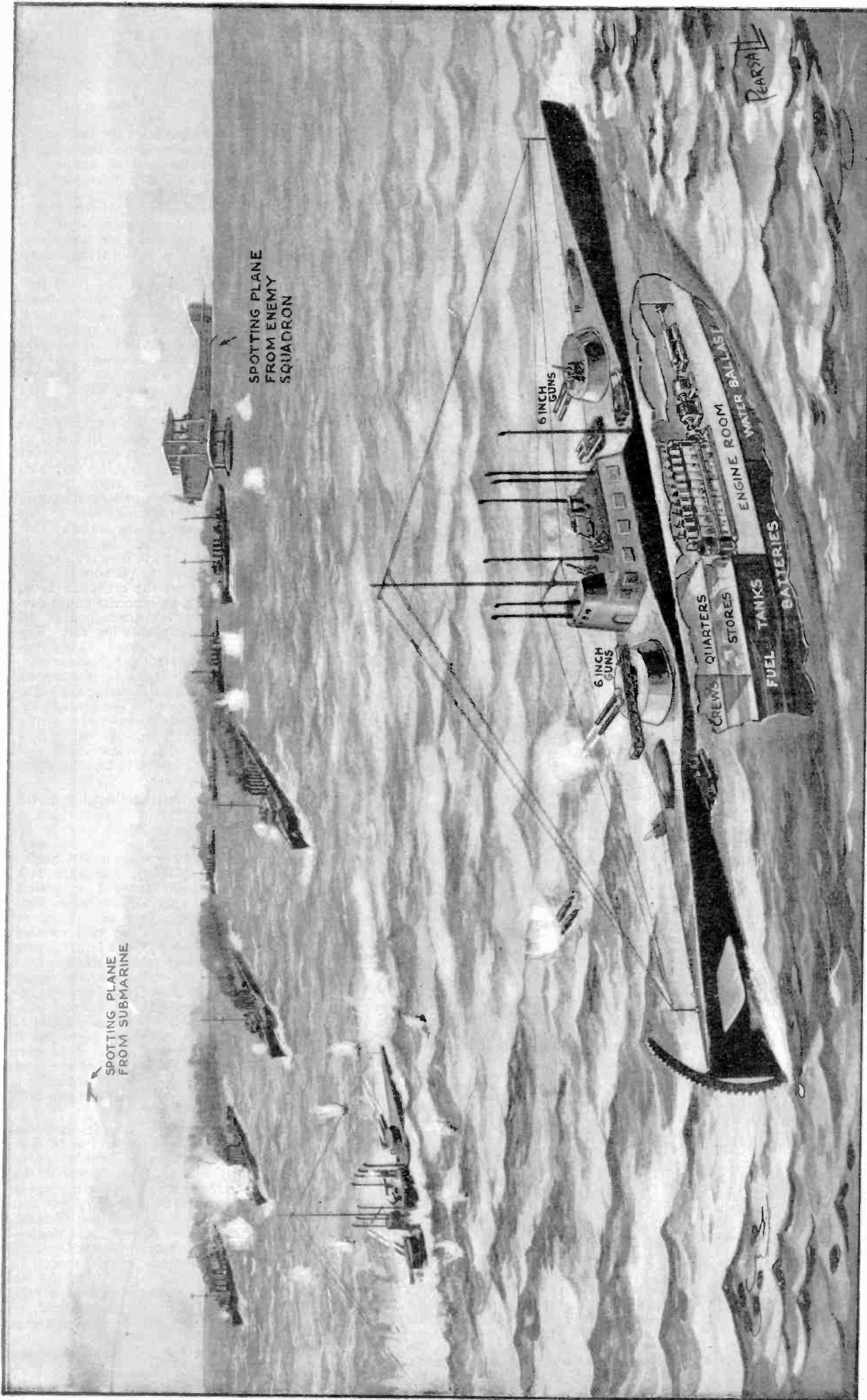

©1923 by Science & Invention.

**THE SUPER-SUBMARINE OF TOMORROW**

The super-submarines of the future in action. The vessel in the foreground is covering the retreat of the second submarine, which has been badly hit by the destroyers. The eight destroyers constitute the attacking force. The first division of four destroyers is attacking the submarine making a crash dive. The second division will shortly make a turn to the left and attack the submarine in the foreground. This action brings into play all the features with which a submarine of the future must be endowed. The six-inch guns, enclosed in water-tight turrets, are far more powerful than the guns carried by the destroyers. One of their hundred pound shells is sufficient to put any destroyer out of action, if it does not sink the vessel. The Diesel engine and the electric drive give a submarine comparatively a far greater speed than the Diesel engine with the electric drive. The vessel in the foreground is operating at a top speed of twenty-four knots. It is quite possible to stow a small airplane, which would be invaluable as a scout and as a spotter for the gunnery. In order that this plane can be launched, a catapult is mounted on the fore turret. The anti-aircraft guns are used to drive off enemy planes attempting to bomb or spot the enemy's gunnery. Note the number of periscopes. It is the practice even nowadays to put a number of these observation instruments on a single submarine, in order that the vessel's usefulness is not put to an end with the destruction of one or more of them. The demonstrated efficiency of the deck torpedo tube is responsible for its use aboard this ship. Note the fore tube on the left, or portside of the ship. The outside torpedoes are scarcely out of the tube before the middle or third tube is discharged.

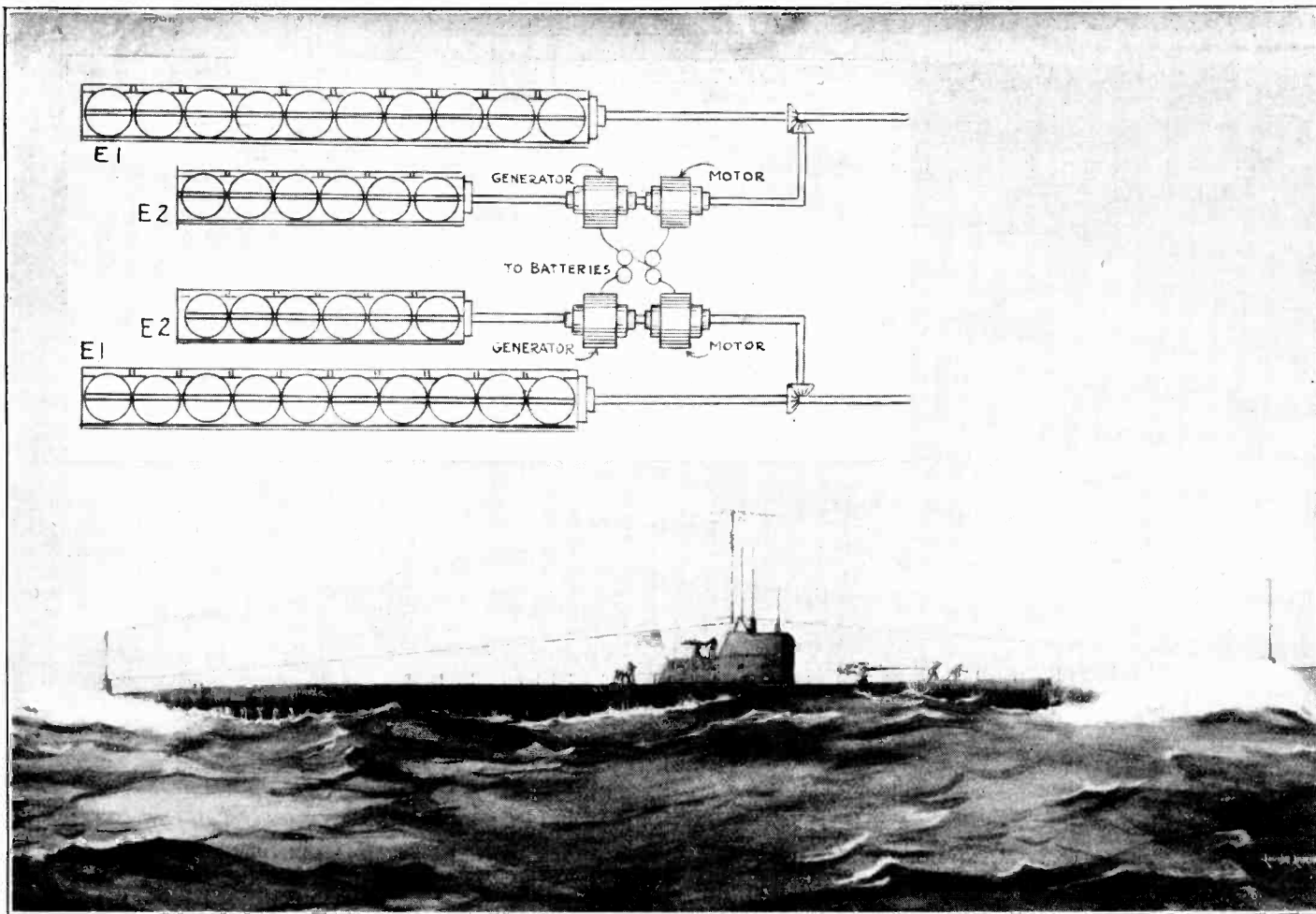

Our new submarines of the V type, which have just been laid down at the Portsmouth Navy Yard. The insert shows their engines, which are of the M. A. N. Diesel type. Those marked "E1" are the main drive engines, which operate on the shafts, at the end of which are the screws which drive the vessel. Those marked E2 are engines of the same type, of less than half the power. They are used to drive the generators, which in turn charge the vessel's storage batteries for submerged cruising. The motors just aft of the generators take their power from the batteries when cruising submerged. In the event it is desirable to use the full power of all the engines on the surface, such as would be the case in fleeing from a more powerful vessel, the E2 motors can add their power to the main drive engines in the following manner: The generators are cut off from the batteries and connected directly with the motors, which in effect gives the same electric drive system as used on our larger battleships. Thus all engines are connected with the main drive shafts, giving the maximum power at the time it is needed. This mechanical feature makes these V boats the forerunners of the super-submarines of the future.

# The Submarine of Tomorrow

By GRASER SCHORNSTHEIMER, Naval Expert

**S**TRANGE as it may seem, the full powers of the submarine were not revealed in the late war. As a commerce destroyer and raider, its use was fully demonstrated, but its value as a scout and as a deterrent to the advance of an enemy force was in no way revealed. The submarine of the future must be capable of all these duties, though each vessel of the future type will probably be designed for specifically one duty or another.

The greatest submarine in service today is the French "Halbroun", formerly the German "U139". She is really a large vessel of 1930 tons surface displacement and 2480 tons submerged. She is considered an ocean-going cruiser. In design she is a forerunner of the great boats which will attempt to control the seas in time of war twenty-five years hence.

She has a complete double hull, which is well sub-divided into many compartments. She is fitted like a battleship with anti-rolling tanks. Her engines are the ultra-modern 6 cylinder, 4 cycle Diesel motors of the M.A.N. type. They are two in number and develop 3500 horse power to give the vessel a speed of 17.75 knots on the surface. Having been designed for ocean cruising as a commerce destroyer, her endurance is very high—18,000 miles at a speed of 8 knots.

The submerged motive power is derived from electric motors operated by great storage batteries, which are charged by genera-

tors operated by the Diesel engines when the vessel is cruising on the surface.

American submarines have not been so successful as those of foreign makes. The principal reason has been the inability of private engine builders to construct a Diesel motor practicable to the submarine.

But our engine difficulties, which seem to be purely those of design, are now over, as the Navy Department is undertaking the manufacture of proper engines in Government shops. German submarines and the latest types of the best German Navy Diesels were brought to this country shortly after the war. These engines, the famous M.A.N. or German Navy type were carefully measured and new ones were built at the Brooklyn Navy Yard. They are wonders of perfection which seem to have overcome the defects of other types. Per horse power they are lighter and more efficient than any engine we have ever had heretofore. Several submarines of the "S" type have been re-designed with these Diesels and they have considerably bettered their past performances, though before this change, the "S" class had proved itself to be the finest in our submarine service.

Last year the Navy Department received the initial appropriations to cover the construction of three of the nine "fleet" type submarines authorized in 1916. With these new boats it will be possible to start anew our submarine history with real vessels built by Navy engineers, on Navy designs

and in Navy yards. They were assigned to the Portsmouth Navy Yard for construction and their engines will be built at the Brooklyn Navy Yard. A most advanced design has been given them.

These boats are known as the "V" class. They will be about 335 feet long, have a beam of around 37 feet and draw about 16 feet of water when on the surface. The normal surface displacement will be 2,025 tons and submerged the ships are reported as around 2,500 tons. The engines will be two 2400 horse power M.A.N. Diesel motors operating on the main drive shafts. There will be two auxiliary 850 horse power engines to drive the electric generators which charge the storage batteries for submerged cruising. *And to test the theories regarding the practicability of the electric drive for increasing the speed of submarines these electric generators are directly connected with the motors which are in turn connected with the main drive shafts and can be used for surface cruising!* All the naval constructors will say regarding these boats is that they are expected to have speeds of about 21 to 22 knots, but others, very well informed, expect that these Diesel driven American submarines will equal the speeds of the British steam driven "K" boats—of 24 knots!

The cruising radii of these "V" boats will be very large, permitting them to operate with the battle fleet on all occasions. It is  
(Continued on page 1100)

# New Process Color Black and White Movie Films

By LEWIS YEAGER

SCORES of experts have been working night and day for months in the Famous Players-Lasky Studios in California to turn out 200,000 feet of colored film for the new Cecil De Mille motion picture *Adam's Rib*. The Company will soon be operating twelve composite automatic machines each capable of producing 1,000,000 feet annually. This new machine, which will be one of the most intricate to be found in the scientific world, will operate automatically after an operator threads the film through it and presses the control button. It will be to the Movie World what the cotton gin is to the Textile World, and what the linotype is to the Newspaper World. Radio appliances are comparatively simple as compared to this new addition to the resources of the scientific field. The unit-block of twelve machines will cost \$70,000.00.

Loren Taylor is the inventor of this new machine which colors black and white films. It is a case of necessity being the mother of invention, for Mr. Taylor already occupies a place in the front row in the leading inventors in the cinema world. The Taylor process requires no modification of camera or projector, and this together with the wonderful color effects made it appeals to Mr. De Mille.

Scenes in the new Cecil De Mille picture to be released by Paramount, used many feet of it. Not only will it be used in

title decorations, but in many intricate movie scenes.

The new machine will do all this complicated work at a stroke. Other systems requiring a variety of equipment have obtained excellent results, but Mr. Taylor has accomplished the impossible. He takes a picture made with the ordinary camera, touches it with his magic wand, and hands it to the exhibitor who may use it in any projector.

We shall now see why machinery is necessary. If you could get into the color laboratories of the Company, which few are able to do, you would find the film passing through many machines, each in charge of an operator. These experts have been working night and day preparing film for the new motion pictures. There are 275 copies of this film; each film is 10,000 feet long, and about 1,000 feet of colored film is used in each picture. In other words, 300,000 feet of colored film is necessary. The sections of colored film are first made in the color laboratory, then assembled and cemented in the proper parts in the main black and white film.

In order for one to understand the system of colored movies, an explanation is required. The motion picture camera only records its views in black and white, and colored pictures as with the ordinary camera are out of the question.

Motion pictures are taken at the rate of

16 per second. The film must actually stop 16 times. Each time it stops, the shutter gives an exposure. The film after perhaps a thousand or more feet have been exposed is then developed giving a negative and the positive is printed on another similar strip and is finally ready to be run through a projector. The projector is a machine which jerks the film in front of the light 16 times per second, so when Dorothy Dalton hits the villain with a pitcher, it is in reality a string of pictures we see. The eye retains one image until the other is before us. This is described by the physiologist as visual persistence.

Inventors have used various types of apparatus to make colored pictures. The majority did not go with standard equipment and hand coloring was often used through necessity rather than choice. This is why Mr. De Mille was greatly interested when he saw the colored piece of film resulting from the work of Mr. Taylor. This process did not require a different camera or projector.

The details of the present process are guarded by the company but the system now used and which will be incorporated into the composite machine can be understood from our illustration.

Colors are due to different wave lengths of light and each has a different effect on

(Continued on page 1105)

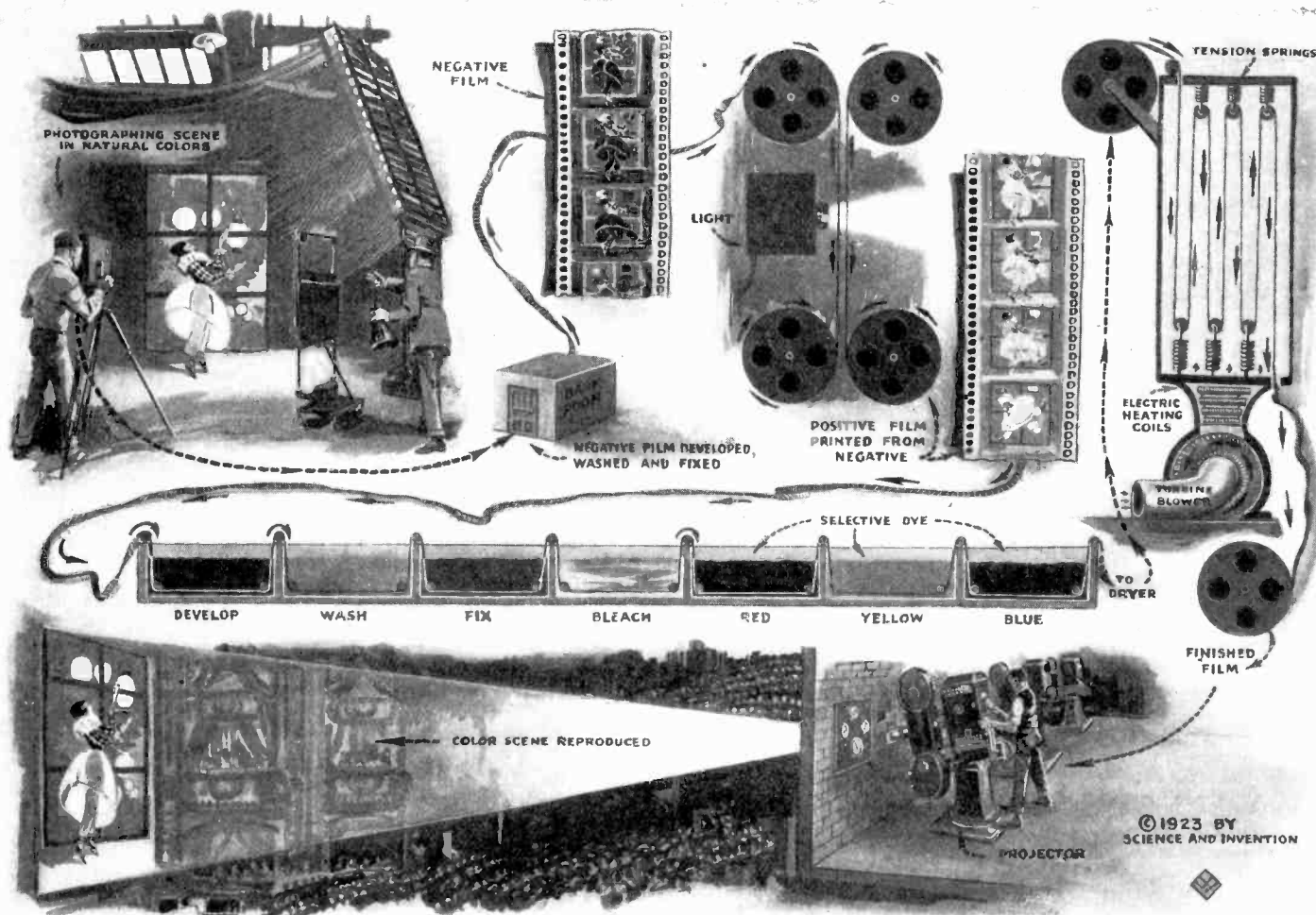

There are several colored movie production schemes now in use which give satisfaction, both with regard to the output and the quality of pictures, but it has remained for Mr. Loren Taylor, a motion picture scientist, to evolve the process here shown, which is at once the simplest and the fastest color movie production method yet evolved. The pictures are taken with an ordinary movie camera with standard negative film. This film after developing, washing and fixing, is passed through the printing machine, and as many black and white positive films produced as are needed. These positive films are then passed through the bleaching and dyeing baths as shown, the various black and white tone values absorbing the proper dyes as the film passes through the successive baths. The film is projected in a standard machine and the films are remarkable for their clearness, there being no fringing of the colors whatever.



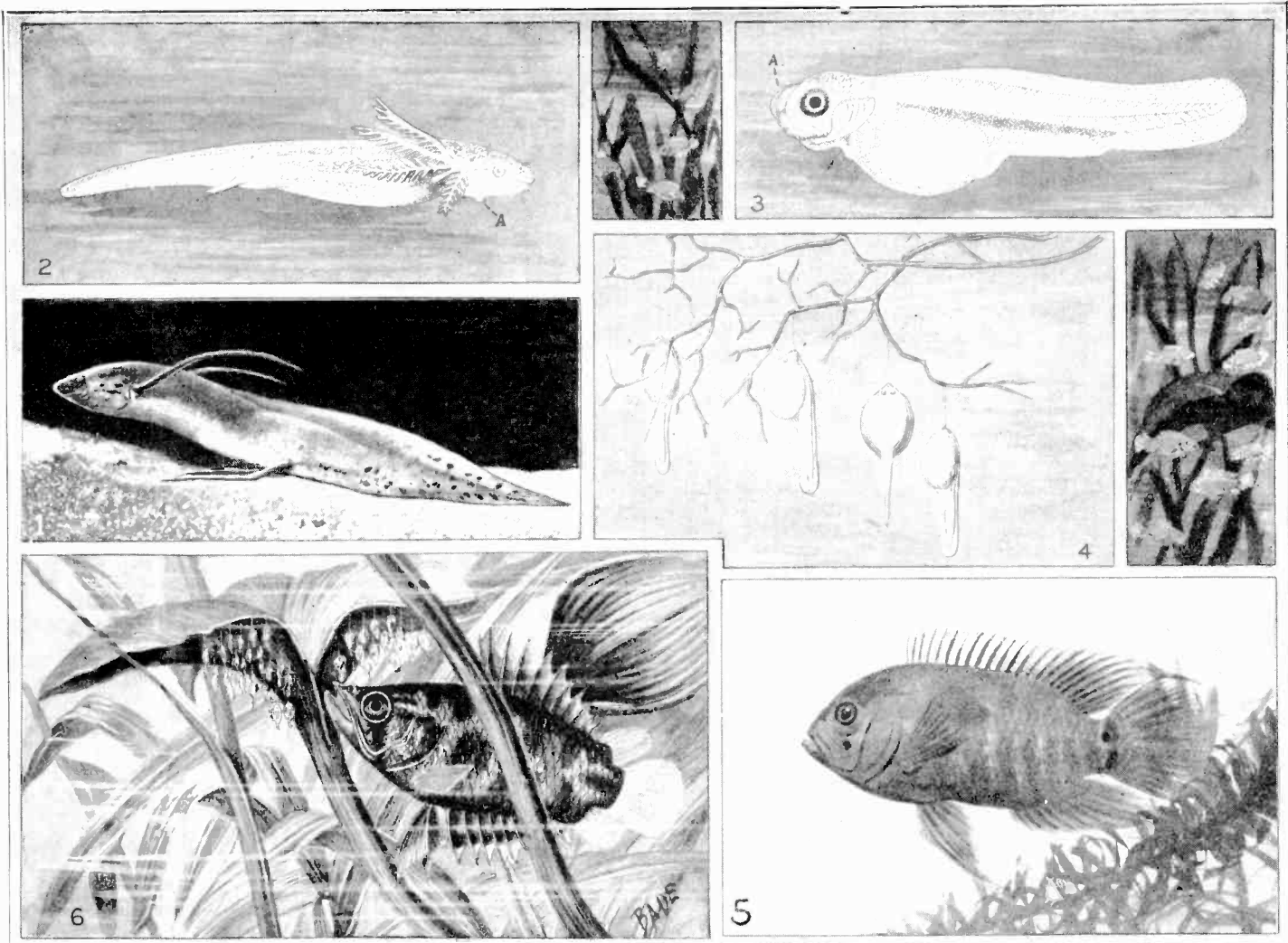

1—The lung-fish *Protopterus*, is able to breathe air directly, as the places in which it lives often dry out. Then it buries itself in the mud and lives by respiration of the air. 2—The young of *Lepidosiren*, another lung-fish, have their cement organ on the under side of their head at A. They also have a strikingly amphibian characteristic in that they have large external gills. 3—A is the large adhesive cement organ borne on the front of the head of the characin, *Sarcodoces odoe*. 4—The larvae of *Hyperopisus bebe* hung from rootlets in the nest by means of threads coming from the cement organ to keep the breathing organ free from mud and to provide them with fresh air. 5—*Acara himaculata*, a fish now often kept by fanciers, also hangs up its young ones: it is a native of South America and attains a length of four inches. 6—A very peculiar fellow is *Polycentropsis abbreviata*. It hangs the eggs on the under surface of some aquatic leaf. The young, recently hatched fry, hang from the leaf by means of a short thread and are further cared for, and protected, by the male.

# Fish Hang' Up Young' to Ripen

By Dr. ERNEST BADE

**N**ATURE often follows peculiar paths to reach its goal. Its inventive genius is unsurpassed. Obstacles are surmounted with such ease and such apparent simplicity just as if they did not exist. And then it makes no difference whether she makes a little side trip now and then to while away an idle hour and get out of the rut of her daily monotonous existence: all that she desires is to accomplish her final task. Then the will to live lights its lantern, as Schopenhauer has pointedly exclaimed, and it is this will to live which finds a way, under certain condition, for existence to be made a possibility.

The meaning of the expression of life, is, everywhere in organic nature, combined with the immutable law of the variation of the individual and this variation together with heredity form the basic principles in the theory of development. Otherwise new properties and characteristics could not have been made a possibility, and without the law of heredity it could not have been retained and passed on to other generations who not only have kept it, but perfected it still further.

Although variation of the individual is a primary characteristic of life, the force of self-preservation and reproduction of the species must be added. Every animated

being feels this force, every individual attempts to push the other fellow against the wall, every species fights for its right to exist. Each change and each new characteristic and property inherited or variability attained, is employed in its battles. And so, through the ages, each species develops its progeny with better adapted weapons. It is, and will remain, a war of all against all, for war is here a better development, an approach towards the perfect and ideal, a fight for higher attainments.

In tropical and subtropical regions where spring with its rainy season is followed by long dry spells which completely destroy the rivers with their tributaries and entirely evaporate both ponds and pools, so that the deep beds of mud and muck are baked to hard and stone-like masses which, under the powerful rays of the scorching sun, crack into fissures and divide into crumbling plates, the aquatic animals must develop peculiar structures in order to keep themselves, as well as their progeny, alive. The bottom of the inhabited ponds, as long as they are filled with water, consists of a dust-like muck, which, on the slightest disturbance, rises in dense clouds only to settle slowly back again, covering the green waterplants with dirt and entering the delicate respiratory organs of the animals, so that the younger and more sensitive creatures would suffo-

cate if they were not protected in some ingenious manner. This is the reason that a kind of parental care has been devised by the fish inhabitants. It is in the building of nests that it is manifested and it is this practise which keeps the spawn and the young clean and also protects them from disappearing into the mud.

Such builders and protectors of the helpless young are the Cichlids or Chromids, native to the tropical regions of both Africa and South America. There are numerous species, and to differentiate one from the other is an exceedingly difficult problem, for with slight and almost imperceptible gradations, they blend into the various species. It is even troublesome to distinguish the genera, especially when they inhabit large, closed-in lakes where they have split into numerous races but whose individual characteristics are not, as yet, firmly established. It is during comparatively recent times that all these many forms have been developed, and this change is by no means completed.

The parental care in some of these species is very peculiar. *Acara festiva*, a beautiful fish from the Amazon, deposits its eggs on flat surfaces which have been previously cleaned by it. The young emerge about two days later: sometimes they are helped from the membranous shell by the parents and

(Continued on page 1137)



# Recovering Sunken Treasures

A NEW device for salvaging sunken ships has lately been brought to the attention of marine engineers. This is the apparatus designed by Dr. C. W. Eveleth, in which (although the details have not been completely worked out, inasmuch as they would differ with regard to the size of the various parts, depending upon the ships which are to be salvaged), many ingenious features are presented. To overcome some of the difficulties found in various other salvaging schemes, Dr. Eveleth has designed a steel frame supported on either side by spherical pontoons.

These are connected together by means of a bridgelike structure. A super-structure attached to this houses the machinery for inflating and deflating the steel tanks, so as to cause them to rise or submerge, as desired by the operator. This super-structure is completely enclosed and is fitted with the necessary safety air-valves, so that it will not be submerged accidentally. The pontoon unit in operation is submerged below all wave motion. In addition to the regular pontoons, the structure is provided with jacks attached to it. These are operated under air or water pressure. The jacks

themselves actuate winches and the winches in turn are connected by means of cables to the lifting members surrounding the sunken vessel, which will be presently described. Safety valves operating the powerful lifting jacks, prevent more pressure being applied to them than the tensile strength of the cable will stand, consequently, the cable will not break.

Although various methods have been devised for fastening bolts and cables to the sides of a vessel, most of the inventors have assumed that the vessel is lying on an even

(Continued on page 1100)

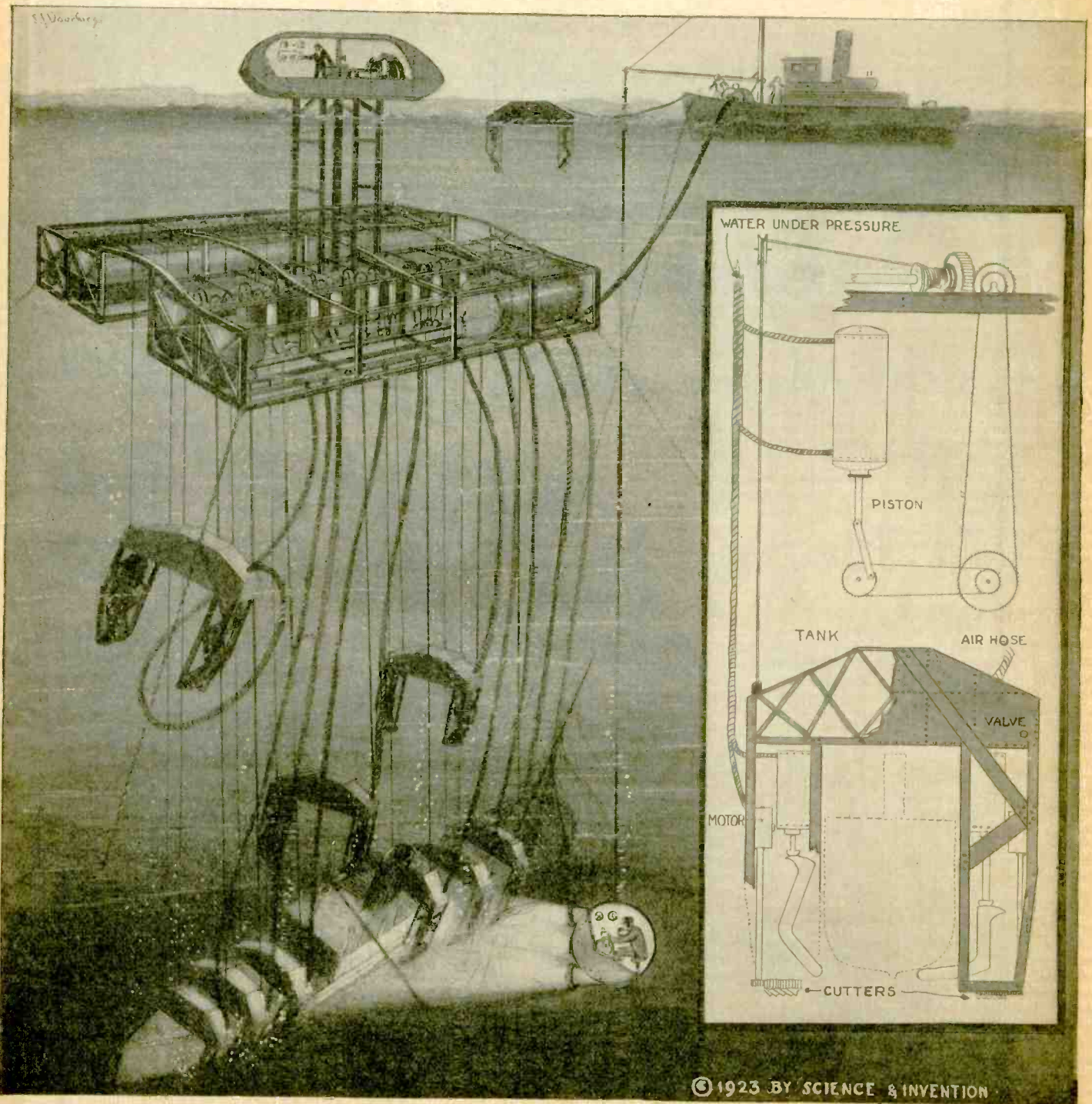

© 1923 BY SCIENCE & INVENTION

Without a doubt the greatest dream of inventors today takes the form of some machine, device or system, for recovering the treasure in sunken ships, or else for raising the ships themselves, so as to recover the cargo as well as the hulls and engines. One of the latest ideas designed by a New York inventor, Dr. C. W. Eveleth, is shown in the above illustration. The main scheme advocated by this inventor lies in the use of a series of large U-shaped saddles, which are lowered individually over the ship, once it is located, and sliding fingers on each saddle are caused to pass under the boat, so that when all of the cables and saddles are lifted by the buoyant pontoons, the ship will be lifted also.



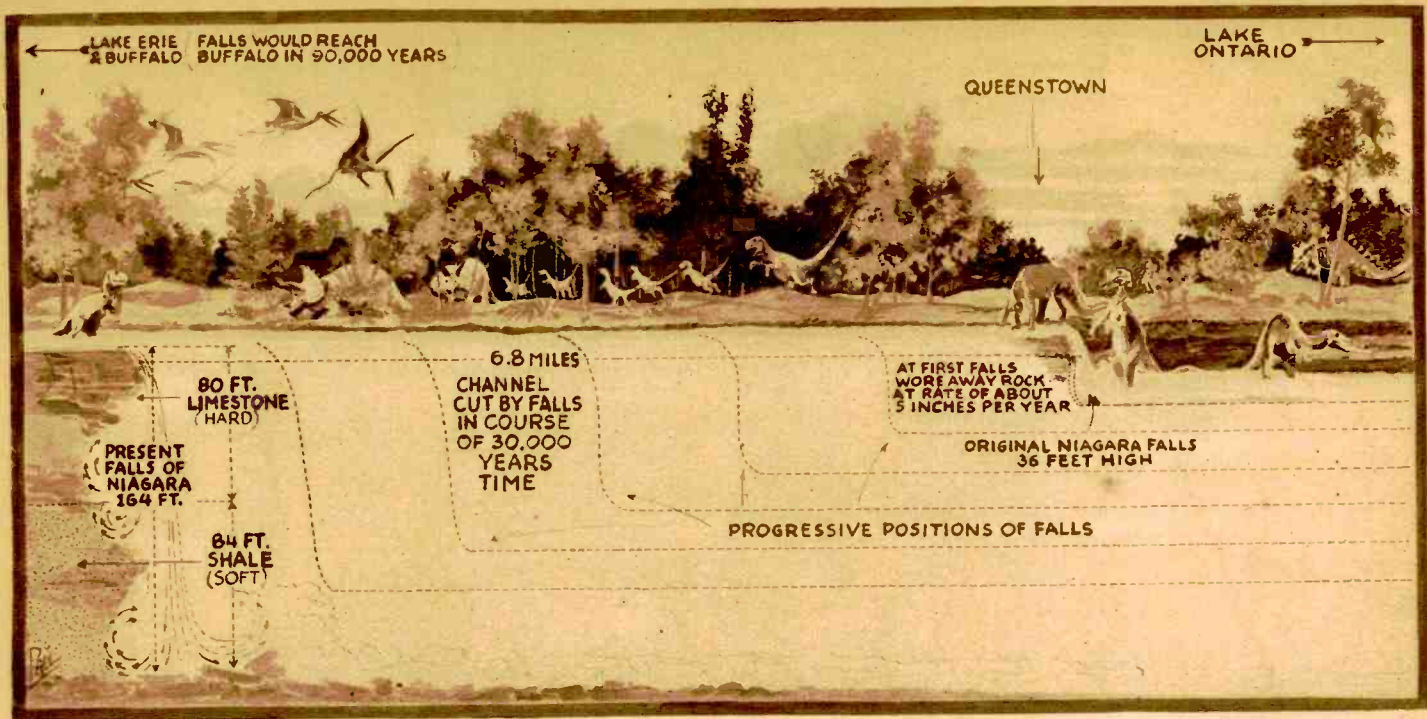

©1923—By Science and Invention

Geologists have attempted to calculate the age of the world, based on the time required for Niagara Falls to cut the gorge that stretches away from the present great cataract, measuring some 164 feet in height and which, according to scientists, measured about 36 feet in height 30,000 years ago. Mr. Paul has illustrated herewith some of the pre-historic animals which no doubt inhabited the country along the Niagara River in the early days of this great waterfall.

# How Old Is the World?

By HARRY VAN DEMARK

**A** SCIENTIST—I believe it was Garrett P. Serviss—once remarked that it is as hard to find out the age of the earth as it is to ascertain the age of a woman.

In both cases, however, wrinkles tell, and it is only the number of years that remains in question. Geologists assure us that the earth is very, very old, but when we ask them to set down its age in centuries, or millennia, or periods of millions of years, they shake their heads and simply reply:

"Its age includes many ages, but we cannot tell the length of any of them, not even of the latest and shortest, which is the Age of Man."

Still, some geologists are not averse to guessing on this subject, occasionally, and some of these guesses are very interesting. One California geologist did not attempt to fix the whole age of the earth, but only that of the wrinkle on its face known as the Sierra Nevada Mountains. Those mountains, he says, are about three million years old.

He reaches this conclusion by a study of the changes that have taken place on the face of the earth in California since the Sierra Nevada Range began to assume its present form. From the observed rates of erosion, and other natural processes affecting the rocks, he deduces the number of years that have elapsed since the commencement of the changes.

All of which recalls the method by which geologists have determined the time required for Niagara Falls to carve out the gorge that stretches away from the foot of the great cataract—though with no great accuracy or agreement of estimates.

As a matter of fact, the data for such a calculation appear to be much more definite and certain in the case of Niagara than in that of the Sierra Nevadas, and yet for the work of the Falls the estimates of time vary from twelve thousand to thirty-six thousand years. At the most, however, it will be observed that Niagara is very youthful, when compared with the great

Californian mountain range, just as the latter appears a mere infant when its age is measured with that of the Laurentian Range of Canada, which has been worn down in the course of ages almost to the root.

The Sierra Nevadas, however, have had a double life. There was an older mountain range on their site which perished, the scientists tell us; perished before the present range with serrated peaks and precipitous chasms was thrust upward like a young tree springing from the stump of its fallen ancestor.

When we study the subject, there seems something almost lifelike in the growth of mountains; they do not attain their maximum stature all at a leap. The first great uplift of the Sierras, the geologist thinks, elevated the range about 2,500 feet. Even that took time, while the giant pressures were at work. Vast periods also elapsed while the growing mountains swelled upward to their culmination of fourteen or fifteen thousand feet. Perhaps they are still growing, though such growth would be inappreciable by the naked eye.

Age has its common marks everywhere. Just as an old man stoops, shrinks in stature, becomes round-shouldered, so a time-worn mountain loses its aspiring peaks, smooths down its jagged outlines, rounds off its steep slopes, sinking lower, and lower under constant wear of the elements, until only a line of green-carpeted hills remains to mark the place where once tremendous summits rose into the region of perpetual snow and flashed back the sunshine from a crown of glaciers.

It seems relatively an easy task to calculate the age of a mountain range which, like the Sierra Nevadas, had a new birth at the beginning of quaternary time, the latest period in the geological history of our planet. It would be far more difficult to apply the measuring tape of the centuries to the great Appalachian Range, which lies just beyond our Atlantic seaboard.

The Appalachians date back to the remote carboniferous age, which ended so long ago

that nobody, probably, would be willing to hazard a guess at the number of millions of years which have since elapsed. The Appalachians may have been magnificent giants in their day, such as the rugged sky-piercing Rockies, but time has conquered them as it will conquer the Sierras, and now their verdured flanks and tops delight the unalarmed eyes of railway tourists, winding on swift trains of steel cars through the rich valleys that have fattened on the substance of the disintegrated peaks.

To quote from Mr. Serviss: "The glory of a sun is gone when it passes from light to darkness, from solar incandescence to planetary opacity."

Likewise, the splendor of life for a mountain departs when it sinks from white to green, and from the abode of snow to the levels of grass and verdure.

Dr. R. Lotze, in his new work *Jahreszahlen der Erdgeschichte* (Yearly Almanac of the Earth's Transformations), says:

"We will now turn to North America, the third greatest source and the third great scene of glacial activity, which, like North Europe, was covered under a huge mass of inland ice. As the ice disappeared, which must have occurred at the same time as in Europe, little by little the region of the Great Lakes of the present day became free of ice; their water had to seek the sea. Between the Erie and the lower level of Lake Ontario, a waterfall formed, and poured over the intervening declivity. This was the beginning of Niagara Falls. By the wearing action of the falling water, the weaker strata at the bottom of the falls were washed away, so that the upper harder strata had to fall.

"In this way the waterfall cut its way constantly backwards into the rocky layer, and even today it is working its way back toward Lake Erie. In the course of time, it has cut away a channel 11.3 kilometers long or about 6.8 miles, which in its various parts shows clearly the history of its production. Originally the falls were only 11

(Continued on page 1123)



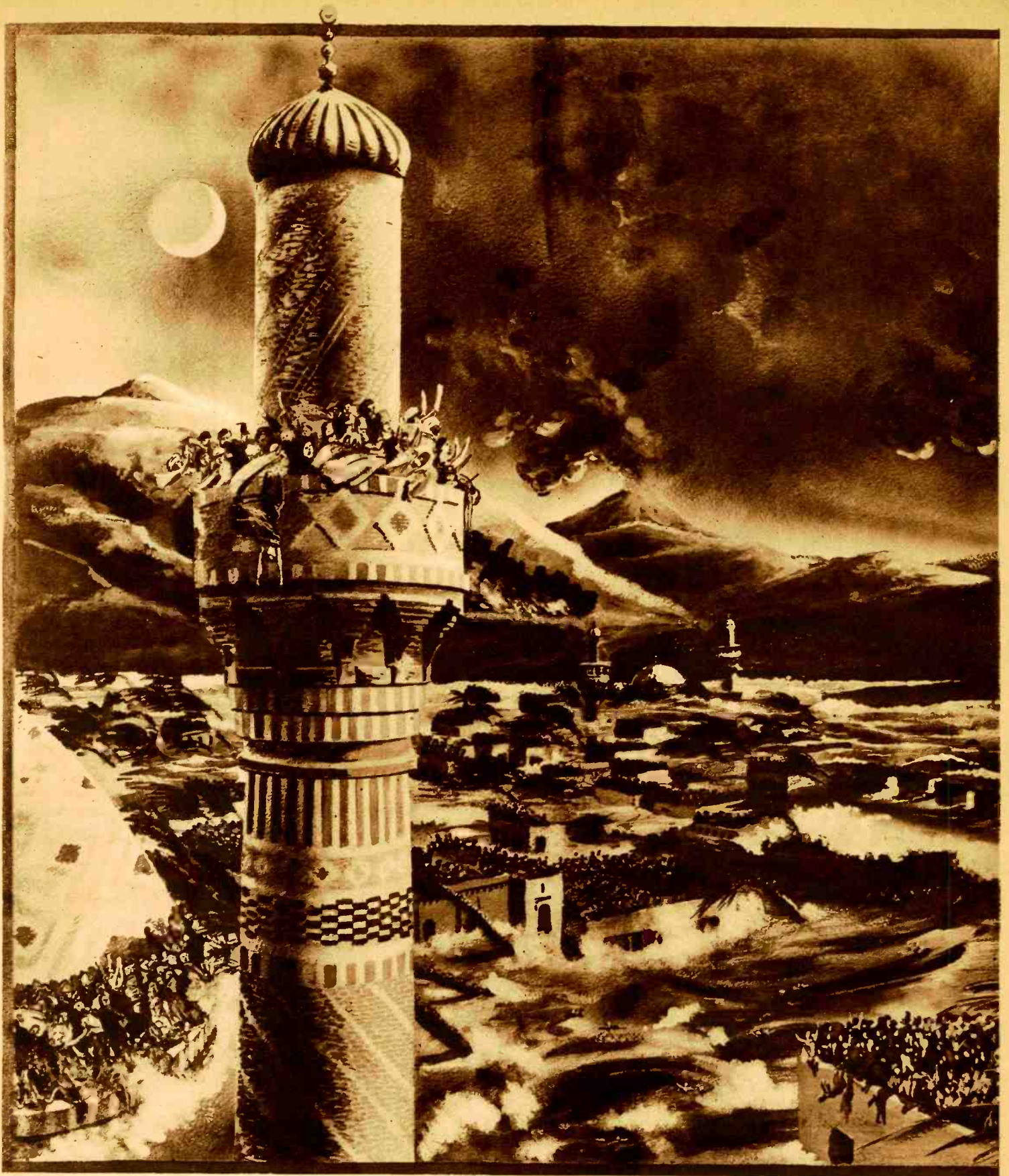

# The Star

By H. G. WELLS

**I**T was on the first day of the new year that the announcement was made, almost simultaneously from three observatories, that the motion of the planet Neptune, the outermost of all the planets that wheeled about the sun, had

become erratic. Ogilvy had already called attention to a suspected retardation in its velocity in December. Such a piece of news was scarcely calculated to interest a world the greater portion of whose inhabitants were unaware of the existence of the planet

Neptune, nor outside the astronomical profession did the subsequent discovery of a faint remote speck of light in the region of the perturbed planet cause any great excitement.

Scientific people, however, found the in-



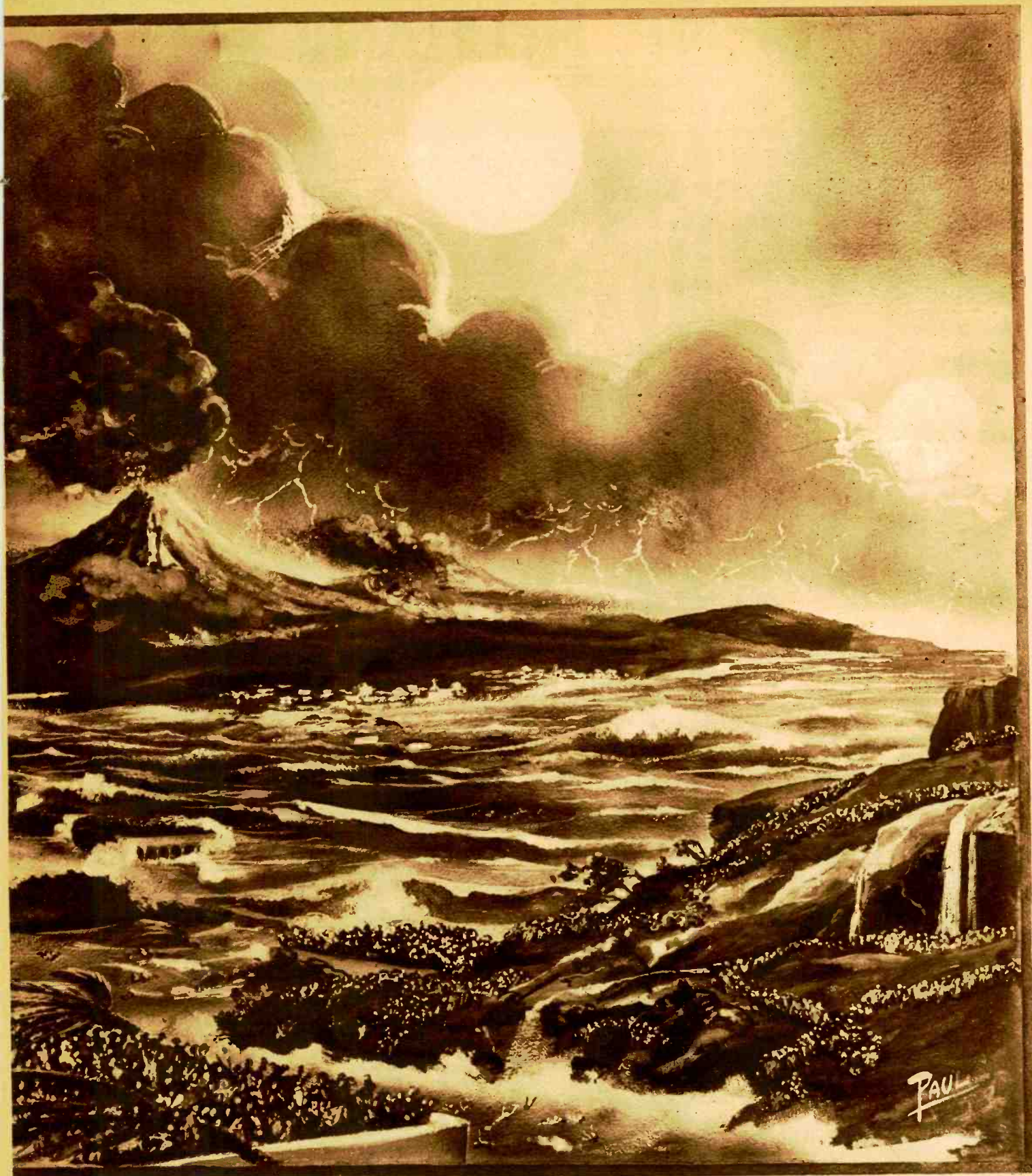

© 1923 by Science & Invention

" . . . Above were the lava, hot gases, and ash, and below the seething floods, and the whole earth swayed and rumbled with the earthquake shocks. Soon the immemorial snows of Tibet and the Himalayas were melting and pouring down by ten million deepening converging channels upon the plains of Burma and Hindustan. The tangled summits of the India jungles were aflame in a thousand places, and below the hurrying waters around the stems were dark objects that struggled feebly and reflected the blood red tongues of fire. . . . "

telligence remarkable enough, even before it became known that the new body was rapidly growing larger and brighter, that its motion was quite different from the orderly progress of the planets and that the deflection of Neptune and its satellite was becoming now of an unprecedented kind.

Few people without a training in science can realize the huge isolation of the solar

system. The sun with its specks of planets, its dust of planetoids, and its impalpable comets swims in a vacant immensity that almost defeats the imagination. Beyond the orbit of Neptune there is space, vacant so far as human observation has penetrated, without warmth or light or sound, blank emptiness, for twenty billion times a million miles. That is the smallest estimate of

the distance to be traversed before the nearest of the stars is attained. And, saving a few comets, more unsubstantial than the thinnest flame, no matter had ever to human knowledge crossed this gulf of space, until early in the twentieth century this strange wanderer appeared.

A vast mass of matter it was, bulky,  
(Continued on page 1117)



# ANCIENT MECHANICS

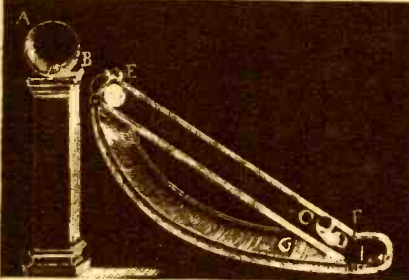

An attempt at perpetual motion. The ball, C, is supposed to be drawn up by the magnet, A, to return to the bottom and be drawn up again repeatedly.

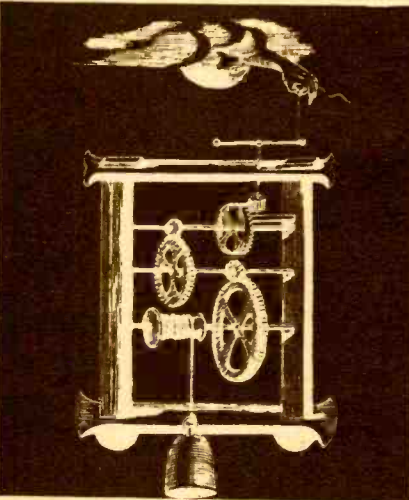

The Bishop's train of wheels, a trivial force raising a great weight.

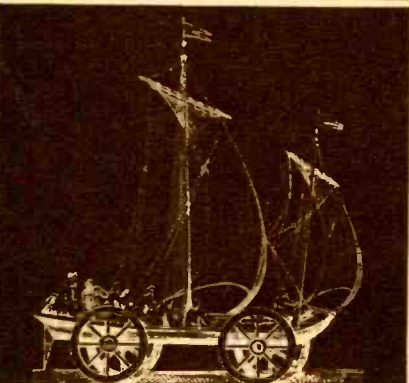

A sailing chariot which was used on the Holland beaches.

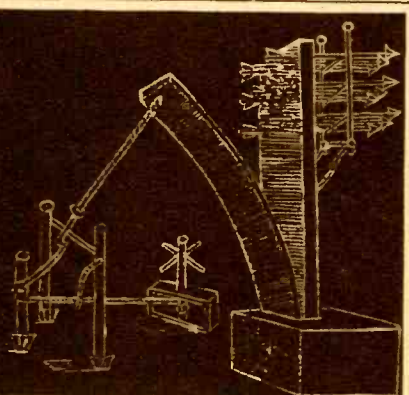

A catapult discharging a flock of arrows; a machine-gun of former generations.

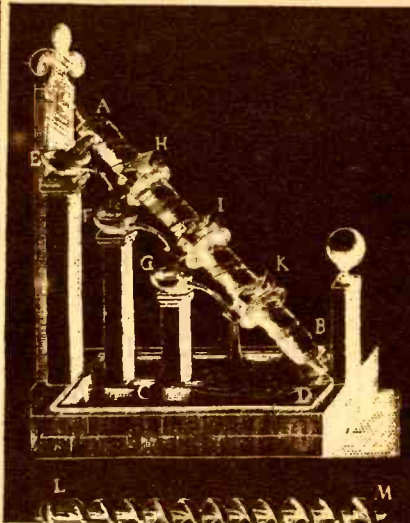

The Bishop's own conception of perpetual motion, based on Archimedes' screw, only it did not work.

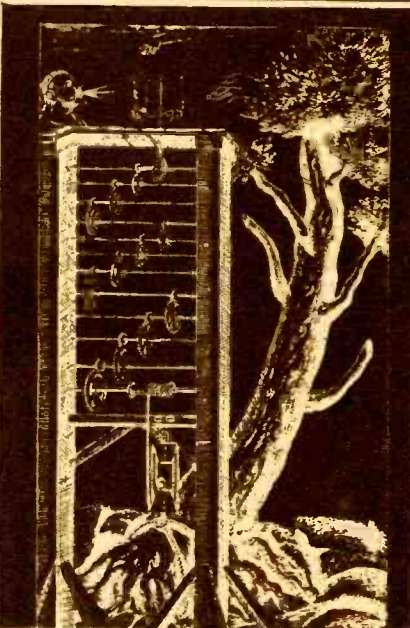

Uprooting a tree by the human breath. What about the friction?

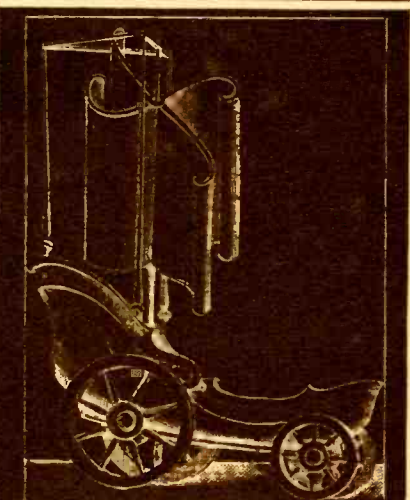

Bishop Wilkin's idea of an improved sailing chariot.

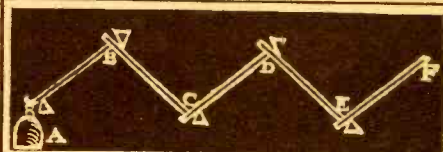

An example of the compound lever, as given in the strange old treatise.

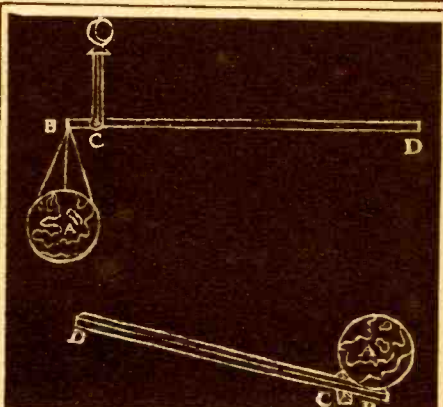

Moving the world and weighing the world. The diagrams illustrate Archimedes' boast about the lever.

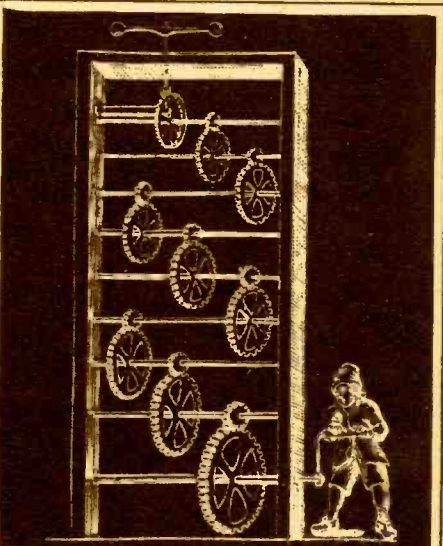

The attainment of the velocity of the celestial bodies by a train of gear wheels.

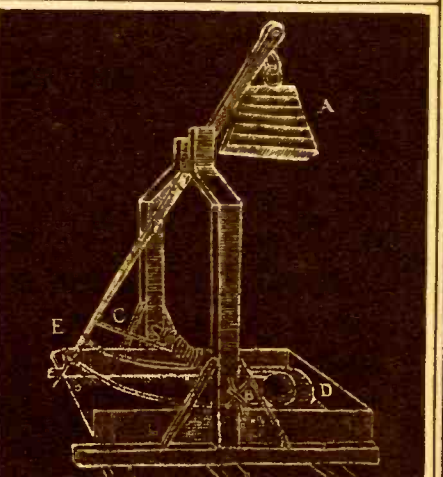

A ballista for throwing great stones. Sometimes human heads or bodies were used as projectiles.



# Bishop Wilkin's Mathematical Magic

By T. O'CONNOR SLOANE, Ph. D., LL. D.

READERS of the amiable Evelyn's diary, and those who have perused the less amiable Pepy's diary, will have encountered several times the name of Bishop John Wilkins, who was born in 1640, and died in 1672, and attaining promotion in the church of England, eventually became Bishop of Chester. Besides his activities in the line of his religion, he was greatly interested in natural science, and he with Evelyn figures among the founders of the Royal Society of Great Britain, one of the leading scientific societies of the world. When twenty-four years old, he published an odd little book which now is a great curiosity, kept in the Reserve Department of the New York Public Library, on the subject of the moon. He claimed that there was every reason to believe that the moon was inhabited, and even seemed to think that there was a possibility of mankind traveling to the moon. This little book gave him considerable celebrity. He also discussed the topic as to whether the earth was a planet. But when we get to another of his works, "Mathematical Magick," also a very small book, but illustrated with a number of engravings, we get at quite an interesting lot of material. On the opposite page we have reproduced some of the illustrations shown in this treatise, in which he investigates many things, including perpetual motion, the mechanical powers, sailing chariots, catapults, ballistae, which subjects we specially name here, because the illustrations appear opposite.

One attempt at perpetual motion is shown, in which a magnetized ball is supposed to draw another free iron ball up an inclined plane, and when the latter reaches its top it is supposed to fall through a hole therein, the magnet being unable to keep it up any longer, and to return to the foot of the inclined plane, to be drawn up again by the magnet. This of course is a very crude attempt and absolutely futile. In a later page he describes an Archimedes hydraulic screw, which by turning draws water up to its top, and which water is discharged into water wheels, which are supposed to turn the screw. He got quite excited about this he says, and felt like calling out with Archimedes, "I have found it! I have found it!" But, he says, when he came to look into it, he found that it too would not work.

We now come to some of his mechanical powers. He shows a set of levers arranged in quite a curious zig-zag fashion, with each one of the power arms ten times as long as the resistance arm. We can go right down the line and find an enormous increase, and this is what interested him. Returning now to his friend, Archimedes, of

whom he speaks quite often, he illustrates the proposition by which the sage of Syracuse said he could move the world on the end of a lever, and shows the world on a steelyard about to be weighed. So much for the lever.

Now we come to his trains of wheels. These he calculates out on the basis of the large gear being ten times the diameter of the small. So again he goes down the line, multiplying by ten, and shows that a man by the least force exercised upon a handle, can raise a great weight. And he goes further than this. With a very large train of wheels, he shows a man pulling a tree up by the roots, by simply blowing against a windmill which turns the gears. Going to the other end of things, he shows how by placing a man at the other end, and turning a handle, a great velocity can be imported to the vane at the top of this gearing, and he figures out that at a thousand turns per hour at the man's end, the vane at the top could be made to move as regards its extremities with the speed of the celestial bodies.

He describes a sailing chariot shown here, which was used on the beaches of Holland. He says it ran from Scaveling to Puttem, a distance of over forty-two miles, in two hours, which he regards as an enormous speed, making a running man seem to move backwards. He made a proposal for a chariot to be operated by a wind mill, and we give a reproduction of his design for this.

He discusses the weapons of the ancients, and those of his own era, and says the catapult, an engraving of which from his book is reproduced on the opposite page, was used to shoot arrows sometimes in various directions, sometimes all at one point, and shows how by releasing the elastic board, a flock of arrows could be sent against the enemy. The ballista he says, on the other hand, was used for throwing stones, and gives us a construction of that implement, which is shown here in reproduction also. This he regards as a very wonderful affair. He says that the biggest shot fired by modern guns, in Europe at least, weighs 64 pounds, while the ballista could throw mill stones and tomb stones, weighing up to 360 pounds, and Archimedes is credited with discharging 1200 pound stones. He says that the combatants used sometimes to put men's heads or bodies into the ballista and discharge these into the town they were besieging.

He now comes to the Turks, and says that they had a cannon which would fire a 1200 pound projectile and it took 150 yoke of oxen to draw it about. Referring to arrows, he has some curious stories. He says that the arrows from the catapult were sometimes ignited from the friction of the

air, so that they burned. He tells wonderful stories of the Turkish archers; of their arrows penetrating thick wood and iron plates. He quotes an earlier author, C. Mersenns, telling of a wonderful air gun, which at a distance of twenty-four paces would flatten a leaden bullet against a plate of iron, and he cites also a curious old theory, that arrows and bullets had their greatest penetrating force at a good distance from the muzzle of the gun, which of course is absolutely false, although he takes it as matter of general knowledge.

Two other things greatly interested our Bishop, flying and the submarine. He believed very properly that if an aviator got high enough in space the earth's attraction would cease, which certainly would facilitate the flying process. He says, "flying so generally derided—being esteemed only as the dreams of a melancholy and distempered fancy". This makes curious reading for us, when we can remember how Professor Langley failed to receive adequate or even serious support in his pioneer work in aviation. Our Bishop refers also to Burton who in his famous "Anatomy of Melancholy", has stated: "Some new fangled wit (tis his cynical phrase) will sometime or other find out this art."

A writer in Blackwood's Magazine of July, 1917, is a little hard on the Bishop. He is inclined to make fun of his long rows of ciphers, which he had to use to express his multiplication of force by his gear wheels. So when Bishop Wilkins begins to describe the possibility of submarine work, he tells of nothing he himself has done, but has to go back to the work of Cornelius Drebbel, born in the sixteenth century in Holland, who is said to have gone under water in the Thames, from Westminster to Greenwich. He is said to have purified the air by a liquid, surmised to have been cream of lime, and the Bishop describes how by a sort of leather bag, the submarine could be entered under water or a person could leave. The bag being fastened tightly in advance of the person first, it would then be tied tightly behind him, and finally by releasing the outer fastening he could emerge, and swim to the surface. Similar bags were to be used for the oars, for the helical propeller had to wait nearly three centuries for its invention.

On one of the copies of *Mathematical Magick* in the New York Public Library some oldtime reader has inscribed his views concerning the Bishop's gears and trains. The faded inscription is only partly legible reading "Good Bishop pray allow some . . . for friction."

## The Ever-Changing Gulf Stream

It has been reported by mariners recently that the Gulf Stream was 30 miles nearer shore than it was 10 months ago. This immediately started up the weather prophets, who now claim that the recent hot spell experienced along the east coast, and especially in New England, can be blamed upon the nearness of the gulf current.

The French scientists claim that the United States are creating a tropical New England and making England and France frigid. The trouble, according to the Frenchmen, lies in an innocent little railroad, built several years ago from Florida out to the Florida Keys. It was built on a trestle with loopholes left between the islands wherever there was an appreciable current.

An authority, Commander Brown, head of the Navy Hydrographic Bureau of Boston, says that the Gulf Stream does not touch New England. It heads out to sea below Nantucket, and only affects people from Boston when they go fishing off the Grand Banks. What influences the New England coast, the commander states, is a branch of the Labrador current swinging counterclockwise from Newfoundland. Accordingly, if the Gulf Stream does change, it could have small effect on New England. Furthermore, western Europe has not had weather recently that could be laid to a change in the stream. England had a rainy summer, which is the normal result of the Gulf Stream being right on the job.

Three factors influence the course of the Gulf Stream. The first and most important of these is the high declination of the moon. The second cause would be a high barometer in the north Atlantic and a low barometer in the south. The combination changes the course of the stream by reducing its rate from two knots per hour to one or one and a half knots per hour. The trade winds off the south of Cuba would be a result of this. The third cause of a change in the stream would be an unusual storm.

The Navy Department, having examined all the available facts, believes that the Frenchmen's theories are unfounded.

Contributed by J. WARREN BARNABY.

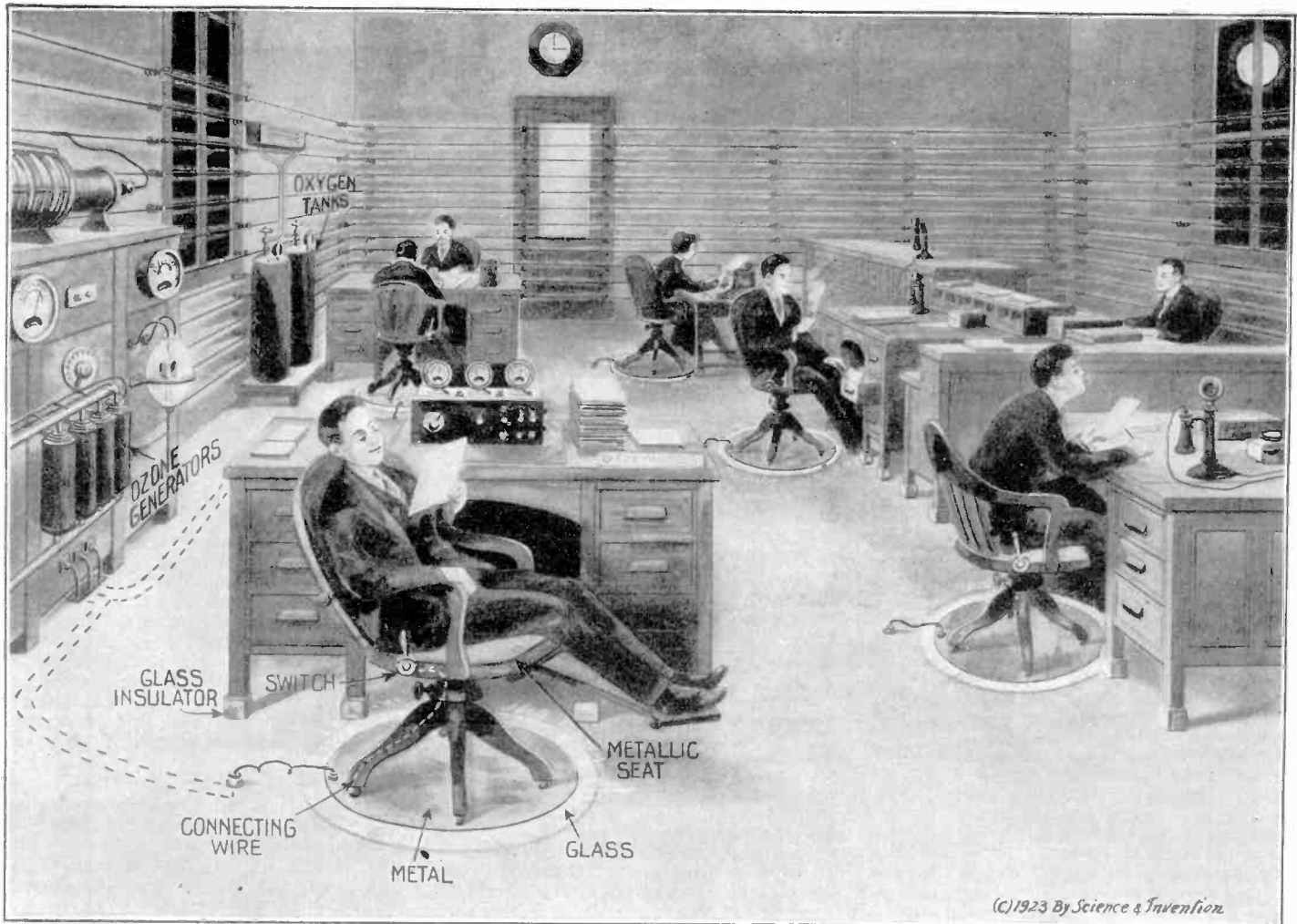

(C)1923 By Science & Invention

The Sleep Eliminator as installed in a modern newspaper office. Mr. Gernsback, in his article, suggests, in order to eliminate sleep, to remove the cause. The cause of sleep is increased blood pressure, also certain changes in nerve cells after the body has performed a certain amount of work during the day. These causes are removed by D'Arsonval currents, which are set up in a huge electric coil, strung along the walls of the office as seen. These currents, as is well known, reduce the blood pressure. The oxygen, as well as the ozone with which the air is charged in small quantities helps to rejuvenate the system. A secondary electrical system gives the nerves certain rhythmic shocks, almost imperceptible to the subject. These are used to stimulate the nerve cells that have become sluggish. It is thought that by these means sleep can and will be eliminated entirely.

# The Sleep Eliminator

By H. GERNSBACK

Member American Physical Society

## COMING INVENTIONS NO. 8

**O**NE of the most ancient and universally-known phase, not only of human existence, but of almost the entire animal world, is *sleep*.

It is such a habit with us that we never give it the slightest thought, and we do not bother our heads much about it, unless we suffer from insomnia or if important work keeps us up, perforce, when we are trying to fight off sleep.

But what is sleep itself? No one knows exactly. There are many theories of sleep today, the best known being the following: the Chemical, the Circulatory, and the Histological.

The *Chemical* theory mainly has to do with auto-intoxication. This theory is based upon the fact that certain products of decomposition of living substances influence the continuance of cell activity, but recent researches in the bacteriological laboratory have proved that while the body is working during the day's activities certain ptomaines are formed in the human system more rapidly than they can be oxidized and eliminated. It is maintained that while we sleep, such poisons gradually become oxidized and are thus removed from the blood.

The *Circulatory* theory has to do with congestion of the blood vessels. It is a theory no longer accepted by scientists.

The *Histological* theory has to do with the nature of the nerve cell, because microscopic examination has shown conclusively that such nerve cells have different chemical properties when the body is in a waking or in a sleeping or fatigued condition.

Other outstanding phenomena, characteristic of actual sleep, are full relaxation of nearly all the muscles of the body; slow and rhythmic, as well as deep breathing; a slow and weak pulse, and considerably lessened arterial pressure.

But is sleep really necessary, and could man or animal do without it? The answer must be in the affirmative, once we discover just the exact reasons why sleep takes place.

We find, for instance, that protozoa and other simple forms of life seem to dispense with sleep, without any trouble. Many fish, for instance, do not sleep, and while their activities may not be the same at all time, they do not seem to know what sleep, as we know it, really is.

In other words, sleep is a habit formed by human beings, mainly due to astronomical reasons. If the sun had been shining upon the earth constantly we probably would not know now what sleep is. For one part of the day we have light; for the other part, darkness. After sundown it is no longer possible to see, and the caveman and our

other ancestors simply lay down and formed the habit of sleeping until the sun came up again. That this is a true statement is best proved by the fact that as soon as artificial lighting appeared, the human race no longer needed as much sleep as did our cave ancestors. Even as recently as 500 years ago, people went to sleep at sundown and got up when the sun rose. That means an average of ten to twelve hours sleep. The modern human being gets along comfortably with from six to eight hours, as his artificial light keeps him awake, and the less he works physically the less sleep he needs.

Naturally this statement does not hold true of a laborer or a man who performs great physical exertions during the waking hours. Such a man becomes really fatigued and his blood pressure during the night time must be brought to normal, and his nerve cells must be regenerated once more.

But we are safe in saying that if the human race continues as it does now with artificial light during the entire night, a time will come, in 10,000 or perhaps 50,000 years, when sleep will be required no longer.

Edison, a few years ago, made some very striking observations when it was necessary to work literally day and night in his laboratory. He selected a number of young men

(Continued on page 1114)

# Waterproofing and Mothproofing by Electricity

By ISMAR GINSBERG, B. Sc., Chem. Eng.

**T**HERE are four important textile fibers, cotton, wool, silk and linen. While they differ in origin, structure and properties, they all possess one characteristic in common, albeit in different degrees, and that is permeability to moisture. Water will penetrate through their structure and naturally through the fabrics woven from them. This fundamental property of the fibers gives rise to a definite disadvantage in the fabrics themselves. The wearer cannot keep dry in water-pervious garments when exposed to rain; non-waterproof fabrics will not keep out the rain, when used as protective coverings, as in tarpaulins, in tents, etc.

Ever since this disadvantage in the fabrics was first recognized, attempts have been made to overcome it. It was found that when the textile cloth was impregnated with India rubber, the product was waterproof, but unfortunately it became air-proof as well. Those of us, who have worn rubber raincoats on a warm day, know how uncomfortable they can be. It was also discovered that chemicals could be used in producing a water-proofing effect in fabrics. This consisted essentially in depositing an insoluble soap on the fibers, by first impregnating them with soluble soap solution and then precipitating, that is, throwing down the insoluble soap by acting on the impregnated cloth with a solution of a proper chemical. Such waterproofing, commonly known as chemical waterproofing, is merely a superficial treatment, for the film of waterproofing material lies on the surface of fibers only and is soon either worn off or washed away.

The process of waterproofing textile fabrics with the aid of the electric current combines all the advantageous waterproofing

effects of the rubberizing process, and still gives a fabric which is ventilating, which allows air to pass through it, while resisting perfectly the passage of water. The electric current causes the chemicals, that are used in the process, to penetrate into the internal structure of the fibers, so that the waterproofing substance fills the fine, hair-like passages in them. In this way a comparatively permanent waterproofing effect is attained. In contradistinction to the chemical process, described above, the waterproofing does not consist of a mere film of substance over the exterior of the fibers, which can be easily washed off, but of a thorough impregnation and filling of their entire structure. Such waterproofing will successfully resist many washings, and not only that but dry cleaning as well, to which the chemically waterproofed fabrics are not resistant.

It is very interesting to trace the history of electrical waterproofing of textiles, for in its origin it is closely and directly allied to the electrical industry and to one of Edison's inventions, the chalk telephone receiver. The inventor of the waterproofing process, Mr. Alfred O. Tate, who has been awarded the Howard N. Potts Gold Medal for his work by the Franklin Institute of Philadelphia, was originally connected with Edison in the very early days of the electrical industry. He worked on the chalk telephone receiver and noted the strong action of the electric current upon an electrolyte which filled the pores of a chalk cylinder, producing thereby sound effects in a diaphragm. Years later, when confronted with the waterproofing problem, he recognized that here was a task which the electric current could solve by forcing or carrying the waterproof-

ing solutions into the fine pores of the textile fibers. The process was perfected and during the war it performed signal service in waterproofing the uniforms of the American and Canadian air forces. At the present time the process is being operated on an industrial scale in the plant at Cranston, R. I., a part of the old and historical Cranston Print Works, where it is possible to waterproof goods at the rate of three million yards of cloth a month.

A specially designed machine is used to accomplish the waterproofing. The machine contains either two or four sets of electrodes, the two-set machine being used for silk and wool, the four-set machine for cotton and linen. The cloth first passes through a bath of sodium oleate, which is a solution of soluble soap. Then it passes between the various sets of vertical electrodes. At that time it is impregnated with a solution of the chemical, acetate of alumina, while the current flows from anode to cathode through the chemical solution and the cloth. Chemical and electrochemical reaction takes place with the formation of an insoluble aluminum soap within the capillary passages of the fibers and on the surface as well. After the cloth has passed between all the sets of electrodes, it goes over a series of drying cylinders, heated with steam, so that it is perfectly dry on emerging from the waterproofing machine.

One of the important features of the process is its applicability to all sorts of fabrics. Such heavy materials as sailcloth, overcoatings, awning goods, tent-cloths, etc., as well as thin fabrics, such as sheer silks, ordinary muslin, etc., pile fabrics, such as plush mohair, velvets, etc., and even such special cloths as large meshed bobinette can

(Continued on page 1107)

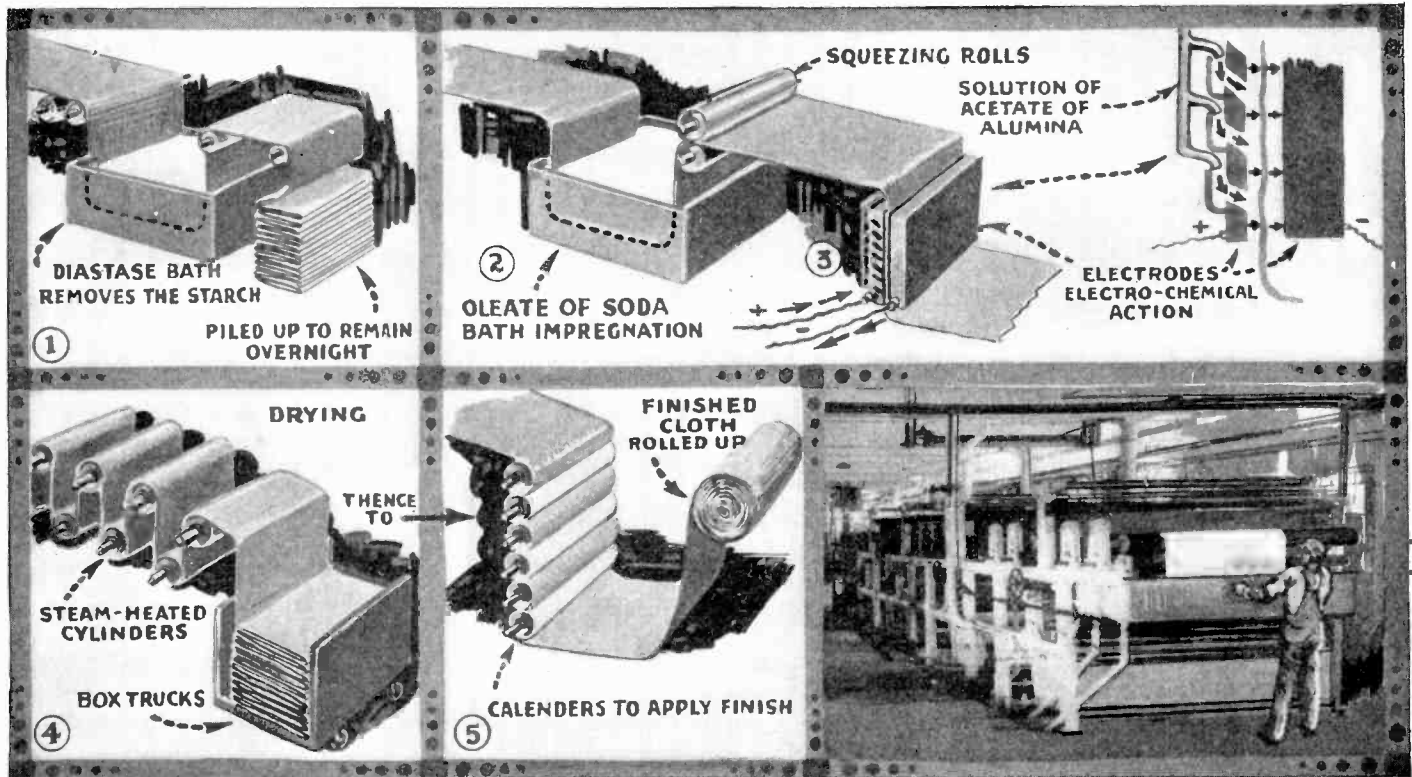

The simplified diagram-chart above shows the important progressive stages followed in the latest method of waterproofing and mothproofing cloth by electricity. Rubber raincoats, for example, are very uncomfortable in warm weather or at any time when it is not cold, as they will not pass air. By the new methods here shown and described by Mr. Ginsberg, an authority on this particular subject, various cloths can be waterproofed and these cloths will, after waterproofing, successfully resist many washings and will even stand dry cleaning, which treatment the ordinary chemically waterproofed fabrics will not stand.



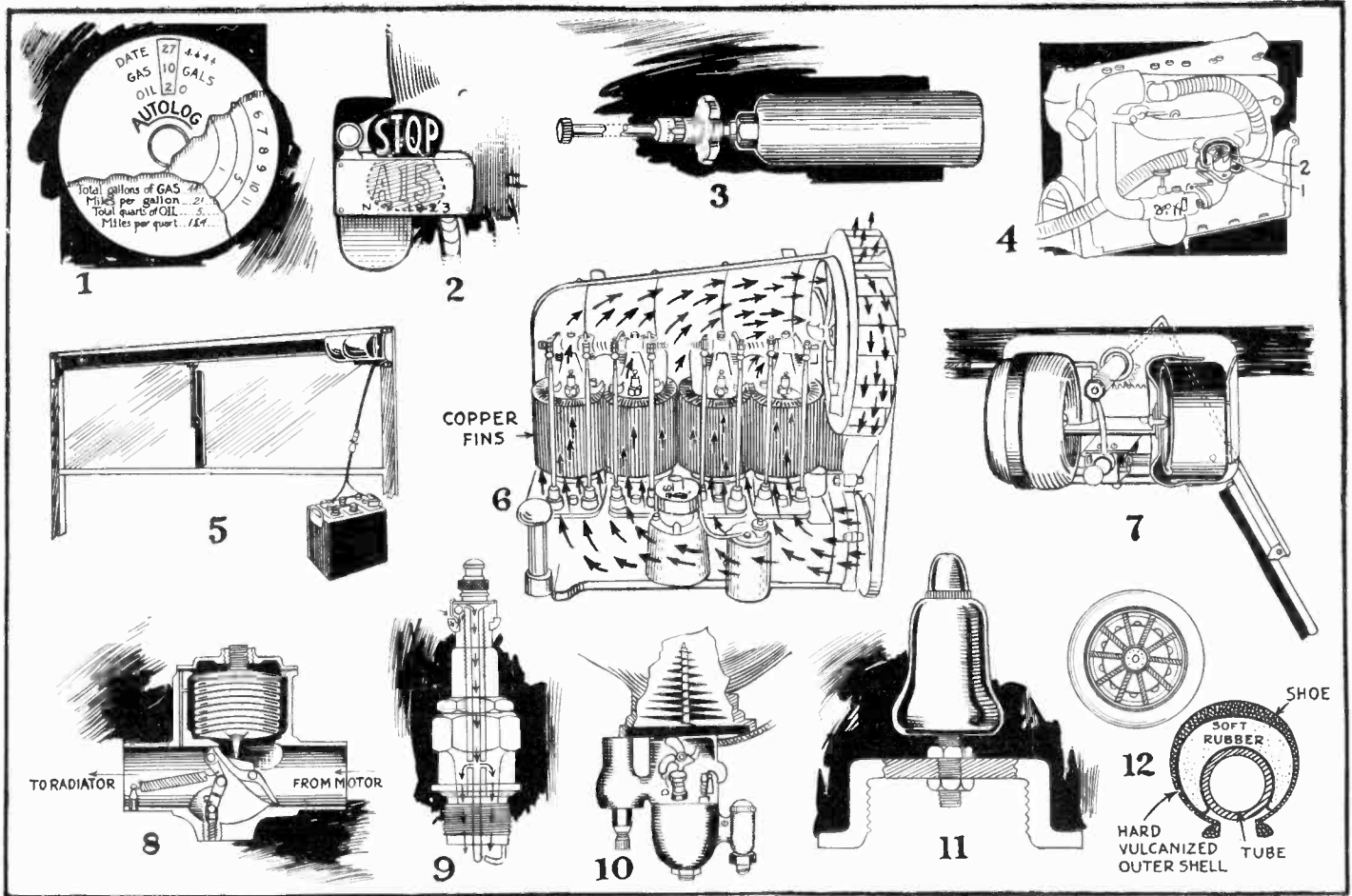

In Fig. 1 is shown a device which allows the driver to keep an accurate record of all gas and oil bought in the course of a month. The metal shell is cut away to disclose the cardboard disc, upon the front of which are spaces for dates and amount of gasoline and oil bought, while on the back are spaces for total records at the end of the month. A combination stop signal, tail light, and license bracket, is shown in Fig. 2. The stop sign disappears in back of the license plate when not in use. A steel tube containing compressed air is shown in Fig. 3. By means of a gauge just above the valve handle, a tire may be inflated to any desired pressure. In Fig. 4 is shown a device for vaporizing low grade fuel. The heavy fuel collects in the basin marked 1, and is held there until heated by the exhaust and vaporized. The fan shaped blades, 2, assist in vaporizing the fuel. A wind-shield wiper which cleans the entire upper surface of the wind-shield, is shown in Fig. 5. This is actuated by an electric motor connected to the starting battery. In Fig. 6 is shown a new type of air cooled motor, employing copper fins electrically welded to the cylinders to increase heat radiation. Fig. 7 shows a wind-shield wiper actuated by the suction of the intake or of the vacuum tank. It can be locked up out of the range of vision when not in use. A thermostat control for the flow of water from the radiator to the motor is shown in Fig. 8. A spark plug with self-cleaning points is shown in Fig. 9. A draft of air actuated by the suction of the motor keeps the points free from carbon. Fig. 10 shows a small resistance coil inserted in the intake manifold, which is heated by means of the starting battery, and assists greatly in vaporizing the fuel. An automatic "low gas" signal, which is fastened on the gasoline tank cap, is shown in Fig. 11. The "super-wheel" is shown in Fig. 12. The spokes consist of heavy spiral springs which absorb a considerable amount of road shock, and within the shoe is a soft rubber insert which protects the tube from punctures.

## Novelties at New York Auto Show

**T**HE second week in January was a momentous one for automobile owners and drivers in and around New York City. For the entire week there was a display of all kinds of automobile accessories, as well as complete cars at the Grand Central Palace, and another smaller, but just as interesting show, at Madison Square Garden.

Do you know just how far your car goes per gallon of gasoline, and per quart of oil? This is a question that very few drivers can answer accurately, as they have never taken the trouble to keep an accurate record. However, if he uses one of the devices shown in Fig. 1, he will be able to very easily keep an accurate record of these figures. Essentially this device is a round metal case which clamps on the steering wheel, and which has a removable cover. Within this case is contained a replaceable cardboard disc, which may be rotated from the outside of the case by means of a knurled ring. As may be seen one side of the disc has several concentric circles drawn thereon, and a number of figures around the outside edge corresponding with the days of the month. Between the first and last figures there is a space in which the name of the month may be written. On the opposite side are spaces provided for the speedometer readings on the first and last day of the month, and for the total amount of gasoline and oil used. Several discs are supplied with each device for various months. The driver inserts the name of the

month, and the speedometer reading on the first day of the month. He now puts the disc into the device, and turns the knurled ring until the day of the month appears in the opening. Then when he buys gasoline and oil he jots down the amount in the spaces provided, and at the end of the month has an accurate record of all purchases. From this and his speedometer readings he can figure out whether or not his car is running as it should. The card can be then exchanged for another one for the next month.

A unique stop sign which combines a tail light, license bracket, and signalling device is shown in Fig. 2. This is electro-magnetically operated, either from a button on the wheel, or a switch on the brake, and a large red and white stop sign appears when needed. A separate signal light is not used, as the white light emanating from the side of the tail light illuminates the stop sign when it is raised. This sign swings up sideways from inside a thin sheet metal container, on the outside of which is bolted the license plate. The storage battery in the car is used as the source of current for actuating the magnets.

At last the nuisance of a hand pump is eliminated. All you have to do now is carry a small bottle of compressed air as shown in Fig. 3 in the tool compartment of your car, and when a tire blows out, you change it and inflate the tire from this bottle. An automatic gauge is arranged on the bottle so that when the required pressure is

obtained within the tire, a whistle blows, attracting your attention thereto. It is possible to operate this device even at night without the use of any lights without endangering the tires by over-inflation. Jacks are also manufactured by this company which work by compressed air supplied by these bottles. They make them in several sizes, the largest one capable of lifting a heavy truck. These compressed air bottles are exchangeable for full ones when exhausted in the same way that the old acetylene gas containers formerly used in automobiles could be exchanged.

Carbon dioxide gas is also put up in these bottles for use in extinguishing fires on automobiles, and the gas can also be used for making carbonated liquids by forcing a quantity of the gas through the liquid. A refrigerating container can be used in connection with this carbon dioxide bottle for keeping foods and liquids at a low temperature. These bottles contain gases at a pressure of 1000 pounds, but the danger of an explosion is done away with by having the containers capable of withstanding ten times that pressure. The bottles are inspected and tested by government officials.

Very often with poor grades of gasoline, it is practically impossible to start the car in cool or cold weather, because of the great amount of liquid gasoline caught in the manifold. This trouble is done away with by the apparatus shown in Fig. 4. Here

(Continued on page 1101)

# Dr. Hackensaw's Secrets

By CLEMENT FEZANDIÉ

(AUTHOR'S NOTE.—At the present moment the French and the Germans are giving considerable attention to the construction of "gliders". At Wasserküppe in Germany, Herr Heitzen recently made a record flight of over three hours duration in a motorless airplane. He traveled a distance of 25 kilometers and reached an altitude of 360 meters. The French have made similar records. The future of such machines is a very bright one. In the following story I give a suggestion for a combined balloon and glider—a combination that seems feasible, and that would, under certain circumstances, possess certain advantages over both the airplane and the balloon, as well as over the simple glider.)

**H**AVE you got anything new on hand, today, doctor?" asked Silas Rockett, as he entered the laboratory and dropped into a vacant chair.

"Nothing much, Silas," returned Doctor Hackensaw—"Things are quiet just at present. Here's a letter, though, that may interest you. It's from a party that wants me to furnish them with a hundred thousand sperm whales."

## No. 14--The Secret of the Motorless Airplane

"What!"

"Yes—Sperm Whales—The order is somewhat unusual, isn't it, even though it is only baby-whales that are wanted?"

"What in the world do you mean?"

Doctor Hackensaw smiled. "I thought you would be astonished, Silas," said he, "but the explanation is really a simple one. You may perhaps know that the Sea of Japan was in former days one of the finest hunting grounds for the sperm-whale or cachalot as it is called. These whales could be found there in large schools. With modern methods of whaling, however, these valuable animals are becoming extinct, and one of the Oriental governments has decided to restock the Japan Sea with whales. Hence this letter. This government wishes me to go to Japan for a few months. They agree to furnish me with a sufficient supply of living egg-cells and sperm-cells taken from the cachalots killed by their whalers. Then

comes my task. I am to fertilize the ova and incubate them in a suitable culture fluid in glass jars until the baby-whales reach the stage at which they would normally be born."

"Good gracious!"

"And that's not all, Silas. Whales, as you probably know, are mammals—that is to say, the mother-whale feeds her young on her own milk. So to feed these hundred thousand prospective baby whales until they are able to take care of themselves, I am to send to Japan several shiploads of condensed milk! What do you think of that for an order?"

"It beats anything I ever heard of. Are you going to accept?"

"I don't know yet. Perhaps I'll take a run over and get things started for them. I haven't much at hand at present except my motorless airplane that I'm going to test out this afternoon. If it proves successful I may take it along with me and use it for whaling purposes."

"A motorless airplane? You never mentioned that before. Do you mean a glider?"

(Continued on page 1124)

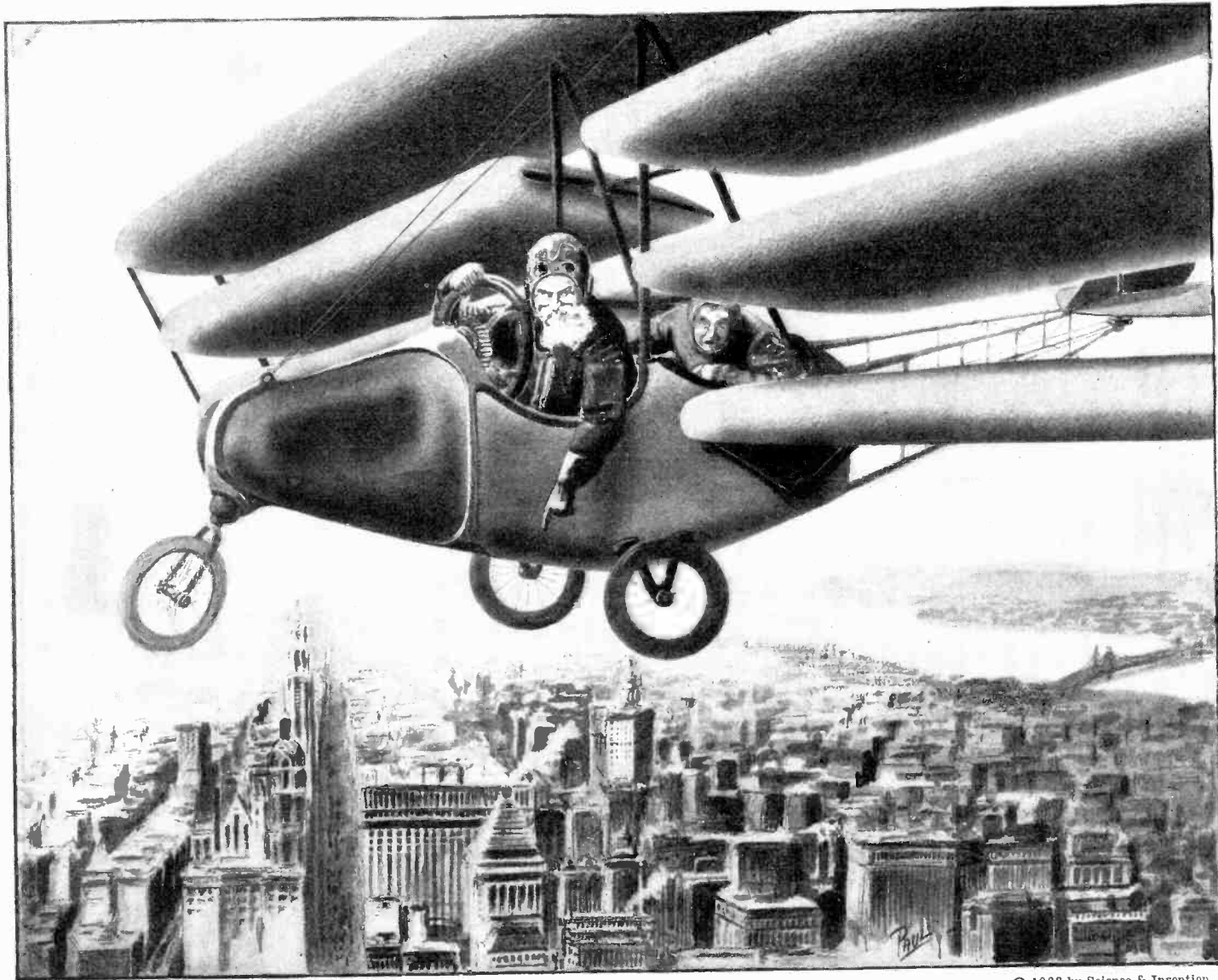

© 1923 by Science & Invention

"You see, Silas, we have none of the noise and fuss here of an ordinary airplane. . . . I can rise and land most anywhere, because my ascent is practically vertical. Then, too, the start and the landing are effected as slowly as I wish, thus eliminating two of the greatest dangers of the airplane. For war purposes, too, this faculty of hovering is very useful. See how easy it would be to drop a bomb on one of New York's skyscrapers from here!"

. . . . Silas looked down and was forced to admit the truth of his companion's remarks."

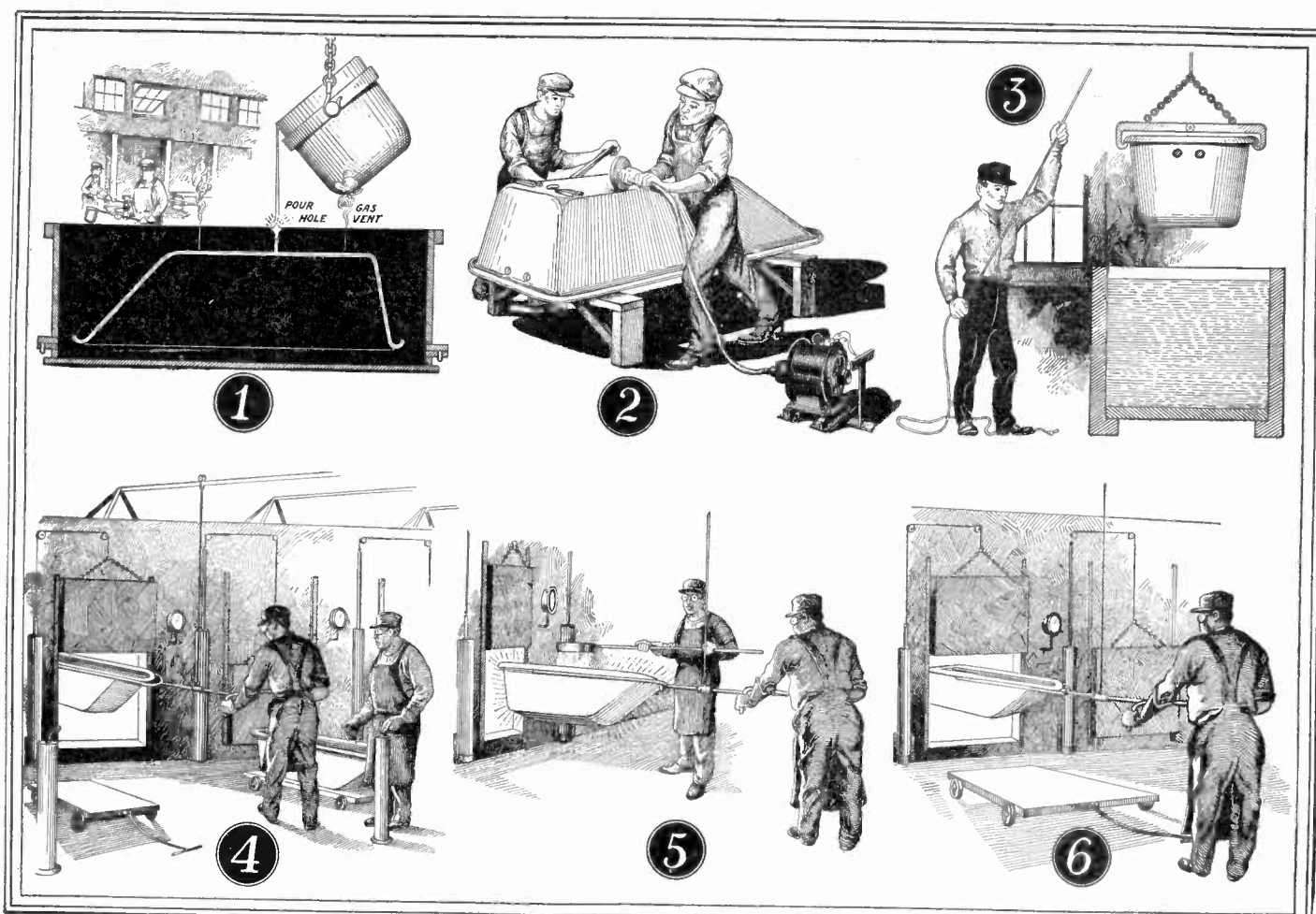

Fig. 1 shows a sectional view through iron tub flask together with sand, two gas vent holes and pouring hole in center, with large ladle of molten iron being poured into the latter. Fig. 2 shows tub upside down with one operative using file, while second man uses flexible shaft emery wheel to grind down and finish rough iron tub. Fig. 3 shows section of pickling solution vat with tub being lowered into it for purpose of cleaning thoroughly before enameling. Fig. 4 shows view of gas heated enameling ovens with compressed air cylinders for opening and closing oven doors, together with electric pyrometers, etc. A man is shown operating an air valve, also another man with leather apron and large boom about to place iron tub in oven. Fig. 5 shows red hot tub removed from oven, and one operative sifting enamel powder over the tub. Fig. 6 shows tub being replaced in oven so as to fuse and bake on enamel.

# How Enameled Iron Tubs Are Made

By H. WINFIELD SECOR

ONE of the commonest things that we see and use every day is the white enameled iron wash basin, and also bath-tub. We buy the iron tub or basin, get our plumber to install it, and promptly forget all about it, except when we want to use it. It is an interesting story which has not been told heretofore, describing the process of casting these large iron vessels and enameling them in huge ovens, which resemble miniature infernos.

In the accompanying illustration the successive stages followed in making an iron bath-tub are shown. The same operations hold true for wash basins and other vessels and containers of this type. There are some smaller water containers of the enameled type, which are made from pressed steel and not from cast iron, but the latter, older process still holds the field to a large extent.

Fig. 1 shows a sectional view through the iron flask or frame in the foundry which is filled with molder's sand, which has been prepared with a wooden or iron pattern of the tub, so that a hollow space is left in the sand into which the molten iron when poured, will flow and form the tub. Gas vent holes are made in the top of the mold as well as one or more pouring holes, into which the molten iron is poured from a large ladle. These large ladles necessary to hold sufficient molten iron, for pouring such a large object as a bath-tub, are handled by two men, a handle extending from either side of the ladle for several feet. In the foundries where these large

castings are made, the traveling cranes carry large clay-lined buckets of molten iron down along the foundry, and any small serving ladles used by the men are filled from these.

After an hour or so when the castings have set, and the temperature has decreased considerably, which slow cooling is adopted to prevent too quick a temperature change and possible cracks occurring in the casting, the molding flasks are knocked apart, the sand cleaned out, and the castings put on small trucks, and run to the cleaning room.

Fig. 2 shows mechanics busy cleaning the rough cast tub. Coarse rasp files are used for some of the work, while most of the rough projections, edges, etc., are finished off smooth with a small emery wheel driven by a flexible shaft, from a motor or line shaft. In this way the mechanic can take hold of the flexible shaft and run the rapidly revolving emery wheel over any part of the tub he desires. The inside and outer surface of the roll rim receives special attention in finishing, as this must be very smooth in order to give a perfect enameled finish.

The iron tub is next thoroughly cleansed of all dust and iron particles by treating it to a pickling bath. This may be an acid or a caustic soda solution; it thoroughly cleanses the iron surface, and prepares it for the enameling process.

The tub then goes to the enameling room. See Fig. 4. Here we find a line of great enameling ovens, which are heated either

with gas and compressed air, or else with fuel oil fed under pressure, the insides of the ovens being lined with tile or fire-brick, with the flame burners placed quite a distance outside, but protected by an outer wall to conserve the heat. When the door of one of these ovens is raised by a compressed air cylinder and plunger arrangement, as shown in the drawing, (the valve controlling the air pipe line being placed quite a distance from the doors, due to the terrific heat,) the inside of the furnace when fully heated looks like a duplicate of Dante's inferno. The leather-aproned men who place the tubs as they come from the finishing room in the furnaces to heat them up to red heat, which takes about eight to ten minutes usually, pick up the tub from the truck with a long bar containing a U-shaped iron cradle at one end, and a double handle on the other. This bar is suspended from its center by a chain or cable from the ceiling. This bar is about twenty feet long and in this way the tub can be placed in the oven or removed without undue discomfort from the heat.

Electric pyrometers or temperature indicators are fitted to the ovens in most modern baking rooms, so that the temperature of the oven can be regulated to the proper degree. When the tub is thought to have been heated sufficiently, that is, to a red heat, the door is opened by one of the men who takes care of this part of the job, and the handler grasps his long tong bar and places a U-shaped crutch under the tub rim, and pushing down and walking backward,

(Continued on page 1098)



# Measuring One Millionth of an Inch

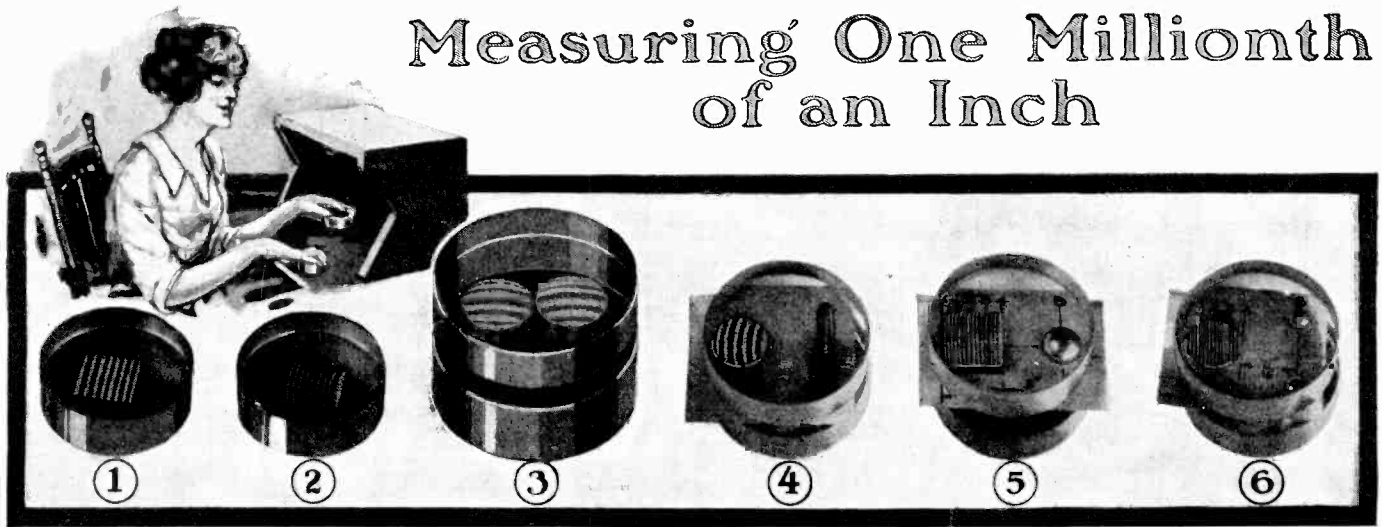

1—A gauge flat within a millionth of an inch. 2—Curved bands show that the near and far edges are lower than the middle of the gauge. 3—Comparing thicknesses of two gauges. The gauge at the left is shorter by a half band, or five millionths of an inch. 4—Measuring the diameter of a plug. 5—The arrangement of the cardboard templet for measuring the diameter of a ball bearing is here illustrated. 6—The two balls here shown are identical, as is evidenced by the parallel lines or light bands. In the upper left hand corner the method of making measurements is demonstrated.

**A**LTHOUGH measurements correct to within a distance of a millionth of an inch are possible, very few individuals understand exactly how such measurements are made. Simplicity is the watchword. Such a thing does not seem possible in such accurate measurements, yet all the instruments required are two so-called glass flats whose surfaces are perfect planes, and a fixed or known gauge. The glass flats are not lenses; they do not magnify, they merely present a perfectly smooth true surface of a plane. The gauge is of known dimensions, accurately ground. If two pieces of flat glass are placed together, so that the film of air between the plates is very thin, a series of colored interference fringes or bands will be seen if viewed in the daylight. This effect is often visible when washing windows with

water containing kerosene. But interference of light waves resulting between two plates when viewed in monochromatic light, or light of one color, gives a series of alternate light and dark spaces rather than the colors seen in daylight.

The average wave length of a beam of light is approximately two one-hundred-thousandths of an inch, or twenty millionths of an inch, but the light and dark spaces noted, result from interference of light waves. It is evident therefore, that the bands which are a noticeable distance apart, are not light waves themselves, but respectively indicate places where interference and reinforcement of the waves occur between the two surfaces at one-half wave length intervals. Therefore, each dark band shows a distance not of twenty millionths of an inch, but ten millionths of an inch, and the num-

ber of bands which are seen, indicate the steepness of the wedge of air occurring between the optical flat and the gauge. If these bands are seen to be parallel, then we are positive that the gauge is accurately flat. For the purpose of measuring the gauge which is not perfect, the optical flat is placed upon the gauge, whereupon a series of curved lines would be noticed. By referring to the diagram, the method of indicating the amount of curvature of the surface may readily be seen. Consequently, our second measurement is easily found, that is to say, a person can instantly tell that the surface of a gauge is not flat, and by simply projecting a line from one edge of the curvature of a dark band to the opposite end, and dividing the distance between the two interference bands into tenths, we are able

(Continued on page 1128)

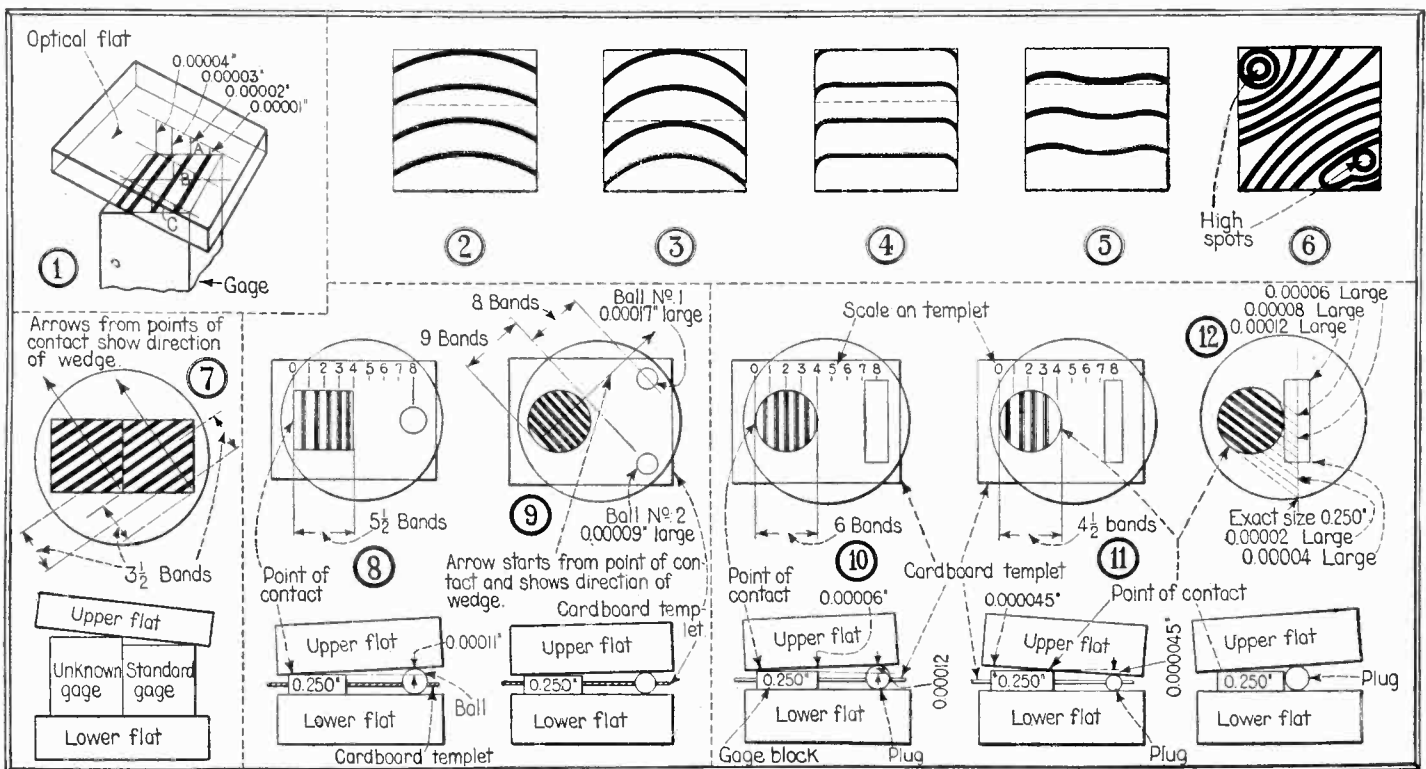

1—The interference bands shown above, locate vertical steps of .00001 inch between the contacting surfaces. They are shown here in an exaggerated condition, the optical flat resting on a gauge. 2—Curved bands indicate curved surfaces. The side edges are low by five millionths of an inch. 3—Convex surface; side edges low by ten millionths of an inch. 4—Side edges rounded; five millionths of an inch. 5—Surface hollow in center, higher on each side of center. Error of three millionths of an inch. 6—Note the high spots in this example; error, sixty millionths of an inch depression. 7—Comparing two gauges; top and side view shown. The standard gauge is three and a half bands, or thirty-five millionths of an inch shorter than the unknown gauge. 8—Measuring the size of a ball by means of a cardboard templet, and lower and upper flats. The ball is oversized by five and a half bands, or .00011 inch. Five and a half bands must be doubled, because of location of the point of contact. 9—Balls are not uniform in size. 10—Measuring the size of a plug, the plug is .00012 inch larger than the gauge. 11—Plug shown above is .000045 inch smaller than the gauge. 12—The tapering plug shows bands as indicated in the illustration, the bands inclining relative to the plug.

# Machine Makes 12,000,000 Keyless Codes

By H. D. HUNTER

OCCUPYING less than a cubic foot of space and weighing less than a portable typewriter, an electrically driven machine which codes, transmits and decodes



nearly 12,000,000 different, unrelated and keyless codes has been invented and patented by Edward H. Hebern, of California.

Hebern's invention, which is now under test by the code experts of five nations, in-

cluding the United States, has been subjected to fifteen months' experiments by agents of the American Secret Service, in an effort to decipher messages sent by it. So far, according to the inventor, they have failed to decode one word out of hundreds on which they have worked. The machine, whose basic principle is that of the telegraph-typewriter, can be used for all secret messages, sending and receiving either by wire or radio.

This tiny machine, weighing less than a portable typewriter, is capable of transmitting codes and also decoding messages. None of the codes are keyed, so that it is quite impossible to decipher the same by ordinary mathematical means. There are about eleven million separate and distinct code combinations possible with it.

The instrument—which is still waiting for a name—presents the appearance of one of the early wax cylinder phonographs. Its case is 8 x 10 x 6 inches in dimensions, and it weighs six pounds. From the top of this box rises a half cylinder of metal, divided in the center by a slot rather more than half an inch in width, into which drops the *key* or *master* wheel, which contains the secret

of the invention. On the upper half of the front of the box are 26 small transparent dials, arranged in three rows, on each one of which is painted a letter of the alphabet. This is the receiving deck. Directly under this, occupying the lower half of the front is a series of 26 keys, also containing the letters of the alphabet, arranged in the same order as on the "universal" typewriter keyboard.

With the machine as far as described, messages may be sent and received in plain English or in any other language using the English alphabet, or one approximating it in characters. The brain of the invention, however, is a little spool, about three inches in diameter, or less, and rather more than half an inch in thickness. Around the sides of the wheel, spaced around its edge at equal intervals, are 26 openings, through which are seen the letters of the alphabet. On the rim, likewise, are corresponding apertures, showing the letters in the same order.

The inventor will say nothing about this spool, which he calls the *key wheel*, and without which no codes, other than the ordinary codes, made by man, and, therefore, decipherable, can be sent. Inside the wheel, each letter-space is connected by a separate wire with a binding post in the center. There are possible, with these 26 letters and 26 wires, entirely different combinations numbering 11,881,376. By means of inter-codes, inside-codes, codes-within-codes, etc., it is possible to make codes to the number of 403,303,146,321,064,400,000.

## Ether Used in Manufacturing Ice Cream

Ether, that light, volatile, inflammable liquid so widely used as an anæsthetic because of its power to produce insensibility to pain, has been adapted to a new role of usefulness. P. N. Peter, a chemist in the Dairy Division of the United States Department of Agriculture, recently discovered its value as an agent in determining the expansion when freezing ice-cream. It is the first time ether has been applied in the process of refrigeration of ice-cream.

The determination of the expansion in freezing ice-cream is essential to the successful manufacture of this popular delicacy. The manufacturer terms this expansion an "overrun," which indicates an increase of the mixture over the original quantity of ingredients. The prevailing method of making known the percentage of expansion is to make comparisons in volume of a sample of the original mixture and a specimen of the "overrun." In the manufacture of ice-cream, air is whipped into the raw product, the injection of this air being primarily responsible for the inflated yield.

The apparatus for making the expansion determinations consists of a large Dewar flask, wrapped with a heavy layer of felt. Two concentric glass tubes extend through a cork into the center of this flask, the space between these two tubes being occupied by air which serves as a means of uniformly lowering the temperature. A dilatometer bulb and a thermocouple are contained in the inner tube. Temperatures are measured by means of a five-junction thermocouple, while dilation is determined in a capillary tube.

The use of ether in refrigeration methods has been occasionally employed in plant experiments in extremely arid regions of the

United States where the application of ice mixtures is difficult because of the excessive temperature in a desert. The use of ether in the manufacture of ice-cream, however, is a fresh application of this liquid commonly identified with operating rooms and hospitals where human pain is to be reduced

to an insensible quantity. The use of ether in determining the expansion of ice creams, gives a cleaner and more easily regulated method than the present system of determination by weight. It is, however, the costlier of the two.

Contributed by

S. R. WINTERS

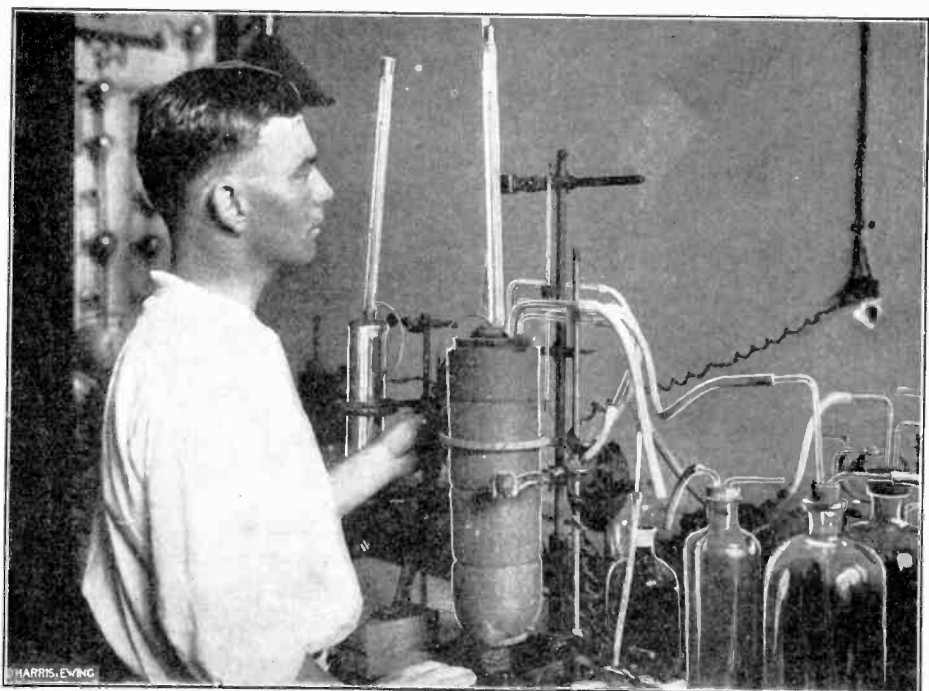

Above we see the modern method of determining the expansion in freezing ice cream by using ether instead of the weight system for indicating the degree of expansion.



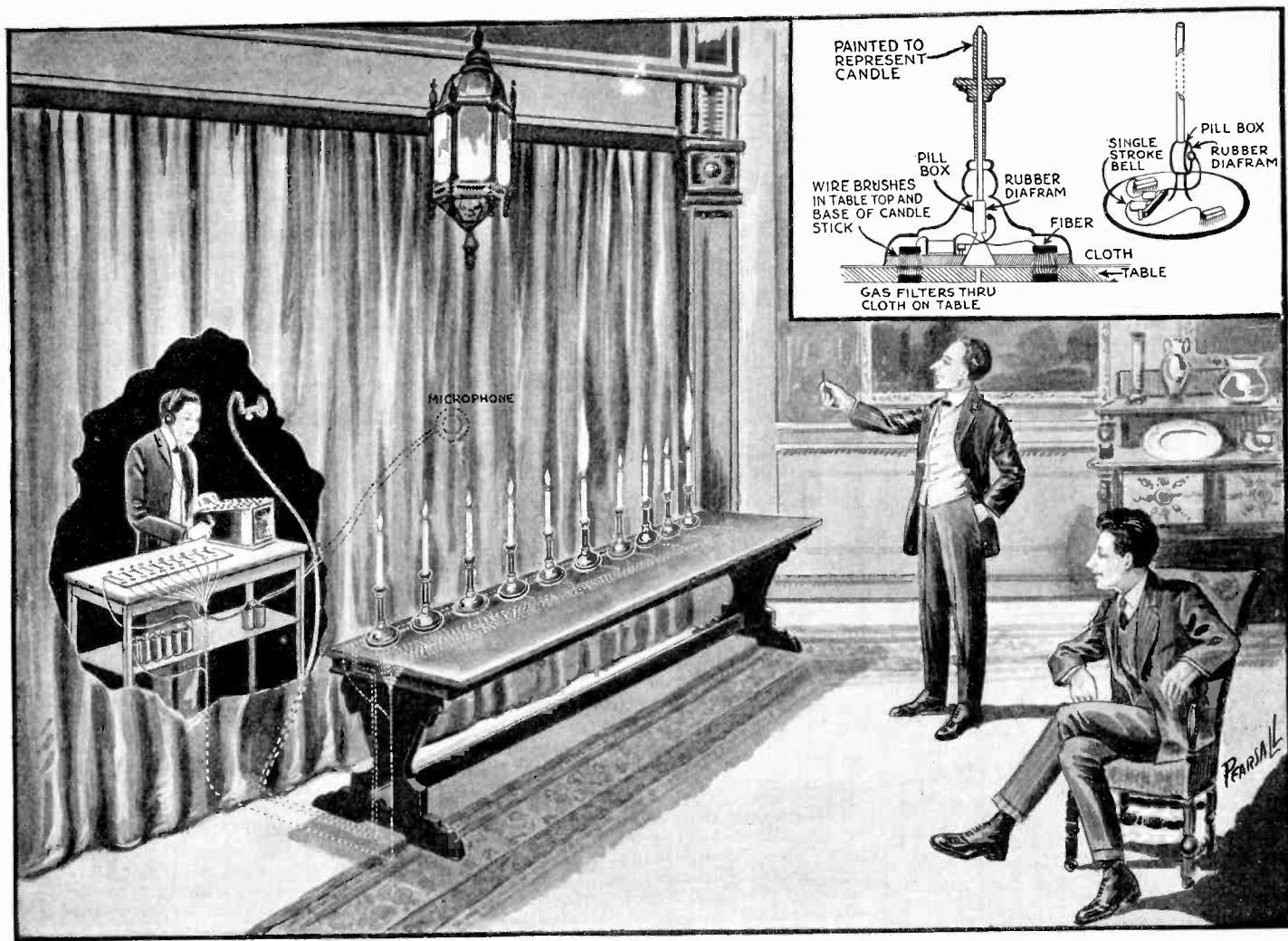

The effects produced by the flames of the candles in which their light flares up at the command of the operator, are developed by a tambour device placed in the gas line of the individual candles. Illuminating gas supplies each candle, the single stroke bells striking against the rubber diaphragm cause the flame to spurt up. The detail in the upper right hand corner shows the apparatus required, which is controlled by an assistant behind the scenes.

# The Amateur Magician

By JOSEPH H. KRAUS

## THE OBEDIENT CANDLES

**H**ENRI HARGRAVE, the famous magician, had promised to give me information regarding the *Obedient Candles*, a new electrical novelty, which he had just invented, so, inasmuch as I already had an appointment with him, which I did not hesitate to keep, I soon found myself in the throes of mysticism.

On a table in Hargrave's laboratory were ten candles in their respective candlesticks. "It won't do you much good to examine them," Hargrave commenced in explaining the trick, "because, as you have heretofore found, nearly all of the apparatus which I build, may be examined by skeptical individuals. So I will show you what the effect is at first and follow this up with the explanation. Suppose you take a sheet of paper and a pencil, and jot down a series of numbers, commencing with the figure 1, if you like, and culminating at the figure 9,999,999. You may choose as many figures as you desire, in any arrangement, and then total them up. Call them out as you write them." While I was calling out the figures, he was busy lighting the candles. Needless to say, I called out a group, jotting them down as I did so, which would stagger a skilful public accountant, if he attempted to total the amount.

Hargrave turned to me just as I had exclaimed "That's enough!" and said, "Before

totalling the figures you have given, I wish you would look at the candles. A flicker denotes a numeral. Three flickers in succession signify 'yes,' and two signify 'no' when numerals are not being considered. In this way, the candles will not only answer your questions, but will also add, subtract, multiply or divide for you. Just write down the number of flicks which emanate from the individual candles for your result."

Immediately my answer came. The first candle at the extreme left did not waver, the next one flared up and down five times in succession, the third one four times, the fourth one seven, and so on. According to Hargrave, my answer was correct. It took me some time to figure up the amount, but when finally I succeeded I found that the candles had told the truth. I asked them to subtract one number from the other, and before I could draw a line beneath the second group of figures I had jotted upon the paper, the candles were responding. I then commenced to ask them several questions. The entire group replied in unison. I then changed my tactics and asked the reply of candle No. 1, which was forthcoming. The flame in the others did not move, except for a slight draught of air, caused by an open window some distance away. When I asked of candle No. 3 whether candle No. 1 replied to my question, two flicks indicated 'no,' and

I was promptly informed which candle had replied by the number of flicks delivered by candle No. 6, to which the next question was put.

My age was given by candle No. 10, and many other replies which were received were extremely humorous.

Hargrave did not manipulate any controls. Finally he reached over, grasped one of the candlesticks, and blowing the flame out, came toward me. I examined it and found it to be an imitation candle, having a metal top with a small hole therein. Aside from that, it did not seem at all suspicious. It was up to Hargrave to give me the details. The base seemed so thin, it would have been almost impossible, in my opinion, to house any electrical apparatus therein. The usual method of making contact by means of points, was not in evidence, although I did notice two small wire brushes projecting from the base of the candlestick-holder.

Hargrave opened up one of the candlesticks, and the entire system was revealed. Essentially it was a gas appliance. A thin copper tube led to the top of a fake candle painted to resemble the real object, but for which a real one could be substituted if desired, the essential fact being that a hole must be drilled through the candle itself, to permit the introduction of the copper tube.

(Continued on page 1113)

# MOTOR HINTS

## FIRST PRIZE, \$25.00 BATTERY CHARGING REGULATOR

The illustration shows the construction and connections for a charging regulator

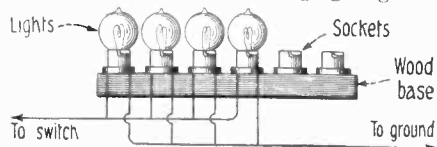

Fig. 1

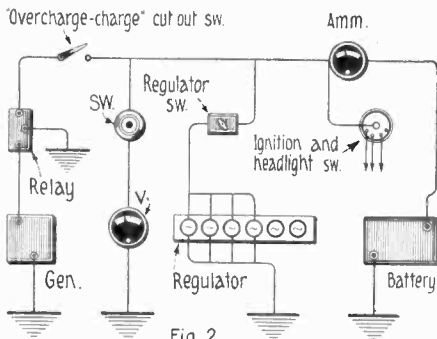

Fig. 2

The circuit diagram above shows how to connect a number of lamps across the battery, so that the dynamo will not overcharge said storage battery, when the car is being used on long distance runs.

switch mounted on the dash board of the car. On long drives, or at any time when there is danger of overcharging the battery, the regulator switch is turned on, and the charging rate will be diminished, the amount depending on the number of lamps used and their candle-power. Extra sockets are provided, which are not in the circuit, and may be used for carrying extra car lamps.

As shown in the diagram, it is the best practice to connect a voltmeter across the charging wire from dynamo to ground, together with a suitable push button switch, so that the condition of the battery can be ascertained before by passing some of the charging current through the headlights as some drivers do, or else through the regulator lamp bank, as here suggested. Some garage mechanics recommend the placing of a switch in the main charging wire from the dynamo as here shown also, so that if there is danger of heat developing within the battery, this switch can be opened, thus allowing the dynamo to run idle, the battery of course receiving no charging current. In this case the ignition and lights are

## SECOND PRIZE, \$15.00 LAMP SIGNAL GASOLINE GAUGE

The accompanying drawing shows an electric gas gauge which I have installed on a

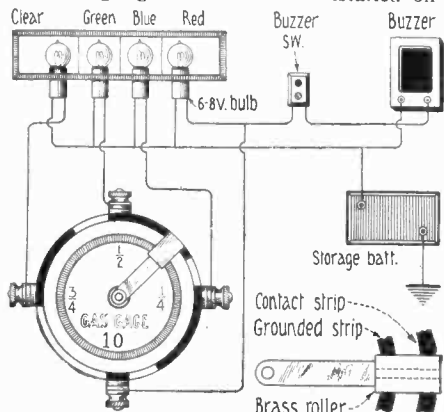

The safety gasoline gauge indicates how much gasoline is in the tank. When the supply is running low a red light is flashed, and a buzzer operated simultaneously.

## ELECTRICITY ON THE CAR

We believe that there are hundreds of new electrical ideas that can be incorporated in the car that our readers would like to know of. What we are particularly interested in are novel stunts, new devices, new kinks, and new hints made possible by the electric current.

In order to win a prize the first requisite is that the device or suggestion be practical. The term PRACTICAL will be the keynote of this contest.

You will be more apt to win a prize if you will design the device yourself, and make a photograph of it, sending the same to us. Ideas are all right, but the reader wants to see that the device actually has been made, and WORKS.

The following prizes will be paid:

FIRST PRIZE	\$25.00
SECOND PRIZE	15.00
THIRD PRIZE	10.00

All other accepted articles which win no prizes will be paid for at the rate of \$1.00. Each article submitted should not be longer than about one hundred to two hundred words.

Address all manuscripts to EDITOR "MOTOR HINTS," care of this publication.

operated from the storage battery, the same as if the engine were not running at all.

The voltage of a storage battery on open circuit does not mean anything, and the potential could be read either while the dynamo is charging the battery, or else while the battery is discharging, lighting the headlights, etc. The potential when fully charged will be about seven volts. If a dynamo is charging the battery, the voltmeter will indicate about nine volts or more; discharging with the dynamo disconnected, the battery potential will register about seven volts or less, when fully charged.

Contributed by FLOYD OAKLAND.

McLaughlin or Buick car, and which has worked quite satisfactorily. Any gasoline gauge can be insulated at the proper intervals by cardboard or fiber for the live side of wiring, and the inner strip is grounded directly to the dial or gauge. Where gauge is used for filler cap also, snap connections can be employed, or a collar of composition with contacts imbedded, could be used to slip over and around the gauge. Roughly when the tank is three-quarters to one half full, the clear light circuit is complete; when one half to one quarter, the green light; on quarter to one gallon the blue, and at the one gallon mark the red light and buzzer circuit is completed. Of course, this would not show the exact number of gallons in the tank with only four lights, but the system could be carried on as far as one should care to go. This notifies the owner of the car that when the buzzer rings, he had better fill up his tank at the next gas station.

Contributed by J. B. HALL.

## THIRD PRIZE, \$10.00 IMPROVED WIRE TERMINALS

A solderless insulated wire terminal, which will keep the wire from breaking where it joins the terminal, is here shown. It is made of a piece of copper or brass tubing. A piece of tubing just large enough to slip over the insulated wire is procured, and this should fit tightly. If the tubing is too large, the wire can be tapped to the proper size, or if too small, the insulation can be cut down. Then strip wire of insulation for about one and a half inches or more, according to the size of the wire, and bend stripped wire in the center. Slip copper or brass tubing over stripped wires, and about one-quarter of an inch of insulated part, so

that the bare wire will not project through the end of the tube. Put in a vise and squeeze the tube, being careful not to break any part covering the insulation. A hammer can be used to close up the tube if a vise is not available. The wire and the inside of the tube should be clean, and the tube pressed, so that the tube and wires are like one



Copper tubing



Tubing pressed

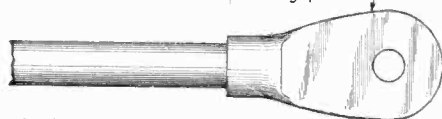

A clever method of making a lug for a wire terminal is depicted above. The rubber wire is bared, twisted into a loop, and pushed into a piece of copper tubing which is then flattened in a vise.

A part of the tube covering the insulation can be broken if thought necessary, so that the insulation is clinched in the terminal.

Contributed by ALVIN HEDWALL.

## A MAGNETIC HAND FOR AUTOISTS

The little device described herewith will prove itself to be of no little value in picking iron objects from the multitude of inaccessible places into which they seem to have the habit of falling.

It consists of a small electro-magnet wound for six volts, attached to a brass rod several feet in length and 1/8 inch in diameter. Current from the storage battery passes through the rod to one terminal of the winding and returns from the other through a well insulated wire which is affixed to the rod by means of thread or tape. The rod, being of small diameter, readily admits being bent into any desirable shape to reach into different places, enabling the workman to easily remove bolts or nuts which defy every effort to take them out with the fingers.

One hundred feet of No. 28 enameled copper magnet wire wound for 1 1/4 inches on an iron core 5/16 inch in diameter will readily lift iron objects weighing up to one-half pound. It draws 9 amperes, and heats up only slightly with continued operation.

Contributed by H. A. HIGHSTONE.

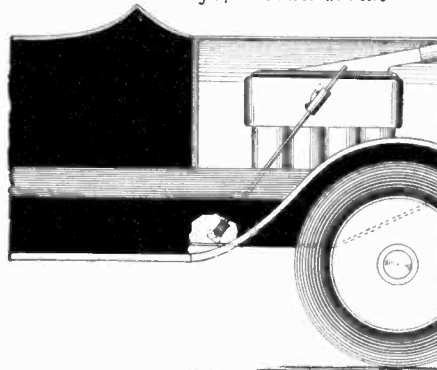
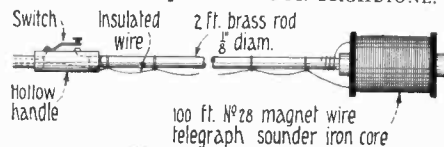

A magnet mounted on the end of a rod enables the automobile owner to pick up screws which have fallen into almost inaccessible places. This does not apply to brass screws, however.



# Scientific Problems and Puzzles

By ERNEST K. CHAPIN

NO. 6 OF A SERIES

## HARD-BOILED OR SOFT?

"WAITER," called the new customer to the man who had just served him, "take these eggs away and bring me some soft-boiled ones as I ordered."

"But you haven't opened the eggs yet, sir," objected the waiter, with difficulty concealing his irritation.

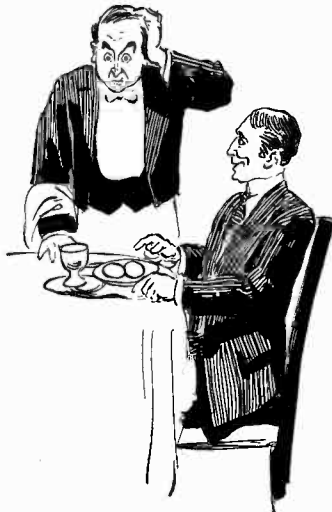

The waiter was puzzled indeed when his customer told him at a glance just how long the eggs had been boiled. Can you tell by looking at an egg whether it is soft or hard boiled?

"Don't have to open 'em," snapped the customer, "but if you don't believe they're hard I'll show you." And so saying he cracked the eggs open and proved his point.

"I'll bet I can tell how he knew the eggs were hard," the waiter said to himself as he went off after more eggs. "He simply shook them close to his ear and noticed that the contents didn't move inside." In a few



A boy showed two barbers a new trick in boiling water. With a glass flask and a tight rubber stopper, he showed them how to make the water boil after it had stopped boiling, without adding heat. Simple—when you know how.

minutes he was back with another pair of eggs.

"That's better," approved the customer this time before he had even touched them, "thank you." And away went the astonished waiter wondering whether to think the man was merely a good guesser or whether he really had some uncanny knowledge about eggs.

Would you venture to explain how the man knew?

## BOILING WATER WITHOUT INCREASE OF HEAT

"Yes sir," said one barber wisely to another, "it's perfectly marvelous the advances science is making these days. First thing we'll know somebody'll show us how to keep warm without coal, cook our food without gas and—"

"Shucks, that ain't so much," interrupted a small boy who had been listening, "I'll tell you what I can do right here and now. Gimme a flask and a tight rubber stopper and

Although it is an invention well over two thousand years old, Hero's fountain still provokes considerable interest wherever one is shown. The problem is to find out how the water keeps squirting upward through the central jet at the top, without the use of pumps, heat, etc., Fig. 1.

The authors Fig. 2, at extreme right, shows plan conceived by a store-keeper for a show-window display. He desired the small balloon to rise and fall alternately, this action to be kept up simply by means of a tank of compressed air. Do you think this scheme will work?

I'll show you how to make water boil again after it has stopped boiling and I won't add anything to it and I won't apply heat."

Can you explain how he did it?

## HERO'S FOUNTAIN

Although it is an invention that is well over two thousand years old, Hero's fountain still provokes considerable interest wherever one is shown. Fig. 1 illustrates the construction of the mechanism. When the upper reservoir (E) has been filled with water and a little water is poured into the upper basin (A), the device delivers a stream of water well above the source in apparent defiance of our notions about the impossibility of perpetual motion.

What is the explanation of its action?

## PROOF OF THE EARTH'S ROTATION

Supposing that our skies were always cloudy so that the rising and setting of the sun and stars could not be observed, are there any facts that could still be observed or any experiments that could be performed which would demonstrate the earth's rotation?

## PRACTICAL LEVITATION

Wishing to attract people to his window displays, an ingenious storekeeper proposes to construct a tall glass cylinder in which a small balloon of light but rigid material alternately rises and falls with its load of miniature passengers. The only motive power which he claims he requires is a tank of compressed air and the only mechanism necessary are two valves operated by levers as

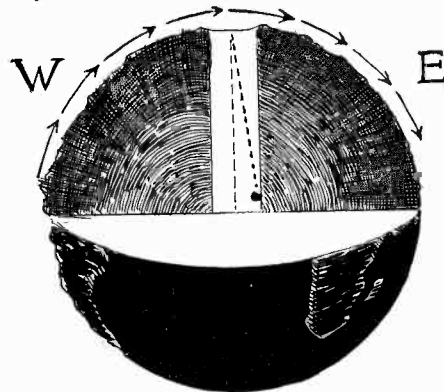

Diagram to accompany the problem on how to prove the earth's rotation on its axis, providing our skies were always cloudy, so that the rising and the setting of the sun and stars could not be observed.

shown in Fig. 2, one of which admits compressed air when the balloon reaches the bottom and the other which releases the pressure as soon as the balloon arrives at the top.

Do you think his scheme can be made to work, and if so, what would cause the balloon to rise and fall?

## THE HYDROSTATIC PUZZLE

Let us suppose that we have a device as il-

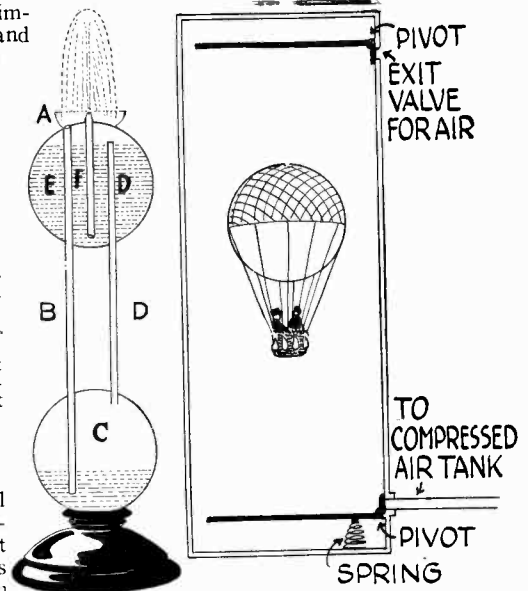

lustrated below, consisting of a piston (P) in cylinder (C) which connects at its base with a small vertical pipe (p) open at the top. The cylinder and tube are first filled with water and then the man stands on the platform on top. Assuming that the area of the piston is 2 sq. ft. and that of the pipe 0.1 sq. in., how high will the weight of the man and piston force the water in the pipe (p) if the man and piston together weigh 200 lbs?

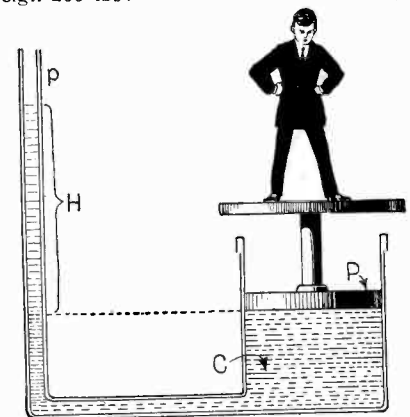

If the man and the piston, P, shown in figure above, weighed two hundred pounds, how high do you think they would force the water in the open tube "p."

Without a doubt the two problems on practical levitation and the hydrostatic puzzle, will attract considerable attention. Those well versed in physics problems will find even then that the results obtained in particularly the last problem, will startle them. The first problem given on this page, if practised, is found to be easily duplicated, and the individual who takes the time to memorize the few simple rules or rather effects which boiled eggs produce when removed from water, will be amply repaid for the time spent in memorizing these facts.

(Continued on page 1108)

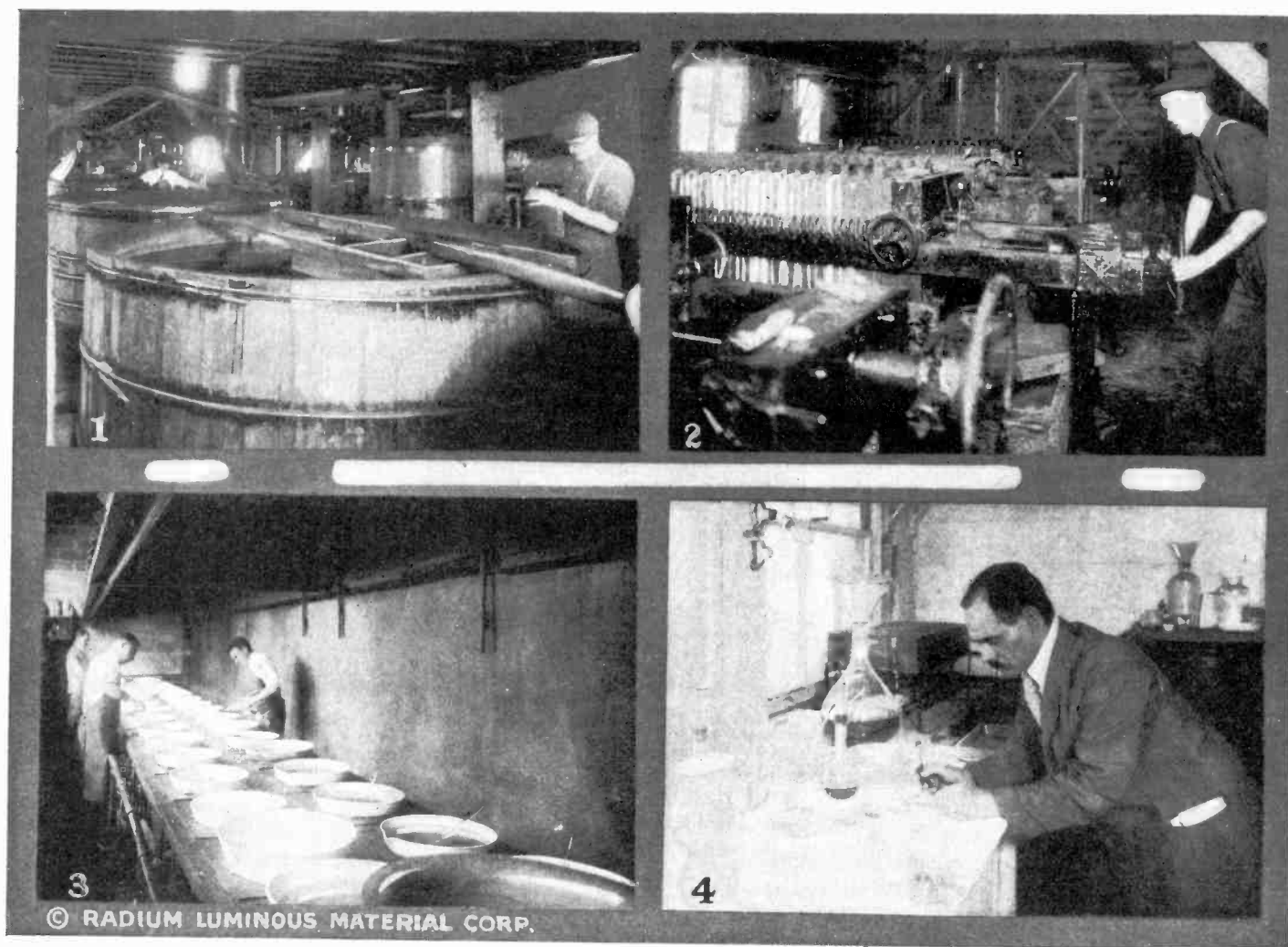

1—Many thousands of dollars' worth of radium are contained in these large vats. The solution is carefully sampled a number of times each hour. 2—Part of the process of extracting radium. 3—No cook ever watched a pot boil more carefully than these chemists with over \$500,000 worth of radium in their care. 4—This picture shows what remains from the big bowls on the long stove.

# Practical Chemical Experiments

By RAYMOND B. WAILES

FIRST PAPER OF A NEW SERIES

**T**HE extraction of radium from the mineral carnotite is as interesting as the application of this wonder element to human life.

Carnotite is a radio-active mineral now being mined in Colorado, for its varied contents, mainly for radium. Its appearance closely resembles a piece of dried-out yellow clay, but with properties totally different from the latter. The mineral is radioactive, or emits radioactive rays, because of its radium and uranium content. The rays which constantly pass off from the mineral are totally invisible, even in the dark, for the substance is not phosphorescent as many believe. The purer compounds of radium do, however, emit their characteristic bluish glow visible in subdued light.

A simple test for radioactivity in a substance such as carnotite is fogging by the mineral of a photographic plate or film wrapped up in paper, which has been exposed to the substance for several days. The radioactive rays of the uranium and radium contained in the mineral will penetrate the paper covering in which the plate has been wrapped just as light will pass through the lens of a camera. A piece of carnotite resting on the film side of a loaded kodak will cause a fogging to appear on the film when developed. The carnotite should be at rest on the camera for several days. "Radiumized" light buttons, pull-chain pendants, etc., can also be used in this manner, their radio-

## Extraction of Radium from Carnotite

active rays passing through the aluminum side or back of the camera.

The Bureau of Mines, co-operating with the National Radium Institute has perfected a method by which the carnotite ore can be worked up and radium salts isolated in a very simple manner.

The author has worked out the Bureau of Mines process with half a pound of carnotite, and has had no difficulty in obtaining radium in the form of radium-barium sulphate. About one gram of this substance was obtained. The presence of radium in the substance was verified by utilizing its radio-photographic effects. A paper clip was placed over a sealed photo plate and the radium-barium sulphate (in its container) was placed over the clip. Developing the plate after twenty hours produced the effect shown in figure 1. Carnotite mineral applied in the same manner did not affect the plate during the same length of time, conclusively showing that the radium barium sulphate contained practically all of the radium contained in the half pound of material processed.

The chemical experimenter should not have the least bit of difficulty in working up a quantity (from a quarter pound or more) of the carnotite mineral for its radium content. The simple precipitations and

filtrations with the resulting by-products make the experiment both practical in value and interesting in schematic chemistry.

### METHOD OF EXTRACTION

The pulverized mineral is first heated with strong nitric acid (step A) and filtered, the residue being treated with more strong acid again and filtered, the two solutions or filtrates being united. The residue is sand etc., and should be discarded as in actual practice. The solution contains radium, uranium, iron, vanadium (with which vanadium steel is made), calcium, aluminum, etc., as salts. Sodium hydroxide solution is now added (step B) until the solution is almost alkaline, but still slightly acid. If alkaline, a precipitate will form which is not desired. Barium chloride solution is now added, and then sulphuric acid. (step C). (Use about 20 cc. of 10% solutions of each). The white precipitate which forms is *radium-barium sulphate*. Filter.

The precipitate is dried, after washing, and preserved. It contains practically all of the radium which was present in the quantity of ore taken. This double salt can be used in many radioactive experiments in which a rather strong unit of radium is required.

In industrial practice, the radium-barium sulphate precipitate is heated with carbon, in furnaces. This reduces the sulphate to the sulphide by taking away its oxygen. The resulting radium and barium sulphides are dissolved in hydrochloric acid and the



solution obtained is fractionally crystallized so as to separate the radium chloride from the worthless barium chloride. It is not practicable for the experimenter to reduce the precipitate with charcoal (carbon) and then dissolve in hydrochloric acid and fractionally crystallize.

The filtrate obtained from the radium-barium sulphate precipitate should now be treated with a boiling sodium carbonate solution (step D). This precipitates iron, calcium and aluminum which were contained in the original mineral. In practice, this is discarded, it being worthless. The filtrate

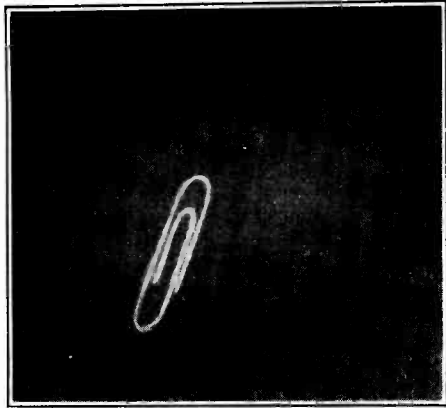

Fig. 1.—To make this radium photograph, the author places an ordinary wire paper clip over a sealed photo plate, while the radium-barium sulphate in its container was placed over the clip. Developing the plate after twenty hours, produced the effect shown.

from the solution now contains sodium vanadate and the double uranium sodium carbonate. The yellow color of the solution at this point is due to the uranium present.

Nitric acid is now added to the filtrate until nearly neutralized and then sodium

hydroxide is added (E). The uranium will precipitate as sodium uranate. This is used in making yellow glass for vases, automobile headlights, etc. Filter. The filtrate is completely neutralized with nitric acid and a solution of ferrous sulphate added. (F). Iron vanadate (black) is precipitated. Filter. The solution now contains nothing but sodium nitrate with impurities. If the solution is concentrated and allowed to cool in a quiet and covered place, crystals of sodium nitrate will form. In actual radium manufacture, these crystals are treated with strong sulphuric acid to make nitric acid which is then used as the neutralizing agent, or, to dissolve the original mineral as in the very first step.

One of the photos shows evaporating pans used to crystallize the sodium nitrate from the final solution. The mass of solid salts on the draining trays is sodium nitrate ready for nitric acid manufacture.

#### UTILIZATION OF BY PRODUCTS

All of the by products find a ready market. The sodium uranate when heated to

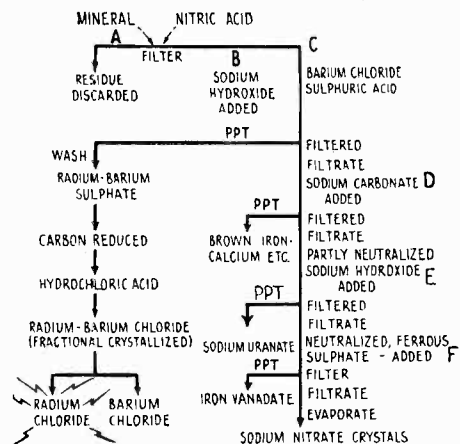

a high temperature yields uranium oxide, finding use in photography, and glass making. The iron vanadate is worked over and the vanadium used to make vanadium steel.

At step D, the sodium carbonate solution is added in excess, i. e., until no more precipitate forms. The solution is then boiled for half an hour, filtered and nearly neutralized with nitric acid and sodium hydroxide solution added (step E), until the yellow precipitate of sodium uranate no longer forms. The solution should be hot at this point. After filtering, the ferrous sulphate solution is added to the cold solution, or filtrate (step F).

The above procedure used by the National Radium Institute and the Bureau of Mines can readily be duplicated by the chemical experimenter on a small quantity of carno-

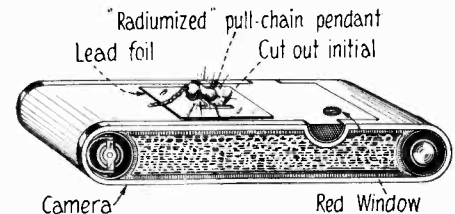

Fig. 2.—You can make a radium picture very easily by using your camera and a radium "button." Cut out a small figure or initial from a piece of heavy lead foil and place this on the back of the camera; then lay the radium luminous button over the cut-out portion of the foil. Do not disturb for several days. Turn the film to the next number and use the rest of the cartridge in the regular way.

tite mineral. The by-products obtained, when bottled and attractively labeled make a very interesting exhibit.

It must be understood that the percentage of radium in carnotite is infinitesimally low, and what may be called "radium chloride" contains only a minute proportion of the salt.

## An Unsuspected Function of Sugar

By C. L. MELLER

IT is twenty-eight below zero: on either side of the sun may be seen the phenomenon popularly known as sundogs, while among the timber is heard an occasional sharp report as of the discharge of a pistol; it is a little uncanny at night. However, the noise comes only from a tree here and there developing a frost crack. A little water lodged in some small wound is sufficient to start the trouble and under the influence of the intense cold a crack develops longitudinally in the trunk just as water pipes burst when the water in them is frozen. Yet trees live through winter after winter of just this kind of weather, altogether unable to defend themselves against the cold, their sap frozen to the very center of the trunk.

Of her means of accomplishing this apparently difficult feat, keeping trees alive through prolonged periods of sub-zero weather, nature makes no secret. She employs sugar to gain her end and has been telling us so ever since we began to use maple syrup for breakfast cakes. With the processes of plant life such as they are, it becomes perfectly obvious to the chemist that sugar is the only substance that nature could have employed without adding another detail to plant metabolism. A scientific determination, a sort of diagnosis so to speak, brings forth the following facts.

To begin with, we find sugar producing trees growing not only where there is a well defined winter season, but where that season includes periods of low temperatures. Not alone the hard or sugar maple but all the maples will

yield sugar, including even that veritable weed of a tree the box elder. Nor is the production of sugar limited to this genus, for we find that the sap of such trees as the walnuts and the birches can be boiled down to a sweet syrup and finally to sugar. Even trees like the ash that do not give their sap by bleeding in spring contain an appreciable amount of sugar, which will boil forth freely from the cut end of a green stick of this wood as it burns. Many an Indian child knows of this source of a bit of sweetness.

In the individual cells, those innumerable little laboratories of each green leaf, the elaboration of starch goes on apace. Now starch being a carbohydrate, a chemical group to which sugar also belongs, it lies within the power of the plant to change starch into sugar. Perhaps it is more accurate to say that plant starch is changed to sugar, sugar being soluble while starch is not. The manner of this change, having no bearing upon the special function of sugar at present under discussion, is a detail which we can spare ourselves discussing here. Sugar then is the form in which this elaborated plant food, this carbohydrate, is transferred from one part of the plant to the other through the medium of solution. When the leaves fall in autumn the manufacture of starch ceases, while that which has been manufactured is in solution but transformed into sugar, though of course by no means all, the greater part of the summer's output having been used up in the process of growth. Enough however remains to start growth again in spring, especially

bud growth. It is this sap, this almost pure sugar solution, that freezes solid during winter's zero weather.

That freezing does not harm this sap is obvious from the very fact that the tree can grow again in spring. The question why the sap is unharmed finds an answer near at hand. The sap of a sugar-producing tree can be boiled down to any desired consistency and then be brought back to its former state by simply adding water. Even the final sugar can be redissolved to its former degree of dilution without any change from the original sap, provided of course that the impurities are not in the water added, a contingency that can be avoided by the use of distilled water. Records show that the yield of sugar from the sap of a tree varies from year to year, as indeed does the yield of the sap itself; the sugar content of the sap may be as low as a fraction of one percent or as high as five percent due altogether to the influence of the season, which as yet is by no means fully understood. But an analysis of the sugar reveals it to be almost pure cane sugar with the addition of about one half of one percent of ash. However, the percentage, of sugar is of little importance as compared with the fact that the sugar is present in an almost pure solution.

It now remains for us to see how this acts in relation to extremely low temperatures. After being thawed out a sugar solution is its old self again and can act its part in every way that it did before it was frozen. It is this fact that solves the problem of a tree's

(Continued on page 1099)

# Experimental Electro-Chemistry

By RAYMOND B. WAILES

## PART 9—ISOLATION OF METALS, DYES; PREPARATION OF METALLOCHROMES, LIGHT BY MEANS OF ELECTROLYSIS

**T**HE electrolysis of aqueous (water) solutions by the electric current plays an important part in modern industry. Copper for instance, which goes to make copper wire for electric lines is recovered or separated from impurities

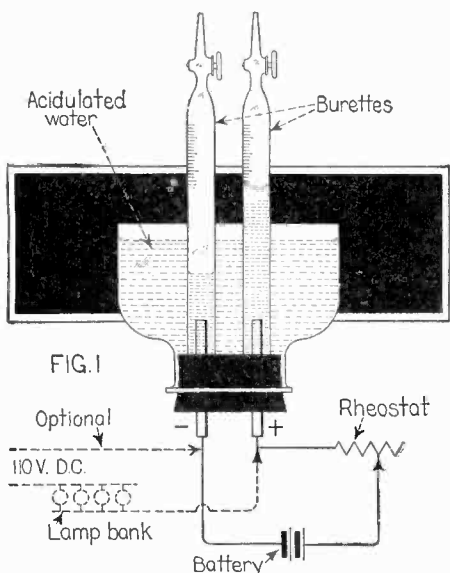

Fig. 1.—Hoffman's apparatus is easily made. The yellow dye, kanarin, can be made with the aid of it.

by means of electrolysis. A general statement can be made that all metals will pass toward the cathode or negative pole when electrolyzed, for the metals in solution have positive charges of electricity upon a portion of their atoms which are called cations, they being ions. So it is with copper, which collects on the negative electrodes in the electrolysis of copper solutions made by dissolving metallic copper in an acid.

A pretty experiment showing how a dye can be produced by electrolysis, or electrolytic oxidation, can be performed with the aid of a home-made Hoffman's apparatus for the electrolysis of water as shown in figure 1.

A bottle is cut off near its bottom by filing a mark around its circumference to a distance of about an inch, and a red hot rod bent in the shape of the bottle is touched to the file mark. Immersion in cold water will start the crack around the bottle. The two electrodes used are carbon rods obtained

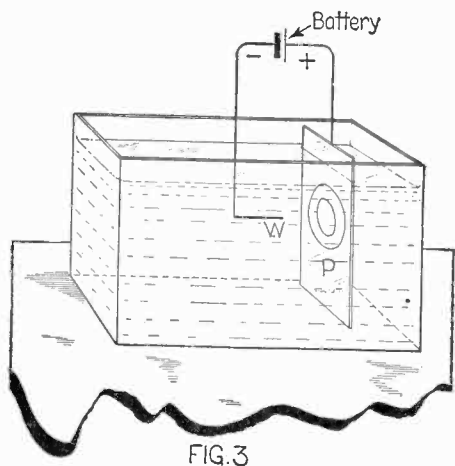
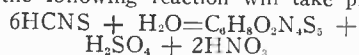

Fig. 3.—Metallochromes are easily produced and are of great beauty.

from flashlight cells. They pass through a stopper. Two burettes are placed over the electrodes as shown. The vessel is filled with water acidulated with sulphuric acid, the stop-cocks at the top being opened and the water sucked by means of a rubber tube, to the top of the stop-cocks, after which they are closed. The electrodes can be connected to a battery (storage) and a rheostat or 110 volts D.C. using a lamp bank resistance in series. On passing the current hydrogen will form in the burette over the negative pole and oxygen over the positive, or anode.

If the acid is replaced by a solution of 1 part potassium sulphocyanide in 5 parts of water and the current passed as before, hydrogen will be liberated as before, but there will be no formation of oxygen at the anode for the following reaction will take place:



The reaction product,  $\text{C}_6\text{H}_5\text{O}_2\text{N}_4\text{S}_3$  is kanarin, a yellow organic dye. The dye forms about the anode and after interrupting the current, can be scraped off the carbon anode, dissolved in alcohol, and cloth can be dyed with the solution formed. It is best to use 100 volts D.C. with several 16 C.P. lamps in parallel for this experiment.

### PREPARATION OF MAGNESIUM

An ordinary clay bubble or tobacco pipe can be used for this metallic separation. A steel knitting needle should be passed through the stem so that its end will project into the bowl of the pipe. This will form the negative pole or cathode. The pipe should be held in a suitable clamp and a Bunsen burner placed beneath the bowl. The bowl is filled with a mixture of magnesium chloride, ammonium chloride and potassium chloride, prepared by dissolving 20 grams of magnesium chloride, 7.5 grams potassium chloride and 3 grams of ammonium chloride in water and evaporating the solution to complete dryness in an evaporating dish. The resulting salts are then introduced into the pipe bowl and the Bunsen burner is lighted so as to melt the mass. A carbon rod from a flashlight battery will serve as an anode and is introduced into the melt in the bowl. A current from a 110 volt D.C. current stepped down with lamps should be passed for about half an hour. When the current is then interrupted and the mass cooled, globules of metallic magnesium will be found to have formed about the steel needle, or cathode. They can be mixed with a small amount of potassium chlorate and ignited, producing the familiar flashlight effect.

### NON-ELECTROLYTIC DEPOSITION OF METALS

Metals can be plated from a solution using two sheets of metals immersed in a solution of a metal and electrolyzing or passing a current, using the metal to be deposited as a solution and the object to be plated with the metal as the cathode or negative electrode. This it will be recalled, is the principle of the copper voltameter.

Metals will displace other metals from solutions without the use of the electric current. A sheet of iron placed in copper sulphate solution will become covered with metallic copper. The coating is not lasting however, its spongy state allowing it to be rubbed off quite readily.

Galvanite is the name applied to a paste consisting of:

Nickel ammonium phosphate	60 parts
Zinc dust	3 parts
Chalk	30 parts
Talc (powdered)	7 parts

This mixture, when rubbed with a moistened cloth over the object to be plated, will deposit a coating of nickel. The talc and chalk act as retarders for the chemical action and as polishing agents. The metal zinc is higher in the electromotive series or more

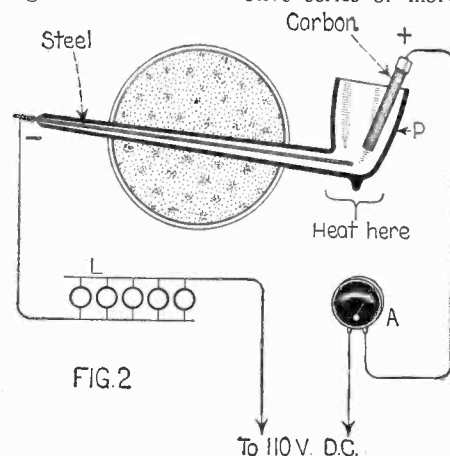

Fig. 2.—Using this simple set-up, metallic magnesium can be prepared from magnesium chloride. An ordinary clay bubble pipe is used as the reaction vessel.

positive than nickel, and displaces it from the solution, which is soaked up by the cloth and the nickel ammonium phosphate, deposits nickel by electrolysis or electric plating, on the metal which is rubbed with the saturated cloth.

### METALLOCHROMES

Using the experimental cell shown in figure 3, beautiful effects called metallochromes can be formed. The electrode (cathode) is a pointed wire, directed toward the anode, a sheet of copper. The following solution is used: 125 cc. water, 3 grams lead nitrate; 25 grams of sodium hydroxide in 125 cc. water. Mix the two solutions when ready for use. This forms sodium plumbate, a salt of plumbic acid.

Colored rings will be produced on the copper plate when the current is passing.

### Nobili's Rings

Nobili's rings are a form of metallochrome and can be produced by laying a sheet of brightly polished iron on the bottom of a vessel containing a solution of lead

(Continued on page 1116)

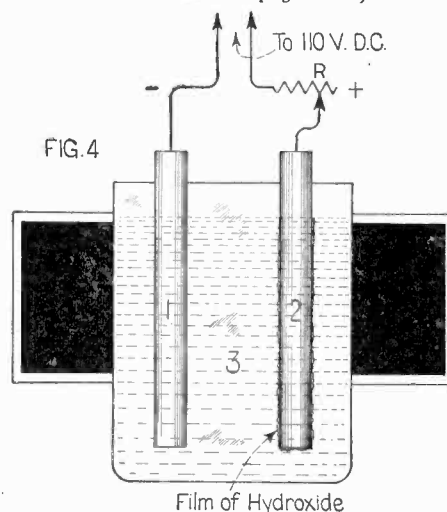
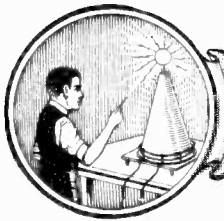
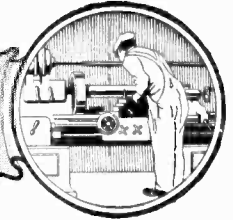

Fig. 4.—This electrolytic cell will produce a light when a direct current of 110 volts potential is passed through it, using a lamp bank resistance.





# THE CONSTRUCTOR



## Refrigeration in the Home

By L. K. WRIGHT, Refrigerating Engineer

**B**Y following the present article closely any one, with a little mechanical inclination, can build his own plant at a nominal sum and enjoy freedom from the messy use of ice. Such a plant as described can be assembled for one hundred dollars or less.

Before attempting to build his plant the layman should understand the principles upon which refrigeration depends. Under pressure the refrigerant is in a liquid state and flows as such to the point where refrigeration is desired. At that place it passes through an expansion valve, which as its name implies, allows the liquid to expand into a gas which absorbs heat. This gas, laden with heat absorbed from the ice-box, is drawn back to the machine, compressed into a liquid and allowed to lose its load of heat in the condenser; the heat being transferred to and carried off by the cooling water. The refrigerant is then ready to

repeat the same cycle, which it does an indefinite number of times with little or no loss.

The item that will give the builder the most work and concern is the compressor. An air compressor with a bore of from one to two inches will answer the purpose. Upon close examination it will be observed that there are several avenues by which the gas is likely to escape. A little patience, skill and ingenuity will remedy them in short order. The following remedies for faults in compressors may seem too numerous, but they are simply stated to cover the various makes of compressors.

The unloading device upon the pressure head will claim first attention. (Some compressors have this head cast solid without unloader.) Remove the unloading lever and have the opening carefully welded, care being taken to get no metal into the unloading valve, which might prevent it from

closing. To facilitate welding and careful inspection the pressure head may be unbolted, after its position has been marked to insure proper replacement. Before resetting, clean the surfaces thoroughly and apply a gasket of thick drawing paper, free from cracks or cuts, dipped into shellac. Apply pressure to the head bolts evenly when resetting.

The blind side of the shaft, opposite the flywheel side, is remedied by cutting off any projection of the shaft, so that after planing smooth the face of the bearing, a piece of sheet iron can be bolted across the opening by means of studs. Before fastening permanently see that the shaft has clearance and that a well shellacked gasket of paper, or a seamless leaden gasket made from wire solder, is used. Leaden gaskets are best and may be used with assurance against leaks caused by vibration.

(Continued on page 1096)

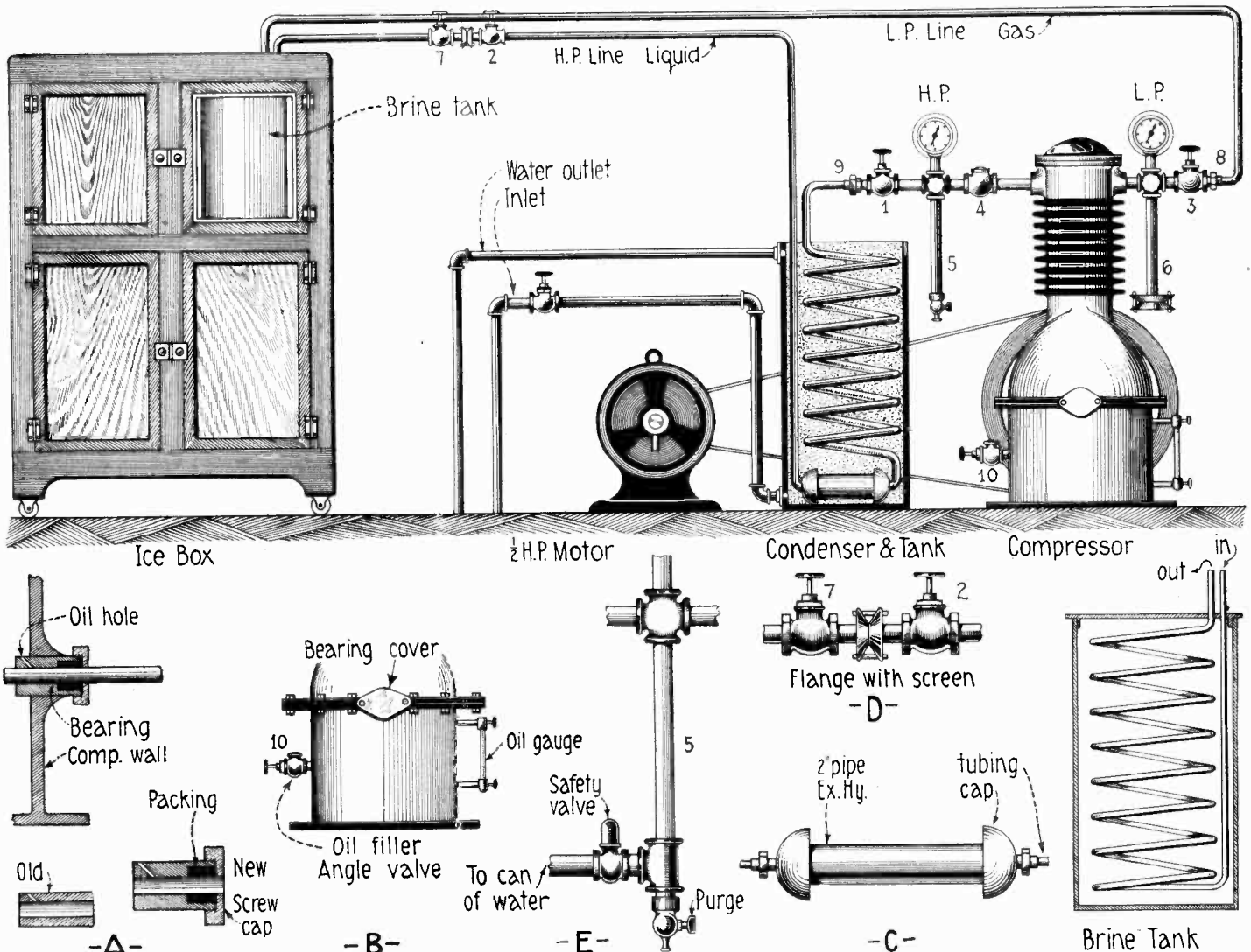

Complete details are given in the above illustration, and accompanying text by an expert, for building an electric refrigerating machine for home or laboratory use. As the commercial machines cost several hundred dollars in their complete form, and are, therefore, out of the reach of the average householder, this article will no doubt prove of extreme interest and value. The ice machine here shown, can be assembled for about \$100.00 or less, as the author points out in his article.

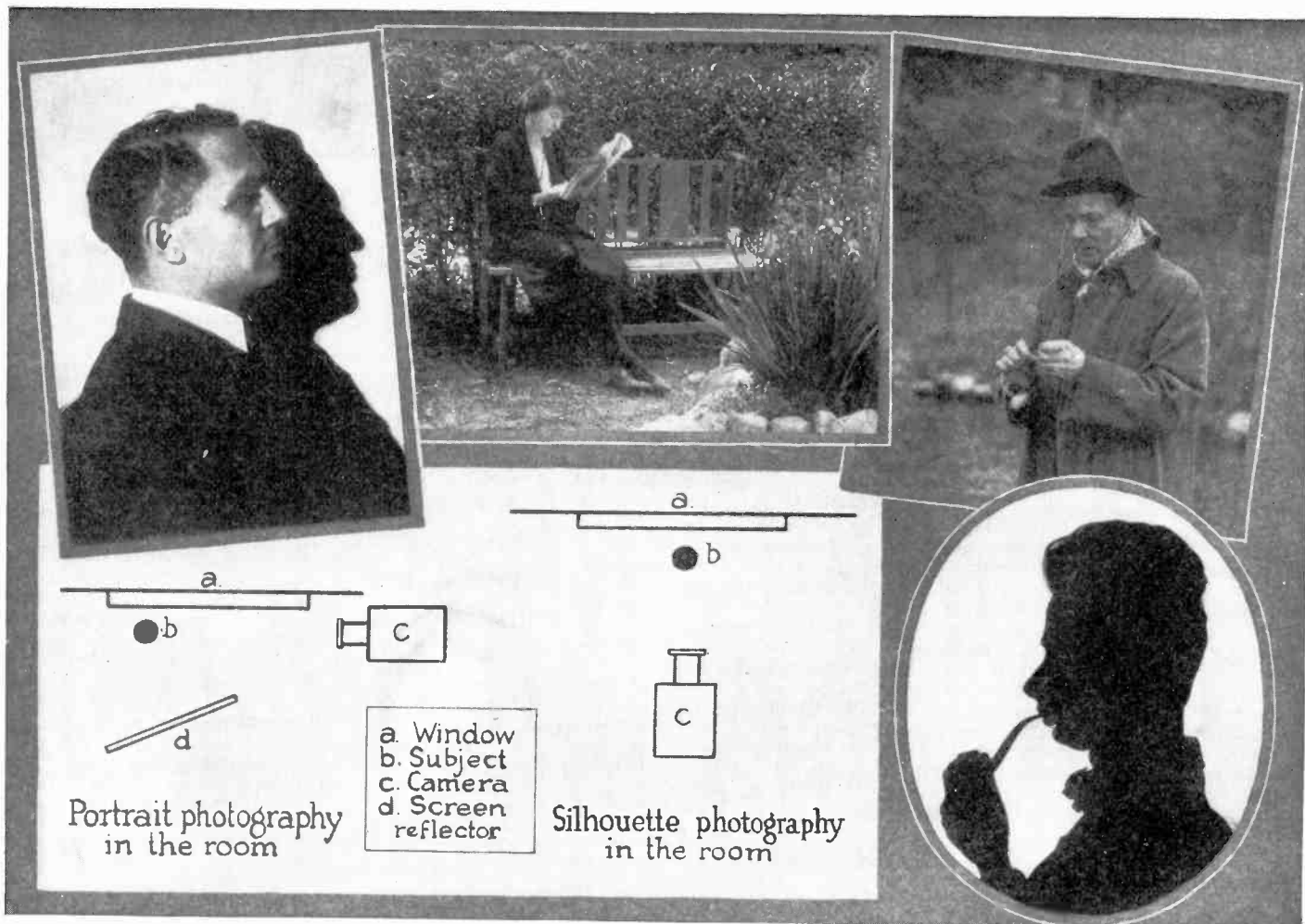

The two diagrams above show how to arrange the camera, reflecting screen and subject, before the window for both portrait photography and silhouette photography. Several excellent examples are shown above of photo-portrait studies, including silhouette and shadow photography.

# How to Use Your Camera

By Dr. ERNEST BADE

## PART III—PORTRAIT PHOTOGRAPHY

A PERCEPTIBLE adverse influence has been felt for some years in portrait photography, the direct cause being traceable to the retoucher's brush. The photographic process is not so incomplete as to make this a necessity, in fact, no negative ought to be retouched. If it is done, it is a sign of the lack of photographic technic. Retouching spoils the negative, although it may often be well to fix smaller plate or film defects such as tiny holes, etc. These, when blackened, show white on the print, and it is this print which is most easily treated. Should the defective part consist of black spots and pin points, they can be removed by carefully rubbing with the point of a needle.

Artificiality in lighting effects, while taking poses, have practically been eliminated, because they tend to produce unnatural and forced facial expressions. Photos are desired, in fact demanded, which show life, individuality, character,—peculiarities destroyed by the retoucher's brush. The original negative should not be touched. All of the many knacks brought to bear upon it for the production of an artistic positive, are employed while enlarging, but mistakes both in lighting and developing, cannot be wholly rectified. The proper lighting, the emphasis placed upon certain parts and the repression of others which may detract from the value of the picture are problems which must be solved *before* the photo is taken. Pictures whose subjects are all out of focus are

far from being artistic, although they are only too often considered as such.

The personal peculiarities of the poser must be brought forth in portrait photography, otherwise it does not tell us anything it then being only a cold immobile reimpression of nature. Every landscape changes its character, it is different in the early morning hours than when the sun rides high in the heavens, far different in early afternoon than in the hours of twilight, different in summer and different in winter. And as nature has its own moods, so are the moods of man comparable to the seasons of the year. The only time a successful portrait can be taken is at a moment of relaxation and rest, then the character of the poser is easily read in his face. A self-conscious picture with a conventional grin is worthless, the face and the expression are distorted, it is a *mask* but not a *portrait*.

Groups and portraits are taken to the best advantage in an indirect light, such as can be found both in morning and afternoon hours, the rays then being lateral. When the sun is hidden behind a cloud, the light will also be perfect for this purpose, as no sharp shadows are cast. A picture taken in the open requires a careful selection of the background. If the latter is too sharp and distinct, with many high and low lights, the person will be lost in obscurity, it should be of the severest simplicity and be placed in the shadow.

If it is a portrait which is desired, then the background must be quiet, it should be of such nature that it lies between the highest lights and the deepest shadows. As a rule the light requirements are amply provided for in the modern dwellings with its large windows, especially if a very sensitive plate or film is used. Then an exposure of a few seconds is sufficient to secure good and well developed negatives. But here it is imperative to somewhat lighten the side of deepest shadow by reflectors of white paper or cloth. Mirrors are not so well adapted for this purpose as they reflect too much light making certain parts stand out too prominently.

Artificial lights, such as electric or gas mantle lights, are suitable for portraiture. But here it is essential that a very good lens, allowing much light to pass through it, is used and also the employment of more than one source of light is requisite, for only then can the hardness of the photo be softened. The lights must be placed quite near the person to be taken and so arranged that one illuminates the subject while the other softens the shadows. Care must be taken that the direct light from the lamps does not enter the lens of the camera. If the source of light is quite brilliant, an exposure of a few seconds will be sufficient. Such plates must be developed in a rapid developing bath.

(Continued on page 1106)



# Electrostatic A.C. to D.C. Converters

By CLYDE J. FITCH

**T**HE conversion of alternating currents into uni-directional currents of small amperage and at high voltage is most easily effected by means of the electrostatic converter—a combination of rectifiers and condensers. This type of converter is so easily and cheaply constructed that it is surprising that it is not more popular, especially among the radio enthusiasts.

If a strip of aluminum and a strip of iron are immersed in a solution of sodium phosphate and connected to an alternating current circuit, a microscopically thin film of oxide forms on the aluminum strip. This film has the peculiar property of allowing current to flow through it in one direction, but not in the other direction. The current will flow from the solution through the film to the aluminum strip, but not from the aluminum strip through the film to the solution. This makes the active element of a very simple and reliable rectifier, and will be used in most of the following circuits.

Another important feature about the rectifying film is its high electrostatic capacity. The film is so thin that it forms an excellent condenser dielectric, for storing up an electric charge. The capacity of one square inch of this film is about 0.09 microfarad.

A simple condenser, of large capacity, that will stand a potential up to 150 volts can be made by immersing an aluminum plate and an iron strip in a solution of sodium phosphate; the aluminum plate constitutes one side of the condenser and the electrolyte constitutes the other side. The iron strip is merely an electric connection to the electrolyte. If the aluminum plate is 6" by 6" the condenser will have a capacity of about 6 microfarads. The aluminum plate is connected to the positive side of the line, and the iron strip to the negative side of the line, if used on a D.C. circuit. If the condenser is to be connected to an alternating current line two aluminum plates are used in place of one aluminum plate and one iron strip.

Figure 1 shows the simplest type of electrostatic converter. This converter consists of a rectifier and a condenser and they are connected in series to an alternating current line, with terminals brought out at A, B, and C. The direct current may be taken from either terminals A and B, or terminals B and C. The voltage across terminals B and C is equal to the maximum value of the alternating circuit voltage, neglecting losses; and if the capacity of the condenser is large and the amount of current withdrawn small, the potential will be

practically constant. The voltage across terminals A and B is pulsating, the maximum value of which is equal to twice the maximum value of the alternating circuit voltage, and the minimum value is equal to zero.

The action of this converter may be explained as follows: Suppose the converter is connected to a 110 volt A.C. line, and the current of the first half cycle flows down the right hand wire. This will charge the condenser to the maximum value of the A.C. voltage, which in this case is  $110 \times \sqrt{2}$  or 155 volts. The current of the next half cycle flows down the left hand wire, but this current cannot flow through the rectifier from the solution to the aluminum, opposite the direction indicated by the arrow, so the current flows from terminal A, through the external circuit to terminal B, and then through the condenser to the other side of the A.C. line. Therefore the condenser, which is charged to 155 volts, is discharged through the external circuit in series with the A.C. line, whose maximum voltage is 155, so that at every other half cycle the voltage across terminals A and B is  $2 \times 155$  or 310 volts. The polarity of the terminals will be as indicated.

The actual D.C. voltage is about 87 per cent of the theoretical value; the losses are (Continued on page 1102)

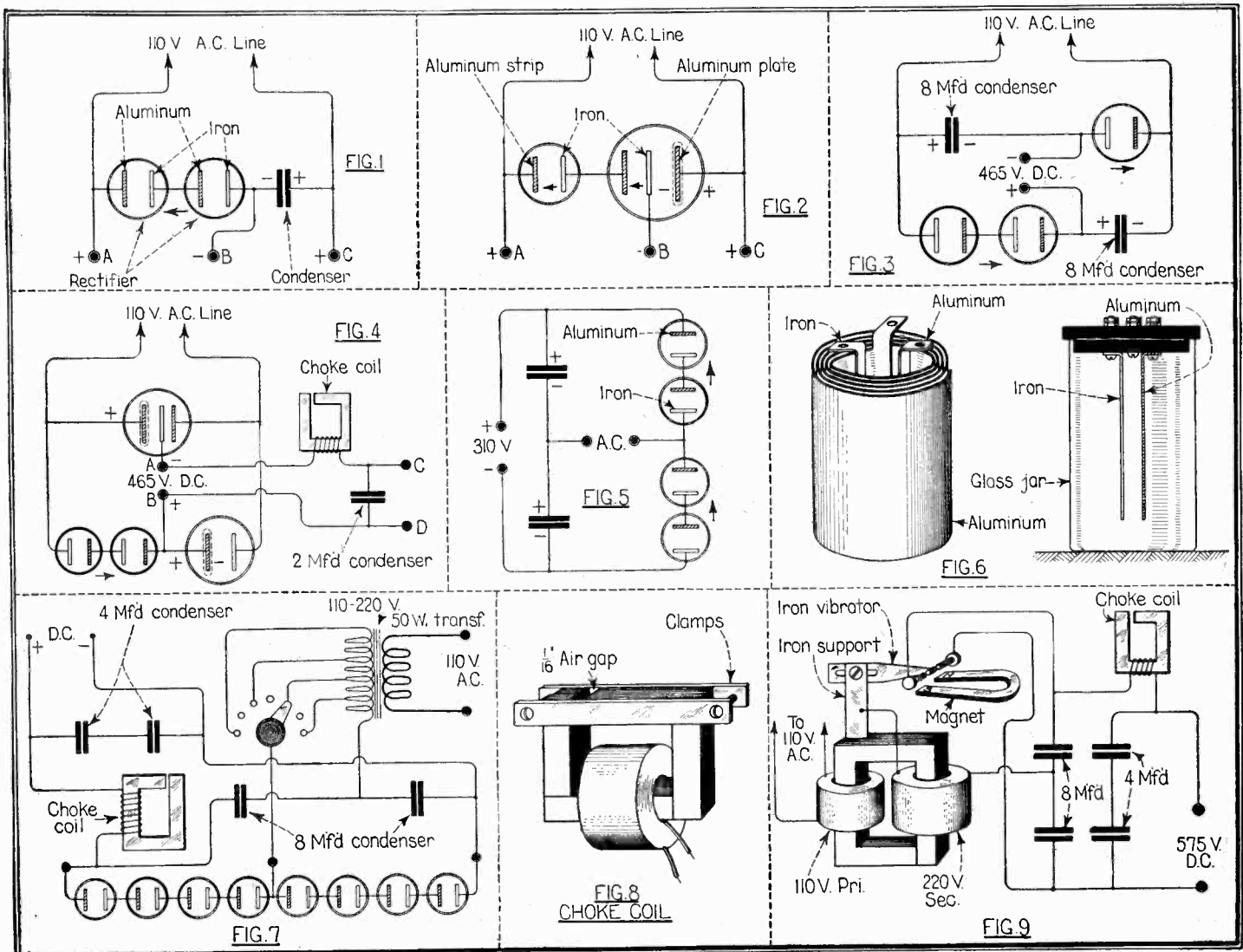

A number of interesting and novel circuit arrangements are shown above, for converting alternating currents into uni-directional currents of small amperage and high voltage, involving the use of the 'electrostatic converter'—a combination of rectifiers and condensers. The rectifier units may be of the V. T. type, or electrolytic units employing aluminum and iron plates immersed in a suitable electrolyte, such as sodium phosphate. These circuits will be found valuable to radio men, and Mr. Fitch has used them for his radio set with gratifying results.

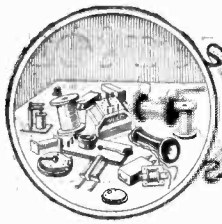

# HOW-TO-MAKE-IT



This department will award the following monthly prizes: First prize, \$15.00; second prize, \$10.00; third prize, \$5.00. The purpose of this department is to stimulate experimenters toward accomplishing new things with old apparatus or old material, and for the most useful, practical and original idea submitted to the Editors of this department a monthly series of prizes will be awarded. For the best idea submitted a prize of \$15.00 is awarded; for the second best idea a \$10.00 prize, and for the third best a prize of \$5.00. The article need not be very elaborate, and rough sketches are sufficient. We will make the mechanical drawings. Use only one side of sheet. Make sketches on separate sheets.

## FIRST PRIZE, \$15.00

### CAMERA DUPLICATOR

Ordinary duplicators for cameras work very well, but one which I recently built was found far more efficient

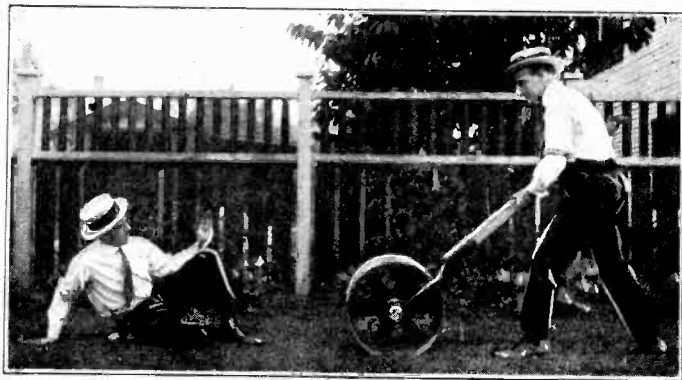
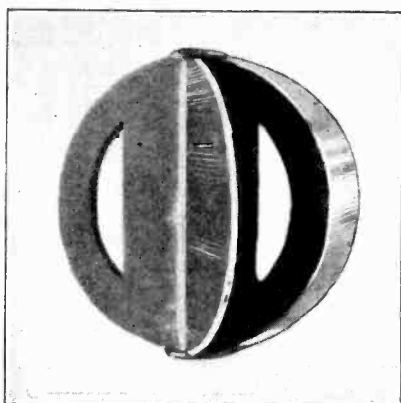

Photo at left shows remarkably clear double exposure made possible with the novel camera duplicator, here described by Mr. Lennox. Both of the figures in the picture represent the same man about to roll over himself with a lawn mower.

than modern duplicators now found upon the market. A metal cap to fit the lens of the camera has two slots cut into it, as shown in the accompanying illustration. The barrel portion which fits over the lens is slotted, so that the cap can be secured rather firmly. Two small lugs are soldered to opposite ends of the barrel midway between the arched slots, and a vane or shutter is pivotally mounted between these lugs, so that it can be flipped to either one side or the other.

With equal exposures, first with the subject in front of the opening in the cap on one side, and then with the shield thrown over in the opposite direction opening the opposite side, the subject changing his position, photographs such as shown herewith, are possible. Notice particularly the fine definition in this photograph and the absence of a dividing line between the subjects. The device can be operated very speedily, and due to the fact that the vent is easily



This picture shows the camera duplicator which fits over the lens. This duplicator results in very fine definition in the double exposure, as is evidenced by the photo reproduced above, the dividing line between the two half exposures being invisible.

## SECOND PRIZE, \$10.00

shifted, it is relatively impossible to disturb the camera on its tripod, as would be the case if the duplicator had to be turned around to make the picture. The

diaphragm should be stopped down slightly for better results.

—Contributed by W. F. LENNOX.

### GREASE GUN

A round bottle of a size according to the choice of the user as in *A* is the first requirement. Take a glass-cutter and cut off as close to the bottom as possible, then make a plunger of wood as in *B* to fit as tight as possible in the bottle. Then to use

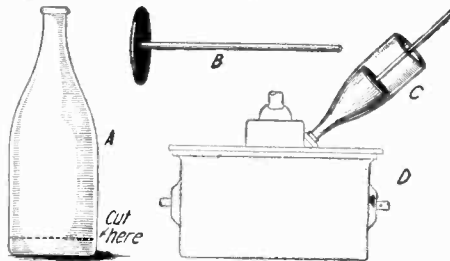

This home-made grease gun will be found handy around automobiles and other machinery.

the bottle as a grease gun fill the bottle with the hard oil and put the small end of the bottle in the place for the grease to be placed, then put the plunger in the bottle and push down thus forcing the grease out. To use it as a sausage stuffer do the same as in using the grease gun.

This same bottle may be used as a funnel as in figure *D* also.

Contributed by WM. LINDEMAN.

## THIRD PRIZE, \$5.00

### ROLL FILM DEVELOPER

Photography is one of my hobbies, and see-sawing films through the air is as tiresome to me as anyone else, if not more so, on account of the position of my developing table. So one afternoon, before developing, I arranged an apparatus such as shown in Fig. 1, out of my builder set, and hung it on a trolley-like arrangement over the developing table. The string-belt, which passed over the three pulleys terminated in two hooks, to which the film clips and film

were fixed; one of these clips was weighted. It will take a bit of experimenting to find the best weight to use; I used a twenty-gram weight. It should be light enough, so that when the film is traveling down, the weight

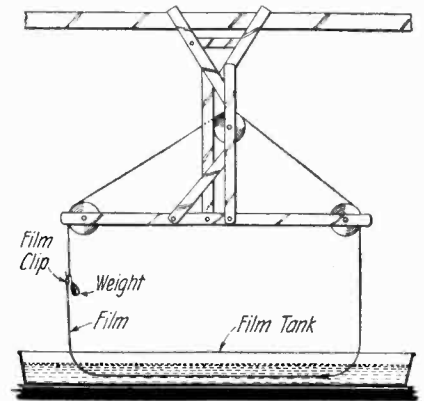

Fig. 1

One view of home-made device for developing roll films.

of the ascending film and clip just counterbalances it. This is so that when the film is released, it will not drop and splash in the tray, but slide down and slowly halt just as the other end is at its highest point. With this apparatus, only one hand is required, and that only moves in one direction.

I tacked a small battery motor on the old frame, and fastened a movable lever with its idler pulley, as shown in Fig. 2, operating this on the same principle as the clutch on the old belt-drive motorcycles. I fitted the controlling arm with a string, trusting to a rubber band to pull it back. Pulling the string would connect the continuously running motor to the film-string, causing the film to walk right up, releasing the controlling string slightly would throw the motor out and Mr. Weight would accompany Mr. Film down again.

Contributed by CLARENCE P. SALMON.

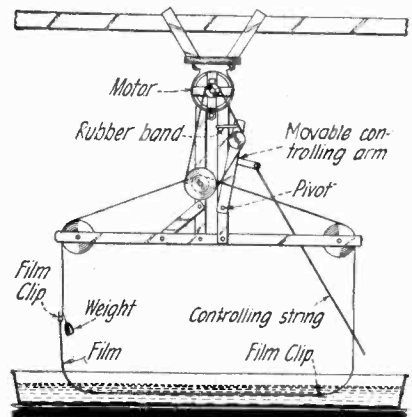

Fig. 2

Second view of home-made roll film developer, which is actuated by a small battery or other motor, in the manner shown. The motor drives the rocking arm through a belt, tightened or loosened by means of an idler pulley, operated by the controlling string shown.





EDITED BY S. GERNSBACK

**THIS MONTH'S \$5.00 PRIZE**

**HOW TO MAKE YOUR OWN SAL AMMONIAC**

Without doubt most of the readers of this magazine have used the ordinary sal ammoniac battery in their experiments.

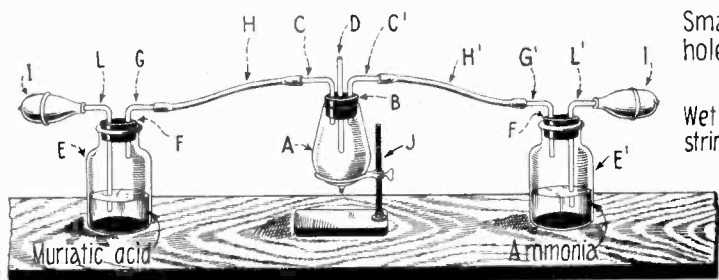

Fig. 1

With the simple apparatus set up as shown above, it is possible to make your own sal ammoniac. Diagram in Fig. 2 shows how to cut off base of incandescent lamp in order to make container A.

Some have possibly also made their own batteries, that is, everything except the battery compound. The following description will tell you how to make your own sal ammoniac.

In the diagram, Fig. 1 (A), is an incandescent lamp bulb with the plug removed. The plug may be removed as follows: File a small hole in the glass near the plug, which must be done cautiously, to admit the air. Then wind a wet string several times around the glass just above the place where the bulb is to be severed, as illustrated in Fig. 2. Then run a hot piece of metal around the lamp between the string and the plug. The glass will then crack in a straight line all the way round. With a slight blow, the plug will fall off.

In Fig. 1 (B), is a rubber stopper with three small holes (not too small), and C and C' are two bent glass tubes which pass through B. The two vapors enter the bulb through these. A straight glass tube D, passes through B, between C and C'. It should extend about three-quarters of the way down the bulb. This tube allows the excess air and gases, which are harmless, to escape. The bottles E, and E' contain muriatic acid and ammonia respectively. Of the other parts, F and F', are two-holed rubber stoppers, G and G' are two bent glass tubes which are connected to C and C' respectively by rubber tubes H and H', and L and L' are also two bent glass tubes, on one end of each there being attached a plumber's furnace bulb. The other ends dip almost to the bottom of the liquids.

A small stand for the lamp bulb may be made as follows: A piece of large gauge copper wire, about No. 8 or 10, is bent into a loop to fit the bottom of the bulb. Then bend the remaining piece at a right angle and insert the end in a base.

One thing is certain that to make the experiment work right, all joints must be tight. Now by pressing each of the plumber's bulbs simultaneously and with equal pressure, an equal amount of each of the gases enter the tube. As the gases mix in the bulb they unite to form sal ammoniac, which will gather on the sides and bottom of the glass in white flaky crystals. When the bulb is full, scrape it out and proceed as before.

Contributed by RAYMOND EKLUND.

**DRILLING GLASS**

I have seen in your magazine and others so many pitiful attempts to describe methods for drilling holes in glass that for sheer pity I am going to tell how it is done professionally. This is a trade secret but—radio youth must be served.

I have drilled as many as 100 holes per

Small hole

Wet string

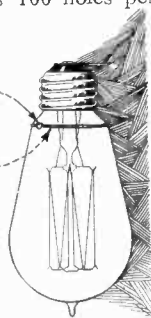

Fig. 2

hour in opalite—so hard that an ordinary glass cutter will not touch it. Many holes are only one-quarter of an inch from corners and I never crack a glass—while drilling.

Nine-tenths of success depends on the drill and one-tenth on the manner in which it is used, both of which I describe.

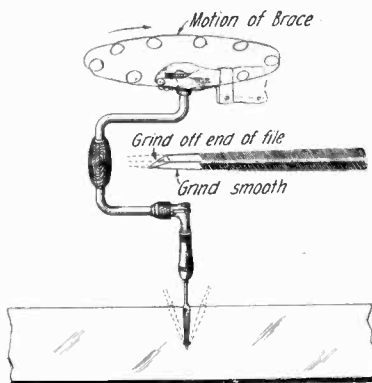

Illustration above shows how file is ground to make drill for use in boring holes through glass, also method of using brace and drill.

Procure a 3-cornered file and dress as per cut, on an emery wheel, turning very slowly and removing file very often, so the point will not burn and lose its temper.

This shape throws the point off center, which is the successful secret of the drill. Sharpen the bevel point often and merely touch up the long sides, on a fine oil stone. Fasten the drill in a common carpenter's brace, place the point on the glass in a drop of turpentine and spin it with the hand on top of the brace and the offset handle as a counterbalance. The slower you spin it the faster it cuts; you cannot use it in an electric drill.

While it is spinning, the hand describes a circle about one foot in diameter, which is the second secret, as this method makes the hole larger at the top and the off-set point takes care of the bottom in like manner, so your drill will never bind, which is the cause of breakage.

Incidentally, this drill is better for bakelite and hard rubber, etc., than a regular drill.

Contributed by W. M. ROCKWELL.

**MAGIC CHEMICAL COLOR CHANGING**

In a test tube half full of water, put about 2 c.c. of phenolphthalein solution. Exhibit this milky liquid to your audience. Then drop a good sized pinch of sodium carbonate in the solution, which turns it red. Now if the same amount of copper sulphate is dropped in, it turns purple; but if shaken a blue color results. A large pinch of Glauber's Salt (sodium sulphate) turns the blue to dark green. Next drop a good sized pinch of sodium bisulphide into it, and a brown color results. Then if that same quantity of tartaric acid is added, the brown turns to dark green. Add still another pinch of the acid and a beautiful light green is formed. A pinch of iron sulphate is added, but nothing happens. Then if a few crystals of potassium bichromate are dropped in the solution, nothing happens until the mixture is stirred, when it turns back to dark green again. It cannot be shaken because gas is liberated. The mixture is liable to boil over, so it is best to perform the tricks over a newspaper spread on the table to prevent soiling it.

Contributed by D. R. HOAG.

**THE MAGIC KNIFE**

In a glass half full of water, put three grams of sodium bisulphate, and when this has been dissolved, put in another glass half full of water, three or four drops of phenolphthalein solution. Rub your arm with a sponge soaked in the first solution, and moisten the knife with the second solution. You are now ready for the experiment. Viciously (but carefully), slash at your arm, making sure that the flat part of the moistened knife comes in contact with your wet arm. After a few moments, the audience will see a reddish substance, like blood, covering the supposed slash.

Contributed by JOSE R. DEL GALLEGO.

**IODINE DROPPER**

A simple way to make an effectual dropper for the iodine bottle is to use an old electric light bulb for this purpose. Break all of the glass away with the exception of the central solid glass stem, and see that all the wires are removed from this. Now slip a rubber washer over the same, so that it fits against the screw plug tightly, and then wind several layers of friction tape around the top to act as a cork. With this dropper, wounds can be treated without soiling the hands.

Contributed by H. W. JACKSON.



Handy iodine dropper for the laboratory or home use, made from the base and glass stem of a discarded incandescent lamp, the glass being broken away with a pair of pliers.

# RADIO DEPARTMENT

## Talking Across the Atlantic

**A**N important demonstration of trans-oceanic radio telephony occurred Sunday evening, Jan. 14th, when H. B. Thayer, President of the American Telephone and Telegraph Company, speaking at the offices of the Company, 195 Broadway, New York City, was heard by a group of well-known electrical engineers and others assembled at New Southgate, a suburb of London, England. The transmission by radio telephone was declared by all who witnessed the test to be in every way satisfactory. The radio apparatus and system used in this test have been made possible by co-operation between the American Telephone and Telegraph Company and the Radio Corporation of America, and are the result of research and experimental work in the laboratories of the A. T. & T. Company and in the laboratories of the Radio Corporation of America and its associated companies.

In 1915, engineers of the A. T. & T. Co. succeeded in talking by radio telephone from the Naval Station at Arlington, Virginia, across the Atlantic to Paris, and the same messages were heard 5,000 miles to the westward at Honolulu. Since then great improvements have been made in the two arts of radio telephony and telephony. In the ex-

periments which are now being conducted and those which are scheduled to follow, use is being made of these improvements.

One of the developments which has been in progress since the telephone company's demonstration of trans-oceanic radio telephony in 1915 has to do with the perfection of high powered vacuum tubes. The tubes used in the present tests are characterized by a large external anode which is cooled by water. By virtue of water-cooling each tube can readily handle as much as 10 kilowatts of power.

In the present installation, which is located at the large station of the Radio Corporation of America, at Rocky Point, the final stage of amplification comprises a group of 20 of these tubes operating in parallel. The output of 100 kilowatts is delivered to the antenna and, due to a new system of radio transmission employed, is as effective as 300 kilowatts would be in the systems commonly used. In the systems commonly in use about two-thirds of the energy goes into waves other than those which comprise the message, these waves being needed by many of the receiving sets in use for detection of the message. The new system suppresses the waves which do not comprise the message and reception is accomplished by

generating locally at the receiving set a small high frequency current, which corresponds in frequency to the suppressed waves.

Just what is provided by the new system of radio transmission is clearly shown in our diagram which should be read from left to right. The speaker's voice supplies a band of speech waves extending from the frequency of about 200 to 5,000. A vacuum tube oscillator supplies a high frequency wave the so-called *carrier wave* which, for the purpose of illustration, we have taken at 50,000 cycles. Before modulation the speech wave and the carrier wave are entirely distinct. After modulation we no longer have any speech waves as such, but we have two new sets of high frequency waves, one ranging from 50,200 up to 55,000 cycles and the other from 49,800 down to 45,000. These two new sets of high frequency waves are known as the side bands.

In the usual radio telephone transmitter both side bands as well as the carrier wave are radiated out into the ether. Approximately, we may say that in these systems two-thirds of the high frequency energy is assigned to the carrier wave and one-sixth to each of the side bands.

(Continued on page 1133)

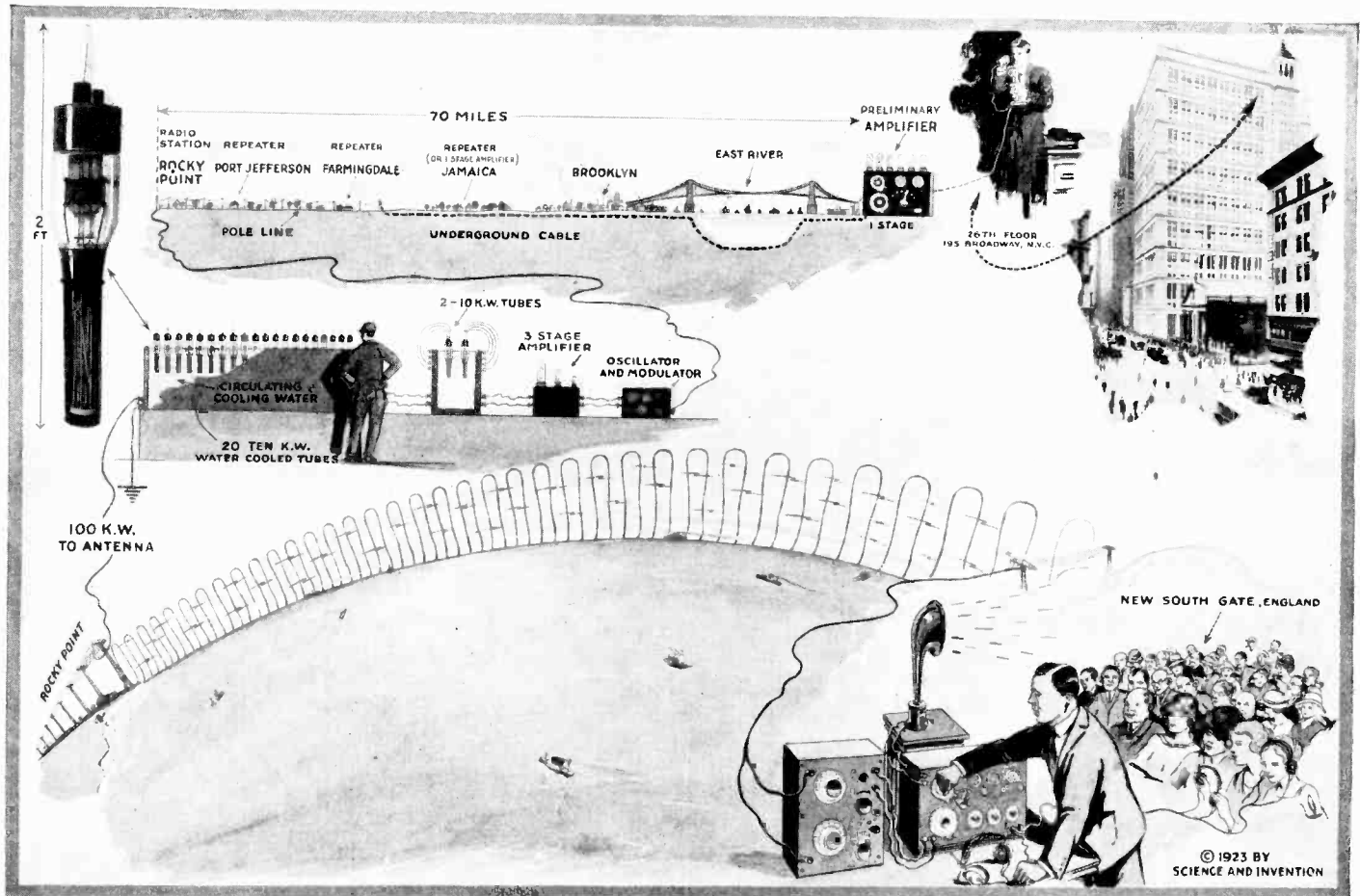

When the human voice was projected across the Atlantic the other day, from the twenty-sixth story of the American Telephone and Telegraph Company's building, in New York City, to a building located at New Southgate, England, the powerful vacuum tube apparatus illustrated above, was brought into action by the weak voice currents of the speakers in New York City. Return speech from England to America was not demonstrated, as the proper apparatus had not been shipped across the ocean in time, but a number of important and interesting tests were made in the transmission from America to England. The various links in the combination wire and wireless circuits, are clearly shown in the photo-diagram herewith, thanks to the courtesy of the company who made this remarkable feat possible.



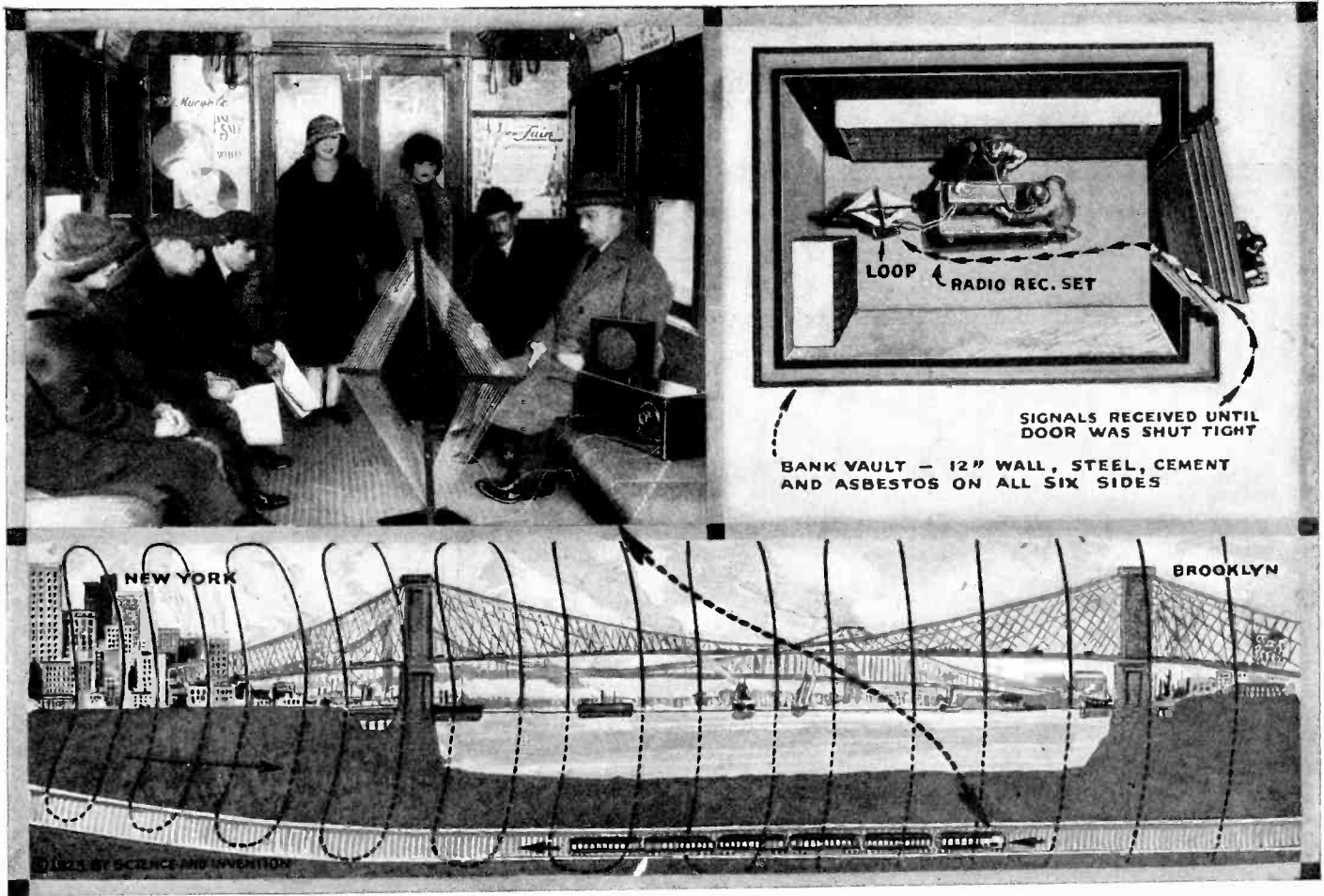

The photograph at left shows the actual receiving apparatus and loop aerial employed in successful reception tests of radiophone broadcast concerts, on tube train while under East River, passing from Brooklyn to New York City. The ground waves are shown as well as the space waves above the ground and water.

# Receives Radio Broadcast Under River

A SUCCESSFUL demonstration of the practicability of receiving radio messages underground, despite intervening steel construction and interference due to induction from other electrical apparatus, was made recently in the subway. Not only were messages received all along the line of the subway tunnel, but part of the concert being broadcast by W.E.A.F., at the station at 24 Walker Street, New York City, was clearly heard in the middle of the tube under the East River, half way between Manhattan and Brooklyn.

The radio receiving set, which is the invention of John Clyde Davidson, a radio engineer, was placed on the rear platform of a regular train, which started at Atlantic Avenue, Brooklyn, and ran to the other end of the line in the Bronx and back again. The door leading to the rear platform was closed and, as head phones were used for receiving, few, if any, of the passengers knew that the test was in progress.

A loop aerial four feet high and two feet wide was used in the receiving set, which, although only eighteen inches long and seven inches wide, was equipped with a radio and audio frequency circuit. W. H. Kinlock, chief telephone and lighting engineer for the Interborough; F. E. Heger, his assistant; E. L. Bragien, a radio expert of Manhattan, and David H. Engelson and Jesse Fishel, were present at the test, which was in charge of the inventor.

Mr. Kinlock said that the test was very

satisfactory and that near-by broadcasting stations could be heard with perfect clearness in the tunnel when the conditions in it were favorable. He said that there was

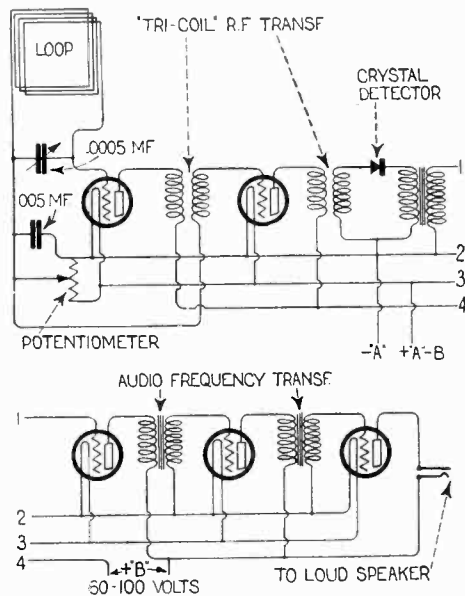

Hook up of radio frequency and audio-frequency V. T. amplifiers, as well as crystal detector used in receiving radio broadcast concerts in tube train under river.

considerable interference by induction from passing trains, as well as from the motors on the train carrying the set.

A little later on a very interesting test was made in a large sealed vault of the Interborough Rapid Transit Company, when the same receiving set, a diagram of connections of which is given herewith, was successful in picking up radiophone broadcast messages inside the steel walled room, up until the point where the heavy safe-style door was almost closed. The radiophone music and talk proceeded until the opening in the door would just permit a piece of writing paper to be placed between it and the door frame. When the door was finally sealed and locked, the radio music ceased.

Off hand, it would have seemed that even with the steel vault door open, there would have been sufficient absorption by the steel walls to prevent the operation of the radio receiving set within it. This philosophy would also seem to have come into effect in the subway experiments, where the receiving set was practically enclosed with the steel shell of the car, and also within the steel and concrete subway tube. It is possible, of course, in the subway experiments under the river, that induction currents or waves were carried along through the subway from land by the two running rails, the insulated third rail, or possibly by the pipes and wires running along through the tube, and that the radio set on board the train picked up waves by induction from these rails or pipes.

# Secrecy in Radio at Last

By A. P. PECK

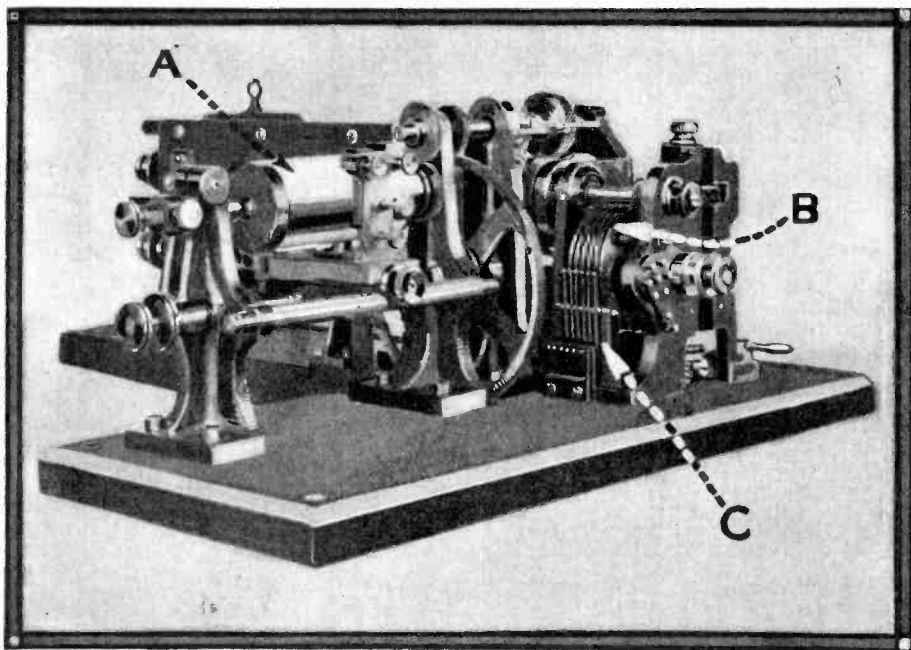

The photograph above shows the Crypto apparatus, and "A," the cylinder upon which is mounted the photograph or message to be transmitted. "B" denotes the Crypto discs, and "C," the pawls which close contacts as the discs revolve.

FOR years the development of radio has been hindered by the fact that messages sent out could be picked up by anyone equipped with a receiving set. Obviously this was a disadvantage in commercial enterprises, as well as in times of war. Various subterfuges, such as high speed transmission and reception by machine, have been used with greater or lesser success, but it has been left to M. Edouard Belin to solve this problem, and he has done it in a very simple, yet positive manner.

M. Belin is the inventor of the well known apparatus for the transmission of photo-

graphs by wire, and his *Crypto* has been applied to this work. The *New York World* has purchased exclusive rights to the apparatus for transmission of photographs by wire, and will use it extensively in their work.

The *Crypto* cannot be applied to ordinary radio communication, but it can serve its purpose in this work by transmitting a photograph or fac-simile of the message by Belin's process, and using the "Crypto" in connection therewith. In the standard apparatus that does not use the *Crypto*, the transmitting and receiving cylinders have to rotate in perfect synchronism. "This is obtained," writes Arthur Benington of the

editorial staff of the *World*, "by making the receiving cylinder revolve a minute fraction of a second slower than the sending cylinder. At the end of each revolution, the latter stops, and a current of the opposite direction to that formerly employed, is sent out for the same fraction of a second. By means of this current the rotations of the two cylinders are synchronized. Thus, at the beginning of the next second, both the transmitting and receiving cylinders will be in perfect synchronism." While it takes some time to describe this action, still the reader must realize that it all takes place in a very small fraction of a minute. Since such perfect synchronism is necessary, the cylinders are controlled by electric chronometers at each end of the line. When the operator at the transmitting station desires to communicate, he sends out automatically, by means of his chronometer, dots corresponding with seconds. These are picked up by the other operator, and his chronometer is automatically set in absolute synchronism with that at the transmitting station. All this accuracy is necessary, for, if there is the slightest amount of lag in either the transmitter or the receiver at any time, the resultant message will be a mere jumble of dots.

This synchronism between the two stations is made use of by M. Belin in his *Crypto* or to quote Mr. Benington, "the anti-capturer". As explained to the writer by M. Belin in a recent interview, the *Crypto* regulates the revolutions of the cylinders in such a way that while the transmitting cylinder is revolving, the receiving cylinder is revolving also, and when the former stops for a fraction of a second, the latter does the same. The intervals of rotation which, themselves, are always of the same length, are interspersed with *periods of quiet*. These latter can be readily controlled, so that thousands of different "codes" are possible.

The *Crypto* consists in the main of six discs mounted upon an axle about 1/12 of

(Continued on page 1134)

A simplified diagram of the Belin apparatus for the transmission of photographs by wire or radio, together with the "Crypto," is here given. For greater simplification only three of the six Crypto discs are shown. The main shaft which is turned by a motor, connects through a friction transmission with a gear which drives the *Crypto* discs; a controlling wheel; the gear which turns the cylinder; and also a "static disc" which sends out manufactured interference so as to prevent reception of the message in case anyone should possibly stumble upon a method of translating it. This is labelled "static disc." By means of the synchronizing clock and its attendant relays and battery, the speed of rotation of the disc M and consequently of its shaft, is kept in absolute synchronism with that in the receiving station. The disc M revolves one turn in 59/60ths of a second, but it is held until the end of that second by the tooth G, whereupon it is released by relay No. 2. The *Crypto* discs are driven at a speed of 1/6th revolution per second, whereupon each disc controls one revolution of the cylinder, by means of the contacts C; the battery and the electro-magnet. The cylinder is driven through the magnetic clutch at a speed of one turn in 2/3rds of a second. By means of the lever H and a slot in the disc J, in connection with the contact B, the magnetic clutch is opened and closed. By means of the contact D, which closes when the clutch is closed, the static disc or interference manufacturer is short-circuited and the actual message or photograph is sent by means of the relay marked K to the radio transmitter. When the clutch is opened, the contact F is opened and closed by the indentations on the static disc, sending out independent signals to create interference. At these periods the contact A is closed because of the fact that the contact on the message is resting in an indentation in the cylinder. In the insert is shown a schematic diagram illustrating graphically the periods of rotation of the cylinder upon which is mounted the photograph to be transmitted, together with the spaces of varying lengths between these periods.

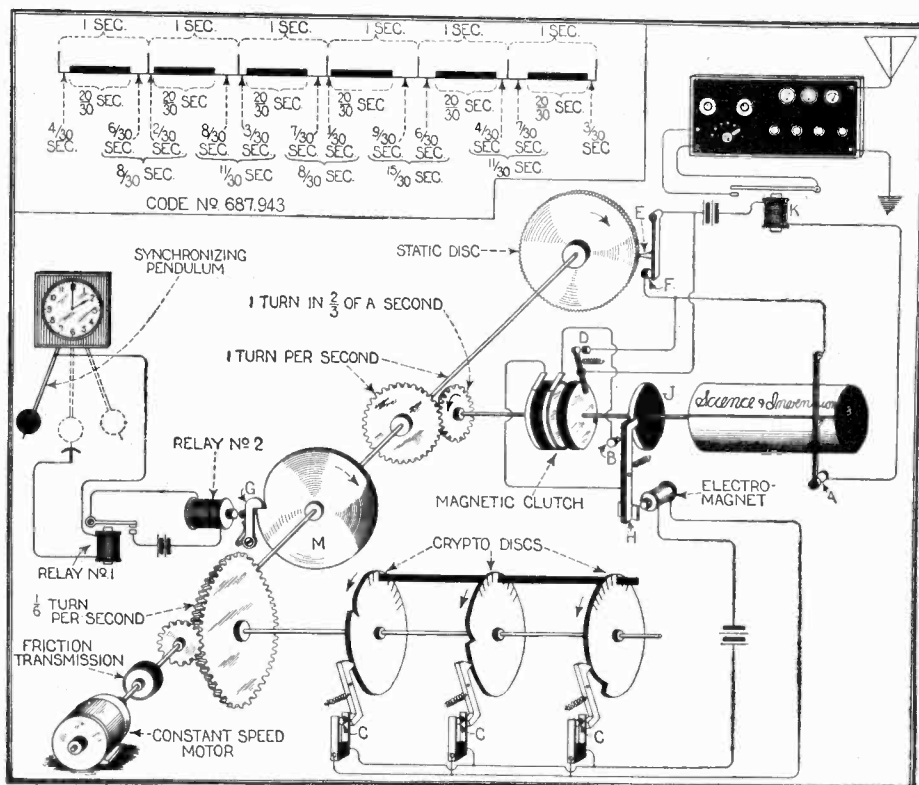



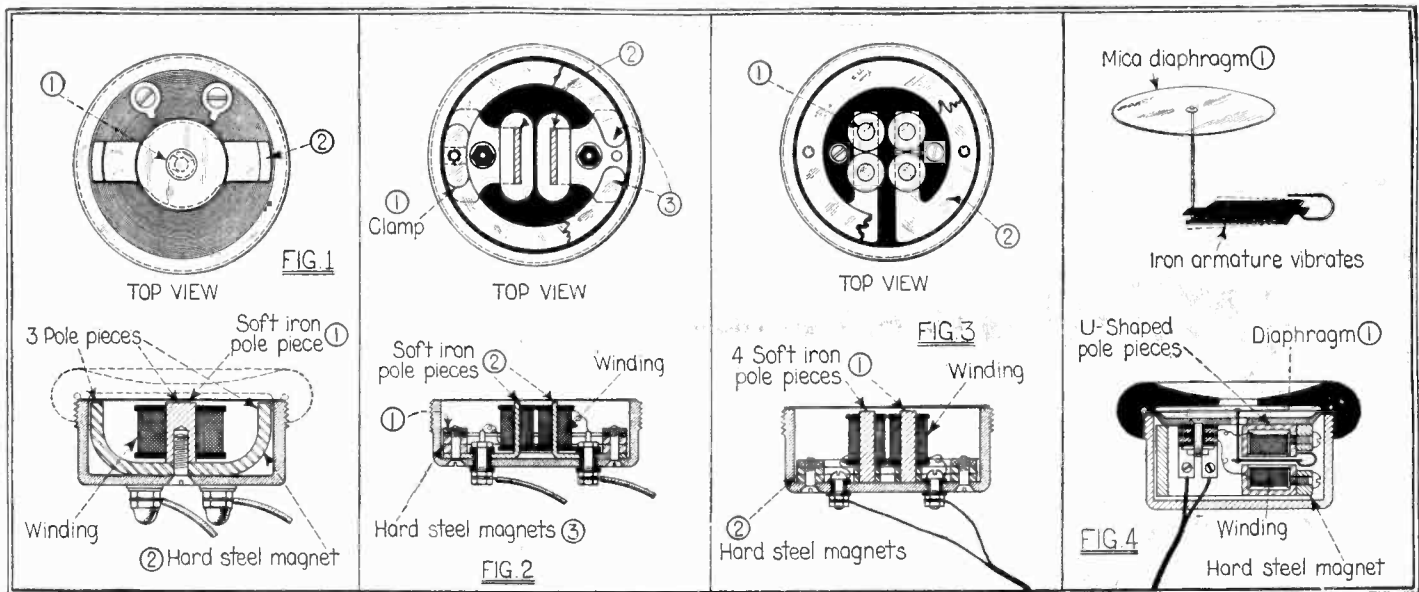

Fig. 1 at left shows one of the latest type radio receivers, having three poles with a magnet coil wound on the center one, giving a very even and well distributed pull on the diaphragm. Fig. 2 shows the "insides" of a well-known double-pole type radio receiver, the two poles being of opposite polarity. Fig. 3 shows one of the newer types of radio receivers having four poles of alternate magnetic polarity. A very even and powerful pull is obtained from this design, and more ampere-turns in a given space are possible, so the makers claim. Fig. 4 shows the "works" of the famous Baldwin receiver, so widely used in building loud-talkers, etc. This phone, owing to the lever arrangement connecting its diaphragm with the light iron armature, suspended in the center of the magnet coil, has a decided amplifying effect.

# Radio for the Beginner

By ARMSTRONG PERRY

## HOW TO SELECT A HEAD SET

**M**Y first telephone was a single 75-ohm ear-piece that cost seventy-five cents plus half a dollar for a leather-covered steel spring to hold it on my head. I still use it sometimes for comparison with others. With from fifty to one hundred feet of antenna wire, properly installed, the usual ground connection through a steam radiator or water pipe, and a crystal detector I can hear most of the local broadcasts in any of the several cities where I have tried it. If the room is quiet I can hear the music, speech and code with satisfactory distinctness. Such an outfit costs less than ten dollars even at the present prices and it would satisfy, at least temporarily, any boy of ten or twelve who was not discouraged by the contempt that persons who are able to own better apparatus sometimes show to others less fortunate.

When I reached a point where I wanted something better I bought a double head set of 3000 ohms resistance, paying \$5.50. The same general type of phone is produced by a number of manufacturers. The diaphragm is metal. It is actuated by a magnet which can be seen by unscrewing the cap and removing the diaphragm. This set has given good service for several years without appreciable wear. Its only serious fault is that the head band is so constructed that it invariably pulls my hair when I try to adjust it to my head or take it off.

Then there came a time when I wanted the best phone regardless of price. The testimony of everyone I asked favored a certain phone with a mica diaphragm. I purchased a double head set for twelve dollars, a price that was promptly increased as soon as the general public went in for radio. I found that this pair would bring in stations that I could not hear at all with less sensitive phones. The reason seems to be that the diaphragm is thinner and therefore more easily vibrated, and that the pull of the magnet is applied through mechanical members that help to produce an amplitude of vibration much greater than usual. The manufacturer's claim that this phone gives as much increase of signal strength as one stage of audio frequency amplification is apparently true, though I have not tested it with mathematical accuracy. This phone is

heavier than some others and that is a disadvantage when it is worn for three or four hours at a stretch, because the weight is tiresome until you get used to it.

The up-and-down adjustment is a great improvement over that on the cheaper phone and it has been adopted by a number of manufacturers. A rod attached to the ear-piece slides in a hole in a piece of metal attached to the head band. The pressure of the springs that hold the ear pieces against the ears is sufficient to keep the rod stationary wherever it is placed. Either ear

springs could be bent without injury I suffered more or less from the tight pressure of the ear pieces on my skull. An operator showed me that by working the springs carefully, bending them a very little at a time at each spot along their whole length and avoiding a sharp bend at any one point, I could adjust them so that they would be neither uncomfortably tight nor too loose.

During the past year I have tried several of the new phones. Most of them use a 1/4-inch metal diaphragm and magnets differing but slightly in construction and application from those of my second pair. There are sometimes noticeable differences in results that seem to be due to better or poorer engineering or workmanship. A carelessly constructed phone usually reveals its character to the eye if it is examined closely but of course a test under the beginner's home conditions is the surest means of discovering what it will do.

One pair, bearing a foreign trademark, has diaphragms 2 1/4 inches in diameter and between the diaphragm and the part, on which it rests, is a thin metal ring. The music or speech heard through this set gives the impression of being somewhat weaker than it is when phones with smaller diaphragms are used, but it has roundness and sweetness that none of the others can equal.

Now in the selection of phones, as in the selection of any other part of the equipment, the beginner needs to consider what use they will have. Usually the manufacturer and dealer rate a phone by its resistance in ohms, which depends upon the material, size and length and material (unfortunately) of the wire in the electro-magnet that actuates the diaphragm. The 75-ohm phone may not respond at all to a weak current that will produce satisfactory audibility in the phone with a mica diaphragm. On the other hand I made one test in which a fifty-five cent phone gave just as good results on code signals from a high power station near at hand as the pair that I paid sixteen dollars for. If what I wanted to hear came entirely from the high power station I would save the fifteen forty-five. Also, if there were young children in the house, I would provide them with a cheap and strongly constructed phone rather than to

(Continued on page 1135)

### Some of the Interesting Articles Appearing in the March Issue of RADIO NEWS

*Experiments With the Two Plate Condenser Antenna.* By John C. Warner.

*A New Non-Interfering Detector Tube.*

*The Radio Flivver.* By Stanley Edgar.

*A Selective Multi-Range Regenerative Receiver.* By Kenneth Harkness.

*Broadcast Reception and Receivers.* By John Bront.

*Electron, Electric Waves and Wireless Telephony.* By Dr. J. A. Fleming.

*The Construction of a Loop Aerial.* By D. R. Clemons.

piece can be moved up or down with one hand in an instant. Some other phones using similar head bands and attachments have setscrews for fastening the ear pieces at the desired height. This may be an advantage when the phones are being used principally by one person and the operator wants to put them on and off frequently, for it saves a moment of readjustment each time they are put on.

The head bands are bent into a small circle so that the set can be shipped in a smaller box than would be necessary if they were more extended. Not knowing that the

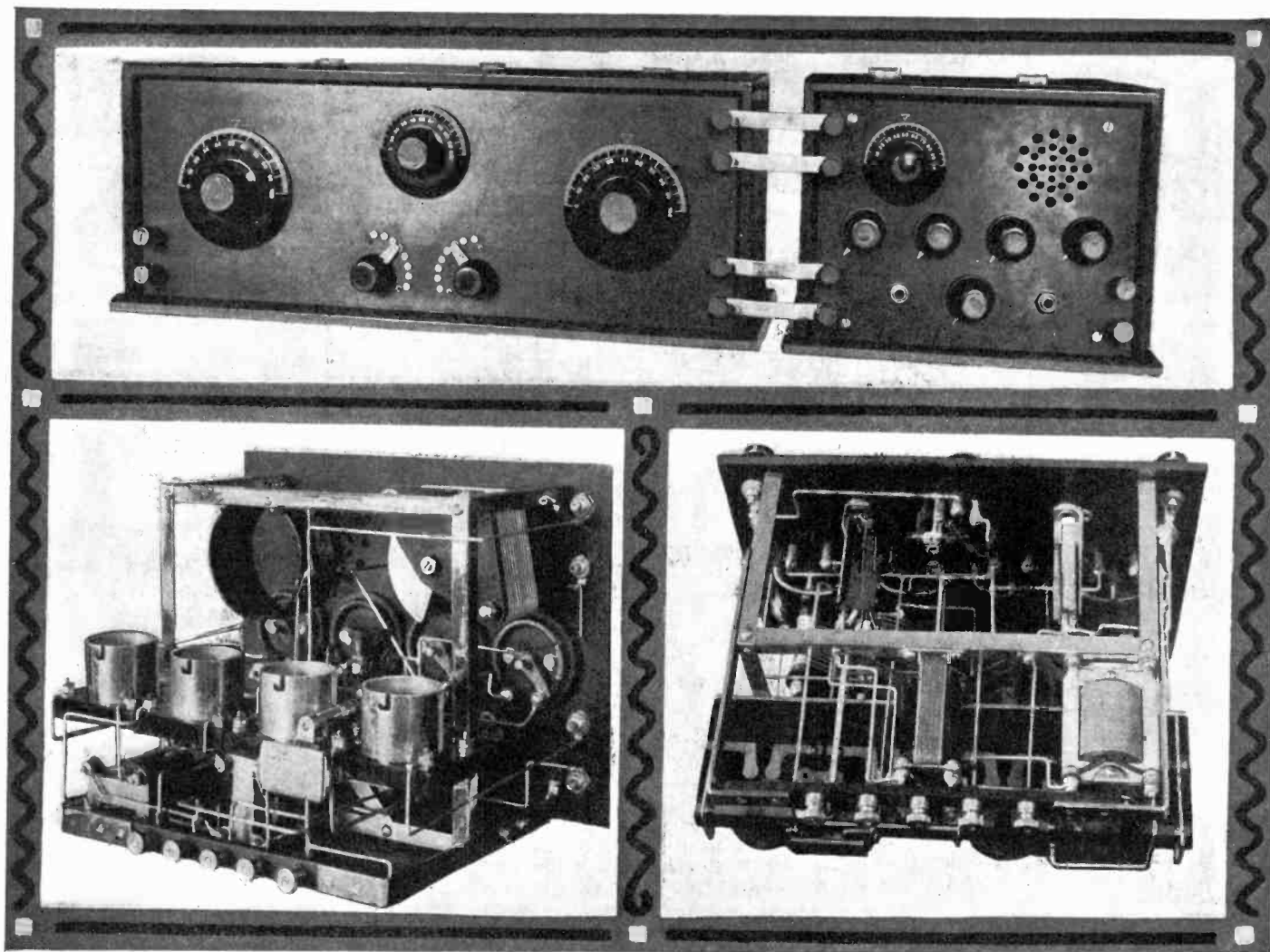

Top photograph shows amplifier described below connected to a standard three circuit tuner. Lower left: General rear view of amplifier. Lower right: Bottom view of amplifier showing transformer and socket mountings.

# An Amplifier for Your Present Tuner

By BERT T. BONAVENTURE

**R**ADIO frequency amplification at present is quite the rage, and not without reason is it so. Many, no doubt, would like to build an amplifier for use in conjunction with their present tuner, that would incorporate at least one stage of radio frequency amplification. It is with pleasure that the writer submits the following design for such an amplifier. It is the last word in compactness, occupying a panel space of but 10 by 7 inches and extends only 7 inches deep. The one stage of radio frequency amplification is of the tuned plate impedance type, recognized as the most efficient method of radio frequency amplification. The compactness in no way detracts from the efficient working of the amplifier, as the layout is such that leads have been kept very short. Ruggedness and efficiency have been the keynotes in this construction and design. The general appearance can be judged from the accompanying photographs.

Below is listed such apparatus as was used in the construction of this outfit. No specific makes of apparatus can be recommended for purely ethical reasons, but it cannot be too strongly recommended that only the best of materials be used in the assembly. Cheap material may please the eye, but invariably such apparatus ceases to give good service in a remarkably short

space of time. The writer has had several unsatisfactory experiences of this nature with the now famous New York "gyp" dealers, and has decided that dependability over-balance low cost by far.

### Apparatus Required

- 1 Bakelite panel, 7 by 10 by  $\frac{3}{8}$  inches.
- 4 Sockets, preferably of the panel mounting type.
- 4 Rheostats, also panel mounting.
- 1 Potentiometer (200 to 400 ohms).
- 2 Audio frequency amplifying transformers.
- 1 23 Plate variable condenser.
- 3 Mica condensers (.001, .005, and .0025 microfarads).
- 1 Double contact filament control jack.
- 1 Double contact jack.
- 1 Grid leak (value varying with tube used; usually 2 megohms for a Radio-tron tube).
- 11 Binding posts.
- 4 feet  $\frac{3}{8}$ -inch angle brass.
- 1 Strip of bakelite,  $\frac{3}{8}$  by  $\frac{1}{2}$  by 8 inches.
- 4 Lengths of bus bar wire.
- 1 Bakelite tube,  $2\frac{3}{8}$  inches diameter by  $1\frac{1}{2}$  inches long.
- Miscellaneous brass stock.

Before starting with our actual construction, let us examine the circuit we are going to use, as illustrated in Fig. 1. It will be seen that only two jacks are used, one in the

detector circuit and one in the second stage of audio frequency amplification. When the telephone receiver terminals are plugged into the first or detector jack, the filaments of the two amplifier tubes on the right are extinguished, as they are not in use. When the second jack is plugged into, the entire power of the amplifier is being used. If the plug is removed from this jack, the current is transferred to the output terminals to which the loud speaker is connected. It is the opinion of the writer that a jack in the first stage audio is not worth the trouble of wiring and the extra cost, the call for its use being limited. If signals are too loud on two stages, the tuner can be thrown slightly out of resonance. For controlling the oscillations inherently present in a circuit where both grid and plate circuits are tuned, the potentiometer is used. An additional binding post is provided for the last stage so that it may be possible to put higher voltages on the plate of the last tube.

The by-pass condenser around the primary of the first stage transformer should be of such a value as to offer radio frequency currents a very low impedance path but to offer a high impedance to audio frequency currents, forcing them to go through the winding of the transformer. If the value of the condenser is too large, audio



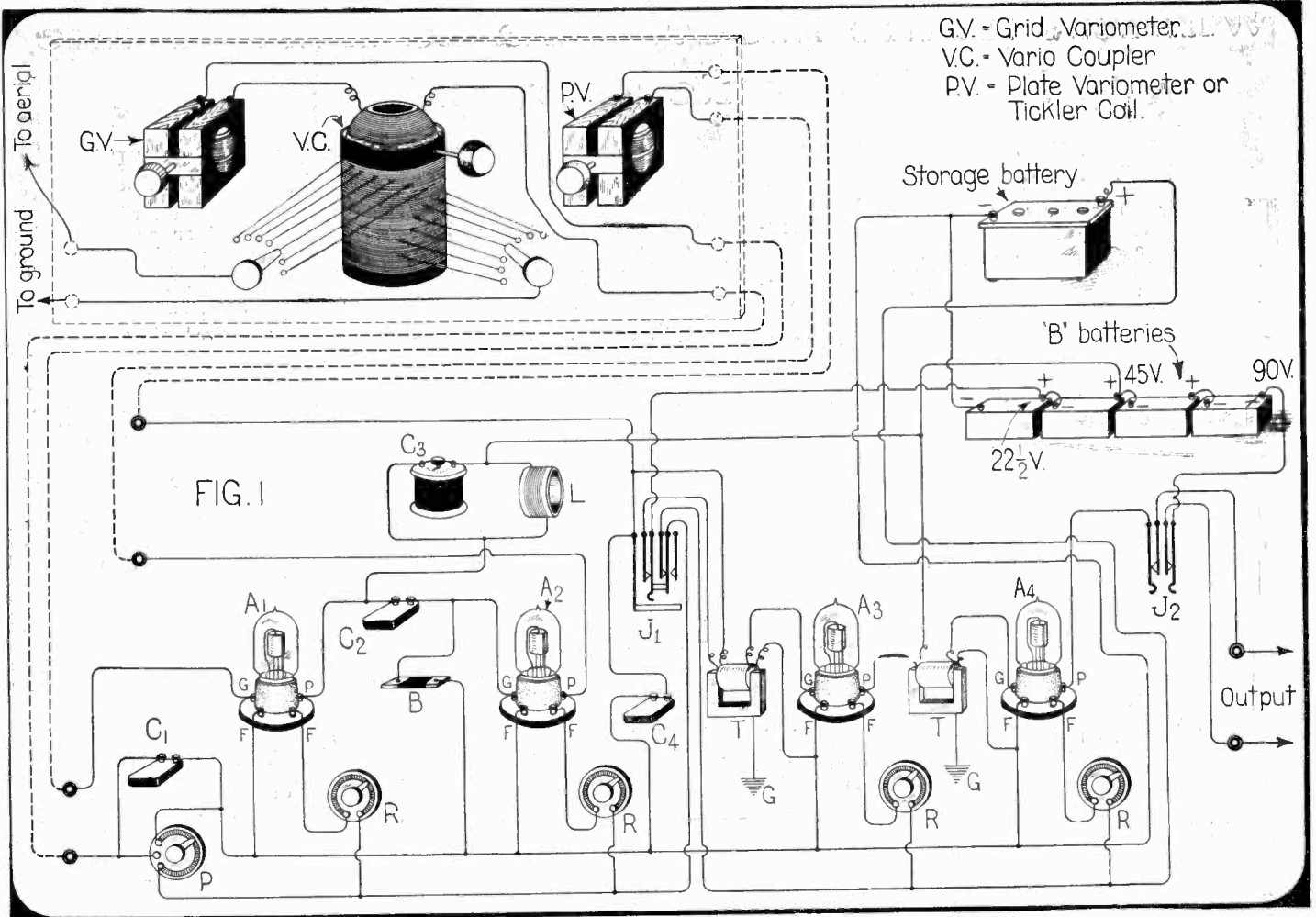

A complete circuit diagram showing the connections of the amplifier in conjunction with a short wave regenerative tuner is shown in Fig. 1.

frequency currents will be passed in addition to the radio frequency currents: if too small, not enough radio frequency current can pass. It has been found that a value of .001 mfd. is a happy compromise between

these two extremes. Around the potentiometer, a .0005 mfd. condenser is quite suitable, as no audio frequency currents are present in this circuit. The coupling condenser to the detector tube should be of the

order of .00025 mfd. A hard amplifier tube (U. V. 201 or similar types) should be used in the first socket, a detector tube in the second, and amplifier tubes in the last  
 (Continued on page 1130)

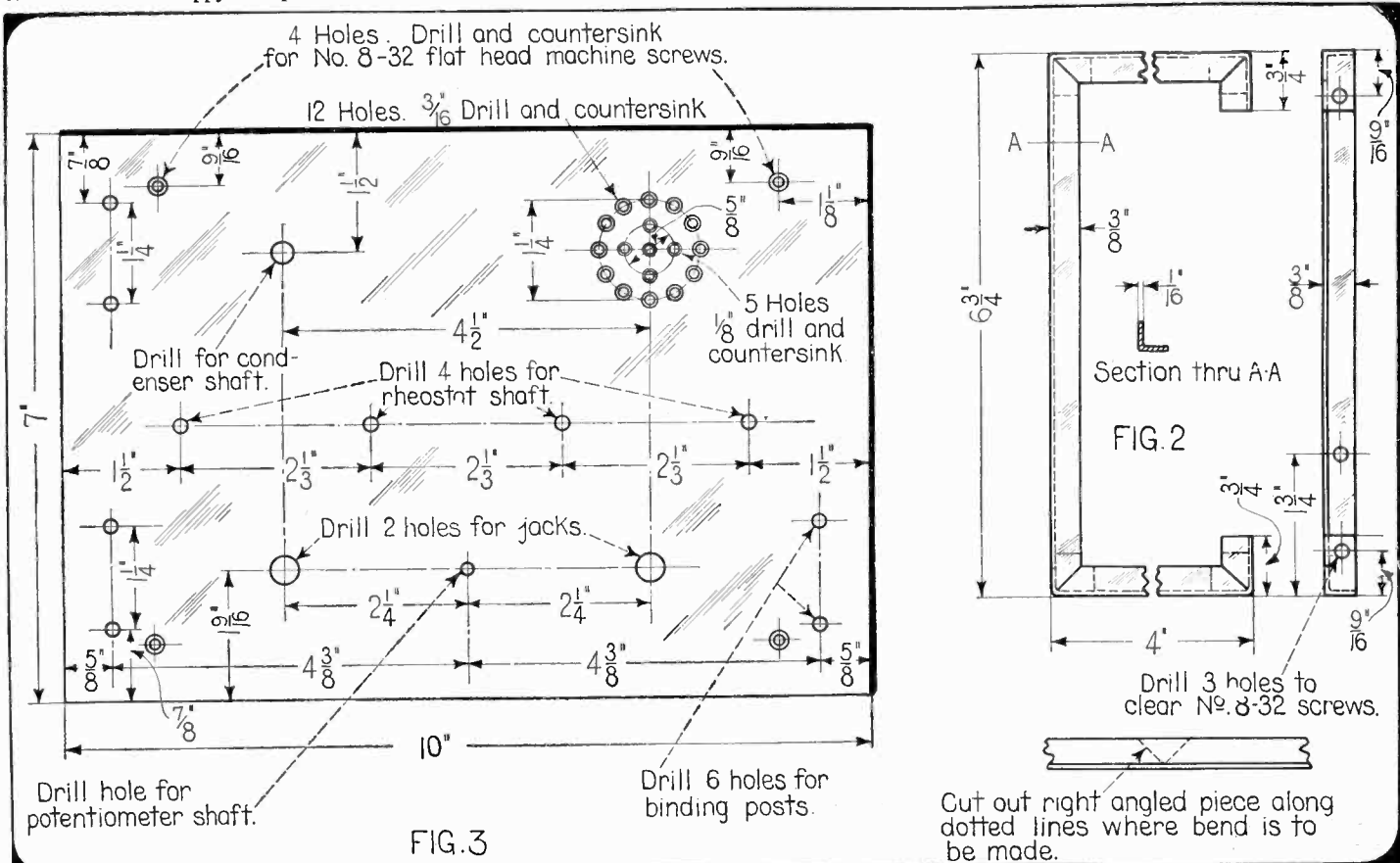

Complete panel layout for the amplifier is shown in Fig. 3. It is advisable to lay out the location of all holes on a sheet of heavy paper 7 by 10 inches. This template can then be pasted on the panel and the holes drilled through both. When the panel has been completely drilled this template can be scraped off and a grain finish put on the panel. Fig. 2 shows the dimensions of the brass brackets used to support the various instruments.

# Winners in the \$100.00 Radio Interference Preventer Contest

## FIRST PRIZE By J. Brydson

**T**HE only apparatus necessary for this very selective tuner is two vario-couplers, a variometer, and a .001 M.F. variable condenser. These are connected up as shown in the accompanying diagram, the two leads marked "To

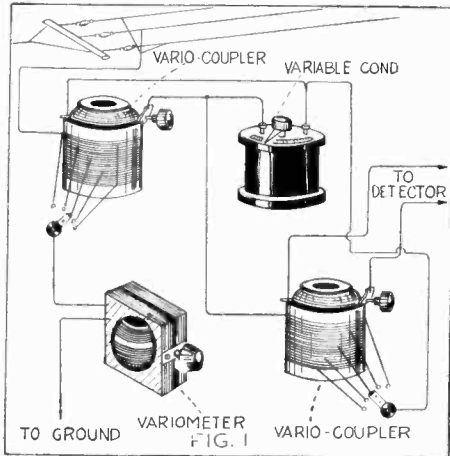

The first prize winning circuit shown above, is of the "wave filter" type.

Detector" being connected either to a crystal detector and fixed condenser or a regular audion detector unit. Sharp tuning is accomplished in two ways with this circuit, one by means of the filter action of the two vario-couplers, and the other by the close regulation of inductance in the primary circuit of the first coupler, which is given by the variometer.

After the coupling is once adjusted, the 360 and 400 meter stations may be separated by manipulation of the variometer and the variable condenser, with practically no variation of the coupling in either vario-coupler.

## SECOND PRIZE

By Caesar De Carlo

The apparatus described below and illustrated herewith, has given excellent results when used by the writer in connection with a standard short wave regenerative set containing a vario-coupler and two variometers. It is of the wave-trap type and consists of a .001 M.F. variable condenser, and a D.L.-75 or D.L.-100 honeycomb cell.

The 75 turn coil is used on wave lengths from 250 to 450 meters, and the larger one

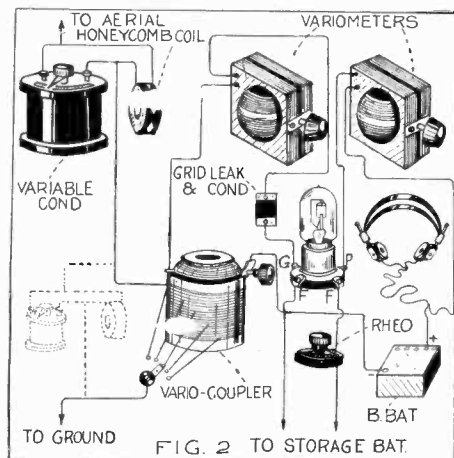

The "wave trap" circuit, which won second prize, is shown in Fig. 2.

## PRIZE WINNERS

### FIRST PRIZE

\$50.00 in gold, Mr. J. Brydson, P. O. Box 314, Austin, Texas.

### SECOND PRIZE

\$20.00 in gold, Mr. Caesar De Carlo, 898 Gravesend Ave., Brooklyn, N. Y.

### THIRD PRIZE

\$15.00 in gold, Mr. E. J. Fancher, Gilboa, N. Y.

### FOURTH PRIZE

\$10.00 in gold, Mr. C. Kenard Eser, 33 N. Linwood Ave., Baltimore, Md.

### FIFTH PRIZE

\$5.00 in gold, J. E. Martin, 75 Allen Road, Beckenham, Kent, England.

for wave lengths of 450 to 700 meters. Two different circuits may be used with this apparatus, one being in series with the antenna and the other across the primary of the vario-coupler. The former is shown in solid lines, and the latter in dotted lines in the diagram given herewith.

The writer has always found it advisable to connect the rotating plates of the condenser to the aerial lead-in. If the wave-trap does not work the first time, reverse the coil connections across the condenser, but do not change the condenser leads.

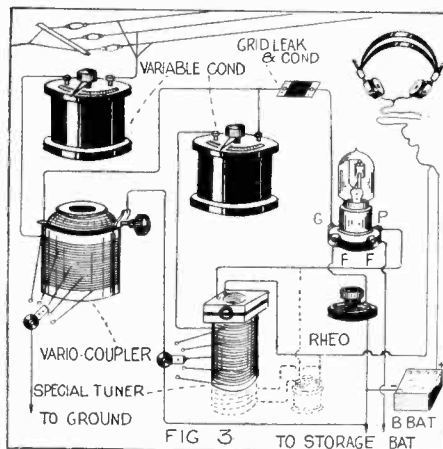

A specially constructed tuner is used in the third prize circuit to obtain selectivity, and is shown in Fig. 3.

## THIRD PRIZE

By E. J. Fancher

A .0005 variable condenser is used in connection with a coil wound on the same sized tube and with the same number of turns as the primary of the vario-coupler. This coil is placed on end, and a variometer connected in series with the plate laid on its side on top of it, so as to provide an inductive coupling between the two. If no plate variometer is used, the coil may be wound on one end of a longer tube, on the other end of which is wound 50 turns of No. 24 D.C.C. wire, tapped at about the 30th, 35th, 40th, 45th and 50th turns. There should be a space of about 1/2 inch between the two windings. In this case, a variable condenser with a capacity of .0005 should be shunted across the plate coil, as no provision is made for varying the inductance as in the case of a variometer. The latter connection is indicated in dotted lines in the accompanying diagram.

With this circuit, the writer could tune out a broadcasting station in Schenectady which is very close to his home, and receive from points as far distant as Chicago.

## FOURTH PRIZE By C. Kenard Eser

The selective tuner described by the writer, makes use of an auxiliary inductance and capacity connected from the aerial lead-in to the plate of the detector tube. This provides a shunt through the phones to the ground, and when the auxiliary circuit is tuned to the undesired signal, it shunts

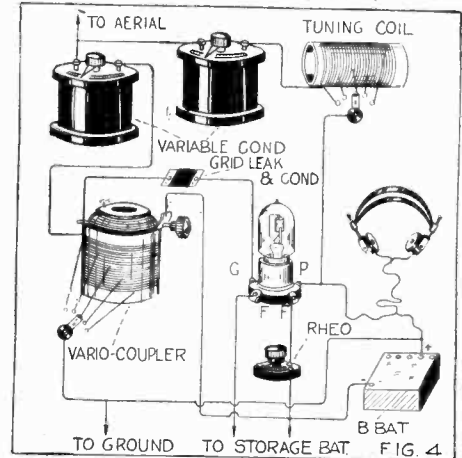

The fourth prize was awarded to the "by-pass" circuit shown in Fig. 4.

that signal directly to the ground, the radio frequency current not affecting the receivers.

The tapped inductance coil is made approximately the same as the primary of the vario-coupler, and the connections are made as shown: a .001 M.F. condenser being used in series with the antenna, and another one of the same capacity in series with the auxiliary inductance.

## FIFTH PRIZE

By J. E. Martin

The inductance A consists of 80 turns of *Litz* wire, wound on a tube 3 1/2 inches in diameter, and tapped every tenth turn. The condenser in shunt with this coil has a capacity of .0015 M.F.

The inductance marked B consists of a tube 3 1/2 inches in diameter, wound with 64 turns of *Litz* and tapped every 3-1/3 turns. The condenser used in connection with this coil has a capacity of .0005 M.F.

The writer found it advantageous in tuning to control both circuits at the same time, one with each hand, with the filament of the tube burning fairly brightly. The tuning is continued very slowly until the carrier wave is heard, whereupon the filament is turned down to normal brilliancy, and the set tuned more carefully.

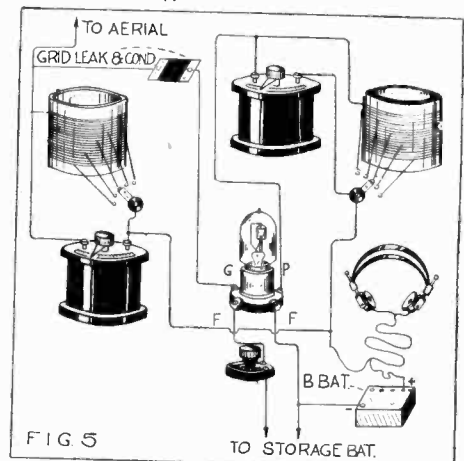

The so-called "phantom" circuit was awarded fifth prize, and is shown above in Fig. 5. The data on the inductances used are given in the text.

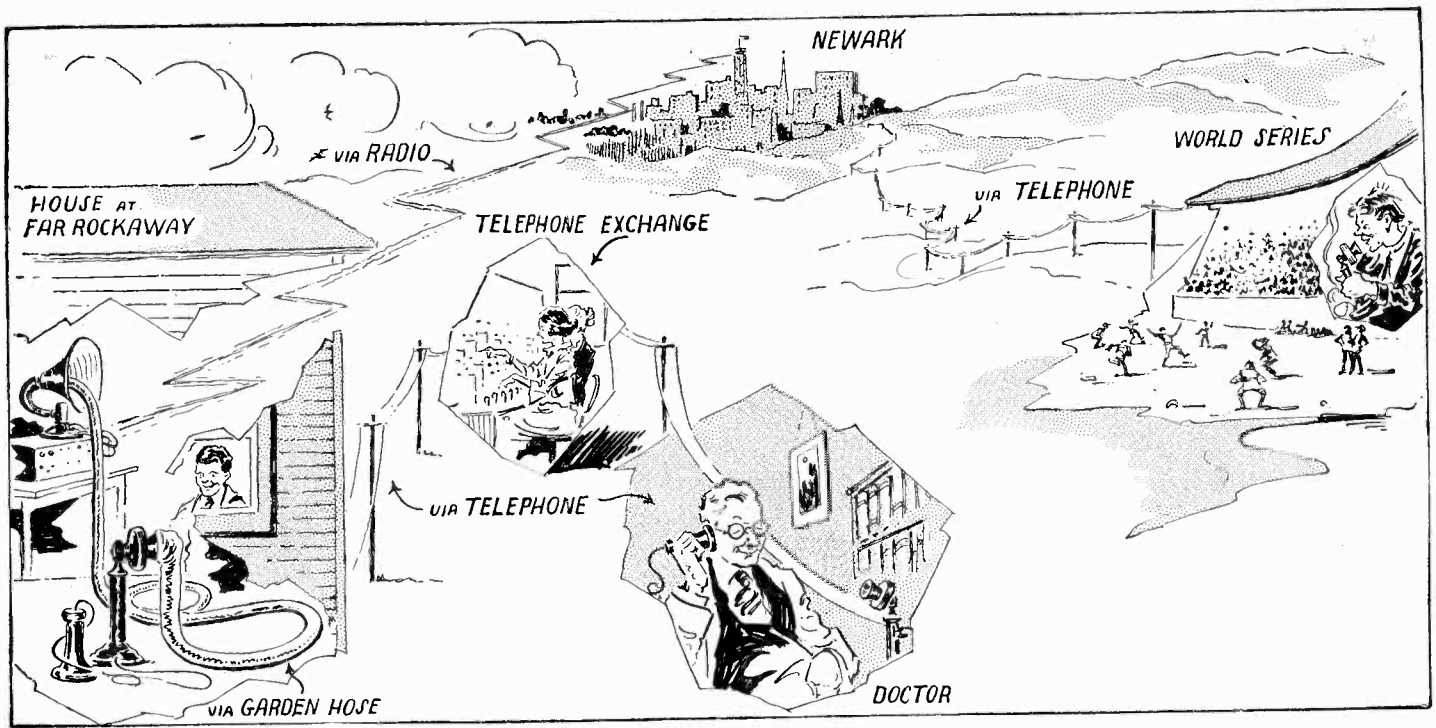

## Garden Hose Saves Day for Radio

WHEN the radio returns of the World Series baseball games were being broadcasted, at least one unique turn was given this event, recent information indicates. As is generally known, the voice of the broadcaster was transmitted from the Polo Grounds, New York City, to Newark, New Jersey, where the wireless broadcasting was done.

One of the directors of a New York radio company was giving a "radio baseball party"

at his home in Far Rockaway, when the telephone bell rang. It appears that Dr. Richard H. Hoffman, a well known New York physician and one of the director's friends, had also been "listening in" to the radio returns at his own home. His storage battery ran down.

In haste, he hurried to 'phone his friend to inquire what to do. The radio corporation director offered to assist him, and this is how it was done.

Instead of continuing to "listen in" on one loud speaker horn, a second was connected in series. Then the gardener brought in the lawn hose, which saved the day. One end of the hose was stuffed down the throat of the loud speaker, and the other fastened to the mouth-piece of the land-telephone. "Central" set the connection to the good doctor's home telephone, and Dr. Hoffman, listening to the receiver of his land-telephone, was able to hear every play.

## \$100.00 Prize "Binding Post" Contest

WE announce herewith a new contest open to everyone except manufacturers of such devices, whether they are readers of this magazine or not, and for which we offer \$100.00 in gold in five prizes for the simplest and most efficient binding post designs. Strange as it may seem, there is still a lot of room for improvement in the realm of binding posts. Some of the commercial products in simple binding posts are shown in the accompanying illustration.

As shown in the accompanying illustration, there are several forms of spring binding posts, millions of which have been sold at a goodly profit to the maker. However, with this class of binding posts, in general, the fingers are often hurt depressing the spring member, so as to engage the wire.

A novel type of binding post patented by H. Gernsback is that incorporating a spring-actuated top member, which slides down within the post, producing an alignment of the apertures, allowing the wire to be passed through the holes in both stationary and moving members. When pressure is released on the top member, the spring forces it upward and the wire is tightly gripped. Another binding post which has met with considerable favor, is that in which the top shell-like member screws downward and clamps the wires in the slot. This is also shown in the illustration.

### FIVE PRIZES IN "SIMPLEST BINDING POST" CONTEST

First Prize	.. \$50.00	in gold
Second	" .. 20.00	" "
Third	" .. 15.00	" "
Fourth	" .. 10.00	" "
Fifth	" .. 5.00	" "

Total, \$100.00

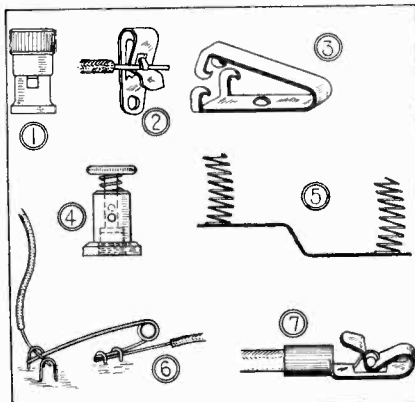

Various styles of spring binding posts.

The other day we saw a new spring binding post possessing the advantage of being flat, so that no matter how hard one might push on it, it would not pinch or injure. This binding post has a double set of hook-like jaws, and the wire is passed through it; as soon as the pressure is released the wire is gripped tightly and cannot jar loose. A simple home-made spring binding post is also shown in the picture which the editor once constructed from a safety pin and four staples. Some time ago there appeared on the automobile accessory market a battery connector fitted with spiral spring terminals, which were intended to be forced over the binding post, so as to grip it tightly.

There is a reasonable possibility that, if some of these binding posts prove as good as we anticipate, it will be possible for the editors to make arrangements for the designers to get in touch with several companies, who are interested in obtaining new devices of this type to manufacture for the commercial market.

A short description of about 100 words or so, will be amply sufficient together with a clear drawing or else a model of the binding post. Make drawings in ink and typewrite descriptions if possible, on separate sheets. This contest closes at noon, May 10th. Should two contestants submit the same idea, the same prize will be paid to both. Address all communications to Editor, Simplest Binding Post Contest, in care of this publication.



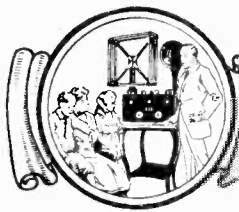

# RADIO BROADCAST



## Complete List of Broadcast Stations in United States

REVISED AND CORRECTED TO JANUARY 2, 1923

All stations operate on 360 meters except as below.

Those with \* on 400; † on 485; o in back of any sign indicates "only," thus †o means 485 meters only.

Call	Name	City and State
KDKA	Westinghouse Elec. & Mfg. Co.,	East Pittsburgh, Pa.
†KDN	Leo. J. Meyberg Co.,	San Francisco, Cal.
KDPM	Westinghouse Elec. & Mfg. Co.,	Cleveland, Ohio
KDPT	Southern Electrical Co.,	San Diego, Cal.
†KDYL	Telegram Publishing Co.,	Salt Lake City, Utah
KDYM	Savoy Theatre.....	San Diego, Cal.
KDYO	Carlson & Simpson.....	San Diego, Cal.
†KDYO	Oregon Inst. of Technology,	Portland, Ore.
KDYS	Great Falls Tribune,	Great Falls, Mont.
KDYV	Cope & Cornwell Co.,	Salt Lake City, Utah
KDYW	Radio Dept. Smith Hughes	Machinery Co.....
KDYX	Honolulu Star Bulletin,	Honolulu, T. H.
KDYY	Rocky Mountain Radio Corp.,	Denver, Colo.
KDZA	Arizona Daily Star.....	Tucson, Ariz.
KDZB	Frank E. Siefert.....	Bakersfield, Cal.
KDZE	The Rhodes Co.....	Seattle, Wash.
KDZF	Automobile Club of Southern	California.....
KDZG	Cyrus Pierce & Co.....	San Francisco, Cal.
†KDZH	Fresno Evening Herald.....	Fresno, Cal.
KDZI	Electric Supply Co.....	Wenatchee, Wash.
KDZK	Nevada Machinery & Elec. Co.,	Reno, Nev.
KDZL	Rocky Mountain Radio Corp.,	Ogden, Utah
KDZM	E. A. Hollingsworth.....	Centralia, Wash.
KDZP	Newbery Electric Corp.,	Los Angeles, Cal.
KDZQ	Wm. D. Pyle Motor Generator Co.,	Denver, Colo.
KDZR	Bellingham Publishing Co.,	Bellingham, Wash.
KDZT	Seattle Radio Association,	Seattle, Wash.
KDZV	Claude W. Gerdes.....	San Francisco, Cal.
KDZX	Glad Tidings Tabernacle,	San Francisco, Cal.
KDZZ	Kinney Bros. & Sipprell,	Everett, Wash.
KFAC	Glendale Daily Press.....	Glendale, Cal.
KFAD	McArthur Bros. Mercantile Co.,	Phoenix, Ariz.
KFAE	State College of Washington,	Pullman, Wash.
KFAF	Western Radio Corp.....	Denver, Colo.
KFAJ	University of Colorado.....	Boulder, Colo.
KFAN	The Electric Shop.....	Moscow, Idaho
KFAP	Standard Publishing Co.....	Butte, Mont.
KFAQ	City of San José.....	San José, Cal.
KFAR	Studio Lighting Service Co.,	Hollywood, Cal.
KFAS	Reno Motor Supply Co.....	Reno, Nev.
KFAT	S. T. Donohue.....	Eugene, Ore.
†KFAU	High School.....	Boise, Idaho
KFAV	Abbot Kinney Co.....	Venice, Cal.
KFAW	Register-Radio-Den-Radiophone,	Santa Ana, Cal.
†KFAZ	Virgin Radio Service.....	Medford, Ore.
KFAZ	C. H. Weatherill.....	Reedley, Cal.
KFBB	F. A. Buttrey & Co.....	Havre, Mont.
KFBC	Normal Heights Station	(W. K. Azbill).....
KFBD	Mercantile Trust Co.....	San Diego, Cal.
KFBE	R. H. Horn (Cline's Electric	Shop).....
KFBG	First Presbyterian Church,	San Luis Obispo, Cal.
KFBH	Thomas Musical Co.....	Tacoma, Wash.
†KFBK	Kimball-Upson Co.....	Marshallfield, Ore.
KFBL	Leese Bros.....	Sacramento, Cal.
KFBM	Cook & Foster & Astoria	Hardware Co.....
KFBN	Borch Radio Corp. (Portable),	Astoria, Ore.
KFBO	Savage Electric Co.....	Prescott, Ariz.
KFBS	Trinidad Gas & Electric Co. and	Chronicle News.....
KFBU	The Cathedral (Bishop Thomas),	Trinidad, Colo.
		Laramie, Wyo.

Call	Name	City and State
KFBV	Clarence O. Ford,	Colorado Springs, Colo.
†KFC	Northern Radio & Electric Co.,	Seattle, Wash.
KFCB	Nielsen Radio Supply Co.,	Phoenix, Ariz.
KFCC	Auto Supply Co.....	Wallace, Idaho
KFCD	Salem Electric Co.....	Salem, Ore.
KFCF	Frank A. Moore.....	Walla Walla, Wash.
KFCH	Electric Service Station, Inc.,	Billings, Mont.
KFCJ	Colorado Springs Radio Co.,	Colorado Springs, Colo.
†oKFCL	Los Angeles Union Stock Yards,	Los Angeles, Cal.
KFCM	Richmond Radio Shop.....	Richmond, Cal.
KFCQ	Motor Service Station,	(Norman R. Hood).....
KFDA	Adler's Music Store.....	Casper, Wyo.
KFDB	John D. McKee.....	Baker, Ore.
KFDC	Radio Supply Co. (E. B. Craney),	San Francisco, Cal.
KFDD	St. Michaels Cathedral.....	Spokane, Wash.
KFDE	Wyoming Radio Corp.....	Boise, Idaho
KFDF	University of Arizona.....	Tucson, Ariz.
KFDH	Oregon Agricultural College,	Corvallis, Ore.
KFDI	Knight-Campbell Music Co.,	Denver, Colo.
KFEL	City of Taft.....	Taft, Cal.
KFEM	Meier & Frank Co.....	Portland, Ore.
KFEN	Billings Polytechnic Inst.,	Polysite, Mont.
KFEI	Guy Greason.....	Tacoma, Wash.
KFEP	Radio Equipment Co.....	Denver, Colo.
KFEQ	Dr. R. O. Shelton.....	San Diego, Cal.
KFER	Eastern Oregon Radio Co.,	Pendleton, Ore.
KFGG	Astoria Budget.....	Astoria, Ore.
KFGH	Stanford University,	Stanford University, Cal.
KFHJ	Fallon Co.....	Santa Barbara, Cal.
KFI	Earle C. Anthony, Inc.,	Los Angeles, Cal.
KFJV	Foster-Bradbury Radio Store,	Yakima, Wash.
KFZ	The Doerr Mitchell Elec. Co.,	Spokane, Wash.
KGB	Wm. A. Mullins Electric Co.,	Tacoma, Wash.
KGC	Hallock & Watson Radio Service,	Portland, Ore.
KGN	Northwest Radio Mfg. Co.,	Portland, Ore.
KGO	Altadena Radio Laboratory,	Pasadena, Cal.
KGU	Marion A. Mulroney,	Honolulu, Hawaii
*oKGW	Portland Morning Oregonian,	Portland, Ore.
KGY	St. Martins College.....	Lacey, Wash.
†KDH	C. F. Aldrich Marble & Granite Co.,	Colorado Springs, Colo.
*oKHJ	Times Mirror Co.....	Los Angeles, Cal.
KHK	Louis Wasmer.....	Seattle, Wash.
KIC	Standard Radio Co.....	Los Angeles, Cal.
KIJ	The Radio Shop.....	Sunnyvale, Cal.
KJL	C. O. Gould.....	Stockton, Cal.
KJR	Vincent I. Kraft (operated by North-	west Radio Service).....
KJS	Bible Institute of Los Angeles,	Los Angeles, Cal.
KLB	J. J. Dunn & Co.....	Pasadena, Cal.
KLN	Monterey Electric Shop,	Del Monte, Cal.
KLP	Colin B. Kennedy Corp.,	Los Altos, Cal.
KLS	Warner Bros.....	Oakland, Cal.
KLX	Oakland Tribune.....	Oakland, Cal.
†KLZ	Reynolds Radio Co.....	Denver, Colo.
KMC	W. W. Lindsay, Jr.....	Reedley, Cal.
†KMJ	San Joaquin Light & Power Corp.,	Fresno, Cal.
KMO	Love Electric Co.....	Tacoma, Wash.
KNI	R. W. Smith.....	Eureka, Cal.
†KNJ	Roswell Public Service Co.,	Roswell, N. Mex.
KNN	Bullock's.....	Los Angeles, Cal.
KNT	Grays Harbor Radio Co. (Walter	Hemrich).....
KNV	Radio Supply Co.....	Los Angeles, Cal.
KNX	Electric Lighting Supply Co.,	Los Angeles, Cal.
toKOA	Young Mens Christian Assoc.,	Denver, Colo.

Call	Name	City and State
†KOB	New Mexico College of Agriculture	and Mechanic Arts,
KOG	State College, N. Mex.	Western Radio Electric Co.,
KON	Los Angeles, Cal.	Holzwasser, Inc.....
KOP	San José, Cal.	Detroit Police Dept.....
KPO	Detroit, Mich.	Hale Bros.....
KQI	San Francisco, Cal.	University of California.....
KQP	Berkeley, Cal.	Hood River News (Radio Shop of
KQV	Hood River, Ore.	Doubleday Hill Elec. Co.,
KQW	Pittsburgh, Pa.	Chas. D. Herrold.....
KQY	San José, Cal.	Stubbs Electric Co.....
KRE	Portland, Ore.	Maxwell Electric Co.....
*toKSD	Berkeley, Cal.	Post Dispatch.....
KSL	St. Louis, Mo.	The Emporium.....
KSS	San Francisco, Cal.	Prest & Dean Radio Co.,
KTW	Long Beach, Cal.	First Presbyterian Church,
†KUO	Seattle, Wash.	San Francisco Examiner,
KUS	San Francisco, Cal.	City Dye Works & Laundry Co.,
KUY	Los Angeles, Cal.	Coast Radio Co., Inc. (El Monte,
KVQ	El Monte, Cal.	Sacramento Bee (Jos. McClatchy
KWG	Sacramento, Cal.	Portable Wireless Telephone Co.,
†KWH	Stockton, Cal.	Los Angeles Examiner,
KXD	Los Angeles, Cal.	Herald Publishing Co.....
KXS	Modesto, Cal.	Braun Corp.....
KYI	Los Angeles, Cal.	Bakersfield Californian,
†KYJ	Bakersfield, Cal.	Leo J. Meyberg Co.....
KYQ	Los Angeles, Cal.	Electric Shop.....
*toKYW	Honolulu, Hawaii	Westinghouse Elec. & Mfg. Co.,
KYY	Chicago, Ill.	Radio Telephone Shop,
KZC	San Francisco, Cal.	Public Market & Dept. Stores Co.,
†KZM	Seattle, Wash.	Preston D. Allen.....
†KZN	Oakland, Cal.	The Deseret News,
KZV	Salt Lake City, Utah	Wenatchee Battery & Motor Co.,
KZY	Wenatchee, Wash.	Atlantic & Pacific Radio Supply Co.,
WAAC	San Francisco, Cal.	Tulane University.....
WAAD	New Orleans, La.	Ohio Mechanics Institute,
†WAAF	Cincinnati, Ohio	Chicago Daily Drovers' Journal,
WAAH	Chicago, Ill.	Radio Dept. Commonwealth Elec-
WAAJ	St. Paul, Minn.	Eastern Radio Institute.....
†WAAK	Boston, Mass.	Gimbel Bros.....
WAAI	Milwaukee, Wis.	Anderson Beamish Elec. Co.,
WAAJ	Minneapolis, Minn.	I. R. Nelson Co.....
†WAAK	Newark, N. J.	University of Missouri.....
†WAAQ	Columbia, Mo.	United Electric Co.....
WAAQ	Wichita, Kans.	New England Motor Sales Co.,
WAAQ	Greenwich, Conn.	Georgia Radio Co.....
WAAQ	Decatur, Ga.	Omaha Grain Exchange.....
WAAQ	Omaha, Nebr.	Radio Service Corp.....
WAAQ	Crafton, Pa.	Yahrling-Rayner Music Co.,
WAAQ	Youngstown, Ohio	Hollister-Miller Motor Co.,
WAAQ	Emporia, Kansas	Midland Refining Co.,
†WAAQ	El Dorado, Kansas	Purdue University,
WBAQ	West Lafayette, Ind.	Andrew J. Potter.....
WBAQ	Syracuse, N. Y.	Sterling Electric Co.,
WBAQ	Minneapolis, Minn.	Fred M. Middleton.....
†WBAQ	Moorestown, N. J.	Diamond State Fibre Co.,
WBAQ	Bridgeport, Pa.	The Dayton Co.....
WBAQ	Minneapolis, Minn.	The Marshall Gerken Co.....
WBAQ	Toledo, Ohio	Wireless Phone Corp.....
WBAQ	Paterson, N. J.	James Millikin University,
WBAQ	Decatur, Ill.	Wortham-Carter Pub. Co.,
*toWBAQ	Fort Worth, Texas	

Call	Name	City and State	Call	Name	City and State	Call	Name	City and State
WBAU	Republican Publishing Co.,	Hamilton, Ohio	WEAS	Hecht Co.	Washington, D. C.	*toWHB	Sweeney School Co.	Kansas City, Mo.
†WBAV	Erner & Hopkins.	Columbus, Ohio	WEAT	John J. Fogarty.	Tampa, Fla.	WHD	West Virginia University,	Morgantown, W. Va.
WBWA	Marietta College.	Marietta, Ohio	WEAU	Davidson Bros. Co.	Sioux City, Iowa	WHK	Radiovox Co. (Warren R. Cox),	Cleveland, Ohio
WBAX	John H. Stenger, Jr.,	Wilkes-Barre, Pa.	WEAV	Sheridan Electric Service Co.,	Rushville, Nebr.	WHN	Ridgewood Times Publishing Co.,	Ridgewood, N. Y.
*oWBAY	American Tel. & Tel. Co.,	New York, N. Y.	WEAW	Arrow Radio Laboratories,	Anderson, Ind.	†WHU	Wm. B. Duck Co.,	Toledo, Ohio
WBL	T & H Radio Co.,	Anthony, Kansas	†WEAX	T. J. M. Daly,	Little Rock, Ark.	†oWHW	Stuart W. Seeley,	East Lansing, Mich.
WBS	D. W. May, Inc.,	Newark, N. J.	WEAY	Will Horwitz, Jr.,	Houston, Tex.	†WIAB	Joslyn Automobile Co.,	Rockford, Ill.
†WBT	Southern Radio Corp.,	Charlotte, N. C.	WEB	Benwood Co.,	St. Louis, Mo.	†WIAC	Galveston Tribune,	Galveston, Texas
WBU	City of Chicago,	Chicago, Ill.	†WEH	Midland Refining Co.,	Tulsa, Okla.	WIAD	Ocean City Yacht Club,	Ocean City, N. J.
*oWBZ	Westinghouse Elec. & Mfg. Co.,	Springfield, Mass.	†WEV	Hurlburt-Still Electrical Co.,	Houston, Tex.	WIAE	Mrs. Robert E. Zimmerman,	Vinton, Iowa
WCAB	Newburgh Daily News,	Newburgh, N. Y.	†WEW	St. Louis University,	St. Louis, Mo.	WIAF	Gustav A. De Cortin,	New Orleans, La.
WCAC	John Fink Jewelry Co.,	Fort Smith, Ark.	†WEY	Cosradio Co.,	Wichita, Kansas	WIAH	Continental Radio & Mfg. Co.,	Newton, Iowa
WCAD	St. Lawrence University,	Canton, Ohio	*toWFAA	Dallas News-Dallas Journal,	Dallas, Tex.	WIAI	Heer Stores Co.,	Springfield, Mo.
*oWCAE	Kaufman & Baer Co.,	Pittsburgh, Pa.	WFAB	Carl F. Woese,	Syracuse, N. Y.	WIAJ	Fox River Valley Radio Co.,	Neenah, Wis.
WCAG	Daily States Pub. Co.,	New Orleans, La.	WFAC	Superior Radio Co.,	Superior, Wis.	†WIAK	Daily Journal-Stockman,	Omaha, Neb.
WCAH	Entrekin Electric Co.,	Columbus, Ohio	WFAD	Watson Weldon Co.,	Salina, Kansas	WIAO	School of Engineering & Wisconsin	Milwaukee, Wis.
†WCAJ	Nebraska Wesleyan University,	University Place, Nebr.	WFAF	H. C. Spratley Radio Co.,	Poughkeepsie, N. Y.	WIAQ	Chronicle Publishing Co.,	Marietta, Ind.
WCAK	Alfred P. Daniel,	Houston, Texas	WFAG	The Radio Engineering Laboratory,	Waterford, N. Y.	WIAW	Paducah Evening Sun,	Paducah, Ky.
WCAL	St. Olaf College,	Northfield, Minn.	WFAH	Electric Supply Co.,	Port Arthur, Texas	WIAS	Burlington Hawkeye & Home	Burlington, Iowa
WCAM	Villanova College,	Villanova, Pa.	WFAJ	Hi-Grade Wireless Instrument Co.,	Ashville, N. C.	WIAU	Leon T. Noel,	Tarkio, Mo.
WCAO	Sanders and Stayman Co.,	Baltimore, Md.	WFAK	Times Publishing Co.,	St. Cloud, Minn.	WIAV	American Trust & Savings Bank,	Le Mars, Iowa
†WCAP	Central Radio Service,	Decatur, Ill.	†WFAI	Hutchinson Electric Service Co.,	Hutchinson, Minn.	WIAW	New York Radio Laboratories,	Binghamton, N. Y.
WCAQ	Tri-State Radio Mfg. & Supply Co.,	Dehance, Ohio	WFAQ	Missouri Wesleyan College &	Cameron, Mo.	WJAW	Saginaw Radio & Electric Co.,	Saginaw, Mich.
WCAR	Alamo Radio Elec. Co.,	San Antonio, Texas	WFAQ	United Radio Corp.,	Fort Wayne, Ind.	WJAX	Capitol Radio Co.,	Lincoln, Nebr.
WCAS	Wm. Hood Dunwoody Industrial	Institute	†WFAI	Daily Argus Leader,	Sioux Falls, So. Dak.	WJAY	Woodward & Lothrop,	Washington, D. C.
†oWCAT	S. Dakota School of Mines,	Rapid City, S. Dak.	WFAJ	Edwin C. Lewis,	Boston, Mass.	WJAZ	Electric Supply Sales Co.,	Miami, Fla.
†WCAU	Philadelphia Radiophone Co.,	Philadelphia, Pa.	†WFAK	University of Nebraska,	Lincoln, Nebr.	WJK	K & L Electric Co.,	McKeesport, Pa.
WCAV	J. C. Dice Electric Co.,	Little Rock, Ark.	WFAI	Miami Daily Metropolis,	Miami, Fla.	WJL	Continental Electrical Supply Co.,	Washington, D. C.
†WCAW	Quincy Electric Supply Co.,	Quincy, Ill.	WFAJ	Daniels Radio Supply Co.,	Independence, Kansas	†WJIP	Gimbel Bros.,	Philadelphia, Pa.
WCAX	University of Vermont,	Burlington, Vt.	WFAK	South Carolina Radio Shop,	Charleston, So. Car.	†WJIZ	Cino Radio Mfg. Co.,	Cincinnati, Ohio
WCAY	Kesselman O'Driscoll Co.,	Milwaukee, Wis.	*toWFEI	Strawbridge & Clothier,	Philadelphia, Pa.	WJAB	American Radio Co.,	Lincoln, Nebr.
WCAZ	Robt. E. Compton and Carthage	College	WGAB	QRV Radio Co.,	Houston, Tex.	WJAC	Redell Co.,	Joplin, Mo.
WCE	Findley Electric Co.,	Minneapolis, Minn.	WGAD	Spanish American School of Radio-	teleggraphy	WJAD	Jackson's Radio Engineering	Laboratories
WCK	Stix Baer & Fuller Co.,	St. Louis, Mo.	WGAE	New Haven Electric Co.,	New Haven, Conn.	†WJAE	Texas Radio Syndicate,	San Antonio, Texas
†WCM	University of Texas,	Austin, Texas	WGAF	W. H. Gass,	Shenandoah, Iowa	WJAF	Muncie Press-Smith Electric,	Muncie, Ind.
†WCN	Clark University,	Worcester, Mass.	WGAG	Macon Electric Co.,	Macon, Ga.	WJAG	Norfolk Daily News,	Norfolk, Nebr.
*toWCX	The Detroit Free Press,	Detroit, Mich.	WGAL	Lancaster Elec. Supply & Con-	struction Co.	WJAJ	Y. M. C. A.,	Dayton, Ohio
†oWDAC	Illinois Watch Co.,	Springfield, Ill.	WGAM	Orangeburg Radio Equipment Co.,	Orangeburg, So. Car.	†WJAK	White Radio Laboratory,	Stockdale, Ohio
†WDAE	Tampa Daily Times,	Tampa, Fla.	WGAN	Cecil E. Lloyd,	Pensacola, Fla.	WJAL	Victor Radio Corp.,	Portland, Me.
*toWDAF	Kansas City Star,	Kansas City, Mo.	WGAQ	Glenwood Radio Corp.,	Shreveport, La.	WJAM	D. M. Perham,	Cedar Rapids, Iowa
WDAF	J. Laurance Martin,	Amarillo, Texas	†WGAR	Southwest American,	Fort Smith, Ark.	WJAN	Peoria Star-Peoria Radio Sales Co.,	Peoria, Ill.
†WDAH	Mine & Smelter Supply Co.,	El Paso, Texas	WGAS	The Ray-Di-Co. Organization,	Chicago, Ill.	WJAP	Kelley-Duluth Co.,	Duluth, Minn.
†WDAI	Hughes Electrical Corp.,	Syracuse, N. Y.	WGAT	American Legion, Dept. of Nebraska,	Lincoln, Nebr.	WJAO	Capper Publications,	Topeka, Kan.
†WDAJ	Atlanta & West Point R. R. Co.,	College Park, Ga.	WGAW	Marcus G. Limb,	Wooster, Ohio	WJAR	Outlet Co. (J. Samuels & Bro.),	Providence, R. I.
WDAK	The Hartford Courant,	Hartford, Conn.	WGAX	Ernest C. Albright,	Altoona, Pa.	WJAS	Pittsburgh Radio Supply Co.,	Pittsburgh, Pa.
†WDAL	Florida Times-Union,	Jacksonville, Fla.	WGAY	Radio Electric Co.,	Washington Court House, Ohio	WJAT	Kelley-Vawter Jewelry Co.,	Pittsburgh, Pa.
WDAO	Automotive Elec. Co.,	Dallas, Texas	WGAZ	Northwestern Radio Co.,	Madison, Wis.	WJAU	Yankton College,	Yankton, So. Dak.
WDAP	Midwest Radio Central, Inc.,	Chicago, Ill.	†WGF	South Bend Tribune,	South Bend, Ind.	WJAX	Union Trust Co.,	Cleveland, Ohio
WDAQ	Hartman Riker Elec. & Machine Co.,	Brownsville, Pa.	WGI	The Register & Tribune,	Des Moines, Iowa	WJAZ	Chicago Radio Laboratory,	Chicago, Ill.
WDAW	Lit Bros.,	Philadelphia, Pa.	†WGL	American Radio & Research Corp.,	Medford Hills, Mass.	WJD	Richard H. Howe,	Granville, Ohio
WDAZ	Samuel A. Waite,	Worcester, Mass.	*oWGM	Thos. F. J. Howlett,	Philadelphia, Pa.	WJH	White & Boyer Co.,	Washington, D. C.
WDAU	Stocum & Kilburn,	New Bedford, Mass.	†WGR	Federal Telephone & Telegraph Co.,	Buffalo, N. Y.	WJK	Service Radio Equipment Co.,	Toledo, Ohio
WDAV	Muskogee Daily Phoenix,	Muskogee, Okla.	†WGV	Interstate Electric Co.,	New Orleans, La.	WJX	De Forest Radio Telephone &	Telegraph Co.,
WDAN	First National Bank,	Centerville, Iowa	*toWGY	General Electric Co.,	Schenectady, N. Y.	WJZ	Westinghouse Elec. & Mfg. Co.,	Newark, N. J.
†WDAY	Fargo Radio Service Co.,	Fargo, N. Dak.	†WHA	University of Wisconsin,	Madison, Wis.	†WKAA	H. F. Paar (Republican Times),	Cedar Rapids, Iowa
WDM	Church of the Covenant,	Washington D. C.	WHA	State University of Iowa,	Iowa City, Iowa	WKAC	Star Publishing Co.,	Lincoln, Nebr.
WDT	Ship Owners Radio Service,	New York, N. Y.	†WHAB	Clark W. Thompson (Fellman's	Dry Goods Co.)	WKAD	Charles Looff (Crescent Park),	East Providence, R. I.
WDV	John O. Yeiser, Jr.,	Omaha, Nebr.	WHAC	Cole Bros., Electric Co.,	Waterloo, Iowa	WKAF	W. S. Radio Supply Co.,	Wichita Falls, Texas
WDY	Radio Corp. of America,	Roselle Park, N. J.	†WHAD	Marquette University,	Milwaukee, Wis.	WKAG	Edwin T. Bruce, M.D.,	Louisville, Ky.
WDZ	J. L. Bush,	Tuscola, Ill.	WHAE	Automotive Electric Service Co.,	Sioux City, Iowa	WKAH	Planet Radio Co.,	West Palm Beach, Fla.
WEAA	Fallian & Lathrop,	Flint, Mich.	WHAJ	Radio Electric Co.,	Pittsburgh, Pa.	WKAK	Okfuskee County News,	Okemah, Okla.
†WEAB	Standard Radio Equipment Co.,	Fort Dodge, Iowa	WHAH	University of Cincinnati,	Cincinnati, Ohio	WKAL	Gray & Gray,	Orange, Texas
†WEAC	Baines Electric Service Co.,	Terre Haute, Ind.	WHAJ	Hafer Supply Co.,	Joplin, Mo.	WKAN	Alabama Radio Mfg. Co.,	Montgomery, Ala.
WEAD	Northwest Kansas Radio Supply Co.,	Atwood, Kansas	WHAJ	Radio Equipment & Mfg. Co.,	Davenport, Iowa	WKAP	Dutee W. Flint,	Cranston, R. I.
WEAE	Virginia Polytechnic Inst.,	Blacksburg, Va.	WHAJ	Robert H. Hdwe. Co.,	Clarksville, W. Va.	WKAQ	Radio Corp. of Porto Rico,	San Juan, P. R.
*oWEAF	Western Electric Co.,	New York, N. Y.	†WHAJ	Lansing Capital News,	Lansing, Mich.	WKAU	Michigan Agricultural College,	East Lansing, Mich.
WEAG	Nichols-Hineline-Bassett Laboratory,	Edgewood, R. I.	†WHAM	University of Rochester,	Rochester, N. Y.	WKAV	Laconia Radio Club,	Laconia, N. H.
†WEAH	Wichita Board of Trade & Lander	Radio Co.,	WHAJ	Frederic A. Hill,	Savannah, Ga.	WKAU	Turner Cycle Co.,	Beloit, Wis.
WEAI	Cornell University,	Ithaca, N. Y.	WHAJ	Ota and Kuhns,	Decatur, Ill.	WKAX	William A. MacFarland,	Bridgeport, Conn.
WEAJ	University of So. Dakota,	Vermillion, S. Dak.	WHAJ	Senmes Motor Co.,	Washington, D. C.	WKAY	Brenau College,	Gainesville, Ga.
WEAK	Julius B. Abercrombie, St. Joseph, Mo.	Borough of No. Plainfield, N. J.	WHAJ	Paramount Radio & Elec. Co.,	Atlantic City, N. J.	WKAZ	Landau's Music & Jewelry Co.,	Wilkes-Barre, Pa.
WEAM	Shepard Co.,	Providence, R. I.	†WHAS	Courier-Journal and Louisville Times,	Louisville, Ky.	WKC	Joseph M. Zamoiski Co.,	Baltimore, Md.
†WEAO	Ohio State University,	Columbus, Ohio	WHAJ	Wilmington Electrical Specialty Co.,	Wilmington, Del.	†WKN	Riechman Crosby Co.,	Memphis, Tenn.
†WEAP	Mobile Radio Co.,	Mobile, Ala.	WHAJ	Pierce Electric Co.,	Tampa, Fla.	†WKY	WKY Radio Shop,	Oklahoma City, Okla.
WEAR	Baltimore American & News	Publishing Co.	WHAJ	The Huntington Press,	Huntington, Ind.	WLAC	North Carolina State College,	Raleigh, N. C.

Call	Name	City and State	Call	Name	City and State	Call	Name	City and State
WLAJ	Johnson Radio Co.	Lincoln, Nebr.	WNAN	Syracuse Radio Telephone Co.	Syracuse, N. Y.	+WPAK	North Dakota Agricultural College,	
*toWLAG	Cutting & Washington Radio Corp.,	Minneapolis, Minn.	WNAP	Wittenberg College.	Springfield, Ohio	WPAL	Superior Radio & Tel. Equipment Co.,	Columbus, Ohio
WLAH	Samuel Wordworth.	Syracuse, N. Y.	WNAQ	Charleston Radio Electric Co.,	Charleston, S. C.	WPAM	Auerbach & Guettel.	Topeka, Kans.
+WLAJ	Waco Electrical Supply Co.,	Waco, Texas	WNAR	C. C. Rhodes.	Bulter, Mo.	WPAP	Theodore D. Phillips.	Winchester, Ky.
WLAJ	Vermont Farm Machine Corp.,	Bellows Falls, Vt.	WNAS	Texas Radio Corp. & Austin	Statesman	WPAQ	General Sales & Engineering Co.,	Frostburg, Md.
WLAJ	Tulsa Radio Co.	Tulsa, Okla.	WNAT	Lennig Bros. Co.	Philadelphia, Pa.	WPAR	R. A. Ward.	Beloit, Kans.
WLAJ	Morrow Radio Co.	Springfield, Ohio	WNAV	Peoples Telephone & Telegraph Co.,	Knoxville, Tenn.	WPAS	J. & M. Electric Co.	Amsterdam, N. Y.
WLAJ	Putnam Hardware Co.	Houlton, Me.	WNAW	Peninsular Radio Club.	Fort Monroe, Va.	WPAT	St. Patricks Cathedral.	El Paso, Texas
WLAJ	Anthracite Radio Shop.	Scranton, Pa.	WNAX	Dakota Radio Apparatus Co.,	Yankton, S. D.	+WPAU	Concordia College.	Moorhead, Minn.
WLAJ	W. V. Jordon.	Louisville, Ky.	WNAY	Ship Owner's Radio Service.	Baltimore, Md.	WPAV	Paul Tinetti & Sons.	Laurium, Mich.
WLAJ	A. E. Schilling.	Kalamazoo, Mich.	WNJ	Shotton Radio Mfg. Co., Inc.,	Albany, N. Y.	WPAW	Radio Installation Co.,	Wilmington, Del.
WLAJ	Mickel Music Co.	Marshalltown, Iowa	WNO	Wireless Telephone Co. of Hudson	County, N. J.	WPAX	S W Radio Co. (J. R. Shumate, Jr.),	Thomasville, Ga.
WLAJ	Central Radio Supply Co.,	Hutchinson, Kansas	WOAA	Dr. Walter Hardy.	Ardmore, Okla.	WPE	Central Radio Co.	Kansas City, Mo.
WLAJ	Radio Specialty Co.	Burlington, Iowa	WOAB	Valley Radio.	Grand Forks, N. D.	WPG	Nushawg Poultry Farm.	New Lebanon, Ohio
WLAJ	Electric Shop.	Pensacola, Fla.	WOAC	Maus Radio Co.	Lima, Ohio	WPI	Electric Supply Co.	Clearfield, Pa.
WLAJ	Police Dept. of New York City,	New York, N. Y.	WOAD	Friday Battery & Elec. Co.,	Siourney, Iowa	WPJ	St. Joseph College.	Philadelphia, Pa.
WLAJ	Putnam Electric Co.	Greencastle, Ind.	WOAE	Midland College.	Fremont, Nebr.	WPM	Thomas J. Williams,	Washington, D. C.
WLAJ	Northern Commercial Co.,	Fairbanks, Alaska	WOAF	Tyler Commercial College.	Tyler, Texas	WPO	United Equipment Co.	Memphis, Tenn.
WLAJ	Hutton & Jones Electric Co.,	Warren, Ohio	WOAG	Apollo Theatre.	Belvedere, Ill.	WQAA	Horace A. Beale, Jr.	Parkesburg, Pa.
+WLB	University of Minnesota.	Minneapolis, Minn.	WOAH	Palmetto Radio Corp.	Charleston, S. C.	WQAB	Southwest Missouri State Teachers	College
+WLB	Hamilton Mfg. Co.	Indianapolis, Ind.	WOAI	Southern Equipment Co.	San Antonio, Tex.	WQAC	E. B. Gish.	Amarillo, Tex.
+WLB	Crosley Mfg. Co.	Cincinnati, Ohio	WOAJ	Ervin Electrical Co.	Parsons, Kan.	WQAE	Moore Radio News Station (Edmund	B. Moore)
+WLB	Radio Supply Co.	Oklahoma, Okla.	WOAK	Collins Hdwe. Co.	Frankfort, Ky.	WQAK	Appel-Higley Electric Co.,	Dubuque, Iowa
WLB	J. Edw. Page (Clive B. Meredith),	Cazenovia, N. Y.	WOAL	Wm. E. Woods.	Webster Groves, Mo.	WQAL	Coles County Telephone &	Telegraph Co.
WLB	Atchinson County Mail,	Rock Port, Mo.	WOAN	Vaughn Conservatory of Music,	Lawrenceburg, Tenn.	WQAO	West Texas Radio Co.	Abilene, Texas
WLB	Round Hills Radio Corp.,	Dartmouth, Mass.	WOAP	Lyradion Mfg. Co.	Mishawaka, Ind.	WQAY	Gaston Music & Furniture Co.,	Hastings, Nebr.
WLB	Tucker Electric Co.	Liberal, Kans.	WOAQ	Kalamazoo College.	Kalamazoo, Mich.	WRAA	Rice Institute.	Houston, Texas
WLB	General Supply Co.	Lincoln, Nebr.	WOAR	Portsmouth Radio Assoc.,	Portsmouth, Va.	WRAN	Black Hawk Electrical Co.,	Waterloo, Iowa
+WMAJ	Drovers Telegram Co.,	Kansas City, Mo.	WOAS	Henry P. Lundskow.	Kenosha, Wis.	WRAR	Jacob C. Thomas.	David City, Nebr.
WMAJ	Norton Laboratories.	Lockport, N. Y.	WOAT	Boyd M. Hamp.	Wilmington, Del.	WRAU	Amarillo Daily News.	Amarillo, Tex.
WMAJ	Trenton Hardware Co.	Trenton, N. J.	WOAU	Sowder Bolling Piano Co.,	Evansville, Ind.	WRAY	Radio Sales Corp.	Scranton, Pa.
+WMAJ	Beaumont Radio Equipment Co.,	Beaumont, Texas	WOAV	Second Battalion, 112th Inf.,	P.N.G., Erie, Pa.	WRK	Doron Bros. Elec. Co.	Hamilton, Ohio
WMAJ	Broad St. Baptist Church,	Columbus, Ohio	WOAW	Woodmen of the World.	Omaha, Nebr.	WRL	Union College.	Schenectady, N. Y.
WMAJ	Utility Battery Service.	Easton, Pa.	WOAX	Franklyn J. Wolff (Monument	Pottery Co.)	WRM	University of Illinois.	Urbana, Ill.
WMAJ	The Fair Corp. & Chicago Daily,	Chicago, Ill.	WOAY	John M. Wilder.	Birmingham, Ala.	WRP	Federal Institute of Radio	Telegraphy
WMAJ	Waterloo Electrical Supply Co.,	Waterloo, Iowa	WOAZ	Penick Hughes Co.	Stamford, Texas	+WRR	City of Dallas, Police & Fire	Signal Dept.
+WMAJ	Paramount Radio Corp.,	Duluth, Minn.	*toWOC	Palmer School of Chiropractic,	Davenport, Iowa	WRW	Tarrytown Radio Research	Laboratory
+WMAJ	Alabama Polytechnic Inst.,	Auburn, Ala.	WOE	Buckeye Radio Service Co.,	Akron, Ohio	WSAJ	Grove City College.	Grove City, Pa.
WMAJ	Wahpeton Electric Co.,	Wahpeton, N. Dak.	WOH	Hatfield Electric Co.	Indianapolis, Ind.	WSAS	Bureau of Markets, State Dept.	of Agr.
WMAJ	K & K Radio Supply Co.,	Ann Arbor, Mich.	+WOI	Iowa State College.	Ames, Iowa	WSAT	Plainview Electric Co.	Plainview, Tex.
WMAJ	Kingshighway Presbyterian Church,	St. Louis, Mo.	WOK	Arkansas Light & Power Co.	(Pine Bluff Co.)	WSAV	Clifford W. Vick Radio Const. Co.,	Houston, Texas
WMAJ	Mercer University.	Macon, Ga.	*toWOO	John Wanamaker.	Philadelphia, Pa.	*toWSB	Atlanta Journal.	Atlanta, Ga.
+WMAJ	Auburn Electrical Co.	Auburn, Me.	+WOQ	Western Radio Co.	Kansas City, Mo.	WSL	J & M Electric Co.	Utica, N. Y.
+WMAJ	Precision Equipment Co.,	Cincinnati, Ohio	*toWOR	L. Bamberger & Co.	Newark, N. J.	WSN	Ship Owners Radio Service, Inc.,	Norfolk, Va.
WMAJ	Doubleday-Hill Electric Co.,	Washington, D. C.	+WOS	Missouri State Marketing Bureau,	Jefferson City, Mo.	WSX	Erie Radio Co.	Erie, Pa.
WMAJ	Park City Daily News.	Bowling Green, Ky.	+WOU	Metropolitan Utilities District.	Omaha, Nebr.	+WSY	Alabama Power Co.	Birmingham, Ala.
WMAJ	Shepard Stores.	Boston, Mass.	+WOZ	Palladium Printing Co.	Richmond, Ind.	WTAC	Penn Traffic Co.	Johnstown, Pa.
WMAJ	Oklahoma Radio Engineering Co.,	Norman, Okla.	+WPA	Anderson & Webster Elec. Co.,	Wahoo, Nebr.	WTAU	Ruegg Battery & Electric Co.,	Tecumseh, Nebr.
+WMAJ	Enid Radio Distributing Co.,	Enid, Okla.	WPAB	Pennsylvania State College.	State College, Pa.	WTAW	Agricultural & Mechanical College,	College Stations, Tex.
WMAJ	Rathert Radio & Electric Shop,	Cresco, Iowa	WPAC	Donaldson Radio Co.	Okmulgee, Okla.	+toWTG	Kansas State Agricultural College,	Manhattan, Kansas
WMAJ	Wilkes-Barre Radio Repair Shop,	Wilkes-Barre, Pa.	WPAD	W. A. Wieboldt & Co.	Chicago, Ill.	WTP	George M. McBride.	Bay City, Mich.
WMAJ	Benson Co.	Chicago, Ill.	WPAF	Peterson Radio Co.	Council Bluffs, Ia.	WWAC	Sanger Bros.	Waco, Texas
WMAJ	Manhattan Radio Supply Co.,	Manhattan, Kan.	WPAG	Central Radio Co.	Independence, Ill.	WWAD	Wright & Wright, Inc.,	Philadelphia, Pa.
WMAJ	R. J. Rockwell.	Omaha, Nebr.	+toWPAH	Wisconsin Department of Markets.	Waupaca, Wis.	WWAX	Wormser Bros.	Laredo, Texas
WMAJ	Ideal Apparatus Co.	Evansville, Ind.	WPAJ	Doolittle Radio Corp.,	New Haven, Conn.	WWB	Daily News Printing Co.	Canton, Ohio

## Would You Answer These Queries for Two Cents

The following is a letter, copied word for word as received from a reader, and addressed to the Question and Answer Department. The reader very kindly enclosed a 2-cent stamp for the return of this information. The letter was received on a Wednesday. Note when he expected a reply.

"Dear Sir:

Will you kindly send me all information of what I am asking. I would like that you would send me drawings and instructions on making the following things about Radio. A varicoupler of the best type, a variometer, also best type, audion and vacuum tube socked, Filament and other type rheostats, variable condenser and Fixed cond., .00025 microfarads. can phone receivers be made, if so send me drawing of a good receiver, also a good receiver with instructions to make all parts to set. The set which can

receive from 3,000 miles or less, also show me how to hook up both sets not in Radio symbol but in simple pictures. And how to mount on a panel. Send me some of the best drawings of high tuning arristers. And instructions how to make and hook up with sets, a loud-speaker, a detector amplifier, all kinds of knobs and switches, a frequency transformer, a few types of vernier condensers, a few types of loop aerials, amplifier set 3 stages to 4, drawings and instructions variable plate Battery (22½) volts. Phone con. .002 microfarads or more. Tell me a way to make fiber or bakelite dials. What is "spaghetti" insulation?

As though this were not sufficient, the writer continues on another page as follows: Dear Sir:

I am writing this second letter because I had not enough space on the other paper. I would like if you would send me the draw-

ings and instructions and hook-ups on these things I describe, a telegraph set (morse) and and telephone also a Wireless telegraph set and wireless telephone set, and a Detector microphone. Is it possible to make a dynamo or electric motor at home. If so send me the drawings and instructions how to make them. I will be pleased with all the answers at my house on FRIDAY if possible. I give much thanks for all answers.

Yours truly,

P. S. also send me how to make a small crystal set, hook-up and parts to make and how to make the parts at small expense."

Faint cry from the Editorial sanctum: "Quick, Watson! the needle!"

But seriously—what this reader needs is a text book. May we suggest the new book by Mr. H. Gernsback, "Radio For All,"



# Radio Oracle

In this Department we publish questions and answers which we feel are of interest to the novice and amateur. Letters addressed to this Department cannot be answered free. A charge of 25c is made for all questions where a personal answer is desired.

## TWO STAGE AUDIO FREQUENCY AMPLIFIER

(116) Carl W. Chase, Amsterdam, N. Y., writes that he has an audion detector which gives very good results when used with a loose-coupler for tuning. He asks:

Q. 1. Will you kindly give me a hook-up of the amplification appliances necessary to add to this set so that the signals may be heard with a loud-speaker?

A. 1. In order to use a loud-speaker with your set you should add two steps of audio frequency

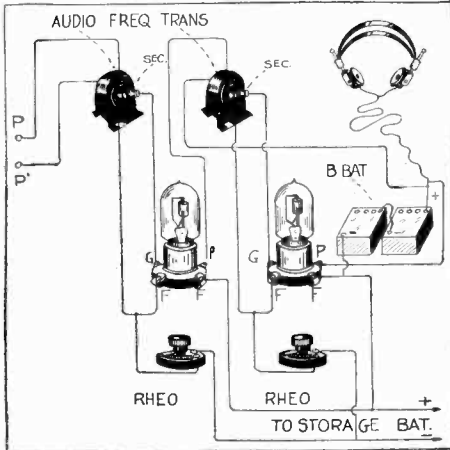

Two stages of audio-frequency amplification may be added to any receiving set, by using the circuit shown above.

amplification. A circuit diagram of the same is given herewith.

## CONDENSER CAPACITIES

(117) Frank A. Hackert, Bellingham, Minn., asks:

Q. 1. What capacity should the condensers enumerated below have for use in a short wave regenerative set consisting of a vario-coupler and a variometer? Series antenna condenser, secondary condenser, and grid and phone condensers.

A. 1. The following condenser capacities may be used with your short wave regenerative tuner.

- Condenser in series with aerial .001 M. F.
- Condenser across secondary .001 M. F.
- Grid condenser .00025 M. F.
- Phone condenser .0165 M. F.

Q. 2. Is it necessary to use a rheostat to control the filament current and a potentiometer to control the plate voltage of a vacuum tube?

A. 2. A rheostat must be used to control the filament of your tube for best results, and a potentiometer is desirable, but not absolutely necessary to control the "B" batteries.

## DETECTOR AND ONE STAGE AMPLIFIER

(118) Edward Claus, Pittsfield, Ill., asks for a circuit diagram of the following apparatus, together with any necessary additional apparatus. One variable condenser, three honeycomb coils, two vacuum tubes, two 22½ volt "B" batteries, a 6 volt storage battery, two sockets, two rheostats, grid leak and condenser, and phones.

A. 1. In order to use the apparatus you mention you will need one more variable condenser and one amplifying transformer.

We are giving herewith a circuit diagram of your apparatus, including the two above mentioned instruments.

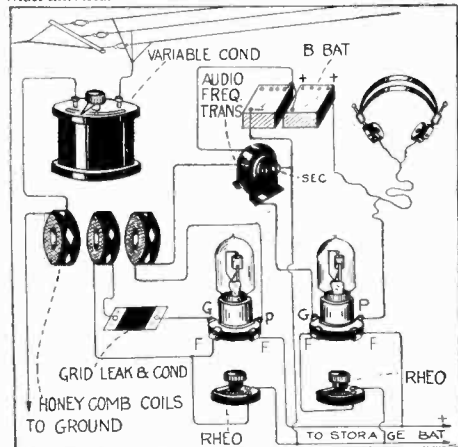

A three honeycomb coil circuit employing a one stage amplifier, is shown above. Greater selectivity can be obtained by shunting the secondary coil with a variable condenser.

## REGENERATIVE TUNER

(119) Carl Boehle, Bay City, Texas, says that he has a receiving set consisting of a variable condenser, a vario-coupler, an audion detector, and two stages of audio-frequency amplification. He asks:

Q. 1. How should I hook these instruments up, with the addition of a variometer, so as to have a regenerative set?

A. 1. We would advise you to use the circuit diagram published on page 56 of the May, 1922, issue of SCIENCE AND INVENTION, the only change necessary being that you insert a variometer in the plate circuit of the detector tube. In other words, disconnect the plate from the primary of the first transformer, and connect the latter to one side of the variometer. Connect the other side of the variometer to the plate, and you will have a regenerative circuit. This circuit, however, can be greatly improved by inserting another variometer in the grid circuit of the detector tube.

## RADIO-FREQUENCY AMPLIFICATION

(120) C. E. Blair, Jr., Laramie, Wyoming, wants to know:

Q. 1. Is it possible to apply radio-frequency amplification to a short wave regenerative set?

A. 1. Radio-frequency amplification may be applied to any sort of regenerative tuner by placing the radio-frequency amplification before the tuner and connecting the input of the first tube of radio-frequency to each side of a tuning coil, one side of which is connected to the ground, and the other side of which is connected to a variable condenser, which in turn is connected to the antenna. The output of the radio-frequency amplifiers is connected directly to the aerial and ground binding posts on the regenerative tuner. If there is a variable condenser embodied in the tuner in series with the antenna lead, this should be short-circuited, or in some other way eliminated entirely from the circuit. It may be found to advantage to connect this condenser across the primary coil of the tuner proper.

## ANTENNA AND RECEIVING RANGE QUERIES

(121) B. A. Hoduct, Memphis, Tenn., inquires:

Q. 1. Would an antenna 300 feet long auswer satisfactorily for the reception of radiophone broadcast?

A. 1. A 300 foot antenna would be much too long for 360 meter reception, and we would advise you to cut it down to about 100 feet.

Q. 2. How far could I hear with the above antenna and a short wave regenerative tuner used in connection with a single audion tube?

A. 2. Your consistent receiving radius with a single tube should be 60 to 75 miles for radiophone.

Q. 3. Would a loading coil increase the range of this set?

A. 3. The addition of a loading coil to the above set would not add to the receiving range in the least, but would merely increase the wave length.

## RECEIVING RANGE

(122) Rex Holmes, Princeton, Mo., refers to a set described in a back issue of this journal which consists of a tuner and an audion detector. He asks:

Q. 1. Can this set be used successfully to receive from a transmitting station located 125 miles from my home?

A. 1. With the set you mention you might possibly be able to receive over a distance of 125 miles, but we would advise you to use at least one step of audio frequency amplification.

Q. 2. Of what use is the rheostat in the filament circuit of the vacuum tube?

A. 1. The rheostat in the circuit is used to regulate the amount of current passing through the filament of the tube.

## DIFFICULTY IN RECEPTION

(123) Lyman Hanes, Minneapolis, Minn., asks: Q. 1. Can you explain what is causing the difficulty in receiving wireless telephone messages from Chicago, Milwaukee and Duluth in Minneapolis?

A. 1. Not knowing anything about the local conditions in Minneapolis, nor the kind of receiving apparatus used, it is impossible for us to say just why you are not able to receive messages from Chicago, Milwaukee and Duluth.

You must realize that there are many factors entering into the reception of radiophone messages, some of which are local topographical conditions, type and location of antenna used, and the quality and sensitiveness of the receiving set.

If there is any particular type of apparatus which you have in mind, and you will give us more details, we will be only too glad to help you as far as possible.

## ONE STAGE RADIO FREQUENCY AMPLIFIER

(124) Malcolm B. Boyse, Bradford, Mass., requests:

Q. 1. Will you please give me a circuit diagram for a vario-coupler, a variable condenser, one step of radio frequency amplification and an audion detector?

A. 1. We give herewith the required diagram.

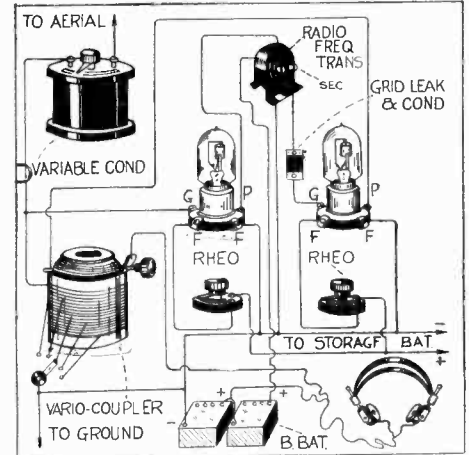

A circuit diagram of a tuner and one stage of radio-frequency amplification, together with an audion detector, is shown above.

## LOUD TALKER QUERIES

(125) E. Paul Hunt, Orrick, Mo., wants to know:

Q. 1. How much and what size wire should be used for winding the field coils of a double pole loud talker similar to a Magnavox?

A. 1. Three pounds of No. 17 S. C. C. wire should be used on each core for the field coils, and the moving coil should consist of 18 feet of No. 38 S. S. C. or enameled wire.

Q. 2. What size diaphragm would you recommend for this loud-talker, and what material and thickness?

A. 2. A 3-inch diaphragm should give very satisfactory results, and we would advise you to try making it from sheet iron .006 inch to .007 inch thick.

Q. 3. Could a standard audio-frequency amplifier transformer be used as the step-down transformer with this loud-talker?

A. 3. You might try using an audio transformer in connection with this loud-speaker, but we would also suggest that you write to the Magnavox Company regarding the purchase of a different type of transformer suitable for use in this connection.

## SINGLE HONEYCOMB COIL TUNER

(126) Harold T. Jones, Oshkosh, Wis., asks: Q. 1. How can I hook up a single honeycomb coil with a variable condenser so as to make an efficient receiving tuner?

A. 1. We give herewith the diagram as requested. The "B" battery should have a voltage of 22½, and the tube should be a "soft" or detector tube.

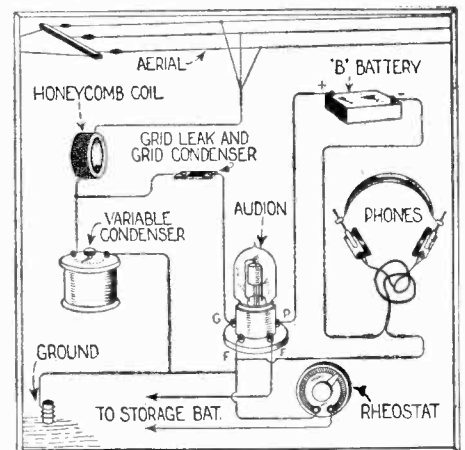

A simple tuner for use with an audion detector, is shown herewith. The size of the honeycomb coil can be varied according to the wave length it is desired to receive.



# LATEST PATENTS

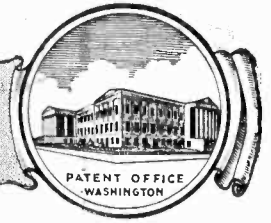

## Fountain Toothbrush

(No. 1,436,883, issued to Charles J. Koepke)

This inventor has developed the fountain toothbrush idea considerably. He employs a casing with a



suitable slot therein (to permit the introduction of the fingers) to house a tooth paste tube. This casing is provided with a threaded portion at its neck, into which the tooth paste tube is screwed after the cap has been removed. From the opposite end of this a rod containing the bristles of the toothbrush projects, and immediately below this an elongated tube may be found through which the tooth paste is to ooze when pressure is exerted upon the tube. An outer casing surrounds the previously mentioned casing, which is also provided with a slot, so that when partially rotated, the fingers may be introduced through the two slots now in juxtaposition with each other. A cap covering the bristles, also contains a needle adapted to fit into the tube through which the tooth paste is to pass. Working this pointed wire back and forth, dislodges any tooth paste which may have caked while the brush was lying idle.

## Swimmer's Motor

(No. 1,433,563, issued to Lyman P. Osterhout)

This is undoubtedly one of the cheapest swimming devices which



has been designed up to the present time. It consists of a belt surrounding the body of the swimmer, with an inflatable buoyant cushion at its lower point, which also acts as the retainer for a bearing post, through which bearing a propeller shaft passes. The second buoyant float has erected upon it a driving gear and a right angle transmission gear, fastened directly to the propeller shaft. By means of this apparatus comparatively great speed can be obtained by an unskilled swimmer.

## Electric Circuit Breaker

(No. 1,438,308, issued to George F. Hunter)

In this electric curling iron, the resistance element is contained within the iron casing which extends downward into the handle of the iron. This causes the temperature within the handle to rise considerably, which in so doing acts on the thermostatic bar, and when the heat is high enough causes this to bend outwardly and open the electric cir-



cuit. As soon as the temperature of the iron drops down again, the circuit is closed and the iron continues to heat. The inventor states that this same system could be employed for electric flat irons, ovens,

etc., but in our opinion such a procedure would cause an arc to form between the contacts, as the circuits were being opened. A quick acting thermostat would be necessary.

## Reducing Valve

(No. 1,437,437, issued to Luigi Mombaruzzo)

If a law were passed to make it compulsory to employ gas valves of the nature described herewith, we can be sure that accidents resulting in the loss of life from gas leakage would be rare. People contemplating suicide will have to do so by deliberately removing the tip of the gas burner. Within the tip, one end of a metallic thermostat bar is found. One end of this bar is secured to a partition and suspended from the other end is a ball which, when the thermostatic metal is cold, fits into a recess in the partition, closing the aperture thereof. A tiny

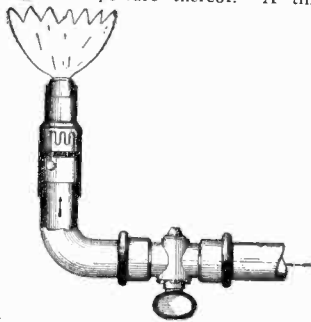

by-pass aperture is also found, through which gas escapes at all times when the main cock is turned on. In order to light the burner, gas permitted to escape through the tiny by-pass is lit; the heat transmitted to the thermostat opens the valve fully.

## Submarine Signaling Apparatus

(No. 1,440,361, issued to Frank Lloyd Hopwood)

A double casing containing a diaphragm for each portion of the casing, that is, four diaphragms in all, also houses a microphone connecting to the ship by means of cables and to the receiving instruments. Sounds in the water can now be picked up by the microphone and an individual at the receiver can interpret them and in that way

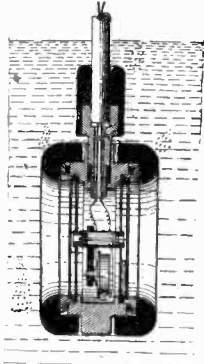

determine the nature of the ship causing the sounds. By varying the distance between the diaphragms, not only is the sensitivity and the tuning varied, but by different adjustments of the two sides the directional effect of the instrument is obtained. The space between the diaphragms may be filled with liquid or some jelly-like material. Screws permit the area in which the microphone lies to be broadened or contracted, causing the different properties of the microphone to be brought out for better tuning and sharpness of signals.

## Polyphone Sound Box

(No. 1,438,642, issued to John Graham)

This invention is ingenious be-

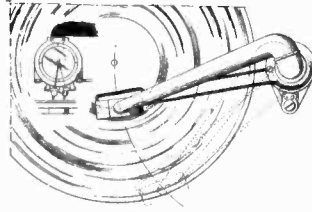

cause of the fact that the inventor employs two sound boxes connected to the same tone arm, each of which is provided with its own stylus. Both of these stylus' fitting into the same groove in the record, reproduce the music therefrom, but due to the fact that there are two diaphragms acted upon each by the same energy, much louder music is claimed for the device. In order that one stylus shall follow the other into the same groove in the record, the inventor employs two arms which orientate the sound box, the latter rotating upon the tone arm.

## Control Mechanism for Headlights

(No. 1,433,080 issued to Edward B. Kaylor)

An automobile provided with the usual headlights, has these headlights so arranged that they may be tipped downwardly or directed straight ahead. Rods connect both headlights with a cross-arm, and thence by means of right angle levers and rod

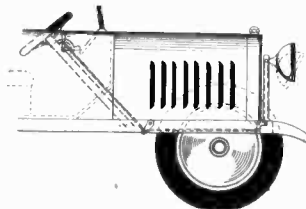

extensions to a controlling clutch, operating about a notched sector securely fastened to the steering wheel of the automobile. For driving on city streets, the headlights of the automobile are directed downward, so that the rays of light which may be brilliant at all times (eliminating entirely the use of the dimmer), flood the ground in front of the vehicle with a pure light. None of the rays are permitted to pass out even on a horizontal plane. When the headlight is raised the beam is directed straight ahead as usual.

## Spark Plug

(No. 1,441,397, issued to William H. Chard and William F. Hills)

This specification gives the description of an unusually novel departure from the ordinary run of spark plugs, for internal combustion engines. The inventor proposes to run preferably five rods through insulating material, such as porcelain, in such a manner that one of the

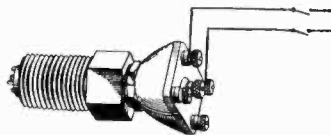

rods will constitute the center electrode, and the other four will be arranged around this center. A T-

shaped piece of metal connects two of the outside binding posts together and grounds them. One or both of the remaining two outside posts are then connected to wires leading to the ignition system. By this method an intensifying spark plug is produced, the spark leaping from one of the outside posts to the center and thence to a post on the opposite side, viz., to the ground. In a plug of this nature, the possibility of its fouling is supposed to be practically eliminated.

## Wave Power Motor

(No. 1,439,849, issued to Edward D. Stodder)

In this patent (the principle of which has been explained in an article appearing several years ago in this journal), the inventor provides for a series of piers or columns of

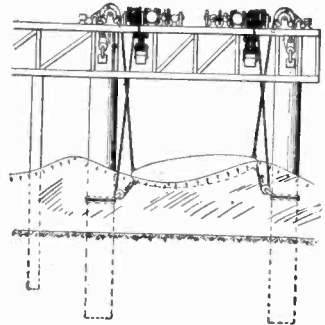

concrete or steel. Floats are secured between these, the floats have a limited lateral movement, but are permitted to ride up and down in comparative freedom. All actions of the waves are taken into consideration, that is, not only is the gravitational influence employed, but the lifting action of the wave is also used to actuate drums. These drums in turn operate air compressors which store the energy for driving turbines and electrical generators, and the horizontal effect produced by steep waves is also employed in developing power

## Aerial Vessel

(No. 1,432,209, issued to Robert C. Rimmer)

In this airplane, the propellers are arranged in the form of paddles much the same as in side-wheel steamships. The orientation of the

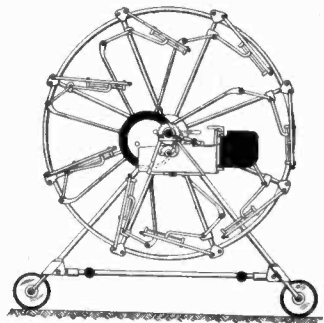

blades is accomplished by means of a cam located off center, which acting upon rollers and thence through intermediary levers, causes the fan blades to assume certain definite positions relative to the desired movements of the airplane. The inventor of this device claims to have built a working model, which has experimentally proved that flight can be accomplished by a machine of his design. These same paddles also permit the airplane to be directed ahead or astern, depending upon the location of the cams, and their effect on the revolving blades.

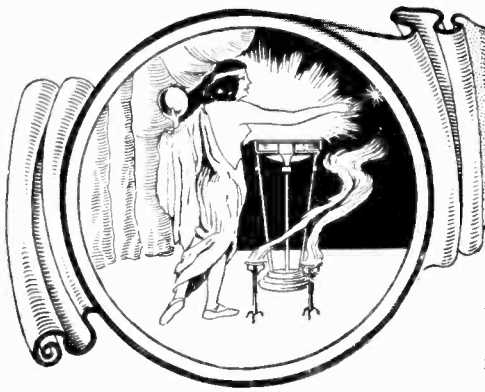

# THE ORACLE

The "Oracle" is for the sole benefit of all scientific experimenters. Questions will be answered here for the benefit of all, but only matter of sufficient interest will be published. Rules under which questions will be answered:

1. Only three questions can be submitted to be answered.
2. Only one side of sheet to be written on; matter must be typewritten or else written in ink, no penciled matter considered.
3. Sketches, diagrams, etc., must be on separate sheets. Questions addressed to the department cannot be answered by mail free of charge.
4. If a quick answer is desired by mail, a nominal charge of 25 cents is made for each question. If the questions entail considerable research work or intricate calculations a special rate will be charged. Correspondents will be informed as to the fee before such questions are answered.

## MAKING PERMANENT MAGNETS

(1411) B. L. Rites, Asheville, N. C., inquires:

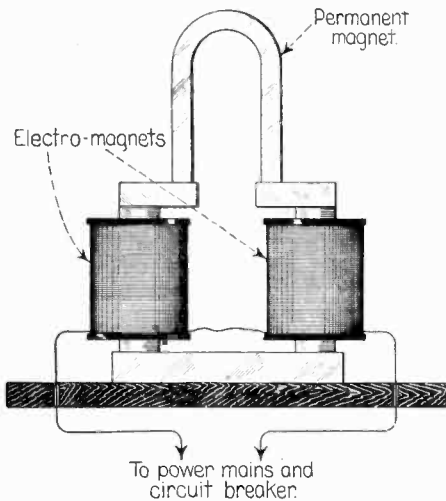

The method of magnetizing permanent horseshoe magnets is shown above.

Q. 1. How are permanent horseshoe magnets magnetized in quantities?

A. 1. Any large sized electro-magnet, operating on a heavy direct current, may be used for this work. We are giving you a diagram here, with showing how the permanent magnets should be placed, one at a time. It is advisable that the direct current supplied to the large magnets be interrupted rapidly.

## ELECTROLYTIC RECTIFIER

(1412) John M. Ramsey, Detroit, Mich., asks:

Q. 1. What is the resistance of a standard solution of ammonium phosphate such as is used in an electrolytic rectifier?

A. 1. To all practical intents and purposes, the resistance of such a solution is practically negligible. Its resistance is about  $1\frac{1}{2}$  ohms varying with the temperature. It is for this reason that in using the electrolytic rectifier, it is absolutely necessary that some suitable form of resistance be inserted in series with the rectifier and the source of alternating current, as otherwise the fuses will blow out. A resistance of about 20 ohms, capable of carrying 5 amperes, is necessary when charging a 6-volt storage battery at a 5 ampere rate, while about 15 ohms, capable of carrying 8 amperes, should be employed for an 8 ampere rate.

## CONVERTING GASOLINE SOD IRON TO ELECTRIC

(1413) Henry Rodenmayer, Clermont, Fla., asks:

Q. 1. How can I convert a gasoline sod iron into one operated by electricity?

A. 1. To convert a gasoline sod iron into an electric iron, it will be necessary to remove the burner on the inside of the same, and line the iron with asbestos. Then go to any electrical supply store, and purchase a heating grid, such as is sold for renewals in electric irons, and place the same within the iron you have. Two flexible leads, well insulated by asbestos, are brought out from the iron, and the job is done.

## VOLTAGE DROP

(1414) Louis T. Roberts, New Orleans, La., asks:

Q. 1. What would be the voltage drop over a line consisting of two No. 10 B. & S. gauge copper wires one mile long, the current being 4 amperes at 110 volts?

A. 1. The two lines of No. 10 copper wire stretching for a distance of a mile, will create a drop in potential of about 10 volts, provided that the lines are insulated.

## HARDENING LEAD

(1415) J. Bartlett, East Toronto, Canada, inquires:

Q. 1. Can soft lead be made hard by dipping it in a chemical solution?

A. 1. There is no method of hardening lead by dipping it into a chemical solution. There is said to be a secret process by means of which lead may be made hard enough to be used in making knives, and other instruments requiring a hard metal. We have no information on this process, however, as the inventor has kept it an absolute secret.

## STEEL SUPPORTING ARM

(1416) Chas. E. Burrell, Shamokin, Pa., says: I would like to make an arm of steel 50 feet long to support a weight of 500 pounds with absolute safety. One end is to work up and down in a groove, and the other end is to be supported by a wire rope. He asks:

Q. 1. Can you tell me how to construct this arm of steel, and how heavy must it be?

A. 1. The arm of steel which you describe will depend entirely on the construction and cross bracing. You will find that a latticed steel arm will be much lighter than a solid steel arm in a derrick similar to the one you describe. This lat-

ticed steel arm sufficiently cross-braced and welded or riveted, will not be so hard on the bearings. We would suggest that you communicate with various concerns regarding breaking and bending stresses on steel girders. Also request that they figure on various types of arms, such as T-arms, I-beams, triangular cross-braces, and four-sided cross-braced arms. They will give you all of the figures available.

## ATMOSPHERIC POTENTIALS

(1419) A. Chapple, Vancouver, B. C., Canada, asks:

Q. 1. If the electrical potential of the air varies according to the height, would not a charge collect upon a metal plate placed at a height, and would not a current flow from this along a wire to the ground, or vice versa? If this is so, why could we not place a vibrator in the connecting wire, and so get a pulsating current from the air?

A. 1. The experiments you mention have been tried time and again, but it has not been found practical to draw electricity from the air by the method you suggest, because the amounts obtainable vary considerably in strength and regularity. An example of drawing electricity from the air may be seen in any large radio station. For instance, at the station of the American Telephone & Telegraph Company in New York City, it is possible at times to draw sparks 1 inch long from the lightning switch when the same is left open. This is because of the static electricity which has collected on the antenna.

## COLLECTING MOISTURE FROM THE AIR

(1420) M. A. Raymond, Washington, D. C., wants to know:

Q. 1. How may the moisture which is contained in the form of vapor in the air of a room, having a humidity of approximately 75 to 90 degrees, be collected?

A. 1. Since you did not give us definite information as to the size of the room in which you wish to extract the moisture from the air, we can only give you suggestions. For instance, place a quantity of calcium chloride in each of four porcelain dishes, and place them in various parts of the room. The calcium chloride will absorb moisture from the air, and if you wish to abstract the water from the same, you may do so by placing the chemical in a retort and heating it, collecting and condensing the water vapor given off. This will probably be the simplest way to obtain the results you desire.

## REDUCING VOLTAGE

(1421) A. A. Rynkiewicz, Techny, Ill., says: I have some wire, the resistance of which is 125 ohms per foot. He asks:

Q. 1. How can I make use of this wire to reduce 110 volts to 50 volts?

A. 1. If you will stretch one foot of wire between two insulators, then take off a tap near the center as illustrated, you will be able to reduce 110 volts A. C. to 50 volts. Eleven inches of the wire might be used, whereupon every inch would constitute a tap delivering 10 volts. With this arrangement the regulation of the voltage is very simple, but very little current would be available, due to the high resistance, and the microscopic thinness of the wire.

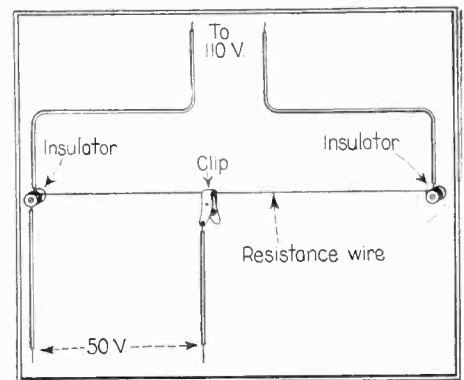

A potential of one hundred and ten volts may be reduced to fifty volts by the method shown above. Very little current will be delivered on the fifty volt side, owing to the small wire used in this case.

## Articles in March

### 66 "Practical Electrics" 99

*New Theory of Magnetism*

*Electrical Pumps*

By F. R. Kingman

*Home Battery Charger*

*Three Brush Automobile Generator.* By H. Highstone

*Motor Without Visible Field*

*Planting Vines by Electricity*

## CHEMICAL IGNITION

(1417) Thos. A. Caplen, Detroit, Mich., inquires:

Q. 1. Is there any chemical substance which will, when lightly rubbed, produce a hot flame without any disagreeable fumes or odors?

A. 1. There is no chemical substance, to our knowledge, which will give a hot flame when lightly rubbed, without producing any disagreeable fumes. Phosphorous will produce a high degree of heat when ignited by rubbing. It is dangerous to work with continually as the white phosphorous attacks the osseous system.

## HANDLING DYNAMITE

(1418) Clarence Cluttenden, Perry, Iowa, says: I have been told that dynamite has been known to explode when punching a hole in the cartridge for the insertion of the cap and fuse. He asks:

Q. 1. Has an authentic case of such an explosion ever been reported?

A. 1. We do not know of any case where dynamite exploded when punching the hole in



**DATA ON THE SOLAR SYSTEM**

(1422) G. A. Steinmiller, Chicago, Ill., wants to know:

Q. 1. Can you give me the following information on the planets Mercury, Venus, Earth, Mars, Jupiter, Saturn, Uranus and Neptune? Their diameters, distance from the sun, time required for one revolution around the sun, and time required for one revolution on their axes.

A. 1. We give herewith the desired information, in which the length of the year represents the time required for one revolution around the sun, and the length of day, the time required for one revolution on the axis. The measures of time given are the standard hour, day and year of the earth.

Name	Diameter	Distance from sun	Length of year	Length of day
Mercury	3,030 miles	36,000,000 miles	88 days	88 days
Venus	7,700 miles	67,200,000 miles	225 days	uncertain
Earth	7,917.6 miles	92,900,000 miles	365 days	24 hours
Mars	4,230 miles	141,500,000 miles	687 days	24 1/2 hours
Jupiter	86,500 miles	843,300,000 miles	12 years	10 hours
Saturn	73,000 miles	886,000,000 miles	29 1/2 years	10 1/2 hours
Uranus	31,900 miles	1,781,900,000 miles	84 years	uncertain
Neptune	34,800 miles	2,791,600,000 miles	165 years	uncertain

Q. 2. Has there ever been, or will there ever be, a time when all the planets will be on one side of the sun and in a straight line?

A. 2. To the best of our knowledge, there has been no time when all the planets were in a straight line, nor do we believe that such a thing is possible, due to the varied speeds of rotation around the sun, and inclinations of the planes of the ecliptics.

**DETECTING DIAMONDS WITH X-RAYS**

(1423) H. S. Bash, Kenton, Ohio, asks:  
Q. 1. How is a fluoroscope used in detecting diamonds which are being stolen and carried out of the mines by workmen in the diamond fields?

A. 1. One of the methods used for detecting the theft of diamonds at the mines, is to examine the workmen with X-rays. Of course, a fluoroscope is used to make the X-ray image visible, and this is the type as is used in any regular X-ray work.

Q. 2. Will a fluoroscope display activity when acted upon by diamonds?

A. 2. No.

**THE HECTOGRAPH**

(1424) J. C. Chess, Des Moines, Iowa, asks:  
Q. 1. Can you give me complete directions for making a hectograph?

A. 1. We are giving the desired information herewith: Melt together one part of glue, two parts of water, and four parts of glycerin, all by weight, evaporating some of the water, and tempering the mixture with more glue or glycerin, as the season or climate requires. The mass, when of proper consistency, which can be ascertained by cooling a small portion, is poured into a shallow pan and allowed to stand. Clean glue must be used, or the mixture must be strained, and air bubbles must be removed by skimming the surface with a piece of cardboard.

A variation of this formula is:

Gelatin	10 oz.
Water	40 oz.
Glycerin	120 oz.
Barium sulphate	8 oz.

Q. 2. What kind of ink is best for use with the above?

A. 2. The best ink for use with a hectograph is purple aniline ink, prepared especially for this purpose. This may be made as follows:

Methyl violet	2 parts
Alcohol	2 parts
Sugar	1 part
Glycerin	4 parts
Water	24 parts

Dissolve the violet in the alcohol mixed with the glycerin; dissolve the sugar in the water, and mix both solutions.

**COATING COPPER WITH MERCURY**

(1425) K. Faulkeper, Winnipeg, Manitoba, Canada, asks:

Q. 1. What is the best way to coat copper with a silver covering of mercury?

A. 1. To coat copper with mercury you should first clean the surface of the copper thoroughly with weak nitric acid and then rub the quick silver on the clean surface until the desired finish is obtained.

Q. 2. Can this finish be made permanent?

A. 2. It will be impossible to "set" this finish and if you wish to obtain a permanent silvered surface, you must electro-plate the copper article with silver.

**ELECTRIC SIGNALS**

(1426) Wm. D. Foster, Mamaroneck, N. Y., asks:

Q. 1. How can I raise, electrically, two or four vertical levers, two at once, or four at once, to a horizontal position, the levers being about 4 inches long, each lever having a small light at the outer end? I want each of the lights to show just before raising the levers:

A. 1. What you suggest could be very easily done by means of movable core solenoids which could be used to raise the arms of the signals, the particular ones to be raised being selected by means of a switch. Small circuit-closers could be arranged to operate in connection with the solenoids, so that just as the solenoids start to raise the levers, the light will light, and as the lever rises further, the light will go out. The size and amount of wire used on the solenoids will depend upon the current used, and can easily be determined by experiment.

**FOUCAULT'S EXPERIMENT**

(1427) M. Brieger, Montreal, Canada, asks:  
Q. 1. Will you kindly explain what the experiment involving Foucault's pendulum consisted of?

A. 1. We quote from Flammarion's *ASTRONOMY FOR AMATEURS*. "The magnificent experiment of Foucault at the Pantheon, just renewed under the auspices of the Astronomical Society of France, demonstrates the rotary motion of the Earth to all beholders. A sufficiently heavy ball (28 kilograms, about 60 pounds), is suspended from the dome of the edifice by an excessively fine steel thread. When the pendulum is in motion, a point attached to the bottom of the ball marks its passage upon two little heaps of sand arranged some yards away from the center. At each oscillation this point cuts the sand, and the furrow gets gradually longer to the right hand of an observer placed at the center of the pendulum. The plane of the oscillations remains fixed, but the Earth revolves beneath, from West to East. The fundamental principle of this experiment is that the plane in which any pendulum is made to oscillate, remains invariable even when the point of suspension is turned. This demonstration enables us in some measure to see the Earth turning under our feet."

**IMPORTANT**

**TO NEWSSTAND READERS**

IN order to eliminate all waste and unsold copies it has become necessary to supply newsstand dealers only with the actual number of copies for which they have orders. This makes it advisable to place an order with your newsdealer, asking him to reserve a copy for you every month. Otherwise he will not be able to supply your copy. For your convenience, we are appending herewith a blank which we ask you to be good enough to fill in and hand to your newsdealer. He will then be in a position to supply copies to you regularly every month. If you are interested in receiving your copy every month, do not fail to sign this blank. It costs you nothing to do so.

To..... Newsdealer

Address .....

Please reserve for me.....copies of **SCIENCE & INVENTION** every month until I notify you otherwise, and greatly oblige.

Name .....

Address .....

**Combination of Weights**

(1428) Everett Thomas, Casper, Wyo., asks:  
Q. 1. If a live fish, weighing 2 pounds is placed in a vessel containing enough water for it to swim in, will the vessel weigh 2 pounds heavier than it did without the fish? Please explain.

A. 1. If a live fish, weighing 2 pounds is placed in a vessel containing enough water to allow the fish to swim, and supposing that the vessel weighs ten pounds, with the water contained within it, when the fish is introduced, the vessel will weigh twelve pounds, the reason being that a floating body sinks until it displaces its own weight of the liquid in which it floats.

If this displaced liquid could flow out of the vessel freely, so that the same level would be maintained, the weight of the vessel and contents would not increase.

**Perpetual Motion(?)**

(1429) J. Striss, New York City, says: Imagine a machine that is actuated by power derived from a chemical compound, which needs but a little water, say a pint a day, to compensate for evaporation only, the chemical itself supplying power and lasting indefinitely. He asks:  
Q. 1. Would such a device be perpetual motion?

A. 1. When you figure on a machine actuated by power from a chemical compound, and state that only a little water is added to compensate for evaporation, such evaporation could be prevented by enclosing the device completely. It will not be perpetual motion.

**Losses in Allowing Coal to Stand**

(1430) Nathan Truman, Bainbridge, N. Y., asks:

Q. 1. Will ordinary anthracite coal in chestnut

or stove size, deteriorate in heat producing power on being kept in an open bin in a cellar for a period of eighteen months?

A. 1. The percentage of loss under the circumstances is very slight if coal is left in a dry bin in a cellar.

It is reported that coal submerged in sea water gives a greater number of B. T. U.s than if left in the open air or if burnt immediately after being taken from the coal mines. There are no accurate figures which can be given because different tests will produce different efficiencies even though the coal is taken from the same shipment.

**Changing the Color of Man**

(1431) Edgar D. Walker, Chicago, Ill., wants to know:

Q. 1. If there has ever been performed an operation on a person of colored origin, in order to make him have a white skin.

A. 1. An attempt to change the color of a man by means of glandular extirpations has never taken place. Medically we know that there are certain glands whose secretions cause pigmentation of the skin. If these glands could be removed prior to birth, it is quite probable that we could get a lack of color not only in the pigmented layer of the skin, but also in the hair, eyebrows, nails, and all other parts of the body which are a direct outgrowth of the ectoderm.

We also know that certain diseased conditions bring on a marked pigmentation of the skin, and that if these conditions are alleviated, the skin pigmentation disappears. Although the effect of which you speak has been theorized upon, we do not know of any attempts that have been made upon either animals or man in an effort to change the color of the skin.

Perhaps some experiments with the electric needle tending to bleach the pigmented skin layer, following the technique used in the removal of birth marks, would be effective in changing the color of an individual.

**Fire Resisting Cement**

(1432) Ray J. Cook, Fort Worden, Wash., requests:

Q. 1. Can you give me directions for making asbestos cements?

A. 1. Ground asbestos may be made into a cement which will stand a high degree of heat by simply mixing it with a solution of sodium silicate. By subsequent treatment with a solution of calcium chloride, the mass may be made insoluble, silicate of calcium being formed.

A cement which will stand a high degree of heat, and be suitable for cementing glass, porcelain, and other vessels intended to hold corrosive acids, may be made as follows:

Asbestos	2 parts
Barium Sulphate	3 "
Sodium silicate	2 "

By mixing these ingredients, a cement capable of resisting the strongest nitric acid will be obtained. If hot acids are dealt with, or the cement is to be used in places where it will be subjected to intense heat, the following will be found to possess still more resistant powers.

Sodium silicate	2 parts
Fine sand	1 "
Powdered asbestos	1 "

Both of these cements take a few hours to set. If a cement which will set immediately is wanted, use potassium silicate instead of sodium silicate. This mixture will set at once, and the resultant cement will have the same power of resistance as that made with the above formula.

**SPARK COIL DATA**

(1433) Edward Kujanik, 62 Bruce St., Galt, Ont., Canada, asks:

Q. 1. Can you give me data on the construction of a small spark coil capable of giving a spark about 1/8 of an inch long?

A. 1. The core of such a coil is composed of a bundle of iron wires three inches long, the diameter of the bundle to be 1/4 inch. The primary consists of two layers of No. 23 D.C.C. wire, over which is placed an insulating tube, with walls 1/32 inch thick. Several layers of Empire cloth may be substituted for this tube if desired. The secondary consists of 1/4 pound of No. 34 enameled wire. The condenser consists of 30 sheets of tin foil 2 inches by 1 inch, separated by sheets of paraffin paper. The primary voltage should be 2.

**SOURCE OF HIGH AMPERAGE**

(1434) John H. McMillen, Iowa Falls, Iowa, asks:

Q. 1. Would it be possible to re-wind a low voltage dynamo in order to use it for an electric arc welding machine with a maximum capacity of about 150 amperes?

A. 1. You cannot re-wind a low voltage dynamo and use current from the same on an arc welder, with a maximum capacity of 150 amperes. There is no low voltage dynamo on the market which you can use for this purpose.

We would suggest that you equip your plant with the alternating current, and then step this down to the desired voltage and amperage.

# FIRST FOR PRICE, QUALITY AND SERVICE. WE SAVE YOU MONEY

## MAKE YOUR SET WITH GREAT LAKES QUALITY PARTS

### WE PAY TRANSPORTATION CHARGES IN THE UNITED STATES AND U. S. POSSESSIONS

#### PHONES

Genuine Frost and Brandes head sets complete with cords.

Frost T162—Double head sets, 2000 ohm .....\$4.25

Frost T163—double head sets, 3000 ohm ..... 4.90

T168—Western Electric latest type double head set. List \$12.00. Our price .....\$10.50

Brandes Superior T166—Double head sets 2000 ohm ..... 7.20



#### MAGNAVOX

The genuine R-3 Radio Magnavox with the 14 inch horn is the ideal loud speaker for use in homes, offices, amateur stations, etc. It operates from your 6 volt storage "A" battery and amplifies as it reproduces. "B" battery voltage should be 90 to 200 for best results. "Radio brings it, Magnavox tells it."

T170—Radio Magnavox .....\$39.50



#### FROST JACKS AND PLUGS

Jacks are polished nickel, nickel-silver springs, pure silver contacts. Nickel washers for mounting on any panel 1-8 to 3-8 inch thick. Spread terminals make soldering easy.

T133—One spring (open circuit). Each .....\$0.46

T134—Two spring (closed circuit). Each ..... .52

T131—Four spring (two closed circuits) Each ..... .63

T135—Three spring (two open circuits, commonly called "single circuit filament control"). Each ..... .70

T136—Five spring (two open and two closed circuits, commonly called "two circuit filament control"). Each ..... .88

T132—Plug, telephone type with short knurled grip ..... .35

T137—Plug (as shown), cord tips fit into plug ..... 1.05

T139—Plug with threaded barrel instead of set screw. Takes cord tips ..... .55



#### VARIABLE GRID LEAK

Pencil mark type. Removable black enameled cap.

T50—Grid Leak ..... 20c



#### GRID AND PHONE CONDENSERS

Mounting holes spaced to fit screws of above Grid Leak. Mica insulation, wrapped with varnished cambric tape. Capacity, .00025 Mfd.

T55—Grid Condensers .....15c

T59—Phone Condenser .001 Mfd. ....20c



#### LOOSE COUPLER AND TUNING COIL

This loose coupler is preferred by many because of its wide range—200 to 3500 meters. Magnohogany finish. All metal parts are brass, nickel and highly buffed. Secondary has 12 point switch mounted on Bakelite coil head. Windings are green silk-covered wire.

T800—Size, 5 1/2 x 6 x 13 inch .....\$6.50

T805—Two Slide Tuning Coil ..... 2.60

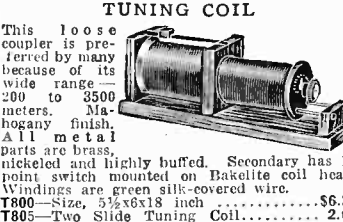

#### CRYSTAL DETECTOR

A very high grade glass enclosed crystal detector including the crystal. All metal parts nickel plated. Adjustable to any point on the crystal.

T20—Enclosed crystal detector .....\$1.30

A lower priced but nicely constructed detector. Crystal included. ....88

T30—Detector

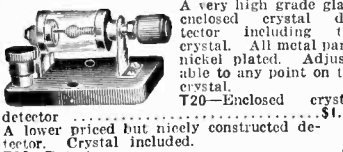

#### TESTED CRYSTALS

Selected and tested galena or silicon. Each box contains enough for four to six ordinary crystals.

T12—Galena, per pkg. ....\$0.12

T13—Silicon, per pkg. .... .12

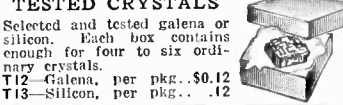

#### LIGHTNING ARRESTER OR PROTECTOR

Mounts indoors. Porcelain base, nickel covered. Listed by the Underwriters' Laboratories under April, 1922, regulations.

T300—Protector .....\$1.40



#### OUR GARANTEE YOUR PROTECTION

Your satisfaction guaranteed. If for any reason you do not feel satisfied with your purchase, you may return it and we will refund your money. We will pay return transportation charges.

#### 180° VARIOCOUPLER

The primary and secondary windings of this coupler are properly proportioned and spaced. The center of the secondary is always in the center of the primary field. Unlike most couplers, it aids in tuning. Black fibre base, brown formica tube and nickelled metal parts. Panel or table mounting.

T1100—Coupler .....\$2.75



#### 180° MOULDED ROTOR TYPE COUPLER

This 180 degree variocoupler has heavy black tube and moulded rotor ball. Wound with green silk wire and has 10 taps on the primary. Metal parts are brass nickel plated. Furnished without base, but can be mounted on panel or table.

T1120—Variocoupler .....\$3.75



#### VARIABLE CONDENSERS

Very best mechanical construction. Heavy, hard aluminum plates. The vernier types are furnished with moulded dial and small knob for adjusting vernier. Plain types have 1/4 inch shaft.

T1443—43 plates .001 Mfd. without dial .....\$2.25

T1423—23 plates .0005 Mfd. without dial ..... 1.75

T1411—31 plates .00025 Mfd. without dial ..... 1.35

T1403—3 plates .00005 Mfd. without dial ..... 1.15

T1441—41 plates vernier .001 Mfd. with dial ..... 4.95

T1442—21 plates vernier .0005 Mfd. with dial ..... 4.25

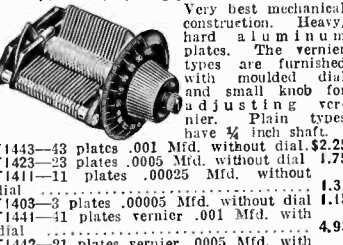

#### THORDARSON VERNIER CONDENSERS

T1523—23 plate vernier .0005 Mfd. with knob and dial .....\$3.65

T1543—43 plate vernier .001 Mfd. with knob and dial ..... 4.35



#### INDUCTANCE COIL MOUNTINGS

For base or panel mounting. Connecting leads furnished, coil settings are adjustable by means of knobs. Made entirely of bakelite with nickel plated brass metal parts. Coil position can be locked by knurled set screws.

T1603—Three coil mounting .....\$3.50

T1602—Two coil mounting ..... 2.75

T1601—Single coil mounting ..... .50



#### INDUCTANCE COILS

Rigidly wound, nicely finished, low distributed capacity. All coils are equipped with standard mountings. We can supply any of these coils without mounting plugs, for 50c less than the prices shown. The wave lengths shown are range limits, based on a variable condenser of .001 Mfd. capacity.

No.	Number of Turns	Wave Lengths	Price, Mfd.
T1725	25	125-250	\$0.95
T1726	35	175-450	0.95
T1727	50	240-720	1.00
T1728	75	390-910	1.10
T1729	100	500-1450	1.14
T1731	200	900-2500	1.28
T1732	250	1200-3500	1.36
T1733	300	1500-4500	1.38
T1735	500	2800-8100	1.95
T1736	700	5000-12000	2.00
T1738	1000	7000-17000	2.30
T1739	1250	9750-19500	2.55
T1740	1500	14500-26500	2.70

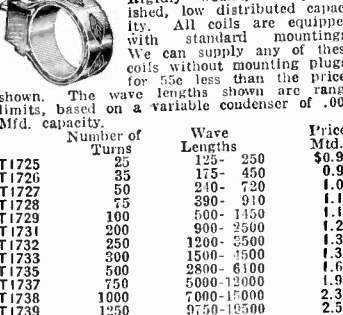

#### STORAGE "A" BATTERIES

Built of entirely new parts. With the proper care they should last several years. The De Luxe type has rubber case and cover for top as pictured, the Standard type has black wood case similar to ordinary automobile type. Guaranteed to give full rated capacity. All 6 volt batteries.

No.	Amp. Hour	Shpg. Wgt.	Price
TD 60—De Luxe	60	40	\$15.50
TD 80—De Luxe	80	60	17.50
TD 100—De Luxe	100	62	20.50
TS 60—Standard	60	35	12.25
TS 80—Standard	80	40	14.25
TS 100—Standard	100	50	16.25
TS 110—Standard	120	60	18.25

The above storage batteries are the only items on which we do not pay transportation charges. We will ship by Express. Collect.



#### HOW TO ORDER

Order from this page. Please give number description and price of the articles you order to help us avoid mistakes. Total amount of your order and send Post Office money order, certified check or draft with street address on both letter and envelope. Do not include money for transportation. We pay it except on storage "A" batteries. We see ads of previous months for other items.

#### VARIOMETERS

For efficiency, perfect inductive ratio, low capacity effect and neatness of design these variometers are unequalled. All metal parts nickel plated. Stator and ball mahogany finish. Furnished completely assembled and tested.

T1200—Variometer, No. 20 wire .....\$2.65

T1300—Variometer, No. 18 wire ..... 2.65

The following knocked-down variometers have the stator windings wound and cemented ready to put in place. Two sizes of wire as listed. Complete with wire and metal parts.

T1205—Knocked-down variometer with No. 20 wire .....\$1.85

T1305—Knocked-down variometer with No. 18 wire ..... 1.85

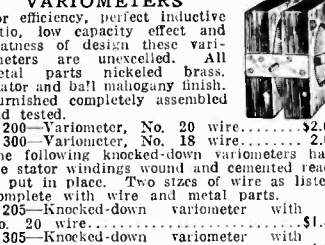

#### MOULDED TYPE VARIOMETER

This variometer is made of high grade black moulded composition. Wound with green silk wire. Metal parts are nickel plated.

T1220—Moulded variometer .....\$4.95

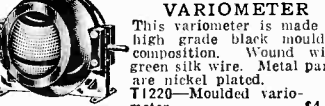

#### THORDARSON AUDIO FREQUENCY AMPLIFYING TRANSFORMER

There is probably no better known transformer. Made by a company that specializes in transformers. Entirely encased in sheet aluminum shield. Heavy connecting straps to binding posts.

T1504—Thordarson Transformer, 3 1/2 to 1 .....\$3.65

T1505—Thordarson Transformer, 5/2 to 1 .....\$4.20



#### AUDIO FREQUENCY AMPLIFYING TRANSFORMERS

Correctly designed for minimum distributed capacity and low core loss. Shielded, beautifully finished in nickel and black enamel. Ratio 5/2 to 1. Transformer—Shielded Transformer—Unshielded types listed below have terminals mounted on Bakelite panel. Two ratios.

T1510—Transformer, 10 to 1 ratio .....\$3.55

T1503—Transformer, 3 to 1 ratio ..... 3.50



#### RADIO FREQUENCY AMPLIFYING TRANSFORMERS

Radio frequency transformer circuits help to eliminate static and interference, thus permitting easy, sharp tuning of long distance stations. Enclosed in metal case for shielding and can be mounted in tube socket if desired. Wiring diagrams furnished with each transformer.

T1500—Transformer. Each .....\$3.47

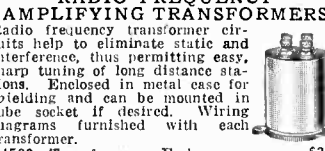

#### "B" BATTERIES

Standard high grade radio "B" batteries. Never over five days old.

T230—2 1/2 volt Signal Corps type. Size 3 1/2 x 2 x 2 1/2 inch .....\$1.08

T235—2 1/2 volt U. S. Navy variable—5 positive taps. Size, 5x3x2 1/2. Price .....\$1.80

T240—2 1/2 volt large variable—5 positive taps. Size, 6 1/2 x 1 3/4. Price ..... 2.25

T245—4 1/2 volt large size. Leads only. Size, 13x13x3. Price ..... 4.00



#### BINDING POSTS

Complete with screw and washer. All brass finished in polished nickel or with black composition top as listed. Order by number.

T110—Large size, all nickel ..... Each Doz. 10c 95c

T122—Medium size, nickel finished, with hole for phone tip or wire 4c 35c

T112—Medium size, black composition top ..... 5c 48c

T120—Large size, composition top ..... 8c 85c

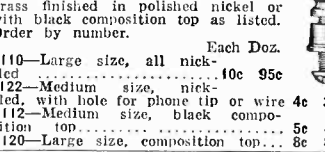

#### SWITCH POINTS & STOPS

Brass, polished nickel finish. Screw size, 6/32 x 5/8 ins. long, two nuts with each contact point and one with the type of lever and point.

T130—Switch Point. Each Doz. 20c

T133—1 1/2 inch. Radius 18c 2.10

T150—Switch Stops ..... 3c 20c 1.40

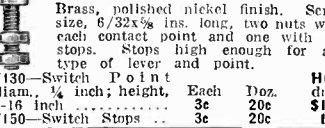

#### SWITCH LEVERS

A high grade, polished nickel-plated lever with solid moulded black composition knob. Complete with panel bushing.

T151—1 inch. Each Doz. \$2.10

T152—1 1/2 inch. Radius 18c 2.10

T155—1 1/2 inch. Radius 18c 2.10

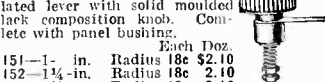

#### VACUUM TUBES

Genuine Cunningham or Radio-tron made by the General Electric Co. Every tube guaranteed new and in original package. We do not sell "bootleg" tubes.

T-C200—Detector .....\$4.40

T-C201—Amplifier ..... 5.90

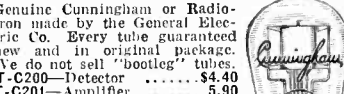

#### METAL AND BAKELITE SOCKETS

Bakelite brown finished socket for panel or base mounting. Double spring contacts held rigidly in place.

T1076—Bakelite socket .....\$0.65

T1075—Nickelled metal socket .45



#### WD11 WESTINGHOUSE TUBES

This tube eliminates storage batteries and is operated by a 1 1/2 volt dry battery. It can be used in any tube having the proper socket or adapter.

T11—Tubes .....\$5.90

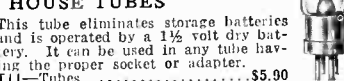

#### WD11 BAKELITE SOCKET

This socket is to be used with the above tube.

T1077—Bakelite socket .....\$0.75

#### WD11 ADAPTER

The purpose of the adapter is to make your regular socket usable for a WD11 Tube.

T1078—Adapter .....\$0.80

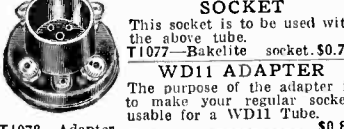

#### VACUUM TUBE RHEOSTATS

This is a reasonably priced, smooth acting rheostat that will mount directly on back of panel. Bakelite arrow knob.

T1050—Rheostat .....45c

Genuine Cutler-Hammer rheostats, we believe, are the best rheostats on the market today. Arranged for panel mounting. The picture shows the vernier type. All metal parts nickel plated. Plain type is similar.

T1061—Vernier type C. H. Rheostat .....\$1.40

T1062—C. H. Rheostat without vernier. .95

T1064—Howard vernier rheostat operates from one knob .....\$1.40

T1065—Howard rheostat without vernier. 1.00

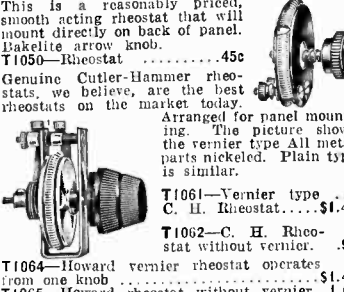

#### DIALS

Genuine Bakelite Dial as pictured. Sharply engraved divisions and figures filled with a brilliant white. Three-inch diameter with bushing for 3/16-in. or 1/4-in. shaft. Set screws included. Each Doz.

T500—Dial ..... 55c \$6.40

Three-inch moulded composition dial as pictured. Has a luster that cannot be told from Bakelite. Set screws included. Each Doz.

T555—Dial, 3/16-in. Shaft ..... 28c \$2.75

T550—Dial, 1/4-in. Shaft ..... 28c 2.75



#### CABINETS

These are reasonably priced but sturdily built cabinets of weathered oak. The top is removable by loosening four screws. End posts are routed to take panel 3/16-in. thick. The panels are not included. See table for panel lengths.

T212—Can be used for detector and two step. Panel space, 5 1/2 x 12 .....\$2.50

T214—Can be used for 2 variometers and 1 coupler. Panel space, 5 1/2 x 11 ..... 2.75

T218—Can be used for 2 variometers, 1 coupler and detector. Panel space, 5 1/2 x 18 3.00

T222—Can be used for 3 variometers, 1 coupler, detector and 2 step. Panel space, 5 1/2 x 22 ..... 3.25



#### PANELS

Genuine Formica. Panels to fit our cabinets.

T262—Panel, 5 1/2 x 12-in. 3/16-in. thick .....\$1.38

T264—Panel, 5 1/2 x 14-in. 3/16-in. thick. 1.64

T268—Panel, 5 1/2 x 18-in. 3/16-in. thick. 2.08

T272—Panel, 5 1/2 x 22-in. 3/16-in. thick. 2.53



#### SPAGHETTI AND WIRE

For cabinet wiring. Yellow finish spaghetti.

T33—Per 4-ft. length .....27c

T32—Tinned Copper No. 16 Wire ..... 2c 20 Ft. 30c

T33—Wire with insulation similar to spaghetti on it. Wire is tinned for soldering. Price 10 feet .....37c

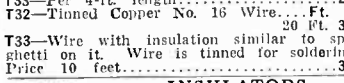

#### INSULATORS

These are very strong strain type insulators. Each Doz.

T360—Moulded insulator shown above .....\$1.10 \$1.10

T365—Porcelain insulators ..... .09 .95



#### ANTENNA WIRE

The following are 100-ft coils of 7 strand cable of No. 22 wire, which makes the best Aerial. Use phosphor bronze, where the span is 100 feet or more. It is stronger.

T350—Stranded Phosphor Bronze, 100 ft. .....\$1.47

T355—Stranded Copper, 100 ft. ..... 1.77

T356—Single No. 14 bare solid Copper Wire, 100 ft. .... 42

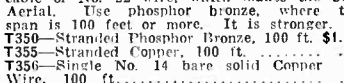

NAME	POSITION	SALARY
John	AUTOMOBILE ENGINEER	\$125 A WEEK
	REPAIR MAN	\$50 A WEEK
	CHAUFFEUR	\$40 A WEEK

## Put Your Name ON THIS Pay-Roll

Men like you are wanted for big-pay positions in the fascinating field of automobile engineering. We have made it easy for you to fit yourself for one of these positions. You don't have to go to school. You don't have to serve an apprenticeship. Fifteen automobile engineers and specialists have compiled a spare time reading course that will equip you to be an automobile expert without taking any time from your present work.

### AUTO BOOKS

6 Volumes Shipped Free

Now ready for you — an up-to-the-minute six-volume library on Automobile Engineering, covering the construction, care and repair of pleasure cars, motor trucks and motorcycles. Brimming over with advanced information on Lighting Systems, Garage Design and Equipment, Welding and other repair methods. Contains everything that a mechanic or an engineer or motorcyclist or the owner or prospective owner of a motor car ought to know. Written in simple language that anybody can understand. Tastefully bound in American Morocco, flexible covers, gold stamped, 2,650 pages and 2,100 illustrations, tables and explanatory diagrams. A library that cost thousands of dollars to compile but that comes to you free for 7 days' examination.

### Price Reduced

Down goes the price on these famous Auto Books. We have induced our printers and binders to cut the price they charge us. We pass this saving on to our customers.

Mail Coupon Now For FREE Trial

#### Partial List of Contents

- More than 190 Blueprints of Wiring Diagrams
- Explosion Motors
- Welding
- Motor Construction and Repair
- Carburetors and Settings
- Valves, Cooling Lubrication
- Fly-Wheels
- Clutch
- Transmission
- Final Drive
- Steering Frames
- Tires
- Vulcanizing
- Ignition
- Starting and Lighting Systems
- Shop Kinks
- Commercial Garage Design and Equipment
- Electric
- Storage Batteries
- Cars and Repair
- Motorcycles
- Commercial Trucks
- Glossary

### Only 10c a Day

Not a cent to pay in advance. First you see the books in your own home or shop. Just mail coupon and pay express charges when books arrive. You can read them and study them for seven whole days before you decide whether you want to keep them or not. If you like the books send only \$2.80 in seven days and \$3 a month until the special introductory price of \$21.80 has been paid. (Regular price \$45.)

### Send No Money Now



Don't take our word for it. See the books without cost. There is so much profit in this offer for you, that we urge you to waste not a moment in sending for the books. Put the coupon in the mails today. Send no money—just the coupon!

American Technical Society, Dept. A-253 Chicago, Ill.

AMERICAN TECHNICAL SOCIETY  
Dept. A-253, Chicago, Ill.

Please send me the 6-volume set, "Automobile Engineering," for 7 days' examination, shipping charges collect. If I decide to buy, I will send \$2.80 within 7 days and the balance at \$3 a month until the \$21.80 has been paid. Then you send me a receipt showing that the \$45.00 set of books are mine and fully paid for. If I think I can get along without the books after the seven days' trial, I will return them at your expense. To insure prompt shipment fill out all lines.

Name .....

Address .....

Employed by .....

# Refrigeration in the Home

By L. K. WRIGHT

(Continued from page 1075)

The flywheel side of the shaft offers the hardest problem, for the old bearing must be removed and the opening drilled an inch larger to take the new bushing. This new bushing will be two inches longer and fitted with a cap to give pressure on the packing. The illustration, A, explains it. Because of the length of the new bearing the idler pulley will have to be removed and the driven pulley moved out to provide clearance. The projecting bit of shaft may be sawed off to give a finished appearance. It is a good plan to drill an oil shaft in the new bearing at an angle, as shown in sketch, to insure proper lubrication. It is best to pack the stuffing box with flax cord that has been soaked in graphite and glycerine. Another packing, though not so good, is butchers' white meat string soaked in a thick mixture of graphite and glycerine.

Next remove the oil filler from the crankcase and set an angle valve, No. 10, in its place. The lubricant used in the crankcase is glycerine, and is poured with a funnel through valve No. 10. Upon the opposite side a glass gauge should be fitted by drilling and tapping two holes in the crankcase, as shown in B.

Any other vents or openings in the crankcase must be plugged or covered by screwing pieces of sheet metal over them. Always gasket any opening so covered. Also be sure that there is a good gasket between the sections of the compressor.

A condenser is constructed by making a helical coil containing about seventy feet of quarter-inch copper tubing. One end of this coil is connected to a small receiver tank, C, made of a two-inch piece of extra heavy galvanized pipe, eight inches long and capped at both ends. These caps are drilled and tapped to take the tubing connectors by which the tubing is secured to the tank. As shown in the sketch the receiver is lying down, but it may be placed in an upright position in the center of the coil if care is taken to see that the outlet line supplying the expansion valve is at the bottom. The coil and receiver are then set into a tank constructed of galvanized iron, which has an inlet and an outlet line for water. The inlet water line should be at or near the bottom and the outlet line near the top. A cover is provided through which the copper tubing projects. After carefully soldering the cover to the tank, and the openings about the copper tubes, test with water pressure and see that it is tight.

After ascertaining your electric circuit factors, purchase a suitable motor of one-half horsepower. Measure the size of the pulley on the compressor and note the speed of the motor to determine the size of the drive pulley. The compressor should run from 150 to 250 R. P. M. The motor, compressor and tank are preferably bolted to a common base constructed of one-inch pine, for if the parts are not rigidly fastened, there is a tendency to draw together. If the motor is equipped with a belt tightener it would be the better policy to use an endless belt, because it is the more silent.

A measurement is taken of the ice bunker and a galvanized tank of suitable size constructed. A coil of sixty or more feet of one-quarter inch copper tubing is fitted into the tank, which is then filled with brine. It is better to provide the tank with a loose-fitting cover as the sweat from the unsubmerged lines would, in time, cause it to overflow; it would also weaken the brine. Dissolve three to five pounds of calcium chloride, depending upon the purity in each gallon of water, until the hydrometer regis-

ters a density of 90°. The density of this solution is about 23° Baumé, its weight about 13.5 pounds per gallon, and the freezing point —9° Fahr. In order to keep the brine from congealing or weakening test periodically and keep to standard density. In placing the brine tank in the ice bunker set it up on pieces of wood (2" x 2"), spacing on all sides to allow for air circulation, for it is upon this that the efficiency of the plant depends.

All valves, nipple and fittings are 3/8-inch extra heavy galvanized iron or brass. Determine the suction side of the compressor and insert a short nipple. It may be necessary to bush down to receive the nipple, to which is coupled a cross fitting, No. 6, the upper opening of which supports a low pressure gauge (reading to 100 lbs.); the under opening has a 6-inch nipple with a pair of flanges at its lower end. The lower flange will have several uses and a plug and nipple should be kept ready. The other opening of the cross fitting is connected by nipple to a shut-off valve, No. 3. This valve is connected to the suction line of copper tubing by means of a reducing tubing connector, or a bushing and a connector, No. 8. Be sure that this suction line is the one that leads to the top of the coil in the brine tank. The discharge side is coupled to the compressor by means of a short nipple, to which the cross fitting, No. 5, is fitted, the top opening supporting a high pressure gauge (H.P. to 100 lb.) the bottom opening being fitted with a nipple, six inches long, capped at the bottom; or a coupling may be used in its place, being fitted with a purge cock. This acts as an oil interceptor and removes all lubricant (glycerine) which escapes past the piston rings and prevents it from entering the system. Oil in the lines is detrimental to refrigeration. This purge should be drained occasionally. The other trap, on fitting No. 6, is for the purpose of trapping any scale and preventing it from getting into the compressor, where it might do damage to the piston and compressor walls. After one or two cleanings all the scale will be removed from the system. Valves, numbers 1 and 2, are stop valves. Number 4 is a check valve that prevents the high pressure side backing through the compressor to the low or expansion side. The needle valve, No. 7, is spaced from the stop valve with a short nipple. In connecting tubing to the valves use tubing connectors, as at Nos. 8, 9, etc. If it is desired a pair of flanges may be placed between the stop valve (No. 2) and the expansion (needle) valve and a disc of fine screening inserted in the flanges to intercept any dirt which would interfere with the proper action of the needle valve. If the expansion valve is suspected of being clogged, mark the position of the wheel with a piece of chalk and open fully, counting the number of turns, then return to exact position for the particles of dirt will have been forced through and away from the needle. Figure D shows how flange may be installed. In fitting all joints use a paste made of glycerine and litharge. Use but little glycerine and mix with the finger tips to insure a smooth, syrupy mass without lumps. Mix but what is needed for immediate use, as it will harden and be useless in a few minutes. Do not get any of this sealing compound inside the fittings, apply to the threads of the nipples only and never in valves or fittings.

Before attempting to charge the machine a high pressure test should be made. This

(Continued on page 1098)



# RADIO BARGAINS

Buying Direct—in Quantities—for Cash, and operating on a "SMALL PROFIT—BIG SALE—QUICK TURN" basis, MAKES POSSIBLE THESE VALUES

RADIO SUPPLIES PURCHASED HERE ARE SOLD UNDER A POSITIVE GUARANTEE OF SATISFACTION. WE CARRY THE LARGEST NEW STOCK OF FIRST QUALITY NEW MERCHANDISE

## COMPLETE PARTS FOR REINARTZ CIRCUIT

Includes 1 7x18 Formica Panel, 1 Bakelite Socket, 1 Howard Vernier Rheostat, 23 Plate Condenser, 11 Plate Condenser, 3 Switch Levers, 2 Dozen Switch Points, 1 Reinartz Wound Coil, 1 Variable Grid Leak, 8 Binding Posts, 25 Feet Tinned Wire, 1 Base for Coil, 1 Mounting Base Board, and 1 Diagram to Construct This Set. **\$11.45**

Complete .....

ORIGINAL TYPE "C" **BALDWIN UNITS....\$4.95**

## COMPLETE PARTS FOR KNOCKDOWN RECEIVING SETS

This includes 2 Variometers, 1 Coupler, 3 Dials, 1 Rheostat, 1 Cunningham Detector Tube, 1 Bakelite Socket, 1 Mahogany Cabinet, 7x18 Formica Panel, 6 Binding Posts, 1 Switch Lever, 12 Switch Points, 2 Stops and 1 Diagram to construct this set. Set is capable of receiving 1,000 miles if installed with outdoor aerial. **\$17.95**

## VARIABLE CONDENSERS

\$4.30 Value, 43 PLATE, now .....	\$1.75
\$3.70 Value, 23 PLATE, now .....	\$1.45
\$3.30 Value, 11 PLATE, now .....	\$1.35
\$3.10 Value, 5 PLATE, now .....	\$1.25
\$2.70 Value, 3 PLATE, now .....	\$1.15

U. S. A. Signal Corps Aviation Type 194-W Western Electric Phones ..... **\$7.95**

Each Phone Cap is covered with large soft rubber ear cushions, and an aviation leather helmet goes with each set! These are the only phones to pass the Government specifications for sensitivity and loudness, the requirements called for in aircraft reception.

## Complete Parts for Flewelling Circuit

Includes 6x14 Formica Panel, 23 Plate Condenser, 3 Micon .006 Condensers, 1 Freshman Variable Grid Leak, 1 Remler Leak, 2 Coil Mount, 2 Honeycomb Coils, 2 Coil Plugs, 1 Socket, 1 Howard Vernier Rheostat, 2 Binding Posts and 1 Diagram to Wire and Construct This Set. **\$12.45**

MAGNAVOX, Loud Speaker, **\$34.95**  
Type R3 .....

VARIOMETERS GENUINE MAHOGANY \$5 VALUE, NOW **\$1.95**

VARIOCOUPERS \$4.50 VALUE NOW **\$1.75**

## HONEYCOMB COILS

1,500 Turns .....	\$1.50	150 Turns .....	60c
1,250 Turns .....	1.50	100 Turns .....	50c
1,000 Turns .....	1.25	75 Turns .....	40c
750 Turns .....	1.00	50 Turns .....	40c
250 Turns .....	75c	35 and 25 Turns .....	40c

**\$8.50 Guaranteed**  
3,000 Ohm  
**HEADPHONES ..... \$3.65**

RHEOSTATS ..... 45c

Sponge Rubber EAR CAPS, Pair. .... 50c

DIALS, 2, 3 and 3 1/2 in. .... 25c

Thordarson Amplifying TRANSFORMERS  
\$4.50 Value, Now ..... **\$2.95**

GREWOL DETECTORS ..... **\$1.45**

Signal Corps Super Sensitive Microphone Transmitters ..... **\$2.45**

Solid Copper Aerial Wire, 100 ft. ....	<b>\$ .35</b>	Phone Caps for mostly all phones	<b>\$ .25</b>
Spaghetti Tubing, Yard .....	.10	Signal Corps Hot Wire Ammeters at	<b>5.45</b>
Cord Tip Plugs .....	.60	Anti-Capacity Switches .....	<b>1.50</b>
Lightning Arresters .....	.95	Lightning Switches .....	<b>2.65</b>
2-Slide Tuning Coils at .....	<b>1.95</b>	Hydrometers, now at .....	<b>.45</b>
3-Coil Honeycomb Mountings. With knobs .....	<b>4.20</b>	Freshman Variable Grid Leaks .....	<b>.95</b>

SWITCH LEVERS ..... 20c

BINDING POSTS, per doz. .... 50c

FORMICA PANEL, 1/8 in. thick, Square Inch, Black or Brown. .... **1 1/2c**

*We Guarantee All Merchandise Purchased of Us*

*Mail Orders Receive Immediate Attention and We Pay Transportation Charges*

# Chicago Salvage Stock Store

511 SOUTH STATE ST.

CHICAGO, ILL.

# Refrigeration in the Home

(Continued from page 1096)

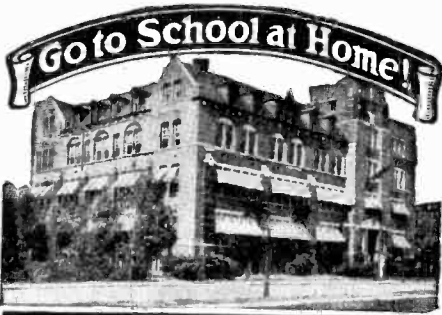

## HIGH SCHOOL COURSE IN TWO YEARS

**YOU ARE BADLY HANDICAPPED** if you lack High School training. You cannot attain business or social prominence. You are barred from a successful business career, from the leading professions, from well-paid civil service jobs, from teaching and college entrance. In fact, employers of practically all worth-while positions demand High School training. You can't hope to succeed in the face of this handicap. But you can remove it. Let the American School help you.

**FIT YOURSELF FOR A BIG FUTURE** This course, which has been prepared by some of America's leading professors, will broaden your mind, and make you keen, alert and capable. It is complete, simplified and up-to-date. It covers all subjects given in a resident school and *meets all requirements* of a High School training. From the first lesson to the last you are carefully examined and coached.

**USE SPARE TIME ONLY** Most people *idle* away fifty hours a week. Probably you do. Use only one-fifth of your wasted hours for study and you can remove your present handicap within *two years*. You will enjoy the lessons and the knowledge you will gain will repay the time spent in study.

Check and mail the coupon NOW for full particulars and Free Bulletin.

**American School**

Dept. H-326

Drexel Ave. and 58th St., Chicago

American School

Dept. H-326 Drexel Ave. & 58th St., Chicago

Send me full information on the subject checked and how you will help me win success.

- |                              |                            |
|------------------------------|----------------------------|
| .....Architect               | .....Lawyer                |
| .....Building Contractor     | .....Machine Shop Practice |
| .....Automobile Engineer     | .....Photoplay Writer      |
| .....Automobile Repairman    | .....Mechanical Engineer   |
| .....Civil Engineer          | .....Shop Superintendent   |
| .....Structural Engineer     | .....Employment Manager    |
| .....Business Manager        | .....Steam Engineer        |
| .....Cert. Public Accountant | .....Foremanship           |
| .....Accountant and Auditor  | .....Sanitary Engineer     |
| .....Bookkeeper              | .....Surveyor (& Mapping)  |
| .....Draftsman and Designer  | .....Telephone Engineer    |
| .....Electrical Engineer     | .....Telegraph Engineer    |
| .....Electric Light & Power  | .....High School Graduate  |
| .....General Education       | .....Fire Insurance Expert |
| .....Vocational Guidance     | .....Wireless Radio        |
| .....Business Law            | .....Undecided             |

Name .....

Address .....

is accomplished by closing valve No. 3 tightly, all other valves being open; be sure that the expansion valve is fully opened. See that the motor cups are filled with oil or grease, the crankcase showing at least a half gauge of glycerine, the belt tight, and that water is flowing through the condenser and that same does not leak. Remove the flange from scale trap (No. 6) and start machine, running high pressure gauge up to 100 pounds. Then stop machine and replace the flange half, meanwhile fitted with a plug. This plug is but temporary, but nevertheless, should be tight. Be sure and use gasket between the flange halves and when thought tight, open up valve No. 3. This will give an air pressure on the whole system. The pressure will fall to about 80 pounds or less and then should remain at a constant. Look over all joints for leaks; bad ones can be immediately detected by the hissing sound; if in doubt, test with soap and water and watch for bubbles.

When satisfied that the system is tight, open the purge cock on the cross fitting No. 5, and allow the air to escape. Then with valve No. 1 tightly closed, start machine, exhausting the air from the system through the purge. A good test to ascertain whether the system is tight or not is to fasten a rubber hose to the purge cock and submerge in a pail of water. This also shows when all the air is exhausted. When so exhausted, close valve No. 3 while the machine is running. Then stop machine and unbolt the lower flange, take out the plug and insert a nipple to which a charging hose has been clamped. A charging hose is made from a length of pressure or rubber tubing, such as is used by confectioners on their carbonic lines. A nipple is fitted into the tubing and secured by three or four hose clamps. The other end of the hose is similarly equipped with nipple and clamps.

Most refrigerants are dangerous to use and require special precautions, but the refrigerant used in this plant is practically odorless, non-injurious, non-explosive, and non-poisonous, yet is efficient and best for household use. The refrigerant, ethyl chloride, is obtained in a steel drum, to which the other end of the charging hose is fitted by means of the nipple. When the drum is hooked up to the machine lay it on or suspend it from a scale so that the amount of refrigerant entering the system can be noted. With the drum in position and hose connected, start machine and exhaust the air from the hose and compressor. Close purge valve while machine is running, and then open valve No. 1; then slowly open valve on chemical drum. Watch high pressure gauge very closely and load machine with about two pounds of refrigerant, and then give it a trial run. The drum of ethyl chloride need not be disconnected for the trial run; all that is necessary is to make sure the valve on the drum is closed. In charging the machine should the high pres-

sure gauge begin to "spin" (mount too rapidly) stop the machine immediately as there is too much refrigerant in the plant giving a hydraulic pressure which might strain the outfit.

To run the plant have all the valves open; see that water is passing through the condenser and then start machine. The needle valve works on a micrometer screw and is very sensitive, a mere touch being sufficient to make a difference of several pounds' pressure on the low side. This valve will have to be adjusted so that the low pressure gauge carries from five to ten pounds of gas pressure, while the high pressure gauge will read from thirty to eighty pounds. Pressures on the high (liquid) side will depend upon the temperature of the cooling water, and pressures on the low side will have to be adjusted, so that the return or suction line frosts up to, but not on the compressor.

If the trial run is satisfactory begin to remove charging hose as follows: Close valve No. 3 and run machine until low pressure gauge shows a vacuum, then close valve No. 1, and disconnect drum by removing lower flange. Insert a plug in flange and replace with leaden gasket or shellacked paper one. Then exhaust air and gas from the compressor through purge. When all exhausted close purge tightly, make sure flange is tight, then open valves No. 1 and No. 3, and plant is ready to run.

The best location for the plant is right next to the ice box, or it may be located directly under it in the basement and the lines carried through the ceiling. The return line can be insulated and prevented from dripping (caused by melting frost) by wrapping a layer of newspaper some two or three inches thick round the line; then sewing on a canvas covering which is finished and waterproofed with a heavy coat of asphaltum paint. Fasten both high and low pressure lines rigidly by means of hangers of strap iron, staples or wire.

The brine tank will take quite a while to cool down on the first run, but once cooled will retain its temperature for long periods and take but a short time to further cool. In mixing brine it is advisable to do so a few days in advance in order to allow it to lose the heat generated in mixing.

If the builder places his plant in an exposed place it will be necessary to install a water drain at the lowest point to drain the water and prevent freezing. The bearing on the compressor may heat up slightly on the first run; the cap should be adjusted to give sufficient pressure to prevent escape of gas and yet not so tight as to heat the bearing. If desired a safety pop-valve may be installed by using a tee as per sketch E to unload at 125 pounds into a five-gallon can of water. But because of the small amount of refrigerant and its harmless nature, this is not absolutely necessary.

## How Enameled Iron Tubs Are Made

By H. WINFIELD SECOR

(Continued from page 1066)

he removes the tub from the oven. If it is hot enough, the second operator shakes the powder-like enameling mixture over the inside of the tub and the top of the rim, this mixture being a secret formula with each manufacturer; after this the door is quickly opened by applying compressed air to the control cylinder, as before described, and the tub is replaced in the oven for a few minutes. The intense heat causes the enamel mixture to melt and fuse together, and adhere to the clean iron surface over the inside of the tub and the rim. The tub is

now removed, placed on an iron truck and wheeled off and allowed to cool.

Fig. 5 shows red hot tub removed from oven momentarily, while second operator shakes enamel powder over the tub, while Fig. 6 shows the tub being replaced in the oven, in order to fuse and bake the enamel.

After the tubs have been carefully inspected for flaws in the enamel, they receive a coat of red-lead paint over the outer surface to prevent rusting, and they are then placed in the storage rooms, ready for shipment to all parts of the world.

**Rapid Scene Changes in "Johannes Kreisler"**  
By JOSEPH H. KRAUS  
(Continued from page 1051)

side wall. Consequently, the actor appearing on the upper deck of the structure will seem to describe an arc as he turns and walks away. The structure of the platforms is at no time seen by the audience, due to the fact that only the characters or the particular scenes which are to be shown, are illuminated. Meanwhile other black robed figures are pushing one or the other of the platforms into place or erecting other scenes so that the moment the lights go out on one of the stagelets, they may be turned on at another place, and the action continued there without a moment's intermission. Of course the full size of the stage is not used at all times. Sometimes one or two, or even three of the smaller scenes, are simultaneously illuminated. These are not all on a level with the stage floor, but arranged in tiers, as our illustration clearly shows. In addition to the platforms already mentioned, there are on either side of the stage two more small stages also on rollers. One of these contains the permanent setting of the interior of a room in which Kreisler is telling the story; the other is so arranged that the scenes thereon can be changed. When any of the stages are not being employed, they are covered by black curtains.

In the full stage utilizations, each of the six sub-stages may have various scenes mounted upon them, and then by placing them in the correct position, the entire stage setting is built up.

When Kreisler floats through the air he is standing in a box, (erected on the moving bridge platform), and seems to float idly through the air landing on the stage beside Donna Anna. As a matter of fact, Kreisler has stepped from the box to the top of a platform made of structural steel, resembling a pair of parallel rules. A cable and a winch hold it in place, an operator releasing the cable gradually, permits Kreisler to descend through the air to the stage. Kreisler may act at all times while on this platform, his position being perfectly secure. A spot-light illuminates his face only.

In another scene where Kreisler cuts the heads from his enemies with his baton, three dummies are employed, the heads of each of the enemies are held over the collar band of the dummy. The arms of an assistant enter the arms of the dummy, and the arms of a second assistant enter the legs. In this manner grotesque dances are produced by the two assistants operating the arms and legs. The head when cut off moves to a side, separating itself from the body completely. A slit in the black cloth background hides the actor's body. Spot-lights follow up the movements of the heads.

**An Unsuspected Function of Sugar**

By C. L. MELLER

(Continued from page 1073)

enduring sub-zero temperatures. In contrast to this clear sap, that will boil down to practically nothing more than sugar, there is the sap of many another genus of trees which even to the touch shows a sticky viscosity and boiled down produces a more or less mucilaginous substance. Rubber is the best known product of such a tree sap. Freezing a sap of this latter type separates it into a number of constituent parts, which seem unable to recombine after thawing, primarily because they were not in solution but were held in suspension; low temperature brings about a form of coagulation in a sap of this kind analogous to that brought about by boiling.

# Technical Training Will Double Your Income

## Send for the Proof

There is no quicker, surer way for a man to get out of a rut and rise to high pay than through technical training. Never before such a pressing need for experts in every line of productive industry and in building enterprises. If you are in a small pay job—if you "can't see the future," mail the coupon for information on where the opportunities are and how you can prepare for them.

We send a **Free Trial Lesson** if you are interested in **Drafting or Plan Reading**. **Free Books and Blue Prints** if your inquiry is about training in the **Building Trades**.

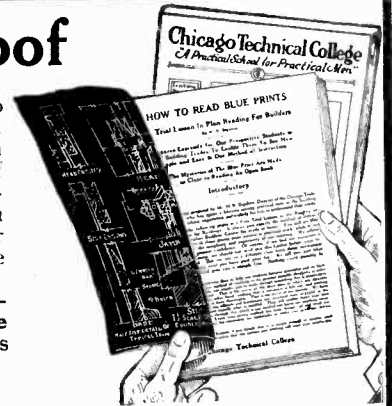

## Drafting, Building (Plan Reading Estimating Superintending) and Other Specialized Training Easily Obtained in Spare Time at Home



**Designer**



**Plant Supt.**



**Plumber**



**Shop Supt.**

Make your spare time count for more money. Put in a few hours a week to get specialized knowledge on any of the subjects listed in the coupon and your future is secure—you step years ahead of the plodder who is "waiting for his chance." With technical training you need not wait for opportunity. You will be the man wanted to plan or direct important work. You will be in line for high salaries and important positions.

### Get Practical Instruction From Chicago "Tech" Experts

Enrolled with Chicago "Tech" you are instructed by practical men. You are taught the way things are actually done in big engineering or building enterprises. That is why Chicago "Tech" men are so constantly in demand. No more certain way to success than to get this kind of training. And now is the time to get it when there is such a pressing demand for experts. No special preparation required for these courses. They are easy to understand—every point is made clear, and at every step you have practical men directing your study.

### Chicago "Tech" Men Succeed

Everywhere you find Chicago "Tech" men in paying jobs or in paying businesses of their own.

J. A. Da Costa was a punch press hand who enrolled with Chicago "Tech" and as a result of his training was made Production Manager.

A. S. Ross took the Drafting Course. Salary was raised \$25 a month. Now in profitable contracting business.

Hundreds of other men send similar reports of success as a result of their Chicago "Tech" training.



**Auto Expert**



**Building Supt.**



**Aero Expert**



**Contractor**

R. L. Cary was a draftsman—took Chicago "Tech" instruction and became Chief Draftsman and Supt. of Construction at 4 times former salary.

O. L. Rosin became a prosperous architect and contractor as a result of his Chicago "Tech" training.

## Send the Coupon—Today

No matter what your present job or where you live, you can get this pay raising technical training from the Chicago "Tech" experts. If you can't come to the

College you can get it by mail. Find out about the Chicago "Tech" Method now. Mark X in the coupon to show which course interests you and mail it today.

CHICAGO TECHNICAL COLLEGE,  
345 Chicago Tech. Bldg., Chicago, Illinois

Without cost or obligation to me please send instructive matter about opportunities in line I have marked with "X."

- |   |  |
|---|--|
| <input type="checkbox"/> Drafting (The Big Salary Course) no experience necessary | <input type="checkbox"/> Aeronautic Engineering All about aeroplanes             |
| <input type="checkbox"/> Building Trade Course for men in the building lines      | <input type="checkbox"/> Plumbing, Heating and Ventilating                       |
| <input type="checkbox"/> Surveying and Map Drafting                               | <input type="checkbox"/> Steam Engineering                                       |
| <input type="checkbox"/> Automobiles, Gas Engines, Starting, Lighting, etc.       | <input type="checkbox"/> Plan Reading for Shop Men—Mechanists, Assemblymen, etc. |

Name .....  
Address .....  
Post Office ..... State .....



## Electrical Experts EARN \$12 to \$30 a Day

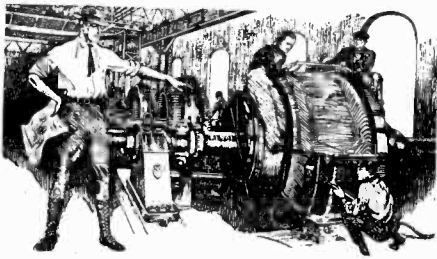

### What's YOUR Future?

Trained "Electrical Experts" are in great demand at the highest salaries, and the opportunities for advancement and a big success in this line are the greatest ever known.

"Electrical Experts" can earn \$70 to \$200 a week. Fit yourself for one of these big paying positions—

#### BE AN "ELECTRICAL EXPERT"

Today even the ordinary electrician—the "screw driver" kind—is making money—big money. But it's the trained man—the man who knows the why's and wherefore's of Electricity—the "Electrical Expert"—who is picked out to "boss" ordinary electricians—to boss the big jobs—the jobs that pay.

**\$3,000 to \$10,000 A YEAR**

Get in line for one of these "Big jobs," by enrolling now for my easily-learned, quickly grasped, right-up-to-the-minute, Spare-Time Home-Study Course in Practical Electricity.

#### AGE OR LACK OF EXPERIENCE NO DRAWBACK

You don't have to be a College man; you don't have to be a High School Graduate. My course in Electricity is the most simple, thorough, and successful in existence and offers every man regardless of age, education, or previous experience, the chance to become, in a very short time, an "Electrical Expert," able to make from \$70 to \$200 a week.

#### I GIVE YOU A REAL TRAINING

As Chief Engineer of the Chicago Engineering Works, I know exactly the kind of training a man needs to get the best positions at the highest salaries. Hundreds of my students are now earning \$3,500 to \$10,000. Many are now successful ELECTRICAL CONTRACTORS.

#### YOUR SUCCESS GUARANTEED

So sure am I that you can learn electricity—so sure am I that after studying with me you can get into the "big money" class in electrical work, that I will guarantee under Bond to return every single penny paid me in tuition if, when you have finished my Course, you are not satisfied it was the best investment you ever made.

#### FREE—ELECTRICAL WORKING OUTFIT—FREE

I give each student a Splendid Outfit of Electrical Tools, Materials and Measuring Instruments absolutely FREE. With me you do practical work right at the start—at home. You start right in after the first few lessons to WORK AT YOUR PROFESSION in a practical way.

#### FREE RADIO COURSE

An up-to-the-minute Course in Wireless Telephony and Telegraphy given free with my great Electrical Course—two Courses for the price of one. Coupon brings particulars.

#### GET STARTED NOW—MAIL COUPON

I will send you a valuable book entitled "How to Become an Electrical Expert," and full particulars of my free outfit if you will send this coupon now.

L. L. COOKE, Chief Engineer.

**Chicago Engineering Works**  
Dept. 23 2150 Lawrence Ave.  
CHICAGO, U. S. A.

CHIEF ENGINEER COOKE  
Chicago Engineering Works  
Dept. 23, 2150 Lawrence Ave., CHICAGO, ILL.

Dear Sir: You may send me entirely free and fully prepaid, a copy of your book, "How to Become an Electrical Expert," and particulars about your Home Study Courses in Electricity and Radio.

Name .....

Address .....

City ..... State .....

## Recovering Sunken Treasures

(Continued from page 1056)

keel, which is often not the case. In some of these methods, holes are to be drilled into the sides of the vessel, and expansion bolts to which the cables are attached, are inserted into the holes. Even in wooden vessels such procedure presents many grave difficulties, and the sides of sail vessels under the stress developed by the lifting pontoons or jacks, would tear out these steel plates as though they were shells of pecan nuts. In the present installation a different method of raising a ship is employed. Here a framework built of structural steel, to meet the lifting stresses placed upon it when the sunken vessel is to be raised, is lowered over the vessel as she lies on the bottom of the sea. A globular diving bell housing an operator, who can communicate with the surface pontoon, directing in this manner by means of telephone or control switches the descent and positioning of the cradle lifting devices, assists in the proper locationing of these cradles. The upper part of the cradles are made buoyant, when filled with air, so that they may be floated around, or the air may be withdrawn, to permit of a gradual descent. At the base of the cradle two steel projecting lugs are to be found. These are perforated, so as to allow air or water at a high pressure to be driven through these openings. The jet of air or water thus formed, clears away the sand at the base of the cradle and under the vessel. Hydraulic pistons drive the lugs beneath the vessel.

In order to be assured of the fact that the cradle will not jam into the ribs of the vessel, cutting tools, found at the base of the cradle, and driven by compressed air or water power motors, clear away the silt at the base, plowing a furrow as they move downward. If a greater downward pressure is desired, some of the air in the top tank of the cradle is replaced by water, decreasing its buoyancy in this manner, and consequently, increasing its pressure. It will thus be seen that the revolving cutting wheels at the base will clear away any extra hard obstruction, while the water or air under pressure takes care of the sand; thus by its own weight the cradle will slip down around the vessel until deep enough, when the hydraulically operated projections closing the base of the cradle come into play. All of the cradles having been put into place and connected with the surface pontoon, which must be considerably larger than the vessel to be raised, the observer below the surface passes the signal up for operation of the jacks.

The pontoon device having been securely anchored at four or more points, is now made as buoyant as possible. All the water from the pontoons which heretofore tended

to submerge it is pumped out, but due to the anchors, the pontoon raft is not permitted to rise to the surface of the water. Its buoyancy, being considerably greater than the counter effect produced by the vessel at the bottom, will cause the raft to maintain its predetermined position with relation to the surface of the water, even when the jacks are operated.

Compressed air is now forced into the projecting lugs around the vessel, and air permitted to pass into the cradles, making them likewise more buoyant and taking up some of the stress, which would otherwise fall upon the lifting cables. The air forcing itself around the base of the vessel to be raised, loosens the sand and agitates it. In this manner the suction effect met with in attempting to raise a vessel, is materially decreased. The lifting jacks are now operated, by opening the valves, permitting water under great pressure to thus enter the cylinders, slowly at first. The result is that a uniform lifting effort is developed, which increases and finally the weight of the ship is over-balanced and it rises until the pistons reach their extreme position. The jacks being automatic in their locking effect, hold the vessel in the position to which it has been brought, and the action of the pistons is reversed, the water under pressure being permitted to escape. This operation is repeated until eventually the vessel has reached its position within the cradle, formed by the partially submerged pontoon or raft structure.

When in this position, locks and chains are swung around it and the anchors are released by either cutting the cables or raising them by means of winches, which necessitates further submergence of the pontoon structure, so that one of the anchors may be lifted at a time. The cradle containing the raised vessel is then permitted to come to the surface and either towed or under its own steam, reaches port and a drydock.

The devices used for raising the vessel must of course be large enough to completely engirdle the ship at the bottom of the sea, regardless of whether it is lying on its side or in an erect position. If necessary, the smoke stacks and masts may be blown off by dynamite, so as to make room for the massive automatic tongs. The inventor proposes also to control the lifting jacks singly, so that the strain will not be upon all of them at one time, and one at a time can be released while the others are being operated.

The cost of salvaging operations with such a device, would, however, be extremely great, but the sea contains enough treasure to permit the salvaging of ships which would more than pay for the apparatus, even if but two or three vessels were raised.

## The Submarine of Tomorrow

By GRASER SCHORNSTHEIMER

(Continued from page 1053)

reported that they will practically have double hulls and will be minutely subdivided. Again, it has been rumored that these boats will have light deck and conning tower armor to protect them against depth charges and light shells. The new large Japanese submarines are also credited with this feature.

Another feature is really comfortable quarters for the officers and men. This feature takes large proportions when it is realized that it was necessary to give the German submarine crews two weeks ashore to every three days afloat, due to the hardships of this service.

The gun battery will consist of one 5 inch, 51 caliber gun mounted just forward of the conning tower and a single 3 inch, 23

caliber anti-aircraft gun mounted on the after part of the conning tower, on the base. The prime armament of the ships will be torpedoes. It is understood that there will be six 21 inch tubes carried in submerged positions, four in the bow and two in the stern. Ten extra torpedoes will be carried making a total of sixteen.

The wireless equipment will be of a most advanced type. It will include both surface and submerged sending and receiving outfits. Submerged, the boats will be able to receive almost as well as though they were on the surface, but their sending power will be limited to about 100 miles, it is said.

As the Naval Treaty, formulated at the Washington Arms Conference, forbids us to build battle cruisers for a period of ten

years, it is important that these boats be successful, as the only two agencies for turning an enemy's line in action, are the battle cruiser and the submarine. Not being permitted to have the ideal type, we must turn to these submarines.

With these boats as a basis, as a last word in modern submarine design, let us consider the next step. A submarine is wanted which will be able to go to sea to raid commerce. This vessel will have to stay at sea for long periods.

First, such a vessel must have great size in order to carry the necessary engine power for high enough speed to pursue and capture a normal merchant vessel. Then, it must have fuel enough to be independent of shore bases for a long period. It must have accommodations comfortable enough to relieve the strain of a nerve-racking cruise on its crew. Lastly, it must mount guns heavy enough to engage and defeat a destroyer and to properly engage a cruiser.

This means a displacement of about 6,000 tons. It means great Diesel engines capable of developing around 18,000 horsepower to get a proper speed. It means the installation of the great electric drive to translate this power into speed and to charge the great storage batteries for submerged maneuvering. It means spacious quarters for officers and men, huge tanks for fuel oil and finally a large and well placed battery.

Speed in submerging and coming to the surface is of prime importance as it measures the time in which the vessel can get into action. Therefore, let us say that the boat's main battery comprises four 6 inch guns which are enclosed in two water-tight turrets, into which the men can go while the submarine is coming to the surface. Modern destroyers have batteries seldom exceeding 4.7 inches and, therefore the 6 inch gun should be capable of answering them, as it is of approximately the size carried by the cruiser of today.

By way of spotting the hits of these guns and scouting for the submarine while it is resting on the surface, a small plane is entirely requisite. A catapult might be mounted on the fore turret to launch it. The plane could be of a very small knock-down type, using little space aboard a crowded vessel.

As wireless progresses it might be possible to install the Telephot aboard the airplane. In this way the submarine commander would at all times have a picture of the sea far beyond the vision of his observation instruments.

This idea as to the submarine of the future may seem to be far in advance of possibility. But even now, it has been reported that the Japanese are building a test vessel closely approximating the one outlined herein. In this story we have attempted to confine ourselves strictly to lines capable of the development of which we speak.

**Novelties at  
New York Auto  
Show**

*(Continued from page 1064)*

only the vaporized gas gets into the cylinders, and the liquid fuel is held in the basin marked 1, until the engine develops sufficient heat to vaporize it. A whirling motion is imparted to the gas being taken into the cylinders by the fan-shaped stationary deflector marked 2. This also aids in keeping the liquid fuel in the basin 1. The bowl is heated by the exhaust and when the liquid fuel is vaporized it passes on into the cylinders and is consumed.

Two windshield wipers are shown in Fig. 5 and 7. The former is actuated by an electric motor, which through a reversing gear and chain drive, pushes the cleaner back and forth across the entire upper section

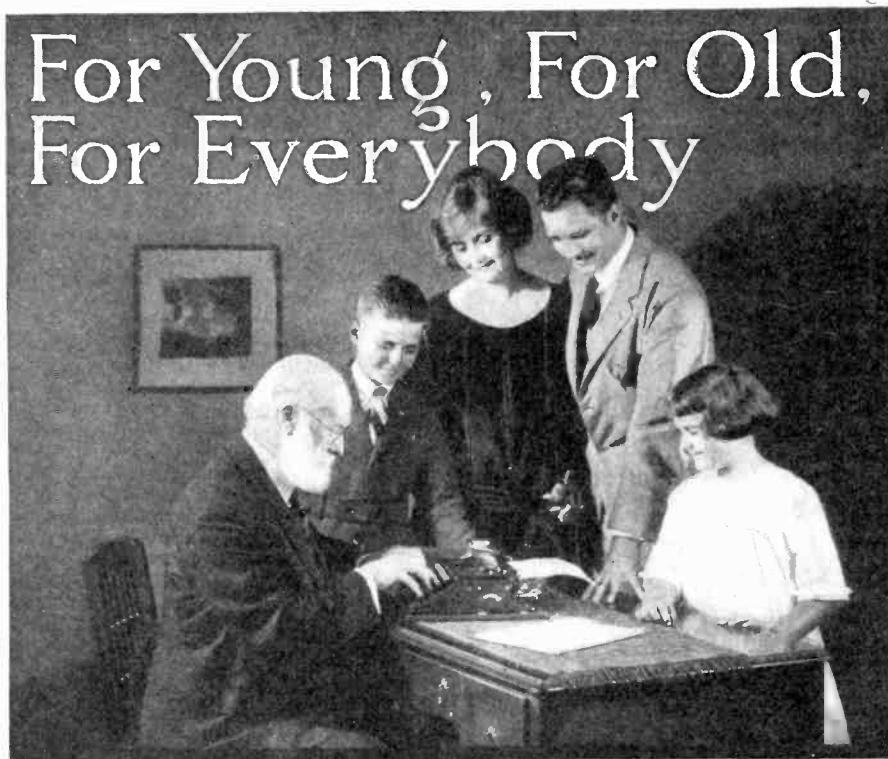

# For Young, For Old, For Everybody

## Remington Portable Typewriter

is the universal machine for personal writing. It has every quality demanded by the individual user.

*Compact*—fits in a case only four inches high.

*Convenient*—can be used anywhere; on your lap, if you wish.

*Complete*—with STANDARD KEYBOARD and other "big machine" conveniences.

It also resembles the big machines in efficiency, for don't forget it's a Remington—with every merit for which Remingtons are famous.

Sold by 2,500 dealers and Remington branches everywhere.

*Write for our illustrated "For You,  
For Everybody." Address Dept. 14*

**REMINGTON TYPEWRITER COMPANY**  
374 Broadway, New York

*Paragon Ribbons for Remington  
Portable Typewriters. Made by  
us. 50 cents each. \$5.00 a dozen*



**Harding is in the White House—so is the Encyclopedia Americana**



©Edmonston, Wash., D.C.

Because the Americana contains the very latest authoritative information on the most recent events in civilization—scientific, political, economic and every other subject of human interest, and hence, is the only encyclopedia which could possibly meet the needs of the Nation's Chief Executive.

**The New Encyclopedia AMERICANA**

**30 Handsome Volumes**

3 Bindings India Paper Size 7 1/4 x 10 3/4

**New Contributions, Type, Pictures, Maps**

It contains a concise history of the World War; Latest progress in wireless telephony; Latest developments in aeronautics; Latest statistics on finance, population, political divisions, etc., etc.

88,000 Subjects	4,000 Signed Articles
10,000 Pictures	24,000 Pages of Text
300 Color Plates	Full Bibliographies
Maps, Diagrams,	Complete Gazetteer
Statistical Tables	Universal Information

**Authoritative—Comprehensive**

A product of the world's highest experts in every branch of information. Designed especially for American readers, all American subjects being covered by American authorities and more thoroughly than has ever before been accomplished in a great work of reference.

**The ideal and necessary reference work for professional men, business men and students**

No other Encyclopedia is more comprehensive in its scope, more satisfying in its treatment of every subject, more invaluable as a source of accurate information in the home, educational institution, office, public library, etc. No higher tribute could be paid to the high value of this great work than its use in America's greatest educational institutions, libraries, etc., including

- |                              |                               |
|------------------------------|-------------------------------|
| Yale University              | New York Public Library       |
| Harvard University           | New York State Library        |
| Princeton University         | California State Library      |
| Columbia University          | Chicago Public Library        |
| Johns Hopkins University     | Mass. State Library           |
| University of Illinois       | Williams College              |
| University of Virginia       | Wellesley College             |
| University of Minnesota      | Dartmouth College             |
| University of Nebraska       | Detroit Public Library        |
| University of Penna.         | Minneapolis Pub. Library      |
| Stanford University          | N. Y. State Teachers' College |
| Mass. Inst. of Technology    | Smith College                 |
| Vassar College               | Pittsb. Carnegie Library      |
| U. S. Naval War College      | University of Missouri        |
| Randolph-Macon College       | McGill University             |
| Syracuse University          | Lehigh University             |
| Boston Public Library        | U. S. Military Academy        |
| Iowa State Teachers' College | Cornell University            |

**Handsome Prospectus Free**

The coupon below brings you our handsome illustrated prospectus of the Americana. You are under no obligation whatever in sending for this. Clip and mail today.

**The Encyclopedia AMERICANA**

ENCYCLOPEDIA AMERICANA CORPORATION, 27 William Street, New York, N. Y. Peoples Gas Building, Chicago, Ill.

Please send me free of charge descriptive literature of the AMERICANA.

Name .....  
Address .....

of the windshield. The automatic reversing gear is located in the box just to the left of the motor. In the latter, Fig. 7, the wiper is actuated by the suction of the motor. The two cups are connected to the intake or vacuum tank, whereupon their rubber ends are alternately drawn in and released, thereby imparting, through a rack gear, an oscillating movement to the wiper. The cleaner or wiper can be locked from the inside of the car so that it will not swing when not wanted.

A novel air-cooled motor is shown in Fig. 6, which makes use of the heat-radiating qualities of copper. In the insert in Fig. 6 it will be seen that the copper is electrically welded to the iron. The copper fins are made of a continuous strip of thin sheet copper so bent that when wrapped around the cylinder walls, the bases of the crimps are in contact with one another, thus completely surrounding the iron cylinder walls with copper. Space is of course left for the push rods, and for close coupling of the cylinders. A powerful air turbine creates a constant draught of air around the motor, as indicated by the arrows in the diagram.

In Fig. 8 is shown a device whereby the water from the radiator to the motor may be stopped until the motor warms up. It is inserted in the water pipe between the motor and radiator and after the water in the hose from the motor to the thermostat reaches a temperature of 178°F, the thermostat automatically opens the valve and allows the water to circulate around the motor. If, for any reason, the thermostat diaphragm should become punctured, a way is provided for automatic expansion of the thermostat, thereby opening the valve.

A novel spark plug is shown in Fig. 9,

which keeps its points clean by means of a draught of air drawn through the plug, the action depending upon the suction of the motor. This draught not only keeps the points clean, but at the same time drives away the burnt gases from the points, thereby rendering them ready to fire the next charge.

Fig. 10 shows a little electrical heating device installed in the intake pipe, which vaporizes the fuel instantaneously, thereby providing easy starting of the motor even in the coldest weather. This device generates a heat of only 500 F, thereby insuring against premature explosion, as gasoline and air mixture do not explode until heated to at least 700°F.

An automatic gasoline signal which depends upon an air-tight gasoline tank is shown in Fig. 11. This is a whistle located upon the cap of the gasoline tank, which when the gasoline reaches a level of about 1/2 gallon, sounds a warning by means of the partial vacuum created within the tank. Obviously, it is necessary that the tank be air-tight for the operation of this device.

The *super-wheel*, so styled by its inventor, is illustrated in Fig. 12. The spokes of this wheel are composed of heavy spiral springs, thereby taking up a great amount of the road shock. Inside of the shoe is a soft rubber insert with a vulcanized exterior as shown, under which lies an ordinary tube. When these inserts are used, the tube is inflated to the usual pressure, but is protected from punctures and blow-outs by the soft rubber insert.

(Editor's note: The names and addresses of the companies supplying the above described accessories, will be furnished upon receipt of a stamped, self-addressed envelope.)

**Electrostatic A.C. to D.C. Converters**

By CLYDE J. FITCH

(Continued from page 1077)

due to the resistance of the electrolyte in the rectifiers, and to the current leakage through the rectifiers, as the oxide film is not a perfect insulator.

The aluminum and iron strips of the rectifier are each 1/4" by 6" long. The solution is made by dissolving sodium phosphate in hot water, after which the solution is allowed to cool before using. The sodium phosphate may be obtained from any drug store. The rectifier will stand from 150 to 175 volts without breaking down, and as the voltage across terminals A and B is 310, it will be necessary to use two rectifiers in series. The rectifiers may be made up similar to the rectifiers shown in the photograph.

The condenser should have a capacity of several microfarads. Four, two microfarad paper telephone condensers connected in parallel will be sufficient when the current withdrawn is small.

The converter is to be connected to the alternating current line in series with a 110 volt lamp. At first the lamp will light up brightly, and as the rectifying film forms on the aluminum electrodes the lamp will gradually go out.

The converter shown in figure 2 will give the very same D.C. voltage as that of figure 1, and the action is identical. The only difference is that instead of using paper condensers advantage is taken of the electrostatic capacity of the rectifier itself for storing up the charge. This type of converter is very cheaply constructed. The small rectifier is made similar to the rectifiers in figure 1. The other rectifier and electrolytic condenser are combined in one

unit and made as shown in figure 6. They consist of a strip of iron and a strip of aluminum, each 1/4" by 6" long, which form the rectifier, and an aluminum plate which forms one side of the condenser of which the solution is the other side—the oxide film acting as the dielectric. An aluminum plate 6" by 24" will give a capacity of about 26 microfarads. This plate may be wound in a spiral as show in figure 6.

The converter shown in figure 3 will give a D.C. voltage equal to three times the maximum value of the A.C. voltage, neglecting losses. This converter is very simple. When connected to a 110 volt A.C. circuit only three small electrolytic rectifiers and two sets of paper telephone condensers will be required. The D.C. voltage will be 3x155 or 465, and will be slightly pulsating, but may be smoothed out or filtered by means of a condenser and a shoke coil as shown in figure 4.

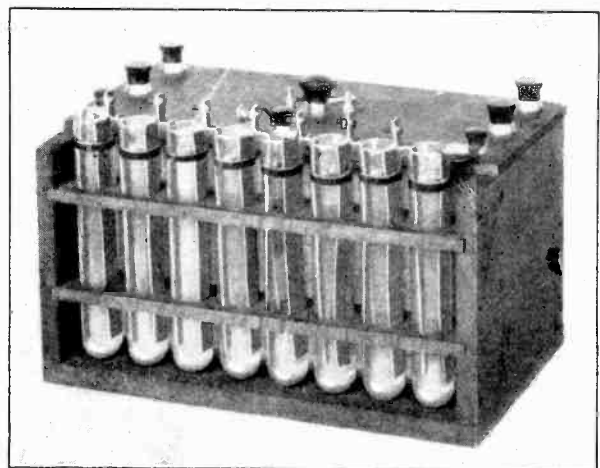

Group of eight rectifier cells and transformer cabinet.



A glance at the diagram will show that one-half cycle of the alternating current wave will charge both sets of condensers in parallel, to the maximum value of the A.C. voltage. The two sets of condensers then discharge through the external circuit, in series with each other and in series with the next half cycle of the alternating current wave, so that the voltage at the D.C. terminals will be three times the maximum value of the A.C. voltage.

Figure 4 is substantially the same as figure 3 except that electrolytic condensers are used in place of paper condensers. This converter requires one rectifier and condenser made up according to figure 6, one condenser made up like figure 6 but without the aluminum strip, and two small rectifiers. The choke coil and paper condenser smooth out the resulting pulsations, thus making the D.C. voltage constant for use on power amplifiers or radio telephone transmitting sets. The design of the choke coil will be taken up later.

The circuit in figure 5 will give a D.C. voltage of twice the maximum value of the A.C. voltage. For use on a 110 volt line this converter will require four electrolytic rectifiers and two sets of paper condensers. Electrolytic condensers cannot be conveniently used on this circuit. One-half cycle of the A.C. wave charges the other set of condensers. The two sets of condensers discharge in series through the external circuit, thus doubling the voltage.

Figure 7 is a complete wiring diagram of the converter shown in the photograph. This converter was constructed by the writer and used for amplifying radio broadcast programs. The rectifier is made up of aluminum and block tin strips in a solution of sodium phosphate, contained in a 1" by 6" test tube. Eight of these rectifiers are used. A layer of oil on the surface of the electrolyte prevents it from evaporating.

The 110 volt line is connected to the primary of a 110-220 volt transformer. The secondary of this transformer has four taps giving voltage variations ranging from 110 to 220 volts. The secondary is connected to the rectifiers and paper condensers so as to double the voltage by using the same circuit as figure 5. It is then connected through a choke coil to the D.C. terminals. Across the D.C. terminals are connected two sets of paper condensers for filtering purposes. These condensers are connected in series so as to reduce the voltage across each condenser and thus prevent the condensers from being punctured. The D.C. voltage is adjustable from 300 to 600 volts, by means of the taps on the transformer. The potential is so constant that it is impossible to hear any A.C. hum in the loud talker when used for amplifying purposes.

The core of the transformer is made up of laminated transformer iron and has a cross-sectional area of 1 1/4" by 1 1/4", or 1.56 square inches. The outside dimensions of the finished core are 5" by 4 1/2". The primary winding comprises 450 turns of No. 24 B. & S. enameled magnet wire wound on one leg of the core. The secondary winding comprises 900 turns of No. 26 enameled magnet wire wound on the other leg of the core. Taps are brought out of this winding at 450 turns, 600 turns, 750 turns, and the end tap at 900 turns. These taps connect to the tap switch as shown; the dead contact points are placed between each live contact point, so that the switch lever will not short-circuit a portion of the secondary winding when moving from one contact point to the other.

The design of the choke coil is very simple. It consists of a coil of wire wound on an iron core as shown at figure 8. The core is made up of laminated transformer iron, and has an air gap in the magnetic circuit. The function of the air gap is to increase the reluctance of the magnetic cir-

# These books will help you make more money!

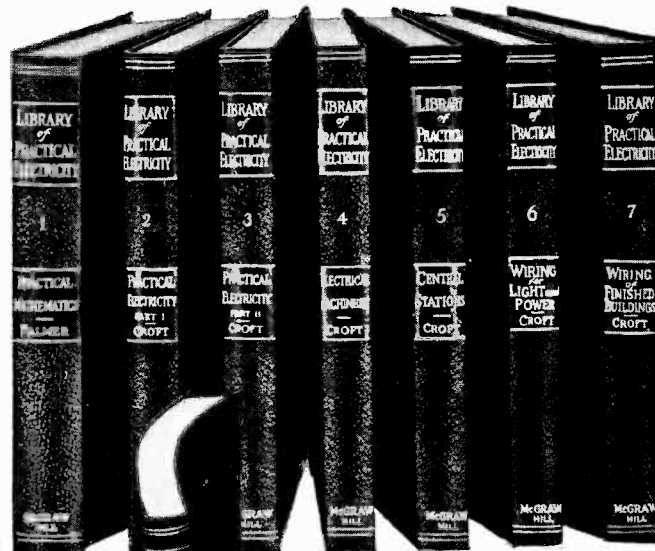

**L**EARN more and learn more. The way to the big-pay job is through the Croft books. They teach you electricity as practiced by experts and put you in line for an expert's pay.

## The Croft Library of Practical Electricity

A Combination Home Study Course and Reference Library  
8 volumes—3000 pages—2100 illustrations—flexible binding

**E**VERYWHERE the Croft Library is acknowledged as the standard—the leader—in practical electrical training. In the Croft books you will find complete, detailed and up-to-the-minute information on electricity, from the simplest principles to complete and economical operation of a central station. You will be told the things you need to know about motors, generators, armatures, commutators, transformers, circuits, currents, switchboards, distribution systems—electrical machinery of every type, installation, operation and repair—wiring for light and power—how to do it mechanically perfect, in accordance with the National Electrical Code—wiring of finished buildings—underwriters' and municipal requirements—how to do the complete job, from estimating it to completion—illumination in its every phase—the latest and most improved methods of lighting—lamps and lighting effects, etc.

## The Sure Way to Bigger Pay

**B**IG salaries are paid in the electrical field for expert knowledge. The man who knows electricity in all its many phases—the man who has completely mastered the subject from A to Z—can pick his own job and name his own salary. Fit yourself for a bigger position by knowing electrical practice complete—inside and outside work—central stations and the whole subject. Croft will teach you. He will take you in quick, easy steps from the simplest principles to the complete and economical operation of a great central station. The Croft-trained man wins because he knows the "why" and the "how" of modern electrical practice.

## Practical Electricity Taught by an Expert

No course, no set of books, offers a quicker, surer method of mastering electricity than the Croft Library. It is founded on practice—on work as it is actually done. It is jammed from cover to cover with the kind of hard-headed, pay-raising facts you want. Written so that the beginner can easily understand it, yet so sound, so thorough that it is the daily guide of thousands of highly paid electrical workers and engineers.

Croft has been through the mill. His knowledge has been gained by shirt-sleeve contact with electrical problems. He has worked his way up from the bottom to the top—from apprentice lineman to electrical engineer for one of the great electrical companies. Now he heads his own consulting company, and his name is known in every corner of the electrical world. He is the one man above all others who can show you the way to permanent success.

### What the Books Contain

- Volume One**—Practical Mathematics, 358 subject headings. Tells you how to use mathematics as a tool.
- Volume Two**—Practical Electricity, 1,000 subject headings. The basic principles of all electrical practice.
- Volume Three**—Practical Electricity, 1,100 subject headings. A continuation of Volume Two.
- Volume Four**—Electrical Machinery, 1,100 subject headings. Contains what every electrical man wants to know.
- Volume Five**—Central Stations, 509 subject headings. All phases of central station operation are covered.
- Volume Six**—Wiring for Light and Power, 1,700 subject headings. Tells how to do the big and little jobs right.
- Volume Seven**—Wiring of Finished Buildings, 1,100 subject headings. The very meat of wiring practice.
- Volume Eight**—Practical Electric Illumination, 1,000 subject headings. Lamp and the art of lighting properly.

### Easy Payments

Pay for these books as you go along. We have made the payments so low that any man can meet them. Only \$1.50 in ten days and the balance at the rate of \$2 a month for nine months. These are the lowest—the easiest—terms ever made on a high-grade electrical library.

### Just send the coupon

We want you to test our statements—we want you to compare the Croft books with others. Fill in and mail the coupon attached and we will send you the entire set of eight volumes for ten days' Free Examination. We take all the risk—pay all charges. You assume no obligation—you pay nothing unless you decide to keep the books. Then \$1.50 in ten days and the balance at the rate of \$2 a month. Send the coupon NOW and see the difference. I will send \$1.50 in ten days and \$2 per month until \$19.50 has been paid. If not wanted, I will write you for return shipping instructions. (Write plainly and fill in all lines.)

Send No Money—Just the Coupon

Name \_\_\_\_\_  
Home Address \_\_\_\_\_  
City and State \_\_\_\_\_  
Company or Employer \_\_\_\_\_  
Occupation \_\_\_\_\_

10 Months to Pay!

McGraw-Hill Book Co., Inc. 370 Seventh Ave. New York

FREE EXAMINATION

Gentlemen:—Please send me the CROFT LIBRARY OF PRACTICAL ELECTRICITY (shipping charges prepaid), for 10 days' free examination. If satisfactory I will send \$1.50 in ten days and \$2 per month until \$19.50 has been paid. If not wanted, I will write you for return shipping instructions. (Write plainly and fill in all lines.)

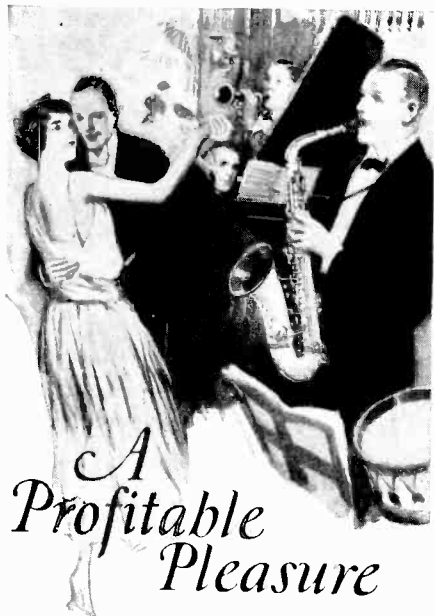

## A Profitable Pleasure

CONN instruments place a world of pleasure, unnumbered opportunities for profit, at your command. For two-score years they have been recognized supreme by the world's greatest artists in concert bands, symphony, opera and popular orchestras.

Exclusive features make Conns easier to play. The most celebrated artists, including the great Sousa, use and endorse them because Conns are *more perfect in tune and tone, have more reliable action, are easier to blow, more perfectly balanced, artistically designed and finished.*

More Conn saxophones are sold than any other make in the world. Simplified key system, patented tuning device, perfect scale, and many other exclusive improvements make them the choice of the great "jazz" kings. You want the best; be sure you get a Conn.

Paul Biese of Chicago, (top) and Max Fisher of Los Angeles, (bottom) are among the popular orchestra directors who endorse Conn instruments.



**FREE TRIAL, EASY PAYMENTS.** Send now for information on how to get any Conn instrument for trial in your home. Conn is the only manufacturer of the complete instrumentation of a band.

Highest Honors at World Expositions. All Exclusive Conn Features at No Greater Cost. Dealers and agents throughout the country. Factory branches in many large cities.

**C. G. CONN, Ltd.**  
356 Conn Bldg.  
Elkhart Ind.



WORLD'S LARGEST MANUFACTURERS OF HIGH GRADE BAND AND ORCHESTRA INSTRUMENTS

CULTIVATE YOUR MUSICAL BUMP

cuit. The function of the air gap is to increase the reluctance of the magnetic circuit so that the iron will not become saturated, thus destroying its magnetic quality. The inductance of the choke coil should be at least  $1\frac{1}{2}$  henries. The choke coil is designed according to the following formula, which is close enough for all practical purposes:

$$L = \frac{3.19n^2}{10^6R}$$

$L$  = inductance in Henries  
 $n$  = number of turns in the coil  
 $l$  = length of air gap in inches, and  $a$  = area of air gap in square inches.

$R$  is the reluctance of the air gap. The reluctance of the iron is so small as compared with that of the air gap that it will be omitted here. If we use a core having a cross-sectional area of  $\frac{1}{2}'' \times \frac{1}{2}''$ , or 0.25 square inches, and a  $1/16''$  air gap,  $1/16 \div 0.25 = 0.25$ . Substituting 0.25 for  $R$ , and  $1\frac{1}{2}$  for  $L$ , in our formula, we have:

$$1\frac{1}{2} = \frac{3.19n^2}{10^6 \times 0.25}$$

Solving we get 3322 turns as the value of  $n$ , which is the number of turns required in the coil to give an inductance of  $1\frac{1}{2}$  henries. No. 36 B. & S. copper wire will do for this coil.

An electrostatic converter employing a step-up transformer and magnetic rectifier is shown in figure 9. This type of converter will deliver a higher amperage than the converters described above, and occupies less space. It has the disadvantage that the magnetic rectifier is not quiet in operation and requires more attention than the electrolytic rectifiers.

The connections are the same as those of figure 7, the potential at the transformer secondary being doubled by means of the rectifier and condensers. A tuned iron vibrator carrying silver contacts is magnetically connected to the transformer core as shown. This vibrates in front of a permanent magnet and makes contact with two adjusting screws. The vibrator is slotted so that its vibrating length can be adjusted in order to accurately tune it to the frequency of the alternating current.

This converter was successfully used by the writer for operating a 10 watt radio telephone transmitter. The hum was practically eliminated by means of the choke coil and condensers.

It should be remembered that one side of the alternating current line is grounded, and if any of the above circuits which do not employ a step-up transformer are used for radio or other purposes, which have a ground connection of their own, a short circuit is apt to result. This difficulty may be overcome in radio sets by connecting a small fixed mica condenser in series with the radio ground lead.

### ALCOHOL AS MOTOR FUEL

Under the decision, announced by Commissioner Blair of the Internal Revenue Bureau, the sale of alcohol "for use in the manufacture of motor fuels" will be permitted when "to every 100 gallons of ethyl alcohol there is added one gallon of gasoline of that quality specified."

Further than to say that the formula had been approved on the application of persons interested in the motor fuel industry, Treasury officials declared they had no information as to the intent and scope of the use of which the formula was to be put.

The formal announcement by the Treasury set forth the following specifications as those which would be required for the gasoline content of the new fuel:

"Volatility—When 5 per cent. of the sample has been recovered the thermometer shall not read more than 65 degrees centigrade nor less than 50 degrees; when 50 per cent. has been recovered the thermometer shall not read more than 95 degrees."

## FOR DEPENDABLE Protection YOU NEED A GENUINE ORTGIES AUTOMATIC

THE PISTOL WITH A NAME AND WORLD-WIDE REPUTATION

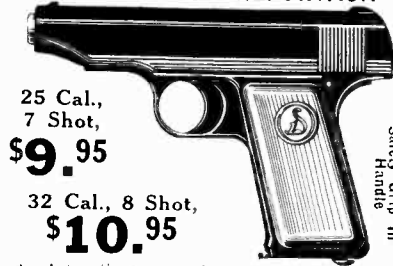

25 Cal.,  
7 Shot,  
**\$9.95**

32 Cal., 8 Shot,  
**\$10.95**

An Automatic you can depend on. Will not jam; safe; reliable. Every one new and perfect. Shoots regular American ammunition. Small size, easily carried. Satisfaction or money back. Sent postpaid. Buy direct from the importers. Send no money, pay postman on arrival. Order Today.

**NASSAU IMPORT CO.**  
150 NASSAU ST. (Dept. 5) NEW YORK

## FINE OLD VIOLINS

On Easy Payments  
30 Days Free Trial



allowed, no matter where you live. If not more than pleased with our values return violin AT OUR EXPENSE—and no harm done. Ability to play the violin brings social and financial success. Get a violin with a rich, mellow tone and it will create in you a desire to master it.

### Free! Magnificent Album-Catalog

containing portraits of the world's greatest violinists since Paganini's time—a half-tone of "Stradivarius in His Workshop," and the romantic story of The King of Musical Instruments. A postal brings all to you FREE—no obligations.

**CREMONA VIOLIN SHOP**  
Dept. G-51 Chicago

## Learn Photography at HOME

Make \$75.00 a Week on the Side

Establish yourself as a Photographic Expert quickly—during your spare time—under a leading photographer. I'll show you how to start your own business—or command a large salary. Send for my unusual offer—it's only temporary. Act at once. A postal will do.

International Studios, Inc., Dept. 7172,  
3601 Michigan Ave., Chicago, U. S. A.



## YOU CAN SAVE \$35.00

By recovering your old auto top frame yourself. Our covers are custom tailor made in our own factory to fit all makes and models of cars. Any person that can drive a car can put it on. We furnish instructions. Roof and quarter panels are sewed together with rear curtain, fasteners, welts and tucks complete. Give us the name, year and model number of your car and we will send you catalog with sample.

**\$5.65 and up**  
Parcels Post Paid

**LIBERTY TOP & TIRE CO., Dept. E-4, Cincinnati, O.**

## ONLY \$10 DOWN \$8 MONTH

10 acre summer home, and poultry farm, 2-room house, 100 chickens, overlooking 2 fine lakes. Near Shelby and Hart, Mich., country seat. Surrounded by splendid farms and orchards. Only \$695.

**TOPPING & CO.**  
810 Reaper Block  
Chicago, Ill.

## Experimental Electricity Course in 20 Lessons

By S. Gornsbach and H. W. Secor, E. E. A course of the theory and practice of Electricity for the experimenter. Every phase of experimental electricity is treated comprehensively in plain English. New experiments are described and explained and nearly every application of Electricity in modern life is given. 160 pages—400 illustrations. Flexible cloth cover, 75c. postpaid. Sent cloth cover, \$1.25 postpaid.

**EXPERIMENTER PUBLISHING CO.**  
Book Dept. 53 Park Place, New York City

## New Process Colors Black and White Movie Films

By LEWIS YEAGER

(Continued from page 1054)

the emulsion on the film, so when each of the colors go back through the lens, it has a distinctive effect on the film. Blue has a different effect from red, etc. A simple example is cited.

Suppose we have a stairway before us, the first step red, the next yellow, the next green, the next blue, the next violet. Mr. Taylor takes a photo of the stairway with the ordinary movie camera with standard negative film. He develops the negative and prints a positive from it. This he later bleaches by a special process, until the image appears to have disappeared, so that it resembles a piece of film from which the emulsion has been removed. The various colors due to the wave length of light have each left a different trace, and the red will select red dye, while rejecting the other colors; the blue will also select its respective dye.

Mr. Taylor says the duplicate positives are printed from a black and white negative. The positives are treated with mordant and select dyes of certain chemical groups. In the laboratory we find an operator in charge of each coloring machine. The color wheel which applies the respective dyes is watched carefully by an operator.

Mr. Taylor gives the following explanation: Bleaching leaves the film selective to dyes of a certain chemical group, only for absorption in certain portions of the image, while another part of the image is selective to dyes of a different chemical group.

The film after being given the required coloring baths, is dried and a colored vase the size of a pea on the film will display all the original colors of a great piece of Sevres or of Cloisomé.

There are 16 individual squares of motion picture film to the foot; each square is a small still picture in itself representing its own bit of action and having its own importance and relation to the entire scene.

Sixteen separate pictures to one foot, 160 separate pictures to ten feet, 1600 pictures to 100 feet and 16,000 pictures to 1,000 feet. Each picture must be an exact duplicate of every other picture in the entire length of film so far as density and color are concerned; otherwise, the continuity of the film's luminosity would be interfered with to the extent that the screen would appear to be a series of flickers and the picture not fit to exhibit. This has been a very serious stumbling block to experimenters who have attempted to apply color to the cinema film. It seemed that they could not duplicate and for this one reason alone, if they were fortunate enough not to have other difficulties, their processes were rendered useless.

Taylor's process duplicates by a very ingenious device and I saw, on my visit to the Lasky Studio, 200,000 feet of film, all of even luminosity from one end to the other, ready to be assembled into a big super picture and shipped to the different cities of the world for exhibition.

I was permitted to see sections of the new release and can say there was absolutely no fringing such as is often seen on colored motion pictures. Any depth of color required may be given. It is not necessary to resort to gaudy scenes on the water edge with the new process. Even night scenes give the same color effects as scenes taken in dazzling sunlight. In the new release, a procession is shown where various colors of lanterns are used and these hues are faithfully duplicated on the screen.

# How Inventive Ability Is Now Being Developed

Develop your inventive ability. A single idea, which solves one of the millions of the world's daily problems can make you independent for life. Fifteen famous inventors now make every step in invention as simple as A. B. C. Spare time at home quickly develops your native instinct for inventions—helps you become successful.

FOR a long time it was commonly believed that every invention was a matter of pure luck—the result of some happy inspiration that suddenly flashed through a man's brain, and which made him fabulously rich without the slightest effort or thought. But you can prove for yourself that this is not so. You can prove for yourself that invention is the result of thinking and acting along definitely exact, scientific lines.

Suppose, when you went home tonight, you found a window rattling. Through your mind would flash, almost instinctively, a regular order of thoughts which characterize the conception and completion of every invention the world has ever known. First you would recognize a problem to be solved—the rattling of the window. Then you would think of several principles of science or mechanics which would solve your problem. You might think of the scientific fact that if you poured water on the frame, the wood would swell and tighten the window. You might think of using a nail. But what you most probably would do, would be to use the oldest mechanical principle known to man—the wedge.

### What Invention Is

Brought down to its simplest terms, that is exactly what invention is—the combination of two ideas; a problem which must be solved and a fact of mechanics or science which solves the problem. That is the way every invention has been made. So, although you may never have thought of it in just this way, every time you solve some problem in your daily life—at home, traveling or in business—you are an inventor; you use the principles of thought and action which govern the Science of Invention!

You can see, therefore, how easy it is for you to develop your natural instinct to "fix things." The same processes of thought that almost instinctively told you to fix a rattling window with a wedge can be so well developed that you can learn to invent other things almost as easily and quickly. You know, too, that every invention is made only by thinking INVENTIVELY. And every inventor is agreed that the principles of Inventive Science are so simple, so easy to learn that anyone, regardless of training or education, can develop himself to become a successful inventor!

### Edison Says: "Invention Should Be Taught as a Science"

But although the fact that Invention is governed by a few simple, easily acquired, fundamental principles has been universally recognized no one ever thought of putting these principles in black and white so that everybody interested in invention could read them. In spite of the fact that Thomas A. Edison made his famous statement that Invention should be TAUGHT as a science, thousands of people continued to work blindly, doggedly, haphazardly to perfect their ideas.

But now you CAN LEARN HOW to invent. Fifteen famous inventors have at last given to the world the laws and principles of Inventive Science. They have shown every ambitious man and woman HOW TO INVENT. They are TEACHING Invention, exactly as other people are teaching law, medicine, bookkeeping. Instead of spending years groping blindly, instead of wasting your time in useless, heart-breaking drudgery, you learn how to complete your ideas quickly; you learn how to think so you are sure to succeed.

### One Little Idea May Bring You a Fortune

With every new advance, with every new discovery that the world experiences, more problems are coming up—and more inventions are needed to solve these problems. Now, as never before, are new inventions wanted, and the world will pay a fortune to the man or woman who gives it just one of the inventions it needs now.

But all inventions need not be enormously big. Little ideas will bring you returns equally as great. Eberhard, who invented the rubber on the end of a pencil, has been paid hundreds of thousands of dollars for his simple idea. The man who invented the metal tip for shoelaces, the man who conceived the idea of the "humped" hairpin, the man who developed the metal tape-measure, all have achieved success and wealth as great or greater than the inventors of large machinery.

### Ideas for Inventions Everywhere

Whatever your position in life, whatever kind of work you do, you are constantly meeting problems which must be solved. Even so small an idea as a new kind of kitchen knife for your wife may prove to be the making of your fortune. As an office worker you may invent some little method which will simplify work, or if you live on a farm, you can invent some idea to meet one of your every-day needs.

The work you do, the life you lead, the problems you meet, all present you with innumerable opportunities to invent things. All you need is the ability to think inventively—to train your mind to connect two ideas—just as you connected the ideas of the rattling window and the wedge—and you can be assured of success.

### Learn How to Invent at Home

Take advantage of the opportunity offered you now. Get the advice and the help of the fifteen famous inventors who tell you all the secrets of invention. Learn how to develop your ideas so they will make money for you.

This is the first course in practical invention that has ever been devised. In simple, easy-to-understand language you are told how successful inventors work; you learn how to think along inventive lines; you learn the short-cuts to successful invention; you learn how to use the secrets of invention that convert a simple little idea into money.

But you learn more than just how to invent in this fascinating course. Thousands of inventors have lost the profits of their inventions simply because they didn't know how to patent and sell their ideas. This complete course shows you just how to apply for a patent, how to protect your rights when your patent is granted, and how to dispose of your invention so you will get the greatest returns possible.

Not one step in invention has been omitted. Everything you want to know about invention—developing your ideas, securing information you need, how to apply for patents, how to protect your rights, how to sell your invention—are taken up, step by step, so that when you have completed the course you have a wealth of information worth thousands of dollars.

### FREE—New Book on Inventive Science

A wonderful new book has just come from the press that tells all about the Science of Invention. It tells you how to avoid the pitfalls that have brought failure to thousands of would-be inventors. It tells you how to learn the secrets of practical invention, which famous inventors discovered only after years of heart-breaking effort, and discouraging mistakes, and it tells you how to do this in only 15 minutes of your spare time each day. This fascinating book will be sent to all those who are genuinely interested. Get the advice of these 15 famous inventors. Let them tell you how you can easily learn the secrets of successful invention.

Send for this Book today, as only a limited number are available for free distribution. Send the coupon below NOW, or a letter or postal-card will do. There is no cost or obligation. This bureau is not connected in any way with patent attorneys or manufacturers. Our only work is to help ambitious men and women to develop their inventive ability—to become successful inventors.

## BUREAU OF INVENTIVE SCIENCE,

Wisner Bldg.  
Rochester,  
N. Y.

BUREAU  
OF INVEN-  
TIVE SCIENCE,  
Dept. 73, Wisner Bldg.  
Rochester - New York

Please send me your free book, "Science of Invention."

NAME .....  
ADDRESS .....  
CITY .....  
STATE .....



Little Inventions Like These Have Brought Fortunes to Their Inventors.



Raymond C. Yates, who with 14 other famous inventors, now make it easy for you to learn how to invent in your spare time at home.





# \$95 an Hour!

"Every hour I spent on my I. C. S. Course has been worth \$95 to me! My position, my \$5,000 a year income, my home, my family's happiness—I owe it all to my spare-time training with the International Correspondence Schools!"

Every mail brings letters from some of the two million I. C. S. students telling of promotions or increases in salary as the rewards of spare-time study.

What are you doing with the hours after supper? Can you afford to let them slip by unimproved when you can easily make them mean so much? One hour a day spent with the I. C. S. will prepare you for the position you want in the work you like best. Yes, it will! Put it up to us to prove it. Mark and mail this coupon now!

### INTERNATIONAL CORRESPONDENCE SCHOOLS

Box 6188-C, Scranton, Penna.

Without cost or obligation on my part, please tell me how I can qualify for the position or in the subject before which I have marked an X:

#### BUSINESS TRAINING DEPARTMENT

- Business Management
- Industrial Management
- Personnel Organization
- Traffic Management
- Business Law
- Banking and Banking Law
- Accountancy (Including C.P.A.)
- Nicholson Cost Accounting
- Bookkeeping
- Private Secretary
- Business Spanish
- Salesmanship
- Advertising
- Better Letters
- Foreign Trade
- Stenography and Typing
- Business English
- Civil Service
- Railway Mail Clerk
- Common School Subjects
- High School Subjects
- Illustrating

#### TECHNICAL AND INDUSTRIAL DEPARTMENT

- Electrical Engineering
- Electric Lighting
- Mechanical Engineer
- Mechanical Draftsman
- Machine Shop Practice
- Railroad Positions
- Gas Engine Operating
- Civil Engineer
- Surveying and Mapping
- Metallurgy
- Steam Engineering
- Radio
- Architect
- Blue Print Reading
- Contractor and Builder
- Architectural Draftsman
- Concrete Builder
- Structural Engineer
- Chemistry
- Pharmacy
- Automobile Work
- Airplane Engines
- Agriculture and Poultry
- Mathematics

Name.....

Street Address..... 6-26-22

City..... State.....

Occupation.....  
Persons residing in Canada should send this coupon to the International Correspondence Schools Canadian, Limited, Montreal, Canada

## Keystone Institute

"The Service School"

A fully equipped school with expert instructors, organized to give intensive instruction in

- 2-Year Courses
- Electrical Engineering
- Mechanical Engineering
- Accounting and Business Administration
- 16 weeks' course in Automotive Engineering

Day and Night Classes. Graduates are sought by large and small industrial establishments and are filling important positions in all sections of the country. Write for information on subject that interests you, to Keystone Institute, Address "The Principal," 133 North 4th Street, Reading, Pa.



### DO YOU LIKE TO DRAW?

Cartoonists are well paid. We will not give you any grand prize if you answer this ad. Nor will we claim to make you rich in a week. But if you are anxious to develop your talent with a successful cartoonist, so you can make money, send a copy of this picture with 6 cents in stamps for portfolio of cartoons and sample lesson plate, and let us explain. The W. L. Evans School of Cartooning 814 Lorain Building Cleveland, Ohio

## How to Use Your Camera

By DR. ERNEST BADE

(Continued from page 1076)

The time required in setting up such an apparatus for taking a portrait will materially increase the value of the finished picture, since the subject will have sufficient time to compose himself so that the features will become more natural.

Another chapter is the taking of pictures of children, pictures showing the lively, carefree folk in the happy abandon of their play. Such pictures are difficult to take and can seldom be posed satisfactorily. The children must be observed either individually or in groups, and when exceptionally effective poses are noticed, they must be remembered. Then a suitable situation must be selected having the requisite lighting effects and the children are to be posed in this new surrounding. But if one can take snap-shots of the children unseen and unnoticed by them, then these are to be preferred to the former as they will be far more natural and spontaneous. For this purpose no other camera is so well adapted as the graphex, but even it has its bad points as it seldom satisfies the high expectations demanded. Two things must be noticed: first the focus or sharpness of the picture must be correctly provided for, and secondly, the correct and most effective pose must be obtained. At this point it must be said that no camera is so well adapted for general portraiture as the long bellows camera,—for this purpose it is still the ideal instrument.

Silhouetted photographs give some very pretty results. Here the subject contrasts strongly, standing out against the background, although all of the superfluous details of the profile need not be suppressed or eliminated. The background consists of a large sheet of white paper fastened to the window frame. It must be entirely smooth and free from folds and wrinkles. The subject is placed before the paper and the picture is taken from the room directly into the light after all other windows have been darkened. The length of the exposure depends upon the light transmitted by the paper. When the diaphragm is almost closed, a second or so will be sufficient provided the background is comparatively bright. If the negative should show too much detail, it can be partially removed by simply overexposing the positive made from it.

Another method of arriving at the same result is to place the subject before a white background and, with diaphragm closed, make a rapid time exposure.

When printing silhouettes, frames, which are either round or oval in shape, are used, they should never be angular.

Peculiar as the silhouette photos may be, those which show the details of the expression as well as the silhouette are far more unique and interesting. They are modern in all that this word implies. Such pictures can be taken both in artificial and natural light, but care must be taken that the shadow is not distorted. Artificial illumination is best accomplished at an angle so that the silhouette lies in front of the profile. The subject is placed before, and quite close to, a white background.

### SPOT FOUND ON SUN

A spot on the sun was discovered recently by Henry Pennywitt, official forecaster of the United States Weather Bureau.

"We have not fully measured the spot," said Dr. Burns of the Allegheny Observatory, "but we suspect it is one of those spots which periodically make their appearance. This one is to the side of the sun. Were it more to the centre we might have some serious weather disturbances."

# New Style OLIVER

## The New 1923 Model Now Ready

Here is the latest and greatest of all typewriters. Send NOW for complete details of this wonderful NEW 1923 machine, and our money-saving offer. The Oliver Quiet Speedster is the crowning achievement of 28 years of manufacturing. Equipped with the NEW standard 3-bank keyboard. ANY operator can run it without loss of time or output.

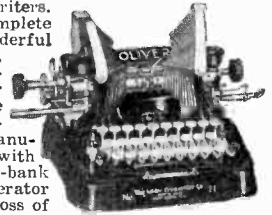

Special Price Offer NOW!

**\$50.00** SAVED

Oliver No. 9 with standard keyboard. Monthly payment price, \$55.00. Net Cash Price..... **\$55.00**  
Oliver No. 11 with newest improvements. Monthly payment price, \$75.00. Net Cash Price..... **75.00**  
**67.50**

This marvelous new model Oliver is offered to you at the lowest price and easiest terms ever offered for a standard machine. It has every modern improvement and many new and original refinements. No expensive branch offices. Simplified model and efficient manufacturing methods make this price possible. What business man will hesitate to save over \$50 when he can get a BETTER machine at half the cost of other standard typewriters? Don't doubt. Make sure. Write for offer and FREE TRIAL.

### WEEK'S TRIAL FREE—FREE CATALOG

Send for this wonderful typewriter on FREE TRIAL FOR A WEEK. Use it. Test it. Compare it. Then after trial, if delighted, you pay a small amount down and the balance on easy monthly terms with nearly a year to pay. If not, return it at our expense. You take no risk. Write today for catalogs and FREE OFFER.

**THE OLIVER TYPEWRITER COMPANY**  
673 Oliver Typewriter Bldg., Chicago, Ill.

# WE TEACH YOU LAW AT HOME

For business or professional purposes a training in law establishes your position both socially and politically. It increases your ability to handle larger responsibilities, it safeguards your own or your employer's business, it enables you to decide matters of importance instantly, with a full knowledge that your decision is right, and it gains for you the respect of all worth while people with whom you come in contact. Send for our free booklet describing the scope and merit of our courses and giving many helpful legal pointers.

**BLACKSTONE INSTITUTE**  
Dept. 216, 4753 Grand Blvd., Chicago, Ill.

## New Single Phase A. C. Motors

1/4 H.P.—110 volt, 60 cycle 1725 speed, complete with cond. plug and grooved pulley... \$13.00 Same motor equipped with buffer and grinder, \$25.00



**ONE YEAR GUARANTEE**

**GENERAL ELECTRIC**  
1/2 H.P. \$39.00 includes pulley 110/220 volt, 60-cycle, 1725 speed. Rep. incl. type. Remittance must accompany all orders.

Satisfaction guaranteed or money refunded

Illustrated Catalog of Motors and Supplies FREE

## HYRE ELECTRIC CO.

631-W So. Dearborn St., Chicago, Ill.

# MAKE MONEY AT HOME

YOU CAN earn \$1 to \$2 an hour writing show cards at home in your spare time. Quickly and easily learned by our new simple "Instructograph" method. No canvassing or soliciting. We teach you how, guarantee you steady work at home, no matter where you live, and pay you cash each week. Full particulars and booklet free. Write to-day.

**AMERICAN SHOW CARD SYSTEM LIMITED**  
Authorized and Fully Paid Capital, One Million Dollars  
110 Adams Bldg. Toronto, Canada.

\*\*\*\*\* (1885A) \*\*\*\*\*  
\*\*\*\*\* **RADIIUM STAR MAP** \*\*\*\*\*  
\*\*\*\*\* OPEN YOUR EYES to the wonders above and get refreshed and strengthened. Learn the stars with a Radium Star Map. It shines in the dark. Constellations shown by shining lines between radiant stars. Sample star group free. 4 ft. map, \$8.50. Used by leading schools, colleges and universities. \*\*\*\*\*  
\*\*\*\*\* C. W. SUNDELL, 643 Ontario St., Oak Park, Ill. \*\*\*\*\*

## Waterproofing and Mothproofing by Electricity

By ISMAR GINSBERG, B. Sc., Chem. Eng.

(Continued from page 1063)

all be treated in the same machine, or rather in either of two machines, depending on whether the cloth is silk or wool, or cotton or linen. The waterproofing effect that is attained in the fabrics is remarkable. A common muslin, treated by the Tate process, will be able to resist as much as 16 inches of water pressure without allowing a single drop of water to penetrate the fabric. The waterproofing is resistant to washing, although in time its original intensity will be lost. A coat or a suit of clothes, made of Tate waterproof woolens, can be dry cleaned and still retain its waterproofing. There is no other known process of waterproofing which can withstand dry cleaning.

The Tate process has been used with great success in waterproofing tent cloth. Circus tents have been made from this cloth and have stood up under the severest weather conditions for extended periods of time. Similar good results have been obtained from Tate treated sailcloth, awning cloth, woolens used in making overcoats, hunting suits and out-door clothing. The rain cannot penetrate a Tate treated raincoat, and moreover the raincoat can be worn in entire comfort, for the Tate process does not destroy the ventilation. The uses to which this process of waterproofing can be put are too numerous to be mentioned here. In fact, wherever the garment or the particular product that is made from textile materials has to withstand the passage of moisture, in other words wherever it has to possess waterproof properties in order to render proper service, there will be found a use for the Tate process.

One of the most interesting tests that has been made up to the present time to determine the efficacy of the Tate process was on the motor boat, *Specjacks*, which recently completed an eighteen month trip around the World. The awnings and spray cloths on the boat were all made from Tate treated cloth. The awnings were never taken down, not even in hurricane weather, and not a single drop of water came through the canvas. The results were really remarkable for the *Specjacks* encountered the severest kind of weather in its record-breaking trip. Furthermore, today, after so much service, the canvas is completely waterproof as it was on the day it was first installed. In the words of the owner, Mr. A. Y. Gowan, the success of the trip was due to the perfect construction of the boat and of the engines, and to the waterproofing secured through the Tate treatment.

There is one other important characteristic of the Tate process. Woolens, that are waterproofed in this way, have been found to be mothproof or moth-repellent as well. The significance of this fact is self-evident.

The fact that Tate treated woolens are really moth-repellent has been proven by scientific experimentation, extending for a period of over one and one-half years. These tests were carried out in the Massachusetts Institute of Technology. Colonies of moth larvae were bred on garments, which had been made from Tate treated cloth and which had been worn for over a year before the test was made. It was found that the larvae could not subsist on the Tate treated fiber. It was not that the chemicals poisoned the larvae, for the chemicals are absolutely non-poisonous, but simply that the animal could not eat the woolen fibers, treated in this manner. The Tate treatment mothproofs the fabric, conferring upon it moth-repellent properties of indefinite duration.

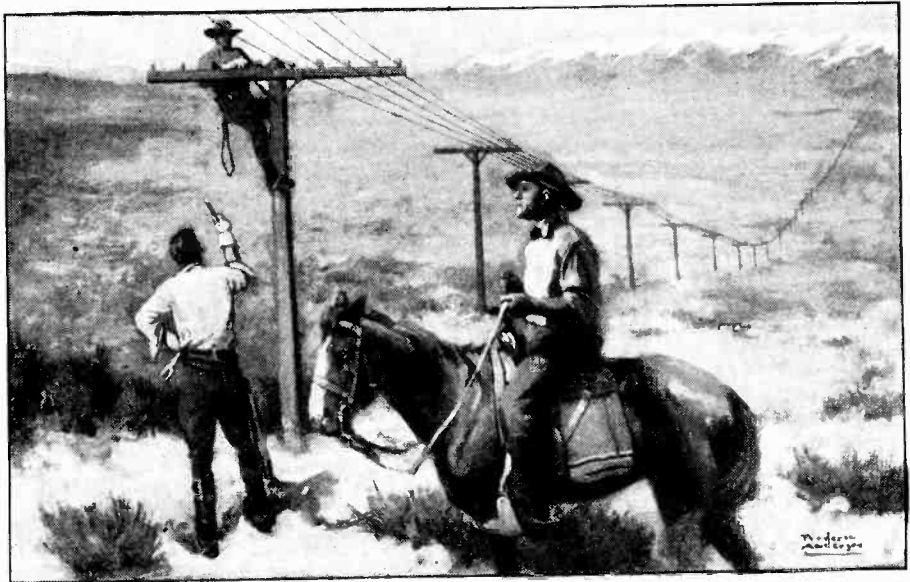

The Bell System's transcontinental telephone line crossing Nevada

## Highways of Speech

Necessity made the United States a nation of pioneers. Development came to us only by conquering the wilderness. For a hundred and fifty years we have been clearing farms and rearing communities where desolation was—bridging rivers and making roads—reaching out, step by step, to civilize three million square miles of country. One of the results has been the scattering of families in many places—the separation of parents and children, of brother and brother, by great distances.

To-day, millions of us live and make our success in places far from those where we were born, and even those of us who have remained in one place have relatives and friends who are scattered in other parts.

Again, business and in-

dustry have done what families have done—they have spread to many places and made connections in still other places.

Obviously, this has promoted a national community of every-day interest which characterizes no other nation in the world. It has given the people of the whole country the same kind, if not the same degree, of interest in one another as the people of a single city have. It has made necessary facilities of national communication which keep us in touch with the whole country and not just our own part of it.

The only telephone service which can fully serve the needs of the nation is one which brings all of the people within sound of one another's voices.



"BELL SYSTEM"  
AMERICAN TELEPHONE AND TELEGRAPH COMPANY  
AND ASSOCIATED COMPANIES

One Policy, One System, Universal Service, and all directed toward Better Service

## Better Work and More of It

—THESE ARE THE RESULTS OBTAINED TO AN AMAZING DEGREE BY HUNDREDS OF USERS OF

### Boice Junior Bench Saw

A wonderfully practical, compact, all metal machine designed for accurate and speedy sawing, ripping, grooving, etc. Cuts 1 1/2" stock. Dadoes 5/8" deep and 3/8" wide. Driven by 1/4 or 1/3 h. p. motor. Special saws cut type-metal, bakelite, brass, etc. Portable. Attaches to lamp socket.

Write for descriptive literature on the Junior Bench Saw, 17" Jointer, 17" Bench Band Saw, Bench Drills, Motors, and Larger Bench Saws.

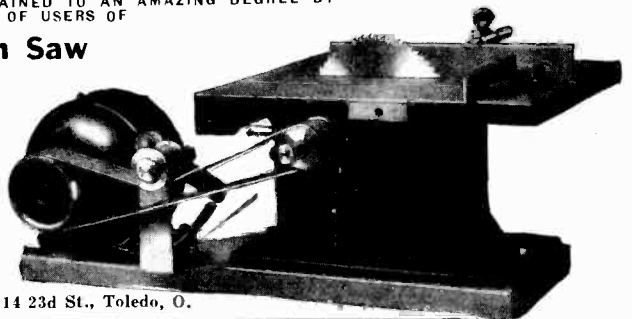

W. B. & J. E. Boice, Dept. S.I. 3, 114 23d St., Toledo, O.

HAVE YOU SOMETHING TO SELL OR EXCHANGE?

A classified ad in SCIENCE AND INVENTION will reach over 160,000 at a cost of only 12 cents a word.

YOU CAN EARN

**\$50 A Week**

six months from now—if you sign the coupon at the bottom of this column today.

We will teach you in half a year's time from the day you enroll as a home student the vital principles of Electricity, and you will be supplied at once with the big laboratory outfit, shown in this advertisement, and other outfits as fast as you require them, absolutely free of cost. You will also receive personal instruction from the President of the school.

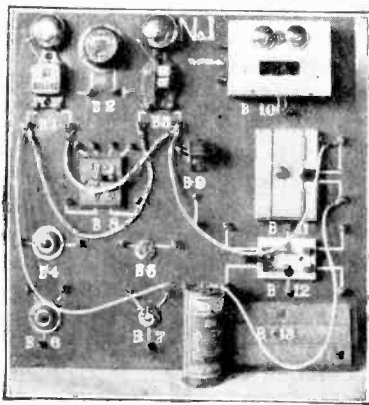

This is Laboratory Outfit No. 1, given to every home study student. It is not a toy outfit, and in a month after you have had it you can do anything an ordinary electrical worker can do.

Have you a Radio receiving set? If you have, you can listen to two lectures a week delivered from our Broadcasting Station by our President. If you haven't a receiving set, you can hear these lectures at places in your home town, that we will send you to as soon as you enroll as a student.

You need not be told that Electricity offers a better chance for advancement and a bigger starting salary than any other trade or profession.

With our certificate of qualification you can enter this great profession at a salary of \$50.00 or more a week, and as you advance in knowledge and expertness, your salary will be increased surprisingly.

We operate, in Milwaukee, the largest Electrical School in the United States. With the help we offer students, who study at home an hour or two each evening, through the President's lectures given in our Radio Broadcasting Department, reaching every city, town and hamlet in the United States, you get, twice a week, free, knowledge that will help you amazingly in your studies.

The lessons are written in simple language, and anyone who can read a newspaper can understand them.

We will make it easy for you to become a member of our great home student body if you will sign the coupon below. It is best not to delay, as our offer will be withdrawn when one thousand additional students are enrolled.

Extension Division,  
School of Engineering of Milwaukee,  
Dept. F3, 415 Marshall Street, Milwaukee, Wis.

Please send me free and without any obligation on my part, full details of your special offer to home students in Practical Electricity.

Name .....  
Address .....  
City ..... State .....

Answers to Puzzles

(See page 1071)

HARD-BOILED OR SOFT?

There are several tests for a hard-boiled egg. First, it will spin readily on the table. Second, if it has been recently removed from the water any drops that cling to the shell very quickly evaporate. And third, as the waiter said, the contents of the egg are rigid.

BOILING WATER WITHOUT INCREASE OF HEAT

This very interesting experiment, which was probably performed for the first time by Benjamin Franklin, may be carried out in the following manner: Fill a flask half full of water; boil for a minute on the stove; remove the flask and stopper it very tightly with a rubber stopper. On inverting the flask under a stream of cold water, the water in the flask will be seen to boil vigorously for some little time before it ceases altogether.

This experiment is frequently used to illustrate the effect of pressure on the boiling point of liquids. Thus water normally boils at 212 degrees F., but if the atmospheric pressure is low, as it is on high mountains, the liquid will boil at a much lower temperature. The effect of pouring cold water on the flask is to condense some of the water vapor above the hot water inside and thereby materially reduce the pressure there. The water then boils, but at a much lower temperature than it would if put in an open dish.

HERO'S FOUNTAIN

As soon as water is poured into the basin (A) some of it at once passes down tube (B) to reservoir (C) thereby increasing the pressure of the air in this chamber. This pressure is then transmitted through (D) to chamber (E) from which it forces water up through (F) to the fountain. As the water falls back into basin (A) the action is repeated, not indefinitely, alas, but until the reservoir (E) is empty.

PROOF OF THE EARTH'S ROTATION

Objects dropped down deep shafts have been observed to fall toward the eastern wall indicating that the surface of the earth is rotating faster than the bottom of the shaft.

But perhaps the most interesting demonstration of the earth's rotation is exhibited by a Foucault pendulum which consists of a heavy bob on the end of a long flexible wire and supported at the top. If started vibrating in one plane, say the north and south, it will gradually shift the direction of its motion until it has made a complete circuit in a time which would be twenty-four hours if the experiment were conducted at the pole and less than a full circle at any lower latitude. At the equator the direction of its motion would not shift at all. This experiment thus shows visibly the turning of the earth beneath the pendulum.

PRACTICAL LEVITATION

To begin with let us suppose the balloon and load to be just heavy enough to make it sink in air. Then if some compressed air is admitted to the cylinder, the density of the air will be increased so that the balloon will now displace a greater weight of air than it did formerly. Now as the buoyant force on a balloon is equal to the weight of the air which it displaces, it is evident that the buoyant force should now be sufficient to cause the balloon to rise. On reaching the top it strikes the upper lever, thereby opening valve V, releasing the excess air and reducing the pressure of the cylinder to normal. The balloon then sinks of its own weight only to strike the lower lever, readmit some air and thus start the cycle all over again.

THE HYDROSTATIC PUZZLE

The pressure produced by the weight of the man and piston must equal the pressure of the water of height (H) above the level of the piston. Then  $200 / 2 = 62.4 H$  (62.4 being the weight in pounds of a cubic foot of water). Or  $H = 1.6$  ft.

How to Hook-Up A Transmitter Button to Make an Efficient Loud Talker

A Transmitter button with a few dry cells and a telephone receiver will make a remarkably simple and efficient loud talker. A Microphonic amplifier of this type is just the thing for use with a radio set. The weak music and signals may be amplified many times their original value. It is possible to entertain a large audience with a simple radio equipment if a transmitter button is used in the circuit as explained in diagram A.

The cost is extremely low and the results are comparable with those produced by highest grade of expensive loud talkers.

As may be seen in the diagram, two dry cells or a small storage battery are connected in series with the transmitter button and a 4 to 75 ohm telephone receiver. The transmitter button is secured to the diaphragm of the telephone in the radio receiving set. To accomplish this properly, scrape off the enamel (if diaphragm is enameled) on the face of the diaphragm and solder the small hexagon nut supplied with the button to the exact center. Care should be taken that the thin diaphragm is not bent or otherwise

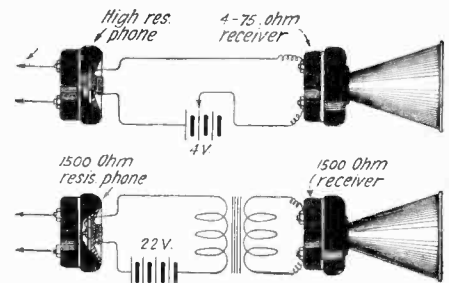

harmed. The transmitter button is then screwed into place. Connections, as shown in the diagram, are made with flexible wire. A horn may be placed over the low resistance receiver if desired. When the radio set is properly tuned and signals are being received, the transmitter button is operated by the vibration of the diaphragm of the receiver. As the receiver diaphragm vibrates, the mica diaphragm on the transmitter button also vibrates. The carbon grains are compressed at varying pressure; the current flowing through the local battery circuit is thus varied and results in an amplification of the sounds in the low resistance telephone loud-talker.

Diagram B, which includes a step-up transformer, is to be used with loud talking receivers of high resistance. The primary of the transformers should have a resistance of about 75 ohms. An ordinary telephone induction coil will serve as the transformer in this circuit.

You can get the above-described transmitter button FREE in subscribing to "Practical Electrics Magazine" at \$2.00 per year (12 months). Send your subscriptions today.

Make all remittances payable to Practical Electrics Co., 53 Park Place New York City.



# A Chemistry Laboratory for \$7.00

Think of it, fellows! Here is a real chemistry outfit with regular chemical apparatus that performs those fascinating, actual chemical experiments.

This outfit is not a toy, put up merely to amuse, but a practical laboratory set, with all the chemicals, apparatus and reagents necessary to perform real work and to teach the beginner all the secrets of inorganic chemistry. With this outfit we give free a book containing a Treatise in Elementary Chemistry, useful data and recipes, and 100 instructive amusing experiments.

## DESCRIPTION OF THE OUTFIT

The outfit consists of forty-four (44) chemicals all C. P. (chemical pure) put up in appropriate wooden boxes, glass bottles and hermetically closed jars. The acids are put up in glass bottles, with ground-in glass stoppers, and there is a sufficient quantity of chemicals supplied (mostly one to two ounces) enough to make dozens of experiments with each.

The apparatus furnished are all of the best obtainable make and of standard laboratory size and shape. 17 pieces of apparatus furnished with this outfit.

The instruction book is a real Chemistry Course for the Beginner. Some of the Contents

are: Division of Matter: This is a Treatise on Elementary Chemistry, and deals with the theory of the Elements, Molecules and Atoms, etc.

## 100 EXPERIMENTS

How to make chemical tricks; how to make invisible and magic inks; how to test flour; how to test soil; how to make chlorine gas and smoke (German War Gas); how to bleach cloth and flowers; how to produce oxygen and hydrogen; how to make chemical colors; how to test acids and alkalies, and hundreds of interesting hints and formulas.

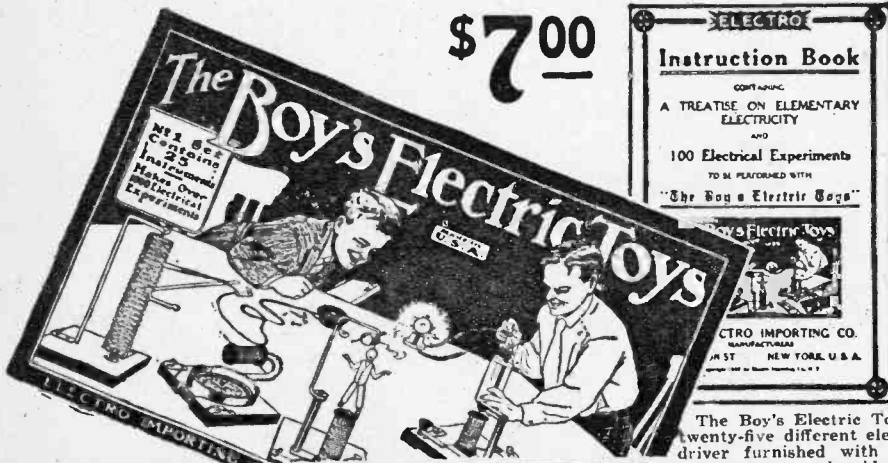
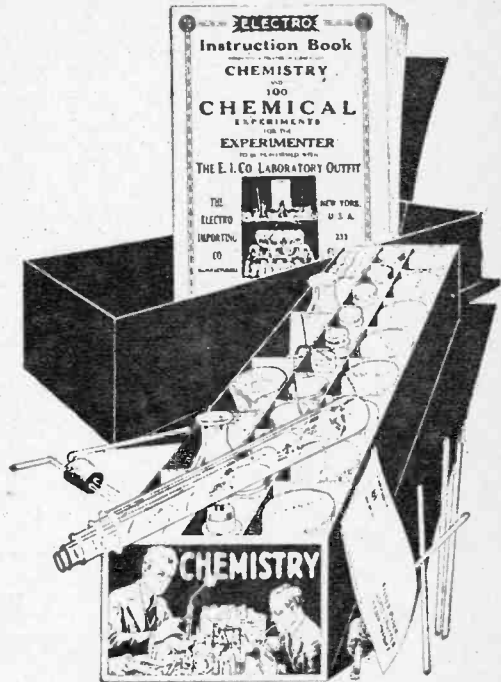

Every Fellow Wants the **BOY'S ELECTRIC TOYS**

The Boy's Electric Toy contains: Enough material to make and complete over twenty-five different electrical apparatus without any other tools except a screw-driver furnished with the outfit. Student's chromic plunge battery, compass-galvanometer, solenoid, telephone receiver, electric lamp. Enough various parts, wire, etc., are furnished to make the following apparatus:

Electromagnet, electric cannon, magnetic pictures, dancing spiral, electric hammer, galvanometer, voltmeter, hook for telephone receiver, condenser, sensitive microphone, short distance wireless telephone, test storage battery, shocking coil, complete telegraph set, electric riveting machine, electric buzzer, dancing fishes, singing telephones, mysterious dancing man, electric jumping jack, magnetic geometric figures, rheostat erratic pendulum, electric butterfly, thermo electric motor, visual telegraph, etc., etc.

This does not by any means exhaust the list, but a great many more apparatus can be built actually and effectually.

With the instruction book we furnish one hundred experiments that can be made with this outfit, nearly all of these being illustrated with superb illustrations. No other materials, goods or supplies are necessary to perform any of the one hundred experiments or to make any of the 25 apparatus. Everything can be constructed and accomplished by the means of this outfit, two hands and a screwdriver.

The outfit contains 114 separate pieces of material and 24 pieces of finished articles ready to use at once.

We guarantee satisfaction. The size over all the outfit is 14 x 9 x 2 1/2. Shipping weight, 8 pounds. "The Boy's Electric Toys" outfit as described, \$7.00. Immediate shipment.

**SEND FOR YOUR SET TODAY**

**REMEMBER**

**JUST CLIP THE COUPON—DON'T SEND MONEY**

**ELECTRO IMPORTING CO., 233 Fulton St., New York City**

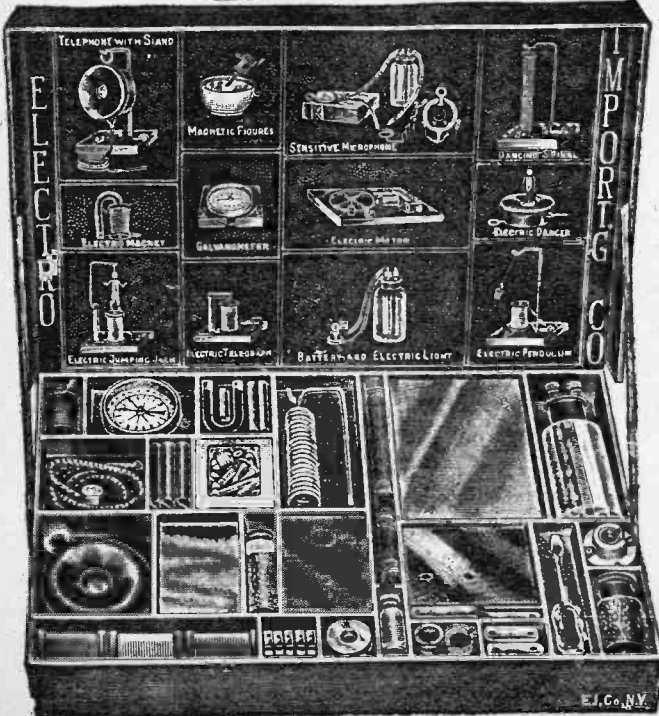

ELECTRO IMPORTING CO.,  
233 Fulton St., New York.  
Please send me by express THE CHEMICAL LABORATORY. If I don't like it I need not accept it. If I want it I only pay \$7.00 plus the few cents express charge.

ELECTRO IMPORTING CO.,  
233 Fulton St., New York.  
Please send me by express THE BOY'S ELECTRIC TOYS. If I don't like it I need not accept it. If I want it I only pay \$7.00 plus the few cents express charge.

# BUILD YOUR SET WITH BARAWIK STANDARD

## PLATE CIRCUIT "B" BATTERIES

You can make real savings on these batteries. Don't pay more. We guarantee them to equal any on the market regardless of price. Absolutely uniform. Extra long life.

- M180 Signal Corps type, small size, 15 cells, 2 1/2 volts. Each... \$5c
- M184 Variable Large Navy size, 5 1/2 x 4 1/2 inches 5 Laps, giving range from 1 1/2 to 2 1/2 volts in 1 1/2 volt steps. Each... \$1.80
- M188 Combination Tapped 45 volts 30 cell, 13x13 battery. Tapped to give 45, 22 1/2, 21, 19 1/2, 13 and 16 1/2 volts. Handles both detector and amplifier tubes. Each... \$3.55

## WILLARD "B" STORAGE BATTERY

Better results. No battery noises. Cheaper in the long run. Easily recharged by our Battery Charging Rectifier. Leak proof glass jars. Will last for years.

- M205 Price... \$9.00

## HOMECARGER BATTERY CHARGING RECTIFIER

Charge your battery at home over night for a few cents. Simply connect to any 110 volt 60 cycle light socket, turn on current and rectifier does the rest automatically. Will work for years without attention. Simple connections. Gives a tapering charge rate which all batteries should have. You can make it pay a profit charging your friends' auto batteries. Long connecting cords with pair of battery clips.

- M201 For 6 volt battery... \$13.95
- M203 For 12 volt battery... 13.95

## STORAGE "A" BATTERY

A very high grade battery especially for radio service. Guaranteed for three years. Properly cared for will give many more years of service for filament lighting. Made of best new materials. Full capacity. The best battery buy on the market. Try one of these batteries on your set for 10 days. If at the end of that time you are not fully satisfied with the battery return it and we will refund the purchase price.

- M194 6 volt, 40 ampere size. Each... \$10.00
- M196 6 volt, 80 ampere size. Each... 12.50

## BATTERY CLIPS

M198 Two for... 28c  
Clip onto storage battery terminals, lead coated. Make positive non-corrosive contact at all times.

## WIRE CONNECTING CLIPS

M199 Per dozen... 30c  
Small connecting clips for quick fastening leads onto binding posts, etc. Handy and useful. Every radioist should have at least a dozen.

## PORCELAIN BASE SWITCHES

Fine white porcelain bases. Copper contacts and blades. Can be used as antenna switches.

- M385 Single Pole Single Throw. Each... 20c
- M387 Single Pole Double Throw. Each... 32c
- M384 Double Pole Double Throw. Each... 50c

## FILAMENT CONTROL RHEOSTATS

Cresley—Wound on vulcanized fiber. Adjustable to any panel. Complete with knob.

- M130 Each... 45c
- M132 Each... 45c

## POTENTIOMETER

Same style as above rheostat. Gives fine "B" battery adjustment. Resistance 200 or 300 ohms.

- M133 Each... 98c

## VERNIER RHEOSTAT

Gives exceedingly fine control of "A" battery current. A necessity for best receiving results.

- M135 Each... 78c

## QUICK ACTING VERNIER RHEOSTAT

Gives very fine control of current and can be switched on or off instantly at any desired point.

- M124 Each... \$1.19

## PORCELAIN BASE RHEOSTAT FOR TABLE MOUNTING

- M136 Each... 78c

## KLOSNER VERNIER RHEOSTAT

- M129 Each... 85c
- Regular \$1.50 value. Limited quantity at this price.

## RADIO TUBES

Tubes for winding coils. Strong solid material, with smooth clean surface.

- M950 Diameter 3 inches, per foot... 20c
- M951 Diameter 3 1/2 inches, per foot... 25c
- M952 Diameter 4 inches, per foot... 30c

## WE PAY TRANSPORTATION CHARGES EAST OF THE ROCKIES

### THE PRICES QUOTED DELIVER THE GOODS TO YOUR DOOR

### FAST SERVICE—TRY US AND BE CONVINCED

**THIS GUARANTEE PROTECTS YOU—Examine the goods we ship you. They must suit you in every respect. If you are not satisfied with your purchase return the goods at once and we will refund the price you paid.**

## AGENT-DEALERS WANTED

We want Agent-Dealers in every locality to handle our line of goods.

**Our Proposition Means Money to You**

Our prices save you money. The quality of our goods insures satisfied customers. Our service will help you do a large business on a small investment.

## SEND FOR OUR CATALOG

We have selected a line of goods—both completed sets and parts to assemble sets—that will enable you to supply every demand and make money. You can make a good income on our proposition with a very small investment. Our catalog shows the merchandise you should handle, gives much radio information and will help you establish a successful business. Enclose 10c for the catalog. Tell us what you can and want to do, and how much you can invest. We'll do the rest.

*For the Person Who Makes His Own Set*

Our catalog is interesting and valuable. Even if you are not interested in radio as a business you will find many interesting things in this catalog and you will save money buying your supplies from us.

## VACUUM TUBES

Standard Brands—Cunningham Radiotrons. Every one guaranteed new and perfect. We will ship brand in stock unless you specify otherwise.

- M105 Detector, UV200 C300 Ea. \$4.45
- M110 Amplifier UV201 C301 Ea. 5 95
- M118 3 Watt Transmitter... 7.20
- M107 WD11 1 1/2 v. Fil. Each... \$3.85
- M108 WD11 Socket. Each... 49c
- M109 WD11 Adapter. Each... 48c

## MYERS TUBES

Can be used in Myers receptacle or in any standard socket with adapter listed. M113 High-Mu Audion. Has 5 times amplification of ordinary tubes. Oscillates anywhere from 2 to 200 volts on plate. We include our best grade rheostat with each tube. Each including rheostat... \$5.00

- M116 Receptacle for above. Each... 1.00
- M117 Adapter to adapt Myers tubes for use in any standard socket. Each... \$1.05

## MYERS CHOKE COIL

Designed to work with Myers tubes. Brings in loudest signals. Flexible over a broad band of wave lengths. Free from amplifier noise and distortion. Mounts in Myers special receptacle.

- M119 For Audio Frequency Amplification... \$3.50
- M120 For Radio Frequency Amplification... 5.00

## FOUR-IN-ONE SCREW-DRIVER

M974 Each... 55c  
Especially suitable for radio work. Will handle any size screw used. Smaller drivers nest inside larger one and are held in place with screw cap. Made of steel, nickel finished. Every radio builder can use several of these handy tools.

## VACUUM TUBE SOCKETS

Our Special Socket. A wonderful value. Moulded entirely of brown bakelite. Four binding post connections. Right angled contact springs.

- M140 Each... 39c

## PORCELAIN BASE AND TUBE

M144 Cresley for either panel or table mounting... 30c

High Grade combination type for panel or table mounting. Metal tube. High insulation base. One of the best sockets made.

- M146 Each... 45c

## TWO AND THREE GANG SOCKETS

These sockets make it easy to build detector and amplifier units and make a neat, compact workmanlike job. Perfectly made of high grade materials. Quickly mounted on panel or base.

- M147 Two-gang socket... \$1.05
- M149 Three-gang socket... 1.45

## FIXED CONDENSERS

Moulded cases, nicked binding posts.

- M804 Each... 48c

## BRADLEYSTAT CARBON PRESSURE VERNIER RHEOSTAT

Current regulation is obtained by changing of pressure on carbon. This permits of infinitely fine variation of current. Very durable. Resistance 15 ohms. Capacity 2 1/2 ampere.

- M131 Each... \$1.65

## VARIABLE GRID LEAK

Penell mark type. Resistance may be varied exactly as needed.

- M160 Each... 19c

## GRID CONDENSER

M162 Mounting holes spaced to fit lens of above leak. Cap. .0025 MF. M163 Same as 162 but higher grade. Enclosed in metal case.

- M162 Each... 24c
- M163 Each... 24c

## PHONE AND GRID CONDENSERS

A compact style of condenser that is very satisfactory. Conducting sheets and dielectric are wound on fiber strip with eyelets for mounting and connections. Each 12c

- M170 Phone Condenser .001 Mfd.
- M172 Phone Bridging Condenser .0005 Mfd.
- M174 Grid Condenser .0025 Mfd.
- M176 Grid Condenser .0025 with penell mark leak. Each... 24c

## TUBULAR GRID LEAKS AND CONDENSERS—MOUNTED STYLE

Very convenient. Permits quick change of leaks or condensers of varying capacitances.

- | Grid Leaks | Price    | Resistance | Price   |
|------------|----------|------------|---------|
| M850       | .5 Mck.  | M855       | .2 Mck. |
| M851       | .1 Meg.  | M857       | .3 Mck. |
| M853       | 1.5 Mck. | M859       | .5 Mck. |

## GRID AND PLATE CONDENSERS

Price, each... M830 .00025 Mfd. Correct for Myers Tubes. M832 .0001 Mfd. For special circuits. M834 .00025 Mfd. For U.V.201 and Cun. 301 M836 .0005 Mfd. For U.V.200 and Cun. 300

## MOUNTINGS

Bakelite base. Spring clip contact. M840 Single mounting. Each... 32c M842 Double mounting. Each... 57c M844 Triple mounting. Each... 76c

## "HONEYCOMB" COILS

Carefully made—fine looking coils. Highest efficiency. Low distributed capacity effect, low resistance—high self inductance. Very firm enamel impregnation. Range given is in meters when varied with standard plug mountings.

- .001 variable condenser. Mounted—each have standard plug mountings.

Turns	Range	Art. No.	Not Mtd.	Art. Price	Mtd.
25	120-	250 M301	\$0.39	M320	\$0.89
35	175-	450 M302	.42	M322	.96
50	240-	750 M303	.49	M323	1.04
75	390-	910 M304	.54	M324	1.08
100	500-	1450 M305	.58	M325	1.13
150	600-2000	M306	.63	M326	1.17
200	900-2500	M307	.72	M327	1.26
250	1200-3500	M308	.78	M328	1.35
300	1500-4500	M309	.82	M329	1.36
400	2000-5000	M310	.97	M330	1.57
500	2800-6100	M311	1.12	M331	1.63
600	4000-10000	M312	1.27	M332	1.78
750	5000-12000	M313	1.43	M333	1.93
1000	7900-15000	M314	1.70	M334	2.28
1250	9750-19500	M315	1.92	M335	2.49
1500	14500-26500	M316	2.18	M336	2.65

## COIL MOUNTINGS

M340 Three-coil mounting... \$3.59 M341 Two-coil mounting... \$2.69 High grade fine looking mountings. Polished black composition. Center receptacle stationary, two outer ones adjusted by knobs. Takes any standard mounted coil.

## COIL PLUGS

Made of moulded bakelite. Fits any standard plug. Mounts any standard honeycomb coil.

- M344 Each... 50c

## PANEL MOUNTING COIL PLUGS

Take any standard mounted coils. Made of moulded bakelite, mounted on brackets.

- M345 Stationary. Each... 89c
- M346 Movable with anti-capacity handle. Each... \$1.10

## RADIO FREQUENCY AMPLIFYING TRANSFORMER

M955 Very special... \$2.95 This transformer will get the long distance stations low and clear. Permits of easy sharp tuning. Helps cut out static and interference. Makes your set sensitive enough to use a loop aerial. Enclosed in metal case affording perfect shielding. Suitable for panel or base mounting. Because of its special design can be mounted in any V. T. socket. Works with any style of tuner. Wave ranges 150 to 550 meters. Wiring diagrams included.

## OUR SPECIAL AUDIO FREQUENCY AMPLIFYING TRANSFORMERS

As high as three stages can be used without howling due to proper impedance with minimum distributed capacity, low core losses and proper insulation. Mounted style has bakelite panel with binding post connections. Unmounted has core and coils assembled with two holes in core for fastening to apparatus.

- M234 10 to 1 Mounted. Each... \$3.46
- M235 10 to 1 Unmounted. Each... 2.95
- M236 3 to 1 Mounted. Each... 3.40
- M237 3 to 1 Unmounted. Each... 2.85

## THORDARSON AUDIO FREQUENCY AMPLIFYING TRANSFORMER

An especially high grade transformer with correct characteristics for Cunningham, Radiotron or A. P. Tubes. Wonderful results without distortion on one, two or three steps. Low distributed capacity. Fully mounted bakelite panel.

- M232 3 to 1 Ratio. Ea. \$3.69
- M233 6 to 1 Ratio. Ea. 4.25

## RADIO CORPORATION TRANSFORMERS

Audio Frequency Amplifying Transformer. Especially designed for Radiotron tubes, 9 to 1 winding ratio.

- M712 Each... \$6.40

## RADIO FREQUENCY AMPLIFYING TRANSFORMERS

Range 200 to 5000 meters. For long distance reception.

- M714 Each... \$5.95

## OUR COMPETITOR AUDIO FREQUENCY AMPLIFYING TRANSFORMERS

While these are very low priced transformers, nevertheless they will give excellent results. They are carefully designed and carefully made. Quantity production and small profits make the low price possible. They will equal in results many transformers selling at much higher prices.

- M239 Unmounted, with wire leads... \$2.00
- M239 Mounted, with binding post connections... \$2.75

## BARAWIK SPECIAL PANEL MOUNTING VARIABLE CONDENSERS

M812 43 plate .001 Mfd. \$2.29 M813 21 plate .0005 Mfd. 1.80 M814 11 plate .0025 Mfd. 1.32 M815 3 plate Vernier... 1.05

These are especially high grade condensers and we guarantee them to be mechanically and electrically perfect. Fine polished end plates of heavy bakelite. Shafts 1/4 inch diameter. Sturdy, heavy aluminum alloy plates perfectly spaced to insure smooth, reliable capacity. Our low prices save you money. These condensers are of the very best make and are not to be compared with many inferior cheap condensers offered. We guarantee them to please you or your money back.

## COMBINATION VERNIER VARIABLE CONDENSERS

M824 23 plate .0005 Mfd. with dial and knobs. Price... \$3.25 M826 43 plate .001 Mfd. with dial and knobs. Price... \$3.95

The latest improvement in condensers consists of regular variable condenser controlled by large knob and dial mounted with a three plate vernier condenser, which is controlled by separate knob mounted above knob on dial. This arrangement permits of very fine tuning. Compact convenient mounting on panel. High grade design and construction. Finely finished.

## ENCLOSED VARIABLE CONDENSERS

One of the best made condensers. Rigid, accurately spaced aluminum plates. Formica ends. Engraved scale. Knob and pointer. Clear transparent case.

- M806 43 plate .001 Mfd. \$3.95
- M808 21 plate .0005 Mfd. \$3.25

## KNOCKED DOWN VARIABLE CONDENSERS

You can save money by assembling your own condensers. Formica top and base. Complete with all parts not assembled. Go together easily and perfectly. Panel mounting type.

- M820 41 Plate .001 Mfd. \$1.95
- M821 21 Plate .0005 Mfd. 1.60



# RADIO GOODS--DEPENDABLE QUALITY--LOWEST PRICES

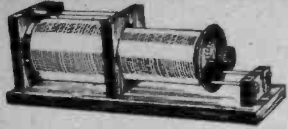

## ARLINGTON RECEIVING TRANSFORMER

Will tune in all stations up to 3,500 meters. Very efficient on short waves and for radio-phone reception. Used with our Detector Two Step Amplifier it produces very excellent results. Also does good work with crystal detector. Silk covered windings on formica tubes. Very fine mahogany finish wood work. Base size 6x18 inches. Slider controls primary, 12 point switch on secondary. Can be tuned very close. Brass metal parts nickel finish. A wonderful value at our price.

M720 Price ..... \$6.39

## TUNING COIL

Range up to 950 meters. Wound with bare copper wire, machine spaced. Ends of mahogany finished hard wood. Two easy sliding contacts on polished brass rods, four binding posts. Substantial, efficient, attractive. Length, 8 1/2 in.

M722 Price ..... \$2.45

## VARIOMETER

M410—Completely assembled, price \$2.69  
Perfect in design and construction. Accurate wool forms of genuine solid mahogany. Correct inductive ratios. Solid bakelited windings. Positive contacts. Highest efficiency. A real bargain. M411—Not assembled nor wound but all parts complete except wire, including winding form, \$1.48

## VARIO-COUPLER

M415 Price, completely assembled ..... \$2.45  
With this loose coupler and two variometers, together with the necessary other parts, a highly efficient tuning set can be made. Easily mounted on panel. No base included. Primary winding on formica tube. Inductively coupled for 180 to 600 meters. Multiple taps permit fine tuning.

M416 Not assembled nor wound but all parts complete except wire. Price ..... \$1.18  
M417 Rotor ball only. Each ..... 29c  
M408 Bakelite stator tube only. Each ..... 35c

## MOULDED VARIOMETER

Polished black moulded rotor and stator forms. Maximum inductance with greatest efficiency and minimum distributed capacity. A high grade durable instrument that will make up into a set you will be proud of and will get the best results. Wave length 180 to 600 meters, 4 1/2 in. square, 1 1/2 in. thick.

M412 Price including mounting brackets \$4.25

## MOULDED VARIO-COUPLER

This coupler is designed to work with the above variometer. The stator and rotor forms are of polished black moulded composition. Primary has seven taps to enable finest tuning. Wave length range 180 to 650 meters. Fitted with panel mounting bracket.

M419 Price ..... \$3.95

## 180° VARIO-COUPLER

M418 Price ..... \$2.89  
Our price shows you a big saving. An instrument of highest quality. The most efficient type of coupler, insures sharper tuning and louder signals. Primary and secondary wound on genuine bakelite tubes. Secondary connections through soldered flexible cables eliminates contact noises. Primary has 7 taps. Can be panel or table mounted. Range 180 to 650 meters.

## BRASS ROD

Supplied only in 12 inch lengths.  
M961 Threaded 8-32, per 12 inch length.. 8c  
M963 Threaded 8-32, per 12 inch length..10c  
M965 Solid 3-16 inch, per 12 inch length..10c  
M967 Solid 1/4 inch, per 12 inch length.....12c

## TINNED COPPER WIRE

Size 14 tinned copper wire. For wiring sets. Best size for neat job and proper results.  
M969 Ten feet for.....12c

## CHOKE COILS AND RESISTANCES

For Super Regenerative Circuit  
M355 100 Millihenrie Iron core choke coil. Each ..... \$1.20  
M354 10 Millihenrie Open core choke coil. Each ..... 92c  
M357 12,000 ohm Non-inductive wire wound resistance. Each ..... \$1.58  
M356 12,000 ohm Moulded resistance. Ea. 45c  
M358 5 Millihenrie Open core choke coil. Each ..... 92c  
M359 1 Henrie Iron core, choke coil. Ea. \$1.20

## PRESERVE THESE PAGES—ORDER FROM THEM AND SAVE MONEY FAST SERVICE—TRY US AND BE CONVINCED

**THE PRICES QUOTED DELIVER THE GOODS TO YOUR DOOR**  
OUR GUARANTEE PROTECTS YOU—We handle only the best goods, carefully tested and checked by expert radio engineers. You are assured of getting guaranteed apparatus that will give superior results. And while our goods are best, our prices are lowest. Our goods equal or surpass the claims we make for them. We do not attempt to deceive or mislead. Our reputation for fair dealing is our most valued asset.

**HOW TO ORDER**—Write your Order plainly, state Article Number, Description and Price of items wanted. Send Postoffice or Express Money Order. Certified Check or Bank Draft for Total of Order. Prompt Shipment is assured when those directions are followed.



## BARAWIK QUALITY HEADSETS

These headsets have proven on rigid tests to be one of the very best on the market. The tone quality is excellent with an unusual volume. Skilled workmen make them from only the best selected materials. The receiver cases are fine polished finish with polished black ear pieces. Fabric covered headbands fitted to the head. Supplied with band comfortably and quickly ear pieces. We guarantee that they are the best value by far yet offered. If they don't suit you we will cheerfully return your money.

M778—2000 ohm ..... \$3.75

## OTHER STANDARD BRAND HEADSETS

M751 Murdock 58, 2000 ohm..... \$4.20  
M752 Murdock 56, 3000 ohm..... 4.95  
M764 Frost, 2000 ohm..... 4.20  
M766 Frost, 3000 ohm..... 4.95  
M758 Western Electric, 2200 ohm..... 9.50  
M754 Baldwin Type C with universal jack plus ..... \$12.60  
M755 Baldwin Type C unit..... 5.50  
M756 Red-Head, 2000 ohm..... 5.75  
M768 Brandes, 2000 ohm..... 7.15

## TWO-WAY ROUND PLUG

M397 Each ..... \$3.98  
Takes two pairs of head set terminals. Quick easy connections. Polished round barrel. Fits any standard jack.

## ENCLOSED DETECTOR

One of the finest crystal detectors on the market. Supersensitive galena crystal enclosed in heavy glass shield. Quick, positive adjustment. Brass parts polished nickel finish.  
M730 Each ..... \$1.18

## GALENA DETECTOR

Easy fine adjustment. Crystal mounted in cup. Moulded base and knob. Brass parts polished nickel finish. An unequalled value.  
M732 Each ..... 59c

## DETECTOR CRYSTALS CAREFULLY TESTED

M736 Galena, Arlington tested, per piece, 19c  
M738 Silicon, Arlington tested, per piece, 19c  
M735 Buzzer tested, Galena, per piece.. 8c  
M737 Buzzer tested, Silicon, per piece.. 8c

## DETECTOR PARTS

M723 Price set 32c  
All metal parts for crystal detector. No base included. Easily assembled. Polished nickel finish.

## BAKELITE DIAL AND KNOB

Moulded of genuine bakelite, polished black finish. Fluted knob. Fine engraved scale with sharp clear graduations and figures in contrasting white enamel. This is the finest quality dial and knob in a very attractive pattern. Two inch cannot be supplied for 1/4 inch shaft.

M915 2 in. Diam. for 3-16 in. shaft. Ea. 40c  
M902 3 in. Diam. for 3-16 in. shaft. Ea. 49c  
M903 3 in. Diam. for 1/4 in. shaft. Ea. 49c  
M916 4 in. Diam. for 1/4 in. shaft. Ea. 74c

## ONE-PIECE DIAL AND KNOB

Moulded in one piece of polished black composition with clean plain engraved scale and numerals in contrasting white enamel. Ribbed knob to fit the hand. An attractive neat pattern.

M900 2 1/2 in. Diam. for 3-16 in. shaft. Ea. 19c  
M901 2 1/2 in. Diam. for 1/4 in. shaft. Ea. 19c  
M904 3 in. Diam. for 3-16 in. shaft. Ea. 25c  
M905 3 in. Diam. for 1/4 in. shaft. Ea. 25c  
M906 4 in. Diam. for 3-16 in. shaft. Ea. 42c  
M907 4 in. Diam. for 1/4 in. shaft. Ea. 42c

## ROBIN CORE SOLDER

M958 Per Coil ..... 22c  
Self fusing. Especially designed for soldering electrical connections. Fine for use with above electric iron. Coil will last a long time.

M959 Per tube ..... 19c  
With this preparation you can solder your connection with the heat of a match. Works fast. Makes a perfect electrical and mechanical joint. Self fusing.

## LONG NOSE PLIERS

M970 Price ..... 95c  
The handiest pliers for radio work. Made of fine hardened steel. Length 5 inches.

## DIAGONAL JAW NIPPERS

M872 Price ..... 92c  
For fine electrical work. Made of hardened steel. Length 5 inches.

## RADIO JACKS AND PLUGS

Finest grade jacks. Improved design. Best materials. Phosphor bronze springs. Silver contact points. Nickel finish. Mount on panels 1/2 to 3/4 in. thick.

M390 Open circuit. Each ..... 43c  
M391 Closed circuit. Each ..... 49c  
Jacks: M392 Two circuit. Each ..... 60c  
Only: M393 Single circuit filament cont. 85c  
M394 Two circuit filament cont. 85c  
M395 Plug. Large space with set screws for attaching cord. Each ..... 49c

## COMPETITOR JACK AND PLUG

Well made, durable, smooth working. Interchangeable with any standard Jacks and Plugs. Solder connections. Nickel finished metal parts.  
M387 Open circuit jack. Each ..... 27c  
M388 Two circuit jack. Each ..... 35c  
M389 Standard plug. Each ..... 35c

## BINDING POSTS

Brass, polished nickel finish. Washer and 6-32 in. screw extending 1/2 in.  
M370 Large size—barrel and knob 3/4 in. long, dozen, 85c  
M372 Smaller size—barrel and knob 9-16 in. long, dozen, 70c  
M374 Large size with connection knob, dozen, 50c  
M376 Large size with hole for phone tip or wire, dozen, 80c  
M378 Small size with hole for phone tip or wire, dozen, 35c

## SWITCH CONTACT POINTS

Brass polished nickel finish. All have 1/2 in. long size 6-32 screws and two nuts. All prices the same.  
Dozen 18c Hundred \$1.05  
Order by Article Number.  
M360 Head, 1/2 in.; Diam. 1/4 in. High  
M362 Head, 3-16 in.; Diam. 1/4 in. High  
M363 Head, 3-16 in.; Diam. 1-16 in. High  
Solder Lugs to Fit Contact Points  
Also for connecting wires to hind-line posts etc.  
M365 Dozen 12c—Hundred 60c

## SWITCH LEVERS

Moulded composition knob. Exposed metal parts polished nickel finish. Fitted with panel bushing, spring and two set screws. A high grade switch.  
M382 1 1/2 in. Radius } 19c Each  
M381 1 1/4 in. Radius }  
M380 1 in. Radius }  
SWITCH LEVER STOP  
Brass, polished nickel finish.  
M386—Dozen 18c—Hundred \$1.05

## INDUCTANCE SWITCH WITH KNOB AND DIAL

Mounts switch point and contact lever behind panel. Enables you to build neat attractive set. Only one hole needed to mount on panel. 15 switch points, any number of which may be used. Dial indicates position of lever. Smooth wiping contacts. Attractive tapered knob.  
M285 Price including knob and dial..... \$1.80

## OUTDOOR LIGHTNING ARRESTER

Including Knob and Dial  
M980 Price ..... \$1.66  
Protect your instruments with this lightning arrester. You cannot afford not to. Weatherproof porcelain case. Air gap type. Permanent. Durable. The most practical quality arrester obtainable. Underwriters approved.

## CABINETS

Fine looking cabinets solidly built. Made of genuine solid mahogany in elegant hand rubbed finish. You will be proud of your set mounted in one of these cabinets. Hinged tops. Front rabbeted to take panels. Panels not included. Prices are transportation paid.

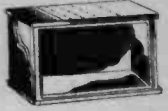

Panel Size	Inside Dimensions			Art. No.	Price Each
	High	Wide	Deep		
6x7"	5 1/2"	6 1/2"	7"	M420	\$2.48
6x10 1/2"	5 1/2"	10"	7"	M422	2.75
6x14"	5 1/2"	13 1/2"	7"	M424	3.30
7x14"	6 1/2"	13 1/2"	7"	M423	3.60
7x18"	6 1/2"	17 1/2"	7"	M426	3.90
9x14"	8 1/2"	20 1/2"	7"	M425	4.20
9x18"	8 1/2"	24 1/2"	7"	M428	4.00
12x14"	11 1/2"	13 1/2"	10"	M430	4.40
12x21"	11 1/2"	20 1/2"	10"	M432	5.25

## SOLID GENUINE CONDENSITOR CELORON PANELS

Notice our very low prices on this fine quality grade 10 genuine solid sheet Condensitor Celoron (a product with mechanical, chemical and electrical properties like formica and bakelite). Machines well without chipping. Won't warp. Waterproof. Highest mechanical and dielectric strength. Attractive natural polished black finish which can be sanded and oiled for extra fine work.

Panel Size	Art. No.	Price	Art. No.	Price	Art. No.	Price
6x7"	M450	\$0.50	M460	\$0.74	M470	\$0.95
6x10 1/2"	M451	.75	M461	1.11	M470	1.47
6x14"	M452	1.05	M462	1.55	M472	2.05
7x14"	M458	1.20	M468	1.8	M478	2.40
7x18"	M453	1.55	M463	2.3	M473	3.10
9x14"	M457	1.78	M467	2.8	M477	3.60
9x18"	M454	1.60	M464	2.3	M474	3.10
12x14"	M455	2.10	M465	3.1	M475	4.15
12x21"	M456	3.15	M466	4.6	M476	6.20

## ETCHED METAL NAME PLATES

Made of brass. Silver plated characters and border on black background. All plates are 1 inch long and 1/2 inch wide, except "INCREASE CURRENT" which are quarter circle 1 1/2 inch over all, and "OFF" which are 1/2 inch long. Attaching holes pierced.  
M503 Per Dozen ..... 35c  
Not less than one dozen assorted sold. Specify marking wanted as follows:  
Plate Variometer Secondary Aerial  
Grid Variometer Primary Ground  
Vacuum Triker Phones  
Primary Condenser Loud's Coil Input  
Secondary Condenser Coupling Input  
Increase Current Parallel On  
(to right) Series Off  
Increase Current Detector 1st Step  
A Battery 2nd Step  
B Battery 3rd Step  
(Blank—takes pencil or pen marks.)

## ELECTRIC SOLDERING IRON



M957 Price ..... \$5.75  
Especially adapted to radio work. Will enable you to do neat clean work quickly. Simply attach to any light socket 110-120 volts. Compatible with six foot cord and attaching plug. Renewable solder point. Will last a lifetime for ordinary home or light shop work. A wonderful value at the price.

## MAGNET WIRE

Insulated copper wire. Best quality even drawn wire, one piece to a spool. Prices quoted are for 8 oz. spools.

Double Cotton Covered	Enameled Insulation	Green Silk Covered
Number M990	Number M992	Number M991
Gauge Price	Gauge Price	Gauge Price
18 ..... 50c	20 ..... 45c	20 ..... \$0.78
20 ..... 60c	22 ..... 55c	22 ..... .90
22 ..... 75c	24 ..... 61c	24 ..... 1.05
24 ..... 85c	26 ..... 65c	26 ..... 1.18
26 ..... 95c	30 ..... 70c	30 ..... 1.70
28 ..... \$1.15	32 ..... 79c	32 ..... 2.05
30 ..... 1.65	36 ..... 96c	36 ..... 2.75

## STRANDED ANTENNA WIRE

Cabled of fine copper strands. Very flexible. High tensile strength. Best for aerials.  
M248—100 ft. coil 65c M249—500 ft. coil \$2.95

## SPAGHETTI

For covering connecting wires in sets. For size 12 and 14 wires.  
M955 Finest quality braided and saturated with best baked lustrous transparent insulating varnish, 3 feet for ..... 20c  
M956 Best quality braid and covered with black insulating compound, 3 feet for ..... 15c

## ANTENNA INSULATORS

M260 Size 12x3/4 ..... 17c  
M262 Size 2 1/2x3/4 ..... 58c  
M264 Size 3 1/2x3/4 ..... 80c  
M266 Size 1 1/2x1 1/2 ..... 35c  
M260 M262 M264-9

## SOLID BARE COPPER WIRE

Solid bare copper wire for aerials, leads or wiring instruments.  
Solid Bare Copper Wire, size 14  
M246—100 ft. coil 45c M242—500 ft. coil \$2.15  
Solid Bare Copper Wire, size 12  
M244—100 ft. coil 61c M245—500 ft. coil \$2.75



## KNOW WHO IS SENDING

Get twice the pleasure and usefulness out of your receiving set. Look up the name and location of any ship or land station whose messages you pick up—learn the name and address of that amateur whose sending set you just heard.

### 4th Edition of the **CONSOLIDATED RADIO CALL BOOK**

In a new large size—280 pages—88 more valuable pages than the 3rd Edition and featuring

## 7 Two-Color Radio Maps

Five of them are Continental Maps showing all stations throughout the world handling commercial traffic, with their calls; one showing the amateur radio districts of the United States and the principal radiophone broadcasting stations with their calls; and a map of the United States Weather Forecast Zones. Seven wonderful, two-color radio maps with a wealth of information that will give you a great deal of pleasure and knowledge.



### *Every Amateur Call in the U. S. and Canada Is Listed Besides Other Valuable Information Contained in This New Book*

All Amateur Radio Calls of the United States and Canada; Every Vessel, Coast Station, and Radio-Compass Station in the World; Radiophone Broadcasting Stations of the United States; Every High-Power Station in the World; Special Land Stations of the United States; Time Signals, Hydrographic and Weather Reports of the United States and Principal Foreign Countries; International Abbreviations; Assignment of International Calls; Press Schedules; Radiogram Rates; Cable Rates; International Morse Code and Continental Signals; and Complete General Information covering Distress Calls, International Safety Signal, Use of 800-Meter Wave Length, Amendments and Changes in Various Governmental Regulations, How to Determine Charges on Radiograms, Free Medical Advice by Radio to Vessels, and much other useful information.

And every vessel and land station in the world is represented and listed alphabetically, according both as to name of vessel or land station, and to call letters.

The Consolidated Radio Call Book is the only book in print officially listing all the Radio calls as issued by the Bureau of Commerce. And the New Radiophone Broadcast Section is particularly complete and gives all available information concerning calls, wave lengths, PROGRAMS, etc.



The third edition of 10,000 copies was exhausted in two weeks. The fourth edition is selling just as quickly. Don't wait until it is all gone. Order at once, either direct from us or from your favorite dealer.

Published by

**Consolidated Radio Call Book Co., Inc.**  
96-98 Park Place, New York City.

## Great 40-page Supplement FREE to all who have the 4th Edition Call Book

As a special service to the readers of the Fourth Edition of the Radio Call Book, we have printed, at great expense, a 40-page supplement containing the latest amateur radio calls of both the United States and Canada, and other calls issued very recently. It is absolutely free to all those who write for it, provided you have bought a copy of the fourth edition of the Consolidated Radio Call Book. This wonderful supplement brings the call book up to the very last moment and on account of the many changes that have taken place and which are fully covered by this supplement, every radio amateur or professional is urged to send for his free copy of this supplement today.

## The Amateur Magician

By JOSEPH H. KRAUS

(Continued from page 1069)



Near the base of the candlestick-holder, a tin pill-box was located, the cover of which had been cut open leaving only the rim and the same was used to clamp a rubber diaphragm to the rest of the box. Another pipe leading from the bottom of this pill-box, led to a small funnel, having at its mouth a diameter of approximately 1½ inches. Close up against the base was a single stroke bell, the gong of which had been removed, and its hammer bent upwardly so that when the bell was operated the hammer would strike the rubber diaphragm. The circuit to the bell was completed by means of two wire brushes resembling pieces of wire hair brush. These were secured to a base of fibre, and the latter screwed to the candlestick base. The table-top itself did not disclose any openings, being covered with cloth, but Hargrave took particular care in placing his candlestick down upon the table. When he removed it again, he showed me that the table also contained two wire brushes, which projected upward, and when the candlestick was placed down upon the table, the brushes interlocked, making, as he said, a more perfect contact that the plate and point method he had heretofore used.

Near the center of the candlestick-holder, directly under the funnel end of the small copper tube, a hole was drilled through the table-top which admitted a ⅛ inch tube. This tube did not pass through the table-cloth or cover, consequently, the opening remained concealed. The tube was connected to the illuminating gas supply line, which furnished the gas for the light, seen emanating from the candles. The gas itself burned with a yellow flame much like that of a tallow candle.

"It is evident," Hargrave continued, "that whenever the single stroke bell is energized, it strikes the rubber tambour. This causes the gas contained within the metallic box, to be compressed, which, finding its path of least resistance is in an upwardly direction, causes the flame to rise considerably above normal. The flame then drops down, and at a word of command, it can be made to fall below normal.

"But why did I not smell any gas when you extinguished the light?" I interrogated.

"For the simple reason," was Hargrave's reply, "that I took the precaution to open one of the windows slightly. The amount of gas passing from one of the candlesticks is very small indeed, and it would take quite some time before the odor would have made you aware of the fact that the candles operated on illuminating gas. By insuring a proper circulation, you would probably never realize that fact. Naturally I get a sort of Bunsen burner effect, except that the air is not forced upward with the gas. The lack of air supply produces the yellow flame. When my assistant, who operates the keys controlling the relative lights, presses any of the switches, the hammer of the bell contained within the base, strikes the rubber diaphragm of the tambour. This causes the flame to lengthen. When the key is released, and the circuit opened, the hammer flies backward and the flame drops below the normal point."

"As to the rapid calculation of figures, that is very simply accomplished. My Japanese valet, who listens to your questions by means of a telephone receiver which connects to a microphone placed in his room, takes down the numbers on a comptometer. By the time you have figured up the result, he has already completed the operation, and the answer is being transmitted by means of the light flashes.

*Do you want  
more money —  
a better job?  
Mark the job —  
mail the coupon.*

### American School

Dept. G, 326 Drexel Avenue  
and 58th Street, Chicago.

Send me full information on the subject checked and how you will help me win success

- |                               |                                |                             |
|-------------------------------|--------------------------------|-----------------------------|
| ..... Architect               | ..... Electrical Engineer      | ..... Steam Engineer        |
| ..... Building Contractor     | ..... Electric Light and Power | ..... Foremanship           |
| ..... Automobile Engineer     | ..... General Education        | ..... Sanitary Engineer     |
| ..... Automobile Repairman    | ..... Vocational Guidance      | ..... Surveyor (& Mapping)  |
| ..... Civil Engineer          | ..... Business Law             | ..... Telephone Engineer    |
| ..... Structural Engineer     | ..... Lawyer                   | ..... Telegraph Engineer    |
| ..... Business Manager        | ..... Machine Shop Practice    | ..... High School Graduate  |
| ..... Cert. Public Accountant | ..... Photoplay Writer         | ..... Fire Insurance Expert |
| ..... Accountant and Auditor  | ..... Mechanical Engineer      | ..... Wireless Radio        |
| ..... Bookkeeper              | ..... Shop Superintendent      | ..... Undecided             |
| ..... Draftsman and Designer  | ..... Employment Manager       |                             |

Name.....  
Address.....

## NOW Make Your Bike a Motorcycle

You, too, can do it easy and in 30 minutes time—no special tools or knowledge required. Your old bike and the Shaw Motor Attachment give you a speedy, dependable motorcycle at a small cost. 2½ H.P. motor. Runs from 4 to 40 miles an hour!

**The Shaw Attachment FITS ANY BICYCLE**  
Easy to control, pleasing to ride, economical to operate. Thousands in daily use. Ironclad guarantee.  
**WRITE TODAY** for full information about this wonderful Attachment and the Shaw Super-Motorcycle, which we also manufacture.  
**SHAW MFG. CO.**  
Galesburg, Ill., Dept. 46



## PLAY A SAW

You can produce wonderful, soft, sweet music from a common carpenter's saw with a violin bow or soft hammer, if you know how. No musical ability required—you need not know one note from another.

**Easy to Learn in 3 Weeks**  
I absolutely guarantee to teach you to play popular and classical music within three weeks. I give you the secrets of my 10 years' success as a saw musician, secrets I guarded carefully until I introduced "The Musical Saw." Successfully instructed thousands. No charge whatsoever if I fail.

**FREE**—a special tempered Musical Saw, Saw Bow, Soft Hammer free with Course of Instruction. This Course is short, simple and easy. Only three lessons, one each week—no months of tedious practice.

**MAKE BIG MONEY** and amaze your friends playing for dances, Lodge and Church Entertainments. Write today for information: "How to Play a Saw"—sent free.

C. J. MUSSEHL,  
322 Mack Bldg., Ft. Atkinson, Wis.



**INVENTORS, ATTENTION  
THE PATENT OFFICE**

is 70,000 cases behind and matters getting worse.

The patent office has made over 8½ million dollars for the government and there is no valid excuse why inventions which mean so much to

**NATIONAL PROSPERITY**

and mark the forward progressive spirit in our economic and industrial life **SHOULD NOT BE KEPT UP TO THE HOUR.**

**THE WORLD OF INVENTION**

a Live Progressive Magazine devoted to the interests of the inventor and the official organ of the

**NATIONAL INSTITUTE OF INVENTORS**

a co-operative society of over 3,500 inventors is offering \$200 in prizes for suggestions relative to relief from the patent office conditions so detrimental to the inventors' interest.

Write for full particulars

**WORLD OF INVENTION**

8 E. 14th Street, New York City, N. Y.

**The Sleep Eliminator**

By H. GERNSBACK

(Continued from page 1062)

and asked them if they would care to undergo an experiment to do away with sleep altogether, for a number of days. He found out that keeping awake for the first twenty-four hours was the hardest task, and the men under observation became very haggard and looked extremely fatigued. After the first sleepless night, the second and the third were not so arduous, and the work went on without so much personal discomfort. At the end of the experiment it was found that three or four entirely sleepless nights could be compensated for by eight or ten hours sleep, without the subject being any the worse for the experience.

When we reflect that if the life of the average human being is 50 to 60 years, one-half of this is actually wasted in sleep; then if we multiply this by the entire human race, we discover a waste that is appalling in its entirety. Suppose we could do away with sleep altogether! Suppose we could lead our regular lives without sleep at all! Would this not be a wonderful boon to the race? Would it not increase our activities and also increase our lives by just 100 per cent? It is a truly fascinating project, and is not half as improbable as it would seem at first.

There are, of course, many ways in which we can do away temporarily with sleep. Authors and writers as well as students, know well that when they become drowsy at about 11 or 12 o'clock at night, the most unflinching expedient to overcome sleepiness is to step to the open window and draw in

fresh air. This is done almost unconsciously. It simply means that the body needed oxygen in order to supply the nerve centers with their needed regeneration.

Then, also, a good many night workers who must, perforce, stay awake, often take to harmless drugs, coffee being one of them. The caffeine seems to stimulate the nerve centers and other centers to again restore the balance and the work can go on again for a number of hours.

The idea which the writer advances in the following lines has to do with the artificial regeneration of the nerve centers, the blood vessels, and other centers that have become fatigued or worn out. The idea in its entirety is simple:

It shows us what will be done in the future. Our text illustration as well as that on our front cover, convey the idea, which is simple enough. No scientist will deny that the more we fight sleep the higher our blood pressure will go. Finally, during sleep, the blood pressure comes down. If, then, high blood pressure is one of the reasons why we feel the necessity of sleep, we have means to overcome this electrically, by means of D'Arsonval high frequency currents. These, as is well known, tend to drive down the blood pressure quickly, and with lasting results.

On our front cover we see the City Editor dictating his work at 3 o'clock in the morning. His body is surrounded by a D'Arsonval spiral, which keeps his blood pressure down as long as he works. We also see on the wall oxygen tanks which give the room atmosphere a higher oxygen value, which value, however, is not high enough to do any damage, just enough to stimulate the worker.

We also see that the chair is upheld by an insulated metallic sheet into which are fed other high frequency currents, which currents serve the purpose of stimulating the nerve cells. There are a number of such currents that can be used. It is the current that gives a sort of very slight twitching action to the nerve centers, the subject being hardly aware of the process. There are a number of machines at our disposal today that do these very things, as they are enumerated, and it is only a matter of experimenting to find out the right combination.

Under the influence of these two sets of currents, and the oxygenated air, it should be possible to eliminate sleep for any length of time without the subject feeling the worse for it, either during the treatment or afterwards.

As we mentioned before, sleep is not of a real necessity as long as we can do away with its causes in such a way that the subject under treatment experiences no ill effects.

In our text illustration we have shown a modern newspaper office, with a Sleep Eliminator. It is realized that in a newspaper office somebody must work during the night and sleep during the day. Such a thing, in a few hundred years from now, will probably be eliminated entirely by means similar to the one suggested.

In this newspaper office we have the D'Arsonval coil which is to reduce the blood pressure, mounted against the walls of the office, so that every worker gets the benefit. The wires are led along the walls, as clearly shown, and are energized by the machine shown at the left. The oxygen tanks are in evidence, as are the glass insulator platforms which insulate the workers from the floor, while the machine is in operation and while the subjects are being electrified.

If one desires to step off his chair, he  
(Continued on page 1137)

# CLARENCE A. O'BRIEN

## PATENT ATTORNEY

REGISTERED IN UNITED STATES PATENT OFFICE

MEMBER OF THE BAR OF

SUPREME COURT OF UNITED STATES    COURT OF APPEALS DISTRICT OF COLUMBIA  
 SUPREME COURT DISTRICT OF COLUMBIA    UNITED STATES COURT OF CLAIMS

PRACTICE CONFINED TO PATENTS AND TRADE MARKS

EXPERIENCE

SERVICE

### Protect Your Ideas

Any new article, machine, design or improvement thereof, or any new combination of parts or improvements in any known article which increases its efficiency or usefulness, may be patented, if it involves invention.

**IF YOU HAVE ANY NEW IDEAS**

which you feel are useful, practical and novel, take prompt action toward protecting your rights. If you have invented any new machine, or new combination of parts or improvement, or new process or design,

**SEND DRAWING, MODEL OR DESCRIPTION**

of it for information as to procedure to secure protection.

**WRITE TODAY FOR BLANK FORM**

**"Evidence of Conception"**

to be returned to me with drawing, description or model of your idea. Promptly upon receipt by me of your idea I will write you fully as to procedure and costs.

**NO CHARGE FOR THE ABOVE INFORMATION**

All communications are held in strict confidence. My personal, careful and thorough attention is given to each case. I offer you efficient, reliable and prompt service—based upon practical experience. *Highest references.*

Write to-day for free book "How to Obtain a Patent." This book will give you valuable information, and it may save you much time and effort. **Send for it NOW.**

My practice is devoted exclusively to United States and foreign patents and trade marks. Very probably I can help you. Write today.

**CLARENCE A. O'BRIEN, Registered Patent Attorney**  
 1900 Southern Building    Washington, D. C.

---

CLARENCE A. O'BRIEN, 1900 Southern Bldg,  
 Patent Attorney, Washington, D. C.

Please send me your free booklet "How to Obtain a Patent," and blank form "Evidence of Conception" without any obligation on my part.

Name.....

Address.....  
 (WRITE CLEARLY)





Edited by  
Joseph H. Kraus

In this Department we publish such matter as is of interest to inventors and particularly to those who are in doubt as to certain Patent Phases. Regular inquiries addressed to "Patent Advice" cannot be answered by mail free of charge. Such inquiries are published here for the benefit of all readers. If the idea is thought to be of importance, we make it a rule not to divulge all details, in order to protect the inventor as far as it is possible to do so.

Should advice be desired by mail a nominal charge of \$1.00 is made for each question. Sketches and descriptions must be clear and explicit. Only one side of sheet should be written on.

NOTE:—Before mailing your letter to this department, see to it that your name and address are upon the letter and envelope as well. Many letters are returned to us because either the name of the inquirer or his address is incorrectly given.

**AUTO TRANSMISSION LOCK**

(692) F. C. Mason, Leicester, England, asks whether he should patent a lock for automobiles, engaging in the transmission. He sends in a very good drawing and description.

A. In the United States at the present time it is not desirable to employ a lock which will engage either the rear wheels or the gears of an automobile.

Such a lock increases the cost of insurance upon a car considerably, because of the fact that the car cannot be moved when once it is locked. Many insurance brokers here insist that a car be permitted to move for a distance of at least 200 feet. This is to enable firemen to remove cars from a burning garage, or to shift the cars should they be blocking a portion of the street to which fire apparatus must move in order to successfully battle with any flames occurring in that vicinity. A car rigidly locked, as you describe, would have to be towed away, which towing would destroy the tires and perhaps even cripple the machine.

Locks of this nature would be very difficult to adjust to the standard cars, as changes in the transmission gear box would have to be effected, which changes are, of course, costly. Consequently, we are of the opinion that your device will not meet with very great favor, and therefore we advise against attempting to patent the same.

**OUR COMMENT REQUESTED**

(693) W. P. McCarty, Electra, Texas, asks us if we will comment on a perpetual motion machine.

A. Yes. We shall be glad indeed to comment upon your theory of a perpetual motion machine, and tell you why your device will not operate. No model is necessary but we would suggest that you make your description clear and your drawings to conform with the description.

**CIGARETTE-MATCH COMBINATION**

(694) Wallace More, Madalin, N. Y., asks whether he should work upon an idea for a combination match and cigarette.

A. Your idea of a combination match and cigarette is not new, and to be perfectly frank, worthless. To convince you of this fact, we would suggest that you cut off the end of a match, so that merely the tip protrudes. Push this tip into the cigarette, and strike this cigarette on a box. Nine chances out of ten, the cigarette will be broken. At the tenth attempt you may light the same, and then as you try to take one puff of smoke, find your mouth full of sulphur fumes.

We also believe that the idea is not patentable, having been fully covered some twenty years ago.

**USE FOR CARBORUNDUM**

(695) Kenneth Moehrl, Marshalltown, Iowa, desired to fit a peculiarly shaped carborundum stone into a handle to be used for a specified purpose. He asks whether he should patent the idea.

A. Carborundum "stones" of the type you described in your recent communication, are neither new, novel, or unusual. If you will write to any of the branches of the carborundum concern, you will find that stones of your size and thickness are obtainable.

Merely fitting a handle to them and specifying a use for the device, does not constitute a claim for a patent, and consequently, we would suggest no further action in the matter.

**CREAM WHIPPER**

(696) John Maxian, Bellaire, Ohio, submits a sketch for a cream whipper and requests our opinion.

A. We see nothing unusually novel in your "cream whipper." You have merely taken one of the old style whipping machines and fitted it with a gear and motor drive. This constitutes no claim for a patent whatever.

**PHONOGRAPH RECORD**

(697) L. W. Mulvey, Newburyport, Mass., claims to have originated a system of making a phonographic record play just twice as much music by inserting another groove between two adjacent grooves, in which groove the music is to be recorded. He inquires as to the patentability of the idea.

A. Although we do not doubt that you can secure a patent on a double-track phonograph record, we see absolutely no advantage in such a record. The music grooves in modern records are very close together. Any attempt to make them closer will break through the side walls. Consequently there is no room for an additional groove between those now found, and there is no way in which you could increase the amount of music by adding another groove, as at the same time you eliminate every other groove now found upon the record. By using a sapphire point instead of a steel needle the record grooves could be put closer together. This is one way of increasing the surface area of a record.

There is another method which we will not mention at the present time because the inventor is patenting the same and he has requested us to keep the idea secret.

**CHECK PROTECTOR AND TYPEWRITER CLOCK**

(698) F. C. McCleish, Memphis, Tenn., suggests that checks be made like money orders with stubs left on the end. His second idea is a lock for typewriters. He requests our opinion.

A. With reference to your check protector, we would advise that such a system could not possibly be patented, the idea itself being very old. Check protectors of this nature would not only be difficult to handle, but would necessitate an increased cost in printing and a mass of added paper. Imagine having a check made out for say \$9,421.64. This would be obviously impossible with a check protector as described in your communication, unless it were made of such a large size as to take in all the figures.

The modern check protector prints the amount right on the check, and in fact perforates the check itself by such printing. It is practically non-raisable, speedy in operation, and inexpensive.

With regard to your second idea, we would like to ask you why anyone should care to lock a typewriter. Typewriters are not left open in offices where undesirable persons may wander.

**U.S. PATENTS**



**Don't Lose Your Rights**

Before disclosing your invention to anyone send for blank form "Evidence of Conception" to be signed and witnessed. A sample form together with printed instructions will show you just how to work up your evidence and establish your rights before filing application for patent. As registered patent attorneys we represent hundreds of inventors all over the U. S. and Canada in the advancement of inventions. Our schedule of fees will be found reasonable. The form "Evidence of Conception" sample, instructions relating to obtaining of patent and schedule of fees sent upon request. Ask for them.—a post card will do.



255 OURAY BLDG.,  
WASHINGTON, D. C.

"Originators of form Evidence of Conception"

**PATENTS**

**TO THE MAN WITH AN IDEA**

I offer a comprehensive, experienced, efficient service for his prompt, legal protection and the development of his proposition.

Send sketch, or model and description, for advice as to cost, search through prior United States patents, etc. Preliminary advice gladly furnished without charge.

My experience and familiarity with various arts frequently enable me to accurately advise clients as to probable patentability before they go to any expense.

Booklet of valuable information and form for properly disclosing your idea, free on request. Write today.

**RICHARD B. OWEN, Patent Lawyer**  
164 Owen Building, Washington, D. C.  
2276-8 Woolworth Bldg., New York City

**PATENTS TRADE-MARKS AND COPYRIGHTS**

Before disclosing an invention, the inventor should write for our blank form, "RECORD OF INVENTION." This should be signed and witnessed and if returned to us together with model or sketch and description of the invention we will give our opinion as to its patentable nature. Radio and Electrical cases a specialty.

Our illustrated Guide Book, "HOW TO OBTAIN A PATENT," sent Free on request. Highest References Prompt Attention Reasonable Terms

**VICTOR J. EVANS & CO., Patent Attorneys**

Chicago Offices:  
1114 Tacoma Bldg.

Pittsburgh Offices:  
514 Empire Bldg.  
New York Offices:  
1001 Woolworth Bldg.

Philadelphia Offices:  
714-715 Liberty Bldg.

San Francisco Offices:  
Hobart Bldg.

MAIN OFFICES: 779 NINTH, WASHINGTON, D. C.

Name ..... Address .....

# Test Your English

## See What Mistakes You Make

Amazing as it may seem, actual tests prove that the average person is only 61 per cent. efficient in the essential points of English. Most people realize that they may be making mistakes, but do not know what they are or how often they are made. Sherwin Cody, America's foremost teacher of practical English, has at last solved the problem of how you can test your knowledge of English and see just where you stand—you can instantly discover your mistakes and correct them forever.



### SHERWIN CODY'S GREAT INVENTION

In his new method, Mr. Cody has made it amazingly easy for you to learn correct English rapidly. He has discarded all the old methods which made English so hard to learn. No time is wasted. All your efforts are concentrated on acquiring a perfect command of English—eliminating your mistakes, and substituting for them the correct way. Only 15 minutes a day, in your spare time, is all you need to learn English this wonderful, new way.

### FREE! GET THIS TEST AND BOOK—FREE

Mr. Cody has prepared a short, interesting, 15-minute test which tells you, privately, just where you stand in your knowledge of good English. If you are better than the average, it will give you added confidence in your ability; if you are deficient you surely want to know it. Write today for this test—it is free. We will also send you our new free book, "How to Speak and Write Masterly English," which explains in greater detail how Mr. Cody's great invention gives you a masterly command of English in only 15 minutes a day. No matter what you may believe you know about correct English, make this FREE test and learn actually what you know! Write for it today. SHERWIN CODY SCHOOL OF ENGLISH 423 SEARLE BUILDING ROCHESTER, N. Y.

## You, Too, Can Play the HAWAIIAN GUITAR Just as the Natives Do—

### After Your FIRST LESSON You Will Play "ALOHA". We Guarantee That—

Our method is so simple, interesting and appealing that you begin in your first lesson to learn the famous Hawaiian Folk Song "ALOHA". Think how happy you will be when you surprise your friends by playing the fascinating Hawaiian Guitar just as the natives do!



### Only Four Motions—and You Master Them Quickly!

In a few minutes you acquire the four motions necessary to play any piece—after that a short period of practice and you will have mastered this wonderful music. Complete course of 52 lessons includes FREE beautiful Hawaiian Guitar, necessary picks, steel bar, etc. No extras.

No Previous Musical Knowledge Necessary If you never read a musical note in your life—if you haven't even the slightest knowledge of music, we can quickly and positively teach you to play this wonderfully popular instrument. Don't be just a "listener" when you can easily be the center of interest among your friends.

Just Mail a Post Card for Details of our remarkable FREE Hawaiian Guitar Offer—simply write: "I am interested"—but do it today!

**FREE**  
A Beautiful Hawaiian Guitar

First Hawaiian Conservatory of Music, Inc. 233 Broadway (Woolworth Bldg.) New York City

## INVENTORS!

Patents procured. Trademarks registered, prompt personal services, fees reasonable. Request free "Inventor's Guide," giving detailed information.

**FRANKLIN H. HOUGH, Inc.**  
520 Washington Loan & Trust Bldg., WASHINGTON, D. C.

**PATENTS** As one of the oldest patent firms in America we give inventors at lowest consistent charge, a service noted for results, evidenced by many well known Patents of extraordinary value. Book, Patent-Sense, free. Lacey & Lacey, F St., Wash., D. C. Estab. 1869.

## PATENTS

Send for free book. Contains valuable information for inventors. Send sketch of your invention for Free Opinion of its patentable nature. Prompt service. (Twenty years' experience).

### TALBERT & TALBERT

441 Talbert Bldg. Washington, D. C.

## PATENTS SECURED

Prompt service. Avoid dangerous delays. Send for our "Record of Invention" form and Free Book telling How to Obtain a Patent. Send sketch or model for examination. Preliminary advice without charge. Highest References. Write TODAY. J. L. JACKSON & CO., 419 Ouray Bldg., Washington, D. C.

They are generally locked with the desk itself. For transportation, a simple and far more effective system is employed. Two plates are screwed on the typewriter which hold the carriage rigidly in place, far more rigidly than any lock; and last but not least, unless the lock is very bulky and heavy, it is a very easy matter indeed to snip it free and sever its connections with the typewriter.

### Changing Our Numerical System

(699) A. Aranza, Fairhope, Ala., writes:

There is a good and bad side to everything, and so it seems to be with our numerical system. This is founded on ten, and ten in my opinion is not the best and most economical number, nine is worse than ten, but eight is much better, and taken all together number sixteen is probably the best. So I have formed my numerals on the sixteen system, because sixteen has a large dimension and is easier to figure and divide. For example, take our dollar. This has a hundred cents; a half dollar fifty cents; a quarter, twenty-five cents; an eighth of a dollar, twelve and a half cents; and on further division we find that our money is in fractions. In my system, however, we can divide the dollar in half, quarter, eights, sixteenths, and even further, without coming to fractions. I have no doubt but that this system is superior to the modern system, and would like your advice regarding the same.

A. We do not think very much of your system of arranging numbers, so that they will be divisible by sixteenths. It is true that we have dollars, half dollars, quarters, but why should our system cut the dollar in half, and then cut the half dollar in half again? Today the decimal system is well established, and if the money and weights and measures systems would follow the decimal system, we would have something really worth while. In this system it is easy to multiply, subtract, divide, raise to any power, and extract any root. All we have to do is to add a few zeros or subtract them. The dollar now contains ten dimes, and each dime ten cents, each cent ten mills, the non-decimal divisions being the nickel, the quarter, and the half dollar. Inasmuch as the world is employing the weight and measures scale on a ten division plan, with the exception of the English speaking countries, who in scientific calculations also employ this system, we believe that there is very little hope for your suggestion. The centimeter, gram, second system is going to become the standard.

## Experimental Electro-Chemistry

By RAYMOND B. WAILES

(Continued from page 1074)

acetate or sugar of lead. A copper plate, cut to any design such as a star, cross, etc., is placed above the iron plate and current passed, using copper as the cathode. The rings formed are very colorful.

### PRODUCTION OF LIGHT BY ELECTROLYSIS

An electrolytic cell which produces cold light, i.e., light without heat, when a current is passed through it has recently been devised. The cell is shown in figure 4. It consists of a glass vessel containing two electrodes and an electrolyte. Electrode 1 can be either carbon or aluminum, while electrode 2, the anode, is made of an alloy of aluminum and manganese or aluminum, manganese and copper. The electrolyte consists of a solution of citric acid or a solution of ammonium citrate, borate or bitartrate.

When a direct current passes through the solution via the electrodes, a film of aluminum hydroxide is deposited on the positive electrode. This is because the hydroxyl radical OH, of water, is negatively charged and passes to the positive pole, is neutralized of its charge and combines with the aluminum metal to form aluminum hydroxide, Al(OH)<sub>3</sub>. This film of hydroxide will then glow on continuous passage of the current, the whole constituting an electrolytic cell producing light radiations.

Alternating current can also be used with the cell, but electrodes of aluminum alloyed with copper and manganese have to be used, forming them first with a direct current so that the hydroxide film is deposited on both electrodes. Both electrodes when formed, will emit light when alternating current is applied to the electrodes.

## CAN YOU

think of a simple, practical idea that will fill one of the many requests we have on file for new inventions? It may mean a fortune for you. Thousands of things are needed RIGHT NOW. Your brains can help. Send today for our great new book—"Inventions and Trade Marks, Their Protection and Exploitation" and learn more about making money from ideas than you ever knew before. It tells many things that are wanted, too. A postal will do— it is free.

We help our clients, without charge, to get the dollars out of their ideas—having facilities none others possess.

Advice free. Don't delay—get the book at once.

AMERICAN INDUSTRIES, INC. 225 Patent Dept., WASHINGTON, D. C.

**PATENTS ADVERTISED For SALE FREE In INVENTION And MANUFACTURING SUPPLEMENT.**

Published for the man with an idea. Send for free sample copy. One year's subscription 50c.

## PATENTS

If you have an invention and desire to secure a patent, send for our Free Guide Book, HOW TO GET YOUR PATENT. Tells our Terms, Methods, etc. Send model or sketch and description for our opinion of its patentable nature.

**RANDOLPH & CO.**  
Dept. 172 Washington, D. C.

## PATENTS

Hand Books on Patents, Trade Marks, etc., sent free. Our 77 years of experience, efficient service, and fair dealing assure fullest value and protection to the applicant. The Scientific American should be read by all inventors.

**MUNN & CO.,** 118 Woolworth Building, New York Tower Bldg., Chicago, Ill. 611 Hanna Bldg., Cleveland, O. Scientific American Bldg., Washington, D. C. Hubert Bldg., 582 Market St., San Francisco, Cal.

## MR. INVENTOR

WE can develop that IDEA and build that working MODEL for you. Consult us—with our staff of expert engineers, and thoroughly equipped experimental machine shops, we can develop any invention into a commercial proposition, whether mechanical, electrical or automotive—simply and perfectly it, and MAKE IT WORK. Designing, building and testing gasoline motors, a specialty. Experts on automatic labor saving machinery. Mechanical drawings made from sketches or specifications. All business confidential and absolute secrecy guaranteed.

**ELK MFG. CO., Inc.**  
1926 Broadway New York

## PATENTS

BOOKLET FREE HIGHEST REFERENCES PROMPTNESS ASSURED BEST RESULTS Send drawing or model for examination and report as to patentability.

**WATSON E. COLEMAN, Patent Lawyer**  
624 F Street N. W., Washington, D. C.

## PATENTS

**PROTECT YOUR INVENTION TODAY**

Write for FREE Illustrated Patent Book. Radio-Electrical, Chemical and Mechanical Experts; Over 25 years' experience. Prompt, Efficient Service, Write today.

**A. M. WILSON, Inc.**  
311-17 VICTOR BLDG. WASHINGTON, D. C.

## PATENTS

**C. L. PARKER** Formerly Member Examining Corps, U. S. Patent Offices. PATENT LAWYER

McGill Bldg., Washington, D. C. Patents, Trade Marks, Copyrights, Patent Litigation Handbook for Inventors, "Protecting, Exploiting and Selling Inventions," sent upon request.



## Whoops Boys It Beats 'Em All

When you hop into your Auto Wheel Coaster with real steel disc wheels—roller bearings—and spin down the street, you go right ahead of the gang—race or no race!

An Auto Wheel is the speediest coaster you ever saw. Goes so easy it almost runs itself—that's due to the patented self-contained roller bearings—and they are thoroughly greased at factory.

## Auto-Wheel

Is sturdily built—steel disc wheels with rubber or steel tires; specially constructed hound brace that makes steering easy and safe; auto type hub caps—just like on Dad's machine. It has a brake—'N Everything! Also comes with spoke wheels—all wheels interchangeable. The Auto Wheel is built to withstand years of hard play and work.

Below is Auto Wheel's Junior Companion—The Auto Cart—for your little brother or sister. Substantially built just like the Auto Wheel Coaster.

Write for a catalog. It shows all the models and sizes and explains the mechanical construction. If you send the names of three coaster wagon dealers in your town, telling which one sells the Auto Wheel Coasters, we will give you a year's subscription free to the Auto Wheel Spokes-man, a dandy magazine for fellows like you.



**Auto Wheel Coaster Co., Inc.**  
North Tonawanda  
New York

## We Want 1000 Men like these

Men or women can sell our line and make big money if they will work four to eight hours a day calling on homes and business houses. Boy Conant quit a \$6,000 a year job to take territory with us. Geo. Powell made \$125 his first week. L. O. Keeton made \$252 commissions on his first sale. Experience not absolutely necessary. We train you free. Prices within reach of all prospects—cash or easy payments. Write today giving past experiences if any, and references.  
**The Fyr-Fyter Co., 3347 Fyr-Fyter Bldg., Dayton, O**

## PATENTS, TRADEMARKS PROTECT YOUR INVENTION!

Prompt, Efficient, Personal Service. Reasonable fee. Full explanation in my booklet PATENTS. Send for free copy today.

**AMBROSE T. BUCKLEY**  
150 NASSAU ST. NEW YORK CITY

## Triple Your Writing Speed

by using JOT, the quick-writing system.  
**LEARN IN FIVE LESSONS**

how to copy verbatim speeches, lectures, telephone messages and verbal instructions. Better and easier than shorthand. Send for details.  
**MILTON WEND RUBY, N. Y.**

## Tooth White

Removes Stains Quickly and Leaves Teeth White and Beautiful Sc. Dental Mfg. Co., Evanston, Ill.

Harmless Full Year's Supply with Tweezers 50c. Trial Bottle 25c Satisfied or Money Refunded

## The Star

By H. G. WELLS

(Continued from page 1059)

heavy, rushing without warning out of the black mystery of the sky into the radiance of the sun. By the second day it was clearly visible to any decent instrument, as a speck with a barely sensible diameter, in the constellation Leo near Regulus. In a little while an opera glass could attain it.

On the third day of the new year the newspaper readers of two hemispheres were made aware for the first time of the real importance of this unusual apparition in the heavens. "A Planetary Collision," one London paper headed the news, and proclaimed Duchine's opinion that this strange new planet would probably collide with Neptune. The leader writers enlarged upon the topic. So that in most of the capitals of the world, on Jan. 3, there was an expectation, however vague, of some imminent phenomenon in the sky; and as the night followed the sunset round the globe thousands of men turned their eyes skyward to see—the old familiar stars just as they had always been.

Until it was dawn in London and Pollux setting, and the stars overhead grown pale. The winters dawn it was, a sickly filtering accumulation of daylight, and the light of gas and candles shone yellow in the windows to show where people were astir. But the yawning policeman saw the thing, the busy crowds in the market stopped agape, workmen going to their work betimes, milkmen, the drivers of news carts, dissipation going home jaded and pale, homeless wanderers, sentinels on their beats, and in the country, laborers trudging afield, poachers slinking home, all over the dusky quickening country it would be seen—and out at sea by seamen watching for the day—a great white star, come suddenly into the westward sky!

Brighter it was than any star in our skies; brighter than the evening star at its brightest. It still glowed out white and large, no mere twinkling spot of light but a small round clear shining disk, an hour after the day had come. And where science has not reached, men stared and feared, telling one another of the wars and pestilences that are foreshadowed by these fiery signs in the heavens. Sturdy Boers, dusky Hottentots, Gold Coast negroes, Frenchmen, Spaniards, Portuguese, stood in the glow of the sunrise watching the setting of this strange new star.

And in a hundred observatories there had been suppressed excitement, rising almost to shouting pitch, as the two remote bodies had rushed together, and a hurrying to and fro to gather photographic apparatus and spectroscopes, and this appliance and that, to record this novel astonishing sight, the destruction of a world. For it was a world, a sister planet of our earth, far greater than our earth indeed, that had so suddenly flashed into flaming death. Neptune it was, which had been struck, fairly and squarely, by the planet from outer space and the heat of the concussion had incontinently turned two solid globes into one vast mass of incandescence. Round the world that day, two hours before the dawn, went the pallid great white star, fading only as it sank westward and the sun mounted above it. Everywhere man marveled at it, but of all those who saw it none could have marveled more than those sailors, habitual watchers of the stars, who far away at sea had heard nothing of its advent and saw it now rise like a pigmy moon and climb zenithward and hang overhead and sink westward with the passing of the night.

And when next it rose over Europe everywhere were crowds of watchers on hilly

## Let Me Make A Man of You



Are you dragging yourself about from day to day, always ailing and complaining—always tired and despondent—suffering from Backache, Indigestion, Constipation, Dyspepsia, Nervousness, Vital Depletion, etc., etc.—your Biliousness showing in your face—your lack of energy in your eyes? Have you and your family given up hope that you will ever be a real man again, achieve success and amount to anything in the world? Have you lost ambition and allowed your youthful ideals to slip down into the bog of physical defects and unfitness? Then, you are the man I want to help.

### Pull Yourself Together

Brace up—you can come back—there is a way out—you can be a real man again. You can regain your vigor and vitality, your health and strength—you can conquer the weaknesses that are undermining your body and brain—you can root out the results of Bad Habits and neglect and fill your life with the success and joy of abundant health.

It is Not Too Late. There is hope for you. It doesn't matter what brought you to your present physical condition—it doesn't matter how many methods you have tried in vain—or how often you have been disappointed. You can be saved from the scrap heap of worn-out humanity and be re-built into a red-blooded specimen of vital, magnetic Manhood. You can be restored and re-created with

**STRONGFORT**  
The Perfect Man

## STRONGFORTISM

*The Modern Science of Health Promotion*  
Strongfortism will go directly to the root of your trouble and remove the cause. Strongfortism will purify and enrich your blood, revitalize your nerves, strengthen your Heart, Lungs, Stomach, Liver, Kidneys, Bowels and other vital organs. Strongfortism will send the rich, red blood to every corner of your being, bringing the nutriment and vital force necessary to restore the half-dead cell life and build up muscle and bone. Strongfortism will drive out the poisonous waste matter that has been accumulating for years in your body and brain and make you clean, wholesome and normal externally and internally. I guarantee it—irrespective of your sex, age, occupation or surroundings.

### Come to Me in Full Faith As You Would to a Brother

Open up the secret chambers of your heart and tell me all of your troubles without reservation. You can confide in me with full faith—I will never betray you. Come to me with your problems as you would to your father, mother, brother, or closest friend, and let me show you the way out of your difficulties with Strongfortism—The Beacon Light of Health, Happiness and Success.

### Send for My Free Book

"Promotion and Conservation of Health, Strength and Mental Energy" is the most interesting and instructive book you can ever read. It will tell you in understandable, non-technical language, just how you can banish your ailments—conquer your weaknesses and make yourself over into a splendid specimen of magnetic, robust Manhood, with 100 per cent. pep and power. It is absolutely free. Just mark the subjects on the free consultation coupon (write additional ailments on extra line) on which you want special confidential information and send to me with a 10c piece (one dime) to help pay postage, packing, etc. It's a man-builder—a success maker and a life-saver. Send for my free book **Right Now—TODAY.**

## LIONEL STRONGFORT

Physical and Health Specialist  
Founded 1895

Dept. 201 Newark, N. J.

### FREE CONSULTATION COUPON

Mr. Lionel Strongfort, Dept. 201, Newark, N. J.—Please send me your book, "Promotion and Conservation of Health, Strength and Mental Energy," for postage on which I enclose a 10-cent piece (one dime). I have marked (X) before the subject in which I am interested.

- |                         |                             |                         |
|-------------------------|-----------------------------|-------------------------|
| .. Colds                | .. Blackheads               | .. Weak Eyes            |
| .. Catarrh              | .. Insomnia                 | .. Gastritis            |
| .. Asthma               | .. Short Wind               | .. Heart                |
| .. Hay Fever            | .. Flat Feet                | .. Weakness             |
| .. Obesity              | .. Stomach                  | .. Poor Circulation     |
| .. Headaches            | .. Disorders                | .. Skin Disorders       |
| .. Thinness             | .. Constipation             | .. Despondency          |
| .. Rupture              | .. Biliousness              | .. Round Shoulders      |
| .. Lumbago              | .. Torpid Liver             | .. Lung Troubles        |
| .. Neuritis             | .. Indigestion              | .. Stoop Shoulders      |
| .. Neuralgia            | .. Nervousness              | .. Muscular Development |
| .. Flat Chest           | .. Poor Memory              | .. Great Strength       |
| .. Deformity (Describe) | .. Rheumatism               | .. Neurasthenia         |
| .. Successful Marriage  | .. Restored Youthful Errors |                         |
| .. Female Disorders     | .. Vital Losses             |                         |
| .. Increased Height     | .. Impotency                |                         |
| .. Diabetes             | .. Falling Hair             |                         |
| .. Pimples              | .. Prostate                 |                         |
|                         | .. Troubles                 |                         |

Name ..  
Age .. Occupation ..  
Street ..  
City .. State ..



# BUILDING TRADES NEED MEN!



## Thousands of good jobs at good salaries

**T**HE business tide has turned! And the building trades are leading the way back to prosperity! Government experts estimate that two to four billion dollars will be spent for building construction this year.

To-day the most vital need of this great building program is men—trained men—men who can step right in and do the skilled work that building construction requires.

There is a simple, easy, fascinating way by which you can prepare for a good position, at a good salary. You can do it right at home, in spare time, no matter where you live, through the International Correspondence Schools.

All we ask is the chance to prove it. That's fair, isn't it? Then mark and mail the coupon printed below and get the full story of what the I. C. S. can do for you.

TEAR OUT HERE

INTERNATIONAL CORRESPONDENCE SCHOOLS  
Box 6190-C, Scranton, Penna.

Without cost or obligation, please tell me how I can qualify for the position or the subject before which I have marked an X in the list below:

**TECHNICAL AND INDUSTRIAL DEPARTMENT**

- |  |   |
|--|---|
| <input type="checkbox"/> Architect               | <input type="checkbox"/> Surveying and Mapping    |
| <input type="checkbox"/> Architectural Draftsman | <input type="checkbox"/> Gas Engine Operating     |
| <input type="checkbox"/> Blue Print Reading      | <input type="checkbox"/> Automobile Work          |
| <input type="checkbox"/> Building Foreman        | <input type="checkbox"/> Airplane Engines         |
| <input type="checkbox"/> Concrete Builder        | <input type="checkbox"/> Plumber and Steam Fitter |
| <input type="checkbox"/> Contractor and Builder  | <input type="checkbox"/> Plumbing Inspector       |
| <input type="checkbox"/> Structural Draftsman    | <input type="checkbox"/> Foreman Plumber          |
| <input type="checkbox"/> Structural Engineer     | <input type="checkbox"/> Heating and Ventilation  |
| <input type="checkbox"/> Electrician             | <input type="checkbox"/> Sheet Metal Worker       |
| <input type="checkbox"/> Electrical Engineer     | <input type="checkbox"/> Steam Engineer           |
| <input type="checkbox"/> Electrical Contractor   | <input type="checkbox"/> Railroad Positions       |
| <input type="checkbox"/> Electric Wiring         | <input type="checkbox"/> Chemistry                |
| <input type="checkbox"/> Mechanical Engineer     | <input type="checkbox"/> Pharmacy                 |
| <input type="checkbox"/> Mechanical Draftsman    | <input type="checkbox"/> Metallurgy               |
| <input type="checkbox"/> Machine Shop Practice   | <input type="checkbox"/> Mining Engineer          |
| <input type="checkbox"/> Toolmaker               | <input type="checkbox"/> Navigation               |
| <input type="checkbox"/> Civil Engineering       | <input type="checkbox"/> Mathematics              |
|  | <input type="checkbox"/> Radio                    |

**BUSINESS TRAINING DEPARTMENT**

- |  |   |
|--|---|
| <input type="checkbox"/> Business Management     | <input type="checkbox"/> Salesmanship           |
| <input type="checkbox"/> Industrial Management   | <input type="checkbox"/> Advertising            |
| <input type="checkbox"/> Personnel Organization  | <input type="checkbox"/> Better Letters         |
| <input type="checkbox"/> Traffic Management      | <input type="checkbox"/> Foreign Trade          |
| <input type="checkbox"/> Business Law            | <input type="checkbox"/> Show Card Lettering    |
| <input type="checkbox"/> Banking and Banking Law | <input type="checkbox"/> Stenography and Typing |
| <input type="checkbox"/> Accountancy             | <input type="checkbox"/> Teacher                |
| <input type="checkbox"/> (Including C.P.A.)      | <input type="checkbox"/> Civil Service          |
| <input type="checkbox"/> Nicholson Cost          | <input type="checkbox"/> Railway Mail Clerk     |
| <input type="checkbox"/> Accounting              | <input type="checkbox"/> Common School Subjects |
| <input type="checkbox"/> Bookkeeping             | <input type="checkbox"/> High School Subjects   |
| <input type="checkbox"/> Business English        | <input type="checkbox"/> Illustrating           |
| <input type="checkbox"/> Private Secretary       | <input type="checkbox"/> Cartooning             |
| <input type="checkbox"/> Business Spanish        | <input type="checkbox"/> French                 |

Name.....  
Street.....  
Address.....  
City..... State.....

Occupation.....  
Persons residing in Canada should send this coupon to the International Correspondence Schools Canadian, Limited, Montreal, Canada.

## EARN MONEY AT HOME

YOU can make \$15 to \$60 weekly in your spare time writing show cards. No canvassing or soliciting. We instruct you by our new simple Directograph system, pay you cash each week and guarantee you steady work. Write for full particulars and free booklet.

**WEST-ANGUS SHOW CARD SERVICE**  
67 Colborne Building Toronto, Can.

Wonderful, new device, guides your hand; corrects your writing in few days. Big improvement in three hours. No failures. Complete outline FREE. Write C. J. Ozment, Dept. 44, St. Louis, Mo.

slopes, on house roofs, in open spaces, staring eastward, waiting for the rising of the new star. It rose with a white glow in front, like the glare of a white fire, and those who had seen it come into existence the night before cried out at the sight of it. "It is larger," they cried. "It is brighter!" And, indeed, the moon a quarter full and sinking in the west was in its apparent size beyond comparison, but scarcely in all its breadth had it as much brightness now as the little circle of the strange new star.

"It is brighter!" cried the people clustering in the streets. But in the dim observatories the watchers held their breath and peered at one another. "It is nearer," they said. "Nearer!"

And voice after voice repeated. "It is nearer," and the clicking telegraph took that up, and it trembled along telephone wires, and in a thousand cities grimy compositors fingered the type. "It is nearer." Men writing in offices, struck with a strange realization, flung down their pens, men talking in a thousand places suddenly came upon a grotesque possibility in those words, "It is nearer." It hurried along awakening streets, it was shouted down the frost-stilled ways of quiet villages, men who had read these things, from the throbbing tape stood in yellow-lit doorways shouting the news to the passers-by. "It is nearer." Pretty women, flushed and glittering, heard the news told jestingly between the dances, and feigned an intelligent interest they did not feel. "Nearer! Indeed. How curious! How clever people must be to find out things like that!"

Lonely tramps faring through the wintry night murmured those words to comfort themselves—looking skyward. "It has need to be nearer, for the night's as cold as charity. Don't seem much warmth from it if it is nearer, all the same."

"What is a new star to me?" cried the weeping woman kneeling beside her dead.

The schoolboy, rising early for his examination work, puzzled it out for himself—with the great white star shining broad and bright through the frost-flowers of his window. "Centrifugal, centripetal," he said, with his chin on his fist. "Stop a planet in its flight, rob it of its centrifugal force, what then? Centripetal has it, and down it falls into the sun! And this—!"

"Do we come in the way? I wonder—"

The light of that day went the way of its brethren, and with the later watches of the frosty darkness rose the strange star again. And it was now so bright that the waxing moon seemed but a pale yellow ghost of itself, rising huge in the sunset hour. In a South African city a great man had married, and the streets were alight to welcome his return with his bride. "Even the skies have illuminated," said the flatterer. Under Capricorn, two negro lovers, daring the wild beasts and evil spirits, for love of one another, crouched together in a cane brake where the fireflies hovered. "That is our star," they whispered, and felt strangely comforted by the sweet brilliancy of its light.

The master mathematician sat in his private room and pushed the papers from him. His calculations were already finished. In a small white phial there still remained a little of the drug that had kept him awake and active for four long nights. Each day, serene, explicit, patient as ever, he had given his lecture to his students, and then had come back at once to this momentous calculation. His face was grave, a little drawn, and hectic from his drugged activity. For some time he seemed lost in thought. Then he went to the window, and the blind went up with a click. Half way up the sky, over the clustering roofs, chimneys, and steeples of the city, hung the star.

He looked at it as one might look into the eye of a brave enemy. "You may kill me," he said after a silence. "But I can hold

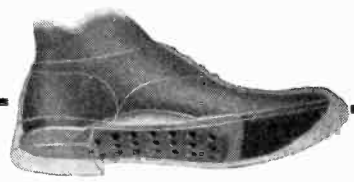

Patent Pend.

## New Invention Makes Happy Feet

If your feet hurt you, you don't feel good. Don't be bothered with sore feet, corns, bunions, blistering hot, or cold feet when you can wear our new invention.

Made of soft, pliable, resilient, sponge rubber and wool felt to be worn in your regular shoes.

Your feet will assume their proper position and stay there, actually making more room in your shoes when this nature-like pad is inserted.

Our natural air-cushion support is comfort personified, and it will do you a world of good.

Thousands are being benefited every day and are remodeling their feet without pain into normal feet.

Send no money. Give us your name and size shoe. We will mail you a pair. On arrival pay the postman only \$2.00 and postage. Try them for ten days. If you are not delighted we will return your money immediately. A postal card will do.

### KOMFORT ARCH SUPPORT COMPANY

327-F West Madison Street  
Chicago Illinois

## \$25 A DAY Selling Shirts

Large shirt manufacturer wants agents to sell complete line of shirts, pajamas, and night shirts direct to wearer. Advertisements brand-exclusive patterns—easy to sell. No experience or capital required. Entirely new proposition. Write for free samples. Madison Shirt Co., 503 Broadway, N.Y.C.

### Single Acting High Speed Model Steam Engine

Type Q. Stationary—1 in. bore x 1 1/8 in. stroke. Weight, 8 lbs. 6 ozs. Price complete, \$17.00, forwarded prepaid. Many other types model Engines, Boilers, Boiler and Ships' fittings, New and enlarged edition of catalogue, 20c (refunded on first order)

Bathe Mfg. Co., Dept. 2-5214 Woodland Ave., Phila., Pa.

## SYCO-GRAF

U. S. Patent Allowed  
A Micro-Physic Machine

Amazingly increases the strength of the feeblest psychic impressions. A mechanical ouija. Operates for one person. Prepaid \$5.00. Free Booklet.

The Syco-Graf Company  
Dept. A, P.O. Box 934, Richmond, Va.

## Delivered to you Free

for 30 days trial on approval. Your choice of 44 styles, colors and sizes of the famous Ranger Bicycles. Express prepaid. Low Factory-to-Rider Prices.

12 Months to Pay if desired. Many boys and girls easily save the small monthly payments.

Tires, wheels, lamps, and equipment at half usual prices. Write for remarkable factory prices and marvelous offers.

**Mead Cycle Company** Write us today for free catalog  
Dept. P 107 Chicago

## You can be quickly cured, if you STAMMER

Send 10 cents for 288-page book on Stammering and Stuttering, "Its Cause and Cure." It tells how I cured myself after stammering 20 yrs. B. N. Bogue, 792 Bogue Bldg., 1147 N. Ill. St., Indianapolis.

# \$100 a Week for Work that is Play



BECOME a high-salaried cartoonist—One of the easiest, pleasantest and best paid of all businesses. Millions of dollars spent last year on serious, comic, sport and animated cartoons—and the demand for cartoons increases every day!

### Easy to Learn at Home

A new method, prepared by one of America's foremost cartoonists, makes learning cartooning *actual fun*. You learn at home, yet all your work receives through the mail the personal, individual attention of prominent cartooning experts. Training starts at very foundation of cartooning—covers every branch—teaches you to draw cartoons that SELL. Many students earn big money from cartoons even before finishing course.

### Send for Free Book

Our new Free Book, "How to Become a Cartoonist," is crammed full of interesting details about cartooning—opportunities, stories of leading cartoonists, letters from students, and full details about this home-study method. No obligation. Mail post card or letter for book TODAY.

WASHINGTON SCHOOL of CARTOONING  
1133 Marden Bldg. Washington, D. C.

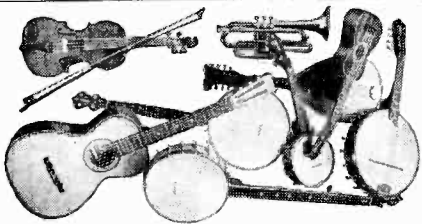

## Your Choice \$2000 MUSICAL INSTRUMENTS FREE

We have a wonderful new system of teaching note music by mail and to the first pupils in each locality we will give free a \$20.00 superb Violin, Tenor Banjo, Ukulele, Hawaiian Guitar, Banjo, Guitar, Banjo-Ukulele, Mandolin, Banjo-Mandolin or Cornet absolutely free. A very small charge for lessons your only expense. Pay nothing if you do not learn to play. We also teach Piano and Organ. Complete outfit free. Write at once, no obligation.  
SLINGERLAND SCHOOL OF MUSIC  
1815 Orchard St., Dept. 176 Chicago, Ill.

### THE MIDGET "FIVE-IN-ONE" SLIDE RULE

is a combination Mannheim, Log-Log, Add and Subtract, Polyphase and Binary Slide Rule. It will instantly add, subtract, multiply and divide any combination involving whole numbers, fractions, decimals and mixed numbers. Gives every possible root and power of every quantity. The graduations are printed on metal, coated with white celluloid and are grease and waterproof. While it is the most versatile calculator ever invented, its operation is simple and easily understood. Diameter 4 inches.  
Price with 16 page Instruction Book, \$1.50. Leatherette carrying case 50c extra. Catalogue Free. Your money back if you are not satisfied.  
Niles, Mich.

GILSON SLIDE RULE CO.

### CONVERT YOUR BICYCLE INTO A MOTOR-CYCLE

with a Steffey Motor Attachment. Fits any ordinary bicycle. Easily attached. In use for over 21 years. PRACTICAL, ECONOMIC, RELIABLE.  
Send stamp for circulars  
STEFFEY MFG. CO., Dep. E. 5025 Brown Street, Philadelphia, Pa.

### Wrestling Book FREE

Tells how to be a Great athlete and scientific wrestler—how to WIN. Starting secrets taught in wonderful lessons by world champions Farmer Burns and Frank Gotch. Be strong, healthy, athletic. Handle big men with ease. Learn self defense. Be a leader. Men and boys, write for Free Book today. State your age.  
Farmer Burns School, 1253 Railway Bldg., Omaha, Neb.

### TELEGRAPHY

(Morse and Wireless) and RAILWAY ACCOUNTING taught thoroughly. Big salaries—great opportunities. Oldest, largest school. Endorsed by Telegraph, Railway, Radio and Government officials. Expenses low—opportunities to earn large portion. Catalog free.  
DODGE'S INSTITUTE, A Street, Valparaiso, Ind.

you—and all the universe for that matter—in the grip of this little brain. I would not change even now."

He looked at the little phial. "There will be no need of sleep again," he said. The next day at noon, punctual to the minute, he entered his lecture theater, put his hat on the end of the table as his habit was, and carefully selected a large piece of chalk. It was a joke among his students that he could not lecture without that piece of chalk to fumble in his fingers, and once he had been stricken to impotence by their hiding his supply. He came and looked under his gray eyebrows at the rising tiers of young fresh faces, and spoke with his accustomed studied commonness of phrasing. "Circumstances have arisen—circumstances beyond my control," he said and paused, "which will debar me from completing the course I had designed. It would seem, gentlemen, if I may put the thing clearly and briefly, that—man has lived in vain."

The students glanced at one another. Had they heard aright? Mad? Raised eyebrows and grinning lips there were, but one or two faces remained intent upon his calm gray-fringed face. "It will be interesting," he was saying, "to devote this morning to an exposition, so far as I can make it clear to you, of the calculations that have led me to this conclusion. Let us assume—"

He turned toward the blackboard, meditating a diagram in the way that was usual to him. "What was that about 'lived in vain'?" whispered one student to another. "Listen," said the other, nodding toward the lecturer.

And presently they began to understand.

That night the star rose later, for its proper eastward motion had carried it some way across Leo toward Virgo, and its brightness was so great that the sky became a luminous blue as it rose, and every star and planet was hidden, save only Jupiter near the zenith, Capalla, Aldebaran, Sirius, and the pointers of the Bear. It was white and beautiful. In many parts of the world that night a pallid halo encircled it about. It was perceptibly larger; in the clear refractive sky of the tropics it seemed as if it were nearly a quarter of the size of the moon. The frost was still on the ground in England, but the world was as brightly lit as if it were midsummer moonlight. One could see to read quite ordinary print by that cold clear light, and in the cities the lamps burnt yellow and wan.

And everywhere the world was awake that night, and throughout Christendom a somber murmur hung in the keen air over the countryside like the buzzing of the bees in the heather, and this murmurous tumult grew to a clangor in the cities. It was the tolling of the bells in a million belfry towers and steeples, summoning the people to sleep no more, to sin no more, but to gather in their churches and pray. And overhead, growing larger and brighter, as the earth rolled on its way and the night passed, rose the dazzling star.

And the streets and houses were alight in all the cities, the shipyards glared, and whatever roads led to high country were lit and crowded all night long. And in all the seas about the civilized lands ships with throbbing engines, and ships with belling sails, crowded with men and living creatures, were standing out to ocean and the north. For already the warning of the master mathematician had been telegraphed over the world, and translated into a hundred tongues. The new planet and Neptune, locked in a fiery embrace, were whirling headlong, ever faster and faster, toward the sun. Already every second this blazing mass flew a hundred miles, and every second its terrific velocity increased. As it flew its course, it must pass a hundred million of miles wide of the earth and scarcely affect it.

But near its destined path, as yet only

# Free Railroad Fare

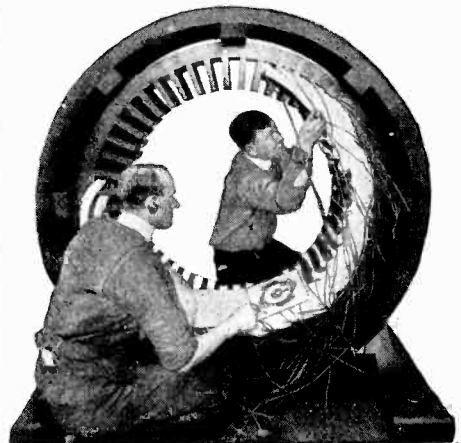

Student Winding a Stator

## To the Great Shops of Coyne

We pay your railroad fare to Chicago—the Electrical Center of the World—from any place in the United States. Grasp the opportunity to see the country at our expense. Come to Coyne—learn electricity in 3½ months. Get a complete training so you can make big money as Power Plant Operator, Superintendent, Telephone man, Construction worker, auto, truck or tractor electrician, battery man, radio expert, or you can go into business for yourself as electrical contractor, dealer, auto ignition or battery expert and make from \$3,000 to \$20,000 a year. Hundreds of our graduates today are making big money and you can do the same if you grasp this opportunity—act now.

## Learn Electricity In 3½ Months

No books or useless theory. You are trained on \$100,000 worth of electrical equipment. Everything from door bells to power plants. You work on motors, generators, house-wiring, autos, batteries, radio, switch-boards, power plants—everything to make you an expert ready to step right into a position paying from \$45 to \$100 a week.

## Radio Course FREE

We include the following free with the regular course: (1) A complete course in auto, truck and tractor electricity and storage batteries. Greatest outlay of auto, electrical and battery equipment in the country. (2) Course in Radio—the marvel of the age. Constructing, installing and operating. You can build your own wireless telephone set. (3) A life scholarship in the Coyne school. You can stay as long as you wish and return for further training at any time in the future.

## Earn While You Learn

We help students to secure jobs to earn a good part of their expense while studying.

## Send Coupon Now

Don't delay a minute—send that coupon in **right now** for our big free catalog and full particulars of Free Railroad Fare offer. Act now!

B. W. COOKE, President

Coyne Trade and Engineering School  
Dept. 5333, 1300-1310 W. Harrison St., CHICAGO

B. W. Cooke, Pres, Coyne Trade and Engineering School,  
Dept. 5333, 1300-1310 W. Harrison St., Chicago, Ill.

Dear Sir: Please send me free your big catalog and full particulars of your special offer of Free Railroad Fare and two extra courses.

Name \_\_\_\_\_

Address \_\_\_\_\_

# "Recommended for appointment"



writes a happy United Y. M. C. A. Schools' student, formerly of Scranton, Pa., and now in the employ of the United States government.

He was an office clerk, working long hours. He says "the light had dawned" that he was tied down to routine work for all time unless he trained himself. So he decided to devote spare evening hours to our excellent correspondence course in accountancy. He earned a salary increase of 60 per cent. before completing his course, and in a year qualified for United States Internal Revenue service (Pittsburgh Division) as auditor of income taxes, with a further substantial increase of salary and responsibility.

The course he selected is just one of more than three hundred that we offer, all reasonably priced, all bringing the close personal service that is a feature of United Y. M. C. A. Schools instruction by mail.

Do you want more power, more money, a broader field? Write us about your ambition and get our friendly counsel free. Soon you, too, can be throwing up your hat over the advance you have made.

### Some of our 300 Correspondence Courses

- |                         |                                    |
|-------------------------|------------------------------------|
| <b>Business Courses</b> | <b>Technical and Other Courses</b> |
| Accountancy             | Insurance Courses                  |
| Advertising             | Applied Psychology                 |
| Banking                 | Architecture                       |
| Better Letters          | Automobile Courses                 |
| Bookkeeping             | Building Construction              |
| Business Arithmetic     | Civil Engineering Courses          |
| Business Administration | Drafting Courses                   |
| Business English        | Electrical Courses                 |
| Business Finance        | English Courses                    |
|                         | Factory Management                 |
|                         | Foreign Languages                  |
|                         | Foremanship                        |
|                         | Highway Engineering                |
|                         | High School Courses                |
|                         | Illustrating                       |
|                         | Business Law                       |
|                         | Complete Letter-Writing            |
|                         | Office Management                  |
|                         | Public Speaking                    |
|                         | Salesmanship                       |
|                         | Secretarial                        |
|                         | Show Card Writing                  |
|                         | Stenography                        |
|                         | Traffic Management                 |
|                         | Mathematical Courses               |
|                         | Mechanical Engineering             |
|                         | Own-Your-Home Course               |
|                         | Plan Reading                       |
|                         | Plumbing                           |
|                         | Poultry Husbandry                  |
|                         | Radio Engineering                  |
|                         | Radio Telegraphy                   |
|                         | Steam Engineering Courses          |
|                         | Structural Drafting                |
|                         | Surveying                          |
|                         | Use of the Slide Rule              |
|                         | Vocational Guidance                |



## Correspondence Instruction

347 Madison Avenue  
New York City

Dept. 64-M

Without obligating me, please advise regarding the course in

Name .....

Full Address .....

(Please write plainly)

## Electrical Engineering

men with training are in demand. For more than a quarter of a century this school has been training men of ambition and limited time for the electrical industries. Condensed course in Electrical Engineering enables graduates to secure good positions and promotions. Theoretical and Practical Electricity. Mathematics. Steam and Gas Engines and Mechanical Drawing. Students construct dynamos, install wiring and test electrical machinery. Course with diploma complete

### In One Year

Over 3000 men trained. Thoroughly equipped fireproof dormitories, dining hall, laboratories, shops.  
Free catalog. 30th year opened Sept. 27, 1922  
**BLISS ELECTRICAL SCHOOL**  
408 TAKOMA AVE., WASHINGTON, D. C.

## 5 Master Keys

Work like magic in emergencies or prove whether your door or padlocks are burglar-proof. Open and test thousands of different locks. Recommended by users in ten different nations. Most wonderful and only keys of their kind. Send \$1 today. Novel key chain FREE with set.  
**MASTER KEY CO., 8-0 Manhattan Block, Milwaukee, Wis.**

slightly perturbed, spun the mighty planet Jupiter and his moons sweeping splendid around the sun. Every moment now the attraction between the fiery star and the greatest of the planets grew stronger. And the result of that attraction? Inevitably Jupiter, would be deflected from its orbit into an elliptical path, and the burning star, swung by his attraction wide of its sunward rush, would "describe a curved path" and perhaps collide with and certainly pass close to, our earth. "Earthquakes, volcanic outbreaks, cyclones, sea waves, floods, and a steady rise in temperature to I know not what limit"—so prophesied the master mathematician.

And overhead, to carry out his words, lonely and cold and livid, blazed the star of the coming doom.

To many who stared at it that night until their eyes ached, it seemed that it was visibly approaching. And that night, too, the weather changed, and the frost that had gripped all Central Europe and France and England softened towards a thaw.

But you must not imagine because I have spoken of people praying through the night and people going aboard ships and people fleeing towards mountainous country that the whole world was already in a terror because of the star. As a matter of fact, use and wont still ruled the world, and save for the talk of idle moments and the splendor of the night, nine human beings out of ten were still busy at their common occupations. In all the cities the shops, save one here and there, opened and closed at their proper hours, the doctor and the undertaker plied their trades, and workers gathered in the factories, soldiers drilled, scholars studied, lovers sought one another, thieves lurked and fled, politicians planned their schemes. The presses of the newspapers roared through the nights, and many a priest of this church and that would not open his holy building to further what he considered a foolish panic.

The newspapers insisted on the lesson of the year 1000—for then, too, people had anticipated the end. The star was no star—mere gas—a comet; and were it a star it could not possibly strike the earth. There was no precedent for such a thing. Common sense was sturdy everywhere, scornful, jesting, a little inclined to persecute the obdurate fearful. That night at 7:15 by Greenwich time the star would be at its nearest to Jupiter. Then the world would see the turn things would take. The master mathematician's grim warnings were treated by many as so much mere elaborate self-advertisement. Common sense at last, a little heated by argument, signified its unalterable convictions by going to bed. So, too, barbarism and savagery, already tired of the novelty, went about their nightly business, and save for a howling dog here and there the beast-world left the star unheeded.

And yet, when at last the watchers in the European states saw the star rise, an hour later, it is true, but no larger than it had been the night before, there were still plenty awake to laugh at the master mathematician—to take the danger as if it had passed.

But hereafter the laughter ceased. The star grew—it grew with a terrible steadiness hour after hour, a little larger each hour, a little nearer the midnight zenith, and brighter and brighter, until it had turned night into day. Had it come straight to the earth instead of in a curved path, had it lost no velocity to Jupiter, it must have leapt the intervening gulf in a day; but as it was it took five days altogether to come by our planet. The next night it had become a third the size of the moon before it set to English eyes, and the thaw was assured.

It rose over America near the size of the moon, but blinding white to look at, and hot; and a breath of hot wind blew now with its rising and gathering strength, and

# Why Miss Half the Fun in Life?

Everyone admires and wants to dance with the person who knows the latest steps. There is no need of being a wall-flower! Arthur Murray, America's foremost dancing teacher, has perfected a wonderful new method by which you can learn any of the newest steps in a few minutes and all of the dances in a short time.



Even if you don't know one step from another, you can quickly and easily master any dance without music and without partner, right in your own home. Your success is guaranteed. The Vanderbilts and scores of other socially prominent people have chosen Mr. Murray as their dancing instructor. More than 90,000 people have learned to become popular dancers through his easy learn-at-home methods.

## New Easy Way

To show you how easily and quickly you can learn his new way, Arthur Murray has consented to send, for but a limited time, a special course of sixteen dancing lessons for only \$1.00. This extraordinary offer is made to prove you will enjoy learning the newest steps in the privacy of your own home—without onlookers to embarrass you. You need not send any money now. When the postman hands you the 16 lesson course, just deposit \$1 with him, plus a few cents postage, in full payment. If within five days you are not delighted, return the lessons and your money will be promptly refunded.

This unusual offer may not be made again. Write today for the sixteen lesson course. If you prefer, send the dollar now and we will pay the postage. The lessons will be sent promptly, in plain cover. Learn at home and surprise your friends. Act now and be a good dancer soon.

ARTHUR MURRAY, Studio 642, 801 Madison Ave., N. Y. C.

# BE A REAL MAN

LOOK LIKE ONE AND FEEL LIKE ONE

Broaden your shoulders, deepen your chest, enlarge your arms, and get a development that will attract attention. Fill yourself full of energy and be powerful.

My New Book "Muscular Development" Will Explain How

This book is illustrated with 26 full page photographs of myself and of some of the world's finest developed athletes I have trained. It will interest and benefit you greatly.

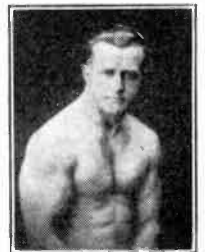

Send 10c (stamps or coin) for a copy NOW, today, while it is on your mind.

EARLE LIEDERMAN, Dept. 203, 305 Broadway  
NEW YORK CITY

## WALTER GEMS

Look Like Diamonds

See how they sparkle and flash! We defy you to tell the difference. Choice of gold or white platinum finish setting.

**SEND NO MONEY** Wear one (or both) free days. Write us what you want free. —ladies' or men's ring or stick pin and setting wanted. Send strip of paper for ring size. On arrival, deposit with postman \$5 for each ring, \$2 for each pin. Deposit refunded within 5 days if not entirely pleased.

R. WALTER, 299-B Montgomery St., Jersey City, N. J.

# CHARGE

YOUR OWN BATTERY

You can do it—without removing your battery or even disconnecting terminals. The Valley Battery Charger will end your battery troubles. Plugs in on lamp socket; clamps to battery. Cannot overcharge or harm battery. Price \$18.00. Send for booklet. Valley Electric Company, Department S., ST. LOUIS, MO.

# You can be quickly cured, if you STAMMER

Send 10 cents for 238-page book on Stammering and Stuttering, "Its Cause and Cure." It tells how I cured myself after stammering 20 yrs. B. N. Bogue, 792 Bogue Bldg., 1147 N. Ill. St., Indianapolis.

158 Genuine Foreign Stamps—Mexico War Issues, Venezuela, Salvador and India Series, Guatemala, China, etc. 10c Finest Approval Sheets 50 to 60 per cent. AGENTS WANTED. Big 72-p. Lists Free. We Buy Stamps. Established 29 years. Hussman Stamp Co., Dept. 133, St. Louis, Mo.

# "BECOME A LIGHTNING TRICK CARTONIST"

Make money chalk talking. Send \$1.00 for snappy program of trick drawings, with instructions by professional cartoonist. Satisfaction guaranteed. Circular free. Balda Art Service, Dept. 4, Oakkosh, Wis.



## Crystal Receiving Set \$2.50

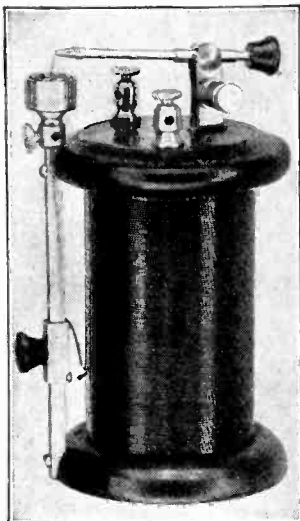

This is the Ritter Grand Crystal Set. It has a variable tuning capacity of 150 to 600 meters and our guarantee to receive concerts 25 miles under normal conditions.

Free circular of set with instructions on how to Direct Your Aerial sent upon request.

**"SPECIAL OFFER"**  
Ritter Grand Crystal Set with full aerial equipment and single guaranteed phone with head band. All neatly boxed.

Price, \$5.00

WE ALSO INVITE DEALERS' INQUIRIES

**RITTER RADIO CORPORATION**  
118 Walker Street New York City

## Agents Splendid Profits

Introducing the New Sun Automatic Regulator and Timer for Ford Cars. Gives proper spark automatically for every speed of motor. Does away with Spark Lever. Back-kick Impossible—Insures instant start in all weather. Prevents fouling of spark plugs and forming of carbon. Engine remains clean giving more power on hills, more speed on level roads at less cost. Grease, dirt and water proof—Fully guaranteed. Sold on 30 days trial. Retail price \$3.50. Large income for active workers. Tremendous sales opportunities. Every Ford owner will buy.

**AUTO SUN PRODUCTS COMPANY,**  
Dept. 31 Cincinnati, Ohio

## Electric Solder Iron

Fits Any Standard Appliance Plug



100 Watts 108-115 Volts  
RADIO—AUTO—HOME  
Does Work of Any \$15.00 Iron. Use your own appliance plug, or send \$1.00 extra for Plugs and Cord as shown. Plain String Solder, 60c lb. Acid or Rosin Core String Solder 90c lb. Add 10c for postage.

**\$1.50**  
Iron Only

M. A. SIMON CO., 520 Pine Street, St. Louis, Mo.

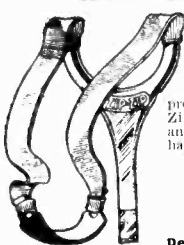

## ZIP-ZIP

**BOYS:** If you like hunting and outdoor sport, you cannot afford to do without this remarkable shooter. Scientifically and practically made, prong made of beautiful metal, fine Zip-Zip rubbers with plenty of pep and force. Thousands of boys are made happy with this wonderful Zip-Zip.

Order from us or your dealer.  
Zip-Zip complete 35c. 3 for \$1.00

**AUTOMATIC RUBBER CO.,**  
Dept. 33 Columbia, S. C.

## 25c Brings Big 3 ft. Telescope

(In 5 Sections)

See people and objects miles away just like they were close, see Moon and Stars as you never did before. Brass bound, useful and entertaining. "Could tell color of newspaper 4 miles away"—Mrs. Yarbrough. "Watch my neighbors on a number of boys arrive at school 2 miles away"—Mrs. Horn. "Read a number of freight cars in 2 miles away, see mountains on moon"—C. P. Warner. Thousands pleased.

**SPECIAL OFFER—** send only 25c with order. On arrival deposit \$1.75 with postman. Or if you prefer, send \$1.50 with order in full payment. Sent postpaid. Satisfaction guaranteed or money returned.

**FERRY & CO., 6832 East End Ave. Dept. 1250 Chicago**

**WHY** not spend Spring, Summer and Fall gathering butterflies, insects? I buy hundreds of kinds for collection. Some worth \$1 to \$7 each. Simple outdoor work with my instructions, pictures, price list. Get posted now. Send 10 cents (NOT STAMPS) for my illustrated prospectus. **MR. SINCLAIR, DEALER IN INSECTS, DEPT. 33, OCEAN PARK, CALIF.**



in Virginia and Brazil and down the St Lawrence valley it shone intermittently through a driving reek of thunder clouds, flickering violet lightning, and hail unprecedented. In Manitoba were a thaw and devastating floods. And upon all the mountains of the earth the snow and ice began to melt that night, and all the rivers coming out of high country flowed thick and turbid, and soon—in their upper reaches—with swirling trees and the bodies of beasts and men. They rose steadily, steadily in the ghostly brilliance, and came trickling over their banks at last, behind the flying population of their valleys.

And along the coast of Argentina and up the South Atlantic tides were higher than they had ever been in the memory of man, and the storms drove the waters in many cases scores of miles inland, drowning whole cities. And so great grew the heat during the night that the rising of the sun was like the coming of a shadow. The earthquakes began and grew until all down America from the Arctic Circle to Cape Horn hillsides were sliding, fissures were opening, and houses and walls crumbling to destruction.

China was lit glowing white, but over Japan and Java and all the islands of eastern Asia the great star was a ball of dull red fire because of the steam and smoke and ashes the volcanoes were spouting forth to salute its coming. Above were the lava, hot gases, and ash, and below the seething floods, and the whole earth swayed and rumbled with the earthquake shocks. Soon the immemorial snows of Tibet and the Himalayas were melting and pouring down by ten million deepening converging channels upon the plains of Burma and Hindustan. The tangled summits of the Indian jungles were aflame in a thousand places, and below the hurrying waters around the stems were dark objects that struggled feebly and reflected the blood red tongues of fire. And in a ruderless confusion a multitude of men and women fled down the broad riverways to that one last hope of men—the open sea.

Larger grew the star, and larger, hotter, and brighter with a terrible swiftness now. The tropical ocean had lost its phosphorescence, and the whirling steam rose in ghostly wreaths from the black waves that plunged incessantly, speckled with storm tossed ships.

And then came a wonder. It seemed to those who in Europe watched for the rising of the star that the world must have ceased its rotation. In a thousand open spaces of down and upland the people who had fled thither from the floods and the falling houses and sliding slopes of hill



## GET THIS WONDERFUL RING. If You Can Tell It From a Genuine Diamond Send It Back

These amazing, beautiful CORODITE diamonds positively match genuine diamonds in every way—same blazing flash and dazzling play of living rainbow fire. They, alone, stand the diamond tests, including terrific acid test of direct comparison. Lifetime experts need all their experience to see any difference. Prove it to yourself.

**Wear a Corodite Diamond 7 Days Free**  
Make this test. You risk nothing. Wear a genuine Corodite and a diamond side by side on the same finger for 7 days. If you or your friends can tell the difference, send it back; you won't be out a single penny. That's fair enough. If you keep the ring, the price printed here is all you pay. No installments. Remember, Corodites alone have the same cutting as genuine stones.

No. 1—Ladies' Solitaire 14K Gold S. Ring	\$2.84
No. 2—Ladies' Heavy Belcher 14K Gold S. Ring	\$3.48
No. 3—Gents' Massive Hexagon Gypsy Ring	\$4.27
No. 4—Ladies' Hand-Carved Basket Setting, plat. finish	\$3.56
No. 5—Ladies' Tiffany Bridal Blossom Engraved	\$3.54

Carat size gems. Beautiful mountings of most modern design. Choice of gold or latest white platinum finish. Unqualified 20-year guarantee. Handsome all-leather case free with each ring.

**SEND NO MONEY** send name, address and number of ring wanted and size as shown by slip of paper, fitting end to end around finger joint. Your ring will come by return mail. When ring arrives deposit amount shown above with postman. If you decide not to keep ring after 7 days' wear, send it back and your money will be immediately returned. Send today.

**E. RICHWINE CO.**  
333 S. Dearborn St., Dept. 363, Chicago, Illinois  
Sole Importers Genuine Corodite Diamonds

## MADE TO YOUR ORDER \$1.95

# Pants



**NO EXTRA CHARGES** Postage Prepaid  
**Send no Money** We make this special offer for 30 days, to prove the wonderful value, style and fit of Progress Tailoring. We will tailor to order, a pair of these stylish, \$6.00 pants—guaranteed to wear like iron—and send them to you postage prepaid for only \$1.95. Send no money or measurements until you receive our samples.

**Write for Samples Today.** Our big free sample outfit will be sent you the same day your request is received.

**AGENTS WANTED—** Earn \$30 to \$35 extra every week, taking orders from your friends and neighbors for our high-class tailoring. No experience necessary. Suits at \$12.45 up and pants at \$1.95 up make orders come easy. Full details will be sent free. Write now.

The Progress Tailoring Co., Dept. Q429, Chicago, Ill.

## Printing Cheap

Cards, circulars, labels, book, paper, Press \$12. Larger \$35. Job press \$50. Save money. Print for others, big profit. All easy, rules sent. Write factory for press catalog, TYPE, cards, etc. **THE PRESS CO., D-47, Meriden, Conn.**

## CHARGE YOUR RADIO BATTERY AT HOME

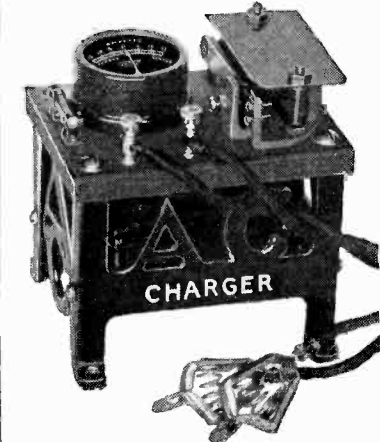

## with an A-C CHARGER

**SELF POLARIZING—**Connects either way to battery.  
**GIVES AUTOMATIC TAPER CHARGE—**Prevents injury to battery through overcharge.  
**STANDARD FUSE** protects against fire hazard.  
**5 AMPERE CHARGING RATE—**The correct for all radio and auto batteries.

The A C Charger is constructed of high-grade materials; closed core transformer; genuine black glazed porcelain panel. Handsome black enameled finish.

The A C Charger always gives satisfaction. Its rugged construction and scientific design insures its uninterrupted service.

## INSIST on the GENUINE A C CHARGER

Comes complete with charging cable, battery clips, ammeter, attachment cord and plug. All ready for use with complete instructions for charging all A and B batteries. At radio and auto supply dealers, or direct from factory.

\$15.00 COMPLETE  
Charges Both A and B Batteries

**HOLMES ELECTRICAL MANUFACTURING CO.**  
3229 Sheffield Avenue CHICAGO, ILL.

# Dr. T. O'Connor Sloane Will Teach You CHEMISTRY Right in Your Own Home



DR. T. O'CONNOR  
SLOANE, A. M.,  
Ph. D.,  
Educational Director  
Chemical Institute of  
New York, formerly  
Treasurer, American  
Chemical Society and  
a Practical Commer-  
cial chemist as well as  
a noted instructor.

Good chemists command high salaries. Industrial firms of all kinds pay tempting salaries to get the right men. Salaries of \$10,000 a year are not unusual for chemists of exceptional abilities. The work of the chemist is extremely interesting. If you are fond of experimenting, take up chemistry. If you want to earn more money, the way is open through our Course in Chemistry.

**You Can Learn at Home**  
Dr. Sloane will teach you Chemistry at home in a practical, intensely interesting way. Our Course is remarkably simple. No special education required—if you can read and write plain English you can thoroughly understand and master every lesson.

### Easy Monthly Payments

The price of our course is very low and the tuition includes everything, even the chemistry outfit—there are no extras to buy with our course. You can pay in small monthly amounts as you go along. Our plan places a chemical education within the reach of everyone.

### Experimental Equipment Given to Every Student

One special feature of our course is that we give to every student, without additional charge, the chemical equipment he will need for his studies, including forty-two pieces of laboratory apparatus and eighteen different chemicals and reagents. The fitted, heavy wooden box serves as a carrying case for the equipment and as a laboratory accessory for performing experiments.

### SPECIAL 30-DAY OFFER

In addition we are making a special offer for a short time only. You owe it to yourself to find out about it. Mail the Coupon to-day for free book, "Opportunities for Chemists," and full details of our special offer. Act immediately before this offer is withdrawn.

CUT HERE

Chemical Institute of New York, Inc.  
(Home Ext. Division 3A), 140-D, Liberty St., N. Y. City

Without obligation or cost, send me your free book, "Opportunities for Chemists," and full particulars about the Experimental Equipment given to every student, your plan of payment and special 30-day offer.

Name .....

Address .....

City..... State.....

watched for that rising in vain. Hour followed hour through a terrible suspense, and the star rose not. Once again men set their eyes upon the old constellations they had counted lost to them forever. In England it was hot and clear overhead, though the ground quivered perpetually; but in the tropics Sirius and Capella and Aldebaran showed through a veil of steam. And when at last the great star rose, near ten hours late, the sun rose close upon it, and in the center of its white heart was a disk of black.

When over Asia the star had begun to fall behind the movement of the sky, and then suddenly, as it hung over India, its light had been veiled. All the plain of India from the mouth of the Indus to the mouths of the Ganges was a shallow waste of shining water that night, out of which rose temples and palaces, mounds and hills, black with people. Every minaret was a clustering mass of people, who fell one by one into the turbid waters as heat and terror overcame them. The whole land seemed a-wailing, and suddenly there swept a shadow across that furnace of despair, and a breath of cold wind, and a gathering of clouds out of the cooling air. Men looking up, near blinded, at the star, saw that black disk was creeping across the light. It was the moon, coming between the star and the earth. And even as men cried to God at this respite, out of the east with a strange, inexplicable swiftness sprang the sun. And then star, sun, and moon rushed together across the heavens.

So it was that presently, to the European watchers, star and sun rose close upon each other, drove headlong for a space, and then slower, and at last came to rest, star and sun merged into one glare of flame at the zenith of the sky. The moon no longer eclipsed the star, but was lost to sight in the brilliance of the sky. And though those who were still alive regarded it for the most part

with that dull stupidity that hunger, fatigue, heat, and despair engender, there were still men who could perceive the meaning of these signs. Star and earth had been at their nearest, had swung about one another, and the star had passed. Already it was receding, swifter and swifter, in the last stage of its headlong journey downward into the sun.

And then the clouds gathered, blotting out the vision of the sky; the thunder and lightning wove a garment around the world; all over the earth was such a downpour of rain as men had never seen before; and where the volcanoes flared red against the cloud canopy there descended torrents of mud. Everywhere the waters were pouring off the land, leaving mud stilted ruins, and the earth littered like a storm worn beach with all that had floated, and the dead bodies of the men and brutes, its children.

For days the water streamed off the land, sweeping away soil and trees and houses in the way and piling huge dikes and scooping out titanic gullies over the countryside. Those were the days of darkness that followed the star and the heat. All through them, and for many weeks and months, the earthquakes continued.

But the star had passed, and men, hunger-driven and gathering courage only slowly, might creep back to their ruined cities, buried granaries, and sodden fields. Such few ships as had escaped the storms of that time came stunned and shattered and sounding their way cautiously through the new marks and shoals of once familiar ports. And as the storms subsided men perceived that everywhere the days were hotter than of yore, and the sun larger, and the moon, shrunk to a third of its former size, took now fourscore days between its new and new.

But of the new brotherhood that grew presently among men, of the saving of laws and books and machines, of the strange

## To Practical Men and Electrical Students:

Yorke Burgess, founder and head of the famous electrical school bearing his name, has prepared a pocket-size note book especially for the practical man and those who are taking up the study of electricity. It contains drawings and diagrams of electrical machinery and connections, over two hundred formulas for calculations, and problems worked out showing how the formulas are used. This data is taken from his personal note book, which was made while on different kinds of work, and it will be found of value to anyone engaged in the electrical business.

The drawings of connections for electrical apparatus include Motor Starters and Starting Boxes, Overload and Underload Release Boxes, Reversible Types, Elevator Controllers, Tank Controllers, Starters for Printing Press Motors, Automatic Controllers, Variable Field Type, Controllers for Mine Locomotives, Street Car Controllers, Connections for reversing Switches, Motor and Dynamo Rules and Rules for Speed Regulation. Also, Connections for Induction Motors and Starters, Delta and Star Connections and Connections for Auto Transformers, and Transformers for Lighting and Power Purposes. The drawings also show all kinds of lighting circuits, including special controls where Three and Four Way Switches are used.

The work on Calculations consists of Simple

Electrical Mathematics, Electrical Units, Electrical Connections, Calculating Unknown Resistances, Calculation of Current in Branches of Parallel Circuits, How to Figure Weight of Wire, Wire Gauge Rules, Ohm's Law, Watt's Law, Information regarding Wire used for Electrical Purposes, Wire Calculations, Wiring Calculations, Illumination Calculations, Shunt Instruments and How to Calculate Resistance of Shunts, Power Calculations, Efficiency Calculations, Measuring Unknown Resistances, Dynamo and Dynamo Troubles, Motors and Motor Troubles, and Calculating Size of Pulleys.

Also Alternating Current Calculations in finding Impedance, Reactance, Inductance, Frequency, Alternations, Speed of Alternators and Motors, Number of Poles in Alternators or Motors, Conductance, Susceptance, Admittance, Angle of Lag and Power Factor, and formulas for use with Line Transformers.

The book, called the "Burgess Blue Book," is published and sold by us for one dollar (\$1.00) per copy, postpaid. If you wish one of the books, send us your order with a dollar bill, check or money order. We know the value of the book and can guarantee its satisfaction to you by returning your money if you decide not to keep it after having had it for five days.

THE McCLURE PUBLISHING CO.

720 Cass St., CHICAGO, ILLINOIS



## Tom Mix Uses RenuLife

"I own a complete set of RenuLife Violet Ray and find it of immense value in retaining a robust physique. I find it especially helpful in curing the sprains and bruises that I often incur in my strenuous career."

*Tom Mix*

### Do You, Too, Want Health and Strength?

YOU can have vigor, energy, health, strength and beauty. You need not suffer from aches and pains—from rheumatism, neuritis or other ailments. The soothing, healing RenuLife drives out aches and pains without shock or unpleasant sensation and searches deep down in your body to eliminate the cause. It carries ozone into the blood, enriching and purifying it.

**Free Trial** Hundreds of people have been rejuvenated and strengthened by the health-giving RenuLife Violet Ray. Prove to yourself how quickly it will aid you. Our free trial plan enables you to use RenuLife for that ailment of yours. Write for this Free Trial Plan—we take the risk.

RenuLife Electric Company  
319 Newberry Bldg. Detroit, Michigan

(In Canada: Pitt St. E., Windsor, Ont.)

# Electricity

Taught by Practical Men

If you expect to become an electrical expert in three or four months you are thinking wrong. Being an electrical engineer is a real job and cannot be learned overnight. Hazardous instruction may get you by for a time, but will not give you the solid foundation for the biggest positions.

You can get the necessary training without losing a day from your present work. Learn at home in your spare time. Hundreds of Burgess trained men have proven this and are earning bigger salaries. Burgess Home Study Methods are approved by Electrical Engineers. If you are in earnest to succeed in any branch of Electricity, write us today. Let us show you how we teach men so they keep on going. Write for the Burgess Catalog on "Electrical" and of opportunities open and how Burgess Methods train you for them.



YORKE BURGESS, Consulting Engineer  
**BURGESS ELECTRICAL SCHOOL**  
745 E. 42nd St., Dept. 2 Chicago, Ill.  
Canadian Branch, 201 Crawford Street, Toronto, Ont., Canada.

## ELECTRICAL HANDBOOK

We have prepared a pocket size note book for practical men. Contains drawings and diagrams of electrical machines and connections; over 200 formulas with problems worked out. **"THE BURGESS BLUE BOOK"** contains drawings for Motor Starters, Controllers, Transformers, Reversing Switches, Lighting Circuits, Calculations include Electrical Mathematics, Units, Resistance, Wire Gauge Rules, Ohm's Law, Unknown Resistances, Dynamo Troubles, Also Alternating Current Calculations, Finding Impedance, Frequency, Speed, Power Factor, Formulas for Line Transformers. Price only \$1.00 postpaid on money back guarantee. **AGENTS WANTED** Agents for special promotional agents can make \$1000 and more a day. Write for details. **THE BURGESS COMPANY, Consulting Electrical Engineers**  
745 East 42nd St. Radio Apparatus and Supplies Chicago, Ill.

## Agents: 90c an Hour

Introduce "Soderoze." A new wonder. A pure solder in paste form. Works like magic. Stops all leaks. For mending water buckets, cooking utensils, milk pails, water tanks, tin roofs—everything including granite ware, agate ware, tin, iron, copper, zinc, etc.

**Quick Sales—Nice Profit**  
Everybody buys. Housewife, mechanic, electrician, jeweler, plumber, tourist, automobilist, etc. No leak too bad to repair. Just apply a little "Soderoze," light a match and that's all. Put up in handy metal tubes. Carry quantity right with you. Write for money-making proposition.

**AMERICAN PRODUCTS CO., 7641 American Bldg., Cincinnati, Ohio**

## ALL MAKES



Underwoods, Monarchs, Remingtons, L. C. Smiths, Oliverts, Royals, Coronas AT **REDUCED PRICES, \$20.00**  
Prices as low as...

Write for our Catalog No. 15  
**BERAN TYPEWRITER CO.**  
Dept. 21, 58 W. Washington Street, Chicago



**Catch Fish** Bels, mink, muskrats and other fur-bearing animals, in large numbers, with our new, Fold-in, Galvanized **Steel Wire Trap**. It catches them like a fly-trap catches flies. Made in all sizes. Strong and durable. Write for Descriptive Price List, and our Free Booklet on best bait known for attracting all kinds of fish.  
**J. F. GREGORY, Dept. 25, Lebanon, Mo.**

change that had come over Iceland and Greenland the shores of Baffin's Bay, so that the sailors coming there presently found them green and gracious, and could scarce believe their eyes, this story does not tell. Nor of the movement of mankind, now that the earth was hotter, northward and southward towards the poles of the earth. It concerns itself only with the coming and the passing of the star.

The Martian astronomers—for there are astronomers on Mars, although they are different beings from men—were naturally profoundly interested by these things. They saw them from their own standpoint, of course. "Considering the mass and temperature of the missile that was flung through our solar system into the sun," one wrote, "it is astonishing what little damage the earth, which it missed so narrowly, has sustained. All the familiar continental markings and the masses of the seas remain intact, and indeed the only difference seems to be a shrinkage of the white discoloration (supposed to be frozen water) round either pole." Which only shows how small the vastest of human catastrophes may seem at a distance of a few million miles.

## How Old is the World

By HARRY VAN DEMARK

(Continued from page 1057)

meters high, or about 36 feet, as the river then only drained Lake Erie, for the three other lakes had their own separate outlets to the sea. The water falling over it was only about 15 per cent of what falls today. The channel cut was narrow, the wearing back of it followed very slowly, only about 12 centimeters or 5 inches, in a year.

After various geologic changes, all five lakes sent their water over Niagara, which today is divided into two falls, the smaller the American, and the Horseshoe Falls, falling from a height of about 50 meters (164 feet) into the cavity, giving an awe-inspiring display of the primitive powers of nature. In later times, a wearing away of the edge of the falls of a little over five feet, has been calculated. A number of geologists, Spencer, Taylor, and Gilbert, have on the basis of all the circumstances during the course of geologic epochs, tried to reckon the time which was required for Niagara to cut the entire channel or gorge. They reached figures varying between 20,000 and 40,000 years, giving a mean of 30,000 years (or at a rate of about one foot per year). At this rate Niagara Falls would reach Buffalo in about 90,000 years, but less water now passes over the falls, due to hydroelectric power developments, and also a harder rock has been reached by the falls, which wears away but slowly.

## PHOTO-BY-WIRE FOR THREE FRENCH CITIES

Edouard Belin, inventor of the photo-telephonic process by which photographs are transmitted through the air and by wire, has gone to Lyons, where he will establish the first of three stations, under the contract with the French Government, which controls communications and which sees a future in M. Belin's new system. The New York *World* recently acquired from M. Belin the North American rights of the invention.

There will also be installations of the Belin equipment at Paris and Strassburg.

Renewed efforts to put the apparatus in action between Madrid and Paris were frustrated in the early tests by poor service. An hour was spent in efforts to talk over the line, but nothing more than dim "hellos" resulted, so it was decided that it would be useless to try to transmit photographs.

# The Proper Finish Makes New Furniture Harmonize With the Old



**S** MALL odd pieces of modern furniture add greatly to the attractiveness of every home. You, yourself, can easily make them for your family. There is no particular trick to constructing porch swings, tables, telephone sets, etc. You can give your work a beautiful finish with

# JOHNSON'S WOOD DYE

Johnson's Wood Dye is very easy to apply—it goes on easily and quickly, without a lap or a streak. It penetrates deeply bringing out the beauty of the grain without raising it—dries in 4 hours and does not rub off or smudge. Made in fourteen beautiful shades.

## FREE-This Book on Home Beautifying

This Book tells how to finish wood in artistic stained and enameled effects. Gives practical suggestions on making your home artistic, cheery and inviting. Tells just what materials to use and how to apply them. Includes color card—gives covering capacities, etc. Use coupon below.

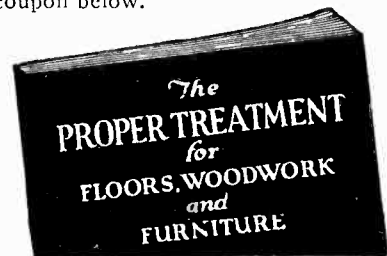

**S. C. JOHNSON & SON, Dept. SI 3, Racine, Wis. (Canadian Factory—Brantford)**  
Please send me free and postpaid your Instruction Book on Home Beautifying and Wood Finishing.  
The best dealer in paints here is.....  
MY NAME.....  
MY ADDRESS.....  
CITY & STATE.....





## Here's The Winner of The \$5000 Cup

Gentlemen—meet Mr. Otto Loesche, winner of the \$5000 Penrose Trophy in the annual Pike's Peak Automobile Race in 1920 and first in his class in 1921.

Mr. Loesche is not only a champion automobile racer, but he's chief of the experimental department of the Lexington Motor Company. That's a pretty good job for a young man.

Recently, when asked for a statement concerning the one thing that had contributed most to his success, he said:

"I believe the greatest source of assistance and encouragement came to me when I became interested in trying to better my position. I wanted an education—that is, a foundation on which to build. So I enrolled as a student in the Mechanical Engineering Department of the International Correspondence Schools, of Scranton, Pa., and began to study. There is no question in my mind but that was the most important step of my life."

Why don't you at least find out what the I. C. S. can do for you? It doesn't cost you a penny or obligate you in any way to mark and mail the coupon printed below, but that seemingly simple little act may be "the most important step" in your life, too.

Today—not "Tomorrow"—is the day to make the first definite move toward Success.

### INTERNATIONAL CORRESPONDENCE SCHOOLS Box 6189-C, Scranton, Penna.

Without cost or obligation on my part, please tell me how I can qualify for the position or in the subject before which I have marked an X:

- | BUSINESS TRAINING DEPARTMENT                            |   |
|---|---|
| <input type="checkbox"/> Business Management            | <input type="checkbox"/> Salesmanship           |
| <input type="checkbox"/> Industrial Management          | <input type="checkbox"/> Advertising            |
| <input type="checkbox"/> Personnel Organization         | <input type="checkbox"/> Better Letters         |
| <input type="checkbox"/> Traffic Management             | <input type="checkbox"/> Foreign Trade          |
| <input type="checkbox"/> Business Law                   | <input type="checkbox"/> Stenography and Typing |
| <input type="checkbox"/> Banking and Banking Law        | <input type="checkbox"/> Business English       |
| <input type="checkbox"/> Accountancy (including C.P.A.) | <input type="checkbox"/> Civil Service          |
| <input type="checkbox"/> Nicholson Cost Accounting      | <input type="checkbox"/> Railway Mail Clerk     |
| <input type="checkbox"/> Bookkeeping                    | <input type="checkbox"/> Common School Subjects |
| <input type="checkbox"/> Private Secretary              | <input type="checkbox"/> High School Subjects   |
| <input type="checkbox"/> Business Spanish               | <input type="checkbox"/> Illustrating           |
| <input type="checkbox"/> French                         |   |

- | TECHNICAL AND INDUSTRIAL DEPARTMENT             |  |
|---|--|
| <input type="checkbox"/> Electrical Engineering | <input type="checkbox"/> Architecture            |
| <input type="checkbox"/> Electric Lighting      | <input type="checkbox"/> Blue Print Reading      |
| <input type="checkbox"/> Mechanical Engineer    | <input type="checkbox"/> Contractor and Builder  |
| <input type="checkbox"/> Mechanical Draftsman   | <input type="checkbox"/> Architectural Draftsman |
| <input type="checkbox"/> Machine Shop Practice  | <input type="checkbox"/> Concrete Builder        |
| <input type="checkbox"/> Railroad Positions     | <input type="checkbox"/> Structural Engineer     |
| <input type="checkbox"/> Gas Engine Operating   | <input type="checkbox"/> Chemistry               |
| <input type="checkbox"/> Civil Engineer         | <input type="checkbox"/> Pharmacy                |
| <input type="checkbox"/> Surveying and Mapping  | <input type="checkbox"/> Automobile Work         |
| <input type="checkbox"/> Metallurgy             | <input type="checkbox"/> Airplane Engines        |
| <input type="checkbox"/> Steam Engineering      | <input type="checkbox"/> Agriculture and Poultry |
| <input type="checkbox"/> Radio                  | <input type="checkbox"/> Mathematics             |

Name.....  
Street Address.....  
City..... State.....

Occupation.....  
Persons residing in Canada should send this coupon to the International Correspondence Schools Canadian, Limited, Montreal, Canada.

### "ELECTRO-CONDITE"

**STARTLES THE WORLD**

Thousands of people are marveling at the wonderful performance of the "Electro-Condite" Converter. Clarifies, purifies, sterilizes, matures and mellows most kinds of beverages. Makes hard water soft, etc. May prevent poisoning.

Send \$5.00 for device with 5 days' trial money-back guarantee or ask for circular.

Best grade Proof Hydrometers, \$1.00 each prepaid.

Dept. X., 200 West 72d St., New York

"Electro-Condite" CONVERTER A-B-C LABORATORIES, Inc.

## STAMMER

NO MORE

Kill the fear of stammering. Re-education the key. The widely famed Hatfield Method fully outlined in an accurate, dependable, worthwhile book—"HOW TO STOP STAMMERING." It has inspired thousands. Free copy today.

THE HATFIELD INSTITUTE, 109 N. Dearborn, Chicago, Ill.

## Doctor Hackensaw's Secrets

By CLEMENT FÉZANDIE

(Continued from page 1065)

"Well, yes, it is a glider, and yet in my opinion it is far superior to the ordinary glider. You have probably seen in the papers that both the French and the German governments are devoting considerable attention to the manufacture of airplanes without engines. The results have been most promising, some of the flights lasting *three hours and a quarter* without a motor of any kind. Shorter flights have also been made with a passenger on board as well as the pilot."

"But how can an airplane travel without a motor?"

"The wind raises it, the same wind which raises an ordinary kite. The difference is that the glider needs no string to hold it in the proper position against the wind. The pilot, on board the machine, by means of his steering apparatus, keeps the wings facing the wind, and so is able to rise to any desired height—that is, of course, so long as conditions remain favorable.

"The disadvantage of these gliders, as at present constructed, is that the equilibrium is not automatically regulated. It requires an expert pilot to run them, and the steering is very fatiguing. Then, too, the starting is difficult. It is not every hill that can serve as a starting-point, and the wind must be just right. To obviate this difficulty, the French are trying hard to devise a glider in which the pilot can assist himself by a kind of bicycle treadle which enables him to work a propeller. This would be of material assistance in starting."

"And your machine?"

"My machine is really a combination of an airplane and a balloon. But why waste time describing it. Come along with me and you can see it for yourself. The man from Missouri who wants to be 'shown', is the man who will learn."

A short ride in one of the doctor's automobiles brought the pair to the hangar where the motorless airplane was stored.

"You see, Silas," observed Doctor Hackensaw, "one great advantage of my machine is that I do not require a large space to start in, because I rise vertically instead of horizontally. Here is the machine—now tell me frankly what you think of it."

The reporter cast a disappointed look at the airplane. Save that it had no propeller and no motor, it was very much like any other flying machine except for the one fact that, instead of being a monoplane or a bi-plane, this machine had no less than *four* planes. This gave it a rather clumsy appearance.

"I see you don't like the looks of my 'quadriplane,'" remarked the doctor, noticing the reporter's air of disapproval. "Well, I don't blame you. I haven't sought beauty yet, I'm just seeking practical results."

"But this machine is only a glider!" cried Silas. "It has no motor, nothing to make it go!"

"It looks so, doesn't it?" chuckled the doctor. But she'll go all right!" Then turning to the man in charge, he added: "Run her out to the starting-place, James,—that is, if she's in good order."

"She do be that, sorr," returned the man. "She hasn't lost a foot of gas since last night."

"Gas?" exclaimed Silas Rocket, "where is there any gas?"

"Why, Silas; didn't I tell you that my machine was a combined glider and balloon,—and did you ever hear of a balloon without any gas?"

"But where in the world is the gas?"



## A Marvel of Utility

For fixing the wiring on your Lenk Automatic \$1.50 car, mending kitchen utensils, repairing electric fixtures, working around your Radio set.

Absolutely automatic—blows itself—produces a 1400° needle-point flame instantly.

Used by electricians, mechanics and experimenters

- |   |        |
|---|--------|
| 60" coil self-fluxing (acid or rosin core) solder   | \$ .25 |
| Lenk "Super" (Mouth Blow Torch)   | .75    |
| Lenk "Jumbo" (Mouth Blow Torch)   | 1.00   |
| Marvel Soldering Kit—one Lenk Automatic and one coil, each of self-fluxing acid and rosin core solder, in neat leatherette case | 2.00   |

If your dealer does not carry them, order direct.

**Lenk Manufacturing Company**  
42 Portland St. Boston, Mass.

## The Patient Teacher

**ART STUDENTS:** Would you like to have a teacher standing by your elbow while you work ready to make a stroke or two for you whenever you are in doubt, to show you how the picture goes? The Patient Teacher will furnish as much help as you ask for and no more. It will furnish outlines of any size desired of any photograph or drawing. It will guide your every stroke if you are a beginner; or it will help you over the difficult parts while leaving you free to express your own individuality.

The Patient Teacher is used, not only for enlarging pictures, but when you are posing a friend or sketching a landscape. Write for full particulars of the instrument and instructions for a course of practice that will develop ability to do original work. Inexpensive. Mention this magazine.

**PATIENT TEACHER COMPANY**  
232 West 116th St., P. O. Box 32, New York City

## RADIO SUPPLIES

All Standard Goods—Immediate Deliveries

Distributors for  
**BALDWIN, BRANDES and FEDERAL PHONES,  
FADA, FEDERAL and MONROE  
RECEIVING SETS**

Erla, Acme, Dubilier, Chelton, Burgess, Meyers Tubes, Magnavox and many others.

A Complete Line. Largest Stock in the Middle West  
WRITE FOR LATEST 64-PAGE CATALOGUE  
DEALERS 35% DISCOUNT

**American Radio Mfg. Co., Dept. F.**  
107 E. 13th STREET KANSAS CITY, MO.

You positively can install and repair any electrical job in the home or business place without previous experience. You can eliminate electrician's bills when you own our new book, **ELECTRICAL KINKS**, explaining everything about bells, lighting, garage wiring, vacuum cleaners, washing machines, etc. Easy money made working for others.

SEND TODAY, \$1.00 cash, or C. O. D., plus postage. Satisfaction guaranteed. Circular free.

HOME BOOK CO., 388 CD Arcade Bldg., Cleveland, O.

### LEARN WATCH REPAIRING

You can learn by our modern and original system of instruction every part of the Watch Repairing Trade at home as good or better than at a shop. You can earn money while learning and secure a well paying position or start in business after completing our course of instruction. Good watch repairers are always in demand and earn from \$50 to \$85 per week. For particulars apply to the

**MILWAUKEE SCHOOL OF WATCH REPAIRING, 166 Mason St., MILWAUKEE, WIS.**

## Easy to Play Easy to Pay

**BUESCHER**

**True-Tone Saxophone**

**Director of Gene Rodemich's Orchestra.** Hear the premier Southern Orchestra in Brunswick Records (for Dancing), playing Band Instruments.

**Easiest of all wind instruments to play and one of the most beautiful.** You can learn the scale in an hour's practice and play popular music in a few weeks. You can take your place in a band within 90 days if you so desire. Unrivalled for home entertainment, church, lodge or school. In big demand for orchestra dance music.

**Free Trial** You may order any Buescher instrument without paying in advance, and try it six days in your own home, without obligation. If perfectly satisfied, pay for it on easy payments to suit your convenience. 75 per cent of all popular phonograph records are played with Buescher instruments. Ask for pictures of the Nation's Record Makers.

**Saxophone Book Free** After nearly 800 years' supremacy, string instruments are almost entirely displaced by Saxophones in all nationally popular orchestras. Our Free Saxophone Book tells which Saxophone takes violin, cello and bass parts and many other things you would like to know. Ask for your copy. Mention the instrument interested in and a complete catalog will be mailed free.

**BUESCHER BAND INSTRUMENT CO.**  
Makers of Everything in Band and Orchestra Instruments  
6073 Buescher Block ELKHART, INDIANA

**Sax Invented the Saxophone  
Buescher Perfected It**

*Learn to Write*

**I TEACH BY MAIL.** I can make a good penman of you at your home during spare time, no matter where you live or how poorly you write. My simplified system has shown thousands the way to good penmanship during the past twenty-five years—it CAN and WILL do the same for YOU.

My beautifully illustrated 32-page Book, "How to Become a Good Penman," FREE!

It contains many beautiful specimens of penmanship showing what others have accomplished by the Tambllyn System, with testimonials and general information about our courses. (Your name elegantly written on a card if you enclose stamp for postage.) Ladies taught as successfully as men. Write Today. Address

F. W. TAMBLYN,  
424 Ridge Bldg., Kansas City, Mo., U.S.A.

## BLUE PRINT READING

**GOOD MEN WANTED NO MATTER WHAT TRADE.** Learn to read Blue Prints and get a big job as Foreman and Superintendent. You will earn more money. We will teach you quickly in your spare time. Don't miss this chance. Write today—state your trade. We will send you blue print, Catalog B, and valuable facts, all free.

**BE A DRAFTSMAN—Earn \$35-\$100 a week.** We train you quickly at home on the pay as you study plan. Book and tools FREE. Write for Catalog G.

Dept. 18-A, Drexel Bldg., Philadelphia, Pa.  
**COLUMBIA CORRESPONDENCE SCHOOL** EST. 1904

## ELECTRICITY

**TWO-YEAR COURSE IN EIGHT MONTHS**

Thousands of trained men needed in the electrical industry. Most effective, easiest understood, latest training methods in existence. Proper home training service now within the reach of every ambitious man. Practical electrical engineering complete. Free, a 56-page book of great value.

Dept. 1, **WORLD TECHNICAL INSTITUTE**  
Jersey City, N. J.

### TO THE MOON AND BACK IN NINETY DAYS

A thrilling story of blended science and adventure. By John Young Brown, A.B. Scientifically accurate, delightfully and absorbingly interesting, profusely and beautifully illustrated, good print and binding with title and side stamp in gold. \$2.50. Postage free.

**LUNAR PUBLISHING CO.,** Box 462-E, Providence, Ky.

"In the wings, my boy. You will notice that the wings of my machine are considerably larger and thicker than those of the ordinary airplane. The space between the upper and lower portion of each wing is filled with helium gas. In a word, each wing is a little balloon, and the combined balloons are sufficient to raise the machine into the air."

"I see."

"When I first set out to build this machine I looked at the problem in this way. If I could only find some simple means of raising a glider to a height, I could do away with a motor altogether, for I could vol-plane or dive down in any direction I pleased and at a high rate of speed. In fact, by utilizing the wind, I could do all that the glider does now, and far more, for my acquired velocity in descending would enable me to make better use of the wind power. I could tack, somewhat as a sailing vessel tacks, and so profit to the utmost by whatever breezes there happened to be. Hence I could travel a long distance before having to rise again."

Silas Rockett's face showed plainly his poor opinion of the machine. "It doesn't strike me as being practical," said he, at length. "Your invention is nothing but a balloon, with wings added for coasting down. But each time you go up, you have to fill it with fresh gas, and each time you come down you have to let the gas escape. The advantage over an ordinary balloon seems to me very slight."

"You're right, Silas," said Doctor Hackensaw approvingly, "or at least you would be right if I were foolish enough to waste my gas at each descent. But I do no such a thing."

"How do you manage, then?"

"In the first place I use helium gas, so as to avoid all danger of fire. Then, if you will notice, I have a specially constructed heating apparatus here. I use kerosene for fuel. When I heat the helium gas, it expands, and consequently the wings of my machine bulge out and occupy more space, the machine thus becoming lighter. Finally it becomes light enough to rise from the ground, and I can control its rate of ascent by means of the temperature."

"I see."

"When I have reached a sufficient height and wish to coast down, I turn off the heat. The cold air of the heights, acting on the enormous wing surface, cools the gas almost instantly, especially as the cooling is assisted by rotary fans, worked by the motion of the airplane, and which I can start or stop at will. The helium gas contracts, my machine becomes heavier than air, like an ordinary glider, and down I coast in any direction and at any speed I please, turning on the heat when I wish to rise again."

"You have an answer for everything, doctor," remarked Silas. "You must have given the subject a great deal of study."

"I should say so. I began my experiments forty years ago. I first experimented by fastening men to kites of various kinds and sending them up in the air. I tried the ordinary kite with a tail, the tailless kite, and the box-kite. But the weight of the kite-string that had to be lifted was the great drawback. I used for the purpose a very light yet strong clothesline, but my kites could not lift very much of it. Then, too, the wind would change and my kites with their human freight, would drop to the ground. My passengers were always provided with parachutes, but when one man broke a leg in falling, I gave up the attempt. Then the airplane was invented, and now the gliding-machines are doing such remarkable work that I decided to take up the subject again on these new lines. And here is the result. If you will take your place in the machine, I'll be the pilot, and we can take a trial spin."

"What!"

"Yes, I want you to come for a little ride with me around New York Harbor."



## Become a Commercial Electrical Engineer In One Year at this Famous School

No calling offers such unbounded opportunities to the modern ambitious young man as that of Commercial Electrical Engineering. It is for this reason that this great school has organized a special course in Commercial Electrical Engineering that may be completed in one year.

Within recent years the Electrical field has become so wide and diversified that there has sprung up a great demand for electrically trained business men, consulting and efficiency engineers, men who can handle Commercial and Engineering problems. This special course offers a thorough, condensed, and very practical Electrical Engineering training, especially adapted to high-school graduates.

Here, you will also find any other kind of Electrical education which you might desire. School of Engineering is the largest institution in America devoted exclusively to the teaching of Electricity and allied subjects.

### ELECTRICAL ENGINEERING With B.S. Degree in 3 Years

A faculty of specialists is leading hundreds of ambitious young men to a sure and substantial success. Why not you?

If you lack some of the educational requirements, you can make them up as you go along. This gives you the opportunity of becoming an electrical engineer in the shortest possible time.

### ELECTROTECHNICS

Only one or two years of this course, and you are a fully trained electrotechnician—prepared to fill such positions as general plant superintendent, director of construction, superintendent of maintenance, chief draftsman, etc. This course will equip you for a position between that of an electrical engineer and that of an electrician, which is a well paying position, leading to higher executive work. A grade school diploma or its equivalent admits you without examination. New terms open every three months.

### PRACTICAL ELECTRICITY

This complete six months' electrical course teaches you house, factory and theatre wiring, testing and meter work, A.C. and D.C. motor installation, repairing and maintenance, including shop work in A.C. and D.C. armature winding and all necessary mathematics.

A three months' course in A.C. and D.C. armature winding, or in light and motor wiring.

### AUTOMOTIVE ELECTRICITY

Electrical specialists who instinctively diagnose and locate automotive electrical troubles command high positions and are well paid. Specialize in starting, lighting, ignition and storage batteries, and command a big job at a big salary!

There are millions of automobiles, motor trucks, tractors, motorcycles, aircraft, farm lighting plants, but few real experts who can put their fingers right on electrical troubles.

Specialists teach this course on actual standard equipment—three months day school, or through home study. Come any time and we will put you in the thick of the work.

Fill out the coupon and mail it today.

## SCHOOL of ENGINEERING of Milwaukee

Founded 1905

School of Engineering of Milwaukee,  
S.I.-3, 415 Marshall Street, Milwaukee, Wis.

Without obligating me in any way, please mail free illustrated book and further particulars on the course I have marked with an X.

- |   |                                   |
|---|-----------------------------------|
| ... Commercial Electrical Engineering   | Practical Electricity             |
| ... Electrical Engineering, B.S. Degree | ... 6 mo. complete course         |
| ... Electrotechnics                     | ... 3 mo. Armature Winding course |
| ... Drafting                            | ... 3 mo. Light and Motor Wiring  |
| ... Automotive Electricity              |                                   |

Name..... Age.....

Street..... City..... State.....

Education .....



**YOUR BOY'S HAPPINESS**

is one of your first considerations. Get THE BOYS' MAGAZINE for him. He needs this great boys' periodical. Parents owe it to their sons to give them clean, interesting and instructive reading that will make them self-reliant, manly and courageous.

**AN 8 MONTHS' TRIAL SUBSCRIPTION FOR ONLY 50 CENTS!**

(This is way below the regular price)

Each issue of THE BOYS' MAGAZINE contains from two to four splendid serial stories and from twelve to twenty thrilling short stories, besides special departments devoted to Radio, Mechanics, Electricity, Popular Science, Athletics, Physical Training, Stamp Collecting, Outdoor Sports, Amateur Photography, Cartooning, etc. Beautiful big pages with handsome covers in colors. Profusely illustrated throughout. A big lot of jokes and Comic Drawings. Eight issues equal 20 big volumes, which would cost, as books, at least \$20.00.

A special feature is the award of \$220.00 in cash prizes for the best amateur work in many subjects. There is no reason why YOUR boy should not win some of these prizes. Remember, only 50 cents for eight months. If you are not satisfied, we will refund your money promptly and without question. Remit in stamps if more convenient.

(On sale at all newsstands—10c a copy.)

TEAR OUT HERE

The SCOTT F. REDFIELD Co.,  
9242 Main St., Smethport, Pa.

I accept your special half-price introductory offer and enclose 50 cents for which send THE BOYS' MAGAZINE for eight months to

(Write name and address plainly)

Name .....

Street or R.F.D. ....

City..... State.....

"But . . . ."  
"Surely you're not afraid, Silas?"  
"No," replied the reporter, dubiously, "but are you sure the machine's all right?"  
"I'll answer for it, sorr," said the mechanic, reassuringly. "Me and Bill was out in it yesterday, and she worked like a charm!"

Too much preoccupied to notice the discrepancy in the pronouns, Silas took his seat, though not without some hesitation. He didn't much like the idea of being made the subject of an experiment.

"That's right, Silas," cried Doctor Hackensaw, encouragingly, "A brave man can only die once!"

But poor Silas did not feel disposed, at the moment, to die even once.

Doctor Hackensaw stepped into the pilot's seat and turned on the heat. Almost instantly the wings of the machine began to swell to several times their original size, and the machine slowly rose and began tugging at the ropes that held it down.

"Now Silas," cried the doctor, "before we start take a good look at your parachute. In case of any accident, grasp that, and it will break your fall. We're all ready, James, let her go!"

A moment later the released machine rose slowly from the ground. The wings themselves were so designed as to tilt upward, thus facilitating the rise, but the seats of the passengers always remained horizontal whatever the position of the car. A special telephone in the car enabled the two passengers to converse as easily as if in a quiet parlor.

Doctor Hackensaw was jubilant. "You see, Silas," he observed, "We have none of the noise and fuss here of an ordinary airplane. We are rising quietly and steadily. That's one great advantage over the flying-machine, the ease of starting. We do not require a special aviation field, I can rise or land most anywhere, because my ascent is practically vertical. Then, too, the start and the landing are effected as slowly as I wish, thus eliminating two of the greatest dangers of the airplane, which must start or land at a high rate of speed. For war-purposes, too, this faculty of hovering is very useful. For example, we are now directly above the Woolworth building. See how easy it would be to drop a bomb on it from here—much easier than from a balloon, for a balloon is at the mercy of the wind, while I can remain in the same relative position by descending in a spiral toward the building."

Silas looked down and was forced to admit the truth of his companion's remarks.

"Don't you see," cried the doctor, exultingly, "that my machine combines the advantages both of the balloon and of the airplane. I can travel in any direction I please, like an airplane, and yet haven't the

**AGENTS** Some Seller at  
**\$2.00**  
Looks Like \$5.00 Worth  
Gives You \$1.10 Profit!



**\$12 AN HOUR!**

W. H. Marion, a beginner, sold 36 "Nifty Nine" Introductory Assortments in three hours, first day, \$36 profit! How? Our representatives introduce our products with a first sale of beautiful combination sets of Toilet Articles, Soaps, etc. You sell at half store prices, no fancy talk, sell on sight. Make 20 to 30 sales a day with \$1.10 profit on each. Easy to average \$100 a week. Could you ask more while introducing line, establishing a permanent business for yourself? Another plan calls for no deliveries, no investment, no delays. You bank quick profits. Also a winning premium plan. Write quick for full details.

**FORD FREE!** No contest. Every producer free. Most amazing offer ever made. Don't waste a minute. Write TODAY for illustrated circulars explaining our "Inique Plans including 30 other packages. ACT NOW.

**E. M. DAVIS CO. Dept. 6703 CHICAGO**

**It Will Pay YOU to Own A MONARCH Junior Lathe**

Hundreds of things, of metal or wood, for the shop, auto and home can be made with a MONARCH Junior Lathe. This sturdy, small engine lathe, guaranteed to work with 1/1000 of an inch accuracy, was especially designed for inventors, experimenters and small shop owners. It is easy to learn to operate—even beginners can't jam it.

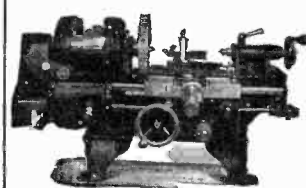

9" lathe  
2 1/2-ft. bed  
with bench  
legs

**\$225**

SEND for Free catalog of MONARCH lathes which are built up to 30" swing

**The Monarch Machine Tool Co.**  
418 OAK STREET SYDNEY, OHIO

**GENUINE GERMAN MAUSER**



Half pre-war prices

Latest model 9 shot automatic. Shoots standard cartridges—lies flat in pocket—World's famous Luger 30 cal. \$20.75—Hand Ejector Revolver, swing out cylinder 32 cal. \$16.95, 38 cal. \$17.95. All brand new latest models. **\$12.95** 25 cal. \$13.95

Guaranteed genuine imported. Pay on Delivery **SEND NO MONEY** Plus Postage

Satisfaction guaranteed or money promptly refunded

**\$6.95** 25 cal. Pocket Automatic; 25 cal. Blue Steel Army Automatic \$8.45; 32 cal. \$10.45; Officer's Automatic, 3 safeties, 25 cal. \$11.95; Military Trench Automatic, 32 cal. 10 shot extra magazine FREE, \$11.65. Just like you used over there. Imported Top Brake Revolver. 32 cal. \$8.65; 38 cal. \$8.95.

Universal Sales Co. 141 B'way, Desk 278 New York

**LEARN THE CODE AT HOME**

"Just Listen—The Omnigraph will do the teaching"

with the

**OMNIGRAPH**

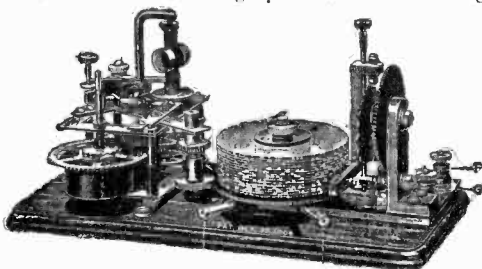

THE OMNIGRAPH Automatic Transmitter will teach you both the Wireless and Morse Codes—right in your own home—quickly, easily and inexpensively. Connected with Buzzer, Buzzer and Phone or to Sounder, it will send you unlimited messages, at any speed from 5 to 50 words a minute.

THE OMNIGRAPH is not an experiment. For more than 15 years, it has been sold all over the world with a money back guarantee. The OMNIGRAPH is used by several Depts. of the U. S. Govt. to test all applicants applying for a Radio License. The OMNIGRAPH has been successfully adopted by the leading Universities, Colleges and Radio Schools.

Send for FREE Catalog describing three models, \$14 to \$30. DO IT TODAY.

**The Omnigraph Mfg. Co., 22 Hudson St., New York City**

If you own a Radio Phone set and don't know the code—you are missing most of the fun

**LATHES**

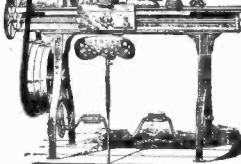

9 to 18-inch Swing  
List price \$150 and up, according to size. When ready to buy, send for Lathe Catalog and prices.

**W. F. & John Barnes Co.**  
442 Ruby Street  
ROCKFORD, ILLINOIS

**A Job For Life** With Good Pay and Treatment

Annual Vacation and Sick Leave under "Uncle Sam," is open to you if between the ages of 17 and 65. Our free book "B-41" will tell you about it. Write today. CHICAGO CIVIL SERVICE COLLEGE, 807 Kesner Building, Chicago



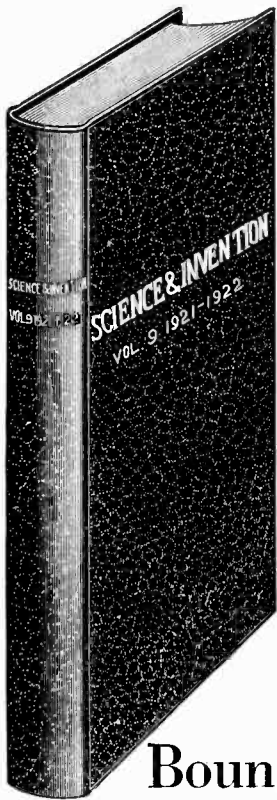

## Bound Volume No. 9

May, 1921—April, 1922  
CONTAINS

1200 Pages with over 1500  
Illustrations

and  
Over 700 Articles by the  
Foremost American and  
Foreign Writers

We have also a limited amount  
of the following Bound Volumes  
of *Science and Invention* (Electrical  
Experimenter):

Vol. No. 6—May, 1918, to  
April, 1919.

Vol. No. 7—May, 1919, to  
April, 1920.

Vol. No. 8—May, 1920, to  
April, 1921.

Each volume bound in stiff  
board covered with green vellum  
and gold stamped.

Price for volume No. 9...\$2.25  
Price for volume No. 6, 7 or 8 2.00  
ALL FOUR VOLUMES.... 7.00  
Sent Express Collect.

EXPERIMENTER PUBLISHING CO.,  
53 Park Place, N. Y.

Gentlemen:  
Enclosed find \$.....for  
which send me bound vol. of S. & I.  
No. 6 ( ), No. 7 ( ), No. 8 ( ),  
No. 9 ( ), by express collect.

Name .....  
Address .....  
Town ..... State .....

heavy and finicky motor to bother with—nor the expense of the gasoline. Traveling is cheap for me. What does it matter if I do not travel quite so fast. I can attain any speed I please in my descent. Neither do I waste my helium gas, as the ordinary balloon does, because I do not allow the gas to escape.

The machine was now well up in the air, and the doctor decided to make his first downward dive. He accordingly turned off the heat, the rotary fans began to revolve—the wings collapsed to a fraction of their former thickness and the car began to glide downward through the air at a rapidly increasing speed. When the motion became too swift, Doctor Hackensaw with a dexterous swerve of the tail would start the machine rising again.

“Look Silas,” cried the doctor, gleefully, “Here we are over Coney Island! If you look sharp, you will see, some distance beyond the bathing place, a basket floating out in the ocean. We’ll suppose that’s a sperm-whale, and I’ll show you how easy it would be to harpoon it, with a buoy attached to the harpoon, and then follow the buoy in our machine without any of the dangers we should run in a whale-boat.”

“Why, doctor, I didn’t know you were such an expert!” exclaimed Silas admiringly, as he saw the ease with which his companion handled the machine.

Scarcely were the words out of his mouth, however, when he was startled by a crackling sound—the steering wheel broke, and the machine, no longer under control, began a series of headlong dives.

“Quick, Silas!” cried the doctor, “Take to your parachute, man! Quick, I tell you, or you’ll be in the ocean!”

Suiting the action to the word, Doctor Hackensaw chose an opportune moment and jumped clear of the falling machine. His parachute opened beautifully and down he came lightly among the gaping crowd of bathers on the Coney Island beach.

Poor Silas, however, was not so fortunate. It took him some time to understand how matters stood, and then his parachute stuck and refused to come free from the falling airplane. When he did finally succeed in making his leap, he was some distance out over the water, and down he went deep into the briny waves. He emerged, gasping and sputtering and was quickly rescued by one of the boats. As he reached the shore, dripping wet and in a pitiable condition, it did not add to his peace of mind to see the doctor genially shaking hands with the pretty girl-bathers who had surrounded him.

“Well, Silas,” exclaimed the doctor, gaily, “how goes it?”

Silas gazed ruefully at his newly bought suit of clothing, now reduced to tatters by the jagged framework of the machine, but he said nothing.

“Never mind, Silas,” cried the doctor, cheerily. “Christmas is coming soon, and I prophesy that Santa Claus will bring you a complete wardrobe of clothing, far superior to any you have ever had. Now mark my words because I pride myself that I am something of a prophet. Now smile and look pleasant because there are some movie-men here and they want to get a *close-up* of you. You will go down to posterity as a pioneer of the motorless airplane, for although this first experiment has failed I feel confident that my machine will eventually open up a new era in the history of flying.”

### THE ULTIMATE COLD

The absolute zero, the lowest degree of cold that can ever be attained, has been approached within less than one degree.

This important announcement was made recently at a meeting of the Faraday Society at the Institution of Electrical Engineering in London by Prof. Onnes, of Leyden, Holland, who in 1908 liquefied the gas helium at a temperature only 4.3 degrees above absolute zero.

# Your Choice 75c a Week



No matter what your occupation, one of the home study sets listed below will quickly fit you for a better job and bigger pay. Any set you select will be sent for seven days' examination, and if you decide to buy you may pay the rock-bottom price at the rate of only 75c a week. But you must act now! The rising cost of paper and binding materials won't permit us to continue the present low prices much longer.

These books are the work of recognized authorities. They are written in plain, easily understood language, by recognized authorities, and contain hundreds of photographs, diagrams, tables, etc., that make difficult points as simple as A-B-C. Handsomely and durably bound in half or full morocco leather (except as noted), and stamped in gold.

## Pay-Raising Books At Greatly Reduced Prices

- Business Management, 8 vol., 2500 pages, well illustrated. Was \$52.50.....Now \$29.80
- Carpentry and Contracting, 5 volumes, 2138 pages, 1000 pictures. Was \$37.50.....Now 19.80
- Civil Engineering, 9 volumes, 3900 pages, 3000 pictures. Was \$67.50.....Now 34.80
- Electrical Engineering, 8 vol., 3800 pages, 2600 pictures. Was \$60.00.....Now 29.80
- Automobile Engineering, 6 volumes, 2600 pages, 2000 pictures. Was \$45.00.....Now 21.80
- Machine Shop Practice, 6 volumes, 2300 pages, 2500 pictures. Was \$45.00.....Now 21.80
- Steam and Gas Engineering, 7 vol., 3300 pages, 2500 pictures. Was \$52.50.....Now 24.80
- Law and Practice (with reading course), 13 vol., 6000 pages, illustrated. Was \$97.50.....Now 49.80
- Fire Prevention and Insurance, 4 vols., 1500 pages, 600 pictures. Was \$30.00.....Now 14.80
- Telephony and Telegraphy, 4 volumes, 1728 pages, 2000 pictures. Was \$30.00.....Now 14.80
- Sanitation, Heating and Ventilating, 4 volumes, 1454 pages, 1400 pictures. Was \$30.00.....Now 14.80
- Drawing, 4 volumes, 1578 pages, 1000 pictures, blue prints, etc. Was \$30.00.....Now 14.80

## Shipped for 7 Days' Trial

Pin your check or money order for \$2.00 to the coupon and we will immediately ship you any one set of these valuable books. Use them for seven days. Then remit only \$2.80 and pay the balance at the rate of \$3.00 a month—75 cents a week. If you don't want the books, drop us a line and we will return the \$2.00 you sent us and send you shipping instructions for returning the books at our expense.

Act now—while these splendid books are being offered at 20% to 50% less than regular prices. This offer is open to every person within the boundaries of the U. S. and Canada. Grasp your opportunity—fill in and mail the coupon now.

**American Technical Society**  
DEPT. X-253, CHICAGO

American Technical Society, Dept. X-253  
Chicago, U. S. A.

I am enclosing \$2.00 as deposit for a set of.....  
.....for 7 days' examination,  
shipping charges collect. I will examine the books thoroughly, and, if satisfied, I will send you \$2.80 within 7 days and \$3.00 each month until I have paid the special price of..... If I decide not to keep the books, I will notify you at once. You will then return the \$2.00 deposit I have sent you with shipping instructions for returning the books at your expense.  
To insure prompt shipment fill out all lines.

NAME.....  
ADDRESS.....  
EMPLOYED BY.....

# The Magic Carpet

**Y**OU could sit on the fabled carpet of Bagdad and view the world. In the whisk of an eyelash it would carry you any place you wanted to go. All you had to do was wish.

Advertising is a sort of magic carpet. Read it and in the twinkling of an eye you can review the merchandise of the world, pictured and displayed for your benefit.

The advertisements introduce you to the latest styles—the newest comforts for the home—the best of the world's inventions. They tell you how to buy, where to buy and when to buy. They keep you posted on things necessary to feed and clothe you and your family and make you comfortable and happy.

Read the advertisements as a matter of education. Read them and keep abreast of progress.



*Read the Advertisements Regularly*

### RADIO PRICES SMASHED

We now announce drastic cuts in our quality lines. All goods prepaid and sold subject to return for rebate or exchange. You simply must be pleased. A sample saving follows. Order from following or send for full list today.

Complete Regenerative Vacuum Tube Receiver		
Range approximately 1,000 miles	Our price	Others
Panel of bakelite 7 in. x 12 in. drilled	\$1.75	\$2.50
Cabinet of 3 ply wood to fit panel	1.50	2.50
3 three-inch dials @ 35c each	.70	1.40
16 switch points with nut @ 01c	.16	.48
4 switch stops with nut @ 01c	.04	.12
3 binding posts, Nickel plated @ 03c	.24	.48
2 switch levers @ 25c each	.50	.90
1 filament rheostat, High grade	.65	1.10
1 vario-coupler with fourteen taps	2.25	4.00
1 23 plate variable condenser	1.95	3.50
1 tube socket of high quality	.45	.85
1 phone and 1 grid condenser @ 15c and 20c	.35	.65
10 feet spaghetti tubing @ 05c	.50	.84
1 tube socket support	.15	.25
15 feet copper connecting wire	.15	.30
1 set blueprints for assembling	.10	.25

\$11.44 \$20.12

Some other articles taken from our price list are—  
 Cunningham detector tubes \$1.25 \$5.00  
 Transformer-Audio frequency 2.95 4.50  
 Frost Tone—2,000 ohms 3.95 5.00  
 Two step amplifier parts complete 12.95 21.50  
**RADIO PARTS MANUFACTURING COMPANY**  
 2150 Montclair Dept. "S" Detroit, Michigan



**Clear Tone**  
FOR  
**PIMPLES**

Your skin can be quickly cleared of Pimples, Blackheads, Acne Eruptions on the face or body, Enlarged Pores, Oily or Shiny Skin. **\$1,000 Cold Cash says I can clear your skin of the above blemishes.**

**FREE** WRITE TODAY for my FREE Booklet—“A CLEAR-TONE SKIN”—telling how I cured myself after being afflicted for fifteen years.  
**E. S. GIVENS, 168 Chemical Bldg., Kansas City, Mo.**

## Measuring One Millionth of an Inch

(Continued from page 1067)

to locate our measurement within one tenth of a half wave length of light, or one tenth of a hundred thousandth of an inch, in other words, one millionth of an inch. This location, although approximate, may be made more accurate by varying the thickness of the wedge of air by pressure upon the optical flat, so that the distance between two adjacent bands is greater.

In making a test to determine the variation between an unknown gauge, and a standard gauge, both gauges are placed upon an optical flat and wrung or twisted on its surface, so as to make sure of contact. Another optical flat is now placed upon them. Consider in Fig. 7 that the unknown block at the left in our illustration, is being compared with the block of known thickness, at the right. It will be seen that the interference bands occur, one-half a band lower on the wedge of the left hand gauge, than do those on the standard. It is quite evident that if both gauges were of the same size, then any bands which occur on one gauge would occur in exactly the same position on the other, and therefore, the bands would appear to be practically continuous, but in view of the fact that the gauges are of different sizes in this illustration, then the one at the left is five millionths of an inch shorter than the one at the right, its interference band occurring lower than the one at the right by the distance of a half-half wave length.

For the purpose of measuring a 1/4 inch plug that is not tapering, the gauge block is placed upon the lower flat, and the upper flat placed upon both this and the plug itself, as indicated in Fig. 10. This plug is usually placed a distance away from the gauge equal to the width or the diameter of the gauge, so that the number of bands may be counted, and if the plug is larger, they may be multiplied by two. The wedge of air increasing in thickness from the point of contact of the upper flat to the end of the gauge, by ten millionths of an inch for every dark band, we can readily count six bands on this illustration. Multiplying this figure by two, we find that the plug is twelve millionths of an inch oversize, or larger than our 1/4 inch plug standard gauge. If the plug is undersize, then the bands will directly indicate how much that plug is under size; we do not have to double the figure.

In measuring a steel ball, Fig. 8 the same procedure is followed, the number of dark bands are counted, and the diameter of the ball readily determined. Of course a standard gauge must always be employed in such measurements.

In order to select balls of uniform size, Fig. 9, a slightly different procedure is followed, both balls being arranged on a cardboard templet a fixed distance away from the standard gauge, and if the lines are parallel to a line joining the center of the two balls, which line is likewise at right angles to a line joining the center of the steel balls and terminates midway between them, we know that our balls are of uniform size. If the bands are angularly disposed, then we can determine, by projecting lines, as illustrated in Fig. 9, just how much these steel balls vary with respect to our gauge.

In Fig. 7 the principles employed in determining these different measurements are illustrated. One can always be sure of his measurements to within an accuracy of a hundred thousandth of an inch. He can approximate his measurement to within a millionth of an inch with very little chance of varying another millionth.

—Photos Courtesy of H. L. Van Kuren.

# Do You Want a Real Headset?

The Dictograph Radio Headset Is the Best in the World at *Any* Price

This is the same supreme Dictograph Headset that has always sold for \$12—same in quality, same in guarantee, same in everything but the price—\$8 complete. Made by the makers of the world standard Dictograph products—the marvelous "Acousticon" for the Deaf, the famous Detective Dictograph, the Dictograph System of Interior Telephones and the Dictograph Radio Loud Speaker for the Home.

Read a few of the many letters we have received from Dictograph Headset users. You, too, can enjoy the utmost in Headsets if you own one.

U. S. MARINE HOSPITAL, No. 43,  
ELLIS ISLAND, N. Y.

"The undersigned has, for the past sixteen years, been an amateur, commercial and government operator, and has used every known make of radio receiver on the market. On April 21st one of your Type R-1 3,000 ohm receivers was purchased and it can be safely said, without dispute, that they are absolutely the best radio receivers on the market today, bar none."—C. H. West, U. S. P. H. S.

LAPORTE, IND.

"I wish to compliment you on the 3,000 ohm headset you now have on the market, retailing at \$12.00 (now \$8). I have been experimenting with the Radio game for the past year. In my experience have tried out 14 different headsets, including the \_\_\_\_\_, which I purchased for \$16.50. I at last have found the ideal phone, where tone quality excels, and harshness is eliminated, and I cannot express myself in words as to the wonderful results I have obtained." J. T. Bachman.

PRICE

\$ 8



The Standard of the World

TYPE R-1—3,000 ohms, for all types of crystal and vacuum tube receiving sets

Step into your dealer's today, and listen in with this supreme instrument. Note the difference!

Buy two or three Dictograph Headsets and let the rest of the family in on the enjoyment.

Always insist on Dictograph Products THEY ARE FULLY GUARANTEED

DEALERS: The Dictograph is the fastest-selling Headset on the market today. Order through your jobber, or write direct for names of authorized distributors.

DICTOGRAPH PRODUCTS CORPORATION Suite 1305 220 W. 42nd St., NEW YORK CITY  
(Branches in All Principal Cities)

## The RADIOGEM

(Patents Pending)

\$1 Receiving Set—The Simplest Radio Outfit Made—Yet as Practical as the Most Expensive!

You need know absolutely nothing about wireless to operate and enjoy the RADIOGEM. It is so sturdy, so simply constructed that it is small wonder radio engineers who have tested it have pronounced the RADIOGEM a brilliant achievement. The RADIOGEM is a crystal radio receiving set for everyone at a price anyone can afford.

**Why The RADIOGEM Can Be Sold For Only \$1**

Here's the secret: The RADIOGEM Construction eliminates all unnecessary trimmings, cabinets and the like, which do not play any part in the operation of a set. You receive the RADIOGEM unassembled, together with a clearly written instruction book, which shows you how to quickly and easily construct the set, using only your hands and a scissor. The outfit comprises all the necessary wire, contact points, detector mineral, tube on which to wind the coil, etc., etc. The instruction book explains simply and completely the principles of radio and its graphic illustrations make the assembling of the RADIOGEM real fun. Remember the RADIOGEM is a proven, practical radio receiving set and will do anything the most expensive crystal set will do.

**The RADIOGEM is the Prize Winner of the Age**

Out of hundreds of radio models submitted recently in a great nation-wide contest, radio engineers, the judges, unanimously chose the RADIOGEM as the winner—the simplest radio-receiving set made! And the RADIOGEM costs you nothing to operate; no form of local electricity is required.

**DEALERS** The RADIOGEM is the wonder item of the radio age. It is storming the country, for the RADIOGEM'S price is so low everyone is able to buy one. Write immediately for full particulars before that shop across the street beats you to it.

Hear the programs of the Broadcasting Stations on the RADIOGEM

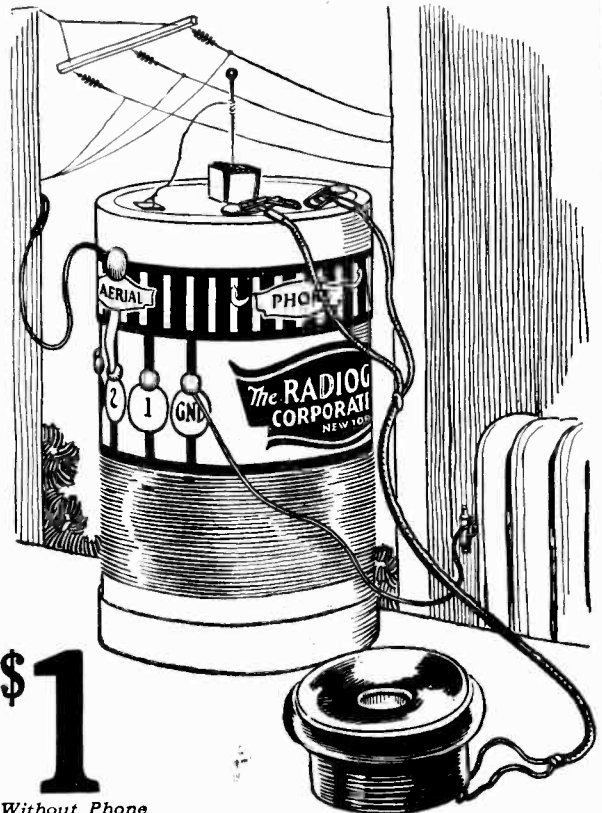

Receives up to 20 Miles

The RADIOGEM CORPORATION  
42-S HUDSON STREET  
NEW YORK CITY

\$ 1

Without Phone or Aerial



# DO YOU?

Do you want to save 20 to 40 per cent on all your purchases of standard radio apparatus?

Do you want the personal advice and counsel of the greatest radio authorities in the country in solving your problems?

Do you want to receive free of charge a quarterly publication giving you a digest of the latest findings of radio science, telling you how to construct and operate both simple and advanced radio receivers and transmitters, together with a fund of other useful information?

## Of Course You Do!

Then send us a post-card immediately, asking for Booklet S-1, describing our Co-operative Service Plan.

### The Radio Guild, Inc.

**Co-operative Service Bureau**  
256 WEST 34th STREET  
New York City

## An Amplifier for Your Present Tuner

By BERT T. BONAVENTURE  
(Continued from page 1085)

two sockets. Using a hard tube as a detector, with higher plate potentials than 22½ volts, will give almost as good a sensitivity as a soft tube with considerably less tube noises.

The first point in the design is the calculation of the tuned impedance used in the plate circuit of the radio frequency amplifier tube. The three circuit tuner for which this amplifier was designed had a wavelength range of from 150 to 650 meters. It is obvious that the impedance should also be able to cover this range. First the approximate capacitance values of the condenser must be known. For a 23 plate condenser if the following values are used in the hypothesis, one will not be far off the averages values: maximum, .00045 mfd., minimum .00015 mfd. In the particular condenser used in this amplifier, the values were .0004275 mfd., and 13.5 micromicrofarads respectively as given by capacity bridge measurements. Care should be taken that the condenser selected should have low dielectric losses. Condensers with fibre end plates should be immediately rejected, as the losses therein are bound to be too high for use in radio frequency circuits. High losses mean broad tuning with resulting interference.

To calculate the inductance of the coil to be used in parallel with the condenser, the following formulæ are used:

(1)  $LC = K$ , with  $\lambda$  constant.  
where L = inductance in centimeters.  
C = capacitance in microfarads.

$\lambda$  = wavelength in meters.

(2)  $L = \frac{4\pi^2 a^2 n^2}{b} K$

where L = inductance in centimeters.  
a = mean radius of the coil in cm.

b = length of coil in cm.  
n = total number of turns in the coil.

$K = \text{factor varying as } \frac{2a}{b}$

(2a)  $n^2 = \frac{Lb}{4\pi^2 a^2 K}$  . . . transposing (2).

Formula (1) gives the oscillation constant squared of the circuit, when the wave length is known. Take 650 meters as the maximum wave length that is desired to be received. The LC value for this particular wave length is 119. (See *Lefax* sheets for a table of these LC values.) Knowing the maximum condenser value, .0004275 microfarads, we may now calculate the inductance required to tune to this wave length, making use of (1).

$LC = 119$  or  $L \times 0.0004275 = 119$ .

$L = 119 / 0.0004275 \times 10^9$  . . . when L is in microhenries.

Therefore,

$L = 278$  microhenries.

Now, let us see if this value of inductance is small enough to tune to the minimum wave length, assuming it to be 150 meters. LC for 150 meters is 6.35. Whence the minimum LC of our coil and condenser should be 6.35 or less in value, preferably less. Substituting the minimum condenser value in (1) solving we get

$LC = K$  or  $278 \times 0.000135 \times 10^9 = 3.75$

This figure corresponds to 115 meters, so that our coil is capable of covering from 115 to 650 meters. Actually these values will be

## A Telephone Receiver for

# \$1

The RADIO INDUSTRIES CORPORATION have been manufacturing their famous RICO TRIPOLE RECEIVERS for some time for radio purposes. These phones are made regularly for 2,000 and 3,000 ohms. There has, however, been a very large demand for a low-priced 75-ohm Receiver. The Corporation has finally decided to place one upon the market at a price that every one can afford.



AS A TRANSMITTER



AS A RECEIVER

### SEND COUPON NOW AND GET THE BIGGEST DOLLAR BUY THAT YOU HAVE EVER SEEN!

For 75 cents additional, we furnish a single head-band with the 'phone. Has regulation soft rubber covering. Will not tire nor hurt you, even if worn for hours.

#### PRICE LIST of Other Receivers We Manufacture

No. 20 2000 ohms Double Head Set	\$5.00	No. 15 1500 ohms Single Head Set	\$3.25
No. 30 3000 ohms Double Head Set	5.50	No. 2 1000 ohms Receiver only	2.00
No. 40 4000 ohms Double Head Set	9.50	No. 3 1500 ohms Receiver only	2.25
No. 10 1000 ohms Single Head Set	3.00	No. 05 5 ohms Receiver only	2.00

**RADIO INDUSTRIES CORPORATION**  
131 Duane Street, New York

Radio Industries Corp., 131 Duane Street, New York City.  
Gentlemen—As per your advertisement, I enclose herewith (Check, M. O.) for \$ . . . . . for which please send me at once RICO 75-ohm Receiver(s) and Head-band(s).  
You agree to send these to me all charges prepaid.  
Also, please send me your illustrated literature and information about your \$350.00 Prize Contest.  
NAME . . . . .  
STREET . . . . .  
CITY . . . . . STATE . . . . .  
S. & I. 3-23

## MAKE BIG PROFITS CHARGING BATTERIES

HB Users clear \$150 to \$300 every month from new HB 8-Hour Battery Charger. Charges auto batteries perfectly in 8 hours, while old systems take 2 or 3 days. No experience needed to operate. Start your own money-making battery charging business NOW. \$30 Monthly Pays for 8-Hour Battery Charging. Small cash payment brings outfit on trial with money-back guarantee. Easily pays for itself from your big monthly profits. Be the first in your town to offer 8-hour battery charging. Get this big business, beat competition. Write today for information.

**HOBART BROS. CO., Box S3, TROY, OHIO**  
Easy Monthly Terms—Absolute Satisfaction Guaranteed.



somewhat higher due to the capacity between elements of the tube also being across the coil. That is why the coil was designed to go as low as 115 meters, so as to allow for the plate to filament capacitance of the tube.

Let us now take up the actual winding of the coil, using formulæ (2) and (2a). Formula (2) is merely given as the starting point from which (2a) is obtained, the latter giving the number of turns of wire for a required inductance. The factor K may be obtained from Bucher's *Wireless Experimenter's Manual* or from *Bulletin 74* of the Bureau of Standards.

The particular coil used in this set had a diameter of  $2\frac{3}{8}$  inches and was  $1\frac{1}{2}$  inches long. It was decided to let the depth of the winding be  $\frac{1}{2}$  inch long, since litzendraht wire was used in winding and banked in two layers to save space, the rest of the coil being used for mounting purposes. Allowing for some distributed capacity of the coil, it was found that an inductance of 250 microhenries would be sufficient for our purpose.

Calculation of n.

$$(1) \dots \pi^2 = \frac{Lb}{4\pi^2 a^2 K}$$

L = 250 microhenries.  
 b =  $2 \times \frac{1}{2} = 1 = 2.54$  cm.  
 a =  $2.625/2 = 1.3125 = 3.34$  cm.  
 $a^2 = 11.12$   
 K = 0.46228  
 $n^2 = \frac{250 \times 10^3 \times 2.54}{4 \times 9.87 \times 11.12 \times 0.46228}$

Whence  $n^2 = 3128$  and  $n = 56$  turns.

The coil was therefore wound with 56 turns of No. 38-10 strand litzendraht wire, giving an inductance by actual measurement, of 257.5 microhenries, a value which is sufficiently accurate for our purposes.

With this coil constructed, the rest of the assembly is purely a matter of a little manual labor. The frame on which the sockets, transformers, and binding posts are mounted is made of  $\frac{3}{8}$ -inch angle brass, with the corners strengthened. In bending the brass at the corners, cut out a right angle triangle from the point where the bend is made. This prevents bulging of the stock when the bend is made by allowing the ends of the cut to come together. Strengthen this joint by soldering an oblong-shaped piece of brass on the inside of each corner, using care to make a neat job. The dimensions of the bends are given in Fig. 2. The dotted line shows where the strengthening pieces are to be soldered. All dimensions given are optional with the constructor, as he can follow his own personal taste.

Two of these brackets are made, exactly alike, and are held firmly to the panel by means of four No. 8/32 machine screws through each leg. The cross-pieces at the top and bottom are made of the same  $\frac{3}{8}$ -inch angle brass and are fastened to the brackets by 6/32 machine screws. Care should be taken in drilling and tapping the holes for these screws, due allowance being made for the thickness of the brass stock when punching the centers prior to drilling.

This rigid frame-work supports the four sockets, the two transformers, the binding post strip and the plate impedance inductance coil. A single strip of  $\frac{1}{2}$  by  $\frac{3}{32}$ -inch brass was cut long enough to accommodate the sockets when they are placed side by side. The sockets are mounted on this strip, which is then fastened to the frame with two 8/32-inch machine screws, one in each bracket, mounting the strip high enough to give sufficient clearance above the transformers. This is done to facilitate wiring to the transformers, and care should be taken not to place the sockets too high, otherwise the tips of the tubes, when placed in the sockets, will protrude from the top of the cabinet and pre-

**The Radio Guild, Inc.**



Receive the new broadcasting on 710 meters and higher wave-lengths with the "Multi-Range" coupler. Wave-length range—170 to 3400 meters. Permits the easy construction of complete radio receiver at low cost.

"The finest bank-wound coupler ever produced." — N. Y. Evening Mail Laboratories.

**The "Multi-Range" Coupler**

Price \$11.00  
From Your Dealer or Direct



**RG 510**

The New Radio Guild Radio-Audio Frequency Complete Receiver of Unequaled Excellence and Efficiency

The RG-510 is the "Distance" receiver you have been looking for. With the small loop aerial supplied with each set it is just as easy to pick up stations a thousand miles away as the near-by stations. Receives hundreds of miles without loop, aerial, ground or any connection whatsoever. Extremely simple to operate and unusually selective. Designed by experts in radio frequency amplification. Operates on one, two or three stages of audio amplification.

WRITE FOR FURTHER PARTICULARS OF THIS REMARKABLE SET

List Price, \$195.00

Dealers: Your customers will be more than satisfied with this set. Write for discounts.

**The Radio Guild, Inc.**

256 West 34th Street New York City

Specialists in RADIO FREQUENCY AMPLIFICATION

Manufacturers of the "VOX HUMANA," "BROADCAST RECEIVER" and "DASH-BOARD SPECIAL." Distributors of DX RADIO FREQUENCY TRANSFORMERS

# HELP WANTED

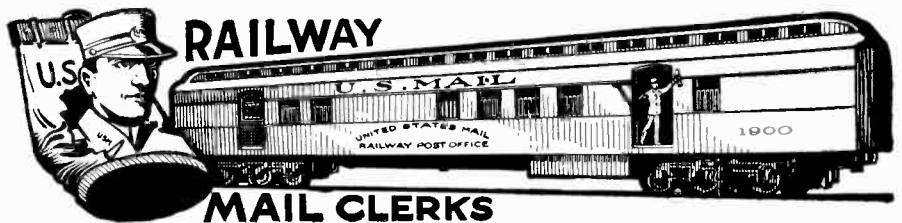

## MAIL CLERKS

\$1600-\$2300 Yearly

Become Railway Mail Clerks, City Carriers, Postoffice Clerks, Customs and Internal Revenue Clerks.

**Railway Mail Clerks Have Pleasant Work—Travelling Continually**

Government positions have yearly vacations with full pay. Promotion to Big Pay positions is very rapid. The position is not affected by strikes, poor business conditions or the whims of some petty boss.

**DON'T DELAY**

Every boy or man 18 or over should send coupon at once

FRANKLIN INSTITUTE, Dept. P182  
Rochester, N. Y.

Kindly send me, without any obligation whatever on my part, and entirely free of charge (1) a full description of the position checked below, (2) Sample examination questions; (3) Free copy of copyrighted book, "Government Positions and How to Get Them"; (4) A list of U. S. Government Jobs obtainable; (5) Tell Me How to Get the Positions Checked.

..... Railway Mail Clerk..... (\$1600-\$2300)  
 ..... Postoffice Clerk..... (\$1400-\$1800)  
 ..... Postoffice Carrier..... (\$1400-\$1800)  
 ..... Rural Mail Carrier..... (\$1800-\$2600)

Name.....  
 Address.....

Use This Coupon Before You Mislay It.  
**WRITE PLAINLY** P182

# RADIO

**\$15 Down**  
\$10.00 a Month



**FAMOUS**  
**SENSITONE**  
LONG-DISTANCE  
**Regenerative**  
**Radio Receiving Set**

Built by Tri-City Radio Electric Co. (Licensed under U. S. Patent No. 1,113,149 and pending Letters Patent No. 807,388)

The "Sensitone" brings in concerts, bands, lectures, market, crop and weather reports, sacred services and sermons, bedtime stories for children—all the wonderful programs of your pick of all the 500 broadcasting stations in the U. S. and Canada.

"Sensitone" Set is complete—including batteries, tubes, head-phone, antenna, wiring-connections—everything you need, ready to install, is equal to sets now sold at \$150.00 to \$175.00, yet our price is only \$95.00.

Set is shipped on receipt of the first \$15.00 payment. You are dealing with a responsible, old-established House. Ask any banker or business man to look up our rating in Dun or Bradstreet reports.

Only a limited number of "Sensitone" sets will be sold on this easy-pay plan. Fill out coupon and attach check or money order for \$15.00. Circular free.

**Harold R. Wakem Co.**  
849 W. WASHINGTON ST., CHICAGO, ILL.

---

**HAROLD R. WAKEM COMPANY,**  
849 W. Washington Street,  
Chicago, Ill.

Enclosed you will find \$15.00 as first payment, upon receipt of which you will send me your complete Sensitone Radio Receiving Set, as described above. I agree to send you \$10.00 every thirty days thereafter, until the full purchase price is paid. This set is to remain the property of Harold R. Wakem & Co., until payments are completed.

Signed.....  
Street Address..... City.....

In the spaces below give the names of two references, banks or business houses preferred.

Name and Address.....  
Name and Address.....

## Our Genuine Skinderviken Transmitter Button



Used by thousands for  
**Wireless, Loud  
Speakers, Amplifying and all  
sound transmission purposes.**

**Price \$1.00**  
POSTPAID  
with instructions  
**Free Literature**

**K. ELECTRIC CO.**  
15 PARK ROW NEW YORK

## CUT RATE RADIO

STANDARD APPARATUS ONLY  
Write for 54-page Catalogue of Bargains

BALDWIN TYPE "C" PHONES	\$10.25
BRANDES SUPERIOR PHONES	\$6.45
RADIOTRON U. V. 200 DETECTOR TUBES	\$4.25
ACME AUDIO TRANSFORMERS	\$3.75

Everything for Radio at less. Immediate Delivery.

**FEDERAL RADIO ELECTRIC CO.**  
1233 GRAND AVENUE KANSAS CITY, MO.

vent the closing of the hinged cover. The two views of the rear of the amplifier show these points clearly. The transformers are mounted directly under the tubes into which they feed, with the secondary leads nearest the tube. In wiring the transformers, make sure that the outside lead of the secondary winding goes to the grid and that the outside of the primary winding goes to the plate of the preceding tube. These leads are the high potential side of their respective windings and have a lower capacity to ground than the inner leads. This capacity effect increases with the frequency, tending to distort high pitched notes, which deleterious effect is minimized by observing the above precaution.

Mount the transformers directly on the frame, at right angles to each other, using braces to give rigidity. This connects the cores to the frame work which will be later grounded to the negative side of the filament, which connection may be seen in the lower right-hand corner of the photograph of the general view of the rear of the amplifier. In mounting the condensers, no special means were taken, since they are so light that the bus bar wiring is sufficiently strong to support their weight. The disposal of these condensers may be seen from the photograph. The grid leak is mounted directly on the detector tube socket, using the spring clips taken from a standard grid leak mounting. As to the binding post strip, 1½ by 3/32-inch brass strip was bent into the shape seen and fastened with 8/32-inch machine screws to the bracket on each side. The rest of the apparatus layout followed the dimensions of the front of the 7½-inch panel, as given in Fig. 3.

It is advised that the outer ring of peep-holes be omitted. They were drilled in an endeavor to balance the panel by having the diameter of the net work equal to the diameter of the condenser dial, but it is believed that the panel will look better if the outside ring be left out. Drill the panel from the face side; to prevent chipping on that side, countersink the peep-holes slightly. All the brass parts of the amplifier were nickel-plated to produce a commercial appearance, but it is optional to go through this trouble, though it does give a business-like effect. It is advised that the connecting bars used to strap over to the tuner unit be nickel-plated, as it will considerably improve the general appearance of the set.

In operating the complete set, proceed to tune the receiver as usual, at the same time tuning the plate circuit of the radio frequency tube by means of the condenser. If oscillations commence, bring the potentiometer adjustment into play, which will throw the grid of the tube sufficiently positive to stop the oscillations. The dial of the condenser may be calibrated to read directly in wave lengths, or a chart made of the wave lengths corresponding to the different positions of the dial. When this is done the tuning is simplified considerably as the condenser is set for a particular wave and left there, the rest of the tuning operations being performed as though the radio frequency tube did not exist.

All the broadcasting stations in the vicinity of New York can be heard with sufficient volume on a loop, using the amplifier alone, and with a good outdoor aerial considerable long distance reception is possible, depending, of course, on the type of tuner used in conjunction with the amplifier.

### A ONE-OUNCE TYPEWRITER

A typewriter weighing one ounce and fitting in a vest pocket has been built by Dr. H. E. Wetherell of Philadelphia. He devised it for his own use.

Held between the fingers and upon the paper, the machine writes by means of a wheel equipped with rubbing letters which special devices bring in contact with the paper.

## A Revolution in Radio Receiving

# NATIONAL AIRPHONE GOLD GRAIN DETECTOR

*Guaranteed Fool-proof*  
**Brings Joy to Every Crystal User**  
An Absolute Necessity  
For All Crystal Sets

**PRICE**  
**\$2.00**

Actual Size  
with Brackets  
and screws for  
panel mounting.  
This Detector  
is not a fixed  
detector but a  
revolving one.  
Instead of a cat-  
whisker, several  
hundred grains  
of pure gold are  
used for contact.  
Is always ready  
and Stays - Put.  
Most sensitive  
point of the  
detector is found  
by revolving the  
cartridge slightly  
while tapping.

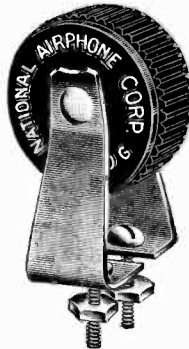

For Panel Mounting  
(Patents Pending)

After you have fussed with cat-whiskers, springs, balls and adjusting handles, and after you have become almost a nervous wreck hunting for the "elusive spot," you will welcome with open arms our

**100% FOOL-PROOF**  
**"GOLD-GRAIN" DETECTOR**

Awarded certificates of Merit by Institutes of New York Eve. Mail and New York Tribune.

**National Airphone Outfit \$12.50**

# NATIONAL AIRPHONE CORPORATION

REG. U. S. PAT. OFF.

**16-22 HUDSON STREET  
NEW YORK**

Dealers—Write for Prices

## LOUD SPEAKER FOR ANY CRYSTAL SET

The STEINMETZ Amplifying Unit now selling for \$8.50 will enable you to hear your crystal set all over the room.

No Storage Battery Required  
ALL STEINMETZ EQUIPMENT  
IS THOROUGHLY GUARANTEED

Steinmetz 3000-ohm Phones	\$6.50
Steinmetz 2000-ohm Phones	\$5.00
Steinmetz 1000-ohm Phones	\$1.75

Equal to any \$10.00 or \$12.00 phones made.  
Complete Catalogue FIVE (5) CENTS  
at your dealer or

**Steinmetz Wireless Mfg. Co.**  
5706 PENN AVE. PITTSBURGH, PA.

## LEARN RADIO

Here's your opportunity. Radio needs you. Win success in this fascinating field. Trained men in demand at highest salaries. Learn at home, in your spare time.

### Be a Radio Expert

I will train you, quickly and easily, to design, construct, install, operate, repair, maintain, and sell all forms of Radio apparatus. My new methods are the most successful in existence. Learn to earn

**\$1,800 to \$10,000 a Year**

**FREE** Wonderful, home-construction, tube receiving set, of latest design.  
Write for "Radio Facts" free. Engineer Mohaupt.  
**American Electrical Association**  
Dept. 63 4513 Ravenswood Ave., Chicago



## Talking Across the Atlantic

(Continued from page 1080)

The new system used in the trans-Atlantic tests is quite different. Since it is possible to build a receiving set such that it is unnecessary to transmit the carrier wave this can be entirely suppressed and is suppressed in the new system. The energy which would otherwise go to it is assigned to the sidebands thereby doubling their useful power.

This is not the only notable feature of the new circuit. When both side bands are transmitted our diagram shows that the ether is called upon to carry a band of frequencies 10,000 cycles wide, extending from 45,000 cycles to 55,000 cycles. Now the transmission of either side band alone is all that is necessary and as good results can be obtained by suppressing one side band and assigning its high frequency energy to the other. It is evident that by the suppression of one side band it becomes possible to transmit twice as many messages through the ether at one time as would otherwise be possible.

In the present tests this frequency is 55,500 and corresponds to a wave length of 5,400 meters.

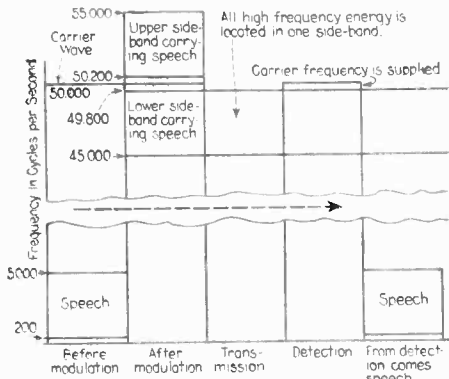

Graphic chart showing how trans-Atlantic radio-telephone, transmitting wave energy, is confined to one side-band, as explained in the accompanying text.

The present system differs from the usual radio transmitting systems in another important respect. The usual type of transmitter sends out, in addition to the group of waves which does not comprise the message, two groups each of which does carry the message. In the new apparatus only one of these groups is radiated. This makes possible the sending of twice as many messages at the same time without interference. This feature is particularly important at long wave lengths where fewer messages can be carried simultaneously than at short wave lengths. The present system was perfected in connection with the so-called carrier telephone which is now in use in this country on certain long distance telephone lines.

Mr. Thayer and the others who spoke to England Sunday night used a telephone located in the offices of the American Telephone and Telegraph Company at 195 Broadway. This telephone instrument was connected to the radio equipment at Rocky Point by a telephone circuit about 70 miles long, half of it being underground cable and half open wire and connecting telephone repeaters and equalizers of a type similar to those used on long distance telephone lines. See picture diagram.

The distance from Rocky Point to New Southgate is about 3,400 miles. Prior to the tests of Sunday evening, other tests were made to measure the transparency of the atmosphere to radio messages over such great distances. Measurements were also made to determine the strength which the signals received in New Southgate must have in that station in order to be clearly heard above the noise of static and interference from other radio stations. For

# Radio

## Catalogue

# FREE

One copy of this complete Catalogue of Radio Outfits, parts, Dictionary of Radio Terms, Instruction Book, and Guide to Successful Radio Work—one copy is yours Free.

Simply write us a post card and we will mail the complete book to you Free, by return mail.

It quotes the lowest prices, amazingly low prices on everything for the expert and the amateur. Every improved part, the most up-to-date outfits, everything that is needed of the most modern type—at the lowest possible prices.

It gives a list of broadcasting stations, and gives much information about radio construction and operation. Every one interested in Radio needs this complete catalogue and book of instruction.

### Why Pay Higher Prices?

Montgomery Ward & Co. has for fifty years dealt on a Money-Back basis, absolutely guaranteeing everything they sell. With quality absolutely assured, why pay higher prices elsewhere? Write today for this Free Radio Book and see for yourself the Saving it will bring you. One copy is yours Free. You need only write us a post card.

Write to the house nearest you. Address Dept. 40-R. Chicago Kansas City St. Paul Fort Worth Portland, Ore.

# Montgomery Ward & Co.

= The Oldest Mail Order House is Today the Most Progressive =

**RADIO "A" & "B" STORAGE Batteries CHARGED At Home For Few Cents With "PATENTED FULL WAVE" 100-130 Volt 60 Cycle A. C. Automatic Magnetic**

## F-F RADIO RECTIFIER

Eventually You Will Buy An F-F RECTIFIER. Why Not Now! The Sooner You Buy It: The More You Save.

It CHARGES All 6 Volt RADIO "A" & AUTO Batteries; & ALL RADIO "B" & LOUDSPEAKER Storage Batteries Up To 120 Volts In Series Inductively At Home Overnight. Disconnecting & Multiple Connections Unnecessary. Charging Circuits Separate. Nothing Like It Made. No Chance For Grounds Or Short Circuits. No Skill Required. AMMETER Eliminates Guess Work. It Costs You Less To Buy An F-F RECTIFIER Than To Be Without One. You PAY FOR ONE WHETHER YOU Buy One Or Not For It Costs An Average Of \$2 For Charging & Rentals Every Time An Auto Battery Is Charged By Others, But Only A Few Cents When You Charge Your Own From A Lamp Socket With An F-F Battery Boosting RECTIFIER. If You Have Never Known The Delightful Feeling Of Having Your Storage Batteries Always Fully Charged For RADIO & AUTO You Will Experience A New Thrill When You Have An F-F RECTIFIER Which Gives You A Fully Charged Battery Overnight At A Cost Of A Few Cents And A Pleasant Feeling Of Things Well Done. Those Who Own Them Feel Their F-F RECTIFIER Is Their Faithful Friend. It Charges Automatically & Being Clean Can Be Placed Anywhere. Nothing To Slop Over, Be Filled, Burn Out, Need Attention Or Cause Trouble. Both Waves Are Rectified Thru Infusible Carbon Rectifying Brushes, Maintaining Constant Efficiency Uninterruptedly. While Its FULL WAVE Delivers RAPID TAPER CHARGE Recommended By All Storage Battery Manufacturers. The F-F RECTIFIER Is A Complete Compact Portably Handy Charging Unit. Delivers Service Day & Night Automatically & Will Charge A Dead Battery. Do Not Think Battery Is Dead & Worn Out Simply Because It Will Not Start Your Car. Buy An F-F RADIO RECTIFIER & Fill It With LIFE. It SAVES MORE Than Its Cost & Lasts Lifetime. Leave Your Battery In Car, Or Where Ever It Is, Without Even Disconnecting It. Screw RECTIFIER Plug In Lamp Socket, Snap RECTIFIER Clips On Battery Terminals; Turn Switch & Battery Will Be Charged In Morning, At Cost Of A Few Cents. Is It Not Gratifying To Be Ready For All RADIOPHONE BROADCAST Music, Sermons & News When Friends Call? Never Having To Be Careful Of, Or Tell Friends Your Batteries Are Dead & To Feel Your Car Respond Like A Greyhound, Spinning Engine With Power When You Throw In STARTER? Fully Charged Battery Starts Car Quick & Requires Fewer Expensive Replacements. **INSIST ON THE F-F RECTIFIER. BUILT BY A MASTER OF THE ART IN 7 TYPES. SO MANY THOUSANDS ARE BEING SOLD IT HAS MADE POSSIBLE THESE POPULAR PRICES.**



**\$20**

- TYPE 6 Charges 6 Volt Radio "A" & Auto Batteries At 6 Amperes \$15
  - TYPE 12 Charges All 12 Volt Batteries At 5 Amperes \$15
  - TYPE B Charges All Radio "B" Storage Batteries Up To 120 Volts \$15
  - TYPE A-B Is A Combination of TYPES 6 & B \$20
  - TYPE 166 Charges All 6 Volt Batteries At 12 Amperes \$20
  - TYPE 1612 Charges All 12 Volt Batteries At 7 Amperes \$20
  - TYPE 1626 Is A Combination Of TYPES 166 & 1612 \$28
- Patented Combination.
- CHARGES "A & B" RADIO & AUTO BATTERIES. ALL TYPES But "B" ALSO CHARGE AUTO BATTERIES. The Lower 3 Are Large TYPES Built For Heavy Batteries Or Where Charging Time Is Limited. SHIPPING WEIGHTS Complete With AMMETER & BATTERY CLIPS 11 to 15 Lbs. Purchase From Your DEALER Or Mail Check For Prompt Express Shipment. If Via PARCEL POST Have Remittance Include Postage And Insurance Charges Or WRITE Us To Ship TYPE Desired C. O. D. Other F-F Battery Boosters Charge Batteries From Farm Lighting Plants & D. C. Circuits & For GROUP CHARGING Economy Use Our 8 Ampere 12 Battery Capacity Automatic Full Wave F-F ROTARY RECTIFIER Described In ROTARY BULLETIN 12A. ORDER Now Or WRITE Immediately For FREE Descriptive RADIO & AUTO BOOSTER & ROTARY BULLETINS 12A & 12.

**FRANCE MFG. CO.** General OFFICES & WORKS: CLEVELAND, OHIO, U. S. A. Canadian Distributor: The Jack V. Elliot Co. Hamilton, Ontario, Canada.

**HAVE YOU SOMETHING TO SELL OR EXCHANGE?**  
A Classified ad in Science & Invention will reach over 160,000 at a cost of only 12 cents a word

# Read This NEW BOOK

ON  
**Super - Regeneration**  
BY  
**KENNETH HARKNESS**

THE CONSTRUCTION  
AND OPERATION  
OF  
SUPER REGENERATIVE  
RECEIVERS

By Kenneth Harkness

With an Introduc-  
tion by Dr. Henry  
Smith Williams

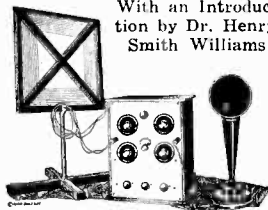

The Radio Guild, Inc.  
256 West 34th Street  
New York, N. Y.

48 pages, 30 photographs, wiring diagrams and mechanical drawings. The most complete book on the subject ever published. Explanation of the theory of super regeneration is a revelation.

The Minneapolis Daily News Says:

"Radio books have come and gone in plenty. None has seemed to be worthy of special mention. One came this week, however, which absolutely demands mention, not to say praise, by its merits. It is 'THE CONSTRUCTION AND OPERATION OF SUPER REGENERATIVE RECEIVERS' by Kenneth Harkness."

SEND FOR YOUR COPY TODAY  
PRICE 50c

The Radio Guild, Inc.  
DEPT. S.

256 West 34th St., New York, N. Y.

**Makes Your Radio Set Work Better**

Perfect reception can be had only when wire connections are soldered. **SOLDERALL** and a match make perfect joints—guaranteed equal to wire or bar solder.

At Leading Jobbers and Dealers or sent Postpaid for 25c a tube.

**SOLDERALL CO.**  
Dept. S. Newark, N. J.

**SOLDERALL**  
A Metal in Paste Form



**Radio Headsets**  
3000 OHMS SUPERSENSITIVE  
Guaranteed One Year  
**Price, \$3.98**  
Plus 20c postage—Total, \$4.18  
Dealers wire for sample  
**Ernest Electric Co.**  
487 Easton Ave. St. Louis, Mo.

the purpose of these tests large numbers of disconnected, single words were transmitted. The use of disconnected words constitutes an unusually severe trial of any telephone system. In ordinary conversation, the continuity supplied by the thought is a great aid to the understanding of each word. It is intended to continue these measurements over a sufficiently long period of time to supply the most reliable data.

The measurements thus far made serve to indicate that the transmission at night is better than during the day. The strength of signals received during the night may be hundreds and even thousands of times stronger than those received during the day. However, it has been found possible to transmit telephone messages satisfactorily during daylight, provided interference is not too great, and when sufficient power is employed.

## Secrecy in Radio at Last

(Continued from page 1082)

an inch apart. Upon the periphery of each disc, are figures from 0 to 9, those on the extreme right hand disc signifying units, those next tens, next hundreds, and so on. The left hand disc corresponds to hundreds of thousands. The discs turn together upon their shaft, and their position in relation to each other may be changed at will. By means of a series of pawls, electrical circuits are closed, and the cylinder is controlled through a space of six seconds, whereupon the starting and stopping times of the cylinder are repeated.

The following explanation may seem rather complex, but upon careful study of the same, and referring to the accompanying photograph and diagrams, the reader will obtain a very good idea of how the apparatus works.

The unit of time is one second, and the unit through which the cylinder rotates, is 20/30, or 2/3 of a second. After the cylinder has revolved during its allotted space of time, 1/3 of a second is left to complete the unit of time. It is this lag that is made use of by the six revolving discs, which distribute this time throughout various parts of the six seconds which they control, thereby making the message undecipherable to anyone who has not a similar apparatus, and the key number.

For our illustration we will take the code or key number to be 687,943. This number is used in connection with the number 000000. The process gone through is now somewhat as follows. Subtracting 6 from 10 we have 4. Each second is divided into thirtieths, and from the above we have that the first *period of quiet* is 4/30 of a second long. This may be clearly seen from the diagram shown herewith, in which the heavy lines denote time of revolution. Now the cylinder revolves 20/30 of a second. Now we have 6/30 of a second left in the first second. This is again a *period of quiet*. In the next second the code number is 8, which subtracted from 10 leaves 2, or 2/30 of a second *quiet*. Again the cylinder rotates for 20/30 of a second, and the remaining part, or 8/30, is a *period of quiet*. So it goes for six seconds, the various time periods being distributed as shown in the diagram. At the end of six seconds, the process is repeated until the message is finished. Obviously, 999,999 combinations are possible.

A message received by a regular Belin machine not equipped with the Crypto, if it is transmitted with the use of the *anticapturer*, would result in a series of irregularly spaced dots, which would have absolutely no meaning. The space between the revolutions may be changed, so that it

## USE A C H SHARP TUNER DIALS

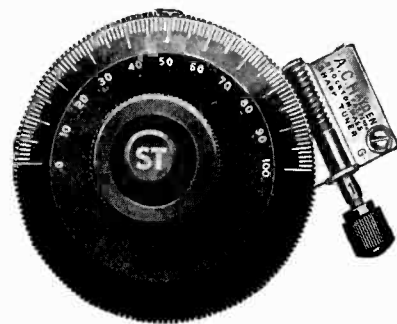

Your Choice of

Rough tuning with dial or one thousandth of an inch in either direction with the Sharp Tuner Knob. Both controlled by center Knob ST.

Eliminates a vernier condenser. Locks instrument automatically. Dial grounded, reducing body capacity.

Yes!

They can be installed on any Receiving Set, making difficult tuning easy.

Guarantee

If purchased direct and you find the ACH Dial does not warrant your own personal award of merit, return it and we will refund your money.

What better guarantee can we give?  
Regular fitting 5/16" hole, 1/4" and 3/16".  
Bushings, 5c. each extra. 10c. for all.  
Price of ACH 3" Dial Complete.....\$2.50  
With ACH Condenser..... 4.00  
ACH Condenser without Dial..... 2.50

Free Plan with mail orders on request.

**A. C. HAYDEN**  
**RADIO & RESEARCH CO.**  
BROCKTON, MASS., U. S. A.  
Mail Orders sent prepaid in U. S. A.



**CRYSTAL RECTIFIER**  
**MULTIPOINT**  
(Patent Pending)

A Synthetic CRYSTAL DETECTOR, sensitive over its entire surface. Eliminates all detector troubles. Extraordinary clearness and volume. Endorsed by Radio experts and press. Sold in Sealed Packages only. Join the ever increasing Rusonite fans.

Price, Postpaid, mounted. 50c.  
Sensitivity guaranteed...

**RUSONITE CATWHISKER**  
14 Karat Gold Multipoint Contact 25c.  
Supersensitive  
Order from your dealer or direct from us.

**RUSONITE PRODUCTS CORP.**  
15 Park Row, N. Y. Dept. "S"

**OTHERS ARE DOING IT  
WHY NOT YOU?**

**Your Spare Time Is Worth  
One Hundred Dollars Per Month**  
Everywhere you can secure yearly subscriptions to

**PRACTICAL ELECTRICS  
SCIENCE AND INVENTION and  
RADIO NEWS**

Every Community is good territory for our solicitors. Thousands of subscribers are waiting to give in their renewals.

Remember—we pay the same big commission for renewals as for new subscriptions.

Send today for order blanks and sample magazines. All will be sent without one cent of expense to you.

Write to C. J. Wolfe  
**EXPERIMENTER PUBLISHING CO.**  
53 Park Place, N. Y.

# HOMCHARGE



Your  
**RADIO  
BATTERY**  
for  
A NICKEL

**E**NJOYABLE concerts and maximum receiving range are obtained only when your battery is fully charged.

## THE HOMCHARGER

charges your "A" or "B" battery over night for a nickel without removing it from your living room. No muss — no trouble — no dirt — requires no watching.

After the concert connect to any lamp socket, snap the clips on your battery and "turn in." While you sleep the HOMCHARGER is silently charging your battery, the charging rate being governed automatically. In the morning it is fully charged. No OTHER battery charger can boast of such *quick* and *economical* performance.

The HOMCHARGER is the only battery charger combining all of these **NECESSARY HOMCHARGING** features: **SELF-POLARIZING — FIVE TO EIGHT AMPERE charging rate — UNDERWRITERS' APPROVAL — beautifully finished in mahogany and old gold — UNQUALIFIEDLY GUARANTEED. OVER 60,000 NOW IN USE.**

Sold complete with ammeter, etc., by all good radio and electrical dealers for \$18.50 (\$25.00 IN CANADA).

See the **RADIO HOMCHARGER DELUXE** at your dealer's or write direct for our **FREE** circular showing why the **HOMCHARGER** is the **BEST** battery charger at any price.

**MOTORISTS** The **HOMCHARGER** will also charge your **AUTO** battery.

**The Automatic  
Electrical Devices Co.**

**116 WEST THIRD STREET  
Cincinnati, Ohio**

Largest Manufacturers of  
Vibrating Rectifiers in the World

would be practically impossible for any operator to guess the code number, and therefore the system is very nearly perfect. The inventor however, has provided for even such emergencies, and by means of a separate disc and contact causes signals to be sent out during the time that the cylinder is stopped. These signals are separate and distinct from the transmission of the message, but to a listener-in would seem to be part of it.

Of course, it is obvious that the actual use of the Crypto must be limited, but under certain conditions its use would be invaluable. In war times, messages could be sent from the commander of an army to his subordinates without the least possible chance of interference or detection. Communication between stock matters without divulging their secrets. It is reported that a certain European nation has placed its order for the apparatus to be installed in its State Department and its Embassy in an important foreign capital.

This apparatus, which is the latest of M. Belin's inventions, has been greeted with acclaim by European scientists, and will no doubt, be received with the same welcome in this country.

### Radio for the Beginner

By **ARMSTRONG PERRY**

(Continued from page 1083)

run the chance of their ruining a highly sensitive one that cost a lot of money and that might be put out of commission in the first scrap for its possession. The phone with the mica diaphragm has an arm attached to the diaphragm that may be broken off if the phone is even dropped to the table. The point of attachment is so critical that it is said that only an expert should attempt to make repairs.

With a receiving set that has amplification enough to bring in everything the operator wants to hear in good volume, the ordinary types of phones give satisfactory results and they are strong enough to stand up under any reasonable demands. With such a receiving set I have found it necessary to detune slightly, or reduce the amplification, in order to get satisfactory results with highly sensitive phones. A very strong current vibrates the mica diaphragm too powerfully and the result is a harsh, rasping sound instead of clear speech or music. But if the incoming currents are apt to be weak, the most sensitive phone in my outfit is none too good.

The materials used in the ear-piece are worth considering. The cap is usually of hard rubber, or something that resembles it. The rest of the case may be either metal or rubber. Metal will stand more hanging but it may rust. A metal head band may rust also, if it is not covered. A leather covered head band may outwear a cloth covered one or, if subjected to heat, it may dry out and crack. Phone cords may be well or poorly made. If the tips are soldered on, the solder may have burned the insulation so that it will come loose where it joins the tip and look messy.

Some receiving sets are provided with jacks for the phones. In this case the phone cords should end in a plug that will fit the hole where the jack is. Other sets have binding posts of a type adapted to hold a wire but not a phone tip. In this case a connector and wires are used. Connectors are sometimes sold as a part of the phone equipment and sometimes they must be ordered separately. If there are clips on the ends of the phone cords they may be able to get a hold on a binding post but cannot conveniently be applied to a jack.



## This Combination Completes any RADIO RECEIVING SET



To own a good receiving set without Magnavox equipment, is like having your house properly wired and then using only small, feeble candle-power lamps in the sockets!

Whether placed in the average living room or large dance hall, Magnavox Radio floods the desired area with clear, resonant music or speech—its volume perfectly controlled from the Magnavox Power Amplifier constructed specially for it.

**Combination R-3 Reproducer and 2 stage Power Amplifier** (as illustrated).

**R-2 Magnavox Reproducer** with 18-inch horn: the utmost in amplifying power, for store demonstration, large audiences, dance halls, etc.

**R-3 Magnavox Reproducer** with 14-inch curvex horn: ideal for homes, offices, etc.

**Model C Magnavox Power Amplifier** insures getting the largest possible power input for your Magnavox Reproducer. 2 and 3 stage

Magnavox Products can be had of good dealers everywhere.

**The Magnavox Co.,**  
Oakland, California  
New York: 370 Seventh Avenue

Write for booklet illustrating and describing the

**MAGNAVOX**  
Radio  
The Power Amplifier  
and Reproducer Supreme



# "BUILD YOUR OWN" WITH "RASCO" PARTS!

**T**HE Radio Specialty Company—"RASCO" for short—now in its third year, is unquestionably the most unique radio parts supply house in the United States, if not in the whole world. This Company makes a specialty of very small orders. No order is too small to get immediate and prompt attention. The reason is simple: 80% of our orders are small. The reputation of this house was built upon service. Ask any of your radio acquaintances what they think of "RASCO" service, "RASCO" promptness. Thousands upon thousands of unsolicited testimonials are in our files, to prove that we serve the public as it has never been served in radio merchandise before. Be sure to get our great 68-page catalog, containing over 500 different parts. Catalog contains over 300 illustrations.

**Order direct from this page. All goods sent prepaid in 24 hours. We pay all transportation charges. Money refunded if goods do not satisfy**



**RADIO FREQUENCY TRANSFORMERS**  
The best Radio Frequency Transformer developed so far. Designed for us by Mr. R. E. Lacault, Associate Editor of RADIO NEWS. For wavelengths of 320 to 420 meters. Air core. Guaranteed to do the work. This Transformer brings in the long distances.  
R-2800 Radio Frequency Transformer, size 1 1/2" x 2 1/2" ..... \$2.00



**VACUUM TUBE SOCKET**  
Made entirely of composition. Gives no rise to capacity effects, as metal sockets do. Positive contacts.  
R-6500, Vacuum Tube Socket ..... \$3.50



**ANTENNA CONNECTOR**  
Made entirely of aluminum. Will not rust. The four wires go to upper holes. Lower hole takes lead-in. Don't solder your aerial. Dimensions, 2" high, 1 1/2" wide.  
R-999, Antenna Connector \$3.30



**MOULDED DIALS**  
Highest grade made. Brilliant black composition. Figures inlaid in white enamel. For 1/4" or 3/16" shaft.  
R-3074, Dial, 2 1/2" ..... \$5.50  
R-3075, Dial, 3 1/2" ..... .65  
R-3076, Dial 3 3/4" ..... .80



**FLUTED KNOBS**  
Made of best black composition, provided with 8/32" bushing. Height 1", Diameter 1 1/2".  
R-2055 Fluted Knob ..... \$1.15



**"RASCO" POSTS**  
R-650, Post made entirely of best black composition—8/32" screw—each ..... \$.08  
R-202, Post has nickel-plated bottom part, each ..... .08  
Dozen, each style ..... .90



**RASCO SWITCH POINTS**  
Nickel-plated and polished. The following have been found the most popular.  
1, 1/4" x 1/4", 6/32" thread, doz. .... \$3.50  
2, 3/16" high, 1/4" dia., 6/32" thread, doz. .... .35  
3, 3/16" x 3/16", 4-36 thread, doz. .... .35  
4, 3/4" dia., 1/2" thick; shank 6/32" dia., 4-36 thread, doz. .... .40  
5, 1/4" dia., 3/16" thick; shank 4-36, doz. .... .40  
6, 3/16" dia., 3/16" thick; shank 4-36, doz. .... .40  
7, 3/16" dia., 1/2" thick; shank 4-36, doz. .... .40  
7 1/2, Switch Stop 3/8" long, 4-36 thread, complete with nut, each ..... .04  
76, New style Switch Point, to be pressed into bakelite panels with forced fit. Wire is soldered to pin end. Head 1/4" dia., 1/16" thick, doz. .... .40  
77, same as above, but head is 3/4" dia. x 3/16" thick, doz. .... .40

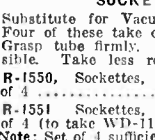

**SOCKETTES**  
Substitute for Vacuum Tube Socket. Four of these take one Vacuum Tube. Grasp tube firmly. Best contact possible. Take less room. Are better.  
R-1550, Sockettes, nickleled, set of 4 ..... \$2.25  
R-1551, Sockettes, nickleled, set of 4 (to take WD-11 Tube) ..... .25  
Note: Set of 1 sufficient to hold 1 Tube.



**VACUUM TUBE FUSES**  
Insure your tubes against blow outs.  
R-2575, Fuse, 1 ampere ..... \$1.15  
R-2576, Fuse, 1 1/2 ampere ..... .15  
R-2577, Fuse, 2 ampere ..... .15

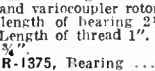

**UNIVERSAL BEARING**  
THE bearing to hold variometer and variocoupler rotors. Total length of bearing 2 1/4". Outside shaft, 1 1/4". Length of thread 1". Length of threaded sleeve, 3/4".  
R-1375, Bearing ..... \$2.25

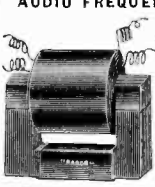

**AUDIO FREQUENCY TRANSFORMERS**  
No better Transformer on the market. Highest class materials. Impregnated coils. Silicon steel stampings used. Save 50 per cent by assembling it yourself.  
R-1100, A.F. Transformer, ratio 4 1/2 to 1 ..... \$2.65  
R-1150, A.F. Transformer, ratio 6 1/2 to 1 ..... 2.65

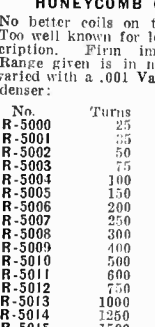

**HONEYCOMB COILS**  
No better coils on the market. Too well known for lengthy description. Firm impregnation. Range given is in meters when varied with a .001 Variable Condenser:  
No. Turns Range Price  
R-5000 25 120-250 \$4.40  
R-5001 25 175-350 .45  
R-5002 50 240-720 .50  
R-5003 75 300-910 .55  
R-5004 100 500-1150 .60  
R-5005 150 600-2000 .75  
R-5006 200 900-2500 .65  
R-5007 250 1200-3500 .80  
R-5008 300 1500-4500 .85  
R-5009 400 2000-5000 1.00  
R-5010 500 2800-6100 1.15  
R-5011 600 4000-10000 1.30  
R-5012 750 5000-12000 1.70  
R-5013 1000 7000-15000 1.70  
R-5014 1250 9750-19500 1.95  
R-5015 1500 11500-26500 2.20



**CORD TIP JACKS**  
Take the place of binding posts on instruments or panel. Cord tip firmly gripped by Jack. Made of brass, highly nickel-plated and polished. Screw to attach lead wire. No soldering necessary.  
R-1500, Cord Tip Jack, each ..... \$1.15

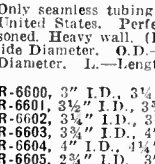

**CARDBOARD TUBING**  
Only seamless tubing made in United States. Perfectly seasoned. Heavy wall. I.D.—Inside Diameter. O.D.—Outside Diameter. L.—Length.  
R-6600, 3" I.D., 3 1/4" O.D. x 7" L. .... \$3.30  
R-6601, 3 1/2" I.D., 3 3/4" O.D. x 7" L. .... .35  
R-6602, 3 3/4" I.D., 3 3/4" O.D. x 7" L. .... .25  
R-6603, 3 3/4" I.D., 3 3/4" O.D. x 7" L. .... .27  
R-6604, 4" I.D., 3 3/4" O.D. x 5" L. .... .35  
R-6605, 2 3/4" I.D., 3" O.D. x 2 3/4" L. .... .15



**MICANITE TUBING**  
Especially suitable for CW work. Nothing better made. Natural color.  
R-250, Micanite Tubing, 4" dia., 6" long ..... \$1.20  
R-251, Micanite Tubing, 6" dia., 6" long ..... 1.60



**JACKS AND PLUGS**  
Best material. Only pure silver contacts used. Factory that makes Postal Telegraph jacks makes these. This is your guarantee.  
R-1000, Jack, 1-springs double circuit ..... \$7.75  
R-1001, Jack, 3-springs ..... .80  
R-1002, Automatic 5-spring Jack ..... 1.00  
R-1003, Plug ..... .65

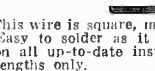

**BUS BAR WIRE**  
This wire is square, measuring 1/16" by 1/16". Easy to solder as it is already tinned. Used on all up-to-date instruments. Sold in 2-foot lengths only.  
R-6400 Bus Bar Wire, per 2-foot length. .... \$0.50

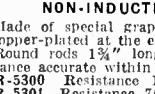

**NON-INDUCTIVE RESISTANCE**  
Made of special graphite copper-plated at the ends. Round rods 1 1/2" long, 3/4" diameter. Resistance accurate within 20 per cent.  
R-5300 Resistance 12,000 ohms ..... \$6.50  
R-5301, Resistance 70,000 ohms ..... .65

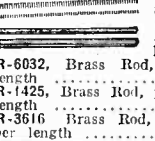

**BRASS RODS**  
Sold in 6" lengths only  
R-8032, Brass Rod, 8/32" thread, per length ..... \$0.80  
R-6032, Brass Rod, 6/32" thread, per length ..... .06  
R-1425, Brass Rod, plain 1/4" round, per length ..... .10  
R-3616 Brass Rod, plain 3/16" round, per length ..... .06



**"RASCO" BABY DETECTOR**  
Base is solid black composition; mounted on same is nickel holder and binding post, which holds the fluted hard rubber knob with its sliding rod member. Patent nickel detector cup and binding post. Patent cup holds crystal.  
R-1898, Baby Detector, with Galena ..... \$5.50



**"RASCO" LUBRICATED PANEL SWITCH**  
Our patent spring fork holds the switch handle always at a uniform tension. At the same time it insures best contact possible. New wiping contact covers every portion of the switch point. Double leaf blades used.  
R-1921, "RASCO" Switch ..... \$4.40



**PANEL SWITCH LEVER**  
Impossible for this lever not to make positive contact. Leg radius 1 1/4". Nickel-plated and polished. Lock fork holds the screw (in which it rotates) securely. Loose contact impossible.  
R-2000, Switch Lever ..... \$3.30



**"RASCO" NAME PLATES**  
The circular plate is our new Binding Post Name Plate. Diameter, 3/4". These denominations: PHONES, GROUND, OUTPUT, BATTERY, LOUD SPEAKER, GRID, LOAD, "C" BATTERY, AERIAL, INPUT, "A" BATTERY, LOOP, TICKLER, PLATE, "E" BATTERY, FILAMENT.  
R-6000 to 6019, Binding Post Name Plates, each denomination ..... \$0.30  
Dozen ..... .30



**Square Name Plates**  
Same denominations as above also these: SERIES 1st STEP, 2nd STEP, 3rd STEP, SECONDARY CONDENSER, TELEPHONE, SECONDARY DETECTOR, TRANSMIT, GRID VARIOMETER, PARALLEL COUPLING, PRIMARY, LOADING COIL, RECEIVE, ANTENNA, PLATE VARIOMETER, "BLANK", AUDION, ON, OFF.  
R-834 to 866, Square Name Plates, each ..... \$0.40  
Dozen ..... .40  
R-830, "INCREASE CURRENT" (Right) ..... .40  
R-840, "INCREASE CURRENT" (Left) ..... .10  
Each ..... .10



**VERNIER**  
Closest vernier made. Can be used with any dial. Soft rubber ring engages dial. Does away with vernier condenser. We guarantee results. All metal parts moulded in best black composition. Nothing to come apart. Biggest hit of the season.  
R-1450, Vernier ..... \$3.30



**"RASCO" CONDENSERS**  
R-5030, Phone Condensers, each ..... \$2.20  
R-5056, Grid Condensers, each ..... .20  
R-5059, Grid Leak Condensers, each ..... .30



**COPPER FOIL**  
Thinnest copper foil made, .001" thick. Comes 4" wide.  
R-5025, Copper Foil, per ft. \$1.10  
10-ft. length ..... .80

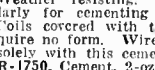

**RADIO CEMENT**  
Weather resisting. Used particularly for cementing covered wires. Coils covered with this cement require no form. Wires hold together solely with this cement.  
R-1750, Cement, 2-oz. bottle ..... \$5.50



**TELEPHONE SHELL AND CAP**  
For the experimenter we list this composition shell and cap. No holes in shell whatsoever. Takes standard 2 1/2" diaphragm.  
R-2700, Shell and Cap, complete ..... \$6.65  
R-2701, Shell only ..... .40

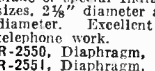

**MICA DIAPHRAGMS**  
Made of special India mica in two sizes, 2 1/2" diameter and 1-13/16" diameter. Excellent for experimentation in telephone work.  
R-2550, Diaphragm, 2 1/2" ..... \$2.20  
R-2551, Diaphragm, 1-13/16" ..... .15



**RHEOSTAT WINDINGS**  
These windings, with the switch arm shown below, constitute a complete rheostat for the experimenter. Resistance wound on flexible black fibre. Carries 1 1/2 amperes, resistance 6 ohms.  
R-4300, Rheostat Resistance each ..... \$2.20  
R-4301, Potentiometer Resistance each (200 ohms) ..... .35  
**BLADE WITH COLLAR**  
Fits above.  
R-1675, each ..... \$1.10



**MAGNET WIRE**  
We list only best qualities. "DCC" means Double Cotton Covered. "GS" means Green Silk. "E" stands for Enameled. The following come on 8-ounce spools:  
R-2500, DCC No. 18 ..... \$5.50  
R-2501, DCC No. 20 ..... .70  
R-2502, DCC No. 22 ..... .75  
R-2503, DCC No. 24 ..... .85  
R-2504, DCC No. 26 ..... .95  
R-2505, DCC No. 28 ..... 1.15  
R-2506, DCC No. 30 ..... 1.65  
The following come on 4-ounce spools:  
R-2507, GS No. 20 ..... \$5.50  
R-2508, GS No. 22 ..... .55  
R-2509, GS No. 24 ..... .60  
R-2510, GS No. 26 ..... .65  
R-2511, GS No. 28 ..... 1.05  
R-2512, GS No. 30 ..... 1.30  
R-2513, GS No. 36 ..... 1.85  
The following come on 8-ounce spools:  
R-2514, E No. 20 ..... \$4.45  
R-2515, E No. 22 ..... .55  
R-2516, E No. 24 ..... .60  
R-2517, E No. 26 ..... .65  
R-2518, E No. 28 ..... .70  
R-2519, E No. 30 ..... .80  
R-2520, E No. 36 ..... 1.00

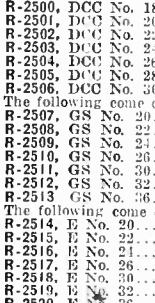

**LITZ WIRE**  
R-323, equals No. 25 B&S, per foot ..... \$0.02  
R-890, equals No. 28 B&S, per foot ..... .01  
R-891, equals No. 21 B&S, per foot ..... .03  
R-892, equals No. 20 B&S, per foot ..... .04  
R-893, equals No. 11 B&S, per foot ..... .12  
Discounts of 10 per cent in 100-foot lots.



**The "RASCO" Catalog**  
CONTAINS 75 VACUUM TUBE HOOK-UPS, 300 ILLUSTRATIONS, 500 ARTICLES, 68 PAGES  
All Armstrong Circuits: These important circuits are explained clearly, all values having been given leaving out nothing that could puzzle you. Just to name a few of the Vacuum Tube circuits: The V.T. as a detector and one-step amplifier; Armstrong circuits; one-step radio frequency amplifier and detector; three stage audio frequency amplifier; short wave regenerative circuits; 4-stage radio frequency amplifier; radio and audio frequency amplifier; inductively coupled amplifier; Armstrong superautodyne; radio frequency amplifier and crystal detector; combination V.T. detector amplifier and detector; two stage radio frequency amplifier and detector with feedback coupling (regenerative); regenerative receiver, using single spider web coil; Armstrong super-regenerative circuit; two stage radio frequency amplifier coupled to a two-circuit tuner, using two slide tuner regenerative receiver, using crystal or V.T.; one stage radio frequency detector; two stages audio-frequency with feedback coupling to first tube; power amplifier with loud speaker; regenerative receiver and one stage amplifier for DX work; one stage radio frequency detector with feedback coupling; three stages radio frequency, two stages audio-frequency loop reception; crystal detector with rectification; one tube super-regenerative receiver; short wave regenerative receiver with two variocouplers, ca. 13-coupled tuner, trap circuit to eliminate interference; selective circuit to eliminate interference. The catalog contains 300 illustrations. On account of its great cost, it cannot be distributed free of charge. Mailed only upon receipt of



**The "RASCO" Catalog**  
CONTAINS 75 VACUUM TUBE HOOK-UPS, 300 ILLUSTRATIONS, 500 ARTICLES, 68 PAGES  
All Armstrong Circuits: These important circuits are explained clearly, all values having been given leaving out nothing that could puzzle you. Just to name a few of the Vacuum Tube circuits: The V.T. as a detector and one-step amplifier; Armstrong circuits; one-step radio frequency amplifier and detector; three stage audio frequency amplifier; short wave regenerative circuits; 4-stage radio frequency amplifier; radio and audio frequency amplifier; inductively coupled amplifier; Armstrong superautodyne; radio frequency amplifier and crystal detector; combination V.T. detector amplifier and detector; two stage radio frequency amplifier and detector with feedback coupling (regenerative); regenerative receiver, using single spider web coil; Armstrong super-regenerative circuit; two stage radio frequency amplifier coupled to a two-circuit tuner, using two slide tuner regenerative receiver, using crystal or V.T.; one stage radio frequency detector; two stages audio-frequency with feedback coupling to first tube; power amplifier with loud speaker; regenerative receiver and one stage amplifier for DX work; one stage radio frequency detector with feedback coupling; three stages radio frequency, two stages audio-frequency loop reception; crystal detector with rectification; one tube super-regenerative receiver; short wave regenerative receiver with two variocouplers, ca. 13-coupled tuner, trap circuit to eliminate interference; selective circuit to eliminate interference. The catalog contains 300 illustrations. On account of its great cost, it cannot be distributed free of charge. Mailed only upon receipt of

**15 Cents in Stamps or Coin.**

This business was originated with the sole idea in mind to cater to the radio amateur who has small orders. ALL OF OUR ORDERS ARE SMALL. THAT IS WHY YOUR SMALL ORDER CAN NEVER BE SIDE-TRACKED BY US. A trial order will make you a life customer. Order from the above illustrations. 24-hour service guaranteed. "WE CAN ONLY DISAPPOINT YOU ONCE." Try us with a 50c. order and make us prove what we say. Prices include delivery to your door.

**100 Park Place, New York City**  
**Radio Specialty Co.**  
Oldest and Original Exclusive Radio Parts House in U. S.  
Factories: Brooklyn, N. Y. — Elkridge, Md.  
**DEALERS**  
Get Our Special Proposition



Talk  
Number  
**2**

**SIGNAL**

**Facts from the Factory**

This radio game is just as much fun at our end as it is at yours. There's genuine satisfaction in knowing that our radio parts and radio sets will "deliver the goods" to some eager experimenter, or unflinching convey a message of international importance to the ear of a waiting world.

At the SIGNAL plant we never forget that if we scrimp on material or slight our work, then someone will surely be disappointed, and perhaps a despairing call for help may be made in vain.

So it is our joy to perform each operation, little or big, with the utmost of conscientious precision, knowing, thus, that no life can ever be charged against defective SIGNAL apparatus.

Radio equipment bearing the name of SIGNAL may safely be depended upon for good, honest service.

**SIGNAL Electric Mfg. Co.**

Factory and General Offices:  
1911 Broadway,  
MENOMINEE, MICH.

Atlanta	New York	Boston
Pittsburgh	Chicago	San Francisco
Cleveland	Minneapolis	St. Louis
Montreal	Toronto	

*You'll find our local address in your Telephone Directory* (2101)

---

**INFORMATION COUPON**

Signal Electric Mfg. Co.,  
1911 Broadway,  
Menominee, Mich.

Please send catalog and bulletins giving complete information about SIGNAL Radio equipment to name and address written in margin.



**KEEP  
A DAY AHEAD**

of the headlines of tomorrow's newspapers!  
Don't be satisfied with the regular broadcasted programs!  
Get the most out of radio!  
Hundreds of radio enthusiasts are doing it!

**Equip your vacuum tube set with a  
FINCH RADIO RELAY**

and you will automatically receive and at the same time have a permanent record of all the important and interesting news events of the world, whether or not you know the code.

Send Today for Booklet S103



**FINCH RADIO MFG. CO.**  
303 FIFTH AVE., N.Y. CITY.

## Fish Hang Up Young to Ripen

By DR. ERNEST BADE

(Continued from page 1055)

placed in a ditch prepared for them. Here they remain for a few days and then they are hung upon a plant by means of a thread which consists of a viscid liquid. In this position they must remain for about five days. Then the parent picks them off, and, under their tutelage, they make their first attempts in swimming.

The reason for the suspension of the young fish which are not, as yet, able to swim, is found in the fact that the young will receive plenty of clean, oxygenated water near the surface, where they can absorb the contents of the food still remaining in the egg sack. Only after this has been devoured are they enabled to swim. Then, under the care of the parents, they hunt the tiny water infusorians, nature's baby-fish food. Without suspension, the young, delicate creatures would soon be buried deeply under the dust-like muck which rises in dense clouds at the least agitation. This would then fill the respiratory organs and the creatures would suffocate.

Young fish with well ossified skeletons, the bony fish (*Teleostei*), are often provided with an adhesive cement organ situated just above the mouth. With its aid, the young, just-hatched fish, attach themselves to the surface of the waterplants, etc., where they then remain until the egg sack has vanished. The larval stages of *Protoperus*, *Lepidosiren*, etc., belonging to the sub-class lung-fish (*Dipnoi*), still possess outer gills and these are all provided with such cement organs and in this respect they closely resemble the tadpoles. This, undoubtedly, refers to the relation existing to these two groups of animals.

Even the electric fish of the group *Mormyridae*, peculiar individuals inhabiting the fresh waters of Africa, are exceptionally characteristic of this region and are provided with adhesive organs in their early stages.

## The Sleep Eliminator

(Continued from page 1114)

simply moves a switch at his right, which disconnects the electrifying current. It is the same when he wishes to use the telephone. If he did not turn off the switch he probably would get a somewhat severe shock. He can, however, work at his desk to his heart's content, because the desk itself is supported by glass insulators, so it makes no difference if the desk is metal or wood.

In this illustration we also see an addition in the form of suggestion. This is another suggestion, because it has been found that ozone is one of the most stimulating and exhilarating agents known, and if used in the right proportions will also greatly help to keep the workers from even thinking about sleep.

With methods such as these, if translated into practice, there is no probability that the subjects will experience any ill effects, and will not be worse off for having worked a week, or even a month, day in and day out.

Of course, any time during the day clothes and linen can be changed, and a shower taken, to refresh the body, just the same as we take it now.



## More Money For You in RADIO

THE amazing expansion of Radio has opened up thousands of wonderful new positions on land and sea. Big salaries, fascinating easy work, short hours, and a wonderful future are offered to ambitious men who get into Radio now.

Take advantage of these wonderful opportunities to step into a big paying position in this great new field. Radio offers you an opportunity to travel and see the world, with all expenses paid, and a fine salary besides. Or you can stay at home and work up to a position paying up to \$10,000 a year. One of our recent graduates secured a position one week after graduating paying a salary of \$300.00 per month.

## Easy to Learn Radio at Home

Hundreds of men are already earning handsome incomes in this wonder science. If you want to get into a profession where opportunities are unlimited make Radio your career—become a Certified Radio-trician.

Thousands of Certified Radio-tricians are wanted to design Radio sets, to make new Radio improvements; to manufacture Radio equipment and to install it; to maintain and operate great broadcasting stations and home Radio sets; to repair and sell Radio apparatus; to go into business for themselves; to operate aboard ship and at land stations.

You can easily and quickly qualify in your spare time at home through the help of the National Radio Institute. Prominent Radio experts will help you. Four wonderful instruments are furnished free, making the work thoroughly practical. The same plan that has already helped hundreds of our graduates to real success and real money in Radio is open to you.

## Big Book Free

No other field today offers such great opportunities as Radio. Take your choice of the many wonderful openings everywhere. Prepare now to step into the most interesting and best paid profession today. Read about the opportunities open now—the different kinds of work—the salaries paid. Write today for the free 44-page book that tells how America's first and biggest Radio school can make you a Certified Radio-trician in your spare time.

## National Radio Institute

1345 PENNSYLVANIA AVE., N. W.

Dept. 14-C Washington, D. C.

### National Radio Institute, Dept. 14-C

1345 Pennsylvania Ave., N. W.  
Washington, D. C.

Send me your free book, "How to Learn Radio at Home," which tells all about the opportunities in Radio, how spare time study at home will qualify me quickly as a Certified Radio-trician so I can get one of these splendid positions, and how your free Employment Service helps me to secure the job I want.

Name..... Age.....  
Street.....  
City..... State.....

## Opportunity Ad-lets

YOU will find many remarkable opportunities and real bargains in these columns. It will pay you to read and investigate the offerings made every month by reliable firms, dealers and amateurs from all over the country. No matter what you may be seeking, whether supplies, automobile accessories, the opportunity to make money, or anything else, you will find listed here the best and most attractive specials of the month.

Advertisements in this section twelve cents a word for each insertion. Name and address must be included at the above rate. Cash should accompany all classified advertisements unless placed by an accredited advertising agency. No advertisement for less than 10 words accepted.

Ten per cent. discount for 6 issues, 20 per cent. discount for 12 issues. Objectionable or misleading advertisements not accepted. Advertisements for the May issue must reach us not later than March 15.

**The Circulation of Science and Invention is over 160,000 and climbing every month**

EXPERIMENTER PUBLISHING CO., INC., 53 Park Place, New York City, N. Y.

### Advertising Service

For quick results use direct mail advertising. Letters, folders, campaigns. Free suggestions. Wilson, 247 Willam St., East Orange, N. J.

### Aeronautics

Boys build three foot model aeroplane at small cost. Write Aero Shop, 3050 Burling Ave., Detroit, Mich.

### Agents Wanted

**Agents—Steady Income.** Large manufacturer of soaps, perfumes, toilet articles and pure food products, etc. wishes representatives in each locality. Manufacturer direct to consumer. Big profits. Honest goods. Whole or spare time. Cash or credit. Send at once for particulars. American Products Co., 8479 American Bldg., Cincinnati, Ohio.

**Big money and fast sales.** Every owner buys gold initials for his auto. You charge \$1.50, make \$1.35. Ten orders daily easy. Write for particulars and free samples. American Monogram Co., Dept. 71, East Orange, N. J.

**Fords run 34 miles on gallon gasoline.** Other cars show proportionate saving. Wonderful new carburetor. Starts easy in coldest weather. Fits any car. Attach yourself. Money back guarantee. Sent on 30 days' trial. Agents wanted. Air Friction Carburetor Co., Dept. 3226, Dayton, Ohio.

**Use Inside Tyres in your old casings** and get from 3 to 5 thousand miles more service. Positively prevent punctures and blowouts. Used over and over again. Low priced. Big money saver. Agents wanted. Write for terms. American Accessories Co., B-784, Cincinnati, Ohio.

**300 per cent. Profit:** Selling Klearette Magic Clothes Washing Compound. Sells, 25¢; Profit, 18¢. Sample free. Beaver Products Co., 1941-W Irving Park, Chicago.

**Make \$25 to \$50 week** representing Clows' Famous Philadelphia Hosiery, direct from factory to wearers. Children. Every pair guaranteed. Prices that win. Free book "How to Start" tells the story. George Clows Company, Desk 27, Philadelphia, Pa.

**Capable Men Wear Earn \$15 to \$25 day** selling high grade Double Wear Shoes direct from factory to wearer. Big opportunity for you. Clever Selling Plan insures your success. Write today for full particulars, style sheets, etc. Doublewear Shoe Co., Manufacturers, 10A, Minneapolis, Minn.

**Big money made silvering mirrors, plating and refinishing metalware, autos, chandeliers, headlights.** Outfits furnished. N. Decie Laboratories, 1133 Broadway, New York.

**Ambitious Men, write today** for attractive proposition, selling subscriptions to America's most popular automobile and sportsman's magazines. Quick Sales. Big profits. Pleasant work. Digest Pub. Co., 9541 Butler Bldg., Cincinnati.

**Agents Wanted in Every City** to sell standard Radio apparatus on a liberal commission basis. A few stocking agencies open to reliable parties. Delfelco, 12 Meeting St., Pawtucket, R. I.

**27,000 Records** guaranteed with one Everplay phonograph needle, new, different; cannot injure records; \$10.00 daily easy. Free sample to workers. Everplay, Desk 37, McClurg Bldg., Chicago.

**We wish representatives in every community** to secure subscriptions for Science and Invention, Radio News, and Practical Electrics. This is a wonderful opportunity for Amateur Radio Enthusiasts to make big money quickly. Write Experimenter Publishing Co., Inc., 53 Park Pl., New York City.

**Agents, Big Profits.** Selling Wunrub Polish, for Furniture, Woodwork, Automobiles, etc. Cleans and Polishes. Write for Big Free Offer. Fritch's Laboratories, 312-D, North Carpenter, Chicago.

**\$10 daily silvering mirrors, plating and refinishing lamps, reflectors, autos, beds, chandeliers by new method.** Outfits furnished. Write Gunmetal Co., Ave. D, Deratour, Ill.

**Housewives Buy Harper's Invention on sight.** New business. No Competition. Ten-Use Set is combination of ten indispensable household necessities. \$7.50 to \$30.00 a day easily. Write for Free trial offer. Harper Brush Works, 112 A Street, Fairfield, Iowa.

**Agents, Our soap and toilet article plan is a wonder;** get our free sample case offer. Ho-Ro-Co., 138 Locust, St. Louis.

**Write and learn how to start profitable business** without capital or experience. Silvering mirrors, refinishing auto headlights, tableware, plating. Outfit furnished. International Laboratories, Dept. 25, 309 Fifth Ave., New York.

**Sell Wall Emblems.** Every Lodge Member wants one. Big money—all or spare time. Free sample and cash bonus plan. Kier Emblem Co., Dept. S.I.3, 538 So. Clark, Chicago.

### Agents Wanted (Continued)

**Earn big money fast** applying gold initials to autos. Every owner buys—\$1.35 profit on \$1.50 sale—particulars and samples free. Write quick. Lithogram Co., Dept. 19, East Orange, N. J.

**Only one sale a day means \$200 per month!** Five sales, \$1,000 per month! Marvelous new adding machine. Retail \$15. Work equals \$350 machine. Adds, subtracts, multiplies, divides automatically. Speedy, accurate, durable, handsome. Five year guarantee. Office stores, factories, garages, buy one to dozen. A fortune for live agents. Write quick for protected territory and free trial offer. Lightning Calculator Co., Dept. W., Grand Rapids, Mich.

**Free, Formula Catalog.** Laboratories, Boylston Bldg., Chicago.

**Large Shirt Manufacturer** wants Agents to sell complete line of shirts direct to wearer. Exclusive patterns. Big values. Free samples. Madison Mills, 503 Broadway, New York.

**Agents, \$60 to \$200 a Week, Free Samples.** Gold Sign Letters for Store and Office windows. Anyone can do it. Big demand. Liberal offer to general agents. Metallic Letter Co., 4322 N. Clark St., Chicago.

**Agents—Just like selling gold dollars at 69¢ each.** That's what J. A. Saunders, of Pawtucket, says about our wonderful pure all virgin wool made-to-order suits, retailing at \$29.50—none higher. Finest selection of fabrics—serges, worsteds and quality unexcelled. Satisfaction guaranteed. This is a line that will bring repeat business and big money. A big opportunity for hustlers. No experience needed. We will teach you. Write today—state territory desired. J. B. Simpson, Inc., Dept. 499, 831 W. Adams St., Chicago.

**Agents—Big returns, fast office seller;** particulars and samples free. One Dip Pen Co., 12 Daily Record Bldg., Baltimore, Md.

**Automobile Free to Tailoring Agents:** Make \$75 a week and up and get an automobile free taking orders for our fine tailored-to-measure suits. Big assortment of All-Wool Fabrics at the one low price of \$29.75. Also wonderful showing of Summer-weight fabrics at \$17.50. Every order pays you big cash profit in advance. We supply finest selling outfit, and give automobile free to every man who qualifies. Write quick for starting offer. Dept. 556, Park Tailoring Company, Chicago.

**Radio Agents—wanted in every town** to sell Ames Radio Products. We manufacture long distance Radio receiving sets and parts. Big profits. Write for plan. Picard Radio Corp., Dept. MC, 18 West 46th St., New York.

**Free Book.** Start little Mail Order business anywhere. Home employment evenings. Beginner's Working Outfit furnished. Instructive Book free. Pier, Dept. 155-A, 71 Cortland St., N. Y.

**Tremendous Opportunity for ambitious agents.** The indispensable, rapid selling Speedy Dish Washer. Price \$3.50. No competition. No investment. Easy selling plan. Convenient sample. Commission daily. Make application today—exclusive territory. Sheppard-Luth Mfg. Co., 16K Hudson St., New York.

**Live Agents Make \$10 Day** selling Eureka Strainer and Splash preventer for every water faucet. Takes on sight. Widely advertised and known. Get details today. A. J. Seed Filter Co., 73 Franklin, New York.

**Build Your Own Business—Renewing and dyeing rugs and carpets on floors of offices, hotels, homes.** New method. Big profits. \$10.00 Day easy. Write for full information. Texply Company, 16-A, Somerville, N. J.

**57 miles per gallon** made with new patented gasoline Vaporizer. Write for particulars. Vaporizer Co., Pukwana, S. Dak.

**Agents—Best seller: Jem Rubber Repair** for tires and tubes; supersides vulcanization at a saving of over 800 per cent; put it on cold. It vulcanizes itself in two minutes, and is guaranteed to last the life of the tire or tube; sells to every auto owner and accessory dealer. For particulars how to make big money and free sample, address Amazon Rubber Co., Dept. 601, Philadelphia, Pa.

### Correspondence Courses

**Dollars Saved.** Used correspondence courses of all kinds sold, rented and exchanged. List free. (Courses bought.) Lee Mountain, Pisgah, Alabama.

### Duplicating Devices

**"Modern" Duplicators save Time, Labor and Money.** Gets Business. Reproduces Typewritten or penned letters, Drawings, Lessons, Music, Menus, Bids, Notices, Specifications, Maps or anything in one or more colors. Prints two per minute. Special Sale On. 30 Days' Free Trial. \$2.25 up. Booklet Free. B. J. Durkin-Reeves Co., Pittsburgh, Pa.

### Electrical Supplies and Appliances

**Blueprints.** Diagrams of Electrical Connections for nearly every purpose. Authoritative works. Particulars free. Samples 20¢. Charles Chittenden, A3024 Matthews, Kansas City, Mo.

### American-Made Toys

**Manufacture metal Indians.** Casting form \$2.00. B. Lanford, 1820 Oliver St., Baltimore, Md.

**Manufacturers on large scale,** also homeworkers, wanted to manufacture Metal Toys and Novelties. Millions needed of Barking Dogs, Wag-Tail Pups, Wild Animals, Automobiles, Indians, Cow-Boys, Baseball Players, Cannons, Toy Soldiers, Crowning Roosters, Statues of Liberty, Miniature castings of Capital, Bathing Girl Souvenirs and others. Unlimited possibilities. Guaranteed Casting forms furnished manufacturers at cost price from \$5.00 up, with complete outfit. No experience or tools necessary. Thousands made complete per hour. We buy goods all year and pay high prices for finished goods. Cash on Delivery. Contract orders placed with manufacturers. Catalog and information free. Correspondence invited only if you mean business. Metal Cast Products Co., 1696 Boston Rd., New York.

### Automobiles—Automobile Supplies

**Automobile owners, garagemen, mechanics,** send today for free copy America's most popular motor magazine. Contains helpful articles on overhauling, repairing, ignition, carburetors, batteries, etc. Automobile Digest, 541 Butler Bldg., Cincinnati.

**Blue Prints.** Automobile Armature connecting diagrams 1922 Edition. Charles Chittenden, B3024 Matthews, Kansas City, Mo.

### Books

**Perpetual Motion,** by Percy Verance. A history of the efforts to discover same from earliest days to the present, together with a scientific discussion regarding the possibility of its ultimate achievement. Profusely illustrated, 357 pages. Price postpaid, \$2.00. The Enlightenment Specialty Co., 305 Fourth St., Edwarville, Ill.

**Books for Sale on Occultism—Mysticism—Theosophy—Mental Science—Advanced Thought—Sex Secrets—Seership—Yogi—Hermesitic and Rosicrucian Philosophy—List Free.** The Grail Press—Desk B, 712 G St., N. E., Washington, D. C.

**Books.** Literature. Instructive. Lists. Higene's, S2141 Post Street, San Francisco.

**Sexological Literature,** the most extensive Catalogue sent on request from the Original Book League, S. I. 5 Columbus Circle, New York.

**Cleanings of a Mystic.** By Max Heindel. New information regarding Initiation. What It Is and Is Not, and many other fine points never before presented in this form. 200 pages. Cloth bound, \$2.00 post free. Ready about Dec. 15th. Rosicrucian Fellowship, Box 17, Ocean-side, Cal.

**Diseases and Their Innate Healer.** Book 50 cents. Arthur Stevens, Wauson, Ohio.

**Hypnotism—Astounds.** Controls others, 25 easy lessons, \$1. "Mindreading" (any distance), 30c. Science Institute, SE1014 Belmont, Chicago.

**How to Make Wireless Receiving Apparatus.** 100 pages—90 illustrations. Only strictly modern radio apparatus are described in this book and the illustrations and descriptions are so clear and simple that no trouble will be experienced in making the instruments. Paper covered, 35¢ postpaid. Experimenter Publishing Co., Book Dept. 53 Park Place, New York City.

**How to Make Wireless Sending Apparatus.** 100 pages—88 illustrations. Written and published entirely for the wireless enthusiast who wants to make his own radio apparatus. Contains more information on "how to make it" than any other book we know of. Paper bound, 35¢ postpaid. Experimenter Publishing Co., Book Dept., 53 Park Place, New York City.

**The How and Why of Radio Apparatus,** by H. W. Secor, E. E. This newest book on radio matters fulfills a distinct gap in wireless literature. In that, while the treatment is made as understandable and as free from mathematics as possible, it at the same time incorporates a wealth of technique and instruction for the Radio Amateur—the Radio Operator—the Installation and Designing Expert—as well as teachers and students of the subject in general. A very broad field has been covered by the author, at the same time giving a great deal of information not found in other text books. If you are engaged in any branch of the Radio or allied arts at all you will surely need this latest contribution to radio literature, which is destined to be found on every radio expert's shelf before long. A glance at the following list of chapters gives but a very scant idea of the extensive and useful radio knowledge provided in its text: The Induction Coil; The Alternating Current Transformer; Radio Transmitting Condensers; The Spark Gaps; Radio-Transmitting Inductances; Radio Receiving Tuners; Radio Receiving Condensers; Detectors; Telephone Receivers; Radio Amplifiers; Construction of a Direct Reading Wavemeter and Decimeter; Antenna Construction; The Calculation and Measurement of Inductances; Appendix containing very useful tables, covering all subjects treated in this very unusual book. This newest of Radio Works, cloth bound in Vellum de Luxe, Gold stamped and Hand Sewed, has 160 pages. Size of book, 6 1/2 inches. The How and Why of Radio Apparatus. Postpaid \$1.75. Experimenter Publishing Co., Book Dept., 53 Park Place, New York City.



**Business Opportunities**

**Become a Landscape Architect.** Dignified, exclusive, uncrowded profession offering fine money-making opportunities. \$5,000 yearly incomes common. Easy to master through our correspondence course. Established 1916. Get information today. American Landscape School, 66-M Newark, N. Y.

**Here's a money-getter!** Manufacture and sell soap, something everybody uses frequently and will buy. For \$1.00 we offer you six formulas for making high-grade soap. Write us today. Box 266, Lynn, Mass.

**Chemical Expert** will furnish formulas and trade secrets. All lines. Lists free. W. L. Cummings, Ph. D., 238 Gordon Ave., Syracuse, N. Y.

**Start a cleaning, pressing, dyeing shop.** Splendid field. Big profits. Booklet free. International System, Dept. 21, Excelsior Springs, Mo.

**Make money with your camera.** P. Lancaster, Box 967, Los Angeles.

**Will pay cash for sole right to novelty idea or invention** that retails for 10 cents. Address Lock Box 66, Station F, New York City.

**Dollars yearly in your backyard.** No mushroom dope. Particulars free. Metz, 313 E. 89th St., New York.

**Join National Institute Inventors.** 8 E. 11th St., New York City, strong protective membership society. Will secure, develop, manufacture, market patents. Dues, \$10. Booklet free.

**Advertise.** Country town newspapers. Lists free. Pennell Company, Covington, Kentucky.

**We start you in a business of your own.** Wonderful opportunity to make money. Make and sell your own products. Booklet explaining our system free. Rogers Consulting Laboratories, 15 Liberty Street, Dayton, Ohio.

**Get into Business for Yourself!** Establish and operate "New System Specialty Candy Factory" in your community. We furnish everything. Money-making opportunity unlimited. Either men or women. Booklet free. Regsdale Co., Drawer 129, East Orange, N. J.

**Enter a New Business.** Earn \$3,000 to \$6,000 yearly in professional fees making and fitting a foot specialty; openings everywhere with all the trade you can attend to; easily learned by any one at home in a few weeks at small expense; no further capital required; no goods to buy; job hunting, soliciting or agency. Address Stephenson Laboratory, 18 Back Bay, Boston, Mass.

**Prepare—Sell.** Your Own Products. Formulas, trade secrets. Different, dependable. Catalog free. D. Thaxly Co., Washington, D. C.

**53 Great Money-Making Plans Free.** Universal Bureau—K. Boston, Mass.

**Silvering Mirrors.** French plate. Easily learned. Immense profits. Plans free. Wear Mirror Works, Dept. 27, Excelsior Springs, Mo.

**Chemistry**

**How to Make and Use Small Chemical Laboratory.** 100 pages, fully illustrated. Construction of laboratory furniture, electric furnace, chemical balance and other apparatus; inorganic chemistry, novel experiments, glass blowing, etc., fully explained, 75c prepaid. Illustrated catalog of laboratory supplies and scientific books sent free. D. Altman Company, 225 East 110th Street, New York.

**Chemical Science,** January March issues 20c. Year 50c. Swadesboro, N. J.

**Learn Chemistry at Home.** Dr. T. O'Connor Sloane, noted educator and scientific authority, will teach you. Our home study correspondence course fits you to take a position as chemist. See our full-page ad on page 1045 of this issue. Chemical Institute of New York, 140 Liberty St., New York City.

**Your chemical problem solved** and working process furnished for Five Dollars. Write me. W. Stedman Richards, Consulting Chemist, Box 2402, Boston, Mass.

**Experimental Chemistry.** Book of over One Hundred Chemical Experiments, many new and original. 50c cash. Oliver Stiller, Oshawa, Ontario, Canada.

**Exchange**

**Used parts for C36 Buick.** Write your needs. Eddie Hirschfeld, Virroqua, Wis.

**Farms, Lands, Etc.**

**Property Owners—Get cash for your real estate, business, invention or other property.** To quickly sell, exchange or buy property, any kind, anywhere, write Western Security Co., 102, Hannibal, Mo.

**For Inventors**

**Inventors—Expert professional service at lowest cost.** Write for explanatory literature. Amon-Baxter, 2240 River Avenue, New York.

**Get Your Own Patent.** \$40 complete. Application blanks and full instructions \$1. Theodore A. Cutting, Campbell, Cal.

**Inventor's Educator.** 900 Mechanical Movements. 50 Perpetual Motions. How to procure and sell patents. Mechanical Movements greatly assist inventors, suggest new ideas. Explains how to select an attorney and avoid patent sharks. Price \$1.50. Postage free. Fred G. Dieterich, 601 Ouray Bldg., Washington, D. C.

**Unpatented ideas can be sold.** I tell you how and help you make the sale. Particulars free. Write W. B. Greene, 106 The Atlantic, Washington, D. C.

**Inventors—Sell patent manufacturers articles similar invention.** Guaranteed addresses 5c each, minimum (money order), 50c. General Information, Ann Arbor, Mich.

**"Inventors' Guide"** free on request; gives valuable advice and information for all inventors. Write Frank Lederman, Registered Patent Attorney, 15-E Park Row, New York.

**Before or after filing your application for patent, it will pay you to read over my "Inventors' Advisor No. 4."** Free for asking. Write: M. Labiner, Registered Patent Attorney, 3 Park Row, New York.

**Scientific Engineer develops valuable ideas or inventions** guaranteeing working models. Nemeth, Consulting Engineer, 2 East 23d Street, New York City.

**Electrical Devices, Tools, Dies, Models, Original Designing Results our Specialty.** Edward C. Porsberg, Northfield, Ohio.

**For Men**

**Homespun Tobacco—Chewing,** 5 lbs., \$1.25; 10 lbs., \$2.50; 20 lbs., \$4.50. **Smoking,** 5 lbs., \$1.25; 10 lbs., \$2.00; 20 lbs., \$3.50. Farmers Union, Mayfield, Kentucky.

**Formulas**

**Money-making Books, Plans, Formulas.** Catalog Free. Ideal Book Shop, 5501-E, North Robey, Chicago.

**Free—Formula Catalog.** Laboratories, Boylston Bldg., Chicago.

**3,500 Money-Making Formulas and trade secrets.** Over 1000 pages, \$1.00. Catalogue free. Englewood Book Shop, 7021-B, South Winchester, Chicago.

**For the Photographer**

**Have You a Camera?** Write for free sample of our big magazine, showing how to make better pictures and earn money. American Photography, 465 Camera House, Boston 17, Mass.

**Games and Entertainment**

**Tricks, Puzzles, Jokes, Magical Apparatus, Plays, Stage Supplies, Mind-Reading, Acts and Sensational Escapes.** Send 10c for 160-page illustrated 1922 professional catalogue. Oaks Magical Co., Dept. 549, Oshkosh, Wis.

**Health**

**Free to Men—Information of a scientific nature that has brought physical vigor and happiness to thousands.** No charge; no obligation. Enclose stamp for reply. Dr. C. I. Wood, 551 East 47th Street, Chicago.

**Tobacco or Snuff Habit Cured or no pay; \$1.00 if cured.** Remedy sent on trial. Superba Co., S. A., Baltimore, Md.

**Help Wanted**

**Detectives Earn Big Money.** Excellent opportunity. Travel. Great demand everywhere. Experience unnecessary. Particulars free. Write, American Detective System, 1968 Broadway, New York.

**Gov't Railway Mail Clerks start \$133 month; expenses paid.** Specimen examination questions free. Columbus Institute H-4, Columbus, Ohio.

**Be a Mirror Expert.** \$3 to \$10 a day; spare time home at first; no capital; we train, start you making and silvering mirrors French method. Free prospectus. W. R. Derr, Pres., 26 McKinley St., Baldwin, N. Y.

**Firemen, Brakemen, Baggage-men, Sleeping car train porters (colored).** \$140-200. Experience unnecessary. 897 Railway Bureau, East St. Louis, Ill.

**Become Railway Mail Clerks.** \$133-\$195 month. Men, 18 to 35. Common education sufficient. Sample examination questions free. Write immediately. Franklin Institute, Dept. N25, Rochester, N. Y.

**Hotels Need Trained Men and Women.** Nation-wide demand for high-salaried men and women. Past experience unnecessary. We train you by mail and put you in touch with big opportunities. Big pay, fine living, interesting work, quick advancement, permanent. Write for Free Book, "Your Big Opportunity." Lewis Hotel Training Schools, Suite 3442, Washington, D. C.

**Make money in spare time mailing letters.** Men, write now, enclosing stamped addressed reply envelope. Normandie R Dept., 147 W. 23d St., New York.

**Earn \$25 Weekly,** spare time, writing for newspapers, magazines. Experience unnecessary; details free. Press Syndicate, 5665 St. Louis, Mo.

**Get posted for Spring—Good prices paid for butterflies, insects.** See Sinclair display advertisement, page 1121.

**Insects Wanted**

**Get posted for Spring—Good prices paid for butterflies, insects.** See Sinclair display advertisement, page 1121.

**Instruction**

**Learn Chemistry at Home.** Dr. T. O'Connor Sloan, noted educator and scientific authority, will teach you. Our home study correspondence course fits you to take a position as chemist. See our full page ad on page 1045 of this issue. Chemical Institute of New York, 140 Liberty St., New York City.

**Used Correspondence Courses only one-quarter original price.** Free bargain price list. 1,000 courses. Courses bought. Students Exchange, 45 W. 42d St., New York.

**Languages**

**World-Romic System, Masterkey to All Languages.** Primers, 23 languages, \$1.94 each language. Arabic, Bohemian, Bulgarian, Cantonese, Chindau, Danish, Dutch, English, Scotch English, French, German, Hungarian, Italian, Japanese, Latin, Panjabi, Polish, Portuguese, Rumanian, Russian, Sechuana, Spanish, Swedish. Pronunciation—Tables, 94 languages, 30c each language. Languages Publishing Company, 8 West 40th Street, New York.

**Machinery and Tools**

**Concrete Building Block Machines and Molds.** Catalogue free. Concrete Machine Co., 305 South Third St., St. Louis, Mo.

**Mail Order Business**

**550 week evenings—I made it.** Mail Order business; booklet for stamp tells how. Sample and plan, 25c. Free, 12 articles worth \$3. Al Exp. Scott, Cohoes, N. Y.

**Manufacturing**

**To Order:** Metal articles, Models, Tools, Patterns, Experimenting Manufacturing Inventions developed. Cleveland Specialty & Mfg. Co., Searsville Ave., Cleveland, Ohio.

**Miscellaneous**

**Get posted for Spring—Good prices paid for butterflies, insects.** See Sinclair display advertisement, page 1121.

**So-Brite Radium luminous pendant Free.** Helps you locate electric light switch in the dark. Send two-cent stamp for details. Radium Application Co., 14 Paterson Street, Jersey City, N. J.

**Joker's novelties.** Great fun. List free. D. Fenner, 2401 Jefferson, Louisville, Ky.

**Polly Wrench—The harder you twist the tighter it grips; it's guaranteed.** Three sizes—75c, \$1, \$1.50. money order or draft. Gloss Polish Co., General Delivery, Peoria, Ill.

**Inventors' Round-up and Convention—get wise.** Round-up, Cincinnati, O. C/o Billboard.

**Blue Prints, Castings, 1/4 1/2-Horse power gasoline engines.** Model steam engines, horizontal or vertical. Blue Prints of any one, 50 cents. Order from ad. Stamp for circular. Master Model Co., Box 212C, Elgin, Ill.

**Choose the Right Vocation.** Ask for Free Vocational Self Analysis Chart St. Vocational Service Bureau, 20 E. Jackson, Chicago.

**Motorcycles—Bicycles**

**Used parts for all motorcycles cheap.** State wants Senuck Cycle Co., 1922 Westlake, Seattle, Wash.

**Don't buy a Bicycle Motor Attachment until you get our catalogue and prices.** Shaw Mfg. Co., Dept. 6, Galensburg, Kansas.

**Musical**

**Song Poems Fitted to music by recognized songwriter.** Sharks exposed. J. Doane, 2128 Alice Place, Chicago.

**Old Money Wanted**

**\$2 to \$500 Each paid for hundreds of old or odd coins.** Keep all old money. You may have very valuable coins. Send 10 cents for New Illustrated Coin Value Book, 4x6. We pay Cash. Get posted. Clarke Coin Company, Ave. 15, LeRoy, N. Y.

**Patent Attorneys**

**Inventors: Protect your invention through A. M. Wilson, Inc., Washington, D. C.** Over 25 years of efficient, expert, confidential service. Skilled in Radio-Electrical, Chemical and Mechanical fields. Our new illustrated booklet, giving much necessary and very useful information which every inventor should know, will be sent free upon request. Prompt and careful attention. Highest references. Moderate fees. Send sketch or model for our careful opinion and preliminary advice. Write today to A. M. Wilson, Inc. (Radio 3 ARH), 312 Victor Bldg., Washington, D. C. (Successor to business established in 1891 by A. M. Wilson.)

**Millions spent annually for ideas! Hundreds now wanted!** Patent yours and profit! Write today for free books—tell how to protect yourself, how to invent, ideas wanted, how we help you sell, etc. 212 Patent Dept., American Industries, Inc., Washington, D. C.

**Inventors.** Send sketch or model of invention for opinion concerning patentable nature and exact cost of patent. Book, "How to Obtain a Patent," sent free. Tells what every inventor should know. Established twenty-eight years. Highest references, prompt service, reasonable charges. Chandiee & Chandiee, 441 Seventh, Washington, D. C.

**Patents.** Send for free booklet. Highest references. Best results. Promptness assured. Send model or drawing for examination and opinion. Watson E. Coleman, Patent Attorney, 624 F Street, Washington, D. C.

**Patents—Prompt, personal efficient service by an attorney-at-law, skilled in all branches of Patent Practice.** Over 18 years actual experience; full information upon request. B. P. Fishburne, 330 McGill Bldg., Washington, D. C.

**Inventors write me about patents.** My fees payable monthly. Booklet free. Frank Fuller, Washington, D. C.

**Patents Secured.** Prompt service. Avoid dangerous delays. Send for our "Record of Invention" form and Free Book telling How to obtain a Patent. Send sketch or model for examination. Preliminary advice without charge. Highest References. Write Today. J. L. Jackson & Co., 418 Ouray Bldg., Washington, D. C.

**Herbert Jenner, Patent Attorney and Mechanical Expert,** 624 F Street, Washington, D. C. I report if patent obtainable and exact cost. Send for circular.

**Protect your rights.** Write for "Record of Invention" and booklet about Patents. Prompt personal service. Advice without charge. J. Reaney Kelly, 612 V Columbian Building, Washington, D. C.

**Inventors—Send for form "Evidence of Conception"** to be signed and witnessed. Form, fee schedule, information free. Lancaster & Allwine, 242 Ouray Building, Washington, D. C.

**Monroe Miller, Ouray Building, Washington, D. C.,** patent attorney, mechanical and electrical expert. Best quality of work and results. Moderate charges.

**Patents! Send sketch for search of pertinent U. S. patents and Report, including copies of patents nearest your idea.** Earlier patents may offer valuable suggestions for improving or perfecting your invention. Preliminary information or advice without charge. O'Connell & O'Connell, 400 Seventh Street, N. W., Washington, D. C.

**Patents Procured.** Trade-Marks Registered. A comprehensive, experienced, prompt service for the protection and development of your ideas. Preliminary advice gladly furnished without charge. Booklet of information and form for disclosing idea free on request. Richard B. Owen, 130 Owen Building, Washington, D. C., or 2278-T Woolworth Bldg., New York.

**Inventors should write us for our book, "How to Obtain a Patent,"** which clearly sets forth what may be patented and the necessary steps to protect an invention. It describes the procedure in Patent Office and tells about assignments, licenses and trade-marks, and gives many useful facts about patents which every inventor should know. Many persons well versed in patent matters have pronounced this book the best of its kind they have ever read. It is written so you can understand it. Copy sent free upon request. Talbert & Talbert, Patent Lawyers, 458 Talbert Bldg., Washington, D. C.

# Aspirin

Say "Bayer" and Insist!



Unless you see the name "Bayer" on package or on tablets you are not getting the genuine Bayer product prescribed by physicians over twenty-two years and proved safe by millions for

**COLDS  
TOOTHACHE  
EARACHE  
NEURALGIA**

**HEADACHE  
LUMBAGO  
RHEUMATISM  
PAIN, PAIN**

Accept "Bayer Tablets of Aspirin" only. Each unbroken package contains proper directions. Handy boxes of twelve tablets cost few cents. Druggists also sell bottles of 24 and 100. Aspirin is the trade mark of Bayer Manufacture of Monoaceticacidester of Salicylicacid.



## SEX

Facts other sex books don't dare discuss are plainly told in "Where Knowledge Means Happiness." Creates a new kind of married love. One reader says:

*It contains more real information than all other sex books put together.*

From "Where Knowledge Means Happiness" Sent in plain cover, by registered mail, for \$1.00, cash, money order, check or stamps. Copyright 1921

COUNSEL SERVICE, Dept. 39, 257 W. 71st St., N. Y.



**DEAFNESS IS MISERY**  
I know because I was Deaf and had Head Noises for over 30 years. My invisible Antiseptic Ear Drums restored my hearing and stopped Head Noises, and will do it for you. They are Tiny Megaphones. Cannot be seen when worn. Effective when Deafness is caused by Catarrh or by Perforated, Partially or Wholly Destroyed Natural Drums. Easy to put in, easy to take out. Are "Unseen Comforts." Inexpensive. Write for Booklet and my sworn statement of how I recovered my hearing.  
**A. O. LEONARD**  
Suite 369, 70 5th Avenue -- New York City



**"BOW LEGS and KNOCK-KNEES" UNSIGHTLY**  
Send for booklet showing photos of men with and without the PERFECT LEG FORMS.  
**PERFECT SALES CO.**  
140 N. Mayfield Ave., Dept. 50, Chicago, Ill.

**ARE YOU BASHFUL, TIMID**  
Self Conscious. Embarrassed in Company. Let us tell you how you can overcome these troubles and acquire Poise, confidence, assurance and a magnetic personality. Address The Veritas Science Institute, 1400 Broadway, New York, Desk 15.



**BUCHSTEIN'S FIBRE LIMB**  
is soothing to your stump—strong, cool, neat, light. Easy payments. Braces for all deformities.  
**H. BUCHSTEIN CO.**  
Minneapolis, Minn.

**ADULTS! SEX KNOWLEDGE BOOKS**  
Instructive, authoritative, profusely illustrated in natural colors, etc. Not the cheap sort. Contains everything one should know both before and after marriage to insure health and happiness. **LARGE CATALOG FREE.**  
**E. SMETANA AND COMPANY, OWOSSO, MICH.**

**OLD MONEY WANTED**  
\$2 to \$500 EACH paid for hundreds of old or odd Coins. Keep all old money as you may have VERY valuable coins. Send 10c for New Illustrated COIN VALUE BOOK, size 1x6. Get posted. We pay CASH. Clarke Coin Co., Avenue 76, Le Roy, New York.

### Novelties

Crystal Gazing. Book 75c. Also Crystals. Crystal Gazing Co., 122 Station "B," Kansas City, Mo.

### Office Devices

Save half on office Machines, Equipment, Addressors, Multigraphs, Duplicators, Dictaphones. Pruitt Company, 172 North Wells, Chicago.

### Patents

Inventions Commercialized. Patented or unpatented. Write Adam Fisher Mfg. Co., 205 St. Louis, Mo.

### Patents For Sale

No. 1,407,175 Combination wineholder and advertising device; makes novelty moving display for counter. Packets everywhere are looking for this sort of device to advertise their product. Cheap to make, newest thing out, chance to make a fortune. Sell outright or royalty. Address B. W. Smith, Oroville, Calif.

### Personal

Astrology Revealed—Dime, birthdate and red stamp brings 2,000 word trial reading. Two questions considered. Prof. Audrey, Section M-18, Box 831, Washington, D. C.

Exchange Cheery Letters with New Friends! Send stamp. Betty Lee, Inc., 4254 Broadway, New York City.

Exchange jolly letters with new friends. Lots fun! Send stamp. Eva Moore, Box 908, Jacksonville, Fla.

### Phonograph Supplies

Build Your Own Phonograph. Big saving. Pleasant, instructive work. Complete instructions, blue-prints, etc., absolutely free. Write today. Associated Phonograph Co., Dept. AP-12, Cincinnati, Ohio.

Perfection Phonograph motors, tone-arms, amplifiers, cabinets, hardware. Highest quality, very low prices. Catalog free. Federal Supply Co., Indianapolis, Ind.

Build Your Phonograph. Quality phonographs. Famous Sereano Motors. Also original Perfection Motors. Electric Motors, tonearms, reproducers, amplifiers, case material, accessories. Free blueprints and building instructions. Big saving. Wonderful results. Prompt delivery. Catalog mailed for ten cents. Hoosier Mfg. & Supply Company, 321 Baldwin Block, Indianapolis, Indiana

### Photoplays, Stories, Etc.

Wanted. Men and women ambitious to make money writing Stories and Photoplays. Send for wonderful Free Book that tells how. Authors' Press, Dept. 131, Auburn, N. Y.

### Postcards and Pictures

30 Actual Photographs of Washington, D. C. 35 cents, postpaid. Nelson Carr, 3921-7th St., N. W., Washington, D. C.

### Printing

We are printers of envelopes, letterheads, and imitation typewriter letter work. Send for price list. Colman Mercantile Co., 1121 Manchester Ave., St. Louis, Mo.

### Radio Outfits and Supplies

Agents Wanted in Every City to sell standard radio apparatus on a liberal commission basis. A few stocking agencies open to reliable parties. Delfeolo, 12 Meeting Street, Pawtucket, R. I.

### Salesmen Wanted

Big Profits—\$250 to \$300 a month selling high-grade leather Fan Belts and Belting to Auto Accessory Dealers and Garages. Full or part time. Write Monarch Belting Co., Ontario Bldg., Cleveland, Ohio.

Big Profits—\$300 to 400 a month selling Leather Belting and Pulley Covering to Factories, Mill Supply and Hardware Jobs. See our ads commencing Dec. Issue "Belting." Side Line or full time. Write Monarch Belting Co., Ontario Bldg., Cleveland, Ohio.

### Short Stories, Manuscripts Wanted

Earn \$25 Weekly Spare Time writing for newspapers, magazines. Experience unnecessary; details free. Press Syndicate, 566 St. Louis, Mo.

Short Stories, poems, plays, etc., are wanted for publication. Literary Bureau, 165 Hannibal, Mo.

### Stamps and Coins

Stamps Free—Variety Packet, Foreign Stamps with catalogue—2c postage. Gray Stamp Company, Station E5, Toronto, Canada.

Stamps—20 Unused, All Different, Free. Postage 3c. Mention paper. Quaker Stamp Co., Toledo, Ohio.

Stamps. 50 varieties—Africa, Brazil, Peru, Cuba, Mexico, etc., 10c. 50 different U. S., 25c; 1,000 mixed, 40c; 1,000 hinges, 10c. List free. C. Stegman, 5955 Cote Brillante, St. Louis, Mo.

California Gold, quarter size, 27c; half-dollar size, 53c. Columbian nickel and catalogue, 10c. Norman Schulz, Box 146, Colorado Springs, Colo.

### Telegraphy

Wanted—Young men and women to learn Morse and Wireless Telegraphy. Railroads and Wireless Companies in great need of operators. We teach you quickly and procure positions at big salaries. Great opportunities for advancement. All expenses low; can earn part. Write today for free catalog. School established 1874. Dodge's Telegraph Institute, "O" Street, Valparaiso, Ind.

### Song Poems Wanted

Write the Words for a Song. We compose music. Our Chief of Staff wrote many big song-hits. Submit your song-poem to us at once. New York Melody Corp., 412 Fitzgerald Bldg., New York.

### Song Writers

Write a Song! Any subject—you can do it. Send words today—I will compose the music. Frank Backer, 6018 Prairie Ave., Dept. 645, Chicago.

### Stamping Names

Make \$19 a Hundred stamping names on keychecks, Send 25c for sample and particulars. Ex Kaytag Co., Cohoes, N. Y.

### Typewriters

Typewriters sold on payments. Free trial. Payne Company, Rosedale, Kansas.

### Ventriloquism

Ventriloquism taught almost anyone at home. Small cost. Send 2c stamp today for particulars and proof. Gen. W. Smith, Room M-743, 125 N. Jefferson Ave., Peoria, Ill.

### Wanted to Buy

Cash for Old Gold, Platinum, Silver, Diamonds, Liberty Bonds, War, Thrift, Unused Postage Stamps, False Teeth, Magneto Points, Jobs, any valuables. Mail in today. Cash sent return mail. Goods returned in ten days if you're not satisfied. Ohio Smelting Co., 303 Hippodrome Bldg., Cleveland, Ohio.

Full value paid for old gold, jewelry, watches, diamonds, crowns, bridges, dental gold, silver, platinum, gold or silver ore, magneto points, war savings stamps, old false teeth. Packages held 4 to 12 days and returned if our offer is not satisfactory. United States Smelting Works (The Old Reliable), 120 So. State St., Dept. 73, Chicago, Ill.

### Wireless

Boys, don't overlook this! The "Rasco" Babra Detector. Greatest detector ever brought out with molded base. Fully adjustable. See former advertisements in this publication or our catalogue. Detector with Galena Crystal complete, 50c; the same Detector with Radiocite Crystal, 75c prepaid. Send for yours today. Radio Specialty Company, 100 Park Place, New York City.

Attention! 50 Vacuum Tube Hook-Ups. The greatest collection of Vacuum Tube Circuits ever brought under two covers at such insignificant cost. These diagrams will be found in the great "Rasco" catalogue which contains raw materials and parts in a greater profusion than any other catalogue. 15c in stamps or coin will bring the catalogue to you. Radio Specialty Company, 100 Park Place, New York City.

How to Make Wireless Receiving Apparatus. 100 pages—90 illustrations. Only strictly modern radio apparatus are described in this book and the illustrations and descriptions are so clear and simple that no trouble will be experienced in making the instruments. Paper covered, 35c postpaid. Experimenter Publishing Co., Book Dept., 53 Park Place, New York City.

How to Make Wireless Sending Apparatus. 100 pages—88 illustrations. Written and published entirely for the wireless enthusiast who wants to make his own radio apparatus. Contains more information on "how to make it" than any other book we know of. Paper bound 35c postpaid. Experimenter Publishing Co., Book Dept., 53 Park Place, New York City.

How to Make Radio Frequency Amplifiers. This book is for the more advanced amateur, showing the construction of the Radio Frequency Amplifying Transformer and giving complete constructional data. It shows the application of Radio Frequency to amplifying units that the amateur may already possess and gives 15 hook-ups showing practically every use Radio Frequency Amplifying Transformers can be put to. 32 pages, 15 illustrations; bound in beautiful two-color cover. Prepaid 25c. The E. I. Company, 233 Fulton Street, New York City.

Wireless Course in 20 Lessons. By S. Gernsbark, A. Lescaurba and H. W. Secor, E. E. Tells you everything you want to know about "Wireless"—theory, practice and history. A clear, concise course on every phase of this subject. 160 pages—350 illustrations, 50 tables. Stiff cloth cover, \$1.75, postpaid. Experimenter Publishing Co., Book Dept., 53 Park Place, New York.

The How and Why of Radio Apparatus, by H. W. Secor, E. E. This newest book on radio matters fills a distinct gap in wireless literature in that, while the treatment is made as understandable and as free from mathematics as possible, it at the same time incorporates a wealth of technique and instruction for the Radio Amateur—the Radio Operator—the Installation and Designing Expert—as well as teachers and students of the subject in general. A very broad field has been covered by the author, at the same time giving a great deal of information not found in other text books. If you are engaged in any branch of the Radio or allied arts at all you will surely need this latest contribution to radio literature, which is destined to be found on every radio man's book shelf before long. A glance at the following list of chapters gives but a very scant idea of the extensive and useful radio knowledge provided in its text: The Induction Coil; The Alternating Current Transformer; Radio Transmitting Condensers; The Spark Gaps; Radio Transmitting Inductances; Radio Receiving Tuners; Radio Receiving Condensers; Detectors; Telephone Receivers; Radio Amplifiers; Construction of a Direct Reading Voltmeter and Measurement of Inductances; The Calculation and Measurement of Inductances; Appendix containing very useful tables, covering all subjects treated in this very unusual book. This newest of Radio Works, cloth bound in Vellum de Luxe, Gold Stamped and Hand Sewed, has 160 pages. Size of book, 8x9 inches. The How and Why of Radio Apparatus. Postpaid, \$1.75. Experimenter Publishing Co., Book Dept., 53 Park Place, New York City.

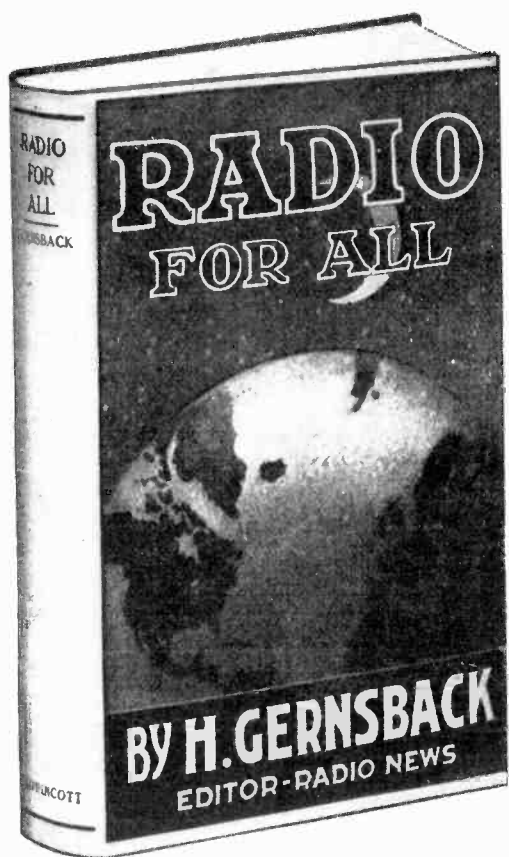

The Complete Book of  
All Radio Information  
**PRICE POSTPAID \$2.00**

# RADIO FOR ALL

By H. GERNSBACK

Editor "Radio News," "Science and Invention" and "Practical Electrics"

With over 130 illustrations and diagrams, and 12 photographs, 300 pages, size 8 1/4" x 5 1/2".

What the novice in radio needs is a book in which he can get all the information necessary for him to understand radio telephony and telegraphy, to make or buy a receiving set suitable to his means, to know how to operate his set, and after he has an understanding of the radio art, information that will enable him to advance and get the most out of his outfit. All this must ordinarily be dug out of text-books, pamphlets and government publications, but the aim of this book is to have all the data and information that the beginner will need from the time that he takes up radio. It is a permanent, comprehensive reference book for the dyed-in-the-wool dabbler in Radio.

### What the Book Is.

A combination of a radio course for the novice in radio telegraphy and telephony with a reference book for the more experienced amateur. Half a dozen books in one.

### For the Beginner.

The theory of radio carefully explained with drawings.  
Description of and instruction for operating instruments of receiving and sending sets, with all picture diagrams of the wiring of the apparatus.  
How to make your own receiving set, costing from \$3.00 to \$50.00.  
How to read diagrams; for every picture diagram there is a corresponding technical diagram using the symbols instead of drawings.  
How to tune sharply and eliminate interference from other stations.  
How to protect your set from lightning and the laws regarding installation.  
Explanation of time and weather signals.

### For the More Experienced Amateur.

How to make a practical vacuum tube detector, two stage amplifier set costing less than \$50.00, that will work.  
How the radio compass works.  
All about underground aeriels, loop aeriels and directional aeriels.  
Formulae for finding wave length, miscellaneous formulae for finding capacity of condenser and other instruments. Tables of wire resistances, wave lengths and their corresponding frequencies, approximate wave lengths for different aeriels, tuning coil data, and much more invaluable information.

### Special Features.

Lists of all the broadcasting stations in the United States and Canada for concerts, time signals, weather reports, press, stock market reports, etc., with their call, wave length and time of sending.

Detailed description of Washington weather signals and their translation.  
Description of a modern broadcasting station and its operation.  
Large map showing location of all U. S. radio telephone broadcasting stations suitable for hanging up in radio room.  
Collection of miscellaneous radio information for the amateur.

### In Other Words.

The information that you ordinarily have to dig out of government publications, text-books, pamphlets, etc., is handily combined in this one book.

## You'll Need These Three "Little Wonder" Radio Books:

### How to Make Wireless Receiving Apparatus



The 20 radio constructors who wrote the book know how articles should be made from simple materials.  
Only modern apparatus is described, such as Receiving set without aerial or ground, magnetic detector, wireless relay, wireless lecture set, etc., etc. Book has 100 pages, each 6 x 7 inches, 90 illustrations, many full pages, paper bound, in two colors.

Price 35 Cents

### How to Make Wireless Sending Apparatus



Contains information on how to make 30 different pieces of wireless sending apparatus from materials, easily obtained.  
Tells How to Make an Experimental Arc Set, Speaking Arc, Quenched Gap, 1/4 K. W. Transformer, Oscillation Transformer, Photo Phone, etc., etc.  
Book has 100 pages (size, 7 x 5 inches), 88 illustrations, paper cover printed in two colors.

Price 35 Cents

### Design and Construction of Audion Amplifying Transformers



Radio and Audio Frequency Type  
This book will be of great interest to all radio amateurs. The transformers have never before been described in print. The possessor of vacuum tubes cannot afford to do without this book. It will enable him to build the necessary amplifying transformers very readily. The book is printed on good paper and has an attractive cover in two colors. Paper bound. Size, 5 inches by 7 inches. Contains many illustrations, diagrams and working data.

Price 25 Cents

## A Thousand and One Formulas

By S. Gernsback

A Laboratory Hand Book for the Experimenter and for Everyone who wishes to "do things."  
A Book brimful with very important and priceless information.  
The recipes and formulas are classified in such a manner as to be available quickly, without long research.  
Invaluable for Students, Engineers, Physicians, Experimenters, etc.  
Here are some of the chapter headings:  
Cements and Glues; Composition of All Kinds; Glass and Glassworking; Inks; Leather Polishes; Metal-craft; Perfumery, Soaps and Extracts; Photography; Blue Print and other Paper; Plating; Pyrotechny; Polishes and Stains; Varnishes and Paints; Various Cleaning Formulas; Wood-craft; Chemical Laboratory Hints and Experiments; Mechanical Laboratory Hints and Experiments; Electrical Laboratory Hints and Experiments.  
There are a score of tables and hundreds of illustrations and Diagrams.  
It contains 160 pages. The paper has been specially selected to stand rough handling in laboratories.  
Size, 6 x 9 inches.  
Cloth bound in Vellum de Luxe, stiff covers, hand-sewed, gold stamped, each **\$1.75**

This Wonderful Volume of Formulas—  
You Should Have It In Your Home



DEALERS—Ask for wholesale discount  
**EXPERIMENTER PUBLISHING CO., Inc. : 53 Park Place, New York**



# EVERY BOY WHO IS INTERESTED IN RADIO

## CAN TAKE ADVANTAGE OF OUR SPECIAL OFFER

EVERY BOY HAS A FEW SPARE HOURS EACH WEEK and can easily obtain a few subscribers to PRACTICAL ELECTRICS.

On this page you will see the special rewards we will send you for only one subscription. You can easily earn every one of them. They will be sent you

### ABSOLUTELY FREE

PRACTICAL ELECTRICS is the electrical magazine for everyone. It is the only electrical magazine a boy can understand. It has a regular department for beginners, but is just as interesting for the experimenter, the electrician, and the electrical engineer. There are articles each month by students, experimenters and famous electricians. The entire progress of the month in electrics is set forth in its pages.

PRACTICAL ELECTRICS is one of the most interesting electrical magazines published. It contains no long, dry technical articles. Every article is completely illustrated. There are hundreds of illustrations, plans, drawings, charts, etc.

On the opposite page you will find complete description of each reward.

## PRACTICAL ELECTRICS is only \$2.00 per year [12 Numbers]

(Canada or foreign 50 cents additional)

### EVERY BOY SHOULD HAVE IT!

All articles are written in plain, everyday language. If you need a sample copy to show we will send it free of cost.

### SEE OPPOSITE PAGE FOR DESCRIPTIONS

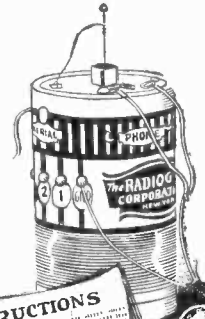

# OH BOYS!

**ABSOLUTELY FREE FOR A FEW HOURS' SPARE TIME WORK.  
READ OUR SPECIAL OFFER AND ACT AT ONCE.**

# Descriptive Details of Rewards

We will send you your choice of these rewards.  
**ONE REWARD FOR EACH SUBSCRIPTION for one year.**

### REWARD No. 1

#### RADIOGEM

A complete crystal Radio Receiving Set, will receive up to 25 miles. The outfit consists of all the necessary wire, contact points, detector mineral, catwhisker, tuning coil, instruction book, etc. When you have constructed the Radiogem, all you need is an aerial and a phone.

### REWARD No. 2

#### MICROPHONE BUTTON

The button may be used to amplify Radio Signals by using it in a local circuit. It should be mounted on the diaphragm of a telephone receiver connected to the radio set and in circuit with a battery and a telephone induction coil. You can easily make a highly sensitive detectophone by using a Microphone Button to collect the sound waves. You can build your own outfit without buying expensive equipment. Think of the fun you would have with such an instrument!

### REWARD No. 3

#### EXPERIMENTAL ELECTRICITY COURSE IN 20 LESSONS

By S. Gernsback and H. W. Secor, E.E.

A Course on the theory and practice of Electricity for Experimenters. One of the most complete and comprehensive treatises of this special subject ever published. Written by the same authors as the famous "Wireless Course." The best electrical text book on the market. Size of books is 6 x 9 in. The book contains 128 pages, and more than 400 illustrations. Limp bound.

### REWARD No. 4

#### Complete Patterns, Diagrams and Instructions How to Make Your Own RADIOPHONE CRYSTAL SET

PATTERN No. 3

Consisting of a 4 page illustrated Direction pamphlet, size 8½ x 11½ inches; one blueprint pattern, size 16 x 12 inches. All contained in two-color printed envelope. 9 x 12 inches.

### REWARD No. 5

#### Complete Patterns, Diagrams and Instructions How to Make Your Own SHORT WAVE REGENERATIVE RADIOPHONE SET

PATTERN No. 1

Consisting of a five-page illustrated direction pamphlet, size 8½ x 11½ inches; one blueprint pattern, size 16 x 22 inches, and one blueprint pattern, size 17½ x 22 inches. All contained in a heavy two-color printed envelopes, size 9 x 12 inches.

### REWARD No. 6

#### Complete Patterns, Diagrams and Instructions How to Make Your Own DETECTOR AND AMPLIFIER RADIO UNITS

PATTERN No. 2

Consisting of a four-page illustrated direction pamphlet, size 8½ x 11½ inches; one blueprint pattern, size 16 x 18 inches, and one blueprint pattern, size 13½ x 15 inches. All contained in heavy, two-color printed envelope. 9 x 12 inches.

### REWARD No. 7

#### 14 RADIO FORMULAE AND DIAGRAMS

All formulae and diagrams are printed on heavy paper in black and blue; and contained in two-color printed envelope 9 x 12 inches.

### REWARD No. 8

#### 2 RADIOPHONE DIAGRAMS AND HOOK-UPS Of Crystal and Audion Receiving Circuits, Amplifier Circuits, Regenerative Circuits, Sending Circuits with Key Chart of Symbols, and Pamphlet "HOW TO READ DIAGRAMS"

All 20 diagrams are printed on heavy paper, each sheet size 8¼ x 11½ inches, and together with Key Chart of Symbols and pamphlet, "How to Read Diagrams," are contained in a heavy two-color printed envelope, size 9 x 12 inches.

### REWARD No. 9

#### WIRELESS COURSE IN 20 LESSONS

By S. Gernsback, A. Lescarboura, and H. W. Secor, E.E. (10th Edition)

A Course that tells you everything you wish to know about "Wireless," starting in lesson No. 1 by explaining the Principles of Electricity. By simple, easy stages, this wonderful Course takes you into "Wireless" by the use of such simple language so skillfully used that of necessity you must understand every word.

Size of book is 7 x 10¼ inches, 160 pages, 350 illustrations, 30 tables. Limp bound.

### REWARD No. 10

#### THE HOW AND WHY OF RADIO APPARATUS

By H. W. Secor, E.E.

This newest book on radio matters fills a distinct gap in wireless literature in that, while the treatment is made as understandable and as free from mathematics as possible, it at the same time, incorporates a wealth of technique and instruction for the Radio Amateur—the Radio Operator—the Installation and Designing Expert—as well as instruction for teachers and students of the subject in general.

160 pages, 6 x 9 inches. Limp bound.

### REWARD No. 11

#### A THOUSAND AND ONE FORMULAS

By S. Gernsback

A laboratory hand book for the experimenter and for everyone who wishes to "do things." A book brimful with very important and priceless information, collected and selected for years. Invaluable for Students, Engineers, Physicians, Experimenters, etc.

It contains 160 pages. The paper has been especially selected to stand rough handling in laboratories. Size 6 x 9 inches. Limp bound.

### REWARD No. 12

(All Three Books)

#### HOW TO MAKE WIRELESS RECEIVING APPARATUS

The 20 radio constructors who wrote the book know how articles should be made from simple materials.

Book has 100 pages, each 5 x 7 inches, 90 illustrations, many full pages, paper bound in two colors.

#### DESIGN AND CONSTRUCTION OF AUDION AMPLIFYING TRANSFORMERS

Radio and Audio Frequency Type

This book will be of great interest to all radio amateurs. The transformers have never been described before in print.

Size, 5 x 7 inches. Contains many illustrations, diagrams and working data.

#### HOW TO MAKE WIRELESS SENDING APPARATUS

Contains information on how to make 30 different pieces of wireless sending apparatus from materials easily obtained.

Book has 100 pages (size 7 x 5 inches), 88 illustrations, paper cover printed in two colors.

**PRACTICAL ELECTRICS CO., Inc., 53 Park Place, New York, N. Y.**

GENTLEMEN:—Please send PRACTICAL ELECTRICS for one year (12 numbers) to each of the following addresses:

Name	Street Address	City and State
.....	.....	.....
.....	.....	.....
.....	.....	.....
.....	.....	.....
.....	.....	.....
.....	.....	.....
.....	.....	.....
.....	.....	.....
.....	.....	.....
.....	.....	.....

Enclosed you will find.....subscriptions at \$2.00 each, making the full sum of \$..... (For each subscription to go to Canada or Foreign addresses 50 cents additional must be added.) Also please send me the Rewards (one for each subscription) numbered as follows:

My Name is.....Street.....  
 City.....State.....

# Get This Wonderful New Book About

## LOUD - TALKERS

### HOW TO BUILD THEM

by **H. WINFIELD SECOR**

Associate Editor of Science & Invention

25 cents, postpaid



This book describes how to build two distinct and different types of radio loud-talkers, which can be built with either electro-magnetic field to be excited from storage battery, as well as permanent magnet field requiring no separate battery excitation. The third chapter deals with improvised loud-talkers and gives clear and complete instructions on how to build suitable horns for use with radio receivers of the Baldwin and other types. Several elaborate hook-ups are given of the author's own radio receiving set, comprising one stage of radio-frequency, detector and three stages of audio-frequency amplification, together with all the connections for the loud-talker.

Complete data is given for all the parts of the loud-talkers, including the field magnet windings, as well as the diaphragm or moving coil windings, and also the step-down transformer to be connected between the vacuum tube amplifier and the loud-talker proper.

In preparing these designs the point has been constantly kept in mind to use the simplest parts possible, so that practically anyone can build a successful loud-talker equivalent to the commercial types costing \$40.00 or more.

Even where the experimenter does not possess the skill or the time to make all the parts himself, which are really few in number, he may save a great deal of money, or at least half the price of a commercial loud-talker, by having the difficult parts made in a local machine shop, and then assembling them and winding the coils himself. Circuit connections and data for the size of wire, etc., are given for placing the loud-talker on a separate floor or in another part of the house not occupied by the radio receiving set. A very valuable book, giving data which cannot be obtained anywhere else and which has not been published before.

64 pages, 25 illustrations, bound in beautiful two-color cover, size 5½ x 7½ inches; Price prepaid, 25 cents

## Have You a Copy of These Two Books?

### HOW TO MAKE RADIO-PHONE RECEIVING SETS

By **ROBERT E. LACAULT**  
Associate Editor RADIO NEWS

25¢

### RADIO FREQUENCY AMPLIFIERS

AND HOW TO MAKE THEM

By **JOHN M. AVERY**

25¢

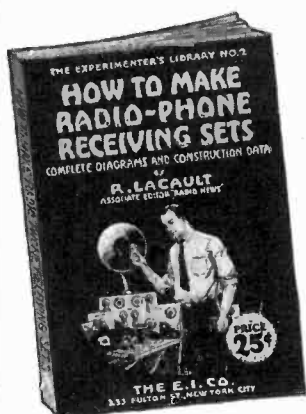

A non-technical book for the beginner. Gives complete constructional data on the building of a complete Crystal Detector Set, Tuning Coil, Loose Coupler and a Single Audion Tube Set with Amplifying Units. It furnishes all dimensions and working drawings of every part that must be constructed by the amateur. Written in plain, simple language that anyone can understand. The opening chapter gives a complete description of the theory of radio and tells what it's all about, teaching the principles of wireless so that the constructor knows what he is doing.

48 Pages, 26 Illustrations  
Bound in Beautiful Two-Color Cover  
Size, 5½x7½ inches. Prepaid 25c.

This book is for the more advanced amateur, showing the construction of the Radio Frequency Amplifying Transformer and giving complete constructional data. It shows the application of Radio Frequency to amplifying units that the amateur may already possess and gives 15 hook-ups showing practically every use Radio Frequency Amplifying Transformers can be put to.

32 Pages, 15 Illustrations  
Bound in Beautiful Two-Color Cover  
Size, 5½x7½ inches. Prepaid, 25c.

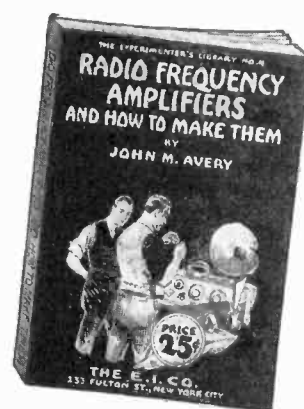

Order from your dealer—or direct from us

**THE E. I. COMPANY** 233 FULTON STREET  
NEW YORK CITY, N. Y.



Let These Guides

Solve Your Problems

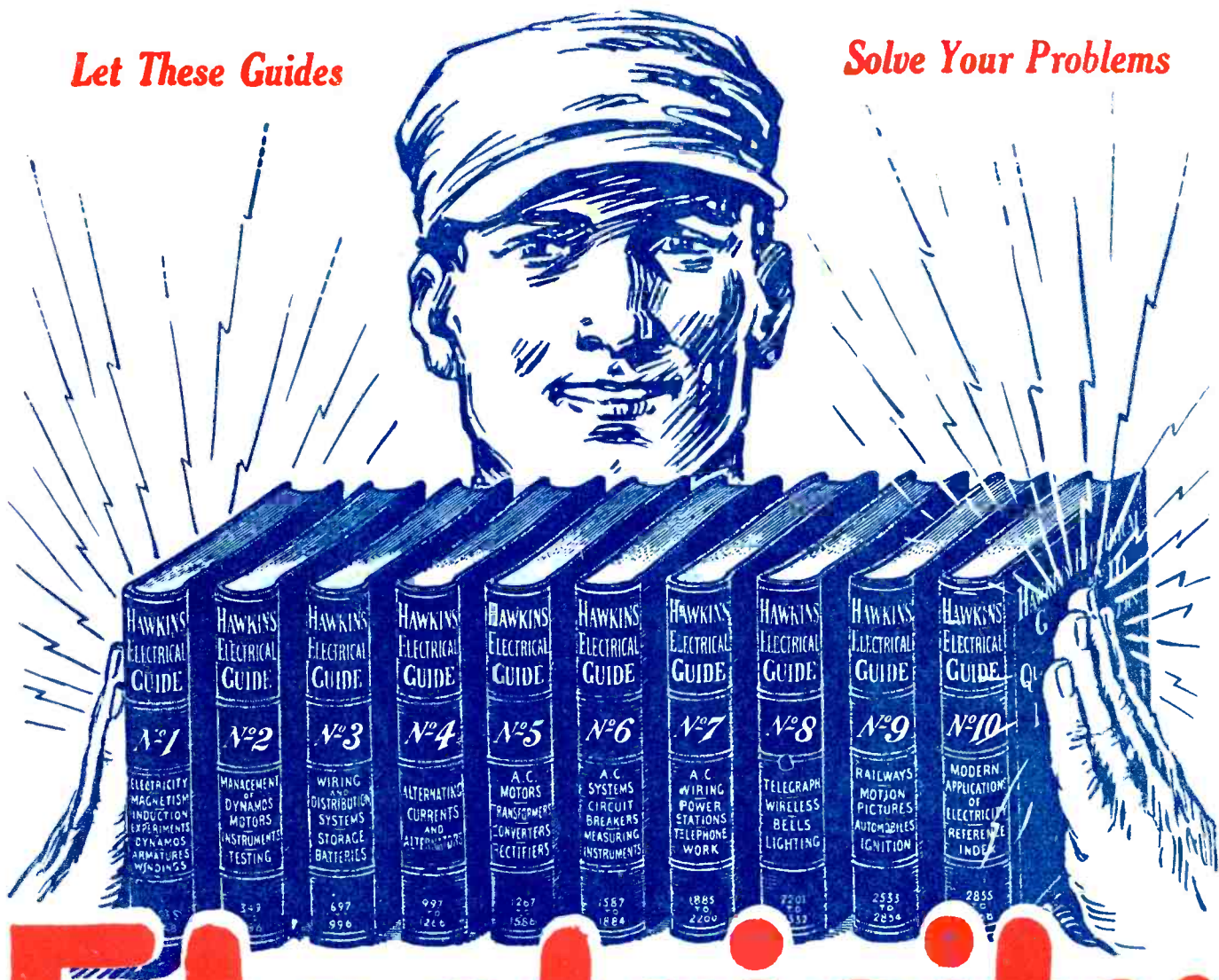

# Electricity at your finger ends

**HAWKINS ELECTRICAL GUIDES** IN TEN VOLUMES

3500 PAGES  
4700 PICTURES

\$1 A VOLUME  
\$1 A MONTH

SEND NO MONEY—SEND ONLY THIS COUPON

Know the facts in Electricity. They mean more money and better position for you. Hawkins Guides tell you all you need to know about Electricity. Every important electrical subject covered so you can understand it. Easy to study and apply. A complete, practical working course, in 10 volumes. Books are pocket size; flexible covers. Order a set today to look over.

**LEARN ALL ABOUT**

Magnetism — Induction — Experiments — Dynamos—Electric Machinery—Motors—Armatures—Armature Windings—Installing of Dynamos—Electrical Instrument Testing—Practical Management of Dynamos and Motors—Distribution Systems—Wiring—Wiring Diagrams—Sign Flashers—Storage Batteries—Principles of Alternating Currents and Alternators—Alternating Current Motors—Transformers—Converters—Rectifiers—Alternating Current Systems—Circuit Breakers—Measuring Instruments—Switchboards—Wiring—Power Stations—Installing—Telephone—Telegraph—Wireless—Bells—Lighting—Railways. Also many Modern Practical Applications of Electricity and Ready Reference Index of the ten numbers.

**SHIPPED FREE**

Not a cent to pay until you see the books. No obligation to buy unless you are satisfied. Send Coupon now—today—and get this great help library and see if it is not worth \$100 to you—you pay \$1.00 a month for ten months or return it.

**THEO. AUDEL & CO.,**  
72 Fifth Ave., New York City

Please submit me for free examination, HAWKINS ELECTRICAL GUIDE (Price \$1 a number). Ship at once prepaid, the 10 numbers. If satisfactory, I agree to send you \$1 within seven days and to further mail you \$1 each month until paid.

Name.....

Occupation .....

Employed by.....

Home Address.....

Reference .....





# Free Proof That Cooke Trained Men

Let us send you Free, this big package of "Vital Facts" showing what "Cooke Trained Men" earn, the big opportunities Electricity offers and how you, too, can earn \$3,500 to \$10,000 a year. The coupon will bring it FREE.

## DO Earn \$3,500 to \$10,000 A Year

Electrical Experts—Trained Men are in big demand at the highest salaries ever known. The opportunities for advancement and a big success are unlimited—positively unlimited. The Electrical Industry faces a big shortage of trained men. It needs you and will pay you well.

### What's Your Future?

It's a shame for you to earn less than \$100.00 a week. You ought to earn more. You can do it, too, when you are backed up with my training—the training that makes "Big Pay Men." Don't be content with an ordinary job paying anywhere from \$3.00 to \$10.00 a day, with no future to speak of. Strike right out—hold the job you've got and prepare for a better one—prepare for a "he man's job" in the \$3,500 to \$10,000 a year class in the greatest profession in the world. I will show you the way.

### Radio Course FREE

My new \$45.00 Radio Course, just completed, given FREE when you enroll for the Electrical Course. Two courses for the price of one. Two professions open to you.

## Be an Electrical Expert and Get This Big Pay Yourself

Today even the ordinary electrician, the screw driver kind, is making money—big money. But it's the trained man—the man who knows the whys and wherefores of Electricity—The Electrical Expert who is picked out to boss the ordinary electricians—to boss the big jobs—the jobs that pay \$70.00 to \$200.00 a week. Fit yourself for one of these big jobs—**Begin Now.**

### Age or Lack of Experience No Drawback

You don't have to be a College Man, you don't have to be a High School graduate. My course in Electricity is the most simple, thorough and successful in existence, and offers every man, regardless of age, education, or previous experience, the chance to become, in a very short time, an "Electrical Expert," able to make from \$70 to \$200 a week.

### Your Satisfaction Guaranteed

So sure am I that you can learn electricity—so sure am I that after studying with me, you, too, can get into the "big money" class in Electrical work, that I will guarantee under bond to return every single penny paid me in tuition if, when you have finished my course you are not satisfied it was the best investment you ever made.

### I Give You A Real Training

As Chief Engineer of the Chicago Engineering Works I know exactly the kind of training a man needs to get the best positions at the highest salaries. Hundreds of my students are now earning \$3,500 to \$10,000 a year. Many are now successful **ELECTRICAL ENGINEERS.**

### FREE—Electrical Working Outfit—FREE

I give each student a Splendid Outfit of Electrical Tools, Materials and Measuring Instruments absolutely FREE. I also supply them with drawing Outfit, examination paper, and many other things that other schools don't furnish. You do **PRACTICAL WORK—AT HOME.** You start right in after the first few lessons to **WORK AT YOUR PROFESSION** in a practical way.

### Get Started Now—Mail Coupon

I want to send you my package of "Vital Facts," including Electrical Book and Proof Lessons FREE. These cost you nothing and you'll enjoy them. Make the start today for a bright future in Electricity. Mail the coupon—**NOW.**

**L. L. COOKE, Chief Engineer**  
**CHICAGO ENGINEERING WORKS**  
Dept. 22, 2150 Lawrence Ave., Chicago, Ill.

L. L. COOKE, Chief Engineer  
CHICAGO ENGINEERING WORKS  
Dept. 22, 2150 Lawrence Ave., Chicago, Ill.

Dear Sir—Send at once the "Vital Facts" containing Sample Lessons, your Big Book, and full particulars of your FREE Outfit and Home Study Course—all fully prepaid, without obligation on my part.

Name.....  
Address.....  
Occupation.....

# The Cooke trained man is the "Big Pay" man