

Radio Call Book Magazine

and **TECHNICAL REVIEW**

NEW AND ENLARGED EDITION

Radio

Service

Schematics

SERVICE - REPAIR - ENGINEERING

SERVICE BLUE PRINTS

FOR SERVICE MEN, TECHNICIANS AND EXPERIMENTERS

ACCURATE, clear and dependable drawings of nearly every standard circuit. These schematics are drawn to a large scale and so simplified that the whole circuit may be visualized almost instantaneously. This enables the service man to work rapidly and accurately. There is no need for microscopes or clairvoyance in reading our prints.

No. SR124	A. C. Dayton Navigator	\$.50	No. SR56	Howard SG-A	\$.50
No. SR13	Arme AC7	.50	No. SR130	Howard SG-B	.50
No. SR14	Arme AC4	.50	No. SR145	Howard H	.50
No. SR1	All-American Mohawk 6	.50	No. SR118	Jesse French Jr. "G"	.50
No. SR2	All-American Mohawk 8	.50	No. SR77	Kellogg 523	.50
No. SR74	All-American Mohawk 96	.50	No. SR38	Kennedy 10	.50
No. SR165	All-American Mohawk (Lyric) B 7	.50	No. SR48	Kennedy 20	.50
No. SR167	All-American Mohawk (Lyric) S 7	.50	No. SR81	Kennedy 26	.50
No. SR128	All-American Mohawk (Lyric) Model J	.50	No. SR129	Kennedy 30 and 32	.50
No. SR22	Anrad 70 A. C.	.50	No. SR31	King Model J	.50
No. SR14	Anrad 81	.50	No. SR8	Kolster K20; K22; K25 and K27	.50
No. SR106	Anrad 84	.50	No. SR45	Kolster K21; K23	.50
No. SR80	Apex 48 Chassis	.50	No. SR72	Kolster K43	.50
No. SR108	Apex Series 31	.50	No. SR150	Kolster 80 and 82	.50
No. SR28	Atwater-Kent 38	.50	No. SR65	Kyletron 70	.50
No. SR51	Atwater-Kent 55 and 55C (Cap. Coupled)	.50	No. SR124	Majestic 20	.50
No. SR52	Atwater-Kent 55 and 55C (Inductive Coupled)	.50	No. SR157	Majestic Chassis 15	.50
No. SR114	Atwater-Kent 66	.50	No. SR98	Majestic Super Chassis 50	.50
No. SR131	Atwater-Kent Super H-2 Chassis	.50	No. SR138	Majestic Super Chassis 60	.50
No. SR79	Audiola 31	.50	No. SR7	Majestic 70	.50
No. SR111	Audiola Super 1931	.50	No. SR55	Majestic 90; 90B; 91; 92 and 93	.50
No. SR112	Audiola Junior	.50	No. SR84	Majestic 130-A	.50
No. SR12	Balkett A	.50	No. SR26	Philco 86-82	.50
No. SR162	Bosch 7 (D.C.)	.50	No. SR156	Philco 90 and 90-A, Series B	.50
No. SR21	Bosch 28 and 29	.50	No. SR69	Philco 95	.50
No. SR73	Bosch 48	.50	No. SR104	Radiette F-14	.50
No. SR94	Bosch Auto Radio 80	.50	No. SR127	RCA 18	.50
No. SR109	Bosch 58	.50	No. SR192	RCA 44	.50
No. SR117	Bosch 60	.50	No. SR30	RCA 60	.50
No. SR10	Bremer-Tully 7-70	.50	No. SR64	RCA 66	.50
No. SR75	Bremer-Tully 81 and 82	.50	No. SR92	RCA 80	.50
No. SR126	Bremer-Tully S 81 and S 82	.50	No. SR107	RCA 48	.50
No. SR23	Brunswick 3KR0	.50	No. SR166	RCA Victor R-50 and R-55	.50
No. SR148	Brunswick 11, 12, 16	.50	No. SR137	RCA-Victor Superette	.50
No. SR71	Brunswick S-14	.50	No. SR115	Sentinel 11; 15; 16; 12 and 12R	.50
No. SR86	Brunswick 15, 22, 32, 42	.50	No. SR113	Sentinel 196 B	.50
No. SR164	Brunswick 17 and 24	.50	No. SR146	Sentinel D8-A	.50
No. SR78	Clarion 50	.50	No. SR155	Sentinel 111	.50
No. SR139	Clarion 80 and 81	.50	No. SR123	Sentinel Super Midget 108	.50
No. SR29	Colonial 31AC	.50	No. SR152	Silver-Marshall D and E	.50
No. SR95	Colonial 33 and 34 A. C.	.50	No. SR140	Silver-Marshall F	.50
No. SR160	Colonial 47 and 48	.50	No. SR153	Silver-Marshall G	.50
No. SR47	Columbia (Chicago) SG8	.50	No. SR35	Silver-Marshall 30	.50
No. SR103	Crosley 53 and 54	.50	No. SR53	Silver-Marshall 30-B	.50
No. SR5	Crosley 608 Gembox	.50	No. SR82	Silver-Marshall 35-A	.50
No. SR6	Crosley 705 Showbox	.50	No. SR144	Silver-Marshall 726 SW	.50
No. SR41	Crosley Jewelbox 704B	.50	No. SR105	Silver Super 36 A	.50
No. SR57	Crosley 408, 418, 428 and 828	.50	No. SR120	Silver Midget 782-12	.50
No. SR67	Crosley "Roaming" (Auto Radio)	.50	No. SR27	Siagle (Continental) 9	.50
No. SR83	Crosley 77	.50	No. SR49	Siagle (Continental) R-20	.50
No. SR133	Crosley 120	.50	No. SR25	Sonora Deluxe 51R	.50
No. SR149	Crosley 121	.50	No. SR161	Spartan 25 and 26	.50
No. SR150	Crosley 124	.50	No. SR91	Spartan 600, 610 and 620	.50
No. SR11	DayFun 5080	.50	No. SR9	Spartan AC89	.50
No. SR66	Delco Auto Radio	.50	No. SR58	Spartan 931	.50
No. SR87	Delco Police Short Wave Receiver 3003	.50	No. SR63	Spartan 589	.50
No. SR99	Edison R6 and R7	.50	No. SR36	Splittdorf E-175	.50
No. SR49	Edison R1, R5, C4	.50	No. SR15	Steinre 261	.50
No. SR33	Erla DuoConcerto R 2	.50	No. SR76	Steinre 70; 80 and 95	.50
No. SR50	Eveready Series 50	.50	No. SR132	Steinre 600, 605, 630 and 635	.50
No. SR158	Fada KW	.50	No. SR147	Stewart-Warner 102 A and B	.50
No. SR13	Fada 7AC	.50	No. SR34	Stewart-Warner 900	.50
No. SR70	Fada 35 and 35Z	.50	No. SR62	Stewart-Warner 950	.50
No. SR19	Federal II	.50	No. SR85	Stewart-Warner R 100A, B and E	.50
No. SR20	Freed-Eisenmann NR-80	.50	No. SR134	Stromberg-Carlson 10 and 11	.50
No. SR11	Freshman 2-N 12	.50	No. SR93	Stromberg-Carlson 12 and 14	.50
No. SR92	General Electric II-31	.50	No. SR151	Stromberg-Carlson 19 and 20	.50
No. SR166	General Electric H-32	.50	No. SR18	Stromberg-Carlson 635 and 636	.50
No. SR107	General Electric T 11	.50	No. SR54	Stromberg-Carlson 846	.50
No. SR137	General Electric S 22	.50	No. SR37	Temple 8-69; 8-80 and 8-90	.50
No. SR68	General Motors A	.50	No. SR125	Temple 861; 881 and 891	.50
No. SR154	General Motors S-3 A	.50	No. SR39	Transitone Auto Radio	.50
No. SR32	Gillfillan 100	.50	No. SR121	Trav-Ler Model C	.50
No. SR42	Graybar 600	.50	No. SR143	U. S. Radio & Television (Gloritone) 26P	.50
No. SR92	Graybar 700	.50	No. SR39	U. S. Radio & Television 37	.50
No. SR107	Graybar 678	.50	No. SR119	Vitatone 54 (Zaney-Gill Corp.)	.50
No. SR96	Grebe Synchronous AH-1	.50	No. SR101	Victor Micro-Synchronous R-35; R-39 and RE-57	.50
No. SR17	Grebe 7AC	.50	No. SR61	Victor R-32; RE45 and RE52	.50
No. SR59	Grebe SK 4	.50	No. SR92	Westinghouse WR-5	.50
No. SR40	Gulbrandsen Nine-in-Line	.50	No. SR107	Westinghouse AVR-4	.50
No. SR110	Gulbrandsen 161	.50	No. SR137	Westinghouse WR-10 and 12	.50
No. SR16	Howard Green Diamond S	.50	No. SR141	Zenith A, B, C and D	.50
No. SR163	Howard 0	.50	No. SR97	Zenith 71; 72; 73 and 77	.50
			No. SR43	Zenith 52; 53; 54; 522; 532 and 542	.50

PUBLIC ADDRESS SYSTEMS

No. SR100	Amer-Tran PA-86	\$.50	No. SR88	Webster (Racine, Wis.) A37-50	\$.50
No. SR90	Silver-Marshall 692	.50	No. SR89	Webster (Chicago) D11-250	.50
No. SR122	Silver 679-B Amp	.50			

The above drawings are intended for service purposes only and are not suitable for the construction of receivers from miscellaneous parts. They will be sent postpaid by return mail upon receipt of the proper amount. C. O. D. orders not accepted.

CITIZENS RADIO SERVICE BUREAU
508 South Dearborn Street, 7th Floor
CHICAGO, ILLINOIS

INDEX

	Page		Page		Page
STANDARD SYMBOLS USED...	2	Kennedy S. G. Model 20.....	46	RESPONSE CURVE SECTION...	97
A. C. Dayton Navigator.....	3	Kennedy Model 26.....	47	Airline Model 8.....	100
All-American Mohawk Model 90..	88	King Model J.....	48	Airline Model 9.....	100
Amrad Model 70.....	4	Kolster 4-Tube Chassis.....	49	Amrad Model 84.....	113
Amrad Model 81.....	5	Kolster Models K21, 23, 24, 28...	50	Atwater-Kent Model 55-C.....	99
Amrad Model 84.....	6	Kolster Model K43.....	51	Atwater-Kent Model 72.....	116
Apex Model 31.....	7	Kylelectron Model 70.....	90	Audiola Model 31.....	114
Apex S. G. Model 48.....	89	Majestic Model 50.....	52-53	Audiola Model 6T Junior.....	124
Atwater-Kent Model 38.....	8	Majestic Model 70.....	54	Audiola Model 8T-31.....	122
Atwater-Kent Models 55 and 55C..	9	Majestic Model 90-B.....	55	Bosch Model 60AA.....	118
Atwater-Kent Model 66.....	10	Majestic Model 130-A.....	56	Brunswick Model 15.....	104
Audiola Series 31.....	11	Philco Models 86 and 82.....	57	Colonial Model 33 AC.....	102
Audiola Junior Model.....	96	Philco Model 95.....	58	Columbia Model 100.....	115
Balkeit Model A.....	12	Radiette Model F-14.....	94	Crosley Model 40S.....	99
Bosch Models 28 and 29.....	13	Radiola Model 44.....	59	Crosley Model 77.....	103
Bosch Model 48.....	91	Radiola Model 60.....	60	Crosley Model 54.....	111
Bosch Model 58.....	14	Radiola Model 66.....	61	Edison Models R-6, R-7.....	109
Bosch Model 60.....	15	Sentinel Models 11, 12, 15, 16...	62	General Electric H-31.....	112
Bosch Auto Model 80.....	92	Sentinel Model 106-B.....	93	General Motors 120-A.....	111
Bremer-Tully 7-70.....	16	Silver Model 30.....	63	General Motors Little General...	122
Bremer-Tully 81 and 82.....	88	Silver Model 30-B.....	64	Grebe Model AH-1.....	106
Brunswick 3KRO.....	17	Silver Model 35-A.....	65	Grebe Model SK-4.....	123
Brunswick S14.....	91	Silver Model 36-A.....	66	Graybar Model 700.....	113
Brunswick Models 15 and 22.....	18	Slagle Model 9.....	67	Gulbransen Model 70.....	120
Brunswick Models 15, 22, 32 and 42	94	Sonora Model 5R.....	68	Gulbransen Model 82.....	120
Colonial Model 31 AC.....	19	Sparton A. C. 89.....	69	Howard Model SG-8.....	121
Colonial Models 33 and 34 AC.....	20	Sparton 589.....	70	Howard SGA.....	101
Continental Star Raider R20.....	21	Sparton 931.....	71	Kellogg Model 533.....	107
Crosley Jewelbox 704-B.....	26	Sparton 600, 610, 620.....	89	Kennedy Model 26.....	109
Crosley Models 40S, 41S, 42S, 82S.	23	Sparton 600, 610, 620.....	95	Kennedy Model 42.....	114
Crosley Models 53, 54 and 57.....	24	Splitdorf E175.....	72	Majestic Model 20.....	123
Crosley "Roamio" Auto Receiver..	22	Steinite 261.....	73	Majestic Model 50.....	107
Crosley Model 77.....	25	Steinite Models 70, 80 and 95....	91	Majestic 90-B.....	98
Day Fan Model 5080.....	27	Stewart-Warner Series 900.....	74	Majestic 130-A.....	102
Delco Automotive Receiver.....	28	Stewart-Warner Series 950.....	75	Montgomery Ward Alexander	
Edison Models R4, R5, C4.....	29	Stewart-Warner R110, A, AF,		Model.....	108
Edison Models R6 and R7.....	30	B, BF, E, EF.....	94	Philco Model 20.....	119
Erla Duo-Concerto Model.....	31	Stromberg-Carlson 635-636.....	77	Radiola 44.....	98
Eveready Model 50.....	96	Stromberg-Carlson Model 846.....	78	Radiola Model 48.....	126
Fada Model 7 AC.....	32	Stromberg-Carlson Model 12, 14... 76		Radiola Model 80.....	112
Fada Models 35 and 35Z.....	90	Temple Models 8-60, 8-80, 8-90... 79		Sentinel Model 106.....	117
Federal Model H.....	33	TCA Clarion Model 50.....	89	Sentinel Model 108.....	124
Freed-Eisemann NR80.....	34	Transitone Auto Radio.....	88	Silver 30-B.....	101
French, Jesse-Junior Model G.....	95	Trev-ler Model C.....	93	Silver Model 36-A.....	115
Freshman Model 2N12.....	35	U. S. Radio & Television		Sparton 620.....	103
General Motors Receiver.....	92	Model 37.....	80	Sterling Model F.....	110
Gilfillan Bros. Model 100.....	36	Victor Models R32, RE45, R52....	81	Stewart-Warner R100-A.....	104
Graybar Model 600.....	37	Victor Models R35, R39, RE57....	82	Stewart-Warner R100-AT.....	125
Grebe Model AH-1.....	40	Westinghouse Model WR-4.....	83	Stromberg-Carlson 12.....	118
Grebe Model SK-4 AC.....	39	Westinghouse Super WR-5.....	84	Stromberg-Carlson Model 10.....	117
Grebe Synchrophase 7.....	38	Zaney Gill Model 54.....	95	TCA Clarion Model 50.....	106
Gulbransen Nine-in-Line.....	41	Zenith Models 52, 53, 522, 523... 85		U. S. Radio Model 26.....	119
Gulbransen Model 161.....	93	Zenith Series 70.....	86-87	U. S. Radio & Television	
Howard Green Diamond Model 8..	42			Model 31.....	108
Howard Model SGA.....	43			Victor R-15.....	126
Kellogg Models 523 to 528.....	44			Westinghouse Columaire.....	121
Kennedy Model 10.....	45			Westinghouse WR-4.....	110
				Westinghouse Super WR-5.....	105
				Zaney Gill Music Box Clarion...	105
				Zenith Model B.....	125
				Zenith Model ZE-70 Jr.....	116
				Radio Engineering Formulas and	
				Shop Hints.....	127-136

STANDARD SYMBOLS USED

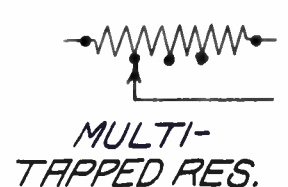
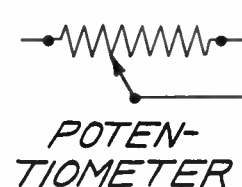
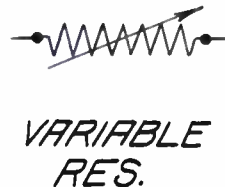
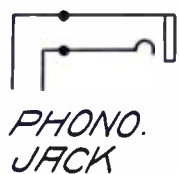
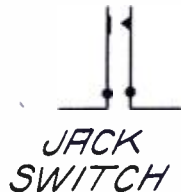
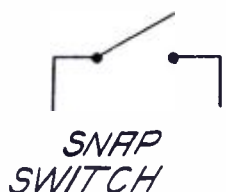
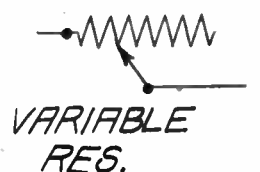
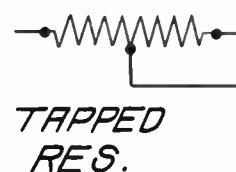
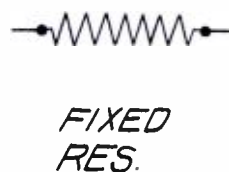
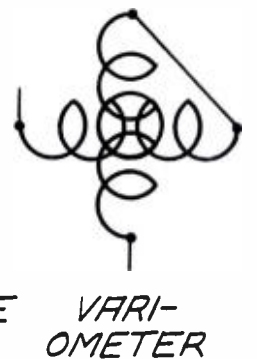
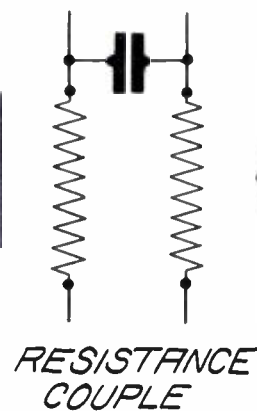
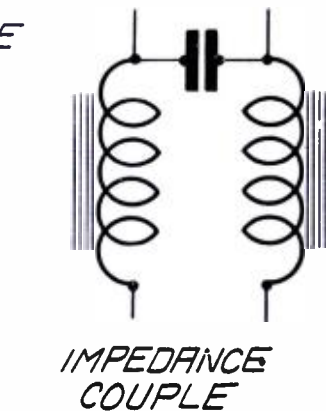
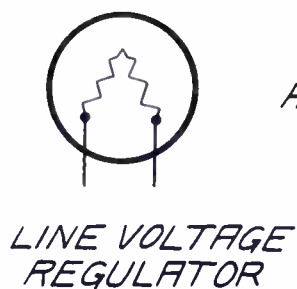
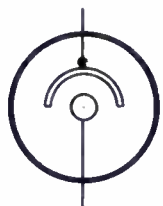
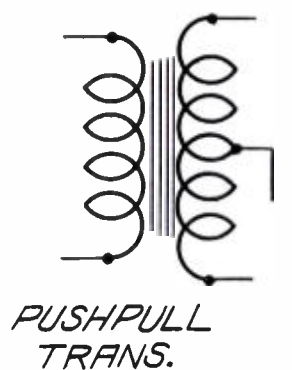
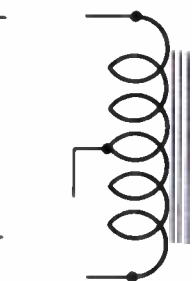
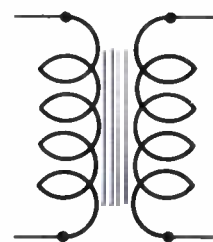
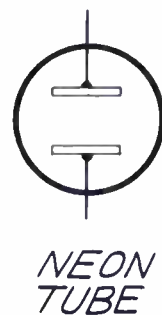
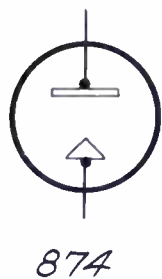
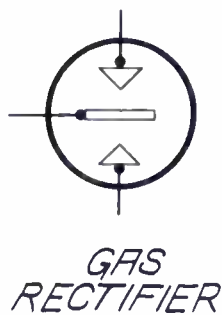
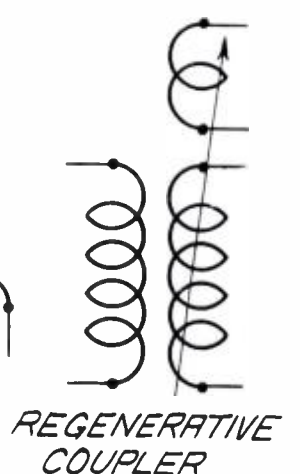
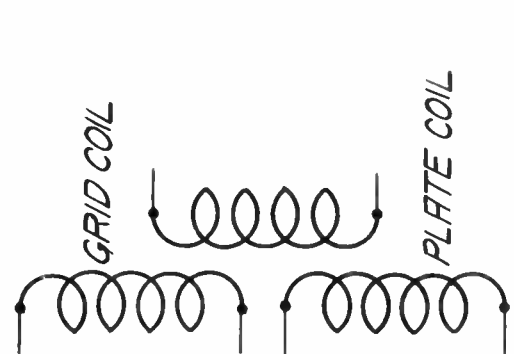
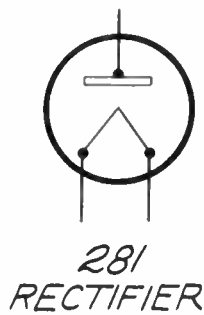
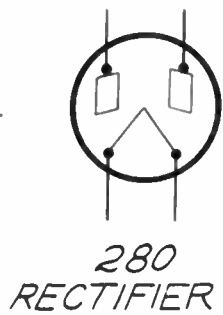
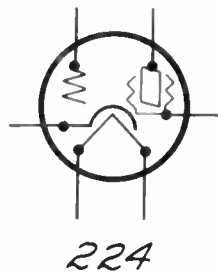
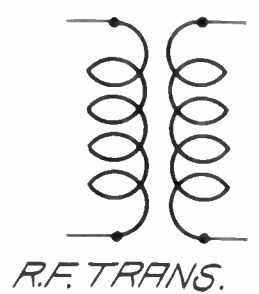
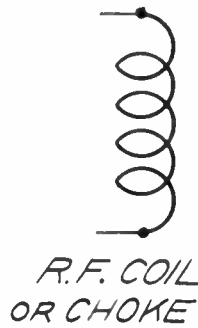
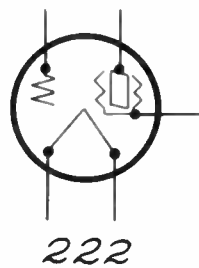
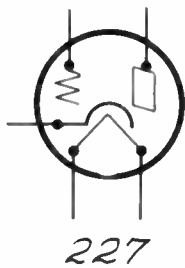
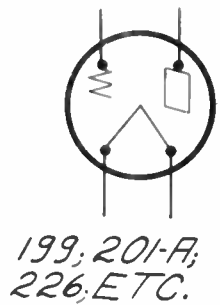

The A-C Dayton Navigator Receiver

THE circuit employed in the Navigator, made by the A-C Dayton Co., Dayton, Ohio, is one built under patents held by the Technidyne Corp. It is a preselection circuit and comprises three parts, the selector, the amplifier and the power pack.

Selector Circuit

The selector is composed of a four gang condenser and four sets of inductance coils. The condenser is enclosed in a shield with openings in the side of the shield for the contacts and for the adjustment of the trimmer condenser. The inductance coils are wound on two coil tubes, each coil tube containing one-half of the windings necessary for tuning one stage. The first pair of coils couple inductively to the second pair of coils and the third pair couple inductively to the fourth pair. The shielding can shields the pairs of inductive coils from picking up any outside signal and also from coupling between the various coils when such coupling is undesirable. Coupling between the second and third

inductance coils is accomplished by the use of a small coupling coil.

The principle of the amplifier is that

due to a change in frequency of the impressed signal. The amplifier is built so that the tubes are in a straight line thus overcoming difficulties due to feed back from tube to tube.

Correct Adjustment

The following is approved procedure for the correct adjustment of the condensers: Ground and antenna wires are connected to the proper binding post on the chassis. The volume control is turned completely on. Tune in a station at approximately 20 to 25 on the dial. Adjust the trimmer on the left-hand condenser as you look at the set from the front until maximum volume is obtained. Then adjust second and third trimmer condensers until maximum volume is obtained. If more sensitivity is desired the main tuning dial should be shifted back and forth slowly until the signal intensity is the greatest and the trimmers can again be more finely adjusted for the final setting. The No. 4 trimmer should not be varied.

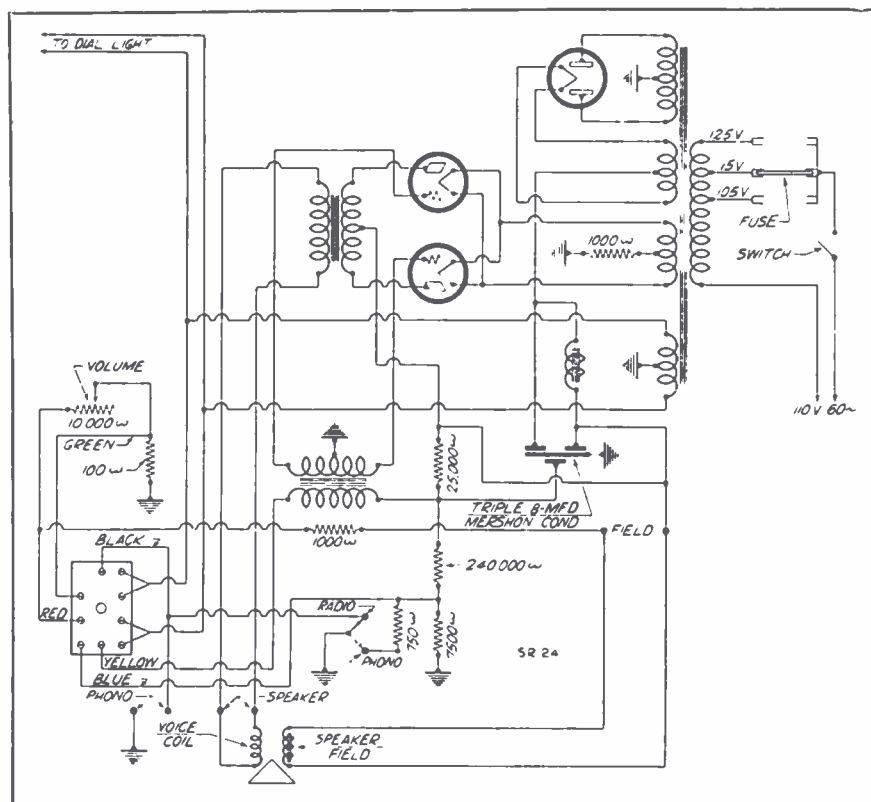

Fig. 10. The power supply for the A-C Dayton receiver described on this page is shown above

of self-tuning accomplished by the correct design of the input and output circuits of the tubes to take advantage of the change in capacity of the tubes

tensity is the greatest and the trimmers can again be more finely adjusted for the final setting. The No. 4 trimmer should not be varied.

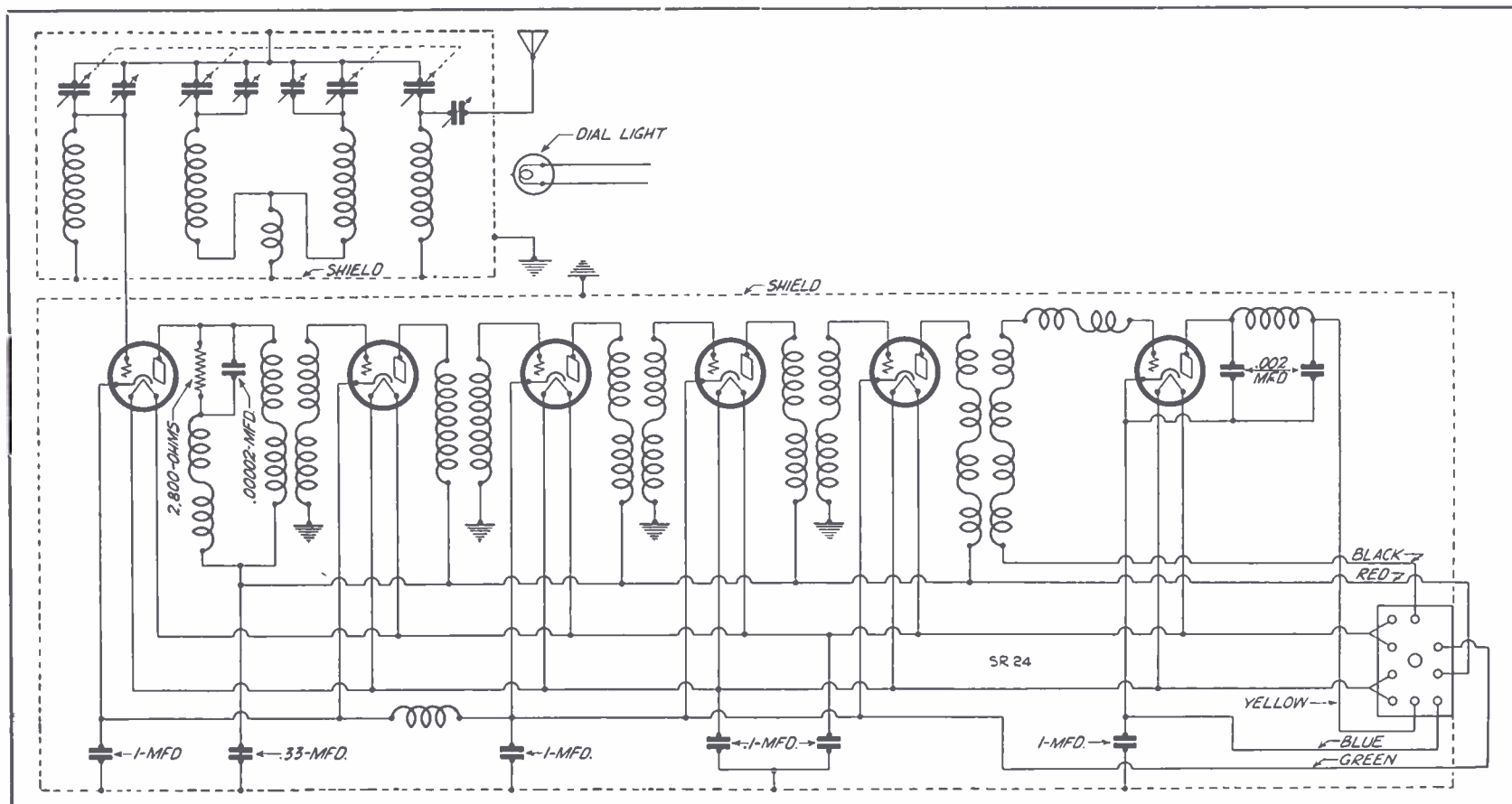

Fig. 11. The preselection tuner used in the A-C Dayton receiver may be seen at the top left of the schematic diagram shown here

The Amrad Model 70 A. C. Receiver

K NOWN as their model 70, the a. c. receiver illustrated schematically on this page is made by the Amrad Corp. at Medford Hillside, Mass. These receivers are neutralized at the factory for average tube capacity of 8.76 mmf.

Should all of the tubes installed in the receiver be at the extreme limits of capacity, the receiver may possibly oscillate on the very short wavelengths at the end of the scale. When this occurs it can be in a great majority of cases stopped by shifting the tubes around. Another cause of oscillation may be high line voltage. This should always be measured and a connection provided on the power pack set to the proper point regardless of whether the set oscillates at the short waves.

Re-neutralizing Set

In rare cases where changing tubes and correct line voltage do not stop this trouble, the procedure for re-neutralization is as follows: Adjust your local oscillator to the shortest wavelength which can be reached by the receiver before it starts to oscillate. Adjust the receiver to exactly the same wavelength

as the oscillator. Remove the third r. f. tube (third tube from the right-hand end of the receiver looking from the back of cabinet). Readjust the tuning until loudest signal is heard. Then cut a narrow strip of stiff paper and push

a very strong signal it may not go out entirely, but will show a very sharp minimum. When zero or the minimum point is reached the stage is neutralized.

Remove tube and the paper strip, replace the tube and cover, then proceed with the second r. f. stage, which is the second from the right and in exactly the same manner adjust NC No. 2. After this stage has been adjusted the tube from the first stage on the right-hand side is removed and after the filament has been masked, adjust NC No. 1 for minimum signal.

Aligning R. F. Stages

The three neutralizing condensers are those nearest the tubes. The condensers furthest away from the tubes are known as the padding condensers and are used for realigning the tuning stages. To ad-

just these it is only necessary to tune the receiver to a weak oscillator signal or to a distant broadcasting station and adjust the padding condensers until the maximum signal is received. This adjustment is also made with the neutralizing wrench.

There are four possible causes of the set oscillating on short waves.

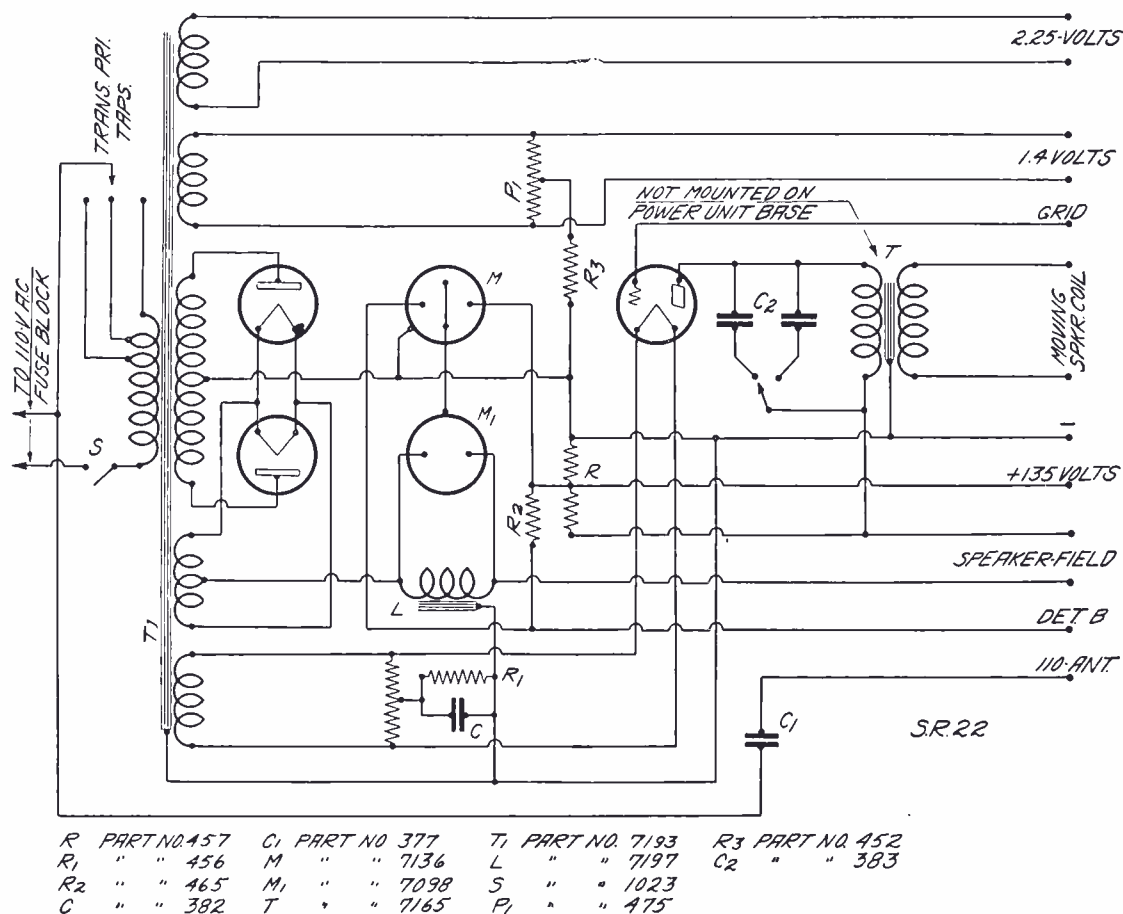

Fig. 6. The schematic diagram of the power supply used on the Amrad Model 70 is shown above

R	PART NO. 457	C1	PART NO. 377	T1	PART NO. 7193	R3	PART NO. 452
R1	" " 456	M	" " 7136	L	" " 7197	C2	" " 383
R2	" " 465	M1	" " 7098	S	" " 1023		
C	" " 382	T	" " 7165	P1	" " 475		

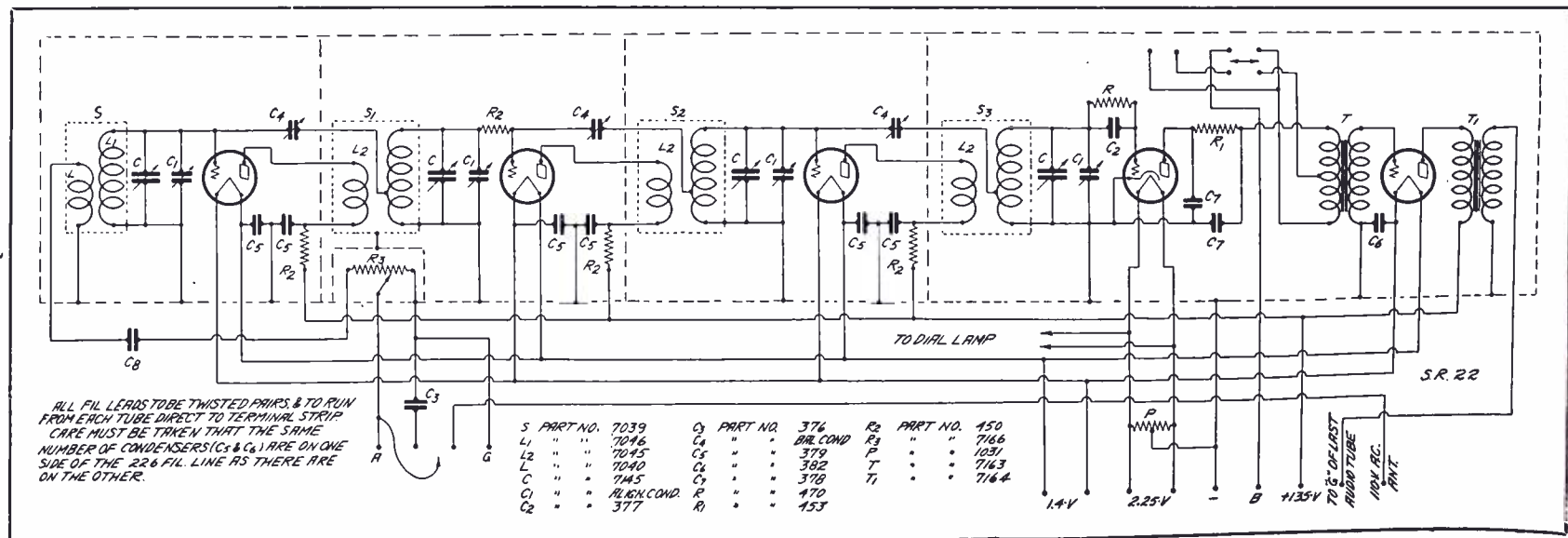

Fig. 7. In this diagram may be seen the schematic details of the Amrad 70 receiver described in the accompanying text

Amrad Model 81, Bel Canto Series

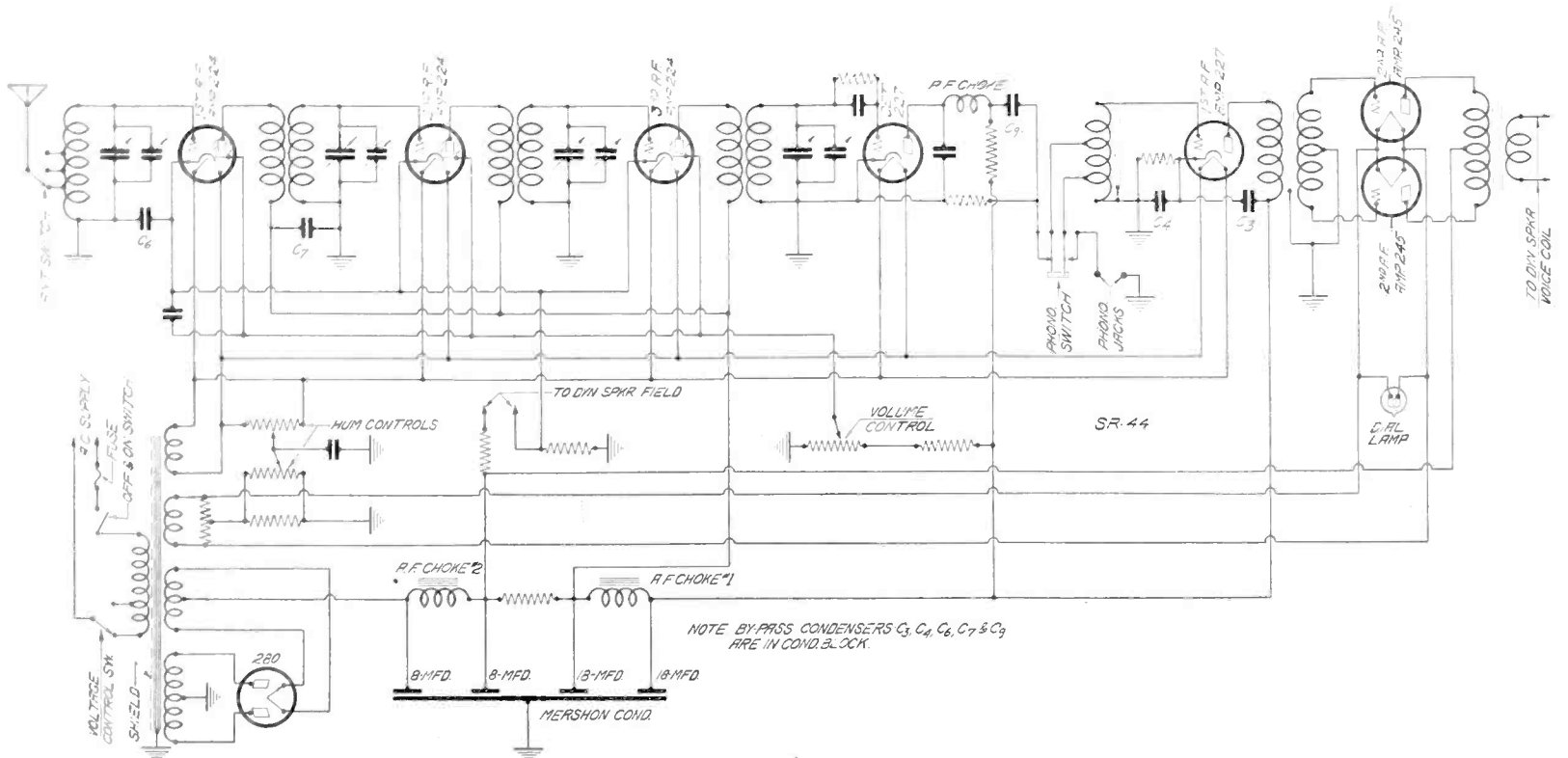

Fig. 1. The schematic diagram of the receiver and the power supply used in the Amrad model 81 is shown in the above drawing

MADE by the Amrad Corporation, Medford Hillside, Mass., the model 81 receiver of the Bel Canto series is illustrated in this page. The receiver and power supply schematic is shown in Fig. 1 while a table of typical tube voltages is shown in Fig. 2. The model 70 Amrad was shown schematically on page 92 of the November, 1929 issue of this magazine.

The receiver uses three 224 screen grid tubes in the radio frequency stages followed by a 227 detector with grid condenser and leak detection. Coupling into the first audio stage is a resistive combination, arrangements being made for the inclusion of a phonograph pick-

up in this circuit by means of a switch shown in the schematic. The power output stage consists of two 245 tubes arranged in push-pull.

The antenna circuit of the first tube has a tapped inductance with a short, long and medium antenna tapoff. A switch is provided for selecting either of the three types of antenna.

Screen Volume Control

The volume control on the receiver is a variable resistance between the high line and ground, the arm of the resistance at the ground end going to the screen grids of the three 224 tubes, al-

tering the potential placed on these screen grids.

The dynamic speaker field is included as a part of the resistance network between the center of the filter chokes and the ground. Hum control on the receiver is afforded by means of two hum controls, one of which is across the filament transformer secondary for the 224 tubes, and the other between ground and the center tap of the 2.5 volt secondary for the 245 tubes. A condenser goes from the two arms to ground.

The lower portion at the left of the schematic shows the condenser for filtering which is a Mershon. It has four sections, two sections of 8 mfd. apiece, one being placed at the entrance to the choke and the other at the output, while the two 18 mfd. sections are disposed around the input and output of the second filter choke. A resistive connection is employed between the output of the first choke and the input of the next.

Voltage Control Switch

The alternating current line is fused, and the primary of the 110 transformer is provided with a voltage control switch. An electrostatic shield is inserted between primary and secondaries on the power transformer and is grounded. Pilot lights are operated across the 2.5 volt secondary for the 245 tubes. The secondary of the push-pull output transformer in the 245 plate circuit goes directly to the voice coil on the dynamic speaker.

Amrad Model 81 Bel Canto Series

Tube Type	Position in Set	A Volts	B Volts	C Volts	Cathode Volts	Screen Volts	Plate M. A.	Normal M. A.	Plate Grid Test	Change
224	1 R.F.	2.25	180	1.5	---	80	4.	7.5	3.5	
224	2 R.F.	2.25	180	1.5	---	80	4.	7.5	3.5	
224	3 R.F.	2.25	180	1.5	---	80	4.	7.5	3.5	
227	Det.	2.25	30	---	---	---	1.5	1.6	.1	
227	1 A. F.	2.25	160	10.5	---	---	4.1	5.2	1.1	
227	1 A. F.	2.25	160	10.5	---	---	4.1	5.2	1.1	
245	2 A. F.	2.25	250	50	---	---	28	32	4.0	
245	2 A. F.	2.25	250	50	---	---	28	32	4.0	
280	Rect.	4.65	---	---	---	---	110	---	---	

Line voltage, 120. Set on 120-volt tap. Volume control maximum.

Fig. 2. Taken with a Jewell analyzer the typical tube voltages would be approximately as shown in the above table

Amrad Receiver Model 84

IN the schematic diagram at the bottom of this page will be found the electrical connections for the Amrad model 84 receiver. A table of the tube operating values will be found in Figure 1, these values being taken from the voltage limits table shown in the Amrad service manual from which extracts have been made.

How Voltages Derived

An examination of the circuit diagram in Figure 2 will show that the return plate circuit from the speaker field is connected directly to the r.f. and first audio plates and through a 100,000 ohm resistor to the detector plate. Thus, practically the same voltage is applied to the r.f. and first audio plates while a somewhat lower voltage is applied to the detector plate. The appropriate positive voltage for the screen grid of the detector tube is applied through a 1 megohm resistor connected to the positive plate circuit return from the speaker field.

Below the first audio tube on the circuit diagram a branch of this positive plate circuit passes down through a string of resistors, 2500, 1100, 330 ohms and thence to ground (chassis). These resistors supply potential to the r.f. screen grids and the first audio emitter. The circuit to the r.f. screen grids runs from the junction of the 2500 and 1100 ohm resistors through a 10,000 ohm (20,000 ohm in later chassis) to the tubes. The emitter of the first a.f. tube is connected to the junction between the 330 and 1100 ohm resistors. Emitters of the r.f. tubes are grounded to chassis through proper resistors shown. Emitter of the detector is biased to ground with a 20,000 ohm resistor.

Output Grid Bias

Grids of the output tubes are biased with approximately 360 ohms from center tap of the filament resistor to ground. Biasing of the first a.f. tube is accomplished by the resistor between the emitter and ground.

Volume Control

In the grid circuit of the first a.f. tube is a variable coupling resistor

taining the emitters at positive potentials with respect to chassis and partially, when grid current is flowing, by the drop due to the grid current in the 60,000 ohm resistor in the detector grid circuit. This latter drop due to grid current is the basis of the automatic volume control. A signal strong enough to cause grid current to flow in this circuit automatically increases the negative bias on the grids of the r.f. and

Amrad Model 84

Tube Type	Position in Set	A Volts	B Volts	C Volts	Cathode Volts	Screen Volts	Normal Plate M. A.	Plate M. A. Grid Test	Change
224	1 R.F.	2.3	170	2.5	---	60.	---	---	---
224	2 R.F.	2.3	170	2.5	---	60.	---	---	---
224	3 R.F.	2.3	170	2.5	---	60.	---	---	---
224	Det.	2.3	95	4.0	---	35.	---	---	---
227	1 A.F.	2.3	130	8.0	---	---	---	---	---
245	P.P.	2.3	220	40.	---	---	---	---	---
245	P.P.	2.3	220	40.	---	---	---	---	---
280	Rect.	1.6	250	---	---	---	---	---	---

Line voltage 117. Volume control maximum.

Fig. 1. Tube operating values in the above table are derived with speaker connected and line voltage of 117, with fuse in high position. Measure plate and grid voltages with a high resistance d.c. voltmeter (600 ohms or more per volt) from plate or grid contact to emitter contact, except for the grid voltage of the first a.f. tube which should be measured from emitter to chassis

which is used as a manual volume control. Since it follows the detector in the circuit, it controls the volume both of the radio signals and of the phonograph reproduction through the phonograph terminals.

R.F. and Detector Bias

The biasing of the r.f. and detector tubes is partially accomplished by main-

detector tubes. This decreases the amplification in the r.f. and detector stages.

Local-Distance Switch

In addition to the manual volume control and automatic volume control, a local-distance switch is provided for adapting the receiver to the reception of powerful signals from nearby stations.

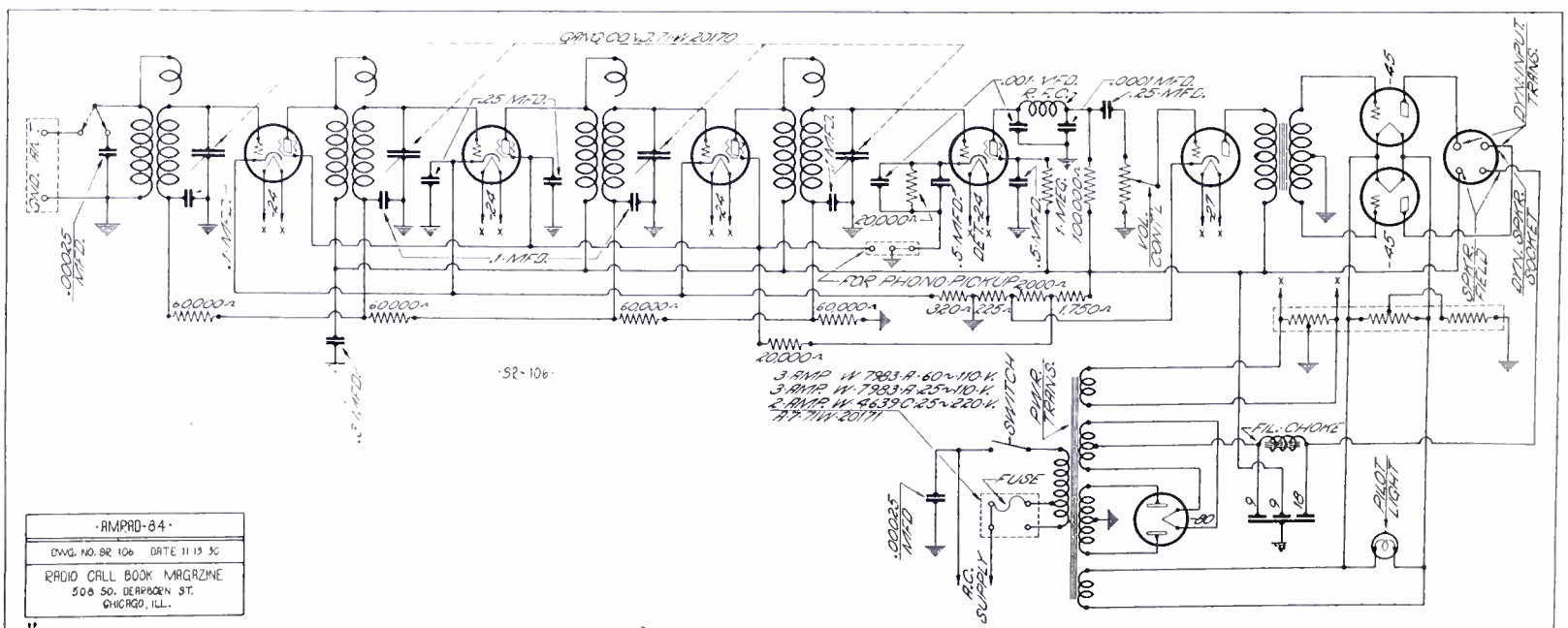

Fig. 2. The schematic diagram of the Amrad model 84 is shown in this drawing

Apex No. 31 U.S. Radio and Television

APEX series 31 is the model made by the U. S. Radio and Television Co., and illustrated schematically on this page. Response curves of this model appeared on page 63 of the November issue of this magazine.

In the section of the service manual devoted to repairs and adjustments are found a number of interesting suggestions that will doubtless be of aid to service men.

Poor Heater Welds

For example, many cases of intermittent operation in receivers are due to a poor weld at the heater connection in the heater type tubes. These tubes will have a complete circuit through the heater one moment and will then go open. After cooling down, the circuit through the heater will be completed again and the tube will function, going open again as soon as the weld contact loosens. If the volume drops during reception look at once to see that heaters are burning.

A cathode to heater short in the 224's will cause excessive hum, and there will be no control of volume due to the shorting out of the bias resistance. Traces of gas in the 224 will cause low volume. A pronounced blue glow in the 280 is caused by gas, results in low B voltage, excessive hum and in some cases distortion. A shorted 280 will cause burnout of the power transformer. For best results the 245's in pushpull should be balanced for plate current within 3 milliamperes. One good and one defective 245 may cause distortion. Dirty tube prongs may cause noisy operation or change the resistance of the filament circuit sufficiently to cause weak reception or appreciable hum in the speaker. Prongs should be cleaned periodically to insure good contact. A fine grade of sandpaper is best for this. Emery cloth or steel wool should not

be used on account of possible short circuits from particles.

Excessive hum may be due to a number of causes, among which are included: defective 280 or 227 tubes; external pick-up (disconnect antenna and ground from set and see if hum disappears); open .1 mfd choke condenser open or shorted; shorted filter choke; open filter condenser; defective wiring in grid circuits; improper grounding of the shield plate in the power transformer between the primary and secondary windings; heater to cathode short in the 224, as well as an open cathode connection in this same type of tube.

tube shield plates which electrostatically isolate the r.f. and detector tubes and grid circuits; an open bypass condenser; shorted detector plate choke; poor ground connection to the subpanel at any point (inspect for high resistance joints and lacquer at ground contact point).

In the table in Figure 1 may be found the operating tube voltages as indicated by the manufacturer of the set. The schematic of the receiver and its power supply is shown in Figure 2.

The tone blender used in this model is an arrangement for controlling the degree of reproduction of the higher

Apex Model 31, U. S. Radio

Tube Type	Position in Set	A Volts	B Volts	C Volts	Cathode Volts	Screen Volts	Normal Plate M. A.	Plate Grid Test	Change
224	1 R. F.	2.25	178	3.0	3.0	86	3.4	5.8	2.4
224	2 R. F.	2.25	178	3.0	3.0	86	3.4	5.8	2.4
224	3 R. F.	2.25	178	3.0	3.0	86	3.4	5.8	2.4
227	Det.	2.25	60	9.0	9.0	---	.25	.30	.05
227	1 A. F.	2.25	160	12.0	12.0	---	4.5	5.5	1.0
245	P. P.	2.35	246	40	---	---	25.0	30.0	5.0
245	P. P.	2.35	246	40	---	---	25.0	30.0	5.0
280	Rect.	4.9	---	---	---	---	37	---	---

Line voltage 115. Volume control maximum.

Fig. 1. Tube operating values as supplied by the maker of the Apex Series 31 are indicated in this table

Uncontrolled oscillation may ensue from any of the following causes: tubes whose mutual conductance is considerably in excess of the standard; the 227 detector has in some instances been found responsible for oscillation (the remedy in either case is to try out another tube of the same type); cover of chassis shield not in place when set is operating, this cover having on it the

audio frequency notes. For certain types of reception it is advisable to reproduce all of the frequencies, while for other types of reception it is more pleasing to the ear to limit the higher audio frequencies. This optional limitation is accomplished with a .006 mfd condenser and a 500,000 ohm variable resistance in series between the grids of the 245's as shown in the schematic.

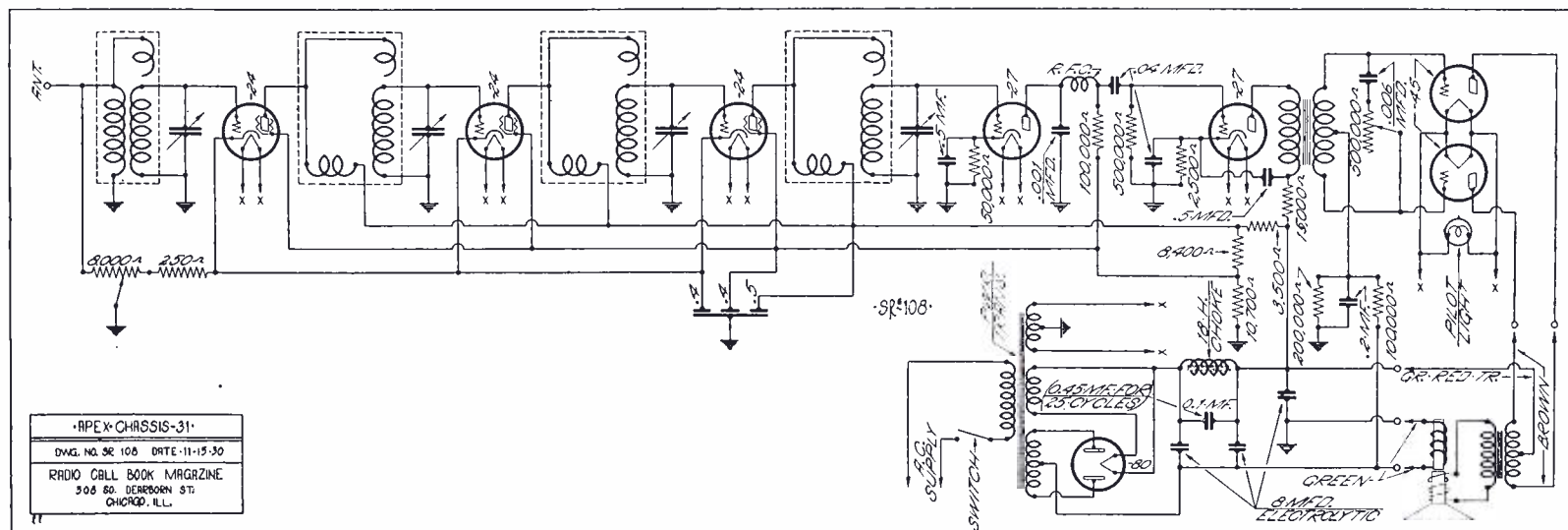

Fig. 2. The schematic diagram of the receiver and power supply for the Apex 31 series is shown in this drawing

Atwater Kent Receiver Model No. 38

ONE of the many receivers made by the Atwater Kent Manufacturing Company of Philadelphia, Pennsylvania, is model 38 illustrated on this page. It is a seven-tube, single dial, a. c. receiver, with a power unit incorporated in a metal cabinet that houses the set.

Four R. F. Stages

As disclosed in the schematic diagram Figure 3, the circuit has four stages of radio frequency amplification, with double coil type r. f. transformers, a tuned detector and two stages of audio frequency amplification. The first radio frequency tube is not tuned and acts as an antenna coupling tube. The second audio stage is of the power type with condenser-choke coupling to the speaker.

Local-DX Switch

Since the volume provided by this set is ordinarily more than required for local reception, a special switch (the local-long distance toggle switch) is provided on the front of the cabinet to open the plate circuit of the second radio frequency amplifying tube, thereby reducing the volume materially.

The volume control consists of an adjustable resistance connected from antenna to ground. It is shown at the extreme left in the schematic circuit, Figure 3. As will be seen, the antenna lead enters the set through a shielded cable.

The schematic diagram of the power unit used with this receiver is shown in Figure 2. The unit is encased in a metal cover which has an opening in the left-hand end of the top for insertion of the rectifier tube. There are two metal containers, one for the power transformer and one for the condensers and choke.

Typical Set Voltages

Using a Jewel No. 199 a. c.-d. c. set analyzer, typical voltage readings on the Model 38 with a line voltage of 115 are shown below:

First r. f. 226, tube out, A voltage 1.3, B voltage 173, tube in tester A voltage 1.25, B voltage 165, C voltage 10, normal plate m. a. 4.8, plate m. a. grid test 8.4, plate m. a. change 3.6.

Second r. f. 226, tube out, A voltage 1.3, B voltage 173, tube in tester A voltage 1.25, B voltage 165, C voltage 10, normal plate m. a. 4.8, plate m. a. grid test 8.4, plate m. a. change 3.6

Third r. f. 226, tube out, A voltage

Second audio 171, tube out A voltage 4.6, B voltage 192, tube in tester A voltage 4.3, B voltage 180, C voltage 36, normal plate m. a. 18.0, plate m. a. grid test 19.5, plate m. a. change 1.5

Rectifier 280, tube in tester, A voltage 4.3, normal plate m. a. 20.

Replacements

It is observed in the Atwater-Kent instruction manual that if one variable condenser is found defective on test, it is necessary to replace the entire group of four variable condensers. If one of the double radio frequency transformers is defective it will be necessary to replace the entire group of four double

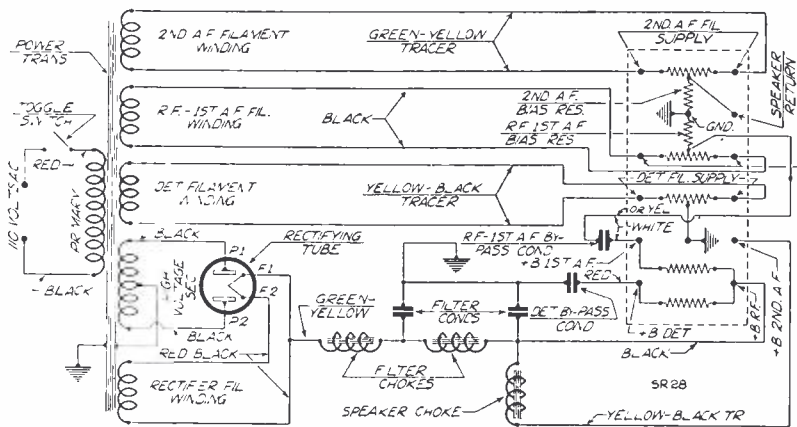

Fig. 2. At the left is shown the diagram of the power unit used on Atwater Kent Models 37 and 38

1.3, B voltage 173, tube in tester A voltage 1.25, B voltage 165, C voltage 10, normal plate m. a. 4.8, plate m. a. grid test 8.4, plate m. a. change 3.6.

Detector 227, tube out A voltage 2.25, B voltage 80, tube in tester A voltage 2.0, B voltage 22.5, normal plate m. a. 2.2, plate m. a. grid test 2.2, plate m. a. change 0.0

First audio 226, tube out A voltage 1.3, B voltage 173, tube in tester A voltage 1.25, B voltage 165, C voltage 10, normal plate m. a. 4.8, plate m. a. grid test 8.4, plate m. a. change 3.6.

r. f. transformers. In replacing the volume control the chassis must be removed from the cabinet.

Color Coding

The schematic diagram in Fig. 3 shows all of the colors used in the cable leads. It will also be seen that the input of the first coupling tube is a choke input, the volume control placed across it. Each of the 226 r. f. stages have a resistor in the grid circuit. None is used in the first tube and none in the detector.

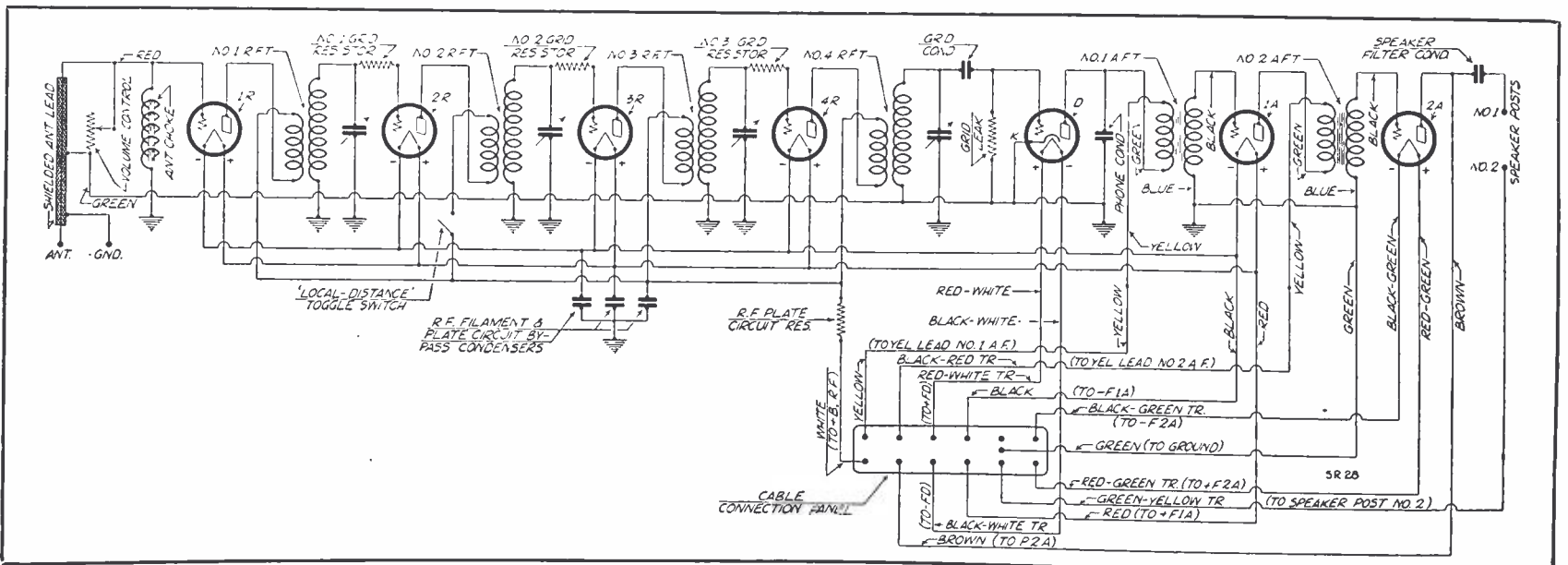

Fig. 3. In this illustration is the schematic wiring diagram of the Model 38 Atwater Kent receiver

Atwater-Kent Models No. 55 and 55-C

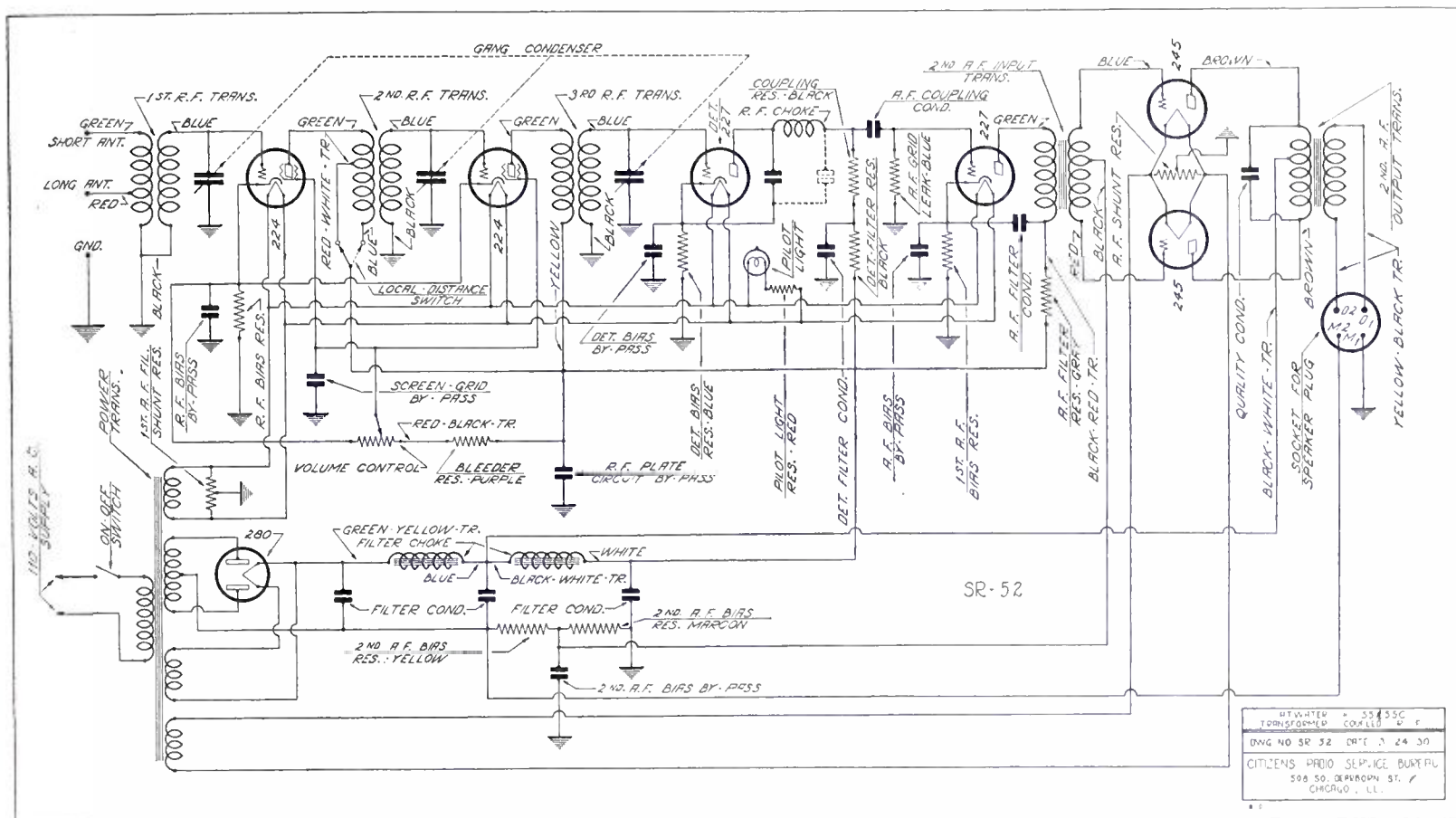

Figure 1. The transformer coupled r.f. early version of the Atwater-Kent 55 and 55-C is shown in this diagram

TWO designs of the Atwater-Kent 55 and 55-C receivers are illustrated on this page, the first being shown in Figure 1, and representing an early version of these models in which transformer coupling was employed for the radio frequency stages. The second is shown in Figure 2 and represents a later design of the 55 and 55-C embody-

ing capacity coupling between the r. f. Two 224 screen grids are used in the r.f.; a 227 in the detector which is of the plate rectification type, a 227 first audio stage, and two 245 tubes in push-pull for the output stage. Rectifier is a type 280 full wave. Connections for the socket plug for the speaker are different in the two

models, the wiring having been simplified in the later model shown in Figure 2. In the early model Figure 1 the volume control governs the screens of the 224's, while in the last model the volume control is across the input primary, although a control is still left for the screens as in the previous model.

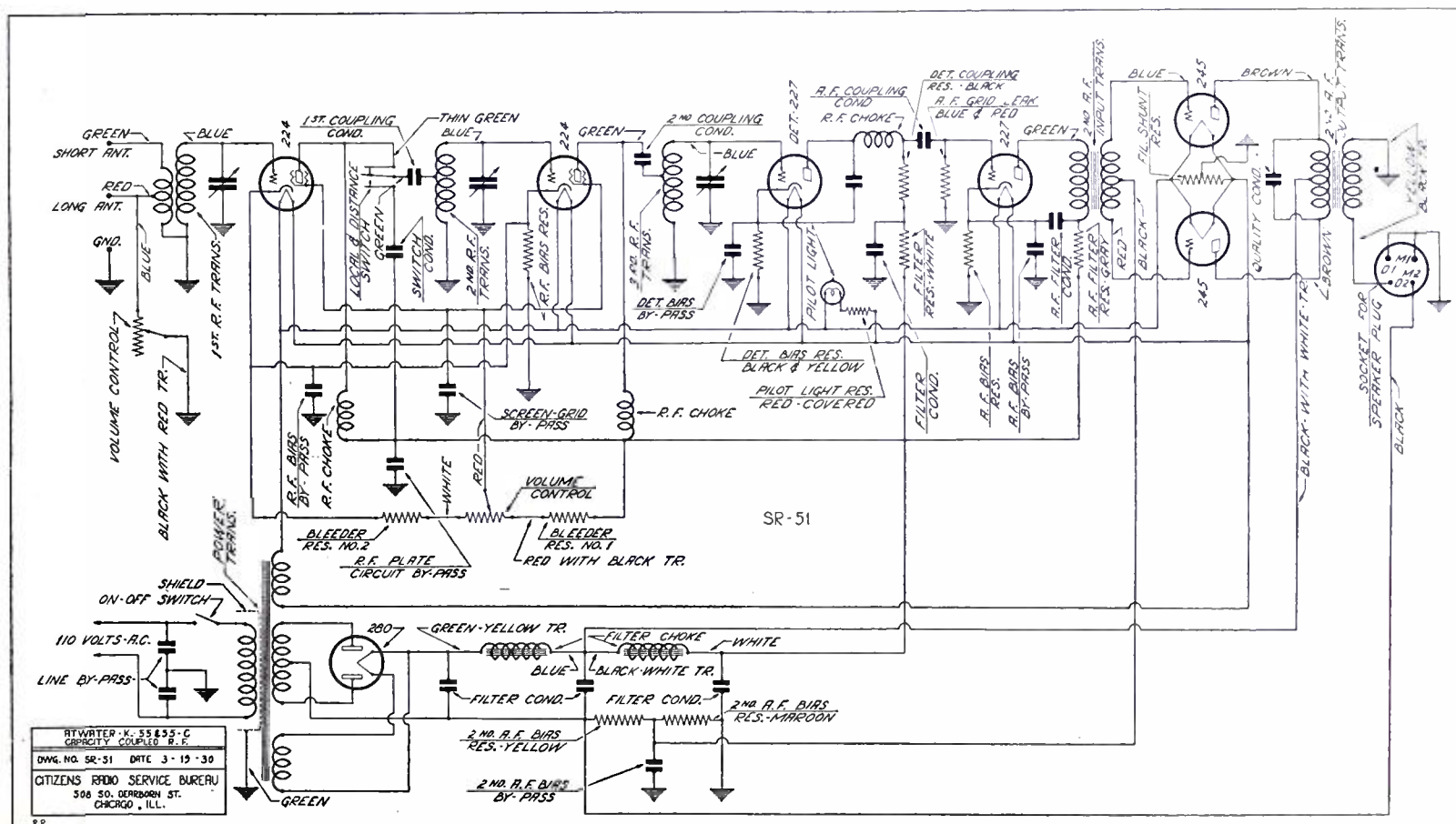

Figure 2. In this schematic is found the later design capacity coupled r.f. job made by Atwater-Kent

Atwater-Kent Model 66

MANY requests have been received from service men for the schematic diagram of the Atwater-Kent model 66 which is illustrated in Figure 2 on this page. A table showing average tube characteristics as taken with a Weston set tester is shown in Figure 1.

According to data shown on the Atwater-Kent service sheet in some early model 66's the volume control resistor in the plate circuit of the first r.f. is connected across the r.f. choke coil in the plate circuit of the first r.f. tube. The slider of this resistor is connected to a tap on the second r.f. transformer through a coupling condenser.

Service hints covering voltage readings are found in the Atwater-Kent wall sheet, which also indicates the various schematics. While on this page is given the voltage table as taken with a set tester the troubleshooting data is abstracted from the wall sheet.

No readings on the filaments indicates open filament winding or connection.

No reading of the plate voltages indicated an open high voltage winding; open filter choke; open r.f. resistor; open r.f. choke in the first r.f. plate circuit; open r.f. bias resistor or first r.f. bias resistor; open speaker field coil; open r.f. choke in second r.f. plate circuit; open r.f. choke in third r.f. plate circuit; open detector filter resistor, coupling resistor, r.f. choke or detector bias resistor, open first a.f.

ATWATER KENT—MODEL 66									
Tube Type	Position In Set	A Volts	B Volts	C Volts	Cathode Volts	Screen Volts	Normal Plate M. A.	Plate M. A. Grid Test	Change
224	1 RF	2.1	165	5.2	+6	110	2.6	5.4
224	2 RF	2.1	175	2.5	+3	80	2.8	5.0
224	3 RF	2.2	165	2.5	+3	74	3.6	5.4
227	Det	2.2	225	23.	+236	.7
227	1 AF	2.2	165	5.	+12	5.8	6.5
250	PP	7.0	440	78*	35.	40.
250	PP	7.0	440	78*	35.	40.
281	Rect	7.1	58
281	Rect	7.1	58

Line voltage 118. Volume Control maximum.
*Resistors in series with grid.

Figure 1. The voltages shown in this table are those obtained with a set tester. In the A-K service data the voltages are given as taken with a high resistance dc voltmeter between the necessary terminals

filter resistor; primary of a.f. input transformer, or first a.f. bias resistor; open primary of output transformer.

No reading of grid voltages may indicate trouble due to an open secondary of the first r.f. transformer; open secondary of the second r.f. transformer; open secondary of the third r.f. transformer, or open secondary of the fourth r.f. transformer; open first a.f. grid leak; open secondary of the a.f. input transformer, or open second a.f. grid filter resistor.

Lack of readings on the screen voltages might indicate an open bleeder resistor (shown at the left in the diagram); open volume control resistor located in the screen of the third r.f. tube.

It will be observed that this model uses two 250 tubes in pushpull for the output stage, and that two 281 rectifiers are employed in the full wave connection for supplying dc voltages for the receiver and its speaker.

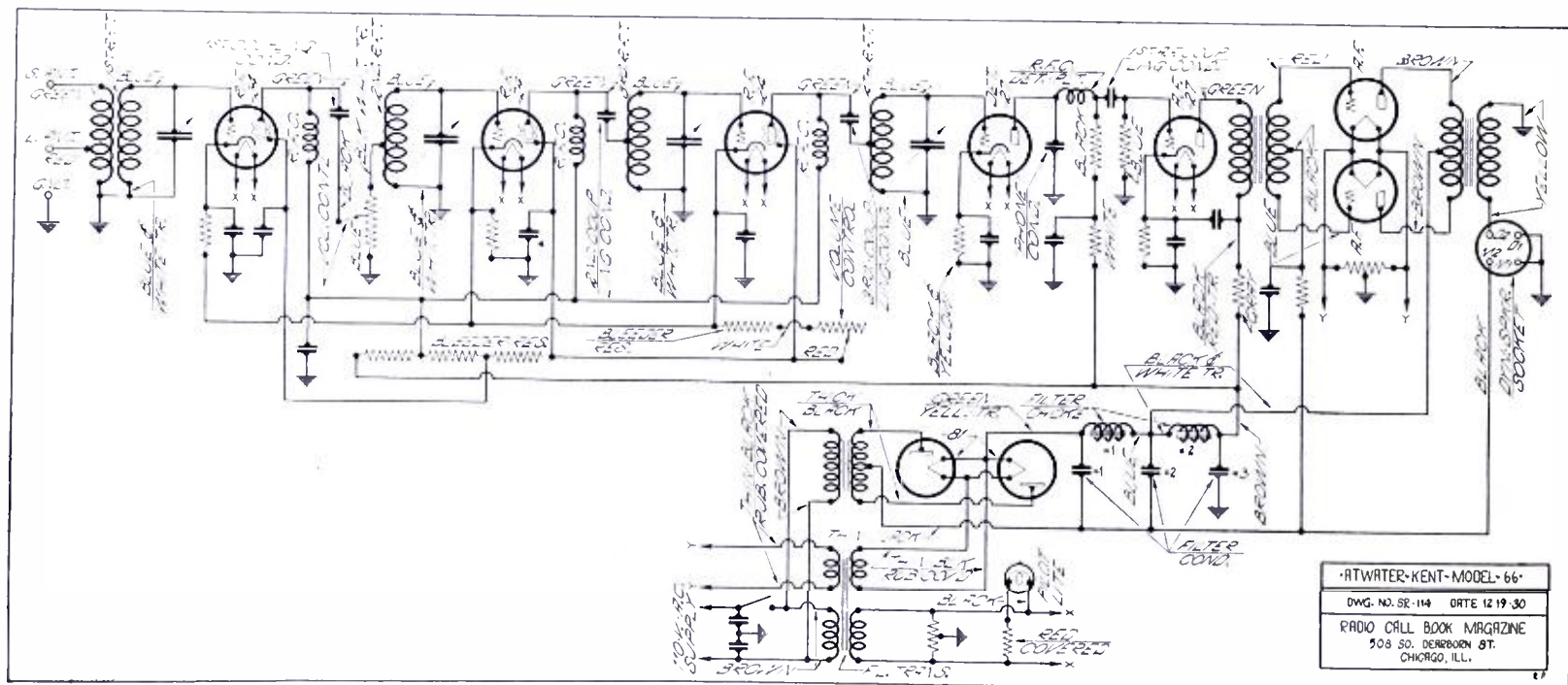

Figure 2. The schematic diagram of the Atwater-Kent model 66 is shown in the illustration above

Audiola Super 1931 Model

ELECTRICAL details of the Audiola Super 31 will be found in the schematic diagram Figure 2 on this page, while the table of average tube characteristics will be found in Figure 1.

Among the causes of improper operation as indicated in the Audiola service manual for the 31 are the following:

Noisy operation. When grating or scratching noises, or excessive hum are heard, it is well to disconnect antenna and ground from receiver before looking for trouble in the chassis. Cessation of such sounds with antenna and ground off indicate trouble is external to receiver. Grounded antenna, poor electrical joints in wiring system, leaking insulators and nearby electrical devices can all cause undesirable noises which can only be eliminated at the source. The more sensitive the receiver the greater the amount of noise it will pick up. Do not blame set for noisy operation until it is definitely shown source is in the chassis. It is always advisable to check tubes by interchanging with others before attempting to service the chassis itself.

Service Notes

If excessive hum develops check the following: poor or broken ground, speaker, aerial or ground lead near detector tube; poor rectifier tube; open audio transformer or C bias resistor in audio stage; open center tap on power transformer, either 224 or 227 heater windings, or 245 filament winding; any open ground in the chassis; poor heater tubes; poor 245 tubes in pushpull sockets; a mechanical hum may be caused by loose iron in the choke or power transformer. This may be determined by disconnecting voice coil leads from the speaker, leaving

field connected and turning set on. Placing ear near chassis may disclose source. Tighten clamping nuts on iron frames enclosing power transformer and choke.

Low volume may be caused by poor antenna or open antenna lead-in. Use of indoor or badly located shielded antenna in steel constructed building or

Change 227 tubes in detector and oscillator sockets. Line speaker compartment with felt or some other sound absorbent material. Oscillation or whistling when volume control is too far is usually caused by a poor 224 in the r. f. sockets; set will also oscillate if shielding cans are left off the r. f. tubes. High resistance joints,

Tube Type	Position In Set	A Volts	B Volts	C Volts	Cathode Volts	Screen Volts	Normal Plate M. A.	Plate M. A. Grid Test	Change
224	RF	2.4	160	2.5	2.5	80	4.0
227	Osc.	2.4	80	12.*	7.0*
224	1 Det	2.4	160	8	8	80	2
224	1 IF	2.4	160	2.5	2.5	80	3.0
224	2 IF	2.4	160	4.0	4.0	80	2.0
227	2 Det	2.4	150	18	18	1.0
245	PP	2.35	245	48	28
245	PP	2.35	245	48	28
280	Rect	4.7	260	58

Line voltage 115. Volume Control maximum.
*Non-oscillating.

Figure 1. Average tube voltages on the Audiola Super 31 as given in the instruction manual will be found in the above table

industrial district; defective tubes; tuned stages out of alignment; open circuit in r. f. or audio.

Howling, whistling or distortion: The most frequent cause of an audio howl of particular frequency is the resonance set up by a microphonic detector tube and a thin-walled cabinet.

poor soldering, corroded connections, etc., may also cause a howl. Poor or weak tubes in detector or audio sockets will cause poor quality of reproduction. A defective speaker will cause distortion. Bad cases of oscillation will usually be found due to open bypass condensers.

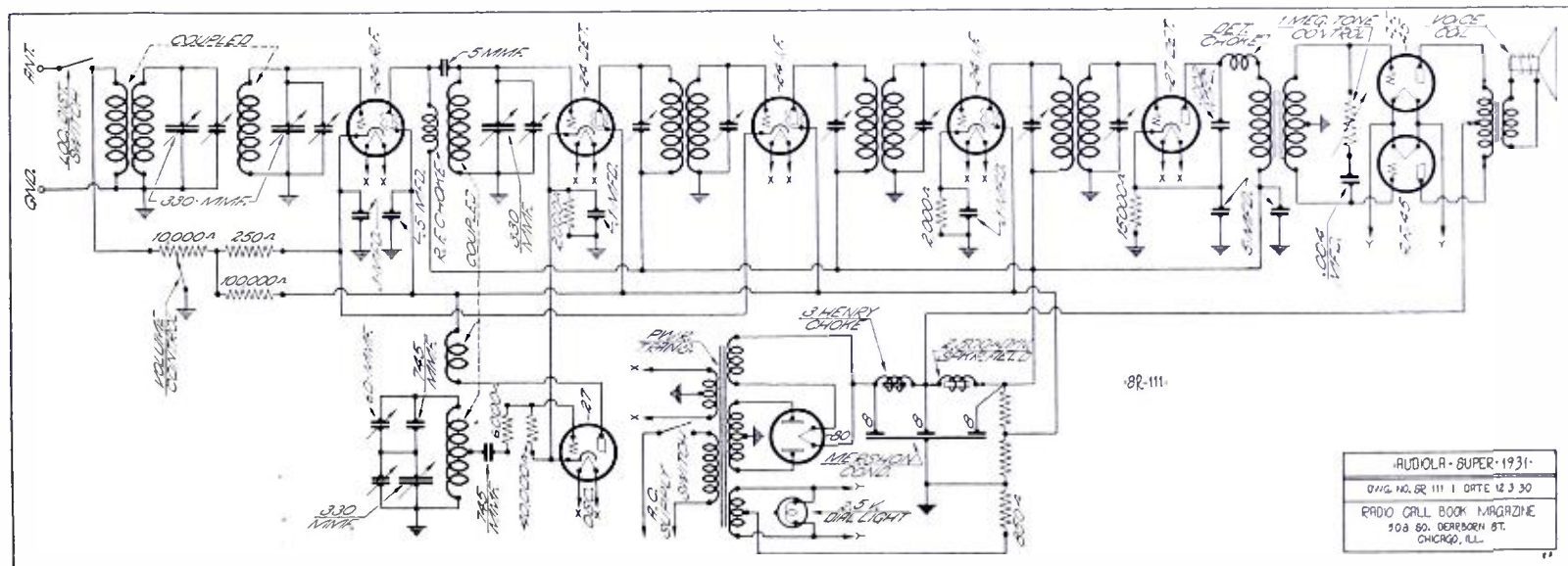

Figure 2. Electrical details of the receiver and its power supply may be obtained by consulting the schematic diagram above

Balkeit Model A Receiver and Pack

DESCRIBED on this page is the Balkeit Model A receiver manufactured by the Balkeit Radio Co., North Chicago, Illinois. It is a seven tube single dial neutrodyne receiver of the antenna type, having four tuned stages including three stages of neutralized radio frequency amplification, a tuned detector, one stage of straight and one stage of push-pull audio frequency amplification. It is equipped with a dynamic speaker field supply and may be used in connection with an electric phonograph pick-up to reproduce phonograph music.

Indoor or Outdoor Antenna

This receiver is entirely self-contained and employs five 227 heater type tubes, two 112-A tubes and a 280 rectifier. Either indoor or outdoor antenna may be used, although if an outdoor aerial is desired it should not exceed 50 feet in length and should be carefully erected and insulated. According to the schematic shown in Fig. 1, there is a hum control provided on the receiver, which is placed across the filament supply for the 227 tubes. This control is mounted near the tubes on the left-hand side of the receiver and has a shaft head arranged for adjustment with a screwdriver. In the event that objectional hum is heard, turn the volume control to the right, adjust the station selector so no signal is received and turn the hum control until a minimum hum is heard in the speaker. There will be two positions of this hum control at which

hum would be at maximum intensity and the proper position will be about midway between these two positions. Ordinarily it will not be necessary to change this adjustment unless a new detector tube is used.

This receiver is designed to supply d. c. power to energize the field of any standard dynamic speaker of the type using 100 to 150 volts d. c. Dynamic speakers designed for use on 6 volts d. c. supply cannot be connected to the field terminals of the receiver. A pick-up jack located on top of the receiver chassis near the left-hand edge is provided for plugging in the cord from an electric phonograph pick-up device when it is desired to use the audio amplifying system of the receiver and the loud speaker to reproduce phonograph music. To use this feature no receiver adjustments are necessary.

Neutralization Data

The neutralizing condensers are shown in the schematic in Fig. 1 and are placed between the grid of one r. f. tube and the neutralizing tap on the secondary of the succeeding inductance. Although the set is neutralized in the beginning, if it becomes necessary to neutralize the set again, the following information may be of help. A full set of good tubes is required. In addition a single 227 tube which has a burned out heater element is used for making the neutralization test. Place all tubes in proper sockets, connect

aerial, ground and speaker and tune in a strong nearby station on the lowest wavelength possible. Adjust receiver so signal is received at maximum volume. Place tube with defective heater element in first r. f. socket. If no signal is heard, this stage is properly neutralized. If a signal is heard, even though of decreased volume, the neutralizing condenser with that tube, which has its adjusting screw located directly in front of the tube, must be adjusted. Use a neutralizing tool (not a screw-driver) and carefully adjust the screw until minimum signal is heard, at the same time moving the tuning dial slowly back and forth across the station signal. Do not press on the tool when making this adjustment, as the capacity may change when the tool is removed. Remove tube with the defective heater and place a good tube in the first r. f. socket. Remove tube from second r. f. socket, place defective tube in socket and repeat as before until all stages have been neutralized.

Trimming Condenser

A fourth condenser which is known as a padding or trimming condenser is located directly in front of the detector tube. To adjust this tune in a low wavelength local station at moderate volume, adjust the tuning drum so maximum signal intensity is obtained with lowest possible setting of volume control. Use neutralizing tool and adjust padding condenser until maximum signal intensity is obtained.

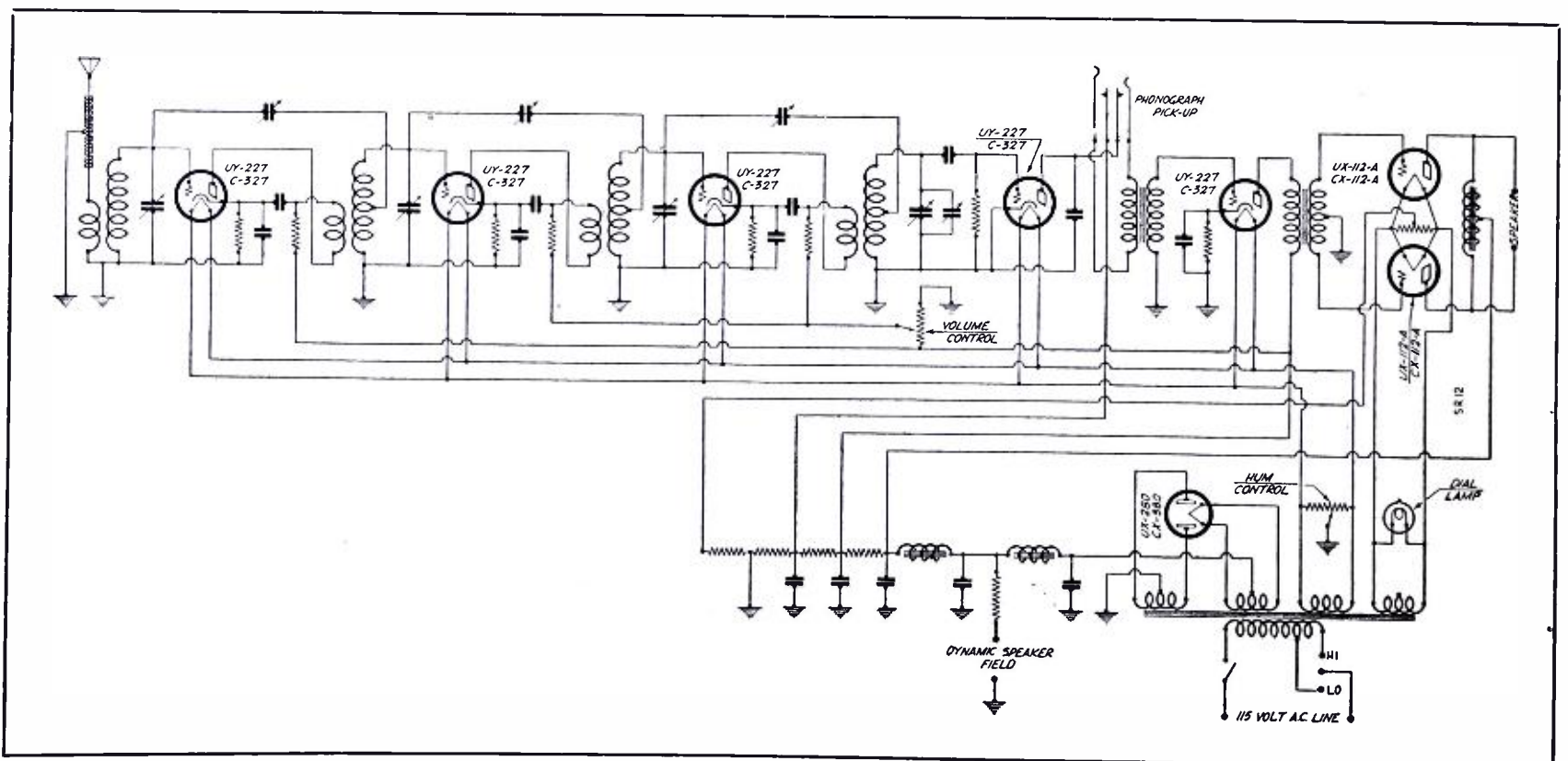

Fig. 1. Both the receiver and power supply schematics are combined in the above diagram of the Balkeit Model A Set

Models 28 and 29 Bosch Receivers

THE model 28 receiver made by American Bosch Magneto Corp. at Springfield, Mass., consists of the standard chassis and standard push-pull power pack mounted in a table model cabinet. The two units are covered by a single shield and the receiver and power unit are already interconnected. Installation of this model consists in connecting the reproducer, antenna, ground, attachment cord, and inserting the tubes.

Use Set Tester

A variable tap switch is provided to take care of line voltages between 100 and 130 volts. It is absolutely essential that the service man determine the maximum line voltage to which the receiver is to be connected. Voltage readings should be made depending on load conditions of the line so that the best average voltage may be ascertained. For this purpose the service man should either use the model 537 Weston a. c. and d. c. radio set tester or the Jewel model 199 a. c. and d. c. set analyzer.

When the receiver is in operation it is desirable to interchange the location of the type 226 tubes to obtain maximum performance. Always switch the receiver off by means of the main switch before changing tubes. Any type 226 tube which works poorly in any radio

frequency socket should be placed in the first audio socket.

On the model 28 the speaker jacks are connected on the rear of the power unit at the left of the receiver. These jacks fit any standard cord tips. Since the output transformer of the push-pull stage eliminates direct current in the speaker jacks attention to polarity is unnecessary.

Adjusting R. F. Stages

The fact that no signal will come through a stage which is perfectly balanced, providing the tube filament is not lighted, is utilized to adjust the receiver should it become necessary to balance the radio frequency stages.

A modulated radio frequency oscillator made by Bosch is used to provide a signal for the receiver to pick-up. A powerful local broadcast station may also be employed, preferably one coming in at from 30 to 50 on the dial scale. When using the oscillator turn the station selector dial to about 40 degrees. Then tune the oscillator until the signal is picked up by the receiver. When using the broadcast signal simply tune it in for maximum volume.

Make sure that the clarifier and selector dial are set at a position of maximum volume. This is important. Turn the volume control fully on.

Now remove the tube from the first radio frequency socket and replace it by a type 226 which has had one of its filament prongs sawed off. The tube must otherwise be in good condition. Do not use a burned out tube.

Due to the fact that the one filament prong has been removed the tube will not light and if the stage is in balance no signal will be heard. If, however, the signal is heard, adjust the nut of the first r. f. balance condenser with the service tool until the signal disappears. If the nut is turned beyond the balance point the signal will again come in. Leave the nut at the point of minimum volume. This completes the balance of the first stage. Second and third stages are balanced in exactly the same manner using the adjusting nut of the second r. f. balance condenser and the third r. f. balance condenser.

Align After Balancing

Alignment of the set must be done after the receiver is balanced. To do this simply adjust the nut of the second r. f. alignment condenser, the third r. f. alignment condenser and the detector alignment condenser to the point of maximum volume. The regular tubes are employed in this adjustment, the special balancing tube not being employed.

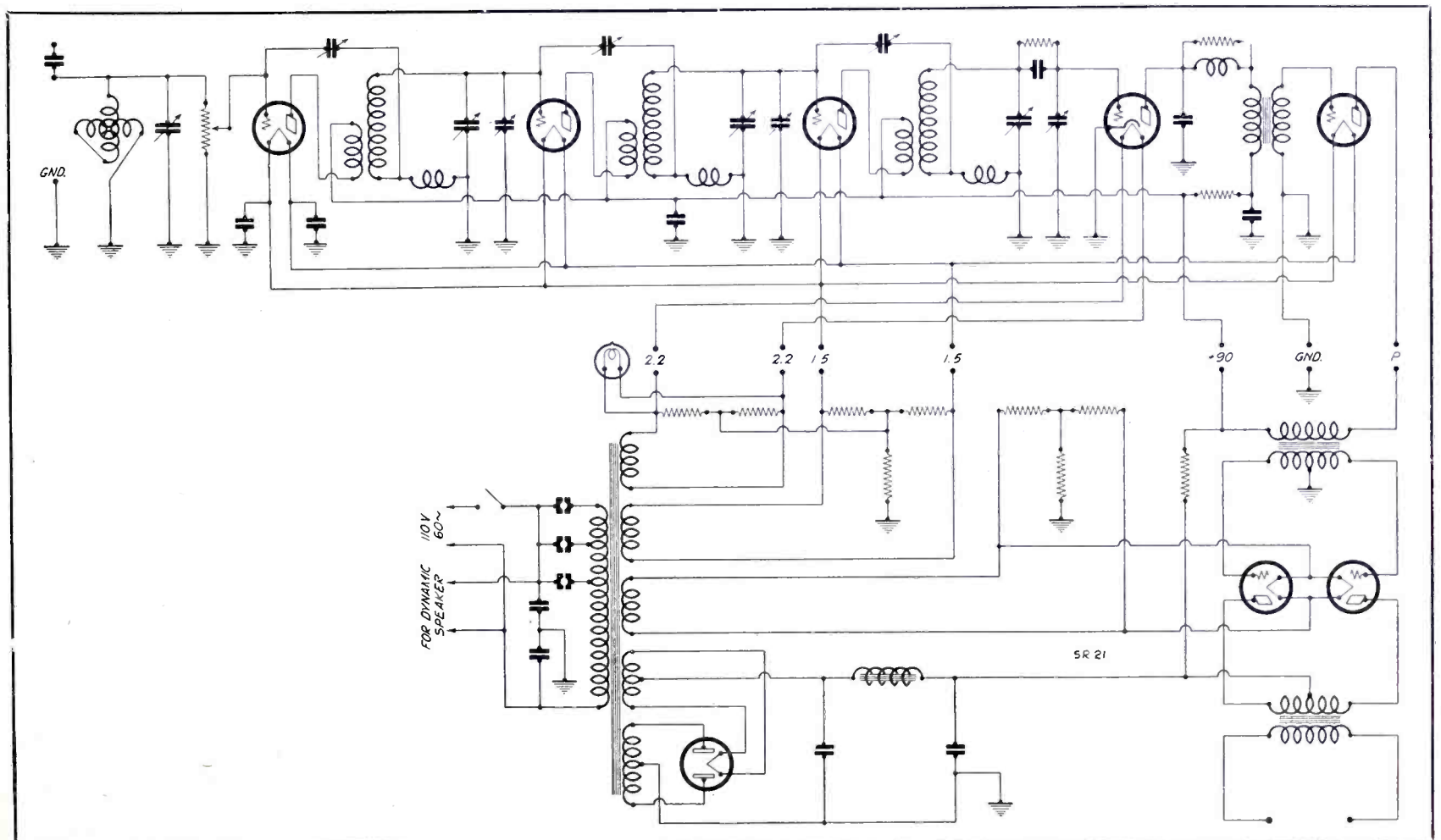

Fig. 5. This wiring diagram gives the schematic circuit of the Bosch Models 28 and 29 described on this page

Bosch Receiver Model No. 58

SERVICE data on the model 58, made by the American Bosch Magneto Corp., is shown on this page, the tube table in Figure 1 and the schematic of the receiver and power supply in Figure 2. The model 60 is practically the same as the 58 except it has an automatic volume control, a mute switch and a larger speaker.

Under service complaints in the Bosch manual are to be found a number of suggestions worth repeating since they cover the most common complaints. Weak or poor reception from distant stations might be caused by inefficient antenna, open or grounded antenna; poor or broken ground connection; defective tubes; condensers not aligned mechanically; condensers not aligned electrically; defective coil or connections; low or incorrect socket voltages; rectifier tube defective. Referring to the trimming condenser, if a peak or point of loudest reception cannot be secured by adjusting the trimmer condenser, look for an open antenna lead-in, grounded antenna, or shorted lightning arrester. A defect in the receiver or a wrongly connected local-distance cable may produce the same effect.

Poor tone quality might be caused by a defective power tube; unmatched power tubes; lack of C bias; incorrect voltages. Rattles and vibration may be caused by a speaker out of adjustment. Make sure the wires from the voice coil are not lying against the diaphragm. Also make sure the vibration is not caused by loose parts, such as the chassis holding bolts, etc.

Noise level is treated of in the manual since it covers a condition that is hard to explain to the lay user of a radio set. Noise level is the term ap-

plied to the amount of static and interference noise heard with the receiver turned on fully but not tuned to a station signal. If the noise level is high it is obvious that a weak or distant station will not be heard above the interference. The noise level is higher in summer, due to natural static, and is higher in congested districts or near trolley lines because of man-made inter-

ference. Experience with receivers for automobile use has shown that a very considerable difference in reception may occur in a very short distance. In general, reception is better in thinly populated or suburban districts than in congested sections.

A loose connection anywhere in the receiver or accessories may produce noisy reception. Check the antenna and

Bosch Model 58

Tube Type	Position in Set	A Volts	B Volts	C Volts	Cathode Volts	Screen Volts	Normal Plate M. A.	Plate M. A. Grid Test	Change
224	1 R.F.	2.2	170	2.2	-	75.	3.0	---	---
224	2 R.F.	2.2	170	2.2	-	75.	3.0	---	---
224	3 R.F.	2.2	170	2.2	-	75.	3.0	---	---
224	Det.	2.2	30*	1.5	-	10.*	.1*	---	---
227	1 A.F.	2.2	150	8.0	-	-	5.0	---	---
245	P.P.	2.4	250	50	-	-	30.	---	---
245	P.P.	2.4	250	50	-	-	30.	---	---
280	Rect.	5.0	-	-	-	-	-	---	---

Line voltage 115. Volume control maximum.

*Approximate, since measured through high resistance.

Fig. 1. The table of tube characteristics as given in the Bosch manual covering model 58 may be seen above. Values marked with an asterisk are approximate since measurements are made through a high resistance

ference. In some locations, therefore, reception of distant, or in some cases even semi-distant stations, may be impossible due to the high noise level.

A word or two about location seems proper. Local conditions have a decided effect upon reception. For this reason identical receivers will perform differently when installed in various different locations in the same town or

ground system, also the speaker cord.

The house lighting system should be checked for loose connections, defective switches or sockets. Jarring the cabinet will frequently indicate if the loose connection is in the receiver. Noise caused by turning the selector control is generally caused by condenser plates touching, or particles of metal between the plates.

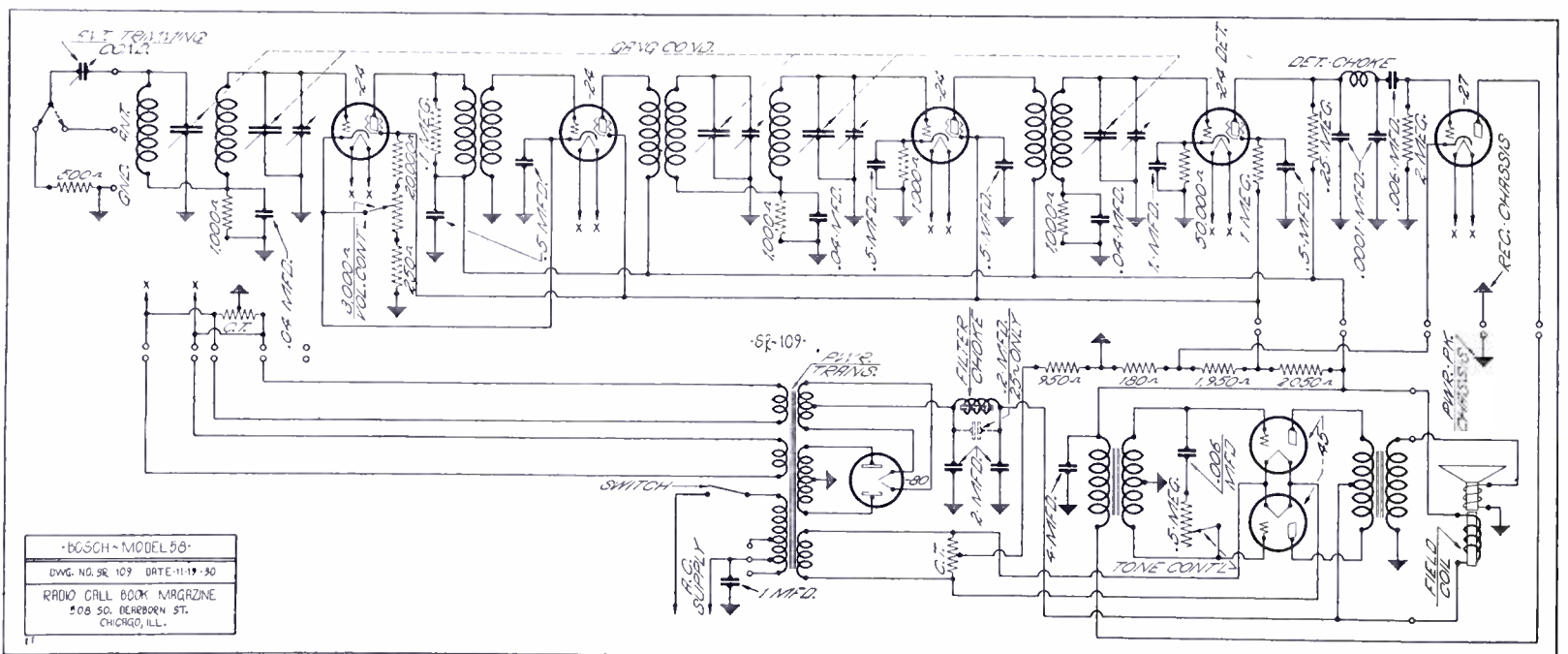

Fig. 2. The receiver and power supply of the Bosch model 58 is found in the schematic drawing above

Bosch Radio Model 60

SCHEMATIC details of the Bosch model 58 receiver appeared on page 67 of our January issue. The receiver described on this page is the model 60 which is slightly different from the model 58 especially in that an automatic volume control tube is provided in the 60. Response curves on this model will be found elsewhere in this section.

In addition to the automatic volume control feature the model 60 is equipped with a mute switch and a larger speaker is employed than in the previous model. The 60 has the same number of radio and audio frequency stages and employs the same tube equipment, with the addition of one type 224 tube for the automatic volume control. Jacks are provided for the connection of a phonograph pick-up. An automatic phono-radio switch is operated by simply turning the tuning dial to zero.

A table of the average tube characteristics as determined by a set analyzer will be found in Figure 1, while the electrical details of the model 60 will be found in the schematic illustration Figure 2.

A description of the action of the automatic volume control feature follows: when the signal being received increases in volume it results in a higher signal voltage on the detector; this higher voltage is applied to the grid of the AVC tube by direct connection; a higher voltage on the AVC grid results in drawing greater plate

AMERICAN BOSCH—MODEL 60									
Tube Type	Position In Set	A Volts	B Volts	C Volts	Cathode Volts	Screen Volts	Normal Plate M. A.	Plate M. A. Grid Test	Change
224	1 RF	2.4	170	2	70	3
224	2 RF	2.4	180	2	80	3
224	3 RF	2.3	185	1.5	85	2
224	AVC	2.3	30*	.2*	20*	.2*
224	Det	2.3	60*	1.0*	10*	.1*
227	1 AF	2.3	150	.1*	6
245	PP	2.4	250	50	30
245	PP	2.4	250	50	30
280	Rect	5.0

Line voltage 115, on 115 volt tap. Volume Control maximum.
 *Not true readings due to resistor in circuit.

Figure 1. In this tabulation will be found the average tube voltages on the Bosch model 60 as determined with a set analyzer

current through the AVC resistor, increasing the drop across this resistor, thereby increasing the grid bias on the first and second radio frequency stages which cuts down the signal.

The tuning meter is in the cathode circuit of the first and second r.f. tubes and simply indicates the plate current of these two tubes. It also indicates, therefore, the action of the automatic volume control, swinging further to the right (low plate cur-

rent) as the signal level rises on powerful stations.

It will be noted that the filament, cathode and grid circuits of the first two r.f. stages are separate from the rest of those of the receiver, and are at approximately the same voltage above ground as the plate of the AVC tube. It is necessary for the proper functioning of the receiver that there be no points in the coils or wiring where leakage to ground may occur.

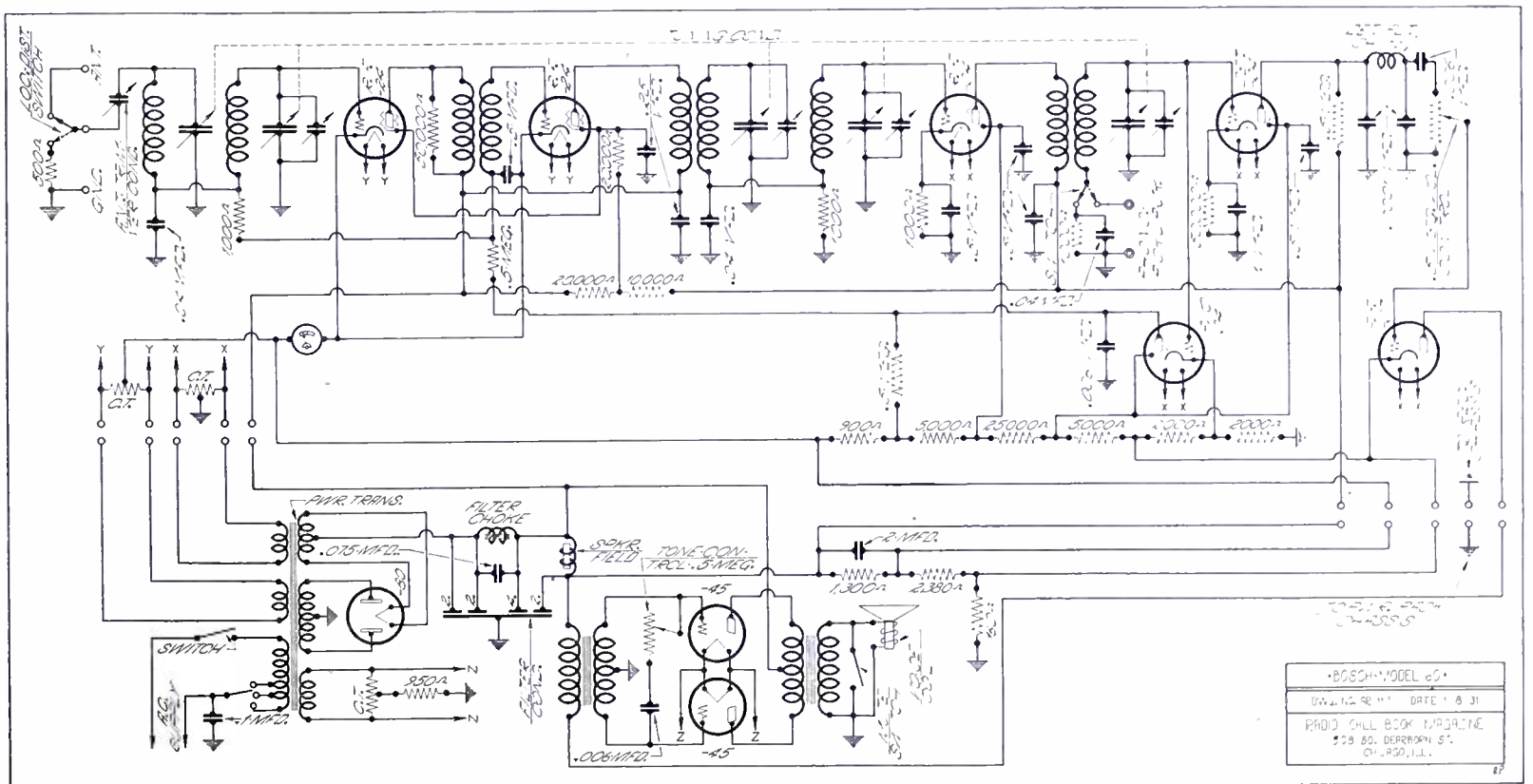

Figure 2. In this drawing will be found the electrical detail of the Bosch model 60 receiver which includes automatic volume control

Bremer-Tully Model 7-70 and Supply

ONE of the models made by the Bremer-Tully Mfg. Co. of Chicago is known as the 7-70, the schematic circuit for which is shown on this page. In addition there is also shown the electrical circuit of the power converter for this model.

The receiver employs three 226 tubes, these being in the three radio frequency stages; two 227 tubes, one in the detector and the other in the first audio; and two 171-A tubes arranged in push-pull for the power output circuit. The schematic diagram of the receiver itself is shown in Fig. 2. The power converter utilizes a single 280 full wave rectifier and the schematic circuit covering this unit is shown in Fig. 1.

Neutralized R. F. Stages

It will be seen by referring to Fig. 2 that the three radio frequency stages are neutralized by means of small neutralizing condensers and a neutralizing winding included in the plate circuit of the tube and a neutralizing tap in the grid circuit of the same tube. The antenna stage condenser has a trimmer by means of which this particular stage may be balanced to take care of varying antenna conditions. The tuning condensers across the second and third r. f. stages do not have the trimming arrangement, although the detector circuit tuning condenser does have a trimmer.

Volume control is secured by means of the potentiometer located between one end of the antenna coil and the grid return portion of the secondary of the second r. f. inductance, the arm of the volume control being grounded. This volume control in one position acts as a short circuit upon the antenna circuit.

In the opposite position it places a high resistance from the antenna to ground.

The tone control shown in the schematic is a three leaf switch, with an "on" and "off" position. In the "on" position, it serves to tune simultaneously the grid and plate circuit of the 227 first audio tube, in the case of the grid circuit it serves to add to the existing .00025 mfd fixed condenser between grid and ground and an additional .003 mfd fixed condenser and at the same time places a .02 mfd fixed condenser between plate and grid. When the switch is in the "off" position,

by the plate circuit of the detector. In the push-pull input side of the 171 tubes a .00025 mfd fixed condenser is placed from the center tap to one grid of the power tube as a means of preventing oscillation or unbalance.

The power supply schematic is shown in Fig. 1, where it will be seen to consist of 110 volt primary with high voltage secondary, a 5 volt secondary for the filament of the 280, a 5 volt secondary for the 171-A filaments, a 1.5 volt secondary for the 226 tubes and a 2.3 volt secondary for the heaters of the 227's. The resistance network is a combination of 4000 ohms resistance for the plate of the first audio, 1700 ohms for the 3 r. f. plates and 34,100 ohms for the detector plate. This method of connection eliminates the bleeder current in the resistances and lessens the tendency of any receiver to motor-boat. The terminals A and B are shorted in the diagram and when a dynamic speaker with a high voltage a. c. field is employed, it is inserted between terminals C and B, the field winding of the dynamic taking the place of the second portion of the filter choke. Center tap across the 5 volt winding for the 171-A's is secured by a 40 ohm center tapped resistance, while the drop across the 1125 ohm resistor between this center tap and the common B negative and ground lead supplies bias for the grids of these two tubes in push-pull. The bias for the r. f. stages is secured through the drop across a 770 ohm resistor between the center of the 8 ohm center tapping resistor across the 1.5 volt filament line and the center B negative and ground terminal. A 227 is used as the first audio.

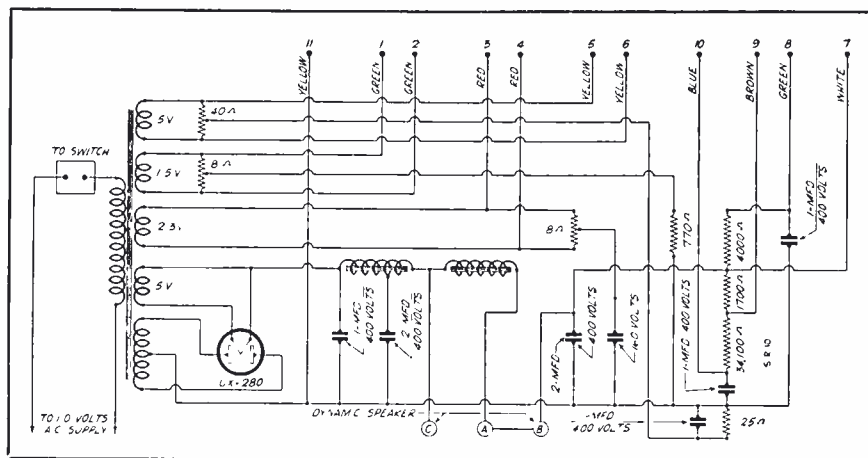

Fig. 1. Shown schematically above is the Bremer-Tully power converter for their 7-70 model

the only condenser across the grid circuit of the first audio is the .00025 mfd previously mentioned. C bias for the first audio stage is secured by the drop across a 1540 ohm resistor bypassed with a 1/2 mfd condenser between cathode of the tube and ground.

Phonograph Pickup

A phonograph pick-up jack is provided on the receiver being placed in the primary of the first audio transformer but at a tapped position, so that more amplification is provided by that particular transformer when used with the magnetic pick-up than is provided

dynamic taking the place of the second portion of the filter choke. Center tap across the 5 volt winding for the 171-A's is secured by a 40 ohm center tapped resistance, while the drop across the 1125 ohm resistor between this center tap and the common B negative and ground lead supplies bias for the grids of these two tubes in push-pull. The bias for the r. f. stages is secured through the drop across a 770 ohm resistor between the center of the 8 ohm center tapping resistor across the 1.5 volt filament line and the center B negative and ground terminal. A 227 is used as the first audio.

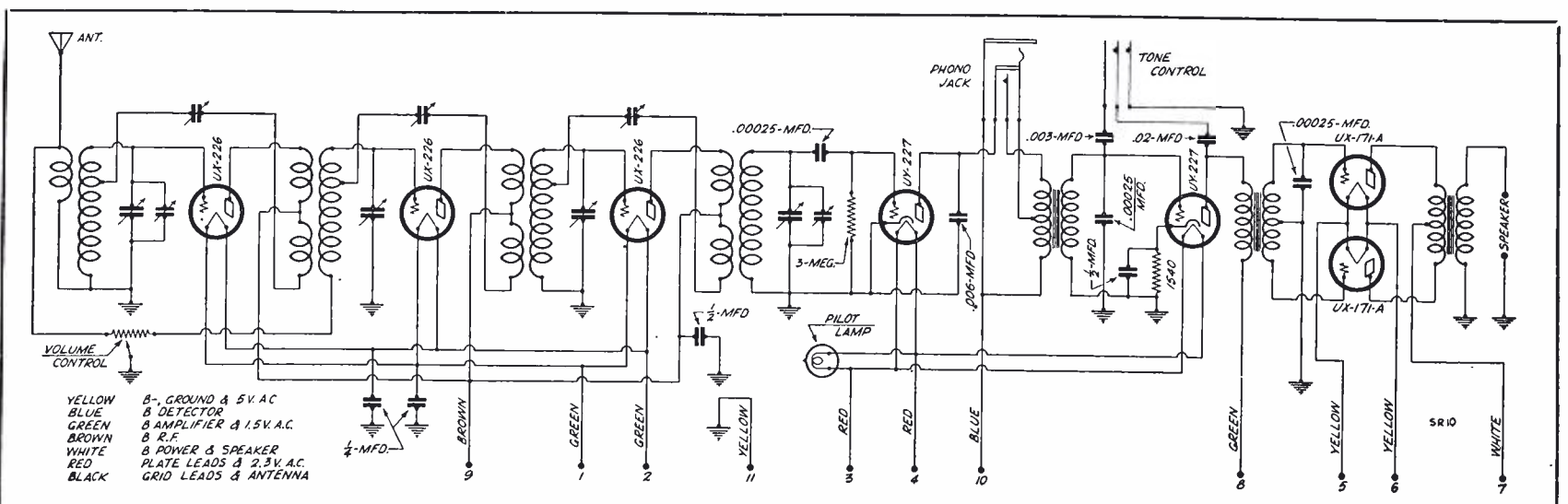

Fig. 2. This diagram shows the electrical circuit of the Bremer-Tully 7-70 model

Brunswick No. 3KRO with Panatrope

BRUNSWICK model 3KRO is made by the Brunswick-Balke-Collender Co. of Chicago. This particular model has in it the Panatrope with Radiola. The circuit used in the X802 radio chassis is a six tube radio frequency circuit employing an untuned input, three stages of tuned radio frequency, detector and two audio stages.

Untuned Input

The untuned input consists of a 2000 ohm resistor in the form of a potentiometer, the antenna and ground being connected to the ends of the resistance and the contact arm connected to the grid of the first r. f. amplifier tube. The variable resistance serves as a volume control, the resistor being in two sections, one of which is of a low resistance and the other high resistance in order to give gradual adjustment.

The necessity for stabilizing resistors has been eliminated by the use of three coil (two primaries and one secondary) transformers in the second and third r. f. stages. In the first r. f. the transformer has an auxiliary secondary winding which is used in conjunction with a small variable capacitor for regulating regeneration in the second 226. The small capacitor is adjusted at the factory and a paper seal placed over the hole in the chassis. If this capacitor is ever readjusted, place new seal over hole.

Any undesirable hum in the speaker must be minimized by one or more of the following methods: Reverse the connections of the power supply plug; interchange the 226 tubes until a satisfactory arrangement is found; make sure that the 280 rectifier is not a low emission tube. It is possible a section of the condenser across the 226 filament

Possible Troubles

Audio howl may be caused by one or more of the following defects: Compensating condenser not adjusted correctly. Open connections to the a. f. condensers on the under part of the chassis, or open connections in one of the condensers. An open ground connection on the radio chassis or a poor ground installation. Open radio frequency coil. Open or shorted resistor in the socket power unit. In some cases it may be found that the 227 is causing the audio howl and if such is the case the tube should be replaced.

The schematic diagram of the socket power unit is shown in Fig. 8. It will be seen that the 280 is used as a rectifier. Filaments of all tubes are supplied with raw a. c. at the proper voltages, three mid tapped resistors being used to minimize hum. Grid bias voltages are obtained by using the voltage drop across resistances connected in the plate return lead. Due to

use of a series resistance arrangement for securing the different plate voltages, all tubes must be in good condition in order to prevent overloading of other tubes. This method also makes possible the use of smaller filter capacity.

Inasmuch as the impedance output unit is incorporated in the socket power unit, the phone tip jacks are placed in a convenient position in the lower part of the power supply.

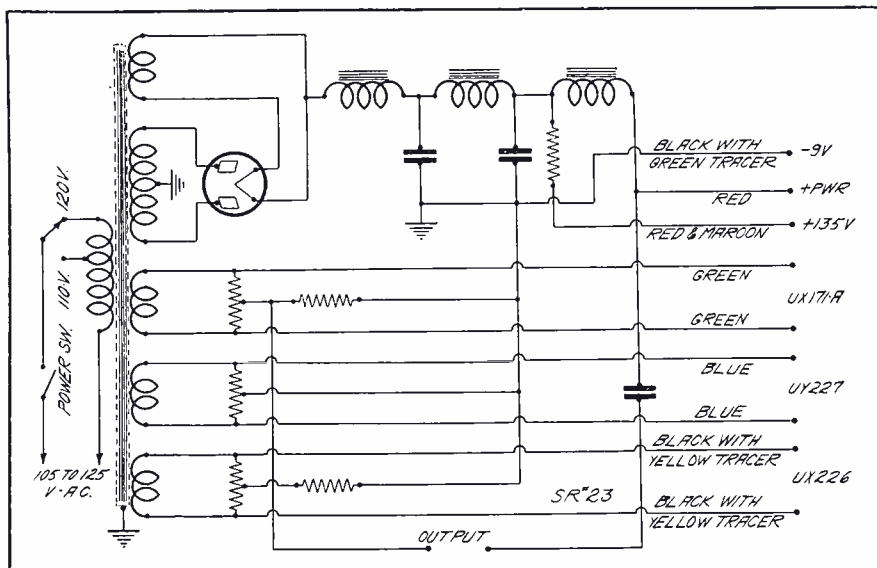

Fig. 8. In this diagram is shown the schematic circuit of socket power unit X-341 used with the 3KRO equipment shown on this page

is shorted. This condenser is one of the two located on the under side of the chassis and is composed of two 1/2 mfd sections with the center tap grounded. A defective center tapped resistor in the socket unit will also cause abnormal hum. Proper contacts should be made at all grounding connections on the chassis in order to prevent undesirable hum. Improper connections may also cause unsatisfactory operation.

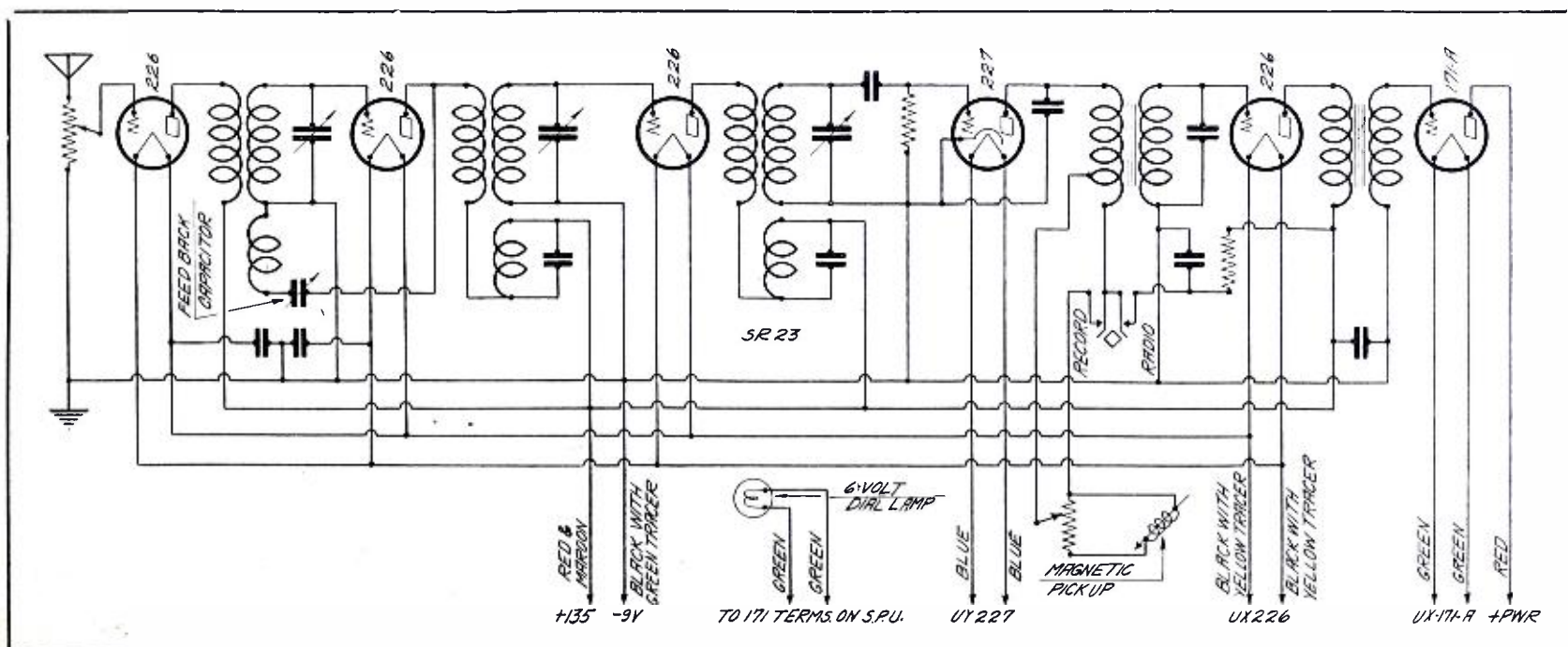

Fig. 9. The schematic diagram of the Brunswick Model 3KRO shows electrical connections of the chassis No. X802

Brunswick Models 15 and 22

RESPONSE curves of the Brunswick models 15 and 22 which are illustrated on this page, appeared in the September, 1930, issue of this magazine on page 68, to which reference should be made for any data concerning sensitivity, selectivity and fidelity.

In this brief article will be found material of interest to servicemen and technicians, much of which is indicated in the manual prepared by the Brunswick Radio Corporation. A table of average tube characteristics appears in Figure 1, while the schematic diagram covering the models 15 and 22 is shown in Figure 2.

Hum

Under general service data we find in the case of hum that it may be traced directly to a gassy or otherwise defective detector tube. Try each of the -2Fs in the detector socket (the one nearest the cabinet) and use the tube having least hum. Excessive hum may also be encountered by a poor or entire lack of ground connection. Try reversing the house lighting plug. Other and more severe causes of excessive hum may be due to a shorted filter choke, defective center tap filament resistor, leaky, open or shorted filter condensers, or an open detector screen grid by-pass condenser.

Oscillation

Oscillation may be caused by an open radio frequency by-pass condenser.

Brunswick Models 15-22

Tube Type	Position in Set	A Volts	B Volts	C Volts	Cathode Volts	Screen Volts	Normal	Plate	M. A. Grid Test	Change
							M. A.	M. A.		
224	1 R. F.	2.5	178	2.5	2.5	60	2.2	---	---	---
224	2 R. F.	2.5	178	2.5	2.5	60	2.2	---	---	---
224	3 R. F.	2.5	178	2.5	2.5	60	2.2	---	---	---
221	Det.	2.5	180		8	24.3	.36	---	---	---
245	P. P.	2.5	242	12			30	---	---	---
245	P. P.	2.5	242	12			30	---	---	---
280	Rect.	4.8	385				40	---	---	---

Line voltage 110, fuse clip in 120 volt. Volume control maximum.

Fig. 1. Data appearing in the service manual is used to compile the above table of average operating values for use by the serviceman in checking the receiver

The connections to these parts should be thoroughly inspected. An open condenser may be easily found by connecting with two short pieces of wire a .5 mfd condenser (known to be good) across the terminals of the condenser under suspicion. This should be done with the set turned on, adjusted to oscillate and with the chassis in an inverted position with the bottom plate removed so that the testing condenser may be momentarily applied across each of the r.f. by-pass condensers. A defective condenser is indicated when the test stops or reduces oscillation. Other causes of oscillation are: r.f. tube

shield making poor contact with inter-tube shields or chassis; leaky or shorted detector grid bias by-pass condenser, or poor contact of gang condenser grounding springs on the rotor shaft.

Other Trouble

Complete absence of any sound in the speaker would indicate the possible source of trouble is in any one of the following points: antenna connections shorted to chassis; defective r.f. coil or plate choke; short circuited by-pass or filter condenser; defective output transformer or speaker voice coil, and defective volume control.

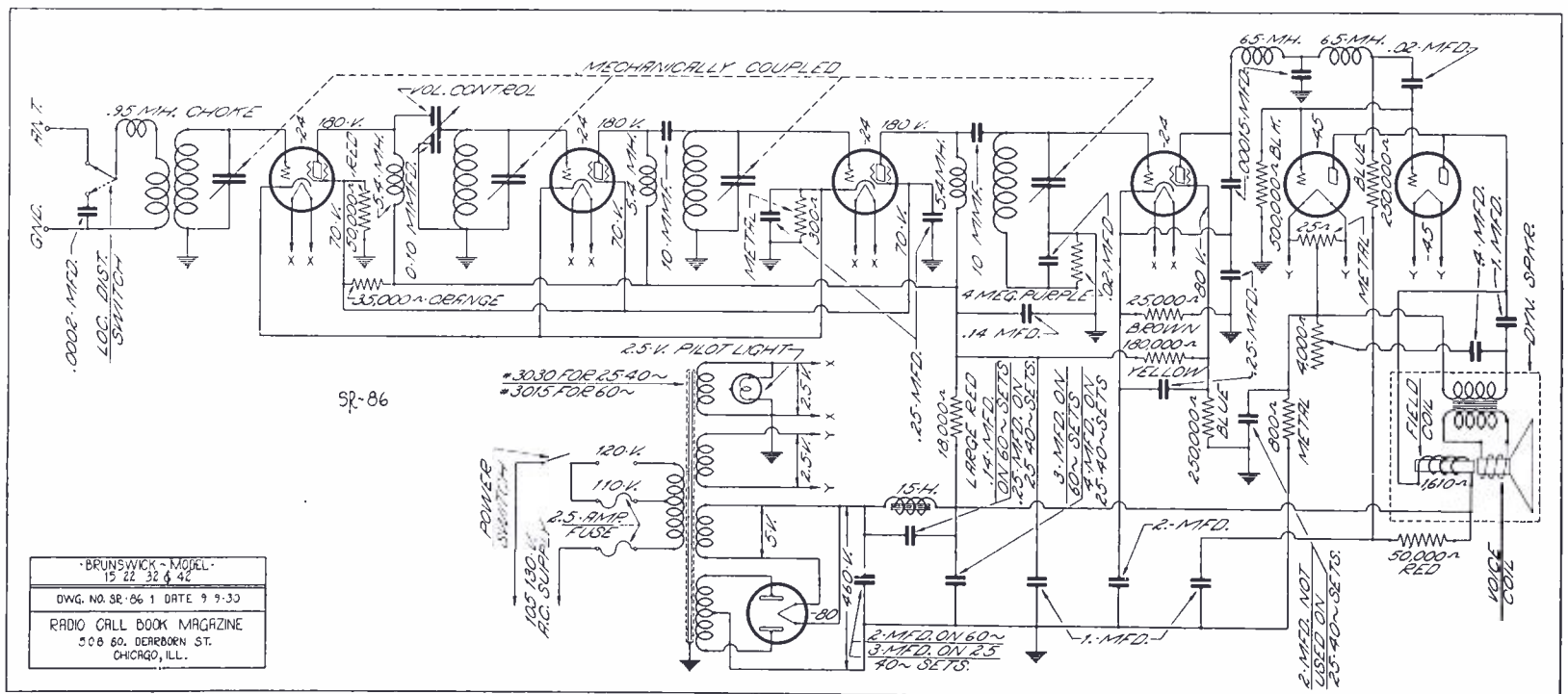

Fig. 2. In this diagram may be seen the schematic details of the models 15 and 22 made by Brunswick. Note in particular the type of volume control which is unique

Colonial Model 31 A. C. and Supply

SHOWN schematically on this page is the Colonial Model 31 a. c. receiver and its power supply, manufactured by the Colonial Radio Corporation, Long Island City, N. Y.

The set consists of a receiver unit employing two 226 tubes in a tuned and inductively balanced r. f. circuit, a 227 detector stage and a first audio stage also using a 227 tube. The second or power unit employs a push-pull stage using two 171 tubes and the 280 rectifier with the associated power supply apparatus. The two units are connected by cable and plug.

The schematic diagram of the power supply is shown in Figure 4, while the drawing of the receiver circuit itself is illustrated in Figure 5.

Using a Weston Model 547 radio set tester the following are typical voltage characteristics of this receiver.

The first stage r. f. 226 tube should measure A voltage of 1.35, B voltage 95, C voltage 4.5, and normal plate m. a. 6. This value and the succeeding ones are those used when the tubes are in the set tester.

The reading of the second r. f. 226 stage is identical with that of the first.

In the case of the 227 detector the A voltage is 2.15, B voltage 30, and the normal m. a. is 2.

The 227 used in the first audio stage has an A voltage of 2.15, B voltage of 80 and C voltage of 4.5. Its normal m. a. is 3.

Both of the 171-A's used in the push-pull stage read alike and the A voltage will be 4.5, B voltage 160, C voltage 38 and the normal m. a. should be 15.

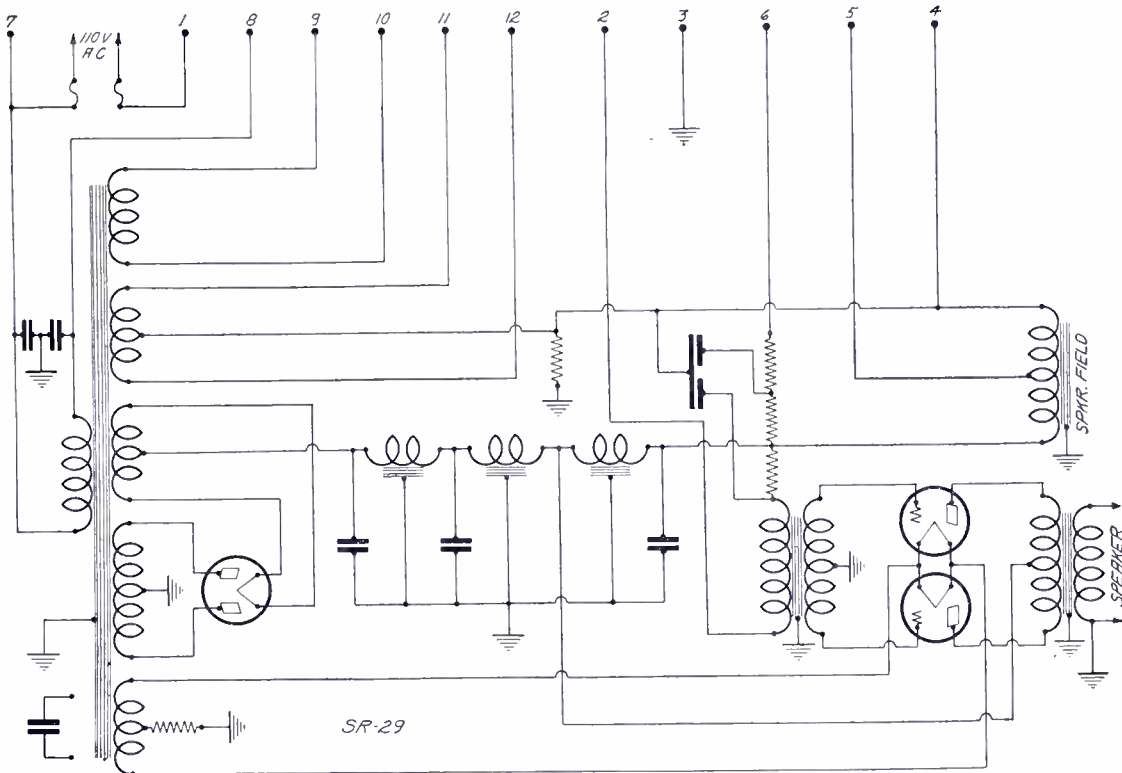

Fig. 4, shown above, is the schematic diagram of the power supply for the Colonial 31 a. c.

With respect to the 280 rectifier A voltage should be 4.5, while the normal m. a. should be 42 per anode.

Possible defects and their accompanying symptoms which may occur:

Distorted output. Low plate voltage on first a. f. generally due to by-pass condenser (1475 p) or voltage divider (1478 p) both located in power units, right-hand side, under shelf near Mershon condenser. No plate voltage on detector. Possible ground in phono jack or open voltage divider. Sometimes this is also due to a ground oc-

curing in the system shunting the first a. f. transformer primary. No plate voltage in this stage is seldom due to a by-pass condenser (1475 p) or the a. f. transformer itself.

Modulated hum is often caused by a defect in the r. f. by-pass condenser (1476 p). In this case grid voltage on the r. f. tubes will be only about two or three volts, which should normally be five or six. It is seldom caused by the line buffers excepting some of the early models 31 which have no buffers.

In case the volume control works on one side only it generally indicates an open input primary or a broken connection in the same circuit.

Very loud hum and no grid voltage on the first and second r. f. and first a. f. may sometimes be caused by the cathode lead from the detector socket grounding on the sharp edge of right-hand bulwark in the chassis.

Ordinary hum is most often caused by an old or defective Mershon condenser, or one from which the liquid has leaked out. Poor external ground or incorrect detector plate voltage may also be a cause.

Radio frequency oscillation may be due to incorrect adjustment of the balancing system. The balancing adjusters 9L-10L are situated inside the second and third r. f. primary coils and are held fast by a round head brass screw which moves in a slot, permitting the adjustment of the adjusters. If an accidental ground occurs in the r. f. grid returns oscillation will result.

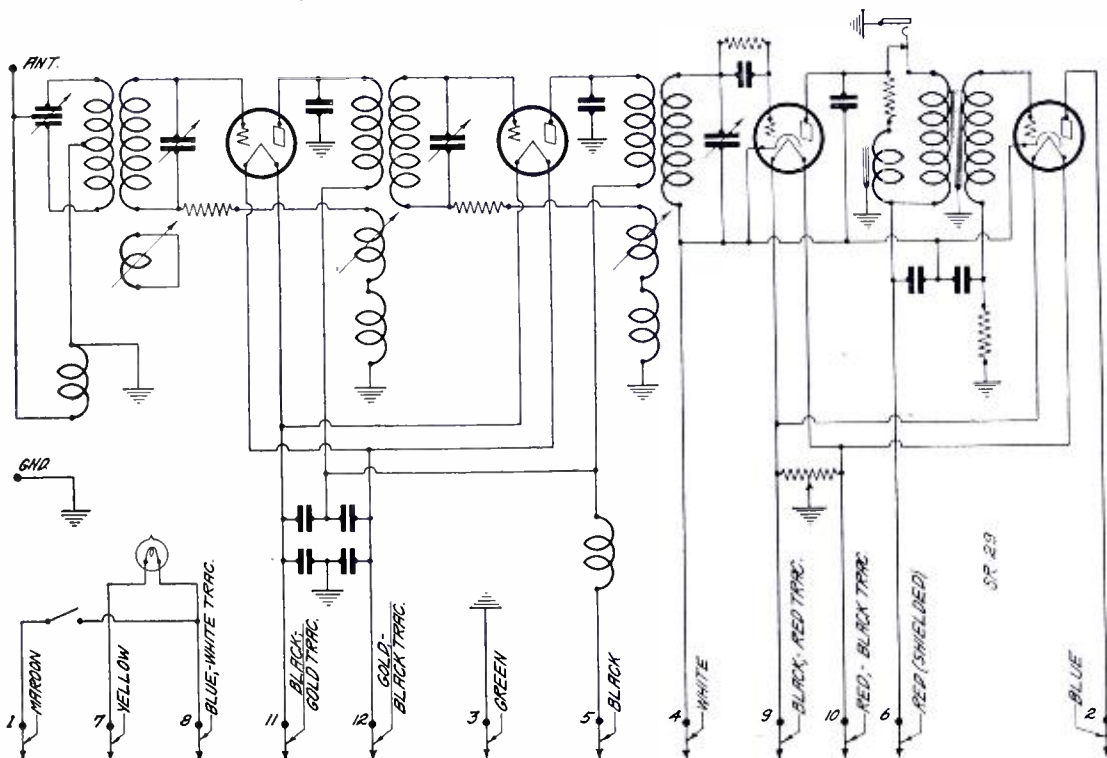

Fig. 5. This drawing is the schematic of the Model 31 Colonial receiver described on this page

Colonial Models 33-34 AC

IN the Colonial models 33 and 34 a.c. illustrated schematically on this page, a band pass filter precedes the two screen grid r.f. stages, giving a substantially flat topped resonance curve and precluding the possibility of distortion due to sideband cutting.

Automatic Coupling

The coupling system used keeps the coupling automatically at the optimum value for all broadcast frequencies, giving excellent amplification so that the average sensitivity runs around 5 microvolts, as will be seen in the response curves published on this model in the September issue, page 66.

Inductive Volume Control

An inductive volume control is used, its operation being completely free from noise since it contains no contacts nor variable resistor elements. The two models 33 a.c. and 34 a.c. are identically the same electrically, except that model 34 has a more sensitive speaker, capable of finer reproduction. The push-pull output of this model is mounted on the speaker frame instead of in the receiver chassis, as is the case with the 33. These models can be had with and without the remote control automatic tuning unit. This unit can easily be installed in these receivers not having it as an integral part. It does not interfere with the manual operation of the receiver if that is desired.

Colonial Model 33-34 A.C.

Tube Type	Position in Set	A Volts	B Volts	C Volts	Cathode Volts	Screen Volts	Normal	Plate	Grid	Change
							M. A.	M. A.	Test	
224	1 R.F.	2.5	180	3		90	3.			---
224	2 R.F.	2.5	180	3		90	3.			---
224	Det.	2.5	150	2		35	.2			---
227	1 A.F.	2.5	100	6			3.			---
245	P.P.	2.5	240	45			28.			---
245	P.P.	2.5	240	45			28.			---
280	Rect.	4.8					50			---

Line voltage, 120. Volume control.

Fig. 1. The average voltage values found under operation in the Colonial 33 are shown in the above table and are abstracted from their service manual

Line Compensation

The fuse in the double mounting on the rear of the chassis provides a means of compensating for deviation of line voltage from normal. Normally the fuse is left in the left side of the mounting, facing the rear of the chassis. It should be put in the right side only when the line voltage is known to be consistently below 110 volts. It is important that this adjustment be made since excessive voltage will shorten the life of the tubes and insufficient voltage will make the set insensitive.

A poor detector tube will create an objectionable hum in the speaker. For this reason it may be necessary to try one or more 224's in the detector socket.

Detector Hum

Should it ever be necessary to replace the tuning condensers, or any of the r.f. coils, the tuning condensers will have to be realigned. Service men are cautioned against changing the compensating condenser adjustment unless it has been made necessary by replacement of the tuning condenser or r.f. coils.

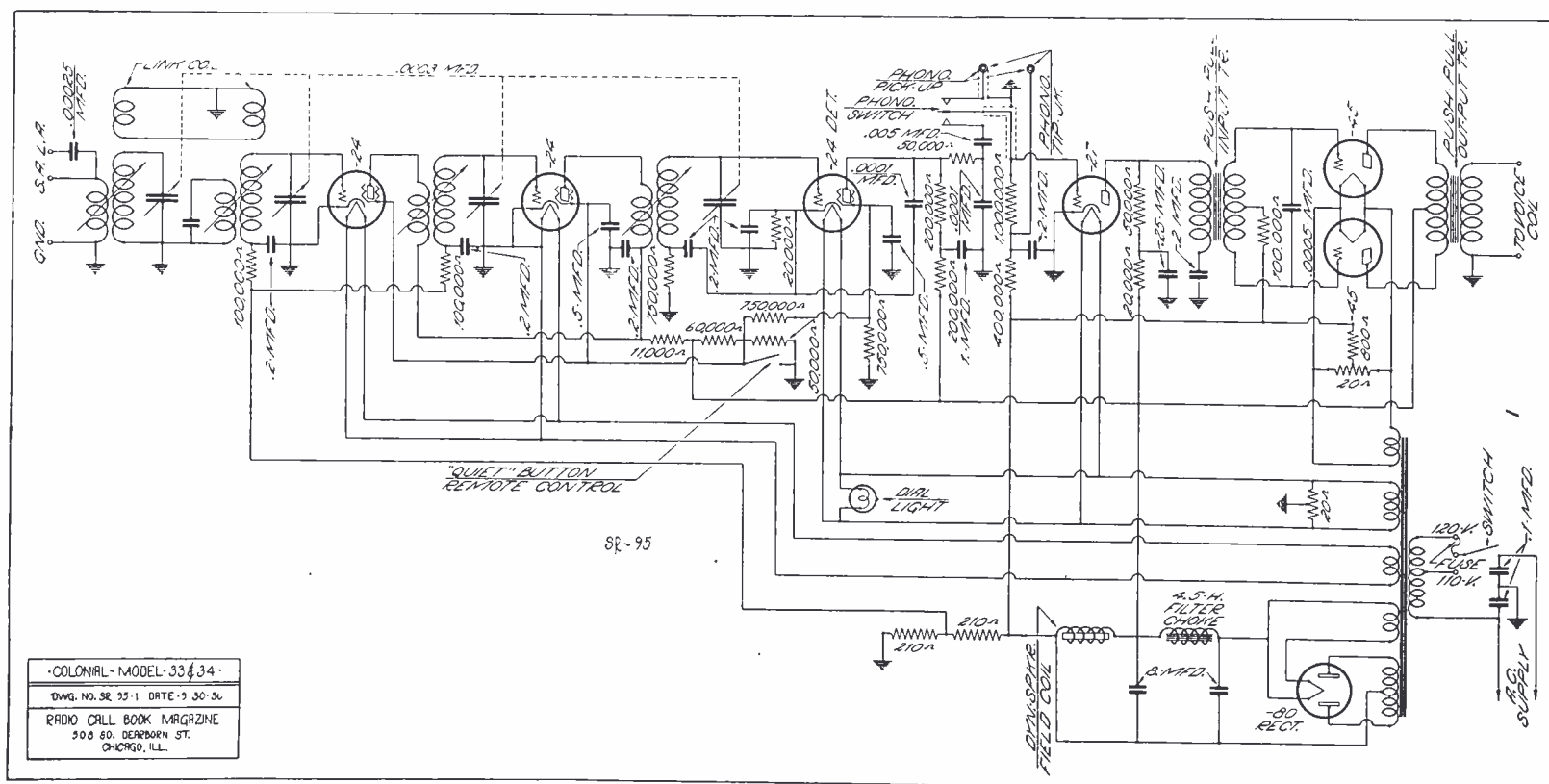

Fig. 2. The electrical details of the Colonial models 33 and 34 are shown in the schematic diagram shown here

Continental Star-Raider Model R20

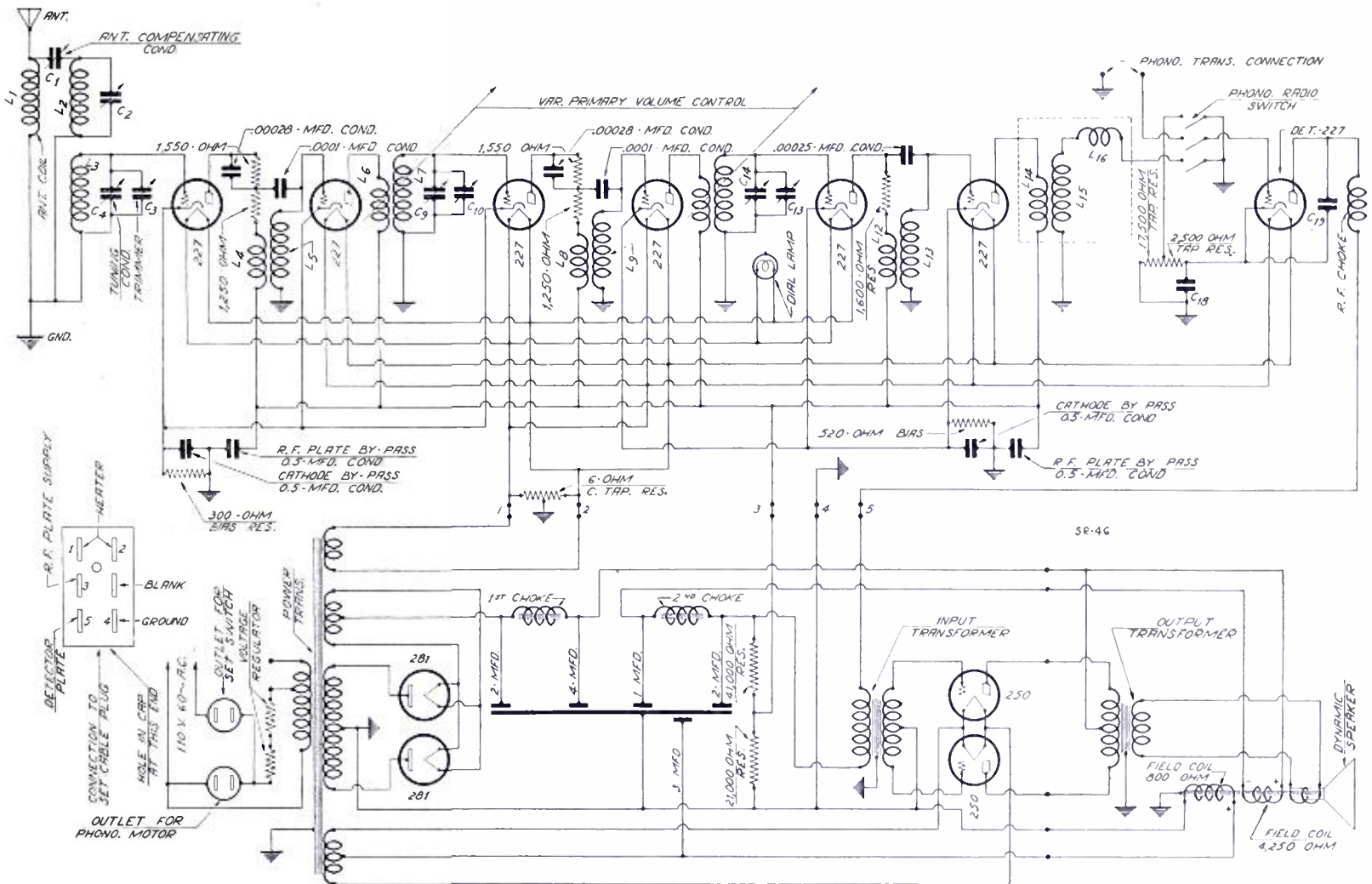

Fig. 1. The complete schematic diagram of the radio frequency end and the power supply of the Continental Star-Raider model R20 is shown above

It will be observed the same circuit is used throughout the Continental line of receivers as is found in the schematic of the Star-Raider R 20 shown in Figure 1 on this page. This circuit is known as the Technidyne amplifier with which our readers are already familiar. The circuit uses six stages of r. f. arranged alternately in tuned and untuned stages. The r. f. amplifying system is preceded by and coupled to a tuned unit without tube, shown as L2 and C2, and is connected to the antenna system through C1, an adjustment of which is dependent largely upon the capacity of the antenna being used.

Following the r. f. amplifier is the detector stage operating on the so-called plate detection method. The detector grid bias which is about 18 volts at no signal, is obtained in such a manner that as the detector plate current rises with an increase of signal input voltage to the grid of the detector tube, the bias voltage increases in proportion to the rise in plate current.

The detector bias resistor is connected in the circuit in such a way that when the radio-phono switch is thrown to the phono side a section of the bias resistor is shorted out, leaving in the circuit the second portion of the bias resistor which furnishes the proper bias voltage to the detector tube to permit it to operate as an audio amplifier. Also with the radio-phono switch in position for phono reproduction the secondary of the r. f. transformer in

the detector stage is disconnected from the grid of the detector tube and grounded, preventing the incoming signal from being transferred to the detector stage through capacity. The grid of the detector tube is connected then to the impedance matching transformer in place of the r. f. transformer.

Continental Model R20, R30, RP40

Tube Type	Position in Set	A Volts	B Volts	C Volts	Cathode Volts	Screen Volts	Normal Plate M. A.	Plate	Change
								M. A.	
484	1 R.F.	2.85	110	5	5	---	5	9.4	4.4
484	2 R.F.	2.85	126	5	5	---	5.4	10.3	4.9
484	3 R.F.	2.85	112	5	5	---	5	9.6	4.6
484	4 R.F.	2.85	126	5.5	5.5	---	4.9	8.8	3.9
484	5 R.F.	2.85	117	5.5	5.5	---	4.0	8.4	4.4
484	6 R.F.	2.85	120	5.5	5.5	---	4.1	6.0	1.9
484	Det.	2.85	250	20	20	---	1.5	1.7	.2
250	Pwr.	7.2	360	66	---	---	38	45	7.
250	Pwr.	7.2	360	66	---	---	38	45	7.
281	Rect.	7.2	---	---	---	---	55	---	---
281	Rect.	7.2	---	---	---	---	57	---	---

Line voltage 115. Volume control maximum.

Fig. 2. A typical tube voltage analysis as taken with a Weston set tester is shown in this table

Crosley "Roamio" Auto Receiver

SERVICE men will be interested in the auto-radio set made by Crosley and known as the "Roamio" model, a schematic diagram of which is shown on this page. The receiver has two stages of r. f. using 224 tubes, a detector using the 227, and two stages of audio using the 112-A tubes; the filaments of the r. f. and detector tubes being in series and those of the a. f. stages in parallel, all operated from the car battery.

Grid circuits of the r. f. and detector stages are tuned with a three section gang condenser with single control. Individual aligning condensers are provided. The antenna coil and the inter-stage r. f. coils are wound to provide a slight amount of extra capacity coupling to make the response of the receiver more uniform throughout the band.

Automatic Volume Control

The detector stage acts both as a detector and as an automatic volume control keeping the level of reproduction as constant as practical while the automobile moves through areas in which the signal strength varies. The automatic control of volume is accomplished by a circuit arrangement which increases the negative bias on the radio frequency and detector grids as the signal becomes stronger, and decreases the bias as the signal becomes weaker. The necessary biasing voltage is obtained from the voltage drop in the 60,000

ohm detector plate resistor located between the D lead and ground. With increased signal more current flows through the detector plate circuit increasing the drop in this resistance and increasing the bias applied to the grids of the first three tubes. This results in a decrease of r. f. amplification tending to maintain the signal current as finally obtained from the audio system, at a comparatively constant level. In addition to the biasing resistor for automatic volume control, there is a manual control which is a variable 80,000 to 100,000 ohm resistor in the detector plate circuit itself. This variable resistor is operated from the panel by means of a knob.

Battery Operated

Both A and B supply is from batteries, the former from the car battery, and the latter from dry B blocks. The plates of all tubes but the detector are connected to the red plus B lead to which 135 volts is applied. A separate plate battery known as the D battery is used for the detector; it furnishes 22½ volts of potential through the blue lead for the detector plate circuit. Potential for the screens of the two 224 tubes is furnished through the white lead, connected to the 90 volt terminal of the B battery. The audio tubes are bias by means of a C battery, the green lead being connected to the minus 12 volts. The minus B and plus C leads are con-

nected to the middle of a 50 ohm potentiometer shunted across the filament leads so that the polarity of the A supply does not affect the biasing or plate voltage of these tubes. This method of connection is necessary because in some automobiles the negative is grounded while in others the positive is grounded.

Suppressing Noises

Two types of suppressors are available from Crosley for use in damping out ignition interference. One is the type for installation in spark plug leads, and the other for use in distributor leads. A spark plug suppressor should be mounted in each spark plug lead at the plug, and a distributor suppressor should be mounted in the center lead of each distributor at the distributor. If difficulty is encountered in installing standard suppressors on some cars special suppressors may be obtained.

It is frequently helpful to ground all oil lines, speedometer cables, control rods, etc., which run through the engine bulkhead. They should be grounded to the metal engine bulkhead, or metal covering of the bulkhead, where they pass through it. Some service men make a practice of grounding these units as a regular routine part of every installation. None of the methods of interference control cited above have any effect upon the operation of the automobile itself.

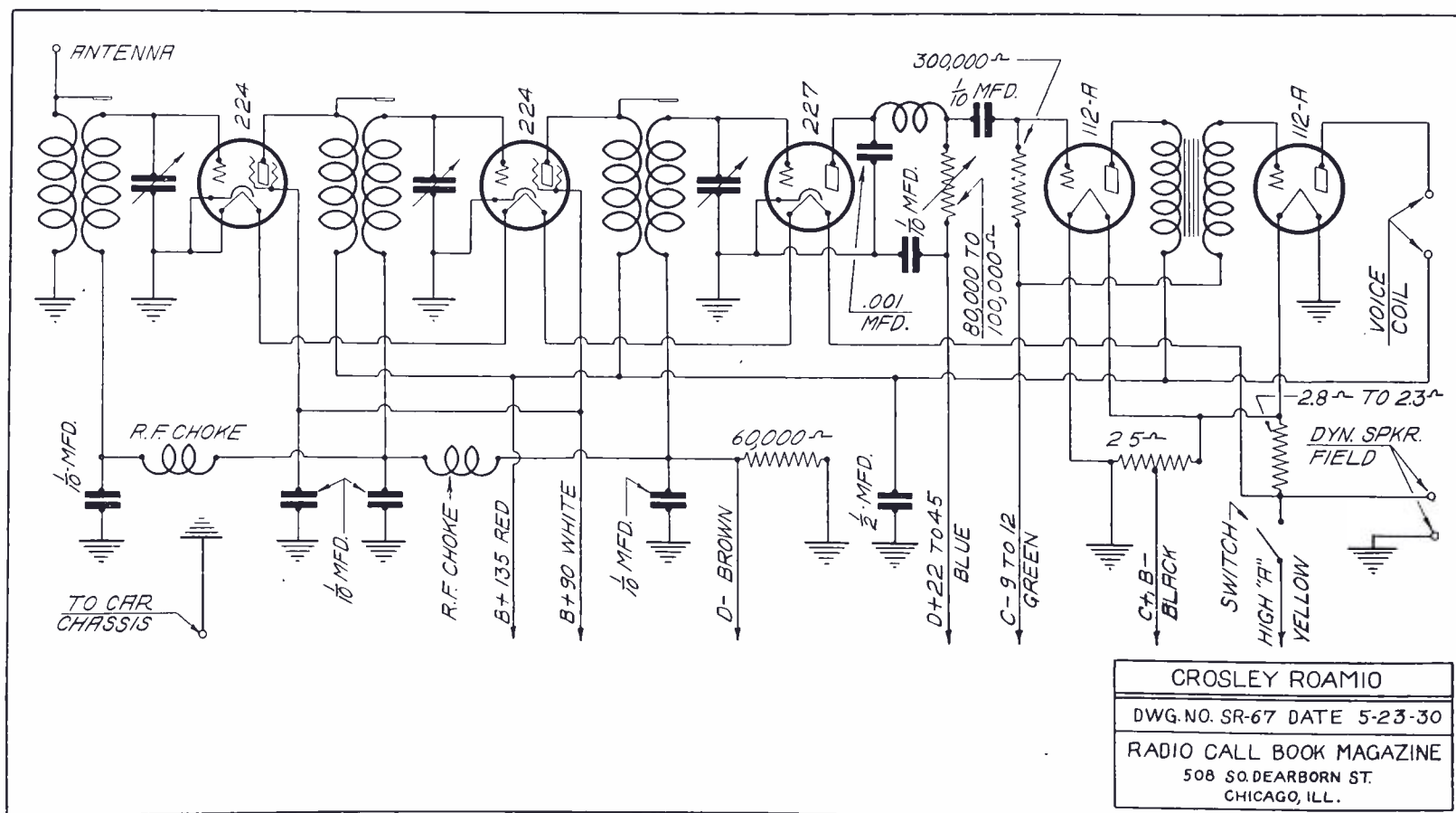

Fig. 1. The schematic diagram of the "Roamio" automobile radio set made by Crosley is shown in this illustration

Crosley Models 40-S, 41-S, 42-S, 82-S

RESPONSE curves of the Crosley models 40-S, 41-S, 42-S and 82-S were printed on page 85 of the March, 1930, issue of this magazine, to which reference should be made for any performance data on these receivers.

The schematic diagram of the receiver and power supply of these models is shown on this page in Figure 2, while the table of tube voltages is illustrated in Figure 1.

Eight tubes, including rectifier, are used in these models, the same chassis being employed in 110 volt 60 cycle, 110 volt 25 cycle and the 220 volt 25 cycle jobs.

Double Volume Control

Receivers of serial numbers with a prefix GC, GCA, GCB or GCC have volume controls composed of two rheostats operated simultaneously. One of

these is shunted across the antenna coupling coil primary so as to regulate the strength of signal passing through the antenna coil primary. The other is used to control the potential of the screen grids of the r. f. tubes. Receivers of serial numbers other than those mentioned above have a volume control consisting of but one rheostat which controls the screen grid potential of the r. f. stages.

The detector is of the C bias type, the plate voltage being 100 volts, which through the 60,000 ohm biasing resistor between the cathode and the chassis, provides a bias of 12 volts for the grid of the tube.

Biasing System

Bias for the first 227 audio tube is secured by the drop across the 3500 ohm resistor between cathode and

chassis. The biasing resistor for the output stage has a value of 850 ohms and is connected between the chassis and the midpoint of the potentiometer shunted across the filament leads of these tubes. The control grid bias for the screen grid tubes is obtained through a resistance shunted between their emitter circuits and the chassis. In this circuit there is a bleeder current as well as the normal tube current flowing in the biasing resistors. Bleeder current is supplied from the high line through a 100,000 ohm resistance.

The first audio stage is resistance coupled to the output of the detector stage. The 150,000 ohm resistance unit in the plate circuit of the detector tube serves as the coupling unit. A 1/2 mfd condenser couples the plate circuit of the detector circuit to the grid circuit of the first audio stage.

If trouble is experienced due to oscillation in the r. f. stages, try different tubes in these sockets, or shift r. f. tubes from one socket to another. Normally when these tubes are of the same grid-plate capacity no oscillation will occur. An abnormal increase in the grid-plate capacity will cause the tubes to oscillate. If receiver oscillates it would be well to examine all connections and soldered joints, and to test all bypass condensers common to the radio frequency circuits. Also try other tubes, and examine the wiring for unusual grid-plate coupling.

The circuit shown in Figure 2 indicates both the old and the new method of antenna connection for the first r. f. stage.

Crosley Models 40-S, 41-S, 42-S and 82-S

Tube Type	Position in Set	A Volts	B Volts	C Volts	Cathode Volts	Screen Volts	Normal Plate M. A.	Plate M. A. Test	Change
224	1 R.F.	2.40	175	1.5	1.5	70	1.5	4.0	2.5
224	2 R.F.	2.40	175	1.5	1.5	70	1.5	4.0	2.5
224	3 R.F.	2.40	175	1.5	1.5	70	1.5	4.0	2.5
227	Det.	2.45	100	12	12	---	.2	.3	.1
227	1 A.F.	2.45	180	15	15	---	4.	5.	1.0
245	2 A.F.	2.30	240	48	---	---	26	30	4.
245	2 A.F.	2.30	240	48	---	---	26	30	4.
280	Rect.	5.00	---	---	---	---	100	---	---

Line voltage 117. High top. Volume control maximum.

Fig. 1. A table of typical tube voltages as taken with a Jewell set analyzer is shown here

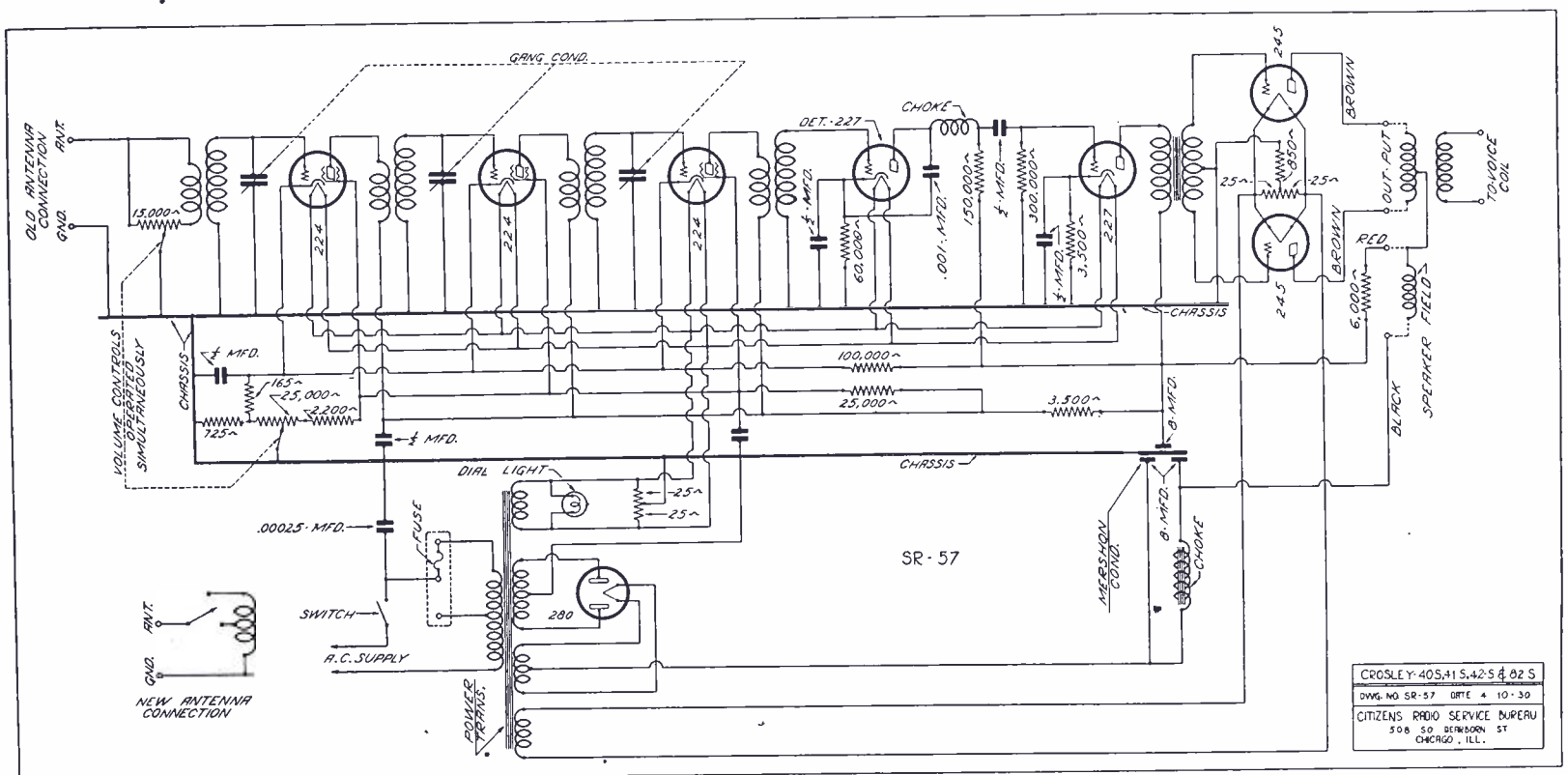

Fig. 2. The complete schematic of the Crosley models mentioned in this article is illustrated in this drawing

Crosley Models Nos. 53, 54 and 57

ELSEWHERE in this issue appear the response curves on the Crosley 53, 54 models, whose schematic diagram and tube operating values will be found on this page. Each model incorporates five tubes, including the restifier: two 224 screen grids in the r.f. stages, one 224 screen grid used as a detector, a 245 power output tube and the 280 rectifier. The single stage audio is coupled directly to the screen grid detector, through the resistance-capacity connection indicated in the schematic diagram. The plate circuit of the output tube is connected directly to the voice coil of the speaker.

The high potential side of the plate circuit is connected to a filter system consisting of a choke coil and a Mershon condenser. Thence it branches into three circuits, one going through the speaker field to the plate of the output tube, one going through a 150,000 ohm resistor and a choke coil to the plate of the detector tube, and the third going through a 10,000 ohm resistor and the primaries of the respective radio frequency transformers to the plates of the radio frequency tubes. The resistors are of proper values to insure proper voltages between the plates and emitters of the tubes.

A branch from the r.f. plate supply circuit passes through a second 10,000 ohm resistor to the screen elements of the screen grid tubes, keeping them at the appropriate positive potential with regard to the emitters. A third 10,000 ohm resistor carries the necessary

bleeder current from the second 10,000 ohm resistor to ground.

Biasing is accomplished by the resistors. The tube grids are connected through transformer secondaries or coupling resistors to the chassis and are at the chassis potential. Voltage drops in resistors keep the emitters at positive potentials with regard to the chassis. The combination of fixed resistors and variable volume control resistor in the emitter circuit at the extreme left of the circuit diagram accomplishes the biasing for the r.f. tubes. A 10,000 ohm biasing resistor is connected from the detector emitter to the chassis. Similarly a 1650 ohm biasing resistor is connected from the output filament to the chassis. This last resistor is connected to the middle of a 50 ohm po-

tentiometer shunted across the output filament leads. Changes in resistor values may be made occasionally by the factory if reports from the field indicate such changes are desirable.

Recommended aerial length for outdoor installations is 50 feet or more; for indoor installations 25 feet or more.

Model Differences

Models 53 and 54, while practically identical in circuit and electrical characteristics, differ in mechanical construction. Model 54 is built on a more compact chassis for use in a mantle type cabinet. Model 57 corresponds to Model 53. It differs from Model 53 only in slight circuit changes, primarily those for enabling it to be adapted to an improved type of speaker.

Crosley Models 53, 54 and 57

Tube Type	Position in Set	A Volts	B Volts	C Volts	Cathode Volts	Screen Volts	Normal Plate M. A.	Plate Grid Test	Change
224	1 R.F.	2.1	160	3.1	--	85	3.	---	---
224	2 R.F.	2.1	160	3.1	---	85	3.	---	---
224	Det.	2.1	215	9.0	--	85	3.	---	---
245	Pwr.	2.2	230	45.0	--	--	33.	---	---
280	Rect.	4.1	310	--	--	--	45.	---	---

Line voltage 110. Volume control minimum.

Fig. 1. Tube operating values covering the Crosley models 53, 54 and 57 are shown in this chart, being transposed from a table of voltage limits shown in the Crosley service manual for these models

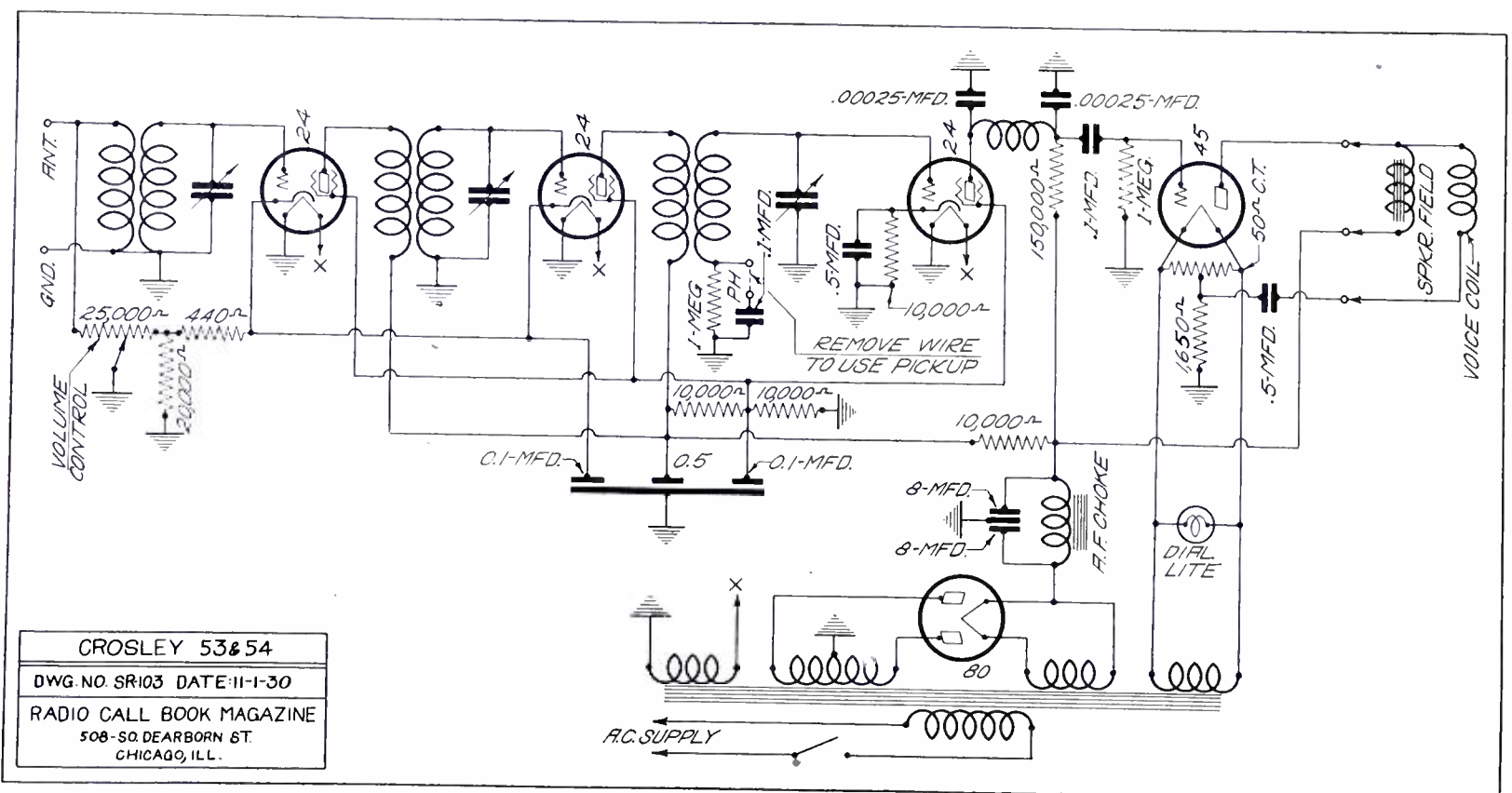

Fig. 2. The schematic diagram of the Crosley models described on this page is shown in this drawing with appropriate resistor and condenser values

Crosley Radio Receiver Model No. 77

HAVING published response curves of the Crosley model 77 in our September issue, the schematic circuit of this receiver is here presented, with a table of tube operating voltages as indicated in the Crosley service supplement dated September 1. The table is in Figure 1 and the schematic in Fig. 2.

Air core r.f. transformers are used for coupling the antenna stage to the first r.f., the first r.f. to the second r.f. stage, and the second r.f. to the detector. These transformers are of special design, introducing sufficient capacity coupling as well as inductive coupling to insure uniform amplification over the broadcast range. The detector stage is resistance coupled to the first audio

stage. The first audio stage is transformer coupled to the output stage.

A local-distance switch in the antenna circuit provides a means of adjusting the energy transfer from the antenna circuit to compensate for the vast difference in signal strength from different stations.

The screen grid of the detector tube is connected to the plate supply through a 1 megohm resistor which reduces the voltage to the proper value. The screen grids of the r.f. stages are connected to the plate supply through 10,000 and 1,750 ohm resistors. After passing through the 1,750 ohm resistor, the plate supply is grounded through a 2,000 ohm resistor and a 225 ohm resistor in series.

The emitter of the first audio tube is connected to the junction of the 2,000 and 225 ohm resistors in the bleeder circuit. Thus the flow of plate current and bleeder current through the 225 ohm resistor serves to maintain the emitter of this tube at a positive potential with regard to the chassis, supplying the bias for this stage. The manual volume control on the receiver operates by adjusting the 300,000 ohm variable coupling resistor connected to the grid of this tube.

The normal bias on the r.f. and detector tubes is obtained by means of a 320 ohm biasing resistor in the r.f. emitter circuit, and a 20,000 ohm biasing resistor in the emitter of the detector circuit.

In addition to the above mentioned biasing resistors in the r.f. and detector circuits, there are three resistors in the grid circuits of these tubes. Two of these marked 37,000 ohms in the circuit diagram have a value of 60,000 ohms in later chassis. The third is a 60,000 ohm resistor connecting all three grids to the chassis. This third 60,000 ohm resistor also acts as an automatic volume or response control, reducing the amplification of the receiver for signals of strength greater than a certain value.

If a signal is received of sufficient strength to cause grid current to flow in the detector circuit, the resulting voltage drop in this resistor increases the negative bias on the r.f. and the detector tubes, thus decreasing the amplification in these stages.

Crosley Model 77

Tube Type	Position in Set	A Volts	B Volts	C Volts	Cathode Volts	Screen Volts	Normal Plate M. A.	Plate M. A. Grid Test	Change
224	1 R.F.	2.3	160	3.2	---	90	---	---	---
224	2 R.F.	2.3	160	3.2	---	90	---	---	---
224	Det.	2.3	110	3.2	---	55	---	---	---
227	1 A.F.	2.3	150	10.	---	---	---	---	---
245	P.P.	2.3	260	65	---	---	---	---	---
245	P.I.	2.3	260	65	---	---	---	---	---
280	Rect.	4.6	280	---	---	---	---	---	---

Line voltage. Volume control.

Fig. 1. The operating voltages indicated in this table are those noted in the Crosley service supplement

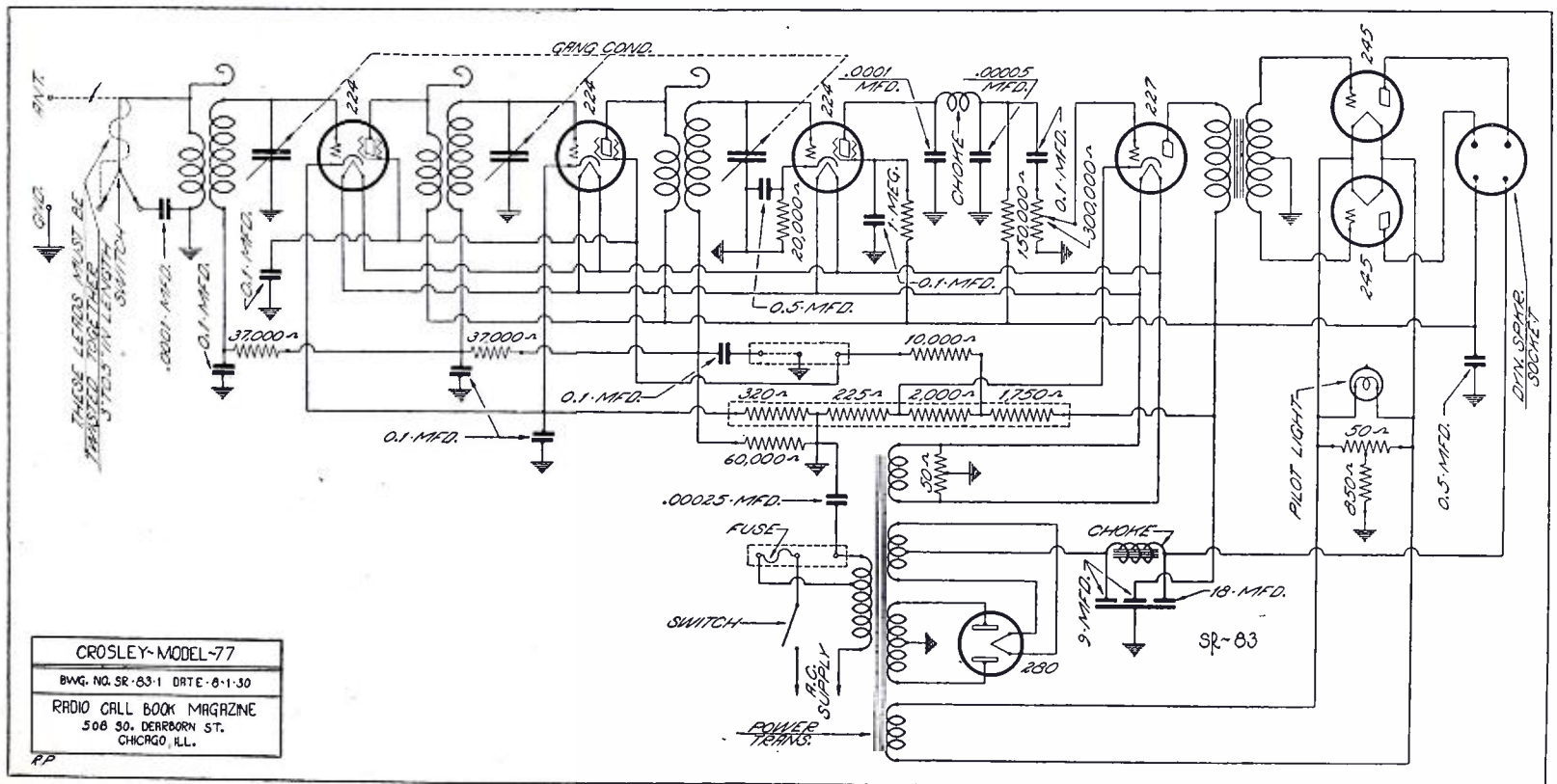

Fig. 2. The electrical details of the Crosley model 77 receiver and power supply are shown in this illustration

Crosley Jewelbox No. 704-B Receiver

ILLUSTRATED on this page is the schematic diagram of the Crosley 704-B a. c. receiver and its power supply. The model is known as the Jewelbox and is but one of the several models manufactured by the Crosley Radio Corporation. A table of typical tube analysis is shown in Figure 1.

This set incorporates three stages of neutrodyned, radio frequency amplification, the latter two of which are tuned; a non-regenerative detector and two stages of audio amplification, the output stage being of the push-pull type. The power supply system is an integral part of the circuit.

Small auxiliary condensers, called "acuminators," are shunted across the first and second tuning condensers. They serve as means of sharpening the tuning when greatest selectivity is required. A small auxiliary variable condenser shunted across the detector tuning condenser serves as a means of aligning the tuning condensers so they will track over the scale.

The power transformer has five secondaries, four of which supply filament current for lighting the tubes, and the fifth of which supplies current to the plates of the 280 rectifier. The high voltage secondary is tapped at the cen-

ter, the ground lead or low line being taken from this tap.

From the midpoint of the transformer secondary connected to the 280 filament, the high line lead is taken for the plate supply. This lead runs to a filter circuit consisting of a Mershon condenser and a choke coil.

From the filter circuit the high line lead runs directly to the plate circuit

of the push-pull output stage. The plate supply for the other stages is reduced to the proper voltages by resistances from the plate circuits to the high line lead of the filter. A 10,000-ohm resistance is used for the first audio, 3,250 ohms for the r. f. stages, and a 60,000-ohm resistor in series with the previously mentioned 3,250-ohm unit for the plate circuit of the detector.

Crosley Model 704-B

Tube Type	Position in Set	A Volts	B Volts	C Volts	Cathode Volts	Screen Volts	Normal Plate M. A.	Plate M. A. Test	Grid Change
226	1 R.F.	1.35	155	12	---	---	5.2	---	---
226	2 R.F.	1.35	155	11	---	---	5.6	---	---
226	3 R.F.	1.35	155	11	---	---	5.6	---	---
227	Det.	1.9	40	11	+11	---	2.25	---	---
226	1 A.F.	1.3	150	10	---	---	5.5	---	---
171A	2 A.F.	4.7	172	38	---	---	17.5	---	---
171A	2 A.F.	4.7	172	38	---	---	17.5	---	---
280	Rect.	4.2	---	---	---	---	25	---	---

Line voltage 110. Volume control maximum.

Fig. 1. This is a table of typical tube analysis made by the service man with a Weston set tester

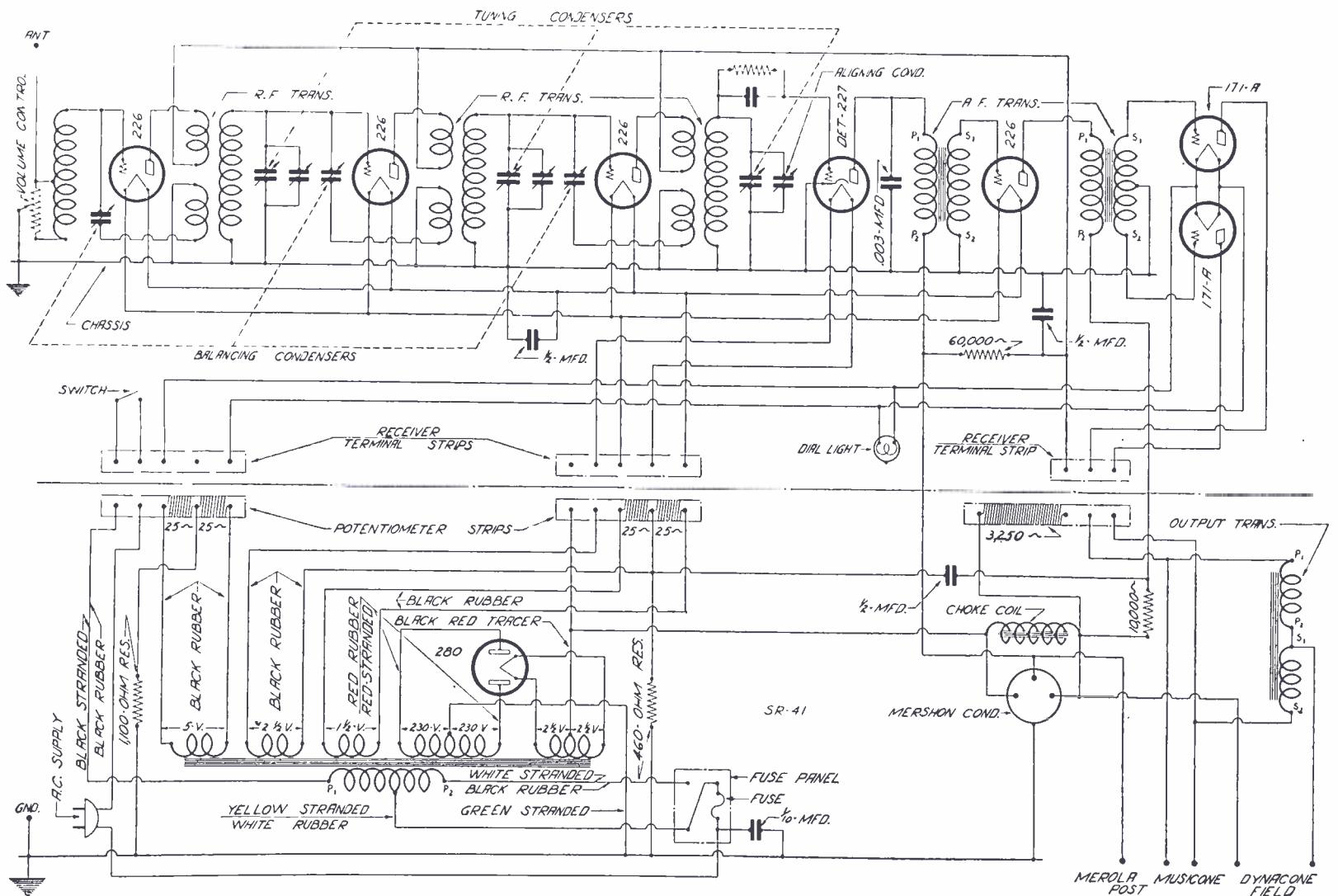

Fig. 2. The schematic diagram of the Crosley 704-B a. c. set is shown in this illustration

Day-Fan 5080 Receiver and Supply

USING eight tubes and a rectifier, the Day-Fan model 5080 receiver, manufactured by the Day-Fan Electric Co. of Dayton, Ohio, is described herewith.

Has Push-Pull Audio

The receiver consists of three stages of tuned radio frequency amplification preceded by an aperiodic antenna stage and followed by a non-regenerative detector, first stage audio and a second power stage employing two 171-A's in push-pull. Five 226 tubes are used in the radio frequency and first audio stages. The heater type of tube, 227, is used in the detector stage, while the 171-A's are placed in push-pull for maximum power output. The model 5080 is for use with the 110 volt d. c. dynamic speaker field winding, a receptacle on the power supply being provided into which the speaker field line may be plugged. The dynamic speaker receptacle is illustrated in the schematic diagram, Fig. 1, and is located between the right side of the filter and the filter system.

Untuned Antenna

The antenna stage of the receiver consists of an inductance in series with the resistance lying between the antenna and ground. This inductance and resistance are spanned by a variable resistance, the movable arm of which goes directly to the grid of the first 226 tube. This tube is neutralized through a neutralizing condenser and the neu-

tralization winding, which is shown as occupying the middle position of the three inductances between tubes. This first stage is not tuned and acts as a buffer between the subsequent tuned stages of radio frequency and the antenna itself. The second and fourth 226 tubes are tuned with variable condensers and each stage is neutralized from the grid of the tube through a small variable condenser and into the neutralizing winding of each coil.

Pickup for Records

Rectification in the detector circuit is by means of the conventional grid condenser and leak. The plate circuit of the 227 detector has provision made for the inclusion of an electro-magnetic pick-up when it is desired to play phonograph records through the audio frequency channel of the receiver.

The proper bias for the grid of the first audio 226 is provided by the drop across the third and fourth resistor sections (reading from the left), while the bias for the two 171-A tubes in push-pull is secured by the drop across the fourth and fifth resistors reading from the left. A stabilizing condenser is placed from the grid of the 226 first audio to the common negative and ground. The same procedure is adopted in the push-pull stage, where a fixed resistance spans the two extremities of the push-pull input transformer.

Output Transformer

The plate circuit of the 171-A push-

pull tubes are connected to the push-pull output transformer with two fixed condensers being placed across the extremities of the primary and the common center being attached to the center tap of that winding, which is the high voltage lead of the power system. The speaker is placed across the terminals of the secondary or output winding of this same transformer.

The center tap for the filament circuit energizing the 226 tubes is secured by a resistance across the 1½ volt line. On account of the detector being of the heater type, there is no necessity for a resistance across the 2.2 volt line.

Electrostatic Shield

The 110 volt primary has an electrostatic shield which is made common with ground. It has four low voltage secondaries and one high voltage, the latter going to the two anodes of the 280 rectifier. The first secondary at the left in the diagram, Fig. 1, handles all of the 226 tubes, the second secondary is 2.5 volts for the 227 tube, while the third secondary is a 5-volt one for the 171-A filament, the fourth secondary energizes the filament of the 280 tube at 5 volts.

In this particular model, filtering is accomplished by one filter choke already in the power supply and the added filtering effect of the dynamic speaker field winding. A receptacle for this has been provided and is illustrated in the diagram as the two contacts within a circle.

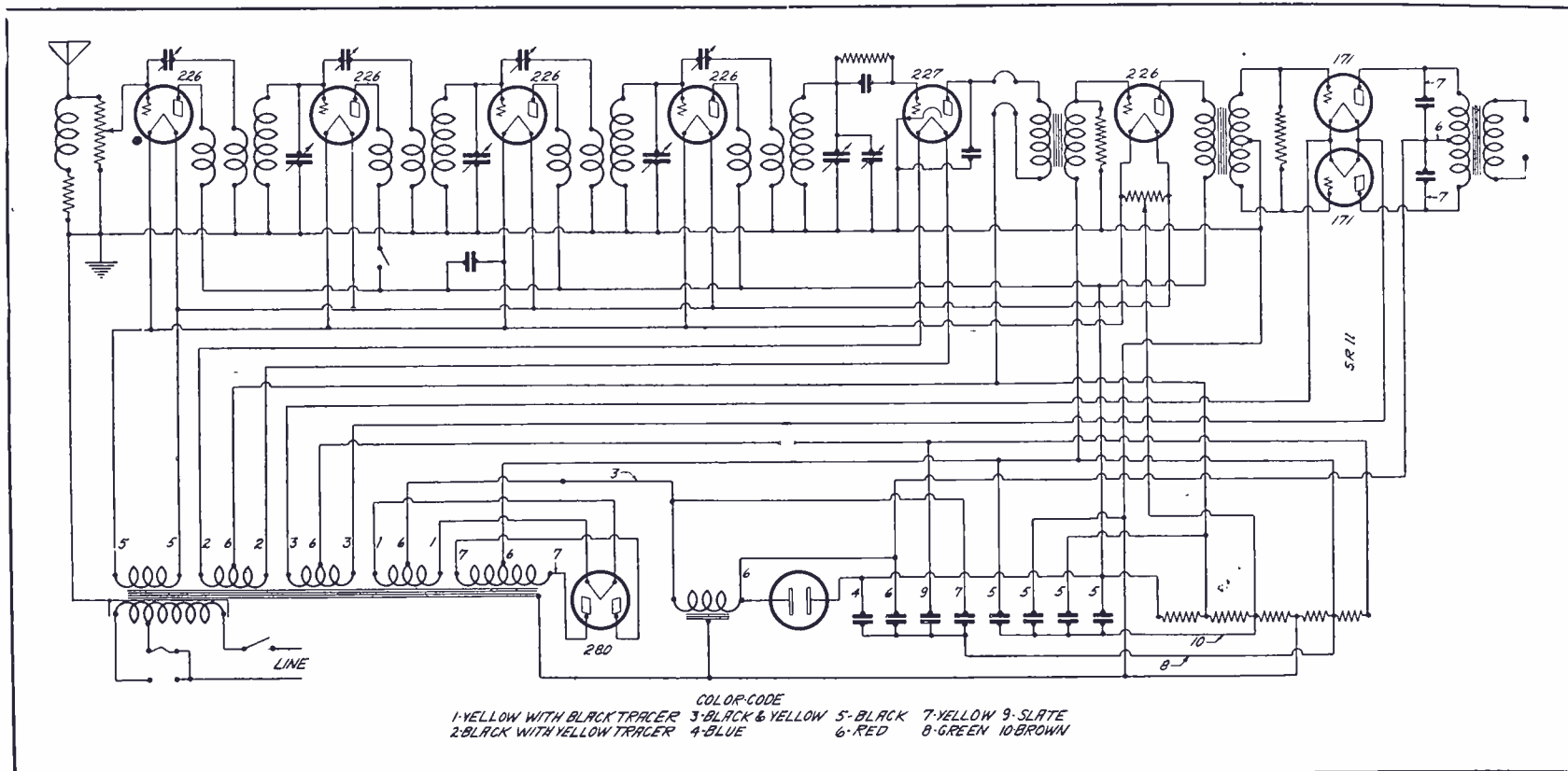

Fig. 1. In the above illustration is given the combined schematic of the Day-Fan model 5080 receiver and its power supply

Delco Automotive Radio Receiver

ACCORDING to a release from the Delco Radio Corporation after a long period of research and experimentation, General Motors has announced a radio receiving set for automobiles together with complete plans for servicing and national distribution. The set has been called the Delco Automotive Radio and is manufactured by the Delco Radio Corporation at Dayton, Ohio. National sales and service are under the direction of United Motors Service with 27 branches and 3,000 authorized service stations.

The Delco automobile radio is a five-tube receiver, using three screen grid tubes, and operated by remote control from the instrument panel. It can be installed without changing a single unit of the car.

Flexible Cable Used

Simplicity and neatness are features of the set, which is entirely out of sight beneath the car's cowl. Only three devices are to be found on the instrument panel—mounted in an attractive manner, at the right, where they do not interfere in the slightest degree with the other instruments. They are a tuning dial, a volume control and a key switch. The tuning dial is connected to the set of a flexible cable and operates three variometers, all mounted on a single shaft.

In the Delco automotive radio, two tuned radio frequency stages are used with 224 amplifier tubes, connected in series. A similar screen grid tube is used as a detector. For radio frequency a 227 tube is used in the first stage and a 112-A in the second. A voltage regulator tube is employed to keep the voltage constant in spite of varying engine speeds or extra drain on the battery when the lights are turned on. This is a desirable feature and prevents surging of volume, keeping the tone even

under all conditions.

Variometer Tuning

Old timers in the radio game will recognize the variometer tuning of the radio frequency and detector grids, the three variometers being on a common shaft arranged for single control. Bias for the grid of the first 224 tube is secured through the drop across a single resistor, properly bypassed, between the cathode of the 224 and ground. The plate circuit of the 224 detector and the grid of the first audio is direct coupled so that automatic volume control is afforded, while a manually operated volume control is also provided for separate control of volume. Detection is by means of the conventional grid leak and condenser. In the audio stage the coupling between the first audio and the 112 output tube is by means of resistance and capacity coupling. The plate circuit of the output tube has an r. f. choke bypassed at each end, and leading into a 100 henry choke coil, the magnetic speaker being capacitatively coupled across the top of the choke and ground.

Interference from passing objects is offset by an automatic volume control to increase the amount of current when the car passes steel buildings or overhead wires, which normally would bring about a reduction of current.

Current is supplied by the car's storage battery and by four vertical type standard size 45-volt "B" batteries and one 22.5 volt "C" battery. The "B" batteries are carried in a specially-designed metal box placed under the floor boards and fully protected against mud and water. The "C" battery is conveniently located, depending on the type of car.

A cone speaker—found to give the best tone value and speech reproduction

—is mounted on the dash, out of sight, and protected by a screen across its face.

Reduced Interference

Electrical interference from the ignition system has been guarded against by the use of specially-designed spark resistors on each plug and on the coil, and by by-pass condensers across the generator contacts and on the starting motor. These spark resistors are designed to prevent oscillations in the ignition circuit and have no effect on the running of the motor.

To protect the tubes against the jars and jolts of road shocks a special cushioning device is used and the dial is held secure in any position by a reduction gear.

Antenna Concealed

The antenna is concealed in the top of the car. Cars of leading makes are now factory-equipped with this aerial, including Cadillac, La Salle, Studebaker, Pierce-Arrow, Marmon, Jordan, Peerless, Packard and Franklin.

In bringing out the Delco automotive radio, General Motors wished to present a set that would produce a reception comparable with the best stationary sets. For many months engineers have been conducting research experiments and testing out every part under all conditions. As a result, the Delco automotive radio is a set which will perform equally well under all running conditions. At the same time, it was realized that a national service was necessary to provide adequate service for owners in all parts of the country. United Motors was selected for this as it offered a nationally established organization, noted for its high-class service in the automotive field and having an organization all equipped to offer service throughout the United States.

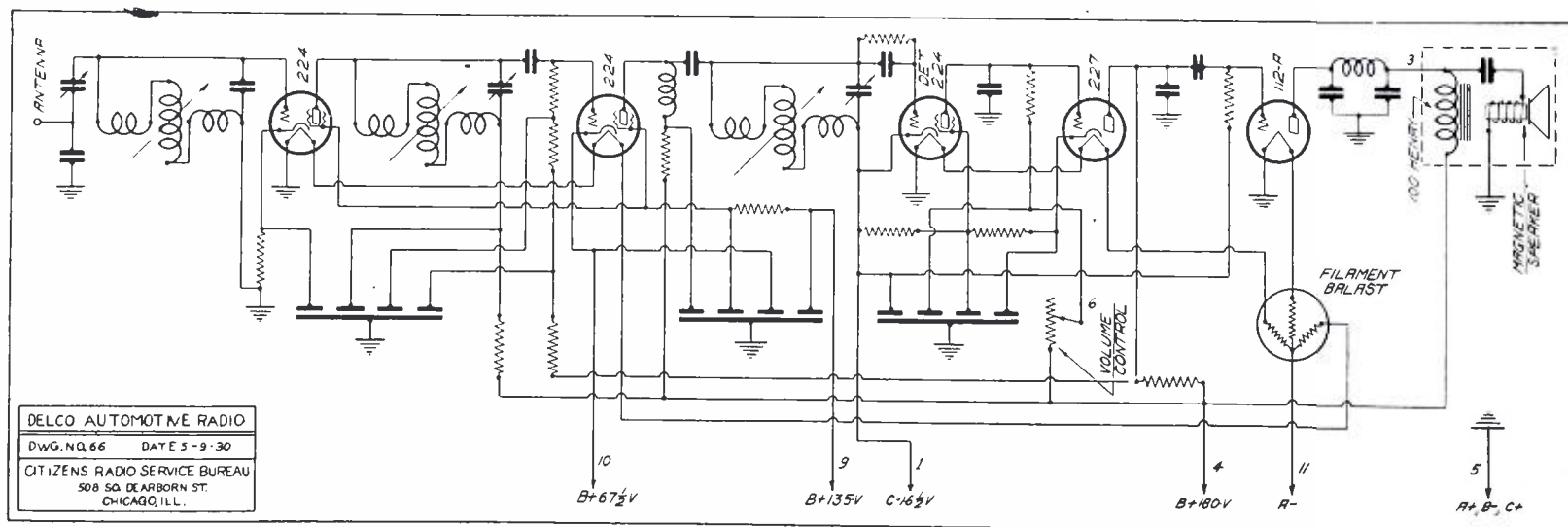

Fig. 1. This drawing shows the schematic wiring diagram of the Delco automotive radio

Edison Receiver Models R4, R5, C4

EDISON receiver models R4, R5 and C4, the schematic diagram of which is shown in Figure 1 on this page, consist of three tuned, neutralized r.f. stages, a tuned input, grid leak and condenser detector, a conventional first audio amplifying stage, a pushpull second audio stage feeding a dynamic speaker, a full wave rectifier and its filter system supplying plate current to the entire receiver and excitation for the dynamic speaker field; and alternating current heater and filament supply for all the receiver. All models are equipped with a switch for transfer of the audio amplifying system to use for phonograph reproduction, pin jacks being provided for the connection of a high impedance magnetic pickup.

Edison Models R4, R5, C4

Tube Type	Position in Set	A Volts	B Volts	C Volts	Cathode Volts	Screen Volts	Normal	Plate	Grid	Change
							Plate M. A.	M. A.	Test	
227	1 R.F.	2.35	114	6	6		5.6		3.2	
227	2 R.F.	2.35	114	6	6		5.6		10	
227	3 R.F.	2.35	114	6	6		6.2		10.5	
227	Det.	2.35	28				2.0			
227	1 A.F.	2.35	112	6.5	7		3.7		5	
245	P.P.	2.35	250	16			27.5		32	
245	P.P.	2.35	250	16			27.5		32	
280	Rect.	4.0					50.1			

Line voltage, 105. Volume control, maximum.

Constant Gain R. F.

It will be noted the r.f. amplifying circuit uses a constant gain system where two primaries are used in each r.f. transformer, one resonated below and one above the broadcast frequency spectrum. These four r.f. transformers are identical, the secondaries being tuned with equal tuning condensers sections. Stabilization of the r.f. amplifier is accomplished with grid circuit neutralization.

Stability Controlled

Substantial resonance of the first r.f. input circuit to the resonant frequency of the second and third r.f. and the detector circuits is maintained by holding the effective ground-antenna capacity to a value of less than 100 micro microfarads. Antenna of less than this capacity goes on the binding post marked "antenna" whereas antennas of greater than this capacity should be connected to the post marked "long antenna." The latter connection places a

condenser in series with the antenna ground capacity, reducing the effective value of the latter to less than 100 micromicrofarads for antenna capacities up to 500 micromicrofarads.

Dual Volume Control

The volume control is a dual arrangement controlling antenna input with the resistance section shown at the left in the diagram, and the grid bias for the second and third r.f. stages with the section shown at the right in the schematic.

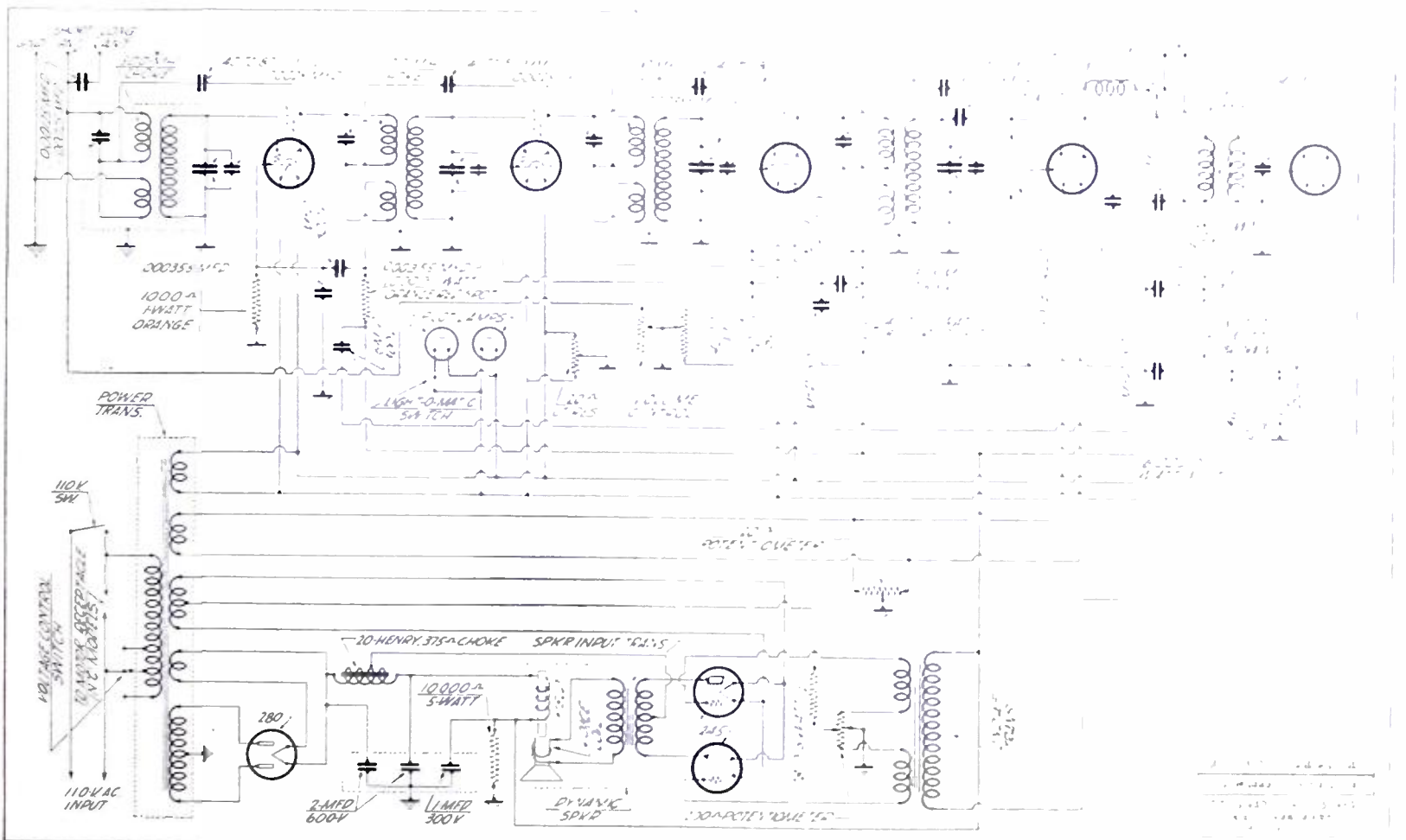

Fig. 1. In this illustration is shown the schematic diagram of the Edison receiver models R4, R5 and C4

Edison Models R-6 and R-7

RESPONSE curves of the Edison models R6, R7 have been published previously, appearing on page 64 of the November issue of this magazine. In that number it was stated the schematic would be found elsewhere in that issue. However, this was in error, since the schematic published on page 77 was that of the Edison models R1, R5, C1, in no way related to the schematic of the R6, R7 shown on this page.

As will be seen from the schematic in Figure 2 these models are the screen grid type as contrasted with the 227's in the previous models. Tube operating values are shown in the chart in Figure 1.

A socket reading analysis chart covering r.f., detector, a.f. and rectifier stages is included in the Edison service manual, from which some of the more interesting servicing aids are taken.

In the case of the first r.f. socket no reading on filament voltage which should be 2.2 volts with the fuse in the 115-volt position indicates: open filament lead to socket; open filament of secondary; shorted filament secondary; open circuit in either connecting cable or six-prong connector. Low reading of filament voltage indicates: low line voltage; incorrect location of primary fuse; shorted turns in filament secondary; shorted turns in primary of power transformer; short circuit in filament wiring. High filament reading indicates: high line voltage; incorrect location of primary fuse.

Normal plate voltage is 190 volts. No reading indicates open plate lead; open cathode lead; grounded first or second r.f. plate lead; open first and

second r.f. plate isolating resistor; shorted first and second r.f. plate by-pass condenser; open low frequency or high frequency primary of 4th r.f. coil; "A" choke open or grounded; B choke

field winding; B choke shorted; grounded high voltage secondary; one lead to 280 socket open; shorted turns in high voltage secondary; one side of high voltage secondary open; shorted

Edison Models R6 and R7

Tube Type	Position in Set	A Volts	B Volts	C Volts	Cathode Volts	Screen Volts	Normal Plate M. A.	Plate M. A. Grid Test	Change
224	1 R. F.	2.2	190		2.5	80	3.5	6.0	2.5
224	2 R. F.	2.2	190		2.5	80	3.5	6.0	2.5
224	3 R. F.	2.2	190		2.5	80	3.5	6.0	2.5
227	Det.	2.2		*					
227	1 A. F.	2.2	10	.5-2.5	±3.0		1.1	1.4	.3
227	2 A. F.	2.2	115	.5	6.0		3.8	4.8	1.0
245	P. P.	2.48	260	46			31.0	36.0	5.0
245	P. P.	2.48	260	46			31.0	36.0	5.0
280	Rect.	4.85					48.0		

Line voltage, on 115-volt tap. Volume control.
*Grid volts 8-10 on strong signal.

Fig. 1. In this table may be found the tube operating voltages for the Edison model illustrated schematically on this page

grounded; open r.f. voltage divider, located in power unit; shorted filter condenser section; grounded rectifier filament winding; open radio-phono switch contacts; open or short circuit in either connecting cable or six-prong connector.

Low reading indicates: low line voltage; incorrect location primary fuse; low emission rectifier tube; grounded 3rd r.f. plate lead; shorted 3rd r.f. plate by-pass condenser; shorted speaker

filter condenser section; short circuit between 3rd r.f. filter condenser and automatic volume control by-pass condenser; open 1 a.f. bias resistor; low potential end of screen grid voltage divider open (located in a.f. filter unit), shorted turns in primary of power transformer. High reading indicates: high line voltage; incorrect location primary fuse; shorted 1 r.f. screen grid by-pass condenser; shorted 2 a.f. plate by-pass condenser.

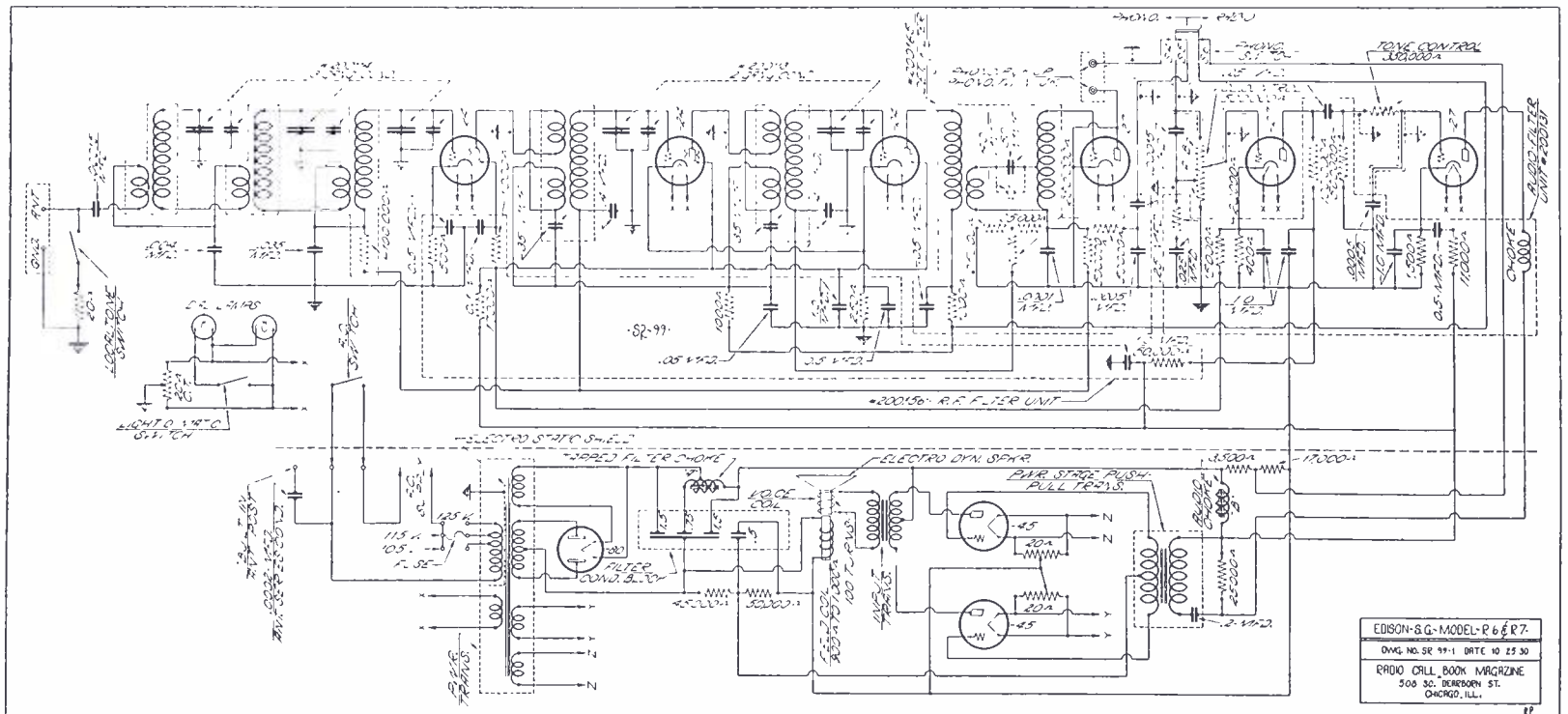

Fig. 2. The schematic diagram of the Edison models R6 and R7 including the power supply is shown in this diagram

Erla Duo-Concerto Model Receiver

MANUFACTURED by the Electrical Research Laboratories of Chicago, Illinois, the Erla Duo-Concerto model receiver is shown schematically on this page. The receiver portion which is known as model R2 is illustrated in Figure 10, while the audio amplifier and power supply units known as model A2 is set forth in drawing, Figure 11.

As will be seen in the schematic of the receiver there are three radio frequency stages using 226 tubes and a detector using a 227 heater type. The radio frequency condensers are all on a gang and the three r. f. stages are neutralized. Input to the antenna stage is across a 10,000 ohm potentiometer in parallel with the primary winding of the first r. f. transformer.

The second stage audio and the two 171-A tubes in push pull are located within the power unit as shown in the drawing Figure 11. A 280 rectifier is employed for the high voltage, while filament current for all tubes is supplied from the necessary low voltage windings on the power transformer.

The complete outfit consists of a chassis R2 carrying the radio frequency, an audio amplifier A2 and its power supply, and a dynamic speaker type D. The job is made up in two forms, one for use in connection with a loop antenna, the other with the regular outside or inside antenna.

Looking at the radio frequency chassis from the front it will be seen that

there are three balancing hex nuts and three neutralizing hex nuts. Beginning at the right the first nut is neutralizer 1, then balancing, then neutralizing two, then balancing, then neutralizing three, and finally the balancing for the third r. f. The order of tubes reading from the right towards the left is first r. f., second r. f., third r. f., and then detector at the extreme left. To balance the receiver tune in sharply a distant station with low volume between 240 and 280 meters. Then with a balanc-

ancing wrench turn the nut N3 (located in line with the tube sockets) left or right until a null or minimum volume position is found. Replace regular tube in its socket. This stage is neutralized. Proceed in the same manner on the second stage, adjusting nut N2 and first stage adjusting nut N1.

According to instructions from the factory the outside or indoor antenna used in connection with this receiver should never exceed 50 feet in length.

In the rear of the radio unit are two

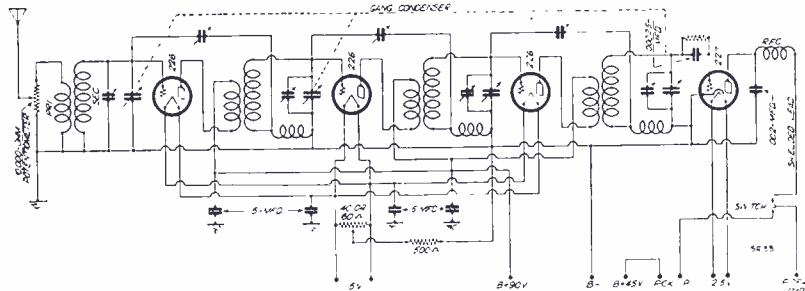

Fig. 10. The receiver portion of the Erla Model described on this page is shown in the above schematic diagram. The audio and power supply end of the receiver is contained in another unit and is illustrated schematically in Fig. 11

ing wrench obtainable from the maker of the receiver turn the balancing nut B previously mentioned for maximum volume.

For neutralizing the receiver in the event this is necessary, a neutralizing tube is required. This tube is a good 226 with one filament prong sawed off. Tune in sharply a local station between 240 and 280 meters, then remove the third r. f. tube and insert the neutralizing tube. retuning the receiver for maximum volume. Then with a special bal-

tip jacks for connecting an electrical pick-up unit. It is merely necessary to place the two phone tips in those jacks. As will be seen in the schematic diagram Figure 10 at the lower right hand corner, arrangement has been made for a switch whereby the listener may turn the receiver from a radio to a phonograph combination.

In the absence of any actual measurement of tube voltages on this model we are not able to supply this information.

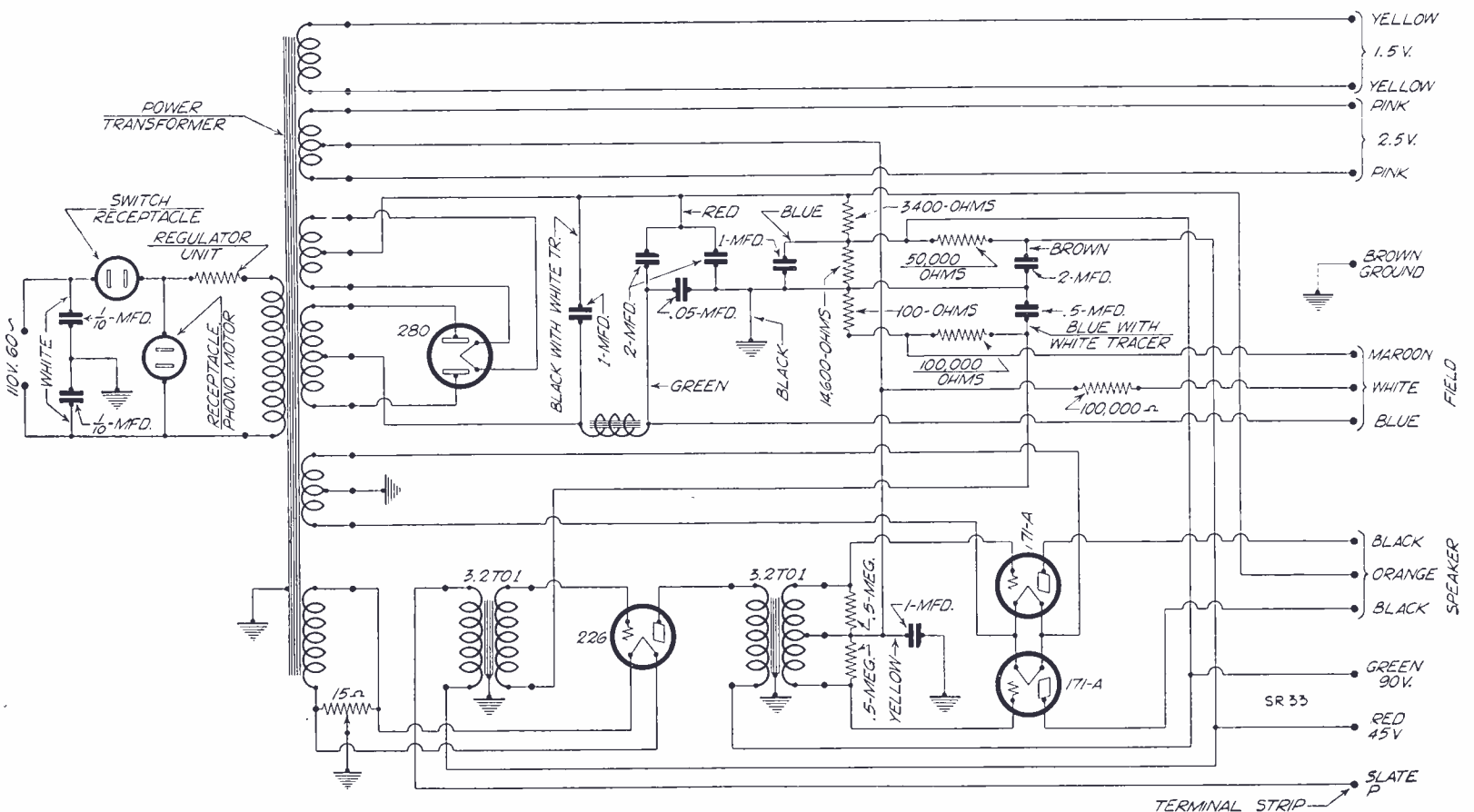

Fig. 11. Electrical constants of the power supply and audio amplifier used on the Erla model are shown above

Fada 7 A C Model and Type C Unit

MADE by the F. A. D. Andrea, Inc., Long Island City, New York, the Fada 7 A C model is described in the accompanying text. It is illustrated schematically in Fig. 2, while its power supply, the type C unit, is shown in Fig. 1.

Permitting use of a loop as the energy collector, the receiver employs six tubes of the 227 heater type and a 171 power tube. Four of the 227 tubes are used in the tuned radio frequency stages which are neutralized, while the fifth 227 is the tuned detector stage. The first audio stage uses the remaining 227.

Shielded and Neutralized

It will be observed by referring to the schematic in Fig. 2 that all of the radio frequency stages are thoroughly neutralized and completely shielded. Type numbers of the different constituent parts of the receiver are shown in the diagram. The receiver may be either operated from an antenna and ground connection or from the loop, which is shown in the schematic diagram. The

loop is plugged into the circuit when desired or it may be shorted out. One of the departures from receiver practice may be seen in the schematic, where it is found that r. f. chokes are em-

known as the 1418 MS. These blocks are located within the stage itself. The plate circuit of the detector stage is also provided with an r. f. choke and its accompanying bypass condenser.

Volume control is by means of the 1430 MS resistance placed across the secondary of the second radio frequency transformer. In the power stage where the 171-A is used, the speaker is located across an output impedance, thus isolating the speaker windings from any d. c. components.

Power Unit Separate

The schematic circuit of the power supply is shown in Fig. 1 at the lower half, while an actual drawing of the wiring is shown in the upper half. A 280 tube is used as the rectifier, whose high voltage output is fed to a double choke and filter condenser arrangement. Suitable voltages for the operation of the set are brought out from taps across the resistance network, these voltages being numbered from one to ten inclusive. A table of cable connections is given in this same diagram.

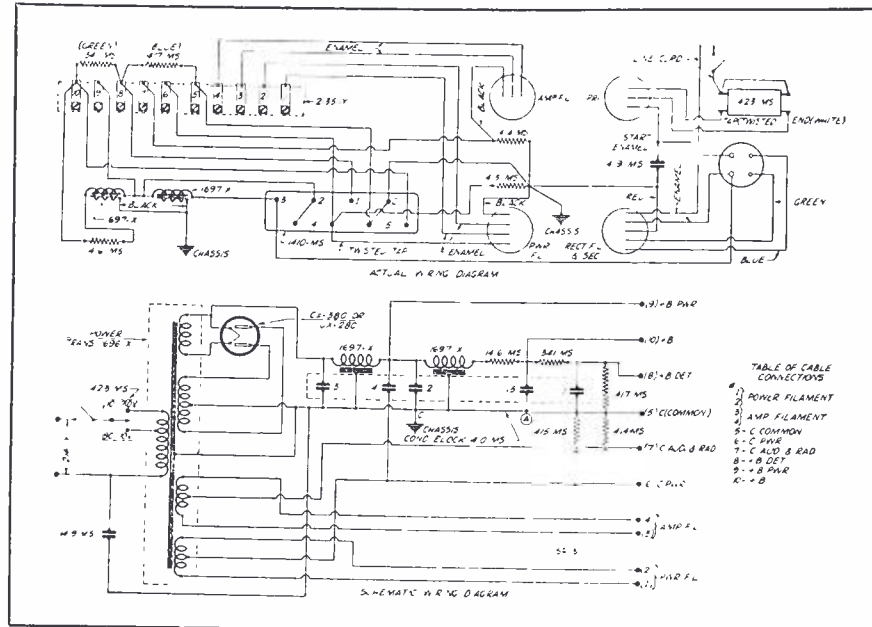

Fig. 1. Here is shown the electrical connections of the Fada type C unit which is the receiver supply

employed in series with the cathode of all of the r. f. stages. Each r. f. choke is bypassed to chassis, while the plate circuit inductance of each stage is likewise bypassed with another condenser, these two being contained in a block

employed in series with the cathode of all of the r. f. stages. Each r. f. choke is bypassed to chassis, while the plate circuit inductance of each stage is likewise bypassed with another condenser, these two being contained in a block

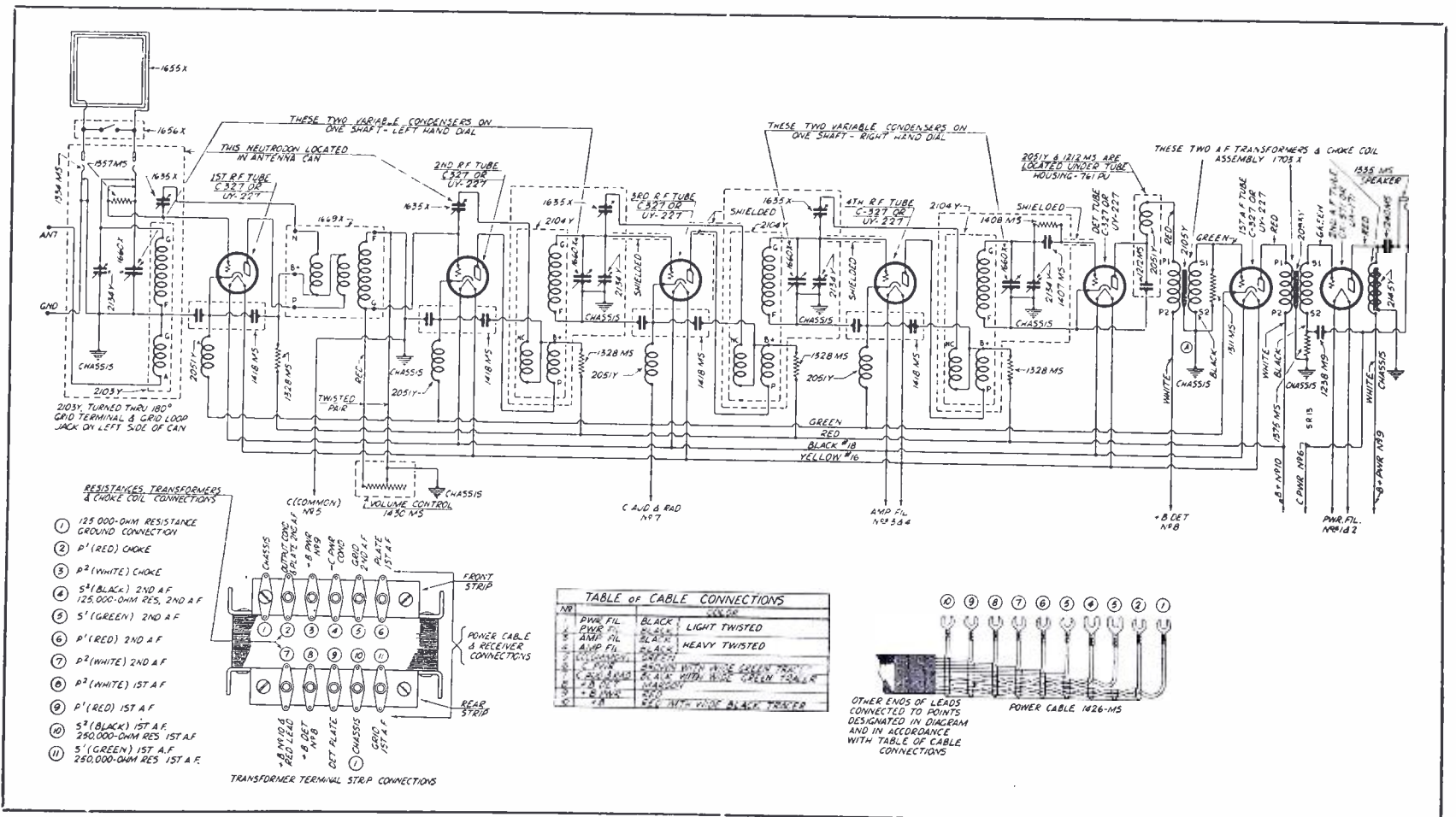

Fig. 2. Schematically is shown above the circuit of the Fada 7 A C model described in the accompanying text

Federal Model "H" A. C. Receiver

MADE by the Federal Radio Corp., Buffalo, N. Y., the model "H" a. c. receiver is described on this page. It is shown in the schematic Fig. 3 which is both the receiver and the power supply portion.

As will be seen from the circuit diagram no grid suppressors are inserted to prevent oscillation. Due to the placing of the r. f. coils mutually at right angles and due to shielding the variable condensers, the receiver is stable and free from oscillation. The volume control is a 500,000 ohm potentiometer shunted across the secondary of the last radio frequency transformer.

The three tuning condensers are of the sliding plate type and are ganged to the single dial control. A vernier knob is provided to the right of the main tuning control which by means of a link motion causes a change in ca-

capacity of the antenna condenser sufficient to allow for the different antennas that may be used.

Power Supply Compact

The power unit is very compact and is housed inside the cabinet directly behind the chassis. A cable is used to feed all of the A, B and C voltages from the power unit to the receiver. The power transformer primary has three taps which provide for voltage ranges of 100 and 110, 110-120 and 120-130 volts. There are six secondaries on the transformer instead of the usual five, one lights the 280 rectifier, one provides plate voltage of the 280 rectifier, one lights the power tube and pilot light, one the r. f. tube, one the detector and one the first audio frequency tube. The first audio frequency tube is heated from a separate winding

in order that hum may be kept at the lowest possible level. It will be noticed that there are two 40 ohm variable resistances across two of the secondaries. These are adjusted so that all trace of hum disappears and need not be readjusted by the owner.

The output of the rectifier tube feeds into the filter system which consists of the usual two filter chokes and filter condensers. Fixed resistors are used to secure the proper plate voltages for the detector and amplifier tubes. C biases are secured by causing the plate currents of the respective tube to flow through resistors inserted in the center tap lead. It will be noted that with this particular arrangement the frame of the receiver is both at C minus and B minus potential and that all grid returns are simply grounded to get the proper bias.

Set delivers 1½ watts to the speaker.

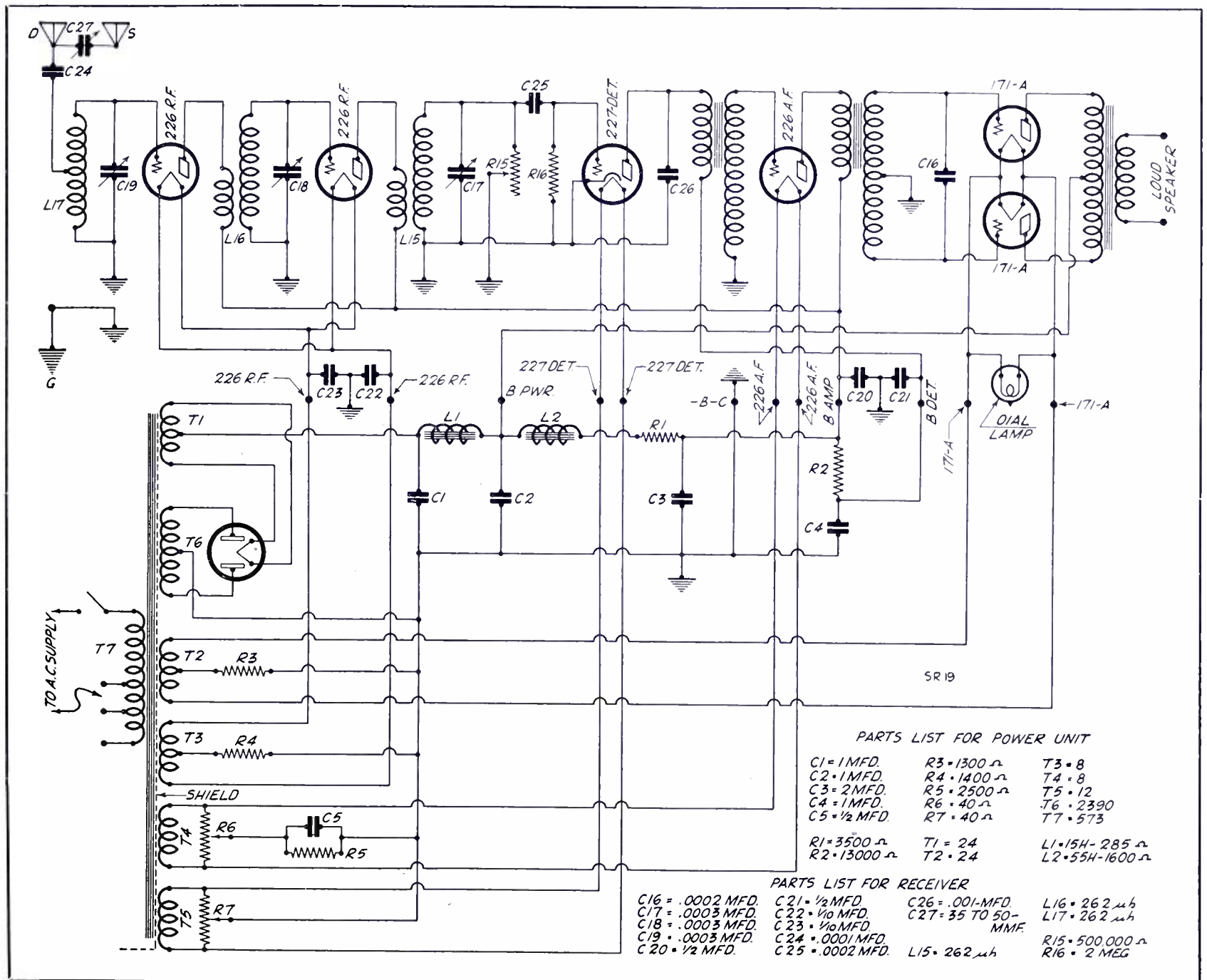

Fig. 3. The schematic diagram printed above gives the electrical arrangement of the Federal Model "H" receiver and its power supply

Freed-Eisemann NR-80 and Supply

DESCRIBED on this page is the model NR-80 a. c. receiver made by the Freed-Eisemann Radio Corp. of Brooklyn, N. Y. The schematic circuit is shown in drawing, Fig. 4.

For reneutralizing the ear phones should be used in the loud speaker tip jacks and a station broadcasting on approximately 1200 kilocycles should be tuned in. Then insulate by means of a small piece of Empire cloth one of the filament prongs in the fourth r. f. tube (the fourth from the right when facing set), from its socket contact. Turn the set on its end so the power pack is towards the table and the bottom of the cabinet faces the operator. Three neutralizing holes will be seen at the top. Insert the special hard rubber wrench in hole No. 3 (at right) and engage the hex nut inside. Rotate the wrench back and forth until the signal disappears or is at its minimum strength. Next insulate the filament prongs of the third r. f. tube (third from the right when facing set) from its socket contact. Insert the wrench in hole No. 2 (at center) and engage the hex nut inside. Rotate wrench until signal disappears or is at a minimum. Then insulate one of the filament prongs of the second r. f. tube (second from right when facing set) from its socket contact. Insert the wrench in neutralizing hole No. 1 (at

left) and engage the hex nut inside. Rotate wrench until signal disappears.

For retuning the process is different. Looking through the large round hole in the bottom of the cabinet, remove the terminal screw of the 45 volts tap (tap No. 2 from right end) and separate the contacts. To one of the contacts connect one terminal of the 0-1.5 milliammeter in shunt with a $4\frac{1}{2}$ volt C battery and a 0-25,000 ohm variable resistance and connect the other terminal of the milliammeter to the other connector contact. As the plate current drawn by the 227 tube is above the range of the 0-1.5 milliammeter, it is necessary to connect in shunt with the meter a $4\frac{1}{2}$ volt C battery and a 0-25,000 ohm variable resistance. When the resistance is turned on, current will flow around to the C battery, meter and resistance. This current will cause the needle to deflect backward. After the meter has been connected to the set and a signal tuned in, the meter can be made to give a suitable reading for making the tuning adjustment by adjusting the variable resistance.

Adjust the variable resistance to maximum and turn on the set. As the detector tube heats up the needle of the milliammeter will rise. As the needle of the milliammeter rises, reduce the variable resistance so as to keep the needle at about the center of the scale.

In about 40 seconds the needle will have reached its maximum point. After this it will cease to rise. Adjust variable resistance to reading of 1 m.a.

Tune in a signal having a frequency of approximately 1200 kilocycles. It will be noted that the needle of the milliammeter drops to a smaller reading and when exact resonance or greater signal is obtained the needle will show the smallest reading. If the needle deflects to the right instead of to the left when a signal is tuned in, reverse the connections of the meter and the connector strip contact. If the drop in reading at resonance is more than .2 milliamperes for maximum meter reading (obtained when set is off resonance), reduce volume by volume control until drop is not .2 m.a.

Insert the special hard rubber wrench in minimum adjuster hole and engage the hex nut inside. Rotate wrench to lowest reading on milliammeter.

Now tune in a signal of approximately 600 kilocycles. Insert the special tuning wrench in tuning hole No. 4 and engage the slotted screw inside. Rotate the wrench back and forth until the lowest reading on the milliammeter is obtained. Repeat the above procedure in the remaining three holes.

Tune the set to the 1200 kilocycles signal again and repeat the minimum adjustment.

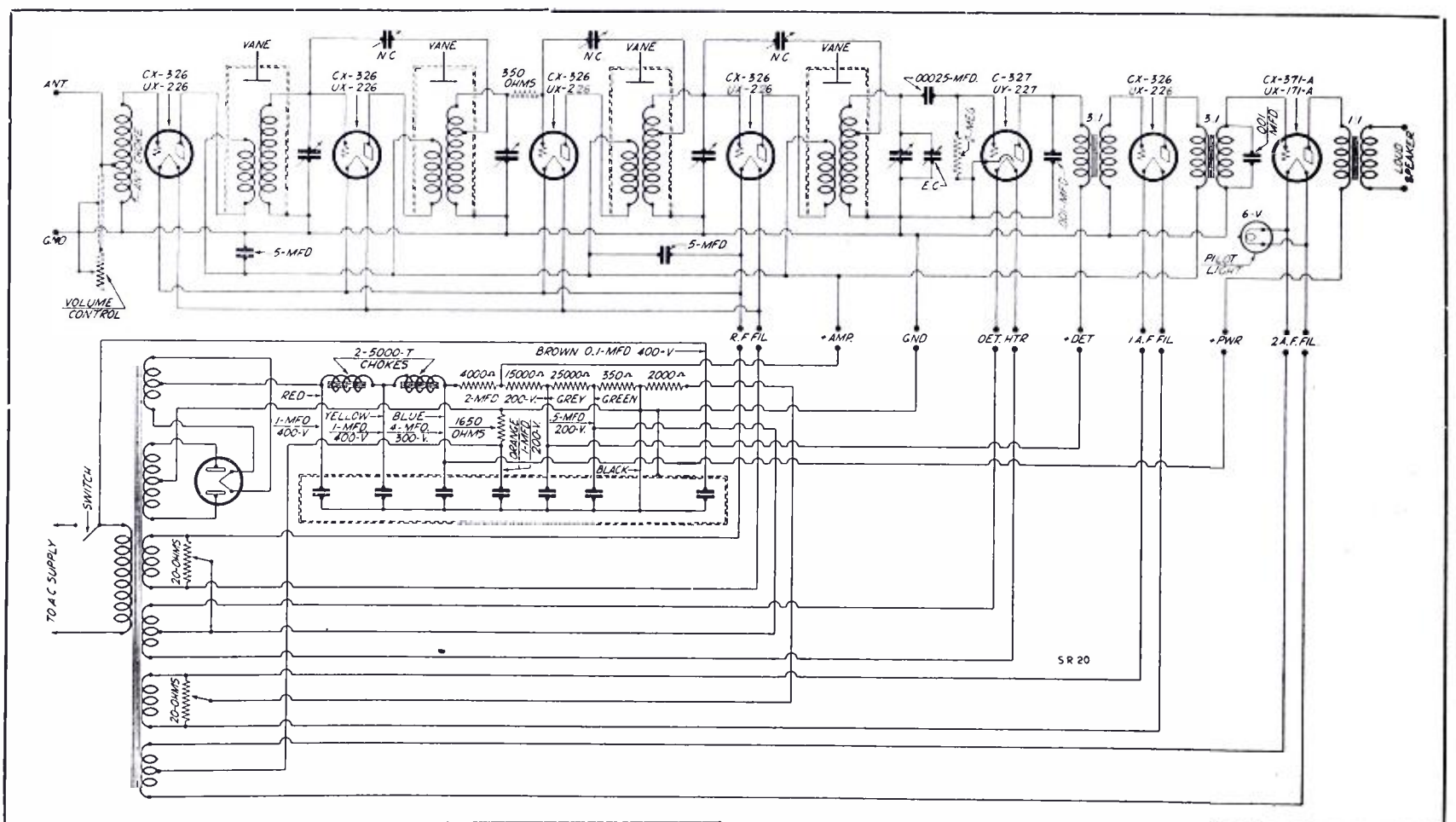

Fig. 4. Electrical connections of the Freed-Eisemann NR-80 receiver and power supply are illustrated in the drawing printed above

Freshman 2-N-12 and Power Unit

THE model 2-N-12 Freshman receiver made by the Chas. Freshman Co., Inc., and described on this page is an a. c. model operating from any ordinary electric light socket, supplying between 100 and 125 volts of from 50 to 60 cycles.

The receiver is of the uni-control type with three stages of radio frequency amplification, detector and two stages of audio frequency, employing the Freshman Equaphase system of stabilization. The chassis and power supply are combined into one unit and is located in the upper section of the console with the dynamic speaker below it.

250 Power Tube

This model uses a 250 in the last stage of the audio amplifier. In order to take full advantage of the characteristics of this tube a dynamic speaker must be used. The dynamic speaker field is included as a portion of the resistance network as will be shown by an examination of the schematic shown in Fig. 1.

The power supply system is illustrated at the lower part of Fig. 1 and consists of a 281 rectifier with the typical choke and filter circuit for smooth-

ing out the pulsations in the rectified a. c. A novel switching arrangement is shown at the center of the diagram, where a 3 ampere fuse is located and by proper switching it may be placed either in the 120 volt line or the 110 volt line, depending upon the condition of the supply line where the receiver is being operated.

This model may also be used to electrically reproduce phonograph records. The two tip jacks (not shown in the schematic) are located at the left front of the receiver and into these the two connections from the pick-up device are placed. In this particular case the receiver should be turned on with the volume control at minimum value and the tuning control at 100 degrees or any other point where no radio stations will be received. Otherwise this would interfere with phonograph reproduction. In order to alter the volume on the phonograph method of reproduction, it is necessary for the volume control accompanying the pick-up to be employed rather than the volume control on the receiver.

Checking for Trouble

Numerous investigations by the Fresh-

man Co. and other large radio manufacturers have conclusively demonstrated that the actual amount of trouble occurring in a radio set itself is small in comparison to the trouble developed in the accessories of the receiver. By accessories is meant tubes, antenna and ground connections and other additions which people have considered necessary on their receiving sets. A careful check-up on these accessories will generally reveal the source of trouble and prevent useless correspondence, delay and inconvenience to the user.

The power supply used with the receiver is designed for use on electric lighting and power lines varying between 100 and 125 volts and from 50 to 60 cycles. Where the voltage is constantly below 115 volts, however, the sensitivity of the set will be somewhat lessened. It is advisable to definitely determine this voltage in order to be sure that it is not in excess of 125.

The size of the antenna used with the receiver affects the set in sensitivity and freedom from interference. As the length of the antenna is increased, the sensitivity of the set increases, but above a certain length this effect is offset by a decrease in selectivity.

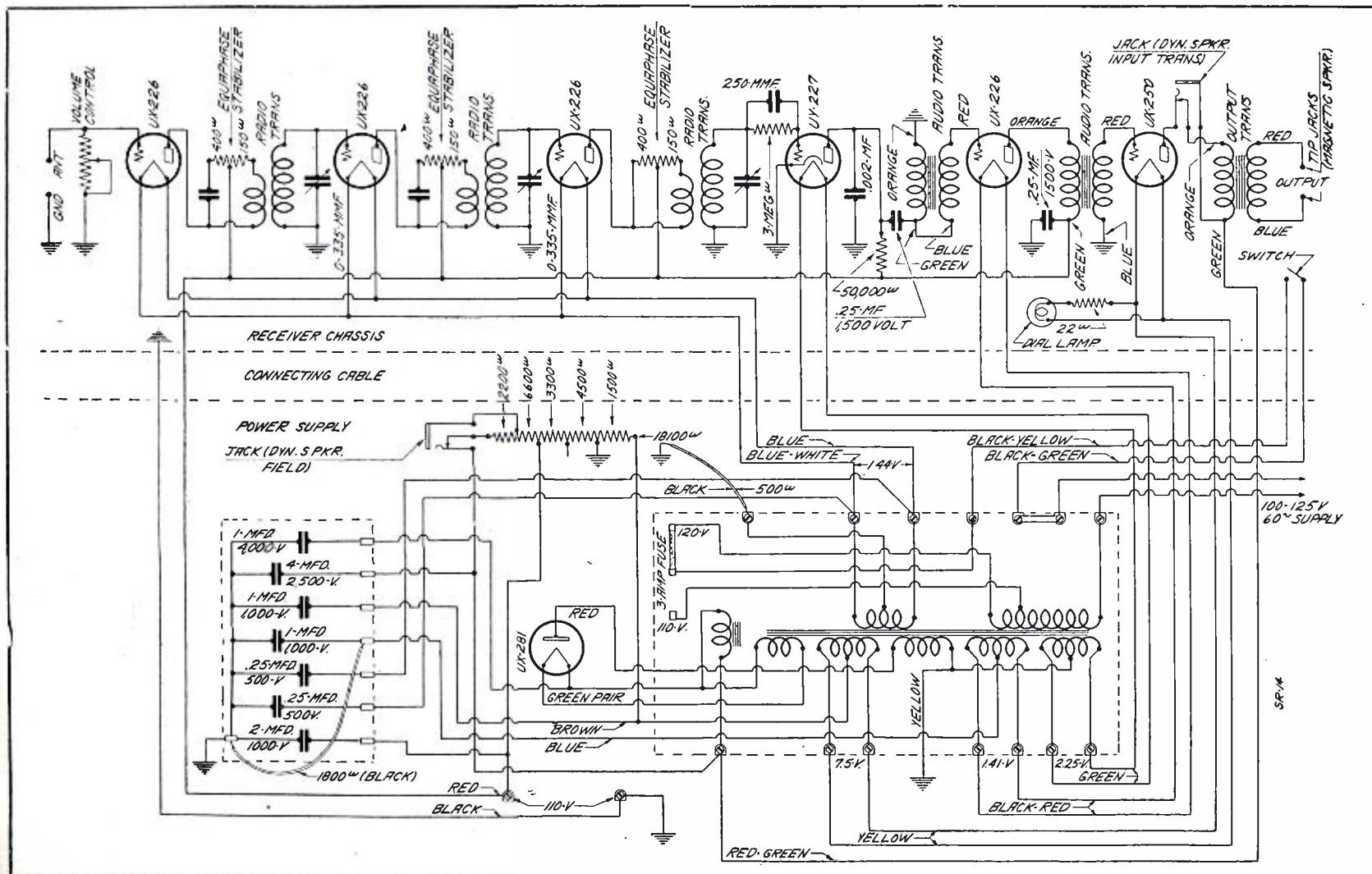

Fig. 1. Both the receiver and power supply schematics are combined in this drawing representing the Freshman model 2-N-12 receiver and the 2N-60-S power source

Gilfillan Bros. Model 100 Receiver

USING six 227 type tubes in the r. f. and first audio the schematic circuit of the Gilfillan Bros. model 100 receiver and its power supply is shown on this page. The output tube is a 245 while all of the r. f. stages, the detector and the first audio employ the 227. The diagram of the receiver is shown in the schematic Figure 9 while the power supply is illustrated in Figure 8. A 280 rectifier is used for the high voltage.

Looking at the schematic of the receiver shown in Figure 9 it is observed that the four radio frequency stages use the stabilizing resistances in the grids of the 227 tubes. These values are shown as 800 ohms. The first 227 used as an antenna stage has a trimmer across the tuning condenser to compensate for various antenna loads. It will also be noticed that from the primary of the first r. f. transformer to the plate of the first 227 is placed a midget capacity. Between the plate of the first and second 227 is another midget capacity while between the plate of the second and third is another capacity and the same applies to the coupling between the plate of the third and the fourth tubes. The condensers previously mentioned are used for phase balancing, one of the several methods of neutralization.

All the r. f. transformers have twelve turns of No. 36 double silk primaries and a secondary of 114 turns. The antenna input r. f. transformer has 15 turns in the primary of No. 36 d. s. and 96 turns on the secondary.

It will be seen by referring to the schematic that two taps are provided for antenna control. The long tap throws into the circuit the entire primary so that energy comes directly from the antenna to the primary and thence to ground, inducing a voltage in the secondary. When the antenna

switches on the short side, it throws the aerial in on a tap 30 turns down from the top of the secondary inductance. As previously stated the trimmer across the first section of the tuning condenser serves to balance up the antenna stage so that it will be in line with succeeding radio frequency stages.

Volume control used on the set is a 10,000 ohm variable in series with a 450 ohm fixed resistance between the common cathode line and the ground.

The plate circuit of the 227 detector has the usual r. f. choke in series with it and is bypassed by a .002 mfd condenser. The coupling to the first audio is a combined resistance and capacity method. The resistor in the plate circuit of the 227 is a .1 megohm while the coupling capacity is a .1 mfd condenser. Bias on the 227 in the first

mon with the top of the primary winding so that the return is from the grid of the 245 through the secondary, through the plate and thence to ground.

Plate voltage for the first, second, third, fourth radio frequency stages and the detector as well as the first audio should be 140 volts from the power supply. The output tube secures 250 or 300 volts. All of the tubes secure their filament current from the 2.5 volt winding.

In the schematic diagram Figure 8 which covers the power supply a 280 is used as the rectifier. A hum control resistance of 10 ohms is placed across the two and a half volt filament secondary. A 1500 ohm resistance between B minus and the center of the hum control resistor serves to provide the bias for the 245 tube. A 30 ohm re-

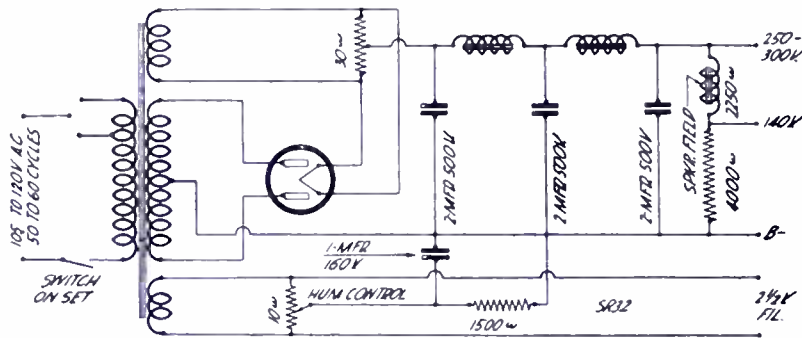

Fig. 8. The schematic of the power pack used with the model 100 Gilfillan receiver is shown in this diagram

audio stage is secured by the drop across the 1500 ohm resistance between cathode and ground, while a .5 megohm is used for grid to ground. The detector circuit uses the high bias for detection, the cathode-ground resistor being .025 megohm.

The second stage audio transformer is also a resistive load arrangement, the d. c. going through the resistor in the 227 plate circuit, the a. c. going through the coupling condenser and primary, the secondary being hooked up in an auto-transformer style, the bottom of the secondary winding being made com-

mon with the top of the primary winding so that the return is from the grid of the 245 through the secondary, through the plate and thence to ground. The resistor between 140 volts and B minus is one having a value of 4000 ohms.

The primary of the power supply is for 105 to 120 volts a. c., the switch being located on the set. Two taps are provided, one for 105 volts and the other for 120.

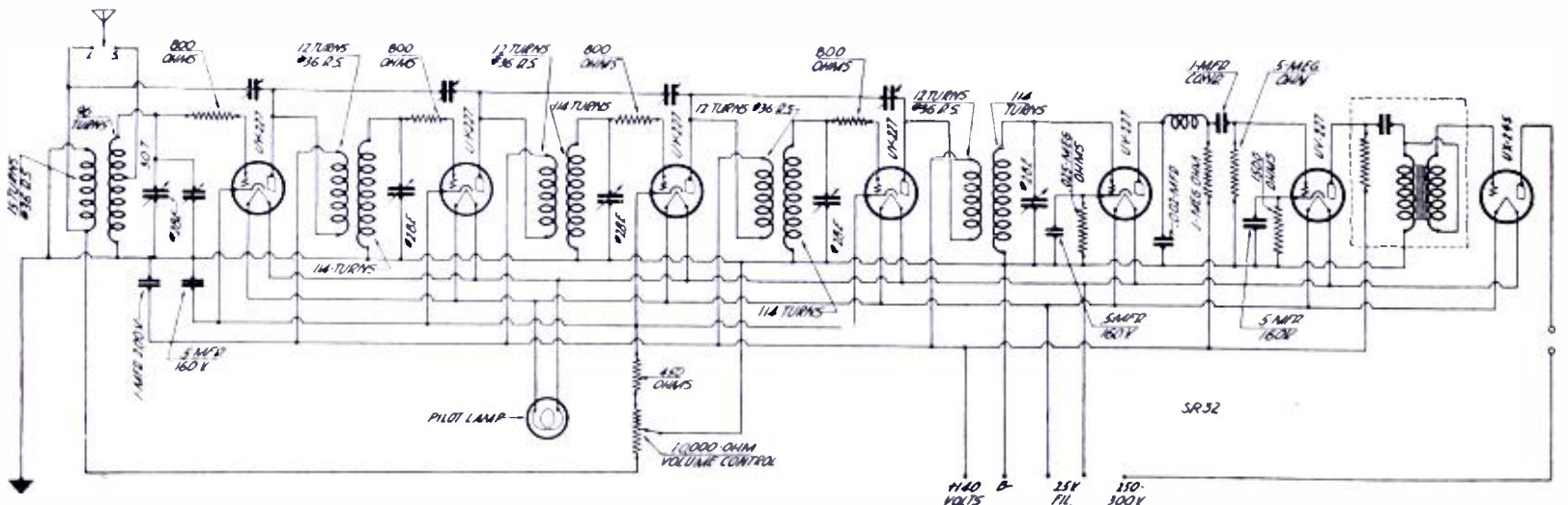

Fig. 9. In this drawing are shown the constants of the model 100 Gilfillan receiver described on this page

Graybar Model 600 Superheterodyne

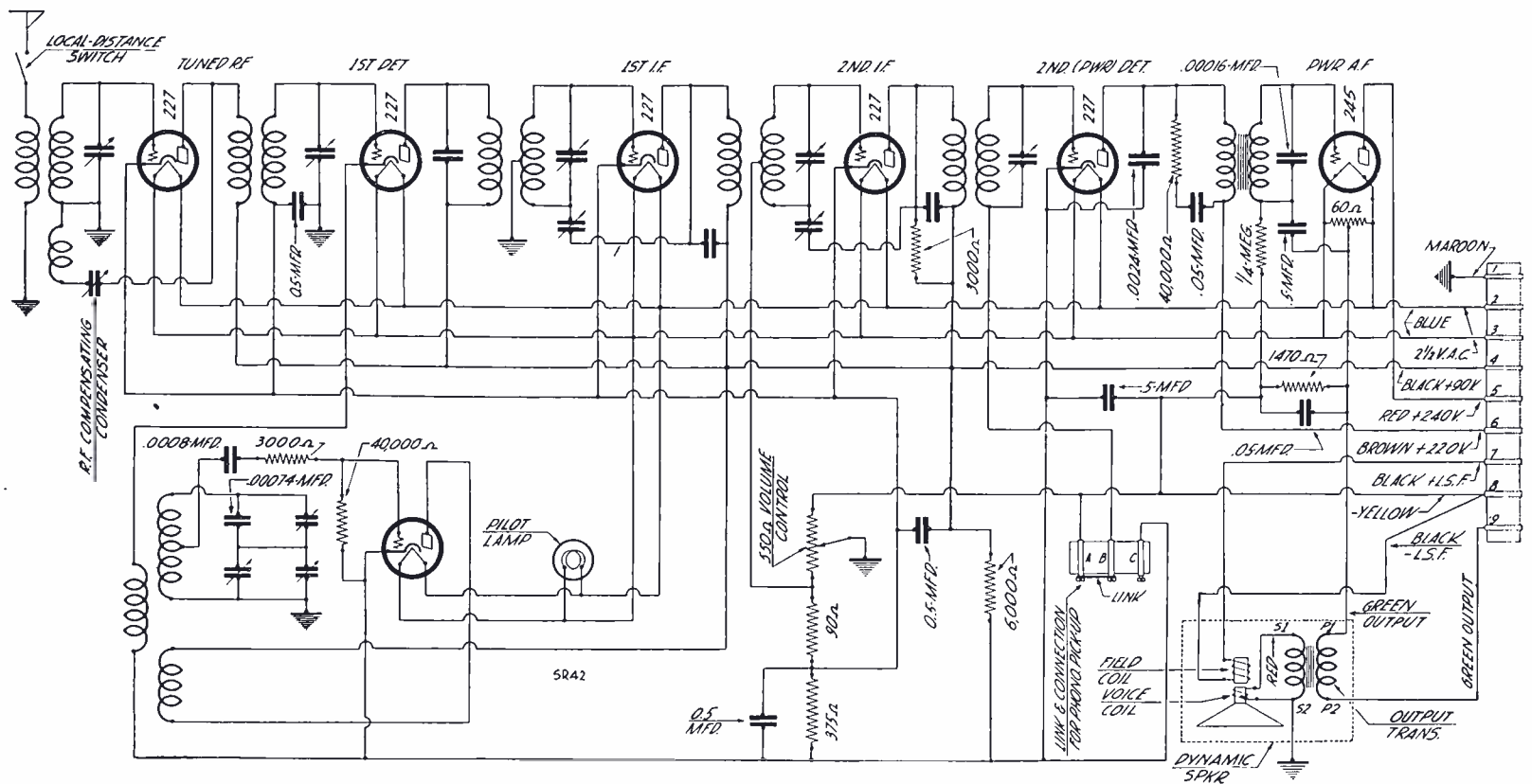

Fig. 1. The receiver portion of the Graybar model 600 is shown in this schematic

THE Graybar No. 600 receiver is a seven tube socket powered console cabinet model receiver using the superheterodyne circuit. It employs six 227 tubes and a 245 in the power output stage. A 280 is used in the socket power unit for supplying all plate, grid and cathode voltages, as well as supplying high voltage d. c. for the dynamic field.

Power detection is used in the second detector, where 235 volts is shown for plate circuit rectification with proper grid bias, which is about minus 29 volts.

With respect to tubes, the tuned r. f. stage (tube 1) is most critical for selection of tubes. For this position the tube giving loudest signal without oscillation should be employed. In the event any tube oscillates it may be necessary to reduce the setting of the r. f. compensating condenser so that no oscillation will take place over the entire tuning scale.

Other stages somewhat critical are the oscillator and the second detector,

Graybar Model 600

Tube Type	Position in Set	A Volts	B Volts	C Volts	Cathode Volts	Screen Volts	Normal Plate M. A.	Plate M. A. Grid Test	Change
227	1 R.F.	2.35	+100	-20	-26	---	0	---	---
227	2 1 Det.	2.35	+95	-9	-17	---	1.6	---	---
227	3 1 I.F.	2.35	+100	-20	-26	---	0	---	---
227	4 2 I.F.	2.35	+100	-3	-26	---	7.3	---	---
227	5 Osc.	2.35	+90	0	-16	---	8.7	---	---
227	6 2 Det.	2.35	+235	-29	-17	---	0.7	---	---
245	7 Pwr.	2.40	+225	-16	---	---	31.	---	---
280	Rect.	4.8	---	---	---	---	19	---	---

Line voltage 120, tap on 120 connection. Volume control at zero.

Fig. 2. Based on measurements shown in the Graybar manual the above table of typical tube analysis will be approximately correct

sockets 5 and 6 respectively. The remaining tubes should be interchanged until a tube is found for the oscillator that gives loudest signal for a given station. The second detector tube should be selected for its ability to handle large volume. Select the tube

for this position that will permit the volume control to be advanced and give the greatest undistorted output without overloading.

Tubes 3 and 4, representing the intermediate frequency stages, should have tubes chosen for best amplification. When changing tubes it is advisable to change only one at a time in order to prevent unnecessary voltage unbalancing. When changing the 280 rectifier turn the switch off.

The volume control regulates the bias on the tuned r. f. stage and the first intermediate. A local-distance switch is incorporated. A high impedance semi-tuned antenna primary in the r. f. stage allows varying lengths of aerial without materially affecting the receiver tuning.

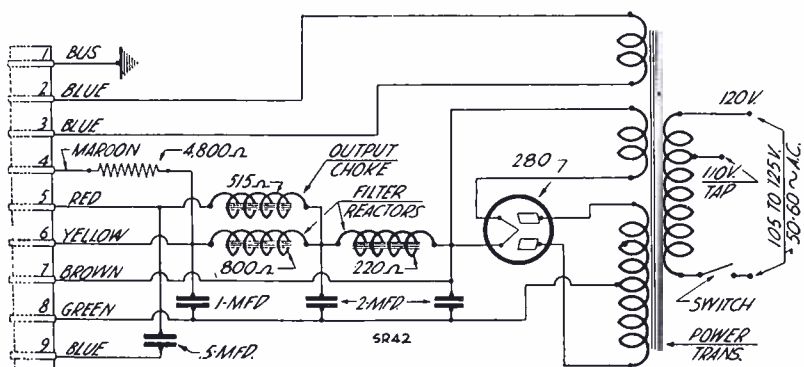

Fig. 3. The power supply, using a 280 rectifier, is shown in the diagram to the left. The resistor network at the left matches that at the right in the schematic shown in Fig. 1

Grebe Synchronphase Seven A. C. Set

SHOWN schematically on this page is the diagram of the Grebe Synchronphase Seven a. c. set and power supply made by A. H. Grebe & Co., Richmond Hill, N. Y. The receiver uses seven tubes, five 226, one 227, one 171-A and one 280 rectifier.

The input stage of the receiver is arranged for employment with either a long or a short antenna. The grid circuits of the first, second, third and fourth tubes are identical as far as tuning and suppression are concerned. The familiar Grebe binocular coils are used to couple the tuned stages. These coils are space wound with 20-38 Litz wire for efficiency and are carefully matched for assembly in the set. This type of radio frequency transformer possesses practically no external field. The only interstage shielding consists of small plates between the tuning condensers preventing feedback between the grid leads of the tube. Necessity for further shielding is eliminated by the use of the binocular coils and the proper arrangement of the wiring.

The volume control used on the receiver is a 2500 ohm maximum variable resistance placed across the primary of the last radio frequency transformer where it affords complete control of the incoming signal before reaching the detector so excessively

strong signals will not introduce distortion in that stage by overloading the tube. A tone color control is also provided and consists of five fixed condensers arranged on a switch so that they are cut in across from the grid to the ground of the 171-A power tube.

Local Reception Switch

Another novel connection which is used for local work consists of a switch of the plate circuits of the first r. f. amplifier, which when set on locals places a fixed resistance across the primary of the second radio frequency transformer and allows the receiver to be operated against strong local stations without overloading. When it is desired to pick up distant signals the switch is open and the fixed resistance is eliminated from the circuit.

The power unit has only two direct current terminals and delivers a total rectified voltage to the receiver terminal strip through the cable to be divided as required by the resistances inside of the set. Between the filament and C minus a 2,500-ohm resistor is inserted which provides the desired C bias for the power tube. A 300-ohm resistor between the 226 filament circuit and deck provides the C bias for these tubes in the same manner as that of the power tube. Finally a 20,000-ohm resistor be-

tween the 226 plate supply tap and detector drops the voltage on the detector plate to the desired value. Since no grid bias is required on the detector the cathode is grounded directly to the set.

Balancing the Hum

This system of voltage distribution permits Grebe to carry out a scheme of 120 cycle hum elimination. The filter system designed allows some hum to remain in the d. c. supply to the set. This is later balanced out in the set through the voltage distribution system. The amount of hum is in the right phase and just sufficient to cancel the effect of hum remaining in certain parts of the set without the necessity for variable hum adjustment. An important feature of the hum balance system is the 1 mfd. condenser and the 4,500-ohm resistance in series with the B plus terminal and the power tube center tapped filament resistor. The by-pass condensers between intermediate and detector voltage supply points and ground provide a resistance capacity filter eliminating the feed-back generally termed motor-boating. The two small 1 mfd. condensers between the ground and two filament bus bars of the 226 tubes prevent radio frequency feed-back which might cause the receiver to oscillate.

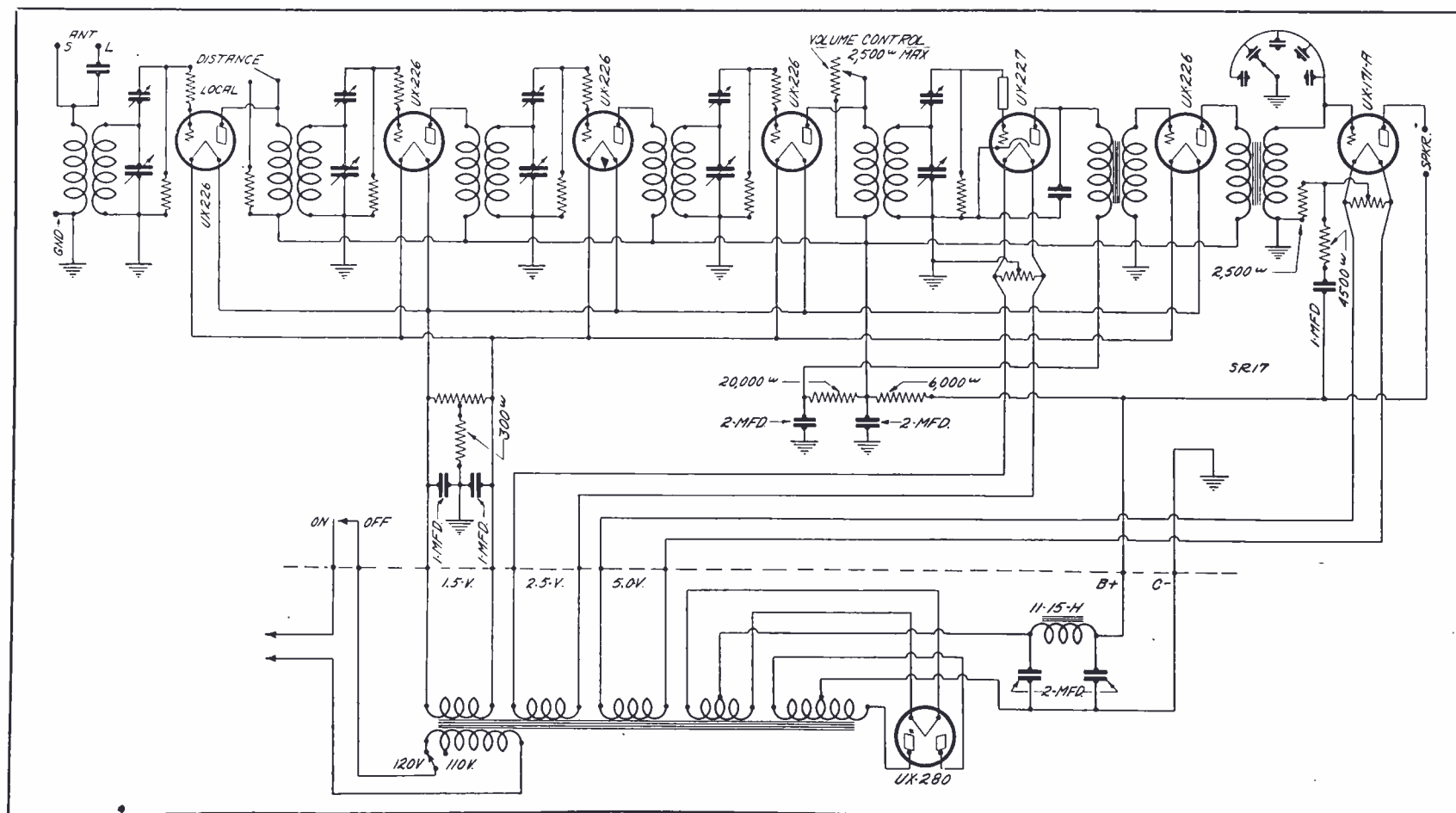

Fig. 1. Schematic wiring of the Grebe Synchronphase Seven A. C. and its power supply is shown in the above illustration

Grebe Radio Receiver No. SK-4 A. C.

THE super-synchrophase SK-4 receiver made by Grebe is designed to operate on 110-volt, 50-60 cycle a.c. supply. Special power units are available on lines of like voltage but 25-33 cycle. The instrument consists of two major units or chassis. The radio amplifier chassis is the unit to which the operating controls are attached, and the audio power amplifier chassis is the unit to which is mounted the dynamic speaker. This one instrument is supplied in different type consoles.

The circuit employs three tuned non-oscillating radio frequency stages, a power detector, a single push-pull audio output stage and a full wave rectifier. A table of typical tube operating values is indicated in the article, Figure 1, while the schematic diagram of the receiver and its power supply is shown in Figure 2.

No hum should be encountered in this receiver. If hum does occur change tubes in the push-pull sockets until a pair is found that give humless operation. The selection of a quiet detector is also important.

Three types of voltage regulators are listed to take care of line variations in different sections. These may be ob-

tained for use in localities where unusual line conditions are encountered. Voltage regulator No. 6420 for 115-138 volts; type 6412 for 105-125 volts and type No. 6310 for 95-110 volts. The type 6412 is standard and is supplied with sets unless otherwise specified.

A good ground is very essential for

the operation of the receiver. Location of the aerial lead-in is important regardless of the shielding used. The aerial lead-in should not run along close to the back of the radio amplifier chassis. The antenna lead should approach the set in the most direct manner, preferably from the right.

Grebe Model SK-4

Tube Type	Position in Set	A Volts	B Volts	C Volts	Cathode Volts	Screen Volts	Normal Plate M. A.	Plate M. A. Grid Test	Change
224	1 R.F.	2.35	188	14	---	57	0	2	2
224	2 R.F.	2.35	188	14	---	57	0	2	2
224	3 R.F.	2.35	188	14	---	57	0	2	2
227	Det.	2.35	210	×	---	---	.8	.8	0
245	P.P.	2.35	245	×	---	---	30	34	4
245	P.P.	2.35	245	×	---	---	30	34	4
280	Rect.	5.20	---	×	---	---	90	---	---

× = Resistors in circuit prevent readings.
Line voltage 120. Volume Control Minimum.*

*Plate current of 224 tubes read at maximum volume control.

Fig. 1. This table gives average tube operating values on the Grebe SK-4 as taken with a Jewell set analyzer

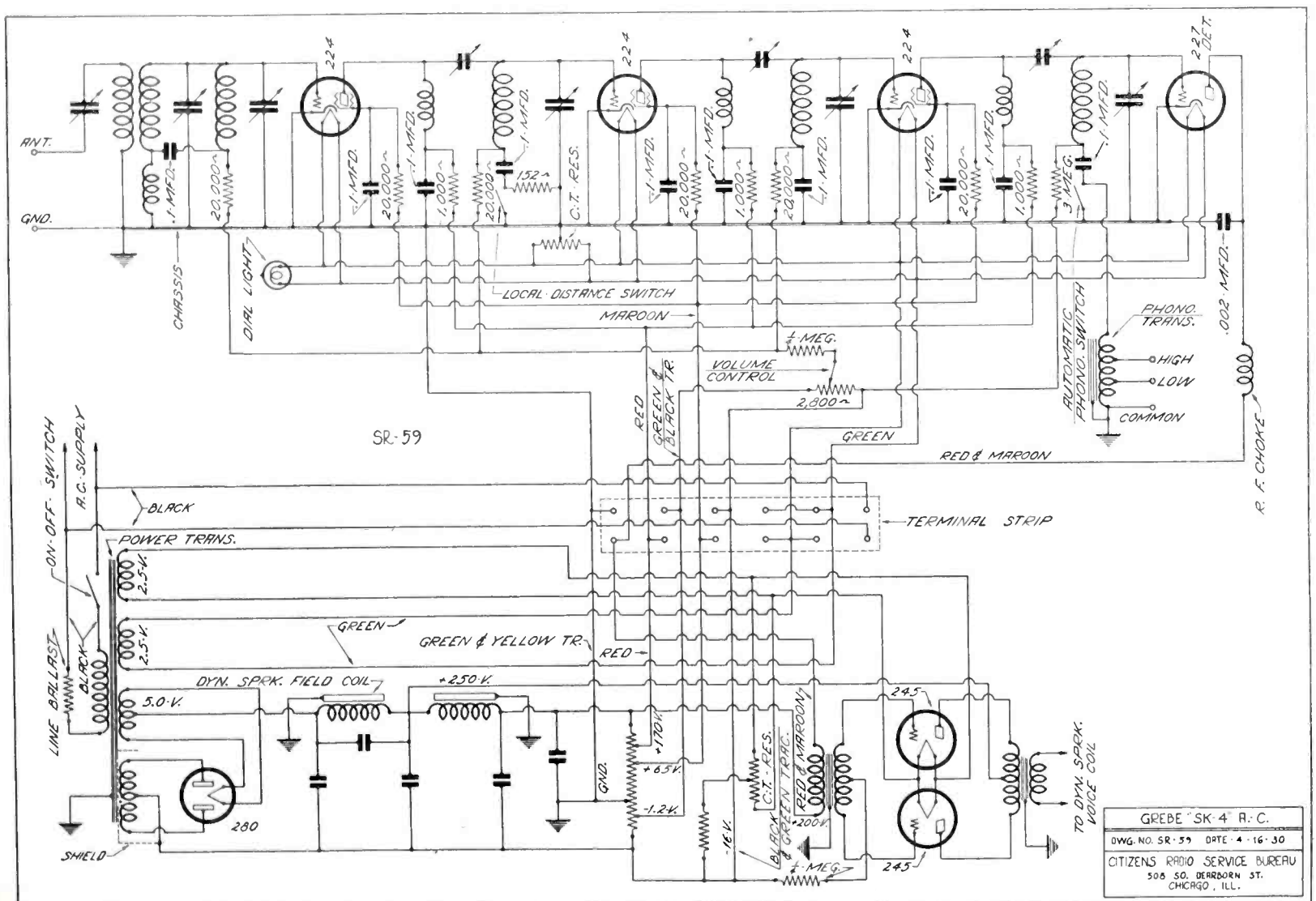

Fig. 2. The electrical details of the receiver described on this page may be seen in this drawing

Grebe Receiver Model AH 1

SERVICE data covering the Grebe model AH1 whose response curves will be found in the Response Curve section of this issue, is given in this article, together with a schematic diagram of the receiver and a table of average tube operating voltages, the schematic in Figure 2 and the tube data in Figure 1.

Suggested Antenna

The model AH1 will ordinarily give best results with a 50 to 75-foot antenna, erected as high above the noise level is very high very long antennas have given better results than short ones. A good ground connection is highly important. Avoid using radiators for ground connections. Preferably run the ground wire into the basement to the point where the cold water pipe enters the house. In apartments and hotels a ground connection to the steel frame of the building may be more satisfactory than the water pipe nearest the receiver.

Service Calls

The majority of service calls arise from defective tubes. Adjustment of the set should only be made after the service man is certain that all of the tubes are satisfactory. Operating a receiver on a line voltage higher than designed for will result in shortened tube life. A line voltage too low will result in a sacrifice in receiver performance. Always measure the customer's line voltage and make set adjustments accordingly. All sets leaving the factory are adjusted for 60 cycles, 115 to 125 line volts. When line is between 100 and 115 remove the fuse cover by loosening

Grebe Model AH1

Tube Type	Position in Set	A Volts	B Volts	C Volts	Cathode Volts	Screen Volts	Normal Plate M. A.	Plate M. A. Grid Test	Change
224	1 R. F.	2.4	160	2.5		80	2.5	---	---
224	2 R. F.	2.4	160	2.5		80	2.5	---	---
224	3 R. F.	2.4	160	2.5		80	2.5	---	---
227	Det.	2.4	200	20			2.0	---	---
215	P. P.	2.4	250	14			50	---	---
245	P. P.	2.4	250	14			50	---	---
280	Rect.	4.8	--	--			50	---	---

Line voltage 115. Volume control maximum.

Fig. 1. In this table are given the voltage readings according to a recent measurement made with a Jewell set analyzer

the holding screw and change the two ampere fuse from the 120 to the 110 terminal. The above voltage range is typical of the great majority of installations. For lines from 125 to 135 volts (rare cases) service men should install a Clarostat automatic line voltage regulator, type A, or a Ward Leonard line resistor No. 507.109 G in series with the line. Be sure to remove the ground plug before doing anything to the fuse in order to avoid a shock or a flash due to accidental short to grounded chassis.

Oscillation

If the receiver oscillates, the following should be investigated before adjustments on the set are altered: a good ground connection is essential; the antenna lead should approach the set in the most direct manner possible; the receiver has been designed to operate

with maximum efficiency with the Cunningham or RCA tubes and was so adjusted at the factory. A complete set of new tubes may have higher emission than usual, causing the set to oscillate when the volume control is wide open. However, after several days of aging the emission of the tubes will become normal and the receiver will have stabilized itself without necessity of adjustments to the set.

Loose Brakes

Poor contact between the contact brakes and the rotor of the gang condenser may cause oscillation between 550 and 700 kc. Lift out the brakes from the gang condenser frame and increase the curvature of the bow spring by bending slightly. Under no conditions should oil be used, as this will completely ruin contact.

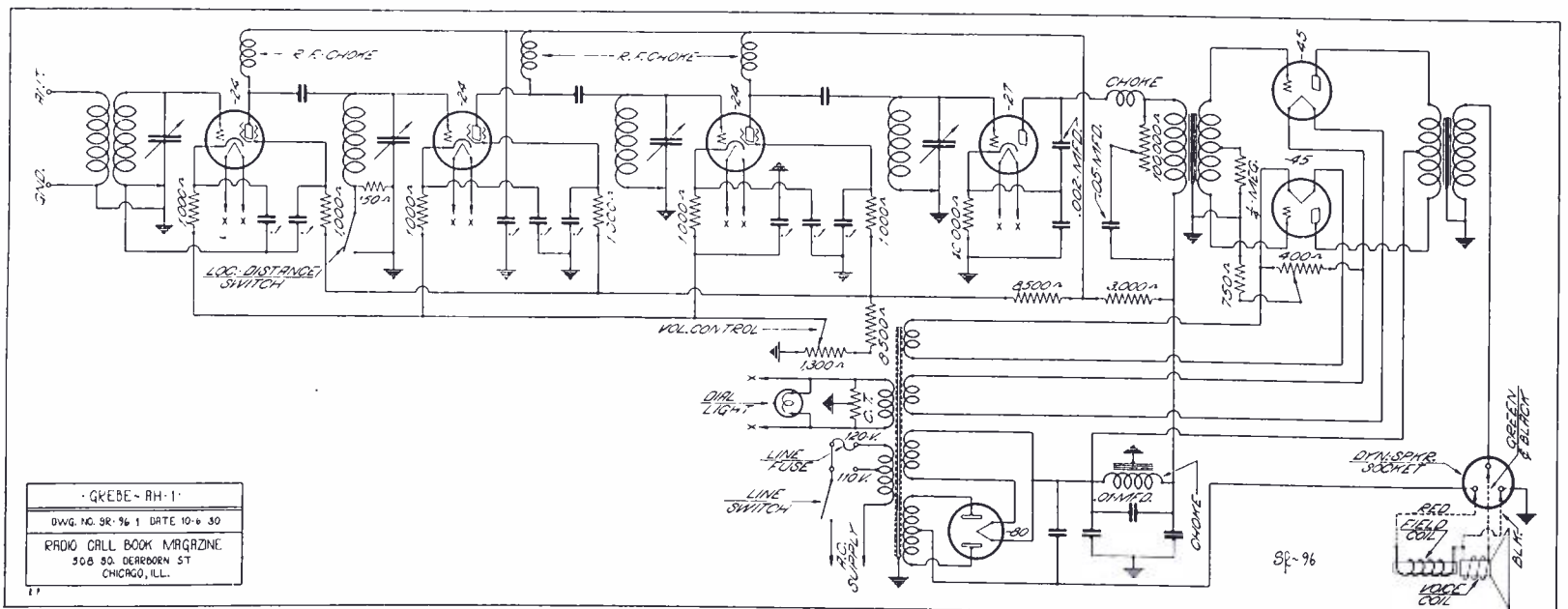

Fig. 2. The schematic diagram of the Grebe AH1 receiver is shown in this illustration

Gulbransen 9 in Line Model Receiver

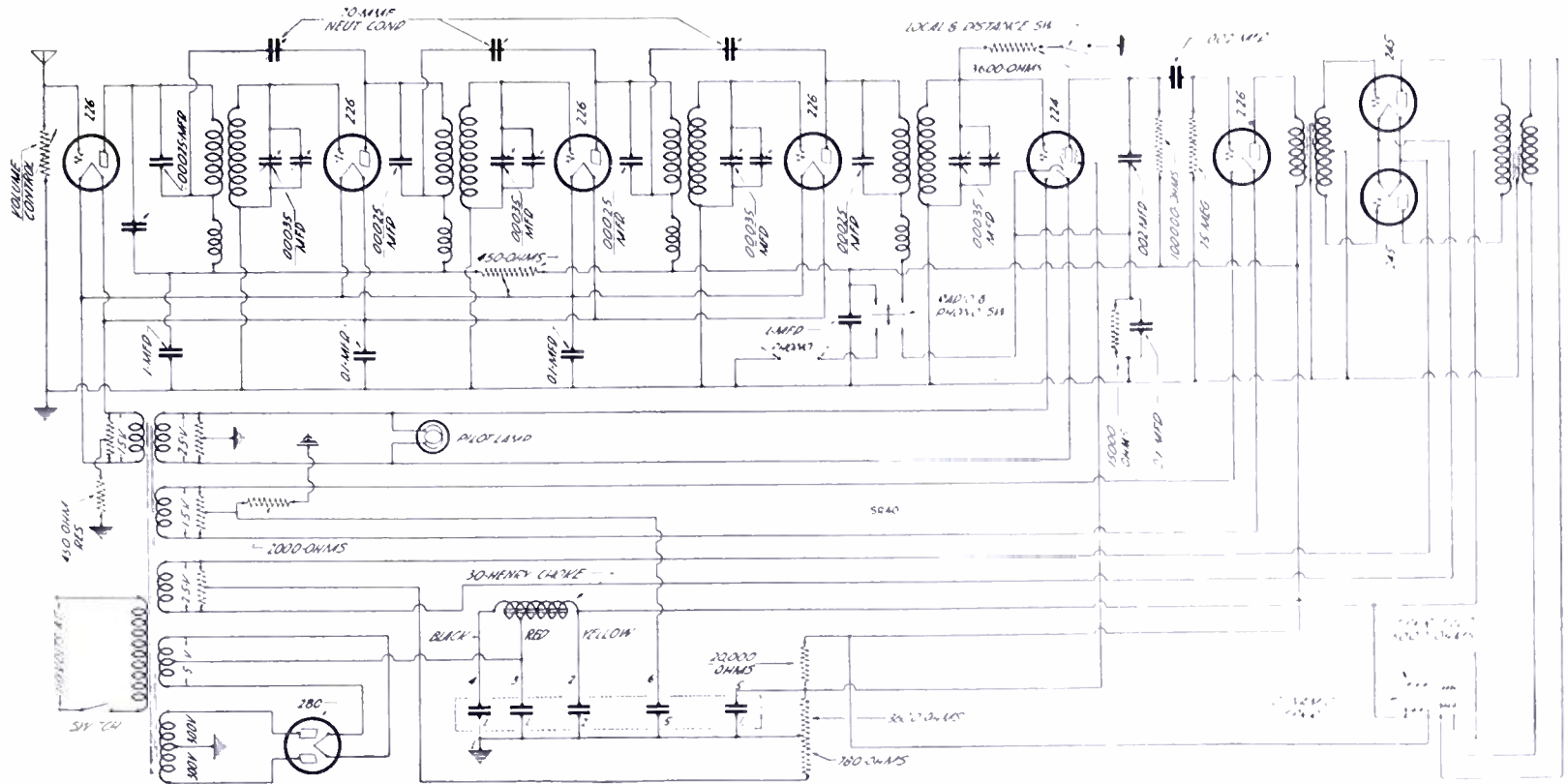

Fig. 1. In this schematic diagram of the Gulbransen receiver may be seen the electrical constants of the set and its power supply

K NOWN as the Nine in Line model, the receiver made by the Gulbransen Co., of Chicago, Ill., is illustrated schematically in Figure 1, the schematic representing the receiver and its power supply. A table of typical tube voltages is shown in Figure 2.

Tuned R. F. Set

As will be seen by inspecting the diagram, the receiver is a nine tube tuned r. f. set including the 280 rectifier tube. It consists of four 226 tubes in the radio frequency end, a 224 screen grid detector, a 226 in the first audio and two 245 tubes arranged in push-pull in the output end.

Untuned Antenna

The antenna stage is not tuned, a high resistance volume control being inserted between antenna and ground.

Renutralizing

Generally the only reason for renutralizing is a change either in tube or circuit capacity. On this receiver the neutralization tolerance is quite wide. When necessary to renutralize, use a good 226 tube from which one filament prong has been severed, close to the base. To neutralize, tune in a strong local, adjust receiver to maximum volume, getting the station right on the

head. Remove the fourth r. f. tube and insert the specially prepared 226. The station should still be heard, but weakly. If it cannot be heard in the speaker, put on a pair of headphones.

Work at 25 Degrees

Adjust the fourth r. f. neutralizing condenser until volume is at a minimum. Continue this procedure with the third and second r. f. tubes, replacing the good tube back in its socket after each stage is neutralized. Neutralization should be done at about 25 degrees on the dial. Be sure to use an insulated screwdriver or tool for adjusting the neutralizing condenser.

Gulbransen Model 9 in Line

Tube Type	Position in Set	A Volts	B Volts	C Volts	Cathode Volts	Screen Volts	Normal Plate M. A.	Plate M. A. Grid Test	Change
226	1 R.F.	1.35	116	8.5	---	---	4.7	8.7	4.
226	2 R.F.	1.35	116	8.5	---	---	4.7	8.7	4.
226	3 R.F.	1.35	116	8.5	---	---	4.7	8.7	4.
226	4 R.F.	1.35	116	8.5	---	---	4.7	8.7	4.
224	Det.	2.2	80	1.3	---	15	---	---	---
226	1 A.F.	1.4	110	1.0	---	---	4.0	5.0	1.
245	2 A.F.	2.2	232	42.	---	---	27.	32.	5.
245	2 A.F.	2.2	232	42.	---	---	27.	32.	5.
280	Rect.	4.6	---	---	---	---	84	---	---

Line voltage 115. Volume control.

Fig. 2. A table of the typical tube voltages as taken with a standard set tester is illustrated above for the benefit of service men

Another Substitute

Occasionally the service man may be called on to neutralize the set and he may not have the specially prepared 226 tube with him. In this case a simple method is to obtain a straw such as is used at soda fountains. Clip off about one inch of the straw and slip the short piece over one of the filament prongs of the tube. Replace the tube in the socket, being careful that the straw is not torn in so doing. This will allow the tube to go into the socket without lighting the filament, and the set can thus be balanced for the tubes actually used. However, this method requires much more patience than the previous method, especially since the repairman must be careful not to tear the straw while inserting the tube in the socket.

Howard Green Diamond Set, Model 8

K NOWN commercially as the Green Diamond, Howard's Model No. 8 manufactured by the Howard Radio Co., South Haven, Michigan, is described in the accompanying article.

As will be seen from an inspection of the schematic circuit shown in Fig. 1, the receiver is completely electrically operated and uses eight tubes, four of these being 226's employed in the tuned radio frequency stages, which are neutralized. The detector is the conventional 227. The fifth 226 tube is used in the first audio stage, while two 171's arranged in push-pull complete the power output stage.

Self-Contained Power Supply

A, B and C supplies for the operation of the receiver are produced by the 280 rectifier and its associated high and low voltage system. The loud speaker field of 2500 ohms, 4½ watts, forms a part of the filter in the rectifier system. Individual resistors in the plate circuit of the first, second, third and fourth radio frequency tubes serve to supply these plate circuits with the proper voltages. Resistance R-6 serves to drop the voltage for the plate of the detector to its proper value.

The audio frequency volume control is represented as R-3 and consists of a variable resistor placed across terminals 1 and 3 of the first audio transformer. This transformer has a tap at terminal 2 so that when a phono pick-up is used, it is placed across terminal

2 and one side of SW-3. When the switch is on the phonograph side, only a portion of the primary winding is in the circuit, whereas when the switch is on the radio side, the entire primary of the first audio is utilized.

Sensitivity Control

Volume control for the radio frequency end of the Green Diamond is made by manipulation of resistance R-1 located between antenna and ground with the movable arm going directly to the grid of the first 226. By controlling the input r. f. voltage, the remainder of the radio frequency stages are operating at a maximum value all of the time, this permitting the neutralization of the receiver at a desirable condition throughout the radio frequency end of the set. Thus for sensitivity, the r. f. volume control is used, while for loudness of signal the a. f. volume control is employed. The method of neutralization is from the grid of the first tube through the neutralizing condenser to a neutralizing tap on the succeeding secondary inductance. This method is followed throughout the four stages so neutralized. Each stage is bypassed in the plate circuit as well as in the filament circuit, so as to assure complete stability of the receiver.

High or Low Lines

A two-way switch on the power supply enables the operation of the set either from 110 or 120 volts, depending upon the condition of the line. In

addition to that there is provided an "on-off" switch by means of which the entire receiver may be started or stopped.

A special Howard speaker is used with the Green Diamond and its field is energized by the rectifier circuit.

Transformer 4 is the push-pull output which feeds inductively the voice coil of the speaker, a reversed or hum neutralized winding being incorporated in that circuit to eliminate a. c. hum.

Covers Full Band

Tuning range of this set is from 200 to 545 meters, or from 1500 to 550 k. c., covering the complete government allocation of wavelengths over the broadcast band.

The left-hand switch on the panel when snapped to the right is in position for radio reception. When snapped to the left, it brings into operation the special audio system for playing phonograph records electrically.

The right-hand volume control prevents overloading of all tubes by governing the strength of signal entering the receiver, while the left-hand volume control prevents overloading of the audio frequency amplifier tubes only.

Type Numbers Shown

Type numbers of all of the parts employed in the completed receiver are shown in the schematic circuit for the benefit of service and repair men who may have occasion to write the factory for such parts.

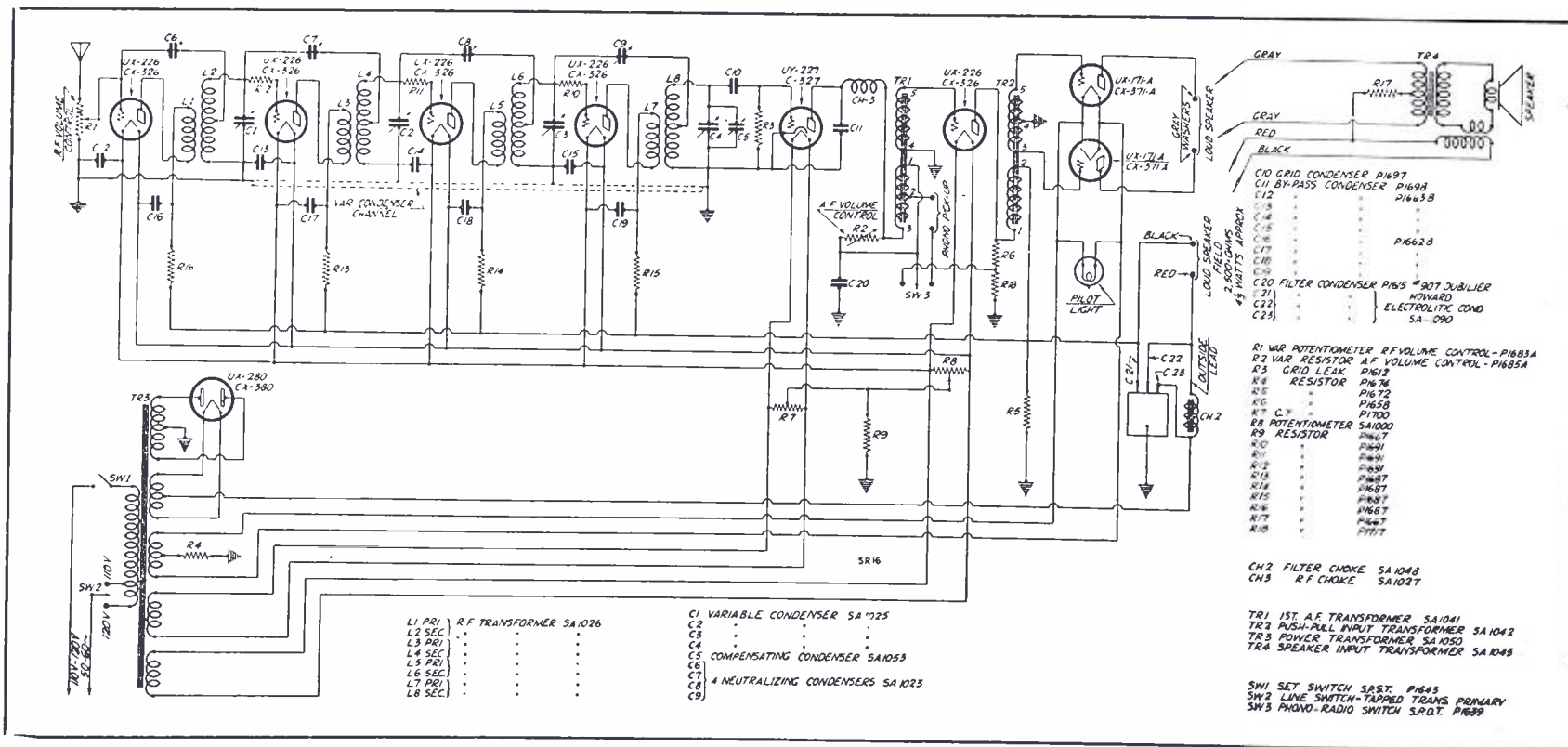

Fig. 1. This schematic circuit gives all of the electrical details of the Howard Green Diamond Model 8, with a table of type numbers for all condensers, resistors, chokes and transformers

Howard Radio Receiver Model S.G.A.

ELSEWHERE in this magazine appear the sensitivity, selectivity and fidelity curves of the Howard S. G. A. receiver described on this page. The receiver schematic is Figure 2, the power supply Figure 3 and the analysis of tube voltages and current in Figure 1.

Some interesting points are to be found in the service manual supplied to Howard dealers. Due to non-uniformity of tubes the set may oscillate with certain tube combinations. A quick remedy is

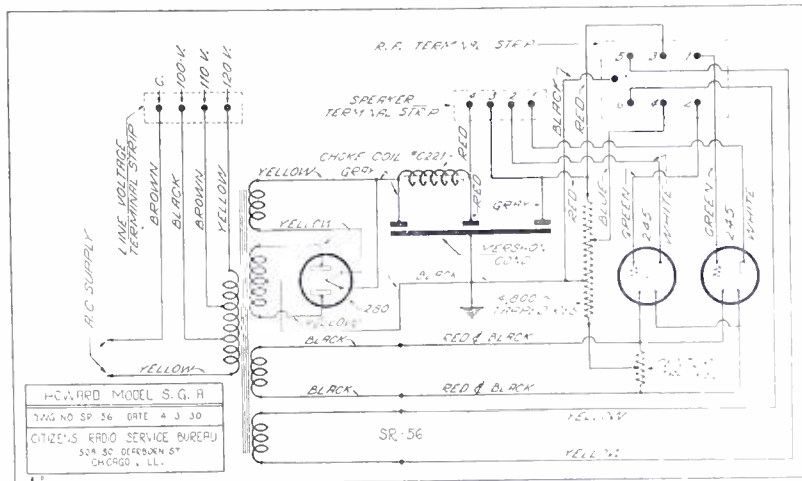

Figure 3. This drawing is that of the separate power supply for the Howard S. G. A.

to shift the r. f. tubes around.

There are two approved methods of testing tubes. The first is to remove the tube from the chassis and place the plug from the Jewell or Weston analyzer in the tube socket, then place the tube in the analyzer and measure its plate current under normal operating conditions. It has been determined in the laboratory that tubes having a plate current from 2.5 to 3.1 milliamperes are normal tubes and operate to best advantage in this receiver.

Howard Model S. G. A.

The second and better method of the two is to measure the mutual conductance of the tube by means of the mutual conductance bridge made by General Radio. (This is described elsewhere in this issue—Editor). It has been found that to give best results with this particular receiver the mutual conductance of the tubes should measure 1000 micromhos. Tubes may be used with a mutual conductance as low as 750 micromhos with a corresponding decrease in amplification. The upper limit of mutual conductance is 1050 micromhos, beyond which values tubes should not be used as they have a tendency to break into oscillation which tendency cannot be curbed in this particular receiver.

Response curves on this receiver were recently taken by our laboratory and appear elsewhere in this magazine.

Tube Type	Position in Set	A Volts	B Volts	C Volts	Cathode Volts	Screen Volts	Normal Plate M. A.	M. A. Grid Test	Change
224	1 R.F.	2.2	162	3.5	3.5	68	3.3	4.7	1.4
224	2 R.F.	2.2	162	3.6	3.5	68	3.2	4.0	.8
224	3 R.F.	2.2	165	2.9	2.9	68	3.4	5.1	1.7
227	Det.	2.2	155	15	15	---	1.0	1.2	.2
245	P.P.	2.1	238	45	---	---	24.4	28.4	4.0
245	P.P.	2.1	238	45	---	---	24.4	28.4	4.0
280	Rect.	4.5	---	---	---	---	58	---	---

Line voltage 110, set on 110-volt tap. Volume control maximum.
 Variable condenser at maximum capacity. Detector coil shorted to give correct voltage when measuring detector.

Figure 1. In this table may be found typical voltages for the Howard S. G. A. as indicated in the service manual of the company. The readings were taken with a Jewell set analyzer

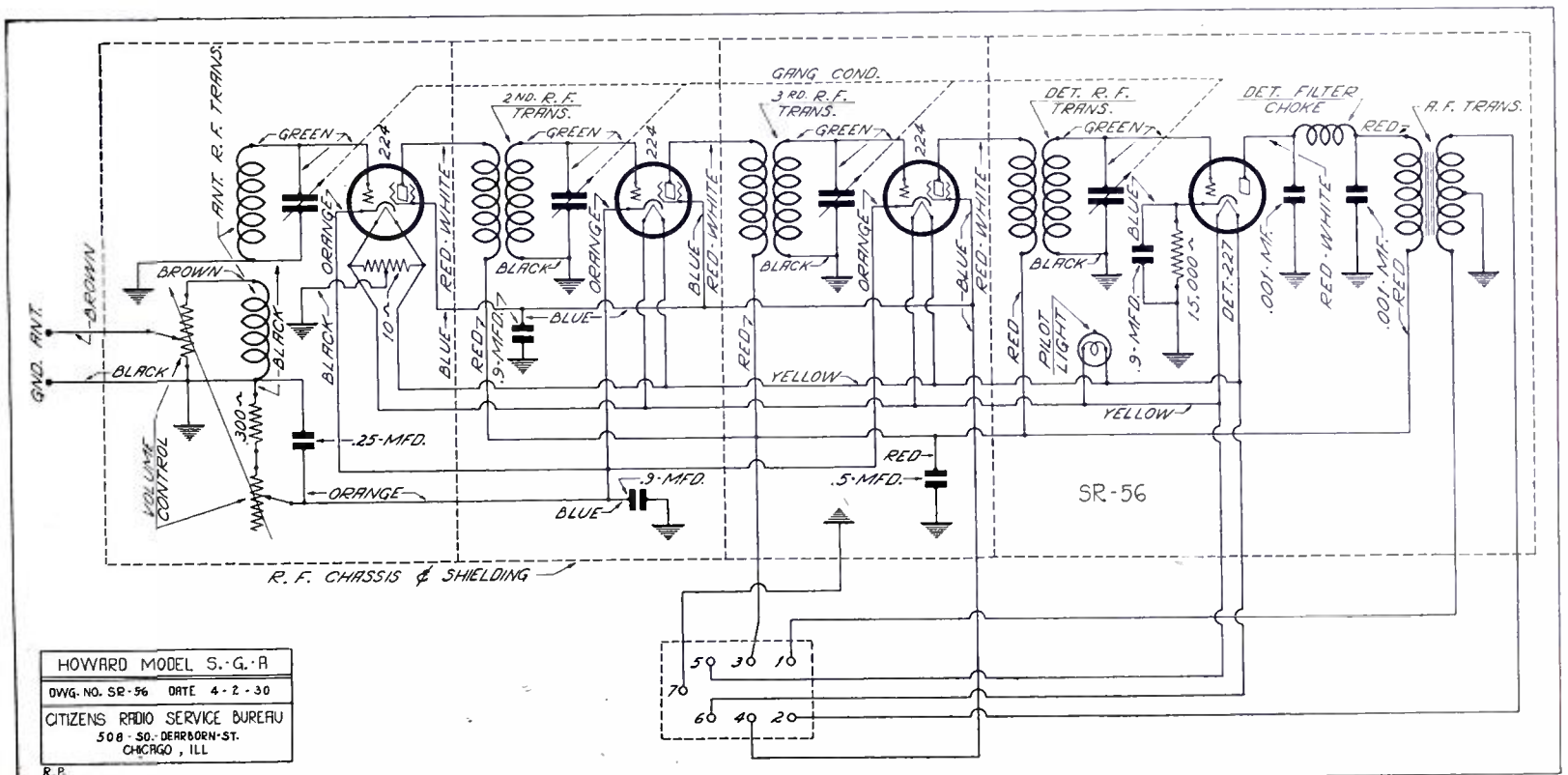

Figure 2. In this drawing may be seen the schematic circuit of the Howard screen grid receiver described on this page

Kellogg Radio Receivers 523 to 528

GENERAL description of the Kellogg models 523 to 528 inclusive, will be found on this page, the schematic circuit being Figure 2, while a table of typical operating voltages is to be seen in Figure 1.

According to the Kellogg manual the radio amplifier has been designed to utilize the high amplification of screen grid tubes and also to provide a satisfactory degree of selectivity. Each stage is tuned and completely shielded to prevent pickup of any signals except by the antenna, or the transfer of energy from one stage to another except

through the desired circuit, thus giving maximum amplification and preventing oscillation. Including the detector input there are four tuned circuits, insuring selectivity.

Condenser Units Separate

Each unit of the gang condenser is in a separate compartment with its associated tube. The coils are completely enclosed in seamless copper cans inside of the steel base. All resistors are non-inductive. All capacitors in the radio frequency circuits are the non-inductive low resistance type.

The antenna coil is so constructed as to eliminate any necessity for trimming devices, insuring a single selector control. The antenna coil input is controlled by a potentiometer to prevent overloading the first r.f. tube when tuning a powerful nearby station.

Automatic Volume Control

The plate circuit of the third radio frequency tube is coupled through a condenser to the grid circuit of an automatic volume control tube. This tube automatically changes the grid bias of the first and second r.f. tubes, which bias governs the amplification of these tubes and tends to produce a constant radio frequency voltage output. A manual setting of the volume control tube is provided so that any desired level of volume may be maintained at any setting within certain limits of the antenna input control. The extreme counter-clockwise movement of the volume control knob operates a switch with which the phonograph binding posts are connected to the audio amplifier, and the detector disconnected. The detector is of the linear type.

The first audio tube and transformer are mounted on the chassis. The input push-pull transformer and power tubes are part of the power unit. An output push-pull transformer is mounted alongside the loud speaker.

Kellogg Model 523

Tube Type	Position in Set	A Volts	B Volts	C Volts	Cathode Volts	Screen Volts	Normal Plate M. A.	Plate M. A. Grid Test	Change
221	1 R.F.	2.1	128	1	1	40	1.2		
221	2 R.F.	2.1	128	1	1	40	1.2		
221	3 R.F.	2.1	128	1	1	40	1.2		
227	Det.	2.3	128	12	12		1.2		
227	Vol. Con.	2.3	24	1	40				
227	1 A.F.	2.3	128	8	8		4.4		
215	P.P.	2.2	228	10			28		
215	P.P.	2.2	228	10			28		
280	Rect.	4.6					100		

Line voltage, 112. Volume control full on.

Fig. 1. Operating voltages on the Kellogg 523 receiver are those shown in this table as taken with a Jewell set analyzer

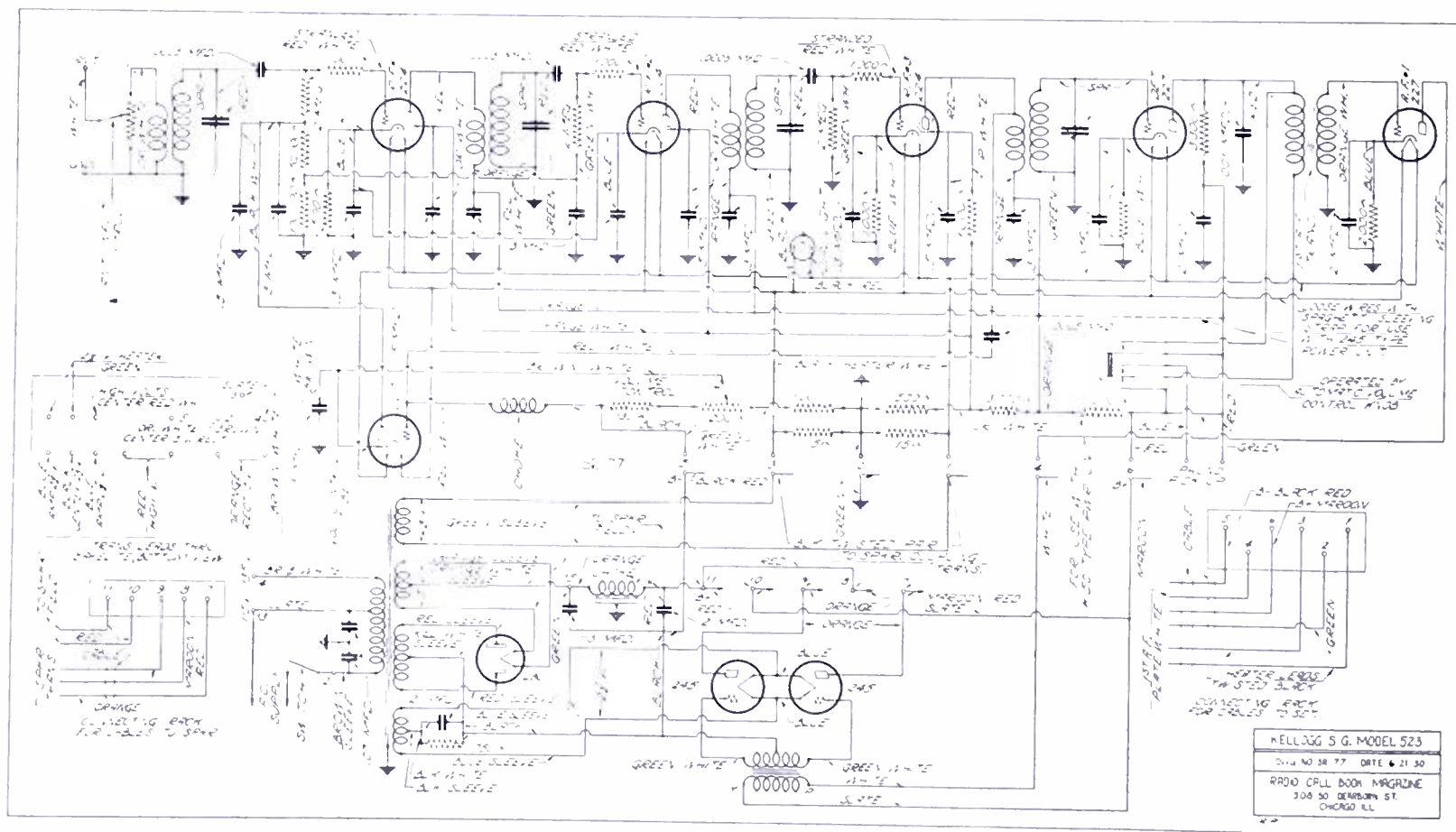

Fig. 2. The electrical details of the receiver and power supply for the Kellogg models 523 to 528 inclusive are shown in this drawing

Colin B. Kennedy Model 10 Receiver

ILLUSTRATED schematically on this page the Kennedy model No. 10 is a 7 tube receiver whose circuits are: a three stage radio frequency amplifier, neutralized, followed by a conventional grid leak and condenser detector. The three radio frequency stages and the detector are tuned by a four gang variable condenser. Two 245 tubes are used in push pull in the power output stage.

A chart of the typical tube voltages on this model is illustrated in Figure 1.

Excessive hum may be coming from some external source and if so will cease when the aerial is removed. If the hum is still loud vary the hum control in the right front corner of the chassis until a minimum of hum is found. In the event the hum is still too loud inspect terminals on the rear base for faulty or shorted connections and check the speaker and tubes. In most every case a hint as to the exact location or cause of the trouble may be found by using a set analyzer. A general check-up of all voltages and biases is usually very helpful in determining the source of trouble.

Distortion when not due to the broadcasting itself is generally caused by weak, old, or defective tubes. If not in the tubes or speaker it will doubtless be due to broken down bypass condensers or grounded resistors. Distortion from these latter causes usually are accompanied by an increase in the

tubes. Microphonic tubes are much more rare in the a. c. types than in the d. c. types, but are encountered from time to time. As in battery receivers the detector tube is usually at fault.

These receivers are so designed as to operate efficiently over fairly wide vari-

former, choke filter, filter condenser block, are mounted to the main chassis by means of bolts and nuts or rivets. They are readily removed without the use of any tools other than those found in the average repair man's kit. Units held to the base by rivets may be re-

Kennedy Model 10

Tube Type	Position in Set	A Volts	B Volts	C Volts	Cathode Volts	Screen Volts	Normal Plate M. A.	Plate M. A. Grid Test	Change
227	1 R.F.	2.37	118	8	+8	5.8	8.8	3.	
227	2 R.F.	2.37	118	8	+8	5.8	8.8	3.	
227	3 R.F.	2.37	118	8	+8	5.8	8.8	3.	
227	Det.	2.37	38	0	0	2.1	2.1	0	
227	1 A.F.	2.37	112	9	+9	4.8	6.5	1.7	
245	Pwr.	2.45	240	45		30.	35.	5.	
245	Pwr.	2.45	240	45		30.	35.	5.	
280	Rect.	5.0				112			

Line voltage 112, set on 120 tap. Volume control on full.

Fig. 1. The typical tube analysis taken on the Kennedy model 10 illustrated on this page is secured from the figures shown by a Jewell set analyzer

hum in some instances causing a noise like a deep growl.

A continuous ringing—humming noise as a rule means microphonic actions in a. c. line voltage. However it is desirable for the service man to be supplied with an accurate alternating current volt meter and measure the line

voltage at each installation. If the voltage should exceed 125 volts it is well to employ some means of reducing it to insure a normal long life to the tubes.

Audio transformers, power transformers by drilling out the rivets and using small bolts and nuts to hold the replacement parts.

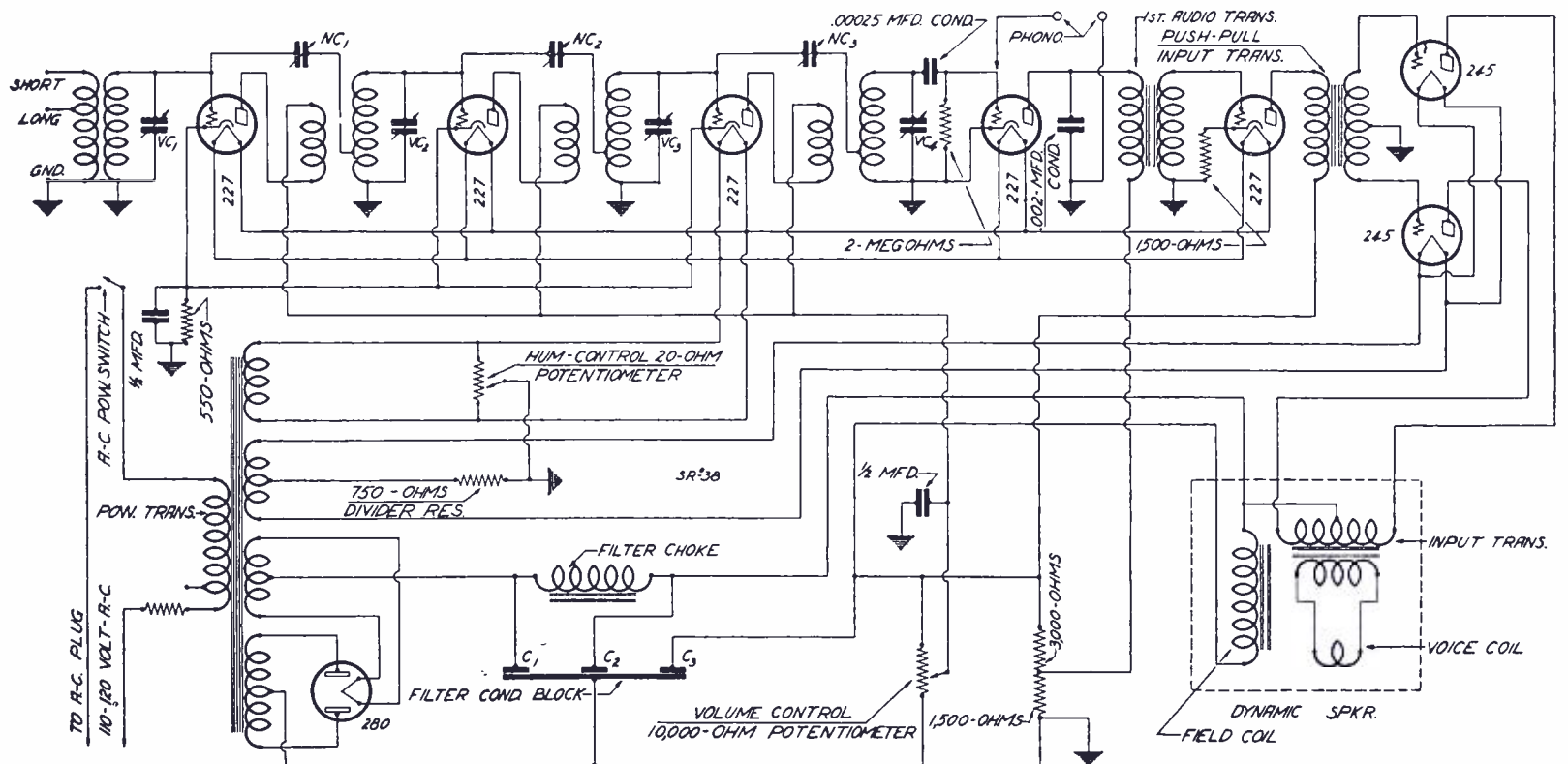

Fig. 2. The schematic diagram of the receiver and power supply of the Kennedy model 10 is shown in this illustration

Colin B. Kennedy S. G. Model 20 Set

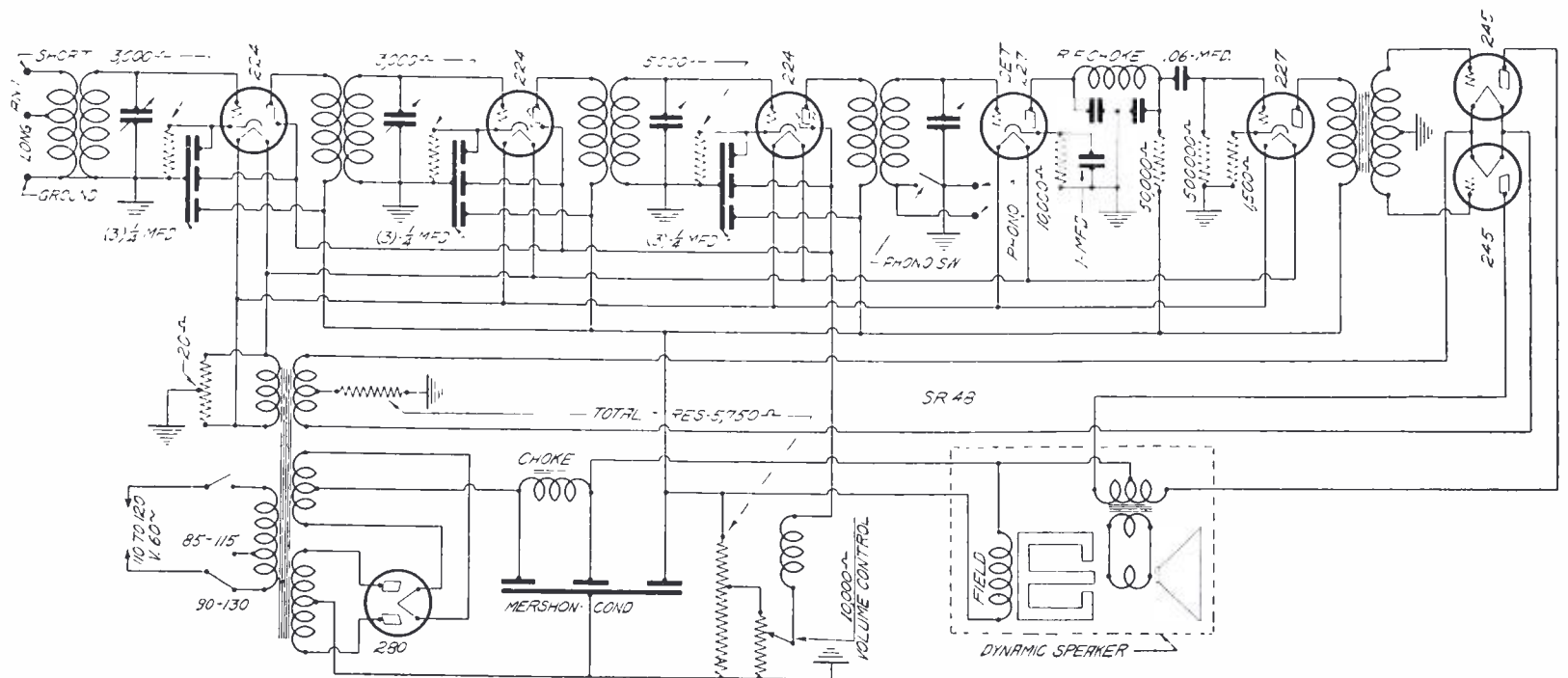

Fig. 1. The schematic of the receiver and its power supply as used in the Kennedy model 20 receiver is illustrated above

KENNEDY'S screen grid model 20, illustrated on this page in schematic form, is constructed on a base similar to the model 10 but with additions and changes in the method and amount of shielding. A portion of the amplification from screen grid tubes is used to provide additional selectivity instead of increasing the audio volume. The first audio stage in the 20 uses resistance coupling as compared to transformer coupling in the model 10.

General instructions for locating trouble that may occur, faulty reception of various kinds and unusual conditions, are similar to the general instruction on the model 10.

Use Set Analyzer

Modern makes of tube testing devices and set analyzer kits are equipped to

check screen grid tubes and to test out circuits designed for their use. In case of trouble tubes should be tested, and if no tester is available for checking the screen grid tubes, these tubes should be replaced, one by one, with tubes known to be good. Set voltages may be checked with an analyzer, or by removing the base plate, and reading with a voltmeter and test leads. The chassis is removed from the cabinet by removing connections from rear terminal panel, clearing the a. c. cord and removing the two bakelite knobs, after taking out the four hold-down bolts in the corners of the chassis.

Voltage Measurements

Screen voltages are measured from cathode terminal to screen terminal of each r. f. socket. Screen is positive.

Bias voltages are measured from cathode terminal to ground of each r. f. socket and detector, cathode positive. Other voltages are measured as in the model 10.

Coils may be tested with a battery, meter and pair of leads. Test from ground (entire chassis is grounded) to the grid terminals of the r. f. and detector sockets. Note that the grid terminals of the screen grid tubes are the flexible leads to the tops of the tubes.

Radio-Phono Changes

The model 20 phono-radio switch and its connections are entirely different from the model 10. Two phosphor-bronze contact springs are mounted behind the switch lever, near the front center of the chassis, and make contact when the switch is thrown to radio. When thrown to phono the pickup is hooked in series with the detector coil. The wire from the detector coil ground terminal to the ground lug is broken and the two ends attached to the two phosphor-bronze contact springs.

Keep Speaker in Circuit

When operating set or testing it, a speaker should be connected at all times as the field of the dynamic forms a part of the filter circuit. Many sets with the electrolytic filter will be found to hum considerably when turned on their sides, or upside down. This is a normal condition however. Because of the method of testing at the factory few receivers should be found that tend to oscillate. A tap on the voltage divider resistance is provided to lower screen voltages if found necessary to do so in case of oscillation tendency.

Colin B. Kennedy Model 20

Tube Type	Position in Set	A Volts	B Volts	C Volts	Cathode Volts	Screen Volts	Plate M. A.	Normal	Plate	Change
								M. A.	M. A.	
224	1 R.F.	2.35	170	3.5	3	65	1	4	3	3
224	2 R.F.	2.35	170	3.0	3	65	1	4	3	3
224	3 R.F.	2.35	170	3.0	3	65	1.6	4	2.4	2.4
227	Det.	2.35	130	-18.	+18.	---	1.8	3.	1.2	1.2
227	1 A.F.	2.35	160	-10.	+10.	---	7.4	9.	1.6	1.6
245	Pwr.	2.36	230	45	---	---	26	30	4.	4.
245	Pwr.	2.36	230	45	---	---	26	30	4.	4.
280	Rect.	4.8	---	---	---	---	80	---	---	---

Line voltage 112, set on 120 tap.

Fig. 2. With a Jewell set analyzer the typical tube voltages on the receiver would be approximately as indicated in this table

Kennedy Screen Grid Set Model 26

IN this article is described the model 26 screen grid Colin B. Kennedy model, the schematic of which is shown in Figure 2, while a table of tube operating values as abstracted from the service manual is shown in Figure 1.

Two Parts

This model is constructed on two bases, one the receiver and the other the power supply. These are connected together by means of a plug and cable. The double unit assembly permits a more flexible design of cabinets and the installation of plain and automatic phonograph units and short wave receivers.

Usual Instructions

General instructions for locating any trouble that may occur, faulty reception of various kinds and unusual conditions that may arise are similar to the general instructions for servicing any standard well designed receiver. Modern makes of tube testing devices and set analyzers are equipped to check screen grid tubes and test out circuits for their use. In cases of trouble, tubes should be tested and if no tube tester capable of checking screen grid tubes is available, these tubes should be replaced one by one with tubes that are known to be good.

Check Voltages

Set voltages may be checked with a set analyzer outfit or, by inverting the

units and removing the base plate from the r.f. unit, with voltmeter and test leads. The units are removed from the cabinet by removing the connections from the rear terminal panels, clearing the a.c. cord, removing the knobs and taking out the cabinet mounting screws in the corners of the bases.

Peppy Tubes Used

According to the service instructions the model 26 receivers are tested with particularly peppy screen grid tubes to prevent them from reaching the user in an unstable condition. Due to the care in testing few sets should be encountered that tend to oscillate. If the set oscillates over the entire dial range it is pos-

sible that the detector output filter is defective and a new one may be tried. Excessively high screen voltages may cause oscillation. The intermediate B voltage in the r.f. unit is dropped by means of a graphite resistor before feeding to the screen voltage section of the volume control. Check the resistor for shorts or breakdown.

Caution

The r.f. tubes have individual biasing resistors and by replacing one or more of these resistors with resistors of higher resistance value the oscillation may be stopped. Under no condition should the detector biasing resistor be changed in value.

Kennedy Model 26

Tube Type	Position in Set	A Volts	B Volts	C Volts	Cathode Volts	Screen Volts	Normal Plate M. A.	Plate M. A. Grid Test	Change
224	1 R.F.	2.3	160	3.5		85			
224	2 R.F.	2.3	160	3.5		85			
224	3 R.F.	2.3	160	3.5		85			
227	Det.	2.3	125	10					
227	1 A.F.	2.3	155	9					
215	P.P.	2.3	230	45					
215	P.P.	2.3	230	45					
280	Rect.	4.8							

Line voltage 120. Volume control maximum.

Fig. 1. The operating values of the tubes in the Model 26 Kennedy are shown in this table as abstracted from the service manual for that receiver

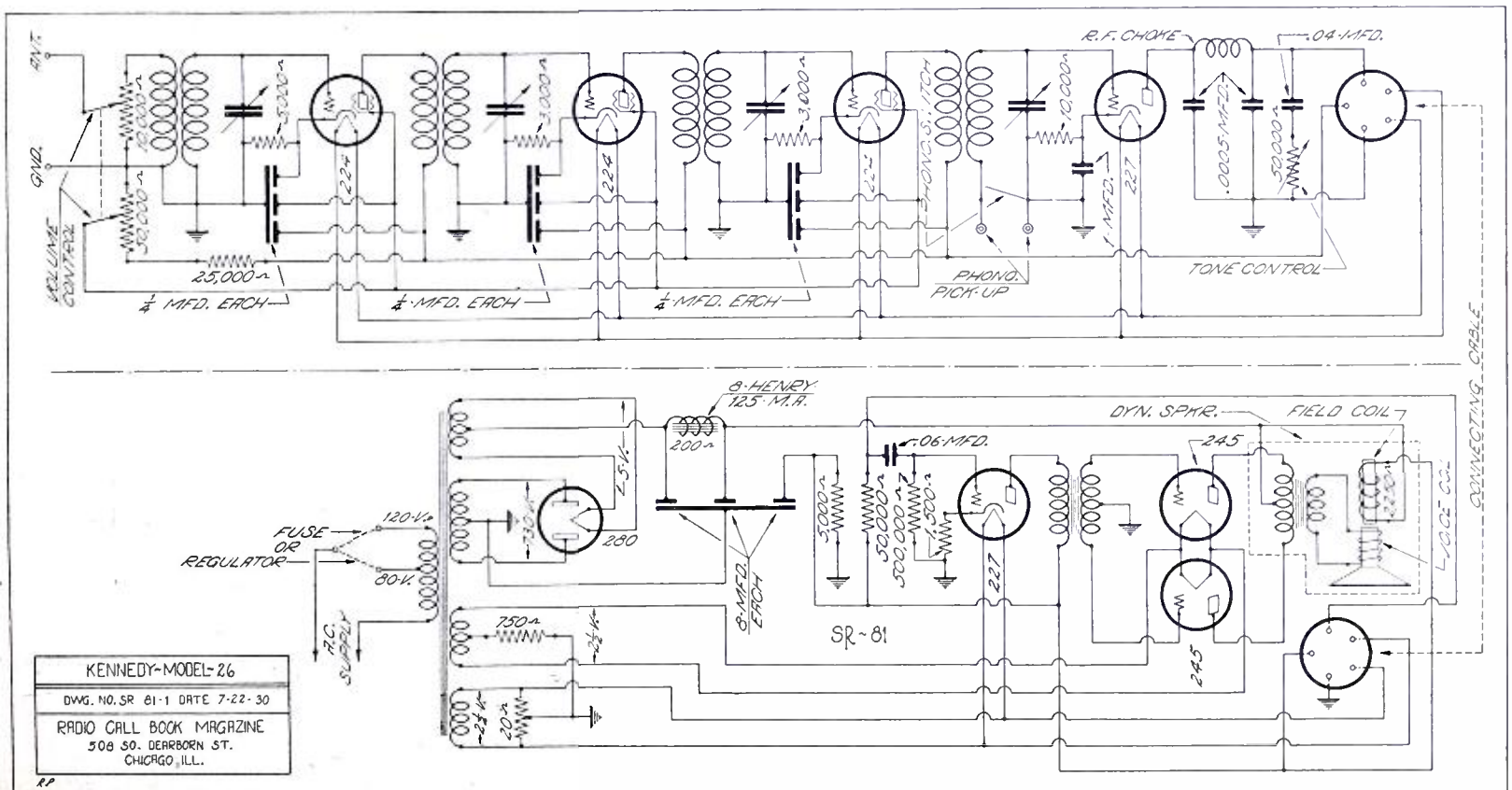

Fig. 2. Details of the receiver and power supply for the Kennedy 26 may be traced from this drawing

King Model J Set and Power Supply

FOUR 226 tubes, one 227, two 171-A's in push pull and a 280 rectifier comprise the tubes used in the King Model "J" and power supply, made by the King Manufacturing Corporation of Buffalo, New York.

According to the instructions provided by King for service men, each of the rotors in the gang condenser is adjusted on the gang at the factory. Under no circumstances should an attempt be made to re-set these rotors. Minimum adjusters are provided to make up for any minor difference in capacity due to wiring. The minimum adjusters are located on the front of the condenser gang and should be adjusted with a strip of flat bakelite slotted on the end to take the hexagonal head of the screw. When connected to an oscillator and output meter a peak should be obtained on each condenser with settings of 280 meters, 400 meters and 480 meters, by turning minimum adjustment screw. Of course, the peak will be much sharper on the lower setting. Failure to obtain a peak may either mean condenser rotors out of gang or coil butterflies out of adjustment.

The neutralizing condensers are located at the rear of the condenser bearing. If it is found necessary to reneutralize this set this may be accomplished in the regular way by using a tube with one filament prong cut off. In case the

rotors are in need of reganging or the plates are out of line, the entire gang should be sent to the factory for adjustment. Another gang may be installed.

The inductance of the r. f. coil is adjusted at the factory by means of the brass inductance adjuster or butterfly, in the end of the coil. These are set on an oscillograph so that every coil has exactly the same value of inductance. The butterfly is locked in the exact position with an especially strong cement. In case this cement is loosened, return the coil and shield assemblies to the factory for adjustment. Another assembly may be installed temporarily.

In connection with neutralizing of the set there are some troubles peculiar to the a. c. tubes. If the set is neutralized at a voltage of 100 and the set is then moved to a locality where the voltage is as high as 120 the set may be thrown into oscillation. This would show up as a loud hum which would blanket all reception. Therefore, be sure when neutralizing the set that the voltage tap on the power transformer is set at the correct line voltage being used. For neutralizing the tap switch should be set one point ahead of the actual line voltage. For instance, if the line shows 110 volt neutralization should be done with a tap switch set on 100 volts.

Voltages for the filament, plate and grid should read within limits as noted

below. Any deviation from this may mean that the transformer is wrong or that the drain of the set is wrong.

With a line voltage of 115 to 120 volt, 120 tap on pack, the 226 filament should read from 1.3 to 1.5; the 227 should read from 2.3 to 2.5, the 171 filament should read 4.8 to 5.2 and the 280 filament reads from 4.9 to 5.3.

Plate voltage on the r. f. stages should be between 115 and 135, while the plate voltage on the detector runs between 30 to 45 volt. Plate voltage on the first audio frequency will measure from 125 to 150. Plate voltages on the 171, measured plate to filament will be 160 to 185, while measured from plate to ground will be 185-210. R. f. grid bias should be from 6 to 7.5 and the 171 grid bias 30 to 40 volts.

The factory has noted in a number of cases where after the set has been in operation for a few hours trouble developed showing up as a distinct loss of volume. This apparently is due to a change in capacity of the detector circuit minimum adjusters due probably to a change in the tension of the spring brass used in this adjuster. As the tuning of this one circuit is especially sharp a small change of capacity affects the operation materially. All that it is necessary to do to correct this is to re-adjust this one minimum adjuster with a small open end wrench.

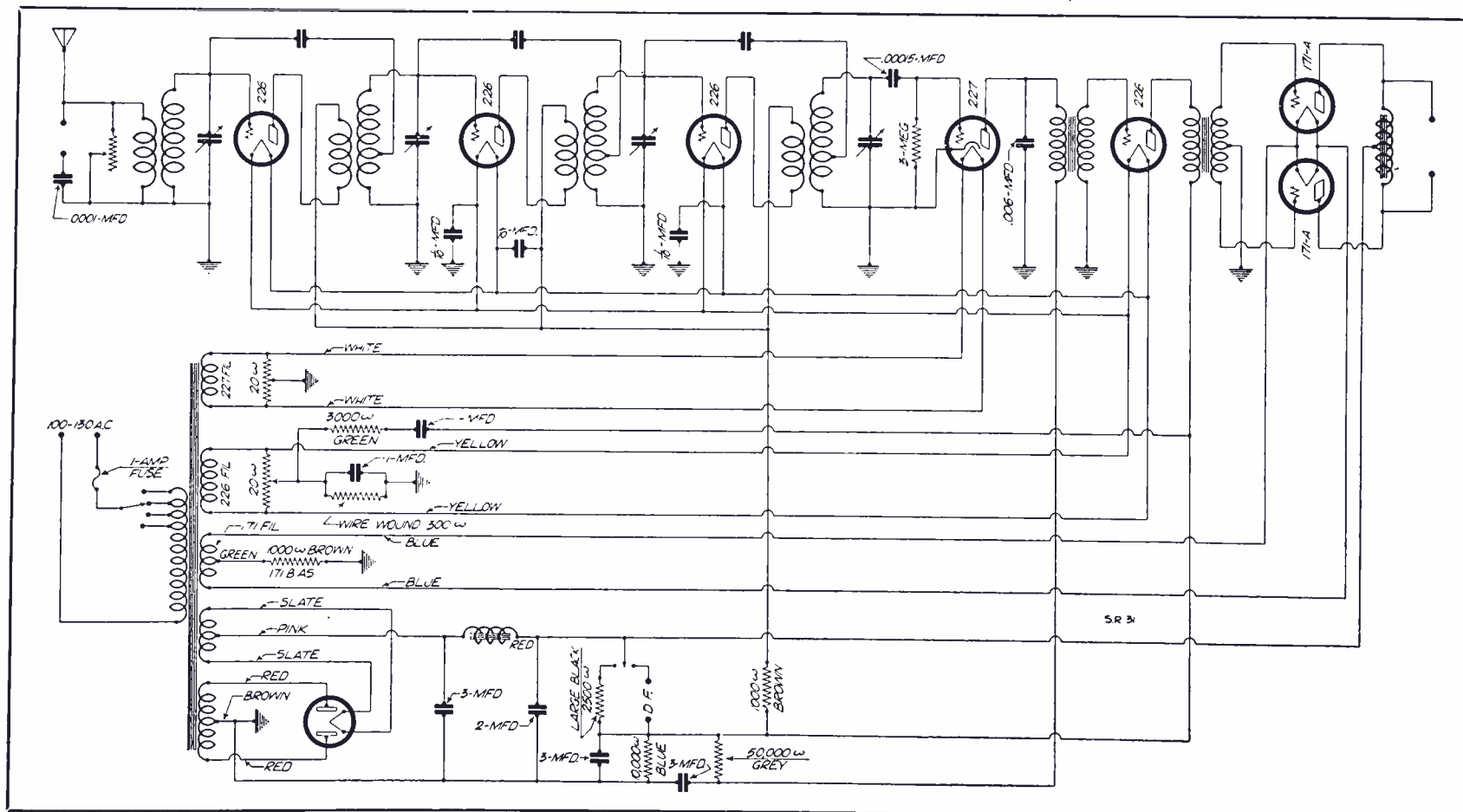

Fig. 7. The general layout of the circuit used in the King Model "J" receiver and power supply is set forth in the above schematic diagram

Kolster 4 Tube Chassis and Supply

SEVERAL models of radio receivers are made by the Kolster Radio Corp. of Newark, N. J. In this article we are giving the schematic circuit of the four tube chassis and its power pack. The Kolster six tube model consists of three stages of tuned radio frequency amplification, detector and two stages of transformer coupled audio frequency amplification, supplied with voltages suitably transformed and rectified through equipment designed and developed by Kolster engineers to operate on a. c. voltage supply.

Set and Supply Separate

Fig. 1 shows schematically the four tube chassis, while Fig. 2 shows the power pack, in which are located the first and second audio stages in addition to the rectifier and the high voltage supply.

Volume control is by a variable resistance across the primary of the last r. f. transformer, enabling the operator to vary the gain of that particular stage. In consequence, the volume may be increased or decreased, as desired.

Antenna input is controlled by means of a switch, while there is also provided a combined variometer-variocoupler

which tunes the first r. f. stage independently of the main control. This allows compensation of this stage so as to be in line with succeeding stages.

This also allows the set to be installed with any antenna or moved without affecting the position of logging on the selector scale. The r. f. coils are solenoidal in type and are wound on composition tubing. They have a very low radio frequency resistance. The

The audio transformers were especially designed by Kolster engineers to match the average tube in impedance. They were designed for compactness, minimum climatic reaction and ease in servicing. They are sealed in a grounded metal housing. The transformers have a comparatively flat characteristic curve, resulting in a relatively even amplification of all sound frequencies.

At the right of the diagram shown in Fig. 2, are two small schematics of the filter condensers used with the power supply, one being for the 25 cycle job and the other for the 60 cycle.

Three 226 tubes are used in the r. f. stages, while the detector is a 227 heater type. The first audio is also a 226 and the

last stage tube is a 171-A. The rectifier tube is a 280 and is located in the power supply and amplifier unit.

Filament voltages are a. c. and cannot be varied from the controls of the set. The power pack is so designed to supply voltages specified by the tube manufacturers under normal a. c. line conditions. There is a voltage regulator switch incorporated in the power pack.

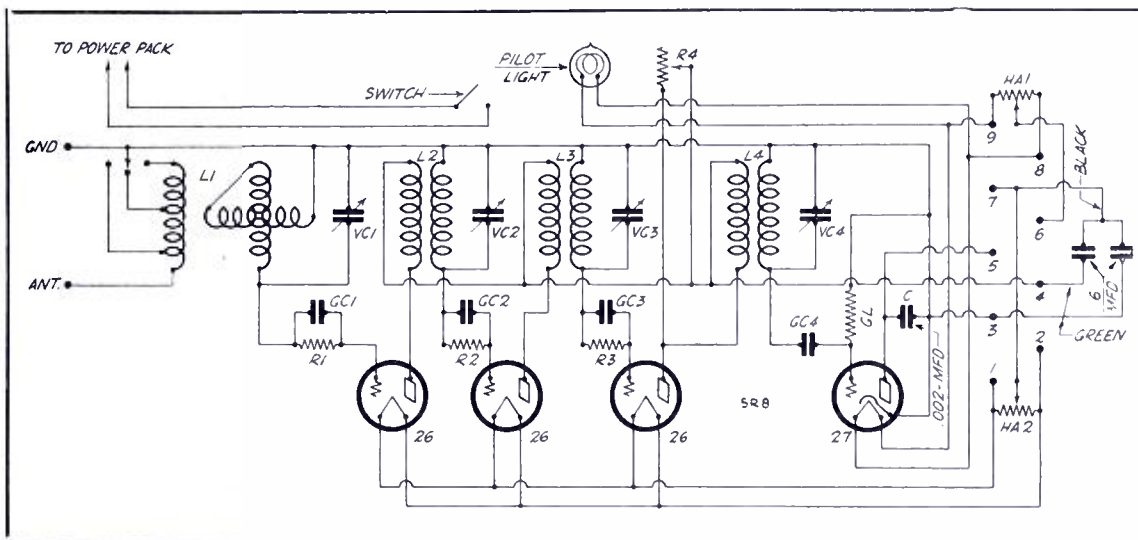

Fig. 1: Schematically is shown above the Kolster 4 tube chassis. The audio is included in the power pack

coils are so placed and shielded that a minimum amount of interstage coupling results.

R. F. Grids Stabilized

Grid resistances are placed in each r. f. grid circuit to prevent oscillation. Signal rectification is accomplished by grid condenser and grid leak method with the grid leak running from grid to ground.

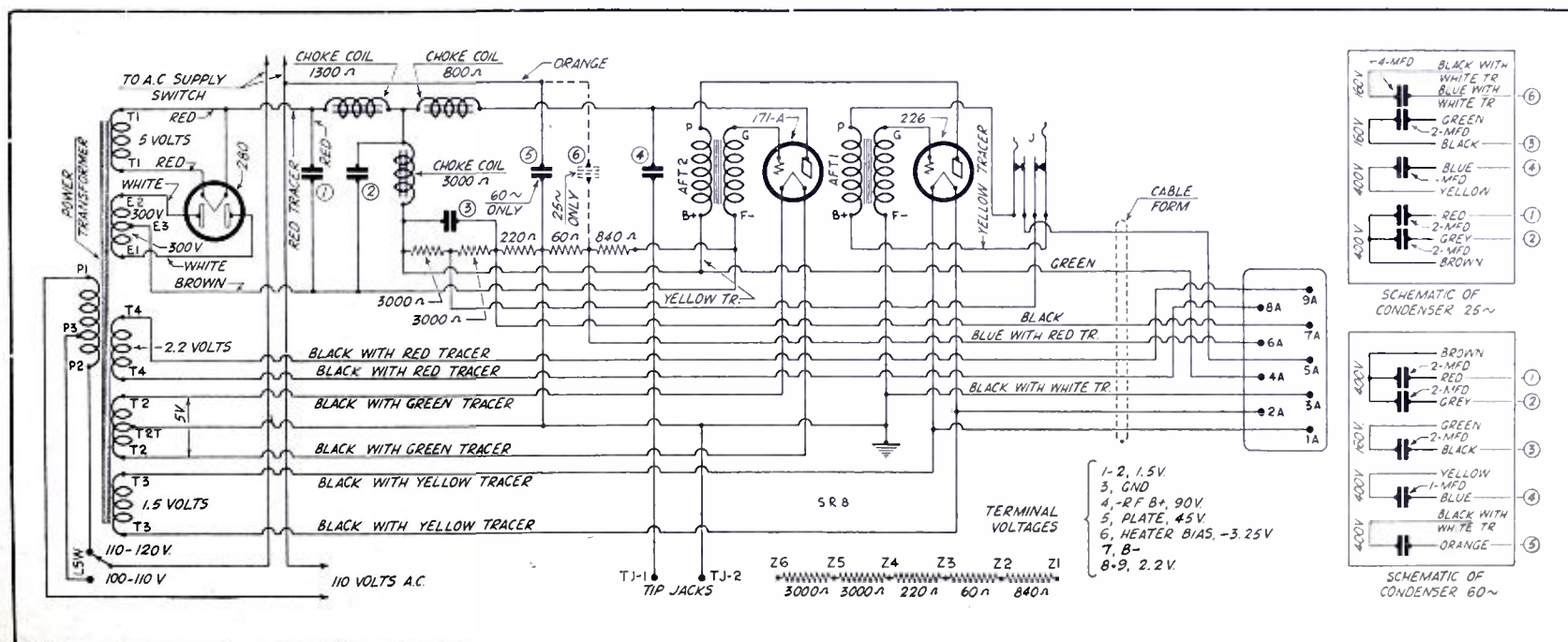

Fig. 2. Aside from the high voltage supplied, the Kolster power pack also contains the two audio stages

Kolster Receiver Nos. K21, 23, 24, 28

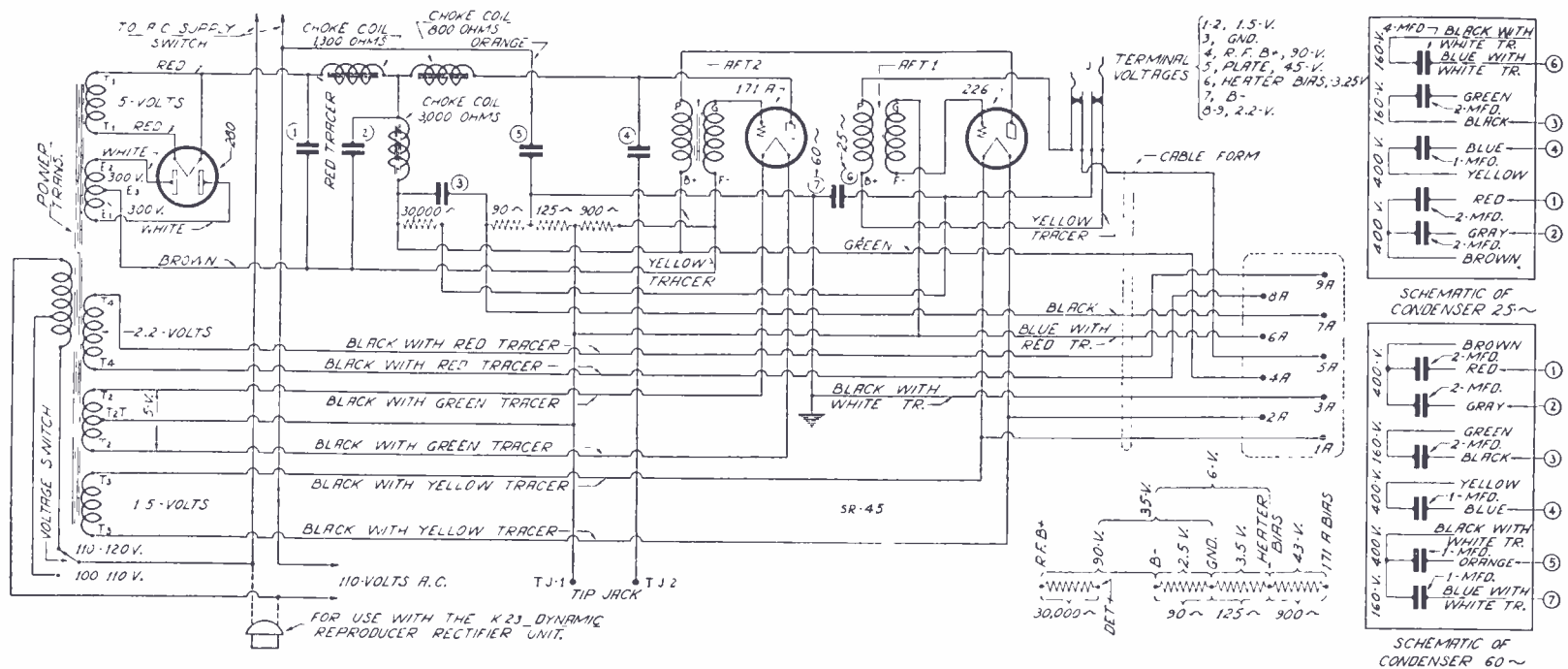

Fig. 1. The power supply used with the Kolster models is shown in this schematic illustration

IN general appearance the Kolster five tube chassis differs very little from the four tube chassis, illustrated schematically on page 81 of the September, 1929, issue of this magazine. With the exception of the longer tube panel, extra tube socket, extra twin .6 mfd bypass condenser and the lack of an antenna switch, the outward appearance is exactly the same.

Volume Control Method

Volume control is by a variable resistance shunted across the antenna inductance directly in the first r. f. grid circuit. (However the schematic shown in the Kolster manual in our laboratory shows the volume control across the primary of the last 226 r. f. stage, and it is thus shown in the diagram Fig. 3 on this page. It is quite likely that changes have been made in later production so that the volume control now appears across the first r. f. grid circuit.)

Alternating current is properly filtered, but to be sure of a minimum of a. c. ripple in the circuits, two hum adjusters are incorporated. One is in the radio frequency filament circuit and bypassed with two .6 mfd condensers

from the ground and plate circuits. The other is in the 227 detector heater circuit and in this position when the tube

els are the same as those in the supply for the 4 tube chassis described in our September issue, except for the method

Kolster Models K 21, 23, 24

Tube Type	Position in Set	A Volts	B Volts	C Volts	Cathode Volts	Screen Volts	Plate Volts	Normal M. A.	Plate M. A.	Grid Test	Change
226	1 R.F.	1.4	84	2.5			5.8	9.8	4.0		
226	2 R.F.	1.4	84	2.5			5.8	9.8	4.0		
226	3 R.F.	1.4	84	2.5			5.8	9.8	4.0		
226	4 R.F.	1.4	84	2.5			5.8	9.8	4.0		
227	Det.	2.0	36	3.5			1.6	1.6	0.		
226	1 A.F.	1.4	72	2.0			4.8	7.8	3.		
210	2 A.F.	7.4	430	32.5			24	28	4.		
281	Rect.	7.0					28				
281	Rect.	7.0					28				

Line voltage 116.

Fig. 2. An idea of the typical tube voltages may be gained from examining this tube chart based on Jewell measurements

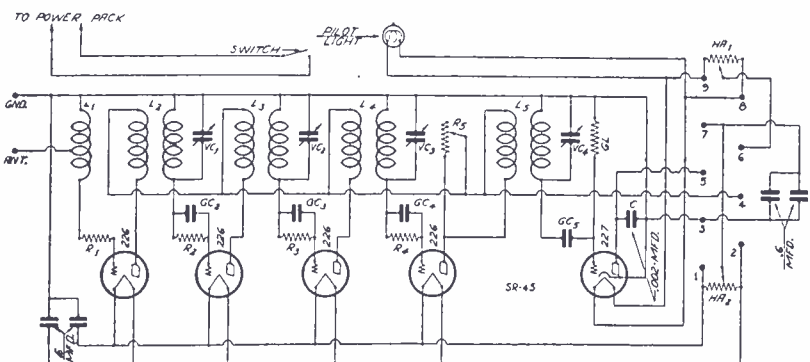

Fig. 3. This illustration at the left is the schematic diagram of the receiver portion of the Kolster models K21, 23, 24 and 28

is properly biased, reduces the possibility of a. c. ripple in this stage.

The audio frequency transformers used in the supply for the K21-23 mod-

of connecting the transformer terminal leads.

The K 21 power pack cannot be incorporated in the K23 receiver combination because of a slight difference in the wiring of the a. c. supply lines in the power pack assembly. The K23 power pack has a female receptacle which the K21 lacks. The a. c. supply cable male connector of the rectifier plugs into this receptacle.

The condenser bank and chokes of the filtering system are mounted in a housing and by simply removing this shield, individual inspection or removal can easily be performed.

Kolster Radio Receiver Model K43

ON this page will be found the schematic diagram of the Kolster K-43, the r.f. chassis and the power supply. A table of average tube values will be found in the chart, Figure 1.

The K-43 uses three 224 and one 227 tubes in four tuned r.f. stages, followed by a first stage 227 working into a pair of 245 tubes push-pulled. The power supply uses a full wave 280 rectifier.

Antenna Input

Antenna input is through a 25,000-ohm variable resistor across the antenna winding with a .0001 mfd fixed condenser. The plate circuit of the first 224 r.f. tube has a 10,000-ohm fixed resistor in series with the primary and a 50-mmf condenser across this resistor. The detector circuit uses the conventional grid leak and condenser detection, while its plate circuit is choked and bypassed. A pair of phono jacks are provided across the primary of the first audio transformer so that a pick-up may be used when desired.

Volume control on the receiver is by means of a 10,000-ohm variable resistance between ground and the plus 45-volt terminal of the power supply, this

resistor feeding the three screens of the 224 tubes. For hum control there is provided a 6-ohm variable resistor across the filament circuit of the first audio 227, the arm of the resistor being common with ground. A fixed resistor of 250,000 ohms is placed in series with the secondary of the first audio transformer, while a 3,000-ohm resistor in the cathode-ground circuit of that stage

provides the bias for the 227 grid. A 108-volt field with 1,800 ohms is used for the dynamic and is included in the filter circuit.

At the bottom, right, of the schematic in Figure 2, may be seen the detail drawings of the condenser block and its numbered connections; also the detail of the cable connector and its numbered terminals.

Kolster Model K43

Tube Type	Position in Set	A Volts	B Volts	C Volts	Cathode Volts	Screen Volts	Normal Plate M. A.	Plate Grid Test	Change
224	1 R.F.	2.2	125	1.5	---	45	1.3	3.5	2.2
224	2 R.F.	2.2	125	1.5	---	45	1.3	3.5	2.2
224	3 R.F.	2.2	125	1.5	---	45	1.3	3.5	2.2
227	Det.	2.2	25	---	---	---	1.5	---	---
227	1 A.F.	2.2	105	6	---	---	4.0	5.5	1.5
245	P.P.	2.3	191	39	---	---	23	27	4.0
245	P.P.	2.3	191	39	---	---	23	27	4.0
280	Rect.	4.8	---	---	---	---	---	---	---

Line voltage 112. Volume Control Maximum.

Fig. 1. The table of typical tube characteristics for the Kolster K-43 is shown here as taken with a Weston test set

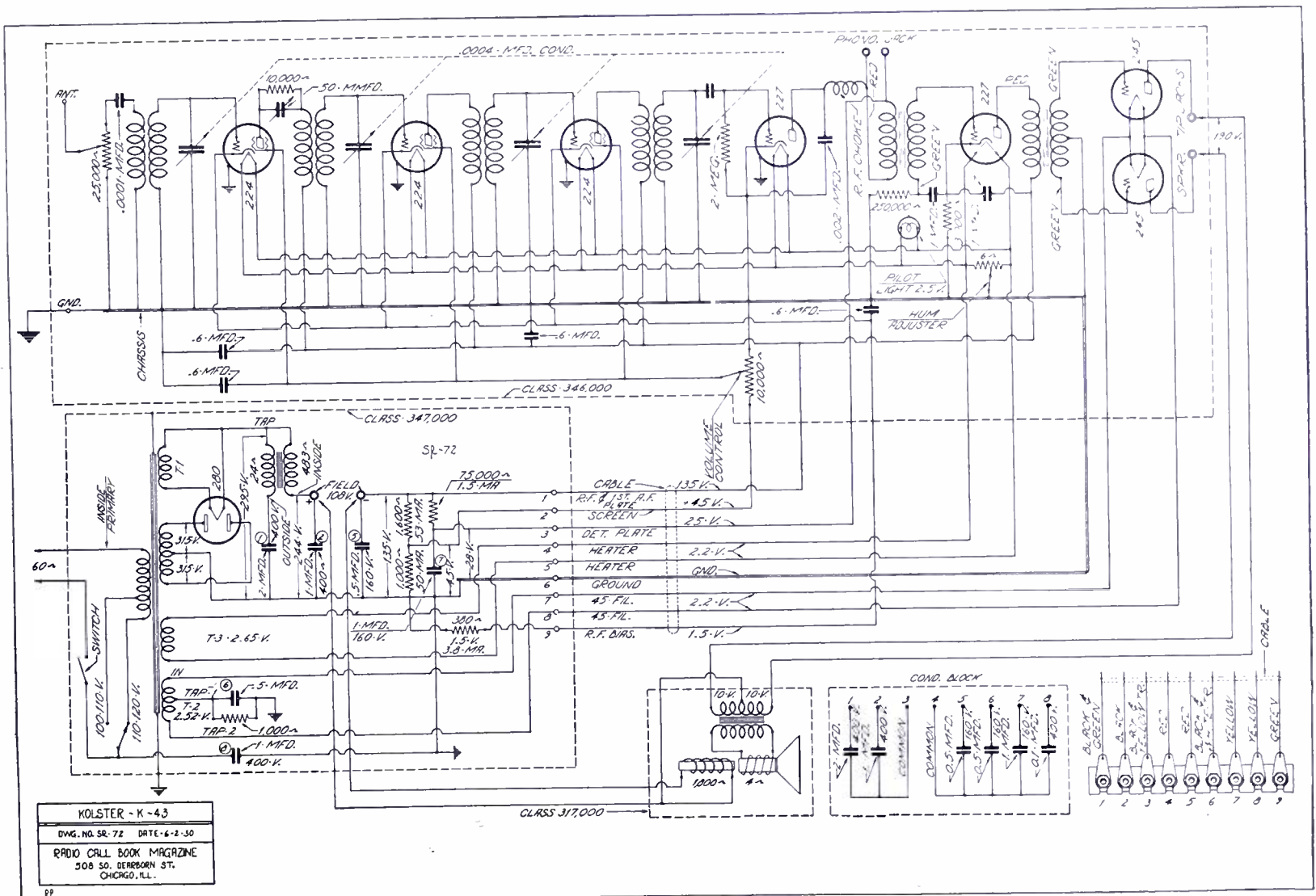

Fig. 2. Receiver and the power supply of the Kolster K-43 are shown in this schematic drawing

Service Data on the New

REPRESENTING as it does a departure from the circuits employed in previous receivers of that name, the Majestic chassis model 50 (used in model 52 receivers), photographed on this page, is a superheterodyne using 175 kc. intermediate frequency amplification. The diagram in Figure 4 gives all the electrical connections of the receiver and its power supply; Figure 1 shows the rear of the chassis, indicating position of the i.f. aligning condensers, and the aligning condenser for the oscillator tracking; Figure 2 is a bottom view of the chassis, showing position of the antenna alignment condenser, and the oscillator alignment screw. The table of average operating tube voltages is shown in Figure 3.

Perhaps the most important data on servicing this receiver is the information covering the alignment procedure. The model 50 chassis being a superheterodyne, employs a somewhat different procedure of alignment from previous Majestic models.

Oscillator alignment condenser is accessible from the bottom side of the chassis, and is located next to the end of the gang condenser on which the cable drive is mounted. See Fig. 2.

Second antenna alignment is accessible from the bottom side of the chassis and is located through the center hole of the chassis bottom. See Fig. 2.

First antenna alignment (compensating) condenser is accessible from the back side of the chassis, slightly upward and to the right of the antenna and ground binding posts. See Figure 1.

The oscillator tracking condenser is accessible from rear side of the chassis through a hole in the r.f. base assembly just to the right of the power transformer. See Fig. 1. The i.f. alignment

positions are also indicated in this photograph.

Alignment Procedure

Tune in at approximately 1280 kc. and align oscillator and antenna circuits.

kc. Slip the dial strip to the correct setting with respect to the index of the dial escutcheon.

Carefully test receiver for sensitivity and selectivity, and if necessary the entire operation outlined previously should be repeated until satisfactory results are obtained. In some cases maximum output may appear to fall at either maximum or minimum capacity of the oscillator tracking condenser. A simple check to determine if this is actually the maximum output is as follows: after obtaining the best setting

of the tracking condenser, try a slight readjustment of the second antenna alignment condenser. If this readjustment results in only a slight improvement, the oscillator tracking condenser is satisfactorily adjusted.

I. F. Alignment

For intermediate frequency alignment, connect the output of the i.f. oscillator to the grid of the first detector. Tune oscillator at 175 kc. and align the first detector plate circuit, intermediate frequency grid circuit, intermediate frequency plate circuit and the second detector grid circuit to this frequency. This alignment should be done with great caution, inasmuch as it materially affects the entire selectivity of the receiver.

If the intermediate frequency circuits are so far out of alignment that no signal can be heard, it may be necessary to put the oscillator output on the grid of the i.f. tube and roughly align the second half of the i.f. stage first, and then proceed as above indicated. The four aligning condensers are located on the rear of the chassis about midway down on the right side (see Fig. 1). From left to right, facing the rear of the chassis, these positions are: first detector plate; i.f. grid; i.f. plate; second detector grid.

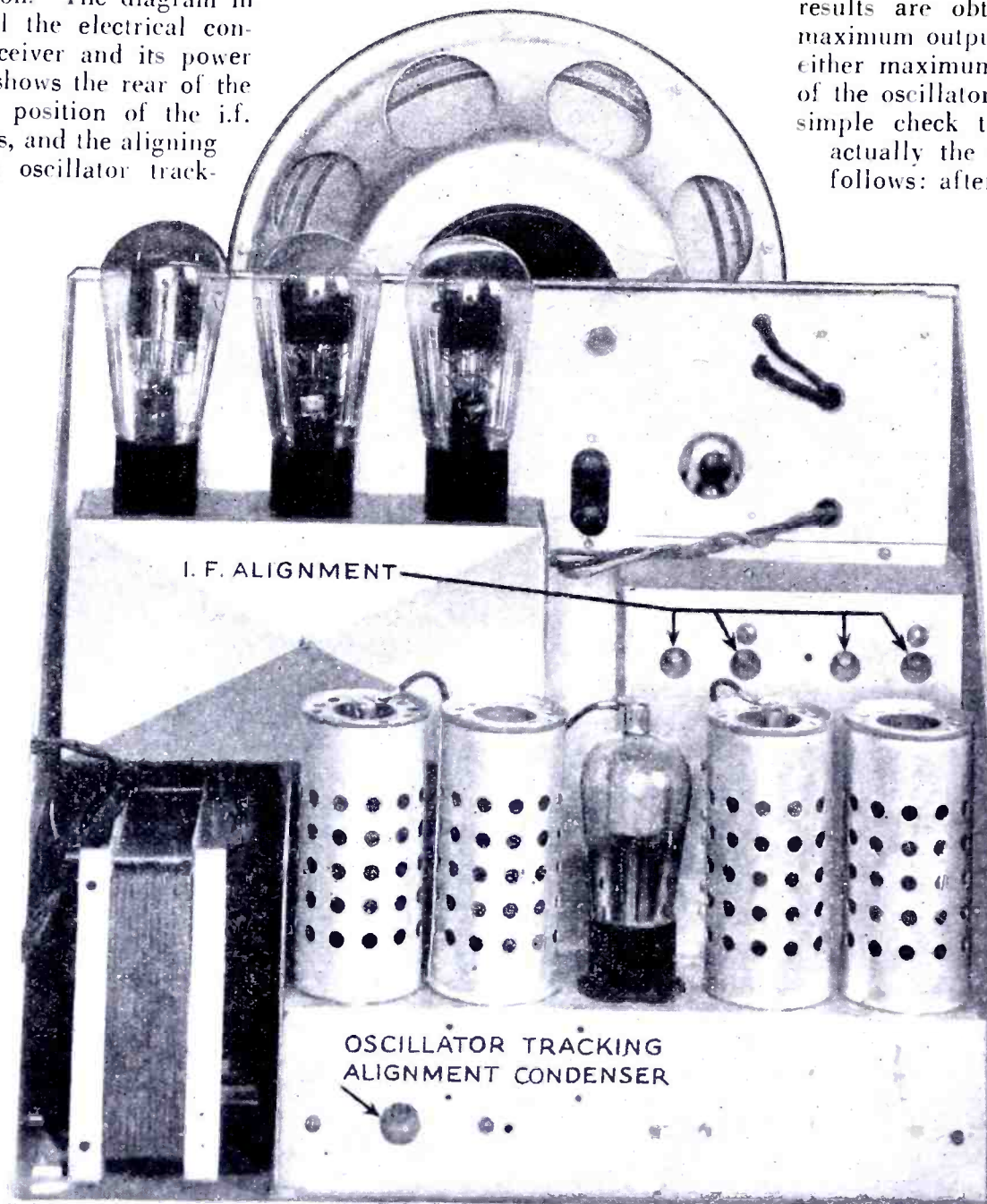

Fig. 1. This photograph of the new Majestic 50 chassis shows the position of the antenna compensating condenser, the four i.f. alignment positions and the oscillator tracking alignment condenser

Tune in at approximately 600 kc. and adjust the oscillator tracking condenser on chassis while rotating the tuning knob slightly back and forth until the maximum signal strength is noted on the output meter.

Next set main tuning dial to exactly 1500 kc. and tune in 1500 kc. signal with oscillator alignment condenser.

Retune antenna alignment condenser.

The dial setting should be checked by tuning in a broadcast station with a known frequency higher than 1000

Majestic Model 50 Chassis

A small compensating condenser is provided to adjust the reflected capacity of the antenna. Adjustment of this condenser is possible through the hole in the rear of the chassis (to the right and above the antenna-ground binding posts in Figure 1). When the installation of the receiver is complete, a station between 1000 and 1400 kc. should be tuned in; volume control set for low volume, and the antenna compensator adjusted until maximum volume is secured. Further adjustment of this condenser is not necessary unless the length or position of the antenna is changed.

The volume control consists of two

Fig. 2. Here are shown the antenna alignment (second) position, and the position of the oscillator alignment screw, both of which are mentioned in the text covering the alignment procedure

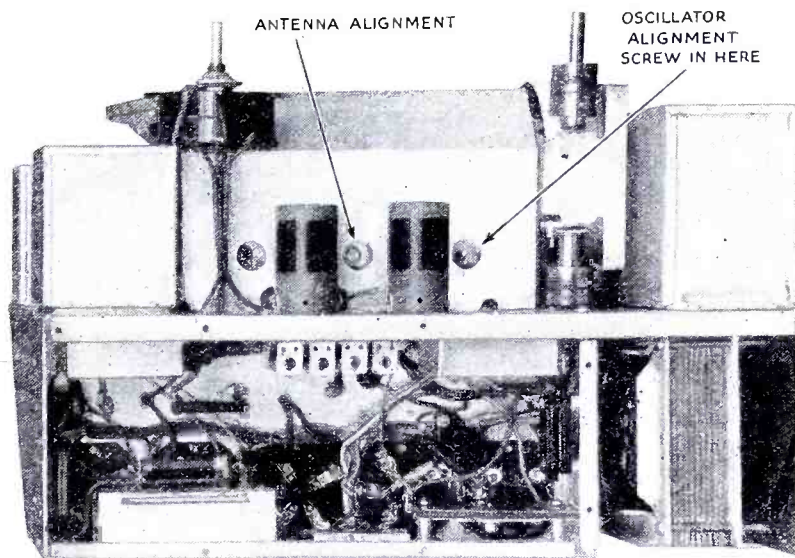

Majestic Model 50 Chassis

Tube Type	Position in Set	A Volts	B Volts	C Volts	Cathode Volts	Screen Volts	Normal Plate M. A.	Plate Grid Test	Change
224	1 R.F.	2.35	180	3	3	90	3.	---	---
227	Osc.	2.35	90	---	---	---	3.	---	---
224	1 Det.	2.35	180	8	8	90	.8	---	---
224	1 I.F.	2.35	256	3	3	90	4	---	---
227	2 Det.	2.35	225	20	20	---	.5	---	---
245	P.P.	2.35	250	1.75*	---	---	25	---	---
245	P.P.	2.35	250	1.75*	---	---	25	---	---
280	Rect.	4.8	358	---	---	---	40	---	---

Line voltage 115. Volume control maximum.

*On analyzer 245 grids may read 1.75 volts. If so, to get true reading measure with voltmeter from filaments to ground. This should be 37.5 volts.

Fig. 3. The tube operating voltages on the model 50 chassis of the Majestic are given in this table as abstracted from the service manual

elements, a 645-ohm potentiometer and a 10,000-ohm rheostat; the latter connected from antenna to ground and varying the signal input from antenna;

the former controlling the bias voltage for the r.f. and first detector tubes. Both controls are operated simultaneously by the same shaft.

According to the Majestic manual on this receiver, under no conditions should an attempt be made to use a ground connection on the antenna binding post. Be certain that the antenna and ground wires are connected to their respective binding posts and that they have been passed through hole in the back of the cabinet as indicated by label.

In territories where the a.c. line voltage is excessive, it is desirable that a voltage control be used. This may be secured from the Majestic distributor and should be used in every case where the line voltage exceeds 118 volts. This voltage regulator has three outlets marked 110, 120 and 130. The receiver plug should be inserted in the proper outlet, as determined by the service man's investigation of the line voltage. If the voltage regulator is not used where line voltage is excessive, rated normal tube life will be reduced.

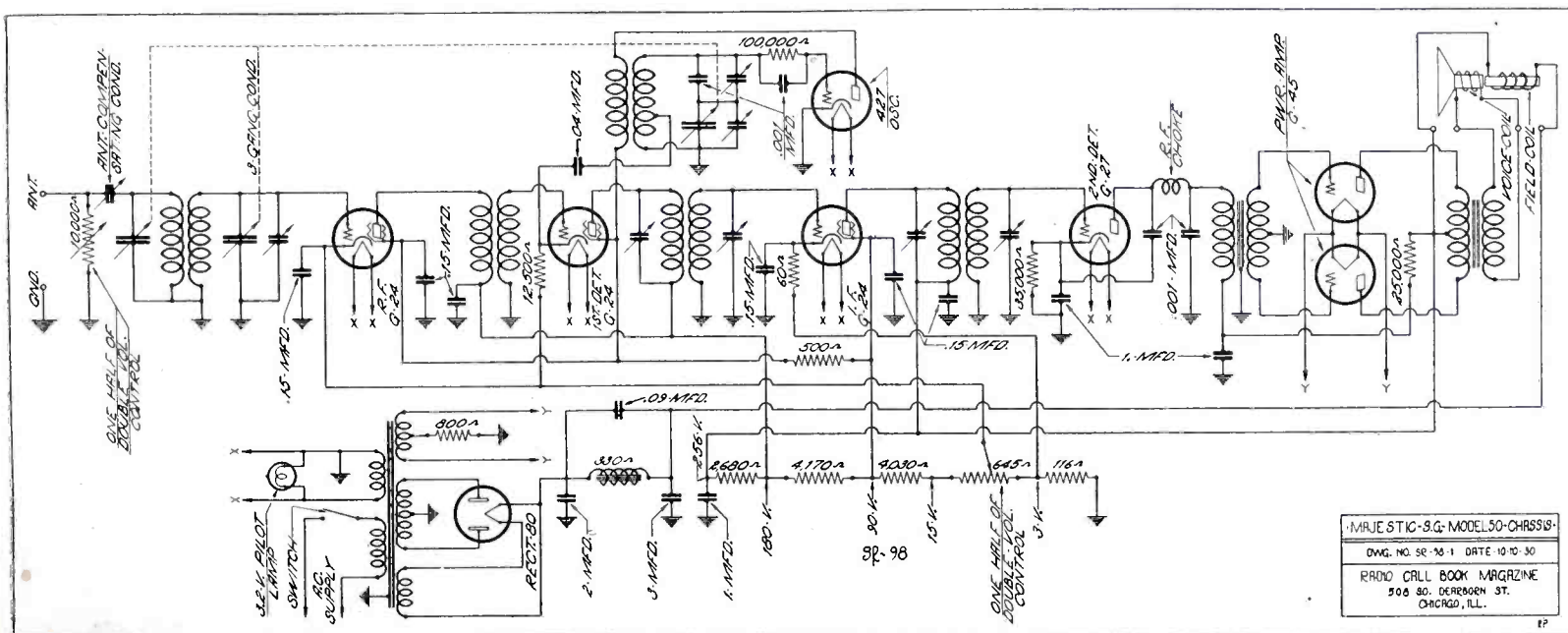

Fig. 4. The electrical details of the circuit employed in the Majestic model 50 chassis are given in this drawing



The Majestic Receiver, Model No. 70

MANUFACTURED by the Grigsby-Grunow Co. of Chicago, the Majestic Model No. 70 receiver and 7P6-7P3 power pack is shown schematically on this page.

The circuit is known as the LMC circuit and is of the balanced type for use with raw a. c. tubes. Seven tubes are employed in the receiver, of which four are 226's, one is a 227. Two 171-A tubes are utilized in the push-pull power stage. The power supply uses a 280 rectifier. Input and volume control is a combination shown in the schematic diagram, Fig. 2, employing a 10,000 ohm variable resistor, which makes possible a smooth control. Instantaneous control of volume is also possible. Along with the input system is the antenna trimmer, which operates to vary the inductance of the antenna input coil and permits adjusting the input circuit to exact resonance with the other three tuned circuits.

A resistance ballast connected in series with the primaries of the transformers across the line provides a practically uniform voltage across the transformers with variations in line voltage of from 90 to 130 volts. This resistance

ballast is incorporated in the power unit shown in Fig. 1.

Grid biasing is accomplished in the Majestic by grounding the grid of the

and the three radio stages is the same as the power tube except that the values of current and resistance are different in each case.

The Majestic receiver comprises five unit assemblies which are: The chassis, the tuning condenser, the radio frequency transformers, the terminal strip and the wiring cable.

In all there are six power units used on Majestic receivers. These power units can be identified by the following symbols: 6P3, 6P6, 7P3, 7P6, 8P3 and 8P6. This coding of the power units is very simple, as the first numeral indicates the type of receiver on which the unit is to be used, where it is 6P, 7P, 8P series receiver; and the second numeral indicates the frequency on which the power unit is intended to be used. Six is to indicate a 60 cycle unit, three is to indicate a 30 cycle.

The Majestic power speaker, which is of the electro-dynamic type, is of the best type suited to handle large volume and at the same time give good quality of reproduction. The resistance of the speaker field coil is 3100 ohms. No adjustments of any kind are required in this speaker.

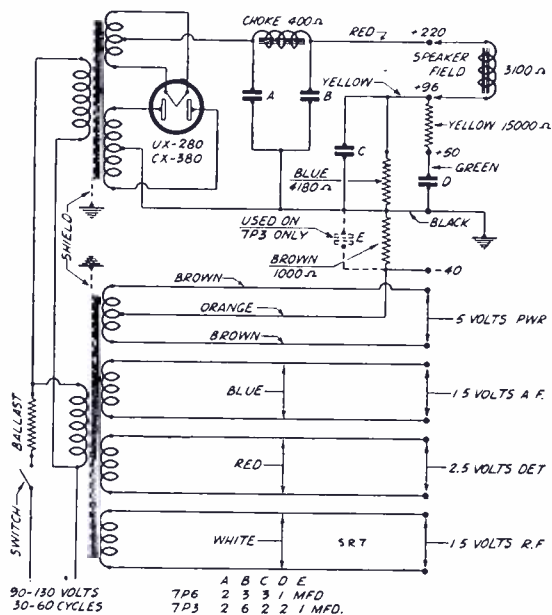

Fig. 1. The schematic circuit above shows the electrical connections in the Majestic 7P6-7P3 power pack

amplifiers and applying a positive potential to the filament. The function of the bias resistors in the first audio stage,

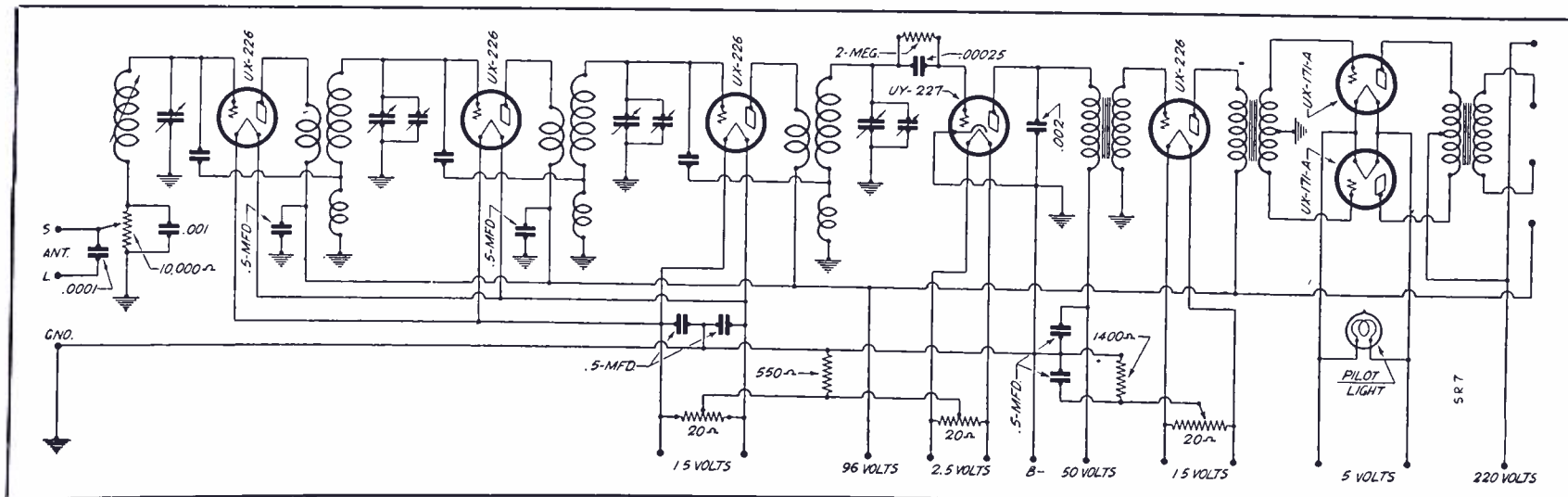

Fig. 2. This diagram is the schematic involved in the Majestic Model No. 70 receiver described on this page

The Majestic Model 90-B Receiver

SCHEMATICALLY on this page is shown the diagram of the Majestic model 90-B, the response curves on which were run on page 84 of the March, 1930, issue of this magazine. The diagram is illustrated in Figure 1 and a table of tube voltages is shown in Figure 2.

Uses 227 Tubes

The receiver itself comprises five 277 tubes, a pair of 245 power tubes and the 280 rectifier. Four of the 227's are in the radio frequency stages and the fifth in the detector circuit. In this latter tube the bias for plate rectification is secured by the drop across the 35,000-ohm resistor placed between cathode and ground and by-passed with a 1 mfd condenser. Bias for the grid of the fourth r. f. stage is secured through the drop across the 1,800-ohm resistor between ground and cathode of that 227 tube.

Volume Control

In the case of the first, second and third 227's used, a 75,000-ohm variable resistance used as a volume control, and the 2,500-ohm equalizer serve to give the bias for these three r.f. stages. Bias for the pair of 245's in push-pull is secured across the 800-ohm resistor between the center tap of the 2.5-volt filament secondary and ground.

The detector plate voltage is secured from the 306-volt maximum through a 50,000-ohm fixed resistor, while the r.f. plates are given 144 volts through one

end of the speaker field winding.

Local-Distance Switch

The receiver is equipped with a local-distance switch. When the switch is closed distance reception is secured. For local work the switch is left open.

Antenna Compensator

In the antenna input stage the trimmer, or compensator is a metal shield on a shaft, altering the position of the shield with respect to the secondary of that circuit, thus increasing or decreasing the inductance of the circuit to maintain the input stage in resonance with the remainder of the tuned circuits at all times.

25 and 60 Cycle

Twenty five-forty cycle and fifty-sixty cycle models of this receiver are marketed, the filter capacities A and B shown at the bottom of the schematic diagram being different for the two frequencies, their values being indicated on the diagram.

Response Curves

Those interested in response curves on the Model 90-B will find them on page 84 of the March, 1930, issue of this magazine.

Sensitivity, selectivity and fidelity curves on the latest model, the 130-A, will be found on page 66 of this number.

Majestic Model 90-B

Tube Type	Position in Set	A Volts	B Volts	C Volts	Cathode Volts	Screen Volts	Normal Plate M. A.	Plate M. A. Grid Test	Change
227	1 R.F.	2.3	150	14	19		3.4	6	2.6
227	2 R.F.	2.3	150	13	17		3.5	6	2.5
227	3 R.F.	2.3	150	13	18		3.6	6	2.4
227	4 R.F.	2.3	158	12	12		6.6	8	1.4
227	Det.	2.3	290	29	28		.8	1	.2
245	P.P.	2.4	285	50			35	40	5
245	P.P.	2.4	285	50			35	40	5
280	Rect.	4.8					60		

Line voltage 114. Volume control maximum.

Figure 2. A table of typical tube voltages as taken with a Weston set tester is seen above

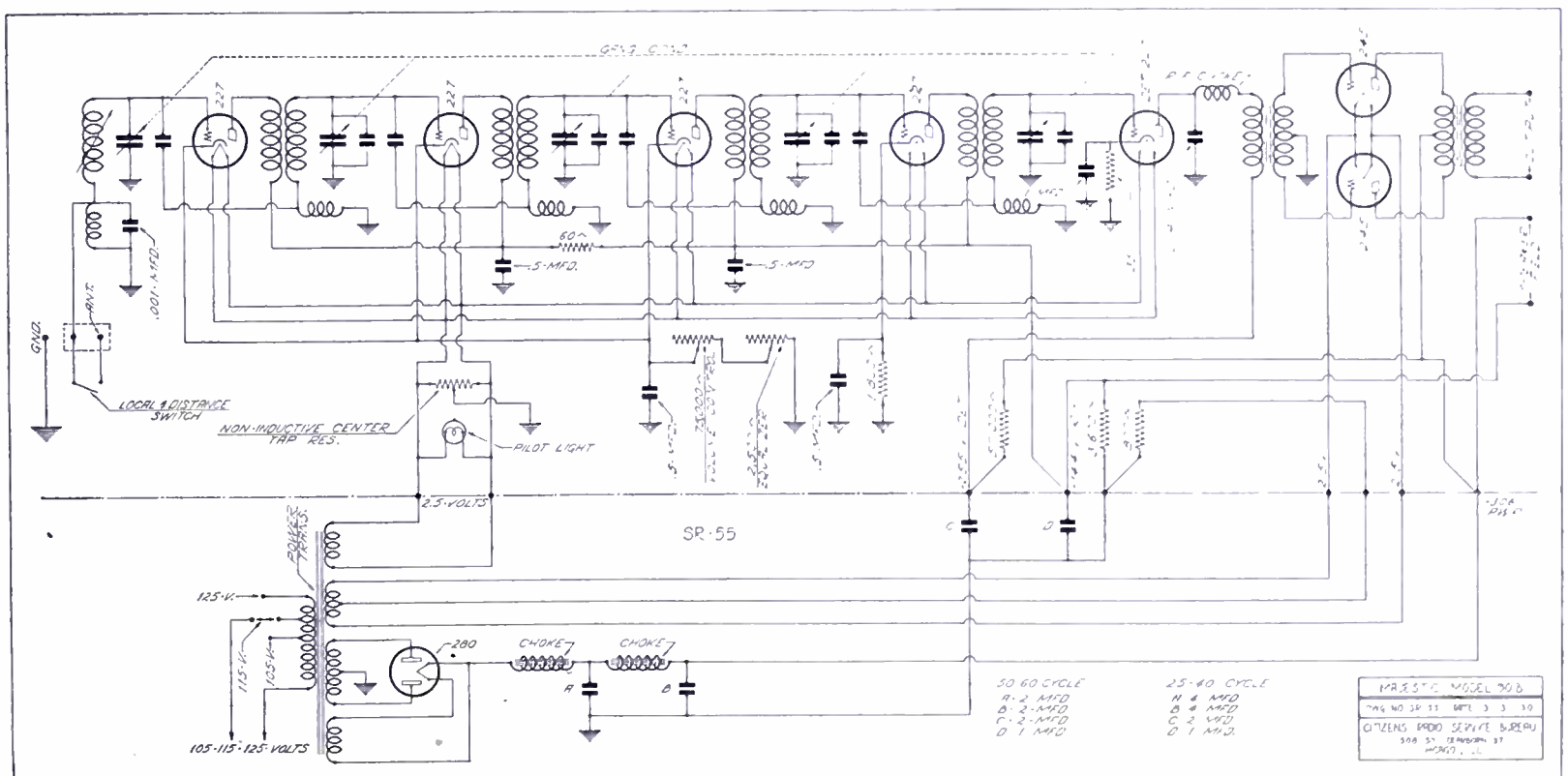

Figure 1. The receiver and power supply schematic of the Majestic 90-B is shown in this drawing

Majestic Radio Receiver Model 130-A

MAJESTIC 130-A and 230-A models incorporate several new and distinctive features, such as the use of the screen grid type of tubes instead of the previously used 227 type. Three screen grids, a power screen grid detector, two 245 type tubes in push-pull and a full wave 280 type rectifier represent the tube quota.

The three controls on the panel are: the left knob is the line switch; the center the tuning control, and the right the volume control. Equalized sensitivity is effected throughout the tuning range by the unique design of the amplifier coupling circuits. Two tuned circuits precede the first amplifier; a fixed tuned transformer precedes the second amplifier; two tuned circuits precede the third amplifier, and one tuned circuit precedes the power detector. A normal pushpull input transformer couples the screen grid power detector to the single stage pushpull power amplifier. The sensitivity, selectivity and fidelity of the 130-A is much improved over previous models. Response curves of this model appeared on page 66 of the September issue of this magazine.

The first and second r.f. tubes are biased by a variable resistor of 1,260 ohms, plus a fixed 151 ohm. Variance of the grid bias voltage on these tubes controls the volume of the receiver. Biasing of the third r.f. is taken care of by the 151-ohm (double orange) resistor. Bias for the detector comes from the drop across the 35,000 ohm

(green) resistor. The power tubes in the pushpull stage are biased by an 800 ohm (white) resistor. Cathodes of the first and second r.f. tubes are bypassed to ground with a .3 mfd paper condenser, and the detector cathode bypassed through a 1 mfd condenser.

The screen grid detector operates directly into the pushpull stages. Better quality, reduced a.c. hum and tube noise

conditions will seriously affect the sensitivity of the receiver.

A small compensating condenser is provided to adjust the reflected capacity of the antenna being used. Adjustment of this condenser is possible through the hole in the rear of the condenser gang housing. When the set is installed, a station between 1000 and 1400 kc should be tuned in, the volume control

Majestic Model 130-A

Tube Type	Position in Set	A Volts	B Volts	C Volts	Cathode Volts	Screen Volts	Normal Plate M. A.	Plate M. A. Test	Grid Change
G24	1 R.F.	2.35	180	3	3	90	3	---	---
G24	2 R.F.	2.35	180	3	3	90	3	---	---
G24	3 R.F.	2.35	180	3	3	90	3	---	---
G24	Det.	2.35	263	12	12	125	.5	---	---
G45	P.P.	2.45	250	50			32	---	---
G45	P.P.	2.45	250	50			32	---	---
G80	Rect.	4.6						---	---

Line voltage 115, on 115 tap. Volume control maximum.

Figure 1. The tube operating values shown in this chart are those indicated in the service manual for this receiver

is attributed to the use of the power detector.

In cases where low sensitivity is encountered, first check all r.f. tubes and the detector. Tubes having a low amplification factor in any of these posi-

set to low volume; then adjust the compensating condenser by turning the black knob until maximum volume is secured. Further adjustment is not necessary unless antenna length or position is changed.

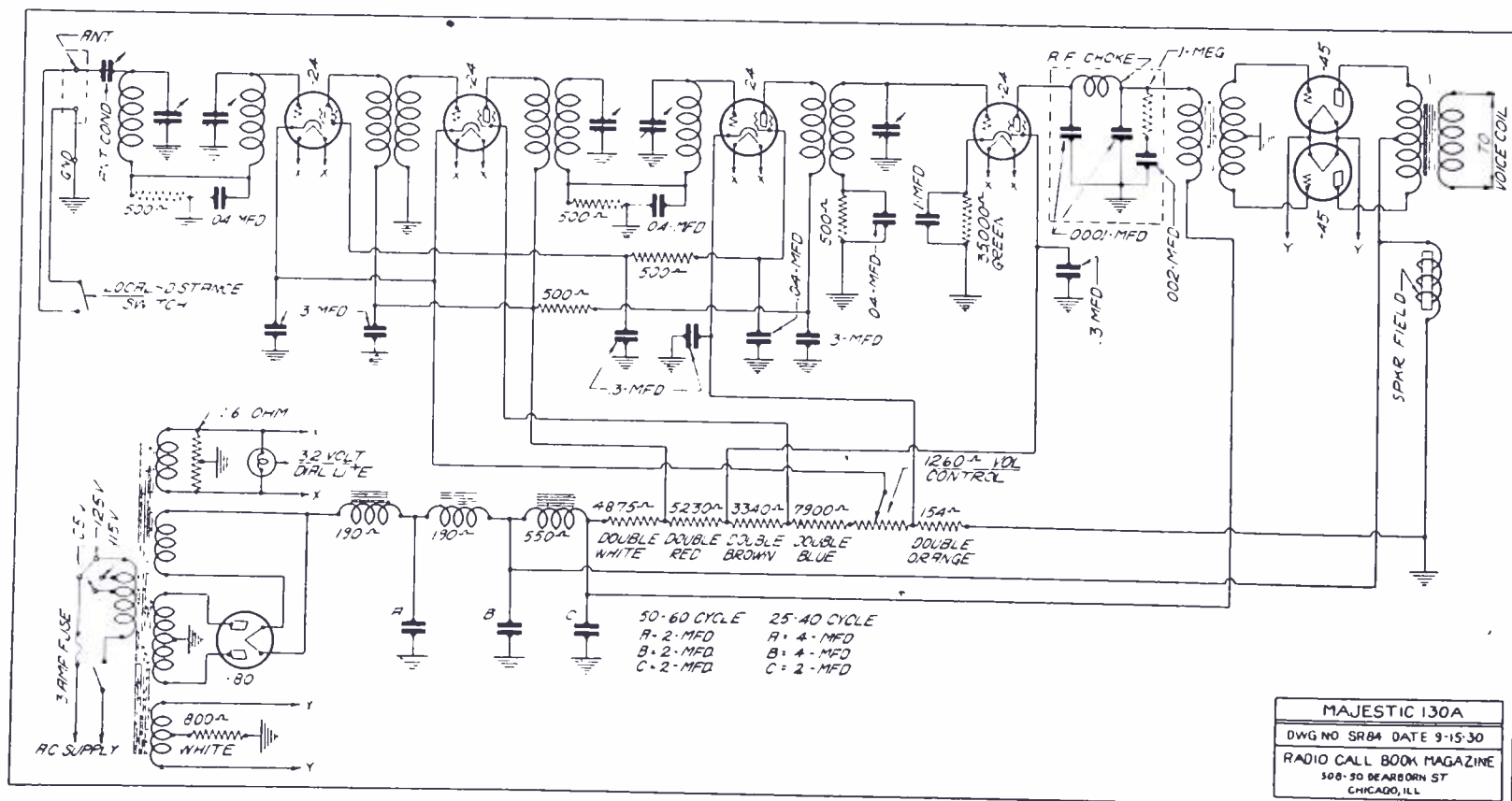

Figure 2. Electrical details of the receiver and power supply covering the Majestic model 130-A are shown in this illustration

Philco Receiver Models 86 and 82

SHOWN schematically on this page is the Philco electric radio, models 86 and 82, manufactured by the Philadelphia Storage Battery Co. of Philadelphia, Pa.

For a service man the best method of neutralizing is by means of a dummy tube and an oscillator. When adjusting the neutralizing condensers use an antenna consisting of a single wire 25 feet long supported by insulators at least 2 feet away from any parallel wall or floor and a good ground connection. Connect the attachment plug to a light socket and have the switch in the "on" position. Set the station selector between 40 and 50. Adjust the oscillator until a signal is heard in the receiver, then tune the receiver to the strongest signal. Final setting of the receiver scale should be approximately 45. Turn the volume control to full volume.

Selecting Dummy Tube

Remove the third (next to the detector) r. f. tube, which is a 226, and insert a dummy tube. [The dummy tube may be made by selecting a 226 which gives normal results when used in a receiver and by sawing off one of the filament prongs about $\frac{1}{8}$ inch below the bakelite base of the tube. With the prong cut off at this point it will not make contact in the socket, so the filaments of the tube will not light. Carefully test a number of tubes by using them in one of the r. f. stages of the

receiver and select one which gives average normal results.]

With the regular tube removed, the signal should be strong. With the dummy inserted, the volume should diminish. Correct adjustment of the neutralizing condenser is obtained when the minimum signal point is reached. This adjustment is quite critical and should be made using a special wrench of fibre or other insulating material.

Repeat this procedure for the second r. f. and the first r. f. stage. It is important the neutralizing be done with the volume control on full and with the receiver scale setting between 40 and 50. After neutralizing receiver should not oscillate at any point on scale.

When adjusting the compensating condenser use an antenna previously described. Set the station selector between 40 and 50 and turn the range control so that the rotor is half way meshed with the stator. Do not change this position throughout the adjustment. Adjust the oscillator until a signal is heard in the speaker and then tune the receiver to the strongest signal without changing the setting of the range control. Final setting should be approximately 45. The regular tubes in the receiver are used in this adjustment.

Using a special wrench made of fibre or some other dielectric, turn the adjusting screws of the compensating condenser. With the volume control on

full shut down the output of the oscillator until the signal is barely audible. This can be done by moving the oscillator away from the receiver until the proper signal strength is obtained. Then adjust each one of the three compensating condensers until the maximum volume is obtained. It is not necessary to adjust the three in any special order, simply make sure each is adjusted for maximum signal.

It is very important that the receiver be retuned after each of the compensating condensers is adjusted. Use the station selector for this tuning. A change in the adjustment of the compensating condenser will change the station selector setting one or more divisions for maximum signal strength. Do not change the range control.

After adjusting the three compensating condensers, as explained above, then disconnect the oscillator and with the volume control of the receiver on full test the receiver to see whether or not it is oscillating. Do this by turning the station selector knob slowly the complete scale from zero to 100.

If the receiver oscillates at any point on the scale, give the first compensating condenser one-eighth to one-quarter of a turn in a clockwise direction. Do not turn it more than one-quarter of a turn, usually less will be sufficient to prevent oscillating. If this does not stop the oscillating, recheck both the neutralizing and compensating adjustments.

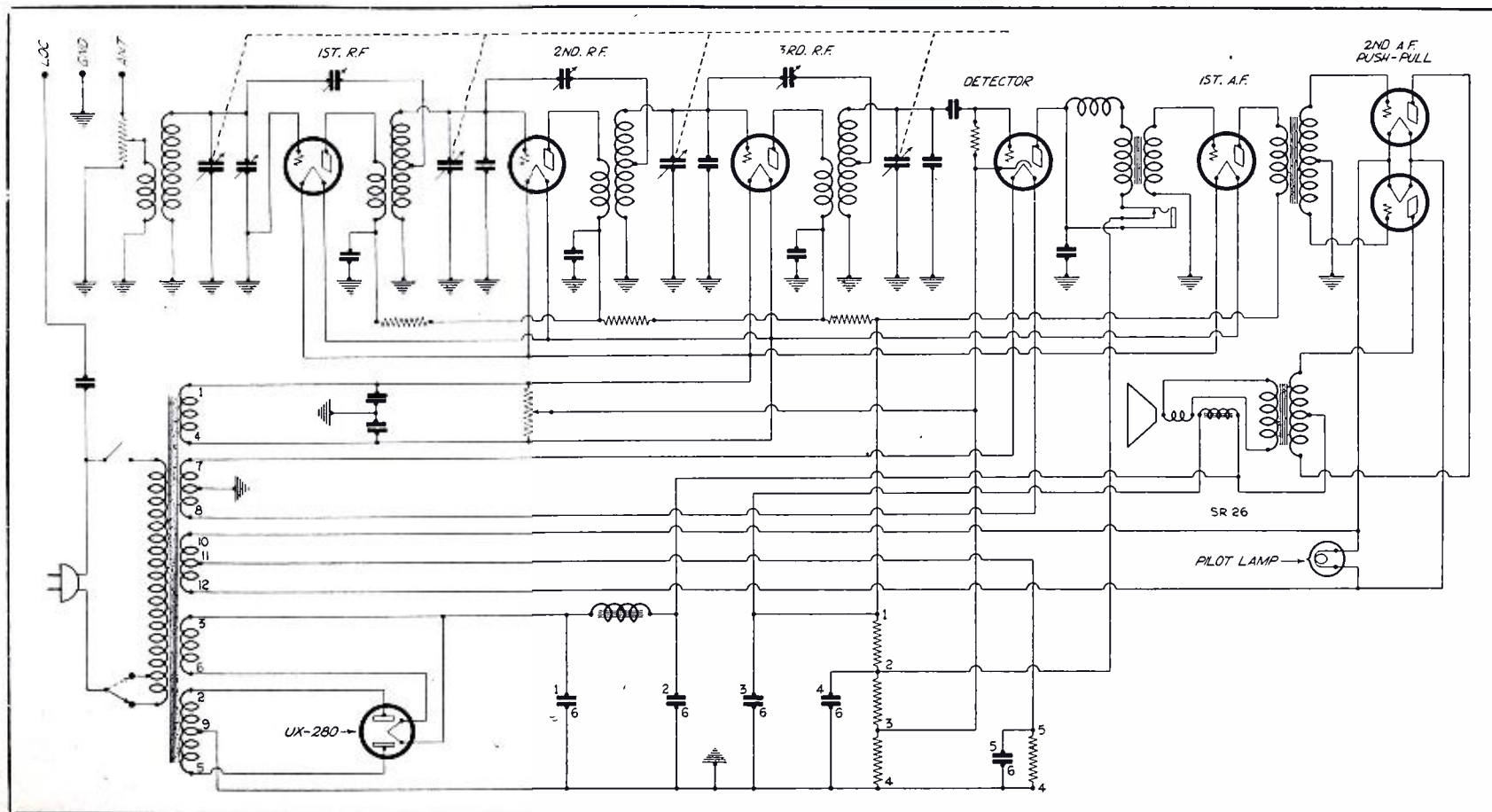

Fig. 13. This schematic diagram shows the electrical portions of the Philco receiver described on this page

Philco Balanced Unit Radio Model 95

ONE of the receivers of which a schematic circuit was desired by service men readers as indicated in our annual questionnaire is that of the Philco model 95 illustrated on this page, the circuit in Figure 2 and the table of tube values in Figure 1.

Probably the most interesting feature of this receiver is the multiplex detector circuit which is thus described by Walter E. Holland, chief engineer of the Philadelphia Storage Battery Co., makers of the receivers:

"The two type 227 tubes which are used in our 'multiplex detector circuit' separate the rectifying and amplifying functions of the usual single detector tube, and provide the necessary means for automatically changing the bias of the control grids of the radio frequency tubes to give automatic volume control.

"The first of these tubes has the grid and plate coupled together and acts as a true two-element rectifier, while the second has its grid directly coupled through a resistance to the grid and plate of the first tube so that it fulfills the audio amplifying functions of a detector independently of the first tube.

"It is for this reason that we call the second tube a 'detector amplifier.' The first tube might be called a 'detector rectifier' but we prefer to merely call it the 'detector tube.' Since it is a two-element rectifier it gives true linear detection without overloading on all signals impressed on it by the radio frequency amplifier."

In the section on testing and servicing in the Philco manual we find 7 headings covering troubles and possible causes, which we produce below:

No signal: Defective tubes; no voltage on receiver; incorrect voltages on one or more tubes; grounded antenna; open antenna circuit; poor contact; grounded compensator; open r. f. coil.

Weak signal: Defective tubes; incorrect voltage on one or more tubes; open antenna circuit; open ground circuit; poor contact; unmatched coils, compensating; bypass condensers.

Broad tuning: Unmatched coils; com-

pensating.

Fading: Defective tubes; poor contact; station and atmospheric condition.

Distortion: Defective tubes; incorrect voltage on one or more tubes; grounded filament; arrangement of wires and shielding; poor contact; defective speaker; bypass condensers.

Hum: Defective tubes; incorrect voltages; grounded filament; arrangement of wires; poor contact; a. c. plug.

Noisy: Defective tubes; incorrect voltages; poor contact; a. c. attachment plug; compensating and external interference.

Philco Model 95

Tube Type	Position in Set	A Volts	B Volts	C Volts	Cathode Volts	Screen Volts	Screen Current	Plate M. A.	Change
224	1 R.F.	2.15	155	0	5.3	95	.8	4	---
224	2 R.F.	2.15	155	0	5.3	95	.8	4	---
224	3 R.F.	2.15	155	0	5.3	95	.8	4	---
227	Det.	2.15	0	-.5	.7	---	---	---	---
227	Det.Amp.	2.15	27	-.5	5.5	---	---	---	---
227	1 A.F.	2.15	85	-2.0*	5.5	---	---	2.5	---
245	2 A.F.	2.2	250	41	---	---	---	28	---
245	2 A.F.	2.2	250	41	---	---	---	28	---
280	Rect.	4.5	---	---	---	---	---	43	---

Line voltage 115. *Read with volume control off. With it on reading will be .2 volt. Do not allow receiver to oscillate when taking readings. Keep R.F. shield on and tune to eliminate oscillator. Have antenna and ground connected.

Fig. 1. Data on tube voltages and currents as given in the Philco service manual for the model 95 is indicated above

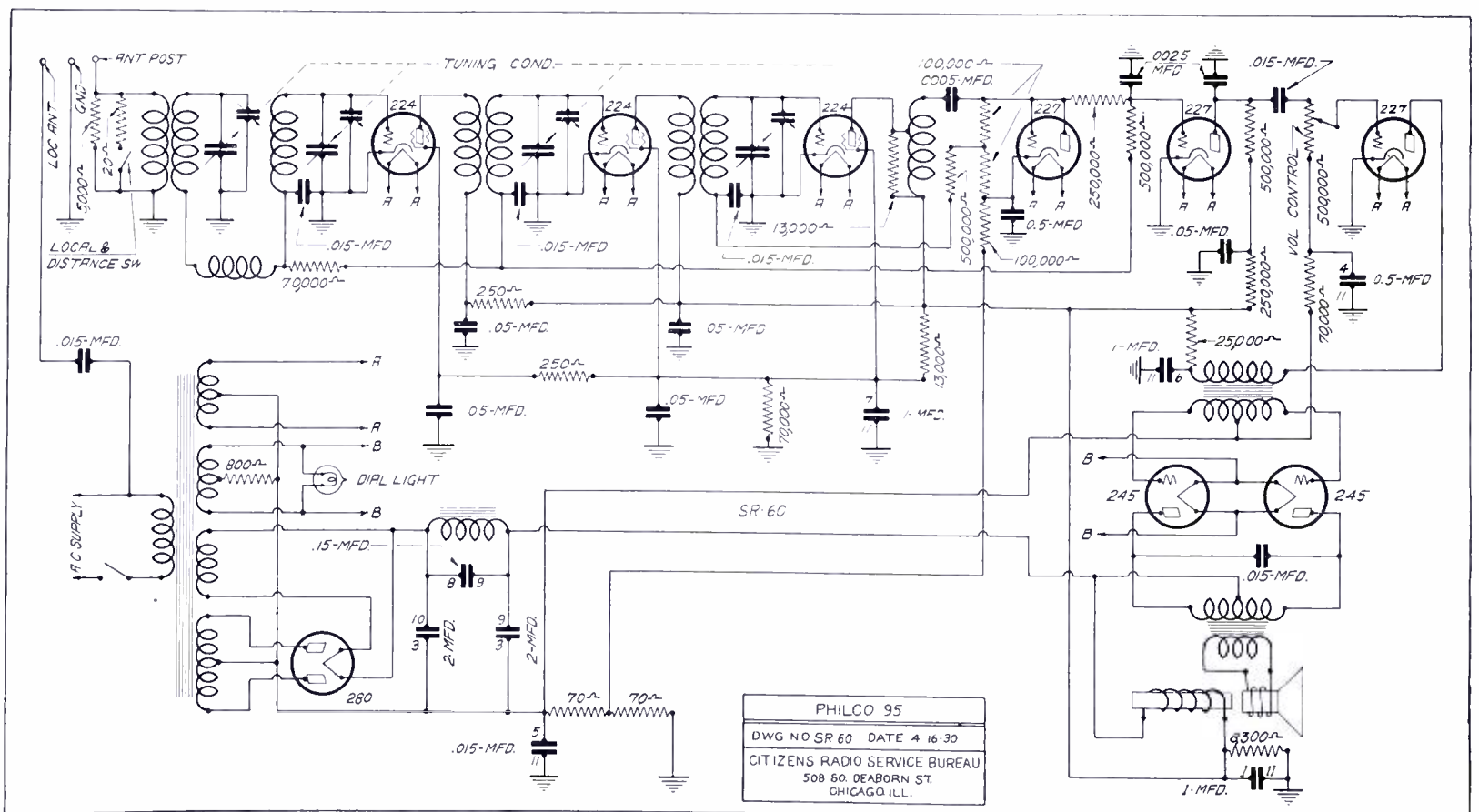

Fig. 2. Schematically we illustrate above the receiver and power supply circuit of the Philco model 95

Radiola Receiver Model 44

PROBABLY on account of the great numbers of these receivers in service in the field, our information department has been besieged with requests for information covering the Radiola 44 receiver. Tube operating values in Figure 1 and the schematic of the receiver and power supply in Figure 2 will be of interest, together with such other important service data as can be abridged from the manual for that model.

Excessive Hum

Excessive hum during operation of the receiver may be due to: external pickup. Throw switch to local position and see if hum disappears; a.c. input plug reversed, try reversing its position; open center tap resistance in socket power unit; shorted bypass and filter condensers, generally accompanied by inoperation; low emission 280 rectifier; defective dynamic if used; open resistance unit, usually accompanied by inoperation; if the .25 and 1.75 mfd tapped connections of the receiver 1 mfd bypass condenser are reversed a loud hum may be present; hum may also be caused by the speaker being out of center, check on this condition by releasing the center screw so that the cone can find its own center, and then tighten the center screw.

Oscillation

Oscillation through any part of the tuning range may be attributable to shields not properly in place, or not making contact with base on account of dirt; shield over antenna lead to local-distant switch not grounded or properly covering the leads; defective r.f. filter in detector plate circuit; there are two filters, one of which is shunted by two condensers in the plate circuit of the detector, oscillating occurring if the filters are defective or the condens-

ers go open; contact clips between shield and condenser shaft broken or not making good contact; open bypass condenser; defective 224 tube.

Service Hints

A brief resume of the service data chart shown in the Radiola 44 manual follows:

No signals: defective operating switch, defective volume control; defective r.f. transformer; defective coupling reactor; defective bypass condenser; defective socket power unit.

fective audio system; open grid in any stage.

Uncontrolled oscillation: shields not in place, or making good contact; tube shields not in place; defective r.f. filter.

Tubes fail to light: no a.c. line voltage; operating switch not on; defective a.c. input cord; defective power transformer.

Antenna Installations

Covering special antenna installations for noisy locations, it is noted: Erect as

Radiola Model 44

Tube Type	Position in Set	A Volts	B Volts	C Volts	Cathode Volts	Screen Volts	Normal	Plate	Change
							M. A.	M. A.	
224	1 R.F.	2.35	164	1.5	1.5	45.0	3.8	2.3	1.5
224	2 R.F.	2.35	164	1.5	1.5	45.0	3.8	2.3	1.5
224	Det.	2.35	100	6.0	7.0	50.0	.8	.7	.1
215	A.F.	250	230	6.0			34.		
280	Rect.	5.0	260						

Line voltage 120, set on 120 tap. Volume control maximum.

Fig. 1. The voltages shown in the above table are those for the Radiola 44, data being values derived through the use of a Jewell analyzer

Weak signals: local-distant switch not on distant position; lineup condensers not adjusted properly; defective main tuning condensers; defective parts in receiver assembly; defective parts in socket power unit; low line voltage.

Poor quality: defective coupling reactor, condenser or resistor in coupling circuit; defective output condenser or choke; local-distant switch not properly operated.

Audio howl: receiver oscillating; de-

long and as high an antenna as possible and then couple it to the antenna lead of the receiver through a small coupling condenser. This condenser with a 200 foot antenna should be about .0003 mfd and smaller with larger antennas. The effect of the long antenna is to increase the pickup to a point where it will be proportionately higher than the noise level. The series condenser then reduces the effective antenna capacity and limits the input energy to the receiver.

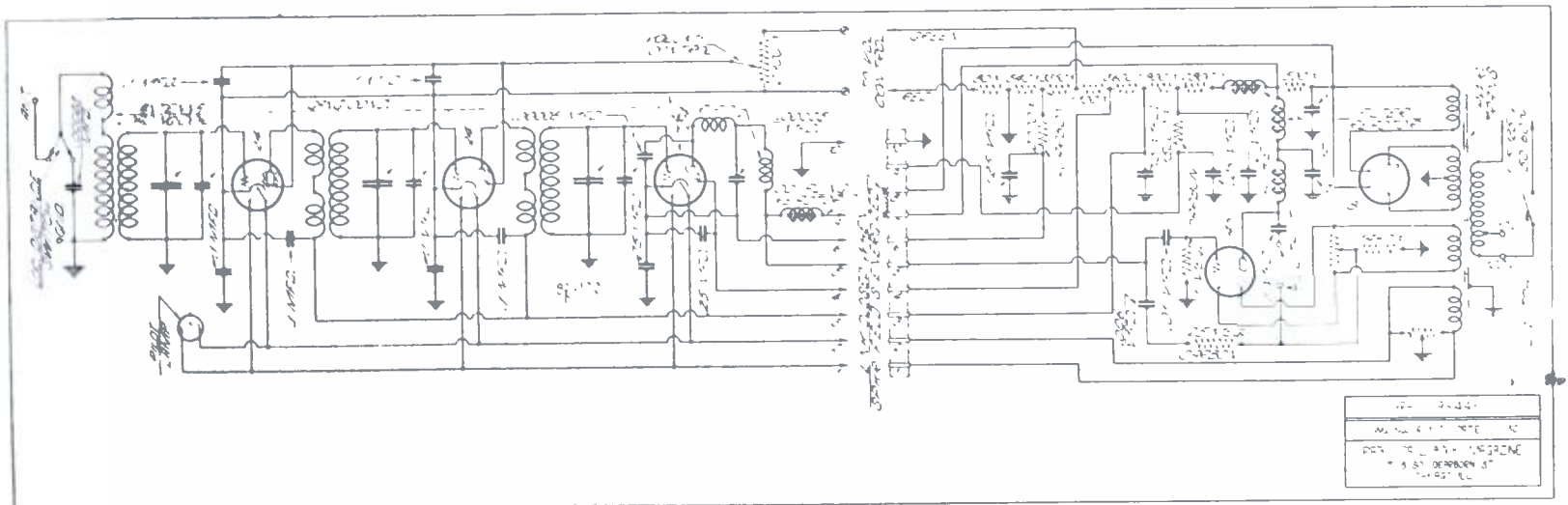

Fig. 2. The schematic of the receiver and its power unit is shown above for the Radiola 44

Radiola Model 60 Superheterodyne

USING nine tubes including the rectifier the Radiola Model 60 superheterodyne is presented schematically in this article. The set is made by the Radio Corporation of America and the model 60 is considered the basic superheterodyne circuit for the Radiola line. Therefore, the circuit shown on this page is substantially the same as the one used in the R. C. A. model 62 and 64. However, in the case of the 64 a slightly different hook-up is used because an extra 227 tube is added which is used on the automatic volume control. This tends to keep the volume constant at all stages regardless of the input signals. In the case of the 64 a 250 power tube is employed.

In the case of the model 60 here described the output stage is a 171.

Mostly 227 Tubes

All of the tubes in the receiver are 227 type with the exception of the power stage which is the 171A and the rectifier which is the 280. The oscillator tube is the third from the left in schematic Figure 6 and has a balanced grid input. A regeneration control is included in the plate circuit of the second 227 from the left.

An analysis of voltage readings on the model 60 as taken with a Jewell 199 set analyzer is given below:

Typical Voltage Readings

These readings are taken from the

line voltage of 117 volts. The volume control should be set centrally with the line vertical in order to get these readings. The C voltage on tubes 1, 2, 4, and 5 will vary from nine to twenty-seven volts, depending upon the position of this volume control, hence these readings are taken at the middle point.

Coupling Tube

With the tube out the antenna coupling 227 shows A voltage of 2.35 and B voltage of 148. With the tube in the tester the A voltage is 2.2, B voltage 144, C voltage 18, cathode voltage 25, normal plate m. a. 1, plate m. a. grid test 3 and plate m. a. change 2.

The first radio frequency 227 tube with the tube out shows a reading of 2.35 for filament voltage and B voltage of 148. With the tube in the tester the A voltage is 2.2, B voltage 144, C voltage 18, cathode voltage 25, normal plate m. a. 1, plate m. a. grid test 3, and plate m. a. change 2.

In the case of the first detector 227 with the tube out the filament voltage is 2.35 while the B voltage is 84. When the tube is in the tester filament voltage is 2.2, B voltage 70, C voltage 9, cathode voltage 10, normal plate m. a. 1, plate m. a. grid test 3, plate m. a. change 2.

I. F. Stages

The first and second intermediate frequency 227 tubes show the same read-

ings. When the tube is out the filament voltage is 2.35 and plate voltage 148. With the tube in the tester filament voltage is 2.2, B voltage 144, C voltage 18, cathode voltage 25, normal plate m. a. 1, plate m. a. grid test 4, and plate m. a. change 3.

Oscillator Voltage

With the oscillator 227 tube out the filament voltage is 2.35 and B voltage 118. With the tube in the tester the A voltage is 2.2, B voltage 70, no C voltage, no cathode voltage, normal plate m. a. 7, plate m. a. grid test 7, and no plate m. a. change.

The second detector is also a 227 tube and when this tube is out the A voltage is 2.35 and the B voltage 162. When the tube is in the tester the A voltage on this stage is 2.2, B voltage 157, C voltage 18, no cathode volt, normal plate m. a. 1, plate m. a. grid test 3 and plate m. a. change 2.

Audio Voltage

The first audio stage is a 171-A and with the tube out the filament voltage is 5, B voltage 178. With the tube in, A voltage is 4.8, B voltage 157, C voltage 31.5, no cathode volts, normal plate m. a. 15, plate m. a. grid test 17, and plate m. a. change 2.

The 280 rectifier has a filament voltage of 5 when the tube is out, and 4.8 when the tube is in with a normal plate m. a. of 19.

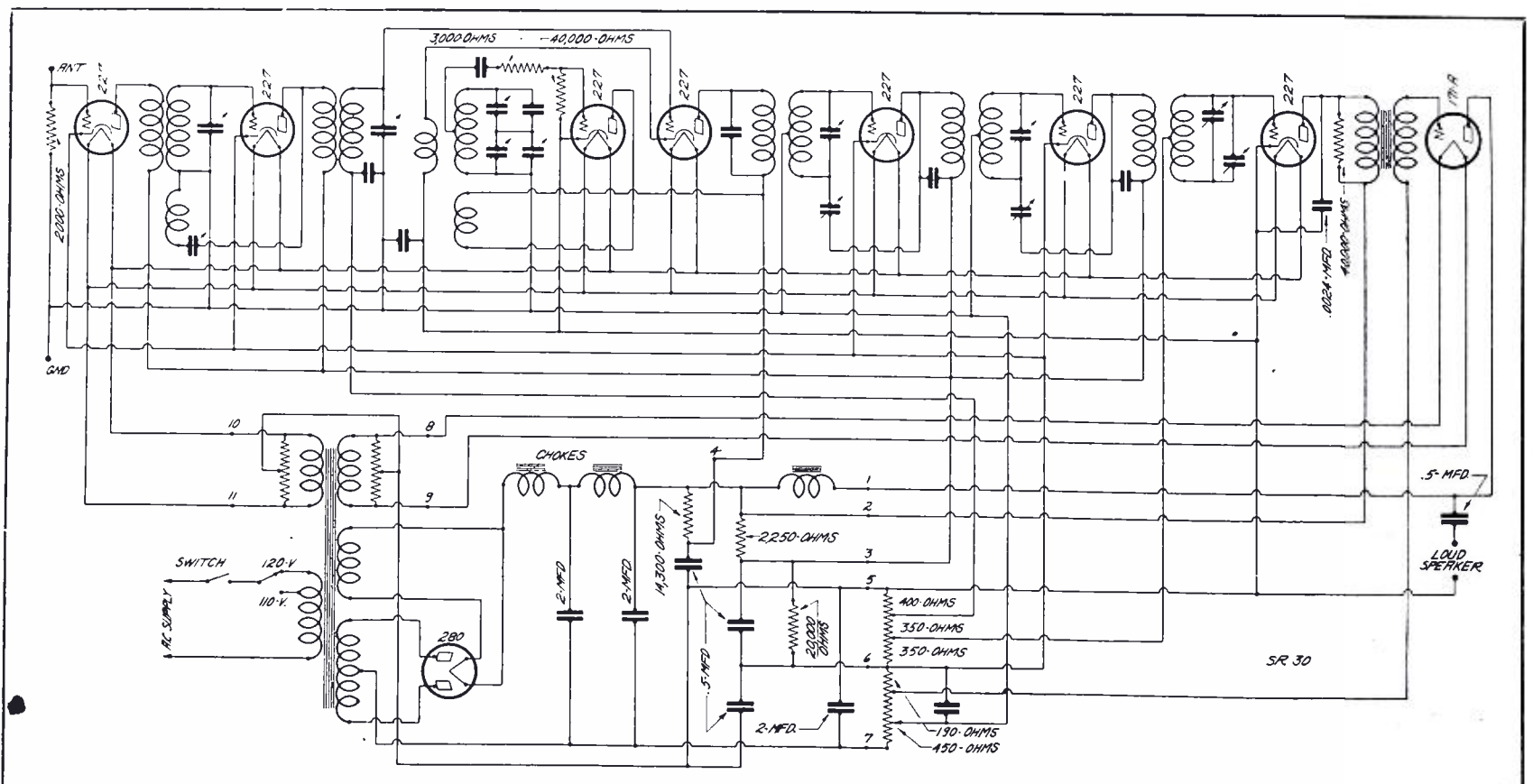

Fig. 6. The complete schematic diagram of the Radiola 60 superheterodyne and its power pack is shown in the illustration her

Radiola Superheterodyne Model 66

ON this page is shown the schematic diagram of the receiver and power supply contained in the Radiola 66 model, this superheterodyne using only one power output stage in the form of a 245 tube.

Altogether there are eight tubes in the 66, six of which are 227 type, one a 245 and the last a 280 full wave rectifier. The diagram of the set is shown in Figure 1 while a table of tube voltages and currents is illustrated in Figure 2.

One R. F. Stage

Only one stage of tuned r. f. is em-

Power Second Detector

Input to the second detector which is of the power detection type is of the conventional kind, a plate voltage of 210 volts being applied, which when passed through the BC section of the resistor at the center of the diagram furnishes a 27 volt C bias for the grid of the second detector. The primary of the second detector circuit is resonated with a 40,000 ohm resistance and a .05 mfd condenser placed in parallel to the winding. The secondary of that audio transformer is also resonated with a .00016 mfd condenser. The bias for the

Slightly less than 70 volts is applied to the plates of the first detector and the oscillator on account of the drop in the windings in those circuits.

Oscillator Input

The oscillator input circuit is also of the balanced type, the center of the inductance going through a .0008 mfd condenser and a 3000 ohm resistor to the grid of the oscillator, a 40,000 ohm resistor between grid and the cathode supplying a direct return for the grid. No bias is indicated on the table of tube voltages in Figure 2. The cathode of

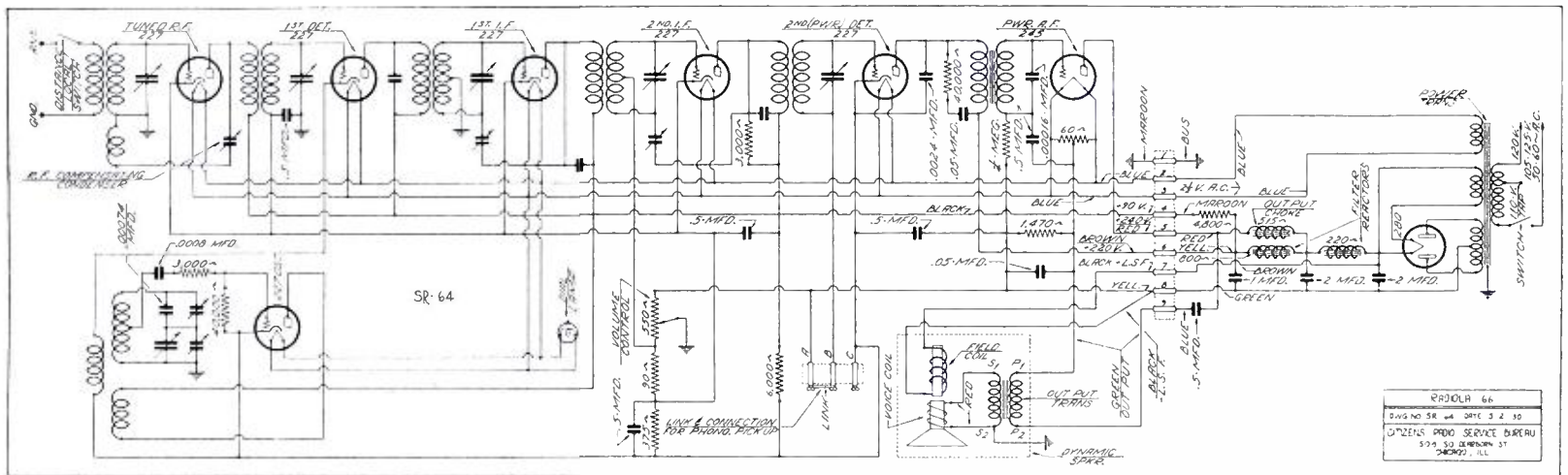

Fig. 1. The schematic of the combined receiver and power supply of the Radiola 66 is shown in this drawing

ployed, this being the antenna input stage. By looking at the schematic diagram it will be seen this r. f. stage can be made partly regenerative by means of the r. f. compensating condenser between the plate of the first 227 and the lower section of the secondary inductance which is grounded. In practice this condenser is set at a value for best operation with a particular 227 and then left untouched. The output of the first 227 plate circuit feeds into the grid circuit of the first detector, mixing current from the oscillator being introduced in the detector cathode circuit of this tube.

Bridge Type I. F. Stages

Only two intermediate stages are used in the model 66. It will be noticed that both of the intermediate frequency secondaries are of the bridge type, the center of the coil being grounded, the tuning condenser spanning the extremities of the coil, with a compensating condenser going from the lower end of the secondary inductance to the plate of each intermediate frequency tube. This type of balanced input permits more stable operation of the two intermediate tubes with a greater amplification than is possible with the conventional coupling.

245 is supplied by the drop across the 1470 ohm fixed resistor between the negative of the system and the center of the 60 ohm resistor across the 2.5 volt filament winding for all tubes. In series with the secondary return of the audio transformer is a 250,000 ohm resistance as indicated in the schematic.

Plate supply for all of the r. f., oscillator, i. f. and first detector is from a common voltage tap of about 70 volts.

that tube returns to the negative of the system.

Power for the dynamic speaker is provided by the field coil being placed in series with the high voltage system at the low potential end. The output transformer from the 245 plate connects to the end of a 515 ohm output choke at the filter; its secondary going into the voice coil of the dynamic.

Radiola Model 66

Tube Type	Position in Set	A Volts	B Volts	C Volts	Cathode Volts	Screen Volts	Normal Plate M. A.	Plate Grid Test	M. A. Change
227	1 R.F.	2.3	70	1.5	-21	---	4	8.5	4.5
227	Det.	2.3	65	7	14	---	.4	2.5	2.1
227	1 I.F.	2.3	70	3	-21	---	3.8	7.2	3.4
227	2 I.F.	2.3	70	3	-21	---	4.0	8.0	4.0
227	Osc.	2.3	61	---	---	---	6.0	11.0	5.0
227	2 Det.	2.25	210	27	-15	---	1.0	2.0	1.0
245	A.F.	2.3	200	12*	---	---	27.0	30.0	3.0
280	Rect.	4.6	---	---	---	---	50	---	---

Line voltage 114, high top. Volume control maximum. *This not true bias voltage, but reading obtained at socket due to series resistance.

Fig. 2. A Table of typical tube voltages as taken with a Weston set tester is indicated above for the guidance of service men

Sentinel Radio Models 11, 12, 15, 16

SERVICE data covering the Sentinel models 11, 12, 15 and 16 is found in the manual issued for these models. Excerpts of the more important matter are given in this article.

Regarding repairs and adjustment the manual states that obviously to obtain best results proper equipment and a well-planned diagnosis are preferable to a haphazard method with no, or inadequate, equipment. Set analyzers as manufactured by Jewell, Weston, etc., are ideal because of their accuracy and portability. A quick check of the plate, screen grid, and filament voltages of each circuit is readily obtainable with these set analyzers, either in the home or on the bench. A well shielded, modulated oscillator is a desirable piece of equipment and when used in conjunction with a proper output meter, an accurate lineup of the variable condensers can be made, and the r-f stages individually checked by coupling into the various stages and noting the deflection on the output meter.

Trouble shooting in a receiver is a series of eliminations, the object in view being to isolate the particular circuit that is causing trouble. While each repair man generally works out his own procedure, the following suggestions are given as a working basis:

Before doing any work on the receiver that is not functioning properly, be certain the trouble is not due to some external trouble such as poor tubes, a poor or inadequate antenna, or ground, as most trouble can be traced to one of these causes. If the

difficulty cannot be traced to one of these, analyze the trouble to determine under which of the following classifications it belongs: No signal, weak signal, broad tuning, distortion, hum, noises, fading and oscillation.

Under no signal the following might be causes: Defective tubes, no voltages on tubes, grounded antenna, open antenna, broken lead-in, open or

antenna too long, high resistance ground, improperly aligned condensers, receiver operated close to strong broadcasting station.

Hum might come from defective tubes, incorrect voltages, open center tap resistor, pilot light grounded.

Under fading: defective tubes, poor contact, station or atmospheric conditions, tuning condenser dirty, swing-

Tube Type	Position In Set	A Volts	B Volts	C Volts	Cathode Volts	Screen Volts	Normal Plate M. A.	Plate M. A. Grid Test	Change
224	1 RF	2.36	176	2.75	87	3.0
224	2 RF	2.36	176	2.75	87	3.0
224	Det	2.37	62.5*	4.5*	10*	.25
227	1 AF	2.4	157	12.5	1.75
245	PP	2.5	237	46	32.5
245	PP	2.5	237	46	32.5
280	Rect	5	55	each plate

Line voltage 115 volts. Volume Control maximum.
*Not true readings due to resistance in circuit.

Figure 1. In this table will be found the average tube voltages on Sentinel models 11, 12, 15 and 16.

shorted r-f coil, defective speaker, no voltage to power transformer primary.

Under weak signal: Defective tubes, incorrect voltage on one or more tubes, open or grounded antenna, open ground circuit, open or shorted r-f coil, defective bypass condenser, inadequate antenna, low line voltage, shielded antenna, condensers not properly aligned.

Broad tuning might be from an-

ing antenna becoming intermittently grounded.

Under oscillation: defective 224 r-f amplifier tubes, or defective 224 detector tube, poor ground, antenna lead running too close to chassis.

Under noises: defective tubes, external interference, poor contact.

Under distortion: defective tubes, incorrect voltages, defective bypass condensers.

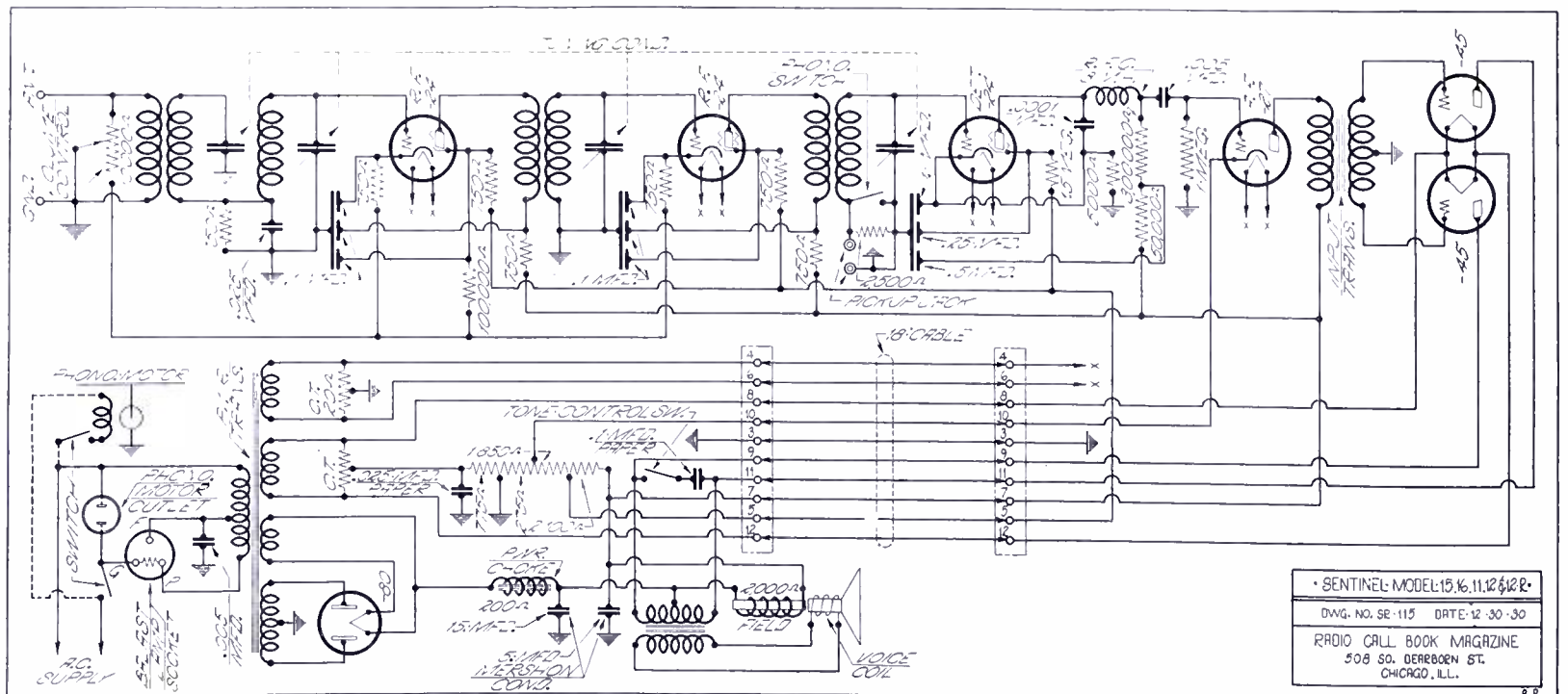

Figure 2. Electrical details of the circuit used in the Sentinel models described here may be found in this schematic diagram.

Silver Model 30 Receiver and Pack

FOUR screen grid 224 tubes, one 227, two 245's and a 280 rectifier are used in the Silver Model 30 receiver described on this page. The schematic diagram of the receiver and its power supply is shown in Figure 13.

Measurements made on two stock Silver chassis with a Jewell 199 Analyzer are given below and indicate normal variations which may be encountered due to the varying tubes and line voltages. Variations within the limits shown or even slightly beyond are no indication of trouble unless some other operating fault is seen.

On one set with a line voltage at 117 and the volume control at maximum the first r. f. 224 showed a shield voltage of 64, A voltage of 2.45, B voltage 152, C voltage 1.5, cathode voltage 1.7 and normal plate m. a. of 4.5.

The second r. f. 224 showed a shield voltage of 64, A voltage of 2.47, B voltage 145, C voltage 2, cathode voltage 2, and normal plate m. a. 3.6.

Third r. f. 224 shield voltage 64, A voltage 2.48, B voltage 148, C voltage 2, cathode voltage 2, and normal plate m. a. 3.3.

Detector 224 showed shield voltage 72, A voltage 2.51, B voltage 68, C voltage 6, cathode voltage 5, and normal plate m. a. .1.

The first a. f. 227 showed an A voltage of 2.51, B voltage 184, C voltage 1, cathode voltage 13 and normal plate m. a. 7.

In the case of the push pull 245 there was a difference of 9 mils between one tube and another. For example, the first tube showed A voltage of 2.49, B volt-

age 223, C voltage 44 and normal plate m. a. 21. The second 245 showed A voltage of 2.49, B voltage 220, C voltage 43.5 and normal plate m. a. 32. This unbalance in the 245 while not desirable did not seriously affect the operation of these two sets.

The second set was tested with a line voltage of 117, volume control at maximum and showed:

First r. f. 224, shield voltage 71, A voltage 2.45, B voltage 170, C voltage 1, cathode voltage 1, and normal plate m. a. 2.8.

Second r. f. 224, shield voltage 71, A voltage 2.48, B voltage 161, C voltage 2, cathode voltage 1.7, and normal plate m. a. 3.1.

Third r. f. 224 showed shield voltage of 70, A voltage 2.48, B voltage 164, C voltage 2, cathode voltage 2, and normal plate m. a. 3.

Detector 224 showed shield voltage of 69, A voltage 2.5, B voltage 76, C voltage 7, cathode voltage 7, and normal plate m. a. .1.

The first a. f. showed a voltage 2.49, B voltage 196, C voltage 1, cathode voltage 14, and normal plate m. a. 7.8.

One of the 245's in the push-pull stage showed A voltage 2.45, V voltage 222, C voltage 44 and normal plate m. a. 32. The other showed A voltage of 2.45, B voltage 224, C voltage 44, and normal plate m. a. 22.

The above readings do not apply to receivers equipped with the external type 30 filter units or to receivers bearing serial numbers above 12,907. In the case of such receivers an additional 10 volt drop in B voltage must be al-

lowed for across the type 339 U choke coil known as L12.

In general, if no voltage is obtained in any measurement with the analyzer, the receiver should be removed from its cabinet and the particular circuit at which no voltage is apparent checked through, using the set analyzer with its test leads. For example, if the first r. f. tube showed no plate voltage, its circuit should be checked through winding of coil L-2, through one winding of the coupling coil L-3, through the choke coil L-7, and through the red-white connecting wire, to the common join of resistors R-9, R-10, and R-11 (mounted on a panel behind the On-Off switch). If no screen potential was observed upon the third r. f. tube, for example, it would be necessary to check the screen circuit through the resistor R-6 and through the slate cabled lead to the arm of the potentiometer P-1 and then through to the joint between the green resistor R-9 and P-1 (and so on).

Again, should no grid bias be observed (read as "cathode volts" on the set analyzer) on the first audio tube, S-5, the circuit should be checked through by disconnecting the lead from the condenser bank (to check for a possible short-circuited condensed) and again determining if voltage appeared across the white resistor R-8. Should it fail to appear, the cathode might be directly grounded (possibly by contact between *both* ends of the resistor and the shielding), or no plate current might be being drawn, which would indicate an open plate circuit, which in turn, would be checked obviously.

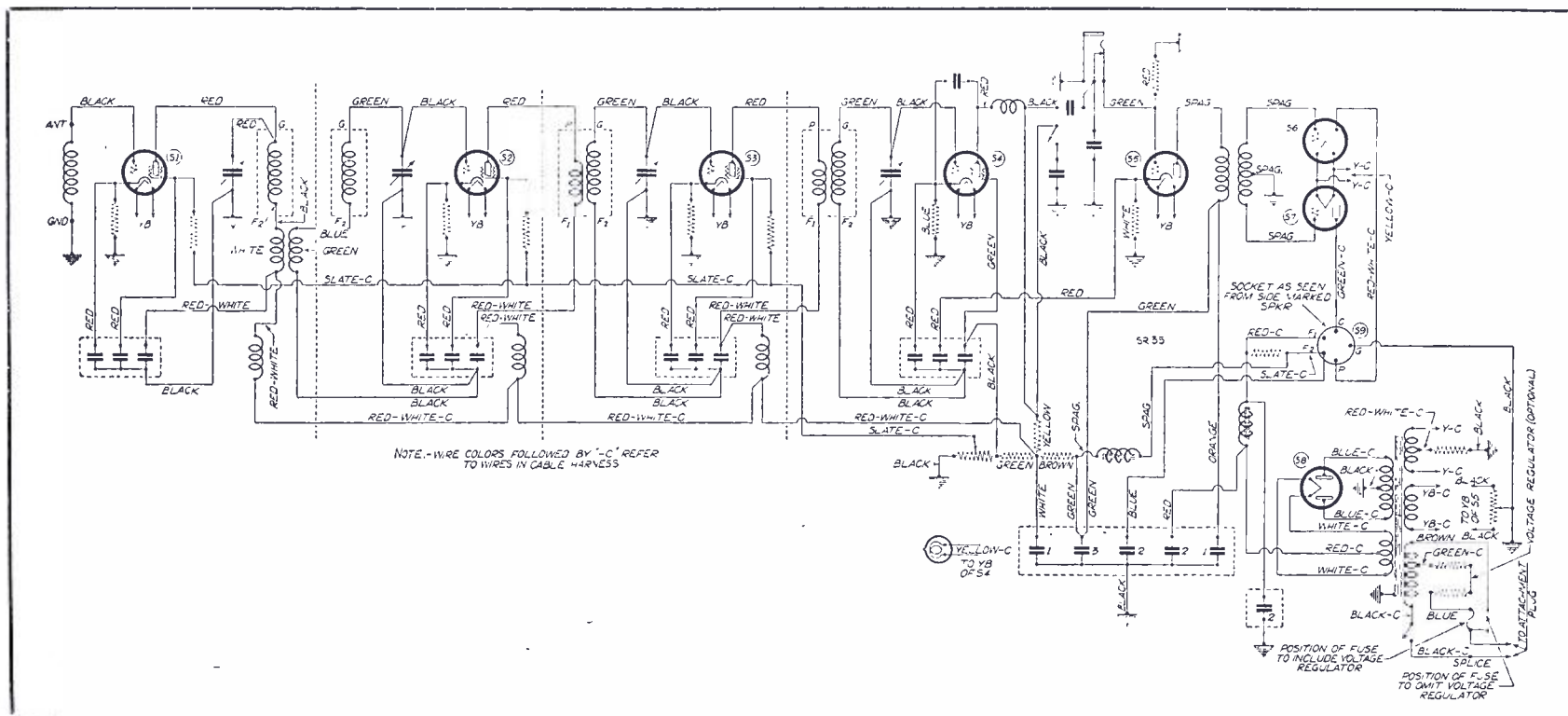

Fig. 13. Schematic diagram of the radio receiver and its power supply is shown in the above illustration. This is the model 30 Silver

Silver Radio Receiver Model 30-B

SERVICE data on the Silver 30-B receiver whose schematic is shown on this page, is practically the same as that given on the 30 and the 30-A which preceded the 30-B. According to the bulletin from the makers, a good modulated r.f. oscillator is desirable if the service department is to properly test receivers for sensitivity and alignment.

The leads from the oscillator to the receiver under test should be shielded, and when used on the 30-B should be connected through a .0001 mfd condenser to the short antenna post. A good ground connection is essential. Oscillator output should be cut down to secure a weak signal when volume control is turned on full. Set oscillator at about 1280 kc. and tune in on receiver. With a long wrench (or screwdriver if panel is removed) adjust the fourth (left) trimmer screw for maximum volume. With a screwdriver inserted through hole in tube shield adjust the third (next to left) trimmer screw for maximum volume. With screwdriver through hole in tube shield adjust the second (next to right) trimmer screw for maximum volume. With screwdriver through hole in tube shield adjust the first (right) trimmer screw for maximum volume.

If during the above operations a vacuum tube voltmeter can be connected across the voice coil of the speaker, or a 100 m.a. thermoammeter inserted in series with the voice coil, visual indication of volume can be obtained and

Silver Model 30-B

Tube Type	Position in Set	A Volts	B Volts	C Volts	Cathode Volts	Screen Volts	Normal Plate M. A.	Plate M. A. Grid Test	Change
224	1 R.F.	2.4	168	4	4	69	5	---	---
224	2 R.F.	2.5	164	4	4	72	5	---	---
224	Det.	2.4	28	8	8	60	.5	---	---
227	1 A.F.	2.5	150	---	10	---	6	---	---
245	1 P.P.	2.4	264	44	---	---	30	---	---
245	2 P.P.	2.5	264	44	---	---	30	---	---
280	Rect.	4.9	310	---	---	---	50	---	---

Line voltage 110. Volume control maximum.

Fig. 1. Typical tube voltages as taken with a Jewell analyzer on the Silver 30-B are shown in the above table

more accurate adjustments effected. During the above operations the drum dial and volume control adjustments must not have been changed. All adjustments should be made on the trimmers exactly in the order named. It will be noted that in the 30-B it is not necessary to disconnect any of the selector leads as was necessary in the model A. After these operations have been made the service man should make sure the receiver will tune up to 1500 kc. and down to 550 kc. If it fails to read 1500 kc. all aligning condensers have been set too far in.

Calibration of the selector dial may be checked as follows: If the dial does not read correctly: that is, if 1300 kc does not tune in at that point, the reading may be corrected. Tune in a good sta-

tion of definitely known and maintained frequency at approximately 1300 kc. With station tuned in not loudly, and dial hub set screws loosened, the dial only may be turned to read correctly and the set screws re-tightened. Check this adjustment at 700 and 600 kc.

When reganging the model 30-B care should be taken to see that all trimmers are not initially set so far in as to prevent the receiver tuning up to 1500 kc. In general, ganging should be done so the fourth, or left hand, aligning screw will be about one-sixteenth of an inch out from the condenser frame, and the three aligning screws to the right screwed in no further than absolutely necessary to secure peak volume. If this caution is not observed the receiver may not tune up to 1500 kc.

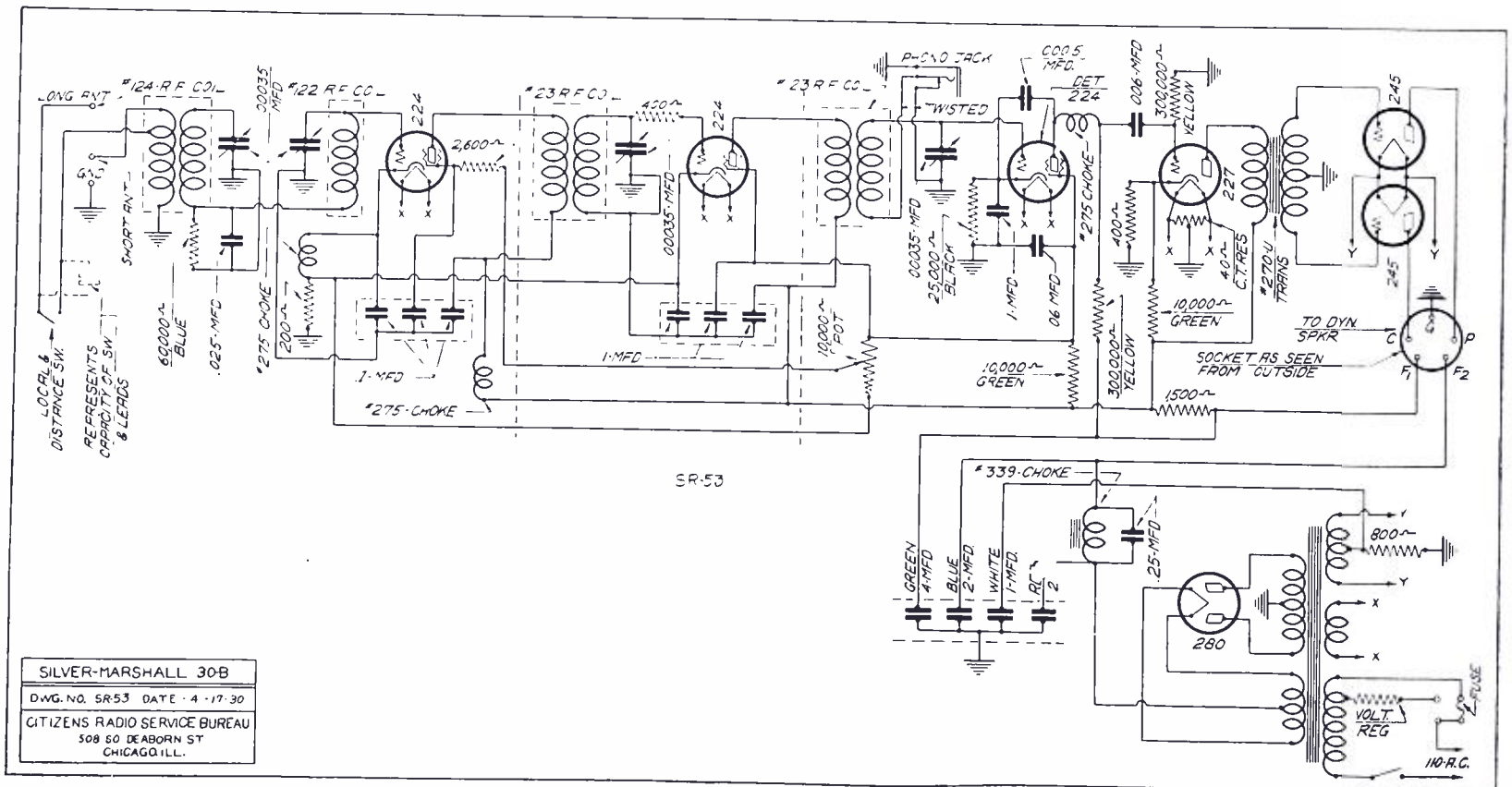

Fig. 2. Details of the model 30-B made by Silver may be seen in the schematic drawing shown here

Silver Radio Receiver Model 35-A

SHOWN here is the schematic diagram of the Silver model 35-A receiver and its power supply, the receiver in Figure 3, the power supply in Figure 2, while a table of operating tube voltages may be seen in Figure 2.

Service notes covering this receiver re-aligning are: The leads from the oscillator should be shielded and connect through a .001 mfd condenser to the short antenna post of the 35-A. A good ground connection is essential. The oscillator signal should be cut down or attenuated to give a very weak signal with the volume control of the receiver turned on full. Turn the tuning dial to 550 kc. Be sure the condenser rotor plates are fully meshed at this point and that the tuning dial hits the stop pin.

Now turn the dial to 1500 kc, where it should also hit the stop pin. With the test oscillator set at 1500 kc use a wide blade screwdriver to adjust the

Fig. 1. The schematic of the power supply for the Silver 35-A is shown in the drawing to the right. It should be noted that the number for the power pack is 33-A regardless of whether intended for the 60 or the 25 cycle current

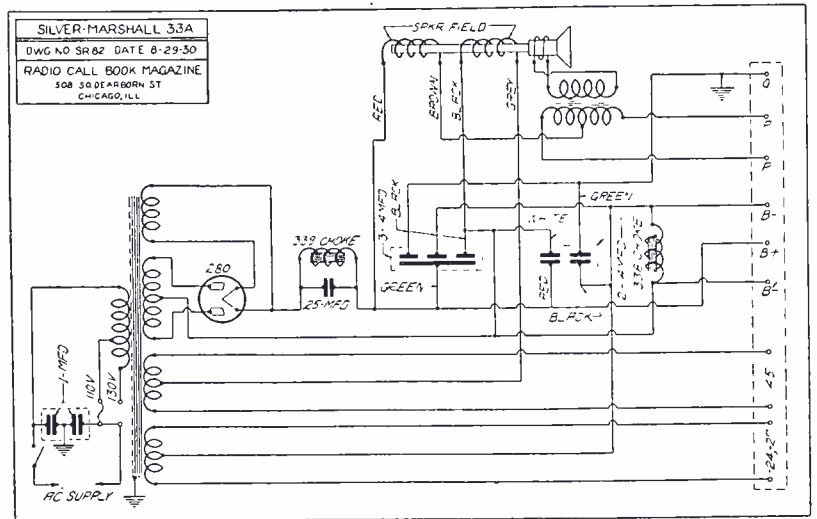

fifth (left) trimmer screw for maximum volume. With the screwdriver adjust each succeeding trimmer for maximum volume. Repeat the above adjustment a second time for finer adjustment.

Next turn the oscillator to 1280 kc and tune the receiver to exactly that fre-

quency. With the screwdriver tune each trimmer to maximum volume. It should only be necessary to make minor adjustments at this point.

If during these operations a vacuum tube voltmeter can be connected across the voice coil of the speaker, or a 100 m.a. thermoammeter inserted in series with the voice coil, visual indications of the volume can be obtained and more accurate adjustments effected.

During the operations mentioned the volume control must be left strictly alone, and alignment adjustments made on the aligning screws exactly in order as given above. The above operations performed make sure the receiver will tune up to 1500 kc. If the dial fails to read properly for 1400 to 1500 kc signals, all aligning condensers have probably been set too far in.

If no oscillator is available, the procedure is exactly as outlined except that a broadcast signal at 1500 and 1280 kilocycles is tuned in instead of the oscillator signal. However, this method of re-aligning is not recommended where an oscillator can be had.

Silver Model 35-A

Tube Type	Position in Set	A Volts	B Volts	C Volts	Cathode Volts	Screen Volts	Normal Plate M. A.	Plate M. A. Grid Test	Change
224	1 R.F.	2.15	176	---	66	74	3.7	---	---
224	2 R.F.	2.15	176	---	66	73	3.5	---	---
224	3 R.F.	2.17	188	3	60	73	2.0	---	---
224	Det.	2.19	118	11	11	40	.2	---	---
227	1 A.F.	2.20	176	3	14	---	2	---	---
245	P.P.	2.30	216	40	---	---	20	---	---
245	P.P.	2.30	216	40	---	---	20	---	---
227	Vol. Con.	2.15	15	8	38	---	---	---	---

Line voltage, 115 volts. Volume control.

Fig. 2. The voltages indicated in this table are given as a guide for service men and are taken with a Jewell set analyzer

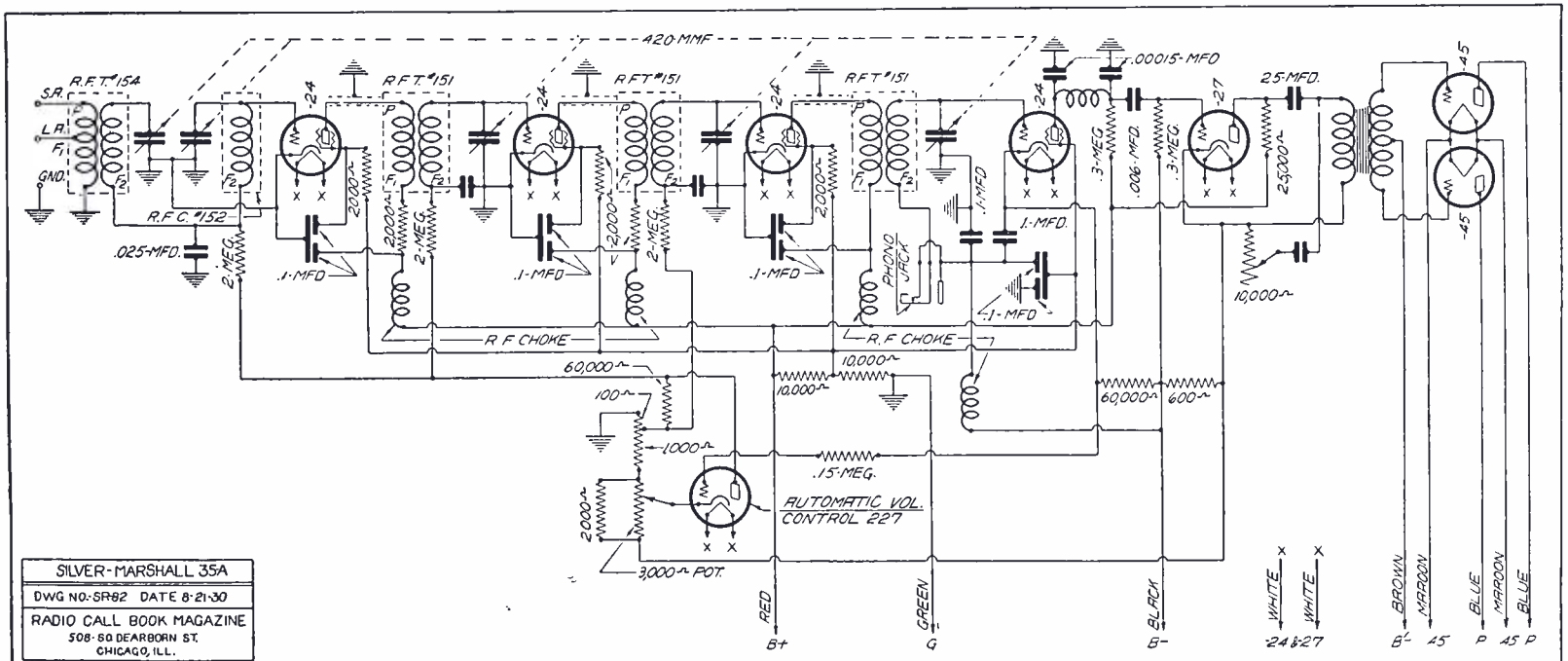

Fig. 3. The electrical circuit of the receiver marketed by Silver as 35-A may be traced from the above drawing

Silver Model 36 A Superheterodyne

ON this page will be found the schematic of the Silver model 36-A superheterodyne, together with a table of tube operating voltages and other service data abstracted from the manual furnished for that receiver. The 32-A power pack, 60 cycles, is designed for the 36-A receiver.

The model 36-A is shipped with a self-contained antenna connected to the antenna binding post. Where the receiver is located in districts remote from broadcasting stations, or in exceptional metropolitan locations where the field strength of various broadcasting stations is greatly attenuated by the shielding effect of metal frame buildings, greater range may be secured by using a small indoor or outdoor antenna. The former may consist of from 20 to 50 feet of No. 18 annunciator wire tucked in the picture molding, or under a rug. An outdoor antenna may be from 20 to 60 feet in length, except in metropolitan sections, where the length should not exceed 35 feet.

Excessive hum may result from: defective 280 rectifier tube; defective 339U choke; open filter condenser; defective field coil in speaker; grounded or shorted by-pass condenser; grounded filament lead. This may be in the filament wiring or dial light circuit.

An acoustic howl may result from: defective detector tube, rare and extremely annoying since the tube may test o.k. in a tube checker. Replace the defective tube. Failure to remove ship-

ping blocks (see instruction card attached to receiver). Any defect in the support of the receiver chassis which will prevent it from being entirely suspended by the rubber cushions, may cause a howl.

Low volume may be caused by: defective or worn out tubes; poor antenna; receiver not properly aligned; audio transformer defective; opens, shorts or grounds in receiver or power pack.

In the event a receiver oscillates it should be seen that the small metal disc has been installed on top of the tube

cover for the first intermediate frequency screen grid tube. This is the third tube from the left facing the receiver, the one nearest the drum dial. It is also important that a good ground connection be made to the receiver. Having made certain of these points, if the receiver still oscillates, it is likely a connection to one of the by-pass condensers has been broken, or that one of the by-pass condensers is open internally. All such connections should be checked, especially the 1000 mmf condenser connected between the plate and cathode of the second detector.

Silver Model 36A

Tube Type	Position in Set	A Volts	B Volts	C Volts	Cathode Volts	Screen Volts	Normal Plate M. A.	Plate M. A. Grid Test	Change
224	1 R. F.	2.27	162		7	85	4		
224	1 Det.	2.27	76*		37.5	80	3		
227	Osc.	2.27	82		37.5		11		
224	1 I. F.	2.27	160		12.5	110	4		
224	2 I. F.	2.27	160		45.0	110	4		
224	2 Det.	2.27	245		7.0	162	4		
245	P. P.	2.4	255	22.5*					
245	P. P.	2.4	255	12.5					

Line voltage. Volume control maximum.

*Misleading due to current drawn by meter.

Fig. 1. From the service manual for the Silver 36-A are abstracted the tube operating voltages shown in this table as taken with a Jewell analyzer

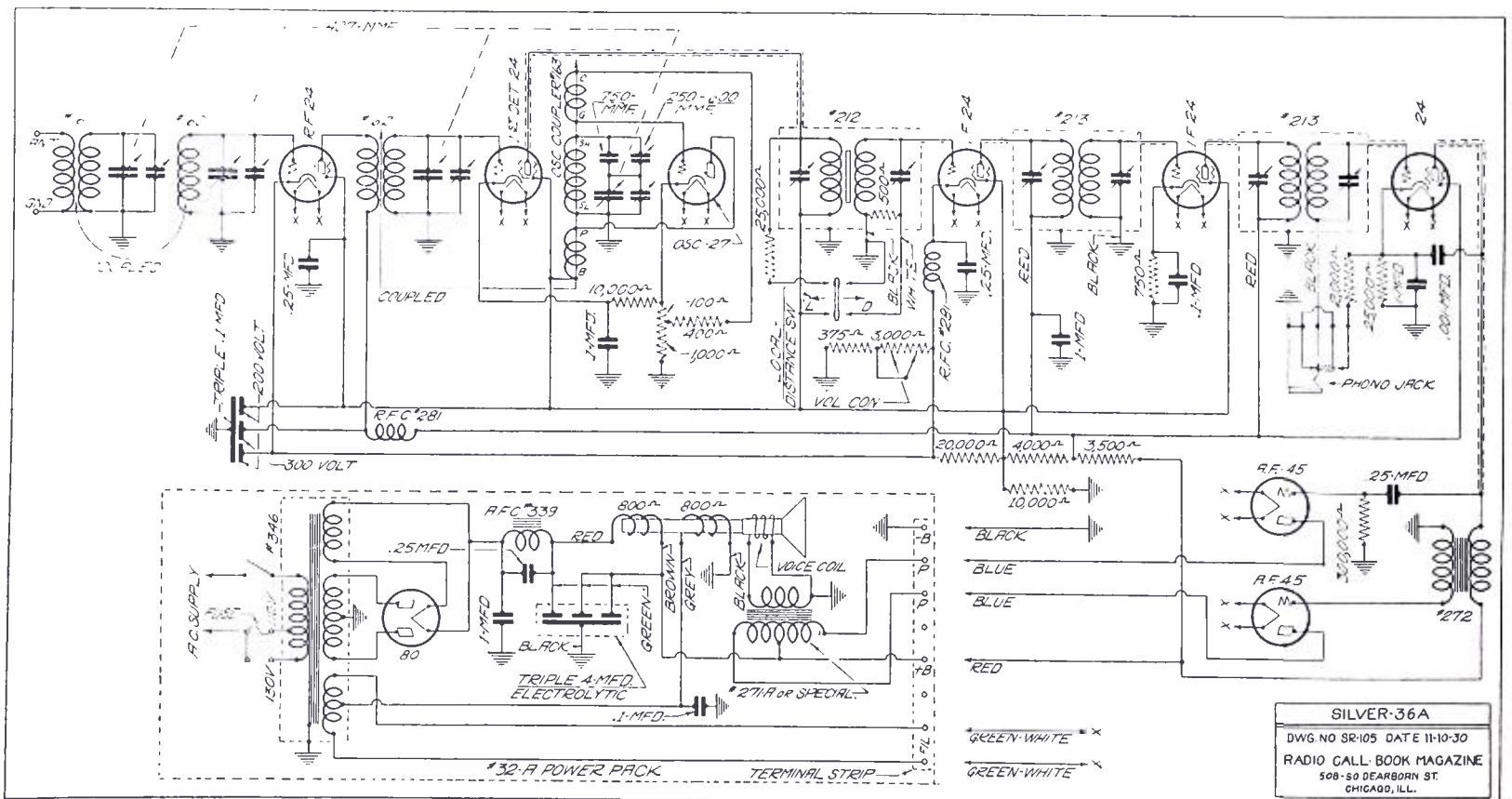

Fig. 2. Receiver and power supply schematics are shown in this illustration of the Silver 36-A receiver and 32-A power pack

Slagle Model 9 Receiver and Supply

THE Slagle model 9 receiver and power supply illustrated on this page is made by the Continental Radio Corporation at Fort Wayne, Indiana. It uses nine tubes, seven of the 227 type, two 171-A, and one rectifier type 280. The set comprises six r. f. stages, and one a. f. push pull stage. The detector is of the untuned grid bias type. The set has an antenna compensating condenser adjustable for short, medium and long antenna. Total watts consumed 109. Plate voltage on the audio stage is 180 volts.

Analysis of Voltages

Using a Weston No. 537, type 2 radio set-tester, the following is a typical analysis of the voltages on the Slagle model 9.

First r. f. 227, tube out A voltage 2.45, B voltage 94, tube in tester A volt-

age 2.15, B voltage 80, C voltage 3, cathode volts positive 3, normal plate m. a. 4.5, plate m. a. grid test 7.

Second r. f. 227, tube out A voltage 2.45, B voltage 98, tube in tester A voltage, 2.15, B voltage 88, C voltage 3, cathode volts positive 3, normal plate m. a. 5.8, plate m. a. grid test 8.8.

Third r. f. 227, tube out A voltage 2.45, B voltage 94, tube in tester A voltage 2.15, B voltage 80, C voltage 3, cathode volts positive 3, normal plate m. a. 3.8, plate m. a. grid test 6.1.

Fourth r. f. 227, tube out A voltage 2.45, B voltage 98, tube in tester A voltage 2.15, B voltage 88, C voltage 3, cathode volts positive 3, normal plate m. a. 5, plate m. a. grid test 8.

Fifth r. f. 227, tube out A voltage 2.45, B voltage 98, tube in tester A voltage 2.15, B voltage 80, C voltage 3, cathode volts positive 3, normal plate

m. a. 4.6, plate m. a. grid test 7.2.

Sixth r. f. 227, tube out A voltage 2.45, B voltage 98, tube in tester A voltage 2.15, B voltage 90, C voltage 3, cathode volts positive 3, normal plate m. a. 4.5, plate m. a. grid test 7.2.

Detector 227, tube out A voltage 2.45, B voltage 192, tube in tester A voltage 2.15, B voltage 177, C voltage 20, cathode volts positive 20, normal plate m. a. 1, plate m. a. grid test 5.5.

Push Pull Readings Same

Readings of the push pull 171-A tubes are identical. With tube out A voltage 5, B voltage 192, tube in tester A voltage 4.9, B voltage 172, C voltage 37, normal plate m. a. 16.5, plate m. a. grid test 53.

Rectifier 280, tube out, A voltage 5.2, tube in tester A voltage 4.5, normal plate m. a. 45.

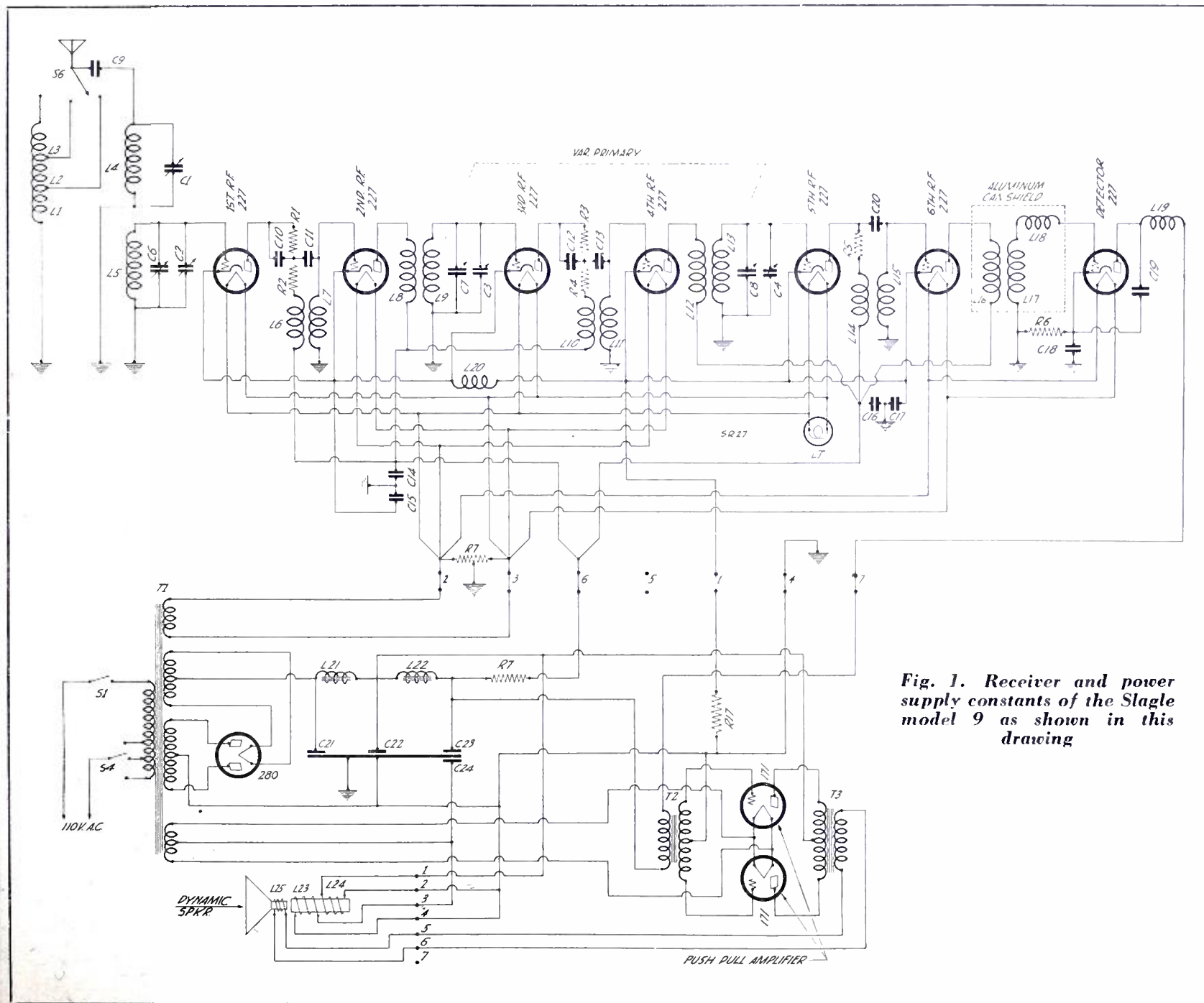

Fig. 1. Receiver and power supply constants of the Slagle model 9 as shown in this drawing

Sonora De Luxe Highboy Model 5R

USING the Loftin and White circuit, the receiver illustrated on this page is made by the Sonora Phonograph Co. of New York, N. Y. The tuner unit consists of three stages of tuned r. f. and detector. The circuit is combined electro-magnetic and electro-static, constant coupled tuned r. f.

Four Tuned Stages

Tuning is effected by means of four variable condensers. The rotating plates operate from a master shaft and are grounded to the tuner case. Fixed plates are insulated from ground and connected to the grid of the corresponding tube. The variable condenser on the right-hand end of the master shaft is the antenna tuning circuit condenser. The capacity of this condenser may be slightly changed without disturbing the setting of the other tuning condensers by means of the antenna fine tuning control directly below it. This adjustment will be found quite helpful for distant reception for cutting out interference from other broadcasting stations operating on a wave near the one being received.

Each variable condenser has a small adjusting fin or blade mounted close to one end of the bank of stationary blades and is grounded to the case. This blade adjusts the capacity of the condenser so

that maximum amplification and sharp tuning is obtained for any wavelength throughout the entire range. If the setting of this blade has been altered it will reduce the sensitivity of the set and may be readjusted by tuning in a very weak or distant signal and reducing the volume control until the signal is barely audible. Then move the blade until maximum signal is received and lock the fin in this position.

The tuning control is operated by means of a pulley and belt attached to the center of the tuner case. The reduction or turning ratio between this shaft and the master shaft of the variable condenser is about 2.5 to 1. Geared to the master shaft is the dial which is calibrated in wavelengths. This dial rotates by means of a friction clutch. If the pointer on the radio panel of the cabinet does not indicate correctly the wavelength of the station received, the dial may be moved ahead or retarded by turning the tuning control knob until the movable plates of the variable condenser are all of the way in or all of the way out and then tightly grasping the calibrated dial with the fingers and moving the dial ahead or back to indicate the correct wavelength received. Once the dial has been set to indicate correctly the wavelength of a station received, all other readings will also indi-

cate correctly.

To control the volume on the signal received a variable resistance of about 2,000 ohms is mounted in the shielded compartment of the detector tube on the left side of the tuner cabinet.

Connections in Cable

A multi-conductor cable connects the tuner unit to the amplifier unit. This cable consists of six conductors which carry the filament and plate voltages to the tuner. A separate conductor, not included in the cable, connects the output of the detector to the primary winding of the audio amplifier unit. The antenna and ground leads are brought out separately and terminate at the antenna and ground binding posts.

The power amplifier unit consists of one stage of transformer coupled audio, one stage of push-pull transformer coupled power amplification. The primary of the first audio transformer receives its energy from the output of the detector tube. The secondary of this transformer has a separate winding for Sonora low impedance magnetic pickup. The push-pull input transformer receives its energy from the first audio amplifier tube and supplies the grid to the two push-pull amplifier tubes. The plate leads of these tubes are connected to an output or step-down transformer.

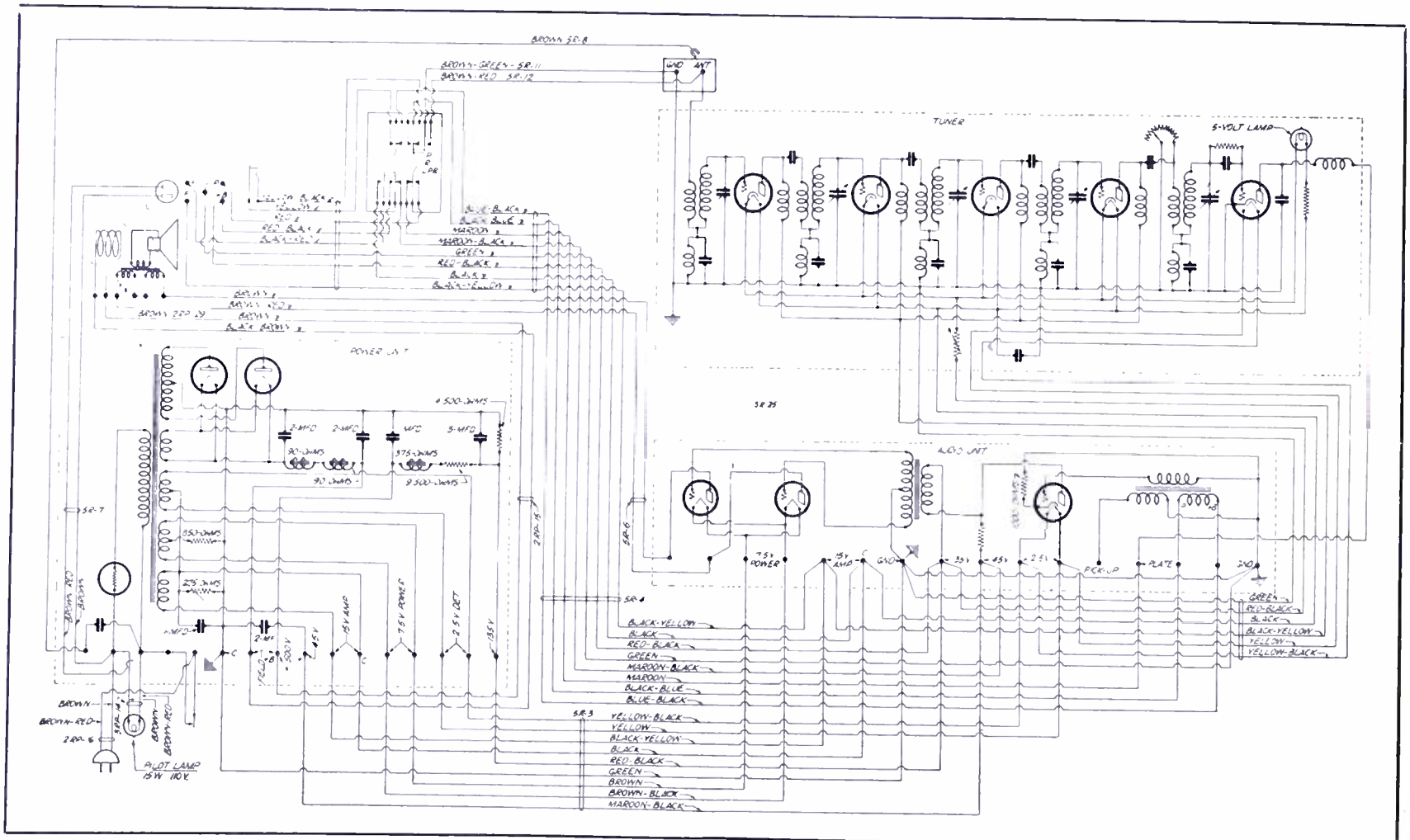

Fig. 12. In this diagram are shown the receiver constants and those of the power supply together with the inter-connecting cables for linking the two units. The model number is 5R

Sparton A. C. 89 Receiver and Pack

K NOWN as the Equasonne circuit, the receiver whose schematic diagrams are shown in the article, is manufactured by the Sparks-Withington Co. at Jackson, Michigan. The particular model diagrammed here-with is called the Sparton model A. C. 89.

Uses 250 Tube

Referring to the receiver's schematic shown in Fig. 2, it will be found that six tubes are used in the receiver proper, these being of the heater type, such as the 227. The power tube is contained in the power supply and is a type 250. The rectifier used is the conventional 280.

Signal Is Pretuned

There are several features of this receiver which are different from the general run of sets with which the service man is familiar. For example: At the left in the schematic, Fig. 2, it will be observed that there is a set of inductances and tuning capacities linked together inductively and all lying between the antenna circuit and the grid of the first radio frequency tube. This is known as the selector system and is used exclusively by the Sparton interests in the various models of their receiver. A signal from the antenna is pretuned before reaching the grid circuit of the first radio frequency tube. From then on towards the detector the signal is amplified through the succeeding radio frequency stages but is not further tuned.

used in the power supply is the 280 type, full wave. Arrangements are also made for a phonograph pick-up that may be used in connection with the receiver.

Aperiodic Amplification

It will be observed that the r. f. coil diagrams in this circuit are not of the conventional type, since these coils function aperiodically to amplify whatever frequency is fed into the receiver by the pretuning arrangement. In the detector stage, rectification is by means of the grid bias.

It will also be observed by following

In the schematic circuit in Fig. 2 it will be seen that the antenna circuit goes through a variable condenser before reaching the selector unit. When the receiver is installed by the dealer or service man, it is necessary that the adjusting screw of this condenser be turned back and forth until maximum volume is secured. If the customer changes aerials it will be necessary to make a readjustment on the antenna compensating condenser.

Voltage Measurements

In making measurements on the receiver, all tests should be made with the volume control full on and the voltage adjuster on the proper tap. Detector plate voltage will normally be 188 volts, without phonograph

pick-up and jack and 115 with the pick-up. The limits of variation are 150 volts to 250 volts without pick-up, and 90 to 140 volts with pick-up. More or less than this indicates a defective plate circuit.

Radio frequency amplifier plate voltages are 112 volts, with the limits being 90 to 135.

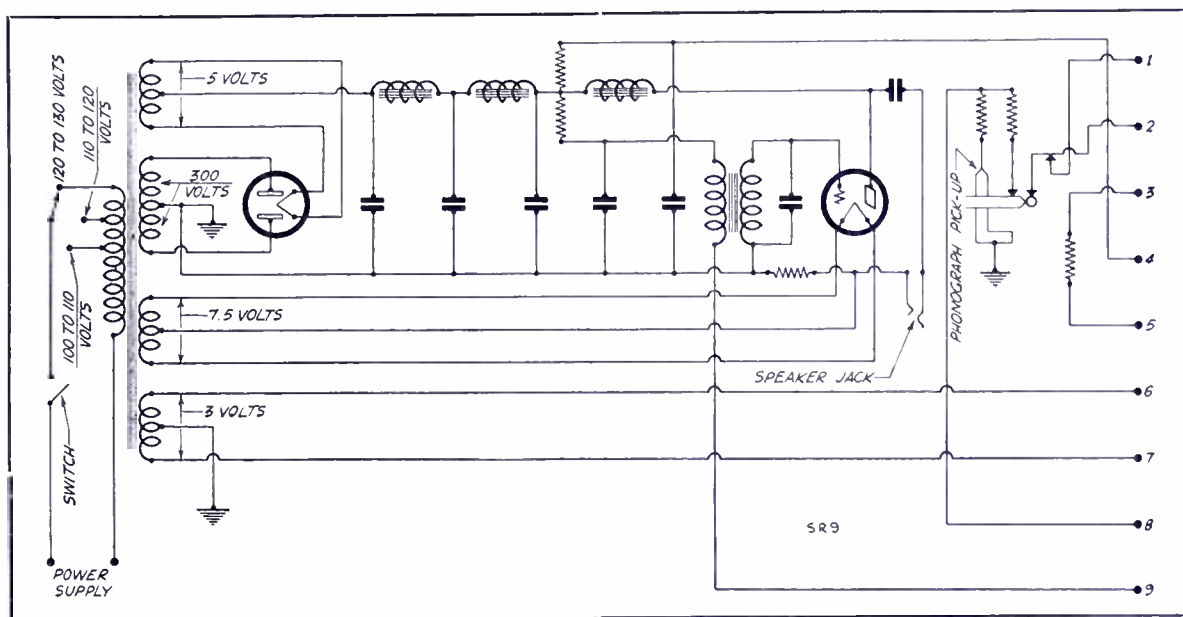

Fig. 1. Here is shown schematically the power pack used with the Sparton A. C. 89 receiver

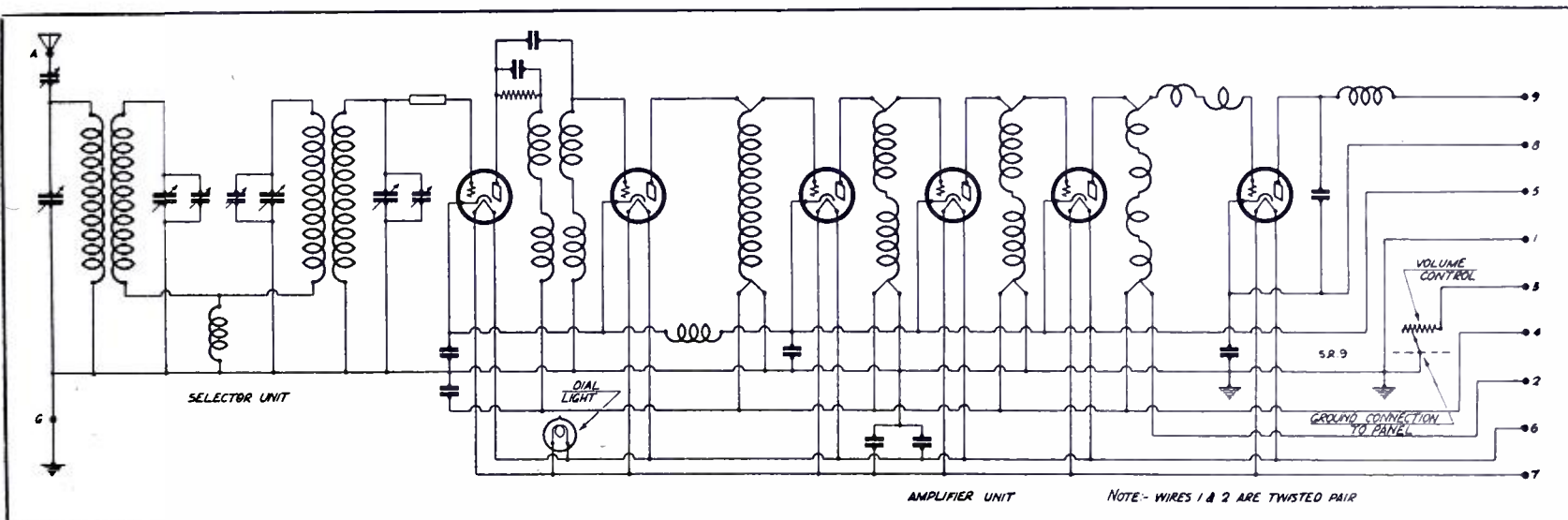

Fig. 2. Shown at the left in this schematic of the Sparton A. C. 89 is the selector system ahead of the first r. f. tube

Sparton Equasonne Receiver No. 589

ANOTHER model made by the Sparks-Withington Co., and known as their model 589 is illustrated schematically in Figure 1 on this page. An earlier model, known as the AC-89, was shown in the September, 1929, issue of this magazine, on page 82.

Technidyne Circuit

The model 589 uses the same Technidyne circuit described in the September, 1929, issue, but employs a total of ten tubes, including the rectifier. One tuned stage of r. f. precedes the two-stage selector which is followed by another tuned r. f. stage, then followed by four untuned stages. The detector is the last tube at the right of Figure 1 and works directly into a transformer whose secondary feeds the two power tubes placed in push-pull.

Bias for the detector is provided by the drop across the 20,000 ohm resistor between the detector cathode and ground, while the bias for the output tubes in push-pull is secured through the drop across the 1,250 ohm resistor between ground and the center of the 5-volt filament supplying the power tubes. Grid bias for all of the radio frequency stages is secured through the drop across the 110-ohm fixed resistor in series with the 15,000-ohm volume control resistance (variable) between the common cathode line and ground.

In a recent service sheet sent out by

Sparton for its service men we note several items of interest which are being passed on to service men readers.

Full Volume Test

All tests on the receiver should be made with the volume control full on, and the voltage adjuster on the proper tap. The line voltage should be tested and the voltage adjuster set at the corresponding voltage or higher. For this test a 0-160 a. c. voltmeter is required to read the voltage.

There are two tests that can be made with the 0-300 d. c. voltmeter. The first is for the detector plate voltage. Measure detector plate voltage between terminals 1 and 2. Normal voltage here should be 140 volts without phonograph pickup in jack, and 135 with pickup. The limits of variation are 120 to 160 volts without pickup, and 110 to 150 with pickup. More or less than this indicates a defective plate circuit, possibly in the 20,000-ohm resistance.

The second measurement is for the plate voltage of the r. f. and selector tubes. Measure between terminals 5 and 6. Voltage should be 145. Limits 130 to 170. More or less than this value indicates plate circuit trouble, possibly caused by 15,000-ohm resistor, or speaker field.

Two measurements may be made with the 0-75 d. c. voltmeter. The first is the detector bias voltage which should be measured between terminals 2 and 9. Normal bias 12 negative; allowable

limits of variation are -10 and -17. Voltages above or below this value indicate defective resistance 20,000 ohms or connections. Detector bias voltage with pickup plugged in should read between 3 and 5 volts. More or less than these voltages indicate defective circuit, probably in the 1,000-ohm resistance.

Bias Voltages

The second measurement is for the bias voltage on the r. f. and selector tubes. Measure between terminals 5 and 9. Normal r. f. bias -4.5 volts. Limits -6 to -3. More or less than this indicates defective resistance, 110 ohms, or abnormal r. f. plate current, and results in loss in volume. With volume control off a wide variation of the above voltages is obtained, but this fact is of no consequence.

With respect to the heater voltages, using 0-4 a. c. voltmeter, measure detector, selector and radio frequency heater voltage between terminals 3 and 4. Normal is 2.97 volts; more than this dangerous to tubes. Maximum allowable on these terminals is 3.1. If voltage higher than this place voltage adjuster on another tap to lower this excessive value.

Aerial Compensator

To adjust the aerial compensating condenser turn volume control full on, tune set to station of 1,250 kc. or higher, and adjust compensating condenser for maximum volume.

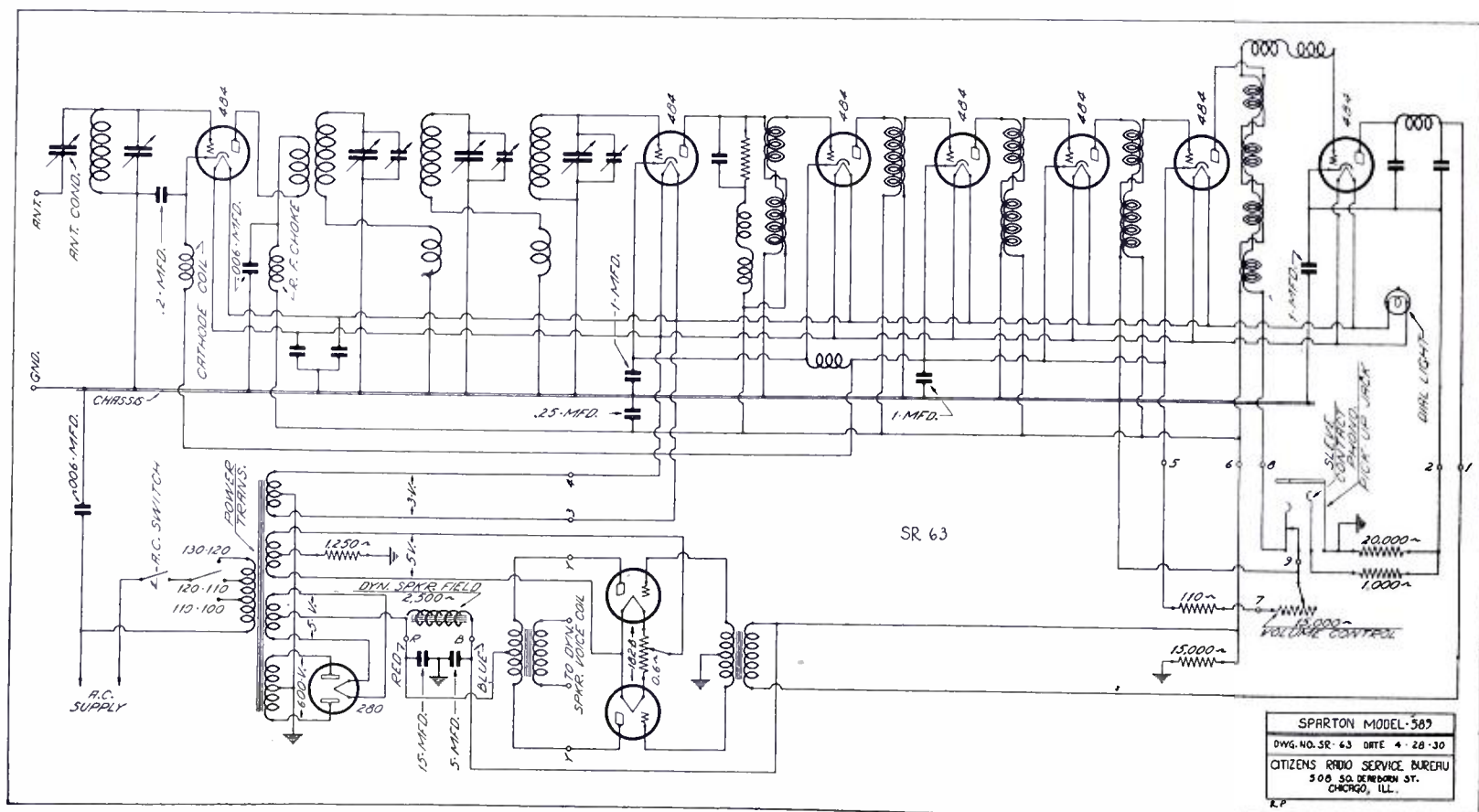

Figure 1. The schematic diagram of the receiver and power supply of the model 589 Sparton is illustrated above

Sparton Radio Receiver Model 931

ANOTHER model produced by the Sparks-Withington Co., and known as the Sparton model 931, is shown schematically in the drawing at the bottom of this page. A table of average tube operating values is also shown so that service men may check operation of the set. The tubes used are special ones designed for the Technidyne amplifier and where replacements are made these special tubes should be used instead of the conventional ones.

As indicated in the diagram the receiver consists of a tuned selector input system followed by the Technidyne amplifier working into a pair of 182 power tubes in push-pull. The antenna condenser noted is set for the particular antenna condition and left alone. A change in the antenna will require a re-adjustment of this antenna condenser.

The volume control is a 50,000-ohm variable resistor and a 110-ohm fixed resistor in series, this combination being placed between the ground and cathode circuits. When the phonograph pickup is plugged into the jack the ground line opens on the phono jack and the ground to the right of the jack becomes effective. The bias for that tube is supplied

through the 20,000-ohm fixed resistor. A 2,500-ohm speaker field is employed, this field being a part of the filter circuit. The secondary of the speaker coil goes directly to the voice coil of the dynamic speaker. Bias for the push-pulled power tubes is secured through the drop across the 1,250-ohm

resistor between ground and center tap of the five-volt secondary for the power tubes.

A fixed resistance of 15,000 ohms is placed between ground and the high side of the power supply at the output end of the dynamic speaker field winding.

Sparton Model 931

Tube Type	Position in Set	A Volts	B Volts	C Volts	Cathode Volts	Screen Volts	Normal Plate M. A.	Plate Grid Test	M. A. Change
484	1 R.F.	2.9	120	4.5	---	---	7.5	13	5.5
484	2 R.F.	2.9	120	4.5	---	---	7.5	13	5.5
484	3 R.F.	2.9	120	4.5	---	---	7.5	13	5.5
484	4 R.F.	2.9	120	4.5	---	---	7.5	13	5.5
484	5 R.F.	2.9	120	4.5	---	---	7.5	13	5.5
484	Det.	2.9	110	10	---	---	1.0	3.5	2.5
182	P.P.	4.9	270	35	---	---	20	25	5.0
182	P.P.	4.9	270	35	---	---	20	25	5.0
280	Rect.	5	---	---	---	---	85	---	---

Line voltage 120; set on 120-130 tap. Volume control maximum.

Fig. 1. Service men will find a guide to the tube characteristics in the table shown above as taken with a Jewell set analyzer

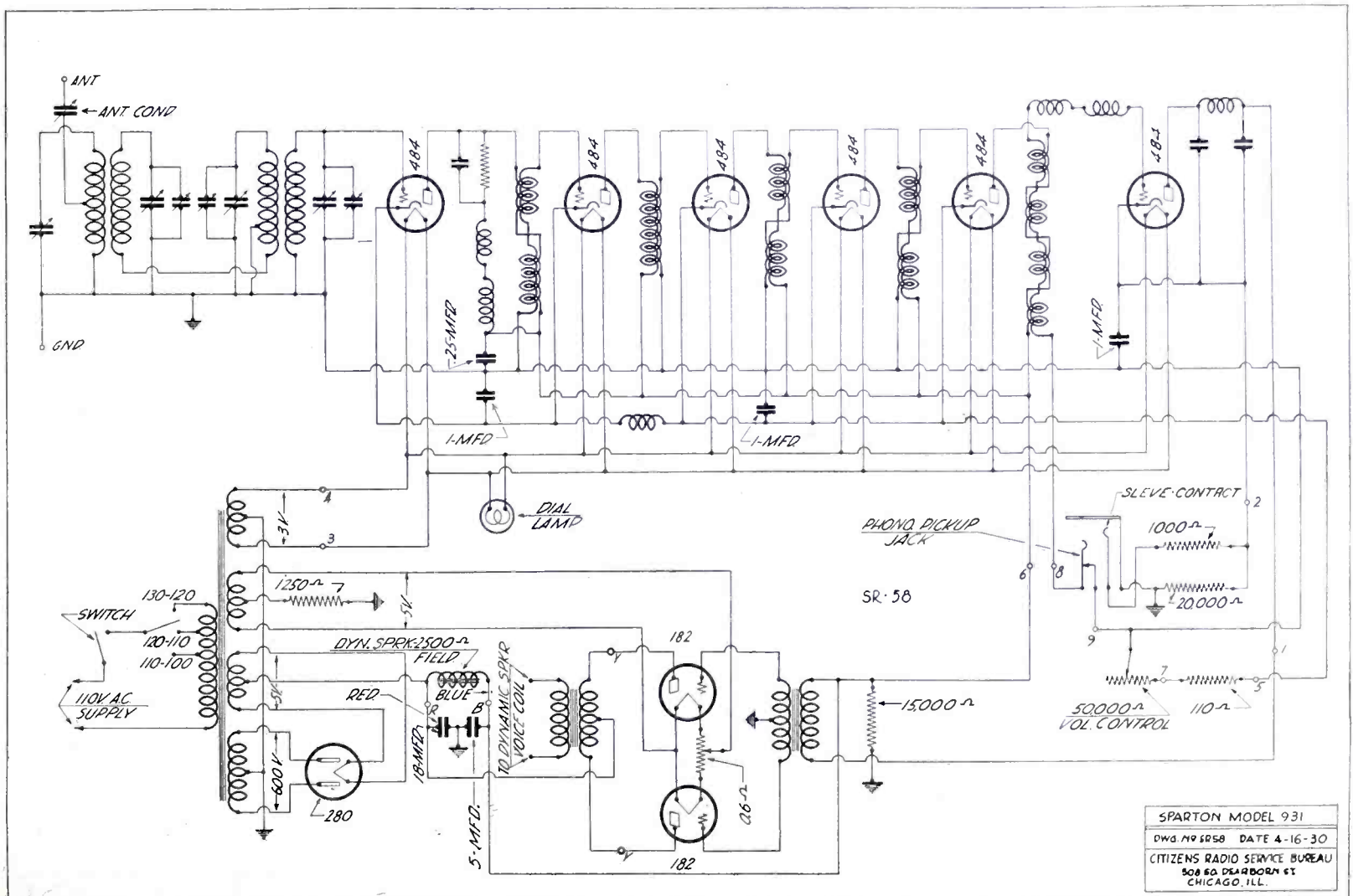

Fig. 2. Sparton's model 931 will be found in the diagram shown here

The Splidorf E175 Receiver and Pack

MADE by the Splidorf Radio Corporation of Newark, New Jersey, the type E175 receiver and power supply is illustrated below. Schematically the receiver and the high voltage supply are shown in Figure 14.

Examination of the schematic circuit will indicate that the antenna stage has three taps on the primary for different antenna lengths. The second radio frequency and third radio frequency stages have a grid suppressor resistance in series between the coil and the grid. No grid resistor is used on the first r. f. stage. Detection in the case of the receiver here described is by means of the grid condenser and grid leak. The secondary of the first audio transformer has a resistor placed across its extremities which is used to flatten out the response curve of that particular transformer.

The detector used in this receiver is a 227, while all of the remaining tubes in the r. f. and first a. f. stages are of the 226 type. The resistance R-6 in Figure 14 is placed across the 226 filament line and is by-passed both ways from the center with condensers C-8 and C-9. Resistor R-8 supplies the required

bias for the 226 grids. In the case of the 227 detector a resistance R-7 is placed across the filament line and the center tap of this resistor is made common with the cathode. The cathode is also at ground potential as are all of the grid returns on the radio frequency stages as well as the first and second audio.

Primary Fused

A switch is provided in the primary circuit of the power transformer together with a fuse and a fixed resistance R-10. The high voltage secondary S-4 goes to the plates of the 280 rectifier, while the filament current for the rectifier is supplied by the secondary S-3. The center tap of S-3 becomes the high voltage terminal of the system in conjunction with the choke coils X-1 and X-2 and the voltage divider resistance R-11. S-2 furnishes the filament current for the 226 tubes while S-1 furnishes the current for the 227 detector. S-5 furnishes current for the output tube. Condensers C-10 and C-11 are arranged around the input and output of the choke X-1. The voltage divider resistor is made up into four sections, A

from the maximum voltage to the voltage for the plates of the 226's, B for the voltage applied to the detector, and C the resistor between the detector voltage and negative. Resistance D is the bias resistor for the power output stage.

The speaker is cut in through a condenser C-14 between the plate of the output stage and the center tap of the filament winding for that particular filament circuit.

It will be observed that the resistance R-4 is placed across the extremities of the primary in the fourth radio frequency transformer. The arm of this variable resistance is common with one side of switch SW-1 and the bottom side of by-pass capacity C-7, this variable resistor serving to give a resistance and capacity coupling between the plate of the third 226 and the plate of the 227 detector.

The hum control for the first audio 226 is resistance R-9 across the secondary S-2 of the power pack. Its center tap is common with the center tap of resistance R-6.

In the absence of any analysis of voltages for this particular model this information cannot be given.

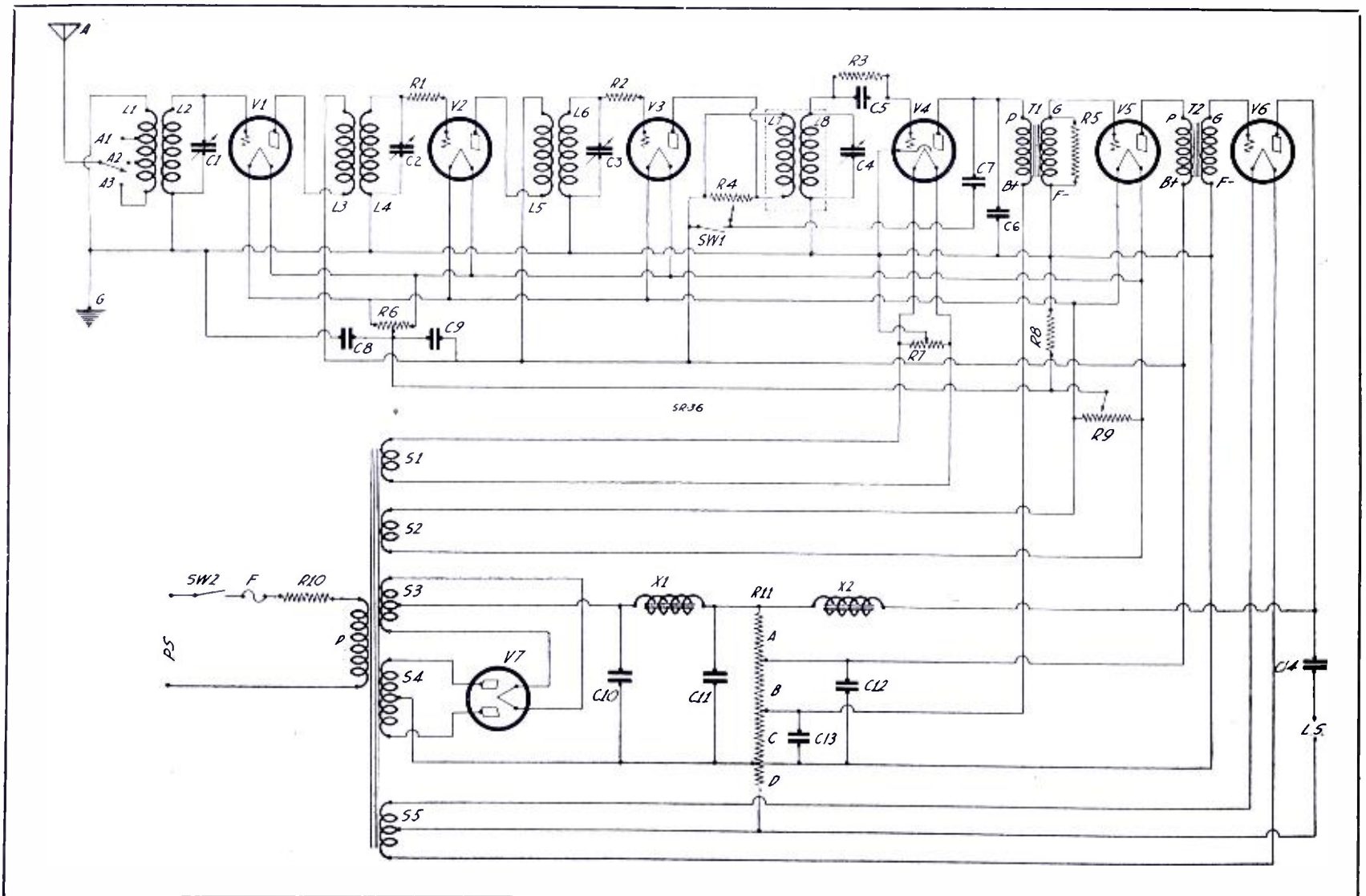

Fig. 14. All details of the receiver and power supply for the Splidorf E175 shown on this page is contained in the schematic drawing above

The Steinite Model 261 and Supply

EMPLYING four 226 tubes, a 227 detector and a 171-A audio power stage the Steinite model 261 receiver is made by the Steinite Radio Co., Chicago, Illinois, and Atchison, Kansas.

Stepped Inductance

Electrical details of the receiver and the power supply are disclosed in the schematic diagram, Fig. 1, on this page. It will be noted that the input stage is tuned by means of an antenna inductance having a number of taps. In the original model there were three inductance steps corresponding to three equal divisions of the broadcast band. However, since September, 1928, the number of steps in the inductance was increased to seven and is controlled by a seven-point switch located immediately back of the volume control knob on the receiver.

The receiver is a grid resistance stabilized tuned radio frequency set having three tuned stages and a semi-tuned antenna coupling stage. Arrangements are made for the employment of a phonograph pick-up unit, which is

plugged into position across the primary of the first audio transformer.

Antenna Conditions

If the set is connected to a very short or a very long antenna, the operation of the antenna compensating switch will not be normal. The maximum volume for stations near the center of the broadcast band will be obtained when the antenna switch is on the left-hand point or right-hand point, depending on whether the antenna is too long or too short, respectively, and there will be a loss of sensitivity on one end or other on the wave band. It should be understood that a medium sized antenna which is run too close to a wall or roof has large capacity and works like an extremely long antenna. A good ground connection is also essential for the best operation of the set, since a high resistance ground may cause weak signals, broad tuning or hand capacity effect. If it is suspected that the receiver is not properly balanced, it may be re-tuned by setting the dial so that a weak signal between 250 and 350 meters is tuned in and then adjusting the variable

condenser compensating plate until the signal is the loudest. These plates may be reached with a screw-driver through the openings in the condenser shield.

Voltage Under Load

Service men when testing the power unit should remember that the correct voltages will be obtained only when the power unit is operating in conjunction with the receiver chassis, which gives it the proper load. Thus a ground on one of the B plus leads tends to reduce the plate voltage while an open circuit tends to raise it. When incorrect voltages are obtained at the power unit terminals, it should not be assumed that the power unit is defective since a fault in the receiver could also cause the incorrect voltage. To determine whether or not the power unit is defective, it should be connected to a receiver chassis which is known to be in good condition and the voltage rechecked. Incorrect voltages will be obtained if any tube is removed, since the load is decreased. Incorrect voltages may also be obtained where the antenna is disconnected since the first r. f. tube may oscillate.

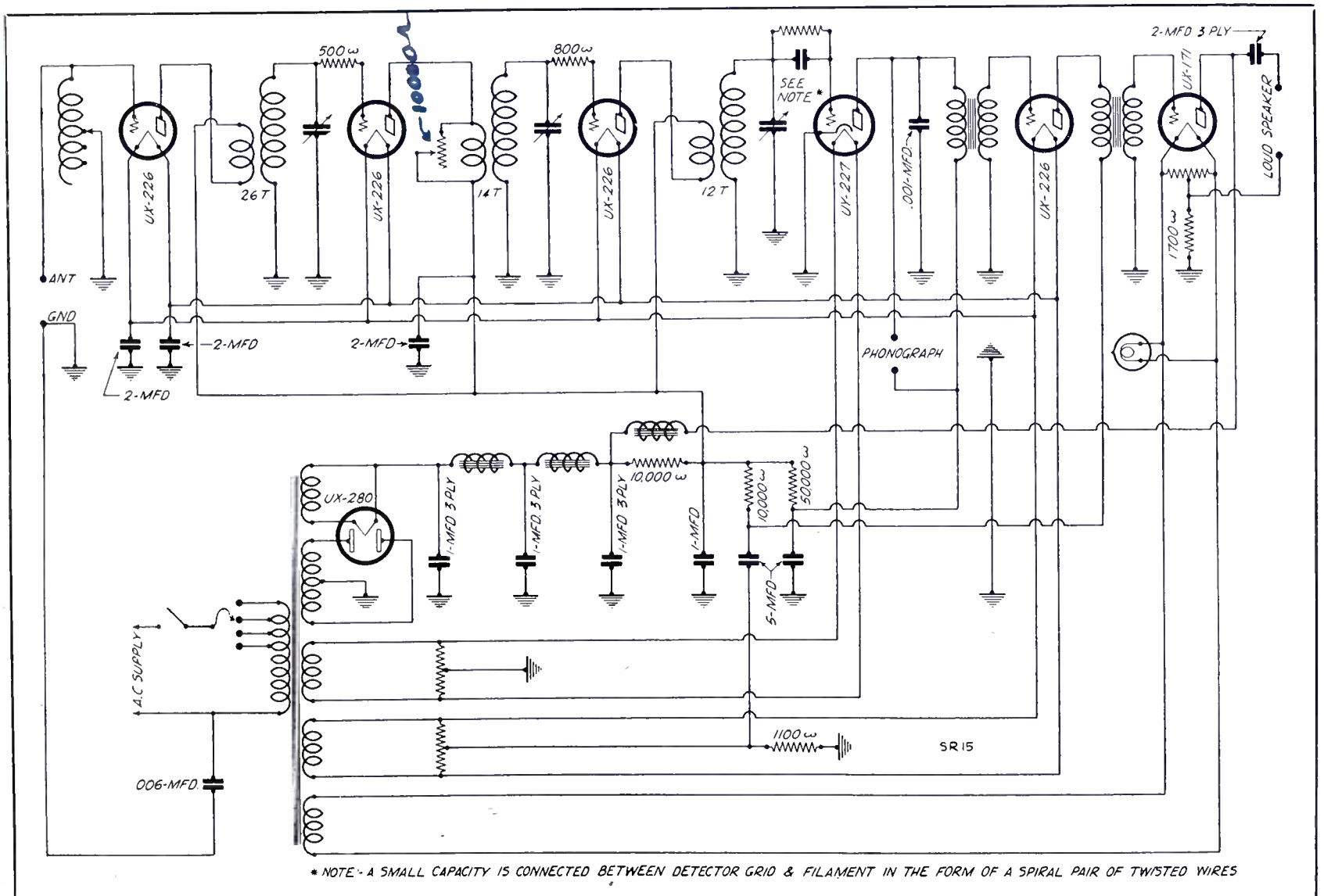

Fig. 1. Both the receiver and power supply schematics are combined in this drawing of the Steinite Model 261 a.c. receiver

Volume control R = 10,000 ohms

Stewart Warner Series 900 Receiver

THE balanced bridge type of circuit is used in the 900 series a. c. radio receiver made by Stewart Warner and shown schematically on this page. This circuit differs from the usual circuit of its kind in that it makes use of shunt capacity through separate choke coils and bypass condensers, thus separating all radio frequency from the power circuit which makes for greater stability, allowing amplification to be carried to a further point without oscillation. The complete circuit diagram is shown in Figure 12.

Voltage Analysis

An analysis of voltages on the series 900 receiver made with a Weston 547 test set shows the following:

First r. f. 227 A volts 2.2, B volts 145, C volts minus 10, cathode heater volts plus 10, normal plate m. a. 3.7, plate m. a. grid test 6.7.

The second r. f. 227 shows A volts 2.2, B volts 145, C volts minus 10, cathode volts plus 10, normal plate m. a. 4.7 and plate m. a. grid test 8.

The third r. f. 227 shows A volts 2.2, B volts 147, C volts minus 10, cathode volts plus 10, normal plate m. a. 3.9 and plate m. a. grid test 7.1.

The detector 227 reads 2.2 A volts, B volts 30, C volts 0, cathode heater volts 0, normal plate m. a. 1.8 and plate m. a. grid test 2.

The first a. f. 227 has A volts 2.2, B volts 140, C volts minus 8, cathode heater volts plus 8, normal plate m. a. 4.5, plate m. a. grid test 5.7.

One of the 245's used in push pull reads 2.2 for A volts, B volts 235, C volts minus 43, normal plate m. a. 27.5 and plate m. a. grid test 39. The other 245 has A volts of 2.2, B volts 235, C

volts minus 41, normal plate m. a. 32 and plate m. a. grid test 35.

The 280 rectifier reads A volts 4.6, normal plate m. a. 47.5. These readings are taken with the volume control full on and a line voltage of 109.

Tube Variation

It is to be noted that a certain amount of variation is to be expected in tube readings. Experience coupled with a knowledge of the circuit of the set should tell whether the variation found with any particular receiver is normal or not.

The standard test with a suitable radio set tester will indicate more or less closely in what circuit the defect may be found. It then becomes necessary to make a series of continuity tests to locate exactly the source of the trouble.

Causes of Noise

Noisy operation is usually due to outside disturbances picked up by the aerial system. To determine its source disconnect both aerial and ground. If the noise continues it is evidently in the set. It may be necessary to turn back the volume control of the receiver and set the dial for a fairly high wave length station to prevent oscillation without the ground.

A loose connection anywhere in the entire receiving system will cause a noise. It is necessary to check all possible points. Jarring or shaking the items under suspicion will frequently indicate the cause of the noise.

Detector Noisy

A defective tube particularly when used in the detector socket may cause noisy reception. An interrupted buz-

zing that continues with the aerial and ground disconnected is almost certain to be caused by the detector tube.

Excessive hum may be caused by a defect in the receiver, the tubes or the power circuit. Most likely source of hum in the set itself is an open or short circuited resistor, particularly of the center tap kind. Check all resistors and fixed condensers particularly those used for bypassing r. f. current.

Poor Tone Quality

Poor tone quality may often be caused by a defective tube, this being more noticeable when the volume is increased. Low voltage, either low filament or plate voltage will cause scratchy reception. Incorrect C bias may also be the cause of poor tone quality. Check all grid bias resistors, make certain their resistances are correct and that they are not short-circuiting anywhere. Check grid voltage.

Mechanical Vibration

Occasionally mechanical vibration of the power transformer cover will result in a decided hum. This can be checked easily by pulling out the speaker plug while the set is in operation. If the hum continues it is almost certainly vibration of the transformer cover. To eliminate it remove the cover, pry off its lid and pull outward on all four sides to give the cover a noticeable barrel shape. Force the lid on again and replace the cover.

Another frequent cause of hum will be a rectifier tube in which the emission on one side will be considerably less than the other. This apparently unbalances the transformer to such an extent that hum is secured.

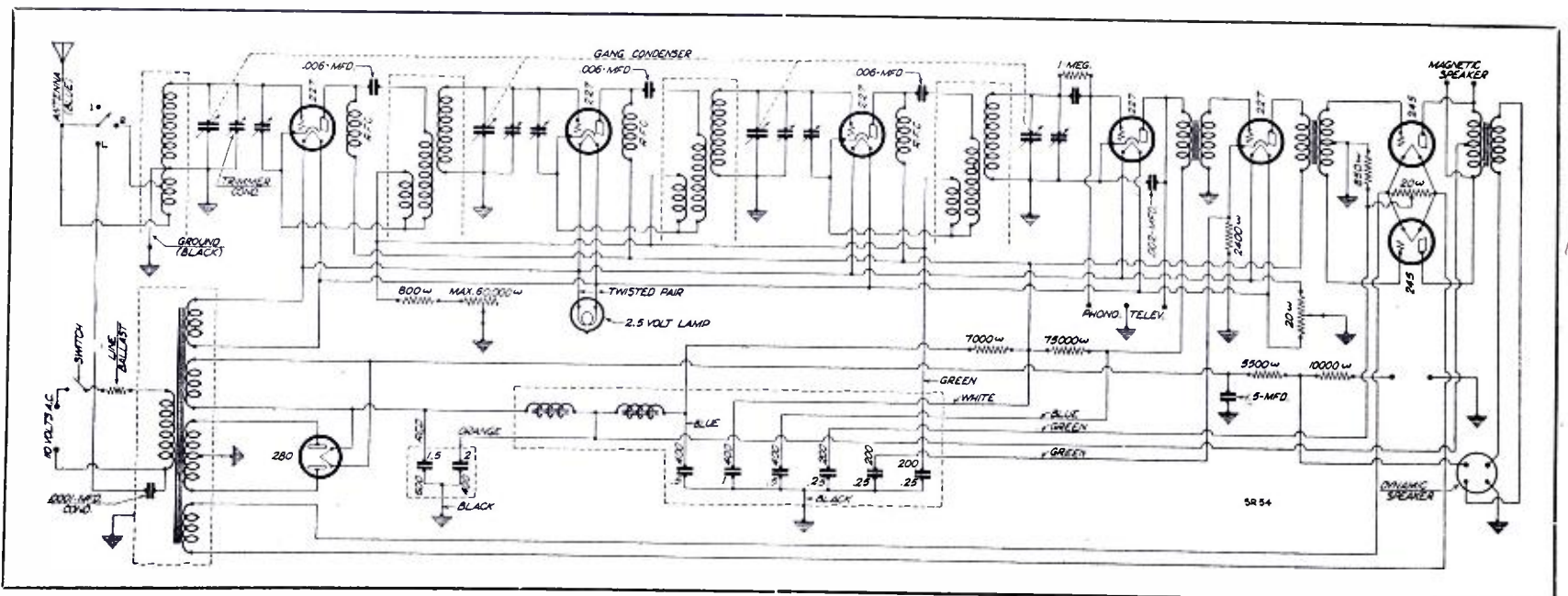

Fig. 12. The electrical circuit of the Stewart Warner series 900 receiver described here is shown in the above schematic

Stewart-Warner Series 950 Receivers

EIGHT tubes in all are employed in the Stewart-Warner series 950 receiver illustrated schematically on this page in Figure 2, while the table of tube voltages is given in Figure 1.

The circuit used in the 950 series is the screen grid type but is somewhat unusual in that it involves a combination of inductive and capacitive coupling in the radio frequency stages. The former coupling is most effective at the lower frequencies while the latter serves best for transfer of energy at the higher frequencies. The coupling capacities are the small adjustable condensers on the right side of the main tuning condensers. Under no conditions should they be touched since these capacities are originally set at the factory for a value of 16 mmf and any

alteration of this capacity will affect the performance of the receiver.

Power detection is used in the detector stage, a plate voltage of 180 volts being applied, a 40,000 ohm resistor cathode and ground supplying the required 18.5 volts bias for the 227 detector.

Coupling from the plate circuit of the detector to the grid of the first audio tube is resistance-capacity through a .1 mfd coupling condenser while a 1 megohm is used from grid to ground of the first audio tube. The bias for this grid is supplied through the drop across a 2400 ohm resistor between cathode and ground of the first audio tube. Bypasses for the various bias resistors are included in a block containing six bypass capacities each with a colored pigtail. The bias resistor for the 245 tubes

in pushpull is of 850 ohms between ground and centertap of the 20 ohm resistor across the 245 filament circuit.

While operating under normal conditions the 950 will not oscillate. A set of this type however may oscillate due to either a defect in the set itself or improper environment for the receiver. Oscillation due to defect in the set itself may be due to an open screen grid bypass condenser, an open r. f. bypass condenser, an open r. f. grid bias condenser, excessive screen grid voltage, or poor contact at the clips between sections of the variable condensers. Oscillation due improper environment may come under the head of feedback caused by a poor ground, or feedback in the external wiring of the receiver, the latter being caused by having the aerial close to the terminal strip in back of the set, or crossing either the speaker cord or the 110 volt cord. An imperfect ground is almost certain to cause oscillation. In this case the usual tests for grounds are insufficient. A very simple, yet infallible test that will definitely establish whether or not the ground is poor, or feedback is present, is to connect a fixed condenser of from .006 to .1 mfd capacity inside the set from the frame to one of the 110 volt wires at the soldering lug on the resistor terminal strip to which the 110 volt cord is connected. If, after reassembling the set carefully all traces of oscillation are gone, the original cause was unquestionably either feedback or poor ground.

Stewart-Warner Model 950									
Tube Type	Position in Set	A Volts	B Volts	C Volts	Cathode Volts	Screen Volts	Normal Plate M. A.	Plate M. A. Grid Test	Change
224	1 R.F.	2.3	166	1.5	-1.3	78	3.9	7.2	3.3
224	2 R.F.	2.3	168	2	-2	75	5.9	9.6	3.7
224	3 R.F.	2.3	167	2	-2	75	6.2	9.8	3.6
227	Det.	2.3	180	18.5	-20	---	6.	.65	.05
227	1 A.F.	2.3	182	2.5	-13.5	---	5.8	6.8	1.0
245	2 A.F.	2.35	260	46	---	---	24	28	4
245	2 A.F.	2.35	260	46	---	---	27	31	4
280	Rect.	4.6	---	---	---	---	---	---	---

Line voltage 115. Volume Control Maximum.

Figure 1. Tube voltages as taken with a Jewell set analyzer are shown here for the Stewart-Warner series 950 receivers

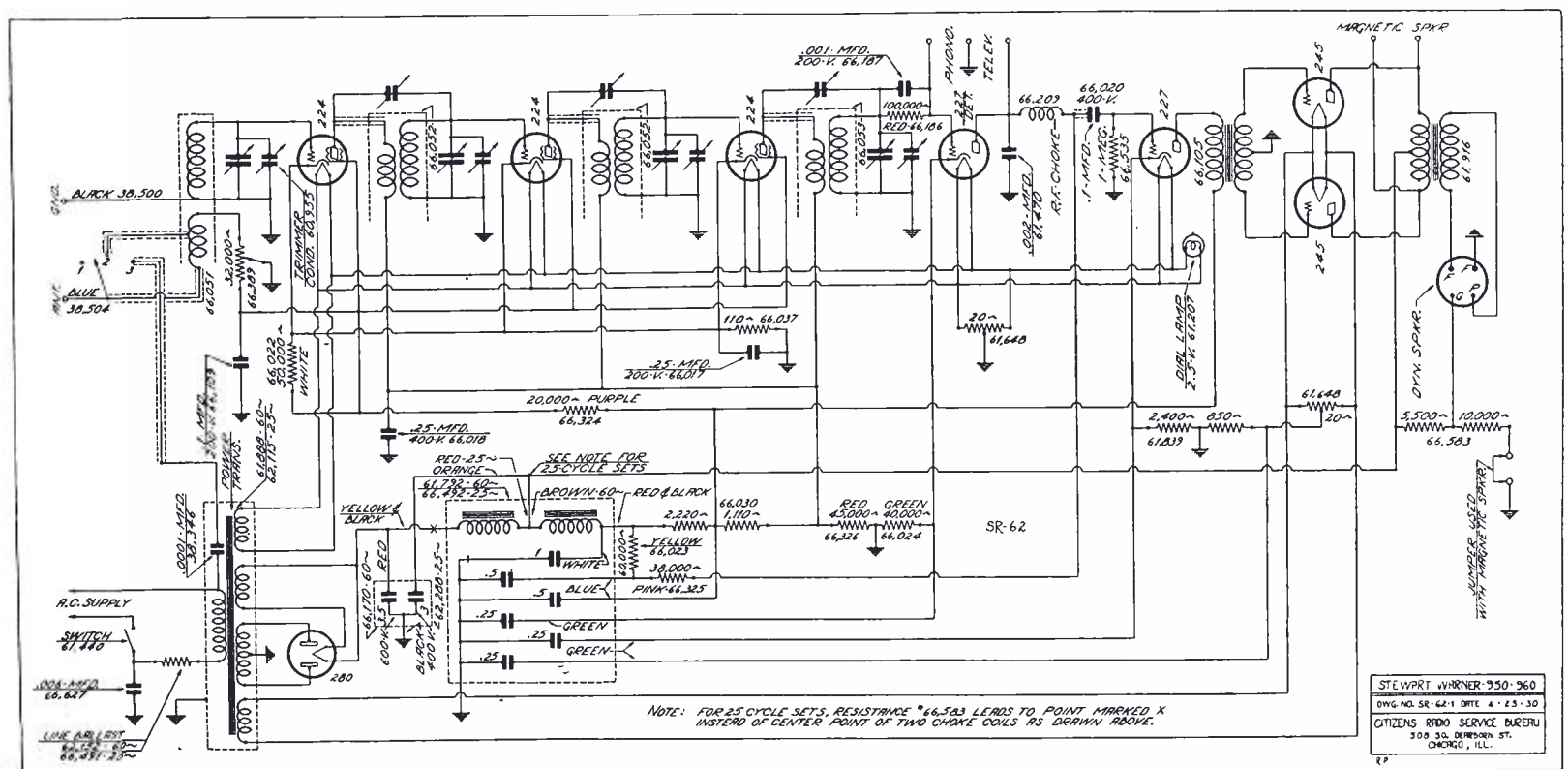

Figure 2. The receiver and power supply schematic of the series 950 Stewart-Warner is illustrated in this drawing

Stromberg-Carlson Models 12 and 14

On this page is presented the schematic diagram of the Stromberg-Carlson models 12 and 14, together with a table of tube operating values as indicated in the service manual for these receivers.

The radio amplifier employs a total of five tuned circuits as well as a broad band interstage coupling transformer. Four of these tuned circuits are used in two "bi-resonators," while the fifth is used to couple the radio amplifier to the detector. A highly effective automatic volume control circuit is employed, using a 227 tube. The detector also uses a 227 tube and is coupled to the first audio 227 by means of a low ratio transformer. The first audio tube is coupled to the push-pull 245's by a special large transformer. One of the 280 rectifiers supplies direct current for the tubes and the second 280 supplies rectified current for the speaker field.

There is a single station selector knob operating an illuminated dial. The volume control and phonograph switch operate from one knob, which is located at the left of the control panel. The on-off switch and the range control (local-distance) are operated by the knob at the right of the panel. The silent key is located directly beneath the selector knob and is illuminated by the same dial lamp. The chassis of the models 12 and 14 receivers are identical.

The antenna coupling system is designed so that absolute single selector operation is obtained without trimming or vernier controls on the first tuning circuit. An arrangement of a cord with

pin tip and two pin jacks is provided to adapt the receiver to the type of antenna used.

The automatic volume control operates by varying the control grid biases of the first two radio amplifier tubes in proportion to the strength of the received signal. When an extremely

strong signal, which cannot be handled by the automatic control, is received, the range control should be pulled out to the local position to decrease the signal input from the antenna to the radio amplifier. Normally the range control should be left in the distance, or pushed in position.

Stromberg-Carlson Models 12 and 14

Tube Type	Position in Set	A Volts	B Volts	C Volts	Cathode Volts	Screen Volts	Where Plate Voltages Measured
224	1 R.F.	2.4	130	.2-3.0	---	85	Between r.f. plates and chassis.
224	2 R.F.	2.4	130	.2-3.0	---	85	Between r.f. plates and chassis.
224	3 R.F.	2.4	130	.2-3.0	---	85	Between r.f. plates and chassis.
227	Det.	2.4	195	25.	---	---	Between cathode and plate.
227	Vol. Con.	2.4	40	8.	---	---	Between cathode and chassis.
227	1 A.F.	2.4	115	8	---	---	Between cathode and plate.
245	P.P.	2.4	250	50	---	---	Between plate and mid-tap of 10 ohm resistor.
245	P.P.	2.4	250	50	---	---	Between plate and mid-tap of 10 ohm resistor.
280	Rect.	4.8	350	---	---	---	Between plate and mid-tap of H. V. secondary.
280	Rect.	4.8	350	---	---	---	Between plate and mid-tap of H. V. secondary.

Line voltage 120, set on "hi." Volume control maximum.

Fig. 1. The tube operating values shown in this table are those abstracted from the service manual for the Stromberg-Carlson 12 and 14

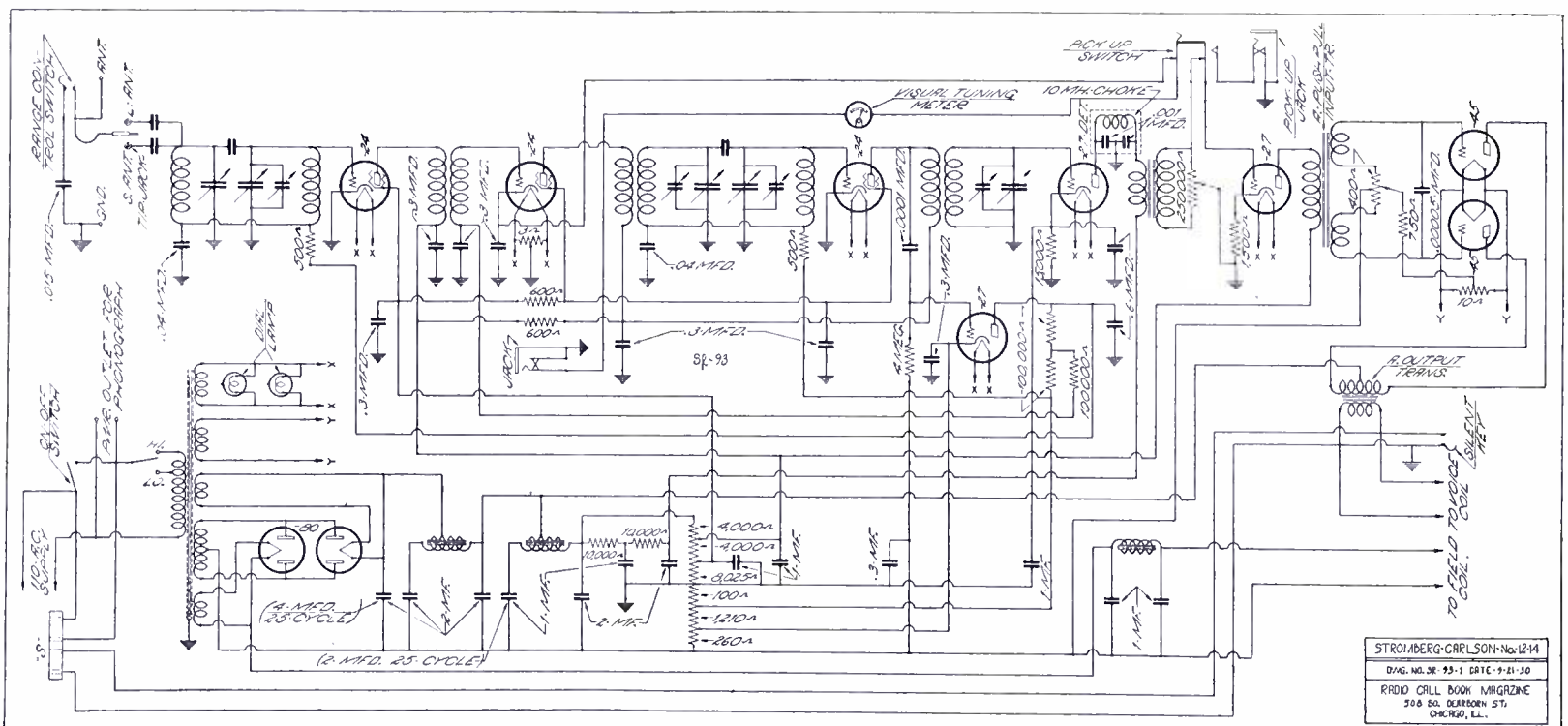

Fig. 2. All details of the receiver and its power supply of the models 12 and 14 Stromberg-Carlson are shown in this illustration

Stromberg-Carlson 635-636 Receiver

RECEIVER models 635 and 636 made by the Stromberg-Carlson Telephone Mfg. Co., Rochester, N. Y., and shown schematically on this page are self contained. All tubes of the receiver with the exception of the output tube and the rectifier are the 227 heater type. The output tube is the 171-A, while the rectifier is the 280 full wave.

Tuning System

The tuning system consists of one tuned antenna stage and three stages of tuned and neutralized radio frequency amplification. The antenna stage is a tuned coupling stage, the r. f. transformers are completely shielded, while one control operates all tuning capacitors simultaneously. The tuning capacities are aligned electrically by means of padding capacitors connected across them. The r. f. stages are stabilized by means of balancing capacitors and neutralizing inductances which are a part of the secondary coils of the r. f. transformers.

Plate rectification or grid bias method of detection is employed. Two stages of high quality transformer coupled audio amplification are used. The secondary of each audio transformer is shunted with a 1 megohm resistor to obtain the desired audio frequency characteristic. The output of the audio system is coupled to the loud speaker by means of the 60 henry choke and a 2 mfd. capacitor. A correctly designed high frequency cut-off type of

audio filter is included in the audio output system. Insulated tip jacks are provided in the rear of the chassis for loud speaker connection. A phonograph pick-up jack is provided in the front panel.

Volume Control

The volume control consists of two separate units operated simultaneously by the same knob. The primary of the antenna transformer has a 10,000-ohm potentiometer shunted across it with a variable contact knob. This controls the amount of signal admitted into the radio frequency amplifier. The second unit is a 10,000-ohm variable resistor shunted across the primary of the third r. f. transformer and controlling the amount of signal admitted into the detector.

The heaters of the three r. f. and first audio tubes are connected in parallel but with separate twisted pair connections to each tube from the power transformer secondary which supplies approximately 2.3 volts, and has a grounded center tap for hum balance. A separate secondary supplies approximately 2.3 volts to the detector tube heater. A 10-ohm potentiometer with its variable contact grounded for hum balance is shunted across the current supply of this tube. The filaments of the audio output tube and the dial light are connected in parallel and are supplied with approximately 4.5 volts. A 20-ohm potentiometer with its variable

contact grounded for hum balance is shunted to this current supply.

The plates of the radio frequency and first audio tubes are supplied with approximately 110 volts d. c., the detector plate with 36 volts and the audio output tube with 180 volts. The r. f. and first audio plate supply is by-passed to ground by a 3 mfd. capacitor. The plate supply of the radio frequency tubes is by-passed to the cathode of each radio frequency by a .5 mfd. capacitor. The detector plate supply is by-passed to ground by a 3 mfd. capacitor. Any radio frequency current present in the detector plate circuit is by-passed to cathode by a .002 mfd. capacitor.

Grids of the r. f. detector and first audio tubes are all returned to ground. Grids of the r. f. and first audio tubes are biased negatively approximately 5 volts with respect to the cathode by means of a 1,500-ohm resistor between each cathode and ground. The detector tube grid is biased negatively approximately 3.5 volts with respect to the cathode by means of a 10,000-ohm resistor connected between the cathode and ground. These biasing resistors are by-passed by .5 mfd. capacitors in the r. f. stages and by a 1 mfd. capacitor in the detector stage. Power equipment supplies approximately 40.5 volts bias to the grid of the 171A.

The primary circuit of the power transformer has a high-low switch which compensates for a high or low line.

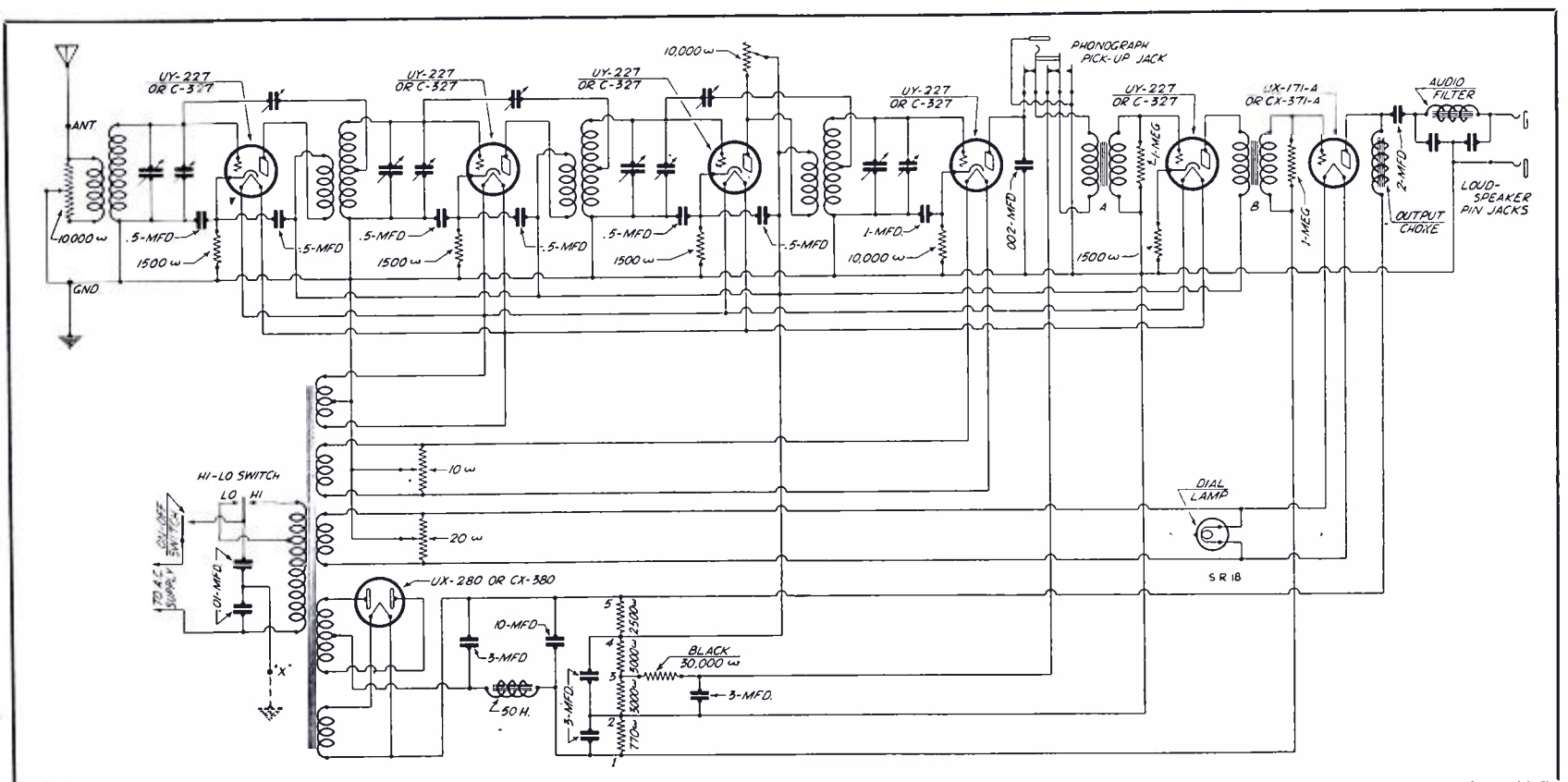

Fig. 2. In this schematic circuit are shown all of the details of the Stromberg-Carlson 635 and 636 receiver complete with power supply

Stromberg-Carlson Receiver, No. 846

STROMBERG-CARLSON'S 846 is an art console model with built-in dynamic. The chassis, according to the engineering data book issued by that company, has a radio amplifying system similar to that in the 612 art console with the addition of an automatic volume control circuit. Three 224 Radiotrons are used in the r.f. portion and a 227 employed in the automatic volume control. A linear power detector is incorporated in these receivers and it also makes use of a 227 type tube. The audio amplifier consists of a low gain first stage, the output of which is used to operate the push-pull output stage where a pair of 245's are employed. One rectifier of the 280 type is used for plate supply for the receiver itself, and another rectifier of the same kind is utilized in the power supply unit for the dynamic speaker.

Automatic Volume Control

The amplification of the radio amplifier is automatically regulated to the strength of the carrier wave being received when the signal is above a certain level. The control circuit increases the control grid bias of the first two r.f. tubes when the strength of the carrier is increased, which action tends to establish a uniform signal level at the detector input. Such an action compensates for fading as long as the signal

does not drop below the level at which the automatic volume control starts to function.

Visual Tuning Meter

This automatic volume control necessitates a visual resonance indicator, which is provided in the form of a milliammeter through which flows the plate current of the second r.f. amplifier tube, the meter being placed in the cathode-ground circuit.

One 227 ube is used as a linear power

detector with automatic bias. This type of detector operates at high r.f. voltages provided by the r.f. amplifier and prevents distortion common to the ordinary square law detector particularly when signals are received from broadcast stations using high percentage modulation, such as the 100 per cent modulated stations. The grid bias is automatically adjusted to the proper value for the strength of the signal received to obtain the linearity mentioned.

Stromberg-Carlson Model 846

Tube Type	Position in Set	A Volts	B Volts	C Volts	Cathode Volts	Screen Volts	Screen Current	Normal Plate M. A.	Plate M.A. Grid Test
224	1 R.F.	2.4	150	.2	+3	58	.8	2.4	3.6
224	2 R.F.	2.4	150	.3	+3	58	.8	2.5	3.7
224	3 R.F.	2.4	155	.7	+3	60	.6	1.7	4.0
227	Det.	2.1	220	22	+22			.1	.2
227	1 A.F.	2.1	110	6	+7			4.4	6.3
227	Vol.Con.	2.5	25	2	-50				
245	P.P.	2.5	270	50				35	40
245	P.P.	2.5	270	50				35	40
280	Rect.Set	5						50	
280	Rect.Spkr.	5						17	

Line voltage 120, set on high tap. Volume control maximum.

Figure 2. A table of typical tube voltages and currents is shown in this chart, readings having been taken with a Weston set tester

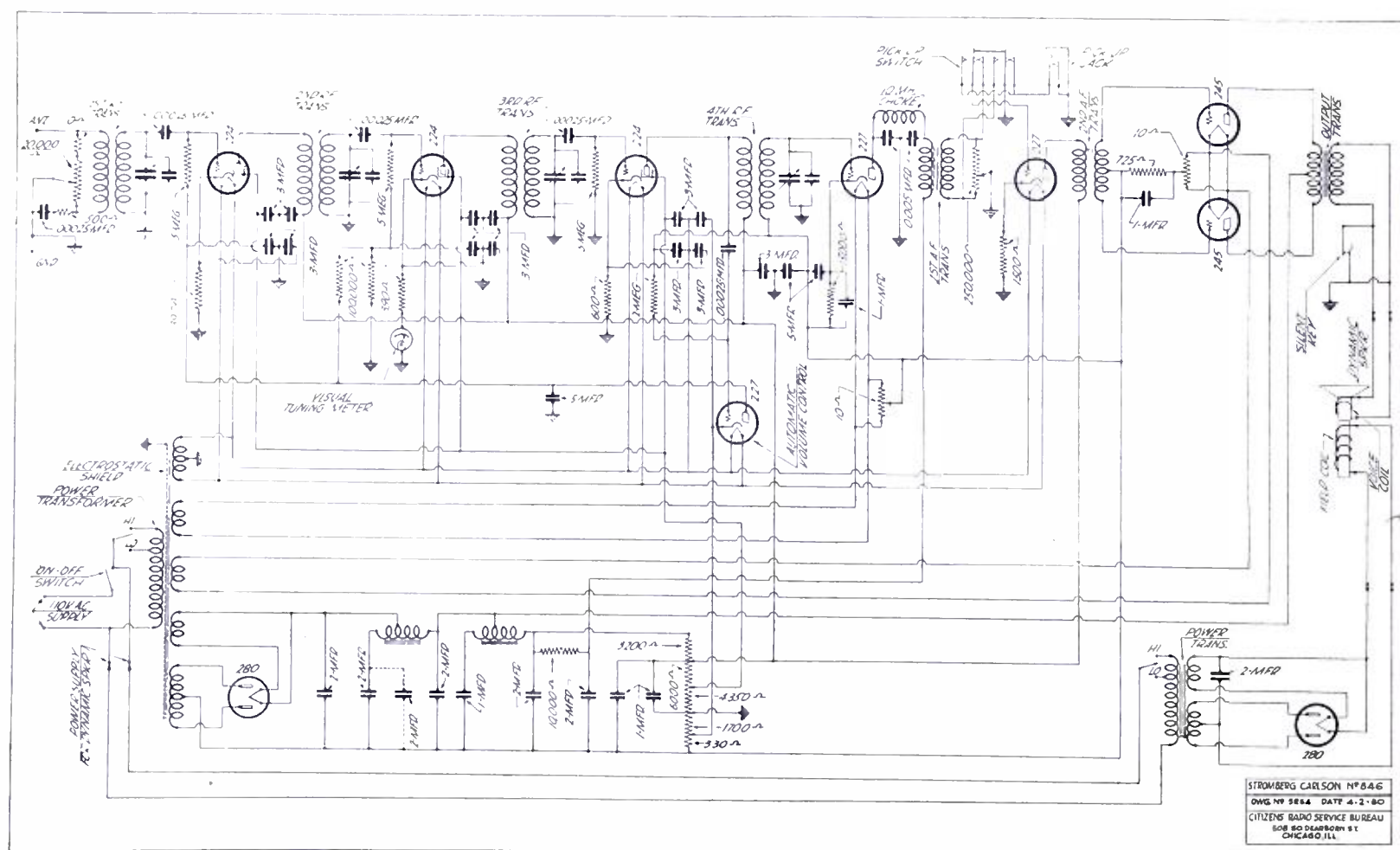

Figure 1. The complete schematic diagram of the Stromberg-Carlson 846 receiver is shown in this drawing

Temple Receiver Nos. 8-60, 8-80, 8-90

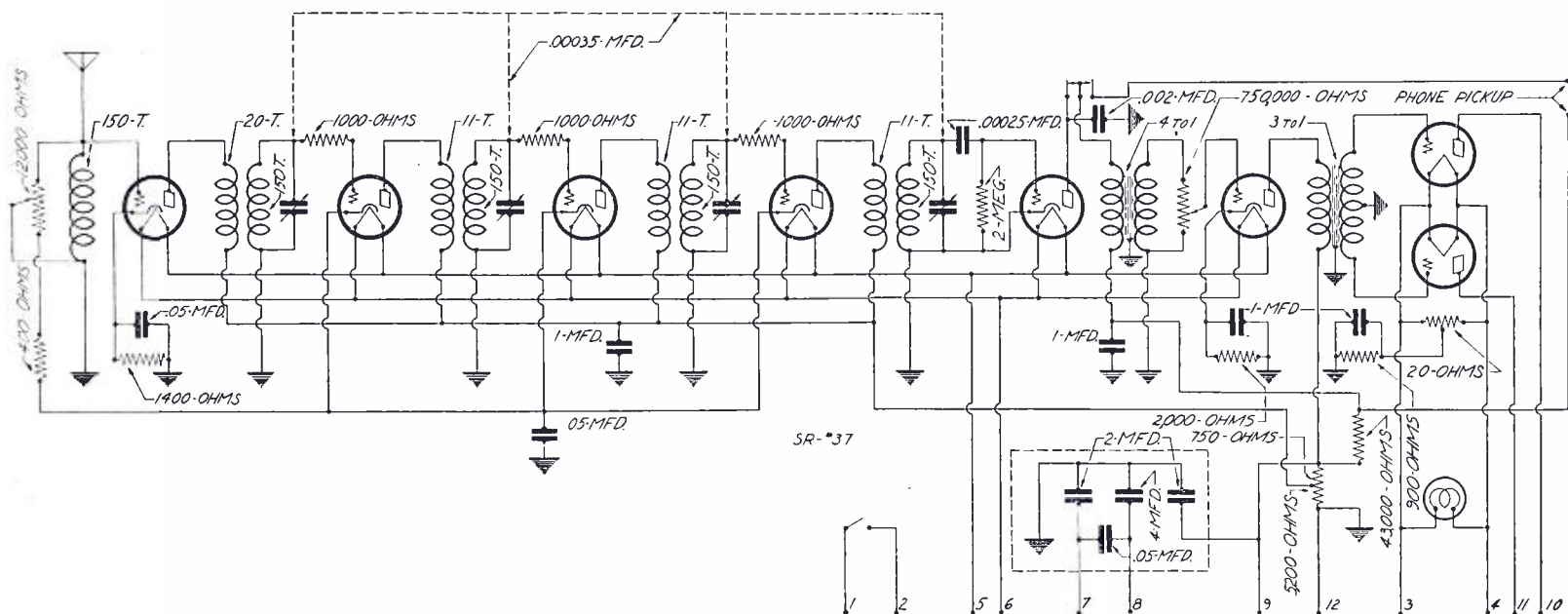

Fig. 1. The schematic of the Temple receiver models 8-60, 8-80 and 8-90 is shown in the above illustration

As will be seen from an examination of the schematic diagram accompanying this article the radio frequency circuit in the Temple receiver is a conventional r. f. circuit using grid

the bulletin issued by the Temple Corporation no C voltage on the 227 tubes indicates either defective resistors in the cathode return or shorted resistor bypass condenser. No C voltage on the

ampere protective fuse.

Service Hints

According to service hints given in 245 indicates a defective resistor in the filament to ground circuit of the 245 or a shorted bypass condenser across the 900 ohm portion of the large resistor. Any great deviation in plate voltages from those found in the chart denotes either a poor rectifier tube or a defective power pack. Great deviation in milliammeter readings indicates unsatisfactory tubes.

Watch Antenna Plug

Be sure that the antenna and ground leads are connected properly. Burned out antenna chokes could be caused either by a shorted antenna plug or a tube placed in the first r. f. socket which has a direct plate to grid short. If by any chance one side of the a. c. line of the power pack was grounded and you reversed the antenna ground leads to the set this would result in a burned out antenna choke.

Temple Model 8-60, 8-80, 8-90

Tube Type	Position in Set	A Volts	B Volts	C Volts	Cathode Volts	Screen Volts	Normal Plate M. A.	Plate M. A.	Grid Test	Change
227	1 R.F.	2.05	100	5	+5	---	3.8	5.5	1.7	
227	2 R.F.	2.05	100	5	+5	---	4.0	6.0	2.0	
227	3 R.F.	2.05	100	5	+5	---	4.2	6.0	1.8	
227	Det.	2.05	35	---	---	---	2.4	2.5	.1	
227	1 A.F.	2.1	115	7	+7	---	4.2	5.7	1.5	
245	Pwr.	2.4	190	38	---	---	27.5	30.	2.5	
245	Pwr.	2.4	190	38	---	---	27.5	30.	2.5	
280	Rect.	4.8	---	---	---	---	40	---	---	

Line voltage, 109. Volume control at maximum.

Fig. 2. A typical analysis of the tubes in this receiver as made with a Weston set tester is shown in the above table

suppressors. All of the radio frequency and the detector stages employ 227 heater tubes while the power stages are handled with the 245 in push pull. The rectifier is a 280.

Dynamic Field Choke

It will be noted that the field coil of the dynamic speaker is in series with the high voltage secondary acting as a second choke coil in the filter system. The first choke is contained in the power pack carrying on top of it fuse connections for the 110 volt primary. This 110 volt primary is tapped for a 110 and 125 line voltage, this change being made by reversing the position of the two

Fig. 3. The schematic diagram of the power supply used in connection with the models illustrated on this page is given here

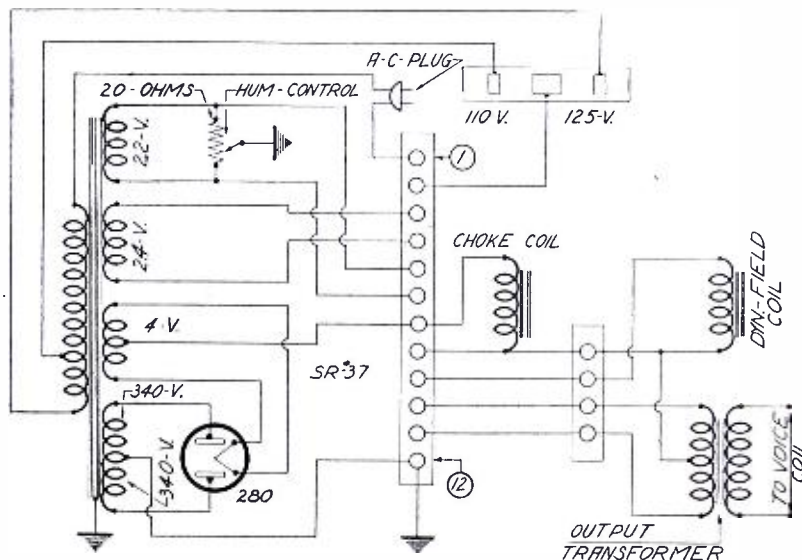

U. S. Radio and Television Model 37

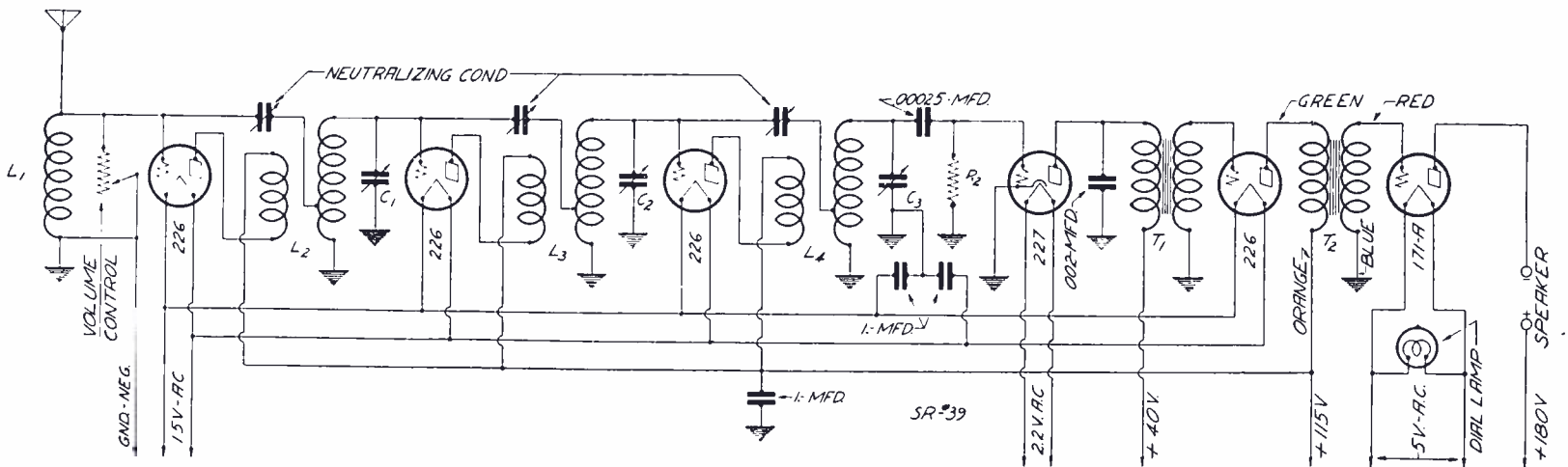

Fig. 1. In this illustration may be seen the schematic diagram of the U. S. Radio and Television model 37 chassis

SCHEMATIC diagrams of the power supply and the receiver itself on the model 37 made by the U. S. Radio and Television Company are shown on this page. A table of typical tube voltages is shown in Figure 2.

The simplest test for determining amplifier may be tested by the following method: Touch the incoming end of the antenna wires of the solder lead of the third variable condenser (reading from right to left facing front of receiver) which tunes the detector stage. If this

condensers. If the signal is heard over the entire dial with the same strength the coil in this circuit has an open secondary which should be replaced. In the case of no signal the coil secondary has shorted turns or tuning condensers shorted.

U. S. Radio & Television Model 37

Tube Type	Position in Set	A Volts	B Volts	C Volts	Cathode Volts	Screen Volts	Normal Plate M. A.	Plate M. A. Grid Test	Change
226	1 R.F.	1.49	115	-9	---	---	5.5	9.0	3.5
226	2 R.F.	1.49	115	-9	---	---	5.5	9.0	3.5
226	3 R.F.	1.49	115	-9	---	---	5.5	9.0	3.5
227	Det.	2.2	26	---	---	---	1.5	1.8	.3
226	1 A.F.	1.49	105	-9	---	---	5.0	8.5	3.5
171A	2 A.F.	4.9	182	-37	---	---	20.	23.	3.
171A	2 A.F.	4.9	182	-37	---	---	20.	23.	3.
280	Rect.	4.9	---	---	---	---	25	---	---

Line voltage 115. Speaker tipjacks shorted.

Fig. 2. A typical voltage analysis on the tubes employed in this receiver may be found in the above table

whether the audio amplifier is operating properly is to place the finger firmly on the grid lug of the detector socket. If this produces a loud steady noise in the speaker the a. f. amplifier is O. K. Another method is to tap the 227 tube lightly, which will produce a ringing sound in the speaker if the audio end is O. K. In the event trouble is located in the audio a careful reading of the voltage from plate to filament by means of a set tester or a thousand-ohm-volt voltmeter will indicate an open, short or ground in the primaries of the audio transformers or the speaker winding. The voltage reading between filament and grid is an indication of the C bias. Failure to get a reading means an open secondary in the audio transformer. When the audio amplifier is O. K. from tests as described the r. f.

stage is functioning properly, strong local signals (or the oscillator if one is being used) will be heard, which can be broadly tuned by rotating variable

With coil removed test variable condenser with battery and voltmeter and examine for plate touching at any point during rotation over the entire dial scale. If condenser is O. K. install new coil. Touch antenna to plate of third r. f. and if signal is still heard it is an indication that the primary is O. K. If the signal disappears, primary is defective and coil should be replaced. Proceed as above indicated to check second and first stage of r. f.

For neutralization procure a 226 tube of average character and cut off one of the filament prongs close to the base. Tune in a loud local signal not higher than 400 meters and insert the specially prepared 226 tube in the first socket (reading from right to left facing front of receiver) and with a fiber screw driver adjust the first neutralizing condenser to minimum volume. The three neutralizers are mounted on the under side of the chassis and are adjusted through openings near coil shields. Do likewise with second and third stages.

Fig. 3. The power supply used in connection with the model 37 receiver described on this page is shown in the schematic illustration at the right

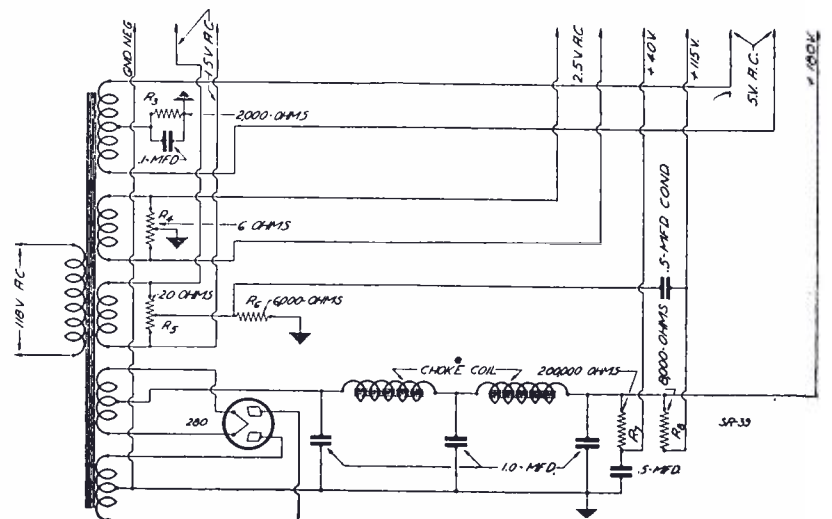

Victor Receivers No. R32, RE45, R52

ON this page will be found the schematic diagrams of the Victor models R32, RE45 and R52 together with typical voltage analysis of the tubes used as taken with a standard set analyzer. The radio frequency and detector portion of the receiver is indicated in Figure 2 while the power supply and audio amplifier is shown in Figure 3.

There are five radio frequency stages, each using a 226 tube, four of these stages being bridge tuned and provided with balancing or neutralizing condensers. The antenna input stage is untuned, using an r. f. choke from grid to ground. The volume control is placed across the r. f. choke; the second section of the dual volume control being placed across a tertiary winding coupled to the plate circuit of the second 226 where it acts as an absorption circuit.

Bias for the radio frequency grids is through a common resistor, 500 ohms,

Fig. 3. The power supply and the audio amplifier for the Victor models described on this page are shown schematically in the drawing to the right

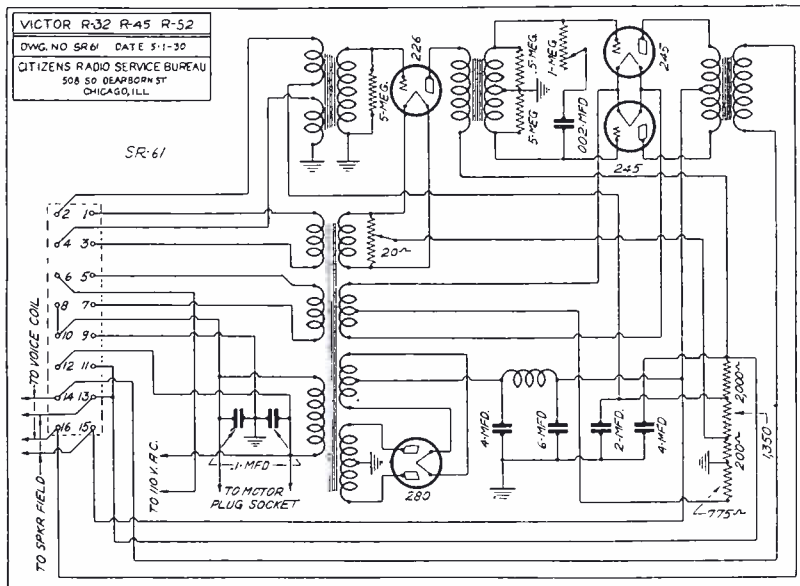

between ground and the center tap of the filament resistor across the supply for the 226 filaments. The detector uses grid leak and condenser of the values indicated in the schematic. The plate circuit has the usual r. f. choke and bypass condenser.

A switch allows change-over from radio to record, a 500 ohm volume control being provided across the terminals to which is connected the phonograph pickup. The primary of the first a. f. transformer has a special winding for the pickup output so that proper impedance is secured for that unit.

Connection between the r. f. and a. f. sections is by means of terminal blocks into which fit the necessary multi-terminal plugs. The receiver is made in three units consisting of the r. f. end, the audio amplifier and the speaker.

In the audio amplifier are found the first a. f. tube and the two 245 tubes in pushpull. The secondary of the first a. f. transformer has a .5 megohm resistance across it, while the secondary of the pushpull input is also provided with .5 megohm resistors across each side of the winding. Across the two extremities of the pushpull input will be found a combination of a 1 megohm variable resistance in series with a .002 mfd condenser, this serving as a variable tone control.

Victor Model R32-RE45

Tube Type	Position in Set	A Volts	B Volts	C Volts	Cathode Volts	Screen Volts	Normal Plate M. A.	Plate M. A. Grid Test	Change
226	1 R.F.	1.3	105	9	---	---	3.9	7.3	3.4
226	2 R.F.	1.3	105	9	---	---	3.9	7.3	3.4
226	3 R.F.	1.3	105	9	---	---	3.9	7.3	3.4
226	4 R.F.	1.3	105	9	---	---	3.9	7.3	3.4
226	5 R.F.	1.3	105	9	---	---	3.9	7.3	3.4
227	Det.	2.1	40	---	---	---	3	3.4	.4
226	1 A.F.	1.3	100	6	---	---	4.5	7.4	2.9
245	P.P.	2.1	230	40	---	---	37	41	4
245	P.P.	2.1	230	40	---	---	37	41	4
280	Rect.	4.4	---	---	---	---	57	---	---

Line voltage 110. Volume Control Maximum.

Fig. 1. Average tube voltages as indicated by a standard test set are shown in this table

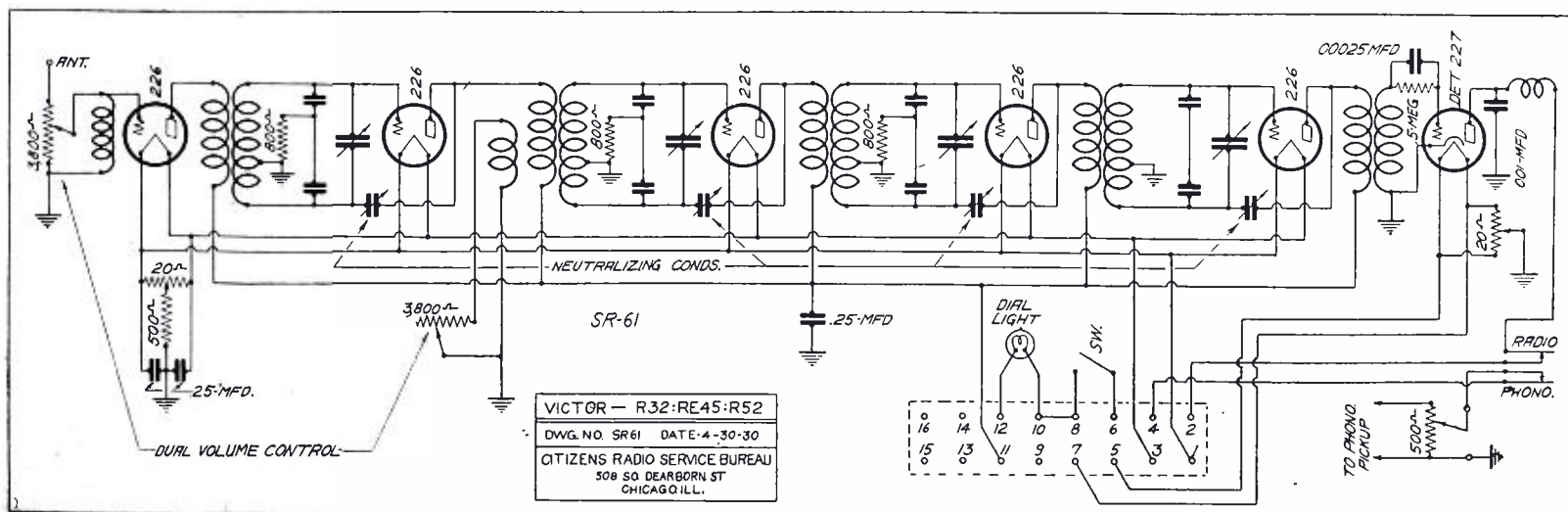

Fig. 2. The radio frequency and detector portion of the Victor models R32, RE45 and R52 is illustrated in this schematic diagram

Victor Models R 35, R 39, RE 57

KNOwn as the "micro-synchronous" model and using four stages of tuned r.f. with screen grid tubes, the Victor models R35, R39 and RE57 are illustrated schematically on this page in Fig. 2 with a table of tube operating values shown in the table in Fig. 1.

An interesting point in the Victor service manual covers installation of the receiver in a room so the receiver faces the length of the room rather than its breadth: also a space of at least four inches be allowed between the back of the cabinet and the wall. Best acoustic results will be obtained if these suggestions are followed.

Under general tests it is indicated that excessive hum may be caused by: faulty 224 in detector socket (at least one 224 out of the four will be found that will give minimum hum in the detector socket); faulty 280 or 227; unbalance in plate currents of the two 245's. (Try new 245 in one socket, then in another): wire or terminal grounded to chassis, or open circuit in any of the various ground connections to chassis; open or shorted center tap resistor in amplifier unit; short or partial short in one of the resistors mounted on the under side of the resistor board; shorted or open condenser in condenser bank or faulty connection to condenser bank; defective 280 socket, one plate not making contact; faulty connection to tapped section of filter reactor.

Microphonic howl may be caused by: defective tube in detector or first audio tube sockets; speaker not properly felt

insulated from baffle on front of the cabinet. (Raise the amplifier-speaker unit to gain access to the felt and re-adjust the felt properly, making sure the rim of the speaker is tight against the felt); loose metal parts such as screws, shields, etc., or an improperly centered cone may set up a howl or

coils or tubes, too much unshielded exposure of the green lead between the control grid of the 224 and coil; open circuit in any of the .1 mfd by-pass condensers, or poor ground (loose rivet) in any of these condensers; ungrounded shield on shielded lead of the radio chassis.

Victor Models R35, R39 and RE57

Tube Type	Position in Set	A Volts	B Volts	C Volts	Cathode Volts	Screen Volts	Normal Plate M. A.	Plate M. A. Grid Test	Change
224	1 R. F.	2.15	172	2.5		80	2.5	5.0	2.5
224	2 R. F.	2.15	172	2.5		80	2.5	5.0	2.5
224	3 R. F.	2.15	172	2.5		80	2.5	5.0	2.5
224	Det.	2.15	75		8	2.5			
227	1 A. F.	2.15	55	0			1.5	1.8	.3
245	P. P.	2.25	185	36			19.0	22.0	3.0
245	P. P.	2.25	185	36			19.0	22.0	3.0
280	Rect.	4.8					36		

Line voltage 112. on 120 tap. Volume control maximum.

Fig. 1. The tube operating values shown in this chart for the Victor R35, R39 and R57 are those taken with a Jewell analyzer, the manual indicating socket analysis together with possible causes of trouble

mechanical rattle, depending upon the nature of the fault; on the home recording model an open circuit in either of the resistors on the microphone reactor may cause a howl.

Oscillation in the set characterized by a generally unstable condition while tuning, may be caused by: Ungrounded or poorly grounded chassis; removal of shielding from any of the condensers,

Under excessive noise the following causes are listed: intermittent short or high resistance in any of the soldered joints, or in the power switch connections; loose or defective pilot lamp, or pilot lamp socket; shorted plates in one or more of the tuning condensers; faulty power or audio transformer; intermittent short on filter or by-pass condensers.

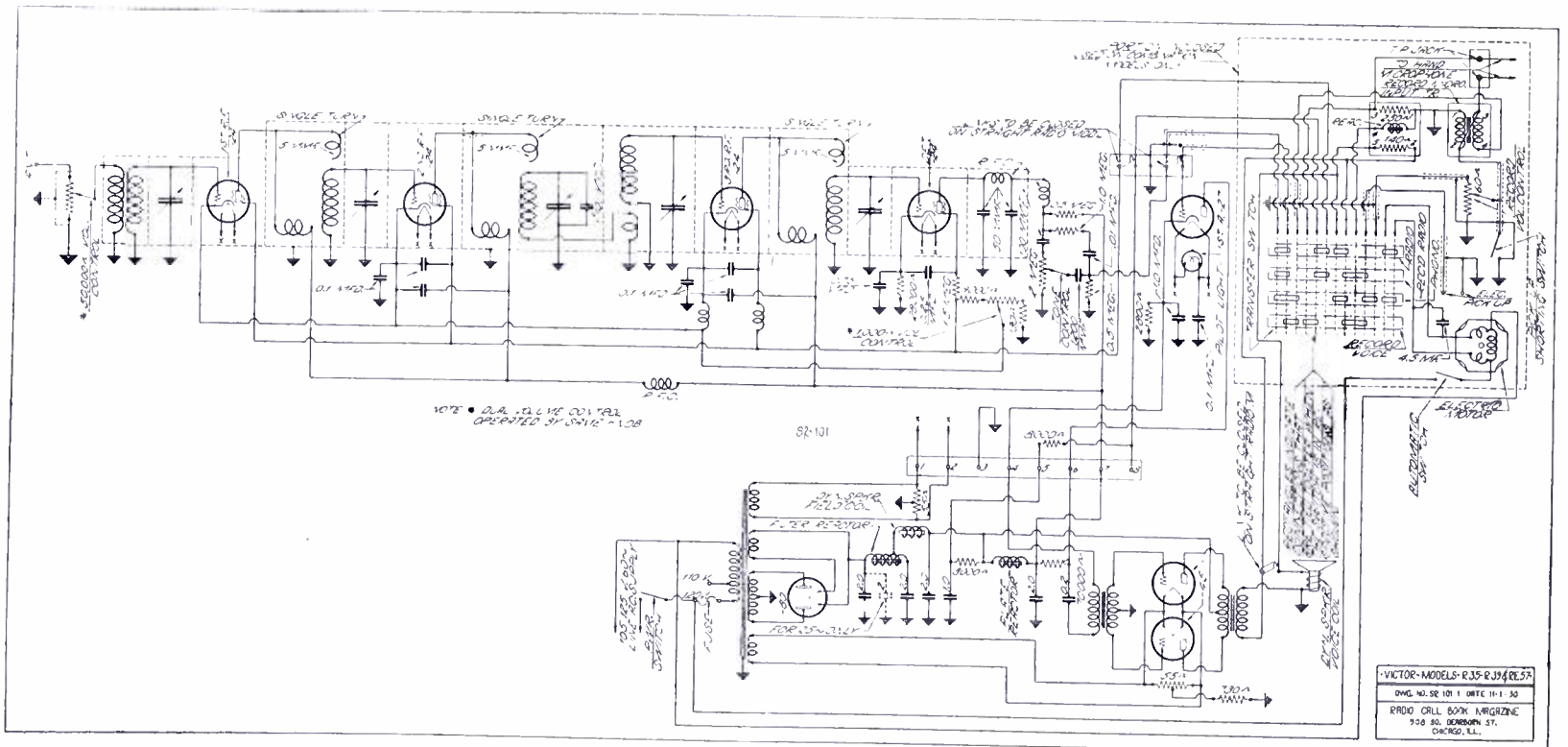

Fig. 2. The schematic diagram of the Victor models described on this page is shown in this illustration together with its power supply

Westinghouse Model WR-4

ON this page are given the tube operating values and the schematic diagram of the Westinghouse WR-4 receiver, a seven-tube tuned r.f. model whose response curves appeared on page 65 of the November issue of this magazine.

Examining the circuit in Figure 2, antenna and ground are connected to each side of a 50,000-ohm potentiometer, the moving contact of the potentiometer connected to one side of the primary of the first r.f. transformer, the other side connected to ground. The action of the potentiometer is one-half the action of the volume control (the other half being in the 50,000-ohm potentiometer across the 12,000-ohm resistor, the movable arm connected to terminal 3 shown in the block in the schematic).

The secondary of the r.f. transformer is connected to grid circuit of the first 224 which is tuned by the first unit of the gang condenser. The plate circuit of this tube contains a high impedance coil inside the grid coil of the second r.f. transformer. This plate coil is of the proper impedance to match the 224 and is at right angles to the grid coil in which it is located. This is done so that the inductive coupling between these circuits is at a minimum. A single turn at one end of the grid coil is connected to the 224 and provides capacitive coupling between the circuits. The reason for using capacitive coupling instead of inductive is that the primaries of the r.f. transformer resonate at about 350 kc. with receiver capacitance and tend to increase the sensitivity at the low end of the range. Capacitive coupling has less reactance to high frequencies than to low frequencies, thereby increasing the effective coupling at the high frequency end. A combination of the two gives about equal gain throughout the tuning range.

The following two r.f. circuits function in the same manner as the one already described. The screen grid voltage of these three 224's is varied by means of the second section of the volume control. This action occurring simultaneously with the variation of input voltage to the first tube gives a positive control of volume without distortion.

The detector circuit functions as a biased-grid power detector, operating at a high plate voltage so that an out-

put sufficient to swing the two 245 tubes to maximum output is obtained. The detector tube is operated at 250 volts plate potential and 10 volts negative bias. It will be noted that the bias reading of 1 volt for the grids of the 245's as shown in the tube operating table is the result of making this reading through a high resistance.

As the 224 detector must work into a high impedance, transformer coupling would not be suitable for coupling into

the 245 tubes. Hence impedance coupling is used; one-half of a tapped reactor being in the plate circuit of the detector. This reactor is of quite high impedance and functions as an auto-transformer. Two coupling condensers are used to pass the a.c. component of the detector output to the grids of the 245 tubes. Two high resistance units are used so that the proper grid bias may be impressed on these tubes.

The output of the 245 tubes is coupled to the cone coil of the dynamic through a center-tapped primary, step-down transformer.

A full wave rectifying circuit using a 280 provides the d.c. voltages necessary for the plate and grid supply of all tubes and also for the dynamic field supply. The filter circuit is of the type employed in the superheterodyne models, except that a .1 mfd condenser is used to bypass any high frequency ripple that may be present in the rectified output.

Westinghouse Model WR4

Tube Type	Position in Set	A Volts	B Volts	C Volts	Cathode Volts	Screen Volts	Normal Plate M. A.	Plate M. A. Grid Test	Change
224	1 R.F.	2.3	160	2.5	---	85	3.0	---	---
224	2 R.F.	2.3	155	2.5	---	85	3.5	---	---
224	3 R.F.	2.3	155	2.5	---	75	3.5	---	---
224	Det.	2.3	225	7.5	---	55	.5	---	---
245	P.P.	2.3	200	1.0*	---	---	25.0	---	---
245	P.P.	2.3	200	1.0*	---	---	25.0	---	---
280	Rect.	4.6	---	---	---	---	---	---	---

Line voltage 120. Volume control maximum.

*Not true reading due to resistor in circuit.

Fig. 1. The tube voltage values shown in this table are taken from the tables shown in the service manual covering the Westinghouse WR-4 receiver

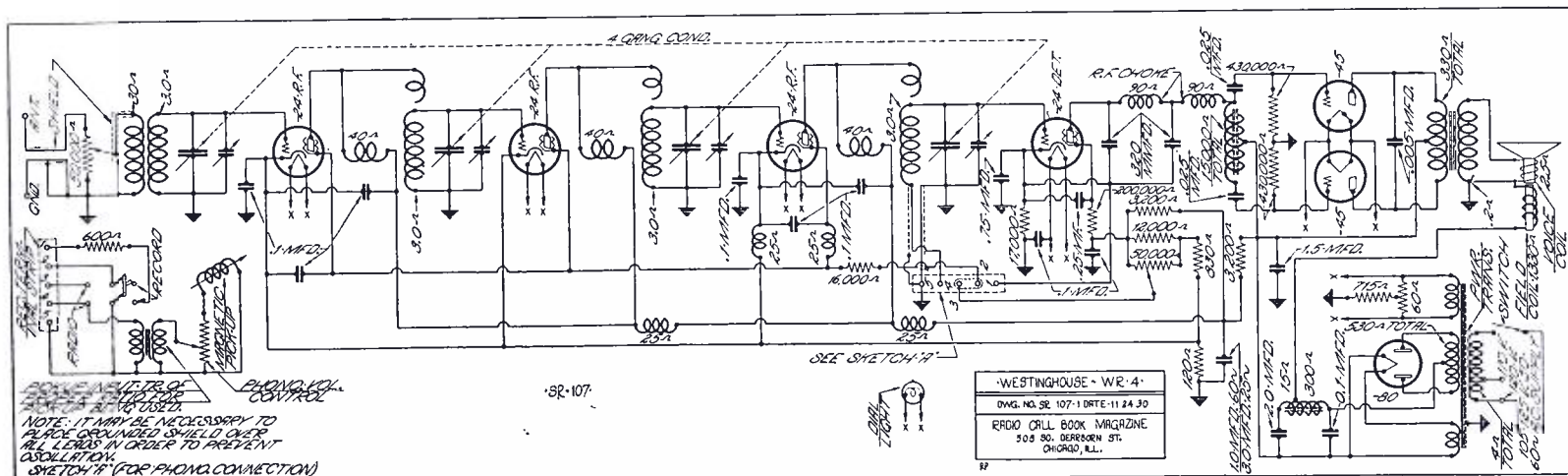

Fig. 2. The drawing here shows the electrical connections of the receiver and power supply of the Westinghouse WR-4 receiver

Westinghouse Superheterodyne No. WR-5

ELECTRICAL details of the Westinghouse superheterodyne, WR-5, response curves on which were given on page 69 of the September, 1930, issue of this magazine, may be found in the schematic diagram, Figure 2, at the bottom of this page.

As will be seen the antenna is coupled to a tuned link circuit by means of a high inductance concentrated coil connected from antenna to ground. The inductance is of sufficient value that variations in the antenna system have little effect on tuning of this circuit.

The tuned circuit consists of a coil and condenser which tunes exactly with the tuned r.f. and first detector. There is no amplification gain in this circuit, it being merely a selection circuit, whose purpose is to eliminate any cross-modulation from stations to which the set is not tuned, or heterodyne whistles as far as possible, and to improve the selectivity of the receiver.

A tuned radio frequency stage follows which uses a 224, this stage giving about the same amplification as obtained from two r.f. stages of an average good receiver. The output of this stage is coupled capacitatively to the grid circuit of the first detector, or mixing tube by means of a small condenser. The plate circuit of the r.f. stage has a high inductance coil which provides a high impedance into which it is necessary to have the tube work in order to get good amplification.

Output of the oscillator is inductively coupled to the grid circuit of the first detector. The oscillator is grid tuned, uses a 227, and has a closely coupled plate coil which gives sufficient feedback to provide stable operation. The grid circuit is so designed that by means

of a correct combination of capacity and inductance a constant frequency difference between the oscillator and the tuned r.f. stages throughout the range is maintained.

First detector is tuned by one of the sections of the gang condenser to the signal frequency. In the grid circuit is the incoming signal frequency and the oscillator signal, the latter being 175 kilocycles different from the former. First detector is biased to operate as a plate rectification detector, and its purpose is to extract the beat frequency produced by combining the signal and oscillator frequencies. The beat frequency, 175 kc, appears in the plate circuit of the first detector, which is accurately tuned to 175 kc.

The next two circuits are the first and second intermediate stages which give a high degree of amplification, the grids and plates of both stages as well

as the plate circuit of the first detector and the grid circuit of the second detector are tuned to 175 kc.

Two resistances are arranged for connecting to the first i.f. transformer, the connection or disconnection of which constitutes the action of the local-distant switch. At the local position a 40,000 ohm resistor is connected across the primary of this transformer and a 500 ohm resistor in series with the secondary and one side of the tuning condenser. The effect of these resistors is to decrease the sensitivity, broaden the selectivity and thus improve the fidelity of the set. At the distant position the resistance is out of both circuits and the original sensitivity and selectivity is obtained. After the high amplification of the intermediate stages the signal appears in the grid circuit of the second detector.

Westinghouse Model WR-5

Tube Type	Position in Set	A Volts	B Volts	C Volts	Cathode Volts	Screen Volts	Normal Plate M. A.	Screen Grid Current Change
224	1 R.F.	2.2	240	2.2	34	80	3.2	.5
227	Osc.	2.2	60	---	22	---	6.5	---
224	1 Det.	2.2	230	9.5	25	72	.25	.1
224	1 I.F.	2.2	240	2.2	34	78	4.0	.5
224	2 I.F.	2.2	240	4.2	31.5	78	1.6	.5
227	2 Det.	2.2	212	22	12	---	.25	---
245	P.P.	2.2	200	19*	---	---	25.0	---
245	P.P.	2.2	200	19*	---	---	25.0	---
280	Rect.	5.0	---	---	---	---	---	---

Line voltage. Volume control maximum.

*Not true reading due to resistor in circuit.

Fig. 1. Voltages and current values of the tubes in the WR-5 are those shown in this table as taken with a Weston set tester

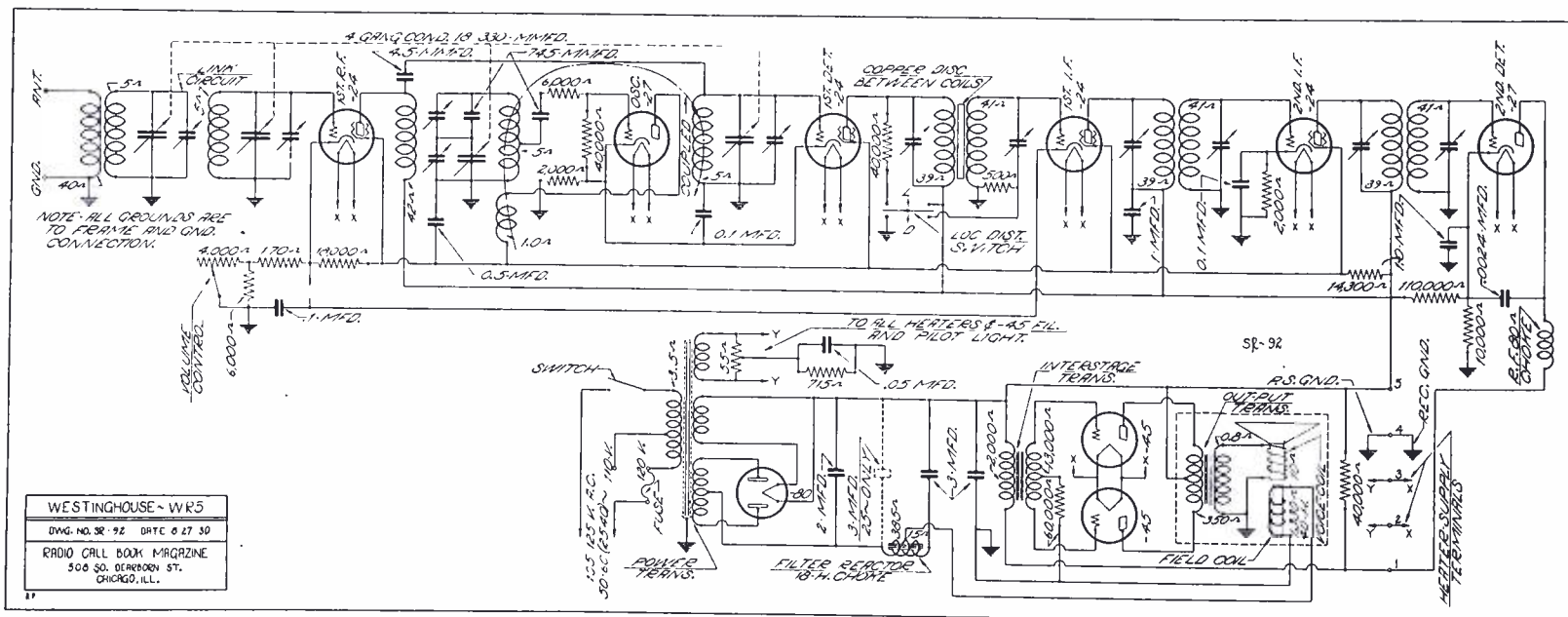

Fig. 2. All electrical details of the Westinghouse WR-5 receiver and power supply are given in this schematic diagram

Zenith Model Nos. 52, 53, 522, 523

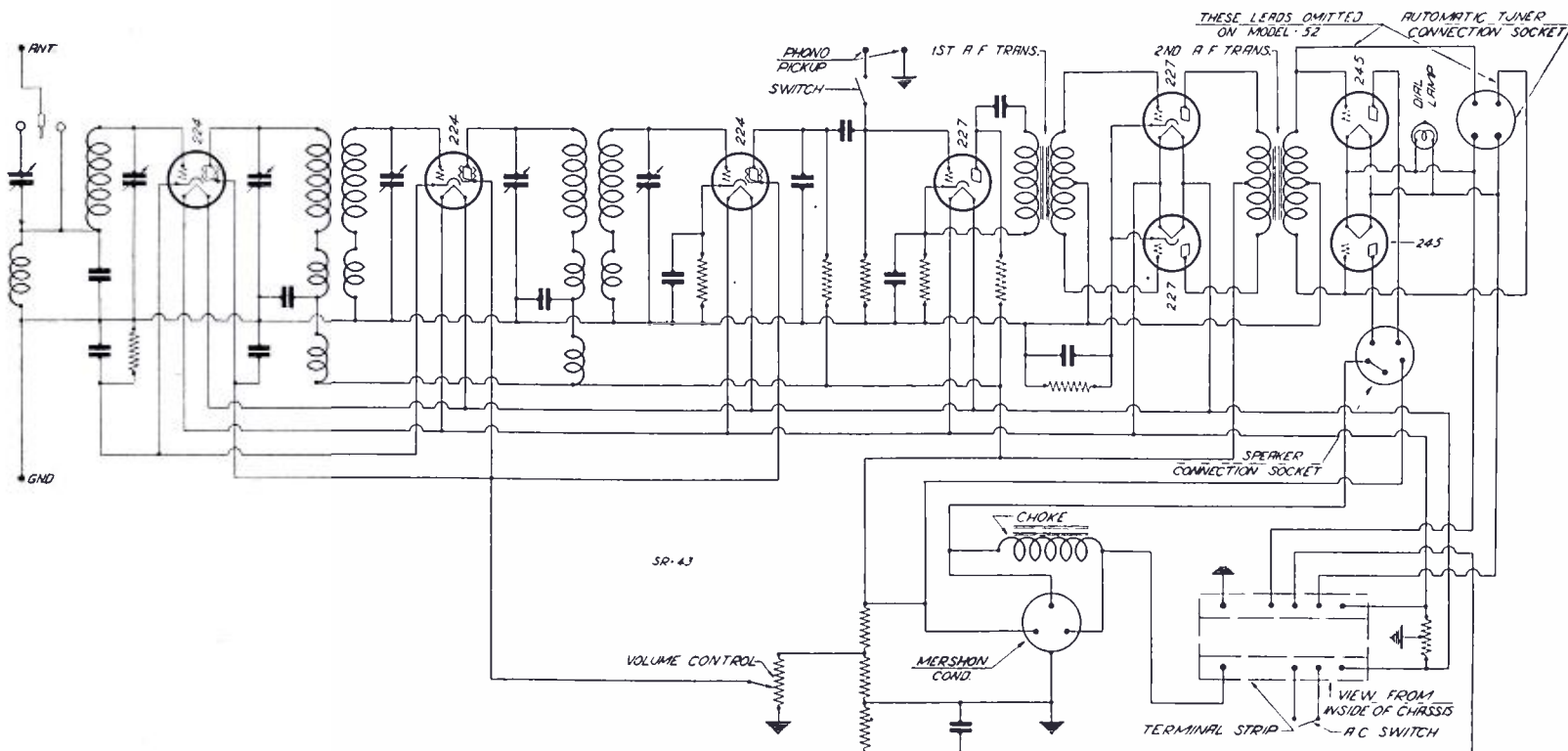

Fig. 1. This drawing is the schematic diagram of the models 52, 53, 522 and 523 receivers made by Zenith. The power pack is shown in Fig. 3

ON this page may be seen the schematic diagram of the Zenith models 52, 53, 522 and 523 together with the power supply drawing and a table of typical tube voltages.

One departure from the conventional may be noted in the fact that two 227 tubes are used in push-pull in the first audio stage, followed by two 245 tubes in push-pull for the power output.

Instead of the usual grid leak and condenser linear detection is used in the 224 detector, a 50,000 ohm resistor and a .2 mfd. condenser being placed between cathode and ground. According to the tube analysis chart the grid voltage is 5 volts. The coupling from the plate circuit of the detector to the grid circuit of the 227 first audio is by resistance and capacity.

The circuit diagram of Models 52, 53, 522 and 523 is shown in Fig. 1. Models 54 and 542 use exactly the same diagram except there is a two point switch in the grid circuit of the first tube which disconnects the inductance

Zenith Models 52, 53, 522, 523

Tube Type	Position in Set	A Volts	B Volts	C Volts	Cathode Volts	Screen Volts	Normal Plate M. A.	Plate M. A. Grid Test	Change
224	1 R.F.	2.4	175	1	2	50	1.6	2.8	1.2
224	2 R.F.	2.4	175	1	2	50	1.6	4.0	2.4
224	Det.	2.4	90	5	5	50*	0	0	0
227	1 A.F.	2.4	55	2	2	---	1	1.2	.2
227	2 A.F.	2.4	143	14	14	---	4.3	5.7	1.4
227	2 A.F.	2.4	143	14	14	---	4.3	5.7	1.4
245	3 A.F.	2.2	248	45	---	---	24	28	4.0
245	3 A.F.	2.2	248	45	---	---	24	28	4.0
280	Rect.	4.7	---	---	---	---	100	---	---

Line voltage 115, set on 120 tap. Volume control maximum.
 *Actually 50 volts, but electrostatic voltmeter needed to show true reading.

Fig. 2. A table of typical tube analysis chart as made with a Jewell set analyzer is shown above

coil from the circuit and connects one side of the loop aerial to the grid of the first tube. The other side of the loop is grounded to the chassis. The

power supply used on the models mentioned above is shown in Fig. 3.

Balancing of the receiver at the factory is done with an oscillator tuned to 203 meters. Since the set has been accurately balanced at the factory it is seldom rebalancing will be required. In the event such a step is necessary, tune in a station (preferably a distant one) about 200 to 250 meters (in the absence of an oscillator). After tuning in the station accurately and leaving the tuning dial alone, start turning the balancing nuts (beginning with the one at the left) until maximum signal is secured. Turning these hexagonal nuts (in the rear of the condenser shield) governs the trimmer capacities. Adjusting may be done with a Spintite No. 5.

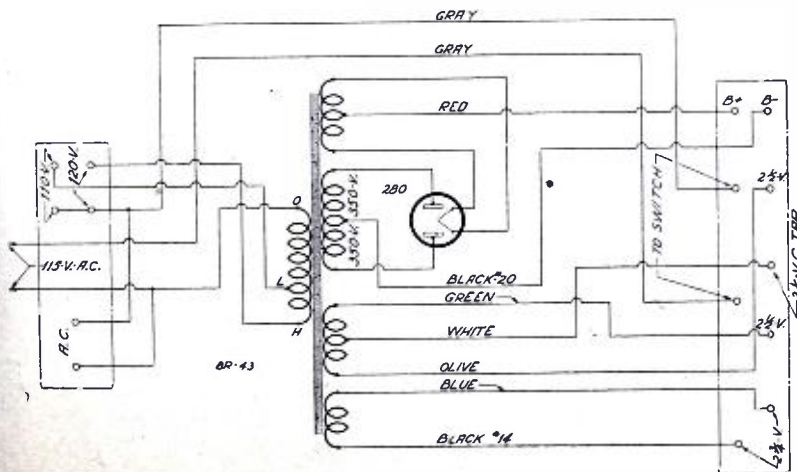
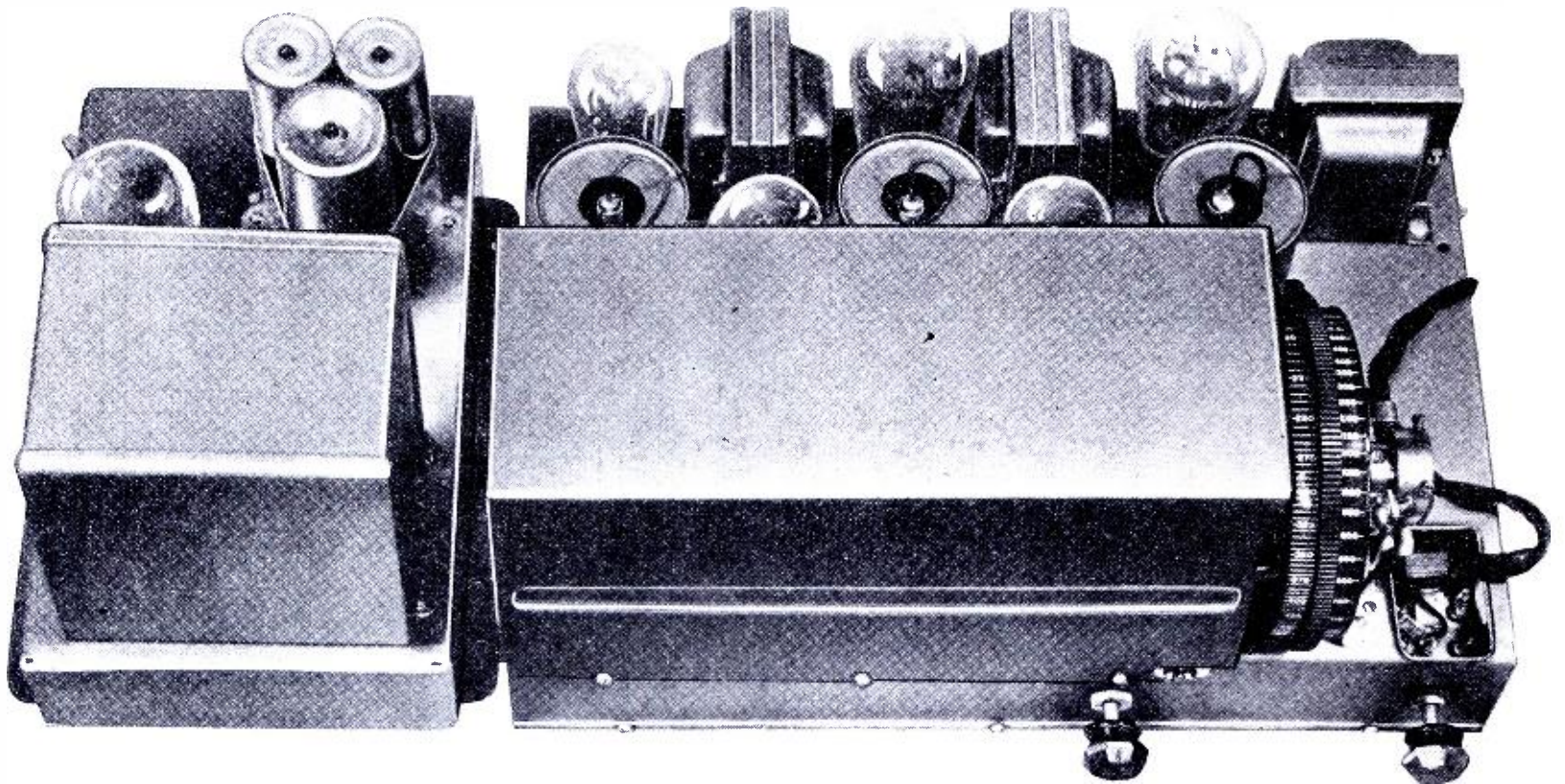

Fig. 3. The power pack used for the 52, 53, 522 and 523 Zenith models is illustrated in the diagram at the left

Servicing the



FOLLOWING our policy of presenting service material for our readers we are now enabled through the courtesy of the Zenith Radio Corporation to give in this issue data covering their 70 chassis.

It may be interesting to know that on our annual questionnaire Zenith stood eighth on a list of 16 manufacturers of whose receivers our readers were requesting schematic diagrams and service helps.

Grid and Plate Tuning

Briefly the circuit used in the 70 series consists of two stages of tuned plate, tuned grid, screen grid r.f., a screen grid power detector, one stage of resistance coupled a.f. using a 227, a second stage of pushpull audio using two 227's, and a third or power stage using a pair of 215's pushpulled. Schematically the receiver is shown in Figure 5; the power supply in Figure 4, the dynamic speaker circuit in Figure 2, and the photograph of the power and receiver chassis in Figure 1. A table of operating voltages for the tubes appears in Figure 3.

Continuing our reading of the service manual Zenith has prepared for this series we find the electrolytic condenser, the voltage divider and the by-pass condenser for the grid bias of the third audio stage are placed in the power unit. The separate type condensers have been incorporated in this pack. A

Zenith has always maintained a strict service policy during the first 120 days of the receiver's life in the field; their own service men are adequately prepared to look after the set during that time. After that time, however, independent service men may be called on to handle such receivers, and the information given here through co-operation with Zenith is intended for those not in possession of the Zenith instructions.

cover has been placed over both the terminal strips on the chassis and the fuse clips on the power pack. All possible wiring has been cabled. All cabled wire has a definite color code. The double volume control has been adopted as standard. Provision has been made

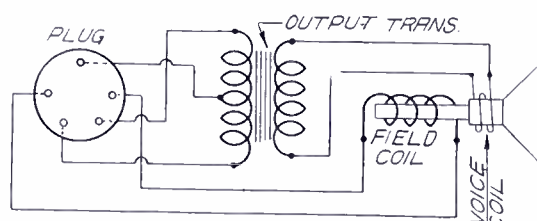

Fig. 2. This shows the dynamic speaker circuit connections

for use of a short antenna with excellent results.

Sensitivity and Selectivity

Tuning both grid and plate circuits of the r.f. and the grid circuit of the detector gives a total of five tuned stages and accounts for the selectivity and sensitivity of the circuit although only using two r.f. stages. Grid and plate coils are bank wound with Litz wire to reduce r.f. resistance. Each coil is shielded from the other by aluminum cans. Coupling between stages is accomplished by a small 12-turn coil, about $\frac{3}{4}$ inch in diameter, placed on the bottom of the r.f. coil assembly. Six interlocking turns of this coil are placed in series with each tuned coil, and the only coupling between the various circuits is made through these coils. In certain remote sections of the country where selectivity is not a main factor, chassis having 18-turn (9 double turn) coupling coils may be used. A 25-turn coil is placed inside the grid coil of the first r.f. amplifier and is connected directly to the short antenna post, which allows the use of a very short antenna.

Use Good Tubes

Laying stress on the use of good tubes of the 224 type, mention is made in the manual that the receiver will not operate efficiently unless good tubes are used. The use of one poor emission tube in either the r.f. or detector sockets, will

Zenith Series 70

result in considerable lack of sensitivity and poor general reception. A poor tube in the detector socket will also cause an audible hum in the receiver. Service men are cautioned to first test the tubes in these positions before judging the receiver faulty. Voltage charts given in the manual show readings obtained when using average good tubes.

Special Tips

A number of special tips for service men are given, some of which we are including here. For example, a grounded filament will give every evidence of a shorted or grounded bias resistor and the service man should determine to his entire satisfaction that the filament is not grounded, either through a piece of solder, a defective dial light, or automatic tuner pilot light. He should bear in mind that a grounded dial light circuit will not affect the heater type tubes, but will remove the bias from the grids of the 245's only. Another point to remember is that if there is plate voltage on the screen grid tubes, then there is no short or ground in any plate resistance or lead of any circuit. In a set where distortion is present such trouble can easily be located in either the audio or r.f. system by simply connecting the output from a magnetic pickup to the set and playing some record that is familiar to the service man. If distortion is still present, then the trouble is logically in the audio system; but if not present, then it lies elsewhere.

Exclusive of tubes, several things may cause lack of selectivity or sensitivity without anything else being radically wrong. The most common difficulty ex-

Zenith Model 70

Tube Type	Position in Set	A Volts	B Volts	C Volts	Cathode Volts	Screen Volts	Normal Plate M. A.	Plate M. A. Grid Test	Change
224	1 R.F.	2.5	185	2	2.5	55	2.5	---	---
224	2 R.F.	2.5	185	2	2.5	55	3.0	---	---
224	Det.	2.5	100	5	5.0	*	.1	---	---
227	1 A.F.	2.5	65	25	5.0	---	1.5	---	---
227	2 A.F.	2.5	160	13	13	---	3.4	---	---
227	2 A.F.	2.5	160	13	13	---	3.4	---	---
245	P.P.	2.3	260	52	---	---	38.0	---	---
245	P.P.	2.3	260	52	---	---	38.0	---	---
280	Rect.	---	---	---	---	---	---	---	---

Line voltage 110, fuse in 110-volt clip. Volume control maximum.

*Actual voltage same as r.f. screens, but can only measure with electrostatic voltmeter.

Fig. 3. A table of operating tube voltages as taken with a Jewell set analyzer is shown above

perienced is the lack of resonance in the five tuned stages. To obtain maximum results it is necessary that each circuit be tuned to approximately the same frequency. To determine whether a receiver is in resonance proceed as follows:

Aligning Stages

Tune the receiver to a station under 300 meters. If necessary remove the aerial and replace with a piece of wire four or five feet long. This short aerial is used to permit setting the volume control at maximum. After tuning in the station, with the shields on the tubes, carefully turn the adjusting nuts on the four trimming condensers to the point of greatest signal response. This should be done slowly and carefully. It is important that the rotor of the gang remain in exactly the same position during this operation. A slight jar might disturb the setting of the rotor. Once the circuits have been placed in resonance the dial should be checked for calibration. Zenith's

(Continued on page 101)

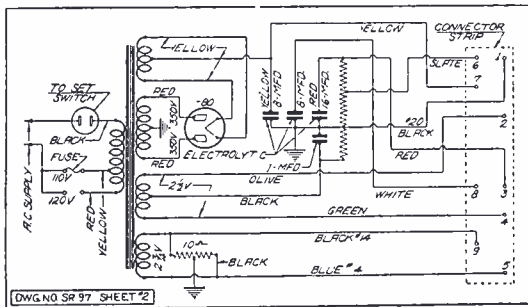

Fig. 4. The power supply of the Zenith 70 is shown here

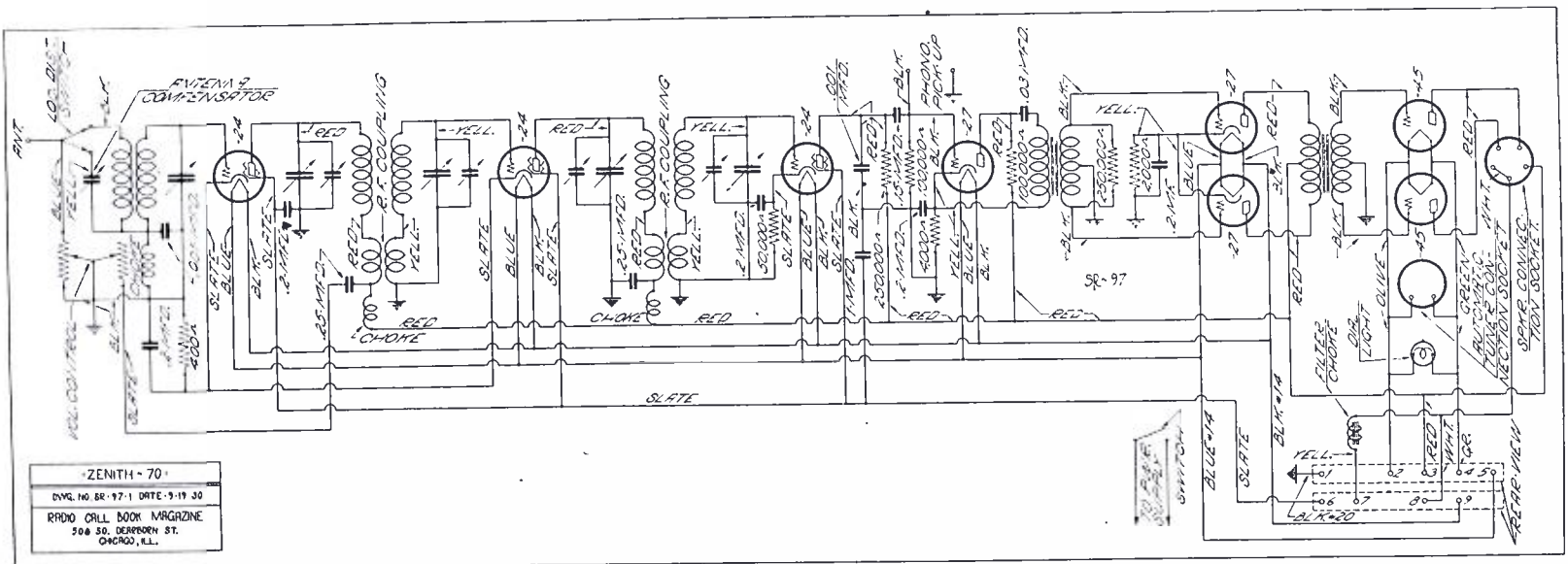
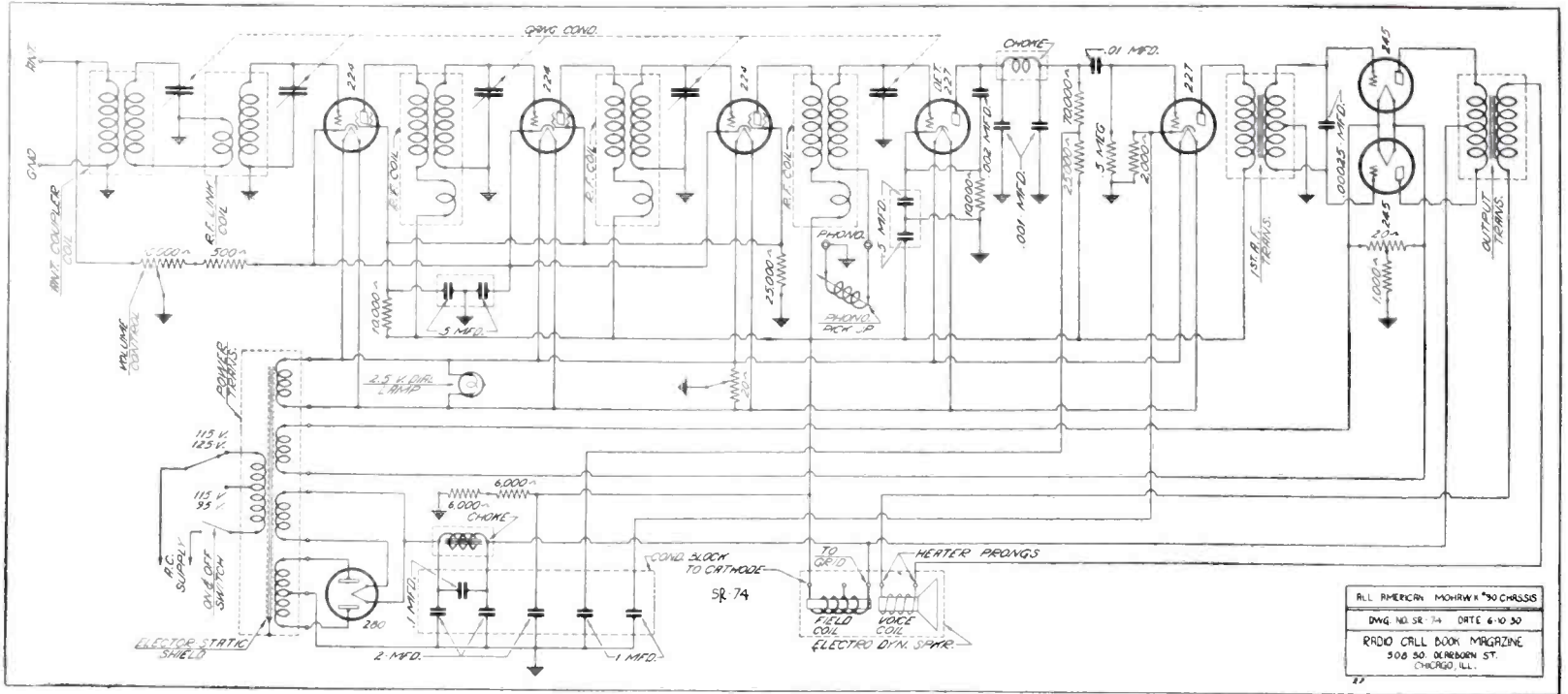
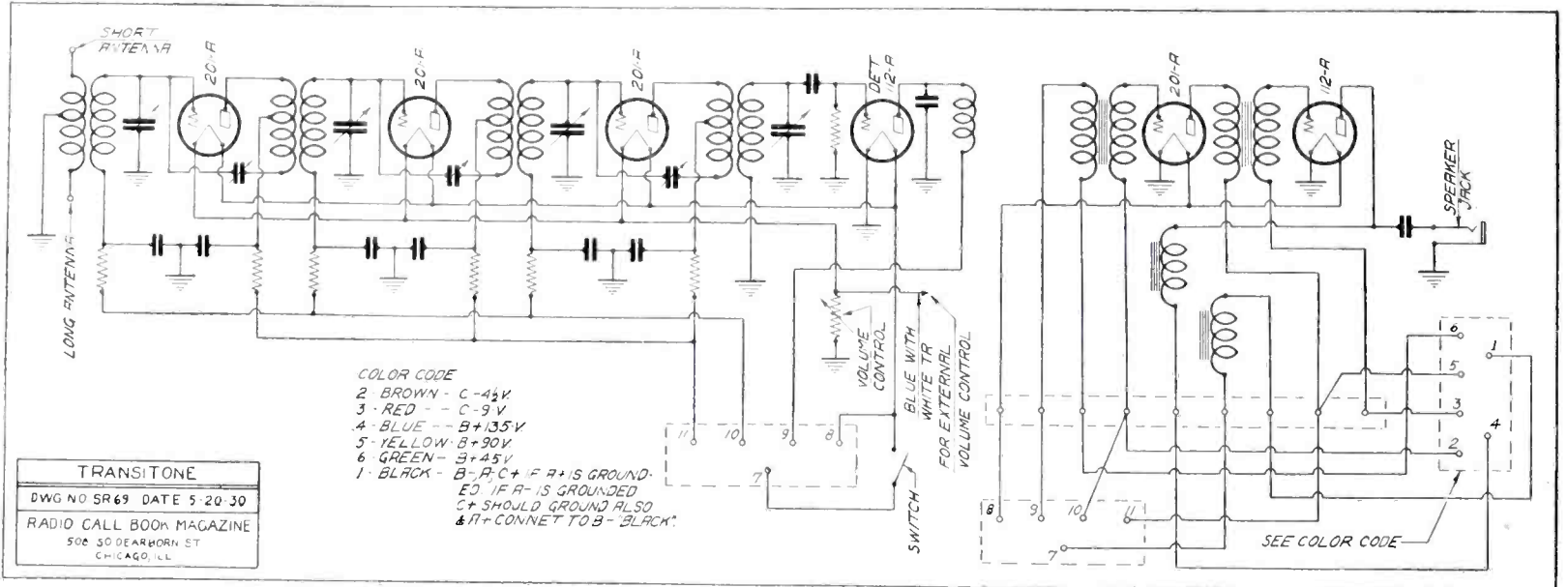

Fig. 5. The electrical details of the Zenith 70 series may be traced from the drawing shown above

ALL AMERICAN-MOHAWK 90



TRANSITONE AUTO RADIO



BREMER-TULLY 81 and 82

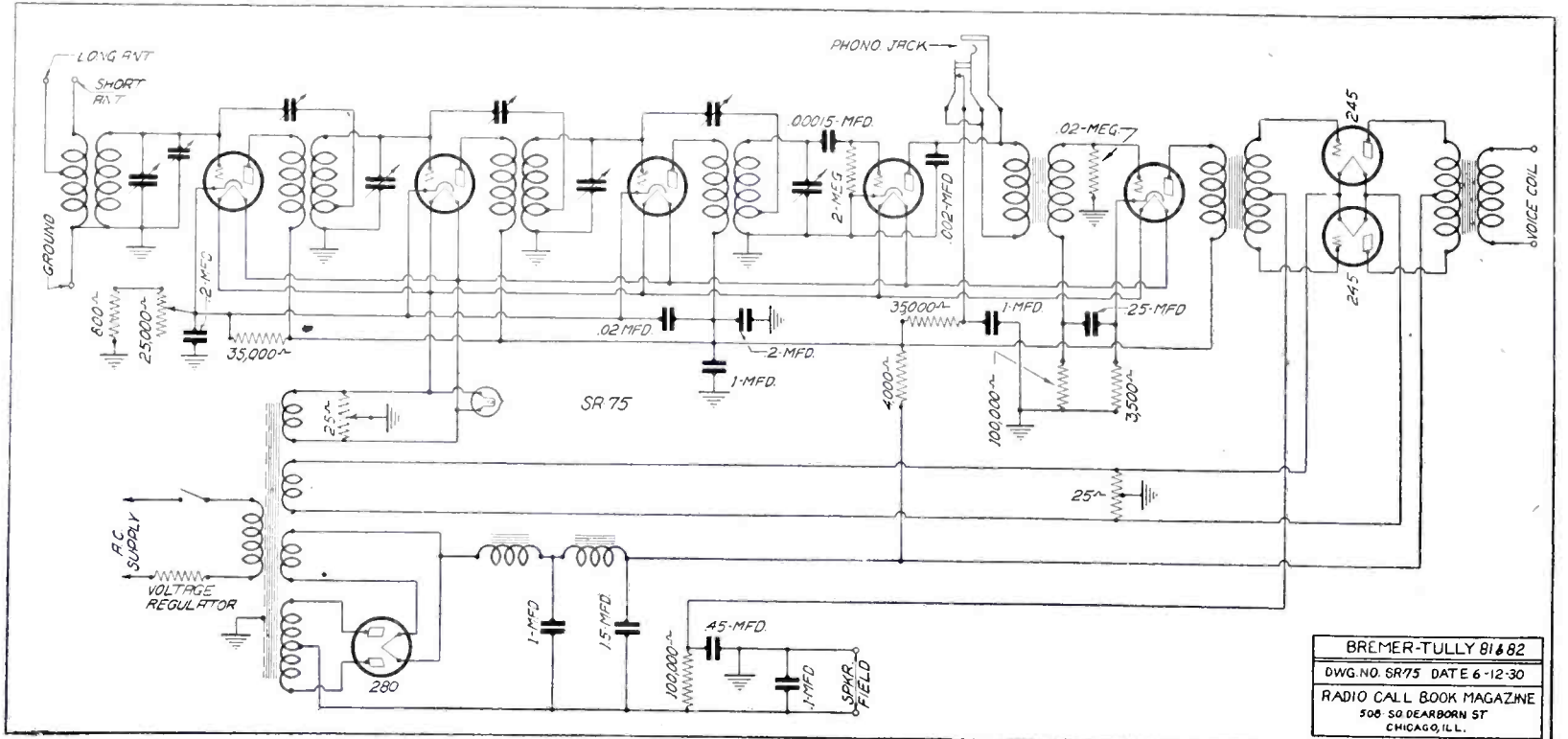

APEX S. G. MODEL 48

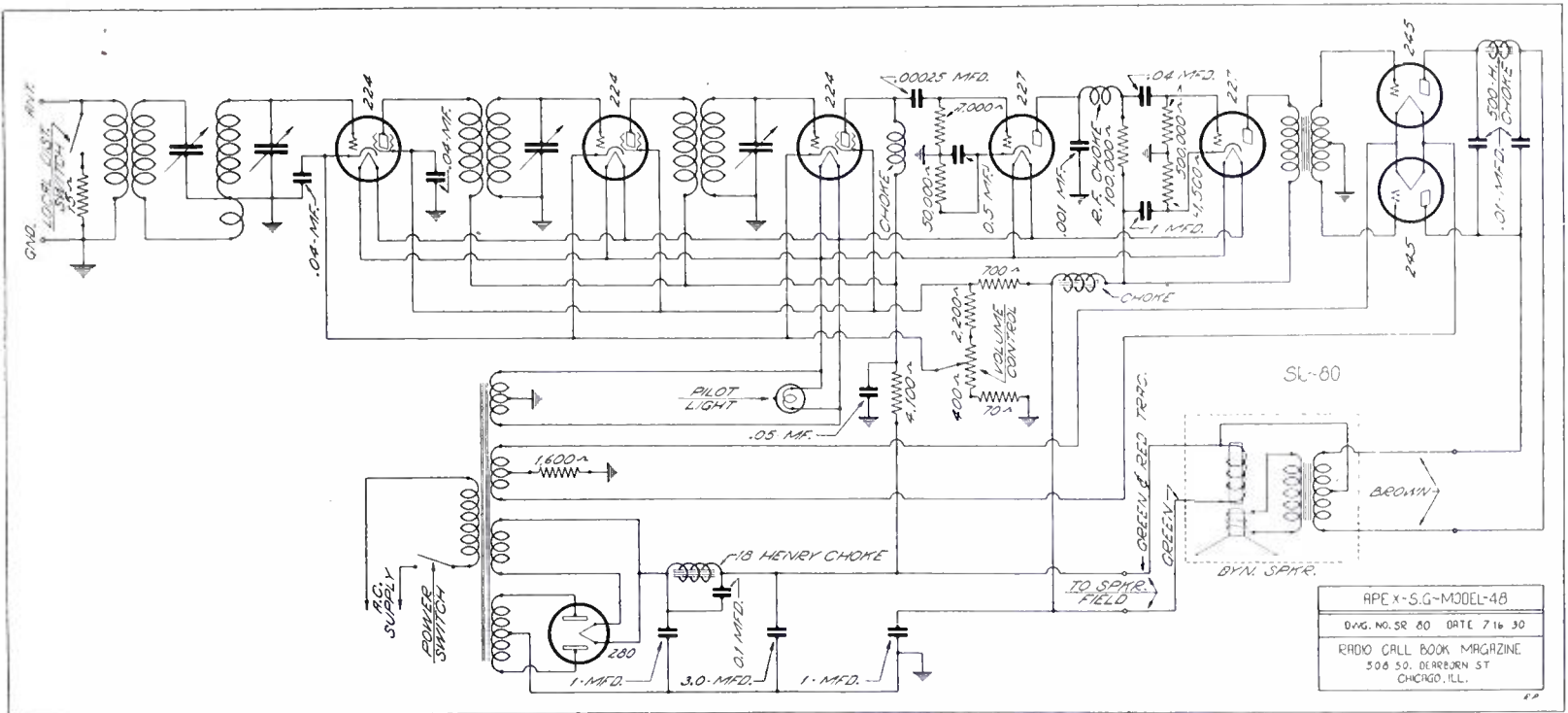

APEX-S.G-MODEL-48
 DWG. NO. SR 80 DATE 7 16 30
 RADIO CALL BOOK MAGAZINE
 506 SO. BERRBORN ST.
 CHICAGO, ILL.

T. C. A. CLARION MODEL 50

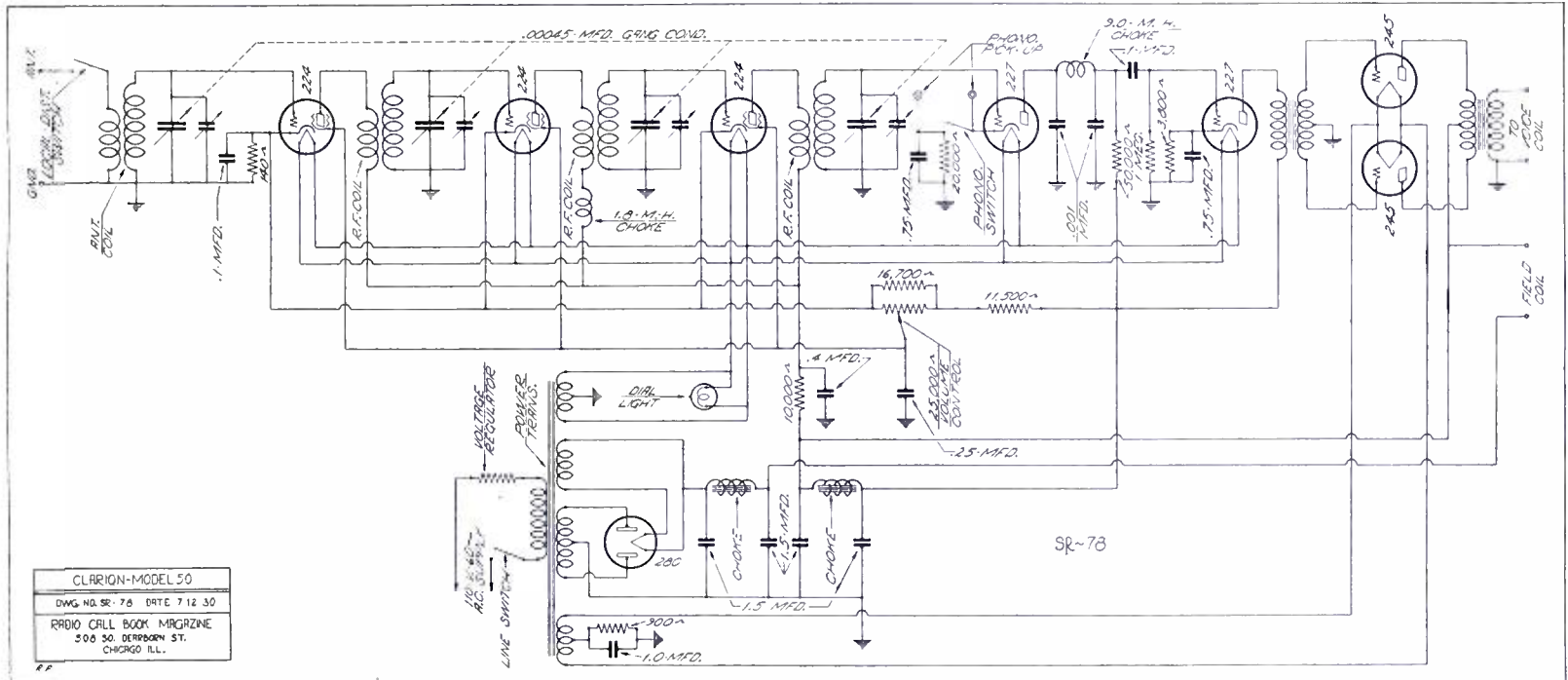

CLARION-MODEL 50
 DWG. NO. SR-78 DATE 7 12 30
 RADIO CALL BOOK MAGAZINE
 506 SO. BERRBORN ST.
 CHICAGO, ILL.

SPARTON MODELS 600, 610, 620

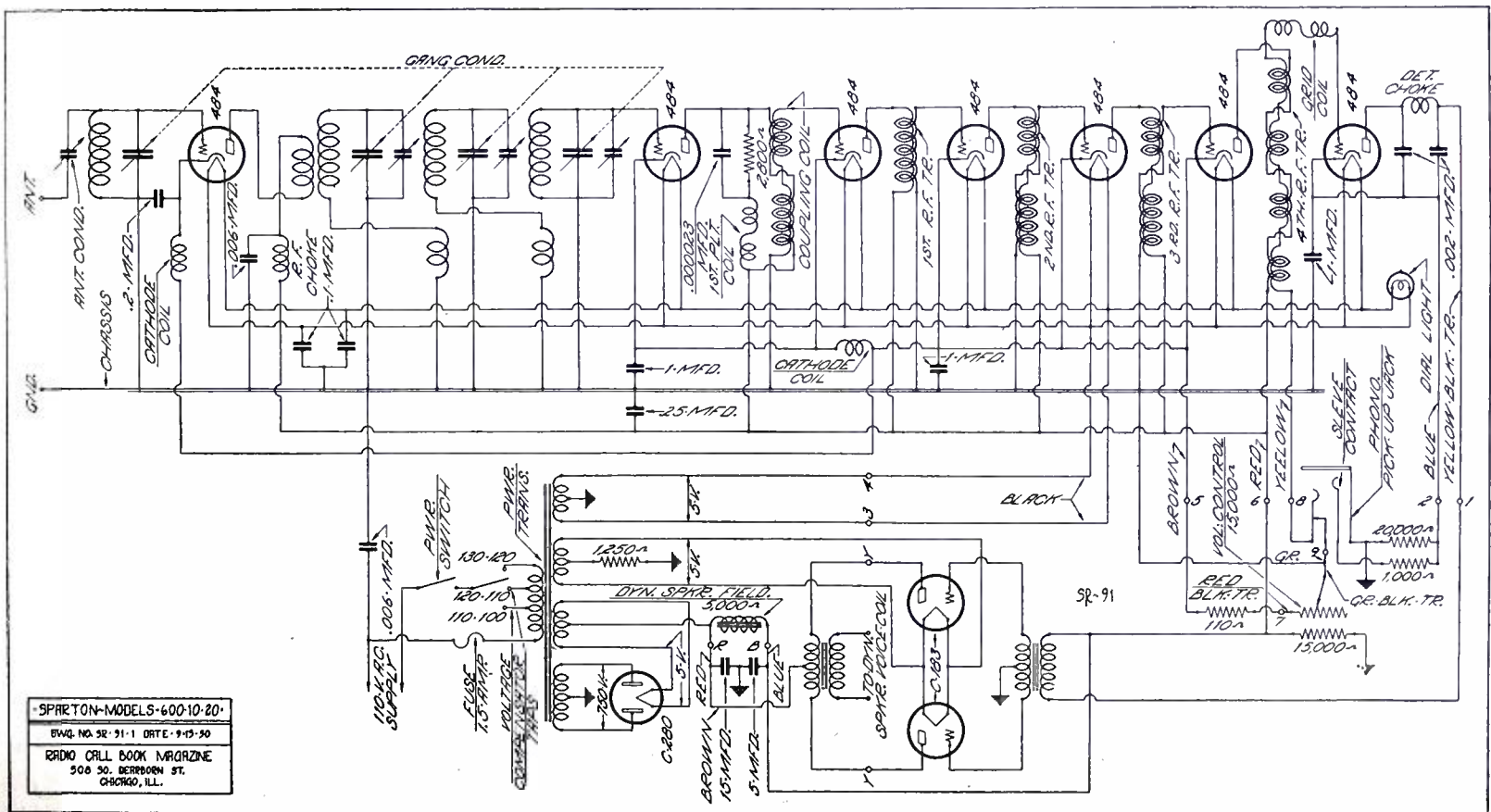

SPARTON-MODELS-600-10-20
 DWG. NO. SR-91-1 DATE 9-15-30
 RADIO CALL BOOK MAGAZINE
 506 SO. BERRBORN ST.
 CHICAGO, ILL.

Fada Radio Models 35 and 35Z

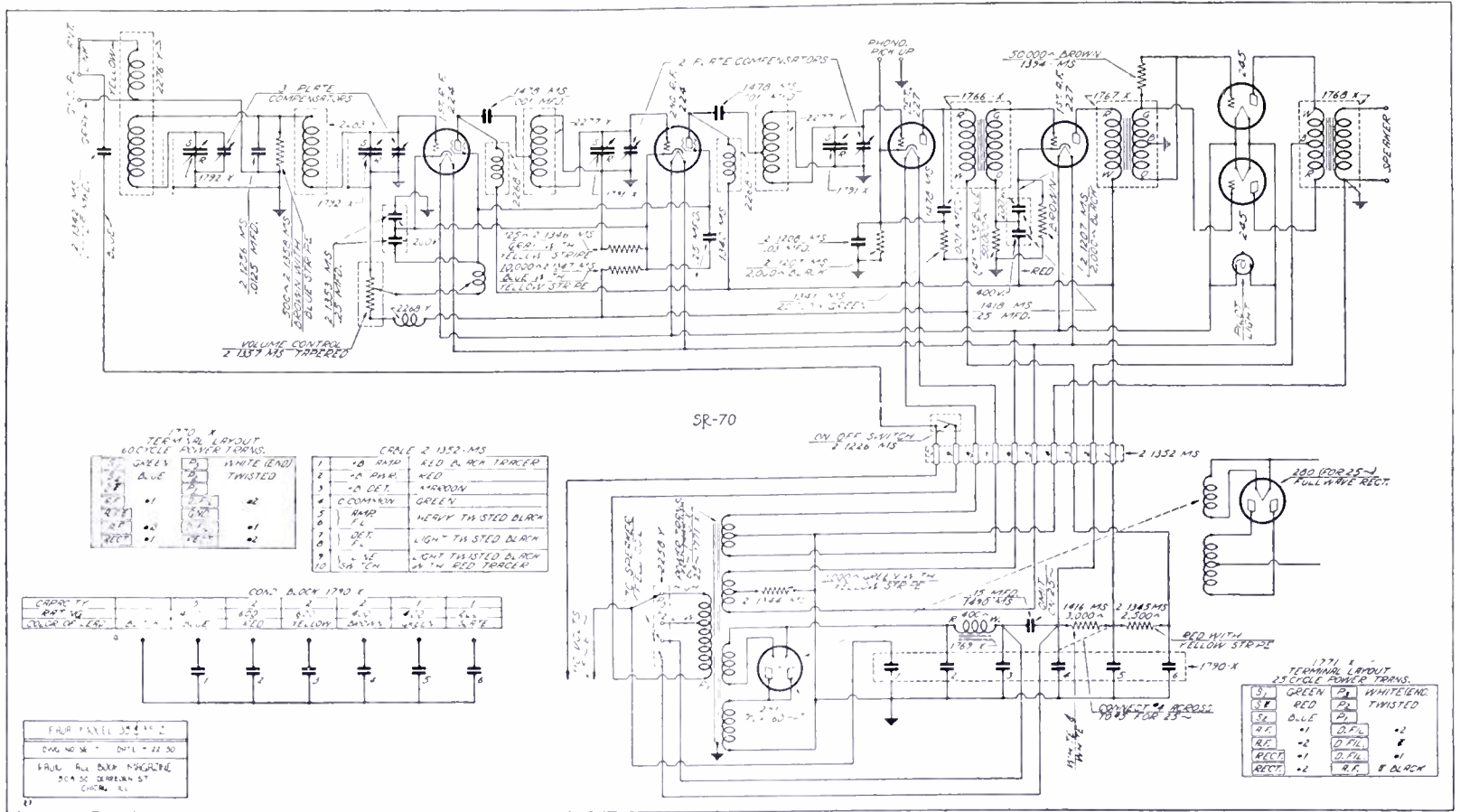

Kylelectron Radio Model 70

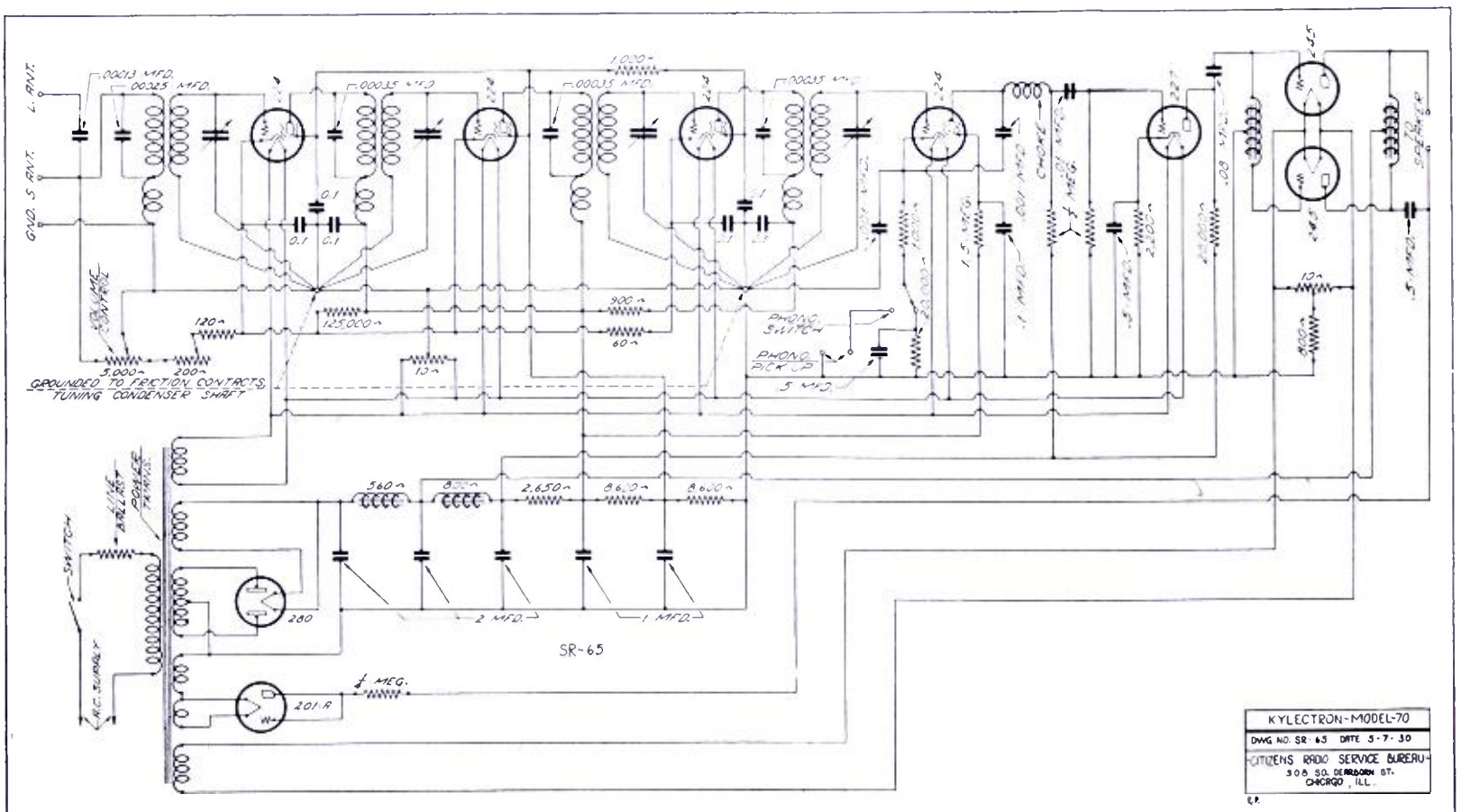

STEINITE MODELS 70, 80, 95

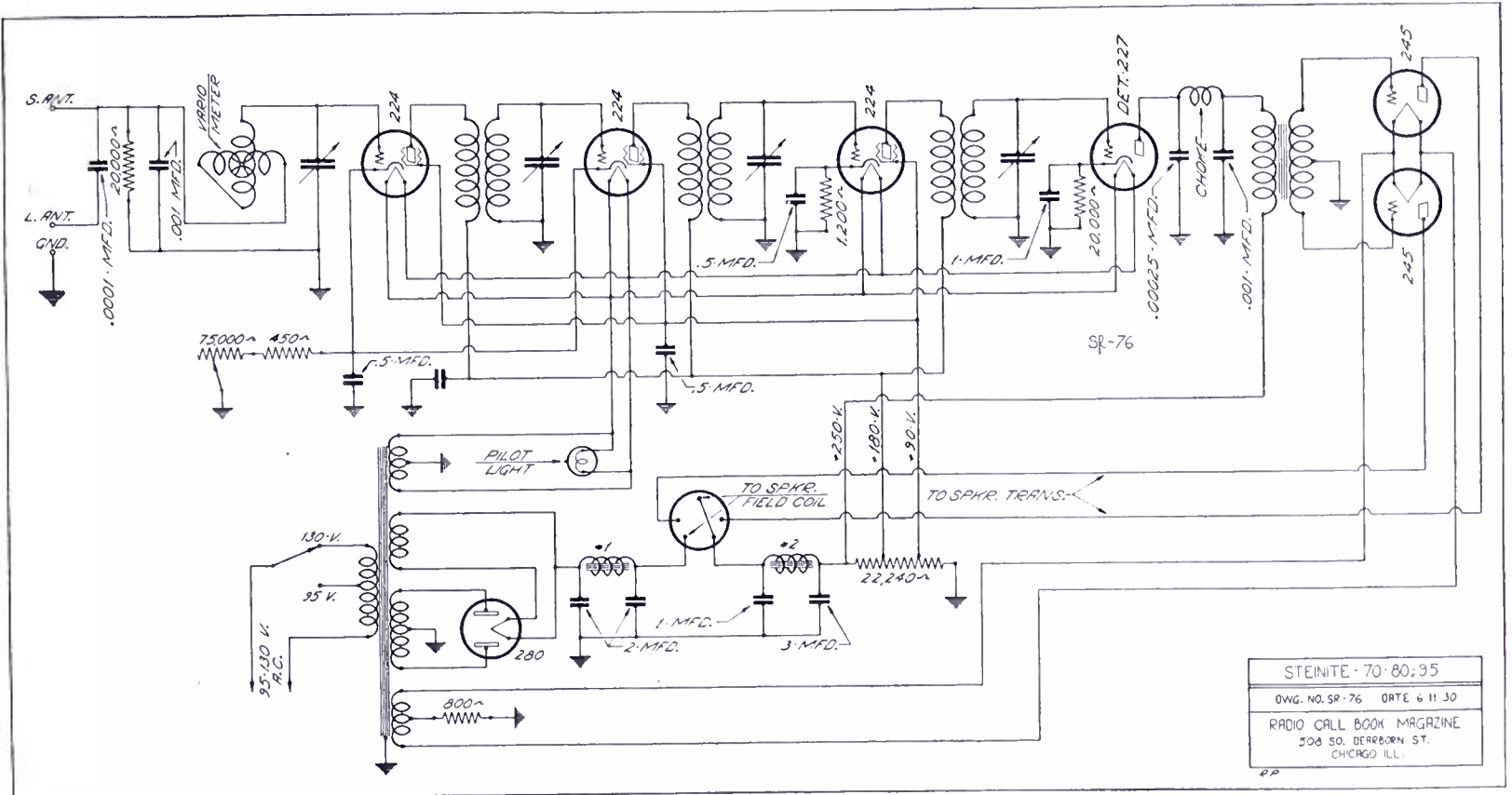

STEINITE - 70-80-95
 DWG. NO. SR-76 DATE 6 11 30
 RADIO CALL BOOK MAGAZINE
 508 SO. DEARBORN ST.
 CHICAGO, ILL.

BOSCH MODEL 48

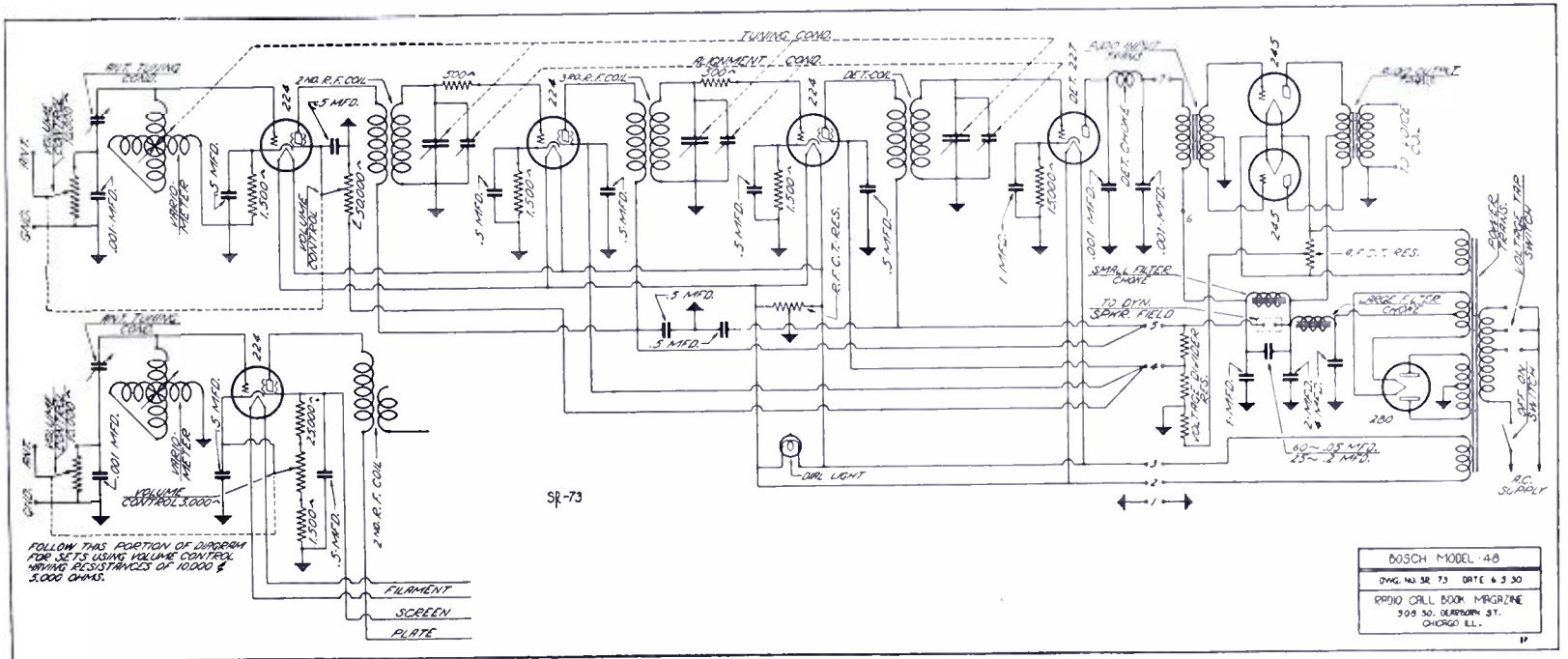

BOSCH MODEL-48
 DWG. NO. SR-73 DATE 6 3 30
 RADIO CALL BOOK MAGAZINE
 508 SO. DEARBORN ST.
 CHICAGO, ILL.

BRUNSWICK MODEL S14

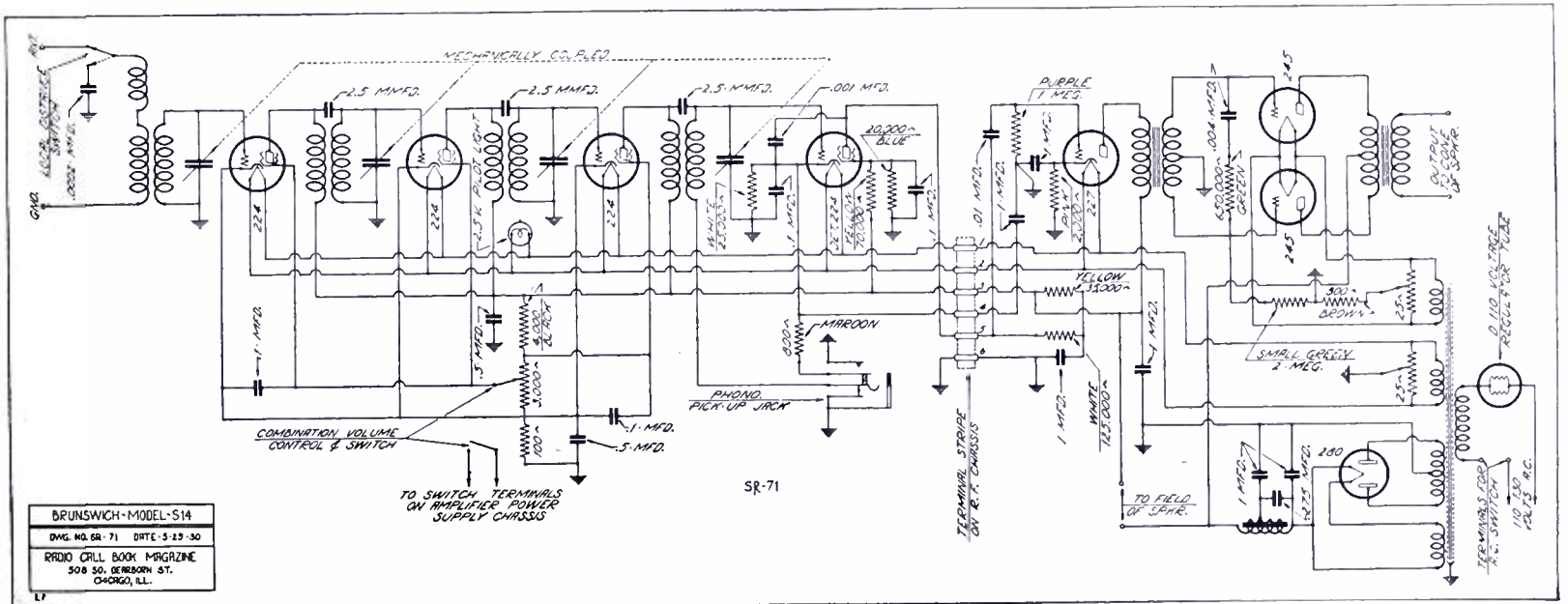

BRUNSWICK-MODEL-S14
 DWG. NO. SR-71 DATE 5-29-30
 RADIO CALL BOOK MAGAZINE
 508 SO. DEARBORN ST.
 CHICAGO, ILL.

Schematic of the General Motors Set

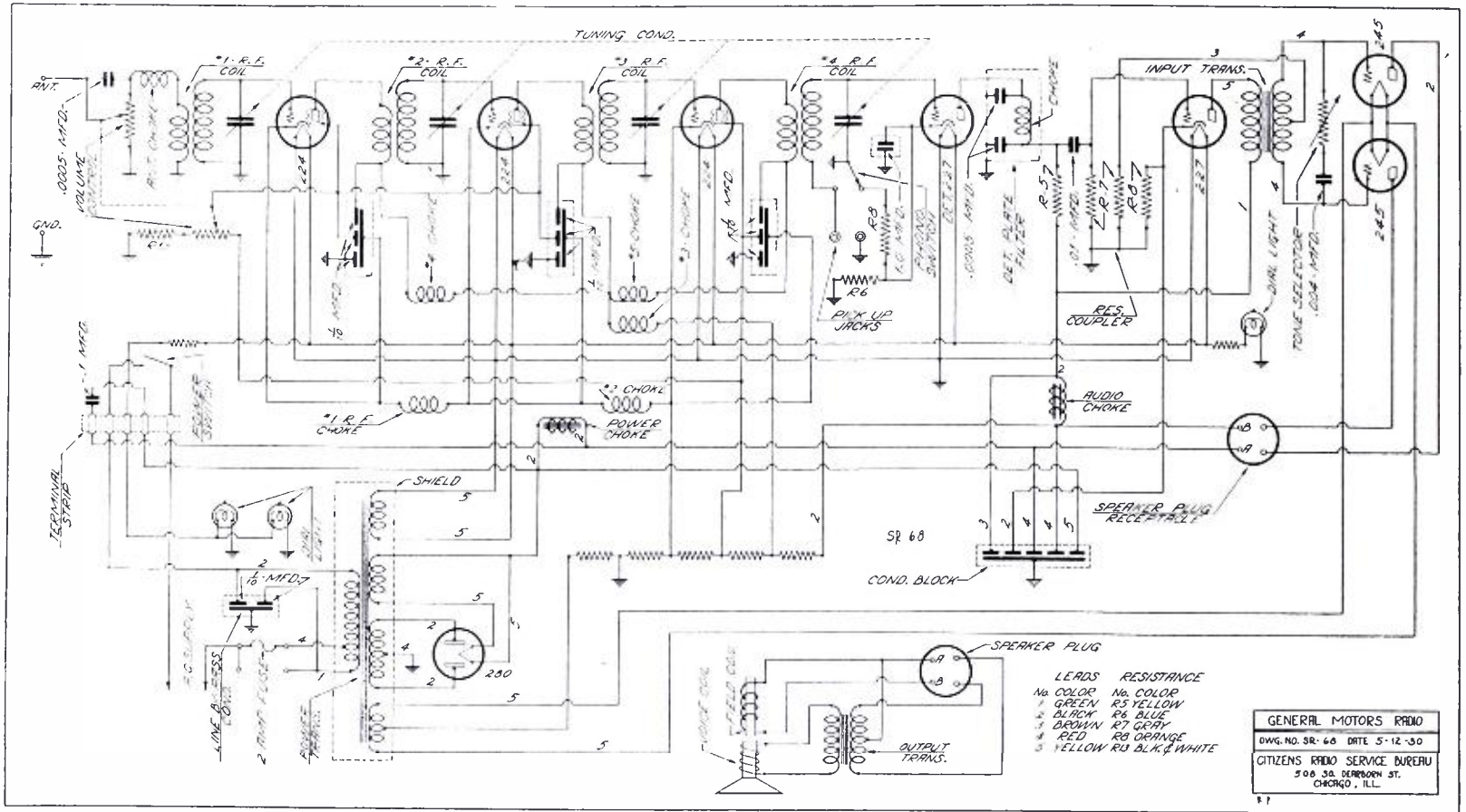

Fig. 2. Details of the General Motors radio set recently announced are shown schematically in the diagram above



Circuit Diagram of Bosch Auto Radio

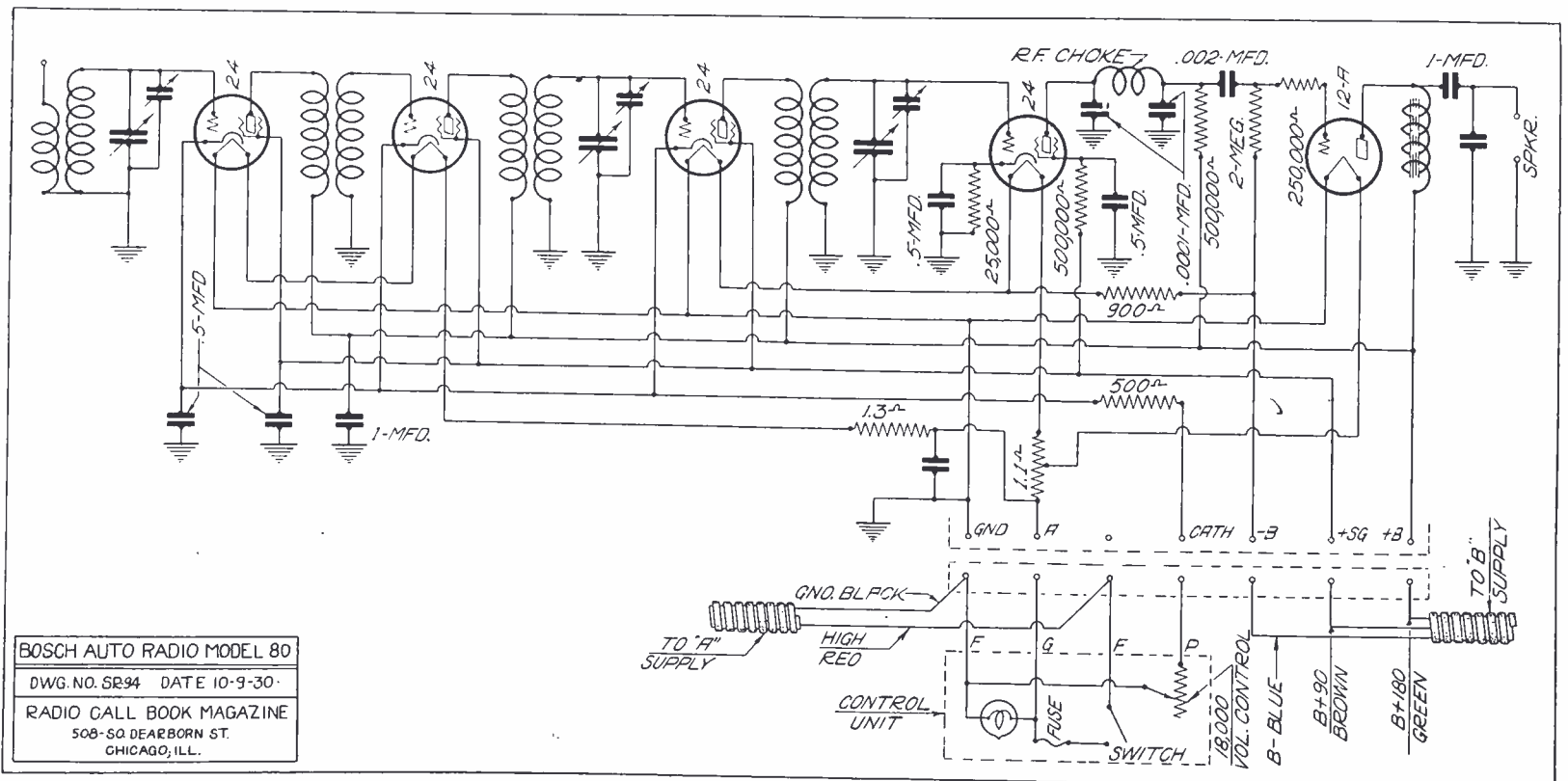
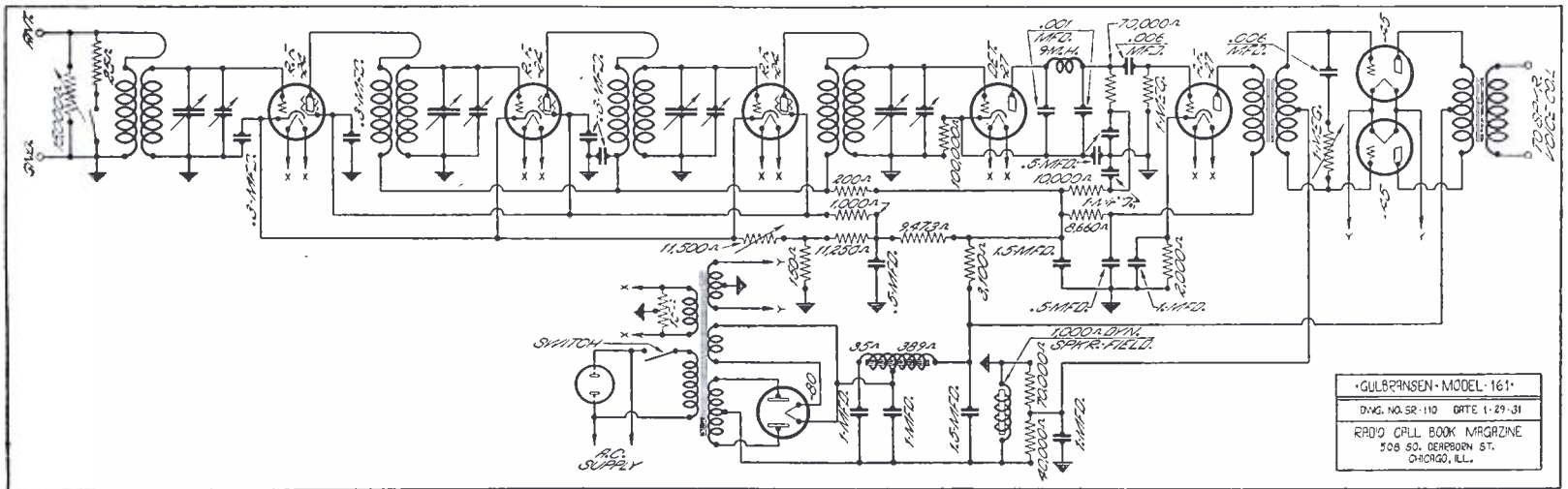
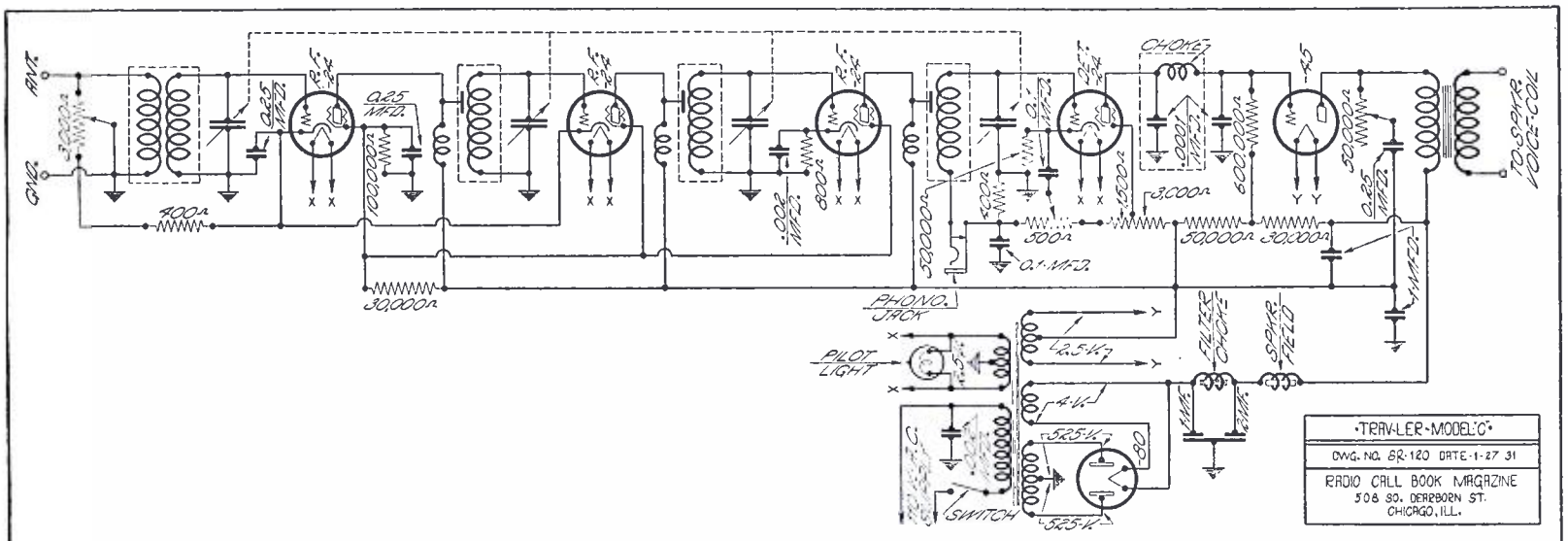

Fig. 1. In this drawing are the electrical details of the Bosch auto radio model 80

GULBRANSEN RADIO MODEL 161



TRAVLER RADIO MODEL C



SENTINEL RADIO MODEL 106-B

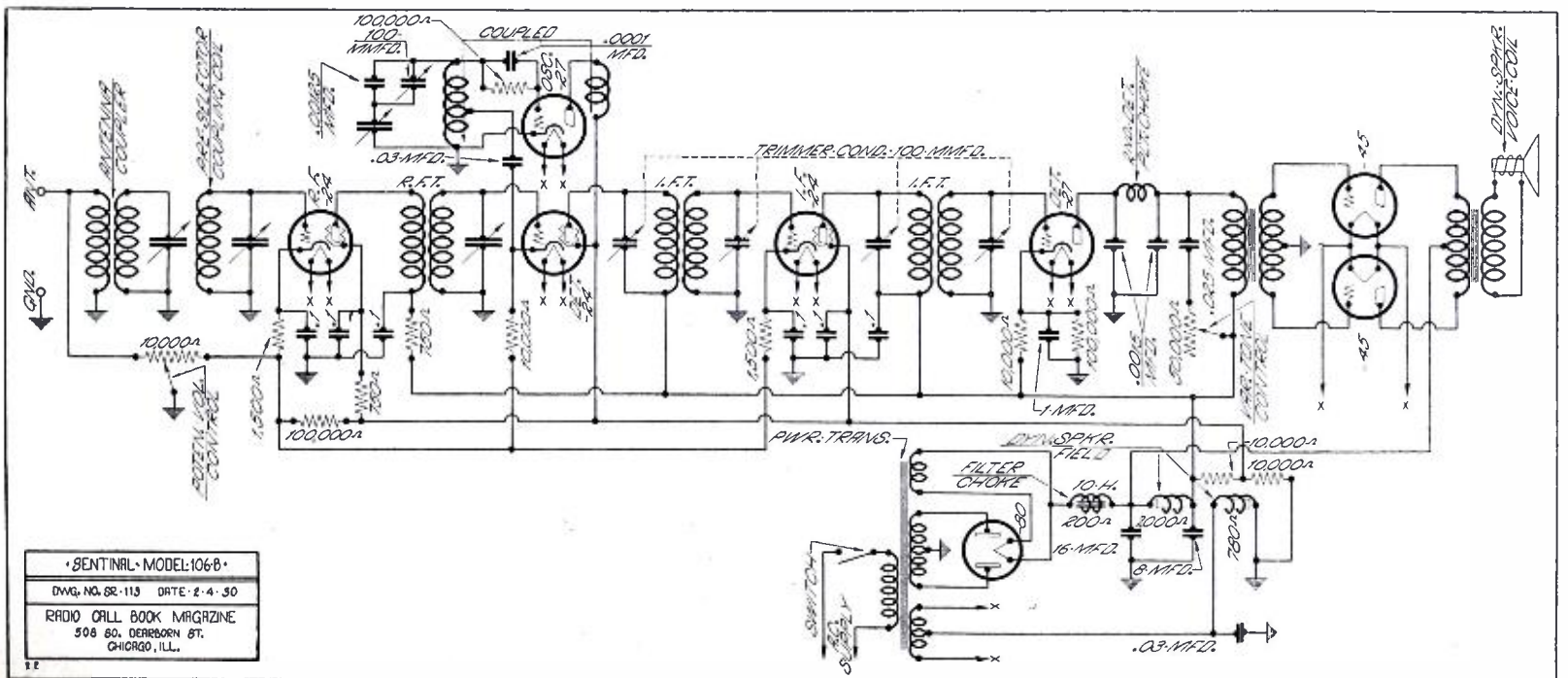

RADIETTE MODEL F 14

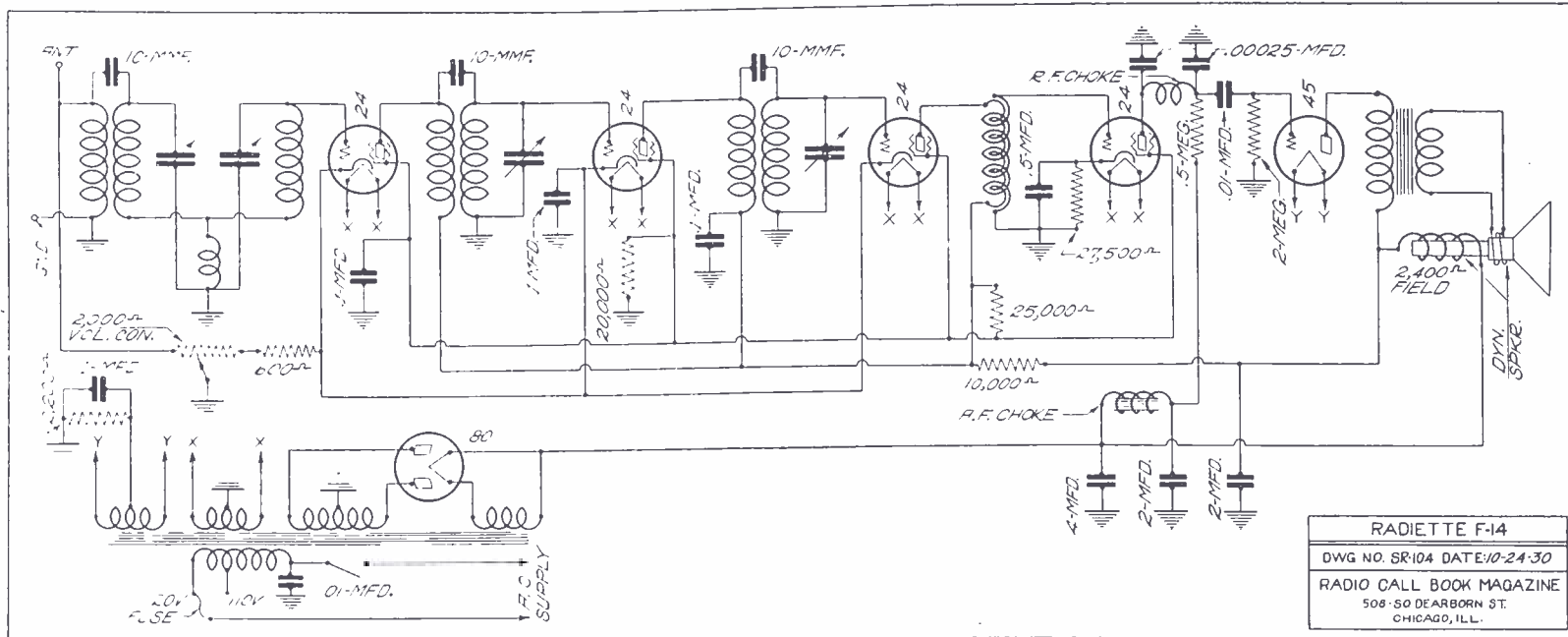

STEWART-WARNER No. R-100, A, AF, B, BF, E, EF

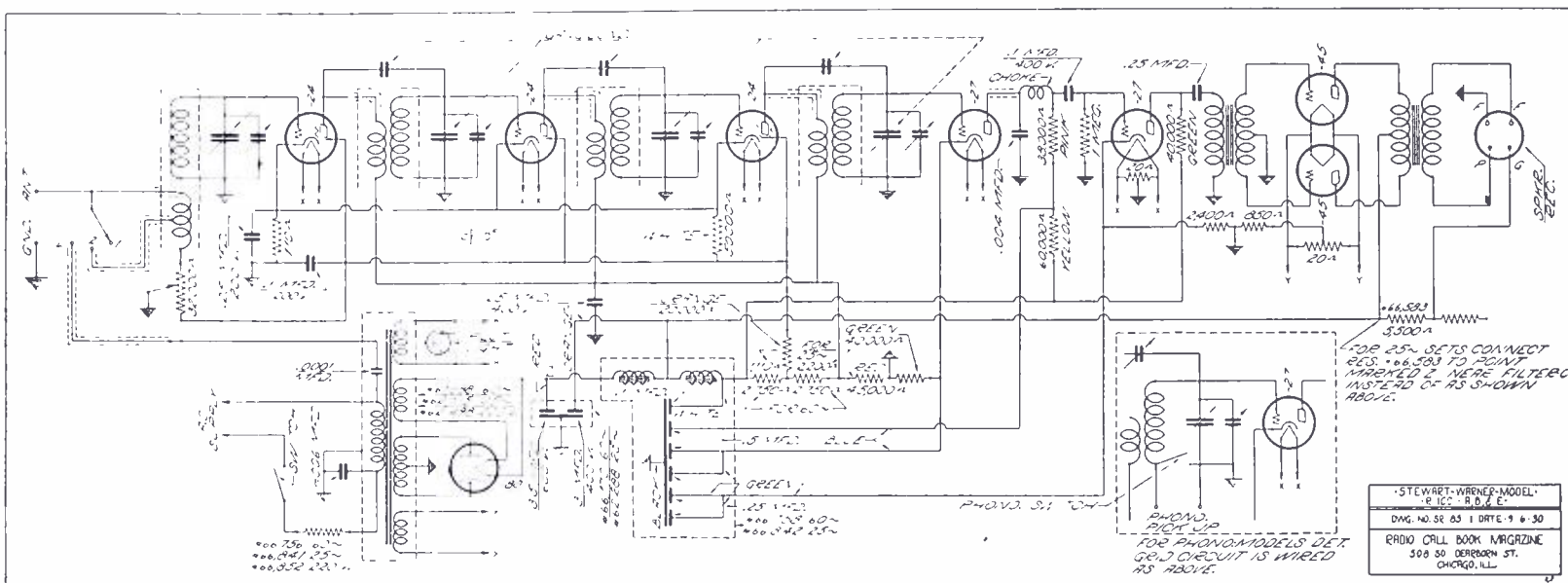

BRUNSWICK MODELS 15, 22, 32, 42

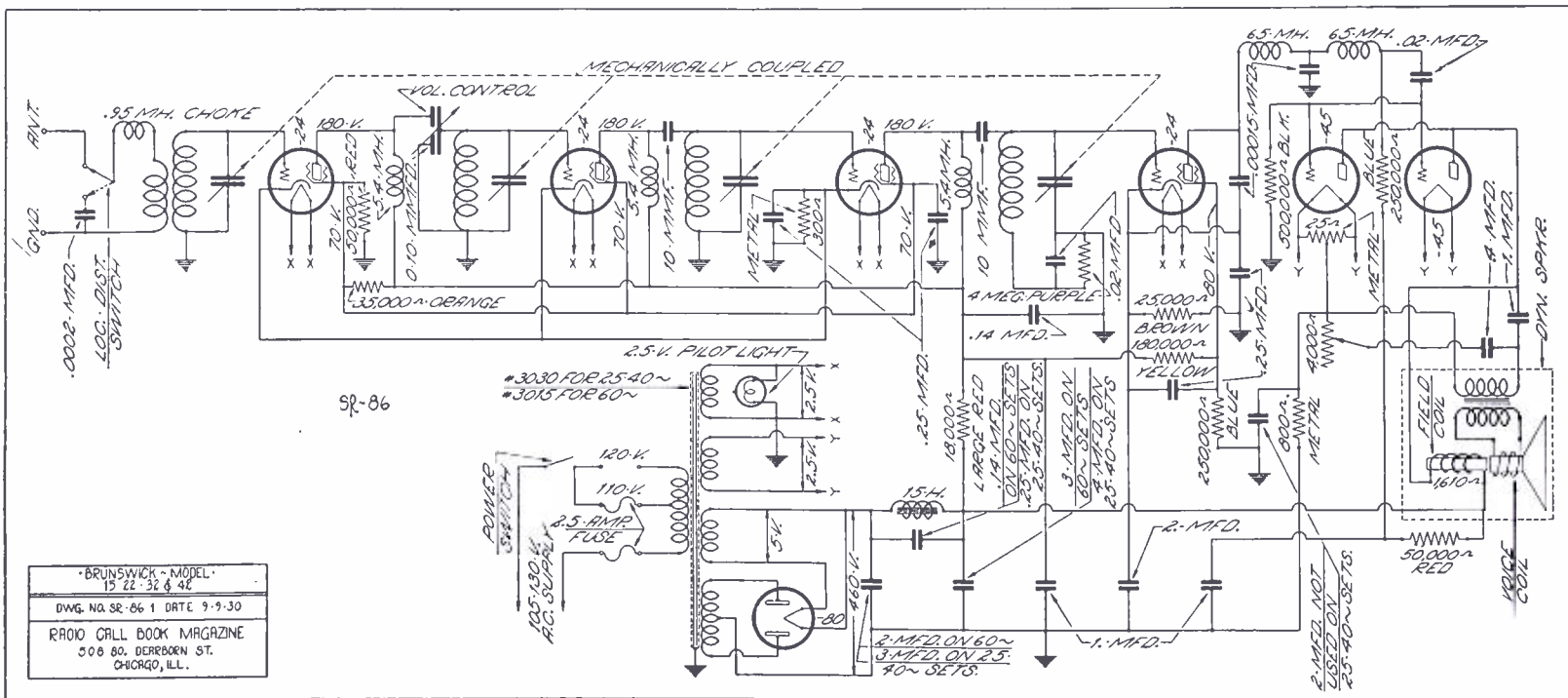

SPARTON MODELS 600, 610, 620

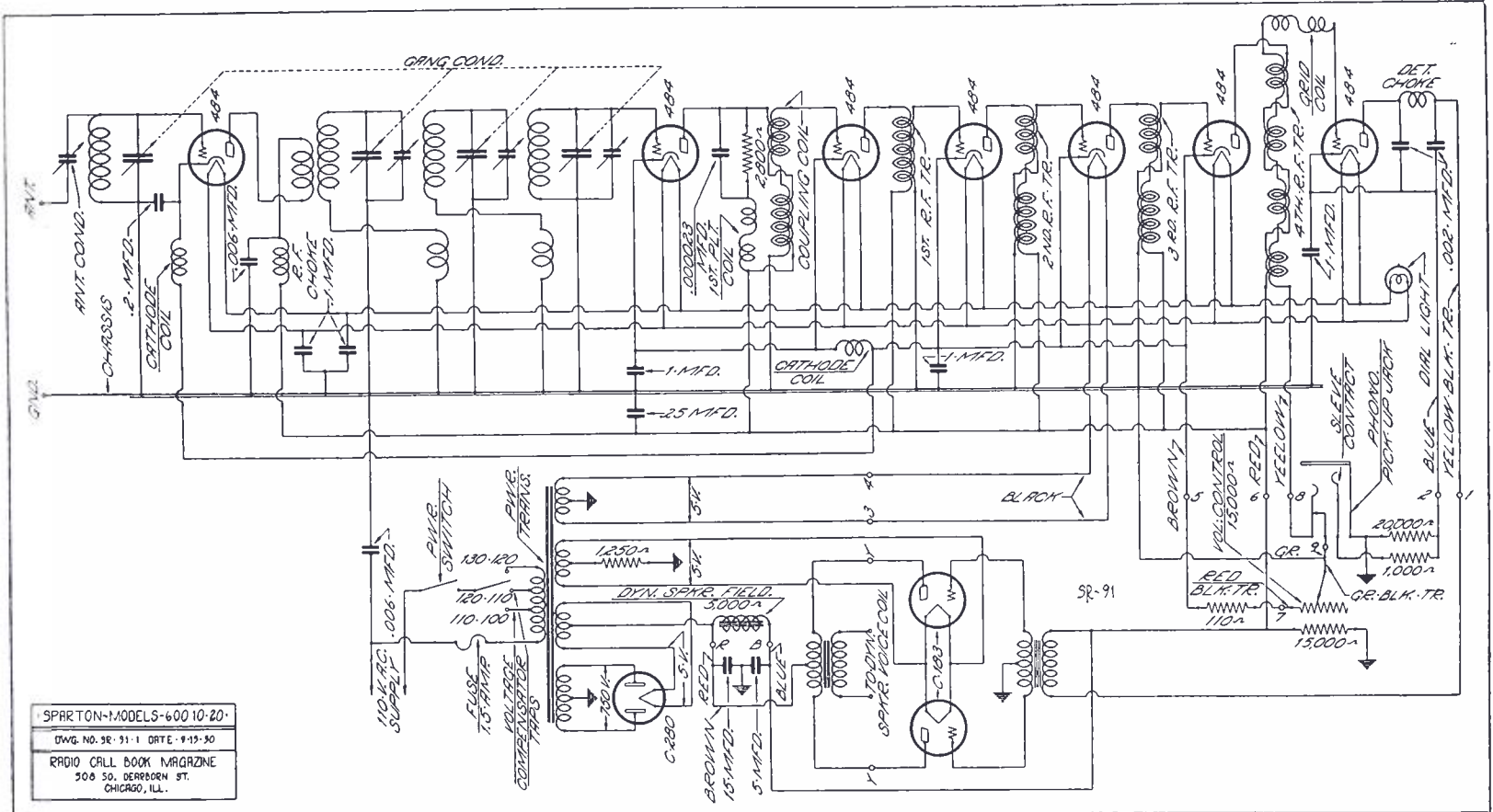

ZANEY-GILL VITATONE 54

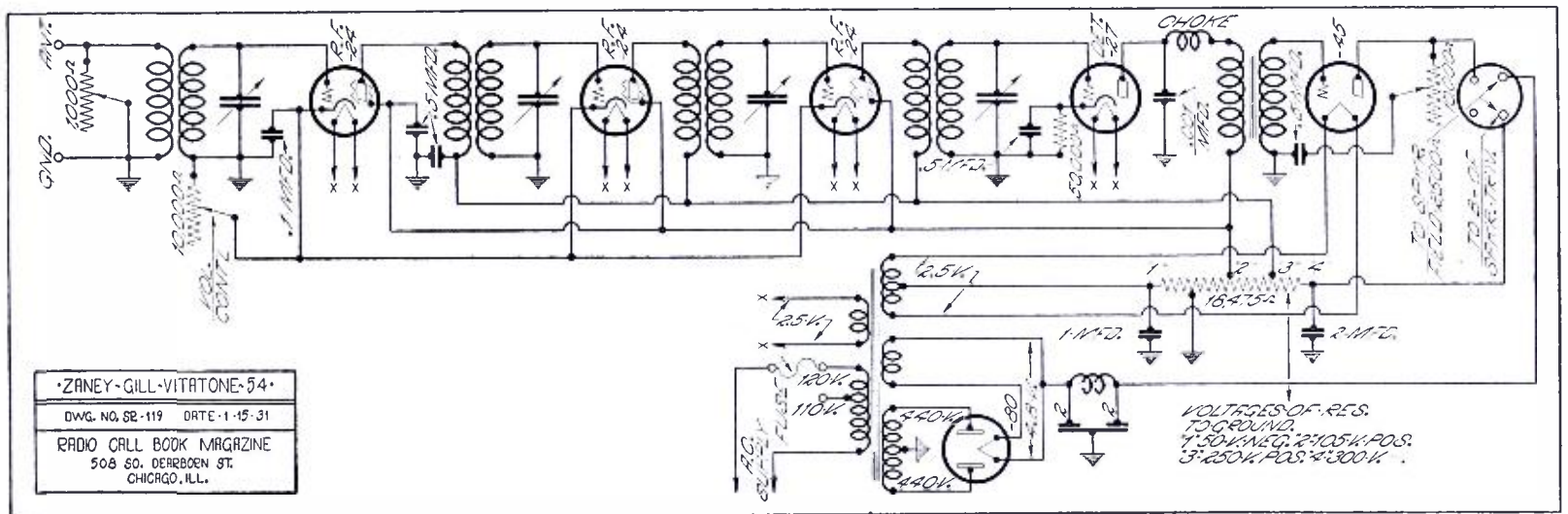

JESSE FRENCH, JR., MODEL G

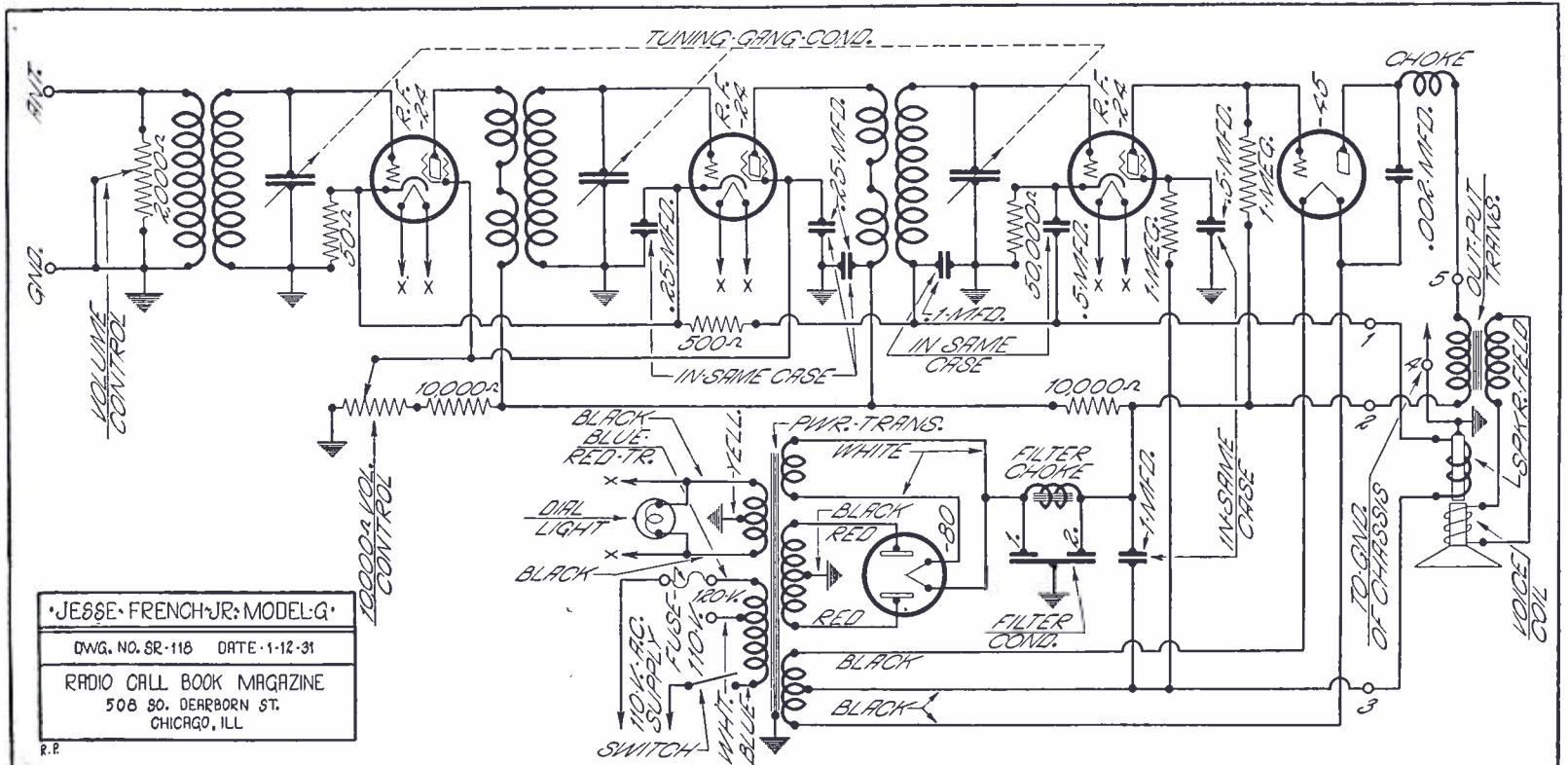

Audiola Radio Junior Model

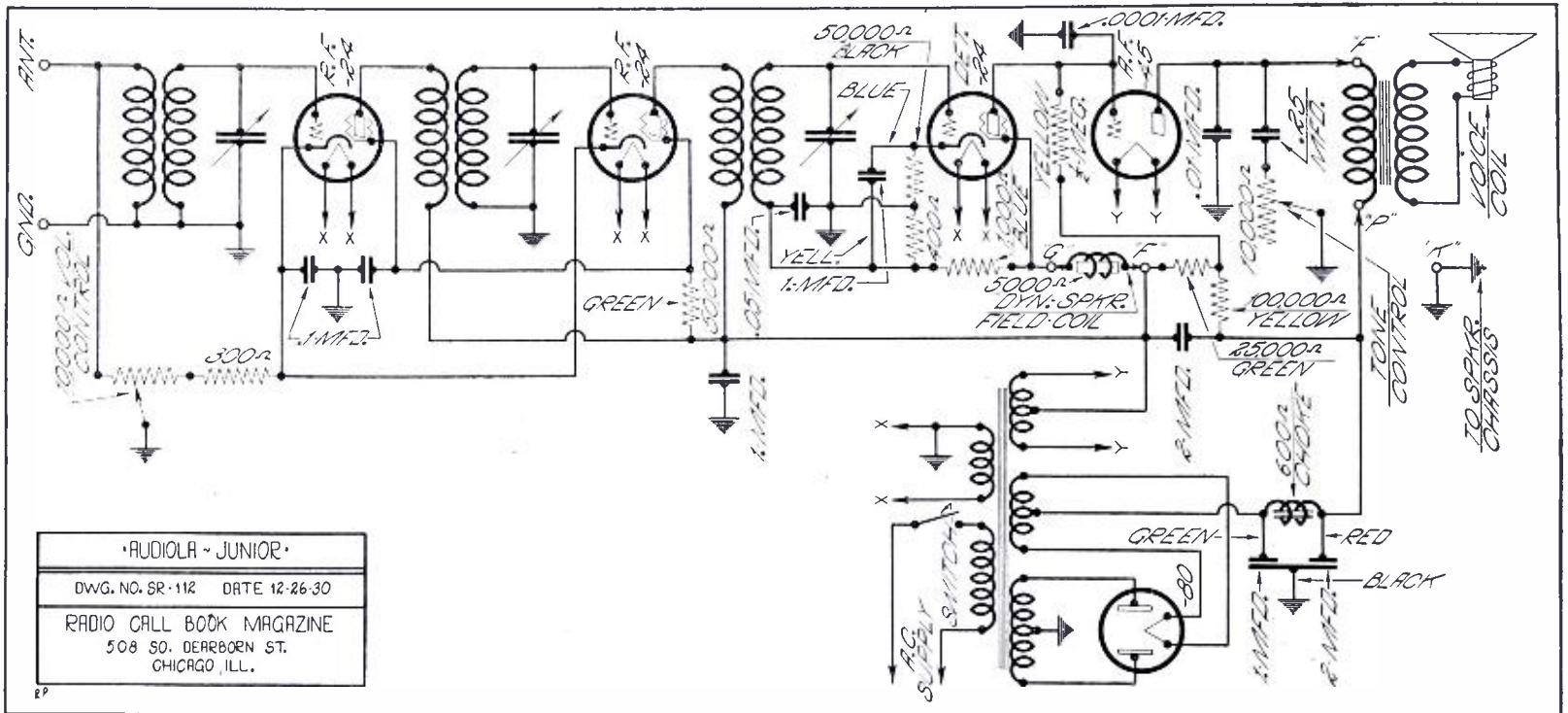

Eveready Model 50 and Supply

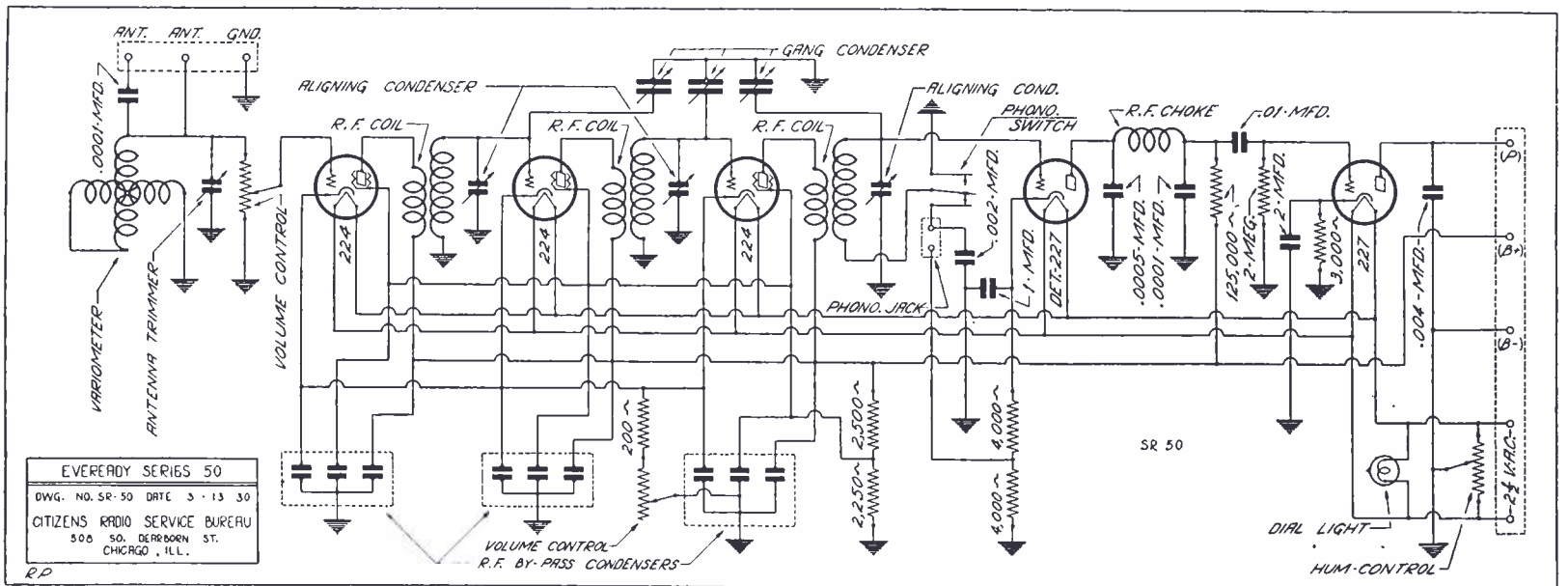

ALTHOUGH the Eveready model 50 receiver is no longer being made, we have had many requests from servicemen for this schematic. The demand apparently has arisen from the fact that a number of these receivers were distributed through department stores and other outlets.

The electrical constants of the receiver itself are shown in the drawing above, while the power supply details are shown in the illustration at the right.

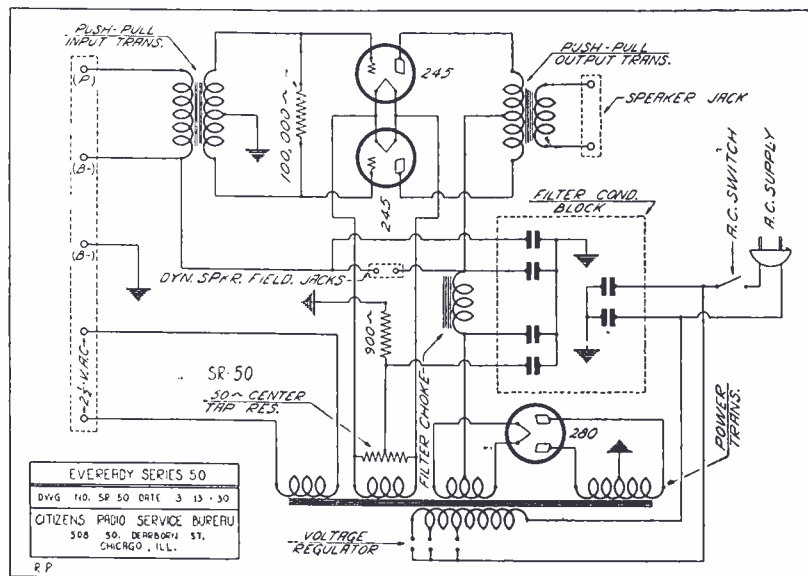

Receiver Response Curve Section

THOSE interested in the response curves appearing in this issue will find on this page a brief summary of the equipment, conditions of measurement, and a description of the meaning of sensitivity, selectivity and electrical fidelity.

The photograph shown here represents the apparatus used in making the measurements in our laboratory. As a rule only the latest models of receivers are measured for publication in this magazine.

Equipment Used

Equipment used in the response measurements conforms to specifications of the I. R. E. and the R. M. A. standardization committee. Such apparatus for the most part is manufactured by The General Radio Co. All test frequencies are determined by zero beat of a crystal controlled dynatron oscillator. Voltmeters and microvoltmeters are periodically checked against calibrated standards for accuracy of adjustment.

Conditions of Measurement

All measurements are made in the manner outlined by the Institute of Radio Engineers Standardization Committee and published in detail in the 1929 Year Book of that organization. The individual conditions of measurements pertaining to each receiver will be found in the article accompanying each family of curves.

Sensitivity

Sensitivity curves show sensitivity in microvolts input plotted against carrier frequency in kilocycles.

Interpretation of this curve follows: A station will cause standard speaker output (.05 watts) when it has a local field strength equal to the microvolts divided by four indicated on the curve directly above the frequency of the station. To find the

sensitivity of the receiver in microvolts per meter (based on a four-meter antenna), divide any point on the curve in microvolts by four. This sensitivity is measured at 30 per cent modulation.

Selectivity

Selectivity curves are plotted in field strength ratios vertically and frequency horizontally. Field strength ratios are determined by the input in microvolts required to obtain standard speaker output at the various frequencies off resonance, divided by the input required to give standard speaker output at resonance. The curves may be analyzed as follows: Resonance is the vertical zero line. A station on any frequency off resonance will cause equal volume interference when its vertical line intersects the

curve of the station desired. The point of intersection indicates a field strength ratio greater than resonance which produces equal volume interference. For general purposes the selectivity of the receiver is the number of kilocycles between the sides of the curve at any specified carrier frequency and field strength ratio.

Electrical Fidelity

Electrical fidelity of a receiver is the loss or gain in faithfulness with which the audio component of the carrier frequency passes through the receiver. The measurements are made with a constant r.f. input voltage required to give standard speaker output when 400 cycles per second, 30 per cent modulation, is used. The r.f. input is maintained and the various test mod-

ulation frequencies varied. The ratio of the output at the modulation frequency of 400 cycles to the output at the other modulation frequencies (30 to 5000 cps) is calculated in decimals and plotted as loss or gain as the case may be from 400 cps. These measurements do not take into consideration the frequency response curves of the speaker.

Since curves of all receivers are taken under the same conditions, it may be said that such curves serve as a yardstick by means of which various receivers of the same class may be compared. This means supers may be compared against supers, or tuned r.f. rated against tuned r.f. It is obvious that comparisons between the super and the tuned r.f. are hardly fair because of their circuit differences.

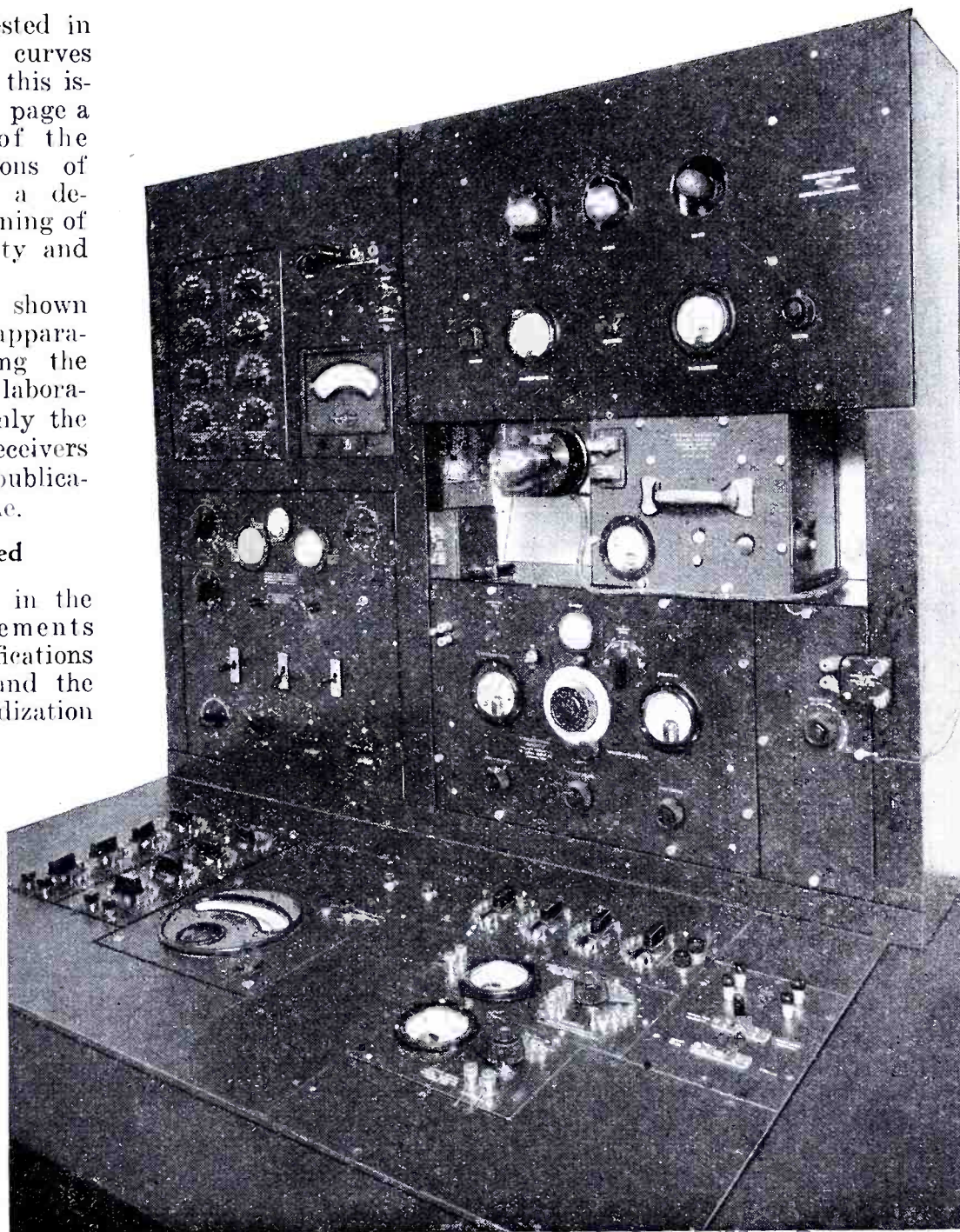

Majestic Model 90-B Response Curves

SENSITIVITY measurements on the Majestic 90-B are shown in Fig. 1. Greatest sensitivity at 1400 kc, least at 600, being most sensitive in the area from 1400 to 850 kc, ranging from about 3 uv/m to 5 uv/m over the best part of the broadcast band and rising to about 11 uv/m at 600 kc.

As could be expected from the sensitivity measurement the selectivity curves in Fig. 2 show the 1400 kc curve the broadest, 1000 kc next and the 600 kc the sharpest. The shape of both the 600 and 1000 kc curves is quite symmetrical, but the 1400 kc curve departs from symmetry on the plus 10, 20 and

30 kc off resonance. This departure might be caused by too great a minimum in the antenna compensator.

The fidelity measurements are shown

in Fig. 3. From about 90 to 1000 cycles the three curves are in complete agreement. The greatest DB loss is on the 1000 kc curve showing a drop of about 17 DB; the 600 and 1400 kc curves dropping only about 16 DB. Of the three the 1400 kc covers the widest audio range, next the 1000 kc and then the 600 kc. The loss would hardly be appreciable to the ear.

Dummy antenna used was the standard 4 meter one having an inductance of 20 uh, capacity of 200 mmf and resistance of 25 ohms. GR 403-C standard signal generator and type 486 output meter employed in measurements.

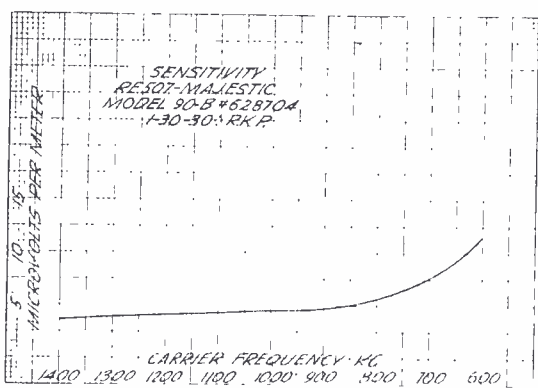

Fig. 1. Measured sensitivity of the Majestic 90-B is indicated in the graph shown above

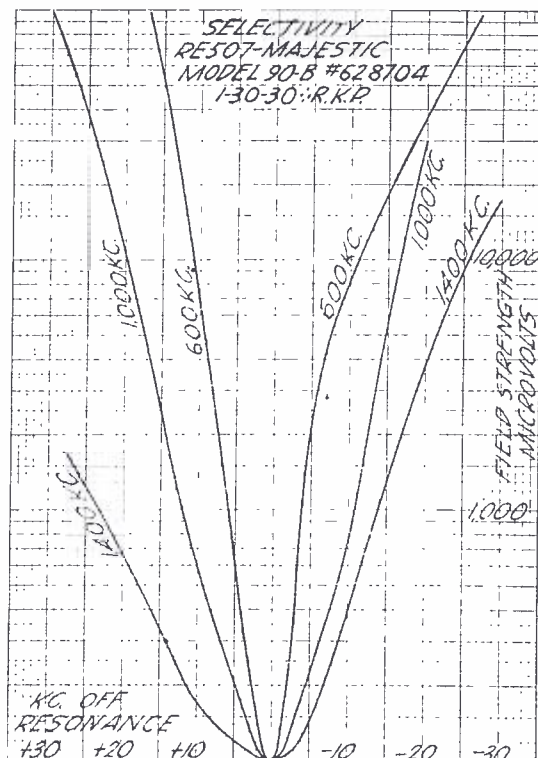

Fig. 2. Selectivity curves taken at three frequencies are shown in this illustration

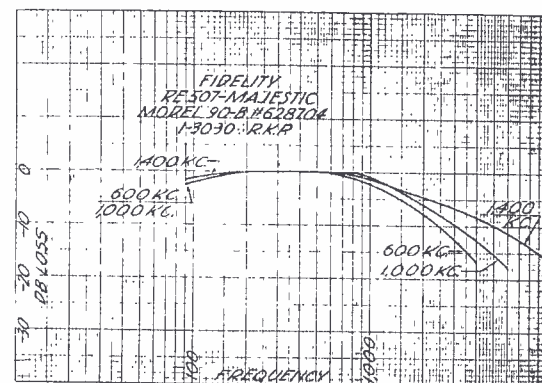

Fig. 3. Fidelity of the Majestic model 90-B recently measured in our laboratory is depicted above

Trio of Curves Taken on Radiola 44

ARATHER unusual sensitivity curve is that shown for the Radiola 44 illustrated in Fig. 1. Most sensitive at 600 kc, least sensitive at 1100 kc, then next most sensitive at 1400 kc. Measurements were made with the local switch and the distance switch on. On the distance switch side the greatest sensitivity was about 7 uv/m, at 600 kc, next most sensitive was 22 uv/m at 1400, and about 60 uv/m at 1100 kc. On the local side the greatest sensitivity was at 600 kc with about 950 uv/m; then 1400 kc with about 3700 uv m, then 1200 kc with 7000 uv m.

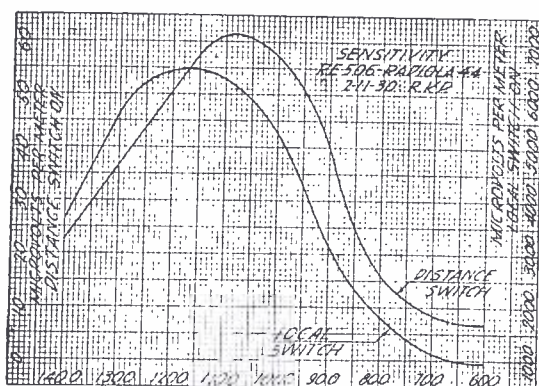

Fig. 1. In this curve may be seen the sensitivity of the Radiola 44 recently measured in our laboratory

In the selectivity curves shown in Fig. 2 the broadest is the 1400 kc, next the 1000 kc curve and the 600 is the sharpest. Considering their width the

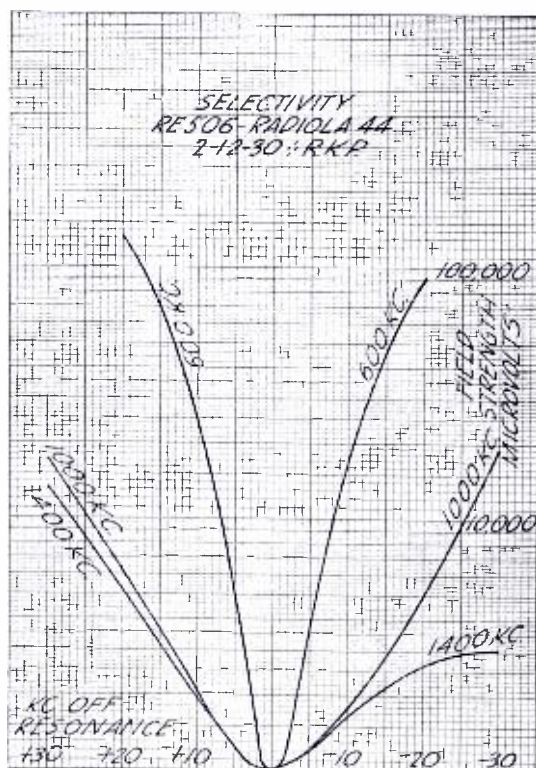

Fig. 2. From this set of curves may be obtained an idea as to the selectivity of the Radiola 44

curves are symmetrical. The 600 kc curves give somewhat satisfactory selectivity, while the 1000 and 1400 kc curves would not give satisfactory selectivity in an area of strong locals.

Fidelity curves on these receivers, especially the 1000 and 1400 kc curves are exceptionally good. They are shown in Fig. 3. The 600 kc curve falls off rather rapidly which is due to the increased selectivity at 600 kc.

Dummy antenna was the standard 4 meter one with 20 uh, 200 mmf and 25 ohms. GR 403-C standard signal generator and 486 output meter.

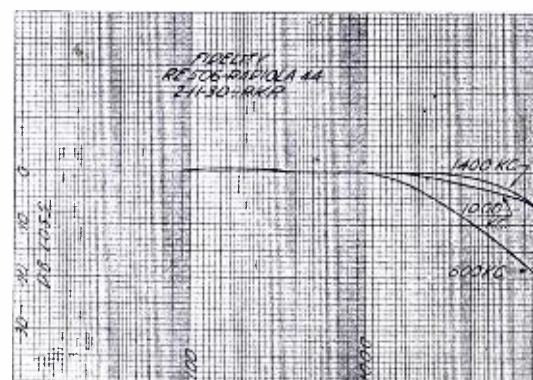

Fig. 3. Tone quality of the receiver is indicated in the above curves taken when the fidelity was measured

Three Atwater Kent 55-C Curves

THREE curves on the Atwater-Kent model 55 C are shown in Figures 1, 2 and 3.

Sensitivity in Fig. 1 has a rather sharp rise above 900 kc but even at its worst the sensitivity is good. At 1400 kc it is less than 1 microvolt per meter which is extremely sensitive. On the local switch at 1400 kc the sensitivity is 20 uv/m with a gradual rise to 160 uv/m at 600 kc. This is good average sensitivity.

The selectivity curves in Fig. 2 show a little better selectivity than is averaged for this type of receiver. It will

be noted that the minus side is not symmetrical with the plus side, probably being due to small discrepancies in tun-

ing capacities which with the extreme sensitivity would show a deviation from uniformity.

The fidelity curves in Fig. 3 are in accordance with the selectivity having cutoffs a little too sharp for high quality reproduction. The 600 kc curve for instance is down 28 DB at 5000 cycles. However it is probable that the speaker characteristics compensate for this loss at the high frequency.

Dummy antenna 4 meter having 20 uh, 200 mmf and 25 ohms. GR 403-C signal generator and 486 output meter.

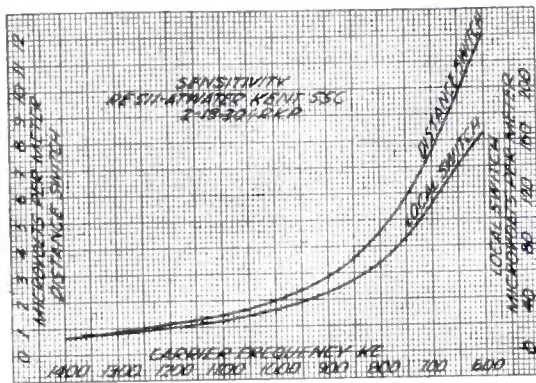

Fig. 1. Sensitivity of the A-K 55-C as measured in our laboratory shows the characteristics illustrated above

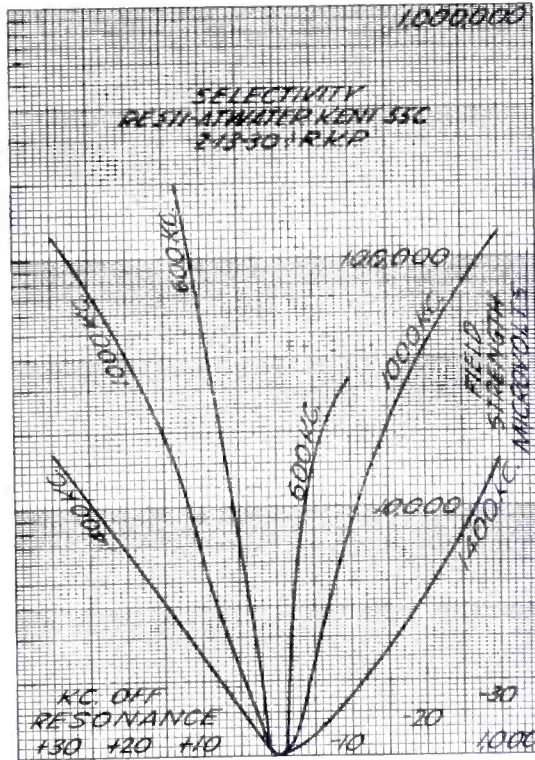

Fig. 2. The selectivity of the receiver under measurement is shown by the three curves in this drawing

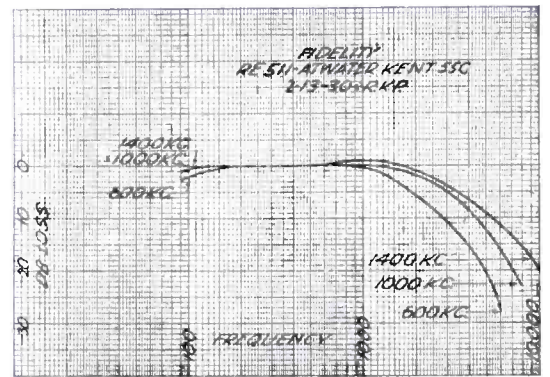

Fig. 3. Fidelity measurements made on the receiver are shown in the graph above

Crosley Model 40-S Has These Curves

THE Crosley model 40-S was recently measured in our laboratory with the following results as indicated in Figures 1, 2 and 3.

Three curves were made on the sensitivity of this model as shown in Fig. 1. Curve A was made with the antenna compensator switch on local, showing a sensitivity at 1400 kc of about 5 uv/m and at 600 kc about 260 uv/m. Curve B was made with the switch on distance showing a sensitivity at 600 kc of 80 uv/m and at 1400 kc of 5 uv/m. Curve C is a combination of both, from 600 to 1050 on distance switch and from 1050 to 1400 made on

the local switch, showing an increase in sensitivity at 1400 kc of about 4 uv/m. The average sensitivity is good.

The selectivity curve of this receiver

has a rather peculiar shape. At all frequencies the selectivity is rather broad and not satisfactory for congested broadcast areas where distant stations are desired. The lack of uniformity is quite likely due to discrepancies in tuning capacities over the wave band, as it was not possible to trim the tuning condensers. The receiver is a good local receiver as far as sensitivity and selectivity is concerned.

The fidelity of this model is not bad, having only 5 DB loss at 5000 cycles, and a maximum loss of 15 DB at 10,000 cycles. This is very probably due to its lack of selectivity.

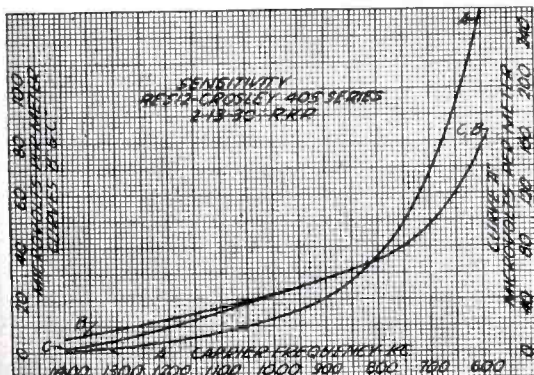

Fig. 1. This curve may be taken as an indication of the sensitivity to be expected from a Crosley model 40-S

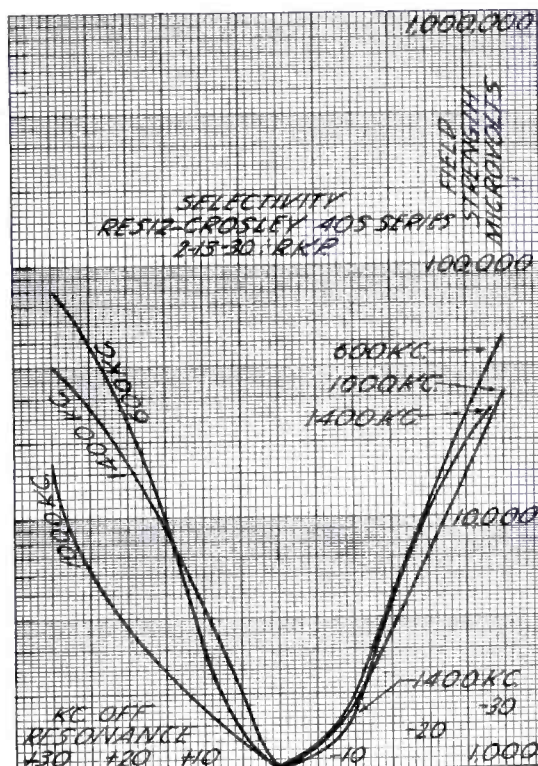

Fig. 2. The selectivity of the 40-S as recently measured in our laboratory is shown in this graph

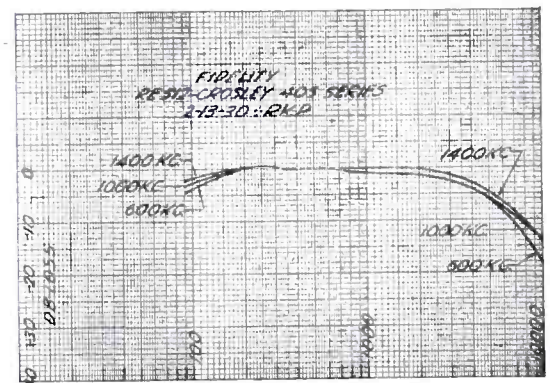

Fig. 3. The tone quality of the set under measurement can be figured out from the fidelity curves can be given above

Airline Receiver Model 8 as Measured

TWO receivers marketed under the Montgomery Ward name of "Airline" are shown on this page.

The sensitivity curve of the Airline 8 in Fig. 1 shows a maximum sensitivity at 1150 and 600 kc of approximately 22 uv/m, the 1400 kc setting having the minimum sensitivity of 43 uv/m, while from 900 to 700 kc the sensitivity will average 27 uv/m. This is a rather peculiar sensitivity curve and it is probably due to a changing antenna load for which there is no compensation, and a slight deviation in tuning capacities.

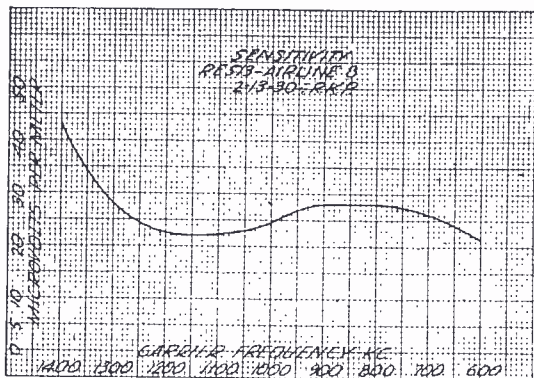

Fig. 1. The sensitivity of the Airline 8 receiver as recently measured in our laboratory is shown above

The selectivity curves in Fig. 2 show fairly good selectivity at 600 kc. At 1000 kc it is fairly broad and at 1400

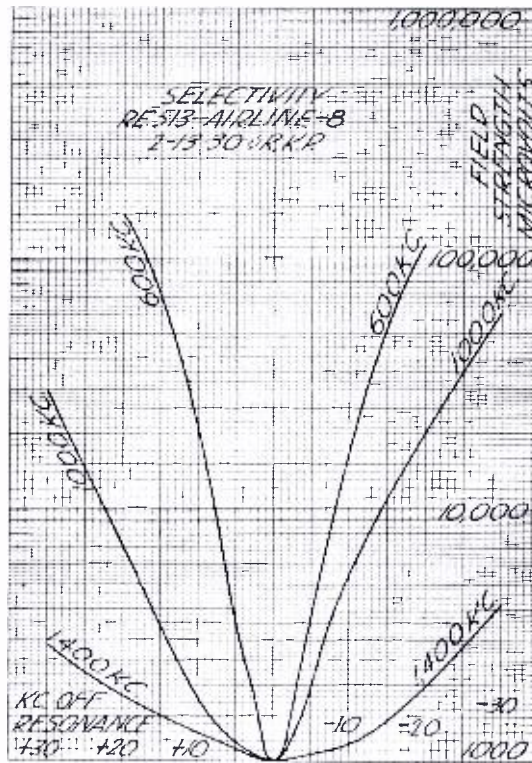

Fig. 2. Based on recent measurements the selectivity of the receiver is depicted in this graph

kc it is very broad. Both of these curves could probably be bettered with antenna compensation.

The fidelity curve in Fig. 3 has a fairly rapid cutoff beginning at about 800 cycles. The various frequency curves vary with the selectivity of the receiver. However it is not likely all of the variation in fidelity is due to selectivity, but that some is due to normal audio response.

Measurements made with GR 403-C signal generator, 486 output meter and standard dummy antenna of 20 uh, 200 mmf and 25 ohms.

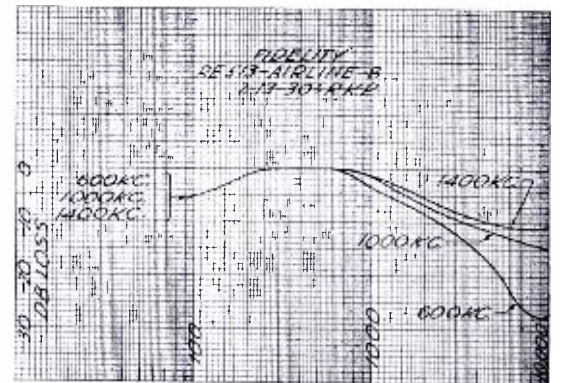

Fig. 3. Tone quality of the receiver is shown in the fidelity curves illustrated here

Curves Taken on Airline Model Nine

IN these graphs are shown the sensitivity, selectivity and fidelity of the Airline 9 model.

The point of maximum sensitivity in Fig. 1 on distance switch is at 600 kc with a gradual decrease of sensitivity up to 1300 kc, and then a sudden increase to 1400 kc. The average sensitivity over the broadcast band may be said to be about 20 uv/m which is slightly below a good average. The sensitivity with the local switch has a variation from 350 uv/m to 510 uv/m which will give ample volume control on strong local signals.

The selectivity curve of this receiver somewhat resembles the fabled band

pass curves (the ones that generally appear in advertisements) with a flat top and a narrow skirt. The 600 and 1000 kc curves show a parallel rise for about three times resonance field strength.

This condition is quite unusual in a tuned r. f. system. The flares at the top of these two curves are more or less symmetrical in regard to each other. The 1400 kc curve has a tendency toward band pass effect, but flares out more rapidly than the other curves at the same field strength. It might be said on a low percentage modulation, a distant station might be too sharp for good tone quality. The average selectivity of this receiver is slightly better than most sets in its class.

The fidelity in this receiver has all the bad features that the selectivity has good features, but the speaker used compensates for this loss.

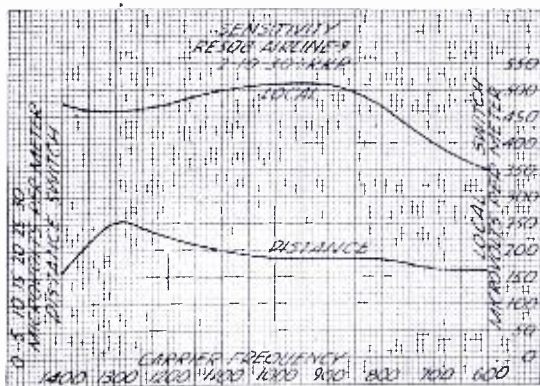

Fig. 1. Two measurements of sensitivity are shown here, one on local and the other on distance settings

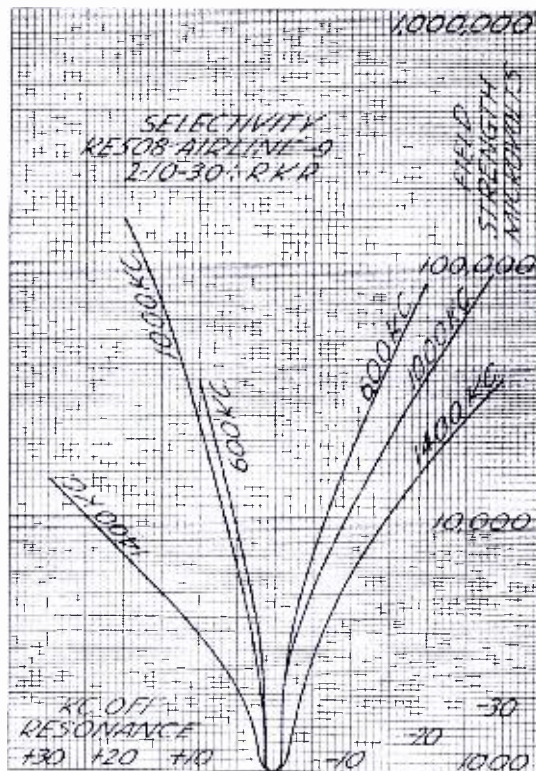

Fig. 2. The selectivity of the receiver under measurement is set forth in the three curves plotted above

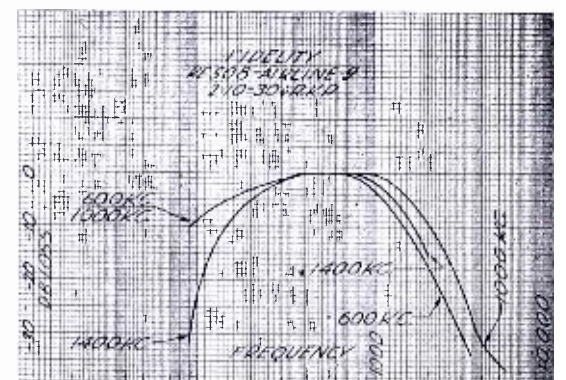

Fig. 3. This graph illustrates tone quality of the receiver as reflected by the fidelity curves above

Curves on the Silver 30-B Receiver

CURVES were taken on the Silver 30-B in accordance with the standards set forth in the text on page 64.

Receiver was phased at 1280 kc. Volume control full on. Audible regeneration began at 600 kc. and stopped at 1500 kc. Hum voltage delivered to output meter connections was .09 milliwatts.

Mutual conductance of tubes: 1 r.f. 1000; 2 r.f. 1050; detector 950; 1 a.f. 1460; PP 2000; PP 2300.

Output impedance load adjusted to 4000 ohms and coupled capacitatively to the 245 plates. Dummy antenna not standard, consisting of 200 micromicro-

farads capacity. These measurements do not consider the frequency response of the speaker. The schematic of this receiver will be found elsewhere in this section.

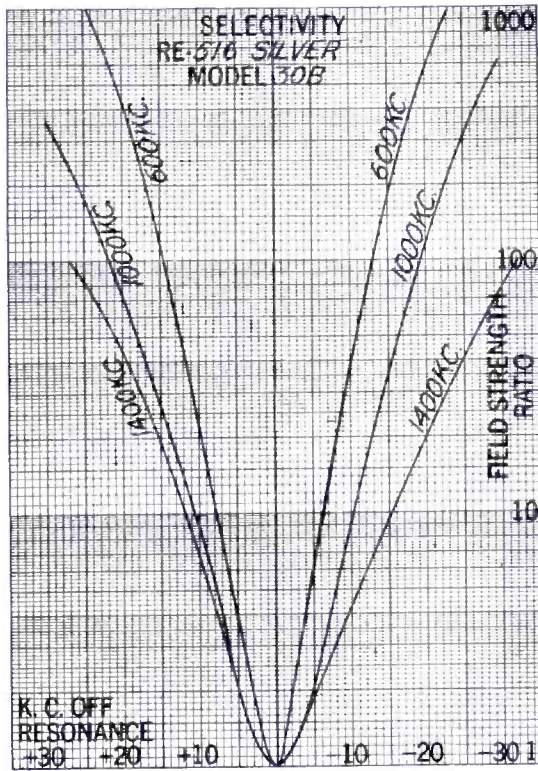
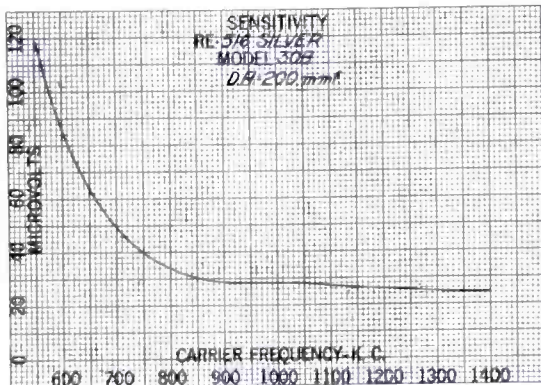

Resonance	Interference Ratio		
	Kilocycles off resonance		
600 kc.	25.60	428.	1932
1000 kc.	9.12	70.2	354.3
1400 kc.	6.50	46.0	-----
	Minus 10	Minus 20	Minus 30
600 kc.	36.95	560.	-----
1000 kc.	8.25	119.4	631.5
1400 kc.	4.00	17.0	86.0

Times field strength	Band Widths		
	Kilocycles wide		
	600 kc.	1000 kc.	1400 kc.
10	14	21	27.5
100	28	41	59
1000	48	---	---

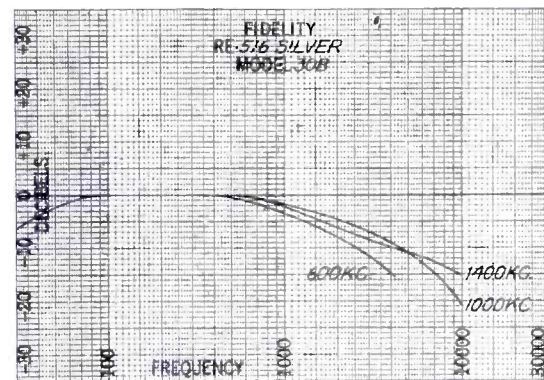

Howard S. G. A. Response Curves

RESPONSE curves on the Howard S.G.A. were taken in accordance with the standards indicated on page 64. Receiver phased at 970 kc.; volume control maximum; no audible regeneration, no oscillation; no measurable hum.

Mutual conductance of tubes: 1 r.f. 1050; 2 r.f. 1040; 3 r.f. 1050; detector 1280; p.p. 2050; p.p. 1770.

Standard dummy antenna used in measurements. Output impedance load adjusted to 4000 ohms, coupled capacitatively to 245 plates.

Sensitivity curve shows a maximum at about 23 microvolts and a minimum at 48 microvolts. In the selectivity curves the 1000 and 1400 kc. curves are

slightly lopsided, but not sufficiently to cause trouble.

The schematic diagram of this model Howard is published in the latter part of the Service and Repair department for the benefit of service men.

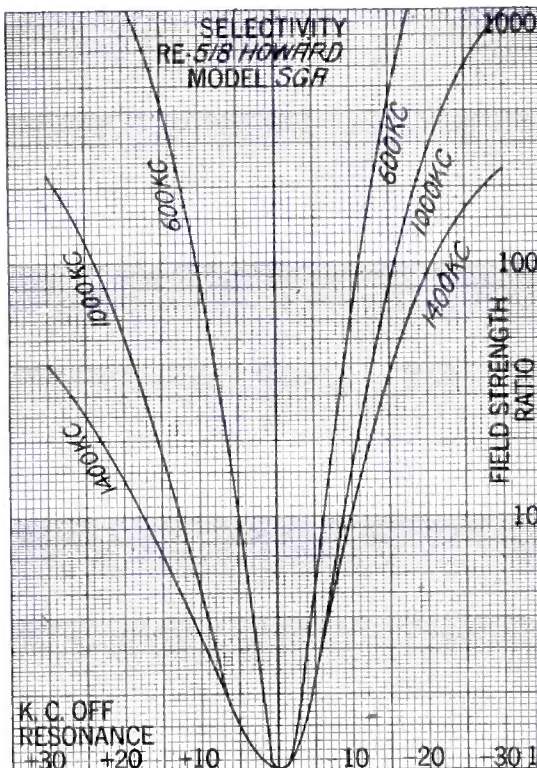
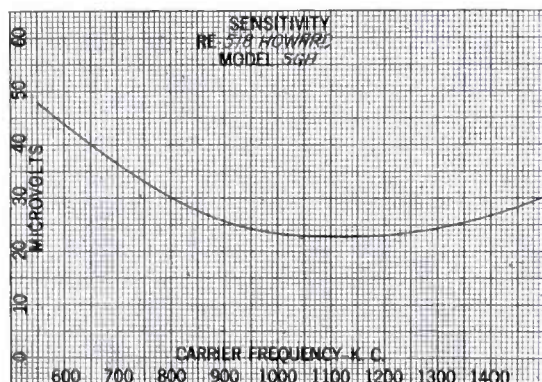

Resonance	Interference Ratio		
	Kilocycles off resonance		
	Plus 10	Plus 20	Plus 30
600 kc.	67.50	1070.	4744.1
1000 kc.	3.26	50.	223.0
1400 kc.	3.00	14.	39.3
	Minus 10	Minus 20	Minus 30
600 kc.	82.50	1163.	-----
1000 kc.	15.00	284.	982.0
1400 kc.	13.65	91.	233.0

Times field strength	Band Widths		
	Kilocycles wide		
	600 kc.	1000 kc.	1400 kc.
10	11.0	21.5	27.0
100	21.5	40.0	---
1000	36.5	---	---

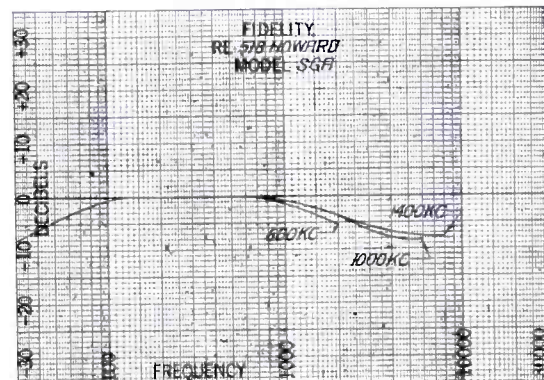

Response Curves on Majestic 130A

AMONG the receivers recently measured in the laboratory of this magazine is the Majestic 130-A, whose response curves are shown in this page. Antenna dummy was not standard, being only 250 micromicrofarads.

Receiver was phased at 1280 kilocycles. Volume control set at maximum. No measurable hum was encountered at the output meter connections.

Mutual conductance of the tubes when used in testing the set was: 1 r.f. 1110; 2 r.f. 1050; 3 r.f. 1070; detector 1030; PP 1690; PP 1760 micromhos.

Least sensitivity is shown at 600 kc.

with 15 microvolts, while greatest sensitivity is indicated from 1200 to 1500 kc. with about 5 microvolts, the average being about 7 microvolts. Interference ratio and band widths are given in the table following:

Resonance	Interference Ratio		
	Kilocycles off resonance		
	Plus 10	Plus 20	Plus 30
600 kc.	118.1	3850	---
1000 kc.	5.0	147.	1393.2
1400 kc.	2.5	9.	48.7
Resonance	Kilocycles off resonance		
	Minus 10	Minus 20	Minus 30
	600 kc.	23.6	1290.9
1000 kc.	7.35	363.2	2565.0
1400 kc.	3.75	76.1	198.

Times field strength	Band Widths		
	Kilocycles wide		
	600 kc.	1000 kc.	1400 kc.
10	12	21	32.5
100	21	34.5	---
1000	35	53	---

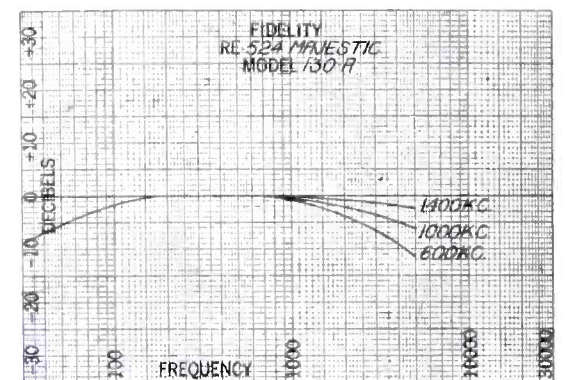
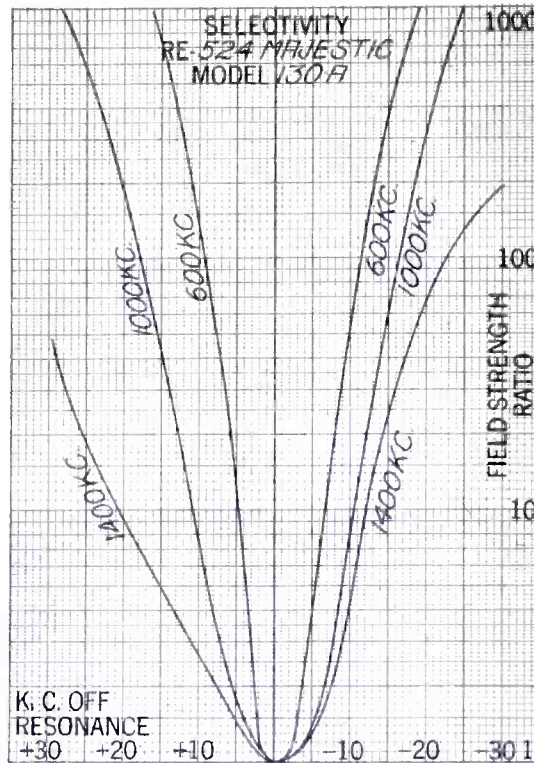
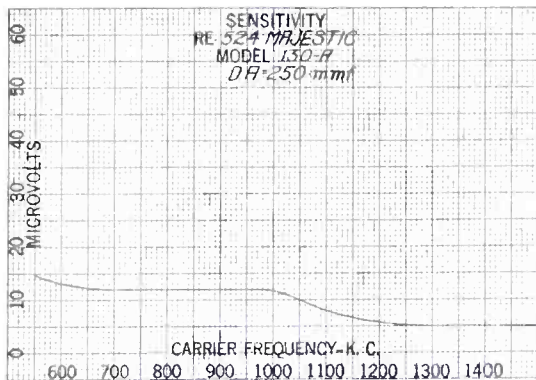

Colonial Radio Set, Model 33 A. C.

ON this page will be found the sensitivity, selectivity and fidelity curves of the model 33 a. c. made by the Colonial Radio Corporation.

Output input impedance was adjusted to 4000 ohms and coupled capacitatively to the 245 plates. Output of .050 watts was maintained. The standard dummy antenna was employed.

The receiver was phased at 1400 kc. The volume control was set just below point of oscillation on frequencies above 1100 kc. On other frequencies volume control wide open. Oscillation between 1100 and 1500 kc.

Mutual conductance of tubes used: 1 r.f. 900; 2 r.f. 940; 3 r.f. 920; de-

tor 1100; P. P. 1660; P. P. 1840 micromhos.

The sensitivity curve was quite flat, as indicated, although the setting of the volume control must be borne in mind.

Interference ratios and band widths

are given in the tables following:

Resonance	Interference Ratio		
	Kilocycles off resonance		
	Plus 10	Plus 20	Plus 30
600 kc.	80.8	1179.0	5641.0
1000 kc.	31.6	176.6	683.3
1400 kc.	8.6	42.5	133.3
Resonance	Kilocycles off resonance		
	Minus 10	Minus 20	Minus 30
	600 kc.	83.3	1308.0
1000 kc.	2.9	55.8	500.0
1400 kc.	2.8	6.0	16.3

Times field strength	Band Widths		
	Kilocycles wide		
	600 kc.	1000 kc.	1400 kc.
10	12.0	21.0	36.0
100	21.0	39.0	---
1000	38.5	69.5	---

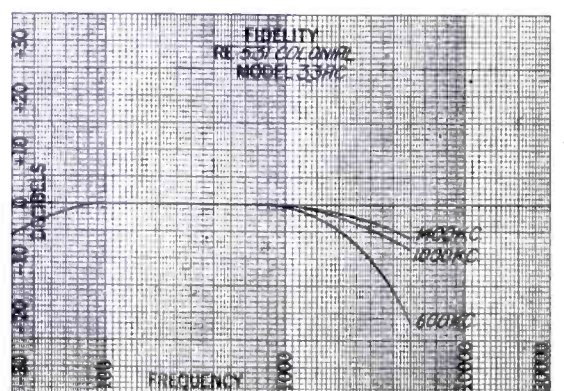
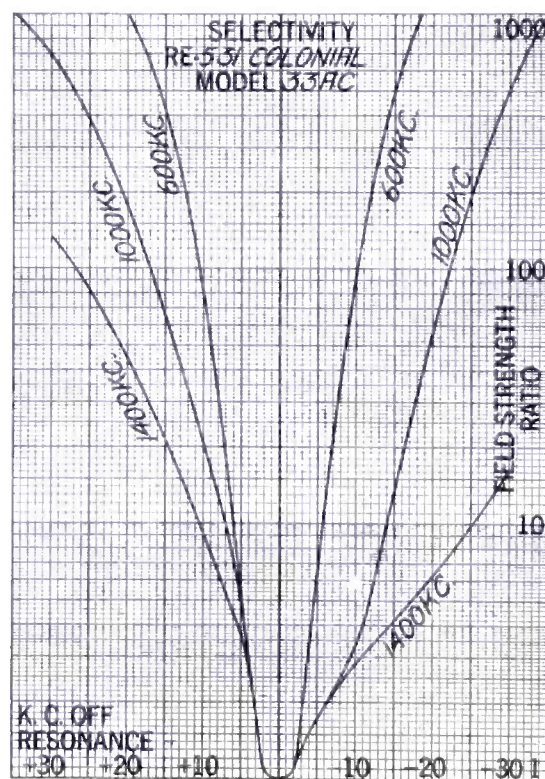
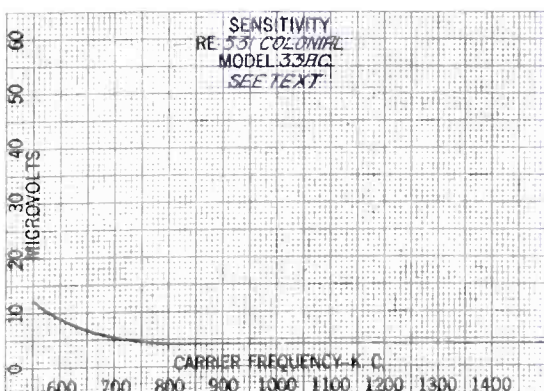

Family of Curves on the Crosley 77

AUTOMATIC volume control is afforded in the Crosley 77 model receiver recently measured in the laboratory of this magazine. The response curves for this model appear on this page.

Output impedance load was adjusted to 4000 ohms and coupled capacitatively to the 245 plates. Standard output of .050 watts was maintained. Standard dummy was employed.

Receiver was phased at 1000 kc. and volume control turned on full. No hum voltage could be measured at output meter connections.

Mutual conductance of tubes used in testing this model: 1 r.f. 990; 2 r.f. 980; detector 1000; 1 a.f. 1100; PP 1980; PP 1700 micromhos.

Greatest sensitivity on this model was between 800 and 1100 kilocycles with about 5 microvolts, while least sensitivity was at 600 and 1400 kilocycles, with 15 microvolts. While the volume control is at maximum for these measurements the automatic feature has not

begun to function.

Interference Ratio

Resonance	Kilocycles off resonance		
	Plus 10	Plus 20	Plus 30
600 kc.	6.4	63.0	243.0
1000 kc.	4.9	33.8	138.0
1400 kc.	1.4	2.7	7.9
Minus 10 Minus 20 Minus 30			
600 kc.	18.4	92.5	290.0
1000 kc.	19.3	118.0	382.0
1400 kc.	5.0	19.0	32.2

Band Widths

Times field Strength	Kilocycles wide		
	600 kc.	1000 kc.	1400 kc.
10	19	20.5	---
100	41	45.5	---
1000	---	---	---

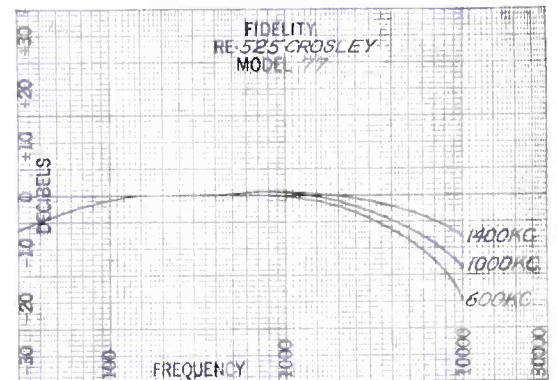
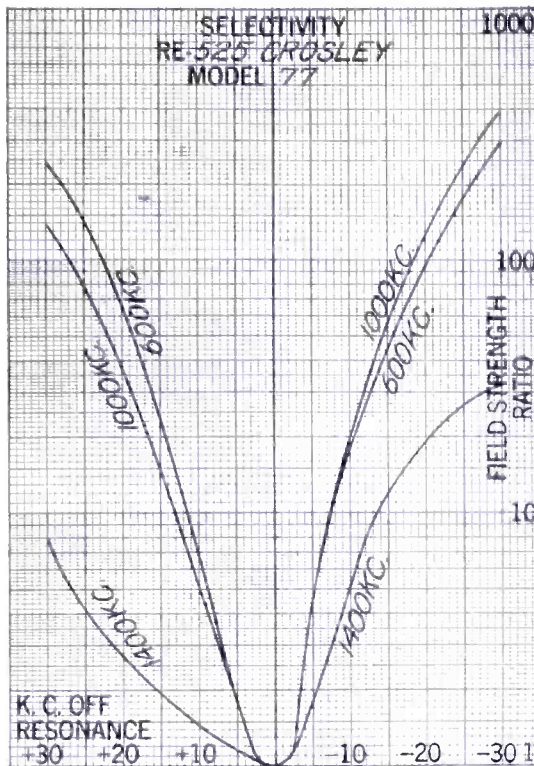
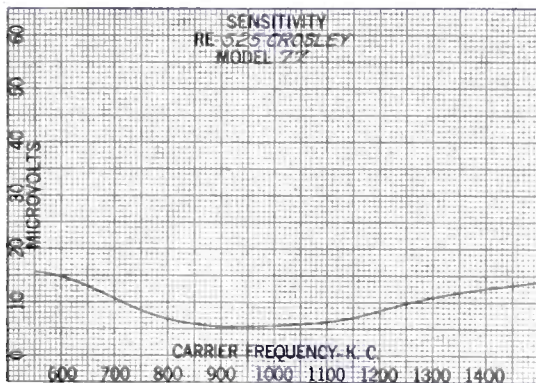

Response Curves on Sparton No. 620

THE most interesting feature of the three curves taken by our laboratory on the Sparton model 620 may be seen in the sensitivity curve which is practically a straight line from 600 to 1400 kilocycles.

Standard procedure followed in making the measurements. Output impedance load was 4000 ohms coupled capacitatively to the 245 plates. Standard output of .050 watts. Standard antenna dummy used.

Receiver phased at 1250 kilocycles and volume control turned on full. No hum could be measured at the output meter connections.

Mutual conductance of tubes: Cardon specials for this receiver.

From the selectivity curves it will be

seen there exists a slight lopsidedness, but not sufficient to cause a decided decrease in tuning efficiency. As will be seen the sensitivity curve is quite remarkable. Electrical fidelity suffers due to selectivity where considerable attenuation of high frequencies exists.

Interference Ratio

Resonance	Kilocycles off resonance		
	Plus 10	Plus 20	Plus 30
600 kc.	50.0	710.	3520.0
1000 kc.	3.8	57.0	296.0
1400 kc.	4.0	10.8	22.2
Minus 10 Minus 20 Minus 30			
600 kc.	45.	570.0	3360.0
1000 kc.	16.0	230.0	1010.0
1400 kc.	16.0	66.0	150.0

Band Widths

Times field Strength	Kilocycles wide		
	600 kc.	1000 kc.	1400 kc.
10	10	21	24.5
100	24.5	38	---
1000	43	---	---

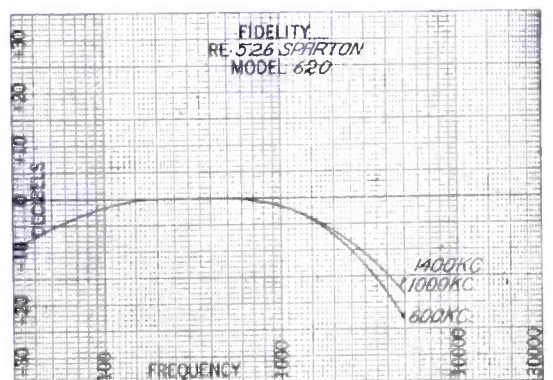
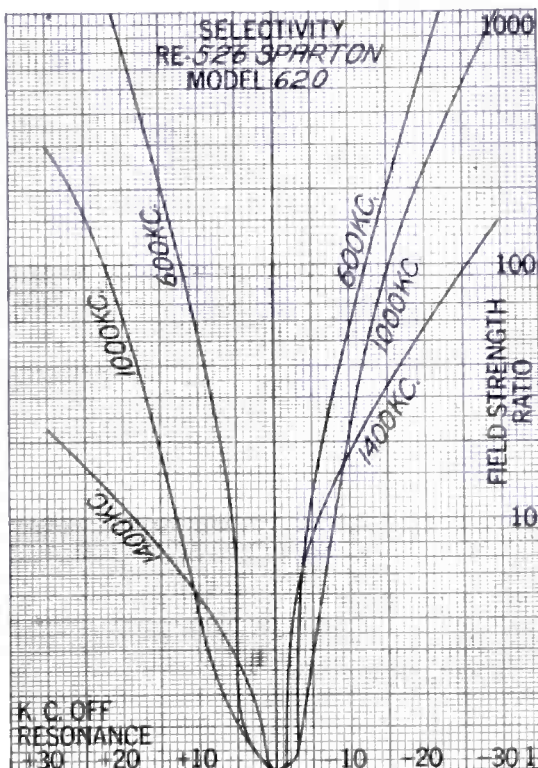
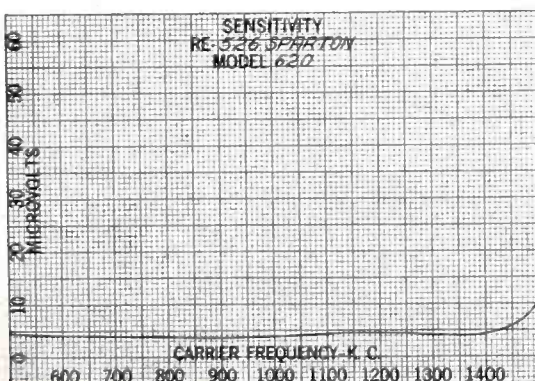

Stewart-Warner No. R-100A Curves

MEASUREMENTS recently made on the Stewart-Warner R-100 A are indicated in this column.

Output impedance load was adjusted to 4000 ohms and coupled capacitatively to the 215 plates. Standard output of .050 watts was maintained. Standard dummy antenna was employed.

Receiver was phased at the factory, this setting being maintained. The volume control turned on full. No hum was measurable at the output meter connections.

Mutual conductance of the tubes used: 1 r.f. 1040; 2 r.f. 910; 3 r.f. 910; de-

tor 1500; 1 a.f. 1200; P.P. 1660; P.P. 1810 micromhos.

Interference ratios and band widths are shown in the following table:

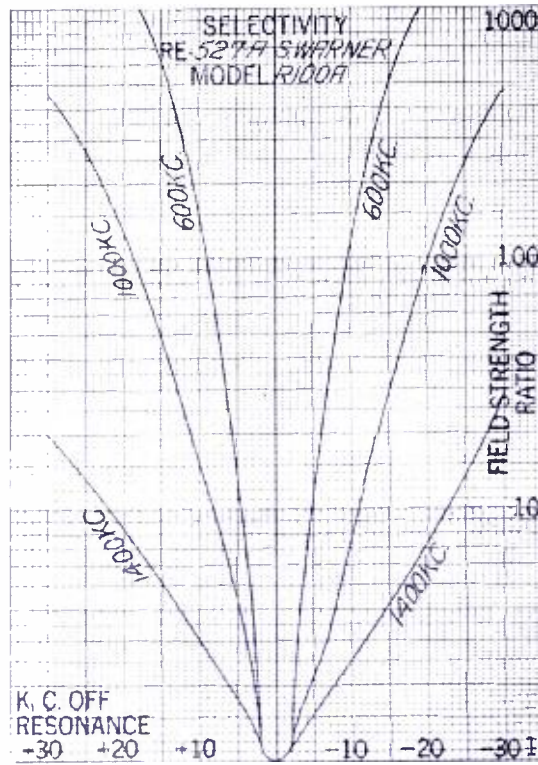
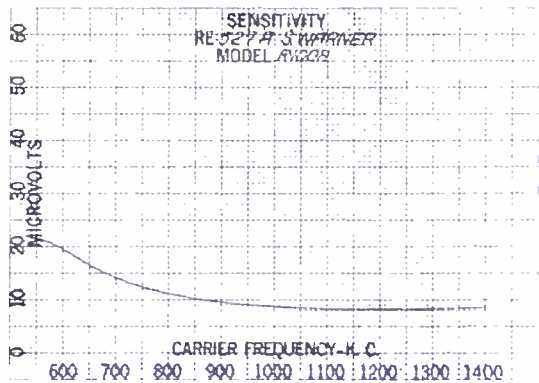

Resonance	Interference Ratio		
	Plus 10	Plus 20	Plus 30
600 kc.	114.	1978	-----
1000 kc.	15.7	128.5	442.8
1400 kc.	2.52	8.23	20.0
Resonance	Interference Ratio		
	Minus 10	Minus 20	Minus 30
600 kc.	81.0	1368	-----
1000 kc.	4.65	92.8	464.2
1400 kc.	2.15	3.70	28.6

Times field strength	Band Widths		
	Kilocycles wide		
10	600 kc.	1000 kc.	1400 kc.
100	9.5	19.0	44.5
1000	18.5	38.5	-----
1000	37.0	-----	-----

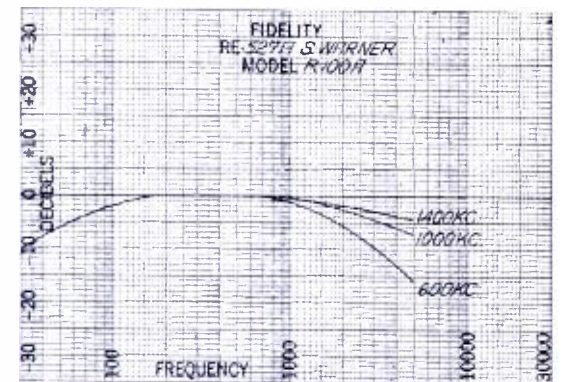

Brunswick Radio Receiver Model 15

AMONG the several receivers recently passing through our measurement laboratory is the Brunswick model 15, the sensitivity, selectivity and fidelity curves of which are shown on this page.

Output impedance load in this case was adjusted to 1000 ohms and coupled to the plates of the 215 tubes placed in parallel. Standard output of .050 watts was maintained. The dummy antenna of 20 uh, 200 mmf and 25 ohms was employed.

Phasing frequency set at the factory was maintained. The volume control was turned on full. No hum could be measured at the output meter connections.

Mutual conductance of tubes used:

1 r.f. 920; 2 r.f. 910; 3 r.f. 910; detector 1210; 1 a.f. consisting of 245 tubes in parallel, one 1660 and other 1810 micromhos.

Interference ratios and band widths are indicated in the two columns following:

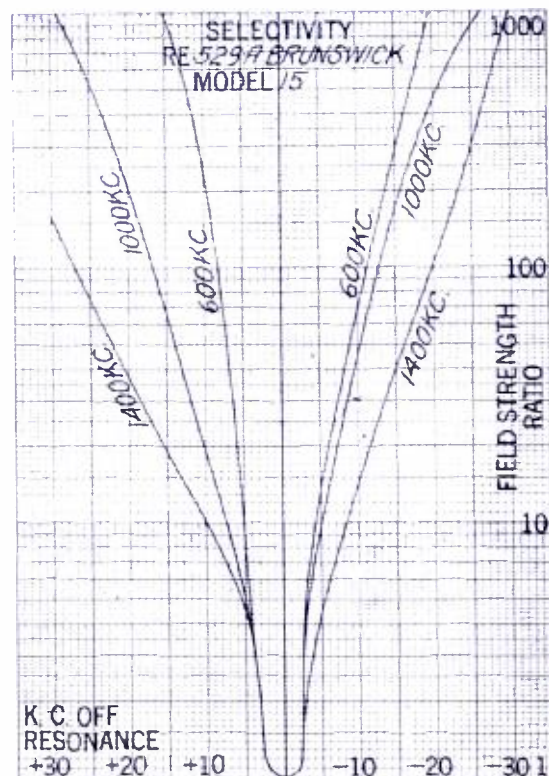
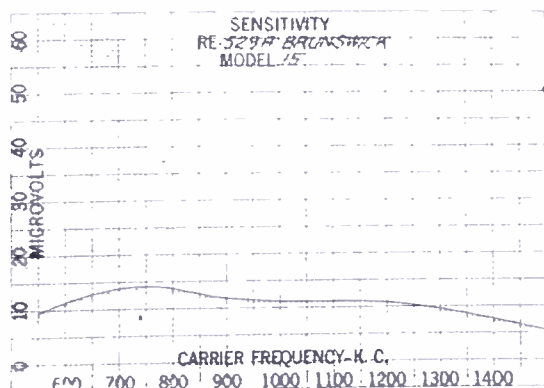

Resonance	Interference Ratio		
	Plus 10	Plus 20	Plus 30
600 kc.	203.6	2772.7	12,000.0
1000 kc.	19.0	190.9	1109.0
1400 kc.	10.0	37.	154.0
Resonance	Interference Ratio		
	Minus 10	Minus 20	Minus 30
600 kc.	66.3	1145.4	6000.0
1000 kc.	37.2	454.5	2409.0
1400 kc.	14.2	90.0	1200.0

Times field strength	Band Widths		
	Kilocycles wide		
10	600 kc.	1000 kc.	1400 kc.
100	9.5	12.5	18.0
1000	20.0	29.5	47.0
1000	34.5	55.0	-----

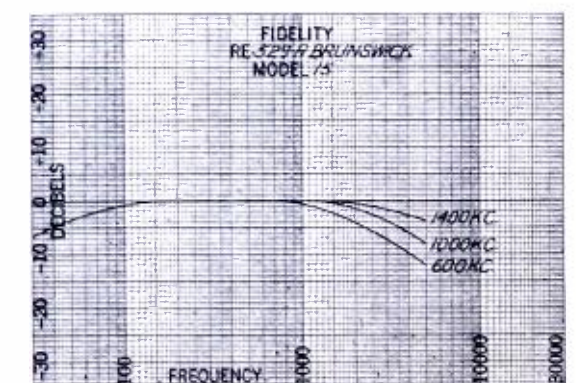

New Westinghouse Super, No. WR-5

JUST as this issue goes to press our laboratory has finished measuring the Westinghouse superheterodyne model WR-5 whose curves are presented on this page. Since it is the first of the superheterodyne models to be run in our laboratory, the curves should be of more than passing interest to all.

Output impedance load was adjusted to 4000 ohms and coupled capacitatively to the plates of the 245 tubes. Standard output of .050 watts was maintained. Dummy antenna was the standard one of 20 uh, 200 mmf and 25 ohms. Phasing frequency set by factory was maintained. Volume control on full. No oscillation. No hum.

Mutual conductance of tubes used: 1 r.f. 940; 1 i.f. 1020; 2 i.f. 900; 1 de-

tor 1000; p.p. 1850; p.p. 1850; 2 detector 1030, and oscillator 1300 micromhos.

It should be observed that in drawing the selectivity curve only the 600 kc curve is shown, since both the 1000 and 1400 kc curves were within a kilocycle

of these values at one thousand times the field strength.

Interference Ratio

Resonance	Kilocycles off resonance		
	Plus 10	Plus 20	Plus 30
600 kc.	900
1000 kc.	900
1400 kc.	900
Minus 10 Minus 20 Minus 30			
600 kc.
1000 kc.
1400 kc.

Band Widths

Times field strength	Kilocycles wide		
	600 kc.	1000 kc.	1400 kc.
10	8.0	8.0	8.0
100	12.5	12.5	12.5
1000	18.0	18.0	18.0

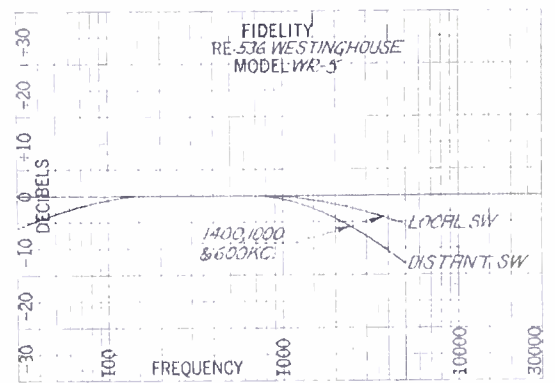
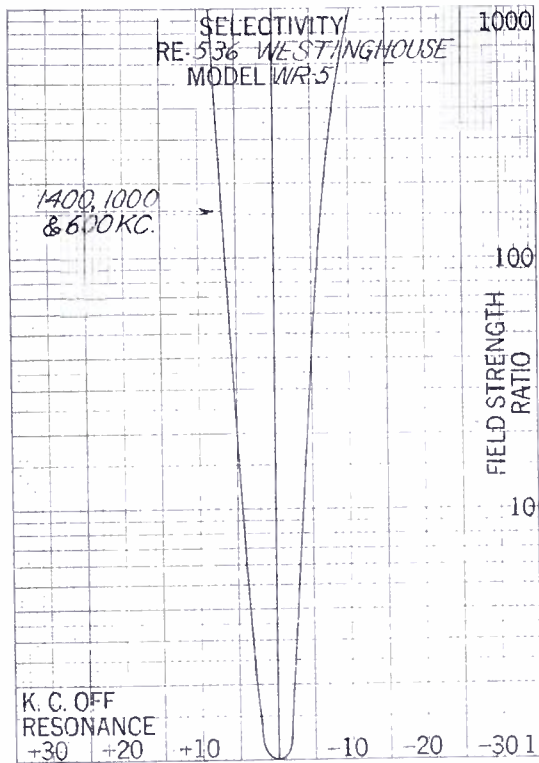
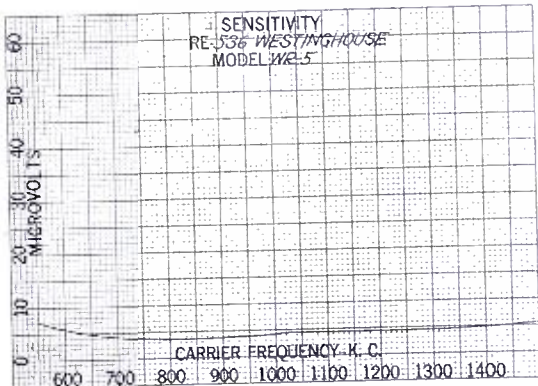

Zaney-Gill Music Box Clarion Curves

READERS may be interested in the response curves on one of the mantle sets so popular in certain sections of the country. We are showing on this page the measurements on the Zaney-Gill model known as the Music Box Clarion which is manufactured in Los Angeles.

As usual, the output impedance load is adjusted to 4000 ohms and coupled capacitatively to the plates of the 245 tubes. The standard output of .050 watts is maintained on all measurements. Standard dummy antenna is used.

The receiver was phased at the factory and this phasing maintained. The

volume control was turned just below the oscillation point. Oscillation began at 550 kc. No hum was measurable at the output meter connections.

Mutual conductance of the tubes used: 1 r.f. 1100; 2 r.f. 1150; detector 1200; 1 a.f. 995, 2 a.f. 2300 micromhos.

Interference Ratio

Resonance	Kilocycles off resonance		
	Plus 10	Plus 20	Plus 30
600 kc.	98.3	478.6
1000 kc.	39.6	102.7	336.3
1400 kc.	5.5	14.7	23.6
Minus 10 Minus 20 Minus 30			
600 kc.	30.5	728.6
1000 kc.	31.8	81.8	309.0
1400 kc.	15.6	26.2	34.8

Band Widths

Times field strength	Kilocycles wide		
	600 kc.	1000 kc.	1400 kc.
10	6.5	22.5
100	6.5	36.5
1000	24

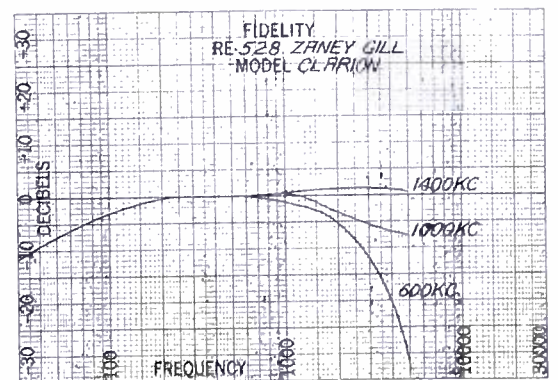
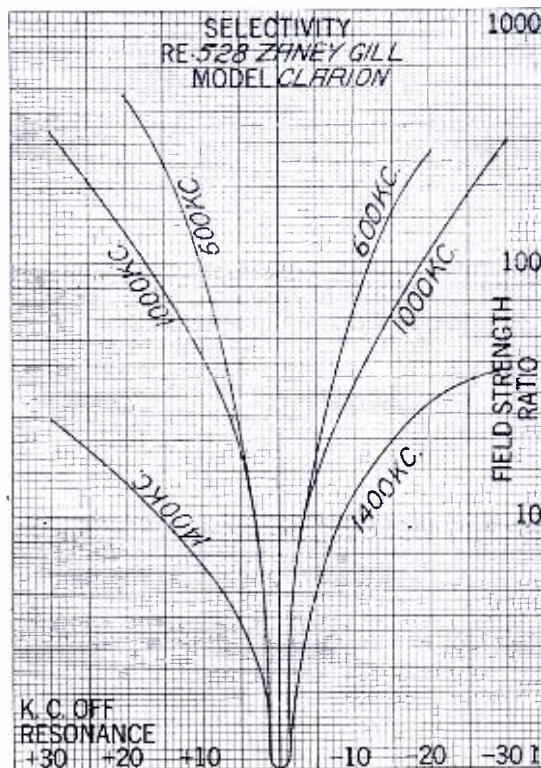
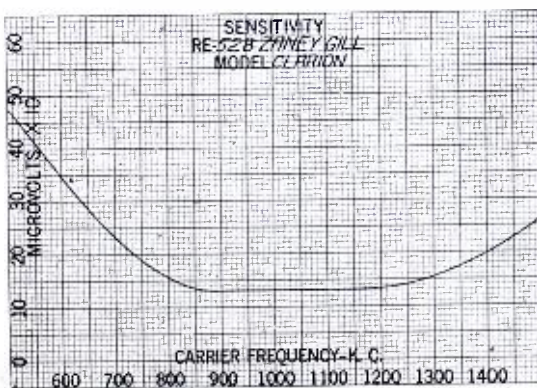

Response Curves on Grebe No. AH-1

CURVES on the Grebe model AH-1 recently measured in our laboratory are shown on this page, being taken on a production, or stock chassis.

Output impedance load adjusted to 4000 ohms and coupled capacitatively to the 245 tubes. Output was maintained at .050 watts. Standard dummy antenna of 20 uh, 200 mmf and 25 ohms was employed in these measurements.

Phasing frequency set at factory was maintained, with the volume control set at maximum. No oscillation observed over range. Hum level could not be measured.

Mutual conductance of tubes used

follows: 1 r.f. 1040, 2 r.f. 1020, 3 r.f. 1200, detector 1400, P.P. 1200, P.P. 1200 micromhos.

A table of interference ratios and the band widths of this chassis is given at the end of this measurement:

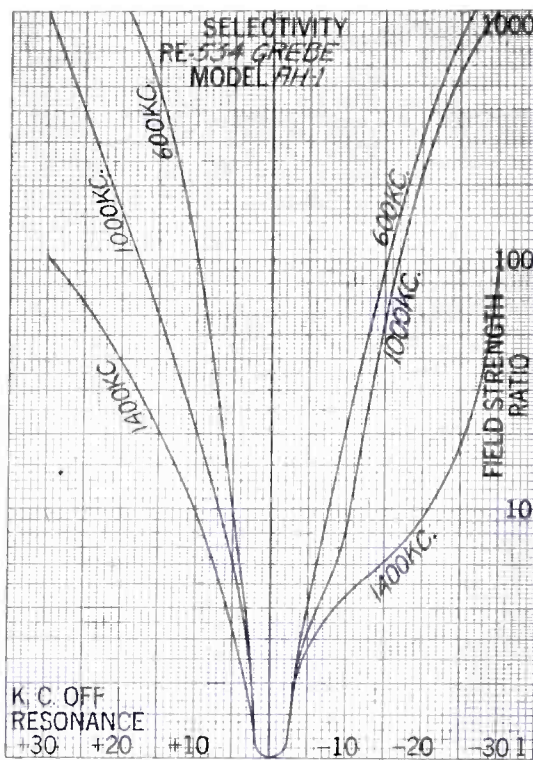
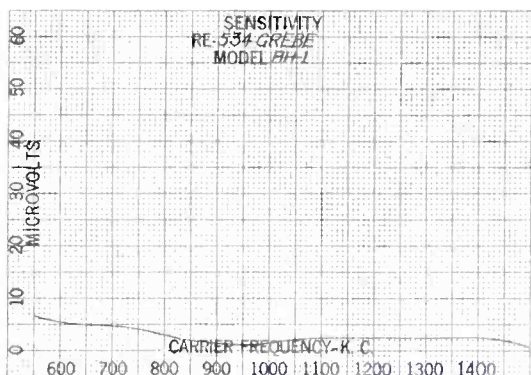

Resonance	Interference Ratio		
	Kilocycles off resonance		
	Plus 10	Plus 20	Plus 30
600 kc.	105.0	1005.0	-----
1000 kc.	21.0	155.0	1000.0
1400 kc.	9.7	39.0	102.0
	Minus	Minus	Minus
	10	20	30
600 kc.	21.0	315.0	-----
1000 kc.	8.2	230.0	-----
1400 kc.	4.5	9.1	90.0

Times field strength	Band Widths		
	Kilocycles wide		
	600 kc.	1000 kc.	1400 kc.
10	12.5	17.5	31.0
100	25.0	34.5	59.5
1000	46.0	66.0	-----

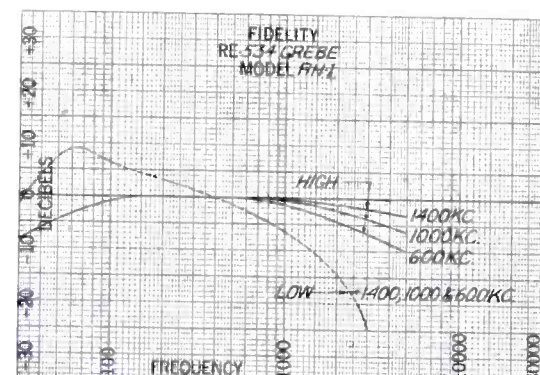

Clarion Model by T.C.A. Is Measured

SENSITIVITY, selectivity and fidelity measurements completed by our laboratory on the T. C. A. Clarion model 50 production chassis are shown on this page.

Output impedance load was adjusted to 4000 ohms and coupled capacitatively to the plates of the 245 tubes. Standard output of .050 watts was maintained on all measurements. The dummy antenna used was that of 20 uh, 200 mmf and 25 ohms.

Phasing frequency as set at the factory was maintained. Volume control was turned on maximum. No oscillation took place over the band covered. No hum could be measured.

Mutual conductance of the tubes used

were: 1 r.f. 1040; 2 r.f. 920; 3 r.f. 1100; detector 1200; 1 a.f. 1100; P.P. 1310, P.P. 1300 micromhos.

In the tables following may be seen the interference ratios and the band widths as developed from the measurements taken:

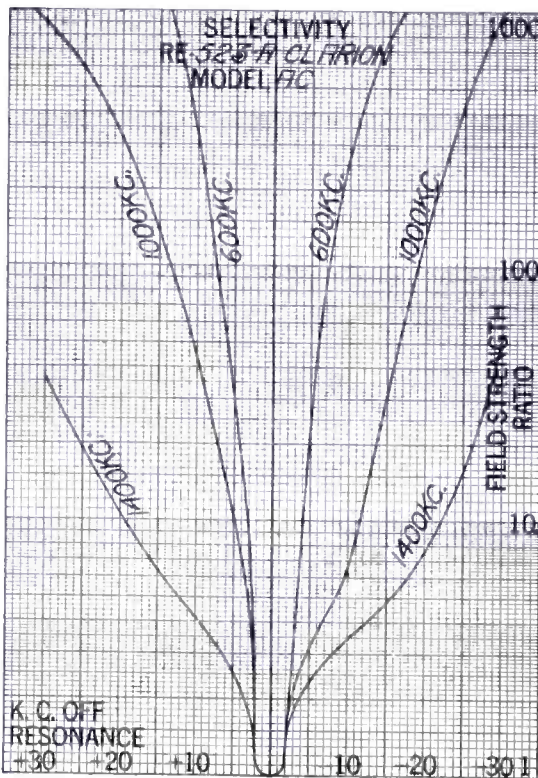
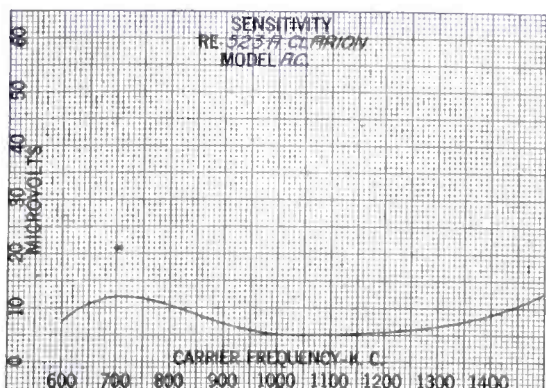

Resonance	Interference Ratio		
	Kilocycles off resonance		
	Plus 10	Plus 20	Plus 30
600 kc.	305.5	4222.0	-----
1000 kc.	41.7	305.0	873.0
1400 kc.	4.5	10.5	36.0
	Minus	Minus	Minus
	10	20	30
600 kc.	270.0	2361.0	-----
1000 kc.	5.6	139.5	1000
1400 kc.	3.5	7.5	54

Times field strength	Band Widths		
	Kilocycles wide		
	600 kc.	1000 kc.	1400 kc.
10	7.0	17.0	42.0
100	14.0	32.0	-----
1000	30.0	62.0	-----

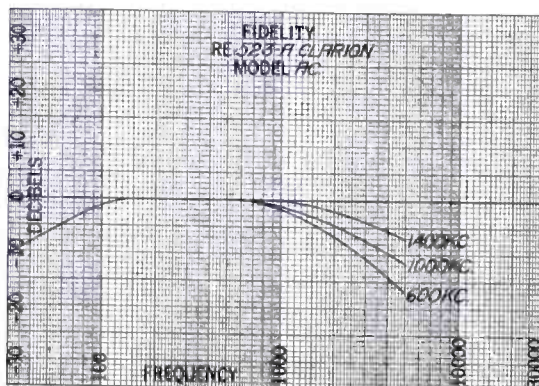

Majestic Model 50

MAJESTIC model 50, serial 5A22931, measured September 17, 1930, with the results shown in the three curves on this page. Data shown below is that abstracted from the laboratory work sheet covering this particular receiver.

Impedance load adjusted to 4,000 ohms and coupled capacitatively to the plates of the 245 tubes. Standard output of 50 milliwatts maintained. The standard dummy antenna was employed in this measurement. Phasing of the receiver was at 1,000 kc for the antenna stage. Volume control turned on maximum. No oscillation, no hum measured.

Mutual conductance of the tubes

used: 1 r.f. 990; 1 i.f. 1,080; detector 1,000; p.p. 1,250; p.p. 1,300; second detector 1,400, and oscillator 1,350 micromhos.

Below are found the interference ratios and the band widths:

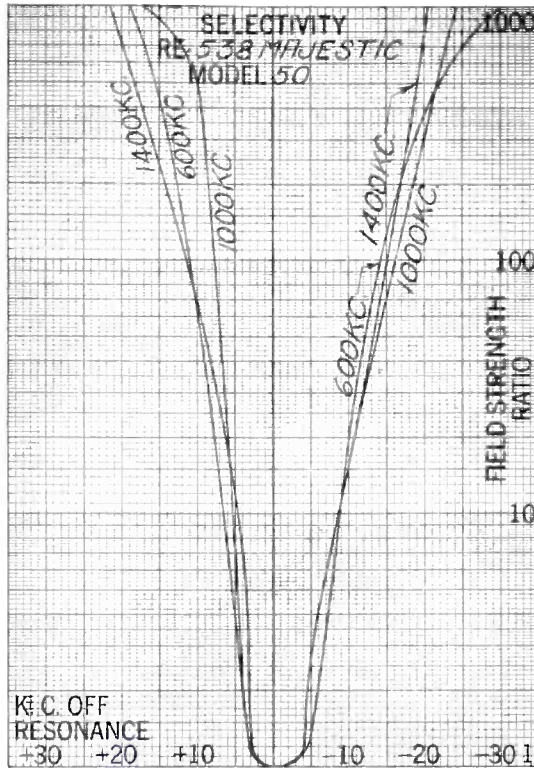

Interference Ratio

Resonance	Kilocycles off resonance		
	Plus 10	Plus 20	Plus 30
600 kc.	500.	-----	-----
1000 kc.	68.	-----	-----
1400 kc.	66.	700.	-----

Resonance	Kilocycles off resonance		
	Minus 10	Minus 20	Minus 30
600 kc.	20.	370.	1,000
1000 kc.	14.5	300.	-----
1400 kc.	14.5	800.	-----

Band Widths

Times field strength	Kilocycles wide		
	600 kc.	1000 kc.	1400 kc.
10	15	14.	14.
100	27.5	24.	26.5
1000	49.	41.5	42.0

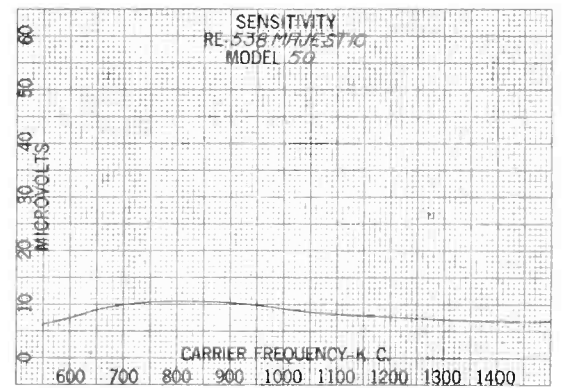
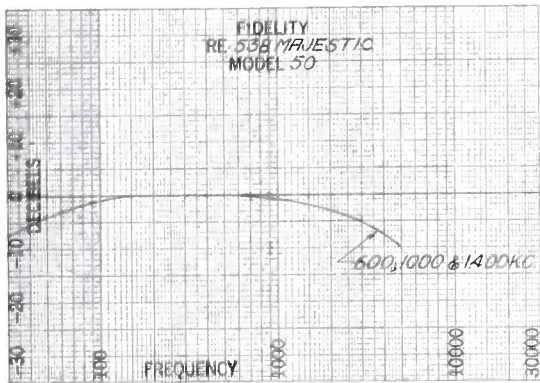

Kellogg Model 533

ANOTHER receiver recently passing through our laboratory is the Kellogg model 533, serial 152211, which was measured for sensitivity, selectivity and fidelity on September 18, 1930.

Output impedance load was adjusted to 4,000 ohms and coupled capacitatively to the plates of the 245 tubes. An output of .050 watts was maintained on all measurements. A dummy antenna having 20 uh, 200 mmf and 25 ohms resistance was used. The receiver was phased at 1,400 kc. The volume control was turned full on.

Mutual conductance of the tubes used: 1 r.f. 1,080; 2 r.f. 1,020; 3 r.f.

1,100; detector 1,200; 1 a.f. 1,460; p.p.a.f. 1,400; p.p.a.f. 1,400 micromhos.

The data on interference ratios and band widths is abstracted from the work sheet made in the laboratory.

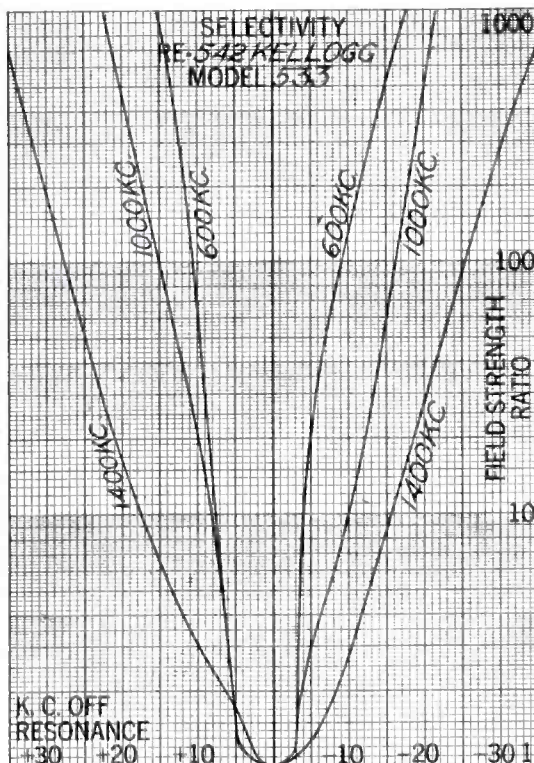

Interference Ratio

Resonance	Kilocycles off resonance		
	Plus 10	Plus 20	Plus 30
600 kc.	65.0	-----	-----
1000 kc.	20.0	450.	-----
1400 kc.	3.0	16.	190.

Resonance	Kilocycles off resonance		
	Minus 10	Minus 20	Minus 30
600 kc.	130.	-----	-----
1000 kc.	10.	480.	-----
1400 kc.	2.7	27.5	275.

Band Widths

Times field strength	Kilocycles wide		
	600 kc.	1000 kc.	1400 kc.
10	11.5	18.0	33.
100	19.5	31.5	53.
1000	33.0	44.0	-----

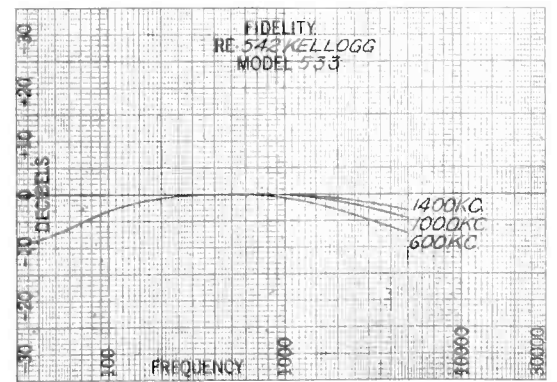
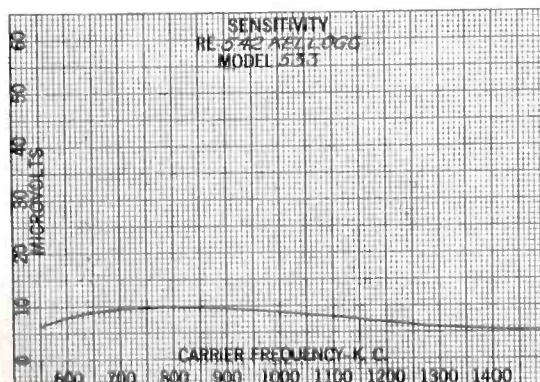

U. S. Radio and Television Model 31

DATA given here covers the recent measurement of the U. S. Radio and Television model 31 chassis, serial 357905, passing through the laboratory on September 22, 1930.

From the work sheet we find the output impedance load was adjusted to 3,000 ohms and coupled capacitatively to the 215 plates. The output of .050 watts was maintained, while a dummy antenna having 20 uh, 200 mmf and 25 ohms was employed. The receiver was phased at 1,100 kc and the volume control turned on full when making the measurements. No oscillation, no hum measured.

Mutual conductance of the tubes used is shown as follows: 1 r.f. 1,000; 2 r.f.

1,030; 3 r.f. 1,050; detector 1,400; 1 a.f. 1,350; p.p.a.f. 1,250; p.p.a.f. 1,300 micromhos.

In the two tables below may be seen the interference ratios and the band widths:

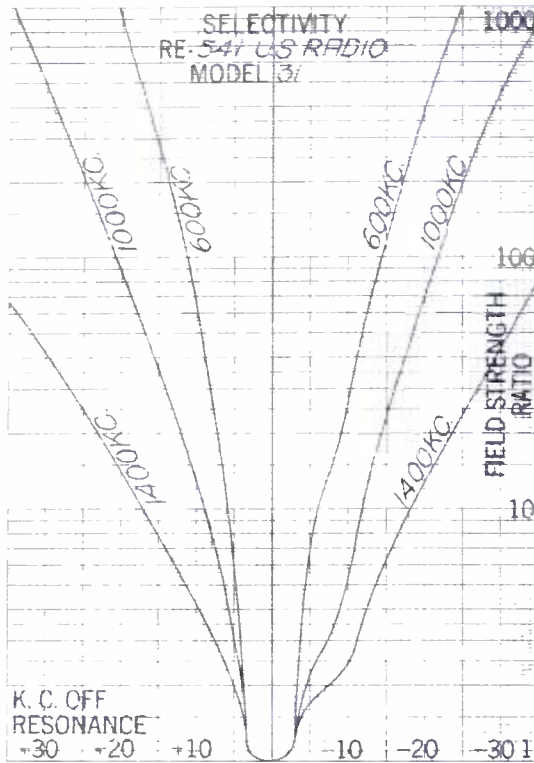
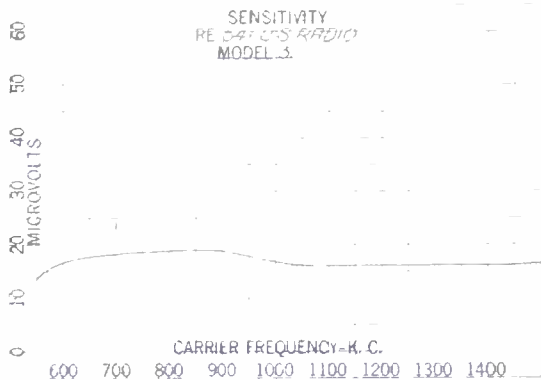

Resonance	Interference Ratio		
	Kilocycles off resonance		
	Plus 10	Plus 20	Plus 30
600 kc.	61.0	880.	---
1000 kc.	12.5	87.	490.
1400 kc.	4.2	14.	42.
	Minus 10	Minus 20	Minus 30
600 kc.	26.	380.	---
1000 kc.	5.2	71.	440.
1400 kc.	2.4	12.7	43.

Times field strength	Band Widths		
	Kilocycles wide		
	600 kc.	1000 kc.	1400 kc.
10	12.	21.	35.2
100	26	13.	---
1000	45.5	72.	---

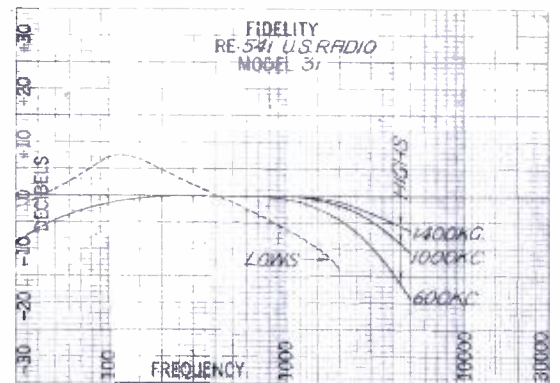

Montgomery-Ward Alexander Model

MEASUREMENTS on the Alexander model made for Montgomery Ward Co., were completed on September 30, 1930, when No. 71285 was checked in our laboratory with the results as shown in the three curves shown here.

Output impedance load was adjusted to 1,000 ohms and coupled capacitatively to the plates of the 215 tubes. Output of .050 watts was maintained. The dummy antenna used was one having 20 uh, 200 mmf and 25 ohms. The receiver was phased at 1,100 kc, and the volume control turned on maximum. No hum, no oscillation measured.

Mutual conductance of the tubes used: 1 r.f. 1,010; 2 r.f. 1,020; 3 r.f.

1,100; detector 1,200; 1 a.f. 1,400; p.p.a.f. 1,300 and p.p.a.f. 1,200 micromhos.

Interference ratios and band widths will be found in the tables of figures given below:

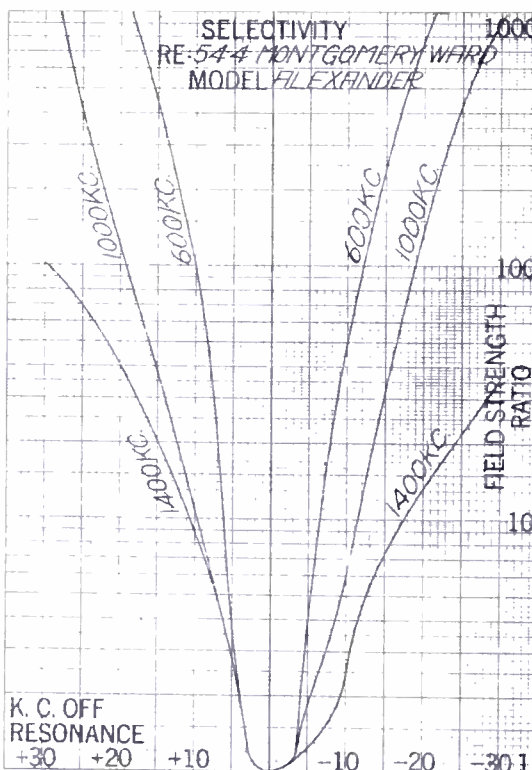
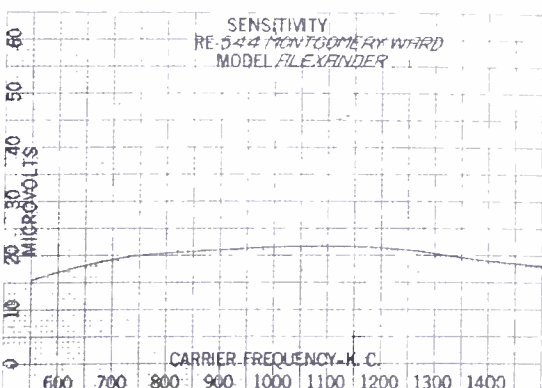

Resonance	Interference Ratio		
	Kilocycles off resonance		
	Plus 10	Plus 20	Plus 30
600 kc.	890.	---	---
1000 kc.	11.	115.	---
1400 kc.	8.8	40.	100.
	Minus 10	Minus 20	Minus 30
600 kc.	480.	760.	---
1000 kc.	5.7	130.	900.
1400 kc.	2.4	13.	35.3

Times field strength	Band Widths		
	Kilocycles wide		
	600 kc.	1000 kc.	1400 kc.
10	13.	21.	28.5
100	22.	38.5	---
1000	40.	59.	---

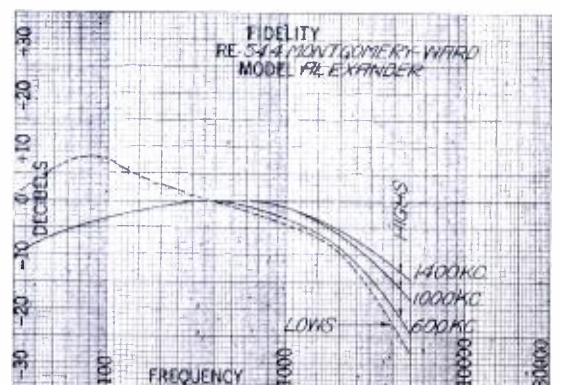

Edison Receiver Models R6, R7

ANOTHER receiver recently passing through the measurement laboratory of this magazine is the Edison model R6, R7 (which in error is shown on the graphs as Model AR). The schematic diagram of this model is shown elsewhere in the Service and Repair section of this issue.

Under measurement the output impedance load is kept at 4000 ohms, coupled capacitatively to the plates of the 245 tubes used in the pushpull output. An output is maintained of .050 watts. The standard dummy antenna of 20 uh, 200 mmf and 25 ohms is employed. The receiver was phased at 1400 kc. and the volume control turned on full. No oscillation was apparent nor was hum encountered.

The mutual conductance of the tubes used in these measurements are shown below: m.m. 1 r.f. 1030; 2 r.f. 980; 3 r.f. 1070; 4 r.f. 1080; detector 1020; 1 a.f. 1130; p.p. 1980; p.p. 1970 micromhos.

The data covering the interference

ratios and the band widths may be found in the tables following:

Interference Ratio

Resonance	Kilocycles off resonance		
	Plus 10	Plus 20	Plus 30
600 kc.....	22.0	330.0	-----
1000 kc.....	25.0	550.0	-----
1400 kc.....	22.0	240.0	-----
	Minus 10	Minus 20	Minus 30
600 kc.....	140.0	-----	-----
1000 kc.....	28.5	640.0	-----
1400 kc.....	23.5	1700	960

Band Widths

Times field strength	Kilocycles wide		
	600 kc.	1000 kc.	1400 kc.
10	13.0	14.0	140.0
100	25.0	28.0	33.0
1000	37.0	44.0	57.0

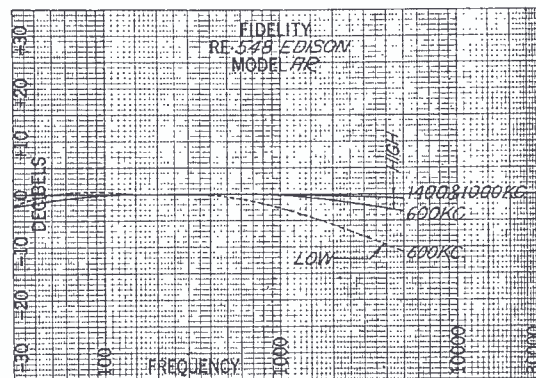
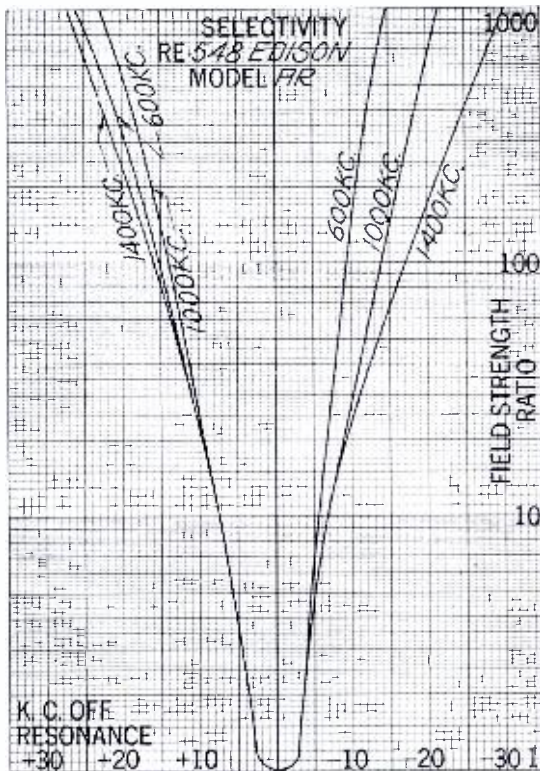
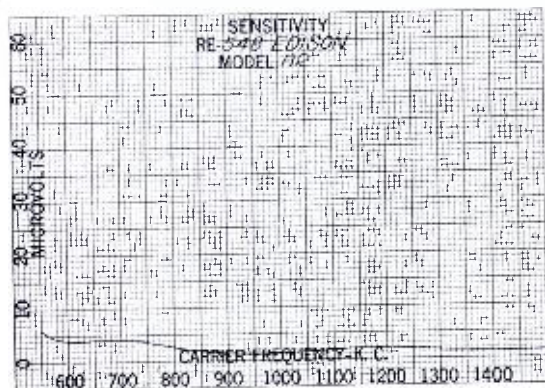

The Colin B. Kennedy Model 26

ON this page will be found the sensitivity, selectivity and fidelity curves of the Kennedy model 26 recently measured in the laboratory of this magazine.

As usual in these measurements the output impedance load was kept at 4000 ohms, coupled capacitatively to the plates of the 245 tubes. Output was maintained at .050 watts which is the standard value for receiver output measurement. The dummy antenna used was one consisting of 20 uh, 200 mmf and 25 ohms. The receiver was phased at the frequency value set by the factory. Volume control was turned on full. No oscillation was encountered nor was hum measured.

The mutual conductance of the tubes

used in this measurement is shown by the following: 1 r.f. 1050; 2 r.f. 1210; 3 r.f. 1140; detector 1030; 1 a.f. 1130; p.p. 1980 and p.p. 1970 micromhos.

In the two tables following will be found the data covering the interference ratios and the band widths, this

information being secured from the work sheet and the curves.

Interference Ratio

Resonance	Kilocycles off resonance		
	Plus 10	Plus 20	Plus 30
600 kc.....	21.5	180.0	600.0
1000 kc.....	9.0	77.0	330.0
1400 kc.....	6.2	27.0	83.0
	Minus 10	Minus 20	Minus 30
600 kc.....	78.0	1002.2	-----
1000 kc.....	6.4	85.0	510.0
1400 kc.....	4.8	30.5	1050.0

Band Widths

Times field strength	Kilocycles wide		
	600 kc.	1000 kc.	1400 kc.
10	12.2	19.0	26.5
100	27.6	42.0	-----
1000	-----	-----	-----

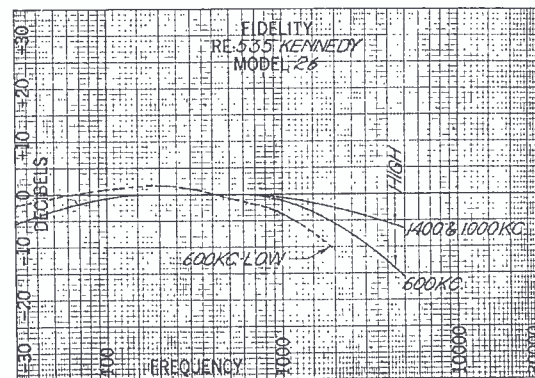
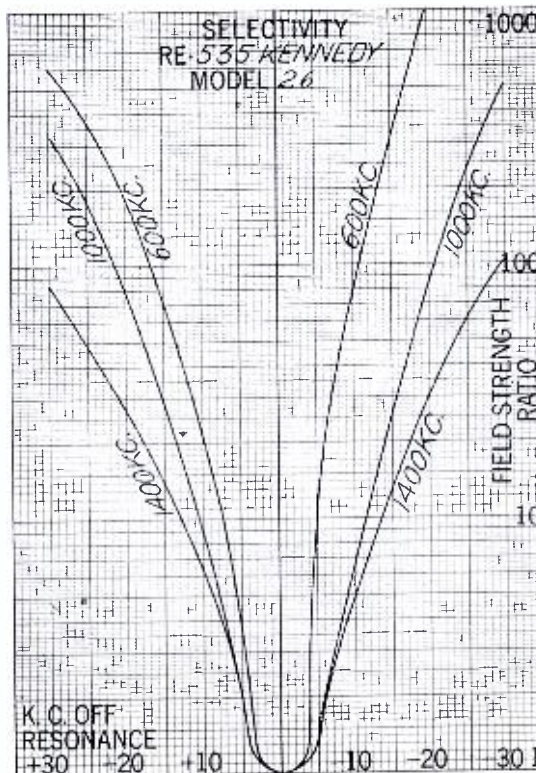
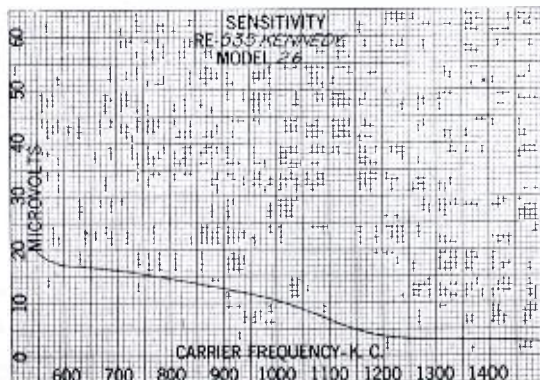

Sterling Receiver Model F

STERLING receiver, Model F, serial F2608 is the last receiver that passed through the measurement laboratory of this magazine at press time, the sensitivity, selectivity and fidelity curves being shown on this page.

Output impedance load was 4,000 ohms coupled capacitatively to the plate of the single 245 used in the output stage. The standard output of .050 watts was maintained on all measurements. The dummy antenna used was one consisting of 20 uh, 200 mmf and 25 ohms. Volume control was turned on full. Neither hum nor oscillation was apparent and hence not measured.

The mutual conductance of the tubes used in measuring the receiver is shown

by the following figures: 1 r.f. 1140; 2 r.f. 1210; detector 1220 and the output stage 1970 micromhos.

A table of the interference ratio and the band widths is shown in the material shown below, the data for which is obtained from the laboratory work sheet and the curves themselves.

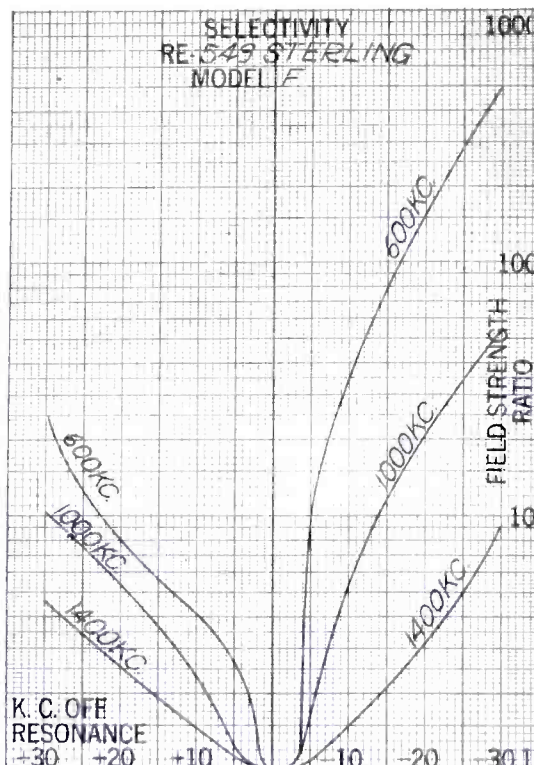
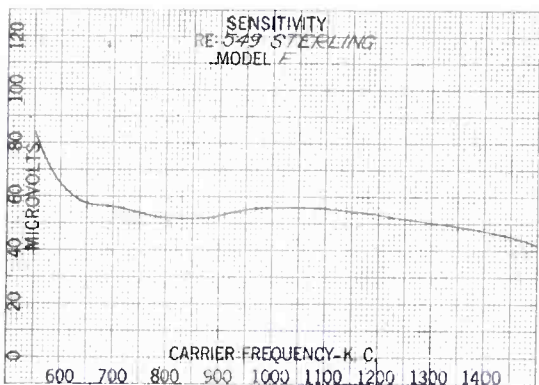

Resonance	Interference Ratio		
	Kilocycles off resonance		
	Plus 10	Plus 20	Plus 30
600 kc.	4.10	8.0	25.0
1000 kc.	2.35	5.4	10.5
1400 kc.	1.15	2.55	4.6
	Minus	Minus	Minus
	10	20	30
600 kc.	34.5	155.0	480.0
1000 kc.	5.3	21.0	55.0
1400 kc.	1.5	3.15	9.0

Times field strength	Band Widths		
	Kilocycles wide		
	600 kc.	1000 kc.	1400 kc.
10	27.5	43.5	---
100	---	---	---
1000	---	---	---

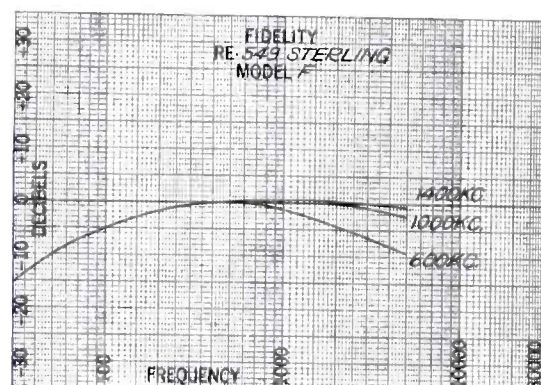

Westinghouse WR 4 T. R. F. Receiver

THE second of the Westinghouse receivers measured in our laboratory is the t.r.f. model WR4, response curves of which are shown on this page.

The output impedance load was 4000 ohms coupled capacitatively to the plates of the 245 tubes. The output was maintained at the standard .050 watts, and the volume control turned on maximum. The dummy antenna used was one having 20 uh, 200 mmf and 25 ohms. The receiver was phased at the frequency for which it was set at the factory. No oscillation encountered, nor was hum found.

The mutual conductance of the tubes used in this measurement is shown by

the following figures: 1 r.f. 1040; 2 r.f. 1080; 3 r.f. 1070; detector 1050; p.p. 1980 and p.p. 1970 micromhos.

In the two tables following will be found the interference ratios and band widths of receiver under measurement.

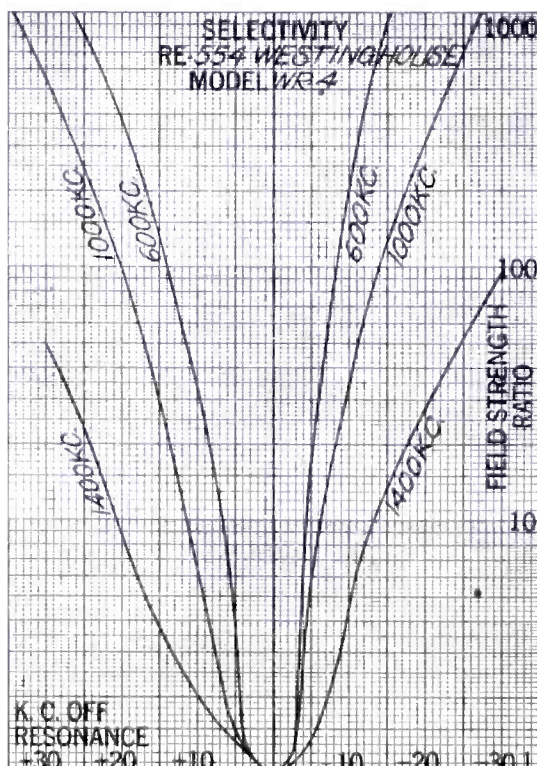
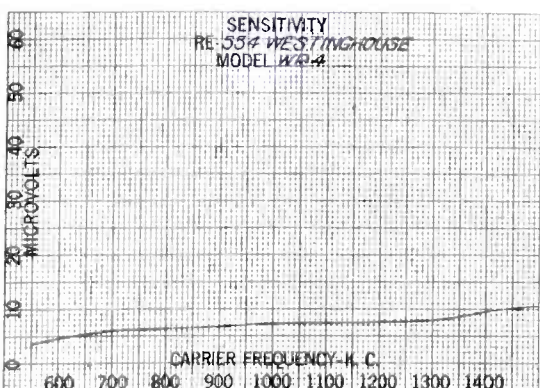

Resonance	Interference Ratio		
	Kilocycles off resonance		
	Plus 10	Plus 20	Plus 30
600 kc.	34.0	380.0	---
1000 kc.	6.2	98.0	540.0
1400 kc.	2.0	87.0	50.0
	Minus	Minus	Minus
	10	20	30
600 kc.	200.0	310.0	---
1000 kc.	34.0	320.0	---
1400 kc.	4.5	27.5	95.0

Times field strength	Band Widths		
	Kilocycles wide		
	600 kc.	1000 kc.	1400 kc.
10	10.0	18.0	34.0
100	22.5	34.0	---
1000	42.0	61.0	---

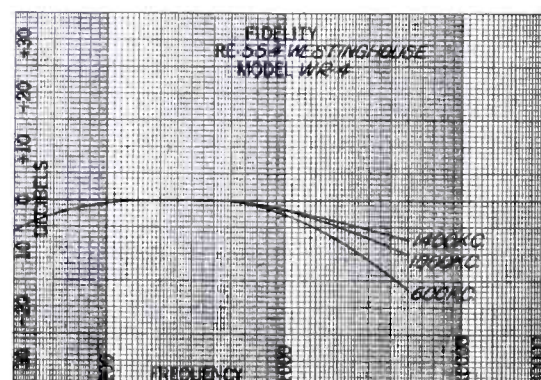

The General Motors Model 120-A

GENERAL MOTORS model 120-A measured in our laboratory on November 17, yielded the curves shown on this page. Serial number of the chassis 64637A. Output impedance was adjusted to 4000 ohms, coupled capacitatively to the plates of the 245 tubes. Standard output of .05 watts was maintained. The dummy antenna employed consisted of 20 uh, 200 mmf and 25 ohms. Phasing frequency at which alignment made was 1400 kc. Volume control turned on full. No oscillation indicated nor hum level measurable.

Mutual conductance of the tubes used in these measurements is shown as follows: 1 r.f. 1045; 2 r.f. 960; 3 r.f.

1030; detector 1050; 1 a.f. 940; p.p. 1730 and 1860 micromhos.

The dotted line in the fidelity chart was taken with the tone control turned to the bass position.

In the two tables below are shown:

Interference Ratio

Resonance	Kilocycles off resonance		
	Plus 10	Plus 20	Plus 30
600 kc.....	80.7	608.0	1800
1000 kc.....	17.05	205.0	977
1400 kc.....	5.02	38.3	138.4
	Minus 10	Minus 20	Minus 30
600 kc.....	103.0	14.5	-----
1000 kc.....	22.7	261.0	1317.0
1400 kc.....	6.3	70.7	181.0

Band Widths

Times field strength	Kilocycles wide		
	600 kc.	1000 kc.	1400 kc.
10	3.5	16.0	18.0
100	20.5	32.7	49.7
1000	40.0	58.0	-----

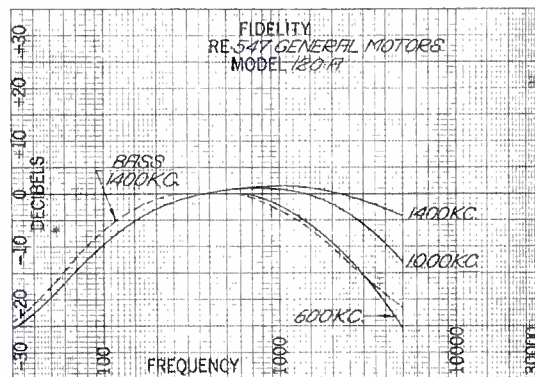
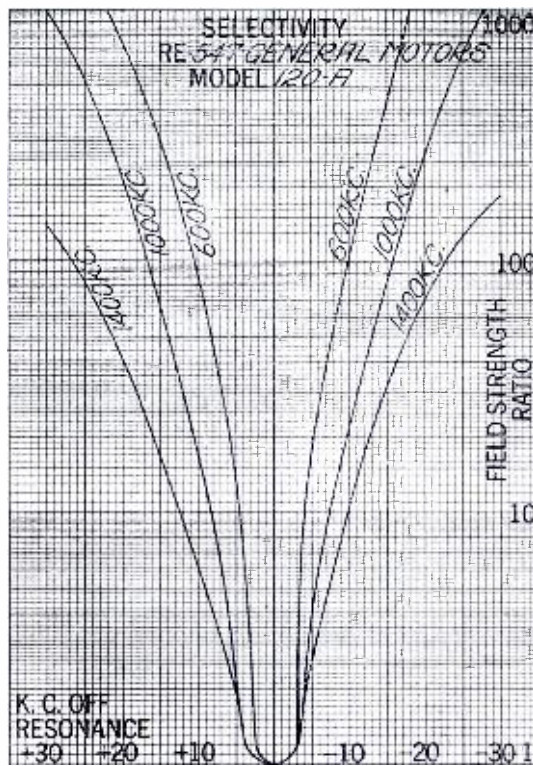
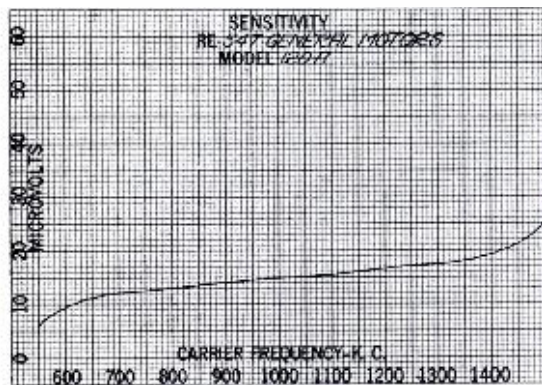

Crosley Radio Model No. 54

A FAMILY of curves taken on one of the midgets made by Crosley, the model 54 whose schematic diagram and service data appears elsewhere in this issue, is illustrated on this page, measurements having been taken November 11.

Output impedance was adjusted to 4000 ohms and coupled capacitatively to the plate of the single 245 output tube. The output was maintained at .05 watts. Input to the set was through a dummy consisting of 20 uh, 200 mmf and 25 ohms. The receiver was phased at a frequency of 1400 kc. The volume control was turned to maximum. No oscillation noted, nor hum level measurable.

The mutual conductance of the tubes used in this measurement is shown here: 1 r.f. 1140; 2 r.f. 1070; detector 1170 and output tube 1970 micromhos.

Interference ratios and the band widths are indicated in the tables shown:

Interference Ratio

Resonance	Kilocycles off resonance		
	Plus 10	Plus 20	Plus 30
600 kc.....	9.62	64.2	172.0
1000 kc.....	3.44	18.4	81.6
1400 kc.....	4.18	9.83	42.2
	Minus 10	Minus 20	Minus 30
600 kc.....	75.7	374.0	1205.0
1000 kc.....	21.0	100.8	274.0
1400 kc.....	15.1	55.2	136.0

Band Widths

Times field strength	Kilocycles wide		
	600 kc.	1000 kc.	1400 kc.
10	14.0	23.5	27.5
100	35.0	-----	-----
1000	-----	-----	-----

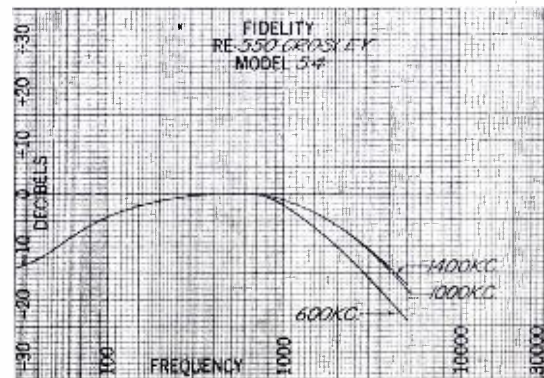
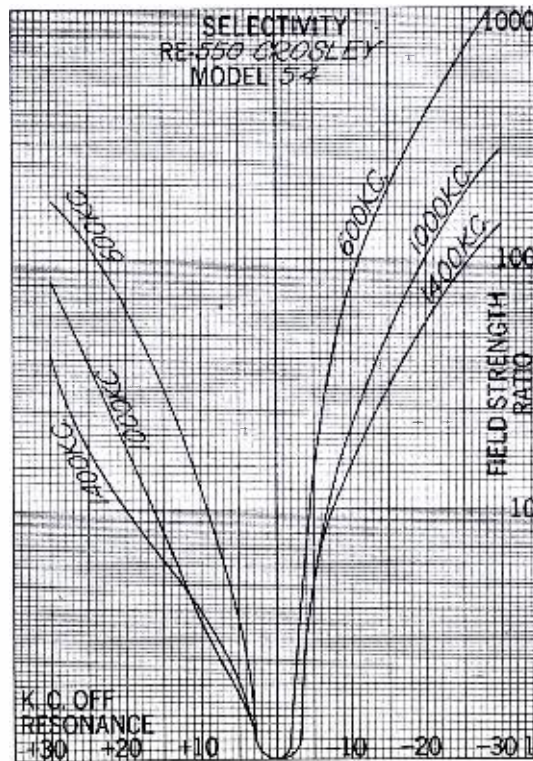
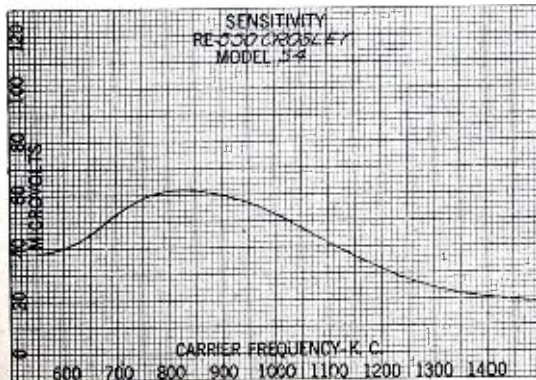

General Electric Model No. H-31

MEASUREMENTS on one of the superheterodynes marketed under the General Electric banner, the model H-31 have been recently completed and the three curves derived therefrom given at the bottom of this article.

An output impedance load of 4000 ohms was maintained, this being coupled capacitatively to the plates of the 245 output tubes. Standard output was .05 watts. The dummy antenna used was the standard having 20 uh, 200 mmf and 25 ohms. No change was made in the phasing frequency since this value was set in the factory. Volume control was turned full on. No measurements could be made covering either the hum level or oscillation.

Tubes have a mutual conductance as

indicated in this paragraph were used on the measurements: 1 r.f. 940; 1 i.f. 1020; 2 i.f. 900; 1 detector 1000; 2 detector 1030; oscillator 1300; p.p. 1850 and p.p. 1850 micromhos.

In the two tables following may be found the interference ratios and the band widths as taken from the curves

on selectivity.

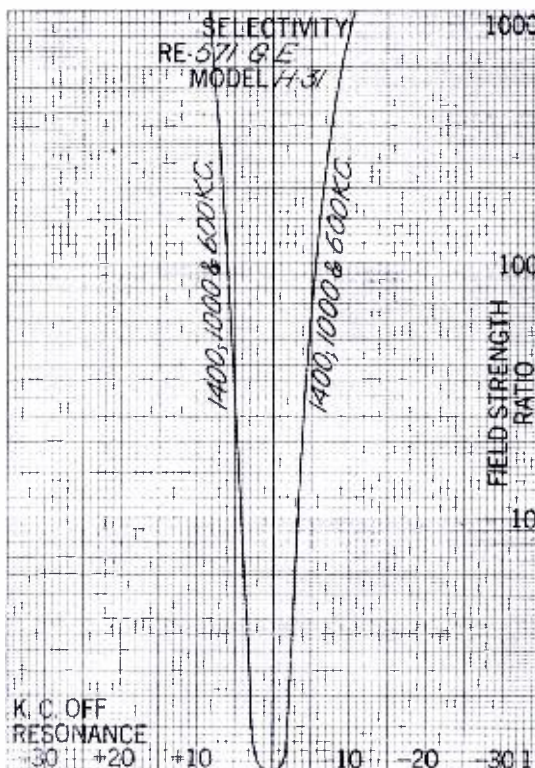
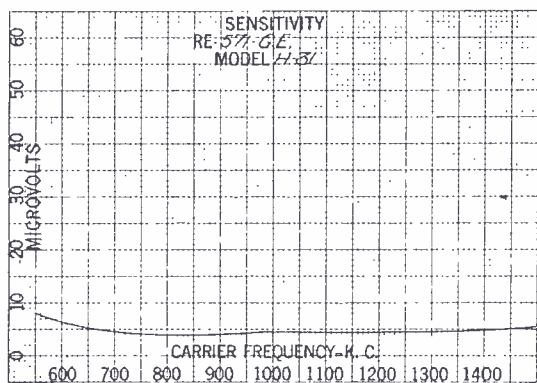

Resonance	Interference Ratio		
	Kilocycles off resonance		
	Plus 10	Plus 20	Plus 30
600 kc.	900	-----	-----
1000 kc.	900	-----	-----
1400 kc.	900	-----	-----
	Minus 10	Minus 20	Minus 30
600 kc.	-----	-----	-----
1000 kc.	-----	-----	-----
1400 kc.	-----	-----	-----

Times field strength	Band Widths		
	Kilocycles wide		
	600 kc.	1000 kc.	1400 kc.
10	7.9	7.9	7.9
100	12.4	12.5	12.4
1000	17.9	17.9	17.9

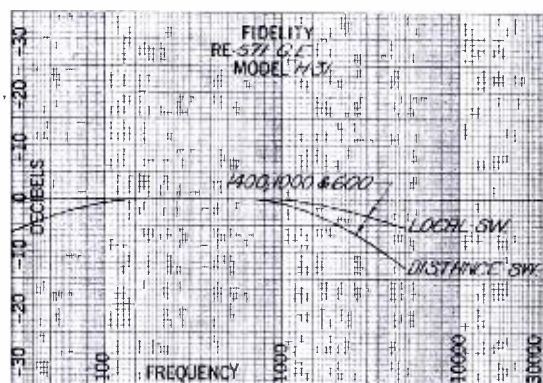

Radiola Superheterodyne Model 80

USING the 175 kilocycle intermediate frequency stages and known as the bell-wether of this type of superheterodyne in commercial production, the model 80 selling under the name of Radiola, has recently been measured in our laboratory, and the response curves of this model taken.

As customary the output impedance load was adjusted to 4000 ohms and coupled capacitatively to the plates of the 245 tubes. The standard output of .05 watts was maintained, the antenna input being from the standard dummy, consisting of 20 uh, 200 mmf and 25 ohms. The phasing frequency set in line production was maintained. Volume control turned on full. No hum or os-

cillation found.

Mutual conductance of the tubes used in this measurement is shown by the following values: 1 r.f. 940; 1 i.f. 1020; 2 i.f. 900; oscillator 1300; 1 detector 1000; 2 detector 1030; p.p.

1850 and p.p. 1850 micromhos.

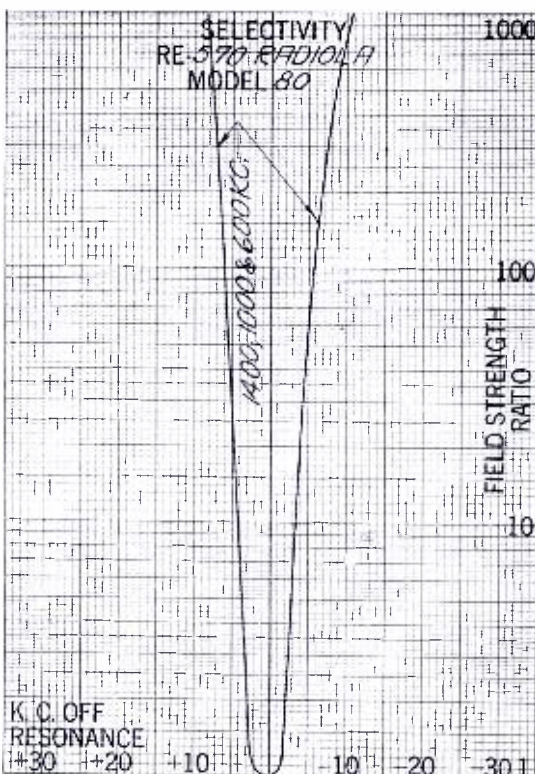
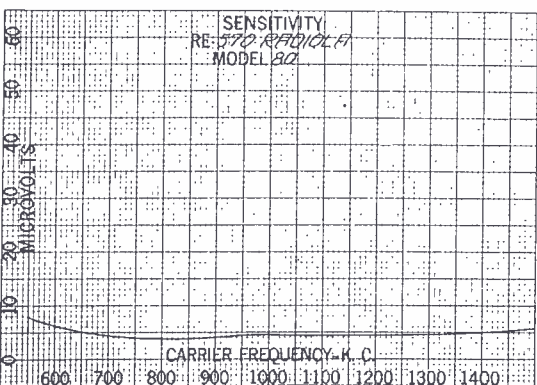

Resonance	Interference Ratio		
	Kilocycles off resonance		
	Plus 10	Plus 20	Plus 30
600 kc.	900	-----	-----
1000 kc.	900	-----	-----
1400 kc.	900	-----	-----
	Minus 10	Minus 20	Minus 30
1000 kc.	-----	-----	-----
600 kc.	-----	-----	-----
1400 kc.	-----	-----	-----

Times field strength	Band Widths		
	Kilocycles wide		
	600 kc.	1000 kc.	1400 kc.
10	8.0	8.0	8.0
100	12.5	12.5	12.5
1000	18.0	18.0	18.0

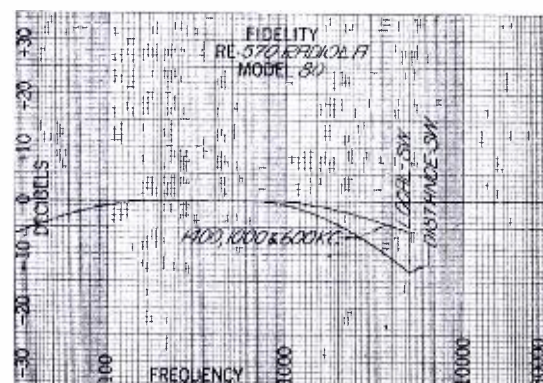

Amrad Receiver Model No. 84

RECENT measurements made on one of the Amrad chassis, model 81, shows the curves resulting in the three graphs with this article.

The output impedance load was adjusted to 4000 ohms and coupled capacitatively to the plates of the 245 tubes. Standard output of .05 watts was maintained on all measurements. The dummy antenna was the standard containing 20 uh, 200 mmf and 25 ohms. The receiver was phased at 1400 kilocycles and the volume control turned on full. Neither hum nor oscillation was found.

The mutual conductance of the tubes used in this measurement follows: 1

r.f. 1140; 2 r.f. 1240; 3 r.f. 1170; detector 1120; 1 a.f. 1040; p.p. 1920 and 1970 micromhos.

Based on the curves of selectivity the interference ratios and the band widths are derived below:

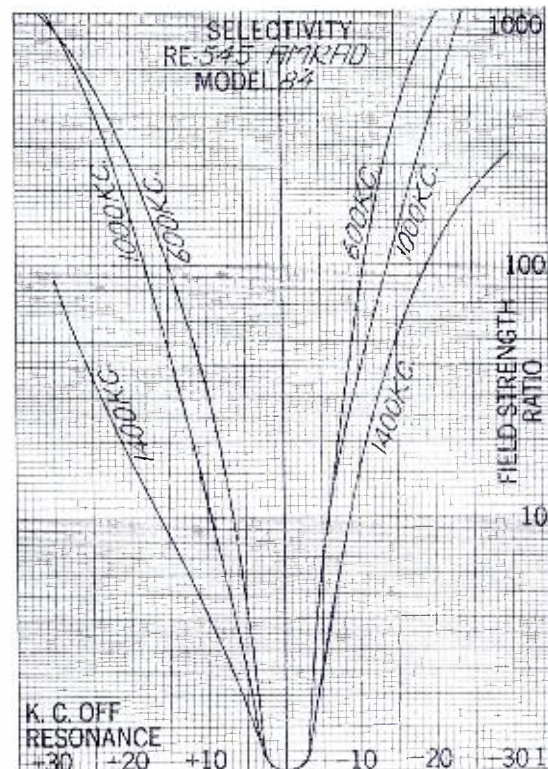

Interference Ratio

Resonance	Kilocycles off resonance		
	Plus 10	Plus 20	Plus 30
1000 kc.	11.5	160.0	880.0
600 kc.	33.0	250.0	880.0
1400 kc.	4.0	17.0	88.0
Minus 10 Minus 20 Minus 30			
600 kc.	6.5	900.0	-----
1000 kc.	6.5	110.0	-----
1400 kc.	2.6	112.0	270.0

Band Widths

Times field strength	Kilocycles wide		
	600 kc.	1000 kc.	1400 kc.
10	12.5	15.5	25.0
100	25.7	32.0	-----
1000	52.5	55.0	-----

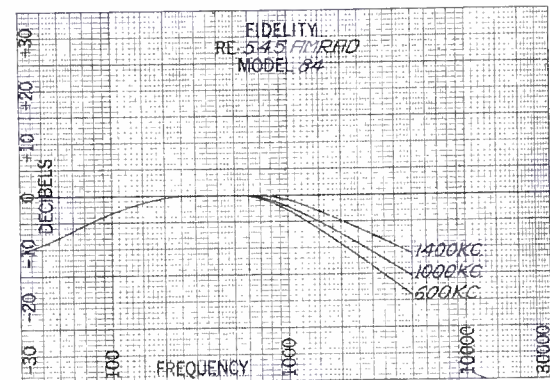

Graybar Superheterodyne, No. 700

THREE of the response curves covering the superheterodyne marketed under the Graybar name and known as model 700 are shown here.

As usual the output impedance load was adjusted to 4000 ohms. Coupling to the plates of the 245 output tubes was capacitive. The standard output for receivers, .05 watts, was maintained on all measurements. Antenna input was through the dummy consisting of 20 uh, 200 mmf and 25 ohms. Phasing frequency was checked at the value set at the factory, and the volume control turned on maximum. No hum nor oscillation was present.

Mutual conductance of the tubes used in this set-up is indicated in the follow-

ing values: 1 r.f. 940; 1 i.f. 1020; 2 i.f. 900; detector 1000; p.p. 1850; p.p. 1850; 2 detector 1030 and oscillator 1300 micromhos.

In the two tables following will be found the interference ratios and the

band widths as taken from the selectivity curves:

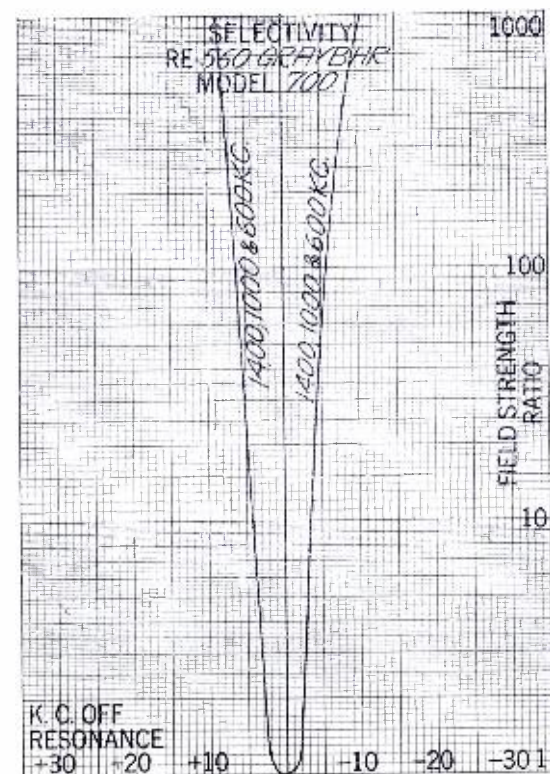

Interference Ratio

Resonance	Kilocycles off resonance		
	Plus 10	Plus 20	Plus 30
600 kc.	900	-----	-----
1000 kc.	900	-----	-----
1400 kc.	900	-----	-----
Minus 10 Minus 20 Minus 30			
600 kc.	-----	-----	-----
1000 kc.	-----	-----	-----
1400 kc.	-----	-----	-----

Band Widths

Times field strength	Kilocycles wide		
	600 kc.	1000 kc.	1400 kc.
10	8.1	8.1	8.1
100	12.6	12.6	12.6
1000	18.1	18.1	18.1

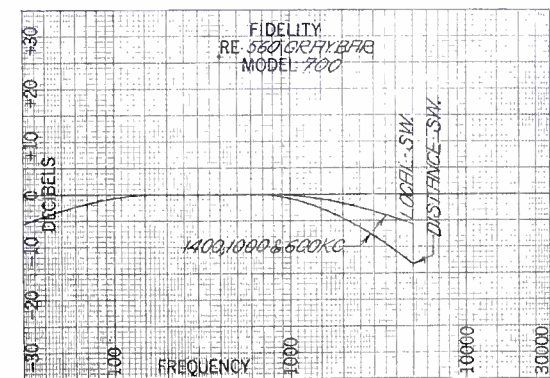
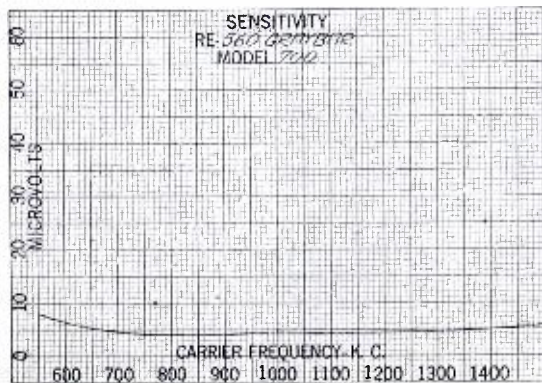

Kennedy Radio Model No. 42

AMONG the midget receivers recently measured in our laboratory is the Colin B. Kennedy model 42 whose response curves are shown on this page.

Output impedance load was adjusted for 4000 ohms, coupled capacitatively to the output power stage plate. Standard output of .05 watts was maintained. Antenna input was through the dummy containing 20 uh, 200 mmf and 25 ohms. Phasing frequency set at the factory was maintained and the volume control turned on full. No oscillation and no hum level was found.

Mutual conductance of the tubes used in this measurement is indicated in the following values: 1 r.f. 980; 2 r.f.

1030; detector 1040; 1 a.f. 1020, and power output stage 1920 micromhos.

In the two tables following will be found the interference ratios and the band widths, this data being secured from the selectivity curves:

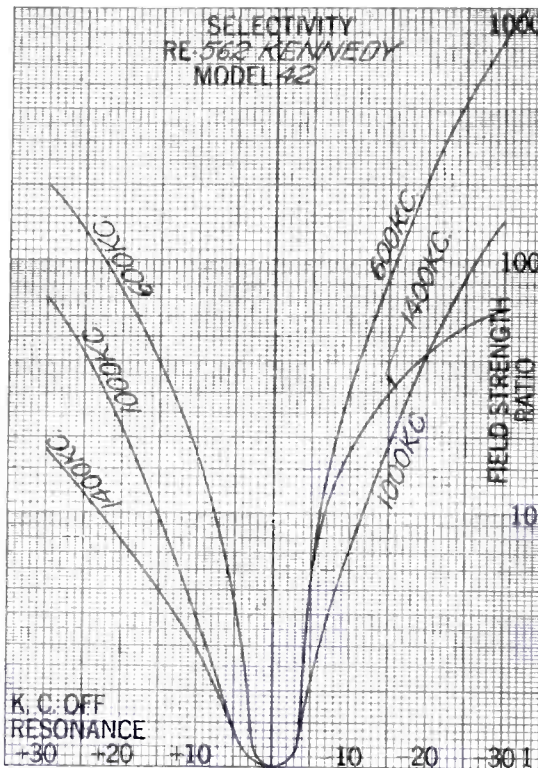
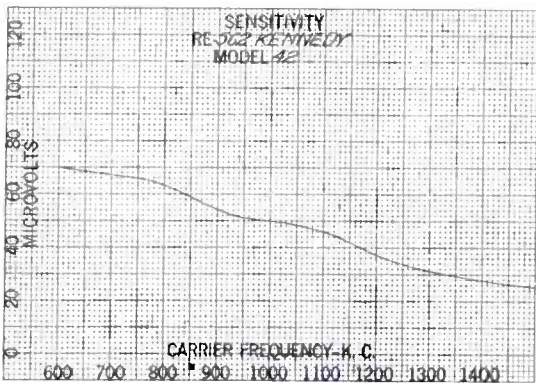

Interference Ratio

Resonance	Kilocycles off resonance		
	Plus 10	Plus 20	Plus 30
600 kc.	17.00	75.0	200.0
1000 kc.	3.90	22.0	71.0
1400 kc.	2.95	7.8	18.0
	Minus 10 Minus 20 Minus 30		
600 kc.	30.0	205.0	750.0
1000 kc.	7.2	42.0	140.0
1400 kc.	17.5	42.0	63.0

Band Widths

Times field strength	Kilocycles wide		
	600 kc.	1000 kc.	1400 kc.
10	13.7	27.0	30.0
100	38.5	-----	-----
1000	-----	-----	-----

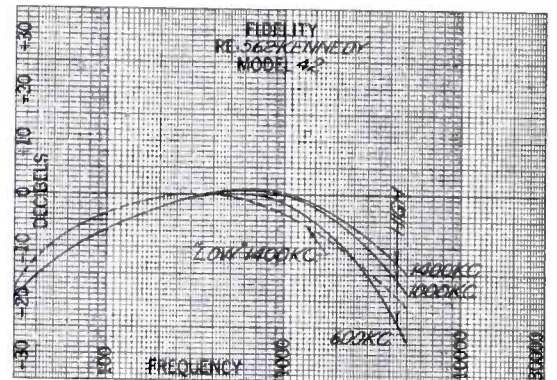

Audiola Super Model No. 31

MEASUREMENTS have been completed on the Audiola model 31 superheterodyne and its response curves are shown on this page. Input for the measurements was through the standard dummy antenna consisting of 20 uh, 200 mmf and 25 ohms. The output impedance was maintained at 4000 ohms and coupled capacitatively to the plates of the 245 output tubes. The receiver was phased at 1400 and 600 kilocycles and the volume control turned on full. Line voltage measured 110 volts and current .9 amperes.

Transconductance of the tubes used in the measurement on this model is in-

dicated: 1 r.f. 1030; mixer 1080; detector 1100; 1 i.f. 1050; 2 i.f. 1020; P.P. 1940; P.P. 1970 and oscillator 1080 micromhos.

In the two tables will be found the interference ratios and the band widths:

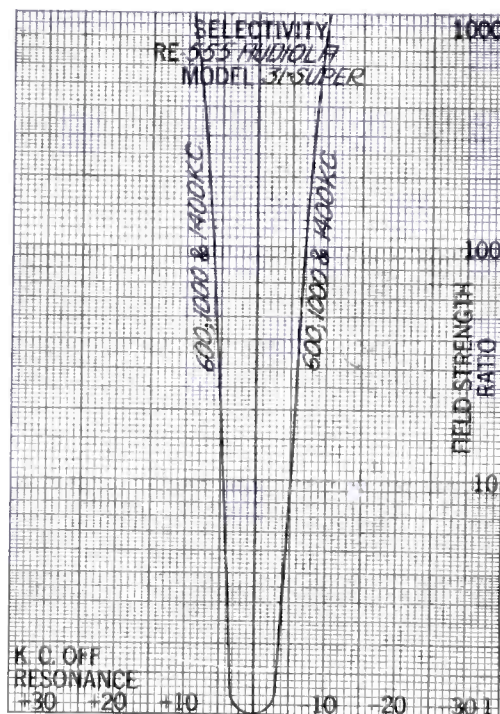
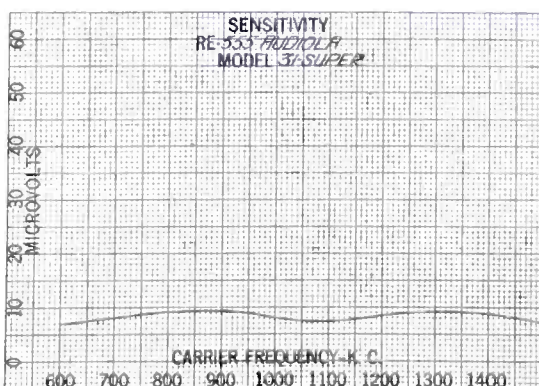

Interference Ratio

	Kilocycles off resonance		
	Plus 10	Plus 20	Plus 30
600 kc.	1300	-----	-----
1000 kc.	1300	-----	-----
1400 kc.	1300	-----	-----
	Minus 10 Minus 20 Minus 30		
600 kc.	900.0	-----	-----
1000 kc.	900.0	-----	-----
1400 kc.	900.0	-----	-----

Band Widths

Times field strength	Kilocycles wide		
	600 kc.	1000 kc.	1400 kc.
10	9.5	9.5	9.5
100	13.0	13.0	13.0
1000	19.5	19.5	19.5

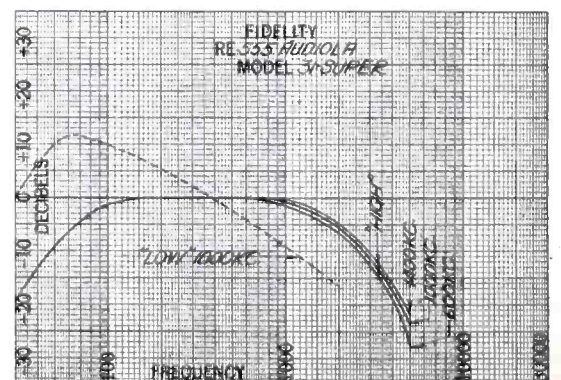

Silver Super Model No. 36-A

RESPONSE curves of the Silver superheterodyne model 36-A are shown on this page. Schematic circuit of the receiver and service data appears elsewhere in this section.

Dummy antenna used consisted of 20 uh, 200 mmf and 25 ohms. Output impedance was adjusted to 4000 ohms, coupled capacitatively to the plates of the 245 tubes in the output stage. The receiver was phased at the factory setting and the volume control turned to maximum. Line voltage 110 volts and current .95 amperes. Standard output of .05 watts was used in the measurements.

Transconductance of the tubes used indicated as follows: 1 r.f. 1120; mixer

1080; detector 1250; 1 i.f. 1140; 2 i.f. 1040; P.P. 1940; P.P. 1980; oscillator 1000 micromhos.

Interference ratios and band widths are shown in the two tables:

Interference Ratio

Resonance	Kilocycles off resonance		
	Plus 10	Plus 20	Plus 30
600 kc.	900	-----	-----
1000 kc.	900	-----	-----
1400 kc.	900	-----	-----
	Minus 10	Minus 20	Minus 30
600 kc.	-----	-----	-----
1000 kc.	-----	-----	-----
1400 kc.	-----	-----	-----

Band Widths

Times field strength	Kilocycles wide		
	600 kc.	1000 kc.	1400 kc.
10	8.5	8.5	8.5
100	12.0	12.0	12.0
1000	18.5	18.5	18.5

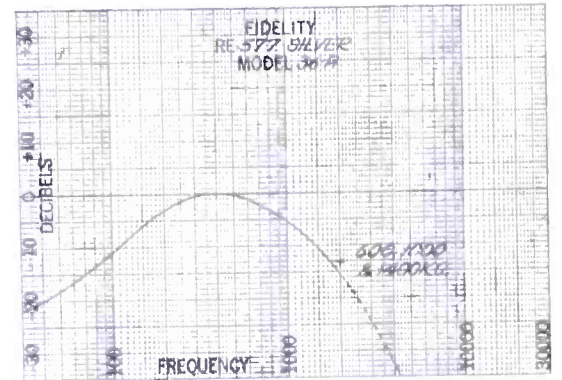
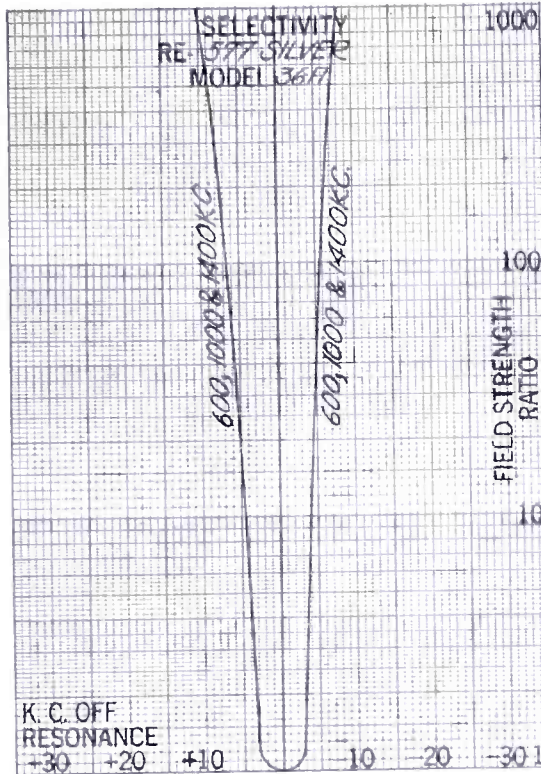
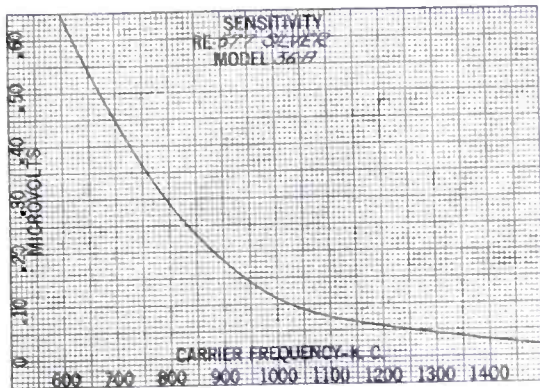

Columbia Radio Model No. 100

MODEL 100 Columbia, used by the Columbia Phonograph Co., is another chassis recently passing through our measurement laboratory. The response curves for this receiver are shown in this article.

Output impedance load was adjusted at 4000 ohms and coupled capacitatively to the plates of the 245 output tubes. Power output was maintained at the standard value of .05 watts. The customary antenna dummy was one with 20 uh, 200 mmf and 25 ohms. The receiver was phased at 1400 kc. and the volume control turned to maximum. Neither hum nor oscillation was encountered.

The tubes used in these measurements

had the mutual conductance values indicated: 1 r.f. 1140; 2 r.f. 1240; 3 r.f. 1170; detector 1120; 1 a.f. 1040; p.p. 1920 and p.p. 1920 micromhos.

Interference ratios and band widths, taken from the selectivity curves, are

set forth in the two tables following:

Interference Ratio

Resonance	Kilocycles off resonance		
	Plus 10	Plus 20	Plus 30
600 kc.	32.0	255.0	-----
1000 kc.	11.5	165.0	870.0
1400 kc.	3.3	18.0	88.0
	Minus 10	Minus 20	Minus 30
600 kc.	60.0	840.0	-----
1000 kc.	36.0	410.0	-----
1400 kc.	14.5	112.0	280.0

Band Widths

Times field strength	Kilocycles wide		
	600 kc.	1000 kc.	1400 kc.
10	12.0	15.5	30.5
100	27.0	31.7	-----
1000	48.5	55.0	-----

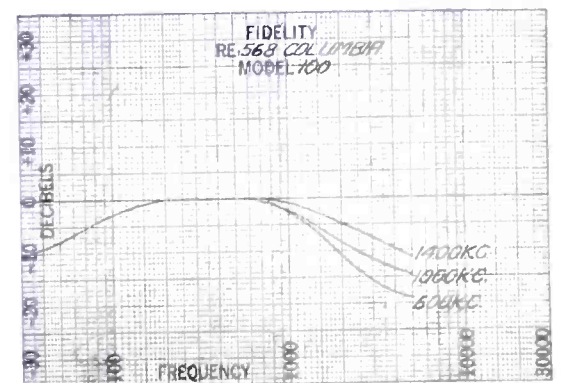
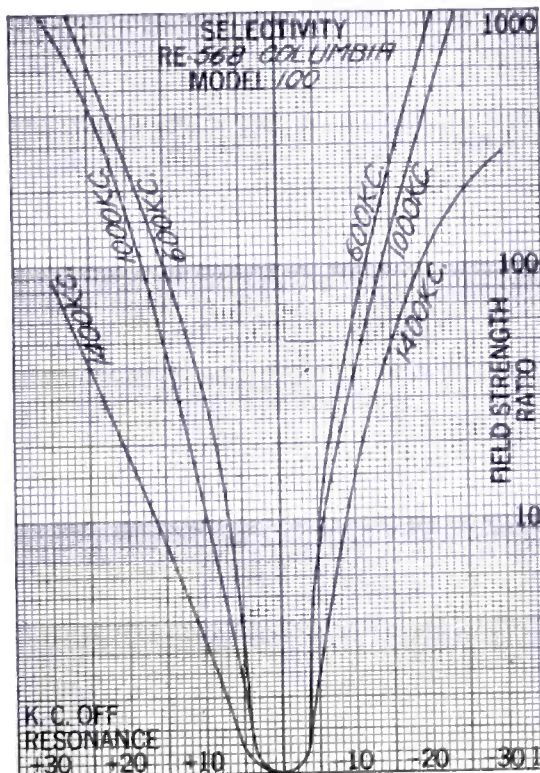
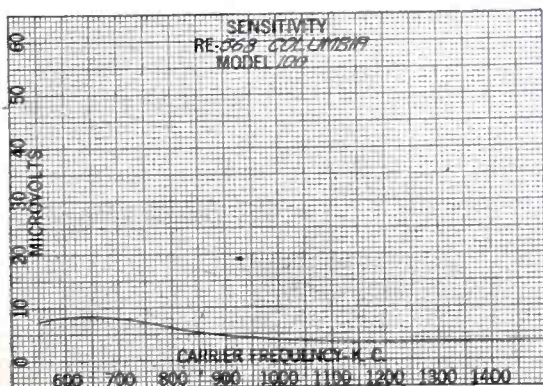

Atwater-Kent Model 72 Super

ATWATER-KENT'S superheterodyne, known as their model 72, has been recently measured in our laboratory and the curves derived are presented on this page. In reading the sensitivity curves, readers should note that microvolts are plotted from 0 to 6, a period being placed between the numeral and the cipher.

Dummy antenna used consisted of 20 uh, 200 mmf and 25 ohms. Output impedance was maintained at 1000 ohms, coupled capacitatively to the output plates. The factory phasing frequency was maintained and the volume control turned to maximum setting. Line voltage 115, current .32 amperes.

Transconductance of the tubes used:

Mixer, 1110; detector, 1000; 1 i.f. 1030; 2 i.f. 1040; 1 a.f. 1000; P.P. 1910; P.P. 1930, and oscillator, 1030 micromhos.

Interference ratios and band widths are shown in these tables:

Interference Ratio

Resonance	Kilocycles off resonance		
	Plus 10	Plus 20	Plus 30
600 kc.	75.0	-----	-----
1000 kc.	-----	-----	-----
1400 kc.	275.0	-----	-----
	Minus 10	Minus 20	Minus 30
600 kc.	-----	-----	-----
1000 kc.	450.0	-----	-----
1400 kc.	210.0	-----	-----

Band Widths

Times field strength	Kilocycles wide		
	600 kc.	1000 kc.	1400 kc.
10	9.5	9.2	9.2
100	17.7	14.0	14.5
1000	28.0	21.0	27.0

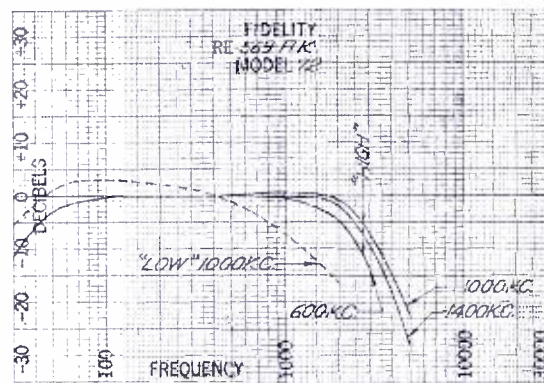
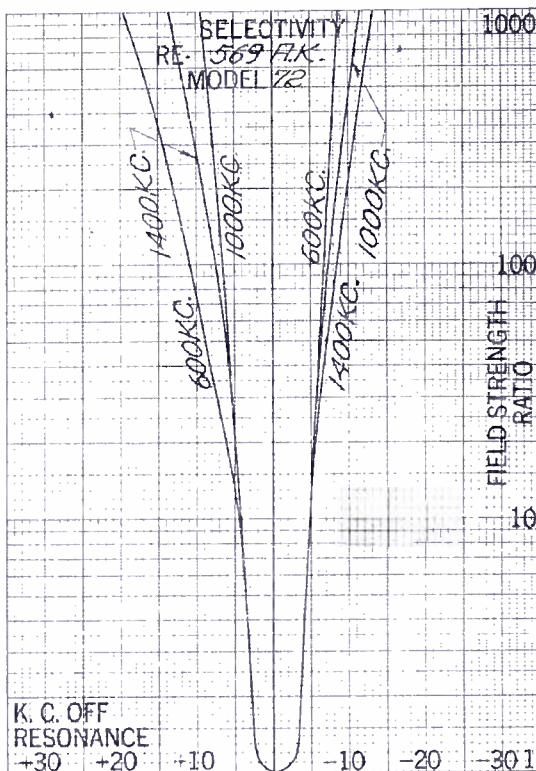
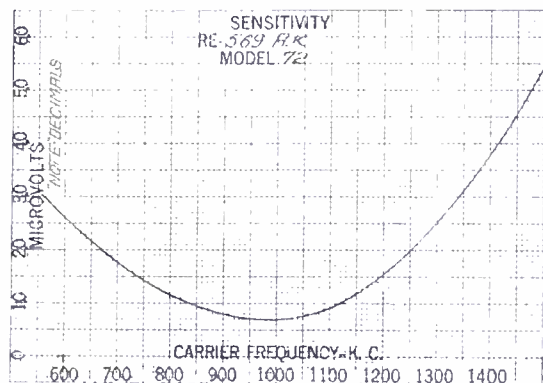

Zenith Radio Model ZE-70 Jr.

RESPONSE curves have been taken on the Zenith model ZE-70 Jr. and are illustrated on this page. R.f. input to the receiver was through the standard dummy consisting of 20 uh, 200 mmf and 25 ohms. Output impedance was kept at 1000 ohms, coupled capacitatively to the plates of the 215 output tubes. The receiver was phased at 1400 kc. and the volume control turned to maximum. Line voltage 115 volts, current .35 amperes.

Transconductance of the tubes used in the measurement are indicated: 1 r.f. 1080; 2 r.f. 1010; 3 r.f. 970; detector

970; 1 a.f. 950; P.P. 1980 and P.P. 1910 micromhos.

In the two tables below will be found the interference ratios and the band widths taken from the selectivity curves:

Interference Ratio

Resonance	Kilocycles off resonance		
	Plus 10	Plus 20	Plus 30
600 kc.	112.0	900	-----
1000 kc.	58.0	550.0	-----
1400 kc.	5.3	31.0	142.0
	Minus 10	Minus 20	Minus 30
600 kc.	210.0	-----	-----
1000 kc.	21.0	550.0	-----
1400 kc.	5.9	46.0	285.0

Band Widths

Times field strength	Kilocycles wide		
	600 kc.	1000 kc.	1400 kc.
10	8.8	13.8	26.0
100	17.5	25.5	51.5
1000	31.5	47.5	-----

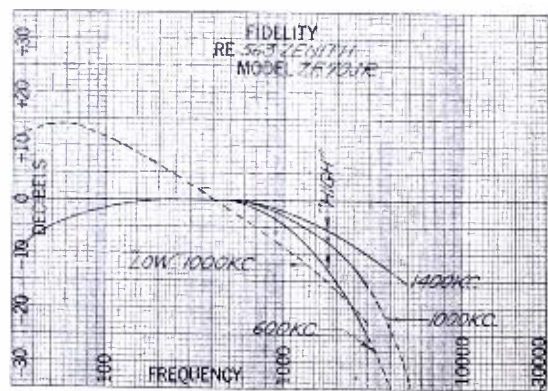
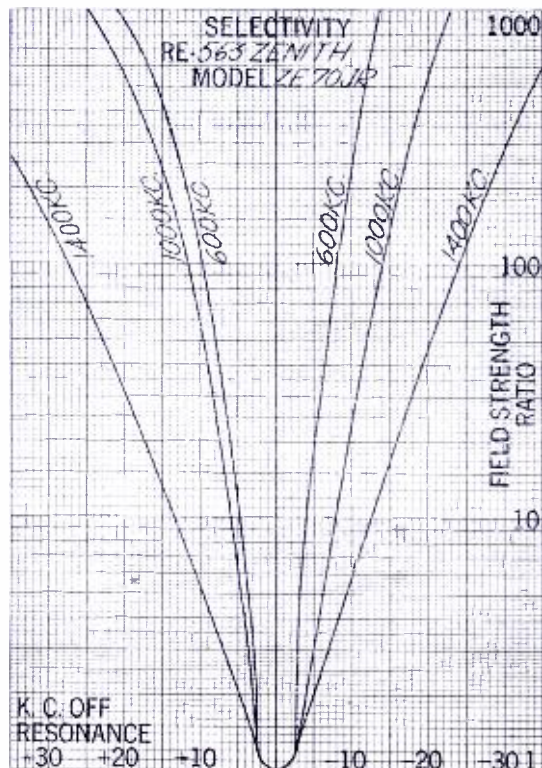
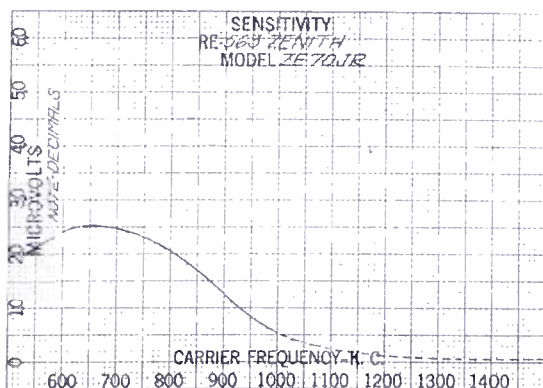

Sentinel Super Model 106

SENTINEL'S model 106 super-heterodyne has recently passed through our measurement laboratory and its curves are shown on this page. The dummy antenna used consisted of 20 uh, 200 mmf and 25 ohms. Output impedance was maintained at 4000 ohms, coupled capacitatively to the plates of the 215 output tubes. Factory phasing frequency was maintained and the volume control turned on full. Line voltage 110 volts, current .72 amperes.

Transconductance of the tubes used in this measurement: 1 r.f. 980; mixer 1080; detector 950; 1. i.f. 1040; P.P. 1980; P.P. 1940 and oscillator 1180

micromhos.

In the two tables here shown will be found the interference ratios and the band widths:

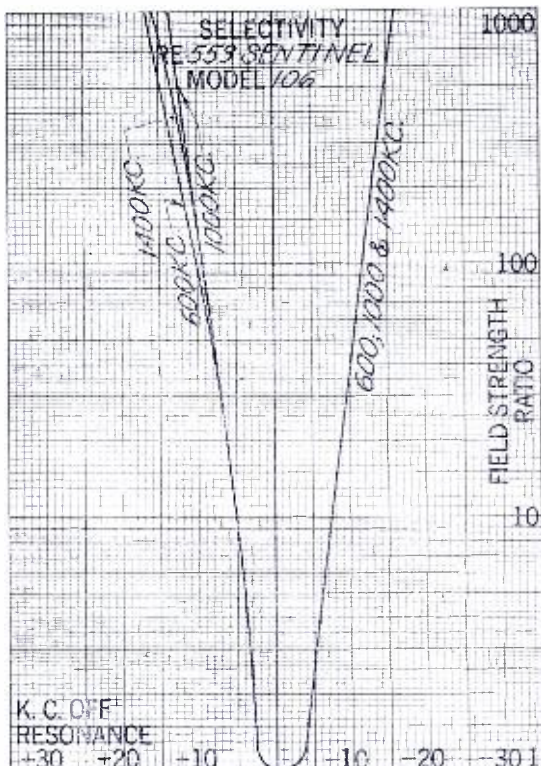
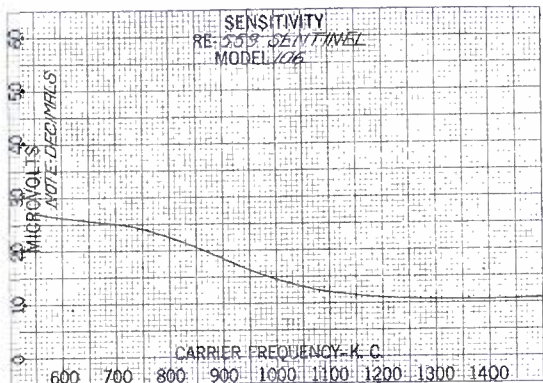

Resonance	Interference Ratio		
	Kilocycles off resonance		
	Plus 10	Plus 20	Plus 30
600 kc.	95.0	-----	-----
1000 kc.	140.0	-----	-----
1400 kc.	140.0	-----	-----
	Minus 10	Minus 20	Minus 30
600 kc.	37.0	-----	-----
1000 kc.	37.0	-----	-----
1400 kc.	37.0	-----	-----

Times field strength	Band Widths		
	Kilocycles wide		
	600 kc.	1000 kc.	1400 kc.
10	12.5	12.5	12.5
100	21.7	21.0	21.7
1000	32.0	29.5	32.5

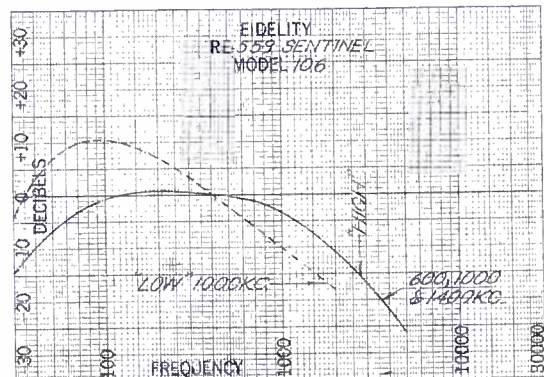

Stromberg-Carlson Model 10

MEASUREMENTS of the sensitivity and fidelity of the Stromberg-Carlson model 10 receiver have been completed and the curves are shown on this page.

Input was through the standard dummy consisting of 20 uh, 200 mmf and 25 ohms. Output impedance was maintained at 4000 ohms coupled capacitatively to the plates of the 215 tubes. The receiver was phased at factory kc setting and the volume control turned to maximum. Line voltage 115 volts, current .9 amperes.

Transconductance of the tubes used in the measurements is indicated by the

following values: 1 r.f. 1060; 2 r.f. 920; 3 r.f. 810; detector 990; p.p. 1620; p.p. 1660 micromhos.

In the two tables following will be found the interference ratios and the band widths:

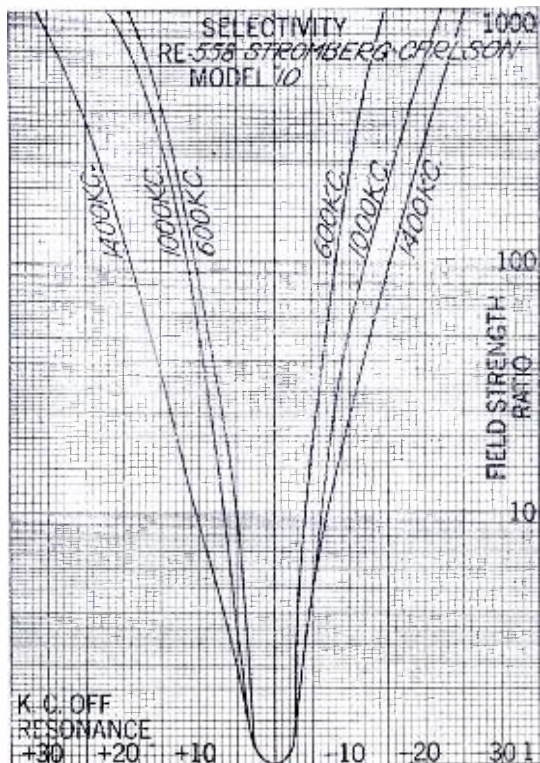
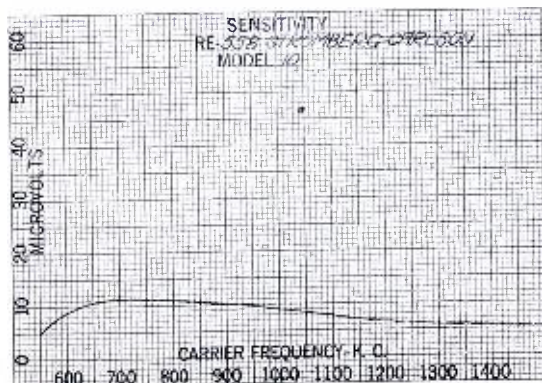

Resonance	Interference Ratio		
	Kilocycles off resonance		
	Plus 10	Plus 20	Plus 30
600 kc.	85.0	-----	-----
1000 kc.	52.0	780.0	-----
1400 kc.	9.0	125.0	-----
	Minus 10	Minus 20	Minus 30
600 kc.	230.0	-----	-----
1000 kc.	54.0	620	-----
1400 kc.	24.0	300	-----

Times field strength	Band Widths		
	Kilocycles wide		
	600 kc.	1000 kc.	1400 kc.
10	9.0	13.0	17.5
100	19.0	23.5	34.5
1000	31.0	41.0	56.0

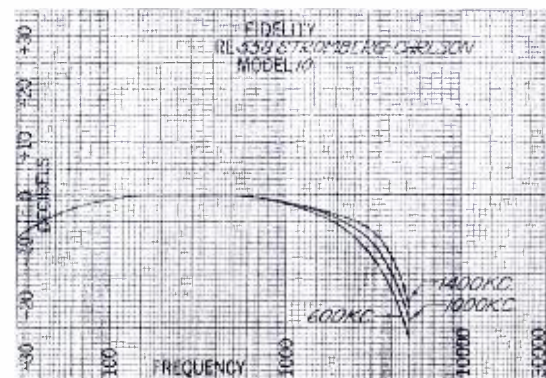

American Bosch Model 60AA

RESPONSE curves of the Bosch model 60-AA made by the American Bosch Magneto Co., are shown on this page.

Dummy antenna used consisted of one having 20 uh., 200 mmf. and 25 ohms. The output impedance was adjusted to 4000 ohms and coupled capacitatively to the plates of the 245 tubes.

The receiver was phased at the frequency at which it was set at the factory and the volume control turned on full. Standard output of .05 watts was maintained.

Transconductance of the tubes used in the measurements was: 1 r.f. 1140; 2 r.f. 980; 3 r.f. 1080; detector 1250;

1 a.f. 1055; p.p. 1700; p.p. 1770, and automatic volume control tube 1040 micromhos.

Interference ratios and band widths are shown on the tables below:

Interference Ratio

Resonance	Kilocycles off resonance		
	Plus 10	Plus 20	Plus 30
600 ke.	48.0	880.0
1000 ke.	33.0	600.0
1400 ke.	7.70	86.0	570.0
	Minus 10 Minus 20 Minus 30		
600 ke.	70.0
1000 ke.	47.0
1400 ke.	14.0	120.0	1000.0

Band Widths

Times field strength	Kilocycles wide		
	600 ke.	1000 ke.	1400 ke.
10	13.5	14.0	19.5
100	22.0	25.0	39.5
1000	37.0	40.5	60.0

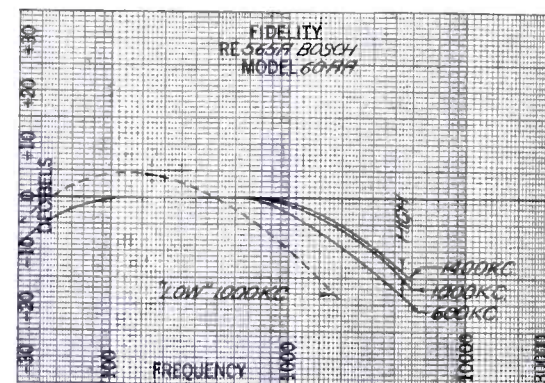
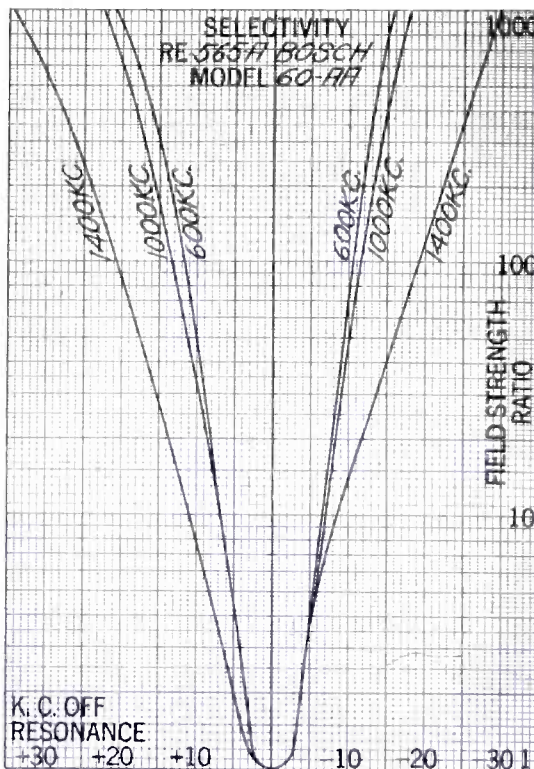
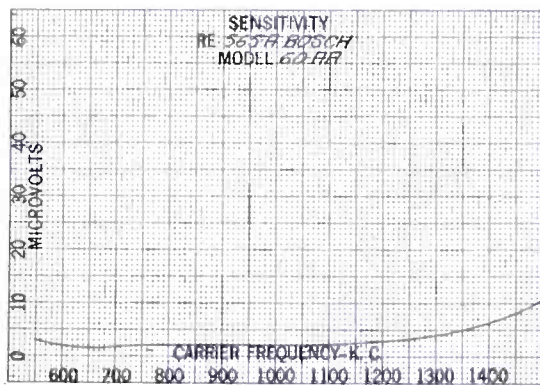

Stromberg-Carlson Model 12

RECENT measurements made on the Stromberg-Carlson model 12 are shown on this page.

Dummy antenna was the standard consisting of 20 uh, 200 mmf and 25 ohms. Output impedance was adjusted to 4000 ohms and coupled capacitatively to the plates of the 245 tubes. Standard output of .05 watts was maintained.

Receiver was phased at the factory setting and the volume control turned on full. Line voltage 110, current 1.1 amperes.

Transconductance of the tubes used is shown by the following values: 1

r.f. 930; 2 r.f. 950; 3 r.f. 800; detector 970; 1 a.f. 1000; p.p. 1500; p.p. 1660; automatic volume control tube 920 micromhos.

Interference ratios and band widths are shown in the two tables below:

Interference Ratio

Resonance	Kilocycles off resonance		
	Plus 10	Plus 20	Plus 30
600 ke.	80.0
1000 ke.	25.0	530.0
1400 ke.	9.4	90.0	700.0
	Minus 10 Minus 20 Minus 30		
600 ke.	135.0
1000 ke.	43.0	900.0
1400 ke.	8.2	120.0	980.0

Band Widths

Times field strength	Kilocycles wide		
	600 ke.	1000 kc.	1400 ke.
10	12.0	15.0	21.0
100	20.0	25.8	39.5
1000	32.0	44.0	61.5

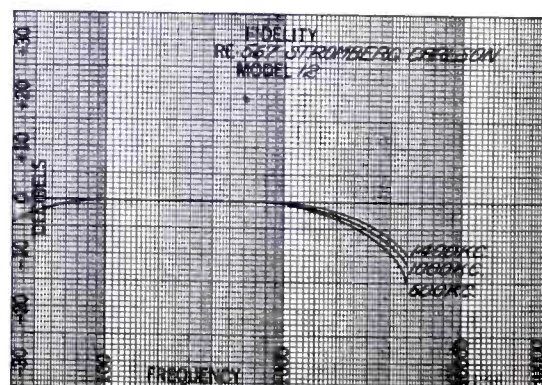
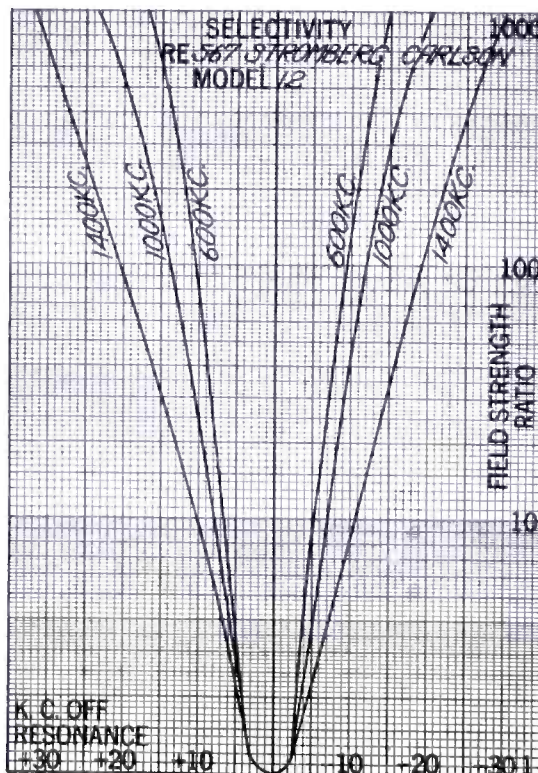
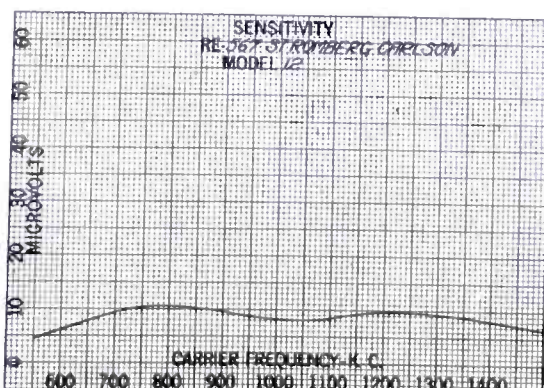

Philco Radio Model 20

PHILCO'S model 20 was recently measured in our laboratory with the results as shown in the curves on this page.

Antenna input was through the standard dummy consisting of 20 uh., 200 mmf. and 25 ohms. Output impedance was adjusted to 4000 ohms and coupled capacitatively to the plates of the 171 tubes.

Receiver was phased at 600 and 1000 kc. and volume control turned on full. Line voltage 115, current .5 amperes. Standard output of .05 watts was maintained.

Transconductance of the tubes used is shown by the following values:

1 r.f., 980; 2 r.f., 1250; detector, 1170; 1 a.f., 1055; p.p., 1400 and p.p., 1430 micromhos.

The two tables below give the interference ratios and the band widths:

Resonance	Interference Ratio		
	Kilocycles off resonance		
	Plus 10	Plus 20	Plus 30
600 kc.	25.0	210.0
1000 kc.	7.3	48.0	160.0
1400 kc.	4.6	16.0	40.0
	Minus 10	Minus 20	Minus 30
600 kc.	30.0	235.0	650.0
1000 kc.	6.3	49.0	150.0
1400 kc.	3.9	12.3	21.5

Times field strength	Band Widths		
	Kilocycles wide		
	600 kc.	1000 kc.	1400 kc.
10	12.7	23.5	33.0
100	31.0	51.0
1000

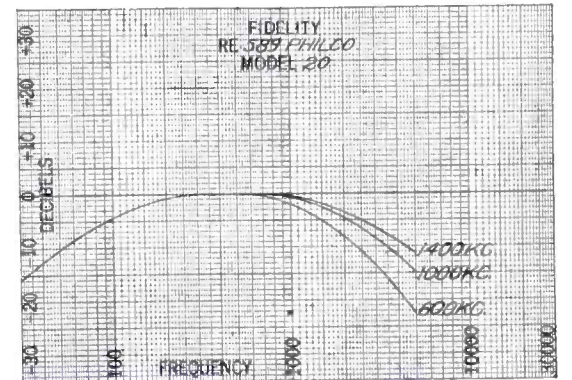
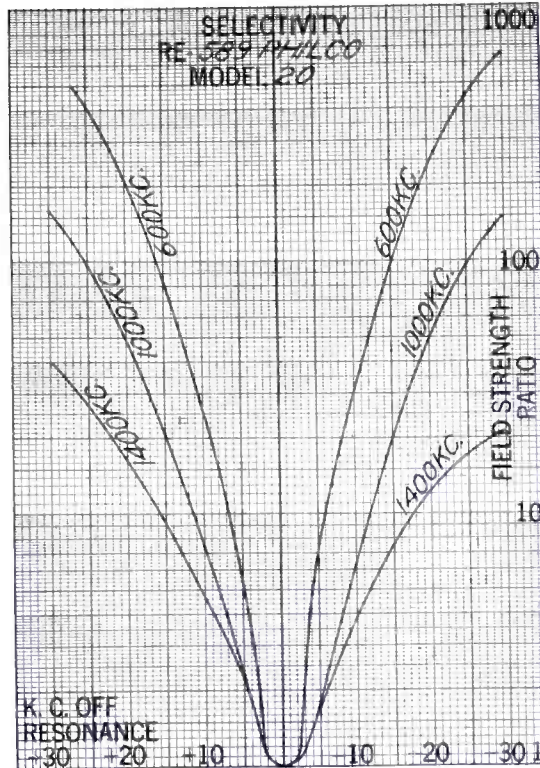
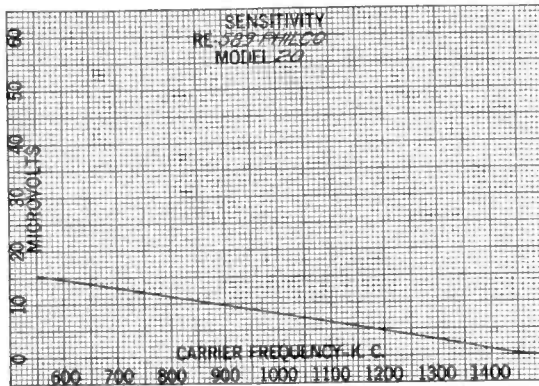

U. S. Radio Model 26

MODEL 26 made by the U. S. Radio and Television Co., on measurement furnishes the curves given with this article.

Standard dummy antenna consisting of 20 uh., 200 mmf. and 25 ohms was used. Output impedance load was adjusted to 4000 ohms and coupled capacitatively to the plate of the 245 used in the output stage.

Receiver was phased at the factory setting and the volume control turned to maximum. Line voltage 115, current .5 amperes. Standard output of .05 watts was maintained.

Transconductance of the tubes used in the measurement is indicated by the

values shown: 1 r.f., 1080; 2 r.f., 1040; detector, 1080; output tube, 1870 micromhos.

Interference ratios and band widths are shown in the tables following:

Resonance	Interference Ratio		
	Kilocycles off resonance		
	Plus 10	Plus 20	Plus 30
600 kc.	5.9	20.0	52.0
1000 kc.	4.6	14.8	40.0
1400 kc.	3.1	9.3	23.5
	Minus 10	Minus 20	Minus 30
600 kc.	8.0	30.5	94.0
1000 kc.	5.0	17.5	53.0
1400 kc.	2.4	8.0	24.5

Times field strength	Band Widths		
	Kilocycles wide		
	600 kc.	1000 kc.	1400 kc.
10	25.0	31.5	42.7
100
1000

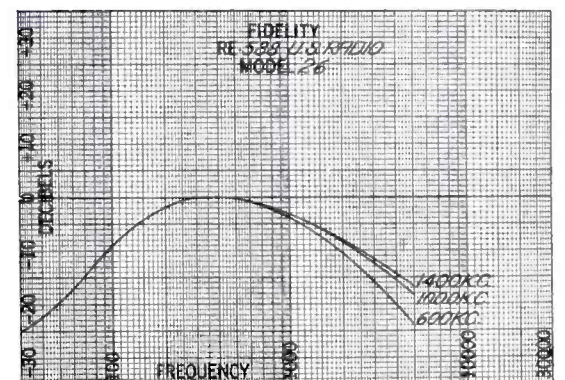
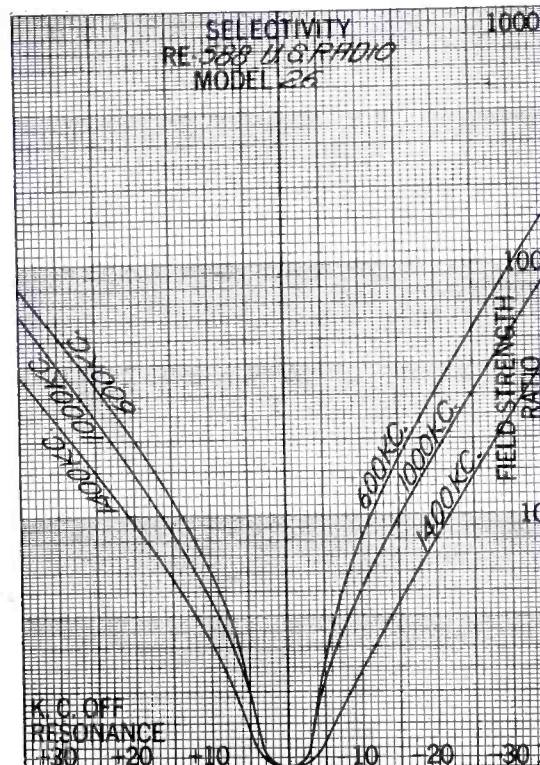
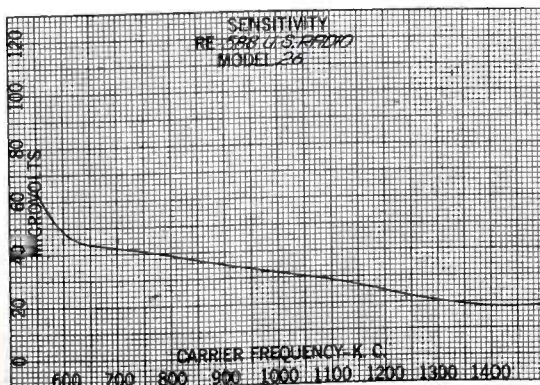

Gulbransen Model 82 Chassis

CHASSIS number 82 used in the Gulbransen model 161 Champion receiver has recently been measured in our laboratory and the response curves are shown on this page.

R.f. input was through the standard dummy consisting of 20 uh, 200 mmf and 25 ohms. The output impedance load was adjusted to 4000 ohms and coupled capacitatively to the plates of the 245 tubes. Standard output of .05 watts was maintained, and the volume control turned to maximum. The receiver was phased at 1400 kilocycles. Line voltage 115, current .85 amperes.

Transconductance of the tubes used in this measurement is indicated

by the following values: 1 r.f., 1080; 2 r.f., 1250; 3 r.f., 1170; detector, 1000; 1 a.f., 1180; p.p., 1870 and p.p., 1700 micromhos.

Interference ratios and band widths are shown in these two tables:

Resonance	Interference Ratio		
	Kilocycles off resonance		
	Plus 10	Plus 20	Plus 30
600 kc.	60.0	520.0
1000 kc.	13.0	130.0	700.0
1400 kc.	8.0	40.0	150.0
	Minus 10	Minus 20	Minus 30
600 kc.	170.0
1000 kc.	19.0	190.0	440.0
1400 kc.	7.4	41.0	150.0

Times field strength	Band Widths		
	Kilocycles wide		
	600 kc.	1000 kc.	1400 kc.
10	8.6	18.7	23.0
100	21.0	35.8	53.0
1000	37.5	65.5

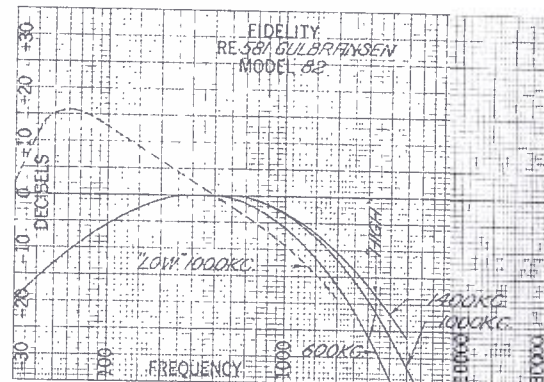
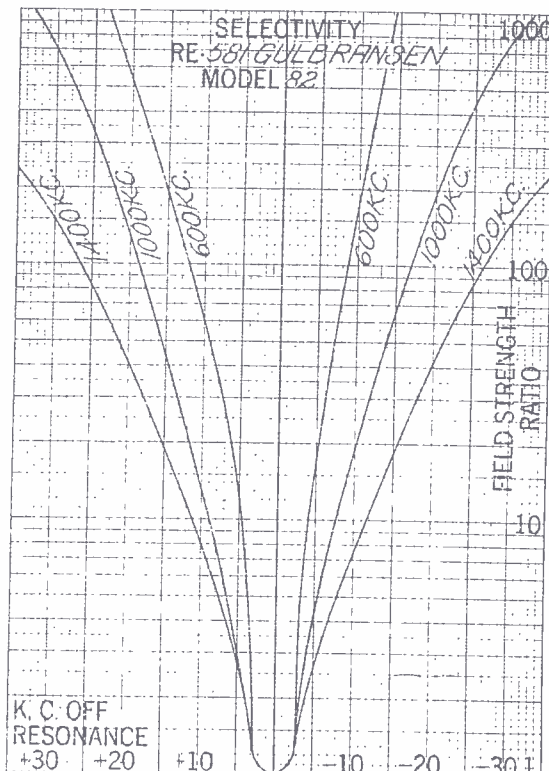
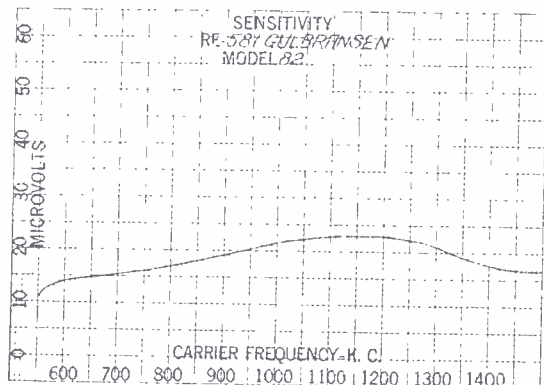

Gulbransen Model 70 Chassis

USED in the Gulbransen models 73 Champion, Jr., and the 173 Minuet receivers, the chassis model 70 has also been microvolted in our laboratory and its response curves presented here.

Antenna input was through the standard dummy consisting of 20 uh, 200 mmf and 25 ohms. Output impedance was maintained at 4000 ohms and was coupled capacitatively to the plates of the output tubes.

Receiver was phased at 1400 kilocycles and the volume control turned on full. Line voltage 115, current .7 amperes.

Transconductance of the tubes used

in this measurement will be found here: 1 r.f., 1170; 2 r.f., 1080; detector, 1250; 1 a.f., 1000; p.p., 1870 and p.p., 1700 micromhos.

In the two tables below are the interference ratios and the band widths:

Resonance	Interference Ratio		
	Kilocycles off resonance		
	Plus 10	Plus 20	Plus 30
600 kc.	20.0	125.0	440.0
1000 kc.	8.5	45.0	160.0
1400 kc.	3.6	14.5	43.0
	Minus 10	Minus 20	Minus 30
600 kc.	24.0	170.0	490.0
1000 kc.	10.5	67.0	180.0
1400 kc.	3.8	15.0	48.0

Times field strength	Band Widths		
	Kilocycles wide		
	600 kc.	1000 kc.	1400 kc.
10	15.0	17.0	34.0
100	35.5	49.5
1000

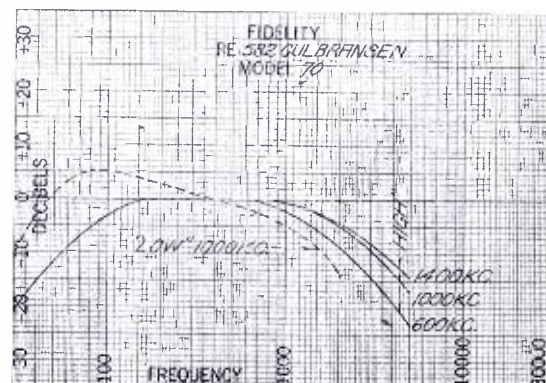
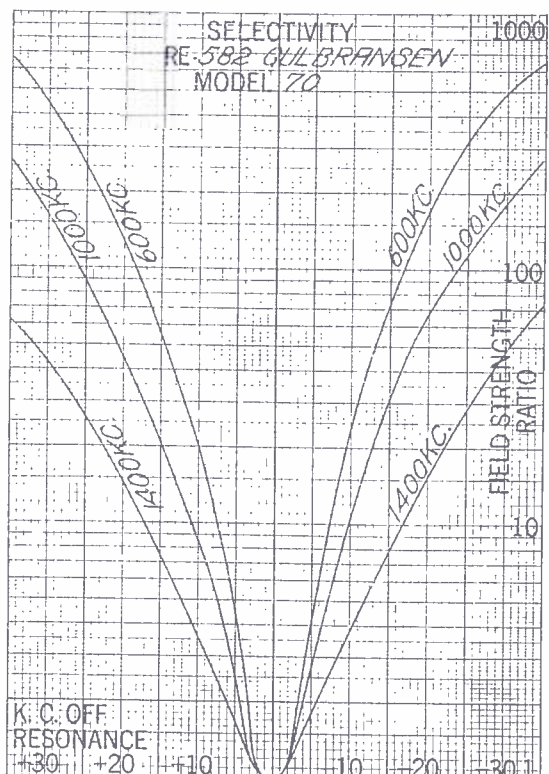
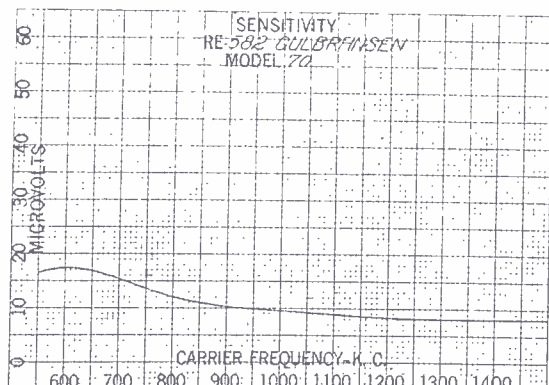

Howard Model SG-B

MEASUREMENTS made on the model SG-B, manufactured by the Howard Radio Co., are shown on this page, this receiver being of the midget type now so popular.

Radio frequency input was through the dummy antenna, consisting of 20 uh, 200 mmf and 25 ohms. Output impedance was maintained at 4000 ohms, coupled capacitively to the plate of the 245 output stage.

Receiver was phased at 1400 ke and the volume control turned on full. Line voltage 112 volts, current .6 amperes. Standard output of .05 watts was maintained during the measurements.

Transconductance of the tubes used is indicated by the figures after each

tube number: 1 r-f 1170; 2 r-f 1250; 3 r-f 1080; detector 1000; output stage 1870 micromhos.

Interference ratios and the band widths as taken from the selectivity curve are shown in the two tables following:

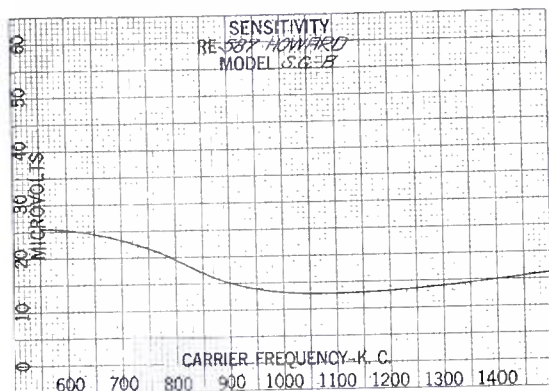
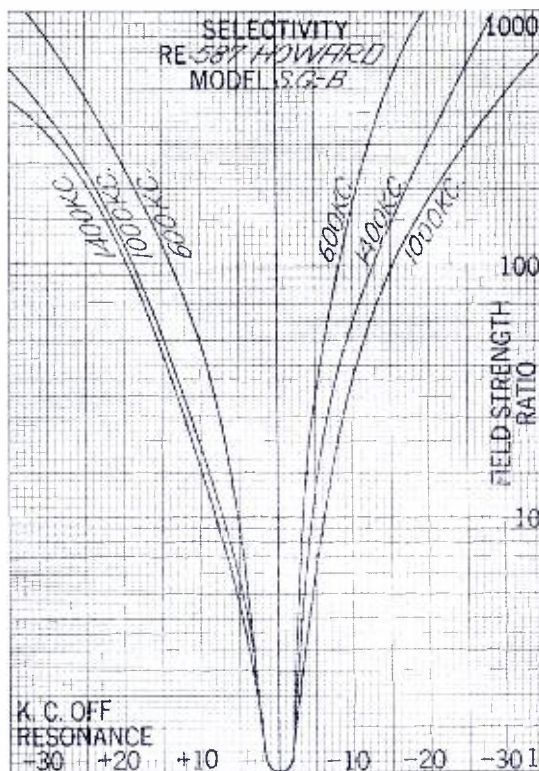

Resonance	Interference Ratio		
	Plus 10	Plus 20	Plus 30
600 ke.	49.0	240.0	780.0
1000 ke.	19.0	120.0	390.0
1400 ke.	15.5	105.0	330.0

Resonance	Interference Ratio		
	Minus 10	Minus 20	Minus 30
600 ke.	170.0	1000.0
1000 ke.	35.0	180.0	470.0
1400 ke.	59.0	300.0

Times field strength	Band Widths		
	600 ke.	1000 ke.	1400 ke.
10	8.5	11.5	14.2
100	22.2	34.0	32.5
1000	52.

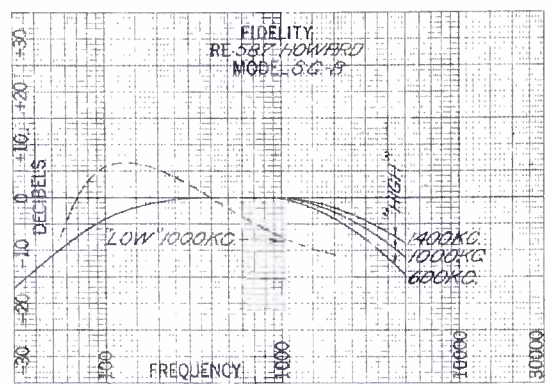

Westinghouse Columaire Model

RECENTLY marketed by the Westinghouse interests, and known as their Columaire model, the WR8-R has been measured in our laboratory and the curves derived from these measurements are shown on this page.

Input to the receiver was through the standard dummy consisting of 20 uh, 200 mmf and 25 ohms. Output impedance was maintained at 8 ohms, being taken across the voice coil.

The receiver was phased at the frequency value at which it was set at the factory, and volume control turned on full. The standard output of .05 watts was maintained on all measurements.

Transconductance of the tubes used in the tests is indicated for each of the

stages: 1 r-f 1070; mixer 1050; detector 1020; 1 i-f 1100; 2 i-f 1060; p.p. 1770; p.p. 1740; oscillator 1100 micromhos.

In the two tables following will be found the interference ratios and the band widths as taken from the selectivity curve:

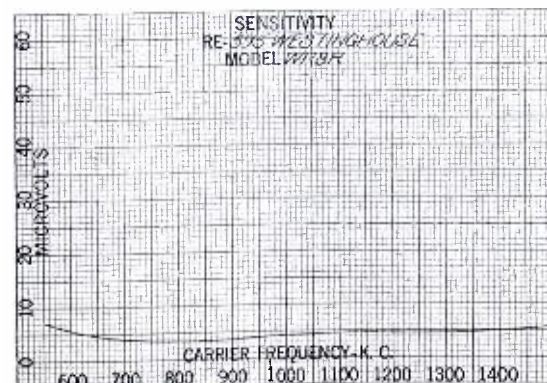
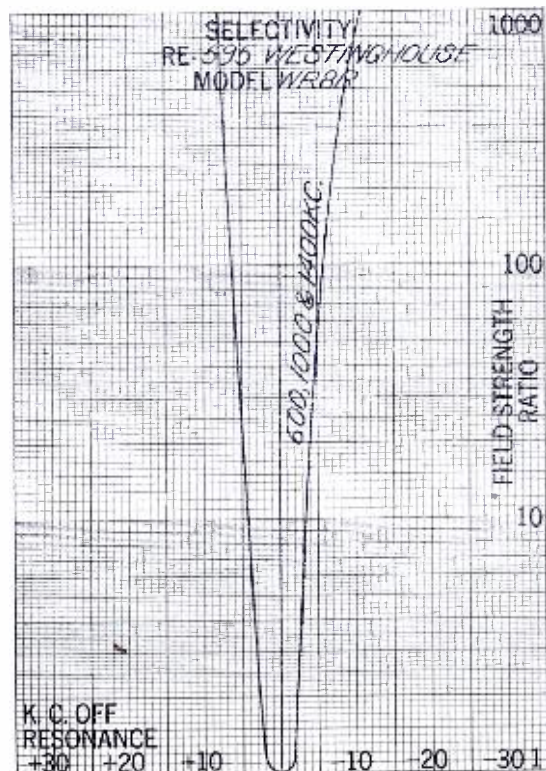

Resonance	Interference Ratio		
	Plus 10	Plus 20	Plus 30
600 ke.
1000 ke.
1400 ke.

Resonance	Interference Ratio		
	Minus 10	Minus 20	Minus 30
600 ke.	770.0
1000 ke.	770.0
1400 ke.	770.0

Times field strength	Band Widths		
	600 ke.	1000 ke.	1400 ke.
10	8.0	8.0	8.0
100	11.5	11.5	11.5
1000	19.0	19.0	19.0

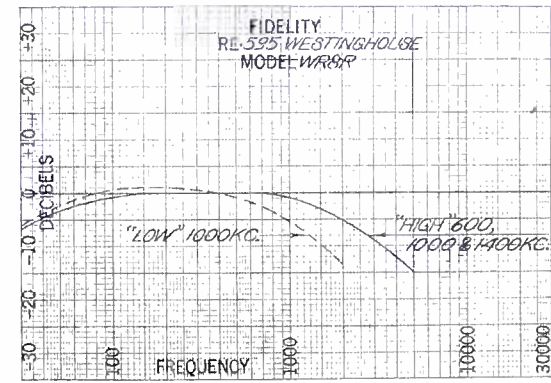

General Motors Little General Model

GENERAL MOTORS' midget known as the Little General has recently undergone measurement in our laboratory with the results shown in the sensitivity, selectivity and fidelity curves as illustrated here.

The standard dummy, consisting of 20 uh, 200 mmf and 25 ohms was used in the input circuit. Output impedance was kept at 4000 ohms and coupled capacitatively to the plate of the single output tube.

Receiver was phased at the frequency setting at which it was aligned at the factory, and the volume control turned to maximum. Line voltage 115 volts, current .55 amperes.

The transconductance of the tubes used in this measurement is indicated

below: 1 r-f 1070; 2 r-f 1020; 3 r-f 1080; detector 1050; output stage 1770 micromhos.

In the two tables following will be found the interference ratios and the band widths as taken from the selectivity curve:

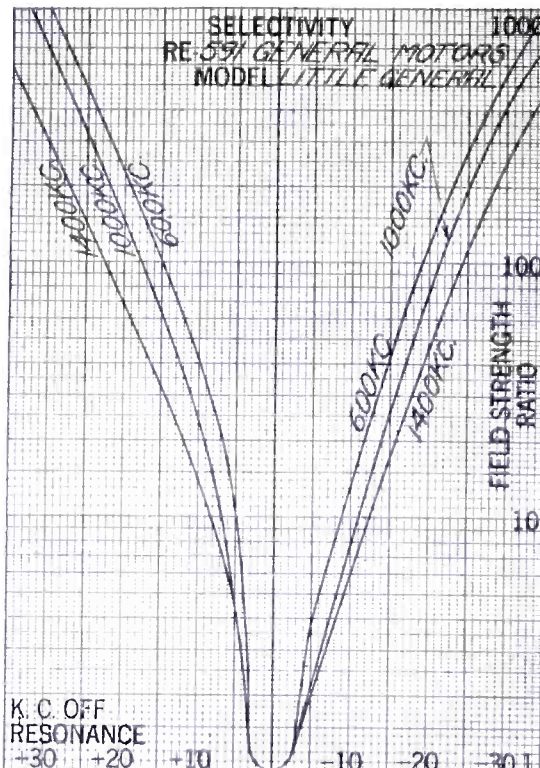
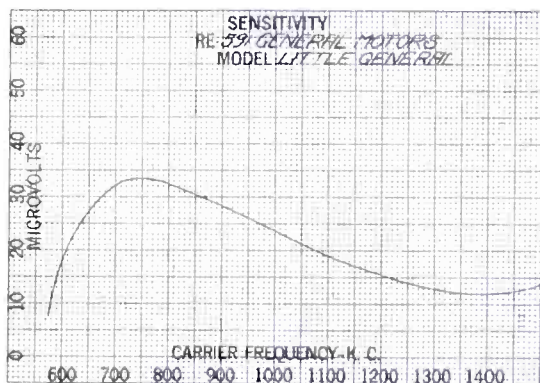

Resonance	Interference Ratio		
	Plus 10	Plus 20	Plus 30
600 kc.	41.0	225.0	1000.0
1000 kc.	24.0	145.0	670.0
1400 kc.	14.0	69.0	290.0

Resonance	Minus 10	Minus 20	Minus 30
	600 kc.	13.0	120.0
1000 kc.	7.7	76.0	410.0
1400 kc.	5.9	45.0	245.0

Times field strength	Band Widths		
	600 kc.	1000 kc.	1400 kc.
10	14.0	17.7	21.0
100	34.0	39.0	47.0
1000	65.0

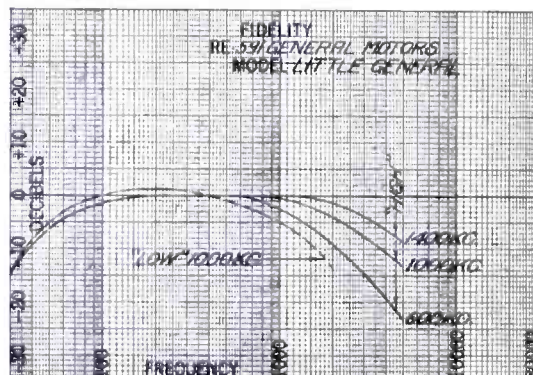

Audiola Radio Model 8T31

MODEL 8T31 made by the Audiola Radio Co., shows the sensitivity, selectivity and fidelity indicated in the three graphs following this article.

Radio frequency input from the generator to the receiver was through the standard dummy consisting of 20 uh, 200 mmf and 25 ohms. The output impedance was adjusted to 4000 ohms, coupled capacitatively to the plates of the output tube.

The receiver was phased at 1400 kc. and the volume control turned to its maximum setting. Line voltage 115 volts, current .8 amperes. The standard output of .05 watts was maintained.

Transconductance of the tubes used in these measurements is shown by the

figures following the tube stages: mixer 1050; detector 1080; 1 i-f 1060; 2 i-f 1100; 1 a-f 1020; p.p. 1800; oscillator 1070 micromhos.

In the two tables following will be encountered the interference ratios and the band widths as disclosed by the selectivity curve:

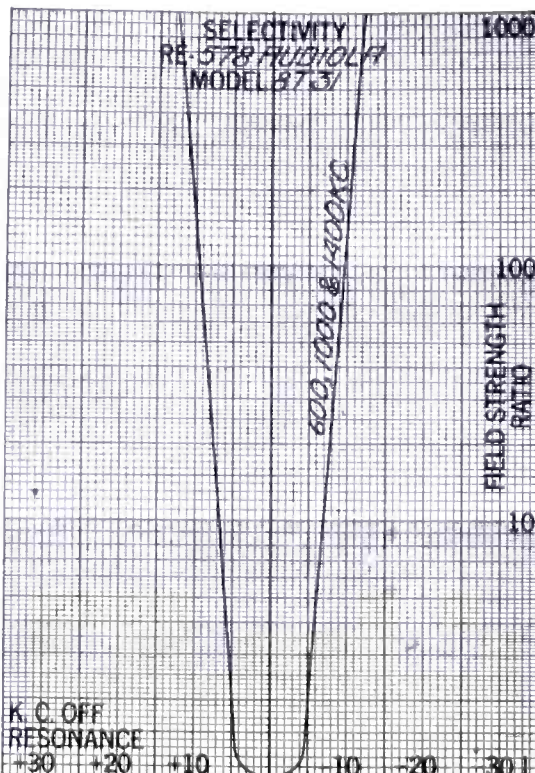
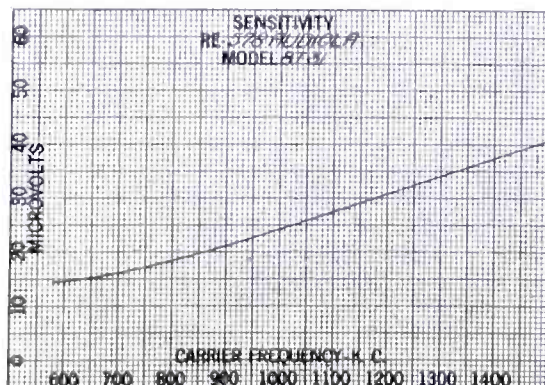

Resonance	Interference Ratio		
	Plus 10	Plus 20	Plus 30
600 kc.	140.0
1000 kc.	140.0
1400 kc.	140.0

Resonance	Minus 10	Minus 20	Minus 30
	600 kc.	130.0
1000 kc.	130.0
1400 kc.	130.0

Times field strength	Band Widths		
	600 kc.	1000 kc.	1400 kc.
10	13.5	13.5	13.5
100	19.0	19.0	19.0
1000	25.0	25.0	25.0

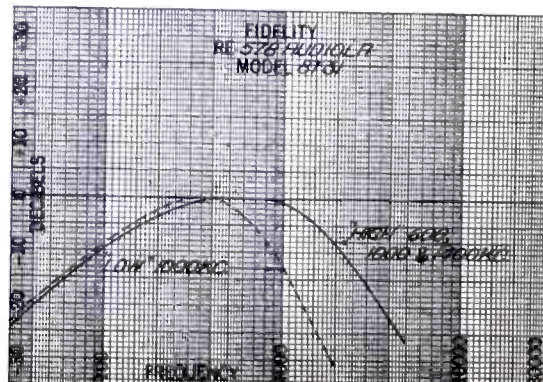

Majestic Radio Model 20

EMPLYING the 550 and 551 type of tubes described by Messrs. Ballantine and Snow in the article on page 42 of our January issue, the Majestic chassis 20 used in their model 23 receiver represents the first factory receiver using these tubes to be placed on the market. This receiver was microvolted in our laboratory and the curves derived therefrom are shown here.

Input from the generator was through the standard dummy antenna, with 20 uh, 200 mmf and 25 ohms. The output impedance was adjusted to 4000 ohms and coupled capacitatively to the output plates.

The receiver was phased at 1000 kc. and the volume control turned on full. The standard output of .05

watts was maintained on all the tests. Line voltage 110 volts, current .95 amperes.

Transconductance of the tubes was not measured since the chassis came equipped with Majestic tubes. In the routine measurements the laboratory tubes are used.

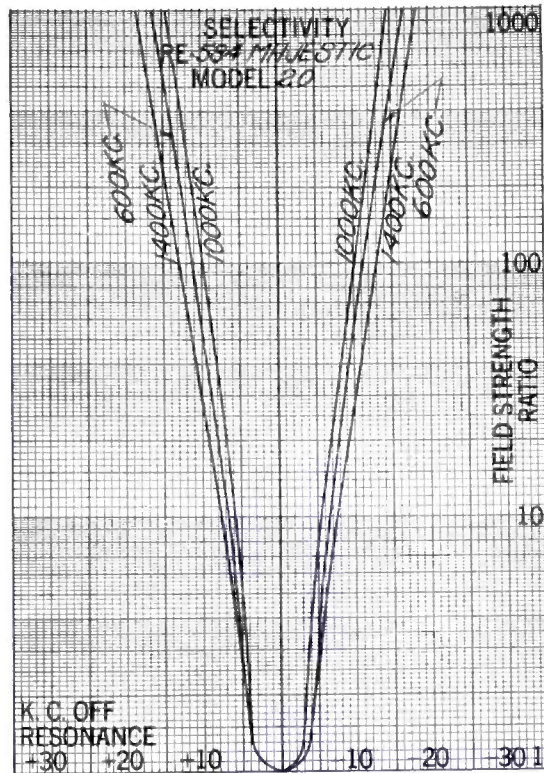
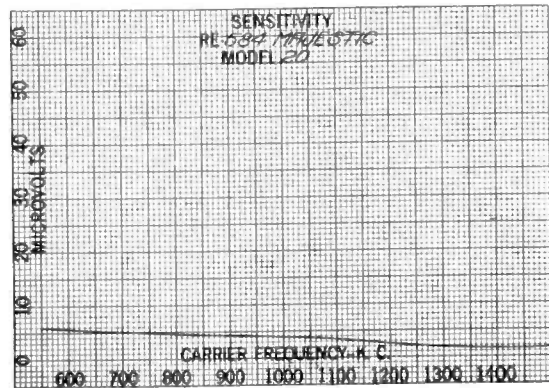

Interference Ratio

Resonance	Kilocycles off resonance		
	Plus 10	Plus 20	Plus 30
600 kc.	54.0
1000 kc.	105.0
1400 kc.	28.0
	Minus 10 Minus 20 Minus 30		
600 kc.	56.0
1000 kc.	95.0
1400 kc.	28.0

Band Widths

Times field strength	Kilocycles wide		
	600 kc.	1000 kc.	1400 kc.
10	13.0	11.0	15.0
100	22.5	20.0	26.0
1000	33.0	34.0	37.0

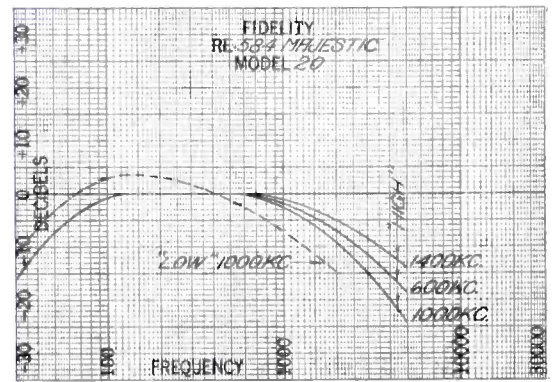

Grebe Radio Model SK-4

GREBE'S model SK-4 receiver is another of the radio sets being recently measured in our engineering laboratory. The curves resulting from these measurements are shown accompanying this article.

Antenna input was through the usual dummy antenna, consisting of 20 uh, 200 mmf and 25 ohms. The output impedance was adjusted to 4,000 ohms and coupled capacitatively to the plates of the output tubes. The standard output of .05 watts was maintained on all measurements.

The receiver was phased at the frequency setting at which it had been aligned in the factory, and the volume control turned to maximum. Line voltage 110, current .95 amperes.

Transconductance of the tubes em-

ployed in these tests is indicated by the values following the tubes indicated: 1 r-f 1050; 2 r-f 1070; 3 r-f 1020; detector 1100; p.p. 1770 and p.p. 1740 micromhos.

In the two tables following will be found the interference ratios and the band widths:

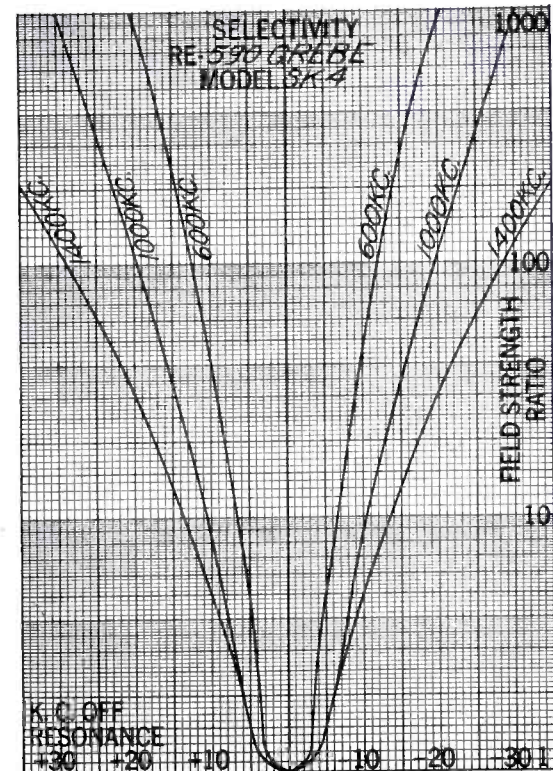

Interference Ratio

Resonance	Kilocycles off resonance		
	Plus 10	Plus 20	Plus 30
600 kc.	45.0	900.0
1000 kc.	8.4	110.0	970.0
1400 kc.	5.0	31.0	117.0
	Minus 10 Min. 20 Minus 30		
600 kc.	45.0	920.0
1000 kc.	8.8	110.0	970.0
1400 kc.	5.0	31.0	118.0

Band Widths

Times field strength	Kilocycles wide		
	600 kc.	1000 kc.	1400 kc.
10	12.0	21.0	27.0
100	24.5	39.0	62.0
1000	41.0	50.5	...

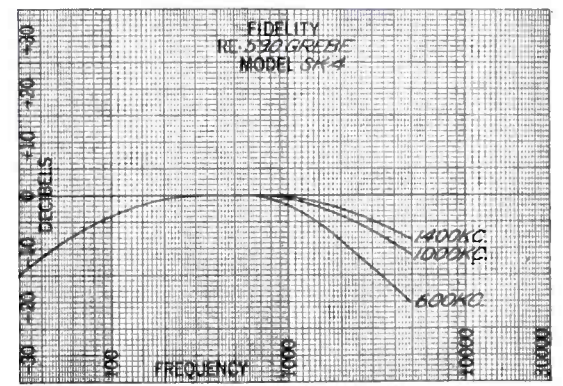
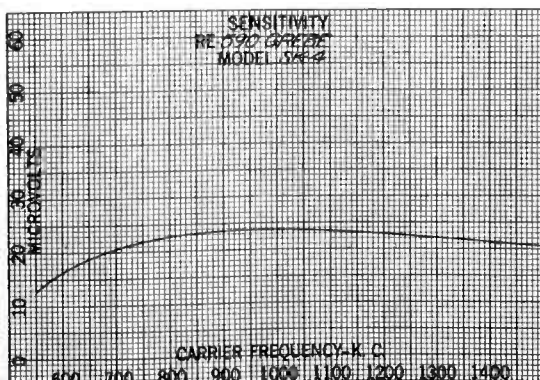

Sentinel Radio Model 108

RESPONSE curves taken on the Sentinel model 108 are shown on this page. Radio frequency input was through the standard dummy consisting of 20 uh, 200 mmf and 25 ohms.

Output impedance was maintained at 4000 ohms, coupled capacitatively to the plate of the single output tube. Standard output of .05 watts was maintained.

Receiver was phased at the frequency setting at which it had been aligned at the factory, and the volume control turned on full.

Transconductance of the tubes used in this measurement is indicated here: mixer, 1070; detector, 1020; 1 i-f

1050; 2 i-f 1000, output stage 1770, and oscillator 1100 micromhos.

Values of the interference ratio and the band widths as taken from the selectivity curve are indicated in the two tables following:

Resonance	Interference Ratio		
	Plus 10	Plus 20	Plus 30
600 kc.	41.0	870.0
1000 kc.	22.0	560.0
1400 kc.	15.0	300.0
	Minus	Minus	Minus
	10	20	30
600 kc.	41.5	900
1000 kc.	23.0	570.0
1400 kc.	15.0	300

Times field strength	Band Widths		
	600 kc.	1000 kc.	1400 kc.
10	14.2	16.5	18.0
100	24.0	28.0	32.0
1000	42.0	46.0	51.0

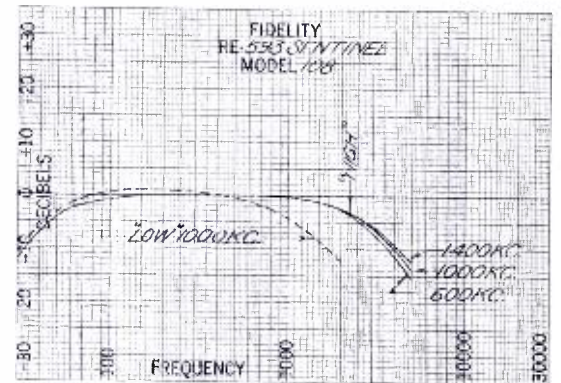
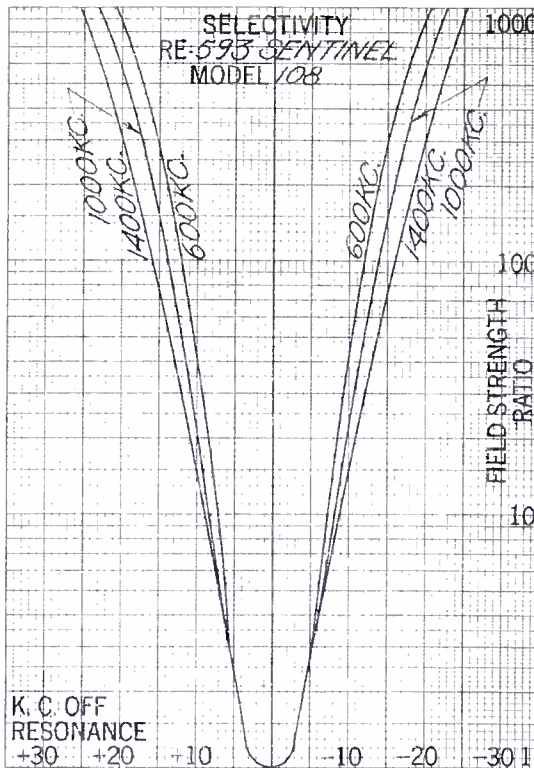
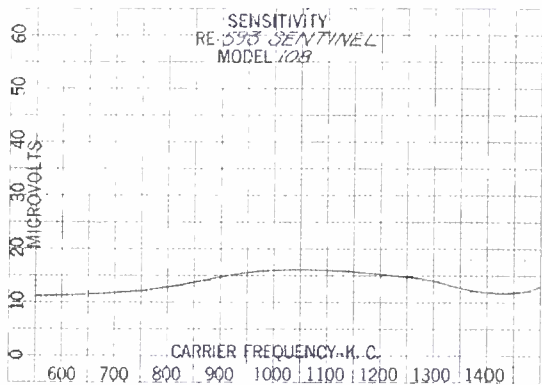

Audiola Radio Model 6T Jr.

ANOTHER of the Audiola receivers, this being the Audiola model 6T Jr., has recently been measured in our engineering laboratory and the curves derived are shown on this page.

Input from the generator was through the standard dummy consisting of 20 uh, 200 mmf and 25 ohms.

The output impedance was kept at 4000 ohms and coupled capacitatively to the plate of the output tube.

The receiver was phased at 1400 kilocycles and the volume control turned on full. Line voltage was 115 volts with line current of .45 amperes.

Transconductance of the tubes employed in this check-up is indicated by the figures following each tube: 1 r-f

1080; 2 r-f 1030; detector 1050; 1 a-f 1100 and output stage 1770 micromhos.

In the two tables following will be found the interference ratios and the band widths as taken from the curves:

Resonance	Interference Ratio		
	Plus 10	Plus 20	Plus 30
600 kc.	8.8	32.0	81.0
1000 kc.	12.5	49.0	136.0
1400 kc.	5.0	18.5	45.0
	Minus	Minus	Minus
	10	20	30
600 kc.	7.0	40.0	112.0
1000 kc.	5.7	28.0	90.0
1400 kc.	4.7	13.7	40.0

Times field strength	Band Widths		
	600 kc.	1000 kc.	1400 kc.
10	23.0	22.0	32.0
100	61.0	58.0
1000

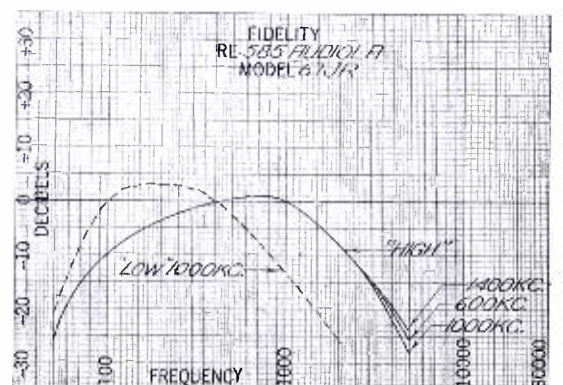
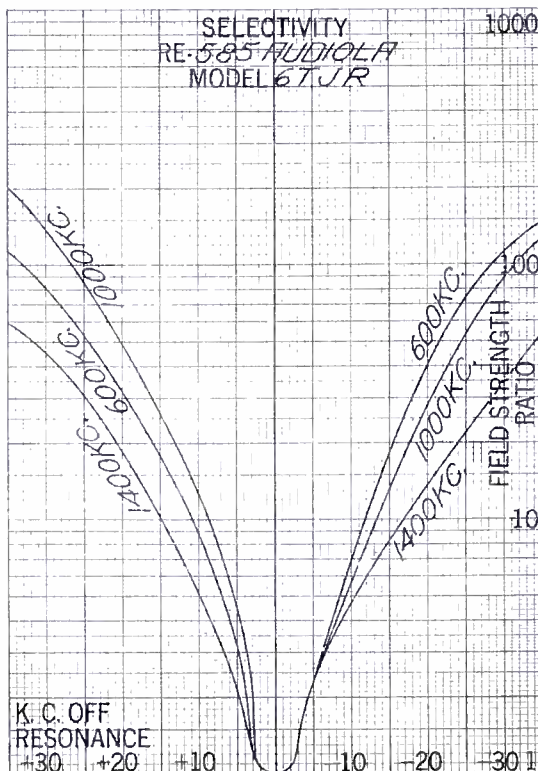
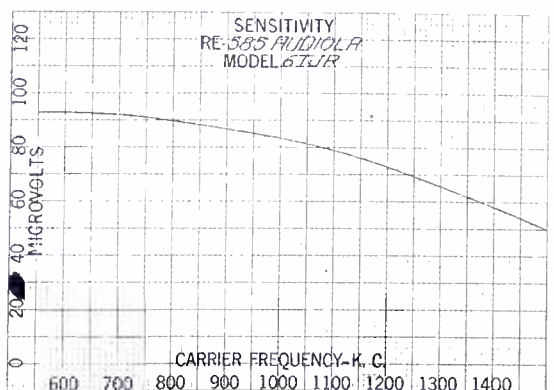

Stewart-Warner Model R100-AT

CURVES of the model R100-AT made by Stewart-Warner are presented on this page, this being the model with the tone control. The previous curves appeared on page 68 of the September, 1930, issue.

Input to the receiver was through the standard dummy consisting of 20 uh, 200 mmf and 25 ohms. The output impedance was adjusted to 4000 ohms and coupled capacitatively to the output tubes.

The receiver was phased at the factory aligning setting and the volume control turned to maximum. Standard output of .05 watts was maintained.

Transconductance of the tubes used

is shown by the figures in the following: 1 r-f 1040; 2 r-f 1060; 3 r-f 1060; detector 960, 1 a-f 930: p.p. 1770 and p.p. 1720 micromhos.

Interference ratios and the band widths are shown in the two tables following:

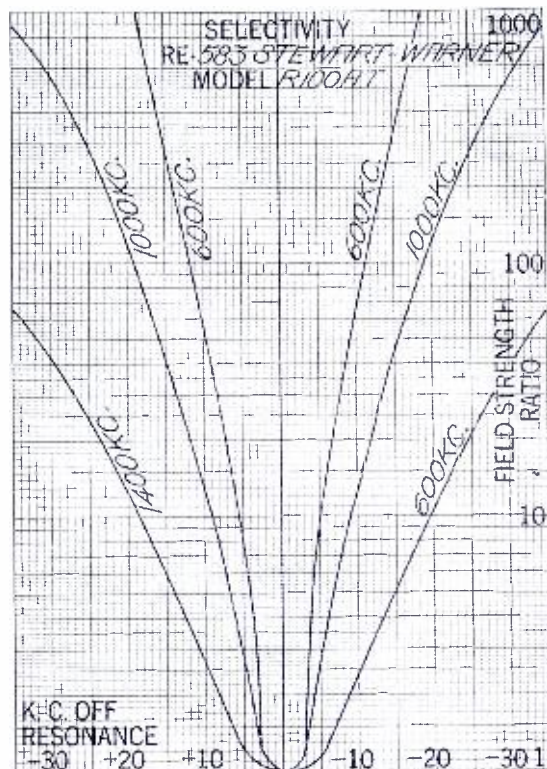

Resonance	Interference Ratio		
	Plus 10	Plus 20	Plus 30
600 kc.	56.0
1000 kc.	12.5	122.0	530.0
1400 kc.	2.6	12.0	41.0
Resonance	Minus 10	Minus 20	Minus 30
	600 kc.	56.0
1000 kc.	13.0	120.0	500.0
1400 kc.	2.4	10.5	37.0

Times field strength	Band Widths		
	600 kc.	1000 kc.	1400 kc.
10 ...	10.2	18.0	38.0
100 ...	23.0	38.0
1000 ...	37.0

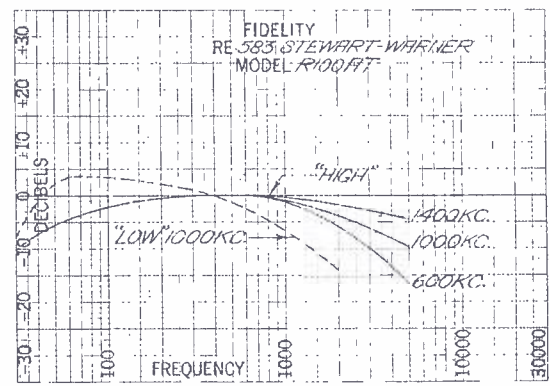
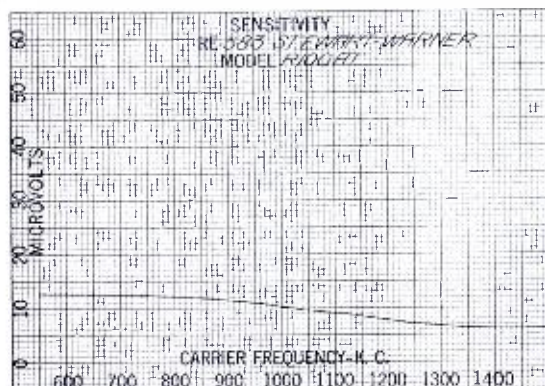

Zenith Radio Model B

RECENTLY measured by our engineering department, curves of the Zenith model B are presented for the benefit of our readers.

Antenna input was through the standard dummy consisting of 20 uh, 200 mmf and 25 ohms. Output impedance was maintained at 4000 ohms and coupled capacitatively to the plates of the output tubes.

The receiver was phased at 1400 kilocycles and the volume control turned on full. Line voltage was 112 volts, line current .8 amperes. The standard output of .05 watts was maintained on the measurements.

Transconductance of the tubes used

is shown by the figures after the tube stages: 1 r-f 1070; 2 r-f 1050; detector 1030; p.p. 1770 and p.p. 1760 micromhos.

In the two tables following will be found the interference ratios and the

band widths as disclosed by the curves:

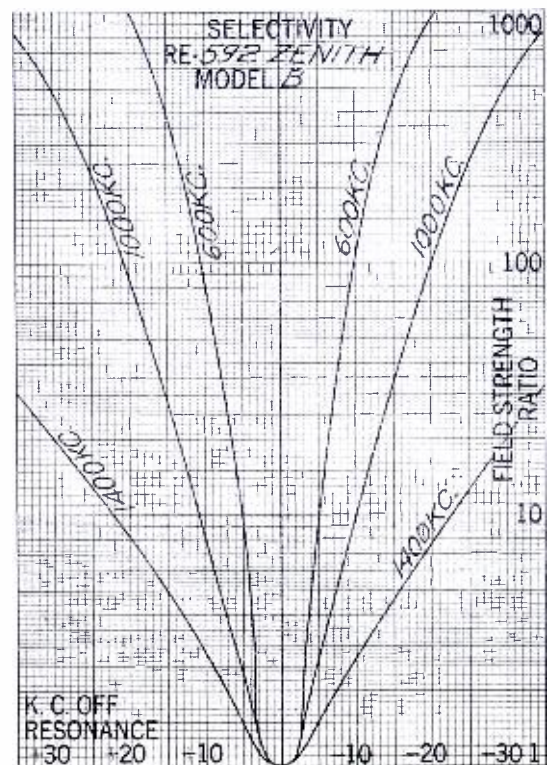

Resonance	Interference Ratio		
	Plus 10	Plus 20	Plus 30
600 kc.	84.0	1000.0
1000 kc.	8.0	87.0	490.0
1400 kc.	2.8	8.0	20.0
Resonance	Minus 10	Minus 20	Minus 30
	600 kc.	105.0	93.0
1000 kc.	10.0	100.0	510.0
1400 kc.	2.7	7.7	20.0

Times field strength	Band Widths		
	600 kc.	1000 kc.	1400 kc.
10 ...	10.0	20.8	45.0
100 ...	20.0	140.7
1000 ...	41.0

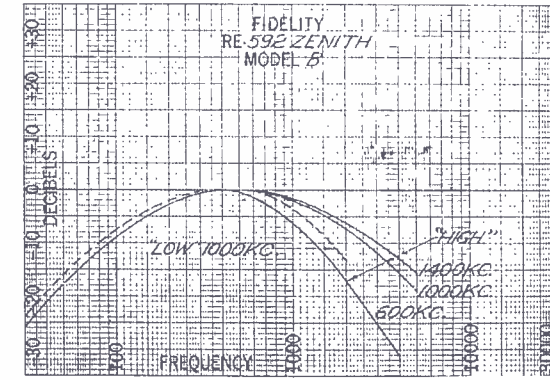
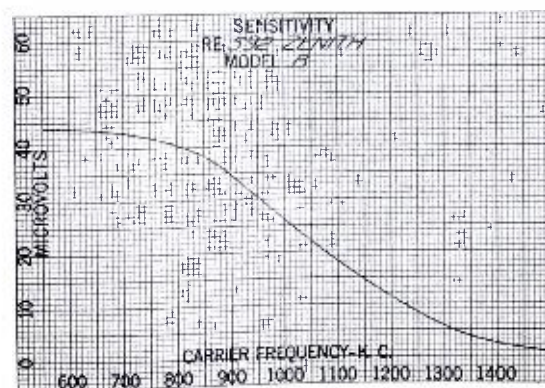

Victor Radio Model R-15

ONE of the radio frequency jobs under the Victor banner, model R15, is shown on this page in response to requests from readers.

The antenna input was through the standard dummy consisting of 20 uh, 200 mmf and 25 ohms. Output load impedance was adjusted to 4000 ohms and coupled capacitatively to the plates of the 245 tubes used in the output stage.

Standard output of .05 watts was maintained on all measurements. The receiver was phased at its factory alignment frequency and the volume control turned on full.

Transconductance of the tubes used in this measurement are indicated in the following values: 1 r-f 1040; 2 r-f 1080; 3 r-f 1070; detector 1050; p.p. 1980 and p.p. 1970 micromhos.

In the two tables shown are the in-

terference ratios and the band widths as taken from the selectivity curve:

Resonance	Interference Ratio		
	Plus 10	Plus 20	Plus 30
600 kc.	33.0	390.0
1000 kc.	6.0	100.0	580.0
1400 kc.	2.3	12.5	49.0
Resonance	Minus 10	Minus 20	Minus 30
	600 kc.	210.0
1000 kc.	34.0	300.0
1400 kc.	5.0	27.5	94.0

Times field strength	Band Widths		
	Kilocycles wide		
	600 kc.	1000 kc.	1400 kc.
10 ...	11.0	18.0	31.5
100 ...	22.0	39.0
1000 ...	42.5	62.0

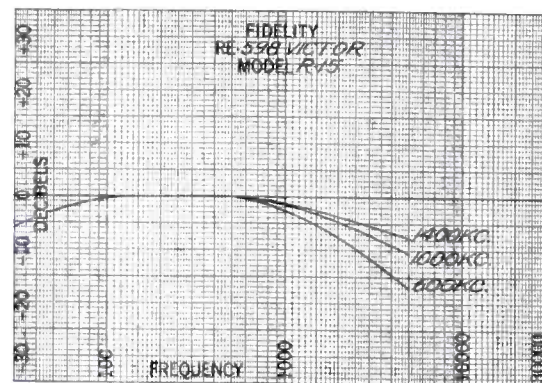
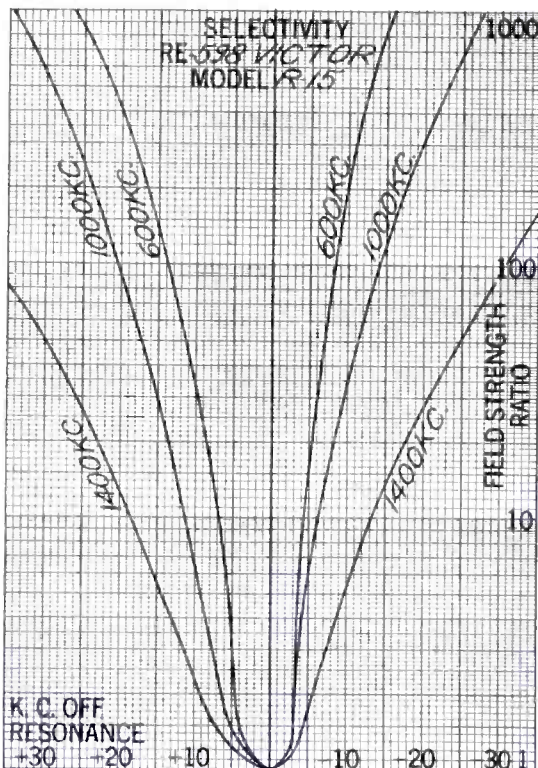
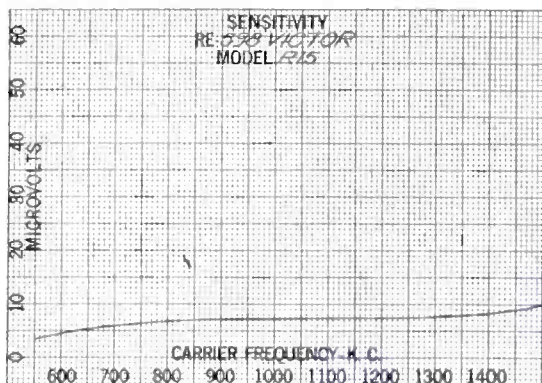

Radiola Receiver Model 48

ANOTHER of the receivers in which reader interest was expressed is the Radiola 48 produced at the Camden factory and whose chassis is marketed under labels of members of the combine. Curves are shown on this page.

Output impedance load was adjusted to 4000 ohms and coupled capacitatively to the plates of the 245 tubes used in the output. The dummy antenna used was one consisting of 20 uh, 200 mmf and 25 ohms. The receiver was phased at the frequency at which it was aligned in the factory, and the volume control turned to maximum. Standard output was maintained at .05 watts as customary.

The transconductance of the tubes used is shown by the values after each stage: 1 r-f 1040; 2 r-f 1080; 3 r-f 1070; detector 1050; p.p. 1980 and p.p. 1970 micromhos.

Interference ratios and band widths

as taken from the selectivity curve are shown in these two tables:

Resonance	Interference Ratio		
	Plus 10	Plus 20	Plus 30
600 kc.	33.0	390.0
1000 kc.	6.0	100.0	580.0
1400 kc.	2.0	10.0	50.0
Resonance	Minus 10	Minus 20	Minus 30
	600 kc.	210.0
1000 kc.	34.0	300.0
1400 kc.	5.7	29.0	105.0

Times field strength	Band Widths		
	Kilocycles wide		
	600 kc.	1000 kc.	1400 kc.
10 ...	11.0	18.0	33.0
100 ...	22.0	39.0
1000 ...	42.5	62.0

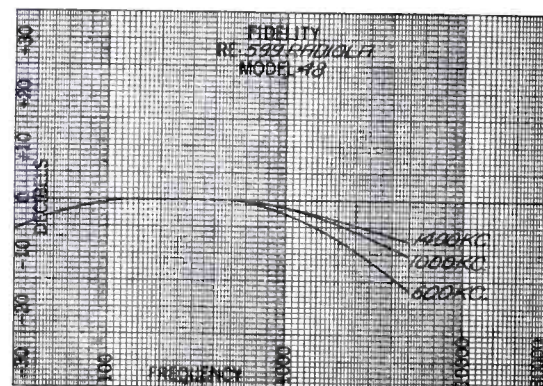
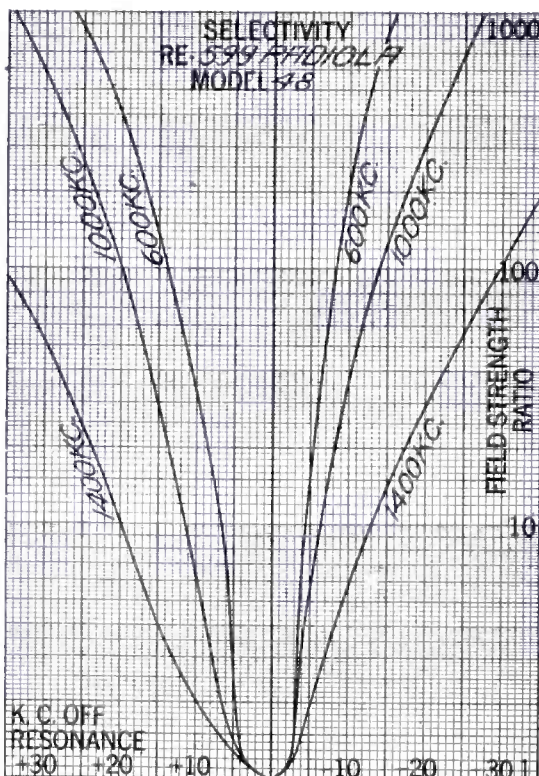
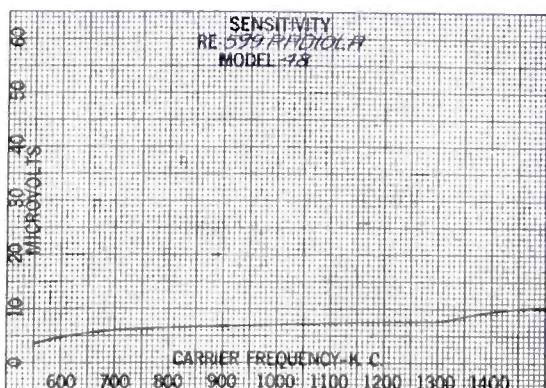

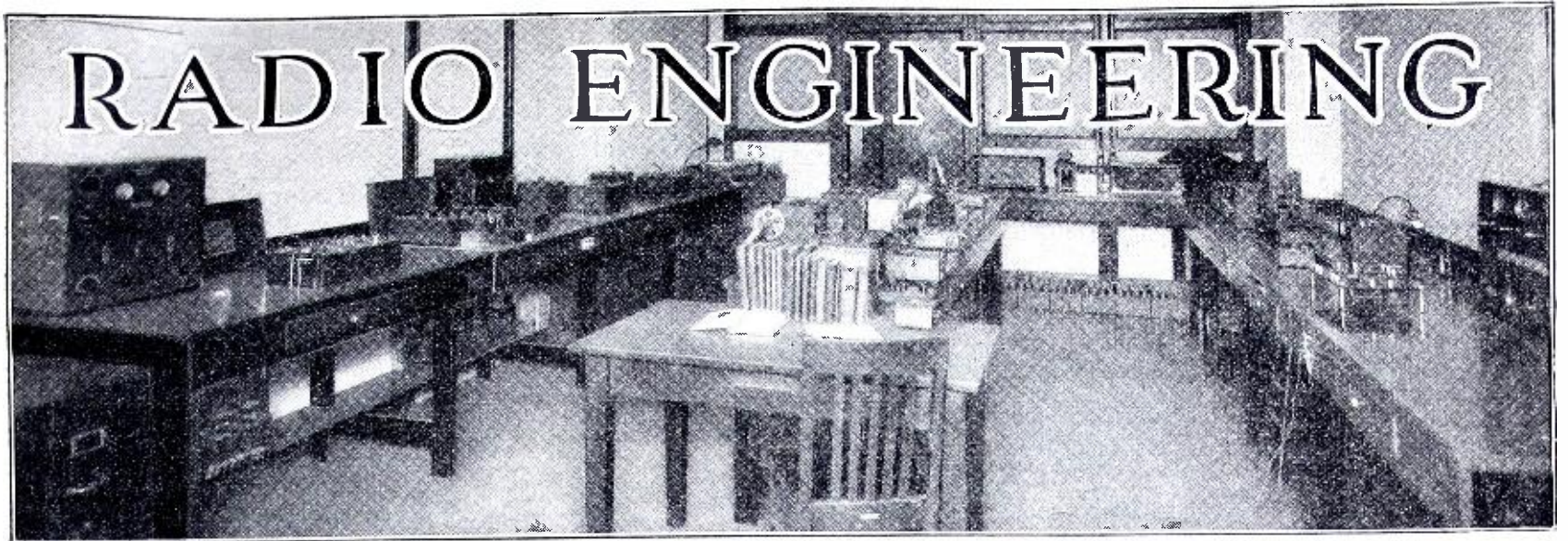

UNLESS an individual is working with formulas and shop methods constantly some of the short cuts are bound to slip his mind from disuse. The greatest problem is then to be able to put one's finger on a particular method without having to refer to several textbooks.

Practically all of the material shown in these columns can be found in most of the references on radio, but usually such a search is a tedious one. The editorial department of this publication thought it might save our readers a great deal of time and trouble if all the data shown here were compiled into a single source for preservation as a reference.

The material shown here is arranged alphabetically under the subheads referring to different functions such as capacity, coupling, current, inductance,

Use of 224 as High Output Screen Grid Detector

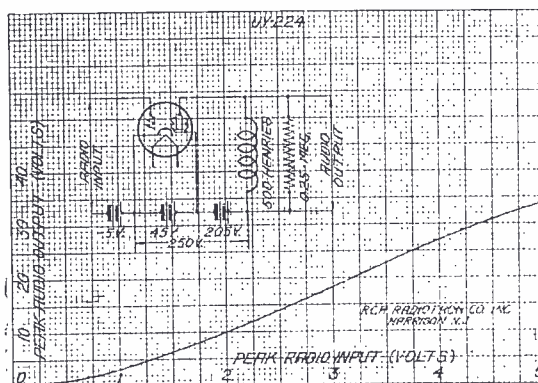

In this graph are shown the characteristics of the 224 used as a high output detector, peak r.f. input versus peak audio frequency output.

- $E_f = 2.5$ volts
- $E_{c1} = 5$ volts
- $E_{c2} = 45$ volts
- $E_b = 250$ volts
- $Z_p = 500$ henries shunted by 0.25 megohms.
- Modulation 15 per cent.

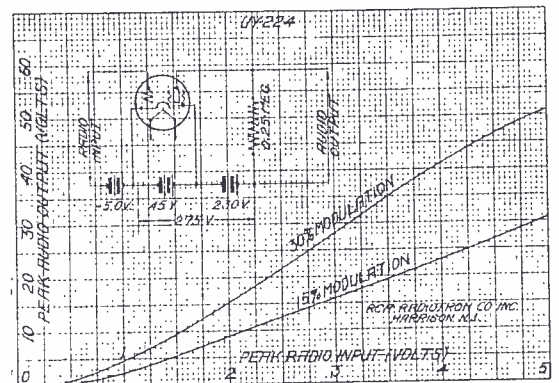

Here is shown the 224 used as high output detector, peak r.f. input versus peak audio frequency output.

- $E_f = 2.5$ volts
- $E_{c1} = 5$ volts
- $E_{c2} = 45$ volts
- $E_b = 275$ volts (supply)
- $R_p = 250,000$ ohms
- Modulation 15 and 30 per cent.

impedance, etc., so that the particular formula relating to that function might be easily found.

It is realized that this compilation is not complete for the

advanced engineers, but it is felt that the material given will serve as a guide to those who have occasional use for such formulas.

Amplification

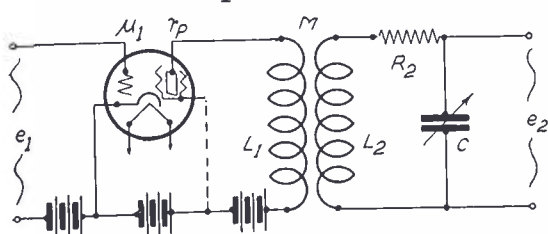

With conditions above:—
Amplification at any frequency = $\frac{\omega^2 M L_2}{\dots}$

$$A = \mu \frac{\omega^2 M L_2}{\left[R_p R_2 + \frac{L_1}{C_2} - \omega^2 L_1 L_2 \alpha \right]^2}$$

$$+ \left[\omega L_1 R_2 + \omega L_2 R_p - \frac{R_p}{\omega C_2} \right]^2 \frac{1}{2}$$

Where $\alpha = 1 - K^2 = 1 - \frac{M^2}{L_1 L_2}$

Amplification at resonance = $\frac{\omega^2 M L_2}{\dots}$

$$A_r = \mu \frac{\omega^2 M L_2}{(R_p R_2 + \omega^2 M^2)}$$

Or more conveniently $\frac{M L_2}{\dots}$

$$A_r = \mu \frac{M L_2}{\left[\frac{R_p R_2}{\omega} + M^2 \right]}$$

Amplification is at maximum when

$$\omega M = \sqrt{R_p R_2}$$

And is equal to

$$A_r \text{ optimum} = A \mu \frac{\omega L_2}{2 \sqrt{R_p R_2}}$$

In the above the resistance apparently added to the secondary by the presence of the primary =

$$R_s^1 = \frac{\omega^2 M^2 R_p}{R_p^2 + \omega^2 L_1^2}$$

At optimum coupling $R_s^1 = R_2$ or

the apparent resistance is doubled and the selectivity halved. This gives a complete picture of the tuned r. f. amplifier stage.

In tuned impedance stages $L_1 = M = L_2$.

Capacity

Distributed capacity of a coil

$$C_D = C_R - \frac{3 C_H}{4}$$

Where

- C_D distributed capacity of coil
- C_R capacity of condenser at resonance
- C_H capacity of condenser at second harmonic

where C_D , C_R , and C_H are expressed in the same terms, micromicrofarads, microfarads, or farads.

Example:—

- C_R equals 50 micromicrofarads
- C_H equals 25 micromicrofarads

From the formula multiply C_H by 3, which will be 75 micromicrofarads divided by 4 which equals 18.75 as value for $3C_H$. Subtract this value from C_R of 50 micromicrofarads which leaves 31.25 micromicrofarads as the distributed capacity of the coil.

A quick method for measuring the distributed capacity of a coil is to tune the coil with a calibrated condenser to the fundamental of a fairly strong oscillator, noting the capacity value at resonance. Now tune the same coil to the second harmonic of the oscillator and note the capacity value at the second harmonic. The capacity value at the second harmonic multiplied by 3 and the result divided by four should be subtracted from the capacity value at resonance, the remainder being the distributed capacity of the coil.

Capacity

Capacity of condensers in parallel

$$C = C_1 + C_2$$

Where

- C total capacity
- C_1 capacity of first condenser
- C_2 capacity of second condenser

where C , C_1 , and C_2 are expressed in the same terms, micromicrofarads, microfarads, farads.

Example:—

- $C_1 = .0003$ microfarads
- $C_2 = .00017$ microfarads

From the formula, merely add the capacity value of the first condenser to that of the second, and the sum of the condenser values added will be the total capacity. Thus .0003 plus .00017 equals .00047 microfarads.

Capacity

Capacity of condensers in series

$$C = \frac{1}{\frac{1}{C_1} + \frac{1}{C_2}}$$

Where

- C total capacity
- C_1 capacity of one condenser
- C_2 capacity of added condenser

where C , C_1 , and C_2 are expressed in the same terms, micromicrofarads, microfarads, farads.

Example:—

$$\frac{1}{C_1} = \frac{1}{.005} \text{ or } 200$$

$$\frac{1}{C_2} = \frac{1}{.002} \text{ or } 500$$

$$\frac{1}{700}$$

$$C = \frac{1}{700} \text{ or } .00142 \text{ mfd}$$

Or more conveniently

$$C = \frac{C_2 C_1}{C_2 + C_1}$$

Capacity

Capacity reactance: See under Reactance.

Conductance

Of vacuum tube (reciprocal of impedance).

$$G_m = \frac{\mu}{R_p}$$

$$\text{or of any circuit } G = \frac{1}{R}$$

Where

- G_m mutual conductance in mhos
- μ amplification constant
- R_p plate resistance in ohms

Example:—

$$\frac{\mu \text{ 420}}{R_p \text{ 400,000}}$$

From the formula, divide the amplification constant 420 by the plate resistance 400,000 which equals 1050 micromhos, the mutual conductance.

Conversion

Factors for conversion, alphabetically arranged.

Multiply	By	To Get
Amperes	$\times 1,000,000,000,000$	micromicroamperes
Amperes	$\times 1,000,000$	microamperes
Amperes	$\times 1,000$	milliamperes
Cycles	$\times .000,001$	megacycles
Cycles	$\times .001$	kilocycles
Farads	$\times 1,000,000,000,000$	micromicrofarads
Farads	$\times 1,000,000$	microfarads
Farads	$\times 1,000$	millifarads
Henrys	$\times 1,000,000$	microhenrys
Henrys	$\times 1,000$	millihenrys
Horsepower	$\times .7457$	kilowatts
Horsepower	$\times 745.7$	watts
Kilocycles	$\times 1,000$	cycles
Kilovolts	$\times 1,000$	volts
Kilowatts	$\times 1,000$	watts
Kilowatts	$\times 1.341$	horsepower
Megacycles	$\times 1,000,000$	cycles
Mhos	$\times 1,000,000$	micromhos
Mhos	$\times 1,000$	millimhos
Microamperes	$\times .000,001$	amperes
Microfarads	$\times .000,001$	farads
Microhenrys	$\times .000,001$	henrys
Micromhos	$\times .000,001$	mhos
Micro-ohms	$\times .000,001$	ohms
Microvolts	$\times .000,001$	volts
Microwatts	$\times .000,001$	watts
Micromicrofarads	$\times .000,000,000,001$	farads
Micromicro-ohms	$\times .000,000,000,001$	ohms
Milliamperes	$\times .001$	amperes
Millihenrys	$\times .001$	henrys
Millimhos	$\times .001$	mhos
Milliohms	$\times .001$	ohms

Millivolts	$\times .001$	volts
Milliwatts	$\times .001$	watts
Ohms	$\times 1,000,000,000,000$	micromicro-ohms
Ohms	$\times 1,000,000,000$	micro-ohms
Ohms	$\times 1,000$	milliohms
Volts	$\times 1,000,000$	microvolts
Volts	$\times 1,000$	millivolts
Watts	$\times 1,000,000$	microwatts
Watts	$\times 1,000$	milliwatts
Watts	$\times .001$	kilowatts

Coupling

Coefficient of direct or inductive coupling.

$$k = \frac{M}{\sqrt{L_1 L_2}}$$

Where

- k coefficient (always less than unity)
- M mutual inductance between two circuits
- L_1 total self inductance of first circuit
- L_2 total self inductance of second circuit

where M , L_1 , and L_2 are expressed in the same terms, millihenrys, microhenrys, henrys.

Example:—

- $M = 1$ millihenry
- $L_1 = 2$ millihenrys
- $L_2 = 2$ millihenrys

From the formula multiply L_1 2 millihenrys by L_2 2 millihenrys, which equals 4 millihenrys. Square root of 4 is 2. M is 1 millihenry divided by 2, which is .5, or the coefficient of direct or inductive coupling.

Coupling

Coefficient of capacitative coupling

$$k = \frac{\sqrt{C_1 C_2}}{C_m}$$

Where

- k coefficient (always less than unity)
- C_1 total capacity of first circuit
- C_2 total capacity of second circuit
- C_m mutual capacity between two circuits

where C_1 , C_2 , and C_m are expressed in the same terms, micromicrofarads, microfarads, or farads.

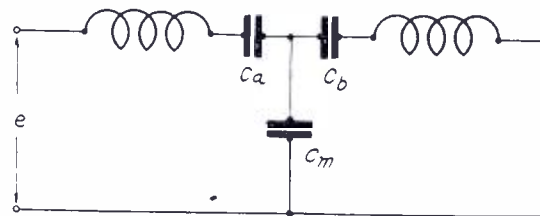

$$K = \frac{\sqrt{C_1 \times C_2}}{C_m}$$

Where

$$C_1 = \frac{C_a \times C_m}{C_a + C_m}$$

$$C_2 = \frac{C_b \times C_m}{C_b + C_m}$$

Example:—

- $C_a = 100$ mmf
- $C_b = 300$ mmf
- $C_m = 200$ mmf

$$C_1 = \frac{100 \times 200}{300} = \frac{200}{3} \text{ mmf}$$

$$C_2 = \frac{300 \times 200}{500} = \frac{600}{5} \text{ mmf}$$

$$K = \frac{\sqrt{\frac{200}{3} \times \frac{600}{5}}}{200} = .444 \text{ or } 44.4\%$$

Current

Various formulas for current.

$$I = \frac{E}{R}$$

$$I = \frac{P}{E}$$

$$I = \sqrt{\frac{P}{R}}$$

$$I = \frac{E}{Z}$$

$$I = \frac{E}{X}$$

$$I = \frac{P}{E \text{ p.f.}}$$

Where

- I in amperes
- E in volts
- R in ohms
- P in watts
- Z in ohms
- X in ohms
- p.f. power factor

Current

In counter e.m.f.

$$I = \frac{E_c}{\omega L}$$

Where

- I in amperes
- E_c counter e.m.f. in volts
- L inductance in henrys
- ω 2 π f
- π 3.1416
- f cycles per second

Current

In parallel circuits (Kirchoff's law).

$$I = I_1 + I_2$$

Where

- I in amperes
- I₁ in amperes
- I₂ in amperes

At any point in a circuit the sum of the current directed toward a point is equal to the sum of the currents directed away from the point.

Current

In series resonant circuit

$$I_r = \frac{E}{\sqrt{R^2 + \left(\omega L - \frac{1}{\omega C}\right)^2}}$$

Parallel Resistances, Series Capacities Chart

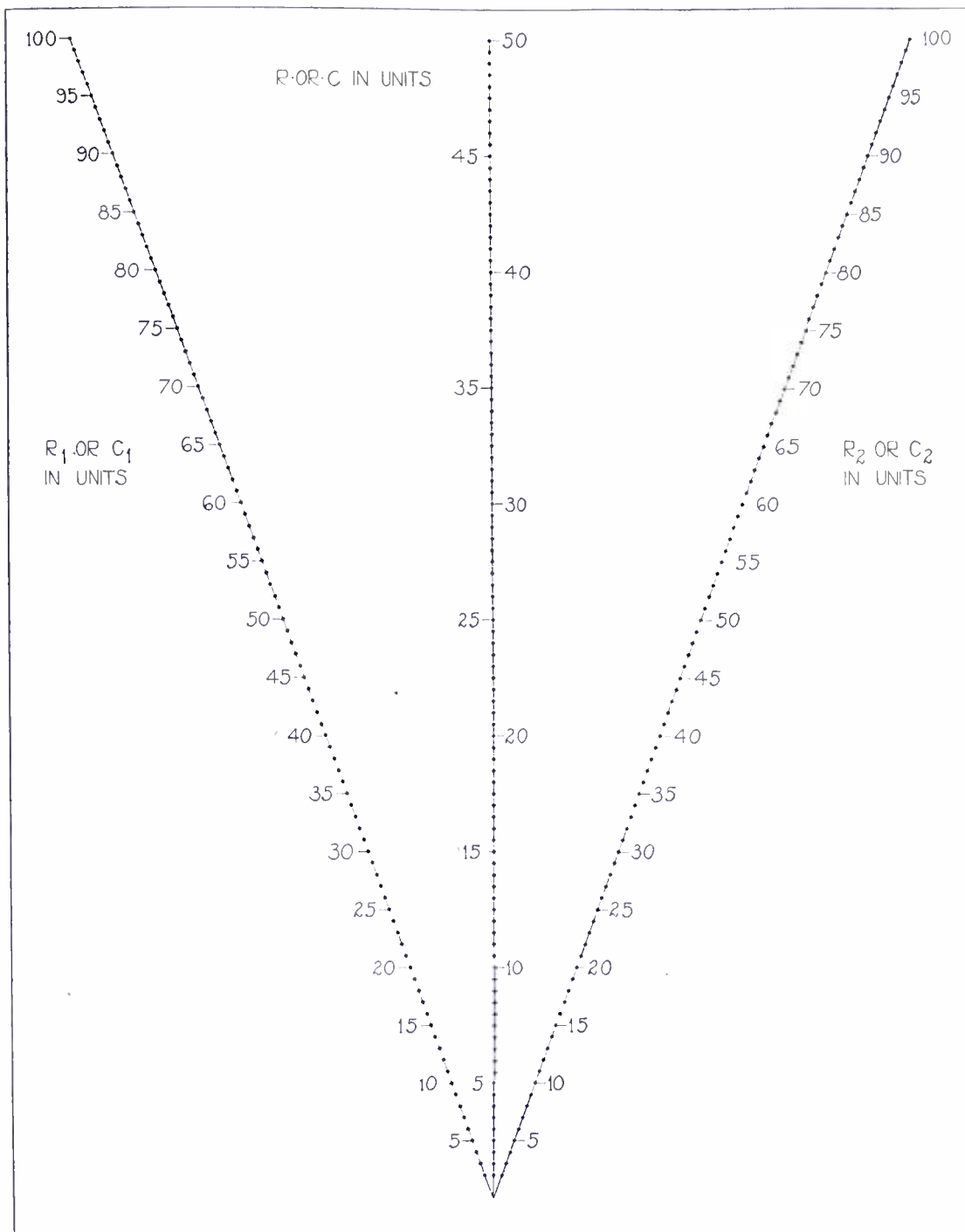

This chart suffices for both resistances in parallel and capacities in series since the formula for each is the same.

Lay a straight-edge from unit desired on the left oblique line to unit desired on right oblique line. Point at which straight edge intersects the vertical line is the resultant value in units.

To increase range of the scale multiply or divide all values by the factor desired, such as one-thousandth, one hundredth, one tenth; ten, one hundred or one thousand, etc.

Where

- I_r current in amperes at resonance
- E in volts
- R in ohms
- L in henrys
- C in farads
- ω 2 π f
- π 3.1416
- f cycles per second

Decibel

Formerly called transmission unit TU.

$$Db = \log 20 \frac{I_2}{I_1}$$

$$Db = \log 20 \frac{E_2}{E_1}$$

$$Db = \log 10 \frac{P_2}{P_1}$$

$$Db = \log 10 \frac{E_2^2}{E_1^2}$$

$$Db = \log 10 \frac{I_2^2}{I_1^2}$$

Where

- I₂ output in amperes
- I₁ input in amperes
- E₂ output in volts
- E₁ input in volts
- P₂ output in watts
- P₁ input in watts

A Db is the number of decibels by which any circuit's output and input

Transformer Turns-Per-Volt Chart

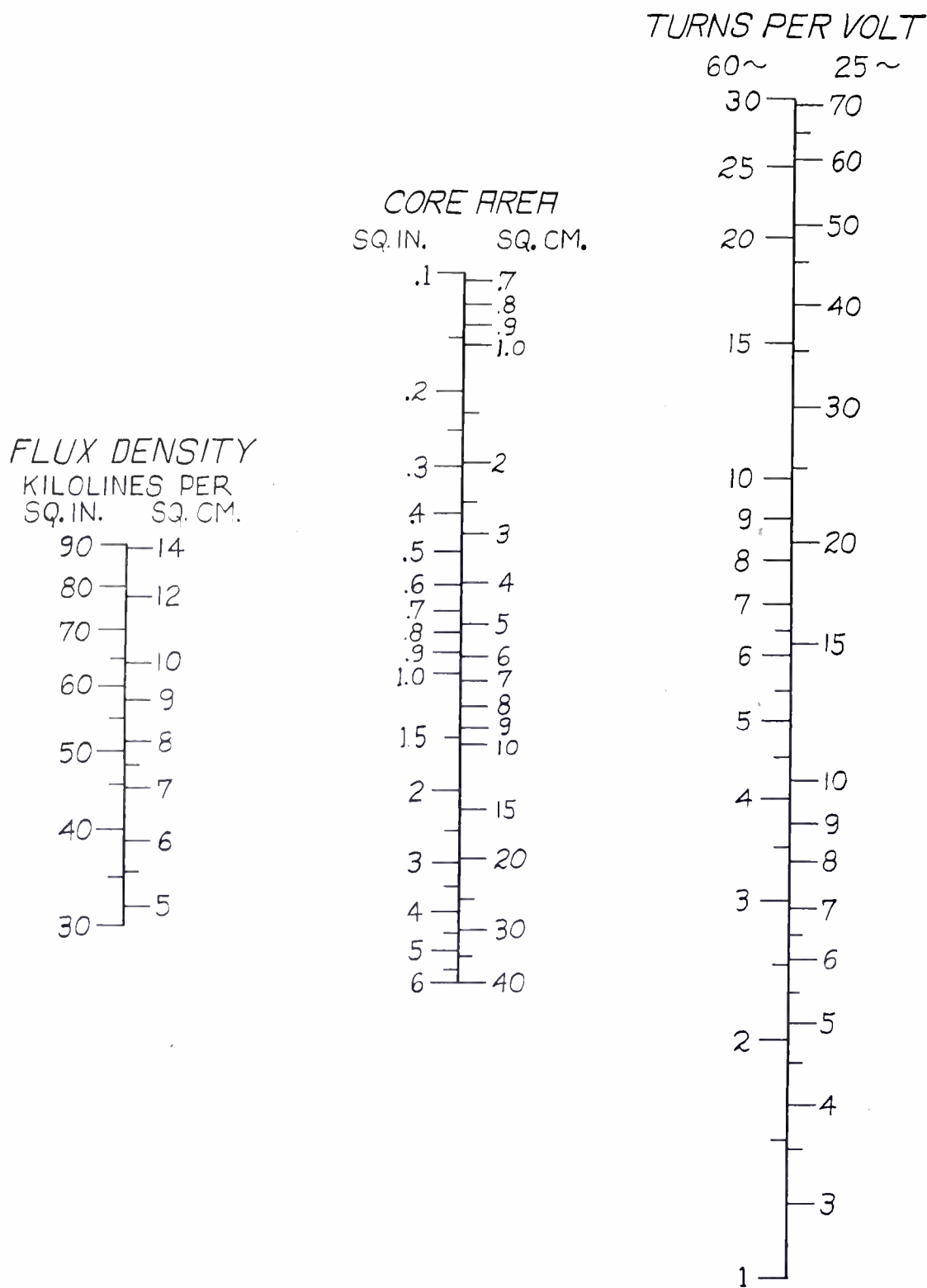

Knowing the flux density and the core area, the turns per volt for either a primary or secondary may be determined by merely drawing a straight line the flux density column through the core area column, the extension of the line terminating in the turns per volt column.

Flux density is a quality of the kind of iron used. The flux density of different types of core material may be found by referring to any of the standard works on electricity.

For convenience the flux density column is divided into kilolines per square inch and kilolines per square centimeter. The core area is also divided into square inches and square centimeters. The turns per volt column gives values for sixty cycle on the left of the column and for twenty-five cycle on the right.

ratio differs, provided that circuit does not contain vacuum tubes or rectifiers.

Efficiency

Efficiency is the ratio which the input bears to the output of any circuit and is expressed in percentage of efficiency. Output and input values must be in the same units.

Example:—

$$\text{Efficiency} = \frac{P_2}{P_1}$$

Where

- P₂ output power in watts
- P₁ input power in watts
- P₂ 400 watts
- P₁ 600 watts

Dividing 400 by 600 equals .66 percentage of efficiency.

Frequency

At resonance in series circuit

$$f = \frac{1}{2\pi} \sqrt{LC}$$

in parallel circuit

$$f = \frac{1}{2\pi} \sqrt{\frac{1}{LC} - \frac{R^2}{4L}}$$

Where

- f cycles per second
- π 3.1416
- L in henrys
- C in farads
- R in ohms

Inductance

In counter e.m.f.

$$L = \frac{E}{\omega I}$$

Where

- L in henrys
- E in volts
- I in amperes
- ω 2πf
- π 3.1416
- f cycles per second

Impedance

Of inductance and resistance circuit in series

$$Z = \sqrt{R^2 + (\omega L)^2}$$

Where

- Z in ohms
- R in ohms
- L in henrys
- ω 2πf
- π 3.1416
- f cycles per second

Impedance

In capacitive circuit, resistance and capacity in series

$$Z = \sqrt{R^2 + \left(\frac{1}{\omega C}\right)^2}$$

Where

- Z in ohms
- R in ohms
- C in farads
- ω 2πf
- π 3.1416
- f cycles per second

Impedance

Resistance, inductance and capacity in series

$$Z = \sqrt{R^2 + \left(\omega L - \frac{1}{\omega C}\right)^2}$$

Where

- Z in ohms
- R in ohms
- L in henrys
- C in farads
- ω 2πf
- π 3.1416
- f cycles per second

Impedance

$$Z = \frac{E}{I}$$

$$E = IZ$$

$$I = \frac{E}{Z}$$

Where
 Z in ohms
 E in volts
 I in amperes

Inductance

Mutual inductance measurement.

$$M = \frac{L_1 - L_2}{4}$$

M = mutual inductance in uh
 L₁ = inductance fields aiding
 L₂ = inductance fields opposing

A quick method of measuring the mutual inductance is to measure inductance of the two coils assisting, then measure inductance of two coils bucking. Divide the difference by 4, which gives the mutual inductance between the two coils.

Inductance-Capacity Ratio

Finding LC of any wavelength when LC at 100 meters is known.

$$LC \lambda_2 = \left(\frac{\lambda_2}{\lambda_1} \right)^2 LC \lambda_1$$

Where
 LC λ₂ = LC ratio wanted
 λ₂ = Any given wavelength
 λ₁ = 100 meters
 LC λ₁ = .002816

Example:—
 For λ₂ substitute 450 at which LC desired
 For λ₁ substitute 100 at which LC is known
 For LC λ₁ substitute .002816
 Dividing 450 by 100 equals 4.5, which squared is 20.25, times .002816 equals .05702, which is desired LC ratio at 450 meters.

For convenience of shop workers the following table of wavelengths, frequencies and LC ratios is given from 200 to 600 meters:

Meters	Cycles	LC Ratio
200	1,500,000	.01126
210	1,429,000	.01241
220	1,364,000	.01362
230	1,304,000	.01489
240	1,250,000	.01621
250	1,200,000	.01759
260	1,154,000	.01903
270	1,111,000	.0205
280	1,071,000	.0221
290	1,034,000	.0237
300	1,000,000	.0253
310	968,000	.0270
320	938,000	.0288
330	909,000	.0306
340	883,000	.0325
350	857,000	.0345
360	834,000	.0365
370	811,000	.0385
380	790,000	.0406
390	769,000	.0428
400	750,000	.0450
410	732,000	.0473
420	715,000	.0496
430	698,000	.0520
440	682,000	.0545
450	667,000	.0570
460	652,000	.0596
470	639,000	.0622
480	625,000	.0649
490	612,000	.0676
500	600,000	.0704
510	588,000	.0732
520	577,000	.0761
530	566,000	.0791
540	556,000	.0821
550	546,000	.0852
560	536,000	.0883
570	527,000	.0915
580	517,000	.0947
590	509,000	.0980
600	500,000	.1013

Power

$$P = I E$$

$$P = \frac{E^2}{R}$$

Self-Indicating Resistance Chart

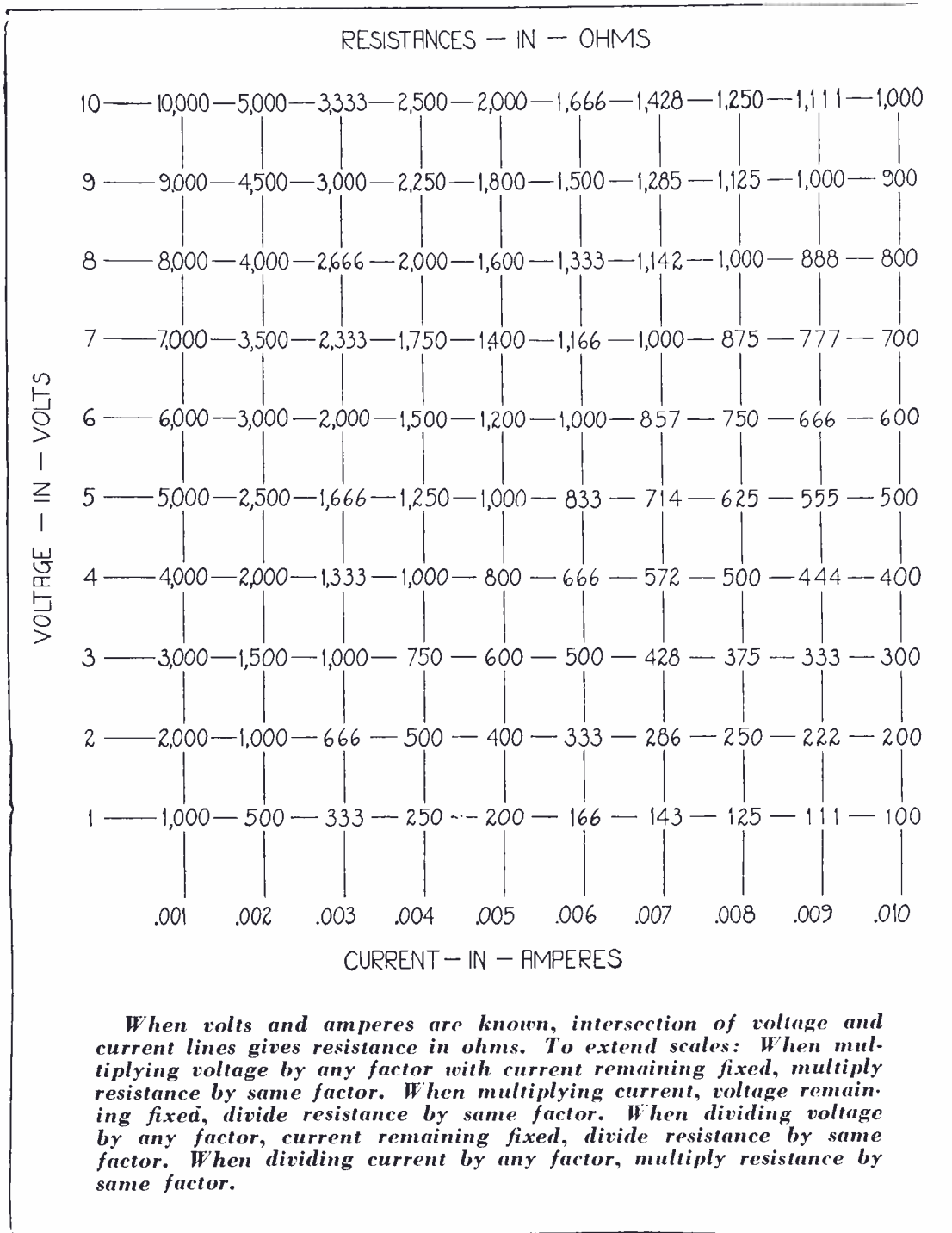

$$P = I^2 R$$

$$P = I E \cos \phi$$

$$P = I E \text{ p.f.}$$

Where
 P in watts
 I in amperes
 E in volts
 cos φ angle
 p.f. power factor

Reactance

Capacitive.

$$X = \frac{1}{\omega C}$$

$$f = \frac{X}{2 \pi C}$$

$$C = \frac{X}{\omega}$$

Where
 X in ohms
 C in farads
 ω 2 π f

π 3.1416
 f cycles per second

Reactance

Inductive.

$$X = \omega L$$

$$f = \frac{X}{2 \pi L}$$

$$L = \frac{X}{\omega}$$

Where

X in ohms
 L in henrys
 ω 2 π f
 π 3.1416
 f cycles per second

Reactance

Net reactance.

$$X = X_L - X_C$$

Where

X in ohms
 X_L in ohms
 X_C in ohms

Capacity, Frequency and Inductance Chart

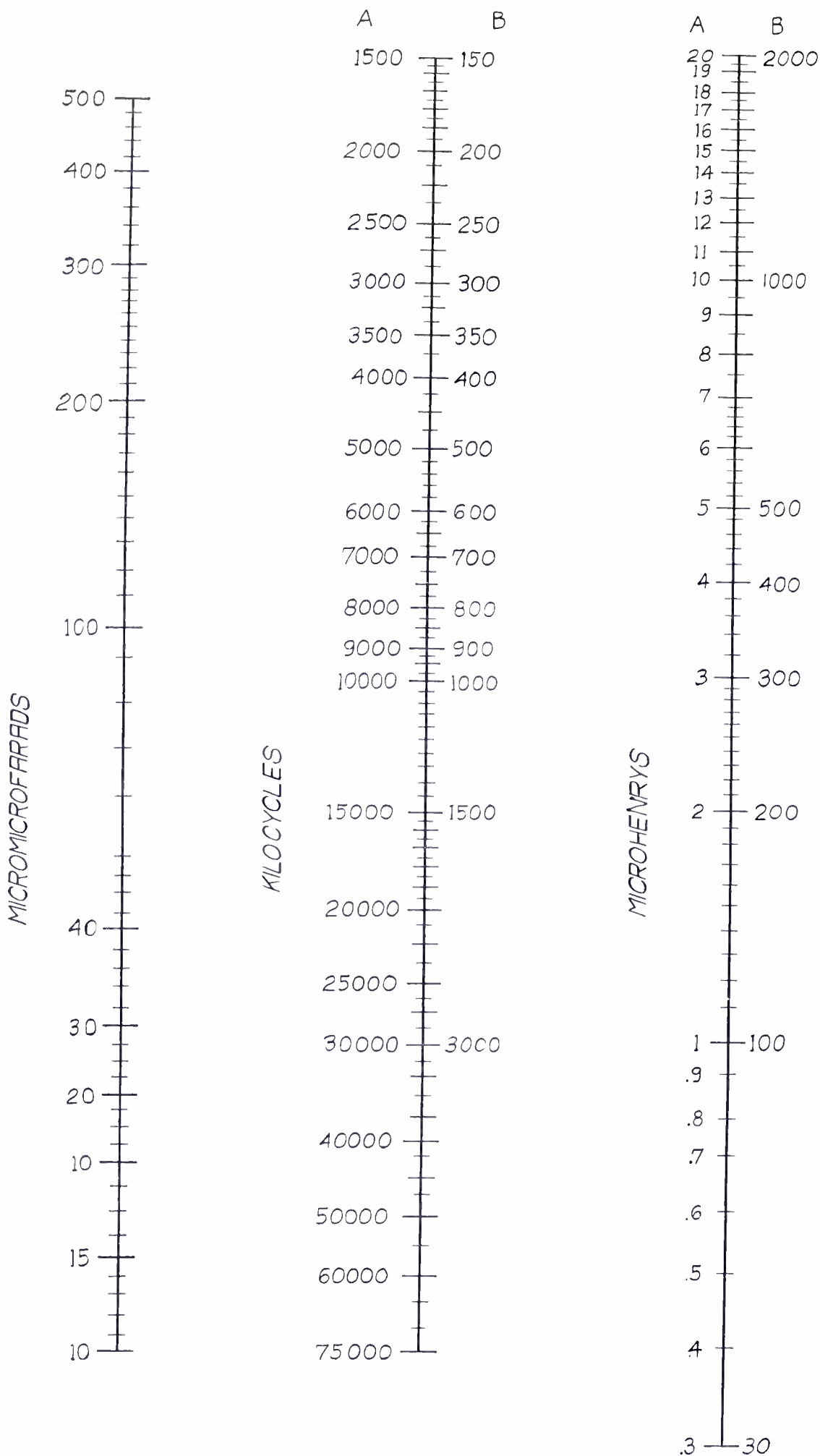

Knowing capacity in micromicrofarads and the frequency in kilocycles to be covered by a condenser at maximum capacity the inductance required for a coil may be found by running a straight line from the micromicrofarads column through the kilocycle column, the line intersecting the inductance column.

Knowing the condenser capacity and the inductance of the coil, the frequency to which the coil will tune can be found by running a line from the micromicrofarads column to the microhenries column, the point of intersection on the kilocycle column will be the frequency of coil and condenser.

Knowing the kilocycles and the inductance, the size of condenser to be used to cover that frequency can be found in the same manner indicated; extension of a straight line from microhenries through kilocycles will terminate on the micromicrofarads line.

Resistance

Measurement of r.f. resistance by reactance variation using undamped c.w and varying the capacity.

$$R = X_1 \sqrt{\frac{I_1^2}{I_r^2 - I_1^2}}$$

X_1 = change of reactance between two observations of current

I_r = current at resonance in amperes

I_1 = current off resonance in amperes

R = resistance in ohms

Resistance

$$R = \frac{E}{I} \quad (\text{d.c. only})$$

or at series resonance

$$R = \frac{E^2}{P}$$

$$R = \frac{P}{I^2}$$

Where

R in ohms

E in volts

I in amperes

P in watts

Resistance

In parallel.

$$R = \frac{R_2 \times R_1}{R_2 + R_1}$$

Where

R in ohms

R_1 in ohms

R_2 in ohms

Resistance

In series.

$$R = R_1 + R_2$$

Where

R in ohms

R_1 in ohms

R_2 in ohms

Resonance

Wavelength of series resonance

$$\lambda = \omega \sqrt{LC}$$

Where

λ wavelength in meters

ω $2 \pi f$

π 3.1416

f 300,000 cycles conversion factor

L inductance in henrys

C capacity in farads

Variants:

$$\lambda = 1.884 \sqrt{LC}$$

where L in microhenrys, C in micromicrofarads

$$\lambda = 1884 \sqrt{LC}$$

where L in microhenrys, C in microfarads

$$\lambda = 59,570 \sqrt{LC}$$

where L in millihenrys, C in microfarads

$$\lambda = 1,884,000 \sqrt{LC}$$

where L in henrys, C in microfarads

Resonance

Frequency of series resonance.

$$f = \frac{1}{2\pi\sqrt{LC}}$$

Where

- f frequency in cycles per second
- π 3.1416
- L inductance in henrys
- C capacity in farads

Variants:

$$f = \frac{159.2}{\sqrt{LC}}$$

where L in henrys, C in microfarads

$$f = \frac{5033}{\sqrt{LC}}$$

where L in millihenrys, C in microfarads

$$f = \frac{159,200}{\sqrt{LC}}$$

where L in microhenrys, C in microfarads

Resonance

Oscillation constant of series resonance.

$$\omega = \sqrt{LC}$$

Where

- ω $2\pi f$
- π 3.1416
- f cycles per second
- L inductance in henrys
- C capacity in farads

Variants:

$$\omega = \frac{1000}{\sqrt{LC}}$$

where L in millihenrys, C in millifarads

$$\omega = \frac{31,620}{\sqrt{LC}}$$

where L in millihenrys, C in microfarads

$$\omega = \frac{1,000,000}{\sqrt{LC}}$$

where L in microhenrys, C in microfarads

Voltage

$E = IR$ d.c. only

$E = \frac{P}{I}$ d.c. only

$E = RP$ d.c. only

$E = IX$

$E = IZ$

$E = \frac{P}{I \text{ p.f.}}$

Where

- E in volts
- I in amperes
- R in ohms
- P in watts
- X in ohms
- Z in ohms
- p.f. power factor

Coil Turns, Inductance and Diameter Chart

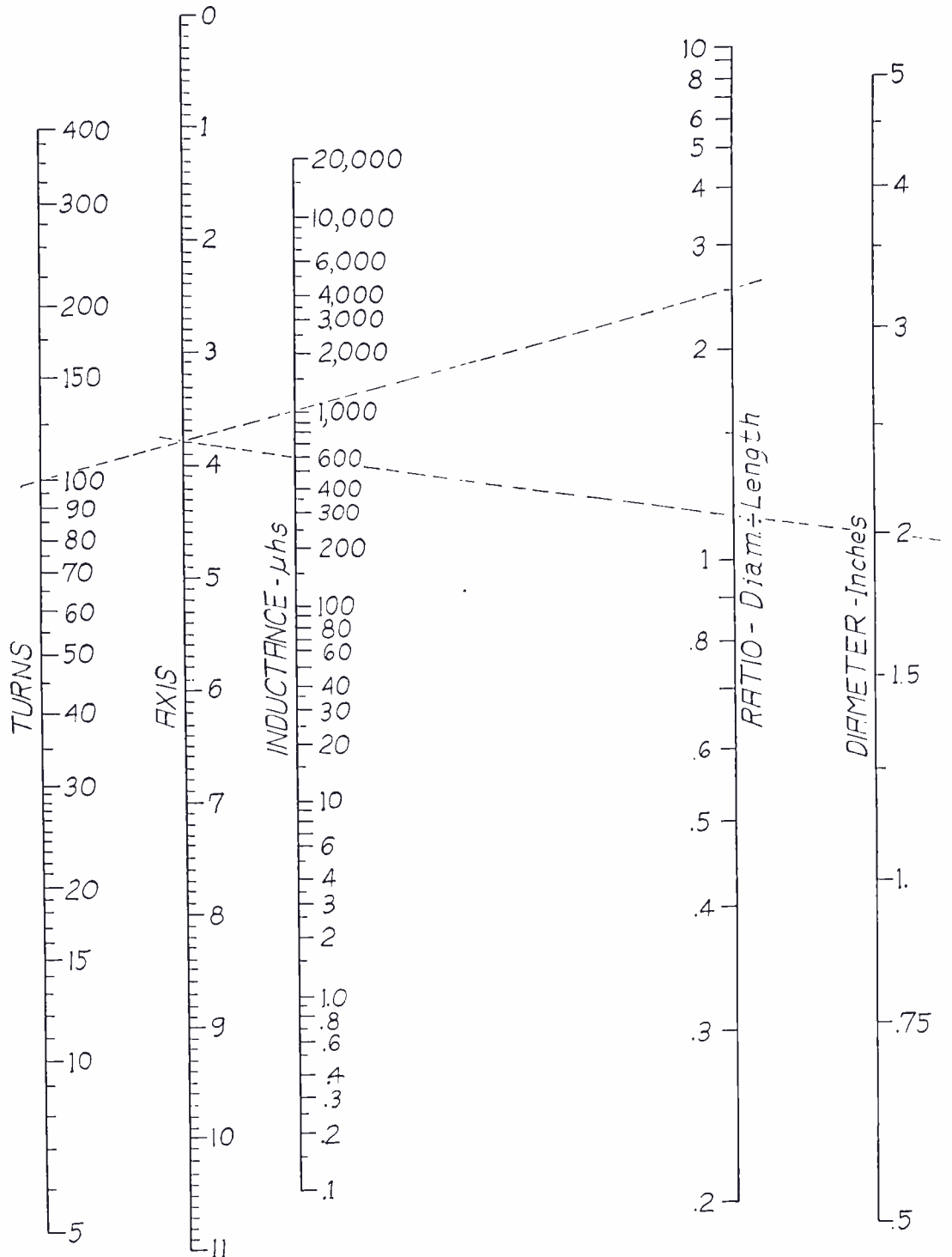

Knowing the turns of a coil, its length of winding, and the diameter, the inductance may be found by using a straight edge from the turns column to the ratio (length of winding) column, intersecting the axis column; then a second line from the intersection of the axis column to the diameter column. The inductance in microhenries will be the point where the second line intersects the inductance column. In the above chart the first line is laid from 100 turns to 2.5 ratio (which is length of winding) this first line intersecting the axis at 3.8 on the scale. The second line is from 3.8 on the axis scale to the 2 inch diameter, intersecting the inductance column at 600 microhenries.

Knowing the diameter, ratio and the inductance, the number of turns may be found by reversing the process. As shown in the chart, draw a line from 2 inch diameter through the 600 microhenries intersecting axis at 3.8 on the scale; then run line from 3.8 on axis scale to 2.5 on ratio (length of winding) the extension of this line cutting the turns scale at 100 which is the number of turns.

After finding number of turns, consult wire table to determine size of wire which will permit given number of turns in a given length of winding.

Voltage

In counter e.m.f.

$E = \omega LI$

Where

- E in volts
- ω $2\pi f$
- π 3.1416
- f cycles per second
- L in henrys
- I in amperes

When capacity present.

$E = \frac{1}{\omega C} I$

Where

- E in volts
- I in amperes
- C in farads
- ω $2\pi f$
- π 3.1416
- f cycles per second

MEMORANDA



MEMORANDA

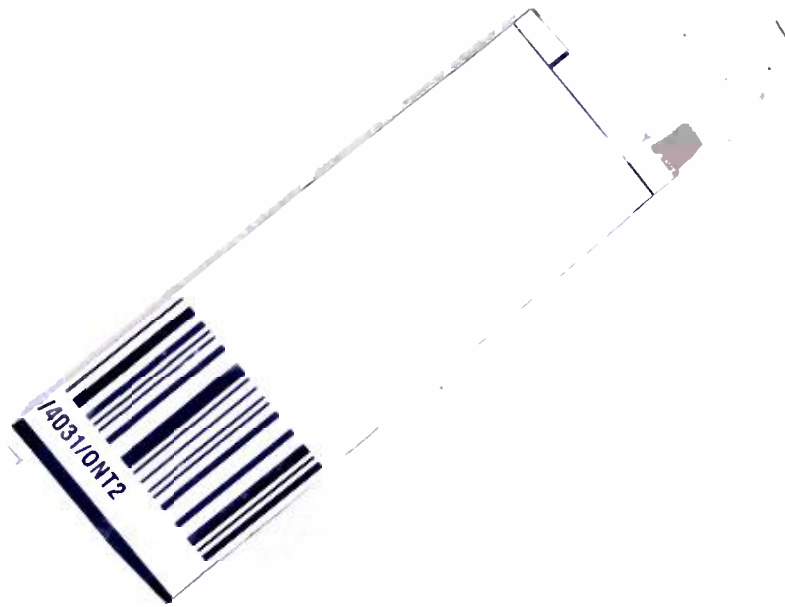

RADIO CALL BOOK MAGAZINE

AND

TECHNICAL REVIEW

NOW A

MONTHLY!



For some time you've wanted the *Radio Call Book Magazine* and *Technical Review* published more frequently than every three months. In answer to this reader demand the publishers have made it a monthly to better serve you and the radio industry.

Now you can get *Response Curves* and *Service Schematics* of receivers you're selling, as fast as measured.

Use these curves as a yardstick to show your prospects what to expect from the set you are offering.

Service men will find *Schematics* in every issue that might ordinarily be delayed for months.

These two features alone (to say nothing of the many others) justify your subscription today.

UP-TO-THE-MINUTE IN EVERY DETAIL DON'T MISS A SINGLE ISSUE!

\$2.00

For The

12 ISSUES

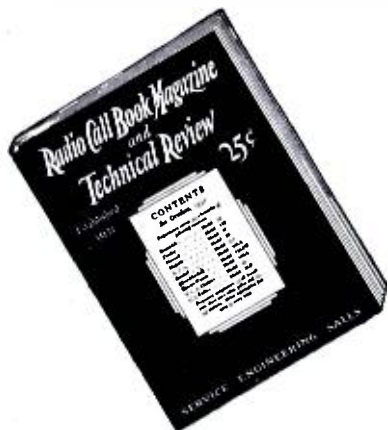

**Use This
Coupon
Today!**

Citizens Radio Service Bureau, Inc.
508 So. Dearborn St., Chicago

I need the *Radio Call Book Magazine* and *Technical Review* every month. Here's \$2.00 for the next 12 issues, starting with the number.

I am a:

(Please put a check-mark opposite your occupation)

Dealer	<input type="checkbox"/>	Distributor	<input type="checkbox"/>
Service Man	<input type="checkbox"/>	Salesman	<input type="checkbox"/>
Engineer	<input type="checkbox"/>	Technician	<input type="checkbox"/>
Manufacturer	<input type="checkbox"/>	Experimenter	<input type="checkbox"/>

Name _____

Address _____

City _____ State _____

RS-12



The Biggest Value Ever Offered in a Radio Set Analyzer



Dealers' Price \$73.12
List Price - - - \$97.50

The Jewell Pattern 199 is unequalled in accuracy, speed, and simplicity of operation by any other analyzer of comparable price.

WHY consider inferior set testers when a Jewell Pattern 199 Set Analyzer, proved through more than two years' service, costs so little?

Accuracy is vital in a radio service instrument. The large meters of the Pattern 199 are inherently accurate. These meters have been proved on thousands and thousands of industrial applications. Their clearly marked legible scales are easy to read accurately.

Why consider an instrument that requires an encyclopedia to tell how to operate it? The Jewell Pattern 199 is so simple to operate that if you leave the instruction book at home you need experience no difficulty.

Why experiment with cheap, inferior testers? The Jewell Pattern 199 is built to the highest standards by an exclusive man-

ufacturer of instruments. The only changes in the Pattern 199 in more than two years are adjustments to take care of new factors in radio equipment.

In the Jewell Pattern 199 you get a proven set analyzer—there are more than fifteen thousand of them in service today—an analyzer with two large, easy-to-read meters—an analyzer that is inherently accurate, durable and reliable—an analyzer that is simple to operate—an analyzer that makes every worthwhile field test—at a price made possible only by quantity production.

Again we repeat—you may be able to buy some kind of a set analyzer for less money, but you can't get as much for your money in any other analyzer on the market as you get in the Jewell Pattern 199.

30 YEARS MAKING GOOD INSTRUMENTS
JEWELL
Pattern 199 Set Analyzer

Jewell Electrical Instrument Company
1642-G Walnut St., Chicago, Illinois

Mail your 16-page bulletin describing the Pattern 199 Set Analyzer and other Jewell Service Instruments.

Name.....

Address.....