

RADIO APPARATUS

For

Amateur and Experimental Use

With INSTRUCTIONS For

CONTINUOUS WAVE OPERATION



Radio  **Corporation**
of America

WOLWORTH BUILDING ~ NEW YORK CITY

RADIO APPARATUS

For
Amateur and Experimental Use
With INSTRUCTIONS For
CONTINUOUS WAVE OPERATION

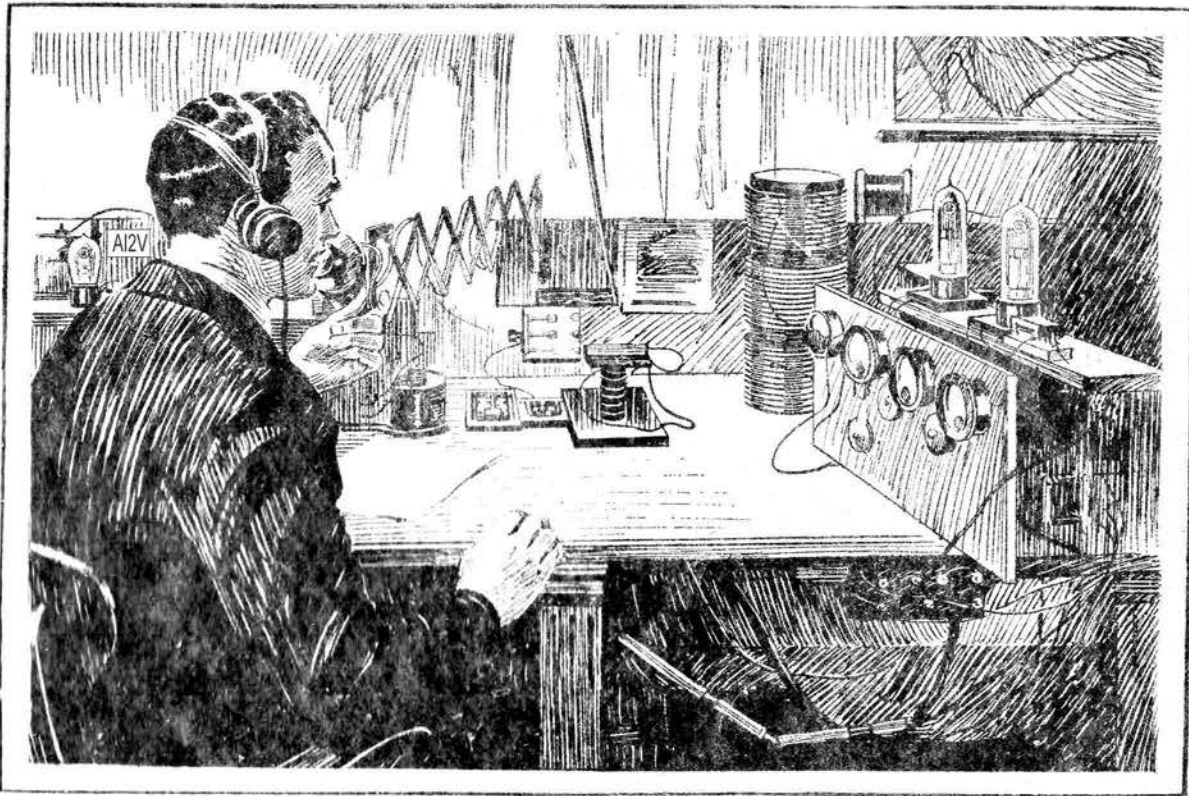

Radio  **Corporation**
of America

WOLWORTH BUILDING ~ NEW YORK CITY

NOTICE

THE power tubes and other radio equipment described in this bulletin are sold for amateur or experimental use only. Any other use will constitute an infringement of the Radio Corporation's patents of November 7th, 1905, January 15th, 1907, February 18th, 1908, and many other patents. A number of circuit diagrams are given in this bulletin which may be successfully used for radio transmission, and the amateur and experimenter is given the privilege of assembling Radio Corporation apparatus in these circuits. The amateur and experimenter may desire to construct the simpler parts of the apparatus in the circuit diagrams which the detailed information in this bulletin will enable him to do. The Radio Corporation is glad to extend this additional privilege under its patents in order to develop interest in the amateur radio art, but these privileges are given to no one except the amateur and experimenter, and then only for their use and not for sale.

RADIO APPARATUS

for

Amateur and Experimental Use

with

Instructions for the Operation

of

CONTINUOUS WAVE APPARATUS



PRICE 25 CENTS

September 1, 1921

RADIO CORPORATION OF AMERICA

Sales Division

Woolworth Building

233 Broadway

NEW YORK CITY

CONTENTS

INSTRUCTIONAL SECTION

	PAGE
FOREWORD.....	3
RADIOTRON TRANSMISSION.....	4
A SCIENTIFICALLY CONSTRUCTED STATION.....	6
GENERAL INFORMATION TO THE AMATEUR.....	8-9
TRANSMITTING TUBE CIRCUITS.....	10-19
THE PRACTICAL USE OF TRANSMITTING TUBES.....	20

CATALOG SECTION

RADIOTRON TRANSMITTER TUBES.....	22-23
KENOTRON RECTIFIER TUBES.....	24
TRANSMITTER ACCESSORIES.....	25-33
RADIOTRON RECEIVER TUBES	34-35
RECEIVER ACCESSORIES.....	36-44
ANTENNA MATERIAL AND ACCESSORIES.....	45-46
THE WIRELESS MAN'S BOOKSHELF.....	47
NOTICE TO PURCHASERS.....	48

All quotations made herein are F. O. B. storeroom, New York City, or factories, and are subject to change at any time without prior notice. The list prices given herein apply to the United States only



FOREWORD

THE RADIO CORPORATION OF AMERICA takes pleasure in offering this, its first catalog, to the fraternity of radio amateurs and experimenters. During the last few years the trend of development in wireless communication has been in the direction of continuous wave transmission and reception. The only suitable method of generating continuous wave energy for amateur radio transmission is the one which employs vacuum tubes and associated circuits as oscillation generators.

The manifold advantages of continuous wave transmission over spark transmission need no longer be emphasized. Prior theory, exhaustive laboratory tests, and current radio practice have established beyond doubt its superiority over the damped wave method. Starting from this premise, the Radio Corporation of America, backed by the research and manufacturing facilities of the General Electric Company, set out to develop continuous wave transmitting apparatus which should be simple in operation, efficient and reasonably priced. This modern system, besides enabling the amateur to cover extraordinary distances with low antenna power and with a minimum of interference to the operation of other stations, makes possible the transmission of wireless speech, i.e., radio telephony.

It is believed that our object has been obtained; and this catalog has been issued to popularize C. W. apparatus, and to furnish the radio amateur with the data necessary for the efficient operation of C. W. transmitters.

The Radio Corporation is proud of the apparatus which it has developed, and is solicitous of its reputation; and in line with this policy it will be glad to have called to its attention any defect in material or workmanship which may be noted by the purchaser. It is the aim of the Corporation to serve the radio amateur, and to establish its trademark as a symbol of quality. Remember that back of the Radio Corporation's products stand the splendid research facilities of its associates in the field of electricity, the General Electric Company, the American Telephone and Telegraph Company, and the Western Electric Company.



RADIOTRON TRANSMISSION

THE USE OF RADIOTRONS IN EXPERIMENTAL CONTINUOUS WAVE TELEGRAPH AND TELEPHONE SETS

CURRENT literature devoted to amateur radio activities affords sufficient evidence that the era of continuous wave transmission has arrived. It has long been known that continuous wave sending apparatus would provide a greater radio transmission range than a spark transmitter of the same power to the antenna, and also that the use of continuous waves would permit the adoption of more efficient methods of reception than the spark system.

The only suitable form of undamped wave generator for short wave transmission is the oscillating vacuum tube. The expenditure of large sums of money in painstaking research conducted by America's foremost scientific experts, has enabled the production of reliable and efficient power tubes—RADIOTRONS—which may be employed as generators of continuous oscillations, of any frequency used in radio communication. The vacuum tube is better adapted to radio transmission at wave lengths in the region of 200 meters than the spark system, for the spark system has certain inherent characteristics which place a very definite practical limit upon the amount of

energy that can be put into an antenna at short wave lengths or high frequencies.

The vacuum tube transmitter using the Radio Corporation's Power Tubes is comparatively simple, both in point of construction and in operation. It is no more difficult to adjust and to maintain than a spark transmitter, and it has many points of advantage over the spark set. There are, however, certain precautionary measures which must be considered in vacuum tube operation, and it is one of the objects of this bulletin to place before the amateur such information as will enable him to secure the

maximum results from a tube set. Moreover, as the operation of the tube transmitter becomes better known among amateur experimenters, it will occupy the premier position in amateur radio work.

Two prime advantages of continuous wave telegraphy should not be lost sight of; namely, the high degree of selectivity, and the greatly increased range obtainable. It is usually possible to trans-

mit two to three times the distance that can be covered by a spark set of the same antenna power, and in addition interference is reduced to an absolute minimum.

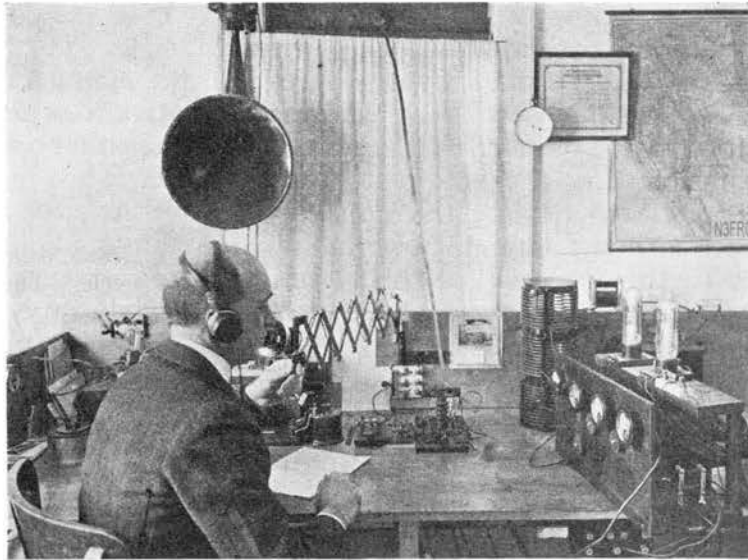

STATION "2ZL," LOCATED AT VALLEY STREAM, L. I. USING TWO 50-WATT RADIOTRONS, THIS STATION HAS BEEN HEARD OVER 1,900 MILES OVERLAND

CONTINUOUS WAVE TELEGRAPHY (C. W.), INTERRUPTED CONTINUOUS WAVE TELEGRAPHY (I. C. W.) AND RADIO TELEPHONE TRANSMISSION

EVERY up-to-date radio experimenter wants a radio telephone; he will also want a long-distance radio telegraph set. With the same set, using the Radio Corporation's Power

Tubes, the amateur can telephone to the neighboring stations over moderate distances, and by shifting a few switches he can adapt the set for continuous wave telegraph transmission and

cover distances by telegraphy three to four times those possible by radio telephony. This is the modern way of doing things in the amateur station, and today there are already several thousand RADIOTRON Power Tubes in use at amateur stations throughout the United States.

The Vacuum Tube Transmitter not only permits wireless telephony, but also enables the amateur to make use of modulated or interrupted continuous wave telegraphy. Thus, if the energy supplied to an antenna by an oscillating tube set is modulated by a microphone transmitter, telephonic communication is possible; or if the antenna oscillations are modulated by a buzzer or preferably by some form of rotary grid chopper, the antenna will radiate wave trains

similar to those sent forth from the antenna of a spark transmitter. By a suitable arrangement of controls, either C. W. transmission, I. C. W. transmission or telephony may be had from the same set, simply by shifting a few switches.

A few amateur receiving stations are still equipped with crystal detectors. In order to transmit to these stations with a tube transmitter the grid circuit should be modulated by a rotary "chopper." Such a chopper is nothing more than a rotary interrupter designed to interrupt the grid circuit of an oscillating tube from 600 to 1,000 times per second. Tests have demonstrated that a tube set modulated in this way gives the same reception efficiency as a quenched spark set of the same power to the antenna.

SOURCES OF ENERGY FOR TUBE TRANSMISSION

A VACUUM power tube requires a low voltage source to heat the filament and a high voltage source to energize the plate or anode circuit. The requisite e. m. f. for the plate circuit may be obtained in three ways:

- (1) *From a high voltage D. C. generator.*
- (2) *From a rectified A. C. Source, using the Radio Corporation's KENOTRON, or two electrode, rectifier valves.*
- (3) *From an A. C. Source directly applied to the plate (self-rectification circuits).*

If only a D. C. source, such as 110 or 220 volts, is available, a high voltage D. C. generator should be obtained. The motor should be supplied with slip rings to provide an alternating e. m. f. for the filament (through the medium of a step-down transformer). The generator should provide high voltage D. C. according to the rating of the power tube.

Amateurs having access to an A. C. source only, should obtain an A. C. transformer and two of the Radio Corporation's KENOTRON Rectifier Valves arranged in a suitable circuit to rectify both halves of the A. C. cycle. The trans-

former should be provided with a high voltage secondary for the plate circuit supply and with two additional secondaries providing a step-down voltage to light the filaments of the Power Tubes and Rectifier Valves. In addition, a reactance and condenser must be supplied to smooth out the ripple in the plate current, as shown in Figure 4 of Page 14.

In the third method two RADIOTRON Power Tubes may be connected in a type of circuit in which alternating current of suitable voltage can be applied directly to the plate circuits of the tubes. The tubes then act simultaneously as rectifiers and oscillators, using both halves of the impressed A. C. cycle. This is called the self-rectification method. By means of a smoothing-out reactance of suitable design (see Figure 2 Page 12), the variation in amplitude of the antenna oscillations may be reduced to a minimum value, giving all the advantages of C. W. transmission. The self-rectification circuit is recommended for telegraph use only. A suitable D. C. source obtained either from a Rectifier Unit or a D. C. generator should be used for telephony.



A SCIENTIFICALLY CONSTRUCTED AMATEUR STATION

By H. H. BEVERAGE

TOO little attention has been paid by amateurs to the ground wire system of their radio stations. Amateurs whose stations are located appropriately should give attention to the interesting series of experiments described below, conducted by H. H. Beverage, Special Engineer of the Radio Corporation's High Power Receiving Research Staff, who has found time to apply the principles utilized in high-power commercial radio stations to amateur stations. By following Mr. Beverage's advice any amateur can duplicate the results he has obtained. Mr. Beverage has analyzed and placed before amateurs the "crux" of a successful tube transmitting station.

MANY amateurs have considerable difficulty in getting a low antenna resistance, particularly in locations where the soil is sandy. Under these conditions, a counterpoise must generally be used to get the antenna resistance down to a reasonable figure. In many cases, however, it is possible to combine a ground connection with a counterpoise, in such a manner as to still further reduce the antenna resistance by a large amount.

In the *General Electric Review* for October, 1920, Mr. E. E. Bucher describes the Alexander-son system for Radio communication. He shows how Mr. Alexander-son has combined a buried wire ground with a capacity ground for more uniformly distributing the earth currents. In Figure 1, the inductance of the helix below the ground tap tunes the capacity ground, while the inductance between the ground tap and the antenna tunes the antenna circuit. The section of the helix above the ground connection may be considered positive with respect to ground, and the section of the helix below the ground connection may be considered negative with respect to ground. By suitable tuning, the total antenna current may be distributed between the capacity ground and the buried wire ground in any desired ratio.

In the case of Station "2BML," at Riverhead, L. I., the soil consists mainly of dry sand under the antenna. There is a small pond near the antenna, but not under it. A good ground was obtained in this pond by running several hundred feet of wire into it. The antenna resistance using this ground was very high, between sixty and seventy ohms at 200 to 300 meters. The writer decided that since the soil under the antenna was sandy, the high antenna resistance was due to the fact that the antenna flux was forced to travel through very high resistance soil for a considerable distance before reaching the low resistance ground wires.

A counterpoise of four No. 14 B. & S. copper wires running parallel with the antenna flat top and directly beneath the antenna was put up, the parallel wires being four feet apart and carefully insulated. The counterpoise extended several feet beyond the antenna at both ends. When the counterpoise was substituted for the ground, the antenna resistance was lowered from

about sixty ohms to ten ohms. By combining the ground with the counterpoise as shown in Figure 2, the antenna resistance was still further reduced to about four ohms. The resistance of the helix used to tune this antenna was about three ohms, making a total antenna resistance of seven ohms. The above resistance values were taken at 280 meters wave length.

When the circuits are properly adjusted, removing either the ground connection or the counterpoise connection will not change the antenna wave length, but will change the antenna resistance only. The easiest way to tune up the counterpoise and ground is to first tune to the desired wave length, using the counterpoise alone, then try the ground clip on different turns until the point is found where the wave length is the same as with the counterpoise alone. The ground clip should be adjusted to within a half turn on a large diameter helix. When the ground clip is at the neutral point, the inductive impedance of the helix below the ground point tunes with the capacity impedance of the counterpoise, forming a series-tuned circuit of comparatively low resistance. The total antenna current divides between the ground and the counterpoise inversely proportional to the effective resistances of the ground and counterpoise circuits.

With the counterpoise on the bottom of the helix and no ground connection, the wave length is 336 meters and the effective resistance is about nine ohms. When the ground clip is put on turn No. 1, the total current divides in inverse proportion to the ground resistance and the counterpoise reactance, and, obviously, most of the current will flow in the ground lead. Since the counterpoise has little effect, the wave length is practically determined by the antenna capacity and the helix inductance between the ground clip and the antenna clip. As the ground clip is moved up nearer the neutral point, the wave length becomes shorter, due to the decrease in inductance between the ground and antenna clips, and the counterpoise reactance is partly tuned out by the inductance of the helix between the ground and counterpoise clips. The effective resistance decreases as the ground clip is moved up, because the counterpoise is taking a greater and greater portion of the antenna current.

When the neutral point is reached, the counterpoise reactance is entirely tuned out, and the counterpoise takes most of the antenna current.

In the case of Station "2BML," the counterpoise capacity was .0007 M.F.D., and the antenna capacity was .0005 M.F.D. When the ground clip was properly adjusted, about 75 per cent of the total antenna current flowed in the counterpoise lead and the other 25 per cent in the ground lead. With this combination, the antenna resistance was only about 40 per cent of the value obtained with the counterpoise alone.

Many amateurs already have a counterpoise, and the writer believes if these amateurs will combine their counterpoise with a ground connection as described, their radiation will, in many cases, be doubled, especially in cases where a good ground connection is available. Very good

The antenna current is six to eight amperes, depending upon the voltage of the local 60-cycle supply. The plate voltage is 2,000, using full wave rectification with two KENOTRONS. The smoothing condenser is $1\frac{1}{2}$ M.F.D., but is not large enough to smooth out the 60-cycle ripple, so the modulation is not particularly good and is seldom used, although it has been heard over distances of 300 to 400 miles several times. The RADIOTRONS draw as much as 600 watts or more from the condensers, so a very large condenser would be required to smooth out the 60-cycle hum completely. The maximum input in the antenna with a single tube varies from 250 to 450 watts without overheating the tube, and doubtless more energy could be put in by using a higher plate voltage.

The helix consists of a power line lightning

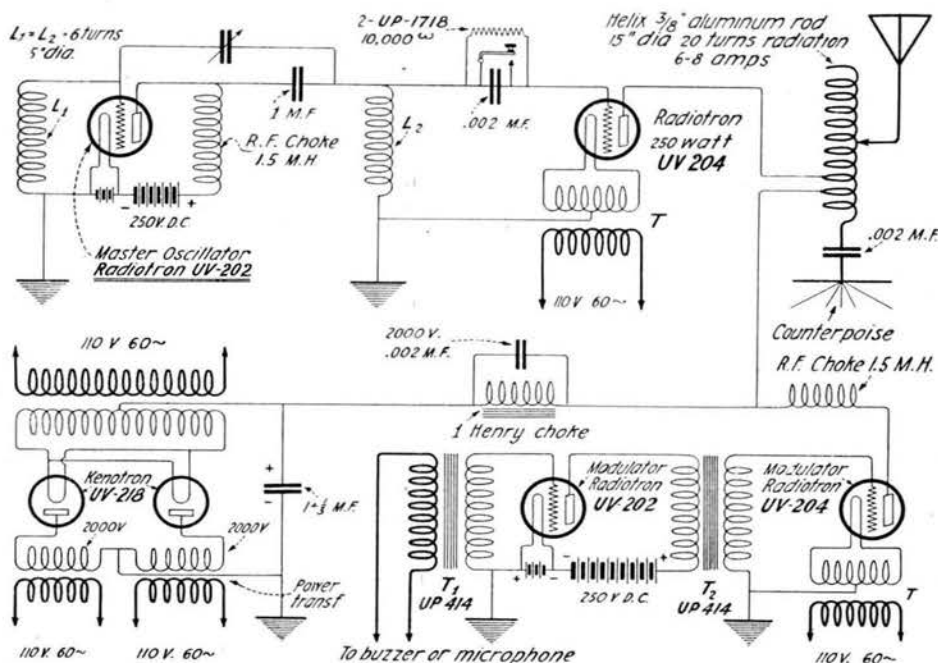

FIGURE 1

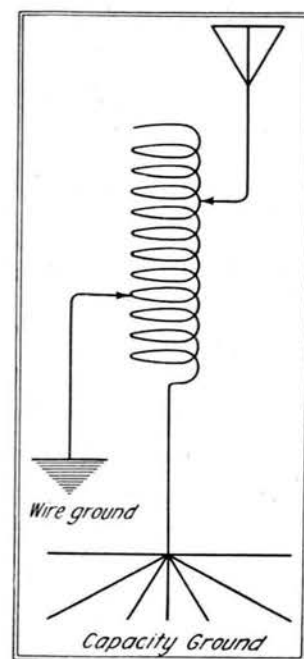

FIGURE 2

results should be obtained even if the ground system is not directly under the antenna, as for example a water-main ground.

Figure 1 is a diagram of connections of the apparatus used at Station "2BML." There are no special features excepting the combination of counterpoise and ground described above. A master oscillator is used to keep the frequency as constant as possible. It is essential to make the condensers in the ground and counterpoise leads large in comparison with the counterpoise and antenna capacities. The condenser in the counterpoise lead is simply a stopping condenser to keep the plate voltage off the counterpoise. Two 250-watt, type UV-204 RADIOTRONS are used. One tube is used as the oscillator and the other as the modulator.

arrester choke coil made of 21 turns of $\frac{1}{4}$ -inch aluminum rod wound in cylindrical form, 15 inches in diameter. Two old 2,000-volt transformers are used for supplying voltage to the KENOTRON rectifiers. One is a five K. W. 133-cycle power transformer, while the other is a 250-watt potential transformer, both having a 20 to 1 ratio and both delivering the same watts to the rectifiers.

The antenna is also a make-shift affair consisting of a small horizontal cage of three No. 14 wires about forty feet high and eighty feet long.

Station "2BML" has been in operation for a number of months, and like many other C. W. stations, the radiation was about one-half ampere at first, but was gradually increased by experimentation until eight amperes was finally

reached. Half-wave self-rectification was also tried with both 60 and 300 cycles. The 300-cycle source gave an exceedingly pure, musical note and was very successful, but the available generator was small and the antenna current

was only about three amperes with full load on the 300-cycle generator. The C. W. signals from "2BML" have been reported QSA on many occasions from stations within a 1,000 mile radius.

GENERAL INFORMATION FOR THE AMATEUR.

THERE are at the present time approximately 25,000 amateur radio transmitting stations in the United States, and probably eight receiving stations to every transmitting station, making a total of 200,000 amateur stations. The large majority of these stations use only a small amount of power for transmitting; consequently, their range is small. There are organizations of amateurs which include primarily those who are interested in the relaying of messages from one station to another, and during the cooler months of the year, when the air is clear of static, it is frequently possible to relay messages through such stations clear across the country within a few hours. As a general rule such messages are relayed over fairly well established lines of communication, including the most efficient stations operated by the best amateur operators of the country. The *National Amateur Wireless Association*, which includes in its membership most of the leading amateurs of the country, is one of the organizations which maintains a national traffic organization and relays messages to all points of the country without charge. The stations which are a part of this relay system of the *National Amateur Wireless Association*

include many of the leading amateur stations which employ tube transmitters, and, because they use C. W. transmitters, exceptional results are obtained, the range of these tube stations frequently exceeding 1,000 miles. During the warm months of the year, when there is considerable disturbance from atmospheric electricity due to thunderstorms, repeated tests have proved that tube transmitters can work successfully through heavy static caused by thunder showers, while spark stations of the same power could not be heard.

One of the problems of amateur activities is that of interference between stations. This is largely the result of the use of spark transmitters which radiate their energy over a wide band of wave lengths. In the case of continuous wave transmission the energy is radiated on substantially *one wave length*, thereby eliminating to a great degree the objectionable interference caused by spark stations. The character of transmitted energy is such that the effect at the distant receiver is much greater, power for power, than a spark set, principally for the reason that the undamped wave transmitter permits the use of highly refined and efficient methods of reception.

RADIO LAWS AND REGULATIONS OF THE UNITED STATES

The owner of an amateur radio transmitting station must obtain a station license before it can be operated if the signals radiated therefrom can be heard in another state; and also if such a station is of sufficient power as to cause interference with neighboring licensed stations in the receipt of signals from transmitting stations outside the state. These regulations cover the operation of radio-telephone stations as well as radio-telegraph stations.

Station licenses can be issued only to citizens of the United States, its territories and dependencies.

Transmitting stations must be operated under the supervision of a person holding an *Operator's License* and the party in whose name the station is licensed is responsible for its activities.

The Government licenses granted for amateur stations are divided into three classes as follows:

Special Amateur Stations known as the "Z" class of stations are usually permitted to

transmit on wave lengths up to approximately 375 meters.

General Amateur Stations which are permitted to use a power input of 1 kilowatt and which cannot use a wave length in excess of 200 meters.

Restricted Amateur Stations are those located within five nautical miles of Naval radio stations, and are restricted to $\frac{1}{2}$ kilowatt input. These stations also cannot transmit on wave lengths in excess of 200 meters.

Experimental stations, known as the "X" class, and school and university radio stations, known as the "Y" class, are usually allowed greater power and also allowed the use of longer wave lengths at the discretion of the *Department of Commerce*.

All stations are required to use the minimum amount of power necessary to carry on successful communication. This means that while an amateur station is permitted to use, when the

circumstances require, an input of 1 kilowatt, this input should be reduced or other means provided for lowering the antenna energy when communicating with near-by stations in which case full power is not required.

Malicious or wilful interference on the part of any radio station, or the transmission of any false or fraudulent distress signal or call is prohibited. Severe penalties are provided for violation of these provisions.

Special amateur stations may be licensed at the discretion of the *Secretary of Commerce* to use a longer wave length and higher power than general amateur stations. Applicants for special amateur station licenses must have had two years' experience in actual radio communication. A special license will then be granted by the *Secretary of Commerce* only if some substantial benefit to the science of radio communication or to commerce seems probable. Special amateur station licenses are not issued where individual amusement is the chief reason for which the application is made. Special amateur stations located on or near the sea coast must be operated by a person holding a commercial license. Amateur station licenses are issued to clubs if they are incorpor-

ated, or if any member holding an amateur operator's license will accept the responsibility for the operation of the apparatus.

Applications for operator's and station licenses of all classes should be addressed to the *Radio Inspector* of the district in which the applicant or station is located. *Radio Inspectors'* offices are located at the following places:

<i>First District</i>	<i>Boston, Mass.</i>
<i>Second District</i>	<i>New York City</i>
<i>Third District</i>	<i>Baltimore, Md.</i>
<i>Fourth District</i>	<i>Norfolk, Va.</i>
<i>Fifth District</i>	<i>New Orleans, La.</i>
<i>Sixth District</i>	<i>San Francisco, Cal.</i>
<i>Seventh District</i>	<i>Seattle, Wash.</i>
<i>Eighth District</i>	<i>Detroit, Mich.</i>
<i>Ninth District</i>	<i>Chicago, Ill.</i>

No license is required for the operation of a receiving station, but all persons are required by law to maintain secrecy in regard to any messages which may be overheard.

There is no fee or charge for either an operator's license or a station license.

C. W. TRANSMISSION AT AMATEUR WAVE LENGTHS

A great many amateur operators have applied to the *Radio Inspectors* of the different districts for special amateur licenses, giving as a reason that they wish to use tube transmitters which would not operate properly on 200 meters, the regular amateur wave length. This belief is entirely wrong. Tube sets will generate power on 200 meters, as well as on any other wave length, providing the antenna is of proper size for 200-meter work.

Some experiments with tube sets on wave lengths below 200 meters were made at "2ZL" Station, Valley Stream, L. I., where a separate antenna, considerably smaller than the main antenna regularly used, was employed for this short wave work. This smaller antenna was about 60 feet long over all, and consisted of four wires. It was found possible to do successful work on this antenna using wave lengths between 140 and 200 meters. Considerable work was done on 175 meters, the antenna current on this wave length being two amperes with two **RADIOTRONS UV-203**. One hundred miles in daylight could be covered readily on this wave length and with the current mentioned.

When the transmitter was adjusted to a wave length of 175 meters it was found, in at least

three instances, that the receiving operators had to adjust their secondary circuit variometers at zero in order to hear the signals. This indicates that many amateur receiving sets will not operate efficiently on wave lengths below 200 meters. After the communication had been carried on for some time on 175 meters, considerable comment was made by other amateur stations on the desirability of working on that wave length in that there was no interference at that wave length. Atmospheric disturbances gave little or no trouble, whereas on wave lengths above 200 meters the interference from this source was very pronounced.

It is entirely possible to work on 175 meters with tube transmitters or on any lower wave length, without trouble, provided the antenna system is of the proper size for that wave length. The belief that tubes will not operate and generate power on 200 meters or below, has evidently arisen through lack of experience. Tubes will oscillate on short wave lengths just as well as on long wave lengths. At "2ZL" Station a 50-watt **RADIOTRON UV-203** was made to oscillate and generate power in a small antenna circuit with a period of only 50 meters.

TRANSMITTING TUBE CIRCUITS

TO show the radio amateur or experimenter how to utilize RADIOTRONS in certain of the well-known oscillating circuits, there is given on the following pages a set of circuit diagrams for radio transmission, together with the component parts of a set for either 5, 50 or 250 watt tubes. Power tubes can be used in a variety of circuits, but the ones shown have been found to give maximum efficiency. Current radio literature discloses numerous tube transmitting circuits which will be found serviceable.

The attention of the amateur who does not possess a high voltage D. C. motor generator set to supply plate voltage is directed to the self-rectification telegraph circuits shown, in which RADIOTRONS may be energized directly from an A. C. source. In these circuits power tubes act simultaneously as rectifiers and oscillators. A suitable source of D. C. may be obtained from an A. C. source by the use of the Radio Corporation KENOTRON Rectifier Valves.

CIRCUIT NO. 1

Figure 1 (page 11) shows a simple yet modern type of radio-telephone circuit wherein two Radiotron power tubes are connected in parallel as oscillators, the plate circuit being energized from a high voltage D. C. generator. The antenna energy is modulated for radio telephony by the Radio Corporation's newly developed Magnetic Modulator (M. M.) as herein described, on page 31.

CIRCUIT NO. 2

Figure 2 (page 12) is the same circuit as Figure 1, except that the input to the antenna is modulated by the Radio Corporation's specially designed "Grid Chopper" Model PX-1638 and that it is intended for radio telegraphy instead of telephony. This circuit is applicable to either Radiotron UV-202 or Radiotron UV-203.

CIRCUIT NO. 3

Figure 3 (page 13) shows a full wave self-rectification transmitter for C. W. tone telegraphy, using A. C. excitation throughout. The circuit is applicable to 5 and 50-watt Radiotrons. The plate circuit is energized from the Radio Corporation's new High Voltage Transformer which is designed to operate from a source of 110 volts, 50 or 60-cycle alternating current. In this circuit, the filament and plate current are obtained from the same transformer.

CIRCUIT NO. 4

Figure 4 (page 14) indicates the circuit of a 10-20 or 50-100 watt radio telephone set using Radiotrons UV-202 or UV-203, one as an oscillator and the other as a modulator. Two of the Radio Corporation's Kenotrons, Model UV-216 or Model UV-217, provide D. C. plate excitation from an A. C. source. The Radio Corporation's Microphone Transformer with side tone winding is used to control the grid potential of the modulator tube, which in turn modulates the antenna input. This circuit is particularly recommended to the amateur having an A. C. power source only.

CIRCUIT NO. 5

Figure 5 (page 15) is a circuit specially developed to provide constant antenna frequency. Two Radiotron power tubes are employed as oscillators, their plates being energized through Kenotron UV-216 or UV-217, giving full wave rectification from an A. C. source. This gives the amateur an excellent outfit for both radio telephony and radio telegraphy. The circuit is suitable for either Radiotrons UV-202 or UV-203.

CIRCUIT NO. 6

Figure 6 (page 16) is a radio telephone circuit using Radiotron UV-203 as oscillator, modulator and speech amplifier. Plate excitation is obtained from a D. C. high voltage generator. The output of the speech amplifier is controlled by the Radio Corporation's new Microphone Transformer.

CIRCUIT NO. 7

Figure 7 (page 17) depicts a full wave rectification set for radio telephony, using four Radiotrons UV-202, two as oscillators and two as modulators. The plate circuit is fed from a rectified A. C. source through four Kenotrons UV-216.

CIRCUIT NO. 8

Figure 8 (page 18) is a combined circuit for telegraphy and telephony, using full wave rectification, which utilizes four Radiotrons UV-202 as oscillators and four Kenotrons UV-216 as rectifiers. The new Magnetic Modulator controls the antenna energy for telephony. Grid Chopper, Model PX-1638, is used for I. C. W. Telegraphy. An intermediate circuit to provide constant antenna frequency is also included.

CIRCUIT NO. 9

Figure 9 (page 19) shows a radio telegraph self-rectifying tube circuit suitable for tubes with outputs in excess of 100 watts. Separate transformers are used for heating the filament and energizing the plate circuit.

FIG. 1. RADIOPHONE CIRCUIT WITH MAGNETIC MODULATOR USING D. C. PLATE SUPPLY

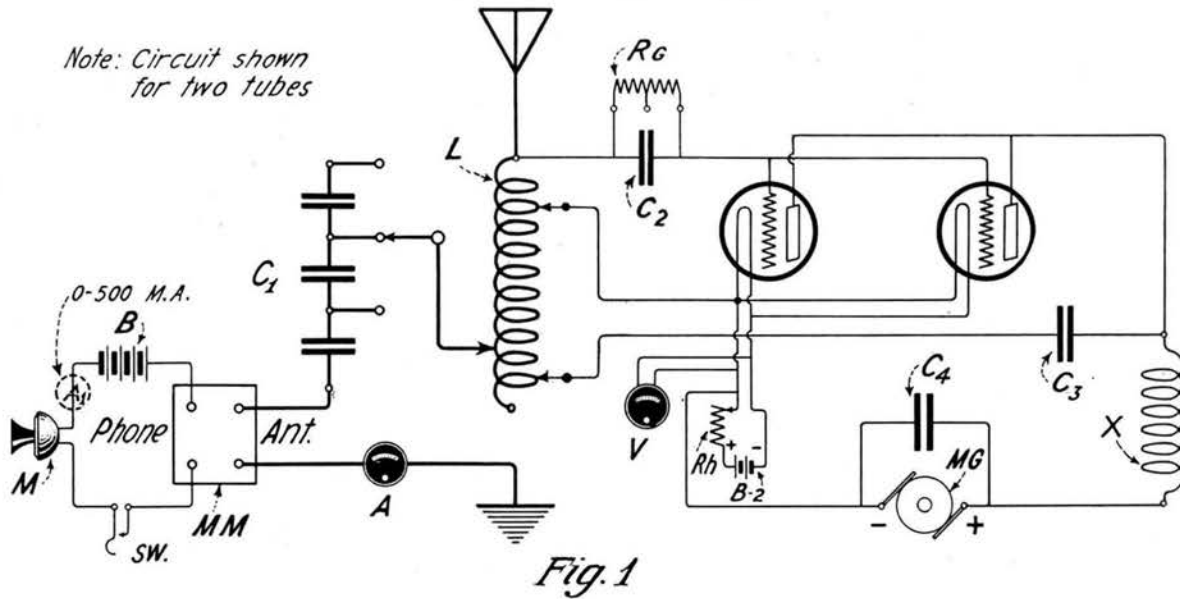

Fig. 1

LIST OF MATERIAL	CIRCUIT SYMBOL	RATING OF RADIOTRONS			
		5-WATT TUBES		50-WATT TUBES	
		MODEL	PRICE	MODEL	PRICE
1 One or more RADIOTRON Power Tubes.....		UV-202	\$8.00 each	UV-203	\$30.00 each
2 One or more RADIOTRON Tube Sockets.....		UR-542	1.00 "	UT-541	2.50 "
3 Filament Rheostat.....	Rh.	PR-535	3.00	PT-537	10.00
4 Oscillation Transformer.....	L	UL-1008	11.00	UL-1008	11.00
5 Antenna Series Condenser.....	C ₁	UC-1015	5.40	UC-1015	5.40
6 Magnetic Modulator.....	MM	(See Note 4)		(See Note 4)	
7 Magnetic Modulator Battery.....	*B	6 Volts		6 Volts	
8 Antenna Ammeter.....	A	UM-530	6.00	UM-533	6.25
9 Transmitter Grid Leak.....	R _g	UP-1719	1.10	UP-1718	1.65
10 Grid Condenser.....	C ₂	UC-1014	2.00	UC-1014	2.00
11 Blocking Condenser.....	C ₃	UC-1014	2.00	UC-1014	2.00
12 Radio Frequency Choke.....	X	(See Note 1)		(See Note 2)	
13 Protective Condenser.....	C ₄	UC-1632	1.85	UC-1634	1.50
14 Filament Battery.....	B ₂	10 Volts		12 Volts	
15 Motor Generator.....	MG	(See Note 3)		(See Note 3)	
16 Microphone.....	†M	284-W		284-W	
17 Microphone Milliammeter.....	A ₁				
18 Microphone Battery Switch.....	S.W.	S.P.S.T.		S.P.S.T.	

NOTE 1:—0.5 Mil-Henry Radio Frequency Choke
Approximately 90 turns No. 30 B. & S. (cotton or silk insulation) on a tube 2¼ in. diameter, length of winding 2 in., inductance 0.5 mil-henry at 1,000 cycles.

NOTE 2:—2.2 Mil-Henries Radio Frequency Choke
Approximately 260 turns No. 30 B. & S. (cotton or silk insulation) on a tube 2¼ in. diameter, length of winding 3½ in., inductance 2.2 mil-henries at 1,000 cycles.

NOTE 4:—Proper Size of Magnetic Modulator

No. of Tubes	UV-202	No. of Tubes	UV-203
1	UP-1346	1	UP-1357
2	UP-1346	2	UP-1367
3	UP-1357	3	UP-1367
4	UP-1357		

NOTE 3:—Rating of Motor Generators
UV-202

No. of Tubes	Watts M. G.	Plate Volts
1 or 2	100	350
2 or 4	200	350

UV-203

No. of Tubes	Watts M. G.	Plate Volts
1	200	750-1000
2 or 3	500	750-1000

* Four Dry Cells or 6-Volt Storage Battery. † Western Electric 284-W is recommended.

REMEMBER—You can convert your C. W. telegraph set into a telephone set by inserting a magnetic modulator in the antenna circuit as shown above.

FIG. 2. C. W. AND I. C. W. (GRID CHOPPER) CIRCUIT FOR OPERATION FROM D. C. SUPPLY WITH RADIOTRONS UV-202 OR UV-203

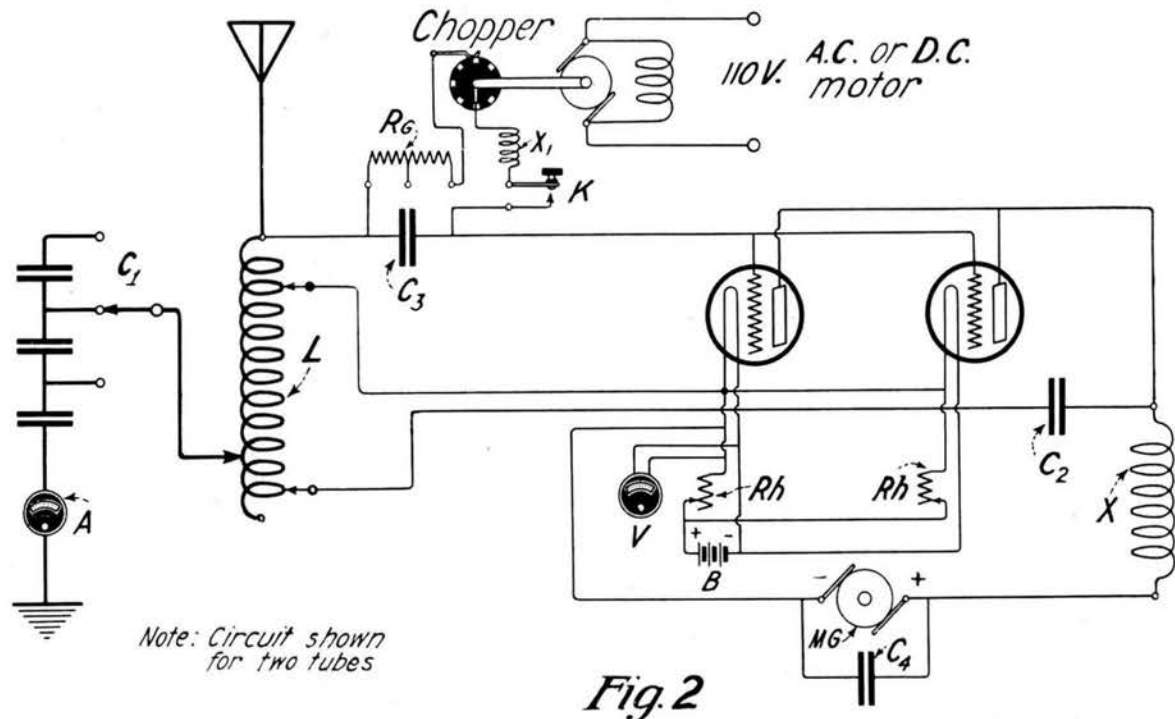

Note: Circuit shown for two tubes

Fig. 2

LIST OF MATERIAL	CIRCUIT SYMBOL	RATING OF RADIOTRONS			
		5-WATT TUBES		50-WATT TUBES	
		MODEL	PRICE	MODEL	PRICE
1 One or more RADIOTRON Power Tubes.....		UV-202	\$8.00 each	UV-203	\$30.00 each
2 One or more RADIOTRON Tube Sockets.....		UR-542	1.00 "	UT-541	2.50 "
3 Oscillation Transformer.....	L	UL-1008	11.00	UL-1008	11.00
4 Antenna Series Condenser.....	C ₁	UC-1015	5.40	UC-1015	5.40
5 Blocking Condenser.....	C ₂	UC-1014	2.00	UC-1014	2.00
6 Transmitter Grid Leak.....	R _g	UP-1719	1.10	UP-1718	1.65
7 Grid Condenser.....	C _s	UC-1014	2.00	UC-1014	2.00
8 Transmitting Key.....	K	UQ-809	3.00	UQ-809	3.00
9 Chopper.....	Chopper	PX-1638	7.25	PX-1638	7.25
10 Radio Frequency Chokes.....	X	(See Note 1)		(See Note 2)	
11 D. C. Filament Voltmeter.....	V	0-15 Volts		0-15 Volts	
12 Filament Rheostat.....	R _h	PR-535	3.00	PT-537	10.00
13 Filament Battery.....	B	10 Volts		12 Volts	
14 Protective Condenser.....	C ₄	UC-1632	1.35	UC-1635	2.00
15 Motor Generator.....	MG	(See Note 2)		(See Note 3)	
16 Antenna Ammeter.....	A	UM-530	6.00	UM-533	6.25
17 Radio Frequency Choke.....	X ₁	(See Note 1)		(See Note 1)	

NOTE 1:—0.5 Mil-Henry Radio Frequency Choke
Approximately 90 turns No. 30 B. & S. (cotton or silk insulation) on a tube 2¼ in. diameter, length of winding 2 in., inductance 0.5 mil-henry at 1,000 cycles.

NOTE 2:—2.2 Mil-Henries Radio Frequency Choke
Approximately 260 turns No. 30 B. & S. (cotton or silk insulation) on a tube 2¼ in. diameter, length of winding 3½ in., inductance 2.2 mil-henries at 1,000 cycles.

NOTE 3:—Rating of Motor Generators
UV-202

No. of Tubes	Watts M. G.	Plate Volts
1 or 2	100	350
2 or 4	200	350

UV-203

No. of Tubes	Watts M. G.	Plate Volts
1	200	750-1000
2 or 3	500	750-1000

REMEMBER—In general a grid chopper gives the same kind of a signal at the receiving station as a spark set gives, and generally over much greater distances.

FIG. 3. METHOD OF USING 5 OR 50-WATT RADIOTRON POWER TUBES WITH 60-CYCLE A. C. SOURCE FOR C. W. TONE TELEGRAPHY

(Full wave self-rectification)

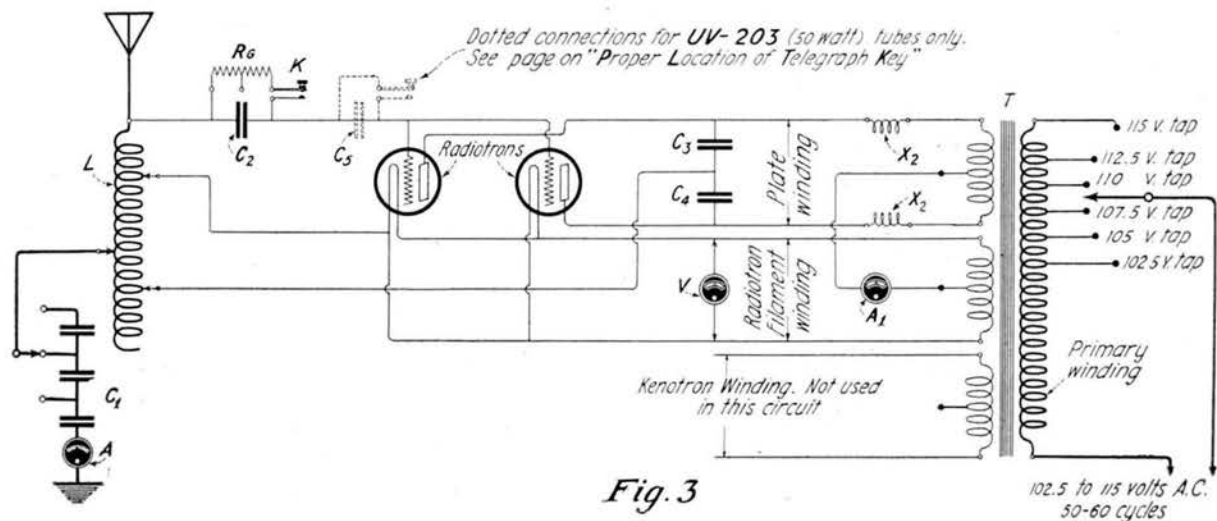

Fig. 3

LIST OF MATERIAL	CIRCUIT SYMBOL	RATING OF RADIOTRONS			
		5-WATT TUBES		50-WATT TUBES	
		MODEL	PRICE	MODEL	PRICE
1 Two RADIOTRON Power Tubes (see Note 3)		UV-202	\$16.00	UV-203	\$60.00
2 Two Power Tube Sockets		UR-542	2.00	UT-541	5.00
3 Power Transformers	T	UP-1368	25.00	UP-1016	38.50
4 Oscillation Transformer	L	UL-1008	11.00	UL-1008	11.00
5 Two Radio Frequency By-pass Condensers	C ₃ -C ₄	UC-1014	4.00	UC-1014	4.00
6 Grid Condenser	C ₂	UC-1014	2.00	UC-1014	2.00
7 Transmitter Grid Leak	R _g	UP-1719	1.10	UP-1718	1.65
8 Antenna Series Condenser	C ₁	UC-1015	5.40	UC-1015	5.40
9 A. C. Filament Voltmeter	V	0-15 Volts		0-15 Volts	
10 Antenna Ammeter	A	UM-530	6.00	UM-533	6.25
11 D. C. Plate Milliammeter	A ₁	O-250 M. A.		O-500 M. A.	
12 Transmitting Key	K	UQ-809	3.00	UQ-809	3.00
13 Radio Frequency Chokes	X ₁	(See Note 1)		(See Note 2)	
14 Keying Condenser	C ₅			UC-1635	2.00

NOTE 1:—0.5 Mil-Henry Radio Frequency Choke

Approximately 90 turns No. 30 B. & S. (cotton or silk insulation) on a tube 2¼ in. diameter, length of winding 2 in., inductance 0.5 mil-henry at 1,000 cycles.

NOTE 2:—2.2 Mil-Henries Radio Frequency Choke

Approximately 260 turns No. 30 B. & S. (cotton or silk insulation) on a tube 2¼ in. diameter, length of winding 3½ in., inductance 2.2 mil-henries at 1,000 cycles.

NOTE 3:—Transformer UP-1368 is capable of handling a total of four UV-202 tubes in a self-rectifying circuit.

In order to obtain a 20-watt set, it is only necessary to add two additional UV-202 tubes, one in parallel with each of the tubes shown in the circuit.

REMEMBER—When using a motor-generator for plate supply to one or more power tubes, be sure that the watts output of the generator is sufficient to supply all the tubes. Do not use a 15-watt generator for plate supply to a 50-watt RADIOTRON. A table showing the generator watts output for various numbers of tubes is shown on page 12.

FIG. 4. COMPLETE DIAGRAM FOR LOW POWER RADIOPHONE SET, USING CONSTANT CURRENT MODULATION SYSTEM WITH 5*OR 50-WATT RADIOTRON POWER TUBES OPERATING FROM 110-VOLTS A. C. SUPPLY.

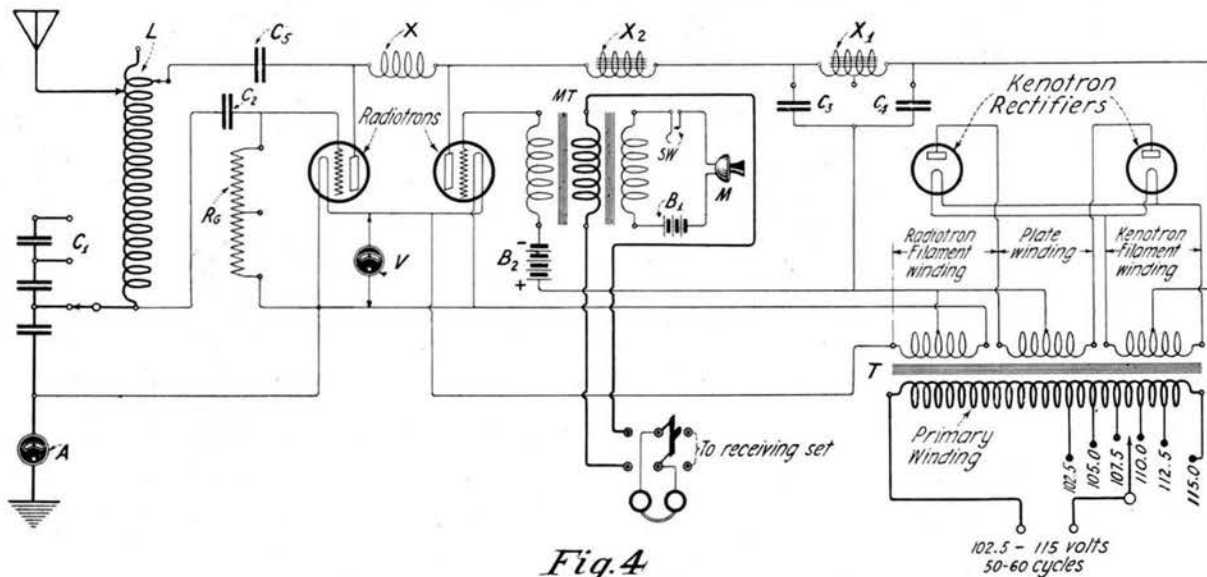

Fig. 4

LIST OF MATERIAL		CIRCUIT SYMBOL	RATING OF RADIOTRONS			
			5-WATT TUBES		50-WATT TUBES	
			MODEL	PRICE	MODEL	PRICE
1	Two RADIOTRON Power Tubes.....		UV-202	\$16.00	UV-203	\$60.00
2	Two Power Tube Sockets.....		UR-542	2.00	UT-541	5.00
3	Power Transformer.....	T	UP-1368	25.00	UP-1016	38.50
4	Oscillation Transformer.....	L	UL-1008	11.00	UL-1008	11.00
5	Two KENOTRON Rectifier Tubes.....		UV-216	15.00	UV-217	53.00
6	Two KENOTRON Tube Sockets.....		UR-542	2.00	UT-541	5.00
7	Radio Frequency Choke Coil.....	X	(See Note 1)		(See Note 2)	
8	Plate Reactor.....	X ₂	UP-415	5.75	UP-415	5.75
9	Filter Reactor.....	X ₁	UP-1626	11.50	UP-1627	15.75
10	Filter Circuit Condensers.....	C ₃ C ₄	(See Note 3)	3.20	(See Note 3)	10.00
11	Microphone Transformer.....	MT	UP-414	7.25	UP-414	7.25
12	Microphone Transmitter.....	†M	284-W		284-W	
13	Microphone Battery.....	*B ₁	6 Volts		6 Volts	
14	Microphone Switch.....	SW	S.P.S.T.		S.P.S.T.	
15	Grid Bias Battery.....	‡B ₂	44 Volts		44 Volts	
16	A. C. Filament Voltmeter.....	V	0-15 Volts		0-15 Volts	
17	Transmitter Grid Leak.....	R _g	UP-1719	1.10	2 UP-1718	3.30
18	Antenna Series Condenser.....	C ₁	UC-1015	5.40	UC-1015	5.40
19	Antenna Ammeter.....	A	UM-530	6.00	UM-533	6.35
20	Blocking Condenser.....	C ₅	UC-1014	2.00	UC-1014	2.00
21	Grid Condenser.....	C ₂	2-UC-1014 (in series)	4.00	2-UC-1014 (in series)	4.00

NOTE 1:—0.5 Mil-Henry Radio Frequency Choke

Approximately 90 turns No. 30 B. & S. (cotton or silk insulation) on a tube 2¼ in. diameter, length of winding 2 in., inductance 0.5 mil-henry at 1,000 cycles.

NOTE 2:—2.2 Mil-Henries Radio Frequency Choke

Approximately 260 turns No. 30 B. & S. (cotton or silk insulation) on a tube 2¼ in. diameter, length of winding 3½ in., inductance 2.2 mil-henries at 1,000 cycles.

NOTE 3:—

	2 UV-202	4 UV-202	2 UV-203
C ₃	1-UC-1631	1-UC-1632	2-UC-1635 in parallel
C ₄	1-UC-1632	2-UC-1632 in parallel	3-UC-1635 in parallel

*Four Dry Cells or 6-Volt Storage Battery.

†Western Electric No. 284-W is recommended.

‡Two Blocks of Burgess' Battery, 22½ Volts each, No. 2156.

REMEMBER — All of the energy of your power tubes can be efficiently delivered to your antenna on wave lengths of 200 meters and lower.

FIG. 5. RADIOPHONE OR TELEGRAPH CIRCUIT, USING FULL WAVE RECTIFICATION FROM A. C. SUPPLY WITH CONSTANT FREQUENCY (INTERMEDIATE) CIRCUIT AND MAGNETIC MODULATOR.

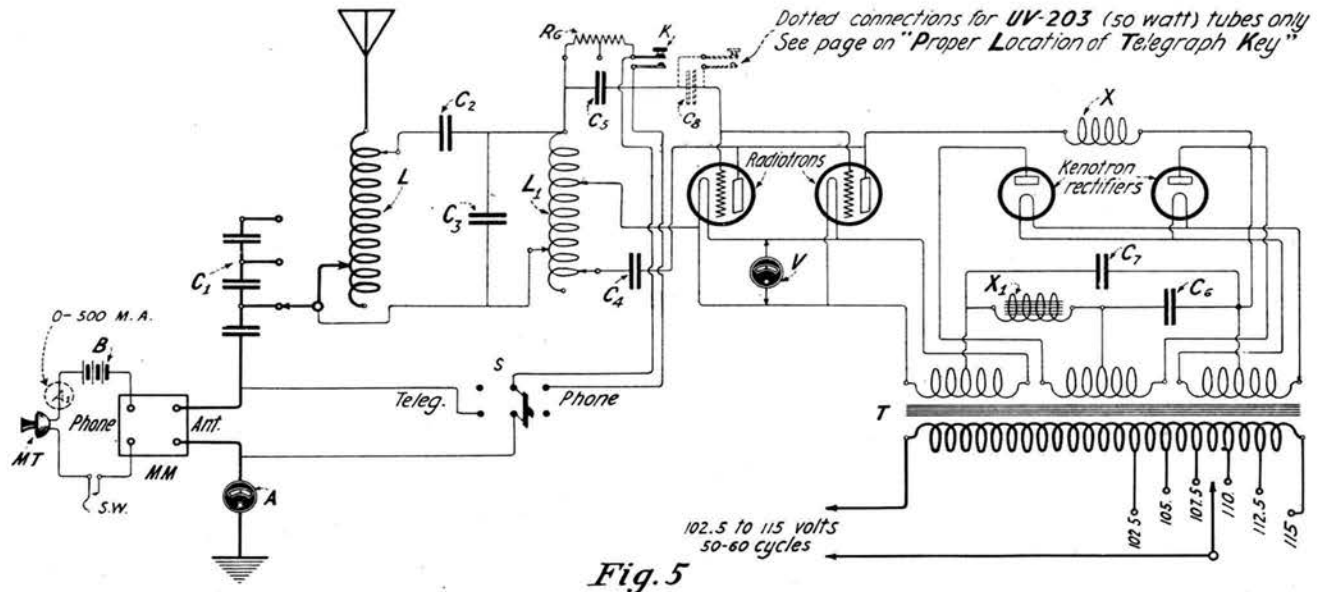

Fig. 5

LIST OF MATERIAL		CIRCUIT SYMBOL	RATING OF RADIOTRONS			
			5-WATT TUBES		50-WATT TUBES	
			MODEL	PRICE	MODEL	PRICE
1	Two RADIOTRON Power Tubes		UV-202	\$16.00	UV-203	\$60.00
2	Two RADIOTRON Power Sockets		UR-542	2.00	UT-541	5.00
3	Two KENOTRON Rectifier Tubes		UV-216	15.00	UV-217	53.00
4	Two KENOTRON Tube Sockets		UR-542	2.00	UT-541	5.00
5	Antenna Series Condenser	C ₁	UC-1015	5.40	UC-1015	5.40
6	Magnetic Modulator	MM	(See Note 3)		(See Note 3)	
7	Magnetic Modulator Battery	*B	6 Volts		6 Volts	
8	Microphone	†MT	284-W		284-W	
9	Antenna Ammeter	A	UM-530	6.00	UM-533	6.25
10	Coupling Condenser	C ₂	UC-1803	5.00	UC-1803	5.00
11	Intermediate Shunt Condenser	C ₃	UC-1015	5.40	UC-1015	5.40
12	Blocking Condenser	C ₄	UC-1014	2.00	UC-1014	2.00
13	Grid Condenser	C ₅	UC-1014	2.00	UC-1014	2.00
14	Filter Condenser	C ₆	UC-1631	1.35	2-UC-1635 in parallel	4.00
15	Filter Condenser	C ₇	UC-1632	1.35	3-UC-1635 in parallel	6.00
16	Antenna Inductance	L	UL-1008	11.00	UL-1008	11.00
17	Transmitter Grid Leak	R _g	UP-1719	1.10	UP-1718	1.65
18	A. C. Filament Voltmeter	V	0-15 Volts		0-15 Volts	
19	Power Transformer	T	UP-1368	25.00	UP-1016	38.50
20	Radio Frequency Choke	X	(See Note 1)		(See Note 2)	
21	Filter Reactor	X ₁	UP-1626	11.50	UP-1627	15.75
22	Oscillating Transformer	L ₁	UL-1008	11.00	UL-1008	11.00
23	Telegraph Key	K	UQ-809	3.00	UQ-809	3.00
24	Keying Condenser	C ₈			UC-1635	2.00
25	Modulator Short Circuiting Switch	S	D.P.D.T.		D.P.D.T.	
26	Microphone Milliammeter	A ₁				
27	Microphone Battery Switch	SW	S.P.S.T.		S.P.S.T.	

NOTE 1:—0.5 Mil-Henry Radio Frequency Choke
Approximately 90 turns No. 30 B. & S. (cotton or silk insulation) on a tube 2¼ in. diameter, length of winding 2 in., inductance 0.5 mil-henry at 1,000 cycles.

NOTE 2:—2.2 Mil-Henries Radio Frequency Choke
Approximately 260 turns No. 30 B. & S. (cotton or silk insulation) on a tube 2¼ in. diameter, length of winding 3½ in., inductance 2.2 mil-henries at 1,000 cycles.

NOTE 3:—Proper Size of Magnetic Modulator

No. of Tubes	UV-202	No. of Tubes	UV-203
1	UP-1346	1	UP-1357
2	UP-1346	2	UP-1367
3	UP-1357	3	UP-1367
4	UP-1357		

* Four Dry Cells or 6-Volt Storage Battery.
† Western Electric No. 284-W is recommended.

REMEMBER—It is not necessary to purchase a motor-generator if you have a source of 110 volt A. C. lighting current, for it can be converted to D. C. by using KENOTRON rectifiers.

FIG. 6. D. C. RADIOPHONE CIRCUIT, USING RADIOTRONS UV-203 FOR THE OSCILLATOR, MODULATOR AND SPEECH AMPLIFIER, WITH 1,000 VOLTS D. C. PLATE SUPPLY.

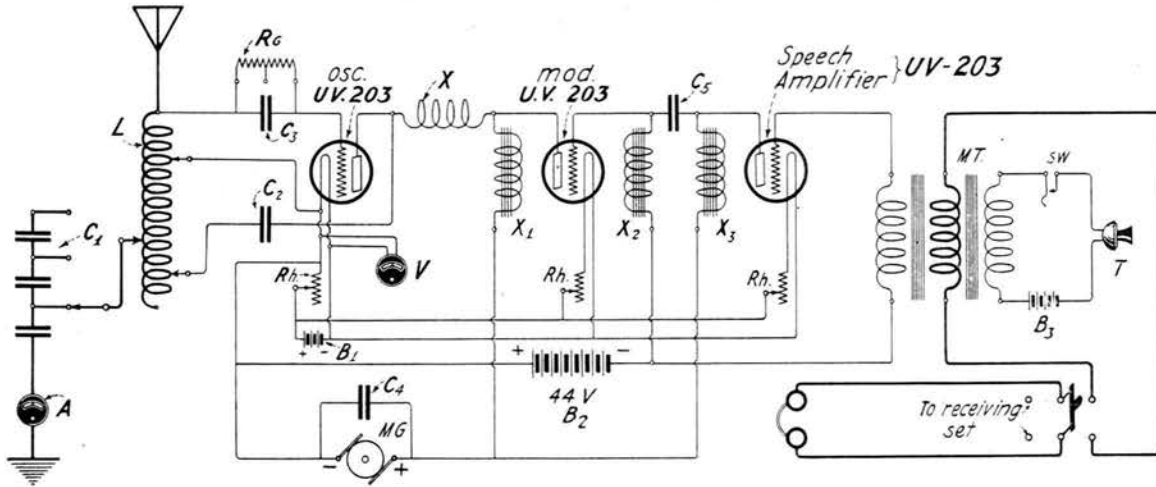

Fig. 6

LIST OF MATERIAL	CIRCUIT SYMBOL	RATING OF RADIOTRONS	
		50-WATT TUBES	
		MODEL	PRICE
1 One RADIOTRON "Oscillator".....	OSC	UV-203	\$30.00
2 One RADIOTRON "Modulator".....	MOD	UV-203	30.00
3 One RADIOTRON "Speech Amplifier".....	SA	UV-203	30.00
4 Three Sockets.....		UT-541	7.50
5 Oscillation Transformer.....	L	UL-1008	11.00
6 Antenna Series Condenser.....	C ₁	UC-1015	5.40
7 Antenna Ammeter.....	A	UM-533	6.25
8 Blocking Condenser.....	C ₂	UC-1014	2.00
9 Grid Condenser.....	C ₃	UC-1014	2.00
10 Transmitter Grid Leak.....	R _g	UP-1718	1.65
11 Radio Frequency Choke.....	X	(See Note 1)	
12 Plate Reactor.....	X ₁	UP-415	5.75
13 Three Filament Rheostats.....	Rh	PT-537	30.00
14 Filament Battery.....	B ₁	12 Volts	
15 Protective Condenser.....	C ₄	UC-1634	1.50
16 Motor Generator.....	MG	(See Note 2)	
17 Grid Bias Battery.....	*B ₂	44 Volts	
18 Amplifier Coupling Condenser.....	C ₅	UC-1634	1.50
19 Modulator Grid Reactor.....	X ₂	UP-415	5.75
20 Amplifier Plate Reactor.....	X ₃	UP-415	5.75
21 Microphone Transformer.....	MT	UP-414	7.25
22 Microphone Battery.....	†B ₃	6 Volts	
23 Microphone Transmitter.....	‡T	284-W	
24 D. C. Filament Voltmeter.....	V	O-15 Volts	

NOTE 1:—2.2 Mil-Henries Radio Frequency Choke

Approximately 260 turns No. 30 B. & S. (cotton or silk insulation) on a tube 2¼ in. diameter, length of winding 3½ in., inductance 2.2 mil-henries at 1,000 cycles.

NOTE 2:—Rating of Motor Generators

UV-202		
No. of Tubes	Watts M. G.	Plate Volts
1 or 2	100	350
2 or 4	200	350

UV-203		
No. of Tubes	Watts M. G.	Plate Volts
1	200	750-1000
2 or 3	500	750-1000

* Two Blocks of Burgess' Battery, No. 2156.
 † Western Electric No. 284-W is recommended.
 ‡ Four Dry Cells or 6-Volt Storage Battery.

REMEMBER—The life of RADIOTRON power tubes depends upon proper operation. Do not use a greater voltage on the filament than that specified, and do not overload the plate by using an excessive plate voltage, that is IF YOU WANT LONG LIFE.

FIG. 7. RADIOPHONE CIRCUIT, USING FOUR RADIOTRONS UV-202 AND FOUR KENOTRONS, UV-216, FOR TELEPHONY, WITH CONSTANT CURRENT SYSTEM OF MODULATION.

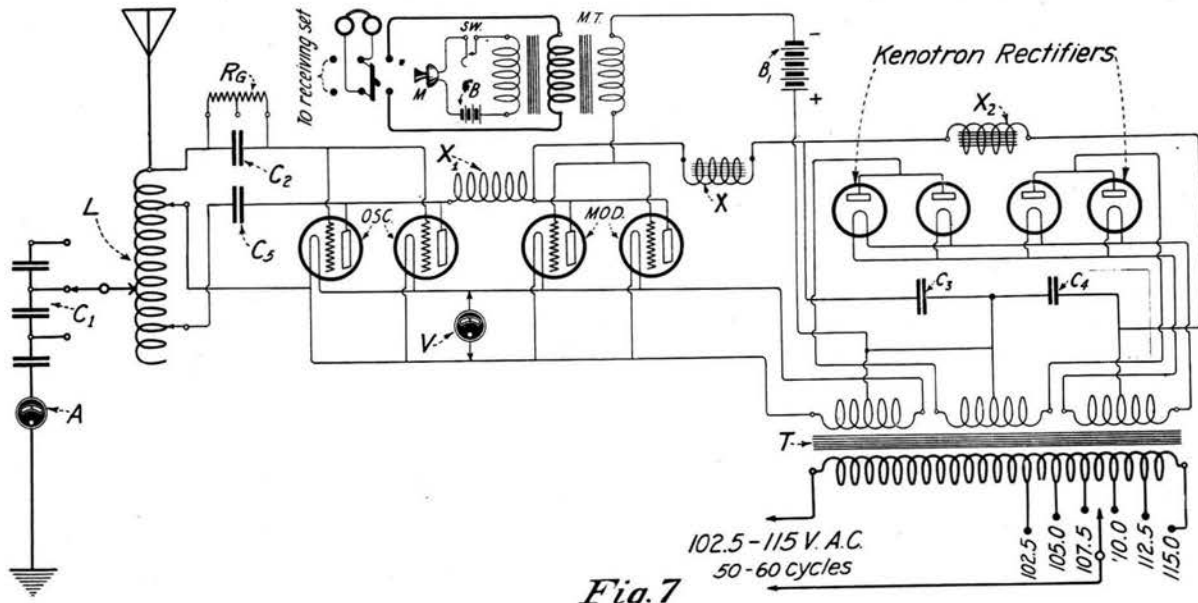

Fig. 7

LIST OF MATERIAL	CIRCUIT SYMBOL	RATING OF RADIOTRONS	
		5-WATT TUBES	
		MODEL	PRICE
1 Two RADIOTRON Oscillator Tubes.....		UV-202	\$16.00
2 Two RADIOTRON Modulator Tubes.....		UV-202	16.00
3 Four KENOTRON Rectifier Tubes.....		UV-216	30.00
4 Eight Sockets.....		UR-542	8.00
5 Antenna Series Condenser.....	C ₁	UC-1015	5.40
6 Antenna Ammeter.....	A	UM-530	6.00
7 Grid Condenser.....	C ₂	UC-1014	2.00
8 Transmitter Grid Leak.....	R _g	UP-1719	1.10
9 Oscillation Transformer.....	L	UL-1008	11.00
10 Radio Frequency Choke.....	X ₁	(See Note 1)	
11 Plate Reactor.....	X	UP-415	5.75
12 Microphone Transformer.....	MT	UP-414	7.25
13 Microphone Battery.....	*B	6 Volts	
14 Microphone.....	†M	284-W	
15 Grid Bias Battery.....	‡B ₁	44 Volts	
16 Power Transformer.....	T	UP-1368	25.00
17 Filter Reactor.....	X ₂	UP-1626	11.50
18 Filter Condenser.....	C ₃	UC-1635	2.00
19 Filter Condenser.....	C ₄	UC-1635	2.00
20 Blocking Condenser.....	C ₅	UC-1014	2.00
21 A. C. Filament Voltmeter.....	V	0-15 Volts	
22 Microphone Switch.....	SW	S.P.S.T.	

NOTE 1:—0.5 Mil-Henry Radio Frequency Choke

Approximately 90 turns No. 30 B. & S. (cotton or silk insulation) on a tube 2¼ in. diameter, length of winding 2 in., inductance 0.5 mil-henry at 1,000 cycles.

* Four Dry Cells or 6-Volt Storage Battery.
 † Western Electric No. 284-W is recommended.
 ‡ Two Blocks of Burgess' Battery, No. 2156.

REMEMBER—Power tube filaments should be burned at constant voltage rather than constant current. This will prolong their useful life.

FIG. 8. CONSTANT FREQUENCY CIRCUIT, USING FULL WAVE RECTIFICATION FOR FOUR RADIOTRONS UV-202 AND FOUR KENOTRONS, UV-216 FOR TELEGRAPH AND TELEPHONE (CHOPPER AND MAGNETIC MODULATOR)

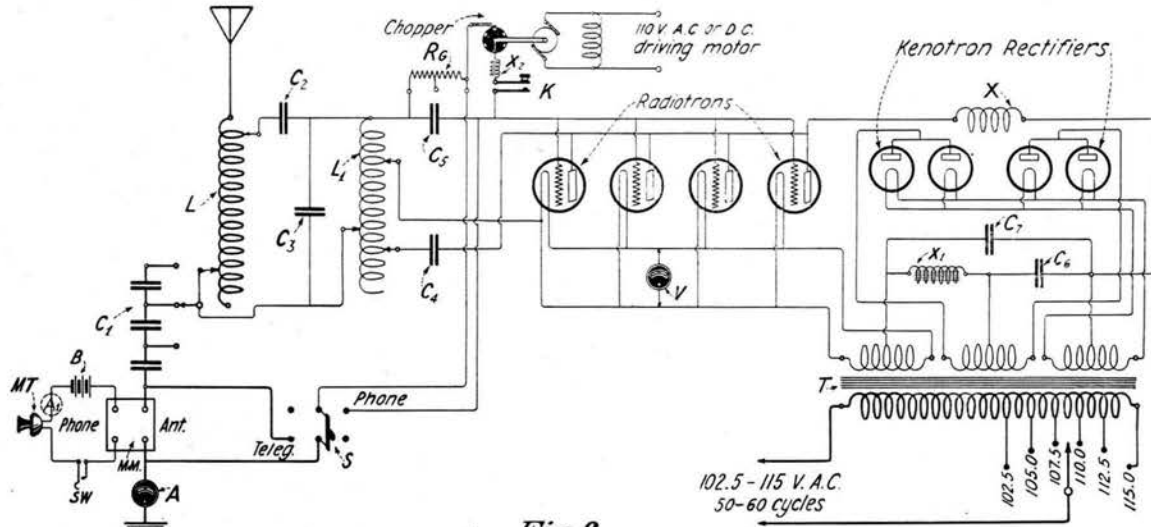

Fig. 8

LIST OF MATERIAL	CIRCUIT SYMBOL	RATING OF RADIOTRONS	
		5-WATT TUBES	
		MODEL	PRICE
1 Four RADIOTRON Power Tubes.....		UV-202	\$32.00
2 Four KENOTRON Rectifier Tubes.....		UV-216	30.00
3 Eight RADIOTRON Sockets.....		UR-542	8.00
4 Antenna Series Condenser.....	C	UC-1015	5.40
5 Magnetic Modulator.....	MM	(See Note 2)	
6 Magnetic Modulator Battery.....	*B	6 Volts	
7 Microphone.....	†MT	284-W.	
8 Antenna Ammeter.....	A	UM-530	6.00
9 Coupling Condenser.....	C ₂	UC-1803	5.00
10 Intermediate Shunt Condenser.....	C ₃	UC-1015	5.40
11 Oscillation Transformer.....	L ₁	UL-1008	11.00
12 Blocking Condenser.....	C ₄	UC-1014	2.00
13 Grid Condenser.....	C ₅	UC-1014	2.00
14 Filter Condenser.....	C ₆	2-UC-1632 in parallel	3.70
15 Filter Condenser.....	C ₇	UC-1632	1.85
16 Antenna Inductance.....	L	UL-1008	11.00
17 Transmitter Grid Leak.....	R _g	UP-1719	1.10
18 A. C. Filament Voltmeter.....	V	0-15 Volts	
19 Power Transformer.....	T	UP-1368	25.00
20 Radio Frequency Choke.....	X	(See Note 1)	
21 Filter Reactor.....	X ₁	UP-1626	11.50
22 Switch.....	S	D.P.D.T.	
23 Grid Chopper.....	Chopper	PX-1638	7.25
24 Telegraph Key.....	K	UQ-809	3.00
25 Radio Frequency Choke.....	X ₂	(See Note 1)	
26 Microphone Milliammeter.....	A ₁		

NOTE 1:—0.5 Mil-Henry Radio Frequency Choke

Approximately 90 turns No. 30 B. & S. (cotton or silk insulation) on a tube 2 1/4 in. diameter, length of winding 2 in., inductance 0.5 mil-henry at 1,000 cycles.

*Four Dry Cells or 6-Volt Storage Battery.
†Western Electric No. 284-W is recommended.

NOTE 2:—Proper Size of Magnetic Modulator

No. of Tubes	UV-202	No. of Tubes	UV-203
1	UP-1346	1	UP-1357
2	UP-1346	2	UP-1367
3	UP-1357	3	UP-1367
4	UP-1357		

REMEMBER—The life of the filament of RADIOTRON power tubes is dependent upon its temperature. A 3 per cent. increase in filament current will halve the life of your tubes, and a 3 per cent. decrease will DOUBLE THE LIFE.

FIG. 9. SELF-RECTIFYING C. W. TELEGRAPH CIRCUIT, USING TWO UV-204 RADIOTRONS (250-WATT POWER TUBES).

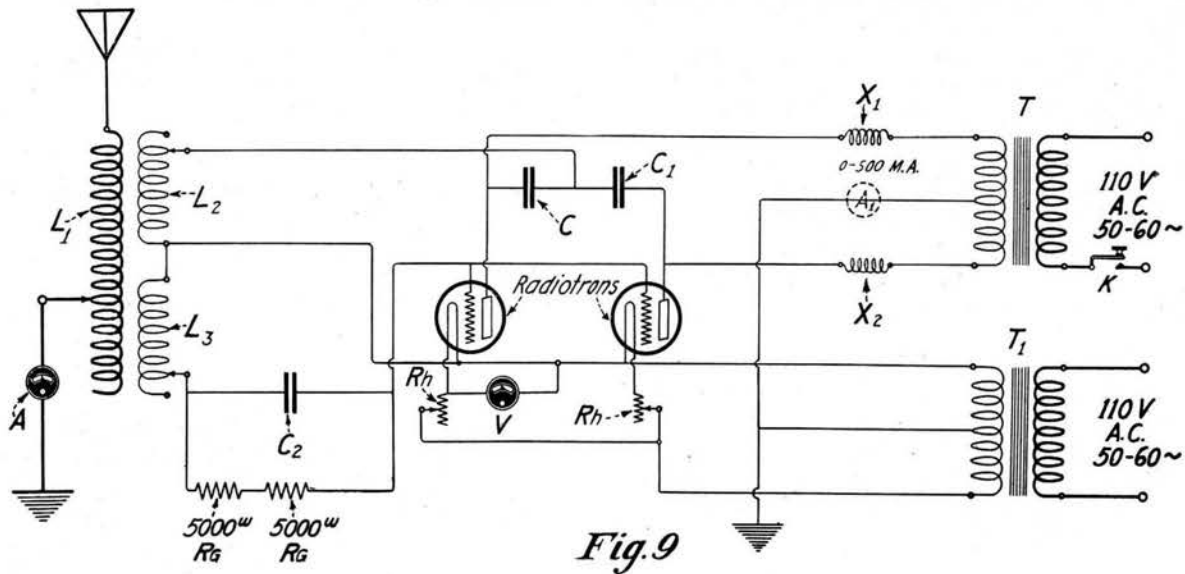

Fig. 9

LIST OF MATERIAL	CIRCUIT SYMBOL	RATING OF RADIOTRONS	
		250-WATT TUBES	
		MODEL	PRICE
1 Two RADIOTRON Power Tubes.....		UV-204	\$220.00
2 Two Sets of End Mountings.....		UT-501-502	4.00
3 Power Transformer.....	T	UP-1636	(See Note 3)
4 Filament Transformer.....	T ₁	UP-1633	(See Note 3)
5 Antenna Coil.....	L ₁	(See Note 1)	
6 Grid Coil.....	L ₂	(See Note 1)	
7 Plate Coil.....	L ₃	(See Note 1)	
8 Antenna Ammeter.....	A	0-15 Amps.	
9 Two Transmitting Grid Leaks.....	R _g	UP-1718	3.30
10 Transmitting Key.....	K	UQ-621	2.69
11 Two Filament Rheostats.....	R _h	PT-537	20.00
12 Grid Condenser.....	C	UC-1014	2.00
13 By-Pass Condenser.....	C ₂	UC-1806	5.00
14 By-Pass Condenser.....	C ₁	UC-1806	7.00
15 A. C. Filament Voltmeter.....	V		
16 Radio Frequency Choke.....	X ₁	(See Note 2)	
17 Radio Frequency Choke.....	X ₂	(See Note 2)	
18 Plate Ammeter.....	A ₁		

NOTE 1:—Oscillation Transformer (for two 250-Watt Tubes) 200 Meters

Coil	Diam.	Turns	Wire
L1	Antenna	6 in.	4-10 No. 10 Bare Copper Wire spaced 1/8 in. (or UL-1008)
L2	Plate	4 5/8 in.	10-20 No. 22 D. C. C. (tapped every two turns)
L3	Grid	4 5/8 in.	15-30 No. 22 D. C. C. (tapped every two turns)

NOTE 2:—2.2 Mil-Henries Radio Frequency Choke

Approximately 260 turns No. 30 B. & S. (cotton or silk insulation) on a tube 2 1/4 in. diameter, length of winding 3 1/2 in., inductance 2.2 mil-henries at 1,000 cycles.

NOTE 3:—Special quotation will be furnished on request.

REMEMBER—On any tube or group of tubes delivering over 50 watts of alternating current energy, or operating at a plate potential above 2,000 volts, a safety spark gap should be provided between the grid and filament terminals at or near the tube socket or mounting. This gap should be adjusted to between 1/32 in. and 1/4 in., depending upon the plate voltage employed and the number of tubes and type of tubes used.

THE PRACTICAL USE OF TRANSMITTING TUBES

ALTHOUGH the principles of construction and operation in the larger power tubes are no different from those applying in the case of the smaller ones, many effects that are negligible in the latter are somewhat magnified in the case of the larger tubes, and certain precautions are therefore necessary. The majority of accidents to power tubes and to their auxiliary apparatus occur during the period of development of circuits and testing and adjustment, rather than during operation, and a little care in

making these adjustments will prove of advantage.

The following points, briefly enumerated, are all of importance and should be studied by the amateur before putting his set into operation. Limited space prevents us from giving in detail the reasons for some of the instructions herein laid down, but the amateur may be assured that they are the result of practical observation and experiment and that he cannot well afford to ignore them.

TUBE SUSPENSION

The life of **RADIOTRON** power tubes may be prolonged by mounting them in the proper position. **RADIOTRONS UV-202** and **UV-203** should be operated in a vertical position,

whereas **RADIOTRON UV-204** may be operated in either a vertical or horizontal position. If mounted horizontally, the plates should lie in a vertical plane, with the seal-off tip down.

OSCILLATING CIRCUITS

In powerful C. W. transmitting sets the circuits should be so arranged that the center tap on the filament coil and also the negative lead of the direct current high voltage source are both at ground potential relative to high

frequency potentials in order to insure safety.

Great care should be taken to thoroughly insulate the grid and plate leads to the tube and the coil sections connected to these leads or any apparatus in them.

SAFETY GAPS AND GENERAL PROTECTIVE MEASURES

In order to guard against excessive transient voltages in connection with **RADIOTRONS UV-203** and **UV-204** a protective gap should be provided at or near the socket terminals between the grid and terminal and one of the filament terminals. One-sixteenth of an inch is correct for **UV-203** and one-eighth of an inch for **UV-204**.

Occasionally in the parallel operation of **RADIOTRON** power tubes ultra high frequency oscillations develop in the plate and grid circuits, which prevent the realization of full output, and cause excessive plate and grid currents.

This effect may be avoided by inserting an inductance of a few micro-henries (10 turns in one layer on a tube one inch in diameter is suggested) in one or more of the individual grid leads of each tube as close to the grid terminal of the socket as possible. The protective gap mentioned in a paragraph above should be placed between this coil and the grid terminal of the socket. The best arrangement is to mount the gap directly on the socket terminals and one terminal of the coil directly to the grid terminal of the socket.

MODULATION OF AN OSCILLATING TUBE'S OUTPUT

One method of modulation employed in a vacuum tube radio transmitting equipment utilizes a tube as a modulator in addition to the oscillator tube, the plate current for these two tubes being fed through an audio-frequency reactor. In a radio telephone transmitting equipment the degree of modulation is of equal importance to the amount of antenna current as far as the strength of the received speech is concerned. The antenna ammeter does not usually indicate whether the output is being modulated in a normal manner. One simple

method of keeping a check on this is to insert a miniature lamp in the plate circuit of the amplifier. This flashes up when the microphone is spoken into and acts as an operating indicator of the microphone and modulation circuits. A type of lamp should be chosen that will show a low degree of brilliancy with the plate currents obtained on the tube used. Even for the 5-watt size of tube such lamps are easily obtainable. Automobile types of miniature lamps are recommended.

INADVISABILITY OF FORCING POWER TUBES

It is unwise to overload a RADIOTRON power tube continuously, as its operating life will be seriously curtailed. It is a much better plan and more economical to operate two tubes in parallel than it is to force one tube to deliver a power output far in excess of what it is rated for; in fact great economy will result from burning tubes slightly below normal brightness. For instance, it can be shown that to double the filament emission will reduce the operating life of the tube by one-half, whereas by burning the tube at 95% of its normal brightness its life will be quadrupled.

When first testing the circuit, or when the set has not been operated for some time, it is wise to cut down all voltages to one-third of the normal

voltage. This will greatly reduce the possibility of burning out the tube through a wrong connection which has been overlooked, as a fault will then instantly be detected before the damage is done.

In a radio telephone transmitting circuit of the usual type a modulator tube is employed and a buzzer is often substituted for the microphone when it is desired to send out interrupted continuous waves. This imposes voltage strains on the oscillator tube and if an over-voltage is also applied to its plate the voltage between grid and filament may be excessive. The protective gaps described in a previous paragraph are a safeguard against breakdown due to this voltage.

RESISTANCE OF THE ANTENNA AND GROUND CIRCUIT

Remember it is the antenna charging current at the transmitter that produces the signals at the receiver, and in order to get a large antenna current with tube sets, the resistance of antenna systems must be reduced to a minimum. In addition to the usual metallic earth plate a counterpoise, consisting of a number of wires spread on

the ground underneath the antenna will materially reduce the total antenna resistance. The antenna should be constructed and supported so that its electrical period will not vary through swinging, for, as will be seen, most of the tube circuits shown in this bulletin use the antenna as the capacity element of the oscillating system.

FILAMENT EXCITATION OF POWER TUBES

The filaments of power bulbs are preferably energized by alternating current, which gives an added factor of safety and prolongs the filament life.

In adjusting the temperature of a filament the amateur should always use a voltmeter rather than an ammeter, and the voltmeter should be connected directly to the socket connections, in order that the voltage drop across the filament may be measured. If tungsten filaments are

operated at constant voltage rather than constant current, it will increase their life in the ratio of three to one.

If alternating current is not available the filaments may, of course, be energized from a D. C. source of suitable E. M. F. It is emphasized, however, that the life of a vacuum tube is considerably prolonged by A. C. filament excitation, and particularly if the filament voltage is maintained at constant value.

LOCATION OF THE TELEGRAPH KEY IN C. W. CIRCUITS

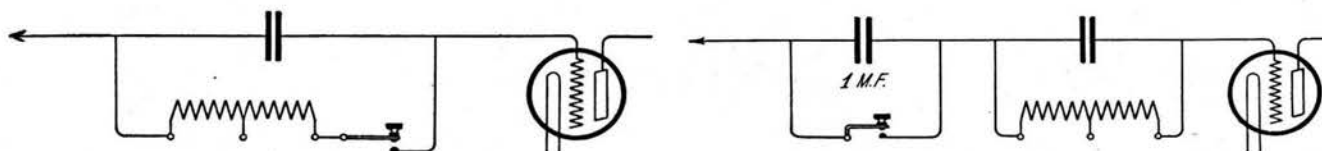

The proper location of the telegraph key in C. W. transmitting circuits is determined by the size of the RADIOTRON power tubes used. In circuits employing one or more UV-202 RADIOTRONS, satisfactory keying can be obtained by inserting the key in series with the grid leak resistance as shown above.

If, however, one or more UV-203 RADIOTRONS are used, the most satisfactory keying will be obtained if a 1 mfd. condenser is inserted in series with the parallel circuit containing the grid leak resistance and grid condenser, and the key shunted around the 1 mfd. condenser as shown above.

RADIOTRON UV-204—250-WATT TRANSMITTER

RADIOTRON UV-204 is the most powerful tube of the RADIOTRON series at present sold for experimental transmission purposes. This tube is equipped with a special filament which gives exceptionally long operating life, and it will be widely used by experimenters desiring to obtain large oscillating outputs. It is particularly adapted for experimental measurements in laboratories and for powerful C. W. radio telegraph and telephone sets for experimental use. Several experimenters using one UV-204 in oscillating circuits have obtained antenna charging currents of from five to six amperes.

UV-204 will be found serviceable in the self-rectifying and other circuits shown in this bulletin, and such a circuit will appeal to

the experimenter because of its simplicity.

Two points are worthy of special mention—namely, the large current input to the antenna that can be obtained with these tubes, and the greatly increased operating life over former tubes of this type.

This tube has been used constantly at "NSS," the official broadcasting station of the Bureau of Standards, used for the recent amateur fading tests. It was also employed in the powerful radio telephone set installed by the Radio Corporation in the Delaware, Lackawanna and Western Railroad Radio Station at Hoboken, New Jersey, which sent out the news of the Dempsey-Carpentier Boxing Bout. The Radio Corporation employs the same tube in its new types of commercial radio telegraph and telephone sets.

METHOD OF SHIPMENT

Each RADIOTRON UV-204 is packed for shipment in a separate crate, the dimensions of which are approximately 11 in. x 11 in. x 25 in. high. The net weight of the tube is approximately 1¼ pounds, and the shipping weight, crated, 7½ pounds.

The tubes are suspended in the crate by ticking.

The safest way to store the tubes is in the crates as received.

Do not expose the tubes to the weather.

Handle the crated tube and the tube itself with the same consideration as any piece of expensive glassware.

ELECTRICAL AND MECHANICAL DATA

- Overall Dimensions . . . 5 in. x 14¼ in.
- Base—Special End Mountings—
UT-501 and UT-502
- Voltage of Filament Source 12 V.
- Filament Terminal Voltage 11 V.
- Filament Current 14.75 amp.
- Plate Voltage 2000 V. normal
- Amplification Constant 25
- Plate Current 25 amp.
- Watts Output 250 normal

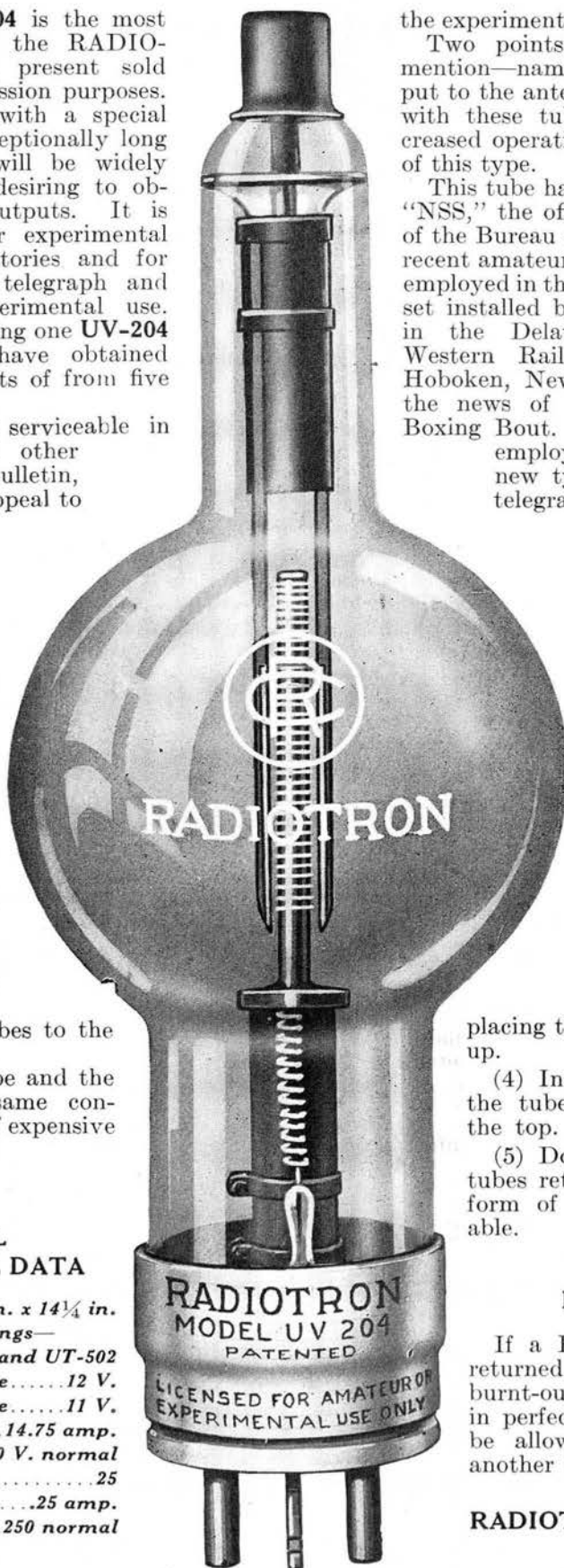

HOW TO UNPACK UV-204

(1) The slats on one side of the crate are fastened with screws. Open this side of the crate by means of a screw-driver.

(2) Remove the three screws which secure the upper strip of ticking and slip the ticking off the upper end of the tube. Then remove the tube from the crate.

(3) In crating a tube to be returned, simply reverse the operations, placing the cathode (the large end) up.

(4) Instructions for operating the tube are inside the crate at the top.

(5) Do not destroy the crate, as tubes returned to us in any other form of packing are not acceptable.

REPLACEMENT

If a RADIOTRON UV-204 is returned to our storeroom with a burnt-out filament, but otherwise in perfect condition, a rebate will be allowed on the purchase of another UV-204.

RADIOTRON UV-204 . \$110.00

RADIOTRON UV-203—50-WATT TRANSMITTER

THE 50-watt RADIOTRON will be universally used by amateurs for long-distance telephony and telegraphy. Two 50-watt tubes connected in a self-rectifying or in a straight D. C. plate excitation circuit will give antenna currents of three to four amperes at amateur wave lengths.

A single tube operated from a D. C. source or a rectified A. C. source will put two and a half to three amperes in the amateur's aerial. Hundreds of these tubes are already in use at amateur transmitting stations throughout the country, and distances up to 1900 miles have been covered by using two tubes in parallel in an appropriate oscillating circuit.

Since these tubes have been specially designed with a view to securing uniformity, several of them may be operated in parallel and large antenna charging currents may thus be generated. Using a number of RADIOTRONS UV-203, speech may be sent out over ranges of hundreds of miles.

A suitable power transformer for use with the 50-watt RADIOTRON is described on page 27.

This tube is a favorite with experimental laboratories.

ELECTRICAL AND MECHANICAL DATA

<i>Overall Dimensions . . . 2 in. x 7½ in.</i>	<i>Plate Voltage 1,000 V. Normal</i>
<i>Base Four Prong Special</i>	<i>Plate Current15 Amp.</i>
<i>Voltage of Filament Source 12 V.</i>	<i>Amplification Constant 15</i>
<i>Filament Terminal Voltage 10 V.</i>	<i>Watts Output 50 Normal</i>
<i>Filament Current 6.5 Amp.</i>	

SHIPMENT

RADIOTRON UV-203 is shipped to the customer in a standard wooden box in which the bulb is suspended in a special way to protect it from mechanical shocks or vibration. Shipping weight, 1½ lb.

RADIOTRON UV-203 \$30.00

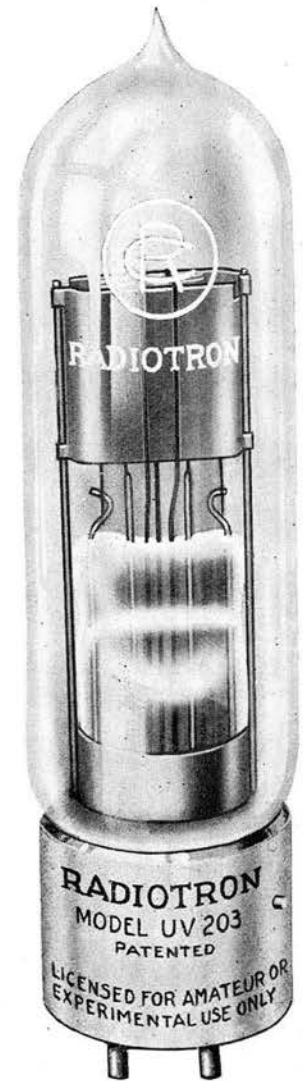

RADIOTRON UV-202—5-WATT TRANSMITTER

THIS transmitting tube is a popular one for low power radio telephone sets and for amateur C. W. telegraph sets for transmission up to distances of two hundred miles. Two 5-watt tubes in parallel will put from one and one-quarter to one and three-quarters amperes in the amateur's antenna. Using one of these tubes as a modulator and the other as an oscillator for experimental radio telephony, distances up to forty miles can be covered, and at least four times that distance when the two tubes are connected in parallel for C. W. telegraphy. Four or five 5-watt RADIOTRONS can be worked in parallel with increased range.

The 5-watt tubes may also be used as power amplifiers in radio receiving circuits. The energy amplification obtained therefrom is particularly useful for the operation of loud speakers.

ELECTRICAL AND MECHANICAL CHARACTERISTICS

<i>Overall Dimensions 2½ in. x 5 in.</i>	<i>Plate Voltage 350 V. Normal</i>
<i>Base Four Prong Standard</i>	<i>Plate Current045 Amp.</i>
<i>Voltage of Filament Source 10 V.</i>	<i>Output Impedance 4,000 Ohms</i>
<i>Filament Terminal Voltage 7.5 V.</i>	<i>Amplification Constant 8</i>
<i>Filament Current 2.35 Amp.</i>	<i>Watts Output 5 Normal</i>

SHIPMENT

RADIOTRON UV-202 is shipped in a standard cardboard carton in which the tube is well protected from mechanical shocks or vibration. Shipping weight, 1 lb.

RADIOTRON UV-202 \$8.00



KENOTRON RECTIFIER, UV-217

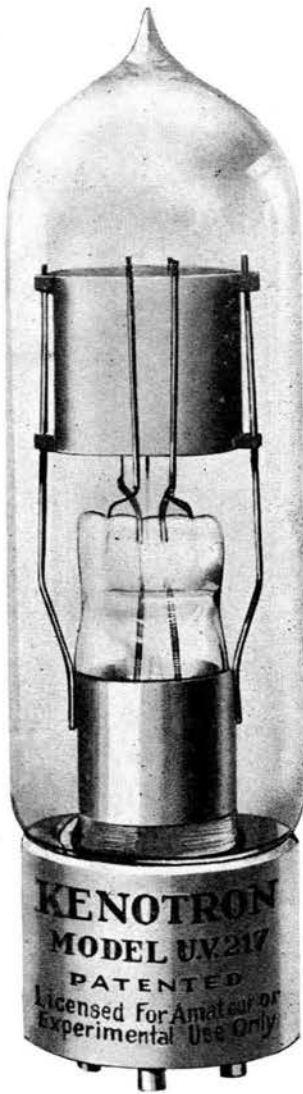

KENOTRON UV-217 is primarily intended for use with the 50-watt power tubes, to produce a D. C. plate supply from an A. C. source. It is rated at 150 watts. UV-217 should be used in connection with POWER TRANSFORMER UP-1016, listed on page 27. The combination of these two units constitutes the simplest and most practical means of obtaining direct current for the plate circuit excitation of power tubes. Remember that these rectifier valves are manufactured with the same care and accuracy as RADIOTRON power tubes, under the supervision of the same experts.

The output energy from this KENOTRON Rectifier is at a maximum when the load is such that the D. C. potential is between 900 and 1100 volts. At no load, under an A. C. voltage of 1250 volts, the D. C. voltage will rise to about 1750. On short circuit, the current will rise to about three-quarters of an ampere. It is recommended, therefore, that the D. C. circuit from the KENOTRON system be properly fused, so as to protect the KENOTRONS in case of short circuit.

Using two KENOTRONS UV-217 in a full wave rectification circuit, the D. C. current and watts output will be doubled, but the voltage at which maximum output can be obtained will be between the same limits. The output drops slightly at lower and higher D. C. voltages. This assumes a fixed A. C. input voltage of 1250.

KENOTRON UV-217 is identical in appearance with RADIOTRON UV-203, and it may be used in the same type of socket, Model UT-541. There are, of course, no connections to the grid binding post of the socket.

ELECTRICAL DATA

<i>Voltage of Filament Source</i>	12 V.
<i>Filament Terminal Voltage</i>	10 V.
<i>Filament Current</i>	6.5 Amp.
<i>A. C. Input Voltage</i>	1,250 V.
<i>D. C. Output</i>	150 Watts at 1,000 Volts D. C.

SHIPMENT

KENOTRON UV-217 is shipped to the customer in a standard wooden box in which the tube is suspended in a special way to protect it from mechanical shocks or vibration. Shipping weight: 1½ lbs.

KENOTRON UV-217.....\$26.50

KENOTRON RECTIFIER, UV-216

KENOTRON UV-216 is primarily intended for use with the 5-watt power tubes, and is rated at 20 watts. The output energy is at a maximum for these tubes when the load is such that the D. C. voltage is between 350 and 400 volts. Using two tubes in a full wave rectification circuit the D. C. current and the watts output will be doubled, but the voltage at which maximum output can be obtained will be between the same limits. The output drops slightly at lower and higher D. C. voltages, so that at 200 and 550 volts it is about 15 watts per tube. This assumes a fixed A. C. input voltage of 550. If the A. C. input voltage is raised, the voltage at which maximum power is obtained will be increased correspondingly. This will decrease the life of the KENOTRON, and lower the factor of safety.

At no load, under the A. C. voltage specified above, the D. C. voltage will rise to about 750 volts. On short circuit the current will rise to about 100 milliamperes. The insulation of the KENOTRON is designed to withstand the first condition, and the anode will take care of the excess energy of the second condition for a considerable time.

KENOTRON UV-216 is identical in appearance with RADIOTRON UV-202, and it may be used in the same type of socket, Model UR-542.

A special Power Transformer, Model UP-1368, has been developed for use with the 20-watt KENOTRON and the 5-watt transmitting tube.

Shipping weight: 1 lb.

ELECTRICAL DATA

<i>Voltage of Filament Source</i>	10 V.	<i>A. C. Input Voltage</i>	550 V.
<i>Filament Terminal Voltage</i>	7.5 V.	<i>D. C. Output</i>	
<i>Filament Current</i>	2.35 Amp.		20 Watts at 350 Volts D. C.

KENOTRON UV-216.....\$7.50

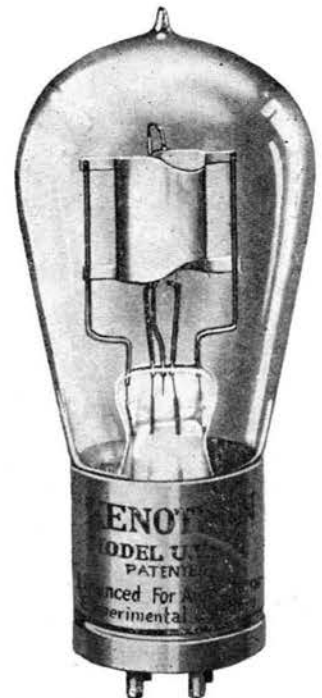

PORCELAIN SOCKETS, UT-541 AND UR-542



UR-542

THESE two sockets have been specially designed to meet the need for a reasonably priced socket which should at the same time be constructed of the very best insulating material obtainable, and should bear the stamp of quality throughout. They are direct duplicates of the types used in commercial radio sets.

Porcelain is the ideal material for use in these devices, on account of its low specific inductive capacity and its high insulating qualities. Production in great quantities enables us to keep the selling price unusually low.

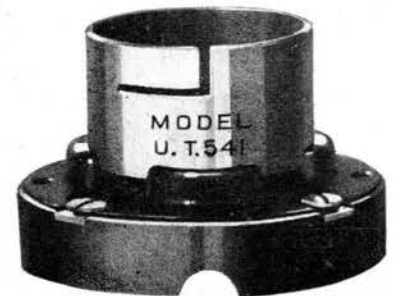

UT-541

Model **UR-542** is designed to accommodate **RADIOTRONS UV-200, UV-201 and UV-202**, as well as **KENOTRON UV-216**. Model **UR-541** is designed for **RADIOTRON UV-203**, the 50-watt power tube, and **KENOTRON UV-217**, the 150-watt rectifier tube.

- PORCELAIN SOCKET, UR-542** **\$1.00**
Size: 2 3/4 in. x 2 in. Shipping weight: 8 oz.
- PORCELAIN SOCKET, UT-541** **2.50**
Size: 3 3/4 in. x 2 3/4 in. Shipping weight: 1 lb.

END MOUNTINGS FOR UV-204

FILAMENT END, UT-501
PLATE END, UT-502

THESE mountings are designed not only to furnish perfect contact with the elements of **RADIOTRON UV-204**, but also to act as a substantial support for the tube itself.

One end of the tube is slipped into mounting **UT-501**, which carries contacts for the Filaments and grid connections. The other mounting, **UT-502**, makes contact with the plate of the tube.

Both ends are firmly held by spring clips. On the filament-end mounting is a safety gap for protecting the tube from transient voltages which might arise if the circuits were not properly adjusted, or if a lead wire were accidentally removed.

Each mounting is provided with two screw holes so that the tube may be mounted in either a vertical or horizontal position.

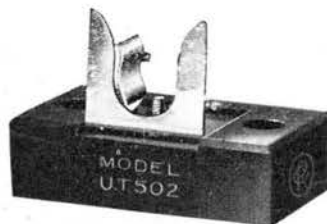

FILAMENT END UT-501

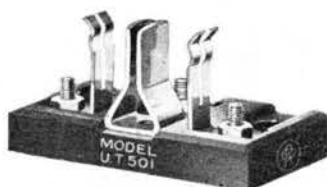

PLATE END UT-502

- END MOUNTINGS, UT-501-502**
Per Pair **\$2.00**

ANTENNA AMMETERS

UM-530 AND UM-533

AN antenna ammeter is a positive necessity in a C. W. transmitting set. Only by the use of such a meter can the amateur hold proper check on the operation of a tube transmitter. At a considerable expense the Radio Corporation has developed a type which, in addition to being low-priced, provides long operating life.

These ammeters are of the hot wire type. They have been designed with a view to accuracy and sensitivity to slight current variations; moreover, particular care has been taken to insure their remaining accurate through a long period of use.

As shown in the illustration, the ammeters are so constructed that they may be mounted flush with the transmitting panel, and are of the back-connected type. A special adjustment for taking care of temperature variations has been provided.



Size: 2 1/2 in. x 3/4 in.
Length of Studs: 3/4 in.
Shipping Weight: 1 lb.

- AMMETER, UM-530—0-2.5 amp** **\$6.00**
- AMMETER, UM-533—0-5.0 amp** **6.25**

OSCILLATION TRANSFORMER, UL-1008

FEATURES OF CLIP DESIGN

- (a) Ruggedness.
- (b) May be attached to and removed from turns with minimum effort.
- (c) Positively hold their position on the coil, and cannot be accidentally moved or detached.

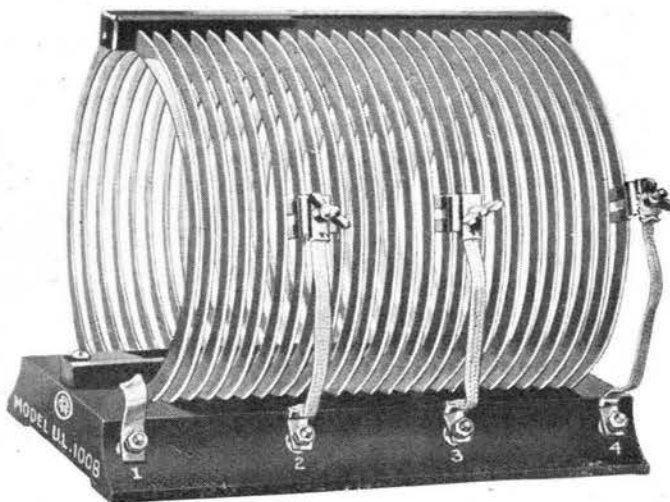

OVERALL DIMENSIONS

Height.....7⁷/₈ inches
 Width.....6¹/₄ inches
 Length.....9³/₈ inches

THIS transformer was developed primarily for use in circuits utilizing RADIOTRONS as generators of radio frequency oscillations. It may be used, however, in any set-up using conductively coupled circuits, such as an oscillation transformer coupling the primary and secondary circuits in spark transmitters.

The transformer consists of 25 turns of .060 in. x 3/8 in. copper strip, nickel-plated, with edges rounded, mounted on a wooden base which includes four binding posts, to three of which are secured flexible conductors and clips for selecting tap points on the transformer.

The clips supplied for tapping on the transformer have been specially designed to overcome the difficulties which have been experienced in the past with such connections. These clips are readily connected to or taken off the turns of the transformer and when secured to the transformer by tightening the wing nut are positive in holding their position on the coil. These clips were developed primarily for use with commercial transmitters, so that the TRANSFORMER UL-1008 includes the same form of clip as the Radio Corporation's commercial transmitters. This feature is of fundamental importance, since it is believed that these clips are the first to be developed which include the above features of design.

All metal parts of the transformer are nickel-plated. The base has a polished black finish, and the overall appearance of the unit is very pleasing.

The coil is liberally designed to withstand the potentials developed in circuits utilizing RADIOTRONS. Holes are provided in the base to permit mounting the transformer in any desired place.

OSCILLATION TRANSFORMER, UL-1008 **\$11.00**
 Size: 7⁷/₈ in. x 6¹/₄ in. x 9³/₈ in. Shipping weight: 7 lbs.

TRANSMITTING GRID LEAKS, UP-1718 AND UP-1719

THE purpose of these grid leaks is to limit the potential accumulating on the grid of an oscillating tube and thus govern the output to the antenna and also the character of the antenna oscillations.

These resistors consist of a conductor wound upon a heat-resisting silicate compound body developed to resist sudden and extreme temperature changes without becoming cracked, weakened, or in any way injured. After being wound upon this compound it is embedded in a blue vitreous enamel which is fused to a dense, uniform, glassy structure at a temperature of about 1,000 degrees Centigrade.

A metal foot is provided at each end of the grid leak to which the resistor windings are connected, and through which external connections are made. In addition, a mid-tap is provided for securing half the resistance of the whole unit.



UP-1719



UP-1718

GRID LEAK, UP-1719 **\$1.10**
 For use with 5-watt RADIOTRONS. Resistance—5,000 ohms, with mid-tap at 2,500 ohms.
 Size: 5 in. x 1¹/₄ in. Shipping weight: 1 lb.

GRID LEAK, UP-1718 **\$1.65**
 For use with 50-watt and 250-watt RADIOTRONS. Resistance—5,000 ohms, with mid-tap at 2,500 ohms.
 Size: 8¹/₂ in. x 1¹/₂ in. Shipping weight: 1 lb.

POWER TRANSFORMERS FOR TRANSMITTING TUBE SETS

Model UP-1368
Model UP-1016

Maximum Input 325 Watts
Maximum Input 750 Watts

For 5-Watt Tubes
For 50-Watt Tubes

IN designing the above transformers the engineers of the Radio Corporation have given the amateur radio experimenters two rugged and flexible units which can be utilized in numerous RADIOTRON Circuits.

The transformers permit operation from a 50/60-cycle alternating current source for (1) continuous wave telegraphy, on either a self-rectification circuit, or a KENOTRON rectified A. C. circuit, (2) interrupted continuous wave telegraphy, with or without KENOTRON rectified A. C., (3) radio telephony.

The use of alternating current provides an excellent and flexible means of supplying power for continuous wave telegraph and telephone sets. It is especially adaptable for the amateur radio experimenter because a wide range of experimentation is opened to him, at a low first cost.

These units have no maintenance cost, and their life is unlimited. The advantages over a motor generator set are obvious. In addition, this practice is exactly similar to that followed in the design of high power commercial tube transmitters. Continuous wave energy may be supplied the antenna from an A. C. self-rectification circuit such as shown on page 19. Rectified A. C. may be obtained from such a circuit by rectifying the plate supply with KENOTRON rectifying tubes as shown on page 15.

The Model **UP-1368** transformer has sufficient capacity to handle safely one to four **UV-202** RADIOTRONS as oscillators. Model **UP-1016** will supply one or two **UV-203** RADIOTRONS as oscillators. A winding is provided for lighting the filaments and a winding for the plate source. In addition, a filament winding for the KENOTRON filaments is supplied.



ELECTRICAL CHARACTERISTICS

UP-1368

Plate Winding: Output 175 watts, 1,100 volts between outside wires, midtap at 550 volts.

RADIOTRON Filament Winding: Output 75 watts, 7.5 volts, with midtap at 3.75 volts. The capacity of this transformer will supply filament current to four RADIOTRONS **UV-202** (5-watt tubes).

KENOTRON Filament Winding: Output 75 watts, 7.5 volts with midtap at 3.75 volts. Windings insulated for 1,100 volts. The capacity of this transformer will supply filament current to four KENOTRONS **UV-216**.

Primary Winding: For operation from a 50/60-cycle supply with voltage from 102.5 to 115 volts. Provision is made for voltage adjustment in steps of 2.5 volts between 102.5 and 115 volts. This is accomplished by means of taps brought out from the primary winding of the transformer to studs on a dial switch. This feature eliminates the need of filament rheostats, since it provides filament voltage adjustment in steps of approximately 2.5 volts.

UP-1016

Plate Winding: Output 450 watts, 3,000 volts between outer wires with midtap at 1,500 volts.

RADIOTRON Filament Winding: Output 140 watts, 10.5 volts between outer wires with midtap at 5.25 volts. The capacity of this transformer will supply current for two RADIOTRONS **UV-203** (50-watt tube).

KENOTRON Filament Winding: Output 140 watts, 10.5 volts between outer wires with midtap at 5.25 volts. The capacity of this transformer will supply filament current for two KENOTRONS **UV-217**.

Primary winding: Operation from a 50/60-cycle supply at a voltage from 102.5 to 115 volts. Provision is made for voltage adjustment in steps of 2.5 volts between 102.5 and 115 volts, eliminating the need of separate rheostats.

A complete rectifier set for tube operation consists of the following:

- (1) **Power Transformer**
 - (a) 325 watt, Model UP-1368
 - (b) 750 watt, Model UP-1016
- (2) **Tube Sockets** (see page 25)
- (3) **KENOTRON Values** (see page 24)
- (4) **Filter Reactor** (see page 28)
- (5) **Filter Condensers** (see page 28)



POWER TRANSFORMER, UP-1368
325 WATTS **\$25.00**
Size: 9 ³/₄ in. x 5 ¹/₂ in. x 4 ¹/₄ in. Shipping weight: 15 lbs.

POWER TRANSFORMER, UP-1016
750 WATTS **\$38.50**
Size: 9 ³/₈ in. x 7 ³/₈ in. x 6 in. Shipping weight: 30 lbs.

FILTER REACTORS, UP-1626 AND UP-1627

UP-1626
160 MILLIAMPERES

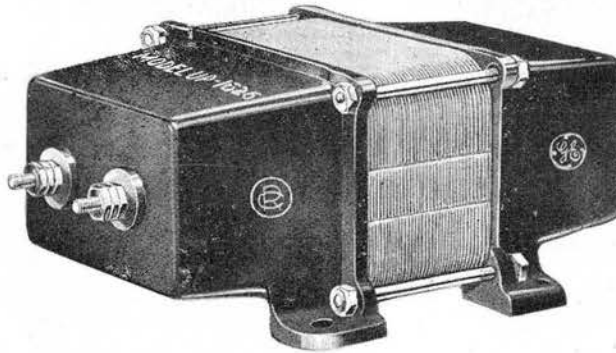

UP-1627
300 MILLIAMPERES

WHEN the plate circuit of a valve transmitting set is energized by high voltage rectified A. C., using the Radio Corporation's KENOTRON valves and power transformers, a suitable filter unit, to smooth out the rectified pulses must be provided. It has been customary heretofore to provide a relatively small inductance unit in combination with a group of condensers of rather large capacity. It is more economical, however, to provide a large inductance unit and a relatively small group of condensers, and as a consequence the two special reactors here listed have been specially developed for the purpose.

These filter reactors are of the "iron clad type," designed for use with the Radio Corporation's KENOTRON rectifier sets. Liberal copper allowance insures the minimum of losses and no change in value through use. Particular attention has been given to its insulation.

Model **UP-1626**, 160 milliamperes, is designed to operate with any circuit, either A. C. or D. C., employing from one to four 5-watt power tubes, **RADIOTRON UV-202**. It can be used in connection with either **UC-1631** or **UC-1632** filter condensers, on any kind of a circuit within the specified voltage and power rating.

Model **UP-1627**, 300 milliamperes, is designed to operate on any circuit, either A. C. or D. C., employing from one to two 50-watt power tubes, **RADIOTRON UV-203**. It can be used in connection with either of the models **UC-1634** or **UC-1635** filter condensers on any kind of a circuit within its voltage and power rating. **UP-1627** may also be used as a "smoothing-out" reactance. For 50-watt tubes, one will suffice; for 250-watt tubes, two in series should be employed.

MODEL UP-1626—160 MILLIAMPERES..... \$11.50

Size: 7 $\frac{3}{8}$ in. x 5 $\frac{1}{16}$ in. x 4 $\frac{1}{16}$ in. Shipping weight: 10 lbs.

MODEL UP-1627—300 MILLIAMPERES..... \$15.75

Size: 9 $\frac{7}{8}$ in. x 5 $\frac{11}{16}$ in. x 4 $\frac{1}{8}$ in. Shipping weight: 18 lbs.

FILTER CONDENSERS

THESE Filter Condensers are manufactured especially for the Radio Corporation's KENOTRON rectifier sets. They are intended for use with the REACTORS **UP-1626** and **UP-1627**, described above.

Figs. 1 to 9, pages 11 to 19, show the manner in which the Filter Reactors and Condensers are connected in rectifying tube sets. The number of condensers required depends upon the type of circuit employed. This is fully explained in the data given under the circuit diagrams.



UC-1631— 750 Volts .. \$1.35
Capacity 0.5 MFD.

UC-1632— 750 Volts .. 1.85
Capacity 1.0 MFD.

UC-1634—1750 Volts .. 1.50
Capacity 0.5 MFD.

UC-1635—1750 Volts .. 2.00
Capacity 1.0 MFD.

Size: 4 $\frac{3}{4}$ in. x 5 $\frac{1}{4}$ in. x 1 $\frac{3}{8}$ in.
Shipping weight: 1 lb.

PLATE CIRCUIT REACTOR, UP-415

STANDARD radio telephone circuits using one or more tubes as oscillators and one or more additional tubes as modulators require a reactor in series to the plate circuit to maintain the D. C. supply voltage to the plate at constant value, even though the output of the set is modulated at audible frequencies.

REACTOR UP-415 was designed for this purpose and for circuits using 5-watt RADIOTRONS. The reactor, in general, is built on the same lines as MICROPHONE TRANSFORMER UP-414. It is intended primarily for use in the common positive plate lead to the oscillating and modulating tubes, and as stated above, provides a constant current system of modulation. This unit has an inductance of 1 henry at audio frequencies. The D. C. resistance is approximately 640 ohms. It is well insulated between layers.

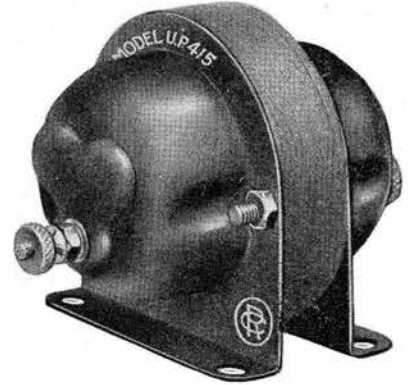

DIMENSIONS

<i>Net Weight</i>	<i>1 lb. 3½ oz.</i>	<i>Overall Height</i>	<i>2¾ inches</i>
<i>Shipping Weight</i>	<i>1 lb. 6 oz.</i>	<i>Area of Base of Mounting</i>	<i>2 inches x 2¾ inches</i>
<i>Overall Length</i>	<i>3⅞ inches</i>	<i>Test Voltage between Winding and Core</i>	<i>1300 volts at 60 cycles</i>

PLATE REACTOR, UP-415 **\$5.75**

SENDING KEY, UQ-809

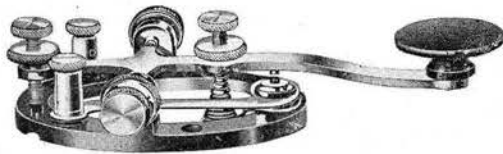

THIS key is especially serviceable for C. W. transmitting sets. The contacts are made of 1/8-inch sterling silver and, besides being interchangeable, are easily replaced. The lever arm is both light and durable and is designed to permit an operator to secure the utmost speed possible. The frame and other metal parts are brass, finely lacquered.

SENDING KEY, UQ-809 **\$3.00**
 Size: 5 in. x 2¾ in. Shipping weight: 1 lb.

MICROPHONE TRANSFORMER, UP-414

ALTHOUGH the Radio Corporation has developed a magnetic device for modulating the output of vacuum tube transmitters, many amateurs prefer to use prior methods of modulation where one or more bulbs are employed to modulate the plate circuit energy of the oscillating tubes; but, in order to obtain efficient modulation from such circuits, it is necessary to couple the grid circuit of the modulating tube to the microphone through the medium of a voltage amplifying transformer. The turn-ratio of the microphone transformer has been selected to give the most effective excitation of the grid of the modulator tubes based upon the characteristics of RADIOTRONS, when used as modulators. They are exactly the same type as used in the Radio Corporation's commercial sets, and represent the best practice in this type of equipment.

The characteristics of the transformer are such that with a suitable microphone and a battery of four dry cells connected in series with the primary coil, a secondary voltage is obtained which will provide effective control of the radiated energy. The transformer is also provided with a side tone winding, which may be connected to the telephone of a receiving set during the periods of speech transmission, thus enabling the operator to check the operation of his microphone.

UP-414 has the same appearance and dimensions as the Radio Corporation's INTERVALVE AMPLIFYING TRANSFORMER, UV-712.

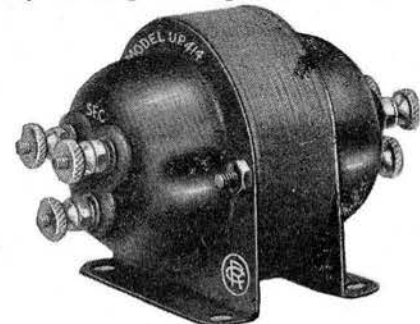

MICROPHONE TRANSFORMER WITH SIDE TONE WINDING, UP-414 **\$7.25**
 Size: 2¾ in. x 3⅞ in. x 2 in. Shipping Weight: 1 lb. 7 oz.

FILAMENT RHEOSTATS,
PR-535 AND PT-537



**FIRE-PROOF
FEATURE**
Body is composed of insulating material containing a large percentage of asbestos, thereby reducing fire hazard.



THESE new rheostats have been designed with a view to overcoming the many difficulties which have been encountered in the past with other types.

The small rheostat, Model **PR-535**, consists of a moulded base, approximately 2½ in. in diameter, on which are secured two concentric windings held securely in place by clamping screws. Connection is made to these windings by means of two sliding contacts of phosphor bronze, which form a circuit between the outside and inside windings. They are so shaped as to make continuous contact with at least two turns of wire, thus reducing tube noises, during adjustment, to a minimum.

The outstanding feature of this rheostat is the provision of three binding posts, by which the concentric resistance coils may be connected in series or parallel according to current requirements.

Model **PR-535** is designed for use with **RADIOTRONS UV-200, 201, 202** and **KENOTRON UV-216**.

If connected in series, the two windings will have a resistance of 6 ohms and a current carrying capacity of 1.2 amperes, whereas in parallel the windings will have a resistance of 1.5 ohms

FILAMENT RHEOSTAT, PR-535 . . . \$3.00
Size: 2 in. x 2½ in. x 2¾ in. Shipping Weight: 1 lb.

and a capacity of 2.5 amperes. These rheostats are thus suitable for various types of tube circuits, providing a greater range of usefulness than the more common types. They may be employed for general laboratory work other than that connected with radio. All these different connections are clearly indicated on a tag which is attached to each rheostat.

The large rheostat, Model **PT-537**, is designed for use with the 50 and 250-watt **RADIOTRON** transmitting tubes, as well as with **KENOTRON UV-217**. In general the design is the same as Model **PR-535**, but with increased dimensions.

When the windings are connected in series, a resistance of 1 ohm and a capacity of 7.5 amperes is obtained, which is suitable for **RADIOTRON UV-203**. When connected in parallel the resistance is .25 ohm and the current-carrying capacity is 15 amperes. This allows it to be used with **RADIOTRON UV-204**.

Both of these rheostats are adapted for front-of-board or back-of-board mounting.

The shaft is square, and is clamped into the sleeve which carries the rotating contact by means of a screw which expands the clamp into the sleeve. Any thickness of panel may be used.

FILAMENT RHEOSTAT, PT-537 . . . \$10.00
Size: 4¼ in. x 4½ in. x 2¾ in. Shipping Weight: 2 lbs

TUNGAR RECTIFIER FOR BATTERY CHARGING

ALL vacuum tube receiving sets require a storage battery for illumination of the tube filaments. When only a source of alternating current is available, the simplest and least troublesome device for battery-charging is the

General Electric Company's **TUNGAR** Rectifier. Two sizes are recommended to the amateur:

- (1) 2-ampere **TUNGAR** No. 195259
- (2) One-battery **TUNGAR** No. 219865

Both Types For 60-Cycle Mains

The 2-ampere **TUNGAR** has a capacity of 15 watts and will charge a 3-cell storage battery at 2 amperes or a 6-cell storage battery at one ampere.

Dimensions
Height 8½ inches
Depth 6 inches
Width 6¼ inches
Weight 8 pounds

2 AMPERE TUNGAR
No. 195259 . . . \$18.00

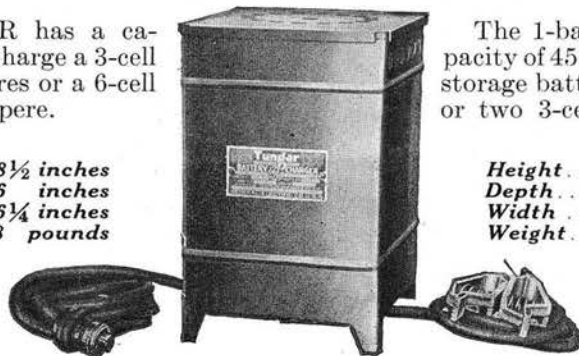

The 1-battery **TUNGAR** has a capacity of 45 watts and will charge a 3-cell storage battery at 5 amperes or a 6-cell, or two 3-cell, batteries at 3 amperes.

Dimensions
Height 10 inches
Depth 8 inches
Width 6¼ inches
Weight 15 pounds

1-BATTERY TUNGAR
No. 219865 . . . \$28.00

MAGNETIC MODULATORS FOR RADIO TELEPHONY

ONE of the most important inventions brought forth in the field of amateur radio telephony during the past year is the MAGNETIC MODULATOR. This development has resulted from the Radio Corporation's experiments with the Alexanderson Magnetic Amplifier, a device which is used at all its high-power transoceanic stations to control the output of 200-KW radio frequency alternators. The same fundamental principle has been adopted in the three magnetic modulators herewith described, and for the first time the amateur experimenter has at his disposal a simple yet thoroughly reliable means of modulating the antenna oscillations of any low-power vacuum tube radio telephone set.

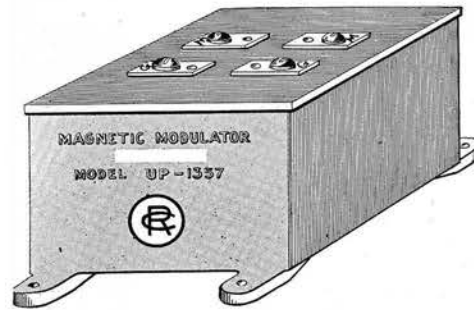

Once connected to a radio telephone set, these modulators positively require no further adjustment or attention. This assures the experimenter that at all times he is obtaining the best possible results from his apparatus. It makes possible practical and reliable radio telephone transmission from a tube transmitter even on the part of an experimenter having a very limited knowledge of radio telephone operation.

The Radio Corporation's MAGNETIC MODULATOR is a device which utilizes the properties of iron at radio frequencies to control or modulate the output of an oscillating vacuum tube or any other undamped wave generator. It is the result of a number of years of research and development work both by the Radio Corporation and the General Electric Company. The device is extremely simple in nature as well as in operation. It simply acts as a variable resistance connected in series with the antenna circuit (preferably the ground lead) of any high frequency oscillating system.

The great advantage of the MAGNETIC MODULATOR over other methods of modulation is that it gives the best and only non-distorting method of controlling the output of a **single tube** for radio telephony. Furthermore, it permits the parallel use of a number of tubes as oscillators and thus eliminates the use of special modulator tubes with their necessary additional accessories and critical adjustments.

This modulator in many respects is similar to the well-known Alexanderson Magnetic Amplifier, except that the latter is operated as a variable impedance connected across the alternator while the MAGNETIC MODULATOR functions merely as a series variable resistance in the antenna circuit. Since the modulator provides a linear control of the antenna current and functions with very small values of control current, such as those flowing in the ordinary low resistance microphone transmitter, it is an ideal modulation device for purposes requiring the control of radio frequency energy at short wave lengths, such as is demanded in amateur radio telephony.

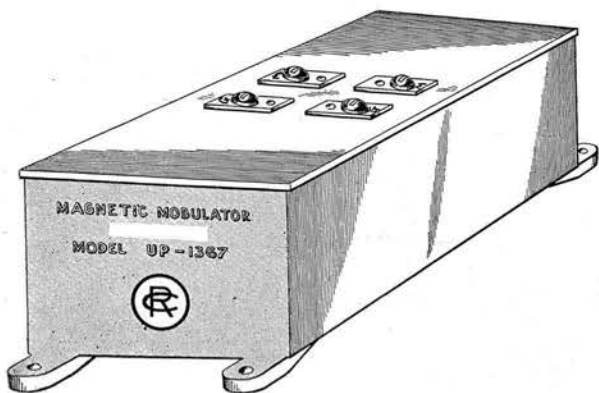

The MAGNETIC MODULATOR is designed specially for the amateur to fill the long desired place for a simple non-destructive and fool-proof device to make a C. W. set into a radiophone set without the use of more tubes or other delicate or costly apparatus. It is made in three sizes; the 1/2 to 1 1/2 amperes UP-1346, the 1 1/2 to 3 1/2 amperes UP-1357, and the 3 1/2 to 5 amperes UP-1369. For outputs above 5 amperes, two or more of the UP-1367, may be used in parallel.

MAGNETIC MODULATOR, UP-1346	\$9.50
Size, 4 3/4 in. x 2 7/8 in. x 3 1/8 in. Shipping weight, 2 lbs.	
MAGNETIC MODULATOR, UP-1357	12.50
Size, 5 1/8 in. x 3 1/8 in. x 3 5/8 in. Shipping weight, 3 lbs.	
MAGNETIC MODULATOR, UP-1367	17.00
Size, 8 3/4 in. x 3 1/8 in. x 3 5/8 in. Shipping weight, 5 lbs.	

**MOTOR-DRIVEN CHOPPER, PX-1638
FOR C. W. TUBE TRANSMITTERS**

LONG experience in the use of audio frequency buzzers to modulate the output of a tube set to produce damped wave trains has proven that this method is not entirely satisfactory, principally for the reasons that the operation of the buzzer is not constant, necessitating frequent adjustment, and that great care is required in adjusting the circuit to obtain 100 per cent. modulation. This method of modulation also involves the use of modulating vacuum tubes in addition to the tubes used as generators of radio frequency oscillations.

The **ROTARY CHOPPER PX-1638** has been developed primarily to overcome the above objections. It may, however, be used in numerous circuits for this or other purposes where an interrupter is required. When used to secure I. C. W. telegraphy, the motor-driven interrupter, or rotary grid chopper, has the following inherent advantages over the other methods:

- (a) Gives positive interruption requiring no adjustments. The note obtained can be varied to any desired pitch by changing the driving motor speed.
- (b) This system of securing damped wave trains does not require modulating tubes, the interrupter being used in series with the transmitting key and functioning in the

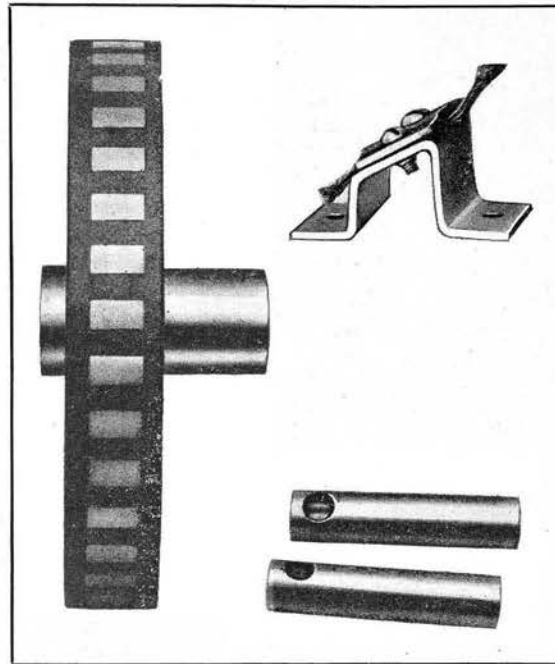

same circuit as the transmitting key.

- (c) The system inherently gives 100 per cent. modulation, since oscillations can be completely started and stopped at audio frequencies.
- (d) The output obtained from a given number of oscillators is in general greater than if some of the tubes are used as modulators.

The equipment includes the following parts:

- (a) Interrupter Wheel, Model PX-1638.
- (b) 2 Bushings, so that the wheel may be mounted on motor shafts $\frac{1}{4}$ in., $\frac{5}{16}$ in., or $\frac{3}{8}$ in. diameter.

(c) Brush Holder and Brush.

No motor is included with this equipment unless specifically requested. If motor is desired, three suitable types are listed below.

The interrupter wheel is built with 34 conducting and 34 insulating segments, making 34 interruptions per revolution. The insulating segments are molded in a single piece, eliminating the possibility of these segments becoming displaced.

No amateur station using tube sets can be considered as complete without a rotary interrupter, as only by its use can tube sets communicate with receiving stations using crystal detectors for reception.

MOTOR DRIVEN CHOPPER, PX-1638 **\$7.25**
Size: 4 in. x $1\frac{3}{4}$ in. Shipping weight: 3 lbs.

SHAFT BUSHINGS for $\frac{1}{4}$ in. or $\frac{5}{16}$ in. Motor Shaft..... each **.20**

NOTE: The following General Electric Company's Motors are especially recommended for use with CHOPPER PX-1638 described above.

- (1) TYPE SD—Frame 315—1/50 H. P.—1,725 R. P. M.—12 Volt Shunt Wound Direct Current Motor.
- (2) TYPE SD—Frame 315—1/50 H. P.—1,725 R. P. M.—110 Volt Shunt Wound Direct Current Motor.
- (3) TYPE SA—Frame 325—1/20 H. P.—1,725 R. P. M.—110 Volt Single-Phase 60-Cycle Induction Motor.

Prices will be furnished upon request.

CONDENSERS FOR C. W. TRANSMITTING SETS

THE use of RADIOTRONS as generators of radio frequency oscillations in radio telegraphy and telephony has brought about the need for comparatively small transmitting condensers, which will stand continuous operation with the voltages used on such tube sets.

Due to the far greater effectiveness of C. W. over spark methods of transmission, ampere for ampere in the antenna, ranges are obtainable with RADIOTRON Transmitters equal to those of spark sets of considerably higher power. The currents for the component circuits of the RADIOTRON tube sets, therefore, in given transmission ranges, are much smaller than for spark transmitters.

There has been developed for the Radio Corporation a series of the FARADON type of condensers which have been especially designed to fit the circuits illustrated in this bulletin, and which will be found the best condensers of their type on the market today.

FOUR TYPES ARE NOW AVAILABLE:

Model UC-1014, rated at 3,000 volts effective, has a capacity of .002 mfd. This condenser was developed primarily for use as a grid condenser, radio frequency by-pass condenser or blocking condenser for circuits utilizing RADIOTRONS UV-202 and UV-203.

Model UC-1015, rated at 7500 volts effective, has three capacities, .0003, .0004 and .0005 mfd., and a current-carrying capacity of 4 amperes at



MODEL UC-1803

200 meters maximum. At lower or higher wave lengths the current-carrying capacity is greater or less, respectively. This condenser is applicable as a series antenna condenser and an intermediate circuit condenser in circuits using RADIOTRONS UV-202 or UV-203.

Both of the above condensers find numerous other applications in the great number of circuits available for C. W. transmission. Their capacities are exact within 2 per cent. and their losses are negligible. They are built with mica dielectric and include the most recent developments in high voltage condenser design.

Model UC-1803 is intended for use as a blocking or coupling condenser, as shown in the various diagrams in this Catalogue. It is rated at 10,000 volts and has a capacity of .000025 Mfd. It is the only compact condenser on the market satisfactory for these purposes.

Model UC-1806, rated at 6,000 volts effective, has a capacity of .002 mfd, and is intended for use as a by-pass condenser in circuits in which the voltages rise to 6,000 volts.

All of the above condensers may be employed in radio receiving circuits as well as in transmission circuits, although they were primarily designed for use with RADIOTRON transmitter tube sets. Experimenters should bear in mind that the break-down voltages of all condensers listed herein are considerably greater than the voltage at which they are rated.



MODEL UC-1015



MODEL UC-1806

MODELS	CAPACITY	VOLTAGE	SIZES	SHIPPING WEIGHT	PRICES
UC-1014	.002 Mfd.	3,000 Volts	2 1/4 in. x 1 1/2 in. x 7/8 in.	1 lb.	\$2.00
UC-1015	.0003, .0004, .0005 Mfd.	7,500 Volts	2 1/4 in. x 1 1/2 in. x 7/8 in.	1 lb.	5.40
UC-1803	.000025 Mfd.	10,000 Volts	3 in. x 3 in. x 4 in.	1 1/2 lbs.	5.00
UC-1806	.002 Mfd.	6,000 Volts	2 1/4 in. x 1 1/2 in. x 7/8 in.	1 lb.	7.00

NOTE: Model UC-1014 bears the same size and appearance as Model UC-1806 shown above.

RADIOTRON UV-200

A VACUUM TUBE DETECTOR FOR AMATEUR AND EXPERIMENTAL WIRELESS STATIONS



PRICE—\$5.00

Overall dimensions, 1 3/4 in. x 4 1/4 in.
Shipping weight, 1 lb.

IN presenting **RADIOTRON UV-200** to the amateur and experimental field, the Radio Corporation of America offers a vacuum tube in which quality is the predominating factor. **UV-200** was designed specifically for the amateur. It is a product of the great Research Laboratories of the General Electric Company. For the first time the experimenter has at his disposal a supersensitive detector tube which will operate from one standard plate battery. This tends towards economy and eliminates one of the objections to former types of tubes, some of which required from three to five standard plate batteries to furnish the requisite plate voltage.

RADIOTRON UV-200 is not only the best detector or "spark receptor" designed to date, but it is also an excellent tone frequency amplifier for magnification of the telephone currents in vacuum tube receiving circuits. It gives unusual results in standard amateur regenerative circuits.

A particularly good combination for radio-telegraphic and radio-telephonic reception is the use of one **UV-200** as a Detector and two additional **UV-200**'s as Tone Frequency Amplifiers. Such a combination can be worked from a single 22 1/2-volt plate battery. Cascade tone frequency circuits (for radio-telegraphic reception), using one or two Model **UV-200** tubes, are remarkably free from tube noises and from "singing," so characteristic of former gas content tubes when operated in this manner.

If the experimenter prefers to adjust the filament by indicating instruments, it should be done by a voltmeter and not by an ammeter. All tungsten filaments show a decrease of current during their life and if constant current is maintained in the filament rather than constant voltage across it, the life will be greatly decreased and no better signals obtained. The normal voltage to be maintained at the filament terminals of **RADIOTRON UV-200** lies in the range 5 to 5.4 volts.

Note that the normal filament current of **RADIOTRON UV-200** is approximately 1 ampere, the maximum allowable current being about 1.1 amperes.

Voltages in excess of 28 to 30 should not be applied to the plate circuit of **RADIOTRON UV-200**. A typical circuit for the use of **RADIOTRON UV-200** is shown below:

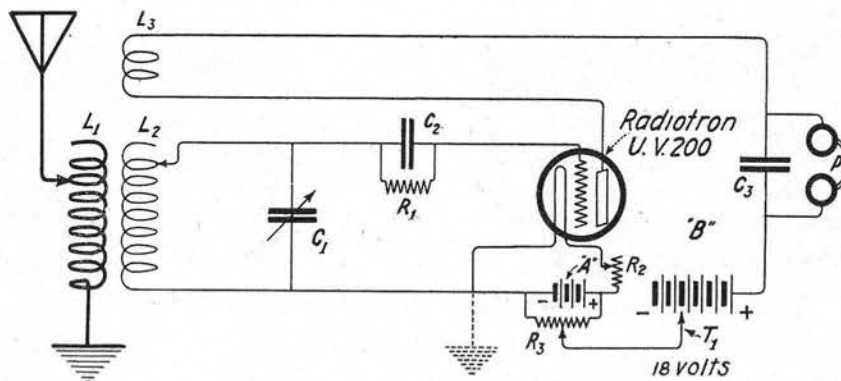

- L-1—Primary coil of tuning transformer.
- L-2—Secondary coil of tuning transformer.
- L-3—"Tickler" coil for regenerative amplification.
- C-1—Secondary variable condenser, .001 MFD.
- C-2—Grid condenser (fixed or variable), .00025 MFD.
- C-3—Telephone condenser (fixed), (optional).
- R-1—Radio Corporation's standard grid leak, .5 to 2 megohms.

- R-2—Standard filament rheostat, PR-535.
- R-3—Radio Corporation's special "A" battery potentiometer, PR-536.
- A—6-volt storage cell (any ampere-hour capacity from 40 up).
- B—Standard 22 1/2 volt plate battery, tapped at 18 volts
- P—Head telephones.

RADIOTRON UV-201

A VACUUM TUBE RADIO AND TONE FREQUENCY AMPLIFIER

COMPLEX amplifying circuits for the magnification of radio and tone frequency currents require an amplifying Vacuum Tube of rigid operating characteristics. There is an increasing demand among radio experimenters for a vacuum tube amplifier which will magnify the telephone currents in a radio receiving set and which can be shifted from one socket to another in a cascade outfit without loss of signal audibility. Moreover, the amplifier must be free from the tube "noises" accompanying the use of improperly designed vacuum tubes.

RADIOTRON UV-201, the second of the new series of Vacuum Tubes designed by the engineers of the Research Laboratory of the General Electric Company for the Radio Corporation, possesses the qualifications outlined above and it should be a part of every experimental radio receiving station. UV-201 may be used as a detector, or as a tone frequency or radio frequency amplifier.

In cascade radio frequency amplifying circuits, UV-201 can be adjusted to magnify without distortion. The use of such circuits is on the increase in amateur stations, particularly where long distance communication is desired on short wave lengths (200 meters or less).

The normal plate voltage of RADIOTRON UV-201 is 40 volts, although increasing amplifications can be obtained at plate voltages up to 100. At 40 volts on the plate, the amplification constant varies from 5.5 to 7.5; at 100 volts on the plate, from 6.5 to 8.5. The output impedance varies from 20,000 ohms at 40 volts to 14,000 ohms at 100 volts plate potentials. The normal filament current for RADIOTRON UV-201 is approximately 1 ampere.

To obtain maximum amplification with UV-201, means should be supplied for placing negative potentials on the grid, although good amplification may be secured without any special provision for such potentials. The requisite negative grid potential for the use of UV-201 in amplification circuits can be secured by connecting a standard "C" battery of two or three volts in the grid circuit, shunted by a 200 to 400-ohm potentiometer, or by connecting the filament resistance in series with the negative terminal of the filament and connecting the "low potential" terminal of the tuner secondary to the negative pole of the battery. The latter method will give a negative grid bias of about 1 volt. The preferred circuit for the use of UV-201 is shown below.



PRICE—\$6.50

Overall dimensions, 1 1/4 in. x 4 1/4 in.
Shipping weight, 1 lb.

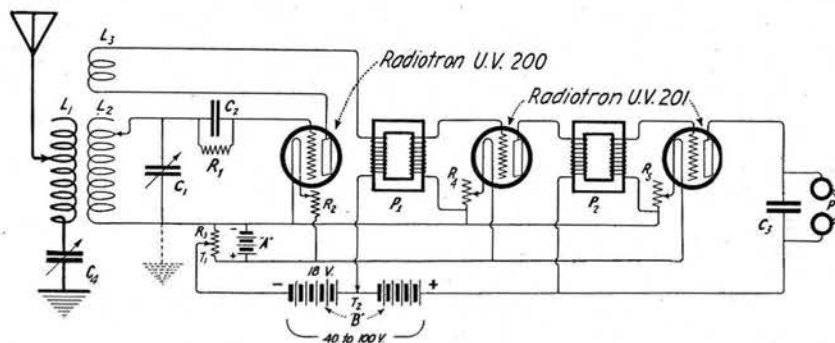

- L-1—Primary coil of tuning transformer.
- L-2—Secondary coil of tuning transformer.
- L-3—"Tickler" coil for regenerative amplification.
- C-1—Secondary variable condenser. .001 MF.
- C-2—Grid condenser (fixed or variable). .00025 MF.
- C-3—Telephone condenser (fixed). (optional).
- R-1—R. C. Standard Grid Leak. .5 to 2 megohms.
- R-2, R-4, R-5—R. C. Standard filament rheostat, PR-535.

- R-3—R. C. Special "A" battery potentiometer, PR-536.
- A—6-volt storage cell (any ampere-hour capacity from 40 up.)
- B—Standard 22 1/2 volt plate batteries.
- P—Head telephones.
- T-2—Tap on the plate battery for applying from 16 to 22 1/2 volts on the plate circuit when using UV-200.
- P-1, P-2—Transformer UP-712.

FOR GENUINE AMPLIFICATION
TONE FREQUENCY INTERVALVE AMPLIFYING TRANSFORMER

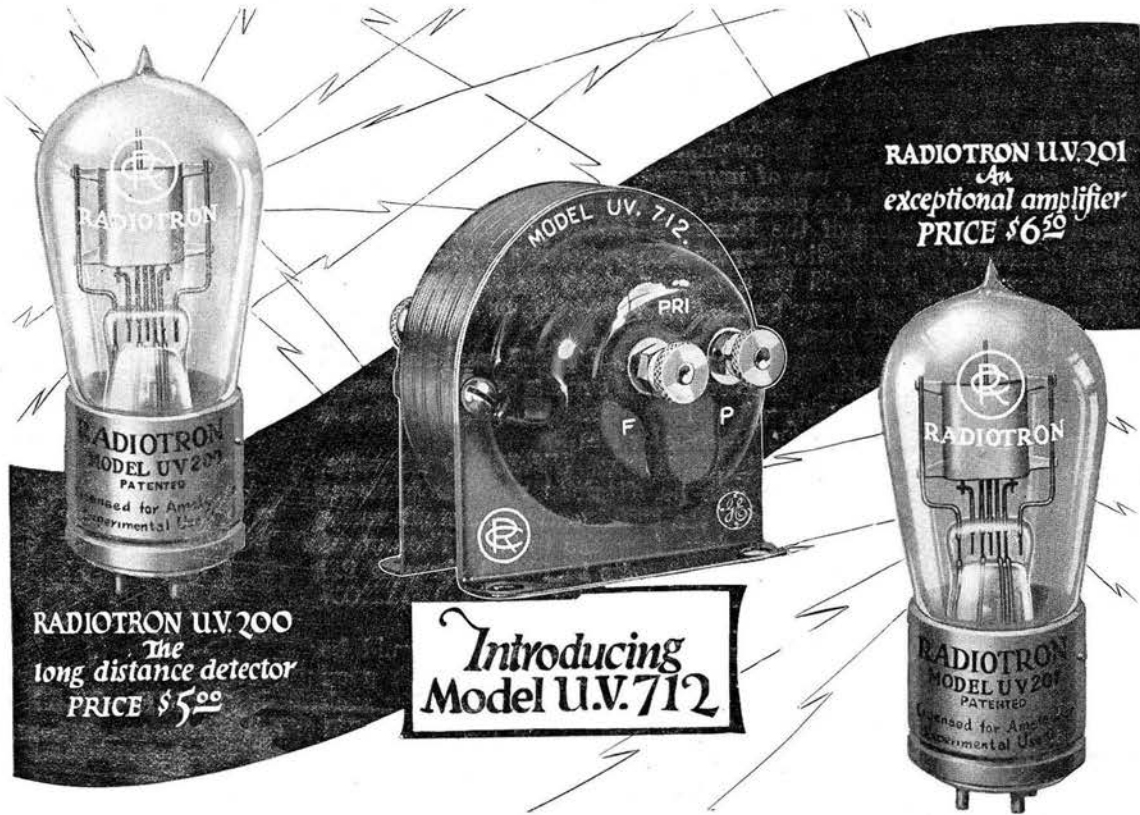

IT is a well-known fact that for maximum amplification the characteristics of an intervalve tone frequency amplifying transformer must be such as to fit the output impedance of the preceding tube in a cascade amplifying set. There is an allowable variation of the constants of the transformer when loaded on the secondary by an amplifying tube, but nevertheless, the maximum signal is obtained from a transformer designed especially to fit the output impedance of the tubes with which it is used.

Prior to the introduction of TRANSFORMER Model **UV-712**, amateur experimenters were compelled to employ intervalve transformers of various characteristics, none of which had been designed specifically for the Radio Corporation's detector tube, **RADIOTRON UV-200**, and the amplifier tube, **RADIOTRON UV-201**. TRANSFORMER **UV-712** not only has been designed to fit these vacuum tubes, but special care has been taken to reduce the transformer losses to the lowest possible minimum.

The accompanying illustration shows the new amplifying transformer, of which there are several thousand now in daily use. TRANSFORMER **UV-712** has been designed and manu-

factured strictly on a quality basis. It is precisely the same type used in the Corporation's commercial types of radio receiving sets. It is not to be compared with other types in which efficiency has been sacrificed to obtain compactness or to reduce manufacturing costs. Many experimenters report that the increase of signal audibility resulting from the introduction of **UV-712** into their receiving sets, has resulted in such a marked increase of signal audibility as to be nothing short of marvelous.

In general, a tone-frequency amplifier transformer should occupy the same position in the output circuit of a vacuum tube as the receiving telephone. The terminals **P** and **F** of TRANSFORMER **UV-712** may be connected to the plate circuit terminals which ordinarily are connected to the telephone receiver. The secondary terminals should connect to the grid and filament of the following tube of a multi-stage amplifier. Such a circuit using two stages of tone-frequency amplification is shown above. This circuit makes use of the detecting qualities of **RADIOTRON UV-200** and the amplifying qualities of **RADIOTRON UV-201**.

In all radio amplifier circuits using TRANS-

FORMER UV-712, the insulation of all apparatus connected to the secondary must be as perfect as possible. Leakage from the grid to the filament of amplifier tubes through the socket, mounting, panel, wiring or otherwise, will decrease the amplification. The lead from terminal G should be kept reasonably short and in cascade amplifier sets adjacent transformers should not be mounted too close; a separation

of at least four or five inches should be allowed. The circuit diagram here given has the secondary F terminal connected to the filament rheostat on the side away from the filament. This puts a bias negative potential on the grid of RADIOTRON UV-201 which will have a value of approximately one volt, provided a six-volt battery is used, and the filament current is adjusted to the normal value of one ampere.

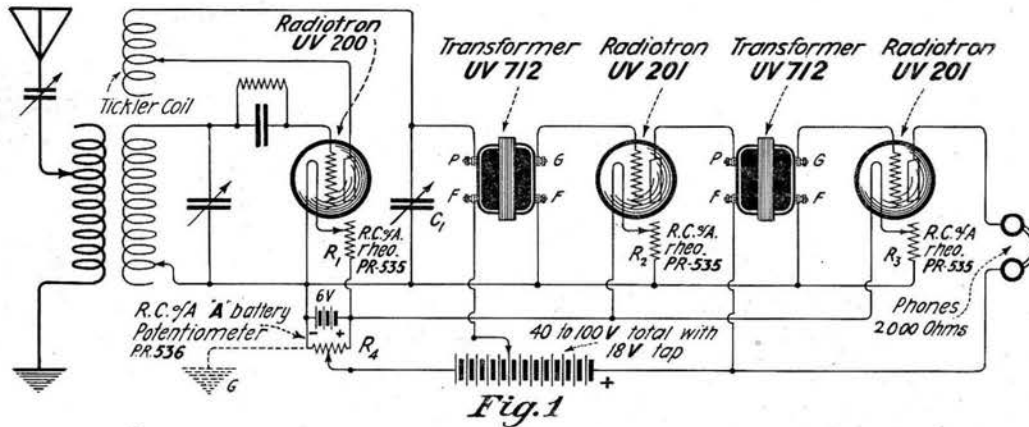

PHYSICAL CHARACTERISTICS

- 1. Totally enclosed
- 2. Net weight, 1 lb. 4 1/2 oz.
- 3. Shipping weight, 1 lb. 7 oz.
- 4. Overall length, 3 7/8"
- 5. Overall height, 2 3/4"
- 6. Base area, 2" x 2 3/4"

ELECTRICAL CHARACTERISTICS

- 1. Ratio of Secondary to Primary Turns, 9/1.
- 2. Useful frequency range, 60/3000 cycles
- 3. Allowable current on each winding, 10 milliamperes.
- 4. Test voltage between windings and between core and windings, 300 volts at 60 cycles.
- 5. Terminal voltage limit of secondary winding, 300 volts.
- 6. D. C. resistance of windings: Primary, 430 ohms; Secondary, 5,100 ohms.
- 7. Impedance at 1,000 cycles (one milliampere):—

Primary with secondary open.....	19,000 ohms (approximate)
Primary with secondary shorted.....	650 " "
Secondary with primary open.....	1,400,000 " "
Secondary with primary shorted.....	43,000 " "

Model UV-712 is the only transformer designed specifically for use with Radiotrons.

AMPLIFYING TRANSFORMER—UV-712.....\$7.00

Size: 2 3/4 in. x 3 7/8 in. x 2 in.

Shipping weight: 1 lb. 7 oz.

GRID LEAKS FOR RECEIVING SETS

THE grid of any vacuum tube, whether employed as a detector or an amplifier, is the controlling member of the tube, that is to say, it controls the current flowing between the plate and filament. The character of the control depends directly upon the bias potential maintained upon the grid. Thus one value of grid potential will be found most suitable for radio detection, while still another value must be maintained to secure maximum amplification. The requisite bias potential for varied conditions of use may be obtained in several ways, the most common of which are: (a) to insert in series with the grid circuit a small battery usually called a "C" battery; (b) to tap one terminal of the grid circuit from a fixed resistance in series with the filament rheostat through which the filament current flows; (c) to employ a GRID LEAK connected across the grid condenser or between the grid and the filament.



a grid resistance of two megohms (2,000,000 ohms) and a grid current of one microampere, the bias negative potential will be two volts.

Different detection and amplification circuits require grid leaks of different value and in order that the experimenter may have

access to a complete line of resistance units from 100,000 ohms to 6,000,000 ohms, the Radio Corporation standardized a number of different values which are certain to meet all requirements for radio reception.

It cannot be told offhand just what value of grid leak unit should be used with any particular amateur receiving set. It depends upon the design of the apparatus, the type of antenna and ground system, grid condenser and other factors. The proper capacity for the grid condenser should be determined by experimenting with different values between .0002 and .0004 microfarad.

The grid leak unit which will give the proper biasing potential on the grid resides between 1/2 megohm (500,000 ohms) and 3 megohms (3,000,000 ohms). Various values can be obtained by purchasing three of the Radio Corporation grid leak units, approximating 1/2, 1 and 2 megohms, respectively. The experimenter can then try three values by employing them singly, in series, in parallel or in series-parallel. Eight or more different values between 1/2 to 3 1/2 megohms may in this way be obtained.

EXAMPLE:

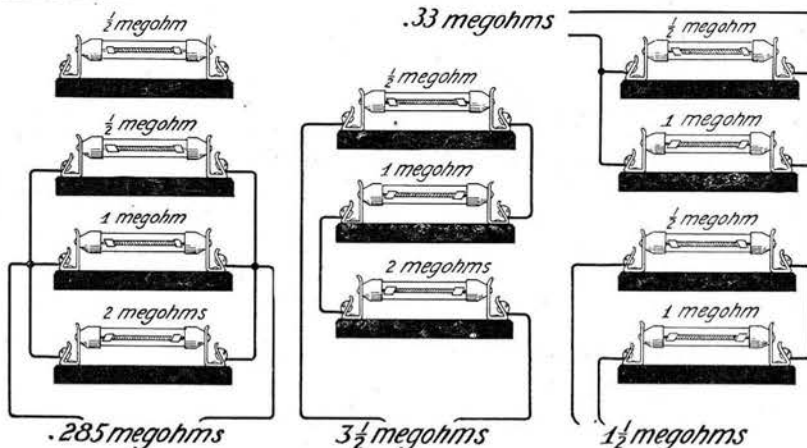

The Radio Corporation Grid Leak Units are manufactured in the following sizes:

Model	Ohms	Megohms
UP-509	50,000	.05
UP-510	100,000	.1
UP-511	150,000	.15
UP-512	200,000	.2
UP-513	250,000	.25
UP-514	300,000	.3
UP-515	400,000	.4
UP-516	500,000	.5
UP-517	600,000	.6
UP-518	750,000	.75
UP-519	1,000,000	1.
UP-520	1,250,000	1.25
UP-521	1,500,000	1.5
UP-522	1,750,000	1.75
UP-523	2,000,000	2.
UP-524	2,500,000	2.5
UP-525	3,000,000	3.
UP-526	4,000,000	4.
UP-527	5,000,000	5.

Radio Corporation Grid Leak Units are accurately made and calibrated. The material used assures a resistance unit which will remain

constant in value. They are not affected by changes in the humidity of the atmosphere, or any other external effect.

- MOUNTING, UX-543..... \$0.50
- GRID LEAK UNITS, UP-509 TO UP-527..... .75

"A" BATTERY POTENTIOMETER

PR-536



IT is impossible to over-estimate the desirability of using a potentiometer in connection with the Radio Corporation's gas-content detector, **RADIOTRON UV-200**. Only in this way can proper detector action and resulting increase of signal audibility be obtained.

It is inadvisable to use any type of potentiometer across a standard "B" battery, as it will exhaust the cells in a relatively short time. To overcome this difficulty the Radio Corporation developed a special potentiometer suitable for connection across the terminals of a 6-volt filament lighting battery.

In appearance, **POTENTIOMETER PR-536** closely resembles the Radio Corporation's Rheostat **PR-535**. It is provided with three contacts. Two of these are shunted across the "A" battery, while the third is connected to a tap on the negative side of the plate battery, giving eighteen volts. This connection gives a plate voltage variation of eighteen to twenty-four volts.

"A" BATTERY POTENTIOMETER . . \$2.00
 Size 2 in. x 2½ in. x 2⅞ in. Shipping weight, 1 lb.

BAKELITE SOCKET

UP-552



SOME amateurs may prefer to use a Bakelite socket rather than our standard porcelain socket, Model **UR-542**, described on page 25. This socket has enjoyed unusual popularity for several years past. It is durably constructed and of fine appearance. One particular feature is the ease with which connection may be made, since the connecting clamps are unusually accessible and provide ample space for permanent contacts. Socket **UR-542** will take **RADIOTRONS UV-200, UV-201 and UV-202**.

BAKELITE SOCKET, UP-552 \$1.50
 Size 1½ in. x 1½ in. x 1½ in. Shipping weight, 1 lb.

TUBULAR GRID AND PLATE CONDENSER

THERE has been an insistent demand in the amateur field for fixed condenser units of various capacities, suitable for amateur receiving sets. The Corporation, after an investigation of existing types, has evolved the four models herein listed, which are designed to fit its Standard Grid Leak Mounting. These condensers are recommended for use in the grid circuit, or as a by-pass condenser in the plate circuit, of standard vacuum tube receiving sets. They are especially useful as a unit of fixed capacity to be shunted to any standard variable air condenser. In this way a variety of capacity ranges may be obtained from any variable condenser.

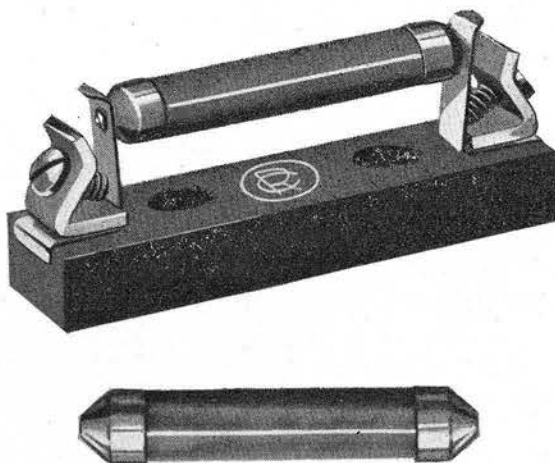

The complete condenser unit is sealed in a glass tube fitted with end caps, in the same manner as the Standard Grid Leaks. Every amateur station should have at least one complete set for general experimental purposes. Nothing equally satisfactory to the four models listed here has been produced for mounting in receiving set cabinets, for if one value of capacity is found unsatisfactory for the purposes at hand, another suitable value may be immediately inserted in its place. These condensers come in four fixed capacities.

Size: 1⅞ in. x ⅜ in. Shipping weight: 4 oz.

- CONDENSER, UC-570—.0025 Mfd. \$2.00**
- CONDENSER, UC-569—.001 Mfd. 1.50**
- CONDENSER, UC-568—.0005 Mfd. 1.35**
- CONDENSER, UC-567—.00025 Mfd. 1.20**
- CONDENSER MOUNTING, UX-54350**



RADIO RECEIVING APPARATUS OF QUALITY

THE Radio Corporation is now in a position to present to experimenters and to the Laboratories of Colleges, Universities and High Schools, equipment which incorporates the highest quality of material and workmanship and the latest technique in radio design.

The radio receivers and accessories listed in the following pages were designed and manufactured under the supervision of one of America's foremost radio receiving experts. Experimenters desiring to purchase receiving apparatus of the last degree of refinement are urged to investigate this line of equipment. The wave length band covered by these receiving sets covers the range 150 to 8,000 meters. By the use of the loading inductances listed on Page 43, these sets can be adapted for reception up to 20,000 meters. Appropriate binding posts are mounted on the receiving cabinets and by removing a short circuit strap, these load coils can be inserted in both the primary and secondary circuits.

All controls are mounted on Bakelite panels and the complete apparatus is contained in an oak box. Suitable detector and amplifier units are also provided.

Radio engineers about to make precision measurements in laboratory research work should investigate the high class variable condensers described on Page 44. These represent the highest grade of workmanship and will retain their calibration with extremely slight variation throughout their operating life. Additional high grade apparatus will be added to this catalog from time to time to meet the demand for instruments of superior performance. All receiving apparatus and accessories described herein are licensed for amateur or experimental use only.



RECEIVER, IP-500

THE IP-500 Receiver is one of the most efficient receivers manufactured. The circuits are designed to give the highest possible efficiency. The wave length range of the receiver is 150 to 6,800 meters. Longer wave lengths may be obtained by the insertion of load coils in the circuit. This receiver possesses a high degree of selectivity, but it is also provided with an untuned or "stand-by" circuit. It is especially adapted for use in laboratories and by advanced radio clubs, where a receiver is desired which is the last word in perfection of design and finish.

A switching mechanism permits the use of either of two tuned circuits on an untuned secondary. The coupling between the antenna and detector circuits is purely electromagnetic and continuously variable, passing from the maximum value through zero to a small reverse coupling. By providing absolute zero coupling between the circuits, desirable low couplings are assured. Interference is greatly reduced by this means.

The coils used in the receiver are bank-wound inductances of high-frequency cable, wound on threaded bakelite tubes. The assembled coils are impregnated in vacuum and baked. The individual sections are automatically connected, entirely disconnected and opened, or entirely disconnected and individually short-circuited, by a mechanism operated by the inductance switch. By this means every coil in the receiver has a natural period when connected with its leads and switch points which is less than the shortest wave length in the range of the receiver. This eliminates the reception of parasitic signals, reduces the absorption of the desired signals by the coils, forces the energy into the detector, and minimizes interference on all wave lengths.

The condensers are of the self-balanced plate type. Insulating bushings are entirely absent in their construction. Their calibration is constant and their losses extremely low.

The receiver is mounted under a 1/2-inch Bakelite-dilecto panel. The containing box is of 5/8-inch oak. A switch is provided for vacuum-tube reception, and also to protect the detector during transmission.

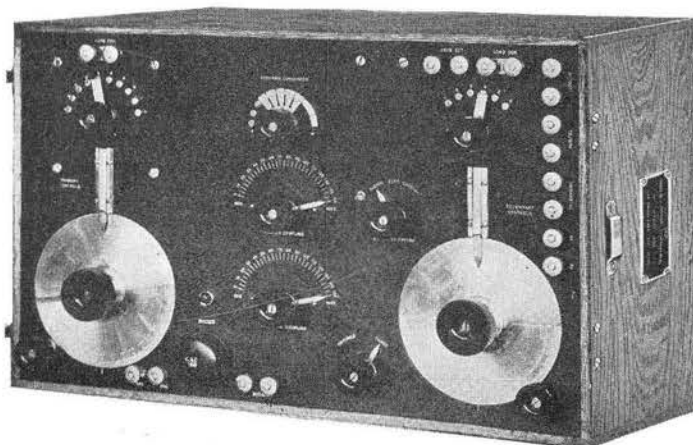

RECEIVER, IP-500 **\$595.50**
 Overall dimensions: 23 in. x 11 in. x 14 1/2 in. Shipping weight: 87 lbs.

RECEIVER, IP-501

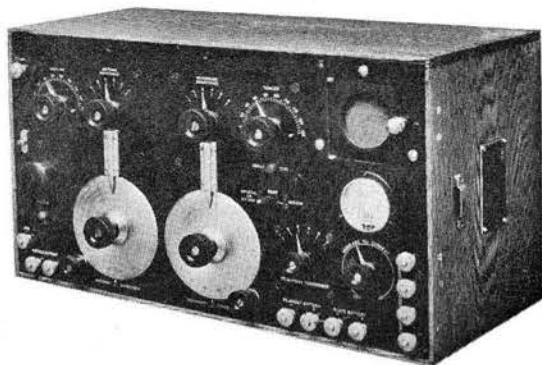

THE IP-501 Receiver shown in the accompanying illustration is a compact unit containing the radio frequency and detecting circuits in a single case. Its range is 250 to 8,000 meters. It is particularly suitable for installations where cost and space factors are of great importance.

The receiver is similar in mechanical design to the IP-500, with the untuned circuit omitted. The capacity coupling between primary and secondary circuits is eliminated in this type by heavy sheet copper boxes separately enclosing the two circuits.

The panel is of Bakelite-dilecto. The coils are bank-wound inductances, of high frequency cable wound on threaded Bakelite-dilecto tubes, impregnated and baked.

The condensers are of the self-balanced plate type. The wiring is of rigid copper encased in varnished cambric tubing. All switch points are located beneath the panel. The detector is mounted on a shock-proof support. The feature of condenser dial pointer control by inductance switch is included in the design.

RECEIVER, IP-501 **\$550.00**
 Overall dimensions: 20 in. x 11 in. x 9 in. Shipping weight: 55 lbs.

DETECTOR AND ONE-STEP AMPLIFIER, TRIODE A

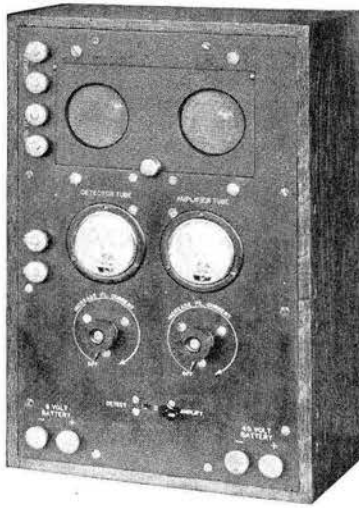

THE amplifier control box shown in the illustration contains vacuum tube detector and amplifier circuits and their controls. A switch permits the use of either the detector or the amplifier. Continuous control of the detector between the damped and undamped methods of reception is obtained by an adjustment in the receiver itself. Amplification is obtained by means of a transformer interlinking the detector and amplifier. Separate rheostats and ammeters are provided with each. The degree of amplification is controlled by the amplifier rheostat. The amplifier is of a type entirely new to the radio art, operating on the principle of low frequency resonance and variable input impedance.

The detector and amplifier have shock-proof mountings that entirely eliminate "noise" due to mechanical vibration. These in turn are mounted on a Bakelite-dilecto panel, and the whole encased in an oak box.

The best of materials and workmanship are employed in the construction of this control unit. It is rugged, and with proper care will have an indefinitely long life in service. It presents the best solution of modern radio problems, and is designed and manufactured in accordance with the best radio engineering practice.

DETECTOR AND 1-STEP AMPLIFIER, TRIODE A... \$190.00

Overall dimensions: 14½ in. x 9½ in. x 6¼ in. Shipping weight: 20 lbs.

TWO-STEP AMPLIFIER, TRIODE B

THIS two step amplifier is a compact unit of the resonance low-frequency type. It provides a maximum of amplification due to the transformer design, which is greatly superior for radio reception to other types on the market. The input impedance of each tube is automatically controlled by the filament rheostat.

The apparatus consists of two vacuum tube receptacles, two filament control rheostats, and two amplifying transformers. Shock-proof mountings protect the vacuum tubes from "noise" due to mechanical vibration.

The apparatus is mounted on the rear of a Bakelite-dilecto panel and enclosed by an oak box. At the bottom of the panel are terminals for connecting the 6-volt filament and the 40-volt plate batteries. At the lower left of the panel are the two input binding posts for connection to the receiver equipment. At the right of the panel are two binding posts for connecting telephones.



TWO-STEP AMPLIFIER, TRIODE B... \$95.00

Overall dimensions: 11⅜ in. x 7½ in. x 6¼ in. Shipping weight: 12 lbs.

TWO-STEP AMPLIFIER, TRIODE E

THE Type Triode E Two-Step Amplifier was designed to provide an instrument in which all the connections would be visible and easily accessible, and thus facilitate experimenting. It functions in a manner identical with the Type Triode B Amplifier, described on this page. It is equally efficient and differs only in its less expensive construction.

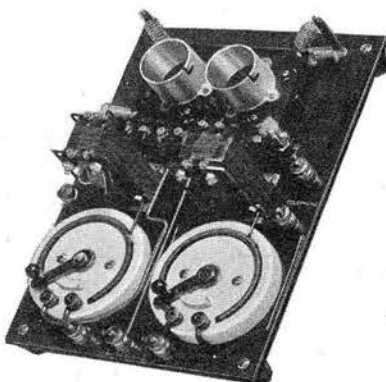

All the necessary apparatus is mounted on a Bakelite-dilecto panel supported by four rubber feet. The amplifier consists of two vacuum tube receptacles, two closed core frequency amplifying transformers, and two porcelain base circular control rheostats.

All wiring in the filament circuits are enclosed in yellow varnished cambric tubing. The wires of the grid circuit are baked with red enamel, and the connecting wires of the plate circuit with green enamel. In this way the various wires may be easily identified. Firm connection is established at each terminal by a special locking nut. Upon loosening these nuts the wires may be disconnected, making it easy to experiment with different circuits.

At the left of the panel are two input binding posts, and at the right are the telephone binding posts. At the bottom of the panel are three binding posts for connecting the 6-volt filament and 40-volt plate batteries. The middle post is common to both circuits. The input impedance of each tube is automatically controlled by its rheostat.

TWO-STEP AMPLIFIER, TRIODE E... \$35.00

Overall dimensions: 11 in. x 8 in. x 3¼ in. Shipping weight: 9 lbs.

EATON OSCILLATOR, TRIODE C

A GLANCE at the photograph will clearly show the extreme simplicity of this ingenious instrument.

A new feature in radio practice is incorporated in this design, in that the wiring diagram of the complete external circuit is engraved upon the cover, so that no instruction is necessary for its use. The external circuit is engraved in white, the internal circuit in red. On the left-hand side is engraved the oscillating circuit, on the right-hand side the tube circuit.

A high insulation resistance between the grid and the ground is provided by a tall corrugated insulator. The complete internal apparatus is thoroughly impregnated in vacuum, and sealed in a moisture-proof, low-dielectric insulator. We recommend its use for wave length ranges between 230 and 45,000 meters. It may be used across circuits having inductance between .05 and 100 m. h., and capacity between .0003 and .005 mfd.

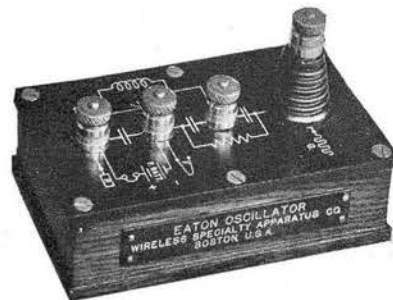

EATON OSCILLATOR, TRIODE C **\$13.50**

Overall dimensions: 5 in. x 3 in. x 3 in. Shipping weight: 2½ lbs.

RECEIVER LOAD COILS



WE offer a high-grade, compact and efficient load coil in three different values, namely, 30, 50 and 100 millihenries. These coils consist of two Bakelite-dilecto side pieces, between which is mounted a highly efficient wave-wound coil of high-frequency cable. The electrostatic capacity of the coil is extremely low. The side pieces are finished square, forming a base for the coil. Close coupling between two or more load coils is possible, as their rear surfaces are plane and close to the central plane of the coil.

The coils are ideal units for loading the receivers listed in this catalogue, and in fact any type, to long wave lengths, as they are efficient and permit easy and very wide variation of coupling.

A pair of these coils, used in conjunction with two variable air condensers of the types shown on page 44, constitute a receiver. Their values are constant and they may be used as standards and for general experimental purposes.

LOAD COIL— 30 Millihenries. Size: 1 in. x 5½ in. x 5¾ in. **\$10.00**

LOAD COIL— 50 Millihenries. Size: 1 in. x 5½ in. x 5¾ in. **13.50**

LOAD COIL—100 Millihenries. Size: 1 in. x 5½ in. x 5¾ in. **21.50**

Shipping weight: 2 lbs.

CONSTANT IMPEDANCE AUDIBILITY METER, IP-306

AN audibility meter is an essential piece of apparatus in all comparative tests of receivers and telephones, for the reason that it reduces the strength of signals to a definite standard basis of numerical comparison; thus, unit audibility, or an audibility of one, is the strength of a signal which is just audible. By means of a variable shunt around the telephones, it is possible to reduce the strength of signal to unit audibility. If the proportional current passing through the shunt is known, the number of times audibility of the signals can readily be determined, provided that at the same time an impedance is introduced in series with the detector output, so as to maintain constant the total impedance across the detector.

The meter is beautifully furnished in a hardwood box, with a bevelled Bakelite-dilecto top, on which the audibility is directly engraved. Connection is readily afforded by four binding posts, two for the receiver circuit, and two for the telephones. The taps and contact arm are of polished nickel, so that the instrument makes an attractive, as well as an invaluable, addition to any radio station or laboratory.

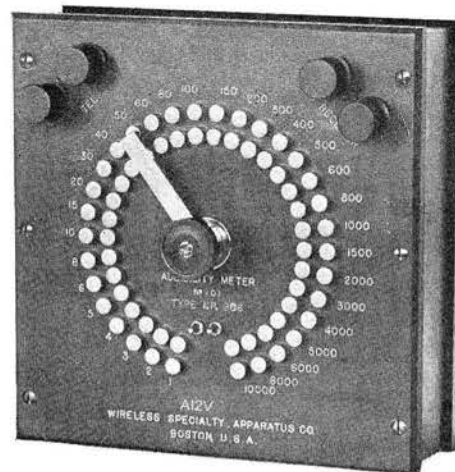

AUDIBILITY METER, IP-306. **\$135.00**

Overall size: 8 in. x 8 in. x 3½ in. Weight: 4 lbs.

PRECISION VARIABLE AIR CONDENSERS



TYPES

- IP-300, .005 mfd.
- IP-301, .003 “
- IP-302, .0015 “
- IP-303, .0007 “

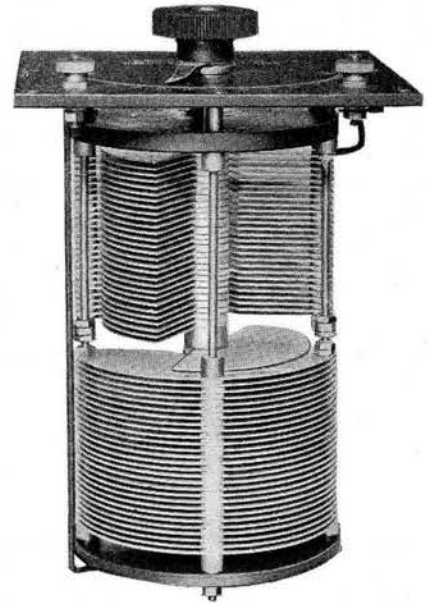

THESE condensers are built in the four different capacities listed above. They are all of the balanced type and will hold any adjustment regardless of the position in which they are placed.

The .005 mfd. condenser shown in the illustration contains a total of 56 semi-circular fixed plates and 58 semi-circular variable plates. The smaller capacity condensers have a correspondingly smaller number of plates. The plates of the upper half of the condenser are mounted on the opposite side of the shaft from the similar lower plates, thus effectively balancing the system mechanically.

The plates are hard aluminum, $\frac{1}{32}$ in. thick. The air space between plates is $\frac{3}{32}$ in. The plates are separated by aluminum washers accurately machined. The rods supporting the stationary plates are of brass. The movable plates are mounted upon a steel shaft. The system is fastened to two circular Bakelite-dilecto end pieces, the upper of which is, in turn, fastened to the Bakelite-dilecto top of the condenser. The unit may be easily lifted from the case by the removal of eight screws. On the Bakelite-dilecto top is the rotary control knob and pointer, which is provided with an engraved 180° scale. Two nickel-plated binding posts are provided for making connections to the condenser.

These condensers are mounted in neat oak boxes, and are provided with calibration charts.

VARIABLE AIR CONDENSER—TYPE IP-300	\$90.00
Size: 7 $\frac{1}{8}$ in. x 7 $\frac{1}{8}$ in. x 7 $\frac{3}{8}$ in. Shipping weight: 15 lbs.	
VARIABLE AIR CONDENSER—TYPE IP-301	72.00
Size: 7 $\frac{1}{8}$ in. x 7 $\frac{1}{8}$ in. x 8 $\frac{3}{8}$ in. Shipping weight: 12 lbs.	
VARIABLE AIR CONDENSER—TYPE IP-302	45.00
Size: 5 $\frac{1}{2}$ in. x 5 $\frac{1}{2}$ in. x 7 $\frac{3}{8}$ in. Shipping weight: 7 $\frac{1}{2}$ lbs.	
VARIABLE AIR CONDENSER—TYPE IP-303	41.50
Size: 5 $\frac{1}{2}$ in. x 5 $\frac{1}{2}$ in. x 4 $\frac{3}{4}$ in. Shipping weight: 6 lbs.	

ANTENNA MATERIAL AND ACCESSORIES

MANY requests have been received for the purchase of complete antenna equipment for radio transmitting and receiving stations. The Radio Corporation is pleased to present to prospective purchasers in tabulated form a list of accessories, including high-grade antenna wire, spruce spreaders, bridles and galvanized hardware fittings, which it carries in stock at all times. Tell us your requirements, after which we will prepare a complete bill of material made up of items taken from the list below. Remember that this list includes the very highest grade of material obtainable, and in fact is the same material used by the Radio Corporation at its ship and shore stations. Antenna spreaders, with bridles, insulators and all necessary fittings, will be assembled and shipped to the customer ready for erection. A small additional charge is made for this assembly, according to the amount of material required by the customer and the labor occasioned thereby. In general the six and ten-foot antenna spreaders are desirable for amateur station, but the stations specially licensed for the use of considerable power inputs will require the fourteen-foot spreaders.

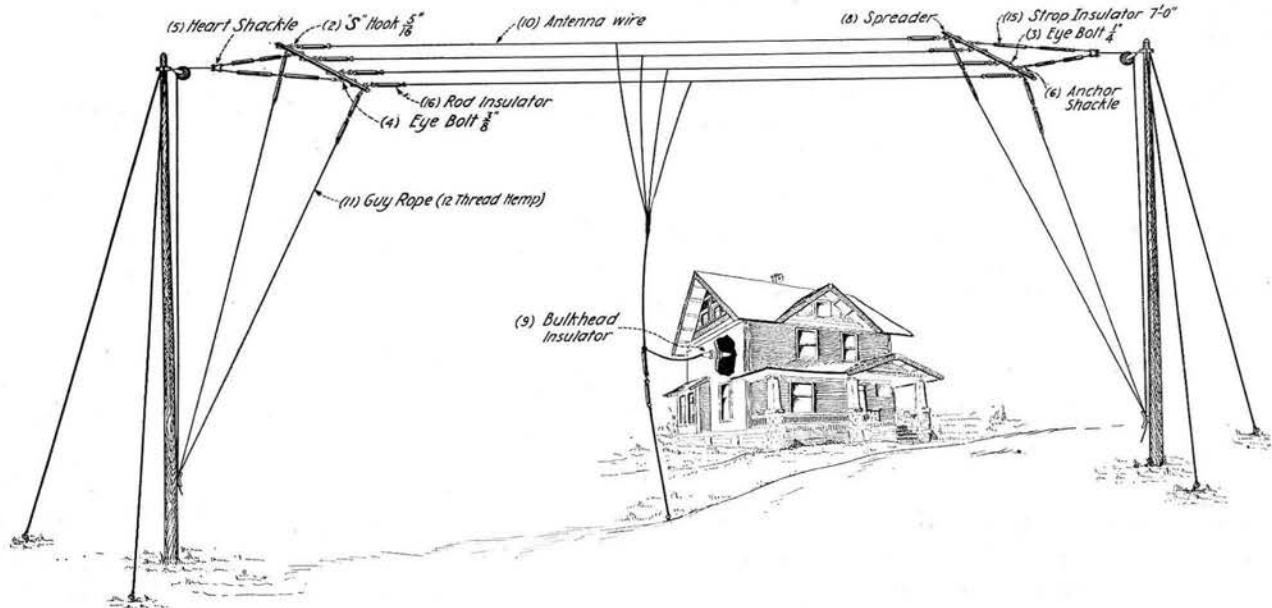

LIST OF MATERIAL FOR THE ABOVE MODEL ANTENNA

Cut No.	8	2 Spreaders, 14 feet long.
" "	3	8 Eyebolts, Nuts and Washers, 1/4 inch (for Wire).
" "	4	4 Eyebolts, Nuts and Washers, 3/8 inch (for Bridles).
" "	15	4 Strop Insulators, 7 feet long.
" "	6	4 Anchor Shackles (for fastening Bridle to 3/8 inch Eyebolts).
" "	5	2 Heart Shackles, 1/16 inch (for Strop Insulators).
" "	11	200 Feet 12-thread Hemp Rope (for Spreader Guys).
" "	16	8 Rod Insulators (24 inches long), for Aerial Wires.
" "	16	8 Rod Insulators (24 inches long), for Guys.
" "	16	1 Electrose Insulator, 12 inches, or
" "	16	2 Rod Insulators (24 inches long) } For Back-staying Leads.
" "	2	18 "S" Hooks, 2 inches, for fastening Insulators to Eyebolts, etc.
" "	—	2 Screw Eyes, No. 2, for anchoring Leads.
" "	10	1 Coil, 7 Strands, No. 18 B. & S. Phosphor-Bronze Aerial Wire (600 feet).
" "	9	1 Bulkhead Electrose Insulator, Nuts and Rubber Gasket.

NOTE: Two 7-foot Strop Insulators Attached to a Spreader are Known as a "Bridle."

RADIO CORPORATION OF AMERICA

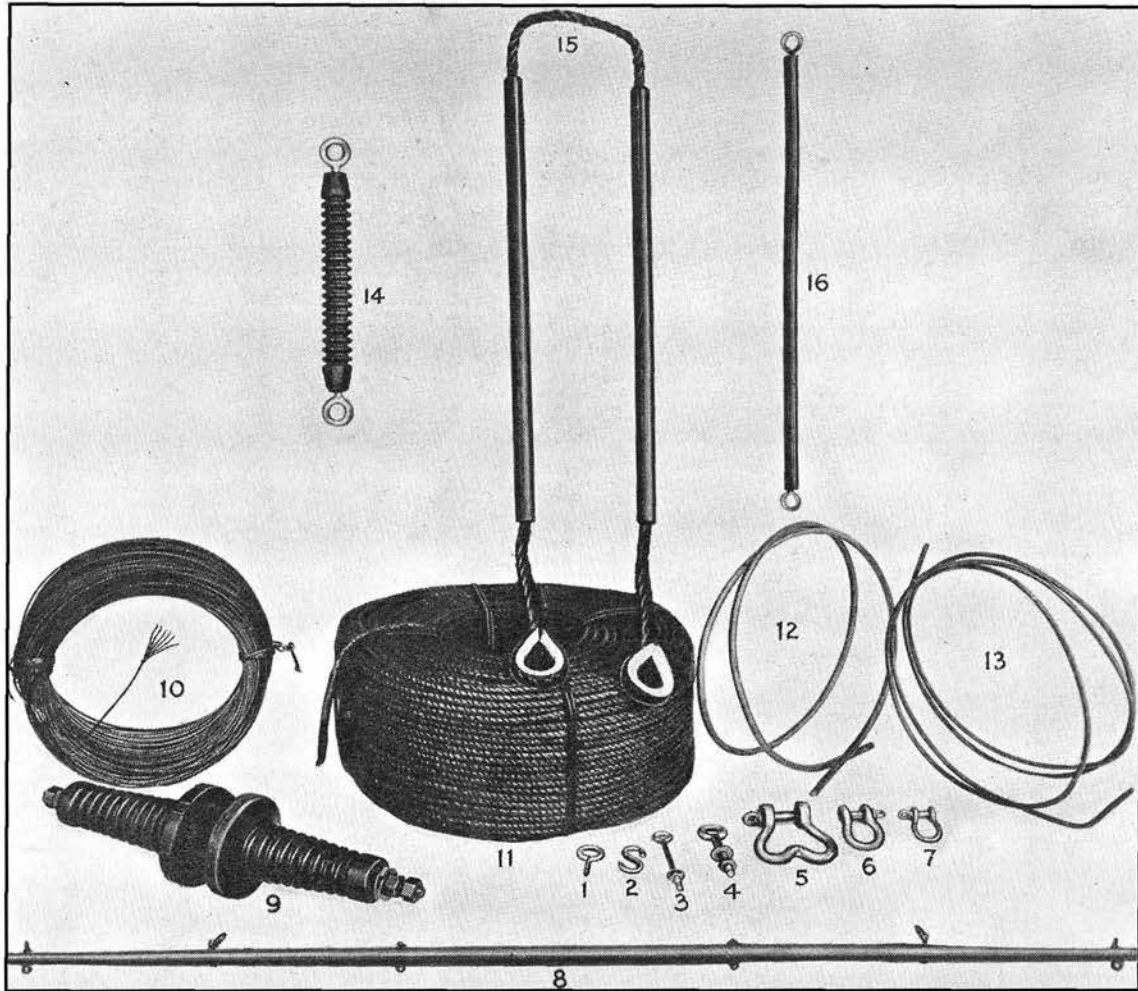

ITEM	PHOTO NO.	MODEL NO.	MATERIAL	PRICE
1	1	PG-744	Screw Eyes No. 2	\$.07
2	2	PG-743	"S" Hooks, 2 inches	.10
3	3	PG-738	Spreader Fittings Eyebolts, 1/4 inch x 5 inches	.25
4	4	PG-739	Spreader Fittings Eyebolts, 3/8 inch x 6 inches	.35
5	5	PG-742	Heart Shackles, 1/16 inch	2.60
6	6	PG-741	Anchor Shackles, 3/8 inch	.45
7	7	PG-740	Anchor Shackles, 1/4 inch	.40
8	8	PG-735	Spreaders, 14 feet	5.75
9	..	PG-736	Spreaders, 10 feet	5.00
10	..	PG-537	Spreaders, 6 feet	4.65
11	9	UI-750	Bulkhead Insulator, 6811	7.00
12	10	PG-745	Antenna Wire, 7 str. No. 18 B&S Phosphor bronze (600-ft. coil)	12.00
13	..	PG-746	Antenna Wire, 7 str. No. 18 B&S Phosphor bronze (100-ft. coil)	2.30
14	11	PG-747	12-thread Tarred Hemp Rope, per 100 feet	2.40
15	12	PP-762	Tubing, Copper, 3/8 inch, per foot	.15
16	13	PP-761	Tubing, Copper, 1/4 inch, per foot	.10
17	..	PP-763	Lugs for Copper Tubing, 1/4 inch, each	.07
18	..	PG-764	Lugs for Antenna Wire, Outside	1.00
19	..	PG-767	Lugs for Antenna Wire, Inside	1.00
20	14	UI-749	Electrose Strain, 8 inches	4.80
21	15	UI-710	Bridle Insulator, (7-foot Strop)	7.60
22	..	PP-758	Wire No. 12, Lead Covered, per 100 feet	7.00
23	..	PP-759	Wire No. 14, Lead Covered, per 100 feet	4.85
24	..	PP-760	Wire No. 18, Fixture, per 100 feet	.85
25	16	UI-748	24-inch Rod Insulator	1.20



The Wireless Man's BOOKSHELF

TITLE	AUTHOR	PRICE
Practical Wireless Telegraphy.....	Elmer E. Bucher	\$2.25
Vacuum Tubes in Wireless Communication.....	Elmer E. Bucher	2.25
Wireless Experimenter's Manual.....	Elmer E. Bucher	2.25
How to Pass U. S. Govt. Wireless License Examinations.....	Elmer E. Bucher	.75
How to Conduct a Radio Club.....	Elmer E. Bucher	.75
The Alexanderson System for Radio Telegraph and Radio Telephone Transmission.....	Elmer E. Bucher	1.25
Practical Amateur Wireless Stations.....	Compiled by J. Andrew White, Editor of Wireless Age	.75
Radio Telephony.....	Alfred N. Goldsmith, Ph.D.	2.50
Radio Instruments and Measurements.....		1.75
Sound Method of Learning the Code.....		.50
Elementary Principles of Wireless Telegraphy (in two volumes).....	R. D. Bangay	
Volume 1.....		1.75
Volume 2.....		1.75
Practical Aviation (including Construction and Operation).....	Major J. Andrew White	2.25
Military Signal Corps Manual.....	Major J. Andrew White	2.25
"What You Want to Say and How to Say It".....	W. J. Hernan	
In French, or Spanish, or Italian, or German.....		.25
In Russian.....		.50
Continuous Wave Telegraphy. Part I.....	W. H. Eccles	8.00
Thermionic Tubes in Wireless Telegraphy and Telephony.....	J. Scott-Taggart	8.00
Radio Communication.....	J. H. Morecroft	7.50
Thermionic Vacuum Tubes.....	Van der Bijl	5.00
Principles of Radio Engineering.....	Lauer and Brown	3.50
Spanish Edition, Elementary Principles of Wireless Telegraphy (complete).....	R. D. Bangay	3.25
Thermionic Valve and Its Development in Radio Telegraphy and Telephony.....	J. A. Fleming	5.00
The Oscillation Valve, The Elementary Principles of Its Application to Wireless Telegraphy.....	R. D. Bangay	2.75
Telephony Without Wires.....	Philip R. Coursey	5.00
The Wireless Telegraphist's Pocketbook of Notes, Formulae and Calculations.....	J. A. Fleming	3.50
Wireless Telegraphy and Telephony—First Principles, Present Practice and Testing.....	H. M. Dowsett	3.50
Handbook of Technical Instructions for Wireless Telegraphists.....	J. C. Hawkhead and H. M. Dowsett	2.50
Spanish Edition Handbook of Technical Instructions.....	Hawkhead and Dowsett	3.00
Standard Tables and Equations in Radio Telegraphy.....	Bertram Hoyle	3.25
Wireless Transmission of Photographs.....	Marcus J. Martin	2.00
Calculation and Measurement of Inductance and Capacity.....	W. H. Nottage	1.75
Short Course in Elementary Mathematics and Their Application to Wireless Telegraphy.....	S. J. Willis	1.75
Selected Studies in Elementary Physics (A Handbook for the Wireless Student and Amateurs).....	E. Blake	2.00
Magnetism and Electricity for Home Study.....	H. E. Penrose	2.25
Alternating Current Work (An Outline for Students of Wireless Telegraphy).....	A. M. Shore	2.00
Pocket Dictionary of Technical Terms Used in Wireless Telegraphy.....	Harold Ward	1.00
Useful Notes on Wireless Telegraphy (set of five books), (paper).....	H. E. Penrose	2.00
Book No. 1—Direct Current, 67 pages.....		.50
Book No. 2—Alternating Current, 50 pages.....		.50
Book No. 3—High Frequency Current and Wave Production, 65 pages.....		.50
Book No. 4—1½ Kw. Ship Set, 76 pages.....		.50
Book No. 5—The Oscillation Valve, 52 pages.....		.50
My Electrical Workshop.....	Frank T. Addyman	2.50
Experimental Wireless Stations.....	P. E. Edelman	3.00
High Frequency Apparatus, Design, Construction and Practical Application.....	T. S. Curtis	3.00
Textbook on Wireless Telegraphy.....	Rupert Stanley	
Volume 1—General Theory and Practice.....		5.00
Volume 2—Valves and Valve Apparatus.....		5.00
How to Make a Transformer for High Pressure.....	F. E. Austin	.75
How to Make a Transformer for Low Pressure.....	F. E. Austin	.75
The Operation of Wireless Telegraphy Apparatus.....	A. B. Cole	.35
Wireless Construction and Installation for Beginners.....	A. P. Morgan	.35
Lessons in Wireless Telegraphy.....	A. P. Morgan	.35
Experimental Wireless Construction.....	A. P. Morgan	.35
Home Made Toy Motors.....	A. P. Morgan	.35
Hawkins' Practical Library of Electricity, 10 volumes.....	Per volume	1.00
Hawkins' Electrical Dictionary.....		2.00
Marconi-Victor Records—6 Records—12 Lessons—For Learning Code Quickly.....		6.00

THE WIRELESS PRESS, Inc.

ROOM 310

326 BROADWAY

NEW YORK



NOTICE TO PURCHASERS

THE radio products of the RADIO CORPORATION OF AMERICA are distributed to the trade through its specially selected jobbers and dealers located throughout the United States and its possessions. These distributors generally carry a complete line of Radio Corporation apparatus. Experimenters are urged to place their orders with these accredited representatives rather than through the General Offices of the Corporation. By placing orders with these distributors, the purchaser not only buys in the most economical way and reduces the time of delivery, but he also assists the distributor to keep his shelves stocked with up-to-date and modern radio apparatus.

The Radio Corporation's jobbers and distributors have been selected after a careful investigation of their methods and practices. Consideration has been given to those who give quick service and are able, in addition to effecting radio sales, to assist experimenters in solving their technical problems.

Purchasers are requested to investigate our faith in these supply houses and if possible to place their orders with them directly. If the purchaser is located so far from any of the Corporation's jobbers or dealers that he cannot conveniently deal with them direct, the Corporation will be pleased to give him counsel and advice, and to point out the type of equipment which it deems most suitable for the purchaser's requirements.



