



*A Publication for the
Radio Amateur Worldwide*

*Especially Covering VHF,
UHF and Microwaves*

VHF COMMUNICATIONS

Volume No.28 . Winter . 4/1996 . £4.50

**Wolfgang Schneider
DJ8ES**

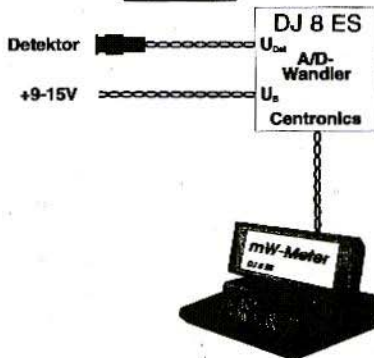
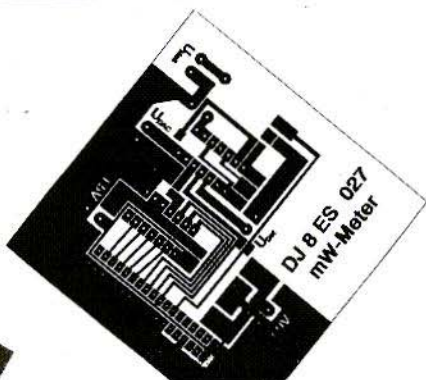
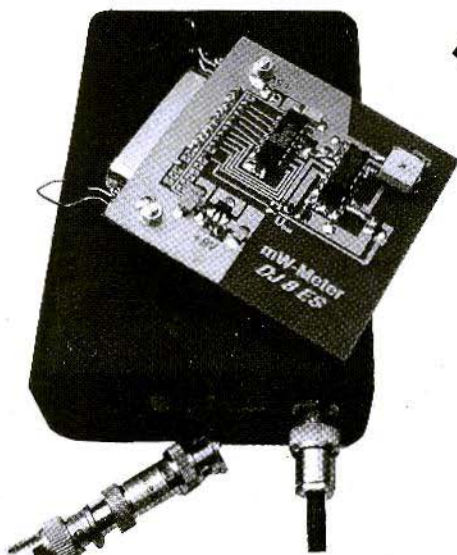

PC Measuring Methods - A Milliwatt Meter

NEW BOOKS FROM NOBLE

Microwave Field Effect Transistors

\$89

By Raymond S. Pengelly

This book covers the use of MESFET devices in microwave circuits such as low noise amplifiers, mixers, oscillators, power amplifiers, switches and multipliers. Included are 703 pages, 470 figures, 356 equations, and 61 tables. This classic reference is a "must buy" for all engineers involved in the development of microwave devices.

Semiconductor theory
Intermetallic compound
Dual gate FET
Schottky barrier
Operation principles
Large signal
Non-linear
Intermodulation
Power FET
FET osciplier
CAD considerations
Power amplifiers
Power combining
GaAs mixing
Image re-ction
Noise figure
Signal handling
Dual gate mixer

Induced neg. resistance
S-parameter mapping
Stabilized oscillators
Dielectric resonators
Packages & Sealing
Thermal resistance
Discriminators
Digital circuits
MESFET & MISFET
Monolithic microwave
Freq. multiplication
Freq. upconversion
Prematched
Phase shifters
FET fabrication
Narrow band
Broadband
Switches



Transceiver System Design for Digital Communications

\$54

By Scott R. Bullock

This system level approach to transceiver system design covers digital communications, building on principles required for military applications and translating those concepts for widely-used commercial applications. Includes 416 pages, 99 figures and 239 equations.

Design principles
Link budget
Receiver specifications
Antenna systems
Transmitter specifications
Frequency conversion
Intermodulation
Dynamic range
Digital signal processing
AGC design
PLL design and analysis
Modulation
Demodulation
Spread spectrum
Pulse theory

Error probability
The eye pattern
Sampling and aliasing
Path characteristics
Multipath analysis
Jamming sources
Jamming resistance
GPS transmissions
GPS code
Time synchronization
Direction finding
Interferometer methods
Pitch and roll conversion
Problems and answers
Index

ORDER BY PHONE, FAX OR MAIL

**BOTH BOOKS
ONLY \$125**

Name _____
Company _____
Address _____
City _____ State _____
ZIP _____ Country _____
Phone _____ FAX _____
Card # _____ Exp _____
Signature _____

Please send the following products

- Both Books \$125
- Microwave Field-Effect \$89
- Transceiver System Design \$54

Shipping & Handling

US \$8, Canada \$20, Intl. Air \$40

Payment Method

- VISA or MasterCard
- EuroCheck
- Bank Check (Must have the name of a US bank on the check)

NOBLE PUBLISHING

TEL (770)908-2320 FAX (770)939-0157
2245 Dillard St., Tucker, GA 30084, USA
editor@noblepub.com www.noblepub.com



Contents

Matjaz Vidmar S53MV	13cm PSK Transceiver for 1.2Mbits/s Packet Radio Part-2 (conclusion)	194 - 1205
Wolfgang Schneider DJ8ES	VHF, UHF and SHF Measuring Methods Using a PC Part-2: Milliwatt Meter from Short Wave to SHF	206 - 214
Bernd Kaa DG4RBF	Sweep Triggered Frequency Counter for the DB1NV Spectrum Analyser	215 - 223
Josef Fehrenbach DJ7FJ	10 GHz EME Basic Principles and Discoveries	224 - 243
Gunthard Kraus Development Consultant	Design and Realisation of Microwave Circuits	244 - 250

It seems only a short while ago that I was laying out out issue 4 of 1995 and now its 4 of 1996 - time flies! Frystyna and I would like to wish you all the very best for 1997 and would also like to thank you for your continued support of VHF Communications, in what can best be described as difficult times.

We endeavour to produce the best magazine we can within the constraints that we are committed to work under. Consequently, the increase of the subscription to L18 is a necessity to maintain a status quo, mainly against the rising tide of paper costs and postal charges. We hope that you will, understand and continue to support the magazine.

Best Wishes ... Frystyna and Mike



KM Publications, 5 Ware Orchard, Barby, Rugby, CV23 8UF, UK

Telephone: (0)1788 890365; INT: +44 1788 890365; FAX: (0)1788 891883

INTERNET: vhf-comm@g6iqm.demon.co.uk

WWW <http://www.eolas.co.uk/ag/vhfcomm.htm> & <http://www.clearlight.com/~vhfcomm>



Matjaz Vidmar, S53MV

13cm PSK Transceiver for 1.2Mbit/s Packet Radio Part-2 (conclusion)

7.

RX IF CHAIN

75 MHz/10 MHz

The circuit diagram of the RX IF chain is shown in Fig.17. The RX IF chain includes the second amplifier stage at 75 MHz (BF981), the second mixer to 10 MHz (another BF981) with its own crystal oscillator (BFX89) and the 10 MHz limiting IF amplifier (CA3189).

To receive correctly the 1.2Mbit/s BPSK signal, an IF bandwidth of about 2 MHz is required. Most of the receiver selectivity is provided at 75 MHz, especially the two tuned circuits with L2 and L3. The contribution of the tuned circuits with L1 at 75 MHz and L5 at 10 MHz is smaller, since the main function of the latter is the attenuation of far-away spurious responses.

The overall IF gain is even too large, although this does not cause instability problems. The IF gain can be decreased by replacing both BF981 MOSFETs with older devices like the BF960. The

second conversion oscillator uses a fifth overtone crystal at 65 MHz. L4 prevents the crystal from oscillating at its fundamental resonance around 13 MHz and/or at its third overtone around 39 MHz.

The integrated circuit CA3189 includes a chain of amplifier stages with a high gain at 10 MHz. In the described circuit, the CA3189 functions as a limiter since limiting does not distort PSK signals. Although the gain of the CA3189 drops quickly with increasing frequency, overloading the CA3189 input with the remaining 65 MHz LO signal has to be prevented with the lowpass filter with L5. The CA3189 includes a S-meter output with a logarithmic response that may be very useful during receiver alignment.

The receiver IF chain is built on a single-sided PCB with the dimensions of 40mm x 120mm, as shown in Fig.18. The corresponding component location is shown in Fig.19. L1, L2, L3 and L4 have about 400nH each or 5 turns of 0.15mm thick copper enamelled wire. They are wound on 36 MHz (TV IF) coil formers with a central adjustable

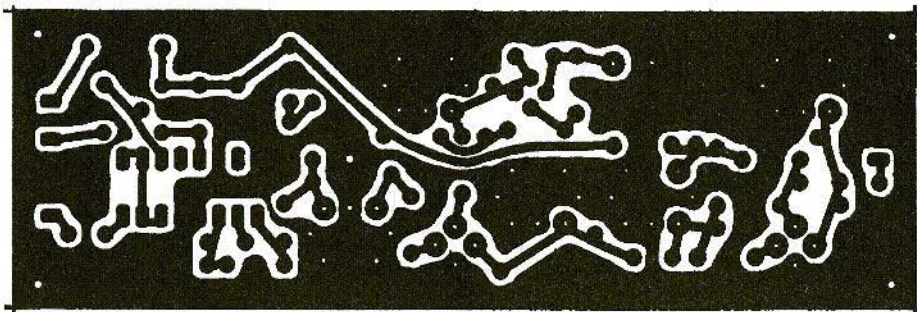

Fig.18: RX IF PCB (single-sided 1.6mm glass-fibre-epoxy)

ferrite screw, ferrite cap and 10mm x 10mm square shield. L5 has about 15uH or 25 turns of 0.15mm thick copper enamelled wire. L5 is wound on a 10.7 MHz IF transformer coil former with a fixed central ferrite core, adjustable ferrite cap and 10mm x 10mm square shield.

The IF chain alignment should start by checking the operation of the 65 MHz crystal oscillator on the desired overtone and adjusting L4 if necessary. All other tuned circuits (L1, L2, L3 and L5) are simply aligned for the maximum gain. Since the same circuits also define the selectivity of the receiver, the alignments have to be performed using a suitable 75 MHz signal source: signal generator or grid-dip meter. The re-

ceiver thermal noise or other noise sources can not be used for this purpose.

8. 1.2MBIT/S, 10 MHz PSK DEMODULATOR

Describing a PSK transceiver to radio amateurs, the least conventional circuit is probably the PSK demodulator. There are several different possible technical solutions for a BPSK demodulator. The circuit diagram shown in Fig.20 is probably one of the simplest coherent BPSK demodulators. Its principle of operation is a squaring-loop carrier

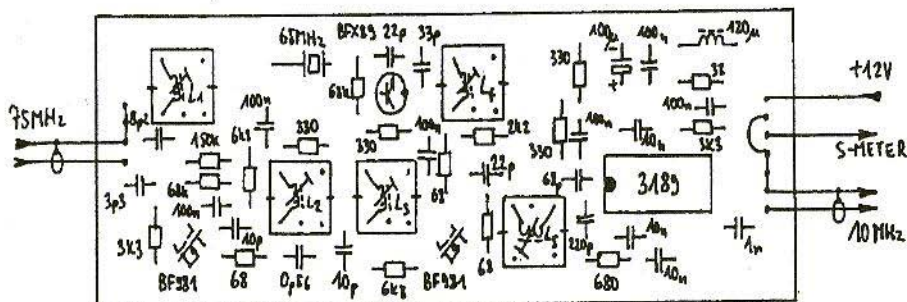

Fig.19: RX IF Component Overlay



recovery, followed by a PLL filter and a mixer. EXOR gates are used elsewhere for the squaring and mixing functions.

The input 10 MHz IF signal is first boosted to TTL level with an emitter follower (2N2369) followed by one of the gates of a 74HC86 (pins-1, 2 and 3). Next the IF signal is multiplied by its delayed replica (squaring or second-harmonic generation) in another EXOR gate (pins-4, 5 and 6). The delay is obtained with a RC network. On the output of this circuit, pin-6 or test point #1, a double IF carrier frequency is obtained, since the BPSK modulation is removed by the frequency-doubling operation. The latter transforms 180° phase shifts into 360° phase shifts or in other words a $0/180^\circ$ phase modulation is completely removed.

The signal available at test point #1 includes a strong spectral component at twice the carrier frequency around 20 MHz, but also many spurious mixing products and lots of noise. The desired 20 MHz spectral component is "cleaned" by a PLL bandpass filter, since the phase shift between the input and output signals in a PLL is well defined. A mixer is used as the phase comparator, in practice another EXOR gate (pins 8, 9 and 10). The VCO operates at 40 MHz, so that a perfect square wave can be obtained at 20 MHz with a simple divider by two (one half of the 74F74).

The regenerated BPSK carrier is obtained by another frequency division by two (other half of the 74F74). The BPSK demodulation is finally performed by the remaining EXOR gate (pins 11, 12 and 13 of the 74HC86). Because of

the division by two, the regenerated carrier phase is ambiguous 0 or 180° . As a consequence, the polarity of the demodulated data is also ambiguous and this ambiguity can not be removed in a $0/180^\circ$ BPSK system regardless of the type of demodulator used.

Fortunately amateur packet-radio usually uses NRZI (differential) data encoding, where level transitions represent logical zeroes and constant levels represent logical ones. The polarity of the signal is therefore unimportant and the above mentioned drawback of $0/180^\circ$ BPSK modulation does not represent a limitation in a packet-radio link. However, the polarity ambiguity has to be considered when designing data scramblers and/or randomisers for NRZI signal processing.

The PSK demodulator is followed by a RC lowpass filter to remove the carrier residuals. The lowpass is followed by an amplifier (74HC04) to boost the demodulated signal to TTL level and eventually drive a 75Ω cable to the bit-sync unit. The PSK receiver therefore only has a digital output, there are no outputs for loudspeakers or headphones.

The PSK demodulator is built on a single-sided PCB with the dimensions of 40mm x 120mm, as shown in Fig.21. The corresponding component location is shown in Fig.22. The VCO components have to be selected carefully to avoid frequency drifts. The VCO capacitors must be NP0 ceramic or Stiroflex types with a low temperature coefficient. The VCO coil L1 has around 400nH or 6 turns of 0.15 thick copper enamelled wire on a 36 MHz (TV IF) coil former with a central

9. SUPPLY SWITCH INTERFACE

The circuit diagram of the supply switch and some additional interface circuits is shown Fig.23. Most of the receiver circuits receive a continuous supply voltage of +12V. The supply switch only turns on the transmitter circuits (+12V TX) and at the same time removes the supply voltage to the RX RF preamplifier (+12V RX). The supply switching is performed by CMOS inverters (4049UB). The high TX current drain requires an additional PNP transistor BD138.

The RX/TX switching is driven by the PTT line. Just like with other transceivers, the PTT input is defined as a switch that closes towards ground when transmitting. The antenna PIN switch is driven by the +12V TX line and does not require any additional switching signals. Since most of the receiver circuits remain operational when transmitting, several of the receiver circuits (converter with PLL, PSK demodulator) can be tested with their own transmitter signal due to the inevitable crosstalk between the transmitter and the receiver.

The supply switch interface module also includes the modulator driver. The TTL input includes termination resistors to prevent cable ringing, if a longer coaxial cable is used between the transceiver and the digital equipment. The TTL input signal is first boosted by a 74HC125, followed by a resistive trimmer for the modulation level and a lowpass filter with the 1uH inductor.

The modulation level is simply adjusted to obtain the maximum transmitter output power.

The 74HC125 receives the supply voltage +5V also while receiving and only its tri-state outputs are disabled during reception. The two 1.8k Ω resistors keep the 33 μ F tantalum capacitor charged to 2.5V to speed-up the RX/TX switching. The 33 μ F tantalum capacitor is the only capacitive signal coupling in the whole transceiver. All other signal couplings allow the transmission of the DC component of the digital signal. If the described PSK transceiver is to be used without a data scrambler or randomiser, the described capacitive signal coupling has to be removed by redesigning the modulator driver only, while the other circuits need not be modified.

The supply switch interface is built on a single-sided PCB with the dimensions of 30mm x 80mm, as shown in Fig.24. The corresponding component location is shown in Fig.25. The PCB is intended to be installed behind the front panel of the transceiver and is intended to carry the RX and TX LEDs.

10. ASSEMBLY OF THE 13cm PSK TRANSCEIVER

Building a PSK transceiver certainly represents something new for most radio amateurs, while the microwave frequencies make the job even more difficult. Except for the careful design of the various circuits, the mechanical layout

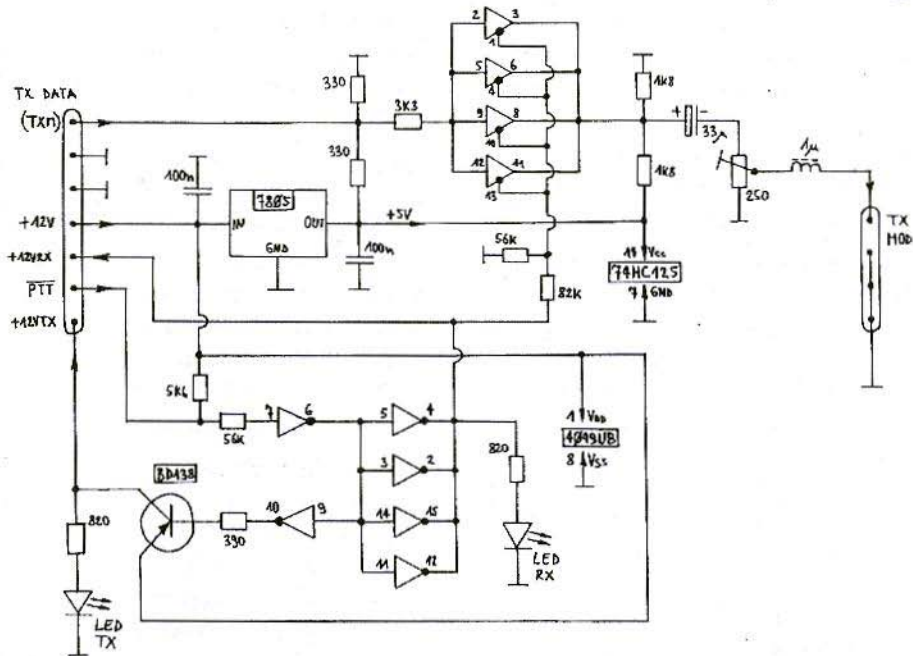

Fig.23: The Supply Switch Interface



Fig.24: Supply Switch Interface PCB (single-sided 1.6mm glass-fibre-epoxy)

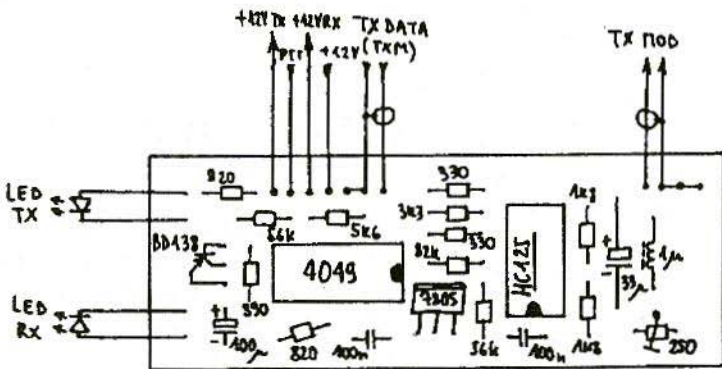

Fig.25: Supply switch Interface Component Overlay

and assembly also have to be considered right from the beginning. To avoid any possible shielding or crosstalk problems, the described transceiver employs a large number of shielded enclosures and feedthrough capacitors.

The PSK transceiver is enclosed in a custom-made aluminium box measuring 320mm (width) x 175mm (depth) x 32mm (height). The individual module locations and RF interconnects are shown in Fig.26. The box is made of two "U"-shaped pieces of aluminium sheet. The front, bottom and back are made of 1mm thick aluminium sheet, while the cover and the two sides are made of 0.6mm thick aluminium sheet. The cover and sides are 190mm deep to exceed the size of the bottom by 7.5mm on the front and on the back.

The individual modules of the PSK transceiver are all (except the supply switch interface) installed in shielded enclosures made of 0.5mm thick brass sheet. The PCBs are soldered into a brass frame as shown in Fig.27. A brass cover is then plugged onto the frame to complete the shielding enclosure.

The shielded module is then installed on the bottom of the aluminium box with four sheet-metal screws. The height of the aluminium box is selected so that the main aluminium cover keeps all seven small brass covers in position.

To retain the shielding efficiency of the single modules, all of the supply and low-frequency interconnects go through 220pF feedthrough capacitors soldered in the narrow sides of the brass frames. The RF interconnects are made with thin 50Ω Teflon cables (RG-188 or similar). It is extremely important that the coax

shielding braid is soldered in a "water-tight" fashion to the brass sheet all around the central conductor using a suitable soldering iron.

The size and shape of the single-module shielded enclosures is selected so that the lowest waveguide mode cut-off frequency is well above the operating frequency of the transceiver in the 13cm band. The described shielded enclosures usually do not require any microwave absorbers or other countermeasures to suppress cavity resonances.

The described PSK transceiver probably represents the first serious construction using SMD parts for many amateur builders. Unfortunately SMD parts can not be avoided: at high frequencies it is essential to keep package parasitics small enough to obtain a good device gain, noise figure and/or output power. The described 13cm PSK transceiver was designed with Siemens SMD semiconductors originally intended for cellular telephones. Since these devices are relatively new, their packages and corresponding pin-outs are shown in Fig.28. Please note that due to space restrictions, the package markings are necessarily different from the device names!

11. EXPERIMENTAL RESULTS

The design goal of the described transceiver was to develop a packet-radio transceiver capable of transmitting data at 1Mbit/s with a free-space radio range between 500km and 1000km using

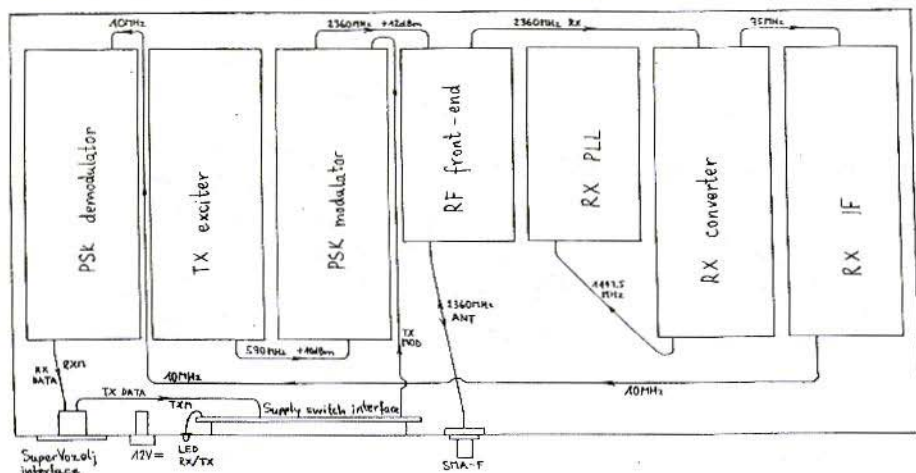

Fig.26: 13cm PSK Transceiver Module Location

moderate-size antennas. Such equipment is required for real-world line-of-sight packet-radio links of 30-100km with a single transceiver connected to more than one antenna (to support more than one link) and with a reasonable link margin of 10-15dB to counter propagation effects.

The first two transceivers were finished in April 1995 and some laboratory bit-error rate measurements were made. The acknowledgements go to Knut Brenndoerfer, DF8CA, supplied the author with up-to-date microwave SMD components. The first packet-radio link was installed in June 1995 between the SuperVozelj packet-radio node GORICA:S55YNG and the experimental node RAFUT:S59DAY at the author's QTH.

Although the distance is only 5.8km, there is no optical visibility between these two locations. The obstacle (hill) exceeds the 10th Fresnel zone at 13cm and the reception of a commercial UHF TV repeater installed in the same loca-

tion is not possible due to reflections corrupting the horizontal sync pulses. Nevertheless, two-way packet-radio communication at 1.2288Mbit/s was found possible although affected by fading, using the described 13cm PSK transceivers, 16dBi short-backfire (SBF) antennas and about 5dB of antenna cable loss at each side of the link!

The first operational 1.2288Mbit/s packet-radio link was installed at the end of July 1995 between the SuperVozelj packet-radio nodes GORICA:S55YNG and KUK:S55YKK at a distance of 22.1km. Next this link was extended to the SuperVozelj node IDRIJA:S55YID in the beginning of October 1995, at a distance of 36.6km from KUK:S55YKK. The measured YKK-YID link margin is 17dB, although there are two SBF antennas at KUK:S55YKK pointed in different directions, but connected to one single 13cm PSK transceiver. The estimated cable losses are around 3dB at each side of the link.

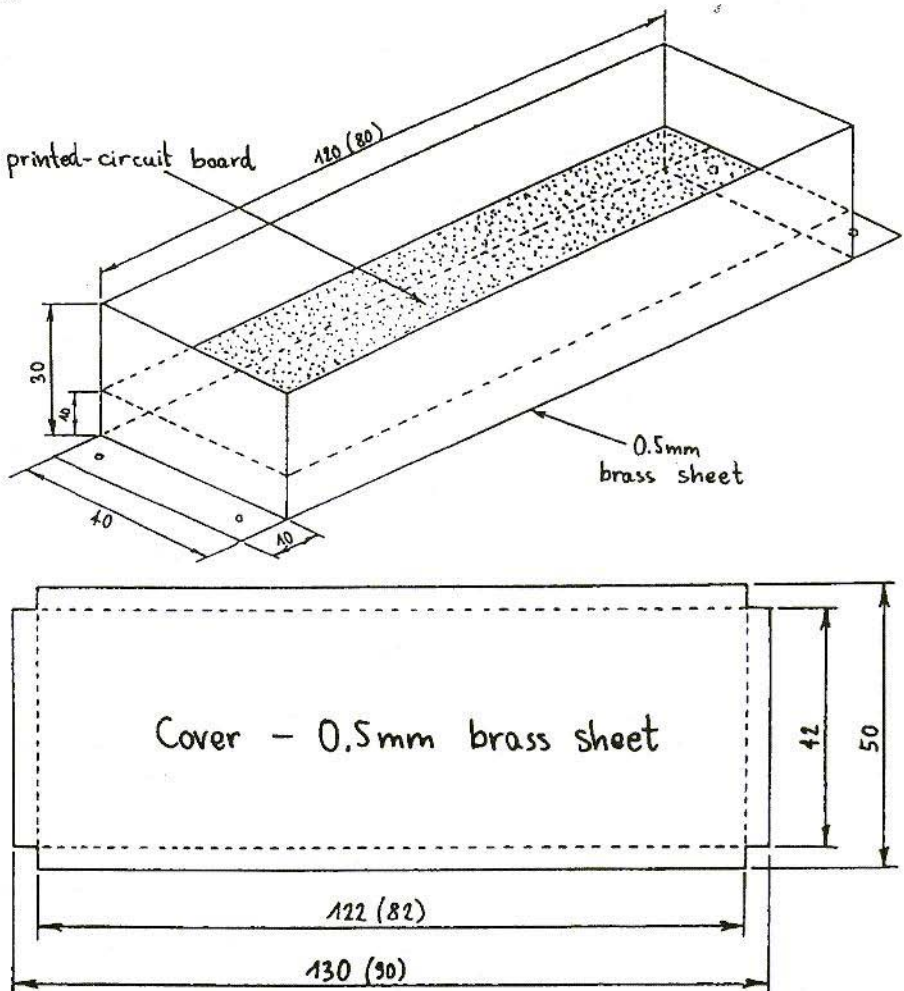

Fig.27: 13cm PSK Transceiver Shielded Module Enclosure

All of these experiments are using SuperVozelj node computers [2]. The SuperVozelj packet-radio node computer is based on the MC68010 16-bit CPU and offers 6 low-speed interrupt-serviced channels up to 76.8kbit/s for user access (three Z8530 SCC chips) and two high-speed DMA-serviced channels for megabit interlinks (Z8530 SCC + MC68450 DMA).

The interface to the described 13cm PSK transceiver includes external bit-sync/clock recovery and a $1+X^{12}+X^{17}$ polynomial data scrambler/randomiser.

Currently seven prototypes of the described 13cm PSK transceiver have been built and four are already installed on mountaintop digipeaters.

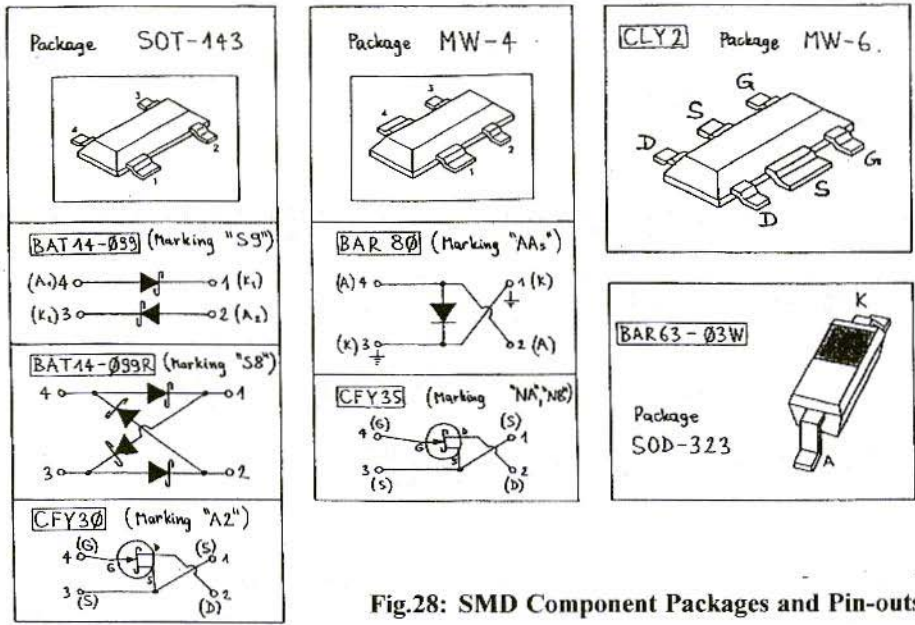

Fig. 28: SMD Component Packages and Pin-outs

Together these prototypes accumulated more than one year of continuous operation with no failures. However, the described transceivers have not been checked in winter conditions yet, under wider temperature excursions to lower temperatures.

The described 13cm PSK transceivers finally demonstrated that megabit amateur packet-radio is not just possible but it is also a practical alternative. Using more sophisticated PSK transceivers with a larger radio range, a single PSK transceiver can be connected to more than one antenna and thus replace many narrowband FM "interlink" transceivers resulting in a simpler and cheaper packet-radio network. Of course, the next logical step is to develop simpler PSK transceivers for the user community, maybe using direct-conversion PSK demodulation.

12. REFERENCES

- [1] Matjaz Vidmar, S53MV: "Ein Front-End fuer den Satellitenempfang im 13-cm-Band", AMSAT-DL Journal 2-94, pages 21-33.
- [2] Matjaz Vidmar, S53MV: "1.2Mbit/s SuperVozelj packet-radio node system", 40. Weinheimer UKW-Tagung, 16./17. September 1995, Scriptum der Vortraege, pages 240-252

Wolfgang Schneider, DJ8ES

VHF, UHF and SHF Measuring Methods Using a PC

Part-2: Milliwatt Meter From Short Wave To SHF

A wattmeter is definitely a necessity for the active radio amateur, and there's probably one in every shack. But what about low-power measurements?

Is the VFO still supplying the correct output level, or what's the control power level for the transverter? Or, or, or... A simple mW meter can help in many such cases.

1. GENERAL

Many descriptions have been written in the relevant amateur radio literature in the past on the assembly of milliwatt

meters - and I hope this will continue in the future. Two main measuring methods could be distinguished:

1. Thermal power measurement (bolometer), and
2. Measurement using high-frequency rectifier diodes

This article will neither be dealing with the theoretical principles of the two options nor contrasting their advantages and disadvantages.

Whether a bolometer or a diode detector is used, they have one problem in common - the linearity over a frequency range as large as possible. It is just not good enough if the milliwatt meter merely works well at 23cm - it must give readings just as accurate for short-wave, from 2m to 70cm.

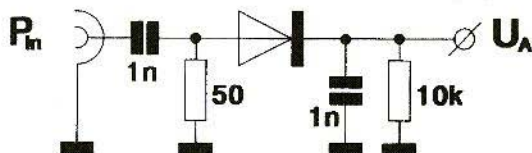
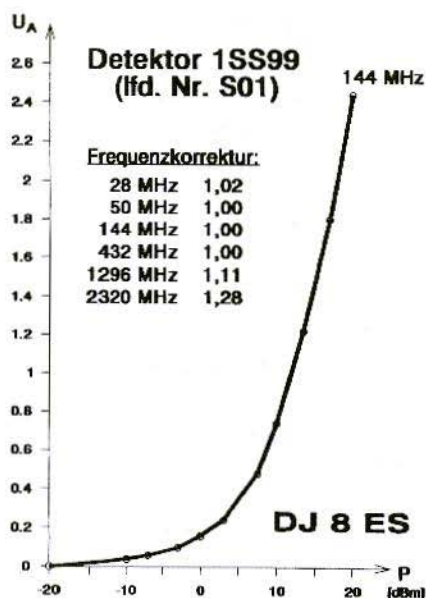

Fig. 1:
Diode Detector with
High-Frequency Rectifier
Diode



dBm	mW	U_A
+20	100,000	2,450
+17	50,000	1,748
+14	25,000	1,195
+10	10,000	0,738
+7	5,000	0,478
+4	2,500	0,315
0	1,000	0,153
-3	0,500	0,085
-6	0,250	0,047
-10	0,100	0,020
-13	0,050	0,012
-16	0,025	0,008
-20	0,010	0,003

Fig. 2:
Output Voltage, dependent on Power and Frequency
Detektor = Detector; Lfd. Nr. = Ser. no.;
Frequenzkorrektur = Frequency correction factor

Many authors offer interesting analogue solutions to this problem in their publications. But there are others too!

Linearisation of characteristics, automatic calibration of the power meter, zero point correction, etc. - you can confidently entrust these jobs to the computer!

What is described below, then, is an mW meter which enjoys the advantages of a PC. A simpler and faster way to measure power is the aforementioned method using high-frequency rectifier diodes. Fig.1 shows the standard circuit.

The output voltage, U_A , which is dependent on the input power, P_{IN} , and the frequency response are important values for the description of the circuit. The characteristics can be plotted simply, using adjustable output power and a voltmeter as accurate as possible, e.g. a digital gauging instrument.

The ratios are shown in graph form in Fig.2 and are listed systematically in the table.

Another simple circuit (Fig.3) operates with simultaneous voltage doubling. Two germanium diodes (type AA119) supply an output voltage proportional to the input voltage.

2. THE CIRCUITS

2.1. The Detector

A measurement detector should fulfil various criteria:

The wide dynamic range is provided by a type 1SS99 Schottky diode. Moreover, the wide frequency range goes from the

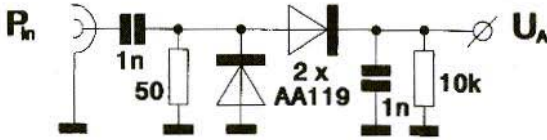

Fig. 3:
High-Frequency
Rectification with Voltage
Doubler

short wave right into the GHz range. Apart from the components selected, the main factor determining the frequency is an assembly appropriate for high frequency! Fig.4 shows the circuit of the measurement detector for frequencies of up to 2.5 GHz.

2.2. The A / D converter for the mW meter

The detector supplies an output voltage proportional to the input voltage (Fig.2). The high-Ohm input de-couples the measurement detector from the rest of the circuit. This is brought about via an operational amplifier ($\frac{1}{4}$ LM324) with $V = 1$. The subsequent comparator compares the reading with a comparison voltage generated by the PC. In accordance with the up-to-date condition, there is 0 V or + 5 V at the PE connection ("paper empty").

The PC controls the entire measurement procedure through the Centronics interface.

The comparison voltage just referred to is generated by a D / A converter (ZN426E-8) from an 8-bit data word.

The validity range runs from 0 to 255_{dez} .

The procedure uses the successive approximation principle.

Rapid D / A conversion is accomplished with the help of this method. An attempt is made to guess the voltage reading. Naturally, this sequential process is not carried out randomly, but is done in accordance with a balancing process, in accordance with which one feels one's way towards the desired value in a few steps. Naturally, this happens very fast if a PC is used.

When the measurement begins, the value is fed into the D / A converter which corresponds to exactly half the maximum voltage. A comparator reports whether the comparison voltage is higher or lower.

If the voltage to be measured lies in the bottom half of the range, this is divided again into two halves. If the upper segment is involved, the procedure is exactly the same.

Thus each new experiment narrows the voltage range down more and more. For 8-bit accuracy, the successive approxi-

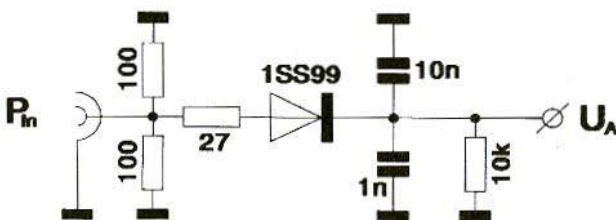

Fig. 4:
The completed Circuit
with an 1SS99 as
Detector

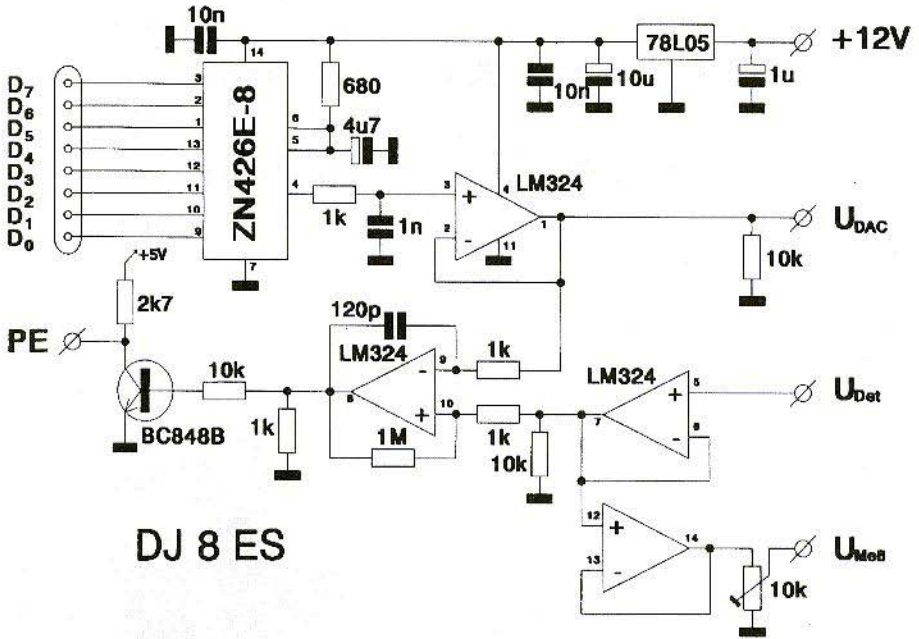

Fig. 5: The complete A / D Converter with Centronics Interface

mation procedure requires only eight steps to yield a result.

The comparison voltage (U_{DAC}) of the A / D converter is fed out as a check. Anyone who wants to may connect a simple direct reading instrument to point U_{MeB} to obtain a relative display.

3. SOFTWARE

The flow chart on the following page-(Fig.7) shows the steps of the process very clearly.

The screen is set up as a first step. This must be done before the actual measurement routine begins.

The prevailing reading is continuously transmitted in an endless loop, and converted into the proportional power with the help of the detector characteristic line from Fig.2.

Last of all, it only remains for a correction factor to be brought into action, corresponding to the measured frequency. The frequency range can be adjusted for this purpose at any time via input through the keyboard.

The measured power is displayed on the screen in mW and dBm. The readings can be displayed as a graph without further ado. There are no limits to what the interested programmer can do here.

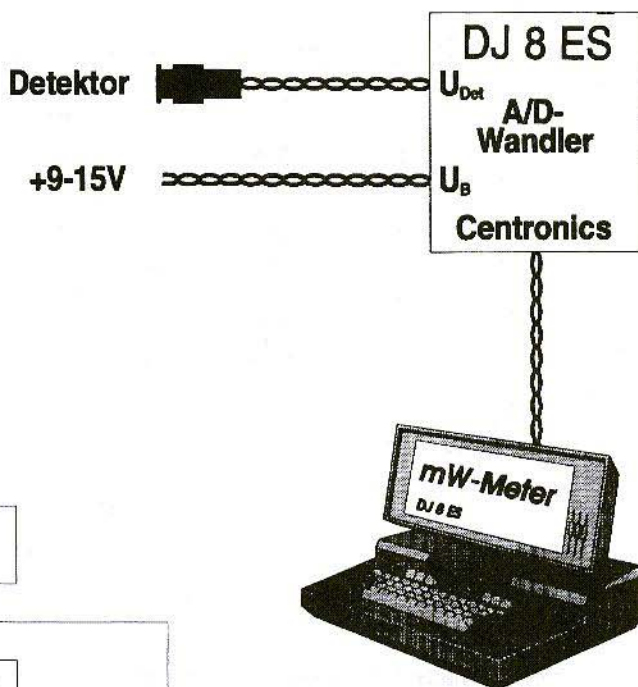

Fig. 6: Hooking up the Detector, the A / D Converter and the PC
Detector = Detector;
A / D Wandler = A / D converter

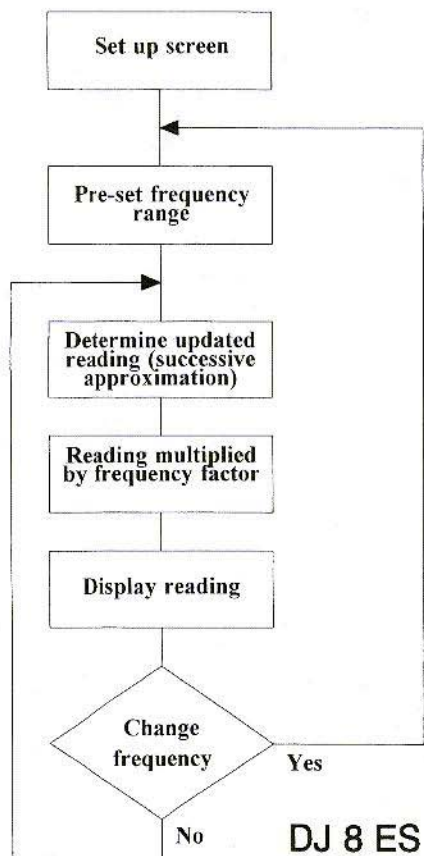

Fig. 7: Flow chart

4.

ASSEMBLY INSTRUCTIONS

Special attention should be paid when assembling the measurement detector. A suitable assembly for high frequency is an absolute must for the desired broadness of band! That means short connecting wires, tidy earth connections and a mechanically stable structure.

The carrier material can be, for example, the hexagon nut from a BNC plug, sawn off in advance. Don't forget to de-burr it!

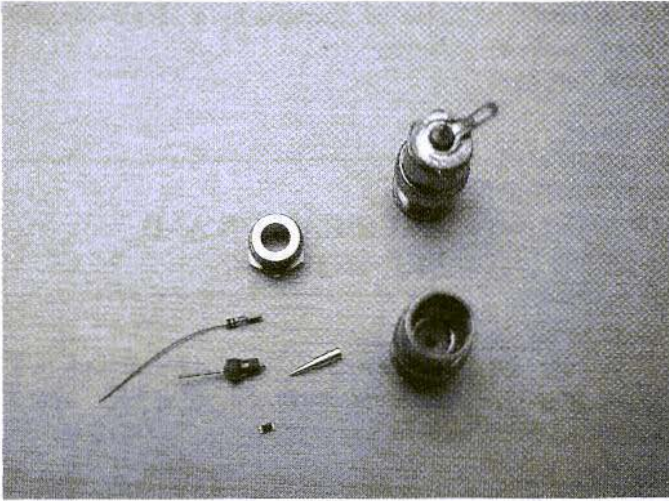

Fig. 8:
Individual Detector
Components

The small number of structural components is soldered onto or into the residual threaded section and then provided with short wire ends (CuAg, diameter 1mm) for plug and socket. The detector prepared in this way is now screwed into the plug and coupling housing. When functionality

has been successfully tested, a drop of rapid-acting adhesive fixes all components of the completed measurement detector.

Fig.8 shows additional details regarding the layout and incorporation of the components.

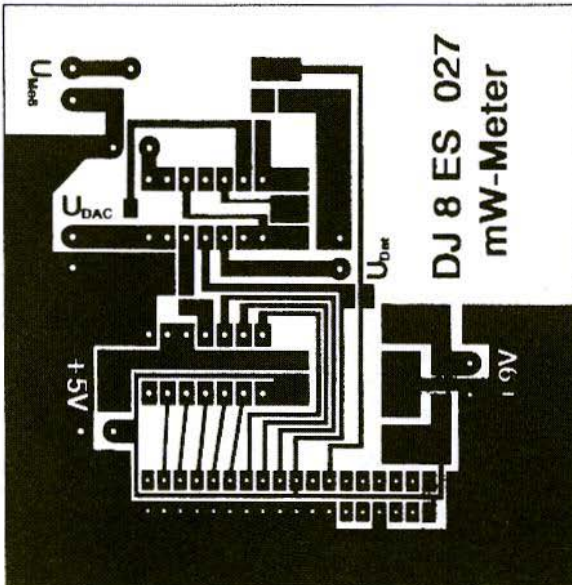

Fig. 9a:
mW Meter Layout
DJ8ES 027

The board for the A / D converter is double-sided coated epoxy material 1.57mm thick. The board measures 75mm x 75mm..

Matching bores are to be provided for the IC's and the trimming potentiometer. The same applies to the Centronics plug and the U_{DAC} , U_{Dat} , U_{MeB} and + 12 V connections.

Right up to the Centronics plug, all the components are mounted on the foil side! This also applies to the IC's and the trimming potentiometer (Fig.9).

All earth connections are soldered on both sides. The earth surface may not be milled down in advance here!

Finally, the entire circuit can be incorporated into a housing, as selected. A high-quality plug connection should be taken into account for the measurement detector (Fig.10).

The low current consumption for the circuit - app. 12mA at 9V - means it can

also be operated by a simple compact battery.

5. CALIBRATION AND PRE-SETTINGS

The complete calibration of the mW meter assembly can be divided into 4 steps:

- Characteristics of Diode Detector

For the diode detector, the output voltage should be measured in relation to the input power. An expedient way to do this is to use a digital voltmeter and a 144 MHz standard signal generator. A transceiver with an adjustable transmission power will also fit the bill, of course. Fig.2 shows the levels and some possible step sizes.

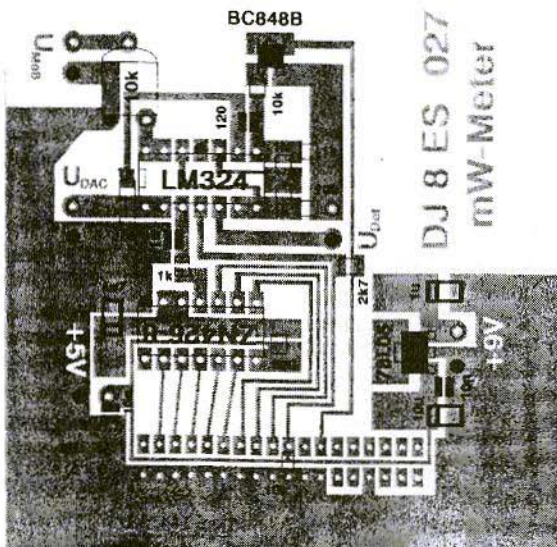

Fig. 9b:
Component Plan of A / D
Converter Assembly

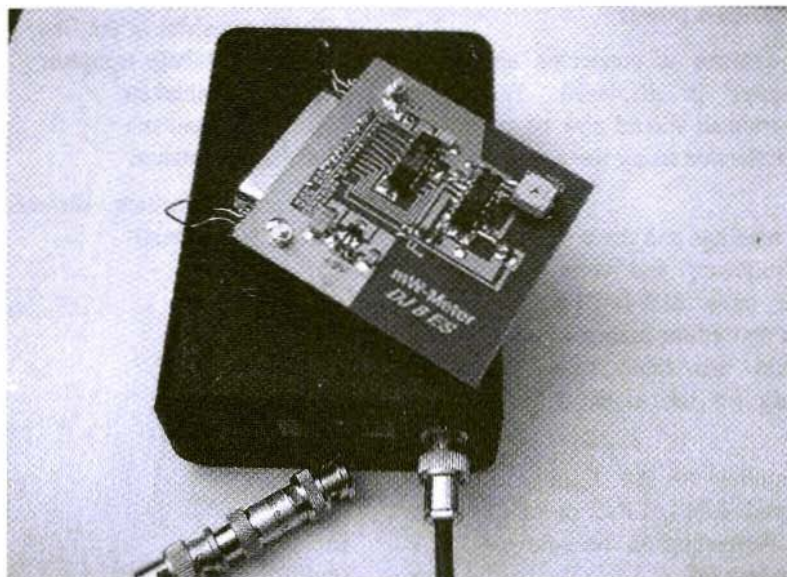

Fig. 10: The Printed Circuit Board alone and as Fully Completed Unit

An appropriate measurement graph is usually provided with ready-made measuring heads.

If we increase the number of measurement points, the accuracy of the equipment can be further increased. The program is designed for a minimum step width of 1dB. The corresponding values should be entered in a table.

– Correction factor δf

Particularly at high frequencies, the actual input impedance deviates from the expected value by 50Ω . A correction factor, δf , theoretically balances this out.

The factor should be measured for the frequency ranges 28, 50, 144, 432, 1,296 and 2,320 MHz, with a control power of, for example, 1mW (0dBm):

$$\delta f = \frac{\text{Rated value at 144 MHz}}{\text{Measured value}}$$

– Correction factor δU

Tight tolerances in the components, or even in the D / A converter ZN426E-8, lead to discrepancies in the measured voltage. The factor δU acts as a theoretical correction factor. It has a value of app. 0.01. The reference voltage, U_{Ref} , can be precisely measured at pin 5/6 of the D / A converter with a digital measuring instrument.

$$\delta U = \frac{U_{\text{Ref}}}{256}$$

**- 10k Potentiometer for relative display of measured power**

If no diode detector is connected up, maximum power is displayed. The measuring instrument should now be set to end-scale deflection using the potentiometer.

The detector readings and the correction factors for frequency and voltage are listed in the table MWTABLE.TXT. Any standard text editor makes it possible to correct this table using the updated values for the diode detector used.

This also applies to the Centronics interface desired. LPT1, LPT2 or LPT3 can be used, depending on the configuration of your own PC.

and in surface-mounted format:

1 x	BC848B transistor or the like
1 x	TA 78L05F voltage regulator
1 x	1.0 μ F / 35V tantalum
1 x	4.7 μ F / 25V tantalum
1 x	10 μ F / 20V tantalum

all resistors and capacitors surface-mounted (1206/0805 format)

1 x	27 Ω
2 x	100 Ω
1 x	680 Ω
4 x	1k Ω
1 x	2.7k Ω
4 x	10k Ω
1 x	1M Ω
1 x	120nF
2 x	1nF
3 x	10nF

6. COMPONENT LIST

1 x	1SS99 Schottky diode
1 x	ZN426E-8 D / A converter
1 x	LM324 operations amplifier
2 x	UG88 A/U BNC plugs
1 x	UG89 A/U BNC cable jack
1 x	36-pin Centronics jack (printing installation)
10 x	1.3 mm. diameter terminal pins
1 x	10 k trimming potentiometer (horizontal, 10mm basic grid)

7. LITERATURE REFERENCES

- [1] Carsten Vieland, DJ4GC: UHF and SHF Broadband Mixers, VHF Communications 1/1989, pp. 39 - 45
- [2] Detlef Burchard: Linear Signal Rectification (Part 1) VHF Communications 3/1994, pp.168 - 179



Bernd Kaa, DG4RBF

Sweep-Triggered Frequency Counter for the DB1NV Spectrum Analyser

The additions to the spectrum analyser from DB1NV which Rainer Schmülling described in his article in issue 3/1995, were of interest to me, particularly the frequency counter which they referred to.

I am grateful to the author in question for sending me a hand-drawn wiring diagram. I liked the design so much that, having made a couple of changes in the circuit, I immediately designed a printed circuit board.

The result was the frequency counter described here, with a mean frequency display accurate to 100 kHz as an addition to the spectrum analyser (SA).

displays the precise mean frequency. This also includes the frequency variation in the fine balancing and any temperature drift in the mean frequency display.

Of course, there is a small amount of inaccuracy if the equipment is used for large display widths with a varying sweep (varying trigger point). This can be avoided if a mean sweep speed is selected for large display widths and if the counter is balanced to it at zero. The accuracy is then sufficiently good.

Alternatively, a null balance potentiometer can also be taken out if a varying sweep is required even for work with large display widths.

For small display widths, the display is also very precise, even with varying sweep speeds. The circuit is laid out in such a way that the frequency is updated after every fourth sweep cycle. This means the display remains absolutely steady.

1. DESCRIPTION

The frequency counter counts the first local oscillator (1.LO) and the second local oscillator (2.LO), so that it always



2. SELECTING COMPONENTS

OM Schmüling selected a 74HC4061 as the oscillator with a divider, to generate the gate time. But since the 4061 can be obtained only with difficulty and the use of a 4060 does not seem to recommend itself (the 4060 interrupts the internal oscillator when reset), I used a ready-made transistor transistor logic oscillator with a subsequent divider (4040). But the option to use an HC4061 was also provided for on the printed circuit board. To do this, the reset connection had to be laid from pin-11 to pin-12 and the external components of the oscillator had to be connected between pin-10 and pin-11.

3. PRE-PROGRAMMING OF SECOND INTERMEDIATE FREQUENCY

If the SA has been assembled in accordance with the design from DB1NV, the following relationship will obtain:

- Measurement range 1 (normal):
- Mean frequency = first LO - second LO - 10.7 MHz
- Measurement range 2 (image):
- Mean frequency = first LO + second LO + 10.7 MHz

It follows from this that in the "normal" position the 10.7 MHz frequency must

Digit	Number	P3 (pin-9)	P2 (pin-10)	P1 (pin-1)	P0 (pin-5)	Measurement Range
0.01	0	0	0	0	0	Normal
0.01	0	0	0	0	0	Image
0.1	3	0	0	1	1	Normal
0.1	7	0	1	1	1	Image
1	9	1	0	0	1	Normal
1	0	0	0	0	0	Image
10	8	1	0	0	0	Normal
10	1	0	0	0	1	Image
100	9	1	0	0	1	Normal
100	0	0	0	0	0	Image
1000	9	1	0	0	1	Normal
1000	0	0	0	0	0	Image

Table 1: Pre-programming

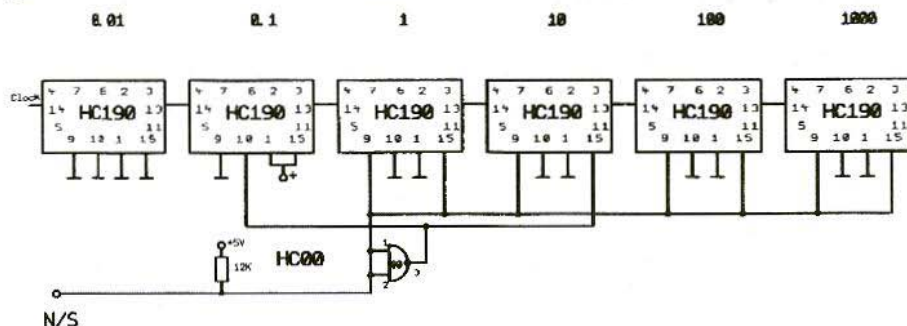

Fig. 2: Pre-programming of Displays for Second Intermediate Frequency

be derived from the display, i.e. negatively pre-programmed (9989.30). In the "image" position, the counter chain is correspondingly positively pre-programmed (0010.70).

To program the 74HC190 counter, the desired number is set at the inputs, P0 to P3, in BCD code. In this connection, the relationships are: P3 = pin-9, P2 = pin-10, P1 = pin-1, P0 = pin-15.

Table-1 shows the pre-programming for the "normal" and "image" conditions. A "1" corresponds to "High" ("Plus") and a "0" to "Low" ("Earth").

Here is an example:

The fourth counter module (IC4) displays the "10-MHz position" and should thus be programmed with "8" in the "normal" position = (1000): pin-9 is connected to +5 V and pins-1, 10 and 15 to earth. The 10 MHz position is pre-connected to the "1" in the "image" position = (0001): pins-1, 9 and 10 are connected to earth, and pin-15 to +5V.

The first NAND gate is wired up as an inverter, so that reversible high and low levels are always available (HC00 pins-1 to 3). The pins, which have to change

their levels, are correspondingly connected to the input or output of the inverter, while the other inputs can be connected to earth or to +5V, in accordance with the number to be programmed. Any number between 0 and 9 can be pre-programmed in this way.

Should anyone have a second intermediate frequency differing from 10.7 MHz, the pre-programming on the printed circuit board must be wired up in a correspondingly different way. The detailed wiring diagram in Fig.2 makes the pre-programming of the counter clear.

If the TTL crystal oscillator does not generate its frequency of 10.24000 MHz absolutely precisely, this can also be balanced out by another pre-programming of the 10 kHz / 100 kHz positions. The printed circuit board is laid out in such a way that this can be done at low cost.

The author's counter was pre-programmed with the numbers (9989.35/00 10.75) in order to obtain an absolutely accurate display. This can be done at no great cost. It is merely necessary to connect pins-10 and 15 of the first HC

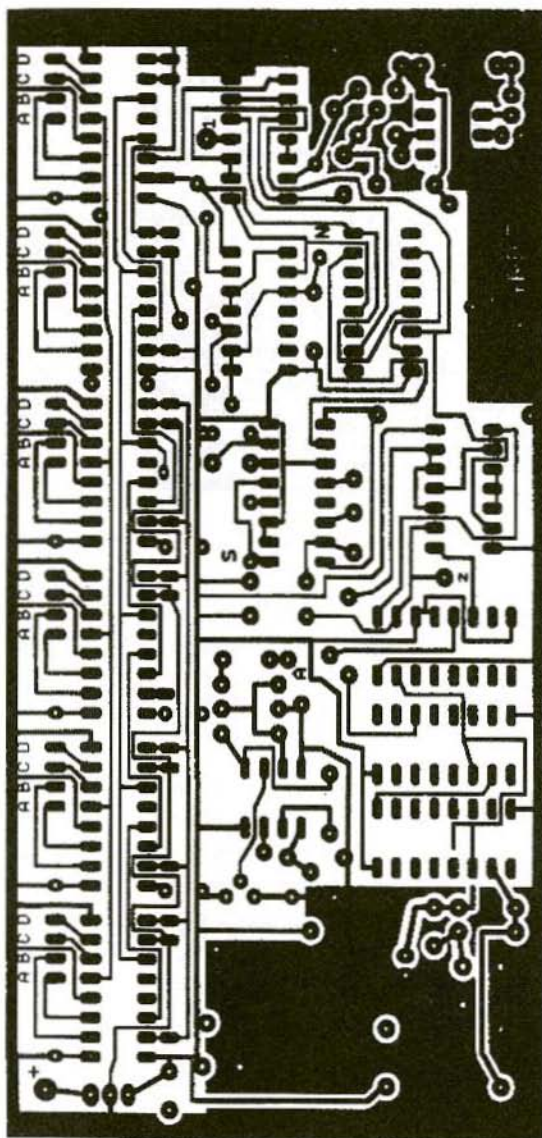

Fig. 3:
Layout of DG4RBF 001
Counter Printed Circuit Board
Zähler für = Counter for

190 to "High". This means the 10 kHz position is pre-allocated to "5", so that the value displayed increases by 50 kHz.

Here's a tip to optimise the layout:

Set the SA to 20 kHz / div and then use the frequency fine setting to move the

zero line alternatively right and left of the centre. While doing this, note when the value of the last digit of the display begins to change. In this way, you can easily see whether any fine correction is required for the "100 kHz position".

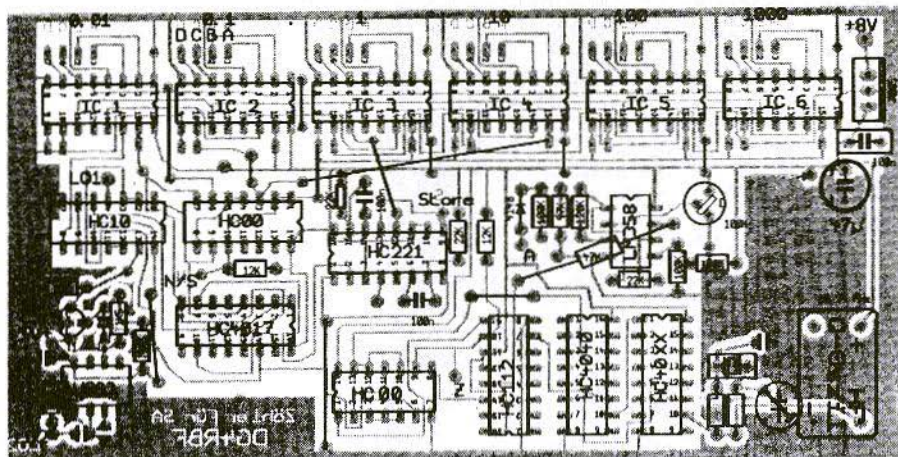

Fig. 4: Components Plan of Counter Printed Circuit Board

Here are the figures from 0 to 9, in BCD code, for each of the pins-9 / 10 / 1 / 15:

0 = 0000	5 = 0101
1 = 0001	6 = 0110
2 = 0010	7 = 0111
3 = 0011	8 = 1000
4 = 0100	9 = 1001

4. CONNECTION TO SPECTRUM ANALYSER

The trigger signal is obtained from the horizontal deflection voltage, which is connected to point A on the counter printed circuit board via a coax cable.

The connections to the first and second LO's are also carried out using coax cable. It is recommended that additional

coax jacks are built-in.

The signal from the first LO is available, already divided by 64, in the DB1NV 007 phase-locked loop assembly.

The connection can be to pin-3 of IC 4 (HC00). For a connection to the second LO, some oscillator power is de-coupled and connected to the input of the divider (U893) of the frequency counter. The U893 divider needs only app. 0.15mW driving power at the input.

5. NOTES

Following the U893 divider there is a level conversion stage, the 1.5kΩ resistor of which leads from pin-6 of the U893 to the transistor, may have to be balanced.



7 - Segment- Anzeige

BCD-7-Segm. -Speicher, Dek. /Treiber

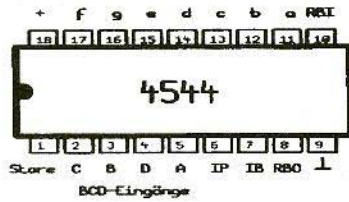
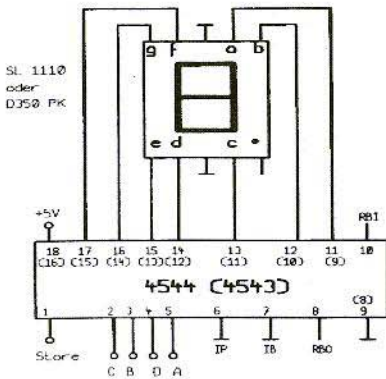

Fig. 5: Connection of Display and Driver Printed Circuit Boards
 7-Segment-Anzeige = 7-segment display; 7-Segment-Speicher = 7-segment memory; Dek. = Decoder; Treiber = Driver; Oder = Or; Eingänge = Inputs

The +5V connection for the U893 still has to be wired up!

The switching between “normal” and “image” is carried out at the connection (N/S) on the printed circuit board.

If the connection is open, the “normal” mode is in operation. If the connection

is earthed, the “image” mode is activated.

No additional switching was provided for the “zero mode” - 10 kHz resolution. The counter thus displays the 5-digit mean frequency, with a resolution of 100 kHz.

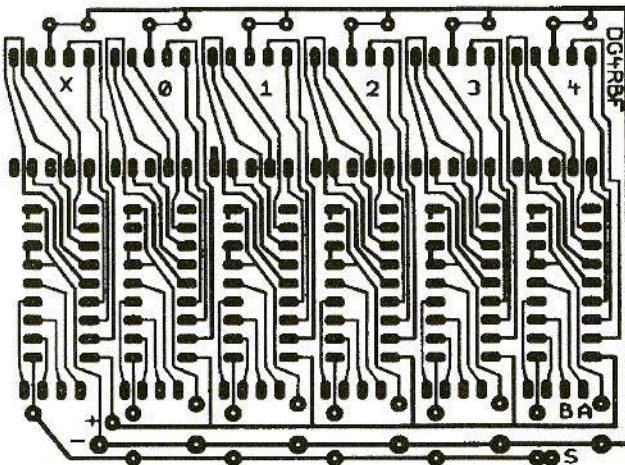

Fig. 6: Display PCB

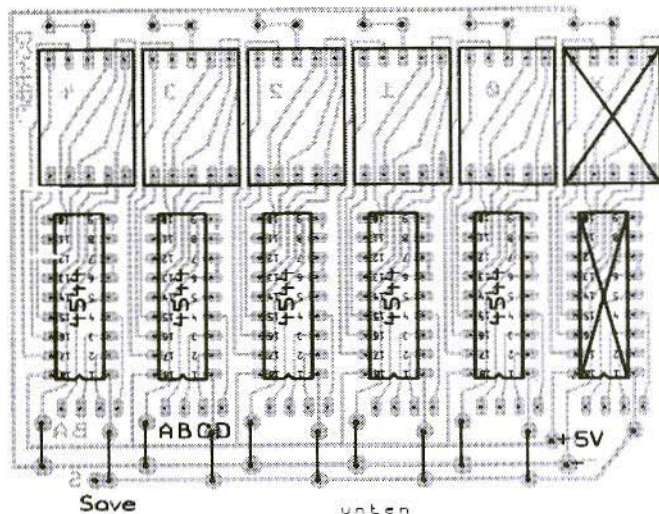

Fig. 7:
Component Plan of
Display Printed
Circuit Board

For the balancing, the trigger point is adjusted by means of a 100k Ω spindle trimmer on LM358.

The component values can be taken from the component plan and the wiring diagram. When the components have been fitted, the printed circuit board can be placed in a standard commercial tinplate housing (148 x 74).

6. 7-SEGMENT DISPLAY PRINTED CIRCUIT BOARD

OM Schmülling's circuit provided for 7-segment displays with internal latch and decoder (TIL 311), but these have become very expensive (app. DM 19 to DM 25 each!). Since the price for these components is probably not quite justified, the printed circuit board was accordingly designed for normal 7-segment displays and external decoder /

driver IC's. Moreover, the printed circuit board is laid out in such a way that 4544 or 4543 modules can be used as an option as 7-segment decoder / drivers.

The 4544 decoder / driver offers an easy option for suppressing initial zeroes:

The RBI connection (pin-10) of the highest digit (1,000 MHz digit) is connected to earth and links the RBO connection (pin-8) to the RBI connection of the next lowest digit. For all following positions, the RBO of the higher digit is connected to the RBI of the next lowest digit.

However, this only makes sense up to the 10 MHz digit, since we want to see the zero when, for example, 0.8 MHz is displayed. However, suppressing the zeroes is a question of taste. Anyone who doesn't mind the zeroes in front of the actual number can use the 4543, which is cheaper and, above all, easier to obtain.

If the 4543 is used, pin-9 must be connected to pin-8, and thus to earth,



due to the differing pin configurations on the printed circuit board. Moreover, it should be ensured that, if a 4543 is used, which is one row of pins shorter, pin-1 of the IC does actually lie at pin-1 of the printed circuit board. The printed circuit board is designed for a maximum of 6 display places. However, the sixth place remains empty. The decimal point is connected to +5 Volts through a $1k\Omega$ resistor.

The display is connected to the counter printed circuit board in a very simple manner. The BCD connections of the display printed circuit board are connected to the BCD outputs of the counter printed circuit board and the connection (S) is linked to the corresponding connection "Store" (S) on the counter printed circuit board.

7. FREQUENCY COUNTER PARTS LIST

All the components below in wired-up format.

6 x	74HC190 (IC 1 - IC 6)
2 x	74HC00
1 x	74HC10
1 x	74HC112
1 x	74HC221
1 x	74HC4017
2 x	74HC4040
1 x	LM 358
1 x	U 893
1 x	BF 324

1 x	TTL crystal oscillator, 10.24000 MHz
1 x	7805, 5V regulator
1 x	1N4148, diode
1 x	spindle trimmer, $100k\Omega$
1 x	$47\mu F$ (electrolytic capacitor)
3 x	$100nF$
4 x	$1nF$ (ceramic)

0.25W resistors, 0207 format

1 x	$120k\Omega$
3 x	$100k\Omega$
2 x	$47k\Omega$
3 x	$22k\Omega$
2 x	$12k\Omega$
2 x	$1.5k\Omega$
1 x	470Ω
1 x	47Ω

8. DISPLAY PRINTED CIRCUIT BOARD PARTS LIST

5 x	CD 4543 (or CD 4544)
5 x	7-segment LED displays with joint SL 1110 or D350 PK cathode
1 x	$1k\Omega$ resistor

9. LITERATURE

- [1] VHF Communications 3/1995 -
Wiring Diagram from Expansion
and assembly of the DB1NV
Spectrum Analyser by Rainer
Schmülling, DK6ZK

Josef Fehrenbach, DJ7FJ

10 GHz EME

Basic Principles and Discoveries

1. INTRODUCTION

The following article goes into the special features which distinguish 10 GHz Earth-Moon-Earth from the well known 2m or 70cm conditions.

These are: firstly, the effects of the small angle of beam; secondly, the Moon's altered reflection behaviour; and, last but not least, the loss of sensitivity which lunar noise gives rise to in the receiving system.

2. PATH ATTENUATION - RADAR EQUATION

Path attenuation is usually calculated with the help of the radar equation, viz.:

$$P_r = \frac{\delta \cdot P_t \cdot G_t \cdot G_r \cdot \lambda^2}{(4\pi)^3 \cdot d^4}$$

where:

- P_r = received power
- P_t = transmitted power
- G_t = transmitting antenna gain
- G_r = reception antenna gain
- λ = free space wavelength
- d = distance between transmitter/
receiver and target
- δ = echo cross-section of target

In this basic form, the power values must be expressed in Watts or mW, the antenna gains as absolute values, the wavelength and distance in the same units - e.g. m - and the echo cross-section as an area - e.g. in m².

The effective echo cross-section, δ , of a body is a unit of area. For a highly conductive sphere with a diameter greater than about 10λ , it corresponds to the cross-sectional area.

$$\delta = r^2 \cdot \pi = d^2 \frac{\pi}{4}$$

For a sphere which is only partly conductive such as, for example, the Moon, the cross-section must be multiplied by a suitable reflection coefficient.



Example with Moon as reflector:

Diameter = 3,500,000 m

Reflection coefficient = 6.5% = 0.065

$$\delta = (3.5 \cdot 10^6 \text{ m})^2 \cdot \frac{\pi}{4} \cdot 0.065$$

$$\delta = 6.25 \cdot 10^{11} \text{ m}^2$$

The Moon reflects like a conductive sphere, with a cross-section of $6.25 \times 10^{11} \text{ m}^2$.

For non-spherical targets, a suitable comparative value is determined from measurements or calculations and inserted into the equation.

One form of the radar equation already prepared in decibels for the radio enthusiast runs:

$$P_r = P_t + G_t + G_r + 10 \log \delta - 20 \log f - 40 \log d - 103.4$$

δ in m^2

f in MHz

d in km.

If we wish to calculate the path attenuation instead of the reception level, the factors 1 and 0dB are used for the power, P_t , and the antenna gains, G_t and G_r , respectively.

A path attenuation of app. 289dB is calculated for the Moon at a mean distance at 10 GHz.

N.B. - the radar equation is not sufficiently accurate unless the lobe of the transmission / reception antenna super-refracts the target many times.

3.

ANTENNA LOBES / LUNAR DISC

On average, the Moon covers a circular area which has a width of 0.5° when seen from the Earth.

More precisely: at perigee, distance 356,400 km., $33^\circ 32''$, at apogee, distance 406,700 km., $29^\circ 14''$.

At 10 GHz, a 1m reflector has a 3dB angle of app. 2° . Accordingly, a 2m reflector gives 1° and a 4m reflector as little as 0.5° . Even larger reflectors therefore have more parts of the Moon fully in their sights.

4.

REFLECTION BEHAVIOUR OF MOON

At low frequencies, such as, for example, 144 MHz, it can be assumed that at least 50% of the reflected energy comes from the relatively small central area of the Moon.

At higher frequencies, especially at 10 GHz and 24 GHz, this area is considerably increased. The reason for this lies in the roughness of the lunar surface. The shorter the wavelength (the higher the frequency), the more the mountains or pieces of rock irradiated become individual reflectors, irrespective of whether they lie in the centre or in the region of the lunar rim. The visible light should be referred to briefly as a

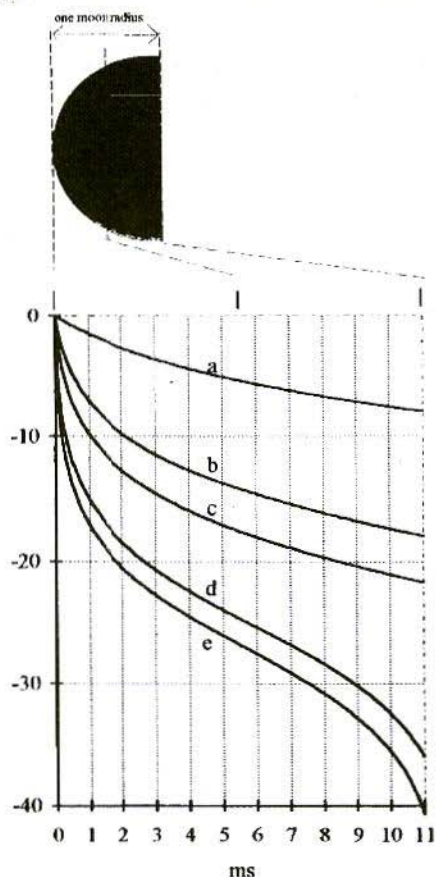

Fig.1a: Relative Reception Level at Moment Echo received

limiting value (full Moon). This effect has little consequence for path attenuation, or consequently on level balance, in so far as the antenna super-refracts the Moon.

It does, of course, favour the formation of the Doppler smearing described in Section 5, and certainly also contributes to the effects of the libration fadings dealt with in Section 6.

The Radar Handbook from M.I.Skolnik (1970 edition) contains measurement

results from radar reflections for various wavelengths. In each case, this involved the transmission of a short, very powerful pulse by means of an antenna, the major lobe of which super-refracted the Moon.

Fig.1a shows the relative reception level, plotted against the time the echo was received.

Fig.1b shows the same cycle, but with the level readings on a linear scale.

The proportional values given for the lunar radius were derived from this database.

Fig.2a gives a logarithmic representation of the level fraction (group of curves a to c), which corresponds to the individual ring section, with the associated radius.

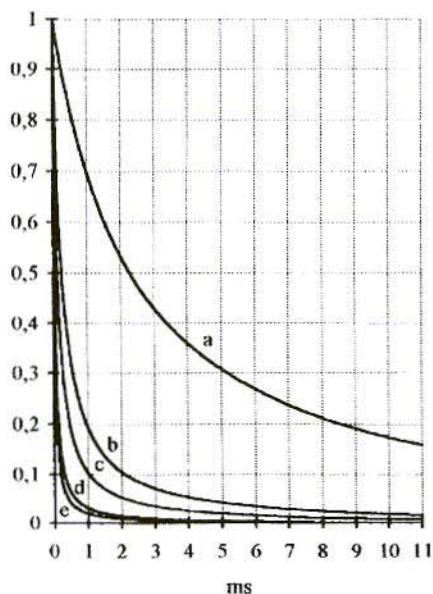

Fig.1b: Same Cycle on Linear Scale



2	f	total output fraction		
		0.5	0.7	0.9
68.0cm	441.00 MHz	6.0%	11%	25%
23.0cm	1300.00 MHz	7.0%	14%	30%
3.6cm	8.30 GHz	12.5%	22%	44%
2.9cm	10.34 GHz	16.5%	29%	54%
0.86cm	34.80 GHz	34.0%	52%	78%

relative radius

The group of curves a' to c' in Fig.2b shows the total fraction of reflected energy, plotted against the radius.

Table 1 extracts the totals for 50%, 70% and 90% fractions in relation to the frequency and radius.

Table 1:

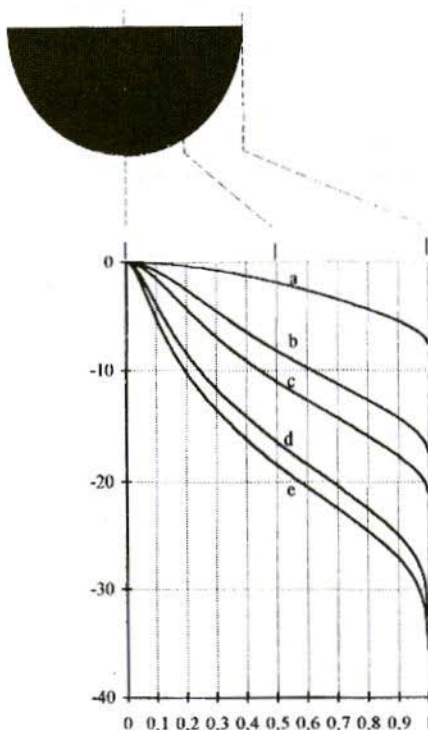
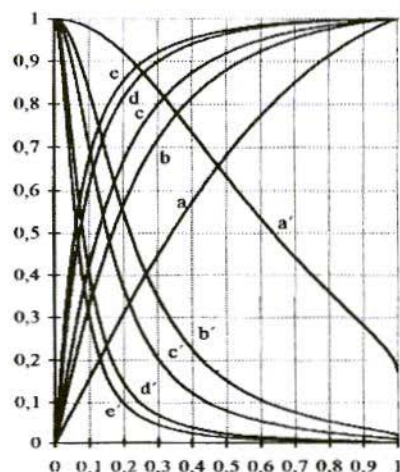

Fig.2a: Level Fraction of Individual Ring Section (Logarithmic Scale)

5. DOPPLER EFFECT AND DOPPLER SMEARING

The Doppler effect frequency shift at 10 GHz can amount to more than 20 kHz. As this Doppler effect can be calculated in advance using the various lunar programs, it poses no problem from the operational technology point of view.



a=0,86cm b=2,9cm c=3,6cm d=23cm e=68cm

Fig.2b: Total Fraction of Reflection Energy in Relation to Radius

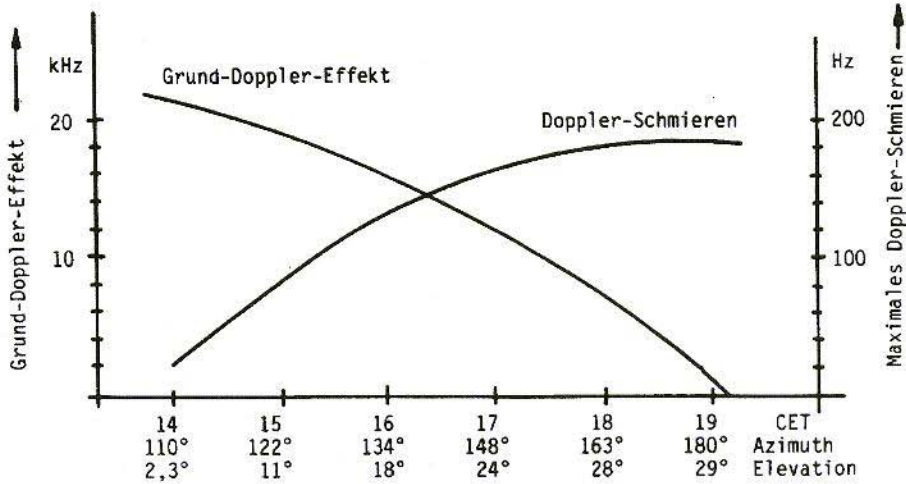

Fig. 3: Doppler Effect and Doppler Smearing using Example of Half-Transit of Moon

Grund-Doppler-Effekt = Background Doppler effect;

Doppler-Schmierungen = Doppler smearing;

Maximales Doppler-Schmierungen = Maximum Doppler smearing

Doppler smearing is an EME effect specific to SHF / EHF. The continuous wave signal which thus arises in the receiver is not a clean, clear tone. The signal has spectrum fractions distributed above and below the mean frequency. It is somewhat similar to the 10 GHz rain scatter signals. However, the rain scatter signals can become considerably coarser.

However, no problem arises for the experienced CW operator in recognising these "melodic" signals. Pay attention to the band width required when using electronic / digital signal processing.

These variations in the Doppler fractions arise from areas of the Moon participating in the reflection which have different relative motions at the observation point on Earth.

Fig.3 shows the relationship between the Doppler effect and the fractions of the maximum frequency deviation in Doppler smearing at 10 GHz.

Examples:

The test station(s) are in the Northern hemisphere of the Earth. The Moon is at apogee or at perigee in the examples.

a) The Moon is at the zenith for the tester (culmination)

The centre of the Moon's surface, like the North and South of the Moon, is not effected by any momentary changes in distance. No background Doppler effect is present. Because of the Earth's rotation, the tester is moving towards the left-hand

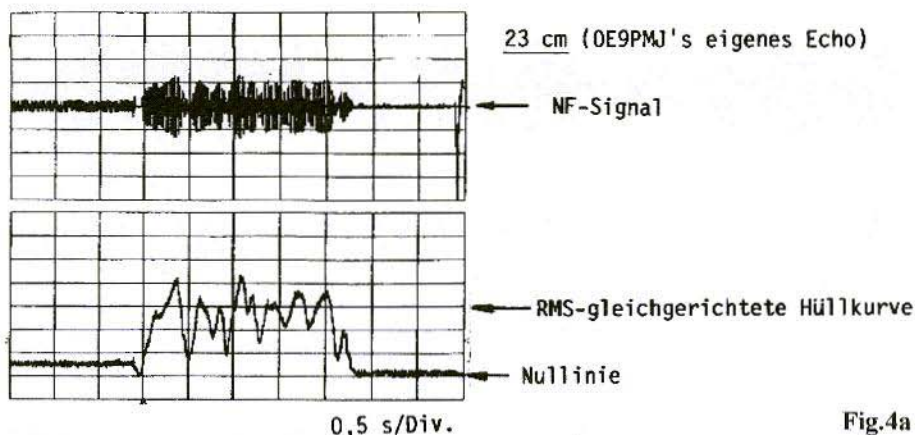

Fig.4a

Fig's.4a-c: Typical Amplitude Curves for 23-cm., 6-cm. and 10-GHz Signals

side of the Moon and simultaneously moving away from the right-hand side. There is thus a positive Doppler effect from the left-hand side and a negative Doppler effect of equivalent size from the right-hand side. On the basis of this assumption, the maximum deviation from the mean frequency is about 180 Hz. The distribution of the frequency fractions is dependent on the relationships described in Section 4 and on the lobe.

b) The test station is operating when the Moon is rising or setting

The normal Doppler effect is at its maximum. The relative changes in distance towards the lateral lunar rims are minimal for the tester. The Doppler smearing is therefore also minimal.

c) QSO between stations in America and Europe

(Both partners are on roughly the same latitude.) Many variations on

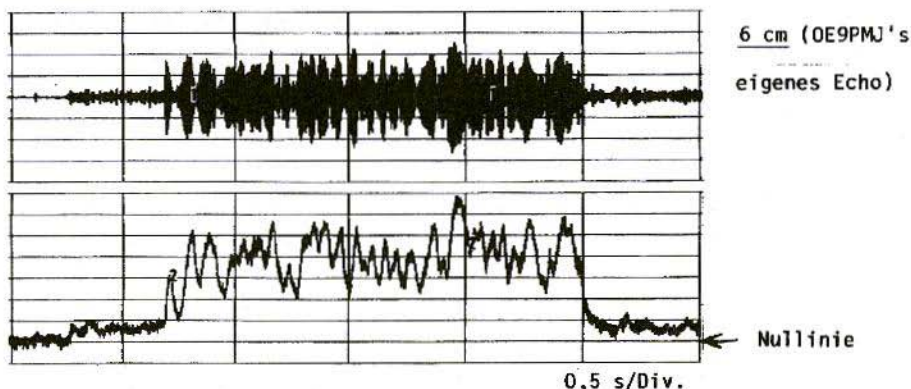
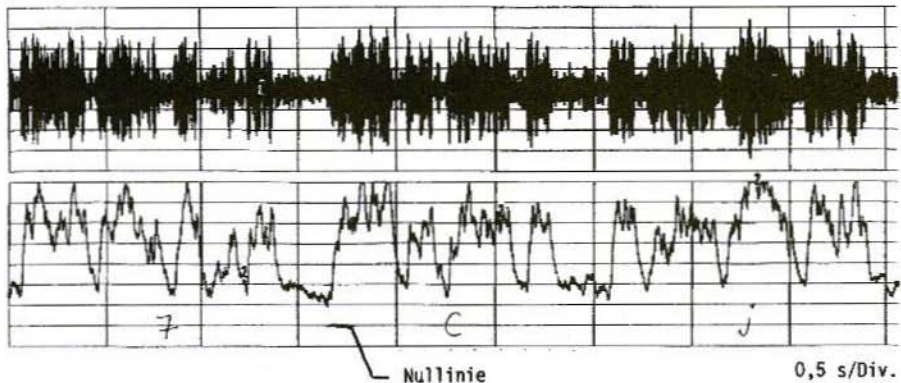

Fig.4b



10 GHz (WA7CJO sendet, DJ7FJ empfängt)

Fig.4c

Doppler smearing are possible. Minimal smearing occurs if the Moon is at the same elevation for both stations.

d) The test station is using a very big antenna

A 20m reflector is used, for example, with a 0.1° 3 dB angle of beam. This sees only parts of the Moon. Even if the Moon is at its zenith, the Doppler smearing will be relatively slight, since the antenna does not illuminate the zones where the relative motion is considerable.

OH6DD has already described this effect in DUBUS, no. 2, 1994. He worked on earlier tests with a very big antenna and writes that he observed scarcely any Doppler smearing.

6.

LIBRATION FADING

A further effect which has a direct influence on the signal reflected from the Moon is the so-called libration fading. Since the author does not have sufficient knowledge of the underlying physics, only the effect will be described here.

The libration of the Moon, i.e. the pendulum motion of the lunar axis, may well not be the main reason for the effect described below. Nevertheless, as it has been established for decades, the term "libration fading" is used here too.

Libration fading brings about very low-frequency AM modulation, i.e. fading of the receiving signal.

Freak value	Mean depth	f_{mod}	Length of negative periods
-------------	------------	------------------	----------------------------

23cm	14dB	6dB	app 5 Hz	app 100-150ms
6cm	10dB	6dB	app 15 Hz	app 60ms
3cm	10dB	6dB	app 30 Hz	app 30ms

Figs.4a to 4c illustrate typical amplitude characteristics for signals of 23cm, 6cm and 10 GHz.

All signals were first recorded

Table 2

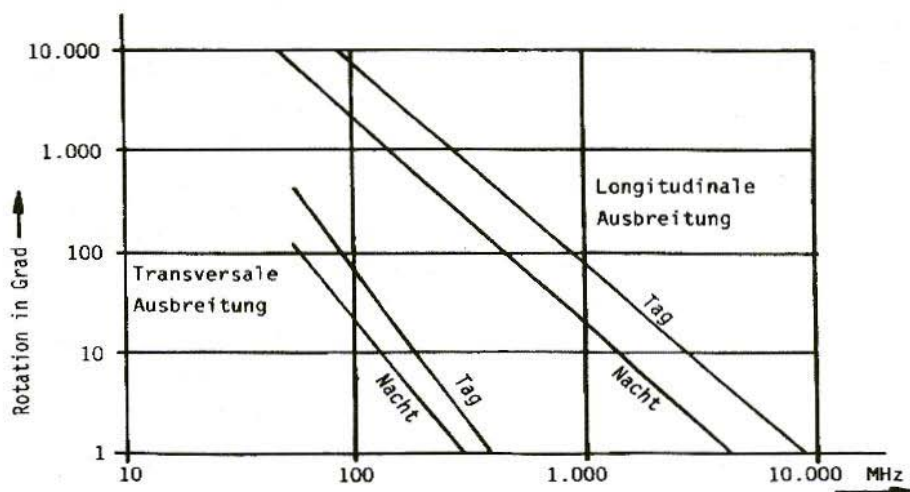

Fig. 5: Typical Faraday Rotation Phenomena

Rotation in Grad = Rotation in degrees; *Transversale Ausbreitung* = Transverse propagation; *Longitudinale Ausbreitung* = Longitudinal propagation; *Tag* = Day; *Nacht* = Night

on tape and processed, using low-frequency filters with a band width of app. 300 Hz, and RMS rectified. The 23cm and 6cm signals are echo recordings, which Peter OE9PMJ was kind enough to record and make available.

The 10 GHz signals are echoes from WA7CJO, recorded by DJ7FJ.

Table 2 gives a rough summary of the readings from the above recordings.

The examples show that in all 3 bands there is a mean scattering of amplitude values over a band with a width of app. 6dB. The freak negative values are about 10dB deep at 6cm and 10 GHz and about 14dB deep at 23cm. The approximate modulation frequencies are 5, 15 and 30 Hz. This means that signal interruptions occur within narrow general levels of app. 150ms, 60ms and 30ms.

If we assume a continuous wave dot of app. 100ms and a 300ms dash, then the effects can be recognised immediately. For weak signals, entire dashes are omitted in the 23cm band, and dashes are often broken up into dots. This can make random QSO's considerably more difficult, as there are big problems in recognising call sign sequences.

In the 6cm band, the freak values last for considerably less time than a complete dot. Thus calls are more easily recognised, apart from the fact that at present there are still no random QSO's there.

In the 10 GHz band, libration fading is almost insignificant, due to the very small sections of a CW signal which are omitted.

Note: The signals compared were typical examples. No comment can be made here on the scatter band of the libration

fadings occurring under various measurement conditions.

7. ADDITIONAL ATTENUATION BY ATMOSPHERE

It is often presumed that, particularly during mist or rain, the atmosphere significantly increases attenuation as the signal passes through it. This may be the case, in general, with an extremely low angle of elevation for the antenna, or in a heavy storm. However, at elevations greater than app. 15° even heavy rainfall has so far caused scarcely any problems. Most of the author's EME QSO's were carried out when it was raining.

If the elevation is high enough, the areas where a signal has to go through bad weather are scarcely a kilometre long, which is the basis for the statements above.

8. POLARISATION, FARADAY ROTATION

Fig.5 shows typical values for Faraday rotation. It can be seen from this that no significant Faraday rotation occurs at 10 GHz.

It is thus not necessary to use circular polarisation. But if linear polarisation is used, the rotation occurring in connection with reflection from the Moon must be taken into account. The American recommendation adopted up to now by most active stations has been shown to be a suitable compromise here.

This runs: North American stations should work horizontally, Europeans vertically.

The rotation remains slight for American stations, while between Europeans it is still less. From America to Europe, it is always nearly 90° .

At the moment, 10 GHz EME stations exist only in Europe and America, so

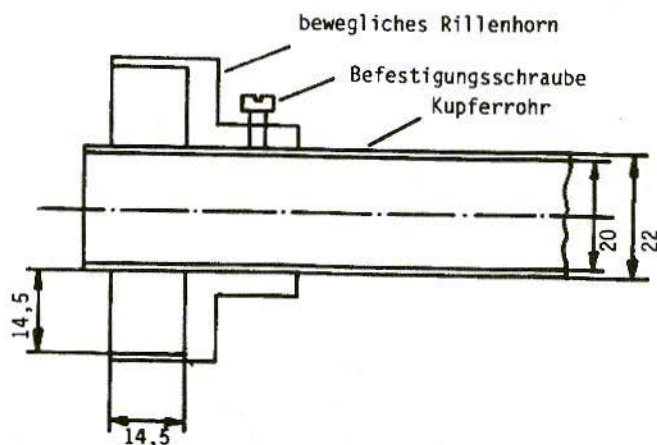

Fig. 6:
10 GHz Horn from DJ7FJ, Modification of Corrugated Horn from VE4MA
Bewegliches Rillenhorn = Movable corrugated horn;
Befestigungsschraube = Fixing screw;
Kupferrohr = Copper tube



anyone can contact all existing partners without any alterations to his or her station, as long as no polar mounts are used.

9.

ANTENNA AND FEED

With regard to antennae, as with all EME systems, care should be taken to find the optimal compromise between gain and picking up Earth noise. For reflectors with an f/d between 0.27 and 0.4, VE4MA corrugated horns have proved to be very practical in various tests.

Fig.6 shows the author's modification for 10 GHz.

In order to find the optimum settings for the feed position and the position of the corrugation, it is recommended that the dimensions should be determined by experiment.

Recommended procedure:

- a) Push corrugation into rated position. Pre-set with corrugation at rated focal point.
- b) Measure the ratio of solar noise to sky noise, using a noise RX (preferably wide-band).
- c) Change horn position in steps of app. 5mm and thus find optimum position.
- d) Fix in best position and move corrugation forward and back in steps of app. 2mm.

- e) Check feed position with fixed corrugation. Repeat all procedures several times if necessary.
- f) After optimising with the Sun, check the lunar noise.
- g) If necessary, make careful secondary corrections using the lunar noise. True, this does all take a lot of time, but it is worth it.

10.

NOISE SOURCES

- a) We try to minimise the Earth noise by optimising the antenna. However, a fraction of app. 20 - 40 K can scarcely be avoided.
- b) The galactic background noise lies 10 GHz below 10 K and can essentially be ignored.
- c) At 10 GHz EME, the lunar noise has the decisive influence on the sensitivity of the system. At 10 GHz, the Moon is almost like a planiform noise source with a temperature of approximately 210 K (irrespective of the phase of the Moon). On the one hand, this can be put to positive use, in order to optimise the antenna direction, while on the other hand it restricts the sensitivity, especially for big antennae. The effect of the noise factor of the pre-amplifier rather moves into the background here.
- d) The noise factor of the pre-amplifier is not a matter for discussion nowadays, since values of 1 dB and better

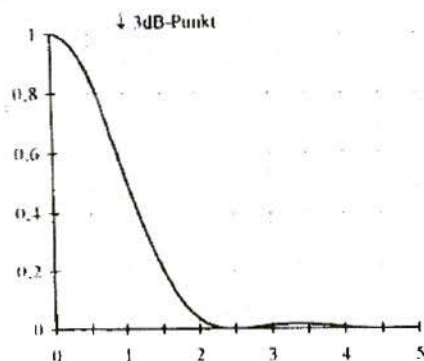

Fig. 7: Diagram of Parabolic Antenna

can be obtained without problems. RX feed attenuation can be minimised by the use of wave guide relays and pre-amplifiers, mounted directly in the feed.

11. ANTENNA FOLLOW-UP SYSTEMS

Antenna follow-up programs such as, for example, the one from VK3UM, calculate, with sufficient accuracy, the necessary azimuth and elevation angles, and / or the declination and right ascension. However, it is recommended that you also check the antenna direction, using the lunar noise, about once a minute. For this purpose, at best, a wide-band noise receiver is built into a parallel reception branch.

Charlie, G3WDG has developed such a receiver.

A so-called PANFI is also excellently suited to this work.

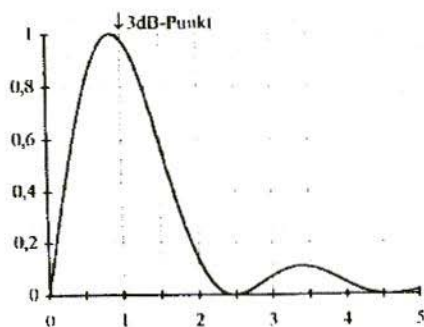

Fig. 8: Distribution of Relative Energy Fractions

12. ENERGY DISTRIBUTION IN AN ANTENNA BEAM

In order to examine the effects from lunar reflections somewhat more closely, we need to investigate the energy distribution in the beam coming from the antenna in greater detail.

A parabolic antenna with a "clean" diagram is taken as the starting point for all that follows. The first side lobe here has fallen by 18dB, and the second by 25dB. Subsequent side lobes are disregarded.

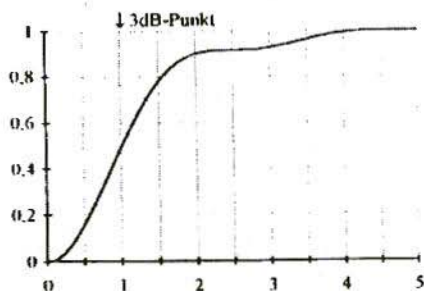

Fig. 9: Linear Total for Radiated Energy

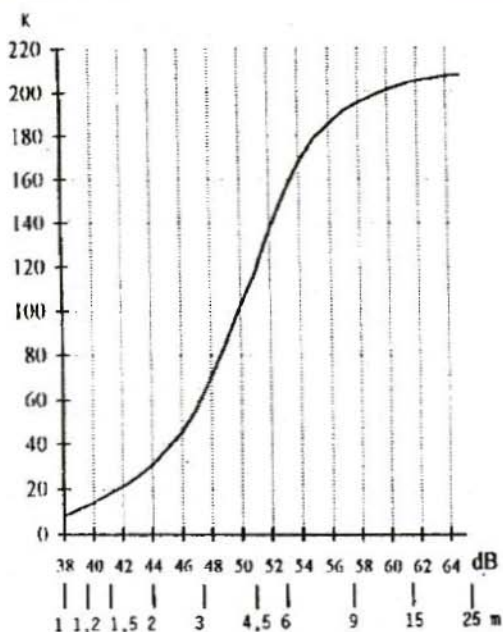

Fig. 10:
Receptivable Noise Output from
Moon, Depending on Reflector
Size

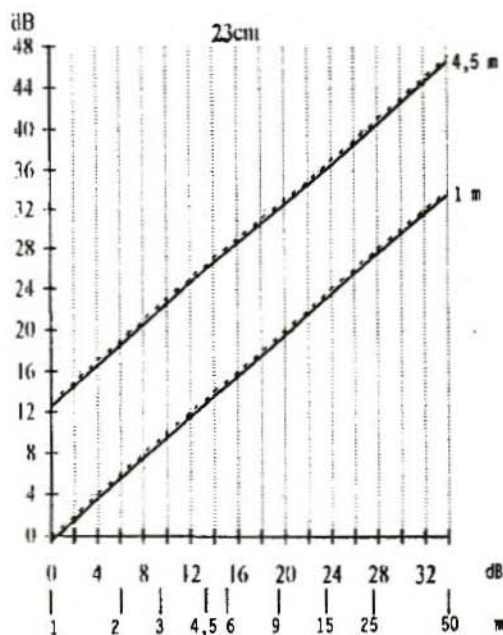

Fig. 11:
Absolute Reception Level at 23
cm. (see Text)

The antenna diagram is assumed to be rotation-symmetrical.

Fig. 7 shows the antenna diagram.

Clarification of Fig. 7:

- The rotation axis is depicted on the x axis
- Only half the directional diagram is illustrated
- The value 1 on the x axis characterises the 3dB point or the standardised half 3dB angle
- The y axis shows the relative level on a linear scale

If we imagine rings in front of the antenna, going outwards from the main beam direction (as far as five times the 3dB angle) and look at the relative energy fractions on the individual rings, we obtain Fig. 8.

- The x axis is once again as in Fig.7
- The y axis shows the relative energy in the associated rings on a linear scale

This diagram shows that, if you are beaming onto a planiform target, the largest energy fraction lies on a ring which is located at app. 90% of the 3dB angle. This energy distribution, then, exerts its main effect on the reflection occurring if the beam is directed at a unifacial, diffusely reflecting body.

Fig.9 shows the linear total for the energy radiated, distributed over an angle up to five times the 3dB angle.

It can be seen from this diagram that there is only just 50% of the energy within the 3dB angle: however, 90% of the energy total has already been amassed at double the 3dB angle.

Among other things, we can obtain from this consideration the noise output being

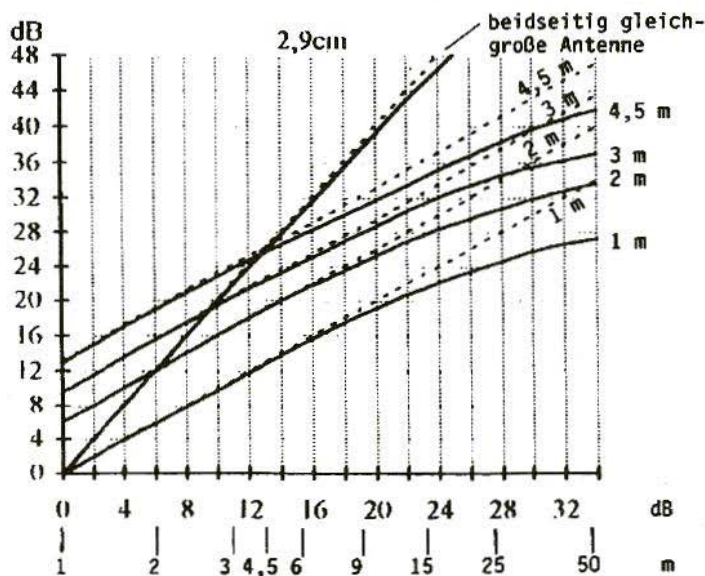

Fig. 12:
Absolute
Reception Level
at 10 GHz (2.9
cm.)
(see Text)

Beidseitig
gleichgroße
Antenne =
Antennae same
size on both sides



received from the Moon in relation to the size of the antenna (see Fig.10).

The irregular curve is a consequence of the antenna diagram.

Example:

- a) How much noise output from the Moon is received with a 1-m reflector? Answer: app. 8 K (Kelvin)
- b) How much noise output does a 4.5m reflector receive? Answer: app. 120 K

It is not difficult to see that the noise temperature (noise factor) of the receiver plays a subordinate role with larger reflectors.

13.

EFFECT OF ANTENNA LOBE ON RECEPTION LEVEL

In this section, we shall take into account only the absolute reception level. The signal / noise ratio will not be considered for the moment.

The effects of the reflection characteristics of the Moon described in Section 1 are connected with the energy distribution in the antenna beam.

The wavelengths 23cm, 2.9cm and 0.68cm are investigated in Figs. to 13. The values are related in each case to a signal level which arises when a 1m. reflector is used on both sides:

- The x axis shows reflector diameters and the relative gain, plotted against a 1m reflector
- The y axis shows the relative signal-growth
- Parameters are different reflectors at one end
- The straight lines are the theoretical signal values, without any attention being paid to the special features of the Moon and the antenna lobe
- The curves are the actual relative levels

Clarification of Fig.11:

The 23cm band was investigated. As a base, a 1m reflector was used once, and a 4.5m reflector was also used.

Examples:

- a) How much relative gain is obtained if we are working with a 1m reflector on one side and a 3m reflector on the other side (based on 1m to 1m)? Answer: app. 9.5dB
- b) How much gain is obtained with a 4.5m reflector to a 9m reflector (based on 1m to 1m)? Answer: exactly 32dB

The special effects arising from reflection and the antenna lobe have no significant consequences for this band in practise.

Clarification of Fig.12:

A 1m reflector, a 2m reflector, a 3m reflector and a 4.5m reflector were used

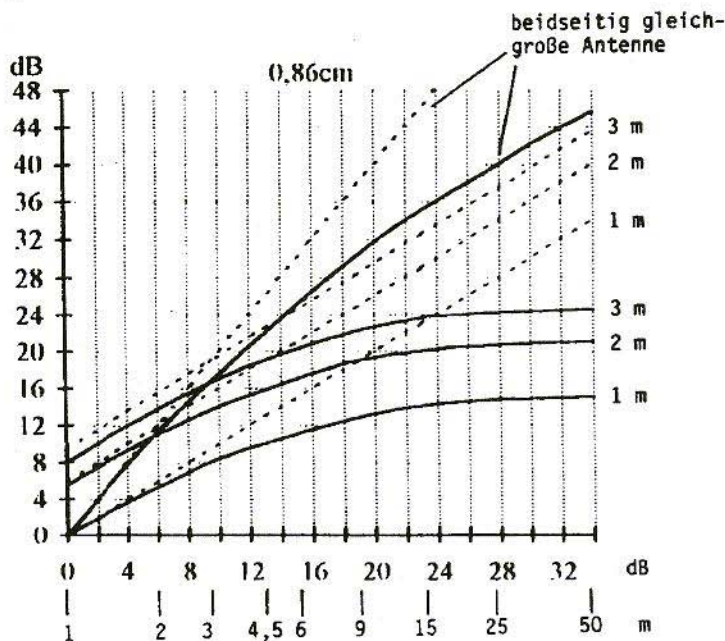

Fig.13: Absolute Reception Level at 0.86cm.

Beidseitig gleichgroße Antenne = Antennae same size on both sides

as parameters here in each case. A diagram has also been plotted for identical antennae on both sides.

- How much gain is obtained if a 2m reflector is used on one side and a 4.5m reflector on the other (based on 1m to 1m)? Answer: app. 19dB
- How much gain is obtained if one side is operating at 4.5m and the other side at 25m? Answer: app. 37.5dB (if the lobe and the lunar reflection were not taken into account, it would be app. 3.5dB more)
- How much relative gain is obtained if 9-m. reflectors are used on both sides? Answer: app. 36.5 dB (about 2dB less than theoretically possible)

The curves show that, if reflectors smaller than 4.5m are used on one side and larger reflectors are used on the other side, the gain available is not the total theoretical gain for both antennae but only a certain part of this. For a 60cm reflector in such a case, app. 6dB of the theoretical gain is lost on average.

Clarification of Fig.13:

1m, 2m and 3m reflectors are used as parameters in this diagram, with the reflectors on the two sides always being identical. In this frequency band, there is a wide divergence between the curves, even at relatively small diameters. If the reflector size on one side is kept the same, e.g. 2cm, then if a 3m reflector is



used on the other side the gain drops by about 2.5dB, and with 4.5m it is already 3dB less than the theoretical value.

It is noteworthy that the level scarcely grows any higher after app. 15m. With reflectors of the same size on both sides, the total growth from 15m falls back to about half of the sum total.

For this range of wavelengths, the Moon is already reflecting in an almost "optical" manner. This is why the above effects are obtained.

Let us look at a few more examples:

- a) Let us begin with an extreme case: Station A uses a 1m reflector, station B a 50m reflector. At a wavelength of 0.86cm and with a reflector diameter of 1m, station A has an angle of beam of app. 0.6° , i.e. still larger than the Moon.

Station B, with a 50m reflector, has an angle of beam of less than 0.01° . It thus illuminates only a spot on the Moon. At the first approach, all the energy transmitted reaches the spot on the Moon. The reflection factor and the scatter determine the attenuation on the way back. If station B reduces the diameter to, for example, 9m, then its beam angle changes to app. 0.065° .

If the Moon reflected diffusely and completely uniformly, then station A would have the same level as before. But since this is not quite the case, station A receives a signal 2dB weaker than from a 50m reflector.

However, the reflector gain differential was precisely 15dB!

If station B reduces its reflector size more, then the loss at 3m will be only app. 1.5dB more, and at 2m only app. 0.5dB more.

- b) If both sides have antennae of the same size, or with the same inherent echoes, the transmitting and receiving antennae see the same spot. The result is that with very big antennae only half of the gain in growth is added.

To look at it another way: on the transmission side, the energy on the Moon spot is always the same; on the receiving side, gain is linked to the size of the antenna.

For the 0.86cm wavelengths described here, the effects are already very pronounced. They become less so for the adjacent 24 GHz amateur band.

In the 10 GHz band, as Fig.13 shows, larger reductions in gain do not occur until the reflector sizes exceed app. 9m. In the 23cm band and below it, these effects can be disregarded completely in practise.

14. EFFECT OF ANTENNA SIZE ON SIGNAL / NOISE RATIO

If the antenna gain is reduced in low frequency bands, then we obtain synchronously growing signal / noise ratios. This relationship undergoes a change if

the lunar noise starts to make a significant contribution to the background noise.

System noise levels of app. 100 K (~1.3dB) are realistic values at 10 GHz. This figure can be made up, for example, of 70 K from the pre-amplifier and 30 K of external noise through the antenna (Earth, feed attenuation, etc.). A system temperature of 150 K still appears generally usable, and a temperature of 50 K would seem to be the lower limit, which can scarcely be reached at present.

The three system noise temperatures referred to above are used as comparison values in what follows.

For 10 GHz EME, the noise temperature received from the Moon should be added to the system temperatures. At 10 GHz, the Moon has a noise temperature of app. 210 K. The noise fraction received will vary, depending on the antenna size. Very large antennae, from app. 6 m. upwards, receive almost all the noise, smaller antennae correspondingly less. If the antennae lobes from Section 13 are taken into account, we arrive at the noise fractions for Fig.10.

Reflector diam.	Gain	3dB Beam width	Lunar noise
1.0m	38.0dB	2.0°	8K
2.0m	44.0dB	1.0°	30K
3.0m	47.5dB	0.7°	65K
4.5m	51.0dB	0.45°	120K
6.0m	53.5dB	0.35°	165K
9.0m	57.0dB	0.23°	190K

Table 3

Table 3 shows the relationship of various reflector diameters to their gain, their angle of beam, and the fraction of lunar noise received. The values have been rounded off. For EME operation, the gain should be reduced by app. 1dB due to reduced super-refraction by the reflector. This will reduce the lunar noise levels slightly as well.

The recommended noise outputs from the Moon have their effects on the system's sensitivity. With a 2m reflector, the noise temperature will be increased by about 30 K, and with a 4m reflector by as much as app. 120 K.

Some examples can be given, so that the effects can be summarised better. Reflector sizes between 1m and 9m are used, with system noise temperatures (without lunar noise) of 50 K, 100 K and 150 K. For a fixed receiver bandwidth, the signals of the partner reflected from the Moon are brought into a relationship with the associated lunar noise.

The signal / noise behaviour is calculated in the form in which it is actually considered:

$$\frac{\text{Signal} + \text{noise} = S + N}{\text{Noise} \quad N}$$

Fig.14 shows a few examples:

The reference level made use of is selected in such a way that, if a 3m antenna is used for both transmission and reception, and if the noise temperature at the receiving station is 100 K, then $(S + N)/N$ will be 3dB. The

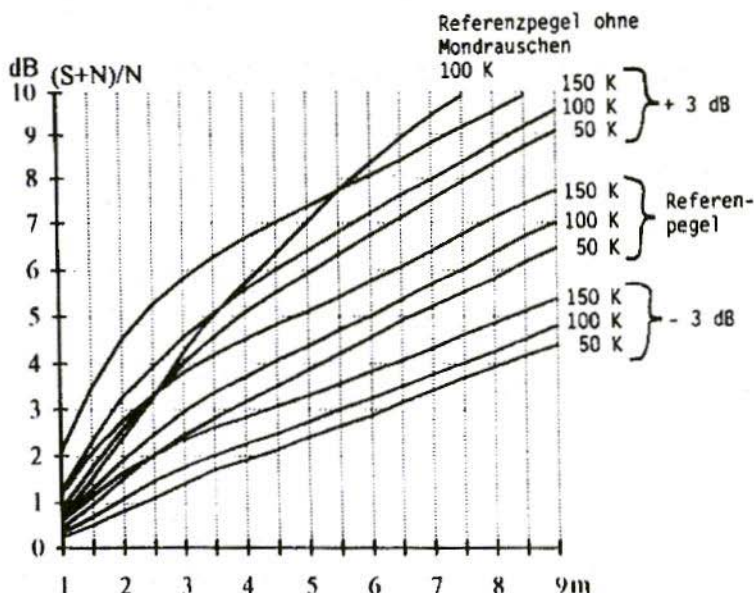

Fig.14: Signal / Noise Ratio for Various Reflector Sizes (see Text)

Referenzpegel ohne Mondrauschen = Reference level without lunar noise; *Referenzpegel* = Reference level

subsequent curves are associated with other noise temperatures, as well as with one signal 3dB stronger and one 3dB weaker.

The effects of the energy distribution in the antenna lobe are considered in connection with the reflection behaviour of the Moon, together with its noise level, in the result. In addition, one curve in the diagram shows the theoretical $(S + N)/N$ if the Moon were to contribute no additional noise at a system temperature of 100 K.

Examples from this investigation:

a) The transmitting station reduces the level by 3dB

Which reception antenna sizes give us 3dB $(S + N)/N$ back?

Answer:

- App. 4.5m if system temp. 50K
- App. 5.5m if system temp. 100 K
- App. 6.5m if system temp. 150 K

b) The transmission power is increased by 3dB

Which antenna sizes give us 3dB $(S + N)/N$ again?

Answer:

- App. 1.2m if system temp. 50 K
- App. 1.8m if system temp. 100 K
- App. 2.2m if system temp. 150 K

If we make another comparison with a system noise of 100 K, then the reception antenna may have app. 4dB less gain.

15. ANTENNA GAIN, NOISE AND OUTPUT CONSIDERED TOGETHER

With 20 Watts, a 3m reflector and a 1dB receiver noise factor, we can usefully listen to the transmitters' inherent echoes.

Assuming that this equipment is available, let us consider the following combinations:-

- Increasing the power is the only effect which has a direct and immediate effect on the reception level.
- Larger antennae raise the reception level for the partner (with small trade-offs). The transmitter's own reception behaviour is less than proportionally better in the fringe range because of the lunar noise.
- Smaller antennae are generally still usable as reception antennae, with good pre-amps. If they are used for transmission, of course, the entire gain differential must be balanced out.
- Increasing the noise factor of the system below 100 K is effectively of use only with small antennae.

16. WORKING WITH COMPUTER PROGRAMS

The following measures are recommended for tying up the results of the program - such as, for example, Budget Calculator from VK3UM - with the preceding clarifications:

RXNF:

The program adds 50 K automatically. So 50 K must be subtracted from the system noise temperature, which is made up of the antenna noise (without the Moon) and the pre-amplifier noise, and the noise fraction of the Moon from Section 14 must be added. This noise temperature is converted into a noise number and applied in dB.

RXBW:

The band width can be assumed to be 100 Hz without any problem. The experienced operator operates with his or her ear / brain combination in this region, relatively independently of the actual band width of the receiver.

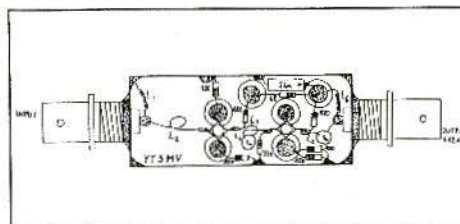

Very low noise aerial amplifier for the L-band as per the YT3MV article on page 90 of VHF Communications 2/92. Kit complete with housing Art No. 6358 £36.55. Orders to KM Publications at the address shown on the inside cover, or to UKW-Berichte direct. Price includes p&p



ANT Gain:

If you want to know it very precisely, then the gain inputs must be reduced here in accordance with Section 13. This correction can be ignored up to a reflector size of app. 4.5m (51dB).

17. CONCLUSION

But it should be clearly emphasised here that, for all the theoretical special features of 10 GHz, most of which are also backed up by experience:

10 GHz EME is not magic and does not automatically require a lot of power!

With a 1.8m reflector, which can even be mounted on a stand, and app. 40 W, you are in a position to pick up your inherent echoes and also to establish contacts.

What other band offers this field of activity for a comparatively small expenditure on an antenna?

CU off the moon, vy 73, Joe, DJ7FJ

18. LITERATURE REFERENCES

- [1] M.I.Skolnik, Gordon H.Pettengill (1970);
Radar Handbook, Chapter 33 - Radar Astronomy;
1970 edition
- [2] Josef Fehrenbach (1995);
Special Features of 10 GHz EME:
DUBUS no. 1, 1995
- [3] Evans and Jessop:
RSGB VHF-UHF Manual
Chapter on "Space Communication"
- [4] Richard Turrin W21MU and Allen Katz K2UYH:
ARRL UHF / Microwave
Experimenter Manual
Chapter 10 - Earth-Moon-Earth (EME) Communications

The British Amateur TV Club

The foremost association on the world, for anyone, anywhere in the world, who is interested in Amateur Television. CQ-TV the quarterly journal of the BATC is recognised as the most professionally produced amateur publication of its kind.

Join the BATC and receive *YOUR* copy of CQ-TV

Membership is *only* £12.00 per year.

BATC, Grenehurst, Pinewood Road, High Wycombe, HP12 4DD

Gunthard Kraus, Development Consultant

Design and Realisation of Microwave Circuits

1. GENERAL STATE OF THE ART

If we look at the radical changes of the last twenty years in relation to electronics and the digital transmission and processing of analogue signals, it has often looked as if the end had come for the "classic communications and high-frequency technology".

But, upon closer analysis it becomes clear that what we are actually dealing with here is a structural change, for it is only the classic gauging equipment, transmitters and receivers with rotary knobs, pointer gauges, linear and circular scales and cylinder dials which have actually disappeared, along with the thick cables and the high-frequency plugs. The wave-guides have also disappeared in the frequency range above 1 GHz (apart from certain areas in which their use can not be dispensed with).

1.1. Review of State-of-the-Art in the Microwave Area

- a. Entertainment electronics ("TV satellite dishes") have driven the development of components with less and less noise forward in the GHz range (e.g. GaAsFET's with noise factors below 1dB at 12 GHz) at ever more favourable prices and with millions of components being produced. Parallel to this development, more and more refined, and also more and more advantageously priced, circuit, design and tuning techniques came into being for GHz converters and receivers.
- b. The further development of mobile radio telephones into ever higher frequency ranges and their simultaneous widely-developed marketing as a consumer product has brought more and more powerful transmission, mixing, modulation, oscillation, synthesiser and receiver IC's onto the market at ever-lower prices. Hand in hand with this, there has been further



development of the long-familiar transmission technology as a time-division or frequency-division multiplex method, combined with new types of modulation (usually phase shift-keyed) and signal processing techniques (e.g. DSP).

- c. "Normal telephone communications" and data services (ISDN, etc.) are continually increasing their transmission speed and / or channel loading, and are suddenly having to use "electronic circuits" again (e.g. within the optical waveguide systems which are used now) which, at elementary frequencies which can be above 1 GHz, have to be built in accordance with the rules of high-frequency technology.

1.2. Microwave hardware

- a. The system resistance (= impedance level, Z , of coax cable, etc.) is 50Ω all over the world.
- b. In consumer electronics (TV satellite technology), the "F plug" dominates, together with double-screened coax cable with best damping values of - for example - 0.4dB per metre at 2 GHz, but with a system resistance of 75Ω .
- c. In commercial technology in the frequency range going up to 18 GHz, the SMA plug represents the predominant standard for the connecting up of assemblies which do not have to be continuously assembled and dismantled; for this there are, for example, SMB plug connectors. The N-plug has certainly not been paid
- off completely, but is being pushed further and further into the background.
- d. The "high-frequency connection lines" of assemblies normally consist of semi-rigid cables. These are small, semi-rigid copper tubes, with Teflon filling and a solid, thin, silver-plated or gold-plated internal conductor. In the SMA plug, the internal conductor of the cable is used directly - pointed and then used as the central pin of the plug and socket connection. These cables are bent into the desired form during manufacture, and should not need to be altered again.
- The two types "RG 405" and "RG 402" are normally used here. They have different external diameters, with the damping on the "RG 402" cable (external diameter 3.58mm) being about 1.95dB per metre for the frequency $f = 18$ GHz, while by contrast that for the "RG 405" cable (2.7mm external diameter) is 3.75dB (at 1 GHz: 0.36 or 0.67dB per m).
- e. For flexible connections - depending on the frequency range and the damping requirements - coaxial cables with varying degrees of insulation and diameters are used. In the application range above 1 - 2 GHz, we find Teflon (PTFE) used exclusively as a dielectric, to keep the losses low.
- f. The circuits themselves are realised almost exclusively by means of the SMD technique, with fibreglass-reinforced epoxy resin printed circuit boards being used up to app. 1.5 GHz (FR4 material). As the



frequency rises, the transfer is made, either to fibreglass-reinforced Teflon (RT-Duriod, Ultralam 2000, DiClad, etc.) or ceramic substrates (Al_2O_3) or to artificial sapphire.

- g. CAD software, which has had a long time to mature, with astonishing efficiency and precision, exists for the circuit design work (including all the calculations for antennae and filters). The interested amateur, instructor or engineer naturally profits by this, since this software is often also on the market in shareware versions at more favourable prices. Here we shall mention only the Puff CAD software, which was actually developed for training purposes in a high-frequency institute.

2. PROPERTIES AND APPLICATIONS OF PUFF

The Puff CAD program can be used to analyse normal circuit structures or strip transmission line circuits and then to optimise them.

But things go fastest if the PC has a mathematical coprocessor to increase the power, which increases the speed approximately fivefold.

Puff determines the scatter parameters (= S parameters) for a pre-selected frequency range, and plots the calculation results, either in complex form in the Smith diagram or in the well-known frequency response form (= rectangular plot).

The reference resistance of the system can naturally be pre-set. 50Ω is standard, but 75Ω is normal in Europe for low frequencies and TV satellite installations.

If desired, from the frequency domain response, Puff can determine the impulse response or, optionally, the time domain response, with the help of the fast Fourier transformation, and plot it in a diagram of its own.

The individual calculation results are stored in a table and can be displayed for every frequency step, in accordance with value and phase, by moving the cursor along the curve.

The Smith charts or frequency responses displayed can be printed out using Printscreen.

To optimise the circuit, an individual circuit parameter (e.g. the value of a component or the length of a strip line, etc.) can be infinitely varied within any limits, which you can select yourself.

Example for altered AUTOEXEC.BAT file is show overleaf.

Finally, the circuit layout can be printed out, to various scales (standard case: somewhere between $m = 1:1$ and a magnification with $m = 5:1$).



```
@LOADHIGH C:\DOS\SHARE.EXE /L:500 /F:5100
C:\DOS\SMARTDRV.EXE
@ECHO OFF
PROMPT $P$G
PATH C:\GEGOWORKS;E:\MSIMEV54;E:\WINDOWS;D:\WINDOWS;C:\DOS;C:\SKETCH3
C:\DOS\NLSFUNC
SET TEMP=C:\DOS
C:\DOS\MODE CON CODEPAGE PREPARE=((850 437) C:\DOS\EGA.CPI)
C:\DOS\MODE CON CODEPAGE SELECT 850
C:\DOS\KEYB GR,,C:\DOS\KEYBOARD.SYS
C:\DOS\GMOUSE.COM
E:\WINDOWS\WIN.COM
```

Modified AUTOEXEC.BAT File

3. INSTALLATION OF PUFF ON A PC

First Step:

A directory called Puff is set up on the hard disc, and all the files from the diskettes are copied into it.

Second Step:

Before starting this program, you must switch over to the American character

```
LASTDRIVE=Z
DEVICEHIGH=C:\DOS\SETVER.EXE
DEVICEHIGH=C:\DOS\HIMEM.SYS
DEVICEHIGH=C:\DOS\EMM386.EXE RAM
DOS=HIGH
COUNTRY=049,850,C:\DOS\COUNTRY.SYS
DEVICEHIGH=C:\DOS\DISPLAY.SYS CON=(EGA,,2)
FILES=40
STACKS=9,256
SHELL=C:\DOS\COMMAND.COM C:\DOS\ /P
BUFFERS=40
```

Modified CONFIG.SYS File

set ("code page 437") (otherwise there is no sign, etc.). To do this, it is necessary to alter the AUTOEXEC.BAT and CONFIG.SYS files. So the code set change must be carried out before Puff is loaded, using the DOS command "chcp" (= change code page).

Example for altered CONFIG.SYS file is shown below.

Third Step:

If the layout of the printed circuit board or the complete screen with all the data and diagrams has to be printed out, the

appropriate resident printer driver must be loaded (just as before the start of PUFF.EXE). In each case, 2 drivers are supplied for: HP Laserjet, Epson and IBM Proprinter (for EGA or VGA screens).

They are called:

ega2eps.com vga2pro.com

vga2eps.com ega2lasr.com

ega2pro.com vga2lasr.com

If you want to make life simpler, then write the following small batch file - "PUFF.BAT" - and store it in the master directory of the C drive (which will be selected when the computer is switched on). Then you only have to call PUFF.BAT up, and everything else takes care of itself.

```
chcp 437
cd c:\puff
vga2pro.com
puff
chcp 850
```

4. S-PARAMETER

A brief introduction to the S or scattering parameter

It is not so easy to measure flows and voltages at high frequencies, moreover

open-circuit and short-circuit measurements can no longer be made correctly (e.g. to determine the internal resistance of a source). The system description and calculation should therefore be based on values which can also be easily measured.

For this reason, another working hypothesis is basically already in use today for frequencies from 50 to 100 MHz:

The central point is a system resistance which is the same everywhere (here, for example, 50Ω), which applies to the input and output resistances, the impedance level of the cable, and the moving loads.

The measurement technique now concentrates on, for example, determining the resistance values present (or their deviations from 50Ω) - in complex form, of course, i.e. according to amount and phase.

- We begin at the signal source with the system resistance as internal resistance - here, 50Ω .
- Our subject - for example, a filter, a moving load, an amplifier, a mixer or an antenna - is connected to this source through a relatively long cable with $Z = 50\Omega$.
- With longer cable lengths, due to the final propagation speed of 30cm per nanosecond in air, nothing is noticed immediately from the consumer.

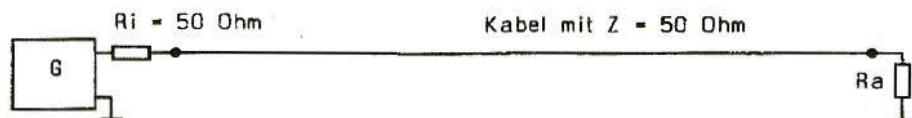

Fig. 1: 50Ω System; *Kabel mit* = Cable with



So the cable displays an input resistance of 50Ω , and forms a voltage divider with the internal resistance of the source. Thus, at first we have "power matching, $R_i = R_a$ " and the active power picked up goes on its way in the direction of the consumer at "cable speed":

$$V_{\text{cable}} = C / \sqrt{\epsilon_r}$$

- d. If this incoming power (correctly described as an incoming wave) reaches the consumer, then it is fully "absorbed" only if power matching occurs here too, i.e. $R_a = Z = 50\Omega$. If there are deviations from the power matching, the "surplus" is returned to the source, and then a "return wave" can be observed on the line from the load resistor in the direction of the source.
- e. For this reason, the concept of the reflection factor, "r" is introduced, which gives us:

$$r = U_{\text{rück}} / U_{\text{hin}}$$

or return voltage:

$$U_{\text{rück}} = r \times U_{\text{hin}}$$

where

$$r = (Z_{\text{last}} - Z) / (Z_{\text{last}} + Z)$$

A voltage at the load is then simply:

$$U_{\text{last}} = U_{\text{hin}} + U_{\text{rück}}$$

Note: for these moving waves, Ohm's law must naturally apply all over the line.

$$U_{\text{hin}} / U_{\text{hin}} = Z (= 50\Omega)$$

and

$$U_{\text{rück}} / U_{\text{rück}} = Z (= 50\Omega)$$

More about the S-Parameters:

Energy transmission on the line naturally always occurs through outputs. But in order to be able to work with the transmitted outputs using expressions in which the voltages appear, we simply take the square root out of the output formulae and christen the result the "wave value".

This gives the incoming wave value, a:

$$P_{\text{hin}} = (U_{\text{hin}}^2 / Z) > a = \sqrt{P_{\text{hin}}} = (U_{\text{hin}} / \sqrt{Z})$$

and correspondingly, for the return wave value, b:

$$P_{\text{rück}} = U_{\text{rück}}^2 / Z > b = \sqrt{P_{\text{rück}}} = (U_{\text{rück}} / \sqrt{Z})$$

The significance of these actions does not become clear until we consider a quadripole - e.g. an amplifier! For this quadripole will, for example, have an amplification value, but there are also return effects from the output on the input.

First step:

If the input is controlled by a signal source, this is described as the incoming wave value, a_1 . If we now consider the "Echo b_1 " arising in the feed line to the input with a directional coupler, then it consists of 2 parts, namely:-

- the reflected fraction of a_1 , which is created by the deviation of the input resistance from $Z = 50\Omega$, and
- a second fraction, which is generated at the input by feedback from the output, where indeed some signals, a_2 , are present

So for the echo:

$$b_1 = (a_1 \times S_{11}) + (a_2 \times S_{12})$$

Significance of coefficients:

If the output is precisely matched, we can not expect echoes to be reflected back from there, and the value, a_2 becomes zero. We thus obtain S_{11} :

$$S_{11} = b_1 / a_1 \quad \text{for } a_2 = 0$$

This is none other than the input reflection factor, r , from the previous calculation example! However, in practise it is always complicated, due to running times and reactive components. Thus, for example, value and phase are always given in relation to the frequency in transistor tables.

The value S_{12} , then, is the "reverse transfer ratio". It supplies data on the feedback values for the quadripole if the input is not controlled and is also matched with $Z = 50\Omega$. In this case, the output is "blown on" by a signal generator with the output a_2 :

$$S_{12} = b_1 / a_2 \quad \text{for } a_1 = 0$$

Second step:

Now we apply the same train of thought to the output. We imagine a signal source on the right, which processes the output of the quadripole with the wave value a_2 . We then obtain, as an echo, b_2 :

$$b_2 = (a_1 \times S_{11}) + (a_2 \times S_{22})$$

If the input of the amplifier is just not controlled, a_1 is automatically zero. For this reason, a "signal coming from the quadripole output" can arise only through a reflection at the internal resistance of the quadripole.

Thus, S_{22} is the output reflection factor of the quadripole!

$$S_{22} = b_2 / a_2 \quad \text{for } a_1 = 0$$

Now only the left-hand summand in the equation remains, and this is already known. If a signal is transmitted at the input alone and the output is simply matched, with $Z = 50\Omega$, we obtain the classic amplifier circuit. S_{21} is now nothing more than the "voltage amplification of the quadripole with correct matching at the output".

$$S_{21} = b_2 / a_1 \quad \text{for } a_2 = 0$$

Practical tips:

The resistance values can be determined from the input and output reflection factors in the following way. (Please take note that we are dealing with complicated values here!)

For example input resistance:

$$Z_{11} = (Z \times (1 + S_{11})) / (1 - S_{11})$$

or internal resistance:

$$Z_{22} = (Z \times (1 + S_{22})) / (1 - S_{22})$$

If we have the resistance values and wish to use them to calculate the reflection factors (see our example above), then, using the well-known method, we obtain:

At the input:

$$S_{11} = (Z_{11} - Z) / (Z_{11} + Z)$$

At the output:

$$S_{22} = (Z_{22} - Z) / (Z_{22} + Z)$$

You can save yourself these conversions by working with the Smith diagram!

To be continued



THE G8OZP RANGE OF MICROWAVE KITS FOR AMATEUR TELEVISION

GUNN DIODE ATV TRANSMITTER KITS

This unit forms the heart of a compact, fully featured FM Gunn diode PAL, SECAM or NTSC ATV transmitter, with 5.5, 6.0 or 6.5 MHz intercarrier sound. The PCB is suitable for most types of 3cm and other frequency Gunn oscillators up to 25mW (up to 300mW Gunn oscillators may be used with the addition of one extra transistor). The single 3" by 2" quality PCB incorporates a stable, adjustable Gunn diode modulator with video pre-emphasis and adjustable deviation, together with a stable intercarrier sound generator with selectable pre-emphasis, audio limiting, input level control and output filtering. The PCB requires a single 10 - 15V DC @ 20mA unregulated supply, excluding the Gunn diode.

PCB with full instructions - you supply components, Gunn Osc., case, connectors etc..... £ 7.50

Kit with full instructions. - you supply Gunn Osc. case, connectors etc (Note 1) £ 25.00

Kit with Gunn oscillator - you supply case connectors etc (Note 1 & 2) £ 35.00

Note 1: Please state 5.5 MHz, 6.0 MHz or 6.5 MHz audio sub carrier frequency. (6 MHz standard)

Note 2: At present Gunn oscillators are good tested surplus units. Gunn oscillators are WG16 square flange mounting, 6 - 12mW output and pre-tuned to 10.278 GHz. Other frequencies as requested.

TVRO3 ATV OR SATELLITE RECEIVER

A TVRO (television receive only) kit. On the single 95mm x 145mm (3.6" x 5.7") quality glass fibre PCB are mounted all the components (less front panel controls) required for a fully featured TVRO, or tuneable IF. All RF signal amplification and demodulation is performed within a screened pre-assembled, pre-aligned signals module. All other circuitry including power supplies are mounted on the same board as the RF module. Construction requires only basic tools, small wire cutters soldering iron, etc., together with basic electronic assembly skills. One major feature of this design is that absolutely no alignment, setting up or test equipment is required. The kit contains the PCB, all board mounted components and full assembly and operating instructions.

Tuneable IF/demod for 13, 9,6, 3cm, etc., or with preamp as a 24cm ATV RX

TVRO tuner/demodulator for satellite use

12V DC operation. 500mA typical consumption (depends on volume and LNB used)

Tunes 750 to 1750 MHz

In-built switchable 13V or 18V LNB supply.

1V Pk./Pk composite video output

Sound fully tuneable from 5.5 to 7.5 MHz * Audio squelch * 3 Watts audio output

In-built dish alignment aid

Video gain control * + or - modulation selection

Signal meter output.

ONLY AVAILABLE AS A COMPLETE KIT (PCB, etc., NOT AVAILABLE SEPARATELY

TVR03 Kit..... £62.50



COMPLETE KITS

for projects featured in VHF Communications

KIT	DESCRIPTION	ISSUE	ART No	PRICE
DB1NV-006	Spectrum Analyser IF Amplifier	2/89	06370	£142.00
DB1NV-007	Spectrum Analyser Lo-PLL	2/89	06371	£ 62.00
DB1NV-008	Spectrum Analyser Crystal Filter	3/89	06372	£108.00
DB1NV-009	Spectrum Analyser Sweep Gen	3/89	06373	£ 48.00
DB1NV-010	Spectrum Analyser Digital Store	3&4/91	06378	£132.00
DB1NV-011	Spectrum Analyser Tracking Gen	2/92	06474	£143.00
DB1NV-012	Spectrum Analyser VCO 1450 MHz	4/92	06483	£ 39.00
DB1NV-013	Spectrum Analyser VCO 1900 MHz	4/92	06484	£ 41.00
DB6NT-001	Measuring Amp up to 2.5 GHz	4/93	06382	£ 60.00
DB6NT-002	Frequency Divider to 5.5 GHz	4/93	06383	£100.00
DJ8ES-001	23cm FM ATV Converter	1/91	06347	£ 93.00
DJ8ES-002	Digital Frequency Indicator	1/91	06352	£ 53.00
DJ8ES-003	IF Amplifier	1/91	06355	£ 55.00
DJ8ES-004	Demodulator	1/91	06362	£ 72.00
DJ8ES-019	Transverter 144/28 MHz	4/93	06385	£143.00
DJ8ES-019mod	Transverter 50/28 MHz	2/95	06392	£143.00
DJ8ES-020	Hybrid Amplifier for 144 MHz	1/94	06387	£179.00
DJ8ES-021	13cm FM ATV Exciter	2/94	06388	£ 67.00
DJ8ES-022	28/432 MHz Transverter Oscillator	2/95	06395	£ 59.00
DJ8ES-023	28/432 MHz Transverter Converter	2/95	06396	£114.00
DC8UG-007	5W PA for 13cm	3/94	06938	£286.00

Minimum postage and packing charge is £6.75. Credit Card orders +5%.

KM Publications, 5 Ware Orchard, Barby, Nr.Rugby, CV23 8UF, U.K.

Tel: (0)1788 890365

Fax: (0)1788 891883

PRINTED CIRCUIT BOARDS

for projects featured in VHF Communications

DB1NV	Spectrum Analyser			Art No.
PCB	DB1NV-006	IF Amplifier	Ed.2/89	06997 £ 17.25
PCB	DB1NV-007	Lo-PLL	Ed.2/89	06995 £ 17.25
PCB	DB1NV-008	Crystal Filter	Ed.3/89	06998 £ 17.25
PCB	DB1NV-009	Sweep Generator	Ed.3/89	06996 £ 17.25
PCB	DB1NV-010	Digital Store	Ed.3&4/91	06477 £ 21.15
PCB	DB1NV-011	Tracking Generator	Ed.2/92	06479 £ 15.50
PCB	DB1NV-012	VCO 1450 MHz	Ed.4/92	06480 £ 16.35
PCB	DB1NV-013	VCO 1900 MHz	Ed.4/92	06481 £ 16.35
DB6NT	Measuring Aids for UHF Amateurs			Art No. ED. 4/93
PCB	DB6NT-001	Measuring Amp up to 2.5 GHz	06379	£ 17.75
PCB	DB6NT-002	Frequency Divider to 5.5 GHz	06381	£ 17.75
DJ8ES	23cm FM-ATV Receiver			Art No. ED. 1/91
PCB	DJ8ES-001	Converter	06347	£ 10.75
PCB	DJ8ES-002	Digital Frequency Indicator	06350	£ 9.65
PCB	DJ8ES-003	IF Amplifier	06353	£ 7.95
PCB	DJ8ES-004	Demodulator	06356	£ 10.30
DJ8ES	28/144 MHz Transverter			Art No. ED. 4/93
PCB	DJ8ES-019	Transverter 144/28 MHz	06384	£ 17.75
PCB	DJ8ES-020	Hybrid Amplifier 144 MHz	06386	£ 17.25
DF9PL	High Stability Low Noise PSU			Art No. ED. 1/93
PCB	DF9PL-001	30 Volt PSU	06378	£ 9.80
PCB	DF9PL-002	Pre-Stabiliser	06376	£ 10.20
PCB	DF9PL-003	Precision Stabiliser	06377	£ 11.20
F6IWF	10 GHz FM ATV Transmitter			Art No. ED. 2/92
PCB	F6IWF-001	DRO Oscillator - PTFE	06485	£ 16.20
PCB	F6IWF-002	Modulator and Stabiliser	06486	£ 12.00
DC8UG	13cm GaAsFET PA			Art No. ED. 3/94
PCB	DC8UG-PA	5W PA for 13cm	06936	£ 19.25
PCB	DC8UG-NT	Power Supply for the PA	06937	£ 7.75

Minimum postage and packing charge is £6.75. Credit Card orders +5%.
 KM Publications, 5 Ware Orchard, Barby, Nr.Rugby, CV23 8UF, U.K.
 Tel: (0)1788 890365 Fax: (0)1788 891883



MICROWAVE AMPLIFIERS

1296 & 2320 KIT AMPLIFIERS & TRANSVERTERS

3400 KITS & 10 WATT AMPLIFIERS

5760 10 WATT AMPLIFIERS - READY TO GO

SEND FOR CATALOGUE

LMW ELECTRONICS Ltd, LMW HOUSE, LEESIDE,
MERRYLEES IND. EST., DESFORD, LEICESTER, LE9 9FS

Tel: 01530 231141; Fax: 01530 231143; Email: lmw@midnet.com

VHF Communications Back Issues

Back issues of VHF Communications Magazine
are available at £2.50 each

Issues available: 1, 2, 4/1972 2, 4/1973 *
1/1974 * 1, 2, 3, 4/1975 3/1976 * 1, 4/1977 * 1,
2/1978, 1, 3/1979, 1980 to 1994

(less 2/80, 1/81, 4/81, all 82, 3/87, 1/88, 2/89, 3/89, 1/90, all 1991)

The above price includes surface shipping, for Air
Mail delivery add £0.75 per issue.

Credit card orders - above prices +5%

KM Publications, 5 Ware Orchard, Barby, Nr.Rugby,
CV23 8UF, UK

Tel: (0)1788 890365 Fax: (0)1788 891883 E-mail:

vhfsales@g6iqm.demon.co.uk



VHF COMMUNICATIONS

A Publication for the Radio Amateur Worldwide

Especially Covering VHF, UHF and Microwaves

Volume No. 28 Autumn Edition 3/1996

Publishers

KM PUBLICATIONS,
5 Ware Orchard, Barby, Nr.Rugby,
CV23 8UF, United Kingdom

Tel: 01788 890365
Fax: 01788 891883

Internet:
vhf-comm@g6iqm.demon.co.uk

Editor

Mike Wooding G6IQM

VHF COMMUNICATIONS

The international edition of the German publication UKW-Berichte is a quarterly amateur radio magazine, especially catering for the VHF/UHF/SHF technology. It is owned and published in the United Kingdom in Spring, Summer, Autumn and Winter by KM PUBLICATIONS.

The 1996 subscription price is £16.00, or national equivalent. Individual copies are available at £4.50, or national equivalent each. Subscriptions should be addressed to the national representative shown in the next column. Orders for individual copies of the magazine, back issues, kits, binders, or any other enquiries should be addressed directly to the publishers.

NOTICE: No guarantee is given that the circuits, plans and PCB designs published are free of intellectual property rights. Commercial supply of these designs without the agreement of the Author and Publisher is not allowed. Users should also take notice of all relevant laws and regulations when designing, constructing and operating radio devices.

© KM
PUBLICATIONS

All rights reserved. Reprints, translations, or extracts only with the written approval of the publishers

Translated by: Inter-Ling Services,
62 Caldecott Street, Rugby,
CV21 3TH, UK

Printed in the United Kingdom by:
Cramphorn Colour Printers Ltd., 15c
Paynes Lane, Rugby.

AUSTRIA - Verlag UKW-BERICHTE, Terry D. Bittan, POB 80,
D-91081 BAIERSDORF, Germany. Tel: (9133) 47-0
Fax: 09733 4747 Telex: 629 887. Postgiro Nbg. 30445-858.

AUSTRALIA - W.I.A., P.O. Box 300, SOUTH CAULFIELD,
3162 VIC, Australia. Tel: 528 5962

BELGIUM - UKW-BERICHTE, POB 80, D-91081 BAIERSDORF,
Germany. Tel: (9133) 47-0. Fax: 09733 4747 Telex: 629 887.
Postgiro Nbg. 30445-858.

DENMARK - KM PUBLICATIONS, 5 Ware Orchard, Barby,
Nr.RUGBY, CV23 8UF, UK. Tel: +44 788 890365.
Fax: +44 788 891883. Email: vhf-comm@g6iqm.demon.co.uk

FRANCE - Christianne Michel F5SM, SM ELECTRONIC, 20bis
Avenue des Clairons, F-89000 AUXERRE, France
Tel: (86) 46 96 59

FINLAND - KM PUBLICATIONS, 5 Ware Orchard, Barby,
Nr.RUGBY, CV23 8UF, UK. Tel: +44 788 890365.
Fax: +44 788 891883. Email: vhf-comm@g6iqm.demon.co.uk

GERMANY - UKW-BERICHTE, POB 80, D-91081
BAIERSDORF, Germany. Tel: 09133 7798-0. Fax: 09133 779833.

GREECE - C+A ELECTRONIC, P.O. Box 25070, ATHENS
100 26, Greece. Tel: 01 52 42 867. Fax: 01 52 42 537

HOLLAND - KM PUBLICATIONS, 5 Ware Orchard, Barby,
Nr.RUGBY, CV23 8UF, UK. Tel: +44 788 890365.
Fax: +44 788 891883. Email: vhf-comm@g6iqm.demon.co.uk

ITALY - ADB ELETTRONICA di Luchesi Fabrizio IWSADB,
Via Vecchia Romana 266, 55100 ANTRACCOLI, (LUCCA), Italy.
Tel: 0583 952612. Fax: 0583 91109

NEW ZEALAND - Judith Holland, AUCKLAND VHF GROUP
Inc., P.O. Box 10 138, AUCKLAND 1030, New Zealand.
Tel: 0 9 412 7659

NORWAY - WAVELINE AB, Box 60224, S-216 09 MALMO,
Sweden. Tel: +46 40 16 42 66. Fax: +46 40 15 05 07.
GSM: 0705 16 42 66
e-mail: waveline@algonet.se <http://www.algonet.se/~waveline>

SOUTH AFRICA - HI-TECH BOOKS, P.O. Box 1142,
RANDBURG, Transvaal 2125, South Africa. Tel: (011) 465 3385

SPAIN & PORTUGAL - JULIO A. PRIETO ALONSO EA4CJ,
Donoso Cortes 58 5° B, MADRID 15, Spain. Tel: 543 83 84

SWEDEN - WAVELINE AB, Box 60224, S-216 09 MALMO,
Sweden. Tel: 040 16 42 66. Fax: 040 15 05 07. GSM: 0705 16 42
66 e-mail: waveline@algonet.se <http://www.algonet.se/~waveline>

SWITZERLAND - KM PUBLICATIONS, 5 Ware Orchard, Barby,
Nr.RUGBY, CV23 8UF, UK. Tel: +44 788 890365.
Fax: +44 788 891883. Email: vhf-comm@g6iqm.demon.co.uk

UNITED KINGDOM - KM PUBLICATIONS, 5 Ware Orchard,
Barby, Nr.RUGBY, CV23 8UF, UK. Tel: +44 788 890365.
Fax: +44 788 891883. Email: vhf-comm@g6iqm.demon.co.uk

U.S.A. - WYMAN RESEARCH Inc., RR#1 Box 95, WALDRON,
Indiana 46182, U.S.A. Tel: (317) 525 6452

- Henry Ruh, ATVQ MAGAZINE, 3 North Court Street,
Crown Point, Indiana 46307, U.S.A. Tel: (219) 662 6395.
Fax: (219) 662 6991

ELSEWHERE - KM PUBLICATIONS, address as for the U.K.

WWW: <http://www.eolas.co.uk/ag/vhfcomm.htm>

<http://www.clearlight.com/~vhfcomm>

<http://www.g6iqm.demon.co.uk/vhfcomm.htm>

ISSN 0177-7505

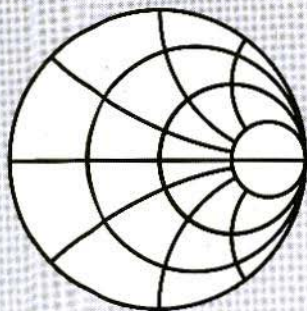

SMITH CHART TOOLSET

\$59

Electronic Applications of the Smith Chart is an updated edition of Phillip H. Smith's original book. This detailed reference is the authoritative work on the Smith Chart.

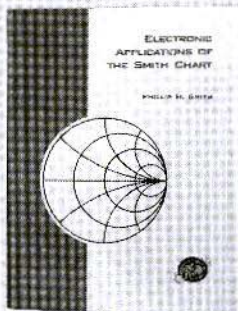

\$79

The winSMITH program which runs on IBM/compatible PCs modernizes the Smith Chart by easily tuning elements and readout of precise values.

\$99

This video is all the instruction you need to start using the Smith Chart to solve all types of matching and transmission line problems.



ORDER BY PHONE, FAX OR MAIL

ALL 3 ONLY \$199
SAVE \$38

Name _____
Company _____
Address _____
City _____ State _____
ZIP _____ Country _____
Phone _____ FAX _____
Card # _____ Exp _____
Signature _____

Please send the following products

- Toolset (includes all three) \$199
- Smith Chart book \$59
- winSMITH software \$79
- Smith Chart video \$99

Shipping & Handling
US \$8, Canada \$20, Intl. Air \$40

Payment Method

- VISA or MasterCard
- EuroCheck
- Bank Check (Must have the name of a US bank on the check)

NOBLE PUBLISHING

TEL (770)908-2320 FAX (770)939-0157
2245 Dillard St., Tucker, GA 30084, USA
editor@noblepub.com www.noblepub.com

THE Autorouter for **EASY-PC Pro' XM!**

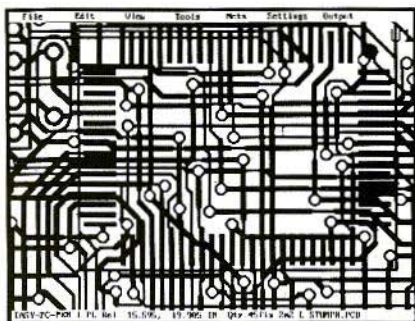

"The Best Autorouter that I have seen costing less than £10,000!" R.H. - (Willingham, UK)

- Uses the latest 32 Bit, Shape Based, Multi-pass, Shove-aside and Rip-up and Re-try Technology
- AutoRoute very large and complex boards
- User Controllable, User Configurable
- 100% Completion where other autorouters fail
- 100% Autorouted 140 Components on a 210mm x 150mm board in less than 10 minutes! (75MHz Pentium)
- *Could Easily Pay For Itself On The First Project*

MultiRouter - only £295/\$475!

Integrated Electronics CAD

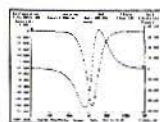
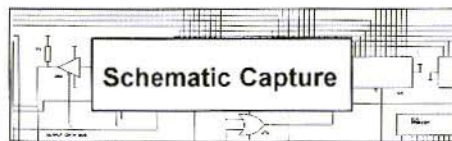

Analogue
& Digital
Simulation



And PCB Design

Affordable Electronics CAD

EASY-PC Professional: Schematic Capture and PCB CAD. Links directly to ANALYSER III, LAYAN and PULSAR.	From \$275	£145
MultiRouter: 32bit Multi-pass Autorouter for EASY-PC Professional XM	\$475	£295
LAYAN: Electro-Magnetic Layout Simulator. Include board parasitics in your Analogue simulations. Links with and requires EASY-PC Professional XM and ANALYSER III Professional	\$950	£495
PULSAR: Digital Circuit Simulator	From \$195	£98
ANALYSER III: Analogue Linear Circuit Simulator	From \$195	£98
FILTECH: Active and Passive Filter Design program	From \$275	£145
STOCKIT: New comprehensive Stock control program for the small or medium sized business	\$275	£145
EASY-PC: Award Winning PCB and Schematic CAD.	\$145	£75
Z-MATCH: Award Winning Smith-Chart based program for RF Engineers.	From \$275	£145

We operate a no penalty upgrade policy. US\$ prices include Post and Packing. Sterling Prices exclude P&P and VAT.

Prices from UK£145 / US\$275

For Full Information and Demo' Disk, please write, phone, email or fax:-

Number One Systems

UK/EEC: Ref: VHF.COM, Harding Way, St.Ives, Cambridgeshire, ENGLAND, PE17 4WR.

Telephone UK: 01480 461778 (7 lines) Fax: 01480 494042

USA: Ref: VHF.COM, 126 Smith Creek Drive, Los Gatos, CA 95030

Telephone/Fax: (408) 395-0249

Email: sales@numberone.com

International +44 1480 461778

- TECHNICAL SUPPORT FREE FOR LIFE
- PROGRAMS NOT COPY PROTECTED.
- SPECIAL PRICES FOR EDUCATION.

