

QST



november, 1943

25 cents

35c in Canada

devoted entirely to

amateur radio



In This Issue:

New WERS Mobile Gear

A.C. - D.C. V.T. Voltmeter

Astronomy and Amateur Radio

Junk-Box WERS Frequency Meter

**HELLS BELLS, THESE
TUBES MUST BE BUILT ON
A FOUR-LEAF CLOVER...**

Amperex transmitting and rectifying tubes have longer operating life packed into them than most hardened engineers anticipate. Now, this isn't a matter of luck... rather, it's the result of unceasing laboratory research and new production methods.

Amperex tubes are extremely precise... They're tank tough... They keep going at rated efficiency up to the very end. Wherever used, in civilian and military communications or in industrial applications—Amperex tubes are as constant and dependable as mathematical formulae.

BLOOD-DONORS ARE URGENTLY NEEDED
MAKE A DATE WITH THE RED CROSS



AMPEREX ELECTRONIC PRODUCTS
79 WASHINGTON STREET • BROOKLYN, N. Y.

Australia
June 18, 1943
Hallicrafters
Chicago, Illinois
U.S.A.

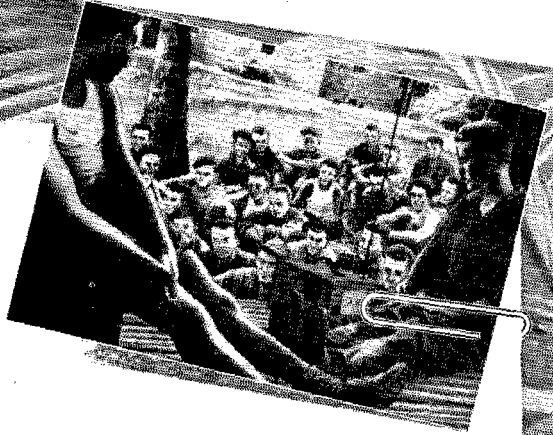

Dear Sirs:

In the May issue of QST, appeared a picture of your Hallicrafters Model S-29 Radio...and a group of men and myself listening in on a program...in the New Guinea area.

The Radio which appears in this picture was purchased by myself in August, 1941. This same radio has been in continuous operation...and has caused no trouble.

This Hallicrafters Model S-29 was one piece of equipment which every man...was anxious to carry. It was carried at all times...through New Guinea jungles...in the midst of a jungle swamp...where tropical rains fell heavily...in extreme damp heat, this radio never once faltered. It brought untold relief to every fighting man...caused tense nerves to become relaxed, bringing happy moments to dark surroundings. The part played by this instrument could never otherwise be duplicated. Every night...the fellows would listen to the news from home. Notes were taken...and news was called to the troops on front line duty. Without this radio there would have been no contact with the outside world.

This same radio is operating perfectly and the only replacement needed was a new set of tubes.

Sincerely yours,
Glen V. Blakeslee

BUY MORE BONDS!

the hallicrafters co.

CHICAGO, U.S.A.

WORLD'S LARGEST EXCLUSIVE MANUFACTURERS OF SHORT
WAVE RADIO COMMUNICATIONS EQUIPMENT

SCR-299

RIDES THE CREST OF THE INVASION WAVE!

To our troops fighting on all fronts, the SCR-299 Mobile Radio Communications unit is a familiar sight. It helped pave the way for the Allies in Africa and Sicily. In Africa alone it operated on five networks, including circuits from Oran to England, Casablanca, Gibraltar, Algiers and Accra.

Whether set up as a fixed radio station or used as a fast-moving mobile unit, the SCR-299 has done an excellent job transmitting commands while in action, no matter how difficult the conditions.

... thus proving that communications systems were adaptable to the "Blitz" tactics of modern warfare.

The World's Largest Exclusive Manufacturers of Short Wave Radio Communications Equipment

the hallicrafters co.

CHICAGO, U.S.A.

BUY
MORE BONDS!



NOVEMBER 1943

VOLUME XXVII

NUMBER 11



STAFF

Editorial

KENNETH B. WARNER, W1EH
General Manager of A.R.E.L.
Publications

CLINTON B. DeSOTO, W1CSD
Editor

GEORGE GRAMMER, W1DP*
Technical Editor

DONALD H. MIX, W1TS
Acting Technical Editor

HOLLIS M. FRENCH, W1LJK
BYRON GOODMAN, W1JPK*
Assistant Technical Editors

EDWARD P. TILTON, W1HDQ
Contributing Editor, V.H.F.

WALTER E. BRADLEY, W1FWH
VERNON CHAMBERS, W1JGQ*
Technical Information Service

LOUISA B. DRESSER
Editorial Assistant

JAMES J. LAMB, W1AL*
Research Engineer, A.R.R.L.

Advertising

F. CHEYNEY BEEKLEY, W1GS
Advertising Manager

Circulation

DAVID H. HOUGHTON
Circulation Manager

RALPH T. BEAUDIN, W1BAW
Asst. Circulation Manager

*On leave of absence



OFFICES

38 La Salle Road
West Hartford 7, Connecticut

Subscription rate in United States and Possessions, \$2.50 per year, postpaid; all other countries, \$3.00 per year, postpaid. Single copies, 25 cents. Foreign remittances should be by international postal or express money order or bank draft negotiable in the U. S. and for an equivalent amount in U. S. funds.

Entered as second-class matter May 29, 1919, at the post office at Hartford, Connecticut, under the Act of March 3, 1879. Acceptance for mailing at special rate of postage provided for in section 1103, Act of October 3, 1917, authorized September 9, 1922. Additional entry at Concord, N. H., authorized February 21, 1929, under the Act of February 28, 1925. Additional second-class entries to cover sectional editions authorized March 20, 1935.

Copyright 1943 by the American Radio Relay League, Inc. Title registered at United States Patent Office.

QST

devoted entirely to

AMATEUR RADIO

PUBLISHED, MONTHLY, AS ITS OFFICIAL ORGAN; BY THE AMERICAN RADIO RELAY LEAGUE, INC., AT WEST HARTFORD, CONN., U. S. A.
OFFICIAL ORGAN OF THE INTERNATIONAL AMATEUR RADIO UNION



CONTENTS

It Seems to Us	9
Splatter	10
CD-WERS, 1944 Style <i>Frederick A. Long, ex-W8NE, ex-W8BSL</i>	11
Astronomy and Amateur Radio <i>Hollis M. French, W1JLJK</i>	17
Radiomen	20
Happenings of the Month	21
1943 Rochester Fall Meeting	22
Missing in Action	22
Prisoners of War	22
Silent Keys	22
On the Spot With a Walkie-Talkie <i>Frederick M. Burkle</i>	23
In the Services	26
A Junk-Box Frequency Meter for 112 Mc. <i>William Adams, W6ANN</i>	30
Gold Stars	33
U.S.A. Calling!	34
A V.T. Voltmeter for A.C. and D.C. <i>A. D. Mayo, W4CBD</i>	36
Hamdom	39
Experimenter's Section	40
The Signal Corps Puts on a Show	42
An Interpolation Oscillator <i>Frank H. Mills, W9HQH</i>	46
AAF Operators Train on Radio Mock-Ups	51
Strays	52
Hints and Kinks <i>That Peterson Pot (Correction) — Emergency Test Board — Plug-In Headphone Adapter for TR-4s — Re-Use of Home Recording Discs — Automatic Circuit Polarizer — Power-Tube Protective Circuit — Simplified Transmitter-Receiver Switching Arrangement — Solder Kink — Soldering-Iron Rest and Heat Control — Simple Method for Investigating Performance of 112-Mc. Antennas</i>	53
Correspondence from Members	56
Operating News	60
The Month in Canada	64
Amateur Activities	65
WWV Schedules	82
Hamads	100
QST's Index of Advertisers	102

THE McELROY CODE

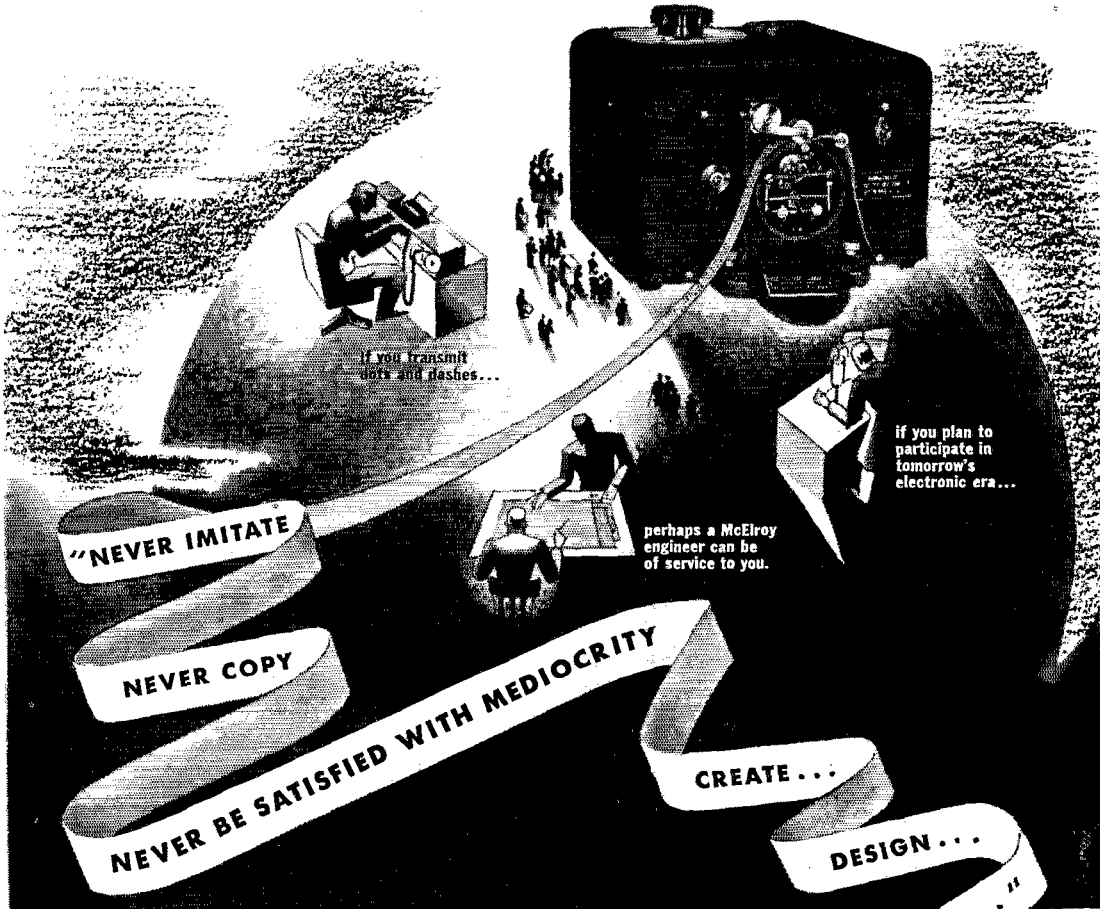

This is the McElroy code. This is the key to our thinking. This is the force which generates McElroy initiative. This is the power of creative engineers in concerted action. The new McElroy Model XTR-442B Automatic Transmitter is *accurately* calibrated in words per minute and will operate at speeds from 5 to more than 200 words per minute. Speed is constant and will not vary. The XTR-442B is one of the reasons why McElroy is the world's largest manufacturer of automatic radio telegraph apparatus. Write direct for additional information.

McElroy

MANUFACTURING CORP.
82 BROOKLINE AVE., BOSTON, MASS.

WORLD'S LARGEST MANUFACTURER OF AUTOMATIC RADIO TELEGRAPH APPARATUS

At home as well as on the battlefield, blood plasma helps save lives . . .
donate a pint of blood to the Red Cross today.

McELROY does it again!

SHIP TO SHIP

SHIP TO SHORE

POINT TO POINT



NEW McELROY WHEATSTONE CODE TAPE PERFORATOR

Aware of the need for an instrument that would provide more efficient marine radiotelegraph communications, Ted McElroy* and his creative engineers have perfected the Model PFR-443 Wheatstone Code Tape Perforator.

Speed limitations of hand sending coupled with certain restrictions of manual operation have oftentimes proved costly in time, money, and lives. Now, because of precise electrical and mechanical features, this new Perforator practically eliminates the human margin of error. These prepared tapes feed through automatic radiotelegraph transmitters.

Simple to operate, the PFR-443 performs automatically or semi-automatically. Anyone with a basic knowledge of signal codes can prepare tapes cleanly and accurately at speeds up to 50 words per minute . . . not only in International Morse, but in all other codes used throughout the world. Wheatstone Perforated Tapes also serve as file records of all transmissions. Additional information may be obtained by writing to McElroy Manufacturing Corporation.

* WORLD CHAMPION RADIO TELEGRAPHER FOR MORE THAN 20 YEARS*

Hasten the peace . . . keep buying war bonds

McElroy

MANUFACTURING CORP.
82 BROOKLINE AVE., BOSTON, MASS.

WORLD'S LARGEST MANUFACTURER OF AUTOMATIC RADIO TELEGRAPH APPARATUS

Section Communications Managers of the A. R. R. L. Communications Department

Reports Invited. All amateurs, especially League members, are invited to report communications activities, training plans, code classes, theory-discussion groups, civilian-defense building or planning each mid-month (16th of the month for the last 30 days) direct to the SCM, the administrative official of ARRL elected by members in each Section whose address is given below. Radio Club reports and Emergency Coordinator reports representing community organized work and plans and progress are especially desired by SCMs for inclusion in *QST*. **ARRL Field Organization appointments**, with the exception of the Emergency Coordinator and Emergency Corps posts, are suspended for the present and no new appointments or cancellations, with the exception named, will be made. This is to permit full efforts of all in Emergency Corps plans.

ATLANTIC DIVISION				
Eastern Pennsylvania	W3BES	Jerry Mathis	6208 Master St. 9701 Monroe St.	Philadelphia 31
Maryland-Delaware-District of Columbia	W3CIZ	Hermann E. Hobbs	Silver Spring P. O.	Linden, Maryland
Southern New Jersey	W3GCU	Ray Tomlinson	625 E. Brown St.	Trenton 10
Western New York	W3MC	William Bellor	186 Dorsey Rd.	Rochester
Western Pennsylvania	W8CKO	E. A. Krall	703 Broadway	East McKeesport
CENTRAL DIVISION				
Illinois*	W9QLZ	George Keith, Jr.	Box 22-A, R.F.D. 2	Utica
Indiana	W9EGQ	Herbert S. Brier	385 Johnson St.	Gary
Kentucky	W9ARU	Darrell A. Downard	116 N. Longworth Ave.	Louisville 12
Michigan	W8DPE	Harold C. Bird	R.F.D. 2	Pontiac
Ohio	W8CBI	D. C. McCoy	Normandy Lane, R. R. 7	Dayton
Wisconsin	W9RH	Emil Felber, Jr.	1625 N. 18th St.	Milwaukee 5
DAKOTA DIVISION				
North Dakota	W9YVF	John W. McBride	420 West 12th St.	Sioux Falls, South Dakota
South Dakota	W9QVY	P. H. Schultz	118 N. Yankton Ave.	Pierre
Northern Minnesota	W9FUZ	Armond D. Brattland	War Production Training School	Glenwood
Southern Minnesota	W9YNQ	Millard L. Bender	608 N. Huron Ave.	Spring Valley
DELTA DIVISION				
Arkansas	W5GED	Ed Beck	2503 Bishop St.	Little Rock
Louisiana	W5DWW	W. J. Wilkinson, Jr.	Room 313, Jefferson Hotel	Shreveport
Mississippi	W5HAY	P. W. Clement	524 Santant St.	Biloxi
Tennessee	W4SP	James B. Witt	R.F.D. 6, Shady Dell Trail	Knoxville
HUDSON DIVISION				
Eastern New York	W2LU	Robert E. Haight	511 So. Holmes St.	Scotia
N. Y. C. & Long Island	W2AZV	E. L. Baunach	102 Central Ave.	Massapequa, L. I.
Northern New Jersey	W2CQD	Winfield G. Beck	617 Spruce St.	Roselle
MIDWEST DIVISION				
Iowa	W9AED	Arthur E. Rydberg		Mitchellville
Kansas	W9AWP	A. B. Unruh	1617 S. Seneca St.	Wichita
Missouri*	W9OOD	Mrs. Letha A. Dangerfield	Box 245	Lee's Summit
Nebraska	W9POB	Roy E. Olmsted	401 Arikari Ave.	Wanetta
NEW ENGLAND DIVISION				
Connecticut	W1KQV	Edmund E. Fraser	48 Willow St.	West Haven 16
Maine*	W1AOL	G. C. Brown	379 No. Main St.	Brewer
Eastern Massachusetts	W1ALP	Frank L. Baker, Jr.	91 Atlantic St.	North Quincy 71
Western Massachusetts	W1JAH	William J. Barrett	239 Columbia St.	Adams
New Hampshire	W1FTT	Mrs. Dorothy W. Evans	P. O. Box 312	Concord
Rhode Island	W1HRC	Clayton C. Gordon	70 Columbia Ave., Gaspee	Plateau, Providence 5
Vermont	W1NLO	Burtis W. Dean	P. O. Box 81	Burlington
NORTHWESTERN DIVISION				
Alaska	K7GNN	James G. Sherr		Homer
Idaho	W7AVP	Don D. Oberbillig	P. O. Box 486	Boise
Montana	W7CYP	Rex Roberts	Box 1088	Glendive
Oregon	W7GNI	Carl Austin	1137 Federal	Bend
Washington	W7FWD	O. U. Tatro	513 N. Central	Olympia
PACIFIC DIVISION				
Hawaii	K6ETF	Francis T. Blatt	837 16th Ave.	Honolulu
Nevada	W6BIC	Edward W. Heim	509 Claremont St.	Reno
Santa Clara Valley	W6IUZ	Earl F. Sanderson	600 Acacia Ave.	San Bruno
East Bay	W6TL	Horace R. Greer	414 Fairmount Ave.	Oakland
San Francisco	W6CIS	Kenneth E. Hughes	590 35th Ave.	San Francisco
Sacramento Valley	W6MDI	Vincent N. Feldhausen	113 South Quincy St.	McCloud
Philippines	KA1GR	George L. Rickard	Box 849	Manila
San Joaquin Valley*	W6MIW	Ralph C. Lowry	315 Santa Barbara	Modesto
ROANOKE DIVISION				
North Carolina	W4CQB	W. Wortman	P. O. Box 566	Morganton
South Carolina	W4BVE/ANG	Ted Ferguson	1213 College St.	Columbia
Virginia	W3AKN	Walter G. Walker	217-51 St.	Newport News
West Virginia	W8JRL	Kenneth M. Zinn	P. O. Box 132	Clarksburg
ROCKY MOUNTAIN DIVISION				
Colorado*	W9VGC	H. F. Heikel	2743 Julian St.	Denver 11
Utah-Wyoming	W7DIE	John S. Duffy	938 "D" St.	Rock Springs, Wyo.
SOUTHEASTERN DIVISION				
Alabama	W4GBV	Lawrence J. Smyth	808 Winona Ave.	Montgomery
Eastern Florida*	W4BYR	Frank C. Fassett	1712 Hills Ave.	Tampa
Western Florida	W4AXP	Oscar Cederstrom	408 S. Pine St.	Warrington
Georgia	W4FDI	Ernest L. Morgan	R.F.D. 4	Lyons
West Indies (Cuba)	CM2OP	Mario de la Torre	Escobar 110 (Altos)	Habana, Cuba
(Puerto Rico-Virgin Islands)	K4KD	Everett Mayer	24 Lindberg St.	Santurce, P. R.
SOUTHWESTERN DIVISION				
Los Angeles	W6QVV	H. F. Wood	723 N. Las Palmas Ave.	Hollywood
Arizona	W6RWW	Douglas Aitken	341 S. Mt. Vernon Ave.	Prescott
San Diego	W6BZE	Richard Shanks	4033 S. Hempstead Circle	San Diego
WEST GULF DIVISION				
Northern Texas	W5IAU	N. R. Collins, Jr.	2230 W. Amherst	Dallas
Oklahoma	W5GFT	Russell W. Battern	Box 290	Enid
Southern Texas	W5MNI	Horace E. Bidy	1746 Schley Ave.	San Antonio
New Mexico	W5HJF	J. G. Hancock	110 S. E. Nevada St.	Portales
MARITIME DIVISION				
Maritime	VE1DQ	A. M. Crowell	69 Dublin St.	Halifax, N. S.
ONTARIO DIVISION				
Ontario	VE3EF	Flying Officer Donald R. Gunn	c/o Canadian Bank of Commerce	New Toronto, Ont.
QUEBEC DIVISION				
Quebec	VE2CO	Sub-Lieutenant L. G. Morris	c/o Room 604, 1111 Beaver Hall Hill	Montreal, P. Q.
VANALTA DIVISION				
Alberta	VE4GE	C. S. Jamieson	581 W. Riverside Drive	Drumheller, Alta.
British Columbia	VE5DD	C. O. L. Sawyer	2634 West 31st Ave.	Vancouver
PRAIRIE DIVISION				
Manitoba	VE4AAW	A. W. Marley	153 Sherbrook St.	Winnipeg
Saskatchewan	VE4SY	Arthur Chesworth	1071 4th Ave., N.W.	Moose Jaw

* Officials appointed to act until the membership of the Section choose permanent SCMs by nomination and election.

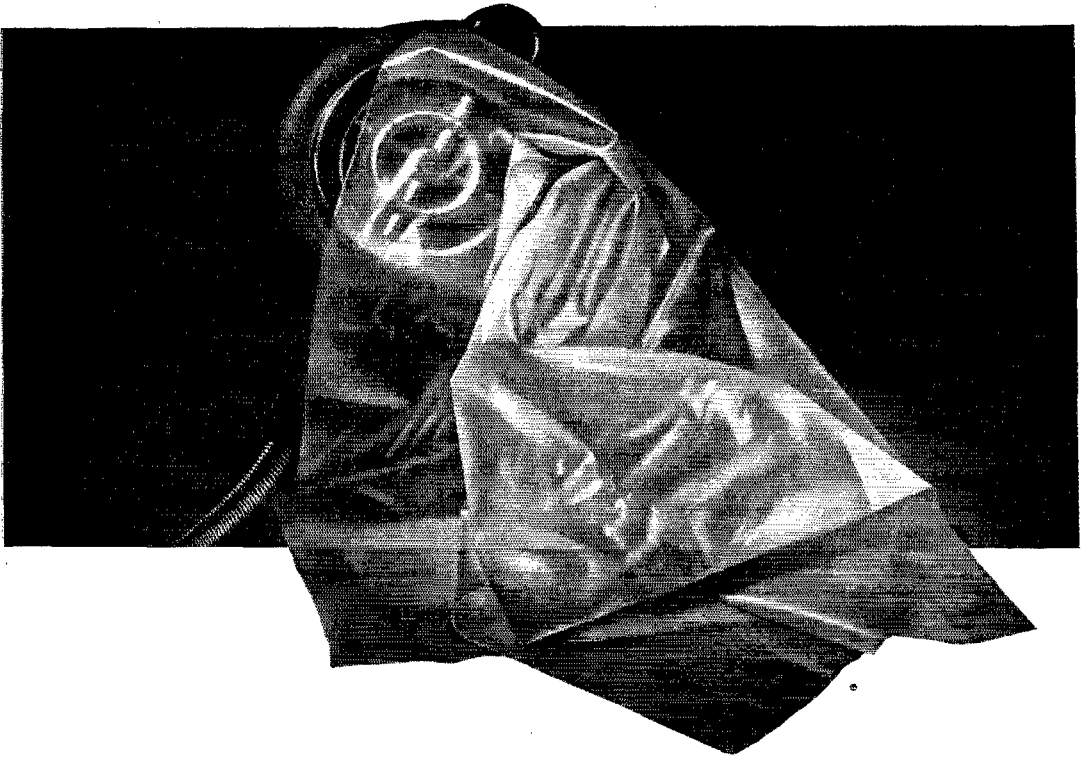

Can you use this new — .0004" — flexible material?

In developing and manufacturing entirely new Electro-Voice Microphones our engineers have had to experiment in nearly all branches of the scientific arts. About a year ago, one important microphone project was delayed because a thin and extremely flexible sheeting material was not available commercially.

Although we aren't chemists, we finally developed, what we believe to be, another Electro-Voice "first" . . . a method of sheeting a flexible material to as thin as four ten-thousandths of an inch. It is a material that can be stabilized, and one that will retain all of its characteristics from -40°F. to $+185^{\circ}\text{F.}$

We design and manufacture microphones . . . have been doing it for the past 16 years . . . and we intend to stick to our own field. However, if you're in war production and can use this new material, we'll be glad to save you the time and trouble of developing it yourself. Just tell us how much you need. . . we'll fill your order.

Blood donors are needed immediately . . . see your local Red Cross



Electro-Voice MICROPHONES

ELECTRO-VOICE MANUFACTURING CO., INC. • 1239 SOUTH BEND AVENUE • SOUTH BEND, INDIANA
Export Division: 13 East 40th Street, New York 16, N. Y. — U. S. A. Cables: ARLAB

THE AMERICAN RADIO RELAY LEAGUE, INC.,

is a noncommercial association of radio amateurs, bonded for the promotion of interest in amateur radio communication and experimentation, for the relaying of messages by radio, for the advancement of the radio art and of the public welfare, for the representation of the radio amateur in legislative matters, and for the maintenance of fraternalism and a high standard of conduct.

It is an incorporated association without capital stock, chartered under the laws of Connecticut. Its affairs are governed by a Board of Directors, elected every two years by the general membership. The officers are elected or appointed by the Directors. The League is noncommercial and no one commercially engaged in the manufacture, sale or rental of radio apparatus is eligible to membership on its board.

"Of, by and for the amateur," it numbers within its ranks practically every worth-while amateur in the nation and has a history of glorious achievement as the standard-bearer in amateur affairs.

Inquiries regarding membership are solicited. A bona fide interest in amateur radio is the only essential qualification; ownership of a transmitting station and knowledge of the code are not prerequisite, although full voting membership is granted only to licensed amateurs.

All general correspondence should be addressed to the Secretary at the administrative headquarters at West Hartford, Connecticut.



Past Presidents

HIRAM PERCY MAXIM, W1AW, 1914-1936
EUGENE C. WOODRUFF, W8CMP, 1936-1940

Officers

President GEORGE W. BAILEY, W1KH
Washington 25, D. C.
Vice-President CHARLES E. BLALACK, W6CG
Yuma, Ariz.
Secretary KENNETH B. WARNER, W1EH
West Hartford, Connecticut
Communications Manager F. E. HANDY, W1BDI*
Washington, D. C.
Treasurer DAVID H. HOUGHTON
West Hartford, Connecticut
General Counsel PAUL M. SEGAL
1026 Woodward Building, Washington, D. C.

*On leave of absence. Address correspondence to the Acting Communications Manager, George Hart, West Hartford 7, Connecticut.

Directors

President
GEORGE W. BAILEY W1KH
1530 P St., N.W., Washington 25, D. C.

Vice-President
CHARLES E. BLALACK W6CG
Box 108, Yuma, Ariz.

Canadian General Manager
ALEX REID VE2BE
240 Logan Ave., St. Lambert, P. Q.
Alternate: Leonard W. Mitchell VE3AZ
78 Raglan Ave., Toronto, Ont.

Atlantic Division
WALTER BRADLEY MARTIN W3QV
Address correspondence to the Acting Director:
HERBERT M. WALLEZE W8BQ
P. O. Box 18, Drums, Pa.

Central Division
GOODWIN L. DOSLAND W9TSN
11831 Longwood Drive, Chicago
Alternate: Everett H. Gibbs W8AQ
405 Broad St., Wadsworth, Ohio

Dakota Division
TOM E. DAVIS W9VVA
915 W. Becker Ave., Willmar, Minn.
Alternate: Donald M. Beaudine W9RFPJ
2821 Carson Way, Sacramento, Calif.

Delta Division
E. RAY ARLEDGE W58I
340 N.E. 20th Terrace, Apt. 7, Miami 37, Fla.
Alternate: B. G. Lowery Smith W4DEP
19 N.E. 41st St., Miami, Fla.

Hudson Division
ROBERT AKERIDGE KIRKMAN W2DSY
250 Albert Place, Elberon, N. J.
Alternate: George Ruffis, Jr. W2CJY
172-21 Highland Ave., Jamaica, L. I.

Midwest Division
FLOYD E. NORWINE, JR. W9EFC
7405 Hlawatha Ave., Richmond Heights, Mo.
Alternate: William H. Graham W9BNC
6915 No. 31st Ave., Omaha, Neb.

New England Division
PERCY C. NOBLE W1BVR
37 Broad St., Westfield, Mass.
Alternate: Clayton C. Gordon W1HRC
70 Columbia Ave., Warwick, R. I.

Northwestern Division
KARL W. WEINGARTEN W7BQ
3219 N. 24th St., Tacoma 7, Wash.
Alternate: R. Rex Roberts W7CFY
110 W. Brennan St., Glendive, Mont.

Pacific Division
J. L. McCARGAR W6EY
66 Hamilton Pl., Oakland 12, Calif.
Alternate: Elbert J. Amarantes W6FBW
1675 Dale Ave., San Jose, Calif.

Roanoke Division
H. L. CAVENESS W4DW
2607 Vanderbilt Ave., Raleigh, N. C.
Alternate: J. Frank Key W3ZA
Box 707, Buena Vista, Va.

Rocky Mountain Division
C. RAYMOND STEDMAN W9CAA
925 So. Gaylord St., Denver 9
Alternate: Willard C. Wright W9BQO
Box 891, Denver

Southeastern Division
WILLIAM C. SHELTON W4ASR
527 Revillo Blvd., Daytona Beach, Fla.
Alternate: William P. Sides W4AUP
Fleming Road, Montgomery, Ala.

Southwestern Division
JOHN E. BICKEL W6BKY
1834 E. Whittier Blvd., Whittier, Calif.
Alternate: Eldridge E. Wyatt, Jr. W6ARW
5291 E. Broadway, Long Beach, Calif.

West Gulf Division
WAYLAND M. GROVES W5NW
% Humble Pipe Line Co., Hawkins, Texas
Alternate: Jennings R. Poston W5AJ
Box 246, Mabank, Texas

"IT SEEMS TO US—"

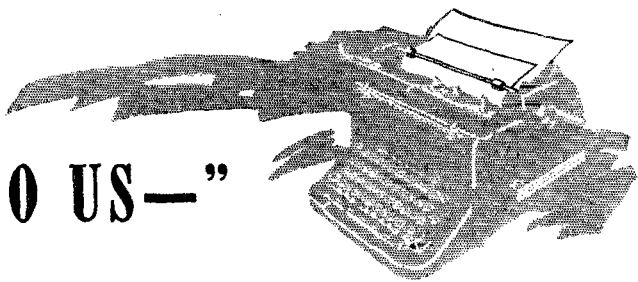

QRD

AROUND the United Nations, and particularly in the United States, there is now increasing talk of the need for planning the postwar future of the radio art to get the maximum benefit from war-born advances. In fact, elsewhere in this issue we report the preliminary organization of one such U. S. planning group, one in which ARRL will act as both a sponsor and a participant. Thus we approach the first small steps on the way back to the resumption of peacetime amateur operating.

As these various studies get under way, we can safely assume that it will be demonstrable that the radio amateur has richly repaid his country for his privileges to date. But it seems to us that the time is arriving when we shall need also to formulate a more complete statement of the eventual objectives of organized amateur radio than we have had in the past. In short, we need something that gives the sailing course for a planned future for amateur radio as an institution. How should we state our aims, our policy? It is a subject on which we should like to invite the reactions of the members of the League.

It is our thought that we shall need some such bright shield, partly to give ourselves guidance, partly to have something to hold up before the world that will commend itself to the minds of legislators and administrators and to the enlightened self-interest of the other segments of the radio community. Where are we going with this art? What is our ultimate intention, as the possessors of the only right accorded the private citizen to engage in private communication? As we see it, we owe it to ourselves to state our principles in terms that far transcend the transitory individual pleasures of pursuing a hobby—which is only the superficial aspect of amateur radio. True, in the brave new world of the future the pursuit of happiness, in the highest sense of that phrase, is, we understand, to be an important ingredient. We are to expect a world with heavy accent on the merit of those intellectual, cultural and plain-amusement things that contribute to the happiness of life. Of course, amateur radio is distinctly one of those things. But we suspect that it is also going to be a hard-headed world, and the radio part of it probably still will be marked by

greed and disfigured by business dog-fights. Unquestionably the radio amateur will have to continue to earn his salt: he must recompense society for letting him pursue his art. ¶

So we propose that we now engage in some self-examination. We at ARRL headquarters have been proud of and reasonably content with the aims and standards of our kind of amateur radio. We have been able to point at the collateral advantages to the nation that flow from this pursuit of a hobby; as, for example, in supplying a reserve of trained operators and technicians for military and industrial needs, in our contributions to the technique, in our constant preparedness to render emergency service. Do these things constitute a sufficient philosophy for the future? We think they do, but we are not entirely sure.

In any such attempt to get down to fundamentals in our thinking, we are inevitably led to examine the definition of an amateur. Both by world treaty and in our own regulations he is defined as a person with a non-pecuniary interest in the *technique* of radio. It is worth noting that in England, for example, the amateur *must* undertake experimental work. In this country we have tended toward simpler qualifying examinations and have done many things that encourage mere operation of a station to the dereliction of individual technical growth or of experimental work. We find it difficult to determine whether this is a weakness or a source of great strength. In this country we always have had additional operating rights not enjoyed by amateurs of other countries; and it has been in our thoughts that, as a result, the American amateur was a better-rounded amateur, and that our traffic-handling skill and our capabilities in emergencies were among the strongest justifications for our existence. Nonetheless, we suggest that in any soul-searching in which we now engage it would be the part of self-interest to re-study the relative emphasis which should be given operating matters and technical matters in the specifications for the postwar amateur. We all know that in the past we have had many amateurs who have had neither interest nor ability in the technical side but who were perfectly content to buy a transmitter and receiver and simply operate them for the pleasures of communicating.

American hams on the average are the best operators in the world — and many of them qualify as the worst informed. We have laid considerable store on building a reservoir of skilled operators. Of course this is very desirable, if it can be done in addition to advancing ourselves in technical proficiency and at no expense to our group security, but in our plans for the future are we sure that will prove to be on the right track? It could be pointed out, for instance, that in almost any other country such a situation would not be tolerated, for there the amateur is primarily an investigator of the technique. When amateur radio is criticized in this country as a useless employment of frequencies, the critics claim that our fellows are merely conversing to amuse themselves and are contributing nothing and learning nothing; or that our traffic activities are an improper and unintended utilitarian expansion of the amateur franchise. Our critics do not appreciate as readily as you and we the fundamental truth of these matters: that these things are the raw material of training, and that an amateur, by tinkering his station to where it got out well and by learning to work through the world's worst QRM, was, despite

these inanities, developing personal skill both in the technique and in operating. And operating has other justifications: its contributions to international amity and domestic friendships, its educational value, the good that attaches to any morally healthful avocation. Even the puerile ragchewing was largely an outlet for people otherwise intellectually starved. But we must also look to the criticisms and ask ourselves whether the old pattern will be a sufficiently persuasive philosophy for our future in a world where there is going to be tremendous pressure for frequencies.

This whole subject of postwar planning is, admittedly, a complex one. Involved in it also are many questions of internal organization and policy. But these come in the second phase; the first phase is the campaign for restoring amateur radio to active status as soon as possible after the war shall end.

It is that phase we are concerned with now. It has many ramifications, of which the above is, to our mind, one of first importance. What do *you* think about it? Our correspondence columns are open for discussion of this and other aspects of our postwar rehabilitation.

K. B. W.

★ SPLATTER ★

OUR COVER

THE March of the Megacycles" might be one title for this month's cover. Or something might be worked out about "The Orbit of the Octaves," or possibly "The Dashing Decades" — or even "The Beat of the Bands." . . .

Before this goes too far, let it be said that the idea (as we hope you've guessed) is to create an impression of the amateur frequency bands marching in octaves up the spectrum to the future. Conventional coils convey us from 1.7 Mc. up to 30 Mc., whereupon coaxial and parallel resonators take us up to the ultrahighs. There, on the border of the unknown, we approach the realm of the (to stay-at-home hams, at least) still-esoteric hollow wave guide and its ilk.

Sort of a postwar phantasy — if you want to take it that way.

... —

FOOTNOTES

WITH one exception, each of the non-staff contributors to this issue qualifies as a bona fide old timer. We might even claim a perfect showing by disqualifying the "exception" on a technicality; as yet he's a ham in name only, having been licensed post-Pearl Harbor.

Anyway, to get down to business, this month we welcome back to *QST*'s pages an old friend — William A. Adams, W6ANN — "Annie" to most of the boys on most of the bands since that other wartime close-down. You may remember

him as the western terminus (Atwater, 2JN, was on the eastern end) of the first transcontinental contact on 10 meters back in 1928. He turned in a superb performance during the 1932 Southern California earthquake emergency, too, constituting himself practically an entire national relay network on 14 Mc. Recent years have seen "Annie's" interests concentrated almost entirely on the very-highs, especially on 112 Mc. That's a subject he tells more about in his story on WERS frequency measurement (p. 30). . . . The newcomer — both to *QST* and to the air — mentioned above is Frederick M. Burkle. He became interested in radio four years ago, simultaneously with buying his first copy of *QST*. He's been reading it ever since, too, apparently with no ill effects — except that it has kept that radiobug infection alive. Following plenty of home study and an ESMWT course at Yale University, he went up for his Class B exam in August and received his ticket September 25th. Meanwhile he'd been active in the Hamden WERS system from the beginning, not only as an operator but in helping with the original installations and building gear (as per p. 23). Right now radio is only a hobby with him — his job is in the information department of the Southern New England Telephone Co., to which he transferred from the engineering department — but sooner or later he hopes to make radio his life work. . . .

A. D. Mayo, W4CBD, became a ham almost exactly twenty years ago. He was just 13 then, and his call was 5DF. The W4CBD tag was assigned in 1932, a year before he graduated from Alabama Polytech as a chemical engineer. The

(Continued on page 84)

CD-WERS, 1944 Style

A Modern Mobile Emergency Transmitter-Receiver

BY **FREDERICK A. LONG,* EX-W8NE, EX-W8BSL**

This article describes a mobile unit which can be mounted conveniently in practically any automobile. The unit is complete in itself and requires nothing more than an antenna and the primary source of power. It is flexible in control and in application to mobile-, portable- or fixed-station use. Many of the supply problems of wartime construction have been solved by the author's ingenuity.

THE advancement of the art of emergency communication within the War Emergency Radio Service presents to the amateur a challenge differing in many respects from any he has met heretofore. True, he has served adequately in local emergencies under serious handicaps many times over, with solid credit to our avocation. Emergency service for the duration of the war is quite another matter, however, and WERS is giving him the first real opportunity to handle such an assignment.

Generally, in meeting past emergencies, he taped a discarded dipole to the car window frame, threw an experimental bread-board rig into the back seat, and tapped the car battery or car radio for power. Then, enlisting the wife as driver, he set off in a cloud of dust, hoping to Marconi that the darn thing would work if and when he got there. Thanks to ham ingenuity, usually it did work. That, however, was the year before last — or the year before the year before that. Now we have an emergency every day and all day. WERS operators live like firemen, waiting for the siren twenty-four hours a day. This business of putting-it-in, taking-it-out, putting it in again and taking it out again eventually brings signs of wear and tear on the car as well as on the gear. After the fifth month and forty-seventh alert, this creates in the soul of the operator an awful pall of boredom, not to mention the oft-repeated comments of the wife on those blankety-blank

gadgets continually cluttering up the car. No, the days of haywire hops are dead and gone. The 1944 CD-WERS mobile rig needs to be an integral part of the car's equipment, ready to go on ten seconds' notice.

The present WNYJ-66 rig is designed for WERS and modern mobile emergency-service conditions. The transmitter, receiver and power supply are constructed as a single unit. The only extra items of equipment needed are the antenna and a source of primary power. A.c. or d.c. power may be used interchangeably. Operation may be mobile, portable, or at a fixed location. The rig is "push-to-talk" controlled. All control is from the panel, which measures 4 × 12 inches and is the only part in sight when installed under the cowl of the car. The part that is out of sight is equally compact: 10 × 12 × 8 inches. With fourteen watts input, furnishing seven watts of 90 per cent modulated carrier output, the rig can work anything the receiver can bring in. It is not critical with respect to antennas; almost any sort can be coupled to it, with approximately the same degree of efficiency. The modified "J" discussed later does, however, seem to have a slight edge in performance, when fed with a good 80-ohm coaxial line. The rig is not difficult to construct or to get into operation. There are no trick circuits, although careful planning of the layout is

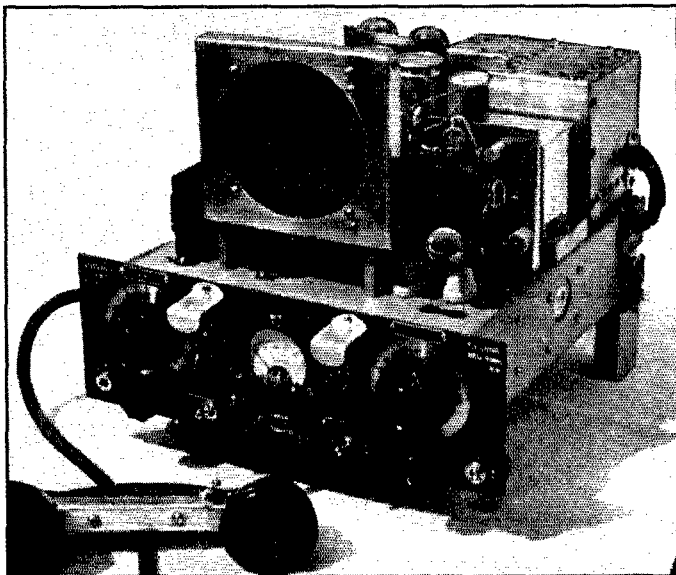

The WNYJ-66 mobile transmitter-receiver, showing panel arrangement and mounting supports for installation under the cowl. Location of the speaker will be determined by the placement of the grill on the car instrument panel.

*46-41 Forest Drive, Douglaston, L. I., N. Y. Borough Radio Coordinator, Queens County.

essential. Rubber-cushioned mountings are provided where needed. Thus we have compactness, adequate power, and flexibility. Approximately one watt of power is delivered to the antenna for every tenth of a cubic foot of space in the unit — and that's with the power supply and receiver being counted in for good measure.

At about this point I hear a voice saying, "Oh, well, sure — if you have a hundred bucks and can get all the parts you want, to say nothing of priorities, then anybody can do it!" Well, brother, this rig was built just like you built yours. I didn't even have any power tools available, beyond a borrowed drill press. No hundred

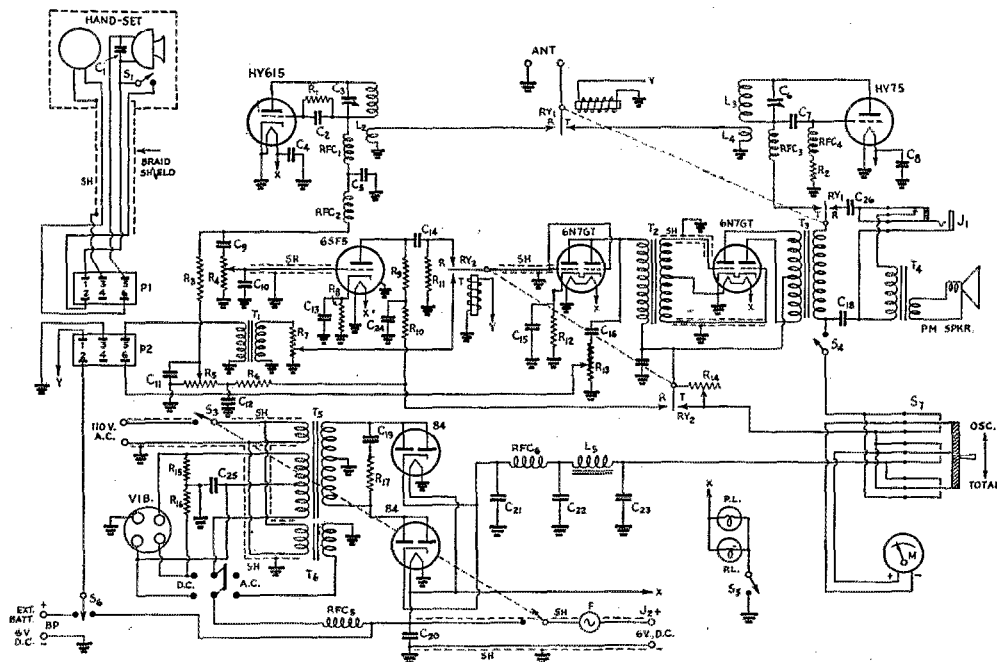

Fig. 1. — Wiring diagram of the WNYJ-66 WERS mobile transmitter-receiver unit.

- C₁ — By-pass condenser in handset (approx. 0.0001 μ f.d.; see text).
- C₂ — 50- μ f.d. mica.
- C₃ — 8- μ f.d. ceramic midget variable.
- C₄ — 0.05- μ f.d. paper, 400 volts.
- C₅, C₈, C₉ — 0.01- μ f.d. paper, 400 volts.
- C₆ — 35- μ f.d. doubled-spaced ceramic midget variable.
- C₇, C₁₀ — 100- μ f.d. mica.
- C₁₁, C₁₆ — 0.1- μ f.d. paper, 400 volts.
- C₁₂, C₁₇ — 8- μ f.d. electrolytic, 450 volts.
- C₁₃ — 5- μ f.d. electrolytic, 25 volts.
- C₁₄ — 0.03- μ f.d. paper, 400 volts.
- C₁₅ — 25- μ f.d. electrolytic, 25 volts.
- C₁₈, C₂₈ — 0.002- μ f.d. paper, 400 volts.
- C₁₉ — 0.008- μ f.d. paper, 1600 volts.
- C₂₀ — 0.5- μ f.d. paper, 400 volts.
- C₂₁ — 1- μ f.d. paper, 600 volts.
- C₂₃ — 8- μ f.d. electrolytic, 500 volts.
- C₂₅ — 16- μ f.d. electrolytic, 475 volts.
- C₂₄ — 4- μ f.d. electrolytic, 450 volts.
- C₂₆ — 5- μ f.d. electrolytic, 50 volts.
- R₁ — 5 megohms.
- R₂ — 3500 ohms, 10-watt.
- R₃ — 25,000 ohms, 1-watt.
- R₄ — 0.5-megohm potentiometer.
- R₅ — 75,000-ohm wire-wound potentiometer.

- R₆ — 50,000 ohms, 2-watt.
- R₇ — 0.1-megohm potentiometer.
- R₈ — 1300 ohms, 1-watt.
- R₉, R₁₁ — 0.1 megohm, 1-watt.
- R₁₀ — 50,000 ohms, 1-watt.
- R₁₂ — 900 ohms, 1-watt.
- R₁₃ — 50,000-ohm potentiometer.
- R₁₄ — 7500 ohms, 25-watt.
- R₁₅, R₁₆ — 50 ohms, 2-watt.
- R₁₇ — 5000 ohms, 2-watt.
- RFC₁, RFC₃, RFC₄ — v.h.f. choke (Ohmite Z-1)
- RFC₂ — 80-mh. r.f. choke
- RFC₅ — 40 turns No. 14 enameled, $\frac{1}{2}$ -inch diameter, wound in 2 layers.
- RFC₆ — 10-mh. r.f. choke.
- RY₁ — D.p.d.t. 6-volt d.c. relay (good insulation).
- RY₂ — D.p.d.t. 6-volt d.c. relay.
- T₁ — Microphone transformer (Thordarson T-86AO2 or equivalent).
- T₂ — Driver transformer (UTC S8 or equivalent).
- T₃ — Modulation transformer (UTC CS24 or equivalent).
- T₄ — Speaker transformer, 4000-ohm input.
- T₅ — Plate transformer, 6-volt d.c. and 115 volt a.c. primaries, 400-volt center-tapped 150-ma., or 300-volt center-tapped 200-ma., secondary.
- T₆ — Filament transformer, 115-

- volt a.c. primary, 6.3-volt a.c. secondary, 50 watts.
- SH — Flexible braid shielding.
- P₁ — Female plug, 6 contacts.
- P₂ — Male socket, 6 contacts.
- J₁ — 4-spring jack.
- J₂ — Heavy-duty banana jack.
- BP — Binding posts.
- S₁, S₄, S₅ — S.p.s.t. toggle switch.
- S₂ — D.p.d.t. toggle switch.
- S₃ — D.p.s.t. toggle switch.
- S₆ — S.p.d.t. toggle switch.
- S₇ — 3-p.d.t. anti-capacity switch.
- PL — Dial light.
- M — 0.200-ma. milliammeter.
- L₁ — 4 turns No. 12 tinned, $\frac{1}{2}$ inch diameter, turns spaced to hit band (about $\frac{1}{8}$ inch).
- L₂ — Swinging pick-up coil, 2 turns No. 12, $\frac{1}{2}$ -inch diameter, spaced only to separate turns.
- L₃ — 2 turns $\frac{1}{8}$ -inch copper tubing or No. 10 wire, $\frac{3}{4}$ -inch diameter, spaced $\frac{3}{8}$ -inch between turns.
- L₄ — Swinging pick-up coil, 2 turns No. 12, $\frac{3}{4}$ -inch diameter, turns spaced half diameter of wire.
- L₅ — 4 to 10 henries, 150 ma.
- SPKR — 5-inch permanent-magnet speaker.
- VIB — Vibrator (Mallory No. 825 or equivalent).
- F — 6-volt 30-ampere fuse.

bucks, no pre-war source of supply, no priorities, no pull! The parts came from friends, bargain counters, junk boxes, and an old b.c. receiver.

To make the vibrator transformer, for example, the power transformer from that old b.c. receiver was rewound turns-per-volt by turns-per-volt, squeezing the core in a vice for easy removal and re-insertion. The shields, boxes and all, were formed from discarded aluminum-base acetate transcription discs. If you have a friend in the right place at a broadcast station, you can probably talk him out of the two or three required; if not, you can make out with the metal from big tin cans, or even galvanized iron or flashing from the hardware store. Incidentally, if you can get the discs, the acetate can be peeled off by soaking for 10 minutes in boiling water, then scraping the edge off with a knife. After running the edge of the knife halfway around under the film, lift it and peel off in one sheet.

If you haven't the two d.p.d.t. relays on hand, they can be built up with solenoids from buzzers or door bells, using clock-spring leaves and contacts made from old silver spoons. (They do say it's agin the law to use a thin dime!). Relays designed for 5-volt operation perform better on the 6-volt supply in mobile service. They have more "snap," and the springs can be tightened to avoid chatter from car vibration. It is a good plan to mount relays on end, or upside down. In those positions the moving contacts are aided both by gravity and by spring tension, in the receiving position. In the transmit position there is usually less trouble with chattering of contacts.

The mike transformer was on hand, but it doesn't work a bit better than one in an earlier rig made from an old 3:1 replacement audio transformer with about 50 turns of No. 36 wire wound over the secondary. There wasn't room for both a 6-volt primary and a 6-volt secondary on the core, so a filament transformer was re-wound from an old toy train transformer. No modulation transformer available? Then use choke modulation.

It is true that, at 112 Mc., rubber insulation isn't as good in a coaxial line as polystyrene, but we aren't looking for DX in WERS. Sure contacts over short distances will result from the use of a coaxial line made of automobile high-tension wire with shield braid drawn over it, if it is wrapped with friction tape and given a coat of varnish to keep the weather out. Of course, you could use glass beads from the dime store for insulators and make up a better cable.

Actually, there is plenty of equipment available for WERS unit construction, if an effort is made to search it out and a bit of ingenuity exercised to adapt what is available to the need at hand. WERS builders need to recapture the spirit of hams of the 1915-1922 era. Remember the drilled marble base for the lightning switch, the graphite pencil-mark grid leaks, the contact points on the loosecoupler filed down from 8-32 brass machine screws, the typewriter knobs for controls, the transmitting condensers built up from photographic plates covered with shellacked tin-foil? Then almost anything needed was built up with limited hand-operated tools from commonly available materials. To-day, despite wartime shortages, we have much greater quantities of both new and used parts available, and most of the materials are easily adaptable to our specific needs. What did they have that we haven't got?

Circuit Details

Now, while that soldering-iron is getting hot, take a look at Fig. 1. WNYJ-66 uses a common Class-A audio driver and transmitter modulator, but the HY 615 detector output is fed into its own first audio stage, a 6SF5. In this way provision is made for separate volume controls for the receiver and modulator circuits, and the HY-615 output is stepped up to drive the 6N7 Class-A stage with "zip" to ensure good receiver performance. A 7500-ohm 25 watt variable dropping resistor, R_{14} , in the audio high-voltage line is adjusted so that the voltage will be the same regardless of whether the supply is switched to

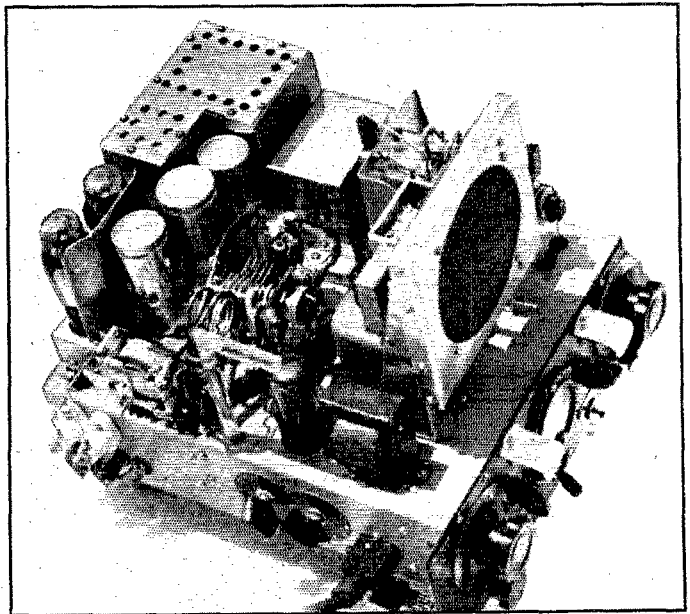

Top and left side of WNYJ-66 mobile chassis. The receiver tank pick-up coil is connected to the antenna change-over relay by means of a short piece of flexible coaxial cable. Insulated terminals for the feed line and binding posts for an external relay battery appear at left rear, and volume controls for mike and hand set are placed near the hand set plug. Note shielding of rectifier tubes and the rubber-mounted can housing the vibrator and power transformer.

the transmitter or the receiver. The audio voltage should be exactly 300. Excess voltage can be taken care of by the insertion of an additional 1500-ohm 25-watt variable dropping resistor (not shown in the diagram) at the input end of the audio high-voltage line. By this means, conditions are provided under which the Class-B modulator will deliver a full and consistent 10 watts of audio. The detector regeneration control is through the 75,000-ohm wire-wound potentiometer, R_6 .

Careful attention to the handset portion of the diagram will indicate the changes required in the normal handset circuit, including the control of the two d.p.d.t. relays from the "push-to-talk" switch, S_1 . The by-pass condenser, C_1 , is already installed in some handsets. It is not required in this circuit, but may well be left as it is. The 50,000-ohm potentiometer, R_{13} , enables the operator to adjust the volume in the handset headphone without disturbing the level of the speaker input. The antenna-switching section of the relay, R_{y1} , should be provided with the best r.f. insulation obtainable. The 3-p.d.t. anti-capacity switch, S_7 , shunts either the oscillator current alone or the combined oscillator-modulator current through the 0-200 ma. d.c. meter.

Two 84s with the elements of each paralleled are connected as a full-wave rectifier to pass the relatively heavy current required. If a power transformer with specifications differing from those given for T_5 is used, some experimenting may be necessary to determine the value of the buffer condenser, C_{19} . Compactness is achieved in the filament choke, RFC_5 , by winding the No. 14 enameled wire in two layers on a wooden dowel.

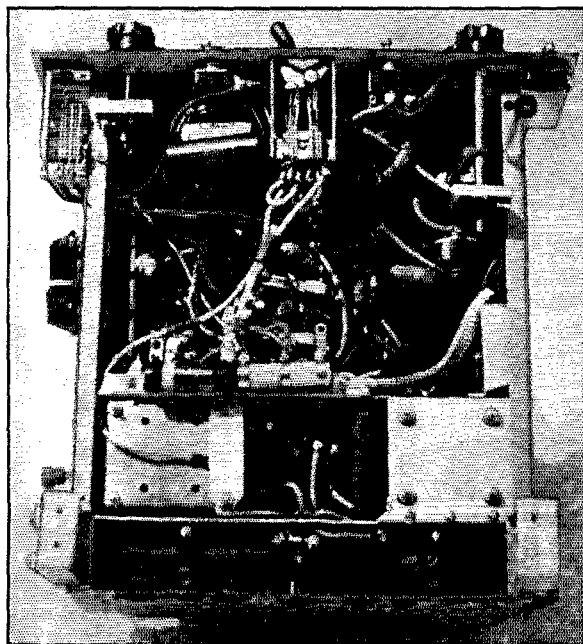

Sub-chassis arrangement of the WNYJ-66 mobile unit. Crowding was necessary to mount the essential parts. Point-to-point wiring was used, even though it meant sacrificing appearance for efficiency.

The 'phone jack, J_1 , enables a second operator to monitor the receiver under conditions that make speaker operation impracticable. More important is the fact that it provides headphone operation for the operator while monitoring weak signals, when external local noise must be excluded and more privacy is required. The handset receiver operates on both transmit and receive, to allow the operator to check continuously on the speech input and to provide sidetone.

The wiring generally is by the "straight-line-shortest-distance" method.

If substitutions are made for the tubes indicated, appropriate circuit changes must be made in accordance with tube characteristics.

The details of layout and construction of WNYJ-66 should be apparent from the pictures (which, incidentally, were made by W2DTE). For the sake of appearance the bakelite panel was rubbed down with steel wool and lettered with a pen and white paint. On it, from left to right, appear the transmitter tank tuning dial, regeneration control, milliammeter, audio volume control and receiver tuning dial. Below, from left to right, are the 'phone jack, transmitter vernier-tuning knob, transmitter high-voltage switch, meter switch, power switch, receiver-tuning vernier and pilot-light switch. The two small shields above the regeneration control and volume controls are the shades for the red pilot lights which illuminate the controls. (Red is used to comply with black-out regulations current in New York City.)

Since the microphone volume control and the handset receiver volume control, once set, usually are left alone, they are placed on the left side of the chassis just back of the handset plug. Also on this side of the chassis are the terminal-insulator mounts for the feed line and the binding posts for the four No. 6 dry cells in series or 6-volt storage battery used as the external relay battery when operating on a.c. On the other side of the chassis are the a.c. input socket and the d.c. input jack. There is nothing on the back of the chassis except holes for ventilation. These would not be required were it not that it was necessary to install series-dropping resistors in the primary of the plate transformer, which originally was designed to be used in series with another transformer, each having a 55-volt primary.

Looking down on the top of the chassis, along the back edge from left to right, are the relay-battery change-over switch, the 84 rectifier tubes, and the shield can holding the vibrator and power transformer. This can is insulated from the chassis by its rubber-grommet mounting, as shown in Fig. 2. A single ground is brought from the can to the chassis, through a flexible braided shield which houses all the wires from the unit to the chassis, on the right side. In front of the rectifiers are the antenna and high-voltage change-over relay, and the

power-supply filter condensers. The power-supply filter choke, r.f. choke and condenser, filament transformer, 6-volt input r.f. choke and condenser, fuse block, and a.c.-d.c. change-over switch all are mounted beneath the chassis, under

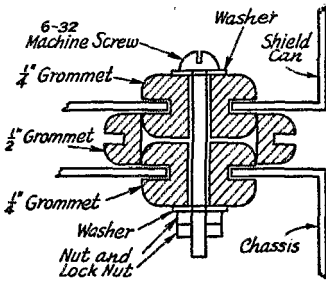

Fig. 2 — Method of using rubber grommets to provide cushioned mounting for the vibrator-transformer shield can.

the rest of the power supply, separated from the rest of the unit by a transverse shield. It takes careful planning to get them all in there, but it can be done.

In front of the filter condensers on top of the chassis is the transmitter tank, and to its right the HY-75 and the modulation transformer. The L-shaped Lucite rod appearing at the left is the support for the transmitter tank pick-up coil. It is spring-tension mounted with a bolt through the chassis. The horizontal arm at the top enables the operator to make adjustments with a minimum of hand capacity. The same type of mounting is used for the receiver tank pick-up, except that it is horizontally mounted and a pointer knob takes the place of the Lucite handle. Later experience indicates that the receiver coupling would have been better controlled if supplied with a Lucite extension handle in place of the pointer knob, like the transmitter coupling. In front of the modulation transformer is the shield housing the receiver tank and component parts, including the HY-615. Just outside this unit, to the left, is the 6N7 Class-B modulator, with the 6SF5 first audio tube in front of it. Again to the left is the driver transformer, and, further left, the 6N7 triode-connected Class-A driver tube, with the microphone transformer in front of it. The p.m. speaker mounting completes the layout on the top of the chassis.

The audio d.p.d.t. relay mounts conveniently under the chassis, along with the remaining incidental components. I found one or two cautions advisable in construction: keep all r.f. components, transmitting and receiving, well insulated and separated as far as practicable from the chassis and near-by grounds; keep all a.c. leads well shielded and as far as possible from the r.f. Ceramics and Lucite were used for insulation in this rig. If you cannot get Lucite in any other form, you will find it in drug stores in the form of cosmetic boxes, in brushes and combs, and in tooth brushes. This is an expensive way in which to acquire it, to be sure, but not much of this grade of insulation is required.

The two tank tuning condensers are belt driven from sub-chassis shafts terminating at the positions desired for panel controls. The verniers are sub-shafts driving the other sub-shafts. All are cut from towel rods, obtained from the dime store all chromium-plated and everything. Pulleys are used to reduce the drive ratio to 4 to 1 on the main dials, with another 4 to 1 on the vernier knobs. If you can't find pulleys of proper dimensions, they can be turned out on a borrowed lathe; or you might just possibly be able to trade the price of a movie for some pulleys from Junior's Erector set. The pulleys should be provided with a spring for tension, even if you have to make the spring. You can get a piece of piano wire from your piano tuner for the springs. Use a good grade of fish-line for belts. Do not use a cheap line that will soak up moisture; if your pulleys are metal, they will be hot with respect to the grid in both tanks.

The unit is mounted under the cowl at the center of the instrument panel, with only its panel extending below. This brings the speaker directly behind the grill provided for a car radio, which I do not have. The rubber-mounted legs on the back of the chassis rest on L-shaped angle brackets bolted to the fire-wall. The front is supported by rubber-mounted brackets on the chassis, suspending the unit from the instrument panel itself. These brackets are not shown in the pictures.

The Antenna

The choice of a practical, inexpensive antenna for mobile use required much time and effort in comparison and experiment. The modified version of the "J" finally developed owes much to helpful suggestions from W2GZO. Substantially, this antenna is an end-fed half-wave dipole with a "Q" section matching it to a low-impedance line.

Fig. 3 — Modified "J" antenna. No shorting bar and no adjustments are required. Leads from the coaxial line are connected directly to the ends of the antenna elements. It is not the intention of the drawing to indicate a delta match. The dimensions given are for a frequency of 115.4 Mc., but the antenna gives satisfactory performance over the entire 112-116-Mc. WERS band.

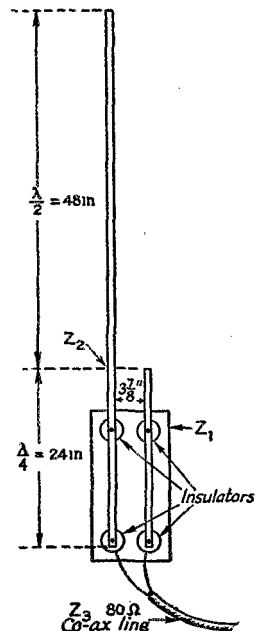

Very sketchy information concerning the impedance at the ends of any given dipole did not restrain us from going ahead.

On reasonably good authority, an arbitrary impedance of 2000 ohms was assumed for the input end of the dipole. On this assumption, we applied the impedance-matching transformer formula, $Z_1 = \sqrt{Z_2 Z_3}$. The dimensions used for a frequency of 115.4 Mc. are as indicated in the sketch, Fig. 3. It is only necessary to cut the elements to the lengths specified in the ARRL *Handbook*, mount them, hook on the feeders, and adjust the tank pick-up coil for optimum radiation. You can miss the measurements as much as an inch either way without serious practical effect. The antenna is extremely simple in construction and mounting, and, in the experience of this writer, out-performs all the other simple antennas.

If you can get it, use a good coaxial line, of course. It will certainly improve operation. However, the antenna will work fairly well if fed by twisted pair. Just be certain that you have the same wire in the pair attached to both the short element and to the ground at the transmitter. By the way, if you can't get auto whip antennas or hard-drawn copper tubing for the elements, you'll find that the copper-washed steel gasoline lines available by the linear foot at automotive supply stores or garages make good inexpensive antenna material. The 5/16-inch diameter size is about right. Give it a coat of clear Duco, lacquer, or even shellac, so that it won't rust after it is installed.

The Frequency Meter

The frequency meter is a simple absorption type designed with a high capacity-to-inductance ratio to give good Q , large surface on the inductance for pick-up purposes, mechanical rigidity, and broadening of tuning by the use of shunt capacities across the variable capacity to get the degree of bandsread desired. It seems to work better when using variable capacity alone, but when built this way it must be used very carefully because of its sharp tuning. Probably a vernier dial would be better than the electrical bandsread, but I haven't tried it this way. If the insulation is good and the unit is mechanically rigid, it will hold its calibration well enough for

WERS applications. The strap (really an external plate for the neon bulb) was installed to make the operation of the bulb more critical. It helps to indicate resonance sharply and to reduce the capacity between the elements. When you do this you have such negligible capacity in the neon-bulb circuit that bulbs can be changed without apparent effect upon calibration. In fact, I have changed from $\frac{1}{4}$ -watt to $\frac{1}{10}$ -watt bulbs without any apparent effect, except that the $\frac{1}{10}$ -watt is more sensitive. The ignition point of either seems to be low enough for satisfactory operation.

Once the bulb has been ionized, it is quite sensitive. With the half-wave antenna (the modified "J") radiating about 5 watts of carrier, I have been able to keep the neon glowing as much as two wavelengths away. Under these conditions the little unit also performs as a simple field-strength meter, and it is useful for determining optimum coupling between the transmitter tank and its pick-up coil. Likewise, if you are careful in your orientation of the inductance to the feed-line you can run it up and down and "see" your standing waves. For lower-power rigs an even smaller neon bulb could be used, but be careful not to burn it out. Of course, the unit will work without neon glow for frequency checking purposes by watching the oscillator plate current for the resonance dip, or, better still, the same procedure in conjunction with a field strength meter. Probably the unit could be made more sensitive by putting a half-wave antenna on it, but I haven't got that far yet.

There are no mechanical problems. The only things to watch in construction are good insulation (I used ceramic and silver-mica condensers) and mechanical rigidity. An insulated shaft coupling should be used on the variable condenser.

Let me say again, in winding up this story, that there is no reason why our WERS equipment should not be professional both in operation and in appearance. The current dearth of tailor-made gear should not stop us. The ham ingenuity for which the amateur fraternity is justly famous can make us all proud of the gang, proud of the gear, and proud of the results. The latter will further justify favorable consideration of amateur radio by the powers-that-be, when this war is over.

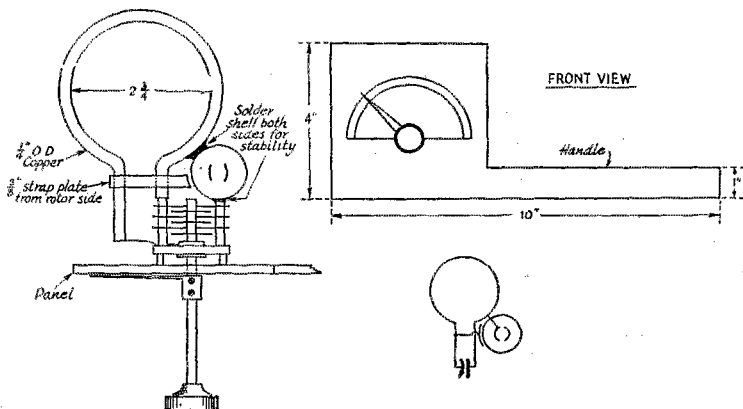

Fig. 4 — Absorption-type frequency meter with $\frac{1}{10}$ -watt to $\frac{1}{4}$ -watt neon-tube indicator, used for checking WERS equipment. The $\frac{3}{8}$ -inch strap soldered to the rotor side of the one-turn copper-tubing coil is bent up around the envelope of the neon tube, with a separation of about $\frac{1}{8}$ inch. If the meter appears to tune too sharply, a 5- μ fd. variable condenser, shunted with a zero-coefficient mica condenser of appropriate capacity, may be substituted. A bakelite extension of a length as great as practicable is used on the condenser shaft.

Astronomy and Amateur Radio

Hitch Your Hobby to a Star

BY HOLLIS M. FRENCH,* WIJLK

RADIO development has entered a stage in which the amateur experimenter of necessity must become an amateur in other vitally related earth and sky sciences. He must learn to understand and use new tools and apparatus in order to make the most effective use of the very-high and higher frequencies. The factors which govern weather and the electromagnetic field of the earth — astronomical, meteorological and topographical — as well as conditions in the ionosphere and in the upper and lower troposphere all serve to determine the range of communications just as definitely as do power input, circuit efficiency or mechanical design of transmitting and receiving components. After the last war, the radio amateur conquered the oceans; after this war, he will explore and master the "ocean of air" in which so much of our power was wasted in other years. Now, while wartime restrictions hold ordinary "hamming" in abeyance, is the time to study the sciences of astronomy and aërology for their bearing upon communications.

Radio is not strictly a terrestrial art. With advancing knowledge, ever closer relations appear between the science of astronomy and the art of radio communication. These are more evident as we pass the limitations of the old astronomy of position and enter the fascinating field of astrophysics, where *radiation* becomes the foundation of the science. Leaders in the field of research, such as the Radiation Laboratory of the Massachusetts Institute of Technology, today employ astronomers and radio engineers alike among their physicists engaged in the investigation of the general field of radiation and its manifold applications to the service of man. In many projects, the astronomer and the radio engineer must work closely on the same problem.

In the study of the propagation of waves, for instance, we find ourselves in a field where a thorough understanding of astrophysics is required to understand observed effects. The sun

* Asst. Technical Editor, QST.

is a star, and certain aspects of the behavior of radio waves in the earth's ionosphere are functions of activities taking place within and upon the surface of this star. The earth's satellite moon likewise has been accused of complicity in the changing patterns of wave propagation. We may well disregard "signals from Mars" or hypothetical influences reaching us from distant stars, but the amateur will be better informed about where his signals are going, and why, if he is willing to look into a few topics of practical astronomy.

We leave for treatment in a later article the influences of the sun upon radio transmissions in the very-high, ultrahigh and super-high frequencies through variations in temperature, humidity and gradients of pressure in the lower atmosphere. The resulting discontinuities between adjacent air masses are potent factors governing communications, but their discussion properly belongs in the science of aërology rather than astronomy. The tidal or gravitational effects of both sun and moon may be considered as belonging to either science or both.

Solar Radiation and the Ionosphere

We examine first, therefore, the direct influences of solar radiation upon the earth's ionosphere. There are daily, seasonal and long-period variations of a cyclic nature which affect distant reception of all radio-frequencies and which are directly attributable to solar radiation. The more familiar of these phenomena are the daylight-to-dark shifts of transmitting range and the summer-to-winter variations. Both of these effects we understand to be related to the position of the sun with respect to the observer's horizon. Similar effects, differing from the solar influences in degree and in period, have been traced by H. T. Stetson¹ to the position of the moon in the ob-

¹ H. T. Stetson, "On the Correlation of Radio Reception with the Moon's Position in the Observer's Sky," *Perkins Observatory Miscellaneous Scientific Papers*, Reprint No. 8, about 1932.

Many radio amateurs, like the late Ross A. Hull, have included amateur astronomy in their hobby interests. This article points out ways in which astronomy serves the advancement of radio. Succeeding articles on "Aërology and V.H.F. Wave Propagation" and "The Influence of Topography on V.H.F.-to-S.H.F. Communications" will further demonstrate the importance of a knowledge of these related sciences to the radio communications art, and will discuss the construction and use of instruments for research and experiment such as the barometer, psychrometer, anemometer, resistance-type thermometer and hygrometer, recording devices, the pilot balloon and all the interesting "radiosonde" gear used in soundings of the lower atmosphere. Other new tools which will be suggested for the radio amateur's use include contour maps, the level and theodolite — all strange gadgets to practitioners of the mike and key, perhaps, but definitely useful in adapting ourselves to present-day and probable future developments in amateur communications.

server's sky. One explanation of these phenomena postulates electrostatic fields for sun, moon and earth, with interaction governed by mutual potential differences. A proved hypothesis applying only to solar influences is that of the ionization of distinct atmospheric layers of differing densities.

We may consider the sun to be an enormous transmitter, with self-contained power supply, which radiates energy over a broad band of wavelengths of an order of magnitude so small that, instead of measuring them in meters and centimeters as we do radio waves, a special unit called the *angstrom* is applied. This unit has a value of about one ten-millionth of a millimeter. The solar band of wavelengths includes heat rays, light rays, ultraviolet rays, X-rays, gamma rays, and other rays of yet shorter wavelengths, some of which are of lethal character. Fortunately for life upon the earth, rays shorter than about 2900 angstroms are filtered out before reaching the surface of the earth by a transformation in the upper atmosphere brought about by the ultraviolet portion of the sun's radiation. This upper region, called the *ionosphere*, lies between 30 and 250 or more miles above the surface of the earth — above both the *troposphere*, or lower atmosphere, and the *stratosphere*. Here the separation between atoms is so great and collisions between them so much rarer than in the denser lower atmosphere that, when an atom becomes ionized by being robbed of one or more of its electrons by the action of the ultraviolet rays, it remains in that condition for a relatively long time. Thus we have an ionized region of a composition so different from that of the lower atmosphere that radio waves are refracted differently. Moreover, there are in the ionosphere itself strata of differing densities, and therefore of differing indices of refraction, which constitute a distinct series of layers. This region has been investigated and, for convenience in comparison, the different layers have been labeled *D*, *E*, *F*, *F*₁ and *F*₂,

according to their relative average heights above the surface of the earth. (See Fig. 2.) None of these layers remain constant in height, and it is the variation in their heights, combined with their various refracting, reflecting and absorbing capabilities, that govern to a very large extent the conditions of long-distance radio transmissions. The heights of the ionized strata and the degree of ionization may vary in accordance with the angle of incidence of the solar rays and also in accordance with changing conditions within the sun, which affect the character and amount of its radiation. Diurnal and seasonal variations arise from the first cause, longer-term cyclic and sporadic variations from the latter.

Sunspots

From an ideal engineering viewpoint, the power supply of our great solar transmitter appears to be very unstable. It is burning up. It overheats to such a degree that the atoms of its incandescent gases are constantly being broken down into simpler structures. Subatomic energy thus released flies off into space as solar radiation. While the entire substance of the sun is constantly emitting energy under enormous pressures and at terrific temperatures and incredible velocities, there occur also from time to time sudden surges of even more violent emission — veritable explosions — at isolated points on the solar surface. (See Fig. 1.) These spots appear relatively dark against the intensely bright photosphere of the sun, so that it is easy for observers to watch for their appearance and trace their course across our field of vision as the sun revolves about its axis over a period of about twenty-seven days. From these "sunspots," beams of intensified solar energy emission are projected to very great distances. When one of these beams sweeps through our atmosphere, the normal phenomena of solar radiation are strikingly modified by the resulting changes in ionization. It is of interest to note that the streams of sunspot radiation are not necessarily straight-line beams, as from a searchlight, but generally are scimitar-shaped. The distortion is caused by the rotational speed of that portion of the sun's surface from which the rays may be emitted. This characteristic partly accounts for the fact that efforts to predict precisely the beginning of the effect upon the atmosphere at the observer's zenith through observation of meridian passage of a sunspot group have failed. Terrestrial effects have been observed from 34 hours *before* to 86 hours *after* the time predicted on the basis of straight-line projection at the speed of light. It is further evident that the propagation speeds of sunspot emissions are only about one per cent of light speeds.²

When all of the factors involved are better known and understood, it should be possible to make reasonably precise predictions of coming changes in wave-propagation conditions caused

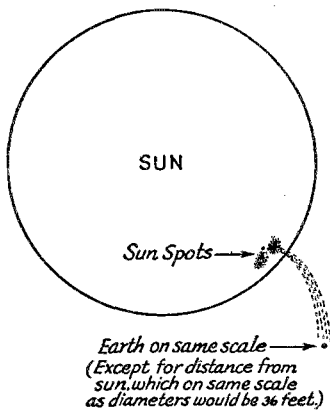

Fig. 1 — Relative size of sun, earth and sunspots. A stream of intensified radiation originating in a region of sun-spot disturbance traces a curved path through space by reason of the rotation of the sun combined with the decreasing velocity of the stream beyond its point of origin.

² "Getting the Signal Across," (by six engineers of RCA Communications, Inc.) *Relay*, Sept. 1943.

by various forms of solar radiation. Two cycles, in addition to those of diurnal and seasonal variations, now are recognized. One of these — the *solar rotational cycle*, of approximately 27 days — marks the average time between reappearances of the same sunspot group at the central meridian of the sun. The approximate time definition arises from the fact that the substance of the sun is gaseous and, therefore, a spot on its surface will not necessarily rotate at a constant rate. The rotation period at the solar equator is approximately 24.6 days, and this period increases with rising latitude. The principal appearances of the disturbances known as sunspots are between solar latitudes 5° and 40°, and the mean rotational period of this belt is approximately 27 days.

The second solar cycle depends upon the variation in number and average size of the sunspots. Its duration has been observed to be approximately 11.1 years from one maximum to the next. There is, however, a considerable degree of variation in the length of this average period and there is no sharply defined maximum or minimum period. Nevertheless, this "*sunspot cycle*," which has been observed now for 17 cycles or nearly two hundred years, is the most significant of all solar cycles, and many terrestrial effects are closely linked with it. Magnetic storms, earth currents, ionization of the upper atmosphere, the aurora, solar ultraviolet radiation and sunspots all increase and decrease together, in the same approximate 11-year cycle.³

Astrophysical Measurements

Quantitative measurements of the effects of solar radiation upon the medium frequencies were commenced by Dr. G. W. Pickard as early as 1926.⁴ Correlation of these measurements with the sunspot numbers on the Wolfer scale was continued by Professor Harlan True Stetson, Director of the Perkins Observatory (astronomical) and Professor G. W. Kenrick of Tufts College Electrical Laboratories.⁵ Sporadic effects of solar eruptions, resulting in "fade-outs" on the high frequencies, were investigated by Dr. J. H. Dellinger of the National Bureau of Standards.⁶ J. A. Pierce, W1JFO, and Melvin S. Wilson, W1DEI, among others, have published summaries of observations of solar radiation effects upon the lower portion of the very-high-frequency range.⁷ By means of these, numbers of amateurs, otherwise innocent of any knowledge of astro-

physics, have become familiar with such terms as "Dellinger effect," "skip distance," "critical frequencies," "virtual height," "aurora skip" and "sporadic E-layer skip."

Many amateurs undoubtedly will be quite content to accept, at second-hand, any astrophysical data relative to their hobby. For those who have a mind to investigate these things for themselves, to seek out first causes and perhaps to

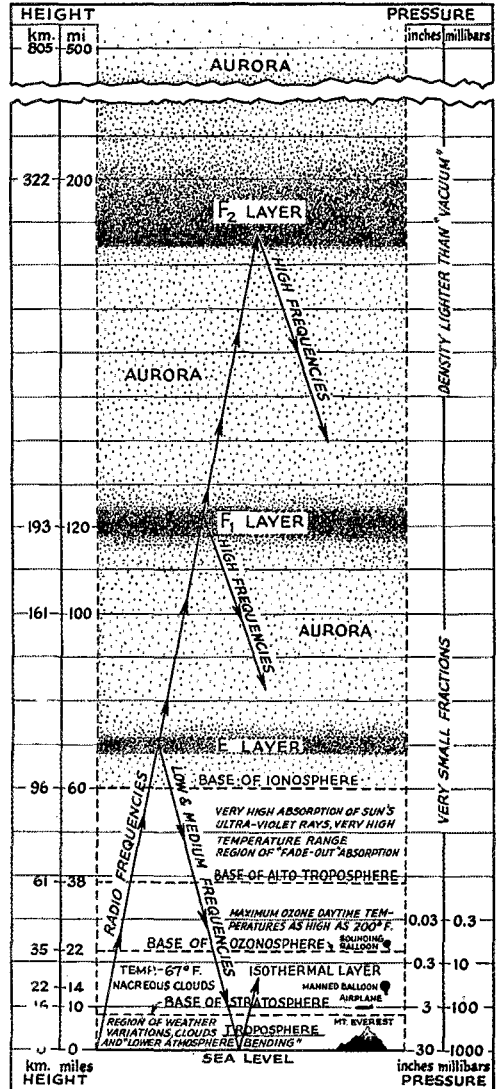

Fig. 2 — The difficulty man faces in plumbing the vast depths of the "ocean of air" is indicated by the scale of this drawing, if the reader remembers that there is yet more beyond. The drawing attempts to include as many points of information as possible, scaled against the indicated heights above sea level. The division by dotted lines roughly separates the horizontally homogeneous regions of upper and lower atmosphere (not to be confused with the layers of intensified ionization, not all of which are shown). Soundings of the ionosphere have been possible only through spectroscopy and the reflections of high-frequency radio waves.

³ J. H. Dellinger, "Some Contributions of Radio to Other Sciences," reprinted from the *Journal of the Franklin Institute*, Vol. 228, No. 1, July, 1939.

⁴ G. W. Pickard, "Correlation of Radio Reception with Solar Activity and Terrestrial Magnetism," *Proceedings of the I.R.E.*, Vol. 15, 1927, Nos. 2 and 9.

⁵ H. T. Stetson, "Radio Reception and the Sunspot Cycle," reprint from the *Proceedings of the Fifth Pacific Science Congress*, Toronto, 1934.

⁶ J. H. Dellinger, "A New Cosmic Phenomenon," *QST*, Jan. 1936; "High-Frequency Radio Fadeouts Continue," *QST*, June 1936; "Radio Fadeouts Through 1936," *QST*, Feb. 1937.

⁷ J. A. Pierce, "Interpreting 1938's 56-Megacycle DX," *QST*, Sept. 1938; M. S. Wilson, "Five-Meter Wave Paths," *QST*, August and September, 1941.

reach a position where they may be able to make further contributions to the field of knowledge, there are excellent textbooks on astronomy, such as the two-volume edition of "Astronomy" by Russell, Dugan and Stewart of Princeton University Observatory, as well as practical manuals on the construction of observational gear. One of the best of these is Ingalls' "Amateur Telescope Making"; another is George Ellery Hale's "Signals from the Stars," in which he describes a complete solar telescope and spectroheliograph of an inexpensive type which, as he says, "can be built and used by professional or amateur astronomers and geophysicists and by *radio students interested in the possible influence of solar eruptions on radio transmission.*"

The amateur with a truly scientific approach to his hobby will study all available sources of reliable information and ground himself thoroughly in the proved fundamental principles of every field of knowledge having a bearing upon his own research. He will patiently test each new theory by known facts. He will carefully record the results of all observations for further study, comparing, analyzing, separating the unknown factors, and testing over and over again. A relevant fact omitted may destroy the opportunity for a real contribution to the development of the art.

The science of radio communications unfortunately has been afflicted with a lunatic fringe spun from pseudo-scientific hypotheses comparable to the claims of astrology in the field of astronomy. Some years ago a "research" article was published in a popular radio magazine in which the author proposed a lunar theory affecting 5-meter DX which, in substance, suggested that the moon exerts a tidal effect upon the earth's atmosphere, as well as upon the earth and the sea, and that the resulting distortion of the atmospheric layers accounted for periodic increases in the range of propagation for 56-Mc. waves. This author counseled his readers therefore to "watch the periods of time between three and four days before and three and four days after *full moon* for long-distance DX (sic) on 5 meters this summer."

What is wrong with this picture? "A little knowledge is a dangerous thing." The gravitational pull of the sun and moon undoubtedly do create atmospheric tides and it is conceivable that herein may lie the explanation for one of the many ways in which the propagation of electromagnetic waves is affected, although the magnitude of increases in effective transmitting distance from such a cause is probably so slight as to be difficult of measurement. However, the theorist obviously was innocent of knowledge of the simplest astronomical principles to a degree that enabled him to ignore established facts. If such an effect is caused at *full moon* by the alignment of earth, sun and moon, the tidal effect is even more marked at the time of *new moon*, and more still at the periods when either new moon or full moon happens to coincide with the time of the moon's perigee (moon's closest approach to the

earth). Nevertheless, this lame lunar theory was widely accepted in the five-meter fraternity, and many a voice was heard on the air passing it along as the latest and most scientific explanation for the mysteries of five-meter DX.

The keenest enjoyment of his hobby is experienced by the amateur when his progress in the art is by means of his own careful study and research, rather than by a process of thumbing rides on the vehicles constructed by other minds. It is with the purpose of encouraging the thoughtful and scientifically minded amateur that these articles are offered on topics which may at first glance seem to some to be but slightly related to amateur radio as they have known it.

Radiomen

The following is reprinted from a recent issue of the U. S. Coast Guard Magazine, a service publication devoted to the interests of the U. S. Coast Guard:

Among the stranger people on this earth are radiomen. A radioman is a person either going on or coming off watch.

Contrary to popular belief, radiomen are not crazy. A radioman has two brains: one perfectly normal brain, which is destroyed during the process of learning radio, and another which is in a constant state of turmoil and is used proficiently in his work. This latter brain is filled with dots and dashes and procedure signs.

Radiomen are like groundhogs. They seldom see the sun, coming up topside only on Saturday mornings at the special request of the commanding officer. If the sun is shining and a radioman sees his shadow, he goes below and everyone knows there will be six more days.

Sitting at his typewriter a radioman receives an endless story of the world flowing through his ears, unable to get out because both ears are stopped up by headphones. The stuff flows out through his fingers and is given out as press news, weather messages, and so forth.

When conversing with a radioman, do not try to point your story by asking if he remembers "the message to Garcia," because he will jump and scream, "What's the number of it? Who sent it? If it's lost, it didn't come in on my watch!"

Radiomen live on black coffee and cigarettes. All through the long midnight watches they sit and dit and dah, so tired and weary of it all and wondering why they ever chose radio as a profession. When they go off duty they hurry home to their little "ham" radio sets and just dit and dah to their heart's content.

Girls who fall for radiomen will find they are courted with considerable sparking, and after they are married will receive much broadcasting both loud and long.

Radiomen are found on all ships and in all stations and are quite harmless if left alone, fed occasionally, and given annual leave so they may rig up new "ham" outfits at home!

HAPPENINGS OF THE MONTH



RADIO TECHNICAL PLANNING BOARD

As the major civilian agency to undertake postwar studies of radio, there came into existence, in mid-September, what is called the Radio Technical Planning Board, a nonprofit agency sponsored and financed by a group of nonprofit associations interested in the radio field, including ARRL. Originally proposed by the chairman of FCC at a joint convention of the Institute of Radio Engineers and the Radio Manufacturers Association, the initial work of launching the agency was undertaken by the latter organizations, who of course are numbered among the sponsors. Others besides ARRL include the American Institute of Electrical Engineers, the International Association of Chiefs of Police, and several organizations representing broadcasting: NAB, FM Broadcasters and National Independent Broadcasters — and there will probably be members representing aviation radio and the communication services. Dr. W. R. G. Baker, vice-president of General Electric Co., was elected chairman for a term of one year.

The objectives of the RTPB are to formulate recommendations for the technical future of the radio industry and radio services, in accordance with the public interest and the technical facts, and to publish those recommendations for the information of government, industry and the public. Its work is restricted to engineering considerations. It will do most of its work through study groups or committees called "panels," with a mechanism providing for the publication of formal reports including majority and minority opinions and the comments of sponsoring organizations. Your League has joined with other organizations both to make this general

study possible and as a participant to look after the interests of amateur radio. The work will take many months to complete, may indeed continue until the postwar structure of civilian radio is reestablished. We shall expect to report upon the work of this board from time to time.

TURNER SUCCEEDS TERRELL

GEORGE S. TURNER, for the last several years assistant chief of the Field Division of FCC, has been appointed chief of the division to succeed William D. Terrell, who recently retired from the government service as reported in our last issue.

Mr. Turner has been in the radio inspection service since 1924 and before coming to Washington was the FCC Supervisor-in-Charge at Atlanta. A native of Independence, Mo., he was for many years a prominent amateur in those parts. Old-time hams will remember that from 1922 to 1924 he was Division Manager of ARRL's Midwest Division, the DM in those days being a sort of super-SCM for the whole division. That job probably taught him plenty, both about radio and about administration!

THE AMATEUR WAR RECORD

ATTENTION, amateurs! At ARRL headquarters we are compiling a name-by-name record of the service being performed in the war by American and Canadian amateurs — so as to be able to show after the war what it has meant to our countries to have the services of amateurs available. There are still thousands of you men and women from whom we have not heard. At the bottom of this page is a convenient form easy to fill out, which we ask you to clip and send to us — or reproduce its essentials on a post card.

AMATEUR WAR SERVICE RECORD

Name

Call, present or ex; or grade of op-license only

Present mailing address

SERVICE

- Army
- Navy
- Coast Guard
- Marine Corps
- Maritime Service
- Merchant Marine
- Civil Service
- Radio industry, 100% war

Rank or rating

Branch or bureau: Signal Corps, AAF, Buships, WAVES, etc.
If civilian industry, give title and company.

ARE YOU LICENSED?

When joining the League or renewing your membership, it is important that you show whether you have an amateur license, either station or operator. Please state your call and/or the class of operator license held, that we may verify your classification.

Wherever you are in this war effort, if you're an amateur engaged in work with radio or any of its associated branches, we need your record for our common good. Please let us hear from you.

NOTICE TO MEMBERS DISCHARGED FROM THE MILITARY SERVICES

THE requirement of continuous membership in the League for eligibility to ARRL offices has been waived for members serving in the uniform of the United States. Particulars on page 24 of July *QST*. Those desirous of taking advantage of this arrangement are asked to claim the right when renewing membership, stating the beginning and ending dates for their military service.

OPERATOR LICENSES EXTENDED

FOR the benefit of you fellows in the armed services who only occasionally see a copy of *QST*, we repeat the following good news:

FCC on May 25th reinstated and extended for three years from the stated date of expiration, all amateur operator licenses expiring between Pearl Harbor and May 25, 1943. And every amateur operator license due to expire between May 26th of this year and December 7, 1944, was extended for three additional years. The action does not apply to licenses suspended by FCC or voluntarily surrendered by the holder, nor to licensees who failed to prove citizenship and file fingerprints under Order 75. Otherwise, we're all fixed up. Thus there will now be no expiration of a ham op license until December of next year, and no action or renewal application is necessary until that time approaches. If the war is still on, there will probably be another extension. FCC no longer receives applications for renewal of station licenses and is letting them expire. Calls, however, will be retained for those who held them as of Pearl Harbor.

1943 Rochester Fall Meeting

The 1943 Rochester Fall Meeting for members of the IRE and the RMA Engineering Department will be held at the Sagamore Hotel in Rochester, N. Y., November 8th and 9th.

The meeting will begin with registration at 8:30 A.M. Monday. A number of interesting papers and reports, ranging in scope from recent advances in Klystron theories to practical discussions of capacitors and ceramic dielectrics, are scheduled. An exhibit of Signal Corps equipment will be featured on both days. The meeting will conclude with a banquet Tuesday evening.

Strays

Here is a little story about the FCC:

It takes place in WAKEFIELD, where Jimmy Jones, having taken his girl to the movies, decides to WALKER home. After he has left her house he gets a CRAVEN for candy. In fact, it is so bad it is almost a PAYNE. To satisfy the urge he breaks into a candy store. He then repents, and decides that if he takes it on the FLY they will not have a CASE against him. So he leaves, being careful to close the DURR behind him. — *An SWL*.

— . . . —

Effective November 1st, f.m. b.c. stations will be issued new calls to replace the present letter-numeral designations. If the licensee of an f.m. station operates a standard b.c. station (for example, "WAAX") in the same city, he may use the standard b.c. station call letter assignment followed by the suffix "FM" for the f.m. station ("WAAX-FM"), or he may be assigned a new four-letter call, such as "WXXR."

Missing in Action

L. H. Richards, W9GDK, of Lake Forest, Ill., has been reported missing in action by the War Department.

Prisoners of War

Albert H. LaFleur, RM3c, USNR, W1MCF who was last heard from on Wake Island, is being held a prisoner of war in the Shanghai Internment Camp, Field Post Office 106, Shanghai, China. He would like to hear from the gang.

Silent Keys

It is with deep regret that we record the passing of these amateurs:

W1CYC, Linwood L. Garey, Portland, Maine
W1GOR, C. E. Chesley, Lynn, Mass.
W1PG, Chief Aviation Radioman Henry F. Rand, USN, Lynn, Mass.
W2CTY, Emil M. Herlin, Long Island City, N. Y.
W4BPM, Thomas Thompson, Memphis, Tenn.
W5KQO, Alfred L. Stout, Beaumont, Tex.
W8DSQ, Rudolph F. Drews, Lansing, Mich.
W9HNJ, George F. Wicklund, Ironwood, Mich.
W9JYX, Victor C. Ingels, Kokomo, Ind.
VE4AEZ, Sgt. Luther Arthur Appelt, RCAF, Wetaskiwin, Alberta, Canada.

The test of any WERS equipment is its ability to establish and maintain communications *anywhere* in the territory served by the licensee, under any conditions. There will be many situations in which only a transmitting and receiving unit with self-contained power supply which the operator can carry wherever he can go afoot will provide the vital link in the chain of communications. In this article, the writer gives his experience with such equipment and offers suggestions for improvements in design.

On the Spot With a Walkie-Talkie

The Pack Set in WERS Operation

BY FREDERICK M. BURKLE*



WJLH-38 in use by its constructor.

IT WAS during a recent daylight air raid defense test. I was walking my assigned beat, when suddenly a voice from WJLH-29 Control, sounded in the headset I was wearing.

"What is your present location?"

I gave the street and nearest house number.

"Stand by there. You will be picked up by a warden in a motor car. I can reach him by telephone, but he has no radio. When you reach the location where he will take you, establish communication with Control through the nearest sector headquarters station at the earliest possible moment. That is all."

A few short minutes later I was at the scene of a simulated "incident." It was beyond the normal

*97 Hartley Street, Hamden, Conn.



range of the control station, and no telephones were near enough to be of service. I made contact quickly with the nearest WERS zone unit and established a relay link to WJLH-29. From that time until the "all clear" sounded, the pack transmitter-receiver strapped to my back was the sole means of keeping that isolated scene of simulated death and destruction in touch with the helping hands of organized civilian defense. The officials at the report center were informed of the details of the "incident" by the local warden — type of bomb, casualties involved, need of additional fire-fighting equipment, and so on. Without prejudice to needs at other places from which incidents were being reported, the heads of the various civilian defense services were then able to dispatch exactly the personnel, equipment and supplies called for by the circumstances. Medical units, fire apparatus and auxiliary police arrived promptly on the scene of action. All were able to keep in touch with their commanding officers at the report center throughout the tour of duty, and to receive further orders from time to time. When at last all was accomplished that could be done to meet the needs of the occasion, and the "all clear" had sounded, it was still through the perambulating radio transmitter that final instructions and dismissal from duty came to the workers.

I remembered the paragraph in *QST* for April, 1942, in which Vernon Chambers called the walkie-talkie the "link in the chain" that makes for a solid line of communications. I know. I built that rig, or one very nearly like it, and after seeing

Panel view of the WERS pack set. A flexible shaft clipped to the operator's belt enables him to control the receive-transmit switch without reaching back to the panel. Receiver tuning, controlled by the upper dial, is generally left adjusted to the control station's frequency. The regeneration control knob is below and slightly to the left of the dial. Jacks for 'phones and mike are on the left edge of the panel, with the "on-off" switch below.



All parts are panel-mounted. In this rear view, the top of the panel as seen in the front view now appears at the left. The detector tube is the lower of the two in the foreground, the other being the oscillator. The modulator tube is above and behind the oscillator.

it in action, I can back up his statement. Truly, under difficult conditions when life and property are endangered and communication must be established without delay — then the radio transmitter that can go wherever a man can go afoot is the one that does the job.

Circuit Details

The circuit diagram (Fig. 1) shows the changes made in the Chambers circuit, incorporating helpful suggestions from W1KV and W1ND. Being unable to get an Isolantite switch section, I reckoned that, if a bakelite section were substituted, the combination of losses arising from long leads and r.f. through the switch would be too great. Therefore, I chose to use separate 1Q5GT tubes in the receiving and transmitting circuits. A further advantage followed from this course, through the facility thus gained for mounting the tuned circuits directly on the tube-socket terminals.

The receiver side of the circuit is still the time-tried "Minute-Man" super-regenerator with the grid returned through the plate circuit, placing a small positive voltage on the grid. C_3 and C_4 are mica padders used as antenna coupling condensers. The quench voltage of the superregenerative detector is filtered out of the audio circuit by the combination of the by-pass condenser, C_7 , and the 80-millihenry r.f. choke, RFC_3 . The value of C_7 is determined by conditions present in any individual circuit, which may vary considerably. Therefore, experimentation with values ranging from $0.003 \mu\text{fd.}$ to $0.006 \mu\text{fd.}$ is in order. This condenser is removed from the circuit while transmitting, to prevent attenuation of the higher audio frequencies.

Maximum audio power and the best possible quality is obtained only by proper biasing of the audio tube. The $4\frac{1}{2}$ -volt battery shown in the circuit diagram may be replaced with a bank of four or five Mallory bias cells.

Increased "A" battery drain introduced by the added 1Q5GT has not proved a serious disadvantage; after two months of operation during WERS alerts and drills, the battery still delivers rated voltage. I chose to use the $4\frac{1}{2}$ -volt audio bias battery as the source of microphone current, as well. However, there are some single-button microphones of recent manufacture which will operate better and remain in good condition for longer periods if the supply is limited to $1\frac{1}{2}$ volts. In this case, the logical source is the filament battery, as in the Chambers circuit.

Provision is made, through one section of the receive-transmit switch, S_1 , for disconnecting the potentiometer, R_4 , used as a detector regeneration

Fig. 1. — Wiring diagram of the WERS "walkie-talkie."

- C_1 — 15- $\mu\text{fd.}$ midget variable with one rotor and two stator plates removed.
- C_2 — 35- $\mu\text{fd.}$ midget variable.
- C_3, C_4 — 3-30- $\mu\text{fd.}$ mica trimmer.
- C_5, C_6 — 100- $\mu\text{fd.}$ midget mica.
- C_7 — 0.006- $\mu\text{fd.}$ midget mica.
- R_1 — 0.5 megohm, $\frac{1}{2}$ -watt.
- R_2 — 15,000 ohms, $\frac{1}{2}$ -watt.
- R_3 — 0.25 megohm, $\frac{1}{2}$ -watt.
- R_4 — 50,000-ohm volume control.
- L — 15-henry 75-ma. filter choke.
- L_1 — $2\frac{1}{2}$ turns No. 14 e., $\frac{3}{8}$ -inch inside diameter, 1 inch long.
- L_2 — $1\frac{1}{2}$ turns No. 14 e., $\frac{1}{2}$ -inch inside diameter, $\frac{3}{8}$ -inch long.
- RFC_1, RFC_2 — v.h.f. choke (Ohmite Z-1).
- RFC_3 — 80-mh. r.f. choke.
- J_1, J_2 — Open-circuit jacks.
- S_1, S_2 — Sections of 4-pole, 2-position bakelite switch (Centralab M, mounted on Centralab index assembly No. K-122).
- S_3 — D.p.s.t. toggle switch.
- S_4 — D.p.d.t. toggle switch.
- T — Transceiver transformer.

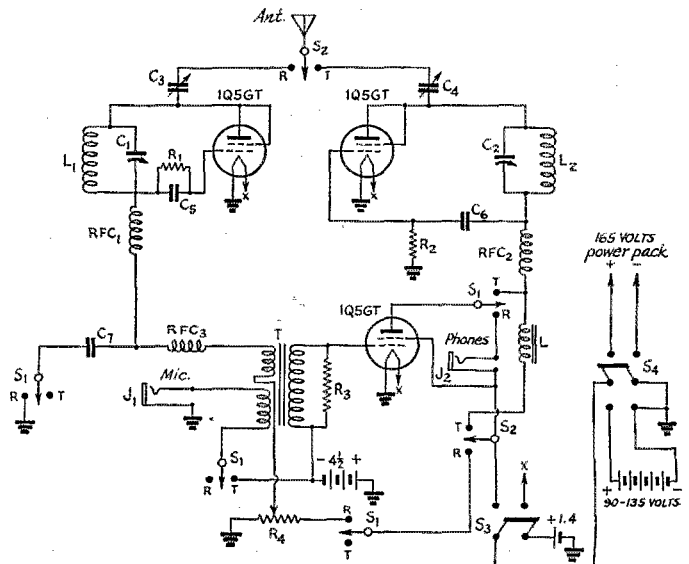

control, so that the battery will be relieved of its drain during transmitting periods.

The power input circuit is taken through a d.p.d.t. switch, S_4 , from either the 90-135-volt "B" battery or an a.c. power pack. There are many times when a.c. is available that the operator is able to conserve hard-to-get "B" batteries for a time of greater need. I adapted the power supply from an old Atwater-Kent broadcast receiver by installing an outlet cable and mounting a suitcase handle on the top of the power pack. This supply delivers 165 volts under load. On the walkie-talkie unit, the connection for the a.c. supply is on the same side as the antenna.

As I was able to obtain a three-winding transceiver transformer, T , the Chambers audio input circuit was modified accordingly, doing away with the necessity for the slightly less efficient impedance coupling used in the original circuit between detector and audio and between the microphone and the modulator circuit.

Construction

The plywood cabinet, painted black, is provided both with shoulder straps and a five-and-dime suitcase handle. Felt padding was sewed around the heavy suitcase straps used for shoulder straps, and was also applied to the back of the cabinet to cushion it. The front panel is of aluminum salvaged from an old receiver. Sufficient slack was allowed in the leads from the power-input terminal strip to allow for removing the panel, on which all parts were mounted, whenever repairs or adjustments are required. The back is hinged for easy access to the batteries and tubes. Inside this hinged cover is mounted a copy of the station license, a circuit diagram, and a copy of the WERS rules and regulations. A cardboard pocket contains the CD arm-band, a sealed envelope with operating instructions for certain contingencies, a card with notes on adjustments, dial settings and circuit changes, and the ARRL portable-mobile log book. When operating, the log-book is attached to a plate snapped on the operator's belt, ready for use.

Further conveniences include a flexible shaft from an old automobile radio, which is attached to the shaft of the rotary receive-transmit switch, S_1 , brought to a clip on the operator's belt and terminated in a knob for easy change-over switching. This provided a marked improvement in ease and speed of operation. The on-off switch, S_3 , is located in the lower left-hand corner of the front panel, where the operator can most easily reach it.

I used an adjustable automobile whip antenna mounted on the side of the cabinet. Best results were obtained with the whip extended to 37 inches, which, with the 12 inches of wire leading to the antenna switch, S_2 , makes a total antenna length of 49 inches.

The microphone mounting is in the form of a home-made breast-plate of Presdwood and a flexible shaft of BX cable with elbow-type BX connectors at either end.

The unit as a whole, complete with batteries and all other accessories, only weighs about twenty

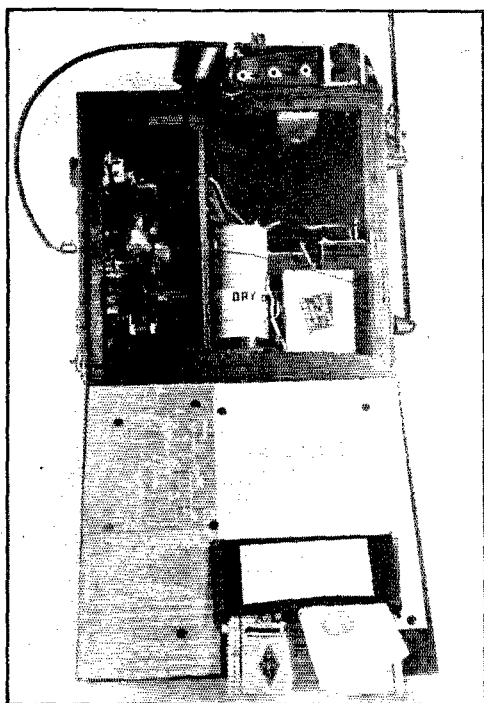

Carrying case with cover opened, showing the battery compartment and antenna mounting. Operating data is on the cover, with pocket for arm-band and log book

pounds, and is really much lighter than it might appear to be in the photographs.

Operating Notes

Considering the fact that they were designed as audio tubes, the 1Q5GTs are doing a swell job in this rig. Excellent operation results from the application of the normal rated maximum voltage of 90 to the plate of the transmitting tube. A range in excess of a mile from the control station, with the pack set operated at ground level, has proved consistent. Receiver sensitivity and audio power are entirely adequate. From the roof of my home location, which is on a hill, I find that I can contact all stations in the Hamden net, including paths up to 5 miles. Here I use either 135 volts from a "B" battery or 165 volts from the a.c. power supply, with results about equal. Operation at the increased input will, of course, shorten the tube life, but no detriment to audio quality or other operating characteristics has been noted.

During one Wednesday evening test one of the TR-4 units required repairs, and my pack set was temporarily substituted for it. The regular antenna was coupled to the pack set by wrapping one of the feeders around the fully extended rod antenna of my unit. All stations in the net reported satisfactory reception under these conditions, including the control station at a distance of about four miles. This unit thus has proved its usefulness not only as a "walkie-talkie" but also as an emergency unit to be put in operation wherever needed with a minimum of delay.

IN THE SERVICES

MORE and more frequently the ITS department is receiving letters from hams asking for the addresses of friends whose names have been printed in the column; fellows who went to school together and who have done a lot of "hamming" together but have lost contact with each other as a result of the war. The ITS files have proved a valuable aid in reuniting amateurs by providing up-to-date military addresses, but occasionally we've had to advise "rank and military address unknown." Therefore, as *QST* goes to press this month we stress once more the importance of that AWSR; not only to bring you a possible QSO by mail, but to aid in the important task of securing the return of the ham bands after the war is over.

We know there are many hams in service who have not yet been included in the roster, so how about sending in that service record? We earnestly request new names as well as changes in rank and address, since our ultimate goal is to have the name of every ham in service recorded at Hq. So get busy on those AWSRs and keep 'em coming! A convenient form is provided in "Happenings of the Month," page 21.

ARMY—SIGNAL CORPS

It certainly is a red letter day when *QST* arrives in India," writes W8FGV. "The old mag is read from cover to cover, and even the advertisements are interesting." (The Adv. Dept. says: "What's he mean — 'even'?")

1JSS, Dineen, T/Sgt., Camp McCain, Miss.
 1LMS, Sheehan, Lt., Ft. Monmouth, N. J.
 1M1N, Trachtman, Lt., Ft. Monmouth, N. J.
 2CAD, Ward, Lt., foreign duty.
 2FTB, Bloom, Lt., Ft. Monmouth, N. J.
 2FPV, Diecks, Pfc., Camp Crowder, Mo.
 2LEC, Bruscella, Pvt., Ft. Monmouth, N. J.
 2TUR, Heptig, Pvt., Camp Crowder, Mo.
 2OCT, Watt, Sgt., foreign duty.
 ex-3FJS, Furman, Pvt., Camp Crowder, Mo.
 3FKM, Santomas, T/3, foreign duty.
 3JBC, Sherbondy, T/3, Ft. Jackson, S. C.
 K5AT, Forde, Lt., Ft. Monmouth, N. J.
 K5AY, Frick, Lt., Ft. Monmouth, N. J.
 K5CR, Gallegos, Lt., foreign duty.
 E5VA, Schneider, Pfc., Camp Hulen, Tex.
 5HH, German, Lt., address unknown.
 5HWH, Hudgins, Lt., Ft. Monmouth, N. J.
 5HMB, Williams, Lt., Ft. Monmouth, N. J.
 5IED, Keith, Lt., Ft. Monmouth, N. J.
 5IID, Schaefer, Lt., Ft. Monmouth, N. J.
 5ISF, Schaeffer, Pvt., Camp Crowder, Mo.
 6N1T, Burns, Lt., Ft. Monmouth, N. J.
 5TF, Welsh, Pvt., Indianapolis, Ind.
 6CVD, Drossel, T/3, San Carlos, Calif.
 6DPK, Barton, Sgt., Indianapolis, Ind.
 6FCF, Nickell, Sgt., Camp Roberts, Calif.
 6MRB, Hansen, Lt., Ft. Monmouth, N. J.
 6QAK, Rugg, Lt., Ft. Monmouth, N. J.
 6RIV, Eker, Pfc., Ft. Lewis, Wash.
 K6TQS, Holbert, Lt., Ft. Monmouth, N. J.
 K6DDQ, Erwin, Lt., Ft. Monmouth, N. J.
 7AEM, Hardman, Pvt., Ft. Lewis, Wash.
 K7GEI, Ellison, M/Sgt., Ft. Lewis, Wash.
 K7GSU, Arthurs, T/4, foreign duty.
 7HOM, Anderson, Lt., foreign duty.
 7HWR, Montelius, T/Sgt., foreign duty.
 8MST, Zellefrow, Lt., Bolling Field, D.C.
 8NGL, Barbiaux, T/Sgt., foreign duty.
 8PMD, Proctor, address unknown.
 8PTK, Horbaty, T/4, Ft. Lewis, Wash.

8QEO, Fleming, T/3, foreign duty.
 8RDZ, Lowenstein, Pfc., Ft. Monmouth, N. J.
 8SXY, Thomas, S/Sgt., Ft. Lewis, Wash.
 8TYB, Mills, T/4, foreign duty.
 8UPQ, Gill, Cpl., Athens, Ga.
 8VAM, Unger, Pvt., Camp Crowder, Mo.
 8WSS, Vayda, Pvt., Washington, D. C.
 9BQS, Bell, Lt., Ft. Lewis, Wash.
 9DDO, Lucas, Pfc., Camp Crowder, Mo.
 9EVV, Kampe, T/3, Davis, Calif.
 9FTH, Ramer, S/Sgt., Camp Murphy, Fla.
 9GAS, Darges, Cpl., Ft. Lewis, Wash.
 9GBV, Doege, T/Sgt., foreign duty.
 9HTD, Swenson, Pfc., Stanford, Calif.
 9JXI, Jones, Lt., Pendleton Field, Ore.
 9NKM, Dow, Pfc., Davis, Calif.

Operator's license only:

Cheesebrough, Pvt., Camp Wheeler, Ga.
 Mack, Pvt., Camp Kohler, Calif.
 Sheehan, Pvt., Camp Kohler, Calif.

ARMY—GENERAL

HAM ingenuity again — one OM used the stray parts from a Zero to build a two-tube receiver. He claims it worked fine, and even brought in Tokyo. Hi!

1BSS, Jackson, T/4, Military Res., Va.
 ex-1EQ, Butler, T/Sgt., foreign duty.
 1GPF, Leach, Pvt., Ft. McClellan, Ala.
 1MB, Mead, Pvt., Ft. McClellan, Ala.
 1MTI, Hicks, Cpl., Foxboro, Mass.
 1NUR, Brown, Pvt., Bloomington, Ind.
 2RIF, Heinis, Lt., foreign duty.
 2UJ, Wootton, T/4, Montclair, N. J.
 2KA, Kimmelort, Capt., foreign duty.
 2MPT, Sherman, Pvt., Camp Shelby, Miss.
 2MXV, Ehrlich, address unknown.
 3BYF, Schuler, Pvt., Camp Edwards, Mass.
 3TIL, Gusewicz, T/Sgt., LaPlata, Md.
 4ESX, Basham, Cadet, West Point, N. Y.
 4HTC, Shepard, Pvt., Raleigh, N. C.
 4ICD, Grady, Cpl., foreign duty.
 5EBS, Fouts, Capt., Camp Adair, Ore.
 5FOH, Maxwell, Capt., Camp Swift, Tex.
 6JTU, Beckmeyer, Lt., Memphis, Tenn.
 6MFB, Hatakeda, T/3, Camp Savage, Minn.
 6RUX, Lindsey, Sgt., foreign duty.
 7IAN, Hook, Lt., foreign duty.
 8PMO, Orehovec, S/Sgt., foreign duty.
 8QLQ, Claypool, address unknown.
 8RXN, Koenig, Lt., foreign duty.
 8SNN, Gosztyla, Cpl., foreign duty.
 8VIC, Shaffer, Pvt., Ft. Eustis, Va.
 8VWW, Swisher, Pvt., New Orleans, La.
 8WIG, Chittenden, Pvt., Camp Fannin, Tex.
 9BTN, Yancey, Lt., Lawton, Okla.
 ex-9EPK, Scott, T/Sgt., Indianapolis, Ind.
 9GTI, Pletttau, address unknown.
 9HHD, Sanders, Pvt., Ft. Logan, Colo.
 9HLL, Wion, Ft. Collins, Colo.
 9IHI, Pagliarulo, address unknown.
 9JUR, Irick, Clarence, Mo.
 9ILP, Terry, Capt., Ft. Collins, Colo.
 9MMQ, Jorgensen, Cpl., Davis, Calif.
 9OAA, Crawford, Sgt., foreign duty.
 9STI, Hunt, M/Sgt., foreign duty.
 9TVU, Stullken, T/4, Ft. Sill, Okla.
 9YKB, New, Pvt., San Diego, Calif.

Operator's license only:

Aschenbrand, T/Sgt., Camp Davis, N. C.
 Braats, Pvt., Ft. Knox, Ky.
 Engle, Pvt., Minneapolis, Minn.
 Horn, Sgt., foreign duty.
 Kowalechik, Cpl., Ft. Monroe, Va.
 McCracken, Pvt., Pasadena, Calif.
 Ryan, Pvt., Brooklyn, N. Y.
 Strachan, Pvt., Camp Shelby, Miss.
 Uminowicz, T/3, Jersey City, N. J.



"Somewhere in Sicily." We're mighty proud of these three dyed-in-the-wool hams now fighting in the European theater. They are veterans of the Tunisian front and of the more recent Sicilian campaign. *L. to r.* — S/Sgt. Knapp, W1AIJ; S/Sgt. Rusczek, WIMPO, and M/Sgt. Schnell, W2HNC

NAVY—GENERAL

RT2c Gibbes, W4HGJ, in a recent letter to Hq. expresses a thought currently uppermost in everyone's mind: "Here's hoping all of the old hams and a lot of new ones will soon be back on a peaceful air."

KA1MN, McNally, Lt., address unknown.
1AB, Goss, Lt. (jg), Groton, Ct.
1BJB, Martin, Lt. Comdr., Boston, Mass.
1LPZ, Bryant, RE, Washington, D. C.
VE2AMK, Anderson, address unknown.
2ANZ, Stein, Ens., New York City.
2NMQ, Honeiser, A/S, Troy, N. Y.
2OLR, Miller, S2c, Newport, R. I.
3HAY, Bowers, A/S, Balmbridge, Md.
3IGB, Sutton, EM3c, Williamsburg, Va.
3IXS, Willa, A/S, Great Lakes, Ill.
3JFF, Reynolds, Ens., Norman, Okla.
3KR, Redington, Lt., Arlington, Va.
4DRK, Stephens, Lt. (jg), Norfolk, Va.
4FZC, Jamison, S2c, San Diego, Cal.
6PN, Russell, Lt. Comdr., Quonset Pt.
6PSD, Cairns, address unknown.
6TOE, Kelley, A/S, Butte, Mont.
7GAV, Palmer, CRM, Pt. Blakely, Wn.
7IWC, Hoguewede, S1c, Chicago, Ill.
7JBK, Miller, S1S, Farragut, Idaho.
8HZE, Hollmiller, address unknown.
8IVY, Hogan, A/S, Great Lakes, R. I.
8TWA, Donnelly, A/S, Cambridge, Mass.
8VGC, Bailey, Ens., Cambridge, Mass.
8VKY, Riley, S2c, Davisville, R. I.
8VZJ, Brinton, RM3c, address unknown.
9BHG, McCullough, S1c, Stillwater, Okla.
9CET, Lanning, Lt. (jg), address unknown.
ex-9DR, Meyers, Lt. Comdr., Bellevue, D. C.
9DRQ, Parr, Ens., Boston, Mass.
9FUY, Junst, A/S, Evanston, Ill.
9IHC, Gardner, Memphis, Tenn.
9JSL, Smith, Ens., Rhode Island.
9NTC, Matthews, Ens., Portsmouth, Va.
9WQC, Robinson, Ens., Hutchinson, Kans.
ex-9ZN, Matthews, Comdr., Columbus, Ohio.

Operator's license only:

Kelley, Lt. (jg), Cambridge, Mass.

ARMY—AIR FORCES

WHILE we know many of the amateurs listed below are serving in some one of the domestic regions of the Army Airways Communications System, their exact address is unavailable and consequently we must enter them as "address unknown." If any of these OMs, or their friends and relatives, will send in more complete data, we'd appreciate it.

IBLL, Ritchie, Cpl., address unknown.
ex-VB1CM, Cramling, M/Sgt., Nashville.
IDEL, Smith, F/O, Stout Field, Ind.
1EKN, Hampshire, S/Sgt., address unknown.
1GDT, Stone, Sgt., address unknown.
1IKQ, Linfield, 2nd Lt., address unknown.
1JDI, Felix, Pfc., address unknown.
1JER, Barwick, Lt., address unknown.
1JYV, McNeil, foreign duty.
1KTU, Oliver, T/3, Lakeland, Fla.
1LLZ, Frost, Pfc., George Field, Ill.
1LOT, Stephen, Sioux Falls, S. D.
1MUN, Fenton, Sioux Falls, S. D.
1QX, Robinson, Pvt., Luke Field, Ariz.
1UOL, Miller, 2nd Lt., address unknown.
2ABH, Andren S/Sgt., address unknown.
2AGC, Couget, Cpl., foreign duty.
2AXU, Abel, Sgt., address unknown.
2CLE, VanEssen, Sgt., Sedalia Air Base, Warrensburg, Mo.
2CSH, Moore, Capt., address unknown.
2EMP, Nacht, Cpl., address unknown.
2ENP, Pascinini, S/Sgt., address unknown.
2GMB, Baranowski, S/Sgt., address unknown.
2IMR, Furman, Pfc., address unknown.
2IVJ, Peters, Pvt., address unknown.
2JDE, Pearson, Sgt., address unknown.
2JNT, Gubits, Lt., address unknown.
2KMA, Malamut, S/Sgt., address unknown.
2KZA, Kayatt, S/Sgt., address unknown.
2LNI, Gensler, Pfc., Farmingdale, L. I.
2MEO, Rhodes, Cpl., address unknown.
2NWP, Artimovich, M/Sgt., address unknown.
2NVN, Stewart, Sioux Falls, S. D.
2NX, Schneider, S/Sgt., address unknown.
2ONT, Lann, Pfc., Sioux Falls, S. D.
2QYZ, Doyle, S/Sgt., address unknown.
2SC, Jacobello, T/Sgt., address unknown.
3CHC, Cox, S/Sgt., address unknown.
3DBT, Loughney, Sgt., address unknown.
3DLA, Rupp, M/Sgt., address unknown.
3ex-3DZJ, Snow, T/Sgt., address unknown.
3G4U, Gilson, Cpl., address unknown.
3GDV, McGee, M/Sgt., address unknown.
3GTS, Stull, Lt., foreign duty.
3ION, Smith, Pfc., Trux Field, Wis.
3JSM, McBride, Cpl., address unknown.
4AHU, Henderson, S/Sgt., address unknown.
4DDD, Robinson, Pvt., address unknown.
4EHK, Moseley, S/Sgt., address unknown.
4BWC, McCraw, A/C, Boca Raton, Fla.
4FNM, Roberts, T/Sgt., address unknown.
4FUM, Cody, Capt., Grenada, Miss.
ex-4GNL, Streamer, 2nd Lt., address unknown.
4GSP, Paladine, Lt., address unknown.
4GUA, Patisilo, S/Sgt., address unknown.
4HLA, Ridolf, Pfc., address unknown.
5ENB, Moore, Lt., address unknown.
5ETG, Jones, Capt., address unknown.
5LXX, McKee, A/C, San Antonio, Tex.
5IKP, Compton, M/Sgt., address unknown.
5IAR, Dutton, Cpl., address unknown.
5JAV, Faver, Cpl., address unknown.
5JML, Shafer, T/Sgt., address unknown.
5JVE, Perez, Sgt., address unknown.
5KMK, Rockett, Pvt., Keesler Field, Miss.
5KPO, Reid, Cpl., address unknown.
5AGH, Shapiro, Sgt., address unknown.
ex-6ARG, Cochran, Lt., Butler, Pa.
6CD, Avary, Major, Chico, Calif.
6COU, Gaddelin, Cpl., address unknown.
6GDU, Huard, W/O, address unknown.
6KEMS, Bobulski, Lt. Col., address unknown.
6KJU, Bly, M/Sgt., address unknown.
6MJJP, Copeland, Pfc., Lowry Field, Colo.
6NMA, Davis, Lt., address unknown.
6OPK, Young, T/Sgt., Tampa, Fla.
6RHF, MacFarlane, T/Sgt., address unknown.
6RYQ, Shook, Lt., Fyote, Texas.
6SEV, Pearson, address unknown.
6TRI, Saling, Pvt., San Marcos, Texas.
6TRQ, Eden, A/C, Seymour Johnson Fld., N. C.
6TUZ, Payne, S/Sgt., address unknown.
6UPF, Richards, Pfc., Sioux Falls, S. D.
7DON, Wilkins, M/Sgt., address unknown.
ex-7GON, Hoy, M/Sgt., address unknown.
7GR, Harrington, T/Sgt., address unknown.
7GRN, Edwards, Capt., address unknown.
7GRS, Shafer, Pfc., address unknown.
7HHK, Rasmusen, Capt., address unknown.
7HKE, Longstreth, Pfc., foreign duty.
7HER, Ingalls, T/Sgt., address unknown.



It's a bit too early to expect much response to our plea for more YL pictures and AWSRs, but just to prove that we earnestly desire a better showing, here's one from the files. Mrs. Leta Bush, W9DBD, is a topnotch radio instructor for the Army Air Forces at Scott Field. (See "Women and Radio," September, 1943, QST.)

7IFG, Bailey, A/C, Miami Beach, Fla.
7JPG, Rayton, T/Sgt., address unknown.
7JZL, Miller, Pfc., address unknown.
7LVW, Marwin, S/Sgt., address unknown.
8AZQ, Darrow, Sgt., address unknown.
8BTG, Beshenich, Cpl., address unknown.
8CHO, Koppe, Lt., address unknown.
8DJD, Scott, T/Sgt., address unknown.
ex-8ENB, McAfee, Lt., address unknown.
8EPO, Cochran, T/Sgt., address unknown.
8FAP, Rankin, S/Sgt., address unknown.
8PPT, Stokes, Pfc., address unknown.
8GPV, Lucas, Sgt., address unknown.
8HNH, Reu, Sgt., Orlando, Florida.
8HQJ, Highfield, S/Sgt., address unknown.
8HSE, Baughn, Cpl., Harrisburg, Pa.
8MEG, Heinlein, Pfc., Sioux Falls, S. D.
8MQA, Peyton, S/Sgt., address unknown.
8NJJ, Roberts, Lt., Fyote, Texas.
8OPJ, Fisher, M/Sgt., address unknown.
8PIQ, Warwick, Sgt., address unknown.
8PYO, Genking, Cpl., address unknown.
8QGN, Regone, Sgt., foreign duty.
8QJP, Bookwalter, address unknown.
8QUQ, Bishop, S/Sgt., address unknown.
8RYM, Fritz, Pvt., address unknown.
8SVV, Peterson, Pfc., Sioux Falls, S. D.
8TDL, Goppelt, Pfc., Sioux Falls, S. D.
8TEQ, VanFleet, Sgt., Bradley Field, Ct.
8TGC, Mayo, Cpl., address unknown.
8TIB, Ruth, Capt., address unknown.
8TOZ, Fleiselman, Sgt., Chauauet Field, Ill.
8UEA, Boyce, Sgt., address unknown.
8UMC, Gondek, Cpl., Sioux Falls, S. D.
8UMQ, Dohner, Sioux Falls, S. D.
8UNI, Pekrul, Sgt., Sioux Falls, S. D.
8UUN, Baumber, Pfc., Sioux Falls, S. D.
8UUZ, Sofranko, S/Sgt., foreign duty.
8UYC, Kasproski, Sioux Falls, S. D.
8VEX, James, Pfc., Sioux Falls, S. D.
8WLC, Duris, Pfc., address unknown.
8WLM, Kalilich, Pfc., Sioux Falls, S. D.
9AJF, Hahn, Capt., address unknown.
9AKU, Stone, Sgt., address unknown.
9ALI, Greenwood, Sgt., address unknown.
9AWU, Mikesell, Sgt., address unknown.
9CAP, Hanley, S/Sgt., address unknown.
9CMX, Kail, F/O, Laredo, Tex.
9DME, Cobb, S/Sgt., address unknown.
9DYW, House, Cpl., Sioux Falls, S. D.
ex-9EOH, Babcock, Capt., address unknown.
9EIS, Murphy, Pvt., Jefferson Bks., Mo.
9EZN, Rogers, T/Sgt., address unknown.
9FAN, Plumlee, M/Sgt., address unknown.
9FKV, Murphy, Sgt., address unknown.
9FTD, Resch, Pfc., address unknown.
9GSL, Velander, Pfc., address unknown.
9HKH, Lahn, S/Sgt., address unknown.
9JAC, Hubenschmidt, Cpl., address unknown.
9JCQ, Johnson, T/Sgt., address unknown.
9JLZ, Dearing, Pfc., Sioux Falls, S. D.
9KJ, Cummings, Sgt., address unknown.
9KEN, Winslow, Pfc., address unknown.
9LER, Tamsai, Lt., address unknown.
9LWJ, Zeuchner, Pfc., address unknown.
9MLA, Beattie, 2nd Lt., address unknown.



Our last word from W7GCT was when he was Corporal Greer, stationed at Ephrata Air Base in Washington with a communications squadron. Bob wrote us then that the fleece-lined jacket was a souvenir of his connection with a heavy bombardment group. These nippy mornings make us wish we had one, too!

9MUE, Cohen, T/Sgt., address unknown.
 9MUW, Johnson, Pfc., Grenier Field, N. H.
 9OCT, Hudson, M/Sgt., address unknown.
 9OIV, Oveson, Sgt., address unknown.
 9ORR, Hagenu, T/Sgt., address unknown.
 9OTK, Ugoletti, Pfc., Scott Field, Ill.
 9OXA, Jacobowitz, Capt., Stockton, Cal.
 9QLK, Frits, Lt., New Orleans, La.
 9QNA, Maysonholder, Cpl., address unknown.
 9RNI, Scholpp, Cpl., address unknown.
 9SOB, Broeder, Cpl., address unknown.
 9TJT, Perry, Cpl., Sioux Falls, S. D.
 9TPT, Smith, Pfc., Sioux Falls, S. D.
 9ULB, Luitink, Sgt., address unknown.
 9UVR, Gornick, Cpl., address unknown.
 9VDR, Stolz, Cpl., address unknown.
 9VPD, Jones, Pfc., Sioux Falls, S. D.
 9WTK, Kavlak, Sgt., Sioux Falls, S. D.
 9YBK, Sarchett, T/Sgt., address unknown.
 9ZMH, Stebbins, S/Sgt., address unknown.

20KT, Arany, Robert
 3DTO, Roberts, R. S., RE
 3EHT, Miller, O. C., Lt.
 3FBU, Miller, E. S., Lt. (jg)
 ex-3FEH, Miller, W. J., Comdr.
 3HPQ, Schimmelpfennig, W., Lt. (jg)
 3IDS, Wright, R. J.
 3IKV, Gray, J. C., RT2c
 3TZ, Bernstein, N.
 4C8S, Mantey, W. F.
 4DDV, Hawkins, H. C.
 4DVX, Stewart, J. M., RT2c
 4FIJ, Fincher, N. W., S/Sgt.
 4FMD, Hood, R. M., RT2c
 4FXZ, Terry, C. E., RT2c
 4GSD, Adams, J.
 4GWM, Woop, R. M., RT3c
 5FLK, Smith, A. M.
 6JMK, Reed, W. A., RE
 6NQD, Klippel, J. E.
 6OEC, Schmidt, B. F.
 6KQLX, Gillispie, T. J., Lt. (jg)
 6QQO, Wingfield, E. A., ARM1c
 6SBS, Newhouse, T. A., RM1c
 6SFS, Jackson, D. E.
 6SSL, Snyder, M. E.
 7AHA, Soules, E. E.
 7EVR, Edlund, R. W., CRM
 7FNJ, Spaug, R. L.
 7HAY, Hall, F. M., S/Sgt.
 7HFY, Kester, R.
 7IKT, Johnson, F. J.
 8LBI, Prostinak, G. A.
 8NAB, Steig, H. D.
 8PSE, Taylor, W. W.
 8QCT, Cirelli, A.
 8SAM, Skowron, J. F.
 8SVN, Poterack, W. J.
 8UCL, Opple, J., RT2c
 8UQF, Barnhart, J. M.
 3WRB, Tenny, R. D.
 9BXH, Wright, L. C.
 9EVS, Russell, C. T.
 9IX, Jensen, Theodore A.
 9JRI, Chapman, Jack C.
 9MCD, Novotny, W. J., RE
 9MQE, Booker, James P.
 9MYA, Barrows, Dale R.
 9NJ, Lewis, H. A.
 9POW, Rexer, E. F.
 9SKB, Burkhardt, P. E.
 9TDI, Hoyt, W. A.
 9VHO, Schaeperkoetter, Louis
 9VVT, Lemme, Earl
 9YDH, Morrison, R. C.
 9YFY, Ewing, R. D.

Operator's license only:
 Nahum, S. J.
 Tocarsic, J.



J. W. Estes, W6OMG, was last reported as a chief radioman on active duty with the Navy in England. His peacetime address was Hollywood.

NAVY—SPECIAL DUTY

ANOTHER parent comes to the fore with additional information for our ITS records: this time the mother of A/S Kelley, 6TCE, who sent data on her son and also several other hams on foreign duty. It's surely grand to have the parents cooperating so wholeheartedly — keep it up!

1JYW, Carlson, RT1c, Quonset Pt., R. I.
 2HZC, Cox, Ens., address unknown.
 2JOB, Wentink, Ens., address unknown.
 ex-2LHG, Brook, RT2c, Houston, Tex.
 2LWS, Galletta, RT2c, Pt. Huencne, Cal.
 2MHJ, Nelson, RT3c, foreign duty.
 2MHK, Nelson, RT2c, Treasure Island, Cal.
 2NKF, Dehler, RT3c, Treasure Island, Cal.
 3FCR, Pontus, ART1c, Elizabeth City, N. C.
 3III, Chorozsy, ART1c, Quonset Pt., R. I.
 4CVH, Mayo, Ens., Brunswick, Me.
 4EVB, Lazenby, ART2c, Alameda, Calif.
 4HVA, Wafford, RT2c, foreign duty.
 4WB, Morgan, ART2c, Corpus Christi, Tex.
 5CJE, Gose, RT2c, Corpus Christi, Tex.
 5HOT, Freeman, RT1c, address unknown.
 6ITN, Jackson, RT1c, foreign duty.
 6KRI, Schuyler, Ens., Brunswick, Me.
 6QW0, Phillippi, RT3c, College Stn., Tex.
 6UGV, Seranton, ART1c, DeLand, Fla.
 7CAL, Earle, ART1c, Lakelhurst, N. J.
 7CC, Parker, RE, address unknown.
 7ITC, Rockne, RT3c, Treasure Island, Cal.
 8RJW, Tichy, Ens., foreign duty.
 8WBT, Miller, RT2c, Grove City, Pa.
 9AIG, Bittner, Ens., Princeton, N. J.
 9BCT, Coil, Lt. (jg), Brunswick, Me.
 9MBE, Klug, RM3c, San Diego, Cal.
 9OZA, Essad, Ens., address unknown.
 9PAR, Johnson, RT2c, Washington, D. C.
 9PUX, Glasnapp, RT1c, Dubuque, Iowa.
 9QFU, Winne, RT2c, Corpus Christi, Tex.
 9SXC, Arbogast, RT2c, New River, N. C.
 9SXT, Frawert, RT2c, Treasure Island, Calif.
 9VCH, Werner, address unknown.
 9VFL, Moore, RT2c, foreign duty.
 9VPU, Hill, Ens., Brunswick, Me.
 9ZAD, Jacobson, ART2c, Corpus Christi.
 ex-9ZBE, Johnson, RT3c, Treasure Island.
 9ZIF, Gordon, RT2c, address unknown.

Operator's license only:
 Logan, RT2c, Atlantic City, N. J.
 Walls, RT2c, Treasure Island, Calif.

CIVIL SERVICE

1AGB, Warden, Philadelphia Signal Depot.
 1AUN, Wiley, Philadelphia Signal Depot.
 1AXD, Zeitlen, Philadelphia Signal Depot.
 1BNE, Toth, Philadelphia Signal Depot.
 1CPA, Snyder, Philadelphia Signal Depot.
 1DKJ, Snyder, inspector, Wright Field.
 1DRE, Smith, Philadelphia Signal Depot.
 1HCU, Taylor, SC Labs, Ft. Monmouth.
 1HJE, Williams, NRL, Bellevue, D. C.
 1HRN, Wood, Philadelphia Signal Depot.
 1IN, Shaw, SC Labs, Ft. Monmouth.
 1IOR, Sandler, Philadelphia Signal Depot.

Operator's license only:

Ellis, Capt., Greenwood, Miss.
 English, Cpl., Sioux Falls, S. D.
 Granger, Pfc., Scott Field, Ill.
 Kane, S/Sgt., Sioux Falls, S. D.
 Kirlian, Cpl., Sioux Falls, S. D.
 Lewis, Capt., foreign duty.
 Lochner, Sgt., Patterson Field, Ohio.
 Mentick, Cpl., Jefferson Bks., Mo.
 Rogers, Pfc., Sioux Falls, S. D.
 Swenson, 2nd Lt., foreign duty.
 Wildachen, Sgt., Sioux Falls, S. D.
 Wolf, T/Sgt., foreign duty.
 Woods, Sgt., Ft. Bragg, N. C.
 Zerichan, S/Sgt., Bowman Field, Ky.

NAVAL RESEARCH LABS

WE'RE indebted to Mr. S. G. Fincher (father of W4FIJ) for the following list of hams at NRL's Radio Matériel School, Bellevue. They're a mixture of Navy, Marines and Coast Guard — officers and enlisted men, students and instructors.

IEOB, Paunoff, V. W., RM1c
 1IEQ, Stevens, R. B., RT2c
 1MEJ, Kimball, L. L.
 1MN, Emery, R. T., RT2c
 1MZM, Supryniewicz, V. A.
 2IES, Randall, W. H., RT3c
 2NYR, Neuman, R. L.



A group of British and American hams, all of whom were working together on secret radio developments in England at the time this picture was taken. Front row (l. to r.) — Ens. Messmer, W3IYH; Lt. Wood, G4JN; Lt. Comdr. Withington, W1KUR and Sub-Lt. Octolony, G60M. Back row — (Lt. (jg) Tremaine, W3BQ; Sub-Lt. McLune, G2BGM; Lt. Comdr. Ederger, W1BOO; Ens. Atkinson, W5GOC and Lt. (jg) Harwood, W1INV.

1JNM, Ryder, SC, radio eng., Presque Isle, Me.
 1JOY, Woodsum, foreign duty.
 1KMH, Shepard, Boston, Mass.
 1KVK, Warman, FCC, operator.
 1LFL, Tuttle, instructor, Warner Robins Fld., Ga.
 ex-1IUP, Stewart, Philadelphia Signal Depot.
 1LVN, Walden, AAF, radio tech., Columbus, Ga.
 1MGR, Sprague, Philadelphia Signal Depot.
 1NDR, Sienko, FCC, radio operator, Pleasantville, N. J.
 1NET, Ricker, FCC, Rhode Island.
 1NGV, Spiller, radio mechanic-technician.
 1NMR, Sheridan, SC Labs, Belmar, N. J.
 2AEL, Schwartz, SC Labs, Ft. Monmouth.
 2AHZ, Schmitt, SC Labs, Belmont, L. I.
 2AIW, Rogers, SC Labs, Ft. Monmouth.
 2AZW, Reed, SC Labs, Ft. Monmouth.
 2BBV, Schlitt, Signal Labs, Ft. Hancock.
 2BHB, Zetekoff, SC Labs, Ft. Monmouth.
 2BPW, Silverman, SC Labs, Ft. Monmouth.
 2BWF, Tepper, SC Labs, Ft. Monmouth.
 2BVB, Ramm, SC Labs, Belmar, N. J.
 2BYK, Wegge, SC Labs, Ft. Monmouth.
 ex-2CIP, Ward, SC Labs, Belmar, N. J.
 2CTI, Woehrer, Signal Labs, Ft. Hancock.
 2CYS, Suhooski, Signal Labs, Ft. Hancock.
 2EDI, Shiffelin, SC Labs, Ft. Monmouth.
 2EHN, Smith, SC Labs, Belmar, N. J.
 2EZV, Verger, Signal Labs, Ft. Hancock.
 2FXE, Tucker, Signal Labs, Ft. Hancock.
 2FYZ, Shaymoa, Signal Labs, Ft. Hancock.
 2GOI, Voigt, FCC, address unknown.
 2HNX, Van Velsor, SC, mechanic, Camp Evans, N. J.
 2HWX, Sharp, SC, Engineer, Camp Coles, N. J.
 2HXF, Tomaso, Signal Labs, Ft. Hancock.
 2ICV, Wiscup, SC Labs, Ft. Monmouth.
 2IVU, Schatz, SC Labs, Ft. Monmouth.
 2IYH, Wingold, FCC, radio operator.
 2JBG, Wiggins, Signal Labs, Ft. Hancock.
 2JWV, Worth, SC Labs, Ft. Monmouth.
 2JKR, Swenson, SC Labs, Ft. Monmouth.
 2KBI, Struble, Signal Labs, Ft. Hancock.
 2KJ, Ross, FCC, radio operator.
 2KNP, Rosen, CAA, communications opr.
 2KXK, Stefania, Signal Labs, Ft. Hancock.
 2LAL, Scott, SC, inspector.
 2LLK, Sobock, SC Labs, Ft. Monmouth.
 2LYY, Wright, SC Labs, Ft. Monmouth.
 2MCH, Soering, SC Labs, Ft. Monmouth.
 2MGX, Weber, Signal Labs, Ft. Hancock.
 2MKI, Reinhardt, Signal Labs, Ft. Hancock.
 2MON, Rosenkrantz, address unknown.
 2MOZ, Zimp, SC Labs, Belmar, N. J.
 2MWV, Wolfe, SC Labs, Ft. Monmouth.
 2NTA, Soules, SC Labs, Ft. Monmouth.
 2NUB, Whitting, SC Labs, Ft. Monmouth.
 2OAI, Waite, SC Labs, Ft. Monmouth.
 2ODF, Ross, SC Labs, Ft. Monmouth.
 2ODS, Willmont, War Dept., technician.
 2OPK, Sheridan, SC Labs, Belmar, N. J.
 3AUR, Speakman, NRL, Bellevue, D. C.
 ex-3AZI, Saum, SC, radio mech.-tech.
 3BAQ, Torretti, SC Labs, Ft. Monmouth.
 3BEK, Turner, Navy Dept., inspector.
 3BGD, Segen, address unknown.
 3COG, Seltzer, Navy Dept., Washington, D. C.
 3COY, Simmons, Philadelphia Signal Depot.
 3CSY, Scott, SC, radio aide, Ft. Monmouth.
 3DF, Sterling, FCC, Washington, D. C.
 3FLO, Trafion, AAF, Washington, D. C.
 3GGH, Rafferty, SC, Presque Isle, Me.
 3GNU, Wilbur, instructor, Ft. Monmouth.
 3HNR, Wilson, SC, inspector.
 3HNZ, Trout, Lexington Signal Depot.
 3HPQ, Riccobono, NRL, Bellevue, D. C.
 3JDS, Stoops, NRL, Bellevue, D. C.
 3JGO, Richie, SC, inspector.
 3JHW, Wilson, NRL, Bellevue, D. C.
 3JZN, Suedekum, Technician, Lowry Field, Colo.
 3JKO, Shaffer, NRL, Bellevue, D. C.
 3JLK, Taylor, NRL, Bellevue, D. C.
 3JLR, Storck, Signal Labs, Ft. Hancock.
 3JUC, Wetherill, Philadelphia Signal Depot.
 3WE, Shreibman, AAF, address unknown.
 3ZI, Raser, SC Labs, Ft. Monmouth.
 5GGE, Williams, Lexington Signal Depot.
 ex-6PTX, Watkins, Lexington Signal Depot.
 8BDV, Thompson, address unknown.
 8DOL, Stutz, Wright Field, Ohio.
 8NCH, Ripple, AAF, instructor.
 9DUC, Reedy, NRL, Anacostia, D. C.
 9EVP, Barnett, FCC, monitoring officer.
 9FDV, Brown, address unknown.

9FSR, Stromberg, Ft. Monmouth, N. J.
 9IR, Bond, address unknown.
 9JCK, Sturek, address unknown.
 9KSE, Richards, SC, instr., Trinidad, Colo.
 9KTN, Oakley, instr., USNTS, Madison, Wis.
 9MZN, Young, CAA, Chicago region.
 9NAK, Smith, instr., USNTS, Madison, Wis.
 9NHP, Nieman, address unknown.
 9NLB, Tucker, SC, mechanic, Tampa, Fla.
 9NMY, Vitkauskas, instructor, Scott Field.
 9NNU, Turner, radio engineer, Omaha, Nebr.
 9NVM, Nemen, SC, trainee, Burr School, Chicago.
 9NVU, Oberman, SC, instr., Trinidad, Colo.
 9NX, Shultis, SC Labs, Ft. Monmouth.
 9NYF, Olson, address unknown.
 9OAW, Poplosky, instructor, Scott Field.
 9OCC, Mortimer, Lexington Signal Depot.
 9OFB, Saunders, Philadelphia Signal Depot.
 9OFP, Ellis, inspector, Marion, Ind.
 9OLX, Olson, SC, inspector.
 9OMT, Strouhal, AAF, Oklahoma City, Okla.
 9OMZ, Oliver, Ft. Monmouth, N. J.
 9ONW, Tevelin, instructor, Scott Field.
 9OWZ, Stryker, engineer, Cheyenne, Wyoming.
 ex-9PCG, Taylor, SC school, Milford, Neb.
 9POD, Weber, NRL, Anacostia, D. C.
 9PSP, Stanton, foreign duty.
 9QDX, Morse, Philadelphia Signal Depot.
 9QMR, Springen, Philadelphia Signal Depot.
 9QMY, Neal, engineer, Omaha, Nebr.
 9RZP, Timberlake, SC Labs, Belmar, N. J.
 9SKH, Ramp, NRL, Bellevue, D. C.
 9SRF, Schisler, inspector, Towson, Md.
 9SVQ, Stief, Lexington Signal Depot.
 9SVU, Sherman, technician, Ft. Hayes, Ohio.
 9SVX, Rotramel, Lexington Signal Depot.
 9TBU, Ramsey, FCC, operator.
 9TII, Tripcony, FCC, foreign duty.
 9TJX, Wingert, SC, Virginia.
 9TL, McCallen, instructor, Scott Field.
 9TVF, North, FCC, Daly City, Cal.
 9TYJ, Wilton, SC, eng., Brookley Field, Ala.
 ex-9UIB, Rountree, AAF, instr., Tomah, Wis.
 9UJF, Peterson, Philadelphia Signal Depot.
 ex-9UKL, Warriner, Wright Field, Ohio.
 9UMQ, Olds, address unknown.
 ex-9UMU, Zmeskal, instructor, Scott Field.
 9UXI, Smith, instructor, Boulder, Colo.
 9VGI, Prell, Fort Monmouth, N. J.
 9VRT, Neary, CAA, Kansas City, Mo.
 9WKD, Underdahl, SC, operator, Omaha, Neb.
 9WOT, Pugh, repair depot, Springfield, Ill.
 9WFM, Opitz, instructor, Scott Field.
 9WCF, Wise, technician, Ft. Hayes, Ohio.
 9YRJ, Mills, inspector, Kearney, N. J.
 9YKS, Morf, SC Labs, Ft. Monmouth.
 9YQJ, Roper, FCC, monitoring officer.
 9YRF, Pochop, technician, Washington, D. C.
 9YSN, Stevenson, SC Labs, Ft. Monmouth.
 9YXC, Vincent, Lexington Signal Depot.
 9ZGR, McGuire, Philadelphia Signal Depot.
 9ZLP, Stenersen, Wright Field, Ohio.
 9ZTM, Williams, Lexington Signal Depot.
 9ZVO, Struve, Traux Field, Wis.

Operator's license only:
 MAvov, Signal Labs, Ft. Hancock.
 Patzerok, SC, inspector, Western New York.
 Rounds, SC, Grand Forks, N. D.
 Vandal, AAF, instr., Sioux Falls, S. D.

CANADA

At the risk of being monotonous, once again we remind you VE amateurs to send your war service records in to Headquarters right away, so that your listing may at least continue its fine showing. Better still, let's hit a new high next time. What say?

... —

Earlier this month we had a fine letter from Sgt. Scantlebury, VE3AMG, now in Westminster Hospital at London, Ont. This ham may be flat on his back with torn back muscles and a hole in

his leg, but he says, "It's swell to be alive and kicking!" Good luck and 73, OM — that's the spirit!

BCA

1HG, Grant, Lt., Halifax, N. S.
 3AKQ, Vollick, Sgt., Ont.
 3ATR, Lautenslager, Sig. Instr., Kincairdine, Ont.
 4A, Duval, address unknown.
 4AID, Grimsrud, Cpl., address unknown.
 4HR, Chase, Maj., address unknown.
 4JW, Sheard, Maj., address unknown.
 4NV, Cooper, address unknown.
 4RS, Goodrich, address unknown.
 4TB, McGowan, address unknown.
 4SA, Sutfin, S/Sgt., address unknown.
 4ZL, Gibson, CSM, address unknown.

BCAF

3AKK, Burniston, L.A.C., Foreign Duty.
 3AKX, Perry, F/Lt., foreign duty.
 3ATF, Marshall, P/O, Clinton, Ont.
 3AVZ, Watson, Sgt., foreign duty.
 3AJY, Arnold, P/O, Vancouver, B. C.
 4AAP, Thompson, Sgt., address unknown.
 4ABC, Romanchuk, Sgt., address unknown.
 4ABG, May, address unknown.
 4AGW, Widdop, Sgt., address unknown.
 4AJF, Kirkby, Sgt., address unknown.
 4AJO, Sargenia, P/O, address unknown.
 4AJR, McCallum, Sgt., address unknown.
 4EH, Holmes, S/L, address unknown.
 4GX, Lawrence, address unknown.
 4LC, Donovan, Sgt., address unknown.
 4NJ, Coram, address unknown.
 4PW, Farmer, Sgt., address unknown.
 4QH, McMillan, P/O, address unknown.
 4RT, Earle, Sgt., address unknown.
 4UE, Richardson, Cpl., address unknown.
 4WM, Carroll, address unknown.
 4ZS, Dicksen, address unknown.
 5HG, Lanskaill, F/L, Montreal.

BCCS

2PX, Sidaway, Cpl., address unknown.
 3AGC, Burrows, Sgt., Foreign Duty.
 4AFN, Nelles, address unknown.
 4AMD, Ferrie, Lt., address unknown.
 4BT, Watt, WO1, address unknown.
 4GS, Grant, Capt., address unknown.
 4IH, MacLeod, Maj., address unknown.

Operator's license only:
 Grant, Lt., address unknown.

RCN

2LC, Stephen, Lt., Ottawa.
 4AAR, Clements, Ldg. Tel., address unknown.
 4AET, Melnyk, address unknown.
 4AFT, Matthews, Ldg. Tel., address unknown.
 4GE, Jameson, EA4, address unknown.
 4QA, Hulbert, address unknown.
 5AJU, Purvis, P.O. Teleg., Halifax, N. S.

RAF

5OR, Southall, P/O, foreign duty.
 5ZM, Wadsworth, F/L, foreign duty.



Canadian amateurs in the war effort are represented this month by a "sparks" in the merchant marine — P. R. Wharton, VE3AWQ, now a radio operator aboard a "little laker," and formerly from Waterford, Ont.

A Junk-Box Frequency Meter for 112 Mc.

A Heterodyne-Type Unit with Ham-Band Crystal Checks

BY WILLIAM ADAMS,* W6ANN

The need for simple apparatus suitable for spotting WERS transmitter frequencies has long been felt. W6ANN shows how the job may be done quite easily with the aid of ham-band crystals.

DURING my spare time, while waiting to get on the air with a WERS license (I am still waiting!), I have been working on a frequency meter to check the frequencies of those who have been so fortunate as to obtain licenses. I've often seen the phrase, "You can make this out of parts found in any ham's junk box —," but I think this is the first time I ever did just that. It wasn't that I wanted to, but the joints where I could bum a condenser or two finally folded and I couldn't buy a second-hand 80 even though I had two old ones to turn in.

Having been on 112 Mc. for a couple of years BPH (Before Pearl Harbor) and being so unfortunate as to live only a couple of miles from a monitoring station, I had to watch my frequency. I found that the best way to do this was to keep it between the 16th harmonics of a couple of my 40-meter rocks. With this in mind, I built the frequency meter around some 7-Mc. crystals. The first circuit I drew up was a beauty, including all known and unknown methods of frequency determination, voltage regulation and frequency stability; but after one trip to the junk box I threw out nine-tenths of it and got down to bare essentials — and not-too-good essentials, at that. There was a great lack of mica condensers, so paper tubulars had to do in a lot of places where

*6405 Corsini Place, San Pedro, California.

normally we would not think of using them. All the parts had been used one or more times before, and many of them had to be patched in order to make them work.

You will get the idea of the system by referring to Fig. 1. An electron-coupled oscillator, whose fundamental output frequency is in the 28-Mc. band, produces harmonics which may be picked up in the 112-Mc. band. Harmonics from a 7-Mc. crystal oscillator are used for constant calibration of the electron-coupled oscillator. To facilitate calibration, a mixer stage is provided so that the beat note between the two oscillator signals may be heard in a pair of headphones. It also helps in determining the frequency of a loud local signal.

There is nothing new about the individual circuits, since they have appeared many times in the *Handbook* and *QST*. The pentode crystal oscillator employs a 6V6 operating at the fundamental frequencies of the 7-Mc. crystals (mostly borrowed crystals from local ham rigs). A switch, S_1 , is provided to permit switching from one crystal to another or to turn off the oscillator by cutting the crystals from the circuit. B is a 60-ma. flashlight bulb or dial lamp which serves as an indicator of crystal current.

The electron-coupled oscillator, using a 6SK7, operates at 28 Mc., chiefly because the fourth harmonic of 28 Mc. gives a better signal at 112 Mc. than does the eighth harmonic of 14 Mc. The electron-coupled oscillator uses a fixed capacity of 35 μfd . which was stolen from the five-meter transmitter. To adjust the calibration when jars or aging have knocked it off slightly, a 2- μfd . air condenser is shunted across the fixed capacity.

One really important item in any frequency meter is a good dial readable to a tenth of a degree, but since nothing of this sort was available,

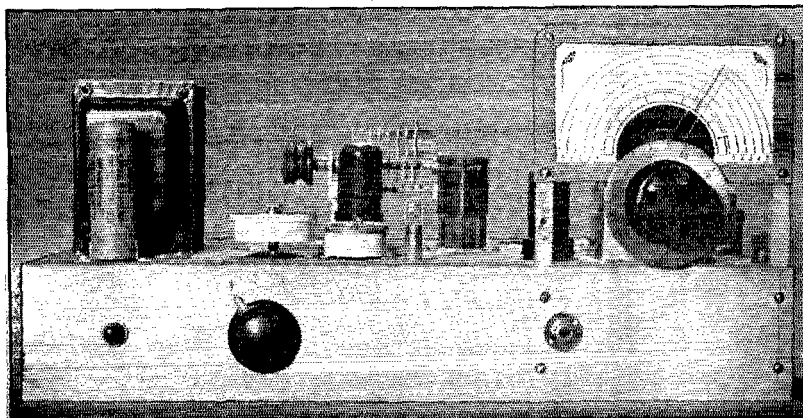

A front view of W6ANN's WERS frequency meter, showing the dial ready for calibration. The crystal switch knob and the pilot lamp are at the left on the chassis front, with the headphone jack at the right. The ACN dial at right controls the e.c.o., while the crystal-oscillator components are grouped in the center.

we got around it by pruning down the tuning condenser until the entire dial range covered little more than the 112-Mc. band. Actually it goes from 111 Mc. to 117 Mc.

Simple resistance circuits are used in the 6SA7 mixer, so no tuning is required. Voltage regulators would be a distinct advantage, but since these were not available we did the next best thing by pulling some high-wattage resistors from our 1-kw. 14-Mc. rig and bleeding the power supply fairly heavily.

The only trouble encountered in placing the unit in operation was from a flock of "birdies," noticeable when tuning the electron-coupled oscillator. This was eliminated by reducing the grid leak from the original 0.5 megohm to 0.1 megohm.

Construction

The pictures show most of the constructional details. No attempt was made to make a fancy job of it. I used an old salvaged chassis for mounting the parts. The power-supply equipment occupies one end of the the chassis. At the other end is the electron-coupled oscillator, with C_5 , the tuning condenser, at the front, and the coil and 6SK7 to the rear. The padding condenser, C_6 , is on the far side of the coil, while the trimmer, C_7 ,

is mounted close to C_6 . The 6SA7 mixer tube can be seen to the right of the tuning condenser.

The crystal-oscillator components are grouped together at the center, with the tuning condenser, C_4 , across the rear, and the tube and tank coil, L_1 , in front. The crystals are grouped directly over the crystal-selector switch, which is mounted underneath the chassis.

Calibration

Just because your crystal boasts a beautifully etched cover with the frequency imprinted thereon — don't you believe it! Not only does the frequency change with the age of the crystal (I have some that have shifted two or three kc. with use), but there's always the chance that crystal holders may have been switched at one time or another in the dim past. And then there was the time during that DX contest when you got out the Bon Ami. If you don't have some accurate method at hand for measuring frequency at 7 Mc., it is better to have someone re-calibrate your crystals. I took the whole unit to a local concern where they are turning out crystals for the Army, and they calibrated the frequencies of the crystal oscillator.

After the crystals have been calibrated, the next step is to draw a calibration curve for the

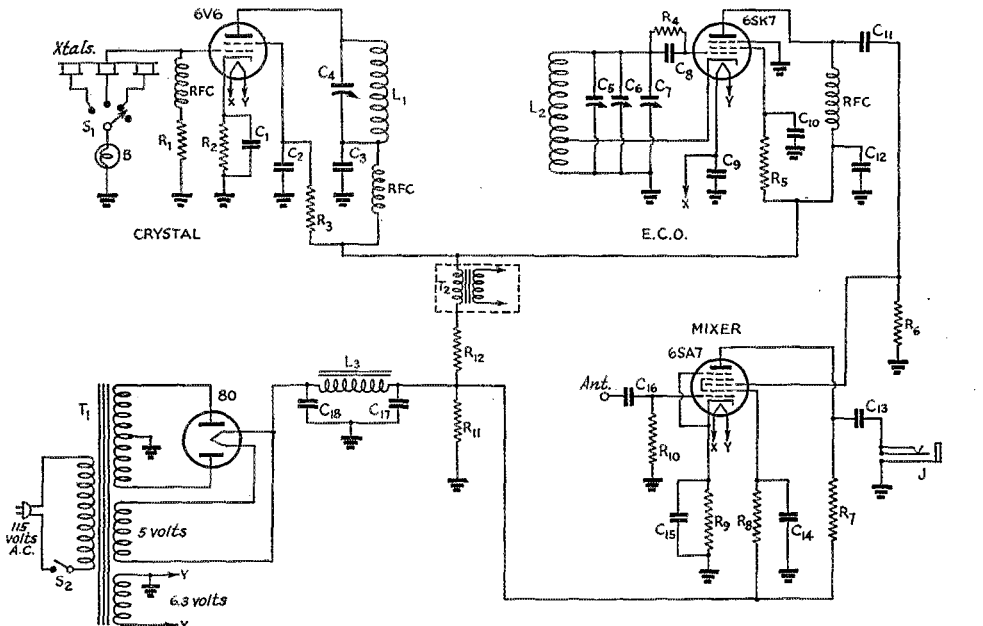
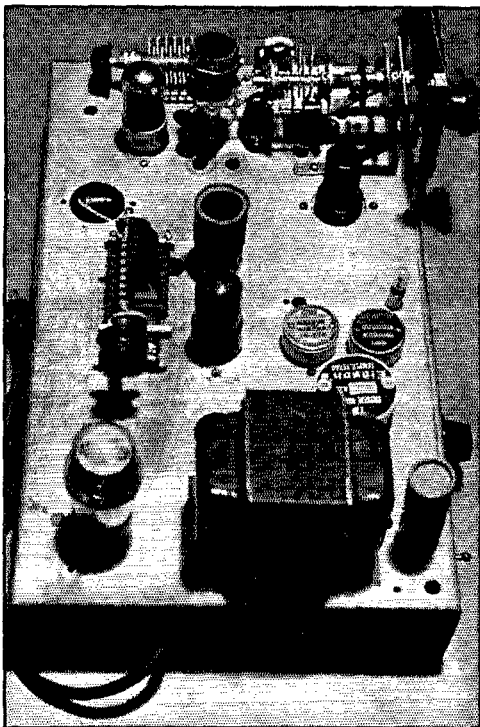

Fig. 1 — Circuit diagram of W6ANN's 112-Mc. heterodyne frequency meter and calibrating crystal oscillator.

- $C_1, C_2, C_3, C_9, C_{10}, C_{12}, C_{14}$ — 0.01- μ fd. paper.
- C_4, C_6 — 35- μ fd. variable.
- C_5 — 10- μ fd. variable.
- C_7 — 2- μ fd. air trimmer.
- C_8, C_{16} — 0.001- μ fd. mica.
- C_{11} — 0.002- μ fd. mica.
- C_{13} — 0.5- μ fd. paper.
- C_{15} — 10- μ fd. 35-volt electrolytic.
- C_{17}, C_{18} — 8- μ fd. 450-volt electrolytic.
- R_1, R_3, R_7 — 50,000 ohms, 1-watt.

- R_2 — 500 ohms, 10 watts.
- R_4 — 100,000 ohms, 1-watt.
- R_5, R_8 — 200,000 ohms, 1-watt.
- R_6 — 1 megohm, 1-watt.
- R_9 — 200 ohms, 1-watt.
- R_{10} — 25,000 ohms, 1-watt.
- R_{11} — 12,000 ohms, 100 watts.
- R_{12} — 5000 ohms, 250 watts.
- L_1 — 23 turns No. 18, $1\frac{1}{2}$ -inch diameter.
- L_2 — 4 turns No. 18, $1\frac{1}{8}$ -inch diameter, $1\frac{1}{8}$ inches long.

- L_3 — 30-henry filter choke.
- B — 60-ma. dial lamp or flashlight bulb.
- J — Open-circuit jack.
- RFC — 2.5-mh. r.f. choke.
- S_1 — Multi-point crystal switch.
- S_2 — Toggle switch.
- T_1 — Power transformer; 800 volts, center-tapped; 6-volt and 5-volt filament windings.
- T_2 — Modulation transformer (if used; see text).



Top view of the 112-Mc. frequency meter, showing the power-supply equipment in the foreground, crystal oscillator in the center, and the e.c.o. and mixer at the top.

electron-coupled oscillator. Pick up a few sheets of graph paper from your local "5 and 10" and go to work. After the unit has warmed up for at least 30 minutes, listen for the beat note between the fourth harmonic of the crystal oscillator and the fundamental of the electron-coupled oscillator in the output of the mixer, as you tune the electron-coupled oscillator. Mark the zero-beat point on the chart, showing the 16th harmonic of the crystal frequency instead of the crystal frequency itself, or the product of 16 and the crystal frequency. Do the same for all available crystals. While I use only three crystals — one for each end of the band and one for the middle — the more crystals you use, the greater will be the accuracy of your interpolation between the known points. Incidentally, the low-frequency edge of the 112-Mc. band corresponds to 7000 kc., the middle of the band to 7125 kc., and the high-frequency edge of the band to 7250 kc. Now that you have all the points on your chart, draw a line connecting them and you have a calibration curve for the electron-coupled oscillator.

Operation

Before using the frequency meter always allow it to warm up for at least thirty minutes, and always run through your crystals to see that the curve is still correct. If it is only slightly off, it can generally be brought back into line by a slight adjustment of the 2- μ fd. trimmer. How-

ever, if some radical change has taken place it may be necessary to draw a new curve for the electron-coupled oscillator. After making sure that the curve is still in alignment with the crystals, turn the crystal switch to the "off" position in order to eliminate any confusion as to which oscillator you are listening.

The simplest thing, of course, is to determine the frequency of your own transmitter. All that is necessary is to turn on your rig and listen in the 'phones for zero beat between the fundamental of the transmitter and the fourth harmonic of the electron-coupled oscillator. Note the dial reading and read your frequency from the calibration curve. In some cases it may be necessary to use a small antenna on the mixer tube, as shown in the diagram, although I have not found this necessary.

The hardest problem is determining the frequency of another station with a reasonable degree of accuracy. The reason for this is that 99 per cent of all receivers in general use are "rush boxes." When the electron-coupled oscillator is tuned, the presence of its harmonic is noted by the receiver being taken out of superregeneration over a rather wide portion of the dial — too wide for accurate results. This was overcome in a similar model made by the Long Beach net by the insertion of a modulation transformer, T_2 , in the common plate lead to both the crystal oscillator and the electron-coupled oscillator. By using a single-tube audio oscillator, enough modulation (probably 10 to 15 per cent) is obtained to modulate the oscillator slightly. In the superregenera-

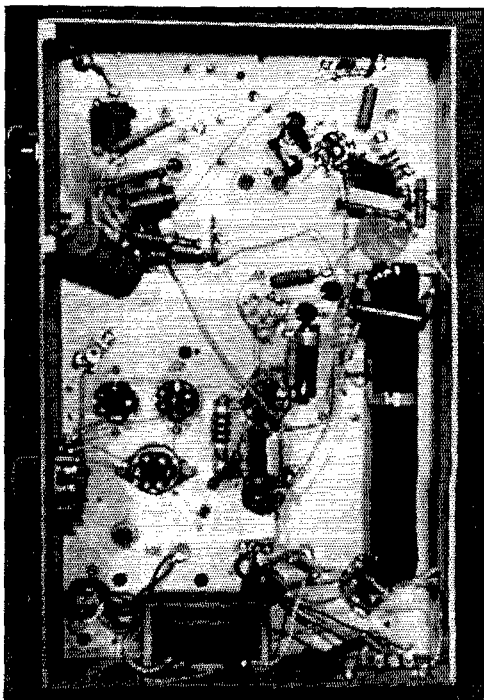

Bottom view of the 112-Mc. frequency meter.

tive receiver this type of signal appears over only a very narrow range, and makes a rather accurate reading possible.

No provision for modulation was made in my model because it was not necessary with either of my receivers. The first, made when I was a bit more optimistic with regard to frequency stability on 112 Mc., is a converter ahead of my RME 69. While this brings in the signals, they are so badly frequency-modulated as to be unintelligible. However, if I can get the station to use c.w. instead of 'phone to identify itself, a very accurate reading can be obtained with the electron-coupled oscillator. The second receiver is a resistance-coupled-i.f. superhet, using a 956 as detector-oscillator. This receiver not only brings in signals better than any other receiver I have ever had, but it also gives accurate results with the frequency meter.

Accuracy

The accuracy of this frequency meter depends upon a number of things, but fundamentally on the accuracy of the calibration of the crystals. However, any kind of a low-drift crystal should hold within plus or minus 1 kc. of its calibrated frequency. If you have some wild X or Y cuts, it would be better not to use them in this frequency meter. If you do have an error of plus or minus 1 kc., this would mean an error of 16 kc. at the 16th harmonic. Then, if another 1 kc. is allowed for error in calibrating the electron-coupled oscillator from the crystals, the total error in the calibration of the electron-coupled oscillator will be 17 kc. If, then, you are using a superheterodyne converter, or a resistance-coupled-i.f. superhet, another 1 kc. should be allowed for error in reading the frequency of the incoming signal. The over-all accuracy then would be approximately 0.017 per cent, in the worst possible case.

However, if you are using a superregenerative receiver, the accuracy will be much worse. From past experience, even with the audio oscillator, the best that can be expected is a total error of about 42 kc. This represents a possible error of about 0.037 per cent.

As a still further check on the accuracy of the frequency meter, I have checked it against two known stations. One is a police station just outside the band, on the high-frequency side, while the other is a harmonic from the voice frequency of a 55-Mc. television station. Both of these check very well. Undoubtedly, you will be able to find similar local signals for checking your own frequency meter.

Strays

Peerless Electrical Products Co. of Los Angeles, has announced production of a new moisture-proof and dust-proof transformer. Its principal feature is glass or porcelain insulators with metal bands which are soldered into the transformer case and thus become an integral part of the case.



Gold Stars

T.(JG) **RALPH HOLLIS**, USNR, W4AFC, communications officer on the U.S.S. *Arizona*, was killed when the Japanese sunk that ship during



the attack on Pearl Harbor. A member of the Naval Reserve for many years, he was called to active service in May, 1941. He attended the post-graduate school at Annapolis before being assigned to the *Arizona*. For his bravery under fire, W4AFC was posthumously awarded the Order of the Purple

Heart, and a recently launched destroyer was christened the U.S.S. *Hollis* in his honor.

Long a diligent and active amateur, W4AFC was a participant in perhaps the outstanding early amateur emergency achievement—the Florida hurricane of 1928. Hollis and Forrest Dana, W4AGR, put W4AFC on the air and contacted the War Department at Washington, giving the first reports of the disaster.

Before being called to active service, W4AFC was in charge of police radio communications for Palm Beach and West Palm Beach.

WARRANT OFFICER **D. S. WILLIAMS**, W4BAH, gave his life while on coastal patrol with the Civil Air Patrol. Motor trouble developed shortly after taking off from the base on afternoon patrol and the two-seater plane crashed, instantly killing both the pilot and W4BAH.

"Steve" Williams made radio his life's work as well as his hobby. He was an ardent amateur, and the voice of "W4BAH (Big Apple Henry), Wallace, North Carolina, the largest strawberry market in the world,"



had circled the globe. When the War Department called for volunteers from the amateur ranks, W4BAH enlisted in the CAP, and in September, 1942, was called to active duty at the Coastal Patrol Base at Beaufort, N. C. He took his ham transmitter and other radio gear with him, and the base began operations using his equipment. W4BAH had been promoted to Warrant Officer just three days before his death.





U.S.A. CALLING!



TECHNICAL LEADERSHIP

THE most pressing wartime radio need known to us is that for highly qualified engineers and physicists capable of supplying technical leadership and doing original work in the application of radio to new military requirements. It is reported to us that that need is a very real one. We have had several items on this subject in recent months but here must repeat the appeal. It is realized that any man worth his salt in such a capacity probably is busy and well connected at present, but there may be some who feel that their present employment does not allow full latitude for their capabilities and who would be interested in exploring, in mutual confidence, the possibility of a more important connection. An avenue for such correspondence has been created: you are invited to write under personal cover to the president of the League, George W. Bailey, Technical Aide to the Director of the Office of Scientific Research & Development, 1530 P Street, N.W., Washington 25, D. C. There is more behind this work than meets the eye, but we cannot talk about it beyond saying that many of the men reached through this contact are doing very important work.

Opportunity in this work exists for available persons of almost all categories of skill — not only engineers and physicists but radio technicians. Women possessing technical radio training are needed as much as men. For whatever grade of work in radio one may be qualified, an interesting connection can probably be developed by corresponding with Mr. Bailey at the above address. Employment in civilian capacity.

INSPECTORS AT WAR PLANTS

INSPECTORS are needed to inspect and test, electrically and mechanically, aircraft radio equipment and associated gear, to interpret specifications, to make inspection reports, etc., at various contract plants throughout continental United States, supplying equipment to the Navy. These are Civil Service positions, known as Inspector of Radio, in five grades running from junior to senior. The particulars are contained in Civil Service Announcement No. 3-100, to be seen at your post office. Salaries in the five grades run from \$1971 a year for the junior grade to \$3163, for the Federal work-week of 48 hours. Men only. No written examination — applicants are judged from a review of their experience.

Appointment is made at whatever grade one qualifies for, but in any event there is a course of instruction lasting about six months. It includes a complete course in radio theory, given at

the radio inspection school of the Naval Aircraft Factory in Philadelphia, with additional training in inspection procedures at the NAF itself at the Philadelphia Navy Yard. Upon completion of training the graduates are stationed at various contract plants, their chief duty being to determine that manufacturers are complying with specifications.

Depending upon the grade applied for, applicants must have had from two to six years' experience in the testing, inspection or repair of receivers, transmitters or sound systems, but with b.c. set repairing counting for not over four years. The completion of various courses of instruction in radio or physics, including the ESMWT course, may be substituted for two years of the required experience; and the possession of an amateur or commercial operator license substitutes for three years. Applicants must have completed the standard high school course of education, except that additional years of experience may be substituted, year for year, for up to two years of high school, except in the senior grade of inspector. Minimum age 18; no maximum limit.

Although applicants all over the United States are invited to reply, applications may be filed only with the Director, Third U. S. Civil Service Region, Customhouse, Philadelphia 6, Pa. The necessary forms may be secured either from him or at any first- or second-class post office in which Announcement 3-100 is posted.

OPERATORS & TECHNICIANS

THE Civil Service Commission is seeking radio operators and mechanic-technicians for positions in the Federal service. No maximum age limit; no written tests. At your local post office, see what is called "Amendment to Announcement No. 134 of 1941."

Radio operators are wanted in a number of Federal agencies throughout the country, who can transmit and receive Continental at a sustained speed of not less than 20 w.p.m. Typing ability is desirable for some of the positions. They pay from \$1970 to \$2190 a year. Applicants who are willing to go anywhere in the U.S. have the most likely chance at appointment.

Mechanic-technicians are needed to assemble and maintain modern communication equipment and other radio gear. Positions are both in Washington and elsewhere in the country, and pay from \$1752 to \$3163. The \$1752 position may be qualified for by meeting any one of the following requirements: at least one year of full-time paid experience in technical radio or related electronic work, such as radio electrician or

engineer, repairman or operator; or completion of an ESMWT course in any branch of radio, or of a six months' resident technical radio course in an acceptable radio school; or of one year of resident study in a school of engineering or technology which included radio courses. For the higher-paying positions, applicants must have had additional paid experience or appropriate resident study.

Application forms are available at first- and second-class post offices and the Civil Service Commission's regional and Washington offices. Applications should be filed direct with U.S. Civil Service Commission, Washington 25, D. C.

SEAGOING OPERATORS WANTED

THE need for seagoing brass-pounders continues as our merchant marine fleet grows. Manning of most of these vessels is a function of the U.S. Maritime Service, which advises us that they are still on the lookout for operators and still maintaining the splendid training program recently described in *QST*.

If you yearn for the open sea, there are few ways in which you can better serve your country than shipping as Sparks. Further information can be obtained from the Maritime Service enrolling office nearest you, or by writing direct to The Commandant, U.S. Maritime Service, Washington, D. C.

LABORATORY MECHANICS

THE National Bureau of Standards in Washington is searching for laboratory mechanics for war work. Amateurs are aware that in peacetime the Bureau develops working standards of measurement, quality and performance for science, engineering and industry, doing the necessary testing and investigating. The war has brought the Bureau many new problems, including projects of a secret and confidential nature. Lab mechanics are needed in connection with the construction, installation, maintenance and operation of electronic and electrical equipment, machine shop equipment, automotive equipment, etc.

These are Civil Service jobs, paying \$1752 to \$2798 a year (including overtime pay). Minimum age 18; no maximum. No written test. A minimum of six months of appropriate experience or training is required for the lowest-salaried positions, with additional training for those paying more. Details and application forms at your post office.

DRAFTSMEN FOR WAR WORK

A HUNDRED draftsmen are being sought by the Civil Service for war work in Federal agencies. Entrance salaries range from \$1752 to \$3163 a year. Draftsmen of all types are needed, particularly ship, electrical, and mechanical draftsmen, as well as topographic draftsmen. Agencies needing these types of personnel in the greatest numbers are the Navy Department, the Coast & Geodetic Survey, and the Geological Survey; the Treasury Department and WPB utilize statistical draftsmen.

Qualified engineering draftsmen in any field are urged to apply. However, persons without previous experience in the fields where needs exist may be appointed and trained. Women are especially desired. Applicants having training or experience primarily in commercial art, interior decorating, etc., which included any drafting training or experience will be considered. For positions paying \$1752 a year, requirements are at a minimum. Persons may qualify with 6 months of practical elementary full-time paid drafting experience, or with completion of one of the following types of study: at least 3 semesters of training in drafting in high school; or a thorough course of drafting requiring actual classroom work in a school specializing in drafting; or an ESMWT course in engineering drafting; or a course in drafting in a college or university.

Interested persons may secure Announcement 283 and application forms from first- and second-class post offices; from Civil Service regional offices; or from the Commission's main office. Applications should be sent to the U.S. Civil Service Commission, Washington 25, D. C.

COMMERCIAL OPPORTUNITIES

THERE was no expected summer slump in industrial needs for radio personnel and currently the demand continues good. Every so often an employer lists with us requirements for a certain type of radio man with little technical or college training, presenting an opportunity of unusual character for the man whose special qualifications fit.

For example, six weeks ago an employer wanted thirty men with no other radio experience than plenty of brasspounding and traffic handling on amateur frequencies. A Class B license was necessary but no other technical background was required. The salary and type of work were both fascinating.

Such specialized opportunities are not referred to us every month, but to the man with limited formal technical training they present the big chance. All of which goes to prove you should not neglect filing an Application of Personnel Availability, even though most of the League's Personnel Bureau calls are for men with college degrees or considerable technical background.

Last month we addressed "Commercial Opportunities" primarily to employers in need of radio personnel instead of to radio men in need of jobs. Although October *QST* has been on the newsstands little more than a week as this is being written, three employers have written us for radio men. They need high-grade electronics engineers, laboratory technicians, test-equipment operators and commercial airlines ground-station men. Could you have qualified for any of these?

Don't overlook a good bet. If you are available, not subject to draft reclassification if you change employment, and want to contribute more to the war effort in essential radio work, write the Personnel Bureau for an application blank now. No obligation of any sort, but the League will do its best to refer your name to an interested employer.

A V. T. Voltmeter for A.C. and D.C.

A Simple Unit Easily Constructed from Available Parts

BY A. D. MAYO,* W4CBB

Effective servicing and testing of modern electronic equipment requires the use of a voltmeter which gives accurate readings when connected across high-impedance circuits. For this reason, the vacuum-tube voltmeter has become an almost indispensable measuring device. The simple but useful instrument described here can be constructed with a minimum of hard-to-get components.

MAYBE you don't need a vacuum-tube voltmeter. But if you do, you will need a rabbit's foot and four horseshoes to get the microammeter for the business end.

Here is how one instrument was built up using a meter that no self-respecting government purchasing agent would look at twice. The meter, a thermomilliammeter having a range of 0-4000 ma., was taken from a spark-gap diathermy machine some 15 or more years old. When the thermocouple was disconnected, the movement was found to be a d.c. milliammeter requiring 8 ma. for full-scale deflection.

The instrument shown in the photographs reads d.c. voltages in 3 ranges up to 500 volts. On the 10-volt scale, the input resistance is approximately 1,000,000 ohms per volt. On higher ranges it is somewhat less, simply because no multi-megohm resistors were available. The d.c. test prod has a 1-megohm resistor in its far end; it may be placed on the grid of a tube to measure a.v.c. voltage, or on the plate of a resistance-coupled audio stage to measure plate voltage. The uses for this voltmeter are almost unlimited, and one need

*610 E. North St., Greenville, S. C.

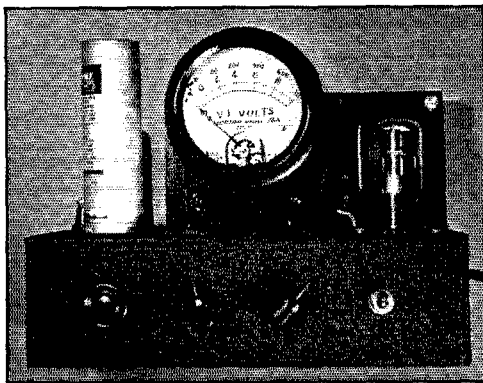

Front view of the vacuum-tube voltmeter chassis. The meter was revamped from a discarded thermoammeter.

never worry about disturbing the voltage distribution of the circuits being measured. Leaky condensers, which automatically repair themselves from the surge created by measuring voltages with the ordinary 1000-ohms-per-volt meter, can be located quickly with this high-resistance meter. If an incidental d.c. voltage appears at a point where a reading is to be taken, such as bias on a grid where a.v.c. voltage is to be measured, the unwanted d.c. can be wiped out by a twist of one control.

Circuit Details

Referring to the circuit diagram shown in Fig. 1, the 0-8 ma. d.c. movement, *M*, reads plate current to a 6J5GT/G tube whose grid is connected to the voltage source under measurement. The more negative the input voltage, the less the plate current. With a meter requiring this much current it is not practical to measure full-scale voltages of less than about 10 volts, but the lower ranges fortunately are not required as often as are the higher ranges. Sticking to higher ranges also avoids trouble with grid current and contact potentials.

R_{11} is a cathode-biasing resistor which is adjusted to give full-scale deflection on the meter with the desired input voltage. A reasonable amount of degeneration is introduced so that any 6J5 series tube can be used in place of the one with which the meter is originally calibrated, without recalibration. In fact, the 6J5GT/G can be replaced with a 6C5, which has a mutual conductance of about 20 per cent less, without disturbing the calibration more than a few per cent. The setting of R_{11} is not especially critical and, once set, it can be forgotten.

S_2 controls a voltage divider which divides the input voltage to provide the proper value for the grid of the 6J5GT/G. The resistors used were not especially selected precision types; some were plain carbon resistors. They were chosen by the cut-and-try method, and the ones in use have proved to be sufficiently accurate. If a handful of 10-megohm resistors had been available, an input resistance of 1,000,000 ohms per volt could have been maintained all the way up to the 500-volt scale. In this case, a double-pole switch at S_2 would not have been necessary.

R_3 and C_1 form a filter which removes any stray a.c. from the input voltage, so that the grid of the 6J5GT/G is not swung positive on peaks. R_3 also performs the important function of limiting the d.c. potential on the grid, thereby protecting the meter. When excessive voltage is impressed on the input, say 100 volts when the meter is on the 10-volt scale, the grid of the 6J5GT/G is driven posi-

tive and the grid current through R_3 biases the tube so that its plate current is limited. The meter is protected, because it is impossible to get more than 10 or 12 ma. to flow through M by application of d.c. to the input. There is a little lag in voltage building up across C_1 , anyway, and the meter pointer does not bang the pin very easily.

R_{19} is a potentiometer which may be used to apply a controllable bias to the input network. Its range is approximately 0 to 20 volts; the voltage is stabilized by the neon bulb, N_2 . Although it was originally intended merely to supply bias to balance out the d.c. drop across the cathode of the 6F5 a.c. tube, R_{19} offers a surprisingly convenient method of spreading out the meter scale. For instance, suppose we start at zero and measure a d.c. voltage which increases up to 9 or 10 volts. This is the end of the scale, and, if the voltage increased further, we would have to go to the 100-volt scale to measure it. However, when the voltage reaches 10 volts we can turn R_{19} so that the meter pointer returns to zero. Then, if the voltage increases, we can just add the 10 volts bias to the reading, retaining the calibration spread of the 10-volt scale. The calibration of the meter scale is not linear, but no error is introduced by this trick since the tube is always operating at the same portion of its curve when the meter pointer is in the same place. In this way, the 10-volt scale can

be stretched to 30 volts, the 100-volt scale to 300 volts, and, I suppose, the 500-volt scale could be taken to 1500 volts, except that the insulation in this meter probably would not stand voltages that high. In measuring negative voltages, the meter pointer can be set at 8 instead of zero and voltages read backwards, to spread out the scale. The markings will not be correct, but the 1-volt divisions will be, and it is simple to count them down from 8.

Because the bias voltage supplied by R_{19} (discussed above) is critical, it is stabilized by the neon bulb, N_2 . The neon bulb gives a 65-volt drop where only 20 is needed, but the desired voltage is tapped off through the resistors shown. Since no current is drawn through these resistors, the voltage remains accurately divided. N_2 carries the cathode current of the 6J5GT/G, and it would extinguish at zero plate current if it were not for R_{22} , which keeps its minimum current at a couple of milliamperes.

Measuring A.C. Voltages

S_1 selects either the d.c. probe or the a.c. probe, which consists of a 6F5 tube mounted at the end of a shielded cable. The 6F5 acts like a degenerative plate detector, with the output voltage built up across the cathode resistor, R_{10} . C_4 by-passes r.f. and C_2 by-passes the lower frequencies, so that

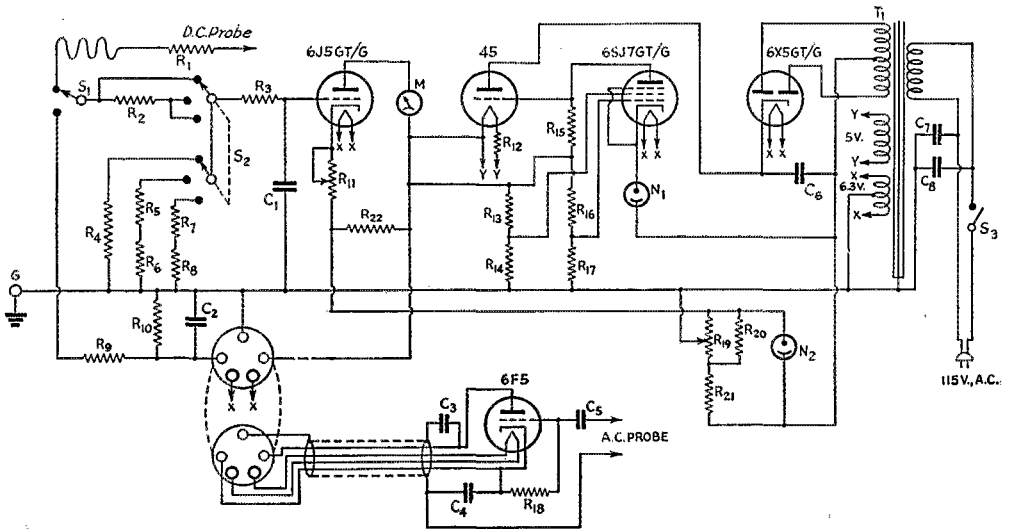
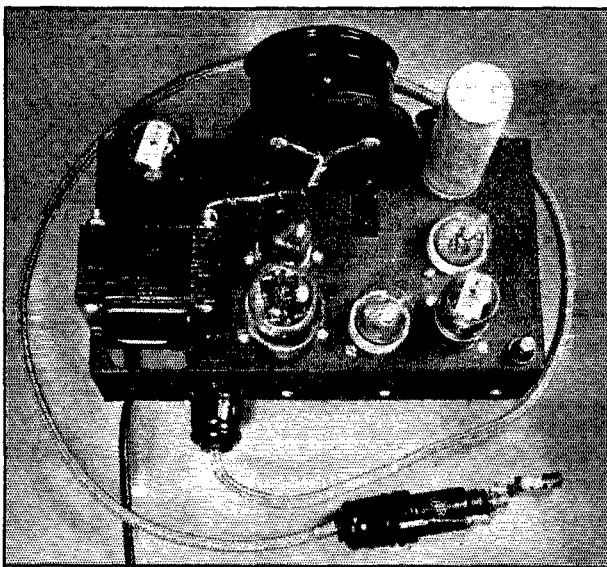

Fig. 1 — Circuit diagram of W4CBD's vacuum-tube voltmeter.

- C_1 — 0.1- μ fd. 600-volt paper.
- C_2 — 0.005- μ fd. 600-volt mica.
- C_3, C_4 — 50- μ fd. mica (in shield on 6F5 socket).
- C_5 — 0.01- μ fd. 600-volt mica.
- C_6 — 16- μ fd. 450-volt electrolytic.
- R_1 — 1 megohm, $\frac{1}{2}$ -watt (in insulated probe handle).
- R_2 — 10 megohms, $\frac{1}{2}$ -watt.
- R_3 — 250,000 ohms, 1-watt.
- R_4 — 10 megohms, 1-watt.
- R_5 — 1 megohm, 1-watt.
- R_6 — 100,000 ohms, 1-watt.
- R_7 — 200,000 ohms, 1-watt.
- R_8 — 20,000 ohms, 1-watt.

- R_9, R_{10} — 1 megohm, 1-watt.
- R_{11} — 1500 ohms, variable, 10-watt.
- R_{12} — 1.67 ohms, 12-watt (six 10-ohm, 2-watt units in parallel).
- R_{13} — 10,000 ohms, 2-watt wire-wound.
- R_{14} — 20,000 ohms, 2-watt wire-wound.
- R_{15} — 500,000 ohms, 1-watt.
- R_{16} — 40,000 ohms, 10-watt wire-wound.
- R_{17} — 13,000 ohms, 10-watt wire-wound.

- R_{18} — 5 megohms, $\frac{1}{2}$ -watt.
- R_{19} — 10,000-ohm wire-wound.
- R_{20} — 7000 ohms, 2-watt.
- R_{21} — 20,000 ohms, 5-watt.
- R_{22} — 50,000 ohms, 2-watt.
- N_1, N_2 — 1-watt neon bulb (without base resistor).
- S_1 — Single-pole double-throw ceramic switch.
- S_2 — Double-pole three-position ceramic switch.
- S_3 — Toggle switch.
- T_1 — Power transformer; 350-0-350 volts, 6.3 and 5-volt filament windings.



Top view of the vacuum-tube voltmeter, showing the chassis layout and the 6F5 a.c. prong on the end of its shielded extension cable.

these condensers charge up to the peak of the a.c. voltage. The 6J5GT/G then acts as a d.c. amplifier, and the peak voltage built up between ground and the cathode of the 6F5 is measured. The same meter scale is used for both d.c. and a.c. but it must be borne in mind that, with the a.c. meter, peak values are indicated. With sine-wave input, the r.m.s. value would be the peak multiplied by 0.707. No means was at hand to check the calibration of the a.c. meter at high frequencies. It checks very well at 60 cycles, and it appears to work well up to 14 Mc.; at least, the 6F5 probe will indicate whether or not a h.f. oscillator is putting out when it is touched to the output circuit. On my ham receiver, at 14 Mc., a peak voltage reading of 3 volts is obtained at the grid of the 6SA7 mixer, and, although it is higher at 3.5 Mc., there is also more grid current at 3.5 Mc. Thus the meter is useful for relative values, at any rate. An acorn tube would be much better in this position than the 6F5, because of the lower loading capacities.

Construction

Since changes in the plate-supply voltage will affect calibration, a voltage-regulated plate supply is used. This is composed of the neon tube, N_1 , the 6SJ7GT/G control tube, and the 45 regulator tube. This regulator system has been described in *QST*¹ and the *Handbook*.

Originally an 80 rectifier tube was used, while a separate winding on T_1 supplied 2.5 volts to the 45 regulator tube, whose filament is at a high positive potential above ground. This winding was not designed to operate at a high voltage above ground, however, and the insulation leaked intermittently to one of the other windings, causing

¹ Grammer, "Battery Performance from the R.A.C. Power Supply," *QST*, August, 1937, p. 14.

erratic operation. The subterfuge shown in the diagram was then resorted to, and a 6X5GT/G is now used in place of the 80 tube. The 45-tube filament has been shifted to the 5-volt filament winding, with the home-made resistance, R_{12} , in series to drop the voltage to $2\frac{1}{2}$ volts. The incoming a.c. line is by-passed to ground through C_7 and C_8 .

All the parts are mounted on the $5\frac{1}{2} \times 10 \times 3$ -inch chassis. A smaller power transformer could have been used just as well. Also, a VR150-30 regulator tube might have been used in place of the three-tube regulator circuit shown, if this tube had been on hand. The meter is not a flush-mounting type, so it had to be supported at the rear with a sub-assembly made up of a piece of plywood and dime-store metal brackets. The front part of the meter projects about $\frac{3}{4}$ inch over the edge of the chassis, so that it becomes effectively a flush-mounted meter when the chassis is placed behind

the panel. This instrument is intended for mounting behind a test panel in conjunction with other test equipment. No case is shown, therefore, but it might just as well be mounted in a wood case with a plywood panel.

Any source of variable d.c. may be used for calibration. I used a 20,000-ohm potentiometer across an old 45-volt "B" battery. An ordinary voltmeter was hooked in parallel with the v.t. voltmeter input leads, and marks were made on a paper scale at different voltage points. These lines were inked in and the new scale then was pasted over the original meter scale.

A handy incidental use for this instrument would be to supply filament and regulated plate-supply voltages for experimental use. When the 6F5 probe is unplugged, the voltages at the 5-contact socket at the rear of the chassis are available by plugging in 'phone-tip plugs. About 10 ma. can be taken safely from the plate supply, if the 6J5GT/G is removed from its socket and R_{11} turned all the way to the right (zero resistance). The voltage will be 170.

Strays

What's the resonant frequency of your log book? No kidding — W1IOR, on a recent visit to Hq., reported that he had one that was tuned to around 7 Mc. It was one of those red-covered ARRL log books with the spiral wire binding. Apparently the inductance and distributed capacity of the spiral winding were such as to make it tune to 7 Mc. Anyway, every time he'd touch it when the rig was on the air he'd get a little r.f. burn. Oddly enough, of the many books of that type he has used, only one displayed such an effect.

★ HAMDOM ★

CAPTAIN FRED H. SCHNELL, USNR, W9UZ, base communications officer at an unnameable Navy operating base, is shown below wearing his new shoulder boards. One of the country's best-known hams, Schnell started before the Law of 1912 and never stopped. In World War I he was called to active duty in the Naval Reserve in May, 1917, first at Great Lakes, then at the trans-Atlantic receiving station at Belmar where he copied the first message from Italy to President Wilson; then to DNC, Washington, where as the operator on watch he not only copied Germany's armistice acceptance message, but transmitted the first message to her after the cessation of hostilities (POZ de NFF, 13,600 meters). He was chief on the *George Washington* on President Wilson's voyage to the peace conference.

From 1920 to 1926 he was Traffic Manager of the ARRL at Hartford, during which time he managed the ARRL Transcontinental Relays (remember that record of 6½ minutes elapsed time, round trip?); made the first amateur trans-Atlantic contact, West Hartford to Nice, France, on 112 meters; copied the first message from South American amateurs. In 1925 the Navy borrowed him from ARRL, in the rank of lieutenant, USNR, to accompany the Fleet on its cruise to Australia to demonstrate the potency of short waves with his ham-built equipment at station NRRL aboard the flagship. He was made a lieutenant-commander in 1925. Radio engineer of the Chicago Police Department as the war neared, he was again called to active duty at Great Lakes in 1940, becoming District Communications Officer and being promoted to commander in July, 1941. His present rank dates from June, 1942.



AN OLD TIMER in ham radio, Captain William J. Lee, USNR, ex-W4IU, ex-W4XE, is Assistant Director of Naval Communications for Administration in Washington. Commissioned a lieutenant (jg) in 1917 in the Naval Reserve Flying Corps, he served throughout that war in various capacities connected with aviation which included participation in the first flight by Colonel Porte of the RAF in his original twin-motored flying boat.

In 1920 he constructed and put 4IU on the air and shortly thereafter, in partnership with John C. Cooper, jr., established 4XE, which incidentally was licensed "from 200 meters to infinity." This call became well known all over the world between 1922 and 1928. The third station in the U.S.A. to make use of crystal control, 4XE made the first short-wave c.w. contact between this country and Holland, and the first 'phone contact between the United States and Sydney, Australia, in May, 1924. At this time 4XE was operating on 30 Mc. and was probably the only v.h.f. station besides that at Schenectady. Between 1924 and 1928, 4XE maintained schedules with Dr. A. Hoyt Taylor of the Naval Research Laboratory, and much of the Navy's experimental gear was tested on the week-end circuit between old NKF and 4XE.

In 1926 he received his commission as a lieutenant commander in the Naval Reserve, at which time he undertook to organize the communication reserve in Florida and the Seventh Naval District. In September, 1929, he entered active duty to organize the NCR on a national basis. He has also served on the *Omaha* and the *Texas* and in the Bureau of Personnel, where he organized and established a number of the Navy's radio and signal schools now in operation. He was promoted to commander in July, 1940, and to his present rank in June, 1942.



EXPERIMENTER'S SECTION

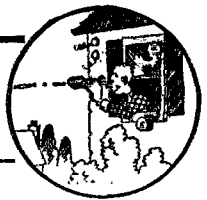

Address correspondence and reports to ARRL, West Hartford, Conn.

PROJECT A

Carrier Current

ONE of the most important phases governing carrier-current transmission appears to have been neglected in the published material I have read. That is the choice of a frequency which will give maximum output under the normal conditions of load on any particular power line. Most experimenters apparently plunk their c.c. rigs on 175 kc. or close to it, probably because they have coils available at that frequency. From wherever they land they try to get out, piling on power and cussing. However, as in space radio, power is not the solution to most transmitting problems. We have made extensive experiments on what I believe to be the most complicated carrier network in existence today, on the basis of power-line ramifications between stations. Our experience has included both "high power" (50-watters well overloaded) with very poor communication results, and, in contrast, low power to an 802 or 807, running cool which provided excellent signals over the same network.

The power-line system between any two stations will have definite individual transmission characteristics. Many frequencies invariably will prove poor to worthless, and only a few will be really good. This is true even on an ideal net, one in which there is a simple power line between stations with no branches taken off the line and no substations or transformer banks along the line. The addition of any of these complications tends further to reduce the possible number of good operating frequencies. To show what can happen, we had one set-up with an ideal net in one section. There were no tap lines off the line and transformer banks only at each end, which were taken care of by traps. Our best operating frequencies proved to be at several points between 43 and 58 kc. Later a tap line was added to the system, with no traps provided for isolation. C.c. communication on the former frequencies then became very poor, in fact impracticable. It was necessary to run new transmission curves on this section of line, after which we were again able to establish good communication — on a new frequency of 120 kc! Practically all frequencies below that proved worthless under the new conditions on the line. We are convinced that the experimenter attempting to operate over complicated low-tension networks, with taps, transformers, etc., galore, faces a really tough job. To

be successful, he must learn how to select operating frequencies.

Running transmission curves on a system will prove a revelation. Such a curve will show at once why one frequency which proves good for c.w. is at the same time practically useless for 'phone. I am certain that many experimenters have run into that difficulty and blamed the whole trouble on the equipment, or else figured that 'phone was no good anyway! If you really want to start right and get somewhere on carrier current, commence by running transmission curves on your line system, be it power line, telephone line or barbed-wire fence. You will be more than repaid for the trouble, and a lot of fun will be had by all (I hope!).

A fairly powerful variable-frequency oscillator will be needed, with tone modulation of any kind which will enable the receiver to follow the signal. Either the oscillator must be calibrated or a low-frequency wavemeter must be used with it. The range covered should be from 25 to 300 kc. or more. It is generally true of long high-tension systems that frequencies below 30 kc. are bad, and likewise those above the neighborhood of 300 kc. If a wavemeter is not available and no means of calibrating the oscillator is at hand, the next best practice is to provide the tuning control with as good a dial as can be obtained. Then dial readings instead of frequencies are recorded, so that one can at least return to good operating points. From such points one can calibrate the regular c.c. transmitter by any one of a number of means. The receiver used with the oscillator for running the curves was a simple non-regenerative detector with a stage of audio and an output meter. A vacuum-tube voltmeter would be better.

Take as many spot readings as possible. On our system we always went over the range in 1-kc. steps. It takes quite a while to cover from 25 kc. to 300 kc. that way, but when you have finished you have a real transmission curve that is worth studying. During the readings the loading of the oscillator should be kept as nearly constant as possible. Using a pair of "cans" at the receiving end, the signal should be followed over the entire run, in order not to record any phony peaks that may result from broadcast band harmonics, commercial transmitters, other c.c. rigs, including the power company's own communications system or relaying system. The plotting should be the output meter or v.t.v.m. reading against the frequency setting. If frequency calibration was not provided, then the signal strength readings will have to be plotted against the dial division numbers. If the dial is not finely divided, $\frac{1}{4}$ -point and $\frac{1}{2}$ -point readings should be taken and plotted.

Examination of your completed curve may possibly reveal steep-sided peaks of voltage reading, less than *one kilocycle* in width! If you set your transmitter precisely on that point, it will be excellent for c.w., but 'phone will sound very badly, since most of the side-bands are chopped off. If you are selecting a 'phone frequency you will probably have to forego some of the "sock" obtainable on one of these narrow peaks, in order to use a peak of say four or five kilocycles width to allow for a voice-modulated carrier. Such a peak need not be flat-topped for the entire 5 kc. A "hump" with one or two kilocycles at maximum and gradual slope on both sides will as a rule prove satisfactory. Ordinary common sense in interpreting the curve will enable you to select a good operating spot for your transmitter.

If three or more stations are to operate on the same net, it is best to run curves between all the stations, in every possible combination of receive and transmit, and using the same oscillator and receiver in each instance. The separate voltage curves, properly identified by using differently colored inks or pencils, should all be recorded on one chart. Then you will really have something! To select the best operating point it will be necessary to determine the best *average* peak of all curves, at all stations. Some stations no doubt will be obliged to sacrifice something in signal strength through operating at a point less than optimum for some of the contacts, but necessary if all stations are to be enabled to keep in the picture. If such a compromise cannot be worked out satisfactorily, then the net must be subdivided into sections which have a relatively good frequency in common.

Another advantage in running the transmission curves is the revealing of particularly noisy spots that may now be avoided, as well as the spots occupied by established communications systems.

Too little consideration seems to have been given to the use of tuned "antenna" circuits. The practice of coupling into the line through a condenser and a hunk of wire, in the case of transmitters, and into the untuned inputs of receivers,

is distinctly bad. In space radio, where we operate over wide ranges, we get away with it on receivers and seldom give an untuned transmitting antenna net a second thought. In carrier current, however, the transmitter will in all likelihood "stay put," so that tuned receiver input and transmitter output circuits will offer no operating complications, once adjusted. They do add materially to results, in fact, in some cases may mean the difference between success or failure.

Taken together, the intelligent selection of an operating frequency and the proper adjustment of coupling circuits to the line will give reasonable assurance of a reliable communication circuit. Even though the process may seem to run into a good deal of time, and perhaps some headaches, isn't it better than going blindly ahead? And isn't it better than copying some other fellow's rig, squatting on 180 kc. because the other fellow happened to have conditions that gave him good results on that frequency, then being disappointed in your own results, tearing up the rig and rebuilding again in a futile effort to get out on 180 kc. or burn down the shack in the attempt, only at last to squeeze out a few squeaks over a mile or two of line, and finally quit in disgust? Let's go at this thing in the right way! — *Herbert M. Walleze, W8BQ, P. O. Box 18, Drums, Pa.*

— . . . —

Are all the hams and s.w.l.s here in Providence defunct or something? I haven't seen a thing in *QST* about wired-wireless activity in the city. I would like to get in touch with anybody interested. I haven't a long-wave transmitter, but I will build if you will! — *Joseph P. Feehan, 401 Orms St., Providence, R. I.*

— . . . —

Two fellow amateurs with myself are interested in wired-wireless transmissions. — *Frank Robbins, 261 Morris Ave., Inwood, L. I., N. Y.*

(Continued on page 78)

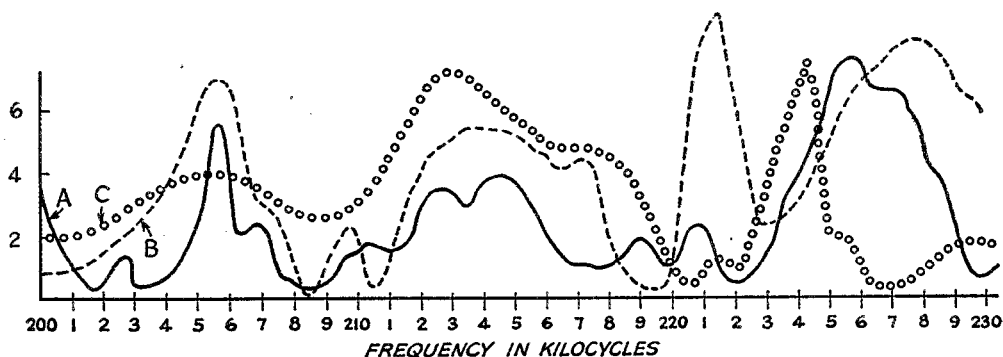

Fig. 1. — A set of transmission curves run by three carrier-current stations to determine optimum operating frequencies for intercommunication. Such peaks as those at 205.6 kc. on the A curve, 221.3 kc. on the B curve, and 224 kc. on the C curve, are suited only for the sharply tuned carrier of a c.w. signal. From a synthesis of the three curves, it would appear that the optimum frequency for these stations to use in common would be 224.5 kc. The units of the vertical axis of the curve are in a.f. volts as indicated by an output meter.

The Signal Corps Puts On a Show

A Pictorial Visit to the Signal Corps Exhibit at the Army War Show

DURING September the U. S. Army staged a gigantic "Back the Attack" show at Washington in support of the Third War Loan drive, exhibiting its latest and best in a manner to make America proud of its military machine.

It was more than a show. It was a miniature world's fair—a military world's fair. Every branch of the Army was represented. Almost every item of armament and equipment now in use was to be seen; the work of every branch was demonstrated. Some of the matériel on display had never been exposed to public view before. Even the enemy was represented, in the form of captured matériel ranging from uniforms and minor weapons to a Messerschmidt and a Zero.

The Army War Show as a whole consisted of acres of large exhibit areas (the Army Air Forces exhibit alone occupied an entire square block) occupied by the individual branches, and an arena in which parades and combat maneuvers as well as speeches and other ceremonies were staged each afternoon and evening for the benefit of lucky bond-buying ticket-holders.

Outstanding in interest, of course, to anyone associated with radio was the Signal Corps section of the Army Service Forces exhibit, occupying



At this realistic division command post, visitors to the Army show witnessed demonstrations of combat messages being sent and delivered by radiotelephone and c.w., wire telephone and telegraph, teletype and facsimile.

an area of 40,000 square feet located near the main entrance at the corner of Constitution Avenue and 15th Street.

In this area three large tents were set up. One of these tents was occupied by the Army Pictorial Service, with its graphic demonstrations of how the motion picture goes to war and of how training films are made. Another tent of equal size was devoted to the Army Communications Service, many of the displays in which are de-

A section of the Signal Corps equipment display at the Army's "Back the Attack" show, showing the smaller portable and mobile units currently in active service. At the left is the guidon radio (*QST*, December, 1942, p. 22), the r.f. units of which are in the small container mounted on the lance antenna, cable-connected to batteries in a chest pack which carries a breast microphone. Next in line is a small vehicular f.m. transmitter-receiver with handset and whip antenna, completely self-contained except for the storage-battery power source, used on every type of vehicle from jeeps and command cars to the smaller armored units. In the center is the new f.m. walkie-talkie, with its familiar predecessor model alongside at the right. Using miniature tubes, the re-designed f.m. model has a materially extended range without increased size or weight. The real live Signal Corps private holds the ubiquitous 5-lb. handie-talkie (*QST*, December, 1942, p. 22), while the imitation Signal Corps horse behind him wears the latest cavalry pack set—which, of course, resembles the World War I model only in general shape.

RADIO SETS

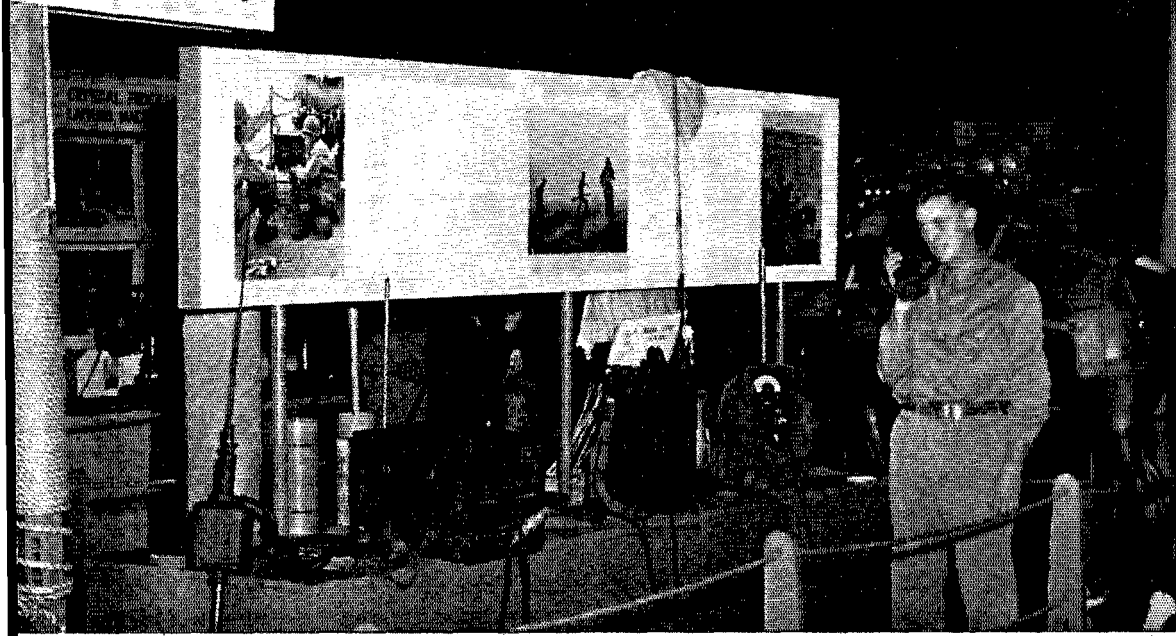

icted in the accompanying photographs. The third and largest tent housed the assorted exhibits of the Personnel and Training and the Engineering and Technical Services of the Signal Corps.

In the midway area bounded by the three tents the larger items of equipment were on view, including an SCR-299 mobile unit, command car and jeep installations, post-hole diggers, and so on. Especially interesting among these outdoor displays, because it was receiving its first public viewing, was a complete radio direction-finder, with the "silo" atop the tower opened up to permit a general view of the installation.

All in all, it was a mighty big show — convincing proof of the Signal Corps' ability to "Get the Message Through!"

A display of captured enemy matériel was a major feature of the Signal Corps exhibit. German radio equipment, captured on the battlefields of Tunisia, Stalingrad and the Caucasus by American and Russian troops, included complete aircraft and tank installations. Most of the equipment showed excellent workmanship. The microphone of a captured German pack-set once used by the Afrika Korps bore the admonishing label: "Feind mit horti! (The enemy listens too!)" while the panel of an all-wave receiver used by German troops for h.c. listening carried a stern warning in the name of Der Fuehrer that listening to foreign stations means the death penalty.

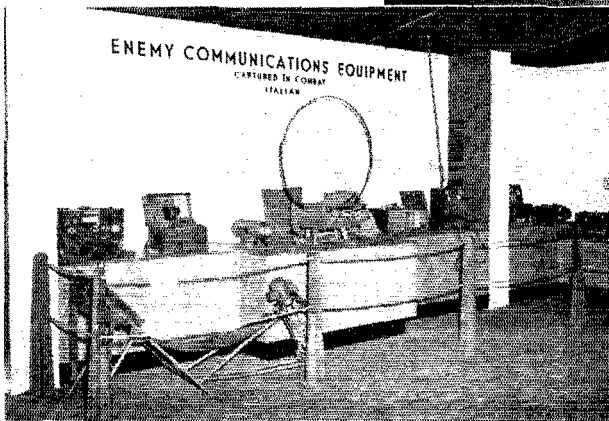

Notable items of captured Italian radio gear were a portable direction-finder using a fixed concentric loop and a walkie-talkie pack-set with whip antenna. The latter was unique chiefly for its complex control panel, including two large vernier-drive dials with magnifying indicators which enlarge the dial numerals to nearly an inch in height. In the left foreground is a foot-powered generator with reclining-back canvas seat, ironically dubbed the "beach chair" by the British.

The assortment of Japanese signaling devices, brought back by American troops from Guadalcanal, New Guinea and the Aleutians, was dominated by a sizable rotatable-loop direction-finder captured on Attu. The d.f. loop is seen in the foreground in the photograph at right. The loop was mounted on a wood-frame supporting tower, just to its right, which also holds the receiving apparatus. Ruggedly but simply built, this outfit was characterized by the Signal Corps as "large and well-made." Visible behind the loop is a "Made in Tokyo" Japanese field telephone outfit also captured on Attu. Other representative items of Jap gear were displayed, including a compact transmitter-receiver salvaged from an obviously more-than-slightly defunct Zero.

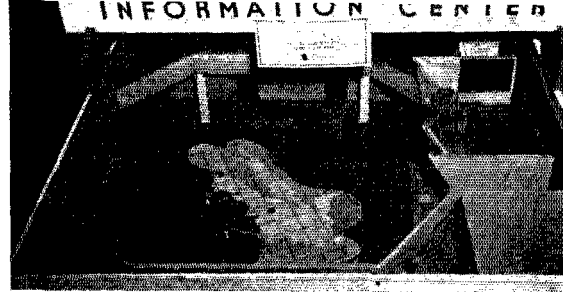
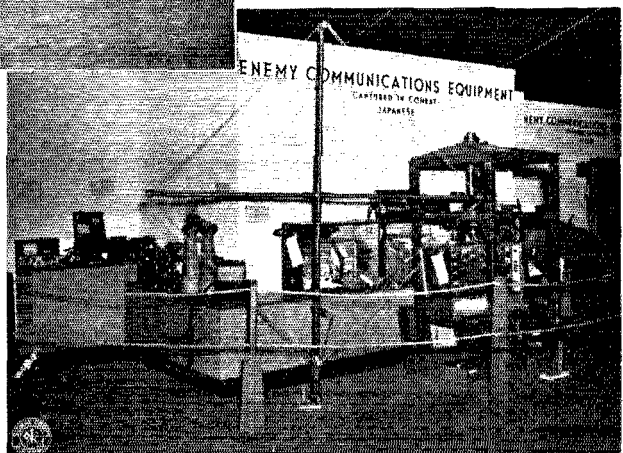

This detailed scale model of a typical information center for the Army's Aircraft Warning Service — the common ground where military and civilian defense workers join hands — showed visiting aircraft spotters exactly what happens to their telephoned reports.

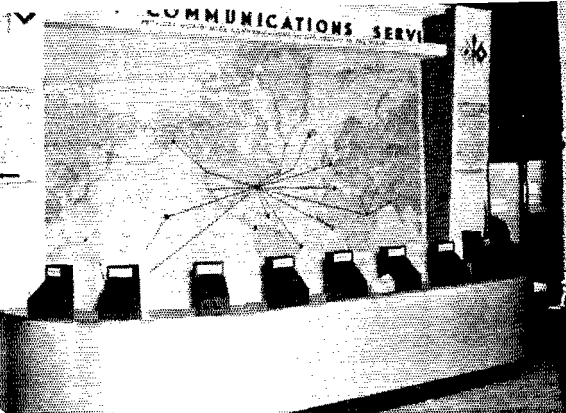

The Army Communications Service occupied an entire tent with its various exhibits displaying the world-wide communications network which keeps the War Department at Washington in constant touch with our troops in the field wherever they may be. Throughout, the greatest emphasis was on the high-speed automatic equipment used by the ACS. Dramatic proof of the extensive character of this service was given in the exhibit pictured at the left. The lines on the world map show the continuous 24-hour-a-day circuits maintained between WAR in Washington and ACS stations in Brisbane, Honolulu, Panama, San Juan, Recife, Iceland, London and Algiers. Ranged around the counter were loudspeakers connected by wire with the actual point-to-point receivers on these circuits at WAR. By throwing the switch on any speaker, the visitor could hear the actual high-speed c.w. signal coming through from the corresponding overseas point as labeled on the panel.

The high-speed radio circuits of the ACS were demonstrated by an operating replica containing all of the units of a world-girdling circuit within the compass of a single exhibit. Here visitors could actually witness their own messages being handled from one end of the room to the other over a duplicate of a world-wide high-speed circuit. On being handed a message written by a visitor, a uniformed Signal Corps operator translated it into a tape on the keyboard at the far left. This tape was fed to a Boehme keying head, the output from which went to the relay-rack assembly containing the transmitter, the three-input diversity receiver, and the recorder amplifier. A fourth rack carried the control panel, and an oscillograph unit. While the message was being "transmitted" the screen of the cathode-ray tube showed the dot-and-dash pulses, as also did the neon tube "lightning flash" above the display. Emerging finally as an inked tape from a Boehme recorder at the extreme right, the message was transcribed on a souvenir blank by another soldier-operator and then handed to the visitor as an appropriate memento of the show.



Adjoining the high-speed-transmission display was the Radiotype exhibit. On the manual high-speed circuits the radio operators, copying behind, transcribe inked-tape "slip" on typewriter keyboards, and in times of heavy traffic the system is so fast that two or more operators may be kept busy transcribing messages from a single tape. In the Radiotype system, on the other hand, messages are directly transcribed on an automatic electric typewriter at 100 words per minute. The apparatus in this display, which also was equipped with a receiver tuned to WAR, transcribed plain language press and general information dispatches being transmitted to the troops abroad, as well as other "canned" material from a tape library. The Radiotype is a dramatic device, in operation, with the robot typewriter noisily slamming its carriage over for every line, automatically adjusting for margins and indentations in exact split-second compliance with the standard typewriter keyboard on which the originating operator is sending the message, properly locating address, text and signature for each message on the long paper roll — and all at 100 words per minute!



Another display on the global theme, showing the functioning of the Army's radio teletypewriter system, contained two ordinary-looking teletype machines. They were like the kind that can be seen in almost any newspaper office except that, instead of being connected to wire lines, these machines were connected to radio circuits between the War Department Signal Center in Washington and various overseas points. Their output, typed on wide roll paper as in a regular teletype, was projected on two large screens of the Trans-Lux variety. On these screens the visitor could read press dispatches from foreign correspondents in the North African zone only a fraction of a second after the Signal Corps operator at Algiers punched them out on his keyboard.



In the largest tent of all were the diverse exhibits of the Personnel and Training and the Engineering and Technical Services. Among these were several training aids and aptitude tests, including one for code-learning ability. The electrical symbol chart at left was equipped with a wired pointer having a contact on its end. When the knob below was turned to indicate one of the electrical devices diagrammed and the pointer was placed on the correct symbol, the illuminated panel would announce "correct." If the wrong symbol were chosen, the panel flashed "wrong." The zero-beat indicator in the center combined a visual and aural demonstration of zero-beat tuning, an audible tone in the speaker varying in frequency as the knob was turned coinciding with a traveling beam of colored light on the screen. The sine-wave chart at right similarly indicated the linear projection of a rotating vector by means of traveling lights.

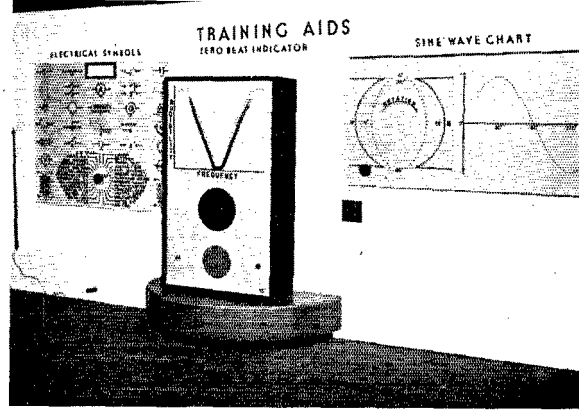

Elementary instruction in telephone circuits was afforded by a retardation-coil cord-circuit demonstration board, on which an operator using the central handset could control the circuits at either end by a simple plug and jack arrangement. Actual speaking and ringing circuits were used, and the youngsters got a kick out of telephoning each other and observing the action of the controlling relays. Other functioning telephone exhibits, including the sound-powered telephone which operates without batteries as well as displays of wire telephone and telegraph apparatus, demonstrated this important phase of Signal Corps communications in detail. The Army's famous field telephone, the EE-8-A, was on display, as were various sizes of switchboards and allied equipment. The wire section of the exhibit included a variety of cable reels and drums, a telephone-pole earth borer, and a cable plow. In the arena shows Signal Corps wiremen demonstrated the technique of setting up wire systems in theatres of combat, including cable splicing, wire laying, the recovery of field wire, digging pole holes and the actual construction of field telephone lines.

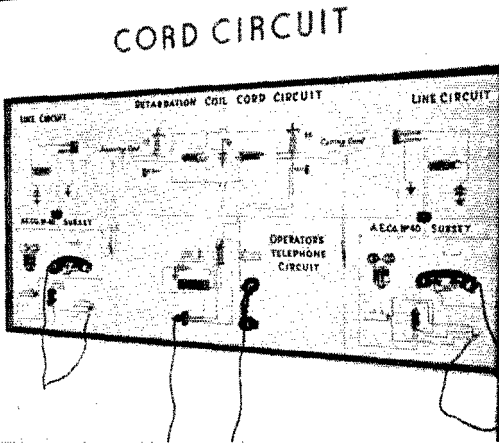

In the various displays were depicted all the widely diversified activities of the Signal Corps. Many had nothing to do with radio, of course, but even the radio exhibits alone covered a wide range of fields. The exhibit of meteorological equipment, for example, centered chiefly around radiosonde apparatus, including hydrogen balloons and tanks and the fragile-appearing "Sonde-Track" radiometeorograph instruments with their transparent plastic cases. Also exhibited was a complete radiosonde receiving installation for these miniature transmitters, with a "1-10" receiver, audio-frequency meter, ink graphic recorder and associated equipment, all mounted on a relay rack. Another interesting exhibit involving the allied field of photography was that of the radiophoto system. There news photos rushed from Mediterranean battlefronts and transmitted by radio from Algiers were reproduced as 7 X 9-inch negatives in seven minutes. In its wirephoto systems the Signal Corps uses both the electric spark and the controlled light beam processes, the former printing a direct positive on electrochemically sensitized paper while the latter first makes a negative on photosensitive film.

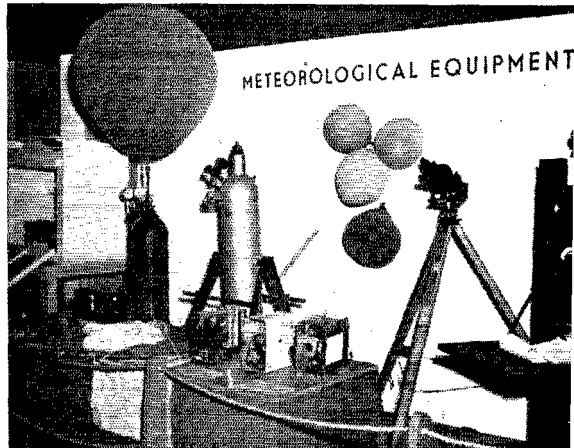

In line with the "Back the Attack" theme, a part of the Signal Corps exhibit was devoted to the processes of research, engineering and manufacture. This portion was typified by the quartz crystal display, presented in co-operation with the National Bureau of Standards. The exhibit showed the various manufacturing processes, stage by stage, from the grading and marking of the raw quartz through the sawing, dicing, finishing and testing stages, from wafers to blanks to finished mounted crystals. Included were examples of the actual machinery used in crystal manufacture. A visual comparison of relative accuracy was afforded by a side-by-side comparison of an ordinary micrometer (1/1000th), a more elaborate precision mechanical gauge (1/10,000th) and the electronic frequency comparator (1/1,000,000th).

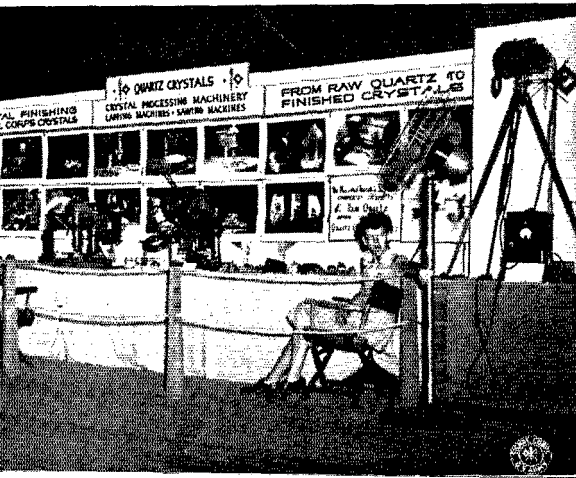

An Interpolation Oscillator

An Aid to Frequency Measurement With a 100-kc. Standard

BY FRANK H. MILLS,* W9HQH

This article describes auxiliary equipment for making precision frequency measurements with the 100-kc. crystal standard. Accuracies to within a part in one million are possible with the aid of the unit here discussed by W9HQH.

Most of those interested in frequency measurement are familiar with the system employing secondary-standard harmonics for generating signals of accurately known frequency which may be used for calibrating and for checking unknown frequencies to within 10 kc. The system consists of a 100-kc. crystal oscillator whose output locks in with and controls a 10-kc. oscillator of the multivibrator type. Since the output of the multivibrator is rich in harmonics, useful calibrating signals of high accuracy are produced every 10 kc. over a wide portion of the radio spectrum. The unknown frequency is measured by comparing it with the known frequency of the nearest 10-kc. harmonic from the multivibrator. Such secondary standards have been described in the *Handbook* and in past issues of *QST*.¹

However, precise measurement of an unknown frequency still requires auxiliary means of determining accurately the difference between the unknown frequency and the nearest standard frequency. Since the multivibrator produces a signal every 10 kc., it is obvious that the unknown frequency can never be more than 5 kc. removed from the nearest 10-kc. harmonic. Therefore, the

difference beat produced in the output of the receiver used to compare the two frequencies always is of some frequency between zero (when the unknown frequency coincides with a 10-kc. harmonic) and 5000 cycles (when the unknown frequency is exactly half-way between adjacent 10-kc. harmonics).

An interpolation oscillator provides a means of measuring differences within this range. This is essentially a calibrated audio oscillator whose frequency can be adjusted to match the audio output frequency of the receiver. When the two frequencies are matched in a suitable circuit, the difference frequency may be read from the calibrated dial of the interpolation oscillator. Such an oscillator can be built so as to be dependable within less than 100 cycles. Higher accuracy requires the use of a standardized check. In the oscillator described, this check is provided by a 100-cycle multivibrator, controlled by the 100-kc. crystal standard. Thus, measurements with an accuracy of a part in one million or better are possible.

The complete frequency-measuring system is illustrated in block-diagram form in Fig. 1. The type of audio oscillator most commonly used for the purpose is the beat-frequency oscillator. It consists principally of two r.f. oscillators and a mixer output stage. The frequency of one of the oscillators is fixed, while that of the other is variable. When the two oscillators are fed into the mixer stage, a frequency is produced in the output circuit whose value is the difference between the frequencies of the two oscillators. For example, if the fixed frequency is 100 kc., we can obtain the desired output-frequency range of 0 to 5000 cycles by designing the variable oscillator to tune from 100 kc. to 105 kc.

* 1525 Diversey Parkway, Chicago, Ill.

¹ Grammer, "A New Type of Frequency-Checking Device," *QST*, June, 1938, p. 21; Brown, "A Precision Crystal Frequency Standard," *QST*, August, 1940, p. 13.

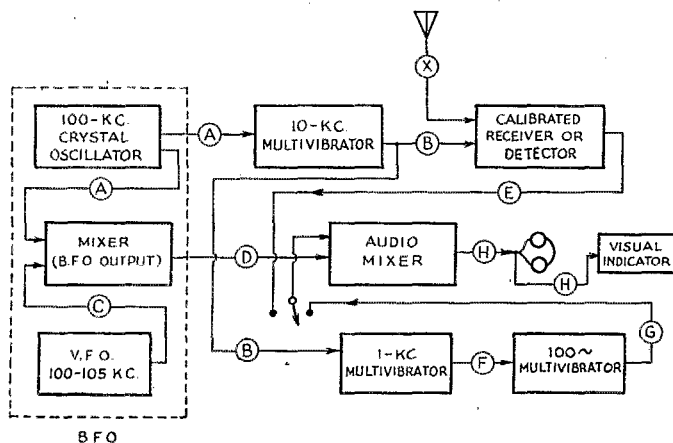

Fig. 1—Block diagram of a complete frequency-measuring system using a 100-kc. crystal secondary standard and an interpolation oscillator. The significant frequencies transferred between various sections are as follows:

- (A) — 100 kc.
- (B) — Signals every 10 kc.
- (C) — Variable, 100 to 105 kc. as v.f.o. is tuned.
- (D) — Variable, 0 to 5000 cycles as v.f.o. is tuned (difference between A and C).
- (E) — Between 0 and 5000 cycles (difference between nearest harmonic of B and X).
- (F) — 1000 cycles (and multiples).
- (G) — 100 cycles (and multiples).
- (H) — Adjusted to zero beat by matching (D) and (E) or (D) and (G).

Of course, if such a b.f.o. is to be used for accurate measurements, its output frequency must be stable and as free from drift as possible. There must be a minimum of "pulling"; that is, the frequency of the variable oscillator must approach that of the fixed oscillator smoothly without jumping suddenly to zero beat, thereby eliminating frequencies close to zero in the output of the mixer. The oscillator shown in the diagram will approach zero beat to within one-third of one cycle without pulling, and will stay within one cycle of a set frequency for a prolonged period.

Oscillator Circuit Details

The circuit diagram of the interpolation oscillator is shown in Fig. 2. Since a 100-kc. crystal oscillator already is available in the 100-kc. standard, advantage of its high stability has been taken by using it also as the fixed-frequency oscillator in the b.f.o. section. Its circuit, there-

fore, does not appear in Fig. 2. Output terminals of the 100-kc. oscillator are connected to the terminals so marked. A 6SJ7 is used in the v.f.o. circuit. The main tuning condenser, C_1 , provides a tuning range of 100 to 105.1 kc. when the adjustable-padder, C_4 , is set correctly. While linear tuning with this main control is not possible without a special condenser, the use of a straight-line-frequency condenser at C_1 prevents excessive crowding at the low-frequency end of the range. C_2 is a 100- μ fd. vernier condenser for fine tuning. This condenser is used for final interpolation. It should be of the straight-line-capacity type. Since the ratio of its capacity to the fixed tank-circuit capacity is so small, its tuning characteristic is very close to linear. Both C_1 and C_2 should be fitted with dials which may be read to one part in 1000 (one-tenth of a dial division), although only the one for the main tuning control need be of the vernier type.

The signal from the v.f.o. is coupled by L_2 to the injection grid of the 6L7 mixer. L_4 - C_{11} and L_5 - C_{10} are series and parallel trap circuits tuned to 100 kc., which help to eliminate harmonic transfer.

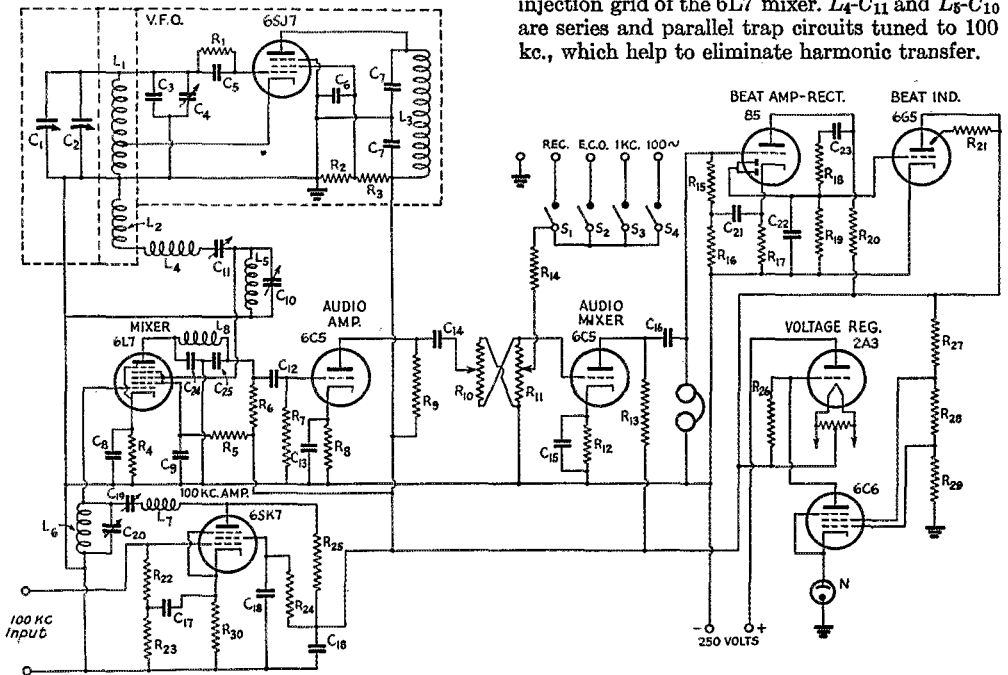

Fig. 2 — Circuit diagram of the interpolation-oscillator unit.

- | | | |
|---|--|--|
| C_1 — 500- μ fd. s.l.f. variable. | $R_1, R_6, R_{15}, R_{16}, R_{22}, R_{23}$ — 50,000 ohms, $\frac{1}{2}$ -watt. | R_{25} — 125,000 ohms, $\frac{1}{2}$ -watt. |
| C_2 — 100- μ fd. s.l.c. variable. | R_2, R_3 — 20,000 ohms, 5-watt. | R_{27}, R_{29} — 10,000 ohms, 10-watt. |
| C_3 — 0.004- μ fd. silvered mica. | R_4 — 450 ohms, $\frac{1}{2}$ -watt wire-wound. | R_{28} — 35,000 ohms, 10-watt. |
| C_4 — 275- to 850- μ fd. mica padder. | R_5, R_{18} — 25,000 ohms, $\frac{1}{2}$ -watt. | R_{30} — 450 ohms, $\frac{1}{2}$ -watt. |
| C_5 — 500- μ fd. silvered mica. | R_7, R_{19}, R_{26} — 500,000 ohms, $\frac{1}{2}$ -watt. | N — Neon lamp, 1-watt (no base resistor). |
| $C_6, C_7, C_8, C_9, C_{12}, C_{17}, C_{18}, C_{22}$ — 0.1- μ fd. 400-volt paper. | R_8 — 2500 ohms, 1-watt. | S_1 — S.p.d.t. switch. |
| C_{10}, C_{20} — 75- to 225- μ fd. mica padder. | R_9, R_{13} — 125,000 ohms, 1-watt. | S_2, S_3, S_4 — Push-button switch. |
| C_{11}, C_{19} — 25- to 100- μ fd. mica padder. | R_{10}, R_{11} — 50,000-ohm linear volume control. | L_1 — 400 turns No. 30 e. on $\frac{3}{4}$ -inch diameter form $3\frac{1}{2}$ inches long, tapped 125 turns from grounded end. |
| C_{13}, C_{15} — 25- μ fd. 35-volt electrolytic. | R_{12}, R_{17} — 3000 ohms, $\frac{1}{2}$ -watt. | L_2 — 50 turns No. 30 e., 1-inch diameter form, $1\frac{1}{2}$ inches long. |
| C_{14}, C_{21}, C_{23} — 0.5- μ fd. 400-volt paper. | R_{14} — 10,000 ohms, 1-watt. | L_3, L_8 — 80-mh. shielded r.f. choke. |
| C_{16} — 1- μ fd. 400-volt paper. | R_{20} — 100,000 ohms, $\frac{1}{2}$ -watt. | L_4, L_7 — 30-mh. shielded r.f. choke. |
| C_{24}, C_{25} — 500- μ fd. mica. | R_{21} — 1 megohm, $\frac{1}{2}$ -watt. | L_5, L_6 — 10-mh. shielded r.f. choke. |
| | R_{24} — 60,000 ohms, $\frac{1}{2}$ -watt. | |

The output of the 100-kc. crystal oscillator is fed to the input terminals of the 6SK7 100-kc. amplifier, whose output is coupled to the signal grid of the 6L7 mixer. L_6C_{20} and L_7C_{19} serve to trap harmonics in this lead.

The two frequencies fed into the input of the 6L7, as well as frequencies equal to their sum and difference, all appear in the plate circuit of the 6L7. All except the desired difference frequency (0 to 5000 cycles) are removed by the filter formed by L_8 , C_{24} and C_{25} . The difference frequency, which forms the audio output from the b.f.o., is fed into a 6C5 amplifier and thence to the 6C5 audio mixer, where it combines with the audio beat from the receiver. The two linear volume controls, R_{10} and R_{11} , are ganged to form a mixing control. They are so connected that the volume of one of the two signals is increased while the other decreases, and vice versa. This provides a convenient means of balancing the two signals. R_{14} prevents a short-circuit of the signal source when the mixing control is set at either end of its range. The switches, S_1 , S_2 , S_3 , and S_4 , are used for selecting any one of several signal sources. The last three are of the push-button type.

The output of the audio mixer is fed into headphones, which may be used as an indicator of matching between b.f.o. and receiver-audio signals except when the audio beat from the receiver is so low in frequency that the 'phones do not give good response. For very low beat frequencies, a visual beat indicator is provided. This consists of an 85 amplifier-rectifier feeding a 6G5 "magic-eye" tube.

An external power supply is used to reduce the possibility of hum, but the voltage-regulating circuit, using a 6C6, a 2A3 and a neon bulb, is included in the unit proper.

1000- and 100-Cycle Multivibrators

The circuit diagram for the low-frequency multivibrators is shown in Fig. 3. This section is controlled by the output of the 10-kc. multivibrator in the crystal standard. Since dependable control cannot be assured over a frequency range much greater than about 10 to 1, it is necessary to insert a 1-kc. multivibrator between the 10-kc. and 100-cycle oscillators. The circuits of the 1-kc. and 100-cycle sections are similar, each having a 6C5 input amplifier, a 6N7 dual triode oscillator, and a 6C5 output amplifier. The 1-kc. section has a separate output amplifier for use when 1-kc. output is desired for some other purpose.

Construction

The complete unit, which includes the multivibrators, is built in a $17 \times 13 \times 2$ -inch chassis, with a $19 \times 8\frac{3}{4}$ -inch panel. The v.f.o. coils, L_1 and L_2 , must be shielded, and all components of this part of the unit must be mounted in a metal box. They fit into a $9 \times 5 \times 6$ -inch can without difficulty. It is very important to have all ground returns connected to only one point in the shield can, and this can must be grounded to a single point on the chassis. All grounds on the r.f. side of the unit (r.f. amplifier and mixer-tube input

circuits) should have separate connections running to the same point on the chassis.

The 1-kc. and 100-cycle multivibrators together with their input and output amplifiers are mounted in a $9 \times 6 \times 5$ -inch box. The two sections must be separated by a buffer shield, and all power leads should be heavily by-passed. All grounds must go to a common point which, in turn, is grounded to the chassis. All resistors in the multivibrators should be wire-wound for best stability. The frequency-determining RC circuits must have the best condensers possible within range of the pocket book. These condensers are C_3 , C_4 , C_5 , C_6 , C_{15} and C_{16} in Fig. 3.

All r.f. and a.f. leads into or out of the unit must be of the concentric-line type. Crystal-mike cable is FB for this purpose. The shield side of the line must be carried directly to the cathode returns, not just connected to the chassis. Crystal-mike connectors should be used for input and output. The audio beat note from the receiver can be carried through a length of ordinary twisted pair, since no r.f. is involved. A lead of this type will not affect the operation of the unit adversely, if care is taken to keep it away from the grid returns. The leads from the multivibrators to the switches also must be of shielded cable with the shield grounded only at the ends, i.e., in the shield can and at the switch.

Oscillator Calibration

After the unit is assembled, the b.f.o. should be given a preliminary test. As soon as the audio tone from the b.f.o. is heard in the headphones in the plate circuit of the mixer, the main condenser, C_1 , should be set at zero (maximum capacity) and the interpolation condenser, C_2 , at half scale. The padding condenser, C_4 , should then be adjusted to bring the oscillator frequency to zero. If the signal is mushy or if "birdies" appear as C_1 is turned through its range, C_{10} , C_{11} , C_{19} and C_{20} , as well as the input level to the 100-kc. amplifier, should be adjusted until a pure tone of good strength is obtained.

Now WWV's 440-cycle modulated signal should be tuned in on the receiver and the tone fed to the terminal marked "Rec" in Fig. 2. (The receiver b.f.o. must not be used. A regenerative receiver must be operated with the detector in a non-oscillating condition.) After closing S_1 to connect the receiver audio output to the input of the 6C5 audio mixer, the 440-cycle tone should be heard in the 'phones with $R_{10}R_{11}$ set at about half scale. As the main dial of the b.f.o. is turned slowly from zero (with C_2 set at 50), a beat between the b.f.o. and receiver signals will be heard. This means that the oscillator is approaching 440 cycles. The mixer control should next be adjusted to obtain maximum deflection on the screen of the 6G5, or the loudest beat in the headphones. When the two frequencies are exactly matched, the 6G5 eye should stay open.

Similar zero-beat points, separated by 440 cycles, should be encountered as the b.f.o. frequency is increased. If the b.f.o. tuning range is correct, eleven of these points should be found

between zero and about 90 on the main dial, indicating a b.f.o. frequency range of 0 to 4340 cycles. This gives eleven accurate points, besides 0, from which a calibration curve for the oscillator may be drawn on graph paper. If this range is not covered, the L/C ratio is too low and turns must be added to the grid end of L_1 . If, on the other hand, the range covered is too great and 4340 cycles comes at 80 on the dial, for example, turns must be removed. In either case, C_4 will have to be readjusted for zero frequency at zero on the main dial.

Multivibrator Adjustment

Adjustment of the 1-kc. and 100-cycle multivibrators is the next step. An oscilloscope is very useful but if none is available a receiver may be used, operating it on the lowest possible frequency band. With the crystal standard feeding the receiver and the receiver b.f.o. turned on, any two adjacent 10-kc. beat notes from the 10-kc. multivibrator should first be spotted. When the 1-kc. multivibrator is turned on and its output also connected to the receiver input, nine additional zero-beat points should appear between the two 10-kc. points. The filter in the 1-kc.

output circuit may have to be removed for this, and R_6 should be set at maximum. If more or less than nine new points are counted between the two 10-kc. points, R_7R_9 and C_3C_5 must be carefully adjusted until the right number can be counted. After the unit is on exactly 1000 cycles, R_6 should be retarded and the output frequency brought back to 1000 cycles by adjustment of C_3C_5 . It may jump from 900 to 1000 cycles or to 1100 cycles while R_6 is changed, but the adjustment will become more tolerant as R_6 is retarded. A point on R_6 will be found where the output frequency of the multivibrator no longer will be stable. R_6 should then be advanced slightly past this point, and C_3C_5 readjusted for 1000-cycle output. Finally, R_6 should be advanced about one-eighth of a turn. This should complete the adjustment of the 1-kc. section. At this point, the output frequency should remain constant from about one-quarter to three-quarters of the full range of R_6 .

In adjusting the 100-cycle unit the interpolation oscillator may be used. Both the 1-kc. and 100-cycle multivibrators should be connected to the oscillator unit at the appropriate terminals marked in Fig. 2. With the b.f.o. set at zero

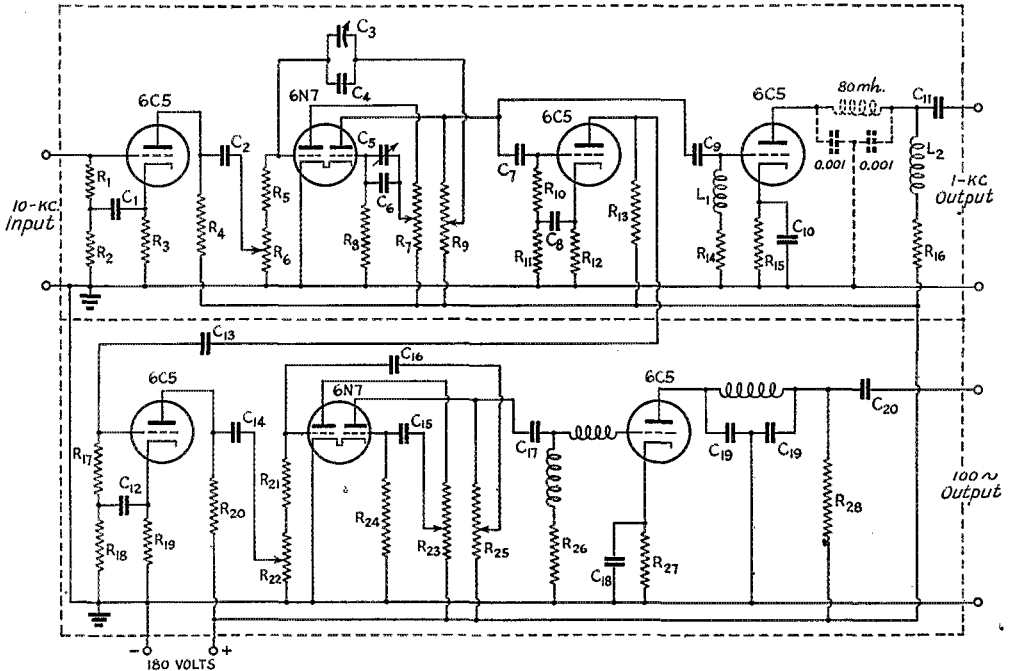

Fig. 3 — Circuit diagram of the 1000- and 100-cycle multivibrators.

$C_1, C_2, C_7, C_8, C_9, C_{10}, C_{11}, C_{12}, C_{13}, C_{14}$ — 0.1- μ fd. 600-volt paper.
 C_3, C_5 — 1800- μ fd. mica padder.
 C_4, C_6 — 0.05- μ fd. mica.
 C_{15}, C_{16} — 0.5- μ fd. 400-volt paper.
 C_{17}, C_{20} — 1- μ fd. 400-volt paper.
 C_{18} — 25- μ fd. 35-volt electrolytic.
 C_{19} — 1000- μ fd. mica.
 $R_1, R_{14}, R_{17}, R_{26}$ — 250,000 ohms, $\frac{1}{2}$ -watt.

R_2, R_{11}, R_{18} — 50,000 ohms, $\frac{1}{2}$ -watt.
 R_3, R_{15}, R_{27} — 2000 ohms, $\frac{1}{2}$ -watt, wire-wound.
 R_4 — 5000 ohms, 1-watt wire-wound.
 $R_5, R_8, R_{16}, R_{24}, R_{25}$ — 10,000 ohms, 10-watt wire-wound.
 R_6 — 100-ohm wire-wound.
 $R_7, R_9, R_{21}, R_{23}, R_{25}$ — 25,000 ohms, 10-watt wire-wound.
 R_{10} — 250,000 ohms, 1-watt.

R_{12} — 3000 ohms, 1-watt wire-wound.
 R_{13} — 50,000 ohms, 1-watt.
 R_{19} — 3000 ohms, $\frac{1}{2}$ -watt wire-wound.
 R_{20} — 5000 ohms, 10-watt wire-wound.
 R_{22} — 1000-ohm wire-wound.
 L_1, L_2 — 10-mh. r.f. choke.
 L_3 — 10-mh. r.f. choke.
 L_4 — 60-mh. r.f. choke.
 L_5 — 80-mh. r.f. choke.

and S_1 closed in the downward position, pressing S_2 should produce tones of 1000-cycle multiples in the headphones. The b.f.o. should now be brought to zero beat with the first harmonic, indicating that its output frequency is 1000 cycles, and the b.f.o. dial reading noted. Returning the b.f.o. to zero, the 100-cycle switch, S_4 , should be closed. Tuning the b.f.o. from zero to the 1000-cycle point as before, but this time more carefully, nine new points of zero beat should be found. For this test, R_{22} should be set at about one-quarter of its range from the ground end. If the correct number of new points is not found, R_{23} and R_{25} should be adjusted until nine, and nine only, can be counted. As soon as the second section of the multivibrator is tuned to 100 cycles, R_{22} should be advanced to about three-quarters scale, making certain that the frequency does not jump during this final adjustment. By continuing the b.f.o. tuning through its entire range, points for each 100 cycles, from 0 to 500 cycles, may be obtained to fill out the b.f.o. calibration curve.

Measuring Frequency

In measuring the frequency of a signal on the air, the output of the 10-kc. multivibrator is mixed with the signal under measurement, and a beat note obtained in the receiver output. The receiver b.f.o. should be turned off. After tuning the receiver for the loudest beat note in the receiver headphones, the beat note is fed into the interpolation-oscillator unit at the point marked "Rec" in Fig. 2, with $R_{10}R_{11}$ set at minimum. The main dial of the b.f.o. is set at zero and the interpolation dial (C_2) set at 50. $R_{10}R_{11}$ is then adjusted so that the receiver output can be heard in the 'phones in the 6C5 mixer circuit. The b.f.o. is then tuned until zero beat with the signal is obtained. Beats at multiples of the signal tone frequency should not be mistaken for the desired beat at the fundamental. The latter will be much stronger, and can be quite easily identified by comparing it with others. The 6C5 will aid in this adjustment, and $R_{10}R_{11}$ should be set for maximum indication.

When the two audio frequencies have been matched, the main-dial reading should be noted. S_1 is now thrown to the multivibrator position and S_4 is closed. C_2 should now be tuned to the first zero beat above 50 on its dial, and then to the first zero beat below 50, and each interpolation-dial reading noted. These will be the readings of the 100-cycle step above the signal and the 100-cycle step below the signal. The readings noted may be something like this:

Main dial — 52.5
 Interpolation dial — 84.2 high
 Interpolation dial — 15.8 low

Since there is a difference between the high and low readings on the interpolation dial of 68.4 dial divisions, and since this represents a range of 100 cycles, there are $100/68.4 = 1.46$ cycles per dial division. There are $84.2 - 50 = 34.2$ dial divisions between the signal and the high mark, or $34.2 \times 1.46 = 49.932$ cycles. Be-

tween the low mark and the signal there are $50 - 15.8 = 34.2$ dial divisions, or $34.2 \times 1.46 = 49.932$ cycles. From the main-dial reading and the calibration curve it is known that the audio beat frequency lies between 2400 and 2500 cycles, so, by adding the 49.932 cycles to 2400, a reading of 2449.932 cycles is obtained. By subtracting 49.932 cycles from 2500, we get 2450.068 cycles. The two readings are then averaged out by adding them and dividing by 2, as follows:

$$\frac{2450.068 + 2449.932}{2} = 2450 \text{ cycles.}$$

From checks with the 10-kc. multivibrator and the calibrated receiver, let us say that we have found that the signal frequency lies between 3600 and 3610 kc., and that we have also determined that it is closer to 3610 than to 3600 kc. By subtracting 2450 cycles from 3610 kc. we get a measurement of 3607.550 kc., which will be correct to within a very few cycles.

As WIEAO has remarked, it is easier done than said, but a little experience will show how easily and accurately such measurements can be made. If the signal to be checked is too weak, or is being keyed, the procedure is the same, but the station frequency meter or any other stable oscillator is first set to zero beat with the signal and then used to replace the signal input to the receiver. If this is done, checks should be made to make sure that the oscillator stays in tune with the signal, since an interpolation oscillator will check to a very small part of a cycle.

With this instrument, in conjunction with a 100-kc. bar and 10-kc. multivibrator, any device for generating alternating current can be checked for drift or frequency, since standards for all frequencies from 100 cycles to about 30,000,000 cycles are made available. The interpolation oscillator makes it possible to attain an accuracy within less than one cycle in measurements of any frequency between 100 cycles and 7 Mc. or even higher.

NOTE — If a condenser with a maximum capacity other than that specified for C_1 under Fig. 2 is used, the same tuning range may be obtained by observing the following relationship:

$$CT = 9.757 C_1,$$

where CT is the sum of the capacities C_2 , C_3 and C_4 , and C_1 is the new maximum capacity of C_1 , all capacities being in micromicrofarads.

The new dimensions for L_1 may be determined by first finding the required inductance from:

$$L = \frac{10^{10}}{4.35 CT}$$

where L is in microhenries, CT is in micromicrofarads and a frequency of 105 kc. is assumed, and then computing the number of turns from:

$$N = \sqrt{\left(\frac{3A + 9B}{0.2A^2}\right)L}$$

where N is the number of turns, A is the diameter of the coil in inches, B is the length of the coil in inches, and L is the inductance in microhenries.

AAF Operators Train on Radio Mock-Ups

Scott Field Constructs Replicas of Bomber Installations

Since it is an accepted fact that it is easier to learn by seeing and doing than by receiving instruction in theory, teaching methods involving practical demonstrations are now receiving widespread application throughout the Army.

The latest devices for realistic training of aerial radiomen are complete mock-ups of aircraft radio installations, recently put into use at Scott Field, parent radio school of the Army Air Forces Technical Training Command. This school has so perfected the teaching of radio communications that a soldier-student may now operate the radio systems of four different bombers under all the conditions of actual flight, without leaving the school building in which he is studying. There the student comes face to face with replicas of a B-17-E Flying Fortress, a B-25-D Mitchell, a B-24-D Liberator and a B-26-D Marauder, on which he receives realistic training in teamwork under conditions simulating those encountered in actual service.

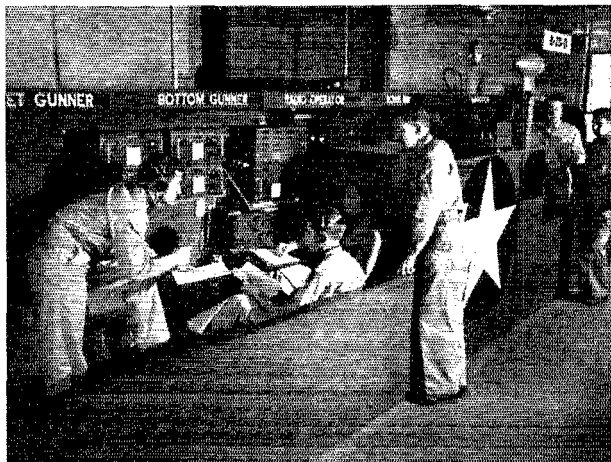

Above — A plywood semi-mock-up of a B-25-D Mitchell medium bomber, built to exact scale. The student at the right will play the part of a pilot on a radio "flight." Left — Rear view of the bomber, showing the various stations of the crew members and their radio equipment. Instructors confer with the students from outside the "fuselage." Below — All sections of the bomber are hooked up to the radio system. Nets between other semi-mock-ups also are established. In addition to being on their toes as far as operating procedure is concerned, the students also must be prepared for periodic inspections of their communications system. The student at the left is making adjustments to the connections on a power unit. As the airplane engine which ordinarily supplies the power is lacking, a three-phase motor generator in the power room acts as the power supply and, in conjunction with an inverter, furnishes the 400-cycle 115-volt a.c. necessary for operation of some of the equipment.

The mock fuselages, more accurately known as "semi-mock-ups," are constructed of plywood, with one side open to facilitate classroom observation. Built to scale, they consist of various compartments such as are found in real planes, and are complete in every detail except that the bomb bays are slightly smaller than in real planes. Each compartment has its necessary communications equipment placed exactly as in the actual aircraft. Besides providing operating practice, the semi-mock-ups acquaint the men with the precise location of the equipment in planes of various types.

The soldiers' first task is to learn the tuning procedure for all the equipment. When this is mastered, inter-mock-up nets are established and inter-plane communication is carried on. Network communications practice keeps the men alert, gives them practical experience in receiving and sending, and helps them become familiar with operating procedure.

Official AAF TTC Photographs

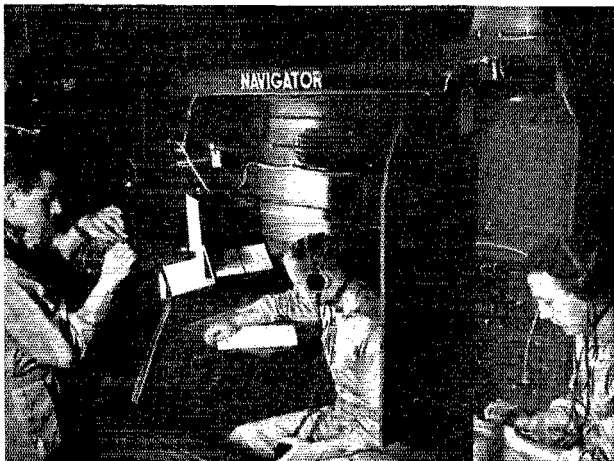



STRAYS



Something we've been looking forward to at ARRL Headquarters occurred on September 9th. We had been watching our recent shipments of *The Radio Amateur's Handbook* for a particular event. When the actual moment arrived, the boys in our shipping room were packing a shipment of a thousand *Handbooks* destined to go to one of our big distributors, McGill's Authorized News Agency, in Melbourne, for use as a wartime training text in Australia. Halfway along the packing process we took out a certain copy and substituted another for it. That copy we had framed to hang on the wall at Hq. The reason? It was the *millionth* copy of the *Handbook*! Look in and see it when you are down this way.

FCC reports that, of the 259 WERS radio aides recorded as of September 1st, 208 are licensed amateurs.

Pre-war solder was composed of tin and lead in about 50-50 proportions. To-day, except for certain applications, solder contains not more than 20 per cent tin, which raises the melting point from 414° F. to 576° F. To obtain best results with the new solder use a hotter iron, design the joints so the two parts overlap, and keep both the parts and the iron clean.

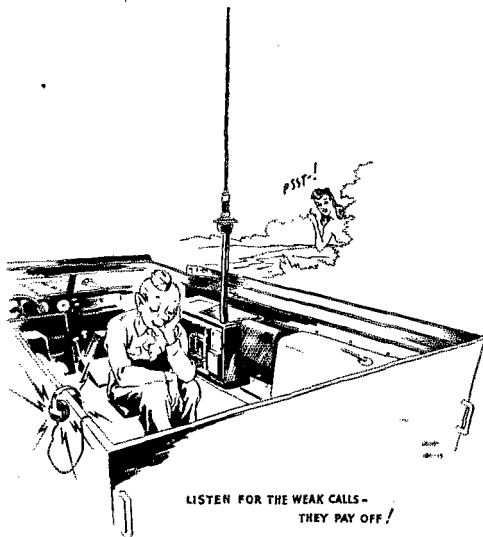

Textbooks liberally illustrated with cartoons like the above make learning radio in the Signal Corps a pleasant task. Such cartoons are part of a program initiated by Capt. H. B. Churchill, W2ZC, officer in charge of Signal Corps instruction literature at the Ft. Monmouth Signal Laboratory (*QST*, Jan., 1943, p. 56). They "wow" the boys and drive home important points.

A new electronic wire recorder is bringing news programs and the "Army Hour" to our fighting men in North Africa. At General Electric's Bridgeport (Conn.) plant, the programs are recorded on hair-like steel wire which is wound on spools. These spools are flown by transport plane to Algiers, where the programs are played back to soldiers who otherwise would not be able to hear them. A combination unit weighing less than fifty pounds has built-in recording, play-back and instantaneous-erasure features. A field set operated by batteries weighs about nine pounds and can be carried on the back.

Frank W. Walker, W8EBN, chief engineer of the Michigan State Police Network, was elected president of the Associated Police Communication Officers at their annual meeting. Ero Erickson, W9HPJ, supervisor of the Illinois State Police Radio System at Chicago, was chosen secretary-treasurer. W8EBN was active on 20 in prewar days, and the East Lansing police department once threatened to throw his gear out of the barracks unless he stopped "cluttering up the place." Apparently he cleaned it up, for he was soon promoted to chief engineer.

Fused quartz has emerged from the laboratory and is now available from the General Electric Co. in the form of ingots, rods and tubes. Possessing unique properties making it useful for many applications, particularly those having to do with electricity, heat, chemistry and optics, fused quartz comes in two types, translucent and clear. The translucent type is made from a very pure grade of sand and gets its name from its satin appearance, caused by the imprisonment of air bubbles during manufacture. The clear type is made from crushed natural crystals and is more transparent than any glass.

Radio "nails," which are described as "needle-shaped shots of radio power," are replacing the use of staples or nails in the assembly of plywood. The operator presses the point of the radio nailer, which resembles a small fat-barreled pistol, against the top layer of wood wherever a nail is needed, and a measured "shot" of radio power drives through the wood. The intense heat in the narrow beam melts the glue between the sheets, producing spots that hold like pins.

A letter from Fil Current, the brother on New Guinea, states that he is getting out FB over there. To date he has worked six Japs with a single-tube Springfield. — "Eddie Current."



HINTS AND KINKS FOR THE EXPERIMENTER



THAT PETERSON POT

SOMEWHERE between the editorial office and the imposing stone it seems that the wrong illustration crept in alongside the Hint on "Cooling the Peterson Pot" in October *QST*, page 59. Below is the correct drawing—with our apologies.

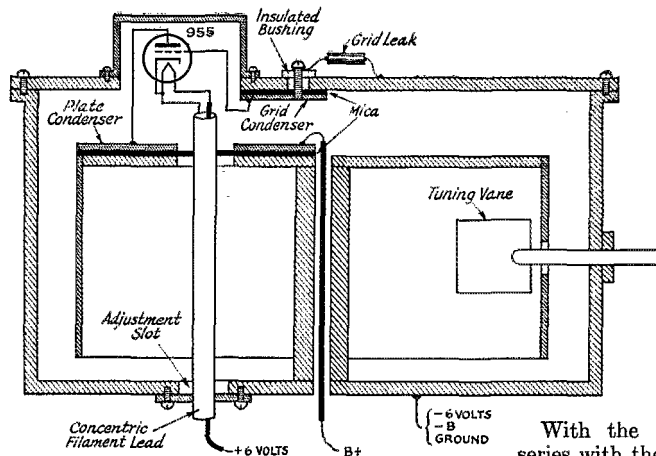

Fig. 1— Method of applying parallel plate feed to a Peterson oscillator, avoiding d.c. voltage on the "pot."

EMERGENCY TEST BOARD

WHILE teaching a course in "operations practice" in a Signal Corps school, an emergency test board was developed as shown in the accompanying photograph. In the project from which the board was developed, we assumed a case in which a radio man, marooned far from the usual test equipment, was facing the necessity for emergency tests and repairs.

One 1- μ f. 100-volt condenser, one 0.1 μ f. 600-volt condenser, a single flashlight cell and ten Fahnestock clip terminals were mounted on the board, as shown in Fig. 2. (The addition of a carbon-pile variable rheostat would be helpful for checking open resistances.)

Some of the uses are as follows: *Audio tests*— Connect the 0.1- μ f. condenser and a pair of headphones in series with the prods. Ground one prod. With the remaining prod, touch the plate connections of the first audio and output tube or tubes, also the second detector. *Condenser tests*— A good paper condenser will hold a charge. Place the 1½-volt cell in series with the headset and prods and connect them across the condenser under test.

A clicking will be heard in the 'phones until the condenser is charged, when the clicks will cease. A leaky or shorted condenser will not charge and the clicks will not stop.

Continuity tests can be carried out with the same hook-up, checking continuity of coils, circuit wiring, transformer windings, headphones, and so on. No click indicates an open circuit. The louder the click, the less resistance in the circuit under test. For example, the primary winding of a 3-to-1 audio transformer will produce a louder click than the secondary winding.

A receiver test-signal source is provided by hooking the 1½-volt cell in series with the prods, grounding one and touching the other to the converter tube grid, i.f. tube grids, second detector grid and grids of r.f. and audio tubes, while listening for a disturbance.

With the high-voltage 1- μ f. condenser in series with the prods, one of which is grounded, contacts may be made at points where voltage should be present. Then try to discharge the condenser by grounding the hot prod. No spark means there is no voltage present. In this way the voltage at tube plates, screen grids and power-supply filter condensers may be checked.

With a little knowledge of radio fundamentals, other applications of this simple device will occur to the user. At a time when lack of priorities prevents many from obtaining ordinary test equipment, such a device may prove invaluable under emergency conditions. — R. N. Kjerland, W9CYL.

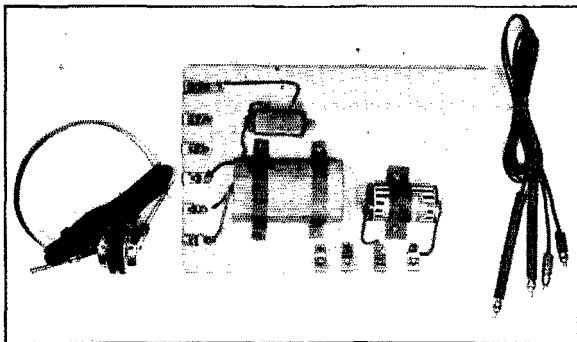

Fig. 2— An emergency test board with simple components, used for checking continuity, voltage, and circuit response.

PLUG-IN HEADPHONE ADAPTER FOR TR-1S

EVERY WERS control station should have provision for headphone reception. This is especially important where the radio installation is in the same room with the telephone operators. A simple way to adapt headphones to an Abbott TR-4, as used in our control station, WJWN, is shown in Fig. 3.

Not wishing to make alterations in the TR-4 circuit, use is made of the oscillator plate current jack, into which this adapter may be connected with an ordinary 'phone plug. The lead from the "B" + side of the jack is connected through the plug and a d.p.d.t. switch (used for shorting out the adapter during transmitting periods, as indicated on the diagram) to a 0.01- μ fd 1000-volt mica condenser in series with the headphone jack and ground. The ground connection may be a panel screw, if the jack or other output connection is not mounted upon the panel. — *Vernon S. Allen, Radio Aide, WJWN.*

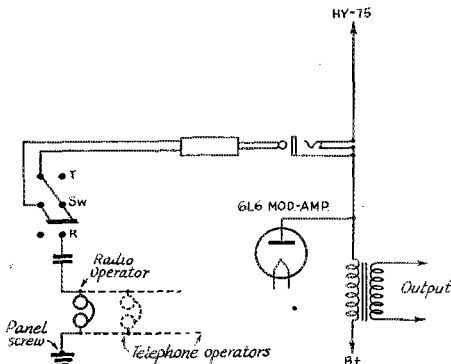

Fig. 3 — Method of adapting the TR-4 for headphone reception without necessity for circuit alterations.

RE-USE OF HOME RECORDING DISCS

IF YOU have home recording discs which have become scrap through normal wear or through unsuccessful cutting, it is practicable to salvage the disc for a second cutting by heating it till the surface softens just enough to permit the cutting lines to run together. Support the disc upon an axle, such as a screw-driver shaft, so that it may be spun during the heating. Hold it close to a red-hot stove or an electric hot-plate or other source of even heat. Spin the disc to secure even heating and so that the centrifugal force will cause the lines to run together. The maximum desirable heat is attained when the surface just begins to smoke slightly. Overheating will blister the coating of the disc, or harden it unduly. Successful heating will produce a disc which, while not precisely "as good as new," will be entirely satisfactory for many purposes. — *Robert K. Holsinger, W8SOF.*

EDITOR'S NOTE. — The disc sent us by W8SOF as a sample of this treatment gives very fair reproduction of his instructions for the process.

AUTOMATIC CIRCUIT POLARIZER

WHEN operating grounded a.c.-d.c. equipment, the danger of short-circuiting the line by inserting the power plug in the wrong direction

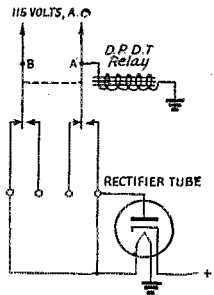

Fig. 4 — Using a d.p.d.t. 115-volt relay as an automatic circuit polarizer to assure correct line-plug connections in a transformerless power supply.

may be overcome by connecting only one wire to the plug, obtaining the other connection through ground. However, it is still necessary to polarize the plug correctly to avoid an open circuit.

A simple device consisting of a d.p.d.t. 115-volt relay will solve this problem. In Fig. 4, if *A* should be the hot side of the line, the relay would be activated and the a.c. applied to the rectifier plates. If, on the other hand, *B* is the hot side, the relay will not be activated and the a.c. will flow normally through the left pole of the relay to the plates. — *Sheldon W. Gates, W8VWK.*

POWER-TUBE PROTECTIVE CIRCUIT

THE writer has used the method shown in Fig. 5 to protect the power tubes and eliminate complete breakdown of a p.a. amplifier in case of failure of the fixed-bias system normally used. In this case, the tubes were a pair of 2A3s drawing a normal plate current of about 80 ma.

The usual self-bias resistor was used with a Littell-Fuse, rated at 125 ma., shunted across it. If the fixed-bias system fails, the plate current on the power tubes will exceed the rated carrying capacity of the fuse and it will blow, thereby removing the shunt across the self-biasing resistor and automatically putting the tubes in normal operation with self bias. The grid return would be through the bias-supply voltage divider to ground. As an added protection, a fuse of the same rating is also used in series with the bias resistor.

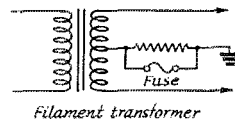

Fig. 5 — Power-tube protective circuit for use on fixed-bias stages, employing an auxiliary self-biasing resistor which is normally shorted by a fuse.

This idea probably can be applied in other ways. In a transmitter, it might be adapted to an overload relay circuit which would remove a short across a self-bias resistor calculated to reduce plate current to a safe value when off resonance, instead of opening the plate circuit and killing the transmitter. — *Henry G. Kuhn, W8IRU.*

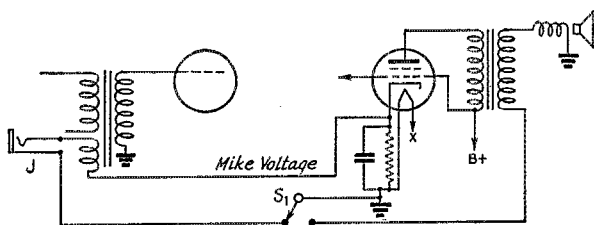

Fig. 6 — Simplified transmit-receive switching circuit for the Alleghany County WERS transmitter-receiver in August *QST*.

SIMPLIFIED TRANSMITTER-RECEIVER SWITCHING ARRANGEMENT

THE diagram above (Fig. 6) indicates changes made since publication of the circuit for the Alleghany County, Md., WERS transmitter-receivers appearing on page 63 of the August, 1943, issue of *QST*, allowing for the use of a four-pole double-throw switch instead of the hard-to-get eight-pole two-section rotary switches. In this revised circuit, the ground is switched from the mike on transmit to the voice coil on receive.

— G. C. Robinson, *WJDG*

SOLDER KINK

A HANDY arrangement for wire solder can be made by winding the solder around a pencil for



Fig. 7 — Convenient form for solder roll.

its entire length, starting at the point of the pencil. After removing the pencil, the end of the solder is passed back through the coil and out through the opening in the pointed end. The coil is then used as a handle. As solder is used, more may be pulled out. Solder in this form does not kink and is in convenient shape for getting into tight places. The idea is shown in the sketch of Fig. 7, showing a completed roll.

SOLDERING IRON REST AND HEAT CONTROL

I SUBMIT a sketch of a soldering iron heat control which I have been using for the past ten years, receiving very fine service.

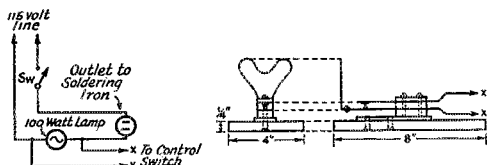

Fig. 8 — Soldering-iron rest and heat control.

In the original I used an old closed-circuit 'phone jack which, with all other components, was mounted on a 4 × 12 × 1/4-inch piece of plywood. The rest for the iron is of sufficient size to dissipate heat rapidly enough to prevent burning of the contacts by conduction. The size of the bulb may be varied to obtain just the right degree of heat with the iron in use.

The leaves and contacts of the jack will have to be altered to correspond with the arrangement shown in the diagram. The tension of the lower spring contact should be adjusted so the weight of the iron on the rest just opens the points, putting the lamp in series with the iron and keeping it just hot enough to use but not hot enough to burn and pit. — Harold F. Houtz.

SIMPLE METHOD FOR INVESTIGATING PERFORMANCE OF 1/2-MC. ANTENNAS

The adjustment of a 2 1/2-meter antenna for best performance usually requires not only some form of field-strength measuring device, but also that a transmitter signal be put on the air. This is very nice when such measuring equipment is available and the testing can be done during a test period. It is not necessary, however, to have either measuring apparatus or a signal from a transmitter (subject to RI observation or investigation) in order to determine with fair accuracy the field pattern of a directive array or the effectiveness of a quarter or half-wave antenna.

Did you know that merely scraping one end of a piece of bare wire approximately one half-wave length long with another short piece of bare wire, or, for that matter, any other piece of metal, will make the half-wave wire radiate a minute signal? Well, it does, and a wire used in this manner has several very useful applications, particularly with 2 1/2-meter antennas. As a matter of fact, it may be used to check any antenna system where the dimensions of the half-wave wire are not so large as to make its use unwieldy.

The first thing to do is to set up the antenna to be investigated in any location which will permit a person to walk around it. The antenna should be on the same level as the test wire when the latter is held by the person operating it. If the receiving antenna is vertical the test wire should be held vertically, since polarization is quite noticeable. Naturally, the preferred location is the spot where the antenna eventually is to be used.

Now couple the receiver (it makes no difference whether it be a superhet or superregenerative job) to the antenna, setting the coupling at its approximate optimum position. Turn the receiver on and set its volume control for full output, since the transmitting range of the test wire fortunately is very limited. It is this limited range that requires the preliminary test to be made while holding the test wire in close proximity to the receiving antenna.

A few words about the proper place to hold the test wire. Since this wire acts exactly like any antenna, it must be held in the operator's hand at a point where a current loop normally would exist. If one holds the lower end of a half-wave wire in one hand and scrapes the upper end with a metal rod held in the other hand, for instance, no signals will be generated, since the end held

(Continued on page 80)



CORRESPONDENCE FROM MEMBERS

The Publishers of *QST* assume no responsibility for statements made herein by correspondents.

ABOUT THE JAPANESE LANGUAGE

Washington, D. C.

Editor, *QST*:

In the editorial comment accompanying your recent article entitled, "The Japanese Morse Radiotelegraph Code," you stated that the article had been written by "a recognized authority on the Japanese language." The author may possibly have some knowledge of the Japanese spoken language, but he very obviously knows little or nothing about the written language which he attempted to describe for you, as you may see from the following comments.

The author begins his section on the Japanese language by saying that the Japanese had no written language until the third century. Far Eastern historians agree that, while a few Japanese might have learned how to write Chinese before that, *the Chinese ideographic script was not introduced to Japan until the sixth century.*

He goes on to say: "Although similar in their origins, the pronunciation of the spoken Japanese language was entirely different from that of the Chinese." The first part of the sentence is nonsense, as *the spoken languages of Japan and China were entirely different in their origins.* The Japanese spoken language, in origin and development, belongs to the Ural-Altai language family, allied to Mongolian and, more remotely, to Turkish, Hungarian and Finnish, while Chinese belongs to a separate language group, including most of the dialects of Southeast Asia.

The same paragraph says: "The Japanese had to make a choice between using the single character for 'man' . . . or combining two of *their own* characters." As the author had previously stated, the Japanese never had any characters of their own. This section in general is both confusingly written and downright misleading.

In the next paragraph the author does not make it clear that "the basic phonetic alphabet . . . arranged in an order known as the Gojuon" is actually the same thing as the Kana syllabary, which he later attempts to explain. It is also ridiculous to speak of "the characters of the Japanese syllabary," as he does in the next paragraph. The Kana syllables are not characters in any sense. Later, the author speaks of the Kana system as having been invented about the close of the 8th century. Kana was traditionally invented in the early 9th century by the Japanese monk Kukai, alias Kobo Daishi.

Chinese ideographs do not "normally represent whole words or complete ideas in a crude picture form," as the author declares. Chinese characters (not all of which are "ideographs") are anything but crude . . . and by no means all of the sym-

bols now used "have been developed from early picture writing." Careful thought has gone into the process of making Chinese characters, which are generally combinations of ideographs and sound elements, or "phonetics" (the phonetics are less obvious in the characters as used by the Japanese, hence the great difficulty of reading the latter language). This is by no means a static system of writing, frozen in the dim past, for the manufacture of new characters, and new word groups from old characters, still goes on, especially in scientific and technical fields, which have been revolutionized by new ideas imported from the West.

It is true, as the author states, that some Sino-Japanese words are formed by combining characters for two or more words, but his examples are patently absurd; for both 川口 (*kawaguchi*) and 人日 (*jinkō*) are not single characters but separate characters used to form one expression, and as such are written as two separate words with a space between them, 川 口 and 人 日.

On page 31 the author says: "Fujiyama (literally 'fire mountain') if written in Kana requires four syllables, whereas only one symbol is necessary if the Chinese ideograph is used." The word "Fujiyama" is a foreign "barbarism." In Japanese the mountain is called Fujisan, literally "prosperous knight mountain" (or, written in alternative characters, "the mountain second to none"). It is never called *the* fire mountain, though Fujisan is by definition a fire mountain, since the Japanese use that expression for any volcano, anywhere. When writing Fujisan (I repeat, no Japanese could or would say "Fujiyama," as that would be against all laws of grammar or usage) in Kana it would require four syllables plus a Nigori, whereas if using Chinese ideographs *three* symbols are required.

In the second section, on the substitution of Roman letters for Kana, the author . . . explains that in 1927 the Japanese government ordered substantial improvements on the Rōmaji system, asserting "the result was labeled 'Nippongo,' sometimes erroneously called 'Rōmazi.'" Nippongo (spelled Nihongo in Rōmazi!) simply means "Japanese language," an all-comprehensive term. Rōmazi is the official name used for the new romanization system. Incidentally, the very small differences between the two systems, actually no more than a change in the pronunciation of the initial consonants in some of the Kana syllables, is illustrated by the old and new terms: Rōmaji and Rōmazi, Nippongo and Nihongo.

In the next paragraph, the author explains that "under certain circumstances, words beginning with hard consonants take the Nigori, that is, the

initial letter becomes soft." Actually the Nigori *hardens* the initial letter, and the author might have pointed out the elementary point that this is only used when the word in question is made the second part of a compound, and that very often this distinction, observed in the spoken language, is ignored in the written.

The false ideas arising from a too-trusting acceptance of the author's flagrant misstatements might well become widespread, due to the great popularity of your fine magazine. Misconceptions regarding an enemy culture are almost as bad as direct enemy propaganda, because only by understanding an enemy and his psychology can one devise adequate means to defeat him. This was no doubt intended as a popular article, perhaps to follow your former language articles into military and naval classrooms. Popularizations are useful for mass education only insofar as they present facts in a clear and simple fashion. The article under discussion has presented, not facts, but one man's misconceptions, presented in a muddle-headed style. I might mention in conclusion that the facts on the subject, which I have cited above, are in no sense specialized information, but are the common property of any student of Far Eastern languages or history. . . .

— *Ens.* —————, *USNR**

A WORD ABOUT THE A.A.C.S.

Editor, *QST*:

. . . After reading the letters on the CAA in September *QST*, I feel that a word regarding the outfit I'm with is in order. Officially it is known as the Army Airways Communication System. It is the military counterpart of the CAA, going them one better in that it is world-wide in scope.

For about a month and a half before being transferred to Fort Knox, I was senior operator at Scott Field. I found the work very exciting and interesting. Except for rigid rules governing transmissions, it closely resembles ham operation. There is a chance to work some real DX, and the transmitters really get out.

Anyone who gets into this outfit will find that three extra pairs of ears will help. . . . Here we monitor several receivers, each of which is "hot." In other words, it may bring in important traffic at any time. This means that the point-to-point work, which occupies most of our time, must be dropped. Since cans are used a good deal, a few extra pairs of ears really would help. . . .

Any amateur who ends up in this outfit will surely feel at home. . . .

— *Cpl. B. L. Dwyer*

A CRYING NEED

354 Cincinnati Ave., San Antonio, Tex.

Editor, *QST*:

. . . Thanks for keeping *QST* the magazine it is to-day. It is the only way amateurs can keep up with what is going on in the radio profession. The articles presented are a great help in keeping

* Name withheld by request.

alive the spirit of hamdom in the minds of all hams and ex-hams. . . .

There is a crying need for experienced radio men in the Air Service Command, Signal Section. There has been a response from the ranks of the amateurs that could hardly be excelled in any branch of the war effort, including the Armed Forces. The work is very interesting and provides an opportunity to really learn the technical side of radio, something that is not obtained in the average position. Even with all the advantages offered, there is a definite need for many more men with better-than-average skill in radio.

May I say thanks again for keeping *QST* the magazine by, for and of the amateurs. Keep up the good work, for it is appreciated by the gang.

— *Joseph B. Rozell, ex-W5EOL*

CRIME TAKES NO HOLIDAY

3728 Harper, Houston 5, Tex.

Editor, *QST*:

At the moment I am burned up. It would seem, from what one reads in *QST* and the "Correspondence from Members" section, that the military services, FCC, CAA and merchant marine are the only services needing operators. Well, crime takes no holiday during wartime, which means that police radio stations must be kept going. Most police radio stations now do not have enough operators to keep their c.w. rigs in operation for the full twenty-four hours per day, seven days a week. A few stations even are faced with the prospect of having to shut down their 'phone rigs during certain hours of the day, due to shortage of operators with 2nd class tickets or better. All stations have equipment sitting around which needs repairing, but the limited personnel doesn't have enough time to work on it.

If you have a 2nd class radiotelephone or telegraph ticket, or can get one, and if you're a worker not interested in just sitting around, go see the chief radio op at your local police station. You might be able to do a little protecting on the home front, or maybe earn a few shekels in your spare time.

— *C. P. Zimmerman, W5ERS*

HATS OFF TO W. D. TERRELL

R. R. 3, Humbolt, Tenn.

Editor, *QST*:

I read with interest your article, "The Traffic Cop of the Air," in October *QST*. The facts you revealed will touch the heartstrings of all "dyed-in-the-wool" hams. It helps tremendously to provide that ever-evasive spark of confidence, often called "morale," to those of us with an interest in the future of amateur radio.

I wish to use this means of expressing my sincere gratitude to Mr. W. D. Terrell, for his considerate recognition of amateur radio throughout his administrative career. No doubt his record as an official in radio will be hard to equal. . . . Our hats are off to you, Mr. Terrell. May your retirement be filled with happy interest! . . .

— *Jerry A. Hardison, W4HQM*

CHINA AMATEUR RADIO LEAGUE EXHIBIT FOR 1944

172 Su Zen Sin Tsung, Hsidolung Kan,
Chungking, China

Editor, *QST*:

It gives us great pleasure to inform you that your special broadcast on May 5th came over very clearly.

Our annual convention was held as scheduled, and we were happy to be honored by the presence of Mr. Akins of W3ART. However, the exhibition had to be postponed until January 1, 1944, for lack of exhibits from abroad. We hope that this postponement will give ample time for your contributed items to arrive. We shall appreciate it if you will inform your members of our proposed exhibition, and take the trouble of collecting the items for transmittal to us by mail. We welcome even a QSL card or a photograph. . . .

— U. T. Hsu, *President,*
China Amateur Radio League

REGARDING SUPERSONICS

Blue Bell, Ambler, Penna.

Editor, *QST*:

Just a passing comment regarding supersonics. Nowhere have I yet seen a comment to the effect that here we are dealing with pure sound projection, with a speed of roughly 6 miles per second at sea level. In other words, A sends a message to B, who is 100 miles away, and B doesn't have to turn on his receiver until nearly ten minutes after A has started sending.

I seem to recall, also, somewhere in history — I think it was in the Napoleonic Wars — a naval engagement took place in the English Channel and that shortly thereafter the sound of the firing was heard clearly in London, over 100 miles away, while the sound was not heard at points only 30 miles from the scene. This may indicate occasional reflection of sounds in a similar manner to our sporadic-E reflection at v.h.f.

My point is this: In the development of supersonics we must allow for sufficient time between transmission and reception in direct proportion to the distances between the two points. . . .

— Jack Morgan, W3QP

A LITTLE HUMOR . . .

A.P.O. 691, c/o Postmaster, New York, N. Y.
Editor, *QST*:

I just received my September *QST* to-day. Like a voice from home, that's what it is to me. . . .

Now, if I may, I have a bit for W4DQA/W5KIX (KIX is correct; he kicks a lot). . . . I thought the article written by "Roger Wilco" was very interesting. Having worked in a control tower (for you, poor soul, a control tower is where operators control the flight of aircraft in their area — and it is a job) for nine months and in AACs stations for seven months, I have added to my faint knowledge of radio and what the CAA men do and why. Also, how and under what conditions.

The article, referred to by you as "half-baked

trash," wasn't blotting the CAA. It was correct to the letter, with a little humor thrown in. It's the little humor one acquires on such a job that makes it interesting and worth working hard at. That is the American way of life — to be able to joke about one's work. The article was intended to recruit new ops and let others in on what they do. . . . The cut-and-dried facts are nice to read, but the human-interest angle is worth more for a moment's reading. Tut, tut, old man; where is your funny bone? . . .

Keeping up your ARRL membership is like buying war bonds, in a way. Keeping your membership up will help keep the amateur frequencies just as buying bonds will help keep the American way of life going.

Now, old man, those articles put a little kick into *QST*. And don't forget to renew your membership. . . .

— S/Sgt. Jesse D. Wheaton, *LSPII*

IT MAY BE A TOUGH FIGHT

72 Merton St.,
Fairfield, Conn.

Editor, *QST*:

With reference to recent comments in *QST* about an ARRL committee to work for the retention of amateur channels after the war, it may be a tough fight. At least that is my first thought after reading "The Promise of Television" in the August issue of *Fortune* magazine. Perhaps this has already come to your attention. It is interesting, in my opinion, for two main reasons:

1) The main point seems to be that there is going to be a great struggle for room in the radio spectrum, as a result of the many new uses of electronics.

2) The isolated reference to amateur radio in the article seems to give the impression that it's something worthy only of passing notice for what it may be worth.

The first point mentioned above is one I hadn't thought much about. The article as a whole refers to the "ultrahigh" frequencies, but the lower frequencies no doubt also will be crowded.

As for myself, my interest in radio was always an operating one — I enjoy sitting down and hamming, but my technical knowledge is little, relatively speaking. I can build a rig that delivers the goods, if I don't depart too far from the practice of others. To those I leave the design and the theory, as I'm no EE.

When the war closes there probably will be thousands of new hams, and QRM will be called impossible. I remember that's the way it was ten years ago, too; but we withstood it. But it gives me a real kick to be able to carry on a QSO at 35 w.p.m. on 40 in the evening, and then listen to the commercial ops who are wont to complain about a signal that interfered with their reception. Poor conditions will give way to better techniques.

Anyway, I look forward to the future with impatience and optimism, provided we retain our channels. . . .

— George G. Symes, jr., *W1EFM*

PRAISE FOR W.E.R.S.

A.P.O. 36, c/o Postmaster, New York, N. Y.
Editor, *QST*:

A few days ago I received the July and August issues of *QST* . . . and I also received my membership certificate. I have really enjoyed reading these issues of *QST*. . . .

I can hardly wait to get back home to continue where I left off and become a ham. However, I do realize very keenly the importance of the job we are doing over here and the job we have yet to do. When this job is done and the forces which have threatened to destroy civilization and the world are conquered, then, and only then, can we return to our families, friends and former occupations, as well as resuming our activities as hams. . . .

I read with much pride and interest the article, "Ole Mississip' Rampages Again." The valiant efforts of the WERS are typical of all hams the world over. They rightly deserve the praise which has been bestowed upon them. I am sure they will continue to fight on the home front as we will continue to fight over here.

— *Pvt. N. E. Kurtz*

FROM AN "ASTROBOTTLURGIIST":

Stokievich and Veerenko,
International Astrophysical Laboratories,
Division of Communications,
61 Brattle Street, Cambridge, Mass.

Editor, *QST*:

We of the Stokievich organization have been following with considerable interest the recent discussion of the use of the words "electronics" and "radionics." At last the American radio industry is waking up to the fact that it has expanded far beyond the present limits of its nomenclature. We are glad to see that a step is being taken in the right direction by one of the great pioneers of American radio. However, we know that, with the high degree of specialization which now exists in radio engineering, the introduction of one new term will by no means relieve the present confusion.

Several years ago Mr. Stokievich foresaw the need for subdivisions in the field of radio engineering. He and his advisors compiled a list of classifications which have been used both in our organization and by the Stokievich & Stokolsky Far East Radio System, with complete satisfaction. Being an expert linguist, Mr. Stokievich has prepared an English translation of this list. I am passing along to you a few of these words, with the hope that the American radio industry will find them as useful as we have.

Trubionics: Study of behavior of electrons inside radio tubes.

Radiowobbulatry: The science of frequency modulation.

Botllurgy: Science of manufacturing glassware for radio tubes.

Circuitology: Science of designing radio circuits.

Circuito-cartography: Art of drawing radio circuit diagrams.

Astrobottlogy: Science of obtaining advance information on radio tube characteristics by astrological methods.

Botllosophy: Science of assigning new numbers to existing types of tubes; reshuffling price lists, preferred lists, etc.

Botllography: Science of placing tubes on a chassis, with due regard for center of mass, moment of inertia, convenience, esthetic balance.

Botllicide: Science of busting no-good metal tubes, so that no one will mistake them for good ones.

Transmitto-sinistro-pedalogy: QLF artistry.

Bottleneckery: Specialization of all radio engineers on Saturday night.

— *Roger Dorr, Astrobotllurgist*

LEXICOGRAPHY VS. "RADIONICS"

4545 W. Augusta Blvd., Chicago, Ill.

Editor, *QST*:

As an editor, words should interest you. It is time to speak a bit on "radionics."

The rules of scientific nomenclature prohibit compounding Latin and Greek roots. This is natural, since science has always been connected with education, conducted by educated men.

Now comes someone, perhaps an advertising man with no knowledge of lexicography, who coins a word from Latin and Greek. Such a bastard word should be rejected. It smacks of "beautician," which is a close cousin, if you note that it came via "electrician," a correct word. I sorrow for the ignorance that produced "radionics."

— *Temple Nieter, W9YLD*

THE TRUE STORY OF THE KEE BIRD

423 North 5th St., Marshall, Minn.

Editor, *QST*:

That epistle written by Major Hunt in your October issue doesn't do the justice to the Kee Bird that it so rightfully deserves. To remedy this situation, I give you the true story of the bird in the form of a poem which my father obtained while he was in Canada.

The Kee Bird

You have heard the wail of the siren
As an ambulance sped down the street,
And mayhap heard the lion's deep roar
Down in Africa's grim desert heat.

Or the piercing cry of the tiger
In the night as he stalks down his prey,
Or the locomotive's shrill whistle
As it speeds through the gloom on its way.

But these sounds all sink to a whisper;
You've heard naught, I assure you, till I've told
Of the blood-curdling cry of the Kee Bird
In the Arctic's cruel frigid cold.

(Continued on page 86)



OPERATING NEWS



GEORGE HART, WINJM
Acting Communications Manager

CAROL A. KEATING, W9WWP
Assistant Communications Manager

Whither WERS? The successes of our armed forces in the European theater of war so far have seemed to bring with them little complacency on the part of WERS licensees, and the service continues to expand. There are now 223 licensed CD-WERS stations, also 10 SG-WERS and 6 CAP-WERS. The 223 CD-WERS stations extend over 35 states and provide coverage to over 25 per cent of the population of the entire nation. Only one of these licensees has allowed its license to expire without securing a renewal, and that licensee was absorbed into a larger system. The rest have kept plugging along, meeting the usual assortment of obstacles but continuing the march as best they are able.

We have often heard it said that WERS has been a big disappointment and that the amateur has not contributed as great a part to its development as he was expected to. With this we disagree. It is a rare CD-WERS organization that does not have an amateur as its leader or amateurs occupying important positions within the organization. As of September 1st, 259 WERS applications had come before FCC; the radio aides of 208 of these were amateurs. Practically every community that desired to establish WERS found at least a few amateurs willing and eager to lend their assistance. More often than not the amateurs of a community made the initial moves in getting civilian defense heads interested in establishing WERS.

We feel confident in saying that, if the nation's amateurs had their way, WERS coverage would be at least double its present percentage. In most vital areas where no WERS licensees exist,

it has been because community officials have preferred not to bother to supplement existing wire lines and messenger service or have had other emergency communication services available. Overtures by amateurs have met with shrugs and indifference if not with downright opposition.

The general conclusion we are trying to draw is that amateurs deserve a lot of credit for the establishment of WERS systems in communities in which they exist, and that they are not to blame in communities which have not been licensed. This conclusion has been indicated by reports we have been receiving not only from licensed communities but also from those contemplating application and those in which no application for WERS is contemplated.

But now that the military situation is presumably pretty well under control and the danger of air raids, especially on the East Coast, is lessened, some WERS organizations are slowing down, and a few are asking, "What good does it do? We'll never have air raids now." Some say that civilian defense is bound to peter out as victory comes nearer, and thus our WERS organization, built at great cost in energy, time and money, will lose its chief sponsor; in fact, its namesake.

This seems to be part of an increasing tendency toward the viewpoint that the war is practically over, that it is time to relax. Enough has been said about the inadvisability of this viewpoint elsewhere without our having to go into it here. Air raids are still possible, and it is still the duty of WERS to become prepared and remain prepared to cope with them. In doing so, we amateurs are increasing our operating technique in a direction

Important Notice!

Here is a bit of good news for those CD-WERS organizations who have been hindered by lack of ability to obtain batteries. OCD has recently secured over 100,000 batteries of various types which have been declared salvage through having outlived their nominal shelf life. Most of them, however, give perfect readings under full load. These batteries have been shipped to various OCD warehouses throughout the United States, and will be shipped to state radio aides ordering them under a quota system based on the number of CD-WERS units in each state.

To order batteries, district or local radio aides of licensees should communicate their needs to the state radio aide or communications officer, who then should order, *immediately*, from the national office, through the state property officer, the number of batteries, by type numbers, which he thinks can be placed in immediate service. Regional directors have the list of type numbers as well as the quota for each state, or ARRL can supply this information if desired. In general, only one shipment per state will be made to a point designated by the state property officer.

The batteries are not available to individuals, and may be ordered only through the proper channels as described above. Because these batteries have outlived their shelf life, it is essential that orders be placed and shipments made with all possible expedition.

away from former peacetime haphazard procedures and are preparing ourselves for participation in important postwar emergency communication which is bound to be one of the greater services amateurs will continue to offer, in even better than the old tradition, to the nation.

In addition, the WERS Rules & Regulations have been amended so that our present networks can take part in disaster communication of practically all types, including the familiar natural disasters for which we established a reputation before the war and also including fires, sabotage attack and many other man-made catastrophes. Our message to you is to keep on practicing, keep on preparing, and if civilian defense *does* peter out (and there is no present indication of it) we shall not peter out with it but, under the sponsorship of our League and our licensing communities, shall be going strong in the service of the nation the day peace is declared and the return of normal amateur activity is in sight. Even then it should not behoove us to drop everything and engage in a mad scramble to prepare ourselves for the opening of the 20-meter band; even then the services of WERS should continue to be rendered to the communities in which it is licensed until the very day when amateurs are allowed back on the air as amateurs, and after that day as an amateur service to the nation in the form of local networks, already well-drilled and disciplined, for the purpose of local emergency communication. Look far, and you will see that what we are organizing under the banner of WERS will continue long after the war under the banner of amateur radio — and let us not cease striving to make that banner a proud one and a clean one.

WERS Coverage. Because WERS is a v.h.f. service and because little nationwide contact is to be had among participating amateurs such as was had in the good old days, most enthusiastic participants have little or no knowledge of the nationwide WERS picture, and a lot of them do not care. While this is natural enough, since the conduct of an organization in Florida would not seem to affect one in Maine, it is too bad, nevertheless, that such a nationwide brotherhood should be divided into comparatively small groups who know little about each other.

ARRL and QST have endeavored to minimize this effect (1) by publishing write-ups of various CD-WERS organizations who have something unique or something typical to offer which might be of interest to other organizations; (2) by soliciting WERS items for the "Amateur Activities" portion of this section of QST, and (3) by soliciting reports from emergency coordinators and radio aides in order that we ourselves may keep a national perspective and not become any more deeply involved or any more interested in Hartford WERS than in San Diego WERS. This has enabled us to keep an eye on the nationwide development of WERS and immediately to be able to tell as much about a licensee on the West Coast as we know about one in the East.

It has occurred to us that many interesting statistics could be gathered from such reports

to show exactly how many amateurs are participating, how many station units are in operation, what percentage of the entire personnel is amateur, how many station units have been built by participating personnel compared to the number purchased already-built, etc. Unfortunately, our success in securing reports has been limited, and such statistics would be meaningless if complete information was lacking. To date, we have received 132 reports of the 223 licensees. Those who have not reported are invited to do so; report forms will gladly be sent upon request.

What we have been able to compile are statistics on CD-WERS coverage using a restricted FCC list and individual reports as a basis. While these are probably not completely accurate, they are nevertheless generally so and amply demonstrate the trend of coverage.

Just what constitutes "coverage" was necessarily arrived at by assuming that the entire population of an area under a single license is covered by WERS. Where licenses have been issued under the district warning area scheme, only those communities in the area who have signed intermunicipal agreements with the d.w.c. city were considered covered. In view of incomplete information it was also impossible to consider such important items as number of station units and operating personnel in order to determine to what extent the licensed area is actually covered.

The percentage was based on population not only because it was impossible to determine area coverage but also because population coverage is the most important, considering that areas of concentrated population are likely to have the most need for emergency communication under any conditions that would necessitate the activation of WERS. SG- and CAP-WERS were not considered in collecting these data because information on them is lacking.

The coverage statistics are given first by civilian defense regions and then by states. They amply demonstrate which are the live-wire sections of the country as far as CD-WERS is concerned:

Region	Number of Licensees	Coverage (percentage of population)
I (New England states)	53	40.8
II (N. Y., Del., N. J.)	46	54.4
III (Pa., Md., D. C., Va.)	26	32.5
IV (Ala., Fla., Ga., Miss., N. C., S. C., Tenn.)	14	10.6
V (Ind., Ky., Ohio, W. Va.)	33	34.4
VI (Ill., Mich., Wis.)	16	40.9
VII (Colo., Iowa, Kans., Minn., Mo., Nebr., N. D., S. D., Wyo.)	11	9.5
VIII (Ark., La., N. M., Okla., Texas)	5	1.7
IX (Ariz., Calif., Idaho, Mont., Nev., Ore., Utah, Wash.)	19	37.8

Note that the first region, while leading in the number of licenses, ranks third in percentage of coverage, which shows that the number of licenses within a certain area does not necessarily mean that that area is most active in WERS. Statistics by states give similar revelations:

State	Number of Licenses	Coverage (percentage of population)
1) Maryland	8	76.9
2) Connecticut	10	71.6
3) New York	18	67.5
4) Illinois	8	56.9
5) California	10	56.6
6) Ohio	19	51.3
7) Massachusetts	27	47.3
8) Michigan	7	40.8
9) Arizona	1	37.3
10) Missouri	3	33.7
11) Rhode Island	11	32.7
12) Indiana	11	28.8
13) Pennsylvania	15	27.9
14) Florida	5	27.1
15) Washington	4	21.7
16) Alabama	2	21.3
17) New Jersey	28	15.5
18) Kentucky	2	14.8
19) Georgia	2	11.5
20) West Virginia	1	10.3
21) Wyoming	1	8.8
22) North Carolina	4	6.9
23) Montana	1	5.4
24) Louisiana	2	5.0
25) New Hampshire	2	3.3
26) Virginia	2	2.7
27) Oregon	3	2.5
28) South Dakota	2	2.3
29) Texas	3	1.7
30) Vermont	1	1.4
31) Maine	2	1.2
32) Wisconsin	1	0.9
33) Tennessee	1	0.5
34) Nebraska	4	0.5
35) Colorado	1	0.3

The most significant thing to note is that many states with a great number of licenses are not covered as thoroughly as many other states with fewer licenses, simply because the average population covered by a single license is lower. Thus Arizona has been able to provide a greater percentage coverage by its one license than New Jersey has with its 28. The leader of them all, Maryland, has found it necessary to apply for only eight licenses. Nebraska, with four licenses, is next to last in coverage. New York, by licensing New York City, has covered over 50 per cent of the most populous state in the union with one license. In Connecticut there are only two communities of over 20,000 inhabitants not covered by WERS.

Generally speaking our largest cities are licensed, but there are some notable exceptions — exceptions which greatly pull down the percentage of coverage. Of the 14 cities with over 500,000 population, ten are licensed, while 47 out of 92 cities with a population of over 100,000 are licensed. Thus, through the WERS licensing of comparatively few of the countless thousands of municipal governments, CD-WERS has attained a population coverage of 28.14 per cent. From this it is readily seen that it is first of all important to license the large cities in order to provide the maximum coverage with the

fewest licenses. This is an invitation to amateurs in large cities which as yet have made little progress in CD-WERS organization to renew their efforts and boost the population coverage by large steps.

The chief obstacle seems to be that many large cities unlicensed for CD-WERS have expanded their police radio systems and feel that they are adequately covered thereby. In many such cities amateurs have lent helping hands to this expansion. Where civilian defense is not interested in radio communication it is perfectly natural and very commendable that amateurs should direct their abilities in this or any one of a number of other directions. In some of these cities, where amateurs have already affiliated themselves with other radio communication services, it is likely that CD-WERS will not be established; or if it is, it will be without the services, for the most part, of amateurs. But to say that it is impossible or unnecessary for a CD-WERS organization to exist in communities which are already "amply" provided with other types of radio communication is nonsense. Municipal communication systems such as police radio are a regular peacetime service, while WERS is an emergency service to be used only during emergencies. OCD would not have sponsored, and 223 municipalities would not have established WERS communication if they thought normal means of communication could handle any emergency; but the most progressive communities are those in which coöperation and coördination is effected among CD-WERS and other existing services.

EC Bulletins. Several radio aides, having had access to one or two *EC Bulletins* through their local Emergency Coördinators, have requested that their names be added to our *EC Bulletin* mailing list. We have gladly granted their requests, since we want these bulletins to go where they will do the most good, and the subject matter is mostly concerned with WERS.

Upon thinking it over, we have further decided that it would be worth while to include *all* known radio aides on the mailing list. These bulletins are written and distributed for the purpose of getting the latest information to our field organization before it will reach them via the pages of *QST*. They also contain various other items of interest to radio aides such as announcements, interpretations, warnings and admonitions. By the time this appears in print many radio aides will already have received their first *EC Bulletin*. Those who do not receive one are not known to us and should send us their name and address if they wish to be put on the mailing list.

—G. H.

BRIEF

When L. A. Walworth, K6CIB, combed his junk-box accumulation recently, he found nearly fifty pounds of pure copper and almost as much covered magnet wire of assorted sizes. Needless to say, it was all turned in to a place where it would help in the war effort. Have you gone through your junk box recently, to look for parts or materials that might be needed in the war effort?

COMMERCIAL "Z" SIGNALS

In answer to a number of requests, we reproduce below the list of commercial "Z" signals printed in the "McElroy Chart of Codes and Signals." These signals are used on commercial radiotelegraph circuits throughout the world.

The signals take the form of advices when the question mark is omitted.

- ZAL Alter your wavelength.
- ZHC How are your receiving conditions?
- ZAN We can receive absolutely nothing.
- ZSU Your signals are unreadable.
- ZWR Your signals weak but readable.
- ZSR Your signals strong readable.
- ZGF signals good for w.p.m.
- ZGS Your signals getting stronger.
- ZGW Your signals getting weaker.
- ZVS Signals varying in intensity.
- ZSH Static heavy here.
- ZLS We are suffering from a lightning storm.
- ZWC Wipers or clicks here.
- ZVP Send Vs, please.
- ZWO Send words once.
- ZWT Send words twice.
- ZCT Send code twice.
- ZPO Send plain once.
- ZPT Send plain twice.
- ZCD Your collation is different.
- ZCO Your collation omitted.
- ZSF Send faster.
- ZSS Send slower.
- ZRO Are you receiving OK?
- ZOK We are receiving OK.
- ZIR Your transmitter has strong idle radiation.
- ZRC Can you receive code?
- ZNG Receiving conditions no good for code.
- ZNN All clear of traffic.
- ZHY We are holding your
- ZCS Cease sending.
- ZMP Mispunch or perforator failures.
- ZCW Are you in direct communication with
- ZHA How are your conditions for auto reception?
- ZUA Our conditions unsuitable for undulator or automatic recording.
- ZTA Transmit by auto.
- ZBY Break, go back a yard (meter).
- ZBN Break and go ahead with new slip.
- ZPR Re-run slip at present running.
- ZRL Re-run slip before one now running.
- ZPP Punch plain only.
- ZFB Signals are fading badly.
- ZFA Failing auto.
- ZRA Reversed auto tape.
- ZYS What is your speed of transmission?
- ZSV Your speed varying.
- ZBS Your signals blurring.
- ZDH Your dots are too heavy (long); adjust lighter.
- ZDL Your dots are too light (short); adjust heavier.
- ZDM Your dots missing.
- ZDV Your dots varying in length; please remedy.
- ZFS Signals are fading slightly.
- ZTH Transmit by hand.
- ZHS Send high speed auto w.p.m.
- ZSO Transmit slips once.
- ZST Transmit slips twice.
- ZOR Transmit revs continuously.
- ZLB Give long breaks, please.
- ZUB We have been unable to break you.
- ZNB We do not get your breaks; we send twice.
- ZLD We are getting long dash from you.
- ZAP Acknowledge please.
- ZMQ Stand by for
- ZMO Stand by a moment.
- ZKQ Say when ready to resume.
- ZOH What traffic have you on hand?
- ZVF Signals varying in frequency.
- ZFF Please observe and furnish frame code reports on (call letters and frequency) kilocycles.
- ZOA We have checked (transmitter call letters)
..... Signals are radiating on air OK.
- ZCP Local receiving conditions poor; please increase to maximum.

Certain other codes and signals are omitted because of present-day restrictions.

Watertown's Amateurs Go to War

There is only one "native" amateur left in the small mid-western town of Watertown, S. D. He is Orville Hanson, W9HBA, father of four children and the plumber and heating-plant repair man of the town.

This fact was discovered by Laurence Geis, W9OKF. Stationed in Watertown with a CAA crew, he went patiently looking for antennas, and then knocking at the doors of houses where the lead-ins ended, to obtain information. Although many of the relatives of the boys gone to war could not remember their ham calls, W9OKF nevertheless was able to make an interesting recount of the collective contribution to the war effort by the hams of Watertown.

It all started in 1929, when a signal company for the 34th Division of the National Guard was organized in Watertown. Although the 34th Division comprised units from Minnesota, Iowa, North and South Dakota, the amateurs of Watertown and vicinity took the lead in the work of this signal company from the very beginning. This they did by supplying the leaders for the company, aiding men to get their tickets during the weekly drill periods and summer encampments, and by recruiting new members for the group.

When war loomed and the 34th Division was mobilized with the rest of the National Guard in February, 1941, the company went to Camp Claibourne, La., where they remained until February of 1942. They were then sent to Northern Ireland, and in the early summer of 1943 they were sent to North Africa — where they have been in the thick of things ever since. Because of war censorship, of course, we cannot go into detail about their work in the Mediterranean theatre, but we may say that they have been highly commended for their activities to date.

Major Stanley L. Burghardt, W9BJV, who was company commander at the time of embarkation for the European area, is now division communications officer. Although there were only 12 licensed amateurs at the time of the 1941 mobilization, the number has since been increased by those who have successfully passed the exam and received ham operator licenses. In addition, of the 42 men who comprised the noncommissioned officers of the company at the time of mobilization, 18 have since been raised to commissioned officer rank, and have either stayed with the company or have been transferred to other organizations. The happiest note of this record is that to date there have been no fatalities among the members of the original company.



A prewar picture taken of the gang that moved W3GLZ to a new QTH. They are, left to right, top to bottom: W3HRJ, W3IFT, W3HEO, W3GLZ's OM, and W3GLZ. Inside the house when the photograph was made, taking it easy with a can of ale, is W3CEU.



Another prewar photograph and example of ham good fellowship is this one, reminiscent of former days when hams gathered on Field Days as well as on the air. This picture is of a group of hams gathered at a Tionesta lumber camp in Modoc County, Calif. *Left to right*—Joy A. Ustick, W7GLF; Lon M. Hildebrand, W6QUE; Vern Kuykendall, W7HKO; Joe Paynter, W6OYU; Harry Austin, W6OYF; Nate Bates, W7FNM; Ray Rivers, W7GTV.

"Bombs" Fall on Allentown

One Sunday morning earlier this year, saboteurs destroyed the Bell Telephone Co. building in Allentown, Pa. They struck at other points, too, killing guards at the Mack Truck Plant, and at small communities near Allentown.

Although the incidents were make-believe, the WERS units were on the job transmitting and receiving dozens of messages from the report of the first incident until the airport was recaptured, in this feigned emergency.

Portable units were operated at the State Armory in Allentown and at bomb squad headquarters, and eight mobile units were in the field with the forces at work intent to liquidate the enemy. The fixed control station received all messages and relayed them to their destination. W3HTS, the Lehigh County WERS radio aide, was in charge of the station at the Armory.

First enemy action was reported at the Mack plant. W3ALX radioed the Armory: "Two guards killed by saboteurs. Situation beyond control. Need help." The message was delivered to the Commanding Officer, and members of the Pennsylvania Reserve Defense Corps Co. F rushed to the scene. A short time later came the report: "Seven saboteurs killed. Three soldiers killed. Two soldiers injured." And later came the message: "Problem solved."

In the meantime, bombs were dropped at the water works and at the power plant. Help was sent from the Armory in answer to messages sent from W3JEV and W3CVJ. After the telephone building was destroyed, radio provided the only means of communication.

The climax of the day's activities was the landing of paratroopers at the airport. Co. F advanced within 200 yards of the airport, but successful precision bombing by members of the Civil Air Patrol was the most effective in halting the advance of the paratroopers. Help was needed quickly and a radio message was sent to the Armory. The Commanding Officer sent Federal troops to the scene and within a short time the paratroopers were either killed or captured. Throughout the airport battle, Armory officials were informed by radio of the progress that was being made. Operators handling airport traffic were W3DOV, W3DRC, and W3CAU.

As far as is known, these maneuvers marked the first time that a WERS unit has provided communication facilities for military organizations. After observing the operation of WJOR and associated units during the weekly test periods and during simulated attacks, officials of the Lehigh County Defense Council are "sold" on radio's importance as a medium of protecting life and property.

— T. S. Wirts

BRIEF

Pvt. Charles W. Hennessey, W1NBS, North Camp Hood, Texas, says: "We hear a lot about ham hospitality abroad—how about some at home?" He suggests that, since there are many hams in Army and Navy posts near various cities, as well as hams in the service of other Allied forces stationed in this country, the local radio clubs try to hold meetings on the weekends, when the men get passes. If some clubs have felt that their hospitality efforts went unrewarded because no servicemen attended, they probably would do better to hold their meetings on Saturdays or Sundays. If this is not feasible for every meeting, perhaps every other meeting of the organization could be held at that time. It sounds like an admirable idea, and it is a chance to help out locally in the matter of entertaining visiting servicemen. How about it, gang?

The Month in Canada

REPORTS of VE ham activities in most sections are conspicuously absent this month. How about it fellows—won't you send your news to your SCM? If he is not active, send it direct to Hq.

BRITISH COLUMBIA—VE5

From Jack Sibson, 5BQ:

WE HEAR that Harold Wise, 5AEZ, and Noel Brittain, 5AJN, were home on leave. Arthur Berg, 5ADO, just joined the RCAF. 5FY is an instructor with the Pacific Coast Rangers. 5ADV is installing radio equipment for Boeing. 5AFL is a civilian instructor for the aircraft ground school at Vancouver. Gordon Wightman, 5HC, flew with the first glider transatlantic flight. Al Blackwood, 5AU, is with TCA ferry transport. Chris Brown, 5CB, is a squadron leader, as is Dud Meakin. Don Murphy, with TCA, has been transferred to Pat. Bay. Marvin, 5OT, looked up some of the boys when he was in Seattle. Art Musket, 5DO, is a married man by now—lots of luck!

MAILBAG

FROM Stan Moir, 3AQB, we have received the following informative letter:

"Here is some of the dope on what the local (Kent County) hams are doing, or have been doing since the war began. We will start with those in the services. All of the following are from Chatham, except those whose home town is otherwise listed.

"3AGC, Cam Burrows, joined the RCCS and was one of the first Canadians to arrive in England. He married an English girl and has a YL jr. op. Now a sergeant, he was wounded in the knee in Sicily and is recuperating in a hospital in North Africa. We wish him speedy recovery.

"3AKK, Gordon Burniston, is in the RCAF. He took that swell radio course and is now somewhere in England doing some of that hush-hush work. His rank is LAC, and he is attached to the RAF. 3VU, Frank Kehoe, is also in the RCAF, and is now a PO. He took the radio course also and at present is instructing at Clinton. Frank became a married man and has a YL jr. op., too.

"3AOG, Bob Chinnick, was recently married. He has his EE degree and is in the RCCS training for a commission.

"3PR, Grant Brandon, from Tilbury, is a squadron leader in the RCAF and is stationed at Ottawa. 3CO, Ted Buller, from Ridgetown, is a sergeant in the RCAF, and is instructing at No. 1 Wireless School, Montreal.

"3ANS, Art Edwards, is a sergeant in the signal branch of the Reserve Army. He also has become a married man and has a brand new YL jr. op.

"3HP, Art Ferguson, has been transferred to Burlington where he is chief operator at the Burlington hydroelectric station. Sorry to hear that his garage burned down, destroying his car and some of his stored radio equipment.

"3LB, Ivan Collins, is still around. He has been building gadgets in his basement workshop, and when the war is over I'll bet he will be able to test or measure any kind of radio gear. 9AT, Jack Beardall, is still running his broadcast station, CFCC. 3AST, Gordon Brooks, is still chief engineer at CFCC and has been keeping very busy. 3AUT, Aubrey Cox, is managing the shoe store as usual.

"3APZ, Fen Jobb, formerly of Chatham, was living in Toronto where he was doing broadcast announcing, but I understand that he is a pilot in the RCAF now.

"3AQB was transferred to Wallaceburg and then back to Chatham by his employer. He is still in the beer business."

AMATEUR ACTIVITIES

ATLANTIC DIVISION

EASTERN PENNSYLVANIA — SCM, Jerry Mathis, W3BES — A swell letter came in from 3GJY, former ORS and traffic man, who has been through the African and Sicilian campaigns and is recuperating for a short time in Ambridge. Since we heard from him last he has taken himself a YF and is s/sgt.; congrats on both counts. 3KT has finished his training in New England and has gone to Florida. The West Philly Amateur Radio Assn. starts its third course in radio telegraphy, Oct. 1st. The course is co-ed. Interested parties should contact 3IBB at the West Branch YMCA. 3COZ is working hard these days for the Signal Corps Repair Depot as an instructor. He lost 115 lbs. 3DMQ went down for his radiotelegraph ticket and thinks he did OK. 3BXE entertained some members of the Frankford Radio Club at a "going away" party for W3KT. 3CFH, now in Wisconsin, expects to pay a visit to the old gang in Philadelphia soon. 3GEM is building a super oscilloscope. 3KJ and 3HFD are rebuilding their rigs. The Philadelphia WERS helped out in a big way at a nine-alarm fire in the Penna. R. R. station after the police radio cars ran down their batteries. They were congratulated by the inspector in charge of police radio. If the SCM election favors me, I will see you next month, 73, Jerry.

MARYLAND-DELAWARE-DISTRICT OF COLUMBIA — SCM, Hermann E. Hobbs, W3CIZ — First meeting of the Washington Radio Club for the Fall of 1943 was held in their old meeting place at the C.R.E.I., 3224 16th St., N. W. on September 11th. The club meets the second and fourth Saturdays of each month. The following officers were chosen at the last meeting: Gilbert Dawkins, president; Eppa W. Darne, vice-president; Elizabeth Zandonini, treasurer; George Sugar, secretary. There are rumors that the club plans to hold a hamfest in November, the exact date to be announced later.

SOUTHERN NEW JERSEY — SCM, Ray Tomlinson, W3GCU; Asst. SCM, ZI; Asst. EC & Radio Aide for Hamilton Twp. WERS, ASQ; EC for Somerville and vicinity, ABS. Seems to me the longer we go, the more apparent is "writers' cramp." Hamilton Twp. WERS still making progress. ABS reports Hillsborough-Branchburg Twps.' WERS application has been honored by FCC with the call WKKXQ. Operators' permits have not as yet been issued them, but are expected any day now. As soon as the ops' cards are forthcoming Stan says their nine units will be ready to go. These units consist of six mobile and three fixed. We have not been successful in obtaining any further reports on other WERS programs which are known to be licensed within our section. Come on, fellows, why all the secrecy? ASQ, radio aide for Hamilton Twp. WERS, has just been appointed New Jersey state radio aide by the New Jersey QCD. We understand Dai is to be in charge of coordinating all radio activity for the state with the exception of broadcast stations. Hamilton Twp. WERS has a new member who is going to take active part in the organization, Ed Woodruff, ex-XF, is now residing at 318 Marshall Ave., Mercerville, N. J. Welcome, Eddie! ASQ was called upon to address a meeting at Leonia, N. J., regarding getting set for WERS recently. ASQ enjoyed a much-needed vacation at Manasquan recently. FBT has returned to Trenton with a release from Pratt & Whitney to accept a position at RCA Research Labs. GRW has just recently returned to duty with the Merchant Marine as radio op after leave of absence; Paul is now with the Clyde-Mallory lines, "opping" on a liberty ship, Cpl. S. Czorga, now an instructor at Army Air Corp Radar, Boca Raton, Fla., has residence at 904 N. E. 1st Ave., Fort Lauderdale. Harry Sherman, formerly of Nidisco Radio, Trenton, is with Army Air Corp Radar somewhere in Missouri. BO was erroneously reported by us as being a member of our armed forces; Gordon is not in the armed services, but is still in a civilian position with Western Electric, Baltimore, Md. EWF spent a month's furlough at his home in Haddon Heights. Ex-KA, formerly of this section, now in Chicago, is regional superintendent for CAA, Chicago Area. Congrats, Ralph! ATF was reported somewhere in the

South Pacific — anybuddy know his APO? ARN, has been reported to have graduated from Bliss School, and to have come out second highest in the entire class. Eddie Peters (LSPH) sent in a V-mail letter recently and while he cannot divulge his whereabouts, he did tell us he is a gunner's mate with Unc Sam's Navy. HPE has recently been promoted to RT1c and has been reported stationed at Naval operations base waiting for assignment to sea duty. QL has been reported as somewhere in West Indian Islands. CFS is now "burning up the leather" delivering mail for Unc Sam. HAQ enjoyed vacation recently. GER, formerly of Trenton, is now taking course on marine engines at the new U. S. Maritime Training School, Sheepshead Bay, and expects to be shipped to sea as soon as he receives his engineer's ticket. FBC, on foreign duty, is now master sgt. CCC was home on week-end leave recently; Ed's two boys are also in the armed services. DQ is now on active duty with U. S. Air Force in India. EFF is with John A. Roeblings Sons Co. electrical dep't. He is also op at local b. c. station WTNJ. EGE is proprietor of Griffith Electric & Supply Co., Trenton, and supplies several large concerns with necessary materials for the war effort; Bill was an ardent 40-meter ham. Ed Beemish, formerly of Beemish & Marotte, Trenton, recently spent vacation with his wife touring around Providence and Boston. Ed is now winding transformers with a local concern. A farewell party was tendered Tony, ARN, while he was on leave recently, by the Sine Wave Club, an alumni group of former radio classmates at Trenton Senior High. Tony was instructor of the lab class and well known to many. Vince Wagner, ex-8BRJ, formerly of Pittsburgh, Pa., now of 336 Beechwood Ave., Trenton, who is president of the Sine Wave Club, was accepted into membership in the Delaware Valley Radio Association at the September meeting of that organization. AFH, although unable to get about, wishes to extend his 73 to all the old gang. Why not pay Bill a visit, fellas? He always has a hearty welcome for the boys who go to see him! Ruth Hirsch, vice president of the Ladies Auxiliary of the D.V.R.A., is taking a nurses' aide course, and spending many of her evenings and Sundays in local hospitals helping out. HVO and AKB have been named by the YLRL as candidates for third district chairman. Pauline, HVO, has been very active in Red Cross centers doing sewing for the boys in uniform. BEI just recently passed the half-century mark. Walt will be remembered as former Southern New Jersey SCM, and has been a member of ARRL for 22 consecutive years. Congrats, Walt! HAV now in Unc Sam's Navy may be addressed Robert Bowers A/S, Co. 4413, Bldg., 426J, U.S.N.T.S., Bainbridge, Md. He is going through boot school, but expects radio work soon. ITU, radio op with Army Engineer Corps at Huntington Beach, Calif., writes that he now does operating when there's no repairing to do. Says there were four hams in that town but they've all gone to war. We know some of you have some nice news up your sleeve, so why not loosen up? It may not seem much to you, but it would be worth its weight in gold to the boys out there to read some news from home. Come on, gang, pass it along. Till next time, 73.

WESTERN NEW YORK — SCM, William Bellor, W5MC — On a recent furlough Lt. Leon Lustyk, OQC, was guest at a party given in his honor by JAD. So many of the Rochester gang were present it looked like an old-time hamfest. Fred Ambrose of WHAM and Dewitt Bogart, who resides about 12 miles from Fred in Spencerport, N. Y., are working on a carrier-current set-up and hope to be able to span the distance. They are quite anxious to hear from anyone else in the area who might want to join their experiments. 6SML has moved from California to Ithaca, N. Y., where he is attending Cornell University and helping on a farm in off hours. He is also interested in wired wireless and wants to hear from amateurs in the Ithaca region who would care to join him. He can be reached at Cherry Rd., RD #1, Ithaca, phone 3-2377. Bill Connell of WPDR left last month for Army service. Pvt. Jim Lee writes from Camp Chaffee, Arkansas, asking news of whereabouts of RCJ; maybe Al will notice this and tell him directly. That's all for this time, fellows. Please keep the news coming in from wherever you may be and keep our section in QST each month.

CENTRAL DIVISION

ILLINOIS — Acting SCM, George Keith, jr., W9QLZ — ODT is still struggling with the paper work required on WERS licenses around Joliet; JVC is getting his share of operating with the armed forces. His address is: Sgt. Ernest

A. Stuart, APO 306, c/o Postmaster New York City. DBO has received an honorable discharge from the Army and is anxious to learn to copy code on the mill. The Joliet gang manages to get about a dozen members out to the meetings of their club. CXT, attending Naval Academy, is kept busy with his books. LIG is installing communication equipment on LST boats. YBY works nights in the machine shop of the Seneca shipyards. If the readers of this section news wish to continue reading the column, someone will have to send in some news. 73, *Geo/W9QLZ*.

INDIANA — SCM, Herbert S. Brier, W9EGQ — SNF, former radio aide and EC for Highland, is now teaching radio operating and procedure for the Army in South Dakota. He was transferred from Chicago when the Air Force radio schools there were closed. YGH is the new radio aide of Highland, assisted by CWO. All activity is suspended pending the arrival of WERS permits for newly trained operators. Gary has applied for modification of its WERS station license. Authorization for 23 units, all but two being portable or portable-mobile has been requested. 3rd class operator permits are starting to trickle through as a result of the classes held several months ago to train additional operators. Another class is now in session for additional volunteers, and for those who failed the first time. MVZ, radio aide; JZA, MTL and WKN made a trip to Ft. Wayne to study their set-up. Gary operators hear many of the Chicago WERS units. DHJ and YWE now have commercial licenses. YWE is attempting to obtain a release from his present employer, so he can use his 1st 'phone. EBB was home the last part of September on vacation from his job in the Naval Research Lab., Washington, D. C. INL, WZY and RFD work at the Naval Ammunitions Depot at Crane, keeping 50 two-way radio units operating. INL will write to or swap QSLs with any ham or SWL. Ex-SCM, YMV, likes the work as a radio op for the Maritime Commission, and "looks just wonderful" in his uniform. NZZ is loafing again, working 8 hours a day, 7 days a week. For a year he also taught code to the Army at Dodge's 6 hours a day, 6 days a week. SVH, who was Acting SCM for several months, sent me 25 pounds of records, forms, etc., but no news of Elkhart's WERS activity. He is busy doing research for Conn. LPQ is working for Republic Aviation installing radio and electrical equipment in P-47s. Sullivan now has five WERS operators, three with 3rd class permits. LPQ being generally unavailable, that gives four active ones; a 100% increase. As always, new ECs are needed. 73.

OHIO — SCM, D. C. McCoy, W8CBI — Toledo: Phil Bloom is in Brownsville, Tex., as radio operator for Pan-American Airways. Mack Lehman is also in that general vicinity, reported doing some fishing in the Rio Grande. Paul Lentz has been promoted to a lieutenant in the CAP in recognition of his good work with the radio equipment in the patrol planes. "Butch" Ball was married on June 2nd. Karl Betz and Ray Lewis celebrated their 10th and 15th anniversaries, respectively. Cincinnati: MFP reports that reorganization, revamping and rebuilding are occupying what time the boys have from regular WERS drills. Cliff Ormston, vice president of Withrow High School radio club, reports GBI is now a lieutenant in the Signal Corps. Club membership has been depleted by June graduation. Cliff is going to take Class A exam soon and now has 2nd class radiotelephone ticket. Bill Novak has his Class B ticket, and Wesley Lorah now holds 3rd class 'phone. VZF, president of club two years ago, is now in Marines; Louis Umbach is now taking EE at Carnegie Tech. Middletown: DGU reports they have their WERS license, call letters WKMT. IBN, former chief operator at local police station, is now in the Signal Corps, and DGU has taken over his duties on police radio in addition to being WERS radio aide. Five students have already secured 3rd class 'phone permits and their papers are in for WERS permits. QIE, TOR, PNP and MSE are participating in WERS activities. Cleveland: AVH, EC and radio aide, reports modifications in license have been applied for to further extend size and scope of local WERS. The Cuyahoga Radio Assn. now meets the first Tuesday of every month. Election of officers was scheduled for July 6th meeting. Members in good standing entering the armed services were relieved of payment of dues for the duration. WERS and post-war planning were the major interests of the June meeting. DXB, TAZ, SRA, FSS, EBJ, MXK and FZN are all busy with WERS equipment problems. POQ was reelected chairman of the board of his company, the Diebold Safe and Lock Co. Twenty-two hams are working with the Brush Development Company in Cleveland. NGZ

is now a lieutenant in the Signal Corps at Camp Crowder, Mo. Harry Tummonds is now a lieutenant in the Navy; he was last reported at Harvard training school. PMP is a captain in the Air Forces, acting as instructor at a training camp in Arizona. CNS is a radio technician with the Coast Guard at Buffalo, N. Y. *East Liverpool*: NDF reports WERS license has been granted, call letters WKPW. Five Abbott TR4 units are ready for service. Four applications now in for WERS operator permits and a number of students are in training for 3rd class 'phone exam. *Youngstown*: Henry Hamm, TAD, reports WERS license granted to Mahoning and Trumbull counties, call letters WKML. Thirty-five units are ready for service and ten are under construction. *Lima*: Application has finally been submitted for WERS license, and Roy Albridge has been appointed radio aide. Fourteen stations are contemplated. *Fremont*: WERS application will be submitted shortly. J. W. Swartzlander of local police department is radio aide. Five units are contemplated. *Salem*: The grapevine brings word of some interest in WERS with CJG trying to stir things up. *Wapakoneta*: SJF says no interest there in WERS, and no personnel available even if the interest did exist. We are sorry to report the death of Gladys' son on March 7th. *Portsmouth*: LEK reports WERS at standstill locally due to lack of personnel and equipment. *Pomeroy*: VUS reports license for WERS granted June 29, 1943, with call letters WKOZ. Four station units are ready to go and four more contemplated. VWW has joined up with the Signal Corps and is now at New Orleans. *Mansfield*: JJM reports that perseverance has finally been rewarded and that the license for Richland County was issued June 26th, with call letters WKNF. JJM is county radio aide. Three TR4s are ready for operation, as are three composite units. Two licensed amateurs are participating in WERS work. Intermunicipal agreement has been completed, with Crestline adding it to the system. *Dayton*: TFC, VMJ, VHN and VAY have joined the ranks with portable-mobile equipment. Ed. Morris, v.h.f. experimenter, has joined up also. Ed is local radio aide for Harrison Township Defense Council. KKH and TDY are having power supply trouble. Earl had his power supply stolen from his car recently and has been unable to replace it. Let this be a lesson to all the gang to keep their car and garage locked. WERS equipment, especially vibrator power supplies for car operation, is difficult to replace. Equipping of stations under modification program for Dayton license is proceeding well. Battery power supplies still are a problem for mobiles. Fixed stations in outlying towns are taking shape and we hope to meet our scheduled date of Sept. 15th for completion. VWL was married June 19th and her OM was promptly shipped overseas. Ruth has been in charge of Red Cross headquarters seven days but has had to QRX for a while as she is working seven days a week now and has no time for WERS. Welcome to 9KSA, who has joined Dayton WERS, and who has secured her WERS operator permit and will sub for Ruth. WOX has entered the Navy. BI is now a captain in the Signal Corps, stationed at Ft. Monmouth. RSQ has his equipment for WERS going, and is trying to soup it up enough to work into Dayton from Vandalia, without relay. NSS has been helping RSQ and Ed Morris get organized and going. Ten more new WERS permits have been received; most of these were students in the training courses conducted during the past year. QDI has been commissioned an ensign in the Navy. Charles Deger, SWL, has been promoted to a lieutenant (jg). SPL is reported to be CO of Signal Corps Depot company stationed in New Orleans. MFV at 3rd Comm. Squadron at Alamo-gordo, New Mexico, has been promoted to a corporal. He is the proud papa of a girl. SVI is in Utah, getting set for overseas duty. NYY is a c.w. operator in Africa on a transatlantic circuit. ENH is on the West Coast on temporary duty and LCO has just returned from a trip to Texas. GCG is trying to get SG-WERS license for local group. OVL's XYL is among our new WERS operator permit holders. *Piqua*: WKN reports that all who applied for WERS permits have been licensed, are actively engaged in operation and have learned to handle equipment and traffic in good shape. Experiments on circuits and antennas are being continued. A recent new layout tried is based on the "horseshoe" inductance job in Dec., 1941. *QST*. VVN is building a new transmitter for main control station. JEI was home on furlough from Orlando, Fla. QHV has remodeled his transmitter. PFC expects to be inducted soon. OHU is building a new transmitter along lines mentioned above. *Greenville*: UWA reports WERS license granted July 20th, call letters

WLDW. Six transmitters are ready for operation. UDP is in Navy as RM1c, in the Caribbean area. UPM is in the Navy on sea duty. Carl Boyer is a Navy radio operator somewhere in the Pacific. ARW is still in Ft. Wayne doing radio work. BHP is following his trade as tinner in an aircraft factory at Troy, Ohio. EOY is also working at the same plant. TDM is doing his bit of war work by lining up front wheels on automobiles. TDN is in the test department of a plant making military radio equipment. TYB is in the Army, somewhere in the Pacific area. SUZ is in the Navy in Texas. **Columbus:** QQ reports a total WERS personnel of about 50 operators now. Classes in procedure are being held to speed up operations and conserve time during drill periods. A new crystal-controlled transmitter with 815 final has been installed in the main control station, resulting in improved operation. Several more mobile units are now in operation. George Brandon is now construction and maintenance officer, and Mr. Andrews has replaced QQ as personnel officer. QQ is now training officer. **Canton:** NXJ reports that at a recent meeting of the radio club the commander of the local defense council gave a talk on the need for WERS radio communication. A crystal-controlled transmitter with 829 final is ready for the main control station; another with self-excited HE24s modulated with a pair of 50s is also ready, and an Abbott TR4 is also available. Ten or twelve transmitter-receivers are under construction. License has not as yet been granted. RQK, former president of CARA, has left for training as an overseas Red Cross supervisor. ADQ is wrestling with WERS paper work. **Marietta:** KWZ has been appointed EC for Marietta. He is maintenance engineer for the local police radio. He says that lack of amateur personnel is going to be a problem in organizing WERS, but he is going to try. **Shelby:** Robert Ellis, LSPH, has received his Class B ham ticket and is anxiously waiting the day when he can get on the air. **General:** Another copy of the YLRL official publication, *YL Harmonica*, was received by the SCM. It is interesting to read what the YLs and XYLs are doing. SSV, Anita's OM, has been home seriously ill. Ex-8GPF, a warrant officer in the Navy, is now stationed in DNC, Vice Chief of Naval Operations Office, Aeronautical Section, Washington, D. C. Since our last report we have been approached by Lt. Dorothy Thompson, local recruiting officer for the WAC, for assistance in locating some women radio personnel. A list of our women students was furnished and we hope some are able to join up. An interesting sidelight to this activity occurred the day a group of WAC personnel called on your SCM at the office, much to the amusement of co-workers, who wanted to know when I was going to join up, '73 'til the next issue *Dan*.

MICHIGAN — SCM, Harold C. Bird, W8DPE — UGR is still working on WERS portable equipment and doing a fine job. Reports Red Cross club working on post-war plans. CSL asks about WERS possibilities for the county. Detroit Amateur Radio Club reports a visit home of Lt.(jg) Ken Glass. He gave the boys some very interesting sidelights on his activities. CLL gave a very interesting talk to the gang about his activities with the FCC. JD, IFT, RMH and 9MLU showed up at the meeting of the DARA. BIU, radio aide for Center Line, reports 45 messages and 17 incidents handled in 42 minutes during recent air raid practice. Nice work, gentlemen. Let's have some more of this kind of report. The following men visited Flint Radio Club September 5th, and had the pleasure of seeing their WERS equipment: DPE, PBP, Forrest Brown, Lou Young, Leon See, Eddie Gocha. The Flint boys were able to demonstrate their equipment. They received their license July 24th and are now going almost full blast. Their license covers 11 fixed and 10 mobile stations. The call is WKOY. Stations No. 1 and No. 2 are at control center. The layout for control station No. 1 is a four-stage crystal-controlled transmitter running between twenty and twenty-five watts input to the final and a superregenerative receiver. The second station at control is an Abbott MRT-3. The antenna for No. 1 is a three-wire folded doublet in a vertical position about 85 feet above ground fed by a two-inch spaced line. Number 2 is similar except that it has a two-wire folded doublet. They both seem to be very effective. The radio aide is Francis Gary, GJH, and he seems to be doing a swell job. The most active members are GJH, QBM, QBO, QBI, QIC, GXA, ACW, AVQ, NGC, MCC, QUY, AAH, DLT, BDS, NJE, PDD, C. Jennings, I. Smith, H. Blumerich, ex-EJU and IQS. They are also training some prospects for commercial license. LkJ was of great assistance in getting WERS activities started but he had to leave for duty before the license

was received. They say the only objection to the set-up is the fact that the test nights, with the exception of Sunday, are rather hard on the boys working in the plants. The Oakland County WERS also received their license under the call WKYM. They have six stations licensed and six more under construction. Their problems now are getting the antennas up and the stations in operation before cold weather sets in. The following operators have been licensed to operate the stations when installations are completed: Carl Bacon, Leon See, Manly Phetterplace, Wayne Cooke, Lyle Dusenberry, Carl Edberg, Howard Cudniff, Forest Brown, Louis Young and Radio Aide Harold C. Bird. The main control station is a complete transmitter and receiver on one chassis with a change-over switch for either a.c. lines or vibracup supply. Another relay-switching arrangement is so arranged that if the a.c. lines fail the battery supply is automatically cut in. Letter from S/Sgt. Francis Martin, who is now somewhere in Arabia, reports receiving his first QST after twelve months overseas. He says he cannot get away from the pages. The issue was July '43. Enjoyed the China Amateur Radio League anniversary write-up, also the article, "Who Killed the Signal?" He also has introduced two new associate members to the League, S/Sgt. Carl E. Wood and S/Sgt. John D. Tigg. We should be proud of him for this solicitation away over there. Says they will make good hams "when." Well, gang, guess this is about all for this time. Your reporter has been away on a special detail and just returned last Tuesday. Saw a very fine police radio set-up and also heard some rumors of more WERS activity. No reports from Lansing, Center Line or Detroit this month. Grand Rapids reports working 28 miles from their control unit using only about 5 watts of power. Their terrain up there is very hilly so this is considered quite a feat. They are training more personnel to cover more stations and report nice progress in this work. Hope to have more favorable reports from their EC for you next month. Guess this is about all from here for this time. Glad to hear from you fellows any time. Lots of luck and 73, Hal.

WISCONSIN — SCM, Emil R. Felber, jr., W9RH — IZO, secretary of The Milwaukee Radio Amateurs Club, reports that the weekly Thursday night meetings have been resumed and attendance is excellent. Half of the meeting is devoted to WERS and progress is being speeded up to get all towns in the county signed up. There now are 15 completed units, and 10 more under construction. We received another letter from YEG, who is now somewhere near Italy. Pvt. Gilbert W. Rink is at Fort Monmouth, N. J. Sgt. James Fischer writes he has his amateur operator's license and is looking forward to getting a station going after the war. He is located at Camp Hood, Texas. Sgt. Oliver Zander, at Grew Field, Florida, would like to hear from more of the members. JWN is RM1c attached to a destroyer tender in the Pacific. JPS is CPO with an aircraft carrier unit in Atlantic waters. Lt. Louis Wollaeger is at Bowdoin College, Brunswick, Maine. Ex-HWY went back to sea in the Atlantic. Clayton Senoff was a club visitor from New York. EC of Madison, UFX, reports HCR is a CPO there. PCX has an 8-lb. junior op. MRY has been promoted to a commissioned officer after being in the services about 5 years. Lt. (jg) Wesley Kelly has a ham license on a bet with UFX. He won. 1NHN, Norma Scholl, is a WAVE at USNTHS. H. Beckman has been promoted to a sergeant. The Four Lakes Radio Club members and hams around Madison regret to report the death of Howard Smithback, W9AFL, from drowning. HMG bought a new home, antenna system all planned. S/Sgt. Jesse D. Wheaton is overseas and would like to hear more about the boys around Superior. What say, fellows, send me some news. He writes that M/Sgt. Glenn Davidson of Signal Corps is still overseas. DDU is in the services somewhere. KYN is in the Maritime Service as a radio op. As for the club there, most of the fellows are in the services and reports are that WERS in Superior is in the wind. **Notes:** Who knows anything about the WERS gang at Appleton? Please report progress to me, fellows. SYT joined the CAP. HRM attending meetings. VDY was visiting at home. He is with Raytheon in Massachusetts. KLN is teaching in Madison. 73, Emil.

DAKOTA DIVISION

SOUTH DAKOTA — SCM, P. H. Schultz, W9QVY — ZBU of Platte reports that MBA has been on furlough. He is now stationed in New York as a naval radio instructor. AFP of Tabor and Dakota Wholesale Radio Co., Yankton, also was at home. He is located at La Junta, Colo., as a

civilian in maintenance of radio equipment at the Army Air Base there. 5EAK was at his farm near Pierre this spring and summer after the NYA folded. ILL is with Inland Airlines and located at Huron and is still teaching some radio in defense classes. YNW of Sioux Falls was home during month of August. Has been in Samoa but now on West Coast waiting for new assignment. EJOJ of Aberdeen dropped in to see the XYL and myself. Had a very FB chat and glad to see some of the gang. STI of Presho was back on leave and visited in Pierre. Ben is now located in Louisiana on maneuvers. ZNM of Gardner has been transferred from Wisconsin to Ashley, N. D. He is still with the CAA. Writes a nice letter and would be glad to hear from the gang. ZRA has moved to a new location. His address: Capt. Ray E. Daly, APO 301, c/o Postmaster, San Francisco, Calif. One or two other Soc Falls hams are in same outfit with him. DKJ is now Lt. (jg) M. M. Hasse, USNR, Room 233-1, 3415-38th St., N. W., Washington (16), D. C. 73, *Phil*.

DELTA DIVISION

ARKANSAS — SCM, Ed Beck, W5GED — As we go to press at this time we are approximately on the eve of the regular quarterly examination. This is always a welcome event because it results in a partial gathering of the clan, and inasmuch as assemblies of the gang are not as frequent as of yore, we are always grateful for any event which permits a get-together. PX finally had the opportunity to complete his well-deserved vacation and reports having had a most enjoyable time so doing. VZ has been transferred from WAR to teletype school at New Orleans. UI is instructor in Massachusetts and wants old timers to write in and report on themselves. EKD is now pushing buttons at KARK. JCN visited GED while in Little Rock recently on business. HOT is again doing his stuff with the Navy. BCZ is again well established in Little Rock and is working for the Mo. Pac. Railroad. LZK is again located in Ft. Smith. CFQ cast his lot in with the Navy and is going good. News is unusually scarce this month, gang, and the only reason is that reports were scarcer, so again we must remind you that this is your column, so if a report fails to appear it is because you failed to report. 7S and all the best; see you next month. — *Ed*.

MISSISSIPPI — SCM, P. W. Clement, W5HAV — EWD, former SCM, and FSS are now in the Army and taking their basic training at Gulfport Field. FQL is in Navy radio school. FCH, who has been serving as radioman in a Flying Fortress on foreign duty, is back in the U.S.A. IBO, now located in Virginia, has been joined there by his XYL and junior op. Sorry about Mississippi Section being missing in last issue, but no reports came in. Let us hear from you Mississippi hams, at home and abroad, and we will have a report each month. 73.

TENNESSEE — SCM, James B. Witt, W4SP — HXC sends in a nice letter and says that the Army specialised training is really FB; college physics, chemistry, math and English plus history and geography. GMU is across now. HDV is working for WPEC in Memphis. HPO is working for WTJS in Jackson and GOI was in Camp Crowder. PGJ says that they are having WERS drills about every three or four weeks in Kingsport. Major James J. Griffith, formerly FUF, has been in the Air Corps for several years. He was awarded a DFC about a year ago for bringing in a B-17 which had been shot to pieces. His home is Kernersville, N. C. Robert L. Blair received his ticket after Pearl Harbor and is with the Signal Corps in North Africa. His home address is Kingsport.

MIDWEST DIVISION

IOWA — SCM, Arthur E. Rydberg, W9AED — Cedar Rapids has organized a radio club to facilitate WERS. The work of the club will be done by committees rather than officers, so they elected an executive committee of five which includes an executive chairman and four other members. The latter four have separate committees and sub-committees. There is a lot of work to be done in order to get WERS started and they thought that the use of committees would make the work easier and more interesting. They elected as follows: executive chairman, Noble H. Hale, W9JUH; membership committee, Wm. F. Stewart, W9VTD; finance committee, Roy H. Olson, W9GJY; activities committee, D. D. Morgan, W9BCC; WERS committee, Dawkins Espy, W8UBT. The Des Moines WERS unit is having difficulty getting equipment for 112 Mc. work, but they are continuing their work of installing receivers to coordinate CD whistles and sirens. To date they have installed thirty

receivers and have fifteen or twenty more to install. The system used, previously described in this column, was tried during a recent blackout and proved very successful. Most of the hams in Burlington belong to CAP and have provisions for CAP-WERS with officers as follows: George Goetz, W9WTD, commanding officer; McGuigan, W9TMY, communications officer; Bischoff, W9QVA, deputy communications officer. The Iowa-Illinois Amateur Radio Club classes have dropped off considerably, but they still have code every week. UDR is now a lieutenant commander and is doing important work on the West Coast. DVP is now RM1c and recently spent a leave at home. ALC is T 4 in the Signal Corps and is making the rounds of various Air Forces fields in the Northwest. HQO was inducted into the Army but his whereabouts are unknown. QGU was recently transferred to sea duty and is RT2c. FDL now with Clinton Engineer Works, Knoxville, Tenn. OJD is in Sicily with Army broadcast outfit. KLC has not been feeling too well since his operation. SQV, radar technician, lost his boat in Sicily and is home on a 30-day leave. UAD in merchant marine, is completing a trip around the world. JYV finished overseas training as aerial gunner and expects to see service soon. TWX is in the ice cream business as a wartime sideline, helping fill the manpower shortage. DIB and AEP are in love with the graveyard shift. Bob Crotinger, Sigourney, who expected to go to the Coast Guard, was rejected by the induction center and is now working for KANS Wichita, Kans. Recently-appointed Emergency Coordinators: PJR, TWX, URK, JIH.

KANSAS — SCM, A. B. Unruh, W9AWP — SOHB, radio maintenance man, and W9OZN, c.w. operator, both of KGPZ, are in the Army now. NLM is AAF technical advisory inspector for new bomber program at Boeing-Wichita. QZT, formerly of Coffeyville, has been doing flight and ground station operating for AAF in Australia. PSE is now Lt. Lynn. RMJ is pounding brass for KGPZ in the wee small hours, in addition to job as electrical test technician in bomber factory. QQI spends his spare time in radio service shop. IJK, formerly of KN net, is a lieutenant in the AAF. He was in hospital seven weeks but is doing OK. He sends 73 to the gang. ECF was married August 8th, and works in crystal factory in Topeka. YYW, formerly with CAP, is in the Navy; his YF, ZUY, accepted job in confidential shops at Boeing. Eileen Hunter (op's license only), whose OM operates at KGZC, accepted job in Boeing radio shop. She also holds commercial radiotelephone second. KNQ, formerly with K. G. & E. is an AAF inspector at Wichita aircraft factory, but expects assignment to modification center. He suggests that hams using carrier current avoid the frequencies used by the utilities for automatic load control (50 to 150 kc.). QEF is at naval training station in Farragut, Idaho. LVZ is in Civil Service, repairing aircraft engines and training personnel for engine shops at Miami, Florida. He enjoys Kansas notes, but suggests that more of the gang make their whereabouts known. Ex-QLI (now 5KRM), is with Empire Pipeline, Gladewater, Texas, where they deliver oil to new "Big Inch" line to East Coast. QQT and ex-BLA returned from radar school, where they were sent by Boeing. OWZ has been in Army construction work for over five years; is now with Corps of Engineers, as chief engineer for area engineer at Cheyenne, Wyo. He gets in a limited amount of camping, fishing, and skiing. OWZ says, "When this is over, we want our old frequencies back, and ARRL can do the job best." NQX, captain of radio division, KGPZ, received commission as lieutenant (jg) USN, and will report for duty soon. LFB had appointment with RI for radiotelegraph first and will help out at KGPZ. As this is written, a bond drive is in progress. Many post-war rigs will be financed by bonds that were purchased to back up the hams overseas. 73, *Abie*.

MISSOURI — Acting SCM, Mrs. Letha Allendorf Dangerfield, W9OUD — OUD and BMS were married August 27th in Joplin. BMS is with the State Highway Patrol as radio op and the new QTH is Box 245, Lee's Summit. Don't forget when you send in your reports. Not one real report this month. A letter from TGN suggests he is willing and eager to get back home and on the air. LEO is operating on a ship in the Navy. NSU and his mother are back in Mountain View after a pleasant visit with his brother in West Plains. WOC is with the FCC in Washington and likes the job, according to brother KG, who is with the Highway Patrol up here. Ex-9IGW, now 4HLN, is at sea again with the merchant marine. And that is really all the dope from here. Do please sharpen up your pencils and write us a letter. Re-

member, I can still put poetry in this column — so be warned. 73 and lots of luck to you all.

NEBRASKA — SCM, Roy E. Olmsted, W9POB — This will be my last week in Milford as my work at the Nebraska State Trade School is finished with the graduation of the last classes of Signal Corps radio students. Send all future communications to me at the old QTH, Wauneta. And may I suggest that more of you fellows, both at home and in the Services, send in monthly activity reports since your letters and cards, brief though they may be, furnish most of the information for this column. When you don't give what help you can, I must conclude that either you don't like the way I edit this report or that you are not interested in the contents. Of course, there are a few old reliables who try to send in something each month and I do appreciate their efforts. Have a nice letter and report from Marvin Olson, MLB, who is EC for the west central district and radio aide for the town of Gothenburg. It may be of interest to know that Gothenburg was issued the first Nebraska WERS license, KFNC, which has seen over a year of service and has been renewed. MLB and EKP have pioneered this activity in our state. Their equipment has given excellent results and stands ready for any emergency. These two amateurs, as a result of their experience, have learned all the answers and will be glad to give pertinent advice to any other communities who are interested in organizing similar nets. I might add that the above remarks apply equally well to the work of Darrell Miller, EAT, and his associates at Ashland where, under the call of KGLZ, the second Nebraska WERS net was licensed. Via the official grapevine I hear that our baby net has gone into service at Brainard but no detailed report has been received from LEF, radio aide. That is understandable as I hear Otto suffered paralysis of his right arm from overwork on his farm and is unable to write for the present. KYD has just finished a vacation and reports that he really caught some fish. ROE spent several weeks in Wichita in connection with his work and, while there, met up with HOT, FXF, GDB, YCG and EAT got together with LEF for a talk-fest on September 6th. EDE is wearing corporal's stripes as he furloughs at home from New Orleans. Several graduating radio students from NSTS have recently passed second and first class 'phone exams at Grand Island monitoring station. YOD and your SCM expect to tackle a few elements at the same place next week. YOP is now working out of Anchorage, doing maintenance for CAA, and KPA, who is pounding brass for PAA at Juneau, says he is going to look around for a homestead when he can get some leave — he believes Alaska would be a good place to re-establish his goat farm. If you are one of the 539 licensed amateurs in Nebraska who still lives comfortably at home, if you would like to put a little push into the war effort, if you are willing to give some time and labor to an essential war-time project that you are qualified to handle, if you want to do whatever you can to enhance the prestige of amateur radio and help to insure future amateur operation after the war, if you can cooperate with other local operators in an activity that is mostly watchful waiting — why not do something about it, huh? Regards to all from Pop.

NEW ENGLAND DIVISION

CONNECTICUT — SCM, Edmund R. Fraser, W1KQY — CD-WERS news: EAO, state radio aide, writes Conn. has only 10 WERS licenses since organization is on the warning district basis as recommended by OCD. Eleven of the 14 warning district areas are licensed and 80% of the population of the state is covered by 450 units. Relay routes interconnect nearly all points. AKG, Shelton radio aide, is recuperating in hospital after recent operation. Our congrats to IM, Bridgeport district radio aide, and XYL, MRC, on the birth of a daughter. New Haven warning district has suffered quite a loss from the resignation of AGT, West Haven radio aide, and the transfer of 5JLZ, E. E. instructor at Yale to Univ. of Texas as assistant professor. Both have contributed much to WJLH. IND, Hamden, is building crystal-controlled unit for control center. WJLH-1 has successfully contacted WKAO, WKWG, WKNQ and WKOJ warning districts, relaying traffic to Hartford. IJ, Madison radio aide, reports hearing WJQN, WJPJ and WNYJ units very consistently. Ex-SF, Branford radio aide, is doing an FB job in organizing and operating units in his area. ALW, Norwich district radio aide, reports he has just remodeled a Stancor 112-P which is operating very well. NEK, New London district radio aide, is experimenting with new antennas. REM, Waterbury district radio aide writes that call

letters WKWG have been assigned, and that several units are in operation. DBM, Middletown district radio aide, has control unit now working on remote control. KKS writes interesting letter from California, where he is still with FCC. GRF and HCU, former GB members, were recent home-comers. IGT is taking movies of the WJLH units and operators for GB. MJC has just returned from Arkansas where she was working as engineer in a broadcasting station. A card from others with a little news would be greatly appreciated, especially former ARRL gang. What say?

MAINE — Acting SCM, G. C. Brown, W1AQL — Edward J. Hudon, LYK, has been appointed EC for the Lewiston-Auburn area. It might be well for those who hold an EC certificate to check the date of expiration and send them in to your SCM at 379 North Main Street, Brewer, for endorsement. IWP, Brockton, Mass., is RM1c with the Navy in Maine. VF is in the Navy. LRQ is a civilian radio service man for the Air Forces. BTY has been having a hard time trying to harvest 40 acres of blueberries. Jim Libby, who was about ready to get his ticket, has joined the merchant marine. BOC is with the Signal Corps film library in Boston. HUT has been promoted to agent of Androscoggin Mills, Lewiston. LOZ, a lieutenant colonel stationed in Arkansas, was home on leave recently. LYK has three sons in the service. LPA is a staff sergeant stationed in South America. IJX is an op with the merchant marine. IGW is chief of a signal crew in the Civil Service in Portland. MML is in the Navy. LIZ is in the Civil Service Signal Dept., Colorado Springs. KYT is an ensign in the Navy. LDC is at the Univ. of Maine. GPJ is working at the Bath Iron Works. Merle Towle is doing research work at Harvard Univ. Tracy White is in the USNR. D. H. Nichols, formerly of Livermore Falls, is with the Navy in Washington, D. C. Senator W. H. White, jr., amateur radio's friend at Washington, spent a month at his home in Auburn. Received a nice letter from Bill Gibbs, DTS; he says that he is attached to the signal section, Civil Service in Mobile, Ala. Many of the old timers will regret to learn of the death of Lt. Col. Paul E. Watson, formerly of Bangor, Col. Watson died in the post hospital at Fort Monmouth, N. J. He was a charter member of the Queen City Radio Club and was very active in amateur circles in this section of the state.

NEW HAMPSHIRE — SCM, Mrs. Dorothy W. Evans, W1FTJ — ITF advises that they are still carrying on with WKRH and maintaining watch and regular skeds with WAYI and WKJY. George says that while they are not very active, nevertheless they are ready to go when and if needed. JDP and YF MWI stopped in on FTJ for a nice visit. They are back in New Hampshire for a time. LVG stopped in to see us while home on leave recently. "Sonny" was one of the most persistent 2½-meter men in the state. We could use men like that now, but he's following his hobby in his present job, and we all wish him loads of luck. HJI writes us that he is working at Naval Research Laboratory as a junior radio engineer and has plenty of hams working all around him.

VERMONT — SCM, Burtis W. Dean, W1NLO — Owing to increased duties as deputy attorney general, KJG has resigned as SCM. "Park" has done an FB job for the last 6 years, and is remaining as state radio aide for WERS. As your new SCM, I will do my best to carry on the good work of my predecessor. Springfield is licensed for WERS with the call letters WJQD and has 7 units. This is the first license to be granted for WERS in Vt. KTB spent a few days visiting friends in Vt. and is returning to his station in Georgia. The XYL, NDY, and the children plan to return with him. AEA spent a short furlough with his family at Waterville. NLO visited KJG. GAN saw FSV in Rutland, who was home on furlough. FSV is Navy op and taking boot training at Samson, N. Y. SCEX has resigned as assistant chief engineer at WCAX and has gone with Press Wireless at their Hicksville, Long Island plant. Cliff and family are living at 45 Florence Ave., Hempstead, L.L., N. Y. JVS is working part time at WCAX. Fifty-five attended the "hamfestette" at the Waterman Bldg., Univ. of Vt. Friday Sept. 10th. Moving pictures, "Telephone Democracy" and "Victory Vignettes" were shown. LMO spoke on the radio compass and its use by planes. Hams inspected the communications and electronics lab and the a.c. laboratories of the EE Dept., Univ. of Vt. Code contest was won by KXP with LML second and LMO third. ARRL club certificates were awarded to KXP, LML, LMO, BD, MJU, IQG, NPM, Dolores Staab, Norma Remily, Donald Richardson, Everett Chapman and Clyde David Holloway. KJG and XYL are rejoicing over their sixth child, William Herbert.

EASTERN MASSACHUSETTS—SCM, Frank L. Baker, jr., W1ALP—This month we are sorry to report the death of two hams from this section, both from Lynn. PG was killed in a collision of a Navy plane off the coast of Florida, and GOR was a radio operator on a tanker that was torpedoed on convoy duty. JGQ reports the activities of Lynn hams: Navy radio work: KWT, JFX, LMJ, FHH, RH, ARQ, KSO, KSN, NIN and KZL; Army Signal Corps: KGN, JZV, JRE, NFP, IOB, NFS, HRA and QGE; Merchant Marine: EYP; radio inspectors: CD and MZH; civilian defense ops: CF, JRR, CAU, BKE, GZI, LHL, MGN, JGQ, GFT, KDM, JFH, KJ, TY, WD, JEA, HI, MYO, JTT, MKJ, KDC, ISX, MHK, JA, MOV, NKW, A. J. Guay and W. T. Langan (LSPH); essential industry: AGV, BWA, AJL, NME, BKJ, KVW, ML, CMM, DCX, BKK, JBO, GBW, GAD and LUE. An SOS is sent to you that are in essential industries, by JGQ, to give a little of your time to civilian defense radio. Please remember that none of us are overburdened with time. What say some of you other hams, how about a nice report about the hams in your town? LJE, BFS and LVA are in the Navy and located at Newport, R. I. NDC and SVCV are in the Army as radio ops and are also at Newport, R. I. JTT, MLL, ALP, MVF, CMG and VL have been working in Newport, R. I. LID and his XYL were home for a few days; he will be located in N. J. LBY is also in N. J. JXU has recovered from malaria and at last report he was in Delaware. CGM is now in the Navy as a lieutenant (sg). AHP in Fall River tests every Sunday on WERS. We hear that VA, who has been piloting planes, had his arm quite badly hurt. MBE is now working at Camp Edwards as an electrician. MMI is still in the merchant marine as a radio op: he has been across three times on a tanker. JMJ is still working in Waterbury, Conn. Another new ham in Vineyard Haven is Steve Rogers. LSPH, MBQ says things are fine but he misses having a QSO. MVF is now in the Navy SeaBees on a special assignment and is down in Newport, R. I. DIR is home again from the hospital in N. Y. JIS has gone to Maine for a vacation. BMB is going to help out in radio unit for Rockland State Guard. HRL is in the Navy and is out in California for schooling, with a rating S2c. KEF was turned down by the Army so he is back making shoes for the Navy. MRQ has moved to Lawrence. NBS is an Army specialized trainee at Camp Hood, Texas. MJK has moved to Jackson Heights, N. Y., and has taken a job with the N. Y. Philharmonic Symphony, playing solo French horn. He also has a new baby YL, born in Feb. NAH writes from Tampa, Fla., where he just landed from duty with the fleet. He is RM3c. DKD writes from Savannah, Ga. where he is working with the FCC. He has a 9-months-old YL and also bought a house. He would like to hear from some of the old gang. KYX writes that HQ was home on leave. We hear that the WERS papers are on the way to Washington for Boston, with GDY as communications officer and GWK as radio aide. KDE, EC for Roslindale-West Roxbury has the following: APH, BSX, KHN, AMK, NBE, AZF, FH, AYI, E.F. Bourque and A.W. Greenlan (LSPH). EAU has the papers ready to send in for WERS for Quincy and surrounding towns. SS has been teaching radio for the Signal Corps in Medford and the class held a banquet and gave him a silver plaque. Ex-JUT is working as a civilian in the Signal Corps in Boston. LVN is in Columbus, Ga., as a radio technician for the Army Air Forces. BIO has been appointed to a permanent teaching job in the City of Boston. L. Russell, our Needham EC, reports WERS license received—call in WKYG. James Lees and George Tiffany, both commercial ops, are helping out. Russell believes they have the youngest ops in the country, averaging 16 years of age.

NORTHWESTERN DIVISION

OREGON—SCM, Carl Austin, W7GNJ; EC, 7JN.—DXF, who wanders around the Northeast inspecting airways radio systems, dropped in on us last week and showed us the new mobile transmitter. It is a 6L6-807 rig, two frequencies, and is mounted behind the driving position, along with a 3-band receiver. Both units are remotely controlled from the instrument panel. The antenna is center-loaded with the radiating portion above the car roof. DXF built the rig and says the results are surprising. Another portable, engineered by FTA and CZJ, consists of a 6L6-807 and plugs in on top of the receiver, the jacks making proper circuit changes for transmitting, when plugged in. The receiver audio modulates the signal for 'phone work. Sandy Richardson, W7—, is now with CAA

at Toledo. MQ is teaching in high school. One of Doc Kessler's 60-foot towers, at North Powder, is down. BKD is selling auto parts at Pendleton. FCG is with United Air Lines at Oakland. KV is now a lieutenant colonel, and C.O. at Austin, Tex. Mrs. Stearns is still at United Radio, and so is Mr. Meissner. QP is back in the states after a year in the Aleutians. HKO is teaching radio at Logan, Utah. IDJ is in Rhode Island, working on planes. 6HQH/7, who has been a radio inspector in the East, called on QP at Hayward, Calif. ITZ admits that she has got her code up to 2 w.p.m. faster than the OM, FTA. Hit HHH hoked a CQ at Giles Lake, and raised HVX in less than a minute. BS battles big fish—badly battered when fish pulls him over rocky river bank. Don Peglow, member CORK, passed the Class B exam. Was it Confucius who said, "It's a good idea to keep up your ARRL membership?"

WASHINGTON—SCM, O. U. Tatro, W7FWD—Olympia WERS took part in a public showing of LCD before a crowd of 6000 interested spectators and demonstrated the reliability of this type of communication and how easy it is to co-ordinate it with phone, blinkers and messenger/runner service. DDY, ERU, FWR, FWD and IWM were on hand. The show lasted two hours, covering every phase of CD and was given liberal praise by the press and radio. EBS, lieutenant (jg), writes from Baltimore that he has been in the Navy fifteen months, fourteen of which were as communications officer. He requested sea duty and was assigned to a special projects school at the Naval Research Laboratory, Washington, and Radio Research Laboratory at Harvard and will soon be working out of bases in the Pacific. He says that it is a great thrill to see the equipment and gadgets in the lab and to play around with them. DLN writes that he volunteered for the Japanese-American combat unit last February while in relocation center and was assigned to the communications platoon as an operator, which came easy, but later was transferred to the radio shack as a repairman and is now technician 5th grade. Reads QST regularly and was prompted to write when he saw HML's picture in QST. W7HTH, former Acting SCM, writes that he was taken away late in February for basic training in field artillery and wound up in the radio section as a "Model T" corporal. Says that he operated the set in the communications officer's command car, so consequently was NCS, with his hands full until the boys boned up on procedure. On the first of May he was "yanked out of the outfit with stripes taken away and stuck in the army specialized training unit. Buay sixteen hours a day, but thank God there's no KP or guard duty." That remark by the SCM of Oregon calls for more letters, fellows. 73, Tala.

MONTANA—SCM, Rex Roberts, W7CPY—9YAP is equipment inspector for the N.P. Ry. and permanently located in Glendive. Butte Amateur Radio Club reports twenty-five members, of which nine are licensed. They put on a bang-up local hamfest in July at Basin with about fifty in attendance. Miss Errose Zwick is the secretary of the club. CC was home to Great Falls on furlough. The same also for HEM who is RT3c. BXL and DSS are contemplating a whirl at e.e. BAY had a bit of hard luck and had to abandon his cruiser in the Missouri and swim for it. HIN reports from the Navy says he has recently worked with HAD, EYE, EVE, BIR, 2BXI, HYN, 6UAO and PWB. Sounds like a hamfest. ELY is in the Air Forces and says he had to kill a lot of time waiting for the rest of his class to catch up on code speed. Sorry, gang, that some of the above is late but I was away on vacation in August and it just had to lay over. Thanks for the nice lot of reports and keep them coming. 73, Rex, W7CPY.

PACIFIC DIVISION

EAST BAY—SCM, Horace R. Greer, W6TI; EC, QDE; EC v.h.f., FKQ; Asst. EC, v.h.f., OJU; OO, v.h.f., ZM. thirty-four of the Oakland WERS gang were present on September 16th at the City Hall in Oakland according to EE, radio aide. A good snappy meeting was had along with some good OCD movies. EHS, ensign USN, is now in Florida. IPK, lieutenant (jg), is at Howard University. QWX, lieutenant (jg), is now stationed at Livermore. DMY was home on vacation, then back to Bell Lab., N. Y. NZG and LOH can be reached at Westinghouse, Radio Div., New York. How about dropping me a few lines for QST? All dope of interest will be welcomed. Another day closer to victory. 77.

San Francisco—SCM, Kenneth E. Hughes, W6CIS—Asst. SCM, RBQ; ECs; DOT and RBQ. The WERS set-up

(Continued on page 72)



A Letter from a Boy Who Is Doing His Part to a Mother Who Is Doing Her Part

Dearest Mother:

Your letter came to hand March 8 and so glad to hear from you, also to know you like your work at the radio place. You asked me in your letter if I knew where it was—Well you bet I do. You also asked me if I had my radio. No, it was lost coming down here and I missed it so much. I know some of the girls that work there in the National Company.

You don't realize how important that radio is in all branches of the Army, Navy and Air. I can't tell you much about where I am. I have just come back from receiving and delivering from one centre to the other. One of the boys in this Company came back from the shore with something under his arm and said, "Hi, fellows, see what I found on the shore." Well you can't imagine how we all felt when he set it on a box near by, opened it up and it was a set from the National Company of Malden, Mass. So we had a Radio technician in our outfit, so he tested it, looked it all over, and found it all intact, closed it up again, grounded it, then tried it. The salt water had not hurt it one bit—it gave us grand reception and each night we, or about 12 of us, listened in and it seemed like a message from home. Some of us cried and then laughed. He hid it each day so we had it after the rest of the Company had gone to bed we had an hour's pleasure. Filled us full of pep to start another day.

I have been separated from that Company now. I am being transferred to the Don't know where the others are going but I will say this much, that the National Company's radio gave me two months of pleasure and kept me near home. I will try and see the Adjutant and see if he knows where that fellow was transferred.

You are in an excellent Company too, because that is something the armed forces need a lot of. I only wish I had one in my locker right now, but I can dream for a while that some day I will have one.

I can't tell you much about this place, only it is so hot days and cool at night. I have seen plenty and that is all I am allowed to say. My hand is all better now but will carry a scar for life. I am in this with plenty of others to win this war. I am in hopes to get home soon. I am sending you a little present. I can't tell you but when you get it don't write me back a letter scolding me. It is the least I can do for you while I am so far away.

Well, Mother, dear, be sure and take good care of yourself for me, because I am coming home to you. Give my regards to all that ask for me. Regards to Grandma. Can you send me a pair of shoes and some cigars—you know the kind I like. I will close now—will write again soon.

From your ever loving son,

Bob



Amateur Activities

(Continued from page 70)

in San Francisco is completely established and test traffic between all units is being handled in fine shape each drill night. JWF is still in Florida and sends in a nice report on his doings. RH would like to hear from his old pals and can be reached as follows: P.E.A. — Architects Bldg., Phila., Pa. We have word from EAR, now a staff sergeant on duty with the Signal Corps in Alaska. ZF is now at Philadelphia. HJP reports from Smoky Hill, Kansas, and questions us about the lack of reports in *QST* lately. 9FA reports all well from the South Pacific. He has recently moved to another base. RBQ has been very busy getting WERS going in his zone. CII, who is still at KRG in SF, reports that BP has been ill. PGB is still traveling around the state as field engineer for the Army. CIS has been made warrant officer and will probably be taking out for parts unknown very soon. The SCM has received several complaints regarding the lack of monthly reports in *QST*. It must be remembered that outside of WERS activity, amateur radio is at a standstill. Since Pearl Harbor I have received about half a dozen reports, and you can't keep a monthly report going on that amount of news. 73. *Bill & Ken.*

ROANOKE DIVISION

VIRGINIA — SCM, Walter G. Walker, W3AKN — Your SCM apologizes for not making the deadline that would have had this material in last month's *QST*, but due to being away on business it was impossible to get it through in time. The following dope received from JHC at Buckroe Beach: JNH is now signalman 2nd class on active duty in the Pacific area. JHC will be glad to exchange QSL cards with any ham or SWL sending him a card. QTH is: J. I. Carlton, P.O. Box 16, Buckroe Beach, Va. I received a postcard from former Va. SCM, Tom Jones, BZE, who is now A/C. T. S. Jones, Class 44B, 87th AAFPTD, Ocala, Fla. Was surprised and pleased to have Tech. Sgt. J. Needre, GGI, drop in on me a few days ago; John was up on furlough from Boca Raton, Fla., where he is instructing in radio and electronics. I received a letter from Mr. G. C. Robinson, who is chief dispatcher. CD-WERS station WJDG located in Blacksburg, Va., containing the following information: The station covers the town of Blacksburg and three miles beyond the town limits. Most of the station personnel are Va. Poly Institute cadets, with the only ham member being R. E. Bailey, HUT, who is radio aide. The control center has HY-75 modulated by a p.a. system amplifier. Portables constructed in the YPI Short Wave Club's station, GIC, make up the rest of the equipment. During a test period a portable set-up at Radford, Va., for demonstration made contact with the master station at Blacksburg. It is reported that the Roanoke CD-WERS station WJUA has been contacted on occasions. This DX is about 30 miles. The Peninsula Amateur Radio Club held its first meeting in about a year on Sept. 23rd. at the home of the president, HJW. The following were present: AJA, AKN, MT, JGZ, IIF. The good old days were discussed as well as prospects for the future in ham radio. Since a misstatement of the facts was made in this column in a previous issue that Norfolk was the first Virginia community to apply for WERS, I have been informed to the effect that Roanoke and Blacksburg preceded Norfolk in application date. The above data given by Mr. Robinson shows activities in both Blacksburg and Roanoke. How about some dope on any activities or applications filed for WERS in either area? Roanoke received its license on Nov. 9, 1942, and Blacksburg on Feb. 11, 1943. Are there any other active WERS stations going? If so, let your SCM know about it. 73, *Wal.*

ROCKY MOUNTAIN DIVISION

COLORADO — Acting SCM, H. F. Hesel, W9VGG — Here is the dope on events since I was appointed Acting SCM. CNL left for California where he expects to continue his agricultural activities just north of the famed Imperial Valley. Good luck to you, Steve. AIG reports he and DRQ are attending school at the Boston Navy Yard and both have commissions as ensigns, USNR, and they expect to get a lot more training before they go to sea. AIG sold all his equipment to the Colorado State College before he left Ft. Collins, Colo. MLL is in the Army and attending school at Ft. Collins, Colo., as a student officer horse doctor. OLL is in Philadelphia, Pa., at the U.S. Army Signal Depot getting the inside stuff on grinding crystals. He says he has learned a lot about the art of grinding and how to use X-ray

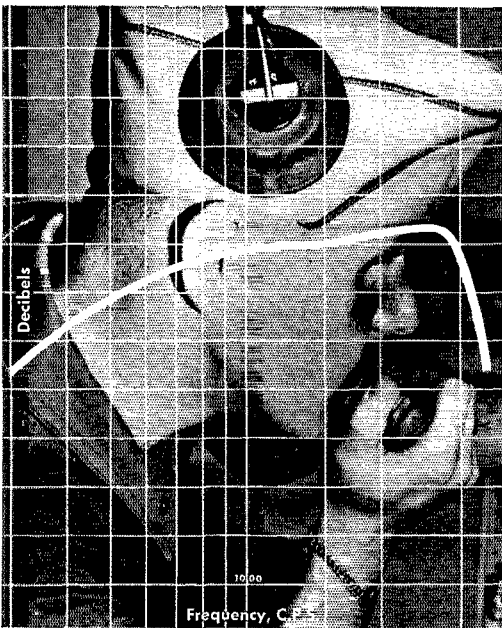

MICROPHONES

designed to bring the message through..

Microphone performance begins with design. Orders, instructions, information must come through — *audibly*. It is the designing engineer's job to bring the human voice through clearly — to eliminate as much as possible the engine noises and tumult that might garble a vital message.

The proven ability to design and manufacture microphones that serve under such conditions — as well as under other severe conditions that attend combat duty — has made Shure Brothers America's foremost manufacturer of microphones.

SHURE BROTHERS

225 West Huron Street, Chicago
Designers and Manufacturers of Microphones and
Acoustic Devices





The Fight Begins!

Everywhere Allied forces are on the march—backed by the finest technical equipment available. HAMMARLUND radio receivers are right in there pitching for nothing less than unconditional surrender of the rest of the Axis.



THE HAMMARLUND MFG. CO., INC.
460 West 34th Street, New York, N. Y.

HAMMARLUND

The Wedding of Theory and Practice

Theory and practice have been wedded in the new **MYE TECHNICAL MANUAL** to provide usable information—data that will help you now—and later. Written in simple concise English, the **MYE TECHNICAL MANUAL** provides the beginner with the ideal text for either class room or self-instruction. The experienced engineer will find it invaluable for reference.

Look at the table of contents:

1. Loud Speakers and Their Use
2. Superheterodyne First Detectors and Oscillators
3. Half-Wave and Voltage Doubler Power Supplies
4. Vibrators and Vibrator Power Supplies
5. Phono-Radio Service Data
6. Automatic Tuning
7. Frequency Modulation
8. Television
9. Capacitors
10. Practical Radio Noise Suppression
11. Vacuum Tube Voltmeters
12. Useful Servicing Information
13. Receiving Tube Characteristics



MYE TECHNICAL MANUAL

408 Pages, 8½ x 11"
Durable Hard Cloth
Covers; Permanent
Sewed Binding. Net
Price: \$2.00

The **MYE TECHNICAL MANUAL** is available from your Mallory Distributor. Get your copy today. You'll be delighted.

P. R. MALLORY & CO., Inc., Indianapolis, Indiana
Cable Address — PELMALLO

P. R. MALLORY & CO. Inc.
MALLORY



(Continued from page 72)

to check orientation of the cuts. URH was a guest at the meeting of AAROD August 27th. CAA and his committee are still working on the Denver city officials to get the local WERS license. Aurora is the only licensed WERS around Denver. WYX got the urge to rebuild again so he started work on a workshop in the basement in his home. I want to ask all hams in Colorado regardless of what part of the country you may be from to lend me a hand by sending me reports to keep this column going and to let the rest of the gang know about yourself. 73 by Heck.

UTAH-WYOMING — SCM, John S. Duff, W7DIE — Word comes from Cheyenne that Shy-Wy Radio Club's new officers are: EUZ, president, JDB, vice president and activities manager, and ICZ, secretary. The club is active and organizing code classes and technical discussions. At Rock Springs, BFC is chief engineer at BC Station KVRB, DIE is operator-announcer and HYO is breaking in as relief operator. DIE just received radiotelephone second class ticket and plans to get first class commercial ticket as soon as possible. HPE writes from Alaska that he is doing radio work as a sergeant in the Army and gets QST, but misses gang at home. He sends 73. Are any hams left in Utah? Please send news to DIE at address shown on page 4 of this issue.

SOUTHEASTERN DIVISION

ALABAMA — SCM, Lawrence J. Smyth, W4GBV — HKZ, now in foreign service, is a lieutenant in the Signal Corps. He says he receives his copy of QST regularly and looks forward to it every month. Your SCM has changed his business address, working now with GIR who is in charge of the FM radio set-up for the Highway Patrol. The following dope sent in by DGS goes a long way in making this column more interesting: DRZ, of 10-meter fame, is now a lieutenant in the Navy and is stationed in the Bureau of Ships in Radio Procurement. EVI is a senior civilian engineer in Marine Corps Radio Design in the Bureau of Ships. AGI visited AWM in Arlington, Va. AGI is now a major in the Marines. EHO is a civilian radio engineer for the Marine Corps in Washington. EBZ is in OGS at Fort Monmouth. BOU is now a captain. He visited DGS enroute to Fort Sutton, N. C. A few more letters like that and the column would be first class. 73, Larry.

EASTERN FLORIDA — Acting SCM, Frank C. Fasset, W4BYR — Report from EYI, EC for Upper Pinellas, only one received in mails this month. ECs, please note that the increasing number of letters and cards received here indicates that the gang away from home depend on us to keep them posted through monthly QST report. CSJ is now chief at WTSP. EWS is chief radio man with Coast Guard. HUX and IGQ report that they are about ready for tests with wire wireless. EPW has left chief's position at WTSP and is now devoting full time to his new radio service business. Saw QN recently in Orlando. He is CPO at Jax base and really looks the part all right. UJ also at Jax base. GVC is working night and day on government contract installations. HRB is due for navigator in AAF. IBW is naval inspector at Philco. Noise from planes in air has handicapped DWI in his getting around of late. Henry has gone north to spend required time with Lead Dog of America Assn., who will furnish him with a faithful dog as a companion in his travels. HGO is up to his neck in activity with QSL swapping and sends new QTH list along with news items of interest to swappers. CLW visited HGO recently. We understand a birthday party was involved. Boyle (LSPH) has turned his law office into a private shooting gallery. HNT has progressed from technical sergeant through master sergeant, etc., and is now a captain in the Signal Corps. Card received from CWV, who is a captain in the Army and located in Miami; sez 3JTQ is there, too, sorta keeping up CWV's morale. Also nice word from HEKJ/2NJX who is a flight radio officer with PAA in Miami; sez he saw DZN's call on a wall in a hotel somewhere, but location not given. DES is back in Winter Haven on short leave from Philco, and is spending some time visiting Tampa gang. Last word from HAD indicates he's still in Seattle. Card received from DRX postmarked San Antonio. Making fine progress, having been classified for pilot training and expects to be in pre-flight in two weeks' time. GLZ on vacation, recently moved his office and is now in new location in Citizen's Building. EUF is at Camp Stewart, Ga., and he'll soon have a junior op. As a contribution to an improved report for next month, it is hoped that word will be received from all ECs in this Section before deadline October 21st.

The New RCA 3-INCH CATHODE RAY OSCILLOSCOPE No. 155-C

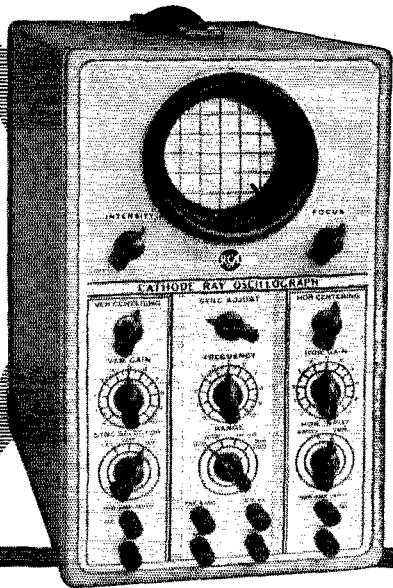

10 TO 60,000 CYCLES!

New improved timing axis oscillator provides extraordinarily wide range—10 to 60,000 cycles—never before available in a 3-inch scope.

EXTRA-BRILLIANT IMAGE!

New built-in, deep, light-shield makes image appear surprisingly brilliant—even in bright daylight. Screen is quickly removable—easily changed.

DIRECT DEFLECTOR PLATE CONNECTION!

A special side opening in case is provided for direct deflector plate connection—facilitating use of tube for the higher frequencies.

NEW RCA UNIVERSAL BINDING JACK!

Extremely handy. A combination binding post and pin jack for universal application. Permits quick, positive connection with any type lead terminals. An exclusive RCA feature.

Rugged enough to withstand every-day field and service usage, yet built throughout to exacting laboratory standards, this RCA 155-C 3-Inch Cathode Ray Oscilloscope is particularly recommended for all-purpose requirements. Note its unusual features, briefly described on this page. Write for special RCA Bulletin containing complete information about this fine instrument. Address Test Equipment Section 44G, RCA Victor Division, Radio Corporation of America, Camden, N. J.



RCA TEST AND MEASURING EQUIPMENT



3-INCH CATHODE RAY TUBE!

Three-inch cathode ray tube assures adequately detailed image for practically all applications.

VERSATILE, PORTABLE, FOR LABORATORY AND SERVICE WORK!

Especially intended for the better class service engineers. For field service, industrial testing, and general commercial and laboratory work.

NOW — a really high-powered RADIO ENGINEERING LIBRARY

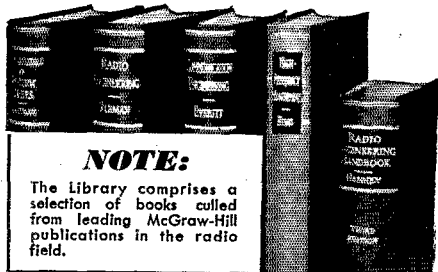

NOTE:

The library comprises a selection of books culled from leading McGraw-Hill publications in the radio field.

- ➔ especially selected by radio specialists of McGraw-Hill publications
- ➔ to give most complete, dependable coverage of facts needed by all whose fields are grounded on radio fundamentals
- ➔ available at a special price and terms

THESE books cover circuit phenomena, tube theory, networks, measurements, and other subjects—give specialized treatments of all fields of practical design and application. They are books of recognized position in the literature—books you will refer to and be referred to often. If you are a practical designer, researcher or engineer in any field based on radio, you want these books for the help they give in hundreds of problems throughout the whole field of radio engineering.

5 volumes, 3559 pages, 2558 illustrations

- Eastman's **FUNDAMENTALS OF VACUUM TUBES**, 2nd edition
- Terman's **RADIO ENGINEERING**, 2nd edition
- Everitt's **COMMUNICATION ENGINEERING**, 2nd edition
- Hund's **HIGH FREQUENCY MEASUREMENTS**
- Henney's **RADIO ENGINEERING HANDBOOK**, 3rd edition

**10 DAYS' FREE EXAMINATION
SPECIAL LOW PRICE EASY TERMS**

Special price under this offer less than books bought separately. Add these standard works to your library now; pay small monthly installments, while you use the books.

SEND THIS EXAMINATION COUPON

McGraw-Hill Book Co., 330 W. 42 St., New York 18, N.Y.

Send me Radio Engineering Library for 10 days' examination on approval. In 10 days I will send \$3.00 plus few cents postage, and \$3.00 monthly till \$24.00 is paid, or return books postpaid. (We pay postage on orders accompanied by remittance of first installment.)

Name.....
 Address.....
 City and State.....
 Position.....
 Company..... QST-11-43

(Continued from page 74)

WESTERN FLORIDA—SCM, Oscar Cederstrom, W4AXP—A few promotions this month among the amateurs in the service here. 6BRG has gone up from CRE to lieutenant (jg). CQF has gone from CPO to warrant officer; he is one of the old West Florida NCR gang. John B. Venters, a ham who got his radio training polished off at Gallups Island, is now an ensign and chief radio op. A letter from him states he had the pleasure of taking over the radio shack on a brand new ship. John was home on a visit to his parents in June. He meets quite a few hams in his travels, and enjoys hearing from the gang via the Section News in QST. He puts in his spare time studying navigation. More letters like John's would give the SCM something interesting to write about. MS, our old friend Eddie, says he is rebuilding. He paid us and the gang over here a visit again this month. DAO is doing the work of four men at the fish house; the war has depleted his crew a good deal. The boys in the service and at home enjoy reading in the section news what the others are doing, so why not send us a bit of dope whether you are wearing a uniform or not, and what you are doing even if you cannot tell where you are. 73 and luck to all of you, especially those of you who are in the thick of the fighting, from The Old Maestro.—AXP.

SOUTHWESTERN DIVISION

LOS ANGELES—SCM, H. F. Wood, W6QVV—Some of the controls in the Los Angeles CD set-up have been energized during the past few weeks and others are ready to go as quickly as the modified license is received from Washington covering the additional equipment. The first tests that were run proved quite satisfactory for the most part. Certain changes in antennas were necessary and some equipment changes will be made from time to time to bring up the efficiency of the system, but the work is going ahead and when the authorization is received for the additional units a real working system can be gotten under way in short order. Inquiries are still being received from those interested in joining in the work and they are being sent through the proper channels as quickly as possible. The personnel lists are nearly full, but we still need to know more about available equipment. Mighty little news to pass along this month, but good old 6AM comes through as usual with some family news to the effect that son William, TCG, is classified as V-12 USN, and is a senior in engineering at University of Southern California while Don C., jr., is a midshipman at U. S. Naval Academy at Annapolis, Long Beach is still waiting. ANN had to pay a bet for he wagered that the Los Angeles gang wouldn't get on the air before October, but lo and behold he heard KGLV-7 on Sunday, August 29th. That's not bad in anybody's language for a starter. Bill thinks it should call for some sort of a celebration. Let's wait until we get this thing over with and then really celebrate. SML states that his new QTH is Cherry Road #1, Ithaca, N. Y., and he surely would like to get the QSLs that are due him for the last few QSOs prior to December 7, 1941. He is studying at Cornell and would like to hear from TWJ, NNN and EOS and any of the Santa Barbara gang, so cheer him up fellows. JQB, way up there above Bishop, is interested in WERS work and Al, if you can get a 2½-meter gang started in that area, go to it. Let me know and I'll get the applications from FCC and send up to you, along with the rules and regs. W4HYB, 12031 Wagner St., Culver City, Calif., will visit all hams in and around Los Angeles who will drop a card with their name and address to the address given above. The old man signed below has been doing a mess of painting at the home, one room at a time and so hasn't been circulating much but will get out soon. Bye now. 73.—Ted.

ARIZONA—SCM, Douglas Aitken, W6RWW—The Tucson Short Wave Assn. keeps up its activities and at the last meeting 36 old members were present. They are starting another of their many code classes. TJH is also starting a new large class. The Tucson gang is to be congratulated on the way they've kept up activities under war conditions. OMH is now on the East Coast, and of all things—a gob with an Army address! IIG has been promoted to first lieutenant. REJ writes that he is at Scott Field, taking communications training. UKB has completed his Navy radio training and given rating on ART2c and is now awaiting assignment to sea duty. QLZ has been discharged from the Army and intends doing BC work over in the Texas country. PDA has a new job. WERS going strong in the Salt River Valley area, with new ops being added to the list each month. OAS pinch hitting for TBR this month. SQN reports little

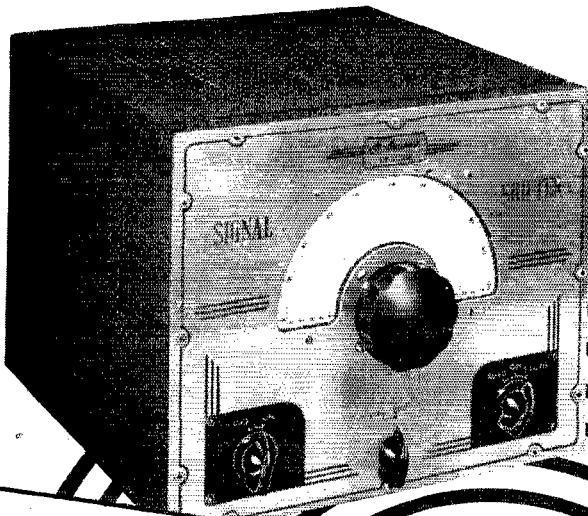

MEISSNER EXTENDED FREQUENCY RANGE SIGNAL SHIFTER

With newly developed general coverage
series plug-in coils... cover frequencies
from 1000 kc. to 16,500 kc.

THE Meissner Extended Frequency Range Signal Shifter is a variable frequency exciter of exceptional stability... may be used alone as an auxiliary or "Short-Haul" C-W transmitter. All tuned circuits are ganged... controlled by a high quality precision vernier dial.

The Signal Shifter permits instant frequency change in any given band... right from the operating position.

Continuous coverage of a frequency range from 1000 to 16,500 k.c. is provided without any sacrifice in stability... no crystals required!

Available only on priority.

MT. CARMEL, ILLINOIS

 *Meissner*

"PRECISION-BUILT ELECTRONIC



PRODUCTS"

DEPENDABLE

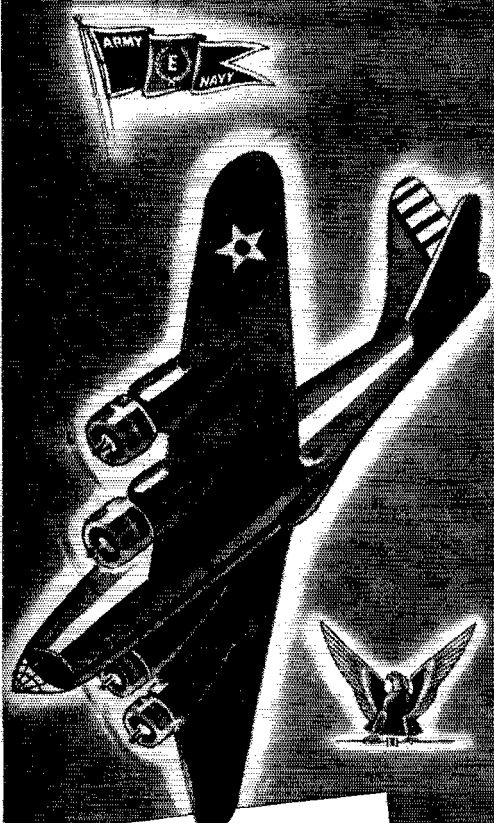

Accuracy and dependability are built into every Bliley Crystal Unit. Specify **BLILEY** for assured performance.

BLILEY ELECTRIC COMPANY · ERIE, PA.

Bliley Crystals

(Continued from page 76)

activity over the hill; all are busy getting out copper for war use. MLL is still dabbling with wired wireless, says he could do more if someone would donate an alarm clock to NRP, so Mike could keep skeds! Have several calls for odd pieces of equipment such as bugs, test meters and the like — anybody have that sort of things? Also a Sky Champ, if one of those things is still around. In normal times the 10-meter band should be good, static season passing away and hamming a full spare time occupation — so here's a wish it may all be wound up soon and we can all meet on the air again as of yore! Vy 73 to one and all — *Doug*.

WEST GULF DIVISION

NEW MEXICO — SCM, J. G. Hancock, W5HJF — No new development in the Clovis-Portales WERS project. DER is taking active part in trying to organize it and was in to see the SCM recently checking the latest dope. DER lost his test equipment in a fire. CNM paid the SCM a nice visit. He will be remembered by a lot of you fellows as the RI that gave you your class Bs and As in 1941 at Albuquerque. He is still with FCC at San Antonio, Texas. HWG is a lieutenant, USNR, and reads this page on the high seas. He writes a request to reserve a place on the N. M. Net after the war and sends his 73 to all the gang. ICD sends in one of the nicest reports we have received. He is in the Veterans' Hospital at Fort Bayard, N. M. His XYL, JXL is in Cottonwood, Arizona. JGV is in Douglas, Arizona. JZQ, his XYL, is employed at the Douglas Airport. FPC of Deming is chaplain in the armed forces. JAE is in Cuba on sugar contract work. HJF is installing a sound system so he can invite his guests in without going to the door. Thanks and tx megas again for all the swell reports, fellows. It is that kind of stuff that makes this ole job worth while for a change. Keep 'em rolling, fellows. 73. — *Jake*.

Experimenter's Section

(Continued from page 41)

Please let me have material for experiments with carrier current. — *Harold Schutzmann, 1662 Hoe Ave., Bronx, N. Y.*

— · · · —

We would like to hear from anyone in Kansas City, Kansas, who is interested in carrier current. — *James McCoy, 4912 Booth St., Kansas City 3, Kansas, and Earl Scholz, 5623 Walnut Street, Kansas City 3, Kansas*

— · · · —

Please print my name in *QST* as interested in wired wireless. — *Ted Noskowitz, 4532 N. Spaulding Ave., Chicago, Ill.*

— · · · —

William P. Crownover of 4209 Massachusetts Ave., Baltimore 29, Maryland, is interested in carrier current and would be glad to get in touch with others of like interest in his neighborhood. A number of questions asked in his letter are well answered in the excellent contribution by W8BQ in this month's column.

Strays

Here's a true story about a student at this school that may brighten your day:

After two weeks of theory this student radar operator-striker "knew it all." He then walked over to a multimeter and, with a baffled look, asked, "What does O.H.M.S. stand for?" — *M. S. Dalmatz, ART2C.*



Bull in a China Shop—

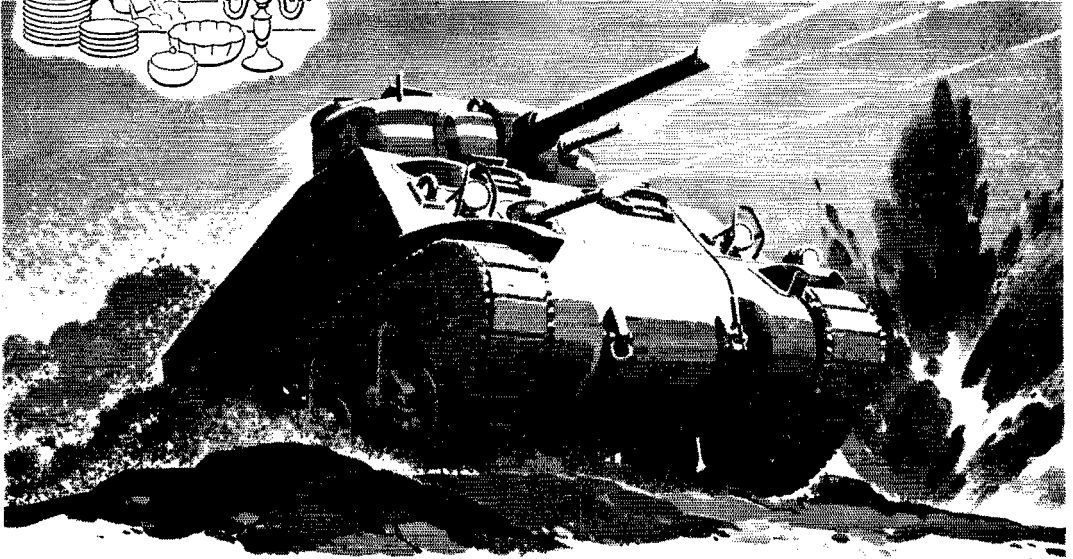

AND HOW HE WAS TAMED

Offhand, the thought of putting a delicate radio set in a lunging, thundering war tank is reminiscent of the dainty china and the proverbial bull.

You expect parts and pieces to start flying.

But they don't. And the story of how these sensitive instruments are able to stand war's mauling—jarring shocks, the concussion of artillery fire, electrical interference, tropic heat and Arctic blizzard—is partially the story of Delco Radio's experience in automotive radio. For years, Delco Radio technicians have been tackling and licking the parallel problems that once made automotive radio impossible. And as a result, when war struck, Delco Radio had a head-start on these old foes of "radio in transit."

Refining and extending its manufacturing and testing methods in cooperation

with military technicians, Delco Radio has helped to provide practical radio communication for war vehicles . . . in large quantity and on time. Thanks largely to years of pioneering research during prewar times, the old foes that once wrought havoc with radio reception in motor vehicles have been subdued. Delco Radio Division, General Motors Corporation, Kokomo, Indiana.

Back the Attack— WITH WAR BONDS

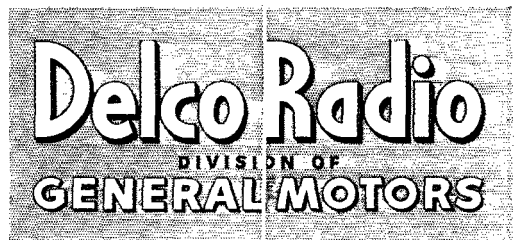



We never laugh at String Savers

The man who saves string knows what he is doing . . . some day those treasured pieces may come in handy. So, rather than laugh, we encourage, for we, ourselves, know something about the value of putting away for a rainy day.

For example, the nuggets of knowledge stored up in yesterday's manufacture of ultra-high frequency transmitters and receivers have a definite bearing on the important war work that we are doing. And the ideas that we're "banking" today will be mirrored in ABBOTT equipment for tomorrow.



We illustrate an ABBOTT Model TR-4 . . . a standard, compact and efficient ultra-high-frequency transmitter and receiver.

ABBOTT
INSTRUMENT, INC.

8 West 18th St., New York 3, N. Y.

Hints and Kinks

(Continued from page 55)

in the hand is effectively grounded. A quarter-wave or three quarter-wave wire may be held at the end. However, since a person's body absorbs considerable energy from the test wire, just as it would from a transmitting antenna, do not stand between the wire and the receiving antenna.

Hold the test wire away from your body and close to the receiving antenna, and start scraping. The "signal" will sound just like what it is — the scraping together of two pieces of metal. Note the volume of noise from the receiver. Back away in a straight line until the noise disappears, and note this distance from the antenna. Repeat this process on lines radiating in different directions from the receiving antenna as a center.

It will be observed that the "fade-out" points vary in distance from the antenna in proportion to the gain of the antenna in any given direction. If these points are plotted on polar graph paper, a line connecting the points will provide a picture of the antenna's field pattern.

There are many applications for this type of checking. For instance, it is possible to judge the approximate front-to-back ratio of any directive array. Simply compare the maximum forward distance to the maximum backward distance at which the "fade-outs" occur and that's the ratio.

Whether or not a certain directive array has a worth-while gain over any half-wave or three-quarter-wave antenna also may be determined. Obtain the maximum "fade-out" distance from first one and then the other antenna, by the method described above. Comparison of these two distances gives the comparable effectiveness of the two antennas. In one instance it was found that a half-wave antenna could not pick up the test signal beyond a distance of five feet, while a three-element array connected to the same receiver made it possible to pick up the test signal at a distance of nearly twenty-five feet. Of course, actual distances in such cases will vary with the sensitivity of the receiver used.

The comparative sensitivity of two or more receivers can be measured, provided each receiver in turn is connected to the same antenna and the coupling is adjusted to the optimum position for each. This seems to suggest an interesting capability test for those who might like to know whether or not their receiver performance actually is superior to the other fellow's. The receiver which can pick up the test signal from the greatest distance has the best sensitivity, of course. Where receivers are being made up in quantity for WERS use, a standard of acceptable performance below which no receiver should fall could be established, and this method used as a check.

— W. E. Bradley, W1FWH

Strays

"Soupy" Groves, W5NW, director of the West Gulf Division, announcing the arrival of his third son, reports: "W5DUR and baby doing nicely."

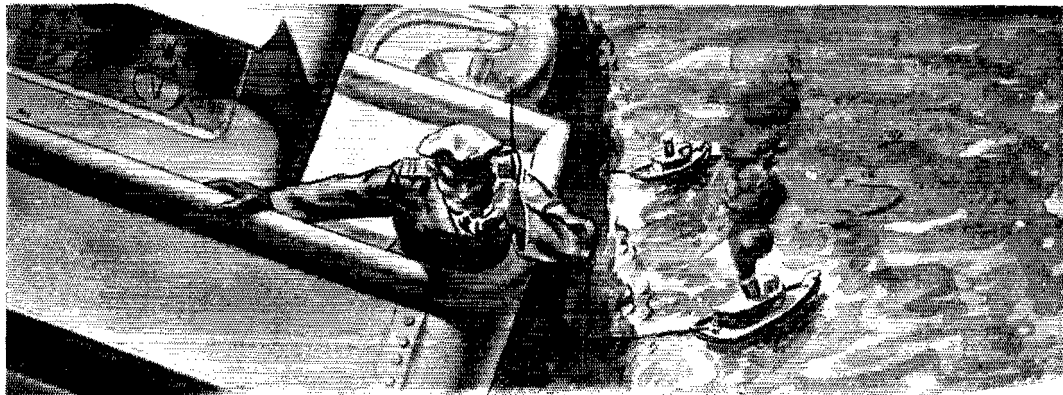

"Tablecloth"

Communications

Just a springboard to start some pencil doodlin' among engineers who have a yen for the sea—and the problems of communications that are present... weather, distance and lack of other facilities for transmission of thoughts and orders.

Operators of tug and transport fleets will have access to this type of HARVEY-WELLS communications equipment after the peace.

Why not send in some of your "Tablecloth doodlin's"?

HARVEY-WELLS
Communications inc.

★
HEADQUARTERS
For Specialized Radio Communications Equipment
SOUTHBRIDGE, MASS.

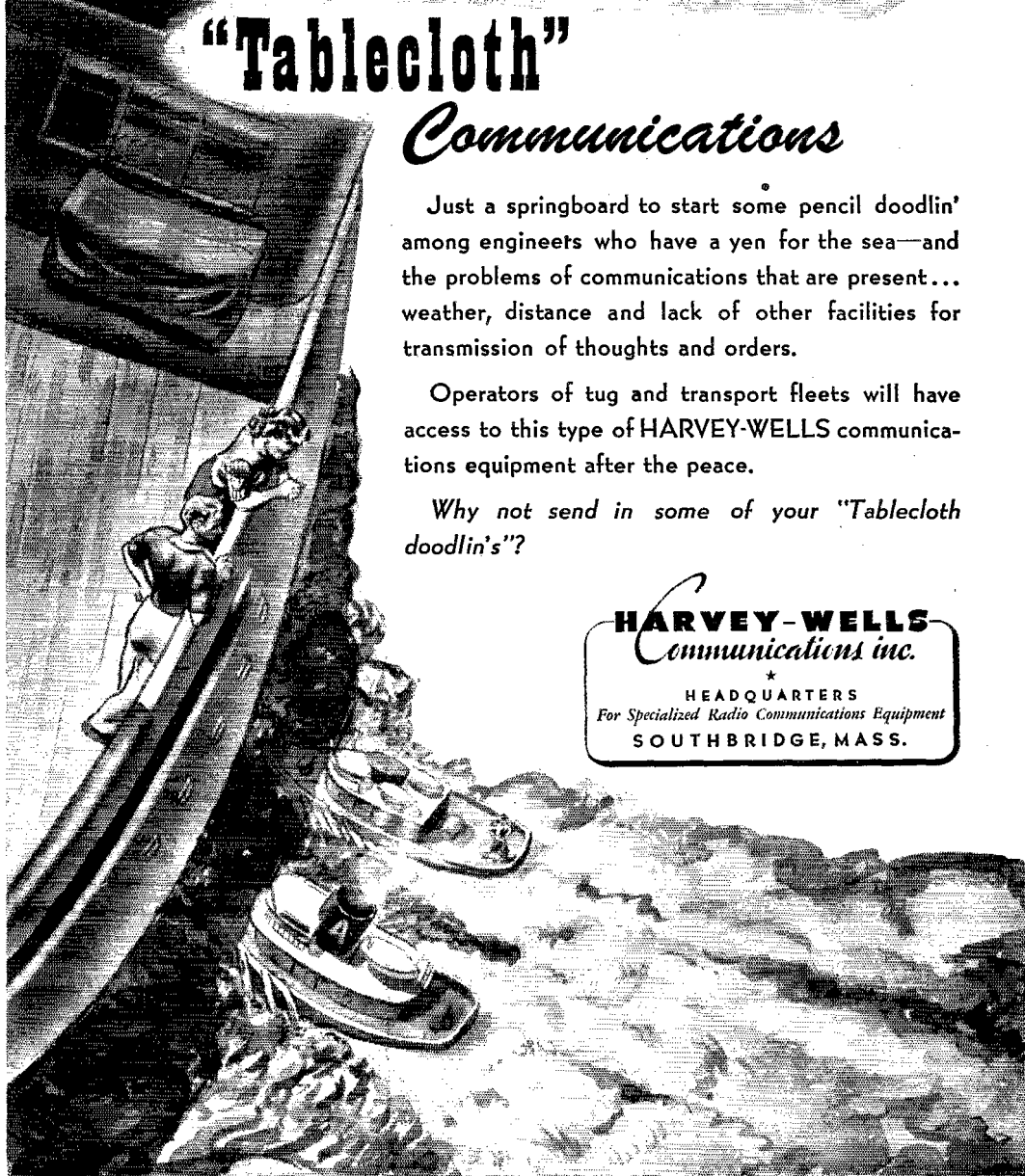



THICKSKINNED BATTLESHIPS HAVE NERVES!

Beneath their many inches of armor-plate, Uncle Sam's battle-wagons are as finely co-ordinated as champion boxers . . . instantly responsive to commands. A network of nerves...the lines of electric communication...runs through the ship. The command, "Battle Stations!" is electric . . . *literally*.

To keep these nerves alive with energy is one of the war jobs now being done by Stancor Transformers. When peace is won, American industry will enter a new age of electronics . . . the transformation of electric power to build and serve a happier world. Stancor engineers are preparing, by foresighted research, to serve the needs of peace after victory.

S T A N C O R

STANDARD TRANSFORMER CORPORATION
1500 NORTH HALSTED STREET - CHICAGO

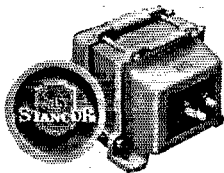

WWV Schedules

STANDARD-FREQUENCY transmissions are made available as a public service by the National Bureau of Standards over its standard-frequency station, WWV. The service is continuous at all times, day and night. The standard radio frequencies transmitted are:

5 megacycles (= 5000 kilocycles = 5,000,000 cycles) per second, broadcast continuously.

10 megacycles (= 10,000 kilocycles = 10,000,000 cycles) per second, broadcast continuously.

15 megacycles (= 15,000 kilocycles = 15,000,000 cycles) per second, broadcast continuously in the daytime only (i.e., day at Washington, D. C.).

Each of these radio frequencies carries two audio frequencies at the same time: 440 and 4000 cycles per second. In addition, there is a 0.005-second pulse, heard as a faint tick, every second. These pulses may be used for accurate time signals, and their one-second spacing provides an accurate time interval for physical measurements.

The audio frequencies are interrupted precisely on the hour and each five minutes thereafter, resuming after an interval of precisely one minute. This one-minute interval is provided to give the station announcement and to afford an interval for the checking of radio-frequency measurements free from the presence of the audio frequencies. The announcement is the station call (WWV) sent in code, except at the hour and half hour, when it is given by voice.

The accuracy of all the frequencies, radio and audio, as transmitted, is better than a part in 10,000,000. Transmission effects in the medium may result in slight fluctuations in the audio frequencies as received at a particular place; the average frequency received, however, is as accurate as that transmitted. The time interval marked by the pulse every second is accurate to 0.00001 second. The 1-minute, 4-minute and 5-minute intervals, synchronized with the second pulses and marked by the beginning and ending of the periods when the audio frequencies are off, are accurate to a part in 10,000,000. The beginnings of the periods when the audio frequencies are off are so synchronized with the basic time service of the U. S. Naval Observatory that they mark accurately the hour and the successive 5-minute periods.

During a winter day good service is given on 5 Mc. at distances from 0 to about 1000 miles, on 10 Mc. from about 600 to 3000 miles, and on 15 Mc. from about 1000 to 6000 miles. In general, reliable reception is possible at all times throughout the United States and the North Atlantic Ocean, and fair reception over most of the world.

Information on how to receive and utilize the service is given in the Bureau's Letter Circular, "Methods of Using Standard Frequencies Broadcast by Radio," obtainable on request. The Bureau welcomes reports of difficulties, methods of use, or special applications of the service. Correspondence should be addressed to the Director, National Bureau of Standards, Washington, D. C.

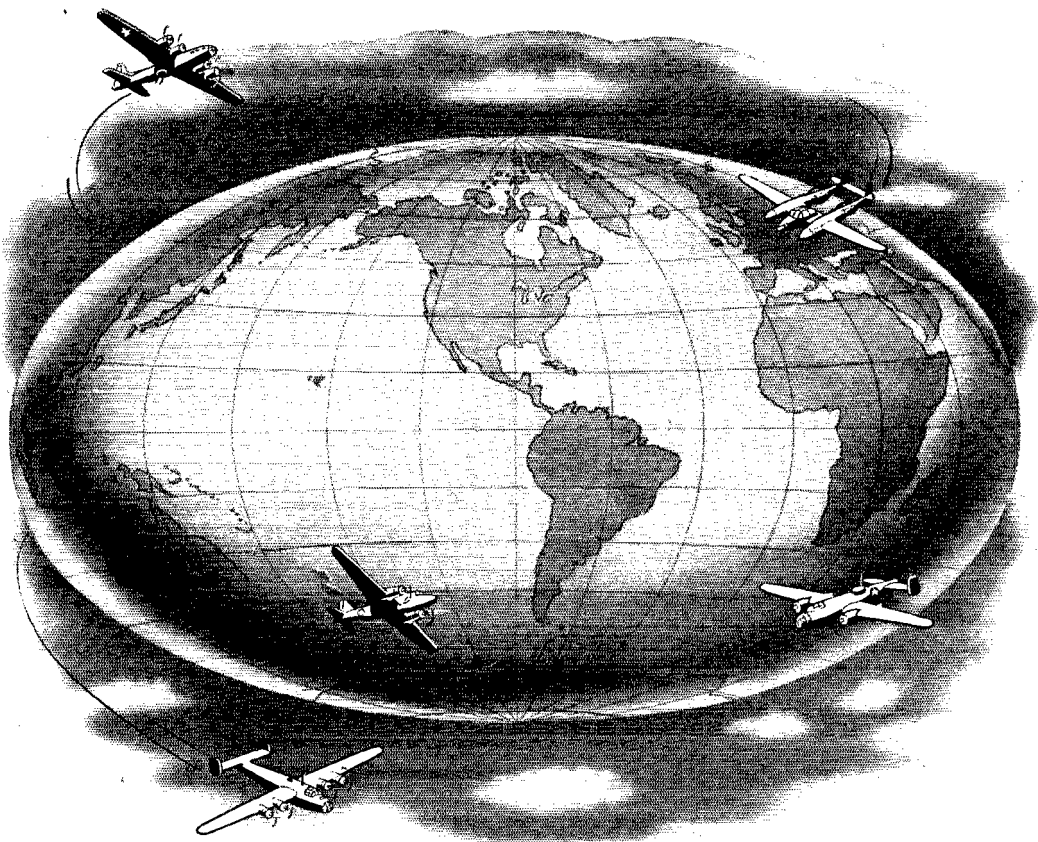

Serving the Air Routes of the World ... *TODAY and TOMORROW*

On established passenger and cargo airlines, as well as on military missions, dependable communications are vital. Wilcox Aircraft Radio, Communication Receivers, Transmitting and Airline Radio Equipment have served leading airlines for many years... and while, today, Wilcox facilities are geared to military needs, the requirements of the commercial airlines likewise are being handled. Look to Wilcox for leadership in dependable communications!

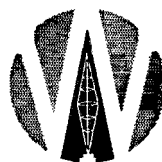

**WILCOX ELECTRIC
COMPANY**

*Quality Manufacturing
of Radio Equipment*

14th & Chestnut Kansas City, Mo.

BOTH are radio jobs!

**EASY TO GET-
FOR DURATION ONLY**

**ABILITY NEEDED-
PERMANENT JOB**



**Don't Be "Let Out" When
The "Let Down" Comes —**

**CREI Technical Training Prepares
You for the SECURE RADIO JOBS
That Pay Good Money for Ability**

Are you finding yourself in a routine job — a job that any other man can handle just as well as you? Today, radio JOBS are many — but radio CAREERS are few! Now is the opportune time for you to equip yourself with the necessary technical training to qualify you for an important engineering position with a secure future in the many branches of radio-electronics and industrial electronics.

NOW when industry needs men is the time for you to investigate radio career training. Your radio experience backed by modern CREI technical training will equip you to share in the good-paying jobs that await trained men. CREI home study courses are prepared for experienced radiomen who realize the necessity of CREI training if they are to rise above the routine jobs to make good in the important positions that lead to security and happiness!

● WRITE FOR FREE BOOKLET

If you have had professional or amateur radio experience and want to make more money — let us prove to you we have something you need to qualify for a better radio job. To help us intelligently answer your inquiry — please state briefly your background of experience, education and present position.



CAPITOL RADIO Engineering Institute

Home Study Courses in Practical Radio-Electronics Engineering
for Professional Self-Improvement

Dept. Q-11, 3224 16th St. N. W., Washington 10, D. C.

Contractors to the U. S. Navy, U. S. Signal Corps and U. S. Coast Guard. Producers of Well-trained Technical Radiomen for Industry

Splatter

(Continued from page 10)

depression was just about getting going good in his part of the country then, he recalls, and after two weeks work practising his profession (the job was hauling manganese in a wheelbarrow), he quit to go to sea on the yacht *Buccaneer*, WCFZ. This cruise was duly chronicled in *QST* at the time. From there he migrated to the 9th District, becoming W9QWQ in 1936 and working successively for Burgess, Thordarson and Rauland. For the past five years he has been back in the 4th call area, doing engineering work for the General Electric X-Ray Corporation. In his time W4CBD has built a lot of ham gear, a good deal of which has found its way into print and some of which is now working for Uncle Sam. Despite parts shortages, he's still building. It's harder now, of course, but his v.t.v.m. (p. 36) is a good example of what can be done with a little effort and ingenuity. . . . **Frank H. Mills, W9HQH** (p. 46), was born on December 31, 1905. By 1912 he was playing with a test tube filled with iron filings, a buzzer, a Morton Salt box and a Quaker Oats box — the latter both wound with miles of copper wire. By 1917 his playthings had become an Arlington loosecoupler and a galena detector, but these childish toys soon were discarded for an audion bulb. He survived the adolescent phases of variometers, variocouplers, dynes, reflexes and what-not, and on attaining maturity went on the air with a kilowatt rig which worked all bands, 'phone and c.w. ORS, OPS, OO, OBS, WAS, AARS — he's done them all, and with a vengeance. From 1930 through 1941 he missed only two days on the air. Considering that he's been wearing the same pair of Baldies for twenty years, it's easy to guess that he has wavy hair. . . .

Back with us this month (p. 11) is **Frederick A. Long, ex-W8BSL**, first introduced in this column in the October issue. To the biographical data then disclosed, he appends this additional note: "Together with another ham of the 1916 era, we designed and built what was intended to be a 1-kw. transformer for 25 cycles. Somewhere our calculations went astray, however, and the input turned out to be nearer 8 kw. We got splendid reports, though — after replacing the fuses with pennies!"

● ● ● **FEEDBACK**

W9QFV writes that the Stray on p. 58 of the October issue was in error in giving 10,115 kc. as one of the three frequencies on which WSL sends press. It should have been 11,115 kc., he says. R. F. Forbes of Indianapolis reports that the transmissions begin at 7:30 P.M. CWT, and usually are over by 9 P.M.

And Basil C. Barbee, W2MWX, writes: "In 'Feedback,' September *QST*, p. 86, I notice a couple of 'corrections' on the audio amplifier for my two-tube f.m. tuner in the May issue. As I pointed out in a letter to you, the connection between the grid and ground should not have been there; but I can't remember mentioning that the values for R_6 and R_7 were messed up. If I did

RADIO AMATEUR "EQUIPMENT"



Hints & Kinks

Amateurs are noted for their ingenuity in overcoming by clever means the minor and major obstacles they meet in their pursuit of their chosen hobby. An amateur must be resourceful and a good tinkerer. He must be able to make a small amount of money do a great deal for him. He must frequently be able to utilize the contents of the junk box rather than buy new equipment. Hints and Kinks is a compilation of hundreds of good ideas which amateurs have found helpful. It will return its cost many times in money savings — and it will save hours of time.

Price 50 cents

★ ★ ★

The Radio Amateur's License Manual

To obtain an amateur operator's license you must pass a government examination. The License Manual tells how to do that — tells what you must do and how to do it. It makes a simple and comparatively easy task of what otherwise might seem difficult. In addition to a large amount of general information, it contains questions and answers such as are asked in the government examinations. If you know the answers to the questions in this book, you can pass the examination without trouble.

Price 25 cents



How to Become a Radio Amateur



Universally recognized as the standard elementary guide for the prospective amateur. Features equipment which, although simple in construction, conforms in every detail to present practices. The apparatus is of a thoroughly practical type capable of giving long and satisfactory service — while at the same time it can be built at a minimum of expense. The design is such that a high degree of flexibility is secured, making the various units fit into the more elaborate station layouts which inevitably result as the amateur progresses. Complete operating instructions and references to sources of detailed information on licensing procedure are given.

Price 25 cents

Lightning Calculators

RADIO, Type A — This calculator is useful for the problems involving frequency, wavelength, inductance, capacity, etc. It has two scales for physical dimensions of coils from one-half inch to five and one-half inches in diameter and from one-quarter to ten inches in length; a frequency scale from 400 kilocycles through 150 megacycles; a wavelength scale from two to 600 meters; a capacity scale from 3 to 1,000 micro-microfarads; two inductance scales with a range of from one microhenry through 1,500; a turns-per-inch scale to cover enameled or single silk covered wire from 12 to 35 gauge, double silk or cotton covered from 0 to 36 and double cotton covered from 2 to 36. Using these scales in the simple manner outlined in the instructions on the back of the calculator, it is possible to solve problems involving frequency in kilocycles, wavelength in meters, inductance in microhenrys and capacity in microfarads. Gives the direct reading answers for these problems with accuracy well within the tolerances of practical construction. \$1.00

OHM'S LAW, Type B — With this concentrated collection of scales, calculations may be made involving voltage, current, and resistance, and can be made with a single setting of a dial. The power or voltage of current or resistance in any circuit can be found easily if any two are known. This is a newly-designed Type B Calculator which is more accurate and simpler to use than the justly-famous original model. It will be found useful for many calculations which must be made frequently but which are often confusing if done by ordinary methods. All answers will be accurate within the tolerances of commercial equipment. \$1.00

ABOVE PRICES ARE POSTPAID • PLEASE DO NOT REMIT IN STAMPS

AMERICAN RADIO RELAY LEAGUE, INC., West Hartford, Connecticut

(Continued from page 84)

make such a statement, I retract it. The correct values are: 250,000 ohms for the upper grid resistor, 300,000 ohms for the lower one, and 250,000 ohms for the resistor between the junction of the grid resistors and the bias resistor. . . .

"The reason for the apparent 'unbalance' is that the circuit is what is known as the 'floating paraphase,' in which degeneration in the inverter tube serves to maintain almost perfect balance in spite of aging or changes in line voltage, provided that the resistances are so proportioned as to give balance initially. This calls for the grid resistor following the inverter tube to be somewhat higher than the other grid resistor, in order to allow both grids of the following stage to receive equal signal voltages and yet maintain the point of junction of the two grid resistors at a voltage suitable for exciting the grid of the inverter. The higher the voltage gain of the inverter, the more nearly at ground potential this point can be and, of course, the more nearly equal the grid resistors can be. . . .

"Looks like the type lice hung on the 'inverse feed-bag' that time. Ooop! 'Scuse it; that was corny. 73."

Correspondence

(Continued from page 59)

This strange bird looks just like a buzzard.
It's large and it's hideous and bold.
In the night it circles the North Pole
Crying, "Kee kee kee rist but it's cold."

Eskimos tucked away in their Igloos
Toss fretfully in their sleep,
While huskies asleep in a snow bank
In their fear start burrowing deep.

For this cry is so awe inspiring
That it freezes the blood, I am told,
As the Kee Bird flies in the Arctic
Crying, "Kee kee kee rist but it's cold."

The Mounties, abroad in their dog sleds
As they visit these wards of the Crown,
When they hear this cry will stare skywards,
On their faces a fierce, sullen frown.

For there are many odd things in the Arctic
And many the weird tales that are told,
But their voices drop to a whisper,
At the cry, "Kee kee kee rist but it's cold."

And many brave men on this base site,
Strong and bold, from a northwestern state,
Take the first train back to their homeland
To forget this fierce bird's song of hate.

They can take it, it seems, in day time,
But when the midnight hour is tolled
They cover their heads in shameless fright,
Crying, "Kee kee kee rist but it's cold."

(Continued on page 88)

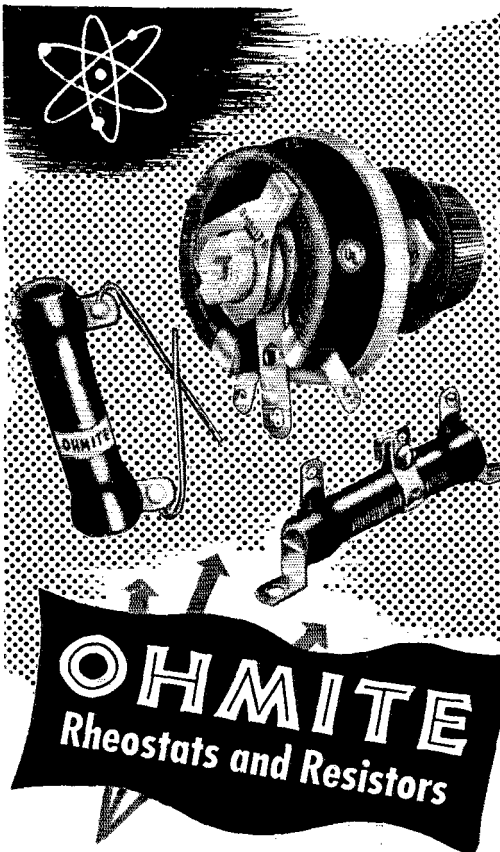

Keep Electrons Under Control in Vital Communications and Other Applications



Busy electrons obey . . . when Ohmite Rheostats and Resistors are on the job. You can always be sure of accurate control and long, trouble-free service.

Because of their time-proved design and construction, Ohmite units serve everywhere day-in and day-out in all types of critical applications. Made in the widest range of types and sizes for every requirement.

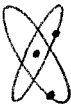

SEND FOR HANDY OHM'S LAW CALCULATOR

Helps you figure ohms, watts, volts, amperes —quickly. Solves any Ohm's Law problem with one setting of slide. Send only 10¢ in coin for handling and mailing.



OHMITE MANUFACTURING CO.
4819 W. Flournoy St. • Chicago 44, U.S.A.



"WIN-THE-WAR" COMMUNICATION EQUIPMENT
has the green light

This company, like many others in the electronic industry, is busy twenty-four hours a day, seven days a week making war products — more and more, better and better to help win the war quickly. We are too busy to worry about post-war products just yet. We realize the great, important role radio and other

electronics will play in the modernization of communication systems postwar.

Out of the laboratories of war will come electronic improvements applicable to every American home, in every city in 194V. But plans for the modernization of your city of tomorrow must wait until the war is won today.

Hudson American

C O R P O R A T I O N
Manufacturers of Electronic and Radio Devices
62 WEST 47 ST. • NEW YORK CITY

BACK THE ATTACK! BUY MORE WAR BONDS!

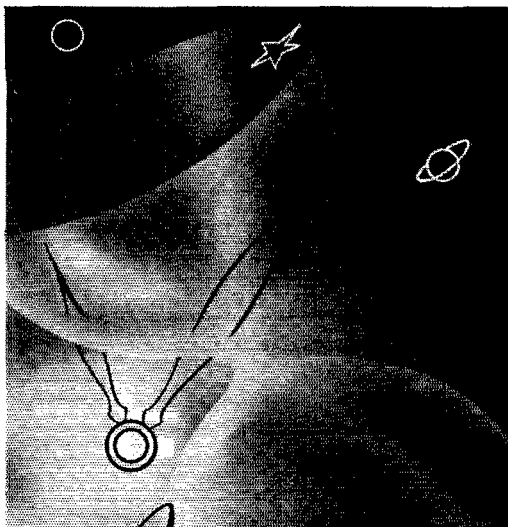

In Time!

The time will come when the horror and waste of these war years will roll by and we can again welcome back our friend, the radio amateur. We will know then, as we know now that we have done all in our power to hasten that day, by freely lending our money and strength to **BACK THE ATTACK.**

BUY WAR BONDS
and **STAMPS**

"The RADIO SHACK"
★ 167 WASHINGTON ST. ★
BOSTON, MASS., U.S.A.

(Continued from page 88)

So back to the States they are going
In a real bed to sleep, as of old.
To slip their strong arms 'round their loved one,
And her fair slender form to enfold.

They'll go off to sleep in warm comfort
But though wife's soft hand they will hold,
They will wake from a Kee Bird nightmare,
Crying, "Kee kee kee rist but it's cold."

And so, you see, there is more to it than Major
Hunt let on.

— Robert Ahmann

HITTING THE NAIL ON THE HEAD

178 Third Street, Rochester 5, New York
Editor, *QST*:

In my work here at Stromberg-Carlson Radio Mfg. Co. I came across a letter in a little magazine published for the Army Signal Corps inspectors. It seems to me that it hits the nail on the head, so I thought I would pass it along.

"Being isolated in the wilds of Pennsylvania . . . this inspector's heart was greatly warmed by the attention given by *The Inspector* to the hams connected with the Signal Corps inspection.

"The sneak attack at Pearl Harbor which threw our switch to the 'off' position, removing the world from our finger tips, shocked out of us that Dictator of Gremlins, namely, Mr. Complacency. To-day the privilege granted us by our government is reaping its dividends. It cannot be denied that the hams of our country are contributing in no small degree the knowledge derived from the pursuit of their hobby.

"The average American ham, pecuniary interest nil, has built equipment that stands first among that in all the amateur world, and continually sets the pace. To-day you will find him in uniform or along the assembly lines in behalf of the Signal Corps. In both cases his self-training, stimulated and privileged by his government, has given him knowledge and confidence for his job. The hours spent in building his transmitter, ironing out its bugs, pounding brass, or at his mike, were anything but wasted. That's our reason why you can't beat a democracy, Mr. Hitler! — Samuel Caryll, W3BGT"

— Albert Keltz, W8TXB

NORTHWESTERN AND THE NAVY

Northwestern University, Evanston, Ill.
Editor, *QST*:

. . . The last of each month always is a nice time for me, since I know then that I can expect my copy of the best radio magazine on the market — *QST*. I've been an ardent reader for at least the last six years, and have yet to receive a dull issue. . . .

(Continued on page 90)



4 WARTIME SERVICES YOUR LOCAL RCA TUBE DISTRIBUTOR OFFERS YOU TODAY



1. Technical "Know how"

He started in Electronics on the ground floor . . . with *radio*. His advice and recommendations about circuits, tubes, and other electronic components are valuable to you.

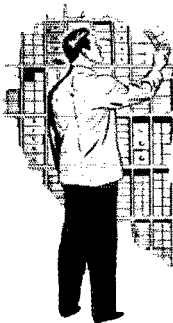

2. Supply of Stocks

He's right around the corner; check with him first for items you need to fill on a rush priority basis.



3. Fast Delivery

If his normally adequate and varied stock should *not* include what you want, he's your one best bet today for locating it *fast!*



4. Intelligent Expediting

He's an old hand at tackling tough jobs. That's his business. When you're in a jam, you'll find him well qualified to act as your expediting specialist.

Get to know this man. He's eager to help you. He's your **EMERGENCY ELECTRONIC EXPEDITER!** If you don't know where to find him, write us for the list showing your nearest RCA Tube & Equipment Distributor. RCA Victor Division, RADIO CORPORATION OF AMERICA, Camden, N. J.

TUNE IN "WHAT'S NEW?" RCA's great new show, Saturday nights, 7 to 8, E. W. T., Blue Network.



The Magic Brain of All Electronic Equipment Is a Tube and the Fountain-Head of Modern Tube Development Is RCA



RCA ELECTRON TUBES



(Continued from page 88)



just when you need it!

1000 AND 1 RADIO AND ELECTRONIC COMPONENTS

Delivered Direct To You As Fast As Wartime
Conditions Permit!

**TUBES! + RHEOSTATS! + RELAYS!
CAPACITORS! + TRANSFORMERS!
RESISTORS! + TEST EQUIPMENT!**
Practically Everything!

Our 17 years of buying and selling experience in the electronic field enable us to cut through the "fog" of shortages and restrictions. If you are engaged in war production . . .

Write, Wire or Phone **HARVEY**

We'll help you with merchandise . . . technical advice . . . recommendations. If we haven't what you want in stock, we'll find it for you. Communicate immediately!

Telephone Orders to **BRYANT 9-1946**

HARVEY

RADIO COMPANY

103 WEST 43 ST. NEW YORK, N.Y.

The Defense Edition of the *Handbook* is in use here at Northwestern University in the U. S. Naval Training School (Radio). At the present time there are 1500 copies in constant use in the theory department, and I have suggested to the University the use of George Grammer's *Course in Radio Fundamentals*, in conjunction with the *Handbook*. The *Radio Amateur's Handbook* is the only theory text in use here other than the regulation Navy manual, which is required in all naval radio schools. . . .

The students at this school all are regular Navy men here for training as radio operators. Upon graduation they become third-class radiomen. The course at Northwestern is a very accelerated one, in that the sailors must complete the whole course in a 15-week period. The requirements for graduation are a general knowledge of radio theory, knowledge of the latest naval procedure, ability to copy code at 22 w.p.m. (plain language and code groups), transmit code at 18 w.p.m., and be able to typewrite from copy (touch system) at 30 w.p.m. . . .

I am in charge of the hand-sending instruction at this school and, as an amateur, I am very proud of the job I am doing to speed this war along. I hope the day will not be long before all of us can get back on the air and have some of the old rag-chews. . . .

For myself and all amateurs I can only say, keep *QST* coming. . . .

— H. L. Haskins, W9FWO

HAMS DON'T DO SUCH THINGS

13 South Franklin St., Madison, Wisconsin
Editor, *QST*:

. . . I should like to comment on W7GZA's letter in August *QST*.

I agree with Bob 100 per cent on the subject of copying messages from Tokyo and asking for compensation. No ham that I've ever known would think of such a thing. Let's set the Red Cross, and whomever else that may entertain such foolish ideas, straight on this. We hams just don't do things like that. W7GZA was not the only one to be disturbed by that bit of information.

— Earl E. Struve, W9ZVO

P.S.: As for the League and *QST* — well, you're doing a bang-up job. Keep it up; we're with you.

AMATEUR ACHIEVEMENT

123 Park Place, Schenectady, N. Y.
Editor, *QST*:

My previous call was W1KTN of Damariscotta, Maine, and I was a member of the AARS.

Have been working for over two years in the crystal department at General Electric Company and I'm now supervising the cutting of mother quartz and the lapping of blanks. Have just re-

DEDICATED TO

Victory

BRACH Antennas and other radio and electrical products are now enlisted for the duration—serving, as in the First World War, to hasten the day of Victory. Their high peacetime standards, today applied to the needs of war, reflect our 36 years' experience in "QUANTITY-plus-QUALITY" manufacture.

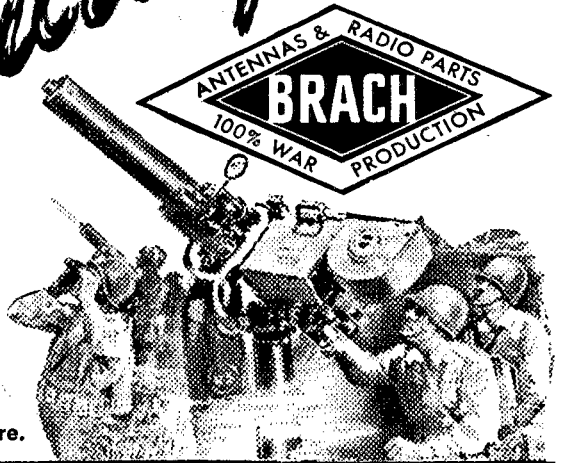

L. S. BRACH MFG. CORP.

55-65 DICKERSON ST
NEWARK, N. J.

World's Oldest and Largest Manufacturers of Radio Aerial Systems

RF Inductances • RF Chokes • IF Transformers
Condensers • Mica Molded Condensers • Trimmer
Condensers • Miscellaneous Apparatus
The F. W. Sickles Co., Chicopee, Mass.



SICKLES *Electronic Specialties*



Founded in 1909

Pre-Induction "RADIO"

A maximum of thirteen weeks to prepare for military service — code — printing — typing — procedure — and fundamentals of tube and transmitter servicing. If interested, write for details.

PORT ARTHUR COLLEGE
PORT ARTHUR, TEXAS

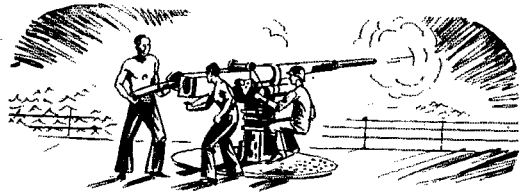

"Manning the Guns"

★ Astatic, today, may be manufacturing only a small part of its old time record-breaking volume of Microphones, Pickups, Cartridges and Recording Heads, due to government restrictions, but it is making and shipping thousands of special parts required by Uncle Sam in wartime radio equipment. In the only way we know how, Astatic is busy "manning the guns" and "making bullets" to speed victory.

ASTATIC

THE ASTATIC CORPORATION
YOUNGSTOWN, OHIO

In Canada: Canadian Astatic, Ltd., Toronto, Ont.

SUN RADIO
OFFERS
FAST DELIVERY
FROM AN
ENORMOUS
STOCK
of
RADIO PARTS
RADIO TUBES
and
INDUSTRIAL
ELECTRONIC
EQUIPMENT

You'll be amazed at the great amount of radio-electronic materials we now have in stock and the precision efficiency with which we expedite priority requirements. No matter whether your order is large or small it receives our immediate, expert attention. Just write, wire or phone us and see for yourself.

★ **SEND FOR THIS**
FREE CATALOG! ★

Everything in radio and electronics at your fingertips! This handsomely bound 800-page catalog listing countless thousands of standard radio-electronic materials is yours simply for the asking if you are actively engaged in the war effort doing purchasing, expediting or engineering. Write today on your company letterhead stating your title.

Address Box QN.



BACK THE ATTACK!
BUY BONDS
— NOW!



FOR PROMPT
SERVICE
Tel. Barclay 7-1840

New York's Oldest Radio-Electronic Supply House

SUN RADIO & ELECTRONICS
COMPANY
212 FULTON ST., NEW YORK 7

(Continued from page 80)

ceived good news. The company has accepted a method which I submitted, to correct angles by means of X-rays, after a test cut is made from a mother quartz.

There are several hams around here, and we frequently go into a huddle talking old times and looking forward to a big future for ham radio. The gang thinks *QST* is better than ever. Keep up the swell work.

— Anthony Conti, W2BVR

PLEDGE

452 No. Grotto St., St. Paul 4, Minn.
Editor, *QST*:

It is with the greatest of pleasure that I request membership in the American Radio Relay League, in response to your invitation. For I owe much of my radio learning and all of my success in passing the amateur and commercial licence examinations to the ARRL *Handbook* and pamphlets, since they were my chief study guides.

I obtained my first instruction and interest in radio through the U. S. Army Signal Corps radio schools, which I attended for nine months. Much of our lecture material was supplemented by ARRL *Handbook* reading references. And, since most of our teachers were recruited from amateur ranks, their use of ARRL material as text reference indicates their appreciation and evaluation of it.

Since my license was received after wartime restrictions on amateur operation were imposed, I have not as yet been issued a station call. Furthermore, I expect to report . . . for training in a branch of the women's military services. . . . I look forward with keen interest to joining the many amateurs who will return to the air after the war, however.

I wish to express my gratitude to the League for the large part it has played in my becoming an amateur, and I pledge to it my wholehearted, loyal support.

— Lois Johnson, Signal Corps Inspector

COMPARISON

Box 2211, Roanoke, Va.

Editor, *QST*:

You know, OM, while this business of keeping us hams off the air is necessary, it certainly is getting on my nerves. I hope the time will come soon when we can all break loose again. Boy, won't it be grand to chew the rag and hear all the gossip from the old timers and the young squirts and renew that feeling of brotherhood that can only go along with our hobby, ham radio?

You certainly have been doing a grand job at ARRL headquarters, and I want to extend congratulations to you and your staff at Hartford for the excellent issues of *QST* that have been coming along so regularly regardless of all the restrictions. Compare it to the complete close-down during World War I, and you will see just what you have

Keep 'Em Running FOR THE DURATION!

It is difficult to secure new Generating Sets or new Rotary Converters . . . Pioneer is devoting all of its resources toward winning the war . . . but we

can, and will, help you keep your present equipment running for the duration. Send your service problems, by letter, to Pioneer's Customer Service Dept.

PINCOR Products

PIONEER GEN-E-MOTOR

CHICAGO ILL. • EXPORT ADDRESS, 25 WARREN ST., NEW YORK CITY
CABLE ADDRESS SIMONTRICE, NEW YORK

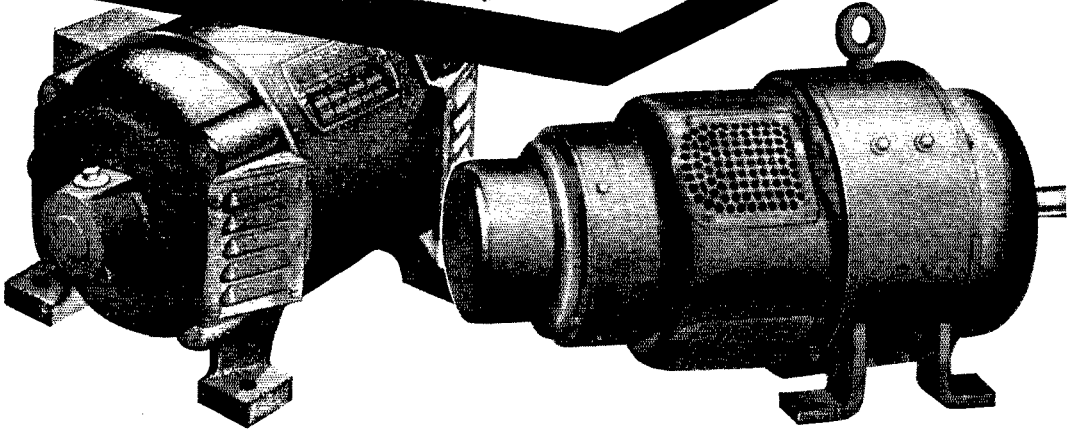

HARVEY RADIO LAB'S, Inc.
Manufacturers of
Radio Transmitters
ELECTRONIC APPARATUS
477 CONCORD AVENUE, CAMBRIDGE, MASS.

RADIO OPERATORS' LICENSE MANUAL

Complete and authentic question and answer manual on commercial radio operator license examinations. 1297 questions and answers, 230 pages of vital information for radio operator license candidates. \$3.00 Post-paid or write for descriptive circular.

1943 Edition **WAYNE MILLER**
The Engineering Building, Chicago

EASY TO LEARN CODE

It is easy and pleasant to learn or increase speed the modern way — with an Instructograph Code Teacher. Excellent for the beginner or advanced student. A quick and practical method. Available tapes from beginner's alphabet to typical messages on all subjects. Speed range 5 to 40 WPM. Always ready, no QRM, beats having someone send to you.

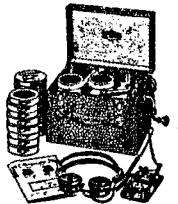

MACHINES FOR RENT OR SALE

The Instructograph Code Teacher literally takes the place of an operator-instructor and enables anyone to learn and master code without further assistance. Thousands have used and endorse the Instructograph System. Write today for full particulars and convenient payment and rental plans.

INSTRUCTOGRAPH COMPANY

4709 Sheridan Road, Chicago, Illinois
Representative for Canada:
Radio College of Canada, 54 Bloor St. West, Toronto

SMACK ON ITS "NOSE"

to concrete, from 3 flights up... but this
B & W Air Inductor still worked

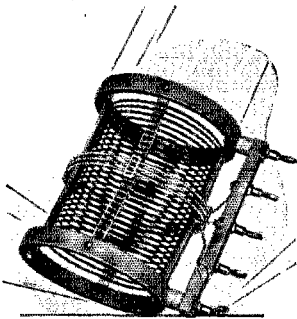

Maybe you've never dropped a coil from a 3rd story window to a concrete sidewalk—but as a ham, you've no doubt dropped one from the table to the floor. If so, you're lucky if it happened to be a B & W Air Inductor.

There's nothing scientific about it, but when the B & W Air Inductor

illustrated was dropped three stories without being put out of commission, it at least proved the practical nature of this unique "form-less" construction. Actually, the only damage was a bent plug-in prong and a cracked ceramic bottom support. The Inductor was immediately "repaired" without tools of any kind, and operated perfectly!

BARKER & WILLIAMSON Manufacturers of Quality Electronic Components
235 FAIRFIELD AVE., UPPER DARBY, PA.

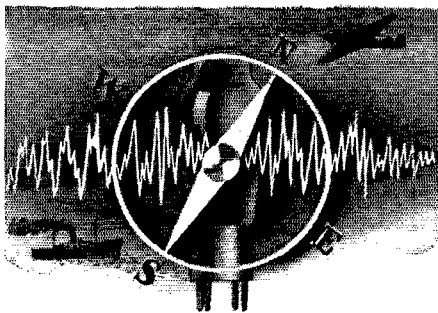

THE NEW WORLD of the FLYING WORD

The swift progress of aeronautical-radio is outstripping all expectations. Even we who have spent our lifetime in aviation communications are astonished by the gigantic strides into the new world of tomorrow.

Here is the young man's future. Electronics is revolutionizing the industrial world—and *electronics* is the *basis* of every course in radio transmission and reception taught at the Melville Aeronautical Radio School, under personal direction of our pioneer-founder, Frank Melville. If you plan to aim your career at aeronautical or marine radio, you'll want to know the facts regarding the value which Army, Navy and Airline officials attach to this organization of experts and authorities in the training of men and women for tomorrow's big jobs.

MELVILLE

AERONAUTICAL RADIO SCHOOL, INC.
 45 West 45th Street New York City
 Training Men & Women for Radio in the Service of
 AIRLINES - ARMY - NAVY - MARINES - MERCHANT
 MARINE - COAST GUARD - INDUSTRY

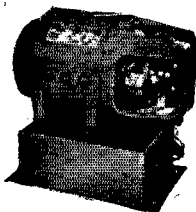

110-VOLTS AC
 from DIRECT CURRENT
 with KATO KONVERTERS. Furnish standard 110-v. AC from 32, 110, or 220-v. DC. Good deliveries on sizes 350 through 1500 watts on priority orders. Good deliveries on 5, 7 1/2, 15 and 25 KW AC generators. Migr's motor generators, frequency changers and high frequency generators.
 KATOLIGHT Mankato, Minn., U.S.A.



Makers of Precision
 Engineered
**ELECTRONIC
 PRODUCTS**

Radell
 CORPORATION

6327 GUILFORD AVENUE, INDIANAPOLIS, INDIANA

(Continued from page 92)

been doing to keep the morale of the boys left behind because of age, etc.

I renewed my membership-subscription a few weeks ago. I received the usual membership card and with it a little pink slip telling me not to be impatient if *QST* didn't come along as expected, that it would soon show up. In all these thirty years or more in ham radio only once has my copy of *QST* been late, and that was caused by a flood in the New England States which delayed the mails. Don't you think that is a real record, both for your excellent work in getting out the magazine and also for the excellent work of the Post Office Department in making delivery? . . .

—J. F. Wohlford, W3CA

READER'S DIGEST

Harwich Port, Cape Cod, Mass.

Editor, *QST*:

Just as I left my house last Monday to start my annual vacation the mailman delivered the September issue of *QST*, so I brought it along to read while getting a good rest in an old armchair down here among the sand dunes of Cape Cod.

In all the years I have been a member of the League (continuously since 1928) I suppose I have never taken the time really to read *QST* and get the benefit of careful reading of a well-edited magazine. The past three days I have taken the time to read and digest the current issue. I feel that I have been a reasonably active amateur and member of the League, as your records will show. I have served as PAM, SCM, and in other appointments, and have had a close personal interest in the League and its actions. However, while there have been many things in *QST* which I either liked or disliked and many things done by the League of which I approved or did not approve, I have never taken the time to write you regarding these things. After reading this September issue of *QST*, I decided to let you know how I feel.

First of all, I wish to compliment you on the swell job you are doing with *QST*, in spite of the fact that we are off the air and there are so many things missing from the picture as it was a few years ago. This issue, to my way of thinking, is full of information, and so well-balanced that it should appeal to amateurs with a wide diversity of interests. This is a vital point and one which helps keep a strong interest alive, even though the only operating we can do is WERS.

I wish to compliment C.B.D. in particular on his very FB editorial. I feel exactly the same way about the matter of radio development and the amateur. The glowing bunk about the new radio sets, cars, television and electronics which will follow immediately on the heels of peace, put out as advertising to tell the public how much this and that company is doing to win the war, makes me a little tired. Such development as is promised can come only after years of work and a trial period before the public.

(Continued on page 96)



Coordination of effort in building airplanes . . . in flying them over the skyways, and in landing them at the airports of the world is the secret of the fine record for safe flights made by PAN-AMERICAN airways.

By the same token, the use of only the finest quality parts in building every plane and in constructing the mechanisms which direct its comings and goings, is another very important factor in promulgating complete safety.

That is why Thordarson transformers were selected by PAN-AMERICAN airways for important uses in the planes

themselves as well as for use in control tower operations, where dependability and quality of material are of such great importance.



ELECTRIC MFG. COMPANY
500 WEST HURON ST., CHICAGO, ILL.



Transformer Specialists Since 1895
ORIGINATORS OF TRU-FIDELITY AMPLIFIERS

You CAN HELP!

We supply radio apparatus for war use. You can help fill this need by selling your equipment to us. We pay highest cash prices without delay or red tape.

Write and tell us what receivers, meters, parts, etc., you have. If in a hurry telephone or telegraph. This is the easiest and quickest way to send your apparatus to war. And we pay you more, too. We promise you a better deal. So let us know what you have.

We also have a store at 2335 Westwood Boulevard, West Los Angeles, California.

HENRY RADIO SHOP
BUTLER, MISSOURI

"World's Largest Distributor of Communications Receivers"

JAMES *Crystals* KNIGHTS

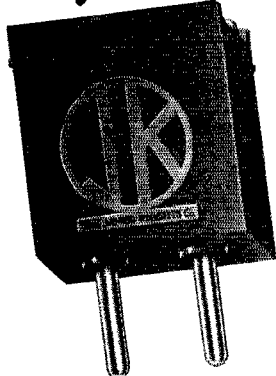

The JAMES KNIGHTS Co.
SANDWICH, ILLINOIS

PRECISION CUTTERS OF QUARTZ FOR COMMUNICATIONS & OPTICAL USES

RESISTORS

FOR

Industry • Research Communications

IRC makes resistor units of more types, in more shapes, for more applications than any other manufacturer in the world.



INTERNATIONAL RESISTANCE COMPANY

401 N. Broad Street • Phila. 8, Pa.

PREPARE yourself now for a well paying radio position after the war. Obtain your FCC commercial radiotelephone and telegraph license through our home study courses, written for the man who has forgotten higher mathematics. An easily read, easily understood course. Moderate tuition fee.

Write for particulars

AMERICAN RADIO INSTITUTE 44 EAST 23rd ST.
NEW YORK CITY
Teaching Radio Since 1935

GOOD JOBS in RADIO for both men and women

Prepare now for jobs in Radio Engineering; Broadcasting; Marine, Aviation, Police Radio; Servicing; Radio Manufacturing. Our streamlined courses give excellent preparation for Army and Navy Service. Expenses low. Write for free catalog.

THE DODGE TELEGRAPH & RADIO INSTITUTE
408-1 Monroe St., Valparaiso, Indiana

MASTER COURSE IN RADIO COMMUNICATION



Fits you for a job, advancement or license examination. Course by A. R. Nilson for home study covers same scope as resident school course. Every Nilson graduate to date has commercial license, or a good radio job.

FREE circular 3-Q gives full information. Write today.

NILSON RADIO SCHOOL, 51 E. 42nd St., New York 17, N. Y.

(Continued from page 94)

For a number of years — in fact, right up to December 7, 1941 — I was a member of AARS. I quite agree that amateur radio was far ahead of military radio as far as equipment was concerned. . . . I, too, feel that most military development will be just that, and will have little or no influence on amateur radio as we knew it — or as we will know it, after the current mess is over. Therefore we can expect to pick up just about where we left off, with the exception that we doubtless will have cheaper and better parts, tubes and receivers. This will be due to the perfection of mass production methods, however, and not to the discovery of new principles. The same can well apply to almost any field of mechanical manufacture.

I feel C.B.D. made a good, common-sense approach to a subject which should be brought to the front and discussed pro and con by the membership of the League with reference to a postwar policy for amateur radio. His article should serve to keep our feet on the ground and prevent our flights into the realm of fancy, as far as amateur radio is concerned. . . .

Secondly, the article by George Grammer, "More Selectivity in WERS Reception," is timely, and will be of interest to many. I think I shall attempt to build one of these supers for the local report center. The superregenerative receiver is OK for most ordinary applications, but does lack selectivity in an area like Greater Boston, where so many WERS stations are trying to operate in a small geographical area. As you know, we have a very heavy concentration of WERS stations in Massachusetts.

I think you are all doing a good job at Hartford, although you got off on the wrong foot after Pearl Harbor as far as the use of amateur radio was concerned. I think you have tried to overcome the mistakes made at that time.

I hope that you will continue to put up a good fight for amateur radio after the war, and I am sure no better man than George Bailey could be found to look out for our interests in Washington. Keep up the good work. . . .

— L. R. Mitchell, W1HIL

LEARN RADIO

Pre-Military training for beginners. Catalog on request. We teach all technical branches of radio.

MASS. RADIO SCHOOL

18 Boylston Street

Boston, Massachusetts

RADIO TECHNOLOGY



RCA Institute offers an intensive two-year course of high standard embracing all phases of Radio and Television. Practical training with modern equipment. Also shorter specialized courses in Commercial Radio Operating, Radio and Television Servicing, and Aviation Communications.

For Free Catalog write Dept. ST-43

RCA INSTITUTES, INC.

A Radio Corporation of America Service

75 Varick Street

New York 13, N. Y.

THE PEACETIME MEASURES OF
REFLECTION AND DEFLECTION
WILL BE READ FROM

TRIPLETT

ELECTRICAL MEASURING INSTRUMENTS
WITH CONFIDENCE
AND ECONOMY

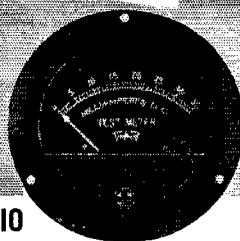

THE TRIPLETT ELECTRICAL INSTRUMENT CO., BLUFFTON, OHIO

BACK UP YOUR BELIEF IN AMERICA ★ BUY WAR BONDS

ORDER FROM NEWARK FOR QUICK SERVICE ON RADIO PARTS

Transformers, resistors, rectifiers, rheostats, condensers, filters, wire, etc., SUPPLIED FROM STOCK on short notice, on properly rated orders.

NEWARK'S SUPER-VALUE FILTER CONDENSERS

9 mfd. 2000 v. DC. With porcelain insulators and brackets for mounting. Size $1\frac{1}{2}'' \times 3\frac{1}{2}'' \times 4\frac{1}{2}''$ high.

\$325

NO PRIORITY REQUIRED!

BARGAIN FILTER CONDENSERS

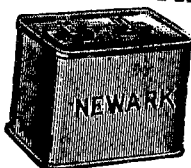

Mfd.	Volts DC.	Size	Price
1	1000 5	$3\frac{1}{2} \times 1\frac{1}{2}$	\$.59
2	2000 4 $\frac{1}{2}$	$3\frac{1}{2} \times 1\frac{1}{2}$	1.50
4	3000 5	$3\frac{1}{2} \times 3\frac{1}{2}$	3.75

ORDER TODAY DIRECT FROM THIS AD. Sorry—NO CATALOGS for the Duration!

NEWARK Electric Company

323 W. MADISON ST.

CHICAGO, ILL.

WHAT DOES THE "BL
BUTTON" MEAN?

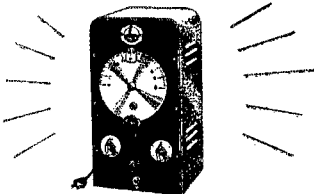

In the case of the Frequency Meter shown above, the "BL button" (shown below) means that by using it, transmitters can be kept "right on the button." On any piece of equipment it means sound design, rugged construction, fair price. Watch for the "BL button" after the war.



BROWNING

LABORATORIES, INCORPORATED, WINCHESTER, MASS.

The Radio Amateur's Handbook

"THE ALL-PURPOSE VOLUME ON RADIO"

Text, data book, operating manual — it is all these and more. As a text it is probably more used in radio schools and colleges than any other single volume. As a practical constructional handbook, it stands in a class alone. As an operating manual, it provides information available from no comparable source.

Standard Edition

The latest Edition of THE RADIO AMATEUR'S HANDBOOK is the largest ever published. It includes a comprehensive chapter dealing with War Emergency Radio Service plus other new material — all added without sacrificing the essential information in previous editions which made the HANDBOOK the world's most valuable and widely-used radio book. The theory and design sections cover every subject encountered in practical radio communication, sectionalized by topics with abundant cross-referencing and fully indexed.

\$1.00 In Continental U. S. A.

\$1.50 Elsewhere

\$2.00 Buckram Edition

Special Defense Edition

This edition of the HANDBOOK is designed especially for use in radio training courses. It eliminates those portions of the regular edition which are not useful for instruction purposes and has added chapters on mathematics, measuring equipment and code instruction. The first chapter covers the elementary mathematics necessary for the solution of all formulas and interpretation of graphs appearing throughout the text. A four-place log table is included in the Appendix.

\$1.00 Postpaid Anywhere

A Course in Radio Fundamentals

By GEORGE GRAMMER

The objective in preparing this course was to accent those principles most frequently applied in actual radio communication. "A Course In Radio Fundamentals" is a study guide, examination book and laboratory manual. Its text is based on the "Radio Amateur's Handbook." Either the special edition for war training purposes or the Standard Edition may be used. References contained in the "Course" are identical in both editions. As a text, this book greatly smooths the way for the student of the technicalities of radio. It contains interesting study assignments, experiments and examination questions for either class or individual instruction. It describes in detail 40 experiments with simple apparatus giving a complete practical knowledge of radio theory and design.

Price **50c**

Learning the Radiotelegraph Code

By JOHN HUNTOON

This booklet is designed to train students to handle code skillfully and with precision. Employing a novel system of code-learning based on the accepted method of *sound* conception, it is particularly excellent for the student who does not have the continuous help of an experienced operator or access to a code machine. It is similarly helpful home-study material for members of code classes. Adequate practice material is included for classwork as well as for home-study. There are also helpful data on high-speed operation, typewriter copy, general operating information — and an entire chapter on tone sources for code practice, including the description of a complete code instruction table with practice oscillator.

Price **25c**

The A.R.R.L. Antenna Book

By GEORGE GRAMMER and BYRON GOODMAN

A comprehensive manual of antenna design and construction. Sixteen chapters, profusely illustrated. Both the theory and the practice of all types of antennas used by the amateur, from simple doublets to multi-element rotaries, including long wires, rhomboids, vees, phased systems, u.h.f. systems, etc. Feed systems and their adjustment. Construction of masts, lines and rotating mechanisms. The most comprehensive and reliable information ever published on the subject. Over 100 pages.

Price **50c**

AMERICAN RADIO RELAY LEAGUE, INC., West Hartford 7, Conn., U.S.A.

CRYSTALS

by

DX XTALS

Complete automatic production plus electronic measuring and testing in temperature ranges from -30° to 130° F. make DX Xtals perfect, modern, tele-communication instruments. Ample production of these "battle-tested" types allow for civilian delivery of many cuts and frequencies - priorities, of course.

'the heart of a good transmitter'

DX CRYSTAL CO.

GENERAL OFFICES: 1841 W. CARROLL AVE., CHICAGO, ILL., U.S.A.



PRACTICAL RADIO COMMUNICATION

Nilson & Hornung's NEW 1943 edition, \$6.00. Text edition for schools and men in armed forces, \$5.00. Radio Operating Questions & Answers, \$3.00. Pre-exam Tests for operator licenses, \$5.00 per element. Money back if all not O.K. Free circular.



NILSON RADIO SCHOOL, 51 E. 42nd St., New York 17, N. Y.

ELECTRICAL COMMUNICATIONS ENGINEER

Boston manufacturer seeks an electrical communications engineer over 30 years old with equipment manufacturing and design experience. To build now for a post war future. Electronic background desirable but not necessary. Salary arranged.

TELEPHONE KENMORE 1472 FOR APPOINTMENT

Out of town, write SUTHERLAND-ABBOTT, 234 Clarendon Street, Boston, Massachusetts

Our staff knows of this advertisement



RADIO OPERATORS WANTED

Be a "key" man. Learn how to send and receive messages in code by telegraph and radio. Army, Navy and Commerce need thousands of men. Expansion of air commerce and freight after war should create an even bigger peacetime demand for operators. The famous Candler System, maker of world's champions, teaches you the "knack" of sound sense and sound consciousness that is the secret of speedy sending and receiving. Good pay, adventure. Learn at home quickly.

FREE 52-PAGE BOOK explains extra course of training. Rush name for it today. It's absolutely free.

CANDLER SYSTEM CO.

Dept. 4-M, P. O. Box 928, Denver 1, Colo., U. S. A. and at 121, Kingsway, London, W.C.2, England

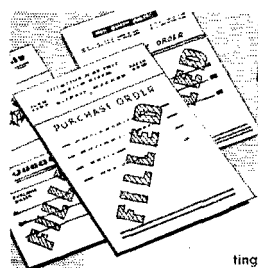

PRIORITY ORDERS FILLED!

Terminal's large, rotating stock... its able staff of experienced men... its thorough knowledge of radio and electronics production problems... all these add up to ability to do more than merely take priority orders. They mean that Terminal can FILL them — on schedule.

For all radio and electronics supplies, turn to:

TERMINAL RADIO CORP.
85 Cortlandt St., New York 7, N. Y.
Phone: WOrth 2-4415

TERMINAL RADIO CORPORATION

HAM-ADS

(1) Advertising shall pertain to radio and shall be of nature of interest to radio amateurs or experimenters in their pursuit of the art.

(2) No display of any character will be accepted, nor can any special typographical arrangements, such as all or part capital letters be used which would tend to make one advertisement stand out from the others.

(3) The Ham-Ad rate is 30c per word, except as noted in paragraph (6) below.

(4) Remittance in full must accompany copy. No cash or contract discount or agency commission will be allowed.

(5) Closing date for Ham-Ads is the 25th of the second month preceding publication date.

(6) A special rate of 7c per word will apply to advertising which, in our judgment, is obviously non-commercial in nature and is placed and signed by a member of the American Radio Relay League. Thus, advertising of bona fide surplus equipment owned, used and for sale by an individual or apparatus offered for exchange or advertising inquiring for special equipment, if by a member of the American Radio Relay League takes the 7c rate. An attempt to deal in apparatus in quantity for profit, even if by an individual, is commercial and all advertising by him takes the 30c rate. Provisions of paragraphs (1), (2), (4) and (5) apply to all advertising in this column regardless of which rate may apply.

Having made no investigation of the advertisers in the classified columns, the publishers of *QST* are unable to vouch for their integrity or for the grade or character of the products advertised

QUARTZ — direct importers from Brazil of best quality pure quartz suitable for making piezo-electric crystals. Diamond Drill Carbon Co., 719 World Bldg., New York City.

COMMERCIAL radio operators examination questions and answers. One dollar per element. G. C. Waller, W8ATV, 6540 Washington Blvd., Tulsa, Okla.

WHY NOT turn your unused equipment into ready cash which may be applied towards new and better equipment after the war? Leo, W9GFQ, offers you the best cash prices for communications receivers and test equipment. Write today for large illustrated catalog. Wholesale Radio Laboratories, 744 W. Broadway, Council Bluffs, Iowa.

CRYSTALS available all types, including 100 KC, 465 KC and 100 KC. Broadcast and Aircraft given prompt attention. Scientific Radio Products, Council Bluffs, Iowa.

SWL'S — Frits, 1213 Briargate, Joliet, Illinois.

USED equipment wanted. Highest cash prices paid for receivers, transmitters, meters, parts, etc. I promise you the best deal. Let me know what you have. Bob Henry, W9ARA, Butler, Mo.

IN STOCK: Mac No. 200 keys, \$2.25. Signatone code oscillators \$11.85; condensers, resistors, panels, chassis, transformers, meter rectifiers, radio supplies of all sorts. Your inquiries and orders invited. Henry Radio Shop, Butler, Mo.

USED equipment wanted. Highest cash prices paid for receivers, transmitters, meters, parts, etc. I promise you the best deal. Let me know what you have. Bob Henry, W9ARA, Butler, Mo.

IN STOCK: Mac No. 200 keys, \$2.25. Signatone code oscillators \$11.85; condensers, resistors, panels, chassis, transformers, Vibroplex, radio supplies of all sorts. Your inquiries and orders invited. Henry Radio Shop, Butler, Mo.

TELEPLEXES, Instructographs, bought, sold. Ryan's, Hannibal, Mo.

WANTED — Hammarlund table model Super Pro (210) octal base tubes; OR National 100X. State condition and price. T. I. Burwell, 565 Quinipiac Ave., New Haven, Conn.

WANTED — To buy Hallicrafter SX20 Sky Champion. Also: tube tester for late type tubes for war work. Good-All's, Ogallala, Nebraska.

SELLING OUT surplus equipment. Having finished training of Signal Corps men, we are trimming down to normal size again and have surplus equipment to offer. Best offer gets the stuff. Partial list follows: Single and double headphones; Morse keys; Teleplex and McElroy code machines; P. A. System; SX-24 Hallicrafter receiver; NC 101X Receiver; Bud audio oscillators; RCA oscilloscope; Supreme tube tester; Superior generator; A.F. Oscillator; Precision 8' meter; Philco analyzer; Supreme analyzer; Triplett tube tester; Meissner kits; soldering irons; storage battery; Presto recorder complete with amplifier; meters; D.C. to A.C. converters; Supreme vedolizer; Janette rotary converter; motor generator; code tables suitable for work bench, etc., 8' by 2 1/2'; etc. American Radio Institute, 44 East 23rd St., N.Y.C.

WANTED — Old Hallicrafter receiver. Prefer SX-17, S-16, SX-25, S-24. Condition not important. E. S. Walsh, Radio Test, Patuxent River, Maryland.

WANTED — Capacitor analyzer, Jackson Model 650-A Sprague Telomide Model TO-2, or equivalent. Submit written bid directly to Bureau of Purchases, State Office Building, No. 1 Sacramento, California. California Highway Patrol, Radio Communications Bureau.

WANTED — Sky Buddy or Echophone EC-1. State condition and price. Gordon Wilkinson, Route No. 1, Box 289A, Tulalake, Calif.

WANTED — Small transmitter. Holstein, 246 East 148th St., Bronx, N.Y.

SELL or trade Supreme 546 3" oscillograph, Solar CC-1-60 capacitor analyzer, and Superior 1280 set tester. WANT Hickok or Jackson, signal tracer, tube tester and multimeter or equal. LeRoy Green, 402 N. Gloster St., Tupelo, Miss.

WANTED — Sky Buddy, Cash or trade good Howard 436A. Bob Bramson, Burleson, Texas.

WANTED — Guardian S-20 Stepping Relays, 100 point, and Guardian No. 4 Solenoids, or equals. 110 volts, A.C. preferred. Give price and description. Grubb, 236 Paiko Drive, Honolulu 49, T.H.

1 KW TRANSMITTER constructed in closed type rack. Eimac tubes incorporated in unit. Guaranteed same as new. Described completely in March 1938 *QST*. Price \$1750.00 f.o.b. W9AXH, 4130 No. Meridian, Indianapolis, Indiana.

WANTED — Thordarson modulation transformer, 19M13 or 19M14. State price and condition. Owen Brown, 305 South First, North Manchester, Ind.

WANTED — Vacuum tube voltmeter. Prefer Hickok Model 110 or Hickok Electronic AC-DC volt-ohm-milliammeter Model 202. Must be in excellent condition. IRC resistors 1/4, 3/8, 1 watt, new. 0-150 A.C. (Triplet) voltmeter. Send best price to W. MacFarlane, Jr., 1138 Palma Ave., Schenectady, N. Y.

WANTED — Quiet operating General Electric Tungar 2 Ampere charger. Cat No. 277153. W1BB

WANTED — Complete transmitters, also parts, receivers, test equipment, meters, etc. Please state price desired. W5KD. 215 NW, 19th St., Oklahoma City, Okla.

WANTED — Communications receiver; Hallicrafter's National, Hammarlund, Howard. Give description, condition, price. Leo E. Horrigan, 214 East Birch St., Walla Walla, Washington.

WANTED — Aircraft radiophone transmitter-receiver for private plane, air frequencies. Give full details. S. J. Weitzer, 44 Moore Terrace, West Orange, N. J.

WANTED — National 1-10, HRO. Junior or Senior. Modern tube tester. Albert Webb, Box 453, Northampton, Mass.

CRYSTALS — Marine, Police, Aircraft, etc. Immediate delivery on time-proven Edson commercial crystal units in the 1600-10,000 kilocycle range. Dependable crystals with temperature coefficients to meet all requirements. "Edson's," Temple, Texas.

INSTRUCTOGRAPH wanted, tapes and oscilator. Ronald Storm, West Main, Mooresville, Ind.

SALE — Readrite 432A tube tester \$12.50, Jackson 441A Signal Generator \$12.00, Superior Channalyzer \$11.00 J. Gowen Route 5, Como Station, St. Paul, Minn.

SELL — Sargent 51TR Receiver, used seven months; two new Federal F123A tubes. Make offer. W6QB. Box 588, Fresno, Calif.

WANTED — Signal generator, tube tester, condenser checker, V.T. voltmeter, Rider's manuals, 0-1 milliammeter. W8VVD, 467 Park St., Birmingham, Michigan.

SELL — National 80X and speaker, excellent condition, \$40. J. P. Kinzer, 543 Elm Ave., Ridgefield, New Jersey.

WANTED — Meissner Signal Calibrator, Bliley SOC100 or SOC100X. William McKay, 2917 Calhoun St., Alameda, Calif.

MEISSNER Deluxe Signal Shifter with five sets coils 10-160. Shifter and tubes A-1. Valpey V-5, 1815 ko crystal with holder A-1 condition. Stamp for particulars. All inquiries answered. Highest bidder takes. Carlyle Stockslager, W8TQT, Lewisburg, Ohio.

ESTATE of W9HNJ offers 400 watt phone rig including: 72" Bud Sectional Cab, 6F6-807-809-T125. Mod. Pr. 203Z; 6 Simpson Meters, ready to go on 160-10 except speech amp. Any reasonable offer considered. Supreme tube tester, Model 385 — \$50.00. Write Mrs. G. Wicklund, 1044 Douglass Boulevard, Ironwood, Mich.

300 WATT Class B modulator, 203Z's, multimatch transformers. 1500/1300 volts d.c. @300 ma. plate supply. Thordarson CHT 1250 volts d.c. @500 ma. plate transformer. K. W. Antenna relay, D.P.D.T., Two C. D. type 86 12500 volt; 002 mms. Vibroplex, 100-100 mmf. 7500 volt variable. Sell individual components or units. Thordarson filament transformer cased 5.25 volts at 13 Amp. 30 Henry 250 Ma. cased choke. NC-150 neutralizing condenser. Ed. Schmeichel, W9YFV 2116 West 35th St., Chicago, Ill.

WANTED — Small communication receiver. State condition, price. P. Loofboro, 1928 North 51st St., Milwaukee, Wis.

WANTED — Pay good price: RCA Signalist, Voltomyst, Channalyst; precision signal generator, tube checker; Hickok vacuum tube voltmeter. F. M. Whitaker, 816 Wilkerson Ave., Durham, N. C.

"HOGARTH SAYS HE CAN'T FEEL
REALLY LOST WHEN HE HAS
HIS ECHOPHONE EC-1 ALONG"



Echophone Model EC-1

(Illustrated) a compact communications receiver with every necessary feature for good reception. Covers from 550 kc. to 30 mc. on three bands. Electrical band-spread on all bands. Beat frequency oscillator. Six tubes. Self-contained speaker. Operates on 115-125 volts AC or DC.



ECHOPHONE RADIO CO., 201 EAST 26th ST., CHICAGO, ILLINOIS

Designed for

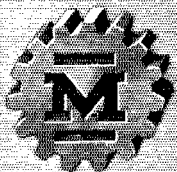

Application

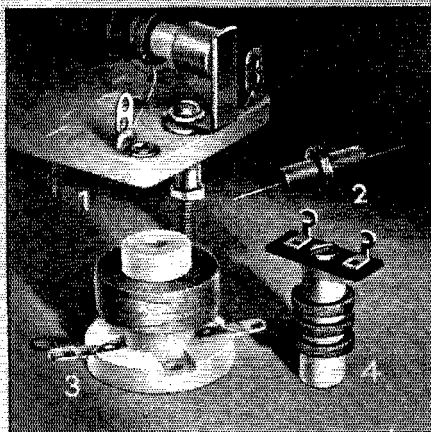

SPECIAL RF CHOKES

In addition to our standard line of "Designed for Application" RF chokes, we illustrate herewith just a few of the special types for special applications. Consult our district offices about your requirements: No. 1 is a tapped delay-line unit; No. 2, a small size universal type RF choke; No. 3, a compact single hole mounting multi-pie unit and No. 4 one of our No. 34200 series of high inductance single pie units on new improved type of pressed steatite form.

JAMES MILLEN MFG. CO., INC.

MAIN OFFICE AND FACTORY
Malden
Massachusetts



Index to Advertisers

	Page
Abbott Instrument, Inc.	80
Aerovox Corporation	**
American Lava Corporation	**
American Radio Institute	96
Amperex Electronic Products, Inc.	Cov. 11
Astatic Corporation, The	91
Ayers Automatic Code Machines	**
Barker & Williamson	93
Bliley Electric Company	78
Brach Manufacturing Corporation	91
Browning Laboratories, Inc.	97
Candler System Company	99
Capitol Radio Engineering Institute	84
Cardwell Manufacturing Corp., Allen D.	**
Centralab	**
Clarostat	**
Crystal Products Company	**
Dodge Telegraph & Radio Institute, The	96
Delco Radio, Div. General Motors	79
DX Crystal Co.	99
Echophone Radio Company	101
Eitel-McCullough, Inc.	**
Electro-Voice Manufacturing Co.	7
Electronic Laboratories	**
Galvin Manufacturing Corp.	**
Hallcrafters Company, The	1, 2
Hammarlund Manufacturing Co., The	73
Harrison Radio Corporation	**
Harvey Radio Company	90
Harvey Radio Laboratories, Inc.	93
Harvey-Wells Communications, Inc.	81
Heintz & Kautman, Ltd.	**
Henry Manufacturing Co.	**
Henry Radio Shop	95
Hudson-American	87
Instructograph Company	93
International Resistance Company	96
Jensen Radio Manufacturing Company	**
Kato Engineering Co.	94
Ken-Rad Tube & Lamp Corp.	103
Kenyon Transformer Co., Inc.	**
Knights, James, Co.	95
Mastel Publishing House	**
Mallory & Co., Inc., P. R.	74
Massachusetts Radio School	96
McElroy Manufacturing Corp.	4, 5
McGraw-Hill Book Co., Inc.	76
Meck, John, Industries	**
Meissner Manufacturing Company	77
Melville Aeronautical Radio School, Inc.	94
Metropolitan Technical School	**
Millen Manufacturing Co., James	102
Miller, Wayne	93
National Company, Inc.	71, 104, Cov. III
Newark Electric Company	97
Nilson Radio School	96, 99
N. Y. YMCA Schools	**
Ohmite Manufacturing Company	86
Onan Electric Plants	**
Oxford-Tartak Radio Corporation	**
Pioneer Gen-E-Motor Co.	93
Port Arthur College	91
Premax Co.	**
RCA Institutes, Inc.	96
RCA Manufacturing Co., Inc.	75, 89, Cov. IV
Radell Corporation	94
Radio Control Headquarters, Inc.	**
Radio Manufacturing Engineers	**
Radio Shack Corporation	88
Raytheon Manufacturing Company	**
Scientific Radio Products Co.	**
Shure Brothers	72
Sickles Co., F. W.	91
Simpson Electric Co.	**
Standard Transformer Corporation	82
Sun Radio Company	92
Taylor Tubes, Inc.	**
Terminal Radio Corporation	99
Thordarson Electric Manufacturing Co.	95
Triplet Electrical Instrument Co., The	97
United Transformer Company	**
Universal Microphone Company	**
Vibroplex Company, Inc., The	**
Wallace, Don	**
Wholesale Radio Laboratories	**
Wilcox Electric Company	83
Vaxley (Mallory)	74
Zenith Radio Co.	**

All of the above advertisers are cooperating with the A. R. R. L. to permit publication of an editorially adequate QST during this period of war-rationing of paper. Using less advertising space but at higher rates, they continue their customary support of QST. Some are using smaller space in each issue and some are using space only every second or third issue. Of the latter, those whose advertising does not appear in this particular issue are indicated by the ** above.



To the hams to the engineers to the technicians
still in mufti to the old hands at the new games
of war

To all the valiant brothers and sisters fashioning
victory in the labs and assembly lines

Ken-Rad dedicates its complete effort to war for
an early Peace

KEN-RAD

TRANSMITTING TUBES
CATHODE RAY TUBES

INCANDESCENT LAMPS
FLUORESCENT LAMPS

SPECIAL PURPOSE TUBES
METAL AND VHF TUBES

OWENSBORO KENTUCKY U S A

1918

The men and women of National Company take great pride in the reception of the Army-Navy "E" Award for excellence in production. To us it brings a special satisfaction, for twenty five years ago we received a similar award for service to the Nation in World War I. Old timers have set the pace in winning both awards, but new members have brought eager hands to join with old skills to supply our boys with the tools of Victory. We are grateful to the armed forces for the confidence they have placed in us. We will not fail them.



NATIONAL COMPANY,

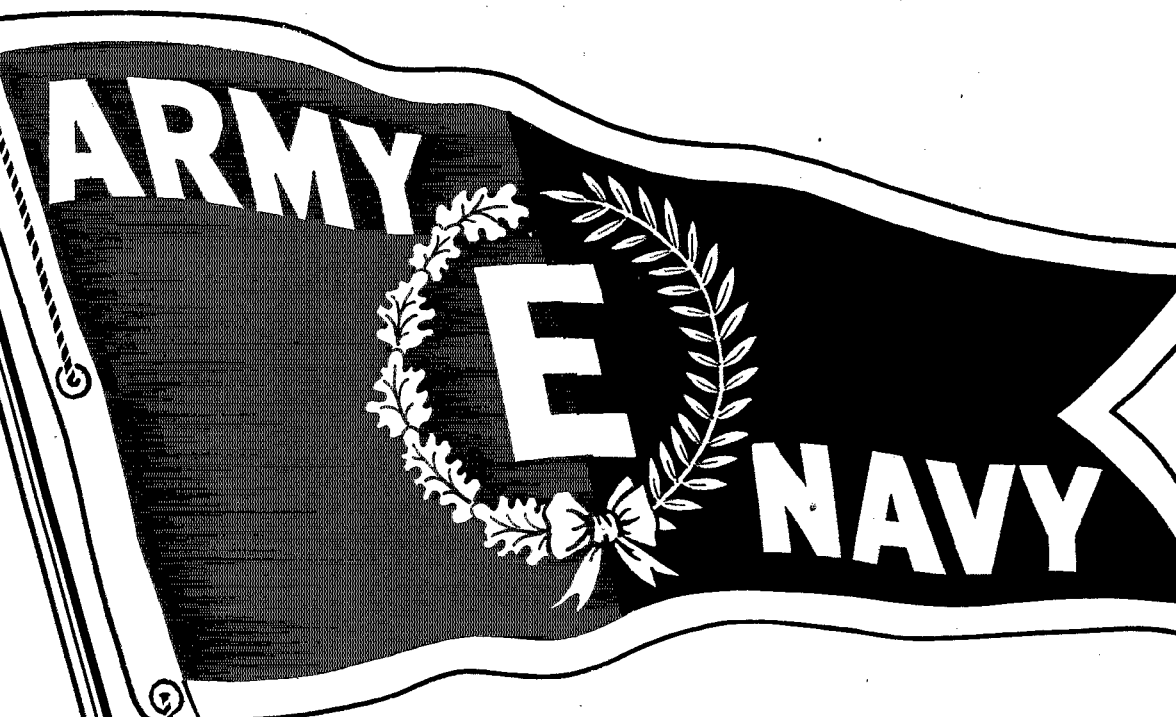

1943

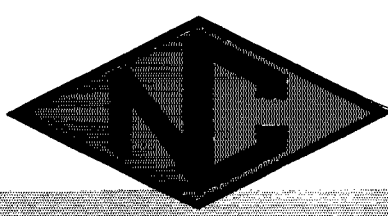

INC.

MALDEN, MASS.

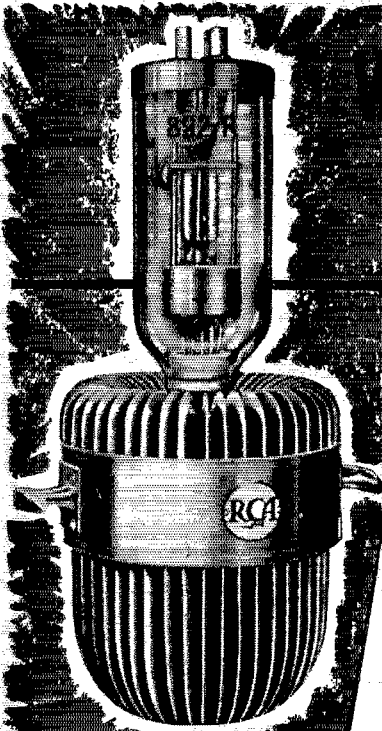

BUY WAR BONDS

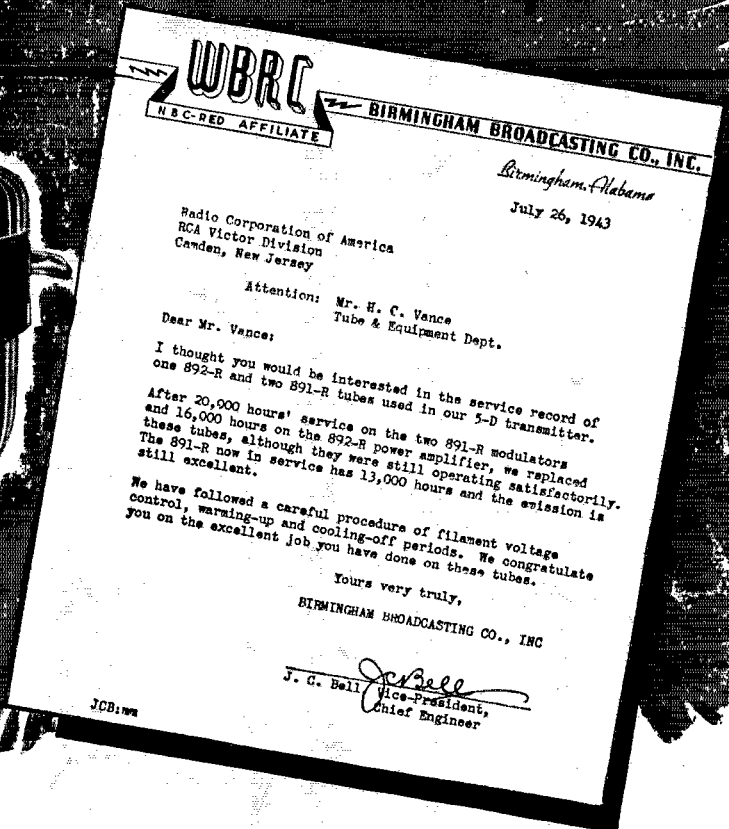

WBRC

NBC-RED AFFILIATE

BIRMINGHAM BROADCASTING CO., INC.
Birmingham, Alabama

July 26, 1943

Radio Corporation of America
RCA Victor Division
Camden, New Jersey

Attention: Mr. H. C. Vance
Tube & Equipment Dept.

Dear Mr. Vance:

I thought you would be interested in the service record of one 892-R and two 891-R tubes used in the service record of one 5-D transmitter. After 20,000 hours' service on the two 891-R modulators and 16,000 hours on the 892-R power amplifier, we replaced these tubes, although they were still operating satisfactorily. The 891-R now in service has 13,000 hours and the emission is still excellent. We have followed a careful procedure of filament voltage control, warming-up and cooling-off periods. We congratulate you on the excellent job you have done on these tubes.

Yours very truly,
BIRMINGHAM BROADCASTING CO., INC

J. C. Bell
Vice-President,
Chief Engineer

JCB:ms



● RCA tubes are lasting longer today than ever before for two reasons:

1. **Better tubes**—RCA tubes are better today as a result of continuous research and ever improving methods of manufacture.
2. **Attention to details of operating practice**—Mr. Bell's letter above shows what has been done in this direction at

WBRC to stretch today's limited tube supplies as far as possible.

Do you want to make *your* tubes last longer? RCA engineers have summarized the things you can do to get better tube life, in a booklet called "Tips on Making Transmitting Tubes Last Longer." Write for your free copy . . . using address below. *RCA Victor Division, RADIO CORPORATION OF AMERICA.*

The Magic Brain of All Electronic Equipment is a Tube and the Fountain-Head of Modern Tube Development is RCA

TUNE IN "WHAT'S NEW?"
RCA's great new show,
Saturday nights, 7 to 8,
E. W. T., Blue Network

RCA ELECTRON TUBES

