

QST

august, 1943
25 cents
35c in Canada

devoted entirely to

amateur radio

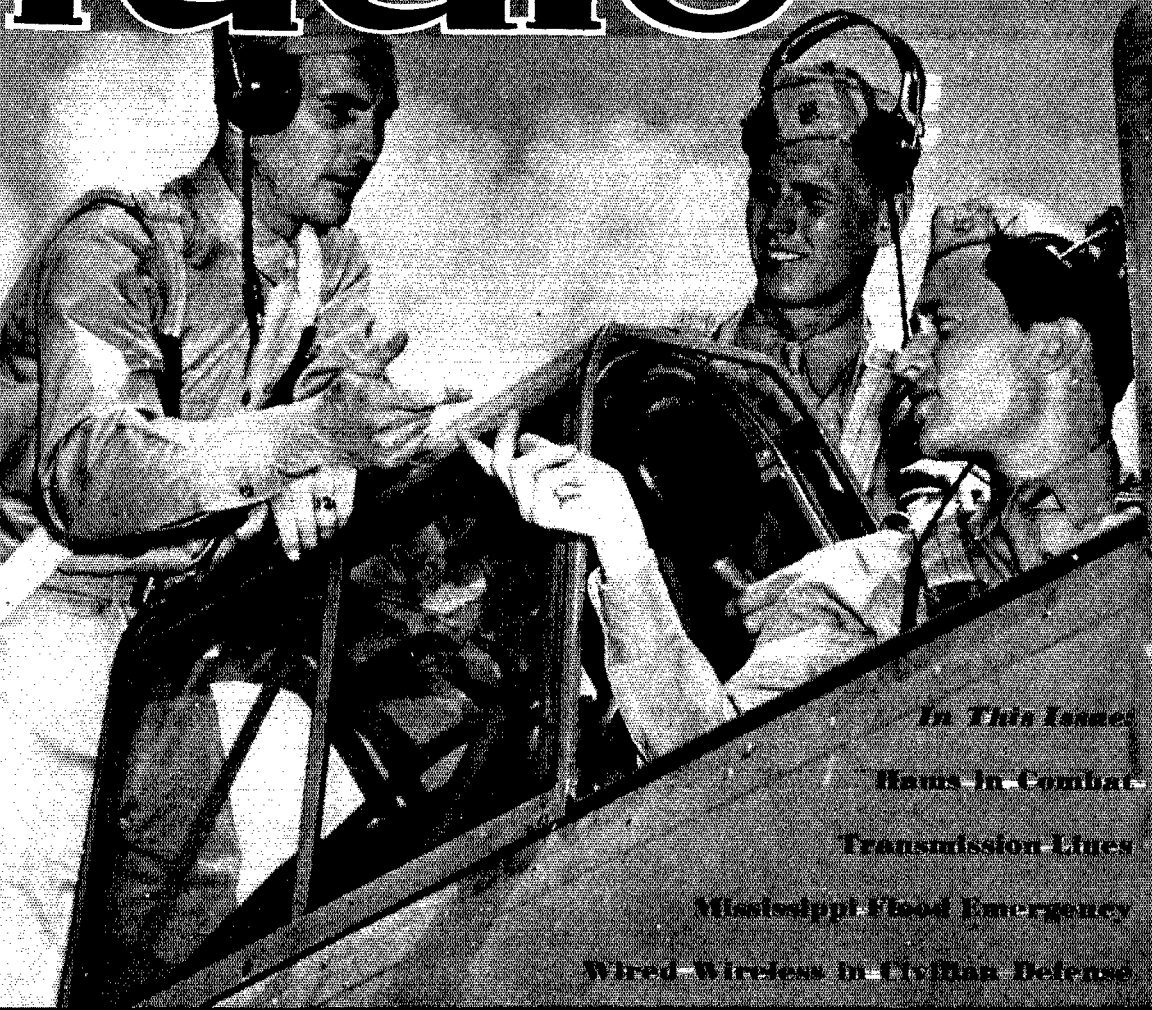

In This Issue:

Waves In Combat

Transmission Lines

Mississippi Flood Emergency

Wired-Wireless In Civilian Defense

PUBLISHED BY THE AMERICAN RADIO RELAY LEAGUE



For a full measure of service

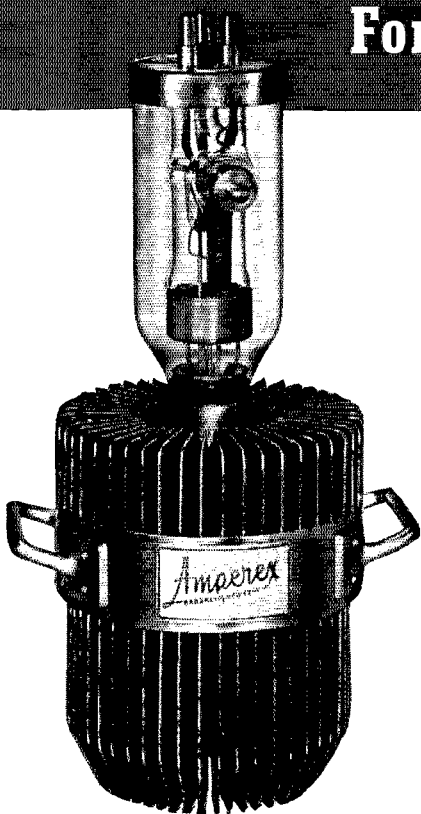

Not only are men being tried on battlefronts, the equipment that they employ is being subjected to equally critical tests . . . with the lives of the men as the stakes. We at home, entrusted with war contracts, are overcoming serious raw material shortages through laboratory and production developments, making each individual tube that we produce do more than its planned job . . . and do it better.

Through a series of design refinements, Amperex engineers have developed transmitting and rectifying tubes that are being operated for longer periods of time than hitherto had been practical. These new Amperex radio and radar tubes present a dual economy . . . many more hours of uninterrupted service . . . and priceless savings of scarce materials.

AMPEREX ELECTRONIC PRODUCTS

79 WASHINGTON STREET

BROOKLYN, NEW YORK



HALLICRAFTERS AMONG THE BUSHMASTERS!

HALLICRAFTERS short wave portable communications receivers are on duty somewhere in Panama, bringing news from the "home front" to our boys on the "fighting front."

Hallicrafters Model S-29 (illustrated) is a completely self-contained portable short wave radio communications receiver.

BUY
MORE
BONDS!



hallicrafters

CHICAGO, U.S.A.

HIGH POWERED
MOBILE RADIO
UNIT SCR-299

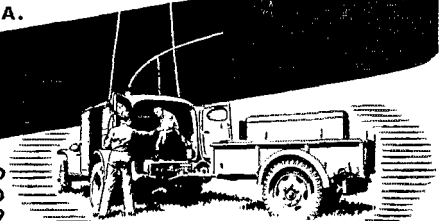



Dear Dad: I'm lucky. I've had the chance to look over these other countries -- good countries as world standards go.

The brass hats on the radio tell me that I am fighting to preserve "The American Way" of life. Now I know what that means. It means my right to earn a good living. To locate my children. Own a house. Have a bathroom and a furnace. The right to be a senator or own my own business. To do as I please where I wish, if I wish. And I don't want anybody telling me what I have to do.

While we're over here taking care of our enemies who think they know what's best for us -- don't you men at home forget what we're fighting for.

Your son

BUY MORE BONDS!



hallicrafters
CHICAGO, U.S.A.

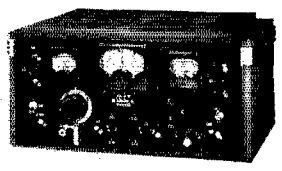

AUGUST 1943

VOLUME XXVII

NUMBER 8



STAFF

Editorial

KENNETH B. WARNER, W1EH
General Manager of A.R.R.L.
Publications

CLINTON B. DeSOTO, W1CBH
Editor

GEORGE GRAMMER, W1DF
Technical Editor

DONALD H. MIX, W1TS
BYRON GOODMAN, W1JPE*
Assistant Technical Editors

EDWARD P. TILTON, W1HDQ
Contributing Editor, V.H.F.

WALTER E. BRADLEY, W1FWH
VERNON CHAMBERS, W1JQ9*
Technical Information Service

LOUISA B. DRESSER
Editorial Assistant

JAMES J. LAMB, W1AL*
Research Engineer, A.R.R.L.

Advertising

F. CHRYNEY BEEKLEY, W1GS
Advertising Manager

Circulation

DAVID H. HOUGHTON
Circulation Manager

RALPH T. BEAUDIN, W1BAW
Asst. Circulation Manager

*On leave of absence



OFFICES

38 La Salle Road
West Hartford 7, Connecticut

Subscription rate in United States and Possessions, \$2.50 per year, postpaid; all other countries, \$3.00 per year, postpaid. Single copies, 25 cents. Foreign remittances should be by international postal or express money order or bank draft negotiable in the U. S. and for an equivalent amount in U. S. funds.

Entered as second-class matter May 29, 1919, at the post office at Hartford, Connecticut, under the Act of March 3, 1879. Acceptance for mailing at special rate of postage provided for in section 1103, Act of October 3, 1917, authorized September 9, 1922. Additional entry at Concord, N. H., authorized February 21, 1929, under the Act of February 28, 1925. Additional second-class entries to cover sectional editions authorized March 20, 1935.

Copyright 1943 by the American Radio Relay League, Inc. Title registered at United States Patent Office.

QST

devoted entirely to

AMATEUR RADIO

PUBLISHED, MONTHLY, AS ITS OFFICIAL ORGAN, BY THE AMERICAN RADIO RELAY LEAGUE, INC., AT WEST HARTFORD, CONN., U. S. A.:
OFFICIAL ORGAN OF THE INTERNATIONAL AMATEUR RADIO UNION



CONTENTS

It Seems to Us	7
Splatter	8
Radio Instruction in the Royal Canadian Air Force <i>Wing Commander K. R. Patrick, VE1BO</i>	9
Wired Wireless in Civilian Defense <i>Perry E. Wightman and Henry H. Lyon</i>	14
Did Marconi Invent Radio?	17
James in Combat	18
Happenings of the Month	22
Prisoners of War	24
Missing in Action	24
Silent Keys	24
Notes on Transmission Lines <i>Harry E. Stewart, W3JXY</i>	25
"Ole Mississipp'" Rampages Again <i>Carol Anne Keating, W9WWP</i>	30
Constructional Aspects of WERS Mobile Installations <i>R. M. Forster, W2DUG</i>	34
In the Services	38
Message Handling in WERS <i>Howard F. Russell, W1MAV, and Albert J. King, W1QR</i>	42
U.S.A. Calling!	44
A Five-Band Transmitter-Exciter <i>Clyde C. Richelieu, W9ARE</i>	46
"CQ" <i>Corporal Earl A. Parker, W2LDV</i>	50
Experimenter's Section	51
Book Reviews	52
The Greeter	53
On the Very Highs <i>E. P. Tilton, W1HDQ</i>	54
Elementary A.C. Mathematics <i>George Grammer, W1DF</i>	56
New Receiving Tubes — 7C4/1203A, 1R4/1294, 3B7/1291, 3D6/1299, 7E5/1201	59
Strays	60
Radio Cross-Word Puzzle <i>Ruth Prindle</i>	61
Hints and Kinks <i>Notes on Commercial Gear for WERS — A.C.-D.C. Gear for 112 Mc. — Notes Covering the WERS Transmitter-Receiver for Allegany County, Maryland — Tuned Lecher Wires — Three-Element Directional Antenna for Portable 112-Mc. Work — Folding Car-Roof V.H.F. Antenna</i>	62
Correspondence from Members	66
Operating News	69
Honor Roll	70
The Month in Canada	72
Amateur Activities	73
WWV Schedules	82
Ham-Ads	108
QST's Index of Advertisers	110

Section Communications Managers of the A.R.R.L. Communications Department

Reports Invited. All amateurs, especially League members, are invited to report communications activities, training plans, code classes, theory-discussion groups, civilian-defense building or planning each mid-month (16th of the month for the last 30 days) direct to the SCM, the administrative official of ARRL elected by members in each Section whose address is given below. Radio Club reports and Emergency Coordinator reports representing community organized work and plans and progress are especially desired by SCMs for inclusion in QST. ARRL Field Organization appointments, with the exception of the Emergency Coordinator and Emergency Corps posts, are suspended for the present and no new appointments or cancellations, with the exception named, will be made. This is to permit full efforts of all in Emergency Corps plans.

ATLANTIC DIVISION			
Eastern Pennsylvania Maryland-Delaware-District of Columbia Southern New Jersey Western New York Western Pennsylvania	W3BES W3CIZ W3GCU W8MC W8CKO	Jerry Mathis* Hermann E. Hobbs Ray Tomlinson William Bellor E. A. Krall	6208 Master St. 9701 Monroe St. Silver Spring P. O. 623 E. Brown St. 186 Dorsey Rd. 703 Broadway Philadelphia Linden, Maryland Trenton 10 Rochester East McKeesport
CENTRAL DIVISION			
Illinois* Indiana* Kentucky Michigan Ohio Wisconsin	W9QLZ W9SVH W9ARU W8DPE W8CBI W9RH	George Keith, Jr. J. P. Gilliam Darrell A. Downard Harold C. Bird L. C. McCoy Emil Felber, Jr.	Box 22 A, R.F.D. 2 422 Goshen Ave. 116 N. Longworth Ave. R.F.D. 2 Normandy Lane, R. R. 7 1025 N. 18th St. Utica Elkhart Louisville Pontiac Darton Milwaukee
DAKOTA DIVISION			
North Dakota South Dakota Northern Minnesota Southern Minnesota	W9VVF W9QVY W9FUZ W9YNQ	John W. McBride P. H. Schultz Armond D. Brattland Millard L. Bender	420 West 12th St. 118 N. Yankton Ave. War Production Training School 608 N. Huron Ave. Sioux Falls, South Dakota Pierre Glenwood Spring Valley
DELTA DIVISION			
Arkansas Louisiana Mississippi Tennessee	W5GED W5DWV W5LAV W5SP	Ed Beck W. J. Wilkinson, Jr. E. W. Clement James B. Witt	2503 Bishop St. Room 313, Jefferson Hotel 324 Santini St. R.F.D. 6, Shady Dell Trail Little Rock Shreveport Knoxville
HUDSON DIVISION			
Eastern New York N. Y. C. & Long Island Northern New Jersey*	W2LU W2AZV W2IIN	Robert E. Haight E. L. Baunach John J. Vitale	25 Crane Ave. 102 Central Ave. 106 Orchard St. White Plains Massapequa, L. I. Elizabeth
MIDWEST DIVISION			
Iowa Kansas Missouri* Nebraska	W9AED W9AWP W9GUD W9POB	Arthur E. Rydberg A. B. Unruh Letha E. Allendorf Roy E. Olmsted	1617 S. Seneca St. 1015 West Third St. Trimble House Mitchellville Wichita Joplin Milford
NEW ENGLAND DIVISION			
Connecticut Maine* Eastern Massachusetts Western Massachusetts New Hampshire Rhode Island Vermont	W1KOY W1AQL W1ALP W1JAH W1FTJ W1RRC W1KJG	Edmund R. Fraser G. C. Brown Frank L. Baker, Jr. William J. Barrett Mrs. Dorothy W. Evans Clayton C. Gordon Clifton G. Parker	48 Willow St. 379 No. Main St. 91 Atlantic St. 239 Columbia St. P. O. Box 312 70 Columbia Ave., Gaspee Box 537 West Haven Brewer North Quincy Adams Concord Plateau, Warwick Morrisville
NORTHWESTERN DIVISION			
Alaska Idaho Montana Oregon Washington	K7GNN W7AVP W7CPY W7GNJ W7FWD	James G. Sherry Don D. Oberbillig Rex Roberts Carl Austin O. U. Tatro	P. O. Box 486 Box 1088 1137 Federal 513 N. Central Homer Boise Glendive Bend Olympia
PACIFIC DIVISION			
Hawaii Nevada Santa Clara Valley East Bay San Francisco Sacramento Valley Philippines San Joaquin Valley*	K6ETF W6BIC W6IUZ W6TI W6CIS W6MDI KA1GR W6MIW	Francis T. Blatt Edward W. Heim Earl F. Sanderson Horace R. Greer Kenneth E. Hughes Vincent N. Feldhausen George L. Rickard Ralph G. Lowry	837 16th Ave. 509 Claremont St. 600 Acacia Ave. 414 Fairmount Ave. 590 35th Ave. 113 South Quincy St. Box 849 315 Santa Barbara Honolulu Reno San Bruno Oakland San Francisco McCloud Manila Modesto
ROANOKE DIVISION			
North Carolina South Carolina Virginia West Virginia	W4CYB W4BOE/ANG W3AKN W8JRL	W. J. Workman Ted Ferguson Walter G. Walker Kenneth M. Zinn	P. O. Box 566 1213 College St. 217-51 St. P. O. Box 132 Morganton Columbia Newport News Clarksburg
ROCKY MOUNTAIN DIVISION			
Colorado Utah-Wyoming	W9CNL W7DIE	Stephen L. Fitzpatrick John S. Duffy	P. O. Box 1101 938 "D" St. Kiowa Rock Springs, Wyo.
SOUTHEASTERN DIVISION			
Alabama Eastern Florida* Western Florida Georgia West Indies (Cuba) (Puerto Rico-Virgin Islands)	W4GBV W4BYR W4AXP W4FDJ CM2OP K4KD	Lawrence J. Smyth Frank C. Fasset Oscar Cederstrom Ernest L. Morgan Mario de la Torre Everett Mayer	808 Winona Ave. 1712 Hills Ave. 408 S. Pine St. R.F.D. 4 Escobar 110 (Altos) 24 Lindberg St. Montgomery Tampa Warrington Lyons Habana, Cuba Santurce, P. R.
SOUTHWESTERN DIVISION			
Los Angeles Arizona San Diego	W6QVV W6RWV W6BZE	H. F. Wood Douglas Aitken Richard Shanks	723 No. Las Palmas Ave. 341 S. Mt. Vernon Ave. 4033 S. Hempstead Circle Hollywood Prescott San Diego
WEST GULF DIVISION			
Northern Texas Oklahoma Southern Texas New Mexico	W5IAU W5GFT W5MN W5HJF	N. R. Collins, Jr. Russell W. Battern Horace E. Bidy J. G. Hancock	2230 W. Amherst Box 290 1746 Schley Ave. 110 S.E. Nevada St. Dallas Enid San Antonio Portales
MARITIME DIVISION			
Maritime	VE1DQ	A. M. Crowell	69 Dublin St. Halifax, N. S.
ONTARIO DIVISION			
Ontario	VE3EF	Flying Officer Donald R. Gunn	c/o Canadian Bank of Commerce New Toronto, Ont.
QUEBEC DIVISION			
Quebec	VE2CO	Sub-Lieutenant L. G. Morris	c/o Room 604, 1111 Beaver Hall Hill Montreal, P. Q.
VANALTA DIVISION			
Alberta British Columbia	VE4GE VE3DD	C. S. Jamieson C. O. L. Sawyer	581 W. Riverside Drive 2634 West 31st Ave. Drumheller, Alta. Vancouver
PRAIRIE DIVISION			
Manitoba Saskatchewan	VE4AAW VE4SY	A. W. Morley Arthur Chesworth	82 Carlton St. 1071 4th Ave., N.W. Winnipeg Moose Jaw

* Officials appointed to act until the membership of the Section choose permanent SCMs by nomination and election.



electronic briefs: television

To produce a moving picture it becomes necessary to break down the action into a series of still pictures. Each still scene is flashed on the screen individually but done so rapidly that the human eye sees a smooth action. If the motion picture projector is slowed down the action becomes jerky. Each still picture is called a frame and the conventional movie projector flashes between 24 and 30 frames per second on the screen. Television is based upon the same principle but the problems involved are much more complex.

Television, using the same basis for creating picture action as the movies, breaks down the picture or scene to be broadcast into a series of still pictures called frames. But each frame must also be broken down into approximately 200,000 tiny segments, each segment being broadcast separately and reassembled at the receiving end so rapidly that 30 frames can be flashed on the screen every second. Thus some 6,000,000 separate signals must be transmitted per second. Furthermore each of these signals starts as light, is converted into an electrical impulse, broadcast and then reconverted to light again. To make television talk, a conventional sound transmitter must be coordinated and synchronized with the picture broadcast.

As with all things in the field of electronics, vacuum tubes are what make television possible. Remember; Eimac tubes enjoy the enviable distinction of being first choice among leading electronic engineers throughout the world.

EITEL-McCULLOUGH, INC., SAN BRUNO, CALIFORNIA
EXPORT AGENTS: FRAZAR & HANSEN, 301 CLAY ST., SAN FRANCISCO, CALIF., U. S. A.

Follow the leaders to



Army-Navy "E"
flag awarded for
high achievement
in the production
of war material.

Eimac
REG. U. S. PAT. OFF.
TUBES

THE AMERICAN RADIO RELAY LEAGUE, INC.,

is a noncommercial association of radio amateurs, bonded for the promotion of interest in amateur radio communication and experimentation, for the relaying of messages by radio, for the advancement of the radio art and of the public welfare, for the representation of the radio amateur in legislative matters, and for the maintenance of fraternalism and a high standard of conduct.

It is an incorporated association without capital stock, chartered under the laws of Connecticut. Its affairs are governed by a Board of Directors, elected every two years by the general membership. The officers are elected or appointed by the Directors. The League is noncommercial and no one commercially engaged in the manufacture, sale or rental of radio apparatus is eligible to membership on its board.

"Of, by and for the amateur," it numbers within its ranks practically every worth-while amateur in the nation and has a history of glorious achievement as the standard-bearer in amateur affairs.

Inquiries regarding membership are solicited. A bona fide interest in amateur radio is the only essential qualification; ownership of a transmitting station and knowledge of the code are not prerequisite, although full voting membership is granted only to licensed amateurs.

All general correspondence should be addressed to the Secretary at the administrative headquarters at West Hartford, Connecticut.



Past Presidents

HIRAM PERCY MAXIM, W1AW, 1914-1936
EUGENE C. WOODRUFF, W8CMP, 1936-1940

Officers

President GEORGE W. BAILEY, W1KH
Washington 25, D. C.

Vice-President CHARLES E. BLALACK, W6GG
Yuma, Ariz.

Secretary KENNETH B. WARNER, W1EH
West Hartford, Connecticut

Communications Manager F. E. HANDY, WIBDI*
Washington, D. C.

Treasurer DAVID H. HOUGHTON
West Hartford, Connecticut

General Counsel PAUL M. SEGAL
1026 Woodward Building, Washington, D. C.

*On leave of absence. Address correspondence to the Acting Communications Manager, George Hart, West Hartford 7, Connecticut.

Directors

President
GEORGE W. BAILEY W1KH
2101 Constitution Ave., N.W., Washington

Vice-President
CHARLES E. BLALACK W6GG
Box 108, Yuma, Ariz.

Canadian General Manager
ALEX REID VE2BE
240 Logan Ave., St. Lambert, P. Q.
Alternate: Leonard W. Mitchell VE3AZ
78 Raglan Ave., Toronto, Ont.

Atlantic Division
WALTER BRADLEY MARTIN W3QV
Address correspondence to the Acting Director:
HERBERT M. WALLEZE W8BQ
P. O. Box 18, Drums, Pa.

Central Division
GOODWIN L. DOSLAND W9TSN
11831 Longwood Drive, Chicago
Alternate: Everett H. Gibbs W8AQ
405 Broad St., Wadsworth, Ohio

Dakota Division
TOM E. DAVIS W9VVA
915 W. Becker Ave., Willmar, Minn.
Alternate: Donald M. Beaudine W9RFJ
2821 Carson Way, Sacramento, Calif.

Delta Division
E. RAY ARLEDGE W5SI
340 N.E. 20th Terrace, Apt. 7, Miami 37, Fla.
Alternate: B. G. Lowery Smith W4DEP
19 N.E. 41st St., Miami, Fla.

Hudson Division
ROBERT AKERIDGE KIRKMAN W2DSY
250 Albert Place, Elberon, N. J.
Alternate: George Rulfs, jr. W2CJY
172-21 Highland Ave., Jamaica, L. I.

Midwest Division
FLOYD E. NORWINE, JR. W9EFC
7405 Hlawatha Ave., Richmond Heights, Mo.
Alternate: William H. Graham W9BNC
6915 No. 31st Ave., Omaha, Neb.

New England Division
PERCY C. NOBLE W1BVR
37 Broad St., Westfield, Mass.
Alternate: Clayton C. Gordon W1HRC
70 Columbia Ave., Warwick, R. I.

Northwestern Division
KARL W. WEINGARTEN W7BG
3219 N. 24th St., Tacoma, Wash.
Alternate: R. Rex Roberts W7CPY
110 W. Brennan St., Glendive, Mont.

Pacific Division
J. L. McCARGAR W6EY
66 Hamilton Pl., Oakland, Calif.
Alternate: Elbert J. Amarantes W6FBW
1675 Dale Ave., San Jose, Calif.

Roanoke Division
H. L. CAVENESS W4DW
2607 Vanderbilt Ave., Raleigh, N. C.
Alternate: J. Frank Key W3ZA
Box 707, Buena Vista, Va.

Rocky Mountain Division
C. RAYMOND STEDMAN W9CAA
925 So. Gaylord St., Denver
Alternate: Willard C. Wright W9BQO
Box 891, Denver

Southeastern Division
WILLIAM C. SHELTON W4ASR
527 Revillo Blvd., Daytona Beach, Fla.
Alternate: William P. Sides W4AUP
Fleming Road, Montgomery, Ala.

Southwestern Division
JOHN E. BICKEL W6BKY
1834 F. Whittier Blvd., Whittier, Calif.
Alternate: Eldridge E. Wyatt, jr. W6ARW
5291 E. Broadway, Long Beach, Calif.

West Gulf Division
WAYLAND M. GROVES W5NW
% Humble Pipe Line Co., Hawkins, Texas
Alternate: Jennings R. Poston W5AJ
Box 246, Mabank, Texas

"IT SEEMS TO US—"

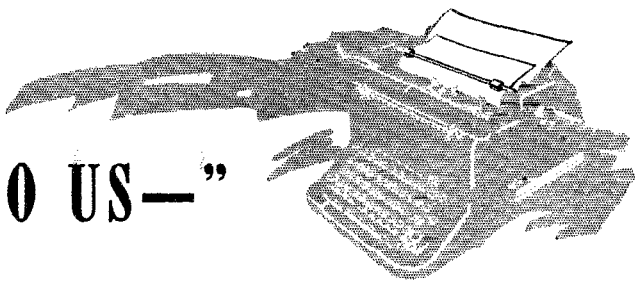

W.E.R.S. IS MAKING PROGRESS

THE amateur has always been noted for his ability to overcome seemingly unsurmountable obstacles in whatever he undertakes. The War Emergency Radio Service was presented to us full of such obstacles, some of them not immediately apparent but showing up as we went along. Perhaps reluctantly and mistrustfully authorized by the military services in the first place, because of security worries, some of the problems have been enough to make the amateur out in the field wonder whether the regulations weren't deliberately meant to be so discouraging that there would be no WERS and hence no security worries. First there were the frequencies we were expected to work on—none but v.h.f. Then we discovered that our personnel was insufficient, because of the drains into the armed services and essential industry, and we had to start training volunteers. On getting around to the preparation of applications, we found that it was a long and complicated process which frequently involved FCC's bouncing the papers back into our laps to remedy minor discrepancies. And then, upon building and servicing our equipment, we discovered that the resources of our junk boxes were not nearly so extensive as expected.

These were only the major difficulties. In addition, many of us found ourselves involved in petty politics; local officials too frequently were cool toward the need for WERS; other ARP services sometimes became jealous and tried to retard our progress; the terrain was not adapted to the type of operation contemplated; there was not enough time for testing. We could go on and enumerate dozens of minor difficulties, but suffice it to say that, considering everything, we have had our hands full. Many of us have spent more time on WERS than was good for us, and have gone places despite all obstacles. Some have done more complaining than working, saying that "ARRL ought to do something about it." A few have simply thrown up their hands.

There is little consolation in knowing that the situation in which we find ourselves is partly of our own making; that we probably would not be subject to so many restrictions now had not one or two irresponsible groups of amateurs made asses of themselves during the December reactivations, thus casting an un-

favorable light over us all. Our hobby is what we make it, and the respect—or lack of it—that the public and the officials have for us is, after all, a reflection of our own conduct. Amateur radio is unique among communications services in that the malpractices of a few reflect upon the whole. If we now labor under unfavorable restrictions, it is because for some reason we have failed to convince the government that we are a responsible group; and if we have failed to make a good impression, it is because a very few of our number have given a bad one. Those few must be made to stay in line. In the meantime we must bear up under whatever difficulties we meet, trying at the same time to get the most troublesome details rectified.

Your League has not been loafing on the job. We are hard at work on these problems, and now our efforts to solve them are beginning to bear fruit. The testing periods have already been lengthened to give us more time for drilling and testing. Consideration is being given to expanding the scope of service of CD-WERS stations to cover fields other than civilian protection from enemy action, thus giving the service a much-needed additional reason for being. The problem of providing equipment is receiving consideration by OCD and ARRL, who are working together on a proposal to procure salvaged equipment and make it available to WERS licensees without priorities. In most cases the personnel problem has been met by training volunteers, who have proved to be perfectly competent as operators and many of whom have interested themselves to an even greater extent.

The amount of paper work involved is still one of the major unsettled problems. Licensees at present are coping with it simply by *doing* the necessary paper work, but many of them are complaining bitterly. The trouble is that complaints are made in general terms, saying simply that there is too much paper work and that some of it should be eliminated. The government attitude is that it is all necessary for "security considerations." If we expect our complaints to be heard we must make them specific; we must put our finger on the items we think can be eliminated and give our reasons. We here at Headquarters believe that there are many such unnecessary items of

paper work in connection with CD-WERS licensing, and we are compiling a list of them to present to FCC in the near future. We invite your help — but be specific.

WERS is making progress — make no mistake about it. That progress is largely the result of unceasing effort on the part of the few pioneering amateurs who established the first CD-WERS organizations and showed that they could work — despite the frequencies, despite the red tape, despite the equipment shortage, despite everything and everybody that has tended to retard progress. Their success stirred to action other more dubious but equally energetic amateurs. It was no cinch. They needed spare time, and they needed effort and cooperation from everyone concerned. There are today in the vicinity of two hundred licensees, with more pending, and WERS is beginning to get the recognition it

deserves in the public eye. With more equipment available, with expanded testing periods and an increase in the scope of service to be rendered, and with the experience of early workers on which to base organization, it is only the beginning. There isn't yet anything like the coverage there ought to be. Two hundred licensees are only a drop in the bucket; we should have thousands, and we will have, now that there are fewer reasons why communities should not establish WERS and more reasons why they should.

CD-WERS is dependent mainly upon us amateurs for its key technical and training personnel. It therefore behooves *every* amateur who has any spare time at all to become active in his local WERS organization; and if there isn't one, to endeavor to interest his community and offer to help in setting it up. This includes *you*, OM!

G. H.

★ SPLATTER ★

OUR COVER

THE authorized caption for this picture (which is an official U. S. AAF Technical Training Command — Scott Field photo) is: "Three heads are better than one." The ham angle comes in, of course, in the fact that the three student radio ops are hard at work — arguing. Ostensibly it's a problem of telephone flight procedure they're discussing, but we've a sneaking suspicion it's something about a new ham rig, instead.

— — —

FOOTNOTES

WITH a grand total of ten new QST authors appearing in this issue, this column achieves a new high. So, without further ado, we present:

Robert M. Forster, W2DVG, submits that he has no claim to distinction other than his WERS-mobile constructional article (p. 34). That, we would say, is ample. Professionally a CPA, W2DVG's ambition is to find a way to combine his work and his hobby, amateur radio — at which he has been active since 1932. He has one other job: editing the *WERS Log*, a monthly (he hopes) newspaper for the Boro of Queens (L. I.) WERS outfit, in which he operates his mobile rig. . . . **Albert J. King, W1QR**, co-author of the WERS operating piece (p. 42) is occupationally a mechanical draftsman. First licensed in 1922, since then he has been Rhode Island SCM, was active in the AARS c.w. net and ORS with the call W1GV, and holds a 35 w.p.m. ARRL code proficiency certificate. Need we add that he was a 3.5-Mc. c.w. man? . . . The co-author of the wired-wireless article on p. 14, **Henry H. Lyon, ex-3LG-3RP**, fits the tradi-

tional character of the old-time ham who has made a success of professional radio. Beginning his ham career in 1909 with the call HL, he was first licensed in 1912 as 3LG with a 1-kw. rotary spark. In 1916-17 he invented underground and underwater antenna systems and did research work for the U. S. Navy, later joining up as a CRE in the submarine force. Following the war he went into broadcasting, building and operating 3NR (later WJII). After four years of loud-speaker research for Lektophone he went with WOL, becoming chief engineer in 1933. . . . **Cpl. Earl P. Parker, W2LDV** (p. 50), describes himself as the sort of fellow who starts building a two-room house and ends up with a mansion. Beginning the construction of a little two-tube s.w. regenerator back in the early '30s, he wound up with an 18-tube superhet. (He still thinks the two-tuber was a pretty darn good receiver.) Unmarried, 27, a native New Yorker (born in the Bronx but now a rabid Brooklynite), he spends such time as is not occupied with Army administrative red tape reviewing fond memories like meeting the postman every morning until that first license arrived (in 1938); the never-to-be-forgotten thrill of that first QSO when he finally got the m.o.p.a. in the 5-meter band; the thrill of working extended ground wave and then skip on 56 Mc.; battling QRM on 10-meter 'phone, "the best band of all"; battling mosquitoes and gnats while working 2½-meter mobile on summer evenings; his disappointment when he learned the Army needed his clerical experience more than his radio training (or did they?) . . .

Wing Commander K. R. Patrick, VE1BO (p. 9), was the first signals officer to be commissioned by the RCAC in this war. Assigned to radio engineering duty in 1939, he opened No. 1 Wireless School in January, 1940. He has been instructing there ever since, and has probably trained more radio men than any other Cana-

(Continued on page 94)

Radio Instruction in the Royal Canadian Air Force

**Training Radio Operators and Mechanics
at Canada's No. 1 Wireless School**

BY

WING COMMANDER K. R. PATRICK,* VEIBO

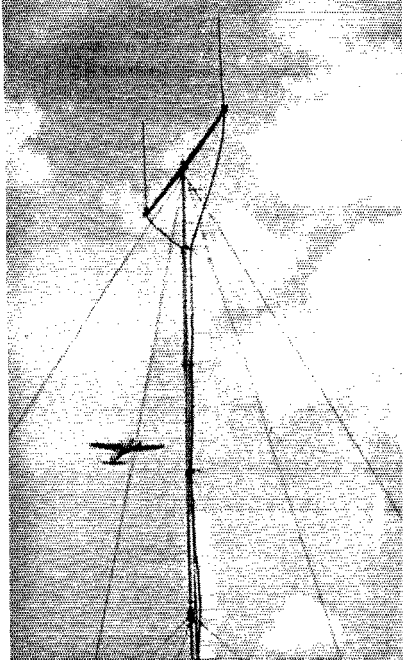

RADIO was credited by Prime Minister Churchill as a prime factor in the winning of the Battle of Britain. It was radio which enabled the Royal Air Force to direct its full weight against the enemy and to inflict a major defeat, despite the huge numerical superiority of the *Luftwaffe*.

The full importance of radio in war, and particularly in air war, was realized by the Royal Canadian Air Force long before the Battle of Britain. This was evidenced in the establishment of No. 1 Wireless School at Montreal in January, 1940, the first of such schools to be opened in Canada to train all radio personnel. Early graduates of this school were prominent among those radio operators in Britain whose contribution brought the tribute paid by Mr. Churchill.

In the four years since the establishment of No. 1 Wireless School, many thousands have graduated in the various wireless trades and have taken up their assignments in practically every country in the world.

In the early days of the war many were trained specifically for work in the Royal Air Force. The importance of this work and the contribution these radio men have made is shown by the many decorations awarded them in aerial combat.

The following citation, outlining the reasons for an award of the Distinguished Flying Medal, is typical of the more than thirty gallantry medals won by graduates of No. 1 Wireless School since the beginning of 1943:

This airman has shown high and consistent ability as a wireless operator during many attacks on enemy territory, including four raids on Berlin. On one occasion, when the starboard engine of his aircraft failed, Sergeant Long succeeded in maintaining two-way communication with base and obtained two vital W/T fixes, thus largely contributing to the safe return of the aircraft. His keenness and enthusiasm for operations have set a splendid example.

* Chief Instructor, No. 1 Wireless School, RCAF, Montreal, Quebec, Canada.

No. 1 Wireless School Trains Ground Crews

In the RCAF there are only three trades that operate, inspect and maintain all wireless equipment. These are the wireless mechanics, the wireless operators (ground), and the radiotelephone operators. All of these ground radio personnel are trained at the RCAF No. 1 Wireless School, Montreal, Quebec.

Opened in January, 1940, this school was one of the first training units to be established under the British Commonwealth Air Training Plan. At that time both aircrew and ground crew wireless trades were trained. Since 1941 the school has been greatly expanded and is now training only ground trades. There are three other wireless schools, operating under the Joint Air Training Plan, now training the wireless air-crew trainees from England, Newfoundland, New Zealand, Australia and other countries.

This school pioneered a large number of developments in ways and means of training wireless tradesmen. In addition to training radio tradesmen for employment in Canada and overseas, this school has produced almost all of the instructional staff of the other three wireless schools. There are over two hundred n.e.o.s. and officer-instructors on the staff of No. 1 Wireless School.

The numbers under training at this school must be considered confidential. Anyhow, they run into four figures. The school is the largest single-purpose training establishment in the British Commonwealth Air Training Plan. It is truly a "school" and an outstanding example of practical "pedagogy." The problem of training large numbers in semi-engineering trades has been analyzed, and training facilities and syllabi are so organized as to give the maximum of instruction in minimum time.

The first trade is the *wireless mechanic*, or "WM." He is the "radio serviceman" of the Air

Force. His trade is the most technical and difficult of all wireless trades. He must be able to install and maintain all aircraft and ground transmitting and receiving equipment, v.h.f. equipment, direction-finding and other special equipment. His knowledge must fit him to maintain high power a.c. and d.c. gas-electric plants, power supplies, electromagnetic bomb gear, and much auxiliary equipment. No untrained enthusiast can possibly cope with the maintenance of such complex equipment!

The *wireless operator (ground)*, known as the "WOG," is primarily a wireless operator for ground installations. This does not, however, restrict him to ground work, as most WOGs get considerable air experience. In addition to operating ability, the WOG must have enough practical knowledge of radio equipment to allow him to do periodic inspections, remedy minor failures and carry out emergency operation. The minimum Morse speed for the wireless operator (ground) on graduation is 20 w.p.m. He is fully qualified when able to do 30 w.p.m. using a typewriter. He is required also to know visual signaling, using semaphore and Aldis lamp. He must, of course, have a thorough knowledge of RCAF signals procedure.

The airwomen (WOGs, WD) must be capable of passing exactly the same trade test as the airmen. They must know the same equipment and operate at the same Morse speed. The Women's Division in the RCAF is known as the "WD," differing from the CWF, WAAC and WAAF, as the women's organizations in other services are known. The reason for this is that the WD is an integral part of the RCAF and not a separate service. This allows maximum flexibility in training and other personnel problems.

The airwomen have shown real aptitude for wireless operating. Their achievement of course is excellent, and the reports from operational squadrons pay glowing tribute to them.

Wireless Mechanic Training

The training syllabus for the trades is also confidential. Briefly, however, the wireless mechanic receives pre-training at some ten civilian-operated schools across Canada, which teach fundamentals to the candidates. On completion of this course, the trainee undertakes a very comprehensive course in advanced theory and practical radio. The graduates must know each of the dozens of radio equipments used in the RCAF thoroughly, so that he or she is able to repair any faults likely to be encountered in the RCAF. Wireless mechanics must be able to use analyzers, signal generators, cathode-ray oscillographs and know aircraft electrical wiring.

The radio equipment in the syllabus includes aircraft and ground communication equipment, v.h.f. equipment, d/f equipment including automatic radio compass, intercommunication amplifiers, public-address amplifiers, cathode-ray direction finders, f.m. equipment and many others.

The wireless mechanic must also be qualified in the handling of tools, and to this end a complete

course designed to introduce appreciation of tools and craftsmanship is included in the syllabus. The trainee does the conventional filing and fitting exercises. He makes a few tools which he is permitted to keep, such as a tap holder, circle cutter and small continuity tester. The trainee also does a few woodworking exercises.

In practical work, the trainee must be able to operate a.c. power plants, synchronizing alternators and performing other conventional power lab exercises. A complete power laboratory for teaching motors and generators is used for this purpose. This instruction leads up to exercises on gas-electric plants varying in size from 300 watts to 20 kilowatts, both a.c. and d.c. A WM is expected to do routine maintenance on both generator and gasoline engine. He also builds a complete receiver, transmitter, audio amplifier and power supply.

During the last three weeks of the wireless mechanic's course, he spends all his time consolidating the knowledge he has gained in the previous months, practicing the principles taught by *doing*. All trainees are sent out on their own to set up a proper radio communication station, using auxiliary power supply and standard radio equipment. Also, the trainees do considerable maintenance on the standard service equipment before they graduate.

Wireless Operators — Air and Ground

The airman wireless operator (ground) course is also a continuation course from civilian schools.

At No. 1 Wireless School the student operator receives practical lectures and laboratory instruction on all service aircraft and ground equipment sufficient to enable him to perform daily inspection and minor repairs and to operate transmitters and receivers rationally.

Signaling is the most important subject for any wireless operator, and signaling for the WOG means operating at the minimum speed of 20 w.p.m. according to service procedure and with service equipment. All signaling instruction is given in a Morse training set-up that simulates as nearly as possible actual operating conditions.

During the final month the wireless operator spends the entire period in synthetic "outstations" which, from the operator's point of view, are isolated and outlying radio stations. Through a system of wired radio, a complex system of radio communication is operated. The trainee during this period is at all times monitored so that his operating speed, signals procedure and other operating qualities may be assessed. As a part of his training program, the WOG also goes out on maneuvers with the wireless mechanic to set up and operate portable radio stations.

Wireless operators (ground) in the Women's Division receive approximately the same course as the airmen, with the exception that all of their training is given at No. 1 Wireless School.

The third class is the *radiotelephone operator*. The term RTO is a misnomer, however, as these tradesmen and tradeswomen are the radio operators who operate all the equipment used in con-

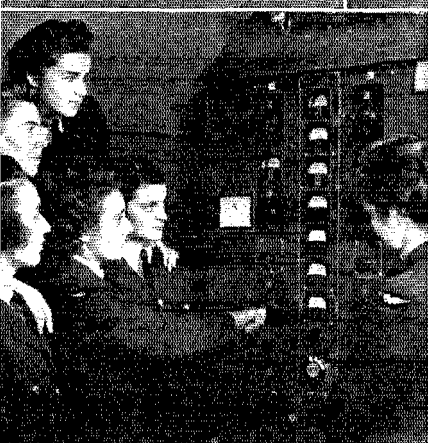
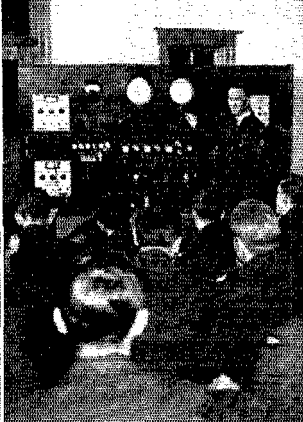

Upper left — Students receive in-flight training on aircraft attached to the school. Above — Radio theory lecture using the cathode-ray demonstration panel with two 10-inch 'scopes. Upper right — WMs practice trouble-shooting exercises. Left — WD WOGs and an AT.3 transmitter. Right — VE5JN teaching a v.h.f. class ground-station receiving equipment. Below — VE3ALX operating a camouflaged portable station.



Left — A graduating class of WDs surround a display of typical aircraft radio equipment. Lower Left — WDs practice visual signaling using semaphore flags. Below — An instructor illustrates a point using the 16-inch c.r. tube. Lower right — Looking down a receiver lab. Under study is an "HRO" ground-station receiver. Right — WOGs receive instruction on an h.f. fighter transmitter-receiver.



Official RCAF Photographs



junction with fighter control. This equipment is v.h.f., consisting of fixed and ground-portable transmitting and receiving equipment, in addition to d/f equipment. The RTO must also know the v.h.f. aircraft equipment. The derivation of the term RTO is probably due to the fact that phone is used exclusively on this system.

The RTO receives a course in radio theory and practical radio. During a final consolidation period the RTO operates this equipment in conjunction with a fighter-control system set up in Montreal. This system employs aircraft, simulating enemy aircraft, which are intercepted by the fighter aircraft controlled by the v.h.f. system.

Training Methods

In every trade a very high standard of achievement is essential, particularly in view of the short courses. This makes it imperative that every minute be used to maximum advantage. None of the tradesmen or tradeswomen is likely to pass the course successfully unless considerable of their spare time is devoted to voluntary study and instruction.

In any production where war material and personnel are involved, time is an important factor. We must, therefore, first reduce the time required to produce trainees to a given standard, and then endeavour to raise the standard and shorten the time required. In an effort to take advantage of every possible minute, the following factors contribute to the efficiency of training and the economy of training equipment: (a) program arrangement and length of period; (b) visual educational aids; (c) development of special training equipment.

In order to obtain maximum economy of instructional equipment, two shifts are employed. The first, beginning at seven A.M., carries on for eight periods of 45 minutes each. There is a 5-minute interval between each period. Two 15-minute recesses are used, one during the first four periods and one during the last four periods. The second shift works from 2:40 P.M. to 10:30 P.M. One period per day of physical training and drill is given during regular instructional hours, plus a second physical training or games period which is arranged outside of regular instructional hours. Classes are on alternate shifts each week,

so that the advantages and disadvantages are distributed equally among all groups. Classes average 32 in size. This is considered most desirable. All classrooms and laboratories are set up on that basis.

Visual Aids

The importance of visual educational aids is recognized at this school. It is known that some visual aspect is always present in educational work. This is another avenue to the mind. Therefore advantage is taken of every possible avenue, not only to improve the effectiveness of our training but, by the use of demonstration, to reduce the number of hours required. Before we adopted our large-scale use of visual education now in effect, the results of several experiments carried out by well-known scientists were investigated. The experiments were carried out by trained educators under scientifically controlled circumstances. The results are as reliable as can be expected from experiments involving human beings. They are simply this: that, through proper use of visual methods, students learn from 28 to 35 per cent more on most subjects and an even higher percentage on some subjects.

At No. 1 Wireless School, moving pictures, slides and demonstration equipment are used. This school is equipped with a theatre fitted with sound-movie projection equipment, in addition to demonstration labs fitted with projectors and screens for slides. The slides or movies are used as a supplementary means and not as a substitute for oral instruction. In demonstration, the visual aspect is carried even further; for instance, the Crowe kit for demonstrating electromagnetic phenomena is used to good advantage. Other demonstration equipment is high-powered ultrahigh-frequency oscillators to demonstrate antenna and wave propagation, an oscillatory circuit demonstrator which, through the use of lines of pea lamps, shows the voltage distribution throughout the oscillatory circuit operating at a very low frequency. The cathode-ray demonstration panels and other c.r. demonstration equipments have done a great deal to simplify and improve the teaching of theory. In equipment labs a separate demonstration set-up for each equipment is used.

Code instruction. *Left* — Instructor sending a test from a master position connected with every room in the Morse section. *Right* — Typical Morse room showing cubicle layout and monitor panel at the instructor's position.

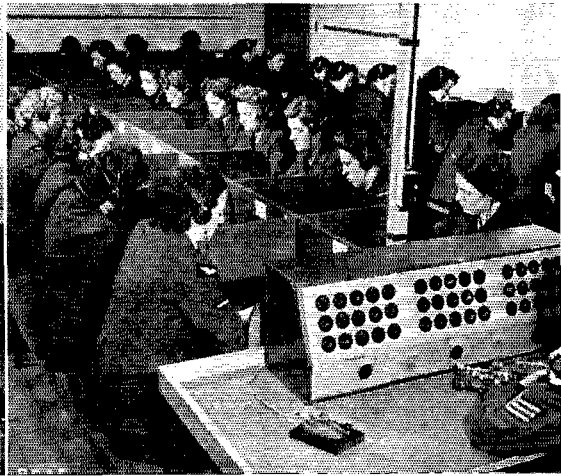
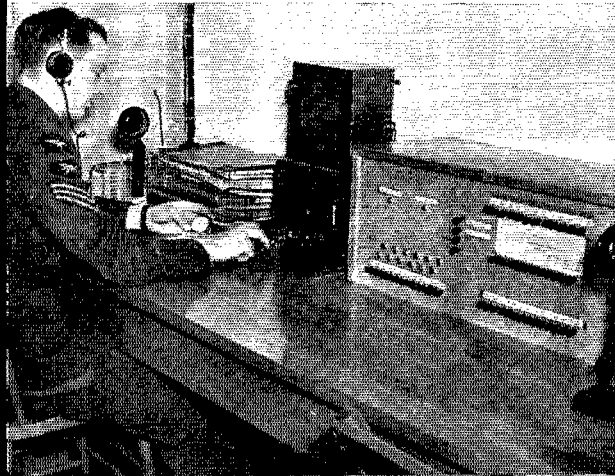

Right — A corner of an automatic radio compass lab, showing complete loop and receiver installations. *Right, below* — Demonstration equipment set-up typical of that used in all equipment and demonstration labs.

Morse Instruction

It is not within the scope of this article to deal with Morse problems. However, it is sufficient to say that Morse training can be analyzed scientifically and special methods of instruction developed which will increase the achievement and reduce the failures. At No. 1 Wireless School a highly specialized group of experts in the art of teaching Morse has produced equipment and instructional methods which have resulted in phenomenal successes.

Trainee wireless operators are selected and classified through use of a Morse aptitude test. The justification of this test and other training methods is based on accurate statistics kept at this school during its nearly four years of operation.

The communication section of this school accommodates 700 positions, all of which are individual cubicles so arranged as to produce every facility for synthetic communication nets.

Morse is first learned by "vocalizing." A special "diet" of Morse is arranged throughout the training program to ensure a proper variety in Morse copy, and exercises are arranged scientifically to produce maximum instruction value. The daily and weekly Morse examinations are analyzed by experts in this work who, through this system, contact the individual trainee and give advice or corrective exercises should these be necessary.

Each Morse room accommodates forty positions. All of these positions can be arranged for intercommunication in the Morse room and any other Morse room in the building. Morse tests and interviews are conducted via the central control panel, through which any individual or group of individuals may be contacted.

The Morse signal originates in the central Morse distribution room. This signal may be keyed by the instructor in the classroom or the individual trainees, or by the Creed or McElroy automatic keying devices.

The level of this master signal is controlled from this central distribution point, to ensure that the trainees are working with the weakest signal possible. After the initial period of Morse instruction the trainee receives a signal that is faded and changed in frequency by an electronic fading device and by motor-driven equipment. In addition, interference taken off the air is injected on the line, producing operating conditions that are more severe than normally encountered on real radio links. The level of the interference depends on the stage of the class. The signals are "clear" during examinations only. The McElroy photoelectric tape recorders are used not only

(Continued on page 108)

Right, above — A typical workshop for metal working and heavy soldering. *Right* — Student wireless mechanics receive instruction in the use of a metal-turning lathe.

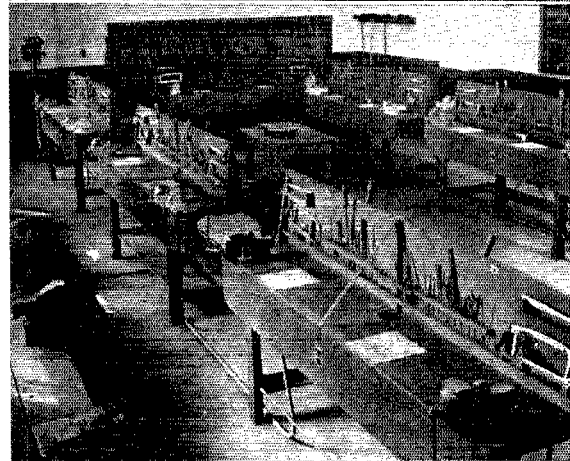
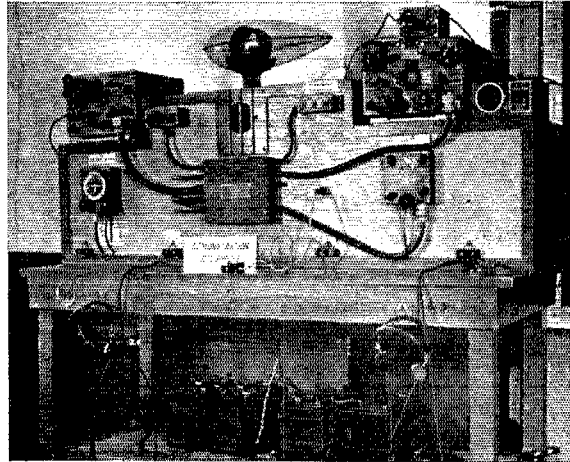

Wired Wireless in Civilian Defense

The Prince George's County (Md.) Emergency Communications System

BY PERRY E. WIGHTMAN* AND HENRY H. LYON**

The successful operation of the wired-wireless system in Prince George's County, Maryland, has generated many requests for detailed information. Here is a description of the circuits and the county set-up. Other semi-rural communities should find it possible to duplicate the results obtained.

WIRELESS or carrier current systems are not new. For a good many years they have been used by power companies for switching, relay protection and voice communication over high-tension lines, and by the telephone companies for multi-channel communication over telephone and telegraph lines.

It is possible to transmit voice over many hundreds of miles of wire, covering a large area, when a 20-watt transmitter is properly connected to the high-voltage distribution system. The signal can be picked up by a car receiver, tuned to the proper frequency, while the vehicle is traveling under the power lines, or by a receiver in the house.

The system is generally useful where the power distribution lines are of the overhead type. This type of distribution is usually found in small towns or cities and suburban areas. Where the underground type of distribution is encountered,

* Radio Aide, Prince George's County, 5717 39th Ave., Hyattsville, Md.

** Chief Engineer, WOL, Washington, D.C.

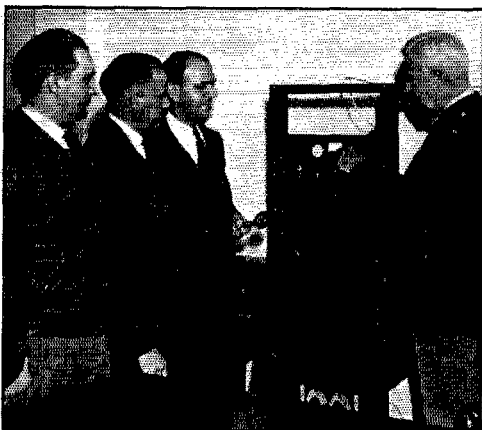

Inspecting the wired wireless transmitter at the Control Center in Hyattsville, Md. *L. to r.* — Karl Stello, W3IVZ; Harry Lyon; Perry Wightman, and Col. Henry S. Barrett. This transmitter was W3IVZ's 160-meter rig, converted to operate on 150 kc. by Wightman and Lyon.

considerable difficulty will be experienced in making use of such circuits.

The writers started experimenting with wired wireless for control purposes in 1934. Not having access to the high-voltage lines, tests were made by connecting the output of a low-power transmitter into a convenience outlet. These tests were made on broadcast frequencies. The signal was received under the wires for seven and one-half miles, with a car radio receiver. The transmitter employed used a Type 45 tube as an oscillator and another as a modulator. Harmonics were bad but radiation from the power lines was low, the signal being lost one hundred feet from the power lines. This showed that the radio-frequency current would go out over the house wiring and through the meter on to the secondary lines, in this way distributing itself over the overhead primary and secondary system.

A friend who knew what was being accomplished asked if a transmitter could be put in a fire chief's house, so that the siren on the fire house a mile and one-half away could be started and stopped. A transmitter, again using a Type 45 tube as an oscillator, was connected into the convenience outlet in the fire chief's home and a receiver with a relay in place of the loud-speaker started and stopped the siren at the fire house.

From then until the war began, tests were made on various frequencies up to 3000 kc. It was found that radiation increased with frequency and was very noticeable from about 1200 kc. on up to 3000 kc. At 3000 kc. there was mostly radiation and very little of the signal traveled over the power lines.

Wired Wireless for War Needs

When war was declared, in December, 1941, there arose a need for an auxiliary method of communication in addition to the established telephone lines — a type of communication which would not radiate into space so that enemy planes could pick up the signal and use it for direction finding. Wired wireless seemed to be the answer, and tests were made with this in mind. The results of the tests indicated that lower frequencies should be used to overcome some of the difficulties. Two transmitters were set up, one at the control center in Hyattsville (Prince George's County, Md.) and one at a report center in Mt. Rainier, a distance of 1½ miles airline (10 miles wireline) using 150 and 160 kc. Two-way communication was carried on between these two points.

Receivers were put in the following report centers and fire houses for one-way communication: Hyattsville, Cottage City, Bladensburg, Tuxedo,

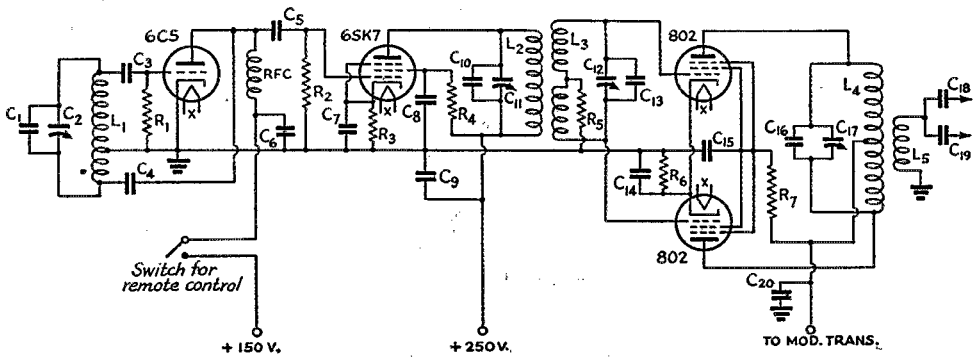

Fig. 1 — Circuit diagram of the wired-wireless transmitter for civilian-defense communication.

- C₁ — 0.002- μ fd. mica.
- C₂ — 350- μ fd. variable.
- C₃ — 500- μ fd. mica.
- C₄ to C₆, inc. — 0.1- μ fd. paper, 600 volts.
- C₁₀ — 0.002- μ fd. mica, 2500 volts.
- C₁₁, C₁₂ — 350- μ fd. variable.
- C₁₃ — 0.002- μ fd. mica, 2500 volts.
- C₁₄ — 0.1- μ fd. paper, 600 volts.
- C₁₅ — 0.002- μ fd. mica, 1000 volts.
- C₁₆ — 0.002- μ fd. mica, 5000 volts.
- C₁₇ — 350- μ fd. variable.
- C₁₈, C₁₉ — These condensers correspond to C₁ in Fig. 3.
- C₂₀ — 0.002- μ fd. mica, 1000 volts.
- R₁ — 0.1 megohm, 1 watt.
- R₂ — 50,000 ohms, 1 watt.

- R₃ — 300 ohms, 1 watt.
- R₄ — 50,000 ohms, 1 watt.
- R₅ — 20,000 ohms, 1 watt.
- R₆ — 300 ohms, 10 watts.
- R₇ — 15,000 ohms, 10 watts.
- L₁ — 160 turns No. 28 enameled on 1½-inch form, tapped 50th turn from bottom.
- L₂ — 90 turns No. 22 enameled on 3-inch form.
- L₃ — 90 turns No. 22 enameled on same form as L₂, half each side of L₂.
- L₄ — 80 turns No. 18 enameled on 3½-inch form, tapped at center.
- L₅ — Adjustable; see text.
- RFC — 30-mh. choke.

Fig. 2 — Modulator circuit diagram.

- C₁ — 10- μ fd. electrolytic, 25 volts.
- C₂ — 8- μ fd. electrolytic, 450 volts.
- C₃ — 10- μ fd. electrolytic, 50 volts.
- R₁ — 0.5 megohm volume control.
- R₂ — 1000 ohms, 1 watt.
- R₃ — 125 ohms, 10 watts.
- T₁ — S.b. microphone-to-grid transformer.
- T₂ — Interstage audio transformer.
- T₃ — Modulation transformer, 5000 ohms plate-to-plate to 3000-ohm load.

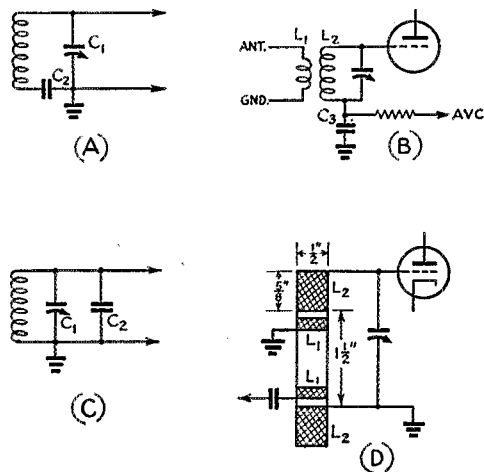
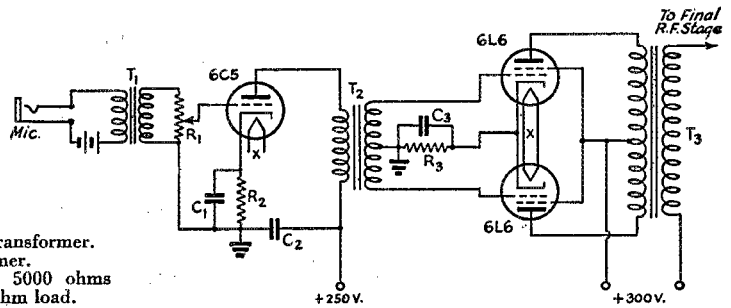

Fig. 3 — Methods of coupling the transmitter to the power line. See text for discussion of constants.

Cheverly, Riverdale, Riverdale Heights, Berwyn Heights and Branchville. The signal was good at all but the Branchville location, where the line noise was high and the signal was not strong enough to overcome it.

The 150- and 160-kc. frequencies overcame line radiation and were found suitable for this type of transmission. The signal passed from the secondary to the primary of distribution transformers and back again from primary to secondary into the home through the meter and over the house wiring. Care should be taken that the carrier-current system does not interfere with established broadcast systems or telephone or power company systems.

Transmitters

The transmitter circuit of Fig. 1 is only one of many possible arrangements; in most cases the circuit to be used will be dictated by local requirements and the materials available. Compared to high-frequency practice, the tank circuits must be

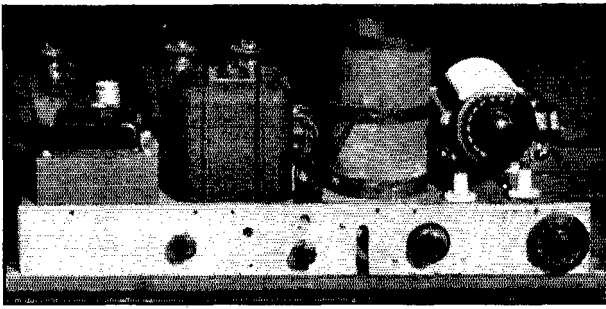

Transmitter, modulator and power supply are built on one chassis and arranged for remote control from the operating position. The final tank coil and variable tuning condenser are at right.

large both electrically and physically, but there is ample latitude for changes in constants to make use of parts which may be on hand. The essential thing is that the circuits must be tunable to the 150-160-kc. region, and the values given in the diagram may be considered simply as a starting point. The required inductance, in millihenrys, is equal to $1120/C$, where C is the capacity in micromicrofarads. The transmitter is tuned in the usual way. The circuit shown is operated with an input of about 20 watts to the plates of the 802s, the plate current being about 70 ma. and the screens taking another 30 ma.

The modulator circuit, shown in Fig. 2, uses a pair of Class-A 6L6s driven by a 6C5 and a single-button microphone. The circuit is standard and needs no further comment.

Various methods of coupling the output of the transmitter to the power line are given in Fig. 3. In these circuits, C_1 serves a dual purpose as a blocking and tuning condenser for the line circuit, the value to be used depending to a considerable extent on the line constants. In practice it has been found that the capacity required varies from about $0.01 \mu\text{fd.}$ to as much as $0.05 \mu\text{fd.}$ This condenser should be able to withstand the line voltage. Once the proper value has been determined experimentally, it may be fixed. The coil, L_2 , should be of sufficient size to provide the necessary coupling to the final tank circuit. It is

advisable to start out with a fairly large coil, wound over the final tank coil and tapped every few turns so that the loading may be adjusted.

While it is possible to work without the use of load-isolating filters, a considerable improvement in over-all efficiency can be obtained if the necessary material is available for the construction of these filters. It may be seen from diagrams C and D, Fig. 3, that the purpose of the filters is to prevent the radio-frequency signal power from being expended in the shunt load connected to the house side of the meter. It should be borne in mind that the inductance coils in these filters must have sufficient current-carrying capacity to carry the total connected load without any serious loss of voltage at the line frequency. C_2 should be a fairly good condenser, but does not have to withstand any considerable voltage. It must have the proper capacity to tune the coil, L_2 , to the operating frequency. Just as in the case of the tank circuit, a wide range of values may be used. If C_2 is a $0.005\text{-}\mu\text{fd.}$ mica condenser, a coil which will resonate at approximately 150 kc. may be wound with 70 turns of No. 14 enameled wire on a $3\frac{1}{2}$ -inch form. The voltage drop in such a coil should be negligible with normal house-wiring loads.

Receiver Circuits

Receivers for frequencies below 550 kc. are not readily available under present wartime condi-

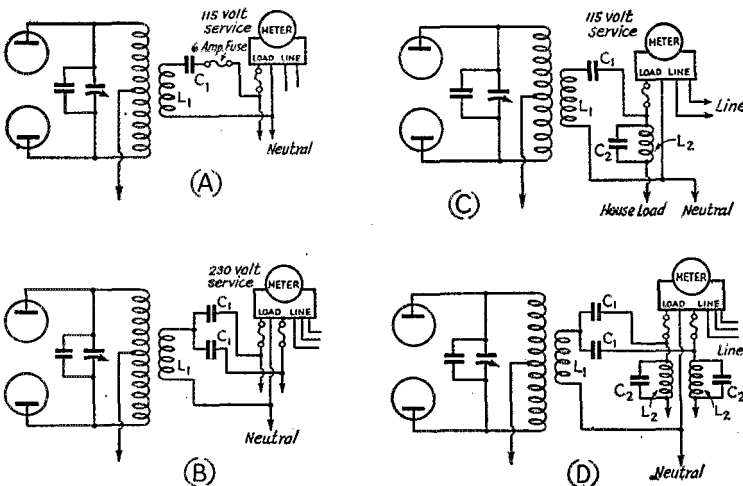

Fig. 4—Circuit changes for converting a b.c. super-heterodyne to operate in the 150-160 kc. region.

A — normal oscillator circuit; B — revised oscillator circuit; C — normal r.f. circuit (mixer input); D — revised r.f. circuit, showing cross-section of coil for tuning to 150 kc. See text for further description.

Did Marconi Invent Radio?

Supreme Court Says "No!" in Recent Decision

THE Supreme Court, on June 21st, in an opinion delivered by Chief Justice Stone, invalidated Marconi's 1904 American patent granted for improvements in apparatus for wireless telegraphy by means of Hertzian oscillations or electrical waves. Justice Murphy did not participate, and dissenting opinions in part were written by Justice Rutledge and Justice Frankfurter, with Justice Roberts joining in the latter's dissent.

Claims of \$42,984 plus interest over many years were invoked, dating back from the last war. The Marconi patent, No. 763,772, together with all assets of the Marconi Company, were assigned to the Radio Corporation of America on November 20, 1919.

The Court's opinion was based largely on the fact that a patent granted in 1902 to John Stone showed a four-circuit wireless telegraph apparatus substantially like that later specified and patented by Marconi.

The opinion of the Chief Justice held that the work of Pupin, Fessenden, Lodge, Tesla and (inventor) Stone anticipated the discoveries of the Marconi patent. Lodge, it was noted, also showed a receiver which "completely anticipated those of the Marconi receiver claims. . . ." Claim 16 of the Marconi patent, No. 763,772, for an antenna circuit at the receiving end, was held invalid in the court's opinion because it was anticipated by the prior art, particularly the patents of Pupin and Fessenden.

Justice Frankfurter, in his dissent, stated that "to find in 1943 that what Marconi did really did not promote the progress of science because it had been anticipated is more than a mirage of hindsight . . . for me it speaks volumes that it should have taken forty years to reveal the fatal bearing of Stone's relation to Marconi's achievement by a retrospective reading of his application to mean this rather than that." Justice Rutledge wrote in dissent that "until now law has united with almost universal repute in acknowledging Marconi as the first to establish wireless telegraphy on a commercial basis. Before his invention, ether-borne communication traveled some eighty miles. He lengthened the arc to six thousand. Whether or not this was 'inventive' legally, it was a great and beneficial achievement. Today, forty years after the event, the Court's decision reduces it to an electrical mechanic's application of mere skill in the art. . . . By present knowledge it would be no more. School boys and mechanics could now perform what Marconi did in 1900. But before then wizards had tried and failed . . . the invention was, so to speak, hovering in the general climate of science, momentarily awaiting birth. But just the right releasing touch had not been found. Marconi added it."

—Telecommunications Reports

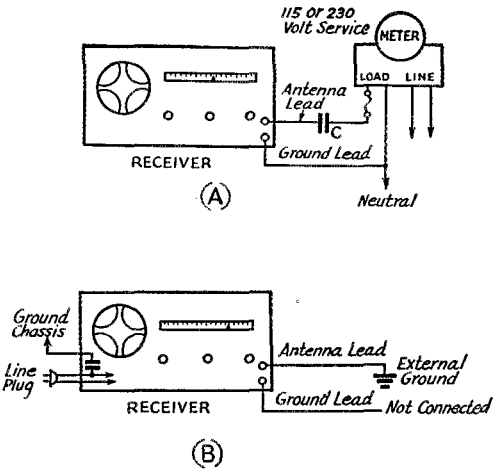

Fig. 5 — Methods of coupling receiver to the line.

tions. However, it is not hard to convert a superheterodyne receiver to operate on 150 kc. by making simple changes in the oscillator and the radio frequency circuits.

While the circuits used in superheterodynes vary considerably from one model to another, a typical arrangement is shown in Figs. 4-A and 4-B. Fig. 4-A shows the oscillator circuit before changes are made, while 4-B shows the revised circuit. C_2 is the series tracking condenser in the oscillator circuit; this condenser is removed and connected in parallel with C_1 , the oscillator tuning condenser. Fig. 4-B shows the radio-frequency circuit. L_1 and L_2 are removed and the coils shown in 4-B are connected in place of those removed. The dimensions of the coils are given in the drawing. Coil L_2 has approximately 300 turns, L_1 approximately 25 turns. Both coils were boiled in wax and, after cooling, were wrapped with cotton tape so they would hold their form.

~~Strays~~

A new method of waterproofing ceramic insulators and other materials has been developed by Dr. W. I. Patnode of the General Electric research laboratories. Articles to be treated are exposed to the vapors of a liquid chemical, called *Dri-Film*. The protective film formed is so thin that its structure cannot be determined by chemical analysis, nor can it be seen under a high-power microscope, yet it is not susceptible to heat up to 300° C. nor to abrasion as a result of handling during assembly. *Dri-Film* has been found to be about nine times as effective as the wax now commonly used for moisture-proofing.

Radio-frequency energy is now being used to detonate the explosive rivets which have helped speed production of aircraft.

Hams in Combat

A Plea for Reports on Amateurs in Active Service; Stirring Stories of Hams Fighting in the Pacific Theatre

RADIO hams as a class are not, to use the now-familiar term, "expendables." Generally speaking, the military services consider the specialized skills of amateurs sufficiently valuable to keep them in the rear echelons, at shore establishments, with the ground crews, back home training others.

Thus, of the 25,000 or so amateurs now in uniform, only a relatively small proportion have yet smelled the smoke of battle. The others, however much they may strain at the leash, must content themselves with doing the less spectacular jobs behind the lines.

But there are those fortunate enough to get assignments to the fighting fronts. There are hams riding the skies as radiomen-gunners in bomber crews, afloat in radio rooms aboard craft from corvettes to battlewagons, with signal units on every front from Attu to Australia, from Tunisia to Timor.

And it need not be added that these fighting hams are rendering an outstanding accounting of themselves. The reports that have so far come back on their performance under fire establish this fact. They demonstrate that hams in uniform lose none of the ingenuity and perseverance characteristic of the amateur — that the radio man is as good a fighting man as they come.

Trouble is that these reports have been few and far between. We get a few, of course, in the mass of miscellaneous correspondence that flows daily into the Hq establishment. In general, however, our mail in this respect is more tantalizing than informative. Letters reporting "In the Services" names only what our curiosity by their hints of things seen and done. Now and then one of the brethren writes at greater length, and — censorship permitting — these communications find their way into our "Correspondence from Members" columns. But even these letters are prone to compress a month of guessed-at excitement in a casual paragraph.

The untold tales these letters imply but seldom reveal come close to verification when we happen to encounter in person a ham who has actually been there. ARRL President Bailey, who in the course of his Washington duties makes it a point to speak to every "sparks" he sees, commented recently on the vivid action reports now being brought back by men returning from overseas duty.

And vivid reports they are — especially vivid now in their freshness and detail. Fresher and more detailed than they will be a few months or even weeks hence, when time and the crowding of new experiences will have diluted recollection.

Combat Stories Wanted for QST

These are the kind of reports we'd like to have — in all their freshness and vividness and detail. We want them at first-hand or second-hand or even third-hand — but we want them. We want them for publication in *QST* where that is practicable within the limitations of censorship and available space — but we want them under any conditions.

To be specific about it, we want such reports for the following purposes:

1) To be passed along to the rest of the gang for their information and inspiration, via *QST*.
2) To be collated and preserved as a detailed extension of amateur radio's war-service record, against the post-war need to establish the amateur's case.

3) To be made part of the basic historical record of the amateur's rôle in World War II.

This, then, is a plea to you who are living the substance of such stories to write us of your experiences. It is also a plea to those of you who can report the experiences of others.

There will be some reports, we know, containing details which cannot be released for publication. These we solicit along with those which can be told, however — with the assurance that any

U. S. War Bonds for Stories of War Service

QST wants reports on the experiences of radio hams in active service on the battle fronts — for immediate publication, where feasible, or to be held confidential where security considerations so require.

Do you have a story of war service to tell — either your own or that of some amateur you know? Then sit right down and write us a letter giving full details, including photographs, clippings and other substantiating data where available. If your story is published in *QST*, you will receive a \$25 U. S. War Bond.

For the kind of material required, read the accompanying article. Please indicate clearly on the report if it is available for publication in its entirety, if names, dates or places should be deleted before publication, or if all information must be held confidential.

That's all there is to it — write us a letter relating your own war-service experience or the record of someone you know. If it is published, you'll receive your \$25 War Bond in return.

details labelled restricted will not be published. Reports designated as confidential will be held in strictest secrecy. We'll lock them in a vault for the duration or until the time comes when they can be released — or forever, if you so instruct. Stories which can be told now only by withholding names and dates and places will be so handled. And we won't slip up — we guarantee you that.

So send them along, those accounts of the things you've seen and done, in any form or any fashion, diary-wise or typed report or scribbled note — it doesn't matter. Send them now, while your recollection is still clear and fresh. Don't be concerned lest the incidents seem trivial or routine; we want the heroic dramas and the inside stories of historic events, of course, but we also want the human-interest stuff, the common-places that delineate life as it is lived in a foxhole or the radio room of a "tin can."

We want stories from all the theatres of war and from all branches of the services — from the Army and the Navy, from the Air Forces and the Marines, from the Coast Guard and the Merchant Marine. We want stories like that of the 22-year-old radioman on the bomber that flew MacArthur out of the Philippines, who went on nearly a hundred missions and became the most-decorated U. S. enlisted man . . . stories like that of the maritime op with one arm and a game leg who took his station in the radio room of the torpedoed merchantman S. S. *Venore* and called the avenging destroyers and planes until the gray waters reached up for him, alone on his doomed ship. . . .

There are tales that can be told only by a fellow's buddies. You don't hear them from the man himself; he's not alive to tell them. These are the third-person stories we want — and it's a debt to the memory of a heroic comrade you'll be paying when you see that we get the facts so that fitting tribute may be rendered.

But we also want the other kind, too — the anecdotes and the personal-experience narratives, the odysseys of global warriors and the trenchant humor of the barracks.

A W5 in the Fijis

We want stories like that of Sergeant Johnny Adel. This 23-year-old ham, a pillar of the San Antonio Radio Club, joined up with the Signal Corps in April, 1941. He progressed rapidly to corporal and then to sergeant — and that was the last anyone in San Antonio heard of him until the end of 1942.

Then word came — a brief report from a California ham just returned from the Fiji Islands. This ham — Dick Joslin was his name — had run into Johnny down there in the South Pacific, and between sniping raids they'd had a long ragchew about the old ham days. The Californian wasn't there long, and he wasn't allowed to bring letters out. But he did bring souvenirs — two pieces of Japanese currency and a snapshot taken in the Fijis. These, of course, were promptly dispatched to Johnny's mother in San Antonio — the 10-yen note, handsomely engraved on fine blue paper,

the other note, printed in English on cheaper blue paper and supposedly worth a shilling in Jap-occupied English-speaking territory, and the photograph of Johnny in his Fiji Island hut.

The money, it seems, had come from the pockets of one of three Jap soldiers Johnny had just captured. For a young squirt, he'd been doing pretty well. Not only was he now a top-rated Signal Corps radio technician, but in frequent



hand-to-hand combat with the treacherous Jap snipers he'd more than held his own.

That's all we know about Johnny Adel — now. We'd like to learn the rest of his story some day. We hope someone will write and tell us about him — and about the dozens of other Johnny Adels around the Pacific from Dutch Harbor to Darwin, and on all the other fronts, as well.

Ham Films the War in the Pacific

They don't have to be stories about men in the Signal Corps — or even in the Army or Navy. They can be stories like that of Jack Rice, W6RTH, who as an Associated Press war photographer has dodged more shells than many a man in military service. The only civilian photographer present when General Jimmy Doolittle's sixteen bombers, Tokyo-bound, took off from the carrier *Hornet*, his shots of the historic flight were those you saw in the newspapers when the story of the Tokyo raid was released a year later.

That was only one of the many key war stories in the Pacific theatre recorded by Jack Rice's cameras. In December, 1941, he was on the first convoy to leave San Francisco for Honolulu. Already an ace news photographer at 32 — he'd been with the AP for five years, following a six-year hitch with the *Dallas News* — he was on the scene at the tide-turning Battle of Midway. He covered the Marshall Islands raid and the Coral Sea battle. During the Marshall raid the cruiser he was aboard fought off twenty-one air attacks in the space of two hours, suffering one direct hit which almost but not quite added W6RTH to that month's list of Silent Keys.

From August through November of 1942 Jack was with a task force patrolling the South Pacific — the task force which included the carrier *Wasp*. He was there when the *Wasp* was sunk. He made a number of bomber flights over the South Pacific, and two visits to Guadalcanal when the fighting was heaviest. Those Guadalcanal assignments

were perhaps the toughest of all — struggling ashore through the surf, carrying a pack filled with photographic gear 15 lbs. heavier than those even of the rugged Marines in the landing parties. And, as if dodging bombs and bullets were not enough, there was the constant struggle to keep

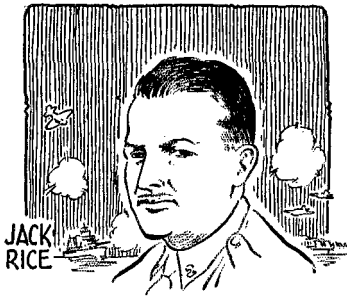

the cameras in working order — fighting the salt air that corroded the shutters, dampness that mildewed bellows and frame, tropical fungi that beclouded lenses.

W6RTH turned up in San Francisco for a brief visit a couple of months ago, following hospitalization in Hawaii for an infected throat. He was on his way back to the battle fronts then; they couldn't keep him away. By now, no doubt, many another thrilling chapter has been added to his story.

True, Jack Rice's yarn wouldn't be radio. But we're sure it would be a fascinating one, all the same. And, being the keen ham he is, we're certain W6RTH managed to see plenty of radio gear in action during his camera-viewing of the South Pacific. Anyway, his is the kind of story we'd like to have.

A Ham Commando in Timor

Here's one more example of the kind of story we want — perhaps the most gallant story of ingenuity and courage that has so far come out of this war. The story as told here is pieced together from a variety of sources, but chiefly from dispatches and broadcasts by war correspondent Bill Marien (of the Australian Broadcasting Co. and *Time* magazine).

It is the story of M. L. "Joe" Loveless, VK7ML, and four unidentified fellow-Tasmanian radiomen.

The story begins back in the first days of 1941. At that time — who will ever forget? — the Japs were in the full sweep of their crushing onslaught.

Joe Loveless and his buddies were the radio detail of a small outfit of Australian commandos called the Sparrow Force. The Sparrows were sent to Portuguese Timor, athwart the pathway to Australia, 450 miles from the Australian mainland. Their orders were to hinder the enemy advance as much as possible. How they carried out those orders is one of the epic tales of the war.

Piece by piece in January and February the Dutch and British bases were overwhelmed. Malaya and Singapore fell. Relentlessly the in-

vading hordes pushed nearer. On February 19th the Japs reached Timor, striking simultaneously at Kupang and at Dilli, the capital. At the same time they raided Darwin to blanket air support and cut off reinforcements.

For three hours the Australian and Dutch troops opposed the Japanese landing at Dilli, but the Japs came ashore in overwhelming force from their three transports, covered by a cruiser and a destroyer. Making a last stand at the air field, twenty Aussies held off five hundred Japs for six hours more, blowing up the runways and buildings before withdrawing.

Finally, outnumbered a hundred to one, the commandos took to the hills. Heavy equipment and surplus clothing were destroyed. They had their rifles, a few machine guns, plenty of ammunition (with additional caches strewn through the hills) — and 400 miles of open sea at their backs.

There had been casualties, but not many. The Sparrows were still a fighting force, and they still had the will and the tools to fight.

But their bases were gone and they were entirely isolated. Their radio station was wiped out. Only the wreckage of a small transmitter remained — useless junk that they nevertheless had dragged with them as one of the indispensables on that agonizing forced retreat.

And communication was the one vital need. Indeed, in the final analysis, their only hope was radio contact with Darwin.

In the face of that imperative need, Joe Loveless and his four pals went to work. They had the remnants of their wrecked transmitter — and that was all. No power, no replacement parts or tubes, not even tools.

Then came a godsend. Over 40 miles of enemy-infested terrain, scouting parties hauled back to the camp two badly mangled broadcast receivers salvaged from Jap-despoiled native huts.

They schemed and tinkered. They collected scraps of wire, solder, odd pieces of tin. Lacking a soldering iron, they used a bamboo soldering stick heated in a bed of covered coals. Even that was risky business, for no tell-tale spiral of smoke must escape.

After days and weeks a receiver emerged. No longer now entirely cut off from the world, they gathered fragmentary reports of the Japanese conquest, the overrunning of the Netherlands East Indies. Rumors came of the conquest of Australia itself — but these the receiver helped to dispel.



THEY SHOT UP ENEMY PATROLS A HUNDRED TIMES THEIR SIZE

Odds 100 to 1

Meanwhile, living in their mountain hide-outs like natives, the Sparrows fought on. By day they sweltered under the tropical sun; at night they shivered as the clouds came down over the hills. Often they were within half an hour's march of the enemy; never were they beyond the threat of attack.

But always they fought. How they fought! Developing perhaps the most aggressive brand of kill-and-run fighting this war has seen, remorselessly they harried the Japanese — blowing up bridges, mining roads, bombing camps, sniping off Jap officers, shooting up enemy patrols a hundred times their size.

Day by day the guerrilla warfare went on. Joe Loveless and his pals did their share along with the others — stalking alone into enemy camps, firing from the hip with tommyguns, killing Japs. But always they found a little time each day to work on the radio gear. . . .

Finally, nearly two months later, there evolved a transmitter. Haywire, built in a four-gallon kerosene tin around one of the salvaged b.c. receiving tubes — but it would oscillate.

All they lacked now was power. They had a storage battery, but it was dead. They attempted to improvise a charger from a discarded automobile generator geared to a hand-turned wooden wheel. It worked, after a fashion, but when they tried it the voltage wasn't high enough to charge the battery.

VK7ML and his companions didn't have much time to feel sad about their wasted labor, however. Somehow the Japs had located their camp, and that night they attacked. Hurriedly collecting their precious gear, the five radiomen joined the rest of the commandos, hastily evacuating the camp for a new hideout.

But that raid provided inspiration. If the Japs could raid the Aussies, the Aussies could raid the Japs. And the Japs had electrical equipment, hadn't they? A couple of night commando raids behind the Jap lines — and Joe Loveless and his crew had an engine-driven Japanese battery charger and the fuel to run it.

During all this time, of course, the Australian mainland believed that resistance on Timor had ceased. When contact had been lost back on the night of February 19th, the Australian military leaders assumed the Sparrows were all either killed or captured.

They were due for a great surprise.

On the Air

On April 19th, just 59 days after Dilli fell, the Timor transmitter went on the air. Hand shaking a little, Joe Loveless called Darwin. He waited. There was no answer. Despite the fatalistic resolve distilled in him by those 59 perilous days, it was an effort to touch that key again. But he did call a second time.

This time Darwin answered. Flooded with elation, 7ML pounded out his startling news. Triumphantlly he announced that the Japs had

not subdued Timor after all, that the AIF commandos were fighting on.

After his "K" there was a pause — silence. Had Darwin lost the signal? The suspense was crushing.

Then the answer came. The Australian officials, unable to credit the news that the Sparrow force was still intact and fighting, were suspicious. They demanded confirmation:

IS JACK SARGENT THERE?

YES HE IS

WHAT IS HIS WIFE'S NAME?

It took a moment to get the information. Then Joe Loveless staccatoed back:

KATHLEEN

Their credentials thus established, Darwin eagerly took their traffic. There wasn't much:

FORCE INTACT STILL FIGHTING BADLY
NEED BOOTS QUININE TOMMYGUNS AM-
MUNITION

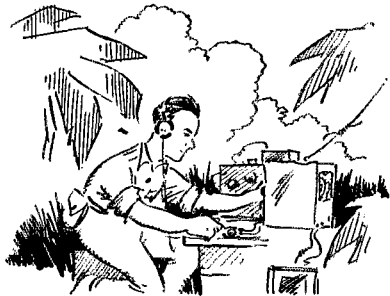

LOVELESS CALLED DARWIN. HE WAITED. THERE WAS NO ANSWER.

That was all. Darwin R'd and SK'd and wished them luck, and they signed off.

The five radiomen on Timor sat back in silence. Then, "How about a smoke?" one of the crew asked. Joe Loveless pulled a sigh from the toes of his boots and nodded. Solemnly, the five radiomen filled their pipes in turn. It was their last tin of tobacco, faithfully preserved through all those days. Lighting up, they celebrated their success.

That, of course, is not the end of the story. The supplies VK7ML had requested were flown in, and the Sparrows went on with the business of killing Japs. They ambushed four enemy officers and fifty men. They dynamited bridges and burned camps. Living on buffalo meat and sticky rice, they patrolled night and day. They sniped and rushed and potshot until, five months later, their net score was more than five hundred Japs killed, against only three Sparrows lost.

At last reports they were still at it — and VK7ML's improvised haywire rig was still chirping periodic reports back to headquarters in Darwin. They'll still be there when the last Jap on Timor is dead.

You can count on that — just as you could count on a ham's skill at improvisation to create a radio station out of worthless scrap.

— C. B. D.

HAPPENINGS OF THE MONTH

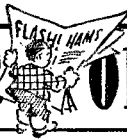

W.E.R.S. AMENDMENTS

At the suggestion of the Board of War Communications, FCC on June 22nd made the following amendments to the WERS regulations to permit civilian-defense stations to provide essential communication for effective protection of life and important property from fire and other disasters:

Modify Section 15.24 by *deleting* the words "be required to" in the second sentence of this Section.

Modify subsection (a) of Section 15.25 by *adding* the words "during operation" after the term "without readjustments" which appears in parentheses.

Modify subsection (g) of Section 15.31 to read:

(g) Signature and title of person maintaining log record. *Provided, however,* That operation in a blackout or during an emergency endangering safety of life or important property, such record of operation shall be reduced to writing at the earliest opportunity and in such detail as may be practicable.

Modify Section 15.54, adding the term "unit" after the term "station" in each instance, so that this section will read:

15.54. *Availability of station license.* — The original license shall be associated with the station unit normally in control of all station units covered by the license, and photocopies of the original license provided by the licensee shall be associated with each of the other station units covered by the license. The original and all photocopies shall be readily available for inspection at any time by an authorized government representative.

Modify Section 15.63, to increase the scope of service, so that this section will read:

15.63. *Service which may be rendered.* — (a) Civilian defense stations may be used during emergencies endangering life, public safety, or important property, for essential communication relating to civilian defense or national security. Civilian defense station licensees, when requested in specific instances by the licensee of any State Guard station or the licensee of any Civil Air Patrol station, may use their licensed civilian defense stations for essential communication with such State Guard or Civil Air Patrol station(s), during emergencies endangering life, public safety, or important property. Civilian defense stations shall not be operated on board any aircraft unless specific authority for such operation has been granted by the Commission upon showing of need therefor.

(b) Upon application and showing of need therefor, individual control units may be authorized to communicate during the first 15 minutes of each hour with control units of the same licensee or other licensees, and with other units of the same licensee, for the exclusive purpose of handling essential communications preparatory to any anticipated emergency involving the safety of life or important property in connection with civilian defense or national security. Units other than control units may transmit, for this purpose, only when directed to do so by an authorized control unit of the same licensee. When operating under this provision, each unit shall comply with operating instructions given by the authorized control unit. The use and operation of control units as provided in this subsection shall be discontinued during such periods as may be deemed necessary by the licensee in order to avoid interference to any tests or drills being conducted in accordance with sections 15.75 and 15.76 of these rules.

Adopt two new sections as follows:

DEFINITIONS

15.5. *Control unit.* — The term "control unit" means any station unit licensed in the War Emergency Radio Service and designated by the licensee, with the approval of the radio aide or communications officer, to direct the use and operation of other station units of the same licensee which, together with the control unit so designated, constitute a coordinated communication system.

LICENSES

15.56. *Service for U. S. Government.* — During emergencies endangering the safety of life or property, the licensee of any station in the War Emergency Radio Service may use any licensed unit of such station to provide essential communication for the United States Government, when requested to do so by the government department or agency concerned, *Provided,* that a written notice of such operation, including designation of the source of the request, is sent within twenty-four hours after the commencement of such operation to the inspector in charge of the radio district in which the station is located, and a copy of such notice is sent to the Federal Communications Commission in Washington, D. C.

The League's Board asked FCC to add a permanent Monday night test period for WERS. On June 8th the Commission granted the request and went the Board one better by making the Wednesday period permanent through the life of the license, instead of existing only during the first three months. We now have three two-hour test periods per week. The amended section of the FCC rules now reads as follows:

Sec. 15.75. *Tests* — The licensees of civilian defense stations are permitted to make such tests as are necessary for the purpose of maintaining equipment, making adjustments to insure that the apparatus is in operating condition, training personnel, and perfecting methods of operating procedure, *Provided,* That such tests shall be conducted only during the following periods:

Time Zone	Eastern	Central
Mondays	10 P.M.-12 mid.	9 P.M.-11 P.M.
Wednesdays	10 P.M.-12 mid.	9 P.M.-11 P.M.
Sundays	5 P.M.- 7 P.M.	4 P.M.- 6 P.M.

Time Zone	Mountain	Pacific
Mondays	8 P.M.-10 P.M.	7 P.M.-9 P.M.
Wednesdays	8 P.M.-10 P.M.	7 P.M.-9 P.M.
Sundays	3 P.M.- 5 P.M.	2 P.M.-4 P.M.

Mountain	Pacific
8 P.M.-10 P.M.	7 P.M.-9 P.M.
8 P.M.-10 P.M.	7 P.M.-9 P.M.
3 P.M.- 5 P.M.	2 P.M.-4 P.M.

All times given are local standard (war) time.

A.R.R.L. PLANNING COMMITTEE

THE ARRL Board of Directors established a Planning Committee at its recent annual meeting "to prepare a plan designed to secure the return of amateur frequencies as they existed before the war." President Bailey, after careful consideration, has announced his selection of the membership of this committee. Chairman is Vice-President Charles E. Blalack, W6GG, who, amongst his other qualifications, will represent

the viewpoint of the far western part of the country. The other members are Major H. L. Caveness, USA, W4DW, and Lt. G. L. Dosland, USNR, W9TSN. Major Caveness is a long-term director, a member of the Finance Committee, and represents the viewpoint of the southern part of the country. Lieutenant Dosland represents our largest division, the Central. President Bailey will be a member of the committee, ex-officio. The group is representative of the Board and should be able to combine effectively to carry out its assignment.

AMATEUR WAR SERVICE RECORD

WE'RE still at it, compiling that Headquarters record of what the amateur is doing in the war — we're going to need it later. On this page is a convenient form which you may cut out, or whose essentials you may duplicate on a post card. The dope on you belongs in our file and is also what maintains our department for those "In The Services." But note also that we are expanding our records to take in amateurs who are applying their skill in the radio and electronic manufacturing industry, providing their personal labors are 100 per cent devoted to war work.

Wherever you are in the war effort, please report yourself to ARRL.

STAFF NOTES

THE wartime Headquarters staff has been bolstered by the addition of Hollis M. French, W1JLK, on a year's sabbatical leave from the Methodist ministry and presently an Assistant Secretary of the League. "Deke," as he is universally known, is not only an amateur since 1910 but a pioneer v.h.f. man and one of the founders of the Connecticut Valley Horse-trader's net, as mentioned in more detail in Ed Tilton's column this month. Also OPS, EC, and holder of a citation for distinguished work in the 1936 flood. To join us, he had to resign two positions as WERS radio aide, one for

Massachusetts Region 6-A and one for his own town of Easton, Mass., WJQI, where he also taught two classes to qualify as WERS operators.

We charge up to D. Cupid the loss from our staff of Miss Barbara Messinger, for the past eight months Secretarial Assistant in charge of amateur war records and the "In The Services" department of *QST*. She is now becoming Mrs. Ensign Richard Crampton, USCGR. Miss Ethel L. Burnham has taken over this work and now signs the letters received by you boys and girls in the services. (See page 23 of July *QST*.)

The Walter E. Bradleys, he of W1FWH and the ARRL Technical Information Service, rejoice in the arrival of a new junior operator.

OPERATOR MODIFICATIONS

Now that operator licenses have been reinstated and given a long-term extension, some amateurs are worrying about the need to apply for modification because they have changed address. (Haven't we all!) No worry. We quote FCC on the subject:

"The validity of an operator license is not limited to a single location, and hence it has never been the practice to modify or reissue such a license due solely to change of address."

RADIO PRODUCTION

IT IS easy to say that every military unit in this war must be equipped for radio communication, but rather difficult to visualize what this may mean in dollars. We remember reading some months ago that radio deliveries to the Signal Corps were averaging about a million dollars a day, but our brain simply refused to go to work with that figure. We can't imagine what a million dollars' worth of radio apparatus looks like.

Some more startling statistics were announced at the recent RMA War Production Conference, by Director Ray C. Ellis of the WPB Radio & Radar Division. He stated that in the past year the production of war radio and radar gear has

AMATEUR WAR SERVICE RECORD

Name

Present mailing address

Rank or rating

Branch or bureau: Signal Corps, AAF, Buships, WAVES, etc.
If civilian industry, give title and company.

Call, present or ex; or grade of op-license only

SERVICE

- Army
- Navy
- Coast Guard
- Marine Corps
- Maritime Service
- Merchant Marine
- Civil Service
- Radio industry, 100% war

ARE YOU LICENSED?

When joining the League or renewing your membership, it is important that you show whether you have an amateur license, either station or operator. Please state your call and/or the class of operator license held, that we may verify your classification.

advanced from \$35 million a month to \$250 million a month, and that the military radio program for the coming year calls for the production of \$4 billions' worth. In urging top speed and the highest degree of cooperation, Mr. Ellis said, "The enormity of our task is so great that it can hardly be conceived. The production of one order for a single type of radar model exceeded in value the entire cost of the Boulder Dam hydroelectric project." We recall reading somewhere a good many months ago about the purchase up to that date of \$7.7 billions of communications apparatus.

We still don't know what these figures mean, but we're sure that they imply the existence, at the end of this war, of an awful lot of radio equipment. We just made a rough calculation on our scratch pad, in terms of what it cost us the last time we rebuilt, and come up with the answer that this money would provide every amateur in the world with 240,625 complete 500-watt stations. What worries us is what to do about that odd 0.625 of a station!

EXECUTIVE COMMITTEE MEETINGS

FOLLOWING is an abstract of the actions of the Executive Committee of the League during the past year between Board meetings, as ratified by the Board at its recent meeting, here published for your information by order of the Board:

Meeting No. 174, Sept. 17, 1942. Authorized Assistant Secretary John Huntoon to sign checks on League depositories on behalf of the Secretary; rescinded previous such authorizations of A. L. Budlong and C. B. DeSoto.

Meeting No. 175, Oct. 16, 1942. Authorized Assistant Secretary Charles A. Service, jr., to sign checks on League depositories on behalf of the Secretary; rescinded previous such authorization of John Huntoon.

Meeting No. 176, Nov. 4, 1942. Examined nominations in regular autumn elections, determined eligibility of candidates, ordered eligible names listed on ballots. In cases where there was only one eligible candidate, declared him elected without balloting. Where there was no eligible candidate, ordered further solicitation of nominations. Affiliated four clubs.

Meeting No. 177, Dec. 22, 1942. Canvassed balloting in regular autumn elections, determined and certified the winners. Affiliated one club.

Meeting No. 178, Jan. 26, 1943. Examined nominations in delayed elections in two divisions, determined eligibility of candidates, ordered eligible names listed on ballots. In one case where there was only one eligible candidate, declared him elected without balloting.

Meeting No. 179, Mar. 22, 1943. Canvassed balloting in delayed election for alternate director of Northwestern Division, certified R. Rex Roberts, W7CPY, as elected.

NOTICE TO MEMBERS DISCHARGED FROM THE MILITARY SERVICES

ARRL by-laws have been amended to preserve your eligibility to hold ARRL offices, insofar as there is a requirement for continuous membership which may have been interrupted while you were in uniform, provided you resume your membership within ninety days after release from active military duty. See further particulars on page 24 of last *QST*. Those desirous of taking advantage of this arrangement are asked to claim the right when renewing membership, stating the beginning and ending dates for their military service. The arrangement applies only to those serving for the United States, and cannot be made retroactive for those who have already been out of military duty for more than the prescribed ninety days.

P.O.W.

G5WG, L/Cpl. George Wakefield, R.S., of Wrayburg, Middlesex, is reported being held as a prisoner of war in Italy.

G8SS, of Queensborough, formerly reported as missing, is now a prisoner of war in Java.

Missing in Action

Paul E. Hope, W1KOO, of Orleans, Vt., has been reported missing in action by the U. S. Navy.

Silent Keys

It is with deep regret that we record the passing of these amateurs:

W1AEF, William H. Blake, Hampton, N. H.

W3FIG, John Lewis Wantz, Camp Hill, Penna.

W7HBC, Fred Rose, Everett, Wash.

W8PMB, Karl M. Pohlman, Cleveland, Ohio.

W8TQA, Jesse E. Moore, Detroit, Mich.

W8VQB, Donald R. Poston, Columbus, Ohio.

W9EI, Joseph Caldwell Anderson, Lexington, Ky.

W9PKE, J. William Jacobson, Racine, Wis.

W9VBI, Sgt. Albert C. McArthur, U. S. A., Villa Park, Ill.

VK3PL, James F. Colthrup, Clifton Hill, Vic.

XE1GE, Dr. James M. B. Hard, Cuernavaca, Mexico.

Notes On Transmission Lines

Use of the General Equations in Determining Line Properties

BY HARRY E. STEWART,* W3JXY

Transmission lines have other uses at radio frequencies than the transfer of power from one point to another. These additional functions become evident from a study of the general properties of such lines, as outlined by the author in the accompanying article.

THE amateur usually is concerned with the use of transmission lines primarily for transferring r.f. power from his transmitter to his antenna system, and gives them little more thought than he does the power transmission line supplying the "rig" with 60-cycle power. In the case of tuned lines, he realizes that the length of the line is important in getting the antenna system to absorb the r.f. power from the transmitter, and accordingly varies the length until the system will "load." He is also aware that the circular mil area of the wire should be sufficiently great to handle the r.f. current efficiently. In the case of untuned lines, he is cognizant of the fact that the impedance of the line should equal that of the antenna it feeds; if it doesn't, then standing waves exist on the line. The match need not be exact, because slight mismatching of impedances does not greatly impair the efficiency of the line; the degree of mismatch permissible depends on the length of line, the characteristic impedance of the line, and the resistance of the wire or conductor comprising the line.

But, in addition to serving as a means for transferring power, the transmission line possesses other very important properties: short-circuited and open-circuited sections of line can be used as either inductive or capacitive reactance devices of extremely high quality; odd quarter-wave sections can be used as impedance-matching transformers and half-wave sections as one-to-one ratio transformers; and sections of line several wavelengths long (commonly referred to as Lecher wires) can be used for measuring wavelength at the very-high and ultrahigh frequencies.

General Equations for Transmission Lines

It is the intent of this paper to indicate how some of these properties can be deduced from the general equations of the transmission line. The fundamental equations may appear somewhat formidable to those not possessing an engineering training, but fortunately they can, for specific cases, be reduced to simple expressions which can be handled by those only having a knowledge of

*241 Mountain View Ave., Vallejo, Calif.

algebra. The general equations for the voltage, E_s , the current, I_s , and the impedance, Z_s , at the sending (or input) end of the line are:^{1,2}

$$I_s = I_r \cosh \gamma l + \frac{E_r}{Z_o} \sinh \gamma l \quad (1a)$$

$$I_s = \frac{E_r}{Z_r} (\cosh \gamma l + \frac{Z_r}{Z_o} \sinh \gamma l) \quad (1b)$$

$$E_s = E_r \cosh \gamma l + I_r Z_o \sinh \gamma l \quad (2a)$$

$$E_s = E_r (\cosh \gamma l + \frac{Z_o}{Z_r} \sinh \gamma l) \quad (2b)$$

$$Z_s = \frac{E_s}{I_s} = \frac{E_r \cosh \gamma l + I_r Z_o \sinh \gamma l}{I_r \cosh \gamma l + \frac{E_r}{Z_o} \sinh \gamma l} \quad (3a)$$

$$Z_s = Z_o \left[\frac{\cosh \gamma l + \frac{Z_o}{Z_r} \sinh \gamma l}{\frac{Z_o}{Z_r} \cosh \gamma l + \sinh \gamma l} \right] \quad (3b)$$

where (refer to Fig. 1)

E_s is the voltage impressed across the sending, or input, end

I_s is the current flowing at the sending, or input end

E_r is the voltage developed across Z_r at the receiving, or load, end

I_r is the current flowing through Z_r

Z_s is the input impedance, i.e., E_s/I_s

Z_r is the load impedance, i.e., E_r/I_r

Z_o is the characteristic impedance, or surge impedance, of the line

l is the length of the line in meters

$\gamma = (\alpha + j\beta)$ the propagation constant of the line

β = the wavelength, or phase-shift, constant

σ = the attenuation constant in nepers per meter length of line

$j = \sqrt{-1}$ is the operator indicating a 90° shift in phase: $+j$ indicates an inductive condition; $-j$, a capacitive one.

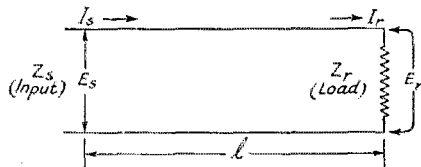

Fig. 1 — Terminated transmission line, showing the quantities under discussion.

¹ Everitt, "Communication Engineering," McGraw-Hill Book Co., New York.

² Woodruff, "Electric Power Transmission and Distribution," John Wiley & Sons, New York.

The characteristic impedance, Z_0 , is familiar to all amateurs, and for two-wire open-air and concentric lines at radio frequencies is given closely by the expressions:

$$Z_0 = 276 \text{ Log } \frac{2S}{d} \quad (\text{for two-wire}) \quad (4a)$$

$$Z_0 = 138 \text{ Log } \frac{b}{a} \quad (\text{for concentric}) \quad (4b)$$

where

S and d are respectively the spacing between the wire centers and the diameter of the wires in any units

b and a are respectively the inner diameter of the outer conductor and the outside diameter of the inner conductor in any units.

The propagation constant, γ , may need a word or two of explanation. It consists of two components: a real component, α , called the attenuation constant, and an imaginary component, β , called the wavelength, or phase-shift, constant. It is defined by the relation

$$\gamma = \alpha + j\beta \quad (5)$$

where α is equal to

$$\alpha = \log_e \frac{I_1}{I_2} \text{ nepers per meter} \quad (6)$$

(when l is measured in meters). This constant is what its name implies: it indicates the amount of attenuation in the line per meter of length. The neper is a unit of attenuation similar to the decibel, and the relationship between the two units is:

$$\text{one decibel} = 0.115 \text{ nepers}$$

or

$$\text{one neper} = 8.686 \text{ decibels}$$

In most instances, the shunt conductance of the line is negligible and the attenuation constant in terms of the line constants is, to a close approximation,

$$\alpha = \frac{R}{2Z_0} = \frac{R}{2} \sqrt{\frac{C}{L}} \quad (7)$$

where

R is the resistance of the line per meter

L is the inductance of the line per meter

C is the capacitance of the line per meter

Equation (7) indicates two very important features: (1) the greater the characteristic impedance, Z_0 , the lower is the attenuation; in other words, a 600-ohm line of a given wire size offers only one-half as much attenuation as a 300-ohm line constructed from the same size wire; and (2) the attenuation of a line varies directly as the resistance, R , of the wire, or conductor, from which the line is made.

The wavelength constant, β , produces a shift in phase but not in magnitude; it is defined by the relation

$$\beta = \frac{2\pi}{\lambda} \text{ radians per meter} \quad (8a)$$

when λ is in meters. A close approximation for β in terms of the line constants is

$$\beta = 2\pi f \sqrt{LC} \quad (8b)$$

The "sinh" and "cosh" terms in equations (1), (2), and (3) are the hyperbolic sine and cosine respectively, and they are defined as

$$\sinh x = \frac{e^x - e^{-x}}{2} \quad (9a)$$

$$\cosh x = \frac{e^x + e^{-x}}{2} \quad (9b)$$

where e is the base of the Napierian logarithms and is equal to 2.7183. These functions are convenient for simplifying expressions where two waves traveling in opposite directions are encountered, i.e., where there is an incident, or direct, wave and a reflected wave. These terms will be eliminated in the equations that follow, so those who are not familiar with them will not be perplexed by their presence.

The Transmission Line as a High-Q Reactance

The term Q is used to indicate the quality of a reactor — it is a figure of merit. The higher the value of Q , the higher the quality of the reactor. Q is defined as the ratio of reactance to resistance, or

$$Q = \frac{X}{R} = \frac{2\pi fL}{R} = \frac{1}{2\pi fCR}$$

A perfect inductance coil would be one in which the resistance of the windings is zero, giving a Q equal to infinity, and a perfect condenser would be one in which the dielectric loss is zero, yielding an infinite value for its Q .

At the very-high and ultrahigh frequencies obtaining a high- Q reactance — which is so necessary in securing good frequency stability in oscillators and high selectivity in receivers — becomes increasingly difficult as the frequency increases. Fortunately the transmission line can be used quite conveniently as a means of obtaining high Q s for these frequencies; the lengths of quarter- and half-wave sections in these instances are sufficiently short to allow them to be easily incorporated into circuits.

Short-Circuited Line

The short-circuited line is commonly used in the circuits of oscillators and amplifiers operating at very high and ultrahigh frequencies. The properties of different lengths of line for this condition can be easily determined from equation (3a) by assigning a value of zero for the voltage across the load, i.e., E_r equals zero, since Z_r for a short-circuit condition is equal to zero. Equation (3a) then reduces to

$$Z_s = Z_{sc} = \frac{I_r Z_0 \sinh \gamma l}{I_r \cosh \gamma l} = Z_0 \tanh \gamma l \quad (10a)$$

where Z_{sc} represents the input impedance for the short-circuited line, and $\tanh \gamma l$ is the hyperbolic tangent.

In most cases the attenuation constant, α , can be considered as zero, since the resistance is very low, simplifying the expression for Z_{oc} to

$$Z_{oc} = jZ_o \tan \beta l = jZ_o \tan 2\pi l/\lambda \quad (10b)$$

The hyperbolic tangent³ has been replaced by the tangent, and the operator j indicates that the impedance is reactive.

To demonstrate the use of equation (10b), consider a line $3/16$ -wavelength long, having a characteristic impedance, Z_o , of 200 ohms:

$$\begin{aligned} l &= 3/16 \\ Z_o &= 200 \text{ ohms} \\ Z_{oc} &= j(200) \tan (2\pi/\lambda) (3\lambda/16) \\ &= j(200) \tan 3\pi/8 \end{aligned}$$

and remembering that π radians equals 180°

$$\begin{aligned} Z_{oc} &= j(200) \tan 67.5^\circ = j(200) (2.4142) \\ &= j 482.84 \text{ ohms} \end{aligned}$$

Since j is positive, the reactance is inductive.

It is possible to determine how the reactance of a short-circuited line varies with the line length by assigning l various values in terms of the wavelength, λ , and solving for the reactance in terms of Z_o . Table I gives the values of reactance in terms of Z_o for both a short-circuited and an open-circuited line in intervals of a sixteenth wavelength up to a half-wave section.

The reactance curves for a short-circuited line, possessing a characteristic impedance, Z_o , of one ohm, are plotted in Fig. 2 for a line length up to one wavelength. The curves repeat themselves every half wavelength, indicating that the length of a short-circuited section of line can be increased in integrals of a half wavelength without affecting the reactance. The curves were plotted for a one-ohm line, because the reactance for any line can then easily be computed by multiplying the value obtained from the curves by the characteristic impedance of the line under consideration.

When the line length is equal to any odd quarter wavelength, i.e., $\lambda/4, 3\lambda/4, 5\lambda/4$, etc., a condition of anti-resonance exists in which the line behaves like a parallel-resonant circuit, and the impedance, Z_{oc} , is a pure resistance. In this case it is not possible to ignore the losses in the line, since these losses become the determining factor in the evaluation of the parallel resistance. The resistance is given by the expression⁴

$$Z_{oc} = Z_o/\alpha l \quad (10c)$$

Substituting the value of α given in equation (7), the input resistance at anti-resonance becomes

$$Z_{oc} = 2Z_o^2/Rl \quad (10d)$$

When the line length is equal to any integral half wavelength, i.e., $\lambda/2, \lambda, 3\lambda/2, 2\lambda$, etc., a condition of resonance exists in which the line acts like a series resonant circuit. The input impedance is a pure resistance, and is equal to

$$Z_{oc} = Rl/2 \quad (10e)$$

³ $\tanh(\alpha + j\beta) = \tanh j\beta$ (when $\alpha = 0$), and $\tanh j\beta = j \tan \beta$.

⁴ Hansell and Carter, "Frequency Control," *Proc. IRE*, April, 1936.

Open-Circuited Line

The input impedance for the case of an open-circuited line can be derived from equation (3b) by making the load impedance, Z_r , equal to infinity

$$Z_o = Z_{oc} = Z_o \frac{\cosh \gamma l}{\sinh \gamma l} = Z_o \coth \gamma l \quad (11a)$$

where Z_{oc} represents the input impedance for the open-circuited line, and $\coth \gamma l$ the hyperbolic cotangent. Assuming the attenuation is negligible, the expression becomes⁵

$$Z_{oc} = Z_o \coth j\beta = -jZ_o \cot 2\pi l/\lambda \quad (11b)$$

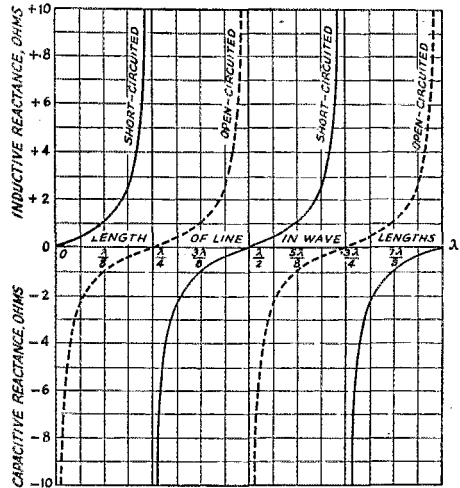

Fig. 2 — Reactance vs. length for a transmission line having a characteristic impedance of one ohm. Values for lines of other characteristic impedances can be found by multiplying the appropriate value taken from the curves by the characteristic impedance of the line.

The variance of reactance with line length is given in Table I and Fig. 2. Considering the line of the previous example as an open-circuited line, the reactance is calculated to be

$$\begin{aligned} Z_{oc} &= -j(200) \cot (2\pi/\lambda) (3\lambda/16) = -j 200 \\ &\cot 67.5^\circ = -j 82.84 \text{ ohms} \end{aligned}$$

and, since j is negative, the reactance is capacitive.

The curves in Fig. 2 will yield the same result: the reactance for Z_o equal to one ohm is 0.414 ohms capacitive reactance, and, multiplying this by 200, a value of 82.8 ohms is obtained. By using the curves, the need for looking up either the tangent or the cotangent is obviated. As in the case for the short-circuited line, the reactance of the open-circuited line repeats itself every half wavelength.

When the line length is any integral multiple of a half wavelength, i.e., $\lambda/2, \lambda, 3\lambda/2, 2\lambda$, etc., a condition of anti-resonance exists, and the line simulates a parallel-resonant circuit. The input impedance is a pure resistance, and is equal to

$$Z_{oc} = Z_o/\alpha l = 2Z_o^2/Rl \quad (11c)$$

⁵ $\coth(\alpha + j\beta) = \coth j\beta$ (when $\alpha = 0$), and $\coth j\beta = -j \cot \beta$.

TABLE I

<i>l</i>	$2\pi l/\lambda$		Short-Circuited Line		Open-Circuited Line	
	Radians	Degrees	Tan $2\pi l/\lambda$	Reactance	Cot $2\pi l/\lambda$	Reactance
0	0	0	0	0	— infinite	— infinite
$\lambda/16$	$\pi/8$	$22\frac{1}{2}$	0.4142	$0.4142 Z_0$	— 2.4142	— $2.4142 Z_0$
$\lambda/8$	$\pi/4$	45	1.0	Z_0	— 1.0	— Z_0
$3\lambda/16$	$3\pi/8$	$67\frac{1}{2}$	2.4142	$2.4142 Z_0$	— 0.4142	— $0.4242 Z_0$
$\lambda/4$	$\pi/2$	90	infinite	infinite	0	0
$5\lambda/16$	$5\pi/8$	$112\frac{1}{2}$	— 2.4142	— $2.4142 Z_0$	0.4142	$0.4142 Z_0$
$3\lambda/8$	$3\pi/4$	135	— 1.0	— Z_0	1.0	Z_0
$7\lambda/16$	$7\pi/8$	$157\frac{1}{2}$	— 0.4142	— $0.4142 Z_0$	2.4142	$2.4142 Z_0$
$\lambda/2$	π	180	0	0	infinite	infinite

The expression is the same as that for the short-circuited line, equations (10d) and (10e), but for a given frequency or wavelength the resistance at anti-resonance for a quarter-wave short-circuited line will be twice that for a half-wave open-circuited line, since the length of the former is just one-half that of the latter. Refer to equations (10d) and (11c).

When the line length is equal to any odd quarter wavelength, i.e., $\lambda/4, 3\lambda/4, 5\lambda/4$, etc., a condition of resonance exists in which the line acts as a series-resonant circuit. The input impedance is a pure resistance and is equal to

$$Z_{oc} = Rl/2 \tag{11d}$$

The resistance of a quarter-wave open-circuited line at resonance will be just half that for a half-wave short-circuited line, since the length of the former is one-half that of the latter.

Calculation of R.F. Resistance

The resistance of a conductor at radio frequencies is made up of three components: (1) skin effect; (2) proximity effect, and (3) radiation effect. The component due to skin effect is the most familiar of the three, and equations have been developed which enable its calculation at any frequency. The skin effect component of resistance for a copper conductor of circular cross-section is given by

$$R = \frac{0.00101 \sqrt{\text{Freq. in Mc.}}}{\text{diameter in inches}} \text{ ohms per foot} \tag{12}$$

Equation (12) is for a single copper conductor. The skin effect resistance for a two-conductor line, both conductors being of the same diameter, is given by

$$R_{\text{two-wire}} = \frac{0.00202 \sqrt{\text{Freq. in Mc.}}}{\text{diameter in inches}} \tag{13a}$$

ohms per foot.

In the case of a concentric line, two different conductor diameters, *a* and *b*, are involved, so the resistance per foot of line is equal to the sum of the resistances per foot of each conductor. The expression is

$$R_{\text{conc. line}} = 0.00101 \sqrt{\text{Freq. in Mc.}} (1/a + 1/b) \tag{14}$$

where *a* and *b* are in inches.

The component due to proximity effect is of importance in the open-wire types of lines where the diameters of the conductors are large and the spacings are small. There is no proximity effect component in the case of the concentric line. Reukema⁶ has developed a factor for determining the effect of proximity upon the resistance of conductors spaced closely. Applying this factor to equation (13a), the resistance per foot of length of a two-wire line becomes

$$R_{\text{two-wire}} = \frac{0.00202 \sqrt{\text{Freq. in Mc.}}}{d \sqrt{1 - (d/S)^2}} \tag{13b}$$

where *d* and *S* are the diameter and spacing in inches.

The radiation effect will not be included in this paper, because the determining of this component involves a great many considerations. Reference, however, is made to Reukema's article⁶ in which he has developed equations and curves for calculating the resistance attributable to radiation. At the ultrahigh frequencies, the radiation component of resistance may be the predominating factor — in fact, it may be several times as large as all other resistances combined. It is therefore highly desirable to limit the amount of radiation as much as possible. In the case of concentric lines, the radiation can be completely eliminated by having the outer conductor fully enclosed by the inner conductor. A line of this type⁸ is illustrated in Fig. 4-A, and it is observed that the inner conductor is completely shielded. In the case of the concentric line of Fig. 4-B, there is some controversy as to whether the short-circuiting plug in the end of the line radiates or not. Reukema contends that it does, and he derives expressions for the radiation resistance of such a line.⁶ On the other hand, Nergaard,⁷ in his paper, "Survey of U.H.F. Measurements," says: "Whether or not a concentric line has any radiation resistance at all except that due to an open end is a controversial point. However, the concentric lines used in this laboratory have always given higher anti-resonant impedances than equiv-

⁶ Reukema, "Transmission Lines at Very High Frequencies," *Electrical Engineering*, August, 1937.

⁷ Nergaard, "Survey of Ultrahigh Frequency Measurements," *RCA Review*, October, 1938.

alent parallel-wire lines, and no radiation from a concentric line with closed ends has ever been detected." The radiation resistance of a two-wire parallel line can be reduced by enclosing the line in a copper cylinder and grounding the cylinder. However, there is an increase in the ohmic resistance because of the coupling between the line and the cylindrical shield — i.e., eddy currents will flow in the shield and the loss will be reflected back into the line as a resistance.

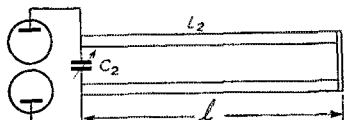

Fig. 3 — Typical push-pull tank circuit using a parallel-conductor line.

Example

An actual amateur problem might prove of value in illustrating the use of the equations discussed thus far. Consider the plate circuit of the 112-Mc. oscillator in Fig. 3, which was taken from Fig. 1526, page 316, in the 20th Edition of *The Radio Amateur's Handbook*.

In this case

$S = 1/2$ -inch center to center spacing of conductors

$d = 1/4$ -inch diameter of conductors (copper tubing)

$l = 15$ inches = 0.381 meters (length of line)

$f = 112$ Mc.

$\lambda = 2.68$ meters

Using equation (4a), the characteristic impedance, Z_0 , is computed to be

$$Z_0 = 276 \log \left(\frac{2 \times 0.50}{0.25} \right) = 166 \text{ ohms}$$

The reactance is found from equation (10b)

$$\begin{aligned} Z_{sc} &= j (166) \tan \left(\frac{2\pi \times 0.381}{2.68} \right) \\ &= j (166) \tan 51.2^\circ \\ &= 207 \text{ ohms inductive reactance} \end{aligned}$$

In order to tune the line to resonance, a capacitive reactance of 207 ohms will be required. The value of capacity can be calculated from the familiar relation (refer to page 29, 20th Edition of the *Handbook*)

$$X_c = 1/2\pi fC$$

and it is found to be 6.87 μfd . The capacity of the condenser, C_2 , must be less than this by an amount equal to that contributed by the tubes, leads, and the like.

The resistance of the line at 112 Mc. is given by equation (13b)

$$\begin{aligned} R &= \frac{0.00202 \sqrt{112}}{0.25 \sqrt{1 - (0.25/0.5)^2}} \\ &= 0.0989 \text{ ohms per foot} \\ l &= 15 \text{ inches} = 1.25 \text{ feet} \\ R \text{ of line} &= 0.0989 \times 1.25 = 0.1235 \text{ ohms} \end{aligned}$$

Since Q equals reactance divided by resistance, the Q in this instance (neglecting loading and radiation resistance) is

$$Q = \frac{207}{0.1235} = 1675$$

Optimum Q

For a given inside diameter of the outer conductor, there is an optimum diameter of the inner conductor that will yield a maximum value of Q . In the case of the completely shielded concentric quarter-wave line of Fig. 4-A, the maximum value of Q is obtained when the diameter ratio is

$$b/a = 3.6$$

This ratio is premised on the condition that the radiation resistance is zero; and, as pointed out previously, there is a diversity of opinion regarding the case illustrated in Fig. 4-B. If there is no radiation then the above-mentioned ratio applies for this case also; but Reukema* contends that the line of Fig. 4-B will radiate, and he accordingly establishes that the ratio for maximum Q is

$$b/a = 4.22$$

In the case of the two-wire parallel line shown in Fig. 4-C, Reukema shows that maximum Q is obtained when the ratio of spacing distance to conductor diameter is

$$2S/d = 6.186$$

The Q of a concentric line can be computed from the relation*

$$Q = \frac{890 b \sqrt{\text{Freq. in Mc.} \log b/a}}{b/a + 1} \quad (15a)$$

where a and b are in inches.

For the optimum ratio of 3.6, equation (15a) reduces to

$$Q = 107.5 b \sqrt{\text{Freq. in Mc.}} \quad (15b)$$

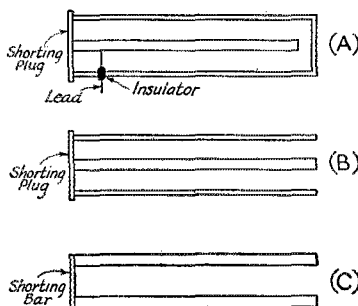

Fig. 4 — Types of transmission lines.

As an example, consider a line in which a is one-half inch; then, for optimum Q , b must be 3.6 times a , or 1.8 inches. If the frequency is 224 Mc., the Q is calculated to be

$$Q = 107.5 \times 1.8 \sqrt{224} = 2890$$

(Continued on page 102)

* Brainerd, Koehler, Reich and Woodruff, "Ultrahigh Frequency Techniques," D. Van Nostrand Co., New York.



“Ole Mississip” Rampages Again

WERS and Military Radio Units Supply Emergency Communications During Flood Crisis in Traditional Amateur Radio Fashion

BY CAROL A. KEATING,* W9WVP

As if chagrined at losing the limelight to Mars, its competitor in the business of havoc, the mighty Mississippi and its tributary streams went berserk during the week of May 18th to 24th. With the exception of the crisis along the Ohio in December, it was the first major flood emergency since the U. S. entered the war — and the first test of the war-emergency communications system set up to replace amateur radio in its traditional role of supplying emergency networks.

The Father of Waters chose as the site of this most recent escapade the central Mississippi Valley and the adjacent region drained by its major tributaries — from Southern Indiana and Illinois, through Missouri, Arkansas and Oklahoma, as far down as northeastern Texas. Augmented by heavy May rains, the River swelled to unprecedented heights, in some instances breaking 99-year-old records.

But Old Man River was defeated in his campaign of conquest, just as the flood of Axis might is being overcome. Although 34 persons were killed and 150,000 were made homeless, and hundreds of thousands of acres of farming land were inundated, the damage suffered was small in comparison to what it might have been.

*Asst. Communications Manager, ARRL.

The fact that complete disaster did not follow in the wake of the May flood is a tribute to the men and women inhabiting the endangered region. Not the least of these were the radio amateurs. Although denied the privilege of using their own amateur stations because of wartime restrictions, they carried on the highest traditions of the fraternity as operators in the War Emergency Radio Service, authorized by OCD and FCC to function “during a period of emergency when normal communication facilities are disrupted.”

Their aid in expediting, coordinating and relaying emergency orders greatly facilitated the task of curbing the rampaging waters in many critical areas where communications were indispensable to the job at hand.

Madison, Illinois

One of the first WERS groups to spring into action was WKHQ, licensed to Granite City, Ill. This station also covers the surrounding territory of Venice, Nameeki, Mitchell and Madison.

On Thursday, May 20th, the first distress call came from Madison, where the river had backed up into the storm sewer pipes and threatened the pumping station at that point. The OCD mobilized immediately, and Central Control Communications Director Jim H. Adamson, W9THB, mustered out eight radio operators and three portable transceivers.

These were dispatched to the emergency area because there was no means of telephone communication from there to the OCD office in the Madison City Hall. Messengers ran to the field radio stations with commands and messages, which were broadcast to the control room. From there the messages were telephoned to the U. S. Army Engineers Depot, which supplied most of the men, trucks, shovels, cement and sandbags, or to local industries and sources of manpower.

Crews of fifty men were maintained all night, on four-hour shifts, to keep the situation in hand.

WKHQ-1, WERS control station at the Granite City (Ill.) City Hall Control Center. Radio Aide Jim Adamson, W9THB (left), and W9GFF at the microphone.



QST for



Since the section is in a critical defense area with great numbers of plants making government war equipment, and also contains the rail bridges and vast power plants that supply the entire St. Louis area, every precaution against the flood menace was taken.

The river continued to rise that night and the following day, and by 2:30 A.M. Saturday morning things started happening — fast. The OCD could not hold the weak spots in the Chain of Rocks bridge area without assistance, so a call was sent out for U. S. Army Engineers and volunteer workers from nearby cities.

One WERS portable station was set up at a spot where the "Chain of Rocks" levee joins the Chouteau Slough levee. The river had topped the levee at this point, and was being held in check by sandbags piled four sacks high on top of the levee. Another portable was set up on the highway leading to the Chain of Rocks bridge, to direct men and supplies. Still another portable was set up near the bridge to keep in touch with the work going on there.

About 9 P.M. that night it became apparent that the levee could not withstand the pressure much longer, and was going to give way. Warning was given over the portables to all the men and drivers of trucks to clear out, as a break was expected any minute.

The operators themselves stuck to their posts until the very last, and at 10 P.M., when the levee finally gave way, the three portables and their six operators were stranded on the bridge. They had to cross the bridge and come back through St. Louis (which is directly across from Madison, on the west bank of the Mississippi) to Granite City to reach home.

In the meantime, crews of men and soldiers had started reënforcing the second levee, known as the Chouteau Slough levee. Other WERS stations were set up at various points along the levee, to keep the men and materials coming by maintaining contact with the net control station, which was located in Granite City.

The battle to hold this second levee promised to be a tough one, and the twenty-five operators settled down for the long and trying job. W9THB and his staunch crew remained on duty from 36 to 48 hours without relief. There was a lot of equipment to be obtained quickly — shovels, lights, boots, food, batteries, first-aid equipment and sandbags — and the WERS crew stayed on the job, sending in the messages that would get it for the Red Cross, Army Engineers, CD and other civilians battling the raging waters.

The portables stood up unbelievably well, the only casualties being 45- and 1½-volt batteries in the DK-3s and one HY-75 in a TR-4. In these cases the Scott Field Radio School and local radio distributors came to the rescue with replacements, and the vital communications link was preserved.

The work went on until the morning of May 27th, when all danger was pronounced over. A weary lot of radio operators then sought the food and rest they had done so uncomfortably long without. Of their work, E. G. Schmitt, chairman of the Central Control Committee of the Civilian Defense Council of Granite City, had this to say: "This emergency offered us a fine opportunity to see just how the WERS boys could perform under fire. I could relate many instances of their fine work. However, I would simply like to state that, if it were not for our radio communications, I doubt very much if we would have been able to win out in our battle to save the

Right — Portable-mobile unit set up on the levee near Madison, Ill., handling communications for the flood control workers. *Below* — Inside the portable-mobile installation in the car, showing WERS operator Carl Spohr.



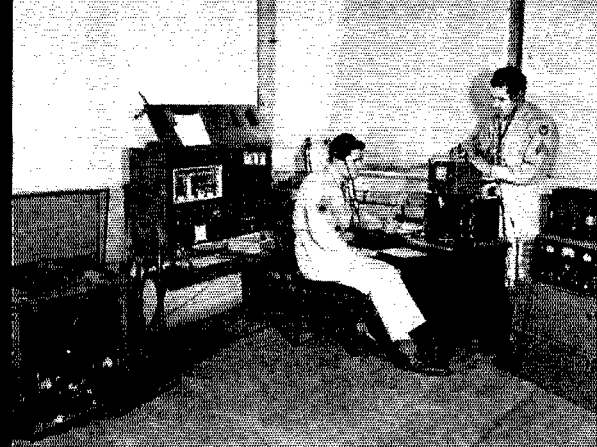

Flood-control headquarters station at Scott Field (Ill.), with S/Sgt. James E. Kaecher at the microphone and Sgt. Albert London logging. Equipment used included a 191-C m.o.p.a. transmitter and two receivers — a 312 and a 342. Rectifier-filter power unit at left. *Official U. S. AAF Technical Training Command Photo*

Anderson, Indiana

Not only along the Mississippi and its major tributaries did the flood threat loom menacingly. Much of interior Indiana was threatened with inundation by the overburdened streams.

At Anderson, Ind., the Park Place levee along the White River was seriously endangered. On May 18th all the Civilian Defense Corps units were mobilized at 1:30 P.M., to aid in saving the levee. This, of course, included the CD-WERS, which went into operation immediately and served through the following day.

The control center and six mobile installations operated throughout the period. A total of 220 messages were officially handled and recorded, and an estimated 75 were handled but not recorded. Participants were: W9EMQ, CTP, EON, DDT, WMJ, MIP, ICY, SUR, and Peak, Jarrett, Humphrey and Vize (op. licenses only).

The CDC headquarters staff in Anderson praised the work of these men highly, saying that CD-WERS had made possible the rapid shifting of men and equipment necessary to save the levee and avoid consequent heavy losses in property.

Fort Wayne, Indiana

In the city of Fort Wayne, Ind., the date of May 19th will also live long in the memories of the members of the local WERS group. After months spent on the construction of equipment, maintaining regular Sunday practice periods and adapting substitute materials for those not available, the members finally got a chance to test their equipment and ability under actual emergency conditions.

At flood control headquarters at Scott Field, parent radio school of the Army Air Forces Technical Training Command, Brig. Gen. Woleott P. Hayes (standing) receives a message from levee troops 125 miles away. *Official U. S. AAF Technical Training Command Photo*



levees in this area." Mayor Steve Maeras of Madison, Ill., also added his compliments to the WERS group for their flood efforts.

Those who took part as WERS operators in this region during the flood were: *Granite City*: J. H. Adamson, W9THB, radio aide; Bud Frohardt, W9GFF, assistant radio aide; Roy S. Rouschkolb; Robert L. Walters; Robert Hall; Howard Poland; Tom Mitchell; Herman Linder; Otto Rhodes; Robert Beason; John H. Graham; Elvis Le Grande; Fred C. Wahrenburg; Leonard Surratt; Francis Pippit, and James Lyle. *Madison*: R. E. Strange; Carl Spohr; Steve Czervinski, and Theodore Kawula. *Nameoki*: R. C. Anderson; Ted Cappelen, and Floyd R. Miller. *Mitchell*: J. R. Williams and Edward Burton.

Outside of W9THB (who organized WKHQ practically singlehanded) and W9GFF, none of the operators had much operating experience. All of the training received had been during the regular WERS drill periods. All quickly adapted themselves to the conditions and procedure, however, and did a remarkably fine job.

Peoria, Illinois

While Madison battled the raging Mississippi, another Illinois town, Peoria, was fighting the flood threat from the swollen waters of the Illinois River, a tributary of the Mississippi. The River soared to 28.82 feet — 17.22 feet above normal — and might have succeeded in over-running the shaky levee had it not been for the constant vigil maintained by employees of the Caterpillar Tractor Company, the Coast Guard, members of the U. S. Army Engineers School at Caterpillar — and, of course, the radio amateurs.

When the call for aid was sounded at the beginning of the flood and the work of protecting the levees was begun, members of the Peoria Amateur Radio Association responded immediately, picking up two of the club's generators and two personally owned generators and putting them into working order. This enabled the flood fighters to carry on their work until the larger units of the Caterpillar Company could be set up.

Special commendation was given the Peoria Amateur Radio Association by the American Red Cross, their prompt service having helped avert what might have been the most serious disaster ever to befall the community.

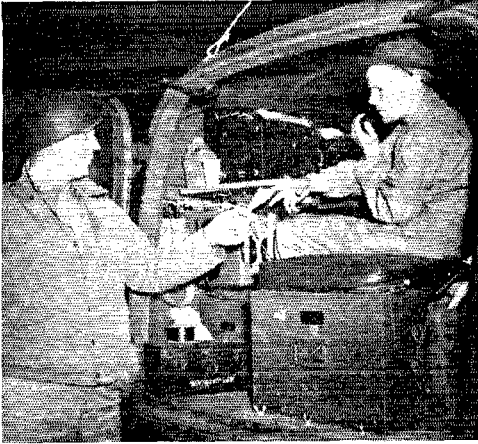

One of the four mobile truck-trailer radio units dispatched from Scott Field is shown above. Maj. Jack Loomis sends a dispatch from the Dupu, Ill., area with T/Sgt. Gene Parker, a Scott grad, serving as operator. *Official U. S. AAF Technical Training Command Photo*

When the rising waters of three rivers threatened to flood the city, telephone calls to members of the WERS advised them to stand by for a possible call to mobilize. As the crisis grew and the difficulties of rescuing citizens who had been flooded out, of preventing damage and keeping officials in touch with the control center increased, several of the WERS radio units were called into the central station at the Signal Department.

Dispatched to their assigned places at 7:45 P.M. on Wednesday, they started calling in during the first 20 minutes, reporting that they were on the job and prepared to handle emergency communications from danger points to the CD control center at the fire station.

All night the messages came. As morning approached the operators on duty were relieved by others, all of whom had been trained in the handling of emergency messages via radio. Still others stood by with additional equipment to be used in case of any failure. One prominent Fort Wayne amateur—Ray Hupp, W9CLF— together with two fellow workers operated a portable-mobile unit all night after working the swing shift at the GE plant.

A total of 219 messages relating to the emergency were handled in the two nights the WERS was activated. The amateurs and operators of WERS station WJGV did a job of which their radio aide, Fred Haneline, W9UDD, and the city of Fort Wayne can be justly proud.

Scott Field and St. Louis, Mo.

Residents of the St. Louis area found that the students at the U. S. Army Air Forces Technical Training Command school for radio operators at

Not all of the radio students at Scott Field were engaged in the operation of radio equipment. Thousands helped fill sandbags and searched for leaks in the dikes. *Official U. S. AAF Technical Training Command Photo*

Scott Field, Ill., could put their practical knowledge into swift use in time of emergency, whether it be a matter of going into battle to lick the Japs and Nazis or of curbing a flood.

When the St. Louis U. S. Army Engineers sent out a hurry call for soldiers to battle the flood, which was threatening the towns of Dupu, Valmeier, Columbia, Wolfe Lake and other communities, it was necessary to effect immediate radio contact between far-flung points of emergency operations.

Four mobile truck-trailer radio units and two portable units were made ready by Scott Field to work with WZAR, the civilian station of the flood control engineers.

The mobile units, consisting of truck and trailer, were complete in themselves, with power developed from the gasoline-motor-driven generator in the trailer supplying the 600-watt transmitter, and two receivers, one for operation on a guarded frequency and the other for stand-by purposes as well as emergency.

These mobile sets were dispatched to various points in the danger area. One portable set was moved about the flood control headquarters at Scott Field. Besides operating on the frequency assigned to flood control headquarters, the units also operated in conjunction with Coast Guard stations, keeping three channels open. Contact from the command headquarters to mobile units as far as 125 miles away was easily maintained. Voice was used in most instances, but during exceptionally bad weather c.w. was used.

Not all the Scott Field students were engaged in the operation of radio equipment, however. Over a thousand of them helped sandbag the threatened levees. Several officer-hams—Lt. Henry Spillner, jr., W2NCY, Lt. Milton R. Rousar, W9EDS, Lt. William Straughan, W9KHY, and Lt. Gale Foster, W2IGM— donned helmets and fatigues and took over a shift when relief and replacements were not available out in the flood area, after having already put in an eight-hour working day.

Flood conditions in the area were finally brought under control by the soldiers and other workers after a week or more of intensive work.

The director of flood control at Scott Field was Col. John M. Davies, designated by Brig. Gen. Wolcott P. Hayes, commanding general. The responsibility for the radio set-up fell to Major G. A. Douglas, director of the department of communications, and Lt. Richard D. Wyeth, his assistant.



Constructional Aspects of WERS Mobile Installations

Some Suggestions for Car Glove-Compartment Jobs

BY R. M. FORSTER,* W2DVG

It's one thing to toss a bunch of gear in the back seat of a car and call it a mobile installation, but it's an entirely different proposition to do the job right. W2DVG not only tells how to make a professional-looking installation, but also gives tips on holding the cost down.

A SURVEY of the WERS mobile rigs in use in this area demonstrated that the mechanical designs seem to have been concocted with certain nefarious purposes in mind, viz.: to dangle from the steering post in such a way that the driver must eventually get hanged from the wheel; to bruise shins and knees, and to rend clothing. Since these functions contribute nothing to the effectiveness of reception or transmission, consideration was given to their elimination in a mobile station to be used in the Queens network. One way open is to place the equipment in the trunk of the car, but this introduces many problems, not the least of which is the arrangement of a method of tuning the receiver. An ideal set-up from one man's viewpoint calls for having the apparatus up front where it can be handled directly, and yet be neither a menace to life and limb nor an eyesore.

The most accessible place in the average car is the glove compartment, which has the further advantage that it can be locked. It is apt to be too small, however, to hold all components of a two-way rig. But, by removing the fibre box and substituting a radio chassis, plenty of space becomes available. The useful panel size is limited to the area of the compartment door, but the rest of the chassis can, in most instances, be made as

large as is necessary to take the standard transceptor components. One of the several possible types of construction based upon the use of the glove-compartment space is shown in the photographs.

Since there is nothing unusual about the electrical circuit employed, most of this article will be devoted to constructional considerations. The parts for the rig were first laid out on a large piece of paper and moved about until a satisfactory arrangement was found — one which put all of the controls and the speaker on the front panel and also allowed short r.f. leads. Then the area of the chassis pan (12 inches broad and 10½ inches deep) was determined. Next, perspective drawings of the chassis were made and, together with the fibre glove-compartment box, were submitted to several tinsmith shops for estimates of cost. At this point the project almost met with abandonment, for prices quoted were in the neighborhood of \$15.00! But a little questioning disclosed that the need to "lay out" the job was putting the cost at that high level. The material and actual tinsmithing labor were admittedly only a small fraction of the amount asked. Laying out the work seemed like expensive service, so it was decided to do an amateur job of this.

Accordingly, full-sized patterns were prepared. These patterns were for the flat metal, before any bends were made, but with the bends indicated on the drawings. To get a pattern of the front curved piece (aperture) to fit the glove-compartment door frame, the fiber box itself was used as a model. A rubber band was stretched around the outside of this box four inches from its bottom open edge. A pencil line, at the center of the top side of the box and perpendicular to the rubber band, was drawn to the open edge. At points separated by two inches along straight portions of the edge and ½ inch on curved por-

*78-37 79th St., Glendale, L. I., N. Y.

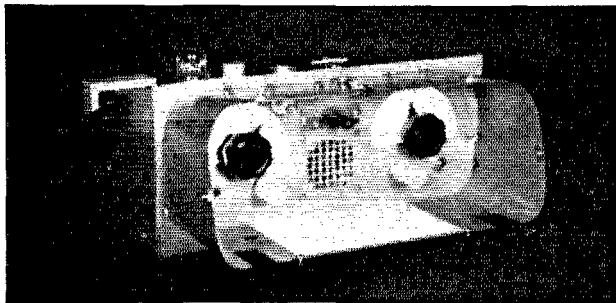

The completed unit before installation in the car. The transmitter control is at the left and that of the receiver on the right, with the speaker grille and send-receive change-over switch in the center.

Fig. 1—Circuit diagram of the glove-compartment mobile transmitter-receiver.

- C₁—20- μ fd. mica.
- C₂, C₅—3-plate variable (Cardwell Trim-air).
- C₃—0.006- μ fd. mica.
- C₄, C₆, C₈—0.001- μ fd. mica.
- C₇—30 μ fd. Isclantite mica variable trimmer.
- C₉—20- μ fd. electrolytic.
- C₁₀, C₁₁—5- μ fd. electrolytic.
- C₁₂—0.5- μ fd. paper.
- C₁₃, C₁₄, C₁₅—20- μ fd. electrolytic.
- C₁₆—100- μ fd. mica.
- R₁—5 megohms, $\frac{1}{2}$ -watt.
- R₂—15,000 ohms, 1-watt.
- R₃—0.5-megohm potentiometer.
- R₄—2250 ohms, 1-watt.
- R₅—0.1 megohm, $\frac{1}{2}$ -watt.
- R₆—20,000 ohms, 1-watt.
- R₇—0.5 megohm, $\frac{1}{2}$ -watt.
- R₈—500 ohms, 1-watt.
- R₉—200 ohms, 1-watt.
- R₁₀—50,000-ohm potentiometer.
- R₁₁—50,000 ohms, 2-watt.
- L₁, L₄—3 turns No. 14, $\frac{1}{2}$ -inch diameter, turns spaced until tanks tune to WERS band.
- L₂, L₃—1 turn No. 14, $\frac{1}{2}$ -inch diameter.
- L₅—Replacement-type filter choke.
- B—6-volt pilot lamp.

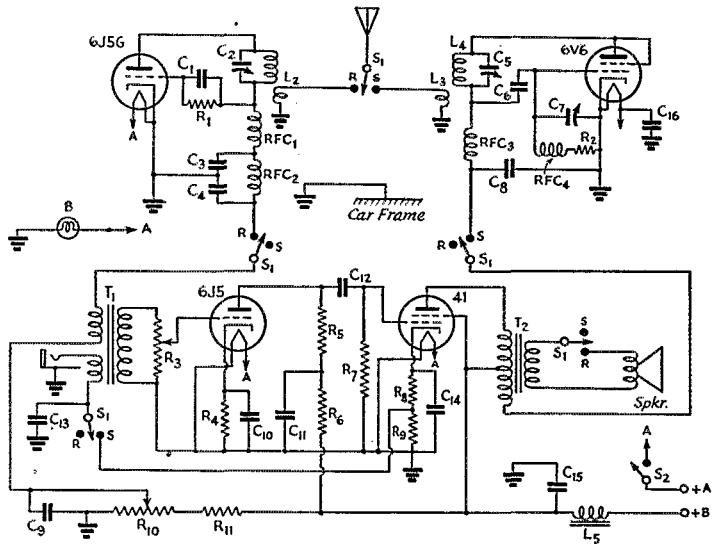

- RFC₁, RFC₃, RFC₄—55 turns No. 30 self-supporting.
- RFC₂—Low-frequency coil.
- S₁—Anti-capacity switch (Federal) with antenna contacts added (see text).
- S₂—Filament switch (on R₁₀).
- Spkr— $1\frac{1}{2}$ -inch p.m. dynamic speaker (Cinaudagraph).
- T₁—Transceiver transformer (WE213D with added microphone winding of 50 turns No. 30 enameled wire. See text).
- T₂—Universal output transformer, push-pull type.

tions, the distances from the band to the edge of the box were measured and laid out on a long, narrow strip of paper. After enough points around the circumference of the box had been plotted, the lines on the paper strip were a reproduction of the shape of the front edge of the fibre box. A straight line was drawn four inches behind the widest part of the front edge of the pattern (in the same position as the rubber band), forming the back edge. There were drawn mounting tabs on this back edge and also an overlap for bolting the ends of the piece together at the top center after the metal had been cut and shaped. When this strip of paper was cut along the lines drawn, the result was a pattern of the aperture piece.

After the six patterns, which included those for the bottom pan, cover for bottom pan, two side pieces, a partition for mounting two tubes, and the aperture piece, were finished, a full-sized cardboard model was made up and fastened together with brass paper clips of the spike type

inserted wherever an assembling bolt was to be placed. The spikes enabled the tinsmith to punch in the assembling-bolt holes without reference to the drawings.

The patterns, cardboard model and fibre compartment box (to be used as a guide in bending the aperture piece) were then submitted to tinsmiths for new estimates. This time the quoted price was \$4.00! While the preparation of the patterns reads like a long job, actually it took only three hours, including the making of the cardboard model. This represents a saving of \$11.00, or almost \$4.00 an hour—which is big money, even in wartime.

The chassis is made of "black metal," of about 24 gauge, and is very strong when assembled. The assembled chassis was trial-fitted into the car and the aperture piece marked for mounting bolts. Holes were drilled for these and 8-32 nuts sweated over the holes, on the outside of the piece.

The transmitter-receiver unit installed in the glove compartment, showing the antenna lead and the microphone jack.

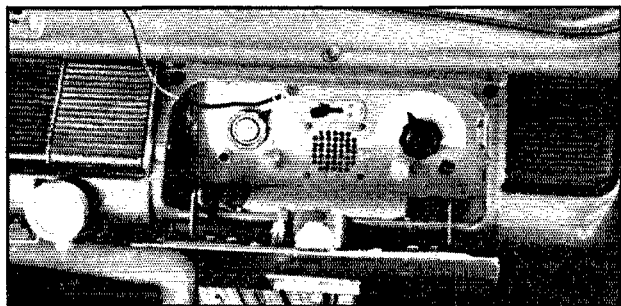

After smoothing off the sharp edges of the metal, all of the holes for the sockets, speaker grille, parts mounting and wiring were drilled. Each of the parts was then mounted to make certain that everything fitted. Then the parts

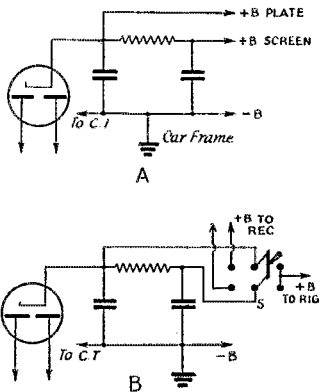
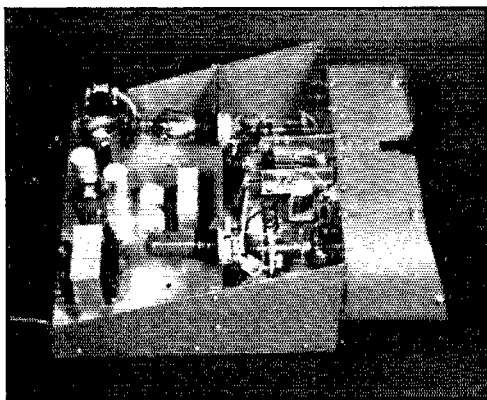

Fig. 2 — Switching arrangement for using the power supply from a car h.c. receiver for the mobile unit. A shows the original power circuit, while B shows the altered circuit. S is a d.p.d.t. toggle switch.

were removed and the metal cleaned of burrs, etc. Next, cellophane-tape masks were put over the threads of the assembling bolts, the mounting nuts and on certain points of the chassis where ground connections were to be made. The chassis was then sprayed with three coats of paint in an auto fender "dedenting" shop. The color matches the paint on the car's dashboard. The chassis was assembled while being painted to insure good electrical contact between the pieces.

Electrically, the circuit, as shown in Fig. 1, follows ideas which have appeared in *QST* and the *Handbook*. Choice of tubes was limited to those available. However, a change in the type of detector tube was found desirable. Three different 6J5GTs used as detectors were sources of noise and microphonics. Replacement with the G-type



Side view of the WERS mobile unit, showing the chassis and mounting-hood arrangement. The metal chassis and hood are made of No. 24 gauge "black metal."

cleared up the trouble. The unusually high values of cathode resistance for biasing the audio tubes are replacements for standard sizes because the modulator had feed-back with the lower standard values. In connection with feed-back, it cost plenty of time to learn that by-pass condensers should by-pass the switching circuits wherever practicable.

The transmit-receive switch is a Federal Radio anti-capacity type, with "outboard" antenna change-over contacts added. Two pieces of polystyrene were mounted on the sides of the switch by means of its own assembling screws plus small self-tapping screws. These pieces project above the top of the switch by $\frac{3}{4}$ inch. On them are mounted leaves from old 'phone jacks, bent as shown in the picture. The original hard-rubber rollers of the switch toggle were removed. One of these was drilled out to take an 8-32 machine screw, and the hole in the toggle arm, by which the rollers had been mounted, was enlarged to the same size. A piece of polystyrene rod, $\frac{1}{2}$ inch in diameter and $\frac{3}{4}$ inch long, was drilled through its center and tapped to take an 8-32 screw. This rod is substituted for the top rubber roller and the toggle reassembled, using an 8-32 screw which goes through the bottom rubber roller, the toggle arm and a maximum of $\frac{1}{4}$ inch up into the rod. A brass cap, taken from an old cartridge fuse, $\frac{1}{2}$ -inch inside diameter, has a soldering lug sweated to its closed end and is fitted over the top of the polystyrene rod and held in place by a screw $\frac{1}{4}$ -inch long. The two screws are thus separated by $\frac{1}{4}$ inch. A short piece of braided wire runs from the soldering lug to the antenna lead. As the toggle arm is swung through its arc, the brass cap contacts the 'phone-jack leaves, completing the antenna circuit.

Below the change-over switch is the $1\frac{1}{2}$ -inch permanent-magnet dynamic speaker; its size is no indicator of the wallop it puts out. To the left side of the speaker are the volume control and microphone jack, and the oscillator, C_5 , C_6 , C_7 , C_{16} , RFC_3 , RFC_4 , R_2 , and the tank circuit, C_5L_4 , are clustered around the base of the 6V6 oscillator tube. Trial showed that C_7 is a worth-while addition; while the 6V6 will oscillate without it, the output is down considerably.

To the right side of the speaker are the regeneration control and filament switch, the pilot light and the detector circuit. C_1 , C_3 , RFC_1 , R_1 , and the tank circuit, C_3L_1 , are bunched about the base of the 6J5G. RFC_2 and C_4 are mounted on the underside of the chassis pan. RFC_2 is a low-frequency r.f. coil whose inductance is unknown, but it has plenty of turns and, together with its associated condensers, forms an effective filter for the quench frequency.

The high-frequency chokes, RFC_1 , RFC_3 and RFC_4 , are homemade; they consist of 55 turns of No. 30 enameled wire wound on a drill shank, sprung loose and fastened with Duco cement. The chokes are very light in weight and are safely mounted by the wire with which they are wound. Car jouncing does not shake them apart, as they store up very little mechanical energy.

Directly behind the tube-mounting partition and between the detector and oscillator tubes is the filter choke, L_5 . The plate power for this rig is taken from the car's broadcast receiver, which has a resistance-capacity filter. When used for the transceptor, the filter resistor is shorted out as shown in Fig. 2, leaving only the condensers; hence the necessity for L_5 and C_{15} .

Behind L_5 is the audio-coupling condenser, C_{12} , which is too large to fit below deck. A smaller capacity could have been used and put below, however. Left to right, across the back of the chassis, are the output transformer, the modulator tube, condensers C_9 , C_{13} , C_{14} and C_{15} , the first audio tube and the audio input transformer. The latter is a WE213D, which has enough room between the original windings and the core for the installation of approximately 50 turns of No. 30 enameled wire for microphone input. The new winding is covered with cellophane tape to keep it in place and to protect it from moisture.

Beneath the chassis are RFC_2 , C_4 , R_5 , R_6 , R_7 , R_8 , R_9 , C_{10} , C_{11} , R_{11} , and most of the audio and power wiring. Only two leads, each fused, leave the chassis. These are marked "A" + and "B" + in Fig. 1. A third connection for negative returns is made through the frame of the car.

Lock washers are used wherever possible under the assembling and mounting screws.

The numbered dials available were either too large to fit on the panel or too small for comfortable gripping. Pointer knobs were used, therefore, together with homemade scales. The scales were drawn in India ink on the backs of filing cards cut to size and fastened to the panel with rubber cement. The white plastic-knob pointers did not contrast with the white scale cards, so the former were roughed up with fine sandpaper and coated with black India ink.

Volume- and regeneration-control knobs were made of $\frac{3}{4}$ -inch Lucite rod, drilled for shaft size and drilled and tapped for set screws. They project out from the panel an inch and a half for easy handling.

Pasted to the bottom of the aperture piece are frequency-calibration charts for receiver and transmitter.

The regular car-radio antenna is used for the transceptor. It is of the telescoping type, passing through the roof. At first it was feared that the "mud" insulation would introduce too much loss, but such is not the case. The antenna is connected to the switch terminal by an 18-inch lead and the system extended to $\frac{3}{4}$ wavelength. A vernier adjustment for antenna tuning is obtained by sliding the antenna up or down inside the car. This does not change its physical length but alters the portion which closely parallels the windshield dividing strip.

The receiver develops more than comfortable volume and the transmitter puts out a couple of honest watts, enough to cover the authorized territory.

As is the case with any rig ever made by any ham, were the job to be done over again certain changes would be made. These would include a

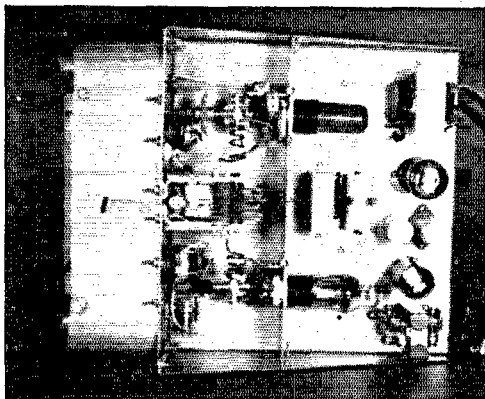

Plan view, showing location of various components. The oscillator and detector tubes are mounted horizontally from the partition, with associated tank-circuit components arranged close to the bases of the tubes. The audio equipment is at the rear. Most of the power wiring is concealed underneath the chassis.

deepening of the chassis pan from the present $\frac{3}{4}$ inch to $1\frac{1}{2}$ inches, incorporation of a 90-degree stiffening bend at the top of the tube-mounting partition, and rectangular instead of triangular side pieces to facilitate the installation of a dust cover.

Strays

An electronic method for automatically painting murals and enlarged paintings on walls from smaller originals, is the subject of a patent received by Paul B. Murphy of South Nyack, N. Y., which has been assigned to Western Electric Co.

On the wall on which the painting is to be made is projected an enlarged optical image of the picture to be reproduced. Mounted adjacent to the wall is a "scanner," consisting of a photoelectric cell which scans the image projected on the wall and sets up electrical impulses corresponding with the tone values of the image. On the same carriage is an air brush which moves simultaneously with the photocell in its scanning operation.

The air brush sprays paint on the wall, but its action is controlled by a valve which in turn is controlled by the photocell. In this way, the amount of paint applied to the wall is in conformity with the tone values of the image.

Where a colored painting is desired, the light image can be broken up into the three primary colors by a prism, and these are scanned by different electric eyes. Different currents are produced by the different colors. These currents control valves which supply correspondingly colored paints that are properly mixed before being sprayed.

-- Radio Retailing To-Day.

IN THE SERVICES

ANOTHER month — and another ITS listing! With the increased space available because of the new style of this department, this time we have room for the Civil Service fellows. Amateurs in 100 per cent war-radio industry will be taking their place in this department before too long!

With the listing of these hundreds of names each month, we need more pictures to add a bit of spice. This is an SOS to all you OMs and YLs. Help pep up your department!

ARMY—SIGNAL CORPS

M/Sgt S. H. BEVERAGE, **W1MGP**, "somewhere in the Middle East," says, "ZL3IC dropped in the other day, reminding us of some of the down-under DX of the old days."

1AVS, Green, 2nd Lt., Ft. Monmouth, N. J.
1B7L, Galvani, Lt., Hammer Field, Cal.
ex-1AYW, Silverberg, Maj., Washington, D. C.
ex-1HFC, Rice, T/4, Fort DuPont, Del.

1LKM, Fiore, Sgt., foreign duty
1MEG, Hopper, Pvt., Ft. Monmouth, N. J.
1MFK, Ricker, Pvt., Hammer Field, Cal.
1NGK, Girard, T/Sgt., Petaluma, Cal.
2ANB, Longley, Capt., address unknown
2FBB, Blasi, Lt., address unknown
2IHG, Kingman, Capt., Washington, D. C.
2LUJ, Whit, 2nd Lt., Mobile, Ala.
3FMH, Rowland, 2nd Lt., Cambridge, Mass.
3FYD, Schantz, Capt., Ft. Monmouth, N. J.
ex-3IRU, Nicholson, S/Sgt., Ft. McClellan, Ala.
3IRU, Weaver, Pvt., Camp Crowder, Mo.
4HSK, Harden, Pfc., Camp Crowder, Mo.
5DEI, Davis, 2nd Lt., Cambridge, Mass.
5CVR, Campbell, Pfc., Enid, Okla.
5IWK, Armstrong, 2nd Lt., Ft. Monmouth.
5JQU, Hays, Pvt., Camp Crowder, Mo.
6JXV, Hall, 2nd Lt., Ft. Monmouth, N. J.
6DQH, Clark, Pvt., Ft. Monmouth, N. J.
6PJR, Choate, Lt., Orlando, Fla.
6QEO, Cline, T/Sgt., Los Angeles, Cal.
6QWE, Meisch, Lt., Oklahoma City, Okla.
6QXX, Rossiter, T/5, Davis, Cal.
6SUL, Freeland, Lt. Col., Camp Carson, Colo.
6TKX, Schellenbach, Pvt., Camp Swift, Tex.
7BAI, King, Sgt., Seattle, Wash.
7BI, Bourne, Capt., Ft. Monmouth, N. J.
8EBY, Shulma, Lt., foreign duty
8EFV, Cornell, Pvt., Camp Crowder, Mo.
8MLF, Stewart, T/5, Ft. Monmouth, N. J.
8PYL, Farinet, S/Sgt., foreign duty
8QHA, Gabil, Sgt., Bolling Field, D. C.
8RTN, Tippett, Lt., Camp Van Dorn, Miss.
8TOP, Fleming, Cpl/T, Omaha, Nebr.
8UTN, Petrowski, Cpl., Ft. Monmouth, N. J.
8VIS, Misner, T/4, foreign duty
8WNT, Wert, Cpl., Ft. Monmouth, N. J.
9WUW, Oeinek, Cpl., Ft. Monmouth, N. J.
9AGF, Banic, Lt., address unknown
9BIY, Aash, Lt., Ft. Monmouth, N. J.
ex-9CPJ, Regier, Pvt., Stanford Univ., Cal.

9DHP, Gould, Pvt., Camp Crowder, Mo.
9FVY, Karr, Pvt., Dow Field, Me.
ex-9HEB, Woodard, Lt., Ft. Monmouth.
9KEE, Cook, S/Sgt., address unknown
9NTY, Miller, Pvt., Camp Crowder, Mo.
9NYU, Fisher, Cpl., Ft. Monmouth, N. J.
9NZF, Linn, Capt., foreign duty
9PKH, Copeland, Lt., Ft. Monmouth, N. J.
9RQG, Lyles, T/4, Brooklyn, N. Y.
9RTV, Orrico, Pvt., Atlantic City, N. J.
9TML, Bodwell, Pvt., Stanford Univ., Cal.
9UEA, Adams, Pfc., foreign duty
9YEG, Lade, Sgt., Camp Crowder, Mo.
9ZML, Kubilius, T/5, New Orleans, La.

Operator's license only:

Badis, T/Sgt., foreign duty
Bennet, Pvt., address unknown
Caldwell, Pvt., Ft. Monmouth, N. J.
Manz, Cpl., Ft. Monmouth, N. J.
Martin, Lt., foreign duty
Merrimat, Cpl., Camp Ritchie, Md.
Milton, T/5, Ft. Monmouth, N. J.

NAVY—GENERAL

RT1c Hodge, **W6RFO**, sent in a "reasonable facsimile" of the **AWSR** in the April issue and says, "Oh, yes, we get hold of **QST** now and then — even out here in the tropics."

ex-1CQE, Chipp, Lt., Washington, D. C.
1HFJ, McEachern, RM2c, Ft. McKinley, Me.
1NUE, Misorski, RM2c, Staten Island, N. Y.
2HEO, Fay, RT2c, Little Creek, Va.
2ICP, Leitner, Ens., address unknown
3AAV, Saxon, Lt., address unknown
3JUE, Heil, S2c, Bainbridge, Md.
3JFE, Hoffman, Lt. Cmdr., Norfolk, Va.
3JMI, Boeltzer, RT1c, Virginia Beach, Va.
3JMO, Mitchell, Ens., address unknown
3JNE, Russell, AS, Bainbridge, Md.
4DGF, Lineberger, RT2c, address unknown
4EOP, Sparks, AR1c, Oakland, Cal.
4EPA, Merrel, Ens., New York, N. Y.
4HDN, Reese, Lt., Washington, D. C.
4IDB, DeBardelaben, S2c, Jacksonville, Fla.
5DPN, Crosby, RT2c, Corpus Christi, Tex.
ex-5EPN, Ragland, Lt. (jg), Washington, D. C.
5GPJ, Patton, ARM1c, Norfolk, Va.
6CBF, Sunderland, CPM, Livermore, Cal.
6KDT, Tuggle, CRM, St. Mary's College, Cal.
6POV, West, ARM1c, Liberty, Mo.
6THX, Madsen, RM1c, New London, Conn.
7CSS, Lowery, Ens., Lockport, Ill.
7ILR, Vanerstrom, RM2c, Port Blakeley, Wash.
ex-7RG, Scott, Lt. Cmdr., Washington, D. C.
7VS, Ehmson, Lt., address unknown
ex-8UTT, Mack, Lt. (jg), Washington, D. C.
8RBC, Harris, RM1c, Cape May Pt., N. J.
8UOR, Gibson, AS, Great Lakes, Ill.
8WJA, Keen, Lt. (jg), Cambridge, Mass.
ex-9EAY, McMillan, Ens., Dahlgren, Va.
9EBB, Nan, RE, Washington, D. C.
9EDV, Kolo, Lt., Oakland, Cal.
9END, Millus, CPO, address unknown
9FOI, Signaigo, RM2c, address unknown
9HUJ, Barnes, SP(T)3c, Memphis, Tenn.
9JWF, Shock, Lt. (jg), Cambridge, Mass.
9KVV, Knowlton, Lt., Wellesley Hills, Mass.
9LZM, Bissell, RT2c, Takoma, Md.
9NLF, Johnson, ARM2c, Pensacola, Fla.
9UPC, Jones, AS, Farragut, Idaho
9WDS, Hamilton, Comdr., Moscow, Idaho
9WQG, Gonterman, RM1c, address unknown

Operator's license only:

Chester, AS, Wilkensburg, Pa.
Chapman, AS, address unknown
Flynn, Ens., Takozza, Md.



Hams and ex-hams, now on duty at the Radio School of the Naval Air Station at Corpus Christi, get together with their favorite magazine! Seated, l. to r. — Lt. (jg) Weidlich, **W4OCU**; Lt. Cmdr. Badger, **ex-W7DBS**; Lt. Talbutt, **W5AUL**; Ens. Stewart, **W6UHF**, **Standing** — E. S. Dorset, **ARM1c**, **W5JOX**; D. L. Ming, **ARM1c**, **W6MCR**, and R. H. Clarke, **ACRM**, **W5HBZ**. *Official U. S. Navy Photograph.*

Gacek, RT1c, Virginia Beach, Va.
Guillemette, AS, address unknown
Trenn, RT2c, San Francisco, Cal.

ARMY—GENERAL

ONE OM wrote in that, after seeing the names of several chaps he used to work in the "good old days" listed in this column, he figured perhaps he should pass the dope along on himself. That's what we want—a record of every ham in the service of his country; those in uniform and civilians too.

1BKV, Cavanaugh, 2nd Lt., Hampton R., Va.
2BZM, Koenig, Cpl., Camp Stewart, Ga.
2EXE, Nott, Columbia, S. C.
2HBE, Weston, Lt., Avalon, Cal.
2MNB, Israel, Pvt., Camp Wood, N. J.
2OIC, Gabbs, Pvt., Vancouver, Wash.
3FBZ, Matlack, Pvt., address unknown
3JWI, Howell, M/Sgt., foreign duty
5HG, Dickens, Pvt., foreign duty
5KHP, Dibrell, Pfc., Springfield, Mo.
5VB, Worthington, Lt., Dayton Ohio
6THU, Paul, Pvt., Camp Ukiah, Cal.
6TQG, Germany, address unknown
7HAB, Holmes, Sgt., foreign duty
8KFP, Kingsbury, S/Sgt., foreign duty
8KUO, Barth, Capt., Washington, D. C.
8KWJ, Grove, Pvt., Blacksburg, Va.
8NMR, Glaug, Pvt., Camp Davis, N. C.
8QVW, Dearth, M/Sgt., foreign duty
8RUC, Fullem, Cpl., Los Angeles, Cal.
8RZD, Schweers, Pfc., foreign duty
8TUS, Salliotte, Cpl., foreign duty
8VAX, Hauck, Pvt., Camp Hood, Tex.
8VUJ, Luton, Pvt., Sharon, Pa.
8WKH, Feeney, Sgt., Los Angeles, Cal.
9ERN, Clemens, Pvt., Camp Wheeler, Ga.
9LTV, Neal, Pvt., Camp Wallace, Tex.

Operator's license only:

Denman, Pvt., address unknown
Froeschle, Pvt., Norman, Okla.
Klipper, Pvt., Camp Wallace, Tex.
Miller, Pfc., Sioux Falls, S. D.
Phillips, S/Sgt., Camp Roberts, Cal.
Thompson, Sgt., foreign duty
Upchurch, T/4, Indiantown Gap, Pa.

NAVY—FOREIGN OR SEA DUTY

W2MBD, B. J. Guerra, RM2c, says he's been meeting hams here and there, but the strangest ragchew came about when an OM came over to admire the new antenna he'd just put up and used a 1942 *Handbook* for introduction.

1FBZ, O'Neil, RE; 1HXB, Nisbet, Ens.; 1LAO, Erlandsen, RM1c; 1MMD, Probert, RM2c; 1NSC, Tripp, RT2c; 1NSX, Gramolini, RM3c; 2ACZ, Dunkelman, RM1c; 2ALD, O'Neil, Lt.; 2BAI, Forsyth, Lt. (jg); 2DI, Hicks, RM2c; 2ISJ, Bunting, Carp.; 2KFW, Dubiel, RM2c; 2KSQ, Brady, RT1c; 2MLO, Columbine, S1c; 2NAU, Windler, RM1c; 2NDS, Hoose; 2OAD, Tanner, RT2c; 2OCF, Grossman, RM3c; 2ODA, Daniels, RT1c; 2ODH, Pyrvyt, RM3c; 2OIL, Burch, CRM; 3BVI, Heller, RM2c; 3FCZ, Breen, Ens.; 3GCI, Wenger, RT1c; 3GSD, Lorentson, RM2c; 3JKX, Lewis, RM1c; 3JNH, Whitlow, S3c; 4BNI, Abrams, RM2c; 4X4DNY, Peters, ACRM; 4DOW, Martin, Ens.; 4EGT, Lanford, Ens.; ex-4EJL, Batey, Lt.; 4EPL, Fielder, Ens.; 4EPU, Diggs, RM1c; 4FDA, Graham, RT1c; 4GJM, Rundlett, Lt.; 4HJQ, Webster, Lt. (jg); 4HPP, Twiddy, RM2c; 4HVN, Perdue, Lt. (jg); 5EXU, Cooper, RM1c; 5GUY, LeRoy, Ens.; 5HFO, McGaffey, RT2c; 5IVG, Reese, RM2c; 5JWA,

Black, RM3c; 6AXC, McLarney, RT1c; 6FGG, Walker, ARM1c; 6GBW, Lee; 6GEI, Kamline, RM1c; 6HAU, Greening, Lt. (jg); 6HOS, Lucking, Lt. (jg); 6IAH, Hyde, CEM; 6MCG, Crosby, RM1c; 6NYW, Urey, SC2c; 6PNI, Taylor, Lt.; 6QPO, Iacombi; 6QXD, Howell, RT1c; 6RMP, Graham, RM3c; 6TE, Bruer, RE; 7CRY, Steele, RT2c; 7EHW, Griffin; 7EYD, Barton; 7FKB, Hoadley, RT1c; 7GWC, Oleson, RT1c; 7HES, Lindstrom, S1c; 7HGA, Lynn, CRM; K7ILU, Jacobson, ARM1c; 7IGY, Ensel, RM2c; 7JAI, Brown, RT2c; 7QP, Cramer, EM1c; 8ETD, Brennan, EM3c; 8MTC, Serotko, RM3c; 8NOU, Goodwin, RM2c; 8PSR, Ramey, Lt. Comdr; 8QHC, Craig, S1c; 8QPK, Halstead; 8SNH, Genaw; 8SVH, Millner, RT1c; 8TIA, DeMars, RT1c; 8TQU, Paone, ART1c; 8WLL, Alsdorf, RM3c; 9AEV, Jones, Ens.; 9AGQ, Fortelka, RM1c; 9DXI, Greely, Lt.; 9GKO, Lindesmith, RE; 9HZK, Frykman, S1c; 9KZH, Epps, RM2c; 9NWJ, Griner, 9QES, Cassutt, Lt.; 9QUF, Smith, RM2c; 9REA, Handel, RT2c; 9RFH, Carl, CRM; 9RKV, Smith, RE; 9UPO, Holan, RT1c; 9UZ, Schnell, Lt. Comdr.; 9VPR, Harrison, S2c; 9WLI, Raschick; 9WTT, Ledbetter, RT1c; 9YJK, Wick; the following have operator's license only, Clark, Lt. Comdr.; Holtzinger, S2c; Lansing, RM2c; Locke, Lt.; Marcus, RM3c; Newman, RT1c, and Petkovsek, RT2c.

ARMY—AIR FORCES

W8SFK, an Air Corps bombardier, says his eagerness to get back on the air is partially relieved by reading *QST* and noting the activities of the rest of the gang.

ex-1AKP, Rhode, Pvt., Maxwell Field, Ala.
1BW, O'Donnell, Lt., San Antonio, Tex.
1CFU, Cushing, Pfc., Scott Field, Ill.
1COB, Wightman, Sgt., Miami Beach, Fla.
1HDJ, Smallman, Cpl., Sioux Falls, S. D.
1HX, Young, Capt., foreign duty.
1IPR, LaMontagne, Lt., Washington, D. C.
1MZE, Hall, Capt., Miami Beach, Fla.
2CFX, Berry, Cpl., Scott Field, Ill.
2DCW, Siegel, S/Sgt., Walla Walla Field, Wash.
2ETT, Avery, Lt., Stockton Field, Cal.
2EWW, Sammon, Pfc., Chicago, Ill.
2HFM, Bedell, Pfc., Sioux Falls, S. D.
2HTL, Board, Lt., Hobbs, New Mex.
2IHW, Heinis, S/Sgt., foreign duty.
2JG, Pierson, Pvt., Atlantic City, N. J.
2IKW, Rhodes, Pfc., Sioux Falls, S. D.
ex-2JGW, Rogers, Sgt., Coffeyville, Kan.
2KMV, Carter, Pvt., Selfridge Field, Mich.
2KPI, Newell, Pfc., foreign duty.
2MKG, Deutch, Cpl., Ft. Wayne, Ind.
2MRB, Levine, Pvt., Westover Field, Mass.
2NT, Martin, Lt., foreign duty.
2OCG, Valgren, Pvt., Blueenthal Field, N. C.
3AXT, Fraim, Capt., Miami Beach, Fla.
3BZE, Jones, A/C, Nashville, Tenn.
3EOE, Day, Maj., Presque Isle, Maine
3FMU, Whitley, 2nd Lt., Phoenix, Ariz.
3JST, Dawson, Pvt., Asheville, N. C.
ex-4CGM, Warren, M/Sgt., Tomah, Wis.
4CIU, Britton, Pfc., Sioux Falls, S. D.
4PHY, Hickey, Lt., Orlando, Fla.
4FOO, Adcock, Lt., foreign duty
4FUZ, Stringer, Cpl., Gunter Field, Ala.
4GDC, Russell, M/Sgt., foreign duty
ex-4IH, Long, Lt., Delray Beach, Fla.
5ARQ, Besancon, Midland, Texas
5COB, Francis, Lt., Miami Beach, Fla.
5G00, Maddox, Tampa, Fla.
5GTY, Floyd, 2nd Lt., Hamilton Field, Cal.
5HMQ, Ruff, Capt., Nashville, Tenn.
5HSN, Fine, Tampa, Fla.
5JJC, Ramsey, Pvt., Dodge City, Kan.
5JGU, Moore, Lt. Col., San Antonio, Tex.
5JSU, Alison, Lt., foreign duty
5KDH, O'Neil, Pvt., Hondo Field, Tex.
5KQO, Riley, Pfc., Sioux Falls, S. D.
5KPV, Taliaferro, Pvt., Ft. Worth, Tex.
5KSU, Wiseman, Pfc., Lowry Field, Colo.
6ANT, Honeywell, Lt., Greenwood, Miss.
6GTH, McIntosh, Tampa, Fla.
6IMA, Beck, Sgt., San Marcos, Tex.
6JBF, Wilson, Sgt., Atlanta, Ga.



Cpl. "Pete" Kowall, W8TGO, has been in radio work of one sort or another since his induction in May, 1942. When last heard from he was on foreign duty doing radio repair work in the U. S. Army Air Forces.

6LHZ, Larson, Capt., Smyrna, Tenn.
6LND, Hurt, Pvt., March Field, Cal.
6NJF, Bowman, Lt., Glendale, Cal.
6NJJ, Davis, A/C, New Haven, Conn.
6QW, Rosenblatt, Capt., Maxton, N. C.
6SRW, Jess, 2nd Lt., Gila Bend, Ariz.
6STX, Ommen, Pvt., Atlantic City, N. J.
6SWT, Beckwith, Pvt., Lemon Grove, Cal.
6TEB, Fribourg, M/Sgt., Laurel, Miss.
6TZX, Mitchell, Lt., Cabanis Field, Tex.
6UAZ, Robson, Pfc., Scott Field, Ill.
6UPI, Owen, A/C, Shaw Field, S. C.
7DUM, O'Neil, Lt., Biggs Field, Tex.
7GBI, Justinak, Lt., Long Beach, Cal.
K7GOJ, Boyle, Lt., LaJunta, Colo.
ex-7HZV, Sherwin, Sgt., Atlanta, Ga.
8DHC, Santti, Lt., Garden City, Kan.
8KPK, Hillbrick, Capt., Minneapolis, Minn.
8PE, Geno, Lt., Grenada, Miss.
ex-8PIV, Simone, Pfc., Madison, Wis.
8RXT, Gant, Cpl., Langley Field, Va.
8SFK, Scott, A/C, Nashville, Tenn.
8NWX, Strong, S/Sgt., foreign duty
8SUJ, Schulz, Sgt., Bolling Field, D. C.
8ZB, Owers, Pfc., Laredo, Tex.
8WDO, Steiger, Pfc., Rome, N. Y.
8WMQ, Dirling, Pvt., Miami Beach, Fla.
9BFU, Quayle, Lt., Pendleton, Ore.
9CGB, Engh, A/C, Carlstrom Field, Fla.
9CNR, Chapin, S/Pvt., Sarasota, Fla.
9ELG, Sodergren, Pvt., Chanute Field, Ill.
9FZS, Urbanski, S/Sgt., Chanute Field, Ill.
9GTD, Ebel, Pvt., Wright Field, Ohio
9ICZ, Allen, Pvt., St. Louis, Mo.
9IOZ, Stell, Pvt., Love Field, Tex.
9IGD, Abbott, Sgt., Perrin Field, Tex.
9JHK, Carlson, Pvt., St. Louis, Mo.
9LPC, Bambrick, Sgt., Carlbad, New Mex.
9MXX, Heinen, Pfc., Chicago, Ill.
9MIA, Pettijohn, Pfc., Scott Field, Ill.
9NEJ, Weber, Sgt., Biggs Field, Tex.
9NWD, Kuure, Cpl., Boca Raton Field, Fla.
ex-9OBI, Davis, Lt., Bainbridge, Ga.
9ODN, Deller, S/Egt., Muroc, Cal.
9IOP, Grob, Cpl., Bolling Field, D. C.
9PLN, Hunter, Pvt., Sheppard Field, Tex.
9PSE, Lynn, Lt., Miami Beach, Fla.
9QBD, Hehner, Davis-Monthan Field, Ariz.
9RCW, Demergian, Pvt., Jefferson Barracks, Mo.
9RZQ, St. Thomas, Pfc., Sioux Falls, S. D.
9TCR, Turner, Maj., foreign duty
9UIN, Kadlec, Pvt., Rosecrans Field, Mo.
9UYD, Hampel, Pfc., Scott Field, Ill.
9VAU, Naidt, Pfc., Altus, Okla.

Operator's license only:

Alden, A/C, Phoenix, Ariz.
Clement, S/Sgt., Bakersfield, Cal.
Cooper, Pvt., address unknown
Ditmer, A/C, Alliance, Ohio

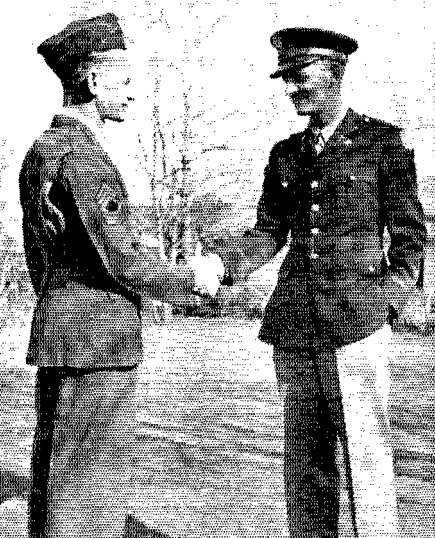

M/Sgt. J. W. Marley, W4EW, says good luck and 73 to Capt. W. B. Britton, jr., W4ECF, before he leaves Maxwell Field for overseas duty.

Dupont, Cpl., Chicago, Ill.
 Evans, Keesler Field, Miss.
 Goldstein, Pfc., Sioux Falls, S. D.
 Hyman, A/C, Nashville, Tenn.
 Kerr, Pfc., Scott Field, Ill.
 McAvey, Pfc., Chicago, Ill.
 Pippin, A/C, Santa Ana, Cal.
 Pohl, Sgt., San Francisco, Cal.
 Ruiz, Sgt., Corpus Christi, Tex.
 Stivers, 2nd Lt., New Orleans, La.
 Superville, Pvt., Sheppard Field, Tex.
 Tapp, M/Sgt., Bradley Field, Conn.
 Thomas, Pvt., Keesler Field, Miss.
 Vick, M/Sgt., Tomah, Wis.
 Winter, Pfc., Scott Field, Ill.

CIVIL SERVICE

THIS list has been compiled over the last year and a half, and undoubtedly many of the men and women listed have changed jobs or joined the armed forces. If you see any incorrect listings, we would appreciate your bringing us up to date.

IASG, Arey, Signal Labs, Ft. Hancock
 ex-1ATG, Hayes, FCC, radio operator
 IBD, Gale, SC, inspector, Baltimore
 IBDQ, Blake, Philadelphia Signal Depot
 IBXE, Haskell, Philadelphia Signal Depot
 ICD, Davis, Philadelphia Signal Depot
 IGTW, Berg, SC Labs, Ft. Monmouth
 IOMG, Cummings, SC radio tech., Boston
 IPEC, Corwell, radio engineer technician
 IPNY, Dorsey, FCC, address unknown
 ex-1PZS, Doolittle, Sig. Cps., Camp Evans
 IGHZ, Graham, Lexington Signal Depot
 IHQV, Checkoway, FCC, Washington
 IHFZ, Baker, Philadelphia Signal Depot
 IIM, Ferguson, civilian Signal Corps
 INN, Austin, SC, radio mechanic, Boston
 IOF, Francoeur, Philadelphia Signal Depot
 IJCU, Driscoll, Signal Labs, Ft. Hancock
 IJFK, Belknap, Philadelphia Signal Depot
 IJWL, Fiore, Signal Corps, address unknown
 IKBH, Harmon, Naval Research Lab, Anacostia
 IKZT, Bauman, Philadelphia Signal Depot
 ILGJ, Deutsch, Naval Research Lab, Bellevue
 ILJP, Canture, Philadelphia Signal Depot
 IMDR, Haynes, Philadelphia Signal Depot
 IMIG, Garber, Philadelphia Signal Depot
 IMOK, Brennan, SC, radio mechanic, Boston
 IMZS, Erskine, Radiation Lab, Cambridge
 INF, Ericson, Radio Repair Lab, Boston
 INTR, Champigny, FCC, jr. monitoring officer

INIU, Harney, AAF, radio work, address unknown
 INP, Gould, SC Labs, Ft. Monmouth
 INV, Hall, SC, instructor, Boston
 IVS, Harrison, radio engineer, Boston
 2AJT, Fonskov, SC Labs, Ft. Monmouth
 2AQC, Carlik, SC Labs, Ft. Monmouth
 2AZU, Dieter, SC, radio mechanic, L. I.
 2BCS, Bernat, radio inspector, New York
 2BLC, Cattani, SC Labs, Ft. Monmouth
 2BJK, Gossland, radio technician
 2BHF, Berger, SC Labs, Ft. Monmouth
 2BND, Braunstein, Signal Labs, Ft. Hancock
 ex-2BWD, Brody, War Dept., radio engineer, Ft. Monmouth
 2COC, Hammarschlag, Sig. Labs, Ft. Hancock
 2CGH, Bawden, Signal Labs, Ft. Hancock
 2COK, Frerichs, SC Labs, Ft. Monmouth
 2CQR, Brandt, Signal Labs, Ft. Hancock
 2CR, Bleier, Signal Labs, Ft. Hancock
 2CRW, Gallagher, inspector of naval aircraft
 2EGM, Babcock, Signal Labs, Ft. Hancock
 2EHL, Balk, SC Labs, Ft. Monmouth
 2ELN, Bradshaw, FCC, radio operator
 ex-2EPS, Fischman, SC, jr. radio engineer, San Bernardino
 2ESN, Antell, SC Labs, Ft. Monmouth
 2FBB, Blasi, Radio Labs, Wright Field
 2FCT, Baird, SC Labs, Ft. Monmouth
 2FTB, Bloom, AC, instructor, Scott Field
 2FL, Akers, Signal Labs, Ft. Hancock
 2PST, Deekert, SC Labs, Ft. Monmouth
 2FFT, Abbott, Signal Labs, Ft. Hancock
 2PFXB, Demsky, Signal Labs, Ft. Hancock
 ex-2GAJ, Bellat, Signal Corps, Ft. Monmouth
 2GDG, Babkes, SC Labs, Ft. Monmouth
 2GUM, Colagouri, SC Labs, Ft. Monmouth
 2HEC, Gozdi, address unknown
 2HPN, Bakker, FCC, radio operator
 2HHW, Haslam, SC Labs, Ft. Monmouth
 2HPK, Brown, SC Labs, Belmar, N. J.
 2HRT, Balter, SC Labs, Ft. Monmouth
 2HWQ, Haimowitz, FCC, asst. monit. officer
 2IID, Berg, SC Labs, Ft. Monmouth
 2IN, Droste, SC, production engineer
 2INO, Farkas, Signal Labs, Ft. Hancock
 2IWI, Gindoff, Signal Labs, Ft. Hancock
 2IYI, Ducore, SC Labs, Ft. Monmouth
 2JKI, Evers, SC Labs, Ft. Monmouth
 2JPU, Gindoff, SC Labs, Ft. Monmouth
 2JZX, Grossman, radio instr., Drew Field
 2KBC, Engberg, SC Labs, Ft. Monmouth
 2KHS, Bryan, SC Labs, Ft. Monmouth
 2KQM, Fischman, Signal Labs, Ft. Hancock
 2KUW, Dames, Radio Labs, Wright Field
 2KXM, Beers, SC Labs, Ft. Monmouth
 2LHN, Dann, Signal Labs, Ft. Hancock
 2LJR, Hawkins, SC Labs, Ft. Monmouth
 2LZX, Gutzeit, SC Labs, Ft. Monmouth
 2MPK, Grob, address unknown
 2MPO, Davis, SC Labs, Ft. Monmouth
 2MGT, George, Signal Labs, Ft. Hancock
 2MOF, Carswell, SC Labs, Ft. Monmouth
 2MPT/3JYZ, Gordon, Sig. Labs, Ft. Hancock
 2MUJ, Clark, SC Labs, Ft. Monmouth
 2NIA, Cram, Signal Labs, Ft. Hancock
 2NNX, Belcastro, SC Labs, Ft. Monmouth
 2NXH, Asheroff, Signal Labs, Ft. Hancock
 2ODO, Gebegan, Radio Lab, Wright Field
 2ODR, Chow, SC Labs, Ft. Monmouth
 2OFM, Dahrouge, Signal Labs, Ft. Hancock
 3ABL, Edwards, SC Labs, Ft. Monmouth
 ex-3AJG, Gifford, Philadelphia Sig. Depot
 3ASH, Duncan, Naval Research Lab, Bellevue
 3AZG, Hatch, SC Labs, Ft. Monmouth
 ex-3BBC, Hassall, SC, inst., Ft. Monmouth
 3BYR, Braidwood, SC Labs, Belmar, N. J.
 3CRR, Conover, SC Labs, Ft. Monmouth
 3COK, Boyd, Naval Research Lab, Bellevue
 3COZ, Dugonis, AAF, sr. radio mech. tech.
 3CUO, Clevenstine, Naval Research Lab, Anacostia
 3EBK, Gordon, Naval Research Lab, Bellevue
 3FVN, Farrell, FCC, monitor
 3FCQ, Giernan, SC, inspector
 3FXJ, Duff, Philadelphia Signal Depot
 3GQU, Carlisle, Signal Labs, Ft. Hancock
 3GUS, Burkart, SC, foreman repair shop
 3GYH, Clark, Naval Research Lab, Anacostia
 3IHB, Bush, Naval Research Lab, Bellevue
 3ICQ, Cresce, Signal Labs, Ft. Hancock
 3IFT, Brandt, SC, radio inspector
 3IHA, Craig, SC Labs, Ft. Monmouth
 3IHD, Edwards, SC engineering service
 3ISY, Dinhorn, Philadelphia Signal Depot
 3ISV, Guthke, Maritime Com., radio inspector
 3IVE, Chambers, Naval Research Lab, Bellevue

3JEI, Hatton, Middletown Air Depot
 3JFI, Carr, SC, radio inspector, Chicago
 3JFO, Bliss, Naval Research Lab, Bellevue
 3JHK, Blake, Naval Research Lab, Bellevue
 3KH/4ES, Bliss, radio engineer, Miami
 3PB, Beam, SC Labs, Ft. Monmouth
 3UD, Boggs, FCC, monitoring officer
 3ZD, Corderman, OWI, asst. chief, Bureau of Communications
 4ACQ, Best, Lexington Signal Depot
 4BFI, Finney, address unknown
 ex-4BFG, Dings, SC, inspector
 4BNK, Bryan, address unknown
 ex-4DEL, Callen, SC Labs, Ft. Monmouth
 4DBS, Evenhouse, address unknown
 4DUN, Clark, Signal Labs, Ft. Hancock
 4DXP, Colbert, Signal Labs, Ft. Hancock
 4EGD, Funches, radio mechanic technician, Phila.
 4ELA, Emons, SC Labs, Ft. Monmouth
 4EQQ, Brookes, chief operator and maint., N. C.
 4EXR, Cunningham, radio repair, Tampa
 4GFF, Ellis, Lexington Signal Depot
 4GRP, Corley, SC, inspector
 4GSK, Eckert, Signal Labs, Belmar, N. J.
 4GXL, Alexander, radio op., Camp Davis
 4GYV, Ponca, radio repair shop, Tampa
 4MS, Collins, asst. radio engr., Pensacola
 4SK, Hill, SC Labs, Ft. Monmouth
 4WL, Freck, instal. radio man, Orlando
 ex-5AGU, Craig, Lexington Signal Depot
 5AVG, Bevers, Lexington Signal Depot
 5AXM, Bolger, FCC, jr. monitoring officer
 5BD, Downing, radio operator, Brooks Fld.
 5BGJ, Handford, radio operator, Laredo
 5BM, Bailey, Philadelphia Signal Depot
 5BZO, Ellis, Lexington Signal Depot
 5CAE, Burch, Lexington Signal Depot
 5CAY, Harrell, address unknown
 5DBN, Chelkowski, radio op., Ft. Sam Houston
 5DW, Ablowick, FCC, monitoring officer
 5DZE, Bray, FCC, asst. intercept. officer
 5EDB, Caruth, Lexington Signal Depot
 5EDC, Easterwood, Lexington Signal Depot
 5EEF, Chilton, Lexington Signal Depot
 5EHQ, Faust, Naval Research Lab, Bellevue
 5EHY, Hawkins, Lexington Signal Depot
 5EZE, Busiek, Lexington Signal Depot
 5FAD, Cadena, instructor, Waco Field
 5FEH, Hamilton, instructor, Cushing, Okla.
 5FH, DeVilbiss, Lexington Signal Depot
 5FNU, Belles, instructor, Scott Field
 5FNA, Case, instructor, San Antonio
 5FPH, Crawford, Lexington Signal Depot
 5FUE, Bradley, Naval Research Lab, Anacostia
 5FWJ, Boucher, sr. technician & electrician, Corpus Christi
 5GHEK, Glueck, Lexington Signal Depot
 5GHEU, Davis, FCC, Portland, Ore.
 5GN, Bennett, Lexington Signal Depot
 5GYS, Baer, radio work, Corpus Christi
 5HBY, Andrews, SC, Camp Beauregard
 5HGB, Breckenridge, Lexington Signal Depot
 5HKN, Arnold, radio work, San Antonio
 5HPJ, Dixon, radio instructor
 5HPL, Gregory, Philadelphia Signal Depot
 5HSV, Darnell, radio operator, Laredo
 5ILC, Council, Lexington Signal Depot
 5ILT, Prunthall, Philadelphia Signal Depot
 5INH, Elliott, Philadelphia Signal Depot
 5IOP, Ebner, radio work, San Antonio
 5ITA, Dougharty, Lexington Signal Depot
 5IXQ, Flatt, radio work, Corpus Christi
 5IZM, Hale, Signal Corps, Indiana
 5JM, Gibbon, FCC, radio inspector, Phila.
 5JHY, Ghesslin, Lexington Signal Depot
 5JKY, Davis, Lexington Signal Depot
 5JMP, Gable, SC, instructor, Phila.
 5JSP, Cook, Lexington Signal Depot
 5JXC, Girard, Philadelphia Signal Depot
 5KDL, Frazier, Lexington Signal Depot
 5KBA, Alverson, Lexington Signal Depot
 5KBB, Cox, Lexington Signal Depot
 5KCS, Carroll, Lexington Signal Depot
 5LE, Cline, FCC, radio operator
 5QA, Hamgrove, radio instructor
 5SA, Arledge, industrial manager, Miami
 5SN, Davison, Lexington Signal Depot
 5TW, Harris, Lexington Signal Depot
 ex-5UD, Bryan, Lexington Signal Depot
 6CZS, Barron, instructor, Scott Field
 6DTB, Ashby, address unknown
 ex-6A6FB, Dresen, assoc. radio engineer, San Diego
 6IWI, Cassidy, SC Labs, Ft. Monmouth
 6KGC, Farrell, instructor
 ex-6OLZ, Bettinger, Radio Lab, Wright Field

PBO, Dimmick, radio repairman
 6QIS, Clemmer, Signal Lab, Belmar, N. J.
 6QOD, Bollinger, address unknown
 6QYF, Gamara, instructor, Scott Field
 6RCT, Dickerson, instructor, Scott Field
 6RIM, Christensen, address unknown
 6RUU, Edwards, Naval Ordnance Lab, Washington
 6RWG, Glavin, SC, inspector
 6SBJ, Hamilton, Signal Corps, Modesto, Cal.
 6SJ, Davis, radio engineer, Wright Field
 6TSL, Bailes, FCC, monitoring service
 6UEF, Clute, FCC, radio operator
 6UOM, Conley, address unknown
 6UQG, Anderson, SC, trainee repairman
 6URS, Hansen, SC, radio mechanic
 7AQU, deLespinasse, Naval Research Dept., Washington
 7PFA, Harland, Naval Rdo. Tng. Schl., Idaho
 7GP, Gunstone, supervisor & inspector of radio installations, Seattle
 7GWG, Couch, address unknown
 7HBE, Brodie, FCC, monitoring officer
 7IMF, Bouchard, AAC, radio mech. tech.
 7LXH, Clark, CAA, operator in charge air-way communications station
 8BJO, Curran, FCC, intercept. service
 8CILL, Atembroski, FCC, radio monitor
 ex-8DDE, Chamberlain, inst., Scott Field
 8DLU, Bernstein, SC, sr. engr. Ft. Monmouth
 8ECX, Fiekel, FCC, radio operator
 8EFW, Cornell, FCC, jr. inspector
 8ECH, Devendorf, CAA, communications operator
 8FO, Foley, Signal Corps, instructor
 8HLM, Affelder, SC, chief engineering aide
 8HQW, Cavillier, asst. engr., Engr. Lab., Annapolis
 8HUX, Beale, FCC, asst. monitoring offer.
 8HZV, Brown, SC, radio inspector
 8KJZ, Godard, SC, assoc. radio engineer, Washington
 8LBE, Farley, Signal Labs, Ft. Hancock
 8MCP, Bostwick, FCC, radio operator
 8MIB, Bryson, insp., Radio Lab, Wright Field
 8NAL, Cioerello, Signal Corps, instructor
 8NIH, Fiedler, Signal Corps
 8NSN, Edgett, Signal Labs, Ft. Hancock
 8NYH, Gillespie, Signal Labs, Ft. Hancock
 8OBS, Grewell, Lexington Signal Depot
 8OGR, Engelman, Radio Lab, Wright Field
 8OOP, Geetz, insp., Radio Lab, Wright Field
 8PYL, Fariuet, Radio Lab, Wright Field
 8QWM, Beaver, Signal Corps
 8RBR, Dasey, address unknown
 8RKJ, Goldstein, inspector, Radio Lab, Wright Field
 8RVM, Aitken, Dept. Justice, patrol insp.
 8RWP, Florman, address unknown
 8SAY, Beetley, FCC, monitor
 8SGY, Adamson, Signal Labs, Ft. Hancock
 8TAU, Allen, Gen. Dev. Lab., Ft. Monmouth
 8TWE, Barchok, Signal Labs, Ft. Hancock
 8UQL, Garra, SC, radio opr., Ft. Thomas
 8UWS, Augenstein, Signal Labs, Ft. Hancock
 8UYA/3, Beardsley, radio research, Washington
 8VHR, Ewerts, Signal Corps
 8VIP, Citrullo, War Dept., radio mech. & tech., Orlando
 8VZM, Elliott, Signal Labs, Ft. Hancock
 8WPA, Berkhimer, sr. engr. aide, Washington
 9AIQ, Castner, SC repair shop, Ft. Hayes
 9AQB, Case, instructor, Scott Field
 9AZT, Carpentier, Radio Lab, Wright Field
 9BDL, Goekler, radio work, Corpus Christi
 9BLC, Greathouse, radio work, Corpus Christi
 9BMM, Brown, instructor, Scott Field
 9BON, Berstein, SC, inspector, Cincinnati
 9BOX, Fredericksen, Phila. Signal Depot
 9BTK, Brown, Lexington Signal Depot
 9CHN, Hankins, Lexington Signal Depot
 9CKO, Friend, address unknown
 9CZV, Gipe, instructor, Scott Field
 9DB, Beck, instructor, Sioux Falls
 9DBD, Bush, jr. instructor, Scott Field
 9DBI, Hayes, radio instructor, Madison
 9DDJ, Hamilton, instructor, ACTS, Ill.
 9DJM, Conger, address unknown
 9DNL, Clary, Signal Corps, instructor
 ex-9DVH, Buchanan, Lexington Signal Depot
 9DWP, Beuerman, assoc. radio instructor
 9ENA, Hakkarainen, address unknown
 9ENX, Hespen, CAA, Montana
 9EQL, Anastasi, Lexington Signal Depot
 9ESP, Cook, SC, instructor, Colorado
 9FEG, Bell, AAFTS, Tomah, Wis.

ex-9FEN, Henden, Signal Corps
 9FIB, Haelen, AAFTS, instructor, Chicago
 9FIK, Jackson, instructor, Scott Field
 9FPP, Erolhard, instructor, Scott Field
 9GGR, Ingling, instructor, Scott Field
 9GHG, Barrett, Philadelphia Signal Depot
 9GZH, McCullough, SC, radio inspector
 9GIG, Knaack, sr. instructor, Scott Field
 9GMI, Austermillier, Navy, radio inspector
 9GOB, Combs, asso. radio engr., Ft. Hayes
 9GOC/9WEO, Lytle, asst. instr., Madison
 9GQO, Irving, SC, instructor, Lexington
 9GDU, Harrison, AAFTS, instructor, Chicago
 9GWL, Elrod, radio inspector, Chicago
 9HCF, Munson, Lexington Signal Depot
 9HIM, Breeding, address unknown
 9HKK, Jergovic, Lexington Signal Depot
 9HLB, Hinman, code instructor, Chicago
 9HOL, Mannen, SC, teacher, Ashland, Wis.
 9HUX, Bailey, FCC, radio operator
 9HYM, Chernikoff, radio instr., Madison
 9HXM, Leub, address unknown
 9IPA, Grauel, radio instructor, Scott Field
 9ILH, Jones, jr. instructor, Scott Field
 9IMC, Koch, asst. radio instr., Madison
 ex-9INF, Coates, address unknown
 9INL, Duncan, Naval Ammun. Depot, Ind.
 9IWN, Capen, radio technician, Ft. Hayes
 9JAJ, Cornelius, SC, radio inspector
 9JLB, Jensen, asst. radio instr., Madison
 ex-9JVB, Henriksen, Lexington Signal Depot
 9KAQ, Frazier, Radio Lab, Wright Field
 9KDF, Macbeth, Radio Lab, Wright Field
 9KEN, Doggett, Philadelphia Signal Depot
 9KJG, Esmay, instructor, Scott Field
 9LBB, Higinbotham, address unknown
 9LGU, Bieser, code instructor, Chicago
 9LKL, Blair, SC, inspector, Wright Field
 9LNP, Holbrook, SC, engr. aide, Chicago
 9LQQ, Hilgers, Philadelphia Signal Depot
 9LRM, Morgan, radio ins., Chicago
 9LVZ, Larkin, instructor, San Antonio
 9MFR/9LTK, Grove, instructor, Madison
 9MHD, George, AAFTS, instructor, Chicago
 9MVO, Dirks, Radio Lab, Wright Field
 9MWL, Holbrook, SC, radio engr. aide, Phila.
 9MZU, Fish, Lexington Signal Depot
 9NFN, Brown, Lexington Signal Depot
 9NKT, Hettinger, asst. radio instr., Madison
 9NKV, Beckley, Lexington Signal Depot
 9NPJ, Bridge, Philadelphia Signal Depot
 9NPL, Beams, Lexington Signal Depot
 9NUE, Bethel, Signal Corps
 9NVB, Knutson, radio work, Corpus Christi
 9NVW, Kawula, radio instructor, Scott Field
 ex-9OBK, Harlan, AAFTS, instructor, Tomah
 9OIQ, Bush, SC Labs, Ft. Monmouth
 9OIE, Hausske, insp. naval material, Chicago
 9OUL, Erhart, SC Labs, Ft. Monmouth
 9OUI, Bush, SC Repair Depot, Dayton
 9OWL, Bear, Lexington Signal Depot
 9OYB, Fisher, SC, operator, Ft. Snelling
 9PCN, Harris, asst. rdo. instr., Madison
 9PCX, Hull, radio instructor, Madison
 9PLG, Combs, SC, radio tech., Ft. Hayes
 9PTH, Hall, SC, inspector
 9QAN, Free, SC, radio technician, Ft. Hayes
 9QCN, Luecker, asst. rdo. instr., Madison
 9QGA, Bowman, Lexington Signal Depot
 9QLW, Cartwright, Navy, inspector, Ind.
 9QQQ, Emery, address unknown
 9QYU, Bloedorn, Naval Research Lab, Washington
 9RBE, Bathiany, asso. rdo. engr., Ft. Hayes
 9RHL, Fuller, address unknown
 9RHS, Blanc, Lexington Signal Depot
 9RHL, Geller, address unknown
 9RPH, Hilsabeck, SC, inspector, Wright Field
 9RQH, Hansel, SC Labs, Ft. Monmouth
 9RQW, Hegarty, SC, operator, Ft. Snelling
 9RSU, Hall, SC, asso. inspector, Chicago
 9RTM, Goldberg, SC Labs, Ft. Monmouth
 9RWH, Biltz, SC Labs, Ft. Monmouth
 9SCU, Alam, FCC, jr. monit. ofcr., Denver
 9SHM, Chevalley, asst. rdo. engr., Wright Field
 9SHY, Hill, Lexington Signal Depot
 9SLE, Iversen, SC, sr. inspector, Chicago
 9SNF, Barry, AAF, instructor, Chicago
 9SXF, Benson, instructor, Scott Field

9SYM, Jones, address unknown
 9SYX, Dalke, SC Labs, Ft. Monmouth
 9TEB, Braidwood, instructor, Scott Field
 9TGG, Cooper, instructor, Scott Field
 9TTT, Bray, Philadelphia Signal Depot
 9TYG, Jacobsen, Signal Corps, inspector
 9UFX, Kennedy, radio instructor, Madison
 9UIC, Dickson, asst. instructor, Scott Field
 9ULN, Jensen, Naval Research Lab, Washington
 9UMP, Kaufman, asst. radio instructor, Madison
 9UOF, Barker, Wright Field
 9UPC, Jones, address unknown
 9UOK, Crouch, jr. communications operator, Ft. Brady
 9VIN, Burnett, Signal Corps, Maine
 9VIX, Jacober, instructor, Scott Field
 9VOA, Burton, SC, radio tech., Ft. Hayes
 9VWN, Nelson, Philadelphia Signal Depot
 9WAO, Cooper, Philadelphia Signal Depot
 9WAY, Casper, SC Labs, Ft. Monmouth
 9WB, Anderson, Philadelphia Signal Depot
 9WSB, Fisher, Signal Corps
 9WET, Christenson, asst. radio instructor, Madison
 9WJD, Gehrke, asst. radio instructor, Madison
 9WKP, Bennett, Lexington Signal Depot
 9YAF, Fauser, Philadelphia Signal Depot
 9YBU, Davis, Lexington Signal Depot
 9YDA, Freeland, Signal Corps, Indiana
 9YED, Jones, instructor, Scott Field
 9YHP, Harrison, instructor, Scott Field
 9YKP, Goff, address unknown
 9YMS, Freeman, Lexington Signal Depot
 9YPH, Hall, SC, operator, Nebraska
 9YWE, Andrews, AAF, asst. instr., Chicago
 9ZNX, Johnson, Navy, radio insp., Chicago
 9ZPP, Beckley, Philadelphia Signal Depot

Operator's license only:

Alison, FCC, radio operator
 Aver, Signal Corps
 Donovan, FCC, radio operator
 Gold, AAF, instructor
 Hart, Signal Corps
 Howard, SC, radio technician
 Howerton, FCC, radio operator
 Hull, SC, associate inspector
 Madison, SC, radio mechanic

HAM HOSPITALITY

THE Radio Society of Great Britain extends a cordial invitation to all hams in service to visit the Society. The address is 16 Ashridge Gardens, London N13. Telephone Palmers Green 3255.

On page 45 of our January, 1943, issue, we reprinted, in part, an editorial which appeared in the October issue of the *RSGB Bulletin*. Reference was made in the article to *Break-In* as the official journal of the Wireless Institute of Australia. This was incorrect. *Amateur Radio* is the official organ of WIA and *Break-In* of the New Zealand Association of Radio Transmitters.

We're mighty pleased with this action photo of Lt. H. E. Taylor, W6PNI, naval aviator on duty "somewhere in the South Pacific." Ed says he's looking forward to meeting you all back on the air when this is over.

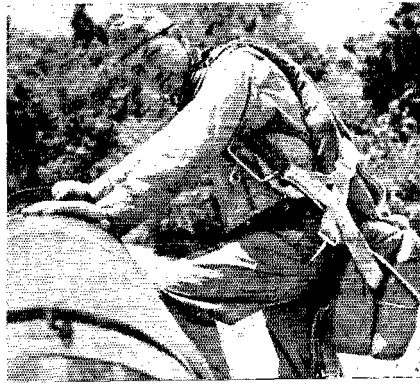

Message Handling in WERS

Speeding Up Operation by Assigning Message Priorities and Revising Control Station Procedure

BY HOWARD F. RUSSELL,* WIMAV, AND
ALBERT J. KING,** WIQR

Six months before Pearl Harbor, radio amateurs in East Providence started 2½-meter experiments for emergency communications. Soon after the Jap attack the Town Council authorized the purchase and installation of several transmitter-receivers. Amateurs contributed generously of their own equipment. Eventually seventeen stations were licensed. Classes were held in radio theory and code practice, and several candidates received their Class B licenses.

After a few practice drills in message handling, the Civilian Defense Council staged full-scale air-raid drills, with all land-wire communications declared out of service.

The resulting confusion was a bitter shock. WERS took an awful beating in East Providence that first drill. When it was over we sat down to figure out what had happened and why, and what we were going to do to prevent it from happening again. As a result, our ideas of air-raid message handling are so changed that we are passing the information along, in order that other communities who have not tried to handle an air-raid drill by WERS may benefit by our experience.

The trouble was that we were set up to handle messages — any type of messages. The air-raid wardens, auxiliary firemen, auxiliary police, and the permanent organizations had developed a system of reporting that made extensive use of telephones, fire alarm and police department circuits. When deprived of these, they tried to carry on by use of radio, both WERS and police. But twenty radio channels could not handle the number of reports they wanted to send. Then, in the middle of the drill, some umpire with sadistic tendencies declared a principal radio station out of service, necessitating the dispatch of a mobile unit to cover that area.

From the start of the drill we were snowed under. Originally it was planned to handle messages in the order in which they were reported in. The result was that we were handling messages of no relative importance, while messages reporting incidents or dispatching apparatus were hanging on the hook.

Something drastic had to be done. The coöperation of the civilian defense organization and the police and fire departments was enlisted. The response was admirable. All organizations were instructed by their various heads to reduce messages to those *vital* necessary, and the police

department offered to restrict their messages as far as possible to the capacity of their own radio system. For our part, we set up a method of priorities (much as we have come to dislike the word) and also set about speeding up our ability to handle messages.

In the many subsequent drills the revised WERS system has worked well. Messages in general have been handled promptly and in the order of their relative importance. The town fathers have expressed themselves as satisfied that WERS will play a vital rôle in saving lives and property if land wires are taken out of service through any catastrophe, man-made or otherwise.

Priority System for Messages

The priority system of handling messages has worked so well that it will be described in some detail. First, in coöperation with the civilian defense officials, we tried to estimate what casualties might happen and their relative importance to the inhabitants of the town. Then we listed the types of messages needed to save lives and property and minimize discomfort. It was decided that all messages would be divided into five classes, as follows:

Class 1 — Messages reporting (a) "gas," (b) "paratroopers," (c) "saboteurs," (d) "casualties."

Class 2 — Messages reporting (a) "fire," (b) "utility damage," (c) "blocked roads."

Class 3 — Messages reporting "apparatus dispatch" (fire, ambulances, rescue squads, decontamination squads, etc.).

Class 4 — Messages reporting "apparatus return" to service.

Class 5 — General messages (not included in other classes).

Control Center Procedure

In conjunction with the above, a control panel was built with five hooks for each of the seventeen stations. A supply of colored tags for each class of message with the appropriate name and number printed thereon was provided nearby.

Four operators man the control station. The first is in charge of the control panel and directs the team. The second operates the equipment, including the microphone. The third copies all incoming messages and keeps the log. The fourth numbers incoming messages, sees that they reach the control center promptly, receives all messages from the control room, and checks them before transmittal to outlying stations. When the incidents bunch, as they tend to do, all four operators are busy.

* Radio Aide, Town of East Providence, 71 Catlin Ave., Rumford, R. I.

** Asst. Radio Aide, Town of East Providence, 70 Metropolitan Park Drive, East Providence, R. I.

The civilian defense organization in East Providence has developed simple comprehensive message forms for incoming and outgoing messages, whereby writing is kept at a minimum. Most of the messages can be handled by checking the appropriate item on the form. Such procedure not only increases accuracy but also reduces the time required to handle the message. It was logical to adopt these forms and thus tie in with the control center procedure. Our operators were drilled in their use, and subsequent tests have proved that, after a little practice, even new operators handle messages promptly and accurately.

When messages bunch, the practice is to allow a listening period at the control station of approximately five seconds on the completion of each message, so that stations having messages for delivery can call in, giving the type. Appropriate tags are immediately set up on the control panel, so that the chief operator has before him at all times a complete picture of the needs of the entire net. The following will illustrate the procedure:

Station Seven: Seven to One.¹ Fire message.

Control: Roger, Seven. (Immediately a "fire" tag goes on the No. 2 hook under Station 7.)

(Control listens for 5 seconds. Number Six calls.)

Station Six: Six to One. Casualty message.

Control: Roger, Six. (Immediately a "casualty" tag goes on No. 1 hook under Station 6.)

Station Fourteen: Fourteen to One. Paratroop message.

Control: Roger, Fourteen. (Immediately a "paratroop" tag goes on No. 1 hook under Station 14.)

(Control listens for 5 seconds but no other stations call in.)

Control: One to Fourteen. Transmit paratroop message. Answer.

Station Fourteen: Fourteen to One. Warden's report form, message No. 1 . . . (proceeding to transmit message).

Control: One to Fourteen, Roger.

(Control listens 5 seconds; no stations call in.)

Control: One to Six. Transmit casualty message. Answer.

Station Six: Six to One. Wardens report form, message No. 1 . . . (proceeding to transmit message).

The same procedure is followed until all messages are cleared. Outgoing messages are sandwiched in between incoming messages, depending

¹ *Editor's note:* As an alternative to this type of identification, many WERS networks have found it better to reverse the order of identification and avoid the use of the preposition "to," which might be confusing because it sounds exactly like the numeral "2" when spoken; thus, "One from Seven," instead of "Seven to One"—which might be received as "7-2-1." It is understood, of course, that this type of identification can be used only after the net has been established and complete station identification exchanged with each net member, as per FCC regulation 15.42.

upon the order of their importance. This method, of course, places much responsibility upon the operator in charge, for he must determine which messages to handle first. Somewhere in the course of the drill or actual air raid he will have to decide to dispatch apparatus, even when messages of seemingly greater importance are still hanging on the hook. However, it is better to dispatch apparatus to the first incident than to accept additional messages while apparatus is standing idle in the stations. There does not seem to be any way of avoiding this responsibility. The control panel at least gives a complete picture of the messages that are waiting. After that it is a matter of judgment.

Conditions in East Providence are such that there are many dead spots where mobiles cannot work the control station direct. It has been found advantageous, therefore, to assign the mobiles to certain fixed stations, through which their messages are relayed to the control station. Not having all the apparatus we would like, we have arranged it so that when a fixed station handles a message from a mobile he first receives permission from the control station. Appropriate tags are immediately placed on the hooks, indicating that the two stations are working in the high end of the band. No time is then wasted calling them.

System Successful in Tests

Local civilian defense officials have expressed themselves as well pleased with the method, after
(Continued on page 98)

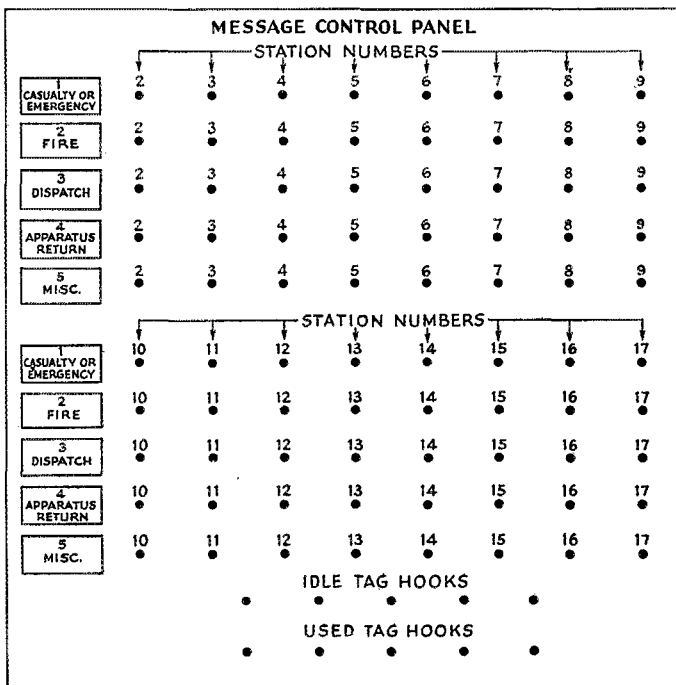

Arrangement of the message control panel described in the text. Colored tags indicating class of message are hung on the hooks. Tags accumulated on the lower row of hooks ("used tags") constitute a record of messages handled.



U.S.A. CALLING!



EXPERIENCED INSTRUCTORS NEEDED

OPPORTUNITY exists for a large number of better-qualified radio instructors, at a school in New England where important instruction in electronics and radio is being given. Males only. Employment under ordinary civil contract, not Civil Service or military commission. Good salary, commensurate with ability and former earnings. While particulars cannot be published in *QST*, the work is of large importance.

Only qualified instructors with teaching experience on the technical side of radio are wanted. We regret that there is no opportunity in this project for student instructors, nor for instructors in code. Pedagogical abilities, successful teaching experience, are perhaps as important as technical radio knowledge. In fact, if you are a good teacher but feel that you are not quite up to date on advanced electronics, opportunity is available to the right men to attend special school to be brought up to date.

Many radio schools are now being closed. The present project offers opportunity for the better-qualified teachers to locate themselves at once in continuing and satisfying work.

For further information, give full particulars on yourself at once to George W. Bailey, OSRD, 2101 Constitution Ave., N. W., Washington 25.

THE W.S.C.T.s

PRONOUNCE it if you can! It means the WAC (formerly WAAC) Signal Corps Trainees, and it's the latest thing in training for women with a leaning toward radio and telephone work. The Signal Corps is back of this plan to give you hamettes and gals who like to tinker with radio a chance to earn from \$1020 to \$1440 a year while you're learning the inside stuff that will qualify you to go on Signal Corps duty with the WAC. And, by the way, that might mean Africa, England, or any of the camps in the U.S.A., where WACs are replacing enlisted men by the hundreds.

This is the official United States Army program which grew out of a civilian organization known as the WIRES (Women In Radio and Electrical Service), which volunteered the services of its members to the Signal Corps. Inasmuch as the Women's Army Corps (formerly the Women's Army Auxiliary Corps) is the only women's organization authorized to serve with the Army of the United States, exclusive of the Army Nurse Corps, and in order to be completely impartial in the selection of personnel, the WSCT plan was authorized so that qualified civilians, whether members of the original WIRES organization or not, could receive Signal Corps training and be placed on communications duty within the WAC.

The plan is that you are enrolled in the WAC and are immediately placed on inactive-duty status under Civil Service to take from three to six months' training in the specialties the Signal Corps needs right now. These are teletypewriter operators, switchboard installers, radio operators, radio repairmen, and radiotelephone operators. The Signal Corps needs 1080 girls in the WSCT to take over the jobs of soldiers who will then be free to go out and hit Hitler, slap the Jap and mop up Mussolini. Any girl between 21 and 44 years of age, with a high-school education, who has an aptitude for this kind of work, who can pass the Army General Classification test with a score equal to the Enlisted Reserve, and is physically qualified, is eligible to join up.

After you have successfully completed your WSCT courses, you will be called to active duty with the WAC, get your uniform and basic military training and be all set to become a part of the Army's great communication system. There's plenty of chance for promotion in the WAC for those who go through the Signal Corps training courses. After the war is over, the experience and training with the Signal Corps, the nerve center of the Army, will come in mighty handy. Jobs in the communication industries will be opening up for men and women who have the know-how. See your nearest Army recruiting officer for details. Here's a chance to learn a trade, earn while you learn, and hold an important job in the WAC — the Signal Corps' job of "Getting the Message Through!"

ENGINEERS AND PHYSICISTS

THE Signal Corps has pressing need for college-trained technical men, to receive commissions in that corps. Graduate radio engineers and electronic physicists between the ages of 22 and 45, and graduate electrical engineers who have reached the age of 35, are invited to get in touch with the nearest office of the Officer Procurement Service, a list of whose addresses and telephone numbers we published on page 27 of our May issue.

Experienced engineers and physicists of high qualifications are needed for technical leadership in work of great importance. The kind of men here spoken of unquestionably are well connected at the moment, but there may be some who are not satisfied that their talents are being used to the utmost and who, without disturbing their present connections, would like an opportunity to explore the possibilities in a confidential way. As mentioned in this department the past several months, such a mechanism has been set up, and professional men of this category are invited to

engage in confidential correspondence with George W. Bailey at the Office of Scientific Research & Development, 2101 Constitution Ave., N. W., Washington 25, D. C.

Women physicists and engineers are also needed and may communicate with Mr. Bailey.

WOMEN INSPECTORS

THE War Department announces that an exceptional opportunity is presented to women seeking war jobs, in a large-scale program being launched by the Signal Corps to train civilian inspectors for duty in factories producing military telephone, radio and radar equipment.

Several thousand women already are engaged in this work, and their services have proven highly satisfactory. Men, too, are sought, but they must be outside Selective Service age brackets or unfit, physically, for military service.

The course lasts six weeks, eight hours a day, six days a week. The pay, at the rate of \$1752 a year, starts when the trainee begins the course. Opportunities for advancement depend on the individual's skill and the available vacancies.

Trainees learn electrical and radio terminology, the use of diagrams and simple blueprints, many factory processes, and the application of such measuring instruments as vacuum-tube meters and cathode-ray oscillographs. In the final week of the course, the individual works under the resident Signal Corps inspector to whom she is to be assigned.

Applicants are advised to apply to the nearest office of the Civil Service Commission, where selections are to be made through interviews and simple aptitude tests. High-school graduates are preferred, but those with equivalent education and experience are eligible. Those selected will receive the training in their home areas.

RADAR OFFICERS

THE several military services continue their search for acceptable candidates for radar officers. Since these officers receive very valuable and special training in electronics, candidates must be graduate engineers and in combat physical condition. Not only is this training of the greatest interest, but it prepares one for a good commercial future. Interested and qualified inquirers may address the following, giving full particulars on themselves:

In the Army, this work is centered in the Electronics Training Group of the Signal Corps. Candidates must be either electrical engineers or science graduates with an electronic-physics major. Age limits, 18 to 35. Address the Office of the Chief Signal Officer, Pentagon Building, Washington.

Graduate electrical engineers between the ages of 18 and 45 are eligible for commission in the Navy as Aviation Volunteers (Specialist). Address The Commandant of your Naval District.

The Marines call this service the Aircraft Warning Service. Graduate engineers between 20 and 45 may address The Commandant, Headquarters, U. S. Marine Corps, Washington.

If you are in doubt about your qualifications or

want friendly amateur advice, address George W. Bailey (W1KH), 2101 Constitution Ave., N. W., Washington 25.

TECHNICAL WOMEN

THE president of the League, Mr. George Bailey, at 2101 Constitution Ave., N. W., Washington 25, is in position to place a number of women with technical radio training in interesting technical work directly connected with the war. Those interested are requested to write to him, with particulars on themselves, for further information.

ENGINEERING DRAFTSMEN

THE Civil Service needs qualified engineering draftsmen in any field, for positions paying \$1752 to \$3163 per year (including overtime for the present 48-hour week). High-school students who have had 3 semesters of drafting training may qualify for the \$1752 positions, as may persons who have successfully completed a course of drafting in college, technical school, or under the ESMWT program. Particulars are to be found in Announcement 283 at your post office.

IF YOUR COPY OF QST IS LATE—

Bear with us and the nation's transportation systems. We are both doing our best — *QST* is being printed one to three days earlier to help keep deliveries on schedule — but unavoidable wartime delays do occur.

ARRL Members:

1. Slowness of delivery is beyond our control; your copy is mailed at the same time as all others for your vicinity.
2. *Don't write us about non-delivery until at least the 10th of the following month; your copy is on the way.*
3. *Renew early and keep your file intact; the supply of replacement and back copies is sharply limited.*
4. *Please allow plenty of time for acknowledgment of new and renewed membership-subscription entries.*

Newsstand Readers:

Because of paper limitations, newsstand quotas are unavoidably reduced. *To make sure of getting your copy, buy it from the same dealer each month. That way we can allocate available copies to maximum advantage.*

Overseas Members:

Note the expiration date on your membership-subscription certificate and *renew 3 to 4 months in advance.* All entries are now being made effective with the issue of *QST* current as of the date new or renewal order is received.

Under present conditions *QST* is mailed overseas at the subscriber's risk and we cannot duplicate copies.

A Five-Band Transmitter-Exciter

A 100-Watt Unit of Conservative Design

BY CLYDE C. RICHELIEU,* W9ARE

Whether it be a purely imaginary process or actual reconstruction of the old rig in such spare moments as are available, rebuilding for postwar operation is a major part of most every ham's thinking. Here is an article on a complete engineered, integrated design of proved merit that may supply some ideas.

THE exciter unit to be described is the result of a concerted search for a versatile unit that would provide ample r.f. drive for a high-power final, be flexible with regard to band changing without the complications of a band-switching arrangement, and which would, in itself, also serve as a complete 100-watt c.w. and 'phone transmitter. The tube line-up used is the outgrowth of practical experimentation at W9ARE in quest of an ideal exciter. I believe this unit will satisfy the most fastidious operator from the standpoints of both appearance and performance. No special credit is claimed for the circuits or mechanical design, and I hope only that I have succeeded in grouping together many of the better features of other designs.

Among the requisites of a modern exciter unit are sufficient output to drive a medium- or high-power triode final stage, and efficient frequency control. Under this latter requirement must come provision for both crystal and self-control of frequency. To insure stable electron-coupled oscillator control, I have spared no effort to make this part of the circuit both mechanically and electrically as secure as possible.

* 369 North Granada St., Arlington Forest, Va.

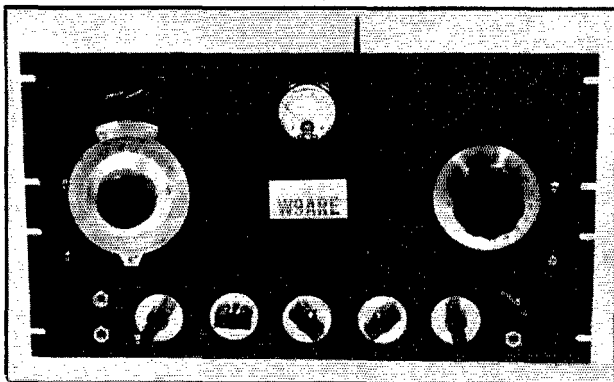

W9ARE's 100-watt exciter unit. The dials control the tuning of the e.c.o. and the output stage, while the small controls are used for tuning the intermediate stages when changing bands.

The E.C.O.

A Type 802 pentode was chosen for the electron-coupled oscillator because its performance had been proved in a previous model.¹ Its special internal shielding helps to stabilize the circuit, while it delivers a husky output with very little grid current, all of which goes to make a more stable oscillator. To provide an e.c.o. circuit of high Q without resorting to the use of an abnormally high capacity, the grid of the 802 is tapped down on the coil.² While the proportion of L_1 included between the grid tap and the end of the tank circuit (see coil table) would seem to be so small as to have a negligible effect, actual tests against a crystal standard showed the improvement in signal quality and stability to be considerable, especially with the higher-frequency coils. A fixed condenser of low temperature-coefficient (silvered mica), forming the main part of the tuning capacity, helps to limit frequency drift with changes in temperature. Negative-coefficient equalizing trimmers were tried for temperature compensation, but after the unit was finished and checked for drift it was found that they were actually a detriment. The use of the low-temperature fixed condenser and the 802 with low input had resulted in an entirely satisfactory limitation of drift. Should it be found that compensating condensers are needed, they should be connected across the coil, as shown at C_3 in the circuit diagram of Fig. 1.

Instead of the conventional coil tapped for the cathode connection, a separate cathode coil is provided for feed-back.³ I found that one of the secrets of good e.c.o. keying is to insulate the entire tuned circuit and by-pass it to ground, rather than to ground the tuning condensers only and place the by-pass in series with the tuned circuit, between condenser rotor and coil, as is sometimes done. The latter connection results in a tendency toward a slight chirp.

A pair of VR-150-30 voltage-regulator tubes in series across one of the 400-volt leads holds the 802 plate, screen and suppressor voltages constant. A regulated voltage of 150 for the screen is obtained by bringing out a tap from the junction between

¹ Tilton and Browning, "Look for Me on . . . Ke.," *QST*, July, 1938, p. 18.

² Norton, "Simplicity in an Electron-Coupled Oscillator," *Radio*, July, 1939, p. 11. Seiler, "A Low- C Electron-Coupled Oscillator," *QST*, Nov., 1941, p. 28.

³ Stiles and Blair, "Let's Talk E.C.O.," *QST*, August, 1941, p. 14.

the two VR tubes, while 45 volts for the suppressor is tapped off the voltage divider formed by R_3 and R_4 . R_5 is adjusted to the correct value for proper operation of the VR tubes. To insure that the operation of the regulator tubes will not be impaired by stray r.f., they are isolated by means of r.f. chokes in all leads.

Previous experience had shown that it was almost impossible to couple a doubler directly to the tuned-plate circuit of the e.c.o. without loading the oscillator too heavily, with consequent reaction on the frequency-controlling grid circuit. As a result of this, an isolating stage, biased for practically Class-A operation, was mandatory. The Type 6L6G was chosen for this stage because of its easy driving properties and the fact that several were on hand. Similar tubes, such as the 6V6 or 6F6, might be used with equal results in this Class-A stage, although the 6L6 with its larger dissipation rating is preferable. Plate voltage of approximately 300 is obtained through the series dropping resistor, R_{32} , with additional drop for the screen voltage through R_{16} . The bias of this stage is adjusted, by means of R_{15} , so that the 6L6G draws very nearly the same plate current (about 23 ma.), with or without excitation. The plate circuit of the e.c.o. is untuned and is coupled to the grid of the 6L6G through the coupling capacity, C_8 .

Crystal Oscillator and Doubler Stages

By means of S_1 , the key may be shifted from the cathode circuit of the 802 to the cathode circuit of the 6J5 crystal-oscillator tube. At the same time, the plate of the 6J5 is connected to the plate tank circuit of the 6L6G. Since the latter tube is required only in conjunction with the e.c.o., its tank circuit is made to serve in the crystal-oscillator circuit and eliminating the need for a separate tank circuit when crystal control is in use. A Kelvin multiple crystal holder, containing eight crystals, provides for a selection of crystal frequency. Bias is obtained entirely from the cathode resistance, R_1 .

In keeping with a desirable policy of using larger tubes and keeping the voltages and currents to low values to improve stability, a Type 807 was selected for the following doubler stage. I doubt if any argument can be presented that will disqualify this tube as the ideal doubler, although for the power I am demanding of this tube the smaller Type 6L6G might serve just as well. However, I maintain that the use of larger tubes and lower currents and voltages always improves stability and prolongs tube life. In this case, plate voltage is limited to 400, while the grid is biased heavily by means of a fixed bias of 45 volts, cathode bias from the adjustable resistance, R_{13} , and grid-leak bias from R_{17} . Screen voltage

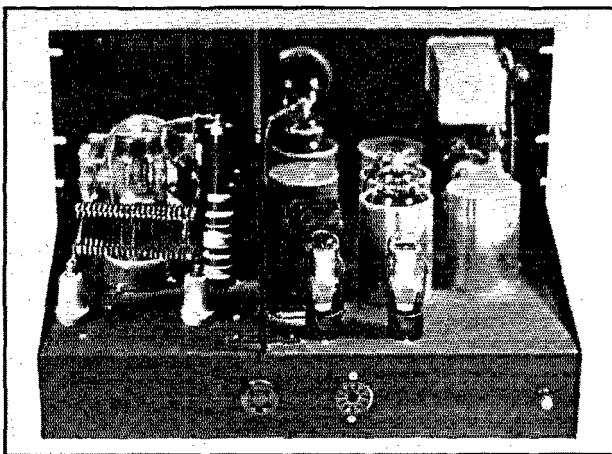

Rear view of the 100-watt exciter unit. An aluminum shield separates the RK-20A output stage and the preceding stages of the exciter.

is obtained from a voltage divider composed of R_{19} and R_{20} . The potentiometer, R_{19} , provides a ready means of smoothly varying the output of the doubler stage. R_9 , R_{10} and R_{11} are for the purpose of suppressing parasitic oscillation in this stage. A keying jack is included also in the cathode of the 807, both for the purpose of keying this stage when break-in operation is not required and also to permit opening the circuit, by means of a dummy plug, while preceding stages are being tuned.

The Output Stage

Now my choice of the RK-20A for the exciter output stage will probably be branded old-fashioned, or at least extravagant. However, after struggling with a lower-power beam-type tube in an effort to obtain sufficient drive for a high-power final, and after using an old RK-20 from 1936 to 1939 with such splendid results, I could not make myself agree to anything but one of the newer and more efficient RK-20As. The initial

W9ARE's complete transmitter, showing the exciter in place with its power supply immediately below in the rack. The exciter drives a pair of TW-75s in push-pull in the final, which is modulated by a speech amplifier and modulator using Class-B 211s. The top unit is a pi-section network for antenna coupling. The lower sections contain power supplies for the modulator and final stage.

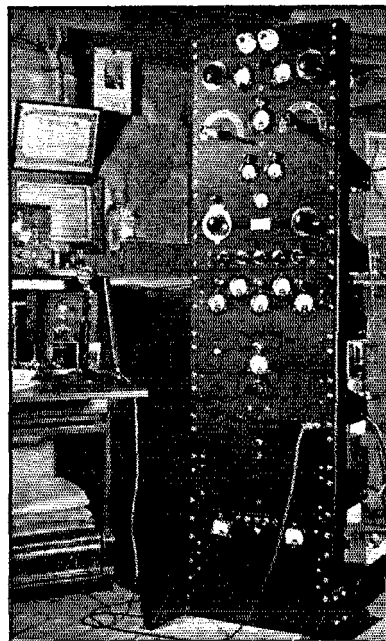

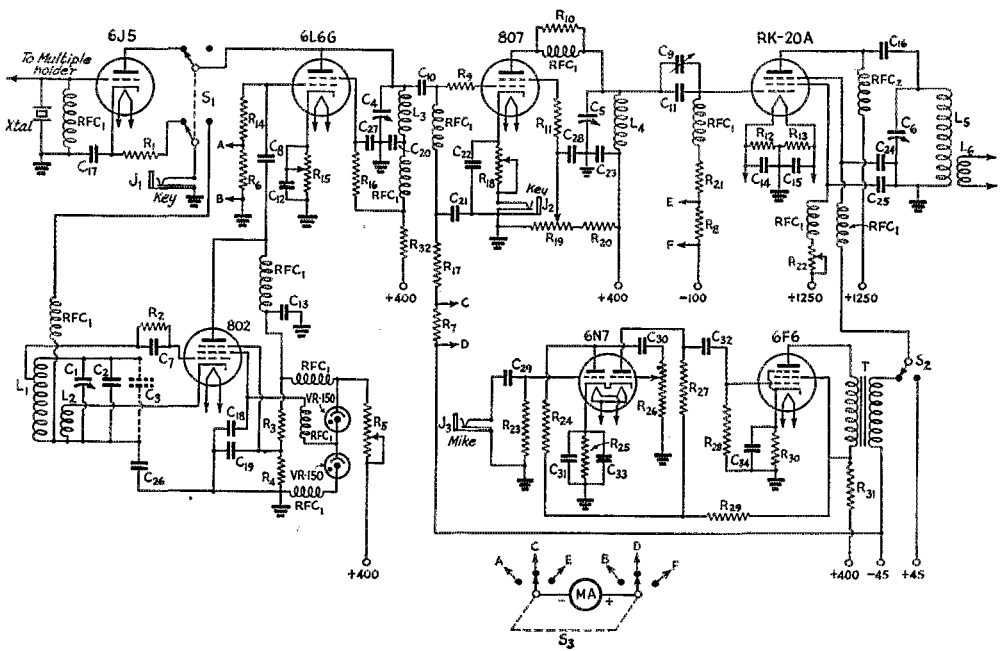

Fig. 1—Circuit diagram of W9ARE's crystal-e.c.o. transmitter-exciter unit.

- | | | |
|--|--|---|
| C_1 —150- μ fd. variable. | R_2 — $\frac{1}{2}$ megohm, 1-watt. | R_{28} —1 megohm, $\frac{1}{2}$ -watt. |
| C_2 —300- μ fd. silvered mica. | R_3 —40,000 ohms, 10-watt. | R_{24} — $\frac{1}{4}$ megohm, 1-watt. |
| C_3 —Negative temperature coefficient condenser if required. | R_4 —10,000 ohms, 1-watt. | R_{26} —1000 ohms, 1-watt. |
| C_4 —75- μ fd. variable. | R_5 —5000-ohm, 25-watt resistor, set at approximately 3500 ohms. | R_{26} — $\frac{1}{2}$ -megohm potentiometer. |
| C_5 —50- μ fd. variable. | R_6, R_7, R_8 —85 ohms, $\frac{1}{2}$ -watt. | R_{27} —0.1 megohm, 1-watt. |
| C_6 —100- μ fd. variable. | $R_9, R_{10}, R_{11}, R_{12}, R_{13}$ —50 ohms, 1-watt. | R_{28} — $\frac{1}{2}$ megohm, $\frac{1}{2}$ -watt. |
| C_7, C_8 —100 μ fd. | R_{14} —75,000 ohms, 1-watt. | R_{29} —6500 ohms, 1-watt. |
| C_9 —100- μ fd. mica trimmer. | R_{15} —1000 ohms, 10-watt. | R_{30} —500 ohms, 2-watt. |
| C_{10}, C_{11} —250- μ fd. | R_{16} —15,000 ohms, 2-watt. | R_{31} —3500 ohms, 10-watt. |
| $C_{12}, C_{13}, C_{14}, C_{15}$ —0.001 μ d. | R_{17} —50,000 ohms, 1-watt. | R_{32} —4000 ohms, 10-watt. |
| C_{16} —0.002 μ d., 5000-volt. | R_{18} —5000 ohms, 10-watt. | J_1, J_2, J_3 —Closed-circuit jack. |
| $C_{17}, C_{18}, C_{19}, C_{20}, C_{21}, C_{22}, C_{23}, C_{24}, C_{25}$ —0.005 μ d. | R_{19} —250,000-ohm potentiometer. | MA —Grid-current milliammeter, 0-10 ma. scale. |
| $C_{26}, C_{27}, C_{28}, C_{29}$ —0.01 μ d. | R_{20} —15,000 ohms, 2-watt. | S_1 —D.p.d.t. switch. |
| C_{30}, C_{31}, C_{32} —0.1 μ d. | R_{21} —7000 ohms, 1-watt. | S_2 —S.p.d.t. toggle. |
| C_{33}, C_{34} —10- μ d. electrolytic. | R_{22} —25,000 ohms, 75-watt. | S_3 —Three-position, double-pole rotary switch. |
| R_1 —300 ohms, 1-watt. | | T —1-1 ratio output transformer. |

cost of this tube is more than offset by the stable way in which it operates and by the small amount of driving power required for more than ample output on all bands. Then, too, as mentioned in my initial paragraph, I wanted a tube with sufficient output on both c.w. and 'phone to permit the unit to be used as a separate transmitter of fairly husky output, and only the RK-20A provides that much-needed suppressor grid for low-level modulation.⁴ Use of the beam-type RK-47 tetrode in place of the RK-20A might be justified for greater power output, were it not for the need of the suppressor element. However, past experience with 807s has shown that beam types are much harder to stabilize than the pentode types. So the RK-20A remained the logical choice and, needless to say, the results have been more than satisfactory. Parallel feed is used in both grid and plate circuits of the output stage. Excitation may

be adjusted by means of the variable coupling capacity, C_9 , and by varying the output of the 807 through a change in its screen voltage. Screen voltage of 300 for the RK-20A is obtained from the plate supply through the adjustable series dropping resistor, R_{22} , while biasing voltage is obtained from a combination of 100 volts of fixed bias and the drop across the grid-leak resistance, R_{21} . The suppressor is biased 45 volts positive or negative, depending upon whether c.w. or 'phone is in use, respectively. The shift in polarity is taken care of by S_2 , which also connects in the output of the modulator for 'phone operation. Coils for the output stage are fitted with low-impedance link windings.

Modulator

The suppressor modulator is a simple arrangement consisting of two stages of resistance-coupled speech amplification, with a single section of a 6N7 dual triode in each stage, and a 6F6 output stage, also resistance coupled. The second

⁴ Reed, "A 'Phone-C. W. Transmitter," *Radio*, January, 1941, p. 83. Harvey and Purinton, "A Medium-Powered 'Phone-C.W. Transmitter," *QST*, August, 1934, p. 27.

dary of the output transformer, T , is connected in series with the suppressor lead. Plate voltage of 300 is obtained through the series dropping resistor, R_{31} . The input is designed for a crystal microphone.

Power Supply

Power for the entire exciter unit is obtained from a separate power-supply rack unit which may be seen immediately below the exciter unit in the photograph of the complete transmitter at W9ARE. This power unit consists of two sections, one of which delivers 1250 volts for the screen and plate of the RK-20A. The second section delivers 500 volts to a voltage divider which is grounded at a point 100 volts from the negative end, thereby providing 100 volts negative for biasing the grid of the RK-20A and 400 volts positive for supplying the plate of the 807, for the regulator tubes through R_5 , for the plates of the 6J5 and 6L6G through R_{32} , and for the plates of the tubes in the audio section through R_{31} . Taps on the voltage divider are also made at points 45 volts positive from ground for the suppressor of the RK-20A during c.w. operation, and 45 volts negative for biasing the 807 and for the RK-20A suppressor when 'phone is desired. Separate 400-volt leads are shown to permit the insertion of individual meters. Grid current to the 6L6G, 807 and RK-20A may be checked by means of the grid-current milliammeter, MA , which is mounted on the panel of the exciter unit and which may be switched to any of the three grid circuits by means of S_3 .

Construction

A front view of the exciter unit is shown in the first photograph. This, together with the power supply, forms a complete medium-power rig for either 'phone or c.w. operation. The left-hand main tuning control is for tuning the e.c.o. The dial is a National Type-N vernier, well adapted to this purpose. Just above this dial is the crystal-selector switch. The row of controls along the bottom, from left to right, are for: crystal-e.c.o. switch (S_1), 6L6G isolating-stage plate tuning (C_4), 807 plate tuning (C_5), grid-meter selector switch (S_3), and 'phone-c.w. switch for RK-20A suppressor bias (S_2). The two jacks at the left are for keying connections in either the oscillator cathode or the 807 doubler cathode. The knob and jack in the right lower corner are for the modulator gain control and microphone-input jack, respectively. The main tuning dial to the right is the RK-20A plate tuning control. The grid-current milliammeter, MA , is, of course, mounted at the top center of the panel.

The bottom view of the exciter is more or less self-explanatory. Mica condensers are used throughout, except in the audio portion. Isolantite sockets are used in all r.f. circuits. The socket for the RK-20A, shown in the upper middle portion of the chassis, is mounted in the bottom of a 2-inch aluminum shield which provides 2 inches of sub-base shielding. A similar shield, one inch in height, extends above the chassis.

The rear view shows the general layout plan. The oscillator-doubler portion is separated from the RK-20A output stage by a vertical aluminum shield. The left-hand portion contains the RK-20A with the output tank coil in back, the Hammarlund 100- μ fd. tuning condenser mounted on the panel and the National R-175 r.f. choke to one side of the tube. The two audio tubes are also mounted in this section, next to the tank condenser, although it might be preferable to use the space next to the VR tubes.

In the right-hand compartment can be seen the multiple crystal holder. Immediately below, close to the panel, is the 150- μ fd. e.c.o. tuning condenser, C_1 , mounted on polystyrene posts. To the rear of this condenser can be seen the e.c.o. coil shield. In the foreground are the two VR-150 voltage-regulator tubes, and just back of the right-hand regulator tube is the 802 oscillator tube mounted within an aluminum shield can. Just ahead of the 802 is mounted the 6L6G in a similar aluminum shield can, and ahead of this, next to the panel, is the 6L6G plate coil, also shielded with an aluminum can. To the left of this row, just ahead of the left-hand regulator tube, is the

(Continued on page 98)

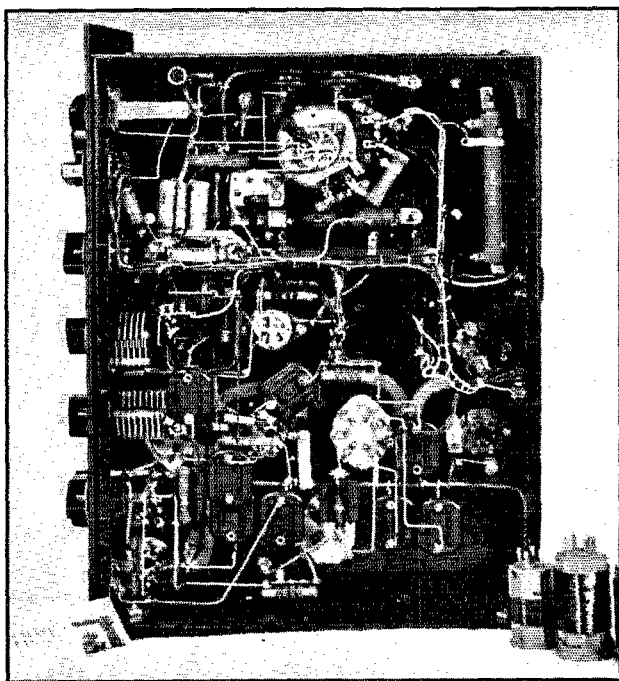

Bottom view of the RK-20A 100-watt transmitter-exciter unit.

"CQ"

A Short Short Story

BY CORPORAL EARL A. PARKER,* W2LDV

THE band was wide open. Joe reached for the "send-receive" switch with a practiced arm, experiencing as he did so the indefinable feeling of expectancy that always accompanied the motion. He'd often thought it was akin to the feeling when you dropped a baited hook over the side of a boat. There was a sort of a sense of anticipation, mingled with curiosity as to what the catch would be. Fishing and ham radio had a lot in common, at that.

As he snapped the switch the heterodyne cacophony spewing out of the speaker abruptly cut. Automatically he glanced up at the pilot bulb coupled to the final tank which acted as an r.f. indicator. Its cheerful gleam assured him that all was well. He brought his lips near the round black disc of the faithful old F-1 button, standing on its mounting like a patient servant waiting to do his bidding.

Pretty good job, that mike stand, he reflected. He'd spotted the old automobile cowl-light housing in a box of miscellaneous junk in Bill's garage. A little work with hacksaw and soldering iron, some chromium polish mixed with elbow grease — and there it was, looking as good as any in the catalogs.

The illumination from the pilot bulb varied in intensity as it followed the tones of his voice. He hoped the W6 wouldn't be smothered in the QRM when and if he came back. He hadn't intended to answer the CQ, at first. The signal wasn't too strong for that particular part of the band, where you really had to put out to keep your head above the bedlam of QRM. Then he'd made a last-second decision to call the fellow, just for the heck of it. In a way it was more fun to pull someone through the mess down around the low end of the band than to wait for a signal out in the clear at the high end.

Too bad more of the fellows didn't make use of the frequencies above 29 Mc. or so. He'd really had some pleasant contacts up there. The boys had kidded him about being so high in frequency when he'd started using that crystal. But it had paid dividends in good solid QSOs. Some of the fellows claimed the high end of Ten "went out" before the low end. He'd have to check into that someday. Arrange to jump from one frequency to another when the band was beginning to fade. . . .

The mute speaker suddenly came to life, as he concluded his call and threw the switch over to "receive." The heterodynes were worse, if anything. Carefully he swung the dial a fraction each

side of its original setting, striving to pierce the din of beat notes and splattering sidebands. No answering call rewarded his ears. Maybe the W6 was slow about coming back. Some fellows had an awful lot of switches to throw before they could come back. . . . Was that him? That fragment of modulation had sounded like his call. Painstakingly he readjusted the dial, leaning forward in concentration as his ears strove to decipher the din.

"Doubleyootuu — — — calling doubleyoo five — — —" The speaker thundered as the R ninety-nine-plus signal vibrated its cone. Oh, nuts. He'd forgotten about that new guy over on East 36th. The squirt usually came on Sunday afternoons and stayed until the band died out. Well, that was that. No use trying to pick up the W6 again. Guess he'd put out a CQ up on the high end, just in case. . . .

CQ? CQ? What was it that was trying to break into his thoughts in connection with those two letters. . . . Joe sat up in his bunk — or at least as close as it is possible for anyone to come to sitting up in a double-decked Army bunk. Frantically he gazed at his wrist-watch through sleep-blurred eyes.

Holy smoke! He went on duty at battalion headquarters as charge-of-quarters at six A.M., and he'd already overslept twenty minutes past the hour. That sarcastic sergeant on the night tour of duty who couldn't leave before Joe got there would be plenty peeved at missing his Sunday morning chow.

Doggone that orderly room CQ! He'd promised to wake him at five-thirty. Boy, would he tell that bird a couple of things about making promises when —

Joe groped under the bunk for his GI shoes with one hand. He shuddered slightly as his feet came in contact with the ice-cold boards of the squadroom floor. C Company must've had fire guard last night, he speculated. Those guys never did. . . .

Say, he'd had a kinda funny dream . . . something about ham radio and being back on the air and calling a W6 . . .

Oh, nuts. That stuff was only pleasant memories now. This was the Army. Maybe some day soon he'd be back in front of the old rig again. . . . Someday.

Joe spent one last precious moment contemplating the prospect. Then he shrugged. In the meantime there was another job to do. He finished lacing his shoes and stood up, shivering in the cold air as he reached for the trousers lying in a crumpled heap on his footlocker.

* Co. B, 784th MP Bn., Fort Mason, San Francisco, Calif.



EXPERIMENTER'S SECTION

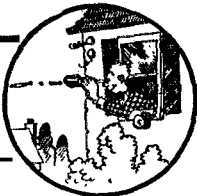

Address correspondence and reports to ARRL, West Hartford, Conn.

PROJECT A

Carrier Current

WE HAVE three fellows at the present time using carrier current and we expect one more very soon. The group consists of W2OKE, Bob Petrina, formerly on 160 'phone; WW2HD, Hal Dickert; and myself, WW2AVC. We are all using c.w. at the present time, with OKE using 'phone occasionally. We have covered the town using 15 to 20 watts, although we have no reports of our sigs from anyone in outlying towns.

W2OKE and I are using superhet receivers in conjunction with converters built after the one described by W3IBB in the Experimenter's Section in the March issue of *QST*, while 2HD has built a special c.c. superhet.

I use a 6L6 in my transmitter and we operate on a frequency of about 190 kc. I have tried various methods of coupling to the line and have found that a 0.1- μ fd. paper condenser in series with a 4-turn coupling coil to the hot side of the line works best and permits good loading. Our tank condensers consist of two or three sections of a 365- μ fd. b.c. tuning condenser in parallel. The power supply delivers about 280 volts under full load.

I want to make an appeal to anyone interested in carrier current, especially those within a five-mile radius, to write me, as I will furnish all data and diagrams.

— Bob Starekus, 485 Post Ave., Lyndhurst, N. J.

Three times recently W8SHY and I have held QSOs on wired wireless at about 170 kc. The 100-200-kc. coils on my HRO came in very handy. I had to build only a transmitter, for the tank inductance of which I used a couple of edge-wound coils that were about big enough to put one's head through.

— W8CMP.

For hams wishing to find the correct frequency of their carrier-current receivers, a handy guide is an aircraft beam station. For example, there is one in the New York district which signs letters NX. This one is on 209 kc. A list of these stations and their frequencies is available at almost any airport. Just couple an antenna to your receiver and the signals from these beams come rolling in fine business.

— Jack Nelson, W8FU.

PROJECT B

Light Beams

I HAVE been experimenting with light-beam communication between my house, which is on a hill, and the house of one of my radio students, and I have obtained some rather startling results, especially in the narrowness of the beam. The beam is so narrow that he can see it only in the one window at which I am pointing and at no other window! I have been using my 4 x 5 Graflex camera as the focusing-lens arrangement, merely placing a 2.5-volt dial lamp at the focal plane and focusing on his window, using a small tripod magnifier from the biology lab for the eye piece. The boy's house must be all of 1½ to 2 miles from me and he reports that the beam almost puts his eye out! Yet no one else can see it.

I have used a piece of Masonite, cut to the size of the film holder, to hold the dial light and I cut a small hole, about ¼ inch or less, in the center for the light to go through. The dial light is, of course, mounted on the back of this Masonite board. This is a stunt which anyone possessing a reasonably good camera can try with little additional equipment.

— James P. Saunders, W1BDV.

Strays

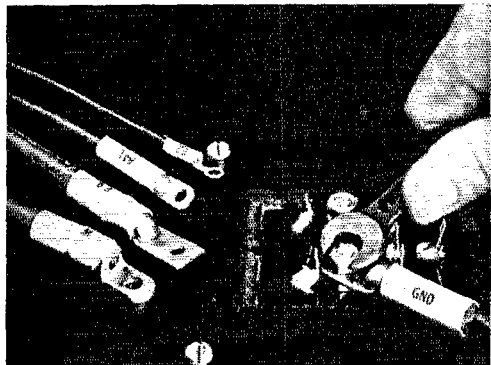

These new extruded plastic cable markers protect and insulate the soldered joint as well as identify the cable. The material of which they are made has very high dielectric strength. Sizes from No. 9 to ¾-inch inside diameter are being produced by the Irvington Varnish and Insulator Co., of Irvington, N. J.

★ BOOK REVIEWS ★

High-Frequency Thermionic Tubes, by A. F. Harvey. Published by John Wiley & Sons, Inc., New York. 235 pages, $5\frac{1}{2} \times 8\frac{1}{2}$, illustrated. Price, \$3.00.

Existing texts on thermionic tubes have for the most part been confined to treatment of tube operation in the comparatively low-frequency region, with ultrahigh-frequency operation getting little more than passing attention. This is understandable, since until recently the great bulk of applications has been at frequencies for which the ordinary triode and its multielement brothers are well suited. It is a sign of the times that there now appears a book in which the emphasis is placed at the opposite end of the frequency scale.

A short opening chapter gives a résumé of tube operation at low frequencies, followed by a second chapter which treats the shortcomings of conventional tubes in the very-high and ultrahigh regions. Chapter III considers Barkhausen-Kurz and Gill-Morrell oscillators. The next two chapters take up the magnetron and its various modes of oscillation; Dr. Harvey is an outstanding investigator in this field, and his interest in and familiarity with the subject is reflected in the fact that almost half of the book is devoted to the magnetron. The concluding chapter reviews various forms of velocity-modulation tubes, wave guides and horn radiators. Extensive bibliographies are supplied with each chapter, totaling several hundred references.

The book makes free use of mathematics, and its treatment reflects the viewpoint of the physicist, in whose province these specialized tubes have largely been.

Basic Electricity for Communications, by William H. Timbie. Published by John Wiley & Sons, Inc., New York. 603 pages, $5\frac{1}{2} \times 8\frac{1}{2}$, illustrated. Price, \$3.50.

The author of several standard texts on electrical fundamentals for the industrial field here turns his hand to the production of a similar volume for the communications field. As indicated by the title, the subject matter is confined to electrical fundamentals common to all types of electrical communication; specific communications systems are only touched upon briefly in the final chapter.

There are fifteen chapters, beginning with one on the electron and the basic nature of electricity, followed by a discussion of Ohm's Law, conductors and resistance, Kirchhoff's Laws, batteries, magnets and magnetic circuits, generators and motors, inductance and capacitance, alternating currents, and vacuum and gas-filled tubes. There is also a chapter on simplification of circuits, outlining methods of reducing complex circuits to simple forms.

The treatment is wholly practical, particular attention having been given to the selection of problems (of which there are many) which have direct application to everyday work in communication and electronics. Each chapter concludes with a concise summary of the subjects considered, highlighting the points to be remembered. Although numerical computation is necessarily a major part of each problem, mathematics is confined to simple algebra and trigonometry.

Elements of Radio, by A. Marcus and Wm. Marcus, prepared under the direction of Ralph E. Horton. Published by Prentice-Hall, Inc., New York. 699 pages, 6×9 , illustrated. Price, \$4.00.

First Principles of Radio Communications by Alfred Morgan. Published by D. Appleton-Century Co., Inc., New York. 366 pages, $5\frac{1}{2} \times 8\frac{1}{2}$, illustrated. Price, \$3.00.

The publishers of both these volumes recommend them for pre-induction courses such as are now being instituted in the high schools. Whether or not they meet the

Office of Education's specifications in this respect is a debatable point; it is certain, at least, that they do not follow the prescribed outlines.

Mr. Morgan, who has had long experience in authoring books on technical subjects for the younger generation, has produced an understandable volume which strikes us as being an excellent text for a person making a first approach to a technical hobby — the sort of book which in normal times would be fine for general reading by a budding ham. But as a textbook for introductory radio courses it suffers from having had almost all quantitative relations eliminated, as well as from lack of problem material.

"Elements of Radio" is a two-part book, the first part being a sort of radio primer largely devoted to working through various types of receiving sets, starting with the crystal detector and finishing with the superhet. In the second, basic principles of resistance, capacity, inductance, alternating currents, vacuum tubes and radio systems are taken up in more detail. Use is made of simple algebraic formulas in the text, but despite the fact that a considerable list of questions is attached to each chapter, only a handful are actual problems involving numerical computations.

It may be that high-school curricula and high-school students have changed since our day, but we doubt that present third-and-fourth-year students need to be addressed in the "Listen, my children" fashion usually associated with early grade-school readers. "Elements of Radio," particularly in its first part, carries this style of presentation to an extreme; "First Principles" assumes a certain amount of maturity on the part of its readers. Nor do we see any reason why the same students should be so carefully insulated from numerical problems that an eighth-grade pupil takes in his stride. "Elements of Radio," while offering examples of typical calculations, does not require the student to work out his own, as stated above; "First Principles" offers little more along these lines than a few simple formulas. For teaching purposes these constitute serious defects, in our opinion, but they undoubtedly enhance the value of both volumes for the reader who wants his science in "popular" style.

Principles and Practice of Radio Servicing, by H. J. Hicks. Published by McGraw-Hill Book Co., Inc., New York. 391 pages, 6×9 , illustrated. Price, \$3.50.

The serviceman who knows the how and why of radio receiver operation is the man who is prepared to cope with unfamiliar sets and unfamiliar situations. This is the thesis on which Mr. Hicks' book is built; it seems to have been a successful one, since this is the second edition. In the four years intervening since the first edition was published, many changes have taken place in radio broadcast receivers. These changes are reflected in the addition of new material and the elimination of now-obsolete practice.

The book combines practical theory as applied to radio receivers with the general practice of receiver servicing. Particular attention is paid to the description and use of modern test equipment. There are of course many hints on the diagnosis and cure of common receiver faults. The concluding chapter, on conducting a successful service business, is probably not quite so applicable under present conditions as it would be in peacetime, but serves to remind the reader that the business side deserves consideration along with the technical. A collection of useful data, including Underwriters' Regulations applying to receiving installations, rounds out the book.

— G. G.

Traffic Handbook for Radio Operators, by J. E. Kitchin. Published by Compass Book Company, Ottawa, Ont., Canada. 163 pages, 6×9 . Price \$3.00.

This book is intended for use by students preparing for examination in the Traffic Section of Canadian examinations for Certificates of Proficiency in Radio. It covers completely all aspects of traffic handling applicable to Canadian communications systems, nine of its twelve chapters being devoted to radio, two to landline and one to examinations and certificates. The style is clear, concise and easily understood, and each chapter is clearly outlined, making it easy for the student to refer to any particular

subject in the book. That it is not intended as a code manual is evident from the fact that the author disposes of the subject of learning and becoming proficient in the code in a little over two pages. As solid reading matter the book is very dry, but as a reference handbook, which after all is what the book is intended for, we can conscientiously recommend it to anyone preparing for the Canadian exams.

Radio Operators' Code Manual (With Touch Typing), by Wayne Miller. Published by the author, Chicago, Ill. 162 pages, 6 × 9, illustrated; paper cover. Price, \$2.00.

Many persons who have studied for commercial examinations are well acquainted with Mr. Miller's "Radio Operators' License Manual." Now he tries his hand at teaching code, and with gratifying results. Following some introductory material, in which he expertly creates a background for the study of code by quoting Ray Hutchens' article, "Conquer the Code with Rhythm," the author goes on to describe the construction of some elementary code-practice equipment of a rather outmoded variety. He then goes into the job of learning the code itself by presenting the characters in relation to their position on a typewriter keyboard, at the same time showing how the characters should be printed if a pencil is used. Practice groups are included for both receiving and sending, to such an intensity that a student who conscientiously practices the exercises given can hardly help but fall into the automatic process of recognizing code sounds when heard without any artificial process of association. Several pages of miscellaneous practice material are included after the exercises and instruction in receiving and sending. This in turn is followed by general pointers in touch typing, but it would probably be more to the student's advantage, if he is interested in studying the code in relation to touch typing, to secure a more detailed text with exercises in touch typing, using the material of this latter section as a liaison between touch typing and code and bearing in mind that the keyboards of most typewriters used in copying code differ slightly from standard keyboards. Five appendices, on FCC Rules Governing Commercial Radio Operators, FCC field offices, "Q" code abbreviations, miscellaneous abbreviations and the complete International Morse Code, are included.

We like this book because it seems to indicate that Mr. Miller is an advocate of the theory that the only way to achieve code proficiency is to develop automatic recognition of the sound of each character, and that the only way to do this is through intensive practice of the right kind.

— G. H.

The Greeter

A "Hey Marge!" Story

WHILE scanning the band for a local contact, you hear an unfamiliar voice calling CQ. His signature indicates that he is from a distant call area but operating locally. Also, the combination of letters comprising his call leads to the conclusion that he has not held a license very long. As you reach for the switch to establish contact, several thoughts flash through your alert mind.

He is a newcomer to the community and, since you are probably the first hereabouts to work him, it is up to you to impress him with the fine, hospitable spirit existing among the local gang.

You decide you will extend the warm hand of fellowship to him, emphasizing your sincere wish to be helpful. You will invite him to the next session of the club and offer to pick him up if he lives on your side of the city. You will assure him that nowhere else will he find a more cordial and cooperative spirit, and suggest that he join the Sunday morning roundtable on 160. You will exercise much tact in pointing out that most of

the boys seek your advice on technical problems and that he is welcome to do the same. And, to show the esteem in which you are held, you will casually remark that you have been secretary of the club for four straight years. You will judiciously omit telling him that the real reason is that you are the only member who possesses both a typewriter and a telephone.



Of course, he, too, has certain obligations. These need not be emphasized too strongly, but you decide to sound him out on such matters as:

Does he have a socket punch, pencil-type soldering iron or electric drill?

Does he have an oscilloscope or a reliable frequency meter?

Does he maintain a fair stock of spare tubes, resistors and condensers?

Then you will ascertain something about his character. Can he be depended upon to offer graciously the use of such of the aforementioned equipment as he may possess? If he joins the club, will he pay his dues promptly or will you have to use coercive methods as is the case with the present membership?

You resolve to set him straight right at the beginning as to who is the real technician in this vicinity. You have just been reading an article on inverse feed-back, and that will do for a starter. He probably won't know what you're talking about and will be duly impressed.

You will be cautious about mentioning your code speed until you find out what, if any, proficiency certificate he holds. You suddenly recall that you neglected to try for one. On second thought, better not even mention the subject.

Above all, you must warn him about taking the advice, criticisms and comments of others too seriously. At the same time, you will point out that you are always ready and willing to assist a fellow ham who is confronted with seemingly unsurmountable obstacles.

You give him a snappy call and listen for his answer, only to find that W3XJA has already hooked him. Your chagrin changes to repugnance as XJA recites his accomplishments and launches into a technical subject about which he knows practically nothing. You deplore the fact that man can sink to such depths and resolve to write something about the subject in the next issue of the club newspaper.

— Whit, W3IBX

ON THE VERY HIGHS

CONDUCTED BY E. P. TILTON,* W1HDQ

SINCE the appearance of our recent column describing some of the problems encountered in WERS antenna installations, we have received a number of helpful suggestions for improving antenna efficiency. All of them revolve around the fact that, though we usually strive for "flat" lines when long feeders are necessary, it is next to impossible to avoid at least a little tuned-feeder effect with open lines and the haywire matching systems normally used. Oddly enough, two of the suggestions came from the co-holders of the amateur 112-Mc. DX record, so they should be worth a try, at least.

Fred Evans, W1JFF, of Newport, R. I., writes that he has had good luck with just a simple two-halfwaves-in-phase, fed with an open line. Fred uses $1\frac{1}{2}$ -inch spacing with No. 14 wire for good mechanical stability, and tunes the system with a small variable condenser connected across the antenna terminals of a TR-4. A simple way of obtaining satisfactory results is to adjust the condenser while receiving a weak signal on approximately the operating frequency. This setting will then be right for transmitting also. It should be remembered that this arrangement is a pure tuned line — with the drawbacks characteristic of all non-matched systems: high voltage peaks, detuning in wet weather, etc.; but for lines under a hundred feet in length it should give good results provided the line is constructed for good mechanical stability and low leakage losses.

Bill Gamache, W2MPY, offers a simple arrangement which is applicable to any line. He suggests mounting a pair of rods (or wires) about two feet in length on the top of the unit. The feeders should be clipped onto these at the point

which gives best reception or most effective antenna loading in the case of transmission. With $\frac{1}{4}$ -inch rods, small grid clips of the type used for metal tubes make good contact clips.

When the location of the radio gear in the Chicopee (Mass.), Report Center was changed, the boys noted a considerable change in the performance of the TR-4, apparently the result of a slightly different feeder length. Obviously the long line up to the top of the city hall tower was not entirely "flat." It would have been a day's work to remove the antenna from its position and make adjustments on the matching stub, to say nothing of the fact that it is next to impossible to determine whether such a line is functioning correctly with the equipment most of us have to work with, so Tom Chapman, W1KK, tried a version of the Collins network so popular in low-frequency applications. Two variable condensers were used, one across the TR-4 terminals and another across the line approximately $\frac{1}{4}$ -wave length from the first. Adjustment of these condensers brought signals which previously had been barely audible up to good solid strength, and a worth-while improvement in transmission resulted with the same settings.

Some of us have never been able to think of a closed-end stub as anything but a short across our feeders, and with the size such a stub assumes in a 112-Mc. extended double-Zepp it certainly looks bad! Winslow Copeland, WINGH, says that the gang at WKKW (Massachusetts Warning District 2-C) avoided the use of the closed-end stub by attaching Q-bars at the point where the stub would normally be shorted. Four such installations in District 2-C are giving excellent results. One in Northampton has a feed-line 165 feet long.

* 329 Central St., Springfield, Mass.



Cpl. G. C. "Chet" Mallory, W1MEP, on a visit to W2OEN. W2OEN and W1MEP made the only New Jersey-Vermont contact in 112-Mc. history on Dec. 3, '41.

The Headquarters Staff has been augmented by another "Horsetrader," in the person of Hollis F. "Deke" French, W1JLK, who has temporarily abandoned the ministry to help make up the loss of several members of the staff to the armed services. Though many of the Hq Gang have had a try at 56- and 112-Mc. work, they were, for the most part, interested primarily in other amateur fields. Not so our new Assistant Secretary!

Back in the early '30s, when we used to get up at crack of dawn and lug our gear out to some mountain top for a Sunday morning of 56-Mc. portable work, there was always one contact we could count on. W1JLK was always there — provided we got set early enough to catch him while he was working mobile on the way to his church at Portland, Conn. Later, when the church authorities, with a callous lack of consideration for the requirements of a 5-meter man, shifted his QTH to Gales Ferry, Conn., a sea-level spot surrounded by hills of discouraging height, Deke went to

work and proved that you can get out on Five from anywhere. One of the first in this area to shift over to crystal control on Five, W1JLK was away ahead of the 1938 regulations that proved so tough (?) for some. Deke was also among the very first to get in on the skip DX that turned the 5-meter band into a madhouse in 1936.

It was out of the nightly chinfests of W1JLK, W1MY and W1FLQ that grew the idea for The Horsetraders, that nebulous organization which has no officers, no constitution and no treasury, but which became the most effective medium for the promotion of v.h.f. interest in the history of the 5-meter band. As Charter Member No. 3, Deke was responsible for much of the good fellowship that helped make the Horsetrader idea so popular with the v.h.f. gang of W1, W2 and W3.

In later years church duties called Deke to North Easton, Mass., where he continued his 5-meter work and also branched out to 2½. His enthusiasm did much to keep interest alive when the 1938 regulations threatened to kill off the 56-Mc. activity in the area around Boston. Before coming to West Hartford he was active in WERS work, serving as radio aide for two different license areas.

Good luck in your new assignment, Deke — we're glad (and fortunate) that you were able to accept it!

— . . . —

The WERS map is still showing a steady increase in dots which indicate the locations of WERS licensees. While the Eastern Seaboard and the Great Lakes area show the heaviest concentration, there are now less than a dozen states which show no dots whatever. And the dots are appearing in many places from which we never heard news of 112-Mc. activity in pre-war days. With the introduction of countless new prospects through ARP work and the training of personnel in the armed services, it would appear that there should be no lack of v.h.f. enthusiasts when we get back to amateur radio once more!

Downers Grove, Ill., received its WERS permit on May 27th, with the call WKDQ. W9OWF is communications officer and Jack Woodruff, W9PK, is radio aide. Nineteen units have been licensed. Jack writes that Chicago also received its license (WHHL) recently.

W2OEN, Middletown, N. J., wonders how to get WERS started in his area. In a fine location, a clear-vision shot to New York City, with 112-Mc. coverage of practically all of the country's number one target area, there is not so much even as a blinker light for emergency communication. There are plenty of hams associated with Ft. Monmouth (among them our old friend W3AC, Mid reports) for a starter.

— . . . —

Not many reports of f.m. DX have been received to date. W5AJG thinks that this season is the poorest yet, and that if we had to have a war this was as good a time as any, as far as interference with 56-Mc. skip-DX thrills are concerned. He anticipates that things may be better by the time the current unpleasantness is cleaned up. Leroy

logged f.m. DX during the first week of March. Police DX was heard on April 15th, May 6th, and May 11th. F.m. DX was fair on April 22nd, but May 17th was the day that really looked good and stirred the old 56-Mc. nostalgia.

Jerry Mathis, W3BES, reports an opening lasting from 7:30 to after 11 p.m. on June 6th. W45CM, W51C, W45V, W47NV and W41MM were logged for long periods at good strength. Frank Huberman, W2JLL/1, logged all these in East Hartford, Conn., and heard W55M on the same date. Things opened up during the morning and the band was still going strong at 10 p.m.

— . . . —

Vince Dawson, W9ZJB-W3JSL, now in the Air Forces at Asheville, N. C., has the good fortune to be in an outfit which has a number of hams among its top officers. Talking about ham radio with a major, Vince was surprised to find that he was a brother Horsetrader — W2HF, who used to be active on 5 and 2½ at Irvington-on-Hudson, N. Y. Another is Major James W. Hunt, W5TG-CCU.

Just about this time last year your conductor was spending his vacation with W1MEP in his cabin atop Glastenbury Mountain, Vermont. Though the thermometer hit well over 100 several days that week in Springfield, the highest temperature on the mountain was in the low 70s. Having been accustomed to summer temperatures of that order, Chet finds the life at Drew Field, Tampa, Fla., rather tough going. Cpl. Mallory is now attending radar maintenance school there, and finding it very fine, except for the weather.

1st Lt. Ansel E. Gridley, W4GJO/G, was amused to find us labelled "very highs," for he was just getting used to this terminology in his work "somewhere in England." The shift to "VHF" is all right with Grid — so long as we'll not make him say "wireless," "accumulator" or "valve" when he gets back home. The QTH is still Hq. 2nd Bombardment Wing, APO 634, c/o Postmaster, New York City.

Strays

A reduction of 85 per cent in the amount of copper used in systems to control outdoor and obstruction lighting and other electrical apparatus at three military bases in North Carolina, Virginia and New Jersey is made possible by the use of carrier-current equipment, according to General Electric Co. engineers. The equipment at the military bases is similar to that used by many electric power stations to control street lights and water heaters. Impulses transmitted over the regular power lines are picked up by receivers, which in turn operate relays to turn on or off the current for electric lights, pumps and other electrical apparatus. This system has eliminated the necessity of running many miles of separate copper cable to control the various electrical circuits.

Elementary A.C. Mathematics

Part VII*—Power, Power Factor, Losses in Reactances

BY GEORGE GRAMMER, ** WIDE

THE discussion on phase relationships between voltage and current brought out the fact that in either inductance or capacity the average power is zero, no matter how large the current or voltage. This is because the energy is alternately stored in the magnetic or electric field and then returned to the circuit, so that on the average no power is taken from the source of e.m.f. The only power dissipated is that consumed in the resistance in the circuit.

When a circuit contains both resistive and reactive elements it is still true that power is actually used up only in the resistance. The amount of power so dissipated is found by the ordinary formulas, $P = EI$ or $P = I^2R$, providing effective values are used for current and voltage, and providing that the current and voltage values used are those associated with the resistance only. For instance, if we have inductance, capacity and resistance in series and assume the following values (taken from the example associated with Fig. 34):

$$\begin{aligned} X_L &= 10 \text{ ohms} \\ X_C &= 20 \text{ ohms} \\ R &= 12 \text{ ohms} \\ E &= 100 \text{ volts} \\ I &= 6.42 \text{ amp.} \end{aligned}$$

we have, for the power actually used up in the circuit,

$$P = I^2R = 6.42^2 \times 12 = 495 \text{ watts}$$

Since this is a series circuit the same current flows through all elements, and there is a voltage drop associated with each reactance. The product of the voltage across the reactance by the current flowing through it, or the product of the reactance by the square of the current (which is the same thing), gives the power stored in the electric or magnetic field during one part of the cycle and returned to the circuit in a subsequent part. This "reactive" power, which is not dissipated but is simply handed back and forth between the fields and the circuit, consequently is found by substituting X for R in the power formulas. In the example, the values of reactive power in the inductance, capacity and the whole circuit are as follows:

$$\begin{aligned} P_{X_L} &= I^2X_L = 6.42^2 \times 10 = 412 \text{ volt-amperes} \\ P_{X_C} &= I^2X_C = 6.42^2 \times 20 = 824 \text{ volt-amperes} \\ P_X &= I^2X = 6.42^2 \times 10 = 412 \text{ volt-amperes} \end{aligned}$$

*This is the final article in the series, which began in *QST* for February, 1943.

** Technical Editor, *QST*.

Notice that the power is expressed in "volt-amperes" rather than watts, to distinguish it from dissipated power. Also, the total reactive power in the circuit is the difference between the volt-amperes in the inductance and those in the capacity. This is because of the opposite phase relationships between voltage and current in these two circuit elements; when the inductance is storing energy the capacity is returning it to the circuit and vice versa, so that the net energy flow at any instant must be the difference between that being stored and that being released.

If we take the product of the applied voltage and the current flowing in the circuit, we find that whenever there is reactance present this product is larger than the actual power dissipated. Thus in the preceding illustration, where the applied voltage is 100 volts and the current was found to be 6.42 amperes, the volt-amperes in the circuit as a whole are

$$VA = EI = 100 \times 6.42 = 642 \text{ volt-amperes}$$

The ratio of the power dissipated to the circuit volt-amperes is called the *power factor* of the circuit. In the circuit above,

$$\text{Power Factor (P.F.)} = \frac{\text{Watts}}{\text{Volt-amperes}} = \frac{495}{642} = 0.771 \text{ or } 77.1 \text{ percent.}$$

The volt-amperes in each circuit element are proportional to the reactance, resistance, or impedance, since the same current is flowing through all. The relationships between resistive volt-amperes (watts), reactive volt-amperes, and circuit volt-amperes are consequently the same as the relationships between resistance, reactance and impedance. We can therefore construct a "volt-ampere triangle" which will be identical in shape with the impedance triangle, as shown in

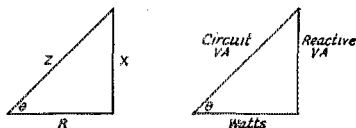

Fig. 46

Fig. 46. Since the phase angle, θ , is the same in both triangles, from trigonometry we find that the power factor, or ratio of watts to circuit volt-amperes, is equal to the cosine of the phase angle, and that the ratio of reactive volt-amperes to the circuit volt-amperes is equal to the sine of the phase angle. Hence, using VA for circuit volt-amperes and P for the power actually dissipated,

$$P.F. = \frac{P}{VA} = \cos \theta, \text{ or } P = VA \cos \theta$$

and, similarly,

$$\text{Reactive volt-amperes} = VA \sin \theta$$

Consequently, if the circuit VA and phase angle are known, both the dissipated and reactive power can be found from the trigonometric functions of the phase angle.

A Circuit Example

As an example of a typical set of circuit calculations, let us assume that we have connected in series a resistance of 25 ohms, an inductance of 20 millihenrys and a capacity of 3 μfd . The applied voltage is 75 volts and has a frequency of 800 cycles per second.

The inductive reactance is

$$X_L = \omega L = 2\pi fL \\ = 6.28 \times 800 \times 0.02 = 100 \text{ ohms}$$

The capacitive reactance is

$$X_C = \frac{1}{\omega C} = \frac{1}{2\pi fC} \\ = \frac{1}{6.28 \times 800 \times 3 \times 10^{-6}} = 66.3 \text{ ohms}$$

(In both cases it is necessary to change the units given into fundamental units; thus 20 millihenrys = 0.02 henry and 3 μfd = 0.000003, or 3×10^{-6} farad.) The circuit reactance is

$$X = X_L - X_C = 100 - 66.3 = 33.7 \text{ ohms}$$

The impedance of the circuit is

$$Z = \sqrt{R^2 + X^2} = \sqrt{25^2 + 33.7^2} = 42 \text{ ohms}$$

The phase angle is found from

$$\tan \theta = \frac{X}{R} = \frac{33.7}{25} = 1.348$$

and the angle is $53^\circ 26'$, from trigonometric tables. The power factor is

$$P.F. = \cos \theta = \cos 53^\circ 26' = 0.596$$

With 75 volts applied, the current is

$$I = \frac{E}{Z} = \frac{75}{42} = 1.79 \text{ amp.}$$

The apparent power in the circuit is found from

$$VA = EI = 75 \times 1.79 = 134 \text{ volt-amperes}$$

The actual power is given by

$$P = VA \cos \theta = 134 \times 0.596 = 79.9 \text{ watts}$$

The voltage drop across the resistance is

$$E_R = IR = 1.79 \times 25 = 44.8 \text{ volts}$$

The voltage drop across the inductance is

$$E_L = IX_L = 1.79 \times 100 = 179 \text{ volts}$$

The voltage drop across the condenser is

$$E_C = IX_C = 1.79 \times 66.3 = 119 \text{ volts}$$

The total reactance voltage drop is

$$E_X = IX = 1.79 \times 33.7 = 60.2 \text{ volts}$$

$$\text{or } E_X = E_L - E_C = 179 - 119 = 60 \text{ volts}$$

As a further check on the work, the power dissipated can be calculated from

$$P = I^2 R = 1.79^2 \times 25 = 80 \text{ watts}$$

The calculations need not be carried out to more than three significant figures, in most practical cases, because the limitations of measuring equipment preclude higher accuracy

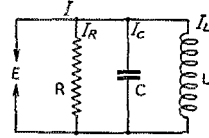
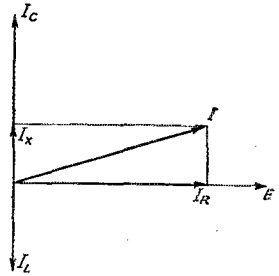

Fig. 47



That the same relationship between power factor and phase angle holds in simple parallel circuits as well as series circuits can be shown by reference to the vector diagram of Fig. 47. The current in the resistance is in phase with the applied voltage, and the product of current and voltage in this element of the circuit represents "real" power, since it is power dissipated as heat in the resistance. The total current, I , is the vector sum of the individual branch currents, and in the drawing leads the applied voltage by the phase angle, θ . From trigonometry, the resistance current, I_R , is equal to the total current, I , multiplied by the cosine of the phase angle, so that

$$P = EI_R = EI \cos \theta$$

The "apparent" power in the circuit is the applied voltage multiplied by the total current, or $VA = EI$. Consequently, since the power factor is the ratio of real to apparent power,

$$P.F. = \frac{P}{VA} = \frac{EI \cos \theta}{EI} = \cos \theta$$

The rule can readily be verified for series-parallel circuits, although the situation is a little more complicated. Let us assume a parallel circuit with two branches, one having inductance and resistance in series, as in Fig. 48. The applied voltage, E , appears across both branches and is equal to the resultant of the series voltages in each branch. Using E as a reference, the vector diagram is constructed as shown in the figure. In the inductive branch the current, I_1 , lags behind the applied voltage by a phase angle, θ_1 , determined by the ratio of reactance to resistance. In the capacitive branch the branch current, I_2 , leads

the applied voltage by a phase angle, θ_2 , similarly determined by the ratio of reactance to resistance. By the rule for series circuits, the power in each branch is

$$P_1 = EI_1 \cos \theta_1$$

$$P_2 = EI_2 \cos \theta_2$$

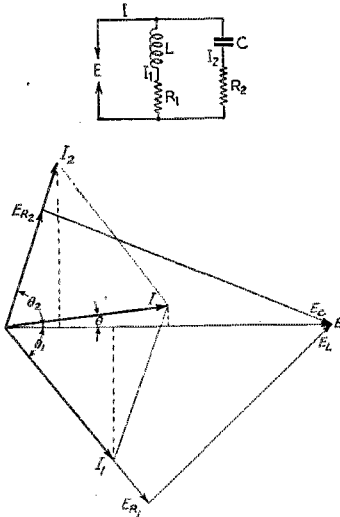

Fig. 48

The total power is the sum of the powers in each branch, since both powers are real — i.e., dissipated. Hence,

$$P = P_1 + P_2 = E (I_1 \cos \theta_1 + I_2 \cos \theta_2)$$

Now $I_1 \cos \theta_1$ is the projection of I_1 on E , and $I_2 \cos \theta_2$ is the projection of I_2 on E , as is obvious from inspection of the drawing. The two projections add to form the projection of the total current, I , which in turn is the resultant of vector addition of I_1 and I_2 . The projection of I on E is equal to $I \cos \theta$, where θ is the phase angle of the circuit as a whole. Therefore,

$$P = E (I_1 \cos \theta_1 + I_2 \cos \theta_2) = EI \cos \theta$$

so that the power factor is again equal to $\cos \theta$. The same method can be used to demonstrate that the rule holds for more complicated circuits.

Losses in Practical Reactances

In all the previous work we assumed that our reactances were "pure"; that is, that no energy loss was associated with them. Only when resistance was intentionally introduced into a circuit did we have power dissipated. Unfortunately, however, no electrical device is completely loss-free.

Consider an inductance coil. It is wound with wire which has a finite, even though small, value of resistance. If the resistance is known, it is a simple matter to calculate the power dissipated in the coil at any assumed value of current; the dissipated power is simply equal to I^2R . Since power must be secured by having current flow through a

difference of potential, the voltage drop corresponding to the power and current is $E_R = P_R/I$. This voltage must be in phase with the current, since the power is all dissipated. The reactive power is similarly equal to I^2X , where X is the reactance of the coil. The voltage drop associated with this power is $E_X = P_X/I$, but the reactive drop leads the current by 90 degrees. Thus we have a single current but two components of voltage, one in phase with the current and the other 90 degrees out of phase. This is exactly the condition existing in a series circuit, so that the practical inductance coil can be considered to be made up of a "pure" inductance in series with a resistance. Of course, the only voltage that can be measured is that actually applied; the separate components can be obtained only by calculation, since the resistance and reactance are distributed throughout the coil and cannot be isolated. The existence of the voltage components is evidenced by the fact that the phase angle between current and applied voltage is not 90 degrees but is always something less when the coil has resistance. The tangent of the phase angle is given, as usual, by the ratio of reactance to resistance; that is, $\tan \theta = X/R$.

It is probably customary, at least in the beginning, to think of real power as the rate at which energy is used up in a physical property of wires called "resistance." However, in a broader sense resistance is simply a medium for dissipating power, not necessarily associated with losses in a conductor. Since, by Ohm's Law, $P = I^2R$, on rearranging the formula we obtain a definition for resistance: $R = P/I^2$. It is convenient to lump a number of kinds of energy loss under the single heading of "resistance," as defined by this formula. For example, in an iron-cored inductance only part of the actual energy loss associated with current flow is in the resistance of the wire; there are also power losses caused by eddy currents and hysteresis effects in the iron. Even the wire resistance is not the same as it is for direct current, because of the tendency of the current to flow more and more near the surface of the wire as the a.c. frequency is increased. The sum total of the power lost in such a coil, when a given current flows, is the measure of the "effective" resistance of the coil.

The effective resistance of a coil, whether or not it has an iron core, is not constant with frequency. In general, the effective resistance increases with frequency in such a way that the ratio of reactance to resistance tends to stay about the same, but this statement is subject to a number of qualifications.

In the case of a condenser there is relatively little true resistance loss because of the fact that the plate area is large compared to the length of the path which the current follows in flowing along the plates. The energy loss in a condenser occurs for the most part in the dielectric between the plates. The loss is consequently almost entirely a function of the kind of dielectric used. The effect of losses can be represented by an equivalent resistance either in series with the con-

denser or in parallel with it, the value of resistance being chosen to have a loss equal to that actually occurring in the condenser. If the equivalent resistance is in series, its value is $R = P/I^2$, where P is the actual power lost and I is the current through the condenser; if the equivalent resistance is in parallel, its value is $R = E^2/P$, where E is the voltage applied to the condenser. The value of equivalent resistance is not constant with frequency, but in general the *power factor* of the condenser is fairly constant with frequency. For this reason it is usual to "rate" condensers in terms of power factor, and since the loss is practically entirely in the dielectric the power-factor rating can be extended to the dielectric alone. In most condensers used in radio work the power factor is very small, indicating that losses are very low and that the reactance is nearly "pure."

Transformation of Loss Resistance

It will be recalled that a circuit containing resistance and reactance in series can be transformed into an equivalent circuit containing resistance and reactance in parallel by determining the susceptance and conductance. Thus, if a reactance, X , and a resistance, R , are in series, the susceptance and conductance are, respectively,

$$B = \frac{X}{X^2 + R^2}$$

$$G = \frac{R}{X^2 + R^2}$$

The transformed reactance and resistance are equal to the reciprocals of these, so that (using the subscript E to denote equivalent reactance and resistance),

$$X_E = \frac{X^2 + R^2}{X}$$

$$R_E = \frac{X^2 + R^2}{R}$$

It is apparent from inspection of the equations that, if R is small compared to X , then X_E is very nearly equal to X . (If R is zero, X_E is exactly equal to X .) For example, if R is 1/10 the value of X , X_E differs from X by only 1 per cent, since R^2 is only 1/100 of X^2 . Since an error of 1 per cent is usually tolerable, we may say that if the reactance is at least 10 times the series resistance the same value of reactance can be used either in the series or parallel equivalent circuit. Allowing the same margin for error we can drop R^2 in the numerator of the equation for R_E , so that this equation becomes, simply,

$$R_E = \frac{X^2}{R}$$

In radio circuits it is generally true that the ratio X/R will be 10 or more. This ratio is usually designated by the symbol Q ("quality factor," on the basis that the higher the Q the higher the quality of the reactance). It is of interest to note that when X is large compared to R , the cosine of the phase angle (which is equal to R/Z) is ap-

proximately equal to R/X , since under these conditions X is very nearly equal to Z . Hence the power factor can be taken as the reciprocal of Q , if Q is of the order of 10 or more.

The process of simplifying mathematical expressions by eliminating elements which, while frequently increasing the complexity of solution, contribute relatively little to the accuracy of the final result, is justifiably common. In fact, a large proportion of the more familiar formulas are approximations—of adequate accuracy for practical work, of course, when the assumed conditions are met, but nevertheless not safely applicable to all problems.

New Receiving Tubes

SEVERAL new receiving types have been announced by Sylvania. These include several designed for v.h.f. receiver applications.

Type 7C4/1203A is a cathode-type diode especially designed for modern very-high-frequency applications. This tube will successfully operate up to 600 Mc. as a detector.

Type 1R4/1294 is a cathode-type high-frequency diode of "lock-in" construction, similar to the 7C4/1203A except for a lower heater rating and reduced physical size of the tube mount.

Type 3B7/1291 is a filament-type double triode of "lock-in" construction, especially designed for modern very-high-frequency applications. The special filament allows the tube to be operated at higher temperatures than normal commercial battery receiving tubes, and is capable of providing high peak currents for Class-C service.

Type 3D6/1299 is a filament-type beam-power amplifier tube of "lock-in" construction, employing the same type of filament as is used in the 3B7/1291, allowing it to be operated over a range of from 1.4 to 1.75 volts. When employed as a Class-C amplifier, the 3D6/1299 will provide power outputs ranging from 2.0 watts at 20 Mc. to approximately 0.5 watt at 200 Mc.

Type 7E5/1201 is a cathode-type triode designed for modern very-high-frequency applications. It can be used as a signal source or local oscillator at frequencies up to 750 Mc. when used in a double-ended transmission-line circuit. This type of operation is facilitated by a symmetrical arrangement of double grid and plate leads.

— D. H. M.

— —

A cross-index of commercial tube types and their corresponding Signal Corps and Navy types may be obtained from Sylvania Electric Products, Inc., Emporium, Penna., upon request.

— —

When the stamped type designation has been worn off the glass envelope of a tube, it can often be made readable for a few seconds by breathing on the glass to steam it. — Chas. Mitchell.



STRAYS



A booklet, "Radio Circuit Handbook," which will appeal to the beginner in radio and electronics, may be obtained for 10 cents from the Allied Radio Corp., 833 W. Jackson Blvd., Chicago. It contains schematic and pictorial diagrams of s.w. and h.c. receivers, p.a. systems, record players, photo relays and v.h.f. gear, including f.m. equipment, with brief technical explanations of the circuits.

— · · · —

Anyone interested may obtain a list of American standards from the American Standards Association, 29 W. 39th St., New York. Among the 600 standards listed are those for electrical engineering and radio.

— · · · —

Transmitter crystals are now being produced sealed against moisture in an octal-based metal envelope, similar to that of a receiving tube.

— · · · —

To separate heat-treated parts from those not heat-treated but of identical appearance, a magnetic discriminator has been developed. It works on the principle that heat treating increases the permeability and thus gives a stronger magnetic field. A system of balanced magnetic fields used with an oscilloscope provides easy visual determination of the difference. — *Ohmite News*.

— · · · —

Eldon ("Pete") Barr, well known on the air as W7CYR, has recently been appointed production director on the staff of KWSC, the 5000-watt h.c. station of Washington State College, from which he graduated with honors. He also teaches several courses at the school. Few are aware that Pete's success has been attained under the handicap of blindness. He obtained his ham ticket in 1938 with the help of the Braille edition of *The Radio Amateur's Handbook*, supplied to him through the American Red Cross.

To make a sensitive polarity indicator, have a druggist prepare a solution of one gram of phenolphthalein dissolved in 5 c.c. of alcohol and diluted to 55 c.c. with water. Then dissolve 10 grams of sodium sulphate in 50 c.c. of water and add this to the first solution. When two wires are dipped into the solution, the area around the negative pole will be stained red while the area surrounding the positive pole will remain unchanged in color. Unsized paper soaked in the solution and then dried need only be wetted and the wires touched to its surface about $\frac{1}{4}$ inch apart to form a portable indicator. Potentials as low as 0.001 mv. can be polarized by this method. — *W8CKO*.

— · · · —

Line-cord resistors have an unfortunate habit of breaking at the point where they enter the chassis. Their life can be considerably prolonged by using the coil-spring cord savers universally found on the plugs used with flat irons and other appliances. — *W8VD*.

— · · · —

A new electronic device has been developed for testing four-engined bombers in flight. During flight, the temperatures of all 72 cylinders, the changing temperature of the carburetors, exhaust and the oil in the fuel lines, and the pressures on wing struts, bulkheads and tail surfaces, are automatically recorded!

— · · · —

The Signal Corps will need 32 million pounds of rubber this year for insulating the wire used in maintaining direct communications. An additional 4 million pounds will be required for friction and splicing tape!

— · · · —

The Associated Amateur Operators' Club of Denver recently purchased its fifth war bond from membership dues.

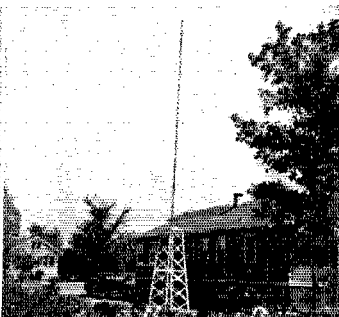
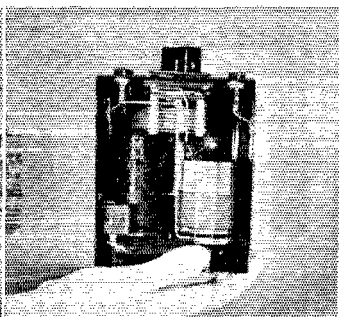
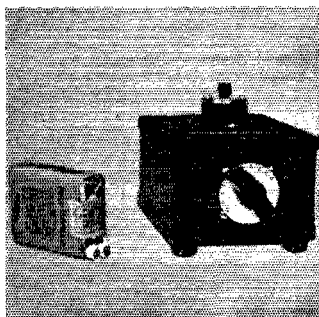

The QRP rig and "beer-can" antenna with which W9GGI once worked all states; as well as K5, K6 and K7, on 7Mc. The rig consists of a simple 6V6 crystal oscillator. The quarter-wave vertical antenna is made up of one-quart oil cans soldered end-to-end. W9GGI built a power supply for the rig in the same size box to match the transmitter.

Radio Cross-Word Puzzle

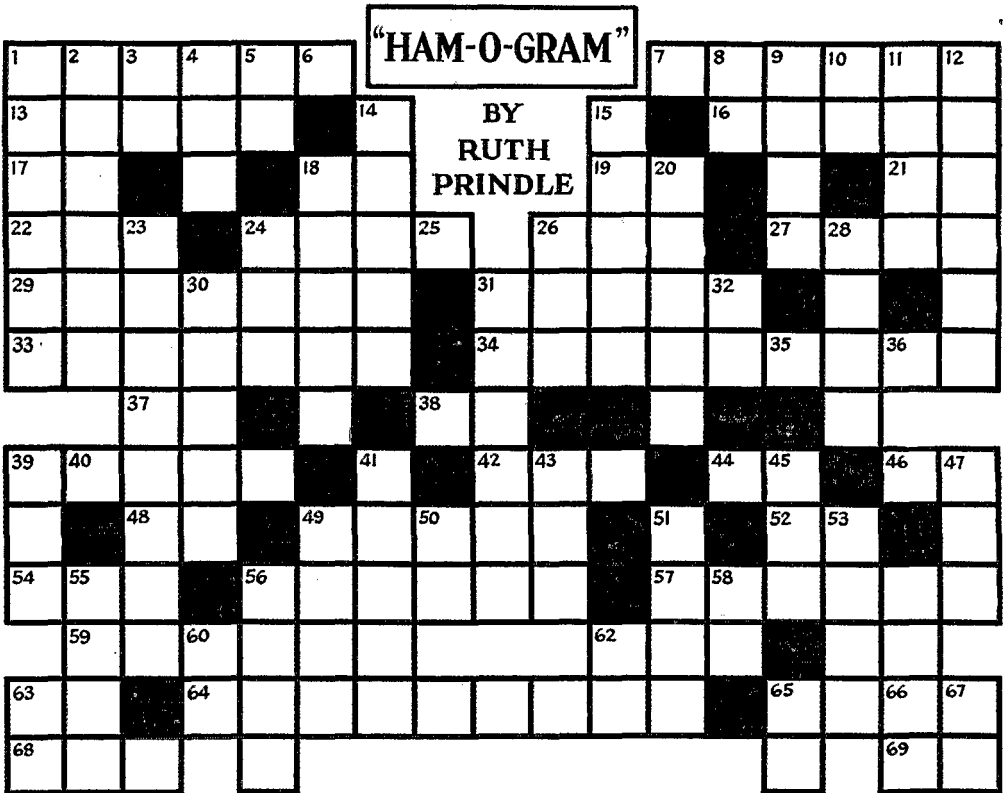

ACROSS:

1. Units of capacitance.
7. Reciprocal action, as of inductances.
13. Alternate i.f. response in superheterodyne receiver.
14. Inductance (symbol).
16. System of matching transmission line to antenna.
17. Listening post (abbrev.).
18. General Electric (abbrev.).
19. Portugal (prefix).
21. The Faeroes (prefix).
22. Type of oscillator-amplifier tube popular several years ago.
24. Insulating covering on wire.
26. Unit of pressure.
27. Electrical dimension.
29. Casein plastic insulating material.
31. Remote circuit-control device.
33. Wax discs or cylinders.
34. Negative particles of electricity.
37. Laughter.
38. Empty (abbrev.).
39. Fundamental harmonic.
41. Capacity (symbol).
42. Undistorted power output.
44. Nothing doing (abbrev.).
46. General call.
48. Jan Mayen Island (prefix).
49. Meter for measuring specific gravity (prefix).
52. Finland (prefix).
54. I am being interfered with.
56. Trigonometric function.
57. Rotating part of a variable device (pl.).
59. Antenna.
62. Point along a coil winding to which a connection is made.
63. Broadcast (abbrev.).
64. Strength (as of current).
65. Schedule (abbrev.).
68. Circuit (abbrev.).
69. Say (abbrev.).

DOWN:

1. Frequency-discriminating coupling circuit.
2. Unit of current.
3. Radio amplifier (abbrev.).
4. Again (abbrev.).
5. From.
6. Switch (symbol).
7. Thousand (symbol).
8. You would (abbrev.).
9. Check.
10. You will (abbrev.).
11. Smallest physical unit retaining all the original characteristics of an element.
12. Sections of the ionosphere.
14. Connecting wires.
15. Calibration.
18. Third element of a triode vacuum tube (pl.).
20. Matching the tuning rate of an oscillator to that of the r.f. circuits.
23. Resistance wire.
24. Call of a key Mutual Network h.c. station.
25. Power (symbol).
26. Ten decibels.
28. Magnetic material.
30. Interference.
31. Connection to a circuit which completes the d.c. path.
32. Yugoslavia (prefix).
35. OK.
38. Meter (symbol).
39. Frequency (abbrev.).
40. Current (symbol).
41. Unit of frequency.
43. Volume control (abbrev.).
44. No (symbol).
45. Dit (code).
47. Send more slowly.
49. Form of energy.
50. Day (abbrev.).
51. Roentgen tube.
53. Switch lever on a telephone receiver.
55. Frame for mounting standard panels.
56. Type of a.c. wave.
58. Operator (abbrev.).
60. Radio inspector (abbrev.).
62. That (abbrev.).
63. Broadcast (abbrev.).
65. Grid-plate (mutual) transconductance.
66. And.
67. Day (abbrev.).

(For solution, see page 94)



HINTS AND KINKS FOR THE EXPERIMENTER

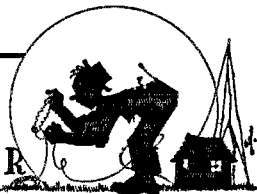

NOTES ON COMMERCIAL GEAR FOR W.E.R.S.

IN ADDING a regeneration control to the Abbott MRT-3, as described by W1EAO in the "Hints and Kinks" section of *QST* for August, 1942, I found that inclusion of a 0.002- μ fd. condenser in the plate circuit of the detector, as shown in Fig. 1-A, reduced the voltage required for regeneration from 175 volts to 75 volts. Besides reducing receiver radiation, the operation of the regeneration control was made much smoother.

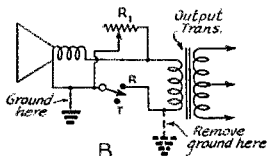
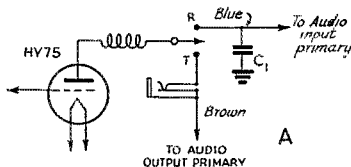
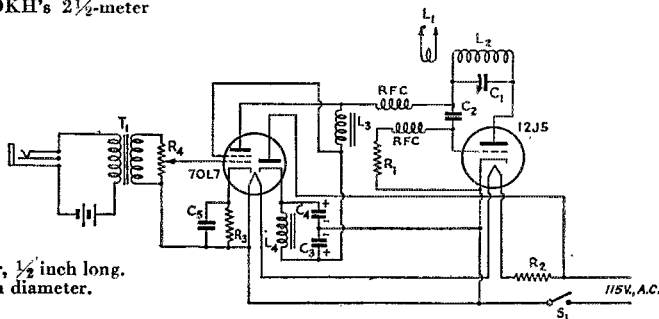

Fig. 1—Changes in Abbott v.h.f. units suggested by W1HUI. (A)—Regeneration at lower plate voltages is obtained by the addition of the 0.002- μ fd. condenser, C_1 , in the MRT-3. (B)—Wiring changes required to install independent control of receiver volume in the MRT-3 and TR-4. R_1 is a 6-ohm rheostat.

Another worth-while improvement in the MRT-3 is the insertion of a shaft bearing for the tuning-condenser shaft and the addition of a small strip of metal behind the dial as an indicator. Before making these changes the dial

Fig. 2—Circuit diagram of W2DKH's 2½-meter a.c.-d.c. superregenerative receiver.

- C_1 —100- μ fd. mica.
- C_2 —2-plate variable.
- C_3 —0.002- μ fd., 400-volt tubular.
- C_5, C_6, C_7 —0.01 μ fd.
- C_8, C_9 —40- μ fd., 150-volt elect.
- R_1 —5 megohms, ½-watt.
- R_2, R_4 —50,000 ohms, ½-watt.
- R_3 —500,000-ohm potentiometer.
- R_5 —½ megohm, ½-watt.
- R_6 —150 ohms, 1-watt.
- R_7 —175 to 200 ohms, 25-watts.
- RFC—V.h.f. choke (Ohmite Z-0).
- L_1 —4 turns No. 14, ½ inch diameter, ½ inch long.
- L_2 —2 turns No. 18 insulated, ½ inch diameter.
- Sw—S.p.s.t. toggle.
- Spkr. field—500 ohms.



reading would vary two or three points for a given frequency, depending on the direction of rotation of the condenser. Now it resets very accurately and is free from all side play.

The addition of a receiving volume control to both the MRT-3 and TR-4 greatly simplifies operation of these units, since it eliminates the necessity for readjustment of volume levels between transmitting and receiving periods. Independent adjustment of received-signal volume can be easily accomplished by shunting the speaker voice coil with a low variable resistance. In our case, a 6-ohm rheostat was used. It was mounted in one of the ventilating holes in the top of the case and connected as shown in Fig. 1-B. The change in grounding of the output circuit was necessary because the rotor of the rheostat was grounded. — Bob Davis, W1HUI.

A.C.-D.C. GEAR FOR 112 MC.

THE thing that got me started on the idea of a.c.-d.c. gear for 2½ was the fact that I loaned my regular gear to one of the WERS units in the New York City system and later found that I was missing something by not having some sort of receiver with which I could listen during test periods when I could not attend drill. Shortage of power transformers naturally brought up the suggestion of a system which wouldn't require one. None of the local v.h.f. gang had ever tried the a.c.-d.c. idea, but most of them agreed that it ought to work. So, with a handful of parts from the junk box and a prayer, I started, following the circuit diagram of Fig. 2.

The superregen detector circuit is the well-known "Minute Man" self-quenching arrangement, using a 6J5. This is resistance-coupled to another 6J5 in the first audio stage, followed by a 25L6 output stage feeding a five-inch dynamic

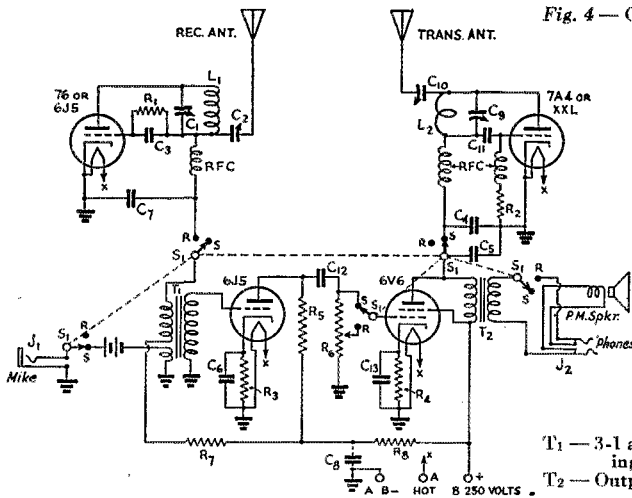

Fig. 4—Circuit of the WERS transmitter-receiver

- C₁, C₉ — 7-35- μ fd., 2-plate variable.
- C₂, C₁₀ — 1.5- i - μ fd. trimmer.
- C₃, C₁₁ — 50 μ fd.
- C₄, C₁₂ — 0.01 μ d.
- C₅, C₁₃ — 0.006 μ d.
- C₆ — 25- μ d., 25-volt electrolytic.
- C₇ — 100 μ fd.
- C₈ — 8 μ d. (see text).
- R₁ — 5 megohms.
- R₂ — 2000 ohms.
- R₃ — 900 ohms.
- R₄ — 200 ohms.
- R₅ — 50,000 ohms.
- R₆ — 250,000-ohm volume control.
- R₇ — 25,000 ohms.
- R₈ — 50,000 ohms.
- L₁ — 4 turns No. 14, $\frac{3}{8}$ -inch i.d.
- L₂ — 4 turns No. 14, $\frac{1}{4}$ -inch i.d.
- RFC — 30 turns No. 28, $\frac{1}{4}$ -inch dia.
- J₁ — Single-circuit jack.
- J₂ — Double-circuit jack.
- S₁ — 8-pole, 2-section rotary switch.
- T₁ — 3-1 audio transformer with microphone winding added (see text).
- T₂ — Output transformer.

The 0.006 μ fd. condenser, C₅, was merely included to improve the quality of speech, and may be changed to meet operating conditions and microphone quality. The 8- μ fd. condenser, C₈, was found to reduce hum and vibrator hash very noticeably in some instances, depending on the type of filter used in the power supply available. It may not be required in all installations. Radio-frequency chokes were constructed of 30 turns of No. 28 d.c.c. wire, $\frac{1}{4}$ -inch inside diameter, and mounted in the set so as to be self-supporting.

Because of differences in the internal capacities of tubes, capacity and inductance of wiring, etc., it may be found necessary to experiment with different values of C₄, R₂, R₇ and R₈ to obtain proper superregeneration with as low a voltage as possible and to eliminate undesirable feedback, squeals, etc., in the first audio stage. T₁ is an ordinary audio transformer of about 3-to-1 ratio with the addition of one layer of No. 30 to No. 40 wire wound over the present windings and connected to the single-button carbon microphone. The connection for 'phones does not deliver optimum power output, but signal strength was found to be more than sufficient for head-phone operation.

All power-plug connections are standardized so that any set or power supply, a.c. or d.c. vibrator pack, may be interchanged, keeping in mind that an a.c. supply having the filament winding center-tapped to ground will not work until the ground tap is opened.

The receiver works best with a long-wire antenna and is not critical when capacity-coupled as shown, while the transmitter performs best with a quarter- or half-wave rod antenna.

We were unable to obtain the proper insulated parts for use at this frequency, and realize that we have considerable losses due to this in sockets, etc., but in actual operation we found this unit to out-perform some commercially-built units using type HY-75 tubes. — L. R. Jenkins, *Radio Aide*, WJZY.

TUNED LECHER WIRES

ALMOST anyone who has used Lecher wires to measure wavelengths over a large range has found cases where the first node obtainable falls near the center of the wires, while other nodes are so far away as to fall off the ends of said wires, unless the wires were unduly long. Wanted: tunable Lecher wires, so one could make the node near the transmitter as near the end of the system as one wished, so that the other node would fall on the wires and not too far away.

This dilemma can be solved by mounting a small variable condenser at the transmitter end of the wires, as shown in Fig. 5. This makes it possible to move the transmitter node back and forth at will. The transmitter end of the system need be only long enough for the coupling and placing of the shorting device, so that the wires have to be only a little over a half wavelength long for the lowest frequency desired. This idea has been tried here and with great satisfaction. I thought at one time that I would have to build another Lecher wire system, for the node of some wavelength in the range always fell near the center of the system in use, terminating the usefulness of the present system for the desired range of wavelengths. However, the use of the small condenser (15 μ fd. maximum) saved the day, and it has made the one Lecher-wire system adequate. This means that a system to measure wavelengths of, say, 2 $\frac{1}{2}$ meters and shorter need be only a little over 1 $\frac{1}{2}$ meters long, thus saving Lecher wires, which are rationed hereabouts. — E. C. Woodruff, *W8CMP*.

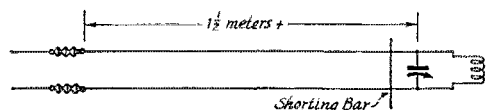

Fig. 5—Tuned Lecher wires need be only slightly over a half wavelength long for the lowest frequency. For 112 Mc. and higher, the required length is therefore slightly over 1 $\frac{1}{2}$ meters, or about 5 feet.

THREE-ELEMENT DIRECTIONAL ANTENNA FOR PORTABLE 112-MC. WORK

Fig. 6 depicts a simple directional antenna which may find application in WERS work. It has been used with a transceiver of conventional design employing a 1G4GT and a 1T5GT.

Wanting to try a beam antenna on 2½ with a minimum of alterations, I hit on the idea of just building something I could add to the half-wave antenna already mounted on the transceiver. This antenna is a vertical ex-car antenna and is tapped at the base with thread of appropriate size to fit the hardware of a bee-hive insulator mounted on top of the cabinet. The reflector and director elements are supported from a pair of cross arms which rotate about the vertical antenna as an axis. These cross arms are made of wood, except where they come in contact with the reflector and director elements. At these points, pieces of plastic are used to improve the insulation. These cross arms should be made as light as possible to keep the weight down. The central holes should fit the antenna snugly and the telescopic joints make convenient points for locating the cross arms.

Fig. 6—Simple three-element rotary antenna for portable 2½-meter gear. Element lengths and spacing given in the text.

telescopic joints make convenient points for locating the cross arms.

Plexiglas discs are used for the reflector and director insulation. The holes for mounting these elements are made somewhat smaller than the diameter of the elements, which are forced through the plastic after heating it. After the plastic cools, there is little danger of loosening of the elements.

For a frequency of 115 Mc., the antenna is 48¾ inches long, the reflector 51¼ inches long and the director 46¾ inches long. The spacing between antenna and director should be 10 inches, while a spacing of 15 inches is used between the antenna and the reflector. However, these dimensions will work over a broad range, considering that it is a three-element beam. If telescopic elements are used for the parasitic elements, their lengths may be adjusted on the nose for any desired frequency in the band, of course. In adjusting the elements, it will be noticed that the presence of the operator in the direct field of the antenna will have a noticeable effect, so he should keep out of the field as much as possible.

The antenna has a very good front-to-back

ratio and it provides considerable gain over a simple half-wave antenna, equivalent to a power increase of several times. — *S/Sgt. J. H. Jeanne, Det. Third Com., Hensley Field, Dallas, Tex.*



FOLDING CAR-ROOF V.H.F. ANTENNA

Fig. 7 shows a sketch of a fitting for a vertical car-roof antenna for v.h.f. which the gang around Torrington, Conn., favor because it provides a good mechanical arrangement for folding the antenna parallel to the car roof.

The pieces A and B are made from sections of brass rod ¼ inch in diameter. One end of A, which has an over-all length of 3½ inches, is turned down for a length of 2 inches, to a diameter to fit the inside of the bottom of the tubular antenna, which is soldered fast. At the other end, a tongue, 1 inch long and ¼ inch wide is cut.

Piece B has an over-all length of 6 inches. One end is turned down and threaded with a ⅜-inch die, while a slot, 1 inch deep and ¼ inch wide to fit the tongue of A, is cut in the opposite end. The slotted end is then drilled and tapped on one side of the slot for a ¼-inch thumb screw, C. A vertical elongated hole is drilled and filed out in the tongue of piece A, so that, with the thumb screw loosened, A can be lifted up slightly to clear the shoulders of B while the antenna is being folded down. The solid seating of the two pieces when the antenna is vertical provides little opportunity for the joint to work loose.

The threaded shank of piece B passes through a hole in the roof of the car. The polystyrene washers, D and E, provide the necessary insulation. Each is 2 inches in diameter and ¼ inch thick, and has a collar or hub ¼ inch thick turned on one side to fit the hole in the car roof. The assembly is clamped to the roof by the locking nuts, F is a soldering lug for making connection to the antenna.

If the assembly is placed near the forward part of the roof, the antenna may be folded back at the hinge without overhanging the rear of the car. — *Ed. Toloski, W1KXB.*

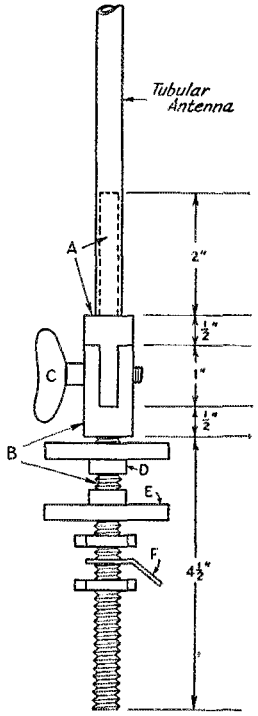
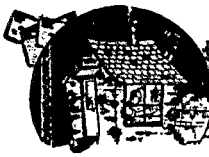

Fig. 7—Feed-through insulation and fittings for folding car-roof mobile antenna. The joint hinges at C so that the antenna may be folded down parallel to the roof of the car.



CORRESPONDENCE FROM MEMBERS

The Publishers of *QST* assume no responsibility for statements made herein by correspondents.

IT'S A RACKET—BUT NOT AN AMATEUR ONE

Stanford, Montana

Editor, *QST*:

This morning I received in the mail a communication to which I should like to call your attention. This letter was addressed to me from the Area Headquarters of the American Red Cross, and was on the subject: "Misinformation or Unofficial Information Received in Connection with Servicemen."

The paragraph which especially disturbed me read as follows:

"Another matter has been brought to our attention by which amateur radio operators pick up short-wave messages purported to have originated through a Tokyo radio, mail copies to the family concerned, and add a request that the family send to the operator a U. S. defense stamp in payment for the service. According to National Headquarters, this is not an uncommon performance. If such instances come to your attention, you will want to explain to those who inquire that this program has no relation to the Red Cross programs of communication and inquiry service which is a part of the Home Service program. The family concerned will have to decide whether or not they desire to send the defense stamp to the short-wave operator relaying the message to them.

"We would appreciate it if you would send to us an account of any unusual or irregular incidents of this type that come to your attention."

My own interpretation of the matter is that these message copies from Tokyo short-wave broadcasts are not being forwarded by amateurs, but by some other civilian short-wave listeners who see in it the possibilities for a racket. I am certain that the Red Cross is entirely sincere in making this statement, but I am equally certain that amateur operators as a group have been done a great injustice. No true ham would be guilty of such a thing. The public, or at least that part of the public which has had contact with the ham fraternity in the past, knows that radio amateurs have rendered invaluable service in times of emergency, with never a thought of compensation.

One definitely does not have to be an amateur nor possess communications equipment to receive these broadcasts, and I, for one, vigorously protest the term "amateur radio operators" being used in this connection.

Best wishes for the continued success of the League and *QST*.

— Robert H. McGuire, W7GZA

WATTS—OR DECIBELS?

4227 S.E. Taylor St., Portland 15, Ore.

Editor, *QST*:

... "Watts — Or Decibels," in the June, 1943, issue, sure hits the spot. A swell rig and lots of power (OK if you can afford it) seems to be the battle cry of all hams. It was a swell article, and Silver is to be commended for it. I hope that all hams get to read it.

There was one thing, however, that Silver left out. That is the overloading of the poor, abused p.a. tubes — rated for 25 watts, but 50 to 75 watts input is not uncommon. A good practice, although still overloading, is to run the input so that if the key is held down for about a minute there will be just a *little* color in the center of the plate. This will get all of the power out of the tube that is available. To use higher input simply means more plate dissipation, and, although some think that it looks good on the p.a. plate meter, it certainly does not mean more power into the antenna. If you can't get out with 100 watts, you won't get out with 1000.

Keep up the good work on *QST*, and let's all hope that we will be QSOing again soon.

— F. E. Kallian, W7CXI

P. O. Box 592, Des Moines 2, Iowa

Editor, *QST*:

I have just finished reading the article in June *QST*, "Watts—Or Decibels?" by McMurdo Silver. It contains a lot of good common "horse sense." Although I have been reading your magazine for over three years, I am little more than a rookie in actual ham experience, but I have seen a shining example of the "abilities" of different radiators.

W9KUM (whose rig I used to operate) had a little Stancor 10P hooked up to an ordinary flat-top arrangement. Under our *very bad* conditions, and on 160, we almost considered 9LPR and 9FEV our DX. They were about 45 miles distant. About 60–75 miles was our limit on c.w. Then, by good fortune, the Oblong (Ill.) NYA, where 9KUM was instructing at the time, came through with a 120-ft. vertical steel tower. It was built similar to a windcharger tower, with all sections welded. We merely switched from the flat-top to the vertical, retuned, and our first CQ hooked a guy in Nashville, Tenn. That was well over 200 miles. From then on, Tennessee was consistent, and when we went after DX we moved into South Texas like a house afire.

I'll grant you that hooking a twenty-buck transmitter onto a two hundred and fifty-buck

antenna isn't exactly rational (like Silver's "corn-fed" kilo), but I do firmly believe that it is more economical to soup up a low-power job at the skypiece than at the power-house. . . .

— Arthur E. Shipman

FIRE INSURANCE

164 W. Jackson Blvd., Chicago, Ill.

Editor, *QST*:

. . . Possibly . . . amateurs having insurance on their transmitters . . . will be interested in a decision recently handed down by the Arkansas Supreme Court in connection with a fire loss occurring in a transmitter. This was reported in *The National Underwriter* recently.

The fire began "somewhere in the lower part of the metal cabinet housing tubes, coils, chokes, condensers, registers [probably meaning resistors], modulators, amplifiers, etc., and referred to as the transmitter" — location not stated, but belonging to the Universal Broadcasting Corporation.

The insurance company sought to deny liability under the electrical exemption clause. This clause, according to the court, excludes only such loss as is caused to the apparatus by electrical currents, artificial or natural (including lightning), and further states that the insurance company "will be liable only for such loss or damage to them (the apparatus) as may occur in consequence of fire outside of the machines, appliances, or devices themselves."

The court held that this latter portion of the clause is not meant to limit further the liability of the insurance company, but is a mere explanation. Furthermore, the court declared that the burden of proof was on the insurance company to show that the loss was caused by an electrical current, and held that, in this case, there was no evidence which would have compelled the jury to find that the fire was caused by electrical currents, whether artificial or natural.

Accordingly, the decision was rendered in favor of the broadcasting company, the loss being held to be covered by the policy.

— Harry Fanckboner, W9BPS

FROM A NAVAL R.T. TRAINEE

Bliss Electrical School, Washington, D. C.

Editor, *QST*:

. . . Your Defense Edition of the *Handbook* received quite a recommendation from one of the instructors here. It is used a lot — and very valuably.

There are quite a few hams here. I don't know very many of them yet. James I. Dodson, W8RYO, RT3c; R. T. Mink, W8WEZ, Sea2c — and a lot of others I could hunt up.

If you get a chance, pass the word along to some of the boys who aren't in the service yet to hurry up and sign up for this work. They really know what radio is all about here. They go very fast but they cover a lot of territory. . . .

— E. H. Boden, W8QYL

MAXWELL FIELD TESTIMONIAL

Cadet Ground School, WRAAF,
Walnut Ridge, Ark.

Editor, *QST*:

I read with a great deal of interest the article by Lt. Thomas E. Campbell, W4GKU, about hams teaching AAF pilots at Maxwell Field. Being a code instructor here at this basic flying school, it was of much interest to me. Those hams at Maxwell are really doing a bang-up job there at pre-flight. We get quite a number of cadets from there, and they sure know their code. We give them a 20-hour refresher course, with speeds up to and including 14 w.p.m. and plenty of transmitting practice. The work is interesting and the hours nice — which is saying something, in the Army. Hi!

— Pvt. John E. Douglas

NECESSARY SERVICE

c/o Fleet Postmaster
San Francisco, Calif.

Editor, *QST*:

My first ARRL membership certificate arrived this afternoon. Though I've been a ham for nearly fifteen years, now I feel more like one than I ever did before. Without a doubt, if the brotherhood doesn't stick together now, there'll certainly be no ham radio after the war. From now on, you can count me as a steady member!

Although, for obvious security reasons, I can't say where I am, I want to say that the hams here who have not gone into the service are showing real hospitality to visiting Ws. I have been treated royally, and sincerely hope that I can have the privilege some day of repaying these fellows for their courtesies.

The thing that surprises them most is the power the American hams were allowed to run. Here it was limited to fifty watts. The opinion is constantly expressed that, if they just had a little more, they could really go places. Also, many of them used to call Ws and never get any response, due to the low power. I have seen expressed several times in *QST* the age-old opinion that all power should be limited to one hundred watts. For gosh sakes, *don't!* When the time comes for the conference table again, stick to the kilowatt. That's what has led to the development of super-selective receivers as we know them to-day.

One thing I would like to see, however, is a regulation that was enforced here; namely, a requirement for six months' operation on c.w. before 'phone operation is permitted. It would go a long way toward clearing up the bedlam on the 'phone bands. If the fellows are griping about interference, what's the matter with single-sideband modulation? We could accommodate twice the number of 'phone stations in the same territory. And I've a feeling we'll be having fewer of those precious kilocycles, instead of more.

However, right now all we can do is work

harder than we ever have, to show Uncle Sam and the Allies that ham radio is not just a play-thing, but a necessary service in the public interest. . . .

— John E. Pitts, jr., RM1c, W6CQK

RADIONICS AND ELECTRONICS

809 Minnesota St., Hibbing, Minn.

Editor, QST:

Anent the discussion of "electronics" and "radionics" which appeared in June QST, I would like to say my piece as a ham of twenty years experience and an electrical engineer.

It seems to me that the matter of semantics is being overemphasized in this connection. Language is a moving force that will grow from current needs and beliefs regardless of the rationalizations of semantics.

To the practical man, the term "electronics" means the control of electric currents and/or e.m.f.s by means of vacuum tubes or "electron" tubes. To Mr. Average Man, an electric current still means an electron movement or, for conductors, an electron drift. Despite Schroedinger's theories of wave mechanics, the quantum principle and other theories that are still in the field of the philosophy of modern physics, the simple electron theory that includes the conception of the electron and positron is the theory that is used to explain and correlate electrical phenomena.

For these reasons, I would suggest that the general term "electronics" be retained to mean the entire field of vacuum tubes and their applications; and that the term "radionics" be used to describe the field of radio communication by code, voice or picture and, naturally, the application of vacuum tubes to this field.

Radio men are apt to overlook the fact that the vacuum tube is becoming the tool of the electrical engineer as well as of the communication engineer. With the coming of high-frequency induction heating, photoelectric cell application, etc., the electrical engineer is becoming an important individual as far as vacuum-tube applications are concerned. There is a natural division of this kind of work from the field of communications. Therefore, in the selecting of terms let us not lose sight of actual field conditions.

Let us retain "electronics" for the field of vacuum tubes as shared by the communication engineer and the electrical engineer; let us also retain the term "radionics" to include vacuum tube applications as well as other radio phenomena, for the communications engineer. As you will note, the large electrical manufacturers are training men from the communications field for vacuum tube applications in industry. However, in the future these men will be electrical engineers who have specialized in "electronics" during their formal engineering training. These men will probably have no special interest in "radionics."

— Arthur L. Bennett, W9ADS

ABOUT C.A.A.

8001 Edgewater Road, Riverside, Ill.

Editor, QST:

. . . Officially, I am principal ground school supervisor for Region 3 of the CAA War Training Service. Through district ground school supervisors I aim to see that the ground schools with whom we contract live up to the instruction required by the contract. This contract also provides for board, lodging and transportation to the airport. A companion contract with a flight operator provides the flight instruction. Region 3 includes North Dakota, Minnesota, Wisconsin, Illinois, Indiana, Kentucky, Ohio and Michigan. Besides the usual aeronautical subjects, these ground instruction contracts require that the schools give instruction in radio code, and the Navy contracts add semaphore. We have been recommending amateurs for this code instruction, and as usual they have responded in fine shape. Our trainees are naval aviation cadets in their second phase of training or army enlisted reservists. . . .

— Fred W. Young, W9MZN

THAT WE WILL

1st Ave. and 52nd St., South Brooklyn, N. Y.

Editor, QST:

. . . I would like to say a word about the great job you are doing with QST. Considering the amount of material that has been cut out due to the restrictions on ham operating, you are certainly making fine headway with other topics. I say keep it coming.

— Robert P. Harrison, RM1c, W1KYL

HAM'S ODYSSEY

Nuñez De Balboa No. 241,

Miraflores, Lima, Peru

Editor, QST:

. . . A brief summary of the activities of W9JID might prove interesting. Received my license in 1931 . . . progressing to equipment which varied from an elaborate kilowatt down to 200 watts. During the following years I actively engaged in RM for Minnesota, OO, OB, OPS, ORS, AARS and made the BPL on twenty different occasions. As SNC of Minnesota and Corps Area Aide I was active in AARS. . . . Cited twice for active part in emergencies, once from the mayor of Los Angeles for earthquake traffic and again in 1936 for active part in the flood traffic from Tennessee and Arkansas. (At that time I had a commercial transmitter in my house trailer and helped direct flood relief boats on the Arkansas River.) In addition, the station set a world's record on 160 during the WAS contest. . . .

These activities are cited because of a parallel result. I became a radio operator (point-to-point) for Northwest Airlines as a direct result of experience gained in amateur nets. After three and

(Continued on page 84)



OPERATING NEWS



GEORGE HART, WINJM
Acting Communications Manager

CAROL A. KEATING, W9WVP
Assistant Communications Manager

More Rule Changes. You will note in "Happenings of the Month" in this issue that FCC has made several new amendments to the WERS Rules and Regulations. There have been several slight textual changes, but most of them are incorporated merely to clarify minor points or to conform to the one great major change in the regulations — increased scope of service for CD-WERS. The crux of the amendments is contained in the revised Section 15.63 and the two new Sections, 15.5 and 15.56. Read them carefully. Annotate your by-now-much-annotated copy of the regs accordingly.

These amendments were released just as this issue of *QST* is going to press, and there is still some doubt as to their significance. With the expansion in the scope of service comes the possibility of applying for authorization to communicate during the first fifteen minutes of each hour under certain limitations as outlined in Sec. 15.63(b). The expanded CD-WERS will require a more extensive system of communication than that in which we have formerly engaged. Heretofore our activity has been confined to operation when normal means of communication were not available. We were to be available "just in case." The new amendments give us a more important and a more constant job to do, in addition to our former duties. It would seem that CD-WERS is evolving from a supplementary service into a service that will be expected to be on the job all the time, and that we shall test in anticipation not only of air raids but also of other "emergencies involving the safety of life or important property in connection with civilian defense or national security."

We have long since ceased speaking of transmitting points as "stations" and have referred to them as "station units" or simply as "units." FCC now recognizes that terminology by incorporating it into the regulations.

More Testing Hours. On June 8th, FCC acted to provide CD-WERS with some much-needed additional testing hours by making the Wednesday period permanent and adding another two-hour period on Monday. Text of the modified section of the regulations is given in "Happenings of the Month" in this issue. This will be good news for those licensees, especially large cities, who have found themselves handicapped by the limited amount of testing time allowed them. Tests and drills during the indicated hours on Monday and Wednesday evenings and Sunday afternoons may now be used without reporting to FCC; all other specially-authorized tests and drills must, however, be reported to your regional FCC

office as usual, with a copy to the Washington office. Be careful to observe the regulations in this respect. *All* operation of WERS stations not conducted during the test periods must be reported, no matter who authorizes it, *within 24 hours* after the operation. With the increasing number and importance of CD-WERS licensees, FCC surveillance is bound to grow closer. Several licensees already have reported that they have been visited by an inspector. If your organization is not in tip-top shape, get it that way now!

Priorities. It becomes painfully necessary to point out at this time that procurement of equipment for WERS carries no priority assignment — at least not yet. Under the provisions of WPB Order P-133, many CD-WERS licensees applied an AA2X priority rating for procurement of much-needed gear; and indeed this Order could have been so interpreted. On June 4th, however, WPB issued an amendment to Priority Regulation 3 which made it painfully clear that no preference rating is available for procurement of "(List B) 33. Any device, equipment, instrument, preparation or other material designed or adapted for use in connection with: c. The protection of civilians, either individually or collectively, against enemy action or attack."

One of the reasons why WERS was so readily approved by the Defense Communications Board (now the Board of War Communications) was that it was understood that equipment would be supplied by amateurs from their junkboxes and that no priorities would be needed. Now that we have discovered that the resources of our junkboxes are not quite as great as we thought they would be, it is all the more difficult, for the above reason, to secure any sort of consideration in the form of a priority rating. We are not giving up the fight, of course. There are still some stones to be turned.

Bootlegging. We have been shocked to receive reports that there is some evidence of unauthorized operation in the 2½-meter band in certain communities. We know that this sort of thing is not widespread, and we hope that no amateurs are responsible for it — but its very existence is a distinct shock to us. The radio aide is responsible for the operators working under his jurisdiction; he likewise should take the responsibility to report the existence of any suspicious signals *in the 2½-meter band* to his nearest FCC office. It would not be correct to say that he should do this *even* if he knows who the offender is; he should do it *especially* if he knows who it is. It must clearly be shown at the very outset that

Honor Roll

The American Radio Relay League War Training Program

Listing in this column depends on an initial report of the scope of training plans plus submission of reports each mid-month stating progress of the group and the continuance of code and/or theory classes. All Radio Clubs engaged in a program of war radio training are eligible for the Honor Roll. Those groups listed with an asterisk teach both code and theory. Others conduct only code classes.

- *Burlington (Vt.) Amateur Radio Club
- *Central Oregon Radio Klub, Bend, Ore.
- *Detroit (Mich.) Amateur Radio Assn.
- *Edison Radio Amateurs' Assn., Detroit, Mich.
- *Hillsborough Twp. ARRL Radio School, South Branch, N. J.
- Knoxville (Tenn.) Radio Communications Club
- Manilla (Iowa) High School Radio Club
- South Jersey Radio Assn., Merchantville, N. J.
- Tucson (Ariz.) Short Wave Assn.
- Vermont Academy Code Club, Saxtons River.

no sort of illegal operation will be tolerated; if offenders are allowed to get away with it, it might make the practice too widespread for comfort.

District Licensing. Now that certain areas are pretty thickly concentrated with WERS licensees to the extent that interference is beginning to become a major problem, the question arises as to whether or not it would be advisable to form into district nets under one license. This would involve (1) appointment of a district radio aide, (2) preparation and submission of application for the entire district, (3) surrender for cancellation of independent licenses, (4) request by independent licensees for special authorization to continue operation under the old license until the district license is issued, (5) re-issuance of operator permits to be signed by the district radio aide and good for operation anywhere in the district.

ARRL will not take the responsibility of advising that such re-licensing be attempted; neither will we advise you against it. It can be done, and there are many advantages to the resulting setup, but it would be naïve of us to suppose that any radio aide would be altruistic enough willingly to surrender his official status and go to all the attendant bother necessary, in order to subordinate himself to a district radio aide. There is also the one disadvantage that there will probably be some delay and confusion in completing negotiations, both locally and through Washington.

By this time, however, radio aides in concentrated independently licensed areas must realize that some sort of mutual cooperation is necessary in order to effect harmony of operation. When adjacent independently licensed communities "get in each other's hair" they should get together, settle their differences and evolve a system by which mutual interference is avoided and mutual aid and cooperation effected. This we do recommend, most heartily.

Special Drills. There is a section of the WERS Rules & Regulations which says, among other things, words to the effect that special drills may be ordered by the proper military or civilian defense authority "during practice alerts, practice blackouts, practice mobilizations or other comparative situations. . . ." (Italics ours.) The italicized part of the above quotation is somewhat broad, and we understand in some cases has been interpreted rather broadly to the extent that radio aides have ordered their stations on the air for test drills simply because they did not have enough testing times otherwise. While we expect that the necessity for this has been eliminated now that we have extended testing periods, an unofficial interpretation has indicated that need for additional testing time is not one of the "other comparable situations," and that the radio aide is not considered the "proper" authority to order the drill. Stick to your regular testing hours if you can. If you operate outside the testing hours for any purpose, be sure to report it within 24 hours. If your report of such operation backfires, with FCC informing you that it was not legal, why not let ARRL know about it? If we think you are right perhaps we shall want to go bat to for you; and if not, others can be warned not to be caught in a similar pitfall.

Honor Roll. There was a time when our Honor Roll of clubs participating in the ARRL War Training Program was long and impressive, but it has now become a mere shadow of its former self. We here at Headquarters have been leaning over backward trying to get names of clubs to put in the Honor Roll. Despite our efforts, the list continues to grow smaller.

We shall not continue to waste valuable *QST* space by including this list if there seems to be no interest in it. If you wish to see this Honor Roll continued, report the progress of your club training program monthly to your SCM or direct to Headquarters. If the list should suddenly disappear from the pages of *QST*, it will be because there does not seem to be sufficient interest to warrant its continuance.

— G. H.

BRIEFS

J. Gosling, the ugly duckling insignia created by W4MS, recently celebrated his eleventh birthday. Although J. Gosling has been associated with Donald Duck, he is, as a matter of fact, much older, having been created in 1931 as an insignia for the Naval Air Station in Pensacola. Collins is drawing the station mascot in an animated cartoon, but since he has to draw all the cartoons himself, it takes a lot of time.

Sgt. Edward R. Stevens, K7BC (ex-W7BB), ACS, ASN 6582101, Box 457, Sitka, Alaska, will send a QSL to any United States amateur who QSOed him at Sitka, on receipt of a card mailed to him at the address above.

Mayor F. H. LaGuardia of New York recently swore in no less than 300 amateurs and volunteers to the ARP services as members of the WERS in that city.

BRIEFS

The Detroit Amateur Radio Association is sponsoring a picnic to be held at Boblo Island on Sunday, August 1, 1943. This will take the place of the usual DARA hamfest and will include a ball game between the "slow dotters" and the "faht dotter5." Boats will leave at 10 A.M., 2 P.M. and 4 P.M. Tickets: Adults, 85 cents; children, 35 cents.

— Ken Conroy, W8DYH

Under FCC rulings, a War Emergency Radio Service operator permit (each applicant for such a permit must already hold a radio operator license of any class) will be acceptable and granted only after the regular operator permit or license has been issued. What this means, in effect, is that simultaneous applications should not be made for such license and War Emergency Radio Service operator permit.

Jerry A. Hardison, W4HQM, R. No. 3, Humboldt, Tennessee, would like to swap QSLs and shack photos with hams and SWLs.

The Australian News and Information Bureau, 610 Fifth Ave., New York, N. Y., has released the following schedule of daily overseas shortwave transmissions: (1) VLG6, Melbourne, 15.23 Mc., 10:11 P.M. PWT, and VLI3, Sydney, 15.32 Mc., same time, directed to the West Coast of the U. S. A. (2) VLG3, Melbourne, 11.71 Mc., 9:31 A.M. GMT (2:31 A.M. PWT), directed to the Allied Forces in SW Pacific. (3) VLI9, Sydney, 7.28 Mc., and VLG2, Melbourne, 9.54 Mc., 8:01 A.M. EWT, directed to the East Coast of the U. S. A. (4) VLG, Melbourne, 9.58 Mc., 8:01 A.M. PWT, directed to the West Coast of the U. S. A.

"The Ham Family of Wisconsin" have passed their 3rd-class telephone examinations and have received their 3rd-class permits. The family consists of papa Bert Nelson, W9BOM, mamma Ella, W9RCM and son Harold, W9LAB. They are all deputy sheriffs of Kenosha County, and Ella is a member of YLRL. Harold's girl friend, Evelyn Bray, also took the exam and now has her 3rd-class permit.

Those interested in the correct time might like to try the following:

1) CHU, Ottawa, maintains continuous 24-hour time service on simultaneous frequencies of 3330, 7335 and 14670 kc. If the time is known within five minutes it is possible to adjust clocks to the second by being familiar with the system of pauses used in their second impulses, as shown in the following chart. Figures in parenthesis indicate second impulses which are omitted, while other figures show the number of pulses sent in succession. Starting exactly on the 5-minute mark:

First minute: 29-(1)-21-(1)-4(4)
 Second minute: 29-(1)-22-(1)-3(4)
 Third minute: 29-(1)-23-(1)-2(4)
 Fourth minute: 29-(1)-24-(1)-1(4)
 Fifth minute: 29-(1)-21-(9)

It will be noted that the next-to-last figure for each minute indicates that, when the pulses begin, there will be exactly that number of minutes to go before the five-minute period is up. If the five-minute period is the one just preceding the hour, a long dash is sent after the nine-pulse pause (ten seconds) at the end of the fifth minute, indicating the hour; this is followed by a minute of adjustment, after which the pulses begin again. At the end of any other five-minute period the pulses simply begin, without the long dash, at the beginning of the sixth minute, or, more correctly, at the beginning of the next five-minute period. Sound complicated? It's really very easy if you will listen to CHU and apply the above chart.

2) The correct time can be obtained from WWV (5000 kc.) more simply but not so quickly. The carrier is modulated by a 440 c.p.s. tone and second ticks. The tone modulation is interrupted at the end of every five-minute period, but the ticks continue. The tone then sends the call letters, WWV, in code several times, and exactly at the beginning of the seventh minute the tone is resumed.

ELECTION NOTICES

To all ARRL Members residing in the Sections listed below:

The list gives the Sections, closing date for receipt of nominating petitions for Section Manager, the name of the present incumbent and the date of expiration of his term of office. This notice supersedes previous notices.

In cases where valid nominating petitions have been received from ARRL members residing in the different Sections in response to our previous notices, the closing dates for receipt of nominating petitions are set ahead to the dates given herewith. In the absence of nominating petitions from Members of a Section, the incumbent continues to hold his official position and carry on the work of the Section subject, of course, to the filing of proper nominating petitions and the holding of an election by ballot or as may be necessary. Petitions must be in West Hartford on or before noon of the dates specified.

Due to resignations in the Missouri, Eastern Florida, Indiana and San Joaquin Valley Sections, nominating petitions are hereby solicited for the office of Section Communications Manager in these Sections, and the closing date for receipt of nominations at ARRL Headquarters is herewith specified as noon, Monday, August 16, 1943.

Section	Closing Date	Present SCM	Present Term of Office Ends
No. New Jersey	Aug. 2, 1943	Edward Gursky, jr.	Oct. 15, 1942
Missouri	Aug. 16, 1943	Robert C. Morwood*
Eastern Fla.	Aug. 16, 1943	Carl G. Schaal*
San Joaquin Valley	Aug. 16, 1943	Antone J. Silva*
Indiana	Aug. 16, 1943	LeRoy T. Waggoner*
Hawaii	Aug. 16, 1943	Francis T. Blatt	Feb. 28, 1941
Sacramento Valley	Aug. 16, 1943	Vincent N. Feldhausen	June 15, 1941
Nevada	Aug. 16, 1943	Edward W. Heim	Nov. 1, 1941
Oklahoma	Aug. 16, 1943	R. W. Batten	Nov. 1, 1941
Alaska	Aug. 16, 1943	James G. Sherry	June 14, 1942
Southern Minn.	Aug. 16, 1943	Millard L. Bender	Aug. 22, 1942
New Hampshire	Aug. 16, 1943	Mrs. Dorothy W. Evans	Sept. 1, 1942
West Indies	Aug. 16, 1943	Mario de la Torre	Dec. 16, 1942
East Bay	Aug. 16, 1943	Horace R. Greer	May 26, 1943
Vermont	Aug. 16, 1943	Clifton G. Parker	June 2, 1943
Maine	Aug. 16, 1943	Ames R. Millett	June 7, 1943
San Francisco	Aug. 16, 1943	Kenneth E. Hughes	July 5, 1943
South Carolina	Aug. 16, 1943	Ted Ferguson	Aug. 25, 1943
Eastern Penna.	Aug. 16, 1943	Jerry Mathis	Aug. 28, 1943
Western Fla.	Sept. 15, 1943	Oscar Cederstrom	Oct. 1, 1943

* Resigned

1. You are hereby notified that an election for an ARRL Section Communications Manager for the next two-year term of office is about to be held in each of these Sections in accordance with the provisions of the By-Laws.

2. The elections will take place in the different Sections immediately after the closing date for receipt of nominating petitions as given opposite the different Sections. The Ballots mailed from Headquarters will list in alphabetical sequence the names of all eligible candidates nominated for the position by ARRL members residing in the Sections concerned. Ballots will be mailed to members as of the closing dates specified above, for receipt of nominating petitions.

3. Nominating petitions from the Sections named are hereby solicited. Five or more ARRL members residing in any Section have the privilege of nominating any member of the League as candidate for Section Manager. The following form for nomination is suggested:

(Place and date)

Communications Manager, ARRL
 38 La Salle Road, West Hartford, Conn.

We, the undersigned members of the ARRL residing in the Section of the Division hereby nominate as candidate for Section Communications Manager for this Section for the next two-year term of office.

(Five or more signatures of ARRL members are required.)

The candidates and five or more signers must be League members in good standing or the petition will be thrown out as invalid. Each candidate must have been a licensed amateur operator for at least two years and similarly, a member of the League for at least one continuous year, immediately prior to his nomination or the petition will likewise be invalidated. The complete name, address, and station call of the candidate should be included. All such petitions must be filed at the headquarters office of the League in West Hartford, Conn. by noon of the closing date given for receipt of nominating petitions. There is no limit to the number of petitions that may be filed, but no member shall sign more than one.

4. Members are urged to take initiative immediately, filing petitions for the offices of each Section listed above. This is your opportunity to put the man of your choice in office to carry on the work of the organization in your Section.

— George Hart, Acting Communications Manager

ELECTION RESULTS

Valid petitions nominating a single candidate as Section Manager were filed in a number of Sections, as provided in our Constitution and By-Laws, electing the following officials, the term of office starting on the date given.

North Carolina	W. J. Wortman, W4CYB	May 3, 1943
Washington	O. U. Tatrow, W7FWD	May 27, 1943
Northern Minnesota	Armond D. Bratland, W9FUZ	June 15, 1943
Southern New Jersey	W Ray Tomlinson, W3GCU	June 22, 1943

In the New York City and Long Island Section of the Hudson Division, Mr. E. L. Baunach, W2AZV, and Mr. Everett G. Kolbe, W2LOS, were nominated. Mr. Baunach received 143 votes and Mr. Kolbe 90 votes. Mr. Baunach's term of office began June 9, 1943.

ARRL AFFILIATED CLUB HONOR ROLL

The list below was compiled by analysis of a questionnaire returned in response to a year-end club survey:

All Members of these Clubs are ARRL Members:

Amateur Radio Researchers, Bell, Calif.
Amateur Radio Transmitting Society, Louisville, Ky.
Asheville Amateur Radio Club, Asheville, N. C.
Binghamton Amateur Radio Association, Binghamton, N. Y.
Central New York Radio Club, Syracuse, N. Y.
Charlotte Amateur Radio Club, Charlotte, N. C.
Dells Region Radio Club, Wisconsin Dells, Wis.
Detroit Amateur Radio Association, Inc., Detroit, Mich.
Edison Radio Amateurs' Association, Detroit, Mich.
Fort Wayne Radio Club, Fort Wayne, Ind.
Galveston Amateur Radio Club, Galveston, Texas
Goshen Amateur Radio Club, Goshen, Ind.
Hi-Q Radio Club, Lynn, Mass.
Huntington Radio Club, Huntington, West Va.
Illinois Ham Club, Chicago, Ill.
Inglewood Amateur Radio Club, Inglewood, Calif.
Iowa-Illinois Amateur Radio Club, Burlington, Iowa
M. A. K. Amateur Radio Association, Boston, Mass.
Original Tri-County Amateur Radio Association, Cranford, N. J.
Parkway Radio Association, West Roxbury, Mass.
Providence Radio Association, Inc., Providence, R. I.
Queen City Emergency Net, Cincinnati, Ohio
The T-9 Club, Danvers, Mass.
West Philadelphia Radio Association, Philadelphia, Pa.
Winston-Salem Amateur Radio Club, Winston-Salem, N. C.
York Road Radio Club, Glenside, Pa.

The Month in Canada

QUEBEC—VE2

From Lin Morris, 2CO:

BILL OKE, 2AH-3AKO, now a sub-lieutenant in the RCNVR (special branch), is the latest addition to the roster of hams located in Ottawa. There are enough at headquarters now to hold a small hamfest, and plans are getting under way to put one on in the near future. **Noel Wright, 2DU**, has been promoted to the rank of lieutenant-commander. **Stan Comach, 2EE**, and **Bill Skarstedt, 2DR**, have returned from trips overseas. **Robert Rowan, 2GO**, is on foreign duty. **3RX** is an RCNVR warrant officer stationed in Ottawa. **Bill Meredith, 2HM**, is a first lieutenant (reserve army) with **RCCS**. **Harry Ashdown, 2IO**, paid a brief visit to Ottawa on a trip East before returning to the Pacific Coast.

Gang, once more I must remind you that I cannot manufacture news out of air. Won't you please drop me a line and say what you can, especially those of you who are overseas? It will be one way of keeping the fellows in touch with one another in these difficult times.

ONTARIO—VE3

From Len Mitchell, 3AZ:

CONGRATULATIONS are due **3IX**, who was recently awarded the decoration known as the M.B.E. Dave was overseas with the RCAF for two years and since returning home has been doing special work in Virginia with the Navy. Congratulations are also due **3IM**, who has been promoted to the rank of flight-lieutenant and awarded the M.B.E. Charlie went overseas in the early days of the war as an aircraftman and through his persistent work and devotion to duty has won successive promotions to his present rank. All Canadians join in wishing these two well-known amateurs continued success.

We hear **3MS** is in India with the RCAF, and has now become accustomed to the climate.

ALBERTA—VE4

From W. W. Butchart, 4LQ:

ABOUT two months ago a daughter, **Joanne Cecilia**, arrived at the home of **4JP** (the Reid Elliotts of Alliance). **4JP** and his **YF** were in Edmonton visiting around May 16th and broke the news. Of further interest is the news that **JP**

has been commissioned a 2nd "Looney" with the Calgary Tanks (Res.). Reid put his "Pip" up in February, and he is O.C. of the Alliance detachment of the unit.

Through kind permission of **4VJ** we were privileged to read over a letter received from **4AOZ**, Slim Marsden, of Milo, Alberta, and when we say the letter was newsy, we mean newsy! Slim runs a service station and radio service shop under the name of "Totem Radio," and by his remarks he is doing **FB**. Slim adds that after a lapse of two years his conscience bothered him a bit so he went out and renewed his subscription to good old "Quist." And he promises that he won't let it stand over so long the next time.

From Slim's letter we gleaned the following kernels: **4HK**, **Tony Kensen**, is still at Standard. His old pal of the Queen Charlotte Islands, **5DO**, is with the B.C. Provincial Police. **Maudie Phillips, 4APA**, of Chancellor (the girl who put Chancellor on the ham map) has taken up stamp collecting since going off the air, but says that she just can't get back on the air soon enough! **4APZ** is located at Innisfail. **4AMA** is located at Pierce Airport, northwest of Lethbridge, where he keeps busy checking aircraft radio equipment. He was at Regina, but his home is Grassy Lake, also **4APZ's** home **QTH**. **4GD** is hanging onto a fading sort of business in Calgary (remember the gyp-joint, boys?), and has one heck of a time with priorities, etc. Slim finishes off his letter by asking **VJ** if he knows where he could grab off a Sky Buddy or a Sky Champ! It couldn't be that **AOZ** has seen the handwriting on the wall in recent Allied victories, and sees chances of being back on the air shortly? Or could it? Thanks for a swell lot of news, Slim, and we're sure the boys will appreciate it.

4AEV is stationed at Currie Barracks Airport, Calgary. **4ALO** is still ferrying Ansons around the country for **CATL**, and has run up an impressive mileage in the last two years or so. For the sake of those who do not know, **CATL** means Canadian Airways, Training Limited.

4IN at last report was working on an RCAF coastal patrol on the West Coast. **4AES** has his **QTH** at Lac La Biche now, and when last heard of had been made a member of the local rating board for that northern metropolis. **Tommy Logan** (I can't remember his call) is back in Canada on leave after serving in the **RAF** as a wireless mechanic. **4AOC**, **Ken Smith**, who has just completed his final year at Varsity, has accepted a position with **RCA-Victor** at Montreal. Good luck, Ken, and we presume that one of these days you will be signing a **VE2** call. What say?

And just as news was getting a bit scarce, from **Osoyoos**, B. C., we heard from **Alf Ackerman, 5LC**, ex-**4SV**, of Waskatenau. **Alf** is in the fruit packing-box industry, and handles a spot of radio servicing on the side. He is much interested in B.C.'s **ARP** net, but gives no details as to how it is to operate. Remember, boys, **LC's** nice fist and note, using a home-brew bug? **Alf** wishes to be remembered to all his **VE4** pals. Tnx a million, **OM!**

In the *Edmonton Journal*, June 8th, the following announcement made its appearance: "Dodds: Born to Mr. and Mrs. R. O. Dodds (née Mickey Turpie) on June 4th at the Misericordia Hospital, a daughter." Yes, boys, it's the Mickey of **4WY**, and at the time of writing both mother and daughter are doing very well and expect to leave the hospital in the next day or two. The proud pappy, **Orton**, is in the RCAF and is stationed down East, so we are not able to obtain his reactions. Congrats to the **Dodds**.

4HM is busy preparing for a trip down to Ottawa about the middle of June, and you may rest assured that he will hunt up all his ham friends while away and will come back loaded with news, new cameras and gear! We eagerly await his return. **4BA** is doing his bit of news announcing at **CPRN** these days and is looking forward to a big summer for taking Kodachrome to add to his rapidly growing file. **4LQ** has been **QRL** gardening for the past few weeks, but seems to have everything under control now.

BRITISH COLUMBIA—VE5

From Jack Gibson, 5BQ:

WELL, gang, here's a new hand at the wheel. I have been asked by your present **SCM, 5DD**, to take over this work as he finds it hard to do along with his other duties. Would like to hear from any of you, no matter what you have to say — hi!

I hear **5EP** has had a raise in pay. Good work, **Don, 5NT** is in the East taking a course with the Air Force. **5HP** has a new future brass pounder. **5OM** has been transferred from land to water, but is still with the B. C. police.



ATLANTIC DIVISION

EASTERN PENNSYLVANIA — SCM, Jerry Mathis, W3BES — 8KAY, an active ham on all bands, is stationed in Phila. with the USCG. 1MVE, who used to haunt 80 meters, is now in Phila. with the A.T. and T. GYV is still training in North Carolina. JBC received his first promotion at Ft. Jackson, S. C. WERS hereabouts has settled down to routine except for a little 1 $\frac{1}{4}$ -meter experimenting going on in Lower Merion Twp. 1KW has been heard from recently and was doing well on sea duty in the Navy. Not many reports of activity were received again this month, hence the brief report. 73, Jerry Mathis, W3BES.

SOUTHERN NEW JERSEY — SCM, W. Ray Tomlinson, W3GCU — Asst. SCM, Ed. Raser, ZI; Interim Emergency Coördinator in charge of Emergency Coördination, Theodore Torretti, BAQ; Asst. EC and Radio Aide for WERS in Hamilton Twp., H. Dallas Fogg, ASQ; EC for Somerville and vicinity including Southbranch, Stan Case, ABS. WERS op permits have been received and great progress is being made with Hamilton Twp. program. Antennae have been erected and tests are now the order of the day, during authorized periods. Main control station equipment, designed by JOL and built by HTJ, is ready for installation in Municipal bldg. as soon as the Twp. carpenter gets the "corner" completed. Identification procedure has been completed for all involved. The antenna on Municipal bldg. stands twenty feet above a fifty-five foot building and is completely in the clear. With tests with a TR4, the signals have been heard satisfactorily in all parts of the Twp. covered. Several additional pieces of equipment have been obtained and will be placed in service as quickly as time will permit. GCU has been appointed in charge of equipment construction by radio aide ASQ. JOL has been requested to take charge of operation, and is working out a program which will coincide with his working hours at Eastern Aircraft. HTJ will be in charge of maintenance. Chairman of Emergency Communications for Hamilton Twp., Frank Priest, has given the "all clear" and is cooperating 100% in all ways and is doing his best to help in obtaining what materials are required for all installations. HTJ and JOL are in charge of antennae erection. Radio aide ASQ is taking complete supervision of all phases of program under his jurisdiction. ABS reports the Hillsborough-Branchburg Twp.-Somerville WERS application is now in hands of FCC and awaiting their action. Hillsborough Twp. radio school still in session with both code and theory, and is forging ahead also with WERS equipment construction, so as to be ready to "hit the ether" as soon as FCC approves fully. Somerville amateurs are cooperating fully in this program as Somerville requested operation under supervision of Hillsborough Twp. control, and setup has been arranged to include this request. Hamilton Square wired wireless setup is still working out nicely throughout that community, as is also regular communication between ABS-ACC and others in Southbranch-Neshanic station area. JAG does a lot of listening on this type communication and reports hearing some, but not much activity, now, due to weather. GCU has given up "land-line" in favor of WERS work. CAP has requested full cooperation of amateur radio in coming program for that branch of Service. We cannot mention what this program is, but we do earnestly request all members of our Section to give CAP every cooperation available, both in time and equipment. Former SCM, CCO, is now stationed at A.R.L., and may be addressed: Lt. Lester H. Allen, S. C., A.R.L., Wright Field, Dayton, Ohio. Les is classified as radio engineer at Aircraft Radio Labs., and is now in El Paso, Texas, on an engineering trip. He put on a successful demonstration for Sec'y of War Stimson, Under-Sec'y of War Patterson, and several high ranking generals and was commended by all. Les reports that in El Paso he has met all but two or three of the hams that made him WAS, and says that he has received swell reception by the whole El Paso gang. ITU, now a student instructor of radio repair, has graduated radio school at Camp

Crowder, Mo., and expects to be assigned to instructor duty. Dave says 3ESO and 9GE are both living at his barracks. JKH is now instructor of radio at Armored Force School, Ft. Knox, Ky. QL was recently promoted to warrant officer, in Navy. He has just returned from the North African combat zone, where he was chief radioman aboard one of Unk Sam's big "bruisers." HTJ now has radiotelephone permit, placing him in the ranks of "CPO." Congrats to CCC's son, Blair jr., who was married April 12th. VE has been assigned to new Armored Division and is now on maneuvers somewhere near Nashville. Sam's address is now: Major Samuel Kale, 95th Armored Field Artillery Bn., APO 255, Nashville, Tenn. JLI is now radio technician with Blimp Squadron, U.S.N., Lakehurst, N. J. ARN has been transferred to Naval Radio School, Chicago. JAG's brother, in Navy a year, is stationed at Virginia Beach. JKI, now 2nd Lt. in Air Corps, is stationed at Ft. Monmouth, N. J. FBZ is now Pvt. Paul Matlack, U. S. Army. DAF recently graduated in radar at Anacostia, D. C., and transferred to Jacksonville, Fla. HTL is at Officers Candidate School, Ft. Monmouth. He joined the Signal Corps two years ago, and was recently transferred from Trinidad. ITU reports having met IHO, stationed at Camp Crowder, Mo. Both ITU and IHO were very active on our Southern New Jersey 'phone net, and now both are assigned to the same communications squadron there. Official communication from ARRL Headquarters advises that because no other valid nominating petition for SNJ SCM was received there by June 1st, the election has been decided in favor of the now Acting SCM, Ray Tomlinson, W3GCU. Thank you all for the support given. Every effort will be expended to maintain the high standards enjoyed by this Section. To maintain these standards we again make the old request, "please send in your monthly reports so that we can keep our activity foremost!" We especially request full information on all WERS projects in our Section, no matter how small or large they may be. Send in the dope to your SCM, W. Ray Tomlinson, 623 East Brown St., Trenton, N. J. The SCM report is mailed in to Headquarters on the 18th of each month. My thanks again, and 73 till next appearance!

WESTERN NEW YORK — SCM, William F. Bellor, W8MC — A large part of our news this month comes from Lt. Don E. Compton, to whom we are indebted for a very nice letter. It gives us the idea that you boys in the Services are a fine source of news as the fellows usually meet up with other hams, often, and hash things over. Let's have some more. OMI! TKM has just returned from the tropics, and is working in War Department stations all through the Caribbean. Don also says QST is the most popular source of reading matter, the copies usually taking quite a beating in being passed around. As letter writing lags, it's the only thing that lets them know what's going on. LTN from Genesee is stationed at Drew Field, Fla., and was granted three weeks leave after a tough siege in the station hospital there. He is a lt. in the Signal Corps, engaged in radar work. BFN, a former engineer at WHDL, Olean, is now located in Alaska, working as chief engineer of two stations for the OWI: KTN and KINY. They tell us the old RI from the Buffalo office, Mr. Grinnell, is now stationed at Tampa, Fla. Many of the Northern boys down in the camps have been pleasantly surprised to meet him there. Auburn is starting some WERS activity and has contacted the highly successful Syracuse group for some pointers. DFN's new xtal WERS transmitter is working fine. He is now considering screen modulating the 829 final. TEX has been building an all-wave precision signal generator in his spare(?) time.

CENTRAL DIVISION

ILLINOIS — Acting SCM, George Keith, jr., W9QLZ — I NQL has returned to Spring Valley. NGG has been transferred to Pontiac where he operates for State Police. ODT, EC Will Co., reports WERS progress. UQT has alarm clock trouble. QKB has first one and second telegraph tickets posted at State Police, Duquoin. BIN is government WX observer at Henry. NIU hears fb dx on FM. ZEN is burning up the mill with Coast Guard radio at Wilmette. QGN has been busy teaching in Navy. JARS, Joliet, continues to be active. AND/1 is instructor in radio operating for Army Air Forces at Yale Univ. and operates WJLH in WERS. OQ works at Rock Island Arsenal. SXT is in Navy. GNU is Army doctor in Miss. WXV is radio instructor, Scott Field. MTJ, YQE and CEW are with U. S. Forces. AND visited ARRL Hqtrs. EWR is BC eng. at WJJD. FWR still remembers old days on 40 and 80 CW. OAV is BC eng. at WGN. Mni tnx for the cooperation, fellows. 73, George.

INDIANA — SCM, LeRoy T. Waggoner, W9YMV — CD-WERS stations were used in communications emergencies resulting from widespread floods in Indiana. In Anderson, units were placed in service to assist other OCD services in protecting the city from the high waters of the White River. Mobile units patrolled the Park Place levee, and were able to dispatch trucks and crews where most needed. The availability of CD-WERS enabled CDC officials to shift men and equipment speedily enough to avoid breaks in the levee and subsequent heavy property damage. In Fort Wayne, CD-WERS was mobilized during the flood and provided communications that aided all branches of the CDC to function more efficiently. Very satisfactory operation was experienced during the emergency, and CD-WERS proved its worth in natural disaster communications emergencies. LTR is employed in the transformer test division of GE Co., at Fort Wayne. He acquired an XYL on April 11th, and they are now living at 705 W. Berry St., Fort Wayne. Terre Haute suffered considerably from the flood conditions along the Wabash River, but the CD-WERS license application had not yet been acted upon, and conditions were not thought dangerous enough to warrant request of emergency license from the FCC. Down river, Sullivan stood ready with WERS, but no need for operation was experienced. South Bend has been licensed for CD-WERS, with the call letters WKQE assigned. This brings the total of licensed Indiana communities to eight. Indianapolis has completed its application for CD-WERS, and it is hoped that immediate action will be taken by the FCC. Initial plans call for a control center station, and one station in each of six zone centers; stations in each of Marion County Control centers, and one each in Beech Grove and Speedway City. Included also are many mobile installations. JYP is radio aide; DSC is assistant radio aide. Howard County has applied for CD-WERS license. Extensive plans have been made for Kokomo, and it is planned to extend the network to cover the entire county at a later date. OKU is radio aide. Grant County has also applied, according to word from LVT at Marion. The local telephone company has agreed to erect antennas wherever needed. Some cooperation Bob gets as EC! Sixteen units will comprise the initial layout. AB informs us that a class for restricteds was completed recently. Graduates, plus a couple of ham applicants, will swell the operator total to thirteen. There's nothing unlucky about 13, says Harry, when you've tried to run a six-station net with six operators! ZYK says WERS ops in Mishawaka offered their services as citizens who had some experience in the field of communications, but CDC personnel still realized that their experience and education came as a result of being hams. FXM succeeds NVA as radio aide at Richmond. Dick has changed employment; however, he is still working at radio. We look for Bruce to continue the fb work that has marked Dick's term as r.a. Horizontal antennas have been tried in Richmond, and were found so much superior, that the extra trouble of "pointing" the car to escape off-end deadspots was felt to be well worth while. MKM enjoys QST, Indiana column, about three editions later than the rest of us. Ery has met hams from every district except the first. WDV is now a second lieutenant in the AAF. OUQ was wounded in action in Africa. UUU is teaching radio to CAP in Terre Haute. Hams in Indiana may take justified pride in the part they have taken in getting started in CD-WERS. A fine job has been done, but the work has just begun. We should have more reports on CAP and SG-WERS. Let's keep right on showing the Hoosier spirit by digging in and showing the world what Hoosiers are made of. We can do it; we will do it! 73, Roy.

MICHIGAN — SCM, Harold C. Bird, W8DPE — DSQ has been unable to participate in the local activities because of sickness. The Oakland County Radio Club, with twelve members, has now completed all the ground work for WERS license and the papers have been submitted to Washington. The ground work followed the usual procedure of meetings and planning, with various committees appointed to carry out certain parts obligatory to the final signing of the papers. After the license is received, the necessary schools will be set up to recruit more personnel. Lewis Brewer, of the Grand Rapids area, reports as follows: "We are holding our Sunday drills regularly, and get our usual chance to practice during alerts and blackouts. During one test, twenty or more reports were handled along with other messages. We have been able to establish definite coverage of an area of about ten miles, and in some directions, up to eighteen miles. We have a total of fifteen stations with two standbys, which are remotely located and in case of failure of the main control,

the remote stations can carry on. These stations are all in contact with the main control. Further developments will follow later." Saginaw Valley is becoming interested in WERS and COW tells me they have the equipment. All they need is the man to get it going. Last report from DARA and Edison Radio Clubs is that they were graduating one of their classes soon. Some of the club members are also participating in the WERS setup in Detroit area. They have lost the services of their secretary, MV, who has joined forces with Uncle Sam. Paul Palmer reports he is trying to work out a handy-talkie, three-tube transceiver. He is looking for a vibropack now. FX tried for commercial license but says nothing more. MKM asks that Vic Crawford contact him. He also says he has contacted quite a few of the gang since joining the Forces. His address: T/Sgt. Ervin A. Hurley, APO 986, Care Postmaster, Seattle, Wash. UFH carried off high honors in this class and was made valedictorian of the class. He is old QMN'er. He passed speed of 40 wpm with an average of 92.9 for the entire course of study. He has now been made part of the academic squadron, and is located in the instructor barracks. Would like to hear from any of the other Michigan cities who are licensed or contemplate WERS setups in the area. We may be able to help you with some of your problems, so let's have your reports! 73, Hal.

OHIO — SCM, D. C. McCoy, W8CBI — Middletown: 4 Abbott TR4 units and 3 composite units are ready for service. Corrected license application is now ready to go back to FCC. PNP has been appointed local radio aide for Monroe, under the Middletown license. Twenty-five are ready for 3rd class 'phone exam. A big Civilian Defense demonstration was held in Middletown on May 16th. DGU and his WERS gang were in the parade and made a good showing. *Fostoria:* CVZ, local radio aide, reports license has been granted under the call WKOV. Six transmitters are ready to operate and three more building. Eight hams have WERS operator's permits: PRJ, RRC, CEW, QYY and EAY. Four prospective operators are in training. *Chillicothe Region:* 8VUS, in Pomeroy, reports that papers have gone to FCC for WERS license and that Edison Forsythe has been made radio aide. Eight candidates are in training for 3rd class 'phone permits and will be examined soon. *Zanesville Region:* 8TGU resigns as EC as he will return to his home in Corning, Ohio, during June. Thanks to Hal for a good job done. *Columbus Region:* 8QQ reports he is busy with WERS, his regular duties at WBNS, and victory gardening. F. H. Gibb has been appointed executive officer of the local WERS organization by the president of the Columbus A.R.A. More active participation of CARA hams in local WERS affairs is now expected. Experiments with antennas are the major WERS activity at present. Vertical polarization is now in favor. Frequency measuring equipment is a major problem. Lecher wires are reported to be not entirely satisfactory. No 0-1 Ma. meters seem to be available in Columbus. How about some of you Columbus hams digging into the junk box, or your equipment stock, and finding a one mil meter for QQ? *Newark:* 8ANJ writes from Cambridge, Mass., where he is now employed by the Underwater Sound Laboratories, Harvard University. Regrets, due to the move, that he cannot accept appointment as EC and suggests NVR as a possible candidate. How about it, NVR? *Dayton Region:* WERS in Dayton is making progress. Regular drills are held every Sunday at the time allotted by FCC. The group participated in a dimout on May 6th, and a blackout on May 27th. In general, good coverage of the city and county is being accomplished, with some problems still to be worked out. In the blackout of May 27th, WERS mobile units were responsible for the operation of the four new victory sirens. Signals to sound the sirens, for each phase of the blackout, were radiated from the control center to a radio car, stationed at each siren, and the siren operators "fired up" the sirens upon receipt of the go ahead from the WERS operator. 8DT, now deputy radio aide in the Washington, D. C. WERS, was guest of the local gang during the dimout on May 6th. Any other radio aides, who happen to drop into Dayton, should get in touch with us. We will be glad to swap yarns. Former deputy r.a. 8TOZ, of the Dayton WERS, can now be reached care 2nd Communication Squadron, Chanute Field, Rantoul, Ill. He is very happy there, learning to use the mill to copy and to be an airways op. 8TPC has been promoted to a Major in the Air Force, and is still stationed at Wright Field. He recently joined WERS, got his operator's permit, and was an official observer from an Army plane during the blackout on May 27th. 8CED has left town and is now with Romec Pump Co.

at Elyria, Ohio. Application for modification of Dayton WERS license has been deferred and license renewed on existing basis. Fifty-five candidates for 3rd class 'phone permits were examined during May, which, if they pass, will bring the number of licensed WERS operators, available for Dayton WERS, including rural licensed operators, over 100. Securing parts to finish up the equipment program is still a problem. The recent limitation order L-265 has further "gummed the works." Deputy radio aide 8NSS suffered a slight heart attack some weeks ago, but has recovered and is now back on the job. 8LJ is busy with details involving the surrounding communities for inclusion in modified license for Dayton, such as intermunicipal agreements, etc. RHH says he has filled out his yearly quota of forms and wants to see no more. 8MFV writes from 3rd Comm. Squadron, Alamogordo, N. Mex., that he now knows how to use a bug, and is studying the touch system of typing so he can use a mill correctly instead of "hunt and peck." Expects to have a furlough soon and is looking forward to seeing the gang if he can get back to Dayton. 8MFV's brother, Duck, writes from Bowman Field at Louisville that he is a mechanic in charge of 34 "Maytag" bombers. Duck can be reached by addressing Corporal Loyal W. Bettelon, 27th Base Hq. and Air Base Squadron, Bowman Field, Ky. Eaton: 8SID, PRS and VYE are standing by, awaiting modification of the Dayton license to permit them to operate with fixed equipment. VYE also has PM equipment in his car and can participate in Dayton drills. VYE is worried about the draft. *Springfield*: 8EQN writes he has heard from friends in Honolulu regarding a visit to them of his son, who has been absent from home in the Army as a radio operator for two years. *Bellefontaine*: 8WUI has been appointed radio aide for the Logan County Council of Civilian Defense. Parts are available for five 112-Mc. transmitters. Material for the necessary receivers is being assembled. WUI is also instructing in radio at Ft. Hayes. As soon as the organization and equipment are far enough along, WERS license will be applied for. 8SXQ, Tampa, Fla., is in the Signal Corps, attached to Drew Field, and likes it fine. Wants to hear from the old gang. Address Pvt. Franklin Knull, ASN 35629558, 2nd Rept. Co., 552nd S.A.W. Bn., Drew Field, Tampa, Fla. 9UYU is now working at Patterson Field and can be addressed R.R. No. 1, New Carlisle, Ohio. *Canton Region*: 8NXJ reports their main control station ready to go on the air and ten or more portable units now under construction. Data for license is being assembled and application will soon go to FCC. 8WJB reports Canton A.R.C. is trying to keep going, but due to six and seven day working weeks, swing shifts, and long working hours, it is tough on the members. 8CJG, Salem, has been appointed radio aide. *Cleveland Region*: The SCM spent a very pleasant evening with 8AVH while in Cleveland on a business trip. June 2nd. This is handled by placing the responsibility on an assistant radio aide in charge of each of thirty report centers. Each assistant is responsible for all functions such as operating staff, equipment, training, etc., similar to the requirements for a radio aide of a smaller WERS system. Considerable equipment is in service, but more is needed, and order L-265 has become a stumbling block. Excellent coverage is had from the main control station, which works with the report centers only. Each report center controls its own portable mobile units. UZJ now has a BC post at WGAR. *East Liverpool*: 8DNF has been appointed radio aide. Equipment is being assembled and an organization is being built up, starting with three or four amateurs still available in the locality. Training will be started to develop twenty 3rd class 'phone operators for future WERS permits. Operating area is expected to include the East Liverpool, Newell and Chester area. *Miscellaneous*: 8VVS, formerly of Fremont, Ohio, writes from 308½ E. Monroe St., Valparaiso, Indiana, that he is instructing Air Corps and Signal Corps personnel at Dodge Radio Institute. Says a large number of Ohio hams have passed through the school. 8SXY is now a sergeant in radio intelligence at Fort Lewis, Washington. 8IAI, well known to Ohio 160-meter 'phone boys, writes that he feels lost without ham radio. Corky wonders what the other "shut-ins" have done with themselves since Pearl Harbor? He has helped use up some of his time by taking on the Moore-Cottrel subscription agency and can take care of new or renewal subscriptions for the gang. Says this with no means replaced ham radio, and is living for the day when victory will be ours and we can resume good old rag chews. 8NAF is still working for the Signal Corps. Has been promoted to inspecting supervisor and transferred to Detroit from Columbus, Indiana. Congrats, Ev! *General*: The pressure of business, consider-

able traveling and many unexpected events have made it impossible for your SCM to keep up with his correspondence. Reports from ECs few and far between the past sixty days; the worst since I took over as SCM. How about a better showing now, in spite of the hot weather, etc.? If nothing is doing, drop me a postcard to let me know you are at least alive. Some ECs have never rendered a report since I have been SCM. To those of you who have been faithful, my heartiest thanks! WERS activity in Ohio is progressing. We are much further along now than six months ago and in many places the gang is getting steamed up and going. There is room for improvement. Is there any WERS activity in your locality? If not, it is up to you, as an individual, to do something about it! Many of our old amateur leaders are now in the services, or so tied up with their business that they cannot take the initiative and get this job done. How about some of you other boys who have been in the background? Come out into the light and take over on WERS in your community if there is nothing doing there! It is work, but a lot of fun too! It offers a chance for those of you who have never tried to do a job requiring leadership to test your abilities. You may surprise yourself, render a real service to your community and to amateur radio. 73, and let's hear from "you all!" — Dan.

DAKOTA DIVISION

SOUTH DAKOTA — SCM, P. H. Schultz, W9QVY — No news again this month except 9ORE, formerly of Gary, is xmtr opr. for KVOX at Moorehead, Minn. Would like to hear from S. D. gang. Sorry abt no news. 73, Phil, W9QVY.

NORTHERN MINNESOTA — SCM, Armond D. Brattland, W9FUZ-00K, now corporal, has been transferred to 187th Signal Repair Co., Ft. Dupont, Del. A/C Jim Martinson (op license) is in Navy training at St. Olaf College, Northfield, Minn. Rodney Rice, (op license) ARM3/c, is training at Naval Station, South Weymouth, Mass. 73. *Army*.

DELTA DIVISION

ARKANSAS — SCM, Ed Beek, W5GED — HYS was in Little Rock a few days and visited FXO. HDR, veteran from North Africa and back on American soil, soon will be headed home. GNV visited Little Rock at the end of May. PX got a well-deserved vacation and visited in Louisiana. FPU back at work with his first love, the railroad. JHL has been recently tied up with a siege of overtime. 1DQ, now in new location, also new victory garden. HQJ is doing naval radar work in the East. BJR expects to finish OCS with a commission from Camp Robinson. DZK is radio mechanic at Walnut Ridge air field. ISX is broadcast operator at Jonesboro. GSY gives out with his melodious voice at KLCN. GJL last heard from as juke box king at Blythville. HDC is broadcast operator at KLCN. GLZ is in Civil Service at Dayton, Ohio. HFP still carries on in sales and service and is only ham left in Paragould. HCP is instructor in brass pounding at cadet ground school in Walnut Ridge, and finds time to submit a fb report. Since we are entering our summer months, let's make this year different and not go into the usual summer slump in regards to getting in reports, experimenting, and news in general of interest to our readers. That is the crop for this time, gang. 73. *Ed*.

MISSISSIPPI — P. W. Clement, W5HAV — DEJ, 2nd lt. in Signal Corps, writes a nice letter from Harvard, where he is taking a special course in electronics. CWQ, 1st lt., is back in U.S.A. from England. FIZ and HAV are the only ones left of the old bunch in Biloxi. FIZ is a Service man, and HAV tells 'em how to go and when they'll get there, at the railroad ticket office. The Gulf Coast hams are looking forward to some pleasant round tables with JRA and KDE, OM and XYL respectively, who are now in the 9th district; and with "Doc" and "Marge," who have moved to the mountains of Tennessee — after this unpleasantness is over. Mississippi hams in all parts of the world are requested to write. We want to have something to report and need your cooperation.

HUDSON DIVISION

NORTHERN NEW JERSEY — Acting SCM, John J. Vitale, W2IIN — EC, Regional EC CQD, Union, was presented with 12 WERS portable-mobile units and a headquarters station (WKNJ) by the WERS Committee headed by LI (RA & EC), ZB, IHR, CIA and J. Hukill; many of the Township and defense officials were present, as well as the Act'g SCM and our Regional EC. A surprise incident

test was pulled, sending 5 of the units into service on 3 incidents. All incidents were covered and completely reported in 17 minutes. All equipment, as well as the service rendered, was highly praised by SCM & REC. On Sunday, June 6th, the SCM and Regional EC observed some fine WERS work being done by local amateurs in Union, Millburn, Livingston and Verona. WERS work by hams in these communities showed a marked transition from the old days of "rag-chewing" and definitely establishes the amateur radio operator as indispensable personnel should a real emergency arise. Despite the critical status of radio equipment, whole communities were found to be covered by networks of as high as sixteen portable-mobile radio units. The ARRL-NNJ committee of two witnessed many demonstrations of mock disasters and the dispatch with which "little black boxes" summoned aid to the scene. Fire, police, ambulance, demolition and other squads were all at the beck and call of these miniature broadcast stations, some of them only 6 by 9 inches and perched on the rolled-down window of a car. COT, of Maplewood, has just been appointed EC and is heading a committee for the establishing of WERS in Maplewood with the assistance of IKS. Bruce (COT) writes us a few lines, stating that ALK of the spark days is learning a lot of new tricks in radio; WERS groups are having a continual turnover of "helpers" in training locals, formerly not interested in radio, reporting that the majority are trainees; BCC is an instructor of code and theory eight nights a week. IZP has completed course and now is an electrical engineer; LAH is now in the Navy. MYH is miniature railroading. COT has been running code training classes at the local high school; his second op, Robbie, ran the theory part of the program. GFW is on Naval Ordnance Work in St. Louis. GNK suggests a WAAC for an assistant to the Acting SCM. MGL is RM2c; NHL is RM3c; EOH is in Signal Corps; MEP, LAF, LJK, MON, OFN, JSE, CHQ, MLA, DWJ, 1HCO, JEB, OCY, BCS, 3IHK, 3EEN and HGI are some of the boys at the Arsenal of Communications, Kearney. Clifton's radio aide is MFF and his staff is IGE, GOM, KEG, LIO, LLT, DDK, OAC, OAR and A. Weinstein. They are waiting for issuance of license. HFN is with FCC. Club members in service are KTM, NJW, NKN, OPB, NCN, NVA, KIH, EMY, F. Soltis and M. Weiner. MFF is being appointed EC and is looking for more WERS ops, address 734 River Drive, Garfield, N. J. FUP and CNP are in aircraft communications. LI of Union has offered his assistance and the use of precision frequency equipment to the Regional Emergency Coordinator for N. N. J., CQD, for checking in other municipalities on the frequency and stabilization of transmitters in N. N. J. to minimize interference between WERS groups. If interested get in touch with CQD. EWL, assistant radio aide of Verona, and MO, radio aide for Livingston are being appointed ECs. Applications and recommendations for additional Emergency Coordinator appointments should be sent to your Acting SCM.

MIDWEST DIVISION

IOWA — SCM, Arthur E. Rydberg, W9AED — URK, radio aide for Des Moines, reports that amateurs in cooperation with OCD are converting old broadcast receivers to the local police station frequency, so that they may be used in the alarm system. Receivers are placed at the siren and whistle positions in several localities of the city. Area wardens will also have receivers for alerts. OLY and UOP are installing receivers. Students at West High School are converting receivers to the new frequency. PNT, procurement officer, is using local broadcast stations and newspapers to secure the old broadcast receivers. FDL and VRD report JRT schools at Lexington, Ky., closing down where they have been instructors. JBY now radio op and gunner on a bomber. TXO going to radio school in Kansas City, Mo. UAD, radio op in Merchant Marine, is most popular man on ship because outside of regular duty he makes up newspaper for the crew. MMZ recently started radio repair service. DIB is president of Prairie City Rifle Club. UAL very busy with his new business — repairing radios. FQJ writes from Biggs Field, Texas, that he is trick chief in the control tower, and says he is married and has baby girl. VFM has just received radio telegraph and telephone license second class; he is working at Rock Island Arsenal. ATE is doing radar work in Navy where he is RT2c. TWX, now of Iowa City, is busy keeping new house, lawn and garden in shape. Bob Crotinger of Sigourney passed Coast Guard physical and expects to be called soon. AEP and SCJ busy on carrier current. 73, *Art*.

KANSAS — SCM, A. B. Unruh, W9AWP — VQG, formerly RM and active on TLK and KN net, is a capt. in a F. A. Hq. Btry. He writes from maneuvers "way out in the desert." He still claims Kansas as home, and would like to hear from the gang, and to have VWU's address. For VQG's address, write the SCM. OZN received commercial telegraph ticket. KNY has been promoted to major and is director of training at an OCS "somewhere in Australia." STC attended Lions' convention in Wichita. WMY, another ex-KN netter, is one of Uncle Sam's boys in Alaska. It is reported via the grapevine that he likes the territory so well, he refused several chances for a furlough home. ZVP, EC for Zone 15, is teaching radio theory and code in Winfield. NJS received commercial ticket. He is employed as radio technician at Boeing Aircraft. Warren Smith, op license only, is radio mechanic for TWA's Intercontinental Division and is stationed on another continent. He is associated with several foreign hams whose call letters used to thrill and gladden the U. S. DX gang. HCU works with confidential instruments at a Wichita aircraft factory; he recently returned from special schooling. Kenneth Hearle, class A op license, writes from Camp Crowder, where he is a corporal and radio instructor. He formerly resided in Wichita, and attended NYA school in Topeka. Let's hear from you, gang. 73, *Abie*.

MISSOURI — Acting SCM, Letha Allendorf, W9OUD — This won't take very long to read unless I put in some of that poetry I mentioned several months ago. I was assured my verses would sabotage the war effort so I had better stick to prose. JWJ and her dad, MCA, have received their WERS permits and will be ready for operation when they return from vacation spent at the Irondale, Mo. Reservation Boy Scout camp, where dad is nature study instructor. The St. Louis WERS worked with the Coast Guard during the May flood. VZU and bride have joined YCB — in the East at work. FNN, Springfield, is an instructor at Camp Crowder. WIS is still teaching those Navy cadets to dit and dah, and how to tell which end of the horse powers in the airplane motors is front. NSU wishes he could join the boys instead of taking pot shots at rabbits in the carrot patch. KJC has the equivalent of a captain's rating and is stationed at U. S. Marine Hospital at Kirkwood, in his professional capacity of pulling teeth. BMS has terminated his job as instructor at the NYA and is taking an operating job with the Highway Patrol at Jeff City. Your SCM is busy pulling weeds and putting chickens in their pens. Lots of luck to you all. And that about covers it. 73, gang, and write soon!

NEBRASKA — SCM, Roy E. Olmsted, W9PBE — Most important report of month comes from EAT, radio aide at Ceresco, who says the WERS license for Ashland is now complete under call of KGLZ. They have a TRA control unit at City Hall, two mobile TRAs and one DK3 portable. HYR, KYD, ROE, DTT and EAT met at Ashland on the 13th to gloat over the new-born license and chew the fat. BXJ now has 1st class commercial and is working on engineering staff of KFAB-KFOR. LEF now working for WERS license for Brainard. Hank Mattison, HOT, is not only in CAP but a singer-announcer for KFAB-KFOR. GFI reports ITM now an aviation cadet, awaiting orders at Fresno; JBK has been transferred to New York City College for specialized training; QWU promoted to cpl., Army Intelligence. Lyle, KNMI, has sold his Hallicrafter's receiver to the Signal Corps, and will enter the SeaBees soon. JRT graduates from Milford School. Stationed at Camp Kohler are: Carney, Pancoast, Barnes and Valentine. Would like to have reports from others in training. Art Sigel, Superintendent of Nebraska State Training School, is an old timer with the call of AY, and two top class commercial tickets. Send in those expired RA and EC certificates for endorsement! Keep me advised on all WERS activities! Send in more reports each month, so that Nebraska amateurs may keep in contact, during this silent period! Regards to every one of you, *Pop*.

NEW ENGLAND DIVISION

CONNECTICUT — SCM, Edmund R. Fraser, W1KQY — Wm. L. Freienmuth, 2nd Lt., S. C., stationed at Harvard Univ. and former op at W9HWW/5 Little Rock, Ark., was a recent visitor at WJLH-1 as was DRA EEM of Waterbury. At a recent state WERS meeting, called by SRA EAO, held in the Hartford Armory May 28th, the following were present: DRAs KDK, Hartford; NEK, New London; KXB, Torrington; DBM, Middletown; IM, Bridgeport; ALW, Norwich; EER, Stamford and KQY, New

Haven. Also present were state com'n. officer Cattaneo; Hamden RA JQK, New London EC IWY and others. Many problems and suggestions of interest were discussed, and among the most important was a case where the FCC cancelled a license because of rag chewing. Let's keep our slate clean of this in Conn., gang! APA, sgt. SG-WERS WKMV, is conducting a code and theory class of 15 in Bridgeport. Their outfit has 3 DK3's, 2 comp. walkie-talkies, and a HY-75 fixed stn.; 4 more DK3's and 2 TR4's will be on hand prior to maneuvers at Madison the 3rd, 4th and 5th of July. At a recent meeting at GB, it was voted to use the club as a WERS monitoring station for the WJLH network, with receivers WJLH-1 tuned to the frequencies of each network, to relieve WJLH-1 from the task of checking frequencies as well as handling the dist. network. MVE was home from Phila. for a few days; he paid 3BES a visit. IJ, RA of Madison, Ex-SF, RA of Branford and KQY, DRA New Haven, recently held examinations for restricted rdo fone oprs. EC's who desire to remain such must return their certificates for endorsement.

MAINE — Acting SCM, G. C. Brown, W1AQL — The Maine section wishes to extend sincere greetings and a cordial welcome to the following out-of-state boys, who are in the Service here in Maine: 1EBO, 1FL, 2UU, 3EOE, 3ASE, 4FMP, 4DTV, 7INS, 7IJZ, 8WME, 8QDW, 8BHY, 9WXH, 9FKW and 9MGV. EBJ is repairing motors for oilburners. DPJ and FNL are working at WLBZ. EFA and ECM are at WRDO. MWH is at Camp Murphy, Fla. CWB is a flying cadet at Mercersburg, Penn. QH recently returned to the Canal Zone after a thirty day shore leave in Bangor. EYI was recently elected Grand Master of Exchequer, Grand Lodge, Knights of Pythias. FBJ is now living in Rockland. KZK is with the Navy at Southwest Harbor. JSY is teaching school in Fort Fairfield. LIP and NST are with the NYA at Quoddy Village. You fellows around the Section must know some interesting news, so why not send it in and give the Maine Section a fb report next month? What say, gang?

EASTERN MASSACHUSETTS — SCM, Frank L. Baker, Jr., W1ALP — A few more WERS licenses that we have just heard about. KCT is the radio aide for Dedham WERS, call WLDM. He has 3 ops and has more in training. Alan B. Cooper is radio aide for WKMJ in Fairhaven. D. P. Keily is radio aide for WKTU in Lincoln. MP is radio aide for WKMB in Wellesley. AJW is radio aide for WJIE in Belmont. MZR says Topsfield is in WERS, but they are having a little trouble with the local hills. MEG has finished training at Camp Edison and now going to Camp Charles Wood, a section of Fort Monmouth, N. J. FEC, MZN, NOX and MVE, who are civilians in the Signal Corps, are back and working out of Boston again. LKT has been promoted to pfc, and is now going to school at Sioux Falls, S. D. JJK moved to West Hartford, Conn. to take up a new job with ARRL. We learn that HDJ is now a radio instructor at Sioux Falls air field, South Dakota. LID writes from Fairfield, Ohio, and he is busy all the time. He recently got married. Another ham, MTP, writes from Arlington, Va. He is now working for the FCC in Washington, D. C. We are very sorry to have to report the death of Joe Cabral, MQT, in January of this year, and the section wishes to extend its sympathy to his family. LK is now in the Army as a pvt. and is going to school at Keystone Radio School, Hollidaysburg, Pa. MQV is now a sergeant and located at Army base, South Boston, Mass. Alice, FRO, has joined the Marines. MPP is still teaching code at Cambridge Adult Centre, and she finished ESMWT course at Boston College. IZE is consultant in radio for CAP at Falmouth. AOT is at WOV. KOQ is working at Raytheon. KON, MJE, MNI and XYL, NAD, NDI and MPP had a petit hamfest recently and gabbed the whole evening. LNX attended a meeting in Watertown recently. MZD moved to Jamaica Plains, is still working at the Navy Yard, and his draft board is getting ready to call him. KQN is with the Navy Dept. now, and also teaching radio at night. CWV just completed OCS at Fort Monmouth and is now a 2nd Lt. KCF is now RM1c, was home on an 18-day furlough, and is going to try for chief's rating. EJU is now a corp. and located at Truax Field, Madison, Wis. KXU is now at Camp Crowder, Mo. Pfc. John O'Neill is at Bangor, Maine. IIL is through at Northeastern School and now working at Sub. Signal. JNV and XYL are the parents of a baby girl. MGV and XYL are the parents of a baby boy. KBS recently married. NEZ is now in the Navy as RM3c, and is located at Sampson, N. Y., teaching basic radio, along with 8VDT. NAH is now going to aviation radio school in Tenn. Congrats to

IXL and AMT; who also got married. CPD joined the Coast Guard Reserves and is travelling all over the country for his company. GRA is up and around again after being in the hospital. MXJ is sponsoring an ESMWT course for his company at Northeastern Univ. Anyone reading this column is welcome to send in any news about hams. Also, I would like news about any cities or towns in this section that have received their WERS licenses, giving the radio aide's name and amateur call if any, the WERS station call, number of operators and any other dope. To the many hams from this section who are away from home, thanks for all the letters and cards and please keep them coming! I will do my part if you will give me the dope.

NEW HAMPSHIRE — Mrs. Dorothy W. Evans, W1FTJ — The New Hampshire Net, The Farmers' Net, in fact all of our Section, will miss the fist and voice of AEF, who recently passed away. Billy was a dandy fellow and will be keenly missed by his associates. KMH now has his Class A ticket. 3MY/1 was home on leave recently and visited with his relatives at Manchester, including BDN and HPM. News has just reached us that JBA took unto himself a bride in California, some months ago, and that he will soon bring her back east for a visit. We understand that LIN was home on leave recently, as was also AWU and HOV. ITF advises that the new forestry station of WKRH is now on the air, and that they are maintaining consistent contact with Concord and Manchester. MUW and JMY have taken to developing and enlarging photographic negatives recently.

VERMONT — SCM, Clifton G. Parker, W1KJG — 9TGI, who has spent time in our section, is now heard from at Presque Isle, Maine. KEX has joined the staff of instructors at the Flight Radio Operators School, Burlington. TJ recently visited GAN, LWN and NLO. GM recently visited hams and saw radio installations in the lake area. MJU is now at UVM for the summer session and expects to return to Stromberg Carlson. NLO has been busy ducking thunderbolts and is looking for antenna-current meters. CBW is now in Newfoundland. The code and theory school, conducted by the Burlington Amateur Radio Club, will start sessions July 5th at the Junior High School there. The club is engaged Mondays and Fridays at Fire Station 3, working on WERS units and giving code lessons. The code and theory school at Morrisville finished its sessions on May 28th after a continuous run of two nights a week since last September. Nearly every enrollee successfully completed the course.

NORTHWESTERN DIVISION

OREGON — SCM, Carl Austin, W7GNJ — EC, JN. If anyone missed the report for Oregon last month, that's exactly how I missed reports from you fellows. With the new acting SCM for Washington, competition again seems in the offing like it was with traffic in the pre-war days. Come on, gang, with a card or note each month so we can hold our own! EDU, who has been conducting a radio class, reports that one of the three who finished passed Eddie test, and is in the Navy. EDU is doing spare time work with radio and electrical repairs. HAL slightly irked at non-WERS activity in Portland. HKI still not fully recovered from a long spell of illness, but coming along slowly. WH still "listens in" and wonders how long we must wait. IEL, in the Islands, says he hasn't seen a hula dance yet. Roy Mickel, LSPH, moved to Hood River, where he will be EC for that area. ARZ, radio aide for KFNX, now EC for Bend and vicinity, taking over for HVX, who has moved to Portland. JN built a "wireless" heat oscillator, placed it near a BC set, works fb. GSI has taken unto himself an XYL, or rather, the YL is now XYL. From CORK: Leo Mickel, LSPH, acting sec.-treas. and Phillis Coe, LSPH, vice-pres., filling unexpired term of HVX, moved. Leo Mickel, William Van-Allen and Paul Mickel have received WERS operator permits. Leo practicing on bug sending, and receiving about 30 wpm. Phyllis receiving on mill at 25 wpm. CORK recently sent in 10 applications for ARRL membership. GNJ, about to drive a nail in a wall, inadvertently placed the head of the nail against the wall. "Hey!" said BS, "that nail has the head on the wrong end." "Naw," said ARZ, "that nail goes in the opposite wall." 73, Carl Austin.

WASHINGTON — SCM, O. U. Tatso, W7FWD — CMX has been named state radio officer by the WSP for the WSCD, and is attempting to coordinate all the WERS of the state and encourage new WERS organizations. Walla Walla and Seattle are getting ready for WERS; no license yet. Tacoma, Spokane, Everett and Olympia holding regular

WERS practices. Everett has applied for permission to install 20 more transmitters. IJZ at Bailey Island, has taken unto himself an XYL. IWM is a proud papa of a girl weighing 6½ lbs. Kenneth Hager graduated from Olympia Radio Club Class and has his license—without a call. JDD attended radio school at Fort Monroe and then Sig. Corps radar, and is now a cadet with two months to go at Luke Field, Arizona. FET was transferred from Texas to Fort George Wright, Spokane. He is teaching radio, of course. DPU is teaching radio in Texas. FDD is at Camp McCoy. BDB is attending radio school at San Diego. CYR, who is totally blind, is active as program director at Washington State College station KWSC. We mourn the loss of Fred Rose, HBC, who passed away June 7th, after a lingering illness. 73. Tate.

PACIFIC DIVISION

EAST BAY—SCM, Horace R. Greer, W6TI—EC: QDE; EC u.h.f.: FKQ; Asst. EC u.h.f.: OJU; OO u.h.f.: ZM. With the additional hours for WERS testing added interest should be taken. With 7 p.m. to 9 p.m. on Monday and Wednesdays, and from 2 p.m. to 4 p.m. on Sundays, we have a better setup all the way around. A nice long letter from Lt. (jg) Sid Glasson, OCZ, gives his qra as 850 Lilac Terrace, Los Angeles. Sid reports that he reads the Pacific section in *QST* religiously, down at the station. Has been there for ten months and has learned plenty more about radio since he rejoined the Navy. If you get a chance, drop Sid a few lines; I know he would enjoy hearing from the gang. QWX, lt. (jg) in the Navy at Los Alamitos Base, is instructor in engines and air navigation. He'd like to meet the local gang. It seems to be all quiet along the Western Front these days, with everyone that's left at home busier than a bird-dog, doing one thing or another for national defense. Any news of the old guard? Let's have the dope for *QST*! Another day closer to victory, TI.

ROANOKE DIVISION

VIRGINIA—SCM, Walter G. Walker, W3AKN—The following news received from II: JNX has left the FCC and is now with the War Dept. in Washington doing research work. FIB is now with the FCC at Falls Church, Va. JCT has returned to Georgia and he is with the FCC. IOO is now with the War Dept. as a co-worker of JNX. NE writes that he is still cruising the broad Pacific and hasn't encountered any Japs to date. IZN is devoting most of his time to building freq. modulation receiving eqpt. He spends his working hours toiling for the FCC in Washington. II is in the market for a record changer. JHC is still at Buckroe Beach and reports 7LHU now stationed at Fort Monroe, Va. at radio school. HKE writes that he has had his draft status extended to October, 1943. He has taken up watch repairing, to replace radio as a hobby, for the duration. He further reports discussion of the formation of WERS in the Norfolk area. If this comes true, forward the dope pronto, so that Virginia will show a spark of life in this long neglected phase of our endeavors! I hear that HLC is still dishing out sodas over Ocean View way. The following are working too hard to be heard from: HJW, HWJ, GSV, ICZ, AJA, MT, GGP, GGI and the rest of the Newport News gang. NT is again in the Navy but laid up on the sick list. He is kept so busy he never sees any of the other Norfolk hams any more. 73. Walt.

ROCKY MOUNTAIN DIVISION

COLORADO—SCM, Stephen L. Fitzpatrick, W9CNI—TNC of Florence is attending the Signal Corps school at Camp Murphy, Florida. His brother, THG, is a staff sergeant with the Air Forces overseas. QDC is a radio operator at a fixed station at Camp Crowder, Missouri. QDC also reports that HCQ is now overseas. EZL is in Hawaii. QCX, along with DKK, PDA, MOH, PPA and SBG, is employed at the Craig Signal Corps radio school located at Craig, Colo. TNC wants the address of FPZ and PBW. Let us hear from more of you fellows. Even if you have changed your address, we still appreciate getting your reports. Remember, please send them along by the fifteenth of the month! 73.

SOUTHEASTERN DIVISION

EASTERN FLORIDA—Acting SCM, Frank C. Fassett, W4BYR—Five WERS licenses have now been issued in Eastern Florida: Clearwater, WJLJ; Sanford, WKMQ; W. P. Beach, MKVW; Dade County (Miami), WKNW and Hillsborough Cty. (Tampa), WKPG. Others applied for. EC

GJI has been appointed RA for W. P. Beach and reports nice WERS activity there with EHZ, DPD, EDN and DZN participating. Applications for additional operators and equipment already in Washington. 38 now undergoing instruction for third-class tickets. DPD is at Camp Murphy radar school. CQZ has been appointed EC for Lee County, has six TR-4s in Fort Myers and is also connected with F.S.G. HGO, EC for Seminole County, is back from Washington and says CPG passed thru Sanford recently en route to new radar job for Raytheon in Miami. HGO and Boyle (LSPH) now with F.S.G. in Sanford. FZW is RTIc. Navy aviation. IGQ is member C.G. Auxiliary. HUY and Crosby (LSPH) are reporting good results with wired wireless. DWU now lt. in Signal Corps. FOD was home on short visit. Only word from Jax is from Kinkade who sez HJU is now with Signal Corps and was home on furlough recently. ES has resigned as EC for Dade County and KK has been appointed in his place. Vote of thanks in order for ES who did a good job while he could. KK reports 60 in the Miami WERS group. Technical and procedure divisions off to a good start under supervision of JO, asst. RA; OK, technical advisor; and BYF, deputy comms. officer. KK is RA. Preliminary tests were held on the 16th June. Two classes a week being held at CD headquarters and 25 were made ready for restricted license exams during June. It appears that the Miami picture is something for rest of Section to shoot at. FB! Word just received from DES indicates he has returned to Dayton from Boca Raton. RQ has been appointed EC for Upper Pinellas County. EYI is EC for Lower Pinellas. AII was in Tampa recently installing radio sondé for USWB, assisted by OZ. EGL graduated with honors from U. of Fla. and now goes to Harvard for PG work. Sandy Geer (LSPH) is in USA Field Artillery, comms. Din sold his home and bought another in Skin Village. Capt. J. W. Hazelton, comms. officer, FSG, has been appointed Regional EC for this Section. WERS licensees should check with their RI's for latest dope on drill and test periods. Watch your expiring licenses. Some already have forgotten until too late. WERS operator permits cannot be obtained unless applicant holds an FCC license.

WESTERN FLORIDA—SCM, Oscar Cederstrom, W4AXP—The ham meeting on June 14th was a decided success. An increase in attendance shows an increasing interest in the meetings. 22 were present; of these 17 were licensed hams: 4MS, UW, VR, PN, QK, UC, DAO, AXP, EGN (Ex-VE3WW), HJA, GBM, 5DRC, IYL, 6LTO, 9FHD, NLF and RSY. The formation of a WERS setup was the main topic. MS and Bert Meade of WCOA are co-ordinating ham facilities and operators with local OCD. Application for WERS was forwarded by Bert Meade. A good talk, about WERS in Georgia, was given by 4UC. Lt. Tompkins, PE, and Joshua Reynolds, BRT of Winston Salem, N. C., got acquainted by a CQ via car horn. Lt. A. Bruce Hangar, 3AVL of Waynesboro, Va., is in training at Corry Field. GQF, Christine and hubby, visited with ECT-FJR. DAO visited AXP. Bryan Hinshaw, a radio op on a sub in the last war, has written a book entitled "Now." He has been an instructor in radio at Naval Air Station here for some time. A. L. Seale is building a BFO. 73, and thanks for nice report. AXP, "The Old Maestro."

SOUTHWESTERN DIVISION

LOS ANGELES—SCM, H. F. Wood, W6QVV—It looks very much like this district is finally going to be heard from in a big way in WERS work as ON reports that FFN heads a group of 14 hams in the San Gabriel area. Their licenses and permits have been received and they are working out regularly under call of KGCL. Inglewood under KGIC is also going to town according to the reports from Stew Walmsley. Their club still meeting regularly and altho 21 of their members are in service they still carry on, and with the help and guidance of SQC as defense coordinator and MSO as radio aide are doing a fine job. And by the way how's about reports from some of the other districts down here. San Marino, Culver City, Huntington Park and other districts formerly so active in the Good Old Ham Days? Let us know what you're doing; we want this area completely covered. KGLV has already sent in applications for more than 70 permits under the Los Angeles City organization. By the time you read this they should be in operation and conducting their drills as all equipment has already been ordered installed in the control centers, antennas put up and the classes in procedure as well as the required classes in first aid etc., to meet the full requirements for a CD

(Continued on page 80)



BEFORE the war, National receivers were literally custom-built. They were made in small lots by workers who were trained in painstaking craftsmanship, workers who tested each soldered joint as soon as it was made. Testing and alignment was done in a special laboratory where the performance and perfection of each receiver became the personal responsibility of one man. He inspected it for elec-

trical and mechanical defects, he aligned all circuits, he adjusted calibration and measured performance. He had time, hours of time, to make minute adjustments, and he had authority to reject the receiver for any defect. His OK on a completed job was a personal pledge that it was as nearly perfect as skill knew how to make it.

Designs were not frozen. The research laboratory was charged with exploring every possibility for improving performance, reliability or convenience. It was so diligent that seldom were a hundred receivers like the hundred made before.

Receivers made this way are superb instruments, but they are costly and they take a long time to build. The small extra expense was not serious, because amateurs were willing to pay the slight extra cost to get that kind of a receiver, just as the government is eager to pay it now. Before the war, speed of production did not make very much difference either.

Now time is everything.

The United Nations needed, and still need, enormous quantities of just such receivers, and time would not wait. National has raised its sights on production over and over. Much more factory space and many more workers helped to get the job rolling, but this alone was not enough. National had to learn how to use and adapt the best in mass production methods, and do it without relaxing quality.

For reasons which you can guess, we will not go into details on our new manufacturing techniques here. However, we do want to say that we have learned a bookfull about fast, precision manufacturing. This is good news for amateurs, just how good you will discover when you read the National Catalogue after the war is won.

WILLIAM LARKIN

National still needs additional workers, particularly skilled amateurs not otherwise engaged in war work. If you can help us, please write us at once.



... a STAR

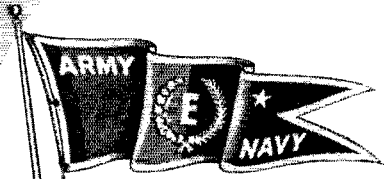

has been added

☆ **SYMBOLIZING**
continued EXCELLENCE
IN WAR PRODUCTION

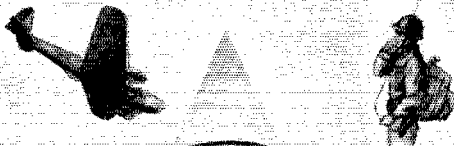

BAILEY ELECTRIC COMPANY · ERIE, PA.

Bailey Crystals

Amateur Activities

(Continued from page 78)

certificate, are well under way. QLM has a fine program set out for all of us, but it does mean work and the giving up of a portion of your free time, until we are thoroughly ready to do the job. PMV is now in radio division at Naval Research Laboratories in Washington, D.C. He and the XYL are expecting. SLF is now back in good old Calif. as an aviation cadet and reports his ham experience is a great advantage for pilots. AM is visiting in Chicago. DEP checked up on the Long Beach WERS license and it is well along its way now. RO is to be congratulated on the way he has held his gang together as it was many months ago that this license was applied for. — *Ted*.

ARIZONA — SCM, Douglas Aitken, W6RWW — RJN now has both telegraph 2nd and telephone 1st, commercial tickets. OMH is at Corpus Christi and says that NGG is there as Lt. (jg), acting as instructor. KIA there also, has RT2c rating. TSZ is RT2c, attending Naval school in Oklahoma. UUN is busy on hush-hush stuff over on the Coast. The Tucson gang continues their fine work of code instruction and report large classes. GS says even the instructors are getting to be able to take it at a good speed! Says that the town is gradually recovering from the hamfest and IYZ! NZU graduated from the Academy, now an ensign, and expects further training in Florida. QWG dropped in with his new XYL, while on their honeymoon. Dick says he'll make an op out of her when the shooting is over and done. He is in the Merchant Marine on this Coast. TOZ completed his last two years of high school in one year by attending State College after hours, and he has enlisted in Navy V-12. Both QNC and SGG dropped in during the month. QEW was over from the Coast for a short visit. We are all interested in what the other fellow is doing, so let's have a word from you! Would like to hear from more of the gang. Vy 73, *Doug*.

WEST GULF DIVISION

NORTHERN TEXAS — SCM, N. R. Collins, jr., W5IAU — ALA reports that ICB and 4DQQ are now working at Lockheed. Jack also reported that GLD is also at Lockheed after serving with the Navy in the South Pacific, where he received the Distinguished Flying Cross for shooting down two Jap zeros. DAD is with the Army in El Paso. DAA is with the FCC in El Paso. FID is now a warrant officer, located somewhere in North Africa with the Signal Corps. JQU is located at Camp Crowder, Mo. 73, *N. R.*

LET THE EXPERTS DO THE JOB!



RESETABILITY

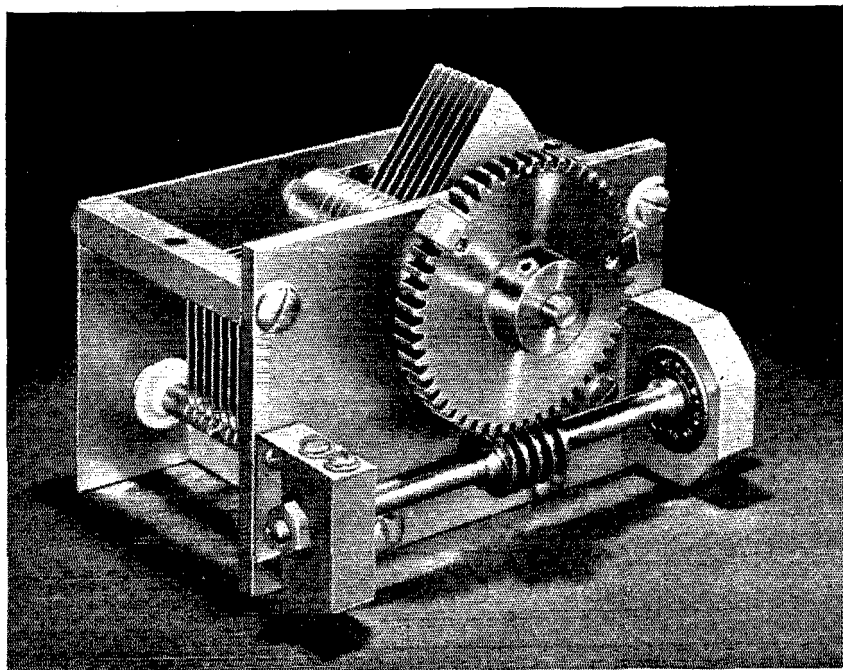

High-stability variable condenser

DAY AFTER DAY intricate military radio equipment responds to the layman's touch . . . a transmission frequency is chosen on a moment's notice — a crank is turned — hairlines blend into one — a command is given, and victory is one step nearer. RESETABILITY is an important feature of all Hammarlund variable condensers.

THE HAMMARLUND MFG. CO., INC.
460 West 34th Street, New York, N. Y.



HAMMARLUND

Important Notice

to Engineers, Operators, Technicians

Who are entering the service of our Armed Forces

A critical shortage of radio test equipment is seriously handicapping radio repair work. But, now, more than ever, good radio reception is vital to our daily lives.

Do not store your radio test equipment for the duration. It will only deteriorate and become obsolete.

Be patriotic. Sell your meters, signal generators and other test equipment so that it will be able to function efficiently where it will do the most good.

Now is the time when your test equipment will bring a fair price, and the money you receive, invested in War Bonds, will help you when the Victory comes. Then you'll be able to start anew, instead of having to utilize out-moded equipment.

We urge that you list your inventory with your Mallory distributor. He will help you dispose of it to someone who has an immediate and urgent need for it.

If you do not know your distributor's name, get in touch with us.

P. R. MALLORY & CO., Inc.
INDIANAPOLIS INDIANA
Cable Address — PELMALLO

P. R. MALLORY & CO., INC.
MALLORY



Standard Frequency Transmissions

From WWV

THE standard frequency service of the National Bureau of Standards station WWV has been extended to include another carrier frequency (15 megacycles). Temporary equipment is still in use while a new transmitting station is being built.

The broadcast is continuous at all times day and night from 1-kilowatt transmitters, and carries the standard musical pitch and other features. The radio frequencies are:

5 megacycles (= 5000 kilocycles = 5,000,000 cycles) per second

15 megacycles (= 15,000 kilocycles = 15,000,000 cycles) per second.

The standard musical pitch carried by the broadcasts is the frequency 440 cycles per second, corresponding to A above middle C. In addition there is a pulse every second, heard as a faint tick each second when listening to the 440 cycles. The pulse lasts 0.005 second, and provides an accurate time interval for purposes of physical measurements.

The 440-cycle tone is interrupted every five minutes for one minute in order to give the station announcement and to provide an interval for the checking of radio measurements based on the standard radio frequency. The announcement is the station call letters (WWV) in telegraphic code (dots and dashes).

The accuracy on the 5- and 15-megacycle frequencies, and of the 440-cycle standard pitch as transmitted, is better than a part in 10,000,000. Transmission effects in the medium (Doppler effect, etc.) may result in slight fluctuations in the 440-cycle frequency as received at a particular place; the average frequency received is, however, as accurate as that transmitted. The time interval marked by the pulse every second is accurate to 0.000001 second. The 1-minute, 4-minute, and 5-minute intervals, synchronized with the seconds pulses and marked by the beginning and ending of the announcement periods, are accurate to a part in 10,000,000. The beginnings of the announcement periods are so synchronized with the basic time service of the U. S. Naval Observatory that they mark accurately the hour and the successive 5-minute periods; this adjustment does not have the extreme accuracy of the time intervals, but is within a small fraction of a second.

The service from the temporary transmitters will continue for some months. It will be continuous except for such breakdowns as may possibly occur because of the use of temporary apparatus. As rapidly as possible the Bureau is establishing a new station to provide more fully than in the past standard frequencies reliably receivable at all times throughout the country and adjacent areas.

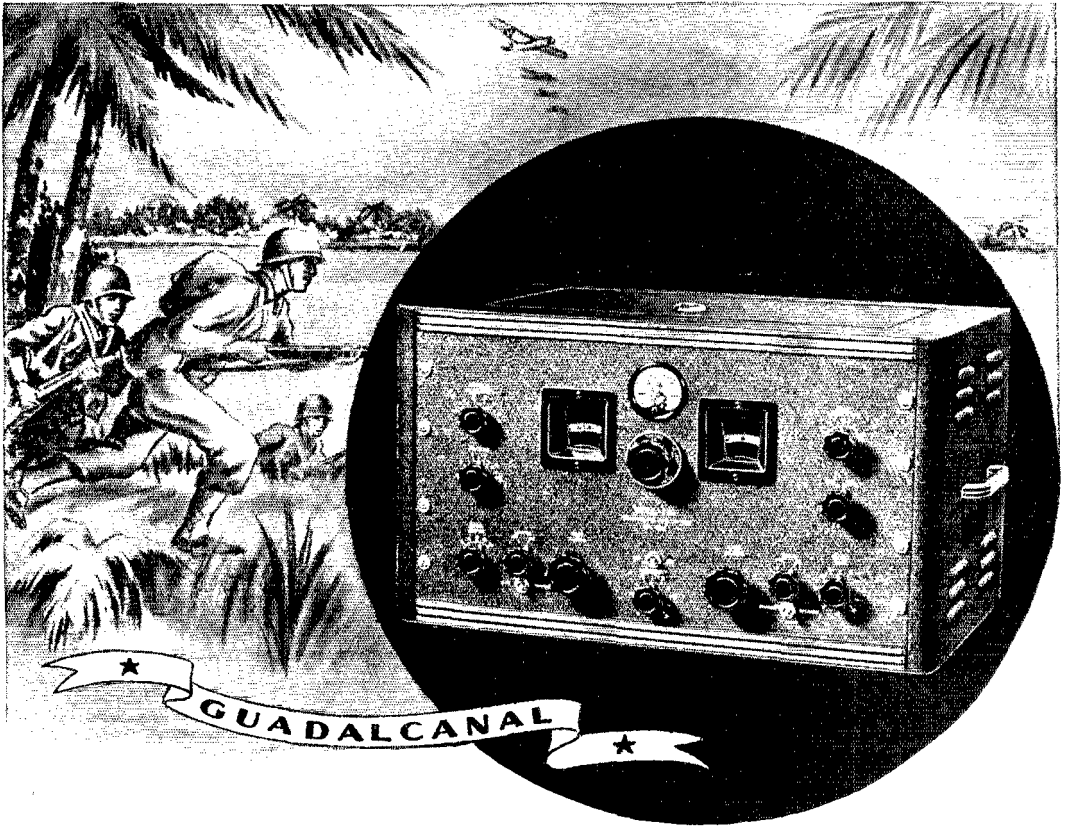

Serving on all our fighting fronts

. . . the SUPER-PRO "SERIES ♦ 200"

IT REQUIRES STAMINA to withstand the steaming wet climate of the Pacific Islands, or the frigid temperature of the Far North. Our boys and our equipment are proving a match for the elements as well as our enemies. We of HAMMARLUND are proud to have aided in the successful battles of Guadalcanal.

THE SIGN OF QUALITY IN RADIO



THE HAMMARLUND MFG. CO., INC.

460 West 34th Street, New York, N. Y.

HAMMARLUND

**THESE ARE...
COMPONENTS
OF *Quality***

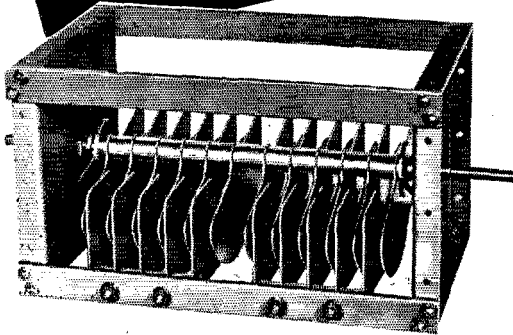

CARDWELL Condensers are made of far sturdier stuff than the sugar and spice of little girls. Tangibly — they are composed of fine *materials* . . . *sound designs* based on constant study and experimentation . . . and precise *workmanship* by proud craftsmen.

But — there is more to a product than its physical aspects. Into **CARDWELL** Condensers go the *heritage* of more than twenty-five years of experience, plus the soundness of *judgment* that comes from maturity. Into them, too, go the *patience, personality* and *sweat* of an *entire* organization.

*These are Components of Quality!
These are CARDWELL Condensers!*

CARDWELL  **CONDENSERS**

The Allen D. Cardwell Manufacturing Corporation
81 PROSPECT STREET BROOKLYN 1, N. Y.

Correspondence

(Continued from page 88)

one-half years with NWA and a year and a half with American Airlines, operating what is known as the fastest manual circuit in the world, I went with the Galvin Mfg. Corp. at the outbreak of the war. There I acted as an assistant engineer in the f.m. research department, helping design high-frequency receivers and transmitters. Later I went to the Illinois Institute of Technology and helped install the Army Radio School there. After assisting in the installation work I took the first class through to its finish, acting as chief instructor. This proved to be a new experiment in teaching radio code and typing at the same time. Its results are probably well known by now and instrumental in the changing of teaching habits throughout the country. From there I went to South America and became a senior flight officer with Pan American-Grace Airways.

This has proved to be highly interesting work. My flights carry me from the Canal Zone in the north to Santiago, Chile, in the south and Buenos Aires to the east. We fly through every country except three in South America and by such interesting landmarks as Aconcagua (which is over 23,000 feet high), the Christ of the Andes, Mendoza, Mount Misty, Lake Titicaca and many other famous landmarks. The flying is perhaps the most dangerous in the world, and yet we have the highest safety record. Among my many experiences, ranging from forced landings to nights in the Bolivian jungles, was a trip on which we carried Vice-President Wallace from Guayaquil, Ecuador, to Cali, Colombia. . . .

One of the interesting features which parallels radio is the short distance the airplane makes of thousands of miles. For example, I do my shopping over the entire continent. I buy my meat in Cali and Buenos Aires. I buy my cigarettes in the Canal Zone, my fruit in Ecuador, my clothes in Chile, canned goods in Argentina and nuts in Bolivia. I do this shopping in the same manner as you would shop downtown in your locality. It's certainly becoming a small world! I'm looking forward to the moment when I can again get on the air from Lima and work the boys back in the States.

In summing up my experience, it's good proof of what amateur radio has done for a great many of us. Undoubtedly ARRL has many records of similar good our hobby has done for us, and I can't urge too strongly that the League and our government remember these things when the war is over and we again bring up the question of frequencies. Many of us hams over the world hear alarming rumors of what's going to happen to our hobby and our bands. Surely the taking away of this pioneering group and replacing it with commercial enterprise would be a sorry plight. I am again coming back to the fold of ARRL for I feel that each additional dollar will help the League in protecting our body of fraternal brothers.

— *W. B. Guimont, W9JID-0A4?,
ex-W5GHQ-9KEE*

(Continued on page 88)

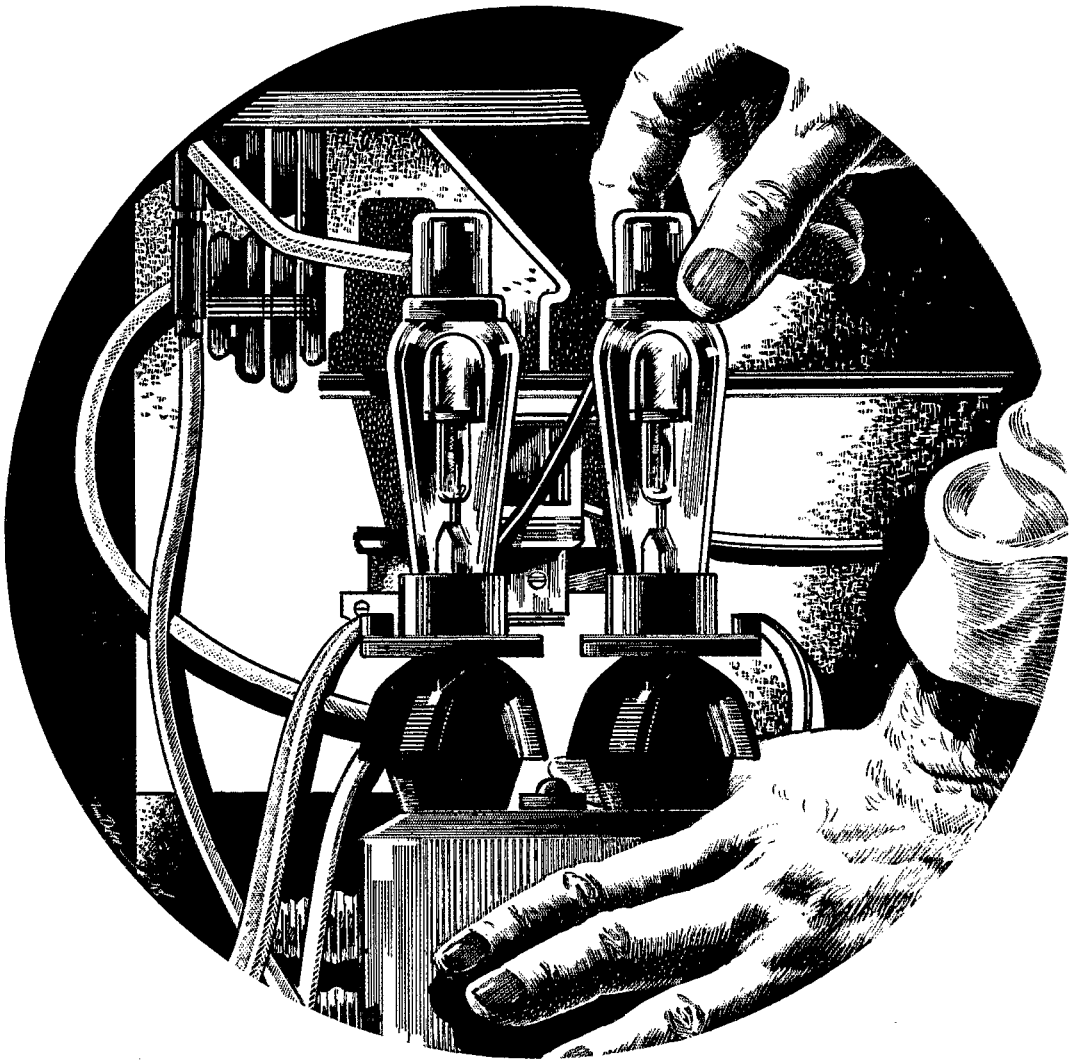

WHEN THE LAST SHOT IS FIRED!

• • • and industry resumes its peacetime production for civilian life...our boys will return to a better place to work...made possible by new uses for electronic tubes in highly efficient air-conditioning

systems using the principle of electrical precipitation.

New tube developments are almost a daily occurrence as Raytheon progresses in its wartime and post-war programs.



RAYTHEON

Raytheon Manufacturing Company

Waltham and Newton, Massachusetts

DEVOTED TO RESEARCH AND THE MANUFACTURE OF TUBES AND EQUIPMENT FOR THE NEW ERA OF ELECTRONICS

NOW—a really high-powered RADIO ENGINEERING LIBRARY

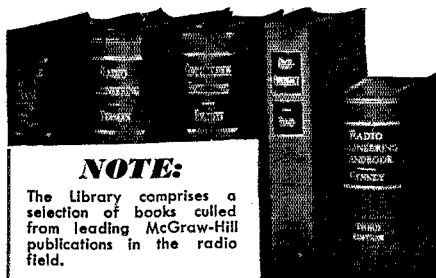

NOTE:

The Library comprises a selection of books culled from leading McGraw-Hill publications in the radio field.

- ➔ especially selected by radio specialists of McGraw-Hill publications
- ➔ to give most complete, dependable coverage of facts needed by all whose fields are grounded on radio fundamentals
- ➔ available at a special price and terms

THESE books cover circuit phenomena, tube theory, networks, measurements, and other subjects—give specialized treatments of all fields of practical design and application. They are books of recognized position in the literature—books you will refer to and be referred to often. If you are a practical designer, researcher or engineer in any field based on radio, you want these books for the help they give in hundreds of problems throughout the whole field of radio engineering.

5 volumes, 3559 pages, 2558 illustrations

- Eastman's **FUNDAMENTALS OF VACUUM TUBES**, 2nd edition
- Terman's **RADIO ENGINEERING**, 2nd edition
- Everitt's **COMMUNICATION ENGINEERING**, 2nd edition
- Hund's **HIGH FREQUENCY MEASUREMENTS**
- Henney's **RADIO ENGINEERING HANDBOOK**, 3rd edition

10 DAYS' FREE EXAMINATION

SPECIAL LOW PRICE EASY TERMS

Special price under this offer less than books bought separately. Add these standard works to your library now; pay small monthly installments, while you use the books.

SEND THIS EXAMINATION COUPON

McGraw-Hill Book Co., 330 W. 42 St., New York 18, N. Y.

Send me Radio Engineering Library for 10 days' examination on approval. In 10 days I will send \$3.00 plus few cents postage, and \$3.00 monthly till \$24.00 is paid, or return books postpaid. (We pay postage on orders accompanied by remittance of first installment.)

Name.....
 Address.....
 City and State.....
 Position.....
 Company..... QST-8-43

(Continued from page 84)

DEMOCRACY IN PRACTICE

RFD 6, Box 415, Bessemer, Ala.

Editor, QST:

... I feel that every amateur should, now more than ever, belong to the ARRL, so that after this war we can be in a better position to ... resume the most democratic hobby in all the world — amateur radio. I also feel that, if properly used, the contacts made by individuals throughout the world can do much to seal the friendship that should exist between our country and other countries. After all, every country is made up of individuals, and the personal friendships created by talking to persons you can't see and probably never will see have wonderful possibilities. It is a most wonderful experience to meet some person face to face after having been a friend, unseen, for some length of time on the air.

As to amateur radio's part after the war, it is my contention that hatred cannot exist where friendship is firmly established. Our government, having committed itself to a world-wide policy of friendship and democracy which is possible only through the efforts of each individual American citizen ... cannot overlook the many friendships developed by individuals in our country with other countries through contacts on the air via amateur radio. Even though most of our conversation has to do with the technical operation of the equipment, the element of friendship is subconsciously established. The absence of formality, where everyone — prince or pauper — is known by his first name, is responsible. What could be more democratic?

— R. H. Norton, W4GQS

DUTY REPORT

Naval Training School (Radio Matériel)
 Treasure Island, San Francisco, Calif.

Editor, QST:

Here comes my \$2.50 for another year's membership in the League — and, of course, for twelve more visits with the gang through the columns of QST.

Inasmuch as I have not as yet made any sort of full report on what sort of life I've been living since having left the rig at W7GMC in a more or less dismembered condition and reporting for active duty with Uncle Sam's Navy, it might at this time be pertinent to include a few groups on what has been going on for the past two years from this one ham's standpoint.

I reported on December 30, 1940, at Bremerton, Wash., for assignment to duty as a radioman first class, USNR. From there, after a comparatively short wait, I was sent to San Francisco to board the U.S.S. *Northampton* at Mare Island Navy Yard for duty. After some time in the Yard for necessary overhaul, we shoved off for Pearl Harbor and the romance of the South Seas. Before December 7, 1941, we had put a lot of



Not an easy one . . .

From guarding the law to — yes! — delivering babies, a policeman's life is not an easy one. Needed in a thousand different places at one time, his head must remain cool, and his orders must be transmitted quickly, clearly, *undistorted by any adjacent noises.*

Here, then, is another vital postwar use for Electro-Voice Microphones. It is impossible now to estimate the "good" which will be accomplished with the entirely new Electro-Voice communication microphones for police applications. They are, we believe, incomparable from the standpoint of articulation, level, reduction of background noise, stability, weight and size.

If you are a builder of communication equipment, directly serving the war, and are in need of this newest Electro-Voice development, we'll gladly send you full particulars. Meanwhile, if limited quantity needs may be filled by any of our Standard Model Microphones, with or without modifications, contact your local radio parts distributor. He can help you solve your problems as well as speed your smaller orders.

Note: *Any model Electro-Voice Microphone may be submitted to your local supplier for TEST and REPAIR at our factory.*



Electro-Voice MICROPHONES

ELECTRO-VOICE MANUFACTURING CO., Inc. • 1239 SOUTH BEND AVENUE • SOUTH BEND, INDIANA

Export Division: 13 East 40th Street, New York 16, N. Y. — U. S. A. Cables: ARLAB

167 WASHINGTON ST. BOSTON, MASS. U.S.A.



Thanks- Fellers

Yes — you at the Radio Shack — in your small way you certainly are doing your share. For all military radio is an assembly of parts — many fragile and delicate. If any single part fails, then in most cases the whole radio fails.

And in this war of communications and electronics, parts are vital — so thanks again for the part you play in the big part towards our coming home.

The RADIO SHACK
★ 167 WASHINGTON ST. ★
BOSTON, MASS., U.S.A.

water under our keel and had visited Brisbane, Australia, as well as Port Moresby and Rabaul in New Britain (which, as you know, have been occupying important positions in the headlines). My duties were varied aboard this heavy cruiser because, besides being an operator, I had been for years a radio serviceman and thus could fit in well with the matériel force (the "TR gang" on shipboard). As a matter of fact, all the receivers on the ship were made my responsibility, so I had a good opportunity to keep my hand in on receiver service. Copying press was about the only operating practice I got, because the second- and third-class radiomen were used as operators while the first-class were supervisors or had other duties.

We were not actually in Pearl Harbor when the Jap attack came, although we were close enough so that we were right in the middle of all the tenseness and activity into which that attack plunged the U. S. Pacific Fleet. After that we were kept very busy, as you might imagine, with various operations covering a lot of territory. Then, one day, after having fueled and provisioned the ship and taken a lot of ammunition aboard, we shoved off for parts unknown (in those days it was *always* for parts unknown) and, after some time, found ourselves in the middle of the attack on the Marshall and Gilbert Islands. There's not much, of course, that may be said about what went on, but from a radioman's point of view not much can be said about any action because, when you're in "main radio" with all the ports and hatches dogged down, there just isn't much you can see.

Not long after our return to Pearl Harbor, orders came for me to report to a point on the West Coast of the United States for a special course in "ultrahigh-frequency wave propagation" — which meant very little since we didn't know, out there, exactly to what sort of work that referred. But when I arrived on the mainland I was sent here to Treasure Island and discovered that I was scheduled to learn a lot about radio, because on Treasure Island was being developed one of the Navy's new radio matériel schools.

After starting at the school I found out that I really *was* going to learn a lot I didn't know about radio — a.c. theory, vectors, impedance relationships and a lot of other things. Although after a couple of months I was selected as an instructor, so far I still haven't discovered a lot of 'em, although I have probably learned many things as an instructor which never would have been included in my work as a student.

I was advanced to the rating of chief radioman last October, and am still telling the Navy's new RTs some of the things I know about radio. At present I am teaching a course in receivers. A lot of the information we use as textbook material here is prepared and presented by the instructors themselves, because of the fact that in many of our courses standard textbook material is either unavailable or not suited to our needs. We are,



and women
MEN AT WORK

WINNING a war is not an easy job. Victory goes to the side that *fights* harder, and *works* harder. ★ From all reports our fighting men will stand up to anybody, anywhere. It is our job, here at home, to prove that we can work as hard as they can fight. ★ The way the women of America have accepted this responsibility is worthy of tribute. Here at Simpson much of our *manpower* has changed to *womanpower*—good soldiers all, taking the place of husbands, brothers and sweethearts. ★ Like all men and women in American industry, we know but one resolution—to make *all* the electrical instruments and testing equipment we can, the *best* we can, as *fast* as we can.

SIMPSON ELECTRIC CO.
 5200-5218 Kinzie St., Chicago, Ill.

Simpson

INSTRUMENTS THAT STAY ACCURATE

Buy War Bonds and Stamps for Victory

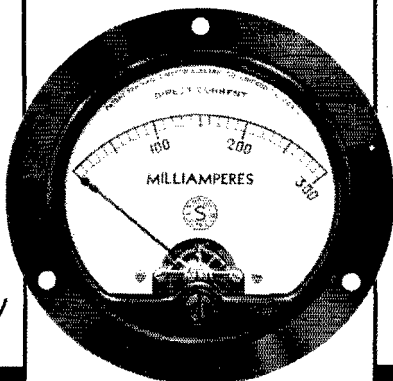
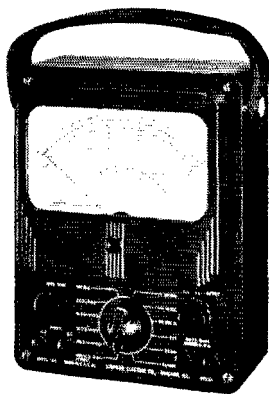

Will YOU Be "Let Out" . . . When The "Let Down" Comes?

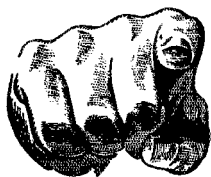

PREPARE NOW FOR THAT PERMANENT RADIO JOB!

After the war . . . what? Will you be lucky enough to carry on in your present job? Probably not! When the "let down" comes, sudden changes will take place as America goes back to peacetime production, and millions of men come back from the Armed Forces to take up their old jobs.

Don't be caught unprepared! To put it frankly, the job you hold today is temporary at least. The important, career jobs that provide you with a secure future . . . the positions with the good-paying salaries, still belong to the technically qualified men, and must be *won* and *held* on ABILITY!

Now is the time to look into the future . . . to make sure of the road ahead. Now is the time to devote your spare hours in creating a secure future for yourself and family. Now is the time to invest a small portion of your present earnings in a proven program for advancement.

CREI home-study courses in Practical Radio Engineering have been studied by more than 8,000 professional radiomen. Today, hundreds of ambitious men, just like yourself, are taking our specialized spare-time training to give them the technical skill to supplement their present ability . . . to earn a better living . . . and to create a secure place for themselves in the great postwar world of radio and electronics.

Don't say YOU haven't the time. CREI courses are designed to be studied in the most crowded schedules. You can study a few hours a week without interfering with your present work. In the years to come, you will "cash in" on your increased knowledge and ability gained from spare-time study. So, write for all the facts now — for this is the time to make sure that your preparation for postwar success shall not be "too little, too late"!

WRITE FOR FACTS TODAY about CREI Home Study Courses

If you have had professional or amateur radio experience and want to make more money, let us prove to you that we have something you need to qualify for a better radio job. To help us intelligently answer your inquiry, PLEASE STATE BRIEFLY YOUR BACKGROUND OF EXPERIENCE, EDUCATION AND PRESENT POSITION.



Capitol Radio Engineering Institute

Home Study Courses in Practical Radio Engineering
for Professional Self-Improvement

Dept. Q-8, 3224 16th St. N. W., Washington 10, D. C.

Contractors to the U. S. Signal Corps, U. S. Navy and U. S. Coast Guard. Producers of Well-trained Technical Radiomen for Industry

as a result, developing some excellent "short courses" in various equipments, techniques and applications associated with radio.

The work here is fascinating. I am learning, I sometimes think, more as an instructor than I would have as a student; and, besides, I'm getting invaluable experience in organizing ideas and clarifying sometimes obscure conceptions for presentation to fellows whose experience and background is limited enough so that standard technical presentations are very seldom satisfactory. Many other hams have gone through here, and several have been, as I was, selected for instructors' positions. If the rest of them have learned and are learning as much as I, the technical level of the postwar average ham is going to be definitely higher than that of the pre-Pearl Harbor one.

Keep up the good work on the home front. Ham radio is going to be even more important to many of us when we get back on the air than it was in the "good old days." Orchids, too, to George Grammer for his course in radio fundamentals; we are not using it directly here, but I understand it is being used in some of our prep schools with good results, and I know that some of the fellows here are receiving valuable help from it.

73 to everybody. Let's fervently hope we need never say 30.

— Richard W. Rose, W7GMC, CRM, USNR

FAST WORK

A.P.O. 957, c/o Postmaster
San Francisco, Calif.

Editor, *QST*:

A little over a month ago I was living at home. Since then I have been drafted, processed and shipped. This Army has certainly stepped things up.

Before I left civilian life I started writing a letter designed to let the gang and you at Headquarters know how one more ham felt about the grand work the League is doing. The draft closed in on me, however, and the letter went unfinished. I'd like to express my appreciation now to the League for keeping *QST* a ham publication and also keeping our interests in ham radio alive until we can return to our pre-war basis.

I walked into the Post Exchange the other day and yelped for joy when I saw about a dozen copies of *QST* on the magazine rack. It's a real pleasure having them that handy and being able to keep up with my favorite hobby. I left instructions with the folks at home to renew my subscription for Christmas and keep the copies at home so they'll be there when I get back. . . .

The boys I used to know and chew the rag with are now serving their country in all parts of the world. To them I'd like to say hello, lots of luck and see you soon on 10.

— *Pvt. James H. Kark, ex-W9EAE*

(Continued on page 92)

THE *Ability* TO GO TO WAR!

In 1929, fourteen years ago, the first JENSEN Auditorium speaker was introduced. The first of its kind, it has during all the succeeding years faithfully served the public and professional need for a heavy duty, high quality loud speaker. We think it is undeniably the world's best known and respected loud speaker product. Now, this fourteen year old JENSEN product goes to war. Naturally it incorporates the refinements and improvements which have been steadily added, but the basic design and function remains the same. Many other JENSEN products are thus endowed with the ability to go straight to war.



Jensen
RADIO MFG. CO.

6601 SOUTH LARAMIE AVENUE
CHICAGO, U. S. A.

AERIAL HAMFEST

Martinsville, N. J.

Editor, *QST*:

. . . Not long ago a small impromptu hamfest took place in an Army cargo plane over W9. The participants in this unique meeting were three flight radio officers and the co-pilot of the plane, which was a C49J. The co-pilot was Ken Cook, W9GDE, of Chicago. H. E. Blough, W9SP, also of Chicago, Bill Plimpton, W3IXH, of New Jersey, and "Stinky" Green, W1JDE, of Boston, Mass., were the f.r.o.s.

After the initial introduction the talk naturally drifted around to the good old days. A contest took place to determine the oldest ham aboard. Blough won by 21 years of ham operation. He told how Ken, W9GDE, used to come into his radio store as a small boy to buy crystal detectors. Both Ken and "Stinky" had had about nine years' experience, while your reporter had but a mere year and four months of ham operation. The old-timers were soon telling the relative newcomer about the good old days of loop modulation . . .

But all things, however good or otherwise, must come to an end, as did this meeting of brothers under the skin—namely, hams. The co-pilot went back to his co-piloting, the radio operator back to the rig, and the extra operators back to watching the beautiful countryside until their turn to relieve the radio operator on duty.

This is just a small incident, but perhaps it will serve to illustrate the spirit of hams to serve where their former hobby will help the most.

— *Wm. Plimpton, W3IXH*

QST INVENTORY

U. S. Naval Hospital, San Diego, Calif.

Editor, *QST*:

Despite the suspension of amateur operation, *QST* has become even more interesting and more important. It undoubtedly plays an important part in the radio phase of the war effort. . . .

When *QST* comes in the mail I turn first to the editorials. To the amateur these seem most important. Although I am unable to do any experimenting I find vicarious enjoyment in the Experimenter's Section. Also, I enjoy the technical reviews and articles like "Radio and Atom Busting" and "Panoramic Radio Spectroscope."

As I'm an SWL much of the time these days . . . I would be glad to send reception reports to any non-Axis stations, if they would be of any value. . . . The press schedules in *QST* have come in handy both for press times and for checking frequencies on the Sky Buddy.

To sum up what I have been trying to say—you gentlemen at Headquarters certainly do know the things that we hams want to hear about in *QST*. Not until recently have I appreciated the ARRL and what it does. Now I am proud to be a member, and I'm sure this is the beginning of a life membership for me. . . .

— *Ivan C. Simpson, W6TET*



WORDS on the WING

Without words winging between planes there'd be no teamwork—without teamwork there'd be no bombing—without bombing there'd be no Victory! But always they must be the *right* words at exactly the *right* instant, spoken by men who *know* their radio! And that's our part of the job! Melville-trained, licensed radio operators and technicians are serving today on every fighting front—in a host of jobs at vital bases—on commercial airlines that thread the world. After the war, many of these Melville-trained men and women will be important executives in the new world of aircraft and radio.

MELVILLE

AERONAUTICAL RADIO SCHOOL, INC.
45 West 45th Street New York City
Training Men & Women for Radio in the Service of
AIRLINES-ARMY-NAVY-MARINES-MERCHANT
MARINE-COAST GUARD-INDUSTRY

RADIO or ELECTRICAL ENGINEER WANTED

Equipment and Circuit Development Work

Capacitor manufacturer located in New Bedford, Mass., wants an electrical or radio engineer—man or woman—for equipment and circuit development work. Permanent post-war future for right person. This firm has excellent laboratory facilities and is a leader in its field. Applicant should be college graduate with degree—or equivalent experience—in radio engineering or electrical engineering.

Interview in Boston, New Bedford or New York, can be arranged. Traveling expenses paid to place of interview.

Write fully, giving age, education, experience, etc.

BOX 50 "QST"



THE LITTLE MAN IN THE PEANUT

Remember when, as a kid, your mother would open a roasted peanut and solemnly say, "Here's the peanut man"? Sure enough, there was a gnome face with stocking cap and long beard. You wondered how he got there but, as time passed, you forgot all about him.

Years went by. You graduated, got a job, married, and the children came along. Then, when you were securely established, the war broke. For many reasons, you couldn't get into active service . . . so you entered civilian defense, and worked like hell at it.

People spoke of rationing, priorities, a second front and inflation. Those things concerned you but, somehow or other, you'd grown used to the war and its impositions.

Without realizing it, you were becoming more and more like the little man in the peanut. No one put you there . . . the shell of complacency grew around you . . . and only occasionally did a familiar name on a casualty list jar you from your apathy.

'Tis said that this will be a long war. If that's the way you want it, that's the way it will be. Need it be? You . . . yes, you . . . have the power to help shorten the war. You have the power to hurry the boys home. If you can't say today that you've done as much to win the war as you promised on December 7th, 1941, you'd better crawl out of that shell, brother, and produce!

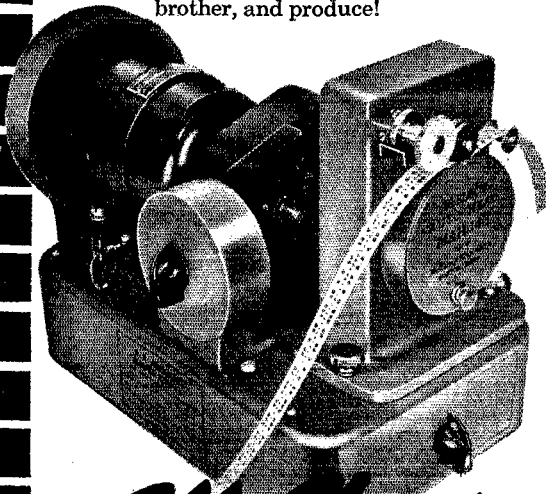

Day and night McElroy High Speed Radiotelegraph Equipment is in there pitching. On the home and battlefronts, this apparatus is rushing the transmission of news, messages, orders. As creative telegraphic engineers, we are doing our share . . . delivering better telegraph apparatus.

McElroy

MANUFACTURING CORP.
82 BROOKLINE AVE. BOSTON, MASS.

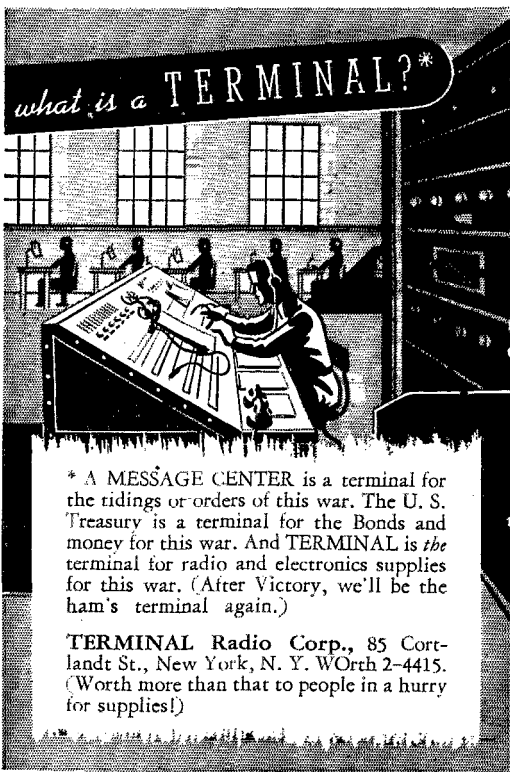

* A MESSAGE CENTER is a terminal for the tidings or orders of this war. The U. S. Treasury is a terminal for the Bonds and money for this war. And TERMINAL is the terminal for radio and electronics supplies for this war. (After Victory, we'll be the ham's terminal again.)

TERMINAL Radio Corp., 85 Cortlandt St., New York, N. Y. WOrth 2-4415. (Worth more than that to people in a hurry for supplies!)

Solution

To Cross-Word Puzzle on Page 61

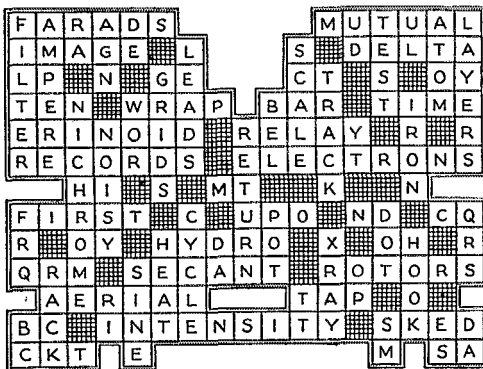

Splatter

(Continued from page 8)

dian. One of the most popular officers in his command, he has devised many training plans and the equipment to improve the training of large numbers of radio men and women. He had much to do with the innovation of training airwomen as WOGs and for RTO work. . . .

Ruth Pringle (p. 62) confesses that she is not a ham as yet but hopes to be one when the war is over. For now she has to be content with working as a radio operator at the local b.c. station in Niagara Falls, N. Y. Knowing that *QST* is read by many radiomen in the services, she thought a cross-word puzzle might be just the thing to while away the time between reveille and mess call — or something. . . . **C. C. Riche-lieu, W9ARE** (p. 46), autobiographies as follows: "Started in radio in 1922. Licensed as W9ARE in 1925 and was continuously active under that call up to Dec. 7, 1941. Entered commercial radio in 1928. Commercial coast station and broadcast operator 1928 to 1932. Entered government service with U. S. Dept. of Commerce in 1932 and worked up from the ranks as radio operator, maintenance electrician and finally radio engineer. Now chief of the foreign section of CAA's signals division at Washington, D. C. Graduate of Dodge Radio Institute. Post-graduate work in engineering at the University of Nebraska and George Washington University. Ham activity: ORS, OBS, OO, WAC, RCC, SCM Iowa 1938-39, Byrd Antarctic contact station 1928, and a 20-meter 'phone landmark since 1932. Summing it all up — ham radio has been very good to me." . . .

Howard F. Russell, WIMAY, East Providence's radio aide (p. 42), first became interested in radio when serving as a pursuit pilot in France and Germany during World War I. Extensive traveling on engineering work prevented him from obtaining a license and a station until about five years ago, however. Since then he has secured a Class A license and built a 275-watt all-band

*Basic Facts
on Electricity
Needed to
UNDERSTAND
ELECTRONICS!*

**BASIC
ELECTRICITY
for
COMMUNICATIONS**

by **W. H. TIMBIE**

603 pages
\$3.50

This clear, concise, practical book gives you a comprehensive picture of the fundamental laws and principles governing communications practice. You will know the instruments and apparatus used — what they look like — how they work. You will know the symbols and language of the trade, and learn to figure quickly daily problems. This book will give you a foundation that will serve you well at all times and prepare you for advanced work in the field.

-----ON APPROVAL COUPON-----

JOHN WILEY & SONS, INC.
440 Fourth Avenue, New York 16, N. Y.

Please send me a copy of Timbie's **BASIC ELECTRICITY FOR COMMUNICATIONS** on ten days' approval. At the end of that time, if I decide to keep the book, I will remit \$3.50 plus postage; otherwise I will return the book postpaid.

Name.....
Address.....
City and State.....
Employed by.....

QST-8-43

RADIONICS*

**“the impossible we do immediately
the miraculous takes a little longer”**

ARMY SERVICE FORCES —

The Army is . . . men . . . trained men . . . equipped and maintained. On the home front . . . in factories and on farms . . . civilians produce the armament and food and supplies. The bridge between civilians who furnish and soldiers who use . . . is . . . the Army Service Forces. Wherever the soldier is . . . whatever he does . . . the Army Service Forces are charged with seeing that he lacks no essential thing. To fulfill the task outlined in the twenty-one words above . . . literally . . . the “impossible” and the “miraculous” become daily routine with the Army Service Forces.

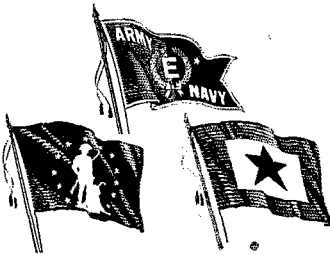

“AYE, AYE, SIR”

In old English, “Aye” meant “yes.”
It means far more in the Navy.
“Aye, Aye, Sir,” means that the order is understood and will be obeyed.

The Navy has given Zenith many “orders” since this war began.

Our prompt “Aye, Aye, Sir,” has, we believe, been justified by the “intelligence and initiative” (as the Navy says) with which these orders have been executed.

—in days of civilian radio, Zenith was proud of its long series of “firsts”—improvements which made radio history and established leadership in the industry.

—today our viewpoint has changed—materially.

—engaged exclusively in war production, the things we have been called upon to do—the tasks we have succeeded in accomplishing, make past improvements in civilian radio literally look like “child’s play.”

—the work of our engineers in radionics has made the “impossible” possible and accomplished the “miraculous.”

*—mark that word “RADIONICS” (with its subdivisions —Electronics, Radar and Radio)—it has brought into reality and being, devices which only a year or so ago came in the “impossible” and “miraculous” categories.

—today Zenith works in the science of radionics for our armed forces alone.

—in that bright “tomorrow” when peace returns—

—we can only say—the post-war radios that Zenith will produce will contain many interesting new developments.

—that statement is based upon experience which we can not now reveal—but you may take our word that it is a fact.

ZENITH RADIO CORPORATION, CHICAGO

BETTER THAN CASH

U. S. War Savings Stamps
and Bonds

ZENITH
RADIO
LONG DISTANCE
RADIO PRODUCTS EXCLUSIVELY—
WORLD'S LEADING MANUFACTURER

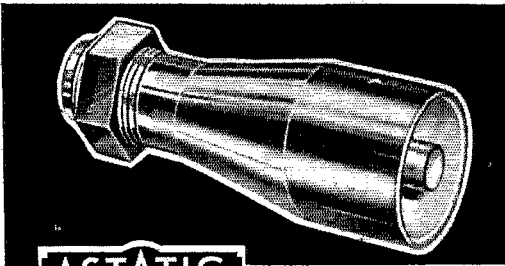

ASTATIC COUPLINGS,
CONNECTORS, PLUGS and
SOCKETS Serve America

* Important to the assembly of special wartime radio and radar equipment, scores of specially designed products, manufactured with the skill and precision for which Astatic is noted, are being made and shipped daily to manufacturers of such equipment for military use at home and abroad.

THE ASTATIC CORPORATION
Youngstown, Ohio

*

In Canada: Canadian Astatic, Ltd., Toronto, Ontario

THE RADIO AMATEUR'S LIBRARY

Many requests are received for the complete list of our publications. The list follows:

Title	Price
OST.....	\$2.50 per year*
List of Stations.....	Discontinued
Map of Member Stations.....	Discontinued
Operating an Amateur Radio Station	Free to members; to others 10¢
The Story of The A.R.R.L.....	Discontinued
The Radio Amateur's Handbook	
a. Standard Edition.....	\$1.00**
b. Special Defense Edition.....	\$1.00
The Log.....	35¢ each; 3 for \$1.00
How to Become a Radio Amateur.....	25¢
The Radio Amateur's License Manual.....	25¢
Hints & Kinks for the Radio Amateur.....	50¢
Lightning Calculators:	
a. Radio (Type A).....	\$1.00
b. Ohm's Law (Type B).....	\$1.00
Amateur Radio Map of the World.....	\$1.25
Two Hundred Meters and Down: The Story of Amateur Radio.....	\$1.00
Building an Amateur Radio-telephone Transmitter.....	Out of print
A.R.R.L. Antenna Book.....	50¢
Emergency Communications Manual.....	10¢
The Minalog.....	25¢
Learning the Radiotelegraph Code.....	25¢
A Course in Radio Fundamentals.....	50¢
*In the United States and Possessions — other Countries \$3.00 per year.	
**Postpaid in Continental U. S. A. — \$1.50, post-paid, elsewhere.	
(No stamps, please)	

The American Radio Relay League, Inc.
WEST HARTFORD, CONNECTICUT

(Continued from page 94)

transmitter. A member of the Farmers Net and the Blackstone Valley Net, and formerly control station for the AARS in Rhode Island, he was active mostly in the 160-meter 'phone band. He is married, has one junior operator and is field manager for four insurance companies. . . . Our info on **Harry E. Stewart, W3JXY**, is limited to the fact that he is employed at the Mare Island (Calif.) Navy Yard as a radio engineer in the radio matériel office, and that his transmission line data (p. 25) has been employed extensively in working out sundry war-time assignments. Oh, yes; there's one more detail. Originally, when he came to Washington, D. C., he held the call W6PNX (and incidentally a Class A operator's ticket), but now that he's out in California his call is W3JXY. Just chalk it up to the perversities of war! . . . Almost as much an old-timer as his wired-wireless co-author, **Perry E. Wightman** (p. 14) started in radio with a crystal set when he was 14 years old. (He's now 40.) Soon afterward he went to work in a radio factory after school hours, and later he found himself on a production line building transmitters and receivers for the military services. For the next twenty years he worked for a power company in radio and electrical fields, ending up as chief radio engineer. Now he is in the national office of OCD, its national radio communications officer. A consulting engineer designing electronic equipment for a number of years, he has been carrying on carrier-current experiments since 1934.

WERS Message Handling

(Continued from page 45)

having tried it out in two full-scale drills with over 300 volunteers and the police and fire departments participating. We have purposely attempted to jam the system and, while we have had as many as fifteen messages waiting on the hooks, they have all been cleared promptly and in the order of their relative importance. Observation indicates that messages can be handled at the rate of one per minute. This is in spite of the fact that more than half the operators had no radio experience eighteen months ago, all of them work five to seven days or nights per week, and actual drills are limited to two hours on Sunday afternoons.

The ideas in this article are contributed for what they are worth and in the hope they may help those in charge of other WERS systems. Undoubtedly, there are further improvements that could be made, particularly if more apparatus or channels were available. In East Providence, however — limited as we are to two channels, seventeen stations, inexperienced operators, and with 32,000 people to guard — the control panel and procedure described here seem to serve our purpose until something better can be developed.

An Open Letter To Married Men!

* * * * *

2797 Fourth Ave. South
Minneapolis, Minnesota

Fellow Americans:

Are you a father (3-A), technically trained, 25 years of age or over, not now employed at your highest skill? Would you like to get into the thick of things without delay and do your bit for your country alongside the military at home or abroad? If so, we have a message for you.

Minneapolis-Honeywell, known for over fifty years as a manufacturer of electrically operated controls, is and has been making important contributions to the war effort. We have created and are manufacturing vital devices used in the operation of combat planes of the United Nations.

Minneapolis-Honeywell requires, at once, the services of additional men trained as Electrical Engineers, or those with a thorough understanding of Electronics. Men selected for this service, after training, will become instructors in the use of critical operating instruments and will be associated on a common basis with military personnel. The training and experience acquired will afford a most advantageous knowledge for post-war use. Only recognized fathers (3-A), of 25 or over, will be considered.

We expect you to meet the following requirements:

1. Must be willing to take, and able to pass, normal industrial physical examination.
2. Must have pleasing appearance and ability to make yourself clearly understood in both written and oral work.
3. Must be an American citizen. Birth certificate required.
4. Character must be such as will pass a thorough investigation.
5. We are not soliciting applications from those employed at their highest skill in essential industry.

EMPLOYMENT - Immediately. Four week training period with pay included. Write air mail - giving full personal history, education and practical experience, selective service classification and order number, or other military connection, and include snapshot. Arrangements will be made for personal interview. Address -

Lawrence L. Smith
Aeronautical Division
MINNEAPOLIS-HONEYWELL REGULATOR CO.
MINNEAPOLIS, MINNESOTA

MEMO:

Today! Get a letter off to Leo W9GFQ for his big catalog of parts and sets. The way they're selling, even his big stock is liable to get mighty slim!

LEO'S PRICES AND TERMS CAN'T BE BEAT. WRITE LEO — W9GFQ

WHOLESALE RADIO LABORATORIES

744 West Broadway

Council Bluffs

Iowa



Founded in 1909

Pre-Induction "RADIO"

A maximum of thirteen weeks to prepare for military service — code — printing — typing — procedure — and fundamentals of tube and transmitter servicing. If interested, write for details.

PORT ARTHUR COLLEGE

PORT ARTHUR, TEXAS

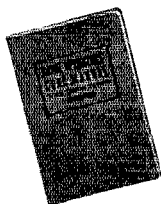

RADIO OPERATORS' CODE MANUAL (WITH TOUCH TYPING)

A complete and thorough self-study and classroom text in code transmission and reception with touch typing procedure. Comprehensive instruction in the construction of code practice equipment and devices. 166 pages, 40 illustrations and touch typing charts. Flexible paperbound edition \$2.00 post-paid or write for descriptive circular.

WAYNE MILLER

The Engineering Building, Chicago U.S.A.

A Five-Band Transmitter

(Continued from page 49)

modulator output transformer, *T*; the doubler tank coil, mounted within aluminum shield; and, next to the panel, the 807 tube within its shield. The grid meter, *MA*, is shown just above the 802 plate cap. The power-cable sockets are at rear of chassis and connect with standard Amphenol connectors to the power-supply unit.

For stability in the oscillator circuit, too much stress cannot be put on the need for solid mounting of components as well as heavy and secure wiring to prevent vibration and circuit change. No. 10 tinned bus wire was used for all r.f. wiring throughout the unit, while all filament circuits were wired with No. 12 duplex lead-covered wire. All d.c. wiring is neatly laced in place; this makes for a more commercial appearance throughout.

It is advisable to follow the customary practice of shielding the microphone input and grid lead to the first audio tube. A small shield of No. 20 gauge copper sheet was made to enclose the grid lead to the 807, which helped to oust the "birdies" in this part of the circuit.

Coils

All coils, aside from those for the output circuit and those for 1.75-Mc. operation, are wound with No. 18 enameled wire. No. 34 enameled wire is used for the lowest frequency in order to accommodate the required number of turns in the space provided on the coil forms. Dimensions for all coils are shown in the accompanying table. The upper part of the table shows which coils should be plugged in each stage, and the frequency band in which each stage operates to obtain out-

COIL DATA TABLE

Output Band EK-80A	807	6L6G	E.C.O.	Xtal
1.75 (A)	1.75 (F)	1.75 (J)	0.85 (M)	1.75
3.5 (B)	3.5 (G)	1.75 (J)	0.85 (M)	1.75 or 3.5
7 (C)	7 (H)	3.5 (K)	1.75 (N)	3.5 or 7
14 (D)	14 (I)	7 (L)	3.5 (O)	7
28 (E)	14 (I)	7 (L)	3.5 (O)	7

Coil	No. Turns	Wire Size	Diam. In.	Length In.
A	42	16	3½	3
B	32	16	2½	2¾
C	20	14	2	2½
D	10	14	2	2½
E	6	12	2	2½
F	100	34	1½	2
G	40	18	1½	2
H	18	18	1½	1¼
I	8	18	1½	1
J	75	34	1½	1¾
K	40	18	1½	2¼
L	22	18	1½	1¾
M*	62	34	1½	2¼
N*	32	18	1½	2¼
O*	17	18	1½	1¾

* Coil M is tapped at 4 turns from grid end and L_2 is 10 turns wound over ground end. Coil N is tapped at 3 turns from grid end and L_2 is 7 turns. Coil O is tapped at 2 turns from grid end and L_2 is 5 turns.

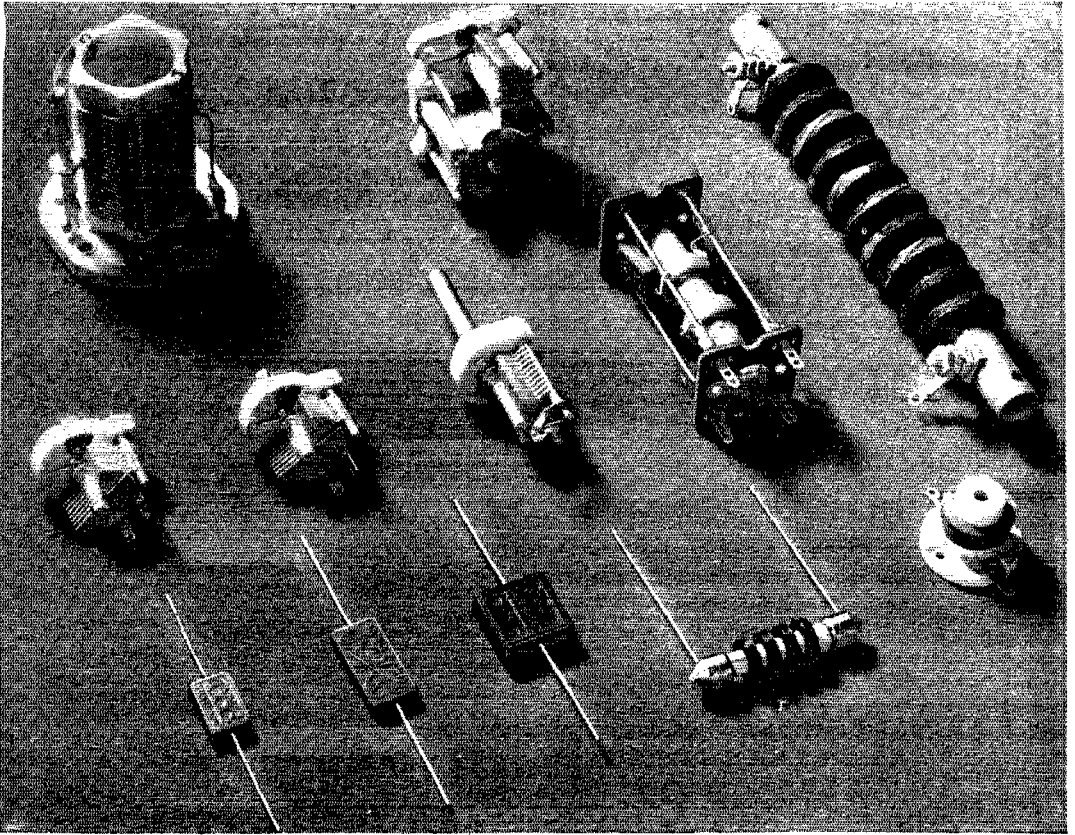

Jewelry? *In a way, yes . . .*

These are Sickles products — coils and condensers —
as precise and clean-cut as a Swiss watch, as handsome as Florentine silver,
and as scarce, for non-military purposes, as rubies . . . though our production is up
in several departments some 400% over that of pre-war days. They're jewels as performers, too . . .
as you might well judge by our recently-won Army-Navy "E."

Superior Sickles specialties of this same high quality will be available
for general use as soon as Victory is won. Meanwhile, please bear us in mind.

The F. W. Sickles Company, Chicopee, Massachusetts.



SICKLES

Electronic Specialties

NEWARK does it again!

 a NEW, lucky buy in

FILTER CONDENSERS

9 mfd. 2000 v. D.C. **\$3.25** NO PRIORITY REQUIRED!

The best condenser and the biggest value Newark has ever advertised. An improved type. Oil filled and oil impregnated. Quality built by a reliable manufacturer and Guaranteed at rated voltage. Complete with porcelain insulators and mounting brackets. Neat gray enamel finish. Not illustrated, but you'll be delighted! Size $1\frac{1}{4}'' \times 3\frac{1}{2}'' \times 4\frac{1}{2}''$ high.

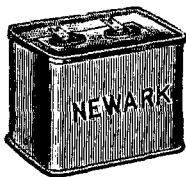

Still have limited stock of the old reliable NEWARK SPECIAL filter condensers, Oil filled and impregnated. Thousands of them have been sold.

Mfd.	Volts DC.	Size	Price
1	1000	5 x $3\frac{1}{4}''$ x $1\frac{1}{4}''$	\$.59
2	2000	4 $\frac{1}{2}$ x $3\frac{1}{4}''$ x $1\frac{1}{4}''$	1.50
4	3000	5 x $3\frac{1}{4}''$ x $3\frac{1}{4}''$	3.75

ORDER TODAY DIRECT FROM THIS AD
Sorry—NO CATALOGS for the Duration!

NEWARK Electric Company.
323 W. MADISON ST.
CHICAGO, ILL.

JAMES

Crystals
KNIGHTS

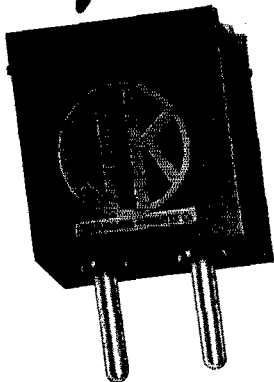

The JAMES KNIGHTS Co.
SANDWICH, ILLINOIS

PRECISION CUTTERS OF QUARTZ FOR
COMMUNICATIONS & OPTICAL USES

(Continued from page 98)

put in the desired band. B & W Series BL (end link) coils may be used instead of those specified for L_5 . The turns on L_1 may require slight adjustment to fit the band.

Adjustment

Tuning is conventional and straightforward. The excitation to the RK-20A should be watched closely. Grid current to the RK-20A should be maintained at a value not exceeding 10 ma.; I usually run it at 8 ma., since no apparent increase in output is obtained with greater excitation. Excessive excitation can ruin the performance of the RK-20A, and I believe this has contributed more than any other factor to discourage the use of this tube. If excitation is maintained at proper value, the life of an RK-20A, or similar tube, equals that of the average triode. This is the reason I have provided for accurate control of excitation through the variable coupling condenser, C_9 , and the 807 output control, R_{19} . Plug-in coils in the e.c.o. grid circuit provide for operation in all bands with the three oscillator coils described in the table. The e.c.o. grid circuit operates at one band lower in frequency than the 6L6G isolating stage's output, the 807 stage doubling to the next-higher-frequency band and the RK-20A operating straight through at the 807 output frequency. Exceptions to this rule are the 160-meter band, where the 807 is operated straight through, and the 10-meter band, where the RK-20A is used as a doubler.

The performance of this unit has been very gratifying. The e.c.o. keying characteristics are particularly good; it is almost impossible to tell whether crystal or e.c.o. is being used. No neutralization is required and plenty of excitation is available on all bands. L/C ratios in the intermediate stages have been chosen so that the 14-Mc. 'phone band can be covered merely by tuning the e.c.o. circuit, while complete coverage of the widest band will require only slight retuning of the output stage, once the other controls are set for the band. To switch to 'phone operation, it is only necessary to throw S_2 , connecting the modulator output in the suppressor circuit.

I had an opportunity to give the rig a good work-out just prior to Pearl Harbor, and it certainly lived up to all expectations, with no indication of instability or overheating whatsoever.

Strays

It has been discovered that, not only does the human species get tired, but molecules do also. Research has shown that the molecules responsible for fluorescence in a special type of glass get "tired" and lose part of their activity when excited by ultraviolet radiations for a long period of time. After suitable rest periods in the dark they regain their strength — *Ohmite News*.



Temperature co-efficient testing is an important job! Crystals must perform perfectly in all degrees. (Fighting men depend on our accuracy!)



LEO MEYERSON ■ W9GFQ



E. M. SHIDELER ■ W9IFI

She Doesn't Wear a Uniform . . . but

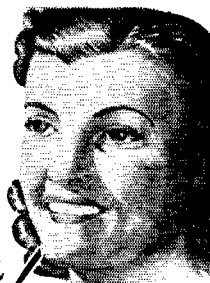

She's a Soldier, too!

. HELPING WIN THE WAR!

She and several hundred others here at Scientific Radio Products Co.

They're turning out the perfect crystals that put life into the radio equipment of our armed forces, and keep alive the vital communications on which depend the very lives of our armies.

With two ingredients . . . loyalty plus skill . . . they're forming crystals that are dependable.

Although we're busy with Uncle Sam's needs right now, our facilities are such that we can take care of your requirements, too! Write us.

Scientific RADIO PRODUCTS CO.

738 W. Bdwy.

LEO MEYERSON W9GFQ
E. M. SHIDELER W9IFI

Council Bluffs, Iowa

MANUFACTURERS OF PIEZO ELECTRIC CRYSTALS AND ASSOCIATED EQUIPMENT

Keep 'Em Running FOR THE DURATION!

It is difficult to secure new Generating Sets or new Rotary Converters . . . Pioneer is devoting all of its resources toward winning the war . . . but we

can, and will, help you keep your present equipment running for the duration. Send your service problems, by letter, to Pioneer's Customer Service Dept.

DYNAMOTORS · CONVERTERS · GENERATORS · DC MOTORS · POWER PLANTS · GEN-E-MOTORS

PINCOR Products PIONEER GEN-E-MOTOR

CHICAGO, ILL. · EXPORT ADDRESS, 25 WARREN ST., NEW YORK CITY
CABLE ADDRESS SIMONTRICE, NEW YORK

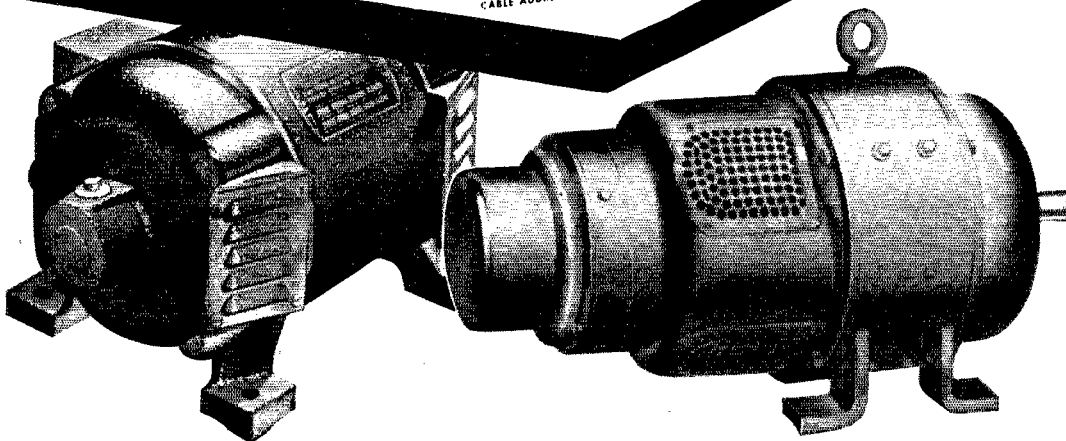

You CAN HELP!

We supply radio apparatus for war use. You can help fill this need by selling your equipment to us. We pay highest cash prices without delay or red tape.

Write and tell us what receivers, meters, parts, etc., you have. If in a hurry telephone or telegraph. This is the easiest and quickest way to send your apparatus to war. And we pay you more, too. We promise you a better deal. So let us know what you have.

We also have a store at 2335 Westwood Boulevard, West Los Angeles, California.

HENRY RADIO SHOP

BUTLER, MISSOURI

"World's Largest Distributor of Communications Receivers"

CAN YOU FILL ONE OF THESE MOST IMPORTANT WAR JOBS?

If you have a college education (not necessarily a graduate) and know theory and practice, you are urgently needed by a non-profit, non-commercial organization assigned to vital war research.

- Electronic Engineers
- Radio Engineers
- Electrical Engineers
- Physicists
- Electrical Designers
- Electronic Designers
- Acoustical Specialists
- Communication Engineers
- Geophysicists
- Seismograph Technicians
- Mechanical Engineers

If you are in one of the above categories and your highest skill is not being utilized to help save lives and materials, to help shorten the war, please write! ACT NOW!

Salaries range from \$3,000 to \$8,000, depending upon experience, ability, education and past earnings. In addition, we will pay all expenses of transportation, moving, etc., for you and your family. You must be free to travel. Living quarters will be made available. If granted an interview, we will compensate you for all expenses incurred in coming to New London. Don't wait! Write, stating background and experience to . . .

PERSONNEL DEPT.

P. O. Box 271, New London, Conn.

Notes on Transmission Lines

(Continued from page 29)

The Transmission Line as an Impedance-Matching Transformer

The quarter-wave section of line is used very extensively as an impedance-matching device by the amateur — the Johnson Q-Bars offer a good illustration of this use. The derivation of the expression $Z_o = \sqrt{Z_s Z_r}$ can be effected by assigning l in equation (3b) a value of $\lambda/4$.

$$Z_s = Z_o \left[\frac{\cosh(0 + j\pi/2) + Z_o/Z_r \sinh(0 + j\pi/2)}{Z_o/Z_r \cosh(0 + j\pi/2) + \sinh(0 + j\pi/2)} \right]$$

In this instance, the attenuation constant, α , has been considered as zero.

Noting that

$$\begin{aligned} \cosh j\pi/2 &= \cos \pi/2 = 0 \\ \sinh j\pi/2 &= j \sin \pi/2 = j(1) \end{aligned}$$

the expression reduces to

$$Z_s = Z_o \left[\frac{0 + j Z_o/Z_r}{0 + j(1)} \right] = Z_o^2 / Z_r$$

and solving for Z_o .

$$Z_o = \sqrt{Z_s Z_r} \quad (16)$$

In the case of an antenna system (see Fig. 5) Z_s is the characteristic impedance of the transmission line, Z_r is the impedance of the antenna, and Z_o is the characteristic impedance of the quarter-wave matching section. If l had been assigned a length of $3\lambda/4$, $5\lambda/4$, or any odd quarter wavelength, the result would have been the same as that of equation (15) — in other words, any odd quarter wavelength of line may be used as an impedance-matching transformer.

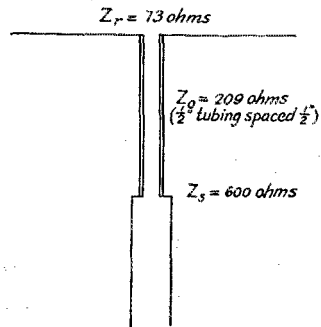

Fig. 5 — The "Q" matching section used between a half-wave antenna and a 600-ohm line.

If l , on the other hand, is assigned a value of $\lambda/2$, or any integral half wavelength, the expression becomes

$$Z_s = Z_o \left[\frac{\cosh(0 + j\pi) + Z_o/Z_r \sinh(0 + j\pi)}{Z_o/Z_r \cosh(0 + j\pi) + \sinh(0 + j\pi)} \right]$$

and noting that

$$\begin{aligned} \cosh j\pi &= \cos \pi = -1 \\ \sinh j\pi &= j \sin \pi = 0 \end{aligned}$$

(Continued on page 104)

PERFECTION
from a
HUNDRED PAIRS
OF HANDS

The "human element" so consistently mentioned as a necessary part of every great accomplishment, is exemplified in the high quality of Thordarson transformers. From engineering laboratory to final inspection, countless pairs of hands and minds work in harmony to bring about in each complete transformer a coordination of effort that makes for superb performance.



THORDARSON

ELECTRIC MFG. COMPANY
 500 WEST HURON ST., CHICAGO, ILL.

Transformer Specialists Since 1895
 . . . ORIGINATORS OF TRU-FIDELITY AMPLIFIERS

CRYSTALS

Any TYPE OF CUT
 AND FREQUENCY

We have facilities for producing crystals to all temperature co-efficient and absolute frequency specifications. Our engineers have wide experience with all crystal types. In our Special Crystal Division we are ready to undertake NOW the development and production of any special and exacting crystal types that may assist you in the war effort. Rush?

Phone CRYSTAL SERVICE DIVISION
 PLYMOUTH (INDIANA) THREE THREE

JOHN MECK INDUSTRIES
 PLYMOUTH, INDIANA



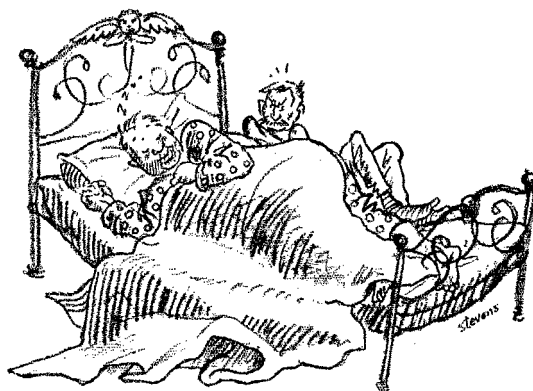

Bad Bedfellows . . .

War has had bedfellows . . . and one of them is production delay. HARVEY'S most important job is to locate and purchase urgently needed radio components for war equipment manufacturers and the Armed Services. In that way HARVEY helps to break production bottlenecks.

If you have Communications Receivers, Test Equipment, Meters, etc. that can help in this war, write immediately. Specify the price you expect to receive. If satisfactory, we'll send our check or, if you prefer, the equivalent amount in war bonds and stamps.

HARVEY RADIO CO.

103 West 43rd Street, New York City, N. Y.

NOW

IS THE TIME TO ACT!

QST BACK COPIES

Vol. 9—1925 Copies—(Except Jan., Mar., May and July)	\$2.00
Vol. 10—1926 Copies—Complete	2.50
Vol. 11—1927 Copies—(Except Jan., July and Oct.)	2.25
Vol. 12—1928 Copies—(Except Jan., Feb., Mar., Aug., Sept.)	1.75
Vol. 13—1929 Copies—Complete	2.50
Vol. 14—1930 Copies—(Except Jan., Feb., Apr., and July)	2.00
Vol. 15—1931 Copies—(Except Oct. and Nov.)	2.50
Vol. 16—1932 Copies—(Except Feb., Aug., Sept., and Oct.)	2.00
Vol. 17—1933 Copies—(Except Jan. and Feb.)	2.50
Vol. 18—1934 Copies—Complete	2.50
Vol. 19—1935 Copies—Complete	2.50
Vol. 20—1936 Copies—(Except February and April)	2.50
Vol. 21—1937 Copies—Complete	2.50
Vol. 22—1938 Copies—(Except January)	2.50
Vol. 23—1939 Copies—Complete	2.50
Vol. 24—1940 Copies—Complete	2.50
Vol. 25—1941 Copies—Complete	2.50
Vol. 26—1942 Copies—(Except September)	2.50

Single copies, 25c each, and Yearly Sets at Price Indicated, Postpaid

In greater demand than ever before
The list of exceptions constantly growing

NOW IS THE TIME TO ACT!

**AMERICAN RADIO
RELAY LEAGUE, INC.**

WEST HARTFORD - CONNECTICUT

the expression reduces to

$$Z_s = Z_o \left[\frac{-1 + 0}{-Z_o/Z_r + 0} \right] = Z_r \quad (17)$$

In other words, the insertion of a half-wave, or any integral half-wave, section of line between a transmission line and its load — or for that matter between any generator and its load — does not produce any change in the system. The half-wave section acts like a one-to-one ratio transformer.

Line Terminated in Z_o

If a transmission line is terminated in its characteristic impedance, i.e., $Z_r = Z_o$, then the input impedance, Z_s , equals Z_o . This is easily shown from equation (3b) as follows:

If

$$Z_r = Z_o$$

then

$$\begin{aligned} Z_s &= Z_o \left[\frac{\cosh \gamma l + Z_o/Z_o \sinh \gamma l}{Z_o/Z_o \cosh \gamma l + \sinh \gamma l} \right] \\ &= Z_o \left[\frac{\cosh \gamma l + \sinh \gamma l}{\cosh \gamma l + \sinh \gamma l} \right] \end{aligned}$$

and

$$Z_s = Z_o$$

The input impedance of such a line, regardless of its length, is always equal to its characteristic impedance, Z_o . Under these conditions the load absorbs power from the line just as rapidly as the line supplies it from the source, therefore none is reflected back along the line towards the input — or sending — end. There is only an incident wave present, so standing waves do not exist on the line.

Simplified Form of General Equations

In the instances where the attenuation of the line is negligible — and this is usually the case for radio frequencies — it is possible to greatly simplify equations (1a), (1b), (2a), (2b), (3a) and (3b) by assuming a value of zero for α . The simplified expressions are:

$$I_s = I_r \cos \beta l + j E_r/Z_o \sin \beta l \quad (18a)$$

$$I_s = I_r (\cos \beta l + j Z_r/Z_o \sin \beta l) \quad (18b)$$

$$E_s = E_r \cos \beta l + j I_r Z_o \sin \beta l \quad (19a)$$

$$E_s = E_r (\cos \beta l + j Z_o/Z_r \sin \beta l) \quad (19b)$$

$$Z_s = E_s/I_s = \frac{E_r \cos \beta l + j I_r Z_o \sin \beta l}{I_r \cos \beta l + j E_r/Z_o \sin \beta l} \quad (20a)$$

$$Z_s = Z_o \left[\frac{\cos \beta l + j Z_o/Z_r \sin \beta l}{Z_o/Z_r \cos \beta l + j \sin \beta l} \right] \quad (20b)$$

The transformations from the hyperbolic functions to the trigonometric functions were effected by utilizing the following two identities:

$$\begin{aligned} \cosh j \beta l &= \cos \beta l \\ \sinh j \beta l &= j \sin \beta l \end{aligned}$$

TRIPLETT

Combat Line INSTRUMENTS

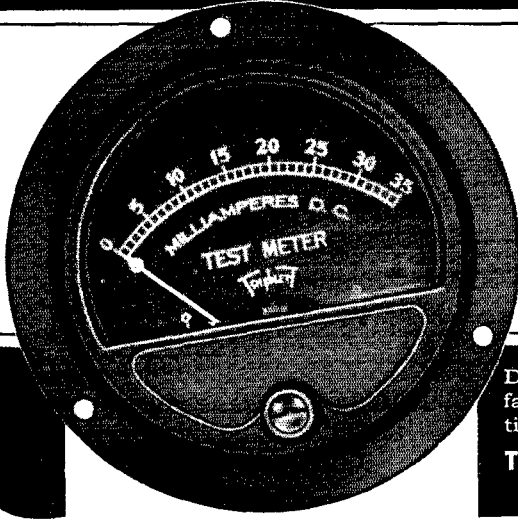

Thin Line
MODEL



Deliveries under government requirements are facilitated by two large sub-contracting organizations combining to greatly increase Triplett output.

TRIPLET ELECTRICAL INSTRUMENT CO.
BLUFFTON, OHIO

Get Yourself a Copy —

"A COURSE IN RADIO FUNDAMENTALS"

By
GEORGE GRAMMER

"A COURSE IN RADIO FUNDAMENTALS" represents an idea unique in the radio educational field. It is not a textbook; instead it contains those elements of a course of classroom study which lie outside the textbook proper — study guide, examination questions and laboratory experiments.

The course is equally valuable for use in connection with home study and as a classroom guide for the teaching profession. For home students it serves to replace the teacher, giving detailed experimental exercises and procedure as well as supplementary explanatory material where needed, in addition to providing an accurate gauge of progress through the probing examination questions accompanying each assignment. For instructors it is a completely synthesized course outline, of particular value to those who find themselves in the new field of radio technician training without the benefit of a planned course or time for thorough preparation.

The material is presented in eight parts, under these major subject headings: (1) Electricity and Magnetism. (2) Ohm's Law for D.C. and A.C. (3) Resonant Circuits. (4) Vacuum-Tube Fundamentals. (5) Radio-Frequency Power Generation. (6) Modulation. (7) Receiver. (8) Antennas. These parts are subdivided into 36 study assignments.

With each assignment there is a group of examination questions carefully designed to test the student's grasp of

each of the significant points brought out in the text. Answers to questions involving mathematical problems are given in a separate section at the end of the book. In cases where more than routine methods are required, the complete solution is given.

Accompanying the text assignments are experiments which illustrate the principles being studied. These experiments are described in great detail, including the construction of the necessary apparatus and giving exact procedure and typical results. All apparatus required for the experiments is simple and can be constructed from "junk-box" or replacement parts selected to be most readily available despite shortages.

The text on which the course is based is "The Radio Amateur's Handbook," long recognized as outstanding in the radio training field. Either the 1942 or 1943 standard editions or the widely-used Defense Edition may be used.

To quote the Foreword: "The individual student undertaking the course may be assured that, if he follows its precepts literally and exactly, performs the experiments and examines himself honestly by the test questions, he cannot fail to learn the principles of radio. Instructors who use this material in their work may be confident that their students will receive thorough training in the essential fundamentals of radio."

PRICE 50 CENTS POSTPAID (No Stamps, Please)

AMERICAN RADIO RELAY LEAGUE, WEST HARTFORD, CONNECTICUT

HAMS, in War Work!

When they ask you, "Where can we get radio-electronic material—quickly and economically?", you can still say (as you have for the past 18 years)—

"HARRISON HAS IT!"

Yep, that's our big job right now, supplying war plants, laboratories, and government agencies with critical parts and equipment.

Call us whenever you need high priority supplies. We probably have it in stock, or we can get it for you — quicker!

If you are directly connected with purchasing, our big **800-PAGE MASTER CATALOG**, available without charge, will assist you in your work. Kindly apply on company letterhead, giving your title.

HARRISON
RADIO CORPORATION

12 WEST BROADWAY
NEW YORK CITY

Phone WOrth 2-6276

MASTER COURSE IN RADIO COMMUNICATION



Fits you for a job, advancement or license examination. Course by A. R. Nilson for home study covers same scope as resident school course. Every Nilson graduate to date has commercial license, or a good radio job.

FREE circular 3-Q gives full information. Write today.

NILSON RADIO SCHOOL, 51 East 42nd St., New York

PREPARE yourself now for a well paying radio position after the war. Obtain your FCC commercial radiotelephone and telegraph licenses through our home study courses, written for the man who has forgotten higher mathematics. An easily read, easily understood course. Moderate tuition fee.

Write for particulars

AMERICAN RADIO INSTITUTE 44 EAST 23rd ST.
NEW YORK CITY

Teaching Radio Since 1935

**SPECIAL
OFFER**

See Page 111

Radio Instruction in the RCAF

(Continued from page 13)

to record standard tapes for instructional purposes, but also to record each trainee's sending during the course.

Considerable work has been done at this school to determine how much effective Morse training can be given in a given time. Experiments including vitamin therapy and audiogram analysis have been in progress for the last two years.

Morse instruction for wireless operators is also carried out in conjunction with radio laboratory instruction. Every radio equipment lab is arranged to provide intercommunication with either individual units in that lab or groups in other labs, providing a continual development of "operating sense" in the wireless operator.

Synthetic Training

Synthetic training is used when such means assists instruction or improves equipment economy. Synthetic direction finding, a system using a master goniometer with satellite goniometers in each loop position, is used in most transmitter and receiver labs. This provides controlled instruction and is independent of interference.

In outstations, the WOGs receive training on a synthetic communications net using wired radio, which provides every problem the operator would likely encounter in real operation work. In visual signaling, model aircraft fitted with lights are used to teach the Aldis lamp. In the equipment labs, large scale models of all equipment, components, meters, etc., are used to facilitate instruction.

An aircraft mock-up is used, completely fitted with aircraft radio equipment. In it trainees make "flights" using radio navigation. This mock-up is complete with mechanical noise, electrical interference, darkness and cramped positions, as in an actual aircraft.

Flying Squadron

A squadron of fast, modern aircraft is attached to the school to provide air experience for trainees to carry out mock-interceptions for the v.h.f. fighter control training, and also provides a real aircraft communication set-up which is used in conjunction with all radio and d/f training.

The trainee wireless mechanics do exercises on these aircraft, in addition to exercises on "instructional airframes," which are craft of all representative types stripped down and used for ground instructional purposes only.

The policy at No. 1 Wireless School is a very flexible working arrangement which allows for any change in syllabus and methods of training. The school operates in very close liaison with operational units, and is therefore able to adapt training to suit their needs. All instructors realize their responsibilities and accept the challenge to continually improve the training.

The staff themselves attend classes, as well. There are lectures twice a week to the instructional staff on pedagogy, advanced engineering problems and the latest radio developments.

CHECKING THE EXACTNESS OF THE ANGLES OF THE SLICE, OR WAFER, OF A CRYSTAL

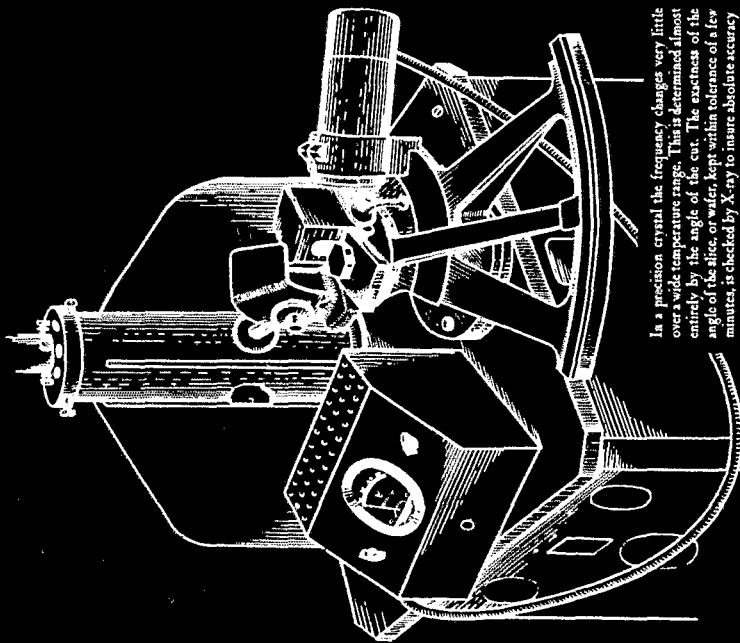

In a precision crystal the frequency changes very little over a wide temperature range. This is determined almost entirely by the angle of the cut. The exactness of the angle of the slice, or wafer, kept within tolerance of a few minutes, is checked by X-ray to insure absolute accuracy.

Crystal

PRODUCTS COMPANY
1519 MCCOEE STREET, KANSAS CITY, MO.

Producers of Approved Precision Crystals for Radio Frequency Control

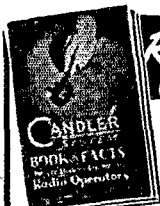

RADIO OPERATORS WANTED

On sea, on land, or in the air radio operators are needed during peace or war. Cargo ships, weather stations, planes, shore and land stations all require radio operators to man them. Interesting, fascinating work. Good pay, adventure. Learn radio code at home and qualify for an operator's license through the Candler System, the famous "sound sense" method of teaching code.

FREE 52-PAGE BOOK explains complete training method. Rush name for it today. It's absolutely FREE.

CANDLER SYSTEM CO.

Dept. 4-J, Box 928, Denver 1, Colo., U. S. A.

Craven House, 121, Kingsway, London, W.C.2.



ONAN
ELECTRIC PLANTS

Electricity for Any Job — Anywhere

ONAN GASOLINE DRIVEN ELECTRIC PLANTS supply power in places where not otherwise available, and for standby or regular service in communications. They provide electricity for many war tasks on all fronts.

From 350 to 35,000 watts. A.C. 50 to 800 cycles, 110 to 600 volts. D.C. 6 to 4000 volts. Also dual A.C. and D.C. output models. Air or water cooled engines.

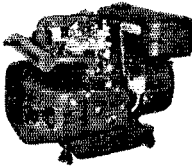

Details furnished on present or past war need for Electric Plants.

D. W. ONAN & SONS
1942 Royalston Ave.
Minneapolis, Minn.

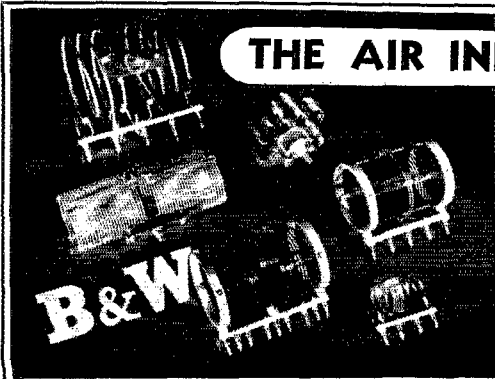

THE AIR INDUCTORS THAT SET THE QUALITY STANDARDS

Probably no radio components have seen greater engineering advances in recent years than Air Inductor Coils — and, just as it did in amateur radio during peace time, B & W engineering has led the field consistently. That's because B & W's are produced by men to whom quality coil making is both a specialized business and a matter of intense personal pride as well.

BARKER & WILLIAMSON

235 Fairfield Ave., Upper Darby, Pa.

Manufacturers of Quality Electronic Components for a Decade

HAM-ADS

(1) Advertising shall pertain to radio and shall be of nature of interest to radio amateurs or experimenters in their pursuit of the art.

(2) No display of any character will be accepted, nor can any special typographical arrangements, such as all or part capital letters be used which would tend to make one advertisement stand out from the others.

(3) The Ham-Ad rate is 30c per word, except as noted in paragraph (6) below.

(4) Remittance in full must accompany copy. No cash or contract discount or agency commission will be allowed.

(5) Closing date for Ham-Ads is the 25th of the second month preceding publication date.

(6) A special rate of 7c per word will apply to advertising which, in our judgment, is obviously non-commercial in nature and is placed and signed by a member of the American Radio Relay League. Thus, advertising of bona fide surplus equipment owned, used and for sale by an individual or apparatus offered for exchange or advertising inquiring for special equipment, if by a member of the American Radio Relay League takes the 7c rate. An attempt to deal in apparatus in quantity for profit, even if by an individual, is commercial and all advertising by him takes the 30c rate. Provisions of paragraphs (1), (2), (4) and (5) apply to all advertising in this column regardless of which rate may apply.

Having made no investigation of the advertisers in the classified columns, the publishers of *QST* are unable to vouch for their integrity or for the grade or character of the products advertised

QUARTZ—direct importers from Brazil of best quality pure quartz suitable for making piezo-electric crystals.

Diamond Drill Carbon Co., 719 World Bldg., New York City. COMMERCIAL radio operators examination questions and answers. One dollar per element. G. C. Waller, W5ATV, 6540 Washington Blvd., Tulsa, Okla.

USED TELEPLEXES, instructographs bought, sold. Ryan's, Hannibal, Mo.

WHY NOT turn your unused equipment into ready cash which may be applied towards new and better equipment after the war? Leo, W9GFQ, offers you the best cash prices for communications receivers and test equipment. Write today for large illustrated catalog. Wholesale Radio Laboratories, 744 W. Broadway, Council Bluffs, Iowa.

CRYSTALS available, all types, including 100 KC, 465 KC and 1000 KC. Broadcast and Aircraft given prompt attention. Scientific Radio Products, Council Bluffs, Iowa.

WANTED: Radio Operators for merchant marine. Must have commercial license. Wages \$340 to \$380 monthly. Radio Officers Union, 265 West 14th Street, New York, N. Y.

GUARANTEED 04A's, 849's, Laboratory instruments, high voltage condensers, etc. Box 1583, Indianapolis.

USED equipment wanted. Highest cash prices paid for receivers, transmitters, meters, parts, etc. I promise you the best deal. Let me know what you have. Bob Henry, W9ARA, Butler, Mo.

IN STOCK: Mac No. 200 keys, \$2.25, Signatone code oscillators \$11.85; condensers, resistors, panels, chassis, transformers, Vibroplexes, radio supplies of all sorts. Your inquiries and orders invited. Henry Radio Shop, Butler, Mo.

QST's complete set \$50, RADIO \$10, 852's \$5 each; W.E. 618A dynamic \$50, G. E. West, 2519 New P. O. Dept. Bldg., Washington, D. C.

WANTED: Amrad Quenched Gap, "S" Tube, DeForest and other "antique" tubes, sets and equipment. ALSO: 1914 Edition "A.R.R.L. List of Stations"; maps of member stations; "Story of A.R.R.L." Franklin Wingard, Rock Island, Illinois.

WANTED: Stancor DC3 kit or Hallcraft HT11 or similar. Address J. T. Morgan, Townsend, Ga.

TRADE new 35TGs, 35T, 808s, 956s, Vibroplex for 12" Turner-Reich, Dagor, similar lens in shutter. W6QG.

WANTED: Low frequency converter. WINIW, 49 Broad, Wethersfield, Conn.

SELL or exchange Shure Cardioid 55C Microphone for Meissner TRF Tuner; also want national ACN Dial, Thordarson T15A74 Transformer, Guardian X-100 and U-200 relays. Denzel D. Murphy, W8WSL, 324 Gaston Avenue, Fairmont, West Virginia.

884, 885, unused, \$2.25 each prepaid. Weston Phonic Cell, \$7.50. Eby, \$2.10. Hal Justice, Canton, N. Carolina.

WANTED: McMurdo Silver Masterpiece 6. McMurdo Silver 15-17 or 1940 Scott Phantom Deluxe with speaker. No cabinet necessary. Must be in good condition. Robert Hoiermann, 401 Milton St., Alliance, Ohio.

WANTED: EC-1 or Sky Buddy. Charles E. Parnell, 1503 S. Carrollton, New Orleans, La.

FOR SALE: Lafayette 5B40W Phone, C.W. Transmitter 40 watts, coils 10-160 meter bands, double-button mike, 3-XTATS, all tubes less 913 oscilloscope tube, grey crackle finish, excellent condition. Price \$125. F.O.B. Wilmette, Ill. Lt. Carleton P. Ross, W9ABA, 118th Signal Radio Intelligence Co., Camp Forrest, Tenn.

WANTED: Used CREI radio course in good condition. Marzycki, 1327 Central Avenue, Wilmette, Ill.

OPERATOR Wanted: With first or second radio-telephone license for 1000 watt Columbia station. Good working conditions, low living cost, fine climate. KROD, El Paso, Texas.

WANTED: 2 RCA 8003 tubes. Faulkner, 3704 Bowne Street, Flushing, N. Y.

WANTED: At once, Hammarlund Super-pro or National HRO receiver. Will pay top cash price. R. C. Payne, 1527 West Main St., Charlottesville, Va.

NC100A or NC100XA wanted. Cash. G. T. Williams, 111 Galvan Drive, Apt. C, Bremerton, Wash.

CRYSTALS: Prompt delivery on time-proven Eidson commercial crystal units in the 1600-10,000 kilocycle range. Dependable crystals with temperature coefficients to meet all requirements. If it's rush, order from us. Eidson's, Temple, Texas.

WANTED: Hallicrafters Marine or Sargent, Model 11-UA, RCUR. State price. W. Britton, Box 28, Houlton, Oregon.

WANTED: Small multimatch modulation transformer; SX-24 or equivalent; 816; 400 V. Power transformer; Hammarlund MC-35-S; ACN Dial. Bob Martin, 918 South 5th St., Temple, Texas.

WANTED: One or two-inch oscilloscope. Also Echophone FC-1, Gingrich, 4613 Derry St., Harrisburg, Pa.

SELL PRECISION E-200 Oscillator, \$40; Communications Audio Oscillator, \$10; Superior Allmeter, #1280, \$22; RK-20, \$8; T-125, \$10; Westinghouse O-5A RF, \$7; 100 watt 10 M Transmitter, Sacrifice. Meters, parts, etc., #639, Central YMCA, Cleveland, Ohio.

SELL: 5" Dumont Oscilloscope. Want Thordarson T-30W55 or T-30W10 amplifier. Gatz, 209 Seeley St., Brooklyn, N. Y.

EXTREMELY RARE—34 Old issues of *QST* in broken runs between 1916-1924. Write your wants. Taber Box 986, Holyoke, Mass.

SELL National HRO Receiver, complete. Also Stancor #10-P Transmitter, Best offer. Robert Chimner, 831 Antoine, Wyandotte, Mich.

WANTED: Precision Transformer Co. Universal power type P-273-D. Amateur net plus postage if A-1 condition. W1HII, 4 Sidney, Wakefield, Mass.

RADIO TECHNOLOGY



RCA Institute offers an intensive two-year course of high standard embracing all phases of Radio and Television. Practical training with modern equipment. Also shorter specialized courses in Commercial Radio Operating, Radio and Television Servicing, and Aviation Communications.

For Free Catalog write Dept. ST-43

RCA INSTITUTES, INC.

A Radio Corporation of America Service

75 Varick Street

New York City

HARVEY RADIO LAB'S, Inc.

Manufacturers of Radio Transmitters

ELECTRONIC APPARATUS
447 CONCORD AVENUE, CAMBRIDGE, MASS.

LEARN RADIO

60-page catalog on request. Oldest, largest and best equipped in New England. New classes now forming. Write for new catalog.

MASS. RADIO SCHOOL

18 Boylston Street

Boston, Massachusetts

**"JUST THINK, HOGARTH, IT TOOK
ECHOPHONE EC-1 AND TOTAL
WAR TO BRING US TOGETHER!"**



SGT. KILDAY
U.S. ARMY

SUGGESTED BY
JUANITA BAUGHERY
WAAC, HERRICKS
FIELD, FLORIDA

Echophone Model EC-1

(Illustrated) a compact communications receiver with every necessary feature for good reception. Covers from 550 kc. to 30 mc. on three bands. Electrical bandspread on all bands. Six tubes. Self-contained speaker. Operates on 115-125 volts AC or DC.



ECHOPHONE RADIO CO., 201 EAST 26th ST., CHICAGO, ILLINOIS

Designed for

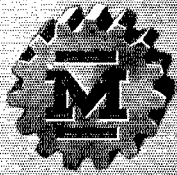

Application

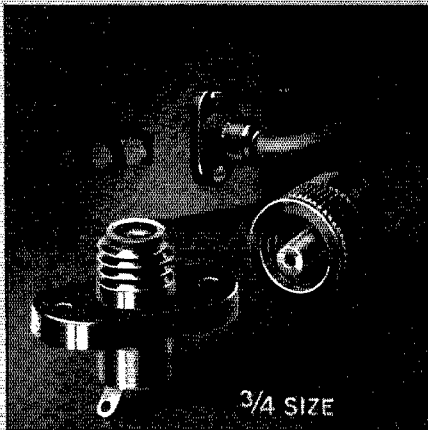

Another exclusive Millen "Designed for Application" product. Combination high voltage terminal and thru-bushing. Tapered contact pin fits firmly into conical socket providing large area, low resistance connection. Pin is swivel mounted in cap to prevent twisting of lead wire. Easy to use. 1/4" o.d. insulation high voltage cable fits into opening in cap. Bared conductor passes thru pin for easy soldering to pre-linned tip of contact plug.

Standard 37001 available in either black or red bakelite. No. 37501 is low loss mica filled yellow bakelite for R.F. applications.

**JAMES MILLEN
MFG. CO., INC.**

MAIN OFFICE AND FACTORY
**MALDEN
MASSACHUSETTS**



Index to Advertisers

	<i>Page</i>
American Radio Institute	106
Amperex Electric Products, Inc.	Cov. II
Astatic Corporation, The	96
Barker & Williamson	107
Bliley Electric Company	80
Candler System Company	107
Capitol Radio Engineering Institute	90
Cardwell Manufacturing Corporation, Allen D.	84
Crystal Products Company	107
Echophone Radio Company	109
Eitel-McCullough, Inc.	5
Electro-Voice Manufacturing Company	87
Electronic Laboratories, Inc.	112
Hallcrafters Company, The	1, 2
Hammarlund Manufacturing Company, The	81, 83
Harrison Radio Corporation	106
Harvey Radio Company	104
Harvey Radio Laboratories, Inc.	108
Henry Radio Shop	102
Jensen Radio Manufacturing Company	91
Knights, James, Company	100
Mallory & Company, P. R., Inc.	82
Massachusetts Radio School	108
McElroy Manufacturing Corporation	93
McGraw-Hill Book Company	86
Meck, John, Industries	103
Melville Aeronautical Radio School, Inc.	92
Millen Manufacturing Company, James	110
Miller, Wayne	98
Minneapolis-Honeywell Regulator Company	97
National Company, Inc.	79, Cov. III
Newark Electric Company	100
Nilson Radio School	106
Onan Electric Plants	107
Pioneer Gen-E-Motor	101
Port Arthur College	98
RCA Institutes, Inc.	108
RCA Manufacturing Co., Inc.	Cov. IV
Radio Shack Corporation	88
Raytheon Manufacturing Company	85
Scientific Radio Products Company	101
Sickles Company, F. W.	99
Simpson Electric Company	89
Terminal Radio Corporation	94
Thordarson Electric Manufacturing Company	103
Triplett Electrical Instrument Company	105
Wholesale Radio Laboratories	98
Wiley & Sons, John	94
Zenith Radio	95

SPECIAL OFFER

DURING



- **ARRL MEMBERSHIP**
for one year, including
- **SUBSCRIPTION TO QST**
(new or renewal or extension)
and the
- **RADIO AMATEUR'S HANDBOOK**
Regular or Defense Edition —
be sure to specify which

\$3.00

U. S. A. Only

THIS OFFER AVAILABLE ONLY DIRECT FROM

AMERICAN RADIO RELAY LEAGUE, INC.
WEST HARTFORD, CONNECTICUT

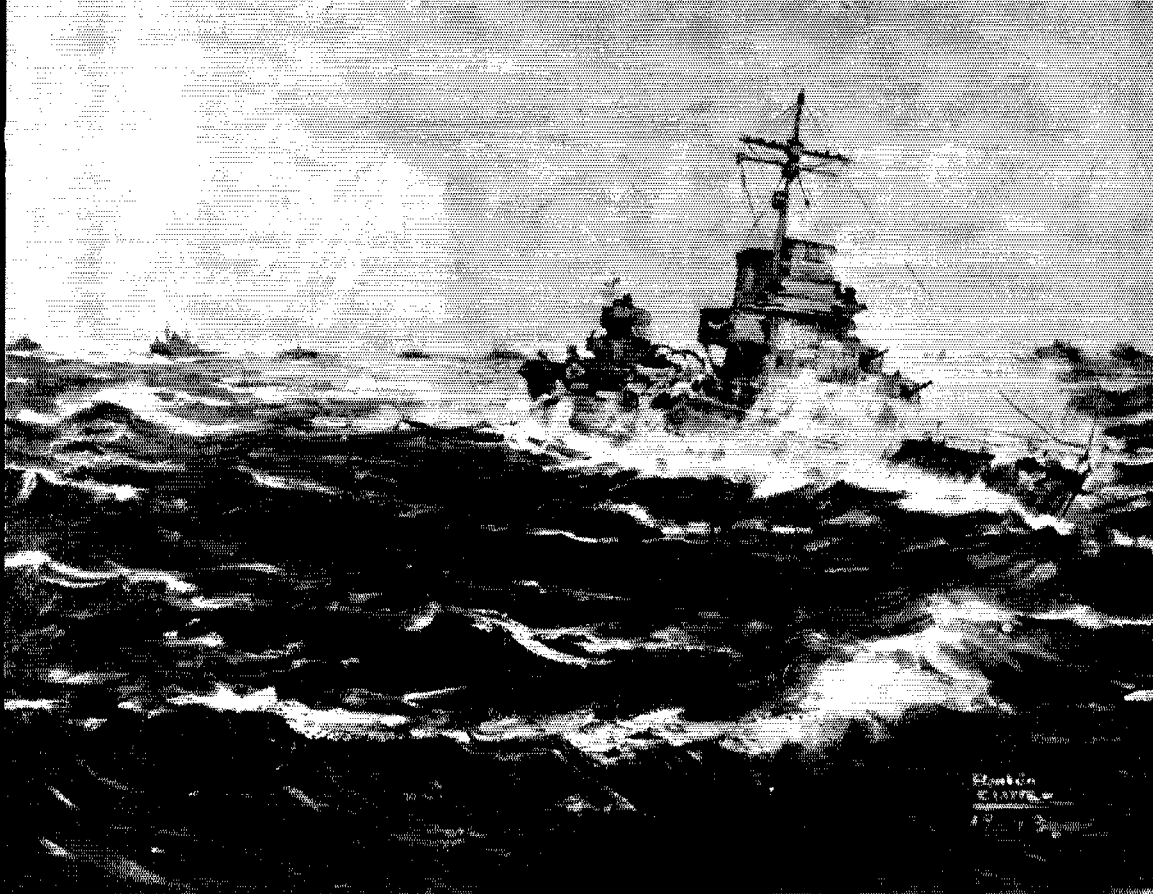

SH-H-H-H! THE ENEMY IS LISTENING!

● Sailors at sea couldn't listen to their favorite radio programs until one of our foremost radio manufacturers was commissioned to build a special sea-going receiver. It was found that ordinary radios "rebroadcast" and tipped off the ship's location. And without any radio, morale suffered.

Now, it's different! Sailors around the world are listening to radio programs from home through this low-radiation receiving set. The speed with which it was produced and put in service is a tribute, in part,

to the *E·L* engineers asked to provide a suitable power supply. They did it—fast, and well.

This is just one of the many contributions to America's war effort which *E·L* research and specialized knowledge of vibrator power supplies and electronic circuits has made possible. You'll find *E·L* Vibrator Power Supplies on the job in all types of service, and on every front where the United Nations are fighting.

Wherever electric current must be changed, in voltage, frequency or type, *E·L* Vibrator Power Supplies and Converters offer a wide range of advantages, for peace, as well as for war.



Electronic
LABORATORIES, INC.

E·L ELECTRICAL PRODUCTS—Vibrator Power Supplies for Communications . . . Lighting . . . Electric Motor Operation . . . Electric, Electronic and other Equipment . . . on Land, Sea or in the Air.

INDIANAPOLIS



For Operating Radio Transmitters in Lifeboats
—*E·L* Model S-1229-B Power Supply. Input Voltage, 12 Volts DC; Output Voltage, 500 Volts DC; Output Current, 175 MA; Dimensions, 7½" x 5½" x 6¼".

For Operating AC Radio Receivers from DC Current—*E·L* Model 262 Marine Power Supply. Input Voltage, 110 Volts DC; Output Voltage, 110 Volts AC; Output Power, 250 Volt-Amperes; Output Frequency, 60 Cycles; Dimensions, 10½" x 7¾" x 8¼".

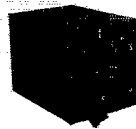

PRINTED IN U. S. A.
RUMFORD PRESS
CONCORD, N. H.



REPUBLIC P-47

OFFICIAL PHOTOGRAPH,
U.S. ARMY AIR FORCE.

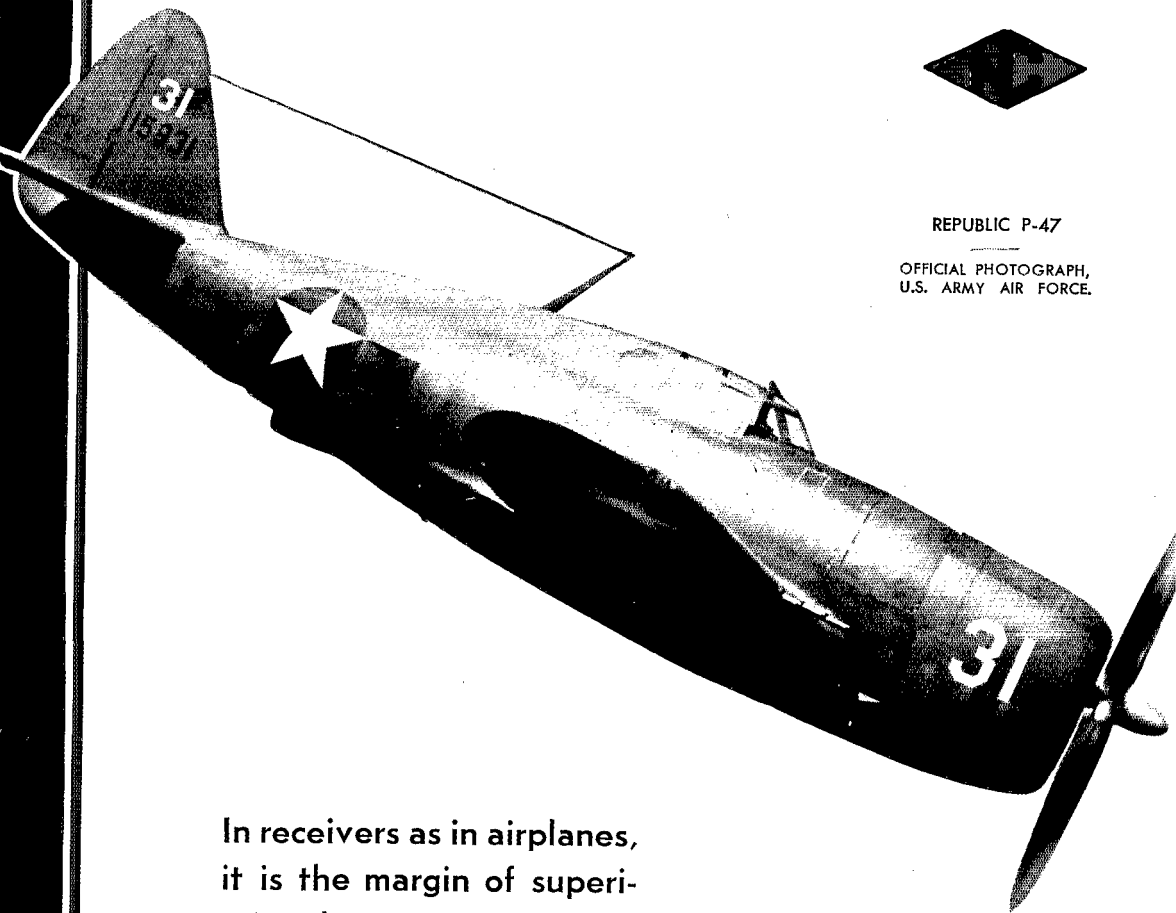

In receivers as in airplanes,
it is the margin of superi-
ority that wins victory. Al-
most good enough is no
good at all.

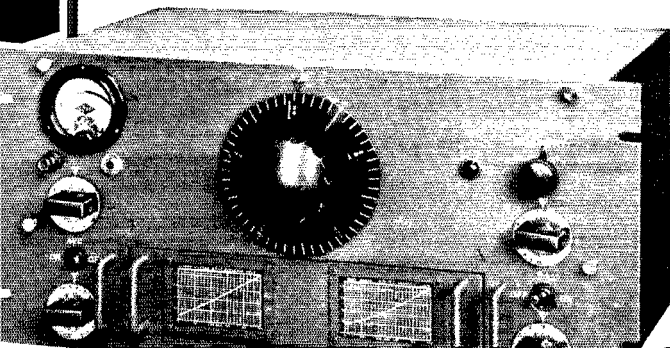

NATIONAL COMPANY

MALDEN, MASS., U. S. A.



RCA TUBE PRICES ARE DOWN!

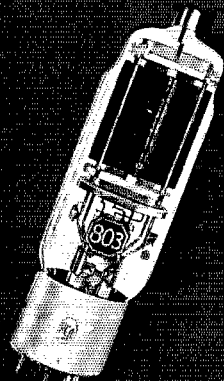

NEW LOW PRICES ON THE VERY TYPES OF TUBES YOU NEED MOST

Here's one thing you can count on *for sure* — right now and in the days to come: wherever improved manufacturing efficiency makes lower tube production costs possible, RCA will pass the savings along to you in the form of lowered prices!

Take a look at these interesting examples among RCA's recently announced tube price reductions — in the face of generally rising commodity prices:

Type	DESCRIPTION	Old Price*	Present Price	Here's What You Save
803	R-f power amplifier pentode: plate dissipation, 125 watts; RCA's biggest pentode.	\$28.50	\$25.00	\$3.50
807	Beam power amplifier: full power output with very low driving power.	3.50	2.25	1.25
833-A	Amplifier and oscillator; one of RCA's most powerful glass-type triodes.	85.00	76.50	8.50
837	Heater-cathode type pentode r-f power amplifier, frequency-multiplier, oscillator; designed for exacting service.	7.50	2.80	4.70
872-A/872	Half-wave mercury-vapor rectifier; max. rating, 10,000 peak inverse volts.	11.00	7.50	3.50

*October, 1941. Between Oct. 14, '41, and Mar. 15, '43, food prices have increased 24% (U. S. Dept. of Commerce Bulletin). RCA Transmitter Tube prices, on the other hand, have been materially reduced — an example of RCA's policy of passing the benefit of production economies on to its customers.



For complete information write for copy of latest RCA Tube Price List.



RCA ELECTRON TUBES