

QST

devoted entirely to

amateur radio



February

25^c

And Now It's
100,000
Readers!

*That's the number who have put their
reliance in the A. R. R. L. Handbook*

We are now distributing
the *Seventh Edition* of

**THE RADIO
AMATEUR'S
HANDBOOK**

*By the Headquarters Staff
of the A. R. R. L.*

Completely overhauled from input to output, the Seventh Edition has been gone over minutely, the old methods and old apparatus junked, and new modern material created to replace it. Twenty-one pages on receivers of every sort, 32 pages on transmitters from beginners' one-lungers to high-power crystal-control, 14 pages on telephony, 21 pages on power supply, in line with modern regulations, 11 pages on antenna systems; additional generous chapters on keying, frequency meters and monitoring, and complete dope on the latest wrinkles in proper operating procedure.

Whatever your interest in amateur radio — beginner, average ham, or advanced amateur, you just can't get along without the new Seventh Edition of this famous manual!

AMERICAN RADIO RELAY LEAGUE
WEST HARTFORD, CONN., U. S. A.

All over the world the Handbook has been sent, in seven successive editions, to tell its story of practical amateur radio to beginner and old-timer alike. It has quickly established itself as the standard manual of the practicing amateur. Everywhere it is hailed as the greatest fund of helpful information that an amateur ever saw.

**RED-AND-GOLD
PAPER COVERS**

\$1.00

Stiff Buckram Binding \$2.00
Postpaid anywhere

STATIONS AND SHIPS IN ALASKA USING NORTHERN ELECTRIC EQUIPMENT

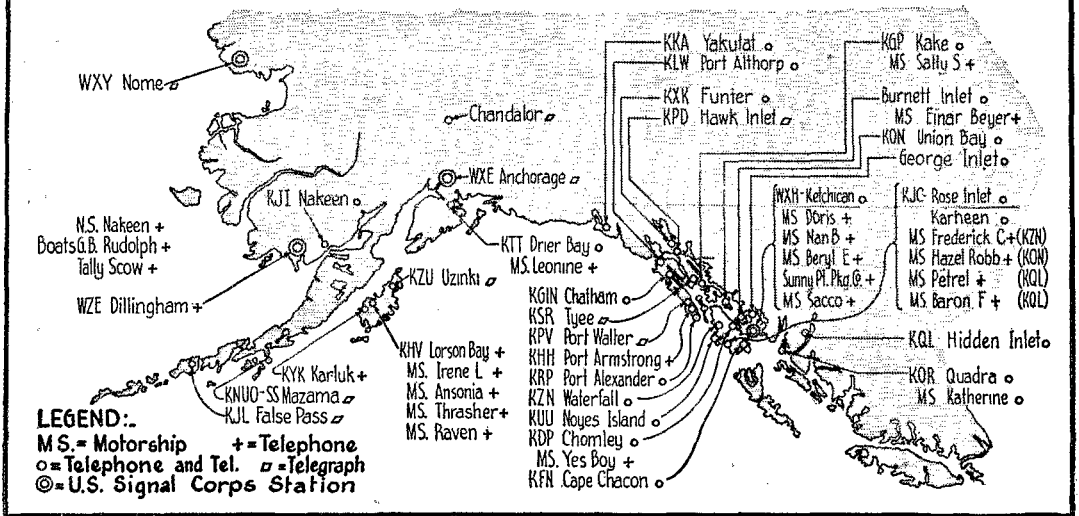

DE FOREST IN ALASKA

In the frozen North where the Aurora Borealis dances over the horizon, the safety, the comfort, and even the lives of men in far-flung stations and ships depend on reliable radio communication. The Northern Electric Company, which has equipped the Alaskan stations shown on the above map, has this to say of De Forest:

"Referring to the stations shown on the map on the inside cover of the catalog, approximately twenty-four of these stations were using De Forest transmitting tubes last season, and this year we are changing over all stations to use De Forest transmitting audions

with the following exceptions: Nome, Dillingham, Anchorage and Ketchikan. These stations are Government stations and naturally use whatever tubes the Government may have.

"We are looking forward to a successful season and are very pleased to say that the service from your transmitting audions as well as the service rendered by the factory itself has been very excellent. We anticipate a much greater volume of business for the coming year than we have enjoyed in any of the previous years, and we assure you that De Forest audions will be standard equipment on any apparatus we manufacture."

After All, There's Nothing Like 25 Years' Experience

WRITE for catalog on De Forest transmitting tubes for every conceivable purpose. Also do not hesitate to place special transmitting and receiving problems before our Engineering Department.

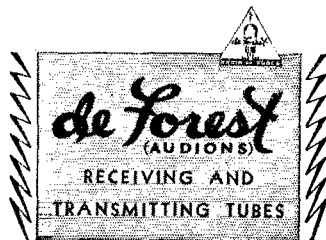

DE FOREST RADIO
 COMPANY
 PASSAIC, NEW JERSEY

Export Department:
 304 E. 45th Street,
 New York City, N. Y., U. S. A.

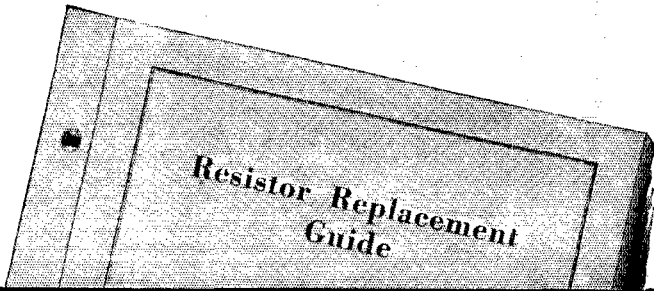

AN ABSOLUTE NECESSITY IN EVERY SERVICE KIT —THIS REPLACEMENT GUIDE

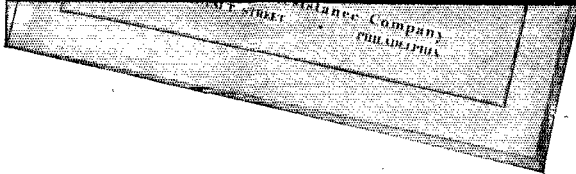

NO more guesswork. No more groping in the dark. The Service Man's Replacement Guide has banished all that.

This remarkable book gives you the value and code, and position in the circuit, of each defective resistor. Your whole job of set repairing is speeded up and simplified, no matter what sets you tackle. All popular makes listed—types and values of resistors shown.

Thousands of service men the country over are finding this famous Guide book a daily and absolute necessity.

*FREE WITH TEN METALLIZED RESISTORS

With the purchase of 10 I. R. C. Metallized Resistors, you will receive our complete Authoritative Replacement Guide free—or it may be bought for 50c.

Loose-leaf sheets, made up by our engineers, are mailed from time to time without charge to every holder of the Guide—and keep it constantly up to date. The I. R. C. Guide is the dominant book of its kind in the world. Fill out and mail coupon today.

INTERNATIONAL RESISTANCE CO., PHILADELPHIA

*All orders for Resistors referred to territorial Jobbers.

INTERNATIONAL RESISTANCE COMPANY
2006 Chestnut Street, Philadelphia

Gentlemen:—

- (Check Offer You Are Interested In)
I enclose 50c, for which send me Replacement Guide.
- Please send price list of Metallized Resistors. I wish to purchase assortment of ten, which will entitle me to Replacement Guide free.

Name.....

Address.....

City..... State.....

Makers of
I. R. C.
Metallized
RESISTORS

QST

Published monthly, as its official organ, by the American Radio Relay League, Inc., at Hartford, Conn., U. S. A.; Official Organ of the International Amateur Radio Union

devoted entirely to AMATEUR RADIO

Contents

Editorials	7
Naval Reserve Control Stations	8
How Uncle Sam Checks Your Frequency <i>Irving L. Weston, WIBHB and Ralph J. Renton, W1CU</i>	9
An A.C. Operated Vacuum-Tube Voltmeter . . . <i>William Wagner</i>	14
Further Notes on the Zeppelin Antenna <i>Don Edmondo Ruspoli, IIMM</i>	17
How Is Your Tone Color? <i>Edwin Ehlinger, W8BBP</i>	19
Election Results	20
A New Type of Peaked Audio Amplifier . . . <i>Howard Allan Chinn</i>	21
WWV Standard Frequency Transmissions	23
Making Records of Amateur Signals . . . <i>H. W. Dreyer, W1ANC</i>	24
Coming—The Fourth International Relay Competition	26
More Power With Better Frequency Stability . . . <i>George Grammer</i>	27
WIMK's Dynatron Frequency Meter <i>R. P. Parmenter</i>	35
An Electrically-Operated "Bug" <i>Charles E. Seymour, W9FMN</i>	37
Second All-Section Sweepstakes Contest <i>F. E. Handy</i>	39
Standard Frequency News and Schedules	42
The Neglected Current-Squared Galvanometer <i>Paul E. Griffith, W9DBW</i>	43
Experimenters' Section	45
IMPROVING DETECTOR OPERATION—SOLDERING ALUMINUM —A NEAT HOMEMADE CABLE PLUG—MAKE THE FILAMENT VOLT-METER DO DOUBLE DUTY—THE SIMPLEST AUDIO-OSCILLATOR—A CHEAP BLEEDER RESISTOR—HOMEMADE FILTER CONDENSERS—REPAIRING FILTER CONDENSERS—A NOVEL CRYSTAL HOLDER.	
W9DXP, Chicago, Ill.	49
Good Practice <i>Jack Paddon</i>	52
I.A.R.U. News	53
Calls Heard	55
Correspondence Department	56
Hamads and QRA's	92
QST's Index of Advertisers	94

FEBRUARY 1931

VOLUME XV
NUMBER 2

Kenneth B. Warner (Secretary, A.R.R.L.) *Editor-in-Chief and Business Manager*; James J. Lamb, *Technical Editor*; George Grammer, *Assistant Technical Editor*; Clark C. Rodimon, *Managing Editor*; Ross A. Hull, *Associate Editor*; David H. Houghton, *Circulation Manager*; G. Donald Meserve, *Advertising Manager*; Ursula M. Chamberlain, *Assistant Advertising Manager*.

Advertising Offices 55 West 42d Street, New York City
Editorial Offices 38 La Salle Road, West Hartford, Conn.

Subscription rate in United States and Possessions, Canada, and all countries in the American Postal Union, \$2.50 per year, postpaid. Single copies, 25 cents. Foreign countries not in American Postal Union, \$3.00 per year, postpaid. Remittances should be by international postal or express money order or bank draft negotiable in the U. S. and for an equivalent amount in U. S. funds.

Entered as second-class matter May 29, 1919, at the post office at Hartford, Connecticut, under the Act of March 3, 1879. Acceptance for mailing at special rate of postage provided for in section 1103, Act of October 3, 1917, authorized September 9, 1922. Additional entry at Concord, N. H., authorized February 21, 1929, under the Act of February 28, 1925.

Copyright 1931 by the American Radio Relay League, Inc.
Title registered at United States Patent Office.

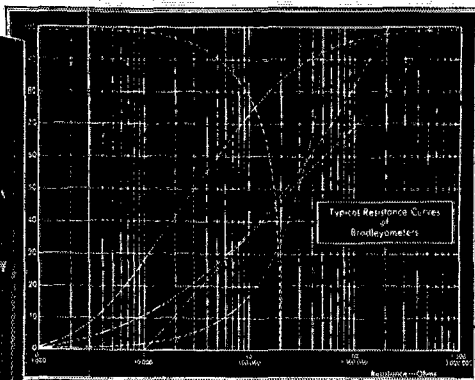
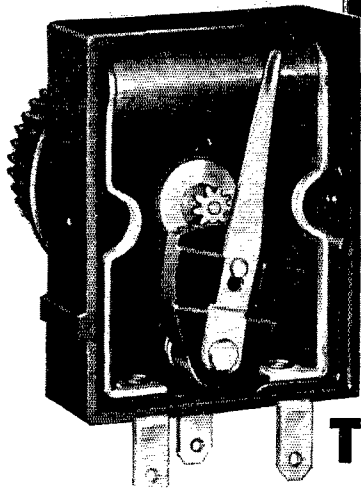

The New Bradleyometer Will Produce Any Resistance-Rotation Curve!



Type AAA, Triple Bradleyometer

One or more Bradleyometers can be arranged to operate with one knob. Mixer controls, T-pad and H-pad attenuators and other complex controls can be provided.

THE Bradleyometer is a "stepped" potentiometer of approximately fifty steps. The resistance value of each step is separately controlled, and the total number of steps are assembled to conform with the Resistance-Rotation curve desired for each Bradleyometer application.



Type AA, Double Bradleyometer



Type A, Single Bradleyometer

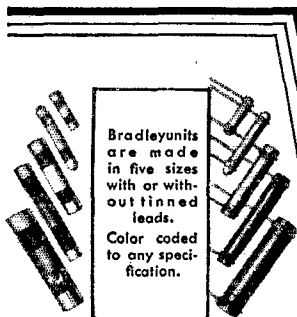

Bradleyunits are made in five sizes with or without tinned leads. Color coded to any specification.

Bradleyunits

Bradleyunits are solid molded resistors unaffected by temperature, moisture or age.

Their accurate calibration, great mechanical strength and performance make them ideal for providing correct C-bias, plate voltage, screen grid voltage and for use as grid-leaks and as fixed resistors in resistance coupled circuits.

The resistor comprises a series of resistance discs interleaved between thin metal discs, and the entire column is retained under pressure in a bakelite case. Contacts are provided at both ends of the column and at the moving contact arm which is geared to a bakelite knob. Thus, the Bradleyometer may be used as a potentiometer or as a variable resistor.

Bradleyometers are used for volume controls, tone controls, mixer controls, T-pad and H-pad attenuators, and for innumerable applications in telephone lines, address systems, radio sets, phonographs, etc. Write for technical data today.

Allen-Bradley Co.

108 W. Greenfield Ave., Milwaukee, Wis.

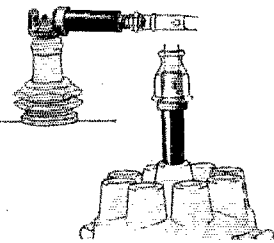

Bradley Suppressors for Radio-Equipped Cars

Interference from ignition systems in radio-equipped motor cars is suppressed with Bradley Suppressors. Individual resistors for each spark plug and for the common distributor lead minimize disturbing oscillations in ignition circuit. When used with suitable by-pass condensers in other parts of the ignition circuit, shielded ignition cables are unnecessary.

ALLEN-BRADLEY RESISTORS

Produced by the makers of Allen-Bradley Control Apparatus

Section Communications Managers of THE COMMUNICATIONS DEPARTMENT, A. R. R. L.

Eastern Pennsylvania	W3ZF	ATLANTIC DIVISION Don Lusk	116 West Wyoming Ave.	Germantown, Phila.
Maryland-Delaware-District of Columbia	W3BBW	Forrest Calhoun	1636 Thomas Ave.	Baltimore, Md.
Southern New Jersey	W3ATI	Rayard Allen	416 Mount View Ave.	Mount Holly
Western New York	W8CKC	John R. Blum	44 Seward St.	Dansville
Western Pennsylvania	W8CFR	Robert Lloyd	175 Allegheny Ave.	Emsworth (Pgh) Pa.
		CENTRAL DIVISION		
Illinois	W9APY	Fred J. Hinds	3337 Oak Park Blvd.	Berwyn
Indiana	W9BKJ	George Graue	824 Home Ave.	Fort Wayne
Kentucky	W9BAZ	J. B. Wathen, III	Mockingbird Valley	Louisville
Michigan*	W8DMS	R. J. Stephenson	8840 Monica Ave.	Detroit
Ohio	W8BAH	Harry A. Tummonds	2073 West 85th St.	Cleveland
Wisconsin	W9VD	C. N. Crapo	2111 E. Newton Ave.	Milwaukee
		DAKOTA DIVISION		
North Dakota	W9BVF	Guy L. Ottinger	326 6th Ave., So.	Jainstown
South Dakota	W9DNS	Howard Cashman	121 N. Spring Ave.	Sioux Falls
Northern Minnesota	W9CTW	Raymond Weihe	E. 3rd St.	Delaho
Southern Minnesota	W9AIR	Herman Radloff	R. 2, Box 15	Sleepy Eye
		DELTA DIVISION		
Arkansas	W5ABI	H. E. Velt	315 No. Jackson St.	Little Rock
Louisiana	W5WF	F. M. Watts, Jr.	1716 Park Ave.	Shreveport
Mississippi	W5AKP	J. W. Gullett	1708 23rd Ave.	Meridian
Tennessee	W5SP	James B. Witt	832 N. Fifth Ave.	Knoxville
		HUDSON DIVISION		
Eastern New York	W2OU	H. J. Rosenthal	Box 740	New Rochelle
N. Y. C. & Long Island	W2BGO	V. Kenney	1836 Home Ave.	Bronx
Northern New Jersey	W2WR	A. G. Wester, Jr.	50 Princeton St.	Maplewood
		MIDWEST DIVISION		
Iowa	W9DZW	H. W. Kerr	915 Lincoln Ave.	Little Sioux
Kansas	W9CET	J. H. Amis	8010 Mercier St.	Topeka
Missouri	W9KR	L. B. Laizure	Green St.	Kansas City
Nebraska	W9FAM	Samuel C. Wallace		Clarks
		NEW ENGLAND DIVISION		
Connecticut	WICTI	Frederick Ellis, Jr.	7 Union Ave.	Norwalk
Maine	W1AOL	G. C. Brown	269 No. Main St.	Brewer
Eastern Massachusetts	W1WV	M. W. Weeks	40 Norfolk Rd.	Chestnut Hill
Western Massachusetts	W1TY	Leo R. Pelouquin	23 Arthur St.	Worcester
New Hampshire	W1ATJ	V. W. Hodge	227 Main St.	Claremont
Rhode Island	W1AWE	N. H. Miller	25 Phillips St.	Providence
Vermont	W1IT	Clayton Paulette	Box 17	North Troy
		NORTHWESTERN DIVISION		
Alaska	WWDN	W. B. Wilson	U. S. LHT Fern	Ketchikan
Idaho	W7AKZ	Oscar E. Johnson	422 Antone St.	Sandpoint
Montana	W7AAT-7QT	O. W. Viers	Route 11, Box 247	Red Lodge
Oregon	W7UN	Wilbur S. Claypool	912 No. Ainsworth St.	Milwaukie
Washington	W7ACS	Eugene A. Piety		Tacoma
		PACIFIC DIVISION		
Hawaii	K6CIB	L. A. Walworth	2737 Ferdinand Ave.	Honolulu
Nevada	W6EAD	Keston L. Ramsay	1151 Buena Vista Ave.	Reno
Los Angeles	W6EQF	B. E. Sandham	4508 8th Ave.	Los Angeles
Santa Clara Valley	W6NXX	F. J. Quement	1348 Hanchett Ave.	San Jose
East Bay	W6CZR	R. G. Walter Frates	439 Grand St.	Oakland
San Francisco	W6WB	C. F. Bane	262 Castro St.	San Francisco
Sacramento Valley	W6DON	Everett Davies	Rt. 5, Box 380	Sacramento
Arizona	W6BWS	Russ Shortman	519 W. Madison St.	Phoenix
Philippines*	KAIJR	John R. Schultz		Calauan, Laguna, P. I.
San Diego	W6EOP	Harry A. Ambler	4101 Hamilton St.	San Diego
San Joaquin Valley	W6BVY	E. J. Beal	Box 246	Newman
		ROANOKE DIVISION		
North Carolina	W4DW	H. L. Caveness	State College	Raleigh
Virginia	W3CA	J. F. Wohlford	118 Cambridge St.	Roanoke
West Virginia	W8JM	D. B. Morris	703 Maryland St.	Fairmont
		ROCKY MOUNTAIN DIVISION		
Colorado	W9ESA	Edward C. Stockman	618 So. Williams St.	Denver
Utah-Wyoming*	W6DPJ	C. R. Miller	134 E. 2nd North St.	Provo, Utah
		SOUTHEASTERN DIVISION		
Alabama	W4AHP	Robt. E. Troy, Jr.	516 Cloverdale Rd.	Montgomery
Florida	W4AII	Harvey Chañin	6002 Suwanee Ave.	Tampa
Georgia-So. Carolina-Cuba-Isle-of-Pines-Porto Rico-Virgin Islands	W4RZ	M. S. Alexander	47 2d Ave., S. E.	Atlanta
		WEST GULF DIVISION		
Northern Texas	W5RI	Roy Lee Taylor	1614 St. Louis Ave.	Ft. Worth
Oklahoma	W5GF	W. L. Gentry	534 W. Pottinger St.	Shreveport
Southern Texas	W5ZG	H. C. Sherrod	4315 La Branch St.	Houston
New Mexico	W5AHI	Leavenworth Wheeler, Jr.	Box 33	Valmora
		MARITIME DIVISION		
Maritime	VE1DQ	A. M. Crowell	69 Dublin St.	Halifax, N. S.
		ONTARIO DIVISION		
Ontario	VE3CB	C. D. Lloyd	22 Jackson St.	St. Thomas
		QUEBEC DIVISION		
Quebec	VE2AC	Alphy Blais	Box 221	Thetford Mines
		VANALTA DIVISION		
Alberta	VE4EC	Fred Barron	Warwick Apts., 95th St.	Edmonton
British Columbia	VE5AL	J. K. Cavalsky	4808 Blenheim St.	Vancouver
		PRAIRIE DIVISION		
Manitoba	VE4HR	A. V. Chase	109 Lanark St.	Winnipeg
Saskatchewan	VE4FC	W. J. Pickering	514 19th St. W.	Prince Albert

*Officials appointed to act until the membership of the Section choose permanent SCMs by nomination and election.

The American Radio Relay League

DIRECTORS

<i>President</i>	
HIRAM PERCY MAXIM.....	W1AW Drawer 2102, Hartford, Conn.
<i>Vice-President</i>	
CHARLES H. STEWART.....	W3ZS St. David's, Pa.
<i>Canadian General Manager</i>	
ALEX. REID.....	VE2BE 169 Logan Ave., St. Lambert, P. Q.
<i>Atlantic Division</i>	
EUGENE C. WOODRUFF.....	W8CMP 234 W. Fairmount Ave., State College, Pa.
<i>Central Division</i>	
LOREN G. WINDOM.....	W8GZ-W8ZG 1375 Franklin Ave., Columbus, Ohio
<i>Dakota Division</i>	
CY. L. BARKER.....	W9EGU Henning, Minn.
<i>Delta Division</i>	
M. M. HILL.....	W5BE P. O. Box 274, Natchitoches, La.
<i>Hudson Division</i>	
A. LAFAYETTE WALSH.....	W2BW 220 West 42d St., New York City
<i>Midwest Division</i>	
H. W. KERR.....	W9DZW-W9GP Little Sioux, Iowa
<i>New England Division</i>	
FREDERICK BEST.....	W1BIG 13 East Crescent St., Augusta, Maine
<i>Northeastern Division</i>	
K. W. WEINGARTEN.....	W7BG 3219 No. 24th St., Tacoma, Wash.
<i>Pacific Division</i>	
ALLEN H. BARCOCK.....	W6ZD 65 Market St., Southern Pacific Co., San Francisco
<i>Roanoke Division</i>	
W. TREDWAY GRAVELY.....	W3BZ Box 245, Danville, Va.
<i>Rocky Mountain Division</i>	
RUSSELL J. ANDREWS.....	W9AAB 169 So. Ogden St., Denver, Colo.
<i>Southeastern Division</i>	
HARRY F. DOBBS.....	W4ZA 292 Spring St., N.W., Atlanta, Ga.
<i>West Gulf Division</i>	
FRANK M. CORLETT.....	W5ZC 2515 Catherine St., Dallas, Tex.

THE AMERICAN RADIO RELAY LEAGUE, INC., is a non-commercial association of radio amateurs, bonded for the promotion of interest in amateur radio communication and experimentation, for the relaying of messages by radio, for the advancement of the radio art and of the public welfare, for the representation of the radio amateur in legislative matters, and for the maintenance of fraternalism and a high standard of conduct.

It is an incorporated association without capital stock, chartered under the laws of Connecticut. Its affairs are governed by a Board of Directors, elected every two years by the general membership. The officers are elected or appointed by the Directors. The League is non-commercial and no one commercially engaged in the manufacture, sale or rental of radio apparatus is eligible to membership on its board.

"Of, by and for the amateur," it numbers within its ranks practically every worth-while amateur in the world and has a history of glorious achievement as the standard-bearer in amateur affairs.

Inquiries regarding membership are solicited. A bona fide interest in amateur radio is the only essential qualification; ownership of a transmitting station and knowledge of the code are not prerequisite. Correspondence should be addressed to the Secretary.

OFFICERS

<i>President</i> * * * * *	HIRAM PERCY MAXIM Hartford, Connecticut
<i>Vice-President</i> * * * * *	CHARLES H. STEWART St. David's, Pennsylvania
<i>Secretary</i> * * * * *	KENNETH B. WARNER West Hartford, Connecticut
<i>Treasurer</i> * * * * *	ARTHUR A. HEBERT West Hartford, Connecticut
<i>Communications Manager</i> * *	F. EDWARD HANDY West Hartford, Connecticut
<i>General Counsel</i> * * * * *	PAUL M. SEGAL 1010 Shoreham Building, Washington, D. C.

Address All General Correspondence to THE EXECUTIVE HEADQUARTERS, at West Hartford, Connecticut

• EDITORIAL •

THE whole high-frequency world realizes now that, in addition to daily and seasonal changes in the performance of a certain frequency, account must be taken of a long-time change in atmospheric conditions seemingly dependent upon solar activity and therefore believed to be a cycle of approximately eleven years' duration. Elaborate transmission measurements made last year are of little value in predicting performance next year. The whole story of course isn't yet known, for high-frequency transmission is not yet eleven years old. In the meantime more than one expensive station has been planned and built only to find that the change in atmospheric conditions between the original tests and the completion of the station was enough to upset all calculations, making rebuilding necessary. Most decidedly there is here another factor which must be considered in picking a frequency for a certain job.

The amateur angle is intensely interesting to examine. Our first transatlantic two-way working, in 1923, was on wave lengths of around 110 meters. The first fifteen stations to succeed in this work, on both sides of the ocean, all had wave lengths between 108 and 118 meters. Although powers of several hundred watts were not uncommon, signals were audible 25 feet from the 'phones in this early work. Gradually shorter waves were tried, drifting down to 110 meters, 90 meters, 80. It was a long time before anybody tried 40. Contrast that with our practice in recent years and you realize with a start that for years we have thought of DX only in terms of the 7-mc. band and the 14-mc. band, and sometimes even the 28-mc. band. Now the average amateur of five years' experience will tell you that DX on these frequencies was at its best about 1928 and that it has been growing steadily worse ever since! This has been a bad year for 14 mc. The commercials have found it a terrible year, with much of the "dope" upset. This winter the 7-mc. band has frequently gone dead as early as 9 p.m. on the east coast, even at transcontinental distances. On the other hand, the signals in the 3.5-mc. band have been tremendous, DX has been surprising, and there has been some nice transcontinental work on those frequencies. European amateurs are boosting the 1.7-mc. band, and a letter in *The T. & R. Bulletin* reports R7-8 signals between England and Czechoslovakia with 3-watts power on that frequency. What does all this mean? We suggest that it means the return of DX on the lower frequencies. Try this experiment: Draw yourself a sine curve, one cycle of which represents the sun-spot cycle of 11.1 years. Mark one "positive" loop *Summer 1923*, the date of the last sun-spot minimum. The next "positive" loop is then *Summer 1934*, when the next minimum occurs. The intervening "negative" loop is then seen to be *End of 1928*, at which time it is known that there was a maximum of solar activity. Where are we now on this curve? It is apparent that we are entering the region of most rapid change, crossing the "node" this coming autumn. That is to say, while there will be irregularities, to be sure, it is reasonable to predict that we approach in 1934 a duplication of the conditions in 1923, that for the next several years the DX value of 7 mc. and 14 mc. will steadily decline, and that by about next winter we should be able to resume transocean two-way communication in the 3500-4000 band!

Regard now, fellows, our 1715-2000-kc. band, valuable but neglected, at present carrying probably less than 5% of our activity. If "80" develops DX potentialities, as seems probable, then "160" will become equally serviceable for our domestic uses — shortly it will do for us those things we normally expect of "80." In fact, if "80" takes

on too much of a DX complexion, as seems likely, it will show skip characteristics and become temporarily valueless for short-range schedules, while "160" will be just the proper stunt. The activity now ensconced in the 3500-4000 region is the heart of the whole A.R.R.L., one that no one would voluntarily disturb, but it is something to think about that short-distance traffic "skeds" may for a while become impossible in that band. The profound ratiocinations of the Editor, then, indicate that everybody interested in present-day "80" operation ought to turn a speculative eye on "160" and start moving into that grand but little-occupied region.

This ought to be of particular interest to the 'phones. They are badly crowded now and they are beginning to get into trouble for out-of-band operation in the aircraft channels near the low-frequency edge of the 3500-4000 band. The whole of the band from 1715 to 2000 kc. is open to 'phone and it is the widest of all the amateur bands, wider even than all of the "80" band. Moreover, the data indicate that the 'phone men can expect DX to improve in the "160" band every winter for the next three or four years and to continue excellent for several years thereafter.

It looks as though we should expect that by the winter of 1934-35, "80" will be doing "40's" wont, with "40" good for daylight work like "20" is supposed to be now. Under those conditions the 1715-2000-kc. band may well become the most valued location for the throbbing heart of amateur radio, our traffic system. It is well worth thinking about. It would be fine to see a greater occupancy of that band by amateurs generally, and it should look particularly inviting to the 'phone men right now.

K. B. W.

Naval Reserve Control Stations

MOST of the Naval Reserve control stations are primarily amateur stations which also have a Navy status when working in the Reserve. This amateur identity, of course, is not apparent in their Navy calls. The following list, corrected to June 2d, will be helpful in identifying the amateur owner behind these stations:

sten filament of the common light bulb — and while the light burns as usual! One explanation is that a spot in the filament burns out but the ash, residue or what's left, forms a path for a little arc and passes enough current to keep the bulb lighted, though close inspection will disclose the presence of a decided flicker. When the light is turned off it's a dud from then on, so to trace QRM from such a source pull the main switch

Naval District	Master Control Station	Amateur Call	Alternate	Amateur Call
1st	NDA, Medford, Mass.	W1KN	NDR, Augusta, Me.	W1BIG
3rd	NDF, So. Manchester, Conn.	W1QP	NDB, New York City	(Navy)
4th	NDM, Camden, N. J.	W3AIP	NDC, Wilmington, Del.	W3AIS
5th	NDE, Baltimore	W3RD	NDK, Norfolk, Va.	(Navy)
6th	NDJ, Atlanta	W4NY	None	
7th	NDL, Orlando, Fla.	W4NKF	NDU, Jacksonville	W4BG
8th	NDD, Pensacola, Fla.	W4HQ	NDZ, Oklahoma City	W5APG
9th	NDS, Chicago	W9ZN	NDP, Kansas City, Mo.	W9RR
11th	NDT, San Diego, Calif.	(Navy)	NDV, Los Angeles	W6NR
12th	NDO, Oakland, Calif.	W6ND	NDH, San Francisco	W6NC
13th	NDQ, Seattle	W7BQ	None	
15th	NDG, Balboa, C. Z.	(Navy)	None	
D. of C.	NKF, Washington	(Navy)	NDN, Washington	W3NL

All these stations use 401 5kc. Station NKF, when using this frequency, acts as senior control station for all stations listed. Station NDH acts as senior control station for the West Coast.

on the lights near the receiver for a moment. If a bulb stays out — that was it. — W6CKS

Strays

A little-considered source of seemingly mysterious QRM in a ham receiver lies in the tung-

Research Paper No. 227, "Note on the Electrical Resistance of Contacts between Nuts and Bolts," details the results of an investigation undertaken by the Bureau of Standards on this subject. It may be obtained from the Superintendent of Documents, Washington, D. C., for ten cents (stamps not accepted).

How Uncle Sam Checks Your Frequency

The Department of Commerce Monitoring Station at Hingham, Mass.

By Irving L. Weston, WIBHB,* and Ralph J. Renton, WICU**

THE following is a description of the monitoring station, located at Hingham, Mass., which is the first of ten such stations to be placed in operation at various points throughout the United States. The object of these monitor stations is, as the name implies, to monitor or police the radio channels. While most of the observations have been confined to broadcasting activities, arrangements are being made to establish regular daily schedules at Hingham, Mass., to cover all radio activities.

By special request, the Hingham station has checked the frequencies of a number of high-frequency transmitters located in all parts of the world. To a limited extent, the frequencies of amateur transmitters have been checked and in several instances licenses actually have been suspended for off-frequency operation and also for failure to comply with the regulations in other respects.

POWER SUPPLY

Power is supplied from storage batteries. Two banks of batteries of 14-ampere-hour capacity, and 280 volts per bank, comprise the high-voltage plate supply. The filament supply is obtained from four 162-ampere-hour 8-volt batteries. The batteries are charged by motor-generator units. Each high-voltage bank is charged by its motor-generator unit, which is rated at 300 volts and 1 ampere capacity. A 12-volt 50-ampere unit charges the "A" batteries. The "B" batteries are floated on trickle charge while in use, audio filters being provided in the charging circuits. The "A" batteries are provided in duplicate sets so

that two batteries may be charging while the other two are in use. Radio-frequency filters are installed in the armature and field circuits of each generator to eliminate interference which would be caused by sparking commutators.

RECEIVERS

Two receivers are employed. The first, which is known as "B" receiver, has a range from 100 to 1500 kc., or from 3000 to 200 meters. It has four individually tuned stages of radio-frequency amplification, regenerative detector and three stages of audio-frequency amplification. Type '10 tubes are used in the radio-frequency amplifier and detector. Two UX-841 tubes are used in resistance-coupled amplification, and the last stage of the audio amplifier is a type UX-842 tube using impedance coupling. Loop antennas

are used on this receiver when it is desired to use the directional properties of the loop in eliminating or reducing interference from distant static and from stations operating on the same or adjacent channels. A set of three loops covers the frequency range. A 150-foot antenna is used where greater pick-up is desired. Three sets of plug-in coils are needed to cover the frequency range.

The second, or "C" receiver, has a range from 1500 to 30,000 kc., or 200 meters to 10 meters.

It has three individually tuned stages of screen-grid radio-frequency amplification, regenerative detector, and three stages of audio-frequency amplification, the audio amplifier being exactly like the audio amplifier used in the "B" receiver. Type '22 screen-grid tubes are used in the radio-frequency amplifier and the detector is a Type '10 tube. Two dynamic loud speakers are used, one for each receiver. Five sets of plug-in coils

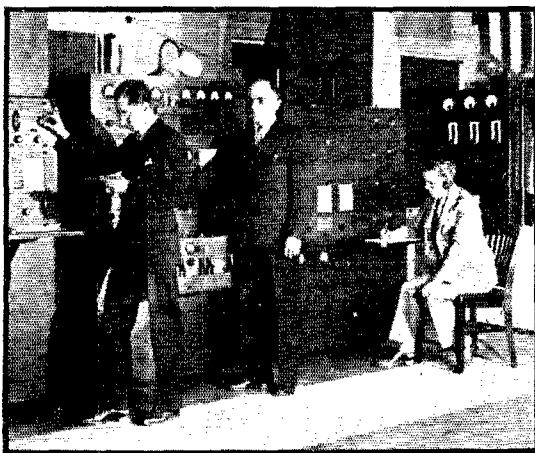

OFF-FREQUENCY OPERATION IS CHECKED AT THE HINGHAM MONITORING STATION

Mr. Charles C. Kolster (center), Supervisor of Radio, First Radio District, supervises a measurement by Irving L. Weston, Assistant Radio Inspector (left), and Ralph J. Renton, Junior Radio Inspector (right).

* Assistant Radio Inspector, 109 Pontiac Road, Quincy, Mass.

** Junior Radio Inspector, 100 Bay View Ave., Quincy, Mass.

are needed to cover the following frequency ranges:

Coil	Kc.
No. 1.....	1500-2700
No. 2.....	2700-5000
No. 3.....	5000-8800
No. 4.....	8800-16,500
No. 5.....	16,500-30,000

THE ANTENNAS

The antenna used for the "C" receiver is to be a Conrad vertical type with a two-wire radio-

ism with the 30,000-cycle crystal. This 10,000-cycle multivibrator in turn controls the tenth harmonic of a 1000-cycle multivibrator, which, in its turn, controls the tenth harmonic of a 100-cycle multivibrator. Thus, known standard frequencies of 30,000, 90,000, 10,000, 1,000 and 100 cycles, together with their harmonics, are available.

The frequency-measuring apparatus is compactly mounted in a rack which sits between the two receivers, making it easily accessible to either. It consists of the following units:

- A — Quartz crystal oscillator and amplifier, with temperature-controlled oven.
- B — Multivibrator unit.
- C — Beat-frequency audio oscillator.
- D — Beat indicator.
- E — Heterodyne-frequency meter.

Time	Stn.	Asst. Freq.	Net. Standard	Hei. Freq. Meter	Audio Oscillator Readings	Meas. A.F. Cycles	Comp. Freq. Kcs.	Dev. Kcs.	H	I	Remarks
3:26 PM	G5SN	11750	1053.2	1780-1579	5-92-7250	636	11746.10	3.70	L		...
4:58 PM	WTIC	1060	471.1	1000-984	1000-984	915	1060.038	0.52	H		...
5:10 PM	WIMK	1000	257.4	3000-224	3000-224	961	1000.190	0.19	H		...

A SAMPLE FROM A TYPICAL DAILY LOG SHEET

frequency feed line. The long antenna is sometimes used on this receiver with a ground connection.

As shown in Fig. 1, the 150-foot single-wire antenna is strung from the top of a 58-foot pole. The Conrad vertical antenna will consist of one-inch copper tubing supported by stand-off insulators on the pole. The feed line is taken from the calculated electrical center of the antenna, which is not the dimensional center because the capacity to ground is greater for the lower half of the antenna than for the upper half. The feeder is transposed by transposition insulators every six feet between the antenna and the receiver.

THE FREQUENCY STANDARD

The standard of frequency is a piezo quartz crystal, temperature-controlled to well within .1 of one degree Centigrade. Under actual operating conditions over a period of six months the temperature did not vary more than .01 of one degree Centigrade. This crystal is ground for a frequency of 30,000 cycles and is certified by the Bureau of Standards. The third harmonic of this crystal locks into synchronism with a 90,000-cycle multivibrator. The third harmonic of a 10,000-cycle multivibrator locks into synchron-

ism with the 30,000-cycle crystal. This 10,000-cycle multivibrator in turn controls the tenth harmonic of a 1000-cycle multivibrator, which, in its turn, controls the tenth harmonic of a 100-cycle multivibrator. Thus, known standard frequencies of 30,000, 90,000, 10,000, 1,000 and 100 cycles, together with their harmonics, are available.

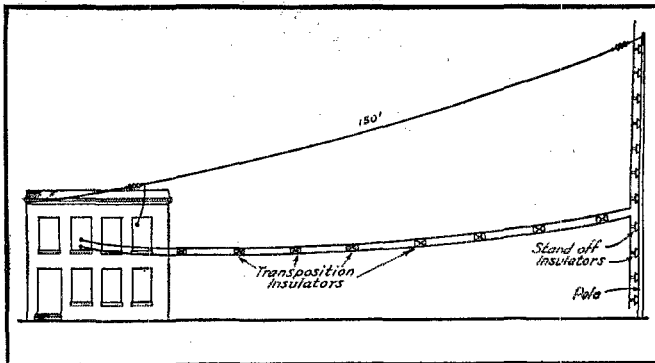

FIG. 1 — THE OUTDOOR RECEIVING ANTENNAS
The 150-foot antenna is used mostly with the "B" receiver. The vertical Conrad antenna is designed particularly for high-frequency reception with the "C" receiver.

the walls of the chamber. The second heater is controlled by a temperature-regulating thermostat.

The oscillator and amplifier tubes are enclosed in a shielded compartment adjacent to the heated chamber. Type UX-841 tubes are used for both oscillator and amplifier.

The multivibrator unit contains eight Type '10 tubes.¹ Two of these tubes are amplifiers, one amplifying the input from the crystal oscillator and the other amplifying the output of the multivibrator. The 1000-cycle multivibrator and the 100-cycle multivibrator each employ two tubes. The remaining two tubes are used in the circuit which is common to the 90,000-cycle and the 10,000-cycle multivibrators. In this circuit a switch adds or subtracts capacity which makes this circuit operate either at a 90,000-cycle or a 10,000-cycle fundamental.

When two frequencies are combined, a third frequency is produced which is the difference between the two. This principle is made use of to obtain an audio beat, the frequency of which can be reduced to zero. A variable oscillator with a frequency range of 30,000 to 35,000 cycles beats with the output from the crystal oscillator which is fixed at 30,000 cycles, thus producing a beat which is variable from 0 to 5000 cycles. Two variable precision condensers in parallel tune the oscillator. One condenser is a vernier, the full scale range of which is only 250 cycles. This unit has a Type '12-A tube as oscillator, another as amplifier, and two Type '22 tubes as input and output coupling tubes. The latter tubes are necessary so that changes in the circuit constants of the coupled circuits will not affect the oscillator.

Into the beat indicator unit is fed the audio-frequency output from the receivers, the beat-frequency audio oscillator, the heterodyne frequency meter, and the 100-cycle multivibrator. A variable pad controls the amount of energy which may be used from each source, exactly as a fading panel is used in a broadcasting station to mix the energy from several microphones. The output from this pad is fed into the grid circuit of a highly self-biased Type '12-A tube, which acts as a vacuum tube voltmeter. A 1-ma.

milliammeter in the plate circuit of this tube gives a visual indication of the beat produced between two audio frequencies which may be introduced from any of the units connected to the input of the beat indicator. The beat may also be heard on a pair of 'phones plugged into the beat indicator.

The heterodyne-frequency meter consists of two units, a Colpitts oscillator and detector and four-stage resistance coupled audio amplifier. A Type '12-A tube is used as oscillator. The last amplifier is a Type '71-A tube. The detector and

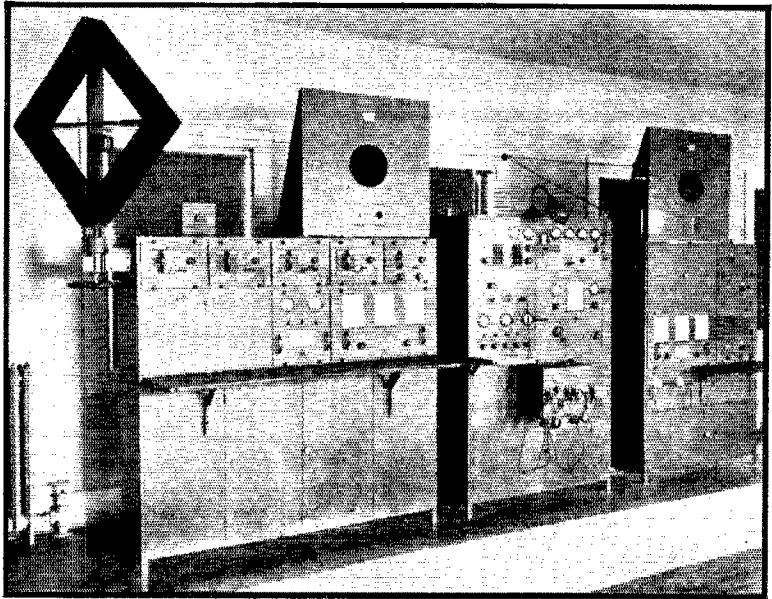

THE RECEIVING AND FREQUENCY MEASURING ASSEMBLY.

The low- and medium-frequency "B" receiver is at the left and the high-frequency "C" receiver is at the right. The frequency measuring equipment — including the piezo standard, multivibrators and heterodyne frequency meter — is between the two receivers. The loop antenna at the left is used with receiver "B". The small coil inside the loop couples energy from the multivibrator and heterodyne frequency meter in the center panel unit into the r.f. input of the receiver.

three stages of audio amplification employ UX-864 tubes. A split precision condenser tunes the grid and plate circuits of the oscillator tube and a set of plug-in coils covers the frequency range of 100 kc. to 2000 kc. In parallel with the split variable condenser are two fixed condensers. The scale of the condenser is thus "spread out," giving greater accuracy in setting and reading the meter.

CALIBRATION

Before the apparatus can be used to measure an unknown frequency, the beat-frequency audio oscillator and the heterodyne-frequency meter must be calibrated.

The large condenser of the beat-frequency oscillator is calibrated with the vernier condenser set

¹ Details of the theory and construction of multivibrators are given in the article *Standard Frequency Station W1XP*, *QST* Jan. 1930. — Editor.

at an arbitrary value of about half scale. The frequency range of the oscillator is 5000 cycles and it is calibrated by beating it with the 100-cycle multivibrator and thus obtaining a calibration point every 100 cycles from 0 to 5000 cycles.

The 10,000-cycle multivibrator is now used to calibrate each coil of the heterodyne-frequency meter. Calibration points are obtained every 5000 cycles and a table is made up.

This table lists the frequency, the correspond-

mately 560 kc. Coil A-10 of the heterodyne frequency meter is then plugged into the meter, since the calibration shows that 560 kc. falls within the range of that coil. The audio output from the receiver is fed into the beat indicator. The heterodyne-frequency meter is tuned to zero beat with the carrier wave of the station and when zero beat is approached a visual beat will be apparent on the milliammeter in the plate circuit of the highly biased tube in the beat indicator or an audio beat may be heard in the 'phones. It is thus possible to obtain a very accurate setting. The reading of the heterodyne-frequency meter scale is recorded on the data sheet. The channel is thus identified and the calibration gives it as 560 kc.

Now the 10,000-cycle multivibrator is turned on and the heterodyne-frequency meter is tuned to zero beat with its 56th harmonic, the audio output from the heterodyne-frequency meter being fed into the beat indicator in order to obtain a visual and audible beat. The setting is recorded. It is now known whether the station frequency is above or below 560 kc., an increased scale reading on the heterodyne-frequency meter indicating an increasing frequency. Therefore, if the setting of the meter for zero beat between it and the station is higher than the setting for zero beat between it and the multivibrator harmonic, then the frequency of the station is above 560 kc., and vice versa.

The number of divisions of the scale between the station setting and the multivibrator harmonic setting, times the cycles per scale division (as obtained from the table) gives the frequency deviation in cycles.

To obtain an accuracy of better than one part in 100,000 the audio beat between the station carrier and the 56th harmonic of the 10,000-cycle multivibrator is compared with an audio frequency from the beat frequency audio oscillator. The coupling between the 10,000-cycle multivibrator and the receiver input is adjusted until the beat is of maximum intensity. The audio outputs from the receiver and from the audio oscillator are fed into the beat indicator where the energy received from each is carefully matched by adjusting the potentiometers of the pad. The vernier condenser scale is set at the arbitrary point at which the large condenser was calibrated and the large condenser is varied until zero beat is obtained as before. The point at which the vernier condenser was left will be the "station setting." The calibration of the large condenser will determine roughly the deviation. That is, it will be determined whether it falls between 200 and 300 cycles, 300 and 400 cycles, etc.

The receiver may be turned off now. The output from the 100-cycle multivibrator is now fed into the beat indicator instead of the receiver output. The vernier condenser of the audio oscillator is adjusted for zero beat between it and the

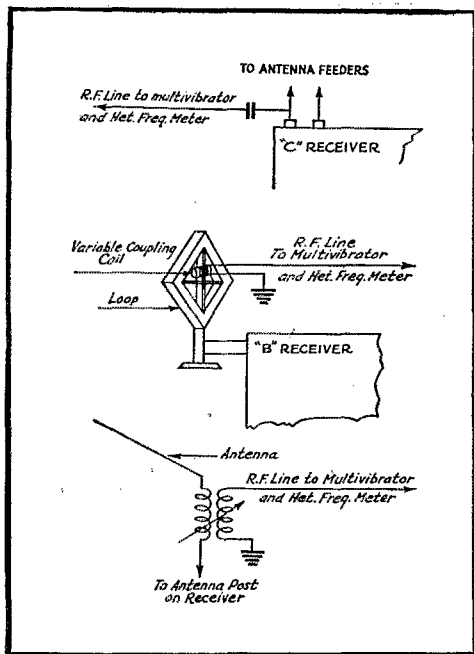

FIG. 2—THREE METHODS OF COUPLING FOR HETERODYNING A STATION SIGNAL BY A SIGNAL FROM THE FREQUENCY MEASURING EQUIPMENT

The method used with the loop antenna of the "B" receiver is especially interesting. The small coil mounted inside the frame of the loop is connected to the multivibrator and heterodyne-frequency meter circuits. The proper ratio of incoming signal to heterodyne signal strength is obtained by adjustment of the position of the coupling coil.

ing condenser setting, and the cycles per scale division of the condenser dial between each 5000 cycle point.

Now, using either the calibrated heterodyne-frequency meter or the 10,000- and 90,000-cycle multivibrators, the oscillating detector of each receiver is calibrated in order to make it relatively simple to tune in a station of known frequency. Calibration curves are mounted on each receiver.

FREQUENCY MEASUREMENTS

Suppose a broadcast station to be tuned in on "B" receiver. The calibration of the detector circuit dial shows the frequency to be approxi-

100-cycle point below the "station setting" and also for zero beat between it and the 100-cycle point above the "station setting." Suppose it to have been determined previously that the deviation fell between 300 and 400 cycles. The 300-cycle point and the 400-cycle point then have been determined and, by interpolating, the frequency represented by the "station setting" may be found.

To measure a code station where the carrier is broken up into dots and dashes so rapidly that it is impossible to obtain a visual zero-beat setting, the heterodyne-frequency meter is set as near zero beat as possible with the station carrier and then the frequency of the heterodyne-frequency meter is measured exactly as the carrier frequency of a station would be measured.

Because the energy from the 10,000-cycle multivibrator becomes very small on the extremely high harmonic frequencies, it is necessary to zero beat a harmonic from the heterodyne-frequency meter with the station and then to measure the fundamental of the heterodyne-frequency meter. The station frequency would then be the measured frequency of the meter times the order of the harmonic. In making the measurement, a switch is thrown connecting the headphones to the receiver. A zero beat between the heterodyne-frequency meter harmonic and the signal is obtained audibly. The switch is then thrown connecting the headphones to the beat indicator. A zero beat is obtained between the audio oscillator and the beat produced by the

receiver and readjusting for zero beat (audibly) between the heterodyne-frequency meter harmonic and the signal. Simultaneously, a readjustment for zero-beat (visually) is made between the audio oscillator and the beat produced by the heterodyne-frequency meter fundamental and the 10,000-cycle multivibrator harmonic. The 100-cycle multivibrator is now switched on and the measurement of the heterodyne-frequency meter fundamental completed exactly as previously described for a broadcasting station measurement. This fundamental frequency is then multiplied by the order of the harmonic, which gives the final measured frequency.

At present a daily watch is kept and a schedule is followed which enables the engineer on watch to monitor the radio channels included between 100 and 30,000 kc. The daily log sheet may contain measurements of stations located anywhere on the map of the world. Frequently this monitoring station is called upon to measure the frequencies of United States and foreign stations which, although separated by thousands of miles, are reporting interference from each other. More and more time is being given to monitoring the amateur bands to check both non-amateur operation in the bands and out-of-band amateur operation. As mentioned at the beginning of this article, several cases have already occurred where amateurs have had their operator's and station licenses suspended for repeated "off-wave" operation.

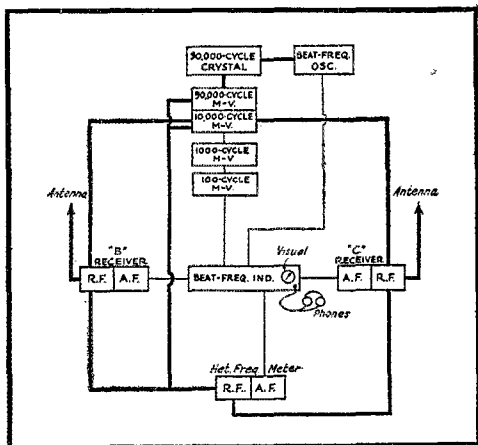

FIG. 3—THIS BLOCK DIAGRAM ILLUSTRATES THE RELATION OF THE VARIOUS UNITS TO EACH OTHER

Radio-frequency circuits are indicated by heavy lines and audio-frequency circuits by light lines.

heterodyne-frequency meter fundamental and the 10,000-cycle multivibrator harmonic, both visually and audibly. The final adjustment is made by throwing the switch placing the headphones in the

Strays

The list of commercial stations by frequency assignments in the *Radio Amateur Call Book Magazine* has been thoroughly revised and enlarged in the December issue. This dope is a big help in checking calibrations of monitors or frequency meters. Short-wave broadcasting stations are also included in the new list.

Ancient "Protecting the Rectifier" in the November "Experimenters' Section," W9GKG suggests putting the flashlight bulb in the high-voltage line between the rectifier and filter. One bulb will take care of both overloads and shorts in the filter condensers.

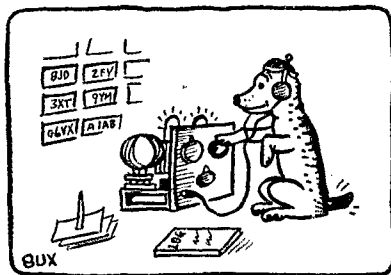

THE DX HOUND

An A.C. Operated Vacuum-Tube Voltmeter

By William Wagner*

THE vacuum-tube voltmeter is an instrument which is deserving of more attention than the average amateur gives it. It can be used for a large variety of voltage measurements which are outside the scope of ordinary voltmeters, such as the gain of amplifiers, comparative measurements of signal strength, measurement of modulation percentage of a 'phone transmitter; and in fact practically all measurements which require the use of a medium-range voltmeter that does not load the measured circuit. Possibly the name of the device creates the impression that there is something complicated and mysterious about it; such a conception is far from actual, as the following description will show.

While the v.t. voltmeter shown in the photographs requires no great amount of apparatus and is probably more compact than the average monitor, a wide range of measurements can be made with it, and it has been found to be generally useful.

A wiring diagram is shown in Fig. 1. The equipment is mounted on the front of a 9" x 6" x 5" aluminum shield can. The filament current, grid bias and plate supply are obtained from a rectifier as shown in Fig. 1, the filament current being kept at 60 ma. by means of a Clarostat, R_3 , or any suitable resistor. The input voltage is controlled by a 500,000-ohm potentiometer, R_1 , so that the maximum voltage to be measured will not cause the full-scale reading of the meter to be exceeded. The 400-ohm potentiometer R_2 in series with the filament has a 24-volt drop across it at 60 ma. This drop is available for grid bias.

A Weston Type 301 (0-1 scale) milliammeter is used for measuring both plate current and grid voltage. This is accomplished by the plug and closed-circuit jack arrangement. This meter can also be used for external voltage and current

measurements, since it is connected to a grid-leak mounting and a third jack.

Grid voltage is measured by placing a resistor, R_3 , suitable for the voltage to be measured, in the proper mounting (the left-hand mounting in the front view of the instrument). For instance, to measure 10 volts bias with the above meter a 1000-ohm resistor is required. With the plug inserted in the grid jack, J_1 , the milliammeter will read volts, 10 being full scale reading with the 1000-ohm resistor.

To measure plate current, the plug is placed in the plate jack, J_2 , the grid jack closing its contacts and keeping the fixed resistor in the circuit to prevent any variation in plate current due to changes in grid voltage. Since the meter has a resistance only of 27 ohms, its removal has but a negligible effect on the grid bias.

The single-pole double-throw switch is used to shunt two different values of resistance across the milliammeter to increase the range.

These resistances are made of Nichrome wire which may be obtained from any burnt-out heating element. They may be wound to increase the range to 10 and 100 milliamperes. The resistance required in the shunt is given by the following formula:

$$R_s = \frac{1}{N - 1} \times R_m$$

where R_s is the resistance of the shunt, N is the multiplying ratio, and R_m is the resistance of the meter. With a 27-ohm meter reading one milliamper full scale, the correct shunt for a 10-milliamper range will be 3 ohms, and for a 100-milliamper range, 0.272 ohms. When using the meter for current measurements externally, the series resistance mounting is short-circuited by means of a machine screw. When the meter is used for voltage readings the s.p.d.t. switch is left open.

The resistors used are ordinary metallized

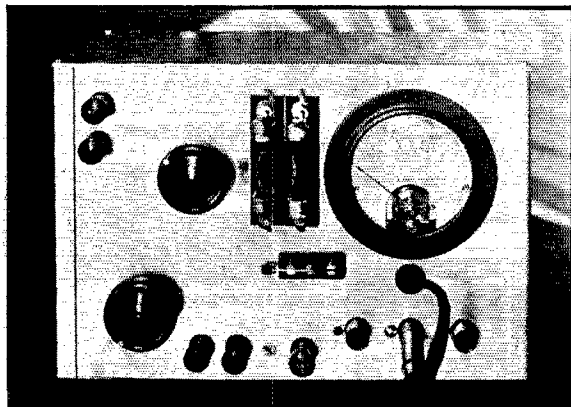

FRONT VIEW OF THE COMPLETED INSTRUMENT

The source of voltage to be measured is connected to the two binding posts in the upper left-hand corner. The knob to the right controls the input potentiometer, R_1 , and the knob below it is the bias adjustment, R_2 . The two grid-leak mountings in the center hold resistors which are used as voltmeter multipliers for the milliammeter, one for grid voltage measurements and the other for external measurements.

*2300 Auburn Ave, Cincinnati, Ohio.

resistors purchased in the "dime" stores. These were selected from stock by placing different resistors in series with the Weston milliammeter and checking against a standard voltmeter. If one is careful, he can obtain resistors that deviate but slightly from the labeled value.

The jacks are wired exactly as shown to insure proper polarity in all cases. The positive terminal of the meter is connected to the sleeve of the plug, the negative going to the tip.

The transformer which supplies all the power for operating the instrument is an ordinary "B" substitute transformer containing a high-voltage winding and a 5-volt winding for the filament of the Type '80 rectifier. The high-voltage winding need supply only about 100 volts each side of the center tap, although higher voltages may be used. R_2 takes care of differences in voltage, since it is always adjusted so that the current through the tube filament is 60 milliamperes.

The resistor R_4 is used to set the plate voltage at a definite value. Since R_4 is in series with the filament it carries a constant current of 60 milliamperes, and the voltage drop across it is utilized for plate voltage. The actual voltage on the plate will be 0.06 multiplied by the resistance of R_4 . For example, the plate voltage when R_4 is 750 ohms will be 45 volts, etc.

SOME WAYS OF USING THE VACUUM-TUBE VOLTMETER

The vacuum-tube voltmeter as described can be used without calibration to measure field and signal strength, as a QSA meter, or for any use that requires the comparative measurement of signals.

With the meter plug in the plate jack, J_2 , the movable arm of R_2 is adjusted until the plate current is zero. The signal to be measured is then applied across the input terminals and the movable arm on R_1 adjusted until the meter reading is of a suitable value. The relative strength of different signals can be estimated by observing the differences in the meter readings as the various signals are applied. Inasmuch as the tube is being worked at the cut-off point, the readings will be proportional to the positive half of the cycle, so long as the peak input voltage does not

exceed the bias voltage. When this happens there will be a rapid increase in the meter reading. A sufficiently high grid bias or a lower setting of the input potentiometer will prevent this condition.

It is essential that the controls not be moved, after once being set, for measurements of this type. If this cannot be done, then a definite grid voltage is applied, the plate current adjusted to zero by an external resistor, and the input potentiometer set at a fixed point. The grid voltage and plate current are obtained by placing the milliammeter plug in the proper jacks, as described. When these adjustments have been made, and the plug is inserted in the plate jack, the

input voltage is applied and the reading noted. The precaution with regard to grid bias and signal voltage pointed out in the preceding paragraph must again be observed.

Peak voltage measurements, such as measurement of percent modulation or voltage swing across the grid of an amplifier, can also be obtained without calibrating the meter. This is done as follows: R_1 is adjusted so that the rotor arm is at the point of maximum

resistance. The meter plug is inserted in the plate circuit jack and the grid bias adjusted so that the plate current is zero. The plug is then placed in the grid circuit and the voltage measured. The input voltage is then applied, the plate current again being adjusted to zero. The grid voltage is again read, the difference between the second and first readings being the peak input voltage. The maximum peak voltage that can be measured is 24 volts.

The resistance of R_1 is such that it has but negligible effect on audio frequency voltages. If greater accuracy is desired, if the voltage to be measured is extremely small, or if radio-frequency voltages are to be measured, R_1 may be disconnected and the input applied directly to the grid of the tube and the arm of the 400-ohm potentiometer.

Another use of the meter is to measure the relative output of a receiver. This is done by shunting a 2000-ohm resistor across the input terminals of the meter (to simulate a speaker or head set), the potentiometer rotor arm being at the point of maximum resistance. Readings are taken as in signal strength measurement at three

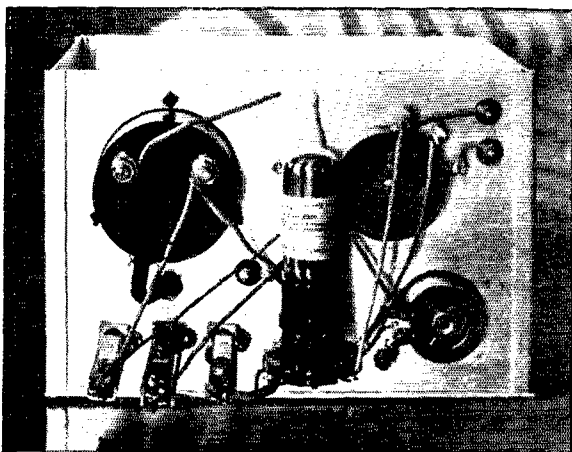

BACK OF THE PANEL
All apparatus is mounted on the panel itself.

frequency settings on the receiver. Comparative selectivity can also be determined by noting the change in the meter reading for a given movement of the receiver dial away from the point of maximum signal intensity.

CALIBRATION

If it is desired to calibrate the meter, the input potentiometer circuit is opened and the input terminals are short-circuited. A suitable plate voltage is then chosen and the plate current is reduced to zero as before. The grid voltage should be noted, as this will be the maximum allowable applied input voltage. The short-circuit across the input terminals is then removed and the input voltage is applied. This voltage can be obtained from a bell-ringing or a filament-supply transformer, different voltage windings being used as well as different combinations of these windings. A rheostat of suitable range in the primary circuit of the transformer will be useful to allow convenient adjustment of the secondary voltage in small steps. The input voltages are measured by means of an a.c. voltmeter, and are plotted against the milliammeter readings on cross-sectional paper to obtain the calibration curve. A higher plate voltage is then used and the same method followed, using higher input voltages. These a.c. input voltage values are r.m.s.

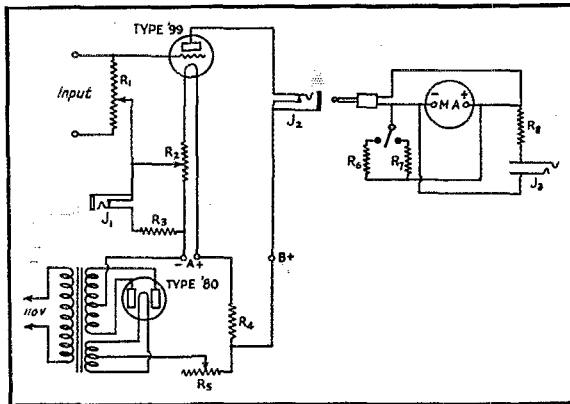

FIG. 1.—THE V. T. VOLTMETER CIRCUIT

- R_1 —500,000-ohm potentiometer
- R_2 —400-ohm wire-wound potentiometer
- R_3 —Multiplier resistor; see text for details
- R_4 —750 ohms; see text
- R_5 —Standard Clarostat
- R_6, R_7 —Shunt resistors for milliammeter. (See text)
- R_8 —Multiplier resistor for milliammeter
- J_1, J_2 —Closed-circuit jacks
- J_3 —Open-circuit jack
- MA—0-1 milliammeter

It is essential in all of these measurements that the current in the filament circuit of the tube be kept at 60 milliamperes, or at some fixed value near this. The plate voltage can be maintained at a definite value by passing this current through fixed resistors (R_4 in the diagram).

For further information on the v.t. voltmeter and practical applications of its use, the reader is referred to the following:

“An Inexpensive Test Set for Broadcast Receiver Performance,” *QST*, Aug., 1929.

“The Superiority of Screen-Grid Detectors,” *QST*, April, 1930.

“The Modulometer,” *QST*, Aug., 1929.

Strays

The membership list of the League is not available for commercial circularizing but may be made available, in an area not exceeding one division, for pro-amateur and non-commercial purposes, upon the application of any member and at his expense. Thus for some years past the headquarters office has supplied lists of names or has addressed envelopes for convention committees, candidates in A.R.R.L. elections, etc., whenever requested to do so. The service is available of course to all candidates in elections, or for other worthy pro-amateur purposes. The actual cost of materials and labor is charged. Because this section of our office is heavily burdened, however, we require at least two weeks' notice to do the work.

A.R.R.L. Headquarters has again outgrown its space and in early January moved to larger and quieter quarters. The new location is on the other side of an imaginary line which divides Hartford from West Hartford, and so the new QRA is 38 LaSalle Road, West Hartford, Conn. We now have much better facilities for handling the ever-increasing volume of work at Headquarters. In an early issue we expect to present a more extensive write-up of the new quarters and of the personnel which handles your headquarters work.

W9ARE has been keeping his Type '10 tube out in the sun so it will acquire plenty of Vitamin D - X for the coming International Contest.

When using stranded drum dial wire be sure to tin the wire so that the point where it is to be cut is in the middle of the tinned area. If this is not done the strands will unravel for as much as six inches each side of the cut.



THE BEAR FACTS ABOUT PORTABLE RADIO

Further Notes on the Zeppelin Antenna

A Novel System of Feeder and Antenna Adjustment

By Don Edmondo Ruspoli, I1MM*

MUCH has been written in *QST* and elsewhere on the Zeppelin antenna, which has become extremely popular in America and Europe. Our only reason for returning to the subject is that we have been using it lately at Italian station I1MM, with some very simple improvements which have proved helpful. As we have not seen them described as yet, we hope that this writing may prove useful to the readers of *QST*.

The first of these methods aims at allowing quick changes from one amateur band to another. As an illustration we will suppose that work has to be done on both the 7000- and 14,000-kc. bands, although the principle will be applicable to 3500- and 28,000-kc. bands as well.

For operation on 7000 kc. the simplest form of the Zepp is the one with the half-wave radiating section and quarter-wave feeders. For the 14-mc. band, the same radiator will be quite satisfactory, working now on its second harmonic as a full wave antenna; the feeders, however, will be wrong since they must be approximately equal to an odd number of quarter wavelengths. The simplest way out of the difficulty is precisely the one which is never used, i.e., to have the feeders 10 meters long for 7-mc. work, and shorten them to 5 meters for QSY to 14 mc. The objection arises: How am I going to take a walk on other peoples' roofs several times in the middle of the night and let feeders in and out of my station

window to alter their length each time it is necessary to change frequency?

This is not necessary; just have the feeders 5 meters long to begin with, and make provision right in the operating room for switching an extra 5 meters in or out at will. A suitable arrangement is shown in Fig. 1.

This method has been tried quite successfully at I1MM; all the 7-mc. work, including 'phone with New Zealand, has been done for over a year with 5 meters of feeders forming a sort of loop inside the operating room and results have been apparently identical to those previously obtained with the whole 10 meters stretched outside, as is usually the case.

The feeders of the Zepp antenna have very small external fields, so they can be bent around in a circle or a zig-zag without any measurable loss ensuing if they are kept fairly close together and two or three feet away from walls and apparatus.

Feeders here are 4 inches apart on the indoor portion and 7 inches on the stretch outside the house. The leads have plugs and sockets which render feeder changes

a very short and simple process.

If another band was to be worked as well — for instance 28-mc. — a second loop of $2\frac{1}{2}$ meters could be used alternatively with the 5-meter loop. In this case the antenna would oscillate on its fourth harmonic, and the feeders would be $\frac{3}{4}$ of a wavelength or $7\frac{1}{2}$ meters long.

Many variations could be made on the principle

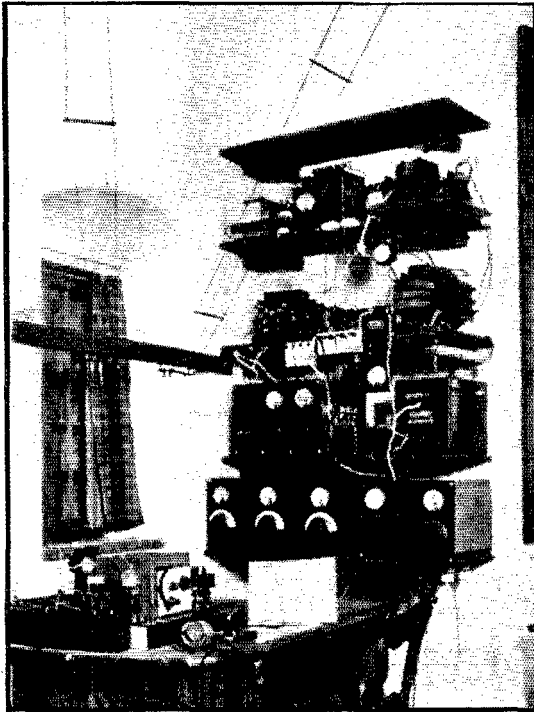

THE AUTHOR'S STATION, I1MM

The indoor feeder section terminates on the bar across the window and is switched in or out of circuit by a plug-and-cord arrangement.

*6 Piazza Belle Arti, Rome, Italy.

outlined. Of course this method is useless unless the radiating section is the right length for the wave chosen. Changes may be made only to frequencies harmonically related.

DETERMINING ANTENNA LENGTH

Another point which has been studied at I1MM deals with the cutting of the Zeppelin antenna the correct length. Data have been given in *QST* for these measurements and by following them, excellent results can be obtained. But if

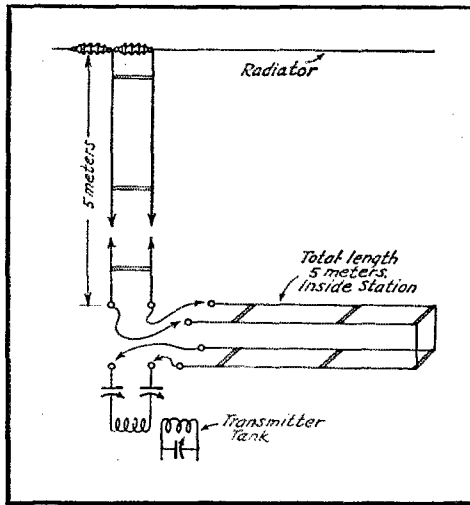

FIG. 1.

work has to be done on one specific frequency, as in the case of crystal control, there is a satisfaction in knowing that the antenna has been cut with almost absolute correctness.

The data referred to do not allow for differences due to individual location, where surroundings affect the natural frequency of an antenna to a varying degree. In some locations space may be limited and the antenna, instead of being stretched out as is preferably the case, will be bent to an angle or otherwise crowded into the available area, with the consequence that the correctness of the data may be noticeably impaired. It is to overcome this difficulty that an effort has been made to get the radiator in exact tune in its own regular working position, independently of the tuning of the feeders.

When a Zepp is tuned to resonance by means of its feeder condensers, what is really tuned is the whole system, comprising radiator and feeders. Resonance can be obtained with the radiator a good deal off its correct length. When this is the case, the current mode which should fall on the antenna-feeder junction is displaced outwards along the antenna or inwards along the feeder. The result is non-symmetrical distribution in the feeders with increasing of their external fields, radiation, and losses by absorption.

Ideal conditions for the Zeppelin radiator are as if it were oscillating alone, with no feeders connected, at its natural frequency or at a harmonic; that is, with a voltage maximum at each end.

In the feeders the distribution should be the same as if they were tuned to resonance, by means of the condensers, with no antenna connected; that is, with a voltage maximum at the open end of the feeder, and a voltage node near the point where it is excited. Only in this case is the external field around the feeder system small and the losses low.

The proper way of obtaining perfect resonance in both sections is to tune them separately. With other methods the tuning of the antenna system simply means introducing an error in the feeder distribution in order to conceal one existing in the radiation section.

The procedure adopted here is as follows:

1. Prepare the antenna and feeders according to orthodox data, but with an insulator inserted at the antenna-feeder junction, as in Fig. 2. The antenna can be connected or disconnected across the insulator.

2. With the antenna disconnected as at A, pull the antenna up in its regular working position. Turn on the transmitter with very low power (or antenna meters may burn out) and very loose

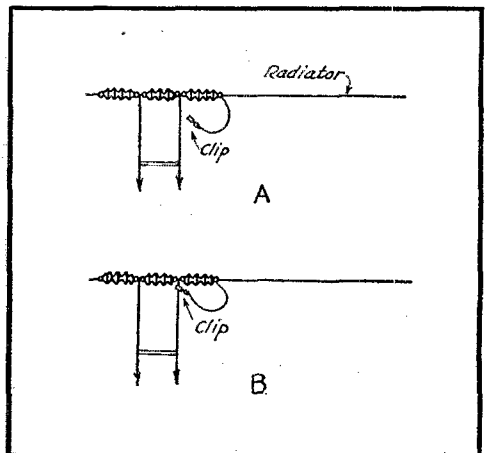

FIG. 2.

coupling. Tune the feeders to resonance and note the readings on the dial of the feeder condensers.

3. Let down the antenna, connect the free end to the feeder around the insulator (Fig. 2B), and pull up tightly as before. Turn on the transmitter again with the frequency the same as before, using enough power to get good readings. Tune the antenna condensers to resonance. If the condensers now give resonance at the same readings as with the antenna disconnected, the antenna

length is exactly right. If the capacity has to be increased, the antenna is too short. If capacity has to be reduced the antenna is too long. The method will show up errors of a very few inches.

Is such precision necessary, and will there be a difference in results on actual distance tests between the incorrectly and quite correctly cut system, if the former has had its incorrectness apparently compensated for by tuning the feeder condensers?

We will not venture to answer the question definitely. Much depends, of course, on how good the guess has been in the first case. We believe the difference would not be noticeable in many cases. But in favor of striving for exactness, there is this to be said: Uncertain elements will always be present in radio work in sufficient quantity to satisfy the poetically inclined, even if efforts are made to suppress a few of them; when small errors are allowed to exist, they easily combine to make

large ones and interfere with results; the method outlined is an excellent check against errors of measurement; and, lastly, that if the antenna is to be worked on harmonics the method will be of the greatest assistance in preventing one harmonic of the antenna-feeder system (having a current node at the feeder-radiator junction) from being confused with another having an inefficient field distribution.

One more point of interest about the Zeppelin antenna is that radiating portions can be connected to both feeders.

In this case it possibly would no longer be called a Zeppelin, but merely a particular form of voltage-fed antenna; or it might be nick-named a "Double Zeppelin." For example, for 7-mc. transmission, one branch could be 20, and the other 40 or 60 meters long. The branches could be disposed for different directional purposes and they could be tuned by the method outlined above, first separately, then together.

How Is Your Tone Color?

By Edwin Ehlinger, W8BBP*

THE other day as I was putting the finishing touches on my new a.c. receiver, that well-known DX mongrel, A.A. of A., better known W8AFG, paid me one of his characteristic flying visits.

Asparagus Adanti of Auburn had no sooner made a solid two point landing in my favorite chair than he made his usual stock remark.

"Ed," he said, "I want you to do me a favor."

"What?" I asked suspiciously.

"I want you to do something special for me. I've come all the way up here to see you because you're the only person I can trust to do it properly."

"I'm sorry, Asparagus, OM," I said, "but I intend to use that extra 210 in a new push —"

"Who wants your old 210?" he broke in testily. "It's something big I want you to do." He pulled a package of cigarettes from his pocket and, knowing that I didn't smoke, offered me one.

"You know, Ed," he said, scratching his match on the core of my filament transformer,

"college takes up practically all my time now."

"I'll bet," I replied sympathetically.

"It certainly doesn't leave me much leisure. I wouldn't bemoan such a condition were it not for the fact that a few days ago the Federal Radio Commission asked me to serve in the capacity of an unofficial adviser and" — he paused dramatically — "I accepted."

"Oh, so you want me to give you some advice, eh?"

"No," said Asparagus, "I want you to write a *QST* article for me."

"Oh, yeah?"

Asparagus picked up a '24 and waved it menacingly.

"At Union," he growled, "we do not use slang."

"Oh, yeah?"

Asparagus raised his arm to dash the '24 against my cranium, but thought better of it and slipped it into his own pocket.

"Hey!" I yelled. "That's my tube."

"Be quiet and listen to what I tell you," he commanded. "You're going to write a *QST* article for me. I'll give you a rough verbal outline

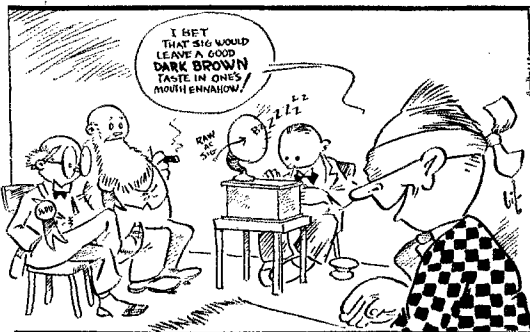

* 25 Auburn Ave., Utica, N. Y.

(Continued on page 88)

Election Results

Three New Directors Come to the A.R.R.L. Board

AS a result of the 1930 A.R.R.L. elections, three new directors take office on the A.R.R.L. Board of Directors. Mr. L. G. Windom succeeds Mr. D. J. Angus in the Central Division, Mr. R. J. Andrews replaces Mr. Paul M. Segal from the Rocky Mountain, and Mr. H. W. Kerr takes the place of Mr. Louis R. Huber from the Midwest.

In many cases the elections this year were marked by spirited campaigning. It is evident that amateurs showed a great deal more interest in who their spokesmen are on the Board than they have shown in many a year. That, we think, is a very fine sign, and quite the proper attitude. The story by divisions is as follows:

CENTRAL DIVISION

Mr. Loren G. Windom, WSGZ-WSZG, of Columbus, Ohio, succeeds Mr. D. J. Angus, W9CYQ, of Indianapolis, who was serving the remainder of WSZZ's term. The new director has been an active amateur for fifteen years and his calls are well known on the air. By profession he is an attorney at law. He is an O.R.S. and the Fifth Corps Area Radio Aide in the A.A.R.S. The balloting:

L. G. Windom.....	967 votes
D. J. Angus.....	647 "
E. Linder.....	81 "

HUDSON DIVISION

In the Hudson, Dr. Walsh, W2BW, scored a marked victory over Mr. George L. Fuller, W2BSH, of Schenectady, and thus continues on the Board. The count:

A. L. Walsh.....	671 votes
G. L. Fuller.....	158 "

NEW ENGLAND DIVISION

Only one candidate was named in the New England Division, the incumbent, Mr. Frederick Best, W1BIG. There was therefore no balloting and Mr. Best has been declared reelected to the Board.

NORTHWESTERN DIVISION

Here there was spirited competition. Mr. Karl W. Weingarten, W7BG, the present director, was returned by a small margin over Mr. John B. Waskey, W7TX-W7UU. The voting:

K. W. Weingarten.....	181 votes
J. B. Waskey.....	143 "
H. K. Lawson.....	83 "

ROANOKE DIVISION

Mr. W. Tredway Gravely, W3BZ, has been the Roanoke's director since its formation, and a

member of the Board before that. The Roanoke again would have no other, and only Mr. Gravely was nominated. Thus, without balloting, he has been declared reelected.

ROCKY MOUNTAIN DIVISION

Mr. Paul M. Segal, the incumbent, was not a candidate, having become ineligible by his removal to Washington. In the voting between Mr. Russell J. Andrews, W9AAB, and Mr. Gerald H. Lovins, W9CSR, both of Denver, the former won by a goodly percentage, although the totals were small. Mr. Russell, a former vice-president of the Associated Radio Operators of Denver, has been in amateur radio since 1919; he is an O.R.S. He is by occupation a tool and die maker, associated with the Mountain Motors Co. at Denver. The count:

R. J. Andrews.....	77 votes
G. H. Lovins.....	33 "

WEST GULF DIVISION

Mr. Frank M. Corlett, W5ZC of Dallas, in point of service the oldest director on the Board except President Maxim, was reelected director from the West Gulf by a substantial majority over Mr. J. Harrold Robinson, W5BG. The tally showed:

F. M. Corlett.....	209 votes
J. H. Robinson.....	133 "

MIDWEST DIVISION

In the Midwest Division a special election was held at the same time as the other elections, to select a director to succeed Mr. Louis R. Huber, resigned account non-residence. Mr. H. W. Kerr, W9DZW-W9GP, is the new director, winning over Mr. John H. Amis, W9CET. His term will expire the end of 1931; consequently there will be another election in the Midwest next autumn. Mr. Kerr resides in Little Sioux, Iowa, where he is the editor of a weekly newspaper. He is perhaps best known to amateurs as the publisher of "Grandpa's Regret," unofficial Midwest Division ham sheet. He has been our S.C.M. for Iowa since 1928, and of course is an O.R.S. His station is also the state net control station for Iowa in the A.A.R.S. The count:

H. W. Kerr.....	339 votes
J. H. Amis.....	238 "

QST greets the new directors as such, and knows that it speaks for the membership in expressing appreciation for the loyal services of the retiring directors.

K. B. W.

A New Type of Peaked Audio Amplifier

By Howard Allan Chinn*

THE use of a peaked amplifier for obtaining good selectivity in the reception of code signals is quite generally recognized as being worthy of adoption but the majority of present day amateur signals are such as to make it highly desirable that the width of the peak of the amplifier be readily adjustable to meet the existing conditions of operation. Furthermore, the use of radiotelephony demands, on occasion, the availability of a high quality amplifier for faithful reproduction.

One type of peaked amplifier, previously described in *QST*, utilizes a screen-grid tube and a tuned plate impedance (Fig. 1). It may be converted to one of variable selectivity or made reasonably non-selective by means of several possible alterations.

A suggested means of varying the selectivity of the screen-grid type impedance-coupled amplifier is to insert a variable resistor in series with condenser *C*.¹ This is a useful arrangement but even with zero resistance in this circuit the selectivity obtainable with a given coil *L* and condenser *C* does not approach that which can be obtained with the circuit to

selective characteristic) has a tendency to discriminate against the low frequencies. One means of obtaining a stage of high quality amplification in place of the selective screen-grid stage is to use a complicated switching arrangement together with the additional tube and attendant apparatus which permits the switching of the

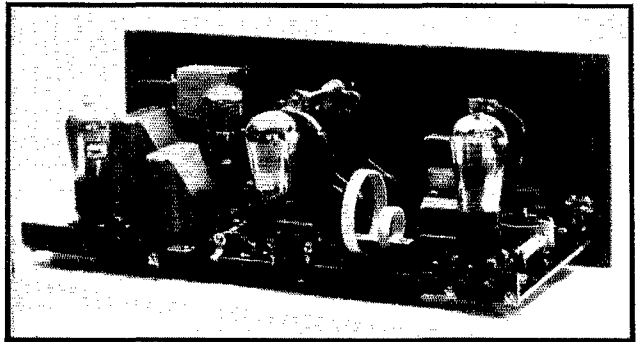

THE EXPERIMENTAL RECEIVER

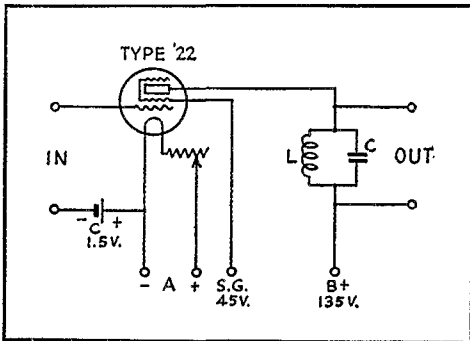

FIG. 1—THE USUAL SCREEN-GRID PEAK-AMPLIFIER CIRCUIT

The sharpness and amplitude of the peak depend largely on the constants of the parallel resonant circuit *LC*. The arrangement is not so readily convertible to flat amplification as that shown in Fig. 2.

be described. By mounting the coil and condenser on plugs and replacing this unit with a "plug-in" resistor of approximately 250,000 ohms¹ the circuit (although having a reasonably good non-

audio input and output to the desired amplifier.²

By using a three-element tube in the circuit arrangement shown in Fig. 2 it is possible by simple means to obtain an amplifier with any degree of selectivity or with as good a frequency response characteristic as may be desired for all amateur operation.

The operation of the circuit may be described briefly as follows:

The coil and condenser combination *LC* is chosen to tune to the audio frequency at which it is desired to obtain the peak. For present purposes it is sufficiently precise to consider this to be determined by the relation

$$LC = \frac{1}{4\pi^2 f^2}$$

where *L* = inductance in henries

C = capacity in farads

f = frequency in cycles per second

This may be written

$$LC = \frac{25,300}{f^2}$$

where for practical purposes the units are

L = inductance in henries,

C = capacity in μ fd.

f = frequency in cycles per second.

* W1AXV-W1XP, South Dartmouth, Mass.

¹ March *QST*, 1929, page 41.

² *QST* Feb. 1930, page 9.

For 1000 cycles, the product
 $LC = .0253$
 and for 500 cycles
 $LC = .101$

from which is obtained the following table:

L (henries)	For 1000	For 500
	Cycle Peak C ($\mu\text{fd.}$)	Cycle Peak C ($\mu\text{fd.}$)
0.5.....	.0506	.202
1.0.....	.0253	.101
2.0.....	.0126	.506
3.0.....	.0084	.0337
4.0.....	.0063	.0253
5.0.....	.0050	.0202

The introduction of the large resistor R in the tuned circuit may seem to indicate the advisabil-

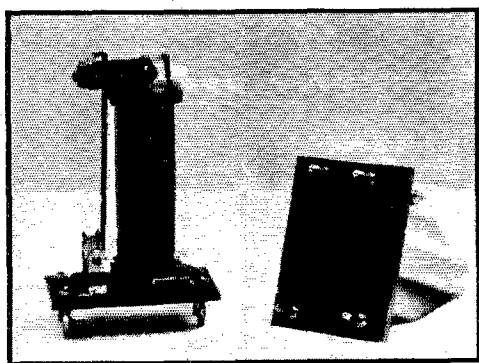

AUDIO PLUG-IN COMPONENTS OF THE EXPERIMENTAL RECEIVER

The tuned audio-frequency unit is at the left and the audio-frequency transformer is at the right.

ity of the use of a more rigorous formula for computing LC . It will be found, however, that the error introduced will not be so great as the deviation from rated values of the commercially available equipment. The $2\text{-}\mu\text{fd.}$ condenser merely serves as an audio frequency by-pass condenser and does not enter into the circuit consideration.

At the resonant frequency the impedance of the series-tuned LC combination between the points 1 and 4 is relatively low and becomes a pure resistance, the magnitude of which is determined by the quality of the coil and condenser used. That is, the better the coil and condenser the lower the effective resistance. If R is large compared to this resistance, then at the resonant frequency the greater part of the alternating current component of the plate current will flow down this LC branch. The impedance drop across the inductance L will be large, however, because of the high reactance of this coil, and it is this voltage that is impressed on the grid of the succeeding tube.

At any frequency other than the resonant frequency, the LC path offers considerable imped-

ance to the flow of the a.c. component of the plate current and as the frequency goes further and further from the resonant frequency a greater and greater percentage of the alternating current goes through the resistor R . Therefore, only alternating current of a frequency in the neighborhood of the resonance frequency can pass through the LC circuit and produce any voltage of appreciable magnitude on the grid of the succeeding tube.

With a given coil and condenser this amplifier can, by proper choice of R , be made to give the same amplification as the circuit of Fig. 1 but with greater selectivity; or if adjustment is made for the same selectivity, the resulting gain will be greater than with the screen-grid type of amplifier. Furthermore, if a high quality transformer-coupled amplifier is desired, it is only necessary to replace the impedance unit by a suitable transformer without necessitating a change of tubes or battery voltages.

In Fig. 3 are shown curves obtained using a Samson No. 3 choke and a Sangamo $.007\text{ }\mu\text{fd.}$ condenser. This coil has a straight iron core and a rated inductance of 3 henries. From the table it is seen that a condenser of $.0084\text{ }\mu\text{fd.}$ should be used to tune to 1000 cycles per second but manufacturing variations in both the particular coil and condenser used necessitated the use of a $.007\text{ }\mu\text{fd.}$ capacitance. The amplification or gain in this case is taken as the ratio of the voltage E_2 to E_1 as indicated in Fig. 2. It will be noted that both the voltage ratio and the frequency scales are logarithmic. This gives a more nearly correct representation of the operating characteristics of the amplifier because of the nature of the response of the ear to changes in intensity and frequency.

From the curves it is seen that the selectivity of

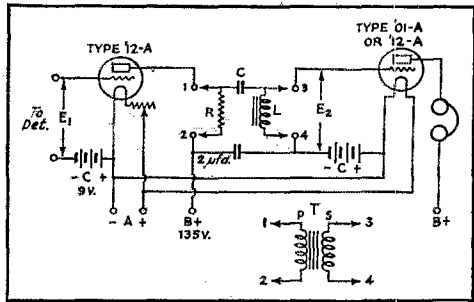

FIG. 2.—THIS ARRANGEMENT USES A THREE-ELEMENT TUBE AND HAS A NUMBER OF OTHER ADVANTAGES OVER THE SCREEN-GRID TYPE PEAK AMPLIFIER

The resonance frequency is determined by the values of L and C while the amplitude and sharpness of the peak depend on the value of R , the amplitude decreasing and the peak becoming sharper as R is made smaller.

this amplifier is readily changed by variation of the resistance R . The use of a 10,000-ohm resistor gives a curve which has approximately the same

amount of peak as obtained when using the same coil and condenser in the s.g. type amplifier. Consequently the use of a 1000- or 100-ohm plate circuit resistor gives an amplifier of much greater selectivity than otherwise obtainable with this coil-condenser combination.

For comparative purposes and to show the relative amplification, the figure also includes the

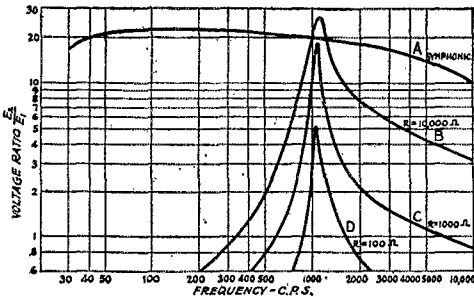

FIG. 3 — FREQUENCY-RESPONSE CHARACTERISTICS OF THE AMPLIFIER

A was obtained with a Samson "Symphonic" audio transformer while B, C and D are for the tuned coupling arrangement with various values of R.

frequency-response characteristic of a Samson Symphonic 3-to-1 transformer substituted for the impedance unit. It will be noted that the peak amplification using the 10,000-ohm resistor is greater than the amplification obtained with the transformer. The mathematical consideration of the circuit shows this to be possible. The transformer characteristic is such that the greatest amplification is obtained in the neighborhood of 200 cycles per second although the curve is quite flat between 30 and 5000 cycles.

The similarity between this amplifier circuit and the usual transformer coupled amplifier permits its adaptation to present receivers with only minor changes in the wiring. It is essential merely that the first tube be a Type 12-A operated at its rated plate voltage of 135 volts and the normal negative grid bias of 9 volts. Under these conditions the output impedance of the tube is approximately 5000 ohms and it is under these conditions that the data shown were obtained. It is evident that the coil L and the condenser C should be the electrically best available.

In the receiver in which this amplifier is being used the tuned impedance unit and the audio transformer are mounted on bakelite bases 2½ by 3½ inches equipped with four G.R. plugs. In the sub-panel of the set four G.R. jacks are mounted and the units are thus readily interchangeable.

WWV Standard Frequency Transmissions

THE Bureau of Standards Station, WWV, will transmit accurate 5000-kc. standard frequency signals on the following Tuesdays: Feb.

3, 10, and 24; March 3, 10, 24, and 31. The hours of transmission are from 1:30 to 3:30 and from 8:00 to 10:00 p.m., E.S.T., on each of the above dates. More complete information concerning these transmissions will be found on page 39 of January QST.

The regular monthly transmissions sent from WWV will take place on the following schedule:

Time (E.S.T.)	Feb. 20	March 20	April 20	May 20	June 20
	(Frequencies in Kc.)				
10:00 p.m.	4000 ✓	550	1600	4000 ✓	550
10:12	4400	600	1800 ✓	4400	600
10:24	4800	700	2000 ✓	4800	700
10:36	5200	800	2400	5200	800
10:48	5800	1000	2800	5800	1000
11:00	6400	1200	3200	6400	1200
11:12	7000 ✓	1400	3600 ✓	7000 ✓	1400
11:24	7600	1500	4000 ✓	7600	1500

A complete frequency transmission includes a "general call," "standard frequency signal," and "announcements." The general call is given at the beginning of each 12-minute period and continues for about two minutes. This includes a statement of frequency. The standard frequency signal is a series of very long dashes with the call letters (WWV) intervening; this signal continues for about four minutes. The announcements follow, and contain a statement of the frequency being transmitted and of the next frequency to be transmitted. There is then a 4-minute interval while the transmitting set is adjusted for the next frequency.

Information on how to receive and utilize the signals is given in Bureau of Standards Letter Circular No. 280, which may be obtained by applying to the Bureau of Standards, Washington, D. C. Even though only a few frequencies are received (or even only a single one), persons can obtain as complete a frequency meter calibration as desired by the methods of generator harmonics.

— J. J. L.

Strays

Tube-base receiver coils have a habit of getting mislaid when left loose on the operating table. W4ACB overcame this by getting a socket strip from an old Atwater-Kent BCL receiver and mounting it inside the lid of the cabinet on his ham receiver, plugging the coils not in use in the strip. They're always in the same place now when needed.

A radio catalog informs us that the such-and-such dial is now microphonic. Intended to help out the Type '99 tube, no doubt.

At a recent hamfest it was resolved that all YL's send a lock of hair with every QSL card. (Those hams were single!)

Making Records of Amateur Signals

By H. W. Dreyer, WIANC*

RECENT attempts at recording amateur signals on the new phonograph home-recording blanks have been so successful at WIANC that the writer believes other experimenters, including traffic and 'phone men, can make good use of the idea. The apparatus required is generally available, not too expensive and surprisingly good results can be obtained even with a hay-wire set-up. Of course plenty of elaboration can be made on the simple layout to be de-

starts with a homemade detector and one stage audio receiver, using a '24 and a '27 tube. This is coupled to the transmitting antenna (for recording weak signals) as recently described in *QST*. A second stage of audio was added after experiments started, and consisted of another '27 coupled by an Amertran second-stage transformer of 3-to-1 ratio. It has about 80 volts on the plate and $1\frac{1}{2}$ volts grid bias.

The output of this second-stage amplifier is fed into a step-down transformer of about 10/1 ratio to match its impedance to the input of the next amplifier, which happens to be the audio end of a standard Victor Type RE 45 radio set (100-ohm input impedance). This amplifier uses one '26 tube feeding a pair of '45 tubes in push-pull. The output is ample for all recording purposes if a fairly good reproducer or pick-up is used as a cutter.

Most of the available cutters are of the high-impedance type, on the order of several thousand ohms. Exceptions are the Victor, the RCA and the Brunswick Panatrophe reproducers which are of about 50- to 100-ohm impedance. If a pick-up of the low-impedance type is used it may be fed from the secondary of an output transformer of the sort designed to couple into the voice coil of a dynamic speaker (excepting the type designed for single-turn voice coils). If the high-impedance type pick-up is used, the output transformer should have a high impedance sec-

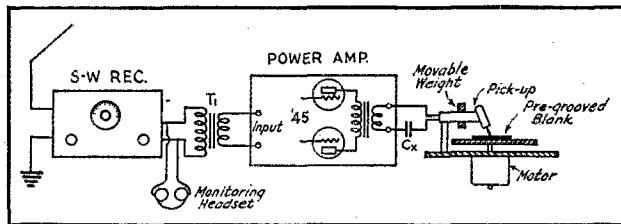

FIG. 1 — A TYPICAL HOME-RECORDING SET-UP

The coupling transformer T_1 will not be necessary unless the amplifier has a low-impedance input winding, as explained in the text. For good results there should be two or three stages of amplification between the detector and output power stage. The condenser C_x is used to attenuate low frequencies, as explained in the text, and may be omitted.

scribed if better quality recording is desired. The general idea is to amplify the output of the usual amateur receiver until it is sufficient to operate the phonograph pick-up which is used as the device for cutting modulation on one of the pre-grooved phonograph record blanks now sold by radio dealers most everywhere. After a record has been made, the process is reversed and the pick-up is used to play back the recording which can be reproduced either by a headset without amplification or by a loud speaker preceded by the same amplifier used for the recording process.

The usual signal source will be the short-wave receiver. The receiver should be a good one with at least one stage of audio following the detector and both the detector and amplifier tubes should be as non-microphonic as possible, because we must take the audio signal and put it through at least two and preferably three more stages of amplification before we have enough energy to cut modulations in a record blank. Two stages added to the first audio will record signals of R6 intensity or louder. Three additional stages (making a total of four audio) will record the background level at 14 and 28 mc., even in a fairly quiet location such as that of WIANC. The actual apparatus used here

*Box 451, Bristol, Conn.

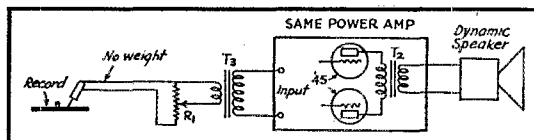

FIG. 2 — THE SAME POWER AMPLIFIER IS USED FOR REPRODUCING

The type of input transformer, T_1 , will depend on whether the pick-up is of the high- or low-impedance type and on the input impedance of the amplifier unit. If the transformer couples into the grid of an amplifier tube, a microphonic transformer having a primary impedance of 100 or 200 ohms could be used with a low-impedance pick-up. The volume control, R_1 , should be a 100-ohm potentiometer for use with a low-impedance pick-up.

ondary such as is used to operate magnetic speakers.

The principal advantage of the low-impedance type reproducer is that long leads between amplifier and cutter can be used without damage

to quality or without back-coupling to the input which may cause audio frequency oscillation. A shielded cable connection between the amplifier and reproducer will be helpful here.

The other necessary equipment is a phonograph motor and turn-table. The special requirements of the motor for recording are: plenty of power, because it is necessary to load the cutter with a small weight to make it engrave a proper groove; lack of vibration, because almost any vibration of the recording table will appear on the record as background noise; constancy of speed, and control of speed between fairly wide limits.

A Victor electric motor of the watt-hour meter type has been used here and, although it is fairly satisfactory, a little more power would be useful. Some spring motors would probably work very well.

MAKING THE RECORD

For recording code signals it is quite OK to record as slowly as 35 revolutions per minute, thereby getting about 2½ minutes of recording on the Victor blank which has a pre-grooved spiral of 90 grooves. For high quality 'phone recording, it is better to record at from 60 to 90 revolutions per minute. Of course the record should be played back at the same speed as recorded for natural reproduction.

The tone arm that holds the cutter should be weighted somewhat when recording. A pressure of about 8 or 9 ounces on the cutter point seems to be about right although more can be used if the motor has power enough to turn the record at a steady speed. The blunt steel needles should be used for both recording and reproducing.

Now for the procedure. Listening as you usually do either with 'phones in the first audio or speaker in second audio, tune around until you hit upon something you want to record. You may have your turn-table motor turning over at the desired speed, 34 or 40 revolutions

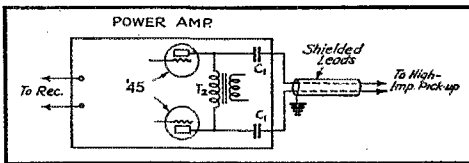

FIG. 3—THIS COUPLING ARRANGEMENT CAN BE USED WITH A HIGH-IMPEDANCE PICK-UP
The condensers C_1 should each be 2 to 4 μ d.

per minute, because after running a few minutes it will settle down to a steady speed. Plenty of light oil on the governor friction surfaces helps to this end.

Gently lower the cutter onto the blank and record while monitoring. When you have recorded all you want of one signal, raise the cutter to stop recording. It is easy to tell where

recording has stopped on the record because the recorded grooves have a distinctive appearance quite different from the unused grooves.

If you seem to have trouble getting enough modulation, it helps to warm up the blanks

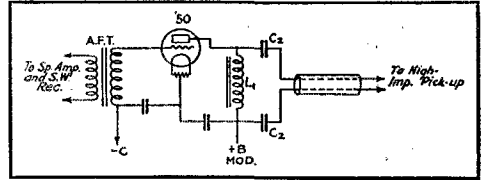

FIG. 4—THE MODULATOR OF A 'PHONE TRANSMITTER CAN BE USED AS THE RECORDING POWER AMPLIFIER

The arrangement shown would be suitable for a high-impedance pick-up. A dynamic-speaker type output transformer should be used in place of L_1 , the modulation choke, for recording with a low-impedance pick-up. The coupling condensers, C_2 , should be of 2 to 4 μ d. capacity.

before recording. Higher temperature than about 140° F. is not recommended because the records are slightly though not dangerously inflammable. Certain pick-ups are far more effective in cutting at low frequencies, as 100–150 cycles, than they are at the middle and high frequencies. If you have one of these pick-ups you can improve matters considerably by connecting a condenser in series with the leads for recording. For low-impedance cutters try ½ to 4 μ d. For high-impedance cutters try 0.05 to 0.5 μ d. This also frequently helps reduce background hum if it is of low frequency.

Now, as to what uses this process of recording can be put. True enough, you can use it instead of QSL cards, even though the blanks cost a quarter each. Some morning when you work a VK or a ZL, record his signal, send him a record QSL and wait for his reaction. (Don't forget to send him a needle, too.) Unless we are very much mistaken, the first thing he will do will be to start gathering the necessary hay-wire to record signals himself — and next thing you know you'll get a record back from him.

Beginners may find lots of help recording their own fist from a monitor signal. Then again, by prearranged tests, the peculiar distortion caused by echo effects can be studied if records of a certain signal at long distances can be compared with records of the same transmission made at the sending station via his monitor.

Perhaps traffic could be handled à la Rocky Point by first recording at low speed, then transmitting and receiving at high speed, and reproducing later at a lower speed to copy the traffic.

Important traffic such as that handled by the Army or Navy network stations would be recorded as sent, thereby giving accurate checks on all messages.

When experimenting with new transmitters

(Continued on page 38)

Coming—The Fourth International Relay Competition

March 8 to 21 Inclusive—Full Details Next Month—United States and Canadian Hams, Send QSL-entry Card to Hq. NOW—Hams Elsewhere, Take Part on Dates Announced

IN this contest entries are solicited from United States and Canadian amateurs so that we may provide special log forms and official test messages to those who want to participate. Last year many of the several hundred entrants put themselves on record just at the last minute, so it was difficult to equip all concerned with full information and official "test" dispatches before the starting time. Get your entry to A.R.R.L. Headquarters on or before February 28 — this is important!!

In this March contest all amateurs with the prefixes W and VE will be taking part in a QSO party with stations in all other parts of the world including Hawaii, the Philippines, Porto Rico, Alaska, etc. (where K and KA are used). Every amateur in the world is invited to take part.

Refer to December, 1929, *QST* for the full announcement of rules for the Third International Relay Party, if you happen to be one of the few

the "high" station in each of the 64 U. S. (mainland) and Canadian Sections! In general the same scoring system will be used as last season, counting one for sending and two for receiving "reply test messages," and multiplying totals by the number of continents worked and the proper factor for each different locality contacted. Hams in remote localities will count one for receiving and two for sending dispatches and multiply scores by the number of different A.R.R.L. Sections worked! As many of the official test dispatches can be sent to a given locality as you can work stations there (but one exchange of messages per station permitted, of course). This contest we trust will help you to add to the list of countries you have worked, quite possibly put you in line for a WAC certificate when the fun is over, too! There were a lot of new WAC's issued after every previous contest.

THIS IS ONE OF THE BIG EVENTS OF THE YEAR. DON'T MISS IT.

Every foreign amateur will have a chance to make an unprecedented number of U. S. and Canadian QSO's!

Every U. S. and Canadian ham should be in on the fun!

Two weeks of opportunity to smash all previous records!

All amateurs in the world are cordially invited to take part.

COME ON IN, OM. Get your station in trim now and plan to grab off some of those certificates. U. S. and Canadian amateurs, get your QSL-entry cards in early. Now!

— F. E. H.



who don't remember how to take part. Anyway, the rules will appear in full in March, 1931, *QST* — but enter, and we'll see that you get all the dope. This contest will run along just about the same lines as the previous one (reported in August, 1930, *QST*), with possible slight changes in the weighted credits for counting contacts with different foreign localities.

There will be newly designed "Certificates of Merit" for every winner in each foreign locality (awarded by list of international prefixes), and for



U CUM IN LIKE A TON OF BRICKS, OM!

More Power With Better Frequency Stability

Practical Suggestions for Oscillator-Amplifier Transmitter Design

By George Grammer, Assistant Technical Editor

THE past few years have seen a sort of about-face in the design and adjustment of amateur transmitters. Prior to 1929 the sole aim of most transmitting amateurs was to get the maximum power output from their sets, whether they employed a single Type '10 tube or a couple of '04-A's. This presented no hard problem, and the fact that the signal occupied many times the space required by a pure wave of constant frequency was of comparatively little practical importance, because there was plenty of room in the bands for large numbers of even the worst types of signals — except in the vicinity of 37.5 meters.

The changed conditions in 1929 brought with them a realization on the part of most amateurs that something had to be done if any kind of satisfactory communication was to be possible — certainly the old order had to be changed or there would be nothing but bedlam. A steady wave of a single frequency, occupying the least possible space in the spectrum, became the order of the day. The fly in the ointment was that such signals could not be produced without the sacrifice of a considerable portion of the possible power output, unless the functions of frequency stabilization and power production were separated and a tube used for each. This of course means the use of an oscillator-amplifier circuit.

It is rather surprising that we amateurs as a whole have been so slow to see the advantages of oscillator-amplifier transmitters. Somehow or other, the impression seems to have gotten abroad that the oscillator-amplifier is not worthwhile unless it is crystal-controlled. There seems to be a further impression that such transmitters are hard to build and difficult to adjust, and that there is something darkly mysterious about them which places them beyond the technical ability of the average amateur.

The truth of the matter is that the self-controlled oscillator-amplifier transmitter is in many respects the ideal outfit. With the oscillator-amplifier transmitter it is possible to get about twice as much power out of a given tube as can be taken from the same tube self-excited, with a similar degree of frequency stability in both cases. For all-band operation the self-controlled oscillator-amplifier set is far less complicated than the simplest crystal-control rig. Properly built and adjusted, it is capable of frequency stability which compares very favorably with crystal control;

and there is the further advantage that the frequency can be shifted at will.

It is not generally realized that a power tube used as a radio-frequency amplifier is working under the most favorable conditions. Its plate circuit can be adjusted for maximum power output without sacrifice of frequency stability. Practically all the power output is available for the antenna, since the amplifier's grid losses are supplied by the preceding tube, and its output circuit can be designed for high efficiency. Contrast this with the self-excited oscillator, which must first of all be adjusted for frequency stability, and which must supply its own grid losses. And unfortunately the adjustments for optimum frequency stability and maximum power output do not coincide. It is usually necessary to sacrifice about half the possible power output to obtain the required frequency stability.

The experience of the last two years has shown that with High-C circuits and tubes suitable for high-frequency work it is possible to achieve really excellent frequency stability with self-controlled oscillators so long as the circuit elements are undisturbed and the operating voltages are maintained at fairly constant values. But when coupled to an antenna the frequency of even the most stable self-controlled oscillator is affected by slight changes in antenna constants, such as the vibration of the wires in a breeze. To overcome this and to avoid loading the oscillator too much — overloading also impairs frequency stability — loose coupling must be used between the antenna and the oscillator. On windy days, however, even the loosely-coupled oscillator is at the mercy of the antenna, so that the use of another tube between the oscillator and antenna simply as a buffer is amply justified even if there should be no gain in power output. The fact that it is possible to obtain more power output is simply a stronger recommendation for the oscillator-amplifier transmitter.

Although there is little authoritative data available on the subject, rule-of-thumb methods have demonstrated that to fully excite an unmodulated radio-frequency power amplifier, the power supplied to the amplifier tube's grid should be about one-tenth the expected power output. For instance, if a Type '03-A tube is to deliver 50 watts to the antenna the tube preceding it must be capable of giving it about five watts; to get 10 watts from a Type '10 tube the grid excitation

should be about one watt. The choice of the oscillator tube is determined by two requirements — it must be capable of delivering the amount of power required by the grid of the amplifier, and while furnishing that power also must maintain excellent frequency stability. In other words, it must be underloaded.

Years ago somebody started the idea that the oscillator tube should have at least the same power rating as the amplifier. Possibly it was

tion. For instance, a Type '10 tube is ordinarily supposed to be used with 350 volts and 60 milliamperes on the plate. But 500 to 600 volts and 60 to 75 milliamperes is quite common; furthermore, with these larger inputs it is no trick at all to get really good frequency stability — and at the same time more power output than the tube is supposed to give. A Type '10 tube in a well-adjusted High-C circuit will deliver 10 watts or more to the load under ordinary conditions, and this power is ample to excite a Type '03-A, '52 or '60 tube to more than rated output.

DESIGNING THE OSCILLATOR

One of the nice things about an oscillator-amplifier transmitter is that in planning the oscillator it is possible to concentrate almost entirely on frequency stability. Power output is of secondary importance. Naturally the circuit will be High-C — in fact, as High-C as it can be made. The capacity actually used in the plate tank circuit should be about 500 $\mu\text{fd.}$ on 3500 kc., 400 to 500 $\mu\text{fd.}$ on 7000 kc., and 250 to 350 $\mu\text{fd.}$ on 14,000 kc. As always, any of the ordinary oscillator circuits will work well. The Types '45, '10, and '52 are the best tubes to use in the oscillator, and will fully excite a Type '10, '03-A or '52, and a Type '04-A, respectively. The Type '03-A is not a very good tube to use as a high-frequency oscillator, especially where frequency stability is of prime importance. Fig. 1 shows some recommended combinations.

Aside from the use of a High-C circuit, there are other factors which affect the frequency stability of an oscillator. Among the most important are the adjustment of grid bias and grid excitation. For optimum frequency stability the bias should be high and the excitation should be such that the grid is positive over only a small portion of the cycle. This condition is also one which gives high tube efficiency, although not maximum output. It is necessary to keep down the plate dissipation of the tube to avoid the frequency creep caused by the changing inter-electrode capacity attributable to heating of the tube elements. The practical way of making this possible is to use a grid leak of higher resistance than ordinary, and to adjust the feedback until the note as heard in the monitor is pure and steady. Values of leak resistance on the order of 20,000 ohms will be found desirable in the case of Type '10 and Type '52 tubes, and 50,000 to 100,000 ohms with a Type '45

The plate supply should be as pure d.c. as the filter can make it, and the voltage on the tube should not fluctuate as the transmitter is keyed. This last requirement cannot be met always, especially when the same plate supply is used for both oscillator and amplifier, but the variations in voltage with keying should be kept at a minimum. The plate voltage on the oscillator tube should not be too low — the *percentage* variation

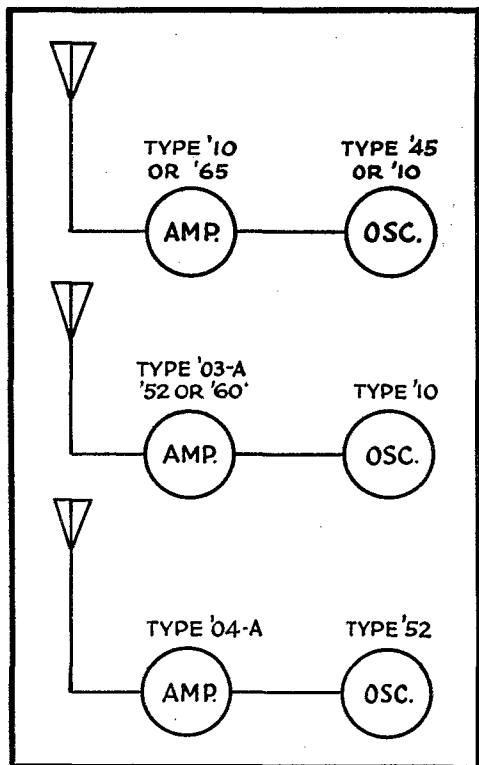

FIG. 1—SOME RECOMMENDED TUBE COMBINATIONS FOR OSCILLATOR-AMPLIFIER TRANSMITTERS

true the way tubes were operated in those days, but it certainly is not true in the light of present practice in transmitter adjustment. There is no reason why a given tube used as an oscillator cannot excite the next larger size of tube as an amplifier; a Type '10 tube can feed a Type '03-A or '52 and a '52 can excite a Type '04-A. Manufacturers' ratings on power tubes are generally rather conservative; in addition, they are based on the plate voltage and plate current specified for the tube. Rare indeed is the amateur who operates a tube at the rated plate voltage and current — especially the smaller sizes of tubes — and 50% to 100% greater power input than recommended is the rule rather than the excep-

in plate voltage, and hence the variation in frequency, is generally less when the plate voltage is high than when it is low. Moreover, the characteristics of oscillator tubes are such that reasonably high plate voltage gives better frequency stability than unreasonably low voltage. It is best to use voltages of the same value as would be used on an oscillator feeding the antenna, and keep the plate current below normal by the use of a high-resistance grid leak, adjustment of the circuit for maximum efficiency, and underloading. This results in better frequency stability and at the same time makes more power available for the grid of the amplifier. The plate of the oscillator tube should never be allowed to show color.

It is generally advisable to allow the oscillator to run continuously while the transmitter is in operation, and key only the amplifier. Several keying methods may be used in this case, but the simplest is regular center-tap keying, which requires separate filament supplies for the amplifier and oscillator. Since different types of tubes, requiring different filament voltages, will be used in most cases, this presents no difficulty. If the same plate supply is used for both tubes, the oscillator takes the place of the "drain" resistor across the plate supply, and helps in eliminating chirps and key thumps.

THE AMPLIFIER

The tube which is to supply power to the antenna should of course be adjusted for maximum power output. The ratio of capacity to inductance in the output tank circuit may in this case be made much smaller than is possible in the oscillator circuit, resulting in increased overall efficiency. There are no hard and fast rules to follow; in general, the tank inductance should have about twice as many turns as are used in the oscillator tank, and a tuning condenser with a maximum capacity of 250 $\mu\text{fd.}$ will be large enough. The mechanical construction should be as solid as that used with the oscillator, however, because the amplifier is bound to react on the oscillator to a slight extent and the possible mechanical causes of frequency change must be minimized.

Unless a screen-grid tube is used in the amplifier the circuit will have to be neutralized. A neutralizing system which is incorporated entirely in the amplifier circuit is preferable, because with such an arrangement adjustment of the neutralizing condenser will change the frequency of the oscillator to a much smaller extent than when the neutralizing voltage is obtained from the oscillator tank. The neutralizing system shown in the diagrams works out nicely.

Although it is customary to use battery bias on r.f. power amplifiers in amateur transmitters, a combination of battery and leak bias is recommended because in addition to saving the cost of a large number of "B" batteries, the bias automatically assumes the correct value for the

amount of excitation available. It is a good idea to have just enough battery bias to hold down the plate current of the amplifier tube to a reasonable value in case the oscillator quits, and let the rest of the bias be supplied by the voltage drop across the grid leak when excitation is supplied to the amplifier. The leak resistance is not particularly critical, and should be of about the same value as would be used with the tube as a self-excited oscillator. Ten thousand ohms will be a satisfactory value in almost all cases. A single 45-volt block will be sufficient for the battery part of the bias with practically any of the amplifier tubes shown in Fig. 1 except the Types '52 and '60, which should have about 90 volts.

COUPLING THE OSCILLATOR TO THE AMPLIFIER

In most oscillator-amplifier transmitters condenser coupling is used between stages, because it requires the least amount of equipment and is the simplest to adjust. One point frequently overlooked, however, is that the coupling condenser is liable to considerable strain in certain circuit combinations.

If series plate feed is used on the oscillator, the coupling condenser must have sufficiently high insulation resistance to withstand the full plate voltage on the oscillator plus the bias on the amplifier, as inspection of such circuits will show. In addition to these d.c. voltages, the condenser is also carrying radio-frequency current. The mica condensers often used for coupling may heat considerably from the r.f. flowing through them, and this sometimes lowers the insulation resistance of the condenser to the point where the dielectric will break down, even though the condenser might test satisfactorily on a much higher d.c. voltage than is actually across it in the circuit. Ordinary receiving condensers will often, though not always, stand up in low-power sets, but only those with high-voltage ratings should be used with sets using anything larger than a Type '10 tube in the amplifier. A regular variable air condenser is perhaps the most satisfactory type, because the plates are generally spaced sufficiently to stand the d.c. voltage — if not, they can be double-spaced easily — and since there is no heating in the air dielectric there is less tendency to break down. Even if the condenser should flash over, however, the short circuit is only momentary and is immediately evident, whereas with a fixed condenser a breakdown may wreck a tube or damage the plate supply before the trouble can be located.

The value of capacity required at amateur frequencies does not seem to be critical. Tests with condensers varying between 70 $\mu\text{fd.}$ and 500 $\mu\text{fd.}$ show that the power output is practically constant over the whole range of capacity; 100 $\mu\text{fd.}$ is a good value to use. The smaller the capacity the less is the reaction upon the frequency of the oscillator when the amplifier plate

tuning is varied, so that there is some gain in over-all frequency stability with the smaller values.

PRACTICAL CIRCUITS

Several schematic diagrams are shown in Figs. 2, 3 and 4, together with satisfactory values for the various constants. The amplifier circuits are the same in all three cases, the only differences being in the oscillator circuits employed. In Fig. 2 is the Hartley, in Fig. 3, the tuned-plate tuned-grid, and in Fig. 4, the fixed grid coil version of the t.p.t.g.

The connections for a screen-grid amplifier are shown in Fig. 5. These connections may be substituted for the amplifier portions of Figs. 2, 3 and 4, using whichever oscillator circuit may be preferred. The choice of a circuit depends largely on the preferences of the individual. The tuned-plate tuned-grid offers some advantage over the Hartley

in that series feed may be used in the plate circuit, and the excitation control is smoother because the grid tuning condenser is more readily adjusted than the filament clip, but has the disadvantage that an extra control is necessary. The fixed grid coil arrangement retains the good features of the tuned-plate tuned-grid and has only one tuning control. Once the correct proportions for L_4 are determined this circuit is probably the easiest to handle. No specifications are given for L_4 in the Table of constants since the size of the coil will vary with different types of tubes. The coil is adjusted until the tube operates normally over the band for which the plate coil is designed.

In the amplifier circuit the neutralizing condenser, C_3 , is connected between the grid of the tube and the lower end of the plate tank inductance. The plate supply tap (at ground potential with respect to r.f.) is clipped on about a quarter of the way up the coil, and the voltage drop between this tap and the lower end furnishes the neutralizing voltage. The antenna may be coupled to the amplifier by any of the ordinary methods; the exact arrangement of the tuning apparatus will depend upon the type of feeder system employed.

It should not be necessary to shield the oscillator if the apparatus is laid out so the stray coupling between the two circuits is negligible. To this end the parts should not be crowded too much, and in addition the oscillator and amplifier

tank inductances should be at right angles to each other. To obviate any possibility of stray coupling in spite of these precautions, a "baffle" shield between the oscillator and amplifier may be used. Such a shield is simply a piece of sheet aluminum or other good shielding metal which is mounted between the two units so they cannot directly react on each other. The shield should be connected to the common filament center-tap lead. If the oscillator is entirely enclosed in a shielding box there should be provision for plenty of ventilation, otherwise the tube and tuning

apparatus may heat badly and the frequency creep in consequence.

Satisfactory physical arrangement of the apparatus is not difficult; regular breadboard construction may be employed or the parts may be mounted on a panel. It is extremely important that the parts should be mounted very solidly and made unsusceptible to jars and vibration. This

point cannot be stressed too vigorously. The inductances, particularly, should be watched in this respect — even a slight quiver will cause the signal to wobble. With the larger coils for the 3500-kc. band it may be necessary to use wooden clamps to keep the turns from vibrating. Poor mechanical construction will ruin the frequency stability of any self-controlled oscillator, and the frequency stability of the oscillator-amplifier transmitter is no better than that of its oscillator.

A description of an oscillator-amplifier using a Hartley oscillator has previously appeared in *QST*¹ and in the *Handbook*, and with a few minor modifications in the circuit may be arranged as shown in Fig. 2. The single-control transmitter described in December, 1929, *QST*, will work well as the oscillator in Fig. 4, and a similar layout may be used in building the amplifier.

The table shows constants to be used with various types of oscillators and amplifiers. One point which should be remembered by those used to operating High-C oscillators is that when a tube is used as an amplifier and adjusted for high efficiency and output, the r.f. voltage in the tank circuit builds up to much higher values than it does in High-C circuits. On the other hand, the circulating current in the tank is smaller. The net result of this is that the tank inductance need not be made of such heavy material; for example, $\frac{1}{4}$ -inch copper tubing is a practical necessity

¹ "The Oscillator-Amplifier Transmitter," *QST*, September, 1928.

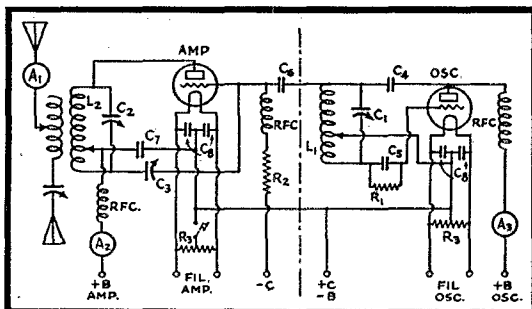

FIG. 2 — AN OSCILLATOR-AMPLIFIER CIRCUIT COMBINING A HIGH-C HARTLEY OSCILLATOR WITH A NEUTRALIZED AMPLIFIER

with a High-C Type '10 oscillator with 600 volts on the plate, while the same tube used as an amplifier with the same plate voltage will require nothing larger than No. 14 copper wire — and the wire will probably develop less heat than the tubing. At the same time, however, the receiving condenser which stands up well in the High-C circuit will almost invariably spark over when used in an amplifier adjusted for high efficiency, especially during preliminary adjustments when the antenna is not taking power.

The same thing applies in the higher-power amplifiers. A safe breakdown rating for variable condensers used to tune amplifier tank circuits would be approximately twice the d.c. voltage used on the amplifier. That is, with 2000 volts on a Type '52 amplifier, for instance, the condenser should be rated for 4000 volts. A 3000-volt condenser might stand up, depending largely on the finish of the plates and the accuracy of spacing between them, but would probably flash over occasionally. In an amplifier adjusted for high efficiency the instantaneous values of voltage in the tank circuit sometimes reach rather surprising values.

TUNING

Very little need be said about tuning the oscillator, since practically all amateurs are familiar with the adjustment of High-C circuits.² First set the frequency at some suitable spot inside the limits of the band on which the transmitter is to work and adjust the excitation until the note is pure and steady. The monitor is indispensable for this work. The adjustments should be made with the amplifier coupled to the oscillator and with the filament of the amplifier tube lighted. No plate voltage should be applied to the amplifier, however.

The next step is to neutralize the amplifier. A flashlight lamp connected to a loop of wire will be helpful. The loop should be held close to the tank inductance of the amplifier and the amplifier tuning condenser slowly varied until the lamp glows. The neutralizing condenser should then be adjusted until the lamp goes out, after which the plate tuning condenser should be readjusted until the lamp glows again. This procedure should be continued until it is impossible to make the lamp glow, even with the closest possible coupling be-

tween the loop and the amplifier tank inductance. This indicates that the amplifier is approximately neutralized.

At this point the signal should be checked again in the monitor. Very probably the neutralizing process will change the frequency slightly, so that the oscillator should be retuned, if necessary. Now the final neutralizing adjustment is made with the help of the monitor. As the amplifier tank condenser is tuned slowly through resonance the frequency of the beat note probably will change suddenly, indicating that the tuning of the amplifier tank circuit reacts on the oscillator. With approximate neutralization the magnitude of the frequency change will be of the order of 1000 cycles or so, and the neutralizing condenser should be carefully adjusted until there is no sudden change in frequency as the amplifier tank condenser is tuned through resonance.

There may, however, be a gradual change as the condenser is swung over its whole range, amounting to possibly one or two hundred cycles over the whole condenser dial.

With the neutralizing adjustment finished, the plate voltage may be applied to the amplifier. Before doing so, however, the amplifier tank should be tuned as close to resonance as possible, and the antenna should be detuned or the coupling coil removed from the vicinity of the amplifier tank coil. It is best to use the transmitting key instead of a switch to close the plate circuit in these preliminary adjustments, because if the amplifier tank is off resonance the tube will draw very high plate current. If the tuning is right the plate current will be rather low. If it is too high, make small changes in the amplifier plate tuning, closing the key for an instant after each change, until the plate current approaches a reasonable value. After it is low enough to be safe hold the key down and adjust the condenser until the plate current is at minimum. The minimum point will usually be rather sharp. With a properly adjusted transmitter the minimum plate current will be between 15% and 25% of the normal plate current of the tube. The greater the excitation the lower will be the plate current of the amplifier with leak bias.

The next step is to couple the antenna to the amplifier and adjust the antenna tuning for maximum current. This probably will necessitate a readjustment of the amplifier tank condenser, since coupling to the antenna circuit will throw

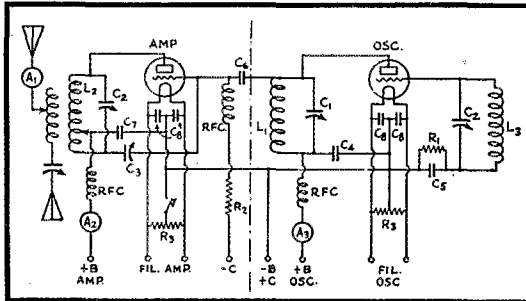

FIG. 3—ANOTHER CIRCUIT USING THE TUNED-PLATE TUNED-GRID OSCILLATOR

² "Overhauling the Transmitter for 1929," *QST*, August, 1928.

the amplifier slightly out of resonance. The amplifier tank condenser should always be adjusted for minimum plate current and the antenna tuning for maximum antenna current. As the antenna takes more load the minimum amplifier plate current will of course rise, but there will always be one setting of the plate condenser at which the plate current is less than at any other, and this setting gives the optimum output and efficiency. The loading process may be continued until there is no further increase in antenna current. With a Type '10 tube it is usually possible to load the amplifier until the tube draws 75 to 100 milliamperes — with about 600 volts on the plate — before the point is reached where a further increase in plate input results in no increase in antenna current.

While making the adjustments described above the signal should be checked continuously in the monitor. If the plate supply for the amplifier is adequate, the note will be the same regardless of the plate current, but with an overloaded plate supply or filter there may be some undesirable modulation if the load is too great. Since the quality of the signal is the first consideration, the adjustment which gives the best note with a reasonable amount of power output should be used.

Even though the amplifier is carefully neutralized there probably will be some slight reaction on the oscillator, so that there may be a small change in frequency if anything happens to change the tuning of the amplifier circuit, such as a change in antenna tuning or a change in amplifier plate voltage. These changes are usually small enough to offer no serious difficulty, however. For instance, in a small set using the circuit of Fig. 2, with a Type '45 oscillator and a Type '10 amplifier, tuning the antenna condenser through resonance and completely off resonance on both sides resulted in a total change in frequency of only a few hundred cycles. Such a change in tuning in the antenna circuit could hardly ever occur in practice even though the antenna were swinging badly, so that for all practical purposes the antenna has no effect on the frequency. With the same set the amplifier plate voltage could be varied from zero to 600 volts with a total change in frequency of less than 100 cycles. Since the plate voltage with any sort of decent power supply will never vary within such limits, the change in frequency with power supply

regulation can also be considered negligible.

The excellent frequency stability of oscillator-amplifier transmitter makes key-thump elimination much less difficult than in the case of an oscillator feeding the antenna. Practically all key-thump elimination methods depend for their success on the fact that surges can be prevented if the plate voltage on the tube being keyed is made to rise and fall slowly when the key is closed and opened. Because of the negligible change in frequency as the plate voltage on the amplifier is varied it is possible to use lag circuits which give a much greater time delay — and consequently, better click elimination — than would be practicable when keying an oscillator, since there is little tendency toward chirps.

Key thump elimination has been discussed many times in *QST*, and endless varieties of practical methods have been shown. Suffice to say that so long as certain well-defined prin-

ciples³ are followed clicks can be eliminated — or at least reduced to a very great extent.

There are several places in the circuit where the key itself may be placed. One of the most satisfactory is in the filament center tap of the amplifier tube, as shown in the diagrams. Separate filament supplies for the oscillator and amplifier are necessary with this form of keying, as was pointed out previously. It is not advisable to key in the plate circuit of the amplifier if the same plate supply is used on both tubes because the key must be placed in the positive lead, and in addition it is harder to eliminate clicks with plate keying. Grid-leak keying is not always satisfactory because there is often enough leakage in the key base to allow the amplifier to draw considerable plate current, resulting in a "back wave" which is often nearly as loud as the main wave. If the key is sufficiently well insulated to allow complete cut-off of plate current this form of keying will function as well as any other, and in addition lends itself readily to thump elimination.

SOME GENERAL CONSIDERATIONS

Although at first thought it might seem that the oscillator-amplifier transmitter is considerably more difficult to build and complicated to adjust than the simple oscillators to which most of us have become accustomed, that is not actually so. The oscillator itself presents no difficul-

³ "The Requirements of Transmitter Keying," *QST*, February, 1929.

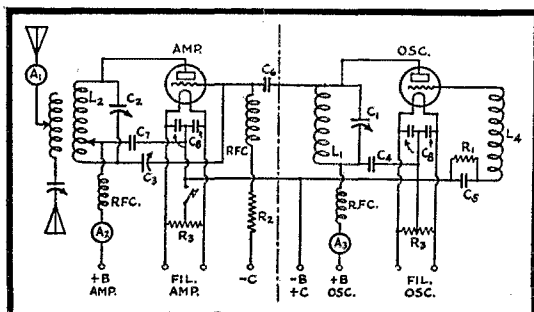

FIG. 4 — IN THIS CIRCUIT THE OSCILLATOR IS THE FIXED GRID COIL ARRANGEMENT OF THE T.P.T.G.

ties to the amateur who has had any experience at all in handling transmitters. The circuit should not be thought of as being a conglomeration of apparatus which only can be adjusted by arduous experimenting combined with good luck. Each unit of the transmitter should be considered separately, starting with the oscillator, and the amplifier should not be attacked until the oscillator has been put in order. After handling an oscillator-amplifier transmitter there is no temptation to go back to straight oscillators—the clean-cut performance of the separately-excited

rig and its greater possibilities in the way of increased frequency stability and increased power output make operating it a pleasure.

The plate supply for the set is important. If at all possible, it is preferable to use separate plate supplies for the oscillator and amplifier. With a low-power outfit this does not represent a great expense—a plate supply such as described in November *QST** can be built at a very reasonable price and is entirely adequate for supplying plate

*"A Complete Push-Pull C.W. Transmitter at Low Cost," *QST*, November, 1930.

TABLE OF CONSTANTS

	OSCILLATORS			AMPLIFIERS					
	Type '45	Type '10	Type '52	Type '10	Type '65	Type '03-A	Type '52	Type '60	Type '04-A
C_1 —500 μ fd. variable condenser	R	R	T_1						
C_2 —250 μ fd. variable condenser				R	R	T_1	T_2	T_2	T_2
C_3 —50 μ fd. variable condenser				T_1	T_1	T_2	T_2	T_2	T_2
C_4 —250 μ fd. mica condenser	R	R	5000 v.						
C_5 —100–250 μ fd. mica condenser	R	R	R						
C_6 —100 μ fd. mica condenser				R	R	5000 v. ¹	5000 v. ¹	5000 v. ¹	5000 v. ¹
C_7 —.002 μ fd. mica condenser				R	R	5000 v.	5000 v.	5000 v.	5000 v.
C_8 —.002 μ fd. mica condenser	R	R	R	R	R	R	R	R	R
C_9 —.25 μ fd. or larger					500 v. ²			1000 v. ²	
R_1 —Grid leak—25 watt size ample	50,000 Ω	20,000 Ω	20,000 Ω						
R_2 —10,000 ohms				10 watt	10 watt	25 watt	25 watt	25 watt	25 watt
R_3 —100 ohms, center-tapped	10 watt	10 watt	10 watt	10 watt	10 watt	10 watt	10 watt	10 watt	20 watt
R_4 —Screen-grid dropping resistor					25,000 Ω 25 watt			100,000 Ω 50 watt	
L_1 —3500 kc.—12 turns, 2½" diameter	¼" c.t.	¼" c.t.	¾" c.t.						
7000 kc.—5 turns, 2½" diameter	"	"	"						
14,000 kc.—3 turns, 2½" diameter spaced	"	"	"						
L_2 —3500 kc.—20 turns, 2½" diameter				No. 14 wire or 3/16" c.t.	No. 14 wire or 3/16" c.t.	3/16" c.t.	3/16" c.t.	3/16" c.t.	¼" c.t.
7000 kc.—10 turns, 2½" diameter				"	"	"	"	"	"
14,000 kc.—6 turns, 2½" diameter				"	"	"	"	"	"
A_1 —R.F. Ammeter				0–1.5	0–1.5	0–4	0–4	0–4	0–8
A_2 —D.C. Milliammeter				0–150	0–150	0–300	0–300	0–300	0–500
A_3 —D.C. Milliammeter	0–100	0–100	0–200						
Plate Voltage	350	500	2000	500–750	500	1000–1500	2000	2000	2500
Negative Bias Voltage (Battery)				45	45	45	90	45–90	45

R—Receiver type (approximately 1000-volt breakdown).

T_1 —Transmitting type, 2500-volt or higher rating.

T_2 —Transmitting Type, 3500-volt or higher rating.

1—Air condenser of lower breakdown voltage may be used instead.

2—Voltage rating should be same as plate supply voltage if no voltage divider is used. With series resistance and condensers of these voltage ratings the plate supply should never be turned on until the filament of the tube is hot.

c.t.—copper tubing.

and filament power to one or two Type '45 tubes. Many amateurs operating medium-power tubes have graduated from the Type '10 class and probably have their old power-supply equipment available. With an outfit using a Type '52 tube

meet the present-day requirements for transmitters, and most listeners can't detect any difference between them and crystal outfits.

Strays

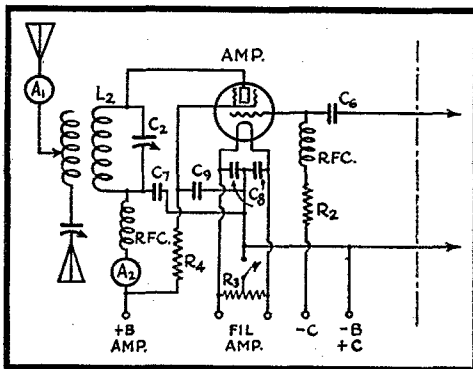

FIG. 5.—THE SCREEN-GRID AMPLIFIER

This circuit may be substituted for the neutralized amplifier in Figs. 2, 3 and 4. Any of the three oscillator circuits may be used. The screen-grid voltage may be obtained from a voltage divider across the plate supply as well as by the series resistor shown.

feeding a Type '04-A, however, the expense of an additional power supply would be rather prohibitive.

As a matter of fact, there is no objection to using the same plate supply for both oscillator and amplifier if the equipment can handle both loads and maintain its regulation at a reasonable figure. The change in plate voltage as the load is thrown on and off is the determining factor. With mercury-vapor rectifiers, now used almost exclusively for high voltages, the regulation is excellent, and the oscillator in most cases simply provides a constant load for the rectifier-filter system which prevents the voltage from building up to high values — as it will if the load is thrown off entirely when keying — and in the end actually improves the regulation. If the oscillator circuit is carefully adjusted, the changes in plate voltage which do occur as the amplifier is keyed will have little effect on the frequency. Incidentally, a secondary advantage of the oscillator amplifier set is that the continuous load on the plate supply furnished by the oscillator effectually prevents blowing of filter condensers from building up of peak voltages.

The old "m.o.p.a." has been overlooked by too many amateurs who are in a position to try it and profit by its many advantages over self-excited oscillators. The circuit is worthwhile without crystal control — personally we believe it is preferable to crystal control in almost all cases except where it is necessary to work on a spot frequency or where mechanical vibration cannot be overcome. The simple circuits shown here may not, in rigorous tests, equal the performance of the crystal set in every respect, but they fully

Hams of some years' standing will remember Howard Mason, ex-7BK, formerly department editor of *QST*, and lately operator with the Byrd expedition. He's modest — how modest can be judged by the following clipping from the *Seattle Times*:

"It's all very well to be retiring, but when you are forced to listen to the ovation given by a city like New York to a party of which you are a member — well, that's stretching this retirement business too far.

"That's what happened to Howard F. Mason, Seattle youth who was radio operator for Rear Admiral Richard E. Byrd on the recent expedition to the South Pole, when the party landed in New York.

"Mason made the trip from Seattle to New York to take part in the celebration. Upon his arrival in New York, Mason was given a ticket which was supposedly good for a ride in any one of three cars in the parade that the city was putting on for the explorers.

"The Seattle man was one of the first to leave the city's welcoming boat, the *Macon*, to take his place in the parade. He found the cars — easily.

"But it was harder to get into them. The first was filled with Army officers who were sorry, but wouldn't make way for him. The second was full of civilians equally unwilling to relinquish their seats. The third had only two occupants, but they convinced Mason that the vacant seats were reserved.

"Mason then cast about for a vehicle in which to ride to the City Hall, where the official welcoming was to take place. He found none — that is, none but the subway, so he took that.

"At the City Hall his troubles continued. The crowd was too closely packed for him to get through to his companions. When he informed people that he was a member of the Byrd expedition, they only laughed.

"But Mason wasn't going to miss the show.

"The one reliable means of transportation was left to him — the subway. So he took that again, this time to the *New York Times* office.

"He asked for the radio room.

"There he made himself known to the operators with whom he had communicated for two years from Little America. He didn't know them, but he felt as if he did.

"May I listen to our reception over your radio?" was his plea.

"He told them of his plight and they assured him he might listen.

"At the end of the program he remarked philosophically: 'I guess I enjoyed it better from here.'"

WIMK's Dynatron Frequency Meter

By R. B. Parmenter*

MANY times WIMK has been unable to give frequency readings to stations requesting them, due to lack of time. Since there is not enough room on the operating table for the G.R. precision wave meter and a separate oscillator, it was necessary to lug them out of their cases each time a reading was given. Besides, we always felt a little worried as to just how accurate our readings were when using this method; there were too many things involved. Therefore, in order to fill the many requests for frequency measurements, to check off-wave operation, and to meet the need for a frequency meter of the heterodyne type to help locate scheduled stations, the dynatron frequency meter described was built for use at WIMK.

The dynatron type of frequency meter was considered to be the best of the heterodyne class and this one is very much like those described in the October 1930 issue of *QST*, particularly the meter built by F. E. Handy. The circuit diagram is shown in Fig. 1. A type '22 tube was decided on since the station is at present equipped with a receiver using d.c. supply and also because a Type '22 is better suited to our purposes than a '24 here at WIMK, the transmitters being only a few feet from the operating position and induced r.f. would surely wreck things if the meter had to be left turned on for long warming-up periods, as a Type '24 tube would have to be.

All of the various parts are mounted on a 3/16" thick bakelite panel 6 7/8" wide by 12 3/4" high, and the whole assembly is mounted in a mahogany cabinet 5 1/2" by 6" by 12", inside dimensions. The Type '22, plate coil, and screen-grid and plate by-pass condensers are mounted on a shelf directly above the tuning condenser. The shelf is 1/8" thick bakelite, 5 7/8" by 3", and is supported rigidly from the front panel by two angles of 1/8" x 1/2" strap iron. One-inch clearance is left between this shelf and the front panel to provide space for wiring and to keep the plate coil some distance from the front panel.

* Chief Operator, A.R.R.L. Headquarters Station WIMK.

The plate coil is held rigidly in place at the back of the shelf by two small brass angles and is mounted so as to be as free from everything as possible. The General Radio tuning condenser has a fixed-capacity section in the front and is the same as their Type 557 except that metal end plates are used, doing away with the necessity of shielding the front panel. It was necessary to mount the tuning condenser 5/8" from the front panel to fit the shaft to the 6" National dial. The shaft may be sawed off but it is a good idea to mount the condenser back because this further cuts down the possibility of hand capacity.

All supply leads are brought in through a Yaxley socket which is supported from the front panel by two 1/4" brass rods 5 5/8" long, tapped at each end to take a 6/32 bolt. This mounting, as well as the condenser and bakelite shelf mounting are lined up so that all bolts are covered by the 6" dial, which keeps the panel free from unsightly mounting screw heads. All wiring is No. 14 insulated bus wire and is tied together wherever necessary to make it more rigid. It is best to avoid running the wiring near the coil or stator section of the tuning condenser since a slight shifting of the wiring would ruin the calibration. An open-circuit jack is connected across the 0-5 milliammeter so that it may be used for other purposes. A jack is also provided directly across the filament of the tube so that by means of an external voltmeter the filament voltage can be checked and held at 3.3 volts — which helps to lengthen the life of the '22.

Some '22's require a higher space current to make them oscillate than others. In our case we were fortunate to get one that oscillated with as low space current as 2.5 ma. but a space current of 3.8 ma. was found better for producing 14-mc. harmonics of useful strength.

While calibrating, the filament voltage is set at 3.3 volts and the space current is set to 3.8 ma. by adjustment of the potentiometer, 90 volts being used on the screen-grid and 45 volts on the plate.

In one set-up at the station a dynatron oscillator using a 3500 kc. coil was used. The signal

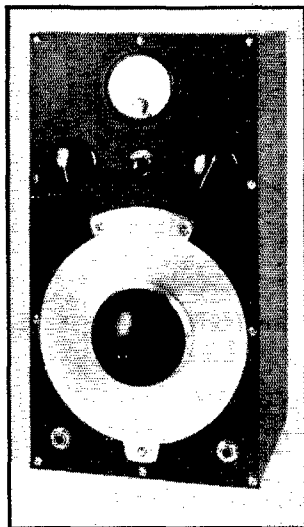

THIS DYNATRON FREQUENCY METER CAN BE USED FOR ALL AMATEUR BANDS FROM 1715 KC. UP

The large vernier dial and micrometer scale make accurate settings and readings possible. The filament rheostat knob is at the upper left and the potentiometer control is the one at the right, the filament switch being in the center. The two jacks at the bottom of the panel are for connecting a filament voltmeter and for connecting the 0.5 milliammeter to other apparatus.

from this oscillator was too great for 3500-kc. measurements even when using "A" and "B" supplies separate from those used for the receiver. It is desirable, of course, not to have too much output because accurate readings are difficult when the oscillator signal is so strong as to block the detector tube of the receiver. Consequently

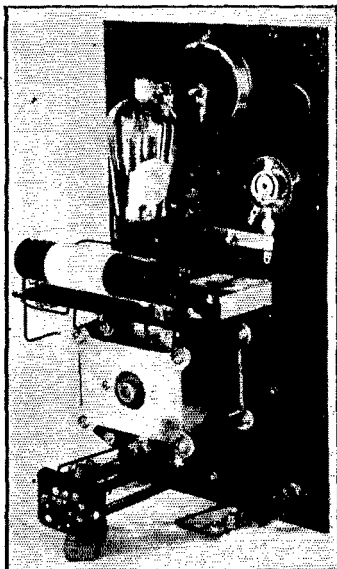

ALL THE COMPONENTS ARE MOUNTED ON THE PANEL

The shelf carrying the tube, plate inductance and by-pass condensers is supported by angle brackets. Insulated "bus" wire is used for making connections; the supply leads are bunched and laced wherever possible.

this frequency meter uses a coil that covers the 1750-kc. band and the harmonics, as far up as those in the 14-mc. band, are all of about the same strength. A separate "A" battery is used on the dynatron and coupling to the receiver is obtained through a common "B" supply. It is impossible to use the same "A" supply for the receiver and the dynatron oscillator since the space-current meter is in the "-A" to "-B" lead and the plate current of all the tubes in the receiver would pass through the milliammeter.

In selecting a coil form for the plate coil one should use a form that is quite rigid, having at least a 1/16" wall in the case of bakelite tubing. Wood dowel may also be used but there is some chance of it absorbing moisture. A small diameter is also desirable: about 3/4-inch to one-inch for a 1750-kc. coil and 1/2-inch diameter for a 3500-kc. coil. A larger diameter than this may emphasize band capacity effects and would be likely to affect calibration because of its larger field. The finished coil should be treated with two coats of "airplane dope" to hold the winding in place and make it moisture proof. "Airplane dope" is

very good for treating coils, by the way, and clear Duco is also good. Collodion is not so good because it does not soak into the winding readily but tends to lie on top.

The 6-inch National dial is the same as the 4-inch type except for size and can be read to one tenth of a degree. Since this makes very close readings possible, it seemed desirable to draw up the calibration chart so that readings could be taken from it directly without trying to estimate tenths of a degree. About 35 degree coverage was allowed for each sheet of cross-section paper and the complete calibration curve is on three sheets. This may sound like overdoing it but in practice it works out nicely. The dial-setting figures are out on the left-hand side of the sheet and the corresponding frequency at the bottom. One small square on the cross-section paper represents two-tenths of a degree or five squares represent one degree on the dial. One square represents 2 kc. in the 3500-kc. band or 4 kc. and 8 kc. on the 7- and 14-mc. bands, respectively. This permits very close readings from the chart,

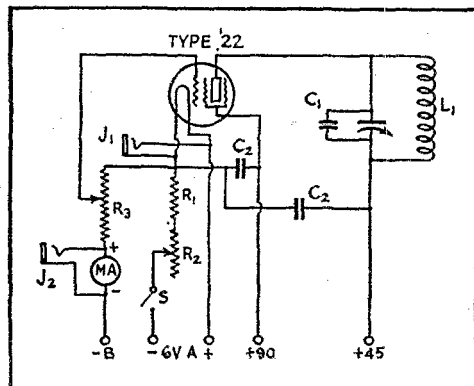

FIG. 1 — SCHEMATIC CIRCUIT OF THE FREQUENCY METER

- C₁ — Band-spreading tuning condenser (see text)
- C₂ — 1-μfd. by-pass condensers
- R₁ — 10-ohm fixed filament resistor
- R₂ — 20-ohm filament rheostat
- R₃ — 2000-ohm potentiometer
- MA — 0.5 milliammeter
- S — Filament switch
- L₁ — 1750-kc. band inductance; 82 turns No. 30 d.c.c. wire wound on a bakelite tube of 1-inch outside diameter, no spacing between turns
- J₁ — Open-circuit jack for filament voltmeter
- J₂ — Jack for connecting milliammeter for other measurements

the nuisance of three sheets of paper for the curve being compensated for by the convenience and accuracy of the readings.

The preliminary calibration was made using the Headquarters frequency-standard set-up. The finished meter covers approximately 3430 kc. to 4035 kc. in the 3500-kc. region, which gives good spread for all bands. Since it is always best

(Continued on page 38)

An Electrically-Operated "Bug"

By Charles E. Seymour, W9FMN*

POUNDING brass," to most amateurs, becomes just that sooner or later. At least the mechanical side of it does. With increased receiving proficiency—and sometimes without it—comes a desire to speed up the sending. Unless one acquires the knack of sending rapidly with a minimum of effort, a "glass arm" and a poor fist result. It is for such as these that the

Making an electrically-operated key is quite simple when one gets down to it. A "side-swiper" is the basis of the gadget; the side contacts are brought out separately, one side operating a time-delay relay arranged in buzzer fashion to make evenly-spaced dots at any desired rate of speed, the other side being worked either as the ordinary dash lever on a mechanical bug or operating another time-delay relay adjusted to make dashes of the right length for the dot speed. The first arrangement is the easiest to build, since only one time-delay relay is required.

The writer's key was made from an old telephone relay, a drawing of which appears in Fig. 1. It will be noted that between the iron core and the solenoid winding is a brass sleeve. It is this

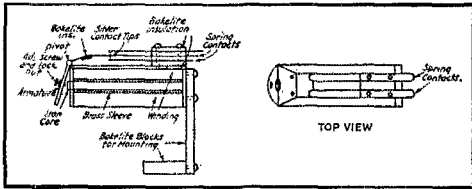

FIG. 1 — THE TIME-DELAY RELAY WHICH FORMS THE NUCLEUS OF THE ELECTRICALLY-OPERATED KEY

automatic key, commonly known as the "bug" key, has been designed. But automatic keys are rather expensive to buy, and there are always other things for the set which seem to be needed more.

With a little mechanical ability it is possible to construct a very acceptable bug key at home, and by exercising a little ingenuity a key can be built which does not depend on mechanical action for

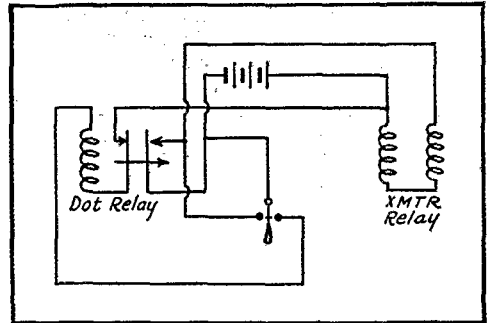

FIG. 3 — AN ARRANGEMENT WHICH ALLOWS KEYING AT SPEEDS BETWEEN TEN AND FORTY-FIVE WORDS PER MINUTE

sleeve which causes the time-delay action; without it the relay, when connected as shown in the diagrams, would act simply as an ordinary buzzer, and could not be slowed up sufficiently to make dots at hand-keying speeds. The principle of operation is quite simple and hinges on the fact that when the current through the coil is broken a current is set up in the brass sleeve which tends to keep the core magnetized.¹

Referring to Fig. 1 it will be seen that an adjusting screw is provided on the armature and the core. By removing the screw the action of the relay may be slowed down to about one dot per second. Even slower speeds could be obtained with a thicker brass sleeve. The sleeves are about a sixteenth of an inch thick on the relays in use here.

¹ This is explained in more detail in *Time Relay Control of Transmitters*, QST, July 1929, page 17. If telephone relays of the type described above cannot be obtained, a suitable relay may be constructed as described in this article, using an old telegraph sounder and jack springs. — EDITOR.

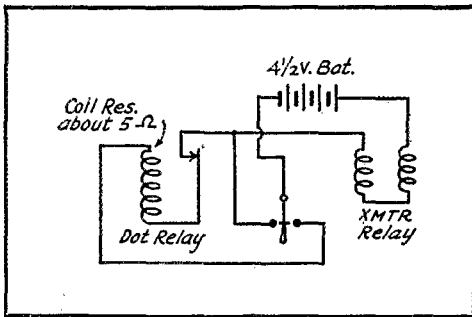

FIG. 2 — THE SIMPLEST HOOK-UP
It is suitable for slow speeds only, however.

making dots. An electrically-operated key will make perfectly even dots for hours on end; further, it can be made to make the dashes, too, if one wants. The telephone company can furnish the vital parts; failing such coöperation, the whole works can be home made with the help of some parts usually to be found in the junk boxes of most stations.

* 290 Northwestern Ave., Milwaukee, Wis.
1738 E. Bennett Ave., Milwaukee, Wis.

Figs. 2, 3 and 4 show three ways of hooking up the relays. In Fig. 2, the relay need have only one set of contacts, but this system is good only for very slow speeds — below ten words per minute. The relay operates on the buzzer principle except that the time-delay feature results in regularly

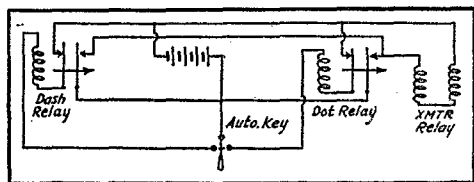

FIG. 4 — IN THIS DIAGRAM TWO RELAYS ARE USED, ONE FOR DOTS AND THE OTHER FOR DASHES

spaced dots instead of a buzz. A separate keying relay is used on the transmitter; the time-delay relays are only part of the key itself and are not intended to usurp the function of the regular keying relay. With a double-contact relay one set of contacts can, of course, be used to key the transmitter if the current to be broken is not too great for the carrying capacity of the contacts. With the sideswiper to the right the dots will roll out; on the left-hand side dashes are made in the usual way.

In Fig. 3 a separate set of contacts is used to break the circuit of the transmitter relay. This system is used for speeds from ten words per minute up. With a fast relay on the transmitter it is possible to get the dot speed up to where sending at 45 words per minute is entirely practical — if the operator can keep up with the key. In this system, also, the dashes are made manually.

Fig. 4 shows how two relays can be used to produce both dots and dashes. The principle of

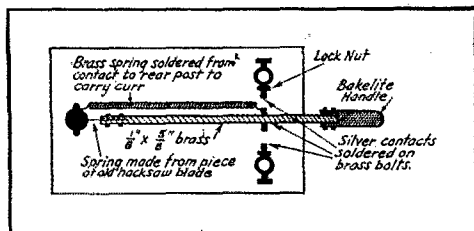

FIG. 5 — HOW THE SIDESWIPER IS CONSTRUCTED

operation is fundamentally the same as Fig. 3; the only difference is that one relay is adjusted for dots and the other for dashes. A little time and practice will be required to get the proper setting of both relays for various speeds. At the writer's station the normal setting of both relays is for a speed of about twenty words per minute. A switch is provided for shorting out the contacts of the dash relay so that if a slower speed is de-

sired the switch is closed and only the dot relay need be adjusted, the dashes being made manually.

To complete the story, a drawing of the sideswiper is shown in Fig. 5.

No doubt a number of modifications will suggest themselves to builders. Almost any sort of time-delay relay which can be adapted to make dots or dashes at the proper rate of speed can be worked into such a keying system. The relay shown is simply one which happened to be available to the writer.

Making Records of Amateur Signals

(Continued from page 25)

or filters, the monitor signal of any given arrangement can be recorded, a change in adjustment made, and results observed by comparison of the two recordings instead of depending on memory.

Short-wave 'phone BCL's will probably find lots of pleasure recording announcements from VK3ME to prove to their friends that they really do hear him. And lastly, are there not many times when you are vainly trying to decipher some futuristic "bug" fist that you would gladly spend a quarter to send the offender a true record of just what he was putting out in the name of the Continental Code?

W1MK's Dynatron Frequency Meter

(Continued from page 36)

to calibrate the meter right where it is to be used, standard-frequency signals from W1XP were used for the final calibration.

In the future we will be pleased to give a frequency check from W1MK to any station requesting it and satisfactory accuracy can be expected since the meter is checked regularly by signals from W1XP and the other A.R.R.L. Standard Frequency Stations.

Strays

As an accompaniment to the renewable filament tubes we have the screw-grid tube advertised recently in one of the radio magazines and pounced upon by W1AUS. If this keeps up we'll be able to buy our tubes in parts — so much for the filament, plate, vacuum, etc., and make up tubes to our own specifications.

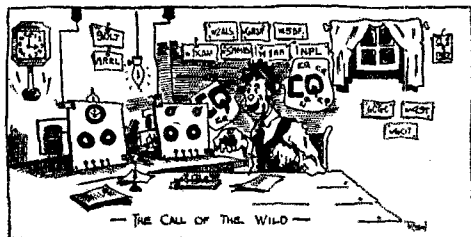

Second All-Section Sweepstakes Contest

Everybody Invited to Take Part February 14 to 28—No Entries Required

By F. E. Handy, A.R.R.L. Communications Manager

WHAT'S it all about? To those who took part in the initial Sweepstakes Contest, held thirteen months ago, no detailed explanation will be required. This will be another competition filled with opportunities for making new contacts and friendships between amateurs in each and every one of our A.R.R.L. Sections throughout both the United States and Canada (including Hawaii, Alaska, P. I., Porto Rico and Cuba, etc.). There will be two full weeks of operating enjoyment. Did you ever sit down before your transmitter and see how many Sections of the A.R.R.L. organization you could contact reliably in fourteen days? Did you ever see how many stations could be worked and messages exchanged in a given time? If you have never tried to work "all Sections" in a given time this will be an opportunity. Any and all stations taking part can add substantially to the list of Sections and states previously worked!

In this Sweepstakes or second National Relay Contest participants can exchange but one dispatch each way with any station for credit in the contest, but may exchange with as many stations as possible. Messages are to be transmitted in complete form with city of origin, number, date, address, text and signature, the text being of ten or more words by plain language count. Messages not complying with this rule will be designated incomplete, and the QSO on which they were exchanged eliminated from the contest. The handling of a radiogram each way is essential to proving each contact a "solid" QSO, the basis for scoring.

Competition: The main competition you will receive in taking part will be that from operators in your immediate Section of our A.R.R.L. organization. Everyone can take part — no entries are required. Of course provision has been made to tabulate Section scores too — to see which S.C.M. has the best organization and teamwork in proportion to the distribution of amateurs or radio-population of the different sections. There's nothing to prevent you from working to be national "high station" if you wish, but certificates will be awarded to the highest or winning stations who run up the best record for each Section. One of the outstanding good points of our first Sweepstakes Contest was the fact that the fellow with low power was able to strut his stuff with the best of them — the certificate winner in one Section actually using just a '01-A with 180

volts of "B" supply! In another Section a station using 3500 kc. 'phone ran up a score of 2592 points, which we mention just to show that 'phone operators can get just as big a kick from the contest as c.w. men. It makes no difference whether you use 'phone or c.w., 1750 kc., 3500 kc., 7000 or 14,000 kc. — use them all if you want to, the choice of frequency, operating hours, and operating judgment exercised will determine

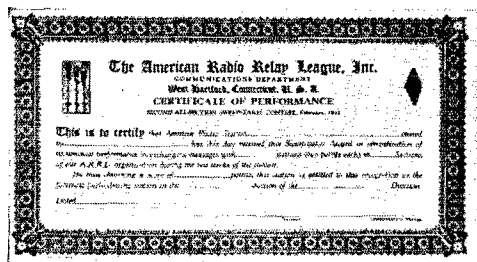

SAMPLE SWEEPSTAKES CERTIFICATE

where you place. Every man who takes part and reports will help his Section and receive the credit fairly due him in accordance with the rules. The chances are equal for everyone. Hop to it!

Messages: The contest will call for individual originality in making up messages to be sent to each station worked. Rubber-stamp messages will be ruled out of the count, which, as will be seen, might be a serious matter affecting the total and final score provided the QSO ruled out is the only contact made with some Section. The method of grading logs has been designed to credit the number of Sections worked in addition to counting the number of points gained by exchange of messages. As many messages can be sent to a given Section as you can work stations there, boosting the score a couple of points for each station worked. However, the final score will be obtained by multiplying the sum of all the points made by the number of Sections worked, by 68 if some station shall have succeeded in exchanging messages with at least one station in every Section, including his own Section. This will make our contest more interesting and general in character.

The main thing to be remembered is that only QSO's proved by copies of messages received and

sent *during* the two weeks' test count. The two necessary messages with a certain station may or may not be handled both on the same day or during the same contact, but they must both be handled sometime between the beginning and end of our message-handling all-Section contest. Most of the messages in our contest will probably be "originated and delivered," addressed to the station being contacted. However, when regular routine traffic happens to be in need of routing in a particular direction for delivery or further relaying, it should be handled and an extra copy made to be submitted with the report of work done in the contest. There is no excuse for routing messages in the wrong direction unless it is learned that a station can forward them by schedules or traffic routes, though. As in our last contest, off-frequency operation will result in disqualifications. The inclusion of messages with rubber-stamp texts or incomplete preambles will result in deductions from the scores of one or both stations responsible. In all cases in which Sections are smaller units than states, the name of the Section should be included in parentheses in the preamble of originated messages to assist the award committee in identifying them. Thus a preamble might read, "Springfield (Western Mass.) W1BWY . . . Feb. . . ."

Scores: Each received message counts one point, and each transmitted message one point, making a score of two points for each QSO, if a message has been successfully transmitted and received. It is possible, therefore, to score *two* for every QSO. Two stations in contact must *each* transmit a message to the other station, as proof of a solid two-way QSO, before any score will be counted for either. Messages count both for the contest and regular traffic totals turned in to Section Manager for mention in *QST*. The messages may be written by the operators during the QSO addressed to the station contacted, or regular traffic can constitute "contest" traffic. In addition, the total contest score made by exchanging messages is to be multiplied by the *number of sections* with which messages have been exchanged. Since there are 68 sections, as a possible multiplier there is practically no limit to the possible scores! After getting a start the score mounts with amazing rapidity!!!!

Certificate awards: "Sweepstakes" signifies "a clean sweep." The highest scoring stations in our February contest will have virtually "swept the air" and by skillful operating piled up points by many successful QSO's with individual stations, and with a surprisingly large number of Sections contacted! The Sweepstakes insignia, significant of victory, and including the A.R.R.L. emblem as part of its design, appears in miniature on each of the award certificates, which are executed this year in an entirely new border style. With just a little effort you may win one of the sixty-eight handsomely lithographed certificates, such as is

reproduced herewith — and you are *sure* to make a lot of enjoyable QSO's if you take part! Last year many fellows in all parts of North America reported the fun they had in taking part, and each day checking scores with friendly rivals as the contest progressed. In making the certificate awards and in all matters which concern division of territory in the contest the list of Sections which appear on page 5 of February *QST* will be followed.

Misapprehensions corrected: It is *not* necessary that the stations contacted be actually participating in the contest in order to exchange messages and make valid points. While considered desirable it is *not* absolutely essential that every station you contact send Headquarters copies of the two messages exchanged before points will be counted. Of course logs will be checked by the award committee wherever possible. It is *not* necessary to submit records and logs on standard League forms — any neatly kept tabulation is acceptable if understandable. There is *no* rule against making advance schedules by mail or radio if you think these will help. We see no special advantage in this, however. Your own log, verified insofar as possible, will be the basis for computing official scores. Just follow the rules and suggestions herein and follow the standard A.R.R.L. form¹ in making up your messages of ten or more words (text) and you will be safe. You can refer any station that doesn't know what it's all about to these pages and urge the operator to read *QST* "more thoroughly" — but first of all just ask 'em to show the right spirit by coming through with a message and taking yours to help you over the hard spots and roll up the total. Not a bad idea to send QSL's to all stations you work with which cards have not previously been exchanged, too — not necessary at all insofar as the contest is concerned, but it adds to the friendly spirit all our operating activities should create and makes a permanent souvenir of each QSO.

In general: Stations having really modern equipment — frequency stability and d.c. notes — will have the advantage and can probably outperform older or "just ordinary" equipment. However, intelligent use of the different amateur bands is one of the essential requirements to win. More than mere stations will determine who will get out certificates. Stations do count, but this is a contest of operating skill, too! The best equipment is only as useful as the ingenuity of the man behind the key can make it.

Choice of operating hours and operating frequencies is probably important. It's not altogether a foregone conclusion that you should

¹ The Sixteenth Edition of the Rules and Regulations of the Communications Department (January 1931) explains message form and A.R.R.L. organization completely. The new booklet also has the complete text of the F.R.C. regulations for amateur stations, and contains a photograph of W1MK. Keep an R. and R. in your station.

read *QST's* editorial this month and devote all your time to 3500 and 1750 kc. Remote sections can be contacted in daylight on 14 mc., or even on 7 mc. When conditions are spotty on these latter frequencies or QRM is bad there, or when exceptionally good conditions exist on the low-frequency bands, remote sections can be reached best on the lower frequency amateur bands. The most methodical and intelligent use of our up-to-date stations and available operating time will make our efforts show most return — always.

While stations owned and operated by members of the staff at A.R.R.L. Headquarters may participate and while the scores will count for Connecticut, the station owners and operators will be ineligible to receive any prizes or certificates as usual. The Headquarters station will transmit its regular official and special broadcasts at the usual times but whenever possible in the remaining time will participate in the contest work to add to the enjoyment and scores of those looking for QSO's.

THE RULES

1. This contest opens February 15 at 0000 G.C.T. and closes March 1 at 0000 G.C.T. Only work falling between these dates and times will be counted. (E.S.T.: Feb. 14, 7 p.m., to Feb. 28, 7 p.m.) (7 p.m. E.S.T., 6 p.m. C.S.T., 5 p.m. M.S.T., 4 p.m. P.S.T.)

2. Participating stations must each send and receive one complete individually worded contest message of ten or more words with one station in any Section. As many stations as desired may be worked in each Section.

3. The sending and receiving of two messages constituting an exchange in both directions between the contacting stations shall be deemed proof of satisfactory two-way communication only when these messages (or copies) bearing notation of the date and time acknowledged with the call signal and frequency band used by the acknowledging station have been properly filed with the award committee at the conclusion of the contest.

4. Unless messages are composed and transmitted in the proper form with city of origin, station of origin, number, date, address, text, and signature complete and unless the text comprise at least ten words (plain language count) they shall be designated as incomplete. The award committee shall disregard such communications as insufficient evidence of satisfactory two-way communication.

5. A special log or tabulation of QSO's shall be submitted by each contestant, showing the number of Sections contacted, the number of stations contacted in each Section worked.

6. Credits: Sending a message counts one point, receiving a message counts one point, but unless a message has been both transmitted and received with each station contacted, no credits shall be entered. The total station score at the conclusion of the contest will be the product of the number of Sections worked and the summation of the credits obtained by all valid two-way QSO's. Section credits shall be the summation of the scores of all individual participating stations entering logs and message files and located in a particular Section.

7. Reports, logs, and copies of all messages for which credit is claimed must be received at Contest Headquarters from all stations, except those in the Hawaiian and Philippine Islands, on or before noon March 20, 1931. Entries from those outlying points must be received on or before noon April 30, 1931. Entries should be addressed to A.R.R.L. Communications Department, 38 La Salle Road, West Hartford, Conn.

Let us suppose at the start of the test that W6ETJ (Los Angeles, Calif.) works W8CUG in the Western Pennsylvania Section. Each station originates and transmits a message of ten or more words which is successfully received

and acknowledged by the other. The score of each station will be two (one originated, one delivered in this case). Next W6ETJ contacts W3GS (Eastern Pennsylvania) and sends him a message which he originates, for the purpose commenting on some phase of the contest perhaps. This is acknowledged, but W6ETJ is unable to get the message which W3GS tries to send him, due to a local power leak which blankets everything. W6ETJ tells W3GS that he will look for him at the same time later in the contest and puts the traffic, on which a full record of the time and date and W3GS's call signal and the frequency band has been entered properly, aside, circling the single point entered in the log, since this cannot yet be counted either as a single point or as a contact with a new Section (Eastern Pennsylvania). The third station worked by W6ETJ is W9GJS in Indiana and messages are successfully handled both ways. W6ETJ has now contacted two stations in two Sections. His score (2+2) can be multiplied by two for a final result if no more work is done. But he works another Western Pennsylvania station, adding two points to the score. (2+2+2) 2 would now be the final score. Another contact with W3GS is made on the last day of the contest and W3GS gives W6ETJ a regular message (of more than ten words) to QSP. This makes it possible to count Eastern Pennsylvania as a section worked, and now it is possible to reinstate the message sent to W3GS several days before, this counting together with the message just received as two points. Should the contest end, the score would be (2+2+2+2) 3. W6ETJ contacts with two different stations in his own home city, exchanging messages both ways with both stations. He thus adds four more points and has qualified as working another (his own) Section. Assume that the contest closes. All the points made in QSO total twelve in number. Stations in four sections have been worked. The score will be 12×4 or 48. In actual practise, much larger scores may be expected.

What is the correct form to be used in contest messages? See the example of proper message form and order in the Sixteenth Edition of the Rules and Regulations of the Communications Department (January 1931) sent free on request. If you haven't this useful pamphlet drop us a postal today. Only messages complete and correct in every respect will count in our January competition. The proper order follows: City and state of origin, station of origin, number, date, check (unless omitted), complete address, text and signature.

Is it necessary when sending a message which you originate for delivery at a station which you contact, to put in the name, street address, etc., or will the call signal, city and state suffice?

As a general rule, the more complete the address the better. Far too many messages on A.R.R.L. message blanks are returned here by the post office department daily because they lacked a sufficient address to insure delivery. In the course of a year we wear out several call books trying to complete the addresses on such communications. Every message to be relayed through even one station should have the name as well as street and number and all other possible information. However, in the case of messages going direct from originator to address the call signal, city and state will be deemed adequate. Participants may guide themselves accordingly.

How should messages complete in other respects but bearing no signature be sent?

With the words "no sig" after a double dash at the end of the text.

Someone asks what type of message texts should be exchanged in verification of a QSO, if the following examples would do, or if these would be considered "rubber stamp" texts: (1) *Do you think we could keep a regular schedule question?* (2) *How many points has your station acquired in these national tests query?*

The texts are O.K. as they differ materially from each other. Many other questions or facts pertinent to the apparatus in stations, localities, opinions regarding conditions,

(Continued on page 44)

Standard Frequency News and Schedules

IT IS hard to believe that there are many amateurs who are seemingly ignorant of the A.R.R.L. Standard Frequency System and the activities of its three standard frequency stations. Anyone who makes even a pretense of reading *QST* must be acquainted with the frequent and universally useful calibration service the system provides. The radio press and even daily newspapers have printed items concerning it. Yet we recently had the experience of having one amateur, as spokesman for a group, tell us that he knew nothing about the standard frequency stations — that he had never heard of W1XP! This is only a single instance, of course, but the continued prevalence of off-frequency operation makes it seem only too likely that there are a lot of other fellows in the same boat. Rank ignorance can be the only explanation for it. And it is axiomatic that ignorance is never an acceptable excuse where the law is concerned. So talk up the use of standard frequency transmissions, you fellows who are using them and know their value. Tell the off-frequency brother about them, over the air or when sending him an off-frequency report. If he is stubborn and insists that he is right and that the rest of the world, the s.f. stations, the Bureau of Standards, and the Inspection Service, are all wrong — well, that's his funeral.

And these off-frequency chaps are not all beginners, either. Many of them are self-confessed "old-timers" who have allowed their experience to make them careless. Moreover, instances of off-frequency crystal-controlled signals are not unknown. Many fellows seem to have a child-like faith in the statement of frequency they get with their crystals. There are enough things to cause a change in a crystal's frequency — they have been explained repeatedly in *QST* — so that one cannot be certain of even a crystal-controlled transmitter's location in the radio spectrum unless the frequency is checked from time to time. A good heterodyne frequency meter (such as the dynatron described in October *QST*) calibrated by standard frequency signals will provide any amateur with a continuously available source of dependable checking frequency. All he has to do is build the meter. The standard frequency stations will furnish the calibration signals.

Here are the schedules of the A.R.R.L. Standard Frequency Stations for the next two months.

DATES OF TRANSMISSION

Feb. 1, Sunday	BB	W9XAN
	C	W6XK
Feb. 6, Friday	C	W6XK
Feb. 8, Sunday	C	W1XP
Feb. 13, Friday	A	W1XP
	B	W9XAN
	B	W6XK

Feb. 20, Friday	BB	W1XP
	B	W9XAN
	A	W6XK
Feb. 21, Saturday	BX	W6XK
Feb. 22, Sunday	C	W9XAN
Feb. 27, Friday	BB	W6XK
	B	W1XP
	A	W9XAN
Mar. 1, Sunday	BB	W9XAN
	C	W6XK
Mar. 6, Friday	C	W6XK
Mar. 8, Sunday	C	W1XP
Mar. 13, Friday	A	W1XP
	B	W9XAN
	B	W6XK
Mar. 20, Friday	BB	W1XP
	B	W9XAN
	A	W6XK
Mar. 21, Saturday	BX	W6XK
Mar. 22, Sunday	C	W9XAN
Mar. 27, Friday	BB	W6XK
	B	W1XP
	A	W9XAN
Mar. 29, Sunday	BB	W9XAN
	C	W6XK

STANDARD FREQUENCY SCHEDULES

Friday Evenings Schedule and Frequency			Friday and Sunday Afternoons Schedule and Frequency		
Time (p.m.)	A	B	Time (p.m.)	BB	C
	kc.	kc.		kc.	kc.
8:00	3500	7000	4:00	7000	14,000
8:08	3550	7100	4:08	7100	14,100
8:16	3600	7200	4:16	7200	14,200
8:24	3700	7300	4:24	7300	14,300
8:32	3800		4:32		14,400
8:40	3900				
8:48	4000				

Saturday Morning Schedule and Frequency

Time (a.m.)	BX
	kc.
4:00	7000
4:08	7100
4:16	7200
4:24	7300

The time specified in the schedules is *local standard time at the transmitting station*. W1XP uses Eastern Standard Time, W9XAN, Central Standard Time, and W6XK, Pacific Standard Time. Schedule BB transmitted by W1XP is intended particularly for European amateurs and starts at 2100 G.C.T. Schedule BX is transmitted especially for amateurs in Oceania and the Far East. It is transmitted starting at 1200 G.C.T. by W6XK. Reports on these special schedules are particularly desired, not only from overseas hams but from those in the Americas also.

Although the frequencies of the transmitting stations are not guaranteed as to accuracy, every effort is made to keep to within 0.01% of the announced frequencies. The frequency standards are calibrated against the National Frequency Standard. Frequent checks on the transmissions

(Continued on page 74)

The Neglected Current-Squared Galvanometer

Some Suggestions for Its Use

By Paul E. Griffith, W9DBW*

ONE instrument that is rarely seen in an amateur station is the current-squared galvanometer. On first thought the scarcity of such instruments in amateur stations might be attributed to their relatively high cost; but after analyzing the situation one sees that it is not so much the cost but rather the lack of appreciation of their many uses which has kept them from being more popular.

The current-squared galvanometer is nothing more than a thermo-couple type meter which has a scale calibrated in 100 evenly spaced divisions of arbitrary value instead of the usual logarithmic scale common to thermo-couple type ammeters. The deflection of the pointer is directly proportional to the square of the current and the scale reading, therefore, is directly proportional to the power in the circuit. Standard types of current-squared galvanometers require 115 to 125 ma. for full-scale deflection and have a radio-frequency resistance of 4.5 ohms. The meter itself, therefore, dissipates less than one-tenth watt at full-scale deflection. Because of its comparatively small current capacity and low resistance, caution must be used in its handling. This applies particularly to its use in making measurements of radio-frequency power, especially in transmitters.

An instrument such as the Weston Model 425 or Jewell Pattern 67 thermo-galvanometer is a most versatile aid in making measurements of alternating currents at practically any frequency used for communication purposes.

A NEUTRALIZING INDICATOR

As a device for use in neutralizing power-amplifier circuit, it is excelled only by much more expensive and elaborate layouts. It is used in place of the usual flashlight bulb and pick-up coils and in exactly the same way. A coil of one or two turns of wire is connected to the terminals of the meter and placed in inductive relation to the plate tank coil of the tube being neutralized. It is surprising how accurately and quickly the minimum current adjustment can be found. One is sure that the set is properly neutralized because there is the visual quantitative indication provided by the meter scale as a basis for judgment. Again, the meter will cause less detuning effect because it needs less current to operate it, the full-

scale deflection requiring only 125 ma. or less as compared to the usual 300 ma. necessary to light a flashlight bulb to full brilliancy.

After all stages have been neutralized it is a simple matter to loosely couple the meter to the output tank circuit and go over the transmitter tuning step by step, tuning for maximum scale deflection of the meter always. The meter deflection is very nearly proportional to the power output, because of the current-squared feature, and the fixed resistance of the pick-up circuit. ($P = I^2 R$.)

One of these meters with its pick-up coil will take the place of several r.f. ammeters in tank circuits, thus reducing the tank circuit resistance. It will also be available for other uses, such as

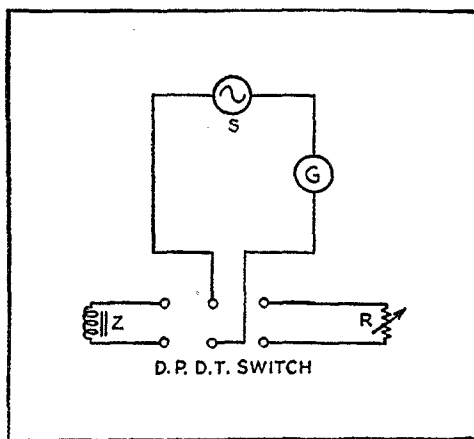

FIG. 1

S — Source of alternating current
G — Current-squared galvanometer
Z — Impedance being measured
R — Non-inductive variable resistor

those mentioned below. By making inexpensive fixed mountings — one beside each plate coil — the meter may be easily supported, enabling one to be sure that any change in deflection is caused by a change in the transmitter and not a change in position of the pick-up coil.

OTHER AUDIO-AND RADIO-FREQUENCY APPLICATIONS

Other uses of the galvanometer are as a volume indicator; as a current indicator in all a.c. meas-

*State University of Iowa, Iowa City, Iowa.

urements; as a resonance indicator in wavemeter circuits; and as a means of measuring percentage of modulation.

A special transformer must be used with the

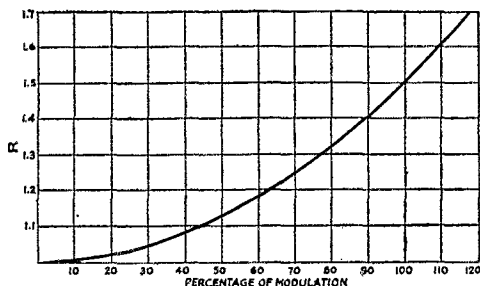

FIG. 2.

meter if it is to be utilized as a volume indicator in conjunction with audio-frequency amplifiers. This may be made from an Amertran Type 854 50-henry choke, or any similar choke with enough room in the core window to permit 80 turns of number 18 d.c.c. wire to be wound over the coil. The large winding is then connected to the primary of the output transformer of the amplifier and the meter is connected to the small 80-turn winding.

It will be noted that any transformer which has a secondary winding of the proper impedance to match that of the meter (4.5 ohms) can be substituted for the one described above, although it should have a high primary impedance in order to reduce the shunting effect on the plate load impedance. The special transformer previously referred to reduces the plate load impedance of the final stage of the amplifier by about 18.8%, which is certainly far from negligible. It would be better to connect a coupling transformer of the proper ratio to the volume indicator, so that the tone quality of the amplifier would remain unaltered. This, and the fact that at least one stage of amplification is needed to operate it, are the only objectionable features of the device.

There are numerous experiments and measurements found in the books listed by the *QST* Book Department in which a galvanometer that will measure alternating current of almost any frequency will prove valuable. The current-squared type is not too large to be used in any of these experiments. Of course, a shunt may be used if it proves to be too small.

A handy method of measuring impedance which is not found in many books uses some sort of a.c. measuring instrument. The meter described is very good in this case. To measure the impedance of a coil or condenser, or a combination of both, it is only necessary to apply an alternating voltage of constant amplitude and frequency to it and to measure the current flowing through it. A non-inductive variable resistor is substituted for the impedance unit and adjusted

until the same current flows. The value of the resistance in ohms is the value of the impedance in ohms. The circuit of the arrangement is that of Fig. 1.

Perhaps the original use to which the current-squared galvanometer was put was that of resonance indicator in the absorption-type wavemeter. It is still used on long-wave wavemeters; but the heterodyne frequency meter and the piezo-oscillator have displaced such instruments in modern short-wave stations.

As a means of measuring the percentage of modulation, the galvanometer is by far the most rapid instrument, although it is not accurate to a very high degree. A full explanation of the method used in such measurements appeared in *QST* for May, 1930, on page 48. To make the employment of this method easier and faster, a curve is given in Fig. 2 which was computed from the formula given in the article referred to above. R is the same as the R in the article: the ratio of galvanometer reading during modulation to that with no modulation.

Second All-Section Sweepstakes Contest

(Continued from page 41)

DX, traffic or radiophone operation, comments on the characteristics of different amateur frequencies, off-frequency operation, regulations, the interference question, high quality signals, beginners, broadcast or ship operating, organization work, Army or Navy Net operation, station descriptions, *QST* articles, message procedure, laws, etc., would make excellent texts for messages to be originated in the contest, not to mention the variety of non-radio subjects that could be called upon when operators in remote districts may find themselves short of regular traffic.

Suppose VE2AC QSO's with W9AZY and takes from W9AZY a message originated at W3BWT and addressed to an individual in Chicago. "Can this count as a contest message?"

Yes, providing the message is handled during the period of the February contest, provided that VE2AC turns in a copy of the message to the contest committee with information on station, date, time, etc., according to Rule 3, and provided that VE2AC also gives W9AZY a *bona fide* message sometime during the two weeks of the competition similarly making a record of this occurrence for the contest judges. This may be either a special message which he originates for W9AZY (or to be further relayed by W9AZY) or a message VE2AC has received in the course of regular relaying for W9AZY or some point beyond.

Strays

W9AQT suggests the following method of making an r.f. choke with comparatively little external field to get mixed up with the fields about the transmitting coils. Procure a piece of half-inch rubber tubing from the dime store and wind enough No. 36 d.s.c. wire on it to make a coil about two inches long. Cut off the ends of the tubing about an eighth of an inch from the ends of the winding and bend the whole works into a circle, after the fashion of the old toroid inductances. This choke was found to be adequate at 3500 kc. Practically all of the field is concentrated inside the coil.

EXPERIMENTERS' SECTION

Improving Detector Operation

IN the conventional detector circuit the grid leak is returned directly to the filament, instead of shunting it across the grid condenser as was common practice a few years ago. The value of the grid leak resistance is rather critical if best detection and smoothest control of regeneration are to be secured, and another problem of no small magnitude is that of obtaining a grid leak of the correct value of resistance which is at the same time quiet in operation.

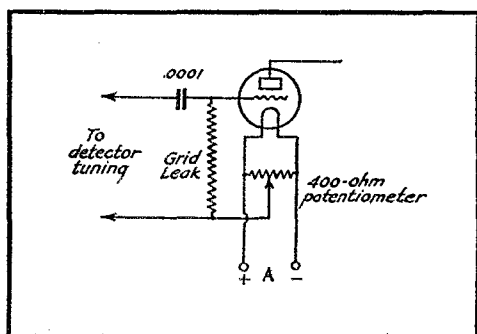

FIG. 1

A system which works wonderfully well is to shunt a 400-ohm potentiometer across the detector filament and connect the grid leak return directly to the arm of the potentiometer, as shown in Fig. 1. With this system the grid leak adjustment can be varied easily and the setting found for best detection and smoothest regeneration. The value of resistance of the leak is almost not important, providing it is somewhere between 1 and 7 megohms. The main idea is to get a quiet leak and then adjust the potentiometer for best results. The detector can be made to go into oscillation just as smoothly as desired.

— C. J. Barker, W9EGU-W9GZ

Soldering Aluminum

Probably every experimenter has at some time or other wished to solder aluminum. In some cases it may have been accomplished after much sweating, but in the majority of attempts the results were most likely nil. The following method is the only one the writer has ever found to give good results.

The first step is to make the solder, using four parts of tin to one part of zinc. Melt the tin first

and when molten add the zinc. Stir well after the zinc has melted and pour out into bars, strips or any other convenient form. These metals are obtainable from a tinshop. The flux is oleic acid, a brown oily organic compound, which should be obtainable from any drug store. The secret of success is this — be sure that the piece of aluminum to be soldered is scraped clean and that the flux is applied immediately after cleaning. If this is not done, the aluminum oxidizes rapidly and of course the solder has no chance to get to the clean metal. The temperature of the iron should be a little higher than that used for ordinary soldering.

This solder will also stick to copper, so a copper wire can be soldered to aluminum if desired.

— C. H. Parker, W6DKF

A Neat Homemade Cable Plug

The credit for the gadget shown in Fig. 2 belongs to Chester W. Ward, W1ARK, of Providence, R. I. It is a home-made cable plug which fits into a 5-prong socket for making battery connections to a receiver. The plug itself is a UY base taken from an old tube, and the cap is a plug of the type used with lamp cords. The rivets which hold the brass parts to the bakelite cap should be drilled out and the metallic members removed. The cap may fit without further alteration in the top of the tube base, as shown in the

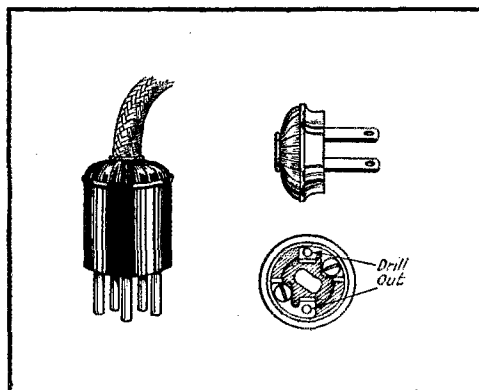

FIG. 2

drawing, but in some cases it may be necessary to file it down a little to make a snug fit. When finished it should be glued in place, and the resulting assembly will be nice-looking and easy to

handle. There is little danger of breaking off connections inside the plug with a cap of this sort.

— Curtis G. Docherty, W1BML

Make the Filament Voltmeter Do Double Duty

"Here is an idea which may be quite old, but which I have not seen published.

"The stunt is a very useful one for financially overburdened hams and consists of combining the filament voltmeter and plate-milliammeter. The meter in question is a Weston 15-volt a.c. meter, of 210 ohms resistance and 71 ma. full scale. If a Type '10 tube is run at rated input the meter may be used just as it is and will work beautifully with only a single-pole double-throw switch in the circuit. For heavier currents as on a Type '50 tube such as I use, I have to add a shunt (which is easily made) so as to have 150 ma. full scale. This shunt will be about 189 ohms, and since it only carries 79 ma. of d.c. it can be made of anything handy. A d.p.d.t. switch is used, connected as in the diagram, Fig. 3.

"Of course the meter cannot be left as a plate milliammeter while actually transmitting because of the loss of the center tap. However, this is im-

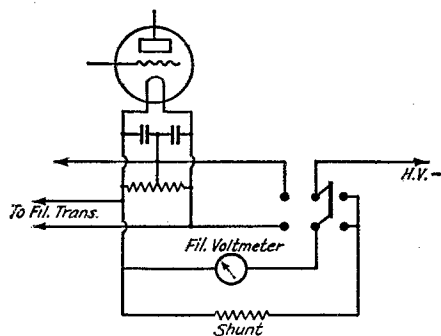

FIG. 3

material because the main use of the plate meter is for adjusting the transmitter and no meter should be forced to stand the jolting incident to keying."

— R. W. Leonard, 120 Euclid Ave., Berkeley, Calif.

Another method of arrangement would be to connect the meter terminals to a plug, and connect an open-circuit jack across the filament terminals and a closed-circuit jack in the negative high-voltage lead. The shunt, if used, would be connected permanently across the latter jack. The meter would serve very well without calibration as a plate current indicator, but should be checked against a d.c. meter if the actual plate current is to be read. By adjusting the shunt to the proper value (a variable resistor of about 200 or 300 ohms will be handy) the plate current can

be read directly; that is, a 0-15 meter can be made to read 0-150 ma.; a 0-10 meter, 0-100 ma., etc., provided the meter is one which does not take more current at full scale than the ma. range desired.

The Simplest Audio Oscillator

Every time we get a new office boy here at Headquarters some intensive code practice is in order. The last time this happened the old faithful (?) buzzer decided to act nasty, as is often the way with buzzers, and added some uncalled for sputters of its own to the otherwise perfect code being pounded out by some one of the gang possessed of tickets. Thereupon the versatile dynatron was called upon to furnish an imitation of

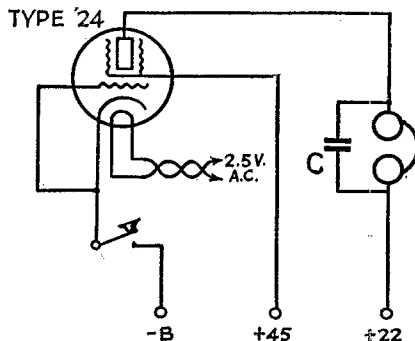

FIG. 4

that nice 500-cycle note that XDA puts out for indignant ham ears.

Anyone possessing a screen-grid tube, a pair of 'phones, a key, tube socket, a 45-volt "B" battery and a source of filament supply for the tube can throw together one of the nicest code-practice outfits you ever saw in ten minutes or less. The circuit diagram is shown in Fig. 4. The pitch of the note will be determined by the inductance and distributed capacity of the 'phones and may be made almost anything desired by shunting a condenser of suitable value (*C* in the diagram) across the 'phones. With a pair of Brandes "Superior" 'phones a .001- μ fd. condenser tuned it up to about 500 cycles — and it's a clear, steady note that never breaks or sticks.

Two or more pairs of 'phones may be connected in series to allow two or three learners to listen in at the same time. The greater the number of headsets, however, the lower is the tone and consequently less capacity at *C* is required. To supply a whole class with code practice a better stunt would be to connect the primary of an audio transformer in the circuit in place of the 'phones and feed the output into an audio amplifier of the usual type, connecting an output transformer of suitable output impedance for the number of headsets to be supplied in the plate circuit of the

amplifier. Any number of headsets could be used with this sort of rig and a power tube of adequate rating. A '71-A in the amplifier should be capable of operating twenty or thirty pairs of 'phones without difficulty.

Of course the oscillator can be put to many other uses besides code practice. It can be successfully used in adjusting the peak on a peaked audio amplifier by using the diagram shown in Fig. 5, which is a modulated r.f. oscillator. The radio frequency will be set by the constants of the circuit L_1C_1 and the modulation frequency by the circuit L_2C_2 , both of which may be adjusted independently. L_2 may be an audio choke, the primary of an audio transformer, or even a head-

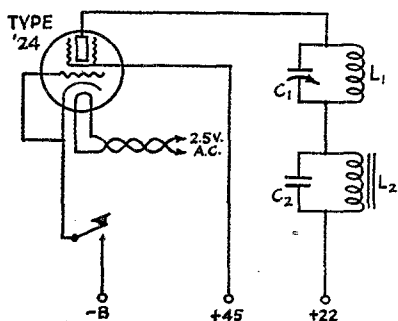

FIG. 5

set. If the r.f. circuit covers the broadcast band the oscillator may be used to test broadcast receivers, line up ganged condensers, etc.

While the circuits shown are for a.c. tubes, the d.c. varieties may be used equally well. Higher plate and screen-grid voltages may help if there is trouble in getting the outfit to oscillate, although those shown were plenty with the tubes tried.

A Cheap Bleeder Resistor

We are all aware of the advisability of having some sort of constant load across the output of the filter to prevent the voltage from building up to high values when the key is open, and to aid in eliminating key clicks. Sometimes a suitable high-voltage resistor comes a little too high for slim ham pocketbooks, and in that case it is necessary to do some home manufacturing. A resistor such as is shown in Fig. 6, suggested by M. A. Williams, W6DYZ, Long Beach, Calif., costs practically nothing and will do the trick.

Procure a piece of quarter-inch glass tubing about eight inches long and make a right-angle bend about three inches from each end, as shown in the drawing. This may be done by holding the tubing in a gas flame at the point where the bend is to be made until it is at red heat and then carefully bending it. Take two jelly glasses and fill them with pure water, connecting them by the glass tube. Water should be siphoned through

the tube to make a continuous liquid connection. A piece of wire is placed in each glass to make connections to the high-voltage supply.

The next step is to connect the resistor across the power supply with a milliammeter in series.

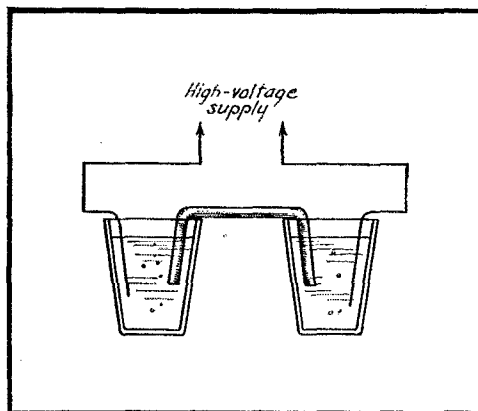

FIG. 6

Then add a little table salt to each jar, noting the current. Continue adding salt until the current through the resistor is about 20% to 25% of the value taken by the transmitting tubes in normal operation and the drain resistor is complete. A little oil on top of each jar will prevent evaporation.

Homemade Filter Condensers

The high cost of high-voltage filter condensers inspired W9CJB, C. W. Herbert, Festus, Mo., to do some experimenting, with the result that an entirely satisfactory 3000-volt condenser was evolved at small cost.

A ream of onion-skin typewriter paper was bought from Sears & Roebuck for something less than a dollar and provided the dielectric. Each sheet of dielectric consisted of ten sheets of paper, all being held together with paraffin, painted on each sheet with a brush while hot. The condenser plates were pieces of tinfoil cut so that a 1½-inch margin was allowed on three sides of each dielectric sheet, the remaining side being brought out to make the connection. The condenser was built up with alternate sheets of paper and tinfoil until all the paper was used. The connection ends of alternate tinfoil plates were brought out on opposite sides of the paper sheets, of course.

While the capacity of a condenser of this sort would not seem to be very great, it proved to be very effective. Used with a High-C Hartley transmitter with a Type '52 tube, a.d.c. note was obtained with this condenser and a 15 henry choke. The voltage was between 2500 and 3000.

W9CJB also suggests a good way to find the

number of sheets of paper to use in each dielectric sheet to stand various voltages. First make two tinfoil sheets and then build up a dielectric sheet from a number of sheets of paper as described above. The single condenser section so formed should then be connected across the power transformer to see whether it will stand the voltage. If the transformer is center tapped and a

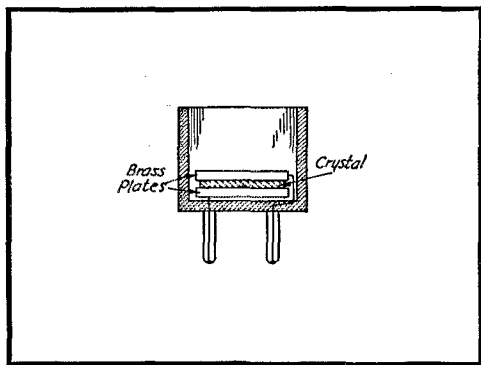

FIG. 7

full-wave rectifier is to be used, the outside ends of the high tension winding should be used for the test. For instance, to build up a condenser to be used with a full-wave rectifier from a transformer giving 1000 volts each side of the center tap, the test voltage would be 2000 a.c. The transformer should be protected by fuses in case the paper breaks down. A little experimenting will determine the number of sheets of paper necessary in each dielectric sheet to withstand the voltage. The thinner the dielectric, of course, the greater will be the capacity of the condenser.

Repairing Filter Condensers

The following letter from H. Guy Moats, W8AE, Pontiac, Mich., needs no further explanation. It may help some of the fellows who have had the sad experience of blowing filter condensers.

"A short circuit recently blew all my filter condensers. It was a case of either rebuild or buy new, so I took a chance at the rebuilding and it turned out to be perfectly satisfactory. The cost is practically nothing, and that is *something*, these days.

"Here's the idea: The condensers were unwound, the waxed tissue and foil separated and the paper thrown away. I procured a roll of the waxed paper such as is used around the house for wrapping bread and such and cut a number of long strips wide enough to cover the foil, with a margin of half an inch over. Then I placed one strip of foil, after first cutting out the punctured spots and tears, on a sheet of the paper, put *two* sheets on and then another strip of foil. A single sheet of the paper was put on top and the whole

thing wound over a cardboard strip one and one-half inches wide by four inches long, care being taken to prevent cracking the wax on the edges. A warm room is essential for this work, as it softens the wax so that it works easily. While the capacity was lowered somewhat, it did not lose enough to spoil operation of the filter.

"Practically any old condenser bank can be made to do good work by this means so long as the foil is OK."

A Novel Crystal Holder

The ever-useful tube base has been pressed into service as a crystal mounting by K. W. Griffith, W5LK, Little Rock, Ark. Fig. 7 shows how it is done. Further explanation is unnecessary.

A cap of the sort shown in Fig. 5 will make a neat dust cover for the holder.

Strays

If spool form chokes are used do not mount the spool on the baseboard by running a steel wood screw through the center. The steel screw acts as a magnetic core and just about wrecks the usefulness of the choke at radio frequencies. — W3DPJ.

Popular Mechanics Press, Chicago, publishes a booklet entitled "A Billion Ideas," which is a catalog of books covering a wide range of scientific and practical subjects. A handy booklet to have when one wants to learn the name of a good book on radio, mechanical and other subjects and where to get it.

The Radio Manufacturers Association is planning to establish a tube "hospital" — no, not to repair tubes, but to investigate causes of short life and ways of lengthening the average life of tubes. We could tell them about one widespread cause of the high mortality rate among transmitting tubes. The plate usually develops a high fever as one of the first symptoms.

VK5HG recently sent W9CKQ a carved boomerang as a souvenir of their 500th contact. A regular schedule has been kept for the past two years. That's consistency.

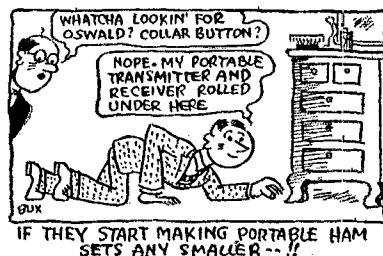

W9DXP, Chicago, Ill.

Unusual Lay-Out; Crystal Control; Effective Three-Band Operation

AT ABOUT the same time a pistol shot in central Europe started "la grande guerre" in 1914, the owner of W9DXP, then living in Des Moines, Iowa, was bitten by the radio bug, and neither the world nor the owner has ever been the same since that fateful year. The meager equipment procurable at that time was gradually augmented until, just before Uncle Sam got into the scrap, 9AKQ was reaching points all over Iowa with a 2-inch spark coil.

The beloved junk hurriedly hidden in the attic at the start of hostilities was brought to light just as soon as the government said "go," and gradually reached the point where a 1-kilowatt spark set boomed hoarsely under the call 9OA. An interruption of four years followed, while the OM went to college, and then one bright day in May, 1927, the present station was inaugurated. The customary UX-210 gave way to a 250-watt job, which was used with fair success until the need for modern equipment became apparent.

To meet the situation brought about by the narrow bands, it was thought that crystal control offered the best opportunity both as to note, steadiness of frequency, and sharpness. There followed a series of crystal-controlled sets using almost every one of the known powers and types of tubes, until the present arrangement was built up. This new transmitter has proved so entirely satisfactory in every respect that it is thought it will do for some time to come.

The general view of the station, now located at 2 W. Walton Place, Chicago, shows that the transmitter is a four-stage affair, mounted on a bench beside the operating table, in front of a window, while the receiver and key are on the table at the right. Extra coils for the receiver, maps, schedules and various other papers are on the panel immediately behind the receiver. This old operating table is a relic of the days of the 2-inch spark coil and has served in this capacity more or less continuously for 15 years.

When designs for the transmitter were considered, the bread-board type of construction appealed greatly, but this transmitter is so large that bread-board construction would very likely be a messy looking job, so an arrangement combining the electrical and mechanical advantages of a "straight four" bread-board type and decent appearance was sought.

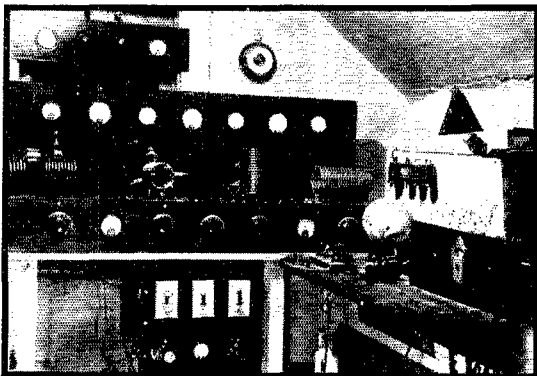

W9DXP

The transmitter, power supply and control switches are on the bench at the left. The operating table is at the right.

How it was worked out is readily apparent from the photograph. The tubes and coils rest on a shelf 10½ inches wide and four feet long, which permits wiring the set much as a diagram is drawn, while the condensers and a couple of meters were mounted below the tube-and-coil panel, which not only hides them and the wiring, but

also makes for convenient connections.

The power supplies are behind the large panel back of the tubes and coils, keeping the r.f. and a.c. wiring separated, and again allowing good appearance. The control panel of the transmitter, containing filament rheostats and starting switches, is hung below the bench, where it affords easy connections to the set and convenience to the operator.

In designing this transmitter, a flexibility was desired that would allow the use of the three principal bands on short notice, which is one of the reasons for using four stages in the set. With this thought in mind, and remembering that the only stage where power losses are really important is the final amplifier stage, none of the coils, with the exception of the power amplifier coil, were made plug-in. By varying the clips on the other coils, the first three stages are made to operate on two or three bands as required, while the last stage is made as "low-loss" as possible.

For the 14- and 7-mc. bands it was decided that a 3.5-mc. crystal would be most satisfactory, and for 3.5-mc. operation a 1.75-mc. crystal was chosen. Utilizing one crystal for all bands would require two stages of neutralization for 3.5-mc. work, and a 3.5-mc. crystal that would operate

on 14 mc. would be too near the 3.5-mc. 'phone band for satisfactory telegraph work on that band. Since a UX-860 is used in the last power amplifier stage no neutralization is necessary in that stage.



A REAR VIEW OF THE FOUR-TUBE RECEIVER

This set is modelled after one described in QST for November, 1928.

The oscillator stage uses a UX-210 tube, with a coil and condenser combination that will tune to 1840 or 3545 kc. by moving a clip on the coil. The frequency doubler, which also acts as a buffer stage, uses another UX-210 with a coil and condenser that will tune to 3680 or 7090 kc. Both these tubes are run by a plate transformer delivering about 600 volts, the output of which is rectified by a UX-280. A resistor drops the voltage on the oscillator to 325 volts while the doubler operates at about 525 volts on the plate.

The first amplifier stage consists of a Western Electric 211-D 50-watt tube, and a condenser-coil combination that may be adjusted to 14, 7, or 3.5 mc. In spite of "dead-end" losses in this stage on the higher frequencies more than enough grid excitation is provided for the final power amplifier. Plug-in coils are used in the power amplifier. These two stages operate from a common power supply, consisting of a plate transformer delivering 1500 or 2000 volts as desired, a pair of mercury-vapor Rectobulbs, and a brute-force filter. A 100-watt, 10,000-ohm resistor drops the voltage to 1000 volts for the 50-watt stage.

The various meters along the panel behind the tubes are plate milliammeters and filament voltmeters, while the meter near the oscillator tuning condenser is the oscillator tank meter. The plate voltmeter, which may be switched to any stage, is on the lower panel at the left, while an a.c. line voltmeter is on the power-control panel.

Looking at the rear view of the transmitter, from left to right are the power supply for the two 210's and the filament transformer for the Rectobulbs, behind which is the filament transformer

for the two 210's. Next come the Rectobulbs, beside the plate transformer for the amplifiers. On top of the plate transformer is the keying relay with a condenser across its terminals. The two 2- μ fd. 3000-volt filter condensers come next, with the keying resistors resting on top of them. The 10-henry Acme choke has been replaced by a 36-henry Thordarson choke since the photograph was taken. At the extreme right is the filament transformer for the power-amplifier tubes, while above it is the screen-grid resistor. The 100-watt resistor used in the 50-watt stage is just to the right of the filter condensers, and is mounted on the back of the panel.

The keying system is of interest, and is the only system that has ever completely eliminated the clicks at this station. In the diagram of the transmitter it will be noted that there is a split resistor across the power supply for the amplifiers. The negative power supply is connected to the grids of both the 50-watt tube and the screen-grid tube through the bias battery. The ground connection is taken off between the resistors R_6 and R_7 through a 1½-henry choke. When the key is up, the grids of the 50-watt tube and the 860 obtain a bias from the plate supply which completely blocks them, but when the key is down, the only bias left is that supplied by the batteries, which are adjusted for proper operation of the tubes. The resistor R_7 is shorted by the key, connecting the negative plate supply to the filament center tap. With the high grid bias removed, the tubes operate in the normal manner

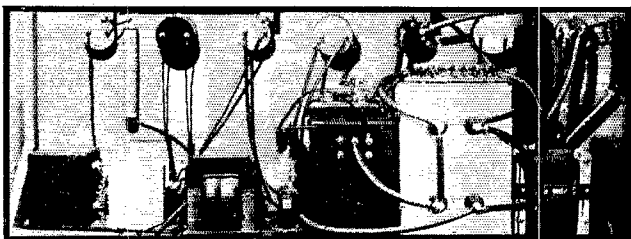

THE POWER SUPPLY

This equipment is behind the large panel of the transmitter. A description is contained in the text.

and the set puts out a signal. The condenser across the keying relay and the 1½-henry choke constitute a thump-filter which is ample, since keying in the grid-circuit is less likely to produce clicks than keying in the plate. Keying the fifty-watt stage as well as the power amplifier stage probably also helps in the elimination of clicks. The oscillator and doubler-buffer run continuously, of course. The resistors across the plate supply keep the peak voltage from reaching a high value and protect the filter condensers from line surges.

The transmitting antenna is a Hertz with a single wire-feed line, as described in September

1929 *QST*. It is built for 3500-kc. operation, harmonics being used for the other bands.

The receiver is a four-tube screen-grid peaked-audio affair as described in *QST* for November

meter was borrowed when this receiver was finished, and it was carefully calibrated in steps of ten kilocycles for every band. Checking against broadcast harmonics and other accurate cali-

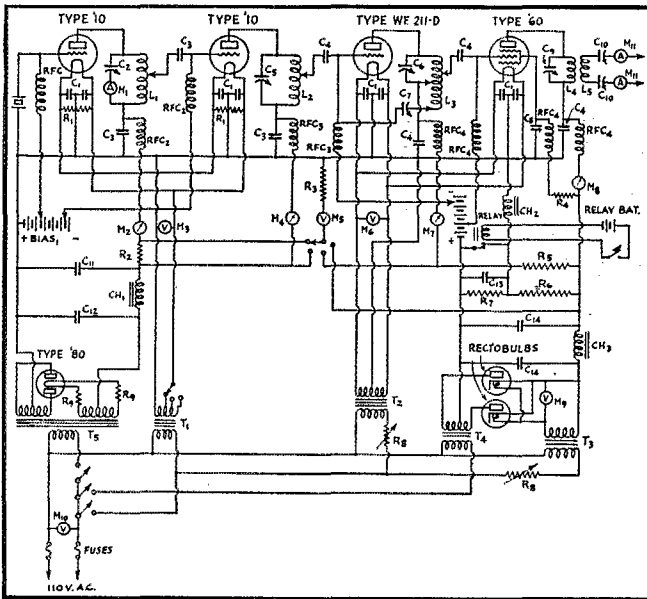

FIG. 1 — THE TRANSMITTER AND POWER SUPPLY AT W9DXP

- | | |
|--|---|
| C ₁ — .006- μ fd. mica condenser | M ₁₀ — 0-150 a.c. voltmeter |
| C ₂ — 250- μ fd. Hammarlund variable | M ₁₁ — 0-5 thermocouple ammeter |
| C ₃ — .002- μ fd. mica condenser | L ₁ — 30 turns $\frac{1}{8}$ -inch copper tubing 3" diameter |
| C ₄ — .002- μ fd. 5000-volt mica condenser | L ₂ — 16 turns $\frac{1}{8}$ -inch copper tubing 3" diameter |
| C ₅ — 500- μ fd. variable | L ₃ — 14 turns $\frac{3}{16}$ -inch copper tubing 3" diameter |
| C ₆ — 500- μ fd. variable | L ₄ — 12 turns $\frac{3}{16}$ -inch copper tubing 3" diameter or 24 turns $\frac{3}{16}$ -inch copper tubing 3" diameter |
| C ₇ — 250- μ fd. National, 3000-volt rating | L ₅ — 6 turns $\frac{3}{16}$ -inch copper tubing 3" diameter |
| C ₈ — .01- μ fd. 8000-volt mica condenser | T ₁ — Toy transformer with tapped secondary; 75 watts |
| C ₉ — 310- μ fd. National, 3000-volt rating | T ₂ — 500-watt filament transformer; 16 volts center-tapped |
| C ₁₀ — 250- μ fd. variable | T ₃ — Filament transformer, 12 volts c.t., 5000-volt insulation |
| C ₁₁ — 2- μ fd. 500-volt condenser | T ₄ — 500-watt, 1500-2000-volt Thordarson plate transformer |
| C ₁₂ — 2- μ fd. 600-volt condenser | T ₅ — 200-watt, 650-volt transformer with filament winding for Type '80 |
| C ₁₃ — 2- μ fd. 600-volt condenser | Ch ₁ — 30-henry 80-ma. Thordarson choke |
| C ₁₄ — 2- μ fd. 3000-volt condenser | Ch ₂ — $1\frac{1}{2}$ -henry 200-ma. Acme choke |
| R ₁ — 100 ohms, center-tapped | Ch ₃ — 36-henry 250-ma. Thordarson choke |
| R ₂ — 5000 ohms; 50-watt rating | RFC ₁ — 400 turns on $1\frac{1}{2}$ -inch form |
| R ₃ — Voltmeter resistor | RFC ₂ — 300 turns on 1-inch form |
| R ₄ — 100,000 ohms | RFC ₃ — 275 turns on 1-inch form |
| R ₅ — 10,000 ohms; 100-watt rating | RFC ₄ — 250 turns on 1-inch form |
| R ₆ — 60,000 ohms; 20-watt rating | |
| R ₇ — 15,000 ohms; 20-watt rating | |
| R ₈ — Bradleystat variable resistor | |
| R ₉ — 1 ohm | |
| M ₁ — 0-3 thermocouple ammeter | |
| M ₂ — 0-100 milliammeter | |
| M ₃ — 0-10 a.c. voltmeter | |
| M ₄ — 0-150 milliammeter | |
| M ₅ — 0-1500 d.c. voltmeter | |
| M ₆ — 0-15 a.c. voltmeter | |
| M ₇ — 0-150 milliammeter | |
| M ₈ — 0-300 milliammeter | |
| M ₉ — 0-15 a.c. voltmeter | |

1928. For traffic handling and ease of operation it would be hard to beat, although an experimental a.c. screen-grid detector receiver recently built has greater sensitivity. The spark coil in the original set has been replaced by an Aero "Hi-Peak," which greatly increased the volume and selectivity of the set. An accurate frequency

bration signals shows that it holds calibration well.

The signal is checked at every transmission by the monitor, shown in another photograph. By utilizing a Yaxley jack switch, the 'phones are switched to the monitor when transmitting

(Continued on page 74)

Good Practice

The Right and Wrong of Ground Circuits

By Jack Paddon*

GOOD practice — or good technique if you prefer the term — is that almost instinctive ability to do the small or rather basic parts of one's work in exactly the right manner. No matter how brilliant a new technical conception, how cleverly the mathematics are worked out or how well the apparatus is built — if its development and production

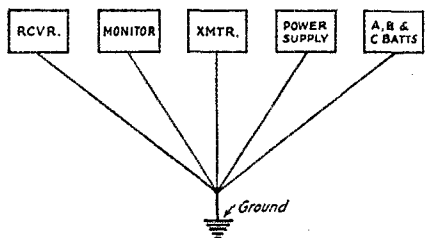
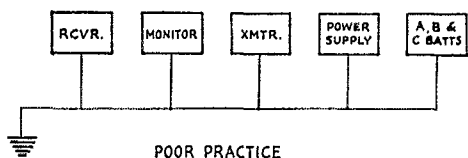

GOOD PRACTICE
FIG. 1

are not based on good practice, there will be trouble. Good practice is the frame of mind that prevents one from putting an r.f. choke in the antenna field; good practice is the quality that makes you instinctively see to it that the soldered joint you have made is an honest "flowed" joint and not two wires glued together with a spot of rosin.

GROUNDS

Grounds are a matter of the greatest importance in all electrical work; in radio — particularly at ultra-high frequencies — their importance is illimitable; and yet grounds are very generally taken for granted. I propose to set forth here several points of good grounding that, while they may seem stupidly simple, will well repay consideration.

We all know a good ground should be a water pipe, a plate buried in moist soil, etc. Starting from that point we will sniff about a bit more.

*Societe Material Acoustique, 1 Boul. Hausmann, Paris, France.

1. The lead from the ground should be at least size twelve B&S and be run from the grounding point to a convenient lug or big binding post in the shack — which, as far as the shack is concerned, is now the ground point.

2. Take an individual line from each piece of apparatus that is to be grounded to the central ground point, i.e., one from the receiver, one from the monitor, another from the transmitter, etc. (Fig. 1.)

3. A line grounding a piece of apparatus must never carry current. If, for instance, you want to ground the C-bias battery of your m.o.p.a. run a separate line to your main ground. Don't shoot the ground return of your by-pass condensers

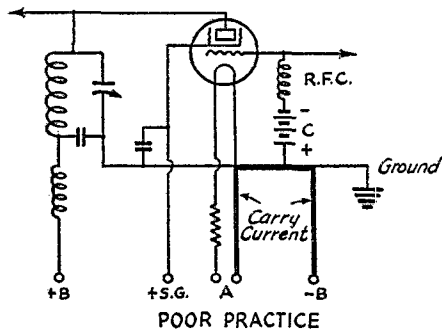

POOR PRACTICE

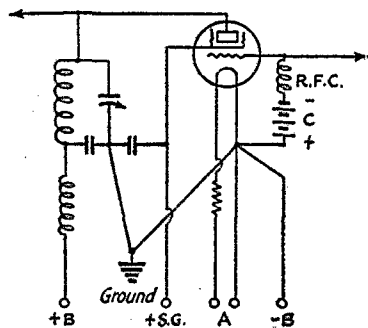

GOOD PRACTICE

FIG. 2

along the same line. Fig. 2 will give a general idea.

4. The matter of shielding is a highly complicated matter. (Continued on page 76)

• I. A. R. U. NEWS •

Devoted to the interests and activities of the
INTERNATIONAL AMATEUR RADIO UNION

President: H. P. MAXIM

Vice-President: C. H. STEWART

Secretary: K. B. WARNER

Headquarters Society:

THE AMERICAN RADIO RELAY LEAGUE, West Hartford, Conn.

MEMBER SOCIETIES

American Radio Relay League
Asociacion E. A. R.
Associazione Radiotecnica Italiana
Canadian Section, A.R.R.L.
Deutscher Amateur-sende-und Empfangsdienst
Experimenterende Danske Radioamatorer

Lwowski Klub Krotkofalowcow
Nederlandsche Vereeniging voor International Radioamateurisme
New Zealand Association of Radio Transmitters
Norwegian Radio Relay League
Radio Society of Great Britain

Reseau Belge
Reseau Emetteurs Français
South African Radio Relay League
Sveriges Sandareamatör
Union Schweiz Kurzwellen Amateure
Wireless Institute of Australia
Wireless Society of Ireland

Conducted by Clinton B. DeSoto

IT WOULD seem that interest in the amateur world is returning to the 3.5-mc. band, judging from the increased amount of international activity found on this band at present, and that promised for the balance of the winter. In this month's reports alone we learn that amateurs in two countries, Great Britain and Norway, have applied to their governments for the permanent grant of operating privileges in the 3.5-mc. region. It is likely that both these requests will be granted. Australia reassures us that her present grant will probably be extended indefinitely. Several European stations in other countries have notified us that they are in this band exclusively at present.

This activity and interest is gratifying. It has been realized for some time that the knee of the solar activity curve has been passed, and that a gradual return to conditions prevailing during the early days of high frequency communication can be expected. That low frequency DX will soon be "looking up" is borne out by recent results in this region. Many East coast United States amateurs are being heard consistently in Europe, and, as has been previously reported in these columns, New Zealand amateurs have been successful in logging many signals from the North American continent.

Granting that conditions for international work on 3.5 mc. have been poor for some years, it is true also that the comparatively slight use of this band outside the United States and Canada has been one of the principal reasons for lack of interest in its international possibilities. The news that other countries are permitting their amateurs to use 3500 kc., and that amateurs are availing themselves of the privilege, is therefore a most encouraging sign.

Aside from its international possibilities, too, "eighty meters" should quickly prove its value for national communication. For years this band has been the principal traffic and relay channel in the United States. Now, Australians, troubled with the difficulty of establishing local contact, have also taken up its use, and with great success. European tests, which are reported in this issue in some detail, indicate the extreme utility of these waves in their own Continental scheme of things.

So it becomes apparent that this renewed international interest in 3.5 mc. is an excellent thing. Naturally, we are all muchly interested in the results we hope will be attained. It will be of value to all of us, then, if amateurs everywhere will report on international work done in this band. United States amateurs can help by advising us of their foreign contacts, while those hearing or working signals from this country are urged to report them to Union headquarters.

THE FOURTH INTERNATIONAL RELAY COMPETITION

March 8 to 21, 1931 (inclusive)

Every amateur should get into this contest and endeavor to win the certificate for his country. Complete details will appear in QST for March, 1931. It will follow the lines of the previous International Relay Competitions. Amateurs whose delivery of QST is delayed are referred to this department of the January, 1930, issue for the rules of the contest.

Considering the number of requests that have come in recently for QSL Bureau addresses, it seems about time that we run a corrected and re-

vised list of these forwarding agencies once again. Cards for the following countries may be addressed as indicated and, if possible, will be delivered to their proper destinations.

- Argentina: "Radio Revista," Lavelle 1268, Buenos Aires.
 Australia: QSL Bureau, W.I.A., Box 3120P, G.P.O., Sydney.
 Austria: D.A.S.D., Blumenthalstrasse 19, Berlin W. 57, Germany.
 Belgium: Reseau Belege, 11 Rue du Congres, Brussels.
 Bermuda and Bahama Islands: Ian C. Morgan, "Southlands," Warwick East, Bermuda Islands, B. W. I.
 Brazil: Vasco Abreu, 89 Rue Riachuelo c/IV, Rio de Janeiro.
 Chile: Luis M. Desmaris, Casilla 50D, Santiago de Chile, S. A.
 China: (*Under cover.*) Send Chinese cards to A.R.R.L.
 Cuba: (*Under cover.*) Send Cuban cards to A.R.R.L.
 Czechoslovakia: Send cards either to S.K.E.C., Smichov "Sumava," 1429, Prague; or to, K.V.A.C., Hlavni Posta, Box 531, Prague.
 Denmark: Experimenting Danish Radioamateurs, 5 Holmens Kanal, Copenhagen K.
 Dutch East Indies: N.I.V.I.R.A., Egh. A. Krygsmann, Sec'y, c/o Bataafsche Petrol Co., Boela, Ceram, D. E. I.

- Hungary: M.R.A.E., I. Zirken Janka, Utca 14/B, Budapest.
 India: R. N. Fox, 6 Pachpedi, Jubbulpore.
 Iraq: C. W. Liversedge, Wireless Station, Royal Air Force, Sulaimania.



AN INVISIBLE HAND STRETCHED OVER TEN THOUSAND MILES OF LAND

and sea to take this photograph, marking the opening of the Seventh Annual Convention of the Wireless Institute of Australia. In the December issue of QST was shown one end of the circuit with President Maxim keying the signal which controlled the taking, at the other end in Melbourne, of the picture above.



THE JAPANESE AMATEUR RADIO LEAGUE

We present with pleasure this picture of the J.A.R.L. which was sent by Asamura, J3CR, to W6WB. The uniforms indicate that the wearers are students. From left to right we see, top row: Kasahara, Kohuo, Kawakami, T. Nakamura, Yamamoto. Middle row: Y. Nakamura, Kamio, Watanabe, Yamaguchi, Hayashi, G. Kikuchi. Lower row: Y. Kikuchi, Takebe, Kajii, Asamura, Kusama, K. Yamaguchi.

- England: R.S.G.B., 53 Victoria St., London, S.W.1.
 Esthonia: (*Under cover.*) Send to A.R.R.L.
 Finland: S.R.A.L., c/o Pohjola, Helsinki, Suomi.
 France: R.E.F., Larcher, B.P.11, Boulogne-Billancourt (Seine).
 Germany: D.A.S.D., Blumenthalstrasse 19, Berlin W. 57.

- Ireland: W.S.I., 12 Trinity St., Dublin. (Cards for Northern Ireland go to R.S.G.B., England.)
 Italy: A.R.I.; Viale Bianca Maria 24, Milan.
 Japan: (*Under cover.*) K. Kasahara, 11 Kitana-tugi, Nisinomiya.
 Jugoslavia: D.A.S.D., Blumenthalstrasse 19, Berlin W. 57, Germany.
 Kenya Colony: Times of East Africa, Box No. 194, Nairobi.
 Latvia: (*Under cover.*) Send cards to A.R.R.L.
 Luxembourg: J. Wolff, 67 Avenue du Bois, Luxembourg.
 Malay States and Asia generally: J. P. C. Bell, F. M. S. Railways, Kuala Lumpur, Xelamgor, Federated Malay States.
 Netherlands: N.V.I.R., Post Box 400, Rotterdam.
 New Zealand: N.Z.A.R.T., Box 489, Wellington.
 Norway: N.R.R.L., Post Box 2253, Oslo.
 Philippine Islands: Send to A.R.R.L.
 Poland: L.K.K., Bielowskiego 6, Lwow.
 Porto Rico: J. Augusty, Box 868, 25 Pershing Ave., San Juan.
 Portugal: R.E.P., 93 Rua da Senhora da Gloria, Lisbon.
 Roumania: (*Under cover.*) Send to A.R.R.L.
 South Africa: S.A.R.R.L., P.O. Box 7028, Johannesburg.
 Spain: Asociacion EAR, Mejia Lequerica 4, Madrid.
 Sweden: S.S.A., Dr. Bruno Rolf, Skaldevager 14, Alsten, Stockholm.
 Switzerland: U.S.K.A., Postfach, Berne 2.
 Uruguay: Resident, Casilla de Correo 37, Montevideo.
 U.S.S.R.: S.K.W., Polytechnic Museum 124, Moscow.

(Continued on page 64)

• CALLS HEARD •

VE4DJ, J. D. Lawson, 150 Roseberry St., St. James, Winnipeg, Canada
7000-cc. and 14,000-ko. bands

cm2xx cm2xa cm2jm ce1ah ho2jm hc1fg celah k6eqm k6dv k6evw k6bjj k6avl kfu5 k6ewb k6egd k6eib k6hex k6dqf k6coq k6dud k6edj k6bjg k6lrl k6dpg k6edd hl1aa nn1nic nn7xj sfen vk5hg vk4cm vk2zk vk2ku vk3es x9a xlax x29a ys1ap ys1x zl2bz zl4am zl1fc zl1bt zl3as

W1AMQ-W1FJ, Emil F. Scholz, 75 New Haven Ave., Milford, Conn.

3500-ko. 'phone

w1abv w1aev w1afk wiagg w1ahb w1ajb w1aji w1ajl w1ajt w1aox w1apk w1arc w1aws w1axd w1abv w1bbm w1lbr w1blh w1bnm w1bod w1cew w1ckq w1cmp w1eu w1ey w1hj w1hq w1ky w1ks w1nh w1pf w2acr w2adf w2ady w2ahr w2aiq w2ajl w2ajw w2ama w2ani w2baj w2bee w2box w2brq w2brv w2brw w2bso w2bwc w2bws w2bxo w2byu w2byy w2bza w2bzb w2bzw w2ebe w2euc w2fn w2fr w2gj w2hy w2iu w2rd w2tp w2uk w2wk w2aae w2aee w2als w2bhz w2cqd w2jif w2jz w2mp w2nu w2oo w2pw w2sh w2aci w2adb w2agu w2aiv w2akf w2amp w2ars w2ast w2bxy w2bye w2caw w2cbf w2cfu w2cra w2osa w2dbq w2dec w2dtk w2duq w2dux w2ef w2sh w2ewx w2gmm w2ldq

14,000-ko. band

ce2ab ce3dg ce5aa cm1jm cm2ay cm5fl cm8uf cm8yb ct1aa ct2ao cx1ao cx2ak ear2l ear98 frear149 ei8b f8acw f8aly f8es f8da f8dmf f8ef f8fg f8gdb f8lx f8sua f8wiz g2bm g5nc g6ej g6dh g6lk g6oa g6rb hc1fg hc2je ilo k4aan k4dk k4kd k6ewb lulez nj2pa oa4e oa4j oa4q oa4z on4dp on4gn on4pj oz7b oz7y pa0zf py1aa py1ac py1aw py1br py1cl noljh ve1ar veldq ve3fv ve4hd ve4hv ve4iq ve4re ve4rw ve5ao ve5aw vk2jn vk2rz vk3jp vk3lp vk3pp vo8aw x9a x29a zilas z1ao z1fr z1zao z1zbg z1zbx z1zcm z1zax w1at w1bt w1jm w1jo w1ke w1sak w1sdp w1som w1wbk w1wfp w5bim w5ef w5ge w5lv w5sq w5saa w5aea w5aoc w5aqj w5abo w5bbn w5bh w5bvy w5byb w5cqq w5csj w5cox w5djp w5dzm w5dxy w5eb w5eje w5eug w5fe w5qo w5te w5th w5zay w5be w5gp w5tu w5uz w5wag w5ahm w5ahk w5anq w5axe w5azn w5ces w5coo w5eyi w5def w5dyu w5ecz w5eva w5evk w5faq w5fgf w5fxo w5ghh w5qt

14,000-ko. 'phone band

w4afq w5ql w6aj w6tk w9anv w9def w9dro w9drc w4mk w2qn

W9FGW, Paul Bouden, Aurora, Ill.

7000-ko. band

cm2xa cm7sh cm8uf cm8yb omx5bbo k5dd k4dk k4kd k6avl k6dek k6dv k6dyo k6eqm k6evw k6ewb k6mxx nn1fx nn1sc nncab tgljr vk2br vk2ea vk2it vk2jt vk2kj vk2na vk3bw vk3ml vk3pp vk3pr vk3ru vk3tp vk4hk vk5hg vk5kj vk5wr vk7ck vk7lj zl1bu zl1fc zl2ac zl2pb zl2bz zl2gq zl3az zl4aa zl4ao

14,000-ko. band

ce1ah ce1ak ce2ab ce3bf ce3ch ce5aa ce7aa cm2jm cm2sh cm2xx cm8uf cm8yb or4sd ot1bx ot1by ct2aa cx1oa cx-lap ear155 f8aap f8axq f8px g5by g5ms hc1fg hc1gj hc2je hc2jm k4dk k4kd k4kf k6boe kfu5 lu2ba lu2ea lu3dh lu3fa lu3fk lu3oa lu3pa lu5aa lu8dj lu9dt nj2pa oa4e oa4h oa4j oa4o oa4p oa4q oa4r oa4t oa4z py1aa py1aw py2ig py2ii qq1a on4dea on4dj on4du on4fp on4jj on4us on4z vk2cx vk2jy vk2zk vk3ox vk3lp vk3vx vk3xo vk5it vo8me x9a x9b ys1ap ys1x zl1ao zl1as zl1be zl1fc zl1fr zl1fw zl2ab zl2ac zl2aw zl2bx zl2gd zl2gq zl2gw zl3ao zl3cm w1at

W8BXY, Riley Parson, Old Forge, N. Y.
3500-ko. 'phone

w1blh w1qk w1hj w1amq w1bmm w1axh veldq w1awd w1auy w1lbr velak w1lt w1byq w1bmb w1kz w1aji w1aox w1lo w1arc w1kn w1aky w1cmp w1fr w1cki w2ga w2agh w2cew w2gr w2byu w2ff w2aih w2bza w2gn w2iu w2st w2abw w2brw w2ajw w2ju w2gj w2jz w2aqt w2er w2ain w2e3ab w2alq w2vj w2dy w2adq w2bq w6tk w6brh w6bap w6brv w6sau w6drj w6brj w6afq w6aqb w6rl w6epl w6agu w6cew w6aei w6dz w6bye w6ddl w6dbq w6ih w6dw w6bgr w6dec w6bji w6ast w6cfy w6ana w6qy

80% of above 1 was QSO more than once, had more than 5% QSO 9 times and had 27 contacts with one.

W2BZN, E. B. Snow, 780 Riverside Drive, New York City, N. Y.

3500-ko. 'phone

w1aeh w1aei w1ahb w1arc w1bjd w1blh w1lbr w1ogr w1emp w1ex w2aaj w2aco w2adi w2agt w2ais w2alc w2alj w2ama w2aif w2aoe w2aif w2asq w2box w2bxo w2bza w2bzb w3blz w2bzw w2cvc w2oct w2ea w2fr w2gj w2hy w2uk w2oz w2tt w2tp w3abn w3aex w3ain w3alq w3bab w3bbo w3bce w3bfz w3ca w3jz w3oo w3qo w4aby w4cw w4hn w4lu w4sf w4sw w4afm w8afq w8ahw w8ahz w8akm w8amy w8asb w8asg w8bae w8bbu w8bw w8by w8bjy w8bxt w8bxw w8bxy w8brv w8cl w8dbq w8ha w8hw w8hzw w8zaq w9aa w9bjw w9fl

fb } 'phones w2gj w2tp w2adi w3aex w8bxy w9bjw
Gud }

W1VE, John E. Reilly, S.S. Eastern Glen (KUVB), 3500 miles southeast of Cape Henry to Durban, South Africa

w1bes w1mk w2alu w2box w2byx w2cew w2kj w3ais w3cin w4abt w4aq w4mm w4on w4pf w4uo w4zx w5abk w5ain w5afx w5el w5fq w5kd w5ty w5uo w5zk w6akf w6ebg w6eou w6epf w6eq w6gt w6zq w6zzg w6zzz w6bot w8bnq w8dqk w9cd w9dt w9ft w9hd w9lf k6dpg nn1nic

CE7AA, Enrique Nielsen, Casilla "C," Magalanes, Chile

28,000-ko. band

nkf w2bg w2jn w4we vq2bh

14,000-ko. band

aulkab ac1bd ce1al ce2a1 ce2bm ce3ab ce3ac ce3ag ce3bf ce3ca ce3ch ce3ci ce3er ce3da ce5aa cm2jm cm2jt cm5fl cm8rx ct1aa ct1by ct1de ct1as ct1au ct1bx ct2ac ct3aa cr4ad cxowk cx1ac cx1af cx1ow cx1na cx1if cx2bt cx2ak d4abg d4aez d4aar d4uuh d4ib d4jl d4qa d4ka d4ku d4vr d4xy d4yt ear10 ear21 ear37 ear65 ear98 ear99 ear116 ei2c ei7c ei8b eu2bu eu8kag f2iz f8bf fmly f8bx f8cp f8ca f8da f8dh f8dt f8eo f8ef f8ej f8ex f8er f8fg f8fk f8fo f8fc f8fr f8gi f8gy f8ha f8he f8hr f8hz f8jz f8jb f8jq f8jj f8jt f8jd f8kz f8lb f8lx f8px f8rb f8sm f8wb f8xz f8zb f8zx f8aap f8aq f8aja f8axq f8aly f8br f8faf f8gdb f8fem f8lbg f8mmp f8moy f8mrq f8olu f8pam f8pro f8prx f8rrr f8rbv f8rgp f8rko f8toy f8oap f8ror f8tan f8wa f8whg f8wba f8wlp f8wrg f8xyo f8yb fupm fq8wb fon4bu fm8lav fm8smu fm8mst freari fr149 g2ej g2kf g2lz g2mm g2ay g2gm g2un g2ap g5bu g5bo g5by g5bd g5is g5jo g5ml g5ms g5rm g5rg g5uw g5ts g5qv g5un g5wk g5wp g6ci g6er g6dh g6ll g6nt g6nx g6lk g6gs g6gc g6hp g6vj g6rb g6qb g6qx g6wl g6wt g6vy g6bx g6yv g6fa

(Continued on page 76)

• CORRESPONDENCE •

The Publishers of QST assume no responsibility for statements made herein by correspondents

Another Contest?

Goldfield, Iowa

Editor, QST:

Why all the adverse criticism about long CQ's? This is a free country, is it not? Those boys have licenses to transmit, don't they? And with the exception of a few things mentioned in the Radio Act, there are no restrictions on what a fellow shall transmit!

Really there is something heroic, when one thinks of it, about the way one of these men will stride up to his table, clap on the caxus with a determined expression, grasp the key, shut his eyes, concentrate his mind on the one tremendous thought, and send it crashing out over the ether to the limits of space. There is magic in those wonderful letters, CQ! Expressed in dots and dashes, there is a swing and rhythm to them which fascinates, hypnotizes their devotees, causing them to go to limits of endurance unheard of in other lines of endeavor.

Now watch him. Having made a record that he thinks will stand, he finally stops, relaxes a few seconds, lights a fag to quiet his nerves from the exertion, and then begins searching the dial to see if any others of his kind are doing better than he did. If he finds such a one, does he quit? Not so! He merely tapes up his aching wrist, settles himself firmly and starts again with renewed vigor.

Show him a little friendly consideration, fellows. Remember his interests in radio are not the same as yours. If you call him, he may stop and work you out of gentlemanly consideration for your hobby, however inferior to his own he may consider it. But he loses valuable time thereby. Remember, he *doesn't want to work you*. If he did, he would have stopped and listened for you a long time ago. So if you cannot join in friendly contest with him, don't interfere with his pastime; let him alone!

The A.R.R.L. is supposed to represent and encourage all amateur radio interests. We have had contests, with prizes, for traffic handling, for foreign contacts, for miles-per-watt, etc. Why not a contest and prize for marathon CQing? As an appropriate trophy I would suggest a 204-A tube, latest model, with two-piece filament, mounted on a gilded concrete base, and hand-decorated with the letters CQ near the top, then a picture of a hound pup with mouth open and nose pointing to the moon, and around the base an inscription.

What shall we say in the inscription? "Champion Nuisance of the Universe"? No; that title belongs exclusively to off-band 'phones! But surely someone can offer an appropriate suggestion.

— R. P. Griffith, W9EJQ

A Possible Explanation

203 Aldeah Ave., Columbia, Mo.

Editor, QST:

It has been demonstrated and conclusively proved that there is a gravitational effect exercised by mass upon the directional distribution of light. The effect is proportional to the mass of the body and to the distance of the source of light from that body.

In other words, when light passes close to the sun, for example, its path will be deflected by the gravitational effect of the sun upon that light. Einstein proved it when a total solar eclipse occurred, and gave us the Special Theory of Relativity. We cannot observe this effect upon the earth, due to such a relatively low amount of deflection, but with the sun it was easily observed and measured. Thus, the phenomenon which involves gravitation and inertia is relative to that which involves electricity and magnetism, for light, according to Maxwell, is due to a changing magnetic field.

Let us now take a disturbance caused by a strong radio transmitter. The signal travels with the same speed as light, i.e., about 186,000 miles a second. The wave of this signal is like that of a ray of light, save that it is of lower frequency. By analogy, as in the case of light, the signal will not travel in a straight path, but will be deflected due to the gravitational influence of the earth. The deflection should be about the same as for light.

The thing, you might say, sounds very nice on paper. The proof of the matter is different. I don't attempt to prove it. Leave that for mathematicians and scientists. But it occurs to me that were radio waves not deflected by some force, they would leave the earth at a point tangent to its surface and to the source of emission, and then become lost in space. Of course, the signal must be strong enough to pass the point of tangency.

Considering skip effect next, we assume that it is due to the presence of a so-called Heaviside Layer that reflects the sky wave back to the earth. It is the same process of reasoning that the ancient Greek philosophers used when they attempted to explain the Universe. "A system of

*Simplicity in design of
1931 Radio Receivers
is aided by this new...*
SPRAGUE
*Inverted Type
Electrolytic*
CONDENSERS

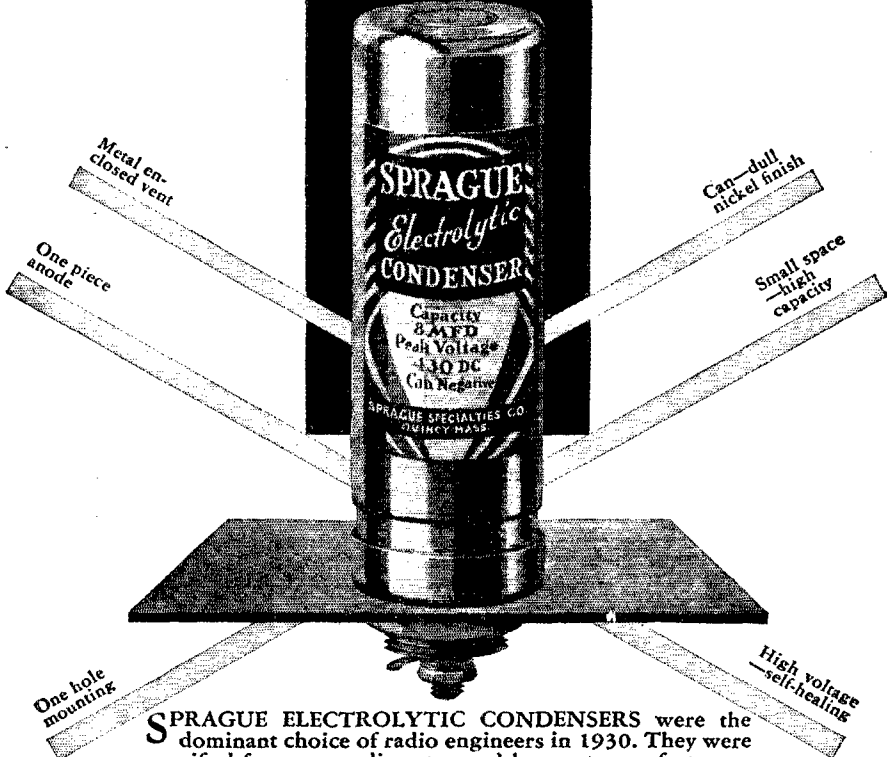

SPRAGUE ELECTROLYTIC CONDENSERS were the dominant choice of radio engineers in 1930. They were specified for more radio sets, used by most manufacturers. The great improvement represented by the new Sprague Inverted Type Electrolytics is sure to be reflected in an increasing use in 1931.

Let our engineering department co-operate with you in the design of filter circuits.

Write for illustrated folder and complete catalog of Sprague Electrolytic and Paper Condensers.

Department 13-G
SPRAGUE SPECIALTIES COMPANY⁷
North Adams, Mass.

SPRAGUE
Electrolytic CONDENSERS

AMERTRAN

TRADE MARK REG. U.S. PAT. OFF.

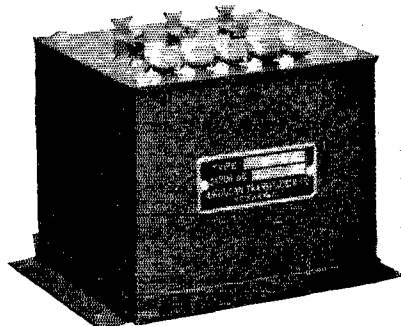
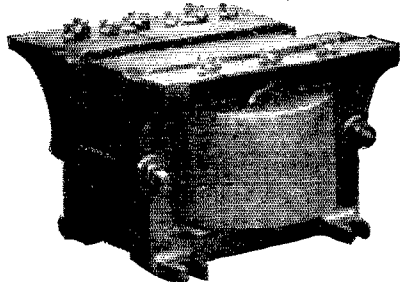

Equipment

Filament Heating Transformers, Plate Transformers and Radio Filter and Modulation Chokes, designed to meet amateur requirements, are of the same high quality that has made AmerTran products outstanding in a highly competitive field.

Bulletin 1066 gives complete descriptions and diagrams of new equipment. Every amateur should have this informative Bulletin as a guide in ordering new equipment.

American

Transformer



Company

172 Emmet St.

Newark, N. J.

AMERICAN TRANSFORMER CO.

Q. S. T. 2-31

172 Emmet St., Newark, N. J.

Please send me Bulletin 1066 containing complete information on AmerTran Transformers, for better radio reception.

Name.....

Address.....

crystal spheres holding each celestial body in place and taking it along in a path of uniform motion."

But there is nothing to prevent us from assuming that there is no such thing as a Heavside Layer. In its stead, let us suppose that there is a gravitational effect on a radio wave that will keep it from leaving the earth. Assume further that this effect of gravity becomes less as the frequency of the signal increases and the skip effect is accounted for.

On the ocean, a forty-meter signal is not heard for a radius of about 400 miles, more or less (depending on various factors). The same signal on twenty meters has a decided increase in skip effect that is noticeable at greater distances. Hence skip effect is directly proportional to frequency. If we could work out a formula for this phenomenon, we might easily compute accurately at what point a five-meter signal will be heard and thus shed further light on a subject which up till now has been shrouded in mystery. That such a formula can be worked out is not hard to understand. If we cannot do it with our present knowledge of mathematics, who knows but what someone can step forth and invent a new branch of mathematics for the purpose. It has been done before with trigonometry and calculus, and it can be done again.

Let me here state that I put no claims for original thought in the foregoing paragraphs. It merely occurred to me that the new system of thought put forth by Einstein could just as easily become applicable to radio waves as to light waves. Someone with lots of time and patience can now come and set about to prove or disprove the thing.

— J. Pascal, W2CEV-W9AQD

More on CQ's

2314 N. Ferry St., Anoka, Minn.

Editor, *QST*:

I see by the latest edition of the good book that the old Spanish custom of suggesting informative characters in the much discussed CQ has been revived. You will undoubtedly remember the overabundance of such suggestions that were displayed in the dear old bible about 1925 and 1926. Why, if all the suggestions had been used a fellow would be able to tell from a plain lowly CQ (just an ordinary one), the history of the CQ'er, his height, weight, the color of his hair, who his grandfather and grandmother were, his occupation and his politics. Think of it — all just from one little CQ! But you will note that they were not used at all and we are still CQing in the good old way.

With due respect to W6DZK and his suggestion for an informative character in the CQ to tell the answerer at which end of the band he is going to start tuning, I have the following suggestion to make.

If one's transmitter is located in the low frequency end of the particular band in which he is working he should start in tuning from the low

RADIOTRON UV-861

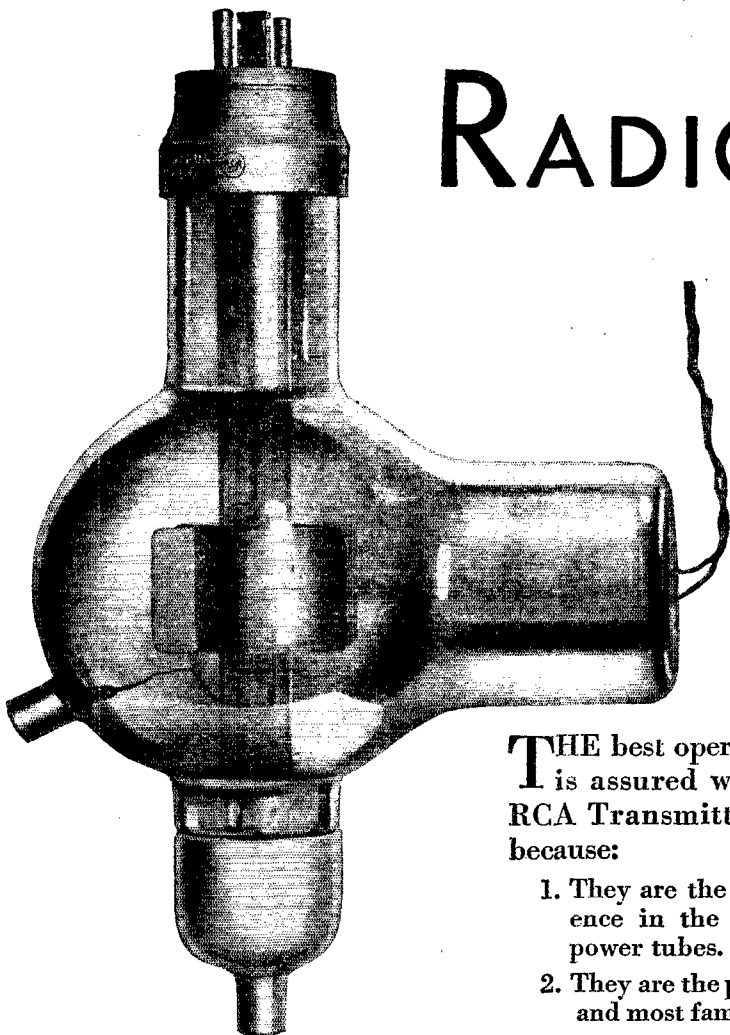

*A screen-grid
500 watt R. F.
Power Amplifier*

THE best operation of any power circuit is assured when it is equipped with RCA Transmitting Radiotrons. This is because:

1. They are the result of the longest experience in the commercial manufacture of power tubes.
2. They are the product of the world's largest and most famous radio engineering laboratory.
3. They are guaranteed to be free from electrical and mechanical defects.

When you use RCA Transmitting Radiotrons, therefore, you get long service and the maximum quality of performance.

Radiotron Type UV-861 (illustrated above) is particularly recommended for high frequency use as a linear (Class B) amplifier. The fourth electrode—the screen—makes neutralization unnecessary.

Engineering Products Division

RCA VICTOR COMPANY, INC.
CAMDEN, NEW JERSEY

155 East 24th Street	New York City
100 West Monroe Street	Chicago, Ill.
Santa Fe Building	Dallas, Texas
235 Montgomery Street	San Francisco, Calif.

UV-861 Rating

Filament Volts 11 Filament Amperes 10
Amplification Factor 300
Mutual Conductance
2.25 Milliamperes/volt

Linear RF Amplifier—Class B

Normal Operating Plate Volts	3000
Screen Voltage (Approximate)	500
*Control Grid Bias Voltage	- 60
Non-modulated Plate Current (DC)	188 M. A.
Peak Power Output	600 Watts
Carrier output (100% modulated)	150 Watts

*Referred to midpoint of filament

Additional technical data will be furnished upon request.

ANNOUNCING A NEW POLICY

Our Amateur trade has grown to such proportions that we are now able to extend even LOWER PRICES to the readers of QST. They are contained in our new Bargain Bulletin No. 66. A card brings it to you.

Radio **AEROVOX** *Faradon* **Webster** *Leak*
EXTRA  **EXTRA**
American SALES COMPANY
 18-21 Warren Street NEW YORK CITY
 Guaranteed Merchandise
 ORDERS SHIPPED SAME DAY RECEIVED
 Take Advantage REAL MONEY MAKERS

Radio and Electric Wholesale Bargain Bulletin

Dealers! Wholesalers!
!! NOW READY !!
New Wholesale Catalog
No. 66 full of real low
prices on: Condensers,
Transformers, Speak-
ers, and other numer-
ous items including re-
placement parts.

GET COPY NOW

Graybar *KOLSTER* *SULLIVAN* *AMERICAN*
Western Electric *POWERIZER* *FLECHTHEIM*

CONTINUING OUR PRE-MOVAL SALE

STROMBERG-CARLSON 1200 volt center tapped transformer with additional winding at 300 volts, center-tapped. Filament windings: two 7.5 volts for two 281's and two 250's or 210's. 3.5 volts for two Tungar tubes. Has universal uses.	\$4.75
THORDARSON 250 watt — 1200 v. center-tapped, two 7.5 and one 3 v. windings. T3202.	4.75
THORDARSON 175 watt — 1150 v. center-tapped, same filament. T3321.	3.50
THORDARSON Filter Choke, 30 henry, 150 mill.	2.75
THORDARSON Double Filter Choke, two windings at 18 henry, 250 mls each.	4.75
C.T.C. Filter Choke, 30 henry, 120 mls.	1.25
AMERICAN 4000 volt transformer, center-tapped and tapped at 3000 volts. 750 watts.	13.50
GENUINE R.C.A. UX-216-B, half-wave rect.	1.95
GENUINE R.C.A. UX-200-A, super Detector.85
BRADLEYSTAT , type E210, 10 amps.65
DUBILIER 1 3/4 mfd. filter cond., 1000 volts.	1.15
DUBILIER 1 1/4 mfd. filter cond. 3 mfd. at 1000, 2 mfd. at 600 and 4, 5 and .25 at 160 v.	2.75
AEROVOX 7 mfd. Block, 2 mfd. at 1000, 2 at 800 and 3 at 400 volts.	2.50

Special Discounts on All Transmitting Apparatus

AMERICAN SALES COMPANY

21Q Warren Street New York City

frequency extremity of said band, and if his transmitter is tuned to a point in the high frequency end of the band he should start his tuning from the high frequency end.

The above is more or less standard practice, I believe, and it gives the desired information without the addition of useless and unheeded information in the process of CQing. Lord knows that some of them are long enough without any additions.

— George Collier, W9CWI

Editor's Note. — A similar suggestion was received from Carl A. Felt, Jr., W3BEX.

Directional CQ's

Editor, QST:

Am writing with respect to a little unpleasantness which came my way a few nights ago.

I was going over the dial on my receiver and happened to catch the end of a CQ from a 9. All I heard was CQ CQ de W9—AR so I switched on the power and gave him a call. He came back and gave me a sure enough bawling out — "When did W5BHV get in Illinois?" and "if I did not know better than to answer a directional CQ that was not meant for me." He said his CQ was for Illinois and I had just wasted his time. I felt very small when he got through with me. One thing in his favor, though, he did say "73" before he signed off. HI.

Since then I have listened to exactly eleven directional CQ's, and eight of them made the same mistake of failing to end the CQ with the direction before signing for the last time, thereby warning off any chance listener who may have come across their signals just before the end of the CQ. If W9—had ended his directional CQ with "CQ CQ III de W9—" I would not have bothered him.

— Harry B. Sorensen, W5BHV

Official Broadcasts

Radio Station W3CFI, Bucknell University,
Lewisburg, Penn.

Editor, QST:

This letter deals with the Official Broadcasts from W1MK and the trouble we and a lot of other fellows have in copying the latest news as sent out by Headquarters. No doubt about it, these broadcasts are both interesting and important, or they wouldn't be sent. And it is very evident that a great many men make it a part of each day's work to try to keep posted on such things as frequency, expeditions, etc. They rely on W1MK to give them this latest dope.

It is gratifying indeed to hear W1MK come on the air right on time and frequency and give the well known "QST de W1MK." We drag out the pencil and pad and settle down to an interesting period of news and good code practice. Then — the war starts.

A nice broad carrier wave appears almost right on top of W1MK and just about smothers the C.

"Our CeCo Radio Tube sales have increased 30% in the last 2 years — proof of CeCo's high reputation."

Arthur Morofsky, Amco Radio Stores, New York City.

"In theaters throughout the world, the CeCo types 866, 250, 281 tubes have proven their superiority. Built to withstand heavy overloads and high voltages these CeCo Tubes maintain uniform characteristics for longer periods. They are products of CeCo's \$200,000 laboratory and tested over WICLN, CeCo's short wave station."

DO YOU KNOW?

1. CeCo's type 866 tube takes 7,500 volts peak and delivers .6 amps load current with only 15 volts drop in the tube.
2. The CeCo Power Pentode P5 may be used as a buffer amplifier in transmitters or as an output amplifier in receivers.
3. For prompt delivery, CeCo maintains warehouses at New York, Chicago, Boston, Philadelphia, Cincinnati, Pittsburgh, Providence, Toledo, San Francisco, Los Angeles, Dallas and Springfield, Mass.

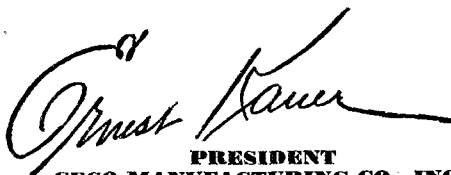

**PRESIDENT
CECO MANUFACTURING CO., INC.
PROVIDENCE, R. I.**

CeCo Radio Tubes

Licensed under Radio Corporation of America patents.

They're better or you don't pay!

ECONOMICAL SELF-HEALING PUNCTURE-PROOF

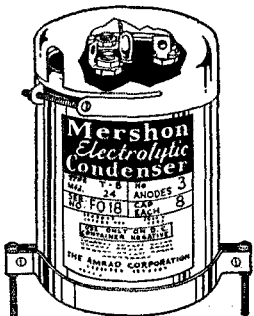

Merphon Electrolytic Condenser
TYPE T-8
24-MFD. CAPACITY

Thousands of servicemen and amateurs have found in the *Merphon Electrolytic Condensers* the answer to troublesome condenser problems.

Send us a drawing of your equipment showing tubes, voltages and other significant information. Our Service Department will gladly tell you how to install *Merphons* and how much they will cost.

Electrolytic **MERPHON** Condenser

Exclusively the product of
THE AMRAD CORPORATION
155 E. OHIO ST.,
CHICAGO, ILLINOIS

THE AMRAD CORP.
155 E. OHIO ST.,
CHICAGO, ILLINOIS

- Tell me how to install the *Merphon Electrolytic Condenser* in my equipment
- Send me your booklet "*Puncture-proof Filter Condensers*"

NAME.....

STREET.....

CITY.....

STATE.....

W. signals. We cuss a bit and twist the dials, and right out of the middle of said carrier wave comes the famous old saying that we all know so well: "This is W— calling CQ, calling CQ."

Now, nothing against the 'phone men. Don't misunderstand us, please. But couldn't something be done about the matter? Couldn't the 'phone men, who are not quite sure just where they are in the band, quit their CQ's for a little while and give us poor devils, who do not have the personality nor the proper voice (nor maybe the desire) to use 'phone, a chance to copy some hot news?

Maybe there is some solution to the problem, and if there is, well — many a man will appreciate clearing it up. Enough said for now. Let's see what can be done, gang.

- S. L. Wandes, W9EWV-W8CVG
- H. H. Bray, W3AKJ-W8CMT
- Sherwood Gethens, W3AUK

The 'Phone Problem

632 W. 20th Ave., Spokane, Wash.

Editor, *QST*:

I certainly agree with the views of Mr. C. S. Hoffman, Jr., W8HD, as published in the August, 1930, issue.

My idea of the disposal of the poor 'phones is this — place all 'phone men on the 1750-ke. band only; this will eliminate those utilizing inadequate and obsolete equipment because of serious interference with B. C. service and consequent suspension of that station's 'phone privilege. Those left at the end of six months of work on 1750 ke. could submit a diagram of the *existing* station with the request that they be permitted the use of the higher-frequency 'phone bands; the diagram, of course, would be accompanied by an affidavit as to its correctness.

This system would certainly satisfy c.w. men by the lessening of off-frequency 'phone in the code section of the band. It would also reduce QRM and allow the good 'phone stations a chance to work. Goodness knows it is bad enough to be put into a 50-ke. band and then have several dozen loop-modulated "peanut" stations on top of the station you are receiving. Loop modulation is OK but for one thing — usually no one knows what's being said except the ham at the mike.

My experience to date is three years as a ham — the last year and a half being m.o.p.a. 'phone work — several months as a broadcast op, and a little theatre sound work. I will be glad to receive letters pro and con on the subject from hams or fight it out on the air if the rotten 'phones will shut down for a few minutes.

— R. B. Sutton, W7QV-W7GZ-W7HF

How About It?

Box 264, Rushville, Ind.

Editor, *QST*:

In all the years I have been reading *QST* this is the first time I have sent in a suggestion. Since this is my first request, see what you can do.

You Don't Work the Stations You Can't Hear

HEAR 'EM ON THIS SENSATIONAL RECEIVER

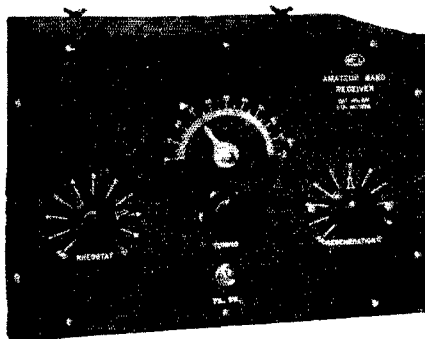

THE most practical Amateur band Receiver yet developed — designed for Amateur work by the oldest reliable manufacturer of Short wave equipment. Just see these outstanding features:

- 1 — Employs new super sensitive 2-volt non-microphonic battery operated tubes
- 2 — Spreads each amateur band over the full range of the dial
- 3 — Equally efficient for DX, CW or fone reception
- 4 — Thoroughly tried and tested circuit guaranteeing consistent results
- 5 — Screen grid RF — detector — power audio
- 6 — Readily calibrated for each band
- 7 — Easily assembled and wired

A complete kit comprising all necessary parts to build this record breaking Receiver — includes drilled and engraved panel, metal cabinet and three special Amateur band plug-in coils allowing each band to be spread over the entire tuning dial. *Price \$30.00*

Don't slip up on this receiver. It will put your station up amongst the record-breakers.

Write for our large loose leaf handbook full of information, kept up to date by regular bulletins. Price only 50c.

Our booklet 50 describes this Modern Short Wave Receiver together with a "bang up" Transmitter.
Write for it, It's FREE!

RADIO ENGINEERING LABORATORIES, INC.

100 WILBUR AVENUE

LONG ISLAND CITY, N. Y.

Export Department: 116 Broad Street, New York City

Cunningham RADIO TUBES

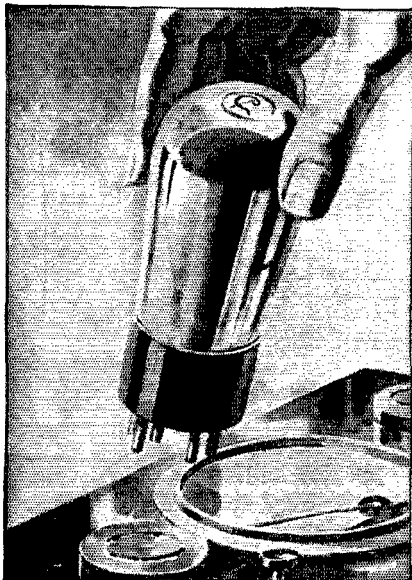

Frequent TESTING informs you when to replace tubes

— and remember *new* tubes “work” better with *new* tubes—insist on a complete set of Cunninghams.

E. T. CUNNINGHAM, INC.
New York / Chicago / San Francisco
Dallas / Atlanta

Why not give us technical information? We can all figure out how long a Zepp should be or how many turns to put on those inductances. Any of us that have pounded a key get tired of simple explanations. We want to know how things happen.

For instance, get some engineer to tell us how vacuum tubes are figured out. We all know that if we load them up enough they will oscillate — but what are they made of? How do they know how far apart to put the grid, filament, and plate? Just think of the good space that is taken up with letters of pain regarding CQ's and QSL cards that could be used giving us fellows the dope we want.

There are a million things that fellows build up and make work. Anyone can build them, but how many hams can tell how they perk?

Let's see how the gang feels. Give us a trial and see if you don't get thanks from a majority of the old-timers.

— M. A. Russell, W9EEY

I.A.R.U. News

(Continued from page 64)

Send cards for countries not listed in the foregoing to the A.R.R.L., West Hartford, Connecticut, U. S. A. Every effort will be made to forward them properly. Corrections to this list, and additional names, will be welcomed.

H. B. Cowan, W3CBT, reports that YI1LM comes through between 6:00 and 7:00 p.m. E.S.T. (1123-1200 G.C.T.) This is on 7 mc. Stations from this section are heard on 14 mc. from 4:30 p.m. to 6:00 p.m.: Here's a chance for that Asian contact to complete your WAC, eastern W's!

Personal nomination for world's most optimistic amateur: One who appeals to his State Department claiming that the A. T. & T. transatlantic telephone interferes with his transmissions.

AUSTRALIAN REPORT

By W. G. Sones, Fed. Publicity Director, W.I.A.

The seventh Annual Convention of the W.I.A. mentioned in last month's report proved to be the most successful yet held. Delegates who were present, some of whom will be familiar to overseas amateurs, were H. K. Love, VK3BM, Federal President; S. W. Gadsden, VK3SW, Fed. Vice-President; Bruce Hardie, VK3YX, our extremely popular Federal Secretary, and voting delegate for Victoria; R. Chiltern, VK2RC, delegate for New South Wales; L. J. Feenaughty, VK4LJ, for Queensland; I. Thomas, VK5IT, for South Australia; Maxwell Howden, VK3BQ, proxy for West Australia; and J. Heine, VK7JK, for Tasmania.

Convention opened on the 20th October, and by working 12 hours at a stretch, business was concluded by the 24th. Social activities were sandwiched in between sessions, and it is reported

(Continued on page 66)

Here's the Oscillator You Have Been Waiting For!

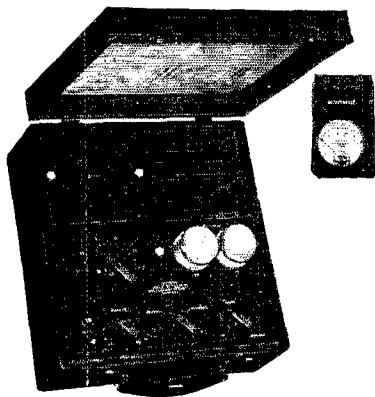

The JEWELL Portable Test Oscillator

A necessary instrument for testing radio receivers

Pattern 560 Test Oscillator, complete with tubes, batteries and output meter. *List Price*.....\$97.00
Dealer's Price.....\$72.75

Pattern 560 Test Oscillator without output meter. *List Price*.....\$82.00
Dealer's Price.....\$61.50

Pattern 559 Output Meter only. *List Price*.....\$15.00
Dealer's Price.....\$11.25

Radio frequency circuits, whether in a tuned radio frequency or super-heterodyne receiver, must be accurately adjusted to obtain the greatest sensitivity and selectivity. To make these adjustments accurately and quickly, a test oscillator of special design is required. No makeshift, cheaply built oscillator can be used for checking modern high gain receivers.

The Jewell Pattern 560 Portable Test Oscillator is designed and built to meet the needs of radio servicemen. Simplicity of operation, hair-line accuracy, and assured reliability are the cardinal features of this portable test oscillator. Each feature has been achieved by incorporating constructional details which actual service tests have proved absolutely necessary.

Some Important Features of the Jewell Test Oscillator

SELF-CONTAINED BATTERIES

The Jewell Test Oscillator is convenient to use because it operates from self-contained batteries. Services both A.C. and D.C. sets. Accurate adjustments cannot be made with A.C. operated oscillators that feed energy back to the receiver through light lines.

LEAK-PROOF INTERLOCK SHIELDING

Every part of the Jewell Test Oscillator is enclosed by a combination aluminum and copper interlocking shield. An oscillator with less shielding is worthless.

BROADCAST AND INTERMEDIATE BANDS

The Jewell Pattern 560 Portable Test Oscillator covers the broadcast band from 550 to 1500 K.C. and the intermediate frequency band from 125 to 185 K.C. Jewell Test Oscillator is adequate for testing every super-heterodyne receiver built today, and provides for future design in that it covers the entire band from 125 to 185 K.C.

NEW '30 TYPE TUBES

Two tubes are used; one a radio frequency oscillator and a second to generate audio frequency notes. Shielded tube compartments are of ample size for the '30 type tubes with present small glass envelope or with the new larger standard size envelope.

OUTPUT METER

The Jewell Test Oscillator may be had with or without Jewell Pattern 559 Portable Output Meter. The meter is carried in a pocket provided in the oscillator case. In use, it is placed near the output circuit of the receiver eliminating long leads and preventing any possible coupling to the oscillator.

EASY TO OPERATE

You do not have to study the instruction book to use the Jewell Test Oscillator. A wiring diagram and set of calibration charts are carried in the oscillator cover where they can never be mislaid.

Built to the same high standards as the Jewell Tube Checkers and Jewell Set Analyzers

30 YEARS MAKING GOOD INSTRUMENTS
JEWELL

Send for descriptive bulletin

Jewell Electrical Instrument Co.
1642-C Walnut Street, Chicago, Ill.

Please send bulletin completely describing the Jewell Pattern 560 Test Oscillator.

Name.....

Address.....

ARE YOU BINDER- CONSCIOUS?

Thousands of League
Members Are

because they know the value of keeping their past issues of *QST* where they can get at them with the least amount of effort.

Handy — and handsome.

Keep them as a unit
in a

QST Binder



Note the wire fasteners.
Unnecessary to mutilate
copies. Opens and lies flat
in any position.

\$1.50 each
postpaid

QST

West Hartford

Connecticut

that most of the delegates obtained very little sleep during the week they were in Melbourne. The Convention was formally closed with a complimentary dinner (a true "Ham-fest" as our American friends would have it) tendered by the quest division, Victoria, as an opportunity for meeting a number of the Victorian members and representative radio leaders including the Radio Inspectors, Navy, Army, Air Force, Broadcast Services, and Commercial organizations.

The items included on the agenda paper were outlined with explanatory notes in last month's report and the main resolutions, which are likely to be of interest to foreign amateurs, are as follows:

TECHNICAL DEVELOPMENT. — A Federal Technical Development Section (Experimental Section) was created with its Headquarters in South Australia. Each Division has been instructed to form a Divisional Technical Development Section to work under the direction of the Federal Section Headquarters.

STANDARD FREQUENCIES. — This was the subject of a number of related resolutions, the substance of which was that the substandard held by the Victorian Division calibrated from a Multi-Vibrator now in the possession of the P.M.G.'s Department, Research Laboratory at Melbourne, should be the standard for calibration by all Australian amateurs. The Federal T.D.S. has been instructed to prepare specifications for Divisional Standards to consist of a balanced oscillator with crystal resonators. Sufficient of these will be constructed by each Division to mark the important frequencies in each band, and will then be calibrated and checked at necessary intervals by the T.D.S. from the Federal Sub-Standard.

Marker stations are appointed particularly for 3.5 mc. and 4 mc.; 7 mc. and 7.3 mc.; 14 mc. and 14.4 mc. All other crystal-controlled stations are to be notified of their true frequencies, and requested to sign off with it at all times.

VIGILANCE COMMITTEES. — It was recommended that Divisions appoint Vigilance Committees to report direct to offending stations causing unnecessary QRM, off-wave working, etc., and to suggest possible causes of the trouble and methods of eliminating it.

EX-TERRITORIAL MEMBERSHIP. — Provision has been made for admitting to membership, persons resident outside of Australia. Such members will be accepted by Federal Headquarters on the recommendation of individual Divisions.

FEDERAL HEADQUARTERS LOCATION is again in Victoria for the 3rd year in succession, and we feel that extraordinary confidence has been rested in this Division in so honoring us again.

COMMERCIAL OPERATION IN AMATEUR BANDS. — It was resolved to communicate with the I.A.R.U. periodically in connection with this subject and to cooperate in its elimination as much as possible.

TRAFFIC MANAGERS. — R. Cunningham, VK-3ML, was appointed to Federal Headquarters as Federal Traffic Manager with instructions to



Every Transmitting Amateur Uses These Forms

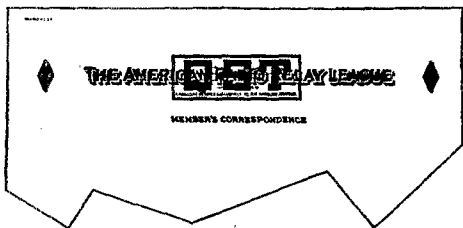

MEMBER'S CORRESPONDENCE STATIONERY

One color (black) heading now being used at greatly reduced cost to members.

Write your radio letters on League stationery — it identifies you.

Lithographed on 8½ x 11 heavy bond paper.

- 100 sheets50c
- 250 sheets\$1.00
- 500 sheets\$1.75

Postage Included

Everything that you've wanted
in a log is in the Official
A. R. R. L. Log Book

New page design to take care of every operating need and fulfil the requirements of the new regulations!

New book form! No more fussing with binders, or trying to weight down loose sheets when the breezes blow!

New handy operating hints and log-keeping suggestions, put where they are always convenient!

THE AMERICAN RADIO RELAY LEAGUE
HEADQUARTERS: HARTFORD CONN. U.S.A.

RADIOGRAM

CITY OF ORIGIN HARTFORD CONN.	STATION OF ORIGIN W1KX	NUMBER 979	DATE OCT 6 47
TO BERN E KCELWAIN W3CZC			
BLANCE 107A			
RELAY CHAIN BEING ORGANIZED BY BIRDS OF ILLINOIS TO OPERATE BETWEEN THE PACIFIC COAST AND CHICAGO CALLS FOR CLOSEST COOPERATION BETWEEN IOWA AND ILLINOIS STOP SUBJECT THAT YOU COMMUNICATE WITH WRAP UP THE SUBJECT			
LOUIS R HUBER			
Rec'd FROM STATION W3CZC	LOCATED AT PORT ADISON IOWA	DATE 10/8/28	TIME 8:23 p
OPERATOR RP			

AMATEUR RADIO STATION LOG

DATE	TIME	FREQ	MODE	CALLLED	CALLLED BY	STATION HEARD	STATION NAME	MESSAGE	REMARKS ETC

THERE are 39 pages like the one above, 8¼" x 10¾", carefully designed to incorporate space for all the essential information you want and need to record about your station's operation. Thirty-nine blank pages (backs of the log pages) to be used for notes, experiments, changes of equipment, etc. Durable covers of heavy stock with space for your station call and dates over which the log entries extend. On the inside covers and first two pages are complete instructions on maintaining your log, convenient tabulations of the most-used Q signals, miscellaneous abbreviations, operating hints, amateur prefixes and signal-strength scales. The information you want, always at your finger-tips.

The new regulations require a log; a well-kept one identifies your station; a uniform series constitutes a progressive and permanent record.

We honestly believe the new Official A.R.R.L. Log Book is the best you've ever seen!

OFFICIAL A.R.R.L. MESSAGE BLANKS
Most convenient form. Designed by the Communications Department of the A.R.R.L. Well printed on good bond paper. Size 8½ x 7¼. Put up in pads of 100 sheets. One pad postpaid for 35c or three pads for \$1.00.

MEMBER OF THE AMERICAN RADIO RELAY LEAGUE

RADIOGRAM

AMERICAN RADIO RELAY LEAGUE

From: _____ Date: _____

To: _____

This message is to be delivered to the following address: _____

At Radio Station: _____

MESSAGE DELIVERY CARDS
Neatest, simplest way to deliver a message to a near-by town. On U. S. stamped postals 2c each. On plain cards (for Canada, etc.) 1c each, postpaid.

40 cents each
Three for \$1.00
Postpaid anywhere

AMERICAN RADIO RELAY LEAGUE, WEST HARTFORD, CONN., U.S.A.



RCA INSTITUTES trains men in RADIO

MEN who need radio training... who wish to know all about radio servicing, radio telephony and telegraphy and broadcasting, can quickly obtain this valuable knowledge through RCA Institutes and its famous Home Laboratory Training Course.

Radio Instruction by America's Oldest and Foremost Radio Training School

You can study at home in your spare time or at any of the RCA Institutes resident schools throughout the country. Thorough and reliable training given you. As a student you also receive the complete RCA Institutes Laboratory Equipment... enabling you to easily solve radio problems at home in your spare time. This is the recognized way to speedily acquire the commercial knowledge and ability demanded in Radio today.

Free Book for Ambitious Men

Send for this free book... many pages of pictures and text giving full details about the Home Laboratory Training Course... the RCA Institutes Laboratory Equipment... RCA Institutes and the noted staff of instructors... that have helped thousands of men to make good in Radio.



RCA INSTITUTES, Inc.

RCA INSTITUTES, Inc.,
Dept. T.S.-2,
75 Varick St., New York, N. Y.

Gentlemen: Please send me your big FREE book which tells about the many opportunities in Radio and about your famous laboratory method of radio instruction at home.

Name.....

Address.....

Occupation.....

organize a Federal Traffic channel in conjunction with Divisional Traffic Managers. Radiograms to VK, intended for Federal Headquarters, should now be relayed to VK3ML. Complete details of the traffic schedules, etc., will be reported as soon as they are available. The Federal Traffic Manager will also have charge of, and arrange for, International Traffic Handling tests so that information of this nature from foreign sections will be greatly facilitated if addressed direct to him. The address, incidentally, of the Federal Headquarters of the W.I.A. is Kelvin Hall, 55 Collins Place, Melbourne C.I., Victoria, Australia.

TELEPHONY ON 7 MC.— It was decided to investigate the possibility of restricting the use of telephony on this band except through M.O.-P.A. and C.C. transmitters. Australian amateurs enjoy a number of privileges in connection with telephone transmission and the object of this resolution is, of course, to restrict the use of the band as an amateur broadcasting band because of its value for DX work. It is not intended to restrict speech telephony other than by means of self-excited and other types of interference causing transmitters.

AIR FORCE RESERVE.— This will be completely reorganized to provide for its control by the Institute and received rather a lengthy discussion in conference with a representative of the Air Force Authorities. Details of the new scheme will be referred to later.

The Convention waited upon the Chief Inspector of Radio regarding several matters, with very gratifying results. The Chief is to recommend to the P.M.G. that the Federal Executive of the Wireless Institute be officially recognized as the controlling authority for amateur radio throughout Australia.

It is also reported that so far as could be seen at present, the 3.5-mc. band is available to us indefinitely.

BRITISH NOTES

By J. Clarricoats, Hon. Sec'y R.S.G.B.

On behalf of all members of the R.S.G.B. and the B.E.R.U. I send best wishes for the New Year.

Preparations have now been made for Empire Radio Week, which is to be held during the inclusive period February 22nd to 28th, 1931. During this week all British Empire stations will concentrate on working stations in other B. E. zones. To the station recording the most points a special award known as the "B.E.R.U. Challenge Trophy" will be presented. This will be competed for annually, and will be donated by the Home members of the R.S.G.B.

The Annual General Meeting of the R.S.G.B. and B.E.R.U. was held on December 19th, when Mr. H. Bevan Swift, G2TI, succeeded Mr. Gerald Marcuse, G2NM, as President, and Mr. Arthur Watts, the well known Publicity Manager of the B.E.R.U. was elected Acting Vice-President. Mr. E. Dawson Ostermeyer and Mr. John Clar-

TECHNICALLY SPEAKING

“THESE FEATURES MAKE THE
RECORDOVOX SUPERIOR!”



**LIST
PRICE
\$25.00**

less microphone
Microphone as illus-
trated, \$10 additional

ELECTRICALLY and mechanically, the PACENT RECORDOVOX is as fine an instrument as you could find even in the professional recording laboratories.

Every possible angle has been taken into consideration in the design of the RECORDOVOX. Supplied with 3 adjustable weights, it can be used with motors that lack sufficient torque to operate the turntable when the head is fully weighted. Like the well-known PHONOVOX, the RECORDOVOX, as the result of careful design, possesses excellent frequency characteristics.

Designed for pre-grooved type of records only.
List Price \$25.00. Microphone \$10.00 list extra.

*Write for information on special types and
models to meet your specifications*

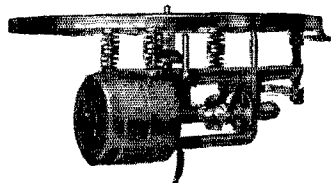

**ELECTRIC
PHONOGRAPH
MOTOR, CATALOG
NO. 140**

Meets every requirement of
radio-phonograph use. Has
sufficient torque to cut even
10" records. List Price
\$25.00.

Manufacturers

PACENT ELECTRIC CO., INC., 91 SEVENTH AVENUE, NEW YORK

Pioneers in Radio and Electric Reproduction for Over 20 Years

Licensee for Canada: White Radio, Ltd., Hamilton, Ontario

P A C E N T

POPULARITY won on performance!

• • • the improved

TRIAD T-210 TUBE

CONSTANT IMPROVEMENTS IN TRIAD T-210 have resulted in a tube as nearly perfect as science can make it. No wonder it has become tremendously popular! Functions equally as well as a power amplifier or oscillator. Special construction eliminates grid and plate emission which is the chief cause of noisy tubes.

Yet this is but one instance of the new and sensational improvements carried out through the entire Triad line. It will repay you to insist upon Triads — the tubes of guaranteed service!



TRIAD Tubes are fully licensed under all R.C.A. General Electric and Westinghouse Electric Mfg. Co. Patents

Triad Manufacturing Co.

Pawtucket, Rhode Island

Send now for Triad bulletin T-210 and for information regarding the remarkable improvements that have been carried out throughout the entire Triad line. A special price is extended to Licensed Amateurs and Members of A.R.R.L.

ricoats continued in office as Honorary Treasurer and Honorary Secretary respectively.

During November certain British stations were given special permission to operate during the evening hours on the 3.5-mc. band, and as a result much interesting work was carried out. It is hoped that a portion of this band will soon be opened permanently to G stations.

Considerable enthusiasm is being shown for the 28-mc. tests which commenced on January 4th. All reports of signals heard should be sent to G5VL, H. J. Powditch, Porth House, Porth, St. Colomb Minor, Cornwall, our Contact Bureau Manager.

Other tests for amateurs who are interested in 56-mc. and 1.75-mc. work are being arranged by Contact Bureau, full details of which will be found in the "T & R Bulletin" which is issued free to all R.S.G.B. and B.E.R.U. members.

Membership of the Society is open to all amateurs in every country — the Headquarters are at 53 Victoria Street, London, S.W.1.

NORWEGIAN NOTES

By G. H. Petersen, Pres. N.R.R.L.

Our 3750-kc. test during the first days of November proved a complete success, signals being received all over southern Norway at all times of day and night. As a consequence, we have applied for the unrestricted use of part of the 3.5-mc. band from our Government. As will be remembered, we got only a temporary permit, lasting till the end of November.

Many of our stations also report European contacts on this band, and we certainly look forward to less congestion on 7 mc. if this band is opened for general amateur work.

The winners of the 80-meter tests were LA1W, as best transmitter, and LA1J, as best receiver.

We are also active in increasing our membership, and might point out in this connection that we gladly receive a representative from each foreign Society as a corresponding member, without any fee, in order that we may improve upon the exchange of regular notes and cooperation between societies in general.

SWEDISH NOTES

By Goran Kruse, Vice-Pres. S.S.A.

Since our last report we have had the pleasure of becoming a member of the I.A.R.U. and have received congratulations from several societies upon the occasion. We are grateful for these kindnesses, and hope to establish a still better cooperation with all in the future.

The Fifth General Convention of the S.S.A. was held on September 27th, and was a great success. The following officers were elected:

President: Dr. Bruno Rolf
Vice-President: Goran Kruse, SM5TN
Secretary: Osborn Duner, SM5ST
Tech. Sec'y: Mats Holmgren, SM7TO
Treasurer: H. Hanell, SM5XH

The QRA remains as before, S.S.A., Stockholm 8 for correspondence, and Dr. Bruno Rolf, Alsten, Stockholm, for QSL cards.

BARGAINS ARMY AND NAVY RADIO SURPLUS

Aviation Helmets, Western Electric, adopted for phones. Genuine leather. List \$24.00. Our price \$5.00

Microphone Cable, 3 wire Shielded, Western Electric heavy duty. Per foot.....12c

Propeller, wood, 15" long, 2" wide, 2" pitch, 9/16" bore. \$1.00

Prop., aluminum, auto speed regulating (Deslauriers), 20" long, 3" wide, 1" to 2 1/4" pitch, 9/16" bore.....\$4.00

W. E. Relay No. B-18 operates on 1 volt cap., 200 mils, very sensitive.....\$3.00

Telephone, desk type, Kellogg, complete with ringer box (A.C. Ringer) \$10.00

Headphones, West. Electric No. 194W same as C.W. 934, 2200 ohms, D.C. slightly used.....\$5.00

Condenser, Dubilier, mica, volts 40,000 cap. .0012-.0018 or .003.....\$25.00

Condenser, Dubilier, mica, op. volts 8500 cap. .004.....\$7.50

Switchboard, 8 line portable Western Electric, magneto ringing; dry cell talking circuit; 8 drops, 20 anti-capacity 12 to 10 terminal key switches, regular price \$175.00, special.....\$30.00

Western Electric Dynamo motor System No. C.W. 927. Two 27/350 volt dynamotors in shock-proof hanger. May be used in parallel to give 100 mils. at 350 volts, or in series, giving 80 mils at 700 volts. Can be used to operate transmitters up to 50 watts power from 32 volt D.C. mains. Ideal for Delco systems. Two dynamotors in hanger \$15.00

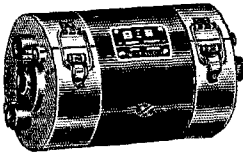

Single dynamo without hanger (as illustrated) \$9.00
Western Electric Switchboard C.W. 928. Control board for dynamo motor system. C.W. 927. Consists of starting switches, fuses, 0-50-500 volt voltmeter with switches for testing main lines and output. Also contains complete filter system. Very special.....\$8.00

Edison Universal motor 1/36 h.p. with governor and regulator. Has one thousand uses. 110 V. Price, each.....\$3.50

Condensers, West. Elec. 21 A.A., 1 mfd, 1000 volt A.C. test.....\$1.00

Motors back geared 110 A.C. variable speed, auto reversible (Slocum oil burner type) has over one thousand uses, a very good buy.....\$7.50

Motor generator, R & M, 110 D.C. 3 1/4 h.p., 2 kw, 20 volt D.C. 80 amp. Great for large station filament supply.....\$125.00

Motor Generators, Holtzer-Cabot, 3/4 K.W., 120 D.C., 320 A.C., 500 cycles.....\$40.00

Also complete line up to 5 K.W. in stock

SPECIAL—U. S. Army instructional book on telephony or telegraphy. Hundreds of pictures and diagrams.....\$1.00

Radio Frequency "Driver", 6000 to 30,000 meters Navy Type SE1103, highly sensitive. Cost \$180.00. Our price.....\$25.00

Ammeter, R.F., 0-10 amp, zero adjuster, 4 in. diameter. A real buy at.....\$4.50

Magnavox anti-noise microphone, good for home broadcasting \$1.50

Century H. P. Buzzers.....\$3.00

HERE'S A REAL BUY!

U. S. Army Signal Corps, 1/4" solid coin silver contacts, flameproof

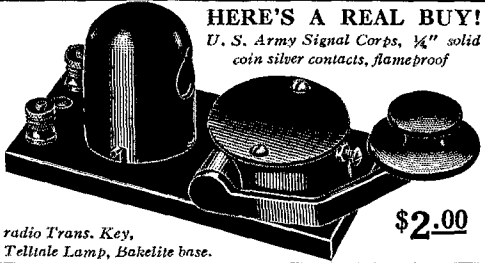

radio Trans. Key, Telltale Lamp, Bakelite base. \$2.00

Holtzer Cabot, "Mike" Utah type, carbon granular transmitter, Special.....\$.95
Western Electric Radiophone Transmitter unit, 326W. Special.....1.50
Dynamotor, GE Navy Airplanes 24/750 volts. Aluminum frame, unsuitable for airplane test work. Specially priced, 200 mils.....27.50
Extra Armature.....10.00
Dynamotor, aircraft 32-275 volt, with shaft, will deliver 400 volts.....5.00
U. S. Navy headphones, excellent for practice and instruction purposes, pair......75
NAVY Dynamotors, General Electric 24/1500 volt, 233 mils.....37.50
Extra Armature.....12.50
Coils, Retardation, West. Elec. Co. 57C, .33 ohm, 2 windings......75
Ret. coil West. Elec., No. 65 A, 1800 ohm 12 henry Ret. coil West. Elec., No. 66 A, 95 ohm 1.3 henry.....1.50
Ret. coil West. Elec. No. 64 B, 11 ohm 1 henry.....1.50
Telegraph and buzzer portable sets, mahogany case, 2 tone 4 contact platinum contact high frequency buzzer, 2 telephone toggle switches, potentiometer, sending key, 3 mfd. condensers, transformer and 2 choke coils, receiver, 830. value.....5.00
Generator, D.C., 12 volt, 33 amp., 5000 R.P.M. with auto regulator.....10.00
Sounders, Signal Corps, 120 ohms, adjustable.....2.50
Spark transmitter, complete, airplane type, rotary gap, transformer, mica condenser, 300 watt 500 cycle with Gen. self excited ball-bearing.....25.00
Generators, Westinghouse 110 volt, A.C. 900 cycles, 200 watts, self excited.....15.00
Generator 1/4 kw, 500 cycle, 300 volt, self excited, can be hand driven.....25.00
Vohmeters, D.C., portable new Weston model 45, 3 scale 0-3-15-150 guaranteed ball-bearing.....40.00
Ammeters, D.C., portable, new Weston model 45, 3 scale 0-1.5-15-150 with 3 scale external shunt and leads 1/4 of 1%, accurate.....40.00
Headphone, Radio School, headband, 75 ohm.....1.50
Keys, transmitting, Navy, back connected on bakelite base, 2 kw. 1/4-inch silver contacts.....5.00
Charging panel, Navy type, S.E. 899, 32 volt, Ward Leonard var. and fixed res., Weston voltmeter and ammeter, Sangamo ampere hour meter. Complete with all switches.....30.00
Receivers, Navy C.N. 240, 1000 meters.....50.00
Receivers, S.E. 143 and P.P. 90.....\$100-\$150
Relay West. Elec. low voltage, 2 upper and 3 lower platinum point screws, 3 contact arms.....5.00
Extra platinum contact screws or arms......35

ANTI-CAPACITY SWITCHES W.E. 12 and 16 Terminal, highly sensitive. Cost \$180.00. Our price, 95c each. Lots of 6.....\$5.00

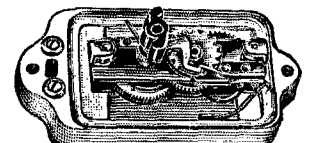

SELECTOR (Call Box) Postal Telegraph type has variety of uses.....\$2.00

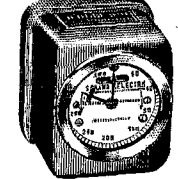

Ampere hour meter, Sangamo, battery charge and discharge, type M S 0-500 scale, capacity 15 amp, \$10.00

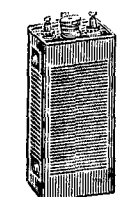

Edison Storage Battery Cells



Type A-4, 1.2 volts, 175 amp., nickel alkali.....\$3.50
Type M-8, 1.2 volts, 11 amp., never used, per cell.....\$1.50
Type A-6, 1.2 volts, 225 amp., nickel alkali.....\$4.00

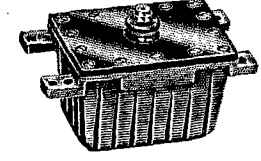

Condensers, Mica, op. volts 12,500 cap. .004.....\$17.50
Dubilier, new.....15.00
Dubilier, used.....15.00
Wire spec. New.....12.50
Wire spec. Used.....12.50

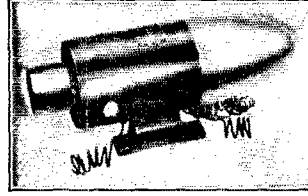

Navy Aircraft Dynamotor, 1 h.w. Gen. Elec., new, 24/1000 volts, 1 amp., with pulley, driven by motor, or propeller, giving 24 volts output for filament, 1000 volts plate. Weight 75 lbs. Value \$250.00. Special price.....\$75.00

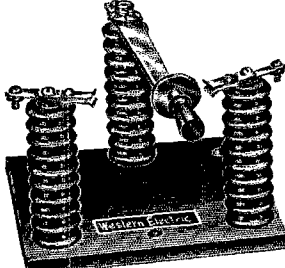

Lightning Switch, High Grade W.E. Heavy Copper Blade and Contacts. Size 7 x 8 x 6 high. While they last.....\$3.50



ARMY HEADPHONE RECEIVER 100 ohm.....\$7.5

Special—Only a few left—Magnets, W. Elec. four bar hand crank.....\$2.50

Largest Radio and Electric Supply House in U. S. specializing on Army and Navy Surplus. Write us your particular requirements. Sufficient postage and deposit of 20% required on C.O.D. orders. NO C.O.D. ON CANADIAN ORDERS. DUE TO LIMITED GOVERNMENT SURPLUS WE DO NOT ISSUE CATALOGS.

Condensers, W. Elec. type 21AB, 1000 volt A.C. test, three caps. 125, 25, .5, \$1

MANHATTAN ELECTRIC BARGAIN HOUSE, Dept. Q, 105-7 Fulton St., New York City

Say You Saw It in QST — It Identifies You and Helps QST

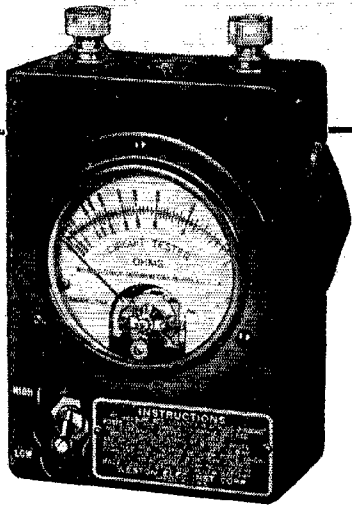

WESTON model 563 checks resistances and continuity of circuits

TRANSMITTING amateurs, set builders, service men and radio engineers will find this new Weston double range Ohmmeter, Model 563, a handy, compact, practical instrument for experimental and repair work. It is well designed, sturdy, thoroughly dependable, yet attractively priced.

Model 563 is most useful in checking resistances, choke coils, secondaries of power transformers and continuity of circuits. The two ranges of the instrument, 0-50,000 and 0-5,000 ohms permit an unusually wide scope of measurement; thus, this one instrument serves for practically all resistance testing.

Because Model 563 is a high sensitivity instrument, the drain on the self-contained 1.5 volt dry cell is very slight—only 1 milliampere on the high range and 10 milliamperes on the low range. Therefore, on the high range, the life of the cell is practically its "shelf" life, assuring long service before replacement. Any changes in its potential may be compensated for by the voltage adjuster on the top of the instrument.

Model 563 is supplied with 30 inch test cables.

For details, write for Circular LL



Weston Electrical Instrument Corp.
602 Frelinghuysen Avenue Newark, N. J.

Probably on account of the variable conditions existing, activity among Swedish amateurs has been at a low ebb during the period since our last report, but seems to be increasing now with the coming of autumn weather and less "QRYL," etc. Hl. SM7TO has been keeping a fine sked with ON4RO from a temporary station at the Technical University (SM5UX) at Stockholm. A visiting Belgian scientist, formerly amateur B9, was kept in daily contact with the University of Brussels whereby lots of important and money-saving traffic was exchanged, a traffic which could not possibly have been arranged over ordinary telegraph lines.

Tests with short wave gear on aeroplanes have been carried out by SM5SV with fairly good results. They will be continued.

Many SM's are regularly taking part in the wave propagation investigations being undertaken by the French Meteorological Institution (ONM) in coöperation with the U.R.S.I. This work was still further stimulated by the conference of the U.S.R.I. at Stockholm this summer, when several of our hams had an opportunity to attend the meetings of the conference, and also to personally meet the president, Professor Kennelly, who proved to be a real friend of the amateurs. It is our opinion that amateurs have much to gain through close coöperation with the U.R.S.I. in their various tests, especially in Europe where the amateur has not so many occasions to prove his usefulness as in America. Then certainly the representatives of the U.R.S.I. at the Madrid conference will assist us amateurs in our struggle to retain privileges to which we are rightfully entitled, against the encroachment of commercial interests.

GERMAN NOTES

By Dr. Curt Lamm, Foreign Office, D.A.S.D.

During the period covered by this report some investigations were made by the District Manager of the Berlin area concerning the relative audibilities of four different stations on 7 mc. as far as the propagation of the surface wave goes all over the Berlin area. Detailed results will be dealt with at a later date. The following stations took part in the tests: D4ADC, D4ADF, D4AEZ, and D4AFA. Reports were received from well over fifty receiving stations.

Conditions on 14-mc. were very bad indeed, only South African stations being heard. At the beginning of November, W's were heard very well, but lately we experienced a bad spell of "dudness" on that band. On 7 mc. VK and ZL stations are to be heard during the early mornings, but no Americans seem to be received. On 3.5 mc. an increasing activity is to be reported, somewhat like in the good old days. D4UAB has made some very interesting investigations on that waveband. The summary was published in last month's "CQ."

Our foremost DX station at present is D4WAO without any doubt, who is making many contacts with all parts of the world.

On January 1, 1931, the new inter-European

BIG FEBRUARY SAVINGS



The Home of RADIO
45 VESEY STREET
NEW YORK

New York's Headquarters
for
Transmitting Apparatus
When in Town Visit Our Store

EVERYTHING IN
 ACME JEWELL PYREX
 BRADLEY FLERON
 THORDARSON
 ELECTRAD NATIONAL
 LYNCH SIGNAL
 FLECHTHEIM
 NATIONAL RECTOBULB
 GENERAL RADIO
 CARDWELL AEROVOX
 WESTON
 IN STOCK

- Acme 500-watt transformer, 1500-2000 volts each side of centre **\$21.00**
- Acme transformer to change 220 A.C. to 110 A.C. — 250 watt **\$10.00**
- Acme transformer to change 220 A.C. to 110 A.C. — 500 watt **\$15.00**
- Acme variable ratio audio transformer **\$1.65**
- Acme 30 K.C. transformer, makes a good mike transformer, **\$6.69**
- General Radio audio transformer, 3 to 1 — 6 to 1 **\$1.85**
- General Radio transformer, 600-0-600 volts; 2-7½-volt fil. windings **\$13.50**
- Thordarson "B" Eliminator transformer, 285-0-285. **\$1.65**
- Thordarson 150-watt power transformer, 400 volts each side of centre, 5 volts fil. centre tapped **\$3.50**
- Radio Foundation, 2½-volt, 10-amp. transformer for 866 tubes **\$2.45**
- Sangamo A.X. audio transformer; list \$6.00. Our price. **\$2.45**
- Sangamo Push Pull transformer for dynamic speaker; list \$13.00. Pair **\$4.45**
- Emcotran Push Pull transformer; list \$10.00. Extra special per pair **\$2.95**
- Special 866 filament transformer, 2½-volts, 10 amps. 10,000-volt insulation **\$5.45**
- Cardwell .0005 variable condenser **\$3.00**
- Cardwell No. 201E condenser; adjustable stator for short wave **\$2.40**
- Cardwell .00045 transmitting condenser; list \$10.00. Special **\$7.00**
- National new type short-wave tuning condenser; 500 mfd. **\$2.10**
- National new type short-wave tuning condenser; 100 mfd. **\$2.25**
- National .0005 variable condenser **\$3.00**
- National .001, variable condenser **\$3.30**
- Aerovox 8 mfd. dry electrolytic condenser self healing; 400-volt D.C. **\$1.45**
- Aerovox 5000-volt test .002 condenser **\$1.45**

- Flechtheim 2-mfd. condenser; 2000 working volts. **\$9.00**
- Siemens & Halske 2 mfd. 2000-volt condenser. **\$8.10**
- Dubilier Condenser 400-volt D.C. working voltage; type 902 — 3 mfd. **\$1.35**
- Dubilier Condenser 400-volt D.C. working voltage; type 902 — 7 mfd. **\$1.75**
- Thordarson double choke 18-Henry each at 250 M. 108 ohms D.C. res. **\$6.25**
- Thordarson 30-Henry 150-mil. choke; only a few left. **\$3.25**
- Hammerlund 85-mil. radio frequency choke. **\$1.20**
- Silver Marshall No. 243 — 150-Henry audio choke. **\$7.99**

- G.E. ½-watt Neon tube **\$6.65**
- G.E. 2-watt Neon tube **\$7.75**
- Standard electric socket for above tubes **\$1.15**
- Bunnell spark gaps; list \$4.00. Special **\$1.00**
- Aluminum shield can; 5 x 6 x 9 **\$1.85**
- National, type "B" vernier dial **\$1.50**
- Marco vernier dial, 4-inch **\$7.75**
- No. 12 enameled copper aerial wire, per foot. **\$0.01**
- No. 10 enameled copper aerial wire, per foot. **\$0.01½**
- Magnavox microphones; special **\$6.69**
- Frost hand microphone; list \$6.00. Special **\$3.25**
- Mesco transmitting keys No. 101 **\$9.95**
- Murdock 2000-ohm headset; special **\$1.65**
- Pyrex lead in bowls, including hardware; per set. **\$2.25**
- General Radio super het. kit, includes 3 intermediate transformers, 1 input transformer; list \$20.00. Special **\$4.95**
- Fleron transmitting lead in insulator **\$8.88**
- Mesco ¼" spark coil. Has many uses; reg. \$7.00. Special **\$1.50**
- Leeds listening monitor; described previous issues, **\$15.00**
- Leeds 50-watt socket **\$2.45**
- Leeds plug-in dustproof crystal holder; special **\$4.25**
- General Radio 50-ohm rheostat, type 214-A. **\$1.50**

LEEDS RADIO LABORATORIES

Precision Custom Built Short Wave Receivers and Transmitters

This department under the supervision of the Short-Wave Specialist Jerome Gross. We design, construct and advise on any material for the "Ham" Broadcasting station or laboratory. Write Jerry Gross for advice on any of your problems.

LEEDS Short Wave Receiver

The successful operation of any Short Wave Receiver depends almost entirely upon its handling (smooth regeneration control, etc.). The LEEDS Short Wave Receiver has flawless regeneration control from 20 to 80 meters with only 22½ Volts on the detector tube.

No fringe howl is present, and absolutely no hand capacity is found to disturb tuning.

Many of these receivers have been sold to people who have tried more elaborate jobs, only to discover that a simpler well balanced receiver would be more efficient and satisfactory for their work.

Three 201-A tubes are used, one as the detector, and two audio stages.

The Universal type has a continuous range from 15 to 100 meters, using three plug-in coils.

The Amateur type incorporates a Cardwell 201-E adjustable type condenser for tuning which can be adjusted to give any spread of the bands desired. The set is supplied with 20, 40 and 80 meter coils to cover the Amateur Bands.

Universal or Amateur type Receiver completely constructed and tested, price **\$37.50**

New Cardwell transmitting and receiving condensers. ⅔ the size, ⅓ the weight. Rounded edges on the stator and rotor plates. A real job to use where limited space makes a more compact receiver essential. Write for full particulars and price.

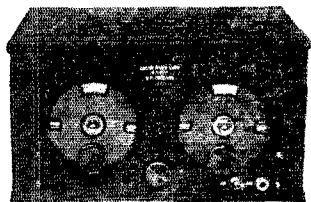

Write for our circulars on our products. Quotations on special transmitters, etc., supplied upon application

PLEASE PRINT YOUR NAME AND ADDRESS PLAINLY TO AVOID DELAY

WRITE FOR SPECIAL PRICE LIST

MAIL ORDERS FILLED SAME DAY 10% Cash Must Accompany All C. O. D. Orders

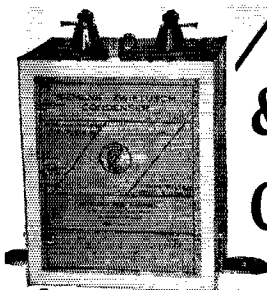

SIEMENS & HALSKE

High Voltage Condensers

Exceptionally well built — Compact
Very Conservatively Rated
Safe to Use

(Standard with Telefunken)

DC Working Voltage	Mfd	Size	List Price
1000	1	2 1/4-1 1/4-2 1/4	\$3.75
	2	6-1 1/4-2 1/4	6.50
	4	4 1/4-2-6	11.00
	1	6-1 1/4-2 1/4	4.50
1500	1	6 1/4-2-6	8.50
	2	4 1/4-4-6	14.50
	4	4 1/4-1-6	8.75
	2	4 1/4-2-6	13.50
2000	1	4 1/4-4-6	26.00
	2	4 1/4-4-6	32.50
	4	4 1/4-3-6	32.50
	2	9 1/4-8-6	60.00

The
BIGGEST
VALUE
for
Your
Money

Sold by

J. H. BUNNELL & CO.
215 Fulton St., N. Y. City
LEEDS RADIO CO.
45 Vesey St., N. Y. City
WIRELESS EGERT
179 Greenwich St., N. Y. C.
and other reliable dealers
throughout the country

MORRILL & MORRILL
30 Church St., N. Y. City
Sole U. S. A. Distributors

If you cannot get SIEMENS
& HALSKE condensers from
your dealer, write us sending
your dealer's name and ad-
dress.

scheme of standard frequency transmissions will be started, and we all hope it will turn out to be a success, and besides foster the cordial relations between the various sections taking part in it. A detailed schedule will be published in next month's report.

Standard Frequency News and Schedules

(Continued from page 48)

are made by laboratories equipped with accurate frequency standards and the transmissions are also checked by the U. S. Department of Commerce monitoring stations.

TRANSMITTING PROCEDURE

The time allotted to each transmission is 8 minutes, divided as follows:

2 minutes — QST QST QST de (station call letters).

3 minutes — Characteristic letter of station interrupted by call letters and statement of frequency. Characteristic letter of W1XP is "G," of W9XAN is "D," and of W6XK is "F."

1 minute — Statement of frequency in kilocycles and announcement of next frequency.

2 minutes — Time allowed to change to next frequency.

THE TRANSMITTING STATIONS

W1XP: Massachusetts Institute of Technology, Round Hill Research, South Dartmouth, Mass., Howard A. Chinn in charge.

W9XAN: Elgin Observatory, Elgin National Watch Company, Elgin, Ill., Frank D. Urie in charge.

W6XK: Don Lee Broadcasting System, Los Angeles, Calif., Harold Peery in charge.

Do not forget to QSL the transmissions. All reports should be sent to the A.R.R.L. Standard Frequency System, Hartford, Conn. A record will be made at Headquarters and the report will be then forwarded to the proper station. S. F. report blanks can be obtained from Headquarters, free and postpaid, upon request.

Don't guess. Use these transmissions and be sure.

— J. J. L.

W9DXP, Chicago, Ill.

(Continued from page 51)

and back to the receiver when receiving. In this way it is easy to check up on the note, frequency drift, quality of keying and quality of the "fist."

A log is kept of the activities of the station, which embrace traffic handling, rag-chewing and some DX.

At the time of this writing the station has just been moved to Chicago from its old location in Des Moines so there has been no opportunity to see what it will do in the way of DX in the new location. In Des Moines all continents except Asia were worked, despite the fact that local hams insist that Des Moines is a dead spot.

It's EASY to Get a New HANDBOOK

(Seventh Edition)

DIRECTIONS:

Realizing that Handbook must be had, proceed as follows:

- (1) Fill out below, tear off.
- (2) Reach in pocket, produce U. S. A. \$1 bill, old or new size (we don't care).
- (3) Clip together, mail us.

Handbook Factory,
West Hartford, Conn.

SEND IT AT ONCE.

(Name)

(Street or P. O. Box)

(City and State)

UNCLE DAVE

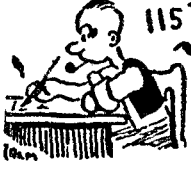

115 No Pearl Street Albany New York

We buy, sell and trade Ham stuff!

24 HOUR SERVICE SHIP ANY PLACE

If we have not got it we will get it for you!

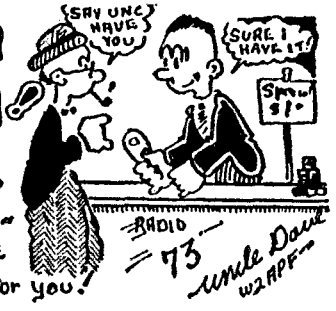

Here's a Real Buy: G.E. 4 mfd 1250 volts working D.C. fully mounted, guaranteed, special, each	\$3.75
G.E. 2 mfd 1000 volts unmounted but sealed in paraffin	1.15
G.E. 3 1/2 mfd 1000 volts unmounted but sealed in paraffin	1.85
Latest type Universal microphones model BB	16.50
Latest type Universal microphones model KK	32.50
Latest type Universal microphones model LL	48.50
Universal Baby Mikes	4.50
Mershon 24 mfd triple anode list \$5.50 special	2.75
Rubber 7 x 9 x 3/16 panels. Good grade	.39
Clarostat 250-watt primary rheostat, list \$6.00	3.50
Tone control Clarostats	1.05
Roller Smith 0-2 1/2 amps radio frequency ammeter	2.69
Brandes Superior phones	1.95
Pilot or Silver-Marshall coil forms. Firsts	.39
1/10 mfd Potter or Fast 200-volt condensers, each	.25
Sprague .025 mfd condensers	.30
Kenmore clocks, all types. Write for quotations.	
Thordarson 2 1/2 volts, 10 amps unmounted transformer (ideal for 866's.)	3.00
Brach 1/4 and 1/2 amp fil. ballast, special price	.39
Screen grid tube shields	20.00
Silver-Marshall round-the-world four, wired	20.00
Broadcast station crystals, 500 cycles plus or minus, including calibration, guaranteed	30.00
200 cycles plus or minus, including calibration	45.00
Manhattan full wave high voltage rectifier tube, 90 mills, 470 volts. No filament type. Ideal for 210 supply. List at \$12.00, special	1.50
Double button microphone cable, 10 ft., three-wire, unshielded	.75
Mesco telegraph keys with board, No. 101	.85
Tested and functioning, not guaranteed, type 210 and type 250	.95
Mesco telegraph keys with circuit closer, No. 103	1.25
Used Wheatstone bridges	\$25.00 and 45.00
10-Wire A.C. cable with Jones plug and receptacle, 6 ft.	1.00
General Radio 1000 cycle audio oscillator, used T213	20.00
Sinb panel four- or five-prong sockets \$1.00 each, dozen	1.00
85 M.H.F. chokes, unmounted, each	1.35
Victor 30 Henry 150 mill chokes tapped	1.35
Power crystals, specify anywhere in the 3500 K.C. band guaranteed to oscillate	5.25
Dustproof bakelite crystal holders	1.50
Crystal blanks, finished and oscillating	2.75
Crystal blanks, unmounted, each	1.75
Calibrated monitors, built for two uses: Oscillator and Monitor. These are individually calibrated and are checked against Piezo oscillators. With batteries and three coils for 20, 40 and 80 meter	9.35
Wave meter for 20, 40 and 80 meter band with individual charts complete with indicator and coils	6.25
Donnan power transformer, 300 watt, 1000 volts each side of center and with the following voltages: 3 C.T., 10 C.T., and one ten volt and one twenty volt not C.T. Fully mounted. Weight 14 pounds	5.95
Ward-Leonard 10,000-ohm 50-watt trans. leaks	.50
Ward-Leonard 5000-ohm leaks	.39
Microphone cases, special	2.25
New Sprague 8 mfd 430-volt electrolytic condensers	1.25
New Mershon 18 mfd electrolytic condensers	2.00
Flechtheim 2 mfd 1500-volt porc. ins. condensers	4.50
Flechtheim 4 mfd 1500-volt porc. ins. condensers	7.75
Rectobulbs mercury vapor R-81 type, just out, new, list at \$7.00, net	4.40
Rectobulbs mercury vapor R-3 type, net, postpaid	10.00
Slightly used Western Electric 21A or D tubes, guar.	35.00
Slightly used Western Electric 50 watters guaranteed	15.00
Slightly used R.C.A. U.V. 211 or 203A tubes, guar.	17.00

Slightly used R.C.A. U.V. 851 1000 watters, guar.	\$175.00
R.C.A. U.X. 240 HIMu tubes	1.00
New Allen-Bradley 500-watt radiostat	5.40
New CeCo 230 — 2-volt (199 type) non microphonic	1.25
New CeCo 231 — 2-volt (120 type) non microphonic	1.25
New CeCo 232 — 2-volt screen-grid D.C.	1.90
Used U.X. 852 tubes, guaranteed	20.00
Sangamo .00025, .0005, .002, .001, 5000 volt condensers	1.12
R.F. chokes for receiver and transmitter	.50
New National A.C. 5 Short-wave A.C. List at \$79.50, net. Dual Screen grid	46.00
National power pack for same, list at \$34.50. Net	19.65
Factory wiring net \$5.75 extra. Above set when ordered complete with power pack and wiring, special	70.00
Microphone stands. Adjustable floor model, brass parts, adjustable to 78 inches, staturary bronze finish	9.25
New Jewell U-1 millimeter. New type bakelite case	6.65
Aluminum can assembled 5" x 9" x 6". Best grade	2.65
Aero listening monitor	10.85
Flechtheim 1 mfd 2000-volt trans. condenser	5.00
Flechtheim 2 mfd 2000-volt trans. condenser	8.00
Flechtheim 4 mfd 2000-volt trans. condenser	14.75
50-watt sockets for 203A or U.V. 211	3.95
250-watt sockets for 212D tubes	3.50
204A — 250-watt sockets, set	1.95
U.X. 281 tested and functioning	.35
Latest amateur call book	.85
Western Electric 205D tubes, new original cartons	3.50
Kelford fully mtd, new fil. trans. Real job. 1-2.5 volt 8 amps, 2-1 1/2 V. 4 amps, one 5 volt 1 amp. All C.T. with extra C.T. fil. resistances, special	3.25
Kelford fully mtd power and fil. trans. 2-1 1/2 volt C.T. 4 amp 1-2.5 volt 8 amp, 1-6 volt 2 amp and high volt-ages. All center tapped and with extra C.T. resistances	4.75
Thordarson 30 Henry 250 mill filter choke 104 ohms resistance mfrs model insulated 2000 volts	3.75
R.C.A. phonograph induction motor, list at \$50.00, new	10.75
Arbophone A.C. amplifier two units power pack with binding post strip uses one 227 ahead of two 171A push pull. Beautiful job. Ideal for speech amplifiers. For pair	10.00
Signal Sematic bug. Special	10.75
C.P. Aluminum sq. ft. 14 gauge	.65
Pyrex 12" large aerial insulators	1.35
Marco vernier dials 2" knobs	.95
Pyrex 7 1/2" aerial insulators	1.05
New Gold Seal U.V. 227, guaranteed	.69
Manhattan phones single with head band cord	.75
Western Electric 21AA 1 mfd 1000-volt condenser	.70
Wardwell 00044 three thousand volt trans. condenser	6.50
Electric soldering irons, each	.90
Electrad large 50,000-ohm bleeder 45 mill 100 watt list \$5.50, net	3.00
National NR-865 screen grid new	12.25
U.X. 852 sockets	1.15
G.E. 5 mfd 3500-volt oil-immersed condensers — used	20.00
G.E. 10 mfd 2800-volt oil-immersed condensers	20.00
G.E. 43 mfd 1200-volt oil-immersed condensers	20.00
Several small motor generator sets at real bargains. Amrad slightly used S tubes but guaranteed	3.50
Stand-off insulators. Each \$1.00, dozen	1.00
Enamelled no. 12 aerial wire, 100 feet	.69
Two hundred feet coils	1.65

We carry about the most complete line of transmitting equipment as well as receiving apparatus. We are short wave specialists. Broadcast transmitting stations built to specifications.

WANTED — USED TELEPLEXES, OMNIGRAPHS AND LARGE TRANSMITTING TUBES

INCLUDE POSTAGE WITH ALL ORDERS AND 20% DEPOSIT AGAINST C.O.D. SHIPMENTS
VISIT OUR RADIO SHACK WHEN IN TOWN — GOOD TIME ASSURED HI — WHAT HAVE YOU FOR SALE OR TRADE?

WE CARRY EVERYTHING FOR THE HAM

MORE FOREIGN TRADE SOLICITED

Write for free Ham Sheet

UNCLE DAVE'S RADIO SHACK

115 North Pearl Street

Phone 45746

ALBANY, NEW YORK

GUARANTEED NEW RADIO BARGAINS

International Microphone—Two button for public address, systems and transmitters. Speech or music. \$9.75

Complete Phone and CW Transmitter 15 to 30 Watts, \$39.50 Including tuned plate, tuned grid oscillator with provision for crystal control. Wired for one or two UX 210 tubes. One or two UX 250's as modulators, two stages of speech amplification. Mounted in beautiful two-tone Walnut cabinet. Has ample space for AC power supply. Price includes one Stromberg-Carlson microphone.

Power Supply Unit for 15 to 30 Watt Transmitter \$19.75. Will deliver 600 volt 150 milliamperes for plate current. Has filament for 281, 210, 250, 227, and 226 tubes.

World Wide 2 Tube Short Wave Receiver, \$11.75. A two-tube receiver in a beautiful shielded metal cabinet. An ideal all around set which will give loud speaker reception on many stations. Very flexible in tuning. Complete with a set of 6 clip-in coils. Covers 14 to 550 meters. Can be used with any standard base tubes.

Tubes UX Type, 30 day replacement guarantee, No. 210, \$2.25; No. 250, \$2.35; No. 281, \$1.85; No. 280, 95c; No. 245, \$1.25; No. 224, \$1.25; No. 227, 75c; No. 226, 65c; No. 171, 75c.

Low Power Transmitter, adaptable for phone or code. With plug-in Coils. \$14.75

Short Wave Sets, one tube complete with 5 coils, 14 to 550 meters. \$6.45

Auto Radio — Uses 3-224, 2-227 tubes and 1-245 Power tube, single dial, tremendous volume. Compact. Fits any car. We guarantee this set to perform better than sets selling up to \$150. \$20.00

Stromberg-Carlson telephone transmitter on desk stand, \$2.75

B Eliminator, Dry, 180 volts, will operate up to 10-tube set, with 280 tube, fully guaranteed. \$6.75

250 or 245 Power Condenser Blocks, 13 Mfd., 1000 volt A. C. test, tapped 2, 2, 2, 4, 1 and 1 mfd., 1 mfd. \$4.75

2 Mfd. Condenser Packs, 2000 volt A. C. test. \$7.90
1500 volt. \$3.80

Double Chokes, 30 henry each, 160 mils., 1500 vt. test, shielded. \$4.95
130 mils. \$3.75

AC-A, B, C. Power Packs, completely assembled. \$8.75
250 V. B. also has A. C. filament for up to 9-tube set. Can be used as B eliminator. Make your battery set all electric, or build your A. C. set around this pack. 280 tube for this pack, 95c extra.

ORDERS SHIPPED PROMPTLY

CHAS. HOODWIN CO.

4240 Lincoln Ave. Dept. B-8 Chicago, Illinois

Good Practice

(Continued from page 52)

cated and technical study but there are some basic rules regarding the grounding of shields.

(a) Though very generally done by commercial people and by amateurs as well, it is very bad practice to ground onto the shielding of a set. Get that! There should be one central "ground bus" to which all the returns to ground should be made. All apparatus should be insulated from the shielding, the only contact being at the one point where the ground bus is connected to the shielding. This means that variable condensers should not be fastened electrically to the shield but a lead should be taken from the moving plates to the ground bus. Above all, filament returns should never be made through the shielding. This article is meant to be brief, so if you want the whys and wherefores of the above statement — look up "Eddy-Current Losses" in any good text.

Grounds mean stability and stability means consistent operating, continual readability and low background noises.

Calls Heard

(Continued from page 56)

gi6mu haf3c hb9d hclfg he2jm fo3sa fo9ar ilau ilao illl
iillb ilcoc jbbb j2by j3fz j4zz k4aan k4kd k6boe la1g la1k
la2b lu1ba lu1bz lu1ca lu1gd lu1dv lu1dy lu1jf lu1jm lu1wb
lu2aa lu2am lu2az lu2dj lu2hz lu2ca lu2fi lu2ga lu3de lu3dh
lu3dx lu3ex lu3fk lu3fc lu3hc lu3fa lu3oa lu3pa lu4da lu4dd
lu4bi lu4ae lu5ac lu5bz lu5dj lu5na lu5de lu6aj lu6bh lu6er
lu6fc lu7e lu8di lu8dj lu8de lu8dy lu8en lu8j lu9ce lu9dt
lu9dw lu9ma oa4j oa4l oa4o oa4p oa4q oa4r oa4s oh2nad
oh2nag oh2nap oh2naw oh2nm oh3na ok1ab ok1fm ok1vp
okaa2 ok2op ok3sk on4au on4bt on4di on4dj on4bz on4caa
on4ea on4eu on4fe on4fh on4fm on4fp on4ft on4gn on4gm
on4hc on4hp on4je on4jj on4jx on4ja on4pj on4ro on4rs
on4uu on4us on4wk on4ww on4zz oz2j os5a os5m os7ag os7bl
oz7hs oz7lk oz7h oz7t oz7y oz7z pa6ja pa6kb pa6dm pa6fp
pa6gg pa6ol pa6qf pa6gw pa6dw pa6vn pa6wx pa6xt pb7
py1aa py1ah py1aw py1ba py1br py2aj py2ad py1cl pylcm
py1cn py1cr py1fb py1ia py1ld py2aj py2al py2ag py2az
py2ax py2ay py2az py2ba py2bc py2bf py2bg py2bu py2bk
py2bm py2bo py2if py2ig py2ih py2ii py2ik py3ac py3ah
py3de py3ag py3gf py3ru py3wa py2qa py2qb py8ia py9le
s1aa sm3tm sm5tn sm5te sm5uk sm5rw sm8ua sm8zb
sm7to sm7us sp1ae sp3ar sp3kr sp3pb sp3yl sp3xx su8an
su8ra sx5m ti2hy un7ww uowg uo1jh ve2be vk2rx vp5oux
vu2kt vq2bh wfa wfat wfbt w1az w1ap w1cek w2fp w2apy
w2aw w2mb w2bn w2bir w2am w2ar w2rs w3ac w3jr w4ly
w4jr w4po w4oa w4acc w4uy w4aef w6ay w6ac w6aw
w6avu w6acl w6bax w6bip w6bsk w6bfb w6kg w6de w6dre
w6dwi w6dmk w6dts w6doy w6din w6dka w6ete w6edt
w6eug w6dgq w7aar w8rd w8ccw w8ded w8bft w9gh w9pv
w9abu w9anb w9beu w9bvh w9bpl w9bmu w9cgy w9dma
w9cuk w9ecz w9exw w9eaj w9eet w9gij w9gjh w9fur
w9dft w9aaz x9a xearn x8fwb x8hp x8oxo xok1fm xpa6ja
xu2uu yilmdz yslz z1lab z1iao z1lba z1lfc z1lfr z1lft z1lfu
z1lff z1lbg z1lbp z1lbr z1lzd z1zgd z1zqg z1zgh z1zbp z1zas z1saw
z14ao z14ap z14bg z1pab z2pab z2fah z2sp zslz zt1t
zt1r zs2c zs2n zs4m zs5u zt5q zt5r zs6z zt6x zu6n

7000-kc. band

ct1as ct1bg ct1br ct1bv ct1cc ct3ab ct3am d4tl d4fk ear122
ei2bx es3aq f8ap f8dp g2gm g5by g5lv j3rm j8ll
kfr6 k4acf he2jc ny1aa oz2h oz5a sm5yu on4jc ti2hy om1tb
uolcm sp3bm w1cr w1ax w1fc w2cx w2ag w2cvj w3aws
w3ahw w3arm w4acc w4rx w5ql w5aqe w6ww w6azd
w6bvo w6bqk w6by w6jz w6dcq w6czz w6eiu w6ebg
w6gbb w6bhy w6ekw w6ju w6hy w7ao w8ayn w8cxc w8cca
w8cau w8ux w9bvw w9ara w9abs w9fis w9bhi y12ad

VE4BQ, J. L. Green, 115 Furby St., Winnipeg, Man.

20 meters

cm8uf ct1bx ear96 f8aw f8arq f8ex f8fo f8fr f8hr gbyb g5by

They Come to JOHNSON For Condensers Like This

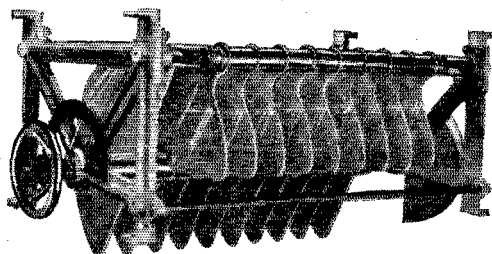

Type C-196, 500 mmf., 30,000 volts. Pyrex insulated. Plates .20" thick, highly polished and edges rounded. Ball bearing counterbalanced rotor. The price is surprisingly low.

Our new catalog will be sent for 10c, describing the full Johnson line of fixed and variable condensers, inductances, carbon and condenser microphones, insulators, and many other items. Contains the pick of other makes of radio, laboratory, and sound equipment.

E. F. JOHNSON CO. WASECA, MINNESOTA



Our New Improved

DOUBLE BUTTON

Microphone.

STAR

MODEL C

Regular List Price

\$35.00

Special Price

\$19.50

TO AMATEURS

Listen for the STAR microphone on the air. CHECK the QUALITY and remember to DOUBLE-CHECK the following features with the man who owns one:—

Non-metallic diaphragm — output level 10 to 20 D.B.s higher than average microphone — flat output curve within voice frequencies — eliminates one stage resistance or impedance coupled speech amplification — minimum carbon hiss — only 10 mills per button — 200 ohms impedance — solid brass construction — chromium-plated.

Packed in modernistic plush-lined pocket carrying-case and sold with a MONEY BACK GUARANTEE

SEND REMITTANCE WITH ORDER AND GIVE CALL LETTERS

See January QST for list of accessories

GAVITT MANUFACTURING CO., INC.

Brookfield, Massachusetts

announced in January issue of QST has already been acclaimed the STAR "mike" on the air, and has won the whole-hearted approval of the leading phone men. We have accordingly given this instrument the trade name STAR (model C).

YOU CAN BUY

any of the items offered here or in our catalog with the assurance that it will be exactly as described and suitable for "Ham" use. If you are not completely satisfied you may return the merchandise within five days and have your money returned. Can anything be fairer? And if you are not already one of our many satisfied customers, send us a trial order and see what real service is.

W. E. Harrison (W2AVA), Mgr.

And here's where you save money!

CONDENSERS			
SPRAGUE 8 mfd., 430 volt electrolytic.....			\$1.25
AEROVON 19 mfd. block, 1000 volt. Tapped for 250 pack			\$5.95
FARADON 4 mfd. block, 2 mfd., 1000 volt and 2 mfd., 600 volt DC Working.....			\$2.20
PARCON TRANSMITTING FILTER CONDENSERS			
The best value in condensers to-day! Fully guaranteed.			
DC Working Voltage	1 Mfd.	2 Mfd.	4 Mfd.
2000 Volts.....	\$3.95	\$6.45	\$10.95
1500 Volts.....	2.45	3.90	6.95
1000 Volts.....	1.50	2.45	3.90
PARCON .002 Mfd., 2250-volt plate blocking condenser.....			\$1.95
FLECHTHEIM CONDENSERS			
New Style, with heavy porcelain stand-off insulators.			
DC Working Voltage	1 Mfd.	2 Mfd.	4 Mfd.
2000 Volts.....	\$5.88	\$8.82	\$15.29
1500 Volts.....	2.65	5.00	8.53
1000 Volts.....	2.18	3.82	6.47
RCA 1 mfd. 800 volt metal-cased.....	\$6.70	7 Mfd., 650 volt.....	\$2.50
DUBILIER .002 mfd., 6000 volt working.....			\$1.75
SANGAMO 5000 volt test. .002, .001, .0005, .00025.....			\$1.18
MICAMOL D or POLYMET .0025.....			\$1.12
.0015 mfd. S.L.F. loss variable condensers.....			\$5.55
CARDWELL: 197-B, T-183, T-199 or 147-B.....			\$8.82
New "MIDWAY" Featherweight Transmitting variable condensers. 3000 Volt rating. 70 Mmf. — \$3.18. 100 Mmf. — \$3.77. 150 Mmf. — \$4.85. Also receiving.			
TRANSFORMERS			
Double and single button <i>Microphone Transformers</i> . Made by the Bristol Talking Machine Co. <i>Break</i> like transformer for P. A. Systems. Ham phones and Broadcasters. This is the first time that a well-designed transformer has been offered at this amazing price so rush your order in. ONLY \$1.95			
POWER Transformer. Heavy duty. Gives 750 CT, 5, 2 1/2, 2 1/2, and 1 1/2 volts. A <i>hussy</i> job for transmitter or AC Set.....			
\$3.50			
DUNCAN Power Transformer. 250 Watts. Which ballast resistor output is 1500 CT, 2 1/2 CT, 1 1/2 CT, 7/8, and 15 volts. Without resistor output is 2000 CT, 3 CT, 10 CT, 10, and 20 volts. Completely mounted and shielded. Terminal board connections. 15 lbs. — \$5.25. Resistor.....			
\$6.65			
FILAMENT Transformer. Unmounted. 7 1/2 Volts center-tapped for one 210, 281, or 250 — 95c. 7 1/2 Volt, 50 watt.....			
\$1.35			
RCA Output or 3:1 Audio Transformers.....			
\$6.65			
CHOKES*			
RCA Double. Each coil 30 H, 125 MA. Metal-cased.....			
\$1.85			
JEFFERSON 30 Henry, 150 Milliamper. Very neat case.....			
\$1.55			

FEBRUARY SUPER-SPECIALS

Good this month only. Only one to a customer.
FRENCH PHONES. High-grade headsets. Aluminum cases. 4000 Ohms. B-I-polar type. Very sensitive. Complete with double band and cord. Get yours now..... **45c**
STROMBERG-CARLSON 7 mfd., 650 volt DC working metal-cased filter condensers..... **95c**
DUBILIER or Igrad 2 mfd., 3000 volt. Metal-cased..... **20c**

THORDARSON: 30 H, 125 MA — \$1.45. Tapped — \$1.85
20 H, 250 MA — \$3.75. Double 18 H, 250 MA — \$6.25
Double 15 H, 350 MA — \$6.95. Double 30 H, 125 MA. — \$2.15
HARGO 30 H, 120 MA — \$1.30. 30 H, 175 MA.
\$1.95
Mounted R F Chokes, 85 Millihenry.....
\$3.35

Save on QSL postage. Send for details.

MISCELLANEOUS

JEWELL METERS. New type bakelite case. 1 1/2, 2, or 3 Millamps. — \$6.62. All other ranges — \$5.52. AC Voltmeter — \$5.52. Thermo-couple Radiation Meters..... \$9.81
 — 25% Discount on Super AKRA-OHM resistances.
 New 500 Watt **RADIOSTATS** — \$5.45 E-210 — \$9.95
UX-245 TUBES. Tested for Oscillation (That's something!) \$1.15
 Complete kit of quality parts for 245 P-P Transmitter described in *New QST*. Less tubes and meters..... \$33.95
 50 Watt Grid-leaks, W-L 10,000 ohm — 45c. RCA 5000 ohm — 39c
 Because of the high cost of handling, we cannot accept orders under \$2.50. Deposit required. Postage Extra.
 24-Hour Service

HARRISON RADIO CO.
 189 Franklin Street Dept. T New York City
 (Visit us when in town. Phone Walker 8-5154)

ALUMINUM BOX SHIELDS

Beautiful Silver Dip Finish Any Size to Order
 Monitor Size 10" x 5" x 7" high..... \$3.25
 Stage Shields 9" x 5" x 6" high..... \$2.99
 Knock Down Coil Shields 5" x 5" x 5" special..... \$1.00
 Intermediates for Schnell Radio News Super-Het. 95c a pair
 Please include postage.
 Sponge Rubber Corn Preventers, 25c each, 3 for 65c Hi
 BLAN, THE RADIO MAN, INC.
 89-QI. Cortlandt Street New York City

g5ml g6vp g2k1 hc1fg k6ewb k7mm la1w on4bk on4bt on4dj
 on4ds on4oj on4ro on4uu on4fe on4fp pk2aj py1aw sm5yf
 40 meters

k4kd k6cb k6evw k6ewb kfr6 vk3bq vk3es vk3hk vk3hl
 vk3jr vk3ns vk3vw vk3wr

Heard at Calgary, Alta.

celah gmq k6avl k6ay k6alk k6bex k6bxw k6bbe k6cib
 k6cog k6dv k6du k6dd k6dye k6dud k6dqg k6dxd k6dqf
 k6dpg k6dmm k6fwb k6erh k6evw k6eqd k6eyd k6eef
 k6kmc k6mx k6oa k6rl k7akv k7alt k7aml k7adc k7aoa
 k7aop k7ch k7cl k7gh k7gx k7ox py1aa sfn vl2au vk2he
 vk3dx vk3jv vk3ml vk3pp vk3sm vk4ab vk4cm vk4kh
 vk5by vk6hg vk6kj vk6vr vk6sa wftb x9a xx23 yx15 55k
 z1aw z1ak z1bt z1fb z1fr z1bz z1zg z1zgx z1zaw z1zbo
 ac5si hc1fg hh7c ve4gd

VEBET, G. V. Lawrence, Care of O. F. B., Norem-
 bega, Ontario, Canada

celah ce2ab ce3ch ce3cr ce5aa em2jt cm2ek cm2xa cm2xx
 cm5fl cm8uf cm8yb cr4ad ct1aa ct1bx cx1af cx1oa cx2ak
 cxxwk cx1ap (CXCLAP) f8acs d4jl d4rh d4uj ear9e ear9h
 ear11c ear149 f8aly f8azo f8ci f8cr f8cs f8da f8dh f8er f8er
 f8ex f8fem f8fe f8gdb f8ha f8lgb f8mrc f8sm f8saw f8wba
 f8sac f8m g2bm g2cj g2ip g2ma g2op g2un g2ya g5bj g5lj
 g5ms g5qa g6bd g6gc g6vp g6wt g6xb g6xq g5nj g1 haf3c
 hc1fg hc2je hc2jm hc2je hc2ej iph i3k4y k4dk k4kf
 kfu5 khkol kulba lulbz lulzj lu2fl lu3de lu3dh lu3fa lu5ac
 lu9de lu9dt nmlnc nncab oa4j oa4q oa4t oa4z ok1aa ok1aa
 ok4caa ok4dj ok4fd ok4nl ok4nt ok4p ok4y ok4j ok4j
 ok4ro ok4zz o5se oz1d oz7dk pa0xg py1aa py1ah py1aw
 py1el pyc1m pyc1er py1ld py2ak py2ay py2az py2ba py2bf
 py2bk py2li py2ik py2sb py3ag sp3kx vo8ae wftb x3a x9a
 xoz7xu yslad yx1x (YS-one-X)

G6YL, Miss B. Dunn, Felton, Northumberland,
 England

w2alu w2jm w3alu w3nh w3awn w4ft w8blm frear149
 frear163 frear1 fm8fa fm8la fm8mt fm8rt cm8mp cm8nb
 cm8rux cm8s0 cm8ar8 cv5bl cv5or cv8vxx cm8yb ql8gm
 k4dk kfr6 t7rq ts4sa ts4sup yi2gq yi6kr subdka au7aa
 au7kac vo8mc zl2be nx1aa

G5UM, 17 Eastwood Road, London N. 10, England

w1afa w1afb w1awe w1axw w1abd w1bet w1bsn w1cdg
 w1cpo w1cqt w1kj w1mh w1mp w2ady w2afw w2alu w2bds
 w2bke w2box w2bss w2bti w2cdg w2ic w2ig w2wt w3aaw
 w3apn w3atz w3bhr w3bm w3bn w3bt w3cx w3wx w4aaq
 w4abt w4ah w4iuke w4aw w4dct w4hu w4jx w4nn w4rx
 w4sj w4ya w5aw w5aop w8bj w8cw w8dl w8dt w8pl
 w8vk w8ya w8ae w8cm w8cwn w9dwa w9foq w9ftt pk3bm

EX9VL, L. M. Allman, Lucerne, Ind.

7000- and 14,000-ke. bands

w6ao w6ael w6aeg w6af w6afi w6agw w6aix w6aj w6ajm
 w6akb w6akw w6alw w6amw w6amy w6aoe w6aj w6ati
 w6atj w6ato w6aut w6awd w6awp w6awy w6axe w6axm
 w6ay w6bax w6bco w6bfe w6bgn w6bhn w6bil w6bjd
 w6blk w6bmu w6bng w6bpg w6brv w6bto w6btz w6bux
 w6bvx w6bxz w6by w6byb w6bz w6bzy w6ced w6ceo
 w6cf w6cgr w6chl w6chw w6cks w6cln w6clq w6coq w6oaj
 w6ocq w6ct w6cto w6ctk w6oue w6uoh w6uom w6ocx
 w6ocw w6eyu w6dbt w6dev w6de w6dep w6dgg w6dgn
 w6dho w6dhp w6dky w6dln w6dmq w6dms w6dpa w6dgo
 w6drb w6dru w6dwi w6dwt w6dwy w6dra w6dys w6dzz
 w6eak w6ebs w6ec w6een w6ee w6edj w6efq w6efo w6efv
 w6egh w6ei w6eic w6emd w6emk w6eou w6eqb w6etj
 w6etr w6eug w6eup w6eva w6ew w6ewe w6fa w6fk w6jn
 w6jp w6ka w6kb w6lh w6ln w6no w6nl w6nz w6oo w6ro
 w6se w6tj w6te w6tb w6xb w6yu w6zq w7aah w7aaz w7abj
 w7ad w7aed w7adg w7aew w7aff w7afz w7aog w7agt w7aiz
 w7akl w7akm w7alm w7amx w7anj w7aog w7be w7dd
 w7dl w7el w7fb w7fh w7gp w7if w7im w7jr w7jt w7ky
 w7li w7mg w7na w7ny w7pr w7qk w7sg w7ud w7uz w7vy
 ce1aw ce1ag ce2ch ce3fb ce5aa ce5ap ce5uf cm5b cm1by
 cm2xx cm5fc cm5k cm8uf cm8yb ct1aa ct2ac ct5vm ear6e
 f8fem hc1fg k4dk k4kf k4rh k6av k6bg k6bo k6ef
 k6ewb k6evw k6mz lulbz lu3de lu3dh lu3pa lu4ae-lu4bi
 lu4du lu9dz nj2pa oa4j oa4q py1aa py1aw py1ld pyc1m
 py2ay py2az py2bf py2qb py2sb py2ik py3aq py7ab
 ve1br ve1da ve1ec ve1dq ve1dr ve2ca ve2be ve2se ve3dd
 ve3gi ve4ai ve4bb ve4bv ve4bz ve4ec ve4ep ve4gu ve4ha

The NEW CARDWELL MIDWAY

FEATHERWEIGHT

HAS THE O. K. OF EXPERTS

Anticipating the need of a condenser smaller and lighter than the usual types at present used for transmitters and receivers and for neutralizing purposes, and at the same time having features that would eliminate the drawbacks found in the smaller or so-called "Midget" type condensers, CARDWELL for some time had been developing and testing a model which could for every practical purpose be substituted for larger and bulkier types. The largest Radio Engineering and Manufacturing Organizations in the world have confirmed our judgment—read and see how it was received by engineers whose judgment is beyond question.

THE INQUIRIES

"We are needing very badly a variable condenser of the following general specifications . . ."

"We of the . . . Company have depended on the Cardwell Mfg. Corp. many times in furnishing desirable apparatus with the rapid advance of the radio arts, and we feel that you will not fail us at this needy time."

"In some of our transmitter work, we have a need for a small capacitor of the air dielectric, variable type, to meet the following specifications:

Maximum capacity 35 mmfd.

Minimum capacity approx. 5 mmfd.

Operating voltage 3300 peak radio frequency.

"Inasmuch as these capacitors are to be employed in aircraft equipment, it is absolutely necessary that their weight be reduced to a very low minimum. It is also desired that the space occupied by a capacitor of this type shall be very small, and the design be such that extreme rigidity be obtained."

THE O. K.'S

"We received your sample light weight condenser, 83 mmfd. . . . and are pleased with it very much . . ."

"We have ordered today some of these condensers for use in sample sets we are building . . . We are deeply obliged for your efforts in this new development work."

"The sample condenser which you sent us July 3rd has been received and tested."

"We find that its mechanical construction is very good, and its voltage breakdown at 6000 KC is within the limit necessary for our purpose, this being approximately 3,200 volts R. M. S."

NOW YOU CAN BUY IT

"STANDARD"
SIZE
CARDWELL
TRANSMITTING
CONDENSER

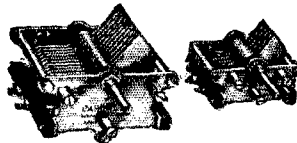

MIDWAY
FEATHERWEIGHT
TRANSMITTING
CONDENSER
(Compare the bulk)

A compact, featherweight variable condenser for purposes where reduction of bulk and light weight are desirable in transmitters, receivers and oscillator-amplifier outfits.

A smaller CARDWELL (not a "midget") but having the same solid, strong construction for which the larger CARDWELL has so long been famous.

Aluminum is used throughout with a few minor exceptions. As a result the largest sizes (.000150 mfd. for transmitting and .000365 mfd. for receiving) weigh only 7 ounces, the smallest only 4 ounces, and a panel space of only 2 3/4" x 2 3/8" is required!

MIDWAY CONDENSERS—SIZES AND PRICES

RECEIVING (.031" Airgap)

(also suitable for low power transmitters using '10 type tube)

Type	Plates	Depth Behind Panel	Max. Cap.	Min. Cap.	Weight (Approx.)	List Price
401-B	3	2-9/16"	26	7	4 oz.	\$2.10
402-B	5	2-9/16"	50	8	4 1/2 oz.	2.20
403-B	7	2-9/16"	70	9	4 1/2 oz.	2.30
404-B	11	2-9/16"	105	10	5 oz.	2.40
405-B	15	2-9/16"	150	11	5 1/2 oz.	2.50
406-B	25	3-9/16"	260	13	6 oz.	2.75
407-B	35	3-9/16"	365	14	7 oz.	3.00

*TRANSMITTING

(.070" Airgap. Suitable for transmitters using up to 75 Watt tube.)

Type	Plates	Depth Behind Panel	Max. Cap.	Min. Cap.	Weight (Approx.)	List Price
408-B	5	2-9/16"	22	6	4 oz.	\$2.60
409-B	7	2-9/16"	35	9	4 1/2 oz.	2.80
410-B	11	2-9/16"	50	11	5 oz.	3.20
411-B	15	3-9/16"	70	13	5 1/2 oz.	3.60
412-B	21	3-9/16"	100	15	6 oz.	4.25
413-B	31	4-1/2"	150	18	7 oz.	5.50

*Rotor and Stator plates of Transmitting Condensers have edges well-rounded and are highly polished over all.

If Your Dealer Will Not Supply, Order Direct

THE ALLEN D. CARDWELL MFG. CORP.

83 Prospect Street, Brooklyn, N. Y.

"THE STANDARD OF COMPARISON"

Say You Saw It in QST—It Identifies You and Helps QST

POWERTYPE CRYSTALS

For Amateurs, Commercial Stations and Dealers



THE STANDARD OF COMPARISON

POWERTYPE crystals are recognized as the best.

No off frequency operation with

POWERTYPE CRYSTALS

FULLY GUARANTEED BY A RELIABLE COMPANY
Ground by experts and calibrated from precision standards. Crystals for amateurs ground to approximate frequency and calibrated to better than 1/10 of 1%.

1715-2000 kilocycle band	\$10.00
3500-4000 kilocycle band	15.00
7000-7300 kilocycle band	20.00
One inch oscillating blanks	4.00
Plug-in duat proof mounting as illustrated above	6.00
Twelve inch minus 10 to plus 110 degrees Centigrade thermometers	3.00

Grinding instructions furnished with crystal blanks.

550-1500 kilocycle band — calibrated at any temperature plus or minus 500 cycles desired frequency complete with plug-in duat proof mounting — \$48.00. Constant temperature heater oven less crystals \$150.00. We do any kind of special crystal grinding for any frequency.

We build dynatron oscillators and monitors.

Just the thing for frequency precision in monitoring that self excited transmitter.

Prices quoted on request.

Introducing a new line of FREQUENCY METERS. High grade instruments for any one amateur band only. These meters are calibrated from accurate standards. Split-stator condenser guarantees maintenance of calibration and generous dial spread means easy reading. In ordering specify the amateur band desired. A curve checked every fifty kilocycles with each meter. Price \$10.00.

The above frequency meter with coils for any three of the amateur bands. Price \$17.00.

You may order direct from this ad C.O.D.

FREE

Send name, no obligation, for full information on crystals, holders, blanks, heater ovens, etc.

"CLEAR AS A CRYSTAL"

AMERICAN PIEZO SUPPLY COMPANY

1101 Huron Building Kansas City, Kansas

Specialists in frequency precision

Consult us on your problems.

Our Engineering Dept. is at your disposal.

TRANSMISSION CONDENSERS



Send for interesting data and price sheet on Transmission Condensers with working voltages up to 3000 D.C. for use with the following tubes: 203A, 204A, 210, 500W, 851, 852, 860, 865.

CORNELL ELECTRIC MFG. CO.
Long Island City New York

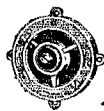

And now Ellis Model 10N for Amateur Radiophone!

The Ellis Model 10N Microphone at \$25.00 list is something entirely new in microphones at this price. By means of a special gold plated corrugated metal diaphragm developed at our laboratory we have attained many of the advantages of the stretched metal diaphragm. Your jobber can secure this for you if he does not have it in stock. Write for details of mechanical and electrical characteristics.

ELLIS ELECTRICAL LABORATORY

Sales Corporation

337 WEST MADISON ST.

Chicago, Illinois

ve4hc ve4hr ve4hu ve4ic vk2gr vk2ns vk2ow vk2wp vk3vp vk5bj vk5hg vk2kh zl1bb zl2ab zl2bl zl2ba zl3fb z29a

14,000-kc. phones

w2wk w3ai w4agr w5aaz w5ql w5awg w8ahm w8aic w8ajh w8arh w8ars w8arw w8bae w8bbf w8bub w8bal w8byr w8bzz w8cyr w8lk w8rw w8wrm w9aid w9bum w9cay w9ow w9daq w9dw w9dpg w9emk w9fmd w9mm w9ym

WSDPF, J. F. Keller, Sulphur Springs, Ohio

14,000-kc. band

w5adp w5aqe w5bbr w5ef w5oy w5ql (phone) w6abb w6aq w6atr w6bax w6bly w6brv w6bus w6bvz w6byv w6bzd w6edi w6egr w6eot w6cpm w6ouh w6exu w6deg w6dmk w6dtu w6eav w6eop w6eqw w6eto w6eup w6id w6kt w6qo w6te w6tx w6vc w7aff w7aho w7ajy w7akm w7aks w7be w7qd w7sg w7eqiy w7ai w7ain w7aib w7hr k4akv kwe kfu5 ce1ah ce2oh ce3cr ce3dg ce5aa py1ah py1aw py1ed py2ak py2az py2ba py2bf py2bk py2ih py2ik py3ah lu2dj lu2fi lu3de lu3dh lu3dj lu3doc oa4x oa4j cx1af ox2ak cxeck sp2ab ho2jm em2jm emb3 cm5cx om8ux x9a la3ho vk2mh wx7 wbt

VU2DF, S. N. Kabra, The Beam Wireless Station, Poona 6, India

14,000-kc. band

af8st au7kad au8at celah ct1aa ct1ka cm8yb ct1ae d4aap d4aex d4fw d4re d4uan d4in ear13 e8ic euiab eu2ii fb8phi fm8mst fq8hpg f5ral f5syy f8bf f8da f8dt f8dx f8eq f8ex f8fem f8fn f8fo f8gdg f8ha f8hpg f8jf f8ji f8kwt f8mmp f8nkt f8phi f8pr f8rr f8syy f8wa f8tex f8wrv f8wrk f8xz g2ao g2by g2gf g2gm g2lz g2nm g2od g2ol g2op g2ux g2vq g5bj g5is g5jf g5jo g5ml g5an g5sy g6dh g6gd g6gs g6mf g6ot g6qb g6rb g6vp g6wt g6wy g6xb g6xm g6xq haf3av haf3c hb0d kaldl kaljr kfu5 la2b oh1nf oh1nx oh2od oh2na oh2nd oh2nm oh3na oh3nq oh5ng oh5nl oh7nb(?) ok1au ok1kx ok2gn ok2ny ok2op ok2rm ok2va on4aa on4ar on4as on4au on4bz on4eca on4ek on4eu on4fe on4fh on4fm on4fp on4ft on4gu on4he on4hp on4jg on4jc on4or on4oz on4re on4ro on4tu on4vu oz2h oz2u oz5a oz7hs oh7lk oz7m pa0dw pa0fr pa0hb pa0hp pa0mm pa0xf pa0qf pa0zfl pa0zk pk1ex pk2aj pk3bm pk3bq pk4pr pk4pa 6las sm6w1 splak sp1yl sp3ar sp3dm sp3kx sp3la sp3li su8rs su8wy un7xo vk3dx vk0nk va3ab vs6ab vs6aw vs6ah vs7al vs7ap vs7td vu2ev vu2vj vq3msn w1ae w1aw w1cmx w1qv xg1ip yiled yi6ht

7000-kc. band

aupan au6dka au7kao au7kao au8ah au8kaf au8rk au8ws b1bbd ct1aa ct1as ct1db e1k d4ado d4ddb ear0 ear04 ear104 ear122 eucskw eu2bz eu2kbx eu2ka eu5do eu5kaa eu5kai eu5kl eua6m eu6kak eu6kar eu9al f8aa(?) f8aap f8azi f8dmf f8ex f8gyn f8jex f8kvt f8ab g2fu g2ok g2ol g2ri g5av g5c g5lw g5rv g6uj g6zr haf2c haf9af hb0d ilcoc kfr6 kalce kaldj kalr oh2ah oh2no ok1gr ok2va on4dj on4gn on4gw on5va oz1k oz2h oz5a oz7ev oz8sv pk1va p3l raro sm6ub sp3dr sp3kx sp3lk sp3nk sp3or vu2bf wf8map yl2ra yi2fy zt2e z8u5 9ib 1fi kalom

W2AGL, John V. Drougal, aboard S.S.

"Catherine"

7000-kc. band

w1adg w1af w1ah w1ara w1axx w1azd w1bdg w1bet w1bil w1bo w1cf w1cmz w1cpr w1dl w1mk w1ok w1rp w1ws w1cfe w2au w2apn w2aun w2aih w2bda w2dl w2evj w2cxl w2kj w2fw w2bay w2nl w2apv w2aik w2wck w2brr w2vrv w2bkg w2up w2alb w2gpn w2jv w2boa w2baz w2ouf w2jn w2aa w2uat w2af w3avk w3on w3wvt w3asg w3vc w3ate w3alk w3anr w3aru w3awo w3abc w3gr w3arp w3mv w4ax w4aef w4ik w4aiq w4pk w4hu w4hd w4ct w4va w4br w4gh w4aka w4gv w5bbe w5bk w5ban w5aad w5cb w5bei w5ta w6akw w6oui w6mg w6bzs w6di w6cha w6atz w6cyg w6akb w6ei w6aod w6bjd w7ed w8pe w8pq w8wo w8sx w8gy w8dvm w8aqx w8bt w8eml w8cvz w8ix w8buh w8dci w8ayh w8enr w8ann w8azq w8afm w8bhh w8cau w8su w8obg w8cwf w8bgj w8bkv w8dgc w8rv w8uf w8akr w8mbw w9cwx w9gdm w9bpd w9fs w9gie w9um w9qfe w9bzq w9cxj w9ftz w9obs w9bdt w9dva w9dec w9uzg w9ahz w9us w9ef w9ban w9dmg w9jex w9emr w9dyz w9dod w9eub w9fdj w9fdk w9gng w9day w9eiv w9bmu w9axh w9oag w9abh w9dgu w9bzk w9cvt w9aah w9efa w9al w9cmv w9so w9brc w9dgg w9bjc w9cet k4aan k4kd k3pr ho2jm xl1ay cm2jm k4caf

FOR THAT DYNATRON FREQUENCY METER

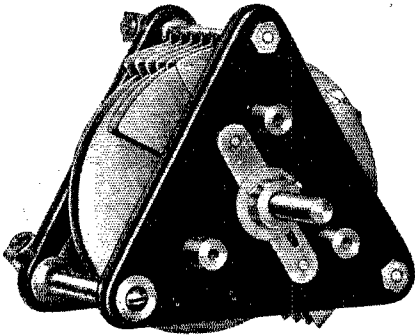

TYPE 557

AMATEUR-BAND CONDENSER

Price \$3.25 POST PAID IN U.S.A. AND
CANADA IF CASH ACCOMPANIES ORDER

we recommend the General Radio amateur-band condenser. The large value of zero capacitance ($43 \mu\text{f}$) is obtained by the use of two rotor plates which are complete circles. The frequency ratio is just right for spanning the 3500-kc. (80-meter) band with one inductor when allowance is made for the dynatron oscillator.

ORDER FROM THIS AD 30 ADDRESS DEPARTMENT Q-1

GENERAL RADIO COMPANY
CAMBRIDGE A, MASSACHUSETTS

PACIFIC COAST WAREHOUSE: 274 BRANNAN STREET, SAN FRANCISCO

Two Way Radio Link Never Interrupted — Capt. Yancey's Radio Makes New Records —

Here's the Story behind These Headlines

The Yancey plane (ESCO equipped) in its non-stop flight to Bermuda maintained direct two way communication with New York. Darkness forced the plane down a little short of its goal. The plane floating on the sea remained in communication with New York.

Later, on its "Good Will" flight to South America the Yancey plane, on the ground at the Canal Zone, maintained two way communication with New York. Zeh Bouck, Radio Operator, said—"I believe this is without doubt a record for Airplane transmission, and it shows very clearly what we could have done had we been forced down in some of the jungle over which we have flown during the last few weeks."

And on July 1, this last record was broken — the Yancey plane, on the ground at Buenos Aires, communicated uninterruptedly for more than an hour with the New York Times Station, 5838 miles away.

The Yancey plane was equipped with an "ESCO" wind driven generator to supply radio power while flying, and a battery operated "ESCO" dynamotor for ground work.

"ESCO" has a very complete line of wind driven generators, and dynamotors for airplane service. Let "ESCO" Engineers help you with your power supply for communications.



Type NA Airplane Generator

**ELECTRIC  SPECIALTY
COMPANY**

225 SOUTH ST.

STAMFORD, CONN.

Manufacturers of motors, generators, dynamotors and rotary converters

Micro-phones

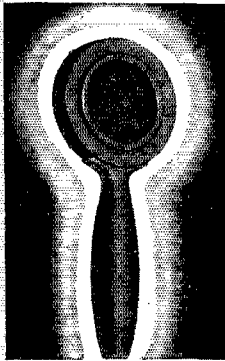

Kellogg hand micro-phones are exceptionally sensitive throughout all tone values. This new instrument was originally designed for amateur broadcasting. **It is today used as the standard microphone on home-recording sets of five leading radio manufacturers.**

Only \$ **6.50** Complete with 5-foot cord

This "mike" is attractively finished, compact, sturdily constructed and registers perfect response curves in tests. Sent prepaid with money order; or C. O. D., plus postage. Order today!

K E L L O G G

SWITCHBOARD AND SUPPLY COMPANY
1020 West Adams Street . . . CHICAGO

W1BBC, Frank B. Hales, 96 Edson Ave. Waterbury, Conn.

3500-kc. band

wlabw wlaew wlagd wlagz wlaaj wlaiku wlasay wlawo wlawk wlawz wlibc wlibds wlibhb wlibhj wlibil wlibod wlibrk wlibz wloek wiclk wicst wicst wids wldy wley wlit wlkr wlmk wlns wipi wisz witi wivr wlyb w2abw w2aik w2aiz w2aoc w2apg w2asm w2avn w2bau w2bdx w2bgu w2bhz w2bue w2buf w2bur w2bw w2cdf w2cdn w2cdg w2du w3dv w2ex w2gp w2lu w2nv w2px w2rd w2wn w3agb w3agu w3ais w3aiw w3asa w3asw w3auo w3avm w3bf w3bwt w3cab w3cev w3dd w3dh w3he w3lc w3os w3gv w3un w3ze w3zl w3zp w3aag w3ald w3cne w3dw w3jr w4ll w4ua w5alf w5ej w5aeg w5aip w5aiv w5ajj w5ajx w5akd w5arx w5ash w5asw w5ayb w5ayf w5azm w5bgu w5bhj w5bkm w5blf w5bpa w5brk w5brt w5bz w5ec w5ees w5ely w5egt w5ehc w5eif w5eij w5elg w5elg w5emj w5eno w5eng w5er w5erh w5ewo w5day w5dbh w5dbz w5ddl w5dfa w5did w5dnr w5dpt w5dra w5dtk w5dyh w5ej w5ey w5fy w5jr w5lw w5rr w5ry w5ael w5agx w5anr w5apx w5axu w5bax w5bex w5btt w5cee w5che w5csp w5cuc w5cuh w5cxz w5djk w5dtk w5dtu w5dsg w5ebx w5elc w5egz w5fij w5fjg w5fnk w5fos w5gka w5gox w5kp velcc velga ve3da ve3dm ve3gk ve3gt ve3zh ve3zz ve4el

W5BAD-W5AJS, George A. Krutelek, 1011 South Paris St., Ennes, Texas

7000-kc. band

wler wlavl w1bnp w1bal w1bke w1sh w1cjc w1cek w1ae w2c1y w2ano w2co w2anv w2axs w2arn w2grv w2hlc w2rt w2at w2bnp w2hc w2za w2ho w2alp w2biv w2atz w2afr w2anx w2bds w2ecj w2c1x w2za w2hle w2z1 w2amt w2amr w3zk w3aaz w3aqk w3ed w3jr w3ejn w3bph w3beq w3aws w3cab w3wal w3aer w3um w3bat w3ajh w3aif w3lf w3aoh w3cm w3amp w3ub w3bmc w3bdo w3awn w3aer w4afk w4aft w4iy w4cz w4abw w4ayd w4aj w4pf w4ajs w4oi w4fk w4mj w4adt w4acj w4ly w4nn w4aa w4qo w4eg w4qo w4ads w4jq w4ami w4hd w4ey w6sf w6bhy w6cwh w6cp w6bvz w6cen w6eou w6bqk w6cmr w6beb w6csp w6abp w6bvb w6ahk w6ecc w6ewk w6aic w6ew w6cbp w6bdp w6dkh w6ecn w6aut w6hp w6eje w6dww w6eje w6sp w6bbb w6qp w6exw w6exq w6wa w6eaw w6anq w6dys w7es w7aah w7abw w7uf w7aag w7lk w7kq w7ta w7af w7dw w7kt w7lw w7ut w7adu w7bhc w7ann w7cvi w7sdu w7ey w8dwj w8dqk w8bck w8dmj w8tw w9eci w9uri w9fcq w9gbq w9grb w9bma w9etc w9igo w9ftv w9bz w9fru w9awo w9gkt w9ekg w9ag w9aab w9feu w9mi w9eu w9chx w9bpb w9bye w9bje w9lf w9eci w9eht w9cek w9cno pk3bq ve4fg ve4bq ve4dg ve2ca ve4gu ys1fm hh7c nalmc waq pxr hr2 j1dv ce3bm x9b x9a vqlaj vplaz k6evw kaljr kalce kalhr kalik cm1jm cm2jm cm2xa cm2wa z1bz z1gt z13rm vk2zk vk2hk vk2ns vk2sa vk2ho vk31z vk3ju vk3hk vk3ao vk3em vk3dx vk3jk vk3kr vk3oc vk6bo vk7jk lefh wlm cm2rz

VK3CX, Alan G. Brown, 8 Mangarra Rd., Canterbury East 7, Victoria, Australia

14,000-kc. band

wiapl wlaaf wlaw w1axv w1bcb w1bdi w1bx w1bw w1cow w1cmx w1vc w1z w2afz w2ajj w2aog w2aws w2ayj w2ayt w2baa w2bdb w2bg w2bvz w2bwc w2bxa w2c1x w2cuq w2el w2fp w2ma w2rs w3amu w3arx w3aqi w3dh w3lz w3mv w3pf w3ut w4afc w4agb w4alg w4ft w4ly w4lt w4mk w4pj w4pz w4sk w4tn w4vk w4zi w5aif w5aom w5abp w5bx w5bto w5cuh w5de w5dpa w5eng w5vz w5adg w5adm w5aj w5axa w5bau w5bgt w5box w5bud w5cfr w5era w5eug w5d1v w5dpo w5dvw w5dv w5ea w5uf w5bba w5bdc w5bos w5def w5dgs w5dku w5ean w5efe w5ell w5flh w5fos w5ka w5at w5ft ac1bd ac1cs ac1ls ac0gh au1bo au5at celak cm5uf ct1aa d4aez ear21 f8acv f8aly f8axq f8bx f8da f8ah f8ex f8fo f8ha f8hr f8ho f8gdb f8lgb f8saw f8toy f8wrg fa8bak f1le g2gm g2ip g2lz g2od g5bz g5ml g5wk g6dh g6rb g6vp g6xq g6yt kaljr k4akv k6aac k6bhl k6bla k6boe k6cpe k6dpg k6erh k6eqm k6ewb k6eze lu3oa lu4dq lu5dj lu8dy lu9dt on4j on4t on4q on4z oh2nd oh2nn oh5no oh7nb on4bz on4dj on4nu on4zz on7ao pa0qf pa0tw pk1bh pk1jr pk1cx pk2aj pk3bm pk3bq pk4az py3aq sm6wl su8rs su8wy ve2ac vo8mc vs3ab vs6ab vs8ae vs6af vs6ag vs6ah vs7ag vs7al vs7ap vs7bj vulat vu2dg vu2zx x3a xc xu2aa xu2uu y1llm 2a

PIERCE AIRO Cardwell Connecticut
Dubilier Westinghouse
THE ACME WIRE CO.
WESTON Electrical Instruments
RADIO ENGINEERING LABORATORIES
Gordon
Raytheon Ward Leonard
Kurz-Kasch
Ward Leonard
Virohm
Farrand ELKON
Rajah PARVOLTS
ELKON HOWARD
Knapp
AD. AURIEMA, INC.
Manufacturer's Export Managers
116 Broad Street, New York, N. Y.
Scientifically equipped to economically export dependable receiving and transmitting radio apparatus

NEW A. C. KEYING RELAY

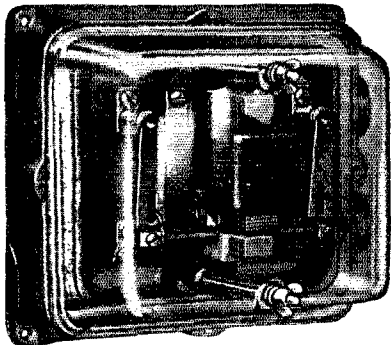

Phantom view of Keying relay
(glass cover used only to obtain this effect)

1. A two pole relay one pole for PLATE CIRCUIT one for the GRID CIRCUIT.
2. Keys directly from 110 volt A.C. lines.
3. It follows a key up to 40 WORDS A MINUTE.
4. TOTALLY SHIELDED by Aluminum Case.

WARD LEONARD ELECTRIC CO.
Mount Vernon, N. Y.

ACME WIRE PRODUCTS

Coils — Magnet Wire Wound

Magnet Wire All Insulations
Varnished Insulations

Parvoit Filter and By Pass Condensers

All products made to Recognized Commercial Standards including those of:

National Electric Mfrs. Assn.

Radio Manufacturers Assn.

American Society for Testing Materials

For more than 25 years manufacturers and suppliers to the largest and most discriminating users.

THE ACME WIRE CO.
NEW HAVEN, CONN.

Branch Offices:

New York Cleveland
52 Vanderbilt Ave. Guardian Bldg.

Chicago
842 N. Michigan Ave.

CONDENSER TRANSMITTERS

The trend is toward quieter microphones and microphones with more precision and greater output. We therefore offer our units separately for those who wish to build their own microphones.

Type "A" List \$60.00
Type "B" List \$100.00

These units will fit most of the existing microphones and make excellent spares or replacements. Unusually high output and fidelity mark them as truly outstanding.

Dealers Discounts

ASTATIC MICROPHONE LABORATORY YOUNGSTOWN, OHIO

West Coast Representatives and service station
PACIFIC ENGINEERING LABORATORY CO.
5155 South Gramercy Place, Los Angeles, Calif.

TRANSMITTING TUBES

We take this opportunity to announce the organization of a laboratory devoted exclusively to the manufacture of transmitting tubes, of the medium and high-power varieties, for amateur or commercial applications.

We particularly desire to acquaint the amateur with our 250 watt screen grid tube especially designed for operation in the high and super frequency bands. We unqualifiedly guarantee this tube to be superior, electrically and mechanically, to any tube of equal rating at present available.

250 WATT SCREEN GRID TUBE

Filament Volts.....	5.0
Filament Amperes.....	10.0
Plate Volts.....	1000-5000
S. C. Volts.....	200-1000
Watts Plate Dissipation.....	500 Max.
Price.....	\$120.00
Socket for Above.....	\$5.00

Above prices F.O.B. Chicago. Terms: Check or M.O. with order. Stock available for immediate shipment. All tubes unconditionally guaranteed against all defects, provided rated voltages and maximum allowable plate dissipation are not exceeded, for a period of 30 days.

Our personnel is composed entirely of men having long association with the amateur field and in addition possessed of many years experience in the commercial manufacture of transmitting tubes. These qualifications enable us to offer the amateur, tubes of exceptional quality at reasonable prices.

We are also in a position to manufacture tubes of all types in ratings up to 20 K.W. Information upon request.

VACUUM PRODUCTS LABORATORY
Box 723 Chicago, Illinois

7000-kc. band

w2amn w2bai w2box w3anh w5zav w6ad w6bch w6bfb w6czk w6ky w6af w8axa w8baz w8cyw w9gfo ac1bd ac8hm ac8zw au1bo ve5bc zk2lk ka1cm ka1cy ka1el ka1hc ka1hr ka1jr ka1xn v6af vk3rx

W9AKZ, Robert N. Stewart, 3328 Brooklyn Ave., Kansas City, Mo.

7000-kc. band

w1agm w1bkf w1cd w1cox w1cpo w1rpr w6akf w6arf w6auu w6awd w6bch w6bet w6bfg w6bjc w6boq w6bug w6bwi w6bz w6cf w6ctp w6cug w6cxv w6cxw w6czz w6da w6dnf w6djp w6dxc w6dyn w6eaw w6ebg w6ecg w6ekf w6eq w6erc w6evp w6jn w6kj w6ky w6wa w6zzg w7acd w7ajh w7cg w7lm w7or w7td cm8yb helfg k4kd k6eqm nncab ve3bf ve3ll ve4ei ve4hy ve4ik x9a x29a xcbm

WSDHC, O. L. Santti, 1546 W. Grand Ave., Detroit, Mich.

14,000-kc. band

g2dh g5by g5in g5jf g6gs g6iz g6rb g6vp g6xb g6wt g6xx g6lk f8aly f8dgb f8da f8ex f8fem f8fg f8ha f8mrc f8sm f8hr f8rd f8cs f8ag f8lw f8rlm f8hpg on4caa on4fp on4u on4z on4j on4fe on4j d4aez d4jl d4rh ct1aa ct1bx ct2aa ct2ac ct5ad ct1ae k4aky k4dk k6boe z1al z1fa z1ft z1zab z1zbg z1zbx z1zcm py1aa py1aw py1ay py1da py1di py1cm py1cr py1id py2ah py2az py2ba py2bf py2bg py2bk py2bm py2ik py2ih py2bo py2qa py2ql py2al py9hc py8ia cm2cx cm2jm cm2yb cm8uf cm2xd cm2al celah ce2ab ce3ab ce3bf ce3ch ce3aa ce1al zszs zszn zszp x9a x9b yslx yslap yslfm cx2ak cx1oa cx4ad cx1pl cxwck oa4j oa4q oa4z oa4c pk3bm ep2ab ear116 rx1aa vo8aw helfg ear39 wfat wfbt kf5 kf5 kf7 fm8hs haf3c vo8s pa0fp pa0qq lu3dh lu2ca lu7ei lu3fa

W. A. W. Stevens, 75 Wilson St., Hawera, New Zealand

3500-kc. band

g2gl velak veldq ve3bb ve4dj ve9al w1afo w1afw w1ajt w1atq w1aby w1aft w1asy w1ach w1bxb w1bsn w1bwj w1bsj w1cne w1mk w2bxw w2ode w2bm w2if w2sc w2vg w3avy w3ajl w3awu w3ale w3aqr w3amu w3aqq w3ati w3abf w3bda w3bj w3bj w3cxm w3cxw w3caw w3am w3za w3zf w3zbb w4as w4cc w4dw w4ey w4fi w4hn w4ia w4jr w4oo w4pm w4qo w4si w4tn w4wl w6azv w5kx w6abf w6akw w6akf w6axf w6ami w6aog w6ajg w6aqa w6awq w6afq w6awt w6awp w6acj w6akb w6ahw w6akw w6bar w6bik w6bql w6brw w6bv w6bfg w6bep w6bxa w6bxi w6bjj w6bf w6bfe w6brv w6bec w6bzz w6brv w6bes w6bjv w6bks w6bnw w6bho w6bis w6bna w6bls w6brw w6bco w6bvz w6dcp w6cne w6crk w6cfr w6con w6ect w6cau w6czz w6cll w6clp w6cla w6cnm w6dfr w6dlg w6dli w6dhe w6dvm w6dqq w6dki w6dik w6drr w6dmm w6dqv w6erk w6edk w6evd w6eai w6ekc w6ek w6ema w6eco w6evd w6eud w6eaf w6fe w6fp w6fn w6gm w6kt w6kg w6oc w6px w6yau w7acj w7akq w7agq w7abl w7amf w7ant w7aiw w7aot w7ce w7hm w7ii w7mk w7pp w7wl w7xx w8amz w8aii w8arx w8agj w8ajf w8api w8aih w8afg w8awt w8ago w8ayh w8bzo w8bzz w8bwp w8bif w8cif w8crk w8cnk w8cy w8cjc w8cvg w8cep w8edt w8eef w8ecq w8clr w8cat w8cmj w8cvk w8cei w8dis w8dyf w8dms w8diq w8dme w8dig w8enz w8gx w8gw w8om w8nz w8rf w8vf w8vs w9aga w9aeh w9afk w9am w9amf w9awv w9aeg w9aau w9aoo w9aca w9bxy w9bny w9bnk w9byb w9bx w9bwc w9bjk w9bg w9bf w9bjw w9bwi w9bwp w9bxo w9bza w9bjk w9cmd w9cnk w9cff w9cms w9cic w9dlf w9djk w9dpg w9dzo w9dzu w9dtk w9dec w9ex w9eab w9ehd w9egq w9eem w9ek w9eme w9eng w9ewx w9eqx w9eux w9eop w9il w9lle w9fu w9fad w9fud w9fu w9fel w9ful w9fnd w9fow w9gp w9gdy w9gfb w9gdt w9gdb w9ghx w9hk w9mm w9ox w9pw w9rr w9ts w9vd

7000-kc. band

ab22 ac2ay ac2co ac3al ac3xj ac3hn ac8ad ac8ag ac8em ac8kd ac8tj ac8yt ac8zw ac9gh au1ce au1kb au1kk au1koc au1kor au1ksw au1wu bam celaa celah ce3bm cm2xa cm2rs ct1aa ct2ac dalv d4ju d4rpi d4san d4sar ear10 ear85 ear96 ear98 ear104 ear110 ear136 ear148 eu2dg xeu2ek eu2kaa eu2kbo eu2kxb fph f3och f3ocm f8aap f8bpo f8ee f8eq f8ja f8pn f8tex f8whz f8zx fm8cfr fm8iva fm8ih fm8lc g2ca g2rc g2la g5by g5bz g5sa g6rb g6hd g6sa g6ed g6wy haf8e helfg hh7e ilau illl jhder jldv jldj jitec

Amateurs!! did you get yours?

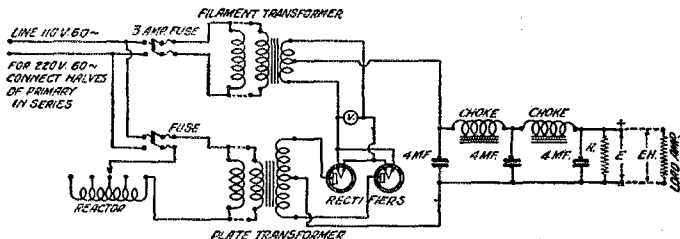

PLATE TRANSFORMER KV. MVA. 60~	REACTOR	FUSE AMP. 220 V.	FL. LIGHTER NO. 220	RECTIFIERS	CHOKES L. RES. Ω	W. ALUMINUM DIA. IN.	D.F. WATTS	HIGH P. V. VOLTS	LOAD AMP.	
T-4430	T-4432	T-4433	3	T-4585	566 OR 566	T-4451	100,000	500	.060	.150
T-4455	T-4457	T-4458	10	T-4585	566 OR 566	T-4456	400,000	2000	.150	.250
T-4460	T-4462	T-4463	25	T-4586	577 OR 577	T-4461	400,000	2000	.400	.750
T-4460	T-4462	T-4463	25	T-4585	566 OR 566	T-4461	400,000	2050	.300	.600
T-4460	T-4462	T-4463	25	T-4585	566 OR 566	T-4461	400,000	2100	.200	.500

... that new Circuit Diagram of THORDARSON'S showing hook-up of their snappy new transmitting apparatus ... including Filament and Plate Supply Transformers, Filter Reactors, and "low power" Primary Reactors! It gives full details on how to get best results. IT'S FREE!!

If you've not yet sent for yours — DO IT TODAY!

Address: Thordarson Electric Manufacturing Company, 500 West Huron Street, Chicago, Ill.

THORDARSON

TRANSFORMER
SPECIALISTS
SINCE 1895...

TRUVOLT — It's Adjustable

The safe resistor for power packs. Adjustable sliding clip enables quick adjustment to exact resistance value desired. Saves time and money for experimenters.

Write Dept. Qs for TRUVOLT DATA

1175 Varick St., New York, N.Y.
ELECTRAD
INC.

YOUR NOTE is the trademark of your station — tells all the world of your operating skill and technical ability or labels you just plain punk. There's no excuse for that when QST tells you how, and all you need is a 2c-stamp to bring you these latest data sheets describing power equipment built just as QST says it should be — for service — not just to sell.

Rectifier Engineering Service, 4837 Rockwood Rd., Cleveland, Ohio

FIRST QUALITY QUARTZ CRYSTALS

Scientifically Prepared for Maximum Power and Unconditionally Guaranteed 1 in. square sections, (close to your specified frequency), supplied promptly at the following prices:

40-75 meters	\$20.00
75-100 meters	12.50
100-200 meters	9.00
200-600 meters	15.00
1 in. Tested blanks, 200-400, 400-600 meters	4.00
Dustproof Bakelite mounts	3.00

(A Calibration furnished with each crystal)

Sections of any practicable dimensions made to order

(Charges for grinding to exact frequencies given on request)

J. T. Rooney, B. Sc., 4 Calumet Bldg., Buffalo, New York
"A pioneer crystal grinder"

Massachusetts Radio and Telegraph School

18 Boylston Street, Boston
Send for Catalogue

Tel. Hancock 8184 Established 1905

Radio Operators Wanted

Radio operators are officers aboard ships. Well paid, pleasant work, travel. You can qualify in a short time in our well-equipped school under expert instructors.

Write now for free booklet on "Opportunities in Radio."

WEST SIDE YMCA RADIO INSTITUTE
111 West 64th Street, New York Established 1910



5s 6s 7s and 9s!

Why send all the way east for your kits and parts? We have the most complete stock west of Chicago right here for you on the coast. Parts by the hundreds at real prices for the licensed ham. Get our catalog.

Everything for the amateur

RADIO SUPPLY COMPANY

H. A. Demarest, Pres.
912-14 So. Broadway Los Angeles, Calif.
W6FB1 Located in Building

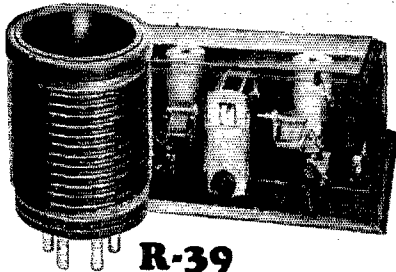

R-39

R. F. Transformers and Coil-Forms

THE ONLY LOW LOSS COIL FORMS

for high frequency use, made of R-39, the new high-dielectric developed by Radio Frequency Laboratories, solely for this use by NATIONAL CO., INC. Sold ready wound in complete sets of 4 pairs, 21.2 to 2.61 M.C. Special pairs cover 33-21 M.C. and 2.61-1.5 M.C.

Available also as 4, 5, or 6 prong Blanks for experimental windings.

Just another reason for the outstanding superiority of the THRILL-BOX.

Send 50c in stamps or coin for new 64-page Short-Wave Handbook. Bulletin No. 143 is free



NATIONAL

A.C.—S.W.S. THRILL-BOX

NATIONAL CO., INC., 61 Sherman St., Malden, Mass.

REMARKABLE BUYS EVERYTHING GUARANTEED

SPECIAL: Filter condensers at less than MANUFACTURER'S COST. Made to sell at five times the price. These condensers were made on special order for use in public address systems. In metal cases; a real good job. **WORKING VOLTAGE (NOT test voltage)** 1250 D.C. 2 mid — Only \$1.95; 3 mid — Only \$2.65.

LAST CALL: Dongan 250-watt transformers with line ballast resistors. Insures absolutely steady voltage regulation. Completely mounted and shielded. Terminal lugs on top. Resistors furnished free. Secondary high voltage output is 1500 volts, centre-tapped at 750 volts. Filament output is 15, 7½, 7¼ centre-tapped, and 2½ centre-tapped. Get your order in fast as there are very few left. Price complete.....\$5.95

RCA-VICTOR power transformers. 150 watts. Just the thing for that 245 transmitter (Nov. QST). Supplies 650 volts centre-tapped, and 2½, 1½, 1¼, and 5 volts for the filaments. Shielded in a metal case. Special.....\$2.75

KNIGHT 150-watt transformers. Ideal for 210 power supply using half-wave rectification. High voltage is 600 volts. Filaments are 2 — two 7½ centre-tapped windings, 2½, and 1½ volts.....\$2.75

COLUMBIA 30 henry, 200-mill chokes. A real rugged choke for heavy duty power filter supply.....\$2.50

COLUMBIA double chokes. Each section is 30 henry, 200 mills.....\$4.75

COLUMBIA 25 henry, 300-mill chokes. Just the thing for that heavy duty transmitter. Special introductory price....\$4.45

COLUMBIA 30 henry, 120-mill chokes. Mounted.....\$1.30

GRID-LEAKS Wire wound and enamel coated. For all tubes up to 250 watts, 10,000 ohms, \$3.95; 5,000 ohms, \$4.65.

TUBES of high quality. Made to stand the gauf. **FREE** 30-day replacement. Type X281, \$1.60; X250, \$2.15; X210, \$2.05; V224, \$1.20; X171A, \$.70; X280, \$.90; X245, \$1.20.

COLUMBIA TRANSMITTING FILTER CONDENSERS. Newer and better. Extra heavy duty and with a REAL replacement guarantee.

Capacity	Working Voltages	
	1000 d.c.	1500 d.c.
1 mid	\$1.50	\$3.10
2 mid	\$2.40	\$4.60
4 mid	\$3.90	\$8.95
		2000 d.c.
		\$3.95
		\$6.95
		\$11.50

FREE! Get our new list for more bargains. It's FREE!
IMMEDIATE SERVICE Terms: Cash or C.O.D.

COLUMBIA SPECIALTY CO.

1032-1038 Longwood Ave.

New York City

jldy jldp jlds j2wv j3ck j3cc j5erl kalaw kaljr kalce
kaldj kalfr kalhw kalsu k4hw ka9pb k4acf k4cd k6avl
k6bj k6acw k6exy k6cmc k6cog k6cib k6cqn k6cdd k6dv
k6dqf k6dpg k6dmm k6ddy k6ddu k6ewb k6eef k6ed k6nl
k7akg k7ox lalb lules ldiq mlnzic nn7xj obe omltb oz5a
oz7s oz7t oh2mm oh3np prx pa0fm pad0w pa0kh pk1cw
pk1vh pklcr tk3pr pk3bp pk4hh rx1aa red rfd9 sfn snw
sp1yl sp3ar ri2rs tg2as tg2clo vs2af vs3ac velco xvclal
velcc ve2bb ve2am ve2ac ve2ca ve2bd ve2gt ve2ax ve3hd
ve3bp ve3dt ve3ha ve3il ve3ez ve3ez ve4ho ve4cv
ve4gt ve4bq ve4dw ve4dj ve4dy ve4gd ve4cv ve4bm ve4bv
ve5gt ve5af ve5al ve5be ve5ec ve5cj ve5cr ve5aw vljql
vn2bg vplaz x1aa xlg xlnq x9a x23a xaulzb xcbm xcbq
xeu2ek xrn xvelal xw6bd xw31 xx3bmd ybpx ylk yalfm
y8itu y8ix zt2e 6rd 22d wlach wlaek wladi wlabn wlaao
wlbes wlcn w1bnp w1bvr w1baj w1bwy w1cdg w1cep
w1cek w1ces w1fm w1kc w1mk w1ai w1w1 w1ys w1zj w2alu
w2aaw w2ama w2afj w2afv w2ais w2ayz w2apy w2afo
w2aey w2afz w2avs w2aws w2ano w2acy w2bds w2bwb
w2bzs w2bxw w2eko w2eel w2cqv w2chj w2cc w2fd w2fk
w2gx w2je w2jk w2kl w2oa w2hw w2rj w2uf w2vg w2vy
w2wk w2wz w2yw w2zg w3amw w3amp w3ajh w3aws
w3agp w3awn w3apj w3bgs w3bwt w3bhy w3bhm w3cxl
w3cem w3hf w3hg w3hy w3na w3pq w3z3 w4agp w4akg
w4adt w4ey w4alf w4agr w4aig w4afm w4ago w4akh
w4eg w4ef w4fe w4ft w4he w4lj w4kp w4kh w4ly w4mi
w4oi w4pk w4qv w4uj w5alp w5aea w5abk w5afx w5aha
w5aux w5apw w5abh w5alp w5aub w5auc w5ar w5bic
w5bjx w5bgl w5bjt w5bld w5bec w5bmp w5bbv w5bol
w5bho w5bmb w5de w5ef w5gz w5hn w5jc w5kx w5ke
w5mh w5mx w5oj w5td w5uv w5uf w5uo w5pad w5aix
w5awp w5atn w5eaj w5afo w5aax w5aqj w5ape w5acf
w5afk w5age w5awv w5akw w5avb w5alp w5ank w5ark
w5abd w5ad w5arv w5agr w5arm w5aqd w5am w5bqf
w5bjp w5bcx w5bjf w5bvy w5bvz w5bek w5bht w5bfa
w5bbp w5blx w5bap w5byb w5bet w5bio w5bhy w5bdd
w5bjc w5bsk w5bgi w5bvc w5bnc w5by w5bvz w5bjf
w5bdd w5bbp w5bbo w5bov w5bax w5cub w5cix w5cj
w5ccc w5cxw w5cig w5cfl w5czk w5chl w5cww w5cql
w5cpb w5chw w5czz w5cf w5cr w5ch w5cht w5clp w5crb
w5chy w5cuh w5cek w5ctk w5cwt w5dkh w5dww w5dky
w5dtt w5dbe w5dvy w5dca w5dob w5duj w5dfr w5dqc
w5dqf w5dep w5dio w5dib w5dyj w5diq w5drh w5dkw
w5dzt w5dva w5dzu w5dzk w5dwi w5dms w5dyn w5dzz
w5dvq w5eke w5ely w5eaw w5ewl w5eb w5eqs w5efo w5ekw
w5eaj w5eaz w5evm w5eje w5epf w5eea w5eep w5eql
w5epz w5egd w5ece w5eje w5ece w5ehl w5ebg w5eak
w5eru w5ecv w5edj w5ebn w5be w5egd w5eqb w5esa
w5eke w5ecn w5eep w5eot w5eri w5rf w5fa w5hh w5hj
w5id w5jm w5jn w5jy w5ky w5ku w5ka w5ln w5mf w5oj
w5pe w5p w5a w5ef w5ep w5ty w5uc w5vi w5wa w5wn
w5wg w5yau w5aw w5az w5zz w5zz w7alm w7ait w7acy
w7ajz w7aud w7adr w7aip w7acd w7afv w7all w7aac
w7aag w7aax w7aly w7aks w7ld w7eo w7gj w7fb w7kt
w7oj w7os w7oe w7qf w7qr w7ix w7ud w7vy w7wl w7wq
w8any w8ant w8adu w8ach w8ab w8bg w8bjx w8bbi
w8bsp w8bet w8bep w8by w8vcq w8cft w8cee w8cj w8cfp
w8dfe w8dpo w8dui w8dyc w8djo w8de w8del w8dub w8ay
w8en w8k w8mv w8al w8aw w8adn w8arm w8ayz
w8aqz w8am w8aln w8amv w8agk w8acy w8adn w8bcb
w8byc w8bir w8bms w8bek w8cyn w8cou w8eme w8cni
w8cn w8cxv w8cck w8cpe w8ckf w8cek w8cdf w8od w8cqz
w8dti w8dtb w8dnp w8dse w8dib w8eto w8eme w8eul
w8ehp w8exw w8ffg w8egd w8eup w8fko w8fur w8fhy
w8fde w8fx w8gv w8gdq w8gka w8gjs w8gdn w8gqv w8ghz
w8gty w8gtj w8hd wkld w8lf w8mi w8yh w8yp

14,000-c. band

celaf celah ce5aa ct1aa ct1ae ct1bx ct2ac d4xn ear39
ear135 f8daf g2gf g2gm g5jf g5ma g6gs g6pv g6wt helgf
jldy jlko kalcm kalhr k6alm lu3de lu3dh lu8dy oa4c
oa4j oa4y oa4w oa4y oa4z on4au on4f on4gn on4hc pa0bp
py1aa py1ah py1cm py1ia py2bf py2ib py3ah ve2aa ve2ac
ve2bd ve2al ve2hg ve4ai ve4gm ve4he ve08a vu2bq ze4a
ze4m ze6p ze2p zt6x zt5l zu6w w1awe w1ae w1agi w1afa
w1bft w1bvr w1bl wd1a w1dp w1mo w1zz w2acy w2atx
w2arb w2ave w2bok w2bir w2bih w2bai w2cvf w2car w2el
w2hi w2ib w2jn w2mb w2rd w2rs w2vd w8aiw w8arp
w8bph w8bd w8hg w8pe w8aua w8ew w8fi w8pk w8awp
w8aqk w8aom w8bhh w8ql w8aog w8akg w8btg w8bix
w8bsn w8box w8cuh w8dyz w8djp w8dts w8dgo w8dmk
w8egh w8eug w8eje w8eem w8vz w7ajq w7dl w7qy w7wl
w8ago w8awf w8bid w8bnu w8chx w8dce w8rd w8aus
w8avp w8azz w8byc w8brx w8civ w8diw w8dqd w8ceq
w8eqt w8ear w8emz w8eyl w8fxo w8gcn w8gh w8gfo w8giu

(Continued on page 90)

QST Oscillating Crystals

"THE STANDARD OF COMPARISON"

AMATEUR BANDS:

Winter is here, and no doubt you are going over your transmitter removing those weak links so as to get the most possible efficiency from your set.

One item of great importance is the *frequency stability* of your set. Does it *stay on one frequency*? If not, our *power crystals* will solve that problem. **SCIENTIFIC RADIO SERVICE** crystals are *known to be the best obtainable*, having **ONE** single frequency and highest output. With each crystal is furnished an accurate calibration guaranteed to *better than a tenth of 1%*. *New prices for grinding power crystals in the amateur bands* are as follows:

1715 to 2000 Kc band \$15.00 (unmounted)
 3500 to 4000 Kc band \$20.00 (unmounted)
 7000 to 7300 Kc band \$40.00 (unmounted)

BROADCAST BAND:

Power crystals ground in the 550-1500 Kc band accurate to plus or minus 500 cycles of your specified frequency fully mounted for \$55.00. In ordering please specify type tube, plate voltage and operating

temperature. All crystals absolutely guaranteed regards to output and frequency and delivery can be made within two days after receipt of your order.

CONSTANT TEMPERATURE HEATER UNITS:

We can supply heater units guaranteed to keep the temperature of the crystals constant to *better than a tenth of 1 degree centigrade* for \$300.00. Two matched crystals, ground to your assigned frequency in the 550-1500 Kc band with the heater unit complete \$410.00. More detailed description of this unit sent upon request.

ATTENTION AIRCRAFT AND COMMERCIAL RADIO CORPORATIONS:

We invite your inquiries regards your crystal needs for Radio use. We will be glad to quote special prices for **POWER** crystals in quantity lots. We have been grinding power crystals for over *seven years*, being *pioneers* in this specialized field, we feel we can be of real service to you. We can grind *power crystals* to your specified frequency accurate to plus or minus .03%. All crystals guaranteed and prompt deliveries can be made. *A trial will convince you.*

SCIENTIFIC RADIO SERVICE

"THE CRYSTAL SPECIALISTS"

P. O. Box 86

Dept. P-13

Mount Rainier, Maryland

1931 Radio CATALOG **RADIO BARGAINS**
WHOLESALE DISCOUNTS
LOWEST PRICES

REGULAR WHOLESALE TRADE DISCOUNTS!

Nationally-advertised, guaranteed radio merchandise, including the new Lafayette Wide World Short Wave Receiver and other short wave apparatus. Write at once for **FREE 1931 Radio Bargain Catalog**. *Don't buy until you see this wonder catalog!*

WHOLESALE RADIO SERVICE CO.
 Dept. B-14, 38 Vesey St., New York

FREE!

Measure Easily Resistance-Voltage-Current

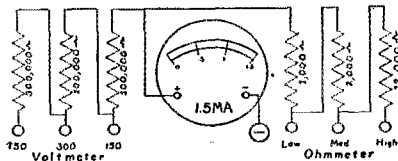

Super Akra-Ohm wire-wound Resistors and Shunts afford an inexpensive means to build test equipment for the measurement of resistance, voltage, and current with accuracy.

A combination for the measurement of voltages and resistances is shown in the above diagram.

Super Akra-Ohm wire-wound Resistors are manufactured in any value from 100 ohms to 10 megohms. They are carefully designed to insure an accuracy of one per cent and a constant permanency of calibration. Their use is highly recommended for Laboratory Standards, High Voltage Regulators, Telephone Equipment, Television Amplifiers, Grid and Plate Resistors, Electrical Apparatus, and Test Equipment, etc.



Prices range from \$1.25 for 100 ohms to \$4.00 for 500,000 ohms

Send us your dealer's or jobber's name and we will send you a copy of **Bulletin 73-C**

We manufacture special multiplying resistors for A.C. voltmeters. Full information will be sent on request.

Shallcross Mfg. Company
ELECTRICAL SPECIALTIES
 700 PARKER AVENUE
 Collingdale, Pa.
 (Over 25 Years)

All You Need to Learn TELEGRAPHY
Morse or Continental with Teleplex

Learn Telegraphy—the world's most fascinating profession — by hearing real messages sending them. Interesting — simple — you learn quickly at HOME. Teleplex is the Master Teacher. Used by U. S. Army, Navy and leading radio and telegraph schools. Write for Folder Q-2.

TELEPLEX COMPANY
 76 Cortlandt Street, New York

FROST-RADIO

maintains a unique
service for your benefit.
Why not use it?

HERE at Volume Control Headquarters we maintain a complete department devoted to engineering research.

This department is organized to serve you in solving any problems that may come up in connection with the fixed and variable resistors necessary to exactly meet your requirements.

We invite you to get in touch with us concerning the application of FROST-RADIO Volume Controls to your product, or the application of other controls involving precise regulation by means of fixed or variable resistors of the several types manufactured by Herbert H. Frost, Inc.

Why not use this service, just as a considerable number of others are doing? You will find the resources of our Engineers of great value in working out your problems. You will discover, as many others have done, that this department fully understands the requirements of present-day radio manufacturing. And you will like the speed, service and cooperation that is directed toward the solution of your problems.

An inquiry on your letterhead will bring full particulars of this unique service to the radio industry.

HERBERT H. FROST, INC.
Main Offices and Factory: ELKHART, IND.
160 North La Salle Street, Chicago

Sending Is *EASY*

With the *Easy-Working*
Genuine Martin No. 6
New VIBROPLEX

Reg. Trade Marks: Vibroplex Bug! Lightning Bug

The smoothest, easiest-working bug on the market. Easy to learn. Easy to operate. Makes sending easy.

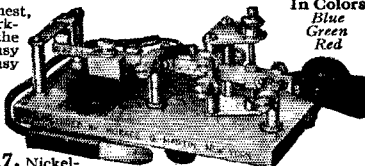

In Colors
Blue
Green
Red

Black or Colored, \$17. Nickel-Plated, \$19

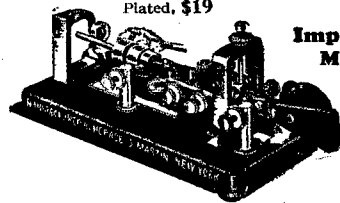

Improved
MARTIN
Vibroplex

Black or Colored, \$17
Nickel-Plated, \$19

Special Martin Radio Bug — Extra large, Specially Constructed Contact Points for direct use without relay. Black or Colored, \$25

Old Vibroplex accepted as part payment
Remit by Money Order or Registered Mail

THE VIBROPLEX COMPANY, Inc.
825 Broadway, New York City
Cable Address: "VIBROPLEX" New York

How Is Your Tone Color?

(Continued from page 19)

and you expand it into the finished product. You may feel flattered, sir, that I credit you with the ability to discharge so important a task."

"Well, if it's so blamed important why don't you do it yourself?"

"Time, my dear man, time. I have just explained that I am already over-burdened —"

"Oh, all right," I cut in. "What's the low-down?"

"I presume that you are asking for the details of the article?"

"I am," I replied. Poor Asparagus. He wasn't like that before he went to college.

"Very well. When you hear a pure d.c. crystal-controlled signal, what color is called to your mind?"

"Pure white," I answered.

"Correct. And when you hear a plain d.c. signal?"

"Just plain white."

"Right again. That is the substance of the article. Instead of trying to describe the note in the ordinary cumbersome way, merely state the color that is suggested to your mind. It is a fact that a certain note will suggest the same color to nearly everyone. For instance, a raw a.c. signal suggests black, near d.c. suggests gray, r.a.c. brown, 1000-cycle light yellow, et cetera. Thus a crystal-controlled near d.c. signal might be accurately described as a light gray (d.c.) signal against a pure white background. Doesn't that give you a vivid picture of the signal?"

"Boy," I said, "I've got to hand it to you. You really have a wow of an idea."

"Will you write that QST article for me then?"

"Will I?" I cried enthusiastically. "Well, you just bet!"

Now, Mr. Editor, I am so busy at present that I won't be able to write that article. I haven't been able to QSO Asparagus to tell him, so I am writing you. It eases my conscience somewhat, for when I make a promise, I always keep it. If you see Asparagus please tell him for me.

Station Licenses

HERE it is middle December and December QST is floating around the country bearing our statement that the new licensing arrangement "at this writing is proceeding smoothly and promptly at Washington," while dozens of chaps have written in to us to say that they made application for renewal six weeks ago and still no license and that the Super has shut them down because the old license expired.

Both statements are true. The new system started off fine and then broke down when a thousand applications for renewal, which had to be sent back along the system for certain missing information, came in in a heap — in what is technically known as "one fell swoop." At one time there were approximately 1500 amateur applications pending before the Commission. A week of strenuous work followed, with extra people on the

THE NEW LEACH . . .

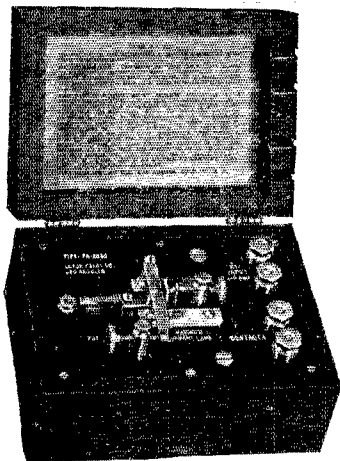

Type FA-2630
Price \$22.50

Ultra Sensitive Relay

For light sensitive cell work, recording radio signals, burglar alarms, fire alarms, etc.

Will operate in excess of 100 words per minute on an input of ONE MILLIAMPERE. Will also operate on as low as 200 MICRO-AMPERES.

Will stand a floating current of three or four milliamperes on the winding, and operate on a variation of this current.

Easily adjusted and all adjustment screws are provided with knurled set screws.

Not affected by ordinary vibration and will operate in any position.

LEACH RELAY CO.

860 So. Los Angeles Street

Los Angeles, California

FOR YOUR FRIEND

Who Wants to Be an Amateur

"How to Become a Radio Amateur," a helpful booklet for beginners, describing simple apparatus and telling the whole story. Ten cents postpaid, \$1 per dozen copies.

American Radio Relay League
WEST HARTFORD, CONN.

BECOME A RADIO OPERATOR

See the World, Earn a Good Income,
Duties Light and Fascinating

LEARN IN THE SECOND PORT U.S.A.

Radio Inspector located here. New Orleans supplies operators for the various Gulf ports. Most logical location in the U. S. A. to come to for training.

Our students qualify for the various branches of radio. Runs to all parts of the world. Positions Ashore and Afloat. Special courses. Day and Night classes. Enroll any time. Oldest and Largest Radio School South.

Literature on request.

GULF RADIO SCHOOL

844 Howard Ave.

New Orleans, La.

WIRELESS EGERT

179 GREENWICH ST., NEW YORK CITY

REMEMBER—Reliability and lowest prices—a combination that's hard to beat.

Write us your requirements.

SPECIALS FOR THIS MONTH.

ALL PRICES LISTED ARE NET.

New! New! Wireless Egert Engineering Keying Relay. A corker—satisfaction guaranteed.....	\$4.95
Kolster Transformer	
Windings 1200 V. C.T. 1-2.5 V.—	
2—7½ V. 2-1.5 V.—	4.95
1—15 V. —	
Concourse 8 mfd. 500 V. peak.....	1.25
10 mfd. 2-8 mfd. sec.—500 V. Peak.....	2.34
Baldwin Genuine type "CV" Phones.....	4.95
Short Wave Coil forms 4 prong (colors).....	.59
National S-101 Couplers.....	3.30
Peanut "N" tube sockets.....	.39
Thordarson 30 Henry 150 M. A. Choke.....	2.95
Universal Microphone Transformer	
Single Button.....	3.49
Double Button.....	6.49
Wireless Egert Filament Transformers, 8000 Volt Insulation	
2½ V.—10 Amps. for 866.....	4.35
7½ V.—5 Amps. for 210-250-281.....	4.35
10 V.—7½ Amps. for 203A-211-852-860.....	5.65
12 V.—10 Amps. for 204A-212D.....	5.65
Wireless Egert 50 Watt Socket.....	2.35
Ward Leonard Grid Leaks with brackets	
5000 ohms 50 watt.....	.96
5000 ohms 200 watt.....	2.25
10000 ohms 50 watt.....	.96
10000 ohms 200 watt.....	2.30
15000 ohms 200 watt.....	2.55
20000 ohms 200 watt.....	2.70
50000 ohms 200 watt.....	5.25

We distribute: Weston, Jewell, National, Vibroplex, Signal, Ward Leonard, Thordarson, Cardwell, Flechtheim, Electrad, Yaxley, R. E. L., Universal, Clarostat, Bradley, Deforest.

Write for our net prices. Mail orders filled same day. Must be accompanied with 10% cash of order plus postage charges.

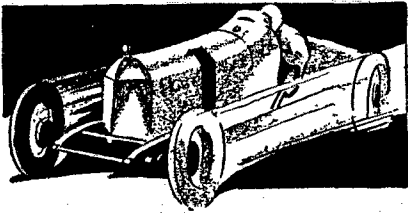

CONTROL rides with the Winner!

Is your radio under perfect control? It is if it is **CENTRALAB** equipped.

The new **VOLUME CONTROL GUIDE** just out gives fundamental circuits for volume control. Shows how to service all old and new sets with **CENTRALAB** units.

Dealers and Servicemen

Send 25 cents at once for this **VOLUME CONTROL** Guide

SEND THIS COUPON NOW

Centralab

CENTRAL RADIO LABORATORIES

Dept. 320F, Keefe Ave. and Humboldt Milwaukee, Wisconsin

Enclosed find 25c for your new **VOLUME CONTROL GUIDE**.

Name.....

Address.....

City.....State.....

Candler System Courses Give You Speed

Increase your speed and *step up* to a better position. **CANDLER SYSTEM** will help you. Scientific methods. Result of 19 years research and experience by world's most successful developer of Morse and radio operators. Eliminates all "hit-or-miss" in telegraphing.

ADVANCED COURSE for Operators.

Trains brain, muscles, nerves to coordinate in doing fast, accurate work. Corrects "Glass Arm" and faulty sending. Develops concentration, confidence, and increases sending and receiving speed to a remarkable degree.



W. H. Candler
World's Foremost Code
Specialist personally
directs you.

JUNIOR COURSE SCIENTIFIC INSTRUCTION for Beginners. With or without Automatic Machine. Teaches fundamentals scientifically. Makes code learning easy, fascinating and rapid.

RADIO-TOUCH-TYPEWRITING. Only typing course teaching correct use of "Mill" in telegraphing. Use all fingers. Copy fastest stuff easily and accurately. Method used by all experts.

DON'T WASTE TIME. Utilize scientific methods of **CANDLER SYSTEM** — only Code Specialist in the World. Tell us your speed, if any, and your problems. Beginner or operator, we can help you.



This Machine and 10 Special Tapes Furnished at Wholesale Price.

THE CANDLER SYSTEM CO.
6343 So. Kedzie Avenue

Dept. Q-1
Chicago, Illinois

90

Say You Saw It in *QST* — It Identifies You and Helps *QST*

job, and the accumulation was overcome. Overcome there, but of course it had to pass through the machinery of the Department of Commerce too. At this writing, however, things are again serene, and there is now no application pending in Washington which has been there longer than three days. Meanwhile the machinery along the line has been oiled up and we believe that we will have good service henceforth.

Although some amateurs were obliged to suspend operation temporarily through no fault of their own, examination of the applications at Washington showed that hundreds of applicants did not apply to the Supervisors for renewal until after their old licenses had expired. General Order No. 89 of the Commission, dated May 1, 1930, requires that "all applications for renewal of license must be filed so as to be received at the offices of the Supervisor of Radio in charge of the District in which the station is located at least thirty (30) days prior to the expiration date of the license sought to be renewed." (Italics ours.) If we don't comply with that, we can't kick if we have to shut down before the new license arrives. Take a look at your expiration date, OM, and arrange to ask for renewal at least thirty days in advance. The new system should give good service to all parts of continental United States within the thirty days; amateurs in the Territories should allow extra time for the mail to and from the mainland.

R. B. W.

Calls Heard

(Continued from page 86)

W8DGX, John F. Drake, 3553 Douglas Road, Toledo, Ohio

February 8th to April 15th
14 mc.

py1aw py2ba py2ad py2ik py1cl py1cm py2ig py1cr py2ay py1ah py2qb py2ih py2il py2az py2bj py2bf py2bg py3aq py2bk py4dq py2bz py1aa py2ab py2c py1ic lu2ba lu8de lu2fi lu9ce lu2aa lu8dy lu4bi lu1ba lu3de lu9dt lu2ca lu1ce lu6aj lu3pa lu8sc lu3da lu5fa lu8dj lu1bz lu5bz lu5ac lu2dj lu3dh lu2je lu4dq lu8djc z12gh z12bx z12bg z11ac z12gq z11fc z11an z14ap z12aw z12ab z11aa z11fu z13as z14ao z12ac z13aj z13cm z14ba z11as z11fw z12gw x9a x1j x3a yslx ys1ap ct1aa ct1bx ct1by ct2ac hc1fg hc1lc hc2je hc2jm vo8an vo8mc vo8a wzs4m zt11 za4t zslp k4akv k5dd k4dk k4kf k6zce k6ewb kfr6 khk0l f8dh f8ha f8fr f8fw f8toy f8gi f8dmf f8vqi f8awp f8bnd f8bq f8hr f8ex ear149 ear96 ear10 ear98 ear21 g6vp g6qb g5by g6rb g5bz g5bj g6kb g2bm g5ia on4fp on4gn on4my on4dj on4aa on4ij o44j o44q o44r o44t o44o o44i o44x o44c n2pa n2fa rx1aa cr4ad cm8uf cm5ex cm8yb cm1f cm2xx cm2jm cm2ah ce8aa ce3bf ce2ab ce1ah ce3ch ce3er cx1af cx1fp cx1ac cx1oa cx1ap cx1fb cx1ap ozd n22y cplaa kblap vk3lp fnra cma2 cx7 1ete moi wef wuv iph cmb3

W9ABB, Paul Hinkle, 4119 Magoun Ave., East Chicago, Ind.

14,000-kc. band

on4fp on4ft on4ij f8aa f8da f8dm f8ex f8fr f8fi f8zw f8gdb f8car g5bd g5by g5vl g6rb g6yq ear2l ear79 ear96 ear98 earl36 ct1aa ct1bx ct2ac pa0fp pa0gg oa4o oa4p oa4q oa4t oa4j hc1fg hc2je hc2jm ce1aa ce1ah ce1ak ce2ab ce3ab ce3bf ce3bm ce5aa ce7aa lu1ca lu3dh lu9dt py1aa py1ah py1as py1aw py1br py1ca py1cm py2aj py2ay py2ba py2bf py2bg py2bk py2ih py2ik py2iq py2qb py2af rx1aa kfr6 kfr5 kfr4 kt2ea t12hv t12wd cm2lq cm2jt cm2sh cm2xx cm5ex cm8uf x1g x3x x8cbt x9a vo8a vo8ae vo8aw n2pa k4aan k4dk k4kd k4kay ys1x cr4ad on4caa z11fw z11as z13cm z13go z14ao vk2hc vk2no vk2rm vk2tw vk3ax vk3es vk3go vk3jj vk3kr vk5lt vk6sa k6ewb vp5oux xy wfa wft wfbt



SPECIAL AUDIO and OUTPUT TRANSFORMERS

Now made in U. S. A. on 48 hours' notice

For the exacting requirements of broadcast stations, public address systems, recording devices, laboratories, speech transmission and other uses where a flat curve over a wide frequency band is necessary. They can be supplied for the following requirements, as well as many others not mentioned:

- | | |
|--------------------|-----------------|
| Microphone step up | Line to Line |
| Microphone mixing | Tube to speaker |
| Microphone to line | Line to speaker |
| Tube to line | Line to tube |

When transformer stages are cascaded the errors resulting from poor curves are multiplied. If transformers are down 3 db. at 35 cycles a three-stage amplifier using three audio and one output stage would be down at least 12 db. With three stages of coupling with our standard AF 5 audio transformers and the new precision output transformers the error or loss at 35 cycles is only about 2.5 db. if a good circuit free from regeneration and feed back is used. Further, the deviation of the curve from a straight line, between 35 and 8000 cycles, is less than 1.5 db. Circuit recommendations will be given on request.

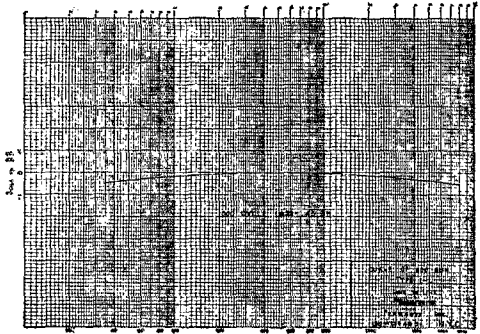

This Curve of 600 Ohm Line to Line Transformers is typical of this newly developed series of Transformers

When ordering these special transformers the details of the primary and secondary operating requirements must be clearly stated. The weight of the special audio and output transformer is 2 lbs. 10 oz. Dimensions: Width 3 ins. Thickness $2\frac{3}{4}$ ins. Height $3\frac{3}{4}$ ins.

FERRANTI, INC., 130 West 42nd Street, NEW YORK, N. Y.

H I L E T

volume controls for constant impedance lines are scientifically correct. Send us your resistor problems for quotations. Adjustable Gap, Chokes — 100 H, 80 MA, 21 lb., \$12.00, 60 H, 160 MA, 22 lb., \$12.00, 30 H, 320 MA, 27 lb., \$14.00, 20 H, 500 MA, 32 lb., \$18.00, 1/2 H, 4000 MA, 22 lb., \$12.00, 20 H, 1000 MA, 190 lb., \$48.00, 30 H, 1000 MA, 225 lb., \$58.00, 20 H, 1500 MA, 240 lb., \$68.00, 30 H, 1500 MA, 290 lb., \$78.00, 20 H, 2000 MA, 310 lb., \$98.00, 30 H, 2000 MA, 350 lb., \$120.00. Transformers, 750 watt, 1500-1850 each side, \$19.50. 500 watt, 1000-1500 each side, \$15.00. 250 watt, 500-750-1000 each side, \$10.50. 150 watt, 325-375 each side, \$9.00. Filament — any voltage, tapped primary, \$6.50. Specials to order.

One Day delivery
HILET ENGINEERING CO., Orange, N. J.

QUARTZ

DIRECT IMPORTERS FROM BRAZIL
OF BEST QUALITY PURE
QUARTZ CRYSTALS

Suitable for cutting into
PIEZO ELECTRIC CRYSTALS

We solicit your inquiries

THE DIAMOND DRILL CARBON CO.
720 World Building New York City

● FIRE! ●

The
New Handbook
is HOT

and its cover is

FIRE DEPARTMENT RED

If your cover isn't red, it isn't the
New Improved Revised Enlarged
Superior Seventh Edition

\$1.00 per copy, postpaid

HANDBOOK FACTORY, West Hartford, Conn.
SEND IT AT ONCE

(Name)

(Street or P. O. Box)

(City and State)

HAM-ADS

(1) Advertising shall pertain to radio and shall be of nature of interest to radio amateurs or experimenters in their pursuit of the art.

(2) No display of any character will be accepted, nor can any special typographical arrangement, such as all or part capital letters be used which would tend to make one advertisement stand out from the others.

(3) The Ham-Ad rate is 15c per word, except as noted in paragraph (6) below.

(4) Remittance in full must accompany copy. No cash or contract discount or agency commission will be allowed.

(5) Closing date for Ham-Ads is the 25th of the second month preceding publication date.

(6) A special rate of 7c per word will apply to advertising which, in our judgment, is obviously non-commercial in nature and is placed and signed by a member of the American Radio Relay League. Thus, advertising of bona fide surplus equipment owned, used and for sale by an individual or apparatus offered for exchange or advertising inquiring for special equipment, if by a member of the American Radio Relay League takes the 7c rate. An attempt to deal in apparatus in quantity for profit, even if by an individual, is commercial and takes the 15c rate. Provisions of paragraphs (1), (2), (4) and (5) apply to all advertising in this column regardless of which rate may apply.

PLATE power for your set, the very heart of its performance. For quietness, DX ability, life-long permanence, absolute dependability, lowest ultimate cost, no other plate source even approaches the achievement of an Edison steel alkaline storage B battery. Built painstakingly; every joint pure nickel, upset electrically welded. Genuine Edison Electrolyte. Our list describes complete batteries, construction parts, enameled aerial wire, silicon steel. Available immediately, filament and plate transformers for the new 872 rectifier, complete plate power units. Rectifier Engineering Service, 4837 Rockwood Road, Cleveland, Ohio.

THE finest in radio for amateur, broadcast and marine. The most modern short-wave receivers. Four to ten tube designs. Radiophone CW transmitters of any power or type. We make a complete line of apparatus, including speech amplifiers, filter coils, inductances, power units, etc. Any special apparatus, designs, built to order, using your parts if desired. Prices on request. New bulletin lists complete line of apparatus. Write for copy. Enssall Radio Laboratory, 1527 Grandview St., S. E., Warren, Ohio.

WHOLESALE discounts. Approved parts. \$50,000 stock. Over four pounds, catalog, circuits, data — 50c, prepaid (Outside U. S. — \$1.00). Weekly (new items, test reports) bulletins — 20 weeks — \$1.00. Experimenters 56 page house organ — 25c, prepaid. Kladag Radio Laboratories (Established 1920 — over 4000 radiowave customers), Kent, Ohio.

LEARN Wireless (Radio) Morse telegraph. School, oldest and largest; endorsed by telegraph, radio, railway and government officials. Expenses low — can earn part. Catalog free. Dodge's Institute, 7 Wood St., Valparaiso, Ind.

CRYSTALS: I grind, test and calibrate each plate myself, and guarantee complete satisfaction. 7000 kc., \$15. 3500 kc., \$12. WDRD, Herbert Hollister, Edwardsville, Kansas.

BEST OFFER takes Scotts World Record and Magnaformer superhets A. B. Clark, Albia, Iowa.

SELL R.C.A. 852s, \$15; 203As, \$10; W. E. 212Ds, \$30. Thorderson cased transformers, 2000-1500 each side, also 1500-1000 each side, \$6. Also filament transformers, meters, condensers, rheostats, etc. E. Donovan, 48 Inman Place, North Arlington, N. J.

SILVER-Marshall Round-the-World Four with coils and tubes. \$20. Box 91, Hemphill Station, Fort Worth, Texas.

SELL or trade 6-400 volt dynamotor W9BRY.

W9BAG for sale cheap. Complete Xtal Radiophone and Superhet receiver. See page 42, Jan. 1930 QST for description. Write Frank Smolek, 4452 S. Troy St., Chicago, Ill.

7 1/2-watt fone complete, \$85. Payments accepted. Send for list. Want 211s, 203As, 212Ds, W9FME, Kingman, Kansas.

COMPLETE transmitting receiving station, five watts, forty meters, all accessories, ready to run, guaranteed, \$75. Hardy, 24 Hedgeway Court, Hempstead, N. Y.

WANTED — motor generator 110 a.c. 500 d.c. Perfect condition. W6DXA, San Anselmo, Calif.

WANTED — HY-7 superhet. Glenn West, 615 Dodge, LaFayette, Ind.

TRADE Teleplex for receiver or meters. W2CRF, Wm. McCleneghan, Jr., 625 Chancellor Ave., Irvington, N. J.

NEW 6-tube band-box complete, \$75. Payments accepted. New 211s, \$25. New 204A, \$50. List, W9FME, Kingman, Kansas.

METERS WANTED — Jewell or Weston, any size, range or condition. A. B. Clark, Albia, Iowa.

MICROPHONES, double button, duralumin gold spot diaphragm, chrome plated, guaranteed to equal mikes selling for double our price. \$25 net. Mike transformer, \$6. Electro-Voice Manufacturing Company, Inc., South Bend, Ind.

SELL — 6/400V dynamotor, 10W c/w and fone xmitter, never used. Excellent condition, \$35. W4ADI.

SELL — 390-volt 300-mill Holtzer-Cabot m.g., \$95. Delivers 500 volts or trade for 250-mill filter choke and 852. W5BMC, Madisonville, Texas.

NATIONAL A. C. SW5, \$31.80 complete — tubes, set, power pack, wired and tested. We band-spread them. Write for price. Hatry & Young, Hartford, Conn.

FILTER condensers, 1.8 mfd. working voltage, alternating 2800 direct current 4000V, thirteen by thirteen by four inches. Weight, 44 lbs. Porcelain insulators made by G. E. Fits my high-voltage transformers, \$15. Fred Dawson, Transformer Man, 5740 Woodward Ave., Detroit, Mich.

TUBES wanted for exchange for a Conn clarinet and case, in good condition. Can use one 203, one 212D or two 203s, one 880. Also can use two 866s. W9CZG.

SELLING four UX852s, used. \$20 takes one; \$75 takes 'em all. WHBU, Anderson, Ind.

BEST Silicon transformer steel. 20c per pound cut. W9EBH, 86 Elm St., Batavia, Ill.

SELL Aero overseas four a.w. receiver. Also see my adv this issue about Grebe and back issues QST. W. L. Holst, 6142 Forest Glen Ave., Chicago.

HAMS: Get our samples and prices on printed call cards made to order as you want them. W9APY, Hinds, 19 S. Wells St., Chicago, Ill.

SALE — low-powered transmitter, \$10. Penney, 32 Princeton St., East Boston, Mass.

SUPERHETERODYNE, built according to March 1929 QST, except for a.c. operation. Selling for cost of parts because frequent travelling prevents radio activity. Set, on experimental panel, has not been completely tested. Price, \$40 cash, less tubes and power supply. T. L. Bowes, 6067 N. Neva Ave., Chicago, Ill.

COMPLETE xmitter described November QST, \$30. Hartley 210, \$15. Neal Brown, Richland Springs, Texas.

GENERAL Electric 24/1500-volt dynamotor, 350-watt ball-bearing, \$37.50; 24/750-volt 150-watt, \$27.50. On 12 volts delivers 375; 18 volts 500; shafts for external motor drive \$3.00 additional. Westinghouse 27.5/350, \$7.50. 10-350, \$18. Westinghouse 4-15 volts, 500 watts, \$15; 200-watt 900-cycle, \$25. 500-watt 500-cycle Special, \$7.50. Western Electric Helmeta with head set, \$10. Fuse 1500 volts, 300 mills, 50c dozen. Henry Kienzle, 501 East 84th St., New York.

TRADE your receiver on HY-7. Write for offer. Get our catalog for 25c — includes dope on HY-7. Large stock of parts. Hatry & Young, Hartford, Conn.

210 push-pull transmitter, complete, \$25. Receiver parts. W2CGI, 922 Crane St., Schenectady, N. Y.

TRANSFORMERS — 750 and 550 volts each side center tap, 125 milliamperes current, two 7 1/2-watt, 2 1/2-ampere center-tapped filament windings, for 110-volt, 60-cycle supply. Mounted complete. Strong construction, high grade insulation, no heating. Fine for one or two 210 tubes as oscillators or M.O.P.A. Price, \$8.75. Remit \$2.00 with C.O.D. orders. Prompt shipment. Amateur Equipment Co., Myrtle, Miss.

TYPE 866 firsts, \$6. Few seconds, \$4. 2.5V 10A, c.t. filament transformers for above, \$2.50. Include postage. E. Ewing, Jr., 29 S. LaSalle St., Chicago, Ill.

QSLs, 100 two-color, \$1. Samples, W9CKA, Corwith, Iowa. SANGAMO, Flechtheim, Tobe, Aerovox, Sprague paper and electrolytic (wet or dry) filter, by-pass condensers. Also pitched-dipped type. All sizes, transmitting and receiving, in stock. Weston, Jewell, Beede, Readrite meters — panel or portable type. For transmitting, test or repair work. Test kits, ohmmeters. Order it — we have it. Hatry & Young, Hartford, Conn.

TRADE Crystals. Need milliammeters, RF meters, AC voltmeters, etc. Also need one pair 866's. Crystals to your specified frequency and absolutely guaranteed. W6EKS, 1944 Lime Ave., Long Beach, Calif.

SELL — short-wave receiver using two 224s and 245, either a.c. or d.c., \$15, or swap for good 203A, UV211, or what have you. Write for details and list of surplus xmitter parts. W8BXY, Riley Parsons, Old Forge, N. Y.

CONDENSERS — Heavy duty, 4 mfd., 1500-V d.c., guaranteed, tested 2000-V d.c. Black duoced case, \$2.25. Five for \$10. W1VC, Richard Baer, 70 Ontario St., Pittsfield, Mass.

RECTOBULBS prepaid R4 \$20, R3 \$10, R81 \$5.25, N65 \$12.50; 85 or 170 meter Power Xtals ground to wave \$12, holders \$4; Super-Wasp kits c.t. \$28.40, a.c. \$33.40; Sangamo .002 5000-V conds. \$1.40; 25% off on Jewell, REL; 35% on Thorderson, Tobe, Flechtheim; 45% on Sagamo A.F. trans. Any other items, too. Henry's Radio Shop, Butler, Mo.

POWER supplies. Transformers. Secs. 550V 7 1/2V c.t., 7 1/2V c.t. Ideal for 210 transmitters, \$2.25. Also 8 mfd. condenser blocks 600V oper., 2.24 mfd. sections, \$2.75. One third of price must accompany all C.O.D. orders. East Bay Radio Corp., 1549 Fifth Ave., Oakland, Calif.

QSLs, 90c per 100, two colors. W9DGH.

POWER crystals: Guaranteed excellent oscillators. Carefully ground one inch square sections within one tenth of 1% of your specified frequency. 1715-ke. band, \$6; 3500 kc., \$7.50; 7000 kc., \$11. Plug-in, dust-proof mounting, \$3. Prompt deliveries. Precision Piezo Service, 427 Asia St., Baton Rouge, La.

SELL or trade: WE211D, 212D; R.C.A. 865, 852, 204-A; power xtals; 24-1500-V. dynamotor; 500-V. MG; mercury arc tube; any other apparatus. W9ARA, Butler, Mo.

SHORTKUTS to Code Reading Speed. Users raise 6/10 to 20/25 few hours' attention. Reports telling details on request. Dodge, Box 100, Manaroneck, N. Y.

QSL cards, two colors, \$1.00 per hundred. Free samples. W8DTY, 257 Parker Ave., Buffalo.

SELL — 7 1/2-watt phone or c.w. station. Write for details. George Goblish, Vesta, Minn.

CRYSTALS ground to your frequency, 3500 kc., \$5. 1" oscillating blanks, \$2. W8AKW, R. L. Tedford, 1804 Waltham Ave., College Hill, Cincinnati, Ohio.

WANTED — 10 watt or less s.w. transmitter. C. T. Asmussen, 622 Indian Road, Davenport, Iowa.

EDISON storage B batteries, 100 volts, \$6.50; 180 volts, \$10. 904 N. 6th Ave., Philadelphia.

WANTED — SE1420 or IP501 receivers. Paul Trautwein, 38 Park Place, New York.

SELL Grebe CR18 special or trade for power tubes or high-power rifle. Want back issues QST — Dec. 1915, May, June, Aug. 1916, Sept. 1917, Dec. 1921, Feb. 1922, July 1924. W. L. Holst, 6142 Forest Glen Ave., Chicago.

CONDENSERS — G. E. oil filled, 1.79 mfd., 2800 V a.c., excellent for ham transmitter, up to 4000 working voltage. Guaranteed \$15 each. Send for photographs. Howard W. Chapin, 17 N. Adams St., Ypsilanti, Mich.

OMNIGRAPHIS, Teleplexes, meters, crystals, wasps, 50-watt transmitters, transformers, microphones, receivers, rectobulbs, chokes. Bought, sold, traded. Ryan Radio Company, Hannibal, Mo.

PHONE equipment: single and double modulation chokes. Modulators, speech amplifiers, transmitters, built or kits. Special work undertaken. Pontiac Engineering Co., 1100 Ave. I, Brooklyn, N. Y.

CRYSTALS: 80- and 160-meter ground to your specified frequency, \$10. Tested blanks, \$3. Will trade. W9CVT, 6320 Main St., Kansas City, Mo.

SELL — new 860 mercury arc, rectobulbs, HV fixed condensers, etc. Want new 852s. W9ERU.

SELL — Esco 1000 volts 300-watt type R-113 generator with 32-volt separate excited field. With coupling, \$48. One Weston model 528 150/8/4 portable voltmeter. Like new, \$8.50. Wayne Faith, Montpelier, Ohio.

SELL G.E. 24/1500V dynamotor, \$20. F.O.B. transmitter, \$5. Crystal plus holder, \$6. Box 235, Gassaway, W. Va.

EXTRAORDINARY-Tube tester and set analyzer, \$45. Kasey Retzlaff, 119 Irwin Ave., Muskegon, Mich.

EVERYTHING guaranteed. UX210, UX281, UX250 tubes, \$1.35; Thordarson 30-henry 100-mill chokes, \$1.35; 3 1/2 mfd., 1000 working volt condensers, 80c; 10-watt transformers 8-volt center-tapped, easily rewound, 35c, postage extra. Hanifan Sales Co., Waterville, Ohio.

SELL transformers, condensers, meters, tubes, crystal, etc. W2AEB.

NAVY standard receivers, Dubilier 12,500-volt condensers, spark gap units. Esco 220 a.c. motor, 1600-volt generator with 16-volt filament. Mariners Radio Service, 38 Park Place, New York.

QSLs by W2AEY. Prices. Samples furnished. 338 Elmora, Elizabeth, N. J.

WILL pay any reasonable price for Volume I of QST, for my personal file. Describe condition. K. B. Warner, c/o A.R.R.L., Hartford, Conn.

CRYSTALS — individually ground and calibrated with an unconditional guarantee. Personal service means your satisfaction. 3500 kilocycle band, \$10; 1750 kilocycle band, \$7.50. Will consider trades. W9DLL, 222 W. 73rd Terrace, Kansas City, Mo.

SELL or trade: Surplus parts. New National drum dial, \$3. New Aero Products Tuning Unit, \$15. 3500 kc. band oscillator in box, long tuning handle, \$10. K.a. transformer, tilting cradle, solenoid, oil bath, 2 rectifiers, all on base ready for arc, \$38 f.o.b. 1/2 HP 110 v-ac or dc motor, series field, ball-bearing, 1/2 in. shaft, reversible, 5000 r.p.m. light load, \$18 f.o.b. 1/2 HP sync motor, Northwestern Elec., pulls in direction of rotation started, 1/2 in. shaft and pulley, \$12 f.o.b. FOUR CRYSTAL HOLDERS, dustproof, nickel-plated, similar to Scientific Svc Type, plates machined and ground, plug into knife switch jaws — a quality holder, \$5 each. Wanted. Multimeter. Crystals. S/w converter or super-het. State condition, best price or swap. F. E. Handy, 38 LaSalle Road, West Hartford, Conn.

Q R A SECTION

50 c. straight with copy in following address form only:

- W1HB — R. S. Jackson, 82 Center St., West Haven, Conn.
 W1MG — St. George's School Radio Club, Thomas W. Brown, 4th opr., Newport, R. I.
 W5BTA — J. N. Reaben, Box 332, University, Miss.
 W6CRI-W6EXG — Eugene B. Kille, 742 Burchett St., Glendale, Calif.
 W6VH — J. H. Brown, L. B. Weston, 725 East Hill St., Long Beach, Calif.

WIMK, A.R.R.L. Headquarters

R. B. Parmenter, Chief Op. "rp"

The following calls and personal sines belong to members of the A.R.R.L. Headquarters gang:

- W1AKW-W1KIP Clyde J. Houdson "ch."
 W1BAW R. B. Beaudin.
 W1BDI F. E. Handy "fh."
 W1CBD Clinton B. DeSoto "dc."
 W1AL J. J. Lamb "jim."
 W1DF Geo. Grammer "hg."
 W1EH K. B. Warner "kb."
 W1ES A. A. Hebert "ah."
 W1FL-W2JR G. Donald Meserve "dm."
 W1SZ-W1BIZ C. C. Rodimon "rod."
 W1UE E. L. Battey "ev."

TRANSFORMERS

Guaranteed — Mounted — Complete

1 KVA 3 phase 1500-2000 v. each side \$40.00
 700 watt 1000 — 1500 each side 14.50

250 watt 500-750-1000 each side
 unmounted \$10.00; mounted \$11.50

Auto-Transformers, Chokes, Polyphase and 25-cycle
 Transformers. Add \$2.00 for fil. winding

W9CES FRANK GREBEN

1927 So. Peoria Street, Peoria, Ill. Chicago, Ill.

Complete stock of replacement parts — all models

Brunswick-Radiola receivers

RPA-1 AP 947	RPA-3 AP 950	RPA-4 AP 832	RPA-5 AP 952	RPA-7 AP 991
-----------------	-----------------	-----------------	-----------------	-----------------

Volume Control Potentiometers	Rectifier and Power Amplifier Assemblies Fixed Capacitors	Receiver Assemblies Catacombs
----------------------------------	---	----------------------------------

Write Us For Prices

BAL-RAD HY VOLTAGE SURGE-PROOF CONDENSERS

For General Repair and Power-Pack Work

We guarantee these condensers for 100 per cent. free replacement. Repair men should carry a few dozen in stock.

	Each
One Mfd. 600 Working Volts	30c
Two Mfd. 600	40c
Four Mfd. 600	60c
One Mfd. 800	50c
One-half Mfd. 300	25c



United Electric Motor and Turntable	\$6.50
Victor A.B.C. Power Transformers	2.75
Philco Power Transformer, Model 87	3.75
Atwater-Kent Power Packs, Model 41-42	11.50
Thordarson Power Transformer	2.75
General Replacement Transformer	2.75
Peerless A.B.C. Power Transformer	2.75
Acme B & C Eliminator	8.00
Potter 1/2 mfd. By-Pass Condenser	.25
Crosley 1/2 mfd. By-Pass Condenser	.25
Bal-Rad Replacement Blocks for Majestic "B" Eliminators	2.95
Bal-Rad Replacement Blocks for Atwater-Kent No. 37	4.95
Dubilier Replacement Condenser	3.25
Victor Replacement Condenser Blocks	2.25
4-Gang Condenser	1.50
Fixed Pigtail Resistors, per doz.	1.00

TERMS: 20% with order, balance C.O.D.
 2% discount allowed for full remittance with order only.
 NO ORDERS ACCEPTED FOR LESS THAN \$2.50

BALTIMORE RADIO CORP.

47-Q Murray Street, New York City
 Send for our latest Bargain Bulletin

To Our Readers who are not A.R.R.L. members

WOULDN'T you like to become a member of the American Radio Relay League? We need you in this big organization of radio amateurs, the only amateur association that does things. From your reading of *QST* you have gained a knowledge of the nature of the League and what it does, and you have read its purposes as set forth on the page opposite the editorial page of this issue. We should like to have you become a full-fledged member and add your strength to ours in the things we are undertaking for Amateur Radio. You will have the membership edition of *QST* delivered at your door each month. A convenient application form is printed below — clip it out and mail it today.

A bona fide interest in amateur radio is the only essential qualification for membership

AMERICAN RADIO RELAY LEAGUE
West Hartford, Conn., U. S. A.

I hereby apply for membership in the American Radio Relay League, and enclose \$2.50 (\$3 in foreign countries) in payment of one year's dues, \$1.25 of which is for a subscription to *QST* for the same period. Please begin my subscription with the issue. Mail my Certificate of Membership and send *QST* to the following name and address.

.....

.....

.....

Do you know a friend who is also interested in Amateur Radio, whose name you might give us so we may send him a sample copy of *QST*?

.....

.....

Thanks

For Your Convenience QST'S INDEX OF ADVERTISERS IN THIS ISSUE

Acme Wire Company	83
Allen-Bradley Company	4
American Piezo Supply Co.	80
American Sales Company	60
American Transformer Company ..	58
Amrad Corporation	62
Arcturus Radio Tube Co.	83
Astatic Microphone Laboratory ..	84
Aurisma, Inc., Ad.	82
A.R.R.L. Apparatus	67
A.R.R.L. Application Blank	94
A.R.R.L. Handbook	74, 91, Cover III
A.R.R.L. Log Book	Cover III
Baltimore Radio Corporation	93
Blan, The Radio Man	78
Burgess Battery Company	Cover IV
Candler System Company	90
Cardwell Mfg. Corporation, Allen D.	79
CeCo Manufacturing Co.	61
Central Radio Laboratories	90
Columbia Specialty Co.	86
Cornell Electric Mfg. Company	80
Cunningham, Inc., E. T.	64
DeForest Radio Co.	1
Diamond Drill Carbon Co.	91
Electrad, Inc.	85
Electric Specialty Co.	81
Ellis Electrical Laboratory	80
Ferranti, Inc.	91
Frost, Inc., Herbert H.	88
Gavitt Manufacturing Co.	77
General Radio Company	91
Greben, F.	93
Gulf Radio School	89
Harrison Radio Company	78
Hillet Engineering Co.	91
Hoodwin & Co., Chas.	76
International Resistance Co.	2
Jewell Electrical Instrument Co.	85
Johnson Company, E. F.	76
Kellogg Switchboard & Supply Co.	82
Leach Relay Company	89
Leeds Radio Company	73
Manhattan Electric Bargain House ..	71
Massachusetts Radio & Telegraph School ..	85
Morrill & Morrill	74
National Company	86
Pacent Electric Company	69
Pilot Radio & Tube Corp.	95
QST Binder	66
Radio Engineering Laboratories	63
Radio Supply Company	86
RCA Institutes, Inc.	68
RCA Victor Co.	89
Rectifier Engineering Service	85
Rooney, John T.	86
Scientific Radio Service	87
Shallcross Mfg. Company	87
Sprague Specialties Company	87
Teleplex Company	87
Thordarson Electric Mfg. Co.	85
Triad Mfg. Company	70
Uncle Dave's Radio Shack	75
Vacuum Products Lab.	84
Van Nostrand Company	96
Vibroplex Company	88
Ward Leonard Electric Co.	83
Weston Electrical Instrument Corp.	72
West Side Y. M. C. A.	86
Wholesale Radio Service	86
Wireless Egert	89

World Famous Radio Receivers

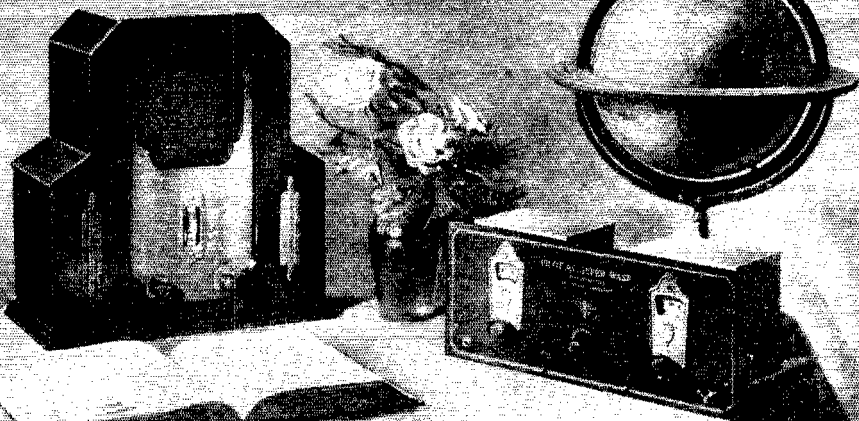

Console Quality in a Midget Broadcast Receiver You Can Place Anywhere

PILOT MIDGET

This attractive two-tone walnut miniature A. C. receiver has proved the equal of high priced consoles in many locations throughout the country. Because—it embodies console features; 2-224 Screen Grid stages, 1-224 Screen Grid Power detector, 1-227 Audio stage, 1-245 Power Audio output stage and specially designed electro dynamic speaker. A super powered 280 voltage supply gives trouble-free operation from any 110-20 volt house current line.

Pilotron tubes are standard equipment because Pilot retailers know none are more reliable.

PRICE
Complete in
Modernistic
Cabinet

\$59.50
less tubes

PILOT
RADIO
TUBES

ENDORSED BY
PROFESSIONALS



For World-Wide Radio Reception

Short and Long Waves, 14 to 500 Meters

PILOT Super-Wasp

Rev. J. W. Nilseñ, Bolonque, Congo-Beige Africa says: "Here in the heart of Africa I have received 9LO, JB, 2BL, 5SW, AFK, PCJ, WGY (W2XAF), WRNY (W2XAL) and more stations on loud speaker with my Pilot Super-Wasp."

David W. J. Jones, Brisbane, Australia says: "I have received on my Super-Wasp all the test transmissions between W2XAF (Schenectady, U. S. A.) and VK2ME (Sydney NSW), and PCJ Holland, G3SW England and Sydney—London phone service."

Austin R. Baldwin, St. Raphael (Var.) France, says: "I heard from KDKA 25.4 meters, 'We will now rebroadcast a concert from London.' Shortly after the music from London came in clearly, 'having twice crossed the Atlantic.'"

Pilot Super-Wasp Comes in KIT FORM
which can be assembled in a few hours

BATTERY SET KIT

\$29.50

Kit K-110: The battery-operated Super-Wasp. Batteries and Tubes extra.

A. C. SET KIT

\$34.50

Kit K-115: The A.C. Super-Wasp. Use your own ABC pack or Pilot K-111, especially designed for the Super-Wasp. Power Pack and Tubes extra.

PILOT RADIO CORPORATION



Chicago, Boston, New York, and Dallas

PILOT RADIO & TUBE CORPORATION

LAWRENCE, MASS.

Chicago Office:
231 S. Wells Street

New York Office: 52 Broadway
OFFICES IN PRINCIPAL COUNTRIES OF THE WORLD

San Francisco Office:
1278 Mission Street

BYRD'S Antarctic Radio Equipment

The advanced types of receivers, transmitters, and navigation aids that triumphed on this epochal flight now fully described in this book.

TELEVISION

Mr. C. F. Jenkins, father of television and radio movies, gives you in his own words complete directions for building practical television equipment.

INTERFERENCE ELIMINATION

Tracking down troublesome interference and eliminating it, systematically outlined by W. F. Fleming, radio engineer.

RADIO AUTO-ALARM

New automatic device on ships to keep the SOS watch while operator is off duty—fully described in this book.

Latest BROADCASTING Equipment

Temperature-controlled Piezo crystal oscillator, 100% modulation panel, and other new apparatus, completely described, with instructions for operation.

SHORT-WAVE Apparatus

Latest types of commercial and amateur short-wave apparatus; directions for securing operator's and station license.

MARINE and AERIAL Radio Equipment

Radio beacons; arc radio transmitter for ships; Reed course indicator; latest developments in high frequency transmitters.

New RADIO LAWS and REGULATIONS

New regulations governing all classes of operators' licenses, U. S. Laws, and I. R. T. C. laws.

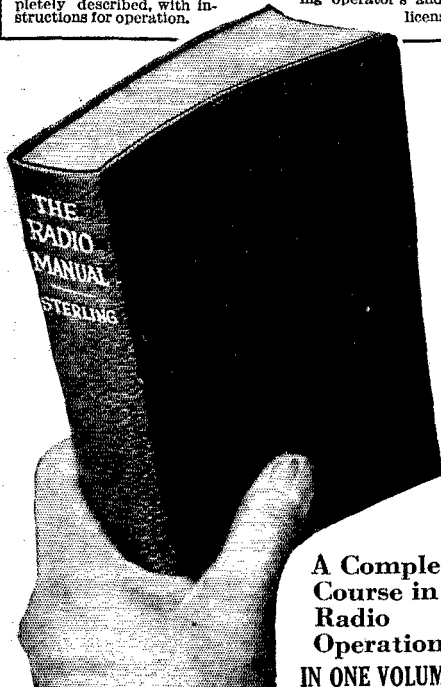

A Complete Course in Radio Operation IN ONE VOLUME

Enables You to Qualify for Gov't License as Operator or Inspector
20 Big Chapters Cover:

Elementary Electricity and Magnetism; Motors and Generators; Storage Batteries and Charging Circuits; The Vacuum Tube; Circuits Employed in Vacuum Tube Transmitters; Modulating Systems and 100% Modulation; Wave-meters; Piezo-Electric Oscillators; Wave Traps; Marine Vacuum Tube Transmitters; Radio Broadcasting Equipment; Arc Transmitters; Spark Transmitters; Commercial Radio Receivers; Marconi Auto-Alarm; Radio Beacons and Direction Finders; Aircraft Radio Equipment; Practical Television and Radio-movies; Eliminating Radio Interference; Radio Laws and Regulations; Handling and Abstracting Traffic.

EXAMINE IT FREE!

This is the Revised Edition of "The Radio Manual". Nearly 800 pages, 369 illustrations. Bound in Flexible Fabrikoid. The coupon brings the volume for free examination. If you do not agree that it is the best Radio book you have seen, return it and owe nothing. If you keep it, send the price of \$6.00 within ten days.

The Latest Data!

Complete and up-to-date information covering the entire field of Radio—all arranged for ready reference in this one big guide book

THE RADIO MANUAL

A Handbook for Students, Amateurs, Operators and Inspectors

Here's the answer to every question about the principles, operation and maintenance of apparatus for radio transmitting and receiving. No detail has been omitted, from elementary electricity and magnetism for the beginner to television and radio movies. Important new chapters have been added to bring it right up-to-the-minute, and an immense volume of facts never before available is now presented in the book. Included are detailed descriptions of standard equipment, fully illustrated with photographs and diagrams. It is now more than ever the one complete handbook covering the entire radio field.

Prepared by Official Examining Officer

The author, *G. E. Sterling*, is Radio Inspector and Examining Officer, Radio Division, U. S. Dept. of Commerce. The book has been edited in detail by *Robert S. Kruse*, for five years Technical Editor of *QST*, the Magazine of the American Radio Relay League, now Radio Consultant. Many other experts assisted them.

Mail This Coupon Today!

D. Van Nostrand Co., Inc.
250 Fourth Avenue, New York

Send me the Revised edition of THE RADIO MANUAL for examination. Within ten days after receipt I will either return the volume or send you \$6.00, the price in full. (QST 2-31)

Name.....

St. and No.....

City and State.....

Business Connection.....



Designed by
F. E. HANDY
A. R. R. L.
Communications Manager



New page design to take care of every operating need and fulfill the requirements of the new regulations!

New book form! No more fussing with binders, or trying to weight down loose sheets when the breezes blow!

New handy operating hints and log-keeping suggestions, put where they are always convenient!

We honestly believe the new Official A.R.R.L. Log Book is the best you've ever seen!

You need more than
“JUST A LOG”—
You need

THE NEW A. R. R. L. LOG BOOK!

THERE are 39 pages like the one below, $8\frac{1}{4}''$ x $10\frac{3}{4}''$, carefully designed to incorporate space for all the essential information you want and need to record about your station's operation. Thirty-nine blank pages (backs of the log pages) to be used for notes, experiments, changes of equipment, etc. Durable covers of heavy stock with space for your station call and dates over which the log entries extend. On the inside covers and first two pages are complete instructions on maintaining your log, convenient tabulations of the most-used Q signals, miscellaneous abbreviations, operating hints, amateur prefixes and signal-strength scales. The information you want, always at your finger-tips.

The new regulations require a log; a well-kept one identifies your station; a uniform series constitutes a progressive and permanent record.

AMATEUR RADIO STATION LOG									
DATE	TIME	BY	FROM	TO	CALLED	CALLED BY	STATION HEARD		MESSAGES REMAINING ETC.
							CLASS	TYPE	

40 CENTS EACH
THREE FOR \$1.00

Postpaid anywhere

SEND IN YOUR ORDER TODAY!

American Radio Relay League
 WEST HARTFORD, CONN. U. S. A.



Outstanding ...

To the amateur and to every other user of dry cell batteries. Outstanding because of unequalled performance under most severe as well as all ordinary circumstances.

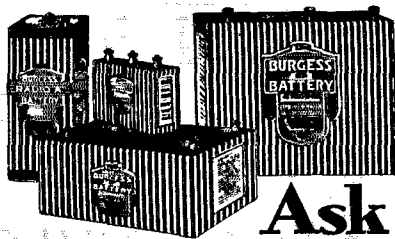

Ask *any* Radio Engineer"

BURGESS BATTERY COMPANY
MADISON, WISCONSIN

THE COMMUNICATIONS DEPARTMENT

F. E. Handy, Communications Manager

E. L. Battey, Asst. Coms. Manager

Those Station Logs

By R. D. Magill*

NOW that the Federal Radio Commission has ruled that all United States amateurs must keep logs "in which shall be recorded the time of each transmission, the station called, the input to the last stage of the transmitter and the frequency band used," many amateurs have doubtless been wondering how to get out of it as painlessly as possible, and still comply with the regulations.

A log may be kept in a stenographer's notebook, which may be procured from any book and stationery store for

Date Time	Called	Called By	Freq. Power	Remarks
6 25 30				Replaced Zepp feeders, adding series tuning condensers
6 26 30 1:21 p.m.	CQ	W7AAT	7mc 120w	He QSA4 — gave me QSA3
2:17 p.m.	W9DXP	(W9CJC)	7mc 120w	QSA4 both ways. Took 2 msgs.

about fifteen cents. It is preferable, but not essential, to get one with half-inch spaces between the lines, instead of the customary $\frac{3}{8}$ -inch rulings. These books are about 3 by 9 inches in size, and have each page divided by a vertical line down the center. Lines are ruled parallel to this one in such a way as to divide the portion to the left of this line into three equal columns, and the portion to the right of it into two unequal ones, as shown in the figure. By ruling a few pages in advance during spare moments, the time required to prepare our log for use will never be missed.

In keeping this log, we glance at the clock when we start each call, and make an entry to the nearest minute. In the left-hand column we note the date. Then we drop down to the next line, and place the time in the same column. In the second column we place the call of the station we tried to raise, or CQ as the case may be. If we raised the station, we enter his call again in the third column. The fourth column we devote to the power and the frequency band in one column to save space for the last or "Remarks" column. Of course, if desired, two narrow columns may be provided. Signal reports, tone, traffic handled — anything that may help us to fill out a QSL card a month hence should go in this column. If we failed to raise the station called, we either leave this space blank or record a laconic ND. Any important change in the station equipment should also be recorded by notations written across the page.

The simple log described takes little room on the operating table. After all the pages have been filled on one side, the book may be turned over, and the back sides filled. It is extremely inexpensive, since with normal operation a fifteen-cent notebook will last a year or more. When completed, it should be filed away as a permanent history of the station's activities. It makes extremely enjoyable reading after it has had a year or two to cool off.

Most of our memories are extremely unreliable and we never know when the time may come when we would give a whole lot to know whether we worked Africa before or after

* W9DQD-W9CLJ, 1040 11th St., Boulder, Colo.

we made that change in our antenna. If the log has been properly kept, the information we want is right there, in black and white. It is also interesting to check up on the percentage of our calls which are answered, and to compare the results obtained using different equipment and at different times of day, etc. A log offers endless possibilities to the ham and he should regard the Commission's rulings, not as a burden, but as a means of improving the effectiveness of his station and of increasing the pleasure he will get from operating.

B. E. R. W.

THE R.S.G.B. announces *British Empire Radio Week* as February 22nd, 0000 GMT, to February 28th, 2400 GMT, 1931. All A.R.R.L. members in the twelve competing Empire Groups, (1) British Isles, (2) Canada, including Newfoundland and Nova Scotia, (3) West Indies, including Bahamas, Bermuda and British Guiana, (4) South Africa, including N. and S. Rhodesia, (5) Kenya, Uganda and Tanganyika, (6) Egypt and Sudan, (7) Iraq, (8) India, Burma and Ceylon, (9) Malaya, (10) Hong Kong, (11) New Zealand, (12) Australia, are urged to get on the air and take part in this most interesting competition. A maximum of 20 contacts on each frequency band with stations in any one Group may be counted, as long as the stations worked are in a different Group than the one in which the competing station is located. Count one point for each station worked and as soon as the contest is over send your entry to Hon. Sec'y, R.S.G.B., 53 Victoria Street, London, S. W. 1, giving date, time and frequency band for each point claimed.

Second All-Section Sweepstakes Contest

SEE page 39 of this issue for complete rules and information on the Second All-Section Sweepstakes Contest to be held February 14th to 28th. Remember the dates! Get on the air and plan to participate as fully as possible. Make a record for your station. And whether your score is large or small, be sure to report it so that you will receive full credit in QST.

Fourth International Relay Competition

THE Fourth International Relay Competition is scheduled for the two weeks March 8th to 21st. Mark your calendar now!! Read the preliminary announcement elsewhere in this issue and prepare to take part. This contest has a number of important objectives. It promotes international fellowship and good will in addition to making possible some rare sport and a pile of new records for every station that takes part. This is one of the biggest events of the year. *Don't miss it.* Send your entry QSL-card right now.

IPH

SECTION Manager B. E. Sandham of W6VO will leave Los Angeles January 10th for a three-months' exploration trip with the Second International Pacific Highway Expedition. Automobile trucks will be driven from Mexico City to Balboa, Canal Zone, starting about January 20th. Sandham will use call signal IPH and 500-cycle note 100 watts on

frequency of 7330 kc. After morning and evening schedules with K9A or Los Angeles stations IPH will contact as many amateurs everywhere as time permits. Look for IPH during next three months and help all you can.

The Chair Warmers' Club

By Charley R. Estes *

SEVERAL times, in the Communications Department of QST, mention has been made of the Chair Warmers' Club, that happy band of brass pounders who, because of some physical disability are called, or miscalled, "shut-ins." The club was organized in April, 1929, by Walt J. Colpus, W8BR8, Pontiac, Mich., and in its 18 months of existence has grown from a small group of some half dozen members to an international organization of nearly one hundred members in this country, Canada and England.

The club is unique in more than one respect. It publishes a neatly mimeographed official organ, made up like a regular magazine with cartoons drawn especially for it by a good friend of the society, Otto Eppers, W8EA. Outside of the illustrations all work of issuing the bulletin is done by the members. James Lisk, W8EQ, Lima, Ohio, is the editor. Hugh Hossler, W8DIK, the assistant editor, prepares the stencils and mails them to Rudy Drews, a junior member in Lansing, Mich., who runs off the sheets, makes up the magazine and mails it to the members. A technical editor in the person of F. R. Gibb, W8BAU, writes an article each month on transmitting equipment and answers the questions of the members.

A system somewhat similar to that of the A.R.R.L. field organization is employed to gather the club news each month. A reporter has been appointed for each radio district. The members send all news and traffic reports to their district reporter to be relayed to the editor for publication.

Shortly after its organization the C.W.C. affiliated with the American Radio Relay League and virtually all members who hold operating licenses are League members. The purpose of the club is to band together all licensed shut-in amateurs and any other "shut-ins" who wish to take up Amateur Radio. The members are divided in two classes: junior and senior. The seniors being those who already have stations and are helping the juniors to obtain licenses.

The club has made only one departure from its original rules. In forming the women's auxiliary it was decided that no physical infirmity need be required to make an applicant eligible. It is headed by the three "yl" operators, Eulalia Thomas, W8CNO, Blanche Driver, W8ADU, and "Dot" Gwynn, W3IB, who take a sincere interest in the activities of the organization. Several shut-in yls are enrolled and are studying for licenses.

The Chair Warmers' Club has had write-ups in several large daily newspapers and magazines and is doing its bit in making amateur radio better known to the public at large. It has several honorary members, and a number of subscribing members who, though not crippled, wish to give their support to the work being done. Some of the well known amateur members not previously mentioned are W2RT, W4ST, W5AFS, W5FC, W6ABR, W6CKS, W8AKJ, W8BTO, W9DOQ, W9EVB, VE4EC, G2ZC, G5BD, G6PP, G6UN and many others.

Walt Colpus, the organizer and managing secretary of this interesting society, says, "A shut-in or disabled amateur must work under difficulties peculiar to his condition. By banding together and cooperating with each other we can accomplish much more than by working alone. We would like to hear from every shut-in amateur." Full information about the club may be obtained by writing to W. J. Colpus, 23 Henderson St., Pontiac, Mich.

Traffic Briefs

W9BAN wants to know why it is that —

A ham sends CQ East for an hour or so without signing so you never know what is east for him.

* W9FYM, 111 South Jackson St., Brunswick, Missouri.

A ham says, "R R R OK OK QRM PSE RPT."

A ham sends CQ with utmost care and then jumbles his call so you never even get the district, much less the call letters.

According to reports you fade completely out under heavy QRM immediately after you announce you have a message.

Directional CQs are so often answered in the wrong direction.

A ham finds that he must test and change frequency right in the middle of the 268, 495th CQ.

Some send 10 per with a bug set at 45 per.

Gosh, O.M, don't ask us. We've wanted those things explained to us for years! Let us know when you dope out the answer.

RADIO OUTLAWS vs. REAL AMATEURS

One night not so long ago, W1 — was heard using a broad I.C.W. signal and QSO a W6 station. During the QSO the operator of W1 — asked W6 — this question, "Can you hear my 500 cycle I.C.W. out there?" His 500 cycle I.C.W. signal occupied 50 kc. of the 7 mc. band, and the call and conversation was logged for future reference.

Recently W1 — was again picked up, and while listening to the QSO the following remarks were copied for record, "This is a crystal with chopper I.C.W. I have been off the air for three years and am glad to get back with the gang again."

It would seem to me that W1 — having been off the air for three years had had time enough to get full information on what could and what could not be used in the way of signals according to law. Then again, no one with common horse sense would use crystal and then modulate what might be a decent and desirable signal with a mechanical chopper, and at 500 cycles at that. Furthermore, no right-minded amateur would reduce his communication range by $\frac{1}{4}$ by the use of a chopper. And still further, in using a chopper he violates the rules of the F.R.C. Surely there are enough rotten signals on the air now, modulated by vibration, plate voltage variations, keying back-wash and what not, without deliberately adding a chopper I.C.W. to the racket. Won't it be great when the Radio Division's Monitoring station at Grand Island, Nebraska, gets into full swing?

On one occasion I treated a W2 to a "dressing down." It developed later that he was using a 204A with 500 cycle a.c. on the plate — and that since January 1, 1930! It is hardly probable that my lecture was very gratefully received, but what a "real amateur" thought of it is best illustrated by this quotation taken from a card received from Clyde DeVinna, W6OJ: "Heard you give W2 — a dressing down. . . . There are too many rotten signs on the air. More power to you."

It is encouraging to note that there are some real amateurs. Some few weeks ago I logged a W3 with a "Prehistoric" signal. The owner of W3 —, a conscientious amateur, wrote HQs asking what was wrong with his signal, and HQs referred him to me. I gave him the dope on his signal, honest criticism without malice. Several nights ago I had the pleasure of a QSO with this same W3, and you can imagine my satisfaction in being able to report his signs as "Vy steady Pure D.C." Would that we had more amateurs like W3 — in this game of ours. Let's think it over, gang.

— E. W. Mayer, K4KD.

CLUB ACTIVITIES

The Associated Radio Amateurs of Southern New England, Inc., held a monster hamfest at Providence, R. I., on November 8, 1930. Forty hams were present with Frederick Best, W1BIG, Director, New England Division, and John L. Reinartz, W1QP, as guests of honor. From the moment that Franklin S. Huddy, W1II, President of the Club, called the meeting together, until he brought it to a close, there was plenty going on. Director Best spoke on traffic and the U.S.N.R. Mr. Reinartz took the boys to Greenland with him once more. There were *beaucoup* prizes and W1QP carried off two fine 866's. A fine banquet served to the assembled hams could not be improved upon. The meeting finally broke up in the wee sma' hours of Sunday morning. Credit for putting over this most excellent get-together goes to W1BW, W1EJ, W1ACV and Vincent O'Neill (Lord Plushbottom).

The Schenectady Amateur Radio Association held its annual banquet at Schenectady on the evening of October 8, 1930. After the "eats" a program similar to a regular convention schedule was carried out. Among the speakers were J. C. Warner, G.E., Frank J. Moles, G.E., W2QU, SCM, E. N. Y., W2BGO, SCM, N. Y. C.-L. I. and W2OP, President of the Club. The film "Cleveland Air Races" was shown during the meeting. A liar's contest was won by W8JS. The S.A.R.A. is planning a heavy program for the winter months. Members of the club intend to change the motto of the city of Schenectady from "Schenectady Lights and Hauls the World" to "Schenectady Lights, Hauls and Tells the World." Meetings are held the first Monday of each month at the Y.M.C.A.

The Frankford Radio Club (Penna.) cooperated at the American Legion Air Races held at the Philadelphia Airport on September 6 and 7, 1930. A 'phone transmitter using one type '10 with 300 volts "B" batteries was set up at Pylon No. 1. Stations were also installed at the other two Pylons, the three stations being tuned to different points in the 3500-ke. 'phone band, and being received simultaneously on three receivers in the control room under the grandstand. The stations reported on the progress of the various planes around the course. The reports were put through amplifiers and rebroadcast at the grandstand. The operators were W3LC, W3AOJ, W3AHZ, W3AKB and W3AVI.

The Miami Amateur Radio Club is holding meetings each Thursday at 8 p.m. in its new club room on the 16th floor of the Congress Building, Miami. A general invitation is extended to all amateurs and commercial operators, who may be in Miami, to visit the club. W4LA is the call of the club's station, which is on the air Tuesday, Wednesday, Thursday and Friday nights. A table is rigged up in the club room so that code practice may be given to as many as ten beginners at once. The MARC expects to again furnish the communications network at the Miami Air Meet in January, 1931.

On October 16, 1930, a group of amateurs in and around Detroit got together to organize a radio club. The name chosen is the Detroit Amateur Radio Association and the officers are W8DYH, President, W8MV, Vice-President and W8CAT, Secretary and Treasurer. The club already has some thirty members. Meetings are held once a month.

The quarterly banquet of the Los Angeles Section sponsored by the Amateur Radio Research Club on December 6, 1930, was a decided success. There were 180 amateurs present, including three "nines" and one "three." Dr. Lee De Forest was the guest speaker. Mr. Bernard H. Linden, Radio Supervisor Sixth District, Mr. Jensen of the Primary Frequency Standard Station at Grand Island, Nebraska and Director Babcock were also present. The banquet started at 8:00 p.m. and lasted until nearly midnight. Every one reported a "good time."

On December 3, 1930, the Cleveland (Ohio) Wireless Association conducted a joint meeting of the local Cleveland radio clubs at the Hotel Winton. Division Director Angus was present and addressed the group. SCM Tummonds spoke a few words relative to O.R.S. appointments and traffic handling. L.L.(G) Scott spoke on the U.S.N.R. and approximately fourteen recruits were obtained. A committee was picked whose duty it will be to keep the Director informed of the wishes of the amateurs in the vicinity of Cleveland. This committee is composed of the officers of the various clubs.

The Cleveland Amateur Radio Association publishes a very fine bulletin called "Crystal Notes." This club boasts a licensed YL on the list of members, W8CKH. W8AKA, the club station, has a 250 wattier with type 866 rectifiers. The club has three rooms, two of which house the operating room and the Chief Op's work shop. Meetings are held every Friday night.

BRASS POUNDERS' LEAGUE

Call	Orig.	Del.	Ret.	Total
W9DZM	471	418	232	1121
W8DYH	46	51	927	1024
KAIHR-	212	235	424	871
W3CXL	74	236	506	816
W6QP	113	84	394	791
W3ZF	87	144	457	688
W6YG	327	70	254	651
W5VQ	24	23	550	597
W6ALU	40	37	472	549
W8BWT	146	121	259	526
W8BGX	25	18	465	508
W1MK	128	150	188	466
W8CUG	20	27	407	454
OMITB	160	129	164	453
W6HM	132	302	12	446
W3CXM	26	25	392	443
W9EIQ	20	28	381	429
W6AXV	375	14	12	401
W1LP	31	29	338	398
W2SC	83	124	167	374
W8BJ	68	48	238	354
W6TM	89	202	59	350
W3SM	26	11	312	349
W3WO	31	29	280	340
W5AHI	2	12	310	324
W9BMA	18	24	276	318
W8BTK	20	8	290	318
W1WV	58	76	186	310
W8CAT	55	50	235	310
W5WF	53	56	180	289
W4JD	33	22	234	289
W8KD	51	20	216	287
W8CMB	42	63	171	276
W1GJD	21	9	276	276
W1BD	102	41	129	272
W8DSA	46	53	164	263
W8DFE	28	16	217	261
W5ACY	124	15	120	259
W1LQ	74	77	106	257
W9GFL	48	56	149	253
W8CO	216	—	36	252
W8QL	28	57	164	249
W5CB	74	27	147	248
W3NF	14	36	194	244
W9C08	64	140	32	236
W1CGX	31	27	178	236
W8DEH	11	9	215	235
VE3GT	108	88	35	231
W8DLG	11	24	191	226
W8DJQ	25	18	180	223
W6ALX	48	109	60	217
W5TV	11	15	188	214
W7QI	33	59	120	212
W9GJX	92	28	90	210
W8APQ	65	29	114	208
W8DSS	43	27	138	208
W9AMO	—	8	200	208
W4CII	147	7	54	208
W8BMG	11	30	166	207
W2LU	42	27	138	207
W8MV	33	20	153	206
W9ECS	50	6	150	206
W1ATF	91	52	62	205
W9DBB	12	12	180	204
W8GZ	16	26	160	202
VE4EI	12	4	186	202
W6WA	73	84	19	176
W6ETJ	10	55	96	161
W7BB	12	62	72	146
W6VH	9	59	76	144
W1ATO	10	52	72	140
W9BN	44	58	28	130
W4SS	15	56	51	122
W9DHJ	20	55	40	115
W8BHK	41	51	18	110
W9DGS	25	50	40	115
W9BBS	56	51	2	109
W6ZX	1	51	50	102
W6DZZ	—	55	37	92
W6EDK	6	76	4	86
W9C9L	15	60	8	83
W6CGJ	—	80	1	81

All these stations appearing in the Brass Pounders' League are noted for their consistent schedule-keeping and dependable message-handling work in amateur radio. Special credit should be given to the following stations in the order listed responsible for *over one hundred deliveries* in the message month: W9DZM, W6HM, W3CXL, KAIHR, W6TM, W1MK, W3ZF, W9C08, OMITB, W2SC, W3BWT, W6ALX.

Deliveries count! A total of 200 or more bona fide messages handled and counted in accordance with A.R.R.L. practice, or just 50 or more deliveries will put you in line for a place in the B.P.L. Why not make more schedules with the reliable stations you hear and take steps to handle the traffic that will qualify you for B.P.L. membership also?

The Amateur Radio Transmitting Society of Louisville, Ky., installed an amateur station at the 1930 Louisville Radio Show. The transmitter was a 50-watt T.P.T.G. Other transmitters and receivers were on display. A corps of operators were on duty constantly and the transmitter was kept working throughout the hours of the show.

Approximately 600 messages were filed, many being moved direct from the show, and the balance being distributed among other Louisville stations. The club's booth drew larger crowds than any other exhibit at the show. FB, OMs.

The University Amateur Radio Club at the State University of Iowa holds meetings every Friday evening. Research and experimental work is carried out by all members interested. They have use of apparatus in the Electrical Engineering and Radio Engineering Laboratories. The club has a building thirty feet square located beneath two ninety foot towers. Two transmitters are to be built, one for C.W. on 14.7 and 3.5 mc., the other a 'phone transmitter.

Official Broadcasting Stations

CHANGES AND ADDITIONS (Local Standard Time)

W5EB (3800 kc.) (7050 kc.) Mon., Thurs., 7:00 p.m.
W6DWH (3545 kc.) (fone) Mon., Fri., 7:00 p.m.
W8CMB (3950 kc.) Mon., 8:00 p.m., 10:00 p.m.; Wed., 7:00 p.m.; Fri., 7:00 p.m.
W8HD (3658 kc.) Mon., 8:00 p.m., 10:00 p.m.; Fri., 7:00 p.m., 8:00 p.m., 9:00 p.m., 10:15 p.m., 11:00 p.m.

With the 'Phones

THE Eastern Amateur Radiophone League is publishing a call book listing all amateur 'phone stations that are members of the E.A.R.L. or that are interested in becoming members of that organization. Any amateur 'phone in the United States and Canada is invited to write to W1BCR, Control Station of the E.A.R.L., 92 Keene Street, Providence, R. I., expressing interest in the organization and giving information on frequency, equipment, power used, etc. There is no charge for the book or for membership in the E.A.R.L.

W1AUU, "The Friendly Voice," reaches out well. Among those who have up to this time signified their interest in starting a message on the 'phone side of the "Phone vs. CW Relay" are VE1DQ, W1ABY, W1AFQ, W1AHH, W1AUY, W1BCR, W1BMB, W1CZ, W1QK, W2AMB, W2BZA, W2FR, W2GJ, W2HY, W3ALQ, W3OO, W3WI, W4HN, W4PW, W6ABF, W6BIU, W6BBJ, W6BNI, W6CLH, W6CRK, W6GM, W7ACJ and W7ANT.

W8RD suggests that we publish the frequencies of crystal controlled 'phone stations operating near the low frequency (3500 kc.) edge of the 'phone band for the use of the gang as markers to prevent overlapping into the Airway's channel. We would welcome the frequencies of any stations having accurately measured crystal controlled frequencies near either edge of the 3500-ke. 'phone band which might serve as "markers."

Since the Airways complaint regarding interference with their assigned channels there have been many 'phones looking for reliable calibration points. A prominent Second District 'phone station in commenting recently said, "Some of the boys announce the same frequency as though sure of themselves, and they are a long ways apart. I almost have to enquire. Don't see why they don't check by the frequency transmissions." All of which is by way of calling attention to the possible deviations in crystals and calibrations, and suggesting the use of the s.f. stations which are on the air every Friday and Sunday rendering a really accurate service. In sending in frequency data for publication please state how and when last checked.

Four radiophones, W9EZR in Nebraska, W5BEZ in Oklahoma and W5EJ and W5BJC in Texas recently held a one hundred percent successful Round Table QSO on the 1750-ke. band.

W5ABO at Oklahoma City, having a death message for the 6th district, called "CQ 6th District." W6ABF came back and took the message. It was addressed to Los Angeles and was to be telephoned. W6ABF did not have a telephone so called "CQ L.A." and raised W6CIF. W6CIF had copied the message direct from W5ABO and said that he would 'phone it to the addressee. When he did 'phone it he was informed that five amateurs had already delivered it, having copied it direct from Oklahoma. W6ABF then advised W5ABO that the message had been delivered several times.

The following are active 'phones in the Midwest: W9DB, W9ESL, W9AAN, W9DRK, W9DID, W9DKL and W9EJE. The Army-Amateur Radiophone Net in the Seventh Corps Area is progressing rapidly. Any radiophone operator in the Seventh Corps Area interested in taking part in Army-Amateur activities is invited to write to H. W. Kerr, W9DZW-GP, Radio Aide, 7th C. A., Little Sioux, Iowa.

Traffic Briefs

Most unfortunately W8VD was omitted from the Navy Day Honor Roll appearing in January QST. He had excellent copies of the messages from NAA and W1MK and should have been listed as fourth high man in the Fourth Naval District. We regret this omission and want at this time to announce W8VD's rightful place on the Roll.

The long winters up in the Hudson Bay and Arctic country are no longer dreaded by the operators at the Canadian Government Radio Stations there. Amateur equipment is being installed at many of the stations, and the operators are able to while away many lonely hours chewing the rag with brother hams. VE5AJ is the call at Cape Hopesadvance. VE5EG is at Nottingham Island. VE4FX at Port Churchill, Manitoba, says that he believes that in proportion to the population, the Northwest Territories have a bigger percentage of hams than any other part of the world.

C. A. Briggs, W3CAB, well-known Washington amateur, was recently appointed to the rank of Lieutenant in the United States Naval Communication Reserve.

Bart Conn at Bunker Hill, Indiana, doesn't like the terms "OW" and "XYL" — he doesn't consider either particularly complimentary. He says, "Since a wife is a wife, why not call her a 'YF'?"

After publishing in January QST the account of emergency work carried out by Nebraska amateurs during the sleet storm which hit that section of the country in November '29, we receive information regarding the part that W9DHO and W9EYE took in this same emergency. The storm raised havoc with the telegraph service in the vicinity of Chadron, Long Pine and Gordon, Nebraska. W9DHO at Wisner made contact with W9EYE, the dispatcher of the Northwestern Railroad at Chadron. They handled important traffic between the railroad stations at Wisner and at Chadron throughout the worst part of the storm until wire communication was reopened. Nice work, OMs.

W5AMC offers the latest possible solution to the problem of eliminating "CQ hounds." He suggests that all stations use sand glasses to time their CQs and calls. He has a five-minute glass mounted directly in front of him at the operating table. A twist of the wrist is all that is necessary to start the sand sliding. This presents a very convenient time indicator for calling. Of course it is not necessary to make the calls of five-minute duration. W5AMC has found by experience that a CQ of a little over one minute, and a call of about one minute brings good results. This does not mean one-minute calls without signing!

Send for the Sixteenth (January, 1931) Edition of the Rules and Regulations of the Communications Department, on the cover of which is a photo of W1MK. If you have been wanting a picture of the Headquarters station, here is your chance to get one. And — you need the R. & R. It contains the full text of the amateur regulations, lists of Q code, international prefixes, information on the qualifications and duties of different officials in the A.R.R.L. field organization, how elections for Section Manager are held, etc. A postal will bring you the latest up-to-date edition of this information for your operating table free of charge. Mail it today.

W5WF says, "Noah was supposed to have had every kind of animal on the Ark. Wonder who the ham radio operator was?"

High Quality Signals

3500-kc. band: W1AOX, W1ASU, W1ASY, W1BDI, W1BJD, W1BU, W1HD*, W1MK**, W1MX*, W1TD, W2ACD, W2AG*, W2AQM, W2BRB, W2BRH, W2BZB, W2BZW, W2CDQ, W2CFV, W2CLX, W2DV, W2DX, W2QN, W2ZC**, W3AQR, W3CXM*, W3GS**, W3QV**, W3UX, W3VL, W4DV, W4LL, W4PM, W5TV, W6FCR, W6CZZ, W71Y, W8AKV*, W8APQ*, W8ARX*, W8ATP, W8AZO, W8BNU, W8BPS, W8CAT, W8CLN**, W8CUG, W8CUO, W8DAQ, W8DBB, W8DII, W8DLX, W8DSO, W8DYH**, W8GU, W8HN, W8IH, W8KR*, W8PK, W8TZ, W8WJ, W9AMO, W9AND, W9BHC, W9BZO, W9COS, W9CYG, W9CYQ, W9DSC, W9DXZ**, W9DYO, W9EHD, W9ERU, W9FHM, W9FLG, W9FYB, VE2AC.

7000-kc. band: W1AAQ, W1MK, W1WV, W2AUP, W2BA, W2BG, W2BHW, W2BMB, W2BOZ, W2BYT, W2MB, W4AEL, W4EI, W4TY, W4WN, W5AHI, W5AHQ, W5EB, W5JC, W5MM**, W5RR, W5WV, W6AGR, W6AHP, W6AOA, W6AOE, W6AYC, W6BVG*, W6CBP, W6CHE, W6DGX, W6ESA, W6EXQ, W6PH, W7AAT, W7ACQ, W7AHO, W7AJH, W7PL, W7PU, W7QK, W7TX, W8AHM, W8AWK, W8BCF, W8BI, W8BYR, W8CGW, W8DAP*, W8DAQ, W8DCI, W8DKZ, W8DPO, W8DSN, W8DHY, W8EA, W8HH, W8LT**, W8QL, W8SG, W8TP, W8TW, W9AIP, W9AVN, W9BFB, W9BRY, W9BUU, W9BZO, W9CET, W9CLO, W9CTW, W9DYK, W9ECI, W9FFD, W9FYK, W9GP, W9LL, CT2AC, G5BY, J1DV, VE3GT, VE3RF, VK3BV, VK3PP, VK3RG, VK3RJ, VE5BJ, VE5HG, VK5IT, VK5JO, VK6MO, ZS2C.

14,000 kc. band: W1AXA, W1BJD, W1CAA, W2BA, W2BG, W2CG, W2GJ, W2JN, W2MB*, W4EJ, W4WZ, W5ACH, W5MM, W5QL*, W6BVX, W6CUH, W6IH, W7IB, W7NA, W9ADN*, W9AKN, W9DFY, W9DKH, W9PV, G5BY*, G5ML*, G6RG, PY1AH, PY2BF, PY2BK, T13XA, VE1AB, VE4DK.

GOOD 'PHONES

3500-kc. band: W1AUY, W1BCR, W2BYU, W2BZE, W2GJ, W2HY, W8AJH, W8RD, W9DAQ, W9ESO, W9FKE*.

14,000-kc. band: W1AXA, W1BJD, W2RR, W5MM, W5QL, W6AJ, W9DEF.

WELL-OPERATED STATIONS

W1BDI, W1HD, W1LQ, W1MK*, W1MX, W1SZ; W1UE, W1WV, W2AG, W2DV, W2SC, W3CXM, W3GS, W3NF, W3UX, W3WO, W3ZF, W4AEL, W5ACY, W5MM, W5QL, W5RR, W5WV, W6AKW, W6CUH, W6EC, W8BA, W8APQ*, W8ARX, W8BGX, W8BQR, W8CAT, W8CEO, W8CNO, W8CUG**, W8DED, W8DEH*, W8DMS, W8DSS, W8DYH*, W8GP, W8JD,

W8KD, W8LT, W8VD, W8WJ, W9AFB, W9BHC, W9BMA, W9BSC, W9BZO, W9CYQ, W9DTK, W9DXZ, W9EHD, W9EJQ, W9ERU, W9EYH, W9GFL, W9GJX, W9MI, W9OX, G5BY, G5ML, PY1AH, T13XA, VE2AC.

REPORTS OF SELF-ISH-CITED SIGNALS

3500-kc. band: W1AWU*, W1BGW, W1CCO, W2AZY, W2BJB, W2BND, W2BUS, W2CEE, W2DO, W3AHL, W3AKH, W3ARM, W3ASO, W3AVP, W3BEB, W3BWT*, W3PU, W3SN, W3WP, W3ZI, W4CF, W4DS, W4LT*, W5AMC, W5VP, W7ACP, W8ABV, W8AGI, W8AIJ, W8AIR, W8ALG, W8AMX, W8API, W8ASQ, W8AUW, W8AYP*, W8BFD*, W8BJ, W8BFI, W8BRG, W8BRK, W8BUG, W8BUP, W8BXX, W8CEI, W8CFI*, W8CFK, W8CGC, W8CHI, W8CJB, W8CNC, W8CQZ, W8CTG, W8CTR, W8CVJ, W8DDW, W8DEF, W8DFY, W8DKI, W8DPI, W8DRA, W8EJ, W8HF, W8IF, W8KM*, W8OK, W8US, W8UW, W8VD, W8WY, W9BCA, W9BFW, W9BGZ, W9BL, W9BYL, W9CKY, W9CNI, W9CO, W9CVQ, W9DDB, W9DEX, W9DKF, W9DKL, W9DRJ, W9EHT*, W9ENQ, W9EPZ, W9EZ, W9GGJ, VE3HD.

7000-kc. band: W1ADE, W1AF, W1AKU, W1AYC, W1BEI, W1BET, W1COX, W1CQG, W1CSY, W1HB, W1QJ, W1ZJ, W2AGM, W2AGS, W2AHP, W2AMT, W2ARP, W2AXG, W2BLA, W2BUC, W2CDK, W2CFH, W2CHL, W2CHK, W2CLH, W2JV, W2CNCV, W2COT, W2CTZ, W3AHL, W3AQK, W3AVD*, W3CBV, W3GF, W3NA, W3OL, W3SZ, W3UA, W3WM, W3WY, W4AEV, W4AFK, W4AFS, W4AGI, W4AGQ, W4AHI, W4AIG, W4AIQ, W4CFH, W4EY*, W4FX, W4HD, W4HI, W4MI*, W4NI, W4NJ, W4QP, W4PY, W4YA, W4ZZ, W5AMW, W5AUB*, W5AUU, W5A5E, W5BQH, W5BOO, W5EP, W5FQ, W5JG, W5LP, W5NJ, W5WF, W5ZZR, W6AIC*, W6AV, W6BEC, W6BFM, W6BNC, W6BQQ, W6BTZ, W6BVS, W6CEL, W6CIH, W6CYI, W6EAK, W6EQ, W6FAC, W6FEK, W7AAG, W7ACX, W7AFL, W7AFT, W7AHC, W7ATW, W7AQB, W7IE, W7OJ*, W7YG, W8AAD, W8ALB, W8AP, W8ATC, W8AXP, W8BHE, W8BIF, W8BNH, W8BTA, W8BTM*, W8BYE, W8CAT, W8CFX, W8CII, W8CIIY, W8CJS, W8CNC, W8COH*, W8CV, W8CVB*, W8CYI, W8DBK, W8DEF, W8DHD, W8DVZ, W8EY, W8FG, W8GO, W8HR, W8IM, W8MB, W8MJ**, W8ND, W8NN, W8QG, W8VK, W8WK, W9AEA, W9AFB*, W9AMV, W9A00, W9BEU, W9BFL, W9BJ, W9BVN, W9BWA, W9CDA, W9CGO, W9C0B, W9CVH*, W9DFT, W9DSU, W9DSZ, W9EGC, W9FDW, W9FEG, W9FIS, W9FNJ, W9GBX, W9GCX, W9GHH, W9GJS, W9GJT, W9GKR, W9JL*, CM2SH, CM2WA, KA1HR, VE3ER, VE5AR, XAB.

14,000-kc. band: W1AOT, W4AGL, W4EW, W9FGD, W9YL.

NOTE. — The stars indicate the number of extra times stations were reported.

1750-KC. CODE PRACTICE STATIONS

Station	Location	Frequencies	Days	Hours (Local Time)
W1ABO	Pawtucket, R. I.	1750 kc.	Sundays	1-2 p.m.
			Wednesdays	7-8 p.m.
			Saturdays	10:30 p.m. on
W1AKY	Quincy, Mass.	1750 kc.	Fridays	7 to about 10 p.m.
W1AOX	No. Manchester, Conn.	1750 kc.	Tues., Fri.	7:15 p.m.
W2CDQ	Ho-Ho-Kus, N. J.	1720 kc.	Daily except Fridays	8:30-9 p.m.
W2GL	Valley Stream, N. Y.	1765 kc.	Fridays	10:30 p.m.
W3MM	Allentown, Pa.	1765 kc.	Mon., Tues., Wed.	7-7:30 p.m.
W5TG	Houston, Texas	1725 kc.	Tues., Wed.	7:00-8:00 p.m.
W6BUZ	Redley, Calif.	1715 kc.	Tues., Thurs.	9:00 p.m.
W7ACD	Shelley, Idaho	1875 kc.	Mon., Tues., Thurs.	9-10 p.m.
W7QV	Spokane, Wash.	1750 kc.	Wednesdays	7:00-8:00 p.m.
W8APQ	Martinsburg, Pa.	1875 kc.	Sun., Tues., Wed., Fri.	6:30 p.m., 10:00 p.m. 7:00 a.m., 7:30 p.m.
W8BYD	Jamestown, N. Y.	1800 kc.	Mon., Wed.	7:15-7:45 p.m.
W8DNT	Rochester, Mich.	1875 kc.	Mon., Wed., Fri.	7:30-8:30 p.m.
W8UF	Youngstown, Ohio	1750 kc.	Daily	Midnight-1 a.m.
W9AAN	Hewitt, Minn.	1970 kc.	Tues., Thurs.	7:15-8:15 p.m.
W9AFP	Tabor, So. Dak.	1750 kc.	Tues., Thurs., Sun.	9:30-10:30 p.m., 9-10 a.m.
W9BPK	Minneapolis, Minn.	1775 kc.	Mondays	7:00 p.m.
			Thursdays	10:00 a.m.
W9BSP	Olathe, Kansas	1795 kc.	Daily	7:30 p.m.
W9DDV	Chester, Ill.	1730 kc.	Mon., Thurs.	7:30-9:00 p.m.
W9EBD	Menasha, Wis.	1715 kc.	Tues., Thurs.	6:30-7 p.m.
			Sundays	11-11:30 a.m.
W9EPW	Geneseo, Ill.	1820 kc.	Tues., Thurs.	10:45 p.m.
W9CGG	Kansas City, Mo.	1750 kc.	Sundays	8:30 p.m.

A Well-Arranged Log Sheet

THE sample log sheet shown below is an exceptionally fine example of an up-to-date log. Under the new regulations the Federal Radio Commission obliges every amateur station to maintain an accurate log of the time of each transmission, the station called, the input power to the last stage of the transmitter, and the frequency band used. This log sheet provides for all those

tions in mid-September: "The hours for foreign QSOing on 14 mc. are changing. Five to seven was the best bet until a week ago and I notice that nearly any DX over there (Europe) now is best from 4 until 6 p.m. E.S.T. The South Americans still come in best from 5 to 7. Here, we suppose it is due to the days becoming shorter and darker early in the evening. VKs and ZLs are very weak at midnight and we have had no luck with them in Washington as yet. 6s and 7s are easily QSOed from 3 to 9 p.m. E.S.T."

DATE TIME		METHOD	FREQ'Y KC	POWER	CALLED	CALLED BY	STATION HEARD			MESSAGES, REMARKS, ETC.	
							C W H	Q R H	TONES		KC
9/28/30											
7:30 AM		W	3575	50	W3BWT	W6ARX	CW	5	1/2 dc	84°	Sent W8ON's \$42, rec'd
7:52		"	"	"	W1BXB	"	W	3	d.c.	52°	W3ZF's \$201 + 202. QSA4 R6 Sent my \$189. His sig QSB.
8:00		-			QST	W1MK	H			3575	Copied two spec. ltr on message, and QRM on 14442 Ke. in addition to spec. ltr on W2DE.
8:40					W9DFR	W9BCL	H	3	rac	25°	Off 10 mins to ans. fone. Said rain there.
45		SW	7240	280	CQ	W8ARX	C				N.D.
50		"	"	"	W3AVI	W6AKU	W	4	rac	44°	Berkeley Calif
55		"	"	"	W6AKU	W8ARX	W	4	rac	44°	Good sig. Sent my \$190 for P.I.
9:18					NS off - hook clear - QRM heavy now.						

A PAGE FROM THE NEW A.R.R.L. LOG BOOK

requirements. Reading the headings on the sheet from left to right we see first a column for the date and time; the next column is headed "Method" and is used for indicating whether CW, 'phone, etc., is used; the next two columns are for the frequency and power input to the last stage, respectively; the Called and Called By columns are self-explanatory; the C-W-H column is used to indicate whether the station was called, worked or heard by you; a complete report on the station heard may be recorded in the next three grouped columns; the remarks column is left open for whatever you may wish to put into it such as the report you received on your signals, record of any messages handled, dope on the weather, notes on interference, or any of the hundred and one other things you might wish to jot down.

Every amateur should keep a log not only because it is a ruling of the F.R.C. The well-kept log is invaluable in checking up reports of any nature concerning amateur station operation. It contains positive evidence of every transmission. It is a permanent record of the achievements of the station. Full records of reception, experimentation and adjustments are interesting and profitable as well. Carefully-kept logs tell a complete story of communication achievement which becomes increasingly valuable historically and likewise more valued for the cherished memories of worthwhile amateur operation that it will recall to you as the years go by. Unless you already have a well-arranged, complete log of some kind, you should plan to start one at once.

Traffic Briefs

The following excerpt from a letter received at HQs from W. L. May, W3ASJ, Washington, D. C., dated September 16th, contains some interesting facts regarding 14 mc. condi-

Every summer a number of amateurs are found among the fellows assembled at the Citizens Military Training Camp, Fort Monmouth, N. J. During the assembly this year the amateurs conceived the idea of forming a club to band themselves together and to further the interests of amateur radio at the camp. On July 7th thirteen amateurs got together at the camp to organize such a club. The name chosen was "The Brass Founders Club of the Citizens Military Training Camp at Fort Monmouth." The following amateurs were present at this "first meeting": W1BKG, W1AHK, W2AI, W2BOF, W2CDK, W3ABG, W3BAF, W3AVA, W3YA, W8BFW, W8DXK, W8TZ, W8CMH and Ogden Bowman. W1BKG was chosen President, W1AHK, Vice-President, W8BFW, Secretary-Treasurer, and W8TZ and W3AVA, Communications Managers. The club may be continued from year to year for the benefit of other amateurs attending the camp.

W9EBO is making use of amateur radio as a means of increasing his postage stamp collection. During QSOs with foreign stations he asks that the operators send him stamps of their respective countries. He has already received quite a bunch of stamps in reply to his requests. Some of the amateurs who have helped him are K4KD, CM2WA, ZS4M, PY2BA, VK4RG and W1CBD-W9KL. W9EBO would be glad to hear from any amateurs who are interested in collecting stamps.

Amateurs passing through the town of Harrison, N. Y., should make it a point to stop in and look over the new club house of the Pioneer Radio Club. This is one of the best amateur meeting places in the country, and houses the Pioneer Radio Club's station, W2ANS. When passing through Harrison on the road to White Plains watch for a one-story building with a hip roof, near the top of which is fastened a sign reading "W2ANS—Pioneer Radio Club—W2ANS."

WIMK Operation

A.R.R.L. Headquarters Station WIMK now operates on a frequency of 14,300 kc. in addition to 3575 kc. and 7150 kc.

At the request of West Coast amateurs a broadcasting schedule has been added on the 14,000 kc. (20-meter) band. Also, we are inaugurating some "general" operating periods so that more west coast A.R.R.L. members may contact Headquarters. Since the operating hours of the station are limited it is not possible to give up much time to 14 mc. operation now, but if this operation works out favorably some further changes in schedules may make it possible to expand it further. The new transmitter described in December QST will be used on 14,300 kc.

OFFICIAL AND SPECIAL BROADCASTS are transmitted on the following schedule: (All hours are given in Eastern Standard time.)

Simultaneously on 14,300 kc. and 3575 kc. at the following times:

8:00 p.m.: Monday and Friday.

10:00 p.m.: Monday and Friday.

Simultaneously on 3575 kc. and 7150 kc. at the following times:

8:00 p.m.: Sunday, Tuesday and Thursday.

12:00 p.m. (midnight): Sunday, Tuesday and Thursday.

GENERAL OPERATION periods have been arranged to allow everyone a chance to communicate with A.R.R.L. Headquarters. These general periods have been arranged so that they usually follow an official broadcast. They are listed under the three headings of 3500 kc., 7000 kc. and 14,000 kc. to indicate whether the watch is devoted to listening on the 80-meter, 40-meter or 20-meter band. WIMK's frequency in each band is given in parentheses.

3500 kc. (3575 kc.)

8:15 p.m. to 9:00 p.m. on Sunday, Tuesday and Thursday
10:00 p.m. to 11:00 p.m. on Tuesday and Thursday (No OBC sent before these periods)

12:00 p.m. to 1:00 a.m. (or later) on Sunday night (Monday morning)

7000 kc. (7150 kc.)

10:15 p.m. to 11:00 p.m. on Sunday, Monday and Friday

12:00 p.m. to 1:00 a.m. on the following nights (actually on the morning of the day following): Mon., Tues., Thurs. and Fri. (Only on Tuesday and Thursday does the OBC precede these periods)

14,000 kc. (14,300 kc.)

7:30 p.m. to 8:00 p.m. on Monday and Friday

8:15 p.m. to 10:00 p.m. on Monday and Friday

SCHEDULES are kept with the following stations through any of which traffic will travel expediently to A.R.R.L. Headquarters, on 3500 kc.: W1ACH, W1BKB, W1CTI, W1ZB, W2JF, W3AVI, W3BWT, W3CXM, W4DV, W8CKC, W8CUG, W8DLG, W9BCA, W9OX, VE9AL: on 7000 kc.: W4AGR, W6OJ and W9ECS.

QSL CARDS for WIMK should be addressed in care of A.R.R.L., 1711 Parv Street, Hartford, Conn. A complete log of every transmission is made and WIMK is always glad to send any station worked a card, but frequently cards are lost when sent direct to the station at Brainerd Field. WIMK always QSLs upon receipt of card from station worked.

ATLANTIC DIVISION

EASTERN PENNSYLVANIA — SCM, Don Lusk, W3ZF — W8EU is looking for schedules. RMs, note. W3EV says traffic is picking up. W3MC installed a new power supply. W3AKB is busy with the Frankford Radio Club. W3AKE is a frequent visitor at W3UX. W8AWO's report for last month was received too late for inclusion in last issue. W3QP reports he will be on regularly now. W8VD is handling considerable army amateur traffic. W8CWO hasn't much time for radio. W3AVI has a nice lot of schedules. W3DZ started his Xmas vacation Dec. 18th. W3AWB is now using a 211 tube. W3OP asks about an ORS. W3GS worked an Englishman on the 3.5-mc. band. Paul Levan, a new man, reported a nice total, but forgot to mention his call letters. W8CFI is turning in some nice reports. W3ZF and W3GS have a nice local 20th-century route feeding the main line. Stations having traffic west should give it to them.

QST FOR FEBRUARY, 1931

Traffic Summaries

(NOVEMBER-DECEMBER)

Central led by Michigan	11296
Pacific led by Los Angeles	8349
Atlantic led by Eastern Pennsylvania	6902
New England led by Connecticut	5593
Midwest led by Iowa	3914
West Gulf led by Oklahoma	2699
Northwestern led by Oregon	2493
Hudson led by New York City & Long Island	2092
Dakota led by Southern Minnesota	1817
Delta led by Louisiana	1621
Roanoke led by Virginia	1405
Southeastern led by Georgia-S.C.-Cuba-Isle of Pines-Porto Rico-Virgin Islands	1147
Rocky Mountain led by Colorado	594
Ontario	466
Vanalta led by Alberta	460
Prairie led by Saskatchewan	361
Quebec	62
869 stations originated 11,179; delivered 9,507; relayed 30,585; total 51,271 (85.2%).	



It's Michigan this month! As a result of real honest-to-gosh effort the Michigan boys place first in traffic totals and claim the Banner, which they have been so steadily striving for. Last month Illinois led, Michigan was second and Los Angeles third. This time it's Michigan 4705, Illinois 2621 and Los Angeles 2161.

Where are all the other Divisions? Look at the traffic summary printed above. Where on the list is *your* Division?

Traffic Briefs

When telephone and telegraph communication between Bedoes Island and New York City was accidentally severed on December 1, 1930, W2SC at the Island contacted W2BVD at East Orange, N. J., who telephoned the traffic received direct to the Signal Officer, U. S. Army on Governors Island, N. Y. W2BVD and W2SC handled official government traffic for four hours, and continued communication until the cables had been repaired. This is another example of the good work being done by amateurs. FR, OMs.

Those who remember "Chain Lightning Hill," 4GL, and the old team, 4GI-3ZY, should listen to operator Kimmel, "GL," at W3CXT-WLM, if they want to bring back thoughts of the "old days." W8GZ says he has sent traffic to this operator "GL" for a half hour at a stretch with the bug wide open, and all that he says at the end is, "faster, please." Think *you* could put him under the table?

W8AXV reports working WFBT, the bark *City of New York*, on approximately 7290 kc. at 7:50 p.m. E.S.T., December 22, 1930. The boat is now making an exhibition voyage to various Atlantic ports. WFBT uses a frequency of 8300 kc. and W8AXV advises that he CQs for ham contacts quite often.

DIVISIONAL REPORTS

W3PB says "No ambish." W3NF is pounding away for the ole traffic banner.

Traffic: W3ZF 688, W3NF 244, W3UX 133, W8VD 118, W3GS 104, W8CFI 103, LeVan 102, W3MC 64, W3EV 48, W3AKB 22, W3AVI 21, W8CWO 19, W3DZ 17, W3OP 12, W3AWB 11, W8AWO 10, W3QP 8.

SOUTHERN NEW JERSEY — SCM, Bayard Allen, W3ATJ — W3SM makes the BPL. W3BEX becomes an ORS this month. W3ANP is President of the Morris Radio Club. W3AWT is busy with Dental Lab. work. H. T. Conklin, Secretary of the Morris Club, built a push-pull TPTG job for the club. W3ABG worked Nebraska. W3JL is a commercial photographer. W3ASG is still working the YK's. W3ACX sympathizes with the SCM in a forlorn attempt to work Asia. W3ZX had a QSA 5 100% QSO with Porto Rico on 14-mc. phone. W3BEL is trying to locate a steadiest job. W3BAN is on the sick list. W3OH is on oc-

asionally. W3AWL has disappeared. W3ADW's sister's cat knocked his monitor over and left it in 98 pieces. W3QL has applied for an ORS. W3BBD does the same. W3ATJ has R9 QRM from the law office. W3QL reports.

Traffic: W3BEX 121, W3ASG 19, W3JL 18, W3ANP 13, W3AWT 7, W3ABG 3, W3ATJ 4, W3BEI 2, W3QL 20, W3SM 349.

WESTERN PENNSYLVANIA — SCM, R. M. Lloyd, W8CFR — W8CUG leads again; he keeps 17 schedules a week. W8DLG has a nice array of schedules and traffic. W8AAG is active in the U.S.N.R. W8AVY has an AC receiver working. W8CMP reports conditions bad at State College. W8CEO is working with the Army-Amateur net. W8DUT is planning to settle down to some good traffic work. W8AG is on every week-end. W8DKS is having receiver trouble. W8BRM is ready to go with a crystal transmitter. W8CAV is working on 7 mc. W8AJE is helping some beginners get started. W8YA is still without a license. W8KD and W8APQ make the BPL for the first time. W8BNU was elected President of the Erie Amateur Radio Club, and W8DKI was made Secretary. W8HT is on 7 mc. with a type '10. W8GU and W8CCR are on occasionally. W8DYL has a new receiver; he is active in the Navy Net. W8CRA sticks to 14 mc. and DX traffic. W8DGW is cramped by business. W8AAQ is building a new transmitter. W8DRA and W8BRC are on for the season. W8BK is working all frequencies. W8AYH is on 3.5-mc. 'phone. W8BXG is still trying to solve his crystal transmitter troubles. W8ASE has a new antenna system. The Amateur Transmitters' Association has gone to work on 'phone interference. Both the off-frequency and BCL varieties are being tackled. W8CFR worked his old friend PY1AW. W8BSO has torn his transmitter down.

Traffic: W8CUG 454, W8DLG 226, W8AAG 27, W8AVY 24, W8CMP 23, W8CEO 14, W8DUT 13, W8CFR 12, W8AG 7, W8DKS 4, W8KD 287, W8APQ 208, W8DYL 22, W8CRA 21, W8DCW 11, W8AAQ 10, W8BK 10, W8AYH 7.

MARYLAND-DELAWARE-DISTRICT OF COLUMBIA — SCM, Forrest Calhoun, W3BBW — Maryland: W3LA says watch his smoke. W3AFF has some QRM he can't find. W3AIL is ready to go. W3WF has a 50-watt 'phone rig. W3ON has his new MOPA going. W3AOO is rebuilding again. W3BBW was reported being heard in Poland by SP3GR. W3ED has two transmitters going. W3ZK has his crystal outfit going. Delaware: W3ALQ is trying to get a super wasp to kick like its namesake, the bug. HI. W3HC wants to be an ORS. District of Columbia: W3CXL leads all of us again this month. W3BWT still holds his own. W3OZ wants us to get that banner. W3ASO sent in a nice total. W3CAB sent in a report on the A.R.R.L. Net for the American Legion. W3ACW reported. W3CDQ is QRL school work. W3GT flew to Hartford and paid the Headquarters gang a visit. W3AKR built his MOPA in a beautiful cabinet, but is going back to bread boards. W3PQ is selling out.

Traffic: W3CXL 816, W3BWT 526, W3OZ 91, W3ASO 55, W3LA 44, W3AFF 39, W3CAB 36, W3AOO 36, W3HC 28, W3ACW 9, W3ED 7, W3CDQ 7, W3BBW 7, W3GT 6, W3ALQ 5, W3ZK 2, W3AKR 1.

WESTERN NEW YORK — SCM, John R. Blum, W8CKC — The Jamestown gang have a monthly news sheet, the "Jimtown QRM." 8 BYD is editor. W8AYM is on 7 mc. W8AWM is off the air until spring. W8CIL has his second class commercial ticket. W8CUC designed the new Jamestown High School station. W8BUT is on 3.5 mc. daily. W8CLB is trying out the type '45s in push-pull. W8DES is a "father and son" station. New officers of the J.A.R.A. are President, W8BUT; Vice-President, W8BIF; Secretary, W8BYD; Treasurer, W8CUG. We welcome old W8ADG back on the air. W8AYM is a new ORS. W8DJA and W8DQT are newcomers up in Cornell Univ. W8CYG is working foreigners with his type '10. W8BDK is old W8BMJ. W8DBE has a new 50-watt bottle. W8ABX is back on the air. W8BWW is another new man reporting. W8CVJ is on 3.5 mc. mostly. W8DSP had some sickness at home. W8CRF is using crystal temperature controlled. W8DEJ reports for traffic. W8DSA makes the BPL. W8BOM is still a "VE." W8CXK makes his first report. W8BFG is building a new Dynatron. W8QL kept his type '01 hot this month. W8TM has a low powered crystal outfit going. W8DME is now working remote controlled. W8DBX wants schedules. W8AAZ and W8CKJ ran up a good total for Buffalo. W8DCX has a new crystal. W8AFM has been busy on 14-mc. 'phone. W8CPC reports 14 mc. is more N.G.

than ever. W8CKC had a bad fire at his house and will be off the air for a few weeks. BPL members this month: W8QL, W8DSA.

Traffic: W8DME 28, W8ON 31, W8CMN 2, W8DCK 18, W8AAZ 112, W8CKI 110, W8DBX 118, W8QL 249, W8BFG 16, W8CXK 42, W8DSA 263, W8DEJ 101, W8CRF 32, W8DSP 30, W8CVJ 2, W8BWW 124, W8CYG 52, W8DJA 17, W8AYM 52, W8ADG 4, W8CKC 20, W8BIF 8, W8BYD 89, W8CLB 7, W8BJI 1, W8BHK 110, W8DII 80, W8CMW 38, W8BYO 20, W8AJ 4, W8DSS 208, W8BMJ 38, W8TZ 45, W8CPL 27. Total—571.

CENTRAL DIVISION

MICHIGAN — Acting SCM, Ralph J. Stephenson, W8DMS — I want to thank the gang for the wonderful cooperation given me this month. W8DYH wants to work duplex with some one. W8PQ winds half-inch tubing around steam pipe. We're sorry to hear of ex-W8DKX's accident, and hope to hear him at W3CMX soon again. W8DMS has a dynatron "freak" meter. W8AF is rebuilding. W8CAT, our R.M., is working up a plan for a city net. W9GJX keeps daily reliable schedules. We need an R.M. up north. The Detroit QSO party in December was well attended. W8DYH tied for first place, but was awarded the prize because he QSO'd a 'phone, regardless of his resolutions otherwise. W8FX won second. The Detroit Amateur Radio Association is growing fast. Seventy-five members at December meeting, elected Felden, W8MV, president; LaDue, W8PQ, vice-president and McNutt, W8CAT, secretary-treasurer. W8AM gave interesting talk on construction of condenser mikes. The Western Michigan hams are getting organized. W8DED and W8BPS are behind the move. W8BBX handled his traffic in four days. W8AM rebuilt transmitter and radiator. W8DNT sends code practice Monday, Wednesday, and Friday, 7:30 p.m. E.S.T., 1875 kc. W8FX, helping W8JX raise 50-foot stick, thought he heard the whistle and let his end drop. Only 44 feet left. W8DDO wants traffic. W8DJQ's transmitter is in same room with four BCL super-hets and no interference. W8GO and W8BJ live across street from each other. Idea: W8MV, glass cutter, 1 x'tal total 2 x'tals. Results (?). W8BRO and W9CSI are expected to observe silent/ER hours because of the two words "I do." W8DEH and W8BTK report 7 hr. 10 min. QSO. W8DFS reports Western Michigan fellows getting active. W8CKZ is shielding power supply. W9HK burnt out his power plant. W9FPF is a newcomer up north. W9DRR is policing the edges outside the bands. W8AJC is working hard on A.A. traffic. W8SB moving to Flint. W8RP, W8DLX, W8BRS, W8CVU and W8CEC all report via W8DYH. We have a great section, fellows, and if we all pull together, can certainly put Michigan on the map.

Traffic: W8DYH 1024, W8BJ 354, W8BTK 318, W8CAT 310, W8DFE 261, W8GO 252, W8DEH 235, W8DJQ 223, W9GJX 210, W8BMO 207, W8MV 206, W8DED 112, W8DMS 93, W8COQ 77, W9EQV 72, W8DAQ 62, W8DDO 60, W8CLN 55, W9HK 50, W8BEX 42, W8GP 36, W8AM 33, W8FX 31, W9CE 30, W8CSR 27, W9CSI 24, W8AJC 23, W8PQ 23, W8DSF 17, W8DOV 13, W8BVG 12, W8CST 11, W8CKZ 10, W8JK 10, W8BV 9, W9FPF 9, W8ACW 7, W8AKN 7, W8AAF 6, W9AXE 6, W9EGF 6, W8JX 6, W8AE 5, W8VL 4, W8DNT 3, W8CJZ 2, W8CYX 2, W8CCE 16, W8CVU 23, W8BRS 20, W8DLX 29, W8RP 22.

INDIANA — SCM, George Graue, W9BKJ — W9FSG leads the state. W9CLF's voltage regulator works fine. W9DME, W9FPQ, W9FOW and W9CSY are trying to break into the commercial racket. W9AAI and W9BHM are working out well on 'phone. W9GJ has a new AC receiver. W9AMI is the most active station in S. Bend. W9BWI is the official pessimist of the Ft. Wayne Radio Club. W9FCX is trying hard to get a crystal rig on the air. W9DBJ is through with women. W9ASX was home for the holidays. W9ETH licks when he sends his call letters. W9AKD is back with us. W9BNP from Anderson has located in Ft. Wayne. W9CKG wants the formula on how to get DX. W9BIA is being infested with the Ham Bug again. W9GJS reports unusually heavy traffic on 7 mc. W9CVX has a Super-het-up receiver. W9ESU is a new ORS at Mitchell. W9AAO is rebuilding his transmitter. W9CIC is clanking along with a keno and chem rectifier. W9ALB's receiver is having heart trouble. W9DOD had his antenna chopped down three times by overheated BCLs. W9DHJ makes the BPL. W9AIP wants a few more schedules. W9AKJ was off the air temporarily, due to moving to new QRA.

Traffic: W9DHJ 115, W9FCX 87, W9BKJ 98, W9FYB

62, W9GGJ 50, W9GJS 41, W9CVX 21, W9DSC 12, W9AXH 9, W9EKA 12, W9AET 8, W9AIP 5, W9AKJ 5, W9FSG 167, W9AMI 143, W9ESU 19, W9CKG 8, W9FQ 10.

ILLINOIS — SCM, F. J. Hinds, W9APY — W9FUL is dragging in the DX. W9DXZ is going strong. W9ERU is pepped up with a new receiver and transmitter. W9BNO and W9AIC are using Mershon condensers. A new power supply at W9FGD helps him roll up the traffic. "Once a Ham — Always a Ham," says W9ETF as he gets on the air again. W9DZG has been in Cuba. W9DAB is a new station at East St. Louis. W9EBX put in a new WE-211-D and pushed into New Zealand on 3500 kc. W9DJG has worked the 6th district on 3 watts. W9CYB is pulling in DX. W9BEO is on with 'phone on 1750 kc. W9AVE has an MOPA. W9DAX is on the 1750-kc. band. W9GFU is on for schedules. W9PK has worked Africa. W9BSR is installing a 3505 crystal transmitter. W9KA is back with a 50-watt Hartley. W9EGA is building an MOPA. W9EAL's new Zepp works nicely with the BCLs. W9ACE has worked 80 stations in his two months on the air. W9DBE has been demonstrating short-wave work to visitors from a nearby Junior High School. W9AHK is rebuilding the station. W9ADN works Australia regularly. W9CKM, W9CGC and W9GCD are on again. W9GFY is on 14,000 kc. The antenna at W9AVL is a 7000-kc. Zeppelin of copper tubing 50 feet high. W9DBB complains of broad RAC QRM. W9DZM now uses push-pull on 14 mc. W9FCW received a congratulatory letter from the Secretary of the Navy on his copying the Navy Day messages. W9LL is adding more power. The air has been dead around W9AFB. W9BRY is on in the afternoons. W9QI is a new ORS. W9CZL is knocking down the 6's. W9AMO is doing some nice schedule work. W9ACU got married Dec. 17th. W9GIV is using remote control. A new National Short-Wave set is in use at W9AD. W9BZO and W9FTX report. W9BIR is on with his new license. W9AFN is now an Amateur Extra First Class. W9BRX and W9FO have been QRL. W9ERZ puts out about 500 watts crystal-controlled pep. W9EZF is doing nicely with 7- and 3.5-mc. transmitters. W9CUX has ordered a new power supply. W9FKC is doing nice traffic work. A new receiver is working overtime at W9CKZ. A new "Bug" has crept into the station of W9FPN. W9CNY is on 7000 kc. with crystal-controlled signals.

Traffic: W9DZM 121, W9AMO 308, W9DBB 204, W9BZO 147, W9FCW 112, W9AHK 110, W9DXZ 90, W9ERU 66, W9FGD 59, W9CUH 47, W9ACU 46, W9MI 34, W9ERZ 26, W9AFN 22, W9CUX 21, W9PK 19, W9AUI 17, W9BRY 17, W9CKM 17, W9DBE 17, W9FZW 17, W9QI 16, W9BIR 14, W9FUL 14, W9AD 15, W9ACR 13, W9ET 12, W9AFB 12, W9LL 11, W9AFN 11, W9DJG 10, W9GIV 10, W9BSR 9, W9FI 9, W9BPN 7, W9CGC 7, W9CZL 6, W9BRX 5, W9BVP 5, W9EBX 5, W9DZG 4, W9ACE 3, W9ADZ 2, W9GIF 2, W9EAL 1, W9FO 1.

KENTUCKY — SCM, J. B. Wathen, III, W9BAZ — W9ALN is well out in front with a nice total. W9BAZ may have a couple 204-A's perking when this is read. W9OX has a fine dynatron. W9CEE is QRT due to school. W9BEW wants schedules with Kentucky stations. W9ZZE has moved to 16 Ashton Rd., Ft. Mitchell. W9JL is rebuilding. W9CDA now has his monitor calibrated. W9AIR gave quarterly reports to Perdue U. on the Male-Manual football game. X9-A please notice — W9CNE says you have a tin-ear. W9AZY has a fine signal. W9CBT is getting into the reports. W9GGB had better put in tube rectifiers. W9GJE expects to have two stations; one at school, t'other at home. W9EQO is a first-class beer-guzzler and pretzel-bender. W9ARU says it is shocking. W9BAN sold his receiver to W9DPK. W9AUH wants Englishers to listen for his 56-mc. tests during February. W9EDQ expects improved results from his new transformer. W9FTV is a new reporter. Come on. W9ELL, an ORS must handle traffic. W9EYW just completed an AC receiver. W9FZY is waiting for his license to be reissued. W9OX as King, and W9TG as The Grand Bum, initiated new members into the Independent Rag Chewers Club. Lieut. Breckle gave a very fine talk to the Louisville unit of the U.S.N.R.

Traffic: W9ALN 163, W9BAZ 67, W9OX 51, W9CEE 41, W9BEW 34, W9ZZE 34, W9JL 27, W9CDA 23, W9ALR 22, W9CNE 20, W9AZY 19, W9GGB 14, W9CBT 15, W9GJE 10, W9EQO 9, W9ARU 8, W9BAN 8, W9AUH 6, W9EDQ 5, W9FTV 3.

WISCONSIN — SCM, C. N. Crapo, W9VD — W9GFL schedules W9FHU, W9ERU, W9FSS and W9FAA.

W9FHU works all directions on schedule. W9FAW wants an ORS appointment. W9EPG reported via radio. W9DIT will be glad to handle any traffic for his district. W9DTC recently received Commercial Second Class license. W9EBO is conducting a Boy Scout Radio Class with 14 students. W9SO is experimenting with antennae to eliminate local power QRM. W9OT is operating at WPDK, Milwaukee Police Broadcast system. W9EPJ entertained L. S. Hillegas-Baird at a recent meeting of the Badger Amateur Radio Club. W9EBD has enlisted in the Naval Reserve. W9FSS is sending code lessons daily, except Sunday, on 3500 kc. from 6:00 to 6:15 p.m. W9ESZ will have crystal control on about 3870 kc. the first of the year. W9BIB has quit making home brew. Hi. W9VD now operates in four bands.

Traffic: W9GFL 253, W9FHU 137, W9FAW 38, W9DIT 36, W9DTK 34, W9EBO 34, W9SO 34, W9OT 17, W9EPJ 12, W9FSS 11, W9EGP 6, W9ESZ 3, W9VD 12.

OHIO — SCM, Harry A. Tummonds, W8BAH — Congratulations, gang, on hitting approximately the 2000 message total this month. For two months in a row every ORS reported. FB! W8BGX, W8CMB and W8GZ make the BPL. W8BGX has been appointed a new Route Manager. Write to him for schedules. W8GZ and W8DU are the key stations for Ohio in the A.R.R.L. Communications Net for the American Legion. Write to them if you want to get in on the work in connection with your local Post Commander and Headquarters at Columbus. W8CK has been awaiting license renewal. W8TK says DX is scarce. W8BDU reports. W8BAC works in a bank and makes change on 7150 kc. W8NP built the two-tube receiver in Dec. QST. W8MH has been in the hospital for an appendix operation. W8BKM is on 3700 and 3965 kc. W8APC wants more traffic for Toledo. W8DBK reports two radio clubs going strong in Dayton. W8CX has taken the eave troughs off the house for a new Zepp. W8RN reports. W8CNM is on 7 and 3.5 mc. W8BCF is on 7060 looking for schedules. W8ADS has finished a new AC monitor. W8BAH wants schedules with Cincinnati. W8DPF had a Christmas vacation. W8OQ finds too much QRM on 7000 kc. so is going to 14 mc. W8BF, RM, has been working on his crystal. W8CWA has a new CW crystal on 3675 kc., also 'phone on 3540. W8CIY wants an ORS. W8BYG is a barber in Cleveland. W8DIH reports a celebration on the fifth year for W8DIH on the air. W8DDQ keeps a couple of schedules. W8AWS is busy with new 'phone job. W8BCR is President of the Shaker Heights Amateur Radio Klub. W8DDS also wants ORS. W8CSS reports the following new hams in Marietta: W8TL and W8CKF. W8CGS also applies for ORS. Here's another who will be an ORS soon — W8ATV. W8CEI is a new ORS. W8AKA, the CARA Club station, held a reliability test last month working 181 stations in 109 hours of continual operation of station by club members. W8CBL and W8BZB are new hams in Youngstown. W8EJ reports much U.S.N.R. activity in Youngstown. W8SG, with W2BXM as operator, wants schedules with Jamestown, N. Y., and Poughkeepsie, N. Y. W8DUD is going up for a commercial ticket. W8HH is another new reporter. Business keeps W8BBH busy. W8DMX is building new frequency meter. W8ANV is on 7275 kc. every day. W8CAI, a new Cleveland ham, delivered a request for a song at a local BC station. W8LI will be going strong soon with higher power on three bands. The U.S.N.R. is active in Cleveland every Monday night and operate W8US on schedule every Friday. W8BYN is in Dayton, and we would like to hear from him.

Traffic: W8BGX 508, W8CMB 276, W8GZ 202, W8NP 96, W8BKM 91, W8SG 79, W8ATV 61, W8ANV 51, W8DBK 50, W8CEI 39, W8BAH 36, W8ADS 35, W8CNM 34, W8BAC 28, W8CGS 28, W8APC 27, W8CSS 23, W8HH 21, W8MH 18, W8BCF 17, W8TK 16, W8DUD 15, W8CX 11, W8OQ 11, W8BYG 11, W8DDS 11, W8DIH 10, W8DPF 10, W8DU 10, W8AKA 9, W8EJ 7, W8BCR 7, W8CWA 5, W8AWS 5, W8CIY 3, W8BDU 4, W8DMX 27.

DAKOTA DIVISION

NORTHERN MINNESOTA — SCM, Ray H. Weihe, W9CTW — The reason for the good showing this month seems to be the direct result of our splendid QSO parties. The SCM kept a week's schedule with W6AXV and took plenty of traffic. W9BVH also with a west coast schedule. W9DOQ is waiting for a new 203A. W9ARE left the Section for the winter. W9EGU is still knocking off the DX. W9BHH says, "Season's Greetings." "A new Naval Reserve 500-watt station is being erected in Duluth," says W9EHI. W9GGG is going after traffic by running an ad in the local newspaper. W9EOZ sent in his first report. W9BBL

comes through again with a nice total. W9BCT got going again. W9FAQ joined the A.R.R.L., and comes across with a report. W9FFL sends in his report, and W9YK's also. The SCM had a nice letter from W9AAN, who has a 17-mgc. 'phone going.

Traffic: W9CTW 117, W9BVH 115, W9BBL 51, WFNJ 45, W9EGU 39, W9GGQ 34, W9EEI 20, W9DOQ 10, W9EOZ 9, W9FAQ 6, W9BHH 5, W9YK 19, W9FFL 2, W9BCT 1.

NORTH DAKOTA — SCM, Guy L. Ottinger, W9BVF — Our OBS is back in the harness, and has five schedules. W9DMM found time to handle a few. W9DOY says thermo electricity and strength are getting the best of him and his time right now. We have one report from a 1750-ke. man, W9DYA. W9DGS helped W9CBM handle some of the emergency traffic. W9DHQ finds it hard to get traffic on 7 mc. W9EGI, a new ORS, says he has the layout perking f.b. now. W9CRL handled a little emergency traffic. The SCM managed to get some traffic. W9BVF did a little work during the wire failure.

Traffic: W9DNQ 25, W9DGS 115, W9DM 3, W9DFG 110, W9BVF 119.

SOUTH DAKOTA — SCM, Howard T. Cashman, W9DNS — All ORS please note that unless you have received a new certificate from me within the past two months, you are no longer ORS. This standing may be renewed by some semblance of activity and consistent reports of same. W9DKL is doing great things with his schedules. W9DGR handled emergency traffic for railroad, power and telephone companies during a sleet storm. W9CIR reports new 1750-ke. crystal set for AA work. W9CFU is a new ORS. W9CIR, W9DGR and W9DNS are pretty crowded with BC work.

Traffic: W9DKL 87, W9DGR 56, W9CIR 6, W9DNS 5.

SOUTHERN MINNESOTA — SCM, J. C. Pehoushek, W9EFK — As this is my last report, I want to take this opportunity to thank every fellow in this Section for the help they have given me in the past two years. In the future please report to W9AIR, Herman Radloff, Box 15, Route 2, Sleepy Eye, Minn., who is your new SCM. W9COS again leads in traffic with the "Oriental" clicking as of old. W9BN was very active logging off-frequency stations. W9BNN has four schedules a week. W9CKU will be on 7 mc. regularly. W9GBZ of Lakefield is on with 'phone, as is W9FAJ. W9DGE had several out-of-town visitors, including W9CWA, W9BPM, W9BLR and W9CYG. Harold says there are several new stations in his locality: W9DWU, W9BQ, W9BPK, W9FQW, W9FCC and W9BVV. W9AIR has a 1763-ke. crystal going on three bands. W9BXE had an 866 go west. W9BXX wants more Minnesota stations to go on 3500 kc. for Army Amateur traffic. W9EFK is on at noon once in awhile. W9EYS and W9BNN visited W9AIR. W9DWG of Ivanhoe visited the Heron Lake gang. W9EJR sold his generator, and is now using tube rectifiers with a dandy note. W9YC has a new crystal. W9FLE has been using 'phone. W9AKN says 14 mc. has been erratic. W9EAT is rebuilding to crystal and 100% 'phone. W9EEB at Wood Lake is using a new Zeppelin antenna. W9EYL is on 14 mc. W9DBC and W9BEB of Minneapolis have been playing checkers on 1750-ke. 'phone. W9GHO is going again. W9FMB wants to QSO the Minnesota gang on 3500 kc.

Traffic: W9COS 236, W9BN 130, W9BNN 113, W9CKU 79, W9DGE 76, W9AIR 76, W9BXE 51, W9BXX 42, W9EFK 9, W9YC 4, W9FLE 1, W9AKN 1.

DELTA DIVISION

TENNESSEE — SCM, James B. Witt, W4SP — W4CW sends in the best report this month. W4AFS fell a little behind his report for last month. W4LQ, our new O.O., sent in his first report. W4AAO, W4ABQ and W4RG all sent in their first reports. W4AFM is responsible for all the new stations reporting. W4HG, formerly W4ABZ, is rebuilding. W4FX has just completed his new set using type '10 crystal Osc., '10 buffer and 852 in output stage. There are several stations reporting to the SCM who have not handled any traffic, but hope to soon. Here they are: W4GO, W4AHL, W4ABX, W4ABE, W4ADX, W4AHR and W4KJ.

Traffic: W4CW 97, W4RO 47, W4AGW 44, W4AFS 38, W4FR 34, W4AFM 34, W4LQ 21, W4AAO 15, W4ABQ 12, W4SP 13, W4RG 8, W4FX 6.

LOUISIANA — SCM, Frank Watts, Jr., W5VF — Look at the totals listed below. Is yours there? Send in a report next month and help us get on top. W5ACY made the BPL. W5NJ reported for the first time. W5WG is on 7000 kc. with

a crystal. W5EB received a card from Poland. W5RR struck some DX on 14 and 7 mc. W5KC has a FB note. W5BKL is awaiting the arrival of a pair of type '81s. W5ANA is installing a portable rig on a Sea Scout ship. Where is W5BJA? W5BRH is the specialty station in Shreveport. W5YW says they formed a radio club, and had a nice crowd present. W5MH seems to listen in on almost any band. W5WF is handling lots of traffic on 7 mc. Say, boys, let's go after that Banner!

Traffic: W5WF 289, W5ACY 259, W5RR 63, W5YW 53, W5BKL 34, W5EB 33, W5KC 30, W5NJ 30, W5WG 18, W5MH 7, W5BJA 4.

ARKANSAS — SCM, Henry E. Velte, W5ABI — I wish to thank the gang for reflecting me SCM. I will do my best to bring our state to the front. Let's make this a 100% reporting state. W5BKB still continues to hold the title of BANNER STATION. W5AAJ has been working a number of schedules. W5DD will soon be on 3.5 mc. with a crystal-controlled 'phone. W5AGB is on 7 mc. W5IQ has rebuilt his receiver. W5HN has been busy on his 3.5-mc. crystal-controlled 'phone. W5BBI is on 14 mc. W5BRI continues to get out well on 7 mc. W5LV, our R.M., is on 3.5-mc. c.w. and 'phone. W5BPE is using a T.P.-T.G. transmitter with one type '10. W5RW has rebuilt his transmitter. W5ARJ is on 3.5-mc. 'phone. W5SI is after a broadcast license.

Traffic: W5BKB 139, W5AAJ 111, W5BBI 45, W5SI 44, W5ABI 32, W5LV 24, W5IQ 14, W5BPE 12, W5RW 6, W5HN 5.

HUDSON DIVISION

NEW YORK CITY AND LONG ISLAND — SCM, N. V. T. Kenney, W2BGO — The second meeting of the official stations was held, and was very interesting. The next meeting will be held at Naval Reserve Headquarters, Washington and Christopher Sts., on Feb. 16th, at 8 p.m. Manhattan: W2SC is the only station making the BPL, and leads the entire Section. W2BSZ is again heard from. W2AOY complains of refusals by others to QSP. W2BBY promises a good total next month. W2BNL is still with us. W2AVK is back on 7 mc. W2LW, a new ORS, keeps three schedules a week. Bronx: W2BGO leads the Bronx in traffic. Spain, France, Portugal, and Austria have been QSO'd by the holder of a new commercial ticket, W2A11. The new receiver at W2CYX is doing what it should. Our Bronx OO, W2AFO, can find plenty of 'em operating outside the bands. A new CC 'phone outfit can be heard on 14 mc. operated by W2FF. W2BQG can be heard on 7 mc. W2VG has gone back to the TPTG. The crystal outfit at W2AQG is giving him lots of headaches. W2APV can now be heard operating from N32PA, Brooklyn: Dave Talley was recently promoted to Captain in the Signal Corps Reserve. He requests that all interested in Army-Amateur work get in touch with him immediately. W2APK has a new outfit perking. W2ARQ was accompanied by the OW when he came to the last meeting. W2AZV has a dynatron on hand. W2BO hears many "2s" off frequency. W2LB, a new ORS, is asking for volunteers for the Naval Reserve Communication outfit. W2BEV gets his traffic on schedule. W2BEG has his 3.5-mc. outfit perking perfectly on 7 mc. W2BJF gets crystal reports with a Hartley. Long Island: W2AVP-W2NO, RM for L. I. reports W2AST, W2ASS, W2DL, W2CDT, and W2CFH all active. W2BVL, Nassau Radio Club, has as its chief operator W2ASS. W2HO is on with an 852 on the popular bands. W2US and W2LR have been appointed OOs.

Traffic: Manhattan — W2SC 374, W2BSZ 24, W2AOY 14, W2BBY 11, W2BNL 4, W2AVK 1. Bronx — W2BGO 141, W2A11 85, W2CYX 48, W2AFO 28, W2FF 24, W2LW 14, W2BQG 9, W2YV 5, W2AQG 4. Brooklyn — W2ARQ 42, W2PF 39, W2APK 36, W2AZV 16, W2BO 17, W2BEV 14, W2BJF 10, W2LB 7. Long Island — W2NO 50, W2BVL 13, W2HO 13.

EASTERN NEW YORK — SCM, H. J. Rosenthal, W2QU — The Pioneer Radio Club reports their 3500-ke. transmitter now ready. W2CBB is adding another tube. W2BAI reports QRM from school. W2CJP reports difficulty in raising stations in the fourth district. W2BJA has made application for an Army Amateur appointment. W2LU has been placed in charge of the Naval Emergency Net in Northern New York. W2OP reports. W2BIC and W2BKA are handling European messages. W2ACD has been ill with grippe. W2AJD has been appointed Official Observer. W2BER has three live schedules. W2AYK reports the most traffic in months. W2FN has his new crystal on the air. W2BKN reports nil in the way of traffic. W2ALI

is on the air in his new home in Newburgh. W2CL reports that most of his traffic was handled on 14 mc. W2BSH is still in Buffalo.

Traffic: W2LU 207, W2ACD 145, W2AYK 64, W2CBB 50, W2CJP 45, W2FN 38, W2OP 32, W2BJA 28, W2BER 23, W2CL 16, W2BIQ 6, W2ALI 6, W2AJD 7.

NORTHERN NEW JERSEY—SCM, A. G. Wester, Jr., W2WR — W2JF says traffic has hit a depression along with business. W2AOS works only with the U.S.N.R. and AA nets. W2CWK likes the new ORS certificates. W2CJX was on the sick list. W2AMR has been having good QSOs with Africans. W2CPD has a new P-P transmitter on 3500 kc. W2DV sent in a fine list of High Quality signals. W2BPY has a poor location. W2CFQ sent in his report by radio. W2CLX is on 3500 kc. looking for schedules. W2CFY complains that stations on 14 mc. will not accept traffic. W2BKE is in line for an ORS. W2CEX has applied for an ORS. W2CDQ worked JIDV in Japan. W2AQM is on with a fifty in TGTP circuit. W2CMK, the YL station, is on 14 mc. W2BHW worked Germany on 7 mc. W2CHZ has a new transmitter using push-pull. W2BZB is installing crystal. W2MQ has a fine schedule with W8KD in Erie, Pa. W2AUP is on 7 mc. consistently. Transmitter trouble kept W2BJZ off the air.

Traffic: W2JF 56, W2AOS 54, W2CWK 22, W2CJX 16, W2AMR 17, W2CPD 20, W2DV 41, W2BPY 3, W2CFQ 20, W2CFY 5, W2BKE 7, W2CEX 22, W2CDQ 8, W2AQM 2, W2CMK 3, W2BHW 6, W2CHZ 21, W2MQ 49, W2AUP 10.

MIDWEST DIVISION

NEBRASKA—SCM, Samuel C. Wallace, W9FAM — W9FAM piles up a total of 176. W9BOQ comes rearing in with 94. W9BHN says he gets traffic, but can't get rid of it. W9CJF says UPRR QRming his receiver. W9EEW reports 21 handled. W9EEW QRXed between train orders handled 13. W9DTH needs some traffic to limber up his arm. W9DFR says he's getting his transmitter tuned up. W9DFE is back at KEFW. W9BQR says QRM fierce. W9DI is very busy with school. W9CHB is busy checking off-frequency stations. W9BBS has been on the sick list. W9QY reports. W9CDB, an Ex-ORS, reports. W9BJI is getting interested. W9DHC is going to try CW to please the rest of the gang. W9EGC, a new station, is asking for an ORS appointment.

Traffic: W9FAM 176, W9BBS 109, W9BOQ 94, W9DHC 77, W9BHN 31, W9CJF 26, W9EEW 21, W9EEW 13, W9DTH 12, W9DFR 15, W9DFE 9, W9BQR 5, W9DI 2, W9CDE 8, W9BJI 24, W9EGC 15, W9QY 2.

IOWA—SCM, H. W. Kerr, W9DZW — Look at W9EJQ's total! W9FFD wants consistent schedules. W9ACL comes along with a few schedules. W9BFL boosts his traffic. W9EIV tops the Sioux City gang. W9EHX and W9FZO follow. W9EHX has a push-pull on 3500-ke. band. W9FZO is experimenting. W9BCA schedules W1MK and W9CRV. W9BPG has a nice total. W9DEA heads the U.S.N.R. Unit with over 20 members. Ens. Morgan of Newton organized the Unit during the week of Thanksgiving. W9AED is heard frequently on 7000 kc. W9FDZ is a new reporter. W9FVY adds to the Des Moines totals. W9DNZ is working on both 3500- and 7000-ke. bands. W9FFD has recently been appointed SNCS for A.A.R.S. Thanks, W9FWG, for your bit. W9CKD is home from Valparaiso. W9EQF is another first reporter. W9AG requests renewal of ORS, formerly issued under W9EHR call. W9EOP says his 203A went haywire. W9AHX is going to try type '45s in TPTG. Coleman of Eagle Grove is waiting for a call. W9FXJ has moved from Waterloo to Eagle Grove. W9FIF asks for ORS blanks, as does W9EIV. W9LT reports a radio club at Marshalltown. W9GCP, home from ISC, reports Campus Club remodeling W9DTI for crystal. W9CZC is adding wall paper to his collection.

Traffic: W9EJQ 429, W9DZW 179, W9FFD 135, W9ACL 98, W9BFL 77, W9EIV 66, W9EEX 58, W9FZO 46, W9BCA 50, W9BPG 45, W9DEA 37, W9FDZ 33, W9FVY 24, W9DNZ 24, W9FWG 22, W9CKD 21, W9AWY 18, W9EQF 14, W9AG 10, W9EOP 1, W9AHX 1.

MISSOURI—SCM, L. B. Laizure, W9RR — St. Louis: W9ECI took first place in traffic, with 99FW second. W9DXY is moving again. W9PW reports general failure of stations to keep their schedules with him. W9GHG has been trying for DX on 14 mc. W9AMR has gone to New Orleans for commercial ticket. W9GHN is expected home soon. W9DYJ has a sax, so the station isn't getting so much attention. W9BEU is keeping A-A net schedules. W9FTA re-

ported by radio. Kansas City: W9DQN is obliged to set up again after moving. W9CFL continued U.S.N.R. schedules. W9BMA handled the usual wad. W9BMT was second with 147 messages. W9GBA was third. W9AKZ reports school QRM. W9AOG reports the same. W9GHA is a new station. W9CVT undertook the job of observer. W9DLL is in the crystal business. W9ZD has been doing more 3.5-mc. work. W9RR acknowledges with thanks the many remembrances of the season received from fellow-hams. General reports: W9BJA turns in a whale of a report as observer. Ex-W9BYI is rebuilding. W9ASV is still on low power rig. W9DHN got in on American Legion traffic. W9FBF remembered the SCM with a letter and photos. W9EPX is starting up in radio business in Columbia with W9BKG. W9CJB says traffic scarce, DX rotten and power QRM strong. W9FVM has built a new layout. W9CDU says job QRM bad. W9ENF turned in old license 60 days in advance of expiration and then was without a valid license 15 days before the renewal arrived. W9DCD was heard several times at W9RR working daylight A-A net schedules with W9BJA. W9FJV is ex9CCQ of Braymer. Last month the SCM mailed out postals to expected reporters who had not come through in time, the net gain being 7 reports and 227 messages, which would otherwise have been lost, to the credit of Missouri.

Traffic: W9BMA 318, W9BMT 147, W9GBA 86, W9BJA 160, W9AKZ 8, W9ENF 15, W9CJB 26, W9CDU 20, W9DHN 135, W9AOG 14, W9ZK 27, W9FTA 15, W9DYJ 19, W9BEU 46, W9ECI 119, W9GHG 2, W9PW 31, W9RR 19, W9CFL 83.

KANSAS—SCM, J. H. Amis, W9CET — W9ECS makes the BPL. W9GKT says he will make the BPL. W9CFN reports a new SG receiver. W9DVG has an increase in traffic due to his ad in local paper and absence of his YL. W9FX Y is on 3500. W9ESL complains about bad QRM on SF transmissions. W9CKV is trying to get lined up in the AARS. W9CET has a new AC receiver. W9FLG moved his QRA. W9HL has been sick. W9BTG-W5ZZR hasn't been on much due to extra programs at KSAC. W9DEB is rebuilding his receiver. W9BGL has a new pole and zepp antenna. The Kansas Association of Static Stoppers held a ham fest, November 30, at Dodge City. The KVRC is planning a series of talks covering all phases of ham radio beginning in January. The SCM would like to have a report from all 'phone men in Kansas, so we may let the world know what the Kansas 'phones are doing.

Traffic: W9ECS 206, W9GKT 69, W9CFN 58, W9CET 57, W9DVG 56, W9FX Y 54, W9ESL 42, W9CKV 29, W9BTG 26.

NEW ENGLAND DIVISION

NEW HAMPSHIRE—SCM, V. W. Hodge, W1ATJ — W1IP again makes the BPL with a big total. W1BAC is on 3500 kc. regularly. W1AEF has his push-pull rig going with a new antenna. W1ANS held open house for the Nashua gang and W1IP, W1LM and W1AEF and a real hamfest was enjoyed. W1NZ is using a type '12 and "B" batts with about 4 watts input. W1AU Y's 3549-ke. 'phone was reported FB in Bristol, England. W1APK is using 'phone on 3525. W1CCM had to cancel his schedules by order of his M.D. W1CAF is building an 852 transmitter for all bands. W1AWU sent in his first report by radio. W1BJF sends in a good report. W1MB has dismantled his station. W1LY is back on the air.

Traffic: W1IP 398, W1BAC 162, W1BJF 131, W1AWU 124, W1APK 38, W1CCM 21, W1AEF 17, W1NZ 6, W1AU Y 4, W1CAF 1.

RHODE ISLAND—SCM, N. H. Miller, W1AWE — This is my first report as SCM. I am pleased to serve you and hope to have your cooperation in putting our little state on the map. You all know about the new ORS system. If you want to hold your appointment, keep sending in reports. "The Associated Radio Amateurs of Southern New England," one of our Providence clubs, is going strong and boasts of 19 licensed hams. The Radio Club of Rhode Island, W1BCR, is on daily with 'phone on 3540 kc. and works DX with ease. W1MO reports 14250 kc. is getting better. W1BML is a coming ORS. W1GV is getting along FB on 3500 kc. W1QR has a 3500-ke. crystal-controlled set. W1AFO, W1OU, W1AUV, W1BDQ, W1TQ, W1BES and W1AVE report that the BCL business keeps them going. W1ASZ will soon have a nice ORS ticket. W1AWE has a good signal on 7100 kc. There are lots of fellows who never report. Why not send in yours next month?

Traffic: W1MO 12, W1AWE 4, W1GV 4.

EASTERN MASSACHUSETTS—SCM, Miles W. Weeks, W1WV—W1WV and W1LQ make the BPL. W1A1S is keeping early morning schedules on 3500. W1ABG had some transmitter trouble. W1CCP has a schedule with NN1NIC. W1ASF has been making good DX contacts on 7 and 14 mc. W1KY has her ORS reappointment. W1WU is troubled with a bad power leak. W1ADK had difficulty finding stations to handle his traffic. W1KH has resumed his schedules with V08AE. W1AZE is doing some 3500-ke. 'phone work. W1BZQ is preparing to use his 203A in an MOPA for 'phone. W1LW had a good traffic month. W1ACH continues to handle Naval Reserve traffic. W1CAW, W1AFP, W1CHR, W1ATX and W1CQN are now ORS. W1CAW took a two weeks trip to Washington, D. C., visiting W2CAY on the way. W1AFP has BPL ambitions. W1CHR reports better results after rebuilding. W1ATX is trying 14 mc. W1CQN has been very QRL. W1WV worked Uruguay on 7000, South Africa, on 14 mc., and the 6th and 7th Districts on 3500 kc. W1BGW handled some traffic with his new 852. W1ACD is also using an 852. W1AOT is rebuilding. W1ANZ is on signing W1ME.

Traffic: W1WV 310, W1LQ 257, W1BXB 184, W1ACH 126, W1LM 119, W1AFP 98, W1ABG 62, W1BGW 61, W1KH 58, W1A1S 35, W1BZQ 34, W1ATX 30, W1CHR 29, W1CAW 22, W1CCP 15, W1KY 13, W1ACD 12, W1CQN 11, W1AZE 6, W1AOT 5, W1ADK 3, W1WU 2, W1ME 20, W1BCF 32.

CONNECTICUT—SCM, Fred A. Ellis, Jr., W1CTI—W1BNB sends in his first report. W1CJD makes the BPL and reports for W1BEO. W1AMG warns the gang to get their renewal license applications in early. W1BVV thinks 7000 kc. better than 3500 kc. for traffic. W1TD says "QRL." W1RP has his new Vibroplex. W1HQ's is working out well. W1BDI reports. Keep them coming, F.E.H. W1NE delivered an important message from Hankow, China, to Bridgeport. W1BBU misses the SCM on the air. W1AFB wonders what has gone wrong with the Southern gang. W1BHM has not heard the SCM. W1UE has been hot on the trail of deliveries. W1HD is another asking for the SCM. W1AMQ is looking for an afternoon schedule with N. Y. C. Get in touch with W1BHM, the RM. W1MK has the usual fine total, and says 14.3-mc. operation after Jan. 1st. W1CTI was inactive after Dec. 1st, due to overworking at the office. At this writing there are exactly eleven ORS in the Conn. Section. Those of you who wish reappointment, please write at once. W1FL has opened up and is keeping some early AM schedules. W1ADW reports by radio. W1BWM says his application for license renewal has not been acknowledged. W1AVC reports DX good on 7 mc.

Traffic: W1MK 466, W1CJD 276, W1AMQ 140, W1HD 136, W1UE 126, W1CTI 110, W1BEO 85, W1BHM 48, W1AFB 43, W1BBU 38, W1BNB 31, W1NE 24, W1BDI 18, W1HQ 12, W1AUC 11, W1RP 8, W1ADW 7, W1TD 5, W1BVV 5, W1AMG 2.

MAINE—SCM, G. C. Brown, W1AQL—Not many of the old ORS have applied for new certificates. Remember that your old ticket became null and void on November 15th. The Portland Wireless Association is having a fine season. The Queen City Club recently held a Christmas party, with Santa and all present. W1BFZ sure makes a good Santa Claus. Hi. W1ATO is high man this month. W1ANH is a close second. The SCM has appointed W1BLI Route Manager for Eastern Maine. W1QH reports that traffic is increasing. W1ACW has filled out his application for ORS. W1AUR has just finished a Bandbox Super-het. W1AQD is back on the air after a brief illness. W1BZG can get traffic through the West and Middle West almost any time. W1AHY says things are at a standstill over his way due to bad weather. W1ACV is getting ready to put his set on the air again; his QRA will be Bangor. W1MP was a recent visitor to the Queen City.

Traffic: W1ATO 140, W1ANH 121, W1BLI 89, W1QH 46, W1ACW 39, W1QK 27, W1AUR 21, W1AQD 17, W1AQL 11, W1BEU 5.

VERMONT—SCM, Clayton Paulette, W1IT—Congratulations, W1BD, on your fine traffic showing. W1CGX, W1ATF and W1BD belong to the A.-A. net. W1IT is very QRL with automobiles at Garage. W1BJP has changed to the bottom of the 3500-ke. band and reports more contacts. We have a newly appointed ORS, W1SV in Burlington. Come on, gang, and let's make this a banner year in Vermont.

Traffic: W1BD 272, W1CGX 236, W1ATF 205, W1IT 16, W1BJP 12.

WESTERN MASSACHUSETTS—SCM, Leo R.

Peloquin, W1JV—All stations, whether ORS or not, should report monthly to the SCM, the number of messages handled. Cards for this purpose will be furnished on request. Correspondence is invited regarding ORS qualifications. Our Route Manager, W1ASY, leads the Section in traffic. He has arranged a new Boston-Worcester route. A Springfield-Worcester route is also working out. FB. W1BVR has received a letter of congratulations from the Secretary of the Navy for being one of the high twenty-five in the Navy Day competition. FB, OM! W1APL has been DX-ing on 14 mc. The SCM's new crystal transmitter is on 3710 kc. All stations can reach him on Wednesdays after 10:30 p.m., as this night has been reserved for communication with Western Mass. ORS.

Traffic: W1ASY 102, W1JV 58, W1BNL 49, W1BVR 32, W1APL 17, W1AJD 16, W1AIF 15, W1ASU 9, W1BWB 3, W1BIV 2, W1UM 3, W1BSJ 1.

NORT WESTERN DIVISION

IDAHO—SCM, Oscar E. Johnson, W7AKZ—W7AIV has a 50-watter in action. W7FB and W7AII are off the air for a short time. W7AOC is "crystalizing." W7AFT worked some hot dx (a W4—hi!). W7IY has become new OO for Idaho. W7AT reports both receiver and transmitter "on the hog." W7AFN has gone into the fuel business. W7ACP has rebuilt. W7ALW was too busy to bring in the big traffic total he promised. W7QD is working on 7 and 14 mc. W7AUR has grown up to a type '10. W7AKZ is now using type '10. W7AHG is "in love," and has no time for ham radio. W7ACD is getting along well with his code practice broadcasts.

Traffic: W7ALW 27, W7AUR 9, W7QD 18, W7AFT 39, W7IY 18, W7AT 12, W7ACP 33, W7AKZ 39, W7ACD 4.

MONTANA—SCM, O. W. Viers, W7AAT—W7ASQ is a new ORS. W7PL is after a new ORS certificate. W7AII, W7CU and W7BW are all out for ORS appointments. W7ANT has a wonderful 'phone transmitter on 3500 kc. W7HP is quite busy at the Bozeman College. W7DD is at Wolfe Point operating WGCX. W7EL says he will be on again soon. W7AAT is now on 7040 kc. with a 250-watter. Let's have more reports.

Traffic: W7ASQ 63, W7FL 17, W7AAT 25.

OREGON—SCM, W. S. Claypool, W7UN—W7LT keeps six daily schedules—look at his total. W7ZD makes a nice total with one week of operating. Coos Bay activity seems centered around W7WL, the RM. W7ALM can be depended upon to report big totals. W7WR did fine work. W7ED and W7AME are being lined up for ORS. W7PL and W7QK are again with us. "No delay in traffic here," reports W7AFL, who has joined the W7LT network. W7AMF sends in his usual FB report. W7APE is heard frequently. W7AIC and W7LE, both of Gresham, report. W7ATC works east coast stations on 3500 kc. W7MV is playing with crystals. W7AHA fears losing his transmitter if the "OM" so decides. W7AIG thinks conditions are terrible. W7AMQ has crystal going at last. W7HD and W7UK both report. W7QY rags with Mexican stations in Spanish. W7ANJ and the SCM, along with future ham, went searching for crystal stock in Southern Oregon.

Traffic: W7JL 117, W7ZD 125, W7WL 129, W7ALM, 104, W7WR 77, W7ED 75, W7QK 65, W7PL 62, W7AFL 44, W7AMF 33, W7AME 29, W7APE 29, W7AIC 24, W7IE 23, W7ATC 17, W7MV 14, W7QY 11, W7AHA 18, W7AIG 5, W7AMQ 5, W7HD 2, W7UK 2, W7UN 138.

WASHINGTON—SCM, Eugene A. Piety, W7ACS—W7QI, a non-ORS, takes the lead this month. W7BB makes the BPL on deliveries. W7OV is planning a nice crystal rig. W7AG has a new receiver. A three-year-old schedule and rag-chewing interest W7KO. W7TX cannot seem to hear Alaska on his schedules. W7RT has been appointed ORS. W7EE is busy with DX on 14 mc. W7AUD is on quite frequently. W7LZ has left for California. W7KZ and W7AIT keep the ether hot in Olympia. W7KZ has good schedules east. W7ATV perches on top of the St. Helen's Hotel. He handled a 220-word message by 'phone with W6ANT and no repeats. W7AJS manages to be on enough to keep his total up. W7ACQ changed his 50-watt set over to a type '10 job. W7ABN's license expired, and he has been waiting for renewal. W7TJ reports. W7APR raises his total again this month. W7AOB hopes to work some of the gang during vacation. W7TE handles a bunch of good traffic. W7ACY stays away from the YLs long enough to do a little work. W7EK is back on the air. W7AFX is getting an 852. The newspapers know a good station when they see it. W7QF got his station photos in the papers. W7AHO helps to keep

Spokane on the air. W7KQ is now OO. W7AAX keeps on DXing. W7AU has his new 50 watt outfit finished. W7AAE sold his MG to the local airport for a radio-phone station. W7KT is back home using a type '45. W7APV, W7AQQ, W7IQ, W7EW, W7ATB, and W7MR get on occasionally. W7ACS sold his transmitter to W7BB. W7OJ keeps the air ionized around Aberdeen, and W7AQB helps him do it. W7AJY is heard. W7BG has been elected Director for the next term, and we will all have to stand behind him. Congratulations, Karl, old-timer.

Traffic: W7QJ 212, W7BB 146, W7OV 92, W7KZ 61, W7OJ 59, W7AHO 55, W7TX 48, W7ACS 48, W7RT 47, W7TK 45, W7QF 30, W7ACY 26, W7AJS 22, W7AQB 24, W7APR 23, W7ATV 20, W7KQ 14, W7AIT 14, W7ACQ 12, W7KO 11, W7EK 9, W7AG 8, W7AFX 7, W7AAE 6, W7FJ 2.

PACIFIC DIVISION

SAN FRANCISCO—SCM, C. F. Bane, W6WB—S W6ERK is taking lots of P. I. traffic originating in S. F. and points east. W6DZZ handled 92 messages in three days. W6EKC's traffic is better than usual. The same applies to our old stand-by, W6DFR. W6ABB reports again. W6BIP hands in a very nice report. W6CAL says the old Hartley is causing lots of trouble. W6WN reports as usual. W6AWA is back with us after a long absence. W7ENM reports considerable activity on 3500 kc. W6DXW reports. W6BNA is intending to ship out. W6AC reports lots of work with the new Junior Op. W6PW has been re-elected President of A.R.A. and is the Convention Chairman. W6DSS, Dave Snyder, was elected Vice-President and Ken Hughes, W6CIS, succeeds George Mesher as Secretary. W6ATI, Bob Skeels, was retained as Treasurer. W6DPF and W6DJX are smoking 'em out together these days. W6KJ sent in his report early. W6ANW barely got under the rope to catch this month's report.

Traffic: W6EKC 98, W6ERK 142, W6DZZ 92, W6DFR 69, W6ABB 50, W6CAL 24, W6WN 15, W6ENM 7, W6DXW 4, W6BNA 3, W6AC 2, W6PW 6, W6DPF 24, W6BIP 147, W6ANW 12, W6KJ 2.

LOS ANGELES—SCM, B. E. Sandham, W6EQF—The clubs are holding annual election of officers. A.R.R.C. results only data at hand at this writing; W6ASM, President; W6MK, Vice-President; W6DTE, Secretary; W6EJZ, Treasurer. The A.R.R.C. offered the last Section banquet, which was a huge success. Highland Park Club has bid for the next one. The following faithfuls make the BPL: W6QP, W6WA, W6ETJ and W6VH. W6QP has a genuine circuit from the Orient to the Atlantic coast which clicks like Notre Dame. Many of the Bakersfield fellows are out of work, and consequently not much radio. W6WA sends in his usual good report. W6ETJ is Chief Route Manager of this Section, and will assist you in lining up schedules. W6VH has had power QRM from dehydraters in nearby oil fields. W6BRO has resigned all of his appointments, including ORS, adding that he must drop actively out of radio. W6OJ schedules have dwindled down to nothing due to bad weather conditions. W6AHP is crystal-controlled. W6CQK, W6DER and W6BAG are on 7 mc. W6AGR has usual good total. W6CXW wants schedules in any direction. W6AM is experimenting with antennas. W6AEO changes from Hartley to TPTG. W6AVJ holds Saturday night jamboree on 3500-kc. 'phone. W6AKW says W6DKN is new ham in Antelope Valley. W6BGF is looking for 3500-kc. schedules north. States Puente Club holds regular meetings, and all members must belong to A.R.R.L.—fine example. W6BNY gets RS from Orient. He is experimenting with W6DHW on receiving antennas. W6WO has had power leak. W6BJC sends in report and states W6FDH, W6EZX, W6FFL and W6EYI are all new hams in Santa Monica Bay district. W6DEP is rebuilding to crystal control. W6CZZ says signals QSA during day, but poor at night. W6DQV says traffic nil. W6DAK is rebuilding for experimentation on 28 mc. W6AKD has separate transmitters in push-pull on both 14 and 7 mc., as per June QST. W6ERL has remotely controlled transmitter. W9DAD will be on the air here soon. W6EZG tells us that W6DJW is married. Here's the best wishes of the Section, OM. W6BFB is sick at Glendale Sanatorium. W6DTE is hooking RS reports from Orient. W6ON works CN and CE. W6ID is going crystal. W6TE is off the air until his license returns from FRC. W6ESA has terrible power leak. His dad and W6EKE have landed in P. I. and will put up o.c. set there. W6EQD is on 7 mc. with c.c. W6AWY using two crystals to QSY from one mess of QRM into another. Hi. W6FFF (ex-W6BHN) is coming

on again. W6HT QRH is 7150 kc. W6DZI tried 3500-kc. 'phone, but QRM'd neighbor two blocks away while BCL set in his own house was not affected. W6BVZ is coming on with new 50-watter. W6FJ hopes to be on the air more now, and have huge traffic totals. W6OF is about settled at new QRA at Riverside. W6MK is going c.c. without crystal. W6CUH says conditions still poor at Hermosa Beach and QRL at Cal. Tech. The Section total this month was 2161. W6DLL and W6LNL report.

Traffic: W6QD 791, W6WA 176, W6ETJ 161, W6VH 144, W6ABR 73, W6OJ 71, W6AHP 69, W6AGR 59, W6CXW 57, W6AM 53, W6AEO 52, W6AVJ 46, W6AKW 44, W6BGF 41, W6BNY 39, W6WO 30, W6BJC 24, W6DEP 23, W6CZZ 21, W6CZT 14, W6AZL 17, W6DQV 16, W6DAK 15, W6AKD 12, W6ERL 10, W6EZG 9, W6BFB 8, W6DTE 8, W6ON 8, W6ID 7, W6TE 7, W6ESA 7, W6EQD 6, W6AWY 6, W6HT 4, W6DZI 3, W6BVZ 3, W6DLI 27.

SAN JOAQUIN VALLEY—SCM, E. J. Beall, W6BVY—By the looks of things this month, this Section will soon be a contender for the white flag. W6BVY heads the list of traffic handlers. W6AHO ran up a good total with a well-established schedule. W6BYH was rushed with Christmas Radio sales. W6BUZ sends code practice on 1715 kc. on Tuesdays and Thursdays at 9:00 p.m. W6BNH took unto himself a wife, so traffic will have to wait a while. Eight new ORS were appointed this month. W6AHO is working hard to make the Section Hamfest at Fresno a success. W6KU has W6AME's 852 on 7 and 3.5 mc. W6AME is standing by for the R. I. to take a commercial exam. W6AV reports for the gang at Lodi. W6EBH swears by the MOPA. W6CUL is getting his new 552 in shape for transoceanic schedules. W6CNM promises good report next month. W6APJ cannot be mistaken for QRN any longer. He has a good rectifier now. W6AV is using crystal on 3850 kc. Two new stations on are W6AFE and W6EHD. W6QA takes his vacation in the winter time. W6BVY is trying TGTP push-pull. W6DCG has a 204-A, and says he will now try to get out of the 6th district.

Traffic: W6DWF 4, W6BYH 28, W6AHO 49, W6BUZ 22, W6KU 74, W6AME 12, W6AV 20, W6BVY 81.

EAST BAY—SCM, J. Walter Frates, W6CZR—W. A. Hammond, W6ALX, heads the Section in traffic. W6EDO lands in second place. He has a daily schedule with OM1TB. W6CGM is the third highest man. W6AKB believes in working two bands, 7000 and 3500 kc. W6ZX is going into traffic in a big way and can route traffic anywhere on the Pacific Coast. W6EDK is working transcontinental on the 3500-kc. band. W6RJ says that he has two transmitters installed in the garage working FB by remote control. W6BTZ is handling considerable traffic from his new location in East Oakland. W6BZU is still riding the kilocycles on the 3500-kc. band. W6ASH announces he has been doing some experimenting with an MOPA, TPTG, and push-pull TPTG. W6ZM is too busy looking for a job to have time for steady schedules. W6EJA has been transferred from the S.S. *Admiral Watson* to the S.S. *Admiral Evans*. W6BUX hasn't got his crystal transmitter going yet. W6CIG is still pounding at the traffic. W6CDA announces that traffic fell down considerably this month, due to illness. W6AOH is coming on the air shortly with a crystal-controlled job. W6BYS reports that he has a lazy 250-watter. The grid is beginning to lean against the plate. W6CZN has been experimenting with AC receivers. W6AUT blew out one of his filter condensers. W6EIB is arranging for the coming section meeting in Vallejo. The Oakland Radio Club held its annual Christmas party and elected new officers. They are as follows: W6CGM, President; W6ZM, Secretary; W6AKB, Treasurer; W6FCO, Program Director; W6ATT, Chief Operator; W6AQO, Sergeant at Arms; and Board of Directors; W6CUG, W6AQO, W6ASJ, W6BGM, and W6IT.

Traffic: W6ALX 217, W6EDO 143, W6CGM 118, W6AKB 111, W6ZX 102, W6EDK 86, W6BYS 45, W6RJ 41, W6BTZ 29, W6BZU 21, W6ASH 20, W6ZM 16, W6EJA 11, W6BUX 10, W6AUT 7, W6CIG 11, W6CDA 5.

SANTA CLARA VALLEY—SCM, F. J. Quement, W6NX—W6YG was the star traffic station with W6EMZ and W6DSZ behind the key. W6HM handled 446 transpacific messages, one morning handling 41 from ACSHM "all single sending" without one repeat or fill. FB! W6ALW's traffic ought to slump next month, as he is a mail carrier. Hi. W6DCP is still bothered by QRM. W6YU had a slump during the month. W6BMW is on 7250 and 7275 kc. W6ACV, W6EEX, W6ECO, W6FBU, W6FPW, W6BET, W6DJP and W6DSE are new hams breaking into the traffic

game with nice initial totals. W6ASE and W6ALW are frequency visitors at San José. W6BAX's Dad lost his life in an accident and the entire Section's sympathy is extended to "BAX." Congratulations are in order for the fine bit of traffic handling put over during the month; 1513 messages were handled, and it seems that the old pep is sure breaking out. Sixteen stations reported to make this month one of the most successful since the section was organized. Thanks, fellows — keep up the good work.

Traffic: W6YG 651, W6HM 446, W5ALW 120, W6DCP 103, W6YU 54, W6BMW 44, W6ACV 17, W6BAX 12, W6EEX 8, W6ECO 8, W6FBU 6, W6FBW 4, W6DJP 12, W6ASE 8, W6BET 8, W6DSE 12.

SAN DIEGO — SCM, H. A. Ambler, W6EOP — W6AXV make the BPL. W6AYK is a new ORS. W6DHA is now with KTAR at Phoenix. W6ACJ had the misfortune to blow up some filter condensers. W6AEP is on with 'phone. W6BAM sent some filter condensers West. W6CTP says he likes long chats if they are YLs. W6EOS has a new radio mast, zepp and receiver so is all set. W6BFF reports trouble with skip distance. W6CNG is experimenting with television. The P. A. T. Club held their semi-annual election for Grand Chancellor, and W6QY is now holding the chair. The club held an open meeting and had as guest Mr. Allen Babeock, our Division Director, who gave us a fine talk. W6EES and W6EPW are applying for ORS tickets.

Traffic: W6AXV 401, W6ACJ 43, W6AEP 13, W6BAM 6, W6EOP 5, W6CTP 2, W6AYK 1.

ARIZONA — SCM, H. R. Shortman, Jr., W6BWS — W6ALU places well in the BPL. W6BLP reports one schedule. W6BJF is operating 3500-cc. 'phone. W6ANO is to be transferred to Cresson, Pa., where he will operate for Transcontinental Western Air Express, Inc. W6AWD is operating on 7000 kcs. W6CWI has a 3500-cc. 'phone set now. W6VV-BWS has a new 50-watt crystal set. W6DHA is a newcomer from San Diego, who is operating at KTAR. W6EFC reported direct to Headquarters. W6EOF resigned at KTAR to accept a position with Southern Air Fast Express operating KGUO in Tucson. W6DJH is relief operator at KTAR. Ex-W6EH is now in Dallas, Texas, with Southern Air Fast Express.

Traffic: W6ALU 549, W6EFC 97, W6BLP 38.

SACRAMENTO VALLEY — SCM, Everett Davies, W6DCM — W6TM wins the prize that your SCM is offering each month for the best traffic report. A prize of at least five dollars' worth of radio parts will be given to the operator turning in the best traffic report each month. W6CGJ is doing most of his work on 3500 kc. W6BYB is now an OBS. W6BSQ will be ready for a lot of winter traffic soon. W6EMX spent the summer brass pounding at sea. W6QT, ex-W9ELJ, is building a crystal-controlled unit. W6EOU is using a type '10 in order to stay friendly with the BCLs. W6AIM is using remote control now.

Traffic: W6TM 350, W6CGJ 81, W6AIM 19.

NEVADA — SCM, Keston L. Ramsey, W6EAD — W6CDZ is the banner station again this month. W6UO has a new mast 65 feet high. W6CRF has his new crystal-controlled push-pull 'phone working FB. W6EAD is off the air until he puts up a new antenna.

Traffic: W6CDZ 94, W6UO 45, W6EAD 2.

PHILIPPINES — Acting SCM, John R. Schultz, KAIJR — This report received by radio at W6DZZ: KAIHR has highest total. KAI1SU has schedule with W6HM. KAI1CE carries a fine regular schedule. KAI1CM is back on regular schedule. KAI1DJ is now C.C. station. KAI1AA has regular schedules with locals. KAI1PB has schedule with KAI1HR nightly. KAI1HW is sick of DX. KAI1RC has schedule with KAI1CE. KAI1JR works his 3500-cc. 'phone with success.

Traffic: KAI1HR 871, KAI1JR 78, OM1TB 453.

ROANOKE DIVISION

WEST VIRGINIA — SCM, D. B. Morris, W8JM — Every one seems to be in favor of a West Va. night, so c'mon, gang, let me hear from all of you real soon. W8OK is quite active in A.-A. net. W8DPO says none of the gang will work him after he reports them off-frequency. W8HD was honored with a visit from Mr. M. T. M. VanSalk, Jr., of Paid, Amsterdam, Holland. W8BTV reports by postal telegraph. W8BOW is out gunning for an "Aussy." W8BIZ furnishes the SCM with the following news. W8AVZ and W8MN are coming on stronger than ever. W8BMT is a new ham. W8BIZ wants all the traffic he can find. W8AYI and W8TI have combined and are using call W8TI at W. V. U. W8BOK got in Dutch with the R. I. because some one was

using his call on 4000 kc. W8DNN plans an increase in power. W8CBY says he can't get schedules. W8JM wants your ideas on how to pull this "W. Va. Nite" off, and how you think the prizes should be awarded.

Traffic: W8OK 108, W8BTV 43, W8BOK 40, W8DPO 24, W8JM 20, W8HD 14, W8BOW 13, W8DNN 12, W8BIZ 5, W8CBY 3, W8TI 2, W8DMU 1.

NORTH CAROLINA — SCM, H. L. Caveness, W4DW — W4AHS has arranged some schedules and is settling down to regular ham business now. W4ABW sends in his first report. W4TR has been doing some experimenting with 'phone. W4KN and W4RR are new hams at Duke University. W4ABV remembered us when he landed in Baltimore, and sent us a card saying that the commercial game is fine business. W4AKC is keeping five schedules. W4JR has not yet learned how to make a living without working, so was off the air most of the month. W4BC has been on 14 mc. working eleven countries using a TPTG circuit with a single type '10. What are the other 24 hams up in Asheville doing? W4ZB has been working on that transmitter he's been telling us about. W4AGO wants ORS blanks. Meet W4AAE, who says that he is but six months old as a ham. W4EC is using a new rig made up according to the following recipe: a type '10 crystal oscillator, '10 buffer, '10 doubler, 203A intermediate amplifier, and finally a 204A amplifier. The chief operator of the U. S. cutter *Modok*, stationed at Wilmington, has put in a type '10 crystal oscillator, '10 doubler, 203A intermediate amplifier, and a pair of 203A's in the final stage. At this writing he has not yet received his ham call. W4TU keeps hammering away. W4AEL complains about unstable line voltage. W4AEL, W4TU, and W4AAE are yelping for schedules. RMs, attention! W4DQ has his portable. W4PAT, completed and is getting crystal reports. W4BV is very much on the air now with DC signals. W4AEW sends in a creditable report. W4EG has erected a zepp antenna. W4RV gets crystal reports with his Hartley. We frequently hear W4FT on the air. W4ALU is a new ham in Concord. W4OC observes that his new 100-watt TPTG 14-mc. transmitter is hot stuff, but not in the right places.

Traffic: W4DW 45, W4EC 31, W4AHS 29, W4AEW 28, W4ZB 25, W4TU 19, W4AKC 13, W4EG 13, W4AEL 11, W4BC 10, W4AGO 8, W4JR 8, W4ABW 7, W4TR 7, W4AAE 1.

VIRGINIA — SCM, J. F. Wohlford, W3CA — W3BZ is still confined to his room on account of illness. Cpt. Baldwin of W3CXM has been in hospital for several weeks recovering from injuries received in a fall. Kimmell of W3CXL is operating W3CXM during BN's absence. W3WO received a letter of congratulations from the Secretary of the Navy for his work in copying the Navy Day broadcasts. W3FJ visited in Washington, calling on W3CDQ and W3BWT. W3AAJ has been doing field work for WRVA. W3CFL was getting ready to celebrate a "first birthday" of his type '10 when it went west. W3SE, new ORS, is anxious for schedules with the larger cities. RM, attention! W3AEW threatens to crash all the cans in Richmond and elsewhere with his new outfit. W3ZU and W3AMB have been appointed OO. W3HY has been appointed OBS. W3ARU has built a dynatron. W3MO hopes to get his license back soon. W3AHW had trouble neutralizing his two 50-watters in crystal outfit. W3AJA has new transmitter. W3APT is just back from a three months' leave. W3BGS and W3KG are still tinkering with the outfit. W3ZA continues to knock them dead with his 'phone outfit. W3BDZ has his 'phone outfit going. W3BDW worked his outfit on 7000 kc., but is getting on 3500 now. The Richmond Short Wave Club held a banquet on December 13th and had a fairly good crowd of hams. Several prizes donated by club members were given away.

Traffic: W3CXM 443, W3WO 340, W3ARU 50, W3FJ 23, W3CFL 4, W3SE 5.

ROCKY MOUNTAIN DIVISION

COLORADO — SCM, Edward C. Stockman, W9ESA — The Associated Radio Operators of Denver sponsored a radio dance, which turned out to be a grand success. W9FRQ is doing good work on 3.5 'phone. W9DNP has been busy building a 75-watter for W9AOD. W9EAM and W9CDE are both strong for the Army-Amateur Net. W9AAB and W9GBQ have received their ORS certificates. W9GBQ is the new Route Manager. Go after him, fellows, if you want schedules. If any one in this Section is interested in Official Observer work, the SCM will be glad to hear from him. W9APZ is trying to get on the air with a new outfit. W9EFP is operating a 1750-cc. 'phone.

Traffic: W9FRQ 12, W9DNP 83, W9AOD 3, W9EAM 24, W9CDE 2, W9AAB 17, W9GBQ 11, W9FQK 40, W9FQJ 16, W9EFP 1, W9AUJ 9, W9ASD 5, W9BJN 23, W9ESA 161.

UTAH-WYOMING — Acting SCM, C. R. Miller, W6DPJ — W7AAH is keeping seven schedules and leads Wyoming as usual. W6BTX is rebuilding for 3.5-, 7- and 14-mc. bands. W7ALI reported by radio. W7HX is in the A.-A. Net and A.R.R.L. Net for the American Legion. W6DWH sends official broadcasts and announcements of UARC activity Mondays and Fridays, at 7:00 p.m., on 3545-ke. 'phone. W6DPO will soon be heard again. W6DPJ is on when he can find time.

Traffic: W6DPJ 62, W7AAH 47, W6BTX 34, W7ALI 26, W7HX 18.

SOUTHEASTERN DIVISION

ALABAMA — SCM, Robert Troy, Jr., W4AHP — W4KP, a new ORS, leads the state in traffic. W4ADL says the Birmingham Radio Club is coming along fine. W4LT is handling his part of the Alabama A.-A. net in fine shape. W4AKM is going to see the Alabama-Washington State game. W4IM is keeping up his fine work. W4VY is working towards an ORS appointment. W4HB, who is in Birmingham now, says several of the fellows there are putting in crystal control. W4TI and W4OH have combined resources in a 100-watt crystal outfit with the call W4RS. W4IA is having better luck with his 3500-ke. fone. W4AHP is rebuilding. W4AAQ is on only for the A.-A. schedules. The SCM was pleased by visits from W4TI, W4OH, and W4HB. The Troy Radio Club now has W4NQ on the air. W4AR is on occasionally. YLitis has W4CB. W4ZX is having trouble with his antenna. We welcome a newcomer, W4AIP of Mobile.

Traffic: W4ADL 62, W4KP 143, W4VY 6, W4AKM 4, W4LM 48, W4LT 46.

GEORGIA-SOUTH CAROLINA-CUBA-ISLE OF PINES-PORTO RICO-VIRGIN ISLANDS — SCM, M. S. Alexander, W4RZ — W4DV has nearly succeeded in taming his R.F. amplifiers. W4AFQ is still at sea. W4VH is expected home from Pennsylvania. The Augusta gang enjoyed a visit from W4LL. W4AAV is back from stay in Atlanta (not where you think — hi). W4VJ visited W4SS. School holds W4GT, W4ABU is snowed under with work at the Arsenal. W4AJH is taking the Army course in Elementary Military Cryptography. W4SS reports for a bunch of the fellows. W4PJ is working for ORS appointment. W4JD, W4SS and W4ACH make the BPL. FB. W4IS reports for first time to say he is glad to accept traffic and will QSP via radio, mail or "break a leg." K4KD is the Porto Rican station in the A.R.R.L. Communications Net for the American Legion. He keeps regular schedule with W2FN. K4RJ and K4UG are on the air looking for DX.

Traffic: W4JD 289, W4ACH 208, W4IS 72, W4SS 122, W4PJ 40, W4GT 39, W4AJH 19, K4KD 18, W4DV 18, W4AAV 13.

WEST GULF DIVISION

SOUTHERN TEXAS — SCM, H. C. Sherrod, Jr., W5ZG — Those keeping regular schedules should advise either RM Ward, W5RL, or RM Nersta, W5AJD. Down in the jungles of Sumatra Ex-W5NW, now signing PK5NW, will come on the air about the middle or latter part of March and is especially anxious to contact some of the Southern Texas bunch. Look for him between 5:30 a.m. and 7:30 a.m. C.S.T. Houston: W5BHO is dividing time between 7-mc. CW and 3500-ke. 'phone. Quite a few of the gang have the 'phone fever; take Havard, W5BKW, for instance! Even Jim Hunt, W5TG! W4EI has come on with a fifty-watter. W5WL reports for the first time. W5TG is broadcasting code instruction every evening on 1760 kes. from 7 to 8 p.m. C.S.T. W5BQF is working on an A.C. receiver. W5LP is heard Saturdays and Sundays in spite of QRM from Rice Institute. W5AZR is heard occasionally. W5AOC is rebuilding. W5BML has been having trouble with the "stop jar." W5VA is nursing a case generally diagnosed as oscillation of the final amplifier. Calveston: W5AUX has the crystal rig going. W5AVC has a new 100-watt push-pull rig. W5BQJ is QRMed by radio work (BCL variety). Corpus Christi: W5MS is going strong. W5ATY is handling traffic. W5AQK and W5BKG are building new transmitters. W5MX has erected a new Zepp antenna. W5ALV is also on with a new rig. W5AB has been in New Orleans for three weeks. Baytown: W5DS is trying to get things lined up for contacts with PK5NW. El Campo:

We are indebted to W5ACT for the following information. W5SY is using an 852 feeding a 7-mc. Hertz. He and W5MA are building a 100-watt crystal rig. W5ACK was hit by the Xmas rush! W5ACT is on quite consistently. Rosenberg: W5PU has been QSO OA4Z and OA4J. Kerrville: W5BKE is now on 14,000 kes. W5MT sends in a nice report also. He is working a schedule with W5ABQ at San Antonio every day except Sunday at 10:30 a.m. College Station: W5AQY is again heard from. Bay City: W5ABH says it has been too cold in the shack for activity during the past month. Your SCM has moved to Houston. His address is now 4315 La Branch St. All reports should be mailed to him there.

Traffic: W5BKE 8, W5AQY 18, W5DS 26, W5MS 26, W5AB 27, W5MT 31, W5EI 81.

OKLAHOMA — SCM, Wm. J. Gentry, W5GF — Sgt., R. F. Hinck, W5VQ, is leading the Section again. W5BQA was married on Dec. 3rd. W5BHQ burned out transformer in his power pack. W5ABB is perking with a type '10. W5PP is going good on 3500-ke. 'phone. W5VQ is falling for 'phone, too. W5CB is second high man. W5AMC reports he worked his first VK. W5OJ reports by W. U. W5BMU is going back to type '10s. W5AHV is on the air now. W5AFH is building a crystal 'phone. W5ASQ has a new car. W5GF is building a 3500-ke. transmitter. W5AUV has left the ranks of ORS again. W5KX has resigned as OBS. W5ABO is a new OBS on the 3500-ke. band. W5MM is going on crystal now. W5AFX has his new rig perking using crystal. W5BQW would like to see more fellows join the Naval Reserve. W5AAV has a crystal going. W5SW has QRM at his place of business. W5BLB is a new station at OU. W5PL reports for first time. Glad to hear from W5BOE.

Traffic: W5VQ 597, W5CB 248, W5AMC 147, W5PL 40, W5OJ 35, W5BMU 33, W5GF 5, W5BOE 6.

NORTHERN TEXAS — SCM, Roy Lee Taylor, W5RJ — W5CF, the father and son station, handled death messages between Ft. Worth and Abilene for W5AAO. W5HY relayed Presidential message from Houston to Washington in two hours. W5AUL is pounding out lots of traffic between fires. He wants schedules with El Paso and San Antonio. W5RH has a new TNT transmitter using a type '10. W5BAM complains of entirely too much off-frequency operation. W5BAD has been appointed OO and is also the RM now. W5WV says that AA schedules are causing traffic to pick up rapidly. Any stations now members of the A.-A. Net who care to take active part in AA activities should communicate with W5WW. The AA call, W1J1, is in use here. W5ALA reports that the SMU school of engineering will be on the air with a crystal job after the first of the year. W5ARV has finally got a card from VK. W5ASP is rebuilding. W5LY just got his new zepp. W5GZ was QSO XCBQ twice while XCBQ was on the Pacific Ocean. W5JV has some FB dope on 28, 56 and 1.75 mc. from G5VL, who is going to run tests in Jan., Feb., and March. For complete dope, write or QSO W5JV. W5AZP has a 'phone going now. W5BND is QRL. W5WB is on the air quite often. W5B11, a newcomer in our ranks, is having his troubles with single wire-fed hertz. W5AFI reports that portable W5AMY went to Corsicana recently when Cleburne played football at Corsicana; through the efforts of the club at Cleburne, a play by play report of the game was relayed back by 3500-ke. 'phone. W5AFI at Cleburne dished it out in the form of messages to about 400 BCLs. W5AJN has a new 15-watt MOPA on 3.5 and 1.75 mc. W5BJB is staying on 7 mc. most of the time. W5BOF, W5HI, W5BBH, and W5QZ are working 3500- and 1750-ke. 'phone. W5GL has a 250-watt 3.5-mc. 'phone going. W5KL is putting the finishing touches on his 250-watt 3.5-mc. 'phone job. W5ARK has moved to Big Springs. W5ACL is on now with his push-pull rig. W5RJ will be on the air with his new 250-watt crystal-controlled ether buster by the time this report is read. W5BQT is having a hard time getting over the back fence with his type '10. W5BAR has sold out to W5RJ. W5GI will soon be ready with his 14-mc. job. W5ACQ-W5AVS are still trying to get a type '10 to kick a pair of 852s in their crystal job. W5EH is off of radio as the YL has become friendly again. HI. W5AEM has a 3.5-mc. 'phone job. W5BG is also on 3.5-mc. 'phone. W5BNN is trying to fix up remote control between his shack and the house so that he can stay with the OW at night. We could use quite a few new ORS, OBS, another RM, and several OOs. If you can qualify for any of these appointments, please apply at once. Come on, gang, let's put Northern Texas in its place.

Traffic: W5CF 130, W5HY 121, W5AUL 68, W5RH 65,

W5BAM 55, W5BAD 54, W5WW 34, W5ALA 31, W5ARV 14, W5ASP 8, W5LY 4, W5GZ 3, W5JV 3.

NEW MEXICO — SCM, Leavenworth Wheeler, Jr., W5AHI — W5TV took over the SCM's schedules for a couple of weeks. W5AJL, W5AJR, W5AND, W5AOD, W5AOE, W5AOU and W5BHY have all enrolled in the Navy Net. W5AOD comes through with a nice total. W5AJR does a little better each month. W5AUW is running him a close second. Be careful W5AOE doesn't come from behind and fool you. W5AJL is still rebuilding. W5BHY rebuilt his receiver. W5BQE was QRL. W5AOU is cramming for the commercial exam. W5AHI busts into the BPL again.

Traffic: W5AHI 324, W5TV 214, W5AOD 139, W5AJR 32, W5AUW 23, W5AOE 17, W5AJL 15, W5BHY 9, W5BQE 8.

CANADA

1931 promises to be a banner year for Amateur Radio in Canada. From coast to coast come reports of new calls being issued, and we fully expect that all previous records in the number of licenses issued will be broken this year.

Fair results are now being had from the All-Canada Route. With a few more Quebec and Maritime stations to schedule Ontario, traffic would be moving 100% via the All Red Line from Ocean to Ocean. Keep Wednesday nights for Canadians.

CANADIAN GENERAL MANAGER

ALEX REID, VE2BE

MARITIME DIVISION

NOVA SCOTIA — SCM, A. M. Crowell, VE1DQ — VE1AB recently completed a new receiver. VE1AS has again flown to 14 mc. VE1AW is going strong on 3.5-mc. 'phone. VE1AX is working the W's right and left with his 'phone. VE1BR paid a visit to the bunch at Glace Bay. VE1CC is proud possessor of foreign QSL card bearing a photo. VE1DA is at it again with new transmitter and receiver. VE1DM returned from the U. S. A. VE1DQ is now crystal-controlled on 3542.1 kc. and 3559.8 kc.

ONTARIO DIVISION

ONTARIO — SCM, C. D. Lloyd, VE3CB — I should like to extend my sincere thanks to all those who made my election to this important position possible, and to ask for the cooperation of all stations in the Third District in sending in reports promptly and regularly. VE3GT makes the BPL two ways. VE3HA is a good runner-up. VE3FC is carrying on in his usual thorough manner. VE3BE is an applicant for ORS. VE3GK and VE3HE have been rebuilding. VE3BV has recently come on with a 50. VE3HG is a newcomer in Toronto. VE3BC has been busy with school. VE9AL is with us with a good report. VE3CS has BCL trouble. VE3GF, VE3CF, and VE3RF are heard consistently. VE3GV is about ready to come on with a 50. VE3HB has rebuilt his receiver using 2-volt tubes. VE3BT is on the air with a new 14-mc. 'phone using crystal. VE3EC is putting in crystal control. VE3OC, VE3XL, and VE3HF are all on the job. VE3GP has a type '10 on both 'phone and c.w. VE9BV says he can work any 'phone he can hear. VE3XA is on occasionally. VE3FJ is working real DX on 14 mc. VE3PB is experimenting on 28 mc. VE3CE is on air every chance he gets. VE3DA is working mostly on 3500 kc. VE3GX reports VE3HN and VE3GB, new hams in Fort William. VE3DW has been making improvements in his station. VE3AD reports difficulty in getting schedules. VE3DM reports weather conditions very poor for radio. VE3HD has a good total. VE3HA reports northern lights very bad. VE3FD is working 'phone on 3505 kc. and C.W. on 3650 kc. VE3CB is on air regularly.

Traffic: VE3GT 231, VE3HA 104, VE3HD 43, VE9AL 29, VE3GK 17, VE3AD 10, VE3GX 9, VE3DW 8, VE3DA 7, VE3FD 3, VE3CB 2, VE3HB 3.

QUEBEC DIVISION

QUEBEC — SCM, Alphy Blais, VE2AC — VE2CA works DX on 14-mc. 'phone and C.W. on 3.5 mc. VE2AP uses crystal control on 3655 kc. for C.W. and on 3530 kc. for 'phone. VE2CL is going fine. Report from VE2AP states VE2BO as active on 7 and 14 mc. VE2CP is handling traffic. VE2CO is on 7 mc. with low power. VE2BE, VE2CA, VE2HV, VE2DN, VE2EV, VE2AV, VE2EM and VE2AL are on 'phone on Sunday mornings. The ORS total is two at present: VE2BE, VE2CA. VE2AC worked five continents on 14 mc. this month. Reports were few this month. We certainly can and must do better. Let's report to the SCM before the 18th each month. The Quebec Division must be the leader in 1931. A very successful ham-fest was held December 17th at VE2BE. Many amateurs were present, including VE4DL. Prizes donated were a 211E won by L. S. Coulton, radio inspector; a UX230 and UX232 won by VE2BY and a UY227 and UY224 drawn by VE2DN.

Traffic: VE2AC 36, VE2CA 15, VE2CL 4, VE2AP 7.

VANALTA DIVISION

ALBERTA — SCM, G. F. Barron, VE4EC — VE4EI crashes the BPL. VE4DT has built the November QST push-pull. A prospective ham at Linbergh will soon be in the game. VE4GM reports via radio. VE4EW and VE4BJ are still QRL. VE4GT still buzzes around. VE4EA is using push-pull. VE4FY is pumping out a FB DC signal on 7000 kc. VE4CU manages to get on once in a while. VE4HM is QRL on the railroad. VE4GD reports with nice traffic total. A banquet, attended by approximately thirty or forty, marked the opening, officially, of the A. R. E. A. station, which is now active at Calgary. VE4DX worked Panama, RX4C. VE4GD, VE4CY, VE4DX, VE4IO, VE4FG, VE4CE, VE4CG, VE4KX, VE4KT and VE4IT are all active stations in Calgary. VE4CY has got the craze for 'phone. VE4EW has a 3500-kc. 'phone outfit. VE4EA is planning on building one.

Traffic: VE4EI 202, VE4GD 150, VE4DT 16.

BRITISH COLUMBIA — SCM, J. K. Cavalsky, VE5AL — VE5BR is on with four daily schedules. VE5AW is on 3500 kc. VE5CO is still fighting QRM. VE5HP burned up his motor generator. VE5EC has rebuilt on 14 mc. VE5CB has been on a few times. VE5AD has a push-pull transmitter. VE5CW reports fine DX on a pair of type '01s. VE5AN lost his job. VE5FI is talking of moving. VE5AM is handicapped by a poor location. VE5AL hasn't had much time lately. VE9AJ is putting out a nice signal. VE5BP hasn't had much success with his Hartley. VE5AC manages to handle the odd message. VE5AG is on again.

Traffic: VE5EC 12, VE5AC 9, VE5AM 6, VE5AN 12, VE5BP 2, VE5FI 1, VE5AL 36, VE5AG 12, VE9AJ 2.

PRAIRIE DIVISION

MANITOBA — SCM, A. V. Chase, VE4HR — VE4DK again leads the section. Three new stations made their appearance this month: VE4AG, VE4KK and VE4KA. VE4BQ, VE4FN and VE4HR are giving code lessons. VE4BD has broken into the traffic list. VE4GQ has been reported heard in England with his 14-mc. 'phone outfit. VE4HR has been trying out 28 mc. during week-ends. VE4BQ is still working DX on 14 mc. VE4BU was out of commission three weeks awaiting replacement of a defunct grid leak. VE4FN is mourning the loss of two type '10s.

Traffic: VE4DK 43, VE4BD 13, VE4BU 7, VE4HR 7, VE4BQ 5, VE4JB 3, VE4FP 1.

SASKATCHEWAN — SCM, W. J. Pickering, VE4FC — VE4BB has been appointed RM. Give him your help, fellows. VE4CN is on again with a new receiver. VE4GN is a new ham at Glaslyn. VE4CV is an aspirant for an ORS. VE4DI is on Sundays. VE4IH wants a sure-fire schedule with a Manitoba ham. VE4GR has been laid up for two months with BCL irritation. VE4HU turns in his first traffic report. VE4BE has been affected by the poor WX. VE4AT is after an ORS. VE4IL has broken into the traffic game. VE4GO has his new power supply working. VE4FC is on more frequently of late. One more OT has come back to the fold, VE4HS-X4GH. VE4FY is coming on shortly with a 50-watt. VE4HL has moved to Regina.

Traffic: VE4BB 102, VE4CV 86, VE4IH 37, VE4GR 18, VE4HU 12, VE4BE 10, VE4AT 8, VE4IL 5, VE4GO 2, VE4FC 2.