

QST

DEVOTED ENTIRELY TO

AMATEUR RADIO

Published by the American Radio Relay League



APRIL
1927

25¢

Cunningham

RADIO TUBES

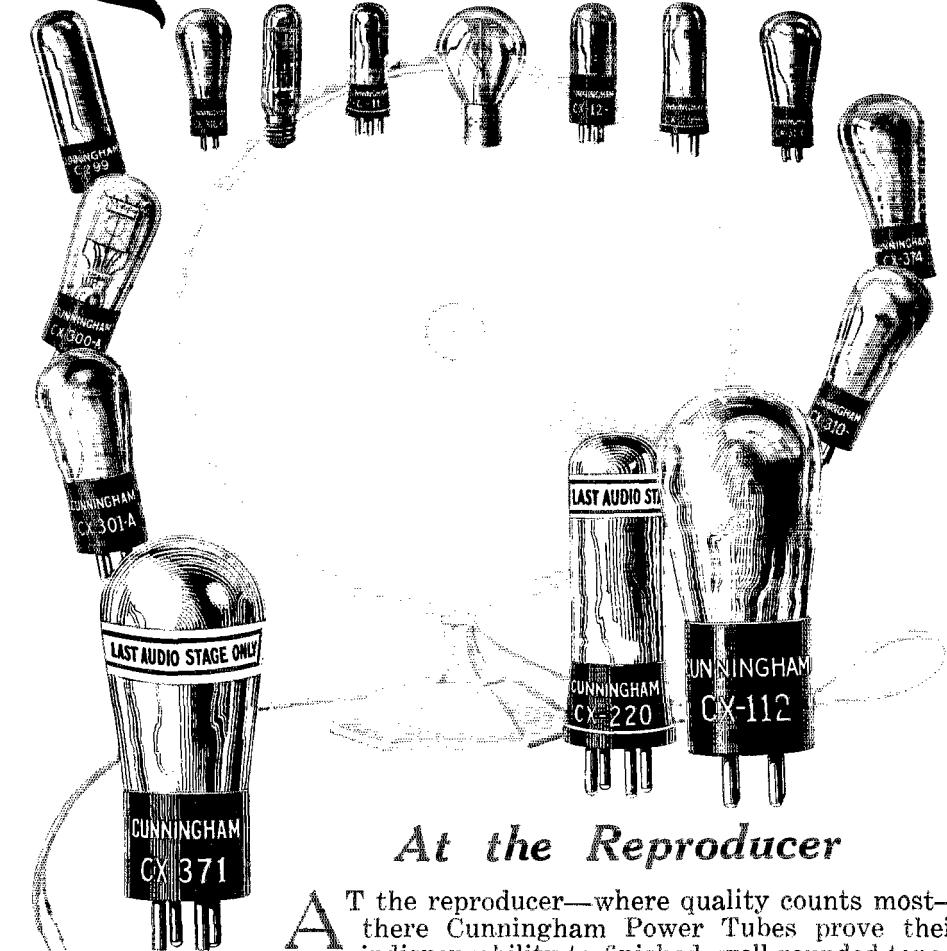

Since 1915
Standard
for all
Sets.

At the Reproducer

AT the reproducer—where quality counts most—there Cunningham Power Tubes prove their indispensability to finished, well-rounded tone.

Just as CX-371, CX-112 and CX-220 are leaders in the crusade for more natural reproduction, so other Cunningham types are leaders in their various fields.

Consult your dealer. He knows the right combination of Cunningham radio tubes for your receiver.

Sixteen Types all in the Orange and Blue Carton.

E. T. CUNNINGHAM, INC.

New York

Chicago

San Francisco

Manufactured and sold under rights, patents and inventions owned and/or controlled by Radio Corporation of America.



The stations are there get them!

You're not getting the most out of that storage battery set of yours. The *set* has a bigger distance reach . . . all it needs is a different tube in the detector socket. Put in the RCA super-detector—Radiotron UX-200-A. You'll get more stations—get the far-away ones more regularly and more easily! It's a small change, but it brings big results.



Bring your storage battery set up-to-date with
a power RADIOTRON UX-171 or UX-112
a detector RADIOTRON UX-200-A
and RADIOTRONS UX-201-A for all-round quality.
Bring your dry battery set up-to-date with
a power RADIOTRON UX-120
and RADIOTRONS UX-199 for all-round quality.



RADIO CORPORATION
OF AMERICA
New York San Francisco Chicago

RCA Radiotron

MADE BY THE MAKERS OF THE RADIOLA

It will never "Run Down"!

Majestic "B" Current Supply

delivers pure direct current—from your light socket

**"B" Power at full strength
any time and all the time**

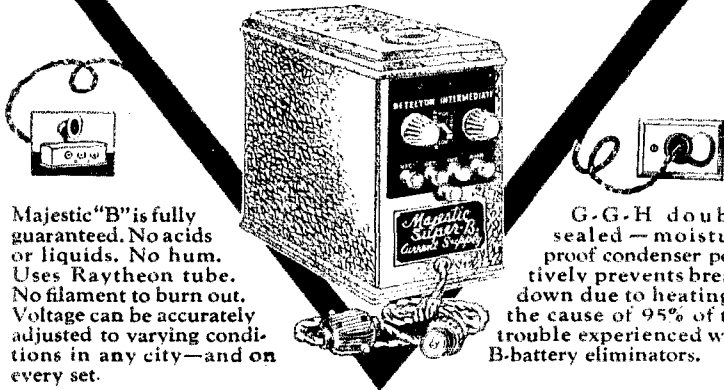

Majestic "B" is fully guaranteed. No acids or liquids. No hum. Uses Raytheon tube. No filament to burn out. Voltage can be accurately adjusted to varying conditions in any city—and on every set.

G-G-H double sealed—moisture proof condenser positively prevents breakdown due to heating—the cause of 95% of the trouble experienced with B-battery eliminators.

When you buy a Majestic "B" you say "Good-bye" to trouble

caused by poor "B" power. Majestic gives you an even, continuous flow of "B" current today, tomorrow—whenever you turn on your set. It's economical, too. When you put a "Majestic" to work it stays put. You'll never have to "replace" it as you did "B" batteries. Majestic's first cost is low, and the upkeep only a fraction of a cent per hour.

To know how good, really good radio reception can be, try a "Majestic" on your radio set. Your dealer will arrange a trial without obligation to buy. Phone him today.

Majestic Standard-B
Capacity, nine 201-A tubes or equivalent. 45 milliamperes at 135 volts.

\$26.50

West of Rocky Mts., \$29.
Raytheon Tube \$6.00 extra

Majestic Super B

Capacity one to twelve tubes, including the use of power tubes. 45 mils. \$29.00 at 150 volts..

AS ILLUSTRATED:

West of Rocky Mts. \$31.50
Raytheon Tube \$6.00 extra

Majestic Master-B

Positive control of all output voltage taps. For sets having high current draw or heavy biasing batteries. 60 mils. at 150 volts.

\$31.50

West of Rocky Mts. \$34.00
Raytheon Tube \$6.00 extra

Can Be Purchased on Deferred Payments

GRIGSBY - GRUNOW - HINDS - CO. 4562 ARMITAGE AVE. CHICAGO-ILL.

Section Communications Managers of THE COMMUNICATIONS DEPARTMENT, A. R. R. L.

Eastern Pennsylvania SBQ
Maryland-Delaware-District of Columbia 3AH
Southern New Jersey 3EHI
Western New York 3PI
Western Pennsylvania 3XE

Illinois 9AAW
Indiana 9CYQ
Kentucky 9ABU
Michigan 8ZZ
Ohio 8BYN
Wisconsin 9VD

North Dakota 9EPN
South Dakota 9BDW
North Minnesota 9EGU
South Minnesota 9BYA

Arkansas 5AIP
Louisiana 5UK
Mississippi 5AKP
Tennessee 4KMI

Eastern New York 2ADH
N. Y. C. & Long Island 2UWR
North New Jersey 2WR

Iowa 9BKV
Kansas 9DNG
Missouri 9RH
Nebraska 9BYG

Connecticut 1BM
Maine 1BIG
Eastern Massachusetts 1BYL
Western Massachusetts 1DR
New Hampshire 1ATJ
Rhode Island 1BYB
Vermont 1AJG

Alaska* 7DE
Idaho 7ST
Montana* 7AAT
Oregon* 7TT
Washington* 7FD

Hawaii 6BDL
Nevada 3UO
Los Angeles 6BUR
Santa Clara Valley 6NX
East Bay 6EX
San Francisco* 6ECS
Sacramento Valley* 6CBS
Arizona 6ANO
Philippines 6PIAU
San Diego 6BQ

North Carolina 4IR
Virginia 3CA
West Virginia 8BSU

Colorado 9CAA
Utah-Wyoming 9RAM

Alabama 5AIP
Florida 4QY
Georgia-South Carolina-Cuba-Porto Rico-Isle of Pine 1KU

Northern Texas 5AJT
Oklahoma 5APG
Southern Texas 5YK

Newfoundland 5AR
New Brunswick 1RT
Nova Scotia 1DD
Prince Edward Island 1BZ

Ontario 6BJ

Quebec 2BH

Alberta 4GT
British Columbia 6BJ

Manitoba 4DE
Saskatchewan 4FC

ATLANTIC DIVISION

H. M. Wallace 597 No. James St. Hazleton
A. R. Goodall 1824 IngleSide Terrace Washington, D. C.
H. W. Densham 140 Washington St. Collingswood
C. S. Taylor 598 Masten St. Buffalo
G. L. Crossley State College

CENTRAL DIVISION

W. F. Schweitzer 4264 Hazel Ave. Chicago
D. J. Angus 310 N. Illinois St. Indianapolis
D. A. Downard 116 No. Longworth Ave. Louisville
C. E. Darr 137 Hill Ave. Highland Park, Detroit
H. C. Storek 694 Carpenter St. Columbus
C. N. Crapo 443 Newton Ave. Milwaukee

DAKOTA DIVISION

G. R. Moir 618 11th Street, South Fargo
F. J. Beck Milbank
C. L. Barker Hennig
D. F. Cottam 3538 Third Ave. So. Minneapolis

DELTA DIVISION

Leonard Clippard 2498 North Pierce St. Little Rock
C. A. Freitag 129 Camp St. New Orleans
J. W. Gullett 1708 23rd Ave. Meridian
L. K. Rush 4 Second St. Beuis

HUDSON DIVISION

Earle Peacock Box 113 Yonkers
P. H. Marston 117-11 140th St., So. Ozone Park, L. I.
A. G. Wester, Jr. 59 Princeton St. Hilton

MIDWEST DIVISION

A. W. Kruse Akron
F. S. McKeever 1317 Mich. St. Lawrence
L. B. Lalzure 3010 Mercier St. Kansas City
C. B. Delmi 3605 Cedar St. Omaha

NEW ENGLAND DIVISION

H. E. Nichols 82 Elmwood Ave. Bridgeport
Frederick Best 13 E. Crescent Blg. Augusta
R. S. Briggs 398 Ashmont St. Dorchester
A. H. Carr 50 Vassar St. Worcester
V. W. Hodges 227 Main St. Charenton
D. B. Fancner 52 Summer St. Westley
C. T. Kerr Poulney

NORTHWESTERN DIVISION

L. H. Machin Box 452 Corvova
Henry Fletcher 1610 N. 10 St. Boise
O. W. Viers Red Lodge
A. C. Dixon, Jr. 1350 East 36th St. Portland
Otto Johnson 4340 30th Ave. W. Seattle

PACIFIC DIVISION

John A. Lucas Box 1142, Fort Shafter Oahu
C. B. Newcombe Yerington
L. E. Smith 340 No. Painter Ave. Whittier
F. J. Quement 51 Pleasant St. San Jose
P. W. Dann 562 35th St. Oakland
G. W. Lewis 748 14th St. San Francisco
C. F. Mason 2530 N. St. Sacramento
H. B. Lamb 229 W. First St. Mesa
Manuel L. Felizardo 252 Galicia St. Manila
G. A. Sears 226 Bonair St. La Jolla

ROANOKE DIVISION

R. S. Morris 413 S. Broad St. Gastonia
J. P. Wohlford 118 Cambridge Ave. Roanoke
C. S. Hoffmann 126 Chantal Court Wincing

ROCKY MOUNTAIN DIVISION

C. R. Stedman 1641 Albion St. Denver
Don C. McRae 211 Belvedere Apts. Salt Lake City

SOUTHEASTERN DIVISION

A. D. Trum 217 Catoma St. Montgomery
W. F. Grosan Box 816 Ft. Myers
H. L. Reid 11 Shadowlawn Ave. Atlanta

WEST GULF DIVISION

W. B. Forrest, Jr. 502 Royal St. Waxahachie
K. M. Ehler 2904 N. Robinson St. Oklahoma City
E. A. Sahn 146 N. Academy St. New Braunfels

MARITIME DIVISION

Loyal Reid Avalon House St. Johns
T. B. Lacey C. N. B. Power Co. St. John
W. C. Borrett 14 Sinclair St. Dartmouth
W. A. Hyndman 25 Fitzroy St. Charlottetown, P. E. I.

ONTARIO DIVISION

W. Y. Sloan 167 Close Ave. Toronto

QUEBEC DIVISION

Alex Reid 292 Birch Ave. St. Lambert

VANALTA DIVISION

A. W. Asmusseu 2123 18th St. W. Calgary
E. S. Brooks c/o Forestry Dept. Radio Court House, Vancouver

PRAIRIE DIVISION

F. E. Rutland, Jr. 452 St. John Ave. Winnipeg
W. J. Pickering 514 19th St. W. Prince Albert

*Temporary officials appointed to act until the membership of the Section concerned choose permanent SCMs by the nomination and election.

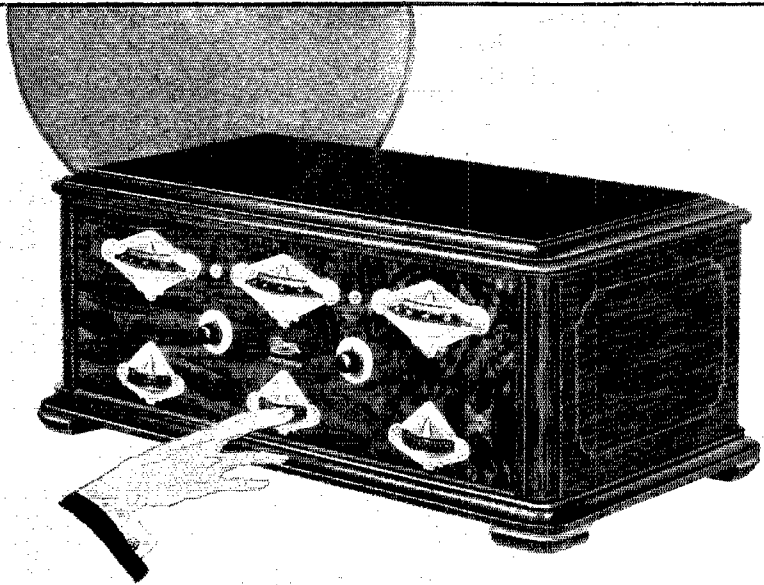

Its Flexible One Dial Control

*is but one of seven reasons
why you'll want a Grebe*

WITH its Flexible Unit Control the Grebe Synchronphase Radio becomes a one-dial control set—a great convenience for tuning local stations—with the added advantage of individual dial setting whenever desired.

Booklet Q tells about all seven advantages of the Synchronphase. Send for it.

A. H. Grebe & Co., Inc., 109 W. 57th St., N. Y. C.
Factory: Richmond Hill, N. Y.
Western Branch: 443 So. San Pedro St., Los Angeles, Calif.
The oldest exclusive radio manufacturer

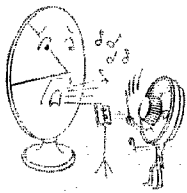

Coloritone

Gives you control of the pitch and timbre of the loud speaker's voice, eliminating the harsh, unnatural sounds which spoil reception.



The Synchronphase is also supplied in five console models.

The **GREBE** Synchronphase **RADIO**



QST



The Official Organ of the A.R.R.L.

VOLUME XI

APRIL, 1927

NUMBER 4

Editorials	7
Re: the International Tests	8
The New England Division Convention	8
Radio Translated for the Experimenter	9
Dakota Division Convention	12
The 1927 Meeting of the A.R.R.L. Board	13
An Overroad Relay	14
A 15-Meter Commercial Station—2XS	15
Which Is the Detector Tube?	17
Power Tube Sockets	19
The Institute of Radio Engineers	20
A Traffic Tuner	23
Radiotron CX-340—UX-240	26
Handy Resistance Units	30
60I Wins the Modesto Wouff Hong	30
A Sensitive Thermo-Couple	31
The Purpose of the Army-Amateur Affiliation	33
Developments in Dry Electrolytic Rectifiers	34
The New Radio Law	39
How Far Is It?	45
The Most Useful Meter	47
A Ten-Cent "Bug" Key	54
Electrolytic Filter Condensers	55
Experimenter's Section Report	58
Amateur Radio Stations 4JR, 6DCQ, 9DNG	60
Calls Heard	63
I.A.R.U. News	68
Correspondence	72

QST is published monthly by The American Radio Relay League, Inc., at Hartford, Conn., U. S. A.
 Official Organ of the A.R.R.L. and the International Amateur Radio Union

Kenneth B. Warner (Secretary, A.R.R.L.),
 Editor-in-Chief and Business Manager

F. Cheyney Beekley,
 Managing Editor and Advertising Manager

Robert S. Kruse,
 Technical Editor

Harold P. Westman,
 Assistant Technical Editor

David H. Houghton,
 Circulation Manager

Subscription rate in United States and Possessions, Canada, and all countries in the American Postal Union, \$2.50 per year, postpaid. Single copies, 25 cents. Foreign countries not in American Postal Union, \$3.00 per year, postpaid. Remittances should be by international postal or express money order or bank draft negotiable in the U. S. and for an equivalent amount in U. S. funds. Entered as second-class matter May 29, 1919, at the post office at Hartford, Connecticut, under the act of March 3, 1879. Acceptance for mailing at special rate of postage provided for in section 1103, Act of October 3, 1917, authorized September 8, 1922. Additional entry as second-class matter, acceptable at special rate of postage provided for above, at Springfield, Mass., authorized September 17, 1924.

Copyright 1927 by the American Radio Relay League, Inc. Title registered at United States Patent Office.
 Member of the Radio Magazine Publishers' Association.

The American Radio Relay League

The American Radio Relay League, Inc., is a non-commercial association of radio amateurs, bonded for the promotion of interest in amateur radio communication and experimentation, for the relaying of messages by radio, for the advancement of the radio art and of the public welfare, for the representation of the radio amateur in legislative matters, and for the maintenance of fraternalism and a high standard of conduct.

It is an incorporated association without capital stock, chartered under the laws of Connecticut. Its affairs are governed by a Board of Directors, elected every two years by the general membership. The officers are elected or appointed by the Directors. The League is non-commercial and no one commercially engaged in the manufacture, sale or rental of radio apparatus is eligible to membership on its board.

"Of, by and for the amateur", it numbers within its ranks practically every worth-while amateur in the world and has a history of glorious achievement as the standard-bearer in amateur affairs.

Inquiries regarding membership are solicited. A bona fide interest in amateur radio is the only essential qualification; ownership of a transmitting station and knowledge of the code are not prerequisite. Correspondence should be addressed to the Secretary.

Officers

President HIRAM PERCY MAXIM, Hartford, Conn.
Vice-President CHAS. H. STEWART, St. David's, Pa.
Secretary KENNETH B. WARNER, Hartford, Conn.
Treasurer ARTHUR A. HEBERT, Hartford, Conn.
Communications Manager . . . F. EDWARD HANDY, Hartford, Conn.

Directors

President
HIRAM PERCY MAXIM
 Drawer 2102
 Hartford, Conn.

Vice-President
CHARLES H. STEWART
 St. David's, Pa.

Canadian General Manager
A. H. K. RUSSELL
 5 Mail Bldg.
 Toronto, Ont.

Atlantic Division
Dr. EUGENE C. WOODRUFF
 234 W. Fairmount Ave.
 State College, Pa.

Central Division
CLYDE E. DARR
 137 Hill Ave., Highland Park,
 Detroit, Mich.

Dakota Division
C. M. JANSKY, JR.
 Dept. of Elec. Eng., U. of M.
 Minneapolis, Minn.

Delta Division
BENJ. F. PAINTER
 424 Hamilton Nat'l Bank Bldg.
 Chattanooga, Tenn.

Hudson Division
DR. LAWRENCE J. DUNN
 480 East 19th St.
 Brooklyn, N. Y.

Midwest Division
PORTER H. QUINBY
 Box 184A, Route 6,
 Omaha, Neb.

New England Division
DR. ELLIOTT A. WHITE
 Dartmouth College
 Hanover, N. H.

Northwestern Division
K. W. WEINGARTEN
 3219 No. 24th St.,
 Tacoma, Wash.

Pacific Division
ALLEN H. BABCOCK
 65 Market St.,
 Southern Pacific Co.
 San Francisco

Roanoke Division
W. TREDWAY GRAVELY
 503 Main St.,
 Danville, Va.

Rocky Mountain Division
PAUL M. SEGAL
c/o District Attorney
 West Side Court Bldg.
 Denver, Colo.

Southeastern Division
HARRY F. DOBBS
c/o Dobbs & Wey Co.,
 Atlanta, Ga.

West Gulf Division
FRANK M. CORLETT
 2515 Catherine St.,
 Dallas, Tex.

Address General Correspondence to Executive Headquarters, Hartford, Conn.

EDITORIALS

BIG news seems to have a habit of breaking on Fridays or Saturdays, just in time for the Sunday morning newspapers but with utter disregard for the limitations of monthly magazines. Here we had the complete text of the new radio law set in type for the last issue, with a nice announcement saying that here was our new radio law, and we even had a nice editorial all written on the subject last month, all waiting for an unheedful Senate to take the final step and pass the bill. We waited as long as we could but finally had to rewrite our editorial to say that we were again about to have a new law, instead of saying "Here it is". And then of course as soon as we got to press the thing got passed, and on the 23d of February the President signed it. It's a crool world.

To form the Radio Commission the President appointed the following men: from the first zone, O. H. Caldwell, editor of *Radio Retailing*, New York, five years term; second zone, Rear Admiral Wm. H. Bullard, U. S. N., retired, of Media, Pa., appointed for six years, and to be first chairman of the Commission; third zone, Judge Eugene O. Sykes, of Jackson, Miss., former justice of the Mississippi Supreme Court, four years term; fourth zone, Henry A. Bellows of Minneapolis, director of Station WCCO, three years; J. F. Dillon, Supervisor of Radio at San Francisco, two years.

Now the merry war begins. We are afraid that the radio situation is by no means cleared up by the passage of this new law. Altho probably as good a law as could be expected for a compromise measure, there are other factors than the law itself to complicate the situation. What of vested rights, what of acquired rights to use one's property, what of the right conveyed in an unexpired license? This last is a very real right that is not to be denied merely by a new law which requires a new license from a new source. These are knotty problems and the possibilities of legal tangles in the readjustment of broadcasting seem sufficient to make recent radio court cases look like a game of tiddledewinks. These commissioners have a fearful job ahead of them. If they get anywhere at all in six months it will be marvelous. If they decline to relicense about eighty percent of the broadcasting stations, which everybody except the owners of said stations believes should be done, they encounter a flock of court proceedings; if they fence off a small

area and dump all the fourth-raters in there to fight it out amongst themselves, ditto; if they leave things alone, ditto. We wouldn't have one of those commission jobs for the combined salaries of the five gents! Life for them may not be happy but it's surely going to be vivid these next few months.

The new law requires that within sixty days (that is, by April 23rd) every station must take out a license from the new commission. How in the world it's going to be done we don't know. At this writing the Commission has not met, and no regulations on how to proceed have been issued. We hope it occurs to the Commission that their task would be greatly simplified if they could find some way of recognizing the existing licenses of the some sixteen thousand amateur stations, rather than try to re-issue them at the time when broadcasting demands so much of their attention. It has been prophesied that it will be a great many months before the Commission can give attention to anything other than broadcasting. Considering that all other services are reasonably content and that in particular in the short waves below 200 meters there has been an allocation in effect for some years which is satisfactory and on the basis of which the numerous services have built and installed their equipment, we venture to hope that it will similarly occur to the distinguished gentlemen of the Commission that they could immensely lighten their labors if they would reaffirm the allocations of the Fourth National Radio Conference respecting the waves below 200 meters, an action which so far as we are aware would be satisfactory to everybody concerned.

This country is now about to test in practice a theory which has been largely expounded in recent years: that a radio law should contain no technical stipulations, no guaranties to anyone, but should give discretionary power in regulations to an administrative authority. We shall very soon see.

The complete text of the new law appears in this issue. It deserves the careful study of every amateur.

IN the December 31st issue of the "Radio Service Bulletin" the Department of Commerce devotes nine pages to a summary of important events in radio—peaks in the waves of wireless progress. The

record starts in 1827 and includes such monumental items as Faraday's discovery of electromagnetic induction, Henry's first production of electric oscillations, Maxwell's and Hertz' developments of their classic theories, Marconi's conclusion that Hertzian waves could be used for telegraphy, the first successful signalling, and so on thru the gradual progress of the art. We don't find anything about amateurs before the war, but in 1919 "The war-time ban on private and experimental wireless stations was removed". Next year "Amateur radio work in this and other countries progressed steadily during the year with the gradual removal of war-time restrictions". Not a word about those record-breaking Transcons, the most thrilling achievement of all American amateur history, but we get ours in 1921: "The progress made in amateur and experimental wireless is exemplified by the attempts made in February and December of this year to effect communication on short wavelengths between the wireless amateurs of the United States and Great Britain. The first attempt was unsuccessful, but during the second test signals from many American amateur stations were heard both by British radio amateurs and by the representative of the American Radio Relay League [Paul F. Godley—Ed.] who was sent over for the tests. The signals were also heard in Holland".

But if that's good, how about the next item?: "The American Radio Relay League held its first annual convention in Chicago, August 30-September 3, at which many thousands of amateurs of the United States were present".

In 1923 "Short wave lengths were used to greater advantage than heretofore" but the record doesn't say by whom. But in 1925 "Amateur operators by their interest have made considerable achievements in the development of short waves".

Thereafter we don't appear in the record, fellows. Nothing about our linking all the countries of the globe by short waves, not a word about any of our 1926 achievements. Let's be so darned good in 1927 that they will have to print a supplement to the blinking Bulletin next year to record our achievements!

K. B. W.

Re: The International Tests

THESE tests which were announced in last QST have a number of important objectives. They promote international fellowship and goodwill in addition to making possible some rare sport with a pile of new records for every station that takes part. Stations must help each other over with test messages to boost the score equally at both ends of a QSO.

U. S. and Canadian Hams: Please note that reply test messages may be accepted from several foreign stations in one foreign locality—though only *one* message may be taken from each station worked. The particular amateurs working MOST stations in any one foreign country and receiving reply test messages will be appointed Official Foreign Contact Stations for that country. Read over the Rules of the Contest in March QST (pages 28 and 29) for further details. In addition to the O. F. C. S. certificates that will be awarded the tests will show the amateur station working two-way with the *greatest number of foreign localities* during the two weeks of the tests—and also the *highest scoring amateur station* under the rules of the contest. Get your entry card in early to make *sure* of getting your message assignment sheet in time.

All other amateurs in the world: The highest scoring stations in each foreign locality will be presented with a fine achievement certificate making them O. F. C. S. for their locality and attesting to the accomplishments of these stations during the contest. The Canadian General Manager especially requests all amateurs in British Dominions to listen for Canadians on the 52.5-meter special band as well as on other waves which are the same as those used by U. S. amateurs. It will be interesting to see which foreign localities can QSO most (a) United States and (b) Canadian amateurs in the two weeks of the contact contest. Amateurs in foreign localities are requested to pay no attention to calls from U. S. stations found on wavelengths below or above the assigned U. S. wavebands.

—F. E. H.

New England Division Convention

PREPARE yourselves for the big annual convention of the New England Division to be held in Hartford, Conn., on April 15th and 16th at the Hotel Garde.

It's going to be the biggest and best in years. The Radio Transmitters' Association under whose auspices the convention will be held has arranged a wonderful program. Talks by eminent radio specialists, a trip to QST factory (incidentally A.R.R.L. headquarters) and many other events of interest will keep you pepped up all the while you are in Hartford.

Cost, including banquet Saturday night, \$4.50. Hotel Garde will furnish you rooms at \$2.00 (single), \$3.50 (double). We suggest that you write them for reservation.

Make plans now, fellows, and COME TO HARTFORD!

Radio Translated for the Experimenter

By C. William Rados*

IT is generally admitted that the experimenter is advancing science. Unfortunately, the majority of radio experimenters in America is investigating (or

.002 meters long which is to say 2 millimeters.² More recent work with spark-type radio transmitters has extended this downward right across the lower boundary of the radio territory shown in Fig. 1 and well into the next territory to the left.

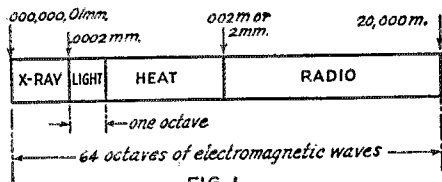

FIG. 1

tinkering) for their own education. They do not advance science much because they think of radio as something peculiar and having no connection with ordinary things. To look at radio in this way prevents the experimenter from using the general information he already has (or can easily get) and thereby to increase the usefulness of his experiments to himself and to the science. It also prevents him from taking advantage of the well tested methods used in other kinds of experimenting.

This article will try to point out the similarities between radio laws and the laws of our old acquaintances; heat, light, mechanics and wave motion—things we have been acquainted with all our lives.

WAVE MOTION

To begin with, radio vibrations are the same in character as heat, light, X-rays and gamma rays. All of these except the gamma rays are familiar to us and even the gamma rays have at least been heard of by most experimenters. All of these (from the heat to the gamma ray) are *electro magnetic waves*. Fig. 1 gives an idea of the range of the electro magnetic vibrations. Although it is not drawn to scale, this figure will give some idea of the tremendous range covered. The shortest vibration has a wavelength of .000,000,000,01-meter. The longest radio wavelength is more than 20,000 meters. This is a range difficult to comprehend.¹ 20,000 meters represents the long-wave transatlantic radio stations. Coming down to the other end we see the shortest *radio* waves usually spoken of which are

HEAT RAYS FROM THE VACUUM TUBE

Next to the radio waves are the heat waves or vibrations. These start at 2 mm., just about where the radio waves are ending. This means that if you can get your tube oscillating at lower and lower wavelengths until you reach 2 mm. you will not be sending out a radio wave but instead will be sending out a heat wave.

LIGHT

Next to the heat waves are the longer light waves. Very often, to be sure, the whole range of vibration shown in Fig. 1 is called light, although the portion we can see is only one octave out of the entire 64 octaves. The word "octave" here means a range of vibrations one end of which is double the frequency of the other end. Thus in radio the range from 600 meters

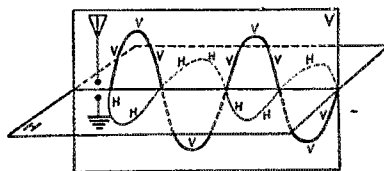

Radiation from antenna

FIG. 2

to 300 meters is one octave since the frequency of 600 meters is 500,000 cycles and the frequency at 300 meters is 1,000,000 cycles or twice as much. One sees that an octave can also be thought of as a range in which the wavelength is twice as great at one end of the octave as it is at the other end of the same octave. Although we have used a radio illustration the rule is perfectly general and applies just as well to light, heat, X-rays, or for that matter to music where we are not dealing with electro magnetic vibrations at all.

THE SHORTEST WAVELENGTH

Below the light waves we have ultra-violet light, beyond that the X-rays and even beyond that perhaps Doctor Milliken's ultra high frequency vibrations.

LAWS COMMON TO ALL

1. Shadows—We all know that when a screen is placed between a source of light

*IBFA, 16 Perth Road, Arlington, Mass.

1. An ordinary piano covers about 8 octaves of sound. Imagine what sort of sounds it would need to make to cover 64 octaves. Of course we could not hear all of these 64 octaves of sound any more than we can see the 64 octaves of electromagnetic vibrations the author speaks of.—Tech. Ed.

2. Wherever we meet the abbreviation "milli" it means "thousandth". A milliamperere is a thousandth of an ampere, a millimeter is a thousandth of a meter, a milligram is a thousandth of a gram.—Tech. Ed.

and a wall we have as a result, a shadow on this wall. Now X-rays, ultra-violet light, heat and radio can likewise be stopped by proper screens. The screen will not be the same in every case, of course. A sheet of black paper will stop light but not some of the other waves mentioned. A sheet of lead will stop the X-rays but heat will manage to get through it. Ordinary glass will stop most of the ultra-violet light though both heat and radio go through. Radio can likewise be stopped by screens of the proper materials—in general those things which will conduct electricity.

2. Reflection—When we project a beam of light on a mirror it is reflected. Exactly the same thing can be done with radio waves.

3. Polarization—Another phenomenon of wave motion is polarization. This is well-known in light and means that a wave is oscillating in one plane only. Fig. 2 attempts to explain what a polarized wave looks like. The two curves together represent the radiations leaving the antenna, or rather they represent the part which is leaving in one direction. Either curve alone gives an idea of the way a polarized wave would look if we could see it. On the other hand if both the curves are pres-

happens for all of the different wavelengths including radio. Other characteristics are: Dispersion or scattering of the radiant energy, interference, refraction, diffraction and absorption. All these things occur in visible radiation (light) and must be true for the invisible radiations; X-ray, ultra-violet, heat and radio. Since we are interested in radio the following description will be confined to it.

EXPERIMENTING WITH THE RADIO WAVE

When Heinrich Hertz, in 1887, conceived the idea that the waves from an electric spark were electro magnetic he proceeded

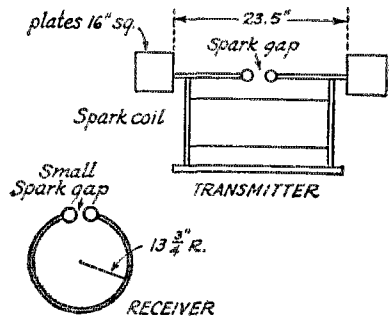

FIG. 4

to test them. If his theory were correct his radio waves would act like long light waves. When they did act just that way it was conclusive proof that Hertz' belief was correct. His pioneer work of 40 years ago is being duplicated with better apparatus (especially the vacuum tube) in the short-wave work of today. If you are an up-to-the-minute experimenter you are doubtless trying out (with modern apparatus) the waves around 1 to 5 meters just as Hertz did with the simple equipment of Fig. 4. By putting a metal screen between the transmitter and receiver Hertz produced a shadow and cut off the signal. He reflected his waves with metal reflectors and he bent them with insulating prisms just as the light is being bent in Fig. 3.

OHM'S LAW

Ohm's law states that, "Electric current is equal to the electromotive force divided by the resistance." Mathematically this is

$$I = E/R.$$

This is familiar enough but did you ever stop to think how universal this law is? The electrical rule is *only a special case of a general law which governs all things.* This general law reads — "The result is equal to the effort divided by the opposition." This is set down in Fig. 5 and applies to all "circuits", whether they are working with electricity, heat, liquids, magnetism or gases.

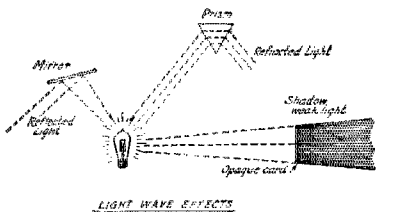

LIGHT WAVE EFFECTS

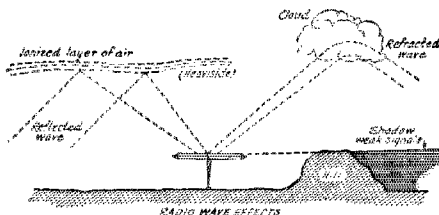

RADIO WAVE EFFECTS

FIG. 3. SIMILARITY OF ACTION FOR LIGHT AND RADIO WAVES.

ent the wave is not polarized. This thing also happens to the radio waves.

4. Others—One need not go through all the various wave effects in detail. It is enough to say that the same thing

3. For some of the practical meanings of this sort of polarization read "Horizontal Reception" in QST for February, "Polarized Transmission" in the June issue and "Examining Quartz Crystals for Oscillator Use" in the September issue. This by no means covers the possible uses of which there are many in commerce and science.—Tech. Ed.

TRANSLATING ELECTRICAL RULES

In fact all of our electrical rules are simply special statements of rules we are thoroughly acquainted with in ordinary life. A few illustrations may be helpful. In mechanics, work is force times distance. This means that if you lift 10 pounds, 5 feet, you will have done 50 foot pounds of work.

Now in electricity, work equals electro-motive force times the electric charge.

$$I = \frac{E}{R}$$

$$\text{Result} = \frac{\text{Effort}}{\text{Opposition}}$$

Ohm's law for all physical phenomena

FIG. 5

We can go on in this way but it is simpler to set down a few examples, as in Fig. 6.

The similarity of the formula is self evident.

TRANSMITTERS AND RECEIVERS

The transmitters and receivers for the exceedingly different wavelengths of Fig. 1 are of course quite different. We can only name a few of them. (See also Fig. 7.)

For radio we have the spark, the arc, the vacuum tube and the high frequency alternator for transmission. For reception we have the tube detector and the crystal detector.

The world is full of heat transmitters. Anything that is "hot" compared to the things around it is radiating heat. The sun, any hot body, fires, chemical effect, electrical effects, mechanical devices, and living plants or animals all radiate heat. Some of these are radiating light at the same time. We can build a good detector of very small amounts of heat energy by constructing an instrument which will change its electrical resistance when exposed to heat.⁴

Light waves are transmitted by most of the heat transmitters. The eye, the camera and the photo electric cell are our light detectors.

Ultraviolet rays are transmitted by the sun and the mercury arc lamp. They can be received and detected by the chemical action of photographic plates or films and also by certain substances which convert them into longer wavelengths which we can see. These substances then glow and we call this fluorescence.

X-rays are produced by the Coolidge vacuum tube and are detected by photographic means or by fluorescence.

4. Our nerves, at least those of the skin, are heat detectors. Incidentally they are indirectly detectors of ultraviolet light. When the skin is "sunburned" the nerves report to us that the skin has been damaged chemically by exposure to too much ultraviolet light.—Tech. Ed.

ALL THE SAME

We now see that these rays are very much alike. The differences are entirely due to differences in wavelength.

Now it is true that much of what has been said will seem to have no relation with radio experimenting. On second thought however, one can see that if you know the action of electric magnetic waves in general you will be much better qualified to experiment on those particular wavelengths used in radio. If a perplexing problem comes up in radio it is likely that your experience with heat or light may give a hint to the solution of the radio problem.

THE GREAT IMPORTANCE OF ATTENTION

The great difference between the ordinary experimenter and the discoverer is the ability to observe. Occurrences which escape the ordinary man are seized upon by the questioning mind of the real experimenter. As soon as something is noticed a big "Why?" springs up in the mind of the real investigator. Then he considers the connection between this incident and others that he has noticed or heard of and attempts to think out a law. Perhaps he does more experimental work before he can do this.

MECHANICS

Work = force x distance
 Power = force x velocity
 Distance = time x velocity
 W = $\frac{1}{2}$ F a
 (Energy of spring)

ELECTRICITY

Work = EMF x charge
 Power = EMF x current
 Q = current x time
 Q = amount electric charge = $\frac{1}{2}$ C E
 (Energy of charged condenser)

FIG. 6

It was in just this way that Heinrich Hertz proved that radio waves are the same as light and heat. In just this way you will also gain ever so much more clear knowledge than by reading alone.

NOTES, SYSTEM AND REFERENCES

The proper way to go about an experiment is to decide first of all what you are trying to do. It is simply amazing how few take this first step. Now read up about it to avoid wasting time in finding out things that others have already done for you. Attempt to decide in your mind how your circuit should work, then connect it up and begin the experiment. Have an 8" x 11" pad or note-book at your side when working. Begin by putting down the date, place, circuit diagram, dimensions and object of the experiment. Then (and not until then) begin your work. Put down everything, trying to reason out what is happening. Afterwards check up on it by reading, asking someone else or making further experiments yourself.

A very important point is to use all the information that you have. Many times a person will not understand a thing be-

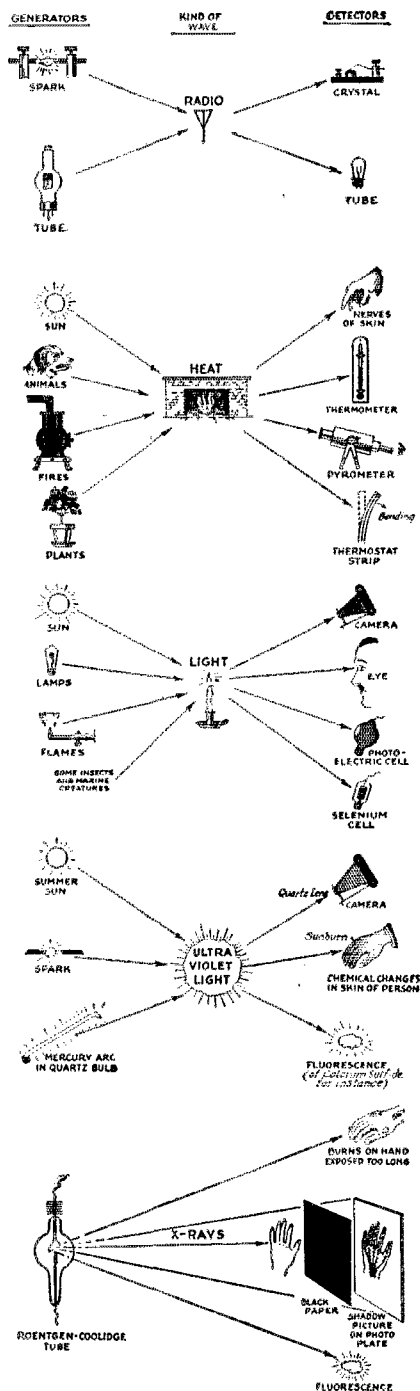

FIG 7 GENERATORS AND DETECTORS FOR 64 OCTAVES OF ELECTRO-MAGNETIC WAVES

cause he has forgotten some trifling detail which everybody knows perfectly well. He has made the mistake of throwing aside his every day knowledge of sound and heat and light and electricity just because he is thinking of this thing as being only a radio experiment. If all the facts are only said over to one's self they will usually give a clue to the understanding of the problem.

A good supply of books for reference is almost a necessity to the experimenter. Among others he should have Circular 74 of the Bureau of Standards, Ballantine's "Radio Telephony For Amateurs", Lauer and Brown on "Radio Engineering Principles" and Morecroft's "Principles of Radio Communication". Morecroft's book is about the best of its kind. Another valuable book is Bucher's "Wireless Experimenter's Manual" which has many tables and considerable information about radio measuring instruments.⁵

In closing I hope that I have pointed out some of the connections between radio and the knowledge and means of the other branches of science. If there are any questions I shall be very glad to hear from any of the readers of QST.

5. To this may well be added Ramsey's experimental manual. Naturally also, the purely radio books must be supplemented by some general science books or the experimenter will fall into the very difficulty the author warns against.—Tech. Ed.

Dakota Division Convention

THE second Dakota Division Convention will take place on April 22nd and 23rd at the University of Minnesota at Minneapolis, Minn. Make your preparations to attend, fellows.

If you remember the previous one you know what there is in store for you. Director Jansky has general supervision and his committee has prepared an unusually good program. A.R.R.L. Headquarters is sending Hebert and Handy. Johnny Reinartz, 1XAM, will be present and will have something of interest to tell us. W. H. Hoffman of Burgess will also be there. The Army and Navy will have representatives and those interested in the Army-Amateur and Naval Reserve work will have an opportunity to discuss their problems. The Electrical Show is taking place during the week and a special time has been set for a visit.

It is needless to say that everybody is invited. Don't miss this opportunity if you want to hear and see the latest in amateur radio, and, besides, have a good time. Cost covering entire convention, \$5.00. Remember, April 22-23, at Minneapolis!

The 1927 Meeting of the A.R.R.L. Board

By Hiram Percy Maxim, President, A.R.R.L.

ANOTHER A.R.R.L. Directors' meeting has come and gone. The duly elected representatives of the members of all Divisions, save one, have come together in Hartford and for two days have deliberated upon the affairs of the transmitting amateur in America and Canada. The officers have reported to them for the past year and the Directors have made their decisions and issued their directions for the forthcoming year. The good old ship settles down for another twelve months' cruise.

It is always impressive, this council meeting of Directors who come from all parts of the country and Canada. They have come thousands of miles, some of them, to attend. They see Amateur Radio from every angle and they sit down and compare their views and in an orderly manner arrive at the conclusion that best reconciles the desires of the whole. Anyone who might sit through one of these two-day sessions would have to admit that the affairs of our A.R.R.L. are handled in a manner typical of the highest form of representative government.

The writer has sat thru many of these meetings down thru the years of A.R.R.L. history. He has seen many delicate and difficult problems thrashed out. At times he has seen the whole structure of our fine organization threatened. He has seen a World War come and bring every trace of amateur radio activity to a dead standstill. And he has seen A.R.R.L. come to life again after the war and grow into a stronger organization than ever. And at this last annual Directors' meeting which is just closed as these lines are written, he has seen the A.R.R.L. reach the height of its glory, for today we have the largest membership we ever had, we have more money laid by for a rainy day than we ever had, our good old QST is more highly regarded than it ever has been, and A.R.R.L. stands for more before the eyes of the world than it ever has in its history.

It is a superb record. We members from the oldest old timers down to the youngest member to wear the diamond button, may feel proud of our organization. Let's all realize what a fine old ship this A.R.R.L. of ours, is.

Some Notes by the Secretary

The Board met in regular annual session at Hartford on February 25th and 26th,

with every director and officer present except Director Gravely of the Roanoke Division, who unfortunately was confined to his home by illness. Thru two days of meetings the Board heard reports, examined conditions, and outlined policies for the coming year.

The annual reports of the officers were received, showing the past year the best financially in the League's history, its current position the strongest, its affairs and activities in excellent shape. Detailed reports on conditions in each division were made to the Board by the respective Directors, and discussed at length, particularly traffic matters. The general state of amateur radio was examined and everything conceivably relating to it came in for its share of attention. The Headquarters property of the League was inspected. A brief summary of other actions: the board ratified the acts of the Executive Committee since the last Board meeting and continued its authority; discussed legislation and regulations and planned for protection of amateur interests; amended by-laws so Communications Manager can declare a single candidate for S.C.M. elected; repealed By-Law 30 as having no further application; amended By-Law 15 to provide for witnesses of ballot counts by Committee of Tellers but without vote on committee; agreed to one year's study of changing certain Division boundaries; rejected a proposal to have two Vice-Presidents; instructed that affiliation applications be first referred to the Director concerned; abandoned the idea of national conventions but pledged assistance to divisional conventions; added the Philippine Islands to the Pacific Division; voted thanks to the A.R.R.L. Official Wavelength Stations Committee and its appointees; ordered improvement and increased power for the Headquarters station; arranged for the establishment of a Directors' Net for radio intercommunication; instructed the officers in the investment of the League's surplus funds.

The action of the Board respecting conventions will be found interesting. The following statement of policy, adopted at the meeting, explains the subject:

"By reason of the adoption of the Constitution of December 18, 1923, it appears that the American Radio Relay League, thru the election of regional directors, now has a representative form of government under which all members of the League have votes in the choice of those who conduct League affairs.

"If therefore is plain that conventions which contemplate a participation in League management are not only impossible but unnecessary.

"The convention plan to which the League is therefore committed is one in which the members get together for technical and traffic instruction, social enjoyment and the formation of Amateur Radio friendships. Under such a plan, members attending these conventions are compelled to attend at their own expense.

"For this reason it appears to the representatives of the members, those who constitute the Board of Directors, that it is unfair to place upon the widely-scattered membership of the League the necessity of making long and expensive journeys to distant places in order to enjoy the manifest advantages of attending a national convention or in lieu of such sacrifice to relinquish such advantages.

"The American Radio Relay League is committed to the convention idea, believes in it and will encourage conventions in every possible way.

"But the only way in which these benefits can be secured for the members and distributed to them fairly and impartially is by means of the divisional convention system.

"We pledge ourselves to do all in our power to insure thoro and successful divisional conventions but feel compelled to discontinue the so-called national convention."

By order of the Board the following statement of the income and disbursements of the League for the fourth quarter of 1926 is published for the information of the membership.

K. B. W.

FINANCIAL STATEMENT

STATEMENT OF REVENUE AND EXPENSES FOR THE THREE MONTHS ENDED DEC. 31, 1926.

REVENUE	
Advertising sales, QST	\$21,717.83
Advertising sales, Handbook	1,507.50
Newsdealer sales	17,081.04
Handbook sales	4,426.45
Newspaper syndicate sales	464.16
Dues and subscriptions	10,625.62
Back numbers, etc.	649.00
Emblems	97.13
Interest earned	201.00
Cash discounts earned	379.53
Bad debts recovered	59.82
	<u>\$57,209.08</u>
Deduct:	
Returns and allowances	5,235.31
Provision for reserve for newsdealers returns	2,148.66
Discount 2% for cash	364.72
Exchange and collection charges	4.84
	<u>\$7,753.53</u>
Net Revenue	<u>\$49,455.55</u>
EXPENSES	
Publication expenses, QST	\$16,038.93
Publication expenses, Handbook	3,350.26
Salaries and commissions	15,637.19
Newspaper syndicate expenses	209.50
Forwarding expenses	643.69
Telegraph, telephone and postage	2,083.08
Office supplies and general expenses	1,950.27
Rent, light and heat	918.29
Traveling expenses	600.92
Depreciation of furniture and equipment	212.18
Bad debts written off	366.89
Communications Dept. field expenses	64.60
	<u>\$42,076.80</u>
Total Expenses	<u>\$42,076.80</u>
Net Gain from Operations	<u>\$7,378.75</u>

An Overload Relay

IT seems that the amateur is perfectly willing to spend all sorts of money and time on equipment that will give him just a tenth of an ampere more in the antenna circuit but absolutely refuses to take any precautions to protect this very same equipment. When one considers the many dollars spent each year for tubes that are practically thrown away because there were no precautions taken to protect them from overloads, which are more the rule rather than the exception, it certainly appears to be a mighty poor business policy.

The illustration shows a relay that is designed to open a circuit when more than a certain amount of current is flowing through it. The winding is of low resistance and

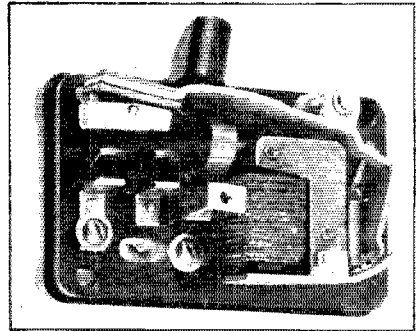

will handle a maximum steady load of nine amperes. The contacts are of copper against brass and the arrangement such that a very snappy and complete break is had when the armature is tripped. The brass contact is used as a jumper between the copper ones and is swivelled so that it breaks from both contacts at about the same instant. This insures a fast break that will prevent serious arcing.

A spring allows for the adjusting of the tension on the armature and therefore the amount of pull necessary to trip it. By loosening the pull of the spring, the current required to trip the relay is reduced. A metal cover protects the instrument from dirt and mechanical injury and also prevents any sparking at the contacts from damaging adjacent equipment. These relays may be obtained from the Precise Mfg. Corp. of Rochester, N. Y.

—H. P. W.

Strays

The Relay Contest is coming. You haven't forgotten the dates May 9-22 inclusive, have you? Better mark them in red on your calendar pad.

A 15-Meter Commercial Station—2XS

A MOST unusual radio station has been in operation for some time at the "Radio Central" of the R.C.A. at Long Island. Dr. E. F. W. Alexanderson of the General Electric Co. suggests that very useful 15-meter transmission information can be supplied by A.R.R.L. men if they will observe the signals of this station, log the intensity and send the observations to the Experimenters' Section, A.R.R.L. This can be done by almost anyone as 2XS is in operation at all hours and therefore fits nicely into anyone's program.

2XS began operation something like a year ago and has operated with various wavelengths and antenna systems, one of the main objects being to find a combination that would put traffic into Buenos Aires consistently. This may not sound like a very impressive job to the man who has worked into that city with a "five watter"—but how many of you would like to do the job 365 days a year regardless of weather?

Dr. Alexanderson therefore tried transmission from a horizontal doublet, in other words the sort of thing we usually call a "Hertzian antenna". This changed the pattern of places at which the signal was

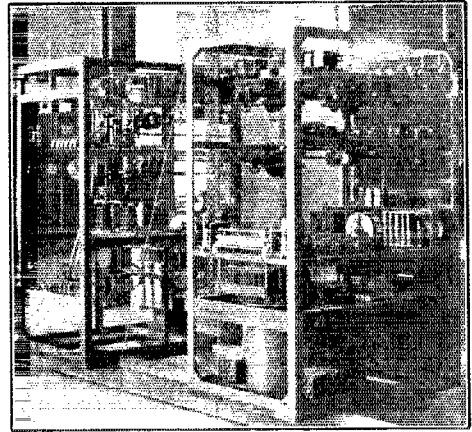

THE MACHINERY BEHIND THE PRETTY PANELS

The nearest frame carries the master oscillator with crystal control, also the frequency-raising amplifier before referred to. Close study of the original photograph makes the details clear and the general layout may probably survive engraving and printing. The farther panel carries the two water-cooled tubes which make up the final stage of amplification. They are connected push-pull in a circuit which grounds the plates to the cooling system and puts the filaments and filament transformer secondary at a high negative d. c. voltage and high r. f., and puts the filaments at a high negative direct voltage above ground. The filament transformer secondary naturally carries the same high negative d. c. potential but the push-pull construction keeps the r. f. out of the transformer.

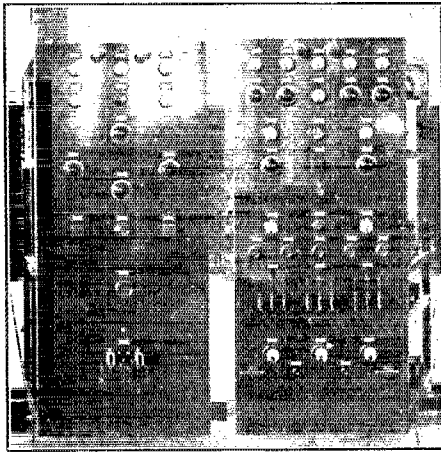

THE TRANSMITTER

At the left is the crystal unit with the frequency-increasing amplifier, at the right is the final power amplifier.

Something different, isn't it? Very well—2XS does it, and is the first station that has done it.

In the earlier attempts to work the circuit various longer waves were tried and while these got thru at times none were consistent performers, especially in bad static. When the shorter waves were tried, the "skip distance" made them miss the receiving point. Whether you happen to call the effect "skip distance" or "polarization" does not matter—the signal did not arrive.

received and in the new pattern Buenos Aires was at a point of good signal intensity—where it has continued to stay, showing that it is not a freakish effect. Just where the signals do come down is now a matter of great interest and that is where A.R.R.L. men all over the world can help. It will be especially interesting for observers in the supposed-to-be skip-distance at present to be sure that 2XS has good signal strength at points where one would not expect to hear it if the skip-distance theory were followed closely. Perhaps this is due to the power of the station—observations of the signal strength at various places will clear that up.

Now as to the station itself. Quoting from a letter of our good friend F. H. Kroger, of the Engineering Department of the R.C.A.

"The transmitter operates on a wavelength of 15 meters. As you know this is not

in exact accord with everyone's standard but is believed to be fairly close to the actual value. There are approximately 7 Kw. in the antenna which consists of a

tion. The output from this power amplifier is to the transmission line feeding the horizontal doublet.

"The transmitter is on the air practically all of the time from six in the morning to early evening, depending upon the time at which Buenos Aires either clears traffic or advises that the signal has faded out for the night."

2XS is located in such crowded temporary quarters that photographs were unfortunately not possible but Mr. Kroger has supplied us with pictures of the new sets being built as a result of the experimental work at 2XS and these are shown herewith.

—R. S. K.

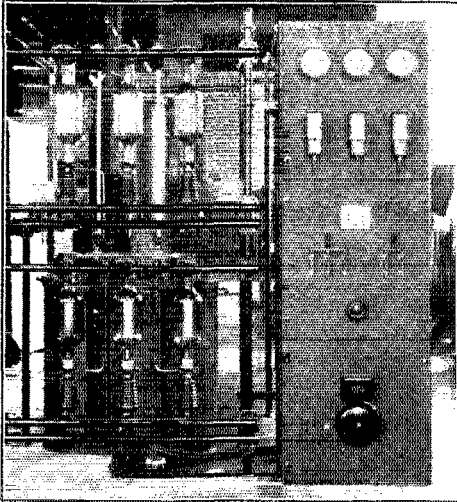

FRONT OF THE RECTIFIER-FILTER. SHOWING THE 6 KENOTRONS

horizontal doublet with a reflector. The antenna is elevated about 20 feet above the ground and points at Buenos Aires. The transmitter proper is crystal con-

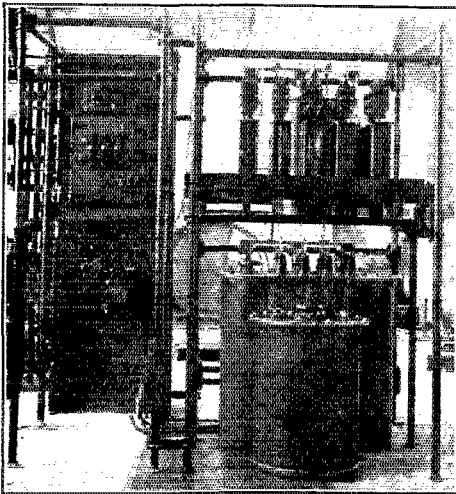

BACK OF THE RECTIFIER-FILTER PANEL THAT SUPPLIES THE PLATE POWER

trolled with the requisite number of stages of amplification, providing excitation to two water-cooled tubes in push-pull rela-

tion. The output from this power amplifier is to the transmission line feeding the horizontal doublet. An ordinary single-pole double-throw battery switch can be removed from its base and mounted on the towel bar by means of brass strips bent as shown.

Strays

The other month we ran a short stray on the Government publication "Radio Aids to Navigation." We confess that we had not seen the book at the time the stray was run. We relied solely upon the information given by our friend Washburn of New York City. In the meantime our copy has come in and we want to say that *no* sea-going brass-pounder should be without a copy of this excellent book. If you are interested in time signals, radio compass stations, radio fog signals, radio "wx" bulletins, storm warnings, navigation warnings and meteorological data you will find a *complete* list of every commercial and governmental station in the world transmitting these signals listed in this excellent manual. It contains 381 pages of real dope you cannot afford to miss, and it costs only 90 cents, from the Sup't of Documents, Government Printing Office, Washington, D. C.

Schweinsberg of 8BMN has a nifty "low loss" switch which can be used in a variety of ways in an amateur station. The

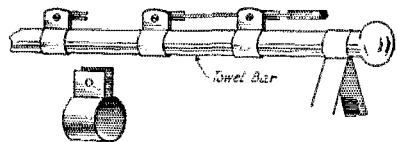

Continuing from page 37 of last month's issue, we note the arrival of another junior op. Harold P. Westman Jr. arrived shortly after noon on February 26th. Next?

Which Is the Detector Tube?

By L. W. Hatry*

WITH circuits such as those shown in Fig. 1 it is often difficult for the layman to tell which tube is supposed to be the detector—and especially *why* that tube acts as a detector and some others do not.

For instance in the circuit of Fig. 1A, the second tube VT is an r.f. amplifier while in 1B it is a detector, in spite of the fact that the connections of the r.f. transformer RFT are the same in both cases as are the grid leak resistances and the condenser connections.

The grid bias determines whether a tube will amplify or detect most effectively. The grid condenser can be of the same size (250 pfd.) in both cases. The grid-leak resistance can also be the same, as has been

poor apparatus or a leaky tube provides an accidental return.

It is thus possible to secure arrangements in which the r.f. is returned to the filament

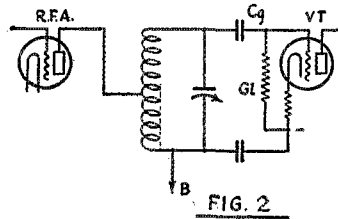

thru some convenient short path while at the same time the d.c. is compelled to take another path to some point which will provide the proper grid bias for the particular tube action that is required.

TROUBLES

When working moderately the tube VT of Fig. 1A will be an r.f. amplifier because the grid leak is connected in such a fashion as to return the d.c. to the negative side of the filament, which gives the grid a negative bias.

In spite of this apparent determination of the tube function by the bias it is perfectly possible for the tube to go wrong and to detect signals by the usual machinery of the grid leak and condenser, which operates as follows.

When an incoming carrier wave arrives at the antenna, r.f. energy is fed thru the receiving set and the grid of VT is made more or less negative at a radio-frequency rate. Whenever it is less positive it has a greater tendency to accumulate electrons from the plate current and thereby to charge the condenser C_g up to such a voltage that no more electrons are accumulated. This happens very soon and things are steady again. Now if the incoming carrier wave is modulated (with key or microphone) there is a tendency for the charge on C_g to rise and fall with the intensity of the incoming carrier and if this happens to any considerable extent it means that the grid is following the modulation and the tube has become a detector.

To prevent this action we can do three things. We can make the condenser C_g of very large capacity so that the grid current is unable to charge it very fast and hence the grid is unable to follow the variations of the incoming carrier. We can make the

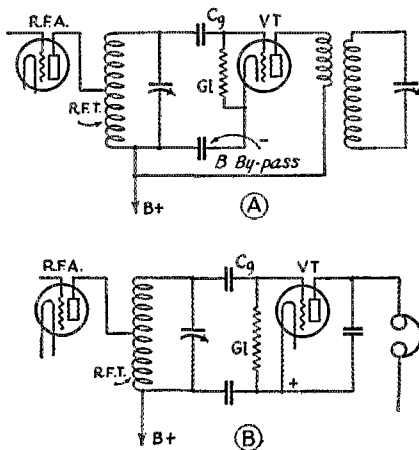

FIG. 1

stated. Nevertheless, the grid bias in the two cases will not be the same, for the "grid return" path is not the same. There are two sorts of grid-return paths. One is the path thru which the r.f. gets back to the filament, the other is the path thru which the d.c. (the so-called grid current) gets back to the filament. The r.f. may be brought back thru a condenser to the filament, because the r.f. passes thru a condenser quite conveniently, but at the same time the condenser insulates the d.c. and some sort of a separate path must be provided for it. Thus in 1A and 1B if we omit the grid leak Gl the tubes will block unless

*Radio Department, Hartford Times, Hartford, Connecticut.

grid resistance low so that there is less of an a.f. drop across it and finally we can make the fixed bias greater (grid more negative) to decrease the tendency to collect electrons on even the strongest of signals.

EXAMPLES

If in 1A we have an r.f. amplifier using a 201-A tube it will rectify (detect) excessively if the G1 resistance is 2 megohms, the capacity of C_g 50 picofarads and the B-battery voltage 45 and the grid-leak return made

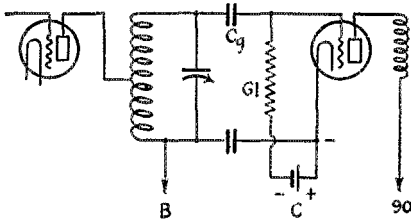

FIG. 3

not as shown but to the positive filament. This is quite natural for we have a bias favorable to detection, a C_g small enough to charge easily and a leak resistance across which an audio drop is easily produced. If we put a pair of phones (properly by-passed) in the plate circuit the detection will be proven.

Now if we increase C_g to 5000 pfd's more amplification will immediately take place in spite of the poor bias conditions. Then if we connect the leak to the negative A-battery as in Fig. 2 rectification (as shown by the headset) will be negligible. The return used in Fig. 2 is even more negative than that used in Fig. 1B since the 1-volt drop thru the filament rheostat is used to give additional negative bias.

To check the correctness of the statements as to the effect of changing the size of C_g , one can cut down the C_g capacity in Fig. 2. When it is reduced to 50 pfd's there will be fair detection even though the bias condition is entirely unfavorable for such action. Of course the detection will not be as good as that in 1B. Detection will, however, improve as C_g is made smaller up to the point where C_g has so high a reactance as to waste r.f. voltage.

In Fig. 1B, detection will occur with any size of C_g but the audio response (detector effect) will be unimportant if C_g has a capacity of 1000 pfd's or more. Slight r. f. amplification will exist, or else regeneration could not exist as it depends on returning r.f. to the grid. As C_g is reduced to 250 pfd's or less, the tube will (according to the headset in the plate circuit) show an increase in audio output as to both quality and quantity. The process can be carried

to 50 pfd's with advantage under some conditions.

Another way to get more r.f. amplification than detection is to use a small C_g condenser with a leak of low resistance which, on the face of it (and practically, too) is not as good as the use of a large grid condenser and a proper bias. Finally, with the large C_g low resistance leak and proper bias r.f. amplification occurs as it should with negligible detection. Fig. 2 then shows the proper conditions for an r.f. amplifier in which the tube is a 201-A, and the plate voltage 45. The curves for the 201-A tube confirm this as the EgIp curve for the tube is struck at its straight center portion when a bias of 1 to 1½ volts negative is used at 45 volts on the plate. From the curve one can also see that for 90 volts on the plate the grid should have a 4½-volt negative bias and this is rapidly checked by the phone-in-the-plate test. The circuit then changes to that of Fig. 3 for the extra bias voltage cannot be obtained readily from the filament circuit and hence must be supplied by a separate C-battery. The rheostat is not used as part of the bias system because a more practical fixed bias is now available. It is generally better to *know* what bias the tube is getting, rather than to depend on a rheostat which is shifted.

EXPERIMENTAL CHECKS

Under receiving conditions some more tests were made with the arrangement of Fig. 3, using plenty of amplification (audio)

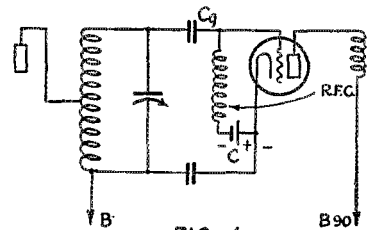

FIG. 4

after the tube VT so that differences would be magnified and made more obvious to the ear. G1 seemed to gain nothing by being of less resistance than ¼-megohm and C_g nothing by being larger than 500 pfd. As low as 100 pfd. at C_g and as high a resistance as 2 megohms at G1 seem quite practical—the larger capacity and lower resistance are more certain to be safe, however.

DETECTION AGAIN

Some detection does occur in most r.f. amplifiers (as shown by the headset test) even when the bias is correct for amplification. This effect is increased in circuits us-

ing a grid resistance as in 1A, 2 and 3. Strictly, this seems to hurt nothing in set performance; theoretically it should have an effect that is harmful.

To get away from this detection in such circuits almost entirely two methods have

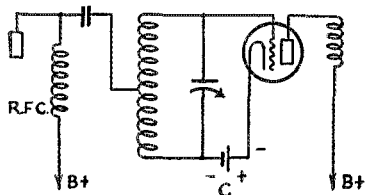

FIG. 5

been tried successfully. The detection is due to the d.c. resistance of the grid leak. Reduce the d.c. resistance (opposition to the flow of direct current) and the detection is decreased. Since a high r.f. reactance (opposition to the flow of r.f.) is necessary at this point the d.c. return can be made thru a choke as shown in Fig. 4. It is important to have a good choke and some good ones are on the market. The choke generally is wound with such small wire as will give a resistance between 100 and 1000 ohms which is not sufficient to cause an a.f. drop of any consequence. C_p may have any capacity greater than 100 pfd—10 microfarads if you wish.

The second way to get around the difficulty is to use "series feed" of the grid bias as shown in Fig. 5 and to do away with both leaks and grid chokes. Since the r.f. transformer used as an illustration has the plate battery connected to it the change in the bias system necessitates the addition of a plate blocking condenser and a plate r.f.c. The blocking condenser should have a capacity of 6000 pfd or more for a little r.f. reactance here can do much harm. The r.f. choke does not need to be so good and can be replaced by a resistance, though that calls for increased plate voltage which is not a practical solution of the problem. In some r.f. coupling devices the plate-blocking condenser and plate choke would not have been necessary when biasing as in Fig. 4 because the coupler has an insulated plate winding to begin with. It is important to note that when biasing as shown in Fig. 4 it is not possible to ground both the filaments and the condenser rotors on the shield of a set. It is best to ground the rotors.

Power Tube Socket

THE accompanying illustration shows a new socket designed for the UV-203 and 3-A tubes. The base consists of a heavy piece of hard rubber, circular in shape, with a center hole to improve the insulation di-

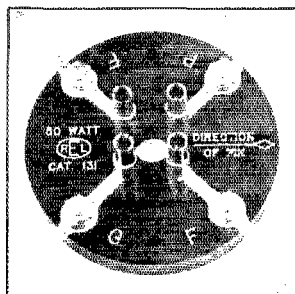

rectly across the pins. It also reduces the capacity between the plate and grid posts. The tube prongs fit into substantial split holders which are fastened to the base by means of machine screws threaded into the lower portion of them. Connections may be made either by soldering to the lugs which extend a generous distance from the edge of the base or to the posts which are the ends of machine screws used to hold the lugs from shifting. A marker shows the proper position in which the tube should be inserted. Care should be taken as the tube may be reversed with possible disastrous results. As will be seen, however, the marking showing the direction of the pin is very noticeable and there should be no trouble from this point. All the markings are deeply engraved. The socket is manufactured by the Radio Engineering Labs of New York City.

—H. P. W.

Strays

In contrast to the usual run of messages handled via amateur radio we were quite pleased to see some really important messages that were handled by 6BVY. These covered various subjects from the recent China trouble to the arranging of a couple of weddings as well as looking out for the bride. 6BVY tells us that in a short time he will have had a schedule with op1AU for a whole year and that the longer you keep a sked, the better the class of traffic becomes.

You should be getting your outfits all shined up and ready for the big tests. It is the chance of a lifetime to make a name for yourself and your station. See the Rules in March QST and send a card to HQ 1010.



The Institute of Radio Engineers

By John M. Clayton*

THE INSTITUTE of Radio Engineers is the technical society representing the radio engineering profession in this country. The remarkable progress in the art of radio communication since 1900 has made eminently desirable the formation and development of an organization of this character. The radio engineering profession owes much to the men who founded the Institute of Radio Engineers, and to those who have carried on its activities. These men have foreseen the possibilities of such an organization; an organization which has fostered and encouraged the development of this highly useful art, and has afforded ample opportunities for its members



MR. R. H. MARRIOTT, FIRST PRESIDENT, I. R. E.

to meet and discuss radio problems. It is clear that the Institute will be no small factor in the future progress of the radio art, in the technical advancement of its individual members, and in the elevation of the radio profession as a whole.

HISTORY OF THE INSTITUTE

Prior to the formation of the Institute of Radio Engineers, two of the most prominent organizations in the radio field were the Society of Wireless Telegraph Engineers of Boston, and the Wireless Institute of New York. To avoid inevitable duplication of effort and to increase their usefulness by co-operation, these societies considered consolidation. The consolidation was effected on May 13, 1912, at which time the Institute of

Radio Engineers, with a charter membership of something less than fifty, came into being. Prominent in the early work of the Society of Wireless Telegraph Engineers, the Wireless Institute and the Institute of Radio Engineers were John Stone Stone, Lee de Forest, Fritz Lowenstein, John S. Murphy, R. A. Somerville, Joseph D. Fountain, R. B. Respress, R. A. Cleva, John Gregg, E. Barnwell, Phillip Farnsworth, Sidney L. Williams, R. H. Marriott, G. W. Pickard, John V. L. Hogan, Alfred N. Goldsmith, Harry Shoemaker and Eugene Thurston.

Many of these pioneers are still actively associated with the Institute, either in its management or through contributions in the form of technical papers.

Since 1912 the growth of the Institute has been quite rapid and healthy. On January 1, 1927, over 3,500 radio people were associated with it in the several grades of membership. The membership of the Institute consists of scientists, research and development engineers, inventors, authors, consulting and practicing engineers, professors of physics and engineering from many colleges and technical schools, professional and amateur investigators, professional and amateur operators, executives in commercial organizations, officers and representatives of many branches of the Government, as well as many others who desire to keep abreast with the latest developments in radio communication not only along research lines but along engineering lines as well. These members are distributed throughout the world, one tenth of the total membership residing in countries outside the United States and Canada.

ADVANTAGES OF MEMBERSHIP

All the members of the Institute are furnished with copies of all issues of the *Proceedings of the Institute of Radio Engineers*, the monthly journal of the Institute in which from three to six technical papers are published. Among the authors of these papers will be found the names of many leaders in the radio art. To the student of radio communication, to the man just entering or just out of college, and to the amateur, the *Proceedings* presents the most recent developments and discoveries in the radio communication field, beginning where the textbooks leave off, presenting radio engineering and practical radio articles which will appear in the radio books in years to come.

There is also issued a report of the Committee on Standardization, which contains

* Assistant Secretary, Institute of Radio Engineers, 37 West 39th Street, New York City, also ex-Assistant Technical Editor QST.

definitions of technical terms used in the radio field, together with carefully drawn diagrams of standard graphical symbols. This is the officially adopted list of standard names, terms and symbols covering the en-



MR. RALPH BOWN, 1927 PRESIDENT, I. R. E.

tire radio field. Future issues of the report are expected to include standard methods of testing and rating radio apparatus.

Members of the Institute are entitled to attend the meetings of the Institute and its various Sections, to present suitable papers before such meetings, to discuss papers at meetings, and to take part in the election of officers of the Institute.

The management of the Institute, insofar as the election of its officers is concerned and in the consideration of constitutional amendments, is entirely in the hands of the membership.

GRADES OF MEMBERSHIP

There are five grades of membership in the Institute.

The Junior is a member not under sixteen years of age, and not over twenty-one, interested in the study or application of radio science or the radio arts. On attaining the age of twenty-one Juniors may be transferred to the grade of Associate.

The largest part of the membership is composed of Associates who have the following qualifications to fulfill:

- a. Must be at least twenty-one years of age.
- b. Either a radio engineer by profession, or a teacher of radio subjects or a person who is interested in and connected with the study or application of the radio arts or radio science. The Associate is entitled to all rights and privileges of the Institute except the right to hold the office of President or Vice-President. (See note.—Tech. Ed.)

A Member is a radio engineer by profession who has designed and taken responsible charge of important radio engineering work for at least four years; or a teacher of physical science or electrical engineering in a school of recognized standing who has been active for a period of four years; or a person regularly employed in radio or closely allied work for at least four years, who by invention or proficiency in radio science, the radio arts, or radio literature, or as an executive responsible for important radio work has attained a standing equivalent to that required of engineers, or a commissioned officer of the Army or the Navy of the U. S. or any foreign Government who has attained the rank of Captain in the Army or Lieutenant in the Navy and has been actively engaged in radio work for at least three years and has had responsible charge of important government radio work.

A Fellow is a member who is a radio engineer by profession and who has done important radio work for a period of at least seven years; or a professor of physical science or electrical engineering who has attained special distinction as an expounder of the principles of radio science and of radio engineering; or a person who has done notable original work in radio science



DR. DONALD McNICOL, RETIRING PRESIDENT

of a character to give him recognized standing at least equivalent to that required for Fellows in the above paragraph.

The Honorary Member is the most distinguished grade. An Honorary Member is a person chosen from among those who have rendered acknowledged eminent service to radio science, or the radio arts.

Note—In the staff at A.R.R.L. headquarters there are 2 Junior members, 5 Associates and 3 full members, of whom one is a Charter Member of the Institute. Many members of A.R.R.L. who are personally acquainted at headquarters have given the names of various ones of the 10 mentioned as references.—R. S. K.

JOINING THE INSTITUTE

Applications for membership of any grade are made on blanks obtained from the office of the Institute at 37 West 39th Street, New York City. Applications should give as references 5 names of I.R.E. members of the grade applied for, or higher. This does



**JOHN M. CLAYTON, ASSISTANT SECRETARY,
I.R.E.**

not apply strictly to Associate or Junior applicants. For these grades it is usually sufficient to furnish the names of 5 business associates who will act as references.

SECTIONS

Throughout the United States there are a number of Sections of the Institute and in Canada there is one Section. These Sections hold meetings at regular intervals. At these meetings prominent radio



THE I. R. E. EMBLEM
The color combination indicates the grade of membership. The Associate emblem is in gold on a red ground; the Member Emblem is in gold on a blue ground and that of the Fellow in gold on a white background.

engineers and scientists deliver technical papers which are discussed by those present. All members of the Institute residing within the territorial limits of a Section automatically become members of the Section as soon as it is formed. In addition to the speakers who appear before the Sections, advance copies of papers which are to appear at some future date in the Proceedings are supplied to the Section officers so that these papers may be read and discussed at the Section meetings.

At present there are ten active Sections in the following localities: Washington, D. C.; Boston, Mass.; Seattle, Washington;

San Francisco, Calif.; Chicago, Ill.; the Canadian Section with headquarters at Toronto.; Philadelphia, Penn.; Rochester, N. Y.; Los Angeles, Calif., and the Connecticut Valley Section with headquarters at Middletown, Conn.

The total membership in the various sections is well over five hundred. Several new sections are now in the process of formation.

MEETINGS

In addition to the meetings of the Sections, the Institute meetings are held monthly in New York, except during July and August of each year. At these meetings, scientific, engineering and other papers relative to the art of radio communication are presented by members of the Institute specially qualified to treat their subjects. The presentation of papers is followed by an open discussion. The material presented at these meetings, together with other material submitted for publication only, constitutes the technical papers which appear in the *Proceedings*.

A list of the past presidents of the Institute contains the names of the leaders in the radio art—men who have contributed to radio engineering and to the advancement of radio science, and who today are among the most prominent people in this newest field of electrical science. They are:

- 1912 R. H. Marriott
- 1913 G. W. Pickard
- 1914 L. W. Austin
- 1915 John Stone Stone
- 1916 A. E. Kennelly
- 1917 M. I. Pupin
- 1918 G. W. Pierce
- 1919 G. W. Pierce
- 1920 J. V. L. Hogan
- 1921 E. F. W. Alexanderson
- 1922 Fulton Cutting
- 1923 Irving Langmuir
- 1924 J. H. Morecroft
- 1925 J. H. Dellinger
- 1926 Donald McNicol
- and
- 1927 Ralph Bown

Due to the rapid growth of the radio art and the interest in radio science and engineering, the Institute has taken an established place among the other engineering societies not only of this country but of the world. In this time of rapid strides in the development of new apparatus and circuits and in the understanding of radio phenomenon, the amateur just as well as the engineer and the scientist finds that he benefits materially through his association with the Institute, and that through the Institute he too can be and is one of the active participants in the progress being made in all branches of radio communication.

A Traffic Tuner

By Harold P. Westman, Assistant Technical Editor

IN this day when amateur radio activities are partitioned off into various small bands, it seems strange that most of our tuners are so constructed that these bands are covered with a dial displacement of 25 degrees or less. It seems that when building a receiver, the object is generally to cover everything from the ground up and not to worry over how few coils are required or how much territory is covered by each coil as long as the various bands

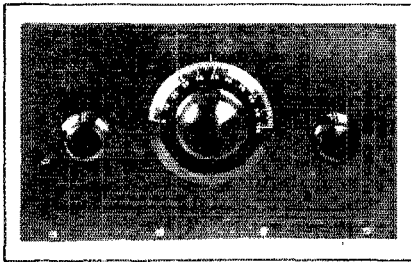

are not broken up and thereby call for two coils to cover a single band. This type of receiver has, no doubt, a perfectly good reason for existing as there are some operators who desire to be continually going from one band into the next adjacent one and back again either in quest of CQs or in answer to their own. However, I believe that the working of a transmitter in one band and a receiver in two or more other bands at the same time is gradually becoming obsolete and that if a man is interested in foreign DX, he does not listen in the U. S. band but devotes his energy and time to combing over the particular foreign band in which he is interested.

There is reason to believe that many of the foreign operators will not answer a general CQ not addressed to his particular country. They have answered so many that were intended for others and were sent by operators who listened on only one foreign band that it has become rather tiresome and uninteresting to them to continue answering CQs intended for someone else.

We have also the case of the man who is primarily interested in handling traffic, either in the 40- or 80-meter band. This man does not get out of his particular band and is usually the man who makes and keeps schedules. In order to keep such schedules, it is necessary not only to note the exact setting of the dial but also it must be possible to come back to that exact setting. If the entire band is covered with a 25-degree rotation of the dial, it becomes rather diffi-

cult to read the dial spacings close enough to make possible rapid and accurate readjustments to a given wavelength unless a wavemeter is used. This is not always convenient. If, for instance, the band is spread out over the full dial, stations will appear to be four times as broad and resetting of the dial will be four times as easy.

In such a set, it is necessary to use a tuning capacity that is very much smaller than those now employed. We have been considering a tuning capacity of 100 μ fs. to be a good size for these tuners but it is quite possible to cover the lower U. S. bands below the 150-to 200-meter one with a secondary condenser having a maximum capacity of about 15 or 20 μ fs.

The set shown in the photograph uses a Cardwell 2-plate double-spaced straight line frequency condenser that has had one of its plates removed and the other adjusted so that the desired capacity range is obtained. The condenser originally had a maximum capacity of 22 μ fs. and this may be used "as is", if a large amount of territory at one or both sides of the band is wanted. This condition will give a tuning range of approximately 8 meters in the

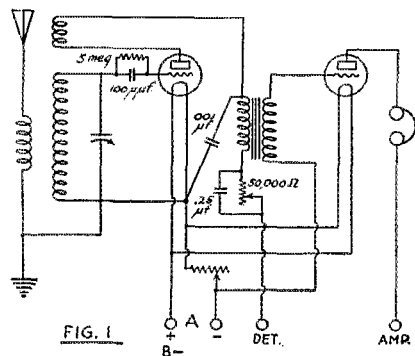

neighborhood of the 40-meter band. The band will be spread over about 50 degrees of the dial. This, in itself, is well worthwhile and will allow the tuning to extend three meters outside of the band. This may be adjusted to come at either the upper or lower ends of the band or some overlap may be left at both the ends.

If it is desired to spread out the band until it covers practically all the dial, it is necessary to cut down the condenser a bit. This is not a very difficult thing to do and with a little care can be done in short order. The two screws holding the hard

rubber pieces to the back endplate are first removed. It is a good policy to use a small box or the cover of one to hold all the screws and bolts taken off instruments when making such adjustments as they always fall on the floor and hide in some dark corner if they are not properly corralled at the start. An old cigar box is excellent.

Next, the three hex-headed studs are removed and then the end plate taken off. See that you don't drop the ball used in the bearing. It will usually stick in the endplate but this is not guaranteed. The rotor

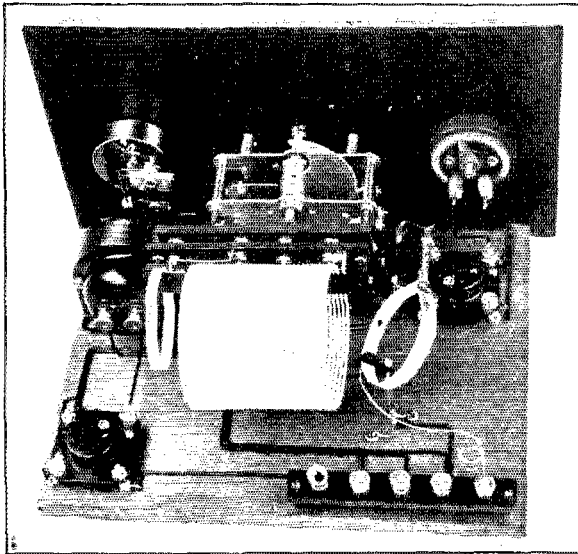

plates are then swung clear of the stator-plate and the rotor assembly removed. It will probably be necessary to hold the shaft in a vise when loosening the nut that holds the rotor plates on the shaft. This is taken off and the nearest rotor plate removed. The spacing washers are then replaced and the nut put on and screwed up good and tight. The condenser is then reassembled by reversing the process used to disassemble it. We then have a condenser having a maximum capacity of approximately half that of the original one. This is a bit small and it is only necessary to bring the plates somewhat closer together to get the proper capacity. This is done quite easily by loosening up on the set nuts which lock the front and back bearings in place. Loosen up a turn or so on the back bearing and follow with the front one. Keep tightening up on the front one until no end play is felt. There is no convenient gauge which will tell you when the spacing is correct but this adjustment can be made with the condenser in the set and the wavelength range checked immediately. If too wide a

band is being covered, it indicates that the capacity is too large and if the band is too narrow, the capacity is small. Moving the plates together increases the capacity.

The circuit is shown in Figure 1 and uses a resistance for the control of regeneration. A 50,000-ohm variable unit is used. It allows the voltage applied to the plate to be varied enough so that complete control of regeneration may be had. The capacity across it tends to smooth out any small fluctuations in current which may occur when adjusting the value of the resistor to control regeneration. This condenser is placed underneath the tuning condenser in the set and is fastened to the baseboard. The relative positions of the other parts may be seen from the photo.

The coils used are made of the Hammarlund coil material and the No. 16 wire wound ten turns to the inch on a three-inch diameter. This is the size used for the secondaries. The ticklers may be made of this same size although somewhat less reaction between the plate and secondary circuits is had when the smaller size coil is used. The smaller coil has 43 turns per inch of No. 26 wire on a two-inch form.

The base into which the separate coils plug is made of a piece of bakelite $4\frac{3}{4}$ " by $\frac{3}{4}$ " by $\frac{1}{4}$ ". It is mounted directly upon the condenser by two 6" by 32" by $1\frac{1}{4}$ " flat head machine screws which take the places of the top studs to hold the frame together. Nuts are used to tighten up the frame and to hold the piece of bakelite at the end of the screws. Three jacks are spaced one inch apart and are located between the mounting screws and the other one is spaced one inch and a half away and is the other side of the mounting screw. The coils are held between two pieces of bakelite which are $4\frac{1}{2}$ " by $\frac{1}{2}$ " by $3/16$ ". General Radio plugs and jacks are used.

When the range of the coil is to be adjusted to cover a band with a minimum of overlap, it becomes difficult to cut coils so that they will have this overlap just where it is wanted. To simplify the making up of the coils and to allow a certain amount of flexibility in operation, a small adjusting condenser is shunted across the secondary coil. This will allow the range of the coil to be shifted within reasonable limits. One of the Hammarlund "neutralizing" condensers are used. The piece of mica is removed to cut down the maximum capacity and to make the dielectric all air. Its long lug will just fit over the end of the plug in the coil base.

The antenna coil consists of 10 turns of

the two-inch stock and is clamped between two pieces of bakelite. These pieces are held together by means of a small machine screw that passes through them. It may be threaded into the under one or else a nut may be used. They are also notched so that they can be clamped over a piece

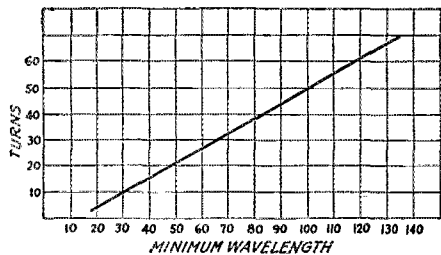

FIG. 2

of bus wire without letting the coil slip. The bus is then bent in the form of a stand and screwed down to the baseboard. When the proper tension of the screw is had, the coil may be shifted and thus allows a variation of the antenna coupling.

No effort was made to make the single stage audio amplifier any more selective to a 1000-cycle note other than the use of an old type UV-712 transformer as a very large percentage of the notes heard on the air are of the 60-cycle variety and if the amplifier is made too selective, these lower frequencies will suffer. Unfortunately, there seems to be no way of telling the peaked transformer and the newer music transformer apart. For a time, the new ones were marked with a star but this has been discontinued and now both have the same appearance. No jack is used to connect the phones to the set as they are connected in series with the "B" lead to the amplifier tube. If desired, another set of terminals may be put on the terminal strip and used for them. It is not advisable to run them from the front of the panel as they usually are always getting in the way.

When the receiver is operating, it may be found that the set goes into and out of oscillation with a high pitched audio howl. This may be overcome by bringing the grid return of the detector tube to the other side of the filament. Although it is usually considered best to return the detector grid to the "A" positive, in this case the negative proved better.

As different operators have different desires as to wavelength ranges for the various coils, there appears in Figure 2 a graph showing the approximate wavelength to which a given number of turns of inductance will tune when the tuning condenser is set at zero and the adjusting condenser is at minimum. These figures can-

not be accurate for all sets as the lumped capacity across the coil due to the wiring, tube, socket, etcetera, will vary somewhat. However, if the proper number of turns is found on the curve and the number reduced by one, the coil should be satisfactory as its wavelength range may be raised by the use of the adjusting condensers. The width of the band which will be covered depends upon the spacing of the condenser plates and may be adjusted to suit the individual operator.

The use of the small tuning condenser makes it possible to use a vernier dial with a lower ratio than is usually employed. A velvet vernier dial is used in the receiver shown and is certainly a pleasure to operate. Its ratio is about right for the job and plenty of regulation of the note may be had by adjusting the secondary condenser. Unlike many tuners that cover a large band, it is possible to vary the note with the secondary condenser without losing the signal entirely. It is not necessary to do the note tuning with the regeneration control.

The grid condenser has a capacity of 100 μ fd. The leak is 5 megohms. This, however, will vary with the tube used. Both 201-A and 199 tubes were used and the lat-

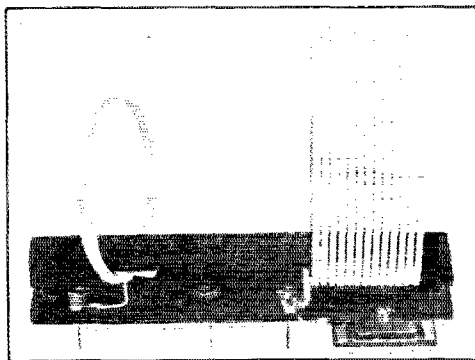

ter gave somewhat less detuning with a change of regeneration. The by-pass condenser is very necessary or the circuit will not oscillate readily. It should not be made too large as it is possible for it to hold its charge and make the regeneration control sluggish. A .001 μ fd. one will allow plenty of oscillation.

Strays

Don't forget to send your card to the International Contest Editor if you want to enter the International Relay Tests.

Radiotron CX-340—UX-240

By Robert S. Kruse, Technical Editor

THE tube known as the UX-240 and CX-340 (these double names are a confounded nuisance), differs from the more usual receiving tubes in being able to do several jobs better. It is a first rate tube for high-distortion audio amplification such as is required for amateur c.w. work and at the same time is excellent for resistance coupled audio amplifiers such as are used in broadcast receivers for mini-

it can serve the double purpose of a maximum-distortion amplifier and a minimum-distortion amplifier.

When as in Fig. 1 a tube works into an audio transformer the results that are gotten depend roughly on:

The amplification constant of the tube. (μ)

The plate impedance of the tube. (r_p)

The impedance of the transformer. (Z)

No one of these makes the thing good or bad. We used to think that as long as μ was large everything was lovely. By that test the 240 would be a wonder, for its μ is (as shown by Fig. 2) very large as compared with that of the 201-A. Now suppose that in Figure 1 we start out with a good audio transformer such as the Amertran or

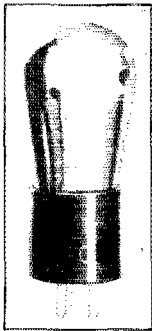

THE NEW TUBE
(Photo Courtesy Radio Corporation)

mum distortion. In addition to this it has some interesting advantages as a detector, especially for amateur c.w. work.

The UX240CX340 (I shall call it the 240 hereafter and save time) differs from the 201-A type in having a higher plate impedance, while the filament remains the same; that is to say, a $\frac{1}{4}$ -ampere, 5-volt thoriated tungsten wire of the so-called "X-L" type.

AS AN AMPLIFIER WITH TRANSFORMER COUPLING

When another amplifier tube is suggested we naturally think—"What excuse is there for still another kind? Aren't 7 kinds

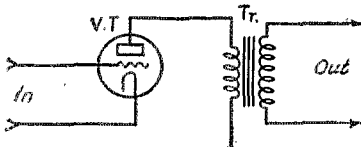

FIG. 1—THE USUAL TRANSFORMER-COUPLED AUDIO STAGE

It can be made into either a high-quality stage or a c. w. distortion stage by using the 201-A and the 240.

enough?" It happens that there is a reason for another sort and as was suggested above

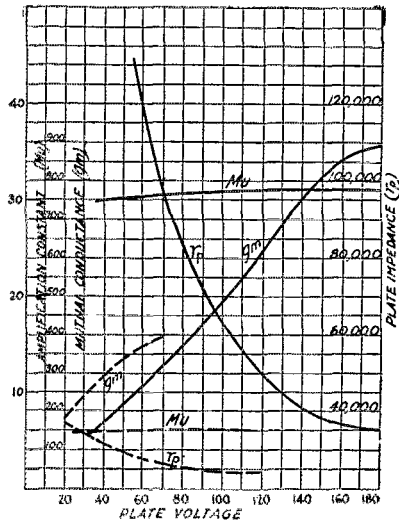

FIG. 2—SHOWING EFFECT OF CHANGING PLATE VOLTAGE ON THE 201-A AND 240 TYPE TUBES

The solid curves are for the 240 and the dashed ones for the 201-A. The higher curves for the 240 do not indicate that it is always best, since one of the curves (r_p) by its height introduces difficulties which prevent transformer coupling.

similar transformer and with a 201-A tube. We feed an amateur c.w. signal (1000-cycle beat note) into the combination and get a certain amplification. Then we try feeding some of WGY's excellent music thru the device and find that the same amplification stays with us on other notes; in other words

that we have a "high grade" amplifier for broadcast reception but one that is entirely too good for c.w. work because all notes come thru. Suppose now we take out the 201-A and put in a 240. We will find that the 1000-cycle amateur c.w. signal will be materially louder but that the broadcast music will be rather terrible. Low notes will be weak and there will be a strong tendency to blare when we strike 1000 cycles or thereabouts.

It looks as if by a simple shift of tubes, we have turned a good broadcast amplifier into a good c.w. amplifier, which is naturally

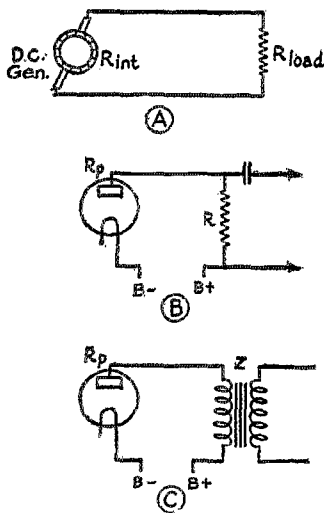

FIG. 2—THE OUTPUT RULE, SHOWING HOW THE RIGHT COUPLING DEVICE IS CHOSEN FOR AMPLIFIERS TO GET MOST AMPLIFICATION AND MOST, OR LEAST DISTORTION AS ONE MAY CHOOSE

terrible for musical purposes. This is the fact and the explanation can be seen from the curves in this paper.

Suppose that we first consider what goes on in the circuit of Fig. 1. Whatever audio voltage comes into the tube V.T. is amplified by the tube by the number of times represented by the "Mu" of the tube, that is 6 or 8 for the 201-A and 30 for the 240. This is voltage in the plate circuit and the next problem is to get it into the audio transformer. For the 201-A that isn't hard tho it has taken manufacturers a long-long time to get up the courage to make transformers large enough. The reason for the size is NOT that much power is to be handled. Quite the contrary, the power is nowhere near enough to warm up the smallest of audio transformers. The reason lies entirely in the good electrical rule

which is sketched in Fig. 3. At A we have a direct-current electrical generator. If the armature has a certain resistance which we will call R_{int} (internal resistance) we will find that the generator is giving the most output when the load resistance (R_{load}) has the same value. If the load resistance is higher the current drops off; if the load resistance is lower the current rises but the voltage drops off and the generator does less and less work outside tho it may heat inside.

Now if we carry the same rule over to vacuum tube amplifiers as in B we find that the tube gives the most output when the load resistance R is equal to the plate impedance r_p . In the same way we find that in the transformer-coupled amplifier at C the out-

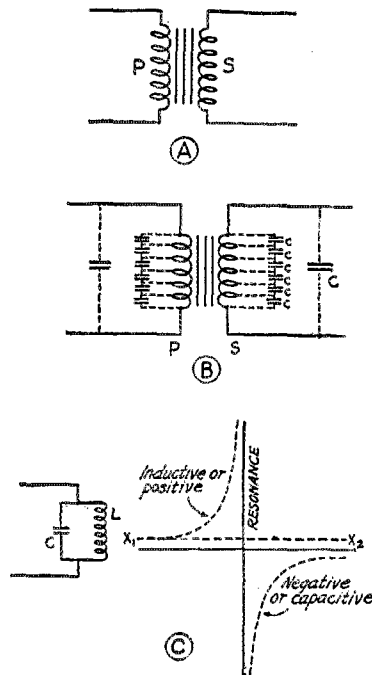

FIG. 4—THE AUDIO TRANSFORMER, SHOWING HOW IT MAY BE MADE TO DISTORT OR GIVE HIGH QUALITY DEPENDING ON THE TUBE USED

- A—Usual picture of transformer.
- B—Distributed capacity taken into account.
- C—Effect of distributed capacity in creating a peak when using a high impedance tube ahead of the transformer.

put is greatest when the impedance Z of the transformer is equal to the plate impedance r_p . In the same way we find that in the transformer-coupled amplifier at C the out-

put is greatest when the impedance Z of the transformer is equal to the plate impedance r_p of the tube.

One may think—"That all sounds well but what has it to do with amplifier distortion?"

Simple enough. Let us look at Figure 4 and we can explain it. We usually think of an audio transformer as being like Fig. 4A. Now that is not all of the story. The transformer not only has windings but these windings have distributed capacity and the complete diagram is that of Fig. 4B. Now

a nice high impedance and therefore the moderately low r_p of the 201-A acts like a resistance load across the primary. The effect of the capacities of 4B is swamped out, the peak goes down and the hollows come up and we arrive at a nice flat curve, just as we found in the test a bit ago.

Now we pull out the 201-A and substitute a 240. The r_p of the 201-A was 22,000 ohms at 40 volts. That of the 240 is 180,000 ohms at the same voltage. Practically speaking, we have taken the load off the primary.

The effect of Fig. 4C gets full opportunity to go to work. This means that off the natural resonance of the transformer we get little amplification while on the peak the transformer acts like a high impedance (200,000 ohms perhaps), loads up the tube and takes power from it. We get good energy transfer at the peak voltage, poor transfer at other voltages and our "good" music amplifier has become a "good" c.w. amplifier. It is a beautifully simple way to shift from purpose to purpose.

AS A RESISTANCE-COUPLED AMPLIFIER

In a resistance-coupled amplifier the amplification per stage is usually very, very poor. Generally speaking 3 stages are not equal to two stages of transformer, tho the quality may be a bit better if we are concerned with music. The cause of this is simple also. With transformers the per-stage amplification is the μ of the tube times the transformer ratio—for instance 7 times $2\frac{1}{2}$ or 17, less a very little that accounts for the losses. In the resistance amplifier we have the opposite condition, the per-stage amplification is *less* than the μ of the tube, in fact we can hardly hope to get over 19 from a tube with μ of 30 while the 201-A tube cannot be expected to give much over 5. Since it isn't much of a trick to obtain first-rate transformer amplification *with high quality* from the 201-A at the rate of 15 per stage and no trick at all to get 12, this puts the 201-A out of the running as a resistance-coupled tube.

The curve of Fig. 5 shows that the 240 under the same conditions will give good per-stage amplification so that one now has the choice of a high-quality transformer amplifier with 201-A tubes, a distortion amplifier with 201-A tubes and peaked transformers, a distortion amplifier with 240 tubes and high-quality transformers, a high-quality amplifier with 240 tubes and resistance coupling, and finally a super-distortion arrangement with peaked transformers (old style) and the 240 tubes. The last provides entirely too much distortion to

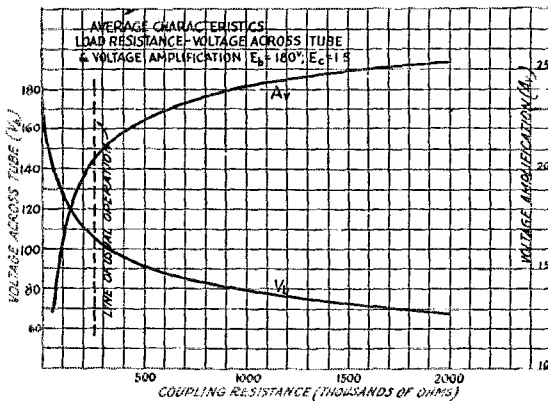

FIG. 5.—EFFECT OF DIFFERENT COUPLING RESISTANCES

This shows the imperative need of a high coupling resistance. Unfortunately it does not show that a low coupling resistance and low voltage are even poorer than a low R and high voltage.

unless the resistance is extremely high a circuit with both inductance and capacity is tuned. This one is. In fact if we take the transformer off *by itself* and measure it "looking into" the primary terminals we will find that it acts like the parallel-tuned circuit of Fig. 4C. If one feeds it a low frequency the affair will show a very low impedance which rises rapidly at resonance, reverses at resonance (still high tho) and then drops again as we leave resonance. This simply means that at resonance the transformer could be used as a very high impedance load but that off resonance it would fall rapidly and have a much lower impedance.

For the sake of brevity we will not start to take the transformer apart but let it go at that and get ahead.

Suppose that we used the transformer first with the 201-A tube. This would almost swamp the resonance peak we have just talked about.

WHAT CAUSES THE PEAK TO COME AND GO

Suppose now that we take the Amertran just discussed and connect it to a 201-A. Our diagram now changes abruptly and becomes that of Fig. 4D. The Amertran has

suit me, even for the reading of crystal-stabilized signals.

AS A DETECTOR

All of the things mentioned apply with additional strength to detection. Here the plate impedance is even higher than before because the gridleak and condenser add to the ordinary bias. (This is why some good transformer makers make a special type to follow the detector.) Therefore the resonance-peak effect of Fig. 4 gets an especially good chance.

My pet amateur receiver at this moment is a 240 detector followed by a "good" transformer and then by a 201-A as will be explained in a moment.

THE LAST AUDIO STAGE

Since the 240 cannot feed into an ordinary audio transformer without manufacturing peaks it certainly should not be expected to feed into a headset or loudspeaker, as these have even smaller impedance and horrible distortion is bound to follow. I find that even the 1-audio arrangement just referred to will give more of a peak than seems useful if both the detector and the amplifier are 240s. When more stages are used the peak becomes too strong.

In broadcast reception one naturally wants to keep the peaks down and the hollows up, therefore the correct combination is one or several 240s feeding into 250,000-ohm resistances and coupled to the next tube thru condensers with capacity between .05 and .005 microfarad. The last tube (which is to feed the loudspeaker) should be a normal 201-A, 112, 171 or a 210 with an output transformer. Anyone who prefers to do his broadcast reception with transformer coupling is welcome to keep right on with the usual 201-A tubes down to the output tube. There will be at least two of us.

MISCELLANEOUS

Because of the high plate impedance of the 240 the coupling resistance should have a value of 250,000 ohms and the B battery should supply from 135 to 180 volts of which about 110 will reach the tube. The amplification will be about 20 which compares well with high-grade 201-A stages, transformer coupled.

The coupling condenser of the resistance-coupler should have a value between .05 and .005 microfarads and be of the very highest grade. Paper condensers are probably not nearly good enough and any but the best mica condensers are likely to fall into the same class. The insulation resistance must lie above 100 megohms, otherwise

the B voltage gets to the grid, likewise there is power loss in the condenser. When using a "B sub" one sometimes runs into the nuisance of a steady howl or rattle and gets rid of it by dropping the coupling capacity or using a low-resistance leak on the next tube. This is hardly good practice. With battery plate supply or a high-grade B sub

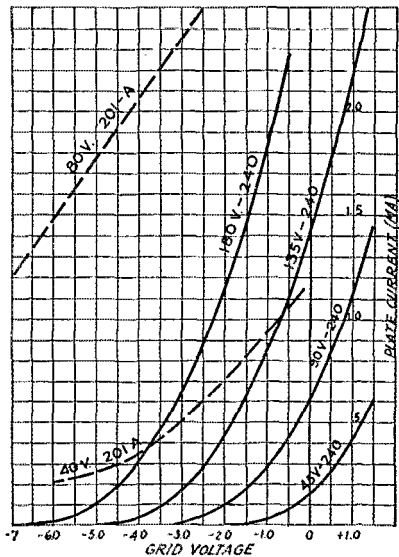

FIG. 6—THE USUAL "STATIC CHARACTERISTIC" CURVES

These curves are more a matter of custom than usefulness to the purchaser of tubes. In this case they are excused by the comparison between the 201-A and 240.

it is not necessary. This is one of the main defects of resistance-resistance and impedance-resistance coupling. It is largely avoided by going to resistance-impedance coupling which is NOT the same as impedance-resistance but the exact opposite.

For detection with leak and condenser the 240 is used normally, for "plate detection" these are dropped and a C bias of minus 3 to 4½ volts is used.

SPECIAL NOTE

When using the 240 for distortion amplification or detection it has a transformer primary in the plate circuit. These do NOT have a resistance of 250,000 ohms (¼ meg) but a rather low resistance and therefore the tube should be supplied from a 90-volt battery which is also correct for the 201-A tubes used in the following stage of audio.

One other matter. If a resistance-coupled amplifier "motor boats" with battery supply

the trouble probably lies in a high-resistance cell in one of the battery blocks or in the use of a long lead to the batteries. The cure is to make sure of the batteries (even new ones are not all good) by making a momentary short-circuit test thru a 10-ampere meter and also to provide a 1-microfarad B bypass in the set.

Note:—

A CX-340 tube was used to replace a 201-A in the c.w. receiver at 1MK, the A.R.R.L. Headquarter's station and has greatly relieved interference from power leak and street car noises. A UX-240 has done similar work at 10A, the writer's station.—Tech. Ed.

Handy Resistor Units

THERE are many uses for small resistor units about the average amateur station and in many cases the man finds it necessary to buy a variable unit as he is unable to obtain a fixed one. This not only calls for a greater outlay of money but the variable unit usually finds its way to the panel where it needlessly crowds other instruments and also invites a certain amount of adjustment which is not necessary.

For the amateur who is just starting up with simple apparatus and is using a step-down toy or bell-ringing transformer that is not center tapped, there is a 200-ohm unit that is tapped at the center. This will replace the two Christmas tree lamps which are used so commonly for the obtaining of the electrical center tap. It has the advantage of being considerably smaller and may be placed directly across the tube socket

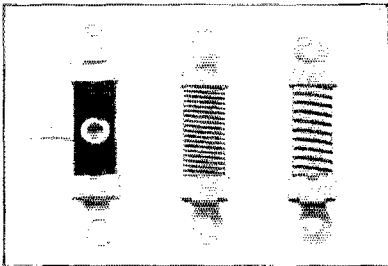

terminals. Thus, it will not only save space but will also save time in its installation. They may be employed for the same use in conjunction with power amplifiers that supply the filament of the last tube (usually a UX-210) with a.c.

In crystal control circuits, it is quite commonly the practise to use a couple of 210s and a 203-A or two. Instead of using separate filament lighting transformers, it is quite possible to use only one and insert resistors between the filament of the fifties

and the 210s. If two of the smaller tubes are used, it will be necessary to use a resistance of one ohm to give the required voltage drop of 2.5 with a current of 2.5 amperes. In order to keep the center tap properly balanced, two half-ohm units should be used, one in each leg of the smaller tubes' filament. If only one 210 is used, the resistor should have twice this value.

The three units shown in the illustration are the center tapped, 200-ohm one and the half and one-ohm sizes. The high resistance one is wound with enameled wire and may be obtained either with the tap or without it. The other two are wound with strip and there is no reason why you couldn't make contact to it at any place to obtain lower values of resistance.

The units may be had in various sizes ranging from 1000 to $\frac{1}{4}$ ohms. The manufacturer is the Carter Radio Company of Chicago, Ill.

—H. P. W.

60I Wins Modesto Wouff-Hong

BECAUSE of a breakdown in the official reporting arrangements for the Pacific Division Convention recently held at San Jose, we had to cook up our own story here in the office from memory and we regret to say we omitted one very important event: the award of the Modesto Radio Club's beautiful Wouff-Hong Trophy to 60I of Stanford University, California, as the best all-around amateur station in the Pacific Division.

Those not familiar with this trophy are invited to see page 27 of QST for January, 1925. It is made from the melted-down plates and grids of some five hundred burnt-out transmitting tubes contributed by amateurs all over the country, a most fitting emblem for the transmitting ham. Each year it is awarded at the Pacific Division Convention to the best "6", to hold until the next convention. The rules give a maximum weight of 35% to DX in miles per watt, 25% to traffic handled, 20% to operating ability, and 20% to the proportion of the apparatus which is home-made. A year ago at Santa Ana the first award was made to Smith of 6BUR and now it goes to 60I, with 6BJX as runner-up.

60I is owned and operated jointly by Brandon Wentworth and Phil Scofield. The award will be a popular one, for everyone admits the excellence of this station and its work. 60I has communicated with almost every civilized country on earth and many uncivilized ones, and was able to present to the judges a complete log that was a model of perfection and a huge stack of cards attesting the work done. Congrats, 60I!

K. B. W.

A Sensitive Thermo-Couple

By Benjamin J. Chromy*

AN extremely useful device rarely seen in the instrument collection of the average amateur is a thermo-couple capable of measuring a very small fraction of an ampere of radio frequency current. A sensitive couple which may be used in conjunction with a small milliammeter is rather easily constructed. No elaborate outlay of tools and equipment

The small platinum wire is next welded to the tellurium lump by the use of a small spark coil. The secondary high voltage terminals of the spark coil are connected to the binding posts of the thermo-couple. The small platinum wire is brought close to the tellurium and allowed to heat to redness; then it is plunged into tellurium quickly but not violently. The spark produced by the spark coil must not be very intense and should be less than one-eighth of an inch long.

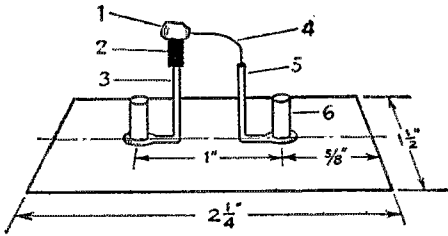

FIG. 1

- A—Tellurium Lump
- B—No. 20 Platinum Wire
- C—No. 14 Copper Wire Holder
- D—No. 30 or Smaller Platinum Wire
- E—No. 14 Copper Wire Holder
- F—Binding Post

When platinum wire of a size smaller than No. 30 A. W. G. is used it may be welded to the tellurium by the electro-percussion method. A one microfarad condenser which is connected to the thermo-couple is charged at 100 to 300 volts d.c. by closing the d.c. circuit to it for an instant. The condenser is discharged by touching the small platinum wire to the tellurium. This method of welding is very satisfactory for use on couples made of fine wire.

The sensitivity of the thermo-couple depends upon the resistance of the small platinum wire and tellurium joint. A very sensitive couple may be made by oxidizing the surface of the tellurium and simply causing the small platinum wire to bear

is necessary. A piece of quarter-inch hard rubber panel $1\frac{1}{2}$ by $2\frac{1}{4}$ inches is finished off and two small holes for binding posts are drilled on the center line which is parallel to the longer sides of the panel. These holes are $\frac{1}{2}$ -inch from the center. Two pieces of No. 14 bare copper wire 2 inches long are cut. A loop to fit the binding post is made on the end of each as shown in Fig. 1. A piece of number 30 A.W.G. platinum wire one-half-inch long is tightly attached and lightly soldered to one of the number 14 copper wire holders. A small lump of tellurium is next welded to a piece of number 20 platinum wire in the following manner: The platinum wire is heated to white heat in the blue portion of the Bunsen burner flame and then plunged into the tellurium very rapidly but not violently. The unit consisting of the tellurium and the No. 20 platinum is next mounted upon the second of the two No. 14 copper wire holders as illustrated in Fig. 1.

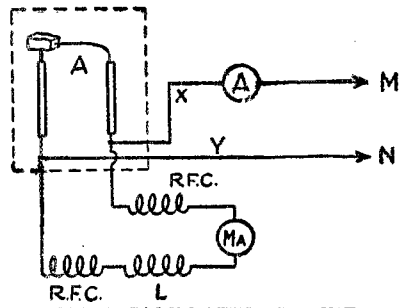

FIG. 2. CALIBRATING CIRCUIT

- A—A. C. meter 0-1 Ampere Low Frequency Type
- Ma—Either a 0-5 or 0-10 Milliammeter
- L—One Henry Inductance
- X and Y are the points at which the radio frequency circuit is connected after the couple is calibrated on the 60-cycle current. When calibrating the 60-cycle supply is connected at M and N.

The joint made by the large platinum wire with the tellurium must be solid and tight since the efficiency of the couple depends upon the low resistance of this joint. The joint between the platinum wire and the copper holder must be tight before the joint is soldered.

down upon it without welding the joint. If the joint is not welded the couple will be very sensitive; it will not, however, hold calibration for any length of time.

The calibration of the couple is not difficult if a one-ampere full scale deflection a.c. ammeter is available. This a.c. meter is connected according to the diagram

* Hopkins, Minnesota, operator 9CJO.
1.—To be obtained from Eimer & Amend, 211 3rd Ave., New York.

illustrated by Fig. 2. The radio frequency chokes and the one-henry inductance are connected in series with a 0.5 or 0.10 milliammeter as also illustrated by Fig. 2. Readings of the low frequency calibrating

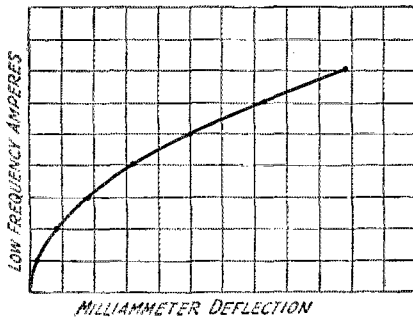

FIG. 3. CALIBRATION OF A SAMPLE THERMO-COUPLE

current as read from the a.c. ammeter and the corresponding deflections of the milliammeter are recorded and a curve similar to that illustrated in Fig. 3 is drawn.

The size of the small platinum wire used determines the range of the couple. If No. 30 wire is used the couple should not be used in circuits carrying more than 0.3 amperes. If the couple is to be used in neutralizing the crystal amplifier then smaller wire than No. 30 should be used. The electro-percussion method of welding must then be employed in making the couple.

The thermo described finds ready application in many experiments. Many times the experimental outfit is made to work properly when it is adjusted according to the information obtained through some meter.

Strays

When the time arrives to fill your rectifier jars with water, you can save yourself some work by using this method. Get a piece of rubber tubing from your neighborhood drug store and hold it under the water faucet until it is at least half full. Place the bowl of water on a chair so that it is above the level of the jars and submerge one end of the hose into it, meanwhile pinching the other end between the finger and thumb. If this end is then held over the jar to be filled and the pressure released, a stream of water will flow. At first, it will be erratic but as soon as the tube is entirely filled, the stream will be just about right for the job. This was suggested by 2EM who says it is old stuff but usually forgotten.

A list of "Calls Heard" appeared in the January issue under the call of pr4KD, U. S. Naval Radio, San Juan, Porto Rico. Some folks got the impression that this indicated that 4KD was a naval radio station. This is not true as the station is owned and operated by E. W. Mayer, who was on duty at that station and therefore his mailing address was as given above. There is no connection between the naval station and 4KD outside of the fact that the owner of 4KD receives his mail through the U. S. Naval Radio Station at San Juan.

G. A. Woodhouse of 7EL says that a good a.c. relay may be obtained from most jobbers who repair electric ranges. It is made by the General Electric Company and goes under the name of "Magnetic Switch", No. CR7002-A2. Its contacts are about $\frac{1}{4}$ " and are well insulated from other parts. It may be used for a keying relay in the plate circuit and has many other uses in remote control work.

An error was made in the map appearing on page 49 of the February QST. The state of Michigan is not divided in the middle as shown as it is only the upper peninsula above Wisconsin and between Lakes Michigan and Superior that are located in the ninth district.

Those who are interested in eliminators and chargers of various sorts will find a booklet "How to Use Resistance in Radio" by the Ward Leonard Electric Co., of Mount Vernon, New York to be useful. It may be obtained from them for 15 cents.

7IT reports that pi3AA says that he is leaving the Philippines and expects to eventually settle in Boston where he will put in a crystal controlled outfit.

9BWI needed some cheap plate meters, so he bought a couple of the \$1. voltmeters at the quarter to a dollar store. These meters are of the vane type with a winding on a flat piece of iron, supported over the pointer vane. There are two other coils in series with this winding to increase the total resistance of the meter. These three windings may be placed in parallel and the meter calibrated as a milliammeter. For a still lower reading meter, these other two windings may be left open and just the main windings used. Calibration may be made by putting the meter in series with a regular one (borrowed) in the plate circuit of a 210 with 200 volts or so on the plate. The filament voltage may then be varied to give the required plate current for each calibration point.

The Purposes of the Army-Amateur Affiliation*

By Capt. A. C. Stanford, U. S. A., Liaison Agent

THE ONE great mission of the Signal Corps in time of war or peace is to furnish communication for the Army. To this end the Signal Corps has a vital interest in any agency of civilian life, whose functions and problems are similar to its own.

The large telephone and telegraph companies have problems which are closely allied to those of the Signal Corps, when wire communication is considered, and these organizations embrace hundreds of qualified men who could be easily shifted from their civilian status to the maintenance and operation of military wire lines.

In radio communication the supply of trained personnel offers a more difficult problem. There is no counterpart in the commercial companies of the field radio systems used by the army. These radio systems are usually portable, work under the most adverse conditions, and have very low power. The distances involved are small but the operating personnel must be highly trained. In any great emergency thousands of qualified operators would be needed.

While commercial radio companies cannot supply the operators that might be needed we are fortunate in having an almost unlimited supply from another source.

For many years there have been banded together in the United States, thousands of young men who are making radio work their hobby. These men are interested in the research, development, and design of transmitting and receiving equipment. They are known as radio amateurs, and are organized into a volunteer organization which promotes their general interests. This organization is the American Radio Relay League.

Members of the A.R.R.L. are interested in handling messages, and the more important those messages, the deeper their interest and the more intense their activity. The leaders of the A.R.R.L. are ever on the lookout for means that will increase the skill and operation of the stations of the various members. The country is now criss-crossed with radio channels which handles hundreds of messages each evening.

In 1925 the Signal Corps requested that it be allowed to cooperate with the American Radio Relay League. The League welcomed this request and arranged with the Signal Corps an elaborate scheme whereby a portion of the members of the A.R.R.L. would become closely associated with the Signal Corps as volunteers, and a new group called Army Amateur Operators, came into being. These young men were especially selected from leading amateurs throughout the country, because of the excellence of their work, and were asked to undertake certain communication problems under the direct supervision of the Signal Corps.

Signal Corps activities are performed in the United States by dividing the country into nine great districts called Corps Areas. In each Corps Area there is a Signal Officer, who works directly with the amateur operators within that Corps Area. He forms radio nets composed of amateurs from the American Radio Relay League. These nets comprise groups of stations which represent certain military units, and in addition embrace some of the political divisions of the states in which the nets are formed. Each net handles messages between its own stations, and with other nets in the Corps Area. Thus the Governor's office of the State of New York is linked directly with the amateur station of the Signal Officer of the Second Corps Area at New York City.

The affiliation between the Signal Corps and the American Radio Relay League offers the amateur many great advantages. Work in Army Nets, in radio operating, in enciphering and deciphering messages, provides a new and interesting activity. It tends to make the American amateur a more skillful operator, since he is proud of the fact that his hobby renders real service in handling official and semi-official government business.

The Army Amateur Operator, who is also a member of the A.R.R.L. takes pride in being a part of an organized communication plan, in identifying himself with the Army, and especially the Signal Corps. He has, when selected by a Corps Area Signal Officer, the official stamp of government approval.

The American Radio Relay League is interested in handling traffic and in the promotion of radio development and research. Here again the affiliation with the Signal Corps, which does this work for the

*From a report to the Chief Signal Officer of the Army. Capt. Stanford as Liaison Agent is in charge of the Signal Corps—A. R. R. L. relationship. Interested amateurs may make application for army appointment to the A. R. R. L. Communications Manager, who will forward to the proper A. R. R. L. army representative—Ed.

Developments in Dry Electrolytic Rectifiers

By Robert S. Kruse, Technical Editor

IN our May, 1926, issue there was described a trickle charger which makes use of a dry electrolytic rectifier. At that time it was pointed out that it would be very fine if the device could be expanded to handle larger currents and higher voltages so as to make the dry and silent rectifier available for other uses. Some of these developments have now become facts, and the purpose of the present paper is to describe the Elkon 2-ampere charger and the Elkon A substitute which is

had not yet been thought of and broadcasting was in the remote future.

For some time past the device has been in final form and one has been at this office but the final story was obtained from

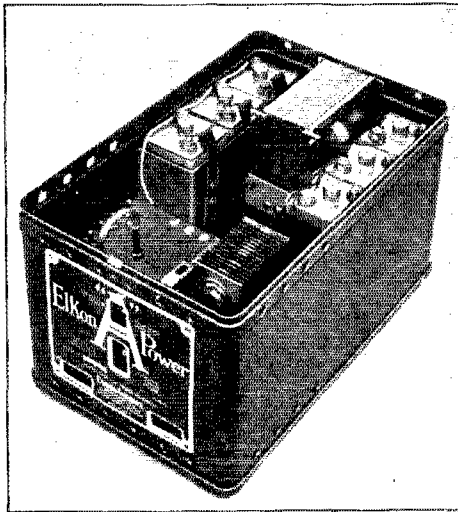

INTERIOR VIEW OF THE A SUBSTITUTE

At the left front is the panel covering the transformer and one of the chokes, also carrying the rectifier assembly whose fins can be seen at the right front. At the center rear are two of the chokes above each other and at the sides are the 6 electrolytic condenser cans. The quick-forming switch is reached thru the opening in the upper part of the letter "A" while the opening between the legs of the "A" exposes the 110-volt snapswitch. The two lower openings are for the input and output cords. The rectifier assembly mounts on a separate base and can be replaced when worn. The condenser electrolyte is a harmless one—Borax.

a filament supply capable of delivering the direct filament current required by any present-day receiver using 5-volt tubes. The rectifier coupler, as was stated in my paper on the trickle charger, was devised by Mr. Samuel Ruben. Its conversion into an A substitute and the electrical and mechanical design of that substitute was done by Dr. Harry Shoemaker who needs no introduction to an audience of radio amateurs because he has been in radio from the days when all were amateurs, the vacuum tube

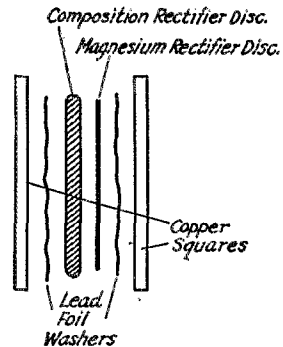

FIG. 1—A SINGLE RECTIFIER ASSEMBLY

These are combined in several ways to work at voltages above the limits of one couple, also to give full-wave rectification.

Messrs. G. N. Sieger and Harry Shoemaker by our good friend Boyd Phelps who after a hasty telephone call rejoined QST's staff for the moment, spent the day at the Elkon Works in Weehawken, N. J. and then drove to Hartford with the complete information.

THE RECTIFIER PROPER

The rectifier, as was the case in the trickle charger, is based on dry rectification between two discs or washers laid face to face. A single unit is constructed as shown in Fig. 1. Between two sheet copper squares is laid a pair of discs of which one is magnesium while the other is of a black composition whose exact nature takes a good deal of explaining tho one can say briefly that it contains zinc selenide and copper selenide. The lead washers next to the copper plates are used as "padding" since it is hard to get good contacts otherwise. Some of the rectifier discs are shown in one of the photographs.

As was said in the article on the trickle charger, the exact nature of the rectifying process is not too well understood. For convenience the process is described as "electronic reaction" between the two discs. The mechanics of the thing are probably not the same as in the lead-aluminum rectifier which we are familiar with, and possibly

not the same as in the copper-oxide rectifier which has recently appeared on the market in trickle-charger form.

One should not be too unhappy at the lack of a more exact explanation; we have not yet found out just where chemistry leaves

of the battery is $7\frac{1}{2}$ and the transformer voltage must be at least 8 to get anything accomplished. The transformer peak voltage is therefore 11 and this added to the $7\frac{1}{2}$ gassing voltage becomes $18\frac{1}{2}$. As a matter of fact the transformer voltage was a bit higher and therefore three units (as in Fig. 2) rather than 2 units were used.

AMPERE CHARGERS

The trickle charger having given a good account of itself one naturally thinks of chargers operating at a higher rate. At first sight one may think that it is a trifle to go from a $\frac{1}{3}$ -ampere charger to one working at three amperes—it is only 9 times as much current and the voltage stays the same.

As a matter of fact the transfer was very slow and very painful. A look at the photograph of the discs will show how they

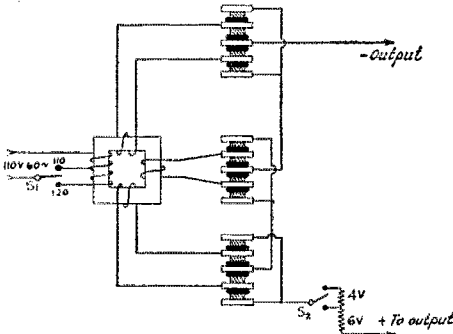

FIG. 2—MANNER OF COMBINING THREE RECTIFIER UNITS OF 4 COUPLES EACH TO OBTAIN A RECTIFIER CAPABLE OF CHARGING AGAINST A VOLTAGE OF $7\frac{1}{2}$

This is the diagram of the trickle charger. The rheostat is made of ballast resistance wire as explained in the text.

off and physics begins, but that does not prevent them from being useful.

At the time of the trickle-charger article it was not possible to operate the Ruben-Elkon discs in series, and as each pair would only stand about 15 volts it was necessary

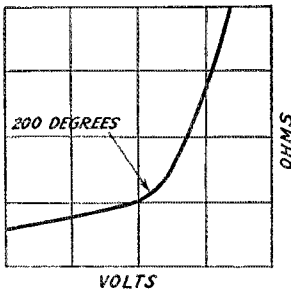
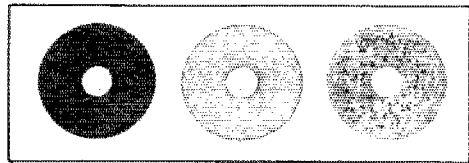

FIG. 3—RESISTANCE-VOLTAGE CURVE OF THE BALLAST WIRE USED IN THE CHARGERS

When the wire has heated to 200 degrees a very slight increase in current raises the resistance rapidly and prevents overloads from becoming damaging.

to resort to the curious connection shown in Fig. 2 which is a set of three bridge-connected rectifiers with their d.c. outputs in series. It may seem curious to speak of endangering a 15-volt device when working into a 6-volt battery but one must remember that on the reverse half of the cycle the rectifier stands the transformer voltage plus the battery voltage. The gassing voltage



RECTIFIER DISCS

At the left is the black "cupric" composition disc. At the center is a new magnesium disc. At the right is a worn magnesium disc from a test-run showing how the surface has been attacked at various points. In the early discs the failures tended to concentrate at one point and to burn short.

wear, for naturally these devices wear out in time. The earlier ones did not wear in this fashion but displayed a disgusting desire to burn across violently at one point, generally short-circuiting the pair and stopping further proceedings. To prevent this the current had to be kept small (which meant a trickle charger) and a protective "ballast" resistance had to be used as is shown in Fig. 2. The problem of producing a 2-or 3-ampere charger was the same as the problem of making the current distribute itself evenly over the disc—and keep on distributing evenly. Those who have tried to make a 3-ampere aluminum rectifier begin to understand that this was somewhat difficult. The thing was finally done however and the 3-ampere charger is a sort of "big brother" to the trickle charger with no very great variation in the arrangement.

ELECTRICAL DETAILS

The ballast resistance material is present for the purpose of preventing any sudden rises of current which would either cause or aid a local "burn" and tend to damage a rectifier pair. This means that the resistance must rise promptly if anything in the nature of an overload takes place. The ballast is accordingly made of a nickel alloy whose resistance rises rapidly as the

temperature is raised. Putting it differently, if the voltage across a piece of the wire is increased the current will increase slowly and then very rapidly. This means that once we have reached the bend of the curve in Fig. 3 the current will have a hard time to increase further. The kink comes when

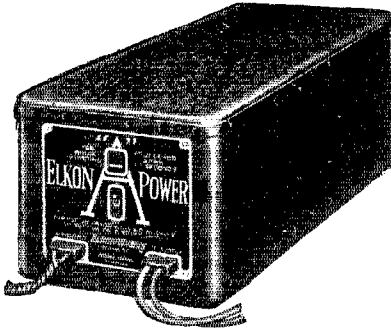

EXTERIOR VIEW OF THE ELKON A SUBSTITUTE

the wire is heated to about 200 degrees, therefore, its size is so chosen that the normal charging current of about 1/3 amp. will heat it to that point.

THE A BATTERY "SUB"

Having built a workable 3-ampere charger one naturally wonders if the device will be useful for filament supply, that is as an "A-battery substitute". This divides into two problems; that of devising a rectifier stack to fit this exact job and that of devising a filter to remove the ripple from the rectified output. First, one has to have the rectifier. The filament-supply device ordinarily is not called upon to supply more than about 1 1/4 amperes, as against the 3 amperes for the charger. This permits the use of smaller rectifier discs and therefore reduces the trouble caused by local current-concentration. The voltage required at the output posts is only 6 as against 7.5 for the charger and this may at first sight seem to be an easier condition. In a way that is true for one can avoid the complex arrangement of Figure 2. On the other hand the rectifier action is such that the tendency is toward a better life when working into a battery than when working into a resistance. This will be explained later. For the present it is enough to say that the disc for the filament supply required a considerable amount of additional work and that those now produced pass thru a complex process during which many are rejected. This of course applies mainly to the "cupric" composition discs.

RECTIFIER DETAILS

Having a pair of suitable discs it is interesting to show how they act. Figure 4

shows the simplest test that one can make easily. A low-voltage battery is connected to an ammeter and a pair of pointed prods. When the prods are put on opposite edges of the cupric disc the current (with the voltage used in the test) was 1.5 amperes. The same result was gotten with the magnesium disc. With the pair put together as at the center of the figure the current in one direction was 1.3 amperes and in the reverse direction 0.1 ampere. At a higher voltage the difference would have been much greater up to the breakdown voltage.

When the voltage used is that of the regular "A sub" the resistance in the two directions (average) is different in a ratio of about 1000/1 or more exactly, the resistance from magnesium to "cupric" is 2/10 ohms and the reverse resistance is 200 ohms.

The rectifier will work cold but operates more smoothly when warm—70 degrees Centigrade. The size of the copper fins is accordingly adjusted to keep the unit not cooler than about 70° C which is the same as 160 degrees Fahrenheit. If it warms up

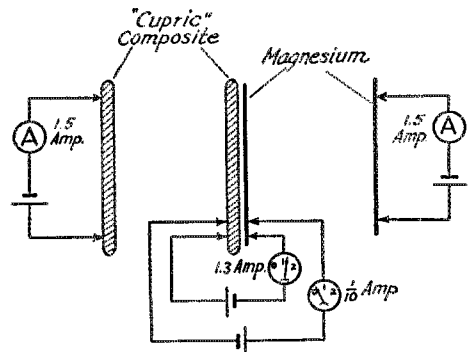

FIG. 4—SHOWING ACTION OF A RECTIFIER COUPLE UNDER D.C. CONDITIONS AT VERY LOW VOLTAGE. THE PERCENTAGES ARE DIFFERENT AT HIGHER VOLTAGE

the resistance of the cupric disc or the contact with it drops and the unit does not overheat. The 3-ampere charger works at 90 degrees C.

Operating at the proper temperature the rectifier has a *static* characteristic like that of Fig. 5A and 5B. As drawn at A the reverse current can hardly be seen at all, therefore the curve has been re-drawn in 5B with two different scales of both current and pressure. Like most d.c. curves on a.c. apparatus these curves must not be taken too seriously. Information that is more to the point can be gotten by using the oscillograph which shows the output current of

the rectifier to be like the curve of Fig. 6. It will be seen that the rectification is not as perfect as one would have guessed from a look at the "static" curves of Fig. 5, the actual rectifier efficiency being 35%. A

For the 3-ampere charger with normal load of 3 amps at 7.5 volts the input is 70 watts, giving an efficiency of 32%.

These figures compare rather favorably with the usual chargers.

The A-battery substitute, whose output is naturally at 6 volts operates as follows tho it must be remembered that the final output in this case is less than the rectifier output as there is a drop in the filter. The input at no load is 14 watts which goes to reverse current loss and possibly some loss in the filter condensers, loaded with 6 tubes, i. e. 1.5 amperes the input is 46 watts, giving an overall efficiency of 19%. With an 8 tube load drawing 2.25 amperes this becomes 56 watts at an efficiency of 24%.

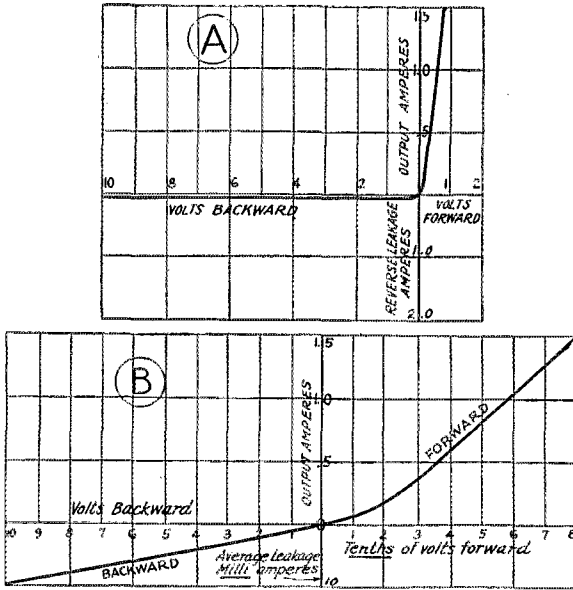

FIG. 5—COMPLETE D. C. CURVES ON RECTIFIER COUPLE
Curve A is to the same scale all the way thru and gives a correct idea of the proportions. Curve B has been drawn on a distorted scale to open out the readings.
Neither curve gives a correct picture of the a. c. action as is explained by Fig. 6 and the text.

very important point is that the curve shows the output to be of the right wave form for easy filtration.

The flat-topped shape of the reverse-current is caused by the fact that the contact resistance disappears during the forward half of the cycle and does not instantly grow up again on the reverse voltage half of the cycle. In battery charging the battery voltage aids the reforming. The reverse current furnishes most of the heat which appears in the unit, the rest being caused by the I²R of the forward current.

The operating efficiencies of the various units are as follows. For the trickle charger (3 units at 2½ volts and 1/3 amp. each).

The operating performance of the rectifier under various conditions is as follows. For the trickle charger whose output is at 7.5 volts. With ½ amp. load the input is 14 watts, the efficiency being about 29%, partly because of the ballast resistance. With a 1-ampere load the input is 22 watts at an efficiency of 34%.

THE FILTER SYSTEM

The filter system of an "A sub" is a very difficult thing to design as has been said before in these pages. If the rectifier wave form is not good, one may almost stop before starting. It is almost imperative that the filter have large capacities though we have in these pages described an A substitute which did surprisingly well with a resistance filter. In the Elkon device there has been used a 3-stage filter devised by Dr. H. S. Shoemaker who also worked out the electrical and mechanical design of the whole device.

The connections of the rectifier stack itself are shown in Fig. 7 while the complete circuit is shown in Fig. 8. The 3-stage filter was chosen because the inductance cannot

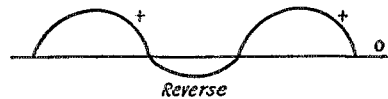

FIG. 6—OSCILLOGRAM OF THE OUTPUT CURRENT

be made extremely high without introducing excessive resistance and on the other hand the capacity in the filter is not so effective when concentrated across a single choke. Design considerations that had to be regarded were that the voltage at the output would need to remain between 5½ and 6 with widely varying line voltages and loads and in spite of the unavoidable IR drop in the filter and the rectifier. Taken together these things work out roughly to the effect

that between the transformer and the output there are the following ratios:

D C Volts	.52	D C Amps	1
A C Volts	1	A C Amps	1.5
Overall 30%			

As shown in Fig. 8 and also the general photo the transformer is equipped with 8

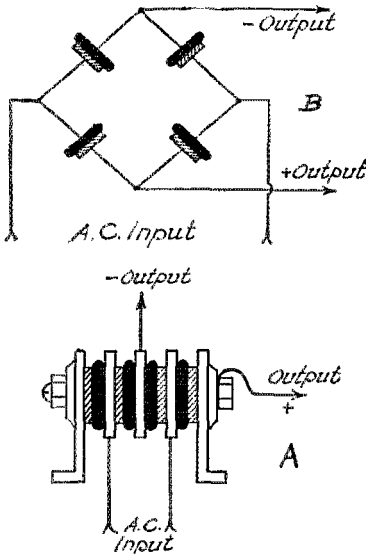
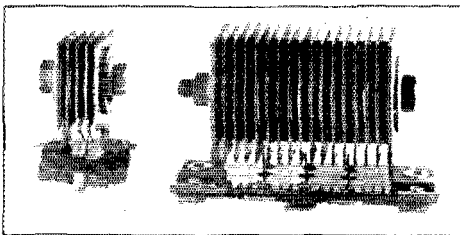

FIG. 7—ARRANGEMENT OF RECTIFIER COUPLES TO FORM FULL-WAVE BRIDGE-CONNECTED RECTIFIER

A is the actual arrangement with the units strung on a machine screw with spring washers while B is the equivalent bridge.

secondary terminals and a traveling plug to permit obtaining various a.c. input voltages so that the d.c. voltage will remain at the proper value. Since the usual re-



RECTIFIER ASSEMBLIES

ceiver has a rheostat this number is very generous and renders it possible to set the voltage at the proper value at the device after which misuse of the rheostat does not endanger the tubes.

The filter chokes have an inductance of

1/10 henry under load and a resistance of .3 ohm, giving a maximum drop of about 1.8 volts. The condensers are electrolytic and have a very large capacity per unit, the total for the 6 cans being 1500 microfarad.

OPERATION

When put into operation initially the rectifier is cold and does not form rapidly. A particular one tried here took about 3 minutes to form sufficiently to give smooth output, after which it slowly warmed up and the voltage rose as it did so. To speed up this operation the set is equipped with a starting switch (SW2 in Fig. 8) which can be closed to throw a temporary overload on the set. This will cause the rectifier to form in 30 seconds.

When used with a 5-tube broadcast receiver having controllable regeneration on the r.f. stages the device introduced no

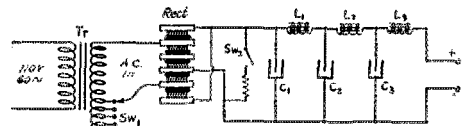

FIG. 8—COMPLETE CIRCUIT DIAGRAM OF THE A SUBSTITUTE

Tr. is the transformer. SW1 is the secondary plug system to adjust for load and line voltage. SW2 is the quick-start switch. C1, C2, and C3 are the electrolytic condensers, each consisting of two cans in parallel L1 L2 and L3 are the filter chokes.

audible hum—although the same receiver has been a star performer in showing up the defects of various A and B substitutes.

Dr. Shoemaker advises that receivers with regeneration be operated with the tubes bright as such sets are inclined to seek out residual ripples and running the tubes too low will cause the remaining ripple to become relatively more important. This precaution was not found necessary here, either with the set just mentioned or with a Browning-Drake receiver, which is another type that demands good plate and filament supply.

A "B" supply is now being worked on. Perhaps some day we may hope for a dry transmitter plate rectifier.

Strays

We have been advised by the Sup't of Documents, Gov't Printing Office, Washington, D. C., that the June 30, 1926, issue of "Amateur Radio Stations of the United States" is no longer available. All copies of it have been distributed.

The New Radio Law

WE print below the complete text of the new radio law which has now superseded the 1912 radio act. Up to the time of closing our forms no regulations or announcements under the new law have been made by the Radio Commission. In subsequent issues, however, we will present the new rules and regulations announced by the Commission and the Department of Commerce.

Be it enacted by the Senate and House of Representatives of the United States of America in Congress assembled, That this Act is intended to regulate all forms of interstate and foreign radio transmissions and communications within the United States, its Territories and possessions; to maintain the control of the United States over all the channels of interstate and foreign radio transmission; and to provide for the use of such channels, but not the ownership thereof, by individuals, firms, or corporations, for limited periods of time, under licenses granted by Federal authority, and no such license shall be construed to create any right, beyond the terms, conditions, and periods of the license. That no person, firm, company, or corporation shall use or operate any apparatus for the transmission of energy or communications or signals by radio (a) from one place in any Territory or possession of the United States or in the District of Columbia to another place in the same Territory, possession, or District; or (b) from any State, Territory, or possession of the United States, or from the District of Columbia to any other State, Territory, or possession of the United States; or (c) from any place in any State, Territory, or possession of the United States, or in the District of Columbia, to any place in any foreign country or to any vessel or (d) within any State when the effects of such use extend beyond the borders of said State, or when interference is caused by such use or operation with the transmission of such energy, communications, or signals from within said State to any place beyond its borders, or from any place beyond its borders to any place within said State, or with the transmission or reception of such energy, communications, or signals from and/or to places beyond the borders of said State; or (e) upon any vessel of the United States; or (f) upon any aircraft or other mobile stations within the United States, except under and in accordance with this Act and with a license in that behalf granted under the provisions of this Act.

SEC. 2. For the purposes of this Act, the United States is divided into five zones, as follows: The first zone shall embrace the States of Maine, New Hampshire, Vermont, Massachusetts, Connecticut, Rhode Island, New York, New Jersey, Delaware, Maryland, the District of Columbia, Porto Rico, and the Virgin Islands; the second zone shall embrace the States of Pennsylvania, Virginia, West Virginia, Ohio, Michigan, and Kentucky; the third zone shall embrace the States of North Carolina, South Carolina, Georgia, Florida, Alabama, Tennessee, Mississippi, Arkansas, Louisiana, Texas, and Oklahoma; the fourth zone shall embrace the States of Indiana, Illinois, Wisconsin, Minnesota, North Dakota, South Dakota, Iowa, Nebraska, Kansas, and Missouri; and the fifth zone shall embrace the States of Montana, Idaho, Wyoming, Colorado, New Mexico, Arizona, Utah, Nevada, Washington, Oregon, California, the Territory of Hawaii, and Alaska.

SEC. 3. That a commission is hereby created and established to be known as the Federal Radio Commission, hereinafter referred to as the commission, which shall be composed of five commissioners appointed by the President, by and with the advice and consent of the Senate, and one of whom the President shall designate as chairman: *Provided*, That chairmen thereafter elected shall be chosen by the commission itself.

Each member of the commission shall be a citizen of the United States and an actual resident citizen of a State within the zone from which appointed at the time of said appointment. Not more than one commissioner shall be appointed from any zone. No member of the commission shall be financially interested in the manufacture or sale of radio apparatus or in the transmission or operation of radiotelegraphy, radiotelephony, or radio broadcasting. Not more than three commissioners shall be members of the same political party.

The first commissioners shall be appointed for the terms of two, three, four, five, and six years, respectively, from the date of the taking effect of this Act, the term of each to be designated by the President, but their successors shall be appointed for terms of six years, except that any person chosen to fill a vacancy shall be appointed only for the unexpired term of the commissioner whom he shall succeed.

The first meeting of the commission shall be held in the city of Washington at such time and place as the chairman of the commission may fix. The commission shall convene thereafter at such times and places as a majority of the commission may determine, or upon call of the chairman thereof.

The commission may appoint a secretary, and such clerks, special counsel, experts, examiners, and other employees as it may from time to time find necessary for the proper performance of its duties and as from time to time may be appropriated for by Congress.

The commission shall have an official seal and shall annually make a full report of its operations to the Congress.

The members of the commission shall receive a compensation of \$10,000 for the first year of their service, said year to date from the first meeting of said commission, and thereafter a compensation of \$30 per day for each day's attendance upon sessions of the commission or while engaged upon work of the commission and while traveling to and from such sessions, and also their necessary traveling expenses.

SEC. 4. Except as otherwise provided in this Act, the commission, from time to time, as public convenience, interest, or necessity requires, shall—

- (a) Classify radio stations;
- (b) Prescribe the nature of the service to be rendered by each class of licensed stations and each station within any class;
- (c) Assign bands of frequencies or wave lengths to the various classes of stations, and assign frequencies or wave lengths for each individual station and determine the power which each station shall use and the time during which it may operate;
- (d) Determine the location of classes of stations or individual stations;
- (e) Regulate the kind of apparatus to be used with respect to its external effects and the purity and sharpness of the emissions from each station and from the apparatus therein;
- (f) Make such regulations not inconsistent with law as it may deem necessary to prevent interference between stations and to carry out the provisions of this Act: *Provided, however*, That changes in the wave lengths, authorized power, in the character of emitted signals, or in the times of operation of any station, shall not be made without the consent of the station licensee unless in the judgment of the commission, such changes will promote public convenience or interest or will serve public necessity, or the provisions of this Act will be more fully complied with;

(g) Have authority to establish areas or zones to be served by any station;

(h) Have authority to make special regulations applicable to radio stations engaged in chain broadcasting;

(i) Have authority to make general rules and regulations requiring stations to keep such records of

programs, transmissions of energy, communications, or signals as it may deem desirable;

(j) Have authority to exclude from the requirements of any regulations in whole or in part any radio station upon railroad rolling stock, or to modify such regulations in its discretion;

(k) Have authority to hold hearings, summon witnesses, administer oaths, compel the production of books, documents, and papers and to make such investigations as may be necessary in the performance of its duties. The commission may make such expenditures (including expenditures for rent and personal services at the seat of government and elsewhere, for law books, periodicals, and books of reference, and for printing and binding) as may be necessary for the execution of the functions vested in the commission and as from time to time may be appropriated for by Congress. All expenditures of the commission shall be allowed and paid upon the presentation of itemized vouchers therefor approved by the chairman.

SEC. 5. From and after one year after the first meeting of the commission created by this Act, all the powers and authority vested in the commission under the terms of this Act, except as to the revocation of licenses, shall be vested in and exercised by the Secretary of Commerce; except that thereafter the commission shall have power and jurisdiction to act upon and determine any and all matters brought before it under the terms of this section.

It shall also be the duty of the Secretary of Commerce—

(A) For and during a period of one year from the first meeting of the commission created by this Act, to immediately refer to the commission all applications for station licenses or for the renewal or modification of existing station licenses.

(B) From and after one year from the first meeting of the commission created by this Act, to refer to the commission for its action any application for a station license or for the renewal or modification of any existing station license as to the granting of which dispute, controversy, or conflict arises or against the granting of which protest is filed within ten days after the date of filing said application by any party in interest and any application as to which such reference is requested by the applicant at the time of filing said application.

(C) To prescribe the qualifications of station operators, to classify them according to the duties to be performed, to fix the forms of such licenses, and to issue them to such persons as he finds qualified.

(D) To suspend the license of any operator for a period not exceeding two years upon proof sufficient to satisfy him that the licensee (a) has violated any provision of any Act or treaty binding on the United States which the Secretary of Commerce or the commission is authorized by this Act to administer or by any regulation made by the commission or the Secretary of Commerce under any such Act or treaty; or (b) has failed to carry out the lawful orders of the master of the vessel on which he is employed; or (c) has willfully damaged or permitted radio apparatus to be damaged; or (d) has transmitted superfluous radio communications or signals or radio communications containing profane or obscene words or language; or (e) has willfully or maliciously interfered with any other radio communications or signals.

(E) To inspect all transmitting apparatus to ascertain whether in construction and operation it conforms to the requirements of this Act, the rules and regulations of the licensing authority, and the license under which it is constructed or operated.

(F) To report to the commission from time to time any violations of this Act, the rules, regulations, or orders of the commissions, or of the terms or conditions of any license.

(G) To designate call letters of all stations.

(H) To cause to be published such call letters and such other announcements and data as in his judgment may be required for the efficient operation of radio stations subject to the jurisdiction of the United States and for the proper enforcement of this Act.

The Secretary may refer to the commission at any

time any matter the determination of which is vested in him by the terms of this Act.

Any person, firm, company, or corporation, any State or political division thereof aggrieved or whose interests are adversely affected by any decision, determination, or regulation of the Secretary of Commerce may appeal therefrom to the commission by filing with the Secretary of Commerce notice of such appeal within thirty days after such decision or determination or promulgation of such regulation. All papers, documents, and other records pertaining to such application on file with the Secretary shall thereupon be transferred by him to the commission. The commission shall hear such appeal de novo under such rules and regulations as it may determine.

Decisions by the commission as to matters so appealed and as to all other matters over which it has jurisdiction shall be final, subject to the right of appeal herein given.

No station license shall be granted by the commission or the Secretary of Commerce until the applicant therefor shall have signed a waiver of any claim to the use of any particular frequency or wave length or of the ether as against the regulatory power of the United States because of the previous use of the same, whether by license or otherwise.

SEC. 6. Radio stations belonging to and operated by the United States shall not be subject to the provisions of sections 1, 4, and 5 of this Act. All such Government stations shall use such frequencies or wave lengths as shall be assigned to each or to each class by the President. All such stations, except stations on board naval and other Government vessels while at sea or beyond the limits of the continental United States, when transmitting any radio communication or signal other than a communication or signal relating to Government business shall conform to such rules and regulations designed to prevent interference with other radio stations and the rights of others as the licensing authority may prescribe. Upon proclamation by the President that there exists war or a threat of war or a state of public peril or disaster or other national emergency, or in order to preserve the neutrality of the United States, the President may suspend or amend, for such time as he may see fit, the rules and regulations applicable to any or all stations within the jurisdiction of the United States as prescribed by the licensing authority, and may cause the closing of any station for radio communication and the removal therefrom of its apparatus and equipment, or he may authorize the use or control of any such station and/or its apparatus and equipment by any department of the Government under such regulations as he may prescribe, upon just compensation to the owners. Radio stations on board vessels of the United States Shipping Board or the United States Shipping Board Emergency Fleet Corporation or the Inland and Coastwise Waterways Service shall be subject to the provisions of this Act.

SEC. 7. The President shall ascertain the just compensation for such use or control and certify the amount ascertained to Congress for appropriation and payment to the person entitled thereto. If the amount so certified is unsatisfactory to the person entitled thereto, such person shall be paid only 75 per centum of the amount and shall be entitled to sue the United States to recover such further sum as added to such payment of 75 per centum which will make such amount as will be just compensation for the use and control. Such suit shall be brought in the manner provided by paragraph 20 of section 24, or by section 145 of the Judicial Code, as amended.

SEC. 8. All stations owned and operated by the United States, except mobile stations of the Army of the United States, and all other stations on land and sea, shall have special call letters designated by the Secretary of Commerce.

Section 1 of this Act shall not apply to any person, firm, company, or corporation sending radio communications or signals on a foreign ship while the same is within the jurisdiction of the United States, but such communications or signals shall be transmitted only in accordance with such regulations designed to prevent interference as may be promulgated under the authority of this Act.

SEC. 9. The licensing authority, if public convenience, interest, or necessity will be served thereby,

subject to the limitations of this Act, shall grant to any applicant therefor a station license provided for by this Act.

In considering applications for licenses and renewals of licenses, when and in so far as there is a demand for the same, the licensing authority shall make such a distribution of licenses, bands of frequency or wavelengths, periods of time for operation, and of power among the different States and communities as to give fair, efficient, and equitable radio service to each of the same.

No license granted for the operation of a broadcasting station shall be for a longer term than three years and no license so granted for any other class of station shall be for a longer term than five years, and any license granted may be revoked as hereinafter provided. Upon the expiration of any license, upon application therefor, a renewal of such license may be granted from time to time for a term not to exceed three years in the case of broadcasting licenses and not to exceed five years in the case of other licenses.

No renewal of an existing station license shall be granted more than thirty days prior to the expiration of the original license.

SEC. 10. The licensing authority may grant station licenses only upon written application therefor addressed to it. All applications shall be filed with the Secretary of Commerce. All such applications shall set forth such facts as the licensing authority by regulation may prescribe as to the citizenship, character, and financial, technical, and other qualifications of the applicant to operate the station; the ownership and location of the proposed station and of the stations, if any, with which it is proposed to communicate; the frequencies or wave lengths and the power desired to be used; the hours of the day or other periods of time during which it is proposed to operate the station; the purposes for which the station is to be used; and such other information as it may require. The licensing authority at any time after the filing of such original application and during the term of any such license, may require from an applicant or licensee further written statements of fact to enable it to determine whether such original application should be granted or denied or such license revoked. Such application and/or such statement of fact shall be signed by the applicant and/or licensee under oath or affirmation.

The licensing authority in granting any license for a station intended or used for commercial communication between the United States or any Territory or possession, continental or insular, subject to the jurisdiction of the United States, and any foreign country, may impose any terms, conditions, or restrictions authorized to be imposed with respect to submarine-cable licenses by section 2 of an Act entitled "An Act relating to the landing and the operation of submarine cables in the United States," approved May 24, 1921.

SEC. 11. If upon examination of any application for a station license or for the renewal or modification of a station license the licensing authority shall determine that public interest, convenience, or necessity would be served by the granting thereof, it shall authorize the issuance, renewal, or modification thereof in accordance with said finding. In the event the licensing authority upon examination of any such application does not reach such decision with respect thereto, it shall notify the applicant thereof, shall fix and give notice of a time and place for hearing thereon, and shall afford such applicant an opportunity to be heard under such rules and regulations as it may prescribe.

Such station licenses as the licensing authority may grant shall be in such general form as it may prescribe, but each license shall contain, in addition to other provisions, a statement of the following conditions to which such license shall be subject:

(A) The station license shall not vest in the licensee any right to operate the station nor any right in the use of the frequencies or wave length designated in the license beyond the term thereof nor in any other manner than authorized therein.

(B) Neither the license nor the right granted thereunder shall be assigned or otherwise transferred in violation of this Act.

(C) Every license issued under this Act shall be subject in terms to the right of use or control conferred by section 6 hereof.

In cases of emergency arising during the period of one year from and after the first meeting of the commission created hereby, or on applications filed during said time for temporary changes in terms of licenses when the commission is not in session and prompt action is deemed necessary, the Secretary of Commerce shall have authority to exercise the powers and duties of the commission, except as to revocation of licenses, but all such exercise of powers shall be promptly reported to the members of the commission, and any action by the Secretary authorized under this paragraph shall continue in force and have effect only until such time as the commission shall act thereon.

SEC. 12. The station license required hereby shall not be granted to, or after the granting thereof such license shall not be transferred in any manner, either voluntarily or involuntarily, to (a) any alien or the representative of any alien; (b) to any foreign government, or the representative thereof; (c) to any company, corporation, or association organized under the laws of any foreign government; (d) to any company, corporation, or association of which any officer or director is an alien, or of which more than one-fifth of the capital stock may be voted by aliens or their representatives or by a foreign government or representative thereof, or by any company, corporation, or association organized under the laws of a foreign country.

The station license required hereby, the frequencies or wave length or lengths authorized to be used by the licensee, and the rights therein granted shall not be transferred, assigned, or in any manner, either voluntarily or involuntarily, disposed of to any person, firm, company, or corporation without the consent in writing of the licensing authority.

SEC. 13. The licensing authority is hereby directed to refuse a station license and/or the permit hereinafter required for the construction of a station to any person, firm, company, or corporation, or any subsidiary thereof, which has been found guilty by any Federal court of unlawfully monopolizing or attempting unlawfully to monopolize, after this Act takes effect, radio communication, directly or indirectly, through the control of the manufacture or sale of radio apparatus, through exclusive traffic arrangements, or by any other means or to have been using unfair methods of competition. The granting of a license shall not estop the United States or any person aggrieved from proceeding against such person, firm, company, or corporation for violating the law against unfair methods of competition or for a violation of the law against unlawful restraints and monopolies and/or combinations contracts, or agreements in restraint of trade, or from instituting proceedings for the dissolution of such firm, company, or corporation.

SEC. 14. Any station license shall be revocable by the commission for false statements either in the application or in the statement of fact which may be required by section 10 hereof, or because of conditions revealed by such statements of fact as may be required from time to time which would warrant the licensing authority in refusing to grant a license on an original application, or for failure to operate substantially as set forth in the license, for violation of or failure to observe any of the restrictions and conditions of this Act, or of any regulation of the licensing authority authorized by this Act or by a treaty ratified by the United States, or whenever the Interstate Commerce Commission, or any other Federal body in the exercise of authority conferred upon it by law, shall find and shall certify to the commission that any licensee bound so to do, has failed to provide reasonable facilities for the transmission of radio communications, or that any licensee has made any unjust and unreasonable charge, or has been guilty of any discrimination, either as to charge or as to service or has made or prescribed any unjust and unreasonable classification, regulation, or practice with respect to the transmission of radio, or practice with respect to the transmission of radio communications, or service: *Provided*, That no such order of revocation shall take effect until thirty days' notice in writing thereof, stating the cause for the

proposed revocation, has been given to the parties known by the commission to be interested in such license. Any person in interest aggrieved by said order may make written application to the commission at any time within said thirty days for a hearing upon such order, and upon the filing of such written application said order of revocation shall stand suspended until the conclusion of the hearing herein directed. Notice in writing of said hearing shall be given by the commission to all the parties known to it to be interested in such license twenty days prior to the time of said hearing. Said hearing shall be conducted under such rules and in such manner as the commission may prescribe. Upon the conclusion hereof the commission may affirm, modify, or revoke said orders of revocation.

SEC. 15. All laws of the United States relating to unlawful restraints and monopolies and to combinations, contracts, or agreements in restraint of trade are hereby declared to be applicable to the manufacture and sale of and to trade in radio apparatus and devices entering into or affecting interstate or foreign commerce and to interstate or foreign radio communications. Whenever in any suit, action, or proceeding, civil or criminal, brought under the provisions of any of said laws or in any proceedings brought to enforce or to review findings and orders of the Federal Trade Commission or other governmental agency in respect of any matters as to which said commission or other governmental agency is by law authorized to act, any licensee shall be found guilty of the violation of the provisions of such laws or any of them, the court, in addition to the penalties imposed by said laws, may adjudge, order and or decree that the license of such licensee shall, as of the date the decree or judgment becomes finally effective or as of such other date as the said decree shall fix, be revoked and that all rights under such license shall thereupon cease: *Provided however*, That such licensee shall have the same right of appeal or review as is provided by law in respect of other decrees and judgments of said court.

SEC. 16. Any applicant for a construction permit, for a station license, or for the renewal or modification of an existing station license whose application is refused by the licensing authority shall have the right to appeal from said decision to the Court of Appeals of the District of Columbia; and any licensee whose license is revoked by the commission shall have the right to appeal from such decision of revocation to said Court of Appeals of the District of Columbia or to the district court of the United States in which the apparatus licensed is operated, by filing with said court, within twenty days after the decision complained of is effective, notice in writing of said appeal and of the reasons therefor.

The licensing authority from whose decision an appeal is taken shall be notified of said appeal by service upon it, prior to the filing thereof, of a certified copy of said appeal and of the reasons therefor. Within twenty days after the filing of said appeal the licensing authority shall file with the court the originals or certified copies of all papers and evidence presented to it upon the original application for a permit or license or in the hearing upon said order of revocation, and also a like copy of its decision thereon and a full statement in writing of the facts and the grounds for its decision as found and given by it. Within twenty days after the filing of said statement by the licensing authority either party may give notice to the court of his desire to adduce additional evidence. Said notice shall be in the form of a verified petition stating the nature and character of said additional evidence, and the court may thereupon order such evidence to be taken in such matter and upon such terms and conditions as it may deem proper.

At the earliest convenient time the court shall hear, review, and determine the appeal upon said record and evidence, and may alter or revise the decision appealed from and enter such judgment as to it may seem just. The revision by the court shall be confined to the points set forth in the reasons of appeal.

SEC. 17. After the passage of this Act no person, firm, company, or corporation now or hereafter di-

rectly or indirectly through any subsidiary, associated, or affiliated person, firm, company, corporation, or agent, or otherwise, in the business of transmitting and/or receiving for hire energy, communications, or signals by radio in accordance with the terms of the license issued under this Act, shall by purchase, lease, construction, or otherwise, directly or indirectly, acquire, own, control, or operate any cable or wire, telegraph or telephone line or system between any place in any State, Territory, or possession of the United States or in the District of Columbia, and any or control any part of the stock or other capital share of any interest in the physical property and/or other assets of any such cable, wire, telegraph, or telephone line or system, if in either case the purpose is and/or the effect thereof may be to substantially lessen competition or to restrain commerce between any place in any State, Territory, or possession of the United States or in the District of Columbia and any place in any foreign country, or unlawfully to create monopoly in any line of commerce; nor shall any person, firm, company, or corporation now or hereafter engaged directly or indirectly through any subsidiary, associated, or affiliated person, company, corporation or agent, or otherwise, in the business of transmitting and/or receiving for hire messages by any cable, wire, telegraph, or telephone line or system (a) between any place in any State, Territory, or possession of the United States or in the District of Columbia, and any place in any other State, Territory or possession of the United States; or (b) between any place in any State, Territory, or possession of the United States, or the District of Columbia, and any place in any foreign country, by purchase, lease, construction, or otherwise, directly or indirectly acquire, own, control, or operate any station or the apparatus therein, or any system for transmitting and/or receiving radio communications or signals between any place in any State, Territory, or possession of the United States or in the District of Columbia, and any place in any foreign country, or shall acquire, own, or control any part of the stock or other capital share or any interest in the physical property and/or other assets of any such radio station, apparatus, or system, if in either case the purpose is and/or the effect thereof may be to substantially lessen competition or to restrain commerce between any place in any State, Territory, or possession of the United States or in the District of Columbia, and any place in any foreign country, or unlawfully to create monopoly in any line of commerce.

SEC. 18. If any licensee shall permit any person who is a legally qualified candidate for any public office to use a broadcasting station, he shall afford equal opportunities to all other such candidates for that office in the use of such broadcasting station, and the licensing authority shall make rules and regulations to carry this provision into effect: *Provided*, That such licensee shall have no power of censorship over the material broadcast under the provisions of this paragraph. No obligation is hereby imposed upon any licensee to allow the use of its station by any such candidate.

SEC. 19. All matter broadcast by any radio station for which service, money, or any other valuable consideration is directly or indirectly paid, or promised to or charged or accepted by, the station so broadcasting, from any person, firm, company, or corporation, shall, at the time the same is so broadcast, be announced as paid for or furnished, as the case may be, by such person, firm, company, or corporation.

SEC. 20. The actual operation of all transmitting apparatus in any radio station for which a station license is required by this Act shall be carried on only by a person holding an operator's license issued hereunder. No person shall operate any such apparatus in such station except under and in accordance with an operator's license issued to him by the Secretary of Commerce.

SEC. 21. No license shall be issued under the authority of this Act for the operation of any station the construction of which is begun or is continued after this Act takes effect, unless a permit for its construction has been granted by the licensing

authority upon written application therefor. The licensing authority may grant such permit if public convenience, interest, or necessity will be served by the construction of the station. This application shall set forth such facts as the licensing authority by regulation may prescribe as to the citizenship, character, and the financial, technical, and other ability of the applicant to construct and operate the station, the ownership and location of the proposed station and of the station or stations with which it is proposed to communicate, the frequencies and wave length or wave lengths desired to be used, the hours of the day or other periods of time during which it is proposed to operate the station, the purpose for which the station is to be used, the type of transmitting apparatus to be used, the power to be used, the date upon which the station is expected to be completed and in operation, and such other information as the licensing authority may require. Such application shall be signed by the applicant under oath or affirmation.

Such permit for construction shall show specifically the earliest and latest dates between which the actual operation of such station is expected to begin, and shall provide that said permit will be automatically forfeited if the station is not ready for operation within the time specified or within such further time as the licensing authority may allow, unless prevented by causes not under the control of the grantee. The rights under any such permit shall not be assigned or otherwise transferred to any person, firm, company, or corporation without the approval of the licensing authority. A permit for construction shall not be required for Government stations, amateur stations, or stations upon mobile vessels, railroad rolling stock, or aircraft. Upon the completion of any station for the construction or continued construction for which a permit has been granted, and upon it being made to appear to the licensing authority that all the terms, conditions, and obligations set forth in the application and permit have been fully met, and that no cause or circumstance arising or first coming to the knowledge of the licensing authority since the granting of the permit would, in the judgment of the licensing authority, make the operation of such station against the public interest, the licensing authority shall issue a license to the lawful holder of said permit for the operation of said station. Said license shall conform generally to the terms of said permit.

SEC. 22. The licensing authority is authorized to designate from time to time radio stations the communications or signals of which, in its opinion, are liable to interfere with the transmission or reception of distress signals of ships. Such stations are required to keep a licensed radio operator listening in on the wave lengths designated for signals of distress and radio communications relating thereto during the entire period the transmitter of such station is in operation.

SEC. 23. Every radio station on shipboard shall be equipped to transmit radio communications or signals of distress on the frequency or wave length specified by the licensing authority, with apparatus capable of transmitting and receiving messages over a distance of at least one hundred miles by day or night. When sending radio communications or signals of distress and radio communications relating thereto the transmitting set may be adjusted in such a manner as to produce a maximum of radiation irrespective of the amount of interference which may thus be caused.

All radio stations, including Government stations and stations on board foreign vessels when within the territorial waters of the United States, shall give absolute priority to radio communications or signals relating to ships in distress; shall cease all sending on frequencies or wave lengths which will interfere with hearing a radio communication or signal of distress, and, except when engaged in answering or aiding the ship in distress, shall refrain from sending any radio communications or signals until there is assurance that no interference will be caused with the radio communications or signals relating thereto, and shall assist the vessel in distress, so far as possible, by complying with its instructions.

SEC. 24. Every shore station open to general public service between the coast and vessels at sea shall be bound to exchange radio communications or signals with any ship station without distinction as to radio systems or instruments adopted by such stations, respectively, and each station on shipboard shall be bound to exchange radio communications or signals with any other station on shipboard without distinction as to radio systems or instruments adopted by each station.

SEC. 25. At all places where Government and private or commercial radio stations on land operate in such close proximity that interference with the work of Government stations can not be avoided when they are operating simultaneously such private or commercial stations as do interfere with the transmission or reception of radio communications or signals by the Government stations concerned shall not use their transmitters during the first fifteen minutes of each hour, local standard time.

The Government stations for which the above-mentioned division of time is established shall transmit radio communications or signals only during the first fifteen minutes of each hour, local standard time, except in case of signals or radio communications relating to vessels in distress, and vessel requests for information as to course, location, or compass direction.

SEC. 26. In all circumstances, except in case of radio communications or signals relating to vessels in distress, all radio stations, including those owned and operated by the United States, shall use the minimum amount of power necessary to carry out the communication desired.

SEC. 27. No person receiving or assisting in receiving any radio communication shall divulge or publish the contents, substance, purport, effect, or meaning thereof except through authorized channels of transmission or reception to any person other than the addressee, his agent, or attorney, or to a telephone, telegraph, cable, or radio station employed or authorized to forward such radio communication to its destination, or to proper accounting or distributing officers of the various communicating centers over which the radio communication may be passed, or to the master of a ship under whom he is serving, or in response to a subpoena issued by a court of competent jurisdiction, or on demand of other lawful authority; and no person not being authorized by the sender shall intercept any message and divulge or publish the contents, substance, purport, effect, or meaning of such intercepted message to any person; and no person not being entitled thereto shall receive or assist in receiving any radio communication and use the same or any information therein contained for his own benefit or for the benefit of another not entitled thereto; and no person having received such intercepted radio communication or having become acquainted with the contents, substance, purport, effect, or meaning of the same or any part thereof, knowing that such information was so obtained, shall divulge or publish the contents, substance, purport, effect, or meaning of the same or any part thereof, or use the same or any information therein contained for his own benefit or for the benefit of another not entitled thereto; *Provided*, That this section shall not apply to the receiving, divulging, publishing, or utilizing the contents of any radio communication broadcasted or transmitted by amateurs or others for the use of the general public or relating to ships in distress.

SEC. 28. No person, firm, company, or corporation within the jurisdiction of the United States shall knowingly utter or transmit, or cause to be uttered or transmitted, any false or fraudulent signal of distress, or communication relating thereto, nor shall any broadcasting station rebroadcast the program or any part thereof of another broadcasting station without the express authority of the originating station.

SEC. 29. No person, firm, company, or corporation construed to give the licensing authority the power of censorship over the radio communications or signals transmitted by any radio station, and no regulation or condition shall be promulgated or fixed by the licensing authority which shall interfere with the

right of free speech by means of radio communications. No person within the jurisdiction of the United States shall utter any obscene, indecent, or profane language by means of radio communication.

SEC. 30. The Secretary of the Navy is hereby authorized unless restrained by international agreement, under the terms and conditions and at rates prescribed by him, which rates shall be just and reasonable, and which, upon complaint, shall be subject to review and revision by the Interstate Commerce Commission, to use all radio stations and apparatus, wherever located, owned by the United States and under the control of the Navy Department (a) for the reception and transmission of press messages offered by any newspaper published in the United States, its Territories or possessions, or published by citizens of the United States in foreign countries, or by any press association of the United States, and (b) for the reception and transmission of private commercial messages between ships, between ship and shore, between localities in Alaska and between Alaska and the continental United States; *Provided* That the rates for the reception and transmission of all such messages, other than press messages between the Pacific coast of the United States, Hawaii, Alaska, the Philippine Islands, and the Orient, and between the United States and the Virgin Islands, shall not be less than the rates charged by privately owned and operated stations for like messages and service; *Provided further*, That the right to use such stations for any of the purposes named in this section shall terminate and cease as between any countries or localities or between any locality and privately operated ships whenever privately owned and operated stations are capable of meeting the normal communication requirements between such countries or localities or between any locality and privately operated ships, and the licensing authority shall have notified the Secretary of the Navy thereof.

SEC. 31. The expression "radio communication" or "radio communications" wherever used in this Act means any intelligence, message, signal, power, pictures, or communication of any nature transferred by electrical energy from one point to another without the aid of any wire connecting the points from and at which the electrical energy is sent or received and any system by means of which such transfer of energy is effected.

SEC. 32. Any person, firm, company, or corporation failing or refusing to observe or violating any rule, regulation, restriction, or condition made or imposed by the licensing authority under the authority of this Act or of any international radio convention or treaty ratified or adhered to by the United States, in addition to any other penalties provided by law, upon conviction thereof by a court of competent jurisdiction, shall be punished by a fine of not more than \$500 for each and every offense.

SEC. 33. Any person, firm, company, or corporation who shall violate any provision of this Act, or shall knowingly make any false oath or affirmation in any affidavit required or authorized by this Act, or shall knowingly make any false oath or affirmation in any hearing authorized by this Act, upon conviction thereof in any court of competent jurisdiction shall be punished by a fine of not more than \$5,000 or by imprisonment for a term of not more than five years or both for each and every such offense.

SEC. 34. The trial of any offence under this Act shall be in the district in which it is committed; or if the offense is committed upon the high seas, or out of the jurisdiction of any particular State or district, the trial shall be in the district where the offender may be found or into which he shall be first brought.

SEC. 35. This Act shall not apply to the Philippine Islands or to the Canal Zone. In international radio matters the Philippine Islands and the Canal Zone shall be represented by the Secretary of State.

SEC. 36. The licensing authority is authorized to designate any officer or employee of any other department of the Government on duty in any Territory or possession of the United States other than the Philippine Islands and the Canal Zone, to render therein such services in connection with the administration of the radio laws of the United States as

such authority may prescribe; *Provided*, That such designation shall be approved by the head of the department in which such person is employed.

SEC. 37. The unexpended balance of the moneys appropriated in the item for "wireless communication laws," under the caption "Bureau of Navigation" in Title III of the Act entitled "An Act making appropriations for the Departments of State and Justice and for the judiciary, and for the Departments of Commerce and Labor, for the fiscal year ending June 30, 1927, and for other purposes," approved April 29, 1926, and the appropriation for the same purposes for the fiscal year ending June 30, 1928, shall be available both for expenditures incurred in the administration of this Act and for expenditures for the purposes specified in such items. There is hereby authorized to be appropriated for each fiscal year such sums as may be necessary for the administration of this Act and for the purpose specified in such item.

SEC. 38. If any provision of this Act or the application thereof to any person, firm, company, or corporation, or to any circumstances, is held invalid, the remainder of the Act and the application of such provision to other persons, firms, companies, or corporations, or to other circumstances, shall not be affected thereby.

SEC. 39. The Act entitled "An Act to regulate radio communication," approved August 13, 1912, the joint resolution to authorize the operation of Government-owned radio stations for the general public, and for other purposes, approved June 5, 1920, as amended, and the joint resolution entitled "Joint resolution limiting the time for which licenses for radio transmission may be granted, and for other purposes," approved December 8, 1926, are hereby repealed.

Such repeal, however, shall not affect any act done or any right accrued or any suit or proceeding had or commenced in any civil cause prior to said repeal, but all liabilities under said laws shall continue and may be enforced in the same manner as if committed; and all penalties, forfeitures, or liabilities incurred prior to taking effect hereof, under any law embraced in, changed, modified, or repealed by this Act, may be prosecuted and punished in the same manner and with the same effect as if this Act had not been passed.

Nothing in this section shall be construed as authorizing any person now using or operating any apparatus for the transmission of radio energy or radio communications or signals to continue such use except under and in accordance with this Act and with a license granted in accordance with the authority hereinbefore conferred.

SEC. 40. This Act shall take effect and be in force upon its passage and approval, except that for and during a period of sixty days after such approval no holder of a license or an extension thereof issued by the Secretary of Commerce under said Act of August 13, 1912, shall be subject to the penalties provided herein for operating a station without the license herein provided.

SEC. 41. This Act may be referred to and cited as the Radio Act of 1927.

Strays

The Radio Engineering Labs of New York City have just put out their new catalog covering the short-wave equipment which they handle. It is more than a catalog as it contains quite a bit of interesting and instructive dope.



How Far Is It?

By C. C. Knight*

MANY readers of *QST* must be interested in knowing how far away the stations are that they hear, or perhaps the distance at which their own signals are heard. Few perhaps, realize that it is impossible to get this information direct from maps.

The earth is a globe and it is impossible to represent any portion of the surface of the earth correctly on a flat map. If the portion is small enough (as for example a single state) the map may be so nearly correct that distances may be scaled off upon it without appreciable errors. In a larger territory, as for example North America, the effects of curvature are considerable and map makers are compelled to compress some distances and stretch others in order to get the map onto a flat surface. Still, distances on a map of this size may be near enough for those who are not exacting, but when it comes to greater distances, such as a quarter way around the world, map distances are hopelessly misleading. Far from being able to *measure* distances, you cannot even *compare* them; the greater, often appearing to be the lesser.

For example, suppose that two amateur transmitters in the neighborhood of New York City have done some good long-distance work and the owners of these transmitters compare notes. A says, "I worked with a station at Cairo last night." B replies, "That's nothing, I talked to a ship operator off Cape Chelyuskin, Siberia." A is probably very much impressed and thinks that B has doubled his distance. It really *looks* that way on the map, but is very far from it, as we shall see presently.

Now if we cannot measure the distances correctly on the map, how *are* we to find them? There are two ways; measure them on a *globe*, or calculate them. The first is not good if you want accuracy. Even an 8-inch globe (which will not give very good measurements) costs several dollars. Such a globe is on a scale of 1000 miles to the inch. Larger globes are very expensive.

To calculate the distance between two places is quite easy. No knowledge of mathematics is required beyond simple arithmetic—for one does not need to understand a formula to use it. You can solve a problem in spherical trigonometry (as this is) without needing to know a cosine from a parallelogram, provided someone gives you the formula. You will need a book of mathematical tables; four-figure tables are good enough. I believe you can buy such

a book for a matter of cents and the more expensive 7-figure tables are no better for our purpose.¹ An atlas is also needed, but you need not buy that. It is generally to be borrowed at a library. A large map of the world on Mercator's projection is also good if you cannot get the atlas. Now for the procedure.

GETTING READY

First get from the map your own latitude and longitude, estimating and measuring as accurately as possible from the nearest parallel and meridian shown on the map (or indicated on the edge). If you are not sure on this matter have a teacher give you your location from his large-scale wall-map.² He will also be able to show you how to go about finding such things on a map. It is important to have your own position right, since an error here will affect all your calculations.

Having found your own position subtract the latitude from 90 degrees and note the figures down thus—

Latitude 41° North colatitude or polar distance 49° (a)

Longitude 73° West

Now refer to your book of tables for the sine and the cosine of your polar distance and note them thus. (Never mind what a sine or cosine is.)

Sine a = .7547 Cosine a = .6560

Keep these handy; they will come into *all* your calculations.

CALCULATING A DISTANCE

Now consult some good map for the latitude and longitude of the place whose distance you want to know. Take Cairo for instance.

Latitude 30° North Colatitude or polar distance 60 degrees

Longitude 33° East

I am only taking whole degrees; for accuracy, closer measurements are needed. If you do make closer measurements you will be dealing in degrees and in minutes. When making your subtractions it is then

1. The "tables" here referred to are those called "Tables of Trigonometric Functions," but it does not matter if one does not remember the name of the study—just ask for the "trig functions."—Tech. Ed.

2. A surveyor can do this sort of thing beautifully. It is his business. He will also be able to give your location down to seconds.—Tech. Ed.

*sajB8, 10 de Mayo 412, Concordia, E. R. Argentina. S. A.

important to remember that a degree is divided into 60 minutes. Getting back to the Cairo problem. The formula we are to use is written so as to give us an "angular distance" which can be converted into miles as will be shown later. For the present this "angular distance" will appear as "cosine c" or simply "cos c".

The formula for the finding of the angular distance is

$$\cos c = \cos C \sin a \sin b + \cos a \cos b$$

In this formula one must understand that when two or three quantities are written after each other this indicates that they are to be multiplied together, that is "cos a cos b" means "cos a multiplied by cos b". Of course we must know what the various things in the formula stand for. Their meaning is as follows:

Cos c is the angular distance we are trying to find so that we can convert it into miles.

Cos C (note this is the one with the capital C) is the cosine of the *difference in longitude* between your location and the other place you are interested in.

Sin a cos a are the sine and cosine of your own polar distance or colatitude—the thing you found by subtracting your latitude from 90. Sin b and cos b are the sine and cosine of the polar distance (colatitude) of the other place.

These things may seem very confusing to those who have not studied trigonometry but they are really very simple as an example will make them clear.

Let us get back to this New York-Cairo problem and finish it. We now know that New York's polar distance (or colatitude) is being called a and that Cairo's polar distance is being called b, also that C is the difference in longitude between the two places. From this we find (part of these figures have already been set down before)

$$\begin{array}{l} a \text{ is } 49^\circ \quad \sin a \text{ is } .7547 \quad \cos a \text{ is } .6560 \\ b \text{ is } 60^\circ \quad \sin b \text{ is } .8660 \quad \cos b \text{ is } .5000 \end{array}$$

The "sin b" and "cos b" were looked up in the book just in the same manner as the sin and cos for a.

Now we still need to find C, and from that we will find cos C.

Now the difference in longitude between 73W (which is at New York) and 33E (Cairo) is 106 degrees. This may look like a sum instead of a difference, but remember that it is distance that we are interested in, so that if both longitudes were west (or both east) we would subtract them, but with one east and one west we must add them. A good look at the map of the world will

make this clear if you will remember that all longitudes are measured from Greenwich, England. If both points are in the same direction from there we will naturally have to subtract to get the difference, but if one is on each side we will need to add as we did for the New York to Cairo example. Very well—we have found that C is 106 degrees and the tables show that cos 106 degrees is *minus* .2756. When you try to find this in the tables you will see that I have introduced a complication that occurs only in long distances. The tables go only to 90 degrees and you have just had to look up the cos of 106 degrees—and will often have to look up values for angles as high as 180 degrees. Fortunately the sine of an angle between 90 and 180 degrees is the same as the cosine of the same angle minus 90 degrees. In the same way the cosine of an angle between 90 and 180 is the same as the sine of the angle minus 90 degrees, *except* that there is a minus in front of it. Thus to find the cos of 106 degrees we first subtract 90 degrees, which gives us 16 degrees. Then we look up the *sine* of 16 degrees and put a minus sign in front of it, which gives us

$$\cos 106 \text{ degrees} = - \sin 16 \text{ degrees} = - .2756$$

When all of these figures have been put into the formula it reads:

$$\begin{aligned} \cos c = & - .2756 \times .7547 \times .8660 + .6560 \\ & \times .5000 \end{aligned}$$

multiplying this we have

$$\cos c = - .1801 + .3280 \text{ or } .3280 - .1801 = .1479$$

Now we look up the angle whose cosine is .1479 and we find that it is 81° 30' or 81½ degrees. Now it happens that 1 degree of a "great circle" (don't worry too much as to the meaning of that) is 69.04 miles. Therefore the distance we are interested in is

$$81\frac{1}{2} \times 69.04 \text{ miles or } 5626.7 \text{ miles—} \\ \text{New York to Cairo.}$$

Now from the same point near New York to Cape Chelyuskin in Siberia is only 59 degrees (straight over the North Pole), which is only 4073.4 miles, so A has beaten B by 1550.4 miles although B's distance looked double on the map.

This proves my contention. If you want to know your distances you **MUST** calculate them. A trial or two will convince you that this calculation is quite simple and easy, even though at first it frightened you.

The Most Useful Meter

By R. F. Shea*

PERHAPS you wonder why the title of this paper does not name the type of meter that is to be talked about. There is a good reason; the name of the thing is so *much* worse than the device itself and it would be too bad to scare anyone off. The meter itself is certainly one of the most useful things in radio, tho simple enough to make and use.

The vacuum tube voltmeter can be built up from the most ordinary equipment, can be operated easily and makes light work of

meter, while if this is omitted and a shunt "Sh." in Fig. 2A is added we have an ammeter. The important point is that no matter whether we put on or leave off "Res." or "Sh." the amount of power needed to make the coil turn is the same and the shunt or series resistance uses up *additional* power. The sensitivity of the whole thing therefore depends on the sensitivity of the milliammeter we started with and it takes power to deflect the milliammeter—not much power but some. It takes a little more power to operate the voltmeter.

That statement is for the d.c. meter which is the most sensitive of the lot. When we come to the a.c. voltmeter and the static voltmeter, considerably less sensitivity is possible and therefore more power is taken by the meter. Since almost all radio work is with a.c. this is very bad, as the meters upset the current rather badly as a rule.

For instance, a common sort of a.c. filament voltmeter is that shown in Fig. 2B. The current through the stator coil S manufactures an a.c. field which attracts the little iron vane mounted on the rotor R. This vane attempts to line itself up with the coil

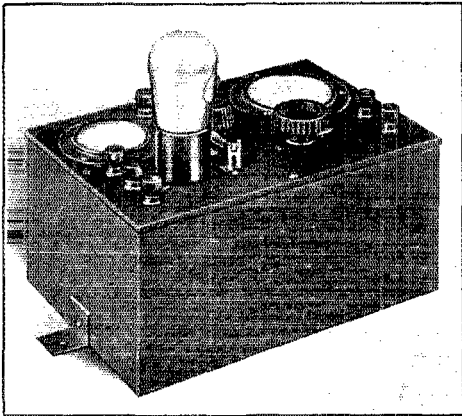

FIG. 1

numerous jobs that are otherwise expensive, difficult, or even impossible. Just why this is so will be understood more easily if we first see what sort of things are possible with ordinary meters and where there is a gap that the vacuum tube meter can fill.

THE USUAL VOLTMETER

Referring to Fig. 2 we have at A the usual direct-current meter which is one of the most useful forms ever devised and which is known as the "moving coil" or "'Arsonval" meter. Here we have a "U" shaped magnet between the poles of which is hung a coil of fine wire. By removing the cover of an ordinary d.c. milliammeter one may examine the constructional details. The little coil will be found secured to a shaft which turns in jeweled bearings. The current is led to and from the coil by hairsprings which also tend to hold the coil in the "zero" position. When a current is passed through the coil it turns to a new position. Splendid meters of this type are built to act as milliammeters. If a resistance ("Res." in Fig. 2A) is connected in series with the coil we have a volt-

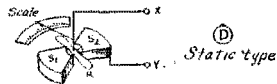
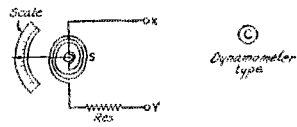
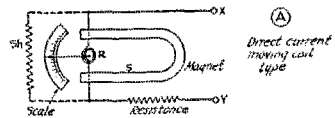

FIG. 2 ORDINARY VOLTMETERS

and therefore turns the shaft and pointer in the usual way, a hairspring tending to resist the motion. This sort of meter is not very sensitive and one of well-known make takes 300 milliamperes at 15 volts, which is full-scale. This does *not* mean that the power taken is .3 x 15 watts by any means because the power factor comes in—but it

*Radio Engineering Dept., American Bosch Magneto, Springfield, Mass.

does mean that the current drawn is large enough to upset many sorts of circuits. The meter is quite all right for filament voltage, of course. It is likewise all right for any ordinary a.c. circuit.

In Fig. 2C we have another sort of a.c. voltmeter. Here both the rotor and stator are coils. This is known as the dynamometer type of meter and has some special advantages as an a.c. meter, but it too takes a fair current and more power than we like to withdraw from an amplifier or oscillator circuit.

THE STATIC VOLTMETER

There is one sort of voltmeter that can be used for both d.c. and a.c. without drawing enough current (or power) from the circuit to be at all troublesome. This is the static voltmeter, shown in Fig. 2D. The rotor is a bit of thin sheet metal (aluminum for in-

power from an ordinary 60-cycle circuit. This begins to sound like the thing we are hunting—but it isn't. As soon as we connect such a meter to an r.f. circuit matters are upset, for one can see that it is a variable condenser whose capacity changes with the position of the needle and therefore the tuning, neutralization, etcetera, of the circuit are almost sure to be upset.

What we need is a meter that takes no power from the circuit, that does not act as a condenser—in other words, that acts just

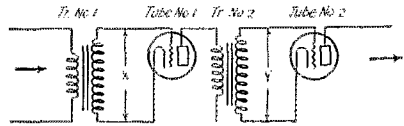

FIG 4

as if it were not there—but works. This seems like a silly and impossible thing to demand, but the vacuum tube voltmeter does that very thing so closely that we can say it does so exactly. Even in r.f. amplifiers the meter does not upset matters, and that is surely a delicate test.

EXAMPLES

All this has been rather general. Let us take a definite case. Referring to Figure 3, suppose that we wanted to find the resistance of the transmitting grid leak R, or the capacity of the filter condenser C or the inductance of the filter choke L. The usual amateur does not have a Wheatstone bridge and if he did have the thing would almost certainly not be suited to a.c. work. The grid leak could be measured with d.c. but the choke and condenser must be measured with a.c.

Suppose we tackle the job with the usual meters on hand in a sending station. They usually run about this way—

Jewell or Weston—0-15 filament voltmeter—a.c.

Thermo-couple antenna ammeter 0-5—Not good for d.c.—O.K. for a.c. or r.f.

Weston thermogalvanometer on wavemeter—0-115 mils a.c. or r.f.

Milliammeter (d.c.) 0-1½ for driver grid circuit.

Now there may be some other meters, and again some may be missing—but let's try it with the ones listed.

Suppose we start with the filter choke as shown in Fig. 3B. The idea is, of course, that if we know the voltage across the choke and the current thru it we can figure its reactance from Ohm's law—

$$X = E/I$$

If we try it, the meters we must use will be the 0-15 a.c. voltmeter and the 0-5 thermammeter. These a.c. instruments are

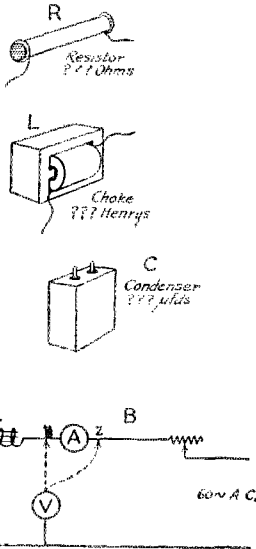

FIG. 3

stance) shaped like a slim figure 8 and mounted so as to turn inside of a pair of "quadrants" shaped as shown in the sketch. The whole affair is, of course, a small variable condenser. One side of the line to be measured goes to the rotor and the other side to both stators S1 and S2. The stators then attract the rotor and it tries to turn to the maximum capacity position (inside the stators) against the usual hairspring.

Such a meter is not particularly sensitive but has the very fine advantage that it draws no current at all from a d.c. system (it would be wonderful as a plate voltmeter for small sending sets) and no measurable

very crowded at the lower end of the scale and we cannot get decent readings on voltages below 5 or currents below 2.

Now if our choke has an inductance of 10 henrys (which is a normal value for a filter choke) the reactance is 3770 ohms at 60 cycles. If we use 10 volts at 60 cycles across the choke the current thru it will be only 2.6 milliamperes. None of the available meters can measure this current and we would have to get a very expensive thermocouple. We could push the current up but that would tend to produce saturation of the core-choke, thereby giving an incorrect value of L.

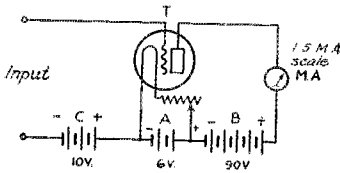

FIG. 5

Even if we had a pair of meters better fitted to the job we would still find troubles. Suppose that the meters fitted the job and we made a measurement. Are we to do it with the voltmeter connected to Y or to Z? If we connect to Y the voltmeter current goes thru the ammeter and the ammeter reading will be badly off—the voltmeter may draw 300 milliamperes. This would not only throw the current reading badly off but might actually burn out the thermocouple suggested above. If we connect to Z the voltmeter will be off because it measures the voltage across BOTH L and A. The results in either case are inaccurate. They can be corrected—but one must know how and in some combinations the correction is a very large part of the whole result, which means that the results are not at all accurate. We need a voltmeter that draws no current.

AMPLIFICATION MEASUREMENTS

To make the thing really bad, let us take a look at the most troublesome measurement of all—amplification. Looking at Fig. 4 we wish to measure the amplification between the points X and Y—in other words, the amplification of the 1st tube and the transformer Tr. No. 2. Imagine what would happen to the amplifier if you tried connecting an ordinary 0-15 voltmeter across it at X and another one at Y. Would it keep on amplifying? Hardly; the meters would short-circuit the amplifier, because their impedance is low and they draw too much current from the system.

So much for the defects of the ordinary voltmeter in radio work. Now for the vacuum tube meter.

VACUUM-TUBE VOLTMETERS

By a vacuum-tube voltmeter we mean a combination of a tube, a sensitive milliammeter and the necessary batteries—this combination being so arranged that the reading of the milliammeter is an indication of the voltage impressed on the input of the vacuum tube.

The general connections of such a voltmeter are shown in Figure 5. T is a vacuum tube of the usual 201-A type; MA is a milliammeter having a full scale range of about 1.5 milliamperes (such as is used in the grid circuit of drivers). Weston makes a small instrument having this range, which serves very well for the amateur's vacuum-tube voltmeters, but for great precision we must naturally use extremely accurate meters.

With the values of filament, plate and grid potentials indicated, the grid of the tube is operating at a point well down on the grid voltage-plate current characteristic, and the plate current will be about one-tenth milliampere. If now an alternating potential is impressed on the input terminals, the grid will fluctuate periodically about this initial bias and, due to the shape of the characteristic, the positive loops in the plate

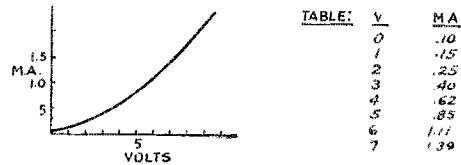

FIG. 6

current will exceed the negative loops, so that we have an increase in our average plate current, this increase varying with the impressed alternating voltage. In other words, our-plate milliammeter will show an increased reading when the a.c. is impressed on the grid. For example, an input voltage of five volts with the values shown in Figure 5 will increase the plate current from about one-tenth milliampere to one milliampere.

If we calibrate such a vacuum-tube voltmeter by varying the input voltage and observing the reading of the plate milliammeter, we can plot a curve from which we may obtain the voltage for any reading of the milliammeter. A typical curve for such an instrument is shown in Figure 6. While this is the general basic type of vacuum-tube voltmeter in actual practise, there are many refinements applied to fit it for various particular uses. Some of the different types of commercial vacuum-tube voltmeters are shown in Figure 7. Type A is the same as the general type with some refinements to facilitate usage. In manipulating this device the proper A, B and C batteries are used and the plate current is always brought to

some predetermined value, such as one-tenth milliampere. The impressed voltage is found from the reading of MA and a curve similar to that shown in Figure 6. This voltmeter is very useful for measuring a.c. voltage

potential. This gives us our type B of Fig. 7, with a blocking condenser of about one microfarad and a grid leak of one-half megohm. These values of condenser and leak have been found quite satisfactory over a range of frequencies going from audio frequencies into the radio band.

There are several disadvantages encountered in the use of the type B voltmeter. One is that the device is not frequency free. The type A meter can be calibrated at one frequency and it will be accurate over the whole range. However, there is a change in reading of the type B meter, as we go down in frequency, due to a loss of input voltage in the blocking condenser when the reactance of this condenser becomes comparable with the input reactance of the tube. The best plan is to use as large a condenser as possible, but the bigger condensers are expensive and bulky and are likely to be leaky. If they are, some of the d.c. that we are trying to block out comes thru and is impressed on the grid. Therefore, our practical considerations limit the blocking condenser to about one μ f.

A more important limitation of this type B voltmeter is that on strong signals it exhibits a saturation effect, that is, an increase in signal produces little or no further increase in plate current. Our characteristic for this device would follow the curve of Figure 5 for a distance and then would branch off to the right, approaching a horizontal line. This limits the upper limit of our voltmeter to the point at which this saturation effect begins to appear, and this is usually uncomfortably low.

The explanation of this effect is that a heavy incoming signal drives the grid positive, causing it to draw considerable current. This current, passing through the grid leak, forces the grid bias down and we arrive at a point where the grid bias is forced down to such an extent that it compensates for the incoming signal and there is no increase in plate current. To avoid this it is necessary to make our C battery large enough to prevent the grid from swinging positive. For instance, if we wish to attain a maximum value of ten volts of a.c. input, our grid bias must exceed this value and will preferably be about twelve to fifteen volts. Of course, if we use a large C battery, we must increase our B battery also in order to avoid working below cutoff.

Up to this point little has been said about the sensitivity of these devices. It is evi-

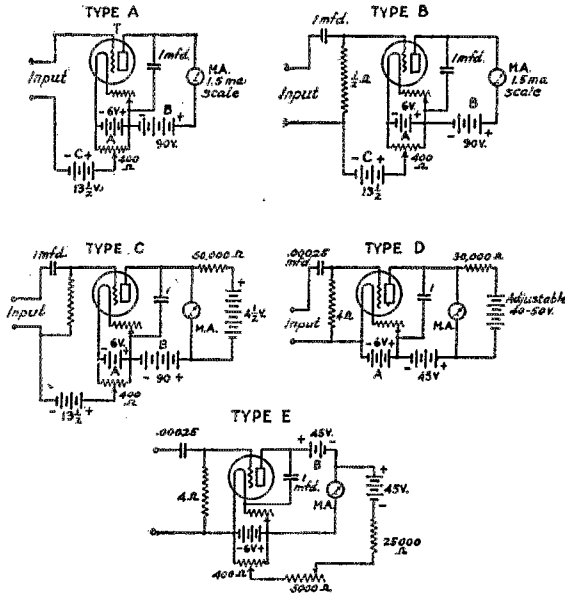

FIG. 7

from one volt up to about twenty volts. The lower limit is set by the precision of the instrument, and the batteries and tube used determine the upper limit, as the plate current cannot increase once saturation is reached.

If the alternating voltage to be measured is superimposed on a direct voltage as for

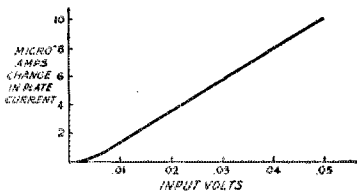

FIG 8 CALIBRATION CURVE FOR A TYPE D METER.

instance, if we were measuring the voltage across the loud speaker in the plate circuit of a tube, where there is both direct and alternating current, the first type V.T. voltmeter would be unsuitable since the bias of the grid will be changed by the d.c. component of the volt ge to be measured. To measure the a.c. voltage we must block the grid of the V.T. voltmeter to d.c. and use a grid leak to tie the grid down to a definite

dent that we will obtain more accurate results if we use precision instruments, but there is a limit even with these. For example, if we set our no-voltage plate current at one-tenth milliampere, our lowest measurable voltage is that giving the low, readable change in plate current. We might use a precision meter having 1-1/2 milliamperes full scale.

Let us say that an input of 1/2 volt on the grid changes the plate current by ten microamperes, or one-one hundredth of a milliampere. Our plate current has gone from .100 to .110 milliampere, which is a very small change even on a precision meter. It is easy to see that a voltage of one-half volt is going to be hard to measure. It is this consideration that fixes our lower limit with the above mentioned types of V.T.

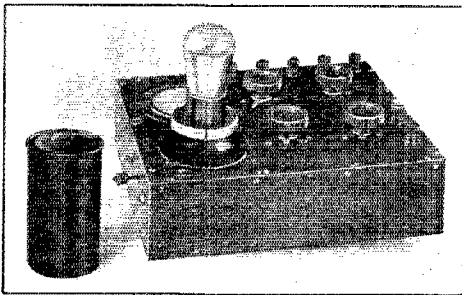

FIG. 9

voltmeters but there is a third type which is capable of still greater accuracy, and this is shown as type C.

It is noticeable that this type is identical with type B except that there is a battery and resistance shunted across the meter. This is called a bucking-out battery. Its purpose is to circulate a direct current thru the meter, equal and opposite to the plate current, so that the net current thru the meter is zero.

In other words, all the d.c. plate current is detoured around the meter thru the bucking-out battery.

If the plate current is changed, however, by the impression of a voltage on the grid, this change in plate current will manifest itself on the meter in the plate circuit. It is thus possible to use a very sensitive microammeter in this place, as it does not pass the one-tenth milliampere plate current, and this microammeter will make changes of a

few tenths of a microampere easily readable. In this manner it is possible to measure accurately as low as one-tenth of a volt, whereas the other types will not go below a volt. There is still one other type of voltmeter

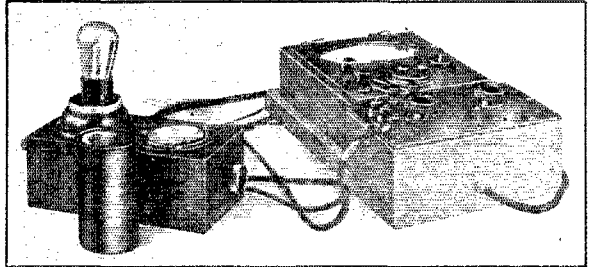

FIG. 10

which is the most sensitive of all and which is of great usefulness in r.f. measurement work where very low voltage levels are used. This type, shown as type D, is called the condenser-leak voltmeter to distinguish it from the others which are called negative C detectors. The first three types depend upon the curvature of the plate current-grid voltage characteristic for their rectification, whereas the fourth uses the principle of cumulative grid rectification, employed in our radio receivers, to obtain greater sensitivity.

This voltmeter is identical with type C except for the addition of a .00025 µfd. grid condenser, a 4-megohm grid leak and the absence of the C battery. There is one fundamental difference in the operation of the two types of voltmeters. The negative C voltmeter causes a rise of plate current

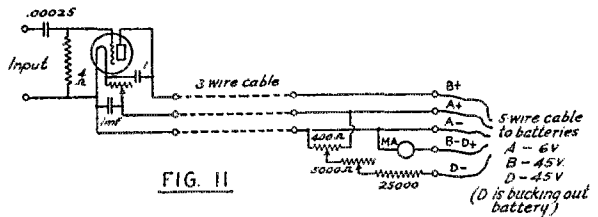

FIG. 11

when a signal is impressed, whereas the condenser-leak type causes a decrease. This means that the microammeter must be connected in the opposite way from Figure 7C in order to read correctly. In the type D voltmeter, the bucking-out battery is larger than in the type C since the plate current is higher due to removal of the C battery.

When using a sensitive meter and a bucking-out battery, it is customary to use either a multi-range meter, such as those made by Rawson and Weston, or to use a shunt,

across the meter, so that the normal plate current can be brought down on the scale before being bucked out. The bucking voltage is now adjusted until the meter reads zero, when it can be shifted to a more sensitive scale, or the shunt removed. The

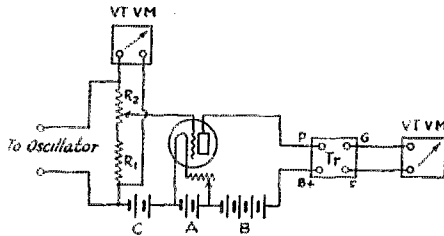

FIG. 12

user must be very careful to either shunt the meter or go back to a higher range before tuning the tube or disconnecting the bucking-out battery, as otherwise the meter will be burned out.

It is evident that a V.T. voltmeter of this last type needs very accurate adjustment of the bucking-out voltage. This is more easily accomplished by the use of a variable resistance than by changing the bucking-out battery. Also, there is less danger of accidentally burning out the meter by shifting taps on the battery with the meter on a sensitive scale.

Figure 7E shows an r.f. V.T. voltmeter of the 7-D type with a few refinements for accurate adjustment of the bucking-out battery. The 5000-ohm variable resistance gives a rough adjustment and when the range has been shifted to the very sensitive scale, the potentiometer can be used to bring the pointer to an exact zero. A typical calibration curve for such a V.T. voltmeter is shown in Figure 8.

The accompanying photographs show some typical voltmeters of the above types.

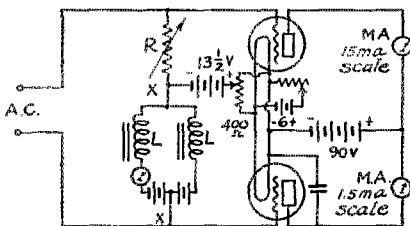

FIG. 13

Fig. 1 is a combination of types A and B—i.e., it is a type B meter with a binding-post connected to the grid so that it can be used without the blocking condenser and leak. This model uses a small Weston Model-301, 1½ milliamperemeter in the plate circuit and has a fair accuracy for

voltages between two and seven volts. Higher voltages may be measured by removing the meter and substituting one having a higher range.

Figures 9 and 10 show photographs of two of the type 7-E vacuum tube voltmeters. Figure 9 is a complete vacuum tube voltmeter, while in the other the meter has been split into two sections for convenience in reading the meter. One section contains the tube, the filament voltmeter and the filament rheostat, while the other has the microammeter and the controls for adjusting the bucking-out voltage. The first half may be placed where the voltage is to be measured and connected to the other half by the three-wire cable, so that the microammeter is placed where it is conveniently readable. The connections in the two halves are shown in Figure 11. It will be noticed that in the r.f. voltmeters, the tube is completely shielded and filament and plate heavily bypassed to prevent undesirable pick-up. This is very necessary when working with great sensitivity at low intensities.

Other refinements have been made from time to time in these fundamental forms of V.T. voltmeters in order to suit them to some particular purposes, but for general usage the types mentioned above will be found to suffice. With a little thought for the limitations and adaptabilities of these devices, they can be made to perform many useful measurements in radio laboratory work.

Probably the most useful field for this type of instrument is in the measurement of gain through either an r.f. or a.f. amplifier. Figure 12 shows a set-up for measuring the gain from grid to grid of a single stage amplifier, using either an r.f. or a.f. transformer. T_r is not shown particularly as either type, as the connections are the same with the addition of the tuning condenser across the secondary if it is an r.f. transformer. It is seen that the gain is measured by taking the input to the amplifier tube off the potentiometer, R_1 - R_2 and placing one vacuum-tube voltmeter across R_1 - R_2 and another across the secondary of T_r . The potentiometer is adjusted until both vacuum-tube voltmeters read alike, in which condition the gain is given by the step-down ratio of the potentiometer or—

$$\mu = \frac{R_1 + R_2}{R_1}$$

If this layout is used in a.f. work, the vacuum tube voltmeters are of the 7-A type. If it is at r.f., they are of the type shown in 7-E. This is one case where only a V.T. voltmeter will serve the desired purpose, as any other voltmeter placed across the secondary of T_r would not simulate the actual load at all and we would get a very erroneous value of gain. This set-up is used

to measure the gain thru various types of r.f. and a.f. transformers at various frequencies.

In connection with the measurement of amplification, another characteristic of V.T. voltmeters comes in handy. Since the change in plate current depends upon the wave form of the impressed signal, we will obtain different readings if we reverse the impressed voltage, unless it is of a symmetrical wave form. This is because one side of the wave form is higher than the other in a distorted wave form and the average values of each side are different. Therefore, if the voltage is impressed on the grid one way, the top average will determine the reading of the voltmeter, whereas if we reverse the voltage the other average is the determinant. We can thus check the wave form of an oscillator by connecting a V.T. voltmeter to its output thru a reversing switch, and if the reading changes on throwing the switch, there are harmonics present.

Another use of V.T. voltmeters is in the measurement of high impedance. Figure 13 shows a set-up for the measurement of high inductances at low frequencies, with biasing current circulating thru the coils. It is seen that the method consists of connecting a resistance in series with the impedance to be measured, and placing a V.T. voltmeter across each. The resistance is adjusted to make both meters read alike when its value equals the desired impedance. When measuring chokes with d.c. the measurement is made as shown, using two chokes and splitting the battery in equal halves, as shown, so that no d.c. is impressed on either V. T. voltmeter. This method can be used to measure large filter condensers

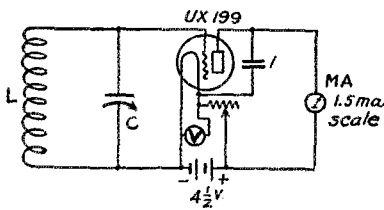

FIG. 14

by connecting them between the points X X instead of the chokes. An extremely useful application of the V.T. voltmeter is that illustrated in Figure 14, which shows a wavemeter with an attached vacuum tube voltmeter. In ordinary wavemeters we are limited in precision by the resistance of our measuring instrument unless we indicate resonance by a meter in the oscillator which is often inconvenient. In this wavemeter the V.T. voltmeter replaces the usual milliammeter or bulb and is placed across the precision condenser. The only resistance in the tuned circuit is that of the coil and con-

denser, plus some dielectric loss, and a small loss caused by the input of the V.T. voltmeter being less than infinite in resistance.

If our coil is low in power factor, we can construct a wavemeter which is extremely accurate and sharper than most other wavemeters. In this particular wavemeter the 4½ volt battery supplies plate as well as filament for the 199 tube for economy of parts. If greater sensitivity is desired it may be obtained by placing a B battery in the plate circuit, but for our purposes the 4½ volt battery was quite sufficient. This wavemeter is shown in the accompanying photo, Figure 15.

There are many other purposes to which vacuum-tube voltmeters will lend their adaptabilities, but these are among the most common and the most important, and will

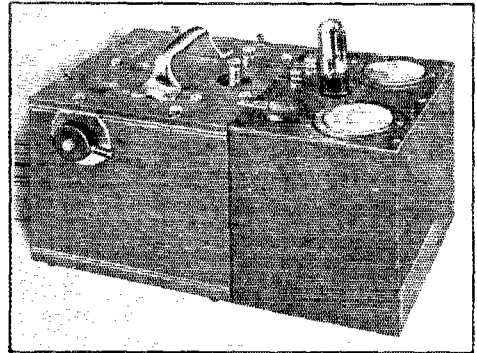

FIG. 15

serve to show the great utility of such a device. It can be easily seen that the scope of this instrument in the field of radio measurement is vast indeed, and that it occupies an enviable position among radio instruments. When we consider that this instrument serves to give us comparative, constructional data from which to design our transformers, our coils, our condensers and even our radio sets, it is evident that this one instrument is easily one of the most useful in all radio work.

Strays

SASQ wants to find out, "Does the relay relay relay?"

3CDQ has been working eiACD and not ei1ER as stated in the January issue.

We are told by 8RL that any stations tuned in on his Grebe Synchrophase may also be heard on 10, 20, 40, 80, 100 or 200 meters on his CR-18 located two floors above it. These sets certainly act like sisters under the cabinets.

A Ten-Cent "Bug" Key

By George P. Taylor*

I HAVE a "bug" that cost me actually only a thin dime; and that was for the necessary nuts and screws.

In 1925, QST described a home-made bug but it was of the double-bar type. The one I will describe is of the single bar type and is a bit easier to construct.

0, 1, 2, 3, 4, and 5 are small metal brackets about $\frac{3}{8}$ " wide and bent at right angles, being screwed to the base with $\frac{1}{2}$ " wood screws. The brackets were not threaded for the machine screws, it was simpler to use a nut on each side.

The base is of wood ($6\frac{1}{4}$ " x $2\frac{3}{4}$ " x $\frac{3}{8}$ "). The arm 6 is of the same metal and size as that of the brackets and about eight inches long before being bent and twisted. The knob or "thumbeater" 7 is a cylindrical piece of wood $1\frac{1}{4}$ " in diameter and $\frac{1}{2}$ " long.

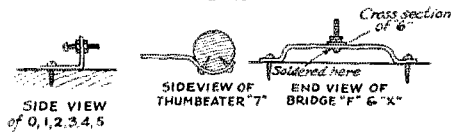
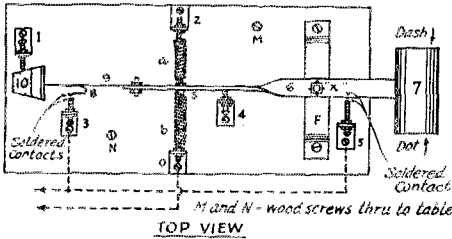

The dot contact extension and the vibrator arm, 8 and 9 respectively, are of spring material. I made them from an old corset stay. The vibrator 9 is $\frac{3}{16}$ " wide and $1\frac{1}{4}$ " long from the opening of the thimble 10 to the beginning of its free end on the main arm. The whole length is about 4". 8 is soldered to 9. All contact points are drops of solder! They are filed a slight bit to insure fair flatness. I used acid core solder.

10 is a common metal thimble filled partially with solder. The solder performs two functions here; holds the thimble on the vibrator arm and acts as the usual weight on the vibrator.

The springs A and B are of brass wire. Both springs are fastened to the main arm by the screw S, which also fastens one end of the vibrator arm 9. This connection, incidentally, is one of the electrical connections and should be made with care.

The main thing in the whole lay-out is

the bearing X. The little bridge F is of $\frac{3}{8}$ " metal strip. A hole is drilled in its center as shown in the diagram, and a machine screw is inserted and soldered to F—also a portion of the screw where it protrudes from F is coated with solder. A similar hole is drilled in the main arm 6. The solder on the screw is filed until it will slide easily into the hole just drilled in the main arm. A nut and lock nut are put on and you have a pretty good bearing. Mine has given me no trouble. A drop of oil will help it.

The wiring is dotted. No binding posts need be used. Connections are just made to the wood screws that fasten the brackets to the base.

The adjustments are a bit tedious I will admit, but all finished you will be proud of the action of your handwork.

In adjusting, start at the springs. With all "set-screws" clear adjust the main arm so that when idle it lies parallel to the sides of the base and with the springs A and B fairly taut. Then set stop 4 up close to the main arm. When the main arm is against the stopping post 4 the dot contact 8 should rest lightly against 3, its other contact. The dash contact 5 is brought up close to the contact on the main arm 6. The arrester 1 should rest against the thimble weight 10 when the arm is idle.

Further adjustments can be made by touch and with a buzzer. Varying the stopping post 4 the slightest degree will change the speed of the bug. Incidentally, this is a nice helpful factor.

I built the thing one afternoon with a soldering iron, a screw-driver and a drill. I hooked it to my regular key and use either according to my moods.

My outfit doesn't look so all-fired neat but it's effective. In the same way I am no artist with the pen or this description would be plainer and in fewer words, but I think it's all here.



*9BAN, 72S Second Street, Henderson, Kentucky.

Electrolytic Filter Condensers

By Louis F. Lenck*

SINCE my transmitter was put back into operation last fall my tone has invariably been reported as "pure d.c." The answer lies in home-made electrolytic condensers with a 50-to 100-henry choke coil in the regular "Brute Force" filter shown in Fig. 1. A very ordinary filter will give a smooth output if very lightly loaded but large condensers help greatly to keep the output smooth when the load is in-

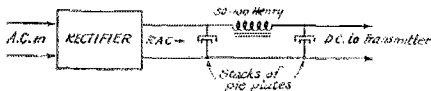

FIG. 1

creased. A really large capacity in paper condensers becomes very expensive—and that's where the electrolytic condenser comes in.

Of course much depends on the proper adjustment of the set. Frequently the tone of the transmitter can be improved very greatly by simply using a grid leak of 2 or 3 times the usual resistance. The plate current will be reduced and the antenna current generally will not fall in proportion. Changing the r.f. choke, loosening the coupling and dropping the input (fewer grid turns) all help to improve the tone. It isn't necessary to wait for reports—just listen to a weak harmonic of the transmitter with your own receiver.

The best proof that these things are really worth while is that by simply ignoring them one can produce any sort of a rough tone (r.a.c. or even a.c.) from a good d.c. generator or even a storage battery.

The axe I want to grind, however, concerns the formation of the plates in an electrolytic condenser. My first attempt along this line was not all that could be desired, in fact I ruined a couple of good electrolytic rectifiers trying to use them as a source of d.c. to form the condenser plates. The instructions I was following stated that a.c. positively was not of any use except to ruin condenser plates that were already formed. Well I didn't even get the plates started to forming with my chemical rectifier. I found that the current required at the beginning of formation was entirely too heavy. It ran up to 100 mills or so per sq. inch at the very beginning.

My next thought was to take the condenser to a power plant where d.c. was available. This was a very fine idea except that

it is quite a trick to move a "pie plate stack" condenser across a room without spilling a good share of the electrolyte.

THE PIE PLATE CONDENSER

Here is the method eventually evolved. Stacks of aluminum pie plates are used. Suitable plates can be purchased at S. S. Kresge's 25c stores for 10c each. Assume we have 750 volts of R.A.C. to be filtered. Allow 60 to 70 volts per plate. The voltage will tend to build up to peak value where large capacities are used in the filter. It is therefore possible to get $1.4 \times 750 = 1050$ volts of d.c. at no load. However, the resistance of the transformer, rectifier and choke (and the load due to slight leakage through the condensers themselves) will pull this down. You will still get 750 volts if the load put on the condenser is not too heavy. Allowing 65 volts per plate we find that 11 plates are required. One of the plates in a stack is simply an electrode so we will use 12.

Now suppose we have them all properly stacked and spaced and we are ready to put in the electrolyte. Put the condenser just where you expect to use it. Now fill

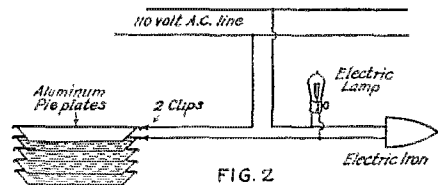

FIG. 2

each plate with electrolyte made by dissolving ammonium phosphate or borax in distilled or rain water. Make a concentrated solution using cold water. Fill the plates to within $\frac{3}{4}$ -inch of the top and add $\frac{1}{4}$ -to $\frac{1}{2}$ -inch of ordinary automobile cylinder oil. The oil is only to prevent evaporation or creeping out and crystallization of the solution.

FORMING

The apparatus required for forming is as follows:

- 110-volt source of a.c.
- 2 clips
- 1 electric iron or toaster
- 1 40-watt lamp with socket
- Some lamp cord for making connections

The apparatus is connected as shown in Fig. 2 which is almost self-explanatory,

1. The ammonium phosphate is probably the better since there is less difficulty with "creeping" of the solution, also because there is a bit less tendency to corrode the aluminum if it is impure.—Tech. Ed.

The 40-watt lamp merely acts as an indicator.

Fix one clip on the upper pan and the other on the one below it. The condenser at first acts very much like a short-circuit and the lamp will glow brightly, but the heavy initial charging current (above 5 amperes) will cause the plates to form rapidly at first. The lamp will immediately begin to get dimmer. At the end of about one minute it will be fairly dim. Now move the clips down one plate each and treat the next pair of plates the same way. By the time you have given each of the 12 pairs a one minute treatment you will find the whole condenser quite warm to the touch. Let it stand until the next day or until it is cold. Repeat the forming process as before but you can continue a little longer this time as the condenser will not heat so readily as it did the first time.

Repeat this forming process a couple of times more or until the lamp shows very little light or none at all (current going through both lamp and iron always).

The condenser is now practically formed and can be connected directly into the filter. It will have a leakage current of only 5 to 15 milliamperes and a capacity around 5 μ fd. After being in use for a while the

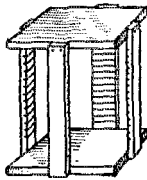

FIG. 3

Material and dimensions for rack to hold pie plates $9\frac{1}{2}$ " in diameter.

2 end pieces $\frac{3}{4}$ " x $9\frac{1}{4}$ " x $9\frac{1}{4}$ ".

4 strips $1\frac{1}{2}$ " x $\frac{3}{4}$ " x 7" with slots $5/16$ " apart and $3/16$ " deep.

Screws, etc.

The end pieces are $\frac{3}{8}$ " less across each side than the diameter of the plates used. The rack can be made double height and will then hold both stacks of plates.

leakage current may be still less. It sometimes gets as low as 3 mils.

It is a good plan to give the condenser a little attention about once every four or six weeks to see that the leakage current is low and remains so. This can be done by putting a

0 to 100 range milliammeter temporarily in series with the condenser. It can also be done by the use of a wooden handled screw-

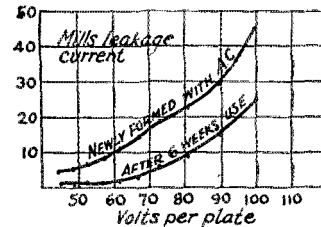

FIG. 4. CONDENSER LEAKAGE

driver. Short-circuit each pair of plates in turn with the current turned on. A fat spark can be drawn from each pair that is still properly formed. In case one or two pair show a weak spark or no spark at all use the original a.c. treatment on them and they will again do their duty.

CAUTION: While forming do not let the solution get so hot as to boil. This will ruin the film already formed and it seems to be harder to form the second time. In fact, do not let the plates become uncomfortably warm to the touch. The cooler they are kept during formation the better.

Do not try to fill the plates too full of solution. It will tend to creep out and to crystalize along the edges. This will be especially harmful if it soaks into any wooden or fiber spacers you may have used.

Fig. 3 shows a convenient way of making a rack for pie plates. Aluminum lightning arrester cones can sometimes be secured from power companies. They discard these plates even if only very slightly defective. Get them if you can and also the spacing washer as they are great. They are easy to mount and space and have about twice the area of pie plates.

Electrolytic condensers of this type have two principal virtues. One is cheapness. Your filter can boast of 20 mikes with about the same cost to its owner as if it had 4 mikes of the ordinary paper dielectric variety. The other is that too high a voltage will not wreck it. Of course the thought of the work required to make one may give a fellow "that tired feeling" but how about the "feeling" one experiences at the pit of the stomach about the time he unexpectedly blows up a bunch of paper condensers?

Just how near pure d.c. will this filtered r.a.c. give? With 15 μ fd. across each end of a 50-to 100-henry choke the twenty meter signals from this station have been reported as "pure D.C." about a third of the time and as "D.C." in every other case where a report has been received.

The two curves of Fig. 4 show how the leakage current through the condenser varies as the voltage across the condenser

2. The capacity of each section depends on the area of the plates and the voltage at which the condenser is formed and used. Forming at 100 volts should produce a condenser with a capacity around 5 microfarads per square inch of plate area or about 500 microfarads per plate. Since the sections are in series this must be divided by the number of plates. There are 11 plates in the string described therefore the resultant capacity is about 45 microfarads. Practically the capacity usually comes out lower. But even 20 microfarads is a good capacity.—Tech. Ed.

is varied. Note that it would be a waste of good pie plates to allow any less than 60 volts per plate, also the leakage increases very rapidly after a certain voltage is passed. According to the lower curve it seems as if 80 or 90 volts would be a safe upper limit. This is not the case, however, as sometimes they do not work out quite as well as the one from which the curve was drawn. 70 volts should be the upper limit.

If 110 or 220 volts d.c. is available no doubt it would do as well or better using the above plan of forming.

By using the above plan each plate is formed separately. All plates will behave about the same when the condenser is put into service. This is not usually the case when a number of plates in series are all formed at the same time from a high voltage source. Some will not start forming as quickly as others and these will turn out to be "duds". Our chem rectifiers are usually formed in series. Did you ever see one without a couple of "duds" in it?

The Army-Amateur Affiliation

(Continued from Page 33)

Army, offers many great opportunities. Amateurs are asked by the Signal Corps to furnish more than message channels. They are asked to assist in the solution of radio research problems, and to report on developments of their own which might be of great value to the Signal Corps in carrying out its own mission.

One of the greatest advantages in the close relationship between the two organizations is that a large group of American citizens is made familiar with the Army and its system of communications and a more friendly spirit can be created between the military and the young men of the country.

The relationship between the American Radio Relay League and the Signal Corps will furnish, at a time of great disaster or emergency, thousands of intelligent, enthusiastic, and skillful radio operators and engineers capable of operating communication equipment of the Signal Corps during the period of the emergency. During normal times, it will promote the cordial feeling that now exists between a large number of young men and the military. It will stimulate the research instinct among those radio amateurs who are so inclined, thereby producing advances in radio communication that have hitherto been undreamed of.



Strays

The new Raytheon type BH rectifier tube has several things about it which should make it a nice low-power transmission device. The maximum a.c. input voltage is 350 per anode. The starting voltage is 165 and in their standard B-eliminator circuit it will deliver 200 volts at 85 milliamperes. The regulation with the new tube is extremely good, the 90-volt drop in the tube remaining constant for drains of from 20 to 85 milliamperes. For use with a 201-A tube in a small transmitter, the Raytheon rectifier should be quite the berries.

Our friend Doc Bidwell of Washington suggests that DuPont's Duco Household Cement is the latest thing for sticking anything around the shack providing the material to be stuck to is *not* rubber. Doc says the Duco stuff is superior to the colodion-celluloid compounds we have been using on coils, etc.

R. Palmer, SPY, makes the following suggestion for adapting the UV bases to

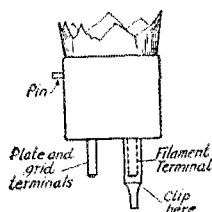

UX sockets. A fone-cord tip is soldered over the filament prongs and the lower ends of them clipped off. The illustration shows how.

5ANL had a close shave. He had some storage batteries on charge and one of the caps that had been removed and laid to the side of the vent hole fell back on it and sealed it up again. He took the clip off the terminal without shutting off the charger and the spark ignited the gas in the cell. It threw acid into his eyes and over his face and hand. As he was only about a block from a doctor, he shouted for some one to take him there. He arrived in less than five minutes and was fixed up immediately. This quick work probably saved his sight. Take this as a warning fellows and *always* turn off the charger before you take the clips off the battery. Don't use any naked flames near batteries either.

Experimenters' Section Report

THE report of this section is brief this time because we are in a betwixt-and-between position at the moment when this must be written, that is to say the end of February. This applies to almost all of our activities, as follows.

THE NEW PROGRAM

Before starting a new "session" it is naturally necessary to gain reasonably complete information as to the past year's work. Some members of the section, perhaps 10% have been very good about keeping in touch thru the year. Another 40% or so reported when requested, mainly sending in first rate reports. The other half should have received a follow-up request before this but we have been short of time because of a combination of things, a short month, the usual winter peak of correspondence, the annual meeting of the Board of Direction and the necessity of

duced to a number that can be supplied with material, or else the original estimate on material raised greatly. As this is read the work will be under way. The problem is naturally a slow one and will take perhaps 6 months until a report can be made.

THE 5-METER WORK

Our 5-meter experiments are in a curious shape. After many months of work we finally started testing in the middle of January, and tests by 2EB and 10A were run twice daily and almost all day Sundays thruout February. 2XM, 2CSM and 9EHT joined in at intervals. Many foreign observers listened and 2EB, which was the most powerful of the stations, was heard in Missouri, Kansas (state) and in Italy, also many times in Hartford by the writer. In addition to this 2EB and 2NZ established two-way contact as was explained in the "flash" on page 55 of the March issue. This contact was found very reliable at all sorts of hours.

So far—so good. We feel encouraged, but we must wait for reports from our distant observers before a complete report can be made. Rather than to make two reports the present one will be let go with the high-points mentioned above. By the time you read this we will have received information from the network and will send mimeographed details to the members of this section. The next issue will, accordingly, contain full information.

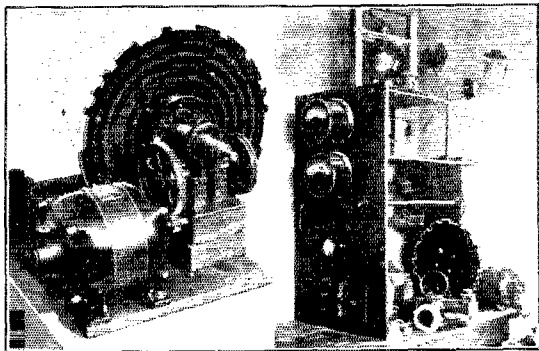

THE SENDING EQUIPMENT AT 2EB, 8505 167TH STREET, JAMAICA, LONG ISLAND

At the right is the sending set with the big automatic key at the bottom, the oscillator circuit at the top and the power supply between. The end-fed antenna branches off to the upper right. The tube is a special "trick" tube. The set is now in more permanent shape and the Ultraudion oscillatory circuit is made up more substantially.

At the left is the auto key in detail. An induction motor thru gears drives the large bakelite cam whose edge is cut so that it pushes a spring arm down at each rise in the cam, causing the key to send "Test 2EB" at each revolution.

getting our work room unsnarled. Of the work room more later. Meanwhile—please report if you have not done so on the second letter which must reach you almost a month before this. The new program will, of course, have been made out before this reaches you.

THE RECTIFIER PROBLEM

A list of volunteers rather larger than we can handle has reported for the investigation of high-voltage aluminum rectifiers. In some manner the list will need to be re-

FURTHER 5-METER TESTS

Naturally after 2 years of 5-meter work Phelps and the writer felt as if it were high time for a little aid to appear. Our only consistent coöperation had come from Norvell Douglas of 9EHT at Lawrence, Kansas. It is therefore a pleasure to report that any number of additional testers has appeared, many of whom are doing excellent work and are anxious to continue the tests. More tests will certainly be run but will perhaps not be announced thru QST as this takes entirely too much time. For instance—suppose that we study the return on the last series of tests and by the end of March have complete plans for another test. The announcement could then go into the "next available" issue of QST, which would be the MAY issue—and we would have to sit around until then to allow even the U. S. A. men to get in on the test. When foreigners are considered it becomes plain that one must allow another month to pass

and that a plan made late in March cannot be put into international action until JUNE—unless we find a means faster than QST.

In the late test this was done. Thru the relay system of the League many long detailed messages were sent to Europe, South America, Asia and Africa and a regular correspondence maintained by Mr. Ross Hull of this Section with Australia.

but the meter board retained. The automatic key took the curse off those dreary weeks and weeks of sending during the months from November until this time. It is very likely that this key will have much more work if we may judge by requests received from Australia and England.

SPECIAL NOTE

As has been mentioned before, this Section is not especially "sold" on any one sort of experimentation. We are very sure that it takes all sorts of experimenters to make a radio league. The man who thinks in terms of integral calculus is welcome—but so is the lad that is finding out some small matter by pure cut and try. Quite often the cut-and-try man if he will think things over and keep trying, has a very excellent chance of doing something worthwhile. He is most welcome, fully as welcome as his mathematical brother in the radio fraternity.

Another matter—The reports of this section have been bearing the signature "R.S.K.", which, incidentally, applied to the whole report and not only to the last paragraph as many of our correspondents seem to think. The signature does NOT mean that this is a one-man section. The reports are written after conference with Ross Hull, "QST's Information Service" who also operates the Section and are edited by him before they go into QST. Any action in the section is taken after asking the members and after a conference which usually includes the writer, Hull and Westman, QST's Assistant Technical Editor.

—R. S. K.

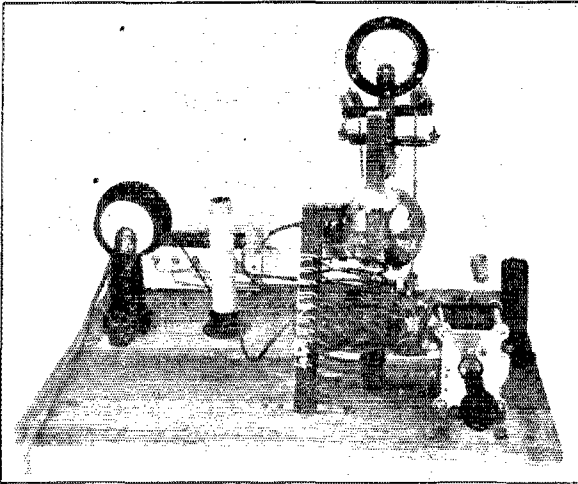

ONE OF THE SETS AT 10A. 27 VAN BUREN AVE., WEST HARTFORD, CONN.

This set was used during the first part of the February tests, and feeding an antenna at its 5th harmonic. The oscillator used the Ultraudion circuit and the tuned circuit at the end of the antenna was coupled to the small helix. The variable condenser acted as a fine adjustment on the tuning of the oscillator. Later this circuit was changed to a Hartley circuit which was more stable and less efficient.

The whole set was replaced in the latter 1-3 of the February tests by a more powerful affair operating in the Ultraudion circuit and end feeding a full-wave antenna.

The first set used an auto key saving simply "test," the signing being done by hand. The second set used another key cam saying "test 10A." No intermediate was given.

The details of that piece of relay work will appear in next month's report. A similar method of contact will need to be used the next time, which will mean during April or May. Amateurs in the U. S. A. will be notified by broadcast from 1MK and other stations in the A.R.R.L. broadcast system; see page IV in the Communication Section of the March issue.

ADDITIONAL STATIONS ON 5 METERS

During the tests, in spite of the many announcements, very few stations joined the transmissions. They have now begun to turn up and the sending network for the next test will seemingly be much larger. Meanwhile, to aid others in getting started, the transmitter at "EB" is shown herewith. It is a frame, taken from a ship's transmitter of the spark days, with all the essential machinery ripped out and nothing

Strays

Clyde Anderson sends us this photo of his collection of deceased transmitting and



receiving tubes. If this is supposed to be a funny stray we will go out and attend a coupl'a funerals for entertainment.

4NH suggests a good new "Q" signal. QTZ? "Are you using crystal control?" QTZ "I am using crystal control transmitter here."

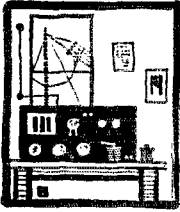

Amateur Radio Stations

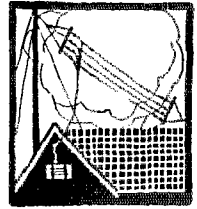

4JR, Gastonia, N. C.



THE operator at 4JR first became interested in radio in 1919 but did not get actively started in amateur radio until the fall of 1923 when 4JR officially got started. The present arrangement got off to a good start since the transmitter panel and meters were purchased from 5AEC shortly after he won fame in the trans-Pacific tests. The transmitter uses one 50-watt tube in an inductively-coupled series-feed Hartley circuit. Plate supply comes from a transformer, rectifier and filter arrangement, the tube receiving 1,100 volts when the power company is in a good mood and lets the transformer have 110 volts at its primary terminals. The chemical rectifier is mounted in a large box under the left end of the table. It is composed of 48 jars plus the purest aluminum and lead Morris could get. This rectifier has been in use over two years, has been cleaned only once during that time and is still going strong. The filter consists of an RCA 40-henry choke in the positive high voltage lead, with two μ fds. of condenser across the line at each end.

The plate and filament transformers are home-made. The filament current is controlled by a Bradleystat in series with the primary, the Bradleystat and filament voltmeter being mounted on the front of the table at the left. In every part of the circuit where there is a chance of any r.f. getting away in the wrong direction, r.f. chokes

have been inserted. The normal plate current is around 130 m.a. The primary inductance consists of ten turns of RCA helix mounted on glass towel rods and spaced by wood "beads" which have been boiled in paraffin. The antenna inductance is spaced-wound on notched wooden strips glued to a cardboard support.

A small series condenser is used in the counterpoise lead. This condenser is mounted on a bakelite panel on the wall next to the transmitter. On the panel a small switch lever to the right of the primary condenser is used to short-circuit part of the grid leak when changing from 80-to 40-meter operation. For 40-meter work the antenna system is operated at its 2nd harmonic and for 80-meter work fundamental antenna operation is employed. Things are so arranged that the only change necessary when QSYing from 40 to 80 meters is the throwing of the small switch in the grid leak circuit and setting the primary condenser at a different and known setting.

The antenna is a single wire 105 feet long from the set to the far end. It is glass insulated. The far end is supported on a 65-foot pole. The station-end of the antenna is supported by means of a 24-foot 2 x 4 on top of the house. The counterpoise is also a single wire, having a total length of 95 feet. Both antenna and counterpoise leads are brought through a plate glass

window pane. As the op is a "southpaw" the power control switch, the antenna changeover switch and the keys are mounted at the left of the receiver where they can be handled easily.

The receiver uses the standard detector and one stage of audio frequency amplification arrangement in a Weagant circuit, a small series antenna condenser being used. The receiving coils are home-made and cover all of the amateur bands. To the right of the receiver can be seen the home-made wavemeter which is a very valuable addition to the station.

The outstanding accomplishment of the station and the record of which the operator

is most proud is the consistent schedule that has been maintained with 8CEO, Oakmont, Penna. This schedule has been in force since the station was first placed on the air in the fall of 1923. Plenty of DX work has been done, including contacts with twenty-two countries in all continents except Asia. The operator is not a DX hound, however, as 4JR has participated in all Communications Department relays and tests since coming on the air. A goodly number of messages are handled each month, the average being around 50. The station was constructed and is owned and manned by Robert S. Morris of 413 South Broad Street. A nifty layout.

6DCQ, Phoenix, Arizona

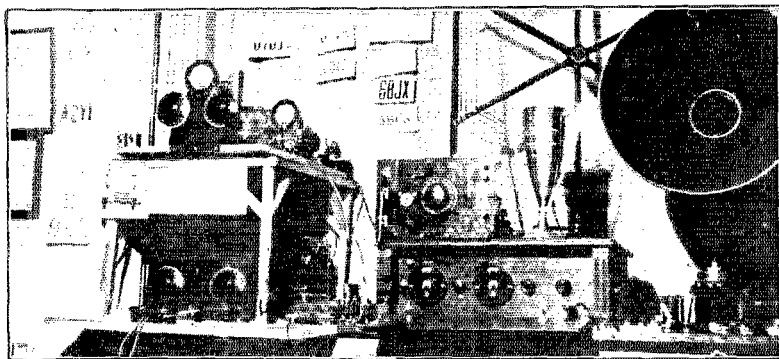

GUY N. Carter is the owner and operator of this station which is located at 509 North First Street. While not an old timer, he had been a telegraph operator and broke into amateur radio after serving an apprenticeship as a BCL. Having tried everything in this field from crystal to super, he turned to the shorter waves for his amusement.

The transmitter is a loose-coupled Hartley affair. The plate supply is obtained from a Westinghouse motor-generator set and an iron core choke that came out of an electric light meter is placed in the positive lead with a 1- μ f. condenser shunted across the line each side of it. The inductance consists of copper ribbon wound in the form of a pancake on bakelite strips. The winding starts at two and a half inches from the center and continues with a spacing of one quarter inch until twelve turns are had. The antenna coil is of the same construction but has only six turns. The grid portion of the coil is tuned with a Cardwell 500- μ f. condenser. It has been found that this allows the changing of wavelength to be accomplished quite easily. However, it is made a point to keep the

wave exactly the same at all times and a wavemeter employing a thermo-galvanometer for a resonance indicator is used for checking it. The grid and plate condensers are supported by their leads which are about three inches long.

The antenna is tuned by a Cardwell condenser of 500- μ f capacity and another one of these condensers with half the plates removed is in the counterpoise lead. With a coupling of about four and a half inches, the wave is reported sharp and steady.

Shunted around the key, which is located in the center tap lead from the helix, is a half mike of capacity in series with a thirty-ohm rheostat. As yet, there have been no complaints about clicks.

The transmitter is mounted on a shelf about two and a half feet above the operating table. It is on sponge rubber to overcome vibration. The motor-generator is also mounted on rubber in back of the receiving set on the table. This makes the machine very accessible both for cleaning and lubricating. The commutator is kept in good shape with the aid of 00 sandpaper as any arcing between segments causes a roughening of the note.

The location is an excellent one for the antenna-counterpoise system. The set is on the second floor of a two story house and the vertical length of the antenna is a piece of No. 4 copper wire, about 27 feet long that runs directly through the ceiling and roof thru two porcelain tubes. This, of course, calls for the use of an extraordinarily good natured landlord. The horizontal length of the antenna is a cage affair, 15 feet long, of four No. 12 copper wires soldered to 10-inch copper rings. This antenna has been found to be the best of many that were tried.

The counterpoise runs directly out of the window back of the transmitter to within about 4 feet of the ground and is a two-wire fan. They are of No. 12 wire and are anchored about 15 feet away from the building, being 30 feet long with the outside ends 25 feet apart. The counterpoise insulators are 10-inch porcelain ones and the antenna uses strain insulators, also of porcelain. The mast and all guy wires, which are broken up every few feet with insulators, do not get within 10 feet of the antenna.

The receiver is a detector and one step. The circuit being the same as used by Schnell on his Australian trip. There is no sense in trying to remember all the names under which it operates. The receiving antenna is 100 feet long and fastens to a 70-foot mast. The large receiving set

is a super which can be worked on the lower waves by inserting small coils. On top of this is the portable 6BCB outfit. The cup was won in a contest held for all

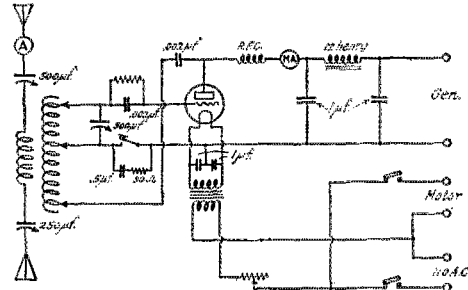

BCLs in Arizona, for stations received and distance in miles, over a period of 10 days.

The two switches by the 6DCQ sign are for changing over from the motor-gen to 90 volts of wet "B" batts for low power work using either a 201-A or 199. As will be seen by the circuit, it is impossible to turn on the plate supply until the filament switch has been closed.

To date, DX is oz, oa, na, aj, op, oh, nc, nm and all U. S. A. It is hoped that this winter our friends across the Atlantic may be worked with the same 7½ watt which I prefer to call the little fifty-watt bottle, my UX-210.

9DNG, Lawrence, Kansas

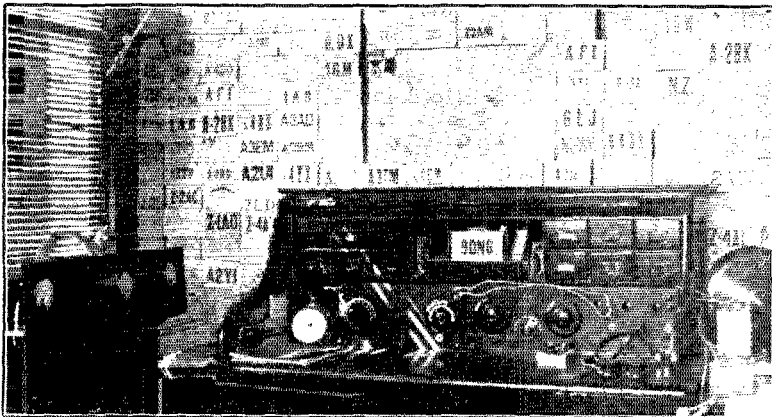

9 DNG is the station of Fergus S. McKeever and occupies a sleeping-porch on the second floor of the house. The house is situated on University Heights and is about one hundred and fifty feet above the city of Lawrence.

The first transmitter was put in and operated during the latter part of 1923.

The antenna consists of a 2-wire, vertical fan, 32 feet long. The counterpoise is of the same length and type but is hori-

(Continued on Page 67)

Calls Heard



1ASR. St. Pauls School, Concord, N. H.
4hq 4fe 4ks 4ob 5adz 5akk 5akm 5aub 5el 5sh
6amm 6auk 6axd 6bhl 6bhx 6bia 6bzm 6bdz 6bax
6cl 6cco 6cuw 6cys 6rf 6dcq 7tk 7uj 7vq 7ek an-4sc
az-4az ca-chl eb-ch5 eb-433 ee-ear44 ef-8fr ef-8udi
ef-8zet ef-ocny ef-8zi ef-8ep ef-8yor ef-8ho eg-2rg
eg-2cac eg-2ao ei-cdl ek-y8 en-0ph en-0pm en-0fp
ep-lax fa-4a fm-8ay fo-3im fu-ocmu na-7kn nc-8aw
nm-1n nq-8kp nr-cr10 oa-3hl oa-2yh tpai sc-2bl.

ICBG, Robert Coe, Litchfield, Conn.
Heard in 20-Meter Band
ladm lafl lrd lxxam 2arr 2xaf 2xaw 2yg 2xo
2xs 2xt 3zk 4af 4aj 4dm 4gz 4gw 4km 4ms 4si 4ta
4tk 4tv 5df 5gg 5rh 5ql 5wz 5yd 5zai 5bau 6bia
6bxr 6cai 6eei 6eln 6emt 6rm 6rv 6rw 6ud 7ek
7gb 7kr 7rx 8ali 8aly 8aub 8avb 8avz 8bsc 8ees
8eve 8cyu 8eal 8dal 8dbm 8dem 8dew 8dse 8dzy
8sx 8vj 8xk 9aem 9ahg 9amb 9an 9atq 9aux 9awb
9axy 9bbl 9bbq 9bhi 9bhq 9bjs 9bkn 9bkk 9bna 9bnd
9btk 9bvp 9bwl 9bwn 9byl 9cak 9caw 9ccc 9cej
9cfl 9ch 9cia 9cib 9cjs 9cid 9cmj 9cmz 9cn 9cp
9cyy 9cye 9cyp 9cys 9dac 9db 9dep 9dfr 9dga 9dgw
9dtr 9doce 9dpw 9dr 9dra 9dxw 9ear 9ebx 9ect 9ef
9ege 9ein 9eir 9eij 9ek 9ekc 9fk 9mz 9ny 9pt 9rk
9ub, 9wk 9xn 9ze.

Heard Between 13-38 Meters
eg-5dh eg-gbh eg-zbk eg-gbm eg-gdhd eg-gmb
eg-ocly eg-ocfn ef-8yor ef-famj en-4pea ek-aga ek-agb
ek-age eei-ice ne-2al ne-4al ne-4bt ne-4dw nd-hik
nm-1n nm-cye nm-nam nj-2pz nj-lqic nq-naaw nq-pwx
np-nau np-nni sa-sd5 sa-lpl sa-lpv sa-lpz sb-lan
sb-laq sb-lib sb-2ab sb-snni sb-spr sb-spw sc-2as sc-2bl
sc-2ab su-2ak oa-vido oa-viz oh-6hm oh-npm ok-npn.
(Guam) x-ryx x-hm x-lw kel wik wlc wl wnu
aat abl av7 ndf vwe vwx wvf.

1RY, 24 Bay St., Taunton, Mass.
(Heard on Feb. 18)
eg-5hs eg-5ku eg-2kf eg-2ao.

H. Elkins, Box 492, Augusta, Maine
(Heard between January 11 and February 10)
eb-n33 eb-z1 ef-8ba ef-8fk ef-8gr ef-8hu ef-8jf
ef-8qrt ef-8udi eg-2cc eg-2jp eg-2sw eg-5by eg-5nw
eg-5rh eg-5sz eg-5tz eg-5uw eg-5wq eg-6pu eg-6yv
eg-6vp ej-acd en-0fp eo-2it es-2co fo-a4l nj-2dz
nm-1j nm-9a nq-2jt nq-8kp oa-2bb oa-2rt oa-2sh
oa-2tm oa-2vi oa-3bc oa-3pl oa-3wm oa-3xo oa-3yr
oa-4cg oa-4rb oa-5ab oa-5bw oa-5wh oa-5wv oa-5ws
oa-7eq oa-7dx oz-4ac oz-4ak sb-1aj sb-1aq sb-1ar
sb-lib sc-2as sc-3ag pr-nrau gfy sgl aga agb agj
cdj wdwo kel.

Albert Wignot, 4, Home St., Worcester, Mass.
Heard Between Jan. 10 and Feb. 4
6abc 6ach 6adm 6adt 6afx 6agr 6ahn 6ahz 6akh
6ala 6awg 6axd 6bam 6bdi 6bl 6bgz 6bhi 6bhr
6bhv 6bia 6byl 6bj 6bjt 6bjk 6bjv 6bkb 6bkd 6bno
6bpa 6bg 6bse 6btz 6bxz 6bxx 6bxj 6bxn 6bxr 6bye
6bz 6bzt 6bzm 6bzn 6cdw 6cwr 6cl 6clp 6cme
6emy 6emz 6eng 6eqi 6eqs 6er 6exs 6eul 6evk
6eww 6exk 6eyz 6dag 6dkd 6dx 6ec 6ew 6h1 6hm
6hu 6jn 6jp 6rj 6ta 6tv 6vz 6zd 6bzj 7ach 7adg
7aek 7alb 7au 7bd 7ec 7rv 7ix 7ll 7iz 7mh 7nt
7ou 7tk 7uj 7vq 7wu 6e-4rs ef-8brn ef-8ceo ef-8ij
ef-8qrt eg-5dh eg-6lr eg-6oo ef-acd ek-4au ek-4xi
fo-a4b fo-lae ne-lak ne-3bl ne-3bt ne-3nj ne-4al
ne-4bb ne-4dw ne-4fv ne-4fz ne-5ct ne-5rg nj-2pz
nm-9a ny-ryx oa-2by oa-2xi oa-2yi oa-3al oa-3bh oa-3bu
oa-3wn oa-4rb oa-4rd oh-7dx oh-6axg oh-6bc oh-6buc
oh-6lj oh-8cy oh-6bda oh-6dfd oh-2me oz-3ai sa-aal
sa-b8 sb-lam sb-salx sc-2bl xbe kdef krdo kjoc
negr ocu sab sgt vs wyl zhc.

NQT, Radio Room, U. S. S. Pampanga, Hongkong, China

1aao 2ayj 5ado 5ako 5alt 5aur 5nw 5sw 6afp 6akw
6aig 6alt 6amm 6awt 6azs 6bbq 6bch 6bdl 6bhr 6bil
6bjd 6bjl 6bjx 6bmw 6bq 6bqt 6bttm 6bux 6cdw
6ekv 6elk 6ety 6eua 6eww 6dag 6dat 6dcq 6ea
6ew 6hm 6mu 6rn 6rw 6abj 7vh 7it 7vq 9bjk 9bw
9bzf 9caj 9ces 9cwx 9dda 9dwd 9lk oa-2sh oa-5br
sb-laf sb-lak sb-laq sb-lao sb-1k ef-8jn aj-laa
aj-lmu aj-lsk aj-lsm aj-3kk aj-3ww aj-3yz op-lat
op-lau op-lhd op-ldl op-lhr op-lrc op-3aa op-3ac
fo-a3y fo-a4e fo-a4l fo-a5o fo-a6a naif ngy not
npe nqv nsx npun nuqe nvp and anf der hva
joc pxx vit.

R. Kreisinger, Branik u Prahy, Na Dobesce 296, Czecho-slovakia.
1ap 1ga 1hk 1li 1ka 1kf 1ql 1rd 1sw 1uz 1xg 1xj
1zn laae laao laap labx lair lazk lamd laef laak
lavl lazi lbcb lbdw lbes lbez lbhm lbhs lbke
lcjc lcxm zbs 2fo 2ha 2mb 2md 2mm 2zm 2qu
2uk 2wh 2zas 2zpc 2agm 2agn 2ags 2ahm 2ami
2anx 2arm 2arv 2ase 2aul 2avb 2awq 2ayj 2baa
2bem 2edr 2cuz 2cxl 3au 3jo 3kr 3ld 3pf 3sj 3ud
3akq 3bwt 3cah 3ak 4bn 4bu 4ft 4if 4io 4mw
4pk 4wh 4rr 5rh 5lt 5nt 5rh samu 5axn 5bzu
5cpl 5ded 5dmz 5drj oa-1dl sb-lab sb-lac sb-lav
sb-5aw sc-lac ne-lda ne-2do oz-2xa anf fbio gfy
gos sic vgjl.

sp-51A, G. Gallo, Arendia Wilson 400, Lima, Peru.
(Heard between Sept. 1 and Dec. 31)
14 to 65 meters

1zd lakm lasf laga lcib lch lbhs lbes lemf
1rd 1ro 1xv 1za 2ahl 2uo 2fj 2amj 2cty 2ctn 2sm
2amh 2azk 2agn 2amj 3cjn 3gp 3hc 3jo 3bms 3pc
4aq 4sl 4km 4fl 4pz 4go 4ak 4rm 4ll 4kb 4vp 4cv
4mw 4gz 5uk 5oa 5ql 5ae 5jw 5aci 5arf 5eb 5zav
5kz 6et 6pr 6wj 6ab 6pw 6eh 6bj 6chq 6bjv 7jf
8asb 8br 8nt 8civ 8mc 8bjz 8ben 8ox 8alu 8brc
9ecz 9cet 9cx 9xi 9sj 9cx 9lc 9alh vwx wl kel kdgl
abl bb3 2xt ne-3xi ne-3kp nm-9a nm-1j nm-1k
nm-5b sa-ha-2 sa-bal sa-hb5 sa-hg8 sa-cb8 sa-4l
sa-dh5 sa-hd4 sa-aas sa-hg2 sa-ha3 sa-dw4 sa-fa3
sa-lpl sa-lor sb-lao sb-lad sb-2af sb-2ab sb-2ab
sb-lar sb-lal sb-2ag sb-lak sb-lbr sb-sul
su-las su-lam su-lbu su-lbr su-lcxm su-2ak su-2ah
su-2cc su-lcg su-lfb sc-2aw sc-2ah sc-nad sc-2ap
sc-2bl sc-2as sc-2ld sc-2ak sc-2hd sc-lfg nj-2pz
oa-4rab oa-2rc oa-2ya oa-2ds oa-fhg oa-4hm
oa-tgh oz-2xa oz-4aa oz-3ur oz-ai oz-4ao oz-2gc
oz-2sg oh-6hm oh-3ai oh-6buc oh-lhr ac-j-9ab
eg-5dh eg-glq ef-8ij ef-8qrt fo-a4l fo-a3z fo-a3m
ek-agb ek-aga gmd oetn vgjl iaeda kat voc.

2AGN, 350 Grand Ave., Englewood, N. J.
(Janu. 1 to Feb. 1)

4jr 4sp 4fw 4uv 4wu 4tc 4un 4ka 4mi 4mw 4of
4ei 4lg 4oh 4nh 4vk 4wa 4te 4ux 5atf 5anl 5abz
5hg 5ado 5fx 5uk 5ev 5bb 5adw 5ava 5ars 5uj
6ano 6eln 6egm 6bgz 6abg 6bux 6rw 6hac 6awg
7uh 7mh 7mp 7us 7ob 7ec 7yz 7we 7st 7vq 7em
7uj 9erj 9dio 9ns 9dri 9dj 9civ 9bwj 9ebv 9eam
9bwl 9axz 9axt 9chs 9avx 9abt 9ub 9xi 9ene 9bah
9asi 9dtk 9ain 9crz 9axb 9bhc 9ec 9em 9eay 9iv
9bxb 9aao 9dyz 9arb 9cjq 9dzv 9egn 9ahk 9avj 9sk
9edi 9each 9aeb 9can 9abz 9dm 9dmt 9ebf 9abr 9bpx
9eki 9bqy 9es 9euw 9rw 9cix 9dla 9ebi 9wv 9qch
9del eb-n33 eb-z1 ef-8yor ef-8udi ef-8ba ef-8gi ef-ocmv
ef-8et ef-8st ef-8dd ef-8ep ef-8xm ef-8ix ef-8if eg-2xw
eg-6za eg-2jp eg-5oc eg-6vp eg-5tz eg-5nw eg-2sv
ei-1pn ei-1rv ek-4mea en-0fp en-0pm en-0cmx
ea-jz ee-car44 es-2co nl-4x nq-2jt nq-8kp nc-4gt

sh-2ay oz-2hc op-1af op-3aa eq-sk2 sq-ga2 sa-bb5 sa-ba1 fo-a2h fo-aav fo-a5z fo-a5x fo-acm fo-acn nj-2pz dnsc dn aaf sqa kte gbm lbl sab tw5

cf-SZB, B. J. Bouchard, Route Se Corcelles Dijon, France

(Heard during November and December) lrd lzs lcib lawe lexm laao lekp lpb laff lenz lbjf lli laxa lcki laer avi aap aof 2c3e 2avr 2c3g 2ctn 2erb 2bm 2xsl 2evg 2br 2md 2beo 2tp 2vz 3ar 3bmz 3auv 3ft 3ps 3to 3tl 3tn 3fm 3bl 3ll 3tr 3bk 3zat 3am 3tol 3aly 3adg 3at 3bth 3ccq 3dgp 3etg 3eke 3zk nc-lar nc-2fo nc-2be nc-lac nc-2hg nc-3fu

cf-ROGI, C. Conte, 24 Allee Du Rocher, Clichy-sous-Boise (Seine-et-Oise) France

(Heard from Dec. to Jan.)

laae laao laaw laei lael laem lads laen laic laer laud laox lakm laxz layl lazd lazg lazr lbam lbbl lbm lbbr lbarm lbdt lbez lbfx lbdw lbyk lbhm lbhs lbms lbif lbyb lbw lbux lbyx icaw ich lcki lekp leic lemf leue lhz lej ley lga lic lin lka lkl lmy lfn lor lpy lqb lql lrd lrf lro lsm lsr lsw luu luz lvy lvz lxam lxi lxm lyd lym lzs lzv 2abp 2abw 2adl 2afx 2aen 2ags 2ahj 2ait 2gy 2aim 2anx 2aoc 2aou 2arm 2aul 2axy 2ayj 2awk 2baa 2bbx 2bqh 2bum 2buy 2bo 2bqh 2bv 2bvz 2bw 2caw 2c3g 2cdr 2cei 2erb 2ctn 2cuq 2evj 2evs 2exl 2dm 2fj 2kx 2md 2in 2mn 2mdj 2nz 2om 2or 2pv 2px 2ro 2rs 2tb 2tp 2tih 2ty 2uo 2xaf 3abl 3ael 3afa 3afw 3agp 3aha 3ah l 3ain 3ajt 3akq 3auv 3awg 3ay 3bm 3bms 3bnj 3buu 3buw 3ckj 3ekl 3ec 3els 3ems 3dw 3gp 3gw 3jm 3jn 3jo 3ld 3lv 3mp 3mv 3pf 3pp 3qr 3tr 3wf 3wu 3ly 4aan 4ak 4ar 4bl 4bq 4bu 4dd 4fl 4ft 4ev 4go 4io 4ob 4rm 4sl 4te 5ajg 5vd 5am 5aou 5api 5ash 5aua 5ev 5if 5oa 5ek 5axz 5afq 5akk 5alt 5aly 5aj 5aua 5avs 5bhe 5bbw 5beg 5bda 5bit 5bhz 5bpq 5brd 5bsq 5bsu 5bre 5bt 5bz 5bvw 5ceb 5cec 5ele 5euv 5eng 5eje 5dal 5dam 5ddn 5dcm 5dhu 5dia 5dif 5diz 5dmz 5dsy 5drs 5gn 5it 5jk 5jm 5qb 5qr 5vv 5ve 5wt 5xae 5xab 5akf 5adn 5axh 5bde 5bjw 5bvp 5bjz 5cca 5ccc 5eed 5evn 5exx 5dke 5dng 5eag 5ell 5ez 5fu 5mc 5hg 5pk 5rk 5rdn 5sl 5xi 5yu

ai-DCR, R. J. Drudge, Coates, Cambridge Barracks, Rawalpindi, India

lasi 2evi 2ath 2acg 2eku 2dcq 2cpu er-2nh eg-2rg eg-2ih eg-2ao er-2xv eg-2oc eg-2jp eg-2dx eg-2vr eg-5vp eg-5hx er-5by eg-5fa eg-5tz eg-5wa eg-5ma er-6uz er-6ta er-6qh eg-5nw eg-6ko eg-6nx er-6mv er-2it eo-1sh eo-1lz ef-8el ef-8yor ef-8ger ef-8xj ef-8gi ef-8bp ed-7bx ed-7zm ed-7lj ed-7bd ed-7mt

ek-4ABN, Franz Noether Paisercil, 3 Kassel, Germany

(Heard between Jan. 10 and Feb. 10)

lasu laxa laxi laxx lbk lga lmy lrf 2bad 2adg 2agf 2akv 2ait 2ev 2cvj 2dh 2tp 3pf 3af 4ak 4cv 4io 5dei 8ve op-1ha fo-a5 kfax kgdq

Amateur Radio Stations

(Continued from Page 62)

zontal. This has been found to give excellent results and is the best of all those tried.

The transmitter employs a 203-A in a Reinartz circuit as shown. The plate supply obtained from an Acme 600-watt transformer is converted into d.c. by the aid of a synchronous rectifier and brute force filter. An "S" tube is placed in the positive lead to take care of the sparking at the rectifier brushes. The input varies from 250 to 800 watts depending upon the plate voltage being used. It is usually 550 watts and an antenna current of 2.2 amperes is obtained on 38 meters. A sepa-

rate 300-watt filament lighting transformer is used and keying is done in the primary of the plate transformer.

The receiver is a Schnell and capacitive antenna coupling has been found to be superior to inductive coupling. The DX is

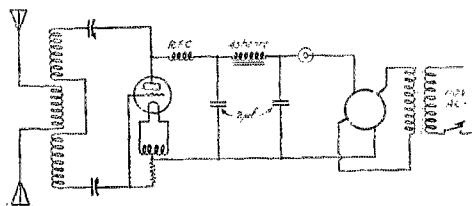

excellent and the WAC certificate earned in a single night. There have been so many different countries worked that a list would look like the index to an atlas. Many of the various expeditions have also been worked.

Besides being SCM for Kansas, 9DNG is an ORS, OO, WAC, RCC and TTY. Traffic is never turned down and quite a little international schedule and traffic work is accomplished.

Strays

If you have tried the Ford coil filter described in the March, 1926, QST and did not get very good results, your trouble may be in that your coils have been wired up differently than shown. SCAJ tells us that he found

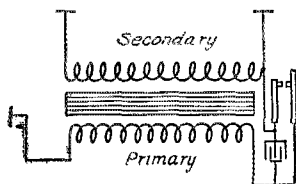

the coils which had a brass backing on the vibrator end to be the same as described in the article but those with wooden ends to be somewhat different. Their wiring arrangement is given in the accompanying diagram. We don't know if this is an unbreakable rule but it applied to all the coils that SCAJ had.





I.A.R.U. NEWS

NEW ZEALAND

R. V. ROBERTS, oz1AE, sends us some news concerning the New Zealand Association of Radio Transmitters. A constitution has been drawn up and accepted by the present 70 members and will stand until after the first election of permanent officers and Executive Committee. While no definite action has been taken regarding an emblem, it will probably be a diamond similar to the A.R.R.L. one, but showing a counterpoise instead of a ground. The letters N. Z. A. R. T. are appropriately arranged about the antenna-counterpoise system.

It is hoped that some of the U. S. stations will return to 80 meters and be QSO "oz" again. It's a long time since one did! Several of the boys are taking portable sets with them on their travels and hope to be QSO the world on 199s and 201-As. Among these are 1AA, 1AE, 1FO, 2GA, and 1AO. They would appreciate reports. 1AF is visiting Australia and anticipates having an excellent trip. 1FQ is expected to increase power shortly as he has just obtained a 1000-volt motor-generator set.

D. G. Kennedy with his wife and two children are the only white people located on Vaitapu of the Ellice Islands in the Pacific Ocean. Two years ago he came to New Zealand to be operated on for appendicitis and there met Frank Bell, oz4AA, who acquainted him with amateur radio. After learning the code, he built a short-wave transmitter and for the last two months has been QSO New Zealand. As he normally receives mail but twice a year, these contacts become of extreme importance to him and anyone hearing his call, DGK, would be doing a great favor in endeavoring to raise him. He will be glad to get all sorts of news and general interest reports. We are indebted to E. A. Shrimpton for this news.

WEST AFRICA

We have several reports of stations hearing and working foPM, located in Ebolowa, Cameroun, West Africa. This is also a case of a white man, Edwin Cozzens, being away from civilization and depending upon short-wave radio for his news and contact with

his friends. As his home is in San Jose, he will appreciate contacts with that part of the country so that he can get some messages there. He is working on 33 meters with a nearly d.c. note. While he was home on a visit last spring, he met the gang at San Jose who took him in tow and helped him get his outfit together. He was heard calling 6CKV by 6HM who called him and



se1FG, QUINTO, ECUADOR

raised him. As 6CKV had had the most to do with getting his outfit in shape, 6HM arranged a schedule between them for the following night. 6CKV, being but 75 miles from 6HM, could not be raised directly due to skip distance effect, but remembering that 6CKV had a sked later with am2SE, 6HM passed the dope to the Singapore station, who in turn handed it back to 6CKV. This constitutes a relay of some eighteen thousand miles in order to advance a message 75 miles airline! Tie that!

AUSTRALIA

Several of the Australian stations have been heard along the East coast of the U. S. between three and four o'clock in the afternoon. This corresponds to the early morning (for bankers) hours.

1BMS remarks that if the "oa" stations insist on tuning through the U. S. A. band from the bottom up that they can expect no other condition than jamming on the lower end of that band. Everyone naturally

wants his signal to be the first one to be run across and we all hop way down. There are many good stations on the higher end of the band (39-42.8 meters) calling "oa" and "oz" all night with no response. I believe that if the Aussies and Zedders would tune from the top down once in a while and give those at this end of the spectrum a chance, it would encourage them to spread out more. Also, let them discontinue working those stations that insist in sneaking down to 35 meters. Some of these stations hold WAC certificates. NO wonder!

We understand that oa5WH and nj2PZ have been working both ways around. The DX between Adelaide and Jamaica in one direction is 9,950 miles and in the other it is 14,950. Fortunately, this is not a freak condition in the general accepted opinion of a freak, as it has been done seven times already!

SOUTH AFRICA

Our monthly letter from Oxenham, foA4L, contains the following. "It is the middle of summer here and very hot. Conditions are still very good for DX work and good performances are being put up by some of our low-powered men. foA3T has worked Australia with ten watts; foA3T has worked Malaya with five watts and many like performances are taking place. A4Z is now well on the air again after a spell of shifting his place of dwelling. A5X, A. J. Jacobs, of Johannesburg, one of our best known men, has been doing very good work these last three months, during which he has been QSO some 25 countries.

"To A5X goes the honor of being the first "fo" to work New Zealand. This is a much cherished desire of all the gang. He worked oz1CX on Christmas night. In an endeavor to work all continents in one night, he was successful in working eg6TD, oa5WH, af8FOK, sbSQ1 and nullC. This is mighty nice work. His transmitter consists of a T250, 250-watt input, Marconi valve fed with 2200 volts of r.a.c. from two MR1 Marconi rectifier tubes. The tuned grid and plate circuit is used and the wavelength is 35 meters.

"There are about fifty active stations and approximately 100 licenses have been issued.

"Australian stations are coming through well now as are Brazilian, Argentine and Chilean ones. The "nu"s are plentiful also. The 30-to 40-meter band is getting full of commercial stations these days. Apparently they have found out like the hams that this band offers the best DX. Let's hope that the amateur is not squeezed out altogether."

CZECHOSLOVAKIA

As mentioned in last month's news, amateur short-wave work is prohibited in this country. There are, however, several stations working under cover and all QSL cards

should be sent in plain envelopes giving no indication that they are destined for an amateur radio station. The Radio Club of Czechoslovakia, which consists mostly of BCLs and a few interested in short-wave work, publishes a monthly magazine which always contains articles regarding the construction of transmitters and receivers for short waves so as to interest as many of the BCLs as possible in this phase of radio. In this manner, the number of amateurs will increase and so add to the strength of those already existing, thus making government sanction more probable.

There is a 5 Kw. broadcasting station (W.E. make) owned by a company called "The Radio Journal". They publish a paper containing the programs for the following week; thus the name. All persons owning a receiver must pay a monthly tax of ten crowns (about 30 cents U. S. money) to the post office department. A part of this is turned over to the broadcasting company and this company is strongly advising the government not to permit the operation of short-wave stations. They fear interference to their programs as well as a loss of revenue due to a widespread interest in amateur work if such operation becomes permissible.

There have been some changes made in the manner in which calls will be assigned. The intermediate will be "ec" followed by a number designating the location and the call will consist of two letters after the number. Those stations in Bohemia will use a 1; those in Moravia, a 2; those in Silesia, 3; in Slovakia, 4; and in Podkarpatská, Russia, 5.

IRELAND

The following is quoted from a letter from Frank R. Neill. "The Northern Ireland stations continue to do splendid work and it is satisfactory to record that the recent low-power tests, under the auspices of the R.S.G.B., were won by eg6YW. The previous low-power work of 6YW is well known and it is, therefore, not surprising that he was the best station in the British Isles during the tests. On five watts, contact was had with the whole of Europe, also many U. S. A. and Canadian stations. eg6MU, another well known station, secured third place in the tests, being QSO many U. S. A. and Canadian stations as well as being heard in India and many other distant places with an output of five watts. Two other stations, 5MO and 5WD, also worked the U. S. on 5 watts or less, so that, when it is remembered that there were only about a dozen stations in Northern Ireland taking part in the tests, these results are very satisfactory.

"At present, good DX continues to be done. 2IT is now going on increased power

using crystal control and has no trouble working up to a dozen or more U. S. stations any evening. Recent results include speech to Australia, two way working with New Zealand, North and South America, Mosul, India and many other places. Time has been limited of late but regular work is now being undertaken again. 6MU, on between 50 and 75 watts input, is doing splendid work, having recently worked Indo-China, Australia, New Zealand, India (on two and a half watts input on one occasion), Mosul and other places. It is expected the station will be on crystal control by the time these notes are in print. Excellent DX has been done by 6SQ on about one half watt input and other active low-power stations are 2BB, 6HI, 5GH and 6QD.

"5NJ, on an input of 75 watts, has had most consistent DX results during the last few months. Countries worked include China and Borneo (for first time from Ireland), also Australia, Tasmania, South Africa (all parts), New Zealand and sundry South American stations including Uruguay, Argentina and Brazil. For some reason, the station is always weak in the U. S. A. The best DX yet done was the raising and working of oz3AR from 11 a.m. until 1 p.m. GMT—possibly New Zealand has never been worked so far into the day from this end, before.

"In the Free State, things seem quiet, and few stations report doing DX. eo11B is, however, making up for the silence of the others, as he has been QSO a large number of U. S. stations lately on 7 watts input. On this power he is usually able to get 'across the pond' any evening, being R 5 to 6 in the U. S. A. His DX is most consistent and good. eo14C has put up a record by working the Straits Settlements on 10 watts, this also being the first two-way contact between Ireland and that country. He is also doing excellent DX work with U. S. A. I have not heard from the other eo's lately."

SHIPS

HM is a Honduran ship with a rough 500-cycle note working on about 37.4 meters. He has been working several of the U. S. stations when off the east end of Cuba bound for New York. LW, who has been working quite a few stations, has been reported off Cuba. Mickey Doran, of the S.S. Stockton, has built a new short-wave receiver and expects to turn in a bigger list than ever before. The City of San Francisco, RXY, is out again with the old operators, Harper and Cohn, who expect to work the usual short-wave overtime. A sister ship, City of Panama, is also installing a short-wave outfit and it is intended that they will work a regular schedule. The "Panama's" call is RXZ. QSLs on RXY go to E. E. Harper,

3110 L Street, Vancouver, Wash'n. We have not the dope on the operator for RXZ but believe the Harper address will do for him also.

Quite a few of the fellows have been woking and hearing CR10. The QRA is: S.S. Canadian Fisher, QRH about 42.5 meters with 250-cycle note. Send all QSLs to 22 Selkirk Avenue, Montreal, Canada. MO2 is a ship in southern waters. We have not the full QRA and would appreciate



NEW EMBLEM OF THE
S. A. R. R. L.

receiving it. SJB and SGL are Swedish boats in transatlantic service. XG is a boot-leg call used by a boat bound from New Orleans to N. Y. C. and then to South America. He uses a 210 on 36.7 meters. 9BPM reports working ARCX who gives his QRA as the Norwegian whaler, S.S. Nilsen Alonso, near the South Pole. His wave is 33 meters.

ITALY

ei1ER, Santangeli, writes us the following news, "During December and January, conditions for DX work were very bad here on the 40-meter band. I have tried some experiments on the 20-meter band and have come to the conclusion that constant traffic is possible between Italy and England at noon. For far-away stations such as WLL, WIK and some U. S. stations, signal strength increases from 15.00 to 20.00 GMT. QSS, however, is bad on this band. Recent regulations on transmitting stations has suspended my traffic but in spite of this, I am always working with the call of REX. QSLs on this call should be sent to me. I am now beginning some new experiments on 5 meters and hope to have some reports on it soon."

SOME NEW ONES

FMH has had his call changed to 1FMH. His QRA is J. Fred Mejia, 14a Avenida Norte No. 21, San Salvador, Rep. of Salvador, C. A. He has been QSO with several U. S. stations and is working on 42.6 meters with a near d.c. note. QSLs for fa4A go to W. Falk, Box MS2, Abed, Abyssinia, Africa. He is on about 34.6 meters and has a steady r.a.c. note. seNAD is an authorized experimental station and se2BL is a general amateur station. Both are operated by Gustavo

Vierling, P. O. Box 1653, 237 Pedro Montt Ave., Valparaiso, Chile. vq1AJ is the call used by V. K. Paice, Pacific Cable Station, Fanning Island. Mail goes via Sydney, Australia. This island is in the Polenesian Group and should use the intermediate of "oo". The QRA of OPZ (zero PZ) is J. Zwerina, 64 Favorite St., Vienna, Austria. He now signs euJZ. His wave is 45 meters and not a.c. QSL's to öhl should be sent to W. Horak, Quellen Strasse, Vienna, Austria. shBZL is located at 61 Hadfield Street, Georgetown, Demerara, British Guiana. The operator is J. P. Tasker or possibly Mrs. Tasker who also pounds brass. Tasker is the chief operator at the local government commercial station and has had quite a bit of trouble in getting the necessary equipment for the short-wave set. He has finally got things going and has been QSO several foreign stations as well as U. S. ones. nrCTO may be reached at P. O. Box 115, Cartago, Costa Rica. He works on 32 meters with an a.c. note. es2CO is Laka Santahamina, Helsinki, Suomi (Finland). German Y4 is now signing 4YAA. e15B is Bjarne Lindemann, Bjerndalen 31, Bergen, Norway. öJI is L. Jenny and R Haas, Via Radio Zentrale, Salzburg, Austria.

WAC

It seems that there are still some stations who are holding out on the WAC certificates. We find that nu4BL was eligible for some time and didn't know about it until recently. Look over the logs, fellows, and shoot in those cards.

There has been some confusion as to what continents the various outlying islands belong to. We will consider an island that is closer to one continent than any other continent and that is farther from your station than the nearest point on the mainland of the continent, to be the equivalent of a station on the continent. It is understood that this applies to such islands that lie along the coast of the continent and do not include such unattached groups as the Hawaiian Islands.

These stations are members: nu6OI, nu6HM, nu1AAO, nc4GT, np4SA, nu9ZT-9XAX, cb4YZ, nu9DNG, op3AA, nu2APV, op1AU, nu5ACL, nu5JF, eg2IT, eg5NJ, op1CW, fo1SR, nu1CMP, nu1CMX, cb4RS-3AA, nu7IT, nu1CH, sc9TC, nu5TW, nu6CTO, op1RD, nu9BSK, nu4TN-4SI, am2SE, eg5XY, sc2LD, ef8CS, nu2CRB, oa2S H, nu7VH-7TM, nu2MK, nu2AHM, nu2CYX, su2AK, su1BU and eg5SZ.

RE: INTERNATIONAL TESTS

Attention! All Hams in localities *outside* the mainland U. S. and Canada.

As a number of letters and radiograms

have been received asking about the Relay Party which will be held May 9 to 22 inclusive, here's the dope in brief for all of you.

1. Read pages 28 and 29 of March QST—also page 8, this issue.
2. During the tests work as many U. S. and Canadian stations as possible.
3. Each station worked will give you a short test message with a special number. This counts *one* in your score.
4. Write a reply of eight or more words, give it the same serial number, and send it through a different U. S. or Canadian station than the one from which you got that serial number. This counts *three* in your score.
5. Work as many stations as you like to run up the score. Tho it's not possible to get more than 4 points for each station worked, you can doubtless work many stations during the contest. Turn in your confirmation promptly at close of the tests (see Rule 7).

The U. S. wavelength bands that will be used lie between the following wavelengths (meters): 18.7—21.4; 37.5—42.8; 75.0—85.7; 150.—200. Canadian amateurs use the same waves and will also be found on 52.5 meters for work with British Dominions. The U. S. gang has recently begun to use twenty meters a lot and foreign amateurs who can use 23 meters will find it to their profit to do so in these tests to make 100% use of the 24-hours in every day.

A word of caution: North American amateurs working *outside* their assigned wavebands will disqualify both themselves and stations they handle test messages with and make it impossible for either to receive an O.F.C.S. certificate in case they should qualify for it. So see that stations you work are well **INSIDE** whatever band they are near before you call them. *You* should use any wave permitted by your government's regulations.

Better get your station ready for the tests **NOW**. If you can't receive on 20, 40, and 80 meters you are going to be handicapped in the tests. The transmitter should be able to QSY quickly from one band to another too to make best use of all the operating time.

Do the best you can in the May tests and let us have a report of each and every score for QST. Even if it proves to be only "1" due to hard luck in burning out a tube we want it just the same.

Here's luck to all. Looking forward to May 9 and to your reports.

Correspondence

The Publishers of QST assume no responsibility for statements made herein by correspondents



Cut 'Em Down

"Holmleigh" Hillside
Prestatyn
North Wales

Editor QST:

As two hams who have spent many hectic and sleepless nights in pounding the brass with the gang, we crave a small space in your most excellent journal for the purpose of addressing a suggestion or two to the "nu" ops on the subject of CQ calls.

In the first place, we propose that fifty be regarded as the absolute limit for consecutive CQs! As a rule, we're satisfied that it's intended for a general call when you have come over with forty. Remember, fellows, it's the "wee sma' hours" with us, and, torn between the lust for another QSO and a longing for bed, things like that make the spine prickle.

Secondly, gang, and perhaps this is the more important, please let us know where you intend listening for answers. Give us a "CQ OZ", "CQ SB" or "CQ EG" and you will find that your percentage of CQs answered will go up with a rush. For our own part, we have now made a definite practise of studiously ignoring all your CQs except those which specifically ask for EG. What is more, we have reason to believe that a considerable number of other EGs are doing the same. It is also safe to say that on any night we have never heard more than three CQs to Europe.

Now, fellows, we are eager and ready to work you—all of you; but, you perpetrators of those dud CQs, we don't like the colour of your whiskers! Cut 'em out, and get down to brass tacks. We also thank all the boys who have been and intend to be QSO us.

GA, OMs, for your own sakes—it's up to you.

Yours faithfully,
—George A. Massey, eg6YQ
—E. Menzies, eg5MQ

Non-Arrival of QSL Cards

22nd and Jay Streets
Lincoln, Neb.

Editor QST:

When I was on the air regularly, I often received cards reporting working my station, or hearing it, at times which I could not find in the log. However, I usually sent

the desired card anyway, feeling that I might have forgotten to enter the transmission.

A few days ago, I received a card from another "9" who appears to have worked with me recently, although my station has not been on the air for over six months.

He is evidently a beginner, and we are hearing much from beginners nowadays on the failure of their brethren to QSL. I wonder how much of the complaint is due to circumstances such as this.

If his ability as a receiving op is bad, he should make sure of the other man's call before sending out cards. If the other man's sending is bad, he should never have tried to work him. The above should help the new man to be pretty certain about his reception of cards.

Sincerely yours,
—D. G. Anderson, 9BNU

The Other Side

892 Southern Blvd.
Bronx, N. Y.

Editor QST:

Here I am, and I'm squaking about the anti-QSL hounds. I want to say something.

It's great sport for the "old-timers" to have schedules and all those pretty nick-nacks, but what about the time when they first got into the game? They were not so interested in traffic handling, I'll wager. I'll bet they tried to collect as many QSL cards as they could plaster on the wall, and then some more. They had the CQ fever at all hours of the day and night.

Well, I'm the same way, and many another new ham is, too. I'm still CQing and collecting QSL cards, if the other fellow is sporty enough to send me one. I always QSL the minute after I work somebody. No delay at this shack, no sir! But still, I have to wait months for the other fellow's card.

—Irwin C. Kodar, 2BBC

Hollow Signals

Mass. Institute of
Technology,
Cambridge, Mass.

Editor QST:

Mr. Kenneth Trost's letter, headed "Is It Fading?" in the February QST, calls forth this explanation of the phenomena

which he describes: "hollow" sounding signals are obtained only when there is a double path transmission between the transmitter and receiver, and when the signals received via the one path are relatively steady as compared with those received via the other path.

The simplest case of these conditions is, of course, when the receiver is so located with respect to the transmitter that a "direct" or ground signal is received in addition to the refracted or "sky" signal. The characteristic of the ground signal is that *it is always quite steady* (no fluctuations in intensity), and further, it is generally weak compared with the sky signal, under *favorable conditions* of reception, as judged by the volume of signals at the receiver. Now, when the conditions for the refraction of waves in the upper atmosphere change, with the time of day most particularly, the sky wave intensity may drop, until this is of the same order of magnitude as the direct or ground signal. Fast fading of the sky wave under these conditions results in the change of tone noted by the writer. If there is no ground wave, or other steady second path transmission, the received signal goes through the usual gymnastics characteristic of short wave, received signals, where the amplitude swings more or less rapidly through a large range. The tonal change described is particularly noticeable on stations carrying an appreciable amplitude modulation, but no frequency modulation, such as crystal controlled 500 cycle a.c. supply transmitters. Here, the sensation of beats is sometimes produced, caused most probably by the shifting of the phase of the received signals via the two paths. The changes in tone are readily observable during the course of an evening on stations such as NKF and WIZ when receiving in this locality.

It is a much rarer occurrence to obtain "hollow" signals on stations several thousand miles away, but occasionally they are heard. In this case, both transmission paths to the receiver are undoubtedly "sky" paths (though they probably bump the earth at one or more points between the transmitter and receiver and bounce off again), one of which gives a relatively steady signal at the receiver, compared to the other.

To readers who are interested in short-wave transmission theories, may I call attention to an article by W. G. Baker and C. W. Rice of the General Electric Company, in the A. I. E. E. Journal, March, 1926.

Very truly yours,
—James K. Clapp



Aurora

33 Sugar Street
Niagara Falls
New York

Editor QST:

I have been much interested in the correspondence in QST on aurora effects. On the last occasion on which I noticed the suppression of short-wave signals during aurora display (both 80- and 40-meter bands being practically blank on the receiver) it was observed that a few stations came in here with fair and even loud signals on the 40-meter band. Practically all of these stations lay in a southerly or almost southerly direction from here. This may or may not have been fortuitous. I intend upon next occasion to make a record of the stations heard under such conditions, and suggest that interesting and useful data might be collected on such nights if a few hams, instead of shutting down the receiver in disgust, would spend an hour or two in listening for and recording such stations. This may or may not be a useful and interesting job for the "Experimenters' Section". I offer the suggestion for your consideration. I should be glad, if you wanted, to act as a clearing house for observations in the matter, and do my best to correlate them and see if they show any sort of regularities.

It is quite possible, of course, that the fact that the only stations heard under the conditions mentioned were southern stations may be due to cessation of operation of northern transmitters under these circumstances while southern transmitters, being presumably less affected, continued operation.

Yours very truly,
—F. A. Lidbury

A Hot One

137 Osborne Terrace
Newark, N. J.

Editor QST:

It was with a great deal of amusement and still more indignation, that most old timers paused over a letter headed with a caption "A Good Suggestion" in the January QST.

Divide us into groups, dubbing us this and that! Who will do this job? Louis XVI had a great knack of dividing his kingdom!

I had the experience of a QSO with the originator of the "Good Suggestion" just before his endeavor to relay the message mentioned to that "5". His answer to my call was "2AQW" (twelve times) u 3--. Then followed a little speech exactly the same as was given to two other hams previous to my QSO. I noticed that he did not

answer any questions put to him by these fellows, so, I decided that perhaps this ham was new at the game and was ashamed to ask for a QRS. To make a long story short, I slowly and patiently asked him a few questions which were answered with a cherry, "73 and cuagn".

Regarding that "5". The poor fellow managed to decipher a long difficult message and asked for a QTA on the signature. The message was promptly repeated and sent double at that! Again the signature was slurred. The "5" attempted to convey the fact that his state of mind was not very amicable right now and "will you please, please QTA signature, signature?"

"Sure", clicked 3-- and let forth the message again. Is it any wonder that the "5" chewed the knob off his key?

A year or so from now, 3-- may read this letter and get a good laugh. Most of us will laugh now at his debut as a "traffic man" and his noble effort to substantiate the A.R.R.L. mien which was never stronger than at the present time.

—Ben Rabinowitz, 2AQW

Handbook Again

2732 State Street
Milwaukee, Wisc.

Editor QST:

Several weeks have passed since I was most agreeably surprised on opening the envelope containing "The Radio Amateur's Handbook" which I had ordered almost as a matter of course. From preliminary announcements read none too closely, I thought I was ordering probably an enlarged issue of "Rules and Regulations of the Operating Department" and knowing that QST publications were all excellent, I felt assured of a dollar value.

Imagine the delightful shock I received when first noting the total size and then, when I discovered, that before me was a real manual for the transmitting amateur. Right then and there, I knew you should receive a letter of praise and congratulation but I put off writing until time and acquaintance with the publication would prevent an outburst of enthusiasm too hastily inspired. Today in the January QST, I find Mr. Warner's editorial apologizing for delays in delivery, and thus, I am reminded of my promise.

Perhaps, you have never noticed it, but books for the amateur which he could really use and enjoy have appeared at the rate of only one for each epoch. Yours is one of these rare productions which will not easily be forgotten. I feel my contact with wireless literature has been a little more extensive than that of the average ham as first of all, it was through reading that I came upon the hobby and since, I have

had a sincere affection for radio books. There are many technical writers who have attempted a "radio amateur's handbook" but a simple essential requirement for success seems to be that the author must be a ham himself.

In the days before the Radio Act of 1912, we had but one book and this was "Wireless Telegraph Construction" by A. P. Morgan (Van Nostrand, N. Y., 1910). From other literary endeavors as well as from his connection with Adams-Morgan of Paragon fame, it seems certain that this gentleman was one of the pioneers whose sparks disturbed the ether for other purposes than to handle paid messages and inspire the purchase of gilt edge stock certificates of doubtful market value.

The outlook of the second period of amateur radio was dismal indeed, for was there not the strict limitations of the Alexander wireless act to be reckoned with: power must be cut to one kilowatt, wavelength to 200 meters, and fatal results to radiation from inductive coupling to be expected. The one bright light was "Experimental Wireless Stations" (published by the author, Minneapolis, 1913) by Philip E. Edleman, an experimenter extraordinary, as demonstrated by this volume and other literary productions. But, in spite of the handicap of meagre advertising, the gang came to seek this repository of knowledge for constructional details of amateur transmitters and receivers. QST came to the rescue in 1916 when this source of facts became obsolete, and fortunate indeed was this, for the burst of DX activity in 1917 and in post-war days was made possible by the A.R.R.L. organization.

The third period was marked by the rise of c.w. and brings us to Ballantine with his justly famous "Radio Telephony for Amateurs" (McKay, Phil., 1923) with a title that must be apologized for, particularly with phone's association with the BCL in the doubtful days of anti-amateur feelings.

This brings us to the present era which is certainly one of short-waves, and your book is the gospel. With its assistance, breaking into the game will be simple. Only old-timers who struggled with word-of-mouth information and dry texts, having little bearing on amateur work will be able to appreciate fully what it means.

May I extend my heartiest congratulations.

Sincerely yours,

—L. S. Hillegas-Baird, 2HO



Ques

Beach Arlington, N. J.

Editor, *QST*:

Under the title "Transmitting Hints" on page 49 of your December issue, you printed a paragraph which stated that the term "Ur QSB fb" was all bunk.

I want to object violently. The writer of the article apparently advocates a very strict interpretation of the International List signals. I advocate a very liberal one.

The "Q" list was made away back in the days of rock-crushers for the purpose of facilitating the handling of commercial traffic and not for two hams having an informal short-wave chat. Since no one has volunteered to make an entirely new list of abbreviations for the amateur he has used the old ones but very, very indiscriminately with regard to their absolute translations.

If you wanted to tell a fellow his note was bad and you sent "QSB", I'll wager he would send back a flock of question marks. If you said, "Ur QSB bad", he would understand perfectly. If you said, "Ur tone bad", you would be eliminating the "Q" system altogether and the abbreviations are pretty handy things, even if you must twist them around to make them suit. As long as the other fellow knows what you are talking about, nothing else matters.

Try and apply the "Ur tone fb" principle to some other "Q" signals? Why pick on QSB? For instance, you couldn't say, "Qrm nil" or "Qrn vy bd", for, if you interpret them strictly, they become "You are being interfered with nil" and "The atmospherics are strong very bad". The ham, however, interprets them liberally and knows what they mean even though the International List meanings make them seem nonsensical. If you apply the meanings strictly, you must say, "Ur not being interfered with at all" instead of "QRM nil". No abbreviation means *precisely* the former expression.

And so on down the list. Very few signals can be taken strictly and still suit the amateur's wants. If we can't get a new list, we'll use the old one in such a manner that is convenient to us and understandable to the other fellow. How many of the gang will support me in interpreting the "Q" signals liberally? —A. Gurtcheff, 2AYE.

Tuned Plate and Grid

78 Ealing Rd., Wembley,
Middlesex, England

Editor, *QST*:

I have just read with interest, in the January issue of *QST*, the second article of your series "How Our Tube Circuits Work".

I would refer to your remarks on the Armstrong circuit, towards the bottom of the right-hand column of page 30.

I remember reading in an English paper, the "Model Engineer" about three years ago, an article in which the author described some experiments he had conducted to determine whether the plate or grid circuit controlled the frequency of oscillation in an Armstrong oscillator. I forget who the

author was but as far as I can remember he was a wireless man in the Air Force and appeared to be an authority. He wrote another article about the same time on "Duplex Telephony".

He found, as far as my memory serves me, that the circuit with the greater capacity in it determined the wavelength. That is to say, if the plate circuit contained more capacity than the grid circuit, the set oscillated at the frequency of the plate circuit and vice versa.

I have always utilized this fact in operating my own transmitter using the tuned-grid and tuned-plate circuit with no magnetic coupling between the respective coils. I use, for 45 meters, five turns in the plate coil with about .0001 μ fds. across it and in the grid circuit I use six or seven turns with correspondingly less capacity. I use a power input of up to 50 watts. I find that no shifting of wavelength occurs and all stations always report that my signals are pure d.c. and very steady, in fact, I am sometimes asked if I am using crystal control. Using 19 watts, measured input, I have been heard in every continent, so I don't think there is much wrong with the QSB especially as stations in South Africa, etc., say that I am a pleasure to copy. Don't think that I am blowing my own trumpet for I am just trying to show that the QSB is steady.

With best wishes both to yourself and *QST*, which gets better and better.

—Bernard J. Axten, eg-2VJ.

Agencies Wanted For New Zealand

Reputable firm in New Zealand, with long experience of Radio trade and good connection with retailers in that Country, has vacancies for two Sole Agencies for American or Canadian Radio Receivers and Components, also Batteries and Phones, to act as sole Distributors.

Only first-class houses will be considered. Details and terms to

A. E. HAY & CO.

Southern Cross Bldg. P. O. Box 1392
AUCKLAND, NEW ZEALAND

RADIO OPERATORS WANTED

THE EASTERN RADIO INSTITUTE can train you quickly and thoroughly because:

MODERN AND EFFICIENT METHODS
THOROUGH INSTRUCTION under staff of
LICENSED COMMERCIAL OPERATORS
MODERN APPARATUS including SHORT WAVE
TRANSMITTER

FOURTEEN years a RADIO SCHOOL
THE OLDEST, LARGEST and MOST SUCCESSFUL
school in New England. RECOMMENDED BY THE

A. R. R. L.

Day or Evening Classes Start Every Monday.

SPECIAL CODE CLASSES

Write for Illustrated Prospectus

EASTERN RADIO INSTITUTE
899 BOYLSTON STREET BOSTON, MASS.

Through this man's invention the
Musicone revolutionizes the
 loud speaker field

Powel Crosley Jr.



Cl. A. Peterson, only 24 years old, is responsible for the amazing tone, the surprising volume and the startling fidelity of reproduction of the Crosley Musicone.

Nearly three years ago a shy and reticent young man walked into the office of Powell Crosley Jr., with an idea for a radio loud speaker under his arm. When he unwrapped the newspaper around it Mr. Crosley instantly saw its great possibilities.

Mr. Crosley offered him the equipment of his laboratories, the assistance of his engineers and the resources of his contacts.

In a short time Peterson produced a marvelous actuating mechanism so designed as to vibrate freely without choking regardless of the heavy electrical impulses applied to it. It revolutionized the loud speaker field.

Within a few weeks after its announcement the Musicone captured the loud speaker market and has dominated it ever since. Horns with their ugly appearance and their harshness of reproduction which so discredited radio in early days were promptly abandoned.

The Musicone has been imitated in appearance but the patented actuating unit has never been equaled. Incidentally Mr. Peterson's royalties on this instrument have been over \$90,000.

Attached to a good radio the Musicone delivers pure, true tones, without distortion regardless of how suddenly the crashes of accents or high shrill notes come through it.

As an ornament its rich bronze frame and the quiet tones of its ornamental cone are an addition to the decorations of any room.

Made in two sizes and at two prices without any difference in quality.

The 12 inch Ultra Musicone for small rooms, apartments, etc. \$29.75

The 16 inch size Super Musicone for large rooms or porch use. \$14.75

NOW!
 The Genuine
CROSLLEY MUSICONE
 \$9.75
 16 inch size . . \$14.75

Prices slightly higher west of the Rocky Mts.
 Crosley Radios \$29 to \$98

**CROSLLEY
 MUSICONES**

**THE CROSLLEY
 RADIO CORPORATION
 CINCINNATI, OHIO
 Powell Crosley, Jr., Pres.**

Write Dept. 18 for Descriptive Literature

*Long prophesied
Often attempted
Makeshifts frequently employed*

CROSLLEY Radio Energy

*with only a
switch to snap*

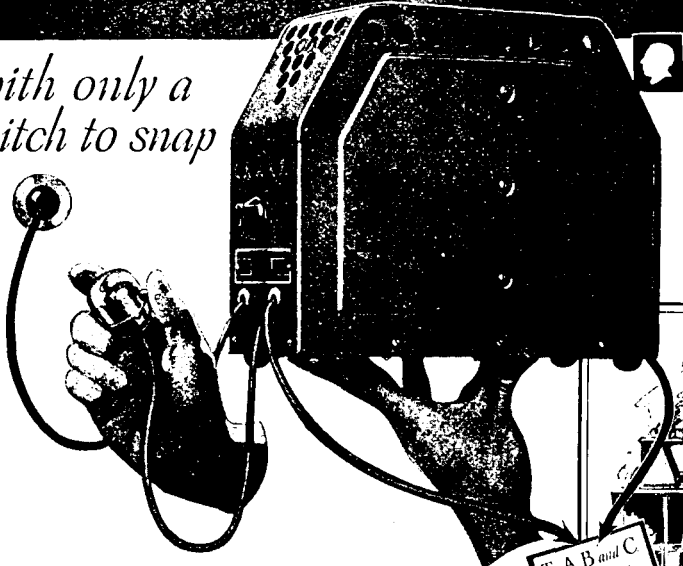

To A, B and C
Binding
Posts



A, B and C Radio Power

from house current outlet direct into your radio with no more attention or thought than you bestow on a vacuum cleaner or your electric iron.

This wonder box weighs only 13 lbs., stands 9 inches high and is 4 inches wide and is about half the size of an ordinary A storage battery. It is a mechanical device transforming ordinary 110 volt 60 cycle house lighting power into smooth, quiet radio energy for the new Crosley radios without slightest interfering hum and with the certainty of an electric motor. Price, **\$50**

Crosley radios designed for use with this marvelous power supply are the AC-7, a 6 tube table model at \$70., and the AC-7-C, a 6 tube console at \$95. See these wonderful sets at any Crosley dealers, or write Dept. 18 for descriptive literature.

Crosley sets are licensed under Armstrong U. S. Patent No. 1,113,149, or other patent applications of Radio Frequency Laboratories, Inc., and other patents issued and pending.

THE CROSLLEY RADIO CORPORATION
Powel Crosley, Jr., Pres.
CINCINNATI, OHIO

- No batteries to fuss with.
- No more batteries or battery charger to water.
- No failure of the power plant just as you sit down to a fine program.
- No batteries to recharge.
- No batteries to renew.
- No apologies to make to callers because "the batteries must be getting low".
- No upsetting the house to have the radio serviced.
- NOW ON.**

REL

REL

does your set need a little *SPRING CLEANING?*

How often are you compelled to replenish your set with new apparatus because of its failure to stand up under usage? Why not have a Spring Cleaning session right now and stock up with REL Products. They will afford you endless satisfaction from every standpoint.

REL can supply you with everything in the Short Wave line, and from one end of the list to the other, "Quality Products" holds good.

TWO SHORT WAVE ACCESSORIES

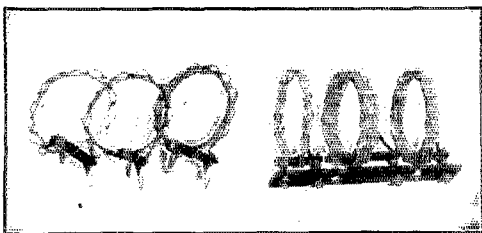

Special Short Wave Coil Kit—designed specially for those short wave circuits that require separate primary, secondary and tickler coils. Wavelength range of three secondary coils, 15-100 meters when tuned with .0001 mfd. condenser.
Six Coils (3 Secondaries, 3 Primaries or Ticklers) with base mounting
PRICE \$6.00 PER SET

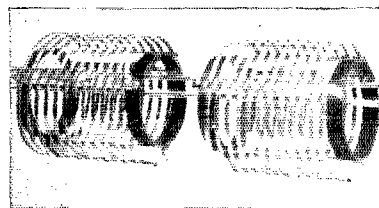

REL Transmitting Inductances—Flat-wise wound on glass. The inductance that you must eventually use.
Type L—(40, 80, 150 meters wavelengths)
Type S—(20 meters and less)
Single Unit, either type, with three clips \$5.50
Double Unit, either type, with six clips \$11.00

(Have you sent your two bits for your catalogue yet? Come clean with yourself—you need it with its complete store of Short Wave dope—send today. P. O. money order or currency.)

REL Owns and Operates Experimental Station 2XV on 15.1 Meters,
19867 Kilocycles, Crystal Controlled.

Radio Engineering Laboratories

27 Thames Street, New York City

REL

REL

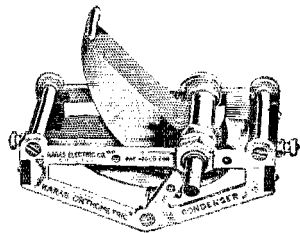
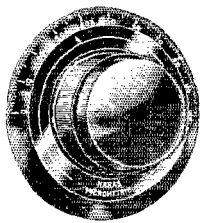

Three KARAS Parts That are Vital To the Success of Your Receiver

To get the three great essentials of Straight Frequency Line Tuning, Maximum Volume with Highest Quality Reproduction of broadcast voice and music, and unbelievable Selectivity and Sharpness of tuning, you must use these three vital "key" parts in your receiver; Karas Orthometric Straight Frequency Line Variable Condensers, Karas Harmonik Audio Transformers and Karas Micrometric Vernier Dials.

Kit manufacturers agree that these parts absolutely insure the successful operation of their receivers if you use them as specified. Note the names of the leading kit manufacturers in the panel in the center of this page, and their recommendations of Karas parts for their kits. When you build any of these sets be sure to use the Karas parts that are specified by the kit manufacturer.

Karas Orthometric Condensers are scientifically designed so as to give absolutely straight frequency line tuning. Every point of the dial of a Karas Condenser is equally separated from its adjoining point in both directions by 10 kilocycles, exactly as stations are separated and allocated by the government. There is no crowding or bunching of stations with Karas Orthometrics. In addition these marvelous condensers are built as accurately as a high grade watch, with all metal parts of fine brass, and the highest quality of hard rubber dielectrics. The special eccentric Karas plates are die stamped from tough brass sheets and soldered at every point of contact. Rotor has pigtail connection, and rotor plates and frame are grounded to prevent body capacity effect. Karas Orthometrics have low-

est losses known. They have no measurable loss.

Karas Harmonik Transformers are all stage ratio high inductance, high impedance low distributed capacity type which give

more total distortionless amplification of fundamental harmonics and overtones that go to make up musical sounds than can possibly be obtained with any cheaper transformers. Harmoniks are perfectly shielded, carefully shielded, and their scientific construction absolutely insures the maximum amount of amplification of all frequencies. Price each \$27.00.

Karas Micrometric Vernier Dials are made of Bakelite, with gold inlay markings, and have a 63 to 1 vernier ratio, which produces a liquid-like smoothness of operation

that is close to 1/1000th of an inch. With these great dials on your receiver you can actually bring in stations that you never before heard—hard-to-get stations that have always eluded your skill in tuning with old-style dials of low ratio. We ask you to try Karas Micrometrics on your set for 10 days at our risk. If they do not delight you and satisfy you perfectly, return them to us for the refund of your money.

Your dealer can supply you with Karas parts for any of the sets listed in this advertisement. Or, if you prefer, you may order direct from us by filling out and mailing the coupon. SEND NO MONEY. Simply hand the postman the price of the parts, plus a few cents postage. Remember, to get the results that the kit manufacturer guarantees you should use the Karas parts he specifies, to insure getting the superb qualities of these receivers.

KARAS ELECTRIC CO., 1034 Association Bldg., Chicago

Karas Parts are Specified in

	Karas Condensers	Karas Transformers	Karas Dials
Aerodyne Receiver	3 17 plate		
Madison-Moore			
1-Spot	1 23 plate	2 Harmoniks	
Dynaformer	1 11 plate	2 Harmoniks	
Nine-in-Line			2 Dials
Victoreen Super		2 Harmoniks	
Aero Transmitter	3 23 plate		
Aero Short Wave	1 11 plate		
	1 7 plate		
Cockaday Univalve		1 Harmonik	
Equamatic	3 17 plate Special	2 Harmoniks	3 Dials

KARAS ELECTRIC CO.
1034 Association Building, Chicago

Please send me the Karas Parts checked below, for which I enclose to pay the postman the prices quoted in this coupon, plus postage.

() Karas Micrometric Vernier Dials, \$3.50 each.

() Karas Harmonik Audio Transformers, \$7 each.

() Karas 23 plate .0005 mfd. Condenser, \$7 each.

() Karas 17 plate .00037 mfd. Condenser, \$6.75 each.

() Karas Special 17 plate extended shaft Condenser for Equamatic Receiver, \$7 each.

() Karas 11 plate .00025 mfd. Condenser, \$6.50 each.

() Karas 7 plate .00014 mfd. Condenser, \$6.50 each.

() Karas 5 plate .0001 mfd. Condenser, \$6.50 each.

Name

Address

City State

(If cash accompanies order, we prepay postage.)

Cardwell

NEW

IN ORDER TO FILL A VERY PRESSING NEED, we have commenced the manufacture of two new transmitting condensers, and have discontinued the Type 183-B.

THE NEW CONDENSERS will be known by type numbers T-199 and T-183. Both will have much heavier plates than have heretofore been used, and much greater comparative spacing. These changes, combined with a buffing process which absolutely removes all rough edges and inequalities in the surfaces of the plates, result in an ability to withstand very high voltages. YOU CAN NOW BUILD WITHOUT FEAR OF BREAK-DOWNS in your tuning condensers. The table shown just below gives the suggested CARDWELL CONDENSER for each of the popular tubes and voltages. Owing to the many possible circuits and combinations of inductance and capacity we cannot state positively either that the indicated size is necessary, or that it will invariably stand up, but the table is correct as far as is possible to determine.

In anticipation of a very large demand for these condensers, we have set the price at only \$10.00 for both sizes. Remember, you order Transmitting Condensers direct from the factory. All good dealers carry CARDWELL Receiving Condensers.

Plate Voltage	Use	U X 171 or smaller	U X 210 U V 202 VT2	"H" Tube	U V 208 U V 203A 211-D	1/2 K W	1/2 K W 1 K W	Higher Power
200 Volts	C. W. or Phone	192-E 169-E 168-E	192-E 169-E 168-E					
500 Volts	C. W. or Phone		137-B 123-B 141-B	137-B 123-B 141-B	137-B 123-B 141-B			
800 Volts	C. W.		147-B 164-B 157-B	147-B 164-B 157-B	147-B 164-B 157-B			
800 Volts	C. W.			147-B 157-B 164-B	147-B 157-B 164-B			
1000 Volts	Phone					T-199	T-199	
1500 Volts	C. W.			T-199	T-199			
1500 Volts	Phone			T-199	T-183	166-B	166-B	Special
2000 Volts	C. W.			T-199	T-199	T-183	166-B	Special
2000 Volts	Phone					166-B	Special	Special
3000 Volts	C. W.					166-B	Special	Special
Higher Voltages						Special	Special	Special

TRANSMITTING CONDENSERS

Type	Price	Capacity (Mmfd.)	Airgap (Inches)	Spacing between adjacent plates	Plate Thickness	Length (Back of panel)
141-B	\$4.25	245	.030	.085	.025	2.375
123-B	5.00	180	.030	.085	.025	2.375
137-B	6.00	954	.030	.085	.025	4.000
164-B	7.00	217	.070	.165	.025	4.000
147-B	10.00	440	.070	.165	.025	5.875
157-B	12.00	217*	.070	.165	.025	5.875
T-199	10.00	330	.084	.208	.040	6.500
T-183	10.00	110	.171	.382	.040	6.500
166-B	70.00	297	.219	.502	.064	10.250

*—Double stator, capacity of each section.

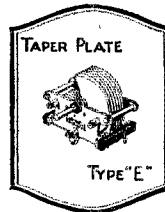

RECEIVING CONDENSERS

Type	Capacity Mmfd.	Price
191E	75	\$3.75
167E	140	4.00
168E	220	4.25
169E	340	4.75
192E	500	5.00

The Allen D. Cardwell Mfg. Corporation
81 Prospect Street
Brooklyn, N. Y.

Condensers

"THE STANDARD OF COMPARISON"

Our
Oldest
Friends
are
Readers
of
Q S T

Back in the days when the General Public had hardly more than heard of radio—when an amateur really was an amateur—the Acme Apparatus Company started the manufacture of transmitting apparatus.

Naturally the readers of QST were among our first friends—the real Lovers of Radio,

the Devotees, the Pioneers, who talked to each other through space, years before the public even dreamed of doing it.

Acme has not forgotten those days. Acme still makes transmitting apparatus for its oldest friends. If you have any trouble in getting it at your dealers, please do not hesitate to write to us direct for it, and we will see that you are taken care of.

Today, Acme is a year ahead in the two most important ends of radio reception—quality and elimination. For quality, Acme offers the new Amplifier in three stages, first, resistance coupling, second, transformer coupling, and last, resistance coupling with impedance leak; as well as three styles of loud speakers that give, “reproduction without distortion.”

See Acme’s contributions to quality and elimination at any good dealer’s, and send 10 cents for new Acme booklet, “Power Supply for Radio Sets.”

ACME APPARATUS COMPANY
Dept. E-22 Cambridge, Mass.

ACME ~for amplification

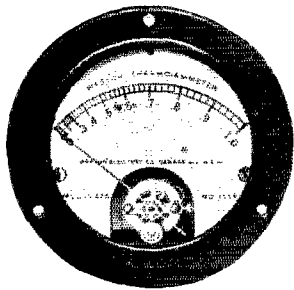

425 Ammeters
\$13.50 to \$14.50

425 Galvanometer
\$15.00

The Famous 425 Group

THESE two instruments give the radio operator the greatest assurance of proper electrical conditions at the lowest cost compatible with accuracy. ¶ Model 425 Thermocouple Type Ammeter overcomes the disadvantages of the hot wire expansion type and perfectly solves the problem of measuring high frequency currents as well as low frequency alternating currents, as well as being accurate on D. C. ¶ Model 425 Thermo Galvanometer or Current Squared Meter is a most sensitive instrument for the measurement of A. C. of either low or high frequency and differs from the Ammeter in that it has a number of thermocouples to increase its sensitivity arranged in the form of a Wheatstone Bridge. ¶ For full and complete information regarding these and other Weston Radio Instruments, write for the interesting free booklet—"Weston Radio Instruments".

WESTON ELECTRICAL INSTRUMENT CORPORATION

158 Weston Avenue,

Newark, N. J.

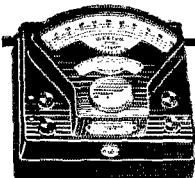

STANDARD THE WORLD OVER

WESTON

Pioneers since 1888

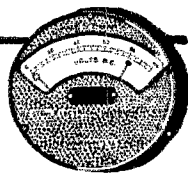

TOBE

Trade Mark Reg'd U. S. Pat. Office

Tinytobe Fixed Condensers

Four TINYTOBE
Fixed Condensers are
used in the new

Official Browning- Drake Kit-Set

Designed by Glenn H. Browning and F. H. Drake. TINYTOBES are a new TOBE product—small capacity condensers of higher insulation and smaller phase angle than are ordinarily found in similar condensers of any construction. Send for special pamphlet Q-4.



Tobe Deutschmann Co.
Engineers and Manufacturers of
Technical Apparatus
Cambridge, Massachusetts

FROST-RADIO FROST-RADIO FROST-RADIO FROST-RADIO FROST-RADIO

FROST-RADIO

VARIABLE HIGH RESISTANCE UNITS

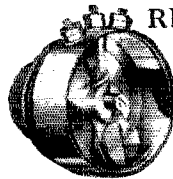

For fine control of tone and volume you should install FROST-RADIO Super-Variable High Resistance Units as indicated in our free booklet. Far superior to wire wound types. Operation is smooth and noiseless because of the exclusive roller contact arm.

Nickel plated brass case. Single hole mounting. Supplied in resistances from 50,000 to 500,000 ohms. List \$1.25.

BAKELITE and METAL FRAME RHEOSTATS

The neatest, most compact and most serviceable rheostats made. Have smooth-working contact, bakelite pointer knob, single hole mounting. Finest nichrome or chromel "A" wire; wide resistance strip keeps rheostat cool under heaviest load. A type to suit every requirement from 2½ to 75 ohms. Bakelite Type, list 75c. Metal Frame Type, list 50c. Your dealer has them.

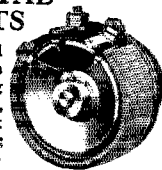

HERBERT H. FROST, Inc.

160 N. La Salle St.
CHICAGO



New York
Los Angeles

FROST-RADIO FROST-RADIO FROST-RADIO FROST-RADIO FROST-RADIO

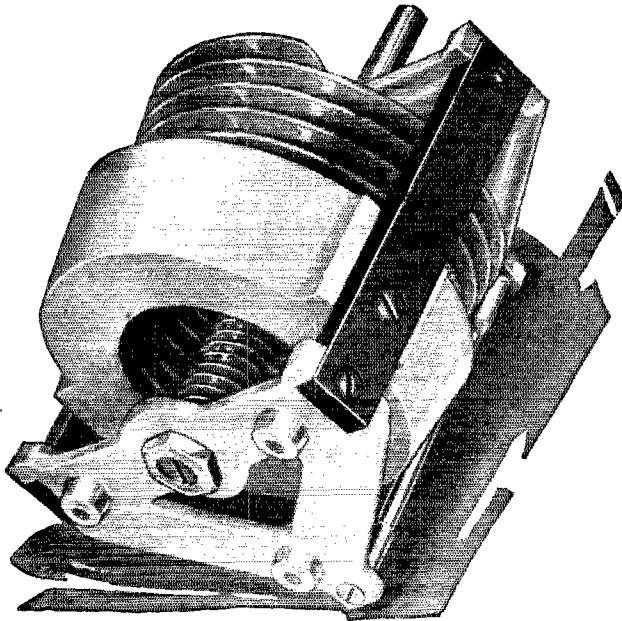

.000340 mfd.
\$6.25
 (Postage Prepaid)

Special \$1.35
 Dial

A MARVELOUS DEVELOPMENT IN VARIABLE CONDENSERS

If You Were Told:

That a variable condenser existed which will give spacing between stations **TEN TIMES** greater than has heretofore been possible with variable condensers;

That a vernier dial is not needed in order to make fine adjustments for good tuning, but that the condenser itself is the vernier;

That this condenser has just two plates, gradually feeding into each other, causing the most sensitive and minute variation in capacity that has ever been obtained with variable condensers of this capacity;

Would You Believe It!?

You'll surely have to, after having used the new **HELICON**.

In search for something better than the old condensers with their semi-circular plates, radio engineers placed on the market the "straight-line wave-length" and the "straight-line frequency" condensers. All of them, however, did not get away from the limited space on 180 degrees on the dial; namely, a half turn. The vernier dial was resorted to, in order to increase the accuracy of tuning. This was not an improvement in the condenser itself.

Radio was up against one big problem, apparently not solved; namely,

HOW TO SPREAD OUT THE WAVE BAND ON A VARIABLE CONDENSER FOR FINE TUNING!

The solution has been found in this new helical, cone-shaped plate design.

Instead of having only about 6.25 inches on a regular four inch dial when tuning from maximum to minimum capacity, imagine this distance increased *ten times!* To 62.5 inches! More than **FIVE FEET** of tuning space! The forty-meter amateur band, for instance, spread out over *ten inches* on the dial instead of just one inch. And no trimmers!

A special four inch dial with sliding indicator records not only the number of revolutions but also the position in each revolution. It is mounted directly on the shaft of the condenser. Five complete turns are indicated.

The **HELICON** has been pronounced mechanically and electrically A-1 by some of the best radio laboratories in which it has been tested.

COMPACT—NATURALLY SELF-BALANCED—BUILT TO PRECISION—AS ONE RADIO FAN SAYS:
 "By far the best condenser for short wave receivers ever designed."

*Descriptive bulletin on request,
 If not obtainable from your dealer get them direct.*

**THE
 HELICON**

RADIO CONDENSER CORPORATION
 PEORIA, 215 Federman Bldg. Dept. 5, ILLINOIS

THE SUPER SYNC

The Synchronous Rectifier That Can Be Filtered

The Super is the only synchronous rectifier than can be filtered with ordinary type of filter circuit. This rectifier is adaptable to both high and low power sets as it easily handles up to 4000 Volts.

The commutator on the Super is eight inches in diameter and by reason of its large diameter it can handle higher voltages without breakdown. Eight

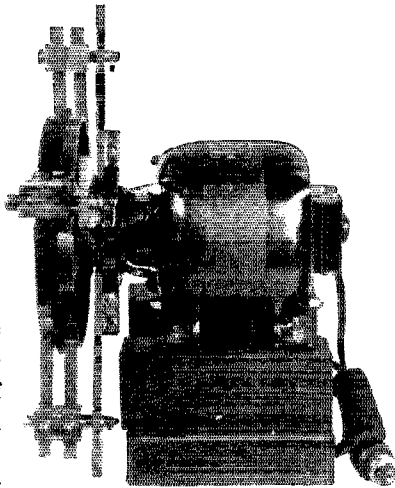

brushes mounted in pairs ninety degrees apart serve to conduct the current. These brushes are mounted on a rocker arm so that they can be adjusted for proper commutation.

The commutator is turned at a synchronous speed by a $\frac{1}{4}$ H. P. Synchronous Motor. This motor can be supplied for either 110 or 220 Volts 50 or 60 cy.

PAT. PENDING

PRICE \$75.00 F.O.B. ST. LOUIS, MO.

MARLO ELECTRIC CO., 5241 Botanical Ave., St. Louis, Mo., U.S.A.



Add the new Balkite Combination to your radio set now — with your "A" battery it supplies all radio power automatically from the light socket.

Ask your radio dealer

FANSTEEL PRODUCTS CO., INC.
North Chicago, Ill.

Centralab Rheostat S

Permanently
Noiseless

Where old design, ordinary rheostats overload, heat-up and quickly become noisy on circuits with several tubes, and on new tubes using increased current, Centralab Rheostats operate smoothly and permanently quiet.

NO DEAD SPOTS
Insulated metal discs eliminate resistance immovable and wick-proof—insuring even regulation and no dead spots. With large area of metal to aid in cooling, and carrying extra heavy current for their size, they improve the quality of any receiver.
Wire wound, 4 resistances, for 1 to 5 tubes, \$1.00.
Ribbon wound, 2 resistances, for 3 to 10 tubes, \$1.25.

At dealers, or mailed direct COB
Central Radio Laboratories
20 Keefe Ave., Milwaukee, Wis.
Makers of a full line of variable resistances for 68 manufacturers of leading standard sets.

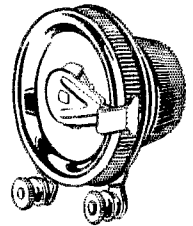

Write
for
Free
Circuit
Hook-Ups

Centralab

TWO WAYS you can be sure of Your Wavelength

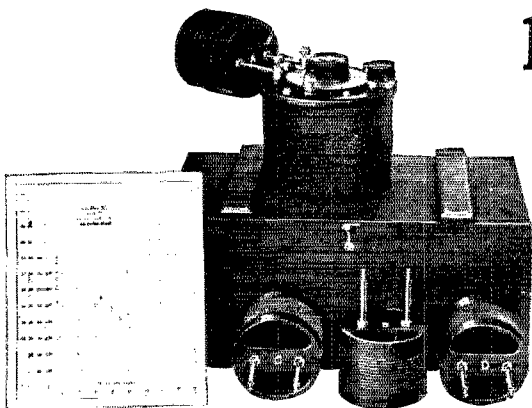

TYPE 358 AMATEUR WAVEMETER, Price \$2

1 By using an accurate wavemeter with a resonance indicator lamp

By placing a Type 358 wavemeter tuned to your proper wavelength close to your transmitter while it is being operated, you have an excellent means of determining whether or not you are on your wavelength.

If your transmitter is properly tuned, the indicator lamp will light every time you touch the key. If the lamp does not light, you may know that your transmitter is off wavelength and should be re-adjusted.

The Type 358 wavemeter is especially designed for amateur use in checking wavelengths. It covers a range from 15 to 220 meters, by interchanging four coils of low loss construction. These coils are carefully wound on threaded Bakelite forms, thereby insuring accuracy and permanence of calibration. Coil ranges are as follows:

Coil A 15 to 28 meters	Coil C 54 to 114 meters
Coil B 26 to 56 meters	Coil D 105 to 220 meters

Type 358 wavemeter, with calibration chart \$22.00

2 By controlling your shortwave transmitter output with a quartz plate

The Type 276A Quartz Plate is intended for use by amateurs in controlling the frequency of transmitters.

The plates are grounded to oscillate at one specified frequency only, and thus limit the output of the transmitter to one particular wavelength.

Type 276A QUARTZ PLATES are supplied at random frequencies between 1750 and 2000 k.c.

They provide harmonics in 20, 40, and 80 meter plates and may be used for transmitter control on these wavelengths. Calibration is to 1/4%. All plates are guaranteed to oscillate when used as directed.

Type 276A Quartz Plate	\$15.00
Type 356 Quartz Plate Mounting	1.00

Other General Radio apparatus for amateur shortwave use includes

Receiving and Transmitting condensers	Vacuum Tube Socket	Potentiometers
Coils and Coil Forms	Audio Transformers	Stand off and Antenna Insulators
	Rheostats	Hot Wire Ammeters

WRITE FOR CATALOG 926-A

GENERAL RADIO CO., CAMBRIDGE, MASS.

GENERAL RADIO

A. R. R. L. MEMBERS ATTENTION!

You are not all located within shopping distance of a dealer stocking General Radio parts. Remember that we will deliver, post paid, anywhere in the United States, any of our radio parts on receipt of current catalog price.

Also if we can be of help to you in supplying technical information, we will welcome your correspondence. Have you a Bulletin No. 926 in your file? If not, a post card will bring it.

"B" Eliminator TESTING Problem Solved by



Model R-415

TO GET full value from your "B" Eliminator you must *know* that your "B" Power is delivering the *right* amount of voltage to detector, amplifier and power tube.

Low resistance voltmeters suitable for testing batteries are worthless for testing "B" Eliminators. This specially designed High Resistance Sterling is accurate for both.

Whether this voltmeter is used in your business or for your own set, it is *essential* if you want the facts about any "B" Eliminator.

It is the Universal Voltmeter for the Amateur R-415

Sterling voltmeter meets the special needs of the amateur in a variety of ways—for testing the output of D. C. Generators, and for every other purpose calling for a *high resistance* voltmeter.

Never before has a laboratory instrument been available at a price so reasonable.

Sterling

R-415 VOLTMETER

A laboratory meter at the remarkably low price of **\$8.50**

Also Model R-417. A New 150v. Sterling A. C. Meter for Testing A. C. line current and all A. C. Circuits\$7.50

THE STERLING MFG. CO.
2831 Prospect Ave. Cleveland, O.

90 Volt Power Unit \$12.75

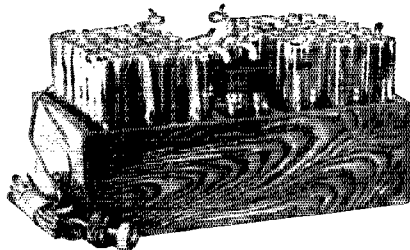

Hums, line noises, etc., positively impossible with this new advanced unit. Plug in and forget Non-acid and noiseless. All detector and intermediate voltages plainly marked. Simpler to hook-up than dry cells. Operates any type set 1 to 12 tubes.

Greater volume and clearness guaranteed. If not thoroughly satisfied return after using 30 days for complete refund. Guaranteed further 2 years. For 110-120 volts A. C. 25 to 60 cycle current. 100 volts, \$12.75; 112½, \$15.25; 135, \$17.50; 157½, \$19.50; 180, \$24.00; 202½, \$26.00.

Also built for D. C. current 110 and 32 volts at only \$3.00 additional, any size above. Ample stocks—same day shipments. Simply say—ship C.O.D. or write for my interesting literature, testimonials, etc.

B. HAWLEY SMITH, 332 Washington Ave., Danbury, Conn., U. S. A.

"Windham" Wire Former

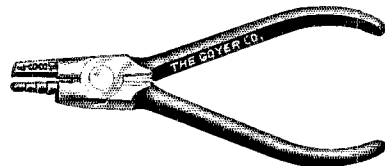

(Pat. Pending)

A complete and handy tool for electricians, radio set builders and mechanics. It will accurately form loops or eyes for No. 4, 6, 8 and 10 screws, make easy radius and sharp right angle bends, has flat jaws and wire cutters. This tool is made of the best quality steel, dropped forged and carefully tempered in oil.

We guarantee every tool against defects in workmanship and materials and will promptly replace or refund money on any found defective by purchaser.

Price \$1.25 Each

Ask Your Dealer

Manufactured by
THE GOYER COMPANY
Willimantic, Connecticut

BUILD

the New Official

BROWNING-DRAKE Kit Set



TH**ERE** has been a great deal of misinformation on Browning-Drake published by over-ambitious radio writers. In fairness to the radio public, it has become necessary to present a standard assembly to be known as the "Official" Browning-Drake Kit Set, which is now on the market. The increased selectivity and rare sensitivity of this new assembly will prove a pleasant surprise.

Parts for this new assembly are now ready. These include:

Browning-Drake Corp. Kit.....	\$25.00
Foundation Unit (including drilled and engraved front and base panels, sockets, fittings, etc.).....	\$15.00
Neutralizing device	\$ 1.00
Resistance Cartridge.....	\$.75

The above, together with the necessary specified parts furnished by other manufacturers, costs less than \$65.00. Booklets containing complete constructional data are available for twenty-five cents, or the booklet with five full size blueprints for one dollar. Get your parts TODAY and build the new "Official" Browning-Drake Kit Set.

[Dealers: Some of you amateurs are dealers. If so we invite you to write] for further information. The new kit set presents new opportunities.]

BROWNING-DRAKE CORPORATION, BRIGHTON, MASSACHUSETTS

BROWNING-DRAKE RADIO

SAY YOU SAW IT IN QST—IT IDENTIFIES YOU AND HELPS QST

HOUDINA RADIO CONTROL CO

RADIO AND ELECTRICAL ENGINEERS

119 DOTY STREET

KAUKAUNA, WISCONSIN

Address reply to:

Nov. 30th 1926

Electric Specialty Co.,
225 South Street
Stamford Ct.

Gentlemen:

This is to advise that we have been using an "E300" dynamotor for almost two years to supply the plate current for the tubes of our Radio Station "QYX" which we use to control "America's First Radio Operated Automobile"

This Dynamotor is operated on 6-8 Volt Storage Battery source and we have found it functioning properly at all times, under all conditions and in all kinds of weather.

We do not hesitate to recommend "E300" products because we know they are meritorious.

Respectfully yours
HOUDINA RADIO CONTROL CO.

EJD/12

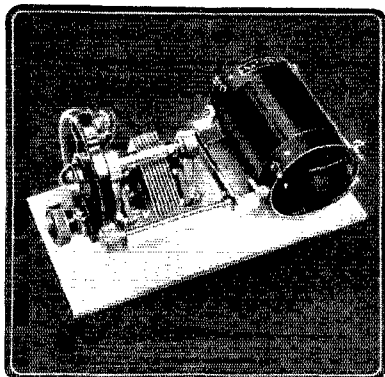

The coils are mounted on the new NATIONAL EQUITUNE Condensers, the plates of which are designed to space out stations evenly over 1/2 revolution. The rigid, structurally designed Girder Frame of the EQUITUNE Condensers occupies a minimum space and are extremely light in spite of their rigidity.

NATIONAL ILLUMINATED Velvet-Vomer Dials are fitted to these tuning units. Each tuning unit is packed completely set up and may be used without change for experimental work or may readily be mounted on any kind of a panel.

Price—BD-1E \$10.75
(with illuminated dial) 151-215 14.25
(with illuminated dial)

NATIONAL

NATIONAL Tuning Units are standard for good Radio sets. So are NATIONAL Impedance Transformers for quality audio, NATIONAL Tone-Filters, for power tube output connection.



NATIONAL CO. makes heavy-duty B Supply Units and 3-Stage Power Amplifiers. Write National Company, Inc., W. A. Reedy, Pres., Cambridge, Mass., for Bulletin 116.

RECEIVERS TRANSMITTERS - EQUIPMENT

Ensall Radio Laboratory Equipment is built to a Quality Standard. Built for use in Amateur Stations, on Board Sea Going Yachts, Cruisers, etc. The Most Rigidly Designed Equipment Available. Highest Quality Parts employed in our Receivers, for Amateur or Broadcast, and in our Transmitters, Self Excited and Master Oscilla or Designs. Special Equipment built to order. Quotations furnished upon receipt of data covering the Equipment you desire. Transmitters, of any Type Reconstructed.

We cater to Special MARINE Installations. Quotations on request.

ENSALL RADIO LABORATORY
1208 Grand View Ave. Warren, Ohio
"Pioneer Builders of Short Wave Apparatus."

QST Oscillating Crystals

DO YOU KNOW that we are specialists in grinding crystals for POWER use? DO YOU KNOW that our crystals give maximum output without an inductance in series with the crystal? DO YOU KNOW that if the crystal you use requires a series inductance, you are taking a chance of cracking it? WHY TAKE ALL THESE CHANCES with a crystal that is not especially ground for power use. Our crystals are POWER CRYSTALS and require no series inductance. Prices for grinding crystals for use in the amateur bands as follows—

80 Meter band crystal \$25.00
150-170 Meter band crystal \$15.00

We state the frequency of the crystal accurate to better than a tenth of one per-cent.

We are at your service to grind you a crystal to any frequency between 40 and 10,000 Kilo-cycles. We will be glad to quote prices on your particular requirement.

SCIENTIFIC RADIO SERVICE
The Crystal Specialists
P.O. Box 86, Dept. 1, Mount Rainier, Md.

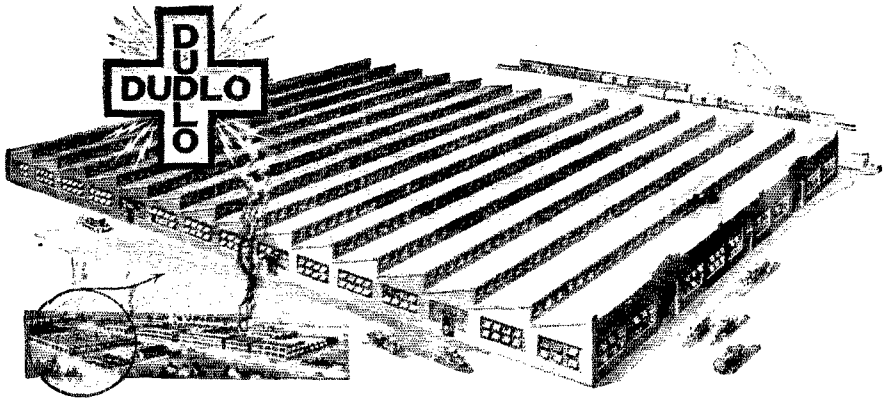

The circled part of the inset picture of all of the Dudlo Factories shows the new plant's location and relative size

a NEW Wire Mill

a NEW Enameled Wire

New Method of Enameling—More Flexible—Greater Dielectric Strength—More Heat Resisting—More Enduring—Better Looking

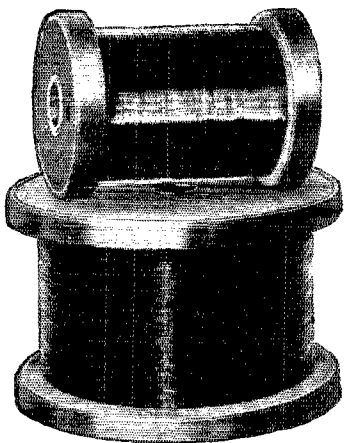

In the large and finely equipped new Wire plant, shown above, Dudlo Engineers are producing an improved enameled wire that sets a standard never before approached.

Dudlo special coated enameled wire now possesses an unheard of flexibility and elasticity.

It has greater dielectric strength, gives greater resistance to heat, is more enduring and better looking.

It can be bent without injury or cracking. High operating temperatures do not lessen its efficiency.

These qualities are due to the special Dudlo system of baking, improved materials and other new features of Dudlo development.

Dudlo enameled wire is made in sizes No. 10 to 44, American Wire Gauge.

One experience with Dudlo Enameled Wire will do more than anything else to explain to you why the world's leaders in the manufacture of electrical apparatus look to Dudlo as the unfailing source of supply of quality magnet wire and coils.

DUDLO MANUFACTURING CORPORATION
FORT WAYNE, INDIANA

56 EARL STREET
 NEWARK, N. J.

160 NORTH LA SALLE STREET.
 CHICAGO, ILL.

4153 BINGHAM AVE.
 ST. LOUIS, MO.

274 BRANNAN ST., SAN FRANCISCO, CALIFORNIA

SAY YOU SAW IT IN Q S T—IT IDENTIFIES YOU AND HELPS Q S T



Sturdy—Reliable —Accurate

Many amateurs owe their long distance records and their general transmitting success to Jewell instruments.

The famous Jewell Trio patterns Nos. 54, 64, and 74, made radio history.

Jewell transmitting instruments are as popular today as ever.

Our radio instrument catalog No. 15-C is available to amateurs on request.

Jewell Electrical Instrument Co.

1650 WALNUT ST. - - CHICAGO

"27 YEARS MAKING GOOD INSTRUMENTS"

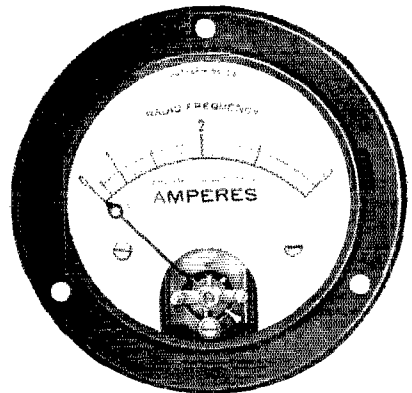

Pattern No. 64 Radio Frequency Ammeter is an ideal instrument for making current measurements at radio frequency. It has a high overload capacity and its losses are less than that of the hot wire type with accompanying higher accuracy. Scales are silver etched with black characters, and movement parts are all silvered. It has the standard Jewell zero adjuster.
Available in ranges from .15 to 15 amperes.



When the Signal Fades—

Change the Range of your Resistors to meet changing characteristics of the set and accessories.

It Works!



DUPILAM RESISTORS

INTERNATIONAL RESISTANCE CO.
Dept. B, Perry Bldg., Philadelphia, Pa

ACME ENAMELED ANTENNA



Best outdoor antenna you can buy. 7 strands of enameled copper wire; maximum surface for reception. Prevents corrosion and consequent weak signals.

The Original Celatsite

—a tinned, copper bus bar wire with non-inflammable "spaghetti" covering, for hook-ups. 5 colors; 30 inch lengths.

We also offer the highest grade of "spaghetti" tubing for Nos. 10 to 18 wires. 5 colors; 30-inch lengths.

Send for Complete Folder of Acme Wire Products

ACME WIRE CO., DEPT. S, NEW HAVEN, CONN.



ACME WIRE MAKES BETTER RADIO

Make any Good Receiver
BETTER

CC TUBES

G. E. Mfg. Co., Inc.
PROVIDENCE,
R. I.



*“We’ve cut down our come-backs
with Faradon equipped sets”*



Manufacturers who equip their sets with Faradon Capacitors free themselves from the complaints and returns caused by condensers of lesser durability.

In assignments where condensers must stand up,—in Amateur Traffic, Direction Finders at sea, and in Automatic Railway Signals—here Faradons have proven their sheer dependability.

For twenty years Faradon experts have combined skill and highest quality materials to make capacitors for each particular need. Faradon engineers are always ready to cooperate with manufacturers having under consideration special equipment which cannot be taken care of by the more than 200 standard Faradon Capacitors ready for prompt delivery.

**WIRELESS SPECIALTY
APPARATUS COMPANY**
Jamaica Plain : Boston, Mass., U. S. A.

Established 1907

Faradon

702

Electrostatic condensers for all purposes

SAY YOU SAW IT IN Q S T—IT IDENTIFIES YOU AND HELPS Q S T

91

Wireless Specialty
CONDENSERS
Capacity .006
25c

Hams Attention!

Don't Miss These Specials!

50-WATT
SOCKETS
\$1.50

Holtzer-Cabot Motor-Generator

1/2 KW 600 cycle. We have been fortunate enough to secure a *limited stock* of these absolutely new and guaranteed motor-generators, and are closing them out at **\$75**

Holtzer-Cabot Headset

Just unpacking a lot of these phones—supersensitive and quality-built. Just the thing for **\$1.95** amateur use. Every one new and guaranteed. **SPECIAL**

Magnavox 2-Stage Amplifier

Complete with a 14 in. speaker. This combination outfit formerly sold for \$45. *Our New Low Price*

\$9.75



Price-Cut on Condensers

Rathbun 11, 13, 17 and 23-plate. *Former price, \$5.00*
Kellogg 5 or 11-plate 5-16 in. shaft.

39c **3 for \$1.00**

Other Condenser Bargains

Federal Transmitting Condensers. **\$2.95**
Factory Double-spaced
King-Cardwell 11-11 plate, Dual **\$1.50**
Condensers

Radio Bliker Practice Set

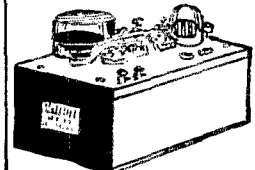

Equipped with both a **\$2.95** buzzer and a blinker light

Telegraph
Keys
49c

2 MFD
Condensers
85c

Plug-in
Coils
Per Set **\$12.00**

Hand
Microphone
\$9.00

Apco Trickle
Charger
\$5.95

High Frequency
Buzzers
75c

A Few R C A
Transformers
Left

NOTE! WE ARE COMPLETELY SOLD OUT OF:
King Cardwell 11, 11, and 15-15 plate
condensers.
Federal and Brandes Headsets.

NOTE! WE ARE TEMPORARILY SOLD OUT OF:
Spring suspended Microphones.
Signal Navy Receiving Transformers. Shipment
of back orders will be made at the earliest possible moment.

Radio Surplus Corporation *Send for our list of New Panels. All sizes.*
250 Washington Street, Boston, Mass.

Mr. Ham:—

HAM—marlund Low-wave Condensers and Coils and HAM—marlund Transmitting Condensers are built to standards of accuracy you appreciate.

Low-Wave Receiving Condensers

Available in two sizes—11 and 5 plates; standard-spaced. Either "Midline" or "SFL" curve. Also double spaced in 11 plate size only. Maximum capacity, 100 mmfd.—minimum capacity 3 mmfd.

Transmitting Condensers

Built to withstand high potentials. The low losses and high quality of Hammarlund construction are emphasized in this class of work, where ordinary condensers are impossible. Three sizes with maximum capacities of .0004, .0002 and .0001.

Low Wave Receiving Coils

Space-wound on a dielectric of very high quality, 5/16 in. thick, No. 16 copper wire, green silk over cotton insulation, 10 turns per inch, 3 in. in diameter. Coils average 20 in. in length and are cut to desired size.

*If your dealer cannot supply
you write us direct.*

HAMMARLUND MANUFACTURING CO.
424-438 W. 33rd Street, New York City

For Better Radio
Hammarlund
PRECISION
PRODUCTS

RELIABLE Transmitting Capacitors

OB-224 2. MFD 2000 Volts Direct Current \$4.00
OB-475 4. MFD 2000 Volts Direct Current 7.50
OB-921 2. MFD 1000 Volts Direct Current 2.10

We Make Good On Defective Capacitors. Merchandise will be sent Postpaid and Insured to Licensed Amateurs upon receipt of full remittance by postal or express money order, check or cash by registered mail.

BRIMBERG & ORTH

277 Broadway New York, N. Y.

Loud Speaker Reception GUARANTEED With MULTIVALVE ONE TUBE SET OR KIT

MULTIVALVE TUBE
with blue prints
of circuit and list
of parts **\$6.50**

MULTIVALVE TUBE
AND COILS
with blue prints
of circuit and list
of parts **\$7.50**

Completely Assembled Kit of
Standardyne
Multivalve Set
ready for wiring **\$19.75**

Standardyne Multi-
valve Set with
tube, complete
in cabinet **\$31.50**

SPARKS RADIO SERVICE CO.

Dept. T, 35 West 25th Street, New York, N. Y.

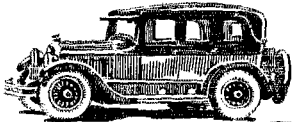

**KEEP YOUR CAR
BATTERIES PROPERLY
CHARGED**

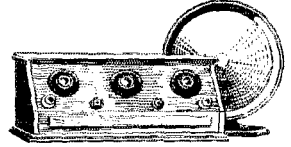
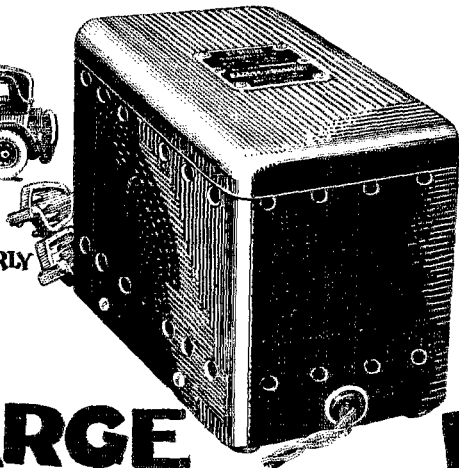

**KEEP YOUR
"A" BATTERIES
PROPERLY CHARGED**

**CHARGE BOTH
DIRECT FROM ELECTRIC LIGHT SOCKET
WITH THE**

REG. U.S. PAT. OFF.

ELKON

3 AMPERE CHARGER

Even if the Elkon 3 Ampere charger were not equipped with the Elkon Rectifier its simplicity, effectiveness, and general economy of operation would still make it a pronounced success.

BUT, equipped with the ELKON BONE DRY rectifier, it occupies an exclusive and unique position, far in advance of any similar device.

It operates at *considerably less cost than other types of chargers . . .* and without attention.

It is bone dry, operating without acids, alkalis, tubes, moving parts or water. . .

It is rugged, strongly built, can be taken or used anywhere, so that it is ideal for charging both "A" batteries and car batteries.

SIMPLY CONNECT IT TO LIGHT SOCKET, TURN IT ON, LEAVE IT ON. It will not overcharge, because it has the inherent Elkon Tapering characteristic, by which the charge decreases as the battery becomes replenished.

It causes no interference, it makes NO NOISE, it has nothing to burn out, break, spill, or spoil. Short circuiting cannot harm it.

As the size of radio sets is increasing, as well as the number of hours of daily use of the set, this charger is becoming more and more popular in all parts of the country.

An almost indefinite life of service, at low operating and upkeep expense.

Descriptive Circular on Request

At dealers everywhere \$17.50

Pacific Coast price slightly higher

ELKON WORKS
Subsidiary of P. R. Mallory & Co. Inc.

Weehawken, N. J.

Inc.

demand AEROVOX

FILTER CONDENSER BLOCKS

For Working Voltages of 200, 300,
400, 600 and 1000 Volts D. C.

Flexible leads for connections elimi-
nate all possibilities of leakage
from soldering.

AEROVOX WIRELESS CORPORATION
60-72 Washington Street
Brooklyn, N. Y.

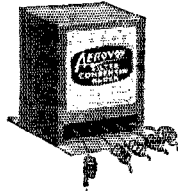

New Transmitting CONDENSERS

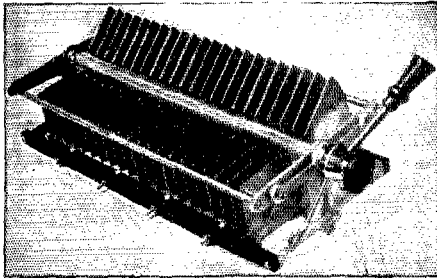

TYPE B, illustrated, has 6" diam. rotor plates,
 $\frac{1}{4}$ " plate clearance, breakdown voltage 3,000,
etched scale, polished handle, pointer and locking
device.

100 mmf. \$36.00	200 mmf. \$48.00
150 mmf. 42.00	300 mmf. 60.00
Counterweight extra	4.50
Panel Mounting Brackets	3.00

TYPE A is similar, but with 10" diam.
rotor plates and with plate spacings of $\frac{1}{4}$ ", $\frac{3}{8}$ ",
and $\frac{1}{2}$ ", for breakdown voltages of 8,000, 12,000,
and 16,000. Either type may be ordered any
capacity.

Strictly a High Power Device
Additional Information on Request

E. F. JOHNSON COMPANY
9ALD Waseca, Minn.

LYNCH METALLIZED

WARRANTED FIXED RESISTORS

HEAVY-DUTY TYPE

THE new Lynch wire-wound heavy
duty resistors for eliminator and
power work are now ready. These
units are ideal for use in Raytheon
and all other power circuits.

EQUALIZORS

For perfect filament control use
the Lynch Equalizers. There is a
type for every type of tube and for
any combination of tubes. A Lynch
Equalizer will take the place of your
filament rheostats. Complete, with
mounting, \$1.00.

Lynch Suppressors and Low-loss
mountings mean better radio.

At All Good Dealers

ARTHUR H.
LYNCH, Inc.



250 W. 57th St.
New York, N. Y.

PORTABLE S. W. TRANSMITTERS

Complete portable 7 $\frac{1}{2}$ Watt Xmitters with Power Supply and
accessories for your summer trip or as emergency standby,
\$85.

Just out a Compact Xtal Oscillator Unit, \$70.

P. A. and Freq. Doubler 7 $\frac{1}{2}$ Watt, \$45; 50 Watt, \$55.

We furnish full instructions how to adapt these Units to
your present Xmitters.

Write for Quotations on complete Ham and Commercial
Transmitters and Power Installations.

TRANSMITTING EQUIPMENT LABORATORIES, 3982 Woodlawn Ave., Los Angeles, Calif.



From a "TWEET" to a "ZOOM!"

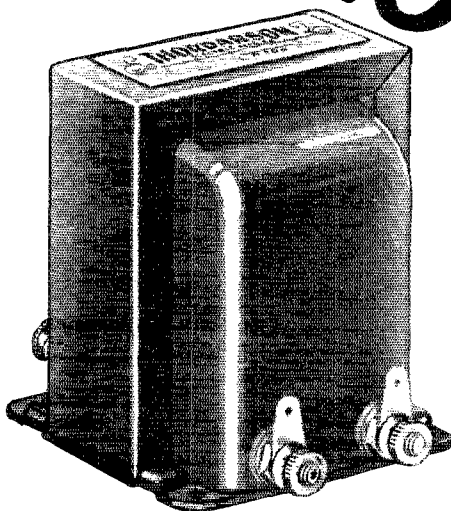

Amplifying Transformer
Type R-200



Thordarson Amplification Reproduces Every Note

NO NOTE of any instrument — not even the faintest harmonic — can escape Thordarson Amplification.

Leading Radio set manufacturers know this secret of musical reproduction. That is why you find more Thordarson transformers in quality receivers than all competitive transformers combined.

Whether you are buying a complete receiver, or whether you are building your own — if you enjoy music — be sure your transformers are Thordarson's.

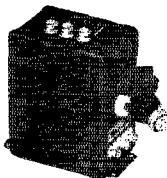

THORDARSON POWER COMPACT

Stop overloading your last audio tube. A power amplifier and "B" eliminator built with the Thordarson Power Compact will give full reproduction to the deeper tones that the ordinary amplifying tubes cannot handle.

POWER COMPACT R-171. Contains a power supply transformer, 2 filter chokes, 2 buffer condensers, a five volt filament supply. For Raytheon BH rectifier and UX 171 power tube. \$15.00.

POWER COMPACT R-210. Similar to type R-171 but designed for UX 216-B rectifier and UX 210 power tube. \$20.00.

THORDARSON

RADIO TRANSFORMERS

Supreme in Musical Performance!

THORDARSON ELECTRIC MANUFACTURING CO.
Transformer Specialists Since 1895
WORLD'S OLDEST AND LARGEST EXCLUSIVE TRANSFORMER MAKERS
Huron and Kingsbury Streets — Chicago, Ill. U.S.A.

Send for this free booklet
"Power From the Light Circuit"

Thordarson Electric Manufacturing Co.		3551
Huron and Kingsbury Sts., Chicago, Ill.		
Gentlemen:		
Without obligation on my part, please send me a copy of your free booklet, "Power From the Light Circuit."		
Name _____		
Street _____		
City _____	State _____	

GET THE BEST! Gross S/W Products

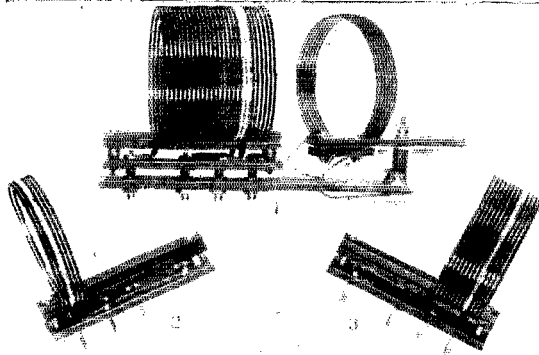

PLUG-IN COILS

Space wound, the most efficient form of winding. Extreme pluggeness another feature; will stand handling and rough treatment without injury. Novel antenna coupling coil will permit any degree of coupling up to 5 inches. These coils can be obtained for use in the 10 meter band up to the broadcast bands. General Radio Plugs and Jacks used; the most efficient plug-in system available.

Kit illustrated complete range 15 to 150 meters, Price..... \$11.50
 Base and Primary complete with one coil for 80 meter band, 38 to 150 meters 5.50
 Base and Primary complete with one coil for 40 meter band, 20 to 60 meters 5.50
 Base and Primary complete with one coil for 20 meter band 5.50
 Plug-in coil only for broadcast reception 3.00
 Plug-in coil only for broadcast reception 3.50
 You can add one stage of R. F. amplification to your short wave receiver. Write for full particulars and prices of coils for this purpose.

Plug-in Transmitter Coils

Above coils now available for 7 1/2 watt transmitters, using the tuned grid tuned plate circuit. Wave-lengths changes easily effected in a few minutes by plugging in another coil and retuning variable condenser.

Complete set of Coils for 20 or 40 meter bands, Price..... \$11.00
 Complete set of Coils for 40 or 80 meter bands, 11.00
 Gross Short-wave Receiver Three tubes, finest parts available, complete \$55. Transmitter Kits and Parts in stock.
 Dealers and jobbers write for discounts on our full line.
 A high grade precision instrument at 1/3 the usual market price. Built into compact carrying case of genuine solid oak, leather handle on top with removable cover. Coils extremely low loss making a very low resistance wavemeter either the flash lamp or galvanometer type will easily respond to an oscillator using 50 volts or less on the plate of the tube. Coils fit into cover, when not in use. Calibration better than 1% warranted. Checked against these oscillator using a minimum of 10 points for each curve, no imaginary curves drawn from 3 or 4 points. Separate curve furnished with each coil.
 Type 1-B—with flash lamp indicator for 20, 40, 80 meter bands \$15.00
 Type 2-B—with flash lamp indicator for 20, 40, 80 and 200 meter bands 18.75
 Type 1-G—with galvanometer indicator for 20, 40, 80 meter bands 30.00
 Type 2-G—with galvanometer indicator for 20, 40, 80 and 200 meter bands 33.75

Gross Wavemeter

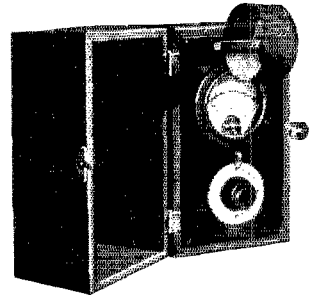

J. GROSS & CO., Manufacturers, 30 Park Place, New York

CARTER

NEW
HEAVY DUTY

Resistance Units



Half Size

All Resistances 1/4 to 1000 Ohms

For vacuum tube filaments circuits to reduce 6 volts to 5 volts without the use of a variable resistance also for use with U.V.199 tubes. There are many other uses for these resistances which are set forth in our illustrated booklet.

Mailed free on request.

Any dealer can show you why

In Canada: Carter Radio Co., Limited, Toronto

CARTER RADIO CO.
CHICAGO

"RADIO THEORY AND OPERATING"

By

Mary Texanna Loomis,
Member Institute of Radio
Engineers and Lecturer on
radio, Loomis Radio College,
386 Pgs. 700 Illustrations.

Third Edition

Price

\$3.50

At your dealer's or send
check or money order to

Loomis Publishing Company, Dept. T, 405 9th St., Washington, D.C.

Become a Radio Operator

See The World. Earn a Good Income. Avoid Hard Work.
Learn in the Second Port U. S. A.

Radio Inspector located here. Opportunities for employment second to no other port. Most logical location in the U. S. A. to come for training.

Practically 100% of radio operators graduating on the Gulf during past four years trained by MR. CLEMMONS, Supervisor of Instruction. All graduates placed to date.

Gulf Radio School 844 Howard Avenue,
New Orleans, La.

SET BUILDERS and SET OWNERS

WE Can Save You From 10 to 50 Percent
on all Standard National Parts and Accessories.

Send for Our Bulletin on Radio Parts.

ASSOCIATED SET BUILDERS

60 BRANFORD PLACE

NEWARK, N. J.

Reliable

LONG DISTANCE COMMUNICATION

on
1 meter to 200 meters

Thanks to the co-operation of members of the A-R-R-L, De Forest has further developed the Type-H tube to a point where it fills *all* the requirements of amateur transmission. The result is still more uniform performance with extended filament life.

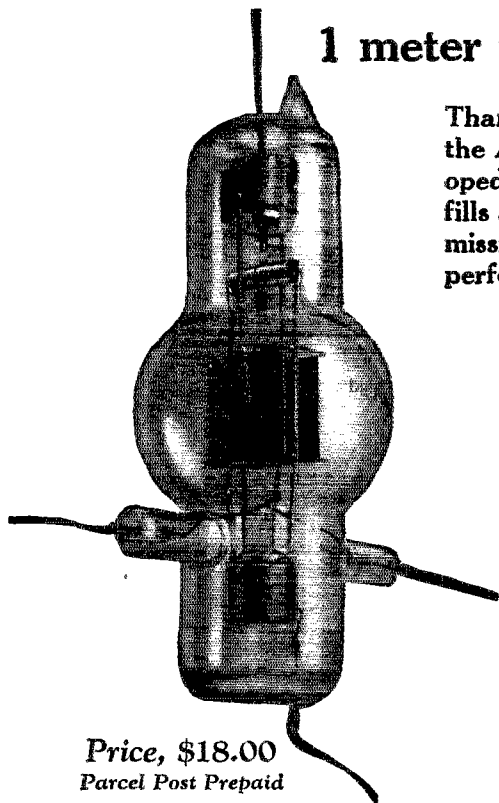

Price, \$18.00
Parcel Post Prepaid

Technical Data

INPUT RATING 150 WATTS

Plate Voltage 500—2000
Plate Current 50-100 MA.
Fil. Voltage 10
Fil. Current 2.35A



HR Thermionic Rectifiers

Will Operate Two H Tubes

Fil. Voltage	10
Fil. Amperes	2.35
Plate Voltage A. C.	2000
Plate Mill Amps.	200 Max
Voltage Drop	300 at 200 Ma
PRICE	\$16.00

Sold and Shipped Direct
Upon Receipt of Money Order

DE FOREST

TYPE-H

TRANSMITTING TUBE

139 Franklin St.

DE FOREST RADIO CO.

Jersey City, N. J.

SAY YOU SAW IT IN QST—IT IDENTIFIES YOU AND HELPS QST

Transmitting Apparatus at Reduced Prices!

TRANSMITTING INDUCTANCES	
Arco No-Loss Pancake 20-200 Meters	\$4.45
Arco No-Loss Pancake 80-200 Meters	\$4.85
R.E.L. Wound on Glass—Single Unit	\$4.85
R.E.L. Double Coil with Rods	\$9.50
New Aero 20 & 40 or 50 Meter S.W. Kit	\$10.25

VARIABLE TRANSMITTING CONDENSERS	
Cardwell .00022, 3000 volt	\$3.29
Cardwell .00045, 3000 volt	\$8.95
Cardwell .00015, 6000 volt	\$13.75
Hammairund .0002, 3000 volt	\$6.25
Hammairund .00045, 3000 volt	\$6.50
National .00015, 3000 volt	\$4.75
National .00023, 3000 volt	\$8.50
National .00045, 3000 volt	\$12.95
National .0001, 6000 volt	\$9.45

HIGH VOLTAGE FILTER CONDENSERS	
Sangamo 1 Mfd. 1000 volt	\$1.65
Sangamo 2 Mfd. 1000 volt	\$2.19
Sangamo 4 Mfd. 1000 volt	\$3.69
Acme 2 Mfd. 2000 volt	\$6.29
Plechltime 2 Mfd. 2000 volt	\$5.19
Plechltime 4 Mfd. 2000 volt	\$8.65
Farrand 1 Mfd. 1750 volt	\$2.29

BY-PASS (BLOCKING) CONDENSERS	
Sangamo .001 & .002	\$.50
Farrand .002, 5000 volt C-1014	\$2.35
RCA, CC-1803, 10,000 volt .00025	\$.95

GRID LEAKS	
Ward Leonard, New, 5000 Ohm Centertapped For sets up to 250 watts	\$2.45

Ward Leonard 5000 Ohm Centertapped 7 1/2 watt sets	\$1.85
General Electric for sets up to 100 watts, 5000 ohms	\$1.65
Crescent Lavite 5000 Ohm Non-Inductive	\$2.19

METERS	
Jewell—3 inch flush mounting A.C. or D.C. 0-7, 0-10, 0-15, 0-20, 0-35	\$6.45
Jewell—3 inch flush mounting D.C. Milliammeters, 0 to 5, 10, 15, 25, 100, 150, 200, 300, 500, 1000 scale readings	\$6.45
Jewell—3 inch flush mounting Thermocouple Antenna ammeters, 0 to 1/2, 1, 1 1/2, 2, 3, 5, 10	\$9.85
Roller-Smith H.W.A. Antenna Current, 0-1	\$4.85
Roller-Smith H.W.A. Antenna Current, 0-25	\$3.85

POWER PLATE & FILAMENT TRANSFORMERS & FILTER CHOKES	
Thordarson Combined Plate & Filament Transformer, 650 Volt Plate Winding (no mid-tap), 7 1/2 Filament Winding with Mid-Tap 110-50-60 Cycle, Pri. Special	\$6.29
Thordarson 80 Watt Filament Transf. 1 to 4, 50	\$6.15
Thordarson 150 Watt Filament Transf. 1 to 4, 50s	\$8.75
Thordarson 200 Watt Filament Transf. 1 to 2, 250s	\$13.55
Acme 75 Watt Plate & Fil. Transf. for 20 Watt Sets	\$13.55
Acme 200 Watt Plate & Fil. Transf. for 20 to 100 Watt Sets	\$18.45
Acme 500 Watt Plate & Fil. Transf. for 100 to 200 Watt Sets	\$23.25
Acme 50 Henry 150 Milliamperes Filter Choke	\$16.45
Acme 30 Henry 500 Milliamperes Filter Choke	\$22.95

AMATEUR RADIO SPECIALTY CO., 77 CORTLANDT ST. - NEW YORK Prompt Mail Order Service - Goods sold on Money-Back Guarantee

ANNOUNCING

Federal Super 65 A. F. Transformer

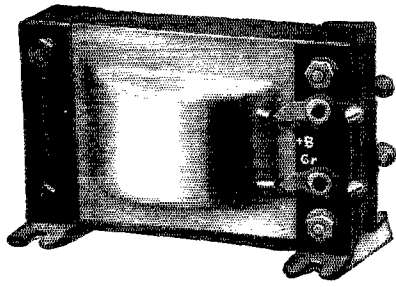

Super 65 and Super 65A Audio Frequency Transformers are the latest development of Federal Engineers in transformer structure. They exemplify all of the splendid qualities of Federal superiority in transformer manufacture and now offer greater efficiency of reproduction.

FEDERAL RADIO CORPORATION
BUFFALO, N. Y.

\$2—The First and Only Complete Authoritative—\$2 RADIO ENCYCLOPEDIA



Compiled and published by S. Gernsback in one volume of 138 pages (size 9 x 12 inches) containing 1930 definitions, 549 photographs, drawings and diagrams and a classified cross index. All circuits, new and old, are described by word and picture; every part and apparatus used in Radio is explained by photographs and drawings. *Hundreds of letters from leading Radio Experts and Engineers proclaim this encyclopedia an invaluable addition to everyone's library as well as a necessity to a Radio Scientist or Student.*

On Sale at Radio, Department and Book Stores, or order direct—two dollars postpaid for copies of the first edition which is limited. (Price advances with the second edition). Act at once.
S. GERNSBACK, 230 Fifth Avenue New York City, N. Y.

MR. S. GERNSBACK
230 Fifth Ave., New York, N. Y.

Dear Sir: I enclose \$2.00. Kindly send me "postpaid" one copy of your Encyclopedia. Money refunded if dissatisfied.

Name

Address

City..... State.....

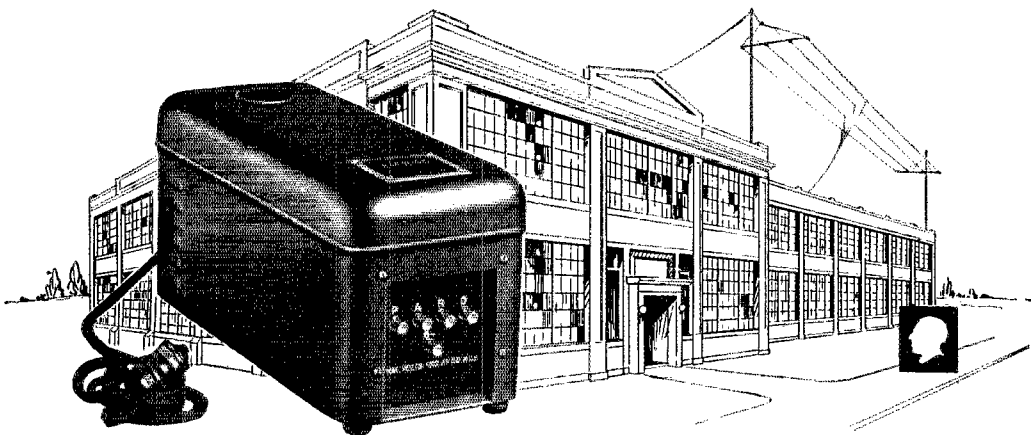

No Noise ~ No Hum in this "B" Eliminator

This B eliminator gives reproduction qualities to your radio that heretofore came only from fresh new B batteries. Quiet in operation, supplying proper voltage and current, reproduction in the loud speaker is not faulty.

The Amrad B eliminator employs the famous Mershon condenser as the principal capacity unit. This condenser has many times the capacity of any other eliminator condenser and constantly provides a sufficient supply of energy for correct reproduction of any tones that may come through your radio.

There are no variable adjustments to get out of order or be misused. It is free from break-downs, the Mershon condenser having such a large capacity that any excessive voltage surges are eliminated; the charge being absorbed. This also protects the receiving set against punctured parts or insulation break-downs.

It is quiet in operation, no line noises—interference or distortion. It furnishes a steady current supply to the set assuring perfect reproduction. The power unit is housed in a steel box and mounted on a metal base, and finished in black enamel.

This remarkable B eliminator is one of the many famous products of the Amrad Laboratories and is a tribute to the Amrad Engineering skill and the influence of mass production methods of Powel Crosley, Jr.

Write Dept. 4D7 for Descriptive Literature

AMRAD CORPORATION

Medford Hillside, Mass.

\$ **35.**

The Amrad B Eliminator Supplies any amount of voltage desired, having voltage taps for 22½, 30 or 45, 67, 90, 135 or 180. Maximum volts 180 with 50 mils output.

AMRAD

SAY YOU SAW IT IN Q S T—IT IDENTIFIES YOU AND HELPS Q S T

How to use Resistance in Radio!

**Send
for this new booklet!**

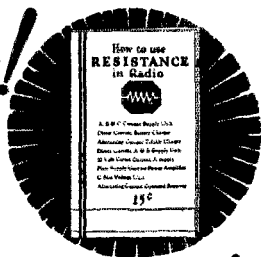

Ward Leonard Electric Company announces a booklet of interest to radio dealers, experimenters, and engineers.

Resistance assumes major importance in radio as higher voltages and currents are employed in power supply units.

"How to Use Resistance in Radio" tells the proper use of resistance and outlines many of the new A.C. and D.C. power circuits. It will be sent postpaid for 15c.

Ward Leonard Electric Company
MOUNT VERNON, NEW YORK

Resistor specialists for more than 35 years. **7135-3**

FOR EVERY BEGINNER

THE SIGNAL PRACTICE SET

Complete in every detail with high grade key, true tone adjustable high pitch buzzer and code plate. R68 \$3.40



SIGNAL WIRELESS KEYS

Strongly made with coin silver contacts. Brass parts polished and lacquered. Very reliable units.

R48 R62 $\frac{1}{2}$ in. contact \$3.50
R65 $\frac{3}{4}$ in. " \$3.70
R64 $\frac{3}{4}$ in. " \$2.90

Signal Buzzer



R60 Small neat high frequency type. Has standard resistance of 2 ohms. Black crystallized lacquer finish. Special resistances on quantity orders.

We manufacture a complete line of telegraph instruments.

SIGNAL ELECTRIC MFG. CO., Menominee, Mich. R60 \$1.25

Cascade Power Tube Breaks the Dam in Your Receiver

The very tones that start out over the air come true to your ears through a **CASCADE POWER TUBE**. You get it all—volume, range, clearness.

\$3.00

Post Paid

**Order
Now**

CASCADE POWER TUBES are made exclusively to our specifications, under patents, by one of the foremost laboratories at the center of the tube industry.

Backed up by a thirty-two year old corporation of first credit and business repute. Sold only direct to users. You get the dealer's profit in the extra quality of the tube. **\$3.00** each postpaid.

Cascade Tubes are also made in Type OIX and shipped direct at \$1.50 each postpaid. Specify whether you want detectors, oscillators, audio or radio amplifiers. Tested sets made up complete for neutrodynes, supers and all standard circuits. Enclose cash or money order. Tubes shipped immediately.

The Lacey Williams Company
1890 East 40th Street, Cleveland, Ohio



**NOW IS THE TIME
TO BUY**

PLUG-IN COILS

AND BE SURE TO GET TECO

Coil No.	Wavelength	Megacycles	Price
1	8.5-18	16.6--35	\$2.50
2	15.8-31	9.7--19	\$2.50
3	25--62	4.85-10.3	\$2.50
4	56--112	2.68--5.35	\$2.50
5	107--216	1.38--2.25	\$3.00

Bottom Mounting strip, \$1.50
Antenna Coil, \$1.50

COMPLETE SET, with Antenna Coil and Bottom Mounting Strip \$7.50

Each Set in Polished Cabinet

OTHER TECO PRODUCTS

Short Wave Receiver. Tuning Range, 10 to 200 meters, \$27.50.

Short Wave Transmitter, \$39.50.

50-watt Socket; has cast aluminum frame, phosphor-bronze springs, and Dilecto insulation, \$1.50.

Full Specifications Upon Request

Transmitting Equipment Co.
19 Stuart St. Boston, Mass.

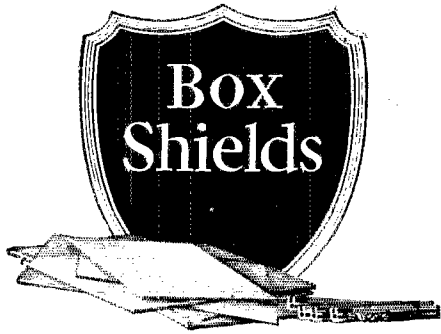

Made of "ALCOA ALUMINUM"

MEEETING the highest radio standards—shipped to you in the most convenient knocked-down form for easy assembly. These Box Shields are made of heavy Aluminum (.080"—No. 12 B. & S.) and are supplied 5" x 9" x 6", which will cover most requirements. If the size does not meet your exact needs, change it—Aluminum is easy to work.

"ALCOA ALUMINUM"
Box Shields
Consist of

- Top, Bottom, Sides
- 4 Extruded Corner Posts
- 8 Aluminum Screws

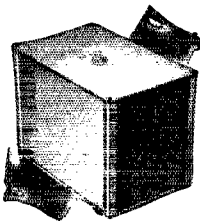

Manufacturers can obtain these shields made to their exact specifications or they can secure the necessary corner-post moulding and sheet to manufacture under their own supervision.

Those who use Aluminum have ample proof of its advantages. Insist on "Alcoa Aluminum", ask your dealer or write us.

"ALCOA ALUMINUM"

Is furnished to manufacturers in the following forms:

Sheet for shields, chassis, variable condensers, cabinets. Panels finished in walnut and mahogany. Die and Sand Castings. Screw Machine Products. Foil for fixed condensers. High Purity Rods for rectifiers. Stamping, rod, wire, rivets.

ALUMINUM IN EVERY COMMERCIAL FORM

ALUMINUM COMPANY of AMERICA

2324 Oliver Building, Pittsburgh, Pa.

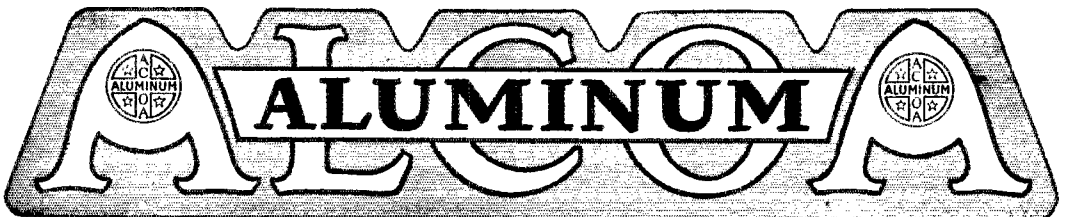

SAY YOU SAW IT IN Q S T—IT IDENTIFIES YOU AND HELPS Q S T

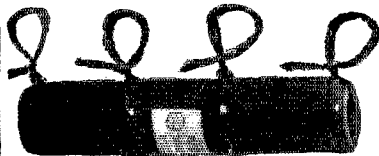

15,000 ohm Gridleak

Tapped at 5,000 and 10,000 ohms with 85 watt capacity. Price \$1.50.

5,000 ohm 85 watts \$1.00

5,000 ohm W. L., 20 watt, 75c.

10,000 ohm 150 watt, \$1.50



UC 1015 Condenser

7,500 volts tested, sulphur and mica insulated, eleven capacities, .0002 to .001 mfd, for grid and plate blocking.

Price \$1.25

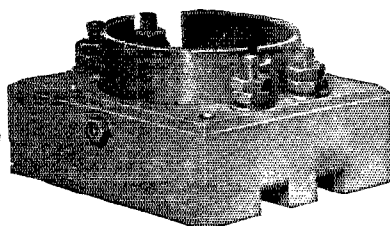

50 Watt Lowloss Socket

Maple treated base with brass airgap shell and heavy phosphor bronze springs. For UV 203A UV 217 and similar tubes. Price \$1.25

Utility Radio Co., 80 Leslie Street, East Orange, N. J.

New Learner's Buzzer Practice Set

on base board, consists of key and buzzer, \$1.00; Western Elecric Co. Radio Phone Transmitter & Receiver, Type CW938, fair condition; 2 Generators 12-350 V; Switchboard, Hand Mike type CW 930; Panel mike, type CW 1053. Price complete \$46.00. Airplane flame proof key with Blinker light, Type CW 1140, Makers International Radio Tel. Co. Price \$4.00. Just a sample of our bargains. Get our new and latest reduced price list for 2c stamp. We bought \$10,000 worth of United States Government Radio Transmitting and Receiving Sets and Parts. Mail orders sent all over the world. WEIL'S CURIOSITY SHOP, 20 South 2nd St., Philadelphia, Pa



PACENT TRANSFORMERS

Used and specified by the leading radio engineers of the country.

PACENT Electric Co., Inc.
91 Seventh Ave., New York

To Our Readers Who Are Not A. R. R. L. Members

Wouldn't you like to become a member of the American Radio Relay League? We need you in this big organization of radio amateurs, the only amateur association that does things. From your reading of *QST* you have gained a knowledge of the nature of the League and what it does, and you have read its purposes as set forth on page 6 of every issue. We would like to have you become a full-fledged member and add your strength to ours in the things we are undertaking for Amateur Radio, and incidentally you will have the membership edition of *QST* delivered at your door each month. A convenient application form is printed below—clip it out and mail it today.

.....1927

American Radio Relay League,
Hartford, Conn., U. S. A.

Being genuinely interested in Amateur Radio, I hereby apply for membership in the American Radio Relay League, and enclose \$2.50 (\$3 in foreign countries) in payment of one year's dues. This entitles me to receive *QST* for the same period. Please begin my subscription with the.....issue. Mail my Certificate of Membership and send *QST* to the following name and address.

.....

Station call, if any

Grade Operator's license, if any

Radio Clubs of which a member

Do you know a friend who is also interested in Amateur Radio, whose name you might give us so we may send him a sample copy of *QST*?

..... Thanks!

Buy Amplification Not Tubes

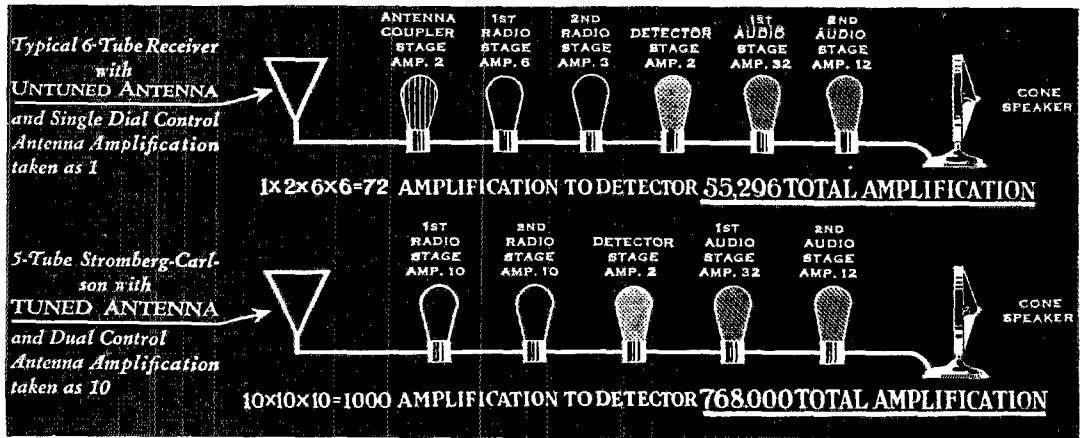

Amplification is one of the vital things in a Radio Receiver. Amplification is necessary for tone quality—for selectivity—for distance—for everything that makes radio enjoyable.

The illustration above shows the amplification comparison between a dual control Stromberg-Carlson 5-Tube Receiver and a typical single control 6-Tube Receiver.

Single dial control does not allow for antenna tuning, consequently the amplification of 10 taken for the tuned antenna is missing. And even the extra tube used before the detector in the single dial set does not compensate for this loss. For this tube is merely a coupling tube—and as such has a relative amplification of only 2 as against 10 when compared with the first radio stage tube in the Stromberg-Carlson.

Further, in this Stromberg-Carlson through the use of perfectly balanced and shielded circuits, the tube in the second radio stage also has an amplification of approximately 10, while the less efficient circuits of the typical 6-Tube single control receiver produce only an amplification of approximately 6 in each of their last radio frequency stages.

Assuming that the remaining tubes in each Receiver correspond as to amplification, the total amplification of this 5-Tube Stromberg-Carlson becomes 768,000, as against 55,296.

Therefore, you can readily see why the single control set described above, although having more tubes than the dual control Stromberg-Carlson, will not give as great total amplification.

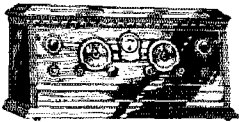

No. 501 Receiver, Treasure Chest, 5-tube, coils shielded; operates off either house current or batteries.
Price, less accessories, \$180.00
East of the Rockies; \$192.50
Rockies and West; \$225.00 Canada.

If radio were sold on a basis of amplification—which is more important than “number of tubes”—the Stromberg-Carlson 5-Tube Receiver with its total amplification of 768,000 should sell at about thirteen times as much as the above cited 6-Tube single control Receiver. That is, if prices were based on amplification and if \$100 were taken as the price for the typical 6-Tube single control receiver, then the Stromberg-Carlson 5-Tube No. 501 Receiver, which now can be purchased for \$180, would sell at \$1,300.

Stromberg-Carlson Telephone Mfg. Co.

Rochester, N. Y.



Stromberg-Carlson

Makers of voice transmission and voice reception apparatus for more than 30 years

SAY YOU SAW IT IN QST—IT IDENTIFIES YOU AND HELPS QST

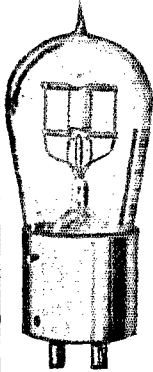

A FEW MORE LEFT
NAVY TYPE CG-1162
5 WATTS
PLIOTRONS

(MFD BY GENERAL ELECTRIC CO.)
 NEW, IN ORIGINAL CARTONS

Filament Voltage 7½ Volts.
 Filament Current 1¾ Amps.
 Safe Plate Voltage 550 Volts.
 Plate Current 40 Milli-amps.

Also Used as Power Amplifying Tube
 STANDARD BASE

PRICE ONLY \$1.00 EACH

Hams Here You Are

2000 VOLT FILTER
 GUARANTEED
TRANSMITTING CONDENSERS
2-MFD—\$2.99 WHY PAY
4-MFD— 4.99 MORE?

R. C. A. .000025 Transmitting
 Condensers, 19,000 Volt-UC-1308 **\$1.95**
 .000075—.000018-U.C.—1846— **\$2.95**

U. S. Signal Corps Spark Transmitters
 Has Pancake Inductance, .002
 5000 Volt Condenser Spark-Coil
 for J. C. W. **\$2.95**

Large 45 Volt "B" Battery . . \$1.69

TUBES

Western Electric	
V. T-1	\$2.19
V. T-2	\$5.65
102-O- High Mu	\$5.50
Type UX201-A	.39
Type UX200-A	.49
Type UX112	.49
Type UX171	.49
Type UX213	1.19
Type UX216-B	1.19
B-Eliminator Rectifier—601Mils., \$1.00	
No order for these tubes under \$3.00 shipped.	

Roller Smith—Hot wire Ammeters, 0-1 Amp—\$3.95, 0-4 Amps—\$4.49, 0-6 Amps—\$5.95, 0-250 Milli-ammeter \$5.49. Weston Meters 0-150 Volts—07½ D. C. Combination—\$7.95. Learn-the-Code with one of our Code Practice Sets. Ruzzer and Key mounted on mahogany baseboard, all wired ready to use—reg. \$10.00; only—\$2.39.

No C. O. D.—No Parcel Post Shipments. Send in your name for our Ham List. No Stamps. Send Certified Check. References—Dun or Bradstreet, Federal Trust Co. Newark, N. J.

THE NEW JERSEY RADIO SUPPLY COMPANY
76 SPRINGFIELD AVE. NEWARK, N. J.



CRESCENT
LAMPE
RESISTANCES

For Distortionless Amplification

Dual resistances for DeForest "H" tube or one or two fifty watters, \$5.65. Special Grid leaks for any tube to order. Let us solve your voltage drop problems. Use all tubes in a crystal controlled transmitter or main generator. Our resistances will take care of the different voltage requirements.

CRESCENT RADIO SUPPLY CO. 1 Liberty St., Jamaica, N. Y.

SPECIAL TO AMATEURS

Our new amateur dept. in charge of F. J. Marco, 92A, has everything that a amateurs desire. The Barawik Radio Guide gives full details. Send for it.

FREE RADIO GUIDE

RADIO BARGAINS
 Shows the latest wrinkles, newest developments in radio at startlingly low prices. Get the set you want here and save up to 50%. The best in parts, kits, complete factory-built sets and supplies. Orders filled same day received. Write for free 16-page copy NOW; also please send names of one or more radio fans.
BARAWIK CO., Dept. 114. CHICAGO, U. S. A.

Never Before At This Sacrifice Price

HIGH VOLTAGE

KENOTRON RECTIFYING TUBES

MODEL U. V. 217

A. C. Plate Voltage 1500 volts. Filament Voltage 10 volts.

Used with U. P. 1016 Power Transformer or similar Transformer.

These Genuine R.C.A. U. V. 217 Tubes are very efficient Rectifiers and they will pass plenty of current and voltage for 50 watters and H Tubes and also can be used for 250 watters. **Every tube is brand new and packed in original carton.**

List Price \$26.50 ea.

EXTRA SPECIAL, \$12.50 EA.

AMERICAN SALES COMPANY

21 WARREN STREET, NEW YORK CITY

THIS EASY WAY TO LEARN THE CODE CUTS LEARNING TIME IN HALF

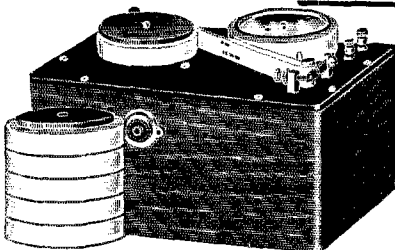

The famous **TELEPLEX** for Self-Instruction at Home

SENDS MORSE OR CONTINENTAL

The quickest, easiest and most economical way of learning Morse or Continental. Replacing all other means. Improves operating ability to a remarkable degree. Faithfully reproduces actual sending of EXPERT operators. The only instrument that sends MORSE and Continental in the exact form used in everyday work. Equivalent to experience. Sends FIVE TIMES as many words with one roll of tape as any other instrument, and SIX ROLLS are furnished. Dustproof cabinet. With or without key and sander. Complete graduated course in Morse or Continental with each instrument. Send TODAY for descriptive literature.

TELEPLEX COMPANY,
76 Cortlandt Street, NEW YORK CITY

Here's the Ideal Amateur Transmitter!

*Built Around the Famous
AERO Transmitter Coils*

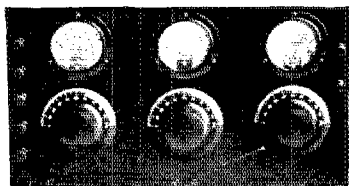

FRONT PANEL VIEW

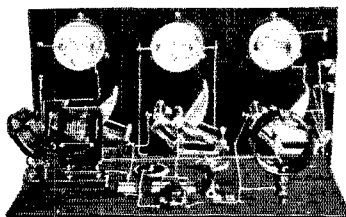

REAR PANEL VIEW

Here's a new transmitter that is sure to appeal to every true amateur! Compact and pleasing in appearance, it has a really remarkable range on low power. Embraces flexibility to a heretofore impossible degree, because it is built around the famous AERO plug-in coils. Two pairs of AERO coils cover the entire band, 16.5 to 90 meters, without gaps, and are instantly interchangeable. These coils operate perfectly on low power, yet handle in excess of 1000 volts just as efficiently. Read the description of this wonderful transmitter elsewhere in this issue. Then plan to change over to this set. It's really very inexpensive, considering its great range on low power. Here are the AERO Kits you should use, tuning either kit with three good .0005 variable condensers:

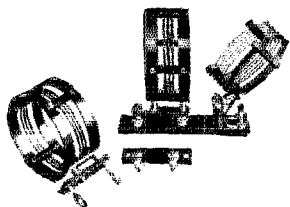

KEY 2040 KIT

Price \$12.00

Kit contains 2 AERO Coils, 17 to 50 meters each, 1 AERO Antenna Coil Mounting Base, 1 AERO Grid Coil Mounting Base, 2 AERO Essential Choke Coils.

If you desire to have this set tune to 90 meters, simply buy two AERO 40 to 80 meter transmitting coils, which plug in the same mounting bases, and work efficiently with the above items.

KEY 4080 KIT

Price \$12.00

Kit contains 2 AERO Coils, 36 to 90 meters each, 1 AERO Antenna Coil Mounting Base, 1 AERO Grid Coil Mounting Base, 2 AERO Essential Choke Coils.

If you desire to have this set tune also to 20 meters, simply buy two AERO 20 to 40 meter transmitting coils, which plug in the same mounting bases, and work efficiently with the above items.

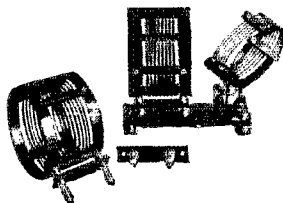

Plan for D. X. Records NOW

Order these coils direct from us if your dealer hasn't them and start now for wonderful records. Specify code or key numbers when ordering. Or write at once for

complete descriptive literature. Remember these coils are made by the makers of the AERO Low Wave Tuner Kit, and other famous AERO Inductance Coils.

Aero Products, Inc.

Dept. 16

1772 Wilson Ave.

Chicago, Ill.

SAY YOU SAW IT IN QST—IT IDENTIFIES YOU AND HELPS QST

Price List of Individual Parts

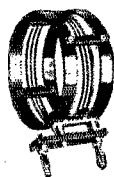

AERO TRANSMITTER COILS

In two sizes.
Range 17 to 50
meters and Range
36 to 90 meters.

Price, each

\$4.00



AERO ANTENNA BASE

Code number Pri.
300 To hold An-
tenna Coil.

Price, each

\$3.00



AERO GRID COIL BASE

Code number Grid.
100 To hold Grid
Coil

Price, each

\$1.00

AERO ESSENTIAL CHOKE COILS

The finest choke
coil made.

Price, each

\$1.50



Engineering and Mass Production

Those two features are important to you, the manufacturers of sets and eliminators.

Dongan's reputation for being a step ahead in transformer design and a large factory devoted entirely to the production of parts has placed Dongan transformers and chokes as standard equipment in many leading sets and battery-eliminators.

As a source of supply you will find the utmost in cooperation in the Dongan organization.

This is **NEW**
Dongan Transformers and Chokes
for use with
RAYTHEON BA 350 MA
and
Q. R. S. 300 MA
Rectifying Tubes
Write for complete details

Dongan Electric Manufacturing Co.
2999-3001 Franklin St., Detroit, Mich.

TRANSFORMERS of MERIT for FIFTEEN YEARS

See that screw

**A SCREW DRIVER
ADJUSTS AN XL
IN CROWDED
PLACES**

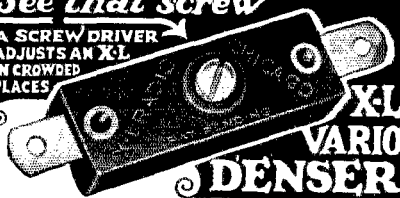

Balance out annoying oscillations and tone up your circuit to the "peppy" point with a slight turn of the screw. X-L Products specified by experts for all popular hookups.

A slight turn obtains correct tube oscillation on all tuned radio frequency circuits. Neutrodyne, Roberts' two tube, Browning-Drake, McMurdo Silver's Knockout, etc., capacity range 1.8 to 20 micro-microfarads. Price\$1.00

Model "G"

with grid clips obtains the proper grid capacity on Cockaday circuits, filter and intermediate frequency tuning in heterodyne and positive grid bias in all sets. Capacity range:

Model G-1 .00002 to .0001 mfd.
Model G-5 .0001 to .0005 mfd.
Model G-10 .0005 to .001 mfd. Price \$1.50
X-L Push Post

Push it down with your thumb, insert wire, remove pressure and wire is firmly held. Releases instantly. Price 15c. Also furnished mounted on strips.

FREE Wiring Diagrams showing use in most popular circuits sent on request. Write today.

X-L RADIO LABORATORIES, 2428 N. Lincoln Ave., Chicago, Ill

Hoyt

Radio Rotary Meter

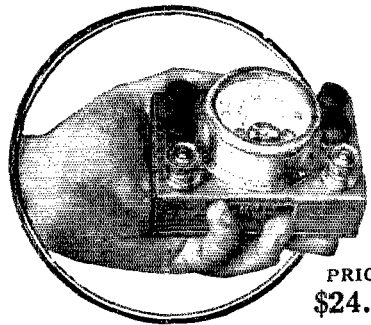

PRICE
\$24.00

This is a unique 5-range precision moving coil voltmeter made especially for the Radio Service Man, Dealer and Owner. It will make all tests necessary on Radio Receiving Sets, tubes and batteries. It is rugged and will last a lifetime, yet will retain its extreme accuracy. Operation is simple and accident-proof.

BURTON-ROGERS CO.

857 Boylston Street Boston, Mass.

Sales Dept. for Hoyt Electrical Instrument Works
HOYT makes a complete line of Radio Meters. Send for booklet, "HOYT Meters for Radio."

TEN BARGAINS! AND WE HAVE MORE LIKE 'EM!

1. Self-feeding Electric Soldering Iron. List, \$3.35. SPECIAL, 95c.
2. Soldering Paste. 2 oz., 5c. 4 oz., 10c. 1/2 lb., 30c. 1 lb., 50c.
3. Magnet Wire, No. 22 and No. 26. 15c per roll; 2 rolls 25c.
4. More Hood Hard Rubber Panels. 7 x 9, & 7 x 10, 2 for 25c.
5. Kennedy Bakelite Sockets, 3 for 25c.
6. Aero-Loop, Type A-1. List \$12. SPECIAL, \$4.75.
7. Warren 2600-ohm Headsets. List \$7.50. SPECIAL \$1.50.
8. More Crosley No. 51, 2-Tube Sets. List, \$23.50. SPECIAL, \$3.95.
9. Kellogg Cabinets, 8 1/2 x 23 1/2. Antique Oak, Walnut, or Mahogany Finish. A \$7.50 Value. \$1.50.
10. Magnavox 1-stage Amplifier. No. A-1. List, \$27.50. SPECIAL, \$2.95.

Everything Guaranteed New and Perfect Condition.

RADIO SURPLUS CORP.
250 Washington Street, Boston, Mass.

HAM-ADS

NOTICE

This department of *QST* is conducted as a service to members of the American Radio Relay League. Advertisements can be accepted only under the following conditions:

(1) "Ham Ad" advertising will be accepted only from members of the American Radio Relay League.

(2) The signature of the advertisement must be the name of the individual member or his officially assigned call.

(3) Only one advertisement from an individual can be accepted for any issue of *QST*, and the advertisement must not exceed 100 words.

(4) Advertising shall be of a nature of interest to radio amateurs or experimenters in their pursuit of the art.

(5) No display of any character will be accepted, nor can any typographical arrangement, such as all or part capital letters, be used which would tend to make one advertisement stand out from the others.

(6) The "Ham Ad" rate is 7c per word. Remittance for full amount must accompany copy.

(7) Closing date: the 25th of second month preceding publication date.

THE life blood of your set—plate power. Powerful, permanent, infinitely superior to dry cells, lead-acid Bs, B eliminators. Trouble-free, rugged, abuse proof, that's an Edison Steel-Alkaline Storage, B-Battery. Upset electrically welded pure nickel connectors insure absolute quiet. Lithium-Potassium solution (that's no lye). Complete, knock-down kits, parts, chargers. Glass tubes, shock-proof jars, poppy elements, pure nickel, anything you need. No. 12 solid copper enameled permanently perfect aerial wire \$1.00; 100 ft. Silicon steel laminations for that transformer 15c lb. Details, full price list. Frank Murphy, Radio 8ML, 4837 Rockwood Rd., Cleveland, Ohio.

25% to 35% discount to amateurs on receiving parts, no sets. Our weekly data sheets give you more dope than all the radio magazines together. 20 weeks' trial \$1.00, 52 weeks \$2.50. Over two pounds data, circuits, catalog, prepaid 25c. Fred Luther Kline, Kent, Ohio.

PURE aluminum and lead rectifier elements holes drilled brass screws and nuts, pair 1/16", 1"x4" 13c, 1"x6" 15c, 1 1/2"x2" 17c, 1 1/2"x6" 19c. Sheet aluminum 1/16" \$1.00, lead \$1.00 square foot all prepaid. Silicon transformer steel cut to order .014" 10 lb. 25c, 5 lb. 30c, less than 5 lb. 35c per lb., .022" thick 5c less per lb. Postage extra. Edgewise wound copper ribbon, 7 sizes, see Jan. *QST* 1/2" square copper wire better than copper tubing 50c lb. postage extra. Air pocket insulators blue glazed porcelain 8" leakage path fine for transmitting, 4 for \$1.00 prepaid. Geo. Schulz, Calumet, Michigan.

YOU'RE next, OM. Westinghouse Cooper-Hewitt Mercury Vapor Rectifier tubes \$13.75 ea. shipped via express only. New, in original crates, guaranteed. Put a note on the air that'll kick out. Tubes will run one fiver or a bank of quarter-kilos. All the dope, blueprint and photo, 10c plus a 2c stamp. Can shoot you all the parts, too. Wilbur E. Gemmill, 484 N. Beaver St., York, Penna. n3SAAC.

500-900 CYCLE alternators and other Army equipment. Robert B. Bridge, 2412 Main Ave., San Antonio, Texas.

NEW W.E. fifty watt 211D \$25.00. R. M. Dennis, 1ME, 82 Maple Ave., New London, Connecticut.

9DIQ selling out. Complete transmitting and receiving equipment—at your own price. What do you need? Write for list. John Stapp, 2323-12 St., Rock Island, Ill.

DODGE Radio Shortcut fixes signals in mind to stick. Kills hesitation. Cultivates speed. Produces results. 9DLJ, Leon Seltzer, reports: "When nine years old (now twelve) studied Shortcut two weeks and passed. Called youngest operator in world. Three ops in family. All used and recommend your method. Harry memorized code in thirty minutes." Quarter coupon and reports progress made by 300 users, all licensed, 25c. Specimen SAY YOU SAW IT IN *QST*—IT IDENTIFIES YOU AND HELPS *QST*

reports each district on request. Shortcut with Appendix and Better Key Work, \$3.50, U. S. and Canada—elsewhere \$4.00. Reg. mail. Nong C. O. D. Send money order. Check may delay. C. K. Dodge, Mamaroneck, N. Y.

TRANSMITTING rheostats for 5-7.5 watt tubes are selling fast for 49c, 3 for \$1.25. Jos. Neubauer, 1220 Pine St., Philadelphia, Penn.

WANTED 10 1 mfd. 1750 volt condensers. Geo. K. Harold, Lebanon, Penn.

AUDIO transformers rebuilt with new best quality windings at half new price. Carefully tested and guaranteed. Loud speakers rewound and repaired, two-fifty to four dollars. A. B. Clark, Albia, Iowa.

HEAVY glass jars, used motors, all radio apparatus at discount. Write for list. F. L. Young, 9CKA, Corwith, Iowa.

ENTIRE station of 9EGY for sale. Short wave receiver: Two stage audio. Aero coils, General Radio transformers, Marco dials, Jewel voltmeter Walnut cabinet. Three tubes. Short wave transmitter, 15 watts, Milli-ammeter, bakelite panel. Two Radiotrons. A very neat job. Radio Corporation power supply ET3620 with five rectifier tubes. Furnishes all power for transmitter. Operates on 110 volt 60 cycle AC. \$135 money order takes it. W. E. Dreyer, Alliance, Nebraska.

OMNIGRAPHS. Vibroplexes, Transmitters, Chokes, Meters, Transformers, S. Tubes, Transmitting Tubes, Rectifiers, Motor Generators, Radiolas, Grebes, All Wave Receivers. Bought, sold, exchanged. L. J. Ryan, 9CNS, Hannibal, Missouri.

S-TUBE Heterodyne Plio-6 Thompson speaker; trade for diamond; also heavy duty filter condensers, choke coil and several meters; sell cheap. Trade or sell printing plates for new game never used; also trade or sell lot molds for casting lead toys. Bargains. Cline, Minnewaukan, North Dakota. Write your wants.

SPECIAL Kennedy long wave receiver with amplifier \$50.00. Junior Heinlein, Butler, Missouri.

SELL advance Sinc rectifier, new. 2UY, Walter Condie, 24 Rossiter, Ave., Paterson, N. J.

TEN watt transmitter \$50. Includes Acme transformer, meters, tubes, condensers, etc., Federal microphone \$6.00. Plate transformer 550v, \$6.00; and other parts. Write 2BZJ, Farmingdale, New Jersey.

FOR SALE—National Radio Institute Correspondence Course with Natrometer like new, cheap. Write Julius Hetland, Osgood, Iowa.

WANTED—Giblin—Remler coils either mounted or unmounted, 600, 750, 1000 and 1500 turns. State condition and price. Also want to trade brand new never unpacked RCA UP1016 power transformer for UP1368 in new condition. L. A. Danse, 2930 Pingree Ave., Detroit, Michigan.

EVERYTHING for the ham: 1/16" sheet lead and aluminum, \$1.00 per sq. ft. No. 12 "Dyflex" solid copper enameled wire, 1c ft., No. 10 "Dyflex" solid copper enameled wire 1 1/2c ft. A full stock of Acme and Thordarson transformers and choke coils, Jewell meters and all the rest of the stuff to make that short wave transmitter or receiver. Send for catalogue. "Dyflex for DX." E. J. Nicholson, 8BIN, 1407 First North St., Syracuse, N. Y.

SNAPS—1500 volts 1 k. w. ring oiled Esco, 110 v. D. C. motor perfect condition. \$70. or will trade for new 500 watt 100watt Esco—new DeForest Q tube 500 watt with grid leak \$50. Brand new Epom B eliminator \$20.00. 500 watt Acme transformer \$18.00. All F.O.B. Miami. Want 1 200 watt Acme transformer. R. B. Ladd, Buena Vista, Florida.

FOR sale 5-10 watt transmitter. Lawrence Fleming, Huntsville, Missouri.

NEW transmitter (twenty five watts input) complete with D.C. plate supply, tubes and key—for less than cost of parts. Also portable receiver. 8RD, 12694 Northlawn Ave., Detroit, Michigan.

WANT to trade gas driven, direct coupled, 110 volt generator for high voltage motor-generator. Ideal for battery charging, farm lighting, or boat lighting system. E. Casev. 71Z, Attalia, Washington.

BOYS! Why not advertise your station? Eight inch Roman letters carved from wood, covered with genuine gold leaf, with metal background. Can be attached to any pole. \$1.35 per letter. Prepaid or C.O.D. Fred Nixon, 2890 N. Griffin Ave., Los Angeles, Calif. 6CZT.

WANTED—Omnigraphs and dials, filament and plate transformers. 90C.

\$2.00 PAIR, one 5 and one 9 plate condenser cut for short waves. Fine biz for RELS and AEROS. Postpaid. 21K, 2101 Avenue O, Brooklyn, N. Y.

51G SELLING out—Schnell 1 step (Cardwell condensers, mahogany cabinet) \$12.50; 50 watt transmitter (Bakelite panel, filament, radiation, meters), \$18; transformers; filter; wavemeter; Baldies \$6. Write for list, Kenneth Tatum, Alamogordo, New Mexico.

\$75.00 WESTON No. 1 voltmeter, 0-15, 0-150 range \$15.00. New Sangamo series B condensers. 4mf \$3.25, 2mf \$2.00. Edward Fanley, 235 Buttes, Columbus, Ohio.

WANTED—2 or 3 h.p. induction motor single phase 25 cycle 110 volts. Must be in tin-top condition. Geo. L. Burgan, Box G, Hubbell, Mich.

“MAHOAGANY or black finish hard rubber panels, seven inches wide, twelve to twenty six inch lengths, five cents per lineal inch.” D. L. Barr, Trenton, Ill.

FIVE watt transmitter for sale. \$45.00. Write for description. John Redmond, Clinton, N. Y.

ALL Postpaid. Sangamo filter condensers, 1000 volt working voltage, 2 mfd. \$2.15; 4 mfd. \$3.65. R.E.L. Transmitting inductances, double with glass coupling rods, \$8.90. R.E.L. shortwave coil kits, \$3.75. Allen-Bradley “Radiostats”, the big Primary rheostat, \$6.29. Allen-Bradley 2000—30,000 ohm variable transmitting grid leas, \$4.89. R.E.L. radio frequency chokes, \$1.00. General Radio Wavemeters, Type 358, \$19.25. Dubilier condensers, Type 700, 1500 volt test, .00225 mfd. \$3.45; .006 mfd. \$8.00. R. E. L. receiver kits, \$29.50. Other prices on request. RBMS, G. F. Hall, 133 East Gorgas Lane, Philadelphia, Pa.

WHY not supply your set with pure “B” current from the new type Edison element lifetime “B” power units of low internal resistance, noiseless operation and recharges from your light socket. 90 volt, \$10.95, 135 volt, \$15.00. Type A elements, drilled, 4c per pair. Welded, 5c. Type 3-G welded, 6c. No. 29 pure nickel wire, 1c per ft. No. 18, 1 1/2c. Separators, 4c per doz. Caustic potash and lithium for 5 lbs. Edison solution, 85c. Pure aluminum and lead rod in stock for “B” chargers, high voltage rectifiers, etc. Send for catalog. J. Zied 904 N. 5th St., Phila., Pa.

A NEW Ham Catalog is ready for you, listing much new apparatus besides giving many changes in the “Hamalog”. Send for it today, mentioning if you have the T-3 “Hamalog.” New stuff includes all DeForest transmitting tubes, new high power high voltage variable condensers, new Coupled Inductances—the finest available for both Ham and Broadcast use, new Meters, fixed condensers, grid leaks, etc. See our display at elsewhere. E. F. Johnson Company, 9ALD, Waseca, Minnesota.

CURTIS-Griffith 250-watt power-filament transformers 350-550 each side \$12.50. Thordarson power-filament transformers for 5-watters \$6.90. Thordarson power transformers 350-550 each side \$11.00; 1000-1500 each side \$16.00. Edgewood Inductance, 6-inch, turn 12c; 4-inch, turn 10c. RCA 50-watt Sockets \$2.50. Aluminum square foot 85c; lead square foot 85c. Jewell 0-15 Voltmeters \$7.50; 0-500 Milliammeters \$7.50. National 23-plate 3000-volt transmitting condensers \$11.50. New “Ham-List” 4c. James Radio Curtis, 5-A-Q-C, 1109 Eighth Avenue, Fort Worth, Texas.

COMPLETE 250 watt 40 meter transmitter: UV204A tube. Jewell Meters. Cardwell condensers, Thordarson Transformers, KFUH circuit. Price complete \$125.00. Price Griffith, 1109 Eighth Avenue, Fort Worth, Texas.

HAM headquarters: Mueller 150-watt input tubes \$15.00; DeForest H-Tubes \$18; RCA 5-watters \$3.15. Potter 2000-volt 1-mfd condensers \$2.50; 2500-volt 1-mfd \$3.25.

Aerovox 1500-volt 1-mfd condensers \$1.75. Tube 2000-volt 5-mfd condensers \$17.00. UC490 Condensers \$2.50. Used 50-watters \$15.00; vibroplexes \$10.00. “Ham-List” 4c. R. Curtis, 1109 Eighth Avenue, Fort Worth, Texas.

A.R.R.L. sweater emblems should be worn by all league members. They are made of the highest grade black and yellow felt, 5”x8” diamond, \$1 postpaid. No COD’s. Eric Robinson, 135 Jefferson Rd., Webster Groves, Mo.

SELL—unused UV203A \$20, cash; two new G. E. fittings, laboratory models, \$15 each. Radiocorp sockets \$1.50. UT1357 magnetic modulator, \$5. Type 166 General Radio audio transformer, \$4. 8DMN, Wilkinsburg, Penn.

TRANSFORMERS for Raytheon, UX216 or UX213 tube \$3.75. 50 Henry choke \$2.00. 30 Henry choke \$1.75 prepaid. Write for list of material. Leitch, 34 South Park Drive, West Orange, N. J.

400 V, 100 W. Esco coupled to 220 V, 3 ph A. C. motor \$25.00; same with 110 V, single phase motor \$30.00, 1500 V, 600 W. Double Commutator Westinghouse motor generator \$175.00. 2500 V, 2 Kilowatt Generator double commutator generator coupled to three phase 220 V, 1750 speed motor. 2500 V, 600 W. Double Commutator generator coupled to 110-220 V, 60 cycle single phase motor 1750 speed. 1 mfd. Western Electric Condensers 50c. New 1/4 H.P. 110 V. 3500 speed Robbins & Myers alternating current motors \$8.50. Prices f.o.b. Chicago. James Smat 1734 Grand Av. Chicago, Ill.

POWER transformers for 7 1/2 watters, filament 7 1/2 v, plate 600v, center tapped \$5.75. For fittings—filament—18v, plate 1100v, center tapped, \$8.00. Milliameters, 0-100, \$2.00. Rectifier elements, aluminum and lead, pair 1”x4”, 7c, 1”x6”, 10c. C.O.D. or cash. Complete list upon request. William Green, 211 West 110 Street, New York City.

TELEFUNKEN 200 watt power tubes, \$35. filament 14 volts 4 amperes. Plate 3000 volts; 30 watt tubes \$12. filament 10 volts, 2 amperes, plate 1000 volts, RCA 1—1500 voltmeter \$15. Magnetic modulators UT 1367, 3-5 amps. \$4.; UT 1357 1 1/2-3 1/2 amps. \$2.; Experimenters Information Service, model C7 8 tube super-heterodyne, \$50. Inquiries invited. Herman Beyer, 56 Pine Street, New York.

QSL cards \$1 per 100, highest quality, orders filled immediately, COD or cash with order. William Green 207 Cathedral Parkway, N. Y. C.

CONDENSERS, Cardwell, Hammarlund, General Radio, Thordarson transmitting, receiving, and B-eliminator transformers at big discounts. Low power transformers special. For low-price list write 2apj, 643-5 West 171st Street, New York City.

SPECIAL—150 watt filament transformer, ideal for 50 watters and fivers, unmounted at the remarkably low price of \$5.50. Also genuine brand new R. C. A. 5 watters. A large buy has enabled us to give them to you at only \$2.30 each. All items postpaid. 9CYN and 9GF, Mitchell, 3520 Sheridan Rd., Chicago, Ill.

700 WATT transformers, 1000-1500 volts on each side of center tap \$14.00. 250 watt transformer 550-700 volts each side \$10.00. Room for filament winding. F. Greben, 1927 S. Peoria St., Chicago, Illinois.

GENERATORS new 275 volt d.c. gives up to 500 volts \$8. UC1831 variable transmitter condensers \$1. RCA Kenotrons \$2. Western Electric microphones \$1. 3 coil geared honey-comb mountings \$1.60. 1/4 h.p. 32 volt d.c. motors \$8. Used generators 30 volts d.c. input, output 300, \$8. 6 volts input, output 400 volts at 200 watts \$15. 1/2 k.w. 500 cycle \$15. 200 watt \$10. RCA 200 ohm potentiometers 50c. Dubilier mica condensers type 600 .002, 20c. Postage extra on all. Send stamp for list. R. Wood, 46-20 102nd St., Corona, N. Y.

QSLs, the SBJT press quality. R. J. Mumaw, Care E. M. S. Harrisonburg, Va.

QSL cards, two colors, government post cards \$1.90 per hundred, white cards \$1.00. Free samples, 8DTY, 257 Parker Ave., Buffalo, N. Y.

CONCERT Magnavox cost \$120, for \$40. Concert power amplifier 3 steps for radio phonograph or speech cost \$350, for \$125. Phonograph tone arm cost \$24, for \$8. Hand transmitter cost \$18, for \$6. VT 2-5 watters for

\$2.50. Variable condensers transformers, etc. Write for list. Everything guaranteed. S. Mayer c/o DeLuxe Apts., Mamaroneck, N. Y.

FOR sale—Robbins and Meyers quarter horsepower D.C. compound motor (good) \$10. Westinghouse dynamotor 10/350 volts (good) \$7. Small Peerless D.C. motor (good) \$8. Five dia) Omnigraph (new) Extra set discs, \$15, 2DQ, F. Ryder, 38 Clermont Ave., Brooklyn, N. Y.

Q R A Section

11C—Herman Sanborn, Beacon St., Shrewsbury, Mass.

10S—Ida C. Elwell, R. F. D. No. 4, Danbury, Connecticut.

2ATB—Henry N. Whitney, P. O. Box 867, Glen Cove, N. Y.

2MK—E. F. Reynolds, Central Valley, Orange County, New York.

3KP—4828 N. W. 16th St., Washington, D. C.

3NN—Robert R. Achey, Quakertown, Penn.

4DP—49 West 4th St., Atlanta, Ga.

4ES—455 N. E. 28th St., Miami, Fla.

5LF—L. J. Arnold, Crossett, Arkansas.

5PM—J. Allen Swanson, Jr., 7103 Freret St., New Orleans, La.

6DHE—Frederick Zerlang, 524 W. Hawthorn St., Eureka, Calif.

6SM—A. E. Ekdale (AE) and C. W. Seamans (CS), 159 S. El Molino Ave., Pasadena, California.

8CCG—Geo. Fagerholm, 948 East 72nd St., Suite 6, Cleveland, Ohio.

8COT—George B. Bairey, 219 E. Swissvale Ave., Edgewood, Penn.

8DEI—Geo. M. Benas, 1801 Genesee St., Utica, N. Y.

8LD—Joseph A. Roell, 2313 15th St., Niagara Falls, N. Y.

8TD—G. Olyn Yough, Petrolia, Butler Co., Pennsylvania.

9DFW—Frank Zurek, 2024 Potomac Ave., Chicago, Illinois.

9DLY—Clayton S. Waldradth, White, S. Dakota.

9DVG—Headquarters Company, 1st Bn., 133rd. INF, Iowa National Guard, Cedar Rapids, Iowa.

9DZT—Parker Gates, 303 Vermont St., Quincy, Illinois.

9MZ—Edw. C. Crossett, 1200 Lake Shore Drive, Chicago, Illinois.

oa2RX—Henry Clive St. John, 82 Gibbes St., Rockdale, New South Wales, Australia.

np4KD—E. W. Mayer, Box 103, Ensenada, P. R.

su1CG—W. Figueira, Magallanes 1070, Montivideo Uruguay, S. America.

The following stations belong to members of the A.R.R.L. Headquarters gang. Mail for them should be addressed care A.R.R.L., Hartford, Conn. When operating 1MK they use personal sines as indicated.

1MK Headquarters 1ES A. A. Hebert "ah"
1AL H. P. Westman "ws" 1GO L. A. Jones "lj"
1BAO R. S. Kruse "lq" 1KP - NRRC F. Cheyney
1BDI F. E. Handy "fh" Beckley "beek"
1BHW K. B. Warner "kb" 1OA R. S. Kruse "lq"
1BUD A. L. Budlong "bud" 1SZ C. C. Rodimon "cr"

SAY YOU SAW IT IN Q S T—IT IDENTIFIES YOU AND HELPS Q S T

Amateurs rely on the ADVANCE "Sync" RECTIFIER

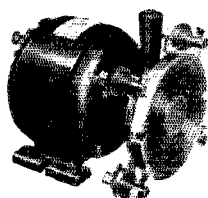

Amateurs all over the world recognize that the Advance Sync Rectifier is far superior in quality in spite of being lower in price. Used in international transmitting more than any other rectifier made.

The Advance Sync Rectifier meets all requirements for heaviest duty.

Improves all transmission—giving clearer tone and better volume. Can be easily and quickly filtered. Speedy starting because of Advance Bakelite wheel. Requires no attention—always ready.

Revolving disk is moulded bakelite six inches in diameter. Nickel plated brush holders with adjustable gauze copper brushes. Convenient control handle. Disk, aluminum brush arm support and brush holders perfectly insulated.

Price complete with Westinghouse 1/4 H. P. Synchronous Motor\$40

Rectifying wheel with complete brush assembly and mounting ring to fit your own motor \$15

We Pay All Transportation Charges in U. S. A.

ADVANCE ELECTRIC COMPANY

1260-1262 West Second St., Los Angeles, Calif.

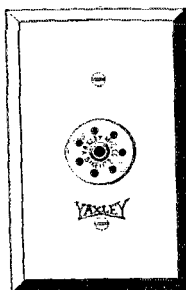

Radio Convenience Outlets

Spring is the time to install Radio Convenience Outlets. They enable you to get greater joy from your radio by eliminating all unsightly wires from the room. The Radio Convenience Outlet shown above is for battery connections—batteries can be placed in basement, closet, nearby bookcase or any out of the way place and wires led to radio set in a neat, attractive way.

Take your loud speaker to the porch this summer by using the No. 135 Radio Convenience Outlet. You can also have radio in as many rooms as you wish without removing the set from original location.

No. 137 For Battery Connections \$2.50
No. 135 for Loud Speaker 1.00
No. 136 For Aerial and Ground 1.00
We have a very interesting bulletin on Radio Housewiring. Copy on request.

YAXLEY MFG. CO.,

Dept. S, 9 South Clinton St., Chicago, Ill.



for REAL RECEPTION!



KINGSTON "B" Battery Eliminator

Guaranteed to remove the battery nuisance and deliver clearer tone and increased volume. Provides three different voltages at the same time. Each tap adjustable over a wide range, making possible any desired voltage from 5 to 150, absolutely harmonizing "B" current supply to your set. Raytheon tube used as rectifier. No noise or vibration. Contains no acid or solution and will not get out of order. Operating cost negligible.

At Your Dealer's

Price, complete with Raytheon tube **\$35.00**

KOKOMO ELECTRIC COMPANY
KOKOMO, INDIANA

FOR YOUR CONVENIENCE QST'S INDEX OF ADVERTISERS IN THIS ISSUE

Acme Apparatus Company	81
Acme Wire Company	80
Advance Electric Company	103
Aero Products, Inc.	105
Aerovox Wireless Corp.	94
Amateur Radio Specialty Company	98
Aluminum Company of America	101
American Sales Company	101
American Transformer Company	111
Amrad Corporation	99
Associated Set Builders	96
A.R.R.L. Application Blank	102
A.R.R.L. Handbook	3rd cover
Barawiek Company	101
Bariberg & Orth	92
Browning-Drake Corp.	87
Burgess Battery Company	4th cover
Burton-Rogers Company	108
Cardwell Mfg. Corp., Allen D.	80
Carter Radio Company	96
C. E. Mfg. Company	90
Central Radio Laboratories	84
Crescent Radio Supply Company	101
Crosley Radio Corporation	76, 77
Cunningham, Inc., E. T.	2nd cover
DeForest Radio Company	97
Deutchmann Co., Tohe	82
Dongan Electric Mfg. Company	106
Dudlo Mfg. Corporation	89
Eastern Radio Institute	77
Electric Specialty Company	88
Elkon Works, Inc.	93
Ensall Radio Laboratory	88
Fansteel Products Company	84
Federal Radio Corporation	98
Frost, Inc., Herbert H.	82
General Radio Company	85
Gensback, S.	98
Goyer Company	86
Grebe & Company, A. H.	5
Grigsby-Grunow-Hinds Co.	2
Gross & Company, J.	96
Gulf Radio School	96
Hammaland Mfg. Company	92
Helson Radio Condenser Corp.	83
International Resistance Co.	90
Jewell Electrical Instrument Corp.	90
Johnson Company, E. F.	91
Karas Electric Company	79
Kokomo Electric Company	110
Lacey Williams Company	100
Loomis Publishing Company	96
Lynch, Inc., Arthur H.	91
Mario Electric Company	84
National Company	88
New Jersey Radio Supply Co.	104
Pacent Electric Company	102
Radio Corporation of America	1
Radio Engineering Laboratories	78
Radio Surplus Corporation	92, 106
Scientific Radio Service	88
Signal Electric Mfg. Company	100
Smith, B. Hawley	86
Sparks Radio Service Co.	92
Sterling Mfg. Company	93
Sromberg-Carlson Telephone Mfg. Co.	108
Teleplex Company	104
Thordarson Electric Mfg. Company	95
Transmitting Equipment Company	100
Transmitting Equipment Laboratories	94
Utility Radio Company	102
Vibroplex Company	112
Ward-Leonard Electric Company	100
Well's Curiosity Shop	102
Weston Electrical Instrument Corp.	82
Wireless Specialty Apparatus Company	91
X-L Radio Laboratories	106
Yasley Mfg. Company	109

An Explanation Of AMERTRAN DE LUXE EFFICIENCY

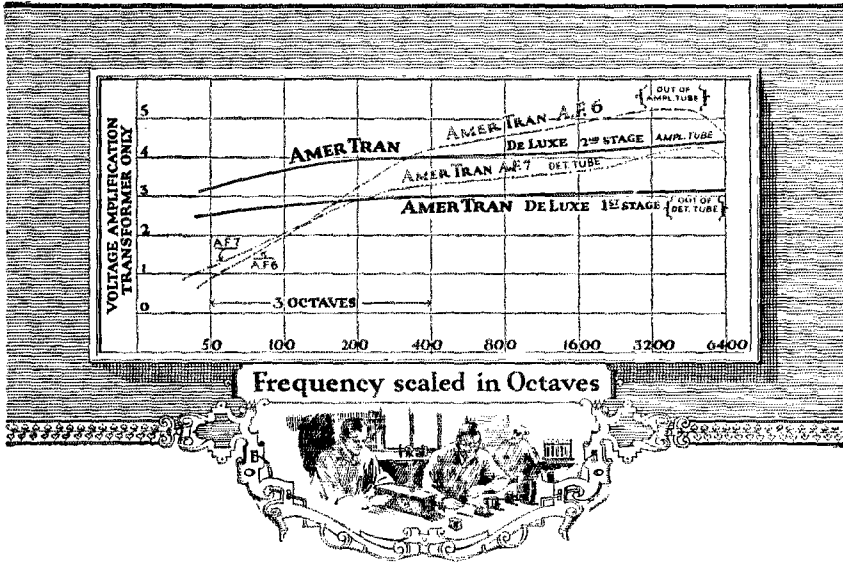

The above curves are plotted from measurements made in accordance with the latest tentative rules of the N.E.M.A. These curves have been proven conservative, and accurately represent the AmerTran De Luxe Audio transformer.

For one and one-half years the AmerTran De Luxe has been used with great success by all those seeking improved audio amplification. The secret of its excellence centers chiefly in the special alloy core material which provides the high inductance needed for the normal amplification of the fundamental base tones. This makes possible an improved coil structure for maintaining the higher frequencies with no appreciable "peak" or "droop" until beyond the useful range.

There is a remarkable absence of the muffling of sibilant sounds and "background"—often noticeable with transformers having "drooping" characteristics.

The AmerTran De Luxe is well made and designed to give long, dependable service. Metal cased and embedded in a solid compound, it is not affected by climatic changes.

The better reception obtained by installing correctly a pair of AmerTrans is final proof of their high efficiency rating.

THE AMERICAN TRANSFORMER CO.
178 Emmet Street Newark, N. J.

Transformer builders for over 26 years

Write for free booklet entitled "Improving the Audio Amplifier," together with other technical data.

The AmerTran De Luxe made in two types for first and second stages. \$10.00 Each.

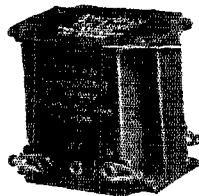

Other AmerTran Products

AmerTran Power Transformer
Type PF52 \$18.00 Each

AmerChoke Type 854
\$6.00 Each

AmerTran Audio Transformers
Type AF7 and AF6 \$5.00 Each

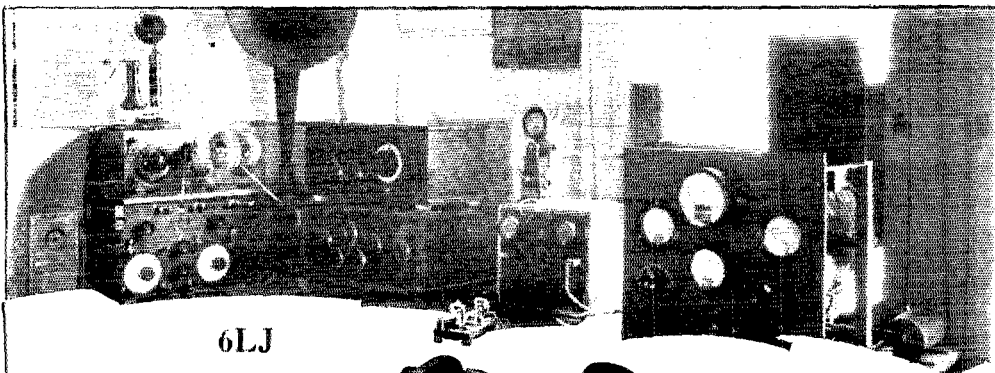

6LJ

*Learn to
Send the
Easy Way*

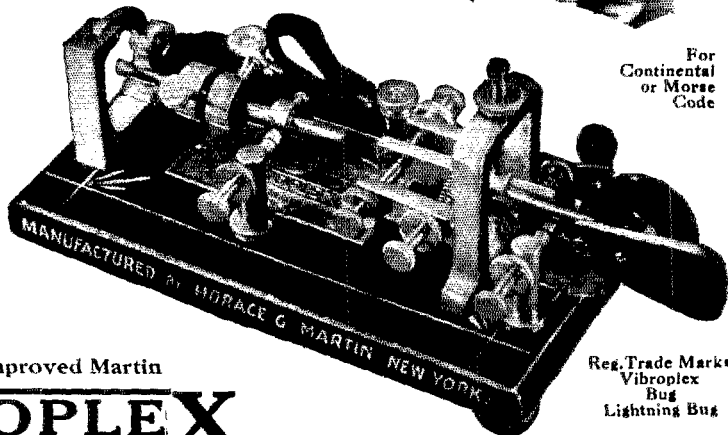

Reg. Trade Mark
Vibroplex
Bug
Lightning Bug

With the Improved Martin

VIBROPLEX

Improves Sending 100%

Japanned Base, \$17
(In Canada, \$22.50)
Nickel-Plated, \$19

Now is the time to get YOUR Vibroplex. A Genuine Improved Vibroplex. This is the **BUG** you want because it is the best that brains, experience and money can build.

Every up-to-date operator nowadays uses a Vibroplex **BUG**. He would be lost without it.

It is the **EASIEST** and **BEST** way to send. You can learn it in almost no time. You simply press the lever—the Vibroplex does the rest.

There's no tensing of the muscles, no cramp, no nerve strain when you send with a Vibroplex. It saves the arm, prevents lost grip and improves sending 50 to 100%.

The Improved Vibroplex is the pride of more than 100,000 Morse and Wireless operators. It is the operators' greatest asset. It is in use in practically every telegraph office and wireless station on land and sea.

Operators prefer this **BUG** to the old key because the sending is more uniform, the signals stronger and easier to read and sending effort is reduced to the minimum.

The Vibroplex is the Only Genuine BUG

When you buy a **BUG**, don't buy a freak key. Don't be misled by false claims of cheap imitators. There's only one Genuine **BUG**—the Vibroplex. Ask any experienced operator. Read this letter from 4FO—he knows.

"Enclosing Postal Money Order for \$25. Please send your Special Radio Model Vibroplex. Have tried everything else, but am forced to get the best at last. Should have done so at the start."

Latest Improved Model Illustrated
This **BUG** can be used in the majority of DX circuits. For speed, clarity and precision there is nothing to equal it. **Japanned Base, \$17.** (In Canada, \$22.50) **Nickel-Plated Base, \$19.**

Special Radio Model

Furnished with extra heavy contact points for direct use in any circuit without relay. Experienced operators say this **BUG** fills a long felt need.

\$25

The Vibroplex is the BUG YOU Want

Learn to send the **EASY** way—with the Improved Vibroplex. If you can use the old key—you can send **BETTER** and **EASIER** with the Vibroplex. Its ease of operation will amaze you.

Place **YOUR** order Now for immediate delivery. Insist on the Genuine Improved Martin Vibroplex. The Vibroplex Nameplate is **YOUR** protection. Sent anywhere on receipt of price. Money order or registered mail. Liberal allowance on old Vibroplex.

Write for **FREE** Catalog

THE VIBROPLEX CO., Inc.

825 BROADWAY J. E. Albright, Pres. NEW YORK
TELEPHONES: STUYVESANT 4828, 4829, 6094



Recognition—

And the Indication That YOU Are Missing Something

The sales of "The Radio Amateur's Handbook" have exceeded all our most sanguine expectations. The second printing, which we expected to fill the demand for the remainder of this year, has now been completely exhausted and a third printing is ready for distribution. Daily sales are greater than at any time since the announcement of the book.

There is only one reason for this. It means that the Handbook is the complete answer to a very real need. It is universally hailed as the most helpful collection of amateur radio information ever assembled under one cover.

If you are a novice, "on the outside looking in" at amateur radiotelegraphy, here is your friendly guide to all the secrets of the game. If you are already a station owner, here is a complete manual of approved amateur practice that leads the way surely to better station performance and better operation. We confidently believe that NO ONE interested in any phase of amateur radio can afford to be without this book at any price. No organization in the world except the A. R. R. L. could assemble such a book and sell it at this low price. Your money cheerfully returned if you don't like it.

Slip a dollar bill in an envelope today and just say "*Send me a Handbook*", and get that contented feeling that comes with the possession of something really worth while.

"The Radio Amateur's Handbook"

By F. E. Handy, A.R.R.L., Communications Manager

224 pp., QST size \$1 postpaid anywhere

**AMERICAN RADIO RELAY LEAGUE
1711 PARK STREET HARTFORD, CONN.**

An acknowledgment of Our Debt to the Amateur

The growth of our amateur call list to proportions forcing, because of lack of space, the discontinuance of its publication in QST, impresses us with the responsibility accompanying such widespread preference for Burgess products. We feel now, that every effort must be made to *maintain* our position with the "ham."

To this group, as much as to any other in radio, we owe a lasting debt of gratitude. It is one that we shall repay through constantly striving to make Burgess Batteries give *longer* and *better* service always.

BURGESS BATTERY COMPANY

General Sales Office, Chicago

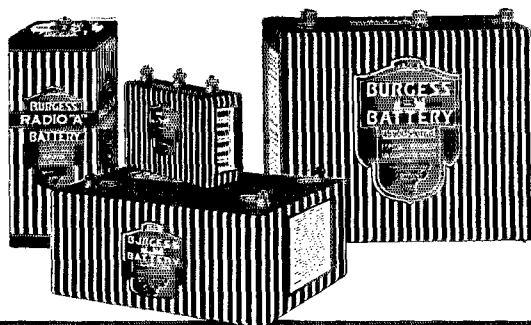

BURGESS
RADIO BATTERIES

The Communications Department

F. E. Handy, Communications Manager
1711 Park St., Hartford, Conn.



Concerning ES and 73

A GREAT many amateurs new to the gentle art of brass pounding have come to misuse some of our commonest ham phrases with little or no thought as to their origin and less thought as to their exact meaning. With this in mind we are pleased to present a few paragraphs written for *The Lightning Jerker* (a most excellent monthly sheet devoted to the interests of the professional radio operator) by Mr. R. O. Koch, Chief Operator WMW. This is presented by courtesy of that publication. Let's study our operating practices more and not only try to make our sending steady and our signals clear cut but also let's clean up our sloppy usage of such meaningless expressions as "QSB DC", "Best 73's", and so on.

First let's get at this "es" business. For the one hundredth time—ES IS TAKEN FROM THE AMERICAN MORSE CODE AND IS ALWAYS COPIED "&"—nothing else! Cut this line out and paste it on your tuner panel until you remember it. It's enough to say, "Best 73's es CUL" in letter writing, but when a man hears "es" on the air and then transcribes it in those letters ON HIS MESSAGE BLANK, he is going too far. "Es" should not be written for "&" any more than "KK" should appear on the blank to denote parenthesis, or "AF" for quotation marks.

Some little objection might possibly be raised to the use of "es" at all in radio work, maintaining that it is an American MORSE character exclusively and not authorized for radio communication. However, men versed in both American Morse and Continental see advantages and disadvantages in each, and as Continental was first introduced to operators who had been accustomed to using American Morse, the result was a more or less hybrid code which we have today.

The Morse letter "C" for example, is a wonderful improvement over the "MIM" signal which is officially recognized on paper and seldom heard on the air. A Morse "C" serves at the same time as a polite inquiry as to whether the air is "clear" for the minute and as a warning that if no immediate reply such as "AS", "QRX" or "QRT" is heard, the station making the "C" will transmit on normal power at once. A fellow will often knock one right off his chair with his first warning of high-power (MIM) and the second of the series of three MIM's required by the book will push the diaphragms right through the receiver cap! A single, snappy Morse "C" answers the same purpose without breaking any bones or wrecking half the operating shack.

"73" is another oft-abused phrase. Reference to a code chart will show the plain figures 73 as meaning, "Best Regards." The addition of a superfluous "s" to it, makes it "Best Regards's"—whatever that double "s" may mean. Cut out the 73's and make it just the two figures. Also, why the prefix "Best" so many of you use? If 73 means "Best Regards" then "Best 73's" means, "Best Best Regards" which looks like a kindergarten effort to express a simple good wish.

Last, but not least, don't be afraid to learn the Morse code, or anything else that will make you a better operator. A knowledge of American Morse will show you a number of advantageous little shortcuts which you can apply to your daily radio work and will help all concerned. In all telegraph work, let brevity, insofar as consistent with good meaning, be your watchword.

More Reports on 20-Meter Work

IN MARCH *QST* (C. D., page III) we discussed what was doing on our twenty meter wavelength band. As this issue has just been distributed there are no important additions we can make at this writing. The good conditions and wonderful possibilities of accomplishment mentioned last month remain just as attractive as ever. Wonderful low-power work is being done regularly over great distances. The new rule for 20-meters seems to be that it is a good wave to use whenever there is daylight at either end of the QSO. That there are plenty of exceptions to this is easily proven, tho. The South American stations on "20" that were mentioned last month continue to be heard and worked with ease at 8 and 9 p.m. CST.

Conditions are getting better on 20 meters day by day in the Northern Hemisphere due to the fact that the sunlight is with us for a greater number of the twenty-four hours. "20" is ideal for work all summer long. It is, therefore, suggested that if you haven't yet tried out the possibilities of this band that you read the dope in last *QST* and get busy at once.

Some of the latest reports follow: From 9AWB (Montrose, Iowa), "I want to say that 20 meters is FB for low power. I use a 301-A tube, magnetically coupled Hartley and 120 volts of dry B-bats for plate supply, operating my single wire antenna on the eleventh harmonic. Best DX worked is ndHLK. The East coast is the usual thing. Calif is worked about every other night with an occasional 7th dist. station. In the daytime about 80% of the stations called are raised—at night the average falls to about 30%."

1CAW (Fall River, Mass.) says, "Daylight contact in the past 3 weeks up to Mar. 6th: eg2AO, eg2OD, eg5BY, eg6BD, emSMTN (G. Kruse, Djursholm, Sweden, 22 meters, 23 watts plate input, R-5 d.c.), np4SA, nu6ZAT, nu3CAW, (also 4, 5, 8 and 9 too numerous to mention here), nd4DW. At night: se3AG, ne5FK, nu6BXI and others. Heard only: Nu's from every district, su2AK, nq2JT, eg5HS, eg5WQ, eb4BC." 1CAW reports the South Americans R-6. It's FB to note that he has a daily schedule with eg2AO and that he has worked most of the stations listed an average of two or three times—these are no passing or momentary contacts.

eg2AO (Eastbourne, Eng.) sends a list of 20-meter calls heard by radio via 1CAW Sun. Mar. 6th. The figures are audibilities in the R nomenclature. Here they are: 1ADM-4, 1AFL-6, 1AMU-4, 2TP-5-6, 1AHC-3, 2JN-4, 2AMJ-6, 2ALP-3, 1ASF-6, 3BMS-4, 2BRB-5, 9CXX-5, 9DON-4, SALLY-4-5, 1AMD-4, 8AXA-4, 1BFY-4, 1AWU-3-4, 1CAW-6, 1RY-3, 1ARD-6, 1ANM-4, 1CDP-4, 1CCR-5, 3JO-6, 4BL-4, 1SW-5.

9UB (La Salle, Ill.) has been on "20" since New Year's day and has been reported in QSO's as R-8 in every U. S. and 3 Canadian districts. "9UB is on 19.85 meters daily 4 to 6 pm C. S. T. I should be glad to hear from anyone who can arrange schedules for that time. I changed to a *straight ground* and found it improved the steadiness of my sigs. That this might help some of the gang even tho the results were due to just a local condition of mine. Use a fundamental antenna. Handled 18 messages in 15 days and QSR'ed 'em all on time. Who can beat that for 20-meter traffic? What I like best of all is that the ole ham spirit is there and a rag chew of an hour is not unusual. Tell the fellows in that Chinese laundry mess on "40" to QSY to "20" and get in on some real fun."

1ZL (Bridgeport, Conn.) with a 6-watter with 30-watts input recently worked eg5HS, ef8CT, ef8YOR, nc4DW, nc3GG, nu's 5AUZ, 5QJ, 5WZ 6BUX 6CLN, 6LH, 6ZAT and 7EK. 35 9's were worked—other U. S. districts in proportion. FB!

1AYJ (West Baldwin, Me.) has worked the west coast a number of times, often in the evening between 9 and 10.30 pm EST. Here are a few of the calls of stations he has worked on "20": 9FK, 9ACY, 9CPQ, 9EAS, 9BNA, 6BIL, 9BI, 6CLN, 6BXI.

8BEV (Bucyrus, Ohio) with one UX-20 and an indoor Hertz worked egBVJ (R5, 21.1 meters) and also heard eg5HS testing on 20.7 meters with a d.c. note, also R5 on 2-step. No antenna or ground was used.

eg2NH (SW7, London, Eng) sends the following radiogram that will answer 9UB's query as to when he should listen for English stations: "All U. S. A. districts QSA here in Europe after 2000 Greenwich. Please ask 20-meter gang to pay more attention to the "eg" stations at this time on 23-meters." This was received via IBMS.

8BAG (Niagara Falls, N. Y.) has sent in several fine reports, all on 20-meter work. On Feb. 6 he worked eg6YQ, also copying eg5HS and eg2KF. eg5HS was heard again Feb. 12th and worked again the 27th. On the 16th, 17th, 20th, 22nd and 23rd he was QSO one or more su's each night after dark. oh6ACG was worked on one of these nights. su1BU is one of the most readable South American stations at 8BAG. Mr. Lidbury says among other things, "I am fully convinced there is fine DX on "20" any night after dark. What we want now is some long distance duration schedules to determine faster than can be determined by hit-or-miss experience over just what portions of the day or night 20-meter signals are audible between two given points. Some of this is now going on between the West Coast and Europeans—the more the better. I shall be glad to make any kind of a schedule, one-way or two-way on "20", say five or ten minutes every hour over any period of a day." Will someone in a position to do so please write nu8BAG, Mr. F. A. Lidbury, 33 Sugar St., Niagara Falls, N. Y. with this end in view? This is the type of work that is really needed most and cooperation on this problem will not only prove interesting to you, but it will uncover some new facts valuable to all. Reports are welcomed from anyone who attacks these remaining 20-meter problems constructively and these columns will devote as much space as necessary to the exchange of ideas for the benefit of those who are working to dig out this information.

A 20-meter radiogram from 6VZ via 8AVB and 1ZL dated Feb. 24 reads, "Was QSO ef8YOR at 1515 Greenwich on 20-meters today. Have been QSA in France for two weeks. Tests continue, (signed) Seymour, 6VZ (Santa Monica, Calif.)" Feb. 22nd nu1ADM by a beautiful piece of break-in work arranged tests working 6VZ, ef8JN and ef8YOR at the same time altho not succeeding in tying up 6VZ with Europe at the time. Feb. 26 a 24-hour test was run. 8BHA and 6VZ taking turns at the key. The result of these tests seem to indicate that 20-meter contact can readily be established (Europe to California) in the daylight hours between 1500 and 1700 Greenwich at this time of year.

9KV (Duluth, Minn.) says, "oh6ACG comes in unbelievably loud from 7 to 10.30 pm, nightly on 19 meters. It's a pleasure to handle traffic with him—and not have to roll out of bed at 3 am. to do it."

eg5GQ requests U. S. hams to report his 23-meter sigs if heard between 1600 and 1900 Greenwich, Sundays according to a message through 1AUR. ARDL mentioned elsewhere in these pages, is testing on 18 and on 4 meters and would like to QSO the gang. 8AHC and 4IZ were copied on "20" by ARDL. 2AMD-2AII went down to "20" and worked ef8ARO, eg2AO, eb4BC, eg5BY, eg2XY and nu7ACP right away. He's down there for keeps now.

1BYM (Hartford, Conn.) has been keeping some 100% 20-meter schedules daily with nc3NI and nu9CZQ. He worked 9FO and 6RM using 45 and 250 volts of B-battery respectively. 6DCK and 6CAU have been worked after 10 pm EST, the signals usually dropping out about 11 pm EST. 7EK, 6CLN, 4LM, 4BL, and 4DM were also worked. Heard: ef8JM, ef8JG, su2AK, su1ZD.

Concerning the first week in March 8GZ (Columbus, O) says, "On "20" I have worked eg, ef, su, sb, oa and get R6 to R8 reports."

By radiogram March 3 from nc9AI, "Worked su1UD and oh6ACG one night recently on 20-meters. Signals from Honolulu very good until eleven pm EST on 20. NPM testing on 18.5 was readable ten feet from tones with no antenna coupling at nc9AI. (signed) Thompson."

All that we can say in addition is "keep up the good work". If you haven't a set that operates on 20 meters get busy right away and fix your outfit so it will QSY. That will insure that you get something new out of the outfit and also that you spend a pleasant and profitable time during all the coming months. —F. H. H.

Amateur Co-operation in San Diego Emergency

By Juan Rodriguez, 6CGC, Route Manager, San Diego Section

ON Feb. 16th things began to happen when the wires went out in the vicinity of San Diego following an exceptionally heavy three-day rain. Amateurs at once got on the job and a number of amateur stations made a good record in the emergency. It is also interesting to note that during those hours when the regular communication lines were broken, all the radio traffic was being handled by amateur operators regardless of what station was being used.

Some of the outstanding work was done by one of the local Official Relay Stations, 6DAU, who handled traffic with 6BJX of Los Angeles for several hours. 420 words of press and private traffic were handled. 6BJX's father took press messages from the Los Angeles office of the Federal Telegraph Co. whose lines were down. 6DAU's mother phoned the press to the San Diego Union as fast as it was received. The radio link was broken at about 9.15 p.m. due to skip distance and the use of 40-meters, the sigs falling off slowly at first and dropping out suddenly at that time.

6FP took 200 words of United Press for the San Diego Sun from 6BZJ at Pasadena. 6FP originated a number of important messages for Los Angeles which were phoned from Pasadena. 6BZJ got a fine appreciative letter from the San Diego Gas and Electric Co. for his good work in this. During the emergency 6BSN was on the air at 6AAK's station handling press for a Santa Barbara paper as well as other important traffic. 6BRO in Los Angeles was right on the job to give 6AAK the news. 6CKF deserves a lot of credit for his good work.

6BAS, another ORS, was unable to be at his own station but sat in at the key of KVVU, the limited commercial station of the Boulevard Express handling free emergency traffic for thirteen hours with KVT, their branch station in Los Angeles. 6ADV, manager of the local Federal Telegraph office worked nearly all day handling his own traffic via amateur radio. 6BXN handled some messages for Los Angeles, also. 6CGC, 6SB, 6BAS, 6BXN and 6FP kept watch until the early hours of the following morning. The danger cleared away as the rain stopped and the normal wire communication was re-established.

6ANQ of Hemet, Calif., sent several hundred words of press to 6BJX who delivered them to the Associated Press. The latter station first got on the air in response to a phone call from 6UD informing him that the wires were out between San Diego and Los Angeles. 6DAU was raised quickly enough and the arrangements made were so good that the O. K. on messages delivered in San Diego was usually received within ten minutes of the Los Angeles filing time. 6HU at Santa Ana was in touch with 1MK for three hours right after the emergency but was unsuccessful in his attempts to phone an important Hartford message and got a reply. Many stations were heard calling QRR from which it may be assumed that other emergency work not yet reported was done by amateurs.

6RJX writes in about the emergency calling attention to the fact that this is the first opportunity Southern California has had to show what can be done by radio amateurs in times of emergency, which arise quite frequently in the East but are rather uncommon in his part of the country.

There are two lessons to be drawn from our past experiences with emergency work. West coast, and in fact all amateurs should have transmitters and receivers capable of operation at short notice on two or more of our wavelength bands. If amateurs in San

Diego and Los Angeles had had 80-meter sets communication might have easily been maintained all might instead of being (in at least one case) broken off on 40-meters with the coming of night. More emergency power supply equipment should be held in readiness, too. Although the power held good at both San Diego and Los Angeles an emergency of the magnitude of the Florida disaster is sure to wipe out commercial power and light mains. Dry cell B-batteries, storage cells, dynamotors, or gasoline-engine driven equipment can be used, the availability to most amateurs being in the order given. Why not BE PREPARED, OM?

Last month was a good one for the emergency gang. During the blizzard that raged in the east Feb. 20 the cable between Norfolk, Va., and Cape Charles was injured and the P.R.R. men came to the rescue with 100% performance. 8AKW, 3ADE, 3CAH, and 8AWT at Philadelphia. 3CEB and 8AHL at Norfolk stood a continuous watch handling nearly fifty long and important railroad messages. The traffic went from Norfolk to Philly by radio and from there back to Cape Charles by wire. 8XE, 3ADE and others also did good work, the whole eastern gang standing by to pitch in if needed. All are to be congratulated on the successful results in the face of real emergency.

The same storm struck Concord, N. H. wiping out telephone service to many points. 1AER, 1AVL, and 1BFT-10C got on the job for the wire chief of the telephone company. On Feb. 19th 1AER worked 1ASA in Cambridge, Mass. handling telephone messages for several hours. In the evening some traffic came thru over the route: 1FQ-1AER-10C. Reply messages were handled over the same route which was still in operation the next morning. Later Feb. 20 1AVL worked 1ADL in Boston who got 1FQ back on the air to take more traffic. Good work in addition was done for the Eagle Hotel of Concord. More congrats are in order!

TRAFFIC BRIEFS

1CAW hooked up with ARCX, the whaler, *Astilsen Alonso Hobart*, Feb. 20, 5.30 am EST. ARCX was then on 35.5 meters with a 500-cycle note, R6, and steady. His position was given as Lat. S. 77° Longitude E. 179° which places this whaling expedition in the Antarctic sea, 3,000 miles south of New Zealand and about 18° from the South pole. 6CUA worked ARCX and took a greeting message for A.R.R.L. Hq. On Feb. 23rd 9CNL in Denver, Colo., connected with ARCX at 4 m MST. The whaler was then QRD the Ross Sea in the Antarctic. He was R3-4, 500 cycles and 9CNL reported the wavelength as about 33 meters. 9KV has a schedule with ARCX which expedition has been out since December. He says they have about 400 whales. Here's a floating opportunity for everyone to make some records in communication with the South pole—or at least the very nearest thing to it.

1ASU-1BCO was in touch with the Swedish motorship *Laponia*, SJB, regularly after they left Cuba. When SJB was 750 miles S. W. of Lands End he took a message for a party in Worcester, Mass. phoned it, and returned a reply to SJB in a very few minutes. FB work! SJB was expecting to dock at Gothenberg, Sweden, Sunday, March 6. 8AXA was QSO Feb. 26. 3QP worked the *Laponia* Feb. 27 reporting the tone as resembling "a loud whisper" through heavy QRM. 1BMS throws further light on this. He worked the *Laponia* when she was 220 miles south of Cape Hatteras QRD Cuba, QRF Philadelphia, and obtained the information that two UV-201-A's were used in the transmitter.

Mr. Karl Zint, operator of the Zane Grey Schooner-Yacht *Fisherman*, KNT, sends us word that the gang can reach him by radiograms through oh6DCF or FX1. He has been unable to run the short-wave outfit all he would like due to the fact that the gas-engine power supply causes bothersome noise at night. 9ARA worked KNT at Whangaroa, N. Z. on March 10 taking a message for HQ asking the gang to watch for KNT sigs and traffic on Monday and Thursday nights (U.S. time) on 36 meters. KNT has a schedule with ne5AQ, will be fishing north of N. Z. until mid-April then anchoring at

Auckland N. Z. and leaving for Tahiti the last of April.

On Feb. 21, 6AAK was QSO ARDI, the *C. A. Larsen*. ARDI was copied at the same time by 9NK. The Larsen has been lying in the Ross Sea, Antarctic circle but is working her way out QRD New Zealand. 9KV sent a fine report, having kept a schedule with both ARDI (about 30 meters) and ARCX, at present working ARCX each Wednesday and Saturday. Mail should be addressed to Chief Radio Operator, S. S. C. A. Larsen, Care Norwegian Consulate, Dunedin, N. Z.

9ABR worked ARDI for an hour March 10 taking one message. ARDI was on 33.5 meters at the time of this QSO but he is also working on 18 meters much of the time.

Gordon Hight, nu4BQ, and Mr. Wall, nu4MW are leaving Rome, Ga., about March 25 for a six weeks' cruise from Tampa, Fla., touching at Cuba, Haiti and Panama. The yacht will use the call KGAW on 110 meters and the portable 4SK on 40 and 80 meters and will attempt to keep in touch with family and friends by amateur radio. Help out by doing your part, gang.

CLUB ACTIVITIES

California—"The Ham-Meter" is a new monthly publication printed at Berkeley. It is of interest to California Radio Clubs and amateurs.

The Santa Clara County Radio Association held a hamfest in honor of the opening of their new quarters. The Club station (6SV) is now on the air and looking for schedules.

CONNECTICUT—The Twin City Radio Club of West Haven installed a ham outfit at a recent New Haven Progress Exhibition, handling many messages and interesting a number of people in amateur radio. Later the club held a mid-winter get-together in its club rooms.

DISTRICT OF COLUMBIA—The Washington Radio Club held an enjoyable dinner recently. Mr. Terrell, chief radio supervisor, Commander Taylor of the Navy's Bellevue Laboratories, and Mr. Hebert of A.R.R.L. Headquarters gave interesting talks. 8AB gave a talk on rectifiers at another meeting of the club.

ILLINOIS—The Chicago Radio Traffic Association is holding regular bi-weekly meetings at the various members' homes. Interesting talks are given at the meetings.

The Chicago Nines Club, better known to members and associates as the "Chi 9's", had its inception in 9VJ's shack, December 1925. The organization now boasts 22 peppy members whose aim is development of amateur radio and good fellowship through both radio and social functions. The future of this live club is a bright one.

The New Trier High School Radio Club of Kenilworth is still busy constructing its new receiver and transmitter, and expects to get started on the air very soon. Meetings have been held regularly, and code practice has been given to "to be" hams.

The Vermilion County Radio Association has been affiliated with the A. R. R. L. since December 1921. Can any other clubs beat this record?

MAINE—The Queen City Radio Club of Bangor has had many good times during the past year, and plans a still better program for this one. Code practice is a regular feature of its meetings. The officers for this year are 1AQL, 1BFZ, 1FP, 1CDB, and 1IU.

MASSACHUSETTS—The Worcester Radio Association is a new organization which has started its activities by giving a public radio lecture. This is fine work. Keep it up!

NEBRASKA—The Cornhusker Radio Club of Omaha recently held a "Nebraska Week" contest, in which a silver loving cup was offered to the station that was successful in holding two-way communication with the greatest number of stations in the state of Nebraska. This contest was won by 9ANZ of Lincoln. Congratulations, OM! The cup was presented to him in Lincoln on March 5th.

With the Route Managers

By Lawrence A. Jones*

THIS little column of ours is now three months old. We have accomplished more than seems possible in so short a time. Reports are getting heavier each month, and more and more of you fellows are getting into the swing of the RM work. Keep it up!

And now we take pleasure in introducing seven new RMs:

N. Y. C. and L. I.: Joseph Toman, 2ANX.

So. Minn.: Kenneth Wolf, 9CAJ.

So. Texas: Derwood Chne, 5IW.

Wisconsin: J. G. Kemmeter, 9DLD.

Tennessee: Polk Perdue, 4FL.

Vermont: Clayton Paulette, 1IT.

Rhode Island: George M. Mathewson, 1BQD.

Before very long we'll have at least one RM from every Section, and then watch the reports roll in. And fellows, please send along some suggestions as to just what you would prefer seeing in this Route Manager column, wont you? Like every new thing it will have to undergo various changes before it becomes just what we want.

Once more we have a traffic map to present. Try originating a few worth-while messages and routing them over some of the lines shown. The heavy lines denote cross-country routes that are working in fine style. Next month we shall probably be compelled to limit the map to what might be termed "trunk line" routes, as there is not sufficient space to include all the local schedules that are now in operation.

And now we have an announcement to make. Your reports are growing to such proportions that it will be impossible to include them in detail as we have done in the past two issues. There is a wealth of valuable information contained in the reports, and it is a matter of much regret that all of it cannot be given to you in *QST*. So wont you send in some suggestions as to what you would most like to see

systems between RMs ought to be of value, as well as many other activities that you may think up yourselves. Let us know of your activities along these lines and before long this department can be chock-full of information of value to all.

A goodly number of messages were recently originated at many points all over the country, all bound for 1MK. These were traced at our request in order to get some dope on traffic conditions. Complete results are not yet available, but some information of interest has already been obtained. One of the most striking features is the ease and rapidity with which messages pass through territory that has been whipped into shape by RM work. A great many messages from distant points were delivered here in much less time than ones coming from nearer points. All this is due to schedules and reliable traffic operation brought about by you fellows. In almost every case it was the Section which had no active route manager, in which messages were delayed the longest. That should be proof enough that your work is not in vain, and that it is going to bring country-wide traffic handling up to standards that the League can be proud of. Progress in this line is bound to be slow at first, but it is sure.

Another most noticeable thing about these messages was the surprising inaccuracy of amateur transmission. Message after message arrived with words changed, lost, and missing. Some messages even lost their original sense, so that we had to await the confirmation copy before we could start a reply. There is absolutely no excuse for this situation, as all that is necessary is a willingness to give or take repeats. Anything that you can do to help along this line will be mighty desirable.

If any of you wish to try message tracing in your district or section to locate weak points, we will be glad to furnish you with a few tracer forms.

In this way you can find out just where your help in forming schedules is most needed.

More attention is needed in securing good delivery of messages, along with these other things. According to theory, the total number of messages delivered per month ought to very nearly equal the total number originated. It has so far been impossible to bring about this condition. Whether your help takes the form of getting your gang to deliver more messages, or whether it consists of suggestions to Headquarters is up to you. But think the thing over, and let us have your ideas. Something must be done. There is no necessity for having a message float

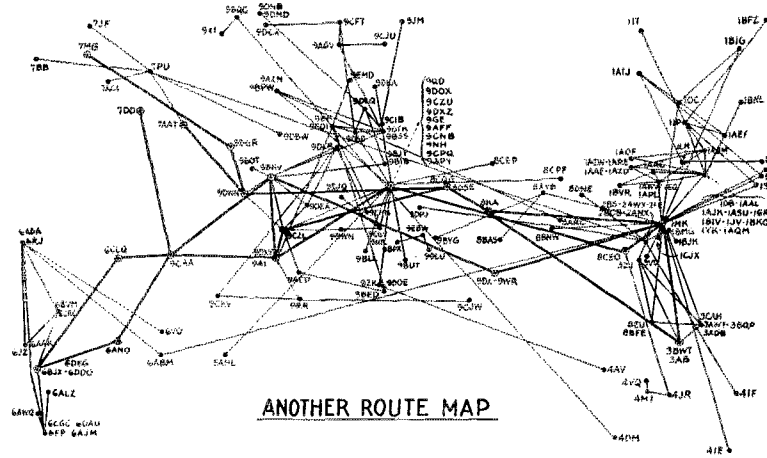

ANOTHER ROUTE MAP

in *QST* regarding your work? It seems as though the most desirable form for your reports to take in the future will be merely the usual schedule map, and nice up-to-the-minute news of worth-while doings of yourself and the men in your section. Suggestions and matter that will be of general interest are particularly desired. This will enable us to print things that will possibly be of more interest to everyone concerned than the previous lists of operating hours.

Start some activities such as have been suggested, and report on the results. Some of you RMs in the midwest might get together and try to form some reliable traffic routes running north and south. East and west through routes seem to be in good shape, as is shown by the three or four reliable cross-country ones shown on the map. Five-point

around its destination for a week or more before being either mailed or phoned. Possibly some change in our system of counting would alleviate this trouble. The fact that a message relayed counts two for the BPL, and one delivered counts only one, might have something to do with it. At any rate, let's hear from you.

Here's one more opportunity for some RM work. In most all the big cities in the country, much difficulty is encountered, both in routing messages into the city, and in relaying them from one part of the city to another. Delivery in cities of this type seems to be assured only when some station outside the city mails the message. This shouldn't be. It should be possible to relay messages into a city, thence to the section of the city they are bound for, and then to deliver them by either phone or mail if a delivery in person is impossible. So get busy, you fellows in large cities—

*Assistant to Communications Manager, "LJ" at 1MK.

why not work out a plan of cooperation between all local traffic stations to help in putting a bigger percent of our messages through ALL the way by radio. If the local stations can exchange lists of their schedules frequently this will be of great help in the prompt relaying of traffic, too.

That clears the hook for this time, gang. Please think some of these things over and drop a line to us once in a while. 73 until next month.

ARMY-AMATEUR NOTES

1st CORPS AREA—The signal Officer has assigned the following officers to maintain liaison between Army Amateurs and the Tactical Units they represent: Capt. P. I. Reynolds, Sig. Res., 23 Ashmont St., Springfield, Mass.; Capt. G. W. Talbot, Sig. Res., 30 Oakland St., Melrose, Mass.; 1st Lt. E. J. Atkinson, Sig. Res., 956 Chapel St., New Haven, Conn.; 2nd Lt. W. R. Chandler, Sig. Res., 341 Brook St., Providence, R. I.; 2nd Lt. Carl Emerson, Sig. Res., 163 Girard Ave., Hartford, Conn.; 2nd Lt. E. C. Lindstrom, Sig. Res., 766 Main St., Worcester, Mass.; 2nd Lt. A. A. Woodward, Sig. Res., 7 Capital St., Concord, N. H.

These officers will assist A-A stations in handling traffic by Army procedure and stimulate the interest of Technical Unit Commanders, utilizing this means of communication as fully as possible.

2ND CORPS AREA—8HJ reports things going fine with Net stations keeping schedules and handling traffic. EASE has organized his Net. 2IZ, 2AAN, 2ADM and 2PX are active in keeping schedules. 2CYX kept his schedules with 2SC from 2CVJ on account of transmitter trouble. 2PF reports 2APD, 2ARM and 2AVR keeping the Net schedules. 2ADO has dismantled but is operating at 2AQD. 2AFV is sick. 2OU is arranging schedules in his Net. All stations are requested to QSY to the 75-78 meter band for Army-Amateur work. 3HW is holding down his end fine.

There is still room for more Army-Amateur Stations. All interested are requested to write David Talley, 2PF, 2222 Avenue O, Brooklyn, N. Y. Also, if any one is interested in the Citizen Military Training Camps, get in touch with 2PF.

3RD CORPS AREA—Army amateurs in the Third Corps Area have shown much enthusiasm in the past month: Thirteen A. A. R. S. certificates are to be issued to new Army amateurs at an early date. 8AGO and 3AAI have done remarkably good work and should be commended for punctuality in keeping schedules.

FOURTH CORPS AREA—4IO has accepted a commission in the USNR and resigned as A.R.R.L. Representative of the 4th Corps Area to take effect upon appointment of his successor. 4IO will continue to operate as Corps Area Control Station. Recent publicity of the Army Amateur Radio Nets being organized in this Corps Area has brought some results. There are still several vacancies in all of the nets and applications for appointment should be made to 4OI or the Signal Officer, 4th Corps Area, U. S. Army, 450 Hurt Bldg., Atlanta, Ga.

6TH CORPS AREA—Army work is going over big here. There are four National Guard Units installing 50-watt sets and a few stations already operating in Michigan and Wisconsin. An amateur station at Springfield, Ill., is needed and is requested to get in touch with W. W. Bingham.

A NEW GAME

It's a lot of fun,—this game. And it will open your eyes to something that has been getting on our nerves for many a day. It's easy to play, so try it.

The next time you originate a message, write out a confirmation copy and mail it to the addressee of your message. When the message finally arrives at its destination compare it with your original copy. You'll be mighty lucky if the original sense has not been lost. Undoubtedly words will have been changed, added, and dropped, but if your meaning is still there all will be well.

We have recently had a large number of messages originated all over the country addressed to us here at HQ, and each of these messages was followed up by a direct confirmation copy and a tracer. Scanning some of the returns has inspired this outburst. Out of the first ten messages in the

file, just one is correct in every detail. Isn't that a wonderful average? About five of the others are very badly garbled, while the other four have only a few mistakes.

Think it over fellows. Out of ten messages received only one was accurate. Must this be? If you are not willing to ask for repeats and fills until you are sure you have the message correctly, it would be much better for you to refuse to QSR. Messages delivered are fine, and the more we can get the better, but only if they are accurate. Remember—ACCURACY COUNTS!

—L. A. J.

OFFICIAL BROADCASTING STATIONS

Changes and Additions
(Local Standard Time)

1BVV (4.25) noon, Mon. Wed. Sat.; 2APD (83 phone) Wed. 9 pm, (76.5) 9.30 pm, (37.5) Thurs and Sat. 7 pm; 4IZ (33.84) 2 pm Sun., 7.30 pm Tues. (77.57) 9 pm Thurs; 6BBJ (85 phone) 7.30 pm Mon., Wed.; 6BUC 10 pm Sat. 1AOX (83) 7.30 and 10.30 pm 1AOX (19) Sun. 2pm.

BRASS POUNDERS' LEAGUE

Call	Orig	Del.	Rel.	Total
1OC	138	20	1000	1158
1AOQ	479	80	203	767
1MK	155	138	390	683
3VZ	356	132	90	628
2ANX	110	48	346	504
6AYC	50	3	372	427
6HHI	75	7	325	407
9BKV	56	30	320	406
3BWT	—	—	384	384
1AEF	5	29	344	378
1RIG	26	33	304	363
1ATJ	19	14	318	351
9DXV	32	27	276	335
9CZC	4	8	318	330
9EK	82	125	122	329
1CRA	91	29	193	318
6ALZ	22	17	274	313
8KA	61	34	216	311
8ANX	1	10	296	307
1CJR	44	6	252	302
9DXB	28	6	268	302
8EU	45	46	210	301
8BAU	19	15	255	289
4AV	120	46	111	277
8DNE	64	12	198	274

6BJX 270, 2CYX 255, 8QU 254, 9CAA 250, 8GI 243, 9DWN 230, 8XE 232, 8GZ 221, 1LM 221, 9BBS 213, 1IP 211, 9DXZ 209, 4DM 204, 9EJQ 203, 9OX 194, 2APD 187, 3CKL 183, 2XI 182, 6RW 177, 9BWN 176, 1KY 175, 2AVR 174, 8CEO 173, 1ADW 166, 6BVY 164, 9CGY 161, 8CQG 160, 6RJ 160, 1ACA 157, 9DGR 155, 1APL 152, 1BYM 150, 9CNL 149, 2QU 147, 3CBT 141, 1AGA 141, 2AWX 140, 9BWL 138, 9DLD 138, 6BXI 135, 7AAT 134, 8CMO 134, 1BJK 133, 1BMG 133, 3SM 132, 6DAU 132, 2AGU 129, 2BCB 129, 5AMO 126, 8CWT 126, 8AVK 125, 6ZBJ 125, 8DLR 124, 1BEM 123, 6BYH 124, 4MI 123, 9DGV 121, 6CTC 120, 2ALM 119, 2ABP 117, 6AGG 117, 3AWT 115, 6ABM 115, 6FJ 114, 1ACTH 114, 4LK 113, 4TR 112, 6AMM 112, 2CTQ 111, 6ANO 110, 1NK 110, 9QD 109, 9CEH 109, 2ADL 109, 7BB 108, 7JF 106, 5OA 106, 9BTX 105, 9DKA 105, 8DED 105, 9APY 105, 1CTI 105, 1BFZ 103, 6BYZ 103, 9NB 102, 6CLQ 102, 8AIL 102, 1ADL 101, 8DJG 100.

Just as was the case in February QST, we find the honor roll of brass-pounders trying to outgrow its QST space. For this reason, we again list the 25 highest stations first, following these station calls with those of all others that qualified by virtue of consistent operating with message totals in excess of the 100 mark. 1OC takes top honors with 1AOQ just a short distance below. The long list proves that every operator is right on his toes for traffic. The operator of every station that rated should be proud of the fact that he is one of such a fine bunch of good ops—and for his part in the general good showing.

TRAFFIC BRIEFS

5APG kept a schedule with 5CK for upwards of 15 days at 7pm daily, giving him reports on his father's condition from the hospital where he is receiving treatment. There is no apparent skip effect between Havana, Ark. and Oklahoma City and the schedules have proved practical and reliable under all circumstances. FB!

April 18 to April 30 inclusive 2XAI will send tests from 8 to 8:30 pm EST to ascertain audibility, fading, and keying throughout the U.S.A. crystal controlled transmitter working on 45 meters will be used. From 8:30 to 9:00 pm amateurs will be worked and further tests will be made. Amateur cooperation is requested. Address all reports to Mr. Gundrum, Manager WAQ-2XAI, W. E. & M. Co., Newark, N. J.

nc1DD claims prominence this month through having played a CHESS game with nc8AR between members of the Dartmouth and Newfoundland Chess Clubs. Play lasted 2½ hours, each player making 23 moves and the game ending in a draw. This is believed to be the first chess game ever played by amateur radio between two British Dominions.

9EFK has a regular schedule with Radio Station NL4X, Antigua Island, Lesser Antilles, West Indies. NL4X is on 23.5 meters, and uses one UX210 with DC power supply. The op is an American from Virginia and as he unfortunately is a leper his cards are QSL'd by a doctor on the island which we might state for the benefit of those not expert in geography is about 300 miles east of Porto Rico. Give NL4X a good word when you work him OMs—he sure knows his stuff in amateur radio and can ham with you as much as you like. A radiogram to 9EFK will bring you the latest dope. To operator "Bill" at NL4X, greeting, OM. We are sure you will find many friends over the air. 73.

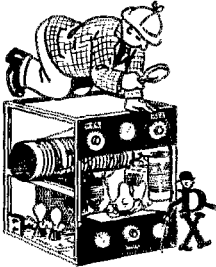

—A clever arrangement taken from 4CU's QSL card. Can anybody go this one better?

nc4CU IS A DETECTIVE

A check up of the log sometimes reveals interesting facts about station operation. nu5ACL finds that 53% of his CQ's resulted in a QSO. Of course the better judgment used in CQing the better the result. How do you stand? Perhaps we ought to put it this way: How many CQ's per QSO were necessary. Hi!

New York Times Station 2UO sends press at 1 a.m. EST nightly on 39 meters for the benefit of ships with short wave receivers. 2ADH-2AXR tells us on good authority that 22 ships take advantage of this service.

If you reside in the U. S. A. or in Canada and have not yet become a member of the WAC CLUB here's your opportunity. During the International Relay Party (May 9 to 22 inclusive) every foreign locality that amounts to much will be on the air looking for one of your test messages. If you haven't sent your QSL-entry card to the INTERNATIONAL CONTEST EDITOR yet be sure to do so now in order to be ready when the contest opens.

If an ordinary man will walk one mile for a Camel worth ¼c, how far will an average ham walk for a new 7½ watt transmitting tube worth nine dollars? —6IM from the Ham-meter

Msg fm Toulouse, France, ef8SM via nu8BEN nr 179 2350 Greenwich Mar. 6 To QST, U.S.A.: Station ef8SM again will begin his Saturday and Sunday tests on 32 meters, 11.50 meters, and 6.25 meters using underground antenna. Please advise via LAUR if QRK, (signed) ef8SM. IAEN took a similar message for HQ from the same source.

9CTO just forwarded another radiogram from nu1FMH saying that he had made QSO's with 37 U.S. stations in five weeks and that we could count on him for the coming international tests. We already know a bunch of stations in the U. S. and Canada that will be looking for San Salvador to add to their list of countries and boost their score, OM.

Don't forget the Midwest Division convention. See you at Ames, Iowa, April 15-16.

So many of the West coast fellows work on "40" exclusively that short distance QSO's are quite an accomplishment. 6HB-6CKV recently pulled a new stunt—a bit of unusual routing but good relayage just the same! One morning he had a message for 6HM but of course this station was weak due to the skip distance. As it was known that 6HM had a schedule with Singapore 2SE, the message was given to this station and shortly after it was given back to 6HM and promptly delivered. Next day 6HB worked am2SE on schedule and got the answer from 6HM. Some QRS, a total of 36,000 miles—18,000 miles each morning in ten minutes!

Here's a scheme that ought to be more generally adopted. Stations in one locality ought to swap lists of five point schedules and cooperate in handling traffic. Example: 3AB and 3BWT in Washington have schedules with many points several times each week. 3AB schedules stations in Cleveland, O.; Philadelphia, Pa.; and Northumberland, Pa. 3BWT schedules Williamsport, Pa.; Baltimore, Md.; Norfolk, Va.; Trenton, N. J.; and Hartford, Conn. Traffic is swapped by land phone daily. Several stations can cover a great many points in this way without much overlap and wasted effort. If any particular stations get swamped with traffic they help each other out. FB!

The U.S.N.R. gang in the 7th Naval District recently sent greetings from the mayor of Orlando to the mayors of Jacksonville, Tampa, Lakeland, Belle Isle and Fort Myers. Replies were returned by amateur radio from each point in quick time, between ten minutes and one hour being required by the different messages.

nbBE4 (ex nc3VH-9CS) is at Nyack, Warwick East, Bermuda. He says it's a ham's paradise with wonderful receiving conditions. Licenses are issued for use of wavelengths of zero to 199 meters, CW, ICW or phone!! The Bermuda Radio Act is ideal as a model for countries where the total number of stations operating is small tho it would be impractical for any part of a continent the size of North America. The principal restriction is to a power of 29 watts but that doesn't mean anything in these days of low-power DX. There are no quiet hours below 125 meters. The local radio store carries everything up to 50-watters, QST comes once a month. Sailing for Bermuda?

March QST (page II and III) listed stations having reliable foreign contact to help in routing important experimental messages to certain countries. This month there are the following additions: Italy *IAEN, France *IAEN, England *ICAN, Germany *IBMS.

8BMN has a break-in system but often finds it impractical to announce that fact when calling CQ as the tuner cannot be worked efficiently during the calling. As soon as he has finished he may run across a station replying that he can work at once. If he then transmits a long dash saying "bk it" or "bk on" the station calling will sign immediately and the QSO can start right then perhaps saving several stations a lot of calling and unnecessary QRM if they all use break-in as every good station does these days.

DIVISIONAL REPORTS

ATLANTIC DIVISION

DEL-MD-D of C — SCM, A. B. Goodall, 3AB — Delaware: 3AIS may be heard entirely on 40 meters after 10.30 pm with an extremely good RAC punch. 3AJH however, has been heard on 80 meters also with a good RAC.

Maryland: 3CJ continues to be active on 80 meters. 3RF reports personal activity, having worked several foreign stations during the closing month. 3ACW is also strong for the DX, having worked an Irish and Italian station within the last four weeks. 3PU has remodeled his transmitter. 3VI is still getting out in fine shape with that steady RAC tone. 3BUR and 3PS are active but they have a hard job keeping radio work and the academy work both going at the same time.

Dist. of Columbia: 3BWT has held the high traffic mark for so long that it's taken as a matter of course. 3JO, one of the youngest ops, is doing good work with foreigners on a 50 watt tube. 3GE took a shot at foreign work this month and besides working a number of foreign stations, reports handling traffic with Germany and England. 3CAB is consistently heard pounding away at traffic handling. 3ASO has changed his phone transmitter over to 80 meters having just dropped down from 176. 3NR is on 80 meters nearly exclusively now as school work limits him to schedule work. 3AB is on 80 m. in the early evening on schedules only. 3ZW is being heard now in the 40 meter band.

Traffic: 3BWT 384, 3AB 56, 3CGC 33, 3PS 28, 3NR 22, 3RF 19, 3CJ 10, 3ASO 15, 3JO 4.

EASTERN PENNSYLVANIA—SCM, H. M. Wallez, 3BQ—The general run of traffic totals improved quite a little over the slump of last month. FB, gang. I hope every one of you make an effort to improve your traffic total each month. If you know of any good stations in this Section, who are not ORS, shoot the dope in on your Form 1 and try to line 'em up. Keep 3EU in mind on your skeds. By the time you have this, we expect to have an RM working in Phila. to help you fellows out down there. Please get your reports in by the 26th.

3SM set the pace for Phila. 3CBT swings a mean key. 3AWT ran up very well, also. 3BQP's 80 m. crystal sure boosted his total. 3CMO is in the BPL again without a sked. 3EU churned out loads, as usual. 2000 v. and 50's don't get along for 3AVK. Look at 3CGZ's total! 3BFE sure puts PRR traffic thru. The sky wire at 3HD flopped in the gale. 3LW's came thru OK. 3BFL is active in club work. 3CCQ canned 40, adding 80 QRM to Billtown and good messages to his total. QRN knocked 3AY hard. 3CDS is DXing yet. 3VF wasn't on much. A husky MG has 3AY happy. 20 m. steps for 3BMS. DX is falling back on 3PY. 3ZM will tear into traffic now. 3CJN had a little xtal trouble. 3JJ has a new junk BC station next door. 3ADQ is burning up 50's. Local QRM worried 3BIT all month. 3AIG was busy at 3XE and failed us some more. 3LM didn't do much. Some new wire is going up at 3BSZ's joint.

3NP is busy building an all-wave station. 3AKW sped up his work nicely. 3ADE is plugging along. Grippe camped with 3WH too long. 3BUV sticks to 40 and not so much traffic. 3RQ, 3WJ and 3BQ are battling BCLs who credit power leaks to us.

Traffic: 3EU 301, 3CBT 141, 3CMO 134, 3SM 132, 3AWT 115, 3AVK 125, 3CGZ 93, 3BQP 86, 3ADE 57, 3BFE 52, 3AKW 52, 3BSZ 49, 3HD 43, 3BIT 31, 3CCQ 25, 3BQ 24, 3CJN 24, 3CDS 18, 3VF 18, 3AY 17, 3BMS 17, 3AY 15, 3NP 12, 3BFL 10, 3JJ 10, 3WH 9, 3ZM 5, 3PY 5, 3LM 3, 3LW 3, 3BUV 2, 3AIG 1.

WESTERN NEW YORK—SCM, C. S. Taylor, 3PJ—Things in this district continue in the same regular fashion as previously mentioned in other reports. 3AYB has schedules going good now and is QRV from 12 until 1 am for schedules with the gang. 3ABG is working schedules with 2DX Sundays. 3AIL has schedules with 3AZE daily. 3AKS has built a new receiver and works England, France and Italy. 3ANX hits the trail again, working 43 states. 3APK is handling traffic with 3QU at Boy Scout show with 3DPR assisting. 3ARG has been handling messages from Yacht Robador in Havana Harbor. 3AMB has schedules with 3EAM, 3BYI, 3RAS, 3AYU, 1MK and 3BAS. 3AVJ is handling traffic and has schedules with 3DHX and 3CIV. 3AYU is now an ORS and OBS and promises to be of great service to the League. 3BAG is hot after schedules. 3CVJ reports 3 new hams in Auburn.

3BAJ has worked Indo-China, Australia, Africa, and New Zealand. 3BFN worked 5 districts again. 3BGN worked oa-5DA. 3BLP handles messages from 2AXX for his Mother in town. 3BQK has handled some traffic but says YLs and 20 meters are bum for traffic. 3CEG and 3RS are new stations and have reported some traffic. 3CIV is back from college on account of the death of his Father. 3CNH worked Germany. 3DDL handled news of sea coast storm to local paper from 3BMC. 3DHX has schedules with 3EM, 2AEF, 3YD, 3QB, 3AHC and 3AVJ. 3DME has schedules with 3AHK, 3AHC and 3WV. 3DNE works motor ship, Sweden. 3HJ reported message traffic but forgot to tell about his schedules. 3NT is on 20 meters now. 3QB is still on the watch for PRR work. 3SD is working low power again. 3WV has schedules with 2SC. 3HX and 3BAL are new ones under construction. 3CLI, on 20 meters, pokes a mean signal. 3BIN will be on soon. 3AXA has schedules with 3BN, 4EZ, and ne-1CO. If you are in doubt, write 3BAG for a schedule with wave check, and keep Western N. Y. the perfect district of the U.S.A.

Four stations make the BPL and 3NT wins the booby prize this month. 3RV has been busy buying furniture and things, etc. which accounts for his report being missing. Guess the rest for yourselves. gang. HI.

Traffic: 3ABG 27, 3AIL 102, 3AKS 8, 3APK 13, 3ANX 307, 3ARG 10, 3AVJ 21, 3AYB 13, 3BAG 29, 3BAJ 12, 3BFN 17, 3BGN 23, 3BLP 95, 3BQK 8, 3CEG 11, 3CIV 15, 3CNH 30, 3DDL 35, 3DHX 64, 3DME 26, 3DNE 274, 3HJ 32, 3NT 6, 3QB 30, 3QU 254, 3WV 41, 3CVJ 25.

WESTERN PENN., SCM, G. L. Crossley, 3XE—Comments come in to the SCM that more news of the section and of certain localities should be included in the report of the SCM each month. But how in the world can there be any more news when the gang don't give it to the SCM? About one fourth of the reports received have no comments. About one half just say they are still alive and the rest give a little news. 3BRM, 3GL, 3ARC, 3BRO, 3DKS, 3CEO and 3XE reported working PRR. 3EW is very busy but did little DX. 3CFR has a schedule with 4LM. 3CRK has worked fone with 3ABI. 3HM is on 80 meters again. 3AWR has been sick. 3AXM will be on 40 meters soon. 3ZD has been busy because of business. 3RW is on the air again. 3VE says kenetrons are much better and is back to them again. 3GI has changed his QRH to 83 but is still crystal controlled. 3GK has changed his wave to 39.6. 3DFY

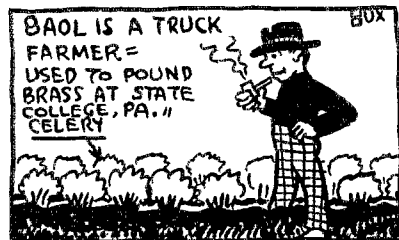

has been having generator trouble, and is putting in crystal control. 3DOQ is increasing power. 3CYP is now on with 100 watts self rectified. 3CLV is located on top of a hill and is having trouble with aerials. 3DHW is still trying to get his crystal operating. 3BRB is now operating on a tropical fruit boat. 3CWT is putting in mercury arc. 3ARC is using carbon brushes on his sine and sez its F.B. 3DNO is rebuilding his entire transmitter from bread-board to panel mounting. 3XE tried 20 meters for a few minutes and is going to put in a transmitter in that band. 3JW is operating a portable transmitter at his dorm in Swatmore. 3AYH is working with fone on 80 meters. 3BRC is building a crystal controlled transmitter. 3BBL is very busy with work at Carnegie Tech. 3CEO is on the transcontinental route from Hartford to Los Angeles. GOOD ROUTE FOR FAST TRAFFIC.

There have been many infractions of operating out of the wave-bands. Of late there has been more

of a move on foot to rid the gang of these pirates and believe me gang they should be gotten rid of. The SCM would be glad to have any station that may be observed as being out of the bands reported to him and he will take the necessary steps to get him to move.

Traffic: 8GI 243, 8XE 222, 8CEO 173, 8CWT 126, 8CFR 66, 8ABW 51, 8DOQ 38, 8AGO 32, 8BBL 23, 8BRM 26, 8VE 25, 8DHW 22, 8CYP 21, 8BRC 19, 8DFY 15, 8GK 13, 8CRK 13, 8EW 12, 8DKS 11, 8ARC 10, 8DNO 9, 8ZD 7, 8BW 2, 8AXD 2, 8AYH 3.

SOUTHERN NEW JERSEY—SCM, H. W. Denham, 3EH—3ZI has come back into the traffic game with a fine total. He is one of the old timers in amateur radio and knows how to push traffic through when given the opportunity. Look out gang, you may hear 3EH coming busting through like old times. 3SJ reports consistent contact with Europe. 3CFG has learned that keeping skeds makes the tlc totals roll up. 3UT comes through with the highest tlc total that has ever been turned in from the Jersey coast. The recent storms raised havoc with a lot of antennas. 3CBX was one of the sufferers but is again on the air. 3BAY and 3ALX are still on the job at 3XE. 90Q was reported to the S.C.M. as using phone on 300 meters recently. That's bad business for any one who does not want to lose his ORS.

Traffic: 3ZI 72, 3SJ 23, 3CFG 60, 3UT 36, 3CBX 2, 3CO 5, 3BWJ 9, 3EP 29.

CENTRAL DIVISION

OHIO—SCM, H. C. Storck, 8BYN—Well gang, here's another month and another report and this fellow SKA, ex8BVR again takes the cake for handling messages, 8BAU running a close second, tho. 8KA sends maps of routes which is shown with his report. 8BAU just received his OWLS appointment from 6AM. 8GZ says Aussies come in FB at 4PM EST. 8DJB, a non-ORS, comes third with a good msg. total. 8BNW is using remote control but blew some more grid leaks. 8CMB has been trying out 20 meters. 8RN is also using remote control. 8DSY says he can't use his DC note when the wind blows his aerial. 8AYS is keeping schedules and doing good PRR work. 8EQ is down on 40 for the summer. 8DII plays checkers every day with 8DEF at 6 PM. 8DBM just caught up with QSL cards from 20 months back. Hi. 8BPL leaves us again until June. 8ACY has been testing on 20 with XIQ. 8CQU blew his 50 and Kenotrons at the same time. 8ALU sent 25 "real" messages to test how many would get thru. Two were delivered. 8AVX is on 20 and reports not much traffic. 8DO and 8CBF are combined but are on only weak ends because of college. 8AOE built a new receiver and is now QRV for traffic again. 8CPQ was very badly burned around the head when he got the juice from his transformer and it threw him onto his rectifier. 8GL says to multiply his total by 5.25311 and he would be in the BPL. Hi. 8CXW will be on 20 meters note when the wind blow his aerial. 8AYJ is having trouble with BLCs but says his new MG is working Aussies great so what does he care? 8AKO has not much time for radio just now but turns in quite a few anyway. 8AVB has been trying for traffic on 20. 8AEU is building an 80 meter portable loop transmitter, call 8BGL. 8CLR and 8SI just enlisted in the U. S. N. R. 8PL has turned DX hound entirely. 8ALW must have YLitis and a guilty conscience because he promises to be more regular on the air after this. 8DPF is going strong for an ORS. 8AYO will be on with Xtal control soon. 8ARW has been teaching code to 8BOW who is a new ham in Greenville. 8BSC says his new set works in fine shape. 8CBI now has a mercury arc rectifier. 8ADH has been working with 180 volts of B on his 50 and stepping out FB. 8KC has been on 20 for a while. 8DQZ now has an antenna working but is pestered with BCL trouble now. 8BBH is with us again with a small portable set and turns in a report. 8DIA has been busy with school. 8AHH is having trouble making his H tube perk. 8AZU is QRW school. 8AWX is a traveling salesman and does not have much time on the road. 8DEM is still QRW school. 8DHS sent a lot of dope but his card got rained on and couldn't read much of it. 8DCF and Manley of VOQ are putting up a set in Cleveland for contact with VOQ this summer. 8AGS is working under the call 9AKK while at school at Purdue. 8BOQ is with us again as 8CCG. He got married

and lost out of the game but is back in again. 8BYN had some luck with traffic and DX lately but has not been on enough to do anything much due to press of SCM correspondence, and other duties.

Summer is coming and most of the stations will be dead for these months while the owners are enjoying the summer breezes and fishing, etc. But don't forget to report anyway, OMs as this will keep you on the active list. Several fellows have asked if relayed messages count two. Yes. If a message is received by radio and goes out the same way, it counts as one each time. More of the gang should get in touch with the RM, SAU, and help work out routes for summer. What do you fellows think of the scheme of having only those fellows who get 10 or more messages per month mentioned in QST in these reports? Would that give some of you an incentive to work harder and turn in more than 1, 2 or 3 messages per month? Don't let's drop out of sight thru the hot months, OMs. Let's get down on 20 and make the summer count for something.

Traffic: 8KA 311, 8BAU 239, 8GZ 221, 8DJG 100, 8BNW 83, 8CMB 65, 8RN 52, 8DSY 52, 8AYJ 45, 8EQ 41, 8DII 41, 8DBM 40, 8BPL 39, 8ACY 37, 8CQU 35, 8ALU 32, 8AVX 25, 8DO 24, 8AOE 21, 8CPQ 21, 8GL 19, 8CXW 16, 8RW 15, 8BKM 11, 8DGP 10, 8AKO 10, 8AVB 10, 8AEU 8, 8SI 7, 8PL 7, 8ALW 7, 8DPF 7, 8AYO 6, 8ARW 6, 8BSC 6, 8CBI 4, 8ADH 4, 8APZ 3, 8KC 3, 8DDQ 3, 8DQZ 3, 8BBH 3, 8BKQ 1, 8DIA 1, 8CLR 1.

MICHIGAN—SCM, C. E. Darr, 8ZZ—Traffic: 8CPM 25, 8DDS 12, 8CQG 160, 9CE 30, 8ZF 13, 8JG 4, 8DCV 15, 8ACU 4, 8ADK 4, 8NQ 16, 8AUD 43, 8DED 105, 8ZZ 14, 9EAY 13.

INDIANA—SCM, D. J. Angus, 9RR—9CEY is rebuilding. 9DJJ worked np-4SA on 20 meters. 9EF is using a 50 and getting lots of foreign DX. 9BSK just came up to 40 meters for air after being on 20 for a few months. 9CP has worked a number of foreigners on 20 in daylight. 9ASX had his rent raised on account of the juice he used. 9DLM and 9BUI have new 50 watters. 9BBJ is putting in a 100 watt station in his room at Purdue, call 9CMV. 9BYI has 5 schedules on 80 meters and is sure pulling the traffic. 9DDZ blew his H tube. 9AUX checked out when his kenotrons blew. 9CJJ works on low power. 9ABP is out because the YLs have him down. 9TL is building a new transformer. 9DVE put up a lattice tower but it collapsed and sent 9CEM to the garage for a general overhauling. 9AHT is a new ham at Goshen. 9BQH uses break-in now. 9DUZ changed to breadboard. 9BJR is busy on 80 meters with a 50 watter. 9ALH has accepted an offer to take charge of WGBF at Evansville. 9EBW and 9ABW are going good on 40 meters. 9AYO blew his 30 Watt Tobe tube but has another one coming. 9EGE still QSO's foreigners. 9CMJ is in on the PRR tests now. 9AIN's motor generator went west. 9CNY has regular eastern schedules. 9AMZ is keeping Chicago schedules. 9BKJ keeps 9DPJ QSO home while he is in Philadelphia. 9DHJ changed from 40 to 80. 9CNC is on 21.7 meters and QSO's England. 9EJU is going good on 80. 9TE is a new station at Muncie, using a 50 watter. 9BCM wants schedules on 80. 9DPI is going again. 9CVX is in on the PRR tests. 9ACR is trying to get the Indianapolis Radio Club traffic prize. 9AEB lost one of his rectifier tubes so is on with raw AC. 9AXO now has an amateur first as he passed the exam. 9BDT is very active at Terre Haute. 9EBW is handling most of the Evansville traffic. 9CLO is going on 80 with a crystal.

Traffic: 9AEB 2, 9CBT 47, 9CRV 36, 9DSC 28, 9CVQ 27, 9CLO 16, 9APG 15, 9ASJ 12, 9AXH 8, 9DWE 1, 9ACR 37, 9CVX 21, 9BCM 11, 9EJU 8, 9CNC 33, 9DHJ 35, 9BKJ 51, 9AMZ 19, 9CNY 22, 9AIN 14, 9CMJ 56, 9EGE 32, 9ABW 13, 9EBW 40, 9DPI 41, 9BJR 50, 9BYI 84, 9EF 63, 9BBJ 37, 9BQH 35, 9DDZ 19, 9ASX 12, 9AUX 11, 9CP 8, 9ABP 6, 9CEY 6, 9AYO 22, 9TE 2.

KENTUCKY—SCM, D. A. Downard, 9ARU—From the number of new stations coming on the air, it looks like this section is finally getting where it should have been long ago. Let's hear from you new fellows. 9OX, 9WR and the SCM were the guests of honor at a hamfest at Lexington Feb. 12 and 13, the hosts being 9ATV, 9BCL and 9EP. The gang visited all stations in Lexington, 9CSO at Dix Dam, 9CJW and 9CIS at Danville, 9BCL at Versailles and 9ALM at Wilmore. Anyone who doesn't believe all they hear about Southern hospital-

ity just stop off at Lexington and look up the gang. 9EP is an ORS again. 9ECL and 9WR are new ORSs. 9WR is a newly appointed 0-0 with a twenty-two-buck General Wavemeter so you fellows off-wave, BEWARE! 9CJW is very consistent on 80 meters. BWJ is having key click troubles. 9ABR worked on-2RC on 88 meters. 9AGP is a new station at Fulton. 9EP reports having worked AGE and fm-8ST on 89 meters. 9ALM is getting 88 reports from the west coast with a couple of 210 tubes. 9AQV is a new station in Frankfort. 90X is still handling most of his traffic thru reliable schedules. 9EI has been temporarily dismantled—due to a visit from 9CDN. HI. 9BAZ has a 208A perking on 41 meters. 9GC says he will have things going soon. 9AVV is a new station in Bowling Green.

Traffic: 90X 194, 9CJW 90, 9BWJ 45, 9BAZ 32, 9ATV 32, 9ALM 29, 9WR 29, 9ABR 27, 9ARU 18, 9HP 6, 9GC 2.

WISCONSIN—SCM, C. N. Crapo, 9VD—9EK has schedules with NAJ, 9DTK, 9VD, 9COI, 9DX, 9DOE, 4DM and 1AMU. 9DLG had his biggest month so far. 9DLQ has schedules with 9DTK, 9BJY, 9DND and 9DLG. 9COI has schedules with 9BQC, 9CGY, 9EMD, 9DLG, and 9EK. 9BJY is improving his traffic total. 9CFT is having lots of fun handling traffic on schedule. 9EMD is QRW with new March route map so not much time for news. 9AGV is on the air every day around 6 to 6.30. 9JM has schedules with 9CIB and 9DDZ. 9CAV worked Australia twice and was heard in Chile once. 9BWO worked 3 Aussies and 1 N. Z. last month. 9EHM believes good routing of messages should still be encouraged.

9AEU and 9ALA are installing a transmitter at school and will be on the air in a couple of weeks. 9EBB has a new CC set perking and expects to resume skeds soon. 9EEM is rebuilding and hasn't been on much this month. 9EEF's transmitter has been increased to a 7½ watt. 9ARE has a 40 meter xmitter going now.

Route Manager's Report: More schedules are urged linking Wisconsin hams with the Minn. sections. The 40 meter hams of our Section can best make schedules with Minnesota as it is about 90% on the 40 band.

Traffic: 9EK 329, 9DLG 188, 9DLQ 71, 9COI 59, 9BJY 58, 9CFT 51, 9EMD 46, 9AGV 53, 9JM 27, 9DTK 387, 9AZN 59, 9DKA 105, 9SA 5, 9CAV 20, 9BWO 18, 9DCX 40, 9AFZ 18, 9VD 17, 9EEF 13, 9EHM 9, 9AEU 7, 9BIB 4, 9HEM 2.

ILLINOIS—SCM, W. E. Schweitzer, 9AAW—A message is counted as one message when received and if relayed to another point it is counted as another message. Please bear this in mind when making out the monthly reports. Although our route manager 9APY was married to the YL from 2CC he is still on the job. Write him for schedules. 9AAE has changed from Armour Institute to Crane College. 9AFF reports national guard units coming along in fine style. 9AFX is working for an ORS appointment. 9AGQ and 9ALK hope to run their traffic totals higher next month. 9AJM is looking for schedules. 9ALJ has a 250 watt. 9ALW is operating 9NV. 9ARM says be sure to renew your license BEFORE it expires. 9BBA says 9MP uses salt to catch the DX birds. 9BHM has a good DC note. 9BHT and 9EHK use battery plate supply. 9BIZ is busy grinding crystals. 9BL thinks he will go to 90 meters to get more traffic. 9BNA has been working on 20 meters. 9BNR is on the air again. 9BPX handled a few. 9BRX is busy at school. 9BUK is now signing 8DGP. 9BVP keeps a schedule with 9DXB. 9BTK reports no foreign DX yet. 9BWL is working for an ORS. 9CCR is another station in Cicero. 9CEC is QRW working. 9CEH is going to rebuild. 9CIA worked 34 foreign stations. 9CJF has his antenna fixed at last. 9CNP is going to try 40 meters. 9CNB handled some urgent traffic. 9CPQ keeps schedules on 20 meters. 9CSB visited Racine and Milwaukee. 9CZL would like the QRA of station SM working on 89 meters. 9CZU is using 50 watts. 9DAY is back again. 9DBI and 9AYB are operating the University of Illinois station 9BCS. 9DGA says 20 meters is great for daytime. 9DLG's aerial is down. 9DOX was off because of sickness. 9DXB owns and operates WNBI on 375 meters. 9DXG is handling two important schedules. School and radio 9DXZ is working with crystal control. 9DYD reports traffic improving. 9EAI is keeping eight schedules. 9EGC uses radio to reach his YL. 9ELR has installed a filter. 9GE works break-in. 9KA,

9IX and 9IZ are new stations in Chicago. A new YL station is 9BA. 9LY is now on the air. 9NH, the Hyde Park High School, is operated by eight local hams. 9QD handled the PRR chain during 9APY's absence. 9RK is operating on 40 and 80 meters. 9SK keeps in touch with his mother in California through a schedule with 6AWQ. 9UX is using a Hertz. 9VV is back on the air after a year's absence. 9PU is very QRW with college work.

Traffic: 9DXB 302, 9DXZ 209, 9BWL 138, 9QD 109, 9CEH 109, 9APY 105, 9BTZ 105, 9NH 102, 9SK 89, 9CIA 84, 9CZL 75, 9GE 69, 9CNB 68, 9CPQ 60, 9DYD 59, 9RK 58, 9DOX 47, 9ALK 40, 9BVP 40, 9CZU 39, 9BHT 38, 9BNA 37, 9LY 32, 9CN 32, 9DAY 32, 9CSB 33, 9EIA 28, 9BL 24, 9BBA 20, 9PU 21, 9CWC 20, 9CZL 19, 9AAW 18, 9UX 16, 9BHM 13, 9ELR 12, 9CSL 12, 9AAE 11, 9AJM 10, 9CJF 9, 9CEL 9, 9BIZ 9, 9AFX 8, 9CNP 8, 9BPX 7, 9DGA 6, 9DXG 5, 9EHK 4, 9EGC 4, 9AGQ 4, 9ARM 3, 9DZR 3, 9BRX 3, 9KA 2, 9DLG 2.

DAKOTA DIVISION

NORTHERN MINNESOTA—SCM, C. L. Barker, 9EGU—9ABV is a new ORS and leads the Section in traffic this month. FB. 9CWN operates regularly at noons and nights and keeps three schedules. 9AKM is another new ORS showing up nicely in all ways, and says he will be in the BPL as soon as he gets the new parts for his receiver. 9CWA reports a new amateur in Keewatin soon. 9EHO complains that he can get no dependable schedules. 9KV seems to have shifted from traffic to DX. 9CTW is building a new 40-80 meter set. 9CKI finally got his H tube but it wouldn't oscillate so is using a 210 while waiting for a new 50. 9BHY a new ORS, is proving a good addition both from his station standpoint, operating and location. 9EEP expects an 80 meter crystal soon but is using a 5-50 master-oscillator set in the meantime. 9BTT seems to be experimenting some with low power. 9BMX says that he is absolutely through with 40 meters and its QRM. He has gone down to 20 meters for good. 9MF has very little time to be on. 9EGU has been on little, due to trouble with the transmitter. 9ADF is in Los Angeles for the rest of the winter. 9GZ is on again after a considerable absence. 9BMR has just completed his new transmitter. 9BVH ground his crystal down to 80 meters so that he can work on 20 meters easier. 9CPO has built a new low-power crystal set which will be in operation as soon as the basement of his home is dry. It was flooded with 8 ft. of water in a recent thaw and covered about everything, including his radio shack.

Traffic: 9ABV 69, 9CWN 50, 9AKM 39, 9CWA 27, 9EHO 24, 9KV 19, 9CTW 19, 9CKI 19, 9BHY 19, 9EEP 18, 9BBT 18, 9CWA 16, 9BMX 9, 9MF 4, 9CUM 2, 9EGU 2.

SOUTH DAKOTA—SCM, F. J. Beck, 9BDW—The chief item of interest this month was the convention at Huron on Feb. 25 and 26. Over half the amateurs in the state were present and enjoyed the fine program put on by the Hurch Radio Club. 9XI and Crozier of S. D. State College gave fine talks. Everyone had a fine hammy time. 9DWN won the traffic prize. 9DGR is a close second and his mercury arc gives him a nice DC note. 9BOW handled a big bunch of traffic with Italy. 9BOT is another B battery station. 9DB took a 20 meter 170 watt AC set to the convention and learned that it would not work inside a steel building. 9DIY is an Army-Amateur station at Sioux Falls. 9EKB has QRM from basketball. 9AGL runs two BC stations, plays in an orchestra, and goes to college so has little time for the key. 9DLY, our new 80 meter station, keeps two skeds. 9DYA reports progress. 9CNK is joining the Navy. 9BBF and 9CJS are on 20. 9DB was QSO foreigners on 20. Traffic: 9DWN 230, 9DGR 155, 9BOW 51, 9DB 41, 9BOT 38, 9DIY 16, 9EKB 5, 9AGL 4, 9DLY 2.

NORTH DAKOTA—SCM, G. R. Moir, 9EFN—The SCM is building several transmitters for boys in his town so will expect to see several new ones on soon. 9BJV is QRW with BCL sets and is on little. 9DIY reports bad QRM from X-ray machine at Doctor's office during daytime making receiving bad and prevents working of more stations. 9DKQ picked up a message for R. A. Hull at HQ from on-2CM in his unsuccessful attempt to give it to nu-6EW. 9DM is going good now on 40. 9CCT sold his large transmitter and is using series Colpits with 201A tubes and getting out good. 9BVF says "80 meters sure is the place for traffic".

Traffic: 9BVF 53, 9EFN 23, 9DKQ 22, 9DM 8, 9DYV 6, 9CCT 3, 9BJV 2.

SOUTHERN MINNESOTA—SCM. D. F. Cottam, 9BYA—Not much work except convention work this month. Fellows, when a convention has the presence of men like Handy, Hebert, Reinartz, Schnell, Hoffman, Prof. Jansky and a lot of others, its going to be a wow. Over \$500 worth of prizes to be given away. Come and gets yours!

9XI comes forward by working a total of 456 stations of which 153 were foreign. 9DBC is on 20, 40 and 80 for traffic. 9EFO bought two 204 tubes and blew one the first crack. 9DBW is on all bands, crystal controlled. 9EFK has a UX210 with 4 coil Meissner and its FB. 9BHZ on 40 and 80 keeps 2 skeds. 9AUU keeps 4 skeds. 9CAJ says, "Haw, haw, I blew my fifty"! 9CIX keeps to skeds. 9AIR is on all bands. 9DWO gets good results from this country but can't QSO foreign. 9DHP keeps one schedule and works fone some. 9DZA has a new panel-mounted transmitter. 9SF is building a 100 watt set. 9AWM attended the South Dakota Convention and reports a very good time. 9DEQ has had the power QRN cleared and is doing much better work. 9COS had a general breakdown; shot his tube, transformer, etc. 9GI has been out of the city during the last month. 9AJU and 9CYA are doing wonderful work with UX210s.

Traffic: 9XI 182, 9DBC 82, 9EFO 77, 9DBW 30, 9EFK 28, 9BHZ 28, 9AAU 27, 9BYA 26, 9CAJ 21, 9CIX 20, 9AIR 20, 9DWO 18, 9DHP 14, 9DZA 12, 9BKK 11, 9SF 10, 9BHB 6, 9AWM 4, 9DEQ 4, 9GH 2, 9COS 1.

DELTA DIVISION

ARKANSAS—SCM. Wm. L. Clippard, Jr., 5AIP—Activities in traffic-handling have dropped off considerably the past month. From the number rebuilding for the summer, we sure will have some "fleet" on the air soon.

5SI, our RM, is now on 40 and 80 and is going FB with his work. 5ALS moved and is now on again. We have four new brothers this month: 5QV, 5JQ, 5LF, and 5NL. FB, OMs. 5LF has a 250 watters. 5HN is the technician and "set him off". 5BI says a bell-

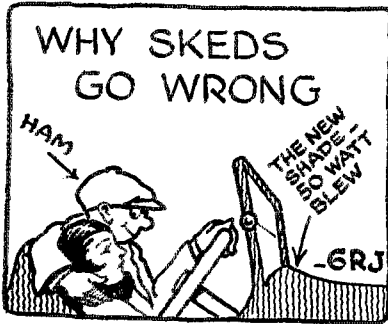

ringing transformer with windings in series makes a good 35 henry choke. 5LV is our first ORS. 5CK kept in touch with his sick father in Hot Springs via 5IR and 5JB. Where's your traffic reports, OMs? 5AQH is proud possessor of a N. Z. card.

Traffic: 5CK 43, 5ABI 23, 5AIP 21, 5LV 4.

LOUISIANA—SCM. C. A. Freitag, 5UK—5QJ has been doing some experimenting on 20 meters and seems to be getting out very nicely. 5NJ has gone out of the game once more (hi). We look for his return, however, at no distant date. 5ANC has been campaigning for the job as Radio Commissioner and for this reason, has not been on the air much. After a fire near 5UK, the set was placed in operation. The flashlamp in the Hertz antenna brought the Assistant Chief Engineer of the Fire Dept. who wanted to take down the antenna because "it was on fire". Hi! hi!

Traffic: 5ANC 34, 5WY 8, 5UK 14, 5EB 36, 5ATN 2.

TENNESSEE—SCM. L. K. Rush, 4KM—We seem to be making some progress in this Section and this month finds us with a route manager, 4FI. All stations who would like to keep a schedule to quickly get traffic thru this Section should address your letters to Polk Perdue in care of WSIX, Springfield, Tenn. 4DK reports a new Hertz and QSO with Australia. 4HL still hangs on to his Hertz. 4FA seems to have as much trouble with tubes as the SCM does with MGs. 4FI leads the gang with traffic. 4LX worked

sv-AYRE for a change. 4KM and 4KX are on the air every Sat. night beginning 2400 and 1600 GMT. 4KM visited the active stations in Memphis on two different week ends this month. 4RP was visited by the SCM and he has the neatest station the SCM has seen lately. 4BU says that it costs him \$6 to work an "8." Laid off from work and that is all he QSO'd.

Traffic: 4FI 26, 4KM 15, 4HL 12, 4LX 10, 4FA 9.

MISSISSIPPI—SCM. J. W. Gullett, 5AKP—5FQ struts a new Schnell receiver but says it regenerates too much. 5ARB's latest DX is Italy and France using 2 UX-210 in self-rectifying circuit. 5QQ has his transmitter on 80 meters. 5ANP works on the 40 meter band during daylight and the 80 meter band at night. 5API is on the 40 band and has a regular schedule with Memphis. 5KR sent his report to 5ANP via radio thence to the SCM by mail. 5AUB has been laid up with a bad foot. 5AGS has installed a new rectifier and says his two H tubes work FB in parallel. 5AKP's transmitter is trying to balk again.

Traffic: 5AKP 32, 5KR 85, 5AGS 23, 5QQ 16, 5ANP 30, 5FQ 9, 5API 18, 5ARB 17, 5AQU 6.

HUDSON DIVISION

EASTERN NEW YORK—SCM. Earle Peacock, 2ADH—2QU leads by three wavelengths. As Route Mgr., Rosie has a brand new one to spring and promises to expose it shortly. 2ASE is second msg. handler and now boasts all USA districts and Australia. 2ANY is on every forenoon and has a sked with 1AWQ. 2AAN modestly submits that the Enzeds report him just as QSA as 2UO and 2AHM. 2PV dispatched one 50. 2AML is QRW. 2AQG is QSO Europe on 20 meters. When every ORS reports as consistently as 2CNS, the SCM will distribute fifty watters with report cards. The 2AAN-2ADH combination has 2AXR for its call. 2CTH-2ACK is QRW—it's the YLs. 2ADH is the silent wonder. 2SZ is QRMed by exams. 2CYH is hogging the Europeans for a change. 2BV has been QSYing but is settled on 40 now. 2AGM threatens to quit the game again. 2APQ kicks out like an Army mule. WIZ, NKF and 2AG are still in nightly operation. 2LA was laid up with a sprained muscle. 2ASF is using low power. 2CUZ is building air castles and counts the days now. 2CTF has a bug on battery plate supply. 2AUB has a brand new Hertz. 2CBG still keeps it red hot. 2UF is due for an ORS appointment. 2DD is at half mast for one of his kenotrons. 2BOW seems to be having trouble. 2AYK busts out with his premier report. 2AAC finds 80 meters free of QRW.

Traffic: 2ASE 42, 2QU 147, 2ANV 17, 2AAN 15, 2PV 9, 2AML 9, 2AGG 8, 2CNS 7, 2AXR 7, 2CTH 6, 2ADH 4, 2SZ 4, 2CYH 3, 2BV 2, 2AGM 1.

NEW YORK CITY & LONG ISLAND—SCM. F. H. Mardon, 2CWR—The Route Managers in the five boroughs are complaining that they cannot get the cooperation of the ORS in their vicinity. This is absolutely necessary so that the Inter-borough traffic routes can become a success. The Route Managers are being supplied with the names of all ORS under them and when they request the ORS cooperation and it is not given and the fact is made known to me, I will consider that sufficient breach of the regulations and cooperation to immediately cancel that ORS certificate. The day of having an ORS certificate as a centerpiece for QSL cards is past. Either an ORS is what he is supposed to be or he isn't an ORS at all. This warning is final!

2BCB worked the west coast twice with 20 watts input. 2AIR is looking for schedules to improve his traffic totals. 2ANX is working hard but reports Manhattan dead as far as traffic handling is concerned. 2EV has a short wave super going with fine results. 2ALS says xtal set going FB. 2KR has been sick and not on the air much expects to get going soon. 2LD and 2BNL just keeps going. 2BO has schedules with England and France.

Bronx: 2CYX is very busy with Army net work. ex2AHG is now 6GJ. The second op. at 2AWU keeps the station on the air while the Chief is at sea. 2ALP has been sick, but we hope he is OK again now. 2BBX is trying 20 and reports it FB.

Brooklyn: 2AVR is very busy at school but says he works Europe and S. A. nearly every time he sits down. 2UD will be back soon with an xtal set. 2AMI is working hard to become an ORS. 2APD is working all the foreigners in existence. 2CRB is still rebuilding. 2BRB now has xtal controlled fone and ICW. 2CLA is rebuilding his transmitter and will soon have an xtal going. It isn't necessary to say

anything about 2PF—everyone knows how hard he is working.

RICHMOND: 2ABH, a new station to report, makes a good start. 2AKR has been keeping schedules with England. 2AFV has been sick but is OK now.

Long Island: 2CSX and 2AGU are new stations to report. 2WH is leaving us for a while. 2AWX is trying 20 for a while. 2AWQ worked BZL recently. 2AV is only on once in a while but will be going strong after Apr. 1st. 2AJE is also trying 20 but reports traffic slow down there. 2AYJ recently got a report from China and it checks with log OK. 2BSL is busy at college and not on often. 2ABF reports QRM from starting a ham club in Jamaica High. 2AVB uses fond on 80 m. 2AAS has started a radio club at Richmond Hill High and is helping 2ABF organize one at Jamaica High.

Traffic: Manhattan: 2BNL 12, 2LD 12, 2KR 13, 2ALS 11, 2EV 45, 2ANX 504, 2AIR 7, 2BCH 129, 2BO 54. Bronx: 2CYX 255, 2BKX 46, 2ALP 38, 2AWU 57. Brooklyn: 2PF 23, 2CLA 14, 2APD 187, 2AMI 10, 2AVR 174. Richmond: 2AFV 54, 2AKR 46, 2ABH 29. Long Island: 2BSL 1, 2AYJ 31, 2AJE 14, 2AV 6, 2AQW 9, 2AWX 140, 2AUE 10, 2AGU 129, 2CSX 48, 2ABP 117, 2AVB 70, 2AAS 7.

NORTHERN NEW JERSEY—SCM, A. G. Wester, 2WR—At the time this appears in print, most of the old ORS will have received their new certificates and the SCM wants to thank those for their kind cooperation for 1926 and looks forward to an increase in ORS for 1927. 2AT has made application for an OBS certificate which will be granted. 2BW has been placed on the inactive list as this station will be inactive for a few months. 2CP will be located at Fords, N. J. after May. 2CW is still having trouble with his "fifty". 2FG reports working Belgium and Germany with a 210. Ex2HL promises a return to the ether. 2EY is putting all his time on getting the new crystal controlled station 2JX on the air. 2FC is maintaining a Tues. schedule with eg-5UW. 2IS will have an xmitter on the 20 and 200 meter bands shortly. 2ADL is now able to work CW on 20, 40 and 80. 2ALM went over the 100 total this month on 38 meters. 2ARC also maintains a daily schedule with 8AVS. 2BLM has been working all points of the globe with a 210. 2BQQ is tied up temporarily due to QRM from a local broadcaster. 2CTQ works plenty of DX and handles lots of traffic. 2DY has been QSO 681 stations in the past 5 months. 2AVK reports working the west coast at last. 2CJD is a new one to report and should be in line for an ORS. 2QI has been off due to sickness which we hope is not serious. 2HC, on top of Jersey, is working with 201A with fair results.

Traffic: 2AT 77, 2BW 5, 2CP 20, 2CW 6, 2FC 1, 2IS 78, 2JC 36, 2KA 4, 2ADL 109, 2ALM 119, 2ANB 7, 2ARC 4, 2BLM 8, 2BQQ 2, 2CPD 40, 2CTQ 111, 2DY 42, 2AVK 22, 2CJD 46, 2QI 5, 2HC 5.

MIDWEST DIVISION

IOWA, SCM, A. W. Kruse, 9BKV—February proved to be a banner month for Iowa and the SCM certainly appreciates your fine cooperation, OMs. The RM reports excellent traffic lanes thruout the Section. 9BKV has enough schedules to keep him busy all night. 9CZC, the RM, has a plug-in receiver working FB. 9EJQ has a big stack of messages leaning toward the BPL. 9BWN works DX on 40 and handles lots of traffic on 80. 9CGY is out of a job and has lots of time to pound brass. 9DLR is going strong and reports 20 meters FB for traffic both day and night. 9DGW burned a lot of mid-night oil and made the BPL again. 9EFS is pound-brass at 9DVG, Iowa Nat'l Guard station at Cedar Rapids. 9DVG has applied for ORS. 9DAU continues his consistent work on 40. 9AMG installed an MG and now gets fine reports on 40. 9EHN blew another H tube. 9DWW, another newcomer, is looking for schedules. 9DRA has applied for ORS and is changing his transmitter for remote control. 9DSL doesn't get much time to pound brass. 9DEA had QRM from power leaks and couldn't work any schedules. 9CS kept schedules with 9LC and 9OC on 40.

Traffic: 9BKV 406, 9CZC 330, 9EJQ 203, 9BWN 176, 9CGY 161, 9DLR 124, 9DGW 121, 9DEA 10, 9CS 8.

KANSAS—SCM, F. S. McKeever, 9DNG—Nearly half the Kansas ORS are off the air due to their some mishap or to QRW. 9GET was working out fine as usual when his rope broke and let his antenna down. 9RHR and 9AEY have had to request ORS cancellation due to QRW. 9CLR has a new 50 and

is out for some real DX. 9LN and 9DIP are on some but are both pretty QRW school. 9COE and 9CMZ are newcomers in Lawrence. 9DNG goes when he has a chance. 9EHT reports hearing 2EB on 5 meters. 9CNT is stepping out on 38 meters. 9BII is a new ORS who plans to put in a 250 watt. 9CV worked a ship near the South Pole and QSR'd a message to Calif. 9AVM and 9DSR report little operation. 9CKU has a mob of schedules on 80 meters.

Traffic: 9CET 37, 9BHR 35, 9CLR 4, 9DNG 54, 9DIP 4, 9EHT 1, 9CNT 23, 9AEK 7, 9CV 9, 9DSR 6, 9CKU 81, 9CN 10.

MISSOURI—SCM, L. E. Laizure, 9RR—9DOE, 9BEQ and 9BHI led in traffic this month in St. Louis. 9ZK kept up PRR skeds and with 9DAE has been hammering on the skip distance barrier between East and West Mo. The latter sked seems to work part of the time. 9BOE, 9DMT, 9DLB and 9DZN handled a few msgs. The RM complains again about the general failure to QSL correspondence. He is proposing an all RM 5-point schedule to RMS in adjoining states. 9BGO applied for ORS. 9BJA is a new station in Coffey. Rebuilding of sets is reported by 9CKU, 9DLX, 9DKG, 9BQS, 9CDF, 9DAE and 9ACA. 9BQS worked WWDO in Alaska. 9DVF and 9BWD resigned ORS on account of being too busy to operate set. 9DIX reports several BCLs are building transmitters. 9DIX is visiting in Chicago and trying for commercial ticket. 9CYC is on for traffic in Clarence. 9ZD is putting the big jug on for the air again. 9RR is keeping schedules in all directions. 9IM is on for traffic in Kansas City. 9ACX was on occasionally. 9ADR is working DX on 20 every Sunday. 9DQN was too QRW for traffic. 9BSB moved to Texas. 9ZD Jr. worked the home station from "somewhere at sea" with the OM on the receiving end.

Traffic: 9DOE 77, 9BEQ 42, 9BHI 32, 9DZN 3, 9DLB 3, 9DMT 12, 9BQS 9, 9DAE 18, 9CDF 10, 9DIX 2, 9DKG 8, 9BOE 3, 9RR 100, 9CYC 4.

NEBRASKA—SCM, C. B. Diehl, 9BYG—9DXY has a good traffic total. 9AL is going good. 9CJT is not so strong this time. 9EEW is busy working on 20. 9AWS about as usual. 9DFR is not so busy. 9BYG is trying to get on again. 9EHW is busy with BCL business. 9ASD is busy with army work. 9DI turns in a good total. 9BOQ is busy with his work. 9DAC is going strong. 9BBS hitting on all two. 9BQR is still trying for 40. 9EBL is sick.

Chatter: Quinby did not get in a full month this time or he would have knocked 'em deader than he did but had to go to Hartford to the Directors' meeting. Fetterman worked his schedules while away to pay for it. 9AL jumps several notches this month. Neilson reports hearing 9AGD back on the air again. Harry also holds sked with Haiti when HIK not QSS. Cox is tinkering with 20 meters and his traffic totals sure show it, too. Williams sure pounds the Nebr. army net, but to date hasn't got much action on it. 9DI, our youngest ORS, turns in a good total for a starter. Magnuson has so much work to do that he cannot devote as much time to radio as he would like and sure does sing about it. Miller, another new ORS, is going good but on account of Nebr. week, is busy right now. Shirk is back after a long siesta. Jones is too busy with a BCL set to listen to us any more. 9BBS has 5 skeds daily and his traffic totals sure show it, too. Chesley is still on 80 trying for 40 meters. 9EBL has been sick but is up and at 'em again.

We find that there are three transcontinental routes across the U. S. A. and Nebraska is on all three of them. Something no other state can boast of.

Traffic: 9DXY 335, 9AL 75, 9CJT 2, 9EEW 2, 9AWS 8, 9DFR 6, 9BYG 1, 9EHW 5, 9ASD 18, 9DI 64, 9BOQ 2, 9DAC 10, 9DUO 4, 9BRS 213, 9BQR 1.

NEW ENGLAND DIVISION

CONNECTICUT—SCM, H. E. Nichols, 1BM—Conditions generally thruout the state are undergoing a healthy increase both as to traffic handling and enthusiasm. We are now approaching our annual N. E. Div. Convention where your SCM hopes to meet all of the boys hand to hand. Our slogan will be "On to Hartford."

1MK, our Headquarters' station, sure must be as busy as a Western Union outfit by the way LJ is rolling up traffic totals. Great work. 1BHM has been doing some very fine schedule work with England on the 40 meter band while 1BJK has been guarding the 80 meter channel. 1KP has been appointed Naval Reserve Control Station for the Third. Dist. with call NRRC. Congrats, OM.

IADW with his many schedules is surely covering his section of our state with wonderful success. This used to be considered a poor spot for radio but ADW has put it on the map. IBEZ is feeling fine since he had a card from Czecho-Slovakia reporting his sigs. IATG, a new ORS, handed a msg for a ship operator off the coast of Mexico much to his delight. IZL with his noted fiver is still hitting the high spots by working two French and one English station in the early afternoon.

We are sorry to report that 1FD is still under the weather and unable to operate. Our sincerest wishes, OM, that you will be back with us again soon. 1BQH took traffic for all points at the New Haven Progress Exposition. 1CTI reports working schedule and sends in a very nice total.

Traffic: 1MK 683, 1ADW 166, 1BJK 133, 1BMG 133, 1BHM 123, 1CTI 105, 1BYM 150, 1BQH 50, 1KP 82, 1AOX 40, 1BEZ 36, 1ATG 26, 1CKP 19, 1BGC 11, 1ACD 3, 1ZL 6, 1IV 4, 1AVX 4, 1TD 6, 1IM 10, 1BCG 48, 1BEW 32.

EASTERN MASSACHUSETTS—SCM, R. S. Briggs. 1BVL—This month brought an increase of traffic over the previous month and there are promising signs of further increase. 1UE, the RM, is arranging an efficient traffic net and asks all to please cooperate. 1XM and 1AHV have been appointed 0-0s so watch your wavelengths, OM.

1CRA, a non-ORS, takes first place this month in the amount of traffic handled. 1CJR follows very closely and is to be given a lot of credit since his totals covered only two weeks of operation. 1BMS has a new fifty and kept schedules with ek-4DBA. 1KY is one of the stations in this Section keeping a schedule with 1MK at Headquarters. 1ALP is on once in a while. 1AVF kept schedules with DCZ, the S. S. Vaterland. 1DI did a lot of DX and was QSO 1a-A4. 1LM is a consistent traffic station and can be depended on to move traffic. 1ADM is handling 20 meter traffic and acted as an intermediate station in a QSO between 6VZ and ef-3JN. 1AYX says that his lamp on his Hertz antenna worries the BCLs. Hi! 1ACA, 1ACH, 1BDV, 1GP, and 1APK are new ORS. 1RR is having trouble working DX. 1GA gets the tin medal because he worked 18 foreign stations within 4 hours. 1AEV is on top of the 40 meter band now with crystal control. 1NQ operates at 1XAW which is on the air again. 1ACH uses a couple of UX210s and is QSO lots of DX and traffic. 1AXA was QSO Australia on five successive afternoons at about 4 pm EST. 1BMB worked a few foreigners. 1ABA is trying hard to QSO a U. S. "seven". 1AIR says that a copper flush closet bulb on each end of a Hertz wire helps a lot. 1YC kept schedules with 2CXL. 1BVL has a new rig that is supposed to make his note sound like a "six" with rectified 50 cycle note. They call 1NK a "210 doctor" because he fixes 201's so easily. 1NV has been QRW with dramatics.

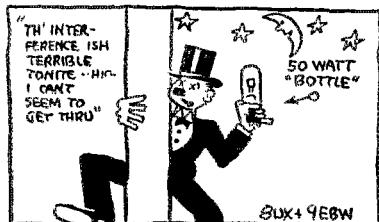

A "BOILED" HAM

1XM is building a new power supply with hopes of a better note. 1AOG is a new operator there. 1BKV overhauled his set and increased his range. 1APK has been doing fine work with fone. School QRM has been keeping 1BDV off the air. 1ADL finds that 80 meters is a relief from 40 meter QRM.

Traffic: 1CRA 318, 1CJR 302, 1LM 221, 1KY 175, 1ACA 157, 1ACH 114, 1NK 110, 1ADL 101, 1AHV 58, 1GA 43, 1ON 39, 1ABA 30, 1BKV 27, 1BMS 24, 1AYX 21, 1ADM 18, 1YC 16, 1PB 15, 1AVY 15, 1AVF 13, 1APK 12, 1DI 12, 1AIR 11, 1GP 11, 1NQ 11, 1BVL 10, 1AXA 10, 1BCN 9, 1BBM 8, 1ALP 2, 1NV 2, 1RP 1.

RHODE ISLAND—SCM, D. B. Fancher, 1BVB—From the looks of the traffic reports this month, too many of our gang are working on 40 meters where there is little traffic now. Let's have some sets that can QSY up to "80" and more interest in the FB traffic work that's going on up there. Starting the first of May, all Rhode Island ORS must handle at

least 10 messages per month or have certificates cancelled. We're going to put this Section on the map and beat some of the bigger ones. Remember, fellows, the FIRST OF MAY which means that your report sent me on the 26th of May must show at least 10 messages or a good excuse for not handling them.

Providence & Pawtucket: 1AMU is on 20 meters and is an OBS on that wave. He reports DX fine and handled several important messages to Calif. after the storm asking about the safety of persons. 1AEI worked SJB and can't find out his QRA? 1CKB reports traffic light. 1EI is off until he can get some aluminum for his rectifier. 1BIL reports QRM from school. 1MO is a new ORS and has a schedule with ne-2BE. 1DP is going at last. 1AHE is moving to a new QRA. Two ORS are being cancelled and if the reports are not better next month, there will be more. 1AWE has a new car and is slipping badly. Don't slip into a pole, OM. Hi! 1AD has been keeping a Providence firm in touch with its branch office in North Carolina by schedules with 4NH.

Westerly: 1BVB has been QSO England, France and Belgium this month. 1AAP has been spending a lot of time on his 0-0 job this month.

Newport: 1BQD has put up a Hertz voltage feed antenna as per the Handbook and says that it's the best yet. He has a schedule with eg-5MO.

Traffic: 1BQD 44, 1BVB 36, 1AMU 17, 1AAP 11, 1BIL 9, 1EI 7, 1AEI 6, 1AWE 5, 1CKB 2, 1MO 2, 1AD 21.

VERMONT—SCM, C. T. Kerr, 1AJG—We must hand it to IIT as he walks off with the traffic honors again this month. He has also just been appointed CRM and expects all the fellows to hang with him as things are now going to hump and remember, fellows, help him all you can. 1BJP has just applied for an ORS. 1TJ is off the air indefinitely. 1PN is showing signs of life. 1BEB is on little now. 1BBJ must have blown up. 1BQ and 1YD have gone to Canada. 1FN and 1BDX are very busy with their BCL business. 1AJG and 1AC are both on 38 meters about every other night.

Traffic: 1IT 43, 1BEB 2, 1AJG 35.

NEW HAMPSHIRE—SCM, V. W. Hodge, 1ATJ—The RM, 1OC-1BFT, leads us all with a total of 1158. He didn't originate it all, either and averaged six msgs per QSO. FB, 1AOQ sent in a sizable total and is doing good DX. 1IP pounded out 211 and worked Bermuda on 76. 1AER kept the Boston Wire Chief in touch with his local Wire Chief for over 3 hours during the recent blizzard when the wires were down. 1ASA was at the other end. 1AVL helped on this, too. FB, OM. 1YB is having a lot of trouble with its receiver. 1ASR is again in action and is a prospect for ORS. 1AVL has worked 72 different foreigners since Jan. 25th. 1JN has increased his power to 50 watts with more reliable operation. 1AEF, a good ORS prospect, had a big total. The SCM took a vacation and QSY'd to 20 meters and found plenty of DX down there. Hawaiian 6ACG gave him a report of R5. Hi. Please let our RM know of any schedules you are keeping so he can include you in our traffic routes. THE SCM wishes to thank every one for the fine reports this month.

Traffic: 1OC 1158, 1AOQ 767, 1AEF 378, 1ATJ 351, 1IP 211, 1AER 97, 1YB 55, 1AVL 51, 1ASR 44, 1JN 28.

MAINE—SCM, Fred Best, 1BIG—To keep our Maine Section up with the head-liners, where she belongs, it is necessary that more of us become members of the BPL. It is easy, fellows. If you can't be on more than once a week, it is possible by means of schedules to gain the BPL. There is little excuse for any ORS not being in the BPL every month. Let's see some action fellows.

1BFZ, one of our most consistent BPL members, turned in a nice total, in spite of his power leak. 1FP did well with two CX301A tubes with 325 volts DC on the plate. His sigs were heard by eg-2AHP. 1AUR has been on 80 but moved to 40 for the benefit of BCLs. He has schedules with 6OH, 7ABK and eg-6JV. Like old times to hear 1AUR hanging them out. 1ATV has a cold shack but expects to see Harry a BPL member next month in spite of it. 1BNL had sickness in the family and little time for relaying but we look for bigger things next month. 1QY is going great on "40" and handling important traffic. Come on, Mac, let's see you in the BPL. 1COM received his ORS and turned in his usual good report. 1CFO is getting out better with his current fed Hertz. 1AYJ has been doing FB on 20 meters working Nu 4th, 5th, 6th and 7th as well as NC 4th and 5th as easy as rolling off a log. FB, OM!

IADI reported as usual but his report did not show much of a traffic figure. How come, Harry? We know you can handle traffic with the best of them. Let's see you up with the leaders once more, OM. IAQL is still away on duty keeping up the Houlton end of the telephone lines which handle the New York-London telephone circuit. He hopes to be back home soon and pounding the brass once more. IAIT has no set. Hurry and dig up a UX210, Carroll, and let's have more of the large totals for which you are famous! IBIG wants to hear from all Maine or N. H. hams who are interested in joining the Naval Reserve drills.

Traffic: 1BIG 363, 1BFZ 103, 1FP 42, 1AUR 84, 1ATV 23, 1BNL 23, 1QY 28, 1COM 26, 1CFO 16, 1AYJ 4, 1ADI 2, 1HB 65, 1BTQ 7.

WESTERN MASSACHUSETTS—SCM, A. H. Carr, 1DB—1AGA, a non-ORS, makes the BPL. 1AUO, another ORS prospect, reports a good total. 1AAC is looking for schedules with other stations in our division. Get in touch with RM, 1AAL, R. S. Brown for schedules. 1AAC kept schedules with oa-5WH and FFJP. 1AAL has been busy all month keeping various schedules and is on the air consistently. 1AJK is on most every night after 10.30 on 80. 1AJM and 1AKZ are on 20 meters. 1AMZ got a total of 27 on his vacation. 1APL says he handled most all his traffic on schedules. FB. 1ASU is working DX. 1AZW relayed an important death message nearly direct in about 8 hrs. 1BKQ are on consistently now. 1EO is on daily from 6 to 7 on 80 meters. 1GR kept two schedules. 1XZ is more or less active according to the Press of the Clark Radio Club.

Traffic: 1AAC 41, 1AAL 74, 1AGA 141, 1AJK 18, 1AJM 9, 1AKZ 7, 1AMZ 27, 1APL 152, 1ASU 6, 1AUO 11, 1AZW 23, 1BIV 43, 1BKQ 48, 1DB 4, 1EO 20, 1GR 2, 1PY 4, 1XZ 6.

NORTHWESTERN DIVISION

IDAHO—SCM, Henry H. Fletcher, 7ST—7JF is doing real work these days. 7QC is trying to rebuild his set. 7ABB has a new rectifier and is out for dx. 7GW is the new OO for Idaho. 7QA is working on the RR and he carries his portable xmitter with him. 7ACN, 7ACK and 7HK are Nampa fellows with 210s. 7IO is back on the air with a five. 7YA has been rebuilt and seems to be getting out fh. 7CJ is perking with a five. 7ADW is the portable call of 7ZN. 7PJ is on occasionally. 7CW has a 210 now. Norquest says he will be back on the air soon. 7GG is back from SL and is perking with a 210.

Traffic: 7JF 106, 7QC 21, 7ABB 15, 1GW 4. 7ACN 4.

MONTANA—O. W. Views, 7AAT—7QT, Acting SCM—7PU had some hard luck (blown tubes, frozen rectifier should BOIL like the one at 7AAT. Hw? with oa8AC working oa5BW on a pair of VT14's. 7AFM is getting in line for ORS and will be with the gang soon. 7AGF has been rebuilding. 7DD was off due to transformer breakdown but is now perking OK. 7EL had battery trouble but is going better now. 7AAT—QT is putting in a "50" for real traffic work with the Mont. gang—he had a nice 3-cornered rag-chew with 9PI and 2AWX on "80". 7PU's rectifier should BOIL like the one at 7AAT. Hw? Hi! Let's have more reports next month gang. TNX.

Traffic: 7AAT—QT 134, 7PU 53, 7DD 23, 7EL 6.

OREGON—SCM, A. C. Dixon, Jr., 7IT—7AEK has a new sync rectifier for his 250-watt Hartley. He has a hard time finding condensers which will stand the voltage. 7SY handled two WU messages when the wires were out. 7WU changed his Hartley to a tuned grid and plate and worked Finland. 7AAC used an H-tube with d.c. on the filament.

Traffic: 7SY 23, 7AEK 8, 7PP 7, 7ABH 14, 7AAC 10, 7WU 9.

WASHINGTON—SCM, Otto Johnson, 7FD—7BB makes the BPL again. He reports working fo-1SR. FB. 7UO and 7EH will soon be ORS. They all keep schedules, of course. 7VL reports growing activity in Spokane. 7ACF and 7IV are newcomers. 7AIY is now back with 50 watts. 7TZ burnt his out. 7DF is back from his trip to the Orient. He reports the Japanese hams as being rather shy. Hi. 7AG has 1500 volts of B bats. 7AM gets home from work at 11.30 pm which makes DX working easy.

7BO is still with the game. The Seattle Club has resumed meetings with a large attendance. ORS are warned that continued failure to report will mean loss of their ORS tickets.

Traffic: 7BB 108, 7LZ 55, 7UO 64, 7EH 43, 7VL 21, 7RL 14, 7AM 10, 7BO 1.

PACIFIC DIVISION

EAST BAY SECTION—P. W. Dann, SCM, 6ZX—The report this month was not so good as only eleven reported against about nineteen for last time. All old ORS certificates are hereby cancelled—that is, all ORS certificates with the N. S. prefix or the large numbers are no good—those who have been assigned EB numbers are OK as long as you report but from now on, three misses means a notification by the SCM. If you fellows with old numbers wish a new ORS and to continue in the good old game, write the SCM.

Chief RM McLafferty and his assistants are to be complimented this month on the fine report sent in. 6RJ has a good scheme for keeping interest among his RMS—he forwards them an RM bulletin which is fine stuff.

6AYC sustained a broken arm and is temporarily paralyzed as far as station work is concerned altho he has a second op. 6CTX works East Coast daylight on 20 meters. 6APA uses Zeppelin antenna and is changing all of East Oakland's hams to that system. 6BZU says his set works as good on 80 as on 40. 6BHM has a 50 watter going now and works

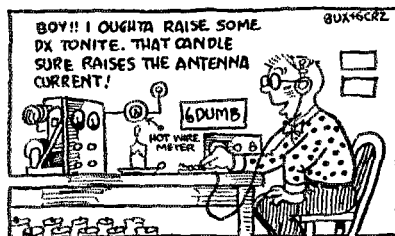

OZ and OA. 6AMI dropped to 40 from 80 and says ND at PRESENT. 6CKC has been laid up in a hospital with a sprained back. 6BBJ is putting up a new station with the assistance of several of the gang. 6CLZ has 20 meter station working with not much luck.

Traffic: 6AYC 427, 6RJ 160, 6CTX 35, 6APA 21, 6CAK 18, 6BZU 17, 6BHM 16, 6AMI 11, 6CKC 3, 6BBJ 2, 6AFT 50.

SACRAMENTO VALLEY—SCM, C. F. Mason—The report this month was received via Western Union which proves than an SCM can report if he really wants to.

Traffic: 6FR 17, 6AVB 15, 6CKA 12, 6ER 9.

ARIZONA—SCM, D. B. Lamb, 6ANO—6AZM reports that his dynamotor is shot and that he will be off the air indefinitely. 6CDU is off for a little while making a super-regenerative rectifier. 6DCQ seems to be having great success with his fone. 6BJI has been using fone with 25 cycle supply and is getting out good. 6BWS, RM for western Ariz., is working fine DX now. 6BJF is also fooling with fone. 6PZ was heard pounding the brass recently. 6CBI uses a sideswiper and he can use it, too. 6APA is the op at 6YB most of the time. They still have the DC but they are planning on making a few changes in the rectifier. 6CUW uses fone and has a nice modulation. 6CAP is another ham that is on occasionally. 6ANO does most of his work in daytime as he has QRM from theater work nights.

Some of you fellows better come out of it and report because the SCM is no mind reader. Let's hear from a few of you.

Traffic: 6BWS 27, 6CDU 37, 6BJI 35, 6DCQ 21, 6BJF 45, 6AZM 2, 6ANO 110.

HAWAII—SCM, John A. Lucas, 6BDL—This report to QST by radio Fort Shafer oh-6BDL via nu-6LH: The air between Hawaii and the West Coast has cleared so that stations on the mainland can be heard and worked during the entire evening. The traffic totals show that more stations are needed on the job, tho. A number of new stations reported. There will be seven new ORS as soon as all requirements are completed. Other new stations

are requested to report their QRA with traffic and other news to the SCM. The Hawaiian reporting month being the 16th to the 15th inclusive. 6ACG has been doing fine traffic work on "20". Both 6AXW and the SCM also contemplate going down. 6DV (exGDI) took some good traffic from KNT. 6BC is still keeping his schedule.

Traffic: 6BDL 17, 6AXW 65, 6ACG 55, 6DV 23, 6BC 18, 6BWV 39.

PHILIPPINES—SCM, M. I. Felizardo, op-1HU—This report by radio to QST from Manila, P. I. op-1AU via nu-6BVY, op-1AU starts things going in the new P. I. Section by making the BPL skeds with nu-6BVY and ac-1CRS. He handles messages from American refugees in China also three messages direct to sa-HA2 from Argentinian training ship visiting Manila. op-1DL, the RM, also keeps sked with nu-6BVY. He worked eg-6BY his first European QSO. op-1AT says traffic is scarce and is QRW at college. op-3AA turned in his ORS ticket as he is leaving for the U. S. soon. Look for him in Boston, Oms. op-1HR handled lots of traffic. Reported by land fone. Hi. op-1GW left for the States late last year. op-1BD and op-3AC are good traffic stations.

Traffic: 1HR 355, 1AU 162, 1DL 50, 1AT 8.

SANTA CLARA VALLEY SECTION—SCM, J. Queument, 6NX—6BVY continued to handle many medical and Chinese refugee messages to and from the Orient and leads the section with messages handed. 6AMM was the connecting link between Philadelphia and PI in some very important traffic work. 6BYH had transformer trouble which kept him off the air part of the time. 6CTE made the BPL and should make him an ORS. See 6BMW if you want schedules. 6BMW finally got his 250 watt crystal xg and is busy lining up ORS with schedules. 6CLP was driven down to the 20 meter band by bad QRM. 6CKV has a schedule with am-2SE. 6CKV has received the new call of 6HB, 6DDN, ran off many QTCs for Hawaii this month. 6BNH worked ac-5RF. 6CJD was on 165 during the month. 6ACQ was limited to 3 watts input this month. 6AZS is QRW college. 6BRJ is still rebuilding. The SCM's location is so poor that he has decided to move to the country and try to do some real DX work.

Traffic: 6BVY 164, 6BYH 124, 6CTE 120, 6AMM 112, 6BMW 47, 6CLP 36, 6CKV 34, 6DDN 19, 6BNH 16, 6CJD 2, 6ACQ 5, 6AZS 4, 6BTJ 1.

LOS ANGELES—SCM, L. E. Smith, 6BUR—Traffic has been moving smoothly throughout the Section and efforts toward more schedules and more consistent work have been bearing fruit. 6BHI cops the month's traffic lead. 6ALZ holds second place. He uses one old style five watt and only operated three weeks of the month at that. 6BJX holds third place in our traffic list. 6ZBJ keeps in the BPL every month and is surely doing consistent work. 6AGG is a newcomer to the BPL and we hope he stays there. 6ANQ did some fine traffic handling for the Hemet News and L. A. Times during the recent rains. 6BXC asks that he be given P. I. traffic since now he is working good schedule work that direction. 6CT has the 20-meter bug and likes it. 6MCT reports that 6OF and he are running. 6AMH at the high school. 6BUX has been doing some good 20-meter work. 6DAQ is working a five-day sked with 6APA. 6BHR is working hard to graduate. 6DEG is all equipped to QSY to 41, 75, 83, 170 and 200 meters. 6AE promises a 203-A soon. 6AM has a new water-cooled watt burner and he is sure tickled with it. 6DDP's health has kept him from doing active work but he will soon be OK again. 6CMQ is back with a 60-watt. 6BXD handled quite a few. 6RF rates a commercial first now and prefers traffic to DX. 6COO reports good reception of two French hams. 6CHT says that a YL at the key sure brings in the QSL cards. School is keeping 6CCL away from the key. 6AKW reports working KDGL in the Yellow sea. 6BAV is on 40 when power leaks let him. 6IH is planning to become a "Sparks". 6AWQ turns in a good total and we hope to make him an ORS soon. 6CMW is a new ORS and reports good work. Sickness kept 6AHS's traffic total down. Another OM who studies at college is 6OR. 6CLK lets his art course keep him off the air. 6BVO, 6BSN and 6DAJ are still going. 6AHP reports that skeds are getting so common that it is hard to QSO the big stations without a schedule.

XIV

From Burbank comes a good report from 6AIO. 6BVM has school QRM.

Traffic: 6BVM 19, 6ANQ 1, 6AHP 26, 6CLK 12, 6AWQ 52, 6IH 16, 6AHS 37, 6BAV 10, 6AKW 7, 6CGL 16, 6CHT 44, 6CCO 32, 6CMT 31, 6RF 35, 6BXD 85, 6CMQ 2, 6DDO 51, 6AM 64, 6AE 3, 6DEG 30, 6BHR 18, 6BXC 39, 6BUX 39, 6AIO 10, 6BVO 6, 6CT 4, 6AGG 117, 6ZBJ 125, 6BJX 270, 6ALZ 313, 6BHI 407. NEVADA—SCM, C. B. Newcombe, 6UO—Traffic: 6ABM 115, 6CZ 72, 6UO 16, 6CHG 9.

SAN DIEGO—SCM, G. A. Sears, 6BQ—This is the first report from the new San Diego Section. 6BXI leads in messages handled closely followed by 6DAU who handled a lot of press during the recent storm. 6BXI is handling traffic on 20. A message from Headquarters was related to N. Z. in 2 hrs and 5 minutes. 6BYZ got it to Australia 2 hrs and 15 mins. after it started. FB, OMS, 6LH is on 20 and 40 at night. 6CGC is bothered by power leak. 6CTP sticks to his 201-A with B batts. YLs keep 6SB QRW. 6BAS is again at NPL. He and 6AJM have C-Cs going now. 6AKZ is not on account of business. 6MB is experimenting with phone.

Traffic: 6BXI 135, 6DAU 132, 6BYZ 103, 6LH 43, 6CGC 15, 6BQ 20, 6BFE 9, 6CTP 6, 6SB 6, 6BAS 3.

SAN FRANCISCO—SCM, G. W. Lewis, 6EX—6RW still continues to lead the Section for traffic. 6CCR has been doing very consistent work on 20 meters. 2CHK is now located in San Francisco and signs 6PN—the present QRA is 805 Leavenworth St., Apt. 410. 6DAW and 6EH have a code practice schedule for beginners. 6DAW is installing a mail box in the school to originate traffic. FB. 6GW has his tuned plate and grid perking on 39 meters. 6VR has been QRW so has been on very little. 6AHE has been laid up with a bad cold due no doubt to the Hertz. 6CJA has just acquired a brand new Buick Six and claims he rides on air. 6CHE, although QRW college and his YL, still manages to keep the old sync warm.

Traffic: 6RW 177, 6CCR 50, 6VR 42, 6GW 23, 6DAW 19, 6KW 18, 6CHE 15, 6PN 9, 6AHE 4, 6CJA 4.

ROANOKE DIVISION

VIRGINIA—SCM, J. F. Wohlford, 3CA—3KU is on 41.5 meters now using tuned plate and grid circuit. 3TN worked eg-6MU and ei-1CE with a 210. 3II is operating at 3JT. 3WM runs a 201A transmitter with old B batteries bummed from a local radio store. Hi. 3GX is putting in MO-PA circuit. 3BMN was burglarized and is moving quarters. 3CEL reports he is only working one schedule with 3SN, the Army Station. 3BN is on regularly.

3CH is a new station heard at times. 3NM is just on the air and asking for traffic for Charlottesville and University. 3RL has closed the station until May. 3EG operates the set at 3BGS on Sat. nights but has now power at his own shack. 3BGS will be ready to work on 40 and 80 soon. 3AAL, xtal controlled station, sent a message to 8DEF Feb. 21, at 12:40 A. M. and it was delivered in San Francisco the next day and acknowledged by Western Union. 3CKL is still going strong on 40 meters and covering about everything that is worthwhile. 3BZ and 3CA are building xtal control sets now. 3BDZ is QRW.

Traffic: 3CKL 183, 3KU 31, 3AAL 9, 3BGS 3, 3CEL 23, 3NM 6, 3TN 23, 3JT 15, 3WM 7.

NORTH CAROLINA—SCM, R. S. Morris, 4JR—Send in your report promptly on the 26th whether you are an ORS, belong to the ARRL or what. We want YOUR report. We have a position as Official Observer for any one who has an accurate wavemeter and who would like to do a little reform work. 4BX has more time on the air now and is making good use of it. 4PT has handled some important traffic to ARRL HQ. 4RI is QRW trying to dope out the whys and wherefores on a super het. 4QK just got back on the air on 80 with a 50 watt. 4MI has QSYd to 80 for good he says. 4JR has about conquered his crystal now and is fixing to rebuild it. 4DB is rushing them on both 40 and 80 now that has two 210s. 4OH has installed a Kenotron rectifier so he now gets more traffic. 4PR is still working front door DX. 4UQ is rewiring his transmitter. 4OC is putting in a crystal controlled fifty. 4DV is doing good DX with fone on 80. 4NH is experimenting and working foreign DX. 4TS is putting in his B battery plate supply. 4PP is off waiting for renewal of his operator's license.

QST FOR APRIL, 1927

4RY has QRM from the college faculty. 4SJ is QRW but manages to knock off a few with a lone 202.

Traffic: 4MI 123, 4RY 87, 4DB 80, 4JR 55, 4PP 35, 4BX 30, 4OH 29, 4SJ 23, 4NH 18, 4UV 11, 4TS 7, 4RF 6.

WEST VIRGINIA—SCM, C. S. Hoffman, Jr. 8BSU—8WK uses a 1 K.W. 500 cycle crystal controlled set. 8BJB uses a Hertz and is fixing up a 50 watt set. 8DBM is on at 8RX. 8CEK sends in a good report; has been QRW on account of holiday rush. 8AUI worked nd-HIK and eg-2CC. 8BTD visited Wheeling. 8DOH is putting in a new set. 8CDV is planning to go to school. 8BSU is putting in new set. Huntington amateurs are requested to cooperate with ex-8AMD, RM of that Section. 8ALG reports via 8VZ. 8VZ makes another record handling 628 messages; also reports working oh-6CXY. 8DCM has schedules with 8LI 9DLU and 8ACX. 8BJG worked WPA.

Traffic: 8VZ 628, 8CEK 45, 8ACZ 33, 8BJB 27, 8QH 13, 8DCM 23, 8AUL 7, 8BSU 6.

ROCKY MOUNTAIN DIVISION

COLORADO—SCM, C. A. Stedman, 9CAA—9CAA is holding down his schedules in fine shape with a good sized total to show for it. 9CNL ran him a good race and with the help of several schedules piled up a fine total. 9DGJ is giving a new type of aerial a tryout with fine results. 9QL and 9DKM are on 20 mostly now. 9DWZ is busy with KGBY and so didn't get on much but says he intends to hold on the ORS just the same. 9BQO tried to swipe one of 9CAA's girls but he forgot to ask for her QRA so is out of luck. Hi. 9EDZ moved his set over to East High School and did some good work with the result that the school board may add a station to the school equipment. 9DLA has moved to Nebraska. 9CDW is putting up a new stick PDQ. 9CAW is on 20 and 40. 9EAM will be more or less QRW with business and won't be on much. 9DSY has gone up to 80 meters now.

9BYC is doing more experimenting than anything now and is working with 5 and 20 meters. He reports another active station in Boulder, 9BVK. 9DVL reported by radio this time. 9CDE is the only station reporting from Dist. 2 this month.

Traffic: 9CAA 250, 9CNL 149, 9EAM 55, 9CAW 47, 9BQO 27, 9CDW 12, 9DSY 27, 9DWZ 5, 9QL 7, 9EDZ 5, 9DKM 14, 9DGJ 7, 9CDE 23, 9BYC 5, 9DVL 24.

UTAH-WYOMING—SCM, D. C. McRae, 6RM—A number of new stations are being lined up and several new ORS appointments will be made shortly. The SCM would like to impress on the gang that reports must be mailed immediately after the close of the operating month on the 25th, to be included in QST. 6RV has been appointed Official Observer so watch your wavelengths, gang. 6CLQ at Fort Douglas, Utah has 3 ops and will add three more soon. 6CLQ has applied for ORS. 6CNX at Ephraim, Utah, has schedules with TDA and can handle Wyoming traffic. He uses a 210 with 500 volts RAC on the plate. "Welcome, OB". 6OVA recently visited many hams in Calif., Nevada and Arizona. 6HTX has schedules with 9DOL.

6AIK at Ogden reports several BCLs learning the code there. The SCM's station seems to be the only one in Salt Lake City that handled traffic. Perhaps some did not mail their reports on time, tho. 6RM was on 20 meters the entire month, and a great number of stations were worked. Let's see more of the gang down on 20.

Traffic: 6CLQ 102, 6BTX 49, 6RM 45, 6CNX 13, 6CVA 6, 6AIK 3.

SOUTHEASTERN DIVISION

ALABAMA—SCM, A. D. Trum, 5AJP—Well, fellows, 'smatter with the reports this month? Coming in mighty slow.

5ADA is plugging away every week-end when QRM from school permits. 5NL is back on the air pounding a 50 with 1500 volts on the plate. Thanks to the fine work of 5ADA and 5IB. 5AJP has been doing most of his brass pounding in conjunction with 5JY at 5JY. 5AFS has been heard very little of late. The ops at WYK are now building a 50-watt ham set and will be on soon. 5IB has gone kerfuey. 5AV is making things hop around Selma and is now working with 2 210A's. 5LX will be on for good soon. 5OA is going strong in Auburn. 5FI is working fine now at Gadsden. 5DF is in the lime-light again working like a Trojan. 5DI and 5AC have been having one grand time at Mardi Gras this month. However, much work was done.

QST FOR APRIL, 1927

Traffic: 5ADA 21, 5AJP 19, 5AV 29, 5JY 41, 5AFS 7, 5NL 4, 5FI 29, 5DF 37, 5DL 77, 5OA 105.

FLORIDA—SCM, W. F. Grogan, 4QY—4CK is keeping schedules. 4OB is doing good work with raw a.c. Keeps schedule with eg-5BY. 4TK also reports good work. 4DD was QSO Europe 14 times in one week. 4TR is building a new rectifier out of pop bottles. 4DM is doing some 5-meter work. 4LG says two more good 60's have gone to rest. 4BL has been admitted to WAC. 4LK sends in a fine report for his first month as an ORS. 4VS is active again also using fone. 4QY has been trying fone and found it OK.

Traffic: 4CK 26, 4OB 16, 4TK 16, 4DD 79, 4TR 112, 4DM 204, 4LG 35, 4BL 16, 4LK 113, 4US 30, 4QY 22. GA-SC-PR—SCM, H. L. Reid, 4KU—South Carolina: A new report comes in this time from 4OY in Spartanburg. He's an old timer but this is his first report in years. Glad to hear from you, OM. 4IT has schedules with 1CTI three times a week.

Georgia: 4AAH is still going strong as well as 4AV and 4SI in Atlanta. 4TU, a student at Ga. Tech., writes in for an ORS and reports working fo-A3B with ease. 4TU's home is in Santiago, Chile, and he has a schedule with sc-2AS to keep in touch with his parents. 4BW is doing nice work and we hope to hear more from this part of the state. 4DV reports he's on and doing nice work. The National Guard station EV8 writes in for an ORS. Business seems to be picking up.

Porto Rico: 4KD is QRV for P. R. traffic. Traffic: 4AAH 21, 4OY 50, 4AV 277, 4DV 21, 4IT 30, 4KD 8.

WEST GULF DIVISION

OKLAHOMA—SCM, K. M. Ehret, 5APG—5AEQ has too many YLs and school work to keep any schedules. 5ADO is too QRW for traffic on the amateur band. 5ANL had lots of QRN on 80 last month. 5APY recently married but expects to have his new transmitter working on 40 as soon as he gets time to put up an antenna. 5QL is ordering a 2500 volt MG to massage the plate of his 250 watt. 5ZAV knocks off some good DX with his 50 watt MO-PA set. 5ARD is still hard at it with a 7 1/2 and Kenotrons. 5AKA had an argument with the power company over the voltage drop caused by his MG. 5AAV traded his transmitter to 5KD and is planning a new MO-PA to take its place. 5SW swings a nasty sideswiper whenever he can get time from building superhets. 5APG knocks 'em cold with his MO-PA on a Zeppelin antenna.

5AMO's 30 watter went west after working much DX and is replaced with a new 210. 5AVF and 5ADX are working some U. S. hams now. 5FJ handled a test message for HQ.

NORTHERN TEXAS—SCM, W. B. Forrest, Jr., 5AJT—5ACL has a schedule with fo-A3B on 20 meters. 5SP is on 38 m. and QSO So. Africa. 5HY is keeping schedule with 5AMN on 39 meters. 5APO continues to be our best bet for traffic. 5APO also has a schedule with 8CFR to clear Eastern traffic. 5RG is keeping schedule with ND-HIK. 5AJJ got his traffic total started up to a nice figure but had to leave town on a trip before he finished a good month of it. 5VU is back with us again on 40 m. 5WW had the misfortune to lose a dynamotor but he will have another set going soon on 40 meters. 5JF works all continents readily except Asia. 5AHU and 5RO are twins. Welcome to the gang. OMS. 5AFU is on 40 meters. 5NW-5MZ is operating short wave station KOS.

Traffic: 5ACL 5, 5SP 21, 5HY 20, 5APO 129, 5RG 12, 5AJJ 60, 5VU 47, 5SH 7, 5WW 2, 5JF 2, 5NW-5MZ 4.

SOUTHERN TEXAS—SCM, E. A. Sahn, 5YK—5IW has been appointed Route Manager. Get behind him, fellows, and help him all you can. 5RV is a new San Antonio ham. Welcome. OM. 5HS is on daily from 6 to 7 and on Sundays. 5HE is doing his usual good work. Traffic handled by him always goes. 5WP is on the air with two fifty-watt jugs. 5RR formerly nc-3RR has finally gotten his set up and is ready to go. 5AVI-5ARF have changed to a vertical Hertz antenna. 5EW is using fifty watts again and says they get out better than his 250s. 5ALH has put in a real 500-watt crystal-controlled set. 5PK does a great deal of relaying for college boys.

Traffic: 5PK 54, 5AVI-5ARF 5, 5HS 2, 5HE 6.

CANADA
MARITIME DIVISION

NOVA SCOTIA—SCM, W. C. Borrett, 1DD—1DA is Cape Breton has been working all Europe with a UX-210. 1DM and 1AR are changing over to low power and using UX-210s. 1BF is getting a new generator this month. 1DD had the pleasure of working a new Maritime station IAP. 1CX is suffering from frozen rectifier. Hi. 1AC is to be our high power station very soon. 1AE is going strong. 1DJ is the only Halifax station on the air these days. 1DQ has been working the world in the early hours of the morning.
Traffic: 1CX 8, 1DD 21, 1AE 5.

PRINCE EDWARD ISLAND—SCM, W. H. Hyndman, 1BZ—1CO is doing good work on the 20 meter band. 1AP, the new station, is progressing well.
Traffic: 1CO 4, 1BZ 1.

NEW BRUNSWICK—SCM, T. B. Lacey, 1EI—Another month has gone with renewed activity in N. B. 1AI has just returned from his honeymoon in the N. E. States and is receiving the good wishes of the gang. (Why not teach her the code, OM?) 1AX is on continuously and doing exceptional DX for his UX-210. 1AQ is on again, having recovered from a serious operation. 1AM has worked England as well as his usual DX on this continent. 1AD worked Belgium and Holland. 1AK reports working nc-4AR, England and the west coast. 1EI is off for a while on account of having to work 6 and 8 hours overtime daily. 1AN has been off lately to assist in building a new amateur broadcasting station in Fredericton. New Brunswick stations can be found on the high end of the 40 meter band.
Traffic: 1AD 43, 1AK 36, 1AM 14, 1AI 5, 1AX 29.

ALBERTA DIVISION

ALBERTA—SCM, A. H. Amussen, 4GT—The SCM was in Edmonton last week and was surprised to see such ham activity. 4HM has a fine layout of equipment, and it works very well. 4CU is using an H tube and is on consistently, with 4HF as second on. 4AH has two H tubes in crystal control. 4CL is QRW but has his H tube working. 4DG is now stepping out FB and expect some real DX reports from all the Igloo Hut gang. 4EL and 4BI will be on soon. 4DQ has not seen his switter for nearly a month on account of scarlet fever at home so the OW has been at the key with no assistance and worked the first real DX from that station. 4AL was QSO ARDI and got an R4 report. 4HO and 4AP can QSY to 20, 40 & 80 and they both were QSO Hawaii. This section will soon be the DX'ers. Watch next report. 4GT tries to QSO all stations in his district Sun. afternoons.
Traffic: 4DQ 8, 4AF 7, 4IO 13, 4DG 13, 4GT 5, 4AL 10.

BRITISH COLUMBIA—SCM, E. S. Brooks, 5BJ—Amateur activities are very brisk in and around Victoria this month and quite a number of new stations will soon be on the air. The Victoria Radio Club reports their ham class is doing fine. 5AR has a Zep antenna working and reports fine results. 5GW is building a power transformer. 5AJ still works OA and OZ stations with R5 sigs. 5AV keeps schedules with 5AC and is QSR nc-4HS any night. 5CT hears lots of DX but still is unable to raise anyone. 5AM finds 80 meters has better operating conditions than 40. 5BK puts R5 sigs into Vancouver with a UX171 and 200 volts B batteries. 5GO and 5GF are trying out 20 meters and report good results.
Traffic: 5AJ 54, 5GO 24, 5AV 14, 5CT 2, 5AM 1.

QUEBEC DIVISION

QUEBEC—SCM, Alex Reid, 3BE—Last month's hamfest was held at 2HV's station and was very well attended. Fred's latest wavemeter and other instruments were the envy of the gang. 2EQ made his first appearance at a hamfest and certainly enjoyed himself. 2AL and 2BE are moving to new QRA's and will be off the air for a few weeks. 2BA has a Sunday schedule with nc-8AZS. 2DN reports that he is rocking the baby and the key at 12 every night looking for traffic on 42 meters. 2BO and 2AV are both getting out well. 2AV turned in a nice traffic report. 2BM has rebuilt and is getting much better results. 2DO is sure putting a nice DC note out. 2AU has his crystal

set going FB now. EX-2AN is rebuilding and will be back on the air shortly.

Traffic: 2AL 15, 2DN 8, 2AV 10, 2BG 10, 2BE 9, 2DO 6, 2AU 12, 2AK 5.

ONTARIO DIVISION

ONTARIO—SCM, W. Y. Sloan, 9BJ—Eastern Dist.: 3JL again makes the BPL. 3KT is running him a close second this time. 3VO and 3AFP are heard enjoying a good rag-chew Wednesday nights on 52.5.

Southern Dist.: 3CS had a streak of hard luck: First, during a heavy windstorm, his mast attempted to do the "black bottom", but collapsed in the effort. After this damage was repaired, the 50 watter departed from this life. 3CS now has a new mast and a WE 250 watter. 3TM is back on 80 meters. 3CB is suffering from the embarrassing attentions of the B. C. Ls.

Northern Dist.: 3HX is getting out on 40 meters and reports 3BG will be with us again soon. 3GG is on the 80 meter band most of the time. 3NI is back again with a vengeance and worked eg-5HS on 20 meters. 3HP is on regularly when his work permits.

Central Dist.: The fellows in this District are apparently down to business. 3BZ has traffic schedules on 80 meters. 3DC is quite busy building a new set, but has been on and handled some traffic. 3CT has been idle this month but is all pepped up and will be on for sure next month. 3AI and 3HT have forsaken brass-pounding temporarily in favor of YLs. 3BT has a new 203A and an H tube. 3CR blew one "fiver" but was on immediately with another. 3CC reports that one "fiver" and a "peanut" went west this month at his station. 3BL has been doing very good work with about 25 watts input to a "fiver." 3EL has also done very good work on schedule. 3AL has been playing with crystals. His brother is on a Mediterranean cruise on the Empress of France, having a shortwave receiver with him. 9BZ has had the misfortune to burn out the bearings on his MG exciter but the sigs are getting out just the same. 3BR complains of school QRM. 9BJ is still using the "fiver" and gets out very well. 3DN is free from most of his worries now and should make a good ORS. 3FC has been fairly active after midnight on nights when QRN is not so bad. 9AI spends such time as is available on the 20 meter band. 3MV has been on regularly but despite warnings, has been very much off-wave. 3NJ is heard on 52.5 occasionally and also on 80 but for some unknown reason fails to report. 3CJ is a new station on 40 with a "fiver" but has lots of pep and will be a good ORS soon. 9AG is on 39 meters and also on 52.5. 9CD is heard on occasionally.

Traffic: 3JL 103, 3KT 85, 3HP 46, 3EL 40, 3AZ 33, 3NI 21, 3AL 28, 3BL 27, 3FC 26, 3FU 16, 3CC 16, 9BJ 14, 3EG 11, 3BZ 11, 3AG 9, 3VO 9, 3CS 8, 3AFP 7, 3BT 2, 3DC 2, 3LV 2, 3IA 2, 3CR 1.

PRAIRIE DIVISION

MANTOBA—SCM, F. E. Rutland, 4DE—Activity this month has been very brisk with several new DX records for this Section being hung up. Traffic for the most part has been handled on 40 meters, while DX has been accomplished on both 40 and 20 meters. Four new ORS have been appointed. Three newcomers have opened up while as many more are building and getting into shape for a license. 4DU, 4FZ and 4DW have hung up the DX shingle. 4DU was QSO fo, sc, nj and nc-4fx, oa and np while 4DW clicked with oh and np. Both 4FZ and 4DW were using a single 210. 4DY is now a salesman with an Electrical concern and is out of town a good deal. 4BT is attending school in the States. 4AW and 4FZ are also QRW out of town mostly but manage to pound the brass with good effect when home. 4DW spends most of his time down on 20 meters. 4DT has not been heard from lately. He changed his address and apparently has not got started yet.

Traffic: 4AW 26, 4DE 32, 4DU 23, 4DW 25, 4EH 36, 4FO 4, 4FZ 15, 4FV 18, 4EK 4, 4DY 15.

SASKATCHEWAN—SCM, W. J. Pickering, 4FC—4CP is on the air now with a 50 watter. 4FA is firing up a rectifier for his Ford coils and would like to hear from the gang and arrange scheds. 4DR is a new station at Kinistino. Would those stations who are not reporting do so and send it in by the 20th of each month?