

QST

DEVOTED ENTIRELY TO

AMATEUR RADIO

Published by the American Radio Relay League



November
1926

25¢

Cunningham RADIO TUBES

All types C & CX in
the orange and blue
carton.



Favorably Known to Millions

These tubes are known to millions of Americans who are interested in radio, but this fact is relatively unimportant. What is of importance is the fact that the **quality** of Cunningham Radio Tubes is so widely recognized. Public recognition of their inner quality, has held these tubes in their position of dominant leadership.

Cunningham Radio Tubes combine solid, substantial worth with unerring accuracy and long life. In your receiver, they will do their work in an efficient and effective manner leaving no doubt in your mind as to what tube is the genuine quality product.

E. J. Cunningham Inc.

New York

Chicago

San Francisco

Mfg'd and sold under rights, patents and inventions owned and/or controlled by Radio Corporation of America.

many times better than in 1921



to get more power

—put an RCA power Radiotron UX-120, UX-171 or UX-210 in the last audio stage of your set.

to get more distance

(on a storage battery set)
—put the new special detector Radiotron UX-200-A in the detector socket.

RCA is not only making Radiotrons steadily better—but is further improving reception with these new special Radiotrons. Keep your set up to date.

WITH four times less drain on your "A" batteries than the storage battery tube of five years ago, the filament of a Radiotron UX-201-A throws across to the plate five times as many electrons—a steady stream of tiny electrical charges that carry the song and speech. This is a big increase in efficiency!

And the Radiotron UX-201-A does not burn out—unless you apply a huge, excessive voltage. It does not die gradually, but keeps its efficiency almost to the very end of its life.

These are but a few of the advances in vacuum tube making that have come from the laboratories of RCA and its associates—General Electric and Westinghouse. Unceasing research brings continual improvement in RCA Radiotrons, making possible ever better reception—at lowered cost.

RADIO CORPORATION
OF AMERICA
New York Chicago San Francisco



RCA Radiotron

MADE BY THE MAKERS OF THE RADIOLA

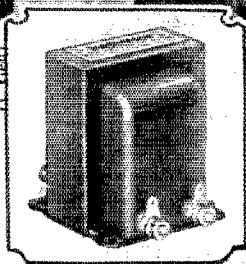
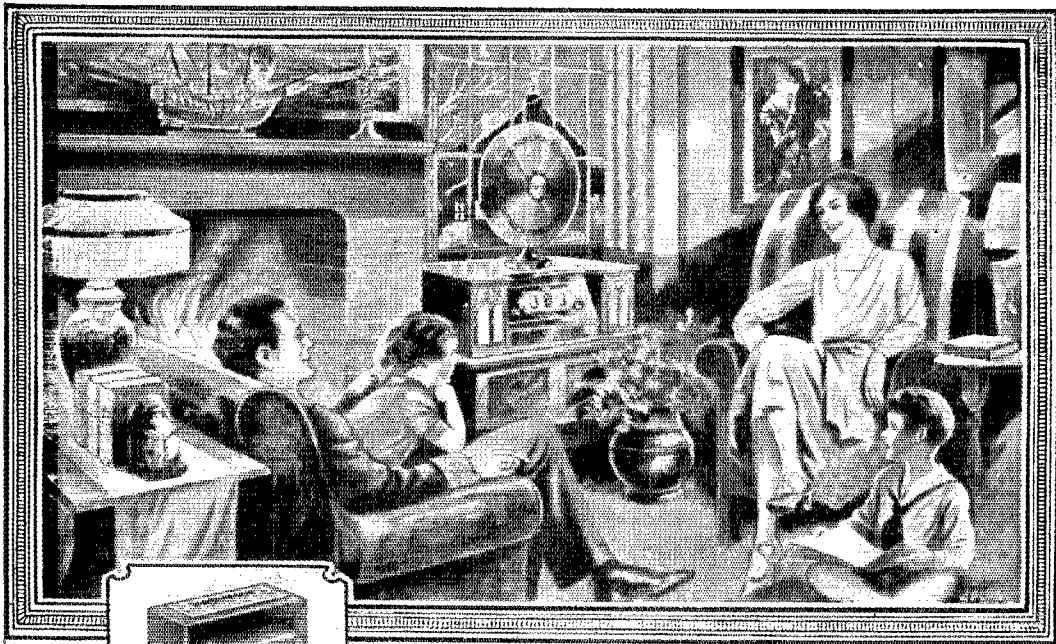

THORDARSON

R-200
AMPLIFYING TRANSFORMER

Supreme ⁱⁿ MUSICAL PERFORMANCE!

THE secret of good reception lies not in attempted correction of the deficiencies of poor broadcasting, but in faithfully reproducing the programs of the better stations.

Thordarson transformers employ neither a "rising" or a "falling" characteristic for corrective purposes. They are designed to give, as nearly as possible, equal attention to all notes.

The majority of leading quality receivers are equipped with Thordarson transformers—a substantial evidence of the musical supremacy of Thordarson amplification.

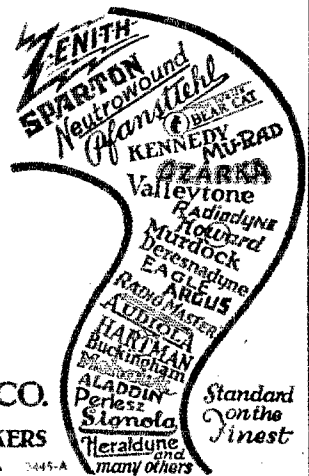

THORDARSON ELECTRIC MANUFACTURING CO.
Transformer Specialists Since 1895
WORLD'S OLDEST AND LARGEST EXCLUSIVE TRANSFORMER MAKERS
Huron and Kingsbury Streets — Chicago, Ill. U.S.A. 3445-A

Section Communications Managers of THE COMMUNICATIONS DEPARTMENT, A. R. R. L.

ATLANTIC DIVISION

Eastern Pennsylvania 8BQ
Maryland-Delaware - District of Columbia 3AB
Southern New Jersey 3EH
Western New York 8PJ
Western Pennsylvania 8XB

H. M. Walleze 597 No. James St.
A. W. Goodall 1824 Ingleside Terrace
H. B. Densham 140 Washington St.
C. S. Taylor 598 Masten St.
G. L. Crossley

Hazleton
Washington, D. C.
Collingswood
Buffalo
State College

CENTRAL DIVISION

Illinois 9AAW
Indiana 9C7Q
Kentucky 9ABU
Michigan 8ZZ
Ohio 8BYN
Wisconsin 9VD

W. E. Schweitzer 4284 Hazel Ave.
D. J. Angus 310 N. Illinois St.
D. A. Downard 116 No. Longworth Ave.
C. E. Darr 137 Hill Ave.
H. C. Storck 894 Carpenter St.
C. N. Crapo 443 Newton Ave.

Chicago
Indianapolis
Louisville
Highland Park, Detroit
Columbus
Milwaukee

DAKOTA DIVISION

North Dakota* 9EPN
South Dakota 9BDW
Nor. Minn. 9EGU
South Minnesota 9EJU

G. B. Mohr 618 11th Street, South
F. J. Beck
G. L. Barker
C. L. Barker

Fargo
Milbank
Henning
Henning

DELTA DIVISION

Arkansas* 5XAB
Louisiana 5UK
Mississippi 5AKP
Tennessee 4KMP

Dr. L. M. Hunter 207 1/2 Main St.
C. A. Frittag 129 Camp St.
J. W. Gullett 1708 23rd Ave.
L. K. Rush 1 Second St.

Little Rock
New Orleans
Meridian
Bemis

HUDSON DIVISION

Eastern New York 2ADH
N. Y. C. & Long Island 2CWR
North New Jersey 2WB

Earle Peacock Box 113
P. H. Mardon 117-11 146th St., So. Ozone Park, Jamaica, L. I.
A. G. Wester, Jr. 50 Princeton St.

Yonkers
Hilton

MIDWEST DIVISION

Iowa 9DOA
Kansas 9DNG
Missouri 9RB
Nebraska 9BYG

L. R. Huber Room 19-C Quadrangle
F. S. McKeever University Heights
L. B. Laizure 8010 Mercier St.
C. B. Deihl 3006 S. 32nd Ave.

Iowa City
Lawrence
Kansas City
Omaha

NEW ENGLAND DIVISION

Connecticut 1BM
Maine 1BIG
Eastern Massachusetts 1BVL
Western Massachusetts 1DB
New Hampshire 1ATJ
Rhode Island 1BVB
Vermont 1AAG

H. E. Nichols 82 Elmwood Ave.
Frederick Best 13 E. Crescent St.
R. S. Briggs 393 Ashmont St.
A. H. Carr 39 Vassar St.
V. W. Hodge 227 Main St.
D. B. Fancher 22 Summer St.
C. T. Kerr

Bridgeport
Augusta
Dorchester
Worcester
Claremont
Westerly
Poultney

NORTHWESTERN DIVISION

Alaska* 7FD
Idaho 7ST
Montana* 7NT
Oregon* 7IT
Washington* 7FD

L. H. Machin Box 452
Henry Fletcher 1107 State St.
A. R. Willson
A. C. Dixon, Jr. 1350 East 36th St.
Otto Johnson 4340 30th St. W.

Cordova
Boise
Ramsay
Portland
Seattle

PACIFIC DIVISION

Hawaii 6TQ
Nevada 6UG
South Section 6BUR
Sect. 4 (No. Calif.) 6NX
Sect. 5A* (No. Calif.) 6AHG
Sect. 5B* (No. Calif.) 6EX
Sect. 6* 6BAP

K. A. Cantlin 1593 Piikoi St.
G. B. Newcombe
L. E. Smith 340 No. Painter Ave.
F. J. Quement 51 Pleasant St.
F. J. Lorscheter 635 52nd St.
G. W. Lewis 748 14th St.
St. Clair Adams

Honolulu
Yerington
Whittier
San Jose
Oakland
San Francisco
Eureka

ROANOKE DIVISION

North Carolina 4JR
Virginia* 3CA
West Virginia 8BSU

R. S. Morris 413 Broad St.
J. M. Wohlford 118 Cambridge Ave.
C. S. Hoffman 126 Chantal Court

Gastonia
Roanoke
Wheeling

ROCKY MOUNTAIN DIVISION

Colorado 9CAA
Utah-Wyoming* 6ZT
7ZO

C. R. Stedman 1641 Albion St.
Art Johnson 247 E. 7th So. St.
N. H. Hood 1029 S. Ash St.

Denver
Salt Lake City, Utah
Casper, Wyo.

SOUTHEASTERN DIVISION

Alabama 5AJT
Florida 4QY
Georgia-South Carolina-Cuba-Porto Rico-Isle of Pine 4KU

A. D. Trum 217 Catoma St.
W. F. Grogan Box 816
H. L. Reid 11 Shadowlawn Ave.

Montgomery
Ft. Myers
Atlanta

WEST GULF DIVISION

Northern Texas 5AJT
New Mexico*
Oklahoma 5APG
Southern Texas 5YK

W. B. Forrest, Jr. 503 Royal St.
K. M. Ehret 2904 N. Robinson St.
E. A. Sahn Box 569

Waxahachie
Oklahoma City
New Braunfels

MARITIME DIVISION

Newfoundland 8AR
New Brunswick 1BX
Nova Scotia 1DD
Prince Edward Island 1BZ

Loyal Reid Avalon House
T. H. Lacey 22 N. B. Power Co.
W. C. Horrett 14 Sinclair St.
W. A. Hyndman 25 Fitzroy St.

St. Johns
St. John
Dartmouth
Charlottetown, P. E. I.

ONTARIO DIVISION

Ontario* 9BJ

W. Y. Sloan 167 Close Ave.

Toronto

QUEBEC DIVISION

Quebec 2BE

Alex Reid 303 Birch Ave.

St. Lambert

VANALTA DIVISION

Alberta 4GT
British Columbia* 5GB

A. H. Asmussen 2133 18th St. W.
Felix E. Batt 211 8th Ave. E.

Calgary
Prince Rupert

PRAIRIE DIVISION

Manitoba* 4DE
Saskatchewan* 4CB

F. E. Rutland, Jr. 453 St. John Ave.
E. L. Maynard

Winnipeg
Morse

*Temporary officials appointed to act until the membership of the Section concerned choose permanent SCMs by nomination and election.

For Amateurs—

A Low-Wave Receiver of Exceptional Merit

THE efficient reception given by the CR-18 is due to Grebe design and construction; eight features are particularly outstanding:

An Antenna Coupling Coil provides variable electro-magnetic coupling between antenna and grid circuit. Permits of harmonic tuning to increase signal strength, gives greater selectivity and reduces interference and induction noises.

Losses are reduced to a minimum.

Plug-in Coils allow rapid change from one frequency band to another.

Grebe S-L-F Condensers insure ease of tuning and maximum signal strength.

Beat Frequency Control permits tuning to a fraction of a kilocycle.

Plate Circuit design gives smooth control of regeneration without affecting wavelength calibration and tuning.

Cushion Sockets eliminate microphonic noises.

The six *Self Supporting Air Dielectric Coils* are very rugged, which insures long life.

Write for Booklet Q and charts. Grebe Short-Wave Instruction Manual contains data valuable to amateurs and experimenters. Send 25 cents for copy.

A. H. Grebe & Co., Inc., 109 West 57th Street, New York

Factory: Richmond Hill, N. Y.

Western Branch: 443 So. San Pedro St., Los Angeles, Cal.

This Company owns and operates stations WAHG and WBOQ; also rebroadcasting stations, Mobile WGMU and Marine WRMU and stations 2ZV and 2XE.



Doctor H. Grebe

General view of interior of CR-18.

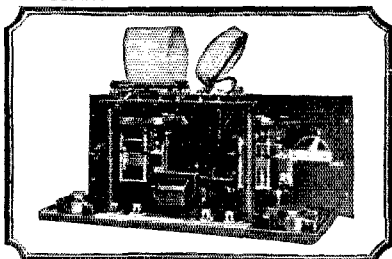

The GREBE CR-18

A modern coupled regenerative circuit receiving between 10 and 200 meters (1500 to 30,000 kilocycles).

Showing coil mounting and Beat Frequency Condenser between dials.

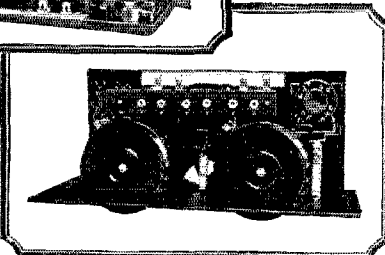

Front view of CR-18 with 200 meter coil intake and additional coils for 10, 20, 40 and 80 meter bands.

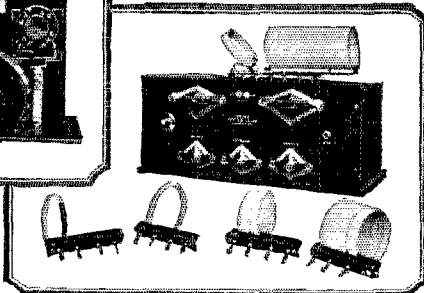

TRADE MARK
Reg. U. S. Pat. Off.

All Grebe apparatus is covered by patents granted and pending.



QST



The Official Organ of the A.R.R.L.

VOLUME X

NOVEMBER 1926

NUMBER 11

Editorials	7
Standard Frequency Schedules	8
WWV Schedules	8
General Electric Short-Wave Test Results	9
A.R.R.L. Information Service Rules	13
R.F. Amplification—A Re-Hash	14
Book Reviews	18
Welding Edison Elements	19
A Sensitive Vacuum Tube Relay	20
A Shielded Crystal-Controlled Unit	22
A Short-Wave R.F. Amplifier	26
New Panel Material	27
Uses of a Calibrated Variable Condenser	28
New Interchangeable Coils	31
Horizontal Wave Experiments at 2AER	32
The Price of Peace	34
The Flying Loop	36
A "Midline" Condenser	40
The Mast at 8LO	41
Amateur Radio Stations, 1XV-1XAN	42
Cage Antenna Hoops	45
Calls Heard	46
I.A.R.U. News	48
Statement of Ownership	51
Correspondence	52

QST is published monthly by The American Radio Relay League, Inc., at Hartford, Conn., U. S. A.
Official organ of the A.R.R.L. and the International Amateur Radio Union

Kenneth B. Warner (Secretary, A.R.R.L.),
Editor-in-Chief and Business Manager

F. Cheyney Beekley
Managing Editor and Advertising Manager

Robert S. Kruse,
Technical Editor

John M. Clayton,
Assistant Technical Editor

David H. Houghton,
Circulation Manager

Subscription rate in United States and Possessions, Canada, and all countries in the American Postal Union, \$2.50 per year, postpaid. Single copies, 25 cents. Foreign countries not in American Postal Union, \$3.00 per year, postpaid. Remittances should be by international postal or express money order or bank draft negotiable in the U. S. and for an equivalent amount in U. S. funds.

Entered as second-class matter May 29, 1919, at the post office at Hartford, Connecticut, under the act of March 3, 1879. Acceptance for mailing at special rate of postage provided for in section 1103, Act of October 3, 1917, authorized September 2, 1922. Additional entry as second-class matter, acceptable at special rate of postage provided for above, at Springfield, Mass., authorized September 17, 1924.

Copyright 1926 by the American Radio Relay League, Inc., Title registered at United States Patent Office.
Member of the Radio Magazine Publishers' Association.

THE AMERICAN RADIO RELAY LEAGUE

The American Radio Relay League, Inc., is a non-commercial association of radio amateurs, bonded for the promotion of interest in amateur radio communication and experimentation, for the relaying of messages by radio, for the advancement of the radio art and of the public welfare, for the representation of the radio amateur in legislative matters, and for the maintenance of fraternalism and a high standard of conduct.

It is an incorporated association without capital stock, chartered under the laws of Connecticut. Its affairs are governed by a Board of Directors, elected every two years by the general membership. The officers are elected or appointed by the Directors. The League is non-commercial and no one commercially engaged in the manufacture, sale or rental of radio apparatus is eligible to membership on its Board.

"Of, by and for the amateur", it numbers within its ranks practically every worth-while amateur in the world and has a history of glorious achievement as the standard-bearer in amateur affairs.

Inquiries regarding membership are solicited. A bona fide interest in amateur radio is the only essential qualification; ownership of a transmitting station and knowledge of the code are not prerequisite. Correspondence should be addressed to the Secretary.

OFFICERS

President
HIRAM PERCY MAXIM
Hartford, Conn.

Vice-President
CHAS. H. STEWART
St. Davids, Pa.

Communications Manager
F. E. HANDY
Hartford, Conn.

Treasurer
A. A. HEBERT
Hartford, Conn.

Secretary
K. B. WARNER
Hartford, Conn.

DIRECTORS

President
HIRAM PERCY MAXIM
Drawer 4
Hartford, Conn.

Vice-President
CHAS. H. STEWART
St. Davids, Pa.

Canadian General Manager
A. H. K. RUSSELL
5 Mail Bldg.
Toronto, Ont.

Atlantic Division
Dr. EUGENE C. WOODRUFF
234 W. Fairmount Ave.
State College, Pa.

Central Division
CLYDE E. DARR
137 Hill Ave., Highland Park,
Detroit, Mich.

Dakota Division
C. M. JANSKY, JR.
Dept. of Elec. Eng., U. of M.
Minneapolis, Minn.

Delta Division
BENJ. F. PAINTER
424 Hamilton Nat'l Bank Bldg.
Chattanooga, Tenn.

Hudson Division
DR. LAWRENCE J. DUNN
480 East 19th St.,
Brooklyn, N. Y.

Midwest Division
PORTER H. QUINBY
Box 134A, Route 6,
Omaha, Neb.

New England Division
DR. ELLIOTT A. WHITE
4 Parkway,
Hanover, N. H.

Northwestern Division
K. W. WEINGARTEN
3219 No. 24th St.,
Tacoma, Wash.

Pacific Division
ALLEN H. BABCOCK
65 Market St.,
San Francisco

Roanoke Division
W. TREADWAY GRAVELY
503 Main St.,
Danville, Va.

Rocky Mountain Division
PAUL M. SEGAL
c/o District Attorney
West Side Court Bldg.,
Denver, Colo.

Southeastern Division
HARRY F. DOBBS
c/o Dobbs & Wey Co.,
Atlanta, Ga.

West Gulf Division
FRANK M. CORLETT
2515 Catherine St.,
Dallas, Tex.

Address General Correspondence to Executive Headquarters, Hartford, Conn.

EDITORIALS

The Five-Point System

AS we've often said on this page, our American Radio Relay League is made up of all kinds of radio people. Some of our members are not always keenly interested in relaying messages (and thereby miss a lot of good sport) but all of us will admit that message handling is one of the most important activities of the League. It has become a pretty complex job to handle messages efficiently to-day and it seems to us at Headquarters that the subject is worthy of a whole lot more serious consideration from the individual amateur than it is getting.

Away back in the dim early days of amateur radio in this country it was also a hard job to relay a message because the stations were so few in number. As they increased and improved in range the job became easier, until in 1915 it was possible for the League to lay out trunk lines or message routes connecting the more important cities. Old-timers remember A. R. R. L. Trunk Line A, which ran from Portland, Maine, to Seattle; Trunk Line B from Chicago to San Francisco; "C" from Boston to Jacksonville, "D" from Philadelphia to New Orleans, "E" from St. Louis to Los Angeles, and "F" from Vancouver to San Diego. It was possible to fit almost every station whose owner joined the League into some one of these trunk lines, and almost all of our traffic moved along them from station to station. As late as 1919 our traffic department was still working with the trunk-line idea, endeavoring to have a station at least every twenty-five miles so that traffic could move under the most unfavorable conditions.

Then came C. W. and with it not only a vast increase in the reliable range of stations but a similar increase in the number of stations that could work these long distances. The trunk-line idea died the death. When you no longer have to string out your stations in a chain, but any one of them is able to work all the others, what have you? You have a "net", and that is what the A. R. R. L. traffic handling system became—what the government services call a "free net". It became our established practice for any station with a message to relay to pass it on to the

greatest possible distance in the desired direction, to whatever most distant station could be worked satisfactorily, without benefit of schedule, clergy or trunk-line.

And then came still another phase: the short waves and division into frequency bands—the four ordinarily-used "amateur bands." It became a fierce job to find anybody you wanted. The number of DX stations increased prodigiously but many of them were temporarily more interested in foreign DX than in domestic message-handling. What to do? Schedules were proposed, but one can't have schedules with all the active stations within range on the off-chance of a message for that particular town. Then about a year ago 6PS came along with his famous "five-point" idea, a plan which seemed made to order for present-day conditions and which has been recommended by our Communications Department ever since. Briefly, this idea is that each station should arrange schedules with four others, one each to the north, south, east and west of it, at a respectable distance but one that can be worked with complete reliability. You may be one station's western connection and another's connection towards the east; these two stations become in turn your own connections to east and west, respectively; all of you have your connections to north and south. The schedules may be whatever you can keep conveniently; if you are an Official Relay Station you will want a schedule for about every night, and then no message will ever be at your station longer than twenty-four hours. If you're a busy person your schedules may be for only one or two nights a week. If you're hungry for traffic you may have more than one five-point system of which you are the center, or you may have several connections in one direction, and clear them all every night. If you have lots to do, your schedules may be crisp affairs in which you clear all four of your correspondents within an hour. The value of these contacts is not confined to message-handling; they are equally useful for experimenting, testing, or "rag-chewing", if your correspondents are chosen with that in view, and your schedules may be scattered out over a whole evening.

The general idea remains the same thru all its variations. Here is the "net" idea reduced to proportions where one can ex-

ist, and yet giving all the sureness of contact that comes from schedules. One's correspondents may be chosen with assurance of congeniality and sympathy for the work in hand, be it messages, tests, or conversation. The idea is simply to arrange schedules with the four stations you would like to work regularly, either over the air or by writing and getting acquainted. The benefits are certain. You will have traffic to handle, you can always

accept a message with the certainty that you can move it along promptly in the right direction, you know you're going to have the enjoyment of that much friendly contact with acquaintances on the air, and between us we will have a "sure-fire" contact system that will always work for any emergency. We think this five-point idea rates a real good whirl at every A. R. R. L. station.

K. B. W.

WWV Schedules

THE standard frequency signals from WWV, Bureau of Standards, Washington, D. C. for the months of October to April, are as follows:

Schedule of Frequencies in Kilocycles

(Approximate wavelengths in meters in parentheses)

Eastern Std. Time	Oct. 20	Nov. 20	Dec. 20	Jan. 20	Feb. 21	Mar. 21	Apr. 20
10:00 to	550 (545)	1500 (200)	3000 (100)	125 (2400)	300 (1000)	2000 (100)	550 (345)
10:10 p.m.	630 (476)	1650 (182)	3300 (91)	133 (2254)	315 (952)	3500 (91)	630 (476)
10:20 p.m.	730 (411)	1800 (167)	3600 (83)	143 (2097)	345 (889)	3600 (83)	730 (411)
10:30 to	850 (353)	2000 (150)	4000 (75)	155 (1934)	375 (800)	4000 (75)	850 (353)
10:44 p.m.	980 (306)	2200 (136)	4400 (68)	166.5 (1800)	425 (785)	4400 (68)	980 (306)
10:56 p.m.	1130 (265)	2450 (122)	4900 (61)	205 (1483)	500 (600)	4900 (61)	1130 (265)
11:08 p.m.	1300 (231)	2700 (111)	5400 (56)	206 (1153)	600 (500)	5400 (56)	1300 (231)
11:20 p.m.	1500 (200)	3000 (100)	6000 (50)	315 (962)	655 (450)	6000 (50)	1500 (200)
11:32 p.m.							

Standard Frequency Schedules

THESE schedules are for the months of November and December 1926, with the co-operation of the following stations (known as OWLS-SF): 1XM, Communications Div'n., Mass. Inst. Tech. and M. I. T. Radio Society, Cambridge, Mass., 9WI, Gold Medal Station (WCCO) Minneapolis, Minn.

SPECIAL NOTICE

The schedules here given are approved by the Bureau of Standards and the A.R.R.L. O.W.L.S. Committee as well as by the co-operating stations. The frequency values are based upon the standards of the Bureau of Standards, and have also been checked by the Cruft Laboratory of Harvard University and the Communications Laboratory of the Massachusetts Institute of Technology.

While the accuracy that may be expected of these transmissions is 0.1%, no financial responsibility therefore is assumed by the League, the Bureau of Standards, nor the co-operating stations. Schedules from these OWLS-SF will be checked at intervals by the OWLS Committee, by the Bureau, and by the M. I. T. Communications Laboratory; schedules not meeting the required accuracy will be suspended immediately.

(Figures are frequencies in MEGACYCLES per sec.; approx. wavelengths in parentheses)

Friday Evening Schedules				Sunday Afternoon Schedules			
Eastern	Standard	Time for		Eastern	Standard	Time for	
Central	Standard	Time for		Central	Standard	Time for	
Time (PM)	Schedule No. A	Schedule No. B		Time (PM)	Schedule No. C	Schedule No. C	
	f λ	f λ			f λ	f λ	
8:30	3.50 (85.7)	6.50 (46.1)		3:00	10.0 (30.0)		
8:42	3.60 (83.3)	6.75 (44.4)		3:12	12.0 (25.0)		
8:54	3.75 (80.0)	7.00 (42.8)		3:24	14.0 (21.4)		
9:06	3.90 (76.9)	7.25 (41.3)		3:36	14.5 (20.7)		
9:18	4.00 (75.0)	7.50 (40.0)		3:48	15.0 (20.0)		
9:30	5.70 (52.6)	7.75 (38.7)		4:00	15.5 (19.3)		
9:42	6.50 (46.1)	8.00 (37.5)		4:12	16.0 (18.7)		
9:54	7.00 (42.8)	8.25 (36.3)		4:24	18.0 (16.7)		
10:06	7.50 (40.0)	8.50 (35.3)		4:36	20.0 (15.0)		
10:18	8.00 (37.5)	8.75 (34.3)					
10:30	8.50 (35.3)	9.00 (33.3)					

Date	Dates Sched.	Sta.	Date	Dates Sched.	Sta.
November 12	A	1XM	Dec. 23, (Thurs.)	B	1XM
November 19	A	9WI	Dec. 30, (Thurs.)	B	9WI
November 26	B	1XM	November 7	C	1XM
December 3	B	9WI	November 5	C	1XM
December 19	A	1XM	December 12	C	9WI
December 17	A	9WI			

Division of Time

The above dates for December are tentative and are here given for the benefit of readers who receive this magazine late in the month.

3 minutes—QST QST QST u (Station call letters).
3 minutes—5 sec. dashes broken by (station call letters) every half minute.

1 minute—announcement of frequency in megacycles per second (8.75 megacycles per sec. is sent as "8 r 75 MC").

1 minute—announcement of next frequency in megacycles per sec.

Note—9WI will very probably have another call when the schedule is sent. The station will therefore sign both 9WI and the new call.

General Electric Short-Wave Test Results

By M. L. Prescott*

DURING the past eighteen months, the Radio Engineering Department of the General Electric Company has conducted a series of investigations for the purpose of securing data pertaining to the propagation of radio waves. The fifty-four acre developmental laboratory, equipped as it is, with several transmitters adaptable to operation over a wide range of frequencies and employing various types of antenna systems, has proven itself of invaluable aid in conducting this series of investigations. Previous to the tests made in April of this year, the major portion of observations was made by field men sent out by the Company. These observers were supplied with receiving equipment capable of covering the frequency band under investigation. This receiving apparatus was described in the April, 1926 issue of *QST* hence no additional comment will be necessary. Suffice it to say that the field observers, with the requisite apparatus installed in a Reo Speed Wagon¹, made a series of trips, each time starting from Schenectady and following a uni-directional course away from the transmitting station. The first of these trips was made in a westerly direction to Buffalo and intermediate points. During this trip comparative signal characteristics were obtained on four different frequencies ranging from 192

servers was to Lake City, Florida, one thousand miles southwest of Schenectady. In order to investigate signal characteristics at distances greater than those which could

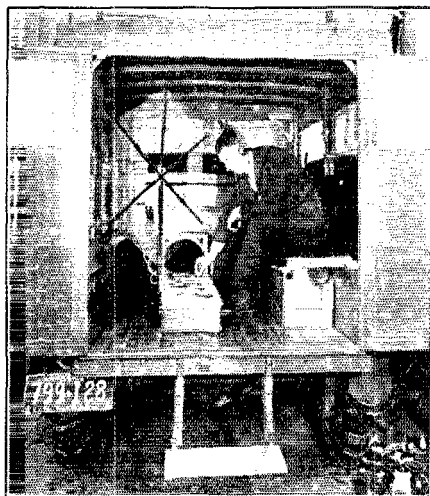

MAKING A FIELD OBSERVATION IN THE SPEED-WAGON



THE REO SPEED-WAGON USED IN THE FIRST TESTS

Kc. to 7170 Kc. Following this, a similar trip was made to Malone, New York, and a little later a third trip was made in an easterly direction, ending at Boston, Massachusetts. The last trip of the special ob-

conveniently be covered by the field men in a truck, another observer boarded a steamer bound for Panama and made observations en route.

Throughout this series of tests, additional reports were received from all parts of the world from individuals who either by accident or intent heard the transmissions. These outside reports showed the possibility of utilizing cooperative observers for a future test. In the tests thus far the data obtained by the General Electric field men was from a decidedly restricted area, and consequently any generalization of results was exceedingly difficult. It was felt by the engineers in charge of the propagation work that simultaneous observations by a great number of especially instructed listeners located in representative portions of the world would yield information of considerable value.

A.R.R.L. Aid

Appreciating the previous active cooperation of amateur radio experimenters, and desiring their further assistance in the proposed test, negotiations were begun with the A.R.R.L. with a view to enlisting the aid of several hundred of its members. An agreement was reached without difficulty.

*Radio Engineering Department, General Electric Co. Schenectady, N. Y.

¹—A report on these tests was printed on pages 38-42, Experimenters' Section, *QST* for April, 1926.
—Tech. Ed.

Accordingly, two thousand letters explaining the proposed test were sent to Robert S. Kruse, Technical Editor of *QST*, who

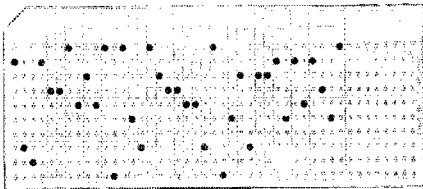
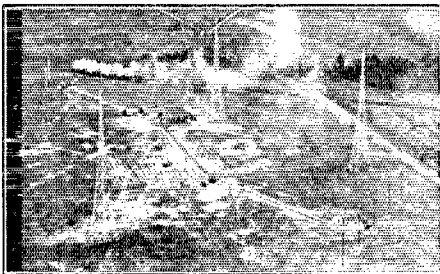

Fig. 1. A punched statistical analysis card to which has been transferred the information contained in a reception report. The unlabelled space at the right was reserved for any additional tabulations that were desired.

mailed them to as many amateurs.² As had been expected, about five hundred replies were received expressing a willingness to assist in observing the test transmissions.



THE SOUTH SCHENECTADY EXPERIMENTAL STATIONS.

A complete description of this plant with some 15 illustrations appeared in the Experimenters' Section for June.

To each of these men the Radio Engineering Department sent detailed recording instructions, especially prepared log sheets, and a schedule of transmissions. In addition, the schedule was published in April *QST*.³

Transmissions were made each week in April from Wednesday noon to Thursday noon., and from Saturday noon to Sunday noon. The transmitters employed are listed below:

Station	Frequency	Power	Control
2XAW	20,000 Kc. (15 M)	0.6 Kw.	Self-excited
2XAD	11,870 Kc. (26.4 M)	1.0 Kw.	Crystal
2XAF	9,150 Kc. (32.79 M)	10.0 Kw.	Crystal
2XAC	5,970 Kc. (50.2 M)	10.0 Kw.	Self-excited
2XK	4,580 Kc. (65.5 M)	10.0 Kw.	Crystal
2XK	2,750 Kc. (109 M)	10.0 Kw.	Crystal

The schedule of transmissions of the various stations and the type of antenna used was as follows:

2—All of the members of the Experimenters' Section plus a large number of engineers and members of the O.R.S. system.—R. S. K.
3—See page 41 of that issue.—Tech. Ed.

Station	Antenna	Date
2XAW	Vertical 1/2 wave	April 3 to 22
	Horizontal 1/2 wave	April 22 to 29
2XAD	Vertical 1/2 wave	April 3 to 11 Inclusive
	Vertical full wave	April 14-15 only
	Horizontal 1/2 wave	April 17 to 22 Inclusive
	Vertical 1/2 wave	First 30 min. each hr., Apr. 24 to 29
	Vertical full wave	Second 30 min. each hr., Apr. 24 to 29
2XAF	Vertical 1/2 wave	April 3 to 13 Inclusive
	Horizontal 1/2 wave	April 14-15 only
	Vertical 1/2 wave	First 30 min. each hr., Apr. 17 to 22
	Horizontal 1/2 wave	Second 30 min. each hr., Apr. 17 to 22
	Vertical 1/2 wave	First 30 min. each hour, single frequency Apr. 24 to 29
	Vertical 1/2 wave	Second 30 min. each hour, Multiple frequency Apr. 24 to 29
2XAC	Horizontal loop	April 3 to 8
	Vertical 3/4 wave	First 30 min. each hr., Apr. 10 to 15
	Vertical 1/4 wave	Sec. 30 min. each hr., Apr. 17 to 22
	Vertical 5/4 wave,	First 30 min. each hr., Apr. 17 to 22
	Vertical 3/4 wave	Sec. 30 min. each hr., Apr. 17 to 22
	Horizontal loop	First 30 min. each hr., Apr. 24 to 29
	Vertical 3/4 wave	Sec. 30 min. each hr., Apr. 24 to 29
2XK	Vertical Triple "T"	April 3 to 8
	Vertical Triple "T"	April 9 to 15
	Vertical Triple "T"	April 16 to 22
	Vertical Triple "T"	April 24 to 29

Of the reports received, approximately 9500 were complete enough to be used in making the final analysis.

The percentage of the total number of observations received for each transmitter was as follows:

2XAW	2.8 per cent
2XAD	11.2 per cent
2XAF	50.8 per cent
2XAC	17.7 per cent
2XK (4580 Kc)	12.0 per cent
2XK (2750 Kc)	5.5 per cent

Considerable labor was involved in getting the information contained in these reports into workable form. Additional data such as the distance, direction and

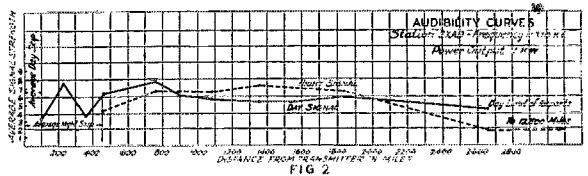

zone of each observer, together with the weather conditions had to be coded and appended to each report. These completed and coded reports were then given to key-punch operators who transferred the information to statistical cards. See Figure 1. These cards form a permanent record of each observation. In order to analyze the cards, they were first put through a sorting machine which grouped them according to transmitter and time. For ex-

ample; in analyzing for average signal strength, the cards were grouped according to transmitter, time, signal strength, and zone. They were then run through a tabu-

not as erratic as those on 20,000 Kc., the reliability was still low at a distance of three thousand miles. Beyond the region of uncertainty, the signal became more reliable and more consistent in its behavior.

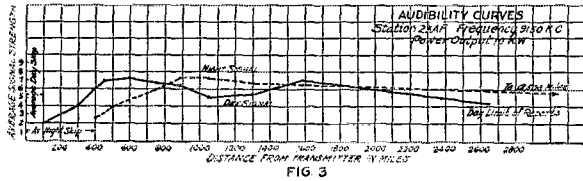

FIG 3

lating machine which printed on a code sheet a card count of all like observations. All of the like observations were then transferred to still another sheet according to each transmitter, time and zone. The signal strength could then be averaged.

Referring to Figure 2, it will be noted that at 2650 miles the night signal audibility is low and down gradient, which might lead to the erroneous conclusion that the useful range was not greater than 3000 miles. As a matter of fact, reports from observers in New Zealand and Australia indicated better reception than that obtained at most points in the United States.

9150 Kc. Transmissions

The great popularity of this transmission was largely due to the fact that previous to the April tests, it had become well known

**Conclusions
20,000 Kc. Transmissions**

As will be noted from the preceding tabulation, a very small percentage of the total reports received were on the 20,000 Kc. transmission. No reports were received on the daylight period within a radius of nine-hundred miles from the transmitter, indicating an apparent skip distance of this magnitude. However, observations made by field men previous to the tests of April, gave an apparent skip distance of six hundred miles. This discrepancy has been attributed to seasonal variation and the type of radiator employed. A skip distance of one thousand miles was indicated for the night period. In the region beyond the day

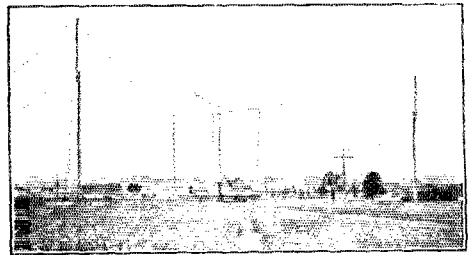

THE TRIPLE T ANTENNA AT 2XK.

through its broadcasting of the WGY programs. Fifty percent of all reports received were on this station (2XAF). These reports contained about 5,000 observations. Analysis showed the day skip distance to be one hundred miles. As was observed on the higher frequencies, this distance increased at night becoming four hundred miles.

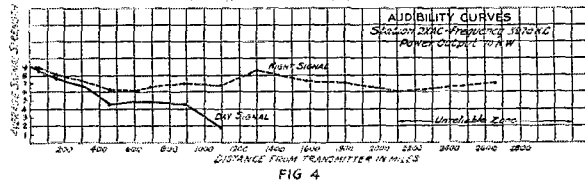

FIG 4

and night skip distances the signal was consistently erratic in its behavior, hence no attempt has been made to plot an average audibility curve similar to those included for transmissions at lower frequencies.

11,370 Kc. Transmissions

About 900 observations were made on this transmission. These indicated a day skip of one hundred miles, which at night increased to four-hundred fifty miles. These limits, however, are not sharply defined, varying considerably from day to day. Although the signal characteristics beyond the limits of the day and night skips were

established definitely due to insufficient reports beyond 2650 miles. Reports on the night transmission were received from all parts of the world indicating fairly consistent high average signal strength for the maximum distance obtainable, i. e., one half the earth's circumference.

5970 Kc. Transmissions

The day and night audibility characteristics given in Figure 4 indicate that no skip distance existed at this frequency. The useful day range of this transmission was definitely shown to be 1100 miles. The curve of night audibility indicates that at

2650 miles the signal strength was still good, about R-7. The analysis showed that reports from distances greater than 2100

tions made previous to those of April, thereby strengthening the belief that it is characteristic of this frequency.

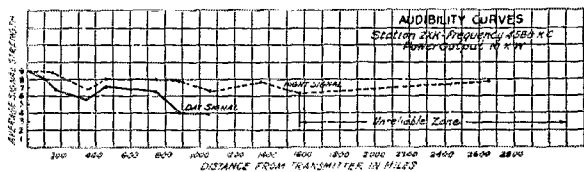

miles were so erratic as to make it impossible to determine the absolute useful limit of the night transmission. This unreliable zone has been indicated in the figure.

4580 Kc. Transmissions

Reference to Figure 5 will indicate that the attenuation of the day signal was not great. At 1050 miles the strength was still fairly high, indicating that satisfactory reception might be had for 200 or 300 miles further. Actually, this was not true, because fading, static, and other factors which prove detrimental to good reception, caused the signal to become unreliable at points greater than 1000 miles from the transmitter. The night audibility curve (Figure 5) shows only slight attenuation at all distances to 2650 miles. This condition is similar to that existing in the case of the 5970 Kc. transmission. Again erratic reports make it impossible to accurately fix the limit of the night range. Accordingly, the region beyond 1600 miles must be considered as an unreliable zone.

2750 Kc. Transmissions

This frequency behaved more in conformity with those of the broadcast and commercial channels than did any of the other frequencies used during the test. Figure 6 shows the day and night audibilities. Both of these were quite rapidly attenuated, the former reaching a lower useful limit at 400 miles while the latter was sufficient to

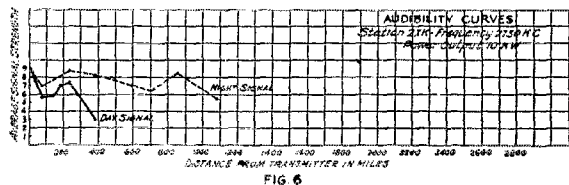

furnish a satisfactory signal for 1000 miles. It will be observed that these audibilities were less at 70 miles from the transmitter than at several of the more remote points. This "dip" was evidenced by the observa-

some directions than in others. However, analysis of average conditions, for all directions, indicated no pronounced differences. As an example, consider the vertical half-wave and the horizontal half-wave antennas

Antenna Comparison

At various times during the test different antennas were used for the same frequency. In every case there was a difference recorded between the signal characteristics of each radiator, being more pronounced in



THE VERTICAL HERTZIAN ANTENNA AT 2XAF.

The signals from this antenna seemed to be the most popular. This was described in June QST.

which were interchanged at various intervals during the 9150 Kc. transmissions from station 2XAF. The pattern of the vertical antenna was practically circular, indicating uniform radiation, which should have permitted the signal to be received as well in one direction as in another. On the other hand the radiation pattern of the horizontal half-wave antenna assumed the general shape of a figure 8, giving a maximum radiation north and south, and a minimum east and west. Figure 7 gives the relative audibilities obtained by averaging all the reports received. It will be observed that the curves are similar, except near the fringe of the skip, where the horizontal antenna gives a slightly higher audibility.

For all points at greater distances than those shown on the curve, reports indicated the continued superiority of the transmissions from the vertical antenna.

The signal characteristics for the horizontal and vertical half wave antennas on 20,000 Kc. and 11,370 Kc. maintain the same relationship given for the 9150 Kc. transmission. Consequently, it is deemed unnecessary to include a discussion of them in this article.

Fading

If a complete account of the findings relative to fading were to be included it would be necessary to write a veritable book. A

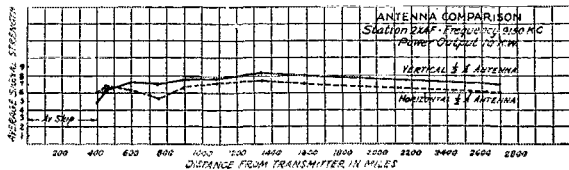
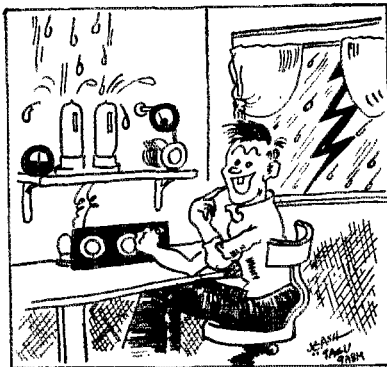

FIG 7

great many interesting phases of fading have been brought out in this analysis, some of which have so conclusively presented themselves as to warrant inclusion in this discussion.

In corroboration of previous knowledge of short wave characteristics, fading was recorded during both day and night transmissions on each of the frequencies under observation. The occurrence of fading was found to be a function of the frequency, becoming more troublesome as the frequency increased. All of the observations received indicated that the fading was more pronounced at night than during the day, and that for both of these periods an increase in the distance from the transmitter showed a lessening of the fading effects.



WATER COOLED TUBES

Experimenters' Section Report

HERE will be no formal report this month; the place of such a report being taken by the article on the April tests run by the General Electric Co. in co-operation with the members of this section and other amateurs both in and out of the A.R.R.L.

We had hoped to give the complete story of the 5-meter transmission between 2AUZ at New York and the receiving station of Mr. Grindle at Hammond, Indiana. However there has been an unexpected delay in the photographs of the apparatus at 2AUZ, hence this must go over.

Meanwhile Miss Elizabeth M. Zandonini of 3CDQ at Washington has returned from a trip to Europe and reports that successful two-way 5-meter tests have been run between Italian station 1ER, operated by Mario Santangeli at Milan and a receiving station in Tripoli. It seems that these tests were run thru a week and communication was established.

—R. S. K.

A.R.R.L. INFORMATION SERVICE

Please help us by observing the following rules:

1. Keep a copy of your questions and diagrams and mention that you did so.
2. Number the questions and make a paragraph of each one.
3. Make diagrams on separate sheets and fasten them to the letter.
4. Print your name and address (not merely your radio call) on your letter. Don't depend on the return address on the envelope as this is destroyed when the letter is opened.
5. Don't ask for a comparison of the various manufacturers' products.
6. Before writing, search your files of QST—the answer probably is there.
7. Address all questions to Information Service, American Radio Relay League, Inc., 1711 Park Street Hartford, Conn.
8. It is not essential to enclose an envelope as long as you supply postage and PRINT CLEARLY your name and address on your letter.

Any back issues of QST to which we refer you are obtainable from the Circulation Department for 25 cents each.

R. F. Amplification—A Re-hash

By Elmore B. Lyford*

DURING the past few months, the writer, in collaboration with Mr. Henry F. Heins, has had occasion to make an investigation of r.f. amplification, in connection with the circuit development of a new broadcast receiver. This investigation was mostly confined to the frequencies used for broadcast purposes, but the results may be useful to the man interested more in the higher frequencies. It has been the writer's experience, and probably that of all other amateurs', that he is often called on to 'trouble shoot'

is controllable so that the r.f. tube may be operated near (but below) the oscillation point the effect may be used advantageously. In the writer's opinion, a stage of controllably regenerative r.f., followed by a NON-regenerative detector gives better results than a fully neutralized r.f. stage followed by a regenerative detector, though just why, is open to some question.

But we are wandering.

Stabilizing Methods

There are many methods of controlling the regeneration of tuned and untuned r.f. amplifiers. These methods may all be grouped into three or four general classes. The first of these classes includes all of the methods which have as their aim control of the tube action itself.

Figure 1 illustrates one of the most common and widely known methods—simply the grid circuit returned to a potentiometer. As the arm of the potentiometer is moved towards the positive end, the tendency of the tube to oscillate is greatly reduced—consequently its tendency to amplify incoming signals. This is a convenient way to control several untuned stages, but that is about all—it is too inefficient.

The tendency of the tube to oscillate may

B.C.L. receivers, and occasionally to build one. Much of the information here conveyed is also applicable in that fertile experimental field—r.f. amplification below 200.

There is no claim to any new discoveries about the circuits to be discussed—simply a summation and comparison, all in one place.

Let us first give a word to what we are trying to do. A vacuum tube is essentially a power amplifying device, but for the purposes of this article we can confine ourselves to the voltage component of that power, and consider the tube a voltage amplifying device. An alternating current impressed on the grid circuit of such a tube is reproduced more or less faithfully, and with increased magnitude, in the plate circuit. If there is any load at all in this plate circuit, it will cause a voltage to appear across the plate-grid capacity, and some of this magnified energy will be fed back to the grid circuit from whence the original impulse came. There is always some plate circuit inductance, and consequently some energy will always be fed back from plate to grid. In the case of r.f. amplifiers at broadcast and higher frequencies, that is usually enough, before compensation or neutralization, to cause oscillation. If it isn't enough, the amplifier is no good!

This oscillation in the r.f. amplifier is highly undesirable, obviously. However if it

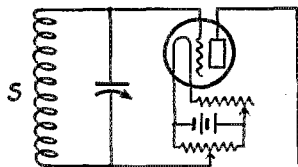
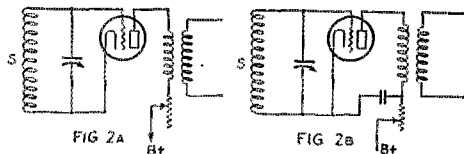

FIG 1



also be lessened and controlled by reduction of either the filament or plate voltage, but with the same string to them as the use of the potentiometer—the amplification goes down proportionately, if not more so. The filament-voltage method of control is self-evident. The plate-voltage method deserves some consideration, at least for one job. Some method of series plate resistance is quite often needed to control two or three stages of tuned r.f. A resistance of about 200,000 ohms in series to the B supply to these tubes will do the work. The amplifier is apt to go into oscillation with a rush as you decrease the resistance, but with a steady hand you can control it fairly well. To control one tube only, the resistance can be put in the r.f. circuit, the d.c. circuit, or both. Figure 2A shows it in both, and Figure 2B shows it only in the d.c. circuit. This latter is preferable, for when used as in 2A, you are really working against

* Design Engineer University Radio Mfg. Corp., 50 Park Place, New York City.

yourself, by adding additional load to the plate circuit of the tube, which, everything else constant, makes the tube more eager to oscillate than ever. The only reason it works is because everything else is not constant—the plate potential is reduced. But 2B is better if you *must* use this method.

That brings us to the second group of methods—controlling the constants of the tube circuit to control its tendency to oscillate. We have said that *any* load in the plate circuit of the tube causes a voltage to appear across its plate-grid capacity, and hence to feed a voltage back to the grid. (For a more complete explanation of this, the reader is referred to the article by L. M. Hull, in QST for Jan., 1924, page 12.) However, only an inductive load or a resistance load in the plate circuit gives a phase favorable to oscillation. By decreasing the inductive load in the plate circuit, we can reduce the possibilities of oscillation, but it is an open question how far it is advisable to go in this direction. The thing can be done in several ways. In the practical forms an attempt is usually made to combine the operation of the oscillation-control with the operation of the tuning condenser so that the greater tendency toward oscillation at the shorter waves is automatically compensated for as the tuning condenser is turned. This idea appears in several commercial forms of which the following are representative. The Karas-King "equi-

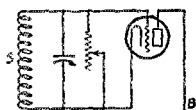

FIG 3A

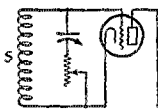

FIG 3B

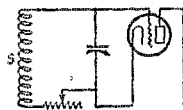

FIG 3C

matic" device uses a primary obliquely mounted on the end of the condenser shaft so as to vary the coupling to the secondary when the condenser is turned. The Hammarlund device employs a sliding primary operated by a cam on the condenser shaft. In both these devices the primary winding is all on the same tube and the primary inductance remains fixed, only the coupling changing. In the Zenith receivers the primary is partly on the same tube as the secondary and partly on a rotor driven by the condenser shaft. Here the coupling and the primary inductance are changed while tuning. Other combinations are obviously possible and some of them have been used. Reducing the coupling reduces the amplification if carried too far—that is obvious. It also increases selectivity—too much so, sometimes, in the case of several cascaded stages. No arbitrary rules can be laid down concerning what the limits of this load or coupling may be. Consideration of all the factors involved in the individual

case is necessary to determine where the happy medium shall fall.

"Losser" Methods

We can also control oscillation in our r.f. amplifier by introducing a resistance into the grid circuit somewhere. These "losser" circuits are widely used because they are simple, not because they are very efficient—for they are not.

Figure 3A shows a resistance of about 500,000 ohms across the grid coil. This

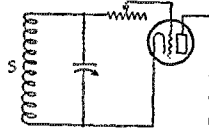

FIG 4A

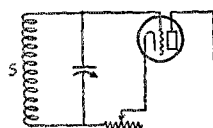

FIG 4B

broadens the tuning scandalously, but has some use in two tuned r.f. stages and a tuned detector combination. Across the second r.f. coil, a resistance of this size will control all three tubes thoroughly, at least, and there is enough gain left so that the amplifier is some good.

3B shows a resistance in *series* with the grid circuit tuning condenser—but here either the resistance or the condenser is 'hot', depending on which is nearer the grid, and the system is impractical because of the 'body effect' it has. Figure 3C, showing a resistance in *series* with the grid coil, is much better, and if R is about 50 ohms it will work fairly well, but it is a 'losser' method at best. Incidentally, Figure 3C represents just about what is happening if the coil is placed too near the tuning condenser or shield—a very effective re-

sistance is introduced in to the tuned circuit. There is no need for naming examples of this practice—they are too common. These resistances have all been shown in the tuned input circuit, but they need not be, as is shown in Figures 4A and 4B. These schemes are better than 3A, 3B, or 3C, electrically, but they each have one disadvantage. In 4A, the resistance must be let alone, for it is too near the grid to be adjustable. (It is also bad on short waves, where the extra load of the resistor is objectionable.) It is however a practical method and is used commercially in the Atwater-Kent receivers. Figure 4B raises the condenser shaft above filament potential, and necessitates an insulated drive shaft, besides requiring the condenser itself to be insulated from filament and shield. This is serious, and practically prohibitive if 'gang' condensers are used, for it means insulated couplings between the condenser rotors—a mean proposition.

Next we come to the Hazeltine "neutro-

dyne" with its several variations. A typical circuit is shown in Figure 5. This method is deserving of its wide popularity, but is prevented mechanically from being ideal. In this system the degree of compensation increases with a change (in the correct direction) of the compensating ele-

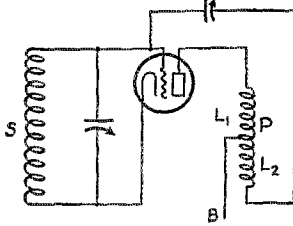

FIG. 5

ment, and the circuit admits of over-compensation, with consequent loss of efficiency. If the magnetic coupling between L1 and L2 could be made unity, and the capacity coupling between these coils at the same time kept zero, all would be well, but it cannot. This unfortunate physical fact is the reason for the usual falling off, or over-neutralization on the higher waves, of most commercial receivers employing this principle. For a fuller explanation of this point, the reader is again referred to Hull's article in *QST* for Jan., 1924.

Another method of control of r. f. amplifier oscillation which has been quite often used is the reversed tickler, some variations of which are shown as Figure 6. The usual tickler circuit constants apply here, except that the coil connections are reversed, so that the coil opposes regeneration, rather than aiding it. It is a very smooth method of control, and efficient, but it is bad in one feature. It balances a magnetic coupling of the plate and grid circuits by means of the coils against a capacity coupling of these circuits through the tube capacity. This circuit also admits of over-compensation, and since the degree of compensation is dependent on the frequency for the reason stated above, the tickler control must be varied to correspond with every variation of the tuned input circuit to the tube. This means a control in addition to the tuning control for every stage of r. f. used, and the thing soon gets too complicated.

Next we come to the general class of compensation schemes known as "bridge" circuits. The neutrodyne may belong in this class, depending just what is meant by a bridge. Strictly, a true bridge is one which is independent of frequency but then

we are indicating Wheatstone himself, and this is no place for an argument of that sort. Take your choice as to the inclusiveness of the term. A bridge circuit used in Bosch, Kellogg and some Crosley receivers is the "R.F.L." circuit shown in Fig. 7, the equivalent schematic appearing as Fig. 7A. A little study will show that the feedback voltage is obtained by tapping the plate coil, not physically but by induction to the tertiary coil labeled "3". The condenser in series with the plate coil does not enter into the argument as its capacity is very large and its reactance therefore low. By making the number of turns in "3" small, the feedback voltage is made a small part of total r.f. plate voltage and therefore the balance is obtained when Cc is large as compared to the plate-grid capacity. This is more convenient in practice.

One familiar, typical form of bridge circuit is illustrated in Figure 8—the Rice circuit, with the equivalent bridge diagram shown in Figure 8A. If this circuit is so proportioned that L2 and L3 are inductively equal, and NC equals the plate-grid capacity of the tube, it is entirely independent of frequency. Practically, though, it presents disadvantages. Neither side of the tuning condenser is at filament potential, necessitating an insulated condenser or a

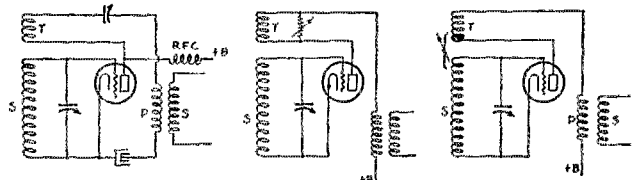

FIG. 6

tandem condenser, part across each half of the L2-L3 combination. There is one other peculiarity of this arrangement which has baffled many experimenters, no doubt, and which has just been explained by Mr. Keith Henney. With the grid on one end of the coil, the plate on the other, and the filament in the middle, and the ends of the coil short circuited, as far as very high frequencies are concerned, by the capacity of the tuning condenser, the coil is in prime condition to oscillate. This oscillation will be at some frequency determined by the inductance and distributed capacity of the coil itself, and with ordinary American apparatus will usually be found to be in the vicinity of 80 meters. Its symptoms are little or nothing getting through the tube, and an excessively high plate current, which in one case the writer had to deal with reached 20 mils—and the tube was a 201-A. The cure is the insertion of an 80-meter choke in the filament lead from the coil. This need not be efficient—a high-resistance, broad-tuned affair will probably handle the situation better

than any other. A dead resistance at the same point will also operate but possibly will also operate in an undesirable fashion on the input energy.

With these difficulties overcome or circumvented, however the circuit has much to recommend it to the experimenter. It cannot be overneutralized, for on either side of the value of capacity of NC required for balance, the tube resumes oscillation. In other words, it is nicely neutralized at all frequencies, once you get it neutralized at all. It may be followed by a regenerative detector tube, but it will prevent any radiation from the antenna due to oscillation of

"bridge" is an inductance, and the other is an inductance in parallel with a capacity, the amount of compensation depends somewhat upon frequency. This difficulty can be nearly overcome by correct proportioning of the circuit constants, however, so that the setting of NC will be correct over quite a considerable band of frequencies. In practice, L1 is made roughly three to four times the size of L2 to achieve this result. This circuit is particularly useful here because it can be applied over a very wide range of frequencies. The investigation before mentioned went down as far as 37 meters, and this method is as practical there as it is on 500. It could doubtless be made to work at much lower wavelengths than 37 meters, but its usefulness on such high frequencies is another question.

For anyone interested in experimenting with this scheme, a few dimensions may be helpful as a start. Best results in the broadcast band were obtained with the following constants. L1 about 65 turns of No. 26 slightly spaced on a three-inch form, C1 a 350- μ fd. variable, L2 about 17 turns of No. 30 close wound, inside of L1 on the filament end, and NC a 55- μ fd. variable. About 35 μ fd. in NC will be actually needed with L2 of these dimensions. It will be found very advantageous to mount this "balance" condenser on the panel. Used ahead of a detector tube, one stage of r.f. neutralized in this manner gives very satis-

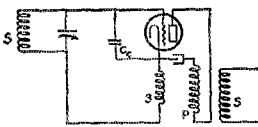

FIG 7

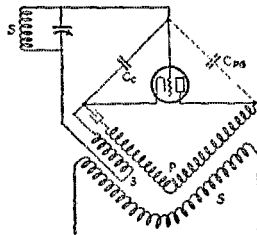

FIG 7A

the detector tube, and the method is applicable below the broadcast band. Considerable work is being done on this circuit at present in an effort to develop it into something which can more easily be applied and handled.

A variation from the Rice circuit of Figure 8 is shown in Figure 9, and its equivalent "bridge" diagram in Figure 9A. Incidentally, this is the circuit finally adopted for the receiver which started all of this investigation. A comparison of this "bridge" diagram with the "true bridge" diagram of the Rice circuit shows but one point of difference, in actual connections; i. e., the tuning condenser is across only the grid-filament part of the inductances instead of across all of it. This is only a small change but it greatly affects the behavior of the circuit.

In the first place we are no longer troubled with oscillation at 80 meters, or thereabouts, for the coil is no longer "shorted" by the tuning condenser. In addition, one side of the tuning condenser is now at filament potential—a big advantage. Furthermore, it is not necessary to have the tap in the inductive center of the coil, or even near it. In fact, it is better practically if L1 is considerably larger than L2, as will be seen later. The point of exact compensation, or "balance" of the condenser NC is in practice very easy to determine.

This all sounds as though the circuit were ideal, but it is not. It permits of overneutralization, and since one arm of the

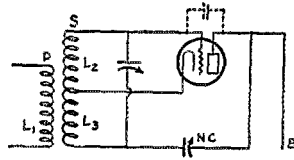

FIG 8

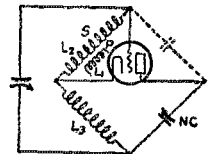

FIG 8A

factory results. Hull, in the article in this magazine before mentioned, shows a circuit using two stages of r.f. compensated in this manner, but results with that circuit are harder to obtain. There are too many controls for practical purposes and coil interaction begins to be a big factor.

Nothing has been said so far about negative grid potentials applied to r.f. amplifying tubes, but they are very important. As a general rule for any circuit, a grid circuit return directly to A-, or to C-, $1\frac{1}{2}$ will give the greatest amplification per tube, assuming a plate potential of 90 volts, or thereabouts. An increase of grid negative potential to $4\frac{1}{2}$ or more volts invariably sharpens the tuning of the circuit, and cuts down the gain per stage. However, the correct bias for the individual case is a matter for

experimentation, as is the plate potential, within limits.

This article may appear to be written in a pessimistic vein, but it is not intended so. R.F. amplification is a prolific and profitable field for investigation, at least in the broadcast band, and undoubtedly lower. True,

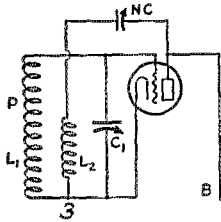

FIG. 9

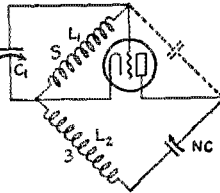

FIG. 9A

every circuit discussed seems to have some disadvantages, but the subject is by no means exhausted. Even the poorer systems, well handled, will give some gain in the broadcast band, and the bridge systems give considerable. A voltage amplification of 75 can easily be realized from two stages of fairly efficient r.f.

If this discussion has served to collect and possibly clarify some ideas, and has presented a fair comparison of systems, it has served its purpose.

Strays

For low power transmitters the Hammarlund No. 16 wire inductances are good (but not hot) stuff, if the transmitting tube is not larger than a 7½ water.

GABN-CXN says that some B.C.L.'s are so dumb the only reason they make short wave sets is to hear the 40-meter band! hi!

If you want to have some fun 6ABN suggests that you ask any of the high powered B.C.L.'s how clear they get the organ numbers from WIZ.



BOOK REVIEWS

By R. S. Kruse, Technical Editor

Elements of Alternating Currents and Alternating Current Apparatus. By J. L. Beaver, Ass't Prof. of Electrical Engineering, Lehigh University. 370 pages, 304 illustrations. Published by Longmans, Green & Co., 55 Fifth Ave., New York City.

Some of QST's readers will feel that the magazine has no business to review a non-radio book. Nothing can be more wrong, for how may we hope to understand the changing and shifting currents that we meet in radio apparatus before learning to know something of the steady currents found in ordinary alternating apparatus? To some of us this is no news, for we have been to an engineering school and have been shown how little we really know. Others of us do not even know that we are ignorant of "A.C.," never having studied it.

For both classes Professor Beaver's book is useful. It is written as a text book, to be used through two terms in a class meeting 2 or 3 hours a week. At the same time its logical arrangement, its great number of examples and its large number of questions for the pupil make it possible to check up one's progress if self-education is necessary.

It would be a fine thing for radio, and especially amateur radio, if many of us were to take such a book up for serious study.

Gedenboek N.V.V.R. 1916-1926.

This memorial volume commemorates the 10th anniversary of the *Nederlandische Vereeniging voor Radiotelegrafie* (Netherlands Society for Radiotelegraphy). The letter of transmittal is signed by Mr. A. Veder, chairman of the N.V.V.R. The book is edited by J. Corver and consists of some 400 beautifully printed pages which constitute a milestone of the radio art, being filled with articles by and autographed photographs of leading radio men of all lands.

Annuaire International de la T.S.F., 2nd year. Edited by Etienne Chiron 40 rue de Seine, Paris, France. Price not known.

This book is constructed somewhat after the fashion of "Marconi's Yearbook of Wireless Telegraphy", consisting of the radio laws of various nations, lists of station calls, and operating information. To a ship's operator familiar with the French language the book must be of considerable value.

Guia Radio. Edited by Revista Telegrafica, Peru 135, U.T. 33, Avenida 1411, Buenos Aires, Argentina. The price is \$0.50—speaking in the coin of the country.

A callbook of the stations in Argentina, Chile, Uruguay and Brazil, together with a brief Spanish-English dictionary, a directory of manufacturers' representatives and the customary tables of international call-assignments and abbreviations.

Les Filtres Electriques, Theorie, construction-applications. By Pierre David, Radiotelegraphic Military Engineer. Printed and edited by Gauthier-Villars et Cie, 55 Quai des Grands-Augustins, Paris 6e, France.

The present reviewer lacks knowledge of the French language and also of the author's subject, hence does not venture to review this book. It is certainly quite safe to accept the rating given the book in a preface written by General Ferris. In this preface attention is called to the precision and ease of the mathematical methods used and their adaptability to practice. The book was received from the publishers but the price was not stated. There are 130 pages of text, charts and bibliography.

Welding Edison Elements

By O. H. Eger*

HAVING a 1,500-volt Edison battery under construction for use as plate supply in my transmitter, I was faced with the problem of drilling the elements and twisting some 3,000 nickel wires which were to be used as connectors between cells, and between elements of the same cell. I did not like the idea of all that drilling and twisting and I feared that sooner or later some of the twisted joints would become eaten away and the battery would be ruined.

Originally the idea of spot welding the wires to the elements was thought of. In this process, a very heavy current is passed through the elements and the wire, with a comparatively heavy pressure being placed on the point of contact between the element and the wire. This method, while satisfactory when one has the necessary facilities for doing the job in a thorough fashion, is difficult for the average amateur to carry out.

Finally the following scheme was hit upon. It has worked entirely satisfactorily—the wires can be attached to the elements much quicker than the holes can be drilled and the wires twisted, and the job is even quicker than soldering would be. The idea is shown in Fig. 1. A step-down transformer—operating from the 110-volt 60-cycle house current—has a low voltage heavy amperage secondary delivering about

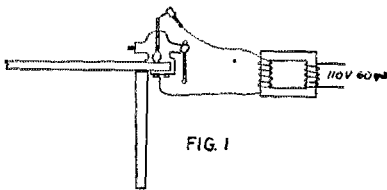

FIG. 1

10 volts. One lead from the transformer is connected to an iron vise, clamped to a table or bench. The other lead is connected to a piece of electric light carbon rod, through a brass or copper tube which serves as a holder for the carbon. The Edison elements are clamped, one at a time, in the vise. The nickel wire is held in place against the element and the carbon is rested on the wire and slowly removed. The heat developed in the arc resulting is more than ample to thoroughly weld the two. The only precaution to be observed is that the arc must not be allowed to maintain itself too long, or the nickel wire

will become brittle and break off later on. Just a fraction of a second is all the time required to thoroughly weld the joint.

Almost any type of transformer can be used for welding. An old quarter, half or one K.W. spark transformer is ideal. Remove the secondary and wind on twenty-five turns of number 4 to number 8 double

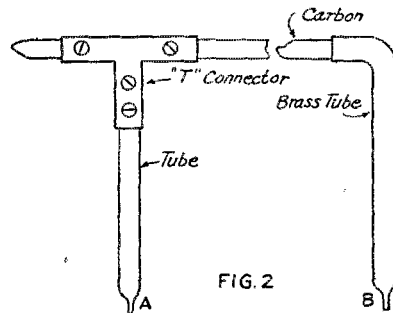

FIG. 2

cotton-covered wire over the core, with several layers of insulating paper between the core and the wire. A sign-lighting transformer, a potential transformer or any transformer having at least a 150-watt rating and a 110-volt primary may be used, or if you are unable to get any of these, a simple home-made transformer can be used. The core should have a cross-section of about $2\frac{1}{2} \times 2\frac{1}{2}$ inches, the primary winding should contain 300 turns of number 14 D.C.C. magnet wire and the secondary 25 turns of the larger wire. The "window" in the core should be approximately 4 inches square.

Some means should be provided for gripping the carbon rods in a cool holder. The rods themselves can be arc light carbons obtainable in almost every city from the Light Company. The holder can take a number of different forms. Two are suggested in Fig. 2. At "A" of this figure, the carbon rod is held in a brass "T" connector built to hold number 00 copper wire. The two set-screws in the horizontal part of the T hold the carbon in place and allow its being adjusted to a convenient length. In the vertical portion a piece of brass or copper tubing about ten inches long is inserted as a handle. This handle should be covered with several layers of electrician's friction tape to prevent the heat from the arc reaching the hands of the operator. The lower end of the rod is flattened out and drilled to hold a terminal screw to which

(Concluded on Page 21)

* ICGQ, Holyoke, Mass.

A Sensitive Vacuum Tube Relay

By W. H. Hoffman and F. H. Schnell*

HOW would you like to hook up a very simple relay that doesn't cost a small fortune, yet will operate a sounder or buzzer or some other form of mechanical noise-maker or recorder? During the past few years there has been nothing that would fit the pocket-book of the average amateur, but here is a vacuum tube relay that is very sensitive and it can be

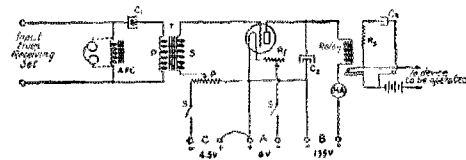

AFC—Audio frequency choke—Thordarson type R-196
 T—Thordarson 2:1 audio transformer
 P—Centralab 250,000 ohm potentiometer
 VT—Either CX-112 or CX-301A (CX-112 better)
 R—General Radio type 301 rheostat of 10 ohms
 Relay—Bunnell Goose-neck pattern standard No. 2, 150 ohms
 R—Ward-Leonard resistance unit 100 to 400 ohms ok
 M.A.—Jewell 0-300 m.a. d.c. milliammeter
 C-C-C—Dubilier type 901 condensers to withstand 200 volts. Any good telephone condenser of 2.0 mfd. will be ok

S-S—Control switches

The battery in the output side should be of the proper voltage to operate the buzzer or sounder or other device being controlled.

made up from the usual parts lying around the shack. With a signal strength of R-5 or R-6, this relay will operate a recorder (Morse or picture!) a sounder, buzzer, auto horn, or bell and the whole thing can be put together in a very short time. It will also operate a call system.

Let us have a peep first into the call system business and see what we can do with it. Suppose you have schedules with a number of amateur stations and these schedules run over a period of hours and late into the night or into the "Wee sma' hours of the morning." Of course, you would like to get as much sleep as you can between schedules, but maybe the old 'larm clock doesn't talk up when it should or maybe your man forgets to keep his schedule at the appointed time. What of it? Throw the alarm clock in the river (if you haven't a river handy, throw it out of the window) and if your man doesn't call you at the appointed time—sleep on. How do you do this? Very simply! Make up the vacuum tube relay and get it "perking" right. Then set your receiver on the frequency of the transmitting

station and crawl in your bunk. When your man calls you, the relay will operate and if you have an auto horn hooked to the output you are going to snap out of it. If your man forgets to call you at the appointed time, you are not going to lose any sleep over it. The drawback is that some other station may happen on this particular frequency and set the thing off. Don't forget, too, that it is best to work this sort of arrangement with stations using crystal controlled transmitters and not with one that has a habit of roaming all over the amateur band. Write your own ticket on what may befall you in the latter instance.

For those who are experimenting with the Jenkins photo machine, this relay will be of immense help as it is a decided improvement over anything we have seen thus far.

And remote control! From 9 BMY, operating on 40 meters, we controlled the 80-meter transmitter at 9EK-9XH. The distance is about 3 miles and 9BMY used a 7.5-watt tube. The more power, the greater possible control distance, allowing for skip distance, etc. French FW and WIZ made the relay chatter for all it was worth as did many amateur signals from several districts. Constant frequency is of utmost importance unless the operator is content to twist the dials and chase the signal around. Had an ink recorder been available, many signals could have been recorded during the entire transmission. Some of them wouldn't be so good to see in print! It is worth all you put into it to make your transmission as clean-cut as you can.

The present relay grew out of a few hours of experimentation with the hook-up that appeared in a recent issue of the Wireless World. It required adjustment of a regenerative circuit very close to the point of oscillation. The audio output was fed to the grid circuit of the tube in the regenerative circuit and when properly adjusted the incoming signal would throw the circuit into oscillation, thereby causing a change in the plate current. A sensitive relay in the plate circuit would then operate. A special circuit arrangement was necessary to balance out the plate current when no signal was being received. Because an extremely sensitive relay was not available and because the whole circuit was too fussy and critical for general use, it was modified with results far in excess of those originally obtained.

The arrangement of the apparatus is shown in the photo, and the circuit diagram. The input terminals of the relay are con-

* Both of 9EK-9XH, E. F. Burgess Laboratories, Inc., Madison, Wisconsin.

nected to the receiving set in place of the head phones. Two stages of audio amplification are desirable ahead of the apparatus shown in the diagram but they are not necessary on very loud signals. The audio choke

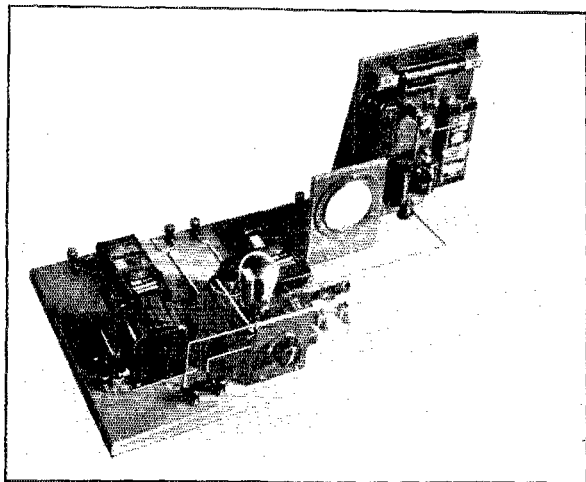

(AFC) and condenser (C1) connected to the input terminals form a parallel feed to the primary of the audio frequency transformer (t) which feeds the grid of the tube. This arrangement gives slightly better results than when the primary of the audio frequency transformer was connected direct to the input terminals. A pair of head phones may be connected in place of (AFC) and these can be used for listening to the incoming signal at the same time. The resistance (Rs) is connected in series with the condenser (C3) and these are connected across the relay armature contacts to prevent sparking and sticking when the tension adjustment is very light for weak signals. The relay itself is mounted vertically to permit finer tension adjustment of the relay armature.

To operate the relay: Heat the tube filament to normal temperature and adjust the potentiometer (P) until the plate milliammeter reading falls to zero when no signal is being received. The signal is then fed to the input terminals, whereupon the milliammeter will show a deflection for each dot and dash of each letter. The spring tension of the relay armature is then adjusted until it responds to the incoming signal. With a little care the relay at 9XE can be adjusted to handle WIZ at 40 words per minute. All that remains is to connect the buzzer or sounder to the output and away she goes. Yes, heavy static and other forms of interference will operate the relay, therefore the incoming signal should be above this noise

level before best results are obtained. However, judging from the many reports we hear of "ur sigs fb om r8" there should be no difficulty in finding plenty of signals to work on. It is possible to lower the noise level when the incoming signal is very strong and louder than the interference. Move the slider of (P) toward the negative side of the C battery until the milliammeter deflection from the interference is reduced to zero. In other words, the noise value is reduced to some value which will not produce a change in plate current and permit the relay to operate. Then, when the strong signal is tuned in, there is sufficient change in plate current to operate the relay. This work is presented "as is" in the hope that other amateurs will show enough interest to carry out further experiments. Better to have the whole amateur fraternity working on it when development will possibly bring about a further exchange of information for presentation in future issues of QST.

WELDING EDISON ELEMENTS

(Continued from Page 19)

the lead from the transformer is connected. All leads in the low voltage side of the transformer should be flexible, and should be equivalent, at least, to a number four wire.

I have used number 20 nickel wire as the connectors between elements but find that the 1/16 inch strip which is used in the construction of the negative elements is much stronger and does not tend to break off as does the wire.

If you do not believe the joints are welded securely, try tearing off the wire after it has been attached to the element. The element itself will tear off before the wire comes loose.

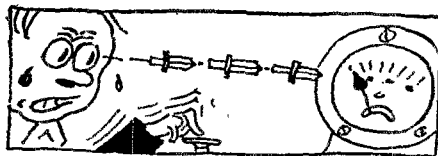

BEFORE, — AND —

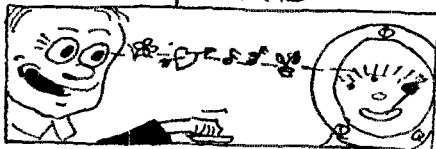

AFTER READING "QST"

A Shielded Crystal-Controlled Unit

By John M. Clayton, Assistant Technical Editor

SO MUCH has been said about crystal controlled transmission, and so many crystal controlled sets have been described in *QST* during the past twelve months, that it hardly seems, upon first thought, that a single stone has been left unturned. One very important matter, however, has never been touched upon in

drive this point home again. Let it be said, though, that when working on the fundamental of the crystal oscillator tube through all successive stages of amplification, shielding is absolutely necessary unless the oscillator and amplifier units are widely spaced. Even when the amplifiers operate on harmonics of each other, shielding and neutralization are very desirable and the gain to be secured from the completely shielded job is certainly worth the time, trouble and money.

Given a good low power shielded unit, it becomes a simple matter to hook on a stage of 204-A amplification, unshielded. With the pep which can be secured from unit to be described no trouble should be experienced in exciting the grid circuit of a 204-A to secure full normal output from the latter tube. Without the 204-A the unit will furnish ample power for the majority of amateurs.

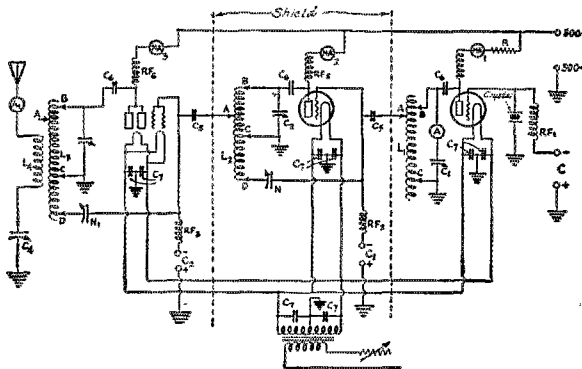

FIG. 1. THE CIRCUIT

- C1—250- μ fd. Cardwell receiving variable.
- C2, C3 and C4—Ditto, double spaced.
- C5-C6—1,000- μ fd. Sangamo fixed receiving condensers.
- C7—Each 6,000- μ fd. ditto.
- N and N1—Hammarlund midget variables. 16- μ fd. maximum.
- L1—Depending on fundamental of crystal. For crystal in 80-meter band, 20 turns of Hammarlund 3 inch No. 16 d.c.c. inductance tapped every 3rd turn.
- L2-L3—Also depends upon wavelength. For 80-meter operation throughout both should have 40 turns of above inductance, tapped every 3 turns. For 40 meters in either stage turns should be reduced to 25.
- L4—12 turns of above inductance tapped as above.
- RF1—Plug-in choke with natural period equal to that of crystal.
- RF2, RF3, RF4, RF5 and RF6. REL 40-80-meter chokes or 150 turns of No. 26 d.c.c. on $\frac{3}{4}$ inch form.
- R—10,000-ohm resistance to supply crystal tube with 325 volts.
- MA1—0-100 d.c. Weston milliammeter.
- MA2—0-300 ditto.
- MA3—0-500 ditto.
- A—0-5 G.E. thermoammeter.
- A1—0-2.5 ditto.
- C—20-to 30-volt C battery.
- C1—45 ditto.
- C2—45 to 67 ditto. The above voltages will depend upon the particular crystal, tubes, and wavelength combinations.

The Layout

The unit was designed to work from a 500-volt supply. The crystal oscillator is a UX-210 tube operating with 325 volts on its plate. The first stage of amplification is also a UX-210 with 500 volts and the second stage is composed of two UX-210s in parallel. In order to make the set as flexible as possible so that all manner of different crystals and different combinations of amplifier arrangements could be used, all of the inductances are of the plug-in variety. Since the closed circuit current through the inductances is comparatively small, it was found possible to use the very convenient Hammarlund space wound coils fitted on bakelite strips and mounting pieces, the plugs and jacks being the now famous General Radio type. Neutralization is provided for each stage of power amplification. If care is taken in the assembly of the apparatus, the neutralizing condensers need not be adjusted when the wavelength of the power amplifiers is changed, it merely being necessary to take off the neutralizing tap from the inductances beforehand, at the proper point. It then becomes possible to jump efficiently from one waveband to

print, as far as we know, and that is the compact completely shielded unit, which may be used either as a real good low power outfit, or as a "feeder" for a larger, and unshielded, amplifier. With this in mind the crystal-controlled unit about to be described was constructed by the writer.

We have so often tried to get over the idea that shielding is absolutely necessary when the set is to be built compactly, and when harmonic operation is not to be used, that it seems hardly worthwhile to

another merely by taking out and plugging in two inductances in the power amplifiers, neutralization being "automatic."

The Set

In Fig. 2, a front view of the set is shown. The panel and baseboard are of one piece of sixteenth-inch brass bent to a ninety-degree angle. The panel is 9 inches high and 24 inches long. The baseboard is 11½ inches deep. Brass partitions are soldered in place at distances such that the oscillator compartment is 8 inches wide, the first stage of power amplification 6 inches wide, and the last stage 10 inches wide. On the front of the panel, from right to left, appear the following meters: a 0-5 thermocouple meter in the tank circuit of the crystal oscillator (A of Fig. 1), a 0-100 Weston d.c. milliammeter in the crystal oscillator plate circuit (MA1); a 0-300 milliampere Weston d.c. meter in the plate circuit of the first stage of power amplification (MA2); a 0-500 Weston d.c. milliammeter in the last power amplifier plate circuit (MA3); and lastly the 0-2½ ampere G.E. thermocouple antenna ammeter (A1). The dials and knobs appearing in Fig. 2 are attached to condensers in the circuit. The first three, from right to left, are on condensers in the plate circuits of the first three tubes and the left hand dial is on the antenna series condenser.

A birdseye view of the set appears in Fig. 3. By referring to it and the circuit in Fig. 1, the construction will be obvious. Unfortunately the "conduit" through which the filament, plate and C-battery leads pass from the terminal strip at the rear of the oscillator (right) compartment to the various tubes, does not appear very clearly in the photo. This "pipe" is a length of ½-inch brass tube passing through notches in the rear and bottom of the shielding partitions, and securely soldered in place. By running the above mentioned wires through this pipe, the only unshielded wires passing from one compartment to the next are the grid excitation feeders from the grids of the power amplifiers to the plate circuit inductance of the preceding tube.

Flush mounting thermocouple ammeters were not on hand, so the old G.E. front-of-board mounting type were pressed into service and made flush mounting. A hole just large enough to pass the face of the meters was cut in the panel and the meters were held against the panel with their surfaces flush with it by means of the long

brass "spacers" which were the Cardwell No. 4735, an inch and a sixteenth long.

The terminal strip carries six terminal posts for the following circuits: (1) positive of the 500-volt supply, (2) negative C-battery to the oscillator grid, (3) negative C to the first amplifier grid, (4) negative C to the last amplifier grid and (5 and 6) the filament leads. As the set frame is grounded it is used as the center tap return, the negative of the high voltage positive of C-battery and center

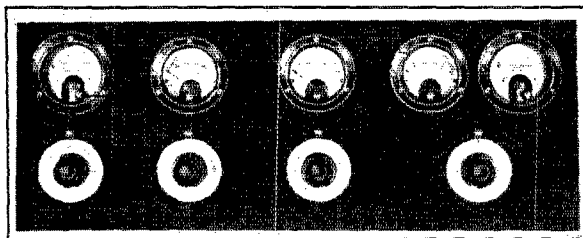

FIG. 2
FRONT VIEW OF SET

tap on the filament transformer being connected directly to the frame.

All of the variable condensers are of the Cardwell type, being their straight capacity line which now cost 75 cents each. The first condenser (C1) has a maximum capacity of 250 μ fd. and the other three (C2, C3, C4) are of the 250- μ fd. type with every other plate knocked out. Although the break-down voltage is doubled by double spacing the condensers, this is not the reason for doing so. The normal condenser will stand up under 500 volts without flashover when it is used with only two 210s. The three condensers were double-spaced to secure a lower maximum capacity.

In the right hand compartment, the small two-terminal mounting strip at the right is for the plug-in choke coil (RF1) in the grid circuit of the crystal oscillator. It is very desirable to use a choke here which has a fundamental very close to that of the crystal. For this reason, and so different crystals could be used, the choke is made plug-in. Incidentally the diameter of the choke should not exceed a half an inch at the most. The plate circuit choke (RF4) consists of 65 turns of No. 28 s.c.c. magent wire scramble wound on a half-inch form and mounted right at the tube socket. Between the socket and the grid choke mounting appears the bottom plate of the crystal holder. This plate is attached directly to the shielding. The top plate rests on the crystal, and has a

flexible lead which is soldered to the first piece of bus-wire toward the panel.

The middle compartment houses the first stage of power amplification. The neutralizing condenser (a 16- μ fd. Hammarlund midget variable) is at the right, the REL grid and plate chokes are mounted vertically on the partition, the plug-in plate inductance appears in the center of the compartment and the tank circuit condenser on the panel. The left hand compartment contains the two UX-210s in the last stage of power amplification. The right hand inductance is the plate circuit one

the coils are wound, was cut away for the entire length of the coil. Then the cotton insulation was bared on every third turn and by means of a hot and *quickly* manipulated iron short lengths of tinned copper wire, bent in the shape of an "L", were soldered to the 3rd turns.

Again, the compartment at the left is the crystal oscillator. Flexible leads from the plugs on the supporting strip for the inductances are temporarily twisted around the taps on the inductance until the correct location has been found. They are then soldered in place. Three taps

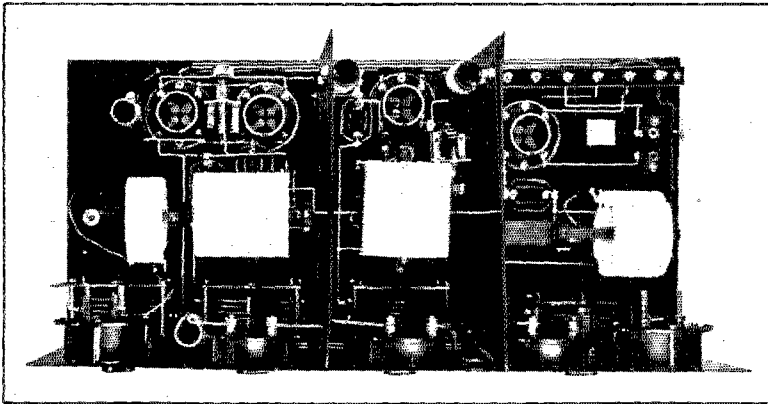

FIG. 3
LOOKING DOWN ON THE SET

and the one at the left is the antenna coil, mounted on a bakelite strip and so arranged that the coupling can be varied either by backing the coil away from the plate coil, or swinging it on a pivot. The neutralizing condenser with this stage of amplification is similar to the previously mentioned condenser and is located between the two tube sockets.

All plate blocking and grid excitation condensers are of the Sangamo receiving type. They stand up beautifully under the 500 volts and have shown no tendency of lying down on the job. The grid and plate circuit fixed condensers have a capacity of 100 μ fd. and the filament bypass and filament transformer by-pass condensers have a capacity of 6000 μ fd. Each filament circuit should be by-passed directly at the tube socket terminals by two (C7) of the 6000 μ fd. condensers connected in series, their midpoint being grounded to the shielding.

A rear view of the unit appears in Fig. 4. The method of taking out taps (which can be done with Hammarlund coils) was as follows: For a width of a half inch, a strip of the insulating material on which

are provided on the first (oscillator) inductance. Referring to Fig. 1 and Fig. 4, they are grid (A), plate (B), and ground (C). The location of these taps will have to be found by experiment, of course, as it will vary with different crystals. Tap A provides the necessary grid excitation to the following tube. The further A is toward tap B the higher will be this excitation.

The coil in the center compartment has four taps; grid excitation (A) to the next tube, plate (B), ground (C) and neutralizing (D). As condenser C2 has its rotary plates grounded to the panel by virtue of condenser being mounted on the panel, it is not possible to place this condenser directly across the whole of coil L2, which would be desirable. For this reason neutralization must be done with each change of condenser C2. That means that when a different crystal is used the amplifier must be re-neutralized, but when operating on harmonics of the crystal and the amplifier, the neutralization becomes automatic since the correct location of tap D (the neutralizing coil) can be determined for each coil, and the proper taps

are picked up when the coil is inserted in the mounting strip. The above remarks also apply to the coil L3 in the last stage of amplification.

The last plate coil (L3) has its terminal strip provided with four plugs. When the unit is used as a complete transmitter (without additional amplification) tap A is not used. When, however, an additional

from the sides and top of the compartments as possible. The coils in this set were plugged into bakelite strips which were supported on the baseboard by means of the Cardwell 15/16-inch spacers.

With a low power unit of this type it is possible to get out all that can be gotten from four little 210s in the way of crystal-controlled energy. And this energy should

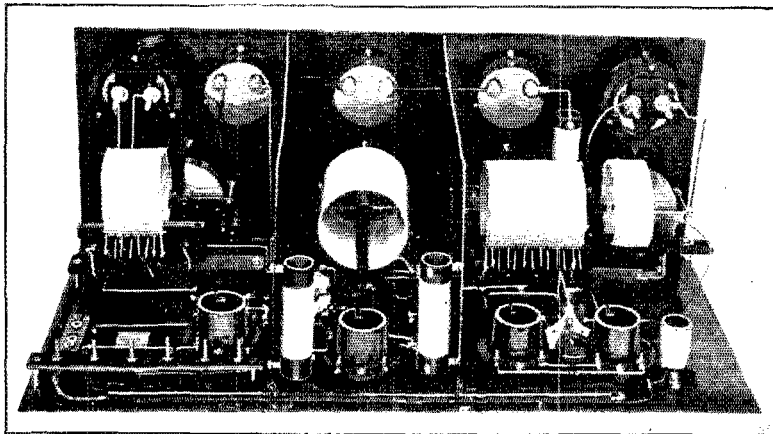

FIG. 4
REAR VIEW

Note "conduit" at back of baseboard (front in photo) through which all low frequency leads pass.

stage is used the socket terminal to which A is connected, should be run to the grid condenser of the next tube. The antenna coil is at the extreme right of the photo. Taps are also provided on this coil, in addition to the variable coupling feature.

In order to make the shielding complete, a back and two sides of sixteenth-inch brass should be soldered to the baseboard and panel. Hinged brass lids are to be used over the tops of each compartment. A hole about an inch and a half in diameter should be cut in the lids directly over the tubes in the separate compartments, to provide some ventilation for the tubes. The shielding of the holes can be taken care of satisfactorily if a piece of metal gauze is soldered on the under side of the lid.

If the lids are made tight-fitting and are held in place by means of spring clips, the shielding is about as complete as one could imagine. A word of warning regarding the inductances. The material on which they are wound is highly inflammable. While the coils will carry the closed circuit of any of the tubes used in this unit, care must be taken that the flexible leads or no other metal pieces are allowed to touch the coils (except where the leads are tied on to the taps). The resulting r.f. arc may cause the coils to go up in smoke.

In all cases the coils should be mounted well above the baseboard and as far away

be amply sufficient to serve as a feeder for any size additional amplifier stage up to and including a quarter Kw. tube. Since the unit itself is thoroughly shielded it will not be necessary to shield the larger amplifier.

Strays

These idiotic "good-luck chain letters" seem to have invaded amateur radio. You know what we mean—the things said to have been "started by an American officer and should go around the world three times. Do not break the chain for whoever does will have bad luck". These things are a fearful nuisance, especially to a busy amateur who has all he can do to answer his legitimate mail. Marcuse of g2NM tells us that he has been favored with four of them from American amateurs. Let's keep this junk out of amateur radio, fellows—squelch it.

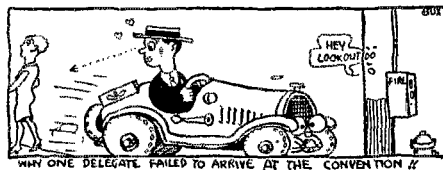

A Short-Wave R. F. Amplifier

By Zeh Bouck*

THE mention of R.F. amplification in the region of megacycles—radio's "misty mid region of Weir"—impels the question, "cui bono?"—what good is it and who benefits by it? Is it worth the bother; do results justify the possible complications; or cannot equal results be obtained with the more simple straight detector arrangements? That there is definite good in short wave radio frequency amplification is most easily demonstrated by building a simple workable set—which after all is the most sensible form of argument. Curves, graphs and formulas in the hands of the radio writer can be made to prove either side of a controversy, particularly if he tacks "Associate I. R. E." after his name.¹

The ostensible justification for high frequency R.F. would be actual amplification—proof that the thing works—and this is quite noticeable in the set I have in mind, contrary to a general idea that it can't be done. The circuit, as shown in Figure 1, is such that a simple test (the swinging of the antenna lead from L1 to an extra primary coupled to L4) will show satisfactory gain in the R.F. stage. Intensification, as would be expected, is most appreciable on weak signals. Station FW (Ste. Assise, France), for instance is received in the writer's New York Laboratory on 7139 Kc. at R9 using two stages of audio frequency amplification. He is often copyable thirty feet from the loud-speaker. Eliminating the radio frequency tube drops audibility to a doubtful R4.

The circuit we are considering is about as non-radiating as a high frequency oscillating system can be made. The form of neutralization employed in stabilizing the R.F. tube is such that very little of the R.F. power present in the oscillating detector circuit can be fed through to the antenna by means of R.F. tube capacity. While there is some difference in opinion in regard to the importance of this factor, there exists a decided consensus among engineering minds associated with the development of short wave transmission, that the use of possible radiating circuits on these high frequencies should be emphatically discouraged.

That more power is radiated when the antenna is coupled directly to L4, has been interestingly demonstrated in the writer's experiments. Due to the erratic field distribution imposed by the characteristics of

the modern cliff dwelling,² accurate observations were impossible. However, radiations from the receiver with the antenna coupled closely to L4 were picked up on a portable oscillator at a distance three times

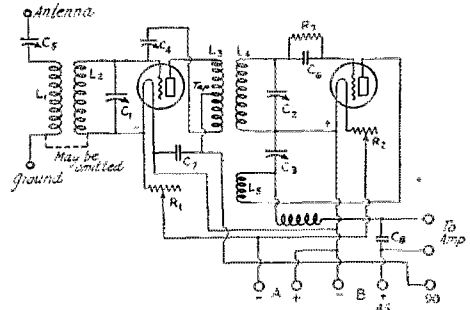

FIGURE 1. THE CIRCUIT

- L1, L2, L3, L4, and L5—Aero Products short wave coils as described.
 C1 and C2—150 μ fd. Amsco straight-frequency-line condensers.
 C3—250 μ fd. Amsco straight-frequency-line condenser.
 C4—Hammarlund Midget Condenser with three plates cut away.
 C5—Hammarlund Midget Condenser.
 C6—150 μ fd. grid condenser.
 C7—.006 μ fd. bypass condenser.
 C8—.0025 μ fd. bypass.
 R1 and R2—30 ohm rheostats.
 R3—three megohm gridleak.
 X—R. F. choke, 200 turns of 36 on one inch tube.

greater than that giving an equal signal on the R.F. arrangement.

The removal of the antenna primary from the immediate vicinity of the oscillating circuit eliminates the "bumps"—the inconsistent dial settings on the feed-back control. In the author's arrangement, the feedback condenser C3 need not be adjusted over the entire tuning band, or, at the most, only lowered a few degrees for the higher frequency half of the dial.

No difficulty whatever is experienced in stabilizing the R.F. circuit, and Cr once set, remains constant for all frequencies covered by the three Aero-coil short wave units—from 18 to 120 meters.

As for the extra control, the lessened attention required by the regeneration dial partially compensates the admitted complication, also, the R.F. dial tunes rather broadly (as compared with the condenser

*Engineer, Amsco Products, Inc., Broome & Lafayette Sts., N. Y. C.

1. Fortunately that practice is dying. Authors are learning that it is just as well not to call attention to an associate membership. The full member is of course quite right in putting "I.R.E." after his name.—Tech. Ed.

2. The author lives in New York.—Tech. Ed.

in the detector input circuit) and an approximate setting is sufficient to pick up any station above the noise level.

The Circuit

Diagram Figure 1 is practically self-explanatory. The R.F. circuit is conventional—a reversed winding on the plate coil providing the neutralizing E.M.F. The detector circuit uses one of the familiar circuits in which the plate is shunt fed thru the R.F. choke x.

The regeneration is controlled by a variable condenser C3 which provides an adjustable R.F. bypass around the R.F. choke and the B battery. The detector output is fed to a two step high ratio transformer-coupled amplifier with a jack in the first stages. The writer used Como 8:1 transformers.

A word must be said about the inductors, L1, L2, L3, L4 and L5. I found the neat-

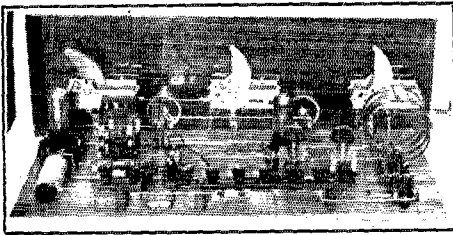

PLENTY OF ROOM TO BREATHE IN!

est and most simple way of obtaining efficient coils was to secure two sets of Aerocoil short wave inductances. Each set consists of a mounting and three coils covering the various amateur and commercial short wave bands. The mountings are wired pretty much as suggested by the initialing on the lugs. However, the tickler connections of the first mount are ignored.

The primary on the second mounting is altered to meet the requirements of the R.F. plate coil. Four of the ten turns of wire are removed, and the remaining six turns tapped in the middle. This is the tap lead, as shown, to the radio frequency plate potential.

Constructional Notes

The parts are mounted behind a seven by twenty-one-inch panel, and on a nine-inch baseboard. Thus, ample room is provided for the adequate spacing of parts. It will be observed that the two sets of coils are mounted at opposite ends of the baseboard and at right angles to each other.

Straight frequency-line condensers were used by the author and are strongly recom-

mended to anyone desirous of duplicating the receiver. It is also important that a first class high ratio vernier dial be ob-

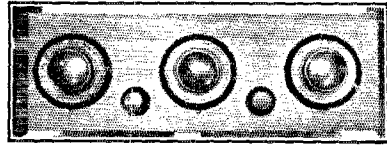

THREE CONTROLS BUT NOT A "THREE HANDED SET"

The left dial R. F. tunes rather broadly. The central dial is the main control. Dial three, the regeneration control, need be touched only twice in tuning over the entire scale.

tained. The author uses the Karas Orthometric.

Operation

When working over the twenty meter band, ninety volts should be used on the detector. The actual operation of the receiver is quite simple, the mechanics of which were suggested a little farther back. The amateur who constructs a set of this type will find that the additional tube has introduced practically no complications which are not justified by superior results, and that, on the whole the operation of the receiver is more consistent and simpler, than that of the average straight detector type.

New Panel Material

SOMETHING very attractive in the form of insulating panels is the new surface finish on Ace panels, made by the American Hard Rubber Company. The material is their familiar "Radion". One side of the surface has the regular polished finish while the other is finished to appear

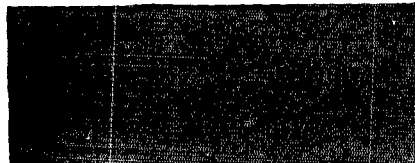

almost indetical to grain leather. The "leather" side will not show finger prints, scratches or dirt nearly as easily as the polished surface. It can be engraved as easily as the polished side, and is available in either black or mahogany. The panels are stocked in regular sizes from 7 x 10 inches up to 7 x 30 inches.

—J. M. C.

The Uses of a Calibrated Variable Condenser

By Raymond B. Roof*

TO the serious experimenter, a calibrated variable condenser is a valuable piece of apparatus. Its uses are many; some of them are to be given in this article, others will suggest themselves.

To be of any real use the calibrated variable condenser must be carefully calibrated and must in addition be of such construction that the calibration will be retained. A flimsy "standard" that keeps changing is worse than useless.

Assuming that there is available, or can be made, such a condenser we come at once to the following uses:

- 1—To find distributed capacity of a coil.
- 2—To find the inductance of the coil.
- 3—To match two dissimilar coils so that they may both be tuned by the sections of the same tandem condenser.
- 4—To find the capacity of fixed condensers.
- 5—To calibrate other variable condensers.
- 6—As a wavemeter in conjunction with an inductance. (A wavemeter with a calibrated v.c. has the advantage that it may also be used to measure decrement and from this it is possible to compute R.F. resistance.)
- 7—Various uses in oscillating vacuum-tube circuits.

Drivers and Resonance Indicators

Before going any further with the seven uses it is necessary to speak briefly of the driver and the method of indicating resonance. A driver is required for the first 5 tests and resonance indication is necessary in all 7. A "breadboard" setup of an oscillating vacuum tube or a carefully made laboratory oscillator may be used. Even an oscillating receiver is often useful. The R. F. energy is transferred to the test circuits by coupling to a coil in the oscillating tube circuit.

Resonance may be indicated in a variety of ways as shown in Fig. 1. At Fig. 1A an R. F. milliammeter (thermogalvanometer) is being used in the oscillating circuit, while at 1B it has been put into the test circuit and at 1C has been coupled to the latter. Finally a D.C. meter may be used, either a 0-10 M.A. meter in the plate circuit of the driver, as at 1D or else a 0-1 meter in the grid return of the driver as at 1E. In some of these arrangements the meter indicates resonance by a deflection and in others it rises at resonance. If a receiving set is being used as a driver (and of course other drivers may also be connected to permit this) the well-known "click method" may

be used.¹ A pair of headphones is put into the plate circuit. When the driver and the test circuit come into resonance the detector tube will stop oscillating. This will manifest itself by a click in the phones, together with a cessation of those peculiar noises heard when a tube is oscillating.

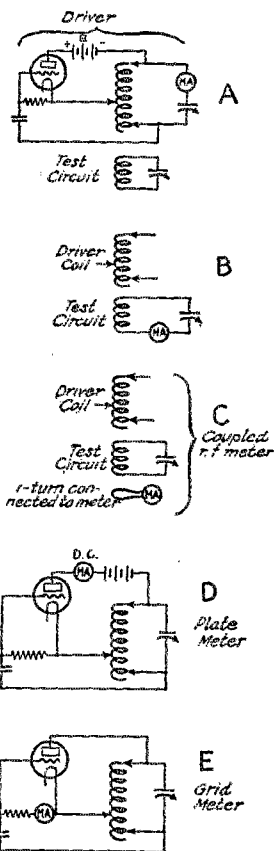

FIG. 1 RESONANCE INDICATORS

FOR USE OF GRID METER SEE AUGUST QST

After resonance is passed there will be another click as the tube starts oscillating

¹—The "click method" was devised by Elbert Judson, then of the Naval radio laboratory at the Bureau of Standards. It is rapid and simple but good accuracy is not gotten with it as easily as with the grid-meter shown at Fig. 1E. The difficulty is that when one has loosened the coupling until the two clicks run together the clicks have also become excessively faint. The only way to get a good click is to turn a condenser fast—and then a good reading is impossible. An audio amplifier in the driver circuit helps. Tech. Ed.

* SBTf, 79 Harvard Street, Battle Creek, Michigan.

again. If the coupling to the driver is now reduced the two clicks can be brought closer and closer together until they become one, which occurs when the two circuits are in resonance.² It is advised that the condenser of the oscillating tube circuit be left at one position and the calibrated condenser rotated to find resonance. This is a very

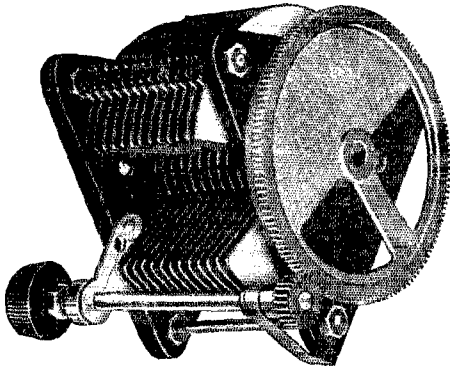

A LOW-PRICED CONDENSER THAT CAN BE OBTAINED WITH A CALIBRATED DIAL

The type 247 General Radio condenser in the 500- μ fd. size. When equipped with a geared vernier as shown and mounted in a metal case with a dial calibrated in μ fds this condenser is known as type 247G. The plates are shaped to give a straight line of dial setting against wavelength, making the condenser especially suitable for wavemeter work.

convenient method of finding the wavelength of a received signal—the receiver being used as a driver and being left set on the desired station's wavelength which is then determined by the use of the click method between the receiver and a wavemeter.

1—Finding the Distributed Capacity of a Coil

A little mathematical basis must first be formed. Most of you are familiar with the wavelength equation

$$\lambda = 1.884 \sqrt{(L)(C)} \quad (1)$$

where L is the inductance in microhenrys, C is the capacity in micro-microfarads and λ is the wavelength, as usual.

The simplest sort of circuit to which this applies is such a one as in Fig. 2. Squaring both sides of this equation we get rid of the radical and have:

$$\lambda^2 = (1.884)^2 L C \quad (2)$$

Now C is the total capacity, part of which is in the condenser and part of which is in

2—If a received signal is being used a somewhat easier method is to set the received beat note at 200 cycles or so, loosen the coupling to the wavemeter and then work NOT on a click but on the shift in beatnote which happens at resonance. Of course the result is off 200 cycles but that can't be found on the ordinary wavemeter—it is hard enough to find on the precision meters. Tech. Ed.

the coil as "distributed capacity." If we call the condenser capacity C_1 and the coil capacity C_2 our equation becomes

$$\lambda^2 = (1.884)^2 [L(C_1 + C_2)] \quad (3)$$

Now connect the coil across the calibrated v.c., making a circuit like that of Fig. 2 measure the wavelength of this circuit when the calibrated v.c. is set at different values. This can be done with a driver and a wavemeter, using any one of the resonance methods indicating methods that have been mentioned. Next we plot λ^2 against the known values C_1 as shown in Fig. 3. It will be seen that the curve does not go to 0 on the λ^2 scale but strikes above the 0 and continues to a point A on the C_1 scale. The distance from A to 0 (marked with the arrows in Fig. 3) is equal to C_2 , that is the distributed capacity.

2—To Find the Inductance of the Coil

The inductance of the coil is proportional to the slope of the line in Fig. 3. To find its actual value we proceed mathematically as follows:

Solving our formula 3 for L we get

$$L = \frac{\lambda^2}{(1.884)^2 [L(C_1 + C_2)]} \quad (4)$$

Where C_1 and λ^2 are taken at some point on the line in Fig. 3; C_2 is already known from the same figure. If λ^2 is in meters

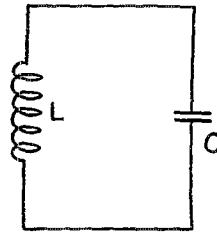

FIG. 2

THE SIMPLE TUNED CIRCUIT

and C_1 and C_2 in micromicrofarads, then L will be in microhenrys.³

3—Matching Two Tuned Circuits

To tune two circuits with a tandem condenser they must both have the same inductance and the same fixed capacity. The fixed capacity is usually present in the shape of distributed capacity in the coils and wiring. To get these conditions with a calibrated condenser is easy enough. One of the inductances (with any wiring that is a necessary part of the tuned system) is

3—Some mathematics have been omitted here in editing the paper. The formula may all be found in circular 74 of the Bureau of Standards which every member of A.R.R.L. should have. Amongst the material unavoidably edited out was an author's recommendation of the circular. Tech. Ed.

connected to the condenser and resonance points (wavelength) are found for 5 or 6 wavelengths. A chart is then plotted somewhat like the one that is shown in Fig. 3.

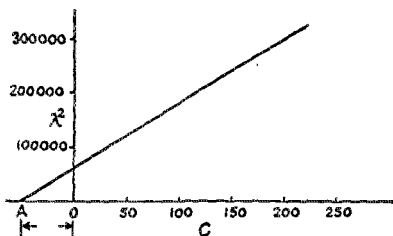

FIG. 3. FINDING THE DISTRIBUTED CAPACITY AND INDUCTANCE OF A CIRCUIT

This is curve A in Fig. 4. It shows the tuning of the first coil, No. 1, to which No. 2 is to be matched. Coil No. 1 is now disconnected from the calibrated condenser and coil No. 2 connected instead. Suppose that when it has been tested we get curve B. This curve is steeper than the one for coil No. 1 showing that the coil has greater inductance than coil No. 1. A few turns are now carefully taken off. When one turn is removed we get curve C. When two turns are removed we get curve D—almost parallel but not quite. One more turn is then taken off and curve E turns out parallel to curve A. (Sometimes one has to remove part-turns to get this result.) The two coils now have the same L but they still do not tune together. What is the trouble? The answer is simple. One of our conditions has been satisfied—the inductances are equal—but the other one is not yet satisfied—the capacities in the coils and wiring are not equal. This can be corrected by shunting a very small air condenser across coil No. 1, sufficient to bring line A up on line E. The capacity can be found by trial or measured by the method next to be described. The writer recently added a tuned R.F. stage to his superheterodyne, tuning this and the loop with a tandem condenser with very gratifying results. The adjustments were made by the method just described.⁴

4—Finding Capacity of Fixed Condensers

The capacity of a small fixed condenser is rather easy to find. Connect a coil of some sort across the calibrated condenser as in Fig. 5A and couple the arrangement to the driver. Set the driver wavelength and the calibrated condenser at some convenient settings where resonance can be gotten, making sure that the calibrated v.c. is set

somewhere near the top of its scale. Then connect on the fixed condenser as shown at 5B *without touching the driver at all*. This detunes the test circuit. Now continue to leave the driver alone and retune the calibrated v.c. until the test circuit is again in tune with the driver. Since the frequency was not changed (the driver having been left alone) the test circuit must now contain as much capacity as before and the fixed condenser capacity must be equal to the difference between the two capacities at which the v.c. was set. This difference can be found by using the scale or chart of the calibrated v.c.

It would seem that the range of the scheme would be limited by the range of the calibrated v.c. but this is not so. A known fixed capacity may be connected across the calibrated variable condenser and the range thus extended.

5—To Calibrate a Variable Condenser

The calibration of a variable condenser is but little different from the above. The cali-

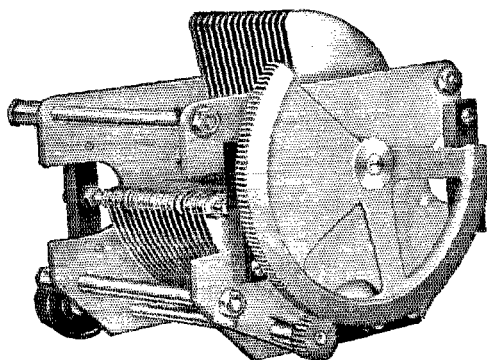

THE GENERAL RADIO TYPE 239 LABORATORY CONDENSER WHICH IS SUPPLIED WITH A CALIBRATION CHART

brated v.c. is first connected to a coil and resonance established as before, then the new condenser is set at 0 and connected across the calibrated condenser. The new condenser is now a small fixed condenser and its capacity is found as explained under heading 4. This performance is repeated with different settings of the new condenser, each capacity being measured just as if it were a new fixed condenser. The values found can then be made into a curve for the new condenser.

6—Wavemeter Use

The use of a calibrated condenser in a wavemeter is mentioned mainly because a few will wish to investigate further. The main advantage is that one can measure decrement and from this compute resist-

⁴—See also "Tuning Tricks", by Paul Mueller, page 22, QST, August, 1926.—Tech. Ed.

ance. The method is found on page 196 of circular 74 of the Bureau of Standards. There are more modern and desirable ways

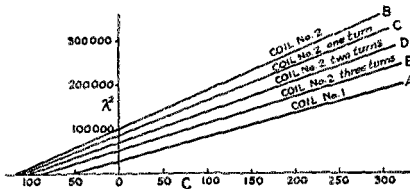
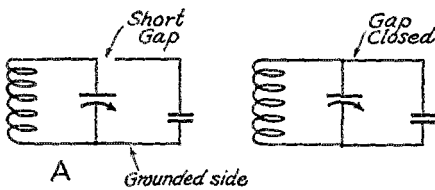

FIG. 4. MATCHING COILS

of measuring R.F. resistance so this use is included mainly for the sake of completeness.

7—In Vacuum Tube Circuits

A calibrated oscillator is very useful. When one is to be made up. In making up receivers, transmitters or laboratory oscillators it is extremely handy to have a calibrated condenser available for the tuned circuit. It is then possible to determine the design before starting to put the apparatus together. The inductance of



NOTE - Keep leads between condensers short

FIG 5 CALIBRATING FIXED CONDENSERS

the circuit can be calculated fairly accurately and since the capacity is known these values can be substituted in the wavelength equation which was given as equation No. 1 in this paper. The wavelength can thus be determined in advance. There will be some reduction of the plate-coil inductance because of the load coupled to it but this will cause only a small error. This statement fails at short wavelengths where the tube capacity may be fully as important as the capacity of the variable condenser.

Several firms manufacture calibrated variable condensers. Because of its low cost the little General Radio type 247 condenser is especially useful. The 500- μ fd. size is supplied with a dial having a capacity calibration and a vernier control. The case is of metal and forms a shield which is very necessary. If a more accurate calibration is desired a chart can be made by calibrating against some other condenser used as a standard.

New Interchangeable Coils

THE coils shown in the illustration were designed for short wave reception. They are space-wound and are supported between two hard rubber strips. The windings themselves are held in place by means of four narrow strips of celluloid cemented to the wire. The coils are wound with number 16 enamel-cotton insulated wire, the diameters of all of them being 2 1/2 inches. As the spacing between terminal pins is the same for each coil, they may be used interchangeably as secondaries and ticklers. The four coils shown, when shunted by a 150- μ fd. tuning condenser will cover all waves between 10 and 117.5 meters

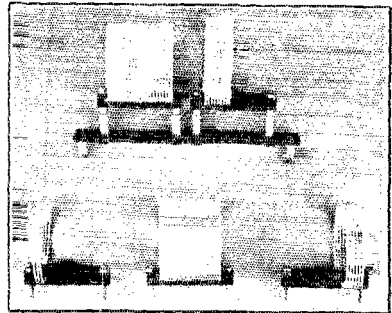

(29982 to 2511 kcs.). An additional close-wound coil wound with number 18 wire covers the band between 90 and 235 meters (3331 and 1275 kcs.). Instead of the usual plug and jack plug-in arrangement the "jacks" are equipped with thumb nuts so that the coil terminal pins can be held in place securely. We wish the coils were equipped with the usual plug-in plug-jack system. Additional coils are available for the broadcast band. The two-coil system was designed for use with a small series antenna system. If you prefer a primary coil, one is available. The coils can be used in low power transmitters advantageously. They are made and sold by The Seattle Radio Laboratory (otherwise known as Howard F. Mason, who was formerly on the QST staff), at Seattle, Washington. And a nice job, OM.

—J. M. C.

Strays

6BWS wants to know where to apply for a patent on his new two-piece-filament five wattor.

9ZT has moved from Minneapolis to the West Coast where he will be going shortly with the call 6AN.

Horizontal Wave Experiments at 2AER

By John M. Hollywood*

THIS article is not quite correctly named. The experiments at 2AER started out to be tests of horizontal waves, but they soon became involved in the mysterious problem of wave propagation in general.

Probably the most familiar theory is that of the "pebble in the pond", illustrated in Fig. 1.

The continuous lines represent waves, and the dotted lines these same waves

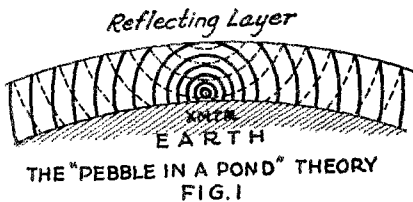

after being reflected from the ionized layers of the upper atmosphere. This theory assumes that waves are propagated in the form of ever widening circles (or rather, spheres, for the waves travel in more than just the one plane illustrated in the figure).

Theory number two is that used by Reinartz in his epoch-making explanation of short-wave action. It is shown in Fig. 2. The continuous lines represent the original direction of wave travel, and the dotted lines, the direction of the wave travel after reflection from the ionized layer of the atmosphere. This theory is really the same as the first.

Then there is the "lines of force" theory, which assumes that radio energy is propagated by lines of force, similar to the magnetic lines of force around a bar magnet. These lines of force, and not the waves, are reflected from the ionized layer. The "lines of force" energy occurs in cycles corresponding to the frequency of the transmitter and therefore *would* travel in waves.

Before illustrating that theory, I am illustrating for reference, lines of force around a bar magnet, Fig. 3—H, and V. The lines of force, as can be seen, are in the form of a series of tangent circles on each side of the magnet. Using the same type of illustration, the figures below H₂ and V₂ show radio lines of force for horizontal and vertical transmission. It is questionable whether lines of force are reflected in straight lines, or in curved lines

like waves, so both types will be shown. For clearness, not all the reflected lines of force will be shown. It will be seen that the theory V₂ shows no horizontal component of vertically transmitted signals although they *do* have a horizontal component at great distances, and quite a large one at that. This theory, then, is false, which makes theory V₂ false also. Now let's see about theory H₂. This one shows no vertical component at great distances, but a large one a short distance away. As far as could be observed at 2AER (observers who could help out in these tests were few and far between) this was true, although it has not been determined positively. Horizontal wave transmission could be heard much better with horizontal than with vertical reception at any great distance, but it could be heard vertically quite well by stations in near-by states. The same thing was noticed here in regard to the horizontal wave transmissions of 4XC and WGY. Diagram V₂ also seems to agree with known facts; it shows both horizontal and vertical components of the vertical transmission at great distances. The only thing that disagrees with these two diagrams is Dr.

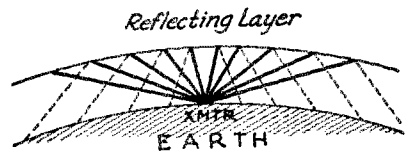

Pickard's observation that vertically transmitted waves can be received best horizontally or vertically but never at an angle; while the diagrams would show that the signals would often be best at an angle.² At any rate, of the theories tested, the "lines-of-force-reflected-in-straight-lines" one seems to be the most probably true.

Now for the actual transmission results of horizontal waves compared to vertical waves. They were as follows:

1. There is room for a controversy here. Depending on one's definitions, the argument may hold, or else it may be interpreted as being a confusion between polarization and direction of propagation.—Tech Ed.

2. There occurs here the same difficulty mentioned in note 1. Unless I have greatly misinterpreted Dr. Pickard's results he was able in many cases to receive at odd angles—that is with both H and V components.—Tech Ed.

* 2AER, 33 Peters Place, Red Bank, N. J.

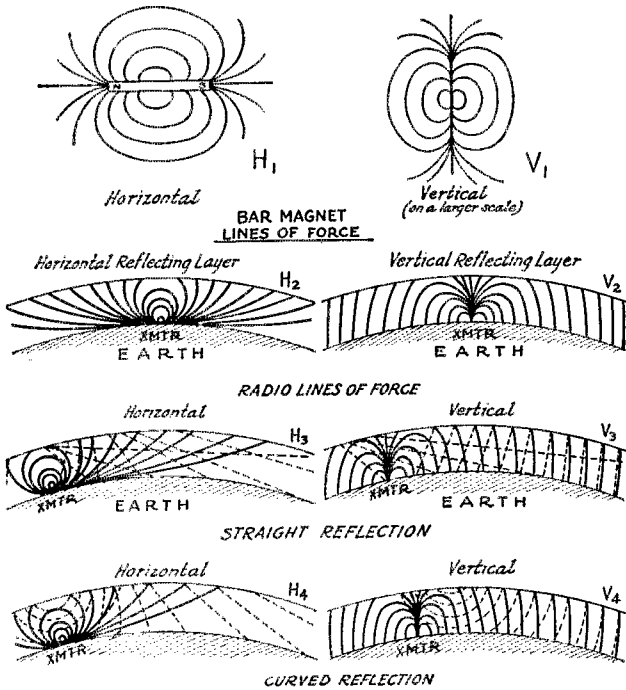

FIG. 3 THE "LINE OF FORCE" THEORY

1. For vertically transmitted signals, local stations are, of course, best received vertically. Semi-locals, say 50 miles away, are received better horizontally, and the same thing is true for all stations up to 1,500 miles². At this point, horizontal and vertical reception are about equal, and stations beyond this distance are best received vertically.

2. For horizontally transmitted signals, locals are best received horizontally. Semi-locals, about 30 to 300 miles distant, are often received loudest vertically. Beyond 500 miles, the signals are best received horizontally.

3. In comparing horizontal wave transmission and reception, the signal strength at all distances and times of the day was approximately equal for the two systems.

4. Skipped distance is less marked when receiving vertically transmitted signals horizontally, although the average skipped distance is just as far away.

5. The figures used are only approximate, and are for five A.M. on 40 meters. Shorter wavelengths or an hour nearer

3. Checking Dr. Pickard's work see page 13 of QST for February, 1926. Tech. Ed.

midnight will have the effect of increasing the size of the numbers used.

Conclusions

My practical conclusion is that for local and long distance work, the transmitting and receiving stations should both use the same type of transmission and reception, either vertical or horizontal. For semi-local and medium distance work, the signals should be transmitted vertically and received horizontally. Ultra-short wave work is also best done in this manner.

My tentative conclusion is that radio energy is transmitted in the form of lines of force, which are reflected from the ionized layer of the atmosphere in straight lines.

This does not by any means settle the matter. Anyone knowing of a wave propagation theory that fits the facts better than those described herein, should write to QST. I shall be glad to supply anyone with information about the details of the experiments at 2AER.

Strays

The circuit shown in Fig. 5 on page 11 of the September issue of QST is balled up. It won't work that way but will do its stuff

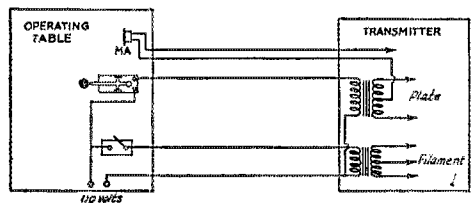

when the apparatus is hooked up as shown in this corrected diagram, presented with our apologies.

6ANB: "Sa you know 6ACL uses a synk on his fifty watter?"

6AUP (who just got his license): "Yeah? Guess you'll have to use a bath tub when you get your 250 watter."

The Price of Peace

By Earle Peacox*

DID you ever want to turn back in radio's pages and review the things that used to happen? Very well—let's turn back to 1923 and see what was going on then.

With a strangely worried frown and a nervously expectant sigh, Professor Josiah McGroop steadied his shaking hand and glared darkly at the small white arrow above the large mahogany colored dial. "31, 31, 29," he muttered, and softly in response came the undulating strains of an aria from Aida. He waited impatiently for a pause. Would the station never sign? His pursed lips and furrowed brow spelt untold endurance. Was it KDKA or was it someone he had never heard before? His trembling hand again sought the first dial as the distant announcer faintly crooned, "The selection you have just been listening to was an aria from Aida. You are listening to station K-F_____"

"Blah-bli-blah-bit Blah-blah-bli-blah"

"_____ next number _____"

"_____Blah-bli-blah-bit Blah-blah-bli-blah_____"

"_____station K _____"

"_____Blah-bli-blah-bit Blah-blah-bli-blah_____"

The phones clattered to the floor. The switch snapped indignantly. Outrageous! These amateurs! In the sanctity of his own home—every solitary evening—ought to be a law against it! His breath came in short gasps, his hands clasped and unclasped behind his back, his eyes bulged from his head as he paced the carpeted floor. The radio set; around the table to the bedroom door; the bedroom door; around the table to the radio set. He kicked the unprotesting phones under the stand and stood contemplating the uncomprehending *Nihildyne*. \$89.95 — and yet it was useless! A bird without wings might twitter, a dog without a tail might bark, even a bull without horns might bellow, *but a radio set without means to insure uninterrupted programs—hopeless!*

From the direction of the bedroom door came the timid voice of a patient woman, supplicating, "Josiah, don't you think it's time you came to bed?"

Overhead, two floors above, a youth in his teens sat at an unkempt kitchen table in a darkened bedroom. Upon his head was tightly clamped an ungainly pair of Baldies; before him was strewn an unseemly collection of junk, leaving scarce-

ly enough room for the pad he was writing upon. Suddenly he dropped the pencil and reached into the mess of wires before him to snap a switch. On the shelf above the table a glass bulb became illuminated with a bright yellow glare, the needle on a solitary meter swung up to midscale, and at the left a long row of mother's fruit jars glowed and scintillated with a million twinkling sparks. He noted all this with satisfaction, and about his mouth played a boyish smile of self assurance that turned to a serious pursing of his lips and a muscular twinge of his chin as he reached for the telegraph key at his right.

"R-r-9NBD - u-2DRH-tks-om-gld-to-raise -u—ur sigs- QSA-hr—hws tngs—gg—out —ur—wa? - - - -"

Just an unimposing corner in a darkened bedroom, just a homely array of apparatus interspersed with wire, but a place where world-wide friendships are formed; a congress for the nations without diplomacy, where naught but honest friendship enters in.

The sole owner and operator of 2DRH slammed the door and hurried down the steps in the deepening twilight, all unaware of the scowl that followed his departure.

The dislike was mutual. "Drat him," muttered Professor McGroop as he watched the figure of his pupil pass thru the gate.

"What a crab!", grumbled George as he paused atop the hill and gazed at his cage antenna, suspended from a new thirty foot pole, and dropping into the areaway to the window of his bedroom. "I don't know why he had to move right into our apartment house. It's bad enough to stay after school and see him without standing the chance of meeting him on the stairs every time I go in or out!" Yet, as he plunged down the hill all thoughts of cranky teachers and broken crucibles faded into insignificance in a mind occupied and overcrowded with the overly important discussion of key click filters.

As he thrust open the door of the vestibule that evening he stopped abruptly. It seemed as though he had never seen such a pretty girl before. Golden bobbed hair that fluffed all up with a natural curl, blue eyes that bored right into you without seeming to stare, a smile that simply left you limp with a sensation that your spine had turned to jelly, and a voice that transported you thru paradise and left you tingling all over with a glow of warmth.

"Oh, I'm so sorry!" she was saying, "I haven't my key and no one seems to be

* 2ADH, Box 113, Yonkers, N. Y.

home—they don't answer the bell—"

"Why, er—no trouble—my—my key—I—er—ah—glad to let you in," he stammered, opening the door with such a masterful display of strength that it nearly shattered against a protruding radiator.

"Thank you—ever so much. You're the boy upstairs, aren't you? —Father says you're in one of his classes."

"Yeah," he admitted, trying to make it sound genuinely pleasant, "that's right".

An awkward pause. What was it they always said in the movies in situations like this! He never could manage to think—

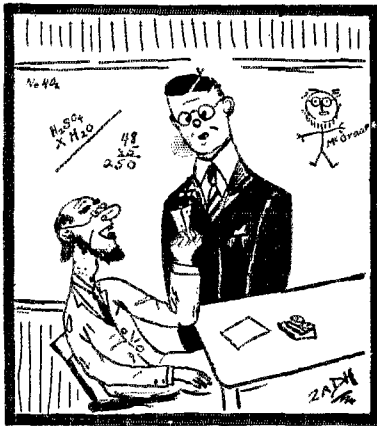

"HERE ARE TWO TICKETS FOR TONIGHT'S PERFORMANCE"

"Are you going to the dance at the school tonight?" she asked, "I didn't see you at the last one."

"Why, — I — yes!" he gasped precipitately. "Is it tonight?" She had noticed him! She hadn't seen him at the last one! "Is anyone—has someone else already —"

"Well you see," (was she actually considering it or was this all a dream?) "I promised Frank Lester, but he hurt his leg at the game yesterday and he can't even walk with it. If you'll call around at half-past seven—" The tone of her voice as she ended left no other course.

It was incredible! For two consecutive nights Professor Josiah McGroop had marked the passing of midnight with an uninterrupted succession of DX stations. This was something like it. Now if only that young scamp upstairs would stay off the air every night. Well, it was simply too good to be true, the Natural Law of Compensation—. With a pagan sigh of comfort he nestled back in his favorite chair which caused the plug to be pulled from the jack in the panel. It jarred his

sensibilities by its unexpectedness; it irritated him because he should have stopped to estimate the distance. Still angry he turned toward the open bedroom door. "Where is Alice at this late hour?" he demanded, "Here it is after twelve o'clock and she's not in yet!"

With a sigh, partly of resignation and partly of thanks that the inevitable had at last arrived, the patient mother replied to excuse her wayward daughter and pacify her irrational husband in the same breath. "She's gone to the pictures with that boy upstairs," she explained. "She'll be in any minute now."

"Huh!" grumbled the professor. "And who was she out with so late last night?"

"She was out to the dance with him last night", the mother replied promptly—now that the cat was out of the bag and running rampant.

"Huh!" grunted Professor McGroop again and lapsed into a deep silence as he re-adjusted his headset and turned back to the set, a strange light of worldly wisdom shining in his eyes.

That same early morning, he crawled into bed with a feeling of deep satisfaction that had not encompassed him in many a year. His list of stations now included KHJ, at Los Angeles. Perhaps Professor Nourse would like to hear of that!

One by one, the others in the darkening classroom had been allowed to go. It seemed like hours since the last one had left. George shuffled up to the desk defiantly.

"Lynn," said the professor, and to a closer observer the expression around the corners of his mouth might have occasioned more than passing thought, "here are two tickets for tonight's performance of the Midnight Frolic. My daughter Alice has always been wanting to see it, and I thought you might be kind enough—that—that you might want to take her. That will be all, young man, thank you, and good day!"

And Professor Josiah McGroop sat far into the night squinting at the small white arrows above the large mahogany colored dials.

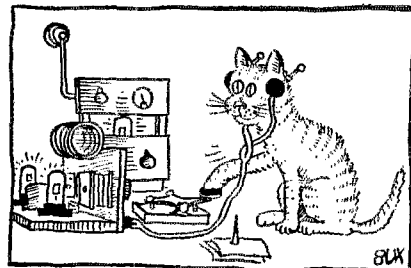

QST ANNOUNCES TRANSMITTING KITS

The Flying Loop

By Oliver Wright*

THE subject of loop transmitting and receiving at short waves has not received the publicity due it. The possibilities are interesting and it is the purpose of this paper to recount (and discount) a few of the experiments with loop transmitters and receivers carried on by myself in Arizona and California.

Introducing the Set

Subsequent to the writing of my previous stories on this subject¹ several improvements

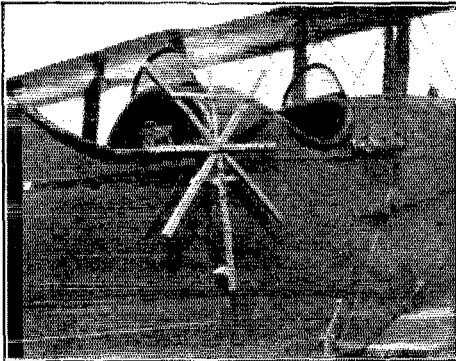

THE LOOP IN PLACE ON THE DE HAVILAND
Note that each turn is supported in eight places to keep the wires from vibrating. The panel dimly visible in the observer's cockpit supports the 900-cycle transformer.

have been made in the "transceiver" design as shown in Fig. 1. The principle has not been changed. The set remains a "super-regenerator" of the blocking-grid variety.

It has been found that grid leak control is the secret of the set. Two No. 10 Bradleyohms and one No. 25 placed in series will function most satisfactorily in making any *hard* tube oscillate and super-regenerate.² One will work alone but the adjustment will be very ticklish as the correct setting is found at about the point where the contact is released.

As yet I have not been able to make any tube super-regenerate with a honey-comb coil choke and even the single layer choke shown in the diagram must be kept as far from everything else as is possible. The current in the loop is usually about two

amperes with 650 volts on the plate of a UX-210 tube.

Assuming the set is complete the following steps should be gone through to place it in actual operation: Screw the Bradleyohms down tight and light the filament to full brilliancy. The set will then oscillate quietly but too strongly to receive any but the strongest of local signals. To check this listen in on another receiver. If the loop set is oscillating properly it will nearly paralyze the second receiver. Now increase the grid resistance slowly and the set will break into a quiet whistle that denotes super-regeneration. This whistle is not at all annoying. By tuning around over the amateur band (with the 40-meter loop and a 13-plate Bremer Tully condenser³ everything will be below 25 degrees) signals will now be heard. To increase their volume increase the grid resistance slowly. The whistle will increase both in volume and frequency but up to a certain point the signal strength will increase faster. After this point is reached the signals will not be heterodyned but will have a blocking effect on the tube, stilling the whistle and giving the effect of a back wave. A back wave effect of this sort from NKF was heard in Pasadena at about 4 p.m. one day last summer at a wavelength of about 75 meters and at a distance of about 20 feet from the phones. It has been found after many tests that 500 cycle or 1000 cycle notes can be received much more satisfactorily on this set than D.C. or well filtered A.C. although they all come in very well.⁴

Happily the correct adjustment for receiving is also satisfactory for transmitting so that the sole operation necessary to change from receiving to transmitting or vice versa is merely to throw the anti-capacity switch and (in case transmitting and receiving are being done on different frequencies) to change the condenser setting. Almost any good *hard* tube will work in this circuit—"five watters" and "seven-and-a-half watters" are excellent. Of course amplifying "A" tubes consume much less filament current, which makes them more satisfactory for portable installations. One UV-201-A worked very satisfactorily for several days with 700 volts on the plate and is still in the land of the oscillating although the same can not be said for two others. Fig. 2 gives the dimensions for both 40- and 80-meter loops and is advisable to build the loops to these exact

* 6GD, 6BKA, 784 S, El Molino Ave., Pasadena, Calif.

1. "Low Power Loop Transmission", *QST* for January, 1924, and "Loops and Fords", *QST* for July, 1925. Author.

2. These are compression-type variable resistances of a compact type. The rated range for the two mentioned is, 10,000-100,000 ohms for the No. type 10, and 25,000-250,000 for the No. 25.—Tech. Ed.

3. Capacity at maximum setting, 500 μ fd.—Tech. Ed.

4. This is in accordance with general experience with super-regeneration.—Tech. Ed.

sizes until some degree of familiarity with the circuit is obtained. There is no need to touch on the constructional details as most of you fellows can put together a better looking and working job than I. The leads to the set should be as short and

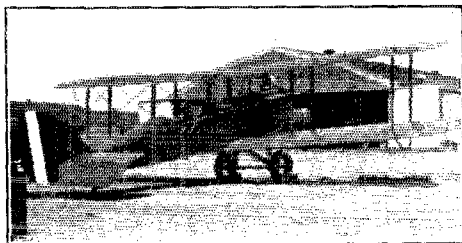

FLYING RADIO SHACK 6BKA

direct as possible and should be rigidly supported if in an auto or any place where vibration cannot be avoided.

Experiences

In June 1925 an entirely new set was constructed incorporating these ideas and including a single step of A.F. amplification. This was soon eliminated as it amplified the A.F. whistle and at the same time killed the signal. If anybody has any better luck with amplification let us know about it. With the second tube eliminated the set worked like a charm. It was tuned to 80 meters and installed in the Ford with 500 volts of "B" battery in the rear seat along with a storage battery for filament supply. With the ignition system properly shielded it was easy to receive while the engine was running and quite a few stations were worked while driving around Los Angeles, Pasadena and the neighboring cities. Directional effects were not very noticeable while in the car but a lot of fun was had from hooking up with different stations and then driving to them from information obtained thru the ether. A YL was usually taken along for company and the experiments were a huge success. It was possible to hear and read WIR on the east coast while driving through the downtown traffic of Pasadena also through YL QRM.

The original set was meanwhile rebuilt and installed in my bedroom until one day the transformer was left running and hot wax was spread all over the floor. Orders were at once received from headquarters to get the thing out of the house. Operations were resumed in the garage and some pretty fair DX results obtained. A little over 600 volts of R.A.C. was supplied the hungry tube and what power it didn't consume it heaved out into the ether (if there is such a thing) to quite incredible distances. The power input was carefully checked at all times

and at no time exceeded 27 watts on a UV-202. The original work of the summer was on 80 meters and in the daytime stations up to fifty miles were worked while at night Portland, Ore., 700 miles to the north was hooked up with—once! Of course as far as receiving was concerned all districts, and the high-power short wave commercial stations on both coasts, could be heard. The 80-meter loop would not work on 40 meters. So it was necessary to design a new one. It has been mentioned before and is described in Fig. 2. On the first morning after this loop had been constructed a station was heard in the Philippine Islands, piHK if I remember rightly. Stations both commercial and amateur were subsequently heard in New

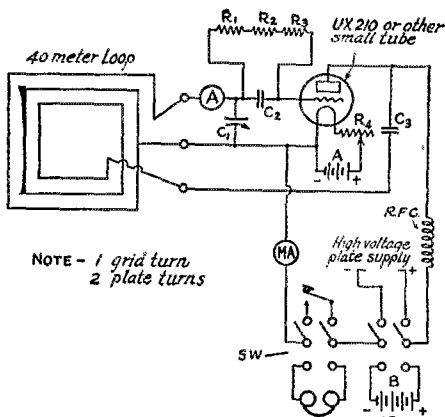

FIG. 1. THE CIRCUIT OF THE TRANSCIEVER
 C1—Bremer-Tully tuning condenser. A capacity of 250 μ fds is enough.
 C2 & C3, grid and plate stopping condensers, 2000 μ fds each.
 R1, R2 & R3—Bradleyohm resistance used as grid leak.
 R4—Filament rheostat.
 A—General Radio 0-2 hot wire ammeter.
 Ma.—Jewell 0-100 plate milliammeter.
 R.F.C.—R.F. choke coil, 50-100 turns on $3\frac{1}{2}$ " tube.
 Sw.—Four-pole, double-throw camswitch.

Zealand, Hawaii, Canada and Mexico. Communication was several times established with 6AWT and other stations in and around San Francisco at 10 a.m. and 3 p. m. The distance is about 255 miles by airplane, a little more if you walk. This work was done without any schedule and not only once but several times. A very peculiar directional effect was noticed during these tests. For working stations locally, up to about 40 miles the best results were obtained when the loop was pointed directly at the other station. When working Frisco or intermediate stations along the coast line I could not be heard when the loop was pointing at

the other station but rather when it was pointing at *right angles*. I am indebted to Mr. Roy Ashbrook of the Southern California Edison Co. for the following plausible explanation of this phenomenon. If a map of California is handy it will be seen that the general trend of the coast line from Pasadena to Frisco is to the northwest and also that the nearest part of

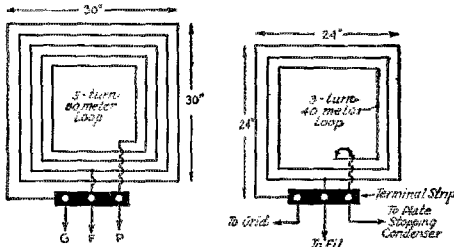

FIG. 2. THE LOOP DIMENSIONS
The frame construction is optional.

the ocean in respect to Pasadena is in a general southwesterly direction. Mr. Ashbrook advanced the idea that the signal traveled to the ocean by the nearest route

The sets were put away in September upon returning to the University of Arizona at Tucson and nothing further was done in that line until the first of this year. In transporting the new set to Tucson it was so badly mashed up that complete reconstruction was necessary. This was a blessing in disguise as it gave me an opportunity to incorporate a few new constructional improvements and make all the soldered connections vibration proof by wrapping them with small wire before soldering. When rebuilt, the set was better than ever and worked like a charm. Signals from every conceivable direction came booming in. Both 40- and 80-meter bands were crowded. Even KDKA came in loud enough to enjoy. At high noon, stations as far east as the Mississippi River came in consistently. Beginning about the middle of March the University Radio Station 6YB-6XAW began a daily schedule with WYH the Army Air Intermediate Depot at San Diego, California. Weather reports were handled every morning for the benefit of Army aviators flying through Tucson in both directions. The distance was 330 miles airline, which is of course nothing to speak of for the ordinary set but about the end of March the loop set was rigged up on the roof of the Engineering Building with 700 volts of R.A.C. on the plate of a UV-201-A and the schedule was maintained for one morning with this set! Communication was also established with El Paso and several cities in Arizona.

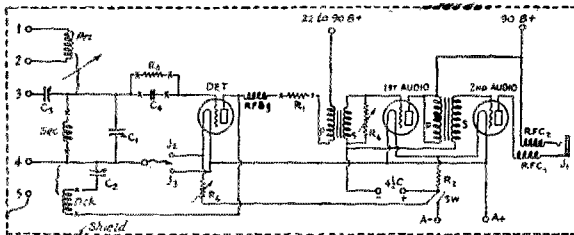

FIG. 3. THE MODULATION SYSTEM

Note that this does not change the original set at all, it merely supplies voice-modulated plate current to the set. The wiring to the left of the dotted line is a part of that shown in Fig. 1.

Ma 2—Meter to show oscillator plate current. The original meter now shows total plate current of three tubes.

Ma 3—Meter to show modulator plate current.

VT2—Modulator tube.

VT3—Speech amplifier tube.

L1—Modulation choke, 40 henry or more.

L2—Choke to prevent modulation from plate of VT3 escaping to filament.

L3—Choke to prevent R.F. from reaching plate of VT3 or A.F. from reaching plate of other tubes directly.

Both L2 and L3 are Ford spark-coil secondaries with the iron cores in place. An air-core R.F. choke may be used at "X" in addition.

MT—Modulation transformer.

Mic.—Microphone.

C1—Large condenser, 1/2 microfarad or more.

A Loop Phone

A little later the set was hooked up in one of the rooms of the same building where, due to the steel framework of the building, it was impossible to work more than a few miles and several tests were made to see how it would work for phone locally under adverse condition. The Heising system of modulation was used and is shown in Fig. 3. The modulation unit was entirely separate from the regular set and required no changes of the oscillator circuit, merely being connected to it as shown in the diagram and in no way interfering with the operation as a receiver. The only

and then followed the shore line to Frisco. That seems plausible to me although I doubt if the signals went on around by way of the Golden Gate in entering San Francisco Bay. Sometime in the future I hope to write a book entitled "Down to the Sea in Loops". Oh yes, the set in the garage signed 6GD and the one in the car 6BKA.

thing to note is that the original meter no longer reads the plate current of the oscillator but reads the *total* plate current of all three tubes. Additional ammeters, as shown are helpful but not absolutely necessary. A

5. Which, contrary to popular belief, is 2/3 of the way across America. The Mississippi river is a long way east of the center.—Tech. Ed.

modulator tube alone will work fairly well but the speech amplifier, from my experience, improves both the quality and the percentage of modulation, and both mean a great deal. The big A. F. choke in the positive lead from the high voltage should have an inductance of 20 to 40 henrys and be of low enough resistance to pass the total plate current for the three tubes. This choke is absolutely necessary for the correct performance of the Heising system of modulation, due to the fact that it is the varying voltage drop across it that (when alternating current of various frequencies and amplitudes is imposed upon it) causes the input to the oscillator to vary in accordance and molds the carrier wave to conform to the speech impressed. However, this is not a treatise on the Heising system so we will let it go at that. These tests were quite satisfactory as it was possible to work around town with very little trouble.

The percentage of modulation and the quality were very good. I am indebted to the operators of stations 6ARX, 6CBJ, 6AZU and 6AZV (all of Tucson) for their assistance.

The Loop Goes Flying

To proceed: Lieut. A. B. Pitts, 6AZ, the Chief Communication Officer at Rockwell became interested in the loop set and extended to me an invitation to come to San Diego, stay there as his guest and test the set out in an airplane.

The place used was a DeHaviland with an extra large rear cockpit for photographic purposes. The loop was mounted on the starboard side of the fuselage with three streamlined supports and holes were drilled through the side to allow the leads to be as short as possible, 7 inches. The set was laid panel upward on a folded blanket placed on the cockpit floor. Power was obtained from a dynamotor and from the 900 cycle wind-driven generator of an old SCR73 spark set and from an overloaded 10-300-volt dynamotor. The latter was supplied with 20 volts instead of 10, thereby giving a D.C. output of almost 700 volts. The 900-cycle supply was stepped up to 700 volts by means of a home-made transformer. To switch from A.C. to D.C. was the work of a second. The key, a light telegraph key, was mounted on the little shelf that ran around the cockpit and everything was ready for the tests. An aviator's radio helmet was obtained but all attempts to receive in the air failed because of the noise from the exhaust. One tube could not push signals thru that terrible racket. I take off my helmet to those who wear a radio helmet for hours at a stretch. The thing raised corns on *my* ears.

Due to the high A.C. peak voltage quite a few "A" tubes and one transmitting tube

were paralyzed but nevertheless some results were obtained. The majority of the tests were on 42 meters but we made one flight when working on 80 meters. We signed 6BKA and the operators at WYH stood by and listened for us whenever their schedules would permit. At no time did our input exceed 25 watts but they copied us with wonderful audibility most of the time. Several times we went about fifty miles up

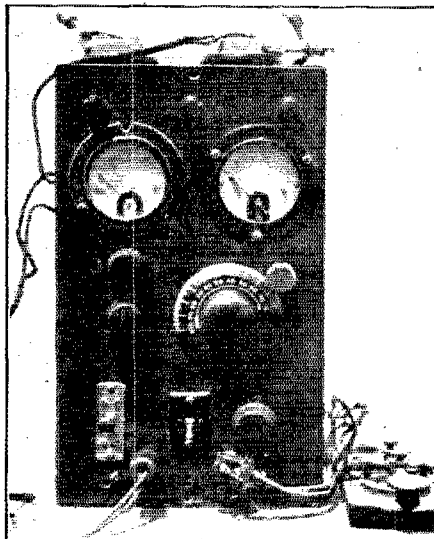

THE BATTLE-SCARRED FRONT OF THE SET

The three binding posts go to the loop. Under the ammeter are the knobs of two of the Bradleyohms used as gridleaks, and alongside these is the dial of the tuning condenser. The filament switch, change-over switch and filament rheostat occupy the lower edge of the panel.

the coast in the direction of Los Angeles and flew in big circles when at that distance but very little directional effect was noticed. When we were anywhere within 50 miles of WYH they could read us out of doors with the phones on the table and a little cardboard horn placed in front of them. When we were anywhere over San Diego or its environs they were reading us 40 feet from the door of the radio shack and watching us at the same time. In response to our instructions they would wave sheets and pillow cases. There is quite a thrill in being able to look straight down 5700 feet and see a dot on the ground moving about in response to your orders. The San Diego amateurs were right there with assistance by keeping watch for us whenever it was possible. The operators of stations 6SB, 6RL and 6FP were very helpful. Pounding the brass for an hour and a half continuously by the sense of feel is no joke but I managed to keep the ground crew informed of our whereabouts so that when

we returned from each flight they had a complete log ready for our inspection. Our average speed was 100 MPH and our average elevation 4500 feet although we went higher and faster at times. A map was kept handy at all times to check our QRA and soon became dog-eared. Last but not least, on Friday June 25, 1926 we made a flight from San Diego to Los Angeles and were on the air and in the air all the way up the coast.

The reports we received from most of our flights were *very* meagre but the report we received from 6CBJ of Tucson regarding this flight made up for all of it. For half an hour around noon he copied our signals as

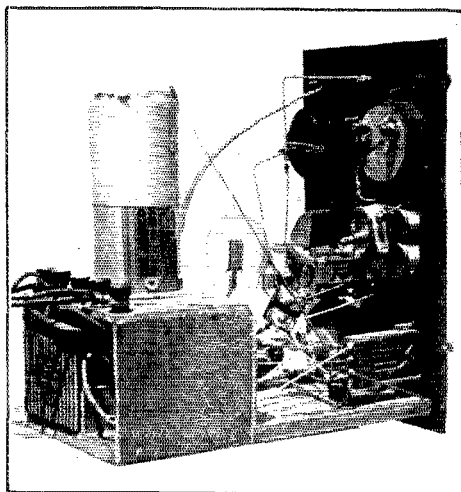

REAR VIEW OF THE TRANSCEIVER SET AS REMOVED FROM THE HEAVY CABINET IN WHICH IT IS USED

The cabinet measures 7" x 12" x 12". The two small Burgess batteries in the compartment are used for receiving and have given 14 months good service. The coil is not an inductance but an R.F. choke. The loop is the tuning inductance.

we were flying up the coast. When you consider that the distance was between 340 and 380 miles it can be seen that the little set was blowing its own horn. I do that too. This winter, circumstances permitting, tests will be carried on in a mine to see if the set would be of any value in mine rescue work.

I want to thank the officers of Rockwell Field and especially Lieut. Pitts, who gave me the opportunity to make these tests. I also want to thank all the above mentioned amateurs and many others not members, who helped me to get this information in these tests of loop transmitters.

A "Midline" Condenser

BELIEVING that none of the "straight-line" condensers on the market at the present time fill the bill from an operating and station separating standpoint, a new type called "midline" has recently been developed. The plates of the condenser are shaped to give a curve somewhere between the straight wavelength

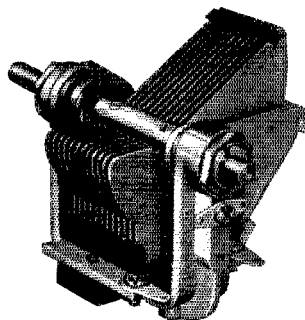

and straight frequency type. The general mechanical construction is certainly novel. One end of the shaft operates in a full ball bearing and a ball bearing and thrust is used at the other end. This leaves the shaft itself "floating". Loosening a set screw allows the whole shaft to be removed without disturbing the alignment of the rotor or stator plates. A longer shaft can be substituted for gear types of verniers, or a primary coil can be mounted on the end of the shaft. Better still, the condensers can be ganged together, a long brass or steel rod being used for the one shaft for all condensers. The plates are of heavy brass, held in position by bars to which they are soldered. A clock-spring pigtail connection is used on the rotor. The condenser is available in a wide range of maximum capacities for broadcast and amateur work. It is made by the Hammarlund Manufacturing Company of New York.

—J. M. C.

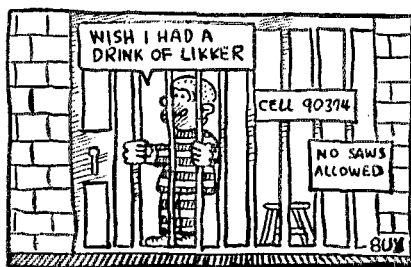

A DRY CELL

The Mast at 8LO

By M. S. Brainerd

BEING in want of a stick and restricted as to space and funds we devised the mast shown in the drawing. It has stood two 60-mile winds and seems to answer our purpose.

I believe this mast cost us a few cents over \$6.00 and was put up in spare time by two men. The lower part is made entirely from crates and pieces of packing cases. There are no pieces in it over five feet long, yet two of us weighing at least 300 lbs. (plus another 50 pounds of gear) have been on top of it. Incidentally, all the nails used in the mast were withdrawn from the crates as we broke them up. These crates were usually of good planed stock, $\frac{7}{8}$ inch by $3\frac{1}{2}$ inches and of various lengths. After we got the material all together we started the corner strips of the mast which were made by nailing the crating slats together. The slats were nailed together on the ground, lapping the strips at least 18 inches and clinching the nails. Four strips 35 feet long were made. We decided that the mast top should be two feet square and the bottom six feet square. Accordingly we set two strips on edge parallel to each other and bound them at the top with a two foot strip, then went to the other end and spread the strips to 6 feet. We then nailed braces in as shown in the drawing. Then we took the other two strips and did the same thing, only making the braces come just opposite to those on the first pair of legs (as shown in the drawings by the dotted lines). Now set these two sides on edge and bind them at the top, two feet apart and at the bottom, six feet apart. Nail on braces the same as before. This also is shown in the drawings. To make the mast rigid for erecting, some tie wires inside can be placed and drawn up tight diagonally about half way up the mast. The mast as built here could easily be lifted by one man and would not sag or even creak when we raised it. Move the mast so the base is where you want it to stand. Drive some stakes in the ground to keep it from sliding and haul her up. That last is getting over a lot of ground but we did it easily here. One man got on the roof with a line and the other pushed with a pole. Have a tail rope on the mast so as to stop it from going past center.

The outriggers A and B were made of narrower stock from the crates and are of

three thicknesses nailed together with joints staggered. Screw eyes were placed in the ends for the guys and wires were threaded thru them before they were fastened in place. Notice that these outriggers have the wires W, X, Z and Y passing thru the eyes and in to the mast at V and that the outriggers have separate guys at H. This is essential

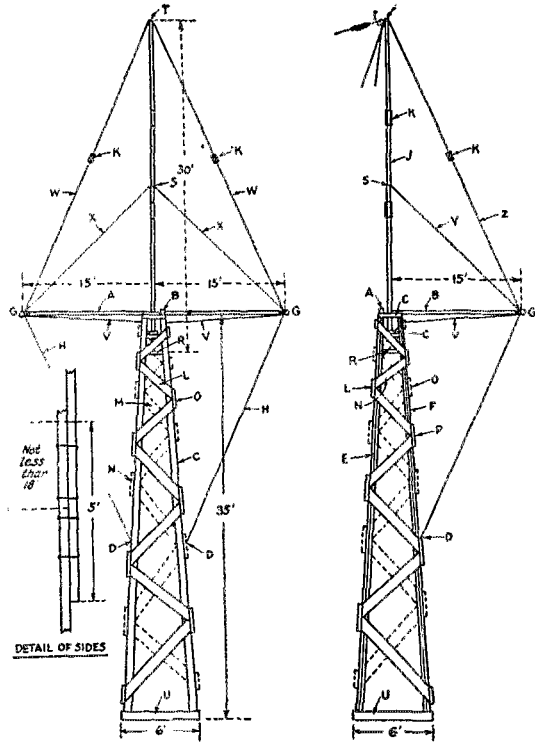

If the wires were continued from W, X, Y, or Z to D they would simply saw back and forth. Insulators K should be placed in the guys. Be sure they are first class insulators as far as strain is concerned. We are using Pyrex.

Look at your back numbers of QST and get the dope on downspout masts. Make one thirty feet long, using the sleeves K, and soldering them into place. Good heavy wire should be used for the bridle for attaching the guys and these should also be soldered. Use more than one at each point. One for each guy is best and put a good washer under the strain side.

Attach the guys to the mast and place your pulley on top, either by means of a

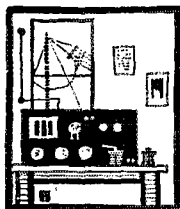

Amateur Radio Stations

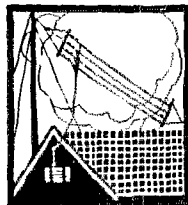

1XV-1XAN, Round Hills, South Dartmouth, Mass.

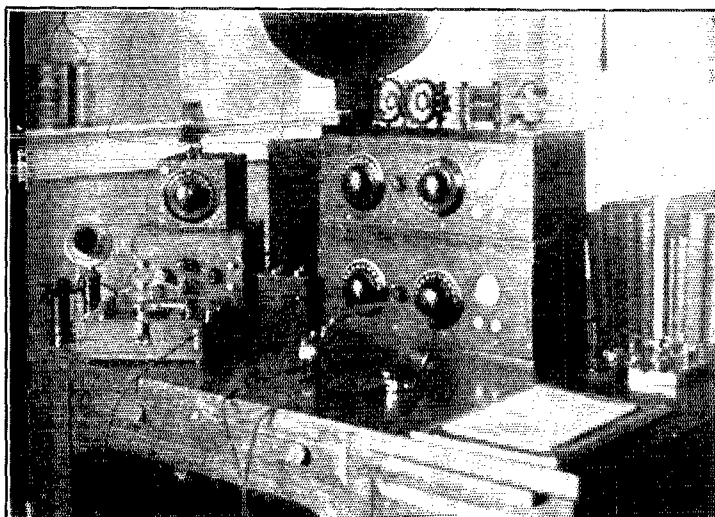

EXPERIMENTAL station 1XV-1XAN is operated for short-wave research under the supervision of the Electrical Engineering Department of the Massachusetts Institute of Technology. The operation of this station is sponsored by Colonel E. H. R. Green, who has provided the facilities and means for short wave experimentation, in which he is deeply interested.

Experimental work at this station since March of this year has consisted of: (1) a study of the variation of the cut-off wavelength (the minimum wavelength on which signals are audible for a given distance for a given time of day) between 1BYX and this station; (2) a study of fading on various wavelengths; (3) a study of practically all types of antennas employed for short

wave transmission; and (5) a study of the variation of signal strength at a given receiver as the plane of the transmitting antenna is changed.

The station is located on the estate of Colonel Green at Round Hills, bordering on Buzzard's Bay. The site of the building from which most of the transmissions are done is within fifty feet of the Bay, and is far distant from other buildings, overhead power lines, telephone lines, etc., and is surrounded by comparatively flat country so that the location is what the average ham terms "ideal."

The main building is the one in which the first WMAF broadcasting station was installed. This building still contains the 100-watt Western Electric 2A broadcast transmitter. The power supply for this

transmitter consists of a direct current Robbins and Meyers generator rated at one-half kilowatt at one thousand volts, and a direct current generator of the same make for filament supply. These machines are also used for the power supply for the other transmitters.

The output of a 500-cycle generator is usually placed in series with the 1,000-volt

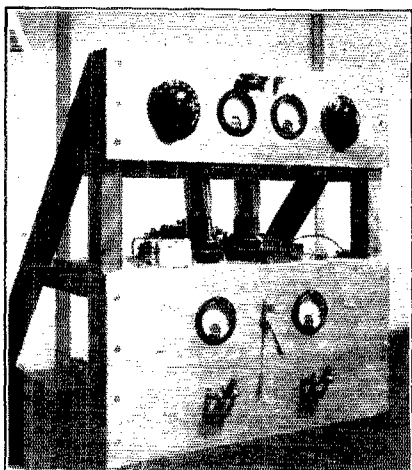

FRONT VIEW OF MAIN TRANSMITTER WITH "SLIDE-IN" COILS REMOVED

D. C. generator for plate modulation when measurements of signal strength are being made so that a non-oscillating receiver may be employed. This arrangement is desirable as it partially eliminates variations in signal strength as measured on a vacuum tube voltmeter, caused by and slow drifting of the transmitted wave.

A switching arrangement is provided which makes it possible to operate any, all, or any combination of, four transmitters at the same time from the direct current filament and plate power supplies with a single relay for keying.

A special transmitter for this station was designed primarily for flexibility and is so arranged that all adjustments may be made from the front of the panel. Normally it uses two 50-watt 203A's with an input of about 150 watts. Most of the apparatus is mounted on the front panel which is of maple. A shelf extending back from this panel supports the tubes, grid-and-bypass condensers, grid leak and the choke coil. Looking at the front of the panel, the upper left hand dial is for varying the capacity of the antenna tuning condenser which is a National 3,000-volt 250- μ fd. variable. Next are two Weston thermoammeters of 1.5- and 5-ampere ranges, either

of which may be used by throwing the knife switch directly above them. To the right is the tuning condenser of the Hartley oscillator. This condenser is identical with the antenna series condenser. The next lower section of the front panel supports the oscillator coil and the antenna coupling coil. These coils are mounted on bases whose long sides are cut on an angle of 45 degrees to fit under the two wooden guides mounted on the panel. This arrangement makes it possible to vary the coupling between the coils very easily. The coils will stay in position when once set. The whole panel on which these coils are mounted is removable from the main transmitter frame, connection between the panel and the frame being made through copper strips on the removable panel, which fit into large copper switch jaws mounted on the frame when the panel is in place. There are seven of these copper strips, two for the antenna coil, two for the oscillator tuning condenser, and three for the grid, plate and filament leads to the oscillator coil. Four of these coil panels are provided with coils of appropriate size so that the transmitter may be used for wavelengths ranging between about 20 and 200 meters.

The lower panel contains a plate mil-

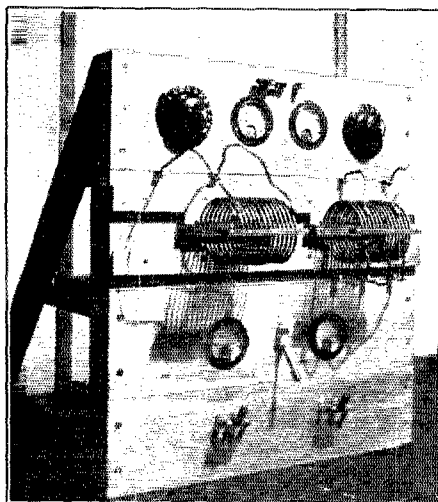

TRANSMITTER WITH SET OF COILS IN PLACE

liammeter and a filament voltmeter with ranges of 300 milliamperes at 15 volts respectively. Between these two meters a knife switch is connected across the telegraph key so that the transmitting relay may be closed while the operator is at the transmitter. At the bottom of the panel are two double-pole single-throw knife

switches connected to the filament and plate power sources. This transmitter is very satisfactory when rapid variations of wavelength are desired as in a recent test for determining the cut-off wavelength for each hour of the day between 1BYX and 1XV in which 141 changes in wavelength were made at 1XV.

Perhaps the most interesting equipment at 1XV, from the experimenters' point of view, is an orientable transmitter mounted on top of a fifty-foot telephone pole. It is fastened to the top of the pole on a table-like platform and is held to this platform by a large bolt so that it can be turned through 360 degrees in a horizontal plane. The connection between the antenna framework and the table at the top of the pole is made through a two-inch wooden dowel so that the vertical angle of the antenna may be varied. With these two degrees of freedom the antenna can be placed in any plane passing through the top of the pole. The antenna itself is mounted on a comparatively light wooden frame and consists of a straight length of forty-eight feet of one-half inch copper tubing. This copper tubing is split in the middle for the insertion of a coil for coupling to the Hartley oscillator which is mounted in a box on the framework directly above the pole. A fifty-watt 203-A tube is employed in the oscillator and under normal condi-

described in reference to a receiving system in a recent issue of *QST*. Some very interesting data has been obtained from experiments on this antenna both from local measurements at Round Hills and

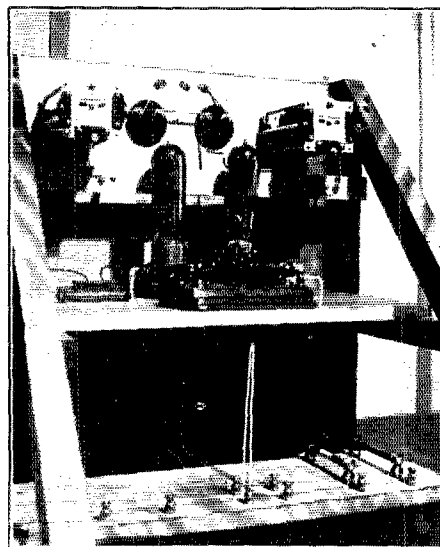

REAR VIEW OF TRANSMITTER

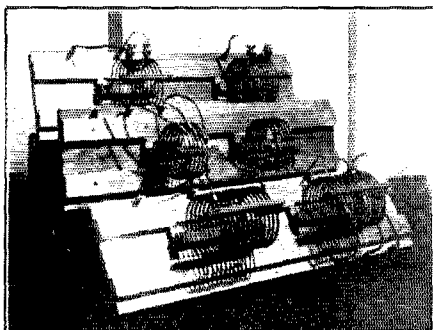

COILS FOR ALL WAVES FROM 20 TO 200 METERS

tions the antenna current is six-tenths of an ampere. Filament and plate sources are connected to the oscillator through flexible rubber covered wires from a distance of about 150 feet. Keying is done from the bottom of the pole or from a station nearby.

The readers will probably recognize that this transmitter is the transmission application of the idea which Dr. Pickard

from 1BYX about sixty miles away, which we hope to publish shortly.

Two receiving sets are employed at 1XV. They are provided with a plug-and-jack arrangement on their output ends so that they may be operated in duplex. That is, one receiver of a split headset may be connected to the output of either of the receiving set thereby making it possible to listen on two waves simultaneously, or for normal work both of the receivers are connected in series to the output of a single receiving sets. These receivers are of standard amateur design and are provided with interchangeable coils fitted with General Radio plugs so that they cover a wavelength range of between about 13 and 200 meters. Capacity coupling to the antenna is used. This coupling is variable from the front panel of the receiving set, by means of a hard rubber shaft attached to one side of the small series antenna condensers. This feature has been found to be very convenient especially when the natural wavelength of the receiving antenna comes within the range of operation of the receiving set. Weston double range voltmeters are used on both receivers and are connected through push buttons so that the filament and plate voltage sup-

plied to the tubes may be read instantly.

A vacuum tube voltmeter is available for connection to the output of either receiving set. This voltmeter consists of the elements of a stage of audio frequency amplification with a Rawson multi-scale micro-ammeter connected in the plate cir-

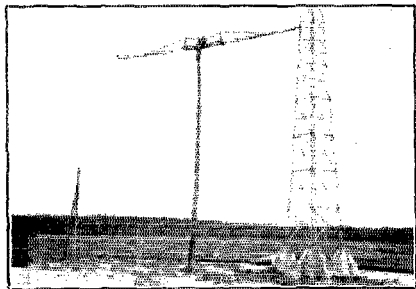

ORIENTABLE TRANSMITTER FOR HORIZONTAL TRANSMISSION

cuit of the tube. This meter is connected through a potentiometer to a balancing battery so that when no signal is being impressed on the voltmeter the micro-ammeter reads zero. With this adjustment, any change of grid voltage of the tube will cause a deflection of the micro-ammeter. With this device signals whose intensity is R2 or R3 when one stage of audio frequency amplification is used, give a readable deflection on the micro-ammeter. A jack is also provided so that this voltmeter may be used as an additional stage of audio frequency amplification, if desired.

A portable measuring set is also available for local measurements. This consists of the elements of a vacuum tube detector in a copper-lined box, with the micro-ammeter in the plate circuit of the tube connected with the balancing arrangement described above. Either a loop or straight antenna may be used in conjunction with this device. Considerable experimentation has been done on the effectiveness of various types of transmitting antennas and for this purpose there are two 150-foot steel masts and seven 30-foot telephone poles, which, at present carry Hertz antennas for 20, 40 and 80 meters, a double half-wave Hertz system for special directive properties and a vertical half-wave Hertz for 40 meters, the bottom of which is 65 feet above the ground. The latter two are fed by means of three-quarter wavelength transmission lines of the two-wire type.

While the purpose of this station is to engage in experimental research on short wavelengths, some time has been devoted to communication with amateur stations

with the result that two-way contacts have been obtained with amateurs in five continents and in 14 countries. Of these contacts, those with Brazil and England are most numerous.

We are indebted to Mr. Walter D. Suddall, research assistant, Electrical Engineering Department of Mass. Institute of Technology, who is in charge of the short-wave field work, for the above very excellent description of 1XV-1XAN, and for the photographs.

Cage Antenna Hoops

A most handy cage antenna "spreader" is shown in the illustration. It is made of a light cast aluminum ring seven inches in diameter, and has twenty four small holes and twenty four notches cast in it. The notches will take

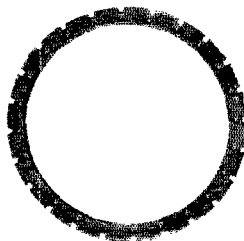

any size wire up to a number six, and are used to rest the antenna wires in. Though the corresponding holes, tie wires are passed, wrapped around the antenna wire itself and when the "spreaders" have been lined up properly the tie wires are soldered to the antenna wires. This doing away with the usual unsightly, and most difficult to construct, cage hoops. The spreader can be used with a four-, six-, eight-, ten- or twelve-wire cage. It is a very neat job and comes from Charles F. Jacobs, 2EM, of Brooklyn, who is manufacturing and marketing them.

—J. M. C.

Strays

3SJ suggests that a practical way to adjust the filament voltage of a transmitting tube without using a primary rheostat and at the same time not throwing the center-tap off, is to use two equal lengths of resistance wire off of an old filament rheostat, and put one on each side of the secondary of the transformer. By keeping both wires the same length the center-tap will not be disturbed.

Calls Heard



9BDQ, Richard Dunlap, Osawatomic, Kansas

1aao 1aae 1aay 1ae 1aci 1adw 1aep 1aap 1axa
 1akz 1ajg 1aew 1aiu 1ala 1atu 1ahv 1atj 1aap 1afg
 1ahd 1ai 1air 1alw 1amd 1amp 1ayf 1aof 1ams 1apz
 1are 1amz 1awe 1avp 1azd 1bjk 1alb 1bbm 1bqt
 1byx 1bvl 1bdh 1ca 1ck 1cmf 1ch 1cmx 1cng 1cnz
 1ckp 1cnp 1co 1cb 1cmx 1cmz 1jb 1pi 1pn 1db 1ed
 1jr 1my 1se 1uw 1uy 1wx 1yb 1xm 2aaa 2aba 2aef
 2abc 2agp 2acp 2aee 2aiv 2axr 2awt 2aev 2afn
 2ane 2amj 2acd 2acy 2anh 2awv 2awz 2ain 2arm
 2awf 2erc 2bir 2ha 2ku 2fb 2fz 2fe 2eij 2ase 2hv
 2hs 2tf 2kg 2kh 2ev 2pl 2px 2wc 2wh 2nx 2va 2zo
 6aon 6hby 6all 6awl 6euw 6buc 6ud 6eun 6hj 6ajj
 6cgv 6aj 6anb 6evo 6att 6brc 6bg 6ahy 6bil 6mb
 6aim 6iy 6fs 6hm 6ts 6oi 6xi 6bya 6bye 6cco 6ccv
 6og 6rn 6rw 6dal 6eb 6bls 6fg 6ke 6oc 6kl 6omg
 6omq 6ckv 6hyd 6bbi 6sv 6wh 6aib 6bpg 6bpn 6cjj
 6eah 6cqa 6pr 6ael 6dgo 6dx 6dab 6bhr 6ih 6bvm
 6bxc 6aas 6coi 6vr 6ahn 6cht 7aa 7aib 7aim 7aex
 7ew 7es 7fd 7dk 7ek 7ev 7op 7or 7no 7ag 7im 7mp
 su-7kx a-2bb n-2cm a-2yi a-2jw a-2lk a-2ij a-2ss
 a-2nh a-2tm a-2g a-2yh a-2kb a-2lm a-2tm a-2cm
 a-2kn a-2ay a-2hl a-2ew a-2df bz-1ap bz-1ax c-1ar
 c-2mv c-2jw c-2br c-2dy c-2ex c-2er c-2bq ch-2ld
 f-2tk f-2dk g-2ec g-2nb g-2kk g-2ox hu-6bdl hu-6aff
 hu-6dea i-1aa m-1n m-1m m-1g m-1af m-1a m-1u m-1j
 m-9a pr-4ja pr-4je z-1aa z-1ax z-2ac c-2xa z-3ac z-3af
 z-3am z-4ac z-4av z-4w z-4xa octn nov kfuh npu nym
 pell ngo npw npp nqa nba naw ntt nve nsf xda
 aye cas sgc snn wkf wux xad.

J-3AA, Osaka, Japan

Galg 6bbq 6btm 6ab 6rw 7it a-2bk a-2ro a-2hl
 a-5lf bn-sk1 bn-sk2 hu-6ahh 0-(zero)-1ar 0-a3e ss-2se
 z-1ao z-2ac abg age b82 dbn noh nat (qra?) lcrs.

PR-4KD, E. W. Mayer, U. S. Naval Station, San Juan, Porto Rico

1aei 1ahc 1akr 1axx 1ay 1bu 1bv 1bcp 1cax 1cc
 1eib 1eiv 1emk 1ev 1kk 1qi 1sq 1uw 1xy 1xz 2aaw
 2afn 2anx 2avj 2agw 2bee 2bhf c2bkid 2buw 2cg 2enn
 2epo 2eg 2mk 2rs 2uo 2vh 2ws 3aib 3aig 3aix 3okk
 3eeb 3cgs 3ejn 3cm 3cpa 3ki 3lk 3mz 3vf 4aae 4bk
 4bx 4da 4dn 4fj 4hx 4jr 4vj 4ix 4kp 4my 4pp 4pu
 4qi 4vl 5af 5amp 5ann 5av 5dh 5dz 5ahc 5azs 5bjz
 5bkm 5hzt 5ek 5dad 5drj 5eo 5arv 5bi 5bse 5dte 5fd
 9ng pi-1x1 val r-cb3 bz-5ab nidk wci.

I-1ER, Santangeli Mario, Via S. Eufemia No. 19, Milan, Italy

1aay 1ag 1ak 1ahc 1akz 1amu 1aoh 1aqa 1ase 1av
 1avf 1awb 1axx 1azj 1bai 1bz 1bhs 1bms 1cjh 1cjc
 1ctp 1fg 1ll 1le 1ll 1qg 1va 1vw 1yh 2ahd 2anx 2apd
 2aag 2aue 2av 2avb 2avf 2avj 2awq 2azv 2bnz 2bx
 2cab 2eid 2dax 2dxj 2ij 2lm 2ol 2or 2tr 2ty 2za 3aai
 3ajt 3bkt 3ec 3hv 3nr 3uv 4dd 4ei 4hx 4iq 4jk 4na
 4pr 4tr 4wj 5ah 5in 5mg 5va 5xc 5zaz 6akm 7bbw
 8ade 8af 8ax 8ayv 8baq 8bpd 8bvl 8bzt 8cwt 8dgg
 8dmz 8dpn 8ku 9be 9cet 9dng 9lf 9zx bz-lac bz-lbg
 bz-lqa c-6ev c-1dd fm-8ra m-1j r-1lp y-1ed y-2ab
 z-2cg z-3af anf anl apd cz-fr5 eyy gbm giz kfue kpl
 kdzia kez4 npw nao nan sad sjo tpay tax voq wtq
 xtt znk.

G-5BY, A. L. O'Heffernan, 2 Chestow Road, Croydon, Surrey, England

1aae 1aar 1ayv 1ace 1aep 1afl 1ahb 1ahg 1air 1ajx
 1aki 1al 1ala 1am 1amd 1ane 1aoa 1aof 1apo 1apy
 1aqi 1awe 1axa 1axr 1aza 1bbk 1eb 1bcg 1bbm
 1bke 1bbv 1bqg 1bvl 1bix 1cal 1caw 1ch 1ckp 1cmf
 1cn 1cnp 1bn 1id 1kl 1or 1re 1rd 1rp 1sw 1vc 1vy
 1zk 2ack 2aev 2ahd 2aky 2atp 2am 2amj 2ann 2aqv

2apv 2atk 2aug 2av 2avb 2ave 2ax 2axq 2baa 2bz
 2bir 2bsl 2bw 2eft 2ejj 2cpd 2evj 2cxi 2eyx 2xev 2dx
 2ed 2ev 2if 2gw 2im 2iz 2jb 2jz 2kx 2le 3mm 2ol
 2or 2of 2pb 2wh 2wr 3acm 3adb 3agz 3ahl 3asa
 3bce 3bne 3bnu 3brv 3bta 3bwt 3eng 3enu 3ems
 3dh 3io 3jw 3ps 4av 4er 4eg 4ft 4gy 4iz 4jk 4rm
 4rr 4rx 4sa 4tv 4ua 4ux 4vy 4we 5yb 8aj 8aol 8au
 8avj 8bbe 8bgn 8bpl 8bt 8bwr 8bzt 8cm 8scr 8scz
 8dmz 8don 8dpl 8hj 8xe 9adk 9bp.

CH-2AH, Guillermo Zeller, Casilla 1840, Valparaiso, Chile 40-meter band

1aaf 1aao 1aav 1ba 1ch 1cib 1cmf 1cnp 1ety 1ety
 2acp 2ahk 2ajs 2amd 2amj 2amo 2apv 2bab 2ena 2ex
 2xli 2ezr 2gk 2ha 2mm 2oc 2tr 2ty 3ahl 3bmz 3cdk
 3hg 3xaq 4gr 4iz 4kb 4nn 4tr 5aav 5acy 5adz 5ahj
 5aii 5akg 5amn 5amt 5amp 5aou 5au 5arn 5asv
 5atx 5ax 5eb 5eh 5fe 5he 5fc 5ie 5ll 5im 5za 5zl 5zo
 6adt 6afs 6ajj 6akm 6akz 6ang 6ann 6ap 6bam 6bar
 6bau 6bbi 6bbd 6bge 6bgy 6bhi 6bil 6bjd 6bjl 6bls
 6bmw 6boj 6bq 6bvi 6bve 6cae 6caj 6cbp 6cco 6ce
 6eev 6egw 6ek 6ek 6elx 6epf 6ep 6ca 6cto 6cub
 6cuv 6cdq 6ddf 6ddy 6dx 6ae 6eh 6ge 6gw 6js 6kh
 6ky 6pr 6qu 6xi 6zlj 7ny 7rl 7ty 8ahc 8au 8edv 8eq
 8pl 9adr 9ad 9ak 9asa 9bex 9bc 9bh 9bhl 9bjk
 9bpb 9by 9car 9cfn 9cgg 9cpo 9ev 9ex 9db 9dmz
 9ndg 9ndj 9dqn 9de 9ek 9rk 9zb nem bz-lad bz-laj
 bz-lao bz-lap bz-lar bz-lax bz-lbd bz-lbh bz-lbi
 bz-lsq bz-bzj bz-dll c-1ar f-8jn f-8jr f-8qt f-8ty
 g-2sz g-6rm i-1co m-1af m-5c m-9a p-1ae r-ac2 r-afl
 r-bq4 r-bid r-db2 r-ddd r-de8 r-d3 r-dw4 r-fc6 r-fz7
 r-ga2 sn-2co sn-2nn smuk y-1cx y-1ka y-1na y-2ak
 y-2bc z-4am.

CH-2AR, Carlos Reiher, Box 3062, Valparaiso, Chile 40-meter Band

1bjk 1zd 2agt 2amj 2xf 2mu 2px 2xaf 3ef 3lv
 4fl 4ft 4iv 4kb 4li 4ni 4si 4ael 5acy 5adz 5afv 5ajs
 5akn 5aky 5amf 5aop 5aq 5ap 5arn 5aro 5asv 5atp
 5atx 5avi 5awf 5ez 5dl 5eb 5gk 5he 5hn 5hy 5hz 5kk
 5lg 5nk 5nw 5ql 5ra 5vu 5ud 5za 5zaz 5zo 6aaf
 6abg 6adt 6agn 6agr 6ahp 6aim 6ald 6ann 6anq 6aoy
 6api 6aps 6arx 6asv 6aus 6awq 6bam 6bau 6bav 6bbq
 6bel 6beh 6bge 6bgt 6bgv 6bhi 6bil 6bjd 6bjs 6bmw
 6bol 6boo 6bq 6bsz 6btl 6btt 6bvf 6bvz 6bxd 6bxi
 6bxr 6cae 6caz 6cet 6cej 6cgw 6chb 6che 6cht 6cii
 6ckv 6elk 6emt 6eof 6eoi 6epg 6es 6etd 6ete 6euw
 6dad 6dag 6dan 6dbe 6dck 6dp 6du 6dx 6fz 6fp 6gw
 6hu 6hv 6ke 6ky 6mu 6no 6or 6pw 6rd 6rf 6ts 6ud
 6vz 6xao 6zw 7ay 7ge 7kf 7ld 7mf 7oy 7im 7ru 7xf
 8abm 8cau 8dab 8eq 8sv 9ael 9aek 9aol 9aot 9avi
 9bdq 9bwo 9bza 9caj 9cau 9edf 9elr 9ev 9ev 9awn
 9ex 9dad 9day 9dte 9e 9eg 9egu 9eii 9ff 9kn 9la
 9mn 9no 9od 9ry 9wi 9xt c-4gt c-5bn f-8jn f-8kf
 f-8ty c-2cc c-6rm age lpl nem npo sgt xda.

ICMA, 94 Allston Street, Cambridge, Mass.

a-7cs bz-5aa bz-law ch-2ah f-8cs f-8kf f-8fer f-8yor
 f-8jn f-ocng f-octn f-iw g-2it g-2lz g-2ar g-2ab g-2xy
 g-2vq g-5dh g-5ms g-6og g-6vd g-lfg i-1co k-k7
 p-lae p-3or q-2mk n-owc n-pb3 n-pb4 y-1cg y-2ak
 agb g83 wnp nidk ntt kgbb hu-6bdl.

10N, Walter B. Jennings, 26 Tapley St., Lynn, Mass.

a-2bk b-f2 b-o8 b-4yz b-4xz bz-1nj bz-lak bz-lar
 bz-law bz-lay bz-lbc bz-2ab bz-2af bz-2aj c-3jl c-3af
 ch-2ld f-ocdj f-octn f-8af f-8cax f-8cs f-8ec f-8fd f-8fr
 f-8hu f-8if f-8jn f-8kf f-8pl f-8rpb f-8yor fm-8ma
 g-2it g-2nm g-5by g-5dh g-5ms g-5nj g-6vd f-1ay f-1a
 f-1gw k-k7 m-jh n-opn n-owc p-lae p-lak p-3bz pr-4sa
 pr-4ja r-2od u-6ro x-jwl y-2ak y-7xx ntt.

F. V. Rice, 202 East Gorgas Lane, Philadelphia, Pa.

a-2tm a-2yi a-3bd b-4yz bz-lac bz-lip bz-2af bz-5ab
bz-spc bz-9qa d-5ay ear4 ear38 f-8akn f-8ba f-8ca
f-8dx f-8ee f-8ez f-8fn f-8gn f-8jr f-8kf f-8ma f-8nx
f-ocdg f-ocng f-8pm g-5dc g-5dh g-5df g-5lf g-5ls g-5tz
g-8ws g-8yf m-laf m-lc m-5c m(?)-cyy n-owe p-lae
p-8gb p-3oc pr-4ja pr-4kf pr-4nr q-2lc q-8kp z-lax
z-2ac z-lac agh asc ber ca fw ffg qbk ido kuh kfuh
kfr lpl nba nwn naj ntt niss nar ndt glq nell pepp
perr pccu pic ptq pti pt3 sce sgl sgy sgc sked ur
vtt wnp xam xda.

4BT, J. Gray McAllister, Jr., Box 118, Montreat, N. C.

6abg 6ael 6afs 6agw 6ahn 6ahs 6aij 6aim 6aiy
6anp 6aod 6are 6asa 6awr 6bbv 6bjd 6bgv 6bij 6bjl
6vib 6hls 6hol 6hql 6hxl 6hxe 6hjb 6hej 6eac 6egw
6ers 6ets 6eto 6eua 6eub 6bdw 6dx 6hh 6hr 6hu
6ia 6mb 6or 6vr 6vr 6bxr 7af 7dl 7ke 7uw 7vl 7wu
6-lab 6-lar 6-3bt 6-3do 6-3el 6-3il 6-3jr 6-3xi 6-3zb
6-4gt 6-5ur 6-5fr m-laa m-lad m-laf m-lj m-lm
m-5c m-9a g-2sa g-5dh z-2ac z-2go z-3ai z-3aj z-4as
z-lac z-4ak z-4am a-2bb a-2cs a-2lm a-2mh a-2yi a-3ad
a-3bh a-3ef a-3em a-3hl a-3kb a-3ls a-3wn a-4an
a-4o a-4rb a-4tv a-6cm a-7cs a-7cw a-7hl au-7mn
hu-6buc hu-6yd v-xeb bnc nau nba nsf nkf rxy vkn wvc
wxf xam.

6ARX, Raymond Moore, Box 1222 Hollywood Stn., Los Angeles, Calif.

a-2bb a-2cs a-2tm a-2yi au-7bh ch-2ar ch-2ld jes
kdf knz ocjd m-lm m-9a cyy ih 2p 5c 6zac ja vvg
o (zero) lsr pi-lar pi-lhd pi-lhr pi-lvr s-2se wnp
y-2ak z-lno z-lax z-2ac z-2ax z-3au z-3ai z-3aj z-3ap
z-3mg z-4aa z-4am z-4ar z-4av.

6AVP, Julius Shulman, 548 N. Cummings St., Los Angeles, Calif.

1ek 1kl 1al 1ao 1adw 1aff 1arz 1ckz 2ah 2ch 2co
2cs 2mu 2pm 2uo 2cxl 3ag 3be 3ge 3rb 3wf 3zo 3ako
4ao 4yt 4il 4re 4si 4uo 4tn 4vr 5ag 5ah 5ai 5ap
5au 5ar 5ek 5en 5er 5dq 5em 5ew 5ts 5gw 5he 5hn
5iw 5ke 5ik 5il 5nb 5uk 5za 5zq 5ad 5adz
5ahp 5aky 5aoe 5aou 5apo 5ehn 7af 7bm 7ck 7cs 7ex
7dk 7ef 7eo 7fo 7hi 7je 7ju 7ki 7mz 7ro 7on
7pm 7pu 7rl 7ru 7tj 7tl 7tx 7uh 7uw 7ya 7abb 7abi
7ait 7aut 7cur 8at 8bk 8an 8ca 8gz 8io 8pl 8aep
8aub 8bep 8bhm 8bhr 8big 8dd 8aw 8q 8wb 9cj
9co 9cu 9ex 9ef 9ek 9el 9ey 9eg 9gk 9jk 9le 9lu 9pm
9qr 9aj 9wf 9ya 9zk 9zt 9au 9ak 9aob 9atv 9bcv
9hdf 9hdq 9bf 9bht 9bjz 9bz 9bu 9bpb 9br 9bt
9bv 9bw 9bw 9bz 9ca 9cc 9cet 9cor 9de 9ew 9cl
9ey 9eb 9bw 9el 9ed 9em 9dk 9du 9du 9ep 9ecp
hu-fxl hu-fxl hu-6qu hu-6af nar nau nkf npl nnp
not nol nri nrz p-5c mlk m-5c m-9a pi-lhr pi-3aa
c-law a-5bg bz-lar f-8ab da kel por voy.

6CWP-6BUX, Walter M. Bolinger, 1485 East 5th Avenue, Pomona, Calif. (30-45 meters)

1aao lamd 1vz 1zd 1zk 2amj 2x1 2ky 2or 2uo 2uw
3ut 3zo 4bu 4fl 4hl 4ja 4jj 4jk 4mv 4ni 4si 4xe
4xj 4xl 8af 8ate 8bbe 8bpl 8dbb 8ef 8im 8pl a-4cm
a-5bg a-6am au-7bb au-7mn c-8ar c-8kp c-4gt c-5ar
c-5ef hu-6axw hu-6bd hu-fxl hu-6tq hu-6xk
6zac m-laf m-lm m-9a pi-lhr r-ha2.

8BKM, Wilburt C. Gross, 453 Mill Street, Conneaut, Ohio

6aod 6aij 6aly 6awa 6bbv 6bgv 6bjl 6bjp 6bjv
6bpg 6bsz 6bux 6bv 6bwt 6bxc 6bxd 6bvx 6bya 6cbj
6ccp 6cge 6cgv 6chl 6chy 6cmq 6cqa 6csd 6cub
6cww 6db 6dx 6hv 6kb 6mu 6np 6nw 6or 6zr
7jf 7ob 7pu 7vl 7vm a-2bb a-2bk a-2cs a-2ij a-2no
a-2tm a-2yi a-3bd a-3kb a-3ls a-3em a-3en a-4an a-5aa
a-5bx a-4ma a-5wh a-7cs a-7cw a-7dx a-7dy b-4z
bz-law bz-2ab bz-5ab bz-9qa bz-spc c-4dq c-4dw c-4ek
c-4hh c-5ef c-8azs cx-ir5 f-8ct f-8kf f-8hu f-8yor
fm-8ma gh-1fh gx-6mu hu-6aj hu-6akp hu-6buc
hu-6dea hu-6xk hu-6l i-lau i-lrm m-lm m-lj m-5c
m-5lx m-9a m-cvy m-ih n-owe pr-4ja q-8kp y-lcd
y-2ak z-lax z-lax z-2ac z-2ae z-2xa z-3ai z-3aj z-3ar
z-4aa z-4am z-4im fw ghdh ngd pccm pctt pccu voq
wnp.

8DKK, L. R. Day, 100 Burgess Street, Pittsburgh, Penna., 40-Meter Band

6afs 6alv 6akm 6akw 6akx 6akz 6als 6amn 6aot
6aou 6apq 6apl 6aps 6apw 6ar 6ars 6aru 6arw 6as
6asa 6sar 6uth 6atn 6au 6auc 6aus 6auz 6avb 6awf
6awt 6aww 6awy 6az 6baf 6baw 6bdc 6bdf 6bev 6bfi
6bgu 6bha 6bhg 6bhz 6bin 6bjr 6bbs 6bol 6bvb 6bra
6brt 6bsa 6bsz 6bt 6bvo 6bws 6cae 6cet 6chl 6chx 6cix
6ckm 6cqa 6ct 6cua 6cuv 6cw 6cx 6dcq 6dx 6hm
6kb 6la 6lg 6mv 6na 6qi 6rn 6ru 6uz 6zi 6zac 7df 7dk
7em 7gb 7hi 7lq 7bt 7pv 7wc 7ws 7xf 7xi 7ya 7yi
au-7av au-7np a-2ak a-2ac a-2as a-3ta a-3yo a-5im
a-7yz c-lak c-lan c-lar c-ldd c-lie c-2ax c-2bg
c-3az c-3by c-3ek c-3dm c-3fc c-3jl c-3jw c-3kt c-3mi
c-3nz c-3el c-4gt c-5ek c-5gt c-8ax c-9am c-9bg c-9bk
f-8dk f-8oi f-8ip f-8xo f-8yor f-8zf hu-6hv hu-6buc
hu-6alf i-ler i-las pr-4rx pr-4je pr-4ur m-9a m-lm
q-2gm q-2lc bz-lab bz-lac bz-hab bz-5ar o-4af z-2ac
z-4jw z-4al ber npm npu nkf fw vvr ur auo nat naj
ipl ago npl.

8CNX, 618 East Washington St., Syracuse, N. Y.

a-2ay a-2bb a-2bk a-2cg a-2cm a-2es a-2dy a-2ij
a-2jw a-2kp a-2lk a-2lm a-2lo a-2rc a-2rj a-2ss a-2sw
a-2tm a-2yg a-2yh a-2yi a-2z a-3ad a-3ay a-3bd a-3bk
a-3bq a-3bm a-3dc a-3ef a-3fp a-3hl a-3jr a-3kb a-3ld
a-3lm a-3ls a-3my a-3n a-3pm a-3wm a-3xo a-3yn
a-3yx a-4an a-4am a-5ah a-5ay a-5bg a-5da a-5kn a-5lf
a-6ad a-6kx a-7dq a-7cs a-7cw a-7dx a-7xt a-7hl a-7jb
au-7mn au-7kx b-4rs b-4yz b-8z b-2 b2 b2 b2 bp7 by2
be-ber bz-laa bz-lab bz-lac bz-laf bz-lae bz-lan bz-lao
bz-lap bz-laq bz-law bz-lia bz-lin bz-2ab bz-2af
bz-2ap bz-5ab bz-7aa bz-9ni bz-9pl ch-leg ch-2ar
ch-2ld ch-3ag ch-3ij ch-9t c-7ee nem earl ear2 ear6
ear9 ear20 ear22 ear24 ear28 f-8au f-8bf f-8cg f-8es
f-8et f-8dd f-8dk f-8dp f-8ee f-8gi f-8ip f-8lx f-8if f-8in
f-8kf f-8mb f-8nn f-8pc f-8sm f-8tok f-8yb f-8ynd
f-8yor f-8zo f-ain f-maroc f-ocng f-onm f-8bl f-8qq
fe-8em fe-8gg hu-6alf hu-6aj hu-6axw hu-6buc hu-6dcf
hu-6tq hu-fxl i-lap i-las i-lay i-lbw i-lco i-ler i-lfg
i-lgw i-lno i-lrm i-lrw j-lpp j-3vw k-y5 k-y8 l-ljw
m-la m-las m-laf m-lj m-lk m-lm m-9a noba nohb
n-2pz n-pb3 o-a3b o-a4z o-a6n p-lae p-3gb pe-6zk
pi-lat pi-lhr pi-3aa pi-neeq pi-dcd pr-4ja pr-4je
pr-4kt pr-4ol pr-4rl pr-4sa pr-4ur q-2by q-2lc q-2mk
q-8kw r-aas r-af r-af2 r-bal r-cb8 r-dal r-das r-fbs
r-fh4 r-iis r-ha2 s-sdky s-smzs s-sd s-gc y-dcr y-led
z-laa z-laf z-lao z-lax z-lfm z-lac z-2aq z-2gc
z-2xa z-3ad z-3af z-3ai z-3aj z-3an z-3ao z-4aa z-4ac
z-4ag z-4ah z-4ak z-4ar z-4as z-4av z-4wm z-4xa z-2bz
g-2cc g-2co g-2it g-2kf g-2kz g-2lz g-2mj g-2nm
g-2nb g-2qb g-2sz g-2wj g-2yq g-2ar g-5dh g-5hs g-5lb
g-2nm g-2nb g-2qb g-2sz g-2wj g-2yq g-2ar g-5dh
g-5hs g-5lb g-5ls g-5pm g-5qv g-5rz g-5sz g-6al g-6gh
g-6iv g-6kk g-6lv g-6lj g-6ox g-6rm g-6td g-6zk
ane agk br7 kfuh voq wnp rxy cz99x.

8GJ, Frances B. Stevens, 77 Grey St., Buffalo, N. Y.

1awo 1ar 1boe 1com 1bv1 2aux 2p 2aa1 2dj 2ou
2ed1 2bce 2bel 2ce 2wf 2jj 2jw 2wu 2cu 2tv 2pf 2bo
2li 2nj 2mj 2rm 2da 2ask 2df 2aj 2ca 2ay 2ij 2ata
2auz 2aag 2ph 2cu 2em 2bbn 6bj 6ca 6bv 7cc 7ais
7vu 7bqa 7vz 7ayo 7caa 7gx 7cks 9qm 9atq 9xn 9ayo
9eku 9be 9eyw 9epj.

8KF, W. R. McShaffrey, Star Theatre, Monessen, Penna.

6auf 6aao 6adm 6adt 6ary 6aff 6aed 6asm 6akt 6amn
6aos 6ahs 6avj 6abz 6ao 6aji 6afs 6ag 6ajm 6atu 6afi
6aur 6bpx 6bza 6bka 6bha 6bhm 6btl 6bjv 6bq 6bat
6bol 6bhz 6bpn 6bmb 6bjd 6bjg 6bhp 6bav 6bjn 6bq
6bxc 6bgo 6bca 6bvd 6bpo 6bv 6bjl 6bvy 6bil 6bsh
6cqa 6cae 6cae 6cbi 6ecz 6ct 6cat 6ctz 6chz 6cmz
6olj 6cm 6cua 6cek 6cav 6cky 6cax 6cft 6evy 6cbj
6cub 6dmg 6da 6dsb 6dai 6dao 6dae 6dax 6dct 6dah
6das 6dcq 6dn 6ers 6eb 6eo 6in 6is 6ekg 6vd 6vz
6ol 6kb 6ws 6ho 6hs 6ge 6xv 6xi 6rn 6wa 6uf 6aek 7alk
7hd 7af 7bg 7fq 7w 7df 7ek 7tl 7vl 7hp 7w 7ng 7hl
7nh 7bb 7yd 7do 7nc 7ww 7pu 7vs 7aa 7c 5ef fm-8mb
i-lau b-3aa j-lpp npll a-5ig a-5ka a-bjd z-4af z-3ar
q-8kp q-3ij bz-2af bz-laa m-laa mv-3cd xc51 m-lj

(Concluded on Page 55)

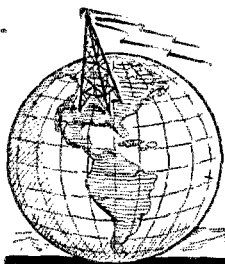

I. A. R. U. NEWS

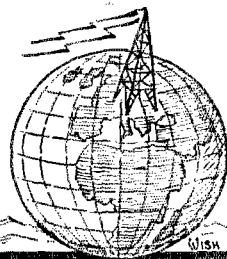

Amateurs in New Zealand Organize

ALATER radiogram from z1AE via u2EV tells more of the organization of the New Zealand amateurs than we reported in the Communications Dept. of October QST. "On August 16th, 1926 the New Zealand Association of Radio Transmitters was formed. z2XA was elected president, z1AX, z1XI, z2GA, z3CG, z1AM and Miss z4AA vice-presidents, and z1AE Secretary and Treasurer. It is the intention to get the whole of the New Zealand amateurs to hold (as soon as possible) meetings in the various centers to discuss the Association from every point of view. The results of such meetings will be published in *New Zealand Radio* which was unanimously made the official organ of the Association. At the end of six months a convention will be held in a convenient center where the whole of the officers will be officially appointed, subscription fixed and the articles of the Association drawn up. It is desired, if possible, to make the Association a New Zealand branch of the I. A. R. U. The address of the Secretary is Box 779, Auckland, New Zealand."—*R. V. Roberts, z1AE, Secretary.*

F. B. OMs. Good luck.

Germany

The first crystal-controlled amateur station in operation in Germany is K-4YAE, formerly K-Y8, the station of Rolf Horkheimer at Rottenburg am Neckar, Wurttemberg, Germany. The crystal oscillator tube is a small receiving tube, the crystal oscillating at 79.6 meters. The second harmonic of the oscillator is passed through a 20-watt tube and finally through a 500 watt. All German amateur call letters have been changed by order of the Postmaster (Oberpost-Direktion). The K calls now are from 4AAA to 4ZZZ.

Japan

From one of the leading Japanese amateurs comes further news of amateur activities in that country. There are two radio organizations in Japan. One, the Japanese Amateur Radio League, is composed of practically all of the transmitting amateurs. At present the J.A.R.L. has 30 enthusiastic

followers, most of whom are students in high school. All amateur work is done "under cover" since amateur operation is not permitted in Japan yet. The majority of the amateurs use either 201-A tubes or 202's. Despite the low power, though, the "J's" are QSO China, the Phillipines and the U. S. almost every night. Some of the stations have been QSO their antipodes. The other radio organization is the Japanese Amateur Radio Union, an assembly of B.C.L.'s, led by a B. C. magazine. It is to be hoped that the Japanese Government will recognize amateur radio soon and that our Japanese friends can then become better known to us all.

South Africa

"Reports are meagre as conditions these last two or three weeks have been very bad, atmospheric conditions being at their worst and fading has been very marked, even in intercommunication throughout the country. U. S. stations are now very weak in the early mornings around 0300 to 0400



THE LAYOUT AT O-A6N, THE STATION OF MAJOR SWART AT MILNERTON, SO. AFRICA

G.M.T. at which time, during your winter, things were formerly good. The best time for QSO with the "U's" is now about 2400 to 0100 G.M.T. when many stations are received very strong and steady. Communication with South America has also been very bad during this off period, the BZ and R boys being very weak when audible at all. It may be the change of season, but

our winters are more or less uniform so conditions should be improving soon. Work with Europe and the North is much better. O-A6N has been in communication with TUK in Siberia besides keeping his regular schedules with F-8JN. He has been reported heard in the States when working at 2 P.M. here. O-A3E on low power in Natal, has been doing excellent work with the U stations. He has been QSO the 6th and 7th districts with daylight all the way across. OA5X has been making new friends in France by working three F's in one week. A4V, A3B, A3K, A4Z, A5J, A7H, A4L and the others previously mentioned are on the air pretty regularly and are very often QSO foreign countries. O-1SR of Rhodesia has been doing some very fine work with the British warship GEFT (*H.M.S. Concord*), keeping regular schedules nightly for eighteen nights while the *Concord* was on the way to England from China. GEFT has been QSO a few of the O stations carrying on experiments in the 30-to 40-meter band. O-A5Z with 20 watts, A6N, A4L and several others have worked the GEFT. O-A4M, Pleass, has at last pushed his signals out of the country using a small tube with spark coil plate supply. He worked ANDIR, the military Airdrome at Java. This station ANDIR is received in fine shape in South Africa. He has worked O-1SR, O-A6N, O-A4Z, O-A5Z, O-A4L, O-A5X, O-A3E, O-A5Q and several others. The PI stations are coming in well here, 3AA, 1HR, CD8 and a few others being received regularly. Australian 6KX is the only amateur reported from the country. New Zealand is still dead. Only a few isolated reports of reception of Z signals in South Africa have come in. QSO with England is few and far between these days, too. NTT is being received all over the country and has established a number of contacts with our amateurs. The S.A.R. R.L., is co-operating with some of the broadcasting stations endeavoring to relay programs on short waves. It is hoped that the tests are successful since we must all pull together. South Africa is a vast country like the U. S. and the large towns are separated by distances of hundreds of miles. A great deal of work is being done by some of the hams on low power, using receiving tubes with inputs of from 2 to 8 watts. Pretty regular communication is being established over distances of from 800 to 1,000 miles.—R. Oxenham.

Madeira

From A. C. de Oliveira, one of the very active amateurs in Madeira, we learn the following about amateur work in that country. P-3CO has been working with an input of 15 to 20 watts and has been QSO the following U. S. Districts: 1, 2, 3, 4 and 8 and has been heard by 5th and 9th district sta-

tions, one of the latter being in Colorado. P-3CO has been heard in Mexico and has worked Brazil. He has been QSO amateur stations in Belgium, England, Scotland, France and Spain and has been heard in Denmark, Holland, Germany and Sweden. P-3GB uses an input of 40 watts and has worked several Europeans and all U districts except the 7th, and also BZ, Z, C, and O stations. P-3FZ, who has been using a 10-watt set has worked many Europeans, Americans and South Americans. Between the three stations mentioned above the total power is about 70 watts, and the three have worked practically everything workable in the world. P-3OR recently joined the Madeira gang with a 20 watt transmitter. He has been doing good DX. His QRA (P-3OR) is O. Cuaha, R. Sta Luzia, 85, Funchal, Madeira

Labrador

2AER tells of his QSO with 8AZS in Labrador. His QRA is Stanley W. Brazil, Battle Harbor, Labrador, and he is very anxious to QSO the U. S. as often as possible. His QRH is 41.5 meters. We believe this is the same station who operated for a short while with "B" battery supply and signed BHL last year. His first QSO at that time was with Chas. Service of 1ID.

Singapore

We are reproducing herewith photos of the transmitter at SS-2SE and a photo of the op himself, Robert E. Earle, of "Ichiban" Keppel Harbour, Singapore, Straits Settlement. It will be remembered that SS-2SE's



R. E. EARLE OF SS-2SE

first U contact was with u6HM. We are indebted to 6HM for portions of the following description of 2SE, the rest of which came to us direct from Earle. 2SE was the first amateur to be licensed to operate in the Malay Straits. He has had to overcome innumerable difficulties in the line of lack of proper facilities and equipment, and his entry into the DX International Ham Game is accordingly an achievement for which Earle deserves all sorts of praise.

2SE started off with a Philips 30-watt tube, the wax filling in the cap of which had become softened and was replaced with a mixture of sulphur and powdered glass. Plate supply originally came from a step-up transformer operating from the 50-cycle mains and two Marconi V3 rectifier tubes. These tubes are overgrown receiving tubes



THE TRANSMITTER AT SS-2SE

minus grid elements. The first U. S. contact was with the above power equipment operating in a coupled Hartley circuit with the equipment shown in the photo. The input to the tube was about 25 watts and the antenna current 150 milliamperes. Shortly afterwards the V3 tubes went west and 2SE tried a chemical rectifier which did not pan out right. He suspects that the auto body aluminum used in the rectifier or poor borax was the cause of the failure of the chem rectifier. Next he purchased a 0/50 Mullard tube (70-watt input) from a "passing" ship operator and the chief op of one of the coast stations let him take a small M.G. set. 2SE immediately was QSO several Australian stations and u6HM again. Then the Chief Op asked for the M.G.! Next raw a. c. was tried and the voltage on the tube pushed up to normal, promptly popped the Mullard tube. Through broadcast inquiries two Mullard 500-watt rectifier tubes were dug up and 2SE went back to a 20 watt Philips oscillator, and has been using this combination ever since. Next the Naval people came along and requested 2SE to get off the 35-meter wave and to QSY to 30 or 45 meters. He QSY'd to 45 meters and has been QSO the Philippines, but none of the U's since then. He has been QSO 6HM, 6OI, 6EB, 6RW, 6RN, a6SA, a2UI, a2CG, a6AG, pi1CW, pi1DL, pi1AT, pi1AU, pi1HR and has had reports of reception of his signals from Cuba, South Africa, Uruguay, England, Brazil and South America. His latest QSO was with u6NX. How many of our U gang would do as well with as little equipment on hand?

W. A. C. Club

A few additional members in the W.A.C. Club have been enrolled. The line-up at present is as follows: U-6OI, U-6HM, U1AAO, C-4GT, PR-4SA, U-9ZT-9XAX, B-4YZ, U-9DNG, PI-3AA, U-2APV, PI-1AU, U-5ACL, U-5JF, G-2IT, GI-5NJ, PI-1CW, O-1SR, U-1CMP, U-1CMX, B-4RS, U-7IT

and U-1CH, the order of listing being the order in which the respective stations applied and qualified for membership. It is desired that at least one amateur in every country on the face of the Globe be a W.A.C. Club man. If you have not made application for membership refer to page 54 of the April, 1926 issue of QST and also to page 54 of the June, 1926 issue.

How Many?

Sometimes we wonder actually how many countries have one or more active amateur stations in operation. To date we can name *fifty four* separate and distinct countries boasting (and alas, sometimes hunting for) amateurs who are doing worldwide DX. Maybe we have overlooked several, but we are *fairly* sure that our list is complete. If you can count up more than 54 countries, won't you send us a list of them, plus the call letters of the amateur (s) in the sparsely populated ones? Tnx.

The Antipodes Meet

Several months ago we announced, in this Department, the marriage of OM Frank Bell of the internationally famous Z-4AA, and



PROMINENT AMATEURS FROM THE OPPOSITE ENDS OF THE GLOBE
LEFT TO RIGHT Z-4AA, G-2NM, MRS. G-2NM AND MRS. Z-4AA

we told you that Frank and The Miz were off on their honeymoon to England. We are mighty pleased to be able to present a photograph of the Bells (Z-4AAs) and the Marcuses (G-2NMs) recently taken in England. From left to right there appear Z-4AA, G-2NM, Mrs. 2NM and Mrs. 4AA. In front of Marcuse stands Miss 2NM said to be the most likely YL op in the British Isles and in front of the young lady sits the Official CQ Hound. During Frank's absence Z-4AA is being operated every night by his sister, Miss Brenda Bell. On several occasions she and Frank have worked each other while he was operating at some British station. Quite recently Frank and Miss

Bell had a long QSO from G-2NM. It is said by all who have heard Miss Bell operate that she runs Frank a very close second. Even their father has taken a trick at Z-4AA. Marcuse says the elder Mr. Bell has a fist which will make a number of our DX boys envious.

Spain

The Spanish amateurs have a very excellent magazine called *EAR* directed and published by Miguel Moya, President of the Spanish Section of the I. A. R. U. *EAR* is the official organ of The EAR Association which in turn is the Spanish I. A. R. U. Section. The magazine is received at A. R. R. L. Headquarters each month with great pleasure. It always contains much of interest in the short wave world, and usually runs a description of one or more of the more prominent Spanish amateur stations. Since the magazine was started eight months ago it has had several very good technical articles in each issue. It costs, on subscription, 6 pesetas (about \$1.00) per year, and is a ham journal every DX man should have in his ham library. In Spain there are now 42 licensed amateur stations. All of the operators of these stations are members of the Spanish I. A. R. U. section. During the past month EAR23 has been QSO TJ-CRJ in Arabia. EAR20 and EAR28 are often QSO Brazil and a number of European countries. EAR4, EAR26 and EAR41 have been QSO Europe and North Africa. For several months EAR1 has been in daily contact with Z-2AC at 0500 on 33 meters. He has also worked Z-1AO, Z-2AC, Z-3AK and a few "A's". EAR1 has also established the first QSO between Spain and Mexico when he was QSO M-1AA. The EAR Association is also organizing the short wave receiving stations, and through the Association the Spanish Government is assigning call letters to these men, the calls being E-001, E-002, E-003, etc.

Another Diamond

In our August issue we showed a group of diamond-shaped emblems adopted by various amateur radio societies around the world and all following the general idea of the original A.R.R.L. diamond. Now we have record of another, the newly-adopted device of the Transmitter & Relay Section of the Radio Society of Great Britain, which we show in our illustration.



STATEMENT OF THE OWNERSHIP, MANAGEMENT, CIRCULATION, ETC., REQUIRED BY THE ACT OF CONGRESS OF AUGUST 24, 1912.

October 1, 1926.

Of *QST*, published monthly at Hartford, Conn., for

State of Connecticut }
County of Hartford } ss:

Before me, a Notary Public in and for the State and county aforesaid, personally appeared K. B. Warner, who, having been duly sworn according to law, deposes and says that he is the business manager of *QST* and that the following is, to the best of his knowledge and belief, a true statement of the ownership, management (and if a daily paper, the circulation), etc., of the aforesaid publication for the date shown in the above caption, required by the Act of August 24, 1912, embodied in section 448, Postal Laws and Regulations, printed on the reverse of this form, to wit:

1. That the names and addresses of the publisher, editor, managing editor, and business managers are: Publisher, The American Radio Relay League, Inc., Hartford, Conn.; Editor, Kenneth B. Warner, Hartford, Conn.; Managing Editor, F. C. Beekley, Hartford, Conn.; Business Manager, Kenneth B. Warner, Hartford, Conn.

2. That the owners are: (Give names and addresses of the individual owners, or, if a corporation, give its name and the names and addresses of stockholders owning or holding 1 per cent. or more of the total amount of stock.) The American Radio Relay League, Inc., an association without capital stock incorporated under the laws of the State of Connecticut. President, Hiram Percy Maxim, Hartford, Conn.; Vice-President, Chas. H. Stewart, St. David's Pa.; Treasurer, A. A. Hebert, Hartford, Conn.; Communications Manager, F. E. Handy, Hartford, Conn.; Secretary, K. B. Warner, Hartford, Conn.

3. That the known bondholders, mortgagees, and other security holders owning or holding 1 per cent. or more of total amount of bonds, mortgages, or other securities are: (If there are none, so state.) None.

4. That the two paragraphs next above, giving the names of the owners, stockholders, and security holders, if any, contain not only the list of stockholders and security holders as they appear on the books of the company but also, in cases where the stockholder or security holder appears upon the books of the company as trustee or in any other fiduciary relation, the name of the person or corporation for whom such trustee is acting, is given; also that the said two paragraphs contain statements, embracing affiant's full knowledge and belief as to the circumstances and conditions under which stockholders and security holders who do not appear upon the books of the company as trustees, hold stock and securities in a capacity other than that of a bona fide owner; and this affiant has no reason to believe that any other person, association or corporation has any interest direct, or indirect in the said stock, bonds, or other securities than as so stated by him.

5. That the average number of copies each issue of this publication sold or distributed, through the mails or otherwise, to paid subscribers during the six months preceding the date shown above is (This information is required from daily publications only.)

K. B. WARNER.

Sworn to and subscribed before me this 30th day of September, 1926.

Caroline S. Crisman, Notary Public.

(My commission expires February, 1931.)



The General Instrument Corporation has produced a socket of a great deal of interest to the receiving and the transmitting amateur in the new "Isolantite" insulated one here illustrated. The insulating material has been kept at a minimum.

Correspondence

The Publishers of QST assume no responsibility for statements made herein by correspondence



Looking at Quartz

1108 Eighth Ave. West,
Seattle, Wash.

Editor, QST:

In perusing the article in September QST entitled "Examining Quartz for Oscillator Use," it occurs to the writer that there is a very much simpler way of examining quartz (and many other objects) than that described in this article. And again most of us will not be able to cut a hole in the Dining Room table and get away with it. Attached is a sketch which is practically self-explanatory. It will be noted that the only materials required are two 5 x 7 photographic plates, one ground glass also 5 x 7, and a few microscope cover glasses (either round or rectangular). The three pieces of glass are erected to form a triangle. It will be found convenient to bind the joints with

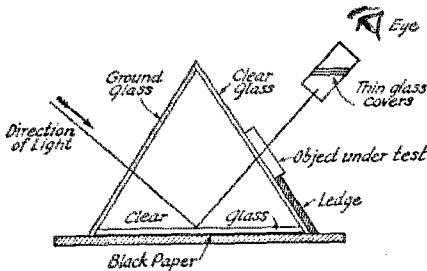

lantern slide gummed tape. Across the lower part of the clear glass is placed a strip of glass 5 inches long and one inch wide. This functions as a shelf to rest the crystal on while it is under examination. The whole affair should stand on a piece of black paper. Daylight or lamp-light is allowed to strike upon the ground glass, and thence passes down to the base and is reflected at an incidence of about 57 degrees to its surface, and so passes a partially polarized beam through the clear glass on its way to the eye. As an analyzer seeing that Nicol Prisms are expensive, a cheap substitute can be found. One that is quite good enough for this purpose, may be made by taking a bundle of fifteen or twenty microscope cover glasses (about one-half inch square will do very nicely). Fix these in a square tube so that they are inclined at an angle of about 33 degrees. With this

very simple tool many very interesting things can be studied such as sugar in solution, mica and camera lenses and quartz plates.

—A. W. Eshelby

Break-In

3335 33rd Ave. South,
Seattle, Washington.

Editor, QST:

Re the article in latest QST on break-in, many hams dislike remote control because they cannot keep one eye on the tube. The next best thing is to keep one eye on the plate milliammeter, as was suggested. However they seem to like to worry about the filament voltmeter, too. Run a twisted pair from the socket terminals to the operating table filament voltmeter, and to make up for the line drop put in one or two dry cells in series in the line, also with an adjustable resistance in series. Then the operator knows that the voltmeter really reads the voltage at the tube. This method is not absolutely accurate, but it is at least as accurate as the general run of voltmeters we get.

Lots of amateurs insist on a .002- μ fd. grid-and plate-stopping condenser for short wave work. They do not understand that the effectiveness of a condenser is due to its reactance, and as the frequency is increased the capacity can be lowered maintaining the same reactance. When you halve the wavelength the capacity can also be halved. Similarly, for R. F. chokes, as the wavelength is halved the inductance can also be halved with the same effectiveness.

Changing the subject, I notice on page 16 of the September QST that Mr. Gilchrist advocates a position of the tickler coil according to the coils we build. At least two of us agree on this now, anyway. I never could see trying to hide the tickler between and inside the secondary.

—Howard F. Mason, 7BU, Seattle Radio Laboratory.

Long Wave DX

R. M. M. S. Aorangi,
Union SS Co., of N. Z.
Vancouver, B. C.

Editor, QST:

What I believe to be a record for consistent long distance two-way communication using Marine commercial wavelengths, i. e. between 300 and 2,400 meters, was es-

published during the last voyage of this vessel (GDVB) when I worked the Canadian Government station at Estevan, B. C. (VAE) at a distance of 6,200 miles. On a schedule with that station good two-way work was carried on every night from the time of our departure from Vancouver, B. C. right up to our arrival at Auckland, N. Z. This consistency, I think, will remove any doubt as to their being anything freakish attached to the performance. VAE was also worked on leaving Auckland.

Estevan reported signals as being QSA, reception at this end being such that I requested some Paid Press which was received completely.

This is certainly an exceptional distance using waves on the order of 2,000 meters. I think it will be of interest to all operators both commercial and ham as many of the latter are of the opinion that DX is only to be obtained through the use of wavelengths between 20 and 80 meters.

I am an enthusiastic ham myself holding experimental license g2KC, and have been a constant reader of your very popular QST for some years. As the "Aorangi" has appeared in several issues from time to time on the short wave side I feel sure that a few lines on the commercial waves should be read with interest.

—H. T. Longuehave

Help to the New Man

Greensburg,
Penna.

Editor, QST:

Please allow me to make a suggestion about new amateurs. I am one, and can give you about the same experiences that the new amateur is up against when he receives his license. Here it is. He thinks everyone is his friend on the air and generally picks out someone who CQ's for about a half an hour nice and slow, and if he gets an answer it is at about 15 words a minute like this, "r r tks OM ur sigs about r6 es gud R.A.C. grn hr hrk? qtc?". After answering him the following reply usually comes back, "glad to work u OM cul 73".

Well!—when the new man runs up against that for about a dozen consecutive times he is afraid to answer anyone, so he CQ's according to A.R.R.L. practice and gets answers from men who are busy handling traffic, but he does not get any traffic from them. Then he is both afraid to CQ and to answer one.

I have found six real hams in my six weeks experience who took the time to help a green operator. They are old men at the game and remember that they too were green at one time several years ago.

I suggest that a club something like the R. C. C. be formed, for operators who have been operating from one day to one year

only, giving them the "sign" OY (meaning one year, or less). Then they can pick up each other, or the real fellows having time could help them along. I think that the formation of such a club would be of tremendous help to the new man and at the same time would not be time-wasting and annoying to the busy traffic man.

—H. C. Morrison, SDOY

Audio Oscillator

3737 South Michigan Avenue,
Chicago, Ills.

Editor, QST:

I notice on page 41 of the September issue of QST a diagram of a self-modulated driver. Why bother with the transformer

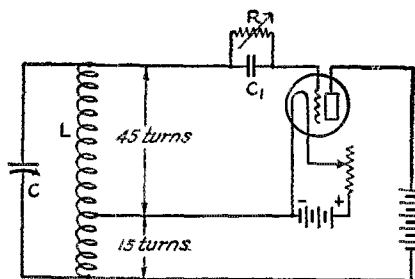

L - 3" diameter

C - 300 - 500 μfd

C₁ - 250 μfd for 500 cycle note

R - 3 Megohms

If turns are changed for different wavelengths keep ratio of plate to grid turns 1:3

when the circuit shown here will do the same thing with only half the constructional work. As you see it is a simple regenerative circuit. The pitch of the audio frequency note can be controlled by the grid condenser. The larger this condenser the lower the frequency of the note will be. I have been using a driver of this type for some time in service work and I have constructed similar ones for distributors in various parts of the country. All of the drivers have worked very satisfactorily.

—A. D. Hines, Service Instructor, Amer. Bosch Magneto Co.

Right?

S. S. Elkton,
Shanghai, China.

Dear Eddie:

Commercial radio is 'o.k. in a lot of ways but there is nothing that gives me quite the kick that the reception of good old QST does out here. I get it sent regularly from home, and when it comes in it generally gets dog-eared in two days. I used to rave when I

tried to do three-thousand miles of DX on 600 meters in the dead of the night and find it hard to do. Then I read where 8GZ-8ZG works South Africa and the Aussies with a 199 tube, and I think what joy it will be to get back to the old shack and try some of that myself. More power to you and the magazine say I, and let's pray that no copy of mine gets lost on the way over.

—R. C. Jones, KOFK-2AEC

More on QSLs

La Junta,
Colorado

Editor, QST:

Every so often we have to break out and write a letter to Headquarters. The thing we want to mention this time is about QSL cards. If this feature were to be removed from amateur radio one of the best parts will be gone. I am one of the old gang, yet there is no one who loves to see the mail carrier bring a card more than I, even from a short distance. There are many stations who do not QSL. Right now there are about sixty stations who owe us a QSL card in the U. S. alone. While working these stations they ask us to QSL and say they will do the same thing, and that is the end of it. What is the reason? I think I can give two causes. One is so many stations work one station after another and then forget who they worked. I keep a little pad of paper, about 2 x 3 inches, on the table and when I have finished QSO a station I log his dope and QSL and then hang this on a hook until he sends me a card.

Again, we have to put a two-cent stamp on all cards unless printed on Government post cards, and whether one or two-cent stamps are used a post card is not returned if not delivered. To take care of this and insure a return if not delivered, I spend a dime and get some cheap envelopes and mail the cards in them.

I have also received many cards whose address was written so poorly I did not see how on earth the mail carrier ever found where it was going. Traffic handling is fine business, DX is all right if we don't go crazy over it and forget the hams in the U. S., visiting radio friends is a lot of fun, but the ham who does not love to receive cards, or does not send them, has no business on the air in the amateur band. It is a great disappointment to a new station to get QSO with a station even in the next state and fail to get a card from him.

—M. O. Davis, 3CDE

F. B.

Yellowstone Park,
Wyoming

Editor, QST:

I want to make a suggestion for changing the little membership brooch pin to increase its value. No doubt everyone has seen a fraternity pin with a little chain from the pin itself to another pin with something else on it. I am giving this suggestion that if the A.R.R.L. pin has a similar chain going to another pin with the call letters of the ham, it would look very attractive. The illustration explains the idea.



—Vernon Goodwin, Jr. 7AAH
(Ed's note—The little gold "50-watt bottle" type of pin with the

call letters on it, as made by F. C. Ballard and advertised in QST for some time would be just the thing to hang on the end of the chain.)

Does This Hit You?

This letter was received by the Communications Manager. It mentions two of the best known stations in amateur radio and while their calls have been omitted the remarks still apply to them—and to others.

Atglen, Pa.
Sept. 23, 1926.

Dear OM:

I am surely glad to hear from you and have your opinion in regards to non-traffic-handling O.R.S. I do not want you to understand me as saying that the following stations will not QSR; I only said that they *did* refuse to QSR that one particular message to the West Coast. The fellows that I had reference to are 9— and 8—. You know that they are both old amateurs and should know their business. I want to say in regard to 9— that he won't help a beginner and won't QSO with one. If amateur radio will stand that kind of selfishness it will not last long.

For contrast to the above: the other day I was CQing and Windom of 8GZ came back at me. I told him to QRS and QSZ. He came back as I requested sending about eight to ten words per minute. We chewed the fat for over an hour, both sending very slowly, not because we had to, but because I wanted to see if Windy would do that when asked. My hat is off to him because *he did*.

I may be wrong and if I am anyone is welcome to tell me about it and they don't have to be pleasant about it either.

With best 73

Sincerely,

—H. B. Cowan, 3CBT

THE MAST AT 8LO

(Continued From Page 41)

bridle wire or an eye bolt. Be sure the hoist rope passing thru the pulley fits snugly otherwise it may become jammed. We used wire clothes line here. Be sure to put a cap T over the end of the downspouting mast. Now raise the pipe up to where you want it, slipping the board R in place under the lower end. Two piece wooden clamps C (see detailed drawing) should be placed as shown in the main drawing and in addition another clamp is nailed down on top of the board R to keep the end of the spouting from spreading.

Tighten up the guys and there you are. If you have done a good job of soldering on the spouting it won't telescope. Here at 8LO we have guyed the top of the mast to our house and also to our neighbor's. We used about No. 10 galvanized iron wire for all the guys.

Briefly the cost of the mast was

Downspouting at 10c per foot	\$3.00
No. 10 wire, 5 lbs. at 6c	.30
Pulley	.20
Screw eyes and eye bolts	.60
Spikes (for spreaders)	.10
Wire clothes line	1.25

\$5.45

Calls Heard

(Continued from Page 47)

m-1n m-1k m-1h f-8kf f-8yor f-8et f-8rz f-8jd f-8jn
f-8gi f-8ca f-8rbq g-5dh g-2sz g-2lz g-2bz g-6mu
g-6mb c-5go c-4gt c-4dy c-4gb c-4io c-4ac pr-4je dx8
cx7 octn whn dphg age adx amx gck gen wwx agb
wsj vxkk gdvb kegk nidk voq lp-1 wnp wap vog npo
npg nbn nkg nbp nar nba njg npm npl nem kel npu.

9AYB. J. O. Weaver, 922 Mulberry Street,
Mt. Carmel, Ill. 40 Meter Band

a-2dj a-2mh a-2tm a-2xa a-2yl a-2yx a-3bd a-3ef
a-3ls a-3sz a-3wm a-5bg a-5lo a-5wh a-7ca a-7ea a-7la
bz-2aj bz-2pc ch-2ar f-8kf g-2sz g-5dh hu-6aj hu-6axw
hu-6dbl i-1ay m-1aa m-1n m-cyy pr-4ja y-led z-1ao
z-1ax z-2ac z-2bg z-2bx z-3af z-3aj z-4ac z-4ak z-4am
gdy ul f-ocdj rxy wnp vak fbio nite npa nba unc wxf.

Parts and supplies for Edison element storage "B" batteries in stock for immediate delivery. Perfect elements. Electrically welded on strip connectors. Type "A", 5c per pair. Type 3-G, 1500 M. A. 6c. Type 5-G 3000 M. A. 9c. 3x6" flat bottom jars, 3c. 1x6", 4c. No. 20 pure nickel wire, 1c per ft. No. 18, 1 1/2c. Separators, 4c per doz. Potassium Hydroxide and Lithium for making 5 lbs. Edison solution, 85c. 100 volt battery in steel case, complete in every detail, \$12.50. 140 volt, \$17.00. Send for complete list.

J. ZIED, 904 N. 5th ST., PHILA., PA.

MASS. RADIO SCHOOL

18 Boylston St., Boston, Mass.

Send for free Catalog

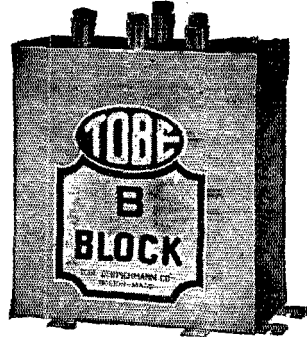

This TOBE B-BLOCK Type 761, containing one 8 Mfd. and two 2 Mfd. TOBE Filter Condensers, is especially suitable for D. C. B-Eliminator Filters for Electrolytic and Raytheon current-supply units where separately cased condensers are used to by-pass the voltage taps. It is suitable for all other filter condenser uses where the D. C. working voltage does not exceed 300 volts.

Cased in an especially finely finished and solid silvered can, with sturdy lugs for attachment and heavy brass binding posts.

PRICE, \$9.50

TOBE DEUTSCHMANN CO.

Engineers and Manufacturers of
Technical Apparatus
CAMBRIDGE, MASS.

CHIMNEY AERIAL. Heavy gauge and special fire resisting, minimum atmospherics, most selective. Price \$3.50. 1 1/2 lbs. BALLOON AERIAL. Initial pick-up very strong, suitable for weak-end tryouts and peak reception. Complete, \$3.00, extras Postge., 5 lbs. Hydrogen flasks procured in all cities or make it. GRAVITY BATTERIES. Gallon size, \$1.25. Runs 1-4 amp. tube 1800-2400 hrs. Also used for charging storage where other facilities are unavailable (7-8 cells)

RIBBON WIRES. For winding inductances. Equivalent to No. 24 round wire, flattened to .003, air-cell insulation, gives maximum saturation for best DX. Honeycomb and pancake coils of this wire also furnished, &c. 1-4 lb., \$2; 1-2 lb., \$3.50. Write for literature and samples.

Everett Scanlon, Radio Specialities, Lakewood, Rhode Island.

Bradleyometer

THE PERFECT POTENTIOMETER

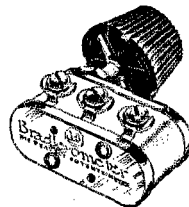

Uses graphite disc resistors which are noiseless and not affected by atmospheric conditions. Metal parts are nickel plated. One hole mounting. Finish and knob match Bradleystat. Made in 200 and 400 ohm ratings.

Allen-Bradley Co.

Electric Controlling Apparatus
277 Greenfield Avenue
Milwaukee, Wis.



POWER RHEOSTATS

Model PR-535

For controlling filaments of U. V. 202, 216, U. X. 210 and 216 B. Tubes.
Each Rheostat has two windings giving four different resistance values from 1.5 to 6 ohms, and has a large rated current carrying capacity up to 2.5 amps.

LIST PRICE \$2.75 Ea. SPECIAL PRICE, 65c Ea.
AMERICAN SALES CO., 21 WARREN STREET, N. Y. C.



RELIABLE--WHY?

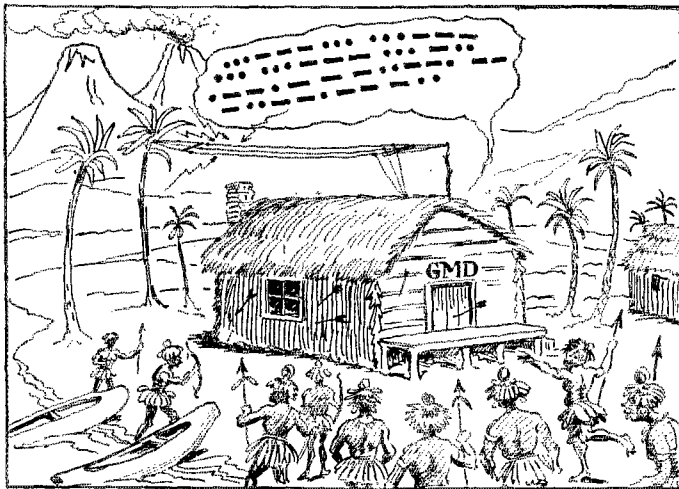

Because **REL** Inductances Are Used

Gain by the Experience of Those Who Know

Boost your signal strength by modernizing your transmitter with REL inductances.

REL Inductances will eventually be used in every short wave transmitter. "Ask the 'Ham' Who Has 'em Now"

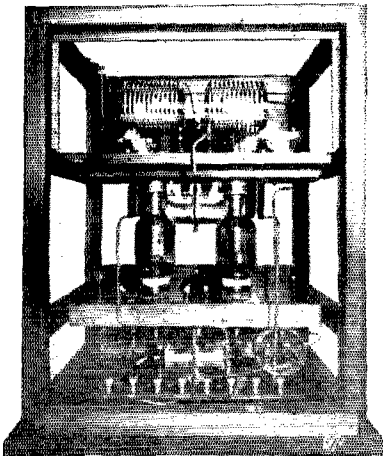

GMD Transmitter.
Main Station.

Commander Dyott of "GMD" uses REL inductances throughout his entire radio equipment—Manley of the "Morrissey," Reinartz, Rives, Clayton, Kruse, Hebert and others of equal prominence are users and boosters.

Flatwise wound on glass means lowest distributed capacity and highest insulating qualities. Positive contact clips that stay put.

TYPE "L"—40-80 AND 150 METERS
TYPE "S"—20 METERS AND LOWER
SINGLE UNITS WITH 3 CLIPS... PRICE \$5.50
DOUBLE UNITS WITH 6 CLIPS AND
TWO 15 INCH GLASS COUPLING
RODS PRICE \$11.00

We manufacture a complete line of Short Wave Apparatus including Plug-in Coils, Receiving and Transmitting Kits, Choke Coils, Wavemeters, etc.

WRITE For the new REL Short Wave Booklet. It contains hookups and data on Tuned Grid, Master Oscillator, Crystal Control, Power Supply, Rectifiers, Antenna and much other valuable information for everyone.
PRICE 25 CENTS.

REL OWNS AND OPERATES EXPERIMENTAL STATION 2XV ON 15.1 METERS, 19867 KILOCYCLES, CRYSTAL CONTROLLED.

RADIO ENGINEERING LABORATORIES, 27 Thames St., New York, N. Y.

Cardwell

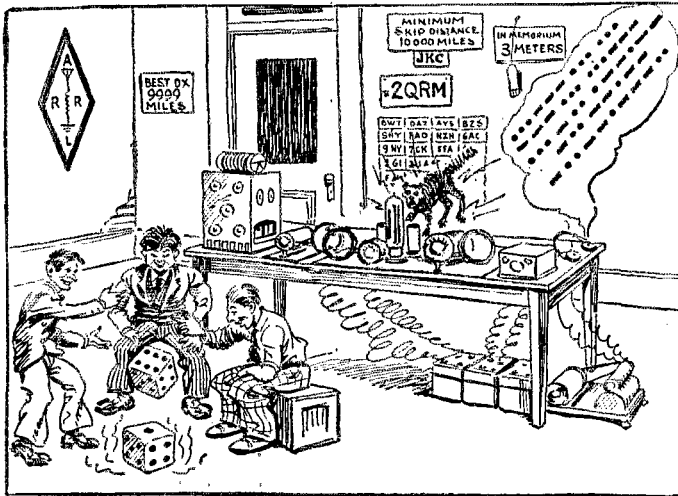

LOWER LOSSES!

IN THE SET than the game, for the heap, like all good Ham outfits, uses Cardwells.

So does GMD, like all good expeditions. Experience, the best of teachers, is responsible for the fact that there are more Cardwell Condensers used in short

wave installations than all other makes combined. The judgment of engineers responsible for the design of sets going to the far parts of the earth, where success, and often life, depends on the functioning of every part, leads them unerringly to Cardwell apparatus.

The Type 198-C Radio Frequency Choke, designed originally for receivers, will easily carry a 50 Watter. It's small dimensions (2" in diameter and $\frac{3}{8}$ " thick) make it darn handy. It's natural period approximates 575 meters. It costs \$1.50. Try it?

Type "C"	Type "E"	Capacity Mmids	Price
167-C	191-E	75	\$3.75
168-C	167-E	150	4.00
170-C	168-E	250	4.25
171-C	169-E	350	4.75
172-C	192-E	500	5.00

Ask for the 36-page Handbook and Catalogue. Also the Short Wave Receiver Book.

Transmitting

VARIABLE			
Capacity Mmids	Type No.	Breakdown Voltage	Price
250	164-B	3000	\$ 7.00
440	147-B	3000	10.00
80*	197-B	3000	8.50
217*	157-B	3000	12.00
156	183-B	5250	15.00
297	166-B	7600	70.00
480	123-B	1400	5.00
480*	156-B	1400	7.00
980	137-B	1400	7.00
FIXED			
250	501	3000	\$ 4.50
440	502	3000	7.00
966	503	3000	10.00
250	504	5250	15.00

*Has two insulated stators-capacity of each.

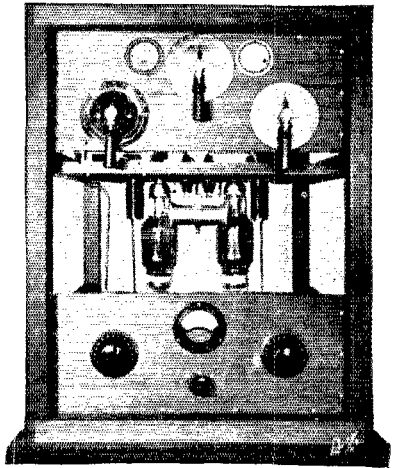

The GMD Transmitter

The Allen D. Cardwell Manufacturing Corporation
81 PROSPECT STREET
BROOKLYN, N. Y.

Condensers

"THE STANDARD OF COMPARISON"
SAY YOU SAW IT IN QST—IT IDENTIFIES YOU AND HELPS QST

American Transformer Company

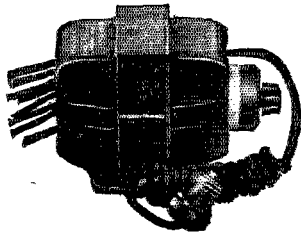

For Power Supply

The AmerTran Power Transformer
Type P F 52

The continued selection of AmerTran Radio Products by leading engineers and experimenters gives ample proof of their high efficiency and dependable performance.

Of particular interest is the AmerTran Power Transformer Type P.F. 52—the transformer for real "honest-to-goodness" power supply. This transformer is intended for use on the standard 110 volt, 60 cycle house-lighting circuit and can be depended on to give and maintain satisfaction.

It has three separate windings—one for 525 volts, and two 8-volt windings for the filament of the Rectifier and power tubes. The windings are enclosed in a strong metal case, provided with mounting feet. There are three primary taps for 110, 118 and 125 volts, connected to a three point snap switch, and a six-foot lamp cord and plug attached to the primary is standard equipment. The price is \$18.00 each.

Other AmerTran Radio Products

The AmerChoke type 854 is a scientifically designed impedance or choke coil of general utility, designed primarily for use in filter circuits—Price \$6.00 each.

The AmerTran De Luxe Audio Transformer sets an entirely new standard of audio amplification. It makes possible a transformer coupled amplifier that rivals all other forms of amplifiers. In two types for first and second stages—Price \$10.00 each.

Write today for interesting free booklet "Improving the Audio Amplifier" and other constructional data.

AMERICAN TRANSFORMER CO.
178 Emmet Street Newark, N. J.

AmerTran Products are Sold Only
at Authorized AmerTran Dealers

**Transformer Builders for
Over Twenty-Five Years**

AGAIN WE ANTICIPATE YOUR WANTS

The New "WINDHAM"
Universal Condenser

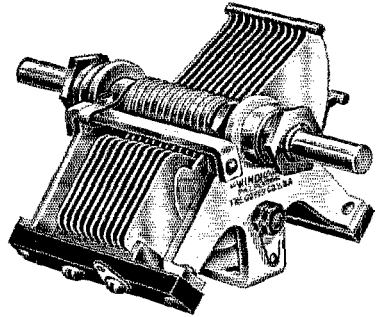

Independent Removable $\frac{1}{4}$ " shaft of desired length passes through a Hollow Spindle permitting clock or counter clock-wise rotation with all the other Windham features so well known to the trade. Single or double spaced 3 to 23 plates panel or test board mounting.

Send for Catalog

THE GOYER COMPANY, Willimantic, Ct.

Learn to Send the Easy Way With The Improved Martin

Reg. Trade Marks
Vibroplex
Bug
Lightning Bug

VIBROPLEX

Trade Mark Reg. U. S. Pat. Offs.

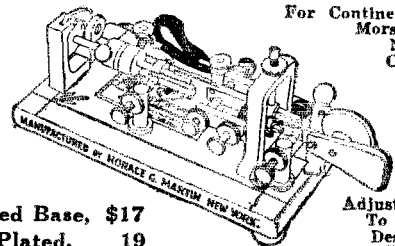

For Continental,
Morse or
Navy
Codes

Japanned Base, \$17
Nickel-Plated, 19

Adjustable
To Any
Desired
Speed

Over 100,000 operators use the Improved Vibroplex because it is **EASIER, QUICKER and MORE ACCURATE** than the old key.

It transmits with amazing ease. **CLEAR, CLEAN-CUT** signals at any desired speed. Saves the arm. Prevents cramp, and enables any operator to send with the skill of an expert.

Special Radio Model

Equipped with Large Specially Constructed Contact Points. Requires no relay **\$25**

Every amateur needs this bug. Easy to learn. Sent on receipt of price. Money order or registered mail. Liberal allowance on your old (Martin) Bug. Order Now!

THE VIBROPLEX CO., Inc.,
285 Broadway, New York

SAY YOU SAW IT IN QST—IT IDENTIFIES YOU AND HELPS QST

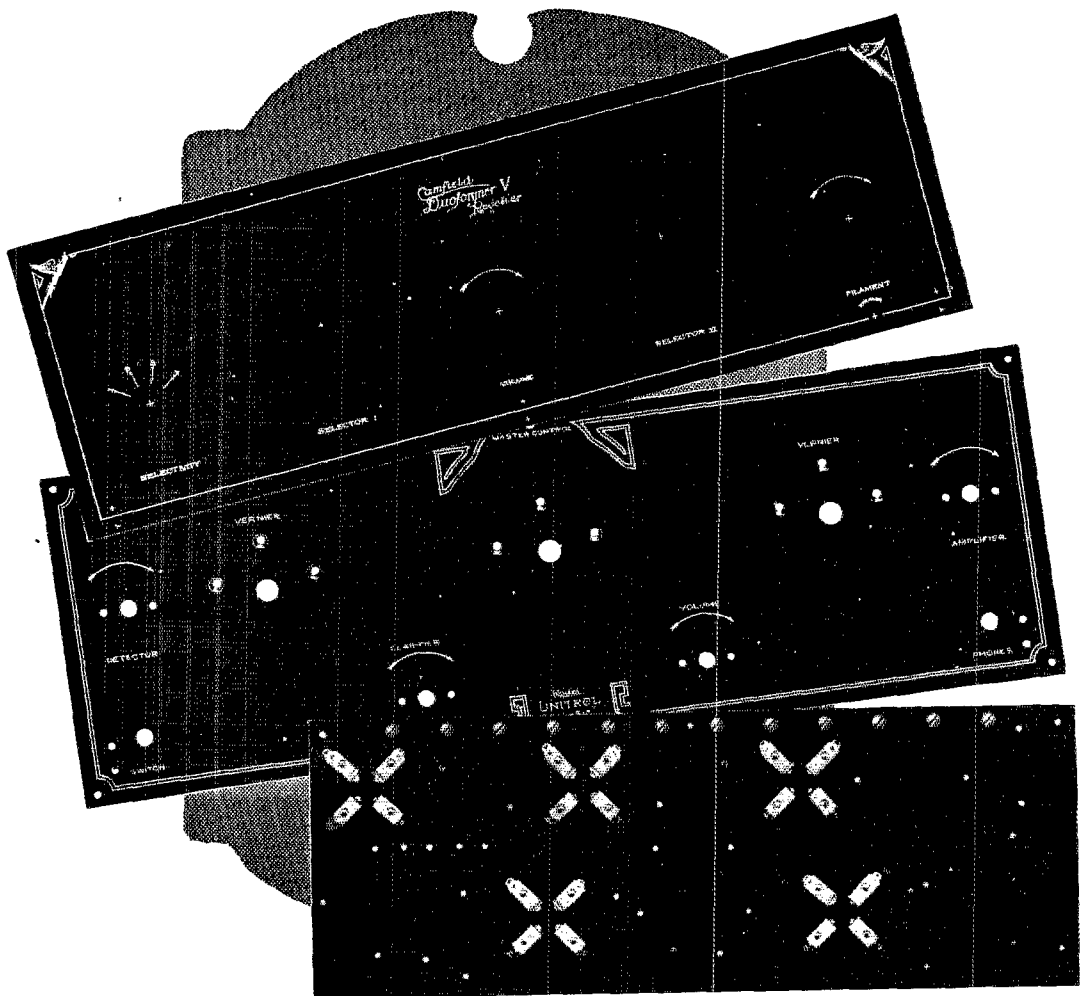

The Popular Kit Panels

FORMICA panels in gloss black finish Veri Chromed in Gold are the popular panels for kits that are offered by leading manufacturers: Bremer Tully Counterphase; Browning Drake National; General Radio Universal; Victoreen Superheterodyne; Madison Moore Superheterodyne; Camfield Duoformer; Aero-dyne Five Tube; St. James 8 Tube; Karas, front and sub panel; and Infradyne.

THE FORMICA INSULATION COMPANY

4620 Spring Grove Avenue

Cincinnati, Ohio

Hear the
Formica Or-
chestra Tues-
day evenings
from 9 to 10
Over station
WLW.

FORMICA
Made from Anhydrous Bakelite Resins
SHEETS TUBES RODS

Formica has a
Complete Service
on Insulating
Panels and
Parts for Radio
Manufacturers

SAY YOU SAW IT IN QST—IT IDENTIFIES YOU AND HELPS QST

THE SUPER SYNC

The Synchronous Rectifier That Can Be Filtered

When properly filtered the super delivers a direct current that is suitable for broadcast transmitters. The super will handle as high as 4000 volts without giving the least bit of trouble.

On installing a super you will find that your DX reports will increase and your wave will be reported much more steady. The commutator on the super is eight inches in

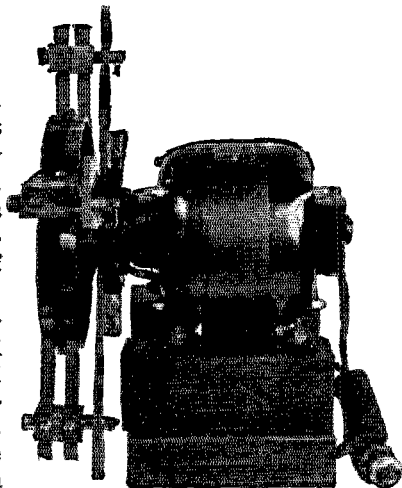

diameter and is turned at a synchronous speed by a 1/4 H. P. synchronous motor. Contact is made by eight brushes mounted in pairs, ninety degrees apart. The brushes run on a smooth surface, thus assuring a clean, smooth contact. There are no air gaps for the brushes to jump.

On installing a super you will find that it is most efficient.

PAT. PENDING
PRICE \$75.00 F. O. B. ST. LOUIS

MARLO ELECTRIC CO., 5241 Botanical Ave., St. Louis, Mo.

Hoyt SWITCHBOARD METERS

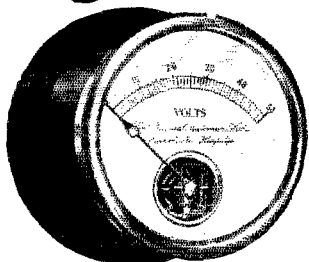

HOYT has made Precision Switchboard Meters since 1904, in all sizes, from 3" to 8" case diameter, both for A.C. and D.C. They all have hand-calibrated scales and are recommended for all transmitting station and amateur uses.

A new catalogue on HOYT Switchboard Meters is ready for distribution and will be gladly sent you free on your request.

BURTON-ROGERS CO., BOSTON, MASS.
Selling Agents for Hoyt Electrical Instrument Co.

ACME FLEXIBLE CELATSITE

Flexible, stranded wire for point-to-point and sub-panel wiring. Non-inflammable "spaghetti" covering. In black, yellow, green, red and brown; a color for each circuit. Put up in 25-ft. coils.



Celatsite Battery Cable

... a silk-covered cable of vari-colored Flexible Celatsite wires, for connecting batteries to set. Prevents "blowing" of tubes; gives your set an orderly appearance.



Send for Complete Acme Wire Products Folder
ACME WIRE CO., DEPT. S, NEW HAVEN, CONN.

ACME WIRE

MAKES BETTER RADIO

Build Better Sets
of **KELBRACKET**

150 PER PAIR WGT. 4 OZ.

FREE ASSEMBLY BOOKLET

KELLERADIO, INC.
621 Market St. San Francisco, Calif.

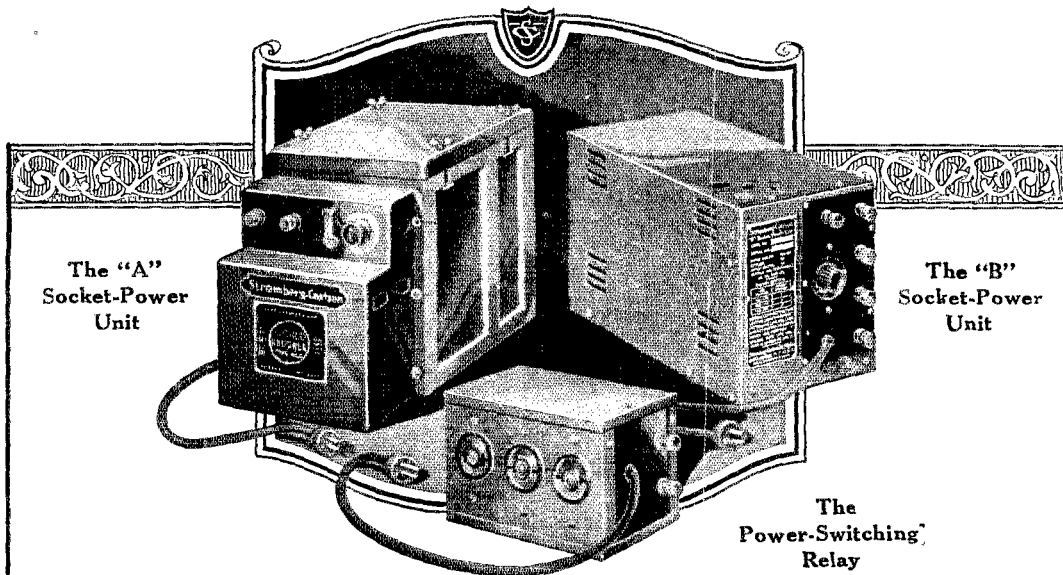

The "A"
Socket-Power
Unit

The "B"
Socket-Power
Unit

The
Power-Switching
Relay

"A" & "B" SOCKET-POWER EQUIPMENT and "SINGLE SWITCH" CONTROL

Owners of Stromberg-Carlson Receivers may now obtain complete socket power equipment—built by Stromberg-Carlson Engineers so that the splendid reception possibilities of these receivers may be fully realized.

The "A" Socket-Power Unit (Gould Unipower) is a trickle charge outfit designed to supply unflinching "A" power to a Stromberg-Carlson or other receiver employing UV-201-A type tubes. This single compact power plant banishes the inconvenience of charging storage batteries—it furnishes full quiet power at all times.

The Stromberg-Carlson No. 401 "B" Socket-Power Unit is a most satisfactory means of securing plate current direct from the house lighting circuit. Extra large condensers in the filter circuit insure an abundance of current, while wire wound resistors, imbedded in vitreous enamel, keep the out-put current constant. This unit operates from a 60

cycle, 100 to 130 volt alternating current house lighting circuit. Its output is especially arranged to operate one 200-A or 201-A type detector tube on the 45 volt tap, three or four 201-A type radio and audio amplifier tubes on the 90 volt tap, and one UX-112 or UX-171 output tube on the 135 volt tap.

The use of the No. 301 Power-Switching Relay with the "A" and "B" socket power units allows automatic control of both power plants through the operation of the filament switch on the panel of the receiver. "Badge wound"—there is no adjustment necessary, regardless of the number of tubes the receiver is utilizing. A third outlet provides a convenient means of hooking up an external power amplifier.

	East of Rockies	Rockies and West	Canada
Gould AC-6HLD. Socket Power Unit	\$38.00	\$43.00	\$51.00
No. 401 "B" Socket Power Unit, less tube	58.00	64.00	79.50
UX-213 Rectron Tube	6.00	6.00	8.00
No. 301 Power Switching Relay	11.00	11.75	15.00

Stromberg-Carlson Telephone Mfg. Co., Rochester, N. Y.

Stromberg-Carlson

Makers of voice transmission and voice reception apparatus for more than 30 years

QUARTZ PLATES

For Crystal Controlled Transmitters

Quartz plates for crystal controlled transmitters are available in the 150-170 meter band. These plates provide harmonics in the 20, 40 and 80 meter bands, and may be used for transmitters on these wavelengths. Calibration is to 0.25%. All plates are guaranteed to oscillate when used as directed. The only licensed plates available to amateurs.

Type 276-A Amateur Quartz Plate, unmounted, \$15.00
 Type 356 Crystal Mounting \$1.00

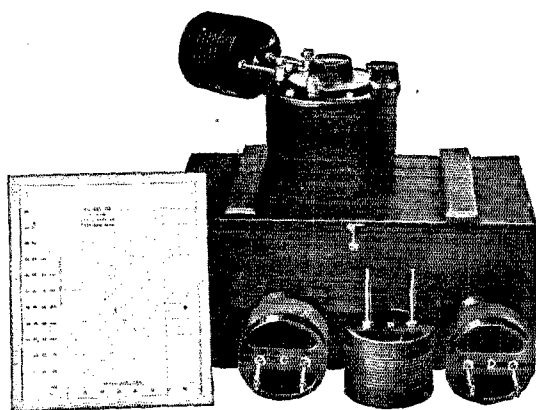

Type 358 Amateur Wavemeter

This instrument is particularly designed for amateur use in checking wavelengths. Consists of a coil mounting directly on the binding posts of a shielded condenser of 125 MMF capacity. A small lamp serves as a resonance indicator.

The 358 wavemeter is supplied with 4 coils, a calibration chart and wooden carrying case.

The coil ranges are as follows:—

- Coil A 14 to 28
- Coil B 26 to 56
- Coil C 54 to 114
- Coil D 105 to 224

Wavemeter complete Price \$22.00

Type 334-T and V Transmitting Condensers

The types 334-T and V condensers are similar in appearance and assembly to all other Type 334 condensers except that they have double spacing for use in short wave transmitting on voltages up to 2000. They have metal end plates with shielded rotor. Plates of the rotor and stator groups are soldered to insure perfect electrical contact. The type 334 transmitting condensers are supplied with counter weights only.

Type 334-T Capacity 100 M.M.F. Price \$4.25

Type 334-V Capacity 50 M.M.F. " 3.75

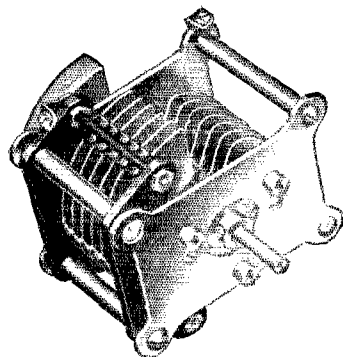

GENERAL RADIO CO.,

Cambridge, Mass.

GENERAL RADIO

INSTRUMENTS

*Here's the Tuning Unit
You've Been Waiting For—The NEW*

Hammarlund "Auto-Couple"

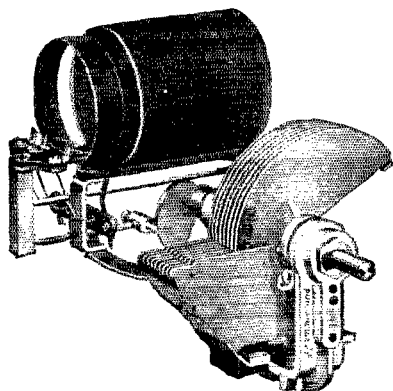

Hammarlund Low-Loss, Space-Wound Coils may also be had for use in neutrodyne and other tuned radio frequency circuits, as well as regenerative circuits using tickler feed-back.

IT is an assembly of Space-Wound Coil, "Midline" Condenser and Aluminum Shield giving automatic, graduated primary coupling at every condenser setting and insuring maximum transfer of energy at each wavelength, with effective control of oscillations.

Coils, condensers and shields are sold separately if desired and are easily assembled. The shield is designed to inclose the complete assembly including a tube and its socket.

Most good radio stores sell Hammarlund-Precision Products—if yours doesn't, write us direct.

HAMMARLUND MANUFACTURING CO.
424-438 W. 33rd Street, New York

For Better Radio
Hammarlund
PRECISION
PRODUCTS

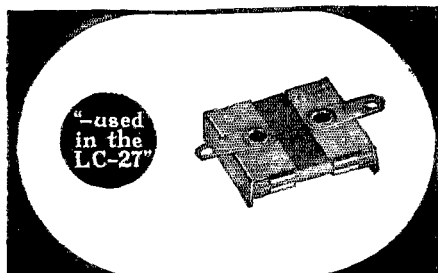

—used
in the
LC-27"

AEROVOX

"Built Better"

FIXED CONDENSERS

are Specified in

- | | |
|-------------------------|---------------------|
| LC ~ 27 | by L. M. Cockaday |
| Diamond of the Air | " Herman Bernard |
| To be announced soon(?) | " John Rider |
| Raytheon "B" Eliminator | " Raytheon Mfg. Co. |
| Ultradyn | " R. E. Lacault |
| To be announced soon(?) | " R. E. Lacault |

AEROVOX fixed condensers have been approved by M. I. T. and Yale Universities.

AEROVOX WIRELESS CORP.
489-491-493 Broome Street, New York

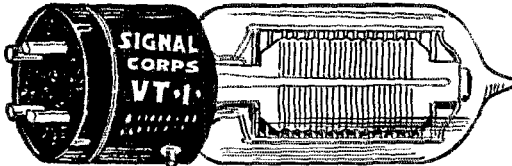

Western Electric Company
VT. 1
\$3.45

Commonly Known as the J Tube
Cost the U.S. Government \$15.00

Fits any Standard Socket. Works on 6 Volt Storage Battery

This is the first time in history that these Super Radio Tubes have ever been offered to the radio public. Radio Amateurs everywhere are amazed at this opportunity to be able to buy these tubes at such ridiculously low prices.

The Western Electric VT. 1, manufactured exclusively for U. S. Navy has a much longer life than any other tube known. Characteristic of this tube—when used as a detector—apply 22½ V. to 45 V. to plate and using terminal voltage of 2.75 will show a milliampere reading of 6½ milliamperes.

When used as an amplifier with the same terminal voltage mentioned above the 45 to 90 volts plate it will show a milliampere reading of 8¼ to 10 milliamperes.

VT. 2. TRANSMITTING TUBES \$7.45

EPPE'S
523 Market St., Philadelphia

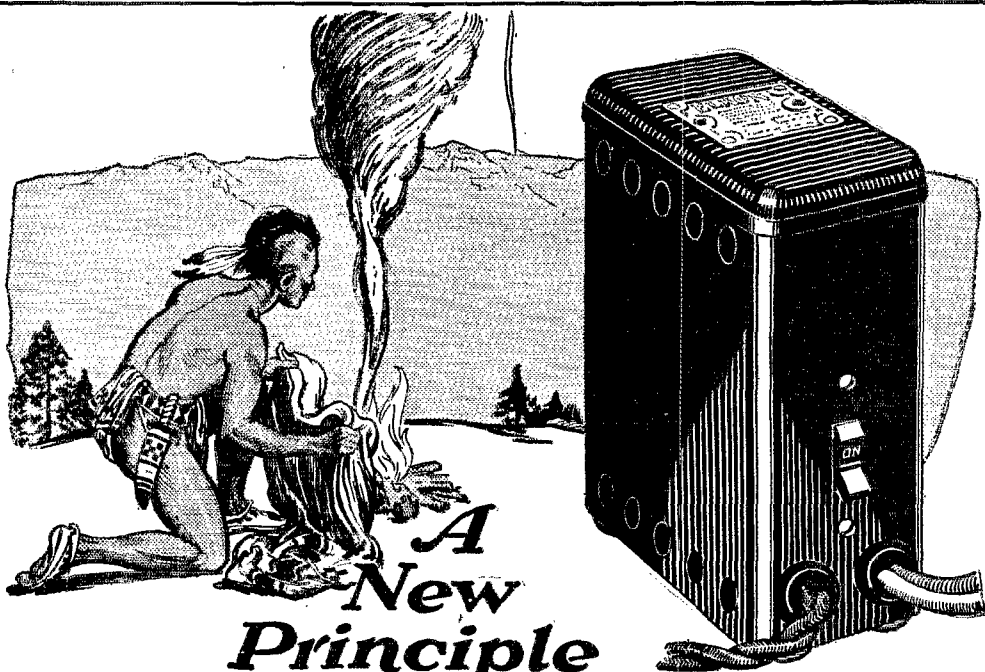

**A
New
Principle
not—just another Charger**

THE ELKON TRICKLE CHARGER is as different from earlier attempts at "A" battery charging as Radio Signalling is from the signal fires of the Indians. All the former expedients necessary to secure current rectification are done away with. Two small discs, of dissimilar substances, in pairs, replace all the water, the acids, the alkalis, tubes and oscillating devices hitherto resorted to. And they not only rectify in a positive manner, but do so without interference, without noise, without heat, *and without attention.*

The Elkton Trickle Charger will operate in *any Position.* Short circuiting cannot harm it. It cannot overcharge for it tapers automatically from 0.7 amps to practically zero. It is full wave.

Install it . . . set it . . . forget it . . . Your "A" battery charging becomes a perfunctory matter, entirely automatic and dependable, and your time is freed for more important work. You need one.

Operates from 105-120 v., 50-60 cycles, direct from A. C. **(\$15.00 complete with switch)** 25-40 cycles also available at a slightly higher price

ELKON WORKS
Subsidiary of P. R. Mallory & Co. Inc.
Weehawken, N. J. Inc.

Sole licensees under patents pending to Samuel Ruben

ELKON TRICKLE CHARGER



*Selected as Standard
by the Hammarlund
-Roberts Board of
Engineers.*

Ruggedness!

THE maintenance of proper resistance in the grid-resistor is vital to efficient, noiseless reception. Sturdy as the evergreens of the mountain slopes, the Durham Metallized Resistor is built like them to endure the stress of changing atmospheric conditions.

500 ohms to 10,000 ohms.....	\$1.00
Above 10,000 ohms to .24 meg.....	.75
.25 meg. to 10 meg.....	.50

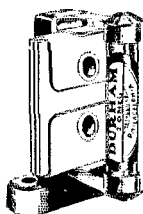

RESISTOR MOUNTING

Made of moulded insulation of exceptionally high resistance. Best quality, tension-spring, bronze contacts. Only upright mounting made.

Single Mounting.....	50c
For Condenser.....	65c

DURHAM
METALLIZED
RESISTORS

INTERNATIONAL RESISTANCE CO.,
Dept. B Perry Bldg., Philadelphia, Pa.

Your Speaker is! not to Blame!

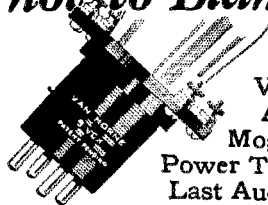

Put a
Van Horne
Adapted
Mogul 5 VCX
Power Tube in the
Last Audio Stage

The distortion that spoils the tone quality and makes natural reception impossible can be eliminated. It is only necessary to put in the last audio stage of your set, a power tube of sufficient capacity that will carry the signal without distortion to the speaker.

An Adapted Mogul 5 VCX power tube—as easy to apply as an ordinary tube—has almost double the signal carrying capacity of the ordinary tube. This greater capacity eliminates overloading and distortion and it can be applied to any set without change in wiring.

With an Adapted Mogul 5 VCX power tube in your set you will immediately note an unusual improvement—a general increase in volume, a roundness of tone and clear cut reproduction in voice and music that is unobtainable when ordinary tubes are used.

This unusual power tube is type 5 VCX with the adapter for sets not wired for power tube voltage. Model 5VC is made without the adapter for recent sets modeled with power tube voltage.

One of these tubes in your set tonight will show you what pleasing tone your set can deliver when distortion is eliminated.

THE VAN HORNE CO., Inc.

101 CENTER ST.

FRANKLIN, OHIO

Second Edition-Revised

Not page after page of dry theory like other radio text books, but a radio text and reference book written in a most interesting style with 885 pages and 700 illustrations. Right up to the minute and worth three times the price asked.

“RADIO THEORY AND OPERATING”

By
Mary Texanna Loomis
President, and Lecturer on Radio, Loomis Radio College,
Washington, D. C.

Price \$3.50

Postage paid to any part of world. Send check or money order. Immediate shipment.

LOOMIS PUBLISHING COMPANY
Dept. T-405 Ninth St. Washington, D. C.

A Master Product!

Designed for Reliable
Long Distance Communication
on
1 Meter to 200 Meters

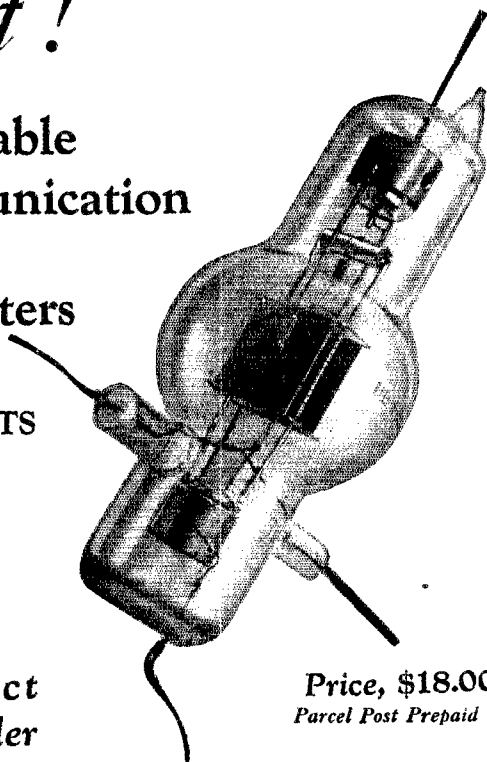

INPUT RATING 150 WATTS

Plate Voltages 500-3000

Plate Currents 40-50 MA.

Fil. Voltage 10

Fil. Current 2.35A

Sold and Shipped Direct
Upon Receipt of Money Order

Price, \$18.00
Parcel Post Prepaid

DE FOREST

TYPE-H

TRANSMITTING TUBE

THERMIONIC HR RECTIFIERS

Fil. Voltage 10
Fil. Amperes 2.35
Plate Voltage A.C. 2000

Plate Mill. Amps 250 Max
Voltage Drop 400 at 250 MA
PRICE \$16.00

Will operate 4 H Tubes

139 Franklin St., DE FOREST RADIO CO., Jersey City, N. J.

For Transmission Assurance

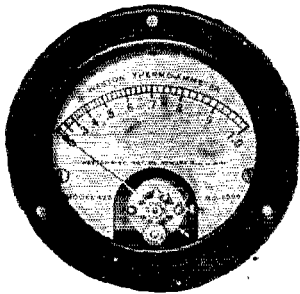

problems in the measurement of antenna currents. They overcome all objections to the hot-wire expansion type.

TRANSMISSION experts use Weston instruments. They give them the greatest assurance not only for their daily tests, but materially aid in solving their problems of tomorrow.

Model 425 Thermo-Couple instruments, originated by Weston, perfectly solve all

WESTON Model 301, 3 1/4 inch diameter D. Voltmeters, Ammeters and Milliammeters have the highest accuracy in panel instruments of the size. Your own work in transmission needs the same assurance required by experts—who choose Westons. You will be interested in the new and more attractive prices on the Model 425 Thermo-couple instruments. Write us for circular "J."

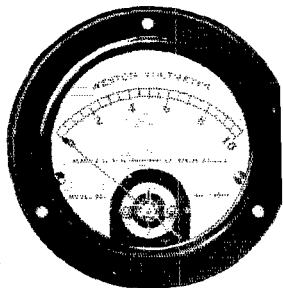

WESTON ELECTRICAL INSTRUMENT CORPORATION
158 Weston Avenue, Newark, N. J.

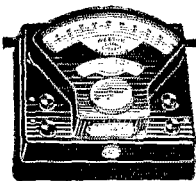

STANDARD THE WORLD OVER
WESTON

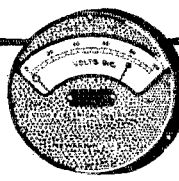

Pioneers since 1888

CECO

TYPE "H"

SPECIAL DETECTOR

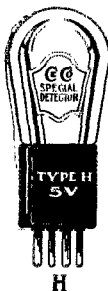

A special detector which is far superior to the old detectors of the gaseous type and is one of the latest achievements of "CECO" Engineers.

Any receiver will be improved by the use of a "CECO" type "H" Detector, which will give improved reproduction and avoid the usual rushing and hissing sounds of the "soft" detectors.

Using a higher plate voltage than previous types, it will handle powerful signals with less overloading. Average mutual conductance 940. Voltage Amplification factor 14.4.

PRICE \$2.50

CE Mfg. Co., Inc., Providence, R.I., U.S.A.

Faradon

CAPACITORS

"Capacitors" is adopted to particularize
Electrostatic Condensers

For All Purposes

Immediate Deliveries Can Be Made
on Over 200 Standard Types of

Faradon

For 19 years the Wireless Specialty Apparatus Company has supplied capacitors to the Radio industry.

Large users such as the U. S. Army, U. S. Navy, Bureau of Standards, General Electric Co., Radio Corp of America, Tropical Radio Telegraph Co., Westinghouse Electric & Mfg. Co., and Western Electric Co., utilize Faradon Capacitors in apparatus of highest quality.

Quotations furnished to Radio Engineers on large or small requirements upon receipt of detailed data. Complete specifications are requested.

WIRELESS SPECIALTY APPARATUS COMPANY

Established 1907

Jamaica Plain

Boston, Mass., U. S. A.

DUDLO

MAGNET WIRE AND WINDINGS

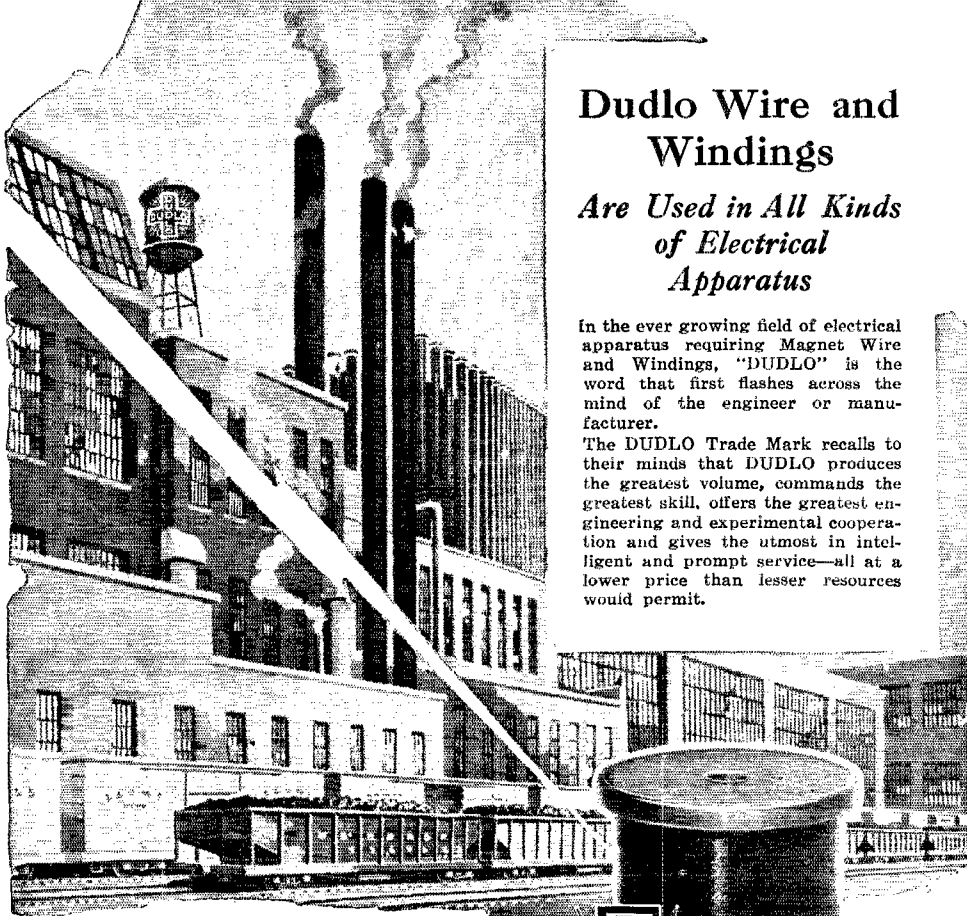

Dudlo Wire and Windings

Are Used in All Kinds of Electrical Apparatus

In the ever growing field of electrical apparatus requiring Magnet Wire and Windings, "DUDLO" is the word that first flashes across the mind of the engineer or manufacturer.

The DUDLO Trade Mark recalls to their minds that DUDLO produces the greatest volume, commands the greatest skill, offers the greatest engineering and experimental cooperation and gives the utmost in intelligent and prompt service—all at a lower price than lesser resources would permit.

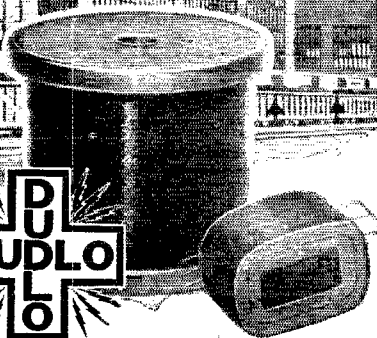

DUDLO MANUFACTURING CORPORATION

412 Chamber of Commerce Bldg., Newark, N. J.
274 Brannan St. San Francisco, Calif.

FT. WAYNE, IND

160 North La Salle St., Chicago, Ill.
4158 Bingham Ave., St. Louis, Mo.

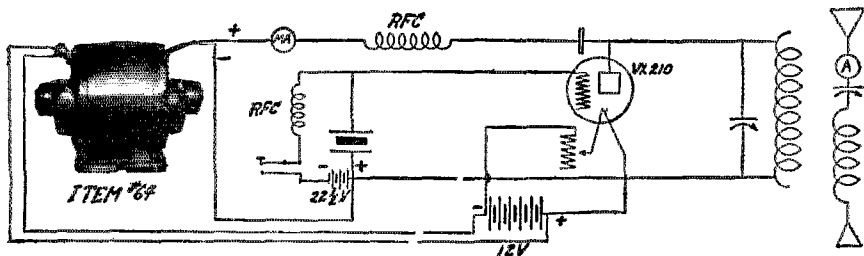

THIS is the first of a series of five "hook-ups" for crystal control transmitters using "ESCO" Maximum miles per watt Power Supply.

The above diagram shows one of the simplest workable controlled transmitters. The key is in the grid bias circuit. The set is operated from a 12 volt storage battery, filament supply being obtained directly from the battery, and plate supply from Item 64 operating from the 12 volt battery. The crystal is to have a fundamental in the 80 meter band for 80, 40 or 20 meter operation.

ELECTRIC SPECIALTY COMPANY

TRADE "ESCO" MARK

225 South Street

Stamford, Conn., U. S. A.

Manufacturers of Motors, Generators, Motor - Generators,
Dynamotors and Rotary Converters for Radio and other purposes

SM

635 Short Wave Kit

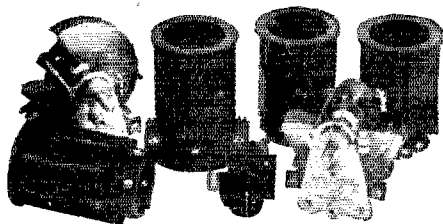

The type 635 Short Wave Receiver Kit contains the carefully designed and matched essentials for a real short wave set. Its range is 18 to 150 meters. The kit contains a set of four plug-in coils, one coil socket, one coupling condenser and two 140 mmf. condensers. These parts are all carefully designed for operation together.

With the four coils supplied, the amateur bands fall well to the center of the tuning scale. "Dead spots" at which the receiver will not oscillate are totally eliminated. The antenna condenser allows coupling adjustment to suit individual conditions.

Price \$23.00 at Your Dealers
Prices 10% Higher West of the Rockies

Silver-Marshall, Inc.

858 West Jackson Blvd.

Chicago, U. S. A.

5 tube SINGLE DIAL Control

\$50

SLIGHTLY HIGHER
ON WEST COAST

SOLID MAHOGANY

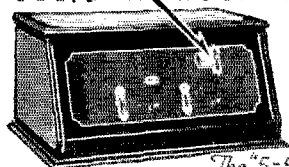

The "5-50"

Other CROSLLEY RADIOS - from 1 tube "PUP"
at \$9.75 to R.F.L.-90 Console at \$90.

CROSLLEY RADIO

Write Dept 18 for Catalog
CROSLLEY RADIO CORPORATION
CINCINNATI

Licensed Under Armstrong U. S. Patent No. 1,113,149

...this
is the trend
of Radio Progress

ALCOA



TRADE-MARK

Only the genuine
bears this mark

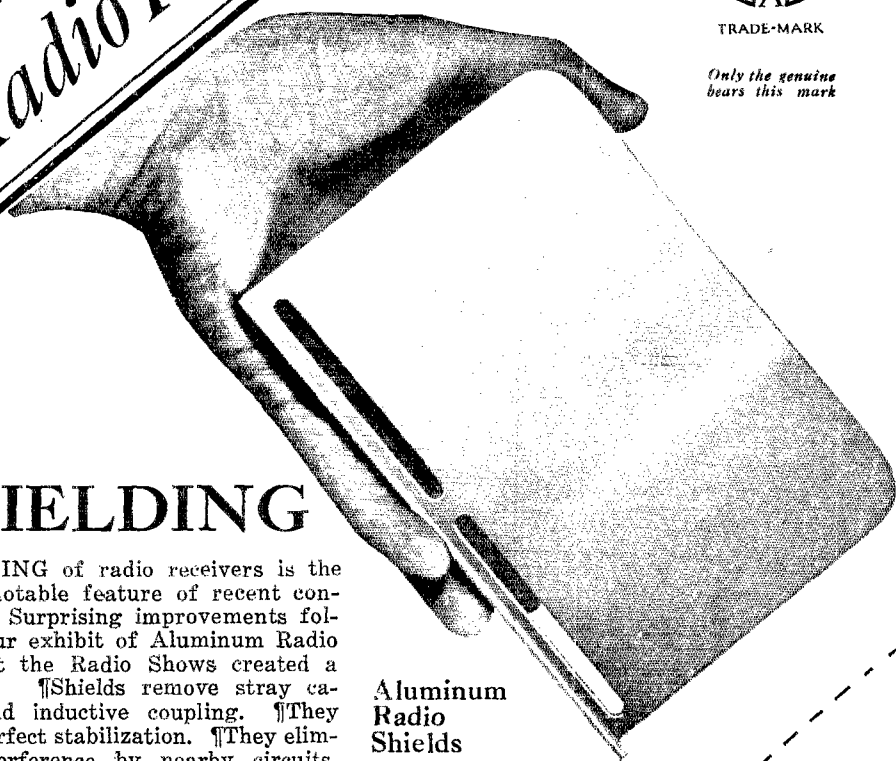

SHIELDING

SHIELDING of radio receivers is the most notable feature of recent construction. Surprising improvements follow. ¶Our exhibit of Aluminum Radio Shields at the Radio Shows created a sensation. ¶Shields remove stray capacity and inductive coupling. ¶They permit perfect stabilization. ¶They eliminate interference by nearby circuits. ¶Tuning controls can be reduced. ¶Alcoa Aluminum Radio Shields are of virgin aluminum with the highest mass conductivity known.

Aluminum Radio Shields

The Cockaday LC-27 uses Alcoa Aluminum Radio Shields. Now—another designer is using them—the Varion Receiver—marketed in kit form by the Morison Electric Supply Co., Inc., 15 East 40th St., New York City. Write them for hook-up and instructions, mentioning the ALCOA Shield.

Aluminum
Company
of America,
Room 2322,
Oliver Building,
Pittsburgh, Pa.

ALUMINUM COMPANY
OF AMERICA
PITTSBURGH, PA.

Gentlemen:
Please send me a complimentary
copy of the booklet "Aluminum
Radio Shields."

Name

Street

City

What Circuit do you now use?

What one will you build next?

Use the coupon. Get our new treatise
"Aluminum Radio Shields" by Cock-
aday, Free and our Research Engineers.



FROST-RADIO

Parts and Accessories



Type
700 and 800
Rheostats

These rheostats were first to meet the new high efficiency tube requirements. They give perfect control of both output (volume) and filament voltage without over-heating. Their smooth, noiseless operation causes no wear even after long use. Type 700 Metal Frame 50c, Type 800 Bakelite Frame 75c.

Type 880 and 890 Series
Super Variable
Resistances

They are non-inductive and give any degree of resistance from zero to maximum, smoothly, noiselessly and without wear. Type 880 has 2 terminals and Type 890 8 terminals. Both types \$1.25.



FROST-FONES for Quality and Distance



GEM-JAC

A small, sturdy jack that projects only 1 inch behind panel. Strong springs, permanently adjusted. Self-cleaning sterling silver contacts.

Price - - - - 40c to 50c

PAN-TAB

A De Luxe radio jack arranged for either panel or table mounting. Made of the finest materials.

Prices - - - - 65c to 90c



HERBERT H. FROST, Inc.
160 N. LaSalle Street
New York CHICAGO Los Angeles

EAGLE



All That's Best in Radio

Eagle Owners have the satisfaction of knowing they have the best Radio Receiver made, regardless of cost.

Ask Your Dealer



EAGLE RADIO COMPANY

16 Boyden Place Newark, N. J.

The Bremer-Tully ABSORBER SOCKET



They kill the vibrations which follow shocks or jars—they simply cannot continue as in the case of spring suspension.

The Detector model has special side dampers to kill microphonics. Positive contacts.

UX Absorber Socket (Illustrated) ..75c
UX Detector Model\$1.00

BETTER TUNING

The 10th (Revised) Edition of Better Tuning contains 56 pages, chock full of information on B Eliminators, Power Six Kit,—how to change the Counterphase—Six to a Power—Six model,—the weakness of changing inductance with capacity,—new forms of amplification and many other subjects.

Sent postpaid on receipt of 10c.

BREMER-TULLY MFG. CO.

520 SO. CANAL ST., CHICAGO, ILL.

FREE

This 84 Page Wonder Book of RADIO Bargains



Send
for
it
TODAY

Save
1/3 to 1/2

Send for this guide to Radio price and Radio quality. All of our vast resources and radio experience have been utilized to assemble for you in one gigantic institution, the best and newest things in radio. The Randolph catalog is indeed the radio market place of the world—a masterpiece of merchandising that befits our house, the largest exclusive radio mail order house in the world.

What Our Catalog Contains

Over 2,000 items—from the most beautiful, fully equipped console model radio set; down to the smallest part or tool for the set builder—kits, parts and supplies of every conceivable type and style. All beautifully illustrated and interestingly described. And to give this book added value, we have included radio data that makes it an invaluable text book for every lover of today's most fascinating and most wonderful achievement—RADIO.

Radio Sets

In this great radio market place you will find table model sets and console types with built-in loud speakers; the newest ampliphonic console sets; new Spanish period consoles; five, six, seven, and eight tube sets, with three dial, two dial, and the most and most popular single simplified control. All sets are assembled in beautiful, genuine mahogany and walnut cabinets in a choice of latest types and designs.

**5 Tube sets as low as \$24.90
Latest 1927 Models**

All Randolph sets are sold at amazingly low prices. No matter what kind of set you want—no matter how little you want to pay—you can select YOUR SET AT YOUR PRICE from the Randolph catalog.

Radio Kits

Include the following well known circuits, designs and approved by the world's foremost radio engineers: Madison Moore Super; Victoreen Super; Silver Marshal Six; Sargent's Infradyne; Remier Super; Short Wave Kits; 9-in-Line Super; New Acme Reflector; Clockaday; Neutrodyne; Browning-Drake; all classes of radio frequency, Super Heterodyne and every other approved popular circuit.

Radio Parts and Supplies

The Randolph catalog also contains a most complete line of "B" Battery Eliminators, including the famous Raytheon Eliminators; the latest type Loud Speakers, Cone Speakers, a complete line of quality "A" power units—in fact, you will find listed in this wonder book every part that goes into the construction of a radio set, or any accessories you desire, at prices that mean a substantial saving to you.

Free Radio Service

Everyone has need for radio service. We employ Radio Engineers who have made Radio their life work. Their expert advice and helpful suggestions solve every radio problem of our customers.

Our Guarantee

Every article in our catalog is based on careful laboratory analyses and tests. We guarantee to back up every item in our catalog with our own as well as manufacturer's assurance of quality.

YOU MUST HAVE THIS BOOK

Space limitations here prevent our telling you more about the Randolph Catalog. Simply fill out and mail the coupon—or you may send a postal or letter—and this truly remarkable Radio book will come to you ABSOLUTELY FREE.

MAIL THE COUPON NOW. ➔

Randolph Radio Corporation
180 North Union Avenue, Dept. 115 CHICAGO, ILL.

SAY YOU SAW IT IN QST—IT IDENTIFIES YOU AND HELPS QST

Why We Save You Money

Because we handle radio exclusively and sell a tremendous volume of everything in Radio, we can concentrate our buying power for the benefit of your customers.

Volume purchase regulates prices. We command rock bottom prices from manufacturers, and in many cases we contract for entire factory output of exclusive products. You will benefit by our great volume of purchases and sales, by securing anything you may want in radio at a substantial saving.

This Coupon Brings the Great RADIO BOOK FREE

RANDOLPH RADIO CORPORATION
180 N. Union Ave., Dept. 115
Chicago, Illinois

Send me—free—your 84-page, 1927 Radio Book.

Name.....

Street and No.....

R. F. D.....Box.....

City.....State.....

Bradleyohm-E

PERFECT VARIABLE RESISTOR

Endorsed by
PHILCO

PHILCO
 PHILADELPHIA SERVICE BARRON-CORRENTISSY
 PHILADELPHIA, PA.
 July 14, 1926.

ALLEN BRADLEY CO.,
 Milwaukee, Wisconsin.

The Bradleyohms which we are using in Philco "30" and "48" Socket Powers for voltage adjustment are very satisfactory. We have tested many variable resistors but have found no other unit equal to yours. We shall continue to use Bradleyohms in season.

Yours very truly,
Walter E. Holland
 Research Engineer.

EVER since radio broadcasting began, Allen Bradley Radio Devices have met the demand for silent, stepless, current control. Today, Bradleyohm-E, perfect variable resistor, is not only adopted



Bradleyunit

PERFECT FIXED RESISTOR

For a fixed resistance unit, Bradleyunit-A offers unusual advantages. It is a solid, molded resistor with silver-plated terminal caps that can be soldered without injuring the resistor. Since the Bradleyunit-A contains no glass in its construction and does not depend upon hermetic sealing for accuracy, it is unaffected by temperature, moisture or age.

Bradleyunit-A and Bradleyohm-E can be obtained from your radio dealer in several ratings. Insist on Allen-Bradley Radio Devices for lasting satisfaction.

as standard equipment by manufacturers of B-eliminators, but is recommended almost universally by radio engineers and writers as the ideal variable resistor for B-eliminator Kits.

The scientifically-treated graphite discs used in the Bradleyohm-E provide the only means of stepless, noiseless control which does not deteriorate with age. Carbon or metallic powders of various kinds have been used as substitutes by imitators of the Bradleyohm-E, but without permanent success. If you want a variable resistance unit for your B-eliminator which will give perfect service, be sure to ask your dealer for the Bradleyohm-E which is furnished in several ratings. Look for the Bradleyohm-E in the distinctive Allen-Bradley checkered carton.

Allen-Bradley Co.



277 Greenfield Ave

Milwaukee

Wisconsin

DON'T MISS IT

GENUINE LOOP

The famous rotatable loop, designed so that it has greater pick-up than any other on the market. Its expert construction assures the owner of reliable action under all conditions. Requires small table space. Brand new and in original carton.



*List price, \$12.00.
SALE PRICE, \$2.95.

More Radiola Specials

Radiola III The famous 2-tube, dry-cell receiver which employs the Armstrong 2-variometer, selective, regenerative circuit. List, \$25.00. **SALE PRICE, \$4.75.**

Radiola III Amplifier Makes an efficient 2-tube Radio-a. List, \$30.00. **SALE PRICE, \$5.50.**

Radiola IIIA A four-tube set of national reputation. Built to give perfect satisfaction in distance-getting, tone, and selectivity. List, \$35.00. **SPECIAL \$9.45.**

RADIO SURPLUS CORPORATION

250 Washington Street Boston, Mass

Reaching Out with PYREX Insulators

PYREX* Insulators help your transmitting set reach out to greater distances. The use of PYREX Insulators in short wave transmitters and receivers eliminates leakage and eddy losses. The country's greatest power stations, the Byrd Polar Expedition, the Navy, the Coast Guard and Air Mail Service, all have depended on PYREX Insulators for greatest efficiency.

Select your equipment from the following list of PYREX Insulators

PYREX—Low Power Transmitting Antenna Insulator, 7 1/4" long	1.50
PYREX—Medium Power Transmitting Antenna Insulator, 12 1/4" long	3.50
PYREX—High Power Broadcasting Station Antenna Insulator, 30" long	22.50
PYREX—Stand-off Insulator, Height 3" overall	2.75
PYREX—Stand-off Insulator, Height 7" overall	3.00
PYREX—Stand-off Insulator, Height 12" overall	8.00
PYREX—Lead-in Insulator, Navy Standard Bowl Type, for voltages up to 15,000	1.50
Complete with metal fittings	15.00

CORNING GLASS WORKS
 Industrial and Equipment Division
 Corning, N. Y.

*Trade-Mark Reg. U. S. Pat. Office

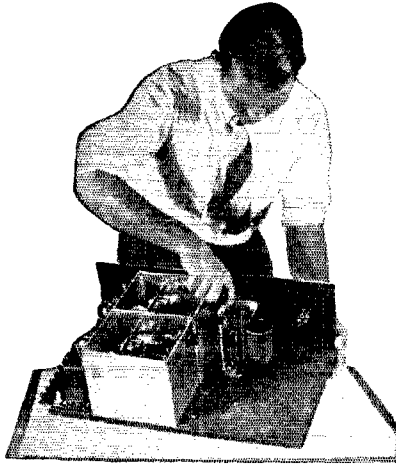

Get This Book!

Interesting as fiction. Thoroughly practical. Complete in description, picture and diagram. As simple as A.B.C.

25c

\$63.05

Complete Parts
(less cabinet)

A thoroughly modern receiver designed for home building and **GUARANTEED TO SATISFY**. Roberts regenerative circuit; every modern feature including Automatic Variable Coupling Complete Stage Shielding; 33 standard parts matched for perfect synchronization. Anyone can build it in few hours.

Hi-Q Foundation Unit



This is the Hi-Q Foundation Unit. Has drilled and improved Micarta panel, drilled Micarta sub panel, two complete shields, two equalizers, fixed resistance, extension shaft, hardware, wire, nuts and screws. Everything tagged. Mistakes impossible.

List, \$10.50

Associate Manufacturers

Carter Radio Co.
Martin-Copeland Co.
Radiall Company
Samson Electric Co.
Sangamo Electric Co.
Benjamin Electric Mfg. Co.
Eby Manufacturing Co.
Hammarlund Mfg. Co.
Durham Resistors
Westinghouse Micarta

Hammarlund-Roberts Performance Means A New Measure for All Radio

In designing the Hammarlund-Roberts Hi-Q Shielded Receiver ten of America's leading Radio Engineers had at their disposal the finest laboratories of the highest quality parts in the world.

This concentration of leaders on the perfection of one Receiver has developed entirely new features which produce results hitherto unknown to the average radio man. For example note the features of Automatic Variable Coupling and Stage Shielding described above. These features, plus perfectly synchronizing parts and a circuit of marvelous efficiency produce a type of reception which cannot be appreciated until heard. Selectivity parallels the expensive "Super"; volume is full and non-variable. Oscillation is practically eliminated; D. X. Stations cut in with knife-like sharpness. And in every instance tone qualities are wonderful.

Anyone Can Build It!

All the research, the selection of parts, the exact placing of units has been done for you by experts. Simply buy the Hi-Q Foundation Unit, the matched parts and the "How to Build It" Book. Follow simple directions and in a few hours have a 5-tube radio which is the practical equal of most 8-tube factory-made sets of higher prices.



★ High ratio of reactance to resistance. High ratio - - Great selectivity - - Loud signals.

HAMMARLUND-ROBERTS, 1182-H Broadway, New York

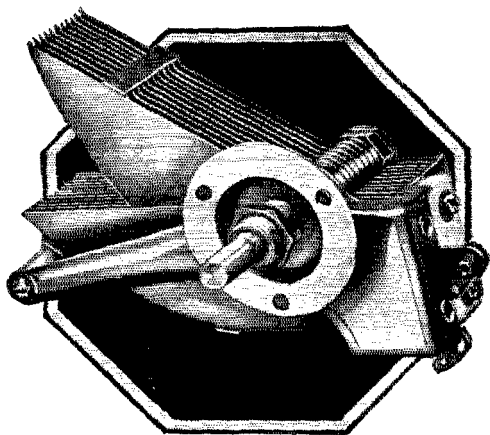

For Separating Stations

The Pacent True Straight Line Frequency Condensers Have No Equal

You can be absolutely sure of perfect straight line frequency operation with wide accurate spacing of stations when a Pacent Condenser is installed in your set.

From start to finish, every part of these compact, sturdy precision instruments was especially designed and constructed for true straight line frequency operation.

17 plates .00035, Mfd. Max. Cat. No. 251B. Price \$3.50
 23 plates .0005, Mfd. Max. Cat. No. 251C. Price \$4.50

Ask your dealer or write us direct about these and other Pacent Radio essentials

PACENT ELECTRIC CO., INC.
 91 SEVENTH AVENUE NEW YORK CITY

Canadian Licensed Manufacturer :
 White Radio Limited, Hamilton, Ont.

Manufacturing Licensees for Great Britain and Ireland:
 Igranic Electric Co., Ltd., London and Bedford, England

Pacent

RADIO ESSENTIALS

THE TUBE WITH THE SENSIBLE GUARANTEE



Stop walking

He.... "Please stop walking—I just missed the announcer—because your walking vibrates these tubes and I can't hear anything but 'noises.'"

She.... "But dear, I must walk—We have no other means for conveying these dishes into the kitchen."

He.... "Pardon me, you're right Honey—I guess I'll take Charlie's advice—your brother Charlie sure does know radio—He went out and bought a set of those New Supertrons—They are internally re-entranced and rigid—Since then he and Maude dance and even Chaleston without affecting reception!"

She.... "Now ain't that grand—You better get some Supertrons now—Be sure they are Isolantited—You'll see the difference"

He.... "Alright Honey—I won't take anything 'Just as Good' this time. I'll insist on Supertron because they are guaranteed by serial number and if I'm not satisfied the dealer will replace or refund within 30 days—So long Honey, will be back soon with Supertrons."

ALL TYPES AT PUBLIC DEMAND PRICES

SX 201 A	\$2.00	SX 171 Power	5.00
SX 199	2.25	SX 200 Detector	5.00
SV 199 small	2.25	SX HIMU	3.00
SV 199 large	2.25	SUPERTHEON Half	4.00
SX 112 Power	5.00	SUPERTHEON Full	5.00
SX 120 Power	2.50	in Canada slightly higher.	

SUPERTRON MFG. CO., Inc., Hoboken, New Jersey
Chicago Office: 39 North Dearborn St. Export Dept.: 250 Broadway, N. Y.



ELECTRAD

Your Set is as
 Good as
 Your Parts

NO doubt about that. If you know radio you know how important your Grid Leaks are. Use Electrad Metallic Leaks and Resistors. New—totally different. No carbon, paper, varnish, fiber. The metallic resistance element is fused to the inside of a glass tube.

Capped with the exclusive Electrad ferrule. Paraffined under high vacuum. Six points of superiority; Noiseless, Constant, Accurate, Non-hydroscopic, Non-inductive, Unvarying under any weather or working conditions. Great current-carrying capacity without overheating or change of resistance. Make this test—try these leaks in your own set. Hear the improvement in reception. Sizes 5000 ohms to 10 meg-ohms. Price: U. S. 60c; Canada 85c.



ELECTRAD

Consistent performance

Among the few radio receivers that have prospered by the radio amateur's keen technical analysis is Browning-Drake.

Willing to recommend a radio receiver only when it proved worthy by actual test, the radio amateur's immediate recommendation of Browning-Drake was but the beginning of its enthusiastic endorsement. Today, over 100,000 Browning-Drake owners are Browning-Drake boosters. And the number is ever growing.

Browning-Drake produces only one model, built complete at its Brighton laboratories. Sold at the fair price of \$95, steadily maintained, every Browning-Drake Dealer has made money.

Inquiries from amateurs are always welcome and receive immediate attention.

BROWNING-DRAKE CORPORATION, BRIGHTON, MASS.

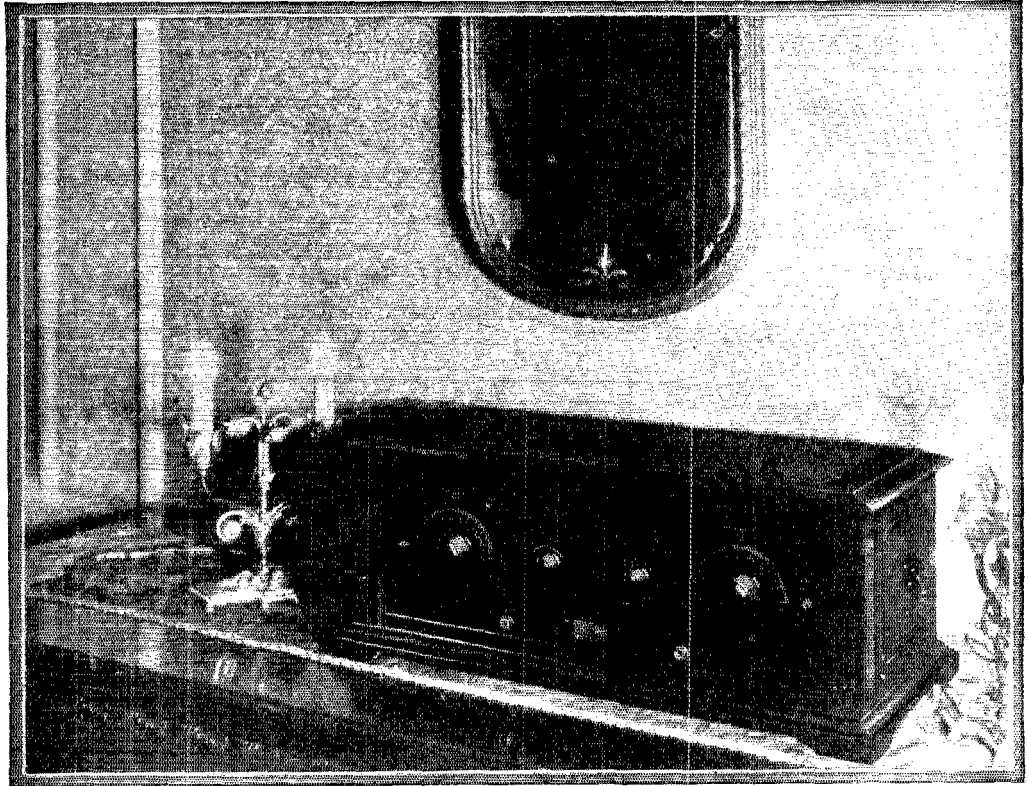

BROWNING-DRAKE



SAY YOU SAW IT IN QST—IT IDENTIFIES YOU AND HELPS QST



RESULTS!

Make Sure They Reflect Your Ability

The better the condensers you employ, the better your construction job. Polymet fixed mica and high voltage condensers are built to help YOU attain the perfect results which give complete satisfaction.

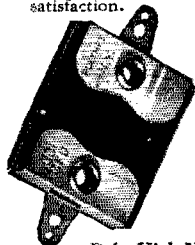

Poly Fixed Mica Condensers

Genuine Bakelite housing. One-piece lugs mean perfect contact and make soldering easy and quick. Individually tested. Capacities stamped, guaranteed accurate.

.00015 to .01 Mfd.
25c to \$1.00

Poly High Voltage Condensers

Guaranteed 1000 V.
Breakdown Test!

Incorporate finest insulating paper, best foil and specially prepared impregnating compounds. Non-inductive. High dielectric resistance for long life. Individual units or blocks—fixed terminals or flexible leads—in cans or unmounted.

.1 to 5. Mfd. 60c to \$4.50

Raytheon Circuit Condensers

Type F 1000, 14 Mfd. \$9.50
Type F 1001, .1-C-.1 \$2.00

Over 125 receiver and power unit manufacturers specify Polymet Products as standard equipment. THEY KNOW! At all good dealers.

Polymet Manufacturing Corporation
599 E Broadway New York City

POLYMET PRODUCTS

CARTER

New "Midget" Rheostat

With Filament Switch

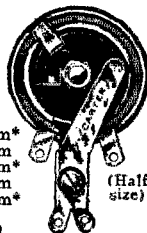

- | | |
|---------|---------|
| 2 ohm* | 20 ohm* |
| 3 ohm* | 25 ohm* |
| 6 ohm* | 30 ohm* |
| 10 ohm* | 40 ohm* |
| 15 ohm | 50 ohm* |
| | 75 ohm* |
- * R.M.A. Standard

(Half size) **\$1**

As soon as knob is turned from "off" position, filament circuit is closed. One less knob on panel, saves space. Resistance element clamped in metal frame. The wire cannot move and short circuit. Smooth, noiseless, compact.

Have you seen the new Carter "HI-OHM" volume control combined with filament switch?

R.M.A. Any dealer can supply
In Canada—Carter Radio Co., Limited, Toronto



What Size Grid and Plate Blocking Condensers?

You have always used .002 mfd. for blocking condensers but who knows that it is the best size for short waves? Our UC 1015 condenser gives eleven different capacities between .0002 mfd. and .001 mfd. so you can select the best size for your set. Why not try them? Tested at 7500 volts.

Price \$1.25 postpaid

General Electric Gridleaks



Enameled porcelain G. E. Gridleaks in 5000 ohm and 10,000 ohm sizes for all tubes. Size 1" x 8"

PRICES, 5000 ohm \$1.25, 10,000 ohm \$1.75, Postpaid.

Utility Radio Co., 80 Leslie St., East Orange, N. J.

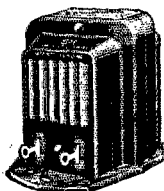

FAMOUS "BH" TRANSFORMERS

BH VIVAPHONIC

For quality of amplification, use the only Low-Loss, Shield Structure Audio transformer made. (Patented) Write for Catalogue Illustrating Audio and Transmitting Transformers.

BENJAMIN HUGHES ELECTRIC CO.
298 Leguachellera St., W. Montreal, Canada
Transformer Builders Since 1910

AERO COIL

SUPER-SENSITIVE

INDUCTANCE UNITS

The most important factors in perfect set performance:

Aero Coils are the perfect supersensitive inductance units! Due to their special patented construction, high frequency resistance is reduced to a minimum. Hence Aero Coils are capable of greater volume, and are sensitive to all the radio frequencies, thereby correcting the real cause of distortion, impossible to correct with other types of coils. But more! No dope is used. So if you are interested in better performance from any set, be sure to build with Aero Coils.

Tuned Radio Frequency Kit

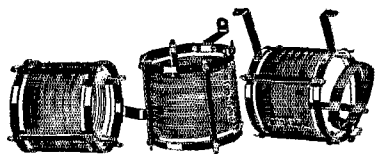

PRICE \$12.00

The Aero Coil Tuned Radio Frequency Kit illustrated above will positively improve the performance of any receiver. Patented Aero Coil Construction eliminates radio frequency losses and brings tremendous improvement to volume, tone and selectivity.

Kit consists of three matched units. The antenna coupler has variable primary. Uses .00035 condenser. 8 page color circuit layout and instruction sheet for building the supersensitive 5 tube Aero-Dyne receiver packed with each kit. Extra copies, 75c each.

Low Wave Tuner Kit

Completely interchangeable. Adapted by experts and amateurs. Range 15 to 130 meters. Includes three coils and base mounting, covering U. S. bands 20, 40 and 80 meters. You can increase the range of this short wave tuner by securing coils No. 4 and 5. Combined range of 15 to 550 meters. Both interchangeable coils fit same base supplied with short wave kit and use the same condensers. Coil No. 4 price \$4.00; Coil No. 5 price \$4.00.

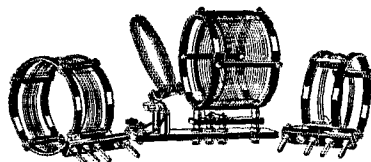

PRICE \$12.50

Aero Interchangeable Coils No. 4 and 5

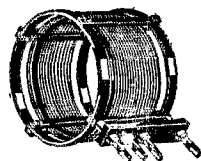

Increase range of your short wave tuner by securing coil No. 4 and coil No. 5, combined range 125 to 550 meters. Both interchangeable coils fit the same Aero base supplied with the short wave kit, and use the same condensers.

Coil No. 4 — Range 125 to 250 meters — \$4.00

Coil No. 5 — Range 235 to 550 meters — \$4.00

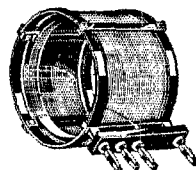

Other Supersensitive AERO Inductance Coils

There is an Aero Coil for every inductance requirement. In addition to these described above we make the following coils: Aero 3 Circuit Tuner, \$6.50. Aero Radio Frequency Regenerative kit, \$10.00. Aero Low-Loss Antenna Coupler, \$4.50. Aero Oscillator (for Superheterodynes), \$5.50. Aero Wave Trap Unit, \$4.00.

You can get any or all of these coils from your nearest dealer. See him TODAY.

AERO PRODUCTS, INC., Dept. 16, 1772 Wilson Ave., Chicago, Ill.

HENGER-SELTZER (Pacific Coast Representatives)

1111 Wall St., Los Angeles, Calif.—337 Brannan St., San Francisco Calif.

Now!



KINGSTON

B BATTERY ELIMINATOR

Do away with troublesome, expensive, bulky batteries, with acid, stained carpets, a dead radio just when you want it most. Install the KINGSTON B battery Eliminator and forget your battery troubles forever. Trim, handsomely finished in black and nickel, and guaranteed not only to remove the battery nuisance, but to deliver clearer tone and increased volume. Three different voltages obtainable at same time, each tap adjustable over a wide range, making any desired voltage from 5 to 150 possible and harmonizing perfectly with your own set. The Raytheon tube is used as a rectifier.

At Your Dealer's

Price, complete **\$35.00**
with Raytheon tube

KOKOMO ELECTRIC COMPANY
KOKOMO, INDIANA

Kingston



Approved "B" Power Parts
For All
Accepted Types of Eliminators
The New ABC Eliniator Units

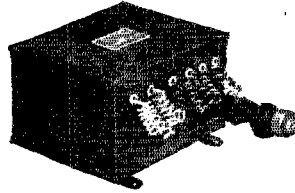

Specify
Dongan
No. 2568
\$17.50

for Raytheon B H Tube. No. 2568 unit consists of one No. 2561 Transformer and two 1591 Chokes. Eliminates all batteries and assures consistent, economical reception of greatly improved quality.

Special units for manufacturers can be worked out in our laboratories.

Fans can build complete eliminators of all types from Dongan diagrams.

Prompt deliveries assured—write or wire for information.

Special Transformers for Trickle Chargers

Dongan Electric Manufacturing Co.
2999-3001 Franklin St., Detroit, Mich.

TRANSFORMERS of MERIT for FIFTEEN YEARS

Nonoise Variable Grid Leak

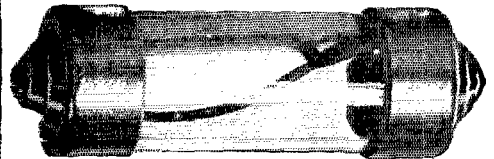

Operates on a new principle. Retains adjustment. Noiseless. Range $\frac{1}{2}$ to 7 megohms. Set Manufacturers who do not skimp on equipment use it in their sets. If your dealer does not stock them send us 85c and we will send you one.

RADIO FOUNDATION, Inc.
25 West Broadway, - - - New York, N. Y.

ELIMINATE ALL BATTERIES

Run ANY set ANY number of ANY type tubes from 110 volt A.C. No hum. Easily done with NEW TYPE ELIMINATOR quickly made for few dollars from STANDARD parts. No liquids. No salts. NO TRICKLE CHARGER! No battery of any kind. Gives perfect "A" and "B" current in any quantity. Nothing like it. Dollar bill brings detailed blue prints and instructions that assure perfect results.

J. M. MULLEN, Consult. Eng. Lab. A, 6549 N. Washtenaw Ave. Chicago

EVERYTHING IN RADIO
AT ATTRACTIVE PRICES

Full line of receiving and transmitting parts for the Ham. We are distributors of the Tohe Transmitting Condensers and other nationally known products. It pays to have your name on our mailing list. Drop us a card—Do it now. Dept E.

M. B. S. SALES CO., 27 School St., Boston, Mass.

it takes you less than one second

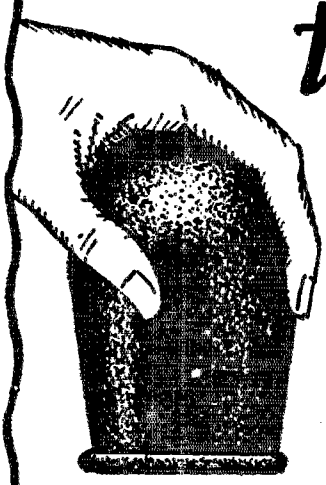

to end microphonic howling for once and all! That's when you slip one of these live rubber "howl absorbers" over the offending tube.

McDONALD HOWL ARRESTER

remember this name! You can get it for every size tube. Just ask your dealer, or write

Sole Selling Agents for the U. S. A.
SPARTAN ELECTRIC CORP.
350 West 34th Street, New York City
Manufactured in the U. S. A. by
Scientific Products Canada, Ltd.

Price 75 cents each
"It Stops that howl"

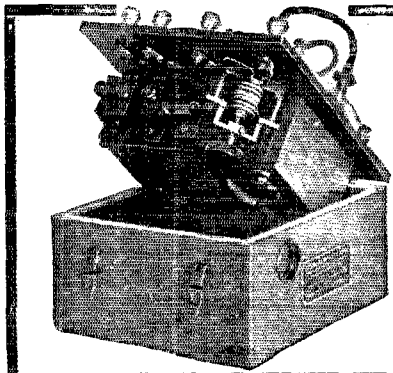
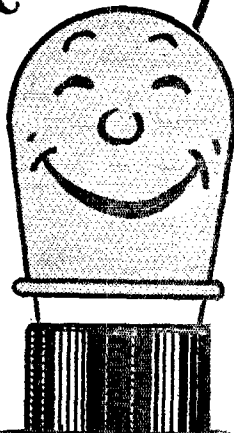
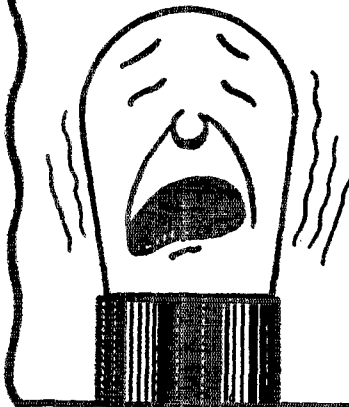

RADIO SPARK TRANSMITTERS (75 WATT PORTABLE)

Made for U. S. Army Aeroplanes

This is a tuned spark coil transmitter, with a wave length of 100-300 meters. The set is made of the finest of materials and the essential parts are the spiral tuning inductance, the induction coil, sending condenser and spark gap. Average range about 25 miles more or less. Just what you want for making

a Spark Coil—C. W. transmitter.

Brand new, in original cartons.

ORIGINAL GOVERNMENT COST, \$47 EACH

OUR PRICE, \$4.75 EACH

AMERICAN SALES COMPANY

21 Warren Street

New York City

Buy By the Name

Success in Set Building
Begins at the Dealer's Counter

ALL BENJAMIN RADIO PRODUCTS ARE
OF THE SAME HIGH STANDARD AS
THE FAR-FAMED CLE-RA-TONE SOCKETS

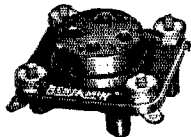

Cle-Ra-Tone
Spring Supported—
Shock Absorbing Sockets
Stop Tube Noises. Greatest aid
to non-noisy operation. Contacts
always clean. 75 cents each.

Improved Tuned Radio Frequency Transformers



Proved through exhaustive and comparative tests to be the most efficient coil for modern radio sets. Better in all important features and characteristics. Space wound. Basket weave. Cylindrical. Highest practical air dielectric. Gives wonderful sharpness in tuning, better volume and purer tone quality.

2 1/4" Diameter Transformer
Compact, especially desirable for crowded assembly. Eliminates interfering pickup.
Set of three, \$5.75. Single Transformer, \$2.10

3" Diameter Transformer
Capacity coupling reduced to lowest degree. For use with .00035 Mfd. Condensers.

Set of three, \$6.00. Single Transformer, \$2.25

Straight Line Frequency Condensers



No crowding of stations. The broadcast range is spread evenly over the complete dial. Stations come in without interference, and tuning is much easier. Adjustable turning tension. Low loss characteristics give a definite and distinct radio reception. Beautiful in appearance—a credit to the looks and efficiency of any set. Finished in dull silver.

Made in three sizes: .00025 Mfd., \$5.00;
.00035 Mfd., \$5.25. .0005 Mfd., \$5.50

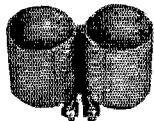

"Lekless" Transformers
Uniform high inductance, low distributed capacity and low resistance. The external field is so slight that it permits placing coils close together without appreciable interaction.

Single Transformers, \$2.50

Brackets



An aid to simplification in set construction. Supports sub-panel, with room underneath for accessories and wiring. Plain and adjustable.

Plain, 70 cents per pair
Adjustable, \$1.25 per pair

Battery Switch



Quick, positive, clean-cut make and break. When it's "in" it's "off," eliminating danger of wasteful use of battery. 30 cents each.

Rewards for Radio Reasoners

Awards for novel and original hook-ups, modifications of existing circuits; trade-names; slogans. Write our nearest office for full details.

If your dealer cannot furnish you with Benjamin Radio Products send amount direct to our nearest sales office with his name and we will see that you are promptly supplied.

Benjamin Electric Mfg. Co.

120-128 S. Sangamon St.
New York: Chicago San Francisco:
247 W. 17th St. 448 Bryant St.

Manufactured in Canada by the Benjamin Electric Mfg. Co. of Canada, Ltd., Toronto, Ontario



Everything For the Ham

Nicholson Electric Co.,
1407 First North Street
SYRACUSE, N. Y.

RADIO OPERATORS WANTED

THE EASTERN RADIO INSTITUTE can train you quickly and thoroughly because:

MODERN AND EFFICIENT METHODS
THOROUGH INSTRUCTION under staff of
LICENSED COMMERCIAL OPERATORS
MODERN APPARATUS including SHORT WAVE
TRANSMITTER

FOURTEEN years a RADIO SCHOOL
THE OLDEST, LARGEST and MOST SUCCESSFUL
school in New England. RECOMMENDED BY THE
A. R. R. L.

Day or Evening Classes Start Every Monday.
SPECIAL CODE CLASSES

Write for Illustrated Prospectus

EASTERN RADIO INSTITUTE
899 BOYLSTON STREET BOSTON, MASS.

Airplane flame proof Blinker Key CQ-1140, at \$4.00. 345 1012-A. S. W. Reg. Receiver, 1 tube, 50-1000 meters, \$40.00. TUBES, CQ. 886, Fil. 3, 8-4, 4V; Amps. 0.91; 3 prong base Socket Pin is 4th Terminal, \$1.50 ea. 70-2500 Meter Wave-meter, Type 2500-B-2. Complete, 3 coils, graphs, meter indicator, \$10.00. Just a sample of our bargains. Get our new and latest reduced price list for a 2¢ stamp. We bought \$10,000.00 worth of United States Government Radio Transmitting and Receiving Sets and Parts. Mail orders sent all over the world.

WEIL'S CURIOSITY SHOP 20 South 2nd Street, Philadelphia, Pa.

LEARN THE CODE

with SIGNAL

a
High Pitch Buzzer and
Key Set



Build complete with key, true tone adjustable high pitch buzzer and code plate. Write us today.
Signal Electric Mfg. Co., Menominee, Mich



B-Eliminator

Voltmeter 800 Ohms per Volt

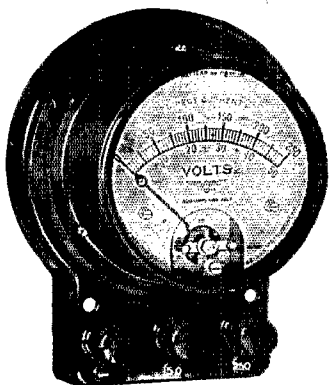

Pattern No. 116

B-Eliminator
Voltmeter

In the efficient servicing of a radio set it is very essential that the voltage of the B-eliminator be checked. This cannot be accurately done with an ordinary Voltmeter.

The Jewell No. 116 Voltmeter has a very high resistance (800 ohms per volt) and was designed especially for voltage measurements when a B-eliminator is under test. Send for special descriptive circular No. 1018.

Jewell Electrical Instrument Co.

1650 Walnut Street Chicago, Ill.

26 Years Making Good Instruments



Is Your Order In?

Now that the season is at its height, orders are pouring in for the TECO short-wave apparatus. We try to fill these as quickly as possible, but naturally it has to be "first come, first served." Give us a chance to serve YOU promptly.

TECO SHORT-WAVE RECEIVER

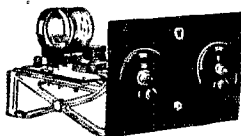

the entire tuning range of 10 to 200 meters (1500 to 30,000 kilocycles). SPECIAL SALE PRICE, \$27.50.

TECO SHORT-WAVE TRANSMITTER

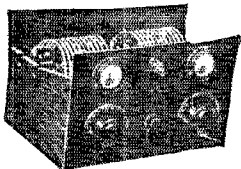

Designed by amateurs, this receiver is laboratory tested and made of the best parts obtainable. The great care exercised in its construction insures efficient operation over

Built to the highest of standards. Has all necessary high voltage filters and chokes. A milliammeter and a hot wire meter are mounted on the panel. Two sockets in parallel give the operator

complete control of the output. Tuning condensers are high voltage Carwells. SPECIAL SALE PRICE, \$39.50.

Write for Information on Teco Plug-in Coils and Crystal Controlled Transmitter

TRANSMITTING EQUIPMENT CO., 19 Stuart St., Boston, Mass.

LYNCH METALLIZED FIXED RESISTORS

ARE WARRANTED—
Absolutely Noiseless
Permanently Accurate
Dependable!

Write us!

ARTHUR H. LYNCH, Inc.

Manufacturers of Radio Devices

Fisk Bldg., Broadway & 57th Street
New York, N.Y.

Become a Radio Operator

See The World. Earn a Good Income. Avoid Hard Work.
Learn in the Second Port U. S. A.

Radio Inspector located here, Splendid Climate. Other advantages to the student unexcelled in any other American port. Every graduate secures position. Nearly 100% of operators graduating on Gulf during past four years trained by Mr. CLEMMONS, Supervisor of Instruction, Day and Night Classes; enroll any time. Write for Circular, Department TWO.

Gulf Radio School 844 Howard Ave.
New Orleans, La.

TELEGRAPH KEYS. A perfect device to use on that low-power transmitter. Silver contacts and phosphor-bronze springs. Made to sell for \$1.75. SPECIAL 49 cents.

A-I BUYS

BLINKER PRACTICE SET

Consists of a small box on which is mounted a telegraph key, which comes equipped with an extension handle. Binding posts are provided for telephone receivers and line so that communication between two points is possible. There is a high frequency buzzer of excellent design and a blinker light. By means of a switch arrangement, either the light or the buzzer can be switched on for practice. A BARGAIN AT \$2.95.

UV-202 TYPE TUBES. Special at \$3.25.
RECTIFYING TUBES. Full wave, \$1.25. Half wave, 95 cents.
210 TYPE TUBES, 7½ watt, \$4.75.
C. R. L. POWER RHEOSTAT for the control of 7½ watt tubes, 75c.

APCO Vernier Dials

Four-inch; geared 10 to 1. Fits tight against the panel. On those low wave stations when selectivity means distance, this dial is supreme. Also acts as a shield to eliminate body capacity. List, \$1.50. OUR PRICE, 45 cents.

Jewett Units



A new shipment of these \$7.50 units to sell at \$2.25.

Federal Phonograph Panels. 5-Tu!

Shielded in a fibre case. Equipped with vernier dials, gold-on-graved. Famous for its selective circuit. 2-dial control. SPECIAL AT \$14.50.



High Frequency Buzzer

Desirable for testing crystals and for practicing code. Gives a sound nearly resembling C.W. SPECIALLY PRICED AT \$1.00.

King-Cardwell Transmuting Condenser

Factory rebuilt for 3000 volts. SPECIAL \$2.95.
King-Cardwell 41-plate Condenser, 95 cents. 11-plate 95 cents.
King-Cardwell 15-15 plate Dual Condenser. Used in grid-motordrive. \$1.95

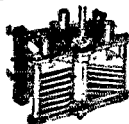

Power Reproducer, R-3. List, \$35. \$11.75.
Power Reproducer, R-2. List, \$50. \$16.75.
Combination Reproducer & Amplifier, A.H. List, \$59.00. \$14.75.

MAGNAVOX Radio

Model A2R. List, \$85.00. \$18.75.
Audio Frequency Power Amplifiers:
A-1. One-stage. List, \$27.50. \$8.75.
A2C. 2-stage. List, \$55.00. \$11.50.
A3C. 3-stage. List, \$75.00. \$16.50.
Write for Complete List of Magnavox Stock.

UV-719 Audio Transformer, 9/1. List, \$7.00. \$1.60.
UP-1018. Power Transformer. List, \$38.50. \$11.50.
UL-1008. Oscillation Transformer. List, \$11.00. \$7.50.
UP-1656. Filament Transformer. List, \$15.00. \$5.50.



UC-1803 Faradon Condenser. List, \$5.00. 95c.
TF Transmitter, 20-watt. SPECIAL, \$42.50.
201 Tubes. Excellent for the short-wave transmitter, 95c.

RADIO SURPLUS CORPORATION 250 WASHINGTON STREET BOSTON, MASSACHUSETTS

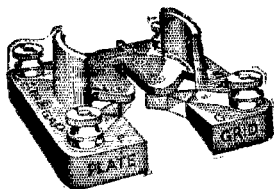

Type U. X. Universal
Price 60c

They help prevent closed circuit, absorption of current, intercoupling of circuits, feedback and undesirable capacity; making your set more stable, sharpening tuning, resulting in purer and clearer tones with more volume on local and distant stations.

Sent direct Post-paid if your Dealer cannot supply you

★ AIRGAP PRODUCTS CO.
13 Campbell Street

The AIRGAP SOCKET

"It Gets That Last Mile"

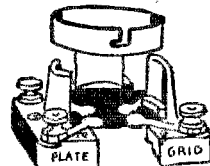

Type U. Y. Standard
Price 75c

Newark, N. J.

GENUINE BAKELITE PANELS 1/4" THICK

First Grade. Highly Polished On Both Sides

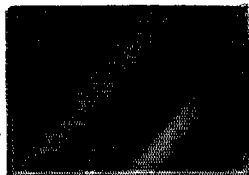

Size	Regular Price	SPECIAL PRICE
9 1/2 x 11 1/8	\$2.63 ea.	\$1.00 ea.
10 1/16 x 14 1/16	3.63 ea.	1.50 ea.
14 9/16 x 17 15/32	6.38 ea.	2.50 ea.
14 9/16 x 17 1/2	6.63 ea.	2.60 ea.
15 1/4 x 17 1/8	6.63 ea.	2.60 ea.
15 1/8 x 16 13/16	6.38 ea.	2.50 ea.

Make your TRANSMITTER and RECEIVER efficient and neat with these High Grade Panels.

AMERICAN SALES CO., 21 WARREN ST., NEW YORK CITY

Centralab Rheostat S

Permanently Noiseless

Where old design, ordinary rheostats overload, heat-up and quickly become noisy on circuits with several tubes, and on new tubes using increased current, Centralab Rheostats operate smoothly and permanently quiet.

NO DEAD SPOTS

Insulated metal discs clamp the resistance immovable and warp-proof—insuring even regulation and no dead spots. With large area of metal to aid in cooling, and carrying extra heavy current for their size, they improve the quality of any receiver.

Wire wound, 1 resistances, for 7 to 5 tubes, \$1.00.
 Ribbon wound, 2 resistances, for 5 to 10 tubes, \$1.25.
 At dealers, or mailed direct COD
 Central Radio Laboratories
 20 Keefe Ave., Milwaukee, Wis.
 Makers of a full line of variable resistances for 60 manufacturers of leading standard sets.

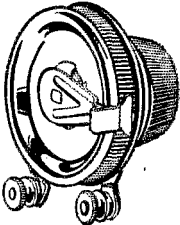

Write for Free Circuit Hook-Ups

Centralab

Write for one Today

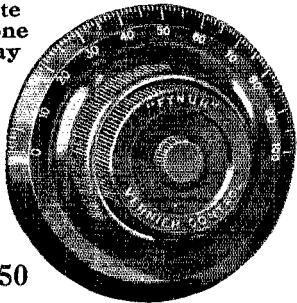

\$2.50

FYNUR VERNIER CONTROL

*Greater Distance!
 Greater Selectivity!
 Longer Life!
 Absolutely Accurate!*

A quality dial. Operated by traction. No gears to backlash. Simple in construction and will outlast your set. Write today and increase the efficiency of your set. Money refunded if not satisfactory. Fits any 1/4" shaft.

August Goertz & Co.,
 270 Morris Ave. Newark, N. J.

YAXLEY

APPROVED RADIO PRODUCTS

Cable Connector Plug

Bakelite Construction

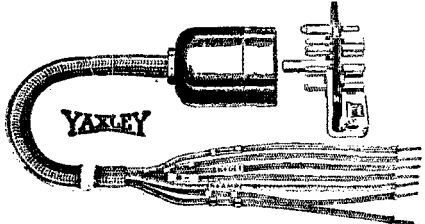

One of the most practical accessories to a radio outfit. Simplifies the battery wiring and makes sure of an instant and correct battery connection any place the radio set may be moved to. Banishes the old-fashioned unsightly mass of battery wires.

Bakelite construction, neat and handsome in appearance. Metal cable markers and a colored template (RMA standard color code) on the connector plate make it easy to attach to any set. The Plug has phosphor bronze double contact springs, mounted in Bakelite, which cannot work loose. Shorting is impossible.

The Connector Plate has brass contact pins, tinned for soldering and is mounted upon a bracket which is reversible or may be entirely removed for subpanel mounting.

The Cable is of extra good quality, in seven strands. (RMA standard colors), and is five feet in length. Six extra markers packed with each plug.

- No. 660—Cable Connector Plug Complete\$3.50
- No. 670—For the set with binding posts. No soldering. Just hook-up the terminal to your set and the batteries and the job is done\$4.00

At your dealer's. If he cannot supply you, send his name with your order to

YAXLEY MFG. CO.
 Dept. S
 9 South Clinton Street
 Chicago, Ill.

CQ. CQ. OM.

Wake up!

Do you use a CRICKET KEY?

If you don't you haven't kept up with the times — you are out of date. We guarantee material and workmanship and that with even ordinary intelligence the CRICKET KEYS will do all that we claim.

NO BUM FISTS. NO GLASS ARMS.

Hams' delight and beginners' best friend.

Highest quality combined with moderate price.

Desk CRICKET

Brass contact, \$9.00 prepaid.
Silver contact, \$10.50 prepaid.

Portable CRICKET

Brass contact, \$10.25 prepaid.
Silver contact, \$11.75 prepaid.

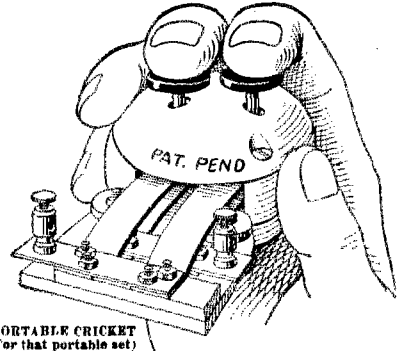

Listen to 5EH

DESK CRICKET
(Recommended especially for beginners)

PORTABLE CRICKET
(For that portable set)

F. F. Mace & Son, 132 Sunset Ave., Dallas, Texas

To Our Readers Who Are Not A. R. R. L. Members

Wouldn't you like to become a member of the American Radio Relay League? We need you in this big organization of radio amateurs, the only amateur association that does things. From your reading of *QST* you have gained a knowledge of the nature of the League and what it does, and you have read its purposes as set forth on page 6 of every issue. We would like to have you become a full-fledged member and add your strength to ours in the things we are undertaking for Amateur Radio, and incidentally you will have the membership edition of *QST* delivered at your door each month. A convenient application form is printed below—clip it out and mail it today.

.....1926

American Radio Relay League,
Hartford, Conn., U. S. A.

Being genuinely interested in Amateur Radio, I hereby apply for membership in the American Radio Relay League, and enclose \$2.50 (\$3 in foreign countries) in payment of one year's dues. This entitles me to receive *QST* for the same period. Please begin my subscription with the.....issue. Mail my Certificate of Membership and send *QST* to the following name and address.

.....
.....
.....

Station call, if any

Grade Operator's license, if any

Radio Clubs of which a member

Do you know a friend who is also interested in Amateur Radio, whose name you might give us so we may write him about the League?

..... Thanks?

Ward Leonard VITROHM RESISTOR



Grid leak for use
with 250 Watt
Transmitting
Tube.

Resistance of 5000 ohms, center tapped.
Wire wound on 8 1/2 inch tube, enclosed
in vitreous (glass-like) enamel.

Practically indestructible; permanently
accurate; non-inductive; zero temperature
co-efficient.

By mail postpaid \$2.90 including mount-
ing brackets.

Can also furnish a
20,000 ohm grid leak unit for the new
De Forest type "H" transmitting tube.
\$6.15 postpaid.

50,000 ohm grid leak unit for the new
De Forest type "P" transmitting tube.
\$8.60 postpaid.

Ward Leonard Electric Company
Mount Vernon, N. Y.

7731-6

Mount Vernon, N. Y.

Broadcasting Station Accessories

Push-Pull Transformers for 7 1/2 w. 50 w.
and 250 w. speech input circuits.
Microphone Mixing and Amplifier Out-
put Transformers. A complete line of
retards and transformers for amplifier
circuits.

Variable and Fixed Air Condensers of
any size required.

High voltage Plate Generators up to 30
k. w.

Broadcast Station erecting, rebuilding
and general engineering.

J. E. Jenkins & S. E. Adair, Engrs.,
1500 No. Dearborn Parkway, Chicago

HALCO

MAIL ORDER SERVICE

For Radio Transmitting Equipment

THE HALCO MAIL ORDER SERVICE Presents the "New Day"

Short Wave Receiver in kit form. The
HALCO kit, for this "New Day" Receiver
is complete down to the last piece of bus-
bar, wire and screws. Front and sub-panels,
drilled and engraved, are also included in
the kit.

A 10% discount will be allowed on the "New Day" kit
to all A.R.R.L. members.

LIST OF PARTS AND PRICES

1 Set of Aero Short Wave Coils.....	\$12.50
1 Cardwell Condenser, type 191-D, .00025 mfd.	4.00
1 Cardwell Condenser, type 192-D, .00025 mfd.	4.00
1 Cardwell Condenser, type 167-E, .00015 mfd.	4.00
2 Benjamin CleRaTone Sockets for UX Tubes..	1.50
1 Amperite No. 112, 1/2 Ampere, Automatic Fila- ment Control	1.10
1 Toba Deuschmann Grid Leak, 10 megohms..	.50
1 Toba Deuschmann Resistor, 25,000 ohms....	.75
2 Single Resistance Mountings.....	.70
1 Sangamo Mica Fixed Condenser, .0002 mfd.	.40
1 Carter Filament Switch65
1 RCA UV 712 Transformer, first stage.....	1.60
1 National Velvet Vernier Dial, type B.....	2.50
2 Kurz-Kasch Pointer Knobs.....	.60
1 Bakelite Panel, 7 x 18 inches, drilled and en- graved	6.50
1 Bakelite Sub-panel, 7 x 15 inches, drilled....	4.00
1 Pr. of Cardwell Sub-panel Brackets.....	.75
7 Eby Engraved Binding Posts.....	1.05
5 Lengths of Insulated Buss-Bar (Celatsite)...	.50
1 Assortment of Screws, Lugs, etc.....	.50
1 Set of Full-size Working Drawings.....	1.00
Price of Kits Complete (less 10% discount to League Members)...	\$37.22

These parts may be purchased individually.

HALCO is right in the Lead!
We are equipped to furnish complete parts
for the
DALLIN SUPER-REGENERATIVE SHORT
WAVE RECEIVER

Super-regeneration is enormously efficient on
short waves and as hams all know, there is
no whistle as on Broadcast wavelengths,—the
variation-frequency being super-audible. Write
us for particulars on this new development.

HALCO MAIL ORDER SERVICE sells to Radio
Amateurs, direct by mail, apparatus of the following
manufacturers:

Acme Apparatus Company	General Radio Co.
Advance Electric Company	Gross & Co., J.
Aero Products Co.	Hammarlund Mfg. Co.
Amer. Transforming Co.	Jewell Electric Inst. Co.
Benjamin Electric Mfg. Co.	Karas Electric Co.
Bremser Tully Mfg. Co.	Marlo Electric Co.
Cardwell Corp., Allen D.	National Co.
Central Radio Laboratories	Radio Engineering Labs.
Corninix Glass Works	Sangamo Electric Co.
Crescent Radio Supply Co.	Silver Marshall, Inc.
DeForest Radio Co.	Thorniarson Electric Mfg. Co.
Deuschmann Co., Toba	Vibroplex Co., Inc.
Dubilier Con. & Radio Corp.	Weston Electrical Inst. Corp.
Electric Specialty Co.	Wireless Specialty App. Co.
General Instrument Co.	Yaxley Mfg. Co.

Descriptions matter covering these items in detail,
with prices, will be gladly send on request if you will
mention CITIZENS AMATEUR RADIO CALL-BOOK.

(We ship you promptly on receipt of your check or
money order). Specify clearly in your letter whether
you wish shipment by express or parcels post.

HALCO Mail Order Service, 132 Hanover St., Boston, Mass.

GROSS WAVEMETER

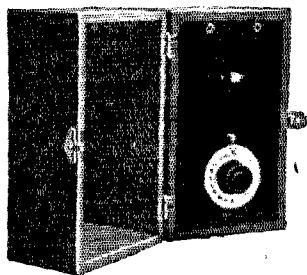

A high grade precision instrument at 1/3 the usual market price. Built into compact carrying case of genuine solid oak, leather handle on top with removable cover. Coils extremely low loss making a very low resistance wavemeter either the flash lamp or galvanometer type will easily respond to an oscillator using 50 volts or less on the plate of the tube. Coils fit into holder in the cover. Calibration better than 1% guaranteed. Checked against Piezo oscillator using a minimum of 10 points for each curve, no imaginary curves drawn from 3 or 4 points. Separate curve furnished with each coil.

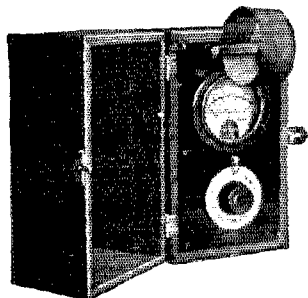

- Type 1—L—with flash lamp indicator for 20, 40, 80 meter bands. \$15
- Type 2—L—with flash lamp indicator for 20, 40, 80 and 200 meter bands \$18.75
- Type 1—G—with galvanometer indicator for 20, 40, 80 meter bands \$30
- Type 2—G—with galvanometer indicator for 20, 40, 80 and 200 meter bands \$33.75

Broadcast Transmitters and Short-Wave Transmitters in Stock.
Full Line of Transmitting Supplies and Receiver Parts on Hand.

J. GROSS & CO.

30 Park Place

New York City

Operate
your radio set
from the
light socket
with the new
Balkite
Combination

ASK YOUR RADIO DEALER

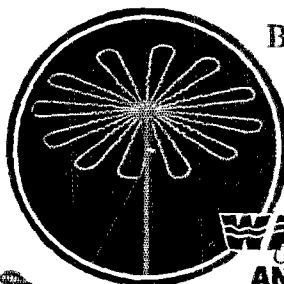

BRING IN

EVERY
STATION
ON THE AIR
WITH A

WAVE-X
Condensing
ANTENNA

An aerial that can be erected on wall, chimney or roof, anywhere 5 foot square is available. Provides sharper tuning, increases selectivity and is non-directional. Two highly conductive feelers reaching out in all directions have the capacity of long single wire. Perfect insulation prevents losses. Erected and dismantled quickly. A single upright to erect, hammer and screwdriver the only tools needed. No. 2, 8 foot pole ready to install, full instructions \$12.50. Get a Wave-X now.

REDI-MAST
FOR AERIALS
FUSING ROOF INSULATION

A strong hand turned rock maple pole 5 or 8 foot lengths. Fits any roof. Will carry heaviest steel covered single or multiple wire antennas in strong wind. Complete, guy rois, web irons, roof sockets, anchor pins and full instructions. 5 foot mast \$3.50 each. 8 foot \$4.25. Ask your dealer.

DEALERS

Wave-X and Redi-Mast are quick sellers. Write today for our dealer offer.

The Zinke Co.
1323 S. Mich. Ave.
Chicago, Ill.

The Pressed Metal
Mfg. Co.
Waukesha, Wis.

**T
R
A
N
S
M
I
T
T
I
N
G**

**KITS-SETS
-PARTS**

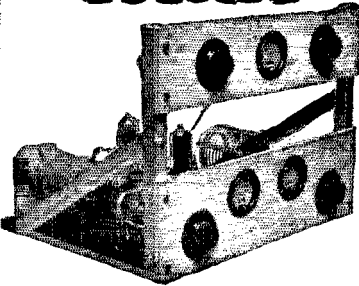

Complete Transmitter Installations 5 to 1000 Watts

Full Line of Transmitting Parts at Reduced Prices

- JEWELL, THORDARSON, ACME, WESTON, HAMMARLUND, CARDWELL, NATIONAL, RCA, FARADON, GENERAL RADIO, ALLEN-BRADLEY, WARD-LEONARD, LYNCH, R. E. L., ARO PRODUCTS, TOBE-DEUTSCHMANN, PYREX, FLERON, SIGNAL, BUNNELL, VIBROPLEX, WESTERN ELECTRIC, G. E., ETC.

Unsurpassed DX with the ARSCO RS-100

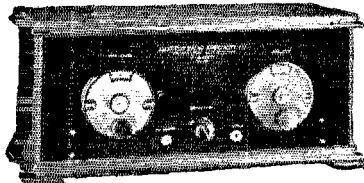

10-110 Meters
1 Stage A. F.

A precision instrument designed and built for maximum efficiency on the short waves.

Price Including mahogany cabinet and full set of plug in coils . . . **\$38.00**

SEND for CATALOG
ARSCO
77 CORTLANDT ST.
New York
AMATEUR RADIO SPECIALTY CO.

ELECTRAD

For Perfect
Tone and
Control, use
ELECTRAD
Royalty
500,000 ohm
Compensator

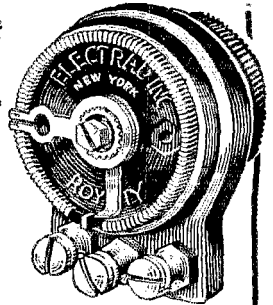

Note these six important features of design and construction:

- 1—Resistance element is not exposed to any mechanical operation.
- 2—Electrical contact is made positive by a metallic arm on the wire-wound strip.
- 3—The same resistance is always obtained at the same point.
- 4—The resistance value is under control in the process of manufacture and does not change in use.
- 5—The entire range of resistance is covered with less than a single turn of the knob.
- 6—There is no mechanical binding and the shaft is turned over the entire range with a perfectly smooth operation.

Licensed exclusively by Techindyne Corporation under U. S. Pat. No. 1593685, July 27, 1926. Made in various types for various purposes. Prices \$1.50 to \$2.00; in Canada, \$2.10 to \$3.00. Write for circular.

**A Better Rheostat—
Six
Reasons
Why**

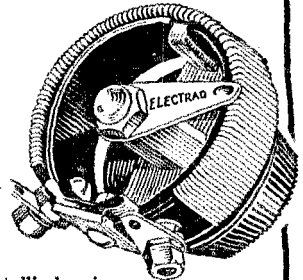

1. Resistance guaranteed within 5%.
2. Milled shaft with squared hole in contact arm insures rigidity—no wobble of shaft.
3. Extra long metallic bearings.
4. Highest grade Bakelite insulation, maximum radiation and mechanical strength.
5. Single hole or three-hole mounting. For three-hole mounting, base is tapped, eliminating need of nuts behind panel.
6. Phosphor bronze spring contact arm insures contact.

In every respect a better rheostat—6, 10, 20 and 30 ohms. Price 85c; in Canada \$1.25. Potentiometers—200 and 400 ohms. List 85c—in Canada \$1.25.

For perfect control of tone and volume use the Electrad 500,000-ohm compensator. For free hookup write 428 Broadway, New York City.



ELECTRAD

"G. I." ALWAYS IN THE LEAD!

From the start of radio broadcasting, General Instrument pioneered every development of variable condensers. General Instrument engineers developed the first low loss condenser, introduced the first true full straight line frequency condenser and for the 1926-27 season introduced the ultimate tuning condenser.

METRALIGN SLT STRAIGHT LINE TUNING

METRALIGN SLT is the only condenser embodying Straight Line Frequency on the low wave lengths, Straight Line Wave Length for the middle band and Straight Line Capacity for the high wave length stations, thereby making it possible to separate and bring in any station no matter on what wave length, low, intermediate or high.

Makes any set a new set in 15 minutes.

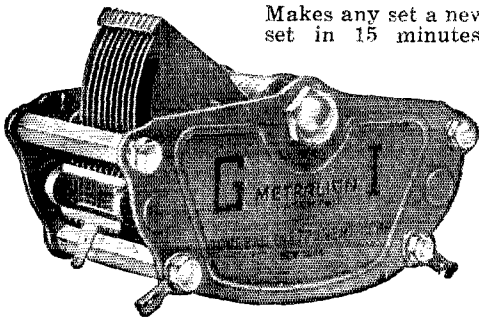

Free

We have prepared a very useful booklet, written in everyday language, covering everything you want to know about condensers. It's FREE—Write for it.

GENERAL INSTRUMENT CORP.

Manufacturers of "Bureau of Standards" Variable Primary Condensers

477 Broadway, New York City

"Don't Guess

Push the Button—see!"



Add protection
to the Set You Build

A

Sterling

PANEL METER



No. 1647
Panel Voltmeter
with push-button
built in.

A combination for measuring "A" Battery and "B" Battery voltages. 0-7½ volts and 0-150 volts with scale division of ¼ volts and 5 volts respectively.

Price \$5.00

No. R-644 A. C. Voltmeter

especially designed to measure voltage across tube filaments when operated on alternating current. Invaluable for mounting in equipment used by transmitting amateurs. Scale: 0-15 volts ½ volt div.

Price \$6.00

Here is the watch-guard of your batteries and tubes. Mount it on the panel, push the button and see the condition of your batteries at a glance. Aids reception by proper filament adjustment and protects tubes. It sure dresses up the set—a battery and tube insurance policy besides!

**Sterling
PANEL METERS**

are made for all purposes and capacities.

Ammeters, voltmeters, voltmeter, combination voltmeters and milliammeters.

With or without push-buttons.

PRICE \$3.00 to \$5.00

Ask your dealer or write us for folders

**THE STERLING MFG. CO.
CLEVELAND OHIO**

HAM-ADS

NOTICE

Effective with the July issue of QST the policy of the "Ham Ad" Department was altered to conform more nearly to what it was originally intended that this department should be. It will be conducted strictly as a service to the members of the American Radio Relay League, and advertisements will be accepted under the following conditions.

(1) "Ham Ad" advertising will be accepted only from members of the American Radio Relay League.

(2) The signature of the advertisement must be the name of the individual member or his officially assigned call.

(3) Only one advertisement from an individual can be accepted for any issue of QST, and the advertisement must not exceed 100 words.

(4) Advertising shall be of a nature of interest to radio amateurs or experimenters in their pursuit of the art.

(5) No display of any character will be accepted, nor can any typographical arrangement, such as all or part capital letters, be used which would tend to make one advertisement stand out from the others.

(6) The "Ham Ad" rate is 7c per word. Remittance for full amount must accompany copy.

(7) Closing date: the 25th of second month preceding publication date.

THE life blood of your set—plate power. Powerful, permanent, infinitely superior to dry cells, lead-acid B3, B eliminators. Trouble-free, rugged, abuse proof, that's an Edison Steel-Alkaline Storage, B-Battery. Upset electrically welded pure nickel connectors insure absolute quiet. Lithium-Potassium solution (that's no lie). Complete, knock-down kits, parts, chargers. Glass tubes, shock-proof jars, peppy elements, pure nickel, anything you need. No. 12 solid copper enameled permanently perfect aerial wire 75c 100 ft. Make easy money with 10-battery service station charger. Details, full price list. Frank Murphy, Radio SML, 6406 Carl Ave., Cleveland, Ohio.

25% to 35% discount to amateurs on receiving parts. No sets. Over two pounds data, circuits catalog—25c, prepaid. Also exchange new receiving parts you want for new parts—what have you? Weekly data bulletin—\$2.50 year, trial 20 weeks—\$1.00. Fred Luther Kline, Kent, Ohio.

HAMS! Announcing "Callzeard", a monthly pamphlet consisting only of calls heard and worked lists from all parts of the world. First issue January. Price only fifteen pennies per copy, \$1.50 per year. Published by hams for hams. We can't do it without help from you. Won't you endorse it by sending us your lists and subscription? Published by 3FI and 3ABH. It's for you men! Don't delay. Send subscriptions now to 2857 North Bailey Street, Philadelphia, Penn.

PURE aluminum and lead rectifier elements, holes drilled, brass screws and nuts, pair 1/16", 1" x 4", 13c, 1 x 6 15c, 1 1/4 x 6 17c, 1 1/2 x 6 19c. Sheet aluminum 1/16" \$1.00, 1/8" \$1.90. Lead \$1.00 square foot all prepaid. Silicon transformer steel cut to order .014". 10 lbs. 25 cents, 5 lbs. 30 cents, less than 5 lbs. 35 cents per lb. 4 cubic inches to the lb. Postage extra. 1/2 cash with order—balance C.O.D. Edgewise wound copper ribbon .350" wide; 3 1/4" outside diameter 10c turn, 4 1/4" 13c turn, 5 1/4" 15c turn, 6 1/4" 17c turn, 7 1/4" 20c turn, prepaid. Geo. Schulz, Calumet, Michigan.

REPRESENTATIVES wanted—Every set owner is a live prospect for our fully guaranteed 180 volt "B" Power Unit. Sells for \$25.00. Liberal commissions. George R. Downs, 755 Carlton Avenue, St. Paul, Minnesota.

JEWELL meters 25% discount. We specialize on parts and carry a complete line of ham transmitting and receiving apparatus in addition to regular broadcast equipment. We carry in stock products of the best nationally known manufacturers, such as Acme, National, General Radio, Thordarson, Raytheon, Philco, Nathaniel Baldwin, Radio Engineering Laboratories, Cardwell, Allen Bradley, Tobe
SAY YOU SAW IT IN QST—IT IDENTIFIES YOU AND HELPS QST

Deutschmann, Kellogg, Centralab, Yaxley, Acme Wire Company, Crescent Radio Company, M. M. Fleron, Aero Products, Inc. Tell us what you want. We allow discounts to A.R.R.L. members and dealers only. Give your call letters. Roy C. Stage, Wholesale Radio, Montgomery and Burt Sts., Syracuse, N. Y.

Ammonium Phosphate, going over big Why? Because it does its stuff. Price .50c per pound, postage extra. CP Aluminum .90c square foot, sheet lead .75c. Makes a hot peppy DC supply from AC. WE heavy duty mike for ur lone set 4.00. UX210 7 1/2 watters 9.00. Write for ham price list, it's free. Harris, 5RM, 104 East 10th St., Ft. Worth, Texas.

AMATEUR radio equipment built to a quality standard, not a price. E-R-L equipment is built of the finest material and is guaranteed. We use your parts, if desired, in any equipment. Our line is transmitters, receivers, master oscillator units, wavemeters, etc. Our new marine type equipment for use on sea going yachts or cruisers. Special equipment to order. Thos. Ensall, 1208 Grandview Ave., Warren, Ohio. Radio 8BDN.

TRADE 5 tube Airomaster broadcast receiver new condition with tubes for good shotgun. J. S. Amsden, Pioche, Nevada.

WANTED—Old 5 kilowatt sixty cycle spark transformer. Also large Dubilier mica condenser for same. Give complete description, condition, and price in first letter. Must be cheap. M. Valentine, 16 Sixth Ave., Whitestone, New York.

HAMS—Get our samples and prices on printed call cards made to order as you want them. 9APY, Hinds, 19 S. Wells Street, Chicago, Illinois.

WANTED—one bug key and other articles. What have you? Write 9AFX, Champaign, Illinois.

BETTER Edison elements. Welded connection, 7c pair. Sample cell 10c. Paul Mills, Woodburn, Oregon.

OMNIGRAPHS, vibroplexes, S tubes, sockets, transmitters, tubes, receivers, coils, meters, chokes. Bought, sold. For sale Grebe CR13, \$25.00, 8 tube super E.I.S. \$50. L. J. Ryan, 9CNS, Hannibal, Missouri.

Wanted—Omnigraphs, vibroplexes, 50-watters, S-tubes. Price Griffith, 1109 Eighth Avenue, Fort Worth, Texas.

WANTED—Burned out UV203As. Name price. 9BLE.

SEND for your copy of the new "Ham-list", price 4c. Thordarson 650-volt power-filament transformers for 5-watters \$6.90; Thordarson power transformers 350-550 each side \$11.00; 1000-1500 each side \$16.00. Curtis-Griffith 250-watt power-filament transformers 550 each side \$12.50. Edgewise copper strip 6-inch, turn 12c; 4-inch turn 10c. Aluminum square foot 85c; lead square foot 85c. Jewell 0-15 voltmeters \$7.50; 0-500 Milliammeters \$7.50. Power gridleaks \$1.60. Postage extra. New "Ham-list" 4c. Service—That's me. James Radio Curtis, 5-A-Q-C, 1109 Eighth Avenue, Fort Worth, Texas.

WOULD like to buy a good ten, twenty or fifty watt transmitter cheap? J. E. Minear, Jr., 425 Warwick Ave., Zanesville, Ohio.

WILL buy D100 and D101 Dubilier Mica Transmitting Condensers .007 microfarads. State price, quantity and condition. Alan Standish Dana, Seymour, Connecticut.

FOR sale—2 Haynes-Griffin superhet kits, 4 transformers and one oscillator per kit. \$15. per kit. All new. Ira P. Coon, Lockport, Illinois.

FOR sale—Grebe CR3, \$25. Western Electric 10A power amplifier complete \$75. George Barclay, 141 E. Lincoln Ave., Mt. Vernon, N. Y.

WE have it! What? REL, Pyrex, Thordarson, Bremer Tully, National, Cunningham, Signal, Jewell and Silver Marshall products. Write for our complete catalog of amateur equipment. Ron Wollard, Newark, Ohio.

DODGE radio shortcut produces results quickly. Raw beginners master code easily; hams increase speed rapidly. ICJX Stetson says: "Quickly raised speed to 27 per"

6QM Connor says: "Mastered code your way in 15 min".
4UN Briggs says: "Shortkut for speed, now do 27 per".
Story of surprisingly rapid progress as told by 200 Users
all now licensed also quarter coupon—25 cents. Reports
each radio discet and information—on request. Shortkut
with appendix and better key work \$3.50 US and Canada,
elsewhere \$4.00—Reg mail—None COD—Money Order
only. C. K. Dodge, Mamaroneck, N. Y.

2ATK—Selling out. Rite for list, OMs. Harold Van
Pelt, Essex St., Rahway, N. J.

FIRST \$7 received takes Jewell 0-3 R.F. ammeter.
Perfect. 3ALX.

General Electric 24/1500 volt 350 watt 6000 RPM 112
segment ball bearing dynamotors \$35.00. With shaft for
external belt drive \$38.00. Ideal for battery plants. Half
voltage tap. Crocker—Wheeler 24/1500 volt 450 watt
\$45.00. GE 12/350 volt 50 watt \$18.00. With shaft \$20.00.
Navy SE 1012 receivers range 50-1000 meters. Navy per-
cision wavemeters 125-2500 meters, keys, Crocker-Wheeler
500 watt cycle motor generators, motor 110 Volt DC and
adapted for external drive, Westinghouse 27.5/350 volt
dynamotors. Fotos, Henry Kienzle 501 East 84th Street
New York.

FOR SALE: Synchronous motor \$12; UL 1008 \$6; 3
UR542 five watt sockets 50c; 2 S4000 S tubes and sockets,
\$16; Stromberg Carlson loudspeaker \$7; Ward Leonard
5000 ohm gridleak \$1; 0-2.5 Westinghouse thermoammeter,
\$5; Westinghouse SE1012A Navy receiver, 50 to 1000
meters, one tube set \$35; Western Electric fifty watt
\$20. Wm. M. Derrick, 30 Leslie Street, East Orange N. J.

What 8EQ thinks of "Callzeard". Dear O.M., You bet I
will help you out and to prove it am enclosing money
order for one fifty for one years' subscription to "Call-
zeard". Will send lists of stations heard. Wish to con-
gratulate you on getting a magazine of this kind started;
it has been needed a long time. I certainly hope it proves
an unqualified success. How soon will your magazine be
on the market? Signed J. C. Lisk. That's only one, gang.
Send lists and subscriptions now to Charles Hartman,
2857 N. Bailey St., Phila., Penna.

WANTED—IP-501 tuner and two UC-1803 condensers.
Must be cheap. Wesser, Alpena, Michigan.

MOTOR generators any current drive 400 volt, 100
watt. All brand new. Real bargain at \$23.50. Trans-
mitting inductances edgewise copper 20 or 40 meter
mounted on G. R. insulators, \$1.00 per set. J. P.
Matthews, Newton, Iowa.

ARE you sick of CQ callers? I want to get schedules
with amateurs, who will carry on conversation, and build
up friendships. Write for schedules. B. Burden, Red
Cloud, Nebraska.

SELL Triumph 1 horse 230 volt DC motor, twenty
dollars. Want 500 volt generator. Myron Steffy, Downers
Grove, Illinois.

1-ZE at Mattapoiset, Mass., has a 125 foot self-support-
ing steel tower. Cost \$500. Wonderful chance for five
or six Hams to make up a party and come take it down,
box it up and ship it home. All 1-ZE wants out of it is a
check for \$5.00. Tower has a 19 foot base.

QSL CARDS: Am glad to announce that I will be QRV
for orders during Xmas vacation. Send for samples now
and avoid the rush. (8BJT PRESS) R. J. Mumaw, Care
E.M.S., Harrisonburg, Va.

WANTED—used UV204s. Canadian 4AH

PAIR All American push-pull transformers, six dollars.
Roy Gale, Plainfield, Vermont.

COMMERCIAL ammonium phosphate, 40c per pound.
You pay postage. Duane N. Hadley, Shelby, Ohio. 8CTD

SELL—100 watt transmitter and receiver parts. 1ASY,
Essex, Connecticut.

BRANDES superior phones \$2.79 a pair. Brandes navy
phones \$3.79 a pair. Signal variable condensers, all sizes,
.78 each. Get my list of fifty watters, transformers, etc.
9MV. Story City, Iowa.

METERS, power amplifiers, chargers, sets, magazines,
horns. List, J. Schindler, 116 Rebecca, Scranton, Penn.
250 WATT Western Electric tube, perfect, little used,
\$70. Taylor, 9566—113th Street, Richmond Hill, New
York.

FILTER chokes unmounted 20H \$1.00, 30H \$1.75, 50H
\$2.00, 275 v transformer 50 M.A. from 110v \$2.00. Use
two for Raytheon tube, impedance amplifiers, audio trans-
formers, etc. Write for list. All prepaid three zones. M.
Leitch, 32 S. Park Drive, W. Orange, N. J.

OLD QST's for sale. All copies since April 1920. Some
earlier. Also Electrical Experimenter, 1915 to 1920, com-
plete. Most issues of Pacific Radio, 1922 and 1923.
DeForest 2Q15 250 watt, much used, \$30.00 postpaid, in-
cluding mounting. Make offer for all or part. A.
Schumacker, 1917 54th Street, Brooklyn, N. Y.

EXPERIMENTAL RADIO by R. R. Ramsey Professor of
Physics, Indiana University. The only scientific experi-
mental manual. Endorsed by A.E.B.L. QST p29, June
24. Measure adjust and perfect your set. \$5 experi-
ments, mimeographed. Price \$2.00 post paid. QST
or University Book Store, Bloomington, Indiana.

NEW generators 275 volts, 120 watts direct current gives
up to 500 volts, \$8. Used in good working order 30 to 300
direct current. Fine for 5 watt tube to run from 32 volt
storage battery \$8. 500 cycle self-excited 1/2 KW \$15.
200 watt \$10. Used, but in good working order. 1016
RCA new transformers 750 watt \$11.50. 1403 RCA
condensers, 50c. 1831 variable \$1.50. Geared honey-
comb mountings \$1.50. 6 to 400 volt generator 200 watt
used \$20. Microphones \$1, postage extra. Stamp for
list. R. Wood, 102 Street, Corona, N. Y.

If you haven't 9ALD's "Hamalog" you don't know the
best place to buy Amateur and Broadcast transmitting
and receiving apparatus. We can't tell you much about
our line in QST, but we're glad to send the Hamalog
free. Acme, Allen-Bradley, Pyrex, Toke, Fleron, Good-
rich, Jewell, Mu-Rad, National, Patent, Thordarson,
Cleartron, Ward-Leonard, Faradon, Hoyt, Kodak, Spar-
tan—these are some of the names famous in radio which
we represent. You can't go wrong on goods with such
names, nor in buying them from 9ALD. Dealers, broad-
casters, educational institutions, etc., will be given usual
discounts. E. F. Johnson, 9ALD, Waseca, Minn.

GR LABORATORY Apparatus. New guaranteed per-
fect condition. No. 224 precision wavemeter complete
\$130.00. No. 222 precision condenser, 1500 mmf. \$50.00.
No. 133C ten ohm standard resistance \$3.50. Resistance
box No. 102G, \$18.00. Resistance box No. 102F, \$17.00.
Thousand cycle oscillator No. 213, \$22.00. Weston 8, 15,
150 DC voltmeter model 45, \$55.00. Weston 200 micro-
ampere meter model 322, \$70.00. Jewell zero-center gal-
vanometer in case, \$3.00. Balkite two ampere charger,
new, \$10.00. New Karas condensers, any size, 50% list.
WE-540-AW Cone Speaker \$18.00. First money order
takes them. Further details on request. Marco, 9ZA,
Chicago, 8723 Winthrop Ave.

FOR Sale. New Westinghouse double commutator 750
V, 20 W, D. C. generators direct connected to 110 V, 40
cycle A. C. motors \$45.00. Field Rheostat \$4.50 each
extra. 25% with order balance C. O. D. Express. Inspec-
tion allowed. 1500 V, 300 W, Holtzer Cabot \$90.00. 2500
V, 600 W, double commutator. Also other bargains.
James J. Smat, 1734 Grand Ave., Chicago, Ill.

FOR sale. 100 watt 500 volt MG set 110 volt 60 cycle
motor A1 condition \$38.00. 150 watt Acme filament
transformer \$2.00. First \$45.00 check takes both. A. H.
Marcy, 2849 Webb Ave., N. Y. City.

WAVEMETERS: Rigidly built; Bakelite panels and coils;
not in cabinets; good condensers and solid coils bulb in-
dicators; curve charts furnished, read in tenths of meters
at short waves; accuracy guaranteed within 1/2 of 1%;
no floppy leads to change calibration. This is all the
dope. One band \$5.00 postpaid, \$1.50 extra per additional
band. Edw. Bromley, Whitewater, Wis. 9CSM.

HAM discount—Acme cones, Majestic and All-American
B-eliminators 25%; Western Electric cones, Elkon and
Tungar trickles 20%; 24 hour shipment in original car-
tons, postage extra. Other highgrade products and kits at
liberal discounts. Robert McCracken (8DLN) Cuyahoga
Falls, Ohio.

BABY gotta be shoed. 7DO gotta sell out. Complete
fifty receiver, et al \$100.

WANTED—new G.E. 50 watt gridleak. Sell good as new
—UP414 mod. tfr., Acme filament transformer, Thordar-
son Autoformer, B T Short wave coils, W. E. 21R By-pass
condenser, W. F. 21U condenser 1/20 mf., 5 watt G. E.
gridleak. Sell new—UV1016 GE 3000v plate transformer,

40-80 meter J. Gross pancake ind., 50 watt sockets. 40C, F. M. Whitaker, 816 Wilkerson Ave., Durham, N. C.

CANADIANS—Sacrifice complete broadcasting equipment used at 10BG. Used only few hours. Owner leaving for college. Write for specifications. C. Welch, Alvinston, Ontario.

TRANSMITTING and receiving supplies. Wholesale and retail. 9EDU, Republican City, Nebraska.

ARRL SWEATER EMBLEMS SHOULD BE WORN BY ALL MEMBERS. They are 5"x8", yellow and black felt wool. Only \$1. ERIC ROBINSON, JEFFERSON ROAD, WEBSTER GROVES, MO.

9CNM—Thomas E. Powers, 7256 East End Ave., Chicago, Illinois.

9CYA—Lloyd A. Felber, 811 East First St., Fairmont, Minnesota.

9EDU—C. R. Waggoner, Republican City, Nebraska.

9HL—T. W. Roelfs, St. Francis, Kansas.

9VF—A. L. Frederickson, St. Francis, Kansas.

ChNAD—Gustavo Vierling, Casilla 1653, Valparaiso, Chile.

Q R A SECTION

1AAP—Clifford A. Langworthy, R. D. No. 1, Westerly, R. I.

1BMG—Chas. H. Stevens, 94 Prospect St., Stafford Springs, Connecticut.

1CRA—Sidney Carter, 16 Balcarres Rd., West Newton, Mass.

1MR—Edward P. Drozek, 31 Dyer Street, Milton, Mass.

1ZA—C. E. Jeffrey, Jr., 725 Commonwealth Ave., Newton Center, Massachusetts.

3AFV—R. A. Osche, Hq. Btry. 52 CAC, Fort Eustis, Virginia.

3AWX—A. S. Doxsey, 11 Devine Street, Lynbrook, Long Island, N. Y.

3DC—Eugene Fritschel, 134 Riverside Ave. Scotia, N. Y.

3MK—E. F. Reynolds, Central Valley, Orange County, N. Y.

3SJ—Raymond K. Strong, 108 Catherine St., Scotia, Schenectady County, N. Y.

3TL—Jos. W. Gibbons, 90 Front Street, Port Jervis, N. Y.

4FO—C. A. Davis, P. O. Box 668, Winter Haven, Florida.

4JB—F. L. McCallum, 10 Seevilla St., St. Augustine, Florida.

5AMT—H. R. Dugger, P. O. Box 367, Renner, Texas.

5AO—Wm. N. Nelson, Burrwood, La.

5WH—W. H. Barber, 50 Somerset Ave., Cumberland, South Australia.

6BAJ—Parley N. James, 430 D Street, Salt Lake City, Utah.

6CUA—Dr. J. W. McElwee, Box 333, 1362 Paseo Del Mar, San Pedro, California.

8ACT—Joseph E. Whiting, 69 Maple Street, Canisteo, N. Y.

8APB—Chas. Kabeiac, 3900 E. 131st Street, Cleveland, Ohio.

8AZD—Edward C. Brichta, 3393 Williams Ave., Detroit, Michigan.

8BEV—Wm. J. Wagner, Box 3, Bucyrus, Ohio.

8DEX—Karl L. McDaniel, 28 Leaman Street, Xenia, Ohio.

8RD—C. H. Vincent, 12694 Northlawn Ave., Detroit, Michigan.

9BCO—L. O. Ekberg, St. Francis, Kansas.

9BGO—Clement E. Carducci, 1669-E 24th St., Chicago Heights, Illinois.

9BLE—A. L. Buckner, 508 Lafayette Ave., Charleston, Missouri.

9CKF—Frank Colclough, Box 211, Philip, South Dakota.

SAY YOU SAW IT IN QST—IT IDENTIFIES YOU AND

The following stations belong to members of the A.R.R.L. Headquarters gang. Mail for them should be addressed care A.R.R.L., Hartford, Conn.

1MK Headquarters	1DQ John M. Clayton
1AL H. P. Westman	1ES A. A. Hebert
1BAO R. S. Kruse	1KP F. Cheynev Beekley
1BDI F. E. Handy	1OA R. S. Kruse
1BHW K. B. Warner	1SZ C. C. Rodimon

PRICES TALK AGAIN

PROMPT-RELIABLE-SERVICE Thordarson, filament and plate transformer for 7.5 watt transmitters. This transformer has 650 volt plate winding and 10 volt filament winding with center tap. SPECIAL PRICE \$6.25. Thordarson filament transformers. 80 watt for one to four 7.5 watt tubes. \$6.15. 150 watt for one to four fifty watters \$7.95. Thordarson plate transformers 100 watt. \$10.95. 450 watt \$14.85. Acme transformers reduced. Acme 30 henry 150 mill choke \$16.20. 30 henry 300 mill \$22.00. Jewell 3 inch flush or panel mount meters. all sizes of milliammeters. A. C. voltmeters and ammeters. D.C. voltmeters and ammeters. SPECIAL \$6.00 each. All sizes of Thermo-couple antenna current ammeters \$9.50. Genuine Cardwell double spaced transmitting condensers cap. .00022. 3,000 volt breakdown voltage. SPECIAL \$3.45. Genuine Cardwell .0005 25 plate condensers \$1.20. .001, 33 plate \$1.80. R.E.L. transmitting inductance (double with rods) \$8.95, single \$4.65. R.E.L. plug-in coils \$3.50. RCA UC 1803 condensers, 10,000 volt breakdown fixed condensers for Hartley and tuned plate & grid transmitters for grid and plate blocking. SPECIAL \$4.50 each. UC 1846 \$1.00. Crescent Lavite 5,000 ohm transmitting grid leak \$2.20. Ward Leonard 5,000 leak 200 mil capacity \$1.85. Fleron lead-in insulators \$.90. ARSCO coupled pancake inductance 20-40-80 meter \$4.45. Aero short wave kit \$9.35.

All merchandise guaranteed and sold on a money back basis. It will pay you to deal with a brother ham.

2MA 207 NEPTUNE AVENUE, BROOKLYN, NEW YORK

SEE THAT SCREW

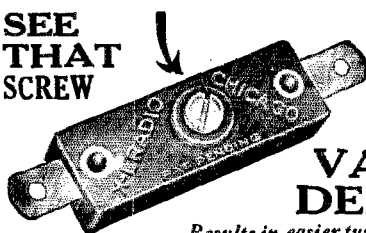

A screw driver adjusts an X-L in crowded places.

X-L VARIO DENSER

Results in easier tuning, more distance, volume and clarity—greater stability. Indorsed by leading radio authorities.

Model "N"

A slight turn obtains correct tube oscillation on all tuned radio frequency circuits. Neutrodyne, Roberts two tube, Browning-Drake, McMurdo Silver's Knockout, etc., capacity range 1.8 to 20 micro-microfarads. Price

\$1.00

Model "G"

A grid clip obtains the proper grid capacity on Cockaday circuits, filter and intermediate frequency tuning in heterodyne and positive grid bias in all sets. Capacity range

Model G-1

.00002 to .0001 mfd.

Model G-5

.0001 to .0005 mfd.

Model G-10 .0003 to .001 M. f. d.

Price \$1.50

X-L Push Post

Push it down with your thumb, insert wire, remove pressure and wire is firmly held. Releases instantly. Also furnished mounted on strips. Price 15c.

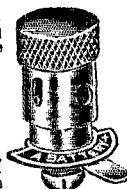

X-L RADIO LABORATORIES

2428 N. Lincoln Avenue

Chicago, Ill.

NATIONAL

NATIONAL
in name

NATIONAL

in fact

NATIONAL

Radio Set Essentials are known and appreciated in every corner of this great United States.

NATIONAL BROWNING DRAKE

Spacewound coils and radio-frequency Transformers.

NATIONAL VELVET VERNIER

DIALS Type A and B and the

NATIONAL ILLUMINATED

Velvet-Vernier Dial Type C with its brilliantly lighted scale and ease of attachment to any radio set.

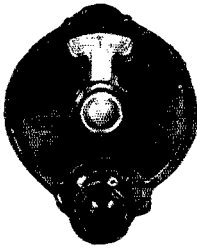

NATIONAL ILLUMINATED

VELVET-VERNIER DIAL TYPE C

NATIONAL

EQUICYCLE and EQUIMETER

Variable Condensers are good and stay good. They space out the crowded stations.

NATIONAL IMPEDAFORMERS

are units for quality impedance—coupled audio.

NATIONAL

Transmitting Condensers are used by hams the world over.

NATIONAL

B-Eliminator Parts will be ready soon.

NATIONAL
Company, Inc.

W. A. Ready, Pres.
110 Brookline Street
Cambridge, Mass.

Will gladly send you bulletins on any or all of these items. Mention *QST*.

FOR YOUR CONVENIENCE QST'S INDEX OF ADVERTISERS IN THIS ISSUE

Acme Wire Company	60
Advance Electric Company	62
Aero Products, Inc.	79
Aerovox Wireless Corp.	84
Airman Products Company	84
Allen-Bradley Company	55, 62, 74
Aluminum Company of America	71
Amateur Radio Specialty Company	89
American Sides Company	55, 81, 84
American Transformer Company	58
A.R.K.L. Application Blank	96
A.R.E.L. Handbook	3rd Cover
Barawik Company	96
Benjamin Electric Mfg. Company	32
Browning-Drake Corporation	72
Fremer-Tull	72
Burkess Battery Company	4th Cover
Burton Rogers Company	60
Cardwell Mfg. Corp., Allen D.	57
Carter Radio Company	76
C. E. Mfg. Company	88
Central Radio Labs.	85
Combing Glass Works	74
Crescent Radio Supply Company	62
Crosley Radio Corporation	70
Cunningham, Inc., E. T.	2nd Cover
DeForest Radio Company	87
Deutscheinnann Company, Toke	55
Dongan Electric Mfg. Company	90
Dudlo Mfg. Company	69
Eagle Radio Company	72
Eastern Radio Institute	72
Electrad, Inc.	76, 89
Electric Specialty Company	70
Elkon Works	65
Eppe's	64
Fansteel Products Company	88
Formica Insulation Company	58
Frost, Herbert H.	72
General Instrument Corporation	90
General Radio Company	83
Goetz & Co., August	85
Gorer Company	58
Grebe & Co., A. H.	4
Gross & Company, J.	88
Gulf Radio School	83
Haleo Mail Order Service	87
Hammarlund Mfg. Company	64
Hammarlund-Roberts	75
Hughes Electric Co., Benj.	78
International Resistance Company	66
Jacobs, Chas. F.	62
Jenkins & S. E. Adair, J. E.	87
Jewell Electrical Instrument Corp.	83
Kelleradio, Inc.	60
Kokomo Electric Company	30
Loomis Publishing Company	66
Lynch, Inc., Arthur H.	83
Mace & Son, F. F.	66
Marlo Electric Company	60
Mess. Radio School	55
M. B. S. Sales Company	90
Mullen, J. M.	80
National Carbon Company	95
National Company, Inc.	94
Nicholson Electric Company	82
Paent Electric Company	76
Polymet Mfg. Corporation	78
Pressed Metal Mfg. Company	38
Radio Corporation of America	1
Radio Engineering Labs.	56
Radio Foundation, Inc.	80
Radio Surplus Corporation	74, 84
Randolph Radio Corporation	75
Sanzamo Electric Company	62
Scanlon, Everett	55
Signal Elec. Mfg. Company	82
Silver-Marshall, Inc.	70
Spartan Electric Corporation	81
Sterling Mfg. Company	90
Stromberg-Carlson Telephone Mfg. Company	61
Supertone Mfg. Company	76
Thordarson Elec. Mfg. Company	2
Transmitting Equipment Company	83
Utility Radio Company	78
Van Horns Company, Inc.	86
Vibroplex Company, Inc.	58
Ward-Leonard Electric Company	87
Well's Curiosity Shop	82
Weston Electrical Instrument Corp.	68
Wireless Specialty Apparatus Company	68
X-L Radio Labs.	93
Yaxley Mfg. Company	85
Zied, J.	55
2MA	93

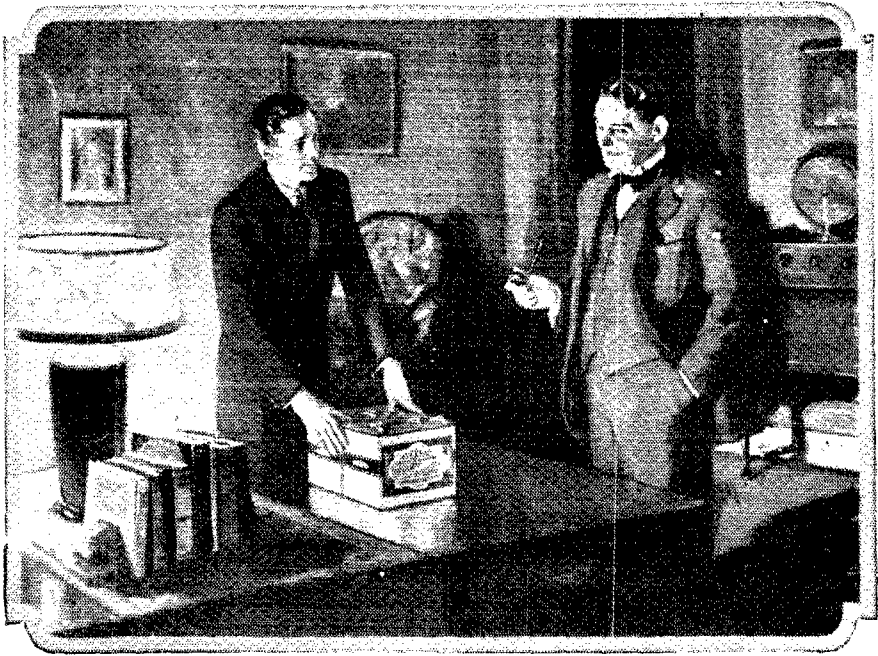

*Here's the most
economical "B" battery ever built
for radio*

IN THE production of Heavy-Duty radio "B" batteries Eveready has established a new standard of economy.

Eveready Heavy-Duty 45-volt "B" Batteries will outlast any Light-Duty 45-volt "B" two to one regardless of the number and kind of tubes used! Moreover, though lasting twice as long, they cost only one-third more!

To cap the climax of "B" battery economy, in Eveready Layerbilt No. 486, Eveready has perfected a Heavy-Duty "B"

battery of unequalled endurance and dependability—positively the best "B" battery its price can buy.

You can make no mistake in buying Eveready Layerbilt No. 486 for any set using normal voltages (45 to 135 volts).

You will be buying the utmost in "B" power dependability—the greatest "B" power operating economy—D. C.

(direct current) in its purest form, which insures pure tone quality.

With colder evenings at hand, radio reception is vastly improving. Equip your set now with Eveready Layerbilt No. 486, the greatest "B" battery ever built for radio.

Manufactured and guaranteed by
NATIONAL CARBON Co., Inc.
New York San Francisco
Canadian National Carbon Co., Limited
Toronto, Ontario

Tuesday night means Eveready Hour—9 P. M., Eastern Standard Time, through the following stations:

WEAF—New York
WJAR—Providence
WEEI—Boston
WTAU—Worcester
WFI—Philadelphia
WGB—Buffalo
WOLB—Pittsburgh
WRO—Washington

WBAK—Cincinnati
WTAM—Cleveland
WWJ—Detroit
WGN—Chicago
WOO—Davenport
WOOO { Minneapolis
St. Paul
KSD—St. Louis

EVEREADY
Radio Batteries
—they last longer

FREE RADIO GUIDE

Members of the American Radio Relay League will be pleased to know that F. J. Marco, 9ZA, well-known in amateur circles and the engineer who designed the B-T counterphase circuit and the aero coils, is now directing our new Amateur Department. The new 1927 edition of the Barawik Catalog and Guide gives a comprehensive listing of the radio sets, parts, kits, supplies and accessories necessary in experimental work. This new Guide contains 164 pages of radio's newest developments, everything that a real fan will need from the complete factory-built set to the smallest screw, including labor-saving devices, tools, power supply units, amplifier equipment; in fact, everything that is necessary in general radio work and amateur work. Standard equipment of the best-known manufacturers at tremendous savings.



Besides the complete radio line there is shown a selection of electrical goods, household appliances, auto accessories and articles necessary in the home—all at a big saving in price.

Write today for your free copy of the 164-page guide. Also please include name of other fans you know would be interested. Mail the coupon below for free copy.

SHORT WAVE EQUIPMENT—Special Amateur Department

The Barawik line features this season the *Special Amateur Dept.* in charge of Mr. Marco. It presents the latest in short wave equipment, transmitting and receiving supplies and everything necessary for the amateur and experimenter. Special attention has been given to short wave kits, including the B-T, Aero Coil and Silver-Marshall Short Wave Kits, and others of well-known makes. It will pay you to get our catalog and see just what is listed. Your wants can be taken care of, we assure you of that.

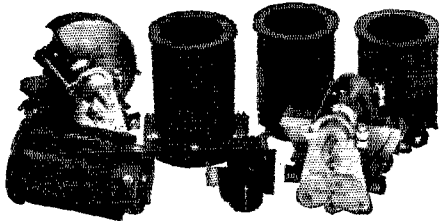

SILVER-MARSHALL 635 SHORT WAVE KIT

This kit contains the essential units—4 interch. coils S-M 117, 1 coil socket S-M 515, 1 S-M 340 coupling condenser, 2—S-M type 317, 140 mmf. tuning condensers—duplicates of those found in Commander Dyott's receiver used so successfully in his expedition to the Brazilian wilderness, where he was able to keep in constant contact with civilization. It has a wavelength range of 18 to 150 meters with the four interchangeable plug-in coils supplied. The other essentials in the kit—all carefully matched and measured parts—are a coil socket, an antenna coupling condenser and two 140 mmf. tuning condensers. The 635 kit built up using a pair of 220 transformers for audio amplification, making a three tube set will give astounding results on short wave broadcast programs—in summer and also in the daytime. Many stations in America—and in other countries too, can be heard regularly on the shorter waves. No. 3QS4875. Price of 635 Kit complete with instructions \$22.60 postpaid.

MAIL THIS COUPON NOW ↘

The Barawik Co.

540-571 Monroe St. Chicago, Ill.

BARAWIK CO., 540-571 Monroe St., Chicago, Ill.
Send me my copy, free, of your new 164-page
Radio Catalog and Builder's Guide.

Name

Address

Friend

Address

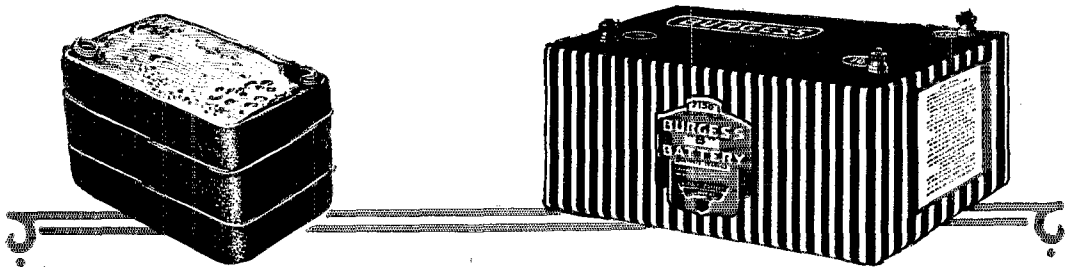

Here's the oldest and newest— How old is yours?

That black little package of pitch and cardboard is the Granddaddy of all dry "B" batteries—the first of its kind in the world.

A lot of old-timers will remember it, and for the next few months we are going to publish on the back cover of Q. S. T. the call of every "ham" who will send a radiogram, a card or letter telling how many years he has used our batteries. Send yours in today. Address it to Burgess Battery Co., Madison, Wis.

Burgess Batteries are used in these "ham" stations

Godley	1CMP	2BAR	3AFA	4KM	6ABG	7NC	8COR	9BDW	9DNG
Byrd	1ES	2BBC	3APV	4LK	6AFP	7ZO	8DJG	9BSO	9DRS
MacMillan	1FD	2BBW	3BMN	4LL	6ALR	8ACY	8DJX	9CAG	9EDU
Wilkins	1FS	2BEE	3BNU	4PX	6BBE	8AEA	8DJY	9CVC	9EGU
1AAO	1K1	2CKA	3CA	5ACL	6BJX	8AMB	8GX	9CET	9EK
1AID	1SZ	2CLA	3QP	5ADD	6BSC	8ATI	8JB	9CFU	9PJ
1AMH	1VZ	2CP	4DD	5ADY	6BUR	8AUB	8ZE	9CP	9RR
1ANQ	1XAM	2CWR	4DK	5AJJ	6BYH	8AZD	8ZG	9CPK	9VD
1AW	2ADH	2EV	4DM	5APG	6CMQ	8BAD	8ZZ	9CYQ	11AF
1AZJ	2ADL	2JK	4EK	5EB	6CTP	8BDG	9AAW	9DB	11DD
1BIZ	2AEF	2KG	4EQ	5ER	6DBH	8BRA	9ARU	9DDP	11BE
1BQD	2AER	2LE	4HN	5GW	6DDN	8BRC	9ASC	9DOA	11AEL
1BVB	2ALS	2NZ	4JR	5JF	7AAB	8BYN	9AYO	9DK	11BI
1BVL	2ASB	2WC	4KD	5KL	7AAW	8CMY	9AZN	9DLK	11I
1CKP	2AZU	3AAI	4RF	5YK	7IY				

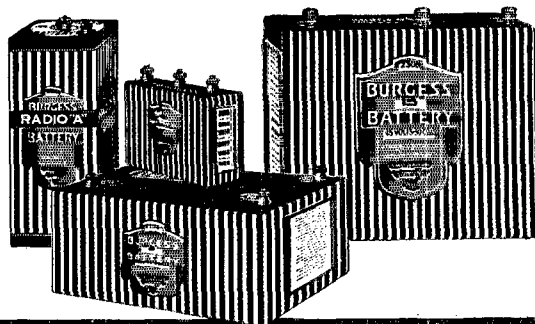

BURGESS

RADIO BATTERIES

The A.R.R.L.

Radio Amateur's Handbook

IS HERE!

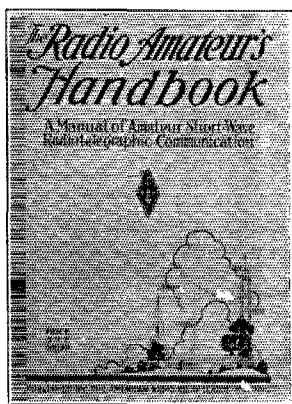

FOR five years the production of an A.R.R.L. Handbook has been under consideration. For ten months it has been in preparation. It is now ready for distribution. It is an official publication of the American Radio Relay League. It is endorsed and recommended by that organization as the best and most informative book on short-wave amateur work ever published. Its production has been governed by the same policies of conserv-

ative treatment and technical accuracy and clarity of description which have long characterized *QST*. It is the indispensable reference book for every radio amateur or experimenter. You *can't* get the best performance or the most enjoyment from your radio work unless you have the handbook always available. You need the handbook and you will find it the most valuable piece of amateur radio literature ever published.

And it only costs a dollar—

postpaid anywhere

You will never have an opportunity to buy more value for one dollar—send for yours today

AMERICAN RADIO RELAY LEAGUE

1711 PARK STREET

HARTFORD, CONN.

The Communications Department

F. E. Handy, Communications Manager
1711 Park St., Hartford, Conn.

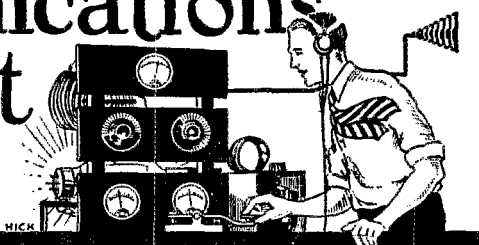

North of the Arctic Circle With VOQ

By Edward Manley, 8FJ

WHEN George Palmer Putnam planned this summer's expedition for the American Museum of Natural History, he naturally planned to carry radio. As short waves are the only waves that will put signals direct to the states with an outfit of moderate size and price, he made arrangements with the National Carbon Company and Atwater Kent to provide equipment. Parts were built in several places; the fine receiver was built by Clayton and Westman of HQ; the 250-watt transmitter was built at Marietta College; the low power B-battery was assembled by 2CTF; a receiver from 8FJ was carried as a spare. The ship was the Effie M. Morrissey of St. Johns, Newfoundland, owned by Captain "Bob" Bartlett of North Pole fame, also her skipper on this trip. She was late in getting to New York so the time was limited in which to get the stuff aboard and working. Amateurs within 700 miles were worked on the B-battery set from the dock at Staten Island. The big transmitter was first put on the air after leaving Rye, N. Y., June 20.

Leaving the Sound, we got a fresh breeze which helped us to cross the Gulf of Maine in fine style. This made me lose interest in all worldly matters until we got in smoother water. Traffic was handled with 2BNZ, 1FD, pr 4RL, 6QL and 9KD before we ran into Sydney Harbor. Enroute Sydney to Davis Strait, 2CRB took a long press message and c1AR sent us some vital information that told us the Straits of Belle Isle were clear of ice. 1AAO took another long message from off Labrador. Some traffic was handled with 1FL, 2AEV and 2NZ. We were now in continuous daylight and all signals dropped considerably in audibility.

All were eagerly looking forward to our first sight of the Greenland coast which came on July 5. The next afternoon, we anchored in Holstensborg harbor. NKF and NISS were heard on 20 meters. After a short stay, we took the Hobbs Greenland Expedition to its destination 50 miles up a fjord. One member of this expedition was 2AZA, who was sandwiched with five other members of his party into the crowded quarters aboard the Morrissey for ten days while crossing to Greenland. It was interesting to see how signals stood up on the trip inland but there was little change from those at sea. The Hobbs party and their stuff was handled here. Oscanyan set up his receiver and low power transmitter, using the call dx1XL, and we were in contact from time to time so news of our progress could be given and plans made accordingly for the meeting at Holstensborg on our way south. 1XL at Holstensborg was worked many times excellently, using one UX-210 and 450 volts Eveready B's on the plate to test the performance of batteries in the Arctic under hard usage. On one occasion, 9CP was also worked with the low-power set.

No time was lost in pushing northward to the hunting grounds north of Melville Bay. Headwinds compelled us to anchor inside Arfit Island, 15 miles north of Holstensborg. Here 2NF, 9EJI, 9ZT and 2UO were worked. A counterpoise was put up inside the main cabin for comparison with our copper plate ground. As it seemed to give better results, it was used for the rest of the trip. This

was Captain Bartlett's first experience using short-wave radio in the Arctic and it made things different from his trips with Peary when they were often out of touch with civilization for as long as two years. Approaching Disko Island, in Disko Harbor, north of the island near Proven, and at Upernivik, 2UO was worked and took all the traffic sent. Near Proven, south of Upernivik and Melville Bay, signals were exchanged with 9KB and traffic handled with 9CTG.

9 CTG had a nice signal and his operating was an example to follow. At Upernivik, 9EJI sent answers to previous messages and a new contact was made with 9BJK in Denver. Stations complained

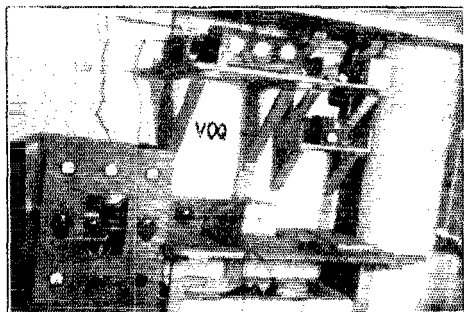

of the static and heat; we rather had the laugh on those to the south who had to hug an electric fan for comfort. There was no static anywhere north of Sydney. The trend of signals to the westward was now noticeable. Although east coast stations were worked, middle western stations both sent and received better signals above approximately 75 degrees north. It is hard to say just where the change takes place. Far western stations were QSA down to the Middle Labrador coast when they dropped off. Hawaiian stations were heard all the time, especially hUBUC, 6AJL and 6DEA.

After a stop at Duck Islands, we headed into "the dreaded Melville Bay" QRD Cape York. At Cape York, it was still easier to work far Western stations. 7AIM was worked on July 22 and 6JP on the 23rd. Then on the 23rd, too, came "the beginning of the wonderful friendship" with 9CP. He was worked almost nightly until he left for the west coast Aug. 23rd, taking most of the important traffic sent while we were in the far north. It was fine to hear his "R K" when there was not too much static and heat below. How he did a full day's work after some of the nights he put in is a mystery, especially after spending five hours the night of August 1-2 taking the longest message sent out, the story of the wreck. He certainly deserves the narwhal tusk that is being presented him by the director of the expedition, Mr. George Palmer Putnam, in appreciation of his good work.

A little after 10 pm EST, the night of July 25, we hit some hidden rocks off Northumberland Island,

staying there for 25 hours, causing excitement in the States, in Greenland and even in New Zealand, as ZLAX told me later. This New Zealand incident interested me greatly, showing how small the world is to short wave radio. Z4AA was listening in and copied what I was sending which was not getting through very well. Realizing that we were in a bad position, he informed the postal authorities who cabled Washington about us. The written accounts are more thrilling than the actual experience, which was mostly hard work. Unfortunately, we grounded at high tide and it was soon evident that we would not get off that tide. Food, clothing, the low-power transmitter and spare receiver were put ashore so if a wind broke up the ship or she did not get free, there would be a means of communication. ZUO took the message advising the outside world that we were in trouble. After these things were done, we waited for the noon tide but it was three feet too low and the ship did not right. That night, we were still listed at an angle of 45 degrees. Some stuff was sent to 1BQQ but communication was difficult. KGBB kindly said he would watch for our low power signals if the big set went out. With three anchors out, lines to the windlass, and the engine going full speed, she did not move at high tide and it looked as if we would have to go through



with our emergency plans. Then Captain Bartlett ordered all sails on her and after a few doubtful moments, the wind that was springing up, pushed her off as the tide was beginning to fall. A little food was brought aboard and the ship was run around to the northeast side of the island from where the next night, July 28th, contact was made with 9CP and word sent that the ship was free. Conditions were better at ZUO and a longer message was copied there while attempting to give it to 9CP. It was fortunate that a counterpoise was already in use as the ground plates were way out of water while the ship was on the rocks. After the storm had blown itself out, the rest of the supplies were picked up and we started south for Upernivik to make repairs. In Melville Bay, contact with 9CP was very good and the long report of the whole affair was sent to the Putnam office and the New York Times. While at Upernivik, the Danish patrol boat, Islands Falk, came in with a diver who repaired most of the leaks. She had a long wave 1 1/2 K.W. Telefunken transmitter aboard, used to work Greenland shore stations. Her operator, Hugo Keichelman, was much interested in the short wave equipment on the Morrissey as he hoped to build a short wave set.

After repairs at Upernivik, we again went north; the third crossing of Melville Bay in one summer. After a brief stop at Thule, we went to Whale Sound for a week's hunting. During this time, 128 stations were heard and much traffic handled. Signals came in with good intensity and there were many pleasant nights. Midwestern stations were best. ZUO and 4JS were worked well. As usual, 9CP took most of the traffic.

The hunting over, many good specimens obtained, and the time getting late, on Aug. 21, the homeward trip via Jones Sound was begun. From Jones Sound south we had sunsets and nights. "Nz" came in to take traffic, with ZUO on the job too, and a new one, 1CCZ. At Ponds Inlet, a pleasant two days were spent with Constable Timbury, c5AO. Then our course was down the Baffin Island coast and across the southern end of Baffin Bay to Holstensborg. Normal conditions were observed here and much traffic handled with 2NZ, ZUO and 1CCZ.

South of Holstensborg, the aurora was very brilliant and killed all but Pacific Coast signals until we reached the Labrador Coast. Our message about the loss of our propeller was delayed until it could be given to 1CCZ. After headwinds and storms in Belle Isle, Sydney was finally reached.

Conditions in the far north were favorable for

36- to 43-meter work but the nights were variable, the signals coming in earlier some nights than others. 20 meters was used only a few times with 9CP. Cooperation by all stations was very fine and they did much hard work for us. The style of operating was good. In spite of what has been said of amateur operating, it rises to a higher plane when necessary. The cooperation of the headquarter's gang was much appreciated. 73 from VOQ.

STATIONS HEARD AND WORKED BY VOQ

New York to Holstensborg, Greenland, June 20-July 6.

1AG, 1AM, 1CH, 1CK, 1DL, (1FD), (1FL), 1RZ, 1VF, 1AAL, (1AAO), 1AAV, 1ADE, 1ADI, 1AEP, 1AFF, 1ALS, 1AMS, 1AOF, 1AOH, 1BHM, 1BLB, 1BMS, 1BUO, 1BZC, 1CAW, 1CCZ, 1CIB, 1CNP, 1CNZ, 1CPI, 1DA, 2FF, 2HA, 2KQ, 2LE, 2LS, 2NF, (2NZ), ZUO, 2AAH, 2AAN, 2ADV, 2ACP, (2AEV), 2AKW, 2AMB, 2AMD, 2ARM, 2ASQ, 2ATC, 2AVB, 2AXV, 2AWQ, 2BAA, 2BNT, (2BNZ), 2BRB, 2BWD, 2CJE, (2CRB), 2CTF 20, 2CVJ, 2CVU, 2HG, 2LN, 2VX, 2WF, 3AUV, 3BLC, 3BMZ, 3BVA, 4BX, 4BY, pr4JA, 4KJ, 4NA, 4NI, (pr4RL), 4VY, (5QL), 5ACL, 5ADE, 6DP, 6BAM, 6CGW, 6CKV, 6BF, 6EH, 6GZ, 6KF, 6SV, 6XE, 6ADE, (8AIP), 8ARG, 8BPL, 8BRC, 8SD, 8BTH, 8CAU, 8CNX, 8CUG, 8DRJ, 8DRQ, (9KD), 9QR, 9ZK, 9ZT, 9AAW, 9AKG, 9BHZ, 9BPD, 9BRZ, 9CEJ, 9CIP, 9CWN, 9CXC, 9DNG, 9DPL, 9DTK, 9EJI, 9EQB, c1AM, (c1AR), c8AF, c2GO, c2IT, c5UW, c6KV, AGB, AGK, FUT, KEKG, NISS, NKF, OCTN, PCLL, WNP, WVA, WVC, WVY, XDA.

At and near Holstensborg, July 7-11.

1FL, 1HA, (1PA), 1AAE, 1AAV, 1AAO, 1AJP, 1AWE, 1BCA, 1BIE, 1CMP, 1CMX, 1CPI, 1VF, 2CZR, 2TB, (2NF), 2HG, 2ZO, 4IZ, 5AMN, 6BVL, 6CGW, 6XOA, 7EF, 7IT, 7NC, 8EH, 8EQ, 8IX, 8ADT, 8AZS, 8BTH, 8DSY, 9KD, 9WI, (9ZT), 9AIZ, 9AEK, 9BPD, 9BBF, 9BFF, 9CIV, 9DQU, (9EJI), 9YAV, c1AR, c5DH, c8KF, NISS, NKF, NTT.

Near and at Disco Island, July 11-14.

(ZUO), 2PX, 2CXL, 3RL, 7EO, 7IT, 9BPD.

Proven and Upernivik, July 14-18.

(ZUO), 2APV, 6DP, 6ANP, 6NP, 6AFF, 6CMW, 8AJ, 8ES, 8CI, 8ADE, 8AHC, 8DTQ, 9CJ, 9EK, 9WI, 9ADK, (9KB), 9BPR, 9BQE, 9BKJ, 9BPD, 9BBF, (9BJK), 9CCX, (9CTG), 9DTE, (9EJI), 9BJZ, 9FPB, NISS, NKF.

Duck Islands and Melville Bay, July 18-20.

1OB, (ZUO), 2CXL, 3LV, 3ZO, 3HJ, hu6BUC, (8EW), 8OQ, 8AHC, 8AND, 8BFO, 8BRC, 9SJ, 9AEK, 9BHX, 9BFB, 9CPR, 9CEJ, 9DQU, 9EJI, c2IT.

Cape York, July 20-21.

1SE, 1ZK, (1HJ), 2BE, (ZUO), 2AMJ, 2CXL, 3BY, 4NI, 5JD, 5AJD, 6BJH, 6CWG, 8EW, 8BRC, 9ZT, c1ED.

North of Cape York to Parker Snow Bay, July 21-22.

1FL, (ZUO), 2MU, 2BGI, 5ZAZ, 7AFO, (7AIM), 8BPL, 9QR, 9ACL.

Wolstenholm Sound and North Star Bay, July 23-25.

1AAO, (ZUO), 2AMJ, 5ZAI, (6JP), 6BMW, 6BPL, hu6BUC, 7DF, 7NW, (9CP), 9KD, 9AGM, 9ACQ, 9BPP, 9CEJ, 9CET, c1AR, c1ED, (c2BE), (dg1XL).

Whale Sound, July 25-26.

1AOF, (1CMP), 4OE, 5ZAZ, (dg1XL).

On rocks Northumberland Island, July 26-27.

(1BQQ), (ZUO), (KGBB).

Anchored NE side Northumberland Island, July 27-29.

1AJP, ZUO, 5AAB, 5ZA, 5QL, 6AAM, 6BGT, 8AHC, 8CES, (9CP), 9ACQ.

Northumberland Island to Melville Bay, July 29-31.

(ZUO), 3BB, 6AKM, (9CP), 9XE, 9BWO, 9CAG.

Melville Bay, July 31-Aug. 3.

(1ACI), 1AOF, 2GK, 2UO, 2WC, 2AIM, 2AJQ, 2CVJ, 2CXL, 3OT, 3BVA, 4JK, 4JR, 4PR, 4QB, 4RM, 5QL, 5PB, (5ATA), 6FP, 6HJ, 6ASF, 6BLS, 7JF,

7VL, (7MN), (7RL), 8ST, 8CV, 9CO, 9CV, (9CP), 9ZT, 9ADK, 9ANQ, 9CKV, (9EJI), (VYG), (KGBB), FX1, 22XA, 22AC, 24XA, DX8.

Upernivik, 10 miles up fjord, Aug. 3-9.

1AAV, 1ALR, 1BIG, 2LE, 2NF, 2RA, (2UO), 2PX, 2TP, 2AES, 2AIM, 2AWQ, 2BEO, 2CXL, 3ZO, 3PL, 3AFQ, 4SI, 6AZY, 6BJL, 6CGW, 6CPF, (7TK), 7ALK, 8SY, 8MC, 8XN, 8UT, 8LF, 8EQ, 8AHC, (8AJN), 8ADG, 8BFX, 8BAY, 8DMZ, 9AM, (9CP), 9KD, 9LN, 9AEK, 9BKJ, 9BWO, 9BOL, 9CYE, 9DUV, c2BE, c2CG, c4DG, DZ8, VYG, f8KG, g2OD, rCB8, RXY, OCDD, NISS, (dgr1XL), NBA, 2XAF, KDKA.

Devil's Thumb and Melville Bay (3rd crossing), Aug. 10-11.
(2UO), (9CP).

Cape York to Thule, Aug. 12-13.

2UO, 6CUB, 6DJL, 7TJ, 7RL, 7UO, 8BTF, (9CP), 9GX, 9ALG, 9CKS, (VYG), DX8, NKF.

Whale Sound, Murchison Sound, Ingfield Gulf, Aug. 13-21.

1QI, 1KA, 1LN, 1ZW, 1ZK, (1AAV), 1AIR, 1ABN, 1RUS, 1EOA, 1BQQ, 1CMX, (2UO), 2PX, 2IZ, 2RS, 2FA, 2APV, 2AYJ, 2ASQ, 2AWQ, 2AGO, 2AXA, 2CXL, 2CVY, 2CVJ, (3ZO), 3NR, (3MV), 3BWT, 3CKV, 4JK, (4JS), 4LL, 4NI, 5AR, 5KC, 5WI, 6JN, 6PW, 6NX, hu6AJL, 6ARX, 6MW, hu6BUC, 6BGT, 6BJL, 6BJV, 6CUA, 6CGW, 6CDW, 7RL, 7UO, 7DF, 7NH, 7NY, 7WU, 8BS, 8TF, 8EW, 8FL, 8SY, 8NF, 8EQ, 8CI, 8SX, 8ATV, 8AHC, 8AKL, 8AJU, 8ADE, 8BBL, 8BNP, 8BRC, (8BPQ), 8PTH, 8BGN, 8CCR, 8CUG, 8CLS, 8DON, 8DBM, 8DJG, 8DAG, 8AMB, (8ZAE), (9CP), 9ZK, 9GX, 9KD, 9SV, 9QR, 9JK, 9UY, 9AEK, 9ALK, 9AOT, 9BPY, 9BWO, 9BQE, 9RSZ, 9BJZ, 9CFA, 9CTG, 9CET, (9CKS), 9DPL, 9DQU, 9DOL, 9DHF, 9DTE, 9EEW, 9APA, 9BWD, 9BPD, 9CKF, 9CPT, c4GT, c9AI, 22XA, VYG, NISS, WWDO, BB8, VVW.

Across north end Baffin Bay to Coburg Island, Aug. 21-22.

2UO, 7AAB, (9CP), VYG, c1AR, LPI.

In Jones Sound, Aug. 23-25.

1DU, 1BOM, (2UO), (2AGQ), 2CXL, 3ZO, (3AHA), 6PW, 6BJL, hu6BUC, 6ZBJ, 7BH, 7MK, 7NH, 7PU, 8CL, 8OV, 8AUL, 8BCG, 9EK, (9ADS), (9AUY), 9DEX, 9EEA, 96KI, g6TD, 22XA, BB8.

Off Baffin Island near Lancaster Sound, Aug. 25.

2UO, 3AHA, 8IM, 8CCQ, 8DSW, 9NK.

Near and at Ponds Inlet, Aug. 26-30.

1DU, 1UW, (2NZ), (2UO), 2CXL, 3PH, 3AHA, 3AQF, 4FT, 4JK, 6ARS, 6BBN, 7KU, 7PU, 7UZ, 7NH, 7RU, 7UO, 8IM, 8SF, 8EQ, 8BA, 8JB, 8VY, 8KC, 8AHC, 8ALY, 8BZT, (8CCQ), 8CCM, 8DQB, 8DHC, 8DLD, 9ZA, 9ACT, 9BCW, 9CSB, 9DPJ, 9DBW, 9DMA, 9DUH, 9EGH, (c1AR), c3QS, (c5AO), f8CT, y1CD, bz1GH, GMPV, (dgr1XL).

Across south end Baffin Bay, Ponds Inlet to Holsborg, Aug. 31-Sept. 5.

1KL, 1WL, 1AU, 1AHL, 1AJP, 1BLF, (1CCZ), (1CMX), (1CKP), 2TP, (2NZ), (2UO), 2AWQ, 2BGI, (2CTH), 3PF, 3ZO, 4FT, 6BIB, 7VH, 8ATV, 8AHC, 8BWB, 8CXI, 8CCM, 8DPN, 8DAQ, 9EK, 9ZA, 9ANQ, 9AXB, 9BAY, (9BFB), 9CET, (9CFL), 9CPM, 9CWO, 9DQU, 9EGH, (9EFS), c1AR, (z1AX), 22XA, NKF, 2XAF.

Holsborg, Sept. 6-7.

1AX, 1CK, (1CCZ), 1CMF, (2NZ), (2UO), 2APV, 3RUV, 5AUR, 6BCN, 6HJ, 9SJ, 9ZA, 9BJZ, 9BPY, 9CEJ, f8JN, f8MN, f8JF, GDVB.

Holstenborg, Greenland, to Sydney, N. S., Sept. 7-22.

1AN, 1CH, 1IS, 1KC, 1LU, 1MY, 1QM, 1OR, (1RD), 1UU, 1VZ, 1WZ, 1ZS, (1AAO), (1AAV), (1ACI), 1ADS, 1AEQ, 1AFP, 1AFL, 1AHV, 1AJX, 1AUC, 1AWY, 1AXA, 1BBR, 1BFT, 1BHS, 1BIG, 1BQT, (1CCZ), 1CIB, 1CJC, 1CJH, (1CKP), 1CMX, 1CVJ, 2BO, 2BS, 2FO, 2GX, 2LC, 2MU, 2NF, (2NZ), 2OT, 2RS, (2UO), 2XI, 2ZV, (2AAN), 2ANM, 2APV, 2BAD, 2BER, 2BOK, 2BUY, 2CJB, 2CJD, 2CTH, 2CUQ, (2CVJ), 2CXL, 2CYQ, (2YX), 2XAF, 3BZ, (3MV), 3NC, 3TR, 3UT, 3YP, 3ZO, 3AAL, 3AFW, 3AUF, 3BDL, 3BWT, 3CJN, 4AF, 4AR, 4BY, 4DU, 4FL, 4FT, 4IU, 4IZ, 4JR, 4LK, 4MI, 4NH, 4NS, 4OA, 4OB, 4PF, 4PI, 4QB, 4RM, 4RY, (pr4SA), 4TV.

4AAH, 5DE, 5DZ, 5HE, 5JC, 5PI, 5QJ, 5QL, 5YB, 5YD, 5ACL, 5ADO, 5AIO, 5APO, 5AUZ, 6KB, 6NX, 6WS, 6AJJ, 6AKM, 6AKX, 6ARE, 6ASA, 6BCN, 6BJL, 6BJV, 6BMW, 6BPL, hu6BUC, 6BYS, 6CCL, 6CGW, 6CKC, 6CPF, 6CXE, 6DAQ, 6DDO, 6DDX, 7JK, 7NC, 7RL, 7SF, 7TX, 7WU, 7ADK, 7AIX, 7KS, (8GZ), 8UU, 8ZG, 8AEK, 8ALK, 8ALY, 8AMD, 8AVZ, 8BBE, 8BCT, 8BJB, 8BMR, 8BPQ, 8BQH, 8BSD, 8BUY, 8CHP, 8CIL, 8CUG, 8CYM, 8DKK, 8DNE, 8DON, 8DSY, 9EK, 9HP, 9MN, 9OO, 9QD, 9ZA, 9AAW, 9AEM, 9AGB, 9AID, 9AOT, 9ATA, 9BAZ, 9BCW, 9REQ, 9BFF, 9BVF, 9BMM, 9BTY, 9BYC, 9CEJ, 9CJA, 9CKU, 9CPQ, 9CSQ, 9CTG, 9CVN, 9CVY, 9CWF, 9DBB, 9DQU, 9DWD, 9DWP, 9EGH, 9EME, BB8, c1AR, c2BE, c2CL, (c4FC), c4IO, c5JT, (i1AU), m1N, z4AC, z4AM, GLQ, GLKY, KDKA, NKF, NRRG, OMP, UTM.

AMATEURS HELP IN FLORIDA EMERGENCY

Amateur radio once again rose to the occasion, establishing communication with the outside world during the recent Florida emergency and maintaining that communication for several days before Western Union wires were available. The night after the hurricane all wires were down. There were no lights, no electric power, no telephone and telegraph service. Cities were cut off completely from the outer world. Conditions were most serious in the Miami district and scarcely better at Pensacola and other points. Many amateur radio operators all over the country stood by to help the Florida stations. Messages asking for help, word of assurance to friends and relatives, requests for news and reports of damage were all handled by amateur radio as soon as contact was established.

John V. Heish, 4KJ, at Miami with a single UX-210 operated from 500 volts of B-batteries deserves special mention for the work he accomplished under many difficulties. The Sunday afternoon after the storm he obtained a supply of B-batteries from the Electrical Equipment Company and got on the air connecting at once with Gifford Grange, 4HZ, at South Jacksonville who also used a UX-210 on a 40-meter wavelength for all the emergency work. An hourly schedule was arranged and kept by these two stations. The first message from stricken Miami was an official message from the Sheriff of the county asking the Governor of Florida for military aid. Government messages, Red Cross messages for doctors, food, and milk, and orders for building materials were sent over the 4KJ-4HZ route together with many messages from Miami people to relatives asking for aid or telling of their safety. Heavy QRN was a hindrance to speedy message handling but nevertheless a large amount of traffic of a very important and urgent "rush" nature was put through. Miami messages were delivered by the Sheriff's office while those bound to northern points were sent via Western Union by filing them with the telegraph company at Jacksonville as requested by the Miami authorities. Death messages and replies to a number of the messages were all handled expeditiously. Despite all that has been said about "skip distance", all the Florida stations handled most of the emergency traffic on a 40-meter wavelength. Severe tropical QRN was at times very discouraging when signals were weakest. The spirit of amateur radio and the will to "do or die" put the traffic through in typical fashion.

After the first day, most of the Miami traffic was cleared by keeping schedules at morning, noon and night leaving time for handling important messages between other points. Grange of 4HZ received the first reports of the reported loss of life and property in Miami and he also picked up 4PU at St. Petersburg who reported casualties light but property damage heavy there. Many important news services deluged amateur stations in touch with Florida for news dispatches but were disappointed because of the fact that real relief emergency messages took precedence over their traffic. Nevertheless, a great deal of the news that went northward took the amateur radio route—the only one available.

Though 4KJ and 4HZ handled the first and perhaps the most important traffic, the assistance rendered by others should also be mentioned. A great deal of storm traffic was handled by other stations in and around the storm-affected area. 4SB of St. Augustine went to Miami with the Florida National Guardsmen and operated a temporary 50-watt station at military headquarters there under that call to keep the troops

in touch with the Adjutant General's office at St. Augustine and to handle other important traffic. 41Z at Tampa manned by three operators, W. P. Moore "WM", W. P. Hunter "PX", and "Bug" Barker "BG", kept a continuous watch keeping schedules with both 4KJ and 4HZ to handle press and messages. A UX210 set supplied by B-batteries was used until the local electric power company got back on the job, after which the big crystal controlled set was put in action. This outfit was reported by stations all over the country as the one getting outside Florida with a "wallop". Florida messages and news were taken on schedule from 4PI, 4PU, NRRG, 4FS, 4HZ, 4KJ and 4SB, and passed north to 4RM, 2UO, 4HU, 2CXL, WIZ and others. 4NH, 4DD, 4PL, 4BN and 4VS each handled their share of emergency work connecting with 4HZ and 4FS at frequent intervals. W. A. Battison, 4MH, put a 250-watt set on the air using plate power from WJAX after having little success with a 1,000-volt B-battery. He succeeded in getting the first news from 4QA at Fort Baracus near Pensacola, also connecting with NRRG and 4AAH and cooperating with naval stations in handling relief messages. It is also reported that 4OB-4TK handled a bunch of traffic to Miami stations. 4VS at Red Cross Headquarters gave two-thirds of his traffic to 2EV.

A number of important messages were handled by amateurs for the Southern Bell Telephone and Telegraph Company during the storm, most of the messages originating at 5DL, Mobile, Ala. Some real amateur relaying was made necessary by the 40-meter skip-distance effects after dark. Messages for 5LE at New Orleans got through from Mobile via 4CU at Memphis, Tenn. 5UK, 4OA, 5FQ and 5YD also deserve a lot of credit for their work in handling messages during the emergency. 9CAA and 9DKM at Denver got Florida dispatches for their local newspapers through 5QJ and 5UK at New Orleans. 9AAW in Chicago Ill. and 9EK at Madison, Wis. were busy trying to break through and helping to get clear air after the hurricane had torn its path of suffering and devastation across southern Florida. 9AFF got 300 words of press about the Florida disaster for International News Service at Chicago through 5QQ and 8AYP. Countless other amateurs co-operated with those named to handle Florida traffic, reports of their work being included with the general traffic this month in some cases.

Many Florida amateurs have written A.R.R.L. Headquarters in appreciation of the response given to their calls for aid from amateurs all over the country who were right at their stations ready to help when help was needed most. Very little interference was experienced from northern amateurs during the transmission of relief traffic. Every amateur stood by for Florida during her trouble and helped to lighten the load until the commercial communication companies again got several wires through to the hard-hit Florida cities, some of which were a number of days without either electric power or telegraph and telephone facilities.

EXPEDITIONS

GMD

First contact with the Roosevelt Memorial Expedition was established when Jefferson Borden 4th, 1CMX, Fall River, Mass. took two messages from GMD Sept. 17, with 2APQ at the key. The expedition was then at Sao Paulo, Brazil getting ready for the plunge into the wilds leading to the headwaters of the Rio Teodoro. GMD was on 37 meters with a D. C. note when worked by 1CMX and Bussey tells us that he will operate close to the upper or lower edge of the 40-meter band unless some more desirable wave is found. The Brazilian government has assigned calls SQ1Z and SQ2A to the base and portable stations but it is likely that GMD will remain in use, too. All amateurs are asked to stand by and relay any news whatsoever to the New York Times passing personal messages along to the proper destination.

BAUM

The Chicago Daily News—Chicago Field Museum—Abyssinian Expedition left Marseilles, France on the S.S. Chambord Sept. 29 bound for unexplored parts of Abyssinia for a six to eight months' hunting trip to obtain certain new specimens for the Museum. Instead of using the call WCND as announced in these columns last month, the correspondent, in charge of communications has announced that the letters BAUM will be used at his portable station. 45 meters has been selected as the wavelength to be used. Amateurs in all parts of the world are requested to be on the

lookout for messages or news broadcasts from BAUM which will be sent between 8 P.M. and 9 P.M. (Abyssinian time is about three hours east of GMT, eight hours ahead of EST etc.) Mondays, Wednesdays and Saturdays. Send press messages to the nearest Chicago Daily News office always reporting hearing or working the expedition to A.R.R.L. Hartford, Conn, as usual.

3RF recently worked ARDI, the S. S. C. A. Larsen, a Norwegian whaler bound for the Antarctic from Norfolk, Va. and proceeding via the Panama canal, San Pedro, Cal. and New Zealand. The operator is L. Jensen of AQE and the set works on both 20 and 40 meter bands using a Marconi tube of unknown rating. The QRH was 37 meters at the time of QSO.

A message via zZAC signed "SS 2SE" reads "Restricted to 23 meters but hope for 44-meter concession later. Anxious to re-establish scheduled communication. Please QRX for tests 0500, 1000, 1100, 1200 and 2300 GMT daily after Oct. 1st." Anybody got any further information on this one?

Don't forget to drop a line to A.R.R.L. Headquarters reporting hearing or working any or all of the expeditions. Information on wavelength, audibility, tone, fading conditions, amount of traffic handled and so on should be included. New QRAs for all the gang are appreciated, too.

ARMY AMATEUR NOTES

The new Army and Navy Radio Procedure has been authorized for training use and all Army Amateur Radio Station operators will receive instructions on it within a few weeks. It is hoped that this will be adopted as standard procedure for all army-amateur net communications.

Plans for fall and winter are taking shape beginning with the establishment of a net including the Headquarters of each Corps Area. The very first night on which schedules were effective brought in all stations but those in the 5th and 9th Corps Areas—a most excellent start. 2CXL at Fort Monmouth calls each station in turn on each Monday and Friday night using either 40 or 80 meters at the scheduled time (6.00 P.M. to 12.45 A.M. EST). Each Corps Area station is assigned a 45-minute period. The stations and the wavelength used by each in answering 2CXL are as follows: 1YC (40); 2SC (80); 3SN (80); 4IO (40); 8EH (80); 9AFF (80); 9DXV (40); 5AIN (40); 6RW (40).

2ND CORPS AREA—The principal Net Control Stations in New York State are 2CYX, 2PF, 2EV, 2AKV, 2ANV and 8HJ for the different Auxiliary A-A Nets into which the state has been divided. 2APV, 2CLA, 2ABT, 2KG and 8VW are the alternate stations thus far appointed. The principal New Jersey N.C.S. is 2ZB with 2CDR as alternate. The Brooklyn Net had its first tests Sept. 29. A 14-group code message was sent by the N.C.S. 2PF and QSL'ed by 2APD, 2CRD and 2ADO. All stations were on 80 m. and worked bk-in, decoding the message and coding a reply which was sent immediately. Accuracy in sending, receiving, coding and decoding messages, is absolutely essential and amateurs in Army nets have had an interesting time of it and learned that no guess-work is permissible when handling army traffic.

5TH CORPS AREA—Regular work will soon be resumed. Applications are still coming in and stations are being appointed just as fast as Capt. Gardner of Fort Hayes can place them. Only so many stations are required for each net but the applications are appreciated and when there are enough additional volunteers in the right locations another net is contemplated. Appointed stations should QSO 8GZ, the N.C.S. at least once a week until further notice.

6TH CORPS AREA—A meeting at 3AFF will be held soon to plan A-A work for the coming season. The station has been rebuilt. It is expected that 9DOX will be appointed as alternate N.C.S. soon. 9DTK is busy organizing the Wisconsin Governor's Net and getting the National Guard units in the state lined up with the active stations volunteering to take their traffic. There are still opportunities for more appointments and applications should be directed to 9AFF, Mr. W. W. Bingham, 2424 W. Monroe St., Chicago, Ill. In eastern Wisconsin information may be obtained by addressing 9DTK. Amateurs west of Watertown, Wis. should write 9ZY instead.

8TH CORPS AREA—The Governor's Net in Oklahoma is now in operation and includes the following: 5AGN (N.C.S.) (Alternates: 5ADE, 5AAV, 5ANY, 5APG, 5ATK, 5ATV, 5GMM, 5ZL), 5AKM, 5ARO (5MV), 5SJ, 5QD, 5AVU (5IB), 5ATA (5BT, 5ABZ), 5WD, 5ZM (5AQW), 5GD, 5AAS (5CH), 5AOV, 5ALU (5AUD), 5AQQ, 5HH, 5ARY, and 5TW. This net like the Texas net, operates on 40 meters daily except Sunday between 6.30 and 7.30 P.M. Nets in Colorado, Arizona, and New Mexico will soon be in operation. The amateurs in this Corps Area find the encoding and decoding of messages using the cipher-disk loaned for that purpose by the government, a very fascinating sport in itself.

9TH CORPS AREA—During the annual encampment of the Oregon National Guard at Medford Oregon, amateurs organized under the direction of William Klein, Radio Section, HQ company, 162nd Inf., to furnish a daily radio service to the 2500 men at camp. Messages were carried to amateur stations 7FR, 7MF and 7NZ at Medford each night and these stations maintained nightly schedules with 7QU, 7AEK, 7DO, 7MH and others. The messages were delivered in fine shape with very few exceptions. It is expected that the arranging of schedules will be begun earlier next year so that the plan can be carried out on a still larger scale.

NOTICE:

Nominating petitions for Section Communications Managers are hereby solicited from the following Sections:

Section	Petitions should be filed on or before:
North Dakota	Noon, Dec. 2, 1926
Arkansas	Noon, Dec. 2, 1926
Alaska	Noon, Dec. 2, 1926
Montana	Noon, Dec. 2, 1926
Oregon	Noon, Dec. 2, 1926
Washington	Noon, Dec. 2, 1926
Sect. 5A, No. Calif.	Noon, Dec. 15, 1926
Sect. 5B, No. Calif.	Noon, June 15, 1927
Sect. 6, No. Calif.	Noon, March 15, 1927
Virginia	Noon, Dec. 2, 1926
Utah—Wyoming	Noon, Dec. 2, 1926
New Mexico	Noon, Dec. 2, 1926
Saskatchewan	Noon, Dec. 2, 1926
Manitoba	Noon, Dec. 2, 1926
British Columbia	Noon, Dec. 2, 1926
Philippine (provisional)	Noon, Jan. 1, 1927

The closing dates for receipt of nominating petitions are given as previously announced or extended when necessary due to the failure of members in filing petitions in certain Sections. The proper form for nomination was shown on page 45 of April 1926 QST. The candidate and five of the signers of a petition must be members of the A.R.R.L. in good standing and the petition must be received before the closing date announced to be valid. Members are urged to take initiative immediately, filing petitions for the officials of each Section now operating under temporary appointees, so that the work of organization can go forward everywhere without delay.

—F. E. Handy, Communications Manager.

CLUB ACTIVITIES

CALIFORNIA—The Santa Clara County Amateur Radio Association sent out nearly 5,000 16-page convention programs to west coast amateurs. The whole-hearted support of club members in working on this and the other details was responsible for the huge success of the Pacific Division A.R.R.L. Convention held at San Jose, Oct. 15, 16, and 17.

The Los Angeles Radio Club had an interesting open meeting Sept. 9 and over 100 people attending crowded the clubroom to capacity. 6CFT, 6AIC and 6AVJ provided entertainment (movies and music) while those present had the opportunity to meet 7SL, 6BXA, 8DGU, 8SF, 28AM, and 2AHG who were present from distant points. Col. Dillon, Supervisor of Radio, 6th Dist., addressed the assembly. 6BUR urged those present to attend the P. D. convention while 6BEV said a few words for the club and its station, 6CWG.

CONNECTICUT—The Radio Transmitters Association of Hartford have just held their election for new officers and started regular fall meetings.

ILLINOIS—The Chicago Radio Traffic Association just had its regular annual election. 9APY was re-elected President, 9DOX and 9LY are the new Treasurer and Sgt.-at-Arms respectively. L. J. Prazak of 9QD is the new Sec'y. The traffic committee is holding regular meetings and preparing to put over a good exhibit at the Radio Show, handling traffic and adding to the club membership.

INDIANA—The Indianapolis Radio Club recently installed a new receiver at its headquarters (19 East North St.). The club station (9JP) has a new short-wave transmitter donated by 9BAD. Following the Florida disaster the club offered through the newspapers to take traffic for Florida. 9EJ1 handled 123 and 9CYQ forwarded 31 of the messages bound for Florida. The local B/C association is using the club rooms for interference committee meetings, helping to improve relations between BCL and amateur.

The Bloomington Radio Club is ready for a busy season. The gang is full of pep and great things are expected from the new club.

LOUISIANA—The Caddo Radio Club of Shreveport has completed its new club house on the Louisiana State Fair Grounds. A model short-wave transmitter was exhibited at the fair, and a good number of messages were handled for visitors.

MISSOURI—The St. Louis O.B.P. backed by the Chamber of Commerce put over a hamfest Sept. 4, 5, and 6 that took on the magnitude of most conventions. An extensive program was carried out including all kinds of contests and stunts in which the successful contestants were awarded a number of valuable prizes. Addresses were made by 9AAU-9ZK, 9DXY, 9EK, and 9AOT and the hamfest was well-attended though preceded by heavy rains that made it impossible for a few to take up their reservations. FB!

NEBRASKA—A new radio club has just been organized at Red Cloud which has some novel features. The shack is on a hill two miles outside the city limits. Power lines are brought in underground. Receiving and sending conditions are perfect and the 15 members are on the lookout for live amateurs with whom schedules will be arranged.

NEW YORK—The Radio Club of Long Island has planned a good series of talks by prominent engineers and speakers for the fall season and offers the services of its QRM committee to amateurs, and BCLs of the vicinity in determining and clearing up interference troubles. For further information get in touch with 2CFT-2AXJ, Alfred Waring, Jamaica, N. Y.

NEW JERSEY—The Eclipse Radio Club at Orange are meeting weekly and alternate meetings are devoted exclusively to code practice and radio talks. A membership campaign is under way. The Amateur Radio Association of Essex County held its annual fall banquet Oct. 16. Hudson Division Director Dunn (2CLA), F. E. Handy of A.R.R.L. Headquarters and several men prominent in the radio manufacturing industry were present. The banquet committee did their part in making the affair a success by planning a chicken dinner that was at least R9. This organization assisted by Mr. Albert Sonn, Radio Editor of the Newark Sunday Call was responsible for an interesting program from WOR on Oct. 9th at which the subject discussed was "The Amateur and How to Become One."

NORTH CAROLINA—The Charlotte amateurs have just organized the Charlotte Amateur Radio Association. 4BX has been elected president and Mr. G. C. Brown of 4NH is secretary and treasurer. The club should do much to help beginning amateurs in breaking into the game.

ONTARIO—The Western Ontario Amateur Radio Association staged a fine exhibit at the Western Fair, London, Ont., Sept. 11-18 operating both a broadcasting and a short-wave station. Over 800 messages filed by visitors at the fair were handled by 3CS and 3IA.

WISCONSIN—The Milwaukee Radio Amateurs' Club have elected a new set of officers for the season just opened. Two booths were reserved for the club at the Fourth Wisconsin Radio Exposition. A collection of priceless relics of early radio days together with a complete modern short-wave station accepting and forwarding messages from visitors at the show featured at the radio show.

Frederick Best—1BIG

13 E. Crescent St.

Augusta, Maine

Orig. 81 Del. 91 Rel. 459 Total 631

This month 1BIG carried off all the honors. We need hardly say that he deserves them. The consistent appearance of his call nearer and nearer the top in the Brass Pounders' League for several months past, speaks for itself. It shows how the starred rectangle can be won by hard and regular work. 5TW is with us again in second place. 6BBQ "rushed" the message business and boosted his call to the third leading position.

Everybody please remember that the Traffic Trophy goes to the operator who sticks in the R. P. L. for three consecutive months. It is *not* a contest between stations—but one between operators. 1BIG is eligible because he operates his own station single-handed and is not paid for his services. At stations manned by several "ops", each one must turn in his totals independently in order to compete for the Trophy. A BIG PRIZE is still waiting for the chap who shows himself the most consistent Brasspounder. Get busy at the key, everybody.

BRASS POUNDERS' LEAGUE

Call	Orig.	Del.	Rel.	Total
1BIG	81	91	459	631
5TW	202	19	324	545
6BBQ	53	47	326	426
3ZO	6	3	406	425
6AJM	11	32	322	365
2EV	22	140	194	356
1AUF	165	6	170	341
1BMS	43	46	207	296
8EU	20	43	208	271
8CMO	47	19	198	264
8CNX	46	54	162	262
6BTM	12	64	180	256
9DVL	17	4	224	245
2CYX	67	62	90	219
1UE	17	38	159	214
6BXC	17	20	173	210
1BFZ	48	29	126	203
8DNE	39	8	142	189
6BSD	20	24	140	184
8BSZ	32	14	137	183
1JL	36	30	116	182
9EK-XH	99	14	58	171
4MI	15	18	136	169
1BHR	39	9	118	166
9DWN	5	2	155	162
6CUW	5	1	150	156
8BLP	54	30	71	155
6CYH	6	11	136	153
9EJI	123	1	26	150
1ABA	29	6	113	148
8AYP	27	22	98	147
3ADE	5	4	138	147
3BWT	19	29	92	140
2AVB	41	14	84	139
9DTK	35	24	78	137
8CGZ	2	7	126	135
8DRL	22	1	112	135
1AIT	8	13	110	131
7JF	17	4	106	127
6MB	112	6	4	122
2AUE	18	27	74	119
1BKV	8	12	98	118
3AIG	7	2	109	118
9BPF	20	13	82	115
2ANX	32	8	74	114
9DKM	34	5	73	112
1UU	40	9	62	111
8CJY	22	16	71	109
9SX	97	3	9	109
6AXW	77	1	30	108
8DBM	41	4	60	105
9AAU-ZK	11	2	91	104

OFFICIAL BROADCASTING STATIONS
Changes and Additions

YOUR attention is again called to the Fall schedules of the League's Official Broadcasting Stations. These stations have agreed to observe certain wavelengths and scheduled times of transmission, making it possible for you to select a station to listen for him at a definite time and wavelength, and to receive the Official Broadcast. A good number of stations send the broadcast so you may "run across" a broadcaster in the course of ordinary listening. We hope to have a more complete list for publication in November QST and to announce a competition at a later date to determine the most consistent broadcaster and to find where and when the broadcast can be copied.

Each week, the latest news of expeditions, schedules of tests that are being run and other important amateur news of the hour are made into a broadcast which is sent to operators of Official Broadcasting Stations weekly. The broadcast has a release date slightly later than the mailing date so that the material to be sent can be in the hands of each operator at the beginning of the week of release no matter in what part of the country he is located.

The operators of the various stations are willingly giving up part of their time to this work and will appreciate it if you will drop them a card saying that you copied the Official Broadcast from them on schedule.

O.B.S. are requested to send the broadcasts slowly enough so that they can be copied by beginners and with steady, even keying. A number of folks on the West Coast copy 6BJX's broadcast regularly one day a week, and a number of people listen to certain of the broadcasters right along for *code practise*. We will be pleased to receive any suggestions regarding ways of making this service through the Official Broadcasting Stations of still more interest and value to you. Only thus can we improve.

Call	(Local Standard Time)			Days of Transmission
	7.00 pm	10.30 pm	12.30 pm	
1AID s	41	—	—	Daily
1AYJ†††	—	—	—	—
1BEP	80	80	—	Mon. Fri.
1BFT	—	—	—	Sat. Sun.
1BIG†††	—	—	—	Mon. Wed. Fri.
1CKP	—	39	—	Sat. Wed.
1GA	37.85	—	—	Tues. Thurs.
1GA†	—	—	18.1	Sun.
1OC	83	—	—	Thurs. Fri. Sat.
1OC	83	83	—	Sat.
2APV	37.57	37.57	—	Mon. Thurs.
2CQZ	(special schedules on 40, 80 and 180 meters)			—
2CTH††	—	—	—	Tues. Thurs.
2PF	—	37.6	—	Mon.
3ALE	40	—	78	Mon. Fri.
3APV	—	—	20	Sun.
3BWJ	40.9	—	—	Mon. Wed. Fri.
3EL	40	—	—	Mon. Wed. Fri.
3EL	—	52.5	—	Wed.
3LL†	38.1	—	—	Mon.
3XAN	—	—	—	Mon. Thurs.
Pr-4JE	40	—	—	Tues. Sat.
4JR	39.3	—	—	Mon. Wed. Fri.
4OB	40	—	—	Wed. Fri.
4TK qqq	—	—	—	—
4TR	40.03	40.03	—	Mon. Wed.
4TR	30.06	30.06	—	Tues.
5ACL	38.5	—	—	Sat.
5ACY	38.2	—	—	Wed. Sat.
5ADA	38.2	—	—	Sat.
5GJ	38	—	—	Mon. Thurs.
6AMM	38	—	—	Tues. Thurs.
6ANO	41	—	—	Daily except Sun.
6BJX‡	—	—	—	—
6BUC	—	39.75	—	Sat.
6CCT	—	39	39	Mon. Tues. Fri. Sat.
6CLP***	—	—	—	Sat.
6HU ss	—	—	—	Mon. Fri.
6UO	—	80	—	Mon. Wed. Fri.
6VC***	—	—	—	Mon. Wed. Fri.
6ZX****	41.5	—	—	Wed.
7NT	40	30	—	Wed. Sun.
8BHM	42.5	85	170	Sun. Wed. Fri.
8BSU †††	40	—	—	Mon. Fri.
8CEO	80	—	—	Mon. Wed. Fri.
8DME	38.5	—	—	Tues. Fri.

8EQ	38	---	---	Tues. Fri.
8EQ	---	38	---	Sat.
9ZH	76	---	---	Tues. Thurs.
9ADR	40	40	---	Thurs.
9AGL	80	80 or 40	---	Mon.
9AYK	79	---	79	Tues. Thurs.
9BFG	79.7	79.7	---	Mon.
9HFG	---	79.7	---	Wed.
9BKJ	39.5	---	---	Tues. Thurs. Sat.
9BR q	---	---	---	Sun.
9BYQ****	178.6	---	---	Tues. Sat.
9CET*	---	---	---	Mon. Thurs.
9CJS	83	---	83	Tues. Fri.
9CPM	---	38.1	---	Tues. Fri.
9CPM	38.1	---	---	Wed.
9CPO	40	---	---	Wed.
9CPO	---	40	---	Sat.
9CVR †††	---	---	---	Fri. Sat.
9DPJ	82	---	---	Mon. Wed.
9DPJ	---	---	88	Sun.
9DVK	200	---	---	Tues.
9DVK	---	200	37.8	Sun.
9DZI	38.5	---	37.8	Sun.
9DZR	80	---	---	Tues. Fri.
9HGU	3.75	---	---	Mon. Wed. Fri.
9HP	39	---	---	Tues. Fri.
9RR	---	82	---	Tues. Thurs.
9ZC	---	84	---	Sat.
WJBA	---	206.8	---	Mon.
WOAX ††	---	---	---	Tues. Fri.
(voice)	---	---	---	Sun.
c1AK	---	40	---	Wed.
c1BZ	42.5	---	---	Sun.
c2AL	---	39.2	---	Sat.
c2BE	---	38	---	Wed.
c8AFP ††††	---	---	---	Tues. Fri. Sun.
c8AZ	41	---	---	Mon. Wed. Fri.
c8EL	40	---	---	Wed.
c8EL	---	52.5	---	Sun.
c4GT qq	---	---	---	---
q 12:00 noon	38.5 meters	---	---	---
qq 12:30 am.	37.7 meters	---	---	---
qqq Fri. 7.30 p. m.	Sun. 6:00 pm—40 meters	---	---	---
* 11 pm.	38 meters	---	---	---
** 7.30 and 8.45 pm.	38 m.	---	---	---
*** 9.30 am.	Sun.	---	---	---
**** 10:30 am Sun.	41.5 meters	---	---	---
***** Sun., 3 pm	---	---	---	---
# 10:00 am.	Sun.	---	---	---
## 39 m., 7:45 p. m.	---	---	---	---
† 12:25 pm.	38 m.	---	---	---
†† 12:20 pm.	240 m.	---	---	---
††† 8 and 12.45 pm.	41 m—8.30 pm.	80 m., Tues.	---	---
Fri., Sat., also 8:30 pm Sun., 80 m.	---	---	---	---
†††† 52.5 m., Midnight	---	---	---	---
‡ 6 pm, daily except Sun., 40 m.	---	---	---	---
§ 42.5 m., 6 pm.	---	---	---	---
§§ 9.00 pm, 40 m.	---	---	---	---
‡‡ 6:00 pm.	---	---	---	---
‡‡ 6 pm and 9.30 pm, 38 m., 1 pm Sun., 19 m.	---	---	---	---
‡‡‡ 12 m., 38 meters	---	---	---	---

TRAFFIC BRIEFS

9AAP is the station of Mr. C. C. Dimock at the Union Depot, Chicago. Amateurs along the right of way of the C. M. & St. P. R. should be on the lookout for this station.

DIVISIONAL REPORTS

ATLANTIC DIVISION

EASTERN PENNSYLVANIA—SCM, H. M. Wal-
leze, 8BQ—The month rolled around fast and the reports rolled in late. You had me worried for a few days, fellows. Figures changed a little this month. 3AIG a new ORS, went and busted our preaching about no traffic on 40 m. He raked in BPL credits—and sent his bundle to be checked, too. 3BVA ran up well on the 40 m. band also. However, the rest of the 40 gang trailed. 60% of the reporting stations handled 10% of the traffic on 40 m. 35% on 80 handled 75% and the balance to those on both bands. Our list of BPLs took a slight drop.

8CGZ says traffic is picking up on 40. 3AIG is at 8XE. Our 80 m. deacon, SEU, hopped to 40 and right back again to 80. HL, 8CMO is playing checkers with 8DIE. 8BSZ thinks QRN is still bad. 3BLC's rig doesn't perk right. The 'A' battery died for 8BFE. 8CW and 8BIR are getting 8DQG in shape. 8WH is still moving around. 40 m. lost another ORS in 3AIY, due to QSY to 80. 8BRT was

5UK reports that eight messages have thus far come through 5WY from the Palm to Pine Automobile party which left New Orleans Sept. 20 on the way to Winnipeg, Canada.

The master-control station of the First Naval District is the station of Ensign R.D. Russell USNR, 1BTR, Wellesley, Mass. A naval call will be assigned in the near future. Crystal control (72.4 meters) is used. Five Naval Reserve units are planned for this District. 1ZD, 1BIG and 1VR took part in the first officer's drill on October 12.

Don't forget QRR! QRR is the official A.R.E.L. "land SOS" for emergency use only. It is not to be used for tests of any kind but only in actual emergencies. When you hear QRR this coming season, stand by to help if you can. If you can do nothing useful, stand by and keep your transmitter from causing needless QRM following the same practice used ship-shore wavelengths when an SOS is heard. QRR could have been more advantageously used in the recent Florida emergency, if more amateurs had familiarized themselves with its meaning.

Give your traffic to station-owners holding O.R.S. appointments and bring the number of message DELIVERIES up to scratch.

"Who gets the biggest kick out of radio? What was YOUR biggest thrill? The first station you worked of course—and the first QSL card rec'd. Wasn't it a beaut? Didn't you nail it up pronto on the wall of the shack and call all visitors' attention to it the first thing? Didn't you watch the mail anxiously for more? Now who gets the biggest kick out of hum radio? The beginner of course. Several cases have been called to our attention (some concerning fellows who should know better) where a beginner has clicked with an old timer and has been cut short—told to QRQ in uncivil fashion, etc.

"Speed is all right in its place—but remember that after all accuracy is the first requisite of a good operator. Courtesy is another quality recognized anywhere, too. So please give the beginner a chance. Work him and keep on working him. Take time to get acquainted with him over the air. Wind up the flivver and go down to see him if possible. Help him get the hang of the abbreviations and proper procedure for a QSO. If he wants you to QRS please do so. You are wasting time if you try to make him admire your speed anyway. First of all, QSL him a card which he will appreciate more than words can tell. Take him under your wing and help him out of all his troubles. Make him a real ham and a friend and you will be amply repaid. True friends are as valuable now as always."—9CJS

Hu 6DDL, 6BUS and NPM are seriously engaged in running some tests on 5 meters and 8 meters using a 204A and automatic keying device. The distance from Oahu to the Island of Hawaii has already been covered and attempts are now being made to QSO the mainland. Amateurs wishing to take part in 5-meter tests should get lined up by writing the Experimenters' Section.

DXing by auto. 3SM is slugging for his ORS. Bottles went west for 8ADQ—along with his AC. 8RT says 40 is dead early AMs. The sick list had 8AFQ down. 3NP has QROed. 3BFL wants his ORS. 3JN threw his slop jars out. Our DX boy, 8CCQ, QSOed 5 continents in one night on a new 50. 3ZM is plugging along. The report of 8AWT was so stamped up enroute that I could not read it. Sorry, OM, 3BVA works them all. A new Zep antenna makes 3AVM step FB. 3LW tore off some consistent DX. 3AUV has both 500 c. and mercury are supply. 3BQP says their club, 8BQJ, has a crystal controlled rig under way. 3BCP is DXing. 8AVL (and almost everyone else) handled Fla. storm traffic. 8BCQ is keeping Wilkes-Barre on the map. Traffic comes to 3ADE on 40 too. 3LK is all upset due to QSY to 20 m. 3AVK fell down due to rebuilding. 3QY wants his ORS. (Yes, but hit the traffic up a little, OM). 3JJ sends a nice report on Harrisburg activities. 3BNG is Chief op at WBAK. 3AQR is pounding 40 hard. 3ABX is bent on fone stuff. 3SLK (?) is reopening. A 250 raises 'em all for

3BCE. Battery trouble is going around—3FE has it too. 3BBV has trouble ahead—a crystal on the road. Hi. A 176 m. fone keeps 3CJM happy. 3SY, who is totally blind, will appreciate calls on fone, 176 m. Keep him QRW, you fone fans. 3BQ is busy with crystals. (OK 3BLP????) 3BLP's report did not arrive.

Traffic: 8EU 271, 8CMO 264, 8BSZ 183, 8CGZ 135, 8AIG 118, 8BVA 79, 8BFE 71, 8ADQ 53, 8SM 46, 8BR 42, 8LM 31, 8CW 24, 8CCQ 24, 8AWT 17, 8AUV 15, 8A1Y 14, 8LW 14, 8BQ 14, 8SM 10, 8AVM 10, 8NWH 8, 8AVL 7, 8RT 5, 8BRT 5, 8BQP 5, 8BCP 5, 8BFL 5, 8AFQ 3, 8NP 3, 8JN 2, 8QY 1, 8BCL 1.

WESTERN NEW YORK—SCM, C. S. Taylor, SPJ—SCHN has been touring the state. 8AIL is back from vacation and expects to have some 50 watters on 40 m. soon. 8BGN is rebuilding his set to fit the new shack and is teaching the YL the code. 8BQK is QRW at G. E. but his 210 perks at times. He would like schedules in W. N. Y. on 80 m. 8CYB is on again. 8ARG is on with a UV203A with 150 watts input. 8AFQ worked S. Africa with his new fifty. 8BFG sent in a good message total. 8CNX says the fall season has begun with a bang. Take a look at his message total. 8ABS reported that he would have a better total next month. 8DRJ works lots of DX. 8CTL just got back from a trip east. He visited the gang in Hartford and had a great time. 8HJ is all set with new tubes and is ready for business. 8BLP is QRW with college now so his traffic will fall off some. 8ABG is trying to put in DC but is having all sorts of trouble. 8DHX is busy at school and may have to cancel all his schedules. 8DME works plenty of DX but complains of QRN on 40 m. 8VW is getting back on after a period of inactivity. 8BCZ has the old 7.5-watt set going again at his new shack. He says he has been having some very freakish radio weather on 80—dead silence sometimes. 8NT is getting ready for winter. 8CYI is at the U. of Michigan now but expects to have a 1/2-Kw. crystal-controlled station signing 8XA on soon. 8AVR is QRW with outside work and only operates the set about once a week. 8BMJ has been handling quite a lot of traffic. 8CNT wants schedules with Buffalo and Rochester. He shot another five but will be on again soon. 8AHK reports that the Radio Club of Rochester held an election Sept. 24 and elected 8KT for president, 8BRD v-pres., 8ALY treas., and 8AHK secretary. 8ARG is off rebuilding. 8ALY had a schedule with 4PI during the Florida disaster and handled messages to and from Florida. 8DPL is on 80 meters now and wants stations having traffic for Buffalo to listen for him on the lower end of the 80 band. 8BEM is using 3 harmonics for 40 m. and will be on soon with pure DC and phone for the high band. 8DPK just got back from Ft. Monmouth where he had a great time operating the Signal Corps sets. 8AHC reported a long string of DX worked. 8DNE is an applicant for ORS. He sent in a good report. 8PK reported for the following: OM Yoe is back at RPL. OM Chuck is laid up with a broken leg so gets lots of time to pound the key. 8PK's 20 meter sigs have been copied by g2AYB. 8CVJ has been QRW school work but hopes to do better next time.

Traffic: 8DNE 189, 8CNX 263, 8BLP 155, 8BHM 94, 8AHK 72, 8ALY 72, 8NT 49, 8CVJ 36, 8CYI 36, 8BQK 33, 8BGN 29, 8DHX 27, 8DRJ 25, 8DME 24, 8BCZ 22, 8AHC 19, 8DPL 18, 8BFG 11, 8ABS 5, 8ABG 5, 8HJ 2, 8ARG 2, 8CNT 2.

MARYLAND-DELAWARE—SCH, H. H. Layton, 3AIS—3AEA borrowed a 250 watter and tried to QSO Florida the night after the hurricane. He was on for 5 hrs but ND. 3AHA worked VOQ last month. 3CGC will be on the air this fall and winter over week-ends only, using a 50 watter on 37.7 meters and a UX210 for traffic on 80 meters. 3RF has been getting out very nicely last month but complains of lack of traffic. 3OP is still at sea. 3ACW is experimenting with antennas. 3FY was QSO France. 3VT, 3GT and 3WA are not very active. 3BUR is rebuilding his station and will be on the air in a month. 3PS is back at the Naval Academy after being on a cruise all summer. Succeeded in getting his hooks on a WE watter which he reports to have perking on 40 meters in a couple of weeks.

3WJ is pounding brass on the SS Olean bound for San Pedro, Calif. He has his 40-meter transmitter along with him using the ship's call, KOBN. 3AIS has a new antenna and is at last reaching out in fine style. 3SL will soon have juice in his house which

is out in the country. His spark coil CW will then be set aside.

Traffic: 3AEA 9, 3CGC 3, 3RF 3, 3AIS 7, 3WJ 5.

WESTERN PENNSYLVANIA—SCM, G. L. Crossley, 8XE—The reports for the month are very light, in fact, it seems that all stations are rebuilding or are out of order. The message totals are very light as compared with other months and most all the ORS are asking for schedules or say they can't find any traffic. Most of the work this month seems to be on the 80 meter band. There also seems to be a trend to the A band which the SCM believes to be very good if we are going to get back that old time chummy spirit for which the A.R.R.L. has been noted. Come on, gang, let's have a little more rag chewing.

8BRC—H. S. Myers, of Venango Co., Pa., has been appointed R-M of Western Pa. All ORS wanting regular schedules arranged, please communicate with Mr. Myers.

The new ORS certificates have been mailed to a number of consistent stations. If you have not received yours, it is because you do not report regularly.

8VE is at Medical School in Pittsburgh now. 8DNO is also in Pittsburgh. 8JW is at Swathmore and 8BRL at Carnegie Tech. All of these collegiates say they will be on the air just the same. 8BRB is operator on a Great Lakes boat but pounds in at 9AAW once in a while. 8CUH, 8ACQ and 8DNE are about ready to come on the air. 8GI reports too much QRM from business (why don't you quit making money and pound the key a while—hi). 8AKI, 8DCV, 8BW, 8CUC and 8XE are still remodeling and before you read this, you will have probably worked all these stations. 8DCV sets in at 8BSN on Tuesday nights. 8CES is rebuilding his sets on B, C and D bands. 8AXD, 8CRK and 8CWT are doing good work on 40 and 80 meters. 8CEO says he craves location for his station so he can set up. 8AGO spends his time trying to get his crystal working while 8SF has 200 watts of crystal control. 8GK is remodeled and waiting for the cold weather. 8ZD is on 39 and 80 meters looking for traffic. 8DHW has a freak Hertz in operation???? (What is a freak Hertz?) 8CKM reports inactivity.

8CMP, the Atlantic Division Director, Dr. Woodruff, has returned from his summer trip to Europe. While there, he visited several English, French and Italian stations. He is one of a few of the US gang that go visiting the stations over the United States, let alone foreign amateurs.

Traffic: 8CWT 65, 8DHW 53, 8BAF 37, 8CEO 23, 8ZD 22, 8ARC 22, 8VE 19, 8SF 15, 8GK 12, 8BBL 9, 8AGO 7, 8AKI 53, 8AGQ 4, 8DNO 4, 8CRK 2, 8AXD 1.

DISTRICT OF COLUMBIA—SCM, A. B. Goodall, 3AB—It is a pleasure to report the active opening up of 3CAB on 40 and 80 meters with a fifty watter. Quite a bit of traffic has already been handled through this station. 3BWT continues to be the most active station in Washington, as usual. 3KT is a new station on 40 meters—crystal controlled. If his transmitter does the same work that his tuner does, there is going to be a story to tell. 3ACM has changed over to crystal control and is getting results. 3JO blew his 201A using it for the transmitter kick and comes back with a 203A.

Traffic: 3BWT 140, 3NR 40, 3CAB 36, 3AB 36.

SOUTHERN NEW JERSEY—SCM, H. W. Densha, 3EH—Traffic at 3KJ suffered last month on account of the famous beauty pageant. Who could work radio with so many beautiful women in town. 3ZI is still on the job with the army-amateur net. 3BMZ is running regular schedules with 6BAV. 3CO, South Jersey's youngest ORS, is again on the air. 3BEI is busy lining up on his O-O appointment. 3BAY and 3ALX are Freshmen at Penna. State College this year.

Traffic: 3BMZ 12, 3BWJ 6, 3KJ 3, 3BEI 1, 3CO 1, 3ZI 1.

CENTRAL DIVISION

MICHIGAN—SCM, C. E. Darr, 8ZZ—The City of Straits Radio Club is actively engaged in getting the Michigan State A.R.R.L. Convention in shape. 8CEP is putting in a mercury arc rectifier. 8SX is QSO Australia and New Zealand with 500 cycles for plate supply. 8ZZ also uses 500 cycles in non quiet hours.

9EAY says he can convert a lot of BCLs now. The night of the big fight, their \$500 sets wouldn't perk so they called 9EAY up and he tuned in 2XAF on

32.79 meters and got them right from start to finish. FB, 9EAY! 8AUB is working good on 40 and 80 m. He reports that 8APM is attending Harvard but has a station, 1GW, on the air already. An old timer, 8DJA, is back on 80 m. 8BGR is still on 80. 8BCV has a 50 watt now and guess he will be on more often. 8DNK is on with R.A.C. 8BGO worked a "BZ". 8DMM is still pounding out good. 8CCM and 8DQB are on also.

Activity is beginning to be noticed in Michigan. Quite a number of new fellows have promised to report next month.

Traffic: 8SX 109, 8CEP 51, 8AUB 43, 8CQC 15, 8ZZ 10, 8ZH 8, 8CPM 7, 8PF 6, 8EAY 4.

INDIANA—SCM, D. J. Angus, 9CYQ—9CP has just returned from a trip through the west and is on the air again. 9BK is coming on again with 80 meters. 9DHJ is operating on the Great Lakes; the call of his boat is WKC. 9DIJ is working the Brazilians regularly now. 9BSK got an R8 report from the PL. 9AFA, ex 9AF, is back on the air again. 9BYI is on again with a new transmitter on both 80 and 40 meters. 9AMI has a new receiver and is ready for winter DX. 9DLM is a new ham at South Bend on 50 watts. 9AEB has started again on 40 meters. 9CNC handled some of the Florida flood traffic for local people. 9DPI is experimenting on 80 meters. 9BQZ is also experimenting and handling very little traffic. 9BCM is going strong on 80 meters. 9EJU is going regularly on 80 and 180 meters. 9DDZ is still waiting for the parts of his set that he ordered last year. 9AXO has been on regularly in spite of the loss of an H tube and two antennas. 9ES is on 85 meters with a good fone and has been QSO 1000 miles with it. 9BDT is on regularly now and wants Terre Haute traffic. 9QR still keeps the air around Fort Wayne hot. 9CMJ is putting in two 7½ watters. 9BNP is rebuilding for winter. 9ABW has about completed rebuilding. 9AIN has a new 1500 volt generator and a 50-watt tube. That should put Bloomington on the map. 9AYO blew his 7½ watt with staying up all night to work DX. 9ASJ is back from New York and is keeping things hot on 80 meters. 9DPJ is building up a crystal set for 80.55 and 40.275 meters. 9ABP is changing to 80 meters. He is operating the Hart Music Shop radio station now. 9DYT is off the air as he is going to Purdue. 9EBW worked be-WGBF during the hurricane and got dope on missing relatives, etc. This information was then broadcast by WGBF.

Traffic: 9EJI 150, 9EBW 64, 9DPJ 48, 9ASJ 28, 9CMJ 26, 9CBT 26, 9CNC 17, 9DHJ 16, 9AXO 14, 9EJU 14, 9BSK 8, 9DSC 7, 9CRV 6, 9QR 6, 9AMI 5, 9ABP 4, 9DIJ 4, 9CP 3, 9BCM 3, 9BYI 2, 9BK 2, 9CLO 2.

KENTUCKY—SCM, D. A. Donard, 9ARU—Notice! New ORS certificates are going to be issued to ACTIVE STATIONS ONLY! If you don't get a new one, don't blame anyone but yourself. Thirteen ORS failed to report this month. ORS are wanted. Write SCM of this section. 9ABR is a newly-appointed ORS. 9OX was on 40 until the QRM got him and he moved to 80. Not so much DX, says he, but more rag chewing. 9HP has a UX210 perking on 80 with an indoor aerial (indoor ground too, OM? Hi) and a 50 watt on 80. Getting out FB. 9ARU is getting ready to install a 250 watt on 40 meters. Ex-9TW of Galesburg, Ill., moved to Louisville and is getting ready to get going on 40 meters. Here's luck, OM. Don't forget about the new ORS certificates, fellows.

Traffic: 9OX 20, 9HP 6, 9ARU 4.

WISCONSIN—SCM, C. N. Crapo, 9VD—9BIB just finished painting a 65 ft. steel tower with aluminum paint. 9EAR hopes to have a better report as soon as it gets colder. 9BKR expects to have more time for operating this year. The MRAC is operating a short wave station and handling traffic direct from the Milwaukee Radio Show. The totals will be sent in with next month's report. 9EAN has left for U. of Wis. but may be on some week ends. 9DZV just back from operating on Lake Michigan. 9EGH brought 9COI a 50 watt from France. 9EK-XH now has three CC sets going. 9CFT was visited on Labor Day by 9DYD, 9LY, 9RK and 9DLD. 9CFT is doing FB with a Zeppelin antenna. 9BPW is a new amateur. 9AZN is going to teach radio telegraph classes at Vocational school this winter. 9AZY is planning to attend school at Dodge's Institute at Valparaiso. 9EHM's set seems to perk well using trap in couples Hartley circuit. 9AEU has again returned to school and his station will be off the air until December. 9BWO says his grid leaked out but

is back on the air after putting a little of the overflow in his B batteries. 9BJY is having some trouble with his transmitter not holding its note. 9DLD entertained 9DUJ, 9DOB and 9DLQ during the past month. He also reports that 9ACM at Columbus, Wis., gave the first news of the Million Dollar bank robbery in his city to the Milwaukee Journal station WHAD who broadcasted during their dinner hour program.

Traffic: 9EK-9XH 171, 9DTK 137, 9AZN 38, 9RKR 20, 9DLD 16, 9EAN 14, 9BWO 10, 9BIB 8, 9EMD 8, 9EHM 9, 9CFT 5, 9BJY 3, 9EAR 3, 9COI 2, 9AEU 2, 9AZY 1.

OHIO—SCM, H. C. Storck, 8BYN—Well, gang. 8DRL takes the cake this time for Ohio. This sure is FB but the rest of the gang fell down badly. That is, most of them.

9BKM nearly got into the BPL. If he hadn't been rebuilding, he would have done it. 8DPN just started again and says he's rarin' to go. 8GZ is using current-fed Hertz now and getting fair results. 8PL reports more traffic on 40. It's his Xtal controlled note, I'll betcha. 8BPL is in school in Georgia. 8DRX built a new receiver and reports good results. 8AZU reports a burnt-out transformer, hence low total, but better luck next time, OM. 8AVH will be ORS soon and QRV for messages. 8RJ just slipped in in time. Says he nearly forgot his report. Hi. 8AEU wants a schedule with Canton, O. but can't QSO. 8DQZ excuses low total because of trouble with Hertz. 8BSA handled his traffic on his portable 8BEY because 8BSA is being rebuilt. FB. 8DIA has been QRV vacation but will be on full blast soon. 8KC turns in 7 but raves about DX. 8AWX's work keeps him away from home but promises more traffic in the near future. 8CLR has a new rectifier and expects better results. 8DSY was QRV getting his set perking but is doing fine now. 8CBI blew his grid leak (so did the SCM—hi). 8BOP is now on the air with the "Big Boy" he won at the convention. 8ZE is now teaching at Purdue, and will keep in touch through 9YB. He sends 78s and would like to hear from any of the gang. Address 9YB. 9CPQ is now on with Xtal control. 8AGS is going to school at Purdue. He and 8ZE should make a good team. 8RY is at Schenectady, messages to him go via 2GK. 8DGP is at college. 8DMX can't get out. Says he hopes to find the trouble soon and get on the air. 8BKQ takes the cake for tough luck. He burned out two 7½ watters and can't make his new set work. 8BAH will be on more now and deplores the fact that so many hams won't take traffic.

In all seriousness, fellows, this business of not accepting messages is getting serious. You should see some of the complaints that roll in here. This is notice, that if any complaint ever reaches 8BYN of any Ohio ORS refusing traffic that ORS will be no more ORS in short order. Let's rare up on our hind legs, be on the prod for traffic and make Ohio show up plenty big in the month reports. Are you with me, gang?

Also, this is notice, that no DX records, except something unusual, dare, or will, go into QST. It's against the rules. But it is a shame for a good ORS to turn in a low total or none at all and use the rest of the card to tell about his DX. We are all DX hounds, even the more rabid traffic fiend, but some are not interested in traffic at all any more. Such stations should not be ORS.

Another time! The reporting month is from the 26th of one month to the 25th of the next month, inclusive and ORS and others should mail their reports on the 26th of the month direct to the SCM.

I wish every one of you in the Ohio Section would drop me a card with this dope: Will you and can you keep regular schedules on regular traffic routes? If so, what bands do you use regularly and what bands can you QSY to? What hours of the day or night and what days of the week can you be on the air? Will you promise if you are appointed on a regular traffic route to carry on your end of it to the best of your ability? Also, recommend some good stations which will be willing to help along.

Traffic: 8DRL 135, 8BKM, 94, 8GZ 60, 8BYN 46, 8DPN 38, 8PL 23, 8RPL 46, 8DRX 20, 8AZU 19, 8AVH 17, 8RJ 16, 8AEU 11, 8DQZ 9, 8BSA 9, 8DIA 8, 8KC 7, 8AWX 5, 8CLR 5, 8DSY 4, 8AVX 3, 8CBI 2, 8BOP 1.

ILLINOIS—SCM, W. E. Schweitzer, 9AAW—9PU is moving to Champaign, Illinois, and while at college, will keep in touch with 9CSB. 9CIA is carrying on all traffic on 40 meters. 9CXC is now using a 204A

and is planning to supply the power with a mercury arc rectifier. 9NK has mounted his new transmitter on glass, claiming additional efficiency. 9DGA blew his H tube and is now using a 50. 9CSL is attending Armour Institute of Technology. 9ALM worked O-A3B twice in one night and then broke into the Spring-bok contest. 9AFF is keeping schedules with 9DPK, 9ZY and 5QJ. 9DXG is lining up schedules with the 6th and 7th districts. 9QD has a new 50 watt and is still puzzling over the glass valve which lights up so brightly. 9BBA reports QRN very bad this month. A transmitter is now working with 50 watts on 40 meters. 9AYB is at the Univ. of Ill. and is operating at 9BDL. He will not be on until Christmas, but hopes to open up at that time with crystal control. 9AAE was on during the Florida disaster getting press. He is attending Armour Institute and working 9NV. 9DYD is using low power at the present time but will open up with 50 watts this month. 9BPX has been at the CMTC for the last month. 9AXF logged PCTT and PXX Java on 27 meters. 9ARM reports Harry Bartell, formerly of the USN, who used to work at NBA, is now located at Manhattan. 9AHJ is rebuilding for the winter and will be on soon. 9BDI is at the Univ. of Ill. 9BBX who has been off the air all summer, is starting up soon. 9ALW is building a room above his garage for his set. He is in Chicago at Armour Inst. now. 9CSW is rebuilding his transmitter. 9BHT is working on a crystal controlled set and expects to be on the air by November. The set will be adjusted so it can be quickly changed to 20, 40 or 80 meters. 9DLG has his outfit rebuilt. 9DDE reports life's little jokes number 492321. "Was using 216-A with low power to work a friend of mine a mile from here and it was heard in England four times in ten days." His 50 watt never got out of the States. 9ATG is a new station using 80 meters with 3 201A's supplied with 400 volts. 9BHM will be on after Oct. 1st with 15 watts. 9AOF, a new station in Danville, will be on in about two weeks. Ex-5AMC is at college at the Univ. of Ill. and has the call 9DGF. 9BPK, 9DTR, 9BDG, 9BQA and 9CTX are going FB. 9APN QSOed China. 9AFX, using a 7 1/2 watt, has Aussies and Zeddies for breakfast every morning.

Traffic: 9PU 81, 9CIA 69, 9CXC 60, 9NK 30, 9BVP 25, 9DGA 24, 9DOX 24, 9CLS 24, 9CSB 15, 9AIM 13, 9AFF 11, 9DXG 11, 9QD 9, 9IX 5, 9BBA 7, 9AYB 7, 9DYD 3, 9AAW 6, 9BWL 3, 9BPX 2, 9AXF 2, 9ARM 1.

DAKOTA DIVISION

SOUTH DAKOTA—0DWN decided to go to school at the last minute and has his station going in Vermillion now. 9DZI did some good work in restricted operating hours. 9CKD is getting out well with a new Hertz. 9DBZ reports QRM from school. 9AGL returned from sea and reports fine time but is very busy operating KUSD. 9DIY is on again after moving into a new QRA. 9DID also moved. 9TI finds a basement is a poor place for transmitters. 9DGR is on the air after a layoff by the R. L. 9DB visited 9CKD, 9CJS, 9BBF and 9CNK this month. 9CJS says the set hasn't worked since 9BBF (O-O) has his new G. R. Wavemeter and reports a bunch of stations off wave. 9CKF, 9CNK and 9DNS are new stations on the air.

Traffic: DWN 162, 9DZI 34, 9CKD 20, 9BBF 20, 9DB 12, 9TI 8, 9CJS 7, 9DGR 3.

NORTH AND SOUTH MINNESOTA—SCM, C. L. Barker, 9EGU—Reports from the Northern and Southern Sections go in together again this month, pending election of an SCM for So. Minnesota. 9IG is busy with construction work. 9KV is building and putting in a crystal. 9BVH has moved but will be on with another crystal soon. His new QRA is 1822 James St., St. Paul. 9BMR is back regularly again with good punch. 9ADS is attending the U. again this winter. 9DKR is on again after returning from the CMTC. 9EGG has hard luck being active. 9CAJ works on all waves, which is something more of us should do. 9GH has resumed regular activity. 9DMA reports very light traffic. 9DZA handled some important traffic, and as a new ORS is doing fine work. 9EGU's usual regularity has been somewhat broken up by house alterations but that is over now and the brass is going to get some real pounding. 9CKI is on again with a 50 watt on the 40 and 80 bands. 9BKX is putting in a mercury arc rectifier. 9EHO is waiting for 350 volts of B batteries. 9DEQ remodeled his whole layout and is on with a new idea

of activity. 9DHP still has trouble with resonance between the house lighting circuit and his transmitted wave. 9EEP works regularly, though he is kept busy with work. 9CUM will be operating at 9CRZ soon. 9CWA blew his H tube and is on with 5 watters. 9DBW rebuilt his transmitter and receiver and is putting in a mercury arc rectifier. 9COS is on with a UV203. 9CPO steps right out with a 50 watt that is about 7 years old. 9DGE has a new 204 fed with 500 cycle juice and is after traffic. 9DUV reports that it is hard to get out lately, even after his former power line fluctuation troubles have been reduced to a great extent.

Traffic: 9CAJ 88, 9DBW 38, 9EGU 30, 9CWA 22, 9BMR 21, 9BAY 20, 9EEP 12, 9DGE 8, 9CKI 6, 9DUV 6, 9DMA 2, 9DZA 2, 9DEQ 2, 9DHP 1, 9BOI 1, 9GH 1.

DELTA DIVISION

LOUISIANA—SCM, C. A. Freitag, 5UK—5KC had transmitter trouble but will be on again soon with a couple of 50s. 5AEN has been rebuilding. He is doing well with his 5 watt. During the past month, the SCM was visited by 4WB and 6BTL. 5QJ and 5UK were quite active during the recent storm which did so much damage in Miami, Fla. Mr. Hebert will reach Shreveport, Nov. 14th and there will be a big hamfest the 15th.

Traffic: 5UK 17, 5WY 8, 5KC 3.

MISSISSIPPI—June W. Gullett, 5AKP—5FQ has changed his mind about the 50 watt transmitter and is constructing a self-rectifying transmitter using two U. S. Government 50 watters and he is also constructing a new receiver and antenna system. His 5 watt died while doing relief work during the Florida storm. 5QZ has his 250 watt on 80 meters and it raises 'em like a top. 5ALZ is having terrible QRM from the Ys and it looks like we will lose him for the winter. 5AGS is rebuilding his transmitter and hopes to be on in a few days again. 5AQU is trying to find an 80 meter crystal, but so far, has had no luck. 5AKP has two UX210 tubes working in a self-rectifying Hartley circuit now and it surely is FB. He is moving to a better location soon and will have a new transmitter on the 40 meter band.

Traffic: 5AKP 45, 5AQU 15, 5API 13.

TENNESSEE—SCM, L. K. Rush, 4DN—4HL has a new ORS ticket. He has just returned from Utah and is on the air consistently. 4CU has become the proud owner of a Commercial First and has gone off to New Orleans to get a job. 4IV is using a 7 1/2 watt and has worked the Antipodes. 4FA has applied for an ORS and it has been sent him. He is a promising station for our state. 4BU has been on lately but the SCM bought his motor on the last trip to Memphis. 4QB is a new ham on the air and has already joined the League. 4PZ suggests that we have a live state (we will if he will pull with us). 4KM is on the air again with a WE 250 and worked some foreigners the first night.

Traffic: 4HL 9, 4KM 5.

HUDSON DIVISION

NEW YORK CITY AND L. I.—SCM, F. H. Mar-don, 2CWR—Bronx: 2BBX put in a 250 watt AC on the plate with much better radiation but no increase in DX so he decided to go back to the old faithful 2 210s with DC. He is the new OBS for the Bronx. 2CYX, the new army net control station, is doing fine work and going to increase power. He handles traffic regularly with VOQ.

Brooklyn: 2BO is one of the stations on our Honor Roll this month, having been one of the stations handling traffic from Florida during the recent disaster. The Boys in the second district sure did their stuff this month and the SCM feels proud to be SCM of fellows showing such fine spirit in times like these. 2CRB is still going strong but reports DX bad lately. 2APD says he is back on the air to stay now. 2WC's crystal-controlled on 42.7 can be heard on the air pretty regularly since he came back from vacation. 2BRB is now using crystal on 19.8, 39.6, 79.2 and can QSY either QRH in less than half minute. 2PF also reports DX bad but is keeping schedules. 2AVR is having a lot of trouble with his filter but considering this, he is doing FR.

Queens: 2AWX is working very hard and can be heard on nearly every night. 2AJE has had to can-

cel schedules on account of GRM from school and football. 2AUE is another station always ready for business. 2AVB is keeping up the old time spirit and we expect to hear great things of him in the future. 2CLG reports he will be back on the air about Oct. 1. 2AWQ is increasing power and will be working MARS in the near future. 2AIZ's new xmitter will be ready about Oct. 15. He is coming back on 170 meters.

Manhattan: 2ANX done very good this month considering that his report was from the 4th to 25th of Sept. 2BCB being a saxophone player with Abrams Orchestra atop the New Amsterdam Theatre does not get on much during the early evening but is on during the afternoon and late night. Congratulations, 2BCB, on your seven pound second op. 2ALL bought a Mercury Arc Rectifier lately and expects to have it perking soon. 2ENZ is going to leave our ranks and move over to Jersey soon. We certainly lose a good relay man in NYC. 2BNL reports hay fever so is not on much. Hi. 2LM is handling lots of government business lately. 2EV is the star station this month. He was on day and night during and after the Fla. disaster. 2LD wants to know where the gang is that is supposed to be on 20 meters. All he hears is 40 meter harmonics. 2ALS, army net station for Manhattan, was also one of the stations handling Fla. disaster traffic this month.

Richmond: 2CEP is off the air until Christmas while attending Cornell. 2AKR has increased his power to 10 watts. 2AKK is keeping traffic moving. 2AFV rejuvenated his fifty by dropping it on the floor—now it's on the air again and perking fine. Let's all try it! 2ATQ finds time to pound brass occasionally. 2CPG is coming back on the air again, soon. 2CLE is rebuilding as usual.

The SCM has moved from the Bronx and is now at 117-11 140th St. S. Ozone Park, Jamaica, L. I. Note this change on your next reports so that they will reach me in time for delivery to HQ by the first.

Traffic: Bronx: 2CYX 219, 2BBX 82. Brooklyn: 2CRB 55, 2APD 36, 2BO 14, 2WC 8, 2PF 8, 2AVR 8, 2BRB 3. Manhattan: 2EV 356, 2ANX 114, 2BCB 48, 2ALS 31, 2LM 30, 2NZ 24, 2LD 16, 2ALL 8, 2BNL 4. Queens: 2AVB 139, 2AUE 119, 2AJE 105, 2AWX 65, 2AWQ 12. Richmond: 2AFV 23, 2AKR 14, 2CEP 12, 2AKK 1.

NORTHERN NEW JERSEY—SCM, A. G. Wester, Jr. 2WR—All traffic reports should be sent to the new address of the SCM which is 50 Princeton St., Hilton, N. J. 2WR will erect a new station which will be heard on the air more often. 2AUI will use pure DC instead of the old AC for plate supply on 40 and 80. 2KA is QRW planning an amateur banquet for the Hams of Newark. 2ANB is remodeling the breadboard transmitter. 2AZU received a report from Scotland. 2ALM, using a UX210, works Australia with 25 watts input. 2CP is moving to a new QRA and his new address is Box 286 South Amboy. 2BQQ is rebuilding for crystal control. 2CGK has a temporary transmitter on the 150-200 meter band. 2AT is another that is putting the place together. 2JC is opening on 40 with crystal control. 2ADU is remote controlling his set. 2AVL using an old VT 14 works the west coast. 2IS is very active and will be in line for ORS. 2FG ex-2FA has returned to the air on 40. 2CW has been on the air with very little traffic to report. 2EY is at last on short waves. 2ALW, a new ORS who was very active, is leaving for the Bronx where a new station will be erected. 2AOB has been vacationing and is now returning to school. 2ADV for the third time blew the whole works which is a record breaker. 2ARC has been keeping a schedule with NEM. 2CXE is now on 200 meters for traffic handling and Army work. 2QI maintains a Tuesday night schedule with 9BJY. 2BV still continues to experiment with crystal control. 2AVK, an old timer, is reporting for the first time and desires to become an ORS.

Traffic: 2IS 25, 2ALM 20, 2CXE 17, 2ALW 14, 2AT 12, 2AVK 12, 2AUI 10, 2CP 10, 2QI 6, 2BQQ 5, 2EY 4, 2ANB 3, 2JC 3, 2ARC 2, 2ADU 2, 2CW 2, 2KA 1.

EASTERN NEW YORK—SCM, Earle Peacor, 2ADH—this report came within an ace of being left out of QST because the brainless wonders insist on sending their reports in late. Is it fair to take a chance of leaving the whole Section out of QST because a few are careless? In the future, the SCM will not wait around a whole week for your report.

2APT and 2ADH were both off and no one else handled any traffic worth mentioning. No Route Managers have been appointed as no station has shown

enough interest in traffic work to rate appointment. We certainly are not going to wish the appointment on someone who will not do the job justice. We need Route Managers for both the 40 and 80 meter bands, but the fellows that get appointed will have to be operators, no hams need apply.

2CDH and 2AKH have asked to have their ORS certificates cancelled due to inactivity. Others will have theirs cancelled without asking. The Section is going to be 100% active even if we only have two dozen ORS left when the smoke clears away. 2QU and 2BOW have been appointed ORS. 2AWZ and 2UF have applied for ORS. 2AAZ is going to N.Y.U. 2PV has an awful sock on 40 and is going consistently again. 2ANV has put up a Hertz and stuck in a filter. 2CYM says he is QRW. 1BVL and 1ALP stopped in at 2AGQ while flivvering through the 2nd district. 2AGQ is stepping out in great style. 2LA is trying to rake up some noise on 200 meters but not many others are on. 2BM is married but he says it doesn't QRM radio a bit. Hi. 2SZ is being put into shape again and the gang expects to report football games between Rensselaer and other colleges by radio. 2ASE was at 2CXL for a month. 2CTF has junked the S tubes for kenetrons. 2ANM has a Zeppelin antenna and is using a self-rectified circuit. It seems to get the Zedders. 2ADQ is using 15 watts on 80 meters. 2CYH has the crystal set perking on 38 meters. 2CNS is still pulling trick relays in the early a. m. He doesn't mind, even if it does make him an hour late for business! 2AML blew a couple of UX210s and is QRW with his orchestra. 2AXS is installing a 50 watter. He says ex-4BV is in Poughkeepsie and will be on soon using the call u-2BE. 2AWZ has the crystal controlled xmitter going. 2AAN is changing his QRA. 2CTF, 2AAN and 2ADH went out to Rye to meet VOQ when she came in. The Morrissey looks like a rejuvenated barge. Perkins is going to rebuild 2APQ so he can work his kid brother with the Dyott Expedition in Brazil. 2ADH and 2BOW are helping him out. The Yonkers Radio Club has its eye on the Dyott Expedition. It supplied the ops and now the gang is after the traffic. Listen for GMD, gang.

MIDWEST DIVISION

IOWA—SCM, L. R. Huber. 9DOA—October finds Iowa ready and organized for systematic relay work. Credit is to be given 9BKV and 9CZC for their diligence and steadfastness in route organization. Neighboring sections are holding us back by not being organized. We have the distinction of being the first in this neck of the woods to deliver the goods. Wot do you say, gang, will we keep it up?

The axe has been used liberally on lagging ORS, with the result that Iowa has a much smaller percentage of ORS, but a livelier organization in place of quantity. Some new ORS have been appointed. Encouraging letters have been received from members of this Section. All letters are welcome and appreciated by the SCM.

9BPF broke loose and hit the BPL for a goal. He goes to Ames this winter. 9BWN brings Des Moines into the picture again. FR. 9AXD put Clinton back on the map. 9CGY blew his high power UV201A with a resultant drop in his usual high total. 9DSL, our ham-proof, faithfully reports as usual. 9CZC is QRW with his job as Asst. R-M. All Iowa hams interested in brass pounding should get QSO with 9BKV or 9CZC and get lined up on the traffic routes. We have something real to offer for good hams. You don't have to be an ORS to get it on it. If you want your call in this report, the only necessary thing is to handle some traffic. Even ORS are not mentioned if they fail to handle traffic.

Traffic: 9BPF 115, 9BWN 62, 9AXD 50, 9CGY 14, 9DSL 10, 9CZC 10, 9AED 7, 9CS 2.

MISSOURI—SCM, L. B. Laizure, 9RR—We must call on the various ORS who are lax in reporting for improvement before we can report everything in first class working order. 9DOE and 9DUD applied for ORS. 9DOE is the holder of a commercial ticket and formerly served on the Great Lakes.

9BSE rejoices in being a new ORS. 9DEA, RM, has circularized the hams for relay route information but regrets poor response. 9CYK left for school in Evanston and is on the inactive list. 9BUE sends the usual dope on skeds. 9DKG received visits from 9AJW and 9UI. 9CXU just received his ORS after a long time. 9DIX was visited by BD from 9EK and 9EBV and rebuilt the works,

arranging skeds with 9EK. 9BYN reports overhauling the set. 9AYK is rebuilding. 9UI and 9AJW are at school. 9LJ received a new ORS. 9CDF is leaving temporarily for WU school. 9DVF built an entirely new station. 9BQS took over the traffic handling in Maryville when 9CKS and 9CYK both left for school. 9AOB reports quiet locally. 9DTA rebuilt his set. 9DJI made HS first team in football. 9CZZ has organized a jazz orchestra. 9CRM reports not much doing. 9ARA and 9CVY are off temporarily. 9DCD is handling some traffic when he can locate it. 9BSH works 40, 80 and 153 meters but no skeds. 9DVK reports little doing on 200 except his OBS sked. The gang assembled at 9BDS's several times to assist in tearing down the old mast and putting up a new one at his new QRA. 9CZI reports ND.

9ACX, 9ADR, 9ACA, 9ELT, 9BND, 9RR, 9ZD and other locals are all on for traffic and report msg's in increasing quantities. 9ACX, 9BDZ, 9ELT, 9RR and others visited the hamfest in St. Louis. The K. C. Radio Club equipped a booth at the radio and electrical show held the last week of the month. 9ZB has been visiting the home town for a couple of weeks.

Traffic: 9AAU-ZK 104, 9AOT 75, 9ACX 23, 9BHI 18, 9AYK 16, 9BUE 12, 9RR 12, 9DIX 9, 9CDF 9, 9DKA 5, 9BSE 4, 9DVK 4, 9AOB 3, 9DVF 3, 9DLB 2, 9CXU 1.

KANSAS—SCM, F. S. McKeever, 9DNG—Kansas saw a much better month than usual; all honors going to the Topeka gang. 9CET worked some new countries. 9AEK and 9CV worked Africa and handled some good traffic, the former having operated the Army station CX7 at Ft. Riley KS., for a while during August. 9DPU reports working Hawaii and Chile. 9CVL and 9BDQ are away at college. 9CLR, 9EET and 9DVR are on once in a while. 9LN worked HZ, Z and A. 9DNG worked PI, FM, O, F and a few others but was not on much. 9CET and 9BYQ are new OBS. 9CKU and 9DBH promise real activity this fall. 9DRD sends in a fine report, having handled some important traffic as well as receiving a souvenir boomcrang from a-SWH. 9CET, 9CV, 9DNG and 9AEK are entered in the South African Springbok Competition.

Traffic: GX7 90, 9CET 87, 9DNG 25, 9LN 16, 9CV 16, 9CKV 9, 9DPU 8, 9DRD 7, 9BYQ 4, 9AEK 3, 9DRH 1, 9CLR 1.

NEW ENGLAND DIVISION

RHODE ISLAND—SCM, D. B. Fancher, 1BVB—Providence—Not much doing this month. (What's the matter, fellows? Some cancellations of ORS were made this month. If I don't get more reports next month, more will be made, SCM). Take a slant at the traffic report of 1AID and then blush with shame some of you fellows. It shows that there is traffic. Going to let a girl get ahead of you? She says DX not much but traffic and rag chewing FB. 1AFO has rebuilt and just got going. He has a phone on the 80-meter band. 1AAU, 1AWE and 1AEI are all running along in fine shape. 1BIE is rebuilding again. Let's hope he gets busy after a while. Hi! 1AHE and 1DP are both pretty busy for radio.

Westerly—1AAP, has his 40-meter set going fine using a galvanized iron wire antenna and counterpoise. He says it's the best yet. How come? 1BLW our low power station, is using an inside antenna for transmission and is heard a lot but can't seem to connect good. He worked Ohio and was heard in West Virginia. He uses 500 volts B-battery on a 201A. 1BVB has moved and is getting out better, using a horizontal antenna instead of vertical.

Newport—1BQD has also moved to a new location. He will be with us stronger than ever by the time this gets to you.

Traffic: 1AID 82, 1BVB 23, 1AFO 18, 1AAU 14, 1AAP 18, 1AWE 11, 1AEI 4.

VERMONT—SCM, C. T. Kerr, 1AJG—1BEB is ready for business now so give him your traffic for Montpelier. 1BD reports his transmitter working well using a small tube. 1BBJ is the star traffic station this month. 1BJP is on the air so route your Canadian traffic to him. 1FN is having a fine time experimenting with the shorter waves. 1AC is on again—watch him go! 1AJG will be on 38 meters starting Nov. 1. 1BDX lost his bottle? Which one, OM??? 1BIQ of 1YD is at 1ATP. Let's hear from 1YD.

Traffic: 1BBJ 46.

MAINE—SCM, Fred Best, 1BIG—1AUF set a stiff pace this month. Considering the distance he lives from the center of our state, his is a remarkable total. Sad news, tho, for he is leaving us soon to join either the New Jersey or the Pennsylvania gang. 1BFZ led the gang in his section and plans on rebuilding in order to do even better next month. 1BHR, an old timer at the traffic game, did some good work and will give the leaders a race the coming fall and winter. 1AIT joined the ranks of BPLs in spite of blown tubes and a rather bad month considering atmospheric. FB, OM! 1UU landed his total in the remarkably short space of three days. College will take up most of his time from now until June, but he hopes to keep up the good work. 1AYJ has just started things booming after a busy summer. He is a regular BPL member from October to June. Watch his smoke! 1BCY (4XE) helped out our total greatly, and we all hated to see him leave for Winter Park. 1AQL has been QRW work but managed to handle a few. 1QY is rebuilding after changing his address and is a prospective BPL in the near future. 1FP has a neat little set and should do good, once he gets up steam. 1AAV has left our midst. He is attending the University of Michigan, and as a result we lose a mighty good traffic man. 1EF, another old timer, formerly located at Ellsworth, but now at Stonington, has a 5'er going on 80 meters and in spite of the fact that he is located in a power house, he manages to work the gang regularly. Traffic is speeding up. The SCM thinks that the whole Maine gang will be BPL members next month.

EASTERN MASSACHUSETTS—SCM, R. S. Briggs, 1BVL—Most of us are dusting off our sets and getting all fixed for an active winter. 1BMS is the first on the list of traffic pushers. He and 1UE, 1JL, 1ABA and 1BKV make the BPL. FB, gang! 1UE is Route Manager.

1AXA handled foreign traffic with his crystal outfit and gets the usual DX. 1AWB and 1ACI are the only live ones in Attleboro but report school QRM. 1BUO is away at school so 1BAT will operate in his place when a 50 watter arrives. 1UE and 1BMS blame the recent punk weather for lower message totals. 1BZQ says he can't seem to leave 80 meters. 1-CN is the latest DX for 1NV. Lynn is getting on the map again since 1JL got back. 1CJR is on during week-ends and operates at 1XM. 1BHS worked Brazil and New Zealand. We have a new station, 1MR, in Milton. 1CJD is attending college. 1BVL and 1ALP went on a camping trip and visited a few 2's. 1AEV, ex-1QX, is starting up full blast in Roslindale. 1BKV is changing his location. 1ABA has been very active on 80 meters. 1LM is rebuilding his station. Two Porto Rico hams, pr-4SA and pr-4KT dropped in to see 1KY. What next! 1AYX and 1AIR are still on the job in Nantucket.

Traffic: 1BMS 296, 1UE 214, 1JL 182, 1ABA 148, 1BKV 118, 1NK 61, 1BZ 52, 1BHS 44, 1MR 36, 1BZQ 25, 1KY 15, 1CJR 11, 1BVL 7, 1AWB 7, 1ACI 7, 1NV 6, 1AXA 5, 1YC 5, 1ALP 4, 1BLU 4, 1AHV 3, 1BUO 3, 1AIR 3, 1LM 2.

WESTERN MASS.—SCM, A. H. Carr, 1DB—1AAL has been appointed RM so give him your support, boys, and let's line up schedules and traffic lanes with the rest of the Sections. Write if you have suggestions. We have begun already looking for traffic in Worcester by having a different station on watch on the 80-meter band every night from 10:30 until midnight. The wavelength of these stations will be about 34 meters. The stations are: 1BCO Mon., 1AJK Tues., 1BV Wed., 1ASU Thurs., 1AAL Fri., 1DB Sat. and 1ASU Sun. Watch out for us gang, and shoot the msg's. We will have some for you.

1AAE says a blanket on the air or the North blinkers keep his total low. 1AJM, a new ORS, gives us a good total and I hope our older stations take notice. 1AKZ is giving West. Union ops code practice and promises to make some new hams. 1AMS says that we work up the 7's in our 1st report and that he actually got a card from one. I hope that we all read all the reports as they are full of good stuff. He says that 1AZW is wearing smoked glasses because he dresses wax women for a dept. store. 1AZW says that his dozen schedules keep his YL guessing so you see all are not wax. 1AMZ is off to Dartmouth but his YL will soon help us handle traffic so be careful of your English when you work that station. 1AOP has some good schedules and wants more. 1APL is betting cigars on making the RPL soon. Good luck, OM. 1ASU reports that he works all districts with ease. Drop

him some of your traffic. 1EO has come to life. We have a few more dead stations and we hope their conscience will prick when they read QST. Your SCM has patience but only a limited supply. 1JE is leaving us as an ORS to go to college. Good luck, OM. 1PY promises action at his station with 2 new ops. He says he handled one important Florida storm msg. We, of West. Mass., solicit suggestions and would like to hear from some of the other sections.

Traffic: 1AJM 58, 1ASU 47, 1AAL 43, 1AMZ 42, 1AZW 34, 1AAE 22, 1APL 16, 1DB 14, 1BIV 12, 1EO 11, 1AMS 9, 1UM 8, 1AQM 8, 1PY 6, 1AOF 4, 1AWW 4, 1BVR 2, 1AKZ 2, 1AAC 19.

CONNECTICUT—SCM, H. E. Nichols, 1BM—We are glad to welcome our C-M's station into our ranks and to see that he manages to find time to handle traffic via schedule. 1BCA left for college but 1LQ will keep the station on the air. 1ADW has succeeded in communicating with Australian 6RM which shows that his new shack has increased in efficiency. Congrats. 1BEZ reports very good strength of his signals in England but doesn't seem to have much success in working with New England. 1AOS has been experimenting with 20 meters. 1CKP is back from vacation and all set for traffic. 1MY has moved his set from the 'ole cornfield into the barn and says it works just as well. Look out for hay fever, OM. 1BHM, Route Manager of New Haven, has been very active in selecting new prospects for ORS and great things are due from this section. 1BGC, 1HJ, 1CTI and 1BFL all report special activity. 1BGC had a new 3½ lb. brass pounder whom he has hopes of developing into second op. 1ZL has been using the Zeppelin antenna as described in July QST and reports very gratifying results. 1ACD and 1BQH are new relay appointments and are anxious for traffic. 1BJK is endeavoring to keep a schedule with the SCM's station. 1LV has a new receiver that brings all signals in on a loud speaker and has built up a fine panel transmitter. 1FD and 1AVX report that sickness has kept them off the air but hope to be with us soon.

Traffic: 1ADW 37, 1BCA 31, 1BEZ 23, 1MY 26, 1BDI 23, 1AOS 14, 1BJK 14, 1BGC 12, 1BHM 12, 1HJ 5, 1CTI 5, 1BLF 4, 1CKP 2, 1BQH 2, 1ACD 1.

NEW HAMPSHIRE—SCM, V. W. Hodge, 1ATJ—Some of the gang have been off the air this month but traffic is still increasing. Several new stations sent in good reports this month. 1AER's pet power leak is still going. 1AOH is at Harvard and will be an op at 1AF. 1AOQ has a new 50 watter. 1AVL says he can't work Australia but is QSO Europe easily. 1OC is on 80 and QRV for traffic. 1CKK has put up a new vertical cage and says it's FB. The SCM's station, 1ATJ, is on the air every night on 78 meters. Always ready for your traffic, OM.

Traffic: 1AOH 26, 1AER 24, 1AVL 20, 1IP 16, 1BFT 14, 1AOQ 9, 1CKK 6, 1JN 4.

NORTHWESTERN DIVISION

OREGON—SCM, A. C. Dixon, Jr., 7IT—There are several new stations which have opened up in Portland recently and several of the older stations have been improving their layouts. Activity has been almost entirely confined to Portland and vicinity.

7AEK, who has kept schedules all summer with Alaskan 7KK, has bought a 204A. With his ability to make a station get out, he will soon be going great guns. 7IT has worked South African A-50. 7VH was the first station Northwest to QSO O-A50. He works South Africa with regularity. 7WU received another report from England. 7AV starred by working South Africa on a 210. 7JO and 7VP handled good traffic and are chanking to 203A's. 7PP, "Peep", is again going strong with fifteen watts.

7AAC has just started up in Heppner. He is a big radio dealer and gets all the BCLs interested in ham stuff. All the stations, with the exception of the SCMs use first harmonic. At 7IT, a broadcast station antenna and ground is most satisfactory.

Traffic: 7JO 33, 7IT 15, 7AAC 14, 7VH 8, 7AV 7, 7PP 7, 7AEK 5, 7WU 4, 7VP 1.

MONTANA—SCM, A. R. Willson, 7NT—7PU continues as the star station and wins the season's prize offered by the SCM last year for a Jewell meter for

the Montana station that maintained the best and most consistent practice. 7DD continues with his steady and reliable traffic handling but is handicapped by his location in the Butte bowl. 7FL has moved to Bozeman where he will go to MSU. He hopes to keep the set on the air. 7NT has been out of town most of the month. Reception and ham transmission are much improved this month and it looks like a better year for the Butte stations. The Butte Radio Club will resume meeting in Oct. A great deal of ham interest was shown last year and we may get some new recruits this fall. 7BE is a new station at Great Falls. 7AAW is a new station at Bonner. He says he is out for an ORS—go to it, OM.

Traffic: 7PU 63, 7DD 33, 7AAT 7, 7NT 2, 7FL 1.

WASHINGTON—SCM, Otto Johnson, 7FD—The greater majority of Washington hams seem to be busy getting back to school or work. This fall promises to be better than ever with many of the gang set for 'bigger and better' DX. 7HL has worked lots of DX and he is on now at W. S. College, as are many other hams through 7UL, the college station. 7NH will alternate between 7UL and 7NH. 7AM does great work on a 201A. 7GE expects to be on steady again. 7WS is back on the job. The Tacoma bunch are QRW with the coming NW Div. Convention. 7AG rebuilt his set. 7TX continues to do good work. 7KO and 7UQ bat out in good style. 7FD is a proud father. It's a boy and promises to become a good brass pounder before long. 7OT writes from Chicago and says he will be back in Seattle before Spring.

Traffic: 7RL 42, 7NH 21, 7AM 19, 7UQ 12, 7KO 6, 7TX 6, 7WS 4, 7GE 3, 7FD 3, 7AG 3.

IDAHO—SCM, Henry Fletcher, 7ST—The SCM is surely glad to be with you, gang, but why not have a few reports? It seems that all the active stations are in Boise. 7YA is a new ORS and is looking for traffic. 7ABB has a new UX210 and is getting out FR. 7ST is going into partnership with 7ABB. 7PJ and 7UD are starting up with fivers. 7PS has a couple of new S tubes. 7VU worked South Africa a couple of times. Ex-7OB, ex-7RQ and 7VU are going to college. 7PT has moved to Torrington, Wyo. 7JF has had a schedule with Hu FX1 for two months. His neighbors next door are mother and father-in-law of Capt. H. J. Adams of the Sig. Corps so quite important traffic was handled during the month.

PACIFIC DIVISION

HAWAII—SCM, K. A. Cantin, 6TQ—6BUC went off the air long enough to rebuild the transmitter into a panel mounted type with change-over switches for straight AC or RAC plate supply. 6AXW secured contact with O-A5B in addition to their traffic work with the mainland and Philippine stations. 6BDL has moved to a new QRA. Business did not give 6AJL much time on the air for the past month. 6CLJ is back from his trip to the Orient. He met a number of Japanese amateurs and had a good time. 6DCU fell heir to a 50 watt tube. 6CFQ returned from a nice trip to San Francisco. 6BUS is assisting hu-6DDL in his experiments on 5 and 8 meters. 6ASR changed from motor-generator plate supply to raw AC and receives about the same reports on his signals and QSB is usually reported as "good RAC". 6CFN is going strong with a lone 5 watter. 6TQ has difficulty in keeping his signals from swinging and jumping up and down the scale. 6NL has schedules with 6SVG and 6NP. 6NL also takes a night pounding brass at 6BUC. 6DBL is back on the air again with 250 watts. Capt. J. Adams of FX1—Hu-6XK has been appointed Official Observer for the Hawaiian Section. 6CST is still kept busy with QRM from school work.

Traffic: 6AXW 108, 6BUC 97, 6CFN 59, 6BDL 43, 6ASR 34, 6TQ 27, 6NL 25, 6AJL 17, 6CLJ 11, 6DCU 10, 6CST 8, 6CFQ 6.

Philippine Section—pi-1AT reports his best DX worked as the US 7th district. He is experimenting with different types of antennas. Pi-1AU has schedules with u-6BVY and 6BHR. LAIX (Norway) is worked every Sunday, also F-8KF of Neuilly, Seine, France.

Traffic: Pi-1AU 35, Pi-1AT 2.

SOUTHERN SECTION CALIFORNIA—SCM, L. F. Smith, 6BUR—The Section boasts seven stations in the BPL, these seven handling 1716 of the Section total, thus showing who is responsible for our traffic

total. The San Diego Club, the Silver Gate Radio Amateur Association, placed a fifty watt transmitter in a booth at the San Diego County fair and did fine work bringing A.R.R.L. services in close touch with the public. The fellows of Arizona have decided that they want a separate Section and are now organizing. The SCM wishes them every success with their new organization.

6CGC is Route Manager of San Diego. Activity has taken a great increase. On Aug. 27th, a weenie roast was held on the beach by the gang and plans were made for the booth at the Fair. If possible, the gang is going to the convention in airplanes. Some class! We are very glad to welcome 6AJM back to our Section. GMB worked day and night at the Fair. We miss 6BQ's usual traffic. He's busy traveling. The crystal control at 6BAS will be on soon. 6CGC complains of transmitter trouble. 6AKZ has moved to San Diego. We are glad to welcome our old friend, 9ZT, Don Wallace, to our Section. He has moved to Long Beach and is on the air as 6AM. Everyone is working So. Africa and the game is now to see who can make their signals go around the world in a different direction. H. 6BBQ leads the Section in the BPL. 6BTM comes in third place. A sked with PI put him there. We now have ex-7OK with us as 6CHY. 6BXD is making the BPL a habit. 6CMQ has developed a remote control outfit and likes it fine. 6BXC leads Los Angeles this month. 6NP keeps up his skeds with HU. 6BO got a message to Fla. and back in 8 hours during the storms. 6BUX is a new ORS coming up. 6CAE finished the month working Africa eight times. 6BBV promises a comeback. 6BCS is on again, having returned from a trip on NIJL. 6CGK is at it again. 6CUW is on consistently. 6AHP has been experimenting with RF feeder lines with no luck. 9DEG works in a radio store and sends postals to customers getting both messages and business. 6DAJ is improving his DX. 6IH has been doing some quality message handling. 6CRZ keeps ham radio alive in San Bernardino. 6AKX was QSO Java PKL. 6RF is a Senior in college, plays football and gets on the air twice a week. 6DDO has made several changes with much success. Two stations in Borneo were worked by 6AE on a 210. Good steady work is being done by 6OR. 6BYZ is a new man. 6CAH was married and now has his transmitter in a jewelry store temporarily. 6NW continues to rebuild. 6HU and 6LH keep Santa Ana on the map. 6AJI and 6OF are back at Riverside and promise activity. 6CLK leads the gang in Whittier working everything hearable. 6CT still works So. A. with ease. 6AKW has erected a 28 ft. brass mast antenna. 6COU and 6ODY keep Oxnard alive. 6ZBJ paid the SCM a visit during the month. The SCM plans a visit to Fresno soon and wants to meet the entire gang. 6BAV, RM of Fresno, is doing good consistent work. 6ALR reports that he has now worked 18 countries with a 7.5 watt.

Traffic: 6BBQ 426, 6AJM 365, 6BTM 256, 6BXC 210, 6RXD 184, 6CUW 155, 6CHY 153, 6MB 122, 6CMQ 69, 6AKZ 6, 6CGC 10, 6BQ 4, 6ZBJ 40, 6COU 5, 6ODY 2, 6CLK 52, 6CT 30, 6HU 6, 6LH 15, 6BYZ 16, 6AE 67, 6DDO 80, 6RF 3, 6AKX 46, 6CRZ 20, 6IH 33, 6DAJ 8, 6DEG 17, 6AHP 26, 6CGK 7, 6BBV 17, 6CAE 43, 6RUX 17, 6BVO 15, 6NP 45, 6ALR 31, 6BAV 46, 6BUR 13.

SECTION 4, NO. CALIF.—SCM, F. J. Qument, 6NX—6BMW is the Chief Route Manager for this Section. He is on the air each evening and stations desiring schedules can reach him easily by air. 6BVY is on vacation but managed to send out another batch of O-O report cards. 6CLP checked his average reported audibility for the month which was R-5. 36, 6AMM is a new ORS. 6BTJ is a new station and will soon be an ORS. 6BCH worked J-AJ and J-ZB. 6HJ is busy overhauling his antenna, but managed to handle a few msgs. 6AJZ, 6HC, 6CKV and 6NX are all busy on convention business this month. 6MP is Chief Op at 6BB-UC Radio Club. 6CEI worked R-DB2. 6BNH gives the QRA of C2 PK5 as Henry Croukhite, France Field, Panama. 6CIS is arranging schedules with 6NX for winter transmission from Yosemite Valley. 6CUL dropped in on the SCM and received his new ORS certificate. 6CJD worked his portable during the Merced County Fair. A resume of messages handled during the past year shows a gradual decline as compared with the figures for the year before. Let's snap to it fellows and get into the BPL. Line up a schedule with 6BMW and solicit messages from your friends and remember that every message delivered makes a potential booster for the A.R.R.L.

Traffic: 6BMW 36, 6CLP 34, 6HJ 13, 6AMM 17,

6BTJ 14, 6BCH 12, 6NX 3, 6AJZ 2, 6CJD 1.
NEVADA—SCM, C. B. Newcombe, 6UO—Several new ORS appointments were made during October. The Reno bunch is getting back on the air with good stations. Watch our next report.
Traffic: 6UO 16.

ROANOKE DIVISION

NORTH CAROLINA—SCM, R. S. Morris, 4JR—Wanted!—More ORS and more reports from active non-ORS. Write 4JR if interested. 4MI gets the headlines this month as he has a big total and is the most consistent station. He handled lots of Florida storm traffic. 4JS left for college Sept. 12. 4NT has QRM from business. 4NH handled some Florida storm traffic. 4PR has been on very little. 4RF is rebuilding. 4BX is working some DX now. 4RI is trying to get junk together for remote control. 4JR has a crystal ordered.

Traffic: 4MI 169, 4JR 33, 4NH 23, 4BX 11, 4JS 8.
VIRGINIA—SCM, J. F. Wohlford, 3CA—3Ti has closed shop and is at VPI for the year. Experts to install a station at Charlotte NC about Xmas. 3CKA is back from camp at 2CXL and has very little time for ham work. 3AEV is now at Hampton-Sydney college and QSO several stations. 3NO has just received a new op. 3BM is busy with the radio shop. He threatens a real comeback this winter. 3RL reports handling some traffic on 30 meters. 3KG spends most of the time with 3BGS who is on the air every Sat. night. 3BGS was again QSO England on his 5 watter. 3RX at VMI Lexington, Va. is again on the air with Downey as chief op. 4TG is missing from this lineup and 3AIK is a new one. This station has been completely overhauled and will have three transmitters all remotely controlled. 3CKL worked WXF. 3BZ has at last been bitten by the crystal bug, and threatens to stick one on the air immediately. 3ZD paid a visit to 3BZ and 3CA and got all het up on short wave stuff and an over-dose of crystal control from 3BZ.

Traffic: 3CKL 12, 3RL 6, 3BGS 8, 3TI 15.
WEST VIRGINIA—SCM, C. S. Hoffman, 8BSU—The coming on of school did not decrease enthusiasm in state activity. 8DEW, 8ACZ, 8BJG, 8CEK and 8AYP are lined up for an inter-state-school-news relay route for exchange of notes for school newspapers. Get in touch with them and have a radio news column in your paper. 8WZ, 8BNE (8BXP at school), 8AWV, 8BBM, 8AYP (3RX at school), 8SK and 8ZW (op EW) are at school. 8AMD and 8CBR did some fine work with the National Guard for two weeks, using two 50s, call CV-6. Sgt. Murrill (8AMD) has been appointed R-M for Huntington. Be sure to give him your hearty co-operation, fellows. 8CAV is located at YMCA, Charleston. 8ACZ heard 15 countries. 8CYR is rebuilding. 8BNE and 8BJG went to Detroit and got amateur first-grade licenses. 8AUL worked his first A, also several BZs. 8CDV worked lots of DX. 8CEK got a message for South Africa and want to know why those DX birds won't lend a hand and QSR. 8BUB is a new ORS in Wheeling. 8BSU was heard by R-091. 8AYP organized a radio club at school call 8CIB. 8SV is using big tubes.

Traffic: 8AYP 147, 8BSU 33, 8SP 26, 8BJG 22, 8AUL 19, 8CDV 15, 8ACZ 10, 8AMD 6, 8BNE 6, 8CYR 3, 8BBM 1.

ROCKY MOUNTAIN DIVISION

COLORADO—SCM, C. R. Stedman, 9CAA—9DKM leads the Denver gang this month in traffic. He and 9CAA were called on by the newspapers to obtain news of the Florida disaster but they could get only such news as was getting through over the wires. They will both be on 200 meters some time this winter. 9EEA is rebuilding but put through a good total in spite of this. 9EAM got his report in at the last minute. He has been too busy to do much and is building a new rectifier. 9CJY has several schedules working smoothly. 9DED has had a bad power leak all month but it cleared up at the last minute. 9CJP has a new 60 foot stick in his yard and is busy trying to make it work as well as the old one. 9DWZ is a new ORS doing good low power work. 9BQO has a new 50 watter doing its stuff. The ORS of 9AMB and 9WO have been cancelled as they will not have time to be on this winter. 9QL says he has been bending rails at night but fails to give details.

9DVL cops the honors for this section this month. He is doing good DX along with the bargain which proves it is possible to be a DX and traffic hound at the same time. 9BYC is a new ORS at Boulder and promises to make one of our best stations. He reports two other stations will be on there. 9AOI hasn't been doing much during September. He has the sprinkling can on the rectifiers now, though, and is going again.

9ADI decided he didn't like other parts of the country as well as Colorado so he came back. 9CDE handled quite a number of important messages. 9EAE is on daytimes at Trinidad.

Traffic: 9DVL 245, 9DKM 112, 9CJY 109, 9EAE 58, 9EEA 39, 9CAA 38, 9BQO 25, 9CDE 19, 9EAM 17, 9BYC 11, 9DWZ 5, 9DED 2, 9CJP 2, 9QL 2, 9AOI 1.

UTAH-WYOMING—SCM, Art Johnson, 6ZT—The fellows are returning from vacations now and are all settled down to business. More stations reported this time than last month, although there are still quite a number who will have to get on the job quick or have their ORS certificates cancelled as we intend to do some snappy business this winter and no efficiency can be had with a bunch of dead stations.

6AIK received his ORS appointment this month. 6BTX handled the most traffic this month. His best work was with 2AED. 6RV has completed rebuilding his outfit and is doing regular work on 40 meters. A 20 meter remote control transmitter is also being installed at this station. 6BUH is back with us on 39.5 meters. 6RM has returned from California.

It is hoped that a number of station owners in this Section will be able to attend the Rocky Mountain Division Convention at Denver on Oct. 29-30. Everyone will be assured of a good time.

Traffic: 6BTX 26, 6BUV 9, 6RV 8, 6BUH 2.

SOUTHEASTERN DIVISION

ALABAMA—A. D. Trum, 5AJP, SCM—Sudden complications arose whereby the SCM had a chance to take a vacation and see the Dempsey-Tunney fight so this report was written while he was in New York enjoying the sights and seeing some good shows.

Alabama is progressing in amateurism and the boys are doing excellent work. Although quite a few hams in Mobile have been lax in their bit, 5DL, R-M and O-O, is deserving of very much praise in his untiring zeal for a higher plane of amateur activity. He is just getting ready to give to the newspaper readers of Mobile and vicinity a taste of the inside working of the amateur and his ways, as well as how to become one. Montgomery is progressing and 5ADA, the most active station, has been handling quite a bit of important traffic. He has a station that any ham would be proud of and the most amazing thing about the shack is that the 210 set works as good as it looks. 5AJP, the SCM's station, is on when time allows. He handled some important messages during the recent disaster. 5AFS is still on the air with his DC note and is making Montgomery proud of him.

Birmingham is coming back into its own and the fellows up there are getting together again. An old timer, 5MI, "Dud" Connolly, is back on again and it surely does seem good to work the old boy again. 5AWP is noted for his efficiency of operation. 5AX has sufficiently recovered from his recent accident to be able to slip away from the wife and do his DX stuff. We have several new hams in Birmingham and as soon as the SCM returns, he is going to line them up for some good activity this season. "WI", "DI", and "ATP" are off studying hard now. Good luck, OMs. Well, fellows, let's have the dope and we'll have some interesting material in this column next month.

GEORGIA—SOUTH CAROLINA—CUBA—ISLE OF PINES—PORTO RICO—SCM, H. L. Reid, 4KU—Reports received by the SCM were pretty slim for the reporting month of September. All active station-owners located in the South Carolina—Georgia—Cuba—Isle of Pines—Porto Rico Section are requested to get in touch with the new Section Communications Manager (formerly Division Manager), Mr. Henry L. Reid, 11 Shadowlawn Ave., Atlanta, Ga. Applicants for the position of Route Manager, Official Broadcasting Station and Official Observer are wanted in each part of the Section. All stations on the air should send in a report to the SCM promptly on the 26th of each month. If you know

of other live stations who ought to be Official Relay Stations, tell the SCM about it when you report.

The only stations that reported this month were 4JK, 4IO, 4OA and 4RM. It will take another month to get the Section lined up but then we will go over the top.

Traffic: 4MV 84, 4LB (AQ8) 46, 4AAH 48.

FLORIDA—SCM, W. F. Grogan, 4QY—Some very fine work was done by the Florida hams during the storm that hit Miami, Ft. Myers and Pensacola. 4HZ was the first to pick up reports from Miami, also kept hourly schedule with 4KJ in Miami. 4KJ did some wonderful work. FB, OM. 4IZ, 4OB and 4TK also did storm work and showed the real ham spirit. 4VS had to grab his stuff and beat it about 4 am when the storm hit Miami. 4QY lost all his junk in the storm and will not be on the air for some time. 4TK sent press news to Atlanta. FB, OM. RL of 4LK has returned from a summer of operating at Nev. 4JV says his transmitter won't perk half the time—oil it up, OM. 4IG says things were blown away in Homestead. 4HY handled traffic with England.

Traffic: 4OB 92, 4DD 85, 4HY 31, 4LK 27, 4TK 25, 4VS 20, 4QY 4.

WEST GULF DIVISION

NORTHERN TEXAS—SCM, W. B. Forrest, Jr., 5AJT—With cooler weather, activities are picking up and the SCM is just about to get things lined up. Applications for ORS can be handled promptly.

5NY is working for T P & L Co. at Garland. 5AQL has been away from home all summer and enjoyed a visit with 5AIV and other stations. 5AMB intends to change back to 80 m. 5NW-5MZ's address is now Box 728, Corsicana, Texas. 5DW is using a crystal-controlled set now. 5JF has just reopened for the fall. 5WW has had trouble with tubes, but is going OK now. 5PQ is at A & M college for the winter. 5AKF reports no time for operation, due to business reasons. 5VD is rebuilding. 5AUA has moved to 3211 Jerome St. and had 500 watter going strong for a while but it went too strong in a westerly direction. 5AKN helmed with the Gulf to Canada Good Will trip. 5ACL and 5HY were also in on the Palm to Pine Tour—they handled traffic for the parties. 5ACL is now using a 200 watt input. CRAC on a 50 watt tube. 5VF hasn't settled his QRA yet. 5AJJ reports that the Dallas Radio Club will resume meetings about the 1st of November. 5CV has been out to sea all summer but is home now and getting things going.

Traffic: 5HY 21, 5SP 15, 5ADD 15, 5AJJ 12, 5AUA 10, 5AKN 8, 5ACL 8, 5PH 4, 5NW-MZ 4, 5WW 4, 5AMG 3.

SOUTHERN TEXAS—SCM, E. A. Sahn, 5YK—Reports this month are quite encouraging. More have been received than usual. 5AVI-5ARF reports the misfortune of blowing his H tube. He switched to a 210 while waiting for the 203A. 5ALE is rebuilding for the coming season. 5APM handled a msg to the Virgin Islands. 5MS reports a new convert, 5ARV, who is QRV for QSO. 5MS handled little traffic due to burning out his tube. 5EW indicates that the YLs and KWWG are about to get him. San Antonio has been well represented by 5HE. He got in on some of the Florida traffic during the hurricane. 5VL is back with us again. He explains a very interesting case of break-in communication that he staged with several amateurs.

Traffic: 5VL 16, 5HE 12, 5AVI 10.

OKLAHOMA—SCM, K. M. Ehret, 5APG—A breath of fall puffed out of the North and the gang climbs out of bed with a cold shimmie running from the nap of their neck downward. Pep! Push! Lots of ambish! Mr. Hebert's a comin' the 8th of November. 5TW is back in the ring. New ideas and new hams to put them into practice. Some good thrilling relay work with stricken Florida. In fact, everything has an enthusiastic promise for a successful and eventful winter among the Oklahoma hams. C'mon, fellows, let's do our stuff.

The Transmitter, a publication by 5ATA, has appeared on the scene and with it the spirit of Tulsa awakens. 5ATU is warming up after a summer's hibernation. 5AVV is doing his stuff and BCL repair work. 5FS has his own troubles with remote control. 5ABZ pecks at the key a bit when in from

selling separators. 5GA, TOM'S uncle, is even getting caggy and rarin' to go. 5ATA and 5QQ took a trip to Cushing and found six real hams with DX lists as long as their arm. 5ASK is all lined up for ORS and is attending the Kow Kollege at Stillwater and using 5AVG portable. 5ADO balling the jack with an uncanny skill for spearing DX. 5ANL, RM, has lined up some good schedules and is pushing his wares on 80 meters. 5AEQ is a new station in Cushing. 5DQ is lining up for ORS after being sold on the traffic idea. 5CE and 5PA are planning to come down to meet Mr. Hebert. 5AAV is back from vacation and has the old set rebuilt. 5APQ is living in Oklahoma City with 5ADE. 5SW built his master oscillator with so much success that he keeps busy with traffic. 5KD is still messing around with his set getting the hang of CW and never ceases to marvel at it. 5QL took unto himself a wife and is actually handling traffic. 5ADX-5AOJ moved up from Norman and has the portable perking. 5ZAV is nearly ready to give her the gun.

5AVF reports Norman inactive but getting started. Traffic: 5TW 545, 5QL 29, 5APG 29, 5SW 21, 5ANL 17, 5ADO 14, 5DQ 11, 5ADE-5APQ 10, 5ATA 2, 5AAV 1.

CANADA

MARITIME DIVISION

NOVA SCOTIA—SCM, W. C. Borrett, 1DD—3JW is taking a rest from the air and has bought a car. 3KT bangs away after midnight on his five watter. 3MP at Cornwall works a bit on 40 but is going to try 75 soon. 3DO is heard occasionally. 3GV is just back from Rouyn City and getting started again. 3JL has been in Halifax with the Naval Reserve for a month and while east, visited c-1DD, 1AR and 2CC. 9CC is out in Vancouver where he will make radio and astronomical observations in connection with Canada's part of the International Longitude Survey in November. Western hams can get in touch with him at the observatory there.

Traffic: 3JL 14.

NEW BRUNSWICK—SCM, T. B. Lacey, 1EI—Radio has been about at a standstill owing to holidays and to several of the gang moving to new QRAs. Traffic has been very small. Our star station, 1AI, has been off the air most of the month for want of power; his batteries ran down and a ten-mile drag to have them charged didn't appeal to him so he has now almost completed installing a gasoline power plant. FR.

1AM is moving and going to have a nice crystal-controlled set going soon. 1AK is also getting started up in a new QRA. A regular BCL nest. 1AN is on now—just returned from a visit to Devon where he spent his holidays. 1AD tossed up to see if he would buy a 250 watter or go on a vacation trip. He has the 250 now and starting up soon. Both 1AD and 1EI are rebuilding for the winter. Say, gang, here's the latest. N. B. is going to have a real ham YL station. It's a secret yet, but watch out for a new call.

Traffic: 1AI 14, 1AD 6, 1AM 5, 1AN 5, 1AK 4. **PRINCE EDWARD ISLAND**—SCM, W. A. Hyndman, 1RZ—The SCM only received one report—that being from 1CO who handled 6 messages.

QUEBEC DIVISION

QUEBEC—SCM, Alex Reid, 2BE—With fall weather here, the old radio fever has taken hold. A real lively hamfest was held at 2BE's station Sept. 17. Over twenty were present. The SCM issued 8 ORS certificates and the gang is now hungry for traffic. We are glad to report that 2AX, who was seriously ill in Ontario, is back home again fully recovered. He has remodelled both transmitter and receiver and is doing good DX. Our old friend, 2RG, is back on the air after an absence of six months. 2FO is back on the air and worked two A's the other morning. 2BB, our newest station, finds his location on the Lake shore ideal for DX. The Division has decided to have a booth at the Montreal Radio Show. They will have a transmitter and receiver in operation and will accept traffic for all points. They will also have on display ancient and modern gear. We also hope to give the A.R.R.L. a big boost at the show. The SCM wants every station to get on 52.5 meters every Wednesday night

to attend the weekly prayer meetings. Try and do this, boys, the rest of Canada is looking for the Second District. Now, you new ORS, don't forget to send your report in to the SCM before the 26th of each month.

Traffic: 2CG 21, 2BE 6, 2AX 5, 2FO 4.

ONTARIO DIVISION

ONTARIO—SCM, W. Y. Sloan, 9BJ—The two outstanding events of the past month were the SCM's annual hamfest and the banquet held in honor of Mr. Hebert on the occasion of his visit here. The annual hamfest was, as usual, held at Hanlans Point, Toronto; and was attended by over forty of the Ontario amateurs from the southern section of the province. After the dinner, the gang adjourned upstairs to the dance hall, where an informal hamfest was enjoyed. The gang was later ferried in relays up to VBG, the local Marconi station, where the apparatus was inspected. This is the fourth annual hamfest held by 9BJ and the fifth for next year is already being planned.

A bang-up reception was tendered Mr. A. A. Hebert by the local gang, at a banquet held in his honor. His address left nothing to be desired and those present were able to carry away a real conception of what the A.R.R.L. means.

Central District—52.2 meters is populated at present by 9AI and 3BI only, in this district. More of the fellows are badly needed on this wave to start a real get-together of all the hams in Canada every Wed. night, 52.5 meters, from 10.30 to midnight E.S.T. Hop to it, fellows, and you will find 9AI there to welcome you. 3CC reported that he has handled no traffic but reports that schedules were kept for a part of the month with 9BJ. He says that he will be on the air quite regularly. His best DX this month has been u-4PR. 3BT reports that he has been on the air in the mornings and has worked a bunch of stations on very low power. His wave is 40.5 meters. 3WG is unable to work his station much except week-ends when he is home from teaching school at Norval, Ontario. 3FC has not been on the air very much during the month, but has managed to keep a few schedules, both from 3FC and 9AI. 9AL is still waiting for reports on his M. G. 9CD, an old timer, is back again and is the star of the month, working i-1AV the first night on. 3AT is also back after two years' absence. 9BJ is still playing with the baby low power set and using a 201A, he works 400 miles in daylight on .48 watt input. 3HY works DX with both high and low power sets but reports traffic scarce. 3EL, 3BL, 3AZ and 3MV are all rebuilding.

Northern District—3HP is active and on the job from 9AQ. No exceptional DX is reported but he is busy keeping four schedules. 3NI will be on again when the Aurora subsides. No other stations are active.

Traffic: 3HP 63, 9AL 26, 3FC 11, 9BJ 9, 9CD 6, 3BR 2, 3CK 1, 3BT 1.

VAN ALTA DIVISION

BRITISH COLUMBIA AND ALBERTA—SCM, A. H. Asmussen, 4GT—4AF working a lone hand in McLeod, Alberta, shows the whole Division now to hang up a message total. Most of his junk pile is Ford coils, haywire and glass beads but consistent efforts and strict attention to schedules does the trick. 4AL is back from a holiday trip and will work the old heap overtime to make up for lost time. 4CC has hit the rural district teaching school—wonder if he will use QST for a text book! 4CL is tuning up for winter traffic—being an old timer, we expect his subsequent reports to show the goods. 4DQ, the OW, is doing good DX work for the power used and is QRV for traffic. 4GT is moving to a new QRA. 4IO is still going strong on 40 meters and wants traffic. 4AX adds to the Sunday afternoon QRM and gets good DX. Our old friend, Harris in Edmonton, is cutting a wide swath in the ether and is QRV traffic for the Igloo huts.

The hamfest for the B. C. Section was held in early October. 5GF is QSO CKA. 5AM reports that he ordered an asbestos unionsuit to bounce off some of the Hadian Heat. 5CT is aspiring to be a Nimrod and reports lots of bites. 5GT has been off lately but is back now with 3APS on the job. 5CR has schedules with u-6RJ and hu-6BUE. 5BM is on a big tug and reports QRW but is going to try and stick in a small transmitter.

Traffic: 4AF 51, 4IO 7, 4DQ 2, 4CL 1, 4GT 1.