

QST

DEVOTED ENTIRELY TO
AMATEUR RADIO



"The early morning relay"

Published by The
American Radio Relay
League

20¢
February 1924

Cunningham

RADIO TUBES

*The Superior Tube
for Radio Receiving Sets*

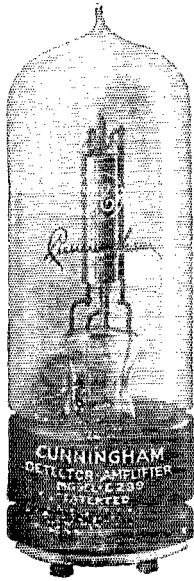

Cunningham Radio Tube
Type C-299 is a Detector and Amplifier of the high vacuum type, designed especially for dry battery filament current supply. The special filament in this tube draws a current so low that as many as four tubes may be readily operated from a single set of three standard No. 6 dry cells. The ideal tube to use in your set.

The care and operation of each model of Receiving Tube is fully explained in our new 10-page "Radio Tube Data Book." Copies may be obtained by sending ten cents to our San Francisco office.

Cunningham Radio Tubes

C-301A—5 Volts 1-4 Ampere filament	\$6.50
C-299—3 Volts .06 amp. Dry Battery Det. and Amp.	\$6.50
C-300—5 Volts Gas Content Detector	\$5.00
C-11—1.1 Volts .25 amp. Dry Battery Det. and Amp. Special Base	\$6.50
C-12—Similar to C-11 with standard base	\$6.50

PATENT NOTICE

Cunningham tubes are covered by patents dated 2-18-08, and others issued and pending. Licensed for amateur, experimental and entertainment use in radio communication. Any other use will be an infringement.

Home Office: 182 Second Street
San Francisco, Calif.
154 W. Lake Street 30 Church Street
Chicago, Ill. New York City, N. Y.

A Radio Statement to the Public

KEEPING its pledge to the public, the Radio Corporation of America has concentrated its vast research and engineering forces upon the solution of certain fundamental problems facing the art—problems which have become more apparent as broadcasting stations and radio receivers multiply.

The phenomenal expansion of the radio industry, and the universal and ever-increasing appeal of radio represent an outstanding development of the present century—for this industry has grown from infancy to maturity in a space of but two years.

—*A receiver for the apartment house* and populated districts, requiring neither aerial nor ground connection.

—*Another type of improved receiver for the suburban districts*, equally capable to that above, for use where the erection of an aerial presents no problem.

• • •

Briefly stated, there is today a necessity for

Painstaking search in quest of these ideals has led to new discoveries, setting new standards of excellence and performance—discoveries, which have established:

—*A radio receiver providing super-selectivity*—the ability to select the station you want—whether or not local stations operate. A selectivity which goes to the theoretical limits of the science.

First—that improved acoustics are possible—a matter of scientific research and not of haphazard design—for truly melodious reception.

—*Super-sensitiveness*—meaning volume from distant stations—along with selectivity.

Second—that dry battery operated sets can be so designed as to give both *volume* and distance.

—*Improved acoustics*—more faithful reproduction of broadcasted voice and music than has ever been possible before.

Third—that the regenerative receiver is susceptible to marked improvement providing selectivity, sensitiveness and simplicity of operation hitherto deemed impossible of accomplishment.

—*“Non-radiating” receivers*—a new development—a type of receiver which, no matter how handled, will not interfere with your neighbor’s enjoyment.

Fourth—that the Super-Heterodyne—the hitherto complicated device requiring engineering skill to operate—could be vastly improved—improved in sensitiveness and selectivity—and simplified so that the very novice and the layman could enter new regions of entertainment and delight.

—*More simplified operation*—a super-receiver requiring no technical skill, thus making the greatest achievements of entertainment immediately available to all members of the family.

Watch For Further Announcements

Radio Corporation of America

Sales Offices:

233 Broadway, N. Y. C. 10 So. LaSalle St., Chicago, Ill. 433 California St., San Francisco, Cal.

Radiola

REG. U. S. PAT. OFF.

Noiseless - Permanent
 $\frac{1}{4}$ to 10 Megohms



E. T. FLEWELLING

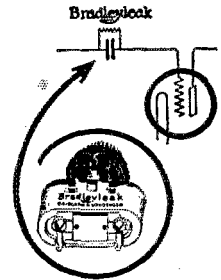

Retail Price
\$1.85
Condenser
 .00025 MF
 35¢ Extra

“The Bradleyleak is the best
 Grid Leak I have tried”
 - SAYS FLEWELLING -

E. T. Flewelling, inventor of the famous Flewelling circuit, recently tested a number of Bradleyleaks in his laboratory and after a thorough test writes as follows:

“The radio market has been sorely in need of apparatus of such a high type as the Bradleyleak, and I feel that you are to be congratulated because of the action of this grid leak as shown under test. I do not hesitate to say that, so far as my tests are concerned, it is the best grid leak that I have tried and the only leak that comes anywhere near approaching the ideal. It is a high-grade piece of apparatus in every respect and I am only too glad to congratulate you again.”

The Bradleyleak is the result of 20 years' experience in the manufacture of graphite disc rheostats. It contains no carbon or metallic powder. It is distinctly a disc rheostat. A smooth range from $\frac{1}{4}$ to 10 megohms is obtainable without steps or jumps by simply turning the adjusting knob. The Crosley laboratory found it unaffected by atmospheric conditions.

Many of the new circuits, such as the Flewelling or other highly-selective circuits, work best when equipped with the Bradleyleak. Try one on your radio set and you will be amazed with the improved operation.

Mail this Coupon - Today!

ALLEN-BRADLEY CO.
 277 Greenfield Ave., Milwaukee, Wis.

Please send me your folder describing the Bradleyleak and its construction.

Name

Address

Allen-Bradley Co.
 Electric Controlling Apparatus

277 Greenfield Ave.  Milwaukee, Wisconsin

Manufacturers of graphite compression rheostats for over 20 years.

Is Your Grid Leak Correct?

The following table gives the approximate values of grid leak resistance recommended by vacuum tube manufacturers:

Audion (DeForest) DV-6	2 Megohms
C-200	2 Megohms
C-299	2 to 5 Megohms
C-301-A	2 Megohms
UV-199	2 to 5 Megohms
UV-200	2 Megohms
UV-201-A	2 Megohms
WD-11	3 Megohms, or more
WD-12	3 Megohms, or more

THE TRAFFIC DEPARTMENT, A.R.R.L.

ATLANTIC DIVISION

Manager
A.D.M. D. of C.
A.D.M. Maryland
A.D.M. So. N. J.
A.D.M. S. N. J.
A.D.M. East. N. Y.
A.D.M. West. N. Y.
A.D.M. East. Penna.
A.D.M. West. Penna.
A.D.M. Delaware

C. H. Stewart
H. J. Wadsworth
G. L. Deichmann, Jr.
R. S. Johnson
H. W. Densham
Dr. E. A. Cyriax
S. Woodworth
J. F. Rau
P. E. Wiggin
H. H. Layton

St. David's, Pa.
Washington
Baltimore
Red Bank
Collingswood
New York City
Syracuse
Philadelphia
Pittsburgh
Wilmington

CENTRAL DIVISION

Manager
A.D.M. Michigan
A.D.M. Ohio
A.D.M. Illinois
A.D.M. Wisconsin
A.D.M. No. Indiana
A.D.M. So. Indiana
A.D.M. Kentucky

R. H. G. Mathews
C. E. Darr
C. E. Nichols
N. C. Smith
C. N. Crapo
M. W. Hutchinson
J. E. Hall
J. A. Kolb

Chicago, Ill.
Detroit
Lima
Peoria
Milwaukee
Ann Harbor
Seymour
Louisville

DAKOTA DIVISION

Manager
A.D.M. Minnesota
A.D.M. So. Dakota
A.D.M. No. Dakota

N. H. Jensen
D. C. Wallace
Orville Wheelon
Bert Wick

Sioux Falls, S. D.
Minneapolis
Pierre
Devils Lake

DELTA DIVISION

Manager
A.D.M. Louisiana
A.D.M. Mississippi
A.D.M. Tennessee
A.D.M. Arkansas

W. W. Rodgers
V. L. Rosso
W. L. Kennon
W. C. Hutcheson
Dr. L. M. Hunter

Memphis, Tenn.
Plaquemine
Mississippi
Wind Rock
Little Rock

EAST GULF DIVISION

Manager
A.D.M. So. Carolina
A.D.M. Alabama
A.D.M. Florida
A.D.M. Georgia
A.D.M. Porto Rico

H. L. Reid
C. E. Wells
V. C. McIlvaine
C. P. Clark
C. B. Transou
Luis Rexach

Atlanta, Ga.
Greenville
Sheffield
Jacksonville
Atlanta
San Juan

MIDWEST DIVISION

Manager
A.D.M. Missouri
A.D.M. Nebraska
A.D.M. Iowa
A.D.M. Kansas

G. S. Turner
Dr. C. L. Klenk
J. G. O'Rourke
D. E. Watts
Clif. Peters

S.W. Bell Tel. Co. Rm. 611, Tel. Bldg., Kan. City, Mo.
420 Metropolitan Bldg.
3064 South 32nd St.
116 Highland Ave.

NEW ENGLAND DIVISION

Manager
A.D.M. Rhode Island
A.D.M. N. Hampshire
A.D.M. Vermont
A.D.M. Maine
A.D.M. West. Mass.
A.D.M. East. Mass.
A.D.M. Connecticut

I. Vermilya
D. B. Fancher
B. H. Stevens
R. P. Slayton
L. Hilton
A. S. McLean
B. H. Chase
D. C. S. Comstock

Mattapoisett, Mass.
Westerly
Manchester
Burlington
Lewiston
Springfield
Winthrop
E. Hartford

NORTHWESTERN DIVISION

Manager
A.D.M. Montana
A.D.M. Washington
A.D.M. Idaho
A.D.M. Oregon

Glenn E. West
H. E. Cutting
K. W. Weingarten
LaVerne Martin
P. R. Hoppe

Polytechnic, Mont.
Bozeman
Tacoma
Nampa
Eugene

PACIFIC DIVISION

Manager
A.D.M. Arizona
A.D.M. Nevada
A.D.M. So. Calif.
A.D.M. Central Calif.
A.D.M. No. Calif.

J. V. Wise
H. L. Gooding
G. M. Lewis
M. E. McCreery
B. R. Coles
E. C. Garrette

Walnut Grove, Cal.
Douglas
Reno
Los Angeles
Los Gatos
Coluso

ROANOKE DIVISION

Manager
A.D.M. West. Va.
A.D.M. Virginia
A.D.M. No. Carolina

W. T. Gravely
J. L. Bock
J. F. Wohlford
T. M. Simpson

Danville, Va.
Farmington
Roanoke
Winston-Salem

ROCKY MOUNTAIN DIVISION

Manager
A.D.M. Utah
A.D.M. Colorado
A.D.M. Wyoming

N. R. Hood
H. C. Wilson
P. M. Segal
P. N. Mitchell

Casper, Wyo.
Salt Lake City
Denver
Greybull

WEST GULF DIVISION

Manager
A.D.M. New Mexico
A.D.M. Oklahoma
A.D.M. No. Texas
A.D.M. So. Texas

F. M. Corlett
Louis Falconi
C. E. Whartenby
R. L. Clinkscales
E. A. Sahn

Dallas, Texas
Roswell
Enid
Amarillo
New Braunfels

HAWAIIAN DIVISION

Acting Manager

K. A. Cantin

Honolulu, T. H.

Manager

W. C. Borrett

Dartmouth, N. S.

ONTARIO DIVISION

Manager
A.D.M. Central Ont.

C. H. Langford
Wm. Choat

London, Ont.
Toronto, Ont.

QUEBEC DIVISION

Manager

J. V. Argyle

Montreal

WINNIPEG DIVISION

Manager
A.D.M. Saskatchewan
A.D.M. Manitoba

J. E. Brickett
E. L. Maynard
G. C. Patterson

Moose Jaw
Morse
Winnipeg

VANCOUVER DIVISION

Manager

A. J. Ober

Vulcan, Alberta



*"Let the instructed
lead the way by ex-
ample."*

—KANG HSI

*In relay work the
wise DX man
uses a dependable
GREBE "13".*

Doctor Wu

The GREBE "13"

A Real Receiver for Radio Men

LOUIS PAULOUIN
SECRÉTAIRE GÉNÉRAL
VILLA GÉNERAL
VAL ROSTE

LEON DELOY, PRÉSIDENT
25, BOUL. MONTE-BURON
(INDICATEUR T. S. F. "B A B") T. 54 87

MANCEAU BESNEUX
TRÉSORIER
107, BOUL. GARIBOLDI

ALEXANDRE PRÉZEAU, TRÉS. HONORIFIÉ
25, RUE PÉRISSAC
T. 44-08

RADIO-CLUB DE LA CÔTE D'AZUR NICE

Mr. E. K. JAMES
c/o A.H. GREBE & Co. Inc.,
Richmond Hill, N.Y.
U.S.A.

Nov. 1st. 1928.

Dear Mr. James,

Back home since four days only I have reinstalled my station for 100 meter work.

I am glad to say the GREBE GR-13 which I brought back has already done splendid work. I tuned down to 100 meters for the first time this morning at 0010 G.M.T. and immediately heard KDKA. I followed him until 0300 and all the time his carrier wave was good, he could have been easily read in telegraphy. At times excellent orchestral music and some words were plainly heard in spite of heavy static and arc interference.

The distance from Pittsburgh to Nice must be about 7,000 kilometers (roughly 4,400 miles); I have all reasons to think this is the world record distance transmission on 100 meter wave.

Please express my hearty congratulations to the GREBE Co. for their wonderful receiver.

Very sincerely yours.

Leon Deloy
PRAB

IT is significant that the Grebe "13" is the choice of those Amateurs who have established worth-while distance records. Each detail of Grebe craftsmanship is fitting testimony of its efficiency.

Combining Regeneration and Tuned R. F., it affords sharper tuning, greater range and quieter operation. Its wavelength range is:—80-300 Metres.

Ask your dealer or write us for complete information



A. H. GREBE & CO., Inc.

76 Van Wyck Blvd.,

Richmond Hill, N. Y.

Western Branch: 451 East 3rd Street, Los Angeles, Cal.

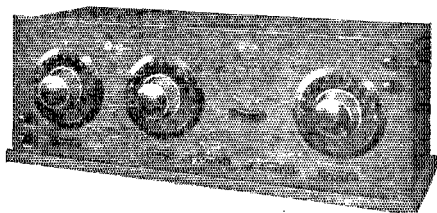

Licensed under
Armstrong U. S.
Pat. No. 1,113,149

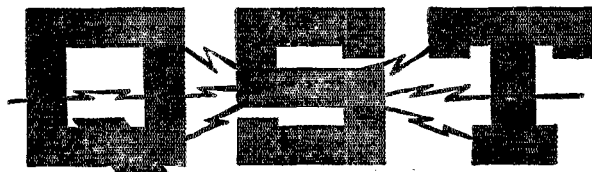

The Official Organ of the A.R.R.L.

VOLUME VII

FEBRUARY, 1924

No. 7

Editorials	7
Low Loss Tuners	8
Direct Contact With Japan	<i>S. Kruse</i> 14
The Progress of Transatlantic Amateur Communication	15
An Amazing World's Record	<i>F. Basil Cooke</i> 18
Get Ready for "IL" Work With Foreign Amateurs	<i>Oscar C. Roos</i> 21
Amateur Wavemeters	<i>S. Kruse</i> 22
Information on Receiving Tubes for A.R.R.L.	
Questioners—Part II	<i>J. C. Warner</i> 24
Coolidge's Holiday Greetings to MacMillan	
Travel Via Amateur Radio	29
Australian Amateur Radio Puts To Sea	<i>F. Basil Cooke</i> 30
What the Department of Commerce Says About Us	31
What the Work With P8AB Teaches the A.R.R.L.	<i>S. Kruse</i> 32
QRY Pan-American Tests?	34
Notice—N. E. Traffic Department Convention	34
Emergency Railroad Communication	<i>A. L. Budlong</i> 35
Wolverine Convention	35
South Dakota Radio Convention	36
A Code of Conduct for A.R.R.L. Members	<i>Charles B. Transou</i> 36
How I Operate UV-202 Radiotrons	<i>H. H. Tilley</i> 37
Election Notices	38
Transpacific Test Report	40
Help Wanted for a Book of American Amateur Stations	40
UIARY and C2CG Help in Emergency	41
The Fourth District-East Gulf Convention	<i>Charles B. Transou</i> 41
A New Type of R. F. Transformer	<i>S. Kruse</i> 42
"OQ Urgent de T1P"	<i>F. M. Curtis</i> 45
The Improved "S"-Tube Rectifier	<i>James L. Jenks, Jr.</i> 46
Automatic Radio Relaying	<i>Porter H. Quinby</i> 49
Motor and Generator Bearings	<i>E. W. Berry</i> 51
Rotten Problems	<i>The Old Man</i> 52
Amateur Radio Stations—F8AB, G2KF	54
With the Affiliated Clubs	56
Who's Who— <i>Carl D. Hoffman, Clyde E. Darr, Harry R. Hick</i>	57
"Strays"	59
The Amateur Builder	62
Some Characteristics of Electrolytic Rectifiers	<i>E. J. Atkinson</i> 66
Radio Communications by the Amateurs	68
Experimenters Section	72
HAM-ADS	122
QST's Directory of Advertisers	127

QST is published monthly by The American Radio Relay League, Inc., at Hartford, Conn. Kenneth B. Warner (Secretary, A.R.R.L.), Editor and Business Manager
S. Kruse, Technical Editor; H. F. Mason, Department Editor
F. C. Beekley, Assistant Editor

Edwin C. Adams, Advertising Manager.

Subscription price in United States, Possessions, and Canada, \$2.00 per year.
Foreign, \$3.50. Single Copies, 20 cents.

Entered as second-class matter May 29, 1919, at the post office at Hartford, Connecticut, under the act of March 3, 1879. Acceptance for mailing at special rate of postage provided for in section 1103, Act of October 3, 1917, authorized September 8, 1922.

Copyrighted, 1923, by the American Radio Relay League, Inc.,
Title registered at United States Patent Office.

THE AMERICAN RADIO RELAY LEAGUE, Inc.
HARTFORD, CONN.

THE AMERICAN RADIO RELAY LEAGUE

The American Radio Relay League, Inc., is a national non-commercial association of radio amateurs, bonded for the more effective relaying of friendly messages between their stations, for legislative protection, for orderly operating, and for the practical improvement of short-wave two-way radio telegraphic communication.

It is an incorporated association without capital stock, chartered under the laws of Connecticut. Its affairs are governed by a board of seventeen Directors, elected every two years by the general membership. The officers, in turn, are elected by the Directors from their number. The League is non-commercial and no one commercially engaged in the manufacture, sale or rental of radio apparatus is eligible to membership on its Board.

"Of, by and for the amateur," it numbers within its ranks practically every worth-while amateur in America and has a history of glorious achievement as the standard bearer in amateur affairs.

Inquiries regarding membership are solicited. Ownership of a transmitting station, while very desirable, is not a prerequisite to membership; a bona-fide interest in amateur radio is the only essential. Correspondence should be addressed to the Secretary.

OFFICERS

President
HIRAM PERCY MAXIM
Hartford, Conn.

Vice President
CHAS. H. STEWART
St. David's, Pa.

Traffic Manager
F. H. SCHNELL
1045 Main St.
Hartford, Conn.

Canadian General Manager
A. H. K. RUSSELL
234 Westmount Drive
Toronto, Ont.

Treasurer
A. A. HEBERT
Hartford, Conn.

Secretary
K. B. WARNER
Hartford, Conn.

DIRECTORS

H. M. ANTHONY
Muncie, Ind.

H. A. BEALE, JR.
Parkesburg, Pa.

A. H. BABCOCK
Berkeley, Calif.

V. F. CAMP
Brightwaters, L. I.

F. M. CORLETT
Dallas, Tex.

C. E. DARR
Detroit, Mich.

A. A. HEBERT
East Hartford, Conn.

S. KRUSE
Hartford, Conn.

H. P. MAXIM
Hartford, Conn.

A. H. K. RUSSELL
Toronto, Ont.

F. H. SCHNELL
West Hartford, Conn.

C. A. SERVICE, JR.
Glastonbury, Conn.

C. H. STEWART
St. David's, Pa.

K. B. WARNER
West Hartford, Conn.

K. W. WEINGARTEN
Tacoma, Wash.

M. B. WEST
Lima, Ohio

G. L. BIDWELL
Washington, D. C.

ADVISORY TECHNICAL COMMITTEE

STUART BALLANTINE
WM. C. BALLARD, JR.
LEROY M. E. CLAUSING
FRANK CONRAD
LEO C. YOUNG

MINTON CRONKHITE
J. H. DELLINGER
C. L. FARRAND
PAUL F. GODLEY
F. C. BLAKE
MELVILLE EASTHAM

L. A. HAZELTINE
C. D. TUSKA
R. H. G. MATHEWS
GERALD M. BEST
S. KRUSE
D. G. McCAA

Address General Correspondence to Executive Headquarters, Hartford, Conn.

EDITORIALS

de AMERICAN RADIO RELAY LEAGUE



International Amateur Radio

THE amateur movement is on the boom the world around! Do you realize that in our Transatlantic Tests of this year there are entries not only from France and the several countries of Great Britain, but from Holland, Belgium, Luxemburg, Italy, and the Madeira Islands? We have our own brand of amateurs in Porto Rico, Alaska, and Hawaii; Cuba and the Phillipines have theirs too. We are very much aware of the extraordinary activity of our confreres in Australia and New Zealand. We know there are hundreds of amateurs to be heard from in South America and in the English-speaking countries of South Africa. Just recently we were immensely surprised to learn of the existence of five hundred active amateurs in Japan! Why, if we could locate an amateur station no better than a dozen we might name, in, say, Cairo, and another in Calcutta, do you realize that a relay could be run around the world by amateur stations—right this month!

The transocean communication accomplishments of the past few weeks, linking Europe with our east coast and Asia with our west coast, have suddenly pitchforked the American amateur into numerous international relations. This intercontinental amateur contact is bound to give a tremendous impetus to amateur activity in every civilized country. One does not have to be a prophet to foresee the result: International Amateur Radio has arrived. With it comes new friendships and the joys of new conquests and accomplishments, but with it come new problems too. Just as we American amateurs always have found it necessary to have our cooperative arrangements, our divisions of hours, our standardized practices, so we believe there will have to be arrangements to govern our international activities, an international forum to which amateurs from all around the world can bring their ideas for cooperative advancement.

Isn't the answer self-evident? We need, as quickly as it can be arranged, an International Amateur Radio Relay League, in which the A.R.R.L., representing American amateur radio, can join the other amateur societies of the world in a common effort. Our president is sailing for Europe at this writing, and he carries this idea with him to lay before the amateur bodies of

other countries. We hope that before long our dream of an I.R.R.L. may become a reality.

Our New Constitution

THE American Radio Relay League has a new constitution, which went into effect by action of the Board of Direction on December 18, 1923. It is printed in its entirety elsewhere in the membership edition of this issue of *QST*. This Constitution and the By-Laws thereunder are the result of many months of study and hard work on the part of the Board and the officers of the League. Probably they are not perfect documents, but they represent a serious effort to give you readers of the A.R.R.L. membership what you want. You should read the new constitution carefully and acquaint yourselves with all its provisions.

With the resumption of amateur activities after the war the League operated under a constitution which provided for the government of its affairs by a Board of seventeen directors, elected at large by the entire membership. While we were a small and rapidly growing organization this probably was the best possible form of government for us. It was lacking, however, in that it did not take into account the idea of *representation*, and there were many large areas of the country which had no particular representation on the Board—every director was a director-at-large, and merely one-seventeenth of the whole governing power. The time has now come when we are a big enough organization to adopt the idea of divisional representation, and the new constitution provides that there shall be one director from each division in the United States, charged with the duty of keeping himself informed on the needs of the membership in his division, that he may act as their representative in the guiding of A.R.R.L. policies. The new Board will consist of these Directors, a Canadian General Manager representing all of A.R.R.L. north of the boundary, and a President and a Vice-President which will be elected by the new Board at its first meeting; the salaried officers of the League will not be directors.

The new Board will be elected immediately, and nominations are called for in notices published elsewhere in this issue. The new Constitution was not submitted to popular

vote, and it is possible that members will find some features of it not to their liking. It provides for the democratic election of a new Board, however, and the new Board will be the League's governing body, so if there is anything you don't like about the new document, give your suggestions to your new director when he is elected—he is to be your personal representative on the Board.

There is a certain element of inefficiency in any democratic form of government, and the dangers arising from this are in proportion to the expansion of the idea of

true democracy. Our new form of government is more democratic than our old and, altho offering much-sought advantages in better representation, introduces added hazards simply because the new directors to a large extent will be primarily the representatives of certain areas. A.R.R.L. members everywhere therefore should give deep consideration to the choice of their new directors and choose men not merely for their ability to represent the division but for their executive ability, vision and wisdom—men who in all things will act for the greatest good of our organization.

Low Loss Tuners

By S. Kruse, Technical Editor

"For the last few years most of us have been using very, very poor tuners—and most of us would not even believe that they were poor. But interference increases all the time and even the slowest are now admitting that we must have sharper tuners. We can so improve the plain two-circuit regenerative tuner that it will make most of the elaborate new circuits look rather sick."

THERE has been a most remarkable amount of interest in the design of good tuners since we published Mr. Hassel's article "Short-wave Tuner Design" in the December issue of QST.* For the past few years most of us had been using very, very poor tuners—and most of us would not even believe that they were poor.

What Is a Good Tuner?

Let us decide at the start what a good tuner must do—then we can start thinking of the ways to make it do those things. Very well, a good tuner must—

- 1—Cover the *right wave-length range*.
- 2—*Tune sharply*; that is, cut out unwanted signals.
- 3—Be *simple and have few controls*.
- 4—*Not send out a strong carrier wave* when receiving C.W. with an oscillating tube.
- 5—Be *absolutely reliable*, so that the same dial settings will give the same result every time.
- 6—Be *low-priced and easy to build*.

These are 6 things that we are going to demand of our tuner. We will now think them over, but at the start I will tell you that, when we are done with requirements No. 1 and No. 2, we will *automatically* have taken care of the rest.

1—Wavelength Range

The average broadcast receiver fits the broadcast waves. The average amateur tuner is a crazy joke that starts at 180 or 190 meters and goes up (not down) to 700 meters or so. Last week I found that

one of the strongest amateur stations in Illinois for years had been using a tuner that would not go below 195 meters; the Lord knows what its upper limit was. Yet the owner of this thing was dead sure that "the short waves are no good—they never get to us"! All hands will now guess who the man was.

Why is this? Partly it is a "hangover" from the times when amateurs had a 375-meter special wavelength, and partly it is just plain carelessness.

The effect of over-large coils and condensers is a very bad one. Not only are all short-wave stations tuned in at the bottom of the condenser scale but the extra hardware introduces needless resistance. Note that in the tuners pictured in this article the range does not go above what is actually needed.

If you don't want to make a new tuner then peel some of the extra wire off your coil and get rid of the extra condenser plates, until the wavemeter tells you that you are just reaching up to 220 meters—then you can get down to 100 without trouble.

2—Resistance and Sharp Tuning

A high resistance circuit will not tune sharply. There are no exceptions to this rule—a high resistance circuit *will not tune sharply*. Put that down as Rule A—the first commandment in making any tuner that will be worth using. Just to get it down good and solid let's say it once more, in capitals—A HIGH RESISTANCE CIRCUIT WILL NOT TUNE SHARPLY!!

Both amateur and commercial tuner-

*Can be obtained from the QST Circulation Dept. at the regular price.

Avoid composition sockets—they save 10¢ and ruin the tuner. Get a good socket that is made of porcelain, hard rubber or moulded bakelite. If you are in doubt as to your socket, write the maker and ask him what the material is.

When running leads from the "high" side of the coil to the stationary plates of

a good coil, a good condenser and a good socket into a tuned circuit the whole result can be entirely ruined by too-close coupling to another circuit which has high resistance. Now an antenna circuit always has resistance that is very high; as a usual thing the resistance is 10 or more times that of a good circuit such as the one suggested.

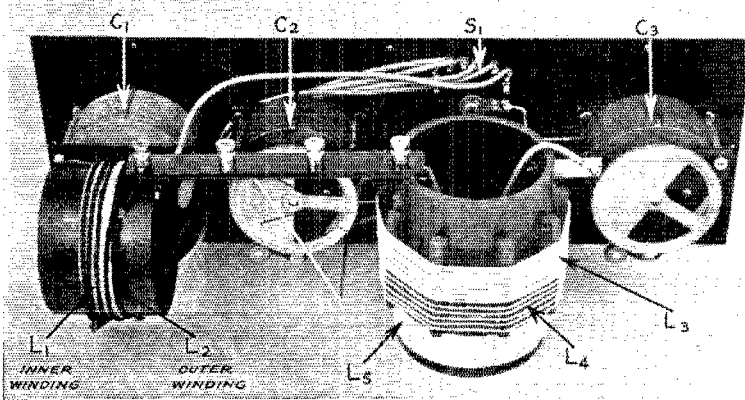

Fig. 4

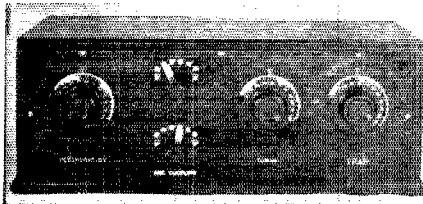

Fig. 5

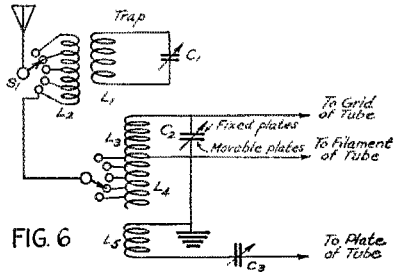

FIG. 6

**A CAREFULLY DESIGNED REINARTZ-TYPE TUNER
BUILT BY BOYD PHELPS AND USED AT 1HX-10A-1XAQ**

A wave-trap is built into this tuner.

- L1—Secondary of the wave trap. 13 turns of No. 16 D.C.C. wound on a 3-5/8" tube.
 - L2—Primary of the wave trap. 5 turns of light single-conductor lamp cord wound directly over L1 and tapped at each turn to the upper switch on the panel. This switch changes the coupling of the trap to the antenna, or cuts the trap out when it is not wanted.
 - L3—12-turn secondary coil, wound of No. 16 D.C.C. wire over wedge-shaped wooden strips 3/8" high. These strips rest on the surface of a bakelite tube 3-5/8" in diameter. The turns of this coil are slightly spaced.
 - L4—5-turn primary coil, wound of the same piece of wire as L3. Turns are spaced so that taps can be taken easily to the lower switch on the panel. This switch does NOT tune but adjusts the antenna coupling.
 - L5—Plate coil. 18 turns of No. 16 D.C.C. wire wound closely on the Bakelite tube, 1/2" below the primary.
 - C1—Trap-tuning condenser. 1000 micromicrofarads (.001 microfarads).
 - C2 and C3—General Radio type 247 panel-mounting condensers with geared verniers. Capacity 500 micromicrofarads (.0005 microfarads).
- Wavelength range with the windings shown is 90-225 meters, no secondary taps being needed for the amateur range. The tuning is practically unchanged with different antennas. Wavelength range of the trap is from 80 to 310 meters, allowing it to cut out troublesome 300 meter sparks such as NAO. To change this tuner to fit the broadcast range, increase the turns of the secondary coil L3 to about 40, increase the turns of the trap coil L1 to about 30.

the condenser, and from there to the tube, run them up in the air. 9 times out of 10 it makes no difference at all, but play safe.

Resistances "Coupled Into" the Circuit

When one is all through assembling a

Naturally it will spoil our beautiful secondary to couple closely to such a bad circuit—the signals will be louder but the sharpness of tuning will be entirely spoiled. The closest possible coupling is that ob-

tuned receiving circuit into four general classes: the coil resistance, the condenser resistance, the resistance caused by things connected to the tuned circuit, and the resistance that is "coupled into the circuit."

Coil Resistance

About the worst defect of most tuners lies in the high resistance of the coils used. This resistance is *not* generally in the wire, at least not in the cases where wire larger than No. 16 A.W.G. (B. & S.) is used. The resistance is in the things that are near the wire—the tube on which the wire is wound, the varnish with which the coil is painted, sometimes even the insulation of the wire itself. A perfect coil would be one wound on air and insulated with air. We can't make such a thing but we can come pretty close to it by using wedge-shaped strips as shown in the Reinartz-type tuner of Fig. 4, or by making "basket" coils as shown in the other two tuners. If you absolutely *must* wind the wire right on a tube, then at least follow the methods given by Mr. Hassel's article (QST for December*); they are very much worth while. Above all things, avoid heavy varnishes, stranded or "Litz" wires, and soldering pastes. Use good heavy solid wires, tie them into place mechanically instead of pasting them down, use rosin for soldering, and *keep the coils at least two inches clear of all other parts of the set—panels, condensers and rheostats included.*

Taps from Coils

Tapped coils in the tuned circuit are always poor business; only careful engineering will enable you to avoid trouble. Try to cover the wavelength range with a single coil and if you do not succeed use a separate loading coil, not too close to the main coil.

Condenser Resistance

As long as one uses a poor coil (like those of most tuners) it does not make much difference whether the variable condenser is good or rotten. But as soon as one uses a really good coil there is a *big* difference between a not-very-good condenser and a really good one. This difference does not show up as a grand increase on strong signals but in the form of a lot of new signals that were never heard before. In one particular case we found that we could read 6PL very nicely with a single tube when using a good condenser (a Cardwell in this particular test) but could barely hear him with a condenser having thick moulded-composition ends. A General Radio 247 condenser gave about the same results as the Cardwell, while it was entirely impossible to hear the signal when using a fibre-insulated condenser.

What Makes a Condenser Good

It is rather hard to set down air-tight

rules for recognizing a good condenser by looking at it. In general a good variable condenser is of the air type and is built so that leakage must go thru long paths in material that is not too thick or wide. In the case of condensers with end-plates this means that the stator bolts should be far from the rotor bearing and that the end plates should be as thin as possible. Where insulating bushings are used they should be large and be turned spool-shaped (as in the large Coto-coil condenser) so that only the rims will touch. Naturally the use of thin insulating washers or small-diameter bushings will result in a poor condenser; it will have high resistance and the zero capacity will be high. In any case the insulating material must be good—black fibre and low-grade compositions are *never* good, while hard rubber or Pyrex glass can always be trusted. Moulded bakelite is also good, if carefully used, but sheet bakelite does not seem to show up quite as well, altho much superior to fibre and compositions.

Measured Resistances

Different manufacturers measure their condenser resistances at all sorts of frequencies—the result being that no one knows anything. When writing a maker ask what the resistance is at 1000 cycles, a convenient value which ought to be standard. A 500 micromicrofarad (.0005 μ f) condenser, set at full capacity, should not have a resistance of over 60 ohms at 1000 cycles: a really excellent condenser will not have a resistance of more than 20 or 25 ohms at 1000 cycles; assuming the same capacity.

Mounting the Condenser

Always connect the condenser so that the wire to the grid-leak and grid condenser comes from the *stationary plates* and the wire to the filament comes from the *rotary plates*. It is then possible to tune in signals without trouble from "hand capacity", one of the most exasperating things in radio. This connection puts the stationary plates at high voltage, hence the screws that hold the condenser to the panel *must not connect to the stationary plates*. If they do, get a different condenser. Do not, however, make the mistake of throwing out a condenser, just because it has metal end plates. This construction is perfectly o.k. as long as the metal end plate is *not* connected to the stationary plates.

Resistances "Connected Into" the Circuit

We are not through when we have made a good coil, mounted it carefully, and connected it to a good variable condenser. The whole affair can be ruined by connecting in a "moulded mud" socket or a camswitch of poor construction. In general stick to the idea of not having any switches at all in the tuned circuit—it is a bad practice.

Avoid composition sockets—they save 10¢ and ruin the tuner. Get a good socket that is made of porcelain, hard rubber or moulded bakelite. If you are in doubt as to your socket, write the maker and ask him what the material is.

When running leads from the “high” side of the coil to the stationary plates of

a good coil, a good condenser and a good socket into a tuned circuit the whole result can be entirely ruined by too-close coupling to another circuit which has high resistance. Now an antenna circuit always has resistance that is very high; as a usual thing the resistance is 10 or more times that of a good circuit such as the one suggested.

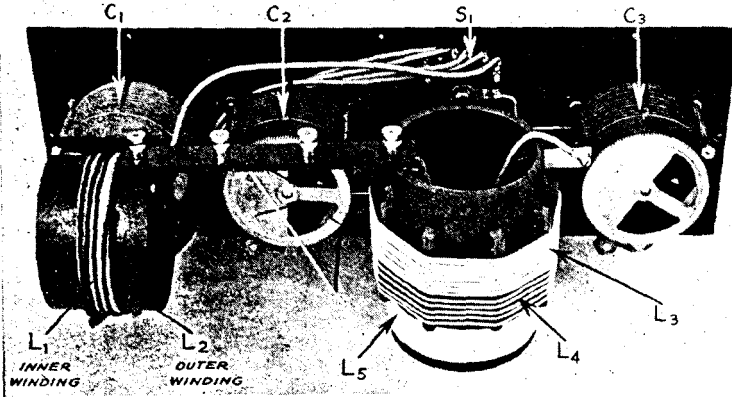

Fig. 4

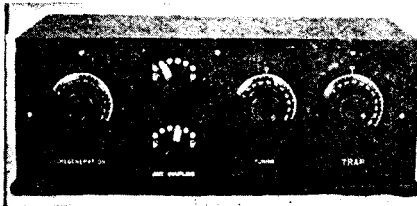

Fig. 5

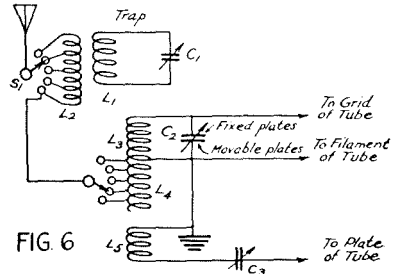

FIG 6

**A CAREFULLY DESIGNED REINARTZ-TYPE TUNER
BUILT BY BOYD PHELPS AND USED AT 1HX-10A-1XAQ**

A wave-trap is built into this tuner.

- L1—Secondary of the wave trap. 13 turns of No. 16 D.C.C. wound on a 3-5/8" tube.
 - L2—Primary of the wave trap. 5 turns of light single-conductor lamp cord wound directly over L1 and tapped at each turn to the upper switch on the panel. This switch changes the coupling of the trap to the antenna, or cuts the trap out when it is not wanted.
 - L3—12-turn secondary coil, wound of No. 16 D.C.C. wire over wedge-shaped wooden strips 3/8" high. These strips rest on the surface of a bakelite tube 3-5/8" in diameter. The turns of this coil are slightly spaced.
 - L4—5-turn primary coil, wound of the same piece of wire as L3. Turns are spaced so that taps can be taken easily to the lower switch on the panel. This switch does NOT tune but adjusts the antenna coupling.
 - L5—Plate coil. 18 turns of No. 16 D.C.C. wire wound closely on the Bakelite tube, 1/2" below the primary.
 - C1—Trap-tuning condenser. 1000 micromicrofarads (.001 microfarads).
 - C2 and C3—General Radio type 247 panel-mounting condensers with geared verniers. Capacity 500 micromicrofarads (.0005 microfarads).
- Wavelength range with the windings shown is 90-225 meters, no secondary taps being needed for the amateur range. The tuning is practically unchanged with different antennas. Wavelength range of the trap is from 80 to 310 meters, allowing it to cut out troublesome 300 meter sparks such as NAO. To change this tuner to fit the broadcast range, increase the turns of the secondary coil L3 to about 40, increase the turns of the trap coil L1 to about 30.

the condenser, and from there to the tube, run them up in the air. 9 times out of 10 it makes no difference at all, but play safe.

Resistances “Coupled Into” the Circuit

When one is all through assembling a

Naturally it will spoil our beautiful secondary to couple closely to such a bad circuit—the signals will be louder but the sharpness of tuning will be entirely spoiled. The closest possible coupling is that ob-

tained in a single circuit tuner—which is enough to account for the well-known broad tuning of that ancient circuit.

sistance, so will any large piece of insulating material. Therefore keep the coils well in the clear as stated before.

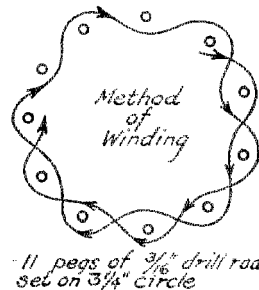
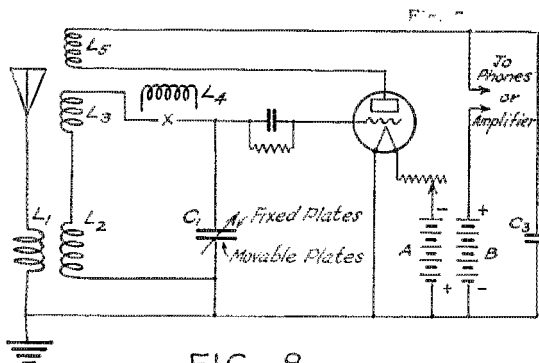
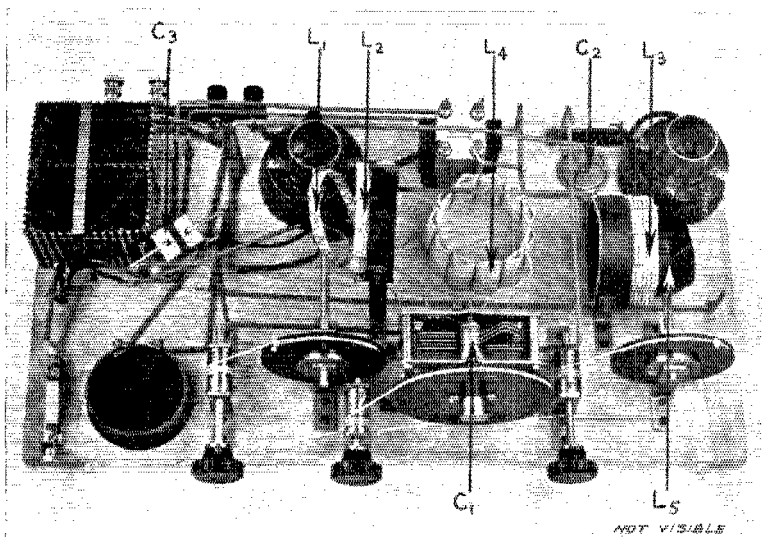

FIG. 8

FIG. 9

A RADICALLY DIFFERENT LOW-LOSS COUPLER BUILT BY F. H. SCHNELL AND USED AT 1MO. 1BHW-1XW

- L1—Antenna coil, 5 turns, 2½" diameter, wound and mounted as in the 1BGF tuner.
 - L2—First section of secondary, 6 turns No. 16 D.C.C. wire, basket-wound as shown below, diameter 3¼".
 - L3—Second section of secondary, 12 turns wound same as L2.
 - L4—Secondary loading coil, 30 turns, wound like L2 and L3. Other positions for this loading coil were tried but it disturbs the tickler action if not cut in where indicated. A really satisfactory switching system has not been found; still the results are excellent over the entire range.
 - L5—Tickler coil, 11 turns No. 28 D.C.C., 2½" diameter, arranged to be turned by tickler shaft.
 - C1—Allen D. Caldwell condenser, 3 rotary, ¼ stationery plates, arranged to be turned by tickler shaft.
 - C2—Grid condenser, mica, capacity 1000 micromicrofarads, (.001 microfarads).
 - C3—Mica by-pass condenser, capacity .001 microfarads.
- Ratio of belted verniers is 6¼:1 on the secondary tuning condenser, but 4¼:1 on the tickler and the primary coil.
- The two-part secondary completely avoids inter-action between the tickler and the antenna-coupling. Either one of them can be moved without causing the note to slide around, as is the annoying habit of ordinary tuners.
- The grid leak has a resistance of 4 megohms as a UV-201-A tube is used.
- Short wave range, 63 to 123 meters; long wave range, 113 to 227 meters. For broadcast range L2 should have 12 turns; L3, 20 turns; L5, 22 turns; and C1 a capacity of .0005 microfarads. Other values and dimensions unchanged.

There are still other ways of coupling resistance into a circuit; any piece of metal placed near a coil will raise the re-

Shielding and Cabinets
Several experimenters have written in to complain that their sets do not work as

well when in the cabinets as when outside. This simply means that the cabinets fit too closely—they violate the rule that coils must be kept in the clear.

Shielding around the shafts is usually worse than needless—it raises the resistance of the tuned circuits and it is quite needless if the tuner was properly designed. Where the purpose of shielding is to keep out static and such noises the cabinet should be made very large and lined with sheet copper, all parts of this lining being kept at least two inches from the tuner coils.

Cutting Down Resistance by Regeneration

We are told by text books that regeneration has the effect of reducing the resistance of a poor input circuit. Ballantine does not agree with this and says (page 209, 1st edition) "The fact that the tickler coupling, or rather the feedback energy, does not compensate for the actual resistance of the grid circuit, at least so far as signal response is concerned..... is also shown by the several curves, representing the effects of various inserted resistances in the tuned grid circuit."

Those who are interested in the theory of the matter may look up Ballantine's Fig. 117. It is only necessary to say that some dozens of us have experimentally checked Ballantine's statement and find that in practice he is entirely correct—regeneration does not make a poor secondary into a good one. The signal strength can be brought up by regeneration but it will never be as high as with a good secondary. Neither will the tuning ever be as sharp as if we had started with a low-resistance secondary; and, finally, the good secondary will bring into audibility some stations that cannot be heard with the poor secondary. These statements are of course beyond doubt when operating non-regenerative, but I am insisting that they are also true when operating regenerative and when operating with the tube oscillating.

About the worst form of the "compensation-of-resistance-by-regeneration" idea is the business of attempting to turn the antenna itself into a low-resistance circuit by regenerating into it. In the first place the desired result does not take place—the thing never tunes sharply—and in addition there is sent out a carrier wave that makes life miserable for a 5-mile radius around, for anyone who happens to listen on the same wavelength.

Shortening Up the Conversation

We have been talking about our two most important points—Wavelength Range and Sharp Tuning. This leaves four more points but luckily we do not have to take them up; they will take care of themselves, as we shall see.

Planning a Good Tuner

If we are to use the lessons learned above it would be a good idea to start by trying them on a very simple tuner; perhaps it will be so much improved that we do not need a more complicated one. The simplest tuner of all is the "single circuit"—but I draw the line at that. It is entirely too good a sending set when it starts oscillating, and it never can be made to tune really sharply, as I have stated above. The next most simple tuner is a two-circuit tuner in which the antenna is not tuned. This has no more adjustments than the single-circuit, but it does tune much more sharply, and it does not transmit so strongly. Then we may add regeneration by means of a tickler or a variometer in the plate. Personally I prefer a tickler as it has much less effect on the secondary tuning, also because it is far less "tricky" in handling.

What Is New About It

What is there new about a loose coupler with a tickler? Not a thing—not a thing in the world. But just the same there will be something very new and different in your radio shack if your coupler is rebuilt along the lines suggested in this paper. That something will be the results obtained. You will hear stations not heard before, you will forget interference that was terrible in the past. This is not mere talk, it has been plentifully proven by a large group of our members. The old "loose coupler with a tickler" is still with us, and doing beautifully in its new form. In broadcast reception also we can so improve the plain two-circuit regenerative tuner that it will make most of the elaborate new circuits look rather sick.

The Other Four Points

The other four requirements have now been taken care of, for we have a tuner that is (3) equipped with very few controls, (4) does not send out a strong carrier, because the antenna coupling is low, (5) is absolutely reliable in operation and (6) is about the cheapest receiver in existence.



Direct Contact With Japan

U7HG Works Japanese JUPU, over Distance Considerably Greater Than Transatlantic Work. Tacoma Gets Over With 100 Watts

A SINGLE unaided amateur has worked across the Pacific! No pre-arranged schedules were used, no special station erected, yet two-way amateur communication has been accomplished between Tacoma, Washington, U.S.A., and Tokio, Japan, a distance of 4650 miles.

Our dream of International Amateur Radio rapidly is becoming a real and living thing. When the world-wide net is complete, U7HG can be proud of having

station. The call is not listed in any of our records. Was it an American ship operator with a ham set abroad? We don't know yet, but amateur wavelengths were used and it has to rate as two-way amateur working.

This excellent work is right in line with the previous performance of 7HG, which has carried on two-way work with c1AC in Nova Scotia, u6CEU in Hawaii, and has been heard in all districts. The station is located on a high hill and gets out beauti-



Charles York at His Station, 7HG, First To Work Two-Way Across The Pacific.

added one of the most difficult threads of all by working into a country where the mere existence of stations capable of doing the job was not suspected.

Here is how it all happened. Charles York, 7HG, got on the air about midnight of November 25-26 and was engaged in handling traffic as usual. At 1 o'clock he heard a pure C.W. signal on 200 meters calling him and signing JUPU. He returned the call at once, and altho QRM was bad, managed to hook up QRK with good communication. The operator at JUPU was an American, and gave York a message to his mother in Cambridge, Illinois. He gave his QRA as Tokio, but unfortunately QRM and QRN brought an end to the contact before his exact location could be learned and whether ship or land

fully. The transmitter itself is a very compact job on a 12x16 panel, using two Telefunken D.R.P. type RS6C2 tubes in a Hartley circuit, with 1000 volts A.C. rectified and filtered to the plates. Altho the set is capable of handling higher power, the input was 100 watts and the antenna current 2.8 amperes at the time of the record. 7HG's antenna is a 6-wire flat-top 50 ft. long, supported by a 65-ft. pole at the free end and a 40-ft. one at the lead-in end; counterpoise used. The receiver is a home-made spider-web affair, condenser-tuned, and uses detector and one-stage audio for traffic work.

This accomplishment is certainly F.B. art., and 7HG has our very hearty congratulations. Well done!

—K.B.W.

The Progress of Transatlantic Amateur Communication

Many More Stations in England, France and Holland Hook Up With U.S.A. and Canada on the Shorter Wave

A MONTH ago in these pages we waxed hugely enthusiastic over the first transatlantic amateur contact, made possible by the pioneering work of DeJoy, Schnell and Reinartz. Following in their footsteps there have been developments in the past few weeks which make our first article seem amusing, accomplishments before which the original one shrinks into relative insignificance. Great Britain has followed closely on France in connecting up with us and at least four British stations have worked America; another Frenchman and a Dutchman have been in communication with our men. On this side at least nine of our fellows have hooked up across "the herring pond" at this writing (goodness only knows what it will be when these words get into print) and the short-wave Europeans have been heard by literally hundreds of Americans, some of them as far west as the Pacific.

It is hard for us yet to realize the tremendous and far-reaching consequences of this new contact. It is revolutionizing many of our technical ideas, it has caused the transfer of much amateur interest from 200 meters to the shorter waves. It is the absorbing topic of amateur conversation these days, on both sides of the ocean. The lucky ones to hook up transocean are enjoying a brand-new sensation in communicating with the amateur of another country, with their new expressions, new abbreviations, new styles. The need for an international auxiliary language looms large. Governments are taking cognizance of the new work their private citizens are doing, and radio legislation both international and domestic probably will be affected. A new kind of "fist" is coming into being—a heavy, firm style that will make each dot carry across separately—the transocean fist. Old-time amateurs who thought they had exhausted every thrill of the game are returning now, to tackle Europe. Oh! for the pen of a Wells, to picture the possibilities opened to amateur radio on both sides of the Atlantic, now that we are QSO!

Working England

Probably the most important development of the past month has been the

establishment of communication between England and America. It was the Editor's good fortune to be the first American ham to hook up with a Britisher, when f8AB connected u1MO on the morning of December 8th with g2KF, the station of Mr. J. A. Partridge at 22 Park Road, Collier's Wood, Merton, London, S.W.19. Contact was first established at 1:13 a.m. E.S.T. and lasted until 3:36 a.m., or 8:36 a.m. in London, at which time 1MO was still readable! G2KF is described in greater detail in "Amateur Radio Stations" of this issue; the station used 100 watts input, with 1.8 amperes in the antenna on a low wave; u1MO used the same equipment and wave as in the communication with f8AB, described last issue. A surprising feature of the communication was that as dawn wore on, on the other side, signals at 1MO became somewhat better. 2KF's signals were quite good up to 3:14 a.m. E.S.T., readable up to 3:21, and last heard at 3:27. It was a great night in the life of both operators.

Since that time 1MO-1XW has worked g2KF eight times, on one occasion hearing his voice on phone, and 2KF has also connected with 2AGB, 1XAQ, 1XAM, 2AWS and c3BP, working some of these stations several times. All the low-power records go to Porter of 2AWS, Freeport, N. Y., who did the job with but two "5-watters", with 0.8 amps antenna current: tie that!

The next Englishman to get QSO was g2SH, Frederick L. Hogg, of Highgate, London, probably QST's most indefatigable British correspondent. Again the Editor had the pleasure of tying up with an Englishman for his first U.S.A. communication, when 1MO and 2SH hit it off on the morning of December 12th from 12:47 a.m. to 2:53 a.m., E.S.T., four messages being handled and the old sock thoroughly chewed. Since that time c1BQ speared him with three "5-watters", and c3BP, u2AGB, and u1XW have worked him several times.

Canadian 1BQ gets the honors with g5BV, working him first on the morning of Dec. 28th and passing messages both ways. U1XW tied up with him the evening of that same date for 20 minutes, but it was pretty unsatisfactory.

More With the Continent

Another Frenchman got in the swim on the morning of Dec. 16th when f8AB connected the Editor at 1MO with f8BF, the station of Mr. Pierre Louis, 8 Rue Mouillere, Orleans, for 36 minutes of perfect working. F8BF has long been a member of the A.R.R.L. and was one of the most successful receivers in last year's Transatlantics. Since then u2AGB has also worked him.

2AGB gets the laurels for the first

has been lost—it's several dozen times, anyway, and the messages handled run in the fifties.

The Short Waves

All of this transocean work has been done on waves between 108 and 118 meters. Probably we went thru so many years of vain struggling for contact with Europe simply waiting for a Deloy and a Schnell to try it on the shorter waves. It is interesting to contemplate why it was successful then, altho all previous attempts on 200



THE FIRST BRITON TO WORK ACROSS THE POND: Mr. J. A. Partridge, at his station G2KF in London. Mr. Partridge is an A.R.R.L. member; his certificate hangs framed on the wall, and on the table is a copy of QST.

Hollander, having worked PCII on the night of Dec. 27th, taking a long message from him for A.R.R.L. headquarters. 2AGB has the record at this writing for the greatest number of Europeans worked, having communicated with f8AB, f8BF, g2SH, g2KF, g2OD (no particulars), and nPCII. All of this was done with one 50-watter with a hole in the plate, putting 1 lonely ampere in the antenna at 118 meters.

Meanwhile f8AB keeps up a merry tattoo and is by long odds the best European bet. His signals have been copied by 7LR in Eugene, Ore., and 7WT in Arlington, Washington, both on the Pacific coast, and he has worked 9ZT, 2CFB, 1CMP, c1BQ (three 5-watters), as well as 1XAQ, 1XAM, and 1MO-1BHW. 1XAQ was one of the first three stations to work him, after which there followed quite an interval before any new ones showed up, and 1XAQ's record really belongs in last month's story of the original contact. 1MO-1XW has worked f8AB so many times that count

meters had failed. Radiation at the higher frequency is somewhat better, it is true, but not enough of itself to account for the difference; QRM is less, it is true, but that can't account for it. As our Technical Editor points out in another article in this issue, the secret undoubtedly lies in the simple fact that we finally have tried a wave which is well below the fundamental of our aeriels, and the greatly increased radiation caused by that method of working has done the trick! Probably if we built special small aeriels for 100 meters we would be no better off than in past years on 200 meters. *Get below your fundamental if you want some real radiation.*

U1MO-1XW's signals are reported the loudest transatlantic signals ever heard by European amateurs, including the American high-power stations! F8AB has been read 25 ft. from a loudspeaker operating on but one audio step at many American stations. Don't these results speak for themselves?

And the receivers? 2AGB uses a super-het, and f8AB has a Grebe CR-13, but most of the other stations used our old familiar autodyne circuit and a single audio stage. When 1MO and g2KF compared notes and found out that both were using this kind of receiving equipment, g2KF said: "Wot abt supers?". "Hi", sed the op at MO, "keep the supers". Take a tip: see the article on low-loss tuners in this issue.

The reliability of the short-wave communication is its most surprising feature. While the transatlantic signals are not of the same intensity every night, and sometimes gradually change during a night, we have never observed anything that could be called fading on those short waves! Strays and QRM permitting, communication can be had any night, it seems. Dely of f8AB in fact found his signals doing so exceptionally well that he has cut his power in two to save tubes. The British amateurs seem to be working on short waves by virtue of short aerials, and not by creeping below the fundamental thru the use of series condensers, and as a result their signal strength is vastly inferior to that of the French and Dutch amateurs (at least as observed at Hartford), but in spite of that handicap, that faint little peeping note, barely readable, will maintain that same constancy for hours at a time and never swing. It's marvelous!

Some Historic Messages

As in every historic amateur communication, many formal messages of greeting have been handled across the Atlantic in



THE AERIAL AT G2KF: A simple 3-wire flat-top inverted L about 50 ft. long and 50 ft. high.

the new contact. Perhaps foremost amongst these was one to Senatore Marconi from our A.R.R.L. president, sent as 1MO's Nr. 3 to g2KF on the morning of December 11th:

MARCONI LONDON.
AMERICAN RADIO RELAY LEAGUE PRESENTS ITS RESPECTS AND THIS EVIDENCE OF DAWN OF INTERNATIONAL AMATEUR RADIO.
HIRAM PERCY MAXIM

HARTFORD 11

Mr. Marconi's gracious reply, a facsimile of which is shown as an illustration in this issue, came back by commercial radio instead of amateur, but perhaps that is useful in certifying the reality of the original amateur contact:

LONDON DEC 17
MAXIM RELAY LEAGUE
HARTFORDCONN.
PLEASE ACCEPT MY THANKS AND APPRECIATION WHICH I OFFER YOU AND ALL CONCERNED FOR YOUR CORDIAL MESSAGE TRANSMITTED AND RECEIVED BY AMATEUR STATIONS.

MARCONI.

A message was sent to Admiral Sir Henry Jackson, past president of the Radio

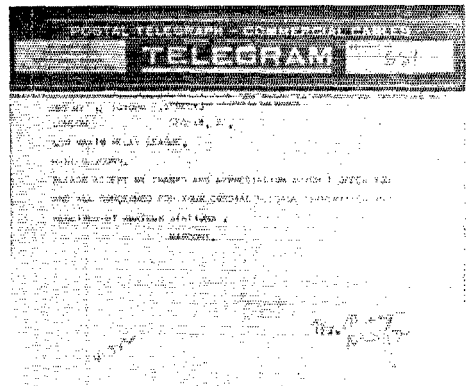

A MILESTONE IN AMATEUR PROGRESS

Society of Great Britain (forgetting for the moment that Dr. Eccles is now the president of the society), as follows:

SIR HENRY JACKSON LN.
A.R.R.L. HAS GREAT PLEASURE IN SENDING R.S.G.B. GREETINGS BY DIRECT AMATEUR CONTACT ACROSS ATLANTIC EXPECT VISIT YOU IN LONDON FEBRUARY.
HIRAM PERCY MAXIM.

G2GF's Nr. 5 on the night of Dec. 15th contained the reply:

THE PRESIDENT AND PAST PRESIDENT OF R.S.G.B. HAVE RECEIVED YOUR GREETINGS AND JOIN WITH YOU IN TENDERING FELICITATIONS TO THE AMATEURS OF AMERICA AND OF BRITAIN NOW UNITED BY THIS TRIUMPH.

ECCLES PRESIDENT R.S.G.B.

QST exchanged greetings with its British contemporary, *Wireless World & Radio Review*, and A.R.R.L. officers shook hands across the pond with the gentlemen in charge of arrangements for this year's tests, Mr. P. R. Coursey in England and Dr. Pierre Corret in France.

Scoping the Tests

The Traffic Manager has said that at the conclusion of the annual tests this year we can all try for first transatlantic communication. Hi!—the short waves have

scooped the tests. But at that we suspect there will be some brilliant additions to the record when the lid goes off of 200-meter work on January 10th.

Meanwhile the Tests have been highly successful, and the following European amateurs have been heard in this country up to January 2d:

British: 2FN, 2FQ, 2IN, 2KF, 2KL, 2KO, 2LO (broadcasting station using code), 2NM, 2KW, 2OD, 2SH, 2SZ, 5AT, 5BV, 5LC, 5PU, 6NI, 6XX, 6YA.

French: 8AB, 8AE, 8AZ, 8ARA, 8BE, 8BF, 8BM, 8CD, 8CS, 8CT, 8LY.

Dutch: PA9, ODV, PCII, PAR14.

Which means, by the way, that Burnham, g2FQ, owes us a clock. Thanks, gang.

It's gettings to be a common thing now to overhear a pair of foreign hams chewing in their native tongue. What do you say, fellow amateurs, about all of us taking up Esperanto or Ido?

—K.B.W.

An Amazing World's Record

Australian Station Sets New Standards for Amateurs

By F. Basil Cooke, F.R.A.S.*

In the early morning of September 25th the following message went from New Zealand 4AA to Australian 2CM:
 "OK Sigs QSA strong and steady throughout. Another world's record gone west! Congratulations O.M. GM—Bell."
 BELL'S STATION, 4AA, IS 1500 MILES FROM 2CM AND HAD JUST COPIED A TEST SENT BY 2CM WITH AN INPUT POWER OF .004 WATTS!!!
 There is no doubt about this—it absolutely happened.
 —Editor

THE experimenters in Australia, especially in the cities, are only allowed 10 watts of power, consequently great attention has been given to reaching long distances with a minimum of power. Mr. C. D.

cently conducted some experiments with Melbourne (500 miles) and New Zealand (1500 miles) using a power of only a few thousandths of one watt. The writer feels that the details of these experiments will be of great use and interest to the experimenter.

How the Tests Were Run

Mr. Maclurcan started up on Monday, September 24th, at 5 P.M., while there was still an hour of daylight, and called 3JU (Mr. Hull of Melbourne at 500 miles). Arrangements had previously been made for conducting low power tests, a code letter to be used for each reduction in power. The code letters were known only to Mr. Maclurcan and it might be mentioned that Mr. Hull was not aware of the power being used. After establishing connection Mr. Maclurcan commenced reducing power and sent the following test on 240 meters.

PLATE INPUT VOLTS	PLATE CURRENT M.A.	PLATE WATTS	CODE LETTER
390	20	7.8	F Received
270	16	4.32	K Received
220	10	2.2	R Missed
122	4	.48	V Received
80	3	.24	L Received
52	1.5	.078	X Received

At this test Mr. Maclurcan took the readings himself and had no witnesses. Consequently at the next test on Tuesday,



CHARLES D. MACLURCAN, Australian 2CM, President Australian Radio Relay League, who made the transmission records.

Maclurcan (2CM), of Sydney, is so far the leader in this work. He has just re-

*—Vice President, Australian Radio Relay League; Secy., Wireless Section, Pan-Pacific Congress, 1923; Director of Radio for David Jones, Ltd.

September 25th, Mr. J. S. Barling was present throughout and certifies to every meter reading.

The readings of this test are of interest:

PLATE VOLTS	CURRENT POWER		CODE LETTER
	IN M.A.	IN WATTS	
330	18	6.8	F Received
192	5	.96	K Received
120	3	.36	R Received
60	2	.12	U Received
44	1	.044	L QRM VIM

VIM (2 k.w. spark) is only about two miles from 3JU while 2CM was 500 miles away, as stated before.

1500 Mile Tests

On the following Wednesday Mr. Mac-

As it was past midnight in New Zealand and nearly that in Sydney, only one further test was agreed to. Mr. Maclurcan this time determined to satisfy even Mr. Bell, so he reduced his plate voltage to 15, thereby securing a plate current of .25 milamp. *The input was only .004 watts.* After repeating the message back, 4AA concluded:—

"OK QSA sigs strong and steady throughout. Another world's record gone west. Congratulations OM GM.

Bell"

Checking Up

The following day Mr. Joseph, an expert in this work, certified Mr. Maclurcan's instruments as correct within one percent.

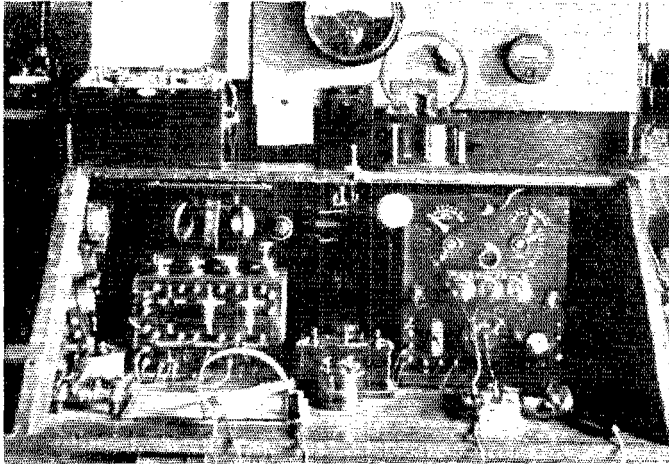

The Set That Did It. Receiver at left, Transmitter at right.

lurcan called Mr. Frank Bell (4AA) of Waihemo, Shag Valley, New Zealand (1500 miles away over land and water), who replied and asked 2CM to conduct a low power test with him then and there. *After chatting for half an hour (with an input of about 8 watts!!!—Ed.)* the test commenced at 9:30 P.M. Conditions for receiving in New Zealand were good. (By American standards they were more nearly miraculous!!—Ed.)

The first test went out at 175 volts with a plate current of 4 milamps., making a power input of 0.7 watt. 4AA replied "QSA QRP give plate current and voltage."

The power was then reduced to 0.04 watts to the plate. (40 volts and 1 milamp.) Again 4AA thot unnecessarily great power was being used.

The next test was at 20 volts, absorbing .5 milamp. This also did not seem to satisfy 4AA who *not only received the code letter but received and repeated whole sentences.*

On the 4th, 2CM received this telegram:

"Heard your lowest power last night, writing. Odjers. Charters Towers, Queensland."

The confirming letter *repeated the whole proceedings, altho Charters Towers is 1400 miles north of Sydney, whilst 4AA is about 1500 miles to the east.*

Station 2CM

Mr. Maclurcan stated that he considered his success was entirely due to an absolute regard for detail. He has an ideal site for his station and has very carefully designed his aerial and all component parts, there are no loose wires or poor contacts in his station, and every part of his gear has been *thoroly measured and tested.*

The antenna consists of a 6-wire cage, T type, with a top 100 feet long and 80 feet high, spaced on 6 hoops 4 feet in diameter. The downlead tapers from 12 inches to 4 inches. The counterpoise is fanned out in a circle of 100 feet in diameter, 7 feet above ground. (*A la 9ZT et*

8AQO—Ed.) The natural wavelength of the antenna system is 185 meters and the resistance at 240 meters is 8.7 ohms. The capacity is .0083 microfarads.

The power input to the set was regulated by the filament rheostat of the Kenotron rectifier valves. The instruments used to measure the input to the sending set were a Weston volt-ammeter Model 280, and a Paul Unipivot Galvanometer with a thermo-couple, the combination having been certified correct within one percent by Mr. Joseph.

Some special tests were run to see with just how low an input the tubes would oscillate. The president of the Kurringai Radio Club, Mr. W. E. Wilson, manipulated the oscillating wavemeter, which was used

aerial connected. The transmitter oscillated strongly but the antenna ammeter was not sensitive enough to show any current. However, the signals were actually getting out as several amateurs 10 and 12 miles away

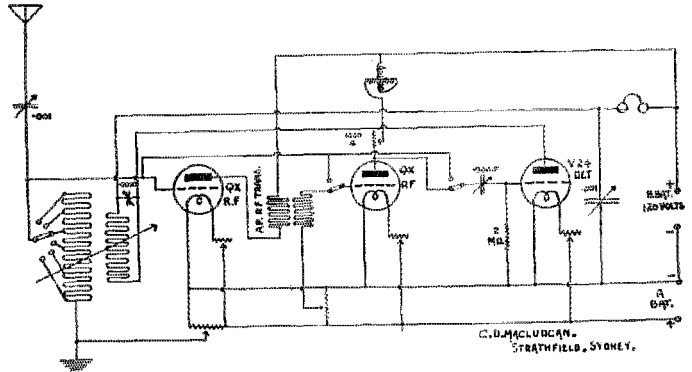

The Circuit That Brings in American Calls. Wiring diagram of the short-wave receiver at 2CM.

heard everything and reported good signals.

Low Power Oscillation Test at 2CM

Plate volts	Plate current	Plate power-watts
3.5	4.2 milamps	.01470
1.1	1.8 "	.00200
.4	.8 "	.00032

Finally a well-used dry cell was used instead of the usual source of plate power and with this Mr. Maclurcan was able to talk to a friend several miles away.

As a result of these many experiments, conducted by Mr. Maclurcan, it occurred to him that this low power transmission could, and should, be turned to some account for the public generally.

(The outcome of this planning is a test of such great interest to all A.R.R.L. that

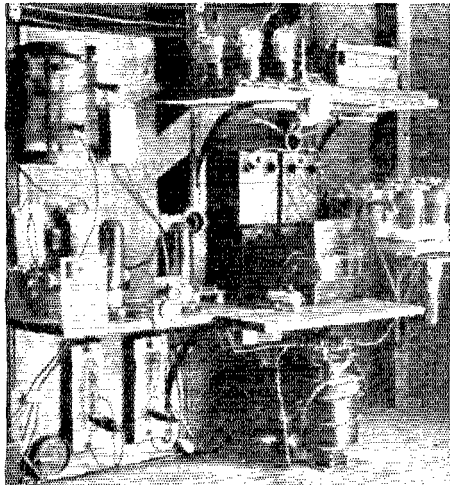

THE SET WITH WHICH 2CM IS TRYING FOR AMERICA.

Two 50-watt Radiotrons are used, the plate supply being from the chemical rectifier at the right or else from kenotrons, one of which is shown just under the chemical rectifier.

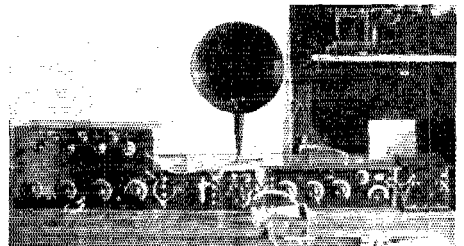

Short-Wave Receiving Set at 2CM. See diagram.

to determine when the set was oscillating. Other members of the same club took the meter readings. It was found possible to make the set oscillate with powers lower than those used in the transmission tests; the following readings were taken with the

we have set this part of the story aside as a special article, which will be found in another portion of this magazine.—Editor.)

Get Ready for "IL" Work With Foreign Amateurs

By Oscar C. Roos*

Now that transocean amateur communication is with us, what are we going to do when we can't talk the other fellow's language and when he doesn't know ours? There is a way out of the difficulty, if amateur radio the world over will adopt an auxiliary international language which everybody can use in addition to their native language. There are two such projects, each well recognized and with its host of followers. For over a year A.R.R.L. Headquarters has been studying the problem with a view to eventually adopting some project for official A.R.R.L. use. In this article Mr. Roos shows how easily these synthetic languages may be learned. Some day we hope to teach one of them thru a regular department in QST. We will be glad to have expressions on the general subject from our readers.—Editor.

WHAT is going to happen to DX work during the next eighteen months? The amateurs of Europe are organizing everywhere.

They have their amateur periodicals and they are working overtime to perfect mutually beneficial arrangements.

If anyone had said a year ago that amateurs would be talking at 3000 k.c. across the ocean for hours, the prophecy would have been ignored or scoffed at. Now it is here as an accomplished fact, and amateurs, broadcast listeners and studio directors will have to figure out quickly a new attitude towards foreign fans.

The American amateur may ask what concern this is of his. He may think, "Suppose Europe does DX us, what of it? Can't we go ahead and wait for their dope to be translated? Don't they understand our ham abbreviations?" This is the amateur's natural attitude of dislike for new policies. European amateurs are very much interested in our performances, and, besides, we want to talk with them. The barrier of a foreign language is a formidable one. It takes five days to cross the United States by rail, and in the journey we encounter but one tongue; Europe can be crossed in two days, yet there are dozens of languages. One can't spend the time to learn them all.

As a result, numerous international-language radio societies are being formed in Europe, where the fans are convinced that some new and very simple language must be used for international DX work, letters, postals, and for radio press service. This is not at all a movement for a universal language to replace national languages; its object is to perfect an auxiliary international language. The I.L. being used by these European amateur societies is called "Ido" by some, but its original name was "Ilo" (from "International Language," with an "o" added to show it is a singular noun).

In eighteen months amateurs will need an auxiliary language. (Sooner than that;

—Ed.) They do not need to learn French, German, Dutch, etc. All of them will recognize roots from his own language in the I.L., which is based on 11,000 roots found in four to eight modern languages. A Frenchman naturally finds most, as French is the "most international" language we have today. But whereas the French verb is a terror, you can learn to write postal cards in ten lessons using I.L. Next to the Frenchman comes the Italian with 83% of the roots readable at sight: Spaniard and Englishman and American, 79%; Scandinavian, 75%; German 65%, Russian 52%. All in all, the I.L. contains 76% of words found in from four to six modern languages. Its predecessors had root vocabularies half of whose words, like "puk" for "speech" or "chiam" for "always", were purely arbitrary. In the I.L., "speech" is "parolado", "always" is "omnatempe". Which do you think is the more natural?

The grammar of the I.L. is absurdly simple—one rule for applying fourteen grammatical terminations! Here's a sample:

Me havas.....I have
 Me havis.....I had
 Me havos.....I will have
 Me vidas il.....I see him
 Il vidis me.....He saw me
 El vidis me.....She will see me
 Me videsas.....I am seen
 Il vidus ol.....He would see it

I. L. grammars can be had from 20¢ to \$1.50 by applying to the writer at Beacon Chambers, Boston, Mass. For the best translation of the following specimen of the I.L. a prize of a complete grammar will be given by the writer. You can get an elementary grammar and 1600-word vocabulary to assist you for 20¢ in stamps.

SPECIMEN-O

La progres-i di la scienc-o e di l' industri-o dum la dek-non-esm-a yar-cent-o mult-ig-is grand-eg-e la relat-i inter omn-a civiliz-it-a popul-i : la fer-voy-i e la vapor-nav-i

*Fellow I.R.E., Consulting Engineer.

proxim-ig-is li reciprok-e, la telegraf-il-o, la telefon-il-o supres-is la dist-o inter li. Mem ti, qui ne ek-ir-is e nul-temp-e ek-ir-os sua patri-o, pov-as su vid-ar subit-e koram stranjer-i ven-int-a per motor-vetur-o o per direkt-eb-l-a aer-navo. Or nul-u pov-as sav-ar omn-a stranjer-a lingu-i, e mem tre pok-i en omn-a nacion-o pov-as sav-ar un o du lingu-i di vica-a land-i. Es-as do neces-a, ke la mond-o hav-ez un lingu-o help-ant-a komun-a por la relat-i inter-nacion-a omna spec-a. Or ca lingu-o dev-as es-ar lern-eb-l-a e kompren-eb-l-a senpen-e da la maxim grand-a nombr-o de

person-i; konsequ-e la *maxim bon-a lingu-o inter-nacion-a es-as ta, qua prizent-as la maxim grand-a facil-es-o por la maxim mult-a homi*: e ca defin-o sufic-as por determin-ar komplet-e la solv-o di la problem-o ⁽¹⁾.

Think this situation over. The need of a special means of international communication between radiomen for business and progress is upon you. It has come like a flash from the blue sky. What are you going to do about it?

⁽¹⁾ Hyphens are only used for beginners to separate the elements of each word.

Amateur Wavemeters

By S. Kruse, Technical Editor

SINCE WWV has begun to send standard-frequency signals there has been an increasing demand for a review of the subject of amateur wavemeters. This review is made here, much of the material being drawn from the Bureau of Standards paper "Portable Wavemeters for Short Wave Radio", which originally appeared in *QST* for September 1922. Those wishing to go over the complete article may obtain this number from the Circulation Dept.

Factory-Made Wavemeters

Among the factory-made wavemeters none is more useful than the General Radio type 247W wavemeter and filter, Fig. 1. This well-built little instrument is not only useful as a wavemeter with a range of 150-500 meters but can also be used as a

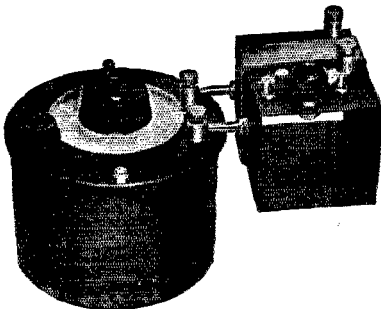

Fig. 1 A Compact Wavemeter and Trap Combined.

wave-trap and as a calibrated condenser for measurement work. When measuring the wavelength of received signals the device can be connected in the usual wave-trap fashion, the switch put on the second point and vernier knob turned until the signal in question is trapped out. Then

read the scale. Sometimes this can be done with the switch on point 1 instead. There is a prospect that this meter will be modified so as to spread the amateur band over the entire scale, making more accurate readings possible.

At the Second National A.R.R.L. Convention Mr. John H. Miller of the Jewell Electrical Instrument Co. displayed a very nice amateur wavemeter having a scale with *one division per meter*. We hope to hear soon that this wavemeter has been put on the market.

Home-Made Wavemeters

A wavemeter consists of a variable condenser and a *fixed* inductance plus an indicating device of some sort. The condenser and the coil provide the tuned circuit while the indicator shows when the tuned circuit has been adjusted to resonance. To make this tuned circuit a good one it is necessary to use a good condenser and a good coil—the indicator does not matter so much.

The Variable Condenser

The first requirement for a wavemeter condenser is that it be very solidly built; the best condenser for the purpose is one of the type that you "can't hurt with an axe". One can even put up with some electrical losses for the sake of getting such a condenser. The plates should be heavy, with plenty of spacing, should be very securely connected together and to their supports, and the bearings should be as substantial as possible. Flimsy plates, spring-supported bearings, or shafts simply run thru the insulating end plates are *not* satisfactory—the wavemeter will change calibration and get you into trouble. Shielding the condenser is not necessary but is desirable. The metal can (or other shield) should be connected to the moving plates,

leaving the fixed ones insulated. Cone bearings are good and a geared vernier is very desirable, tho a long extension handle is almost as good and sometimes better.

Too large a condenser should not be used; one with a capacity of 500 micro-microfarads (.0005 microfarads) is amply large. Such a condenser is not nearly as likely to get off wavelength as is a large one.

The Coil

The requirements of a wavemeter coil are: first, that its inductance be such that, with the condenser used, it can cover the wavelengths desired; second, that the resistance and capacity be low; and, third, that the resistance, capacity and effective inductance all be constant. Let us start with the first requirement which has to do with the range of wavelengths. It is well to restrict the part of the condenser scale used to the parts shown in Figure 2. Since the capacity at 170° (or 95/100) will almost always be more than four times the capacity at 15° (or 8/100) this will mean that the highest wavelength reached by the wavemeter will be at least twice the lowest wavelength. This makes it possible for a single coil to cover the range from 175-375 meters and another coil to cover the range from 150 down to 75 meters, etc.

The following coils will do the required work. It will be noticed that the size of the wire and the spacing between turns are not specified. This is not an oversight; the inductance of the coil is nearly independent of the size of wire used as long as

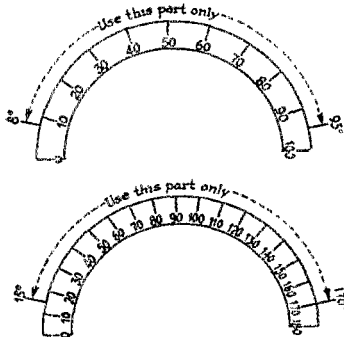

Fig. 2

the proper number of turns is used and spaced as directed. It is absolutely necessary to make the winding one inch long as directed. This can be done with the size of wire given or with smaller wire.

Wavemeter Coils

Diameter of coil: 4 inches. Length of

winding, one inch. Wire must be so spaced that winding is exactly one inch long. Condenser is to be one with capacity of 500 micro-microfarads (.0005 microfarads).

Wavelength Range	Number of turns in coil. (Winding to be one inch long)	
	16	Largest Size of D.C.C. wire that will wind in 1 inch
90 to 175 meters	16	16 A.W.G. (B&S)
175 to 375 meters	23	20 A.W.G. (B&S)
375 to 750 meters	33	23 A.W.G. (B&S)

The wavelength of the coils should overlap somewhat. If they do not, reduce the

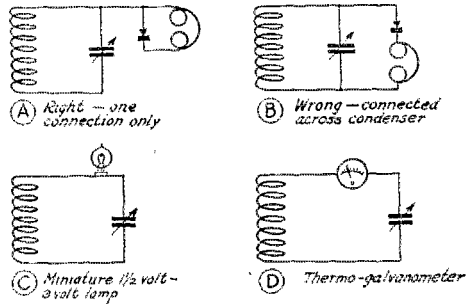

FIG. 3 WAVEMETER CIRCUITS

number of turns on the two larger coils until the desired overlap is secured.

The Coil Form

The second requirement was that the resistance and effective capacity must be low. No one will attempt to defend high resistance. The reason for requiring low effective (distributed) capacity is that it acts as a fixed condenser across the variable one and prevents one from covering the desired wavelength range. The best core for the coil of an amateur wavemeter is a hollow spool of dry wood, lightly varnished. Wood is chosen in preference to Bakelite, glass and pasteboard. Bakelite and similar compositions increase the resistance of the coil. Glass is mechanically poor; as is pasteboard.

Putting on the Windings

The wire should be of the size stated above or smaller, but not less than No. 24 A.W.G. (B.&S.). Double cotton covered wire is good. After winding, it should be fastened down with a light coat of shellac, Sterling varnish or the like, preferably baked on. Do not try fancy windings or litzendraht; almost invariably the coil resistance will be higher.

The Indicator

The third part of the wavemeter is the device that indicates resonance. The simplest device is the crystal detector and phones which should be connected as shown in Fig. 3a. This makes the calibration of the

wavemeter independent of the position of the phone cord, at least so long as they are not dragged across some part of the wavemeter.

For C.W. work the crystal detector is not very satisfactory and a small (so-

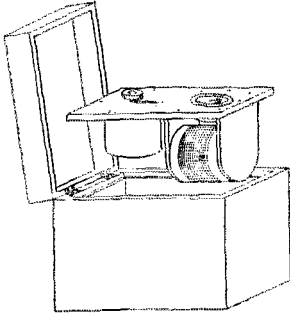

Fig. 4. A Good Form of Mounting.

called "minature" or "flashlight") tungsten-filament lamp may be used connected directly into the tuned circuit as shown in Fig. 3c. To avoid any possibility of chang-

ing the calibration of the wavemeter the lamp should not be changed unless another of the same sort can be put in.

The best indicator is the so-called "thermo-galvanometer", such as the Weston. In addition to being more reliable than the hot-wire type it will stand more overload. See Fig. 3d.

Sometimes the instrument or other indicator is connected to a small coil (two or three turns) coupled to the main coil.

Assembling the Wavemeter

A very good mounting for the wavemeter is shown in Fig. 4. In any case it is convenient to have the coil horizontal and near one end of the box so that it can be coupled to easily. The leads by all means should be heavy, short, and rigid. The coil should be placed so that it is *several inches away from the condenser*.

Calibrating the Wavemeter

The calibration and use of the finished wavemeter will be taken up next month. In the meantime, *don't put any faith in ready-made charts or curves printed in magazines*; they are no good when tried on another home-made wavemeter of the same sort.

Information on Receiving Tubes for A.R.R.L. Questioners

By J. C. Warner*

In Two Parts: Part II

Connections of Tube and Attached Circuits

In many of the tube circuits which are being published from time to time the details of such connections as the plate and grid returns, the position of the filament rheostat, etc. have been completely ignored. It is no wonder then that considerable doubt should exist in the minds of tube users as to the correct connections and why they are best. This is shown by the fact that more questions were asked about these connections than any other subject.

The general rules for connection of the grid and plate returns and the location of the filament rheostat are given in the accompanying table, page 27. While these rules apply to most tubes and circuits, there will occasionally be found exceptions which require different conditions. These usually must be determined by trial.

Figure 8 illustrates the connections for the UV-200; Figure 9 the connections for the high vacuum tubes as detectors; and Figure 10 for the high vacuum tubes as audio amplifiers.

*Research Laboratory, General Electric Co.

For radio frequency amplifier tubes the connection of the grid return depends to some extent upon the type of amplifier; that is, whether a so-called stabilizer is used to prevent oscillations or whether some other means is provided. If the stabilizer is used the grid return of one or more of the radio frequency tubes must be connected to the moving contact of the stabilizing potentiometer as in Figure 11. In this way a positive bias is given, the purpose of which is exactly opposite to that given previously. That is, the positive bias increased the grid losses and so prevents oscillations, also reducing the amplification incidentally, while the negative bias as already explained increases amplification by reducing the grid circuit losses. If some other means than a stabilizer is used to prevent oscillations the grid returns should be to the negative side of the "A" battery as shown in Figure 12 and even when using a stabilizer it is best to return only the first grid to the stabilizer and the others to the negative battery terminal if the oscillations can be stopped. In this way the amplification of the first tube is reduced

somewhat, but the others work at full efficiency.

If it ever becomes necessary or desirable to use more than 60 volts on a radio frequency tube a grid biasing battery becomes very necessary in order to prevent

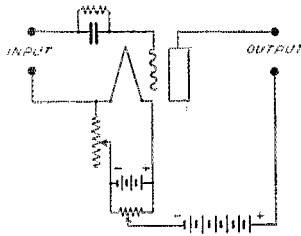

CONNECTIONS FOR UV 200 DETECTOR TUBE

FIG. 8

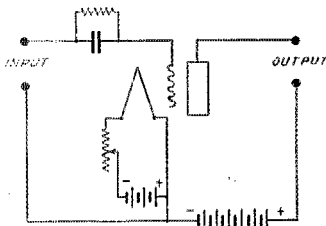

CONNECTIONS FOR HIGH VACUUM DETECTOR TUBE

FIG. 9

excessive plate current. Usually the higher plate voltages should be employed only when some other means than stabilizer control is provided for stopping oscillations; otherwise the tube may be overloaded by the high plate current. Occasional departure from these rules given for radio frequency tubes must be allowed due to individual peculiarities of the circuit. For example, there may be times when it is convenient to connect the grid return of one tube to the positive filament terminal in order to prevent oscillations without the use of a stabilizer. This method, however, cannot be recommended for general use, although the rectifying action which may result does not cause noticeable distortion since the rectified components are not transmitted on to succeeding tubes.

The connection of the grid return on a detector tube depends first upon the type of tube. Gas tubes work best with the grid return connected to the negative side of the filament whether grid leak and condenser are used or not.

For the high vacuum detector the general rule is to connect the grid return to the positive side of the filament when grid leak

and condenser are used. If no grid condenser and leak are used, that is, if the detection is made in the plate circuit by virtue of the curvature of the plate characteristic, the grid return should be to the negative side of the filament. The former method is the one commonly used and since it is by far the most effective of the two it will be considered in detail.

The reason for the connection to the positive side of the filament involves a brief explanation of the process of detection which goes on in a tube when a grid leak and condenser are used. The action is best explained by separating the process into two distinct parts—rectification in the grid circuit and amplification in the plate circuit. That is, the tube performs two functions: the grid circuit rectifies the wave and causes a change in the average potential of the grid and this potential then changes the plate current just as in any ordinary audio frequency amplifier. The grid and plate circuits should then be arranged according to their separate functions which are easily understood by reference to Figure 13.

Diagram A shows the grid circuit which, in this case, is the rectifier designed to supply the highest possible voltage to the amplifier circuit. For this condition the grid leak resistance R should be high compared to the input resistance of the tube, that is, two megohms or above. When a radio frequency voltage is applied to the input, the rectifying action of the grid circuit of the tube causes a voltage to be built up across the resistance R, the action being much the same as in an ordinary two-element rectifier tube. If the incoming wave is modulated this voltage is alternating according to the modulation frequency. If the incoming wave is not modulated, the voltage across R builds up to a fixed value and remains constant as long as the signal

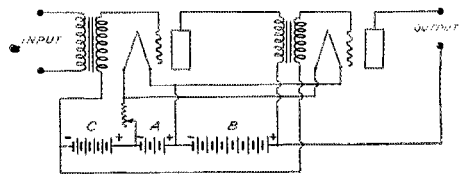

CONNECTIONS FOR TWO AUDIO FREQUENCY AMPLIFIER TUBES SHOWING COMMON BATTERIES

FIG. 10

lasts. The condenser C bypasses the radio frequency current around the high resistance leak. When the voltage across R rises, this condenser becomes charged and after the wave has passed this charge must leak off through R, restoring the grid potential to its original value. For this reason, the values of C and R must be so chosen that this charge can leak off between suc-

cessive wave trains; otherwise distortion will occur. The rate of discharge depends on the product of RC so that for small values of C, R can be made large, and vice versa. However, since a rectifier gives maximum output voltage when the load resistance is high, it is usually customary to make C as small as is consistent with low reactance over the operating range of

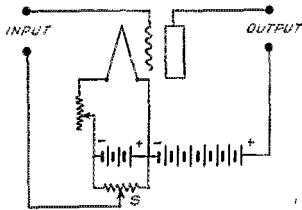

CONNECTIONS FOR R.F. AMPLIFIER
WITH STABILIZER
FIG. 11

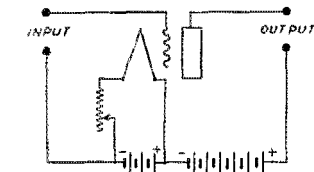

CONNECTIONS FOR R.F. AMPLIFIER
WHEN NO STABILIZER IS USED
FIG. 12

radio frequencies and then to make R as high as possible without causing distortion. If strong signals are to be received or if static is strong, the value of R cannot be increased too far or the charges will not leak off between wave trains, but for weak signals the leak resistance can be made much higher. The customary value of capacity is .00025 μ f. and of resistance 2 to 5 megohms for strong signals and up to 10 megohms or more for weak signals. This assumes spark or telephone reception. For unmodulated C.W. reception with oscillating detector the grid leak resistance should not be over about 2 megohms, otherwise when oscillations start there will be an objectionable click in the phones.

The detector action in a soft tube is similar to that described above except that no grid leak is required to carry off the negative charge on the grid, since the gas ions form a conducting path inside the tube, and that irregularities in the grid and plate characteristics probably influence the rectifying action to a large extent.

The mean potential of the grid is determined by the D.C. voltage drop in the grid leak and the point at which the grid return is connected. Taking the negative

end of the filament as the reference point the average grid potential, if the grid return is to the positive side of the filament, is equal to the filament voltage minus the drop in the leak, which usually brings the potential down to less than one volt. If the grid return were connected to the negative side of the filament the average voltage of the grid would be negative because even under those conditions a very small grid current flows, which, however, is not sufficient to produce good rectifying action except on very weak signals. This is the reason for the recommendation that the grid return of a high vacuum detector be connected to the positive end of the filament. In some cases slightly better results may be obtained by connecting the return to a point between the positive and negative ends. This can be accomplished by using a potentiometer as shown in Figure 14. The gain in intensity is seldom worth the additional expense and the extra adjustment however.

Most circuits show the grid leak connected across the grid condenser but if the grid leak resistance is high compared to the input resistance of the tube, which should be the case as already stated, it makes little difference if the leak is connected directly to the filament. In some circuits this is absolutely necessary since there is no other D.C. circuit back to the filament. An example of this may be seen in Figure 15 where the detector tube is supplied from a tuned radio frequency amplifier. Here the grid leak cannot be connected across the grid condenser since this would place one end of the leak at the potential of the preceding plate. Hence the leak must be connected directly to the filament.

Rheostats

It will be noticed that Figure 7 indicates that the filament rheostat should be in the negative lead regardless of the type of tube or its use. In some cases, with the UV-200, for example, the position of this rheostat is of no importance, but since it is very important in other cases, such as with the audio amplifier tube, it is recommended that for convenience in wiring and for the sake of uniformity that the rheostat always be placed in the negative lead.

Very often tube sockets have their terminals marked F+ and F-. This is for convenience in tracing the wiring and does not mean that the polarity marked has anything to do with the action of the tube so far as the filament itself is concerned. Either end of the filament may be made positive without affecting the operation of the tube.

Detector Sensitivity

With regard to the sensitivity of detectors, reference has often been made to a so-called "threshold value" of signal voltage

below which the tube fails to respond. There is no theoretical or experimental basis for this idea, which has probably grown up from the fact that high vacuum detectors are more sensitive on strong signals than on weak. A gas content tube on

often had to be given precarious heat treatments to restore their sensitive condition after a period of use. Because of this lack of uniformity and difficulty of operation, it is very doubtful whether the modern amateur would be satisfied with these tubes if

Tube	Grid Return			Plate Return	Rheostat
	Det.	R.F.	A.F.		
UV-200, C-300	Negative Filament Terminal			To Potentiometer Across Filament Battery	In negative Filament lead
UV-199, C-299, UV-201-A, C-301-A, WD-11, 12, C-11, 12	Positive of Filament Battery (when grid leak and condenser are used)	Negative of Filament Battery or to Stabilizer	Negative of Filament Battery	To Positive of Filament Battery	In negative Filament lead

the other hand is often as sensitive or more so on weak signals than on strong.

Much has been said and written recently concerning the great sensitivity of the old soft tubes of pre-war manufacture. It is quite true that some of these tubes were

they were available in quantities today.

The Choice of a Tube for a Particular Service

No general rules can be laid down for the choice of a receiving tube for a particular set or circuit, since much depends upon the other available equipment. However, each of the tubes has certain features which make it the most suitable under certain circumstances.

If dry cells are to be used to supply filament power the UV-199, WD-11 or WD-12 are usually the most suitable, although for single tube and even two tube sets the UV-201-A can be used with good economy. In the latter case four dry cells in series should be used with each tube.

The filament power consumption of the UV-199 is lower than in any other tube and for this reason the UV-199 is especially suitable for portable single tube sets since the filament may be operated from a single set of three flashlight cells.

The WD-11 or WD-12 is more conveniently used in stationary single tube sets since one standard dry cell may be used making the initial battery expense comparatively small.

If a storage battery is available, the UV-201-A is the best tube for use as an amplifier and the UV-200 as a detector, although provision for plate voltage adjustment must be made for the detector. If this is inconvenient the UV-201-A may be used both as amplifier and detector with excellent satisfaction.

For operating loud speakers the UV-201-A is the most suitable because of its great electron emission and high mutual conductance although if careful attention is paid to proper plate voltage and grid bias the UV-199 and WD-11 or WD-12 will operate a loud speaker very successfully.

In radio frequency amplification circuits the UV-199 gives less trouble from internal capacity effects than any other tube, but when such effect can be neutralized in some

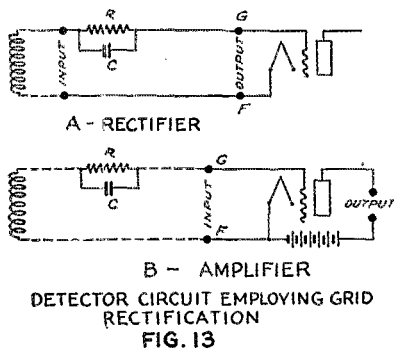

DETECTOR CIRCUIT EMPLOYING GRID RECTIFICATION
FIG. 13

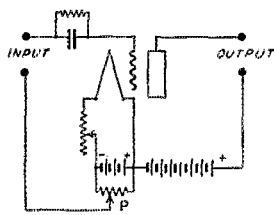

CONNECTIONS FOR HIGH VACUUM DETECTOR TUBE SHOWING POTENTIOMETER FOR VARYING THE LOCATION OF THE GRID RETURN
FIG. 14

exceptionally sensitive detectors. But it is just as true that in order to find one of these super-sensitive tubes it was necessary to pick over and reject a number of tubes which were worthless. Also, these sensitive tubes were extremely critical and required very careful adjustment of plate voltage and filament temperature and they

way externally the other tubes become excellent for this purpose.

The number and arrangement of cells to be used with multi-tube sets must be determined for each individual case. Battery manufacturers recommend that the drain per cell should never exceed .25 ampere and that about .125 ampere per cell gives the

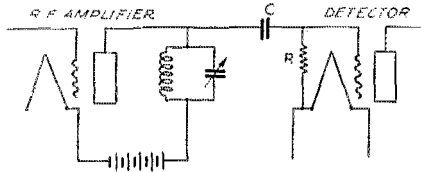

RADIO FREQUENCY AMPLIFIER AND DETECTOR SHOWING CONNECTIONS OF GRID CONDENSER AND GRID LEAK.

FIG. 15

greatest battery efficiency, also that sufficient cells should be used to allow the voltage per cell to fall to 1.0 volt before the battery is discarded. With these facts in mind, the number of cells to be used with a given set can easily be determined and with the aid of Fig. 16 which gives the average service life of a six-inch "general purpose" dry cell at various loads, the life of the complete battery may be found.

Miscellaneous Answers

Several questions were asked which do not fall into the groups already discussed, but which relate either directly or indirectly to receiving tubes. The answers to these questions will be taken up in the succeeding paragraphs which are necessarily somewhat disconnected.

The effect of a magnetic field on a high vacuum tube is to lengthen the path of the

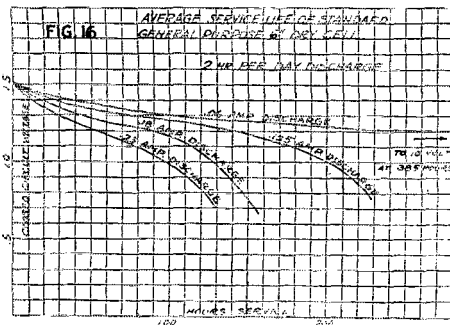

electrons as they pass from filament to plate. This has no beneficial effect on the action of the ordinary tube so that the use of such a field is of no advantage. The field strength of a small permanent magnet is too slight to produce any noticeable effect whatever. In a gas tube the lengthening of

the electron path may increase the ionization of gas atoms and so produce a change in the characteristics of the tube. This explains the changes in sensitivity of such a tube when a magnet is brought close to the bulb.

The change in the light given off by an X-L filament when the plate voltage is applied is due to an actual change in the temperature of the filament which is caused by two independent effects. If the two ends of the filament are observed closely when the filament is lighted with the plate voltage off, it will be seen that at each end of the filament there is a region which is not glowing. This is due to heat being conducted away from the ends of the filament by the heavy leads. Now if the plate voltage is applied, particularly if it is 80 or 100 volts, it will be seen that at one end of the filament this dark section increases in length while at the other end it decreases. That is, one end of the filament has become hotter, while the other end has cooled. This is explained by reference to Figure 17. The double arrows on the inside of the filament show the direction of the normal heating current while the other arrows show the plate current. The plate current divides in the two ends of the filament according to the resistance of the two sides of the parallel circuit. Therefore, in one-half of the filament the plate current adds to the heating current and in the other half subtracts from it thus causing the difference in temperature of the two ends.

Another independent effect tends to lower

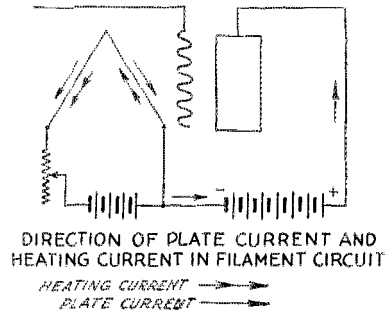

FIG. 17

the temperature of the whole filament so that the resultant effect is usually an apparent dimming when the plate voltage is applied. The electrons which leave the filament carry with them a certain amount of energy and since this must be supplied by the heating current there is less energy left for heating the filament and the temperature falls slightly. This effect is similar to the cooling of a liquid when evaporation is going on from its surface.

If the plate voltage were made negative,

the voltage required to cause a current to flow, neglecting leakage currents, would simply be the breakdown potential of the tube parts, such as stem and base. Lighting of the filament would have no effect except in so far as the tube insulation might become warm and accordingly break down at a somewhat lower potential.

The last question to be answered is one which no doubt has often arisen in the minds of radio experimenters; that is, the possibility of using radium as a source of electrons for a vacuum tube. A gram of radium gives off approximately 10^{10} elec-

trons per second. This seems like a large quantity until it is remembered that about 6.6×10^{10} electrons per second are necessary to give one milliampere of current which would mean that 660,000 grams (about 1500 pounds) of radium would be required to furnish this current. In other words, not all the available radium in the world could directly supply the electron emission for one vacuum tube.

Part I of this article appeared in the January, 1924, QST, which can be obtained from the QST Circulation Department at the regular price.

Coolidge's Holiday Greetings to MacMillan Travel Via Amateur Radio

ON December 22d President Calvin Coolidge filed a message of holiday greetings to the MacMillan Arctic Expedition with the Radio Corporation of America in Washington.

That morning the traffic department of the Radiocorp in New York City called A.R.R.L. Headquarters on the long-distance telephone and told us about it. They had no way of putting the message thru; didn't know what to do; had heard that we amateurs could communicate with MacMillan—would we handle this one for them? Would we? Say, *would we!*

We took down the text over the phone right then and there. The Traffic Manager decided to try the job all the way from Hartford by amateur radio, so Kruse of 1XAQ-1HX-10A was given the text and he climbed on the air with it that night right after the Transatlantic listening period ended. Straightway there ensued the darndest streak of hard luck that has been seen for many a day. Everything went like a radio set on the night you invite your friends over to stage a little demonstration—you know. First off, Hartford was blanketed by a line escape which drowned out all but the unreasonably loud signals. It was a freak night and the message got exactly as far as 8IJ—no farther.

Darr of 8ZZ in Detroit was heard merrily chewing the rag with Mix of WNP, the MacMillan vessel "Bowdoin", and so Kruse went after him—hard. No dent. So he got help, and soon a half-dozen real good eastern stations, including 1CKP, 8AGO, and 8BDA with his rock-crusher, were calling their heads off for 8ZZ. The only effect was to make Darr complain casually to WNP of the QRM! Could Darr have been hooked that night the Coolidge message would have been handed Capt. MacMillan a couple of days before Christ-

mas; but Darr hit the hay without ever knowing how narrowly he missed a chance for still greater fame.

Then the attack centered on 9DKB of Minot, N. D., who had been the best hopping-off place to MacMillan since Jack Barnsley of c9BP went on vacation. 8IJ gave the message to 9AAW, who passed it to a Nebraska station, and 1HX gave it direct to 9AOG in Lawrence, Kansas. No luck. It was several days before we knew the reason—Weeks of 9DKB was spending the holidays in Detroit!

The next night Kruse went after Darr again. He wasn't on, but two other Detroit fellows, 8APT and 8RM, were raised and they went around to Darr's place and got him out of bed. 8ZZ then took the air with the message and made a valiant attempt to raise Mix, but WNP was not to be heard. Kruse gave the message to a few more good stations and then sat back to watch the fun. In all, 22 stations were logged that night actually at work trying to further the progress of the message. Apparently WNP was off the job, enjoying the holidays, for nobody heard him and the message continued to float around the country undelivered. Finally on the morning of Dec. 24th 8ZZ raised some "five station", we don't know whether Canadian or United States, who said he was QSO c9BP, Barnsley, and so the message came eventually to Prince Rupert, B. C., always the best point of contact with WNP.

Then more hard luck, for Mix could not be heard, and days rolled by. At length, on the night of January 1-2, Barnsley and WNP connected, and the message was delivered to MacMillan. Of all this stew and all this calling, this was the first that Mix had heard of it. Some beautiful little streak of freak conditions had almost ruined us. Our much-vaunted service to

the North Pole took a real setback when it took us ten days to put thru a message from our country's president, but it was



DON MIX, OPERATOR ON "WNP"

From a snapshot taken in Labrador on the way up to the Expedition's present location, frozen in the ice above Etah, Greenland, 600 miles from the Pole.

not the fault of the stations or the organization.

Barnsley, c9BP, went on a three-weeks vacation on December 1st and left the

game wide open to all comers. U9DKB, Minot, N. D., had the best luck, and connected frequently with Mix, on one occasion copying a 1500-word press story all about how MacMillan had discovered where Santa Claus hung out, etc. It made good reading for the kiddies, anyway. C4HH in Moose Jaw, Sask., was probably the next best contact, and took part in much of the traffic handling. Many other stations succeeded in hooking up with WNP, and all in all it seems that the effort to keep the "Bow-doin" in communication with this country was quite successful during December.

The following reports of WNP's signals were received during December:

NOVEMBER

Nov. 14, c5GO; Nov. 17, 9DKB; Nov. 29, 9BFF; Nov. 24, 6CRW; Nov. 25, c9BP sent 10 and received 13 messages in addition to copying about 300 words of press. Nov. 26, 6BQS; Nov. 28, 2CLA; Nov. 29, 7ADQ; Nov. 30, 1AWW.

DECEMBER

Dec. 1, 9DBF; Dec. 2, 7GT; Dec. 3, 7KS; Dec. 4, 6CKV; Dec. 5, 6CKV; 6AKD; Dec. 6, 6CKV; Dec. 7, 5FU; Dec. 7, 7ABB sent 15 messages; 9DKB sent 7 and received 3 msgs. Dec. 8, 7ABB worked WNP but no traffic handled. 6CKC and 6AOA heard WNP. 7CO also worked WNP. 9DKB heard WNP. Dec. 9, 9DKB took 1500 words of press, heard by 8BLP. Dec. 10, 9DKB worked but no traffic; heard by c5HK. Dec. 11, 9DKB worked, but no traffic; 6XAD sent 4 messages. Dec. 13, 9DKB sent 2 and received 2 messages; heard by 9EPO. Dec. 14, 8BOA. Dec. 16, 7CO; 9DKB sent 4 messages (total 400 words). Worked by c4FN, but no traffic, QRM. C4HH received 9 messages. Dec. 17, 7CO sent 1 message; heard by c4HH. Dec. 18, O. C. Miller, Marshall, Minn. Dec. 18, c4HH received 17 messages; 9DKB sent 1 and received 1; heard by 8DLI. Dec. 19, 1ARL, 1COC. Dec. 20, O. C. Austin, Madison, Wis., c4HH, 9BJL, 9DKB; 6XAD received 178 words of press under adverse conditions. Dec. 21, 9BLY; O. C. Austin, Madison, Wis.; 3BAU. C4HH sent 5 messages and received 220 word message. Dec. 25, 6RCL. Dec. 27, 8LU; Dec. 29, 8CDI. 9DKB sent 7 and received 1 message. Dec. 30, 9DKB.

—K.B.W.

Australian Amateur Radio Puts to Sea

By F. Basil Cooke, F. R. A. S. *

The wonderfully efficient transmission of Australian 2CM is described elsewhere in this issue under the heading "An Amazing World's Record". As a result of this work an amateur station, Australian 2CDM, is being put on the S.S. Tahiti. During February and March all A.R.R.L. stations should keep a bright lookout for 2CDM-Australian.

THE amateur movement was never stronger than at present. The day is nearly here when amateurs all over the world will be able freely to exchange greetings and discuss points of mutual interest through their own organizations.

The American Radio Relay League was the first step in this direction and Australia announces the fact that a similar move-

ment is inaugurated under the banner of "The Australian Radio Relay League". The ideals of this body are similar to those of their friends in America and letters are being freely exchanged. It is only a matter of a little time when there will be an International Radio Relay League covering the whole world.

The first president of the Australian Radio Relay League is Mr. Charles Maclurcan, 2CM, of Sydney, Australia. This gentleman is world-wide-known for

*Vice President, Australian Radio Relay League; Secretary Pan-Pacific Congress, 1923; Director of Radio for David Jones, Ltd.

his remarkable long distance low-power work. (See the article "An Amazing World's Record" in this issue.)

As a result of the many experiments conducted by Mr. Maclurcan, it occurred to him that this low power transmission could, and should, be turned to some account for the public generally.

Reliable data is needed as to the range that could be reasonably expected when using low power transmitters.

With this object in view Mr. Maclurcan approached Messrs. The Amalgated Wireless (Australasia) Ltd. to see if it could be arranged to duplicate 2CM on a ship and establish definite two-way communication on low power and low wave length at sea.

After some negotiation with Mr. E. T. Fisk, Managing Director of the Amalgated Wireless, an arrangement has been made under which the Company is to install on shipboard a duplicate of Mr. Maclurcan's station at Strathfield.

The S.S. Tahiti, going to San Francisco and back, has been chosen. The transmitting and receiving sets will be quite apart from the usual ship's commercial equipment. A separate cage aerial will be run from the mainmast and an especially-tuned counterpoise erected. The station will be run as any other experimental station and will be operated by Mr. Maclurcan and Master Jack Davis. Master Jack Davis, aged 16, has been especially chosen as he has been doing some remarkable work on low power on his own account.

The Tahiti will leave Sydney about the end of February. The station call will be 2CDM. Tests will be carried on with 2CM and schedules will be worked with other experimenters in Australia and New Zealand and probably America. All signals will be measured by audibility meter and the ranges, day and night, logged. Special attention will be paid to the fading of low wavelengths and any other curious phenomena noted. A continuous watch will be kept and much valuable information should result.

The idea of the trip is not to break records but to determine what the low powers are good for.

A number of experimenters in Australia constantly log American amateurs, using power no greater than that used here when endeavoring to "get across" to America. At first sight it would look as if the conditions for reception are more favorable in Australia and the conditions for transmission more favorable in America. This latter is hardly likely, since it has been shown what can be done on low power here.

Mr. Maclurcan hopes, on the homeward trip, to conduct experiments with amateurs in America and it is hoped that this trip will cement a lasting friendship between

the lovers of this wonderful science on both shores of the Pacific.

The writer has been given the honor of arranging the Australian part of the performance while Mr. Maclurcan is away and he will have the difficult, but interesting, task of seeing that no hitch occurs in the program. Final compiling of results will not take place until we collaborate upon the return of the wanderer.

In conclusion, again, it is to be hoped that this trip will be the first of many and

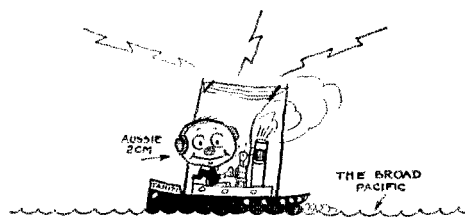

that Australia will be honored by the visit of her wireless brothers from America. In this way we see the beginning of a new era when the amateur movement will recognize no boundaries and so bring about that long-prayed-for state; The Brotherhood of Man.

What the Department of Commerce Says About Us

THE following extracts from the annual reports of the Secretary of Commerce and of the Commissioner of Navigation show what the Department of Commerce thinks about us amateurs and our A.R.R.L.

From the Secretary's report we quote the following:

"There is no abatement in amateur activity. The number of licensed amateur transmitting stations has increased from 15,504 in 1922 to 16,570 on June 30, 1923. Serious effort is being made by the amateurs to improve their apparatus so as to reduce interference and increase the efficiency of their stations. Annually these experimenters conduct trans-Atlantic tests with European amateurs. The last test was in December, 1922, when 315 were successful in getting their signals across to Great Britain, France, and Switzerland. The record compiled by the American Radio Relay League shows that each of the nine radio districts had a successful representative.

"Few realize the importance of our amateur auxiliary communication system which can be put into immediate operation and

temporarily provide a means for dispatching trains, giving flood warnings, and transmitting emergency messages to and from sections temporarily deprived of wire facilities”.

And the Commissioner of Navigation says:

“Amateur stations continue to increase in number. . . . The amateurs are making all reasonable effort to improve and perfect

their transmitters. The progress already made is noteworthy. Considering the number of amateur stations, the age of the operators, and the inability of our inspectors to get in touch with the majority of them it is essential that our service have the close cooperation they are giving us. Their respect for the law and rights of others is commendable.”

Let us continue to earn that high reputation!

What the Work With F8AB Teaches the A.R.R.L.

By S. Kruse, Technical Editor

The Lessons.

- 1—Use a larger antenna with series condensers.
- 2—Get off the crowded waves by moving downward.
- 3—Make a wavemeter and calibrate it from WWV.
- 4—The “200-meter-plus” outlaw is THROUGH—his last excuse is gone.

THE prime reason for the present success of two-way amateur transatlantic communication is in station F8AB, the first really capable European amateur station. Success was due mainly to the thumping signal that Delyo pushed across to us, and with the aid of which a number of other European

that we ought to have the 100-meter wave, regardless of the fact that it is already occupied. *There are plenty of wavelengths on both sides of 100 which will do the trick as well.*

Very well, if 100 meters is not a magic wavelength, *how* did it come to do the trick? For several reasons. One's first thought is that there was little interference. Compared to 210 meters that may be correct but there is more QRM on 100 meters than on 176, quite a bit more.

First of all there is KDKA's short-wave transmitter, then there is a large family of harmonics from all sorts of stations. In Hartford the most troublesome ones are those of NAO, NBD, WIM, WOR, 5EK, 4FT and 6PL!! The last station can be copied beautifully on the harmonic when totally inaudible on his main wave. The most troublesome of these harmonics are those of the sparks at NAO and NBD—they have been that way for a long time, too. WOR is second, being especially troublesome because of its wavering nature, rather than its actual strength. No—the explanation does not lie in freedom from interference.

The First Lesson

Larger Antennas with Series Condensers

We are for the first time doing consistent 3500-mile work because we are (for the first time) using antennas that are large—very large—for the waves at which they are working. Working an antenna that way gives high radiation efficiency.

The moment that statement is made the tribe of ampere-hounds will rise in protest—“But the series condenser causes a big loss—we only get half as much current with a big antenna and series condensers.”

Buncombe, Brother—absolute and complete buncombe!!! How on earth can the series condenser be using up power when it does not get hot? Don't you know that wasted electrical power will always show up as heat?

“B-but—” says the ampere-chaser, “if

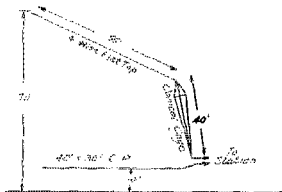

FIG. 1a

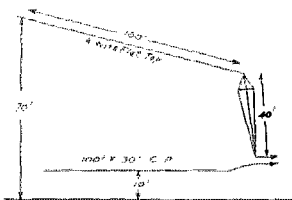

FIG. 2

stations have been connected with many American stations.

Two-way transatlantic work just *happened* to start on 100 meters; it has been done since on 90 meters and also at 130; in past seasons we have put good signals across on waves all the way up to 225 meters. There is not the slightest excuse for the present grand howl to the effect

there is less current we must have increased the resistance—we are wasting power *somewhere*.

Yes—we have increased one of the resistances in the antenna. We have increased the radiation resistance. We are now putting more power into the ether than before, even tho the antenna current does drop. Certainly no one can object to that.

Proving It

A large part of the audience will now say "Rats!! More of this theoretical bunk that doesn't work out. Bet he never tried it."

Yes, originally the idea was theoretical. And right here is a good place to say that *almost everything we have learned about radio has been worked out first on paper and then tried in the field*. Don't sneer at the theoretical radio man. Now we have practical proof that the theory was absolutely right—that we did not know as much as we thot—and that our antennas are all wrong.

Tests at 8XH-8AQO

A few months from now we will offer a considerable surprise in the way of a report on some sending tests made from 8AQO-8XH at Cazenovia, New York. Just now we will only give a few of the results.

A large antenna 90 feet high was used in one test, working against a ground connection. The fundamental wavelength of the affair was almost 270 meters. Too big for an amateur antenna? Not a bit of it; that is the antenna which put the tremendous signals into half a dozen European countries last year at 200 meters and in these tests it developed that the antenna was *not big enough for 200-meter work*, but did its best work at a wavelength down around 176.

This was not "laboratory work"—it was actual transmission and the hardest-boiled brass-pounder will find it hard to doubt results that checked at half a dozen receiving stations in broad daylight and checked again when measured with a loop near the sending station.

Now here is the important point:—the waves around 300 meters could hardly be heard in Hartford (daylight) and no great change happened as the wave was lowered until we passed thru the fundamental. Then the signals built up until at 176 meters they were truly tremendous. Yet this wavelength was "handicapped" by a series condenser in the sending antenna and the antenna current was a small fraction of that gotten at 300 meters and upward.

Tests at 1XAQ

Naturally one would now expect that an ordinary amateur antenna would work best on wavelengths that are still lower. This has been tried out roughly at 1XAQ. The

antenna is the sort of "compromise vertical" shown in Fig. 1, rather under-sized, and can be worked down to 160 meters without any series condenser at all. The location is a good one and transmission is very fair at even 200 meters. It has been very hard to test further down because so few stations have tuners that will receive even

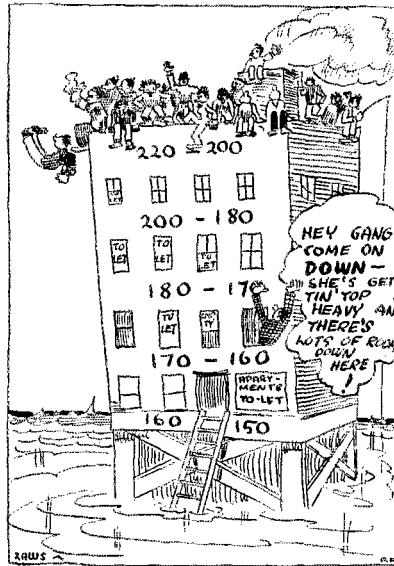

as far down as 180 meters—a disgraceful state of affairs.

Average results at distances around 1000 miles (night) were as follows:

Wave-length	Series Condensers (two used)	Ant. Cur.	Power to set	Reports on Signals (Average)
200	No	6.4	600	Good—some QSS
180	No	5.2	600	Good—less QSS
160	No	4.8	600	Good—no QSS
130	.00025	2.8	500	Stronger—no QSS
110	.00012	1.5	400	Very strong
90	.00005	.6	350	Very strong

Our antenna seems to be far too small for the standard amateur band—it ought to be much longer, somewhat like Fig. 2.

This was test work but now the idea has been put thru some weeks of steady work with European amateurs and in every case the successful American stations have been using *big antennas with series condensers*, the arrangement being that described by Reinartz in the last issue.

What It Means to the Amateur

Most of us do not have "X" licenses, so we cannot work at 100 meters, but the lesson is just as good at 150 meters. Make your antenna longer, give it a fundamental wavelength of at least 220 meters, put in a couple of series condensers as explained

by Reinartz and we will be ready for some real low-power long-distance work.

Lesson No. 2

The last few weeks I have listened at Hartford and logged the wavelengths of amateur stations in all U.S. and Canadian districts, also in two European countries. 90% of the U.S. amateurs are between 195 and (I regret to say) 225 meters. Below 190 there is little going on, below 180 there is almost perfect silence, and at 150 one can listen for hours with never a peep from an amateur except a canny few that are seeing the lesson of the F8AB work and get below the mob.

Lesson No. 3—Make a Wavemeter

F8AB was first located by using a wave-



meter and hunting on the exact wavelength on which he had agreed to send. Then the sending set at 1MO was also set at exactly the wave agreed on and the first call brought results. Supposing that Deloy and Schnell had gone at it in the usual madhouse fashion—guessed at their wavelengths and “shot blind”. Chances are they would still be hunting for each other. Since that time F8AB has QSP’d for several other English and French stations, giving the exact wavelength, and every time a careful search on that wave has located the man.

Things are not so with the American amateur. We had nine different amateurs in the 9th district tell us that 1XAQ was “on about 150 meters” when we were actually on 180 flat—checked by Navy wavemeter and by WWV to within 1 meter. Several of these same men were immensely surprised to learn that they were from 10 to 30 meters on the wrong side of 200.

But that is not the worst of it—we have found that over half of the amateurs we work cannot receive below 180 meters. They never know this until we move our wave slowly downward to the limit of their tuners.

Build a wavemeter and calibrate it from WWV!

Lesson No. 4—The Outlaw’s Finish

A.R.R.L. has long been patient with the member who worked on a “super wave”—again and again we have begged off someone who was above 200. Again and again the Inspection Service has restored licenses to such offenders, or let them off with a warning. This was because all hands felt that the longer waves were better and that it was natural for everyone to crowd up toward 200 and then accidentally get on the wrong side of it.

That excuse is now finished! We know that better work can be done with the ordinary amateur antenna at 176 or 150 than at 200. This is not guesswork—it has been proved through many months by 9ZN, 9XW, KDKA, 5XV, 3ALN, 1XA, 3XM, 1XAQ, 9AOG, 8XK, 1MO, F8AB, 1QP-1XAM, 2AJF, 2BRB, 8XH-8AQO, WNP—the list could be extended for many lines.

Since there is no longer any excuse for crowding to the upper waves it is time to do something that will cure the excess-wave pest. The broadcast listener is heartily sick of it, and he is right. The Department of Commerce has stretched its patience about as far as can be expected and our own Operating Department feels that it is time to use the axe.

Let’s make a last effort to cure the thing peaceably. Alter your own receiving set so it will tune below 150 meters, make a wavemeter and keep it near the set, and then send a card or radiogram of warning to every man caught above 200 meters. If he got there by accident he deserves a fair warning and will get down. If he is doing it knowingly, the sooner he loses his license, the better for A.R.R.L.

QRV Pan-American Tests?

Tests with our southern cousins probably will be held during the month of April or May. Will your transmitter be ready for the job? And how about your receiver—is it all primed after the Transatlantic Tests? Interested amateurs are requested to signify their willingness to participate by dropping a card to A.R.R.L. Headquarters.

—F.H.S.

NOTICE

The annual New England Division Convention of the Traffic Department will be held in Springfield, Mass., during the month of March. Watch next QST for details.

Emergency Railroad Communication

By A. L. Budlong,

Secretary, A.R.R.L. Railroad Emergency Service Committee

THOSE who saw the editorial on "Railroad Service" in the November issue of *QST* and who filled out Traffic Department questionnaires regarding railroad emergency service, are no doubt wondering what has been done toward developing the service and giving the railroads what they want—a real, dependable emergency communicating system.

The plan, as was mentioned in the November *QST*, originated at the Chicago convention when a member of the American Railway Association was appointed to see our League officials as to the possibilities of the scheme. As a preliminary step, the railway representative was furnished with a list of the Official Relay Stations and was told in the event of emergency the nearest O.R.S. could be notified and would be willing to do all in his power to help. Naturally this was a purely temporary arrangement, designed to fill the need in some fashion while the League took hold of the scheme and developed a more efficient and detailed plan.

The first thing after the convention, questionnaires were prepared by the Traffic Manager and sent to all O.R.S. At this writing several hundred returned questionnaires are on file, and have given us a great deal of statistical information that will be of help in laying further plans.

The second step in the work was the appointment of an emergency committee. The chairman of this committee is G. L. Bidwell, one of the Washington gang, and the man who is directly responsible for much of the present outlined scheme of emergency service. He was given authority to go ahead with the preliminary plans, the idea being that some scheme should be developed which could be put into immediate operation, as winter had already settled in the Northwest station, and the service might be called upon at any time. Mr. Bidwell has been conferring with Norman Hood, who has done so much excellent work in the Rocky Mountain Division, also several others of the division managers, and the plan for the immediate future is this:

It will be practically impossible to get any highly organized system into operation within several months at least, and for this reason it will not be attempted just now. Instead, every amateur station, whether O.R.S., A.R.R.L., or not, must automatically become an emergency relay point for any railroad that calls upon him

during the winter, and do everything in his power to see that nothing ever fails to get through on *his* account. At the present time, the Committee wishes anyone who has an opportunity to go ahead on his own account in furthering this work to do so, the only thing asked of such individuals being that they report all activities to the traffic officials with whom they ordinarily communicate, who will in turn keep the Committee informed of important steps being taken in various sections of the country.

Later, as more detailed plans are worked out and a real organization begins to develop, we will map out communication lines along the more important railroads and divisions. From information already obtained it is also very apparent that we will have to get some stations who are not members of the League to serve at strategic and critical points, especially in the mountain divisions, with the probability, however, that they will become A.R.R.L. members in short order.

This railroad emergency work is assuming greater proportions than anyone realized at first. The railroads themselves are coming to us for service. Five big railroads have individually asked for immediate action. We are going to try to give them what they want, but the success of the whole plan will depend on each individual operating amateur. As we stated in the middle of the article, the work this winter will be more or less unorganized, and we are going to let each individual go ahead on his own hook, asking only that he report all such activities to his usual traffic officials. But let's go ahead with this thing and show the railroads and the public that when emergencies occur the North American amateur will be found ready and willing to jump into the breach and do his part in carrying on.

Wolverine Convention

The Third Annual Michigan State A.R.R.L. Convention will be held at the Hotel Fuller in Detroit on February 28-29 and March 1st. Preparations are being made for the biggest convention ever held in Michigan. The Original Wouff Hong Gang (Supreme Council) from Flint will put on the initiation. The "Glad Hand of Michigan" is extended to all.

South Dakota Radio Convention

SEVENTY-FIVE enthusiastic amateurs attended the Third Annual South Dakota Radio Convention at Sioux Falls on December 27 and 28. The Y.M.C.A. Radio Club of Sioux Falls had charge of the convention, and the entertainment consisted of two technical meetings, a stunt party for prizes, vaudeville show at a local theatre, a sight-seeing trip to local stations and points of interest in the city, and a banquet.

Prof. B. B. Brackett of the University of So. Dakota Engineering School delivered an interesting talk on the subject "Are Radio Waves Real". Winfred C. Hilgedick (9AUA) of St. Paul gave some good dope on transmitting circuits and apparatus; E. A. Gruhlke, a Sioux Falls amateur, talked on receiving circuits; and Norvell A. Canfield of Luverne, Minnesota, enlightened the gang on his DX station 9DYR. Twenty-five prizes were awarded to the winners of stunts which consisted of running races, swimming races, cracker-eating contest, liar's contest, code-test for accuracy and neatness, and other stunts. M. G. Gold-

berg, Supt. of Minnesota District No. 3, sent two special prizes which were awarded to the amateur in attendance having the best record for the past year determined by vote, and for the person having done the most to make the convention a success. The first named was awarded to 9CGA and the second to 9EHC.

A distinguished visitor was Lloyd V. Berkner, 9AWM, of Sleepy Eye, Minnesota. Mr. Berkner gave an interesting talk on his experiences as a commercial operator during the past summer. Huron was favored as a place for holding the convention next year.

—N.H.J.



The Eclipse

A Code of Conduct for A.R.R.L. Members

Prize Winner at the Atlanta Convention

By Charles B. Transou, 4QF

1—*Friendships.* Let each man so conduct his station that sincere friendships will grow out of our relations on the air. The greatest thrill in amateur radio is in the making of such friendships.

2—*Experimentation.* Never forget that half of the joy in radio lies in experimentation. The pleasure and experience gained from such work will never be regretted.

3—*Foreign Relations.* We must not forget our foreign brothers. For years American Amateurs have had the co-operation of foreign amateurs but have given little in return; let no effort be spared to bring about inter-continental communication.

4—*Your Neighbor.* Let every amateur take it upon himself as a *personal* matter to see that co-operation, with the utmost sincerity, is given to the Broadcast Listener, who deserves his rights, even as we deserve and claim ours.

5—*Traffic.* The A.R.R.L. should advance some practical method for assuring the delivery of messages. Let us all work for it.

6—*Membership.* Every amateur should take it upon himself *personally* to bring into this organization those who are just beginning—to support the League by actions as well as by sympathy.

7—*Development.* Build your own equipment as carefully as you can.

8—*Interference.* The interference problem begins at your own sending set.

9—*Co-operation.* Let us put our personal enjoyment in our pockets and give the co-operation of every amateur in America when the League conducts a test or an experiment.

10—*Proportion.* Let no man among us lose sight of the greater things in life, friendships, education and health. These are the things that in later years will enable us to continue our true enjoyment of Amateur Radio.

How I Operate UV-202 Radiotrons

By H. H. Tilley, 1GV

The tube arrangement at 1GV is one of the prettiest things we have ever seen in an amateur station. The six tubes work together perfectly, altho it is generally thot impossible to make more than four tubes operate in parallel.—Technical Editor.

WHEN tubes are to be operated in parallel the sockets should be mounted in such a manner that all the grid leads are of equal length and all the plate leads are of equal length. The photographs show a convenient way of doing this. The filament ring-busses go around in *opposite*

stems heat the plate power may arc across in the base of the tube.

If a tube sparks in the base or turns blue inside, remove it from the socket *at once* and lay it aside until it is thoroly cool. If left in the circuit the sparking will continue and soon break down the seal, then the air will leak in and the filament will "go up in smoke".

If the plate current is *too high* it can be reduced as mentioned above by putting in more plate turns. If the grid current is too high it can be reduced by using fewer grid turns or else by using a higher resistance grid leak.

Overloading the Tubes

When the set is properly adjusted high voltages can be applied safely. (We can hardly agree with this—*perhaps the tubes do not blow up at once but they will not last*

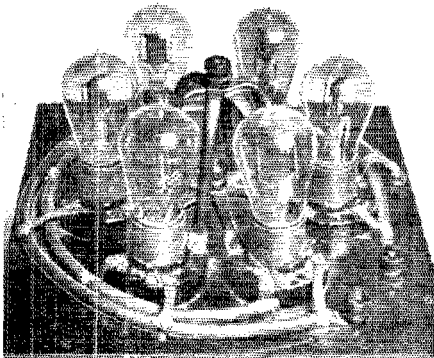

THE TUBE ARRANGEMENT

directions, so that the voltage brought to all filaments is exactly the same.

Any standard amateur circuit may be used. Begin by putting tubes in all the sockets and connecting meters in the plate lead and in series with the grid leak. The plate meter should have a 300 or 400 milliamper scale and the grid meter should have a scale of about 100 milliameters.

Tune the set using a low plate voltage. When the antenna current is highest and the plate current about normal (45 mils per tube) move the plate clip about three turns further out so as to add three plate turns. This will reduce the plate current—and of course the output also—but will raise the efficiency so that the plates run quite cool. Now apply a higher plate voltage and watch the meters closely. Do not allow the plate current to go above 50 mils per tube nor the grid meter to go above 5 mils per tube. The grid current is especially important, as if it is too high the tubes will heat very badly, and if the

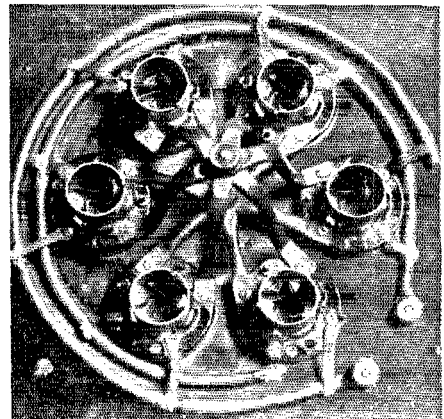

THE LAYOUT WITH TUBES REMOVED TO SHOW CONNECTIONS

Upper center post connects to plate.

Lower center post connects to grid.

The two posts at the side are for the filament supply.

This arrangement stands on a shelf directly under the helix, permitting very short leads.

very long if more than double normal voltage is used.—Tech. Ed.) During last year's Transatlantic Tests 2000 volts were applied to these 6 UV-202 tubes. The plate current was 400 milliamperes (which is 800

watts!!!) and the antenna current 8 amperes. A large counterpoise lowered the plate current considerably. With this arrangement the station was heard in five European countries, every radio district in the U.S.A. and Canada, in Porto Rico, Mexico, Hawaii, and by the U.S.S. Arizona at the Equator in the Pacific Ocean.*

Plate Supply

Small transformers and bridge rectifiers were not satisfactory; the voltage drop was too great when the load came on. It was found necessary to use a 600-watt transformer with a center tap and a rectifier with 80 jars.

*Our European members have been finding it very hard to understand the large antenna currents obtained by some of our stations which are given low power ratings. It will interest these men to consider the station just described. It is the American custom to state the tube rating when giving the power of a station. According to this 1GV is a "30-watt station"—yet the power input is given as 800 watts. The normal plate dissipation of these tubes is about 15 watts and the plates at 1GV do not run excessively hot, indicating that they are certainly not dissipating over 25 watts each. This would leave 550 watts for the antenna. That seems reasonable, as the antenna current was 8 amperes in a rather short antenna about 60 feet above its counterpoise.—Tech. Ed.

ELECTION NOTICES

To All A.R.R.L. Members Residing in the Central, New England, Northwestern (including Alaska), Roanoke, Rocky Mountain, and West Gulf Divisions:

1. You are hereby notified that an election for a new A.R.R.L. Director, for a term of one year, is about to be held in each of the above Divisions, in accordance with the new A.R.R.L. Constitution and By-Laws, which are published in the membership edition of this issue of *QST* for your information. Your attention is invited to Sec. 1 of Article IV of the Constitution, providing for the government of A.R.R.L. affairs by a Board of Directors; Sec. 2 of Article IV, defining their eligibility; By-Laws 12, 13, 14 and 15, providing for their nomination and election; and particularly By-Law 27, which especially for this election stipulates dates differing from those specified in the other By-Laws cited.

2. The election will take place during the month of April, on ballots which will be mailed from Headquarters in the first week of April. The ballots for each Division will list the names of all eligible candidates nominated for the position by A.R.R.L. members residing in that Division. There will be one Director elected from each Division.

3. Nominating petitions are hereby

solicited. Ten or more A.R.R.L. members living in any Division have the privilege of nominating any member of the League in their Division as a candidate for Director. The following form for nomination is suggested:

(Place and date)

Executive Committee,
A.R.R.L. Headquarters,
Hartford, Conn.

Gentlemen:

We, the undersigned members of the A.R.R.L. residing in the Division, hereby nominate of as a candidate for Director from this Division, for the election of April, 1924.

(Signatures)

The signers must be League members in good standing. The nominee must be a League member in good standing, and must be without commercial radio connections. His complete name and address should be given. All such petitions must be filed at the headquarters office of the League in Hartford, Conn., by noon of the first day of April, 1924. There is no limit on the number of petitions that may be filed.

4. Under the former constitution of the League, Directors did not represent specific territories. However, those now occupying the office of Director from the above-named Divisions are as follows: Central: H. M. Anthony, Muncie, Ind.; C. E. Darr, Detroit, Mich.; M. B. West, Lima, Ohio. New England: A. A. Hebert, East Hartford, Conn.; S. Kruse, Hartford, Conn.; H. P. Maxim, Hartford, Conn.; F. H. Schnell, West Hartford, Conn.; C. A. Service, Jr., Glastonbury, Conn.; K. B. Warner, West Hartford, Conn. Northwestern: K. W. Weingarten, Tacoma, Wash. Roanoke: none. Rocky Mountain: none. West Gulf: F. M. Corlett, Dallas, Tex.

5. This is your opportunity to put the man of your choice in office as the representative of your Division. Members are urged to take the initiative and file nominating petitions immediately.

For the Board:

K. B. WARNER, Secretary.

Hartford, Conn., Jan. 2, 1924.

To All A.R.R.L. Members Residing in the Atlantic, Dakota, Delta, East Gulf (including Porto Rico), Midwest, and Pacific (including Hawaii) Divisions:

1. You are hereby notified that an election for a new A.R.R.L. Director, for a term of two years, is about to be held in each of the above Divisions, in accordance with the new A.R.R.L. Constitution and By-Laws, which are published in the membership edition of this issue of *QST*

for your information. Your attention is invited to Sec. 1 of Article IV of the Constitution, providing for the government of A.R.R.L. affairs by a Board of Directors; Sec. 2 of Article IV, defining their eligibility; By-Laws 12, 13, 14 and 15, providing for their nomination and election; and particularly By-Law 27, which especially for this election stipulates dates differing from those specified in the other By-Laws cited.

2. The election will take place during the month of April, on ballots which will be mailed from Headquarters in the first week of April. The ballots for each Division will list the names of all eligible candidates nominated for the position by A.R.R.L. members residing in that Division. There will be one Director elected from each Division.

3. Nominating petitions are hereby solicited. Ten or more A.R.R.L. members living in any Division have the privilege of nominating any member of the League in their Division as a candidate for Director. The following form for nomination is suggested:

(Place and date)

Executive Committee,
A.R.R.L. Headquarters,
Hartford, Conn.

Gentlemen:

We, the undersigned members of the A.R.R.L. residing in the Division, hereby nominate of as a candidate for Director from this Division, for the election of April, 1924.

(Signatures)

The signers must be League members in good standing. The nominee must be a League member in good standing, and must be without commercial radio connections. His complete name and address should be given. All such petitions must be filed at the headquarters office of the League in Hartford, Conn., by noon of the first day of April, 1924. There is no limit on the number of petitions that may be filed.

4. Under the former constitution of the League, Directors did not represent specific territories. However, those now occupying the office of Director from the above-named Divisions are as follows: Atlantic: H. A. Beale, Jr., Parkesburg, Pa.; G. L. Bidwell, Washington, D. C.; V. F. Camp, Brightwaters, N. Y.; C. H. Stewart, St. David's, Pa. Dakota: none. Delta: none. East Gulf: none. Midwest: none. Pacific: A. H. Babcock, Berkeley, Calif.

5. This is your opportunity to put the man of your choice in office as the representative of your Division. Members are

urged to take the initiative and file nominating petitions immediately.

For the Board:

K. B. WARNER, Secretary.

Hartford, Conn., Jan. 2, 1924.

To All A.R.R.L. Members Residing in the Dominion of Canada, Newfoundland, and Labrador:

1. You are hereby notified that an election is about to be held for a new A.R.R.L. Canadian General Manager, in accordance with the new A.R.R.L. Constitution and By-Laws, which are published in the membership edition of this issue of QST for your information. Your attention is invited to By-Law 26, defining the policy of the League in Canada; Sec. 1 of Article IV of the Constitution, providing for the government of A.R.R.L. affairs by a Board of Directors, of which the Canadian General Manager is a member; Sec. 2 of Article IV, defining the eligibility of Directors; By-Laws 23 and 24, specifying the duties and authority of the Canadian General Manager; By-Laws 20, 21 and 22, providing for his nomination and election; and particularly By-Law 27, which especially for this election stipulates dates differing from those specified in the other By-Laws cited.

2. The election will take place during the month of April, on ballots which will be mailed from Headquarters in the first week of April. The ballot will list the names of all eligible candidates nominated for the position by League members residing in Canada, Newfoundland and Labrador.

3. Nominating petitions are hereby solicited. Ten or more A.R.R.L. members living in the Dominion of Canada, Newfoundland or Labrador, have the privilege of nominating any Canadian member of the League as a candidate for Canadian General Manager. The following form for nomination is suggested:

(Place and date)

Executive Committee,
A.R.R.L. Headquarters,
Hartford, Conn.

Gentlemen:

We, the undersigned members of the A.R.R.L. residing in the Dominion of Canada, Newfoundland or Labrador, hereby nominate of as a candidate for A.R.R.L. Canadian General Manager, for the election of April, 1924.

(Signatures)

The signers must be League members in good standing. The nominee must be a Canadian member of the League in good standing, and must be without commercial

radio connection. His complete name and address should be given. All such petitions must be filed at the headquarters office of the League in Hartford, Conn., by noon of the first day of April, 1924. There is no limit on the number of petitions that may be filed.

4. Mr. A. H. K. Russell, of 234 Westmont Drive, Toronto, Ont., is the present Canadian General Manager.

5. This is your opportunity to put the man of your choice in office as the Canadian member of the A.R.R.L. Board. Members are urged to take the initiative and file nominating petitions immediately.

For the Board:

K. B. WARNER, Secretary.

Hartford, Conn., Jan. 2, 1924.

Transpacific Test Report

WHILE no official report has been received from Australia on the results of the recent Transpacific Tests in which A.R.R.L. cooperated with *Radio Journal* and the Southern California Radio Assn., Mr. H. Kinsley Love, 3BM, in charge of Australian arrangements, announces that 150 American and Canadian amateurs got across according to reports received at Melbourne, with probabilities that the total will reach 200. Stations as far east as u2BY were logged.

The tests were run under very poor conditions at the receiving end, July being their best period. During the whole of the tests there was not a single really good DX night. Whenever strays were at all weak they were incessant, so that only strong signals could be read thru them, and on the other nights there were strong splashes that choked the receiver frequently. Commercial spark stations caused added difficulties in the form of harmonics.

Many more calls would have been logged, the Australians say, if we had sent a bit slower, made our dots firmer, and paid attention to good spacing.

6KA was the strongest station of the lot. At a3BM, Mr. Love's station, which acted as the observation station for the tests, 6KA's messages to Australia were recorded on dictaphone records. KA was received on a loop by one station, and in another case was copied in the late afternoon before the sun went down, signals QSA on one-step radio and detector.

We will publish further information as soon as the official reports arrive in this country.

—K.B.W.

Help Wanted For A Book of American Amateur Stations

A SMALL "Stray" in a recent issue announced the desire of Mr. James A. Wilson, of 8CPY-8DKC, Kalamazoo, Mich., to undertake the publication of a profusely illustrated book of American amateur radio stations, on behalf of amateur radio. The little item caught the eye of many and the returns received by Mr. Wilson were most gratifying in the co-operation offered. Hundreds of letters attest the idea to be "just the thing".

And so now we are pleased to solicit material for Mr. Wilson. He wants photographs of stations. Every amateur is invited to send to Mr. Wilson at once, in care of the Crescent Engraving Co., Kalamazoo, a real good photo of his station, also one of the owner and operator, together with a complete but brief description of the station and biographical notes on the owner-operator. The book will be primarily pictures, so good photographs are more important than text. The photographs will be returned as soon as they have served their purpose. Five-watt stations will get the same consideration as the big fellows with 250's—everybody is wanted.

Mr. Wilson takes the gamble. He will do a good high-class job if there is a chance of putting it across. Whether or not it can be done depends purely upon the response you fellows make to this appeal for photographs and descriptions. If he gets them, he has the material to make a successful book; he can do nothing if nobody displays interest. Let's show him—shoot your stuff.

—K.B.W.

"I don't know why there is no music."
— Maybe there ain't enough OHMS in your set."
"Wouldn't be surprised, the amateurs around here use 'em all up."
— an actual episode chronicled by BZZ

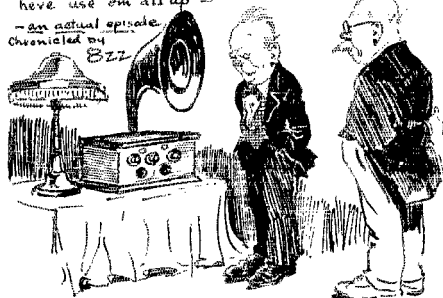

UIARY and C2CG Help in Emergency

Amateur Radio Again Serves In Terrific Storm

AMATEUR Radio added a new feather to its cap of achievements and the public was given a new insight into the possibilities of amateur service when IARY and Canadian C2CG rendered invaluable service on Nov. 25th during a heavy storm which tied up communication out of Burlington, Vermont, especially to the north. When telephone and telegraph service went out after a hard struggle with the storm, amateur radio was given the SOS and immediately jumped at the opportunity to bridge the gap.

Shortly after 2 o'clock in the afternoon the telephone test man in Burlington called up the chief operator, R. P. Slayton, at the University of Vermont station, and informed him that all means of communication between this city and Montreal had been cut off. Radio seemed to be the only possibility left and the test man wanted to know if the U.V.M. station could assist. Mr. Slayton went immediately to the station, only to find that the storm had taken toll there too—the receiving aerial was down. With characteristic amateur ingenuity he connected the set to one side of the electric light circuit and IARY was ready.

Within ten minutes after the first call

went out, Burlington was in first class communication with the Canadian metropolis, for C2CG, owned and operated by J. V. Argyle, Quebec Division Manager of the A.R.R.L. in Montreal, was on the job and answered! The first messages sent were between the telephone test men of the two cities. Information was checked and an attempt made to establish communication by wire. The first message, to Montreal, read:

PLEASE TRY TO GET IN TOUCH WITH BURLINGTON VIA RICHFORD OR WHITE RIVER JUNCTION RUSH INFORMATION CONCERNING CONDITIONS OF WIRES VIA STATION DELIVERING YOU THIS MESSAGE.

The following reply came back:

WIRES OK ON CANADIAN SIDE BUT ST ALBANS REPORTS 14 POLES DOWN BETWEEN ST ALBANS AND BURLINGTON.

The second message from Burlington read:

MEET YOU AT 4:30 VIA RICHFORD OR SHERBROOKE YOU HAVE NEGATIVE BATTERY ON YOUR WIRE.

In the meantime, rush telegraph messages were handled by radio, avoiding dangerous delays. By 5 o'clock telegraph communication had been re-established and the wires once more took over their work.

The Fourth District-East Gulf Convention

*By Charles B. Transou, 4QF**

WELL, the old Fourth District-East Gulf has busted loose, fellows. The first Annual Convention was a whooping success—"as good as the Chicago Convention" was all we could hear from those who had been fortunate enough to have attended the National Convention last September.

December 27 saw all the gang down in Atlanta, and a good gang it was, too, with representatives from seven districts—the missing ones being the sixth and the seventh as would naturally be expected—and they all started with a whiz and a bang. They hadn't been in an hour before the Ansley Hotel sounded like a swarming bee hive. But soon things got under way.

*A.D.M. for Georgia and City Correspondent for Atlanta.

The first was a trip by special car to WVR, the station at Fort McPherson, one of the biggest army tubes set in the country—five K.W. with fifteen thousand volts rectified A.C., supplied by Kenotrons, on the plate, and an antenna current around twenty-six amperes. How'd you like to get hold of that for a few minutes, OM? Wouldn't we work old FSAB blue in the face, though?

And the banquet that night on the Ansley Roof opened things up in good shape—introductions and short speeches by the notables at the Convention, just to get us all acquainted, and lots of entertainment thrown in; it was certainly a gala occasion.

Friday Morning the gang turned out in a bunch for the first technical meeting,

and some good dope it was that we got, too. At this time we heard from Fred Schnell about the famous receiver at 1MO-1XW on which F8AB is being worked. We also had a talk by Mr. H. E. Bussey of the General Electric Company on the Super-Heterodyne, and a little talk by Mr. Hebert on the A.R.R.L. Friday afternoon everybody went for a trip to Stone Mountain—one of Atlanta's proudest possessions. Here the work on the famous Confederate Memorial which is being hewn from the sheer face of the great Rock was reviewed, and then followed a little "jaunt" to the top of the Mountain, a mile above the surrounding country. The inducement was a little slip of paper entitling the holder thereof to an "Esco" motor-generator set. Incidentally our good friend 5QF ran off with it—hi!

Friday night came another technical meeting and with it the best lectures which we have ever had the pleasure of hearing. This time we heard from Prof. C. M. Jansky, Jr., of the University of Minnesota, on the possibilities of the vacuum tube and the future of Experimental Radio; and from Mr. John L. Reinartz on his justly famous short wave transmitter, used at 1MO-1XW and 1QP-1XAM, respectively first and second stations to work F8AB. It is considered quite an honor that we could enjoy the pleasure of having Mr. Reinartz here to explain his circuit in detail.

Saturday was the crowning day of the Convention. In the morning and early afternoon some minor prize contests were run off and that night all gathered at the Club Rooms of the Atlanta Radio Club for the initiation into the Royal Order of the Wouff Hong. Though some had a hard time of it they all came out more than delighted at now being members of the

widely famed fraternity of the amateurs of the American Radio Relay League. The rest of the prize contests were held and the prizes awarded, and right here a gang of the fellows became the proud owners of lots of apparatus. 3FB ran off with the Paragon outfit in the code contest and 4QF got the Grebe CR-13 for the "Ten Best Suggestions for the Betterment of Amateur Radio", and so things rocked along until that huge pile of prizes had been reduced to nil. The final windup had come—the Convention had gone across with a BANG—and everybody resolved then and there that the Fourth District-East Gulf should have no equal in the country from now on.

Fellows, the Atlanta Radio Club pushed this thing and has got the ball rolling—now let's keep it going. Let some good snappy club in one of the larger cities put in bids for the next year's Convention and decide right now where it'll be. The good work is on foot—now let's keep it up. And we also might give a word of thanks to those in the Atlanta Radio Club who specially pushed the Convention and did their best to make it the success which it was. The Convention Committee was as follows:

Dr. M. M. Burns, 4DO, President, Atlanta Radio Club, General Chairman.
 Harry F. Dobbs, 4DN-4ZA, Chairman, Ways and Means.
 Henry L. Reid, 4KU, Chairman, Publicity.
 Capt. Walter Van Nostrand, Jr., Chairman, Prizes.
 Chas. B. Transou, 4QF, Chairman, Registration.
 Walter E. Dobbins, 4AP, Chairman, Programme.

Convention Pictures may be had at \$1.00 each by writing Walter F. Winn, care the Atlanta Journal, Atlanta, Ga.

A New Type of R. F. Transformer

By S. Kruse, Technical Editor

We do not know what form the radio-frequency transformer will finally take; fixed transformers and tuned transformers both have their advantages. The Ballantine "Variotransformer" combines some of the advantages of both types.—Tech. Ed.

IN the amateur world the early form of the "Variotransformer" is well known, for few sending stations are without a copy of "Radio Telephony for Amateurs"—and fewer still should be. But for the few who do not have the book, and for the man not interested in transmission, it is interesting to follow an explanation of the underlying idea.

When a radio-amplifier uses a fixed transformer the wavelength range is also

fixed. By using various tricks it has been possible to broaden out the range of such transformers; a few makers have done it in a really quite satisfactory manner. The effect of these tricks is usually to reduce the amplification; that is to say, a narrow high peak is replaced by a broad, low one. In no case is it possible to make the amplification over the entire range as high as the original peak.

This situation has driven amplifier-

makers to the use of *tunable* devices, whose peak can be *shifted to suit*, instead of attempting to broaden it out.

The Two Kinds of Tuned R.F.

The first form of tuned amplifier that one thinks of is that in which the transformer has two air-core windings, each tuned by a variable condenser. Naturally that is hard to handle and it has been simplified by taking out the primary condenser and coupling the windings so closely that they tune as one circuit and the secondary condenser can handle them both (See Fig. 1) Such devices amplify very well. Their tuning is quite sharp, which is an advantage when a single stage is

the second grid in a satisfactory fashion, especially if there are to be two stages of r.f. amplification and the second tube is not to act as a detector. Still the basic idea is a good one—the thing gives good amplification, is not too sharp in tuning, and several stages can be handled.

The Variotransformer

These considerations led Ballantine to consider improving the variometer-type of tuned r.f. amplifier by supplying the variometer with a winding of such a sort that the plate and grid circuits would be insulated. This would make it possible to do away with such troublesome things as blocking condensers and leaks in the r.f.

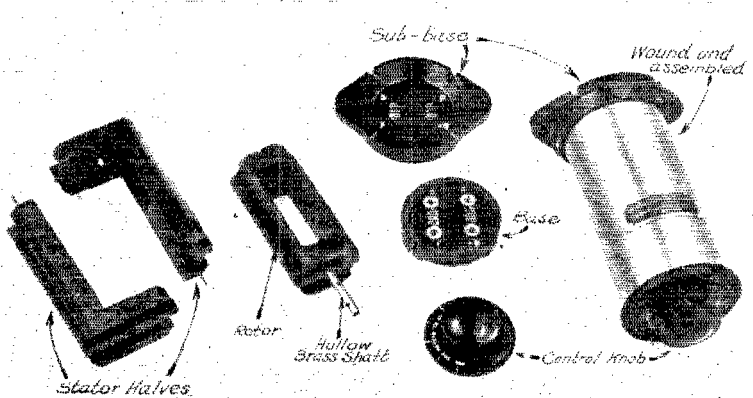

BALLANTINE VARIOTRANSFORMER

Note diagram of connections on bottom of base and sub-base

used. When more stages are used it becomes rather hard to tune all of them together. More than two stages are not ordinarily used. One immediately thinks of introducing resistance to broaden the tuning, but that causes a drop in the signal strength.

The second of the usual methods is to put a variometer into the plate circuit of the first tube and feed the plate power (B-battery) to the tube thru this variometer. When a signal is coming in, this variometer is so adjusted that the radio-frequency current causes a considerable voltage-drop across the winding; it is then only necessary to feed this voltage to the grid of the next tube. Right there the trouble begins—the variometer is connected to the B battery, the windings carry the B-battery voltage, and a direct connection to the next grid will injure or destroy that next tube. It is necessary to put in a blocking condenser and a gridleak as in Fig. 2. This is not a good state of affairs, as it is not possible to control the bias of

grid circuits. The thing has been done quite simply: the variometer is wound with a 2-strand wire, the strands being insulated from each other (see Fig. 4). When the winding is complete one strand is connected into the plate circuit and becomes the primary; the other strand is connected into the grid circuit and becomes the secondary. We now have a *transformer*: whose primary and secondary, and therefore the wavelength range, can be varied by turning the knob on the shaft of the variometer-rotor. This is the "variometer-transformer" or "Variotransformer".

The actual construction of the device is shown in the photograph and does not seem to need much comment. However, a great deal of time and patience was spent in determining the proper proportions and in arriving at a construction which will keep down the resistance and still permit a wide wavelength range.

Testing Radio Amplifiers

Before one starts to speak of amplifica-

tion it is well to explain how it is measured. The amplification of a radio (or audio) amplifier can be expressed as the output voltage divided by the input voltage—in other words the voltage amplification is simply the number of times that the input

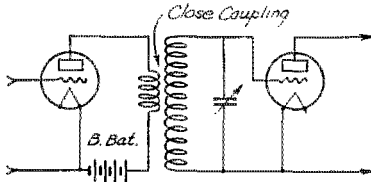

FIG. 1

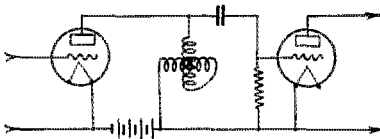

FIG. 2

voltage has been multiplied in going thru the amplifier. Let us look at this another way: suppose that the tuner supplied to the detector a potential of one micro-volt (one millionth of a volt). Now if we put a r.f. amplifier ahead of the detector and

is extremely easy to get false results. Ballantine and Hull therefore spent many months in devising an apparatus set-up that they were sure did really measure the r.f. voltage amplification, and nothing else. All manner of check-tests and precautions were taken and the results may be regarded as trustworthy, especially as both men concerned had put some years on this particular sort of work.

In Fig. 3 are shown curves for the Variotransformer and several commercial transformers with fixed windings. Curve 1 is an air-core transformer and, as stated above, it shows the tendency to amplify very strongly over a narrow range—and not at all otherwise. This particular transformer performs beautifully on 450 meters. Nos. 2, 4, 5 and 6 are normal iron-core transformers. No. 3 is a somewhat special type intended mainly for long-wave work and it can be seen that above 600 meters it performs better. The outstanding thing about the group of curves is the flat-topped curve of the "Ballantine 5". This curve gives the same high amplification over the entire broadcast band, and does not fall below 5 in the amateur band. None of the others approach this. Now it is not pretended that the curves show all commercial transformers, none the less it is true that no fixed transformer can show a flat-topped curve.

Handling the Variotransformer

The curves perhaps give the impression

Curves of Non-Regenerative amplification comparing several Commercial R.F. Transformers with Model 5 Ballantine Variotransformer.

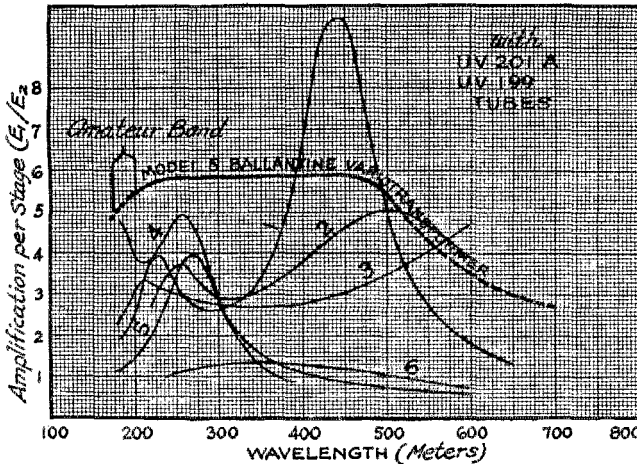

FIG. 3

find that we are supplying 5 micro-volts to the detector it is evident that the voltage-amplification is 5.

The devices for measuring such amplifications must be very carefully handled—it

that the "variortransformer" is non-selective and will "let everything thru at once". That is not correct, for it must be remembered that at any one setting the transformer gives a curve which (altho higher) is

of the general type of curve No. 4, Fig. 3. The curve shown therefore is the one made by the various peaks that can be obtained. Putting it in another way, if we turn the



FIG. 4

knob of the variotransformer we can cause the peak to slide along and draw the curve shown—but if we stop at any point we have

a peak and will therefore not be bothered by waves much to either side, tho the tuning is not so sharp as to be bothersome.

The process of tuning a set with Variotransformers accordingly is to set the knobs of all of them at the same value—a bit below the desired wave,—then to tune in the desired station with the condenser, etc., of the input tuner; and, finally, if that seems necessary, to make more exact setting of the Variotransformers. Any tendency to oscillate can be avoided by keeping the settings a bit low (this makes the plate load capacitative instead of inductive) or by some permanent device such as described in the paper "Anti-Regenerative Amplification," QST for January, 1924.

"CQ Urgent de 7IP"

Amateur Radio Again Proves Itself Useful in Emergencies

By F. M. Curtis, 7SZ

HUH, that's a new one on me", muttered 7GI to himself, as he turned on the filaments of his two five-watters preparatory to answering 7IP's general inquiry, which was liberally sprinkled with the word "urgent". "Wonder who this bird is, anyway? Don't remember hearing his call before. Well, here is where we get acquainted.

7IP 7IP 7IP de 7GI 7GI 7GI QRA? QTC? K".

"7GI de 7IP GM OM QRA NEAH BAY WASH. QTC LONG MSG QSR? VY URGENT BD STORM HR ALL COMMUNICATION CUT OFF MUST GET IN TOUCH WITH MAINLAND 7GI de 7IP K".

"7IP de 7GI OK OM GA K".

"HR NR1 FM A A MCCUE NEAH BAY WASH DEC 8 3AM TO P H MCCUE NORTHWESTERN FISHERIES CO 600 MARINE BLDG SEATTLE WASH. CANNERY COURT SOLDER HOUSE AND CHINA HOUSE READY TO FALL STOP MESS HOUSE OK STOP CLOSE NIPPLE BETWEEN SHUT OFF VALVE AND PURL TANK BROKE ALL—QRX BATTERY FAILING".

That was all. No longer was 7GI nodding with drowsiness. "Bd storm hr—all communication cut off" was enough to cause an attentive tenseness in him as he sympathized with 7IP in his helpless position out there on the storm-battered point. He tuned around in vain—the pleading chirp of Neah Bay was not heard. Minutes dragged by. After a space that seemed like hours, again the signals reached his ears:

"7GI 7GI de 7IP 7IP SORRI OM QRV? HW? K".

From his little shack in Spokane, 7GI again joined Neah Bay to the rest of the

world. Traffic was resumed without wasting time:

"...ALL CRUDE OIL LOST STOP FIVE PILES GONE UNDER STOP BOILER STILL STANDING ALL MACHINERY MOVED OUT OF CANNERY INTO WAREHOUSE STOP SUGGEST YOU COME OR SEND SOMEONE TO LOOK THINGS OVER AFTER STORM ANSWER SIG A A MCCUE. HW? 7GI de 7IP K".

7GI had it, of course, and arrangements were made for the delivery of the message via Western Union to Seattle. 7GI received the answer from Seattle and forwarded it to 7IP. Several days later GI received the following letter from IP:

Neah Bay, Wash.,
Dec. 14, 1923.

Mr. Carlos S. Yerian, 7GI,
Spokane, Wash.

Dear Mr. Yerian:

I wonder if you realize how important that message to Mr. P. H. McCue was? Up until the night of our communication I had not done any amateur work since I

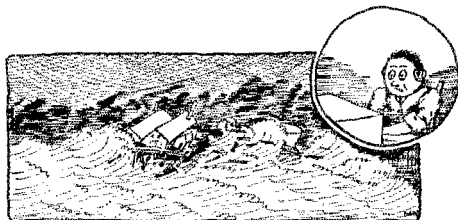

disposed of my transmitter in Alaska four years ago. (By the way, I was the first ham in Alaska; my 1-k.w. spark set was in

operation up there in 1916.) I gave up amateur work when I took charge here three and a half years ago, as it interfered with my work, but after the good work thru amateur radio the other night, I am back in the game for good. I am going to Seattle the first of January and while there I am going to build a 250-watt C.W. transmitter—so you see I am going into it right.

My dad, Mr. P. H. McCue, general manager and vice-president of the Booth Fisheries Co., is here now looking over the damages done to our cannery by the storm.

He certainly appreciates the good work you did for us and he is all for amateur radio. He is writing you a letter to show his appreciation.....Allow me to thank you again for the good work. I hope I may have the opportunity of meeting you some time.

Respectfully yours,
A. A. McCue,
Supt. & Mgr., Neah Bay Branch.

As 7GI folded up the letter and put it back in the envelope, he knew that amateur radio is indeed more than a mere plaything.

The Improved "S"-Tube Rectifier

By James L. Jenks, Jr.*

IT is an interesting fact that, during the past fifteen years, the transmitting amateur has been constantly perplexed and harassed in mind as to how he may supply the necessary volts and amperes to his sending-equipment without breaking a bank or committing forgery. In the very early days dry-cells, an army of wet batteries, or even an occasional storage battery, furnished the energy for the famous "squeak box," at that time the very acme of transmitting perfection. A few years later the electrolytic interrupter made its appearance, and city mains supplied the necessary wherewithal for "half-kilowatt transformer coils" and such gentry. Next

problem pops up again—"What shall we use for the necessary D.C.?" To some, a high voltage "B" battery or a motor generator may be the answer, although both have their drawbacks. To the great rank and file, however, the high voltage rectifier, capable of efficient filtering, is the most satisfactory solution.

In QST, August, 1922, a new rectifier known as the "S"-Tube was described. This device was of considerable interest for the following reasons:—

1—It would rectify comparatively high voltages without filament or other electron emitting device.

2—Its life was not determined by any one element within its construction, such as filament, etc. In other words, the life of the tube depended largely upon its treatment, and with care, the tube was known to average several thousand hours of service.

3—It was extremely simple to connect up and operate since it was merely necessary to insert a common porcelain lamp receptacle, and connect to the alternating current source. The tube was free from the inconvenience of separate filament lighting supply, sloppy chemicals, magnetic fields, etc.

The chief limitations of the tube, however, were in its voltage and current output. 50 M.A. at 750 volts D.C. was considered the maximum safe output of the old style tube. With the ever-increasing popularity of the 50-watt transmitting tubes, it soon became evident that the original "S"-Tube would not handle the job. Accordingly, late in the spring of 1923, an improved "S"-Tube was developed in the Amrad Research Laboratory, which is now marketed under the title of "S'-Tube, #4000." This new tube possesses the following advantages:

1—Its voltage and current output has

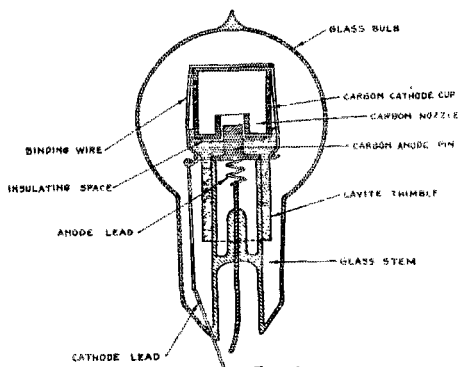

Fig. 1

came the good old transformer and spark gap with its host of relatives in the form of blinking lights, annihilated fuses, uncanny telephone troubles, etc., ad infinitum. And now, with the little transmitting bottles here apparently to stay, the same old

*—Laboratory Manager, Research Department, American Radio & Research Corporation.

been considerably increased; 100 M.A., D.C. at 1000 volts are now considered a safe operating output.

2—Owing to improved internal construction, temporary overloads can be much better withstood than with the old style of tube.

3—Improved methods of treating and design have lowered the starting voltage and internal losses.

The new tube operates very successfully both in series and in parallel, which means

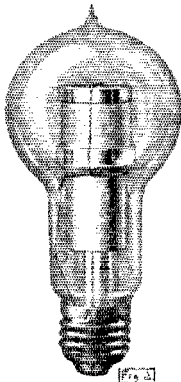

extended usefulness where extra high voltage or current is required.

A glance at Fig. 1, which is a cross-sectional cut of the tube, shows its extreme simplicity of construction. It consists essentially of a treated carbon cup and nozzle, supported on a thimble-shaped insulator of baked lava. An anode pin projects into the nozzle space, and is insulated from the cathode by means of the lava thimble. One reason for the tube's increased output is the fact that lava maintains its resistivity at very high temperatures. Glass, on the other hand becomes a fairly good conductor when heated above 300 degrees centigrade. The increased simplicity of construction has permitted making the over-all length of the tube considerably less, thereby increasing its mechanical strength. Fig. 2 shows the tube as it appears completely assembled and in a regulation lamp socket.

It has been found to be an excellent source of plate power for all types of tube transmitters, owing to the excellent wave form inherent in its principle of operation. Properly smoothed by filters and chokes, the "S"-Tubes will furnish direct current that can hardly be told from that furnished by a storage battery.¹

Fig. 3 shows an oscillogram of two "S"-Tubes rectifying 60-cycle A.C. with and

without a filter. Note the almost perfect wave form, and absence of reverse current. Frequencies as high as 800,000 cycles have been successfully rectified with the new style tube.

Station "WGI" has been using "S"-Tubes with perfect success for charging a 500-volt Exide storage battery used in phone transmission. High voltage batteries of this sort may be charged direct with no complicated paralleling switch or similar device.

By properly filtering the output of one or two "S"-Tubes, a very satisfactory source of plate-potential for *receiving* sets may be provided, free from all hum or ripple.² Such a plate-supply is clean, compact, always ready for use, and amply sufficient to operate a power amplifier where several hundred volts are required.

In conjunction with a high capacity condenser, such as the Mershon Electrolytic Condenser, very heavy currents are made

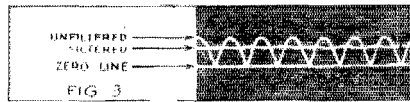

available for short intervals of time. This type of power is useful for such work as time clocks, relay signals, etc. Two "S"-Tubes, charging four E.M. Condensers in parallel, and having a total capacity of about 120 mfd., will put several amperes through a magnet coil of the proper resistance; and solenoids have been made capable of lifting several pounds by this method.

Chart #1 shows a single "S"-Tube in the process of warming up. It will be

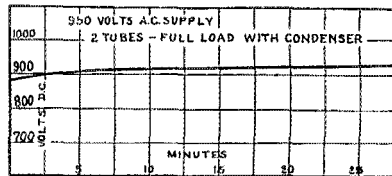

CHART 1 TEMPERATURE REGULATION

noticed that, when the tube starts cold, the output is somewhat below normal, the voltage drop decreasing in the course of a few minutes as the elements become heated.

Chart #2 shows the remarkable voltage regulation of the "S"-Tube under varying load.

Chart #3 shows two "S"-Tubes in double half-wave rectification with the usual center-tapped secondary. The four curves

¹—Refer to "Amateur Filter Problems" page 23 of QST for August, 1923. This issue can be supplied by the circulation department at the usual price.

²Refer to p. 13, QST, April, 1923 for full details. It can be supplied by the circulation department at the usual price.

show output under four conditions, namely: load with and without condenser, and no load with and without condenser.

Chart #4 shows a similar series of curves, but with two tubes in series on

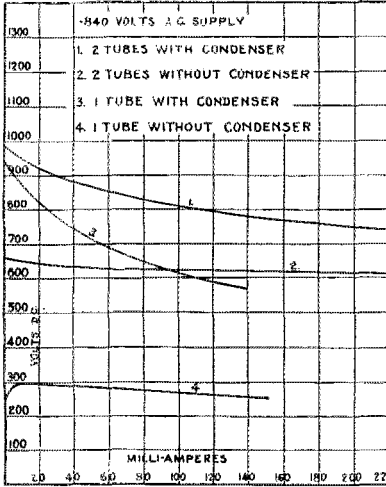

CHART 2 REGULATION 1 & 2 TUBES

each half of the secondary. It will be noted that the so-called "bridge" connection puts two tubes in series for each half-cycle, as does the other connection shown. The

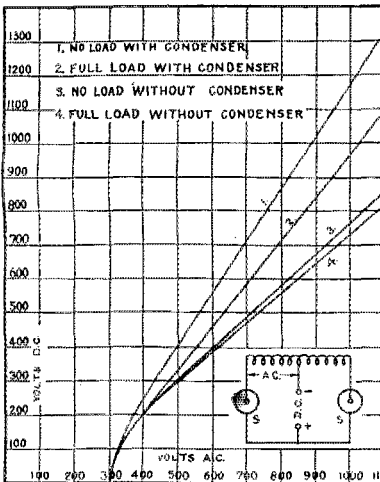

CHART 3 2 TUBES-TAPPED TRANSFORMER

"bridge" connection incidentally is useful where very high voltage is required, or where no center tapped transformer is

³—These balancing resistances should be of metal so that an excessive current thru one will cause its resistance to rise rapidly. Thus a Ward-Leonard resistance unit or a tungsten lamp is O.K. but a carbon lamp or a water rheostat is not good.

available. (However the "bridge" connection passes quite a large amount of 60 cycle current. The "center tap" connection passes nothing below 120 cycle hence is easier to filter.—Tech. Ed.)

Chart #5 shows the "S"-Tube operation in parallel. As the "S"-Tube is purely a gas discharge device, it is necessary to put balancing resistances of from 500 to 1,000 ohms in series with each tube in order to evenly divide the load.³ The reason for this will be apparent if one tries to run two-spark gaps in parallel. Invariably, the shorter gap will take all the current unless it is forced to divide by some form of balancing resistance. Ward-Leonard 500-ohm and 1000-ohm wire-wound resistance units are excellent for balancing resistances as are 110 volt tungsten lamps. Use lamps that run cold or at a dull red heat. 25 and 50-watt lamps are also useful when charging "B" batteries.

From the above charts transformers may be designed for any desired output of recti-

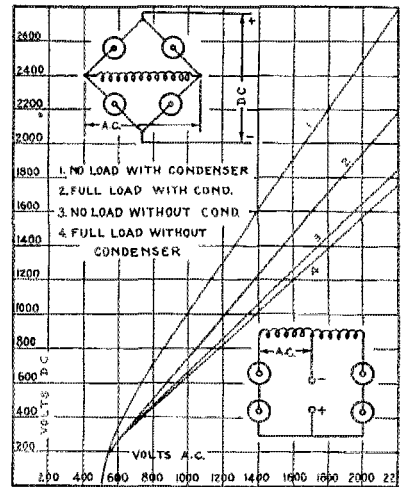

CHART 4 SERIES TUBES BY BRIDGE METHOD OR TAPPED TRANSFORMER

fied D.C. In normal operation the "S"-Tube starts conduction at about 300 volts A.C., and has an internal drop of approximately 150 volts.

The following hints on practical operation may not prove amiss:

Allow the tubes to warm up a few moments before expecting full output, as moderate heat improves conduction.

If applied potentials are too high, the tubes will usually glow or flash over externally, warning the operator to lower the voltage. With smoothing condensers, a tube will sometimes flash over at no-load, but be perfectly steady at full-load, as with high leakage transformers the no-load volt-

age frequently rises very high. Unless flash-over is prolonged, a tube is rarely injured by this phenomena and, properly observed, it makes an excellent overload indicator.

Unlike thermionic rectifiers there is no limit to the current the "S"-Tube will pass, until breakdown occurs. This is an extremely useful feature since very heavy current may momentarily be drawn without permanent injury to the tube. Should a tube be accidentally overloaded for a prolonged period and cease to rectify, several hours' operation on low voltage and light load will frequently repair the injury. The reason for this is that overloading gives rise to impurities in the gas, which, upon ageing, again disappear, leaving pure gas and renewed service.

In parallel or series operation care should be taken to see that the tubes are connected properly. The tube passes current when entering by way of the anode which is the center contact of the lamp base. The current leaves by way of the cathode, which is connected to the ferrule, or outside of the base. With a split secondary, it is convenient to connect the outside taps to the two anodes, or center terminals of the "S"-Tube, thus making the center tap of the transformer the negative lead, as shown in the diagrams.

In conclusion, it is safe to say that the improved "S"-Tube will find favor with all

who wish for a cheap, efficient, fool-proof, high voltage rectifier, which requires absolutely no attention, or auxiliary equipment,

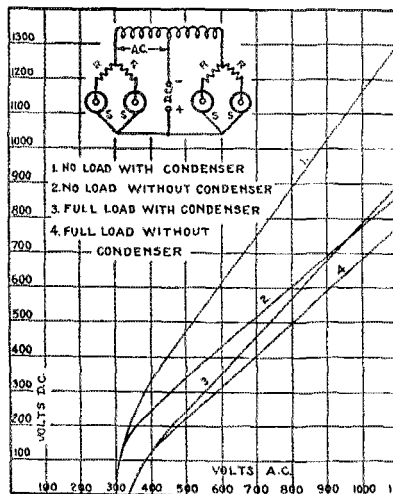

CHART 5 PARALLEL TUBES - TAPPED TRANSFORMER

has nothing to burn out, is durable, very long-lived, clean and compact, and which, when properly filtered, gives a tone that cannot be excelled.

Automatic Radio Relaying

By Porter H. Quinby, 9DXY

WARNING—This article is presented as the record of an interesting stunt, but NOT to encourage general copying of the stunt. Endless trouble would follow if the practice of auto-relaying were to become common, no one would know whom he was hearing, a wild mess would be the final result.

Remember also that it is a violation of the radio laws to sign a call that does not belong to you—no matter how the sending set is being keyed. Don't try to blame it on someone three states away from you.—Tech. Ed.

AUTOMATIC radio relaying devices are usually built around the idea of receiving a signal, amplifying it until it will operate a magnetic key, and then using this key to operate a sending set on a wave very much different from the receiving wave. Such stunts have been used often; perhaps A.R. R.L. members will best remember the twin operation of WWV and NSF during the Fading Tests of two years ago. At that time the signals of WWV were received at NSF, amplified until strong enough to operate a keying relay, and then caused to operate the key at NSF. Because the stations were close together and special tuners were used it was possible to crowd the two waves together; quite regular operation was got-

ten with WWV on 200 and NSF on 190. The stations were operated when tuned more nearly together than that but some interference followed. Such systems are good only when the received signal is very strong or the re-transmission wave is quite different from the received wave. That is the first novelty in the system tested at 9DXY, the re-transmission wave is the same as the received wave.

9DXY's Stunt

A sending set with a tuned grid circuit was used and operated as follows: First the switch was closed and normal voltage applied to the tubes, which at once began to oscillate. The variable grid-tuning condenser was then very slowly turned until

the tubes just stopped oscillating; and then slowly turned back again until the point was found where the tubes *just failed to start oscillating*. The set was then in a very unstable condition and a small voltage in the antenna system would cause it to "break over" and begin oscillating. Unreasonable as it may seem it is *perfectly possible for a received signal to furnish this "trigger voltage" and to start the set going*.

The next problem was to make the sending set stop oscillating when the received

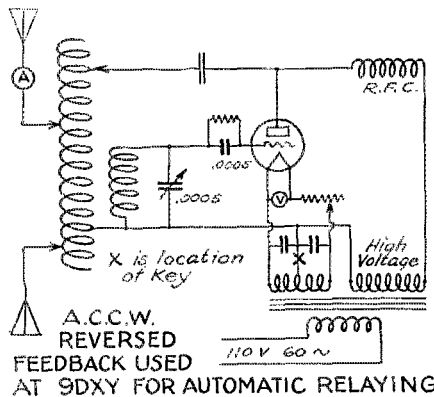

signal stopped coming in, and this at first sounded very difficult. However, it was really quite simple. It was perfectly plain that the tubes would stop if we removed the plate voltage, and that was the method used at 9DXY. It was only necessary to supply the tubes with 60-cycle alternating current. This sort of plate supply shut off 60 times per second, and each time the tubes stopped oscillating. Then they did not start again unless the distant operator still had his key down so that the "trigger voltage" was supplied for the next half-cycle. Putting it differently, the sending set continued to be triggered off at each half cycle as long as the distant operator held his key down. As soon as he let his key up the sending set at the relay point finished that particular half cycle and stopped. The same effect can be had by using rectified-but-not-filtered plate supply.

The Set at 9DXY

The circuit used at 9DXY was the familiar reversed-feedback with a tuned grid coil. Both series and parallel feed have been used with equal success and the latter is shown in the diagram. The only unusual thing about the set is that the diameter of the grid coil is only 4 inches, altho that of the helix is 7 inches. This grid coil may at first glance seem small but is the result of much experimenting and is found to be the most satisfactory

size for obtaining full output over a band of wave lengths. With this coil in use we find it possible to QSY over a band of fifty meters by simply changing the antenna clip and the grid-tuning condenser. This takes less time than the telling, usually about 10 seconds, and the antenna current remains about the same; how different from the Hartley! It has been our experience that the controls are not interlocking but that the plate clip controls the load on the tubes and the grid condenser controls the feedback. Thus we have reduced the controls of our wave length to two—the antenna clip and the grid condenser. [Almost—but not quite. To secure best operation from such a set the nodal point cannot be allowed to wander around but must be kept at the point where the filament and grid circuits connect to the helix, as often explained in QST. In general this means that the counterpoise and antenna clips will be about the same number of turns away from the filament-grid clip. Result: it takes 15 seconds to change wave instead of 10.—Tech. Ed.]

The Stunt in Operation

Any strong incoming signal could be re-transmitted as desired in the following manner: First we tuned in the distant station on our receiver, then by means of the antenna inductance clip we adjusted the transmitting set to the wave length of the received signal at which the receiver was set; this was done easily enough when listening and took less than 60 seconds. Then we put the grid circuit in the critical condition as explained above and at once the signals began to break thru, and with a little readjustment began to re-transmit themselves as clearly and as cleanly as tho the original operator were handling the key at 9DXY! Operation was equally successful on five, ten, fifty and a hundred watts. The phenomenon is not a peculiar characteristic of one individual set for we have built two and they worked in the same manner.

Automatic relaying is interfered with by heavy atmospherics and other stations on its own wave length in the same manner as a receiving set. But under favorable conditions signals have been re-transmitted from 5ZA, SCWP, 3ZO, 4EB, Can. 4DY, and others equally distant, and have been copied up to 800 or 900 miles from our station. At one time we QSRed a message in this manner from Ohio to Denver on 10 watts and received a QSL immediately. We never did get done explaining to those fellows how it all happened. Hi!

The suggestion may be offered that our receiving set re-acts upon the transmitter in aiding this phenomenon but we found it made no difference whether the receiver was turned on or off. However, the re-

ceiving set was used if we wished to copy the message as it went through, and we also found it an aid in tuning our transmitter to the distant station as described above.

Sometime ago we wrote a little article to the editor and spent most of our spare time for several months thereafter in answering correspondence on that subject.

So to avoid this would suggest that any inquiries on the above be piled upon the broad shoulders of "LQ" and his department. Will be glad to furnish any further details that he may require. The old mill needs water-cooled bearings now, so please, oh, please, gang, don't turn loose on me again! I want a little time to handle my O.R.S., O.B.S., C.M. and A.D.P.M. work. Hi!

Motor and Generator Bearings

By E. W. Berry*

THE greatest cause for dissatisfaction on the part of users of motor-generator sets does not arise from the inability of the manufacturer to produce a machine that fulfills the requirements, but rather from failure of the machine thru ignorance, neglect or willful misuse. This statement is made after a careful survey of the work of the repair department of one of the largest makers of motor-generator sets for radio work. A large percentage of generator and motor breakdowns are either in the bearings or are the result of bearing trouble.

Bearings may be divided into three types: wick oiling, ring oiling and ball bearing. Without commenting on the disputed merits of each type we will consider them individually.

Figure 1 shows a typical *wick-oiled bearing* with its oil cup. The bearing, B, is mounted, tight fitting, in a housing, H, and is held in place by the nozzle, N, of the oil cup, C. The nozzle also serves as a guide for the wick, W, and as a mounting for the cup. The wick and the spring should be so adjusted that the wick bears firmly on the shaft. Do not loosen the nozzle or the bearing may become loose in the housing. The proper fitting of wick-oiled bearings without accurate bearing and lining reamers is a dangerous undertaking in so far as the machine is concerned. If new bearings must be installed be sure that they are provided with a small groove extending from the wick hole nearly to the ends of the bearing. This groove may be chiseled provided the burrs are carefully removed.

Figure 2 is a *ring-oil bearing*. The ring, R, hangs in the groove, G, riding on the shaft and turning thru the groove with its lower side immersed in an oil well. This revolving ring carries a steady flow of oil over the exposed surface of the shaft. The grooves convey the oil from here to the inner surface of the bearing. In placing a machine of this type into service three precautions should be taken. First, see

that the ring rides on the shaft and turns with it. It may be held by an unremoved burr, or it may have slipped out of the groove and lodged on the bearing proper. Second, be sure that there is a good supply of oil in the well; a small amount of oil, thru which the ring does not run, is useless. Third, be sure that the oil well is free from burrs or grit that may be carried with the oil into the grooves.

Ball bearings should not be meddled with. They are accurately fitted and inspected before leaving the manufacturer. Provisions for oiling or greasing are made; use them. Removal of the end caps is only inviting grit to enter.

Keep the cup of wick-oiled bearings well filled. The manufacturer has originally

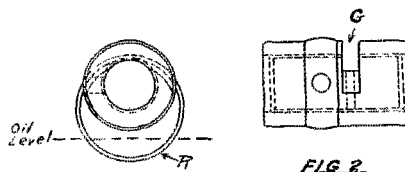
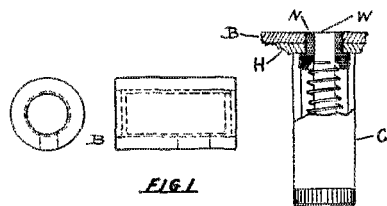

filled it with the proper lubricant. Ask him where to buy the right oil or obtain it from him. In any case the oil or grease should be fluid enough to be absorbed by the wick. Ring-oiled bearings should have a fairly heavy oil, ball bearings a light grease, and vertical-shaft ball bearings a slightly heavier grease.

In mounting machines be sure that they are so arranged that the bearings will lubri-

*Engineering Department, Electric Specialty Co.

cate properly. Wick-oiled and ring-oiled bearings must always be mounted with the shaft horizontal. This is to let the armature line itself up in a normal position in the magnetic field. In this position the armature should tend to hug neither bearing but to "float" between the two. On the other hand with ball bearings there should be no end play. The bearings are so designed that the armature is held in its proper position. This permits less care in mounting.

Use the proper lubricant and use it freely.

A tight bearing causes excessive heating and may result in burning the bearing and shaft.

A loose bearing is noisy, wears rough, and often allows the armature to rub against the stator; then the machine re-

fuses to start or does so with heavy vibration.

A ring-oiled bearing is designed to be mounted in one position only, with the oil well down and the shaft horizontal.

Ball bearings may be mounted in any desired position but the preference should be given to the position for which they were designed.

An improperly floated armature will cause inefficient operation. The shaft will hug one bearing, wearing away the fibre washers, whereupon the bearing, with metal against metal, becomes noisy and overheats.

Don't dismantle the machine until you know that by doing so you can repair the difficulty. Otherwise get into touch with the manufacturer. He would a great deal rather help prevent trouble than to repair the machine after the harm is done.

Rotten Problems

By The Old Man

You who belong to the order of the Wouff Hong have seen the Old Man. Old-time readers of QST know him thru his writings. Newer members need an introduction, and here it is. The Old Man has been with us from the earliest days of the A.R.R.L., he has plugged his way through all the problems we have met on the road, and he has taken every problem seriously and done his best with it. Sometimes this has been a pretty severe strain on his disposition, and when his temper lets go, a story results. Other times the stories just happen anyway, because something funny has occurred at the radio club to which T.O.M. belongs. With that introduction we now present—The Old Man.

SAY Son, send help, will you please. The Radio Club dug up one last night that has not been equalled since the old spark days when we used to break up the furniture trying to agree where the ground began and the ground lead ended. It began when Final Authority explained in words of one syllable the

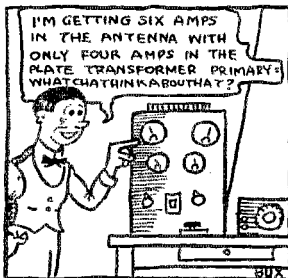

"The poor gink to whom his remarks were addressed—"

"Law of the Conservation of Energy." The poor gink to whom his remarks were addressed was trying to make out that his six amps in his antenna and his four amps in his plate transformer primary indicated that he was getting something for nothing

from somebody. He got about as much out of Final's lecture on the Conservation of Energy as I would get out of a discussion of the "Background of Eternity". I don't know what the latter means and the poor gink didn't know what "conservation" meant. The lecture got just exactly nowhere with the muddle-plated one, but it did wake Radical up. I noticed his attention being drawn to the subject in hand, just about the time that Final got on to the matter of radiation resistance. I knew there would be some old time doings, so I stuck around and threw a monkey wrench into the works now and again when the opportunity offered.

When Final had been led along by Radical to a point where the radiation resistance of the antenna represented actual energy sent out, the fire began to fly the way it did in the good old spark days. It sure did seem like old times. Radical asked Final what made the phone diaphragms at the distance receiving station move, and of course Final said it was the A battery energy triggered off by the feeble incoming current. Radical's questions had about ten words in them, and Final's explanations had about fifteen hundred. We waited while Final wandered around through the mazes of the vacuum tube

detector and the vacuum tube amplifier. Radical after a long time got him down to the energy placed on the grid of the detector tube. All hands agreed, after about an hour and a half, that this energy was unconditionally a part of the energy that had been radiated from the transmitting antennae. This is just where Radical wanted to land Final. It took a long time to get down to brass tacks, but he finally got him down. Then he proceeded to swat him in the intelligence.

If the law of the conservation of energy held, then would Final please explain what became of the energy that left the earth and was radiated into outer space?

Final replied that energy can neither be created nor destroyed and that which escaped into outer space, could not have been destroyed and probably reappeared in the form of heat somewhere.

Radical touched a tender spot when he asked, "heated the air, I suppose—HOT AIR?"

Final didn't see the point at all. He rejected the hot air proposition altogether, and did not believe that the air had anything to do with it, but that it was an ether proposition. This got him in still deeper. Radical asked him if he meant that the "ether got hot."

Final had evidently never given consideration to heating up the ether, and he began to flounder. It was evident that the knock-out was drawing near.

"Then what does get hot?" asked Radical.

Final had a terrible time trying to put his finger on something in outer space which would get hot as a result of the hundreds of thousands of ergs of energy that were being squirted into outer space by the radio stations every month that rolled around. But he had said that the energy positively must reappear somewhere on account of the conservation business. It usually appears in the form of heat, and he positively must find something that got hot. He could not think of a blamed thing out in inter-stellar space that would get hot, and there he was hung up in space, getting colder and colder every minute and wondering what in timentation *did* become of this radiated energy. The best he could do was to say that if it did not encounter anything, it simply went on and on and on.

Radical asked how long it would keep on going on and on and on.

Final hadn't anything better to suggest than "forever".

Everybody began to get up on their toes about this time and Radical expressed the views of the rest of us very eloquently when he replied "Gosh! Forever's a darned long time."

Final had to account for friction and various other losses which we electrical and mechanical tinkerers know so much

about, but he simply ran clean out of ammunition and for once in his long radio club career sat down speechless.

There was a long pause when you could hear the watches all ticking around you. Radical finally broke it by exploding, "If all this conservation dope is OK, I'm still looking for somebody to tell me where the



"Final didn't see the point at all."

energy reappears that escapes into outer space.

I'll be horned-swoggled if there was a soul in the room who could tell him.

I've sat up half the night trying to figure it out myself, and I haven't got the answer yet. It's like the old timer, that Japanese school boy, who asked the one about the air condenser and what became of the charge on the dielectric when somebody blew out the air between the plates. This radio energy that we fellows radiate out from our antennas must escape into outer space in pretty big gobs. That which escapes from these 350-kilowatt transoceanic stations must be some respectable amount of energy. There is so darned much vacant space that this stuff must miss the target a good deal of the time. What becomes of it?

Send us help, some of you wise guys.
TOM.

NOTICE TO OUR NEWSSTAND READERS

As announced in our last issue, the Operating Department Report and the "Calls Heard" Department have been eliminated from the newsstand edition of *QST* because our non-member readers in general are not particularly interested in them. This results in a saving in expense which makes possible the publication of a larger and better *QST*.

These two departments are included in the edition supplied to members of the A.R.R.L. If you are interested in them, it is proof positive that you ought to be a member of the League. May we not direct you to the handy application blank appearing on page 88 of this issue?

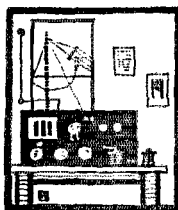

Amateur Radio Stations

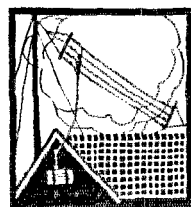

F8AB, Nice, France

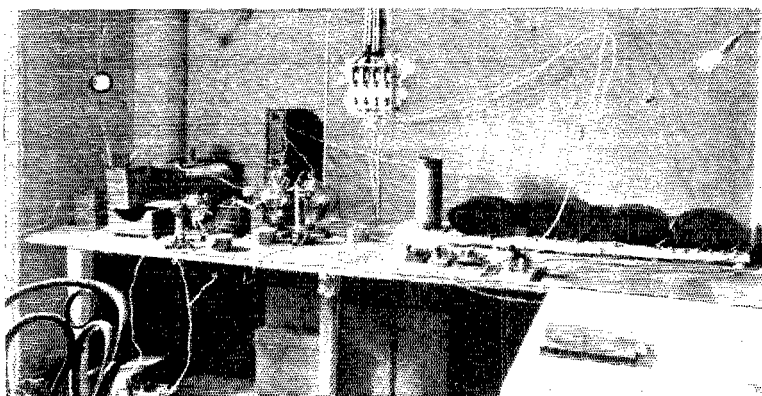

The 25-cycle signals from Leon Deloy's station, F8AB, at 55 Boulevard Mont Boron, Nice, France, have been heard all over the United States and southern Canada during the past month. Amateurs everywhere are curious to know the details of this station's transmitter. F8AB was not only the first French amateur to work American amateur stations, but his signals are still the strongest amateur signals that have ever come across the Atlantic.

M. Deloy, when on his recent visit to America, spent a good deal of his time visiting amateur stations and getting information and ideas on the tube transmitters used by amateurs here. When he sailed for France he was confident that he could go home and build a transmitter that would reach this country—and it was not long before that was done and his signals were heard on this side.

The photograph shows the transmitter just as it was when it was first heard in this country. It is just an experimental layout and no attempt was made to make a finished job of it. The Hartley circuit is used with variable series condensers in both the antenna and counterpoise leads after the fashion described by 1QP on page 26 of the January QST.* Two S.I.F.

French 250-watt (input) tubes are used in parallel as oscillators, with high voltage 25-cycle alternating current applied directly to their plates.

Looking closer, the two series condensers can be seen at the extreme left in the wooden boxes. Next is the inductance, made of copper tubing and wound on a wooden frame. In front of the inductance is a 50-watt (input) French tube, the plate-to-filament resistance of which is utilized as a grid leak for the oscillator tubes, as suggested by Mr. T. Appleby. The boxes behind the transmitting tubes contain fixed condensers made of photo plates. To the right of these is the radio frequency choke coil; a single layer of cotton or silk covered wire on a cardboard tube. The high voltage current is supplied by the four transformers seen in the right-hand side of the picture. These have their primary windings connected in parallel and their secondary windings in series, the sending key being connected in series with the primary windings.

Passing to the outside of the station,

*Can be obtained from the QST Circulation Dept. at the regular price.

the antenna is an inverted L, the flat top of which is a four-wire cage on three-foot spreaders with an average height of 76 feet above the ground. The lead-in is about 46 feet long and consists of two wires running to the operating room on the top floor of the house. The counterpoise, nearly underneath the antenna, is a three-foot cage running from the operating room to a point six feet above the ground. It is slightly longer than the antenna.

A Grebe CR-13 receiver has been used lately in the transatlantic work, but an experimental super-heterodyne set and several other receivers are in the station and are used at times.

The normal antenna current at F8AB on a wave length of 108 meters is in the vicinity of 3 amperes, but good communication has been carried on with American amateurs with as little as one ampere in the antenna!

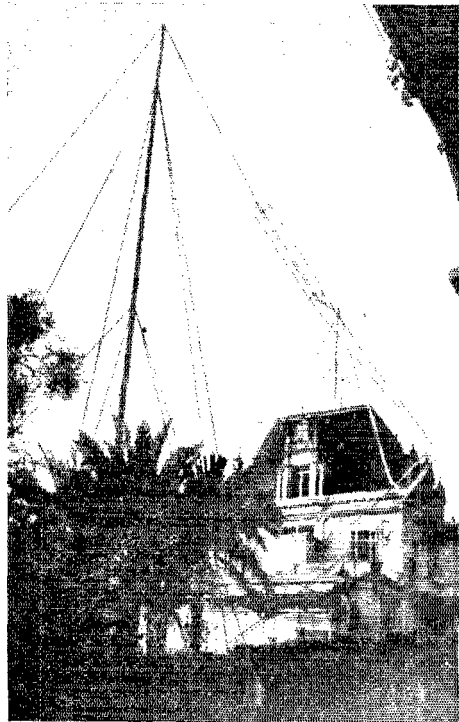

Since the above was written, and since this photograph was taken, M. Deloy has rearranged his antenna system and altho he is now getting less antenna current he comes in nearly twice as loud on this side as he did before. Details of what the changes were have not yet been received but will probably be published later.

G2KF, London, England

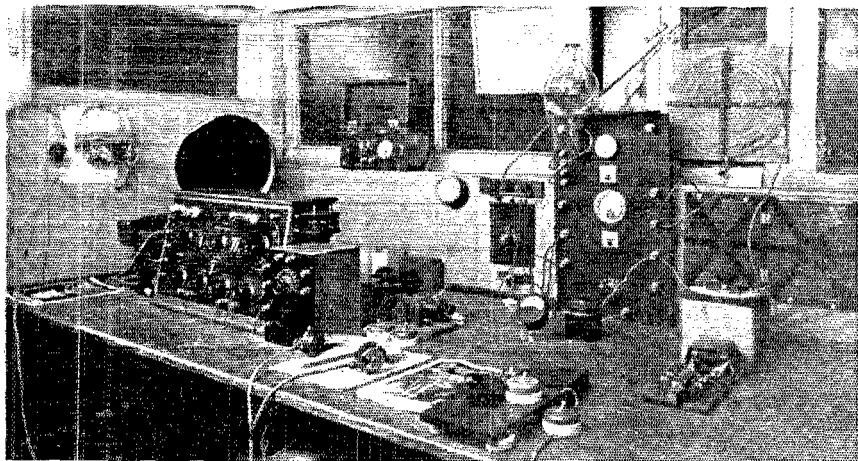

British amateur station 2KF was the first English amateur station to carry on reliable two-way communication with America. For that reason we are especially glad to get a peep at the inside of this

pioneer station and have Mr. J. A. Partridge, the owner and operator, tell us about the apparatus and connections employed at his station.

(Concluded on page 56)



GETTING TOGETHER WITH THE B.C.L.'s

By H. Eugene Watkins, President,
Worcester County Radio Asso.

THE Worcester County Radio Association pulled off a stunt recently in their "shack" on the roof of the Y.M.C.A. that can easily be copied by other radio clubs. It came about this way:

Worcester has hundreds of B.C.L.'s who have been blaming the local ham for all the sins in the decalogue and a few that have come in with radio. They organized as the Worcester Radio Club, and began holding their meetings in the City Club. They elected their officers: President, a dear little old man who is as "set" in his own opinions as any "down east Yankee." He is the owner of the "best radio receiver money can buy, sir." (A certain infamous single-circuited.) The Secretary is a young chap who holds down the job as Radio Editor on one of our local papers—who cannot read code and wonders who CQ is. And so on all down the line.

Now I do not want to make fun of these men, for they are "terribly" in earnest and want to clean up radio. They have started a petition to the Government to stop "ship to shore" communication three days a week so "we can have decent concerts for those nights."

So much for them. Now two week ago I was invited with two other members of our Club to come down to their meeting and explain why we existed at all; why we should not have our licenses taken away and allow the B.C.L.'s to have the air to the themselves forever Amen. Well, we three threw a wrench into their aspirations and were able to convince them, partially perhaps, that we were pretty good fellows after all and we invited the whole bunch to attend our next meeting.

Here are the stunts we pulled off there and they opened the eyes of the B.C.L.'s quite a bit. We had an R.C. set with 1 stage amplifier and Radiola II (portable) set side by side on the table and one was attached to our receiving aerial and the other to the sending aerial. We were able to tune in WIP and KDKA separately and have music

in one and a lecture in the other—this without the slightest interference one with the other. We showed them how to tune in without causing howling in the other set and how to stop the howling when it did occur from outside sources. Then we demonstrated the interference of X-Ray machines, violet ray, vacuum cleaners, trolley cars, buzzers, etc.

After the demonstrations we exhibited the two-reel motion picture "The Wizardry of Wireless" gotten up by the General Electric Co.

We had about 65 B.C.L.'s present and they all went home with better feelings toward the Hams and carrying with them a hearty invitation to join our club and learn the code.

AMATEUR RADIO STATIONS

(Continued from page 55)

Radio 2KF is situated at 22 Park Road, Collier Wood, Merton, London, S.W. 19. This is near Wimbledon, some miles southwest of London proper. Mr. Partridge is the sole owner and operator and all of the apparatus employed, with the obvious exception of such items as phones, tubes, and generator sets, is of his own construction. He commenced his radio activities in 1911 with the usual spark coil and crystal detector equipment and held an experimental permit prior to the outbreak of the war in 1914, when all amateur permits were cancelled by the P.M.G. Soon after demobilization in 1919 a new "ticket" was obtained and spark coil and crystal gadgets gave way to storage batteries and vacuum tubes. So 2KF is quite an old timer.

The actual site of the station is very favorable for short wave experimental work as the antenna and radio house are well in the clear. A three-wire invert-

(Continued on page 58)

Who's Who in AMATEUR WIRELESS

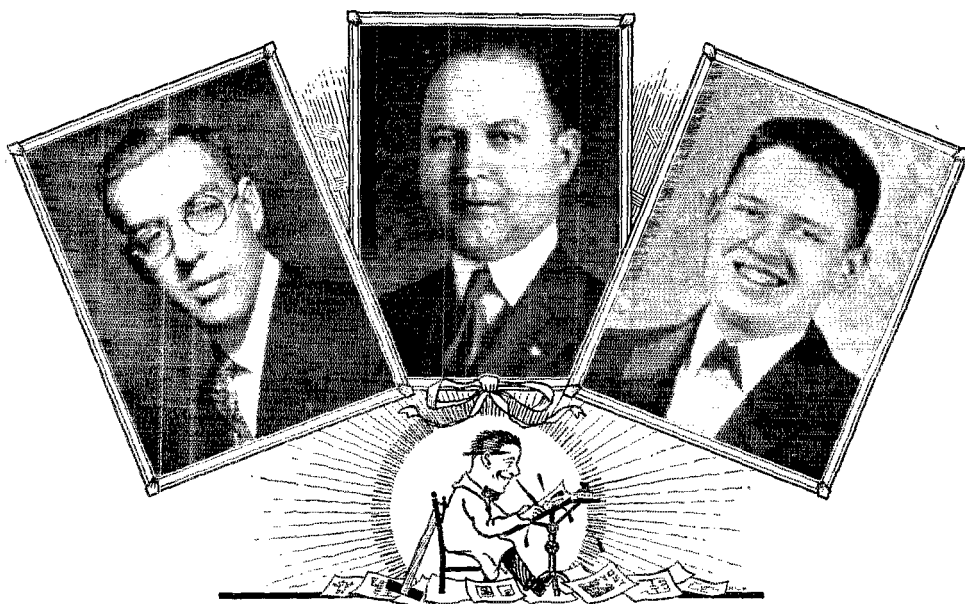

Brother hams,—attention! Allow us to present to you the smiling visages and a brief history of the three hard working amateurs that do the illustrating of our *QST*. On the right is Carl D. Hoffman, 8UX and *QST*'s cartoonist; in the center is Clyde E. Darr, 8ZZ, who makes *QST*'s cover drawings, and on the left, Harry R. Hick, who draws the diagrams and other illustrations in *QST*.

The earliest ambition of 8UX was to be a newspaper cartoonist. However, he fell for radio some eight years ago and was soon in a close race with the other bugs of Akron, Ohio, for the biggest layout of apparatus. Those were the good old pre-war days, when his call was SADU. He started drawing for *QST* about the fourth issue that was published and has been at it ever since, putting over the funny side of radio with his clever pen.

During the period of the war he was in the Military Intelligence Service, Radio.

Upon his return he attended the Cleveland School of Art for half a year, but forgot about his art career and started a radio store shortly afterwards. He recently sold out and is now with the Republic Electric Co., 1740 Chester Ave., Cleveland, Ohio, as assistant to the radio department manager.

Don Hoffman was one of the organizers of the Akron Radio Club. He is not a busy relay worker, preferring experimental and radio newspaper work. As editor of a fine radio column in Akron's largest daily paper, he puts forth the truth about the ham. "Occupational cartoons," started recently, has made such a hit that Don is swamped with suggestions in every mail. He figures that to use them all would require an art staff of ten men working for one year to draw them up.

Besides being an able cartoonist, 8UX has the distinction of starting the present system of using post cards for letting the other fellow know you heard his signals.

A letter from Mr. Hoffman in the August, 1919, *QST* on page 25 reads:

'Here's a little idea—run a suggestion that the fellows with long distance ham receiving sets make themselves up a form for postcards something like this (specimen cut shown) and send one each time a new long distance station is heard. In this way numerous relay possibilities will be discovered where some were careless and didn't notify stations heard formerly. Fellows receiving cards would keep them on file, etc. I used to do this and got a lot of thanks for it from the ones I wrote the cards to.'

This letter was the beginning of the idea that has now developed to the point where every amateur station has its walls filled with these printed post cards.

Clyde E. Darr is so well known as the man behind the big noise at 8ZZ that he needs no introduction. Outside of making *QST*'s cover drawings, his chief hobby seems to be drawing cartoons for convention crowds. It is estimated that he dashed off 860 cartoons at the Chicago convention last year without batting an eye.

He, too, was interested in radio prior to the world war when 8AJD was his call. In the early days of broadcasting his station, 8ZZ, was the first to broadcast music to the Detroit public. He could not leave the amateur game, however, and at present his station is one of the best known and most consistent in the eighth district. Incidentally, fellows, he will tell anyone who sends him a stamped self-addressed envelope how he gets that queer "clank" on the tail end of his dots and dashes. His address is 137 Hill Ave., Highland Park, Detroit, Michigan.

Mr. Darr is a commercial illustrator when not pounding brass. He also is one of the Traffic Department's Ass't Division Managers in charge of Traffic Department affairs in Michigan and is a member of the A.R.R.L.'s Board of Direction.

Harry R. Hick is the man who draws the diagrams and many of the other illustrations that go towards making *QST*. He is a Hartford man who became interested in radio in 1912 and later put up a spark coil transmitter with the call 1ESS. When the first issue of *QST* appeared in 1914, shortly after the A.R.R.L. was formed, he was very much interested. Believing that *QST* would look much better with a few illustrations here and there he tried his hand at it, and has been illustrating *QST* ever since. His first work appeared in the fifth issue of *QST* for April, 1916, illustrating the story of the first Washington's Birthday Relay. This was the A.R.R.L.'s first big relay and caused more excitement in the amateur world than even our Transpacifics and Transatlantics do today. Mr.

Hick, in the early days of *QST*, made many of the cover drawings, though at the present time his work is confined wholly to the inside of the magazine.

He is employed as illustrator for the Aetna Life Insurance Co., and does *QST* work in his spare time. Many times he has stayed up till the wee hours completing a rush job in order that the magazine would not be delayed. Attending art school takes the rest of his spare time, so he really has no time for radio. He is an amateur in spirit, however, and reserves for some future date the pleasure of again having a set of his own.

AMATEUR RADIO STATIONS

(Continued from page 56)

ed-L antenna is supported by two 50-foot steel masts approximately 60 feet apart. A five-wire fan counterpoise, suspended 7 feet above the ground, is secured to the radio house at one end and extends outward to well beyond the free end of the antenna. Ground connection is made to buried copper plates, gauze and cables sunk to a depth of about three feet. Both the counterpoise and ground connections are used when transmitting.

As there are no company's power mains in the vicinity, all power for operating the station is supplied by a power plant consisting of a direct-coupled gas-engine-driven D.C. generator having a maximum capacity of 3.5 K.W. and a set of 100-ampere-hour lead-acid storage cells. The generating set and batteries are located

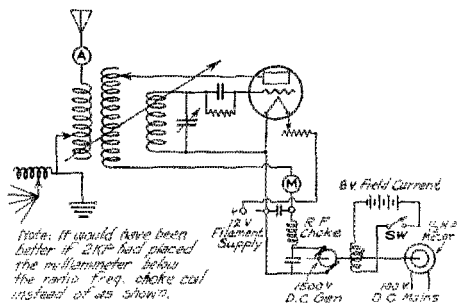

THE WIRING OF BRITISH 2Kf's TRANSMITTER

in an adjacent building.

The circuits employed both for transmission and reception are not out of the ordinary. The transmitting circuit is of the so-called reversed feedback type with series power supply and a separate antenna coil. When communication with America was first effected on Dec. 8th an old Mullard 0-150-watt tube was used

(Concluded on page 72)

Strays



This Never Happened

Com'l Op to Ham: "Copied your C.W. sigs off the coast of Chile on Nov. 6th, OM. How does that compare with your log?"

Ham to Com'l Op: "Sorry, OM, you must be mistaken. I wasn't on that night and am sure my sigs wouldn't reach that far."

Our idea of a hero is the ham who, upon receiving the w.k. "How is my modulation?" truthfully answers "Your modulation is rotten."

Who will write some honest-to-goodness ham radio stories for QST? And by the way—just because "Rip" Bennett's wonderful story "The Land of Blue Lightning" happened in a dream it isn't necessary for *everyone* to follow the same idea. Let's have some yarns in which the hero is awake.

A pipe cleaner is just the thing to use for brushing the dust from plates of your variable condensers. This is important in transmitting condensers as a little dust will cause a flashover.

Why not include the watt-input to the plates of your transmitting tubes on your station cards? Surely everyone knows that the watt input to the plates is equal to the plate voltage times the plate current in milliamperes divided by 1,000.

Appropriate wording for cards to be sent to several w.k. hams: "Dear OM: Your station heard here very QRM this date. You were calling-working ?? CQ (129 times) de (7 times) and signing (273 times). Good work, OM, congratulations! Will be glad to work you when you can spare the time. 73's."

Good connectors for the elements of an Edison storage B battery can be made by cutting the old battery cans into strips $\frac{1}{8}$ inch wide and fastening the strips to the elements with the aid of silver solder and a small torch.

San Diego Radio Club Passes Resolution of Protest Against NPL

The San Diego Radio Club, acting for the 7,000 users of radio in that vicinity,

adopted, at their Nov. 23rd meeting, a definite resolution of protest against the operation of Naval Radio Station NPL. It is claimed among other things that "notwithstanding the almost constant stream of complaints and requests filed with the proper authorities", the use of the broadly tuned spark set, and the arc set that has long been noted for its harmonics, has been persistently continued, "causing a form of pernicious interference entirely preventable and the cause of great annoyance and discomfort to thousands of citizens within the range of said NPL."

Copies of the resolution were sent the Secretary of the Navy, Congressmen and Senators representing the San Diego district, the Secretary of Commerce, the Radio Inspector for the 6th District, and the Press.

Amateurs in the Maritime Division held a miniature convention of the first order on November 23rd through the kindness of 1DT, who supplied the dinner and the meeting place. This was the first meeting of its kind in the division and it went over big. Great sorrow was manifest at the absence of the "Mighty 1AR" but we guess Joe could not find his collar! During the dinner a shout went up when the D.M. was called to the telephone and was heard saying something about the "middle coil, dear." The OW at home wanted to listen to broadcasts! After dinner, several contests and a general good time ensued. One of the competitions consisted of each victim being handed a clever verse about one of the local radio gang and being made to sing it to the tune of "Mr. Gallagher and Mr. Shean." 1EF's face lit up like a fifty-watter when he received the prize—a five-watt tube. The meeting was considered a great success by all hands. A real convention where all the amateurs from New Brunswick, Prince Edward Island, Nova Scotia, and Newfoundland may meet at a central point is one of the big things that is being planned for the future.

Speaking of bets for brown derbies or walking sticks, C. P. Sweeney, ex-5KM, now aboard the U.S.C.G.C. Modoc, wants

to bet K.B.W. a suit of purple silk underwear on anything he's willing to bet on!

Another Distant Control Idea

Ralph E. Kepler of Cleveland suggests the following simplification on the method of distant control by one wire which was described by IANA in the November 1922 QST on page 57. In Mr. Kepler's arrangement A and B are both simple relays, two polarized relays being necessary. Relay A controls the current to the fila-

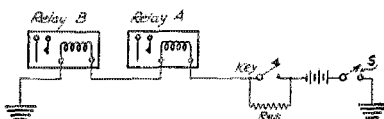

ment of the transmitting tube or tubes while relay B is the regular keying relay. The spring on relay A is adjusted so the relay will actuate on a feeble current while a stronger pulse of current is required to actuate relay B. In operation, switch S is first closed. This actuates relay A with the weak spring, because of the immediate small current flow thru the resistance, thus heating the filaments. The key is then operated in the usual way and relay B is actuated. To shut down the set open the switch S. The resistance across the key may be anything from 6 to 30 ohms, depending somewhat on the sensitivity of the relays employed, while the whole circuit runs from a six-volt battery.

Through the courtesy of Mr. R. Y. Cadmus, Supervisor of Radio for the Third District, the call 3DRC has been assigned to the Third District Radio Convention's station and will be reserved from year to year for that station. FB.

Have You Lost a Friend? A Good Suggestion from 7OE

There comes a time in the life of every amateur when, because licenses do run out and there are such things as Supervisors of Radio, he must relinquish his station call. Usually he does so with the hope that it will not be reassigned to the "lid" in the next block, and lets it go at that. Inwardly, though, there is a deeper feeling of sorrow for he feels as one who has lost an old friend. Perhaps, in the time he has had that call, his station has hung up many DX transoceanic and transcontinental records. Cards bearing this call adorn the walls of stations throughout the world. His station has carried on important storm relief work, and hundreds of citizen radio messages have been transmitted—prefixed by this call. Yet, after working so hard and losing so many hours of sleep to attain

glory for this combination of letters and numerals, he must eventually bid it goodbye. In these days of changing regulations and readjustments of wave lengths an immense number of changes are taking place in the assignment of calls.

If you have been so unfortunate as to have been parted from an old call, what have you done to insure that the next holder of your call will uphold its honor and continue to add to its glory?

Stanley M. Mathes, ex-7OE, suggests that those amateurs who have lost their call letters or had them changed, should write up the history of their old call, telling everything from the joyous day when you first received a letter from the Supervisor of Radio marked "Official Business"; bearing the precious license and call assignment, until the present time. Tell of all the tests in which this call was transmitted; of the many records it has made; and how the station has always been operated in accordance with the U.S. Radio Laws. Then conclude the letter with a few paragraphs of friendly advice that you have gained from your many years of experience in the amateur game and forward the letter to the next holder of your station call, requesting that he keep the letter, add to it, and pass it on when he relinquishes the call. Your Supervisor of Radio can tell you who the next holder of your call is.

In all probability, the person who gets your call will be some poor lad, who with more enthusiasm than apparatus has just succeeded in making a five-watt tube oscillate. For him to inherit a call that has been made famous and stands dear in the hearts of the amateurs of the district will prove a mighty big inspiration to him. It will become his constant endeavor to add to its glory. Help the next holder of your call and he will be everlastingly grateful.

Has anyone actually filtered a "sink" so as to kid anyone into thinking it was D.C.? This isn't an attempt to be funny—we want to know.

"TT" in English radio parlance means "tonic train." *Amateur Wireless* (London) defines it as "CW chopped up into chunks so that it does not require to be heterodyned." "I.C.W." is the American ham term meaning the same thing.

The way to help QST is to help build up the League—go and get some members.

A circuit a day keeps the signals away.

About five guys have written in lately all excited about the big discovery they made by changing the value of the grid leak resistance on their set and getting more antenna current. Just because grid

leaks come already made up is no sign they are of the correct resistance for your particular set. Have you tried it on your set?

If your neighbor owns a radio transmitter he ought to belong to A.R.R.L.—if he owns a receiver there's still a good chance that he's interested in radio. In any case, get him.

If you haven't got what you need, make it and then tell us how you did it.

If a fellow says he hears you with 199 tubes, does that mean he used a seper-het?

And does the high Mu in a tube cause the squeal?

A ham out in the ninth district called CQ on the buzzer in the trolley car and the motorman came right back. Hi!

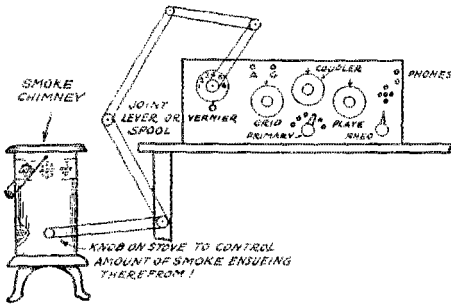

The above diagram, which is self-explanatory, shows a useful addition to any receiver. During the winter months it will enable you to regulate the amount of smoke in the room without falling over backwards in your chair, a common failing.

If you cannot make a Modulascope work (described in the June, 1923, QST*) connect a plate of tinfoil or metal about one foot square to the lower end of the inductance secondary and place it just beneath the 'scope. This will provide a more intense electrostatic field, causing the spinner to work much better.

The easiest way of finding the nodal point on the antenna inductance of your transmitter is to use a wire, one end of which is grounded. Hold the key down and touch the other end to various points on the inductance. A point will be found where antenna ammeter and plate milliammeter are not affected at all when this wire is touched and taken away from a turn. This is the nodal point. Use care

in doing this as the point is quite sharp; a quarter of an inch either way on a turn will sometimes make a big difference. After the nodal point is found it can be shifted to the proper location by following the information in the article "The Nodal Point Explained" in the September issue of QST*.

New Mexico State College Receives Gift of Radio Station

Through the efforts of Dean Goddard, the New Mexico College of Agriculture and Mechanic Arts is the recipient of the gift of a new radio station. The donors have requested that their names be withheld. This gift will include the equipment for constructing a 100 watt vacuum tube transmitter and the building to house it. The station will be utilized for experimental purposes and amateur relay work under the call of 5XD. It will be separate and entirely distinct from the present radio house and its equipment, which will then be used solely for broadcasting. Plans for the new radio house call for a frame building 15 by 24 feet with a concrete floor. An operating room will occupy the east end of the building, while a club room for the College Radio Club will be at the west end. The center will contain a work shop and closets for the storage of equipment and batteries.

When completed, this new station will give the college radio experimental facilities which, combined with its present extensive equipment, will be unsurpassed by any college in the West, if, indeed, by any in the United States.

Old Faithful

Old two-oh-two, you're treated rough,
A martyr to the game.
Old faithful five, you know your stuff,
You've put the sparks to shame.

To thousand volts upon your 'node
And ten across your fil';
Two hundred mils your normal load
And all of that uphill.

There's one thing more, at any rate,
We've never tried before:
We're going to put upon your plate
Our one K.W. Thor.
—C. W. Hound, (5AMH).

The deepest heartfelt sympathy is extended to the wife of the man on the cover of the December QST by Mrs. A. L. Presley, wife of 5AIX. So true to life it is, she says.

How many men in your radio club are not members of A.R.R.L.? Go get 'em.

(Continued on page 71)

*Can be obtained from the QST Circulation Dept. at the regular price.

THE AMATEUR BUILDER

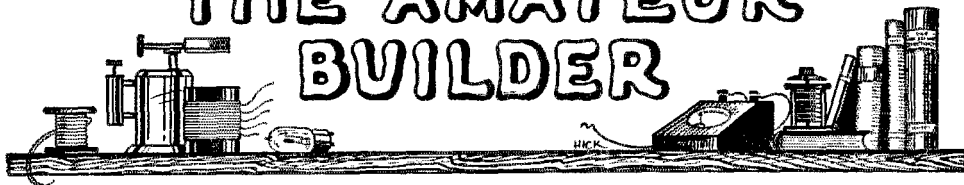

SOLDER AND SOLDERING

By H. F. Mason, Department Editor

THE first need in constructional work is that the amateur know how to use tools. He has undoubtedly had experience with the ordinary hammer-and-saw variety of tools ever since his boyhood days, but a soldering copper is a tool peculiar to electrical and radio work and should be skillfully handled for good results.

Soldering consists of joining two metals together by means of a softer metal which melts at a comparatively low heat and can be made to run in and around the other metals. When allowed to cool, a continuous and permanent metallic contact is thus formed. Corrosion and the consequent poor contacts would cause unlimited trouble in radio, electrical, and telephone work were it not possible to solder all current-carrying joints. Radio men can well take a tip from the large telephone companies, who carefully solder all of the millions of connections in their mammoth switchboards. The only connections that are not soldered are those that must be opened as a matter of routine, as in replacing worn-out batteries or cords.

Soldering Coppers

When about to purchase a soldering outfit it will be found that there is quite a wide variety of sizes and shapes of soldering coppers to choose from. They are built for many different classes of service

having ends of various shapes. Type A is a chisel point, common on small electric soldering coppers. This is perhaps the most useful type of point for radio and small electrical work. Fig. 1-B shows a soldering copper with a long pyramid shaped point while C is a similar copper with a short and blunt pyramid shaped point. The last, D, is a type of large copper, usually having a rather blunt pyramidal point, and is used extensively by tinsmiths and plumbers. These large coppers are rated in pounds.

There are several things to keep in mind when choosing soldering coppers. First, be sure that you get one the right size for the work you have to do. You can never do good work with a soldering copper too big and clumsy for the job. On the other hand one too small will not be able to transfer enough heat to the joint to make the solder run smoothly. Speaking further of the various kinds of points, the chisel type is to be preferred for radio work in general. The pyramid types of point are useful where all the heat is to be concentrated at one place as when a tinsmith solders a seam in tin roofing. A long slim point will lose its heat quickly while a short and stubby point will hold its heat for a considerably longer time. At the same time the copper must be of such a shape as to be convenient to handle in soldering joints that are not very accessible.

The amateur will find that for work on receivers, a good electric iron with a bit three eighths of an inch in diameter, or if the copper is to be externally heated, at least two of them $\frac{1}{2}$ inch or $\frac{3}{8}$ inch square with fairly slim points will be as satisfactory as anything. The object of using two is so that one can be left on the fire while the other is being used, thus obviating the necessity of waiting for the copper to be reheated.

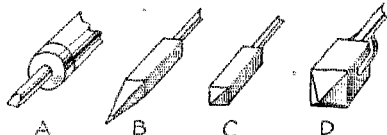

FIG. 1

and range from the small ones used by jewellers in connection with blowpipe work to the large and heavy ones used by tin-smiths and plumbers. Sometimes a soldering copper is called a soldering bit or a soldering iron but it is the same thing. All but the very cheapest ones are made of solid copper.

Figure 1 shows some soldering coppers

Methods of Heating

Soldering coppers other than the electric type should be heated in a clean and colorless flame such as that given by a good gas burner or gasoline torch. A red or white flame denotes imperfect combustion and a copper heated in it will become sooty and greasy. A pale blue flame is much better

and hotter. In emergencies the copper may be heated in a wood or coal fire, but extreme care should be taken not to get it too hot as will be explained later.

Electric soldering coppers are heated by a heating element consisting of a coil of fine resistance wire, insulated by mica and asbestos and connected to the electric light circuit. This coil encases the soldering bit which becomes hot in a short time after the current is turned on. The heating coil in turn is enclosed in an asbestos lined metal shell, which confines the heat mostly to the inner portions of the coil and soldering bit proper. A good electric copper is built so that both the bit and the heating element can be renewed, for sooner or later the element will burn out and the bit will wear away, necessitating replacement. It pays to get a good electric iron for cheap ones have a habit of going dead after being heated only once or twice.

A gasoline torch is almost a necessity for outside work on antennas as it permits the heat to be applied directly to the joint to be soldered. A soldering iron, unless very large and heated on the spot, will cool too quickly to be of much value. A torch is also handy for inside work when large pieces of metal are to be heated and forms a very convenient medium for heating the soldering coppers. Next to a good electric soldering copper, then, a gasoline torch should be a part of the soldering equipment of every radio workshop. Torches are rated as half-pint, pint and quart; according to their capacities. Rules for operating gasoline torches are always furnished by the makers, so it will be needless to explain in detail how they are operated.

If an electric copper is not to be had, a gas connection and a small gas plate in the radio workshop will be excellent for heating the coppers. A metal hood should be placed over the stove to keep air currents from disturbing the flame. For very fine work a bunsen burner and blowpipe are employed but an amateur will find so little use for this method of soldering that it deserves no more here than mere mention.

Solder

Solder is usually simply an alloy of tin and lead and is graded by the proportions in which it contains these metals. For instance, "half-and-half" solder is composed of 50 percent tin and 50 percent lead, and melts at a temperature of 370 degrees Fahrenheit. The greater the percentage of lead, the higher will be the melting point. Solder containing 40 percent lead and 60 percent tin is the best all around solder for radio use, although "half-and-half" is perhaps the most common in other lines.

Solder can be obtained in one pound sticks or in the shape of wire solder. The

latter is generally about $\frac{1}{8}$ inch in diameter. The amateur will find this form most convenient for his needs as there is practically no waste when it is used. It can be cut from the spool a few feet at a time, coiling the piece around the hand and slowly uncoiling it again as it is used.

Some forms of wire solder have a hollow core that is filled with the soldering flux. This kind of solder can be fed to a heated joint and if the proportions are right the

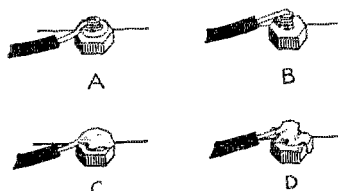

RIGHT FIG. 2 WRONG

correct amount of flux will melt and be used at the same time as the solder. The objections to wire solder having the flux in its center are that the flux may be a paste containing acid, and second, that it is not possible to use a little solder without getting a supply of flux along with it. This excess flux is liable to run all over the work and not contribute to a good looking job. Rosin-core solder, which comes on five pound spools, is a form of wire solder used quite extensively, especially in telephone work where there are multitudes of small connections to be soldered. It is here that this kind of wire solder finds its real utility.

Care of Soldering Coppers

It is just as necessary that your soldering coppers be kept in good condition as it is for a carpenter to keep his saws and chisels sharp. Neat and quick work cannot be done with neglected tools. Keeping a soldering copper in condition consists of keeping the bit the correct shape and well tinned.

A copper is tinned when the flat or working surfaces of the bit are covered with an even coating of solder, which should be maintained at all times. This film of solder is put on by the process of cleaning the heated iron with a file; then rubbing the copper briskly to and fro on a chunk of sal-ammoniac, one surface at a time, and applying solder simultaneously. Heated copper oxidizes very quickly when exposed to the air and solder will not adhere to it unless every bit of oxide is removed. The action of the sal-ammoniac is to destroy the thin film of oxide and let the molten solder adhere to the hot copper before more oxide can form. If you cannot get a chunk of sal-ammoniac at your corner drug store, the iron can be tinned by dipping the clean, hot copper into soldering paste and then quickly rubbing solder over it. The paste

will destroy the oxide on the copper just as the sal-ammoniac did and the solder will flow on the clean copper just as water will wet a clean board but not a greasy one. The solder on the heated copper will now act as a ready means of carrying heat from the body of the copper to the work. This can be seen by touching a piece of cold solder first to the black, oxidized surface of the copper, then to the tinned tip; it will melt more quickly on the bright surface.

Once the copper is well tinned, care must be taken to preserve the bright and silver-

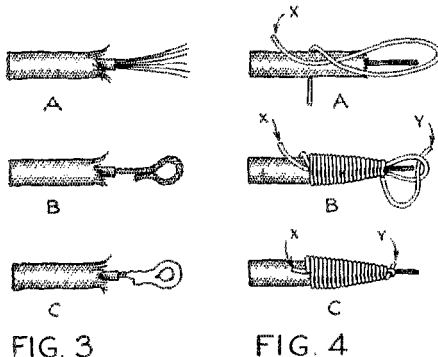

FIG. 3

FIG. 4

like surface. Hot solder oxidizes just as copper does, but fortunately the solder is in a molten state on the heated copper and so the bright surface can be restored by merely brushing off the oxide with an old rag. This should be done after every heating when the coppers are heated in a flame and should be done every few minutes when using an electric iron. Another way to clean the copper is to dip it into a solution of sal-ammoniac and water, but this is not advisable for the copper is eaten away and the bit gradually destroyed if this practice is followed.

Excessive heat will always spoil a copper that is well tinned for the thin film of solder and also the copper beneath it will turn into a black oxide. When a copper has been "burned" in this manner it must be filed clean and re-tinned before any work can be done. Never allow a soldering copper even to approach a dull red heat and it will never become burned. The necessity for keeping the soldering copper clean cannot be over-emphasized for it is practically impossible to do good work with a dirty iron.

Soldering Flux

Two pieces of metal cannot be soldered together unless their surfaces are clean, and after they are cleaned they must be heated. When metal is heated, however, it quickly oxidizes and prevents the solder from sticking to it. In order to further

the union of the metals to destroy this film of oxide that has formed since the joint was cleaned, and to prevent the formation of additional oxide while the joint is being soldered, some sort of flux is necessary. Soldering flux may be in liquid paste, or dry form and almost invariably is some mixture consisting mostly of rosin or of acid.

The usual process in soldering a joint in a wire, for instance, is to clean the wires with sandpaper, twist them together; then apply a little of the flux to the joint. The heat from the iron or torch is then applied and, as the temperature of the joint becomes greater, solder is fed to the joint. It will then unite with the metal being soldered and firmly join them together. If no flux were used the surfaces would oxidize from the heat; the solder would act like a drop of water on a greasy board and not unite with the metals being soldered.

Rosin flux does not have the same power to destroy an oxide film as does an acid flux. Indeed, an acid flux not only destroys the oxide film but will eat away the metal. For this reason small copper wires should never be soldered with an acid flux, or any other joint for that matter where corrosion will prove injurious. This is despite the fact that it is easier to solder using an acid flux on account of its greater ability to cleanse the surfaces being soldered.

The only way to be on the safe side with regard to soldering flux is to regard all kinds of soldering flux as containing acid, regardless of manufacturers' claims or trade names, and for work in radio, use only rosin and alcohol, mixed to a paste by yourself or some good rosin-core wire solder. You can get ten cents worth of rosin at your drug store and mix it with wood alcohol which will make enough paste to last the whole A.R.R.L. for one season. A very satisfactory soldering paste will result and you need not worry about corrosion, for there will be none.

Soldering Receiver Connections

Now that a general outline of soldering and soldering methods has been given it will not be out of place to give some practical suggestions that will enable the amateur to more skillfully use his soldering tools and produce better results.

An important point in soldering connections is never to rely on solder for mechanical strength if it is possible to avoid it. Rather twist the wires together or fasten the parts together in some way first; then apply the solder to make the electrical connection sure. Figure 2, A and B, shows right and wrong methods of soldering a wire to a switch point or terminal post. Take a complete turn around the post before soldering to it and a joint

(Continued on page 65)

(Continued from page 64)

that is both mechanically and electrically good will result.

Use soldering flux sparingly. Put only a very little on the joint. When the joint is heated it will melt and run to all parts without trouble.

Good work cannot be done with a soldering copper that is not hot enough. The solder will not flow smoothly and the joint looks like Fig. 2 D instead of 2 C. In addition, the solder will not unite readily with the metal parts when a cold iron is used, causing a joint which is supposedly soldered to be only stuck together with rosin. The resistance of a joint which is not properly soldered is of course high and, if it occurs on a receiving set, frying noises are liable to occur in the phones. A well-soldered joint will require a good yank before it will come apart and will tear the solder in doing so. After a joint has been soldered, it must be kept absolutely motionless until the solder has set; otherwise the solder will crystallize and the joint will come apart. This emphasizes the necessity for fastening parts together before soldering.

Be careful in soldering to metal parts that are imbedded in molded parts or set in panels, for some moulded compositions and hard rubber soften very readily when heated, and the heat transferred to it from the soldering iron, through the piece you are soldering to, may be enough to melt the composition in the vicinity and spoil the work. When soldering to terminals in hard rubber or moulded composition, be sure to have the parts clean and use a hot iron, so the job can be done very quickly, before the heat has a chance to get to the moulded parts. If you are using binding posts with black, moulded tops, it is well to remove these tops before soldering wires to the posts, for the same reason.

In reality a joint must be tinned before it is soldered, just as a soldering copper is tinned before the solder will stick to it. Ordinarily, pieces of metal are tinned and soldered at the same time but sometimes it is desirable that the surfaces to be soldered be tinned before they are put together. This makes the soldering much easier but the process is longer.

Wires that fasten to the binding posts on the front of the set and other wires that may have to be removed at some time or another should be soldered into copper lugs. If the wire is stranded lamp cord and no lugs are available, an improvised one can be made as shown in Fig. 3. It consists of haring the wire for about an inch, cleaning it thoroughly with sandpaper and then tinning it after it is bent back upon itself in the shape of a loop. The solder will make the loop stiff.

Figure 4 shows how to bind the ends of lamp cord to prevent their fraying. The

binding is, of course, done after the lug is put on and should be done with strong cotton or waxed thread. In Figure 4, A, B and C show progressive steps in binding the end of the wire. The start is at X and the end at Y. 4B is changed to 4C by pulling Y and laying it tight; then pulling upon X till the loop just disappears. The ends are then cut off.

Soldering Antenna Connections

On outside work a torch is handier than a soldering copper. If you do not believe this, try heating your soldering copper over the gas flame in the kitchen, then making a wild dash for the backyard or roof, as the case may be, and see if you can get at least one joint soldered before the iron gets cold. Using a gasoline torch, the heat

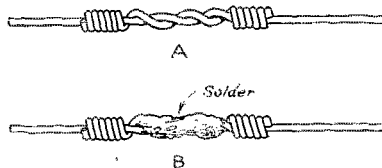

FIG. 5

can always be quickly applied to a joint and the solder caused to run evenly with no trouble whatever.

The details of antenna construction will be dealt with in a future article, so at present only a few pointers as regards soldering the joints in your antenna are given.

How many amateurs can make a good Western Union joint and solder it correctly? This is something fundamental, yet we know of many antennas that come down yearly because the joints in the wires are not properly made. Figure 5 shows a Western Union joint. The ends of the wires are scraped or cleaned with sandpaper before they are twisted together. Some soldering paste or other flux is then smeared on the center of the joint. The flame from a torch is applied to the center of the joint and just as soon as it gets to the temperature of melted solder, the solder is run into the joint. Do not get the joint any hotter than it must be for the solder to run smoothly, as the wire is weakened by heating. All joints in the antenna should be soldered, but put the solder only on the parts of the joint where the wire is double.

Aluminum wire cannot be soldered in the ordinary way and should not be attempted by the average amateur unless it is absolutely necessary. Then use Venice turpentine for flux; not too much heat, and a solder with a bit of mercury in it.

If your antenna is made of phosphor-bronze wire, do not solder the joints in the

usual way, but use McIntyre connectors. These are made of copper and look a great deal like the barrels of a miniature double-barrelled shot gun. They are made for 7-18 stranded wire or larger and can be bought from any large electrical supply house. The wires are inserted in the two tubes and the whole is twisted to form a very strong connection.

Most of us have had the experience of spending a couple of hours trying to solder a wire to a water-pipe filled with water. This is a waste of time for it is much easier to turn off the water where it enters the

building and drain the pipe. You can then heat the pipe and solder to it without much difficulty, if a soldering paste or flux containing acid is used. Clean the pipe with a file and sandpaper and wrap the clean wire around it several times; making it thoroughly fast before soldering. It may even be desirable to tin the pipe and the wire before wrapping the wire around the pipe. If you cannot drain the pipe that is being soldered to, get a good ground clamp and put it on the pipe after both the pipe and clamp have been thoroughly cleaned.

Some Characteristics of Electrolytic Rectifiers

By E. J. Atkinson, ICEK

PERHAPS one of the most satisfactory methods of rectifying the high-potential low-power outputs of plate transformers lies with the very much used Electrolytic Rectifier. It is equally true that when this particular unit is not properly designed it at once becomes one of the most unsatisfactory methods of obtaining rectification. Some time ago the writer made several tests with the object in mind of determining, for once and for all, the reasons behind some of the peculiar conditions encountered in practice with a device of this nature. The results of these tests furnished several important as well as basic facts that must be rigidly incorporated in the design of this device to obtain satisfactory operation.

The apparatus necessary for these tests was hooked up as shown in the figure.

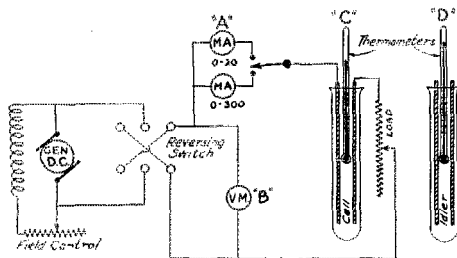

The rectifier cell was made up of a standard Myers Culture-Tube, 6" long by about 1" in diameter. A saturated solution of ordinary "20 Mule Team" Borax was used. An additional culture tube was filled with

water and inserted in it was a Taylor thermometer calibrated in degrees Fahrenheit. This furnished the "idler" with which actual test readings were compared in obtaining the final temperature rise of the cell under test. This method prevents fluctuations of temperature due to outside causes from affecting the accuracy of the tests.

The elements of the cell were made up of aluminum and lead strips $\frac{1}{2}$ "x5" and adjusted until 2 sq. in. of each element were offered to the solution. In this cell there was also a Taylor thermometer inserted, this one being a duplicate of the one used in the idler. The cell was connected with the necessary instruments and a direct current generator, and a 200-ohm rheostat used for a variable load.

Formation of the film was found to take place almost instantly in the cell when set up for the first tests. A few days after, however, it was found that our film was nearly 50% less effective than at first, but this alarming feature corrected itself in a few seconds to its original condition. Therefore, the long fussy operation of "forming" plates of rectifiers is unnecessary and a waste of time. When a new rectifier is put in circuit, a heavy charging current will flow for a few seconds only; the film will be fully formed before the transformer will have a chance to show any signs of distress. This first film will be, no doubt, the best that the cells will ever have. As the cells get old the lead elements take on an aluminum deposit which cuts down the over-all efficiency of the cell; therefore, we must clean up the cells every so often, depending upon the condition of the elements

and the amount of sediment collecting in the bottom of the jars.

Test 1—Heating With Normal Load

Time in Minutes	A	B	C	D	Temp. Rise °F
0	50 M.A.	20 V.	72.°	72°	0.
1.	"	"	"	"	"
1.5	"	"	"	"	"
2.	"	"	"	"	"
2.5	"	"	"	"	"
3.	"	"	72.5	"	0.5
4.	"	"	73.0	"	1.0
5.	"	"	73.2	"	1.2

Test 2—Heating on Overload

Time in Minutes	A	B	C	D	Temp. Rise °F
0.	200 M.A.	10 V.	72.0°	72°	0.0
1.5	"	"	73.5	"	1.5
2.0	"	"	74.8	"	2.8
2.5	"	"	77.0	"	4.0
3.	"	"	81.0	"	9.0

Test No. 3 was made to determine the dielectric strength of the insulating film. The leads from the direct current generator were reversed so that the cell was connected reversed and therefore did not pass current.

Test 3—Reverse-Voltage Breakdown

B	A	Remarks
0 V.	0.0 M.A.	
10	0.0	
20	0.0	
30	0.5	Film beginning to pass small reverse current.
40	0.6	Film now passing small reverse current.
50	0.9	Blue halo now evident.
60	12.3	Breaking down of film evident.
70	120.0	Complete rupture of film accompanied by scintillation of aluminum.

Test 4—Reverse-Voltage Breakdown When Ammonia Is Added (5 Drops Commercial Strength Per Cell).

B	A	Remarks
0 V.	0.0 M.A.	
10	0.0	
20	0.0	
30	0.0	
40	0.3	Film beginning to pass small reverse current.
50	0.5	Film now passing small reverse current.
60	3.0	Breaking down of film now evident.
70	180.0	Complete rupture of film.

From Tests No. 1 and No. 2 we find that a current density of 100 milliamperes per square inch of aluminum sheet* can be used for intermittent duty but the density must not be run above 50 milliamperes per square inch for continuous operation. Putting it differently, a strip of aluminum one inch wide and immersed to a depth of one inch will pass 50 milliamperes continuously, but will NOT behave well if loaded above this current density.

Tests No. 3 and No. 4 show a very sharp dividing line between safe operating voltage-per-cell and over-voltage. The blue glow appears at about 5 to 10 volts-per-cell below the point where the film begins to suffer. *Scintillation, or sparking, is positive evidence that an over-voltage is being applied and that more cells are needed.* The sparking is due to the partial rupture of the insulating film. We find, on reviewing the tests above, that the voltage-per-cell should never, under any circumstances, exceed 50 volts per cell—and even that can be used only with the best of materials. Any single cell that shows sparking of the aluminum should be examined and if the rest of the rectifier is operating well the sparking cell should be washed out and re-assembled with new aluminum and new solution. [However the trouble may be due to the fact that the sparking cell is the *only one* in good order and the sparking is caused by the brave attempt of this single good cell to do the work of the whole string. Therefore if all the rest of the cells are dark it may be well to short circuit, or remove, the sparking cell to see if the rest of the string is working.—Tech. Ed.] Tests show that the addition of a small amount of ammonia tends to give additional strength to the insulating film. Compare the results of tests 3 and 4.

Summary and Design Rules

In each string of rectifier jars allow one jar per 30 volts when borax solution is used. Remember this is in *each* string of jars; if you have a transformer with 1500 volts on each side of the center tap you must allow 1500/30 or 50 jars in each of the two strings, a total of 100 jars.

The size of the aluminum is found by allowing a square inch for each 50 milliamperes to be drawn; do not exceed this.

*There is an entirely needless confusion about this business of the area of the aluminum electrode. A piece of aluminum sheet 5 inches by 10 inches represents 50 square inches of sheet aluminum—it decidedly does *not* represent 100 square inches. The size of a sheet of metal is determined by the area of *one side*; what would you think of a tinner that tried to sell you a "square yard" of tin that measured 18 by 36 inches?—Tech. Ed.

Radio Communications by the Amateurs

The Publishers of QST assume no responsibility for statements made herein by correspondents



A Boost for Coupled C.W.

Riverbank, Calif.

Dear Eddy:

Just a few lines to let you know I have tried out the coupled C.W. circuit shown on page 8 of the October QST and it's F.B. I wound the coils in a hurry from whatever I had handy, which happened to be some No. 14 and No. 18 D.C.C. wire and some cardboard tubes of a size near that given in 3BWT's article. Hooked 'er up to a 5-watter with 400 volts of storage battery on the plate at about 60 or 80 mills with an old 43 plate condenser for tuning and no series condenser in the antenna circuit.

After using it about a week I found that I could change my wave from 150 to 200 meters in a few seconds with the antenna current and plate current remaining the same thruout. Suppose I am on 150 meters and hear a bird on 160 who evidently cannot tune down to my wave. I just clip in two or three more turns in the antenna coil and swing the .001 tuning condenser around until the antenna and plate current come to the proper readings. I then set the homemade wavemeter near the inductance and swing the condenser until the flashlight bulb flares up; then sit the meter on top of my Reinartz cabinet and swing the knob of the secondary condenser until a click is heard. I now have my wave on the receiver and with a little experience it can be quickly shifted to any point. The plate and grid taps need no changing for waves between 150 and 200 meters. Hows 'at?

If the fellow I am working says "QRM, pse QSY lower wave," it just takes a moment for me to cut a few turns out of the inductance in the antenna circuit and a swing of the condenser will do the rest. I am sure tickled with that circuit.

Robt. H. Potts, GAME.

Let There Be Justice!

Shreveport, La.

Editor, QST:

The fact that nearly every radio magazine published nowadays carries some article on the "regulation of amateurs so as to decrease interference with broadcasting reception" seems to have planted a psy-

chological seed in the minds of all B.C.L.'s so that they have an idea that the only source of interference to their reception comes from the amateur class. This isn't fair to the amateurs, and such magazines should tell the whole truth about it.

As an instance, a short time ago a prominent man of my town called me and asked me to come over to his house and show him how to tune his new set which he had just installed. Of course, his expectancy was at a high pitch. I went over and tuned in WWJ. The program came in clear and loud, free from any QRN; but just as a speaker on the program was getting well warmed up, a ship station, KZP, began, called WSA, and drowned out Mr. Speaker. Immediately my friend exclaimed, "Just listen at those d--- amateurs interfering!" (And this man lives in Louisiana!—Editor.)

Now this man had never listened in on a set more than an hour in his life, yet he immediately laid the interference at the door of the poor amateur! He had, however, been absorbing the various radio magazines, and it is clear where he got his idea. He had been reading about the conduct, regulation and restriction of the amateur to such an extent as to blind him to the fact that WWJ is on 517 meters while the amateurs are below 220.

Of course, I explained the situation to him, and he apologized; but he could not understand why it was that the Government was so particular to regulate one class of interference and leave the other to run wild. That, of course, I could not answer.

I am a B.C.L. myself, but can read the code. When a telegraph station "slops" over into my program, I always try to catch his "sig." I have heard these ship stations anywhere from 250 to 600 meters. For instance it was almost impossible to hear Mr. Lloyd George from KDKA on 326 meters because of ship station interference. And when Mr. Woodrow Wilson spoke on the night of November 10th notwithstanding the shutting down of other B. C. Stations for the occasion, there was a constant interference from ship stations. Tonight I was listening to a church service on 448 meters when the following government and commercial stations were heard: "NKB de NAT," "KKN de NAT,"

"WCY de KEX," "WSA de KOBN," "WCY de KIT." These are only a few, but I cite their calls to show conclusively that the interference to broadcasting at present doesn't come from the amateurs but from other stations; and also to show a reason for a re-assignment of commercial and ship stations' wave lengths, or for the better policing of the present wave lengths in this class. This is particularly pertinent since the Department of Commerce has just asked that amateurs kindly observe a further quiet period during the earlier evening church services on Sunday.

Let there be *justice!*

Bradford Hearn.

Double Reception

Farnham, Quebec.

Editor, QST:

Did you ever hear of an actual attempt to receive western DX during the silent hours while the family are receiving the broadcasts in the other room on the same antenna? I have tried it using the Reinartz scheme of untuned antenna circuits by connecting the antenna coils in series. Results are fine so long as I do not try to tune to the same station with both sets. I can receive distant broadcast stations on the loud speaker; then go down on 200 meters with the other receiver and log amateur DX signals to beat the band, all on the same antenna. This stunt ought to keep peace in some radio families.

A. J. Lorimer

The Western Wireless Press Ass'n

Spokane, Wash.

Editor, QST:

A movement has been started in the northwest corner of the United States which, if fostered and talked up by the amateurs of the country, can develop into an institution of exceptional usefulness to the educational institutions of the nation. This movement has been styled the Western Wireless Press Association. It is an organization among high schools for the exchange of school news by radio and originated about two years ago at the North Central High School, Spokane, Wash. Form letters on the subject was first sent to the news editors of the larger schools in Washington, Oregon, California, Idaho and Montana. The idea met with a hearty response among a number of high schools and that winter several of them printed a column of peppy news items in their school papers gathered from other schools by radio.

However, about this time, broadcasting stations began to get in their work and

our old 1K.W. sawmill at the North Central school brought such storms of protests from listeners that we closed it down. The next fall we set about raising funds for a C.W. set. Other stations with whom we had handled school news were undergoing a similar change.

We have now finished the installation of a 100-watt C.W. set that was heard clear across the continent the first night we operated it. With the announcement of this fact in our school paper, requests came from schools in Washington, Idaho, Montana, and even one from the Central High School in Minneapolis, to revive the Western Wireless Press Association. Accordingly we are now preparing to start the work again. North Central, 7YL, has four capable operators working under a regular schedule from dark till 7:30 P.M. every evening except Sunday, and from 10:30 P.M. to 1:30 A.M. on Friday and Saturday nights. The operators will receive school credits for this work. Schedules are being arranged with other high schools and within a few weeks we expect to be going in full swing. In a city where there is a school that does not own a radio set there are usually several amateurs in the school or in the city who are willing to co-operate in this work. Only news items of general interest are transmitted.

The details of exchanging school news on a large scale have not been worked out as yet. In fact 7YL is very anxious to receive suggestions along this line.

This is an idea that can grow and grow. If you amateurs are members of a school or are interested in the schools of your city, go to the news editor of your school paper with this proposition and start it going in your vicinity. It is worth much more than much of the "Pse-QSL-card" stuff that is now being relayed.

A. L. Smith,

Radio Station Director, 7YL, North Central High School, Spokane, Washington.

Things in General

Ambridge, Penn.

Editor, QST:

You asked for some dope on the standard waves that are sent out by WWV, so here is a bucketful. In the first place the signal strength on 176 to 200 meters was about five times that on 600 meters. There's one strike against the idea of slopping over 200 meters.

At the time the standard waves were being sent I was using a General Radio wave trap and filter to check with WWV and was very agreeably surprised to note that the wave meter was absolutely correct.

On the other hand I was very disagreeably surprised to note that the large number of amateurs who thought they did not need to calibrate their sets were operating on illegal waves from 201 up to 278 meters. What in the name of key-thumps is wrong with these guys, anyhow?

Another thing that makes a fellow froth at the mouth is to have some sap send out a CQ a mile long during the quiet hour.

Well, I feel much relieved, now that that's that. 73's.

—Harley L. Sairs, 8LW

Loose-coupled Transmitters

Courtland, Kansas

Editor, QST:

Several nights ago I tried for about two hours to QSR sum msgs—and got exactly nowhere because of the interference. I decided that something must be done to reduce this QRM and that the right place for me to start was with my own set—so I decided to try loose coupling the transmitter.

The results have been excellent. Local interference is very slight, the wave is very sharp, no key thumps are reported, and it is easily possible to adjust the set so as to obtain larger antenna current and

might even be possible to omit the inductance L_2 . Then the antenna inductance L_4 could be coupled directly to the primary inductance L_1 . This is not a very important change, tho.

I don't know what my plate current is as I haven't any milliammeter at present but the plates never show any signs of heating, while with direct coupling it was difficult to keep them from staying red hot all the time.

The range of this set is better than before, the antenna current is about two amperes, and I have worked several 5's in daylight. This morning at 10:10 A.M. I worked 5ZA, the distance being 570 miles.

Have found a way of working this set as a radiophone with no equipment except a microphone and a single-pole switch. The scheme is to start the set oscillating and *after* the set is in operation to close the switch S. The clip connected to this switch must be placed a little ways below the nodal point the proper position being one where the antenna current rises a little when the switch is closed. I always start the set with the switch open, otherwise it will not modulate well.

I would like to see more of the gang try inductively coupled sets as I believe they can get farther and at the same time cause very much less QRM.

Ed. Barricklow, 9CCV.

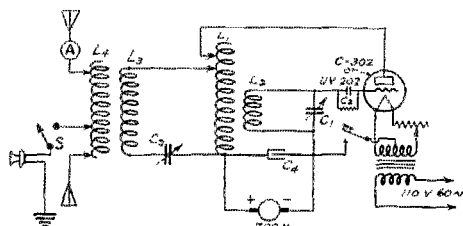

9CCV'S LOOSE-COUPLED TRANSMITTING SET

- L1—30 turns No. 12 B & S
- L2—20 turns No. 18 B & S
- L3—6 turns No. 4 B & S, pancake form.
- L4—Same as L3. Coupled to it with 3 inch spacing.
- C1—Variable condenser, capacity .001 microfarads max.
- C2—Fixed condenser. Anything over .001 will work.
- C3—Variable condenser, capacity .0005 microfarads max.
- C4—Filter condenser, at least 1 microfarad; the larger the better.

Only one tube is shown in the diagram but the actual set uses three, making what we are in the habit of calling a "15 watt" set, the actual power-input probably being about 100-125 watts.

Results are slightly improved by dividing L3 into two EQUAL coils and putting one on either side of L4.

cooler tube-plates than with the direct-coupled set.

Connections are made as in the diagram, but I don't see why any other circuit would not work as well. If the inductance L_1 had a few more turns it

Help the Bustan

Washington, D. C.

Editor, QST:

In view of the fact that the Bureau of Standards, Radio Laboratory, has been endeavoring to help the amateur by scientific research and the transmission of standard frequency signals, we feel that it is only just for us to recommend to our *representative in Congress*, to make a larger appropriation for this good work so that the Bureau may still help the amateur as well as radio in general. It is a well known fact that the appropriations of Congress are not now enough to carry on the work at the Bureau.

As you know, the Bureau has in the past calibrated receivers and wavemeters for the amateur at a nominal price. This service has been discontinued because Congress did not appropriate enough money to hire the personnel to carry on the work.

Furthermore, we believe it our duty, as radio amateurs, to recommend to our fellow members of the A.R.R.L. to stress the attention of their representatives on this most important situation. We believe that the Bureau will greatly appreciate our interest in their work and if Congress sees fit to

make larger appropriations, the Bureau will endeavor to help the amateur.

Hoping you will give this matter your most careful consideration and approval, we beg to remain, fraternally yours,

O. M. Lewis, 3ALB.
E. P. Kampf, 3CCK.

On Behalf of the Beginner

Phoenix, Ariz.

Editor, QST:

I have noted various articles for the hams but have seen very little in defense of the beginner. For the love of Pete, fellers, remember you were all beginners once and be a little patient with the amateur who is just starting out. I am an amateur, I'm glad to say—so much so that I haven't a license yet, but expect one as soon as the over-worked government clerks get to it. I have my set all ready and am "rarin' to go." I have heard several amateurs talking about hearing or working so-and-so and how slow he was and they were not going to monkey with him again. Now that is strictly unfair. I "think" I know the code and can pass the 10 per examination easily, but gee, we all get stage fright the first time we get a call and when a fellow starts out about 25 per, spacing his letters any way to get it done with, signs off so dad-blamed fast that it sounds like a gatting gun, he leaves the poor beginner wondering who the deuce it was. It's a grand and glorious feeling to hear a ham come back at you after you have answered his CQ but, if a guy sends QRS, be patient and remember you were a beginner once and the courtesy of the air is to be maintained.

H. D. Wilson

The Hot-Dog Ammeter

Brooklyn, N. Y.

Editor, QST:

The hot-dog ammeter, although much used on the Continent, is utterly unknown

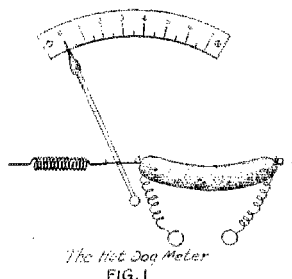

in this country. The reason for this appalling state of things is the policy of the ammeter trust to "Keep 'em ignorant of better things and they'll buy ours." The

writer discovered the use of the hot dogs as delicate current measuring devices in this manner:

Last summer I took a trip to Scotland and after a month's stay in that marvellous country I became even more Scotch than the natives. This was accomplished by a

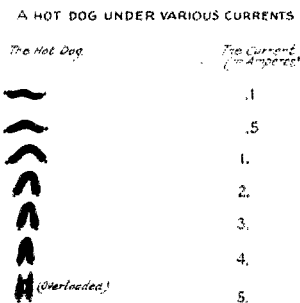

FIG. 2

continuous process of absorption. Then, on that momentous day, June thirty-first, while visiting the English station IRUM, I first saw a hot-dog ammeter. The owner explained that he had conceived the idea one day as he stood with his nose flattened against the window of those small shops where they cook hot dogs over a gas flame while you wait.

The technical description of the Hot-Dog meter follows: The age and size depends on the use it is to be put to. I have found that for heavy currents a bologna or liver-wurst is suitable. For delicate work the hot dog (*canus frankfurtus delicatessen*) is unparalleled.

Figure 1 shows a complete hot dog meter. Figure 2 is a calibration chart showing the reaction of this meter to various currents. The hot dog in this case was 7.863 mm. by 3.1729 mm.

In closing, it may be said that the normal operating period is six months, after which time they may be cooked and eaten. It will be found that they will have a slight current taste.

—H. E. Fairman.

STRAYS

(Continued from page 61)

If you expect to have that master oscillator really stay on one wave, do not use a mercury type variable condenser for tuning the master circuit. It may stand the voltage but the mercury will invariably flop around and the signals will swing when you pound the key. If you do not believe it, set up your wave meter near the antenna lead and watch it change when

you hit the brass. The best air condenser made is none too good for tuning the master oscillator.

On a Card From Texas

"Say, OM, your signals have reached my ears several times, always QSA. Last night one of my neighbors shot at me for keeping him awake at two in the morning and he put a big hole in the wall and I would appreciate if you would send me one of your call cards to stop this hole up and still adorn my wall. Let me hear from your soon, OM."

Amateurs are cautioned against the use of silicate of soda (water glass) for waterproofing coils, as it will absorb moisture and raise the high frequency resistance of the coil. Celluloid dissolved in acetone is also hygroscopic. Dissolve the celluloid in amylacetate and you will have a really good dope for coils. A Southbridge, Mass., amateur suggests this as a cure for poor coils in receivers.

At the December 8th meeting of the A.R.R.L. Board of Direction, Mr. George L. Bidwell of Washington, D. C., was appointed member of the Board to fill an existing vacancy. Mr. Bidwell, who is vice-president of the Washington Radio Club, is chairman of the A.R.R.L. Railroad Emergency Relief Committee, a most important new branch of our activities. He is an able leader, a man of vision and of ideas, and a strong addition to the Board.

The Headquarters Staff wishes to thank heartily all of our members and friends for the numerous holiday greetings showered upon us.

Experimenter's Section

THE report this month will be very brief—too busy attending to the correspondence of the section to talk much about it in QST.

Many additional men continue to enroll for experimental problems, interest being especially strong in receiving sets, antennas and radio amplification. The roll is now being catalogued and men wanting to know of others in their own neighborhood who are interested in the same sort of work may write the Technical Editor, indicating what they are doing, what equipment they have, and as much other detail as possible.

These letters positively will not be answered unless they are correctly addressed and relate to experimental work and nothing else. Please don't write about half a dozen other things in the same letter.

Additional Problems

Men are wanted to work on the following things—

- Curing interference from leaky power lines.
- Preventing harmonics from sending sets.
- Preventing interference on twice the working wave.
- Resistance and capacity of various sorts of coils.
- Curing the keying click.
- Screening X-ray and violet-ray outfits to cure interference.
- Frequency multipliers (getting 500 cycles or better from 60).
- Electrolytic Rectifiers (considerable data available on this).
- 3,000 meter and 10,000 meter R.F. Transformers for Super heterodynes (*urgent!*)

The General Idea

The general nature of the Experimenter's Section is given on page 35 of the January issue. Come on in!

—S.K.

AMATEUR RADIO STATIONS

(Concluded from page 58)

in the transmitter. The transmitting inductances, seen on the wall to the right of the picture, are rather out of the ordinary and are constructed by winding wire in slots in six hard rubber strips mounted on a hard rubber slab. During the tests with American amateurs, slightly over two amperes were being put into the antenna on wave lengths in the vicinity of 100 meters. The high voltage supply for the plate of the transmitting tube is obtained from a 1,500-volt Mackie double-ended generator used in connection with the usual filter condenser and choke coil. The generator is belted to a ½ h.p. D.C. motor.

The receiver is the customary three-coil arrangement; primary, secondary and tickler, with tuning condenser across the secondary. It has a tuning range from 100 to 1100 meters, being equipped with dead-end switches. Two English type D.E. tubes are used, one as detector and the other as an audio amplifier. During last year's tests 56 American amateur stations were logged on this arrangement on a single morning.

Mr. Partridge explains that, under favorable conditions, American amateur stations transmitting on wave lengths slightly below 200 meters are received very well in England. On wave lengths from about 180 upwards, however, the "hash" and "mush" from arc stations generally render reception most difficult over there and of course the more tubes they employ the stronger the QRM is also.

“Knowing radio batteries as I do, I consider yours most remarkable”

—a statement made by one of the most prominent radio engineers.

The efficiency of your receiving set depends largely upon the quality of batteries used.

That is why engineers, manufacturers, amateurs and the public at large prefer Burgess Radio Batteries.

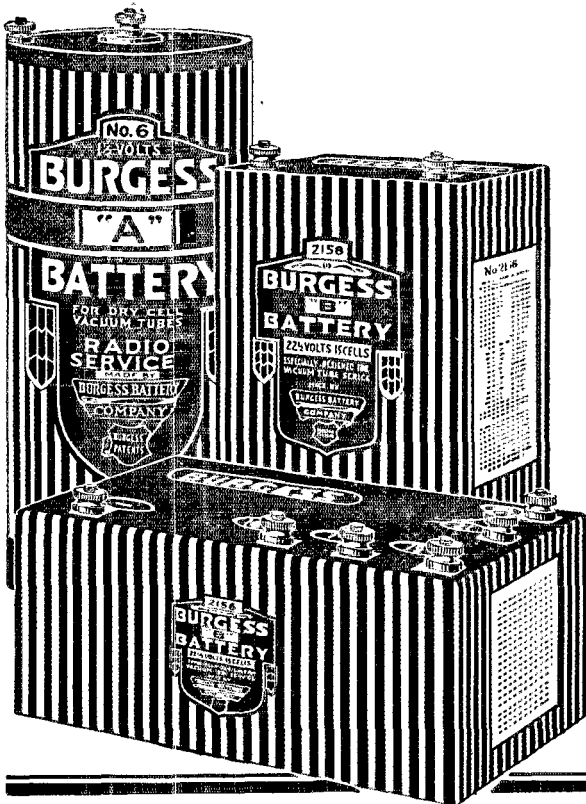

“ASK ANY RADIO ENGINEER”

BURGESS RADIO BATTERIES

A Laboratory Product

BURGESS BATTERY COMPANY

ENGINEERS - DRY BATTERIES - MANUFACTURERS
FLASHLIGHT - RADIO - IGNITION - TELEPHONE
GENERAL SALES OFFICE: HARRIS TRUST BLDG., CHICAGO
LABORATORIES AND WORKS: MADISON, WISCONSIN

BRANCHES

NEW YORK BOSTON KANSAS CITY MINNEAPOLIS
WASHINGTON PITTSBURGH ST. LOUIS NEW ORLEANS

IN CANADA

PLANTS: NIAGARA FALLS AND WINNIPEG
BRANCHES: TORONTO MONTREAL ST. JOHN

"THE AIR IS FULL OF THINGS YOU SHOULDN'T MISS"



Eveready "Three"

4½ volts, three distinct uses. Length, 4 in.; width, 1¾ in.; height, 3 in.; weight, 14 oz. At all reliable radio dealers.

This "C" Battery
is a Wonder Worker

"THE AIR IS FULL OF THINGS YOU SHOULDN'T MISS"

For Quality Reproduction

YOU can make the loud speaker respond with a new fullness and naturalness of tone. You can save money by adding months to the life of your "B" Batteries. These things you can do by using the new Eveready "Three" as a "C" Battery

You already have an "A" Battery for the filament and a "B" Battery for the plate. A "C" Battery is connected to the third element of your vacuum tube, the grid, affording a control that is marvelous in action on audio frequency amplifiers.

As a "C" Battery the Eveready "Three" prevents distortion and excessive flow of current from the "B" Battery, lengthening its life. It is a wonder worker that saves its small cost many times over. Connect it in your audio frequency amplifier and note the difference. Full directions on the label and in "How to Get the Most Out of Your 'B' Battery," a booklet on "B" and "C" Batteries, sent free on request.

This triple-use battery can also be used as an "A" Battery in portable sets. Light and full of pep. Its third use is as a "B" Battery booster.

Use the Eveready "Three"—a tested product of the world's leading electro-chemical battery laboratory. It serves more radio uses and effects more economies than any radio battery heretofore developed.

If you have any battery problem, Radio Battery Information Headquarters will solve it for you. Write G. C. Furness, Manager, Radio Division, National Carbon Company, Inc. 124 Thompson Ave., Long Island City, New York.

NATIONAL CARBON COMPANY, INC.

Headquarters for Radio Battery Information

New York

San Francisco

CANADIAN NATIONAL CARBON CO., Limited.

Factory and Offices: Toronto, Ontario

EVEREADY
Radio Batteries
- they last longer

Determining Quality

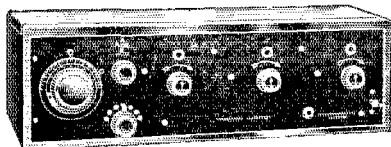

This new Ace Type 3B Armstrong Regenerative Radio Receiver is the height of perfection. It is equal to a combination of the Ace Type V and the Ace two-stage amplifier. For volume and distant reception it out-performs most sets costing a great deal more. The new Ace Type 3B has a filament switch which eliminates necessity of turning out rheostats when set is not in use. Sells for \$50.00 but worth much more. Has genuine mahogany cabinet with engraved panel.

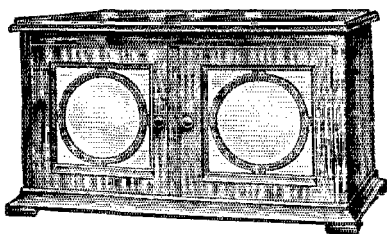

ACE TYPE 3C CONSOLETTTE

This is the last addition to the Ace Family. Has beautiful solid mahogany, wax finished cabinet. Set consists of a regenerative tuner, detector and two stages of amplification with built-in loud speaker. Due to the particular method of winding Crosley coils it is exceptionally selective. Has sufficient room inside Cabinet for dry batteries, making a complete self-contained long range receiving outfit. Phone jack for tuning with head phones; Crosley multistat; filament switch, engraved Formica panel. Uses all kinds of tubes. An efficient set at a remarkable price, \$125.00—without tubes or batteries.

Your dealer can supply you.
Ask for "Simplicity of Radio"
—your copy is free.

DEALERS: Write on your
letterhead for attractive sales
proposition.

A RADIO set or product is no better than the science and skill that creates it.

Those men in this Institution who are intrusted with the responsibility of producing up to the standards of Powel Crosley, Jr., are experts who have won national recognition in their chosen scientific field.

Honest Merchandise uses Truth in Advertising

Ace Type 3B and Ace Type 3C Consolelette manufactured under Armstrong U. S. Patent No. 1,113,149

THE PRECISION EQUIPMENT CO.
217 VANDALIA AVE. POWEL CROSLY, JR., Pres. CINCINNATI, OHIO

The WANDERING MINSTREL of TODAY

HOW far have we progressed from the days when the minstrels, singing their self composed ballads to the accompaniment of harp or lute, or telling their stories illustrated with crude mimicry, wandered from castle to castle in old England furnishing to the nobility, practically the only entertainment available.

Today every American, no matter how far removed from the centers of activity has within his reach up-to-the minute news and amusements that would have delighted the hearts of the nobility of old. The air is filled with merriment waiting to be captured and brought to your very fire-side.

Radio is the magic wand that attracts to you the desired entertainment, Crosley Radio Receivers are the instruments by which this entertainment may be clearly and distinctly converted into a true reproduction of the original voice thousands of miles away.

You can own and enjoy a Crosley Radio Receiver. Unique features and quantity production have enabled us to offer the greatest value in radio ever produced. Actual tests by hundreds of satisfied users in all parts of America have proven that in performance, Crosley Instruments are unexcelled. And the prices are remarkably low.



CROSLEY

MODEL VI \$30
Two Tube Set
MODEL X-J 65
Four Tube Set
MODEL X-L 140
Four Tube Set
With Built-in Loud Speaker



CROSLEY
Better - Cost Less
Radio Products

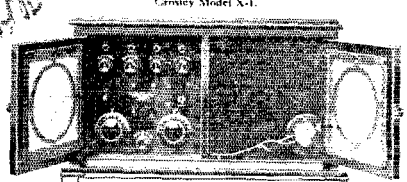

Crosley Model X-L

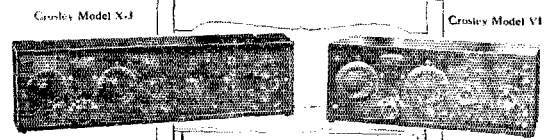

Crosley Model X-J

Crosley Model VI

Special mahogany stand for Model X-L, \$25 extra.
Cost of necessary accessories \$40 up.

MODEL VI—\$30. A wonderful efficient two tube set, one stage of Tuned Radio Frequency Amplification and Detector.
MODEL X-J—\$65. A four tube radio frequency set combining one stage of Tuned Radio Frequency Amplification, a Detector and two stages of Audio Frequency Amplification. A Jack to plug in on three tubes for head phones, the four tubes coupled up for loud speaker.
MODEL X-L—\$140. A duplicate of Model X-J except the arrangement and mounting into a beautiful cabinet with the addition of a built-in loud speaker and space in the cabinet provided for housing the necessary batteries.

Crosley Manufacturing Company owns and operates broadcasting Station WLW.

—Mail this coupon Today—

CROSLEY MANUFACTURING COMPANY.
Powel Crosley, Jr., President.
218 Alfred St., Cincinnati, Ohio.
Gentlemen:—
Please mail me free of charge complete catalog of Crosley instruments and parts.
Name
Address

Let a Crosley Radio Receiver Bring Perpetual Entertainment to Your Home.

For bringing in distant stations no set can excel it.

For Sale By Good Dealers Everywhere.

CROSLEY MANUFACTURING CO.
Powel Crosley, Jr., President
218 Alfred St. Cincinnati, O.

—The Largest Manufacturer of Radio Receivers in the World—

ALWAYS MENTION Q S T WHEN WRITING TO ADVERTISERS

RADIO SHOW

AND

CONVENTION

OF THE

SECOND DISTRICT

The Fourth Annual Second District Radio Show and Convention, under the auspices of the Executive Radio Council, Inc., will be held in New York at the

HOTEL PENNSYLVANIA

(GRAND BALLROOM)

March 3-4-5-6-7, 1924

—See QST and Amateur Radio for Details—
A few of the noteworthy features

Over 50 of the best manufacturers; visit to the famous WJZ-WEAF studios; Amateur Club Booths and exhibit of apparatus; Initiation of the R.O.W.H.!!! Contests, Lectures, Stunts, etc. Grand Banquet and Hamfest with everyone prominent in radio present.

General Admission—50 cts. (Inc. Magazine Program)

Banquet—Season Pass—Hamfest-Trips—\$5.00

**Make Your Reservations Early To
Executive Radio Council—120 Liberty St.**

N. Y. C.



What's Inside

THE most important thing to know about an amplifier is "What's Inside." Outwardly there is little vital difference. Inwardly there's all the difference in the world—the difference between clear, mellow reception and poor reception full of squeaks and squawks.

Many radioists unconsciously put the "squeaks and squawks" into their sets through the use of improper transformers. They have yet to learn that "RATIO" means absolutely nothing—that 10 to 1, 9 to 1; etc. do not spell maximum amplification.

The very next time you buy an amplifier insist on a Genuine JEFFERSON for these reasons:

1st—A JEFFERSON is scientifically designed.

2nd—The windings are carefully calculated to produce 100% amplification—they are not built up to a ratio.

3rd—The JEFFERSON line embraces a variety of amplifiers to meet every demand—six Audio and two Radio Frequency types.

As pioneer transformer manufacturers JEFFERSON Engineers designed audio amplifiers long before Radio reached its present popularity. You will appreciate JEFFERSON'S extra years of experience.

And remember this—the first cost of an amplifier is unimportant. Results count—buy an amplifier for what it will do—the service it will render—the tone and volume it will produce. Receiving is fun when one doesn't have a lot of pesky distortion to struggle with. You eliminate distortion when you use JEFFERSON. Your set operates more quietly and

clearly—the volume is greatly increased—distant stations are easily tuned in. You are invited to write our Radio Engineering Department for amplification data. Attractive descriptive literature is also available. This service is gratis.

Jefferson Electric Mfg. Co.,
425 So. Green St., Chicago, Ill.

 **Jefferson**
Super-sensitive
Amplifying Transformers 

Generators — Motors — Dynamotors — Motor-Generators
Stand Supreme in Wireless Field

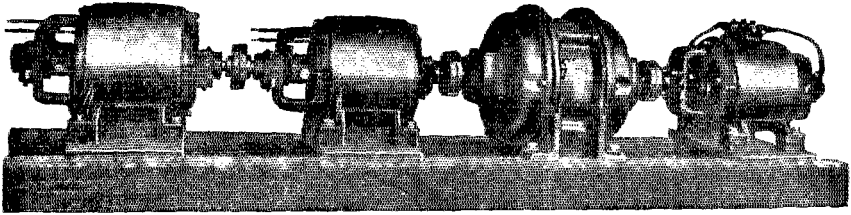

This Special 4 Unit Set made for Wis. Dept. of Markets—the largest Broadcasting Station in existence. A 10 H.P. Motor—two 1000 V., 2000 W. Generators to operate in series, producing 2000V. and 4000 W. and one 12 V. 2000 W. Filament current Generator.

SEND FOR BULLETIN 237A listing over 200 combinations. We design and develop Special Apparatus for Special Purposes.

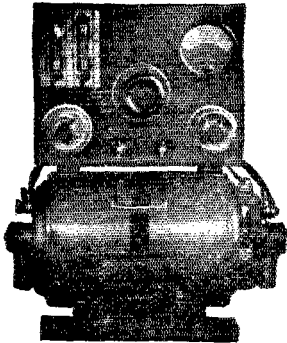

BATTERY CHARGER
 Many Sizes with or without panels

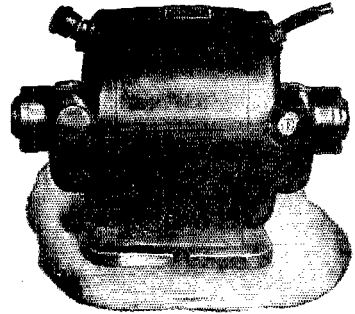

DYNAMOTOR
 Sizes to fit all requirements.

SOLD BY PRINCIPAL DEALERS EVERYWHERE

ELECTRIC SPECIALTY COMPANY

225 South Street,

Stamford, Conn., U.S.A.

Pioneers in developing High Voltage Apparatus

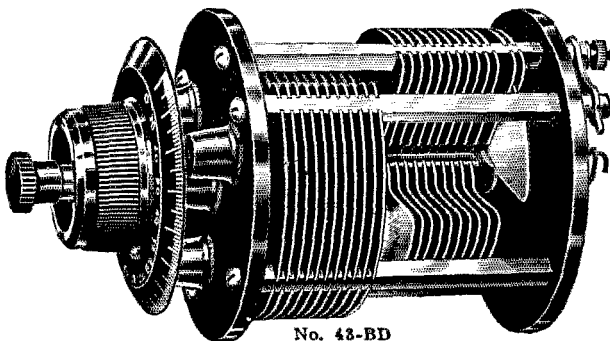

No. 43-BD

Sexton Condensers
 Double Knob Vernier
 (Balanced Model)

FURNISHED WITH 3" BLACK BAKELITE DIAL AND VERNIER BUTTON

Incorporates the following features:

- Ball Thrust Bearing between Vernier and Rotor Shaft.
- Half Capacity Switch.
- Pig-Tail Connections.
- Genuine Bakelite End Plates.
- Exact and Uniform Spacing of Plates.

Write for Circular "R."

The Hartford Instrument Co.
 308 Pearl St., Hartford, Conn.

Radio Frequency Ammeters

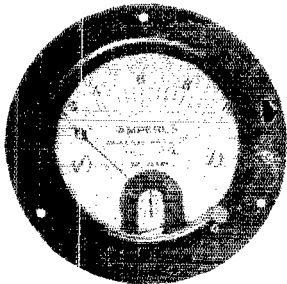

Type 127A

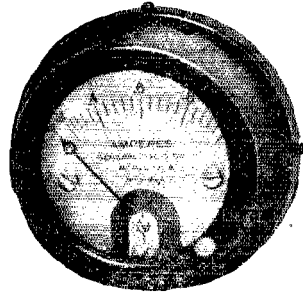

Type 127B

HOT WIRE AMMETERS

All transmitting sets, and continuous wave sets in particular, require ammeters to obtain the best results. You cannot depend on the other fellow's ear. The circuits from input to output must be adjusted by ammeters.

The hot wire ammeter is the universal meter for this service. It is adapted for direct current, low frequency alternating current and for radio frequency. It can be checked at any time on direct current and will be equally accurate on radio frequency. As this action depends on the fundamental I^2R law, it always measures actual effective amperes.

We recommend for this service our Type 127 hot wire ammeter. This meter employs a platinum expansion element and is rugged and reliable. The diameter is three inches and this meter is made in front-of-panel and flush-mounting models. It is supplied in a variety of convenient ranges. The price is also right.

PRICE \$7.75

SEND FOR FREE RADIO BULLETIN 916-Q

GENERAL RADIO COMPANY

MASSACHUSETTS AVENUE AND WINDSOR STREET

Cambridge 39

Massachusetts

Do not confuse the products of the GENERAL RADIO CO. with those of other concerns using the words "General Radio." The General Radio Co has been manufacturing radio and scientific instruments for many years. It has no affiliation with any other company.

You will marvel and be thrilled by the performance of



**Federal
Radio Parts
Always
Ideal Gifts**

Groups of Federal Radio Parts to make complete sets.

Federal Telephone and Telegraph Company

Boston New York
Brigdeburg, Canada

Factory: Buffalo, N. Y.

Philadelphia

Chicago

San Francisco

Pittsburgh
London, England

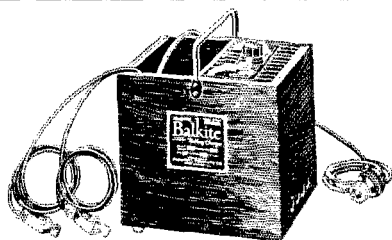

FANSTEEL

Balkite

PATENTS
APPLIED FOR

Battery Charger

Noiseless and Indestructible

A new charger for Radio "A" 6 volt batteries. Entirely noiseless. Has no moving parts to adjust or get out of order, and no bulbs to break. Cannot discharge, overcharge or short circuit the battery. Can be used while the radio set is in operation. Simple, positive and unfailing in action. Sent direct on receipt of price if your dealer cannot supply you:

Price \$18 (\$18.50 West of Rockies)

Dept. Q2 Fansteel Products Co., Inc.
North Chicago, Illinois

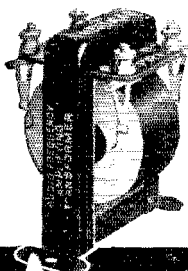

**STANDARD
of
EXCELLENCE**
for audio amplification
With all tubes
In all stages

AMERTRAN
TRADE MARK REG. U.S. PAT. OFF.

Improve your set with an AmerTran

Its flat-top, distortionless amplification curve assures faithful reproduction of speech and of music over the full musical scale.

In one stage audibility is increased 30 to 40 times in the flat part of the curve, depending on the tube constant—the amplification is approximately 5 times the tube constant. Send for Circular 1005.

Type AP-6: turn ratio 5:1. Price \$7. Ask your Electrical Dealer; or, sent carriage charges collect.

American Transformer Co.

Designers and builders of radio transformers for over 22 years.

176 Emmet Street, Newark, N. J.

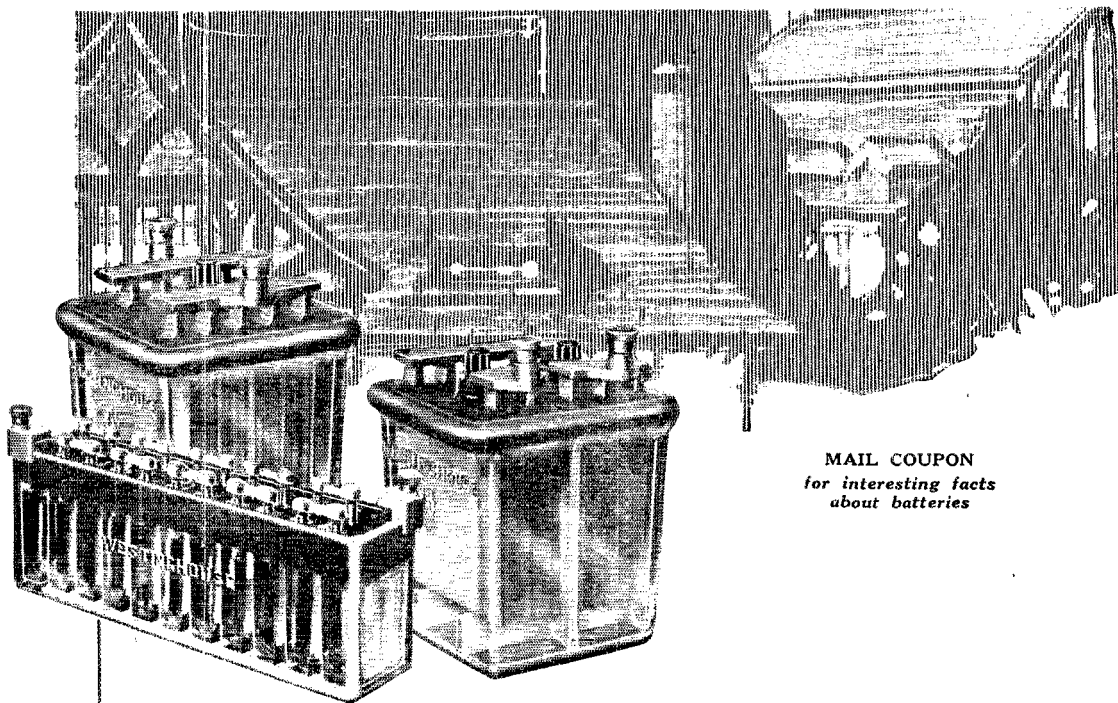

MAIL COUPON
for interesting facts
about batteries

FULL voltage battery current all the time! That's what you want. Westinghouse Radio Storage Batteries will give it to you. No more operating with run-down batteries! No more sudden drops in battery voltage! No more throwing away worn-out batteries! Westinghouse Batteries last. They hold their charge. They can be easily recharged. There's a size and type for every radio need. Built by Westinghouse, you *know* it's RIGHT!

Westinghouse **CRYSTAL CASE** Batteries have one-piece clear glass cases, with solid glass cell partitions and high plate rests (deep sediment spaces). Perfectly insulated against current leakage. "A" Batteries. 2 volts, for low-voltage tubes, such as WD-11 and WD-12. 4 volts, for tubes like UV-199. 6 volts, for tubes UV-201A or C-301A. Also rubber-case types. "B" Batteries. 22 volts. Regular and quadruple-capacity types. "C" Batteries in 6-volt units.

WESTINGHOUSE UNION BATTERY CO., Swissvale, Pa.

WESTINGHOUSE

RADIO

"A," "B" and "C" BATTERIES

Westinghouse Union Battery Co.
Swissvale, Pa.

Send me Westinghouse Radio Battery
Folder A-3-D.

.....

.....

.....

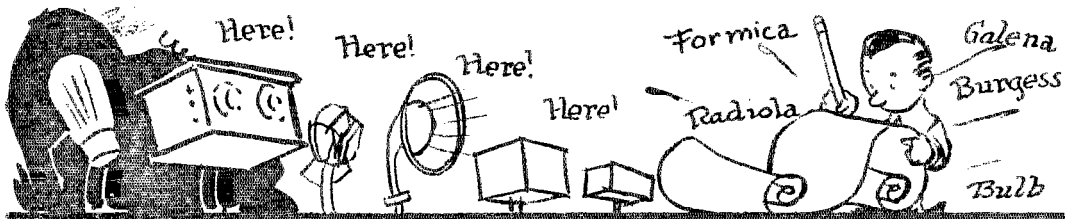

HOMMELS STOCKS are ALWAYS COMPLETE
waiting to serve you promptly

AMATEURS —

Tell us what you are interested in—send us the name of your dealer and we will see that you are supplied promptly.

Enormous stocks of high grade nationally advertised radio equipment are always carried by this organization to assure prompt shipments any time anywhere.

Hundreds of dealers throughout the country have found "Hommel Service" most dependable and satisfactory. A trial order will convince you of Hommel ability to serve you likewise.

Dealers—Let us send you the new Hommel Encyclopedia 246T.

LUDWIG HOMMEL & CO

530-534 FERNANDO ST.

PITTSBURGH, PENNA

WEIGHS ONLY 8 OZ

The Scientific

THE PHONE IT TOOK A SOLID YEAR TO DESIGN

A \$200,000.00 COMPANY stands squarely back of the guarantee on every Scientific headset

SEND NO MONEY!

20,000 TURNS EQUIVALENT TO 3,000 OHMS

Order TODAY by Postcard

\$2.95

and Pay Postman on arrival

POST-PAID

LOUD SPEAKER UNIT \$1.95

We Guarantee The *Scientific* Headset to be the greatest value on the market. Try it for five days. If not satisfactory send it back and your money will be refunded immediately. Circular on request. Dealers wanted.

THE SCIENTIFIC ELECTRIC WORKS

98 Brookline Ave.

DEPT. G

BOSTON, MASS.



ELECTRASOTE

REG. U.S. PAT OFF

TRADE

MARK

Important Announcement About Radio Panels

ELECTRASOTE is the latest addition to the famous family of products whose names end in "Sote".

The unvarying high quality of these celebrated products has made THE PANTASOTE COMPANY, Inc., well known the world over. Listen to what the U. S. Bureau of Standards says about ELECTRASOTE for Radio Uses:

"Electrasote has an average phase difference of about 1.8 degrees. Since phase difference is a dependable property on which to base an opinion of a material for use in radio apparatus, it seems to us that in this respect Electrasote is as good or better than the average phenolic insulating materials for such uses."

Here's What You Get in ELECTRASOTE

- 1. HIGH QUALITY**—Electrasote is as good as any other panel material regardless of price. High Surface and Volume Resistivity. Low Phase Difference. Absence of Abrasives. Cuts clean without dulling tools.
- 2. LOW PRICES**—From 25 to 50% lower list prices than any other standard high quality Panel Material.
- 3. FINE FINISH**—Each panel finished in a high gloss finish on one side and a very fine satin-grained finish on the other side, thereby filling the bill whatever the demand.
- 4. INDIVIDUAL PACKAGE**—Every Electrasote Panel wrapped in a durable, attractive envelope.

ON SALE AT GOOD RADIO DEALERS

JOBBER AND DEALERS: Write for our attractive proposition.
Some territory still open.

Address all communications to

M. M. FLERON & SON, INC.

Exclusive Sales Agents for Electrasote Radio Panels

113 North Broad Street

Trenton, New Jersey



PATTERN No. 95

RADIO TEST SET

- ¶ This radio test set has been designed to meet the demands coming to us from serious experimenters, manufacturers and dealers in radio equipment and supplies, for a complete radio testing outfit.
- ¶ While the various ranges of readings permit making practically every test necessary in connection with radio receiving sets, it has been particularly designed for the taking of characteristic curves on vacuum tubes, the only extra equipment required being the batteries.
- ¶ The several instruments, any of which may be used independently, include a 0-1.2 filament ammeter, a 0-6 filament voltmeter, a 0-120 plate voltmeter, a 0-10 plate milliammeter, and a 10-0-10 grid voltmeter.

Complete With Instructions

Price, \$75.00

Send for Circular

ORDER FROM DEALER

**JEWELL ELECTRICAL
INSTRUMENT CO.
1650 WALNUT ST.
CHICAGO**

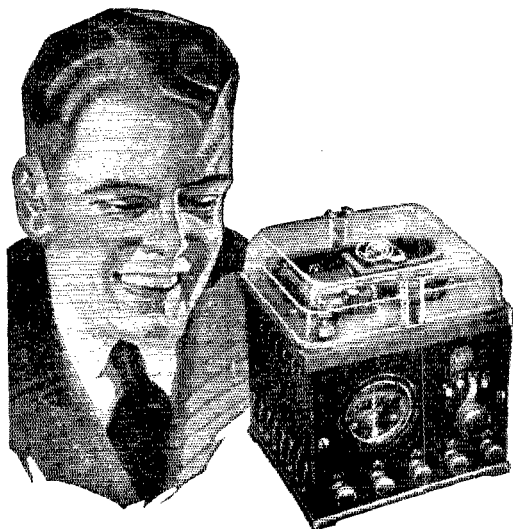

Simple as A-B-C

Longer distance and clear signals are the pleasing results which you can be sure of when both the A and B batteries of your radio set are storage batteries. No other source of power for radio equals the storage battery.

The Valley Type ABC Battery Charger is so simple and so easily operated that it makes storage batteries the most convenient and inexpensive source of power for radio. Enjoy radio at its best. Use storage batteries and charge them with the Valley Type ABC Battery Charger.

The Valley Type ABC Battery Charger is made to charge:

- 2-volt Peanut Tube Batteries
- 6-volt A Batteries
- 6 and 12-volt Automobile Batteries
- 1 to 4 B Batteries

Bakelite panel, glass top. Harmonizes with any receiving set. And as simple as ABC to operate. Plugs in on the light socket like a lamp and connects to battery by means of regular battery clamps.

At all good radio shops.

VALLEY ELECTRIC CO.
3157 S. Kingshighway St. Louis, Mo.

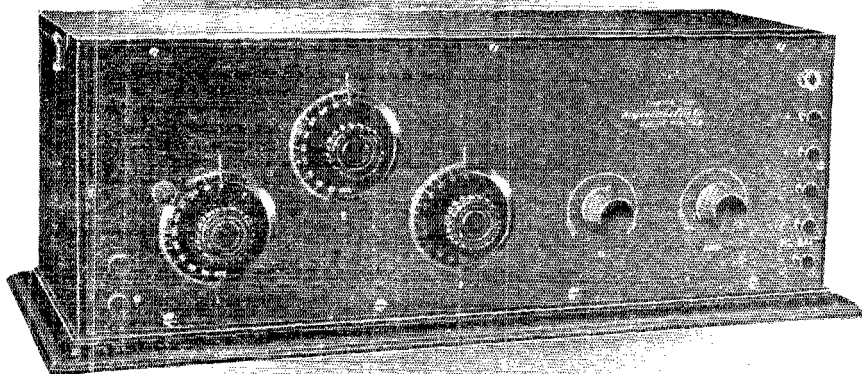

ARE YOU HAVING TROUBLE GETTING SHORT WAVE SIGNALS ?

The WC-5-SW shown above picks up signals on wave lengths from 90 to 380 meters sharp and clear. It is the most practical set for low wave specialists. Built by short wave experts the WC-5-SW eliminates the trouble which transmitting amateurs are having with ordinary receiving sets. If you are interested in getting better results it will be to your advantage to investigate the WC-5-SW. Enthusiastic operators from all parts of the country write us praising its efficiency.

WC-5-SW

Built especially for Transmitting Amateurs

The WC-5-SW is a 4 tube set. One stage of tuned Radio Frequency amplification is employed ahead of the detector to make it super-sensitive. Two stages of audio frequency are used to bring up the signal strength. Uses any type of tubes. Gives perfect control of audibility. Detector rectifies only. Uses antenna compensating condenser. Only two control adjustments. Pure negative biasing on all tubes. thus marked saving on B Battery cur-

rent. Tuned Radio Frequency sharp-est known and most selective principle ever adopted. Plate potential non-critical. Mono-block tube socket. No grid plate leads on audio amplifiers. Audio amplification absolutely necessary when using low efficiency receiving antenna, i.e., underground or indoor. Mahogany cabinet, piano rub finish. Rabbited-in panel, Split lid cover. The price is only \$85.00.

Write for complete description and illustrated folder on this practical set for low wave specialists. All transmitting amateurs will be interested in this literature.

OTT RADIO, Inc.

224 Main Street

La Crosse, Wis.

OT

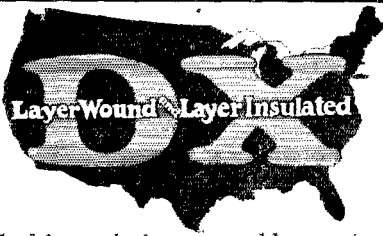

Cover the Continent—

Every radio enthusiast is interested in long distance reception. No matter how loud and clear the nearby stations come in, the big thrill comes when you hear a station thousands of miles away.

Stromberg-Carlson

RADIO HEAD SETS

enable you to utilize every bit of energy that your set picks up. The layer wound and layer insulated construction increases their capacity and enables them to function properly under the high plate voltages now in use for loud speaker hook-ups.



Send for our booklet No. Q which will tell you more about these head-sets.

STROMBERG-CARLSON TELEPHONE MFG. CO., ROCHESTER, N. Y.

To Our Readers Who Are Not A.R.R.L. Members

Wouldn't you like to become a member of the American Radio Relay League? We need you in this big organization of radio amateurs, the only national amateur association that does things. From your reading of *QST* you have gained a knowledge of the nature of the League and what it does, and you have read of its purposes as set forth on page 6 of every issue. We would like to have you become a full-fledged member and add your strength to ours in the things we are undertaking for Amateur Radio, and incidentally you will have *QST* delivered at your door each month. A convenient application form is printed below—clip it out and mail it today.

1924

American Radio Relay League,
Hartford, Conn.

Being genuinely interested in Amateur Radio, I hereby apply for membership in the American Radio Relay League, and enclose \$2 in payment for one year's dues. This entitles me to receive *QST* for the same period. Please begin my subscription with the.....issue. Mail my Certificate of Membership and send *QST* to the following address.

.....
.....
.....

Station call, if any.....
Grade operator's license, if any.....
Radio Clubs of which a member.....
Do you know a friend who is also interested in Amateur Radio, whose name you might give us so we may write to him too about the League?.....

.....Thanks.

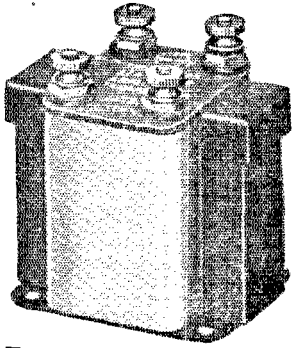

YOUR SET WILL BE A MUSICAL INSTRUMENT

WHEN YOU USE

THE THORDARSON SUPER AUDIO FREQUENCY AMPLIFYING TRANSFORMER

Heretofore, audio frequency amplifying transformer manufacturers have given too much attention to volume of amplification and have sacrificed the most important function of their transformers,—that of perfectly reproducing the broadcasted programs. Consequently many listeners have complained about the musical qualities of radio reception.

No matter how good your phonograph, you could not expect to obtain good music from a poor record. Likewise, although your loud speaker be the best you cannot expect to enjoy radio reception if the signals you put into it have been distorted in the process of amplification.

The new THORDARSON SUPER Audio Frequency Transformer was designed to correct the shortcomings of amplifying transformers of the past and embraces the following cardinal features:

- (1) Perfect reproduction of voice and instrument.
- (2) Even amplification over the entire musical range. (You will be surprised to hear the amazing reproduction of the bass notes).
- (3) Increase in volume to the extent that tonal purity will permit.

This SUPER TRANSFORMER is the result of several months research work in the thoroughly equipped Thordarson laboratory and represents the culmination of twenty-eight years experience in manufacturing small transformers.

Such leading set manufacturers as the Colin B. Kennedy Company, Chicago Radio Laboratories Company (Zenith), and the Western Coil and Electric Company (Radiodyne) along with many others proclaim the merits of the THORDARSON SUPER TRANSFORMERS.

Install a pair of Thordarson Super Transformers now and your receiving set will be converted into a real musical instrument.

YOUR DEALER HAS THEM

THORDARSON

ELECTRIC MFG. CO.
CHICAGO — ILLINOIS

SIGNAL

New Vernier Variable Condenser

Positive contact between Vernier and Rotor plates. Special designed Vernier closest tuning.

Vernier but 2-1/100 of large dial.
Pigtail connection to soldering terminal.
Special bushing holding Vernier and shaft.

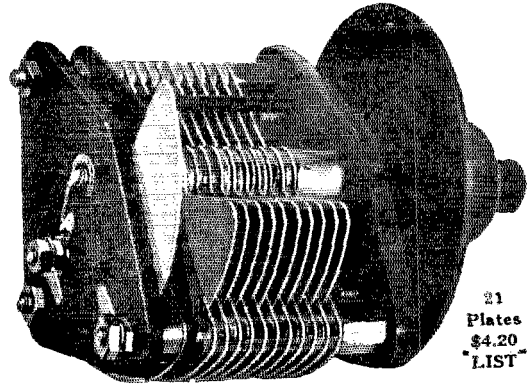

21
Plates
\$4.20
LIST

Ensures:
Closest tuning obtainable.
Positive contact.
Clear signals.
Less interference.

Ask your dealer to show you the new Signal Vernier Variable Condenser. Catalog on request.

SIGNAL Electric Mfg. Co.

Factory and General Offices
1915 Broadway,
Menominee, Michigan

Boston, Chicago, Minneapolis, Montreal, New York, Pittsburgh, St. Louis,
San Francisco, Toronto, Philadelphia, Los Angeles.

You'll find our local address in your Telephone Directory

ARE YOU A 1923 MAN? IF YOU ARE—GET OUT OF THE RUT

Radio has improved with leaps and bounds since last year—to be a 1923 man is to be satisfied with last year's results—Broadcasting and CW will accomplish wonderful results this Fall and Winter and for you to share in these coming successes—both receiving and transmitting—you need a good set, made from the latest and most improved parts.

ROSE RADIO HAS IT !!
(and I don't mean maybe)

ROSE RADIO AND ELECTRICAL SUPPLIES
129 CAMP STREET, NEW ORLEANS, LA.



DeLuxe Contact

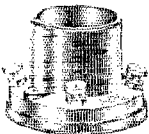

Na-ald DeLuxe
No. 400

NA-ALD

De Luxe Socket

The laminated phosphor bronze contacts of the Na-ald De Luxe Socket press firmly on both the ends and sides of tube prongs, keeping the surface clean and insuring clear reception.

Moulded of genuine Bakelite this socket expresses the very highest quality in appearance and workmanship.

ALDEN MANUFACTURING CO.
Largest makers of Radio Sockets and Dials in the world.
Springfield, Mass.
Dept. M 52 Willow St.



RADIO "B" BATTERIES
At Factory Prices

Greatest radio "B" battery on market. Full number voltage taps: **QUALITY GUARANTEED; LOWEST PRICES;** brings in concerts **LOUDER AND STRONGER;** will work on any tube or loud speaker. Order by number **TODAY** with check, money order or pay postman C. O. D.
No. 222B 22½ volt variable, regularly \$2.25.. \$1.52
No. 222A 22½ volt variable, regularly 3.00.. 1.85
No. 245A 45 volt, 8 taps, regularly 5.50.. 3.25
AYRES BATTERY CORPORATION. Cincinnati, Ohio

RADIO FREQUENCY AMPLIFICATION

WITH

Ballantine Variotransformers

(Patents Pending)

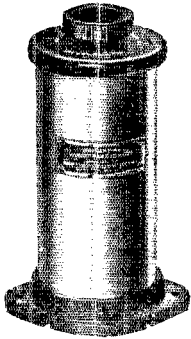

Model 5 \$9.60

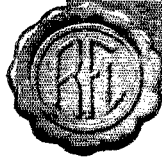
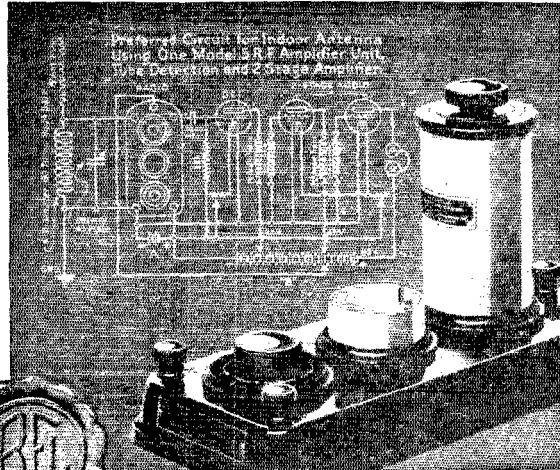

Complete Unit \$15.00

"TURN THE KNOB"

1. Continuous variation in wave length.
2. Self-contained and shielded.
3. Control of regeneration and tuning by single knob: *no potentiometer.*
4. Fits your set — either base or panel mounting.
5. Improved tone quality.

"Radio Frequency Amplification with the Ballantine Variotransformers" — a 25-page booklet — mailed free on request.

BOONTON RUBBER MFG. CO.

Pioneers in Bakelite Moulding

124 FANNY ROAD

BOONTON, NEW JERSEY



CHELTEN QUALITY RADIO PRODUCTS

THE LATEST IN CONDENSERS

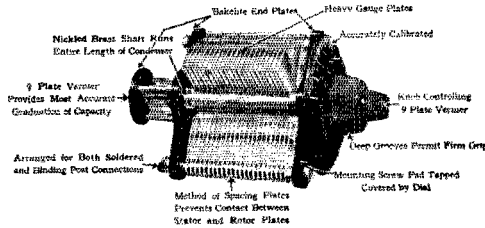

THE CHELTEN RADIOSCOPE

Accurately spaced heavy gauged plates mounted between Bakelite ends, a special Chelten 9 Plate Vernier, and many other improvements makes the Chelten **RADIOSCOPE** stand out as one of the most selective and satisfactory **Variable Condensers** money can buy. The 9 plate Vernier will surprise you with its unusual selectivity. You'll find stations you never imagined your set could receive. Made in 45 and 23 Plate type.



CHELTEN MIDGET VERNIER

Can be used as a Vernier with any variable condenser. Its 13 plates makes possible unusually fine graduation of capacity. Will increase the efficiency of all of the better circuits. Costs but \$1.50.

CHELTEN MICROFARAD JR.

Specially designed as a Neutralizing Condenser of Low Capacity. Has 9 plates. A turn of the knob changes the adjustment without body capacity effect. Absolutely retains adjustment. Price but \$1.75.

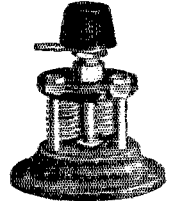

Send for Catalogue of Chelten Radio Products

THE CHELTEN ELECTRIC COMPANY

4861 Stenton Avenue,

Philadelphia



Keep a Record of the Stations You Receive With a Moon Radio Log Book

The only book that gives you a complete, permanent record of your reception over a long period. A book bound in stiff, durable cover giving such valuable information as the Morse Code; latest list of broadcasting stations with new wave lengths and call letters; list of slogans of the various broadcasting stations; logs for over two hundred days and other valuable information for the amateur.

SEND NO MONEY

Just send us your order in a letter or on a postal card and we will immediately send you a copy of the **MOON RADIO LOG**. You will pay your postman fifty cents, plus a few cents for insurance and C.O.D. fee. Present edition limited, so mail orders at once to

MOON RADIO CORPORATION

Log Dept. 501 Steinway Ave., Long Island City, N. Y.

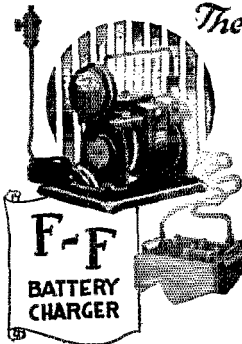

The TRIPLE SERVICE Battery CHARGER

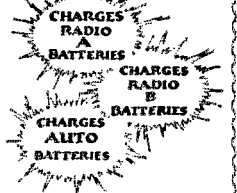

Buy the FF charger—a success for many years. Simple—shockproof—self exciting—automatically tapers charge. Attach two wires—turn switch—a jitney and a few hours charges the battery. No fluids to spill or corrode—no expensive parts to replace. Satisfaction guaranteed. Price \$15 to \$28. Look for the FF—buy none of the imitations—write for literature explaining many exclusive features also name dealer who can furnish the genuine article.

THE FRANCE MFG. CO.

31 Berea Road,

Cleveland

"New York's Grand Opera - one of the many events enjoyed by Magnavox owners"

MAGNAVOX
Radio
Reproducers and Amplifiers



MMAGNAVOX instruments are never subject to those internal interferences which, at critical moments, are so apt to mar the performance of ordinary radio reproducers.

To measure the success which Magnavox engineers have accomplished in the design and manufacture of Magnavox products, remember that they have been sold in far larger quantities than any other radio units in the world.

- | | |
|----------------------------------------------------------------------------------|-------------------------------------------------------------------------------------------------------------------|
| Magnavox Reproducer | in. curvex horn and 1 stage of amplification . . . \$59.00 |
| R2 with 18-inch curvex horn . . . \$60.00 | |
| R3 with 14-inch curvex horn . . . \$35.00 | A2-R consisting of electro-dynamic Reproducer with 14-in. curvex horn and 2 stages of amplification . . . \$85.00 |
| M1 with 14-inch curvex horn. Requires no battery for the field \$35.00 | |
| Magnavox Combination Sets | Magnavox Power Amplifiers |
| A1-R consisting of electro-dynamic Reproducer with 14- | A1—1-stage . . . \$27.50 |
| | AC-2-C—2-stage . . . \$55.00 |
| | AC-3-C—3-stage . . . \$75.00 |

Magnavox Products are for sale at Registered Magnavox Dealers everywhere. Write for new 32-page Magnavox Radio Catalogue.

THE MAGNAVOX CO., Oakland, California
New York Office: 370 Seventh Avenue
Perkins Electric, Limited, Toronto, Montreal, Winnipeg
Canadian Distributors

For every receiving set there is a /
MAGNAVOX

2R

Sterling

FILAMENT METERS

Sees all -
Tells all -
Saves all -

The
Sterling
Manufacturing
Company
2833 Prospect
Avenue,
Cleveland, Ohio.

Like the motor meter on an automobile, the filament meter of your radio set is the signal that says: "Danger" or "All's well". Don't take a chance on burning out your tubes because you do not know the voltage conditions. Set the Sterling meter to work guarding your property and saving you worry and unnecessary costs. Unusually accurate and reliable. Magnetic type. Flush mounted type and require a hole in the panel only 2" in diameter. Price \$4.00 & \$5.00.

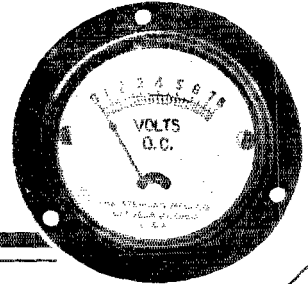

GENERAL ELECTRIC DOUBLE CURRENT GENERATORS

May Be Used as Dynamotors for C.W. Transmission

Driving Voltage	Plate Voltage	Mills
12	550	130
8	400	90

Made for the United States Army Air Service. Equipped with a Dubilier Filter System. Using 2 1/4 MF. 1800 volts Mica Condensers. Ball Bearings Equipped. All new, in original cases. Price \$29.75. Half Cash With Order—Remit by Money Order to Facilitate Immediate Shipment We also have: CW-936 Sub Chaser Telephone Transmitting and Receiving Sets including:—Remote Control System, Power Amplifier, Loud Speakers, Tubes, Spare Microphone, etc. Can be tuned down to 150 meters. Absolutely new sets. Navy Long Wave Tuners Type CN-240, Tuning Range 1000-30000 meters. You will want one for long wave reception—SPECIAL PRICE \$75.00.
EKSAF TRADING CO., 1515 Eastern Parkway, Brooklyn, N. Y.

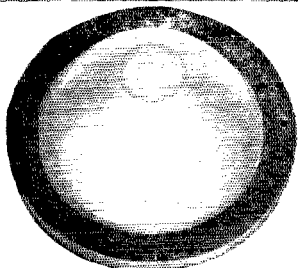

PYREX
LEAD-IN
INSULATOR

\$3.75
Complete

Prepaid to anywhere in U. S.
P. F. BECHBERGER & CO.
NORWALK, OHIO

FROST-RADIO Catalog and Instruction Book

THIS new booklet on the care and operation of FROST-PONES and FROST-RADIO is now ready. Contains 36 pages of valuable information on radio apparatus. Your copy mailed free on request.

Address Dept. 11F62

Herbert H. Frost, Inc.
154 West Lake Street
CHICAGO, ILLINOIS



A post card from you will bring this 40-page catalog.

ELECTRAD PRODUCTS

THEIR QUALITY ABSOLUTELY GUARANTEED

You are safe when you buy Electrad Products. They are absolutely guaranteed, electrically and mechanically, to be of the finest materials and workmanship.

Most good dealers carry them because they are fairly priced, and give their customers good service.

Double Your Distance with an ELECTRAD VARIOHM



The latest invention in grid leaks. A simple turn of the knob and you can get any resistance from $\frac{1}{2}$ to 30 megohms. Eliminates circuit noises, is moisture proof and non-microphonic. Is equipped to take any standard condenser. Absolutely guaranteed.

ELECTRAD INDORARIAL



Ideal for sharp tuning. Wonderful directional effects. Particularly effective where several local stations are broadcasting at once. Can be used also as ground. By using Indorarials for antenna and ground you can get any coupling you desire. Hang on wall, door or lay under rug.

ELECTRAD LEAD-IN



Fits under closed window. Can be bent to any shape. Covered with fireproof insulation which prevents grounding on wet window sills. No holes in window frames and takes the place of unsightly porcelain tubes. Fitted with Fahnestock clips.

ELECTRAD GRID LEAKS



Absolutely uniform unvarying fixed resistance. A superior product of dependability, in all resistance from $\frac{1}{2}$ to 10 megohms. Price 30 cents.

Dealers: Write for samples and details on our special group assortment.

ELECTRAD, Incorporated

Dept. "G", 428 Broadway, New York City

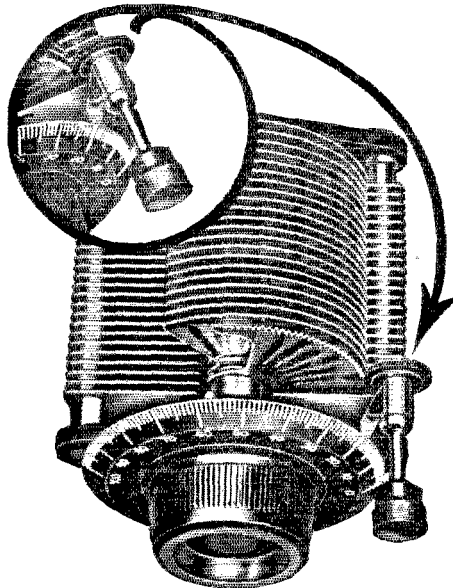

HEATH'S Radiant Condensers

When you put *Heath Radiant Condensers* behind a panel, you can forget about them. They will *always* tune as perfectly as the day you mounted them. Absolute alignment is permanent, because the plates are protected against warping and buckling by the *Heath* process of stamping and tempering. Each plate is PERMANENTLY FLAT—

Vernier with a Hairline Adjustment

Separate vernier adjustment—reducing gear meshed into teeth cut in rim of vernier plate. Ordinary adjustment reduced to infinite fineness. Absolutely positive adjustment—without backlash.

Write for illustrated booklet and the name of the nearest Radiant dealer.

LIST PRICES—VERNIER TYPE

- 13 Plate including $2\frac{3}{4}$ " dial and knob... \$5.00
- 25 Plate including $2\frac{3}{4}$ " dial and knob... \$5.50
- 45 Plate including $2\frac{3}{4}$ " dial and knob... \$6.50

HEATH RADIO & ELEC. MFG. CO.
207 First St., Newark, N. J.

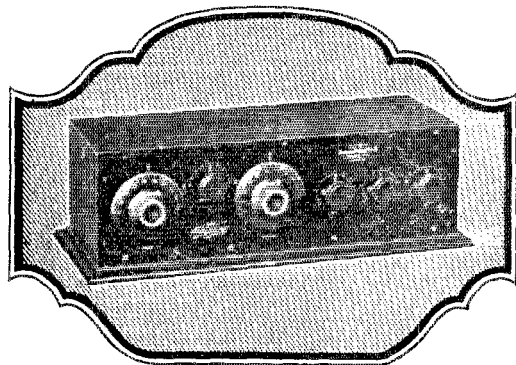

RADIODYNE

"The Voice of the Nation"

NO LOOPS — NO ANTENNA

The RADIODYNE is operated by simply grounding to a water pipe or radiator, and throwing a few feet of wire on the floor. Uses any standard tubes—dry cell or storage battery. Extremely selective. Simple to operate—*only two controls.*

Stations within a radius of 2000 miles can be picked up on the loud speaker; any wavelength from 200 to 700 meters.

Price \$150.00

For use in apartments, boats, automobiles, railroad trans, etc., the RADIODYNE is enjoyable where other receiving sets would not be practical.

When interference, strays, static, etc., make other types of reception utterly useless the RADIODYNE picks up broadcast programs clear and distinctly.

TO THE A.R.R.L.

We appreciate your efforts in boosting W.C. sets and are always pleased to furnish full information about them to members who have not yet had the opportunity to operate a Radiodyne. We want every member to know the merits of this efficient outfit.

Just drop us a line and we will see that your enquiry gets prompt attention

Western Coil and Electrical Co.
305 Fifth St., Racine, Wis.



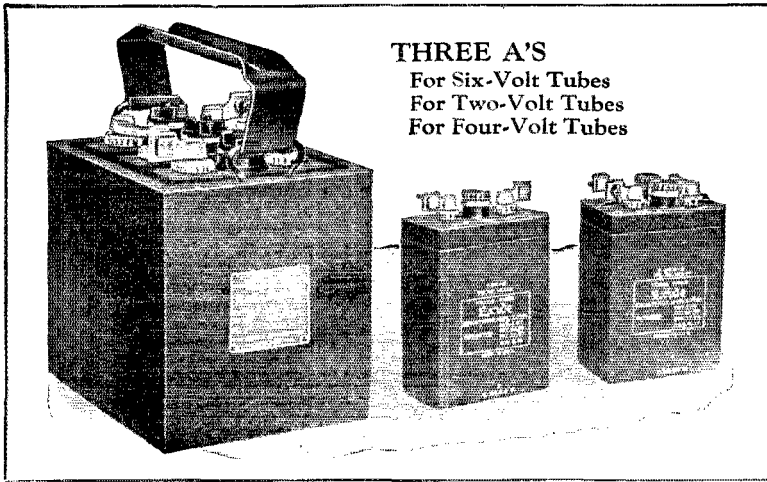

If you take radio seriously

YOU want to tune in distant stations, but there is another thing you want just as keenly—to get what you get *clearly*.

No matter how far or how near the station is, for greatest clearness and for all-round satisfaction, you must use storage batteries. Once you hook up to Exide Radio Batteries you will never be satisfied with anything less. They give uniform current, smoothly, quietly, over a long period of discharge. Like good little boys, they are seen and not heard.

For low-voltage tubes

The two newest members of the Exide family are midgets in size but giants in power. These sturdy little A batteries weigh only five and six pounds each. They furnish in full measure that uniform and unflinching power so essential to clarity and distant reception.

They were specially designed for WD-11 and UV-199 vacuum tubes, but can be used with any low-voltage tube. The two-volt Exide A Battery consists of a single cell. It will heat the filament of a WD-11 or other quarter-ampere tube for approximately 96 hours. The four-volt A battery, having two cells, will light the filament of a UV-199 tube for 200 hours.

For six-volt tubes

Like all Exide Storage Batteries, the Exide A Battery for six-volt tubes is dependable and long-

lasting. It is made in four sizes—of 25, 50, 100, and 150 ampere-hour capacities.

On land, at sea and in the air

It is the experience back of Exide Batteries that makes the Exide give such exceptional service in radio. There is an Exide Battery for every purpose. Exides run trucks, start and light automobiles, operate drawbridges, propel under the sea a majority of the world's submarines, send your voice over the wire every time you use the telephone.

A majority of all government and commercial radio plants both on land and at sea are equipped with Exide Batteries. The Leviathan is Exide-equipped. The giant dirigible "Shenandoah" carries Exide Batteries for ignition, lights and radio.

It does not pay to get any but a known-to-be-reliable storage battery for radio. Exide Radio Batteries are sold by radio dealers and Exide Service Stations everywhere. Ask your dealer for booklets describing in detail the Exide Radio Batteries, or write us direct.

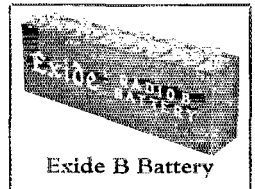

Exide

RADIO BATTERIES

THE ELECTRIC STORAGE BATTERY COMPANY, PHILADELPHIA

Manufactured in Canada by Exide Batteries of Canada, Limited, 133-157 Dufferin Street, Toronto

A tip for the Set Building Industry

You fellows who build sets for the "friendship trade" have had a taste of the "service" problem. Customers are very fussy about results—particularly squawks and mushy tones. Not so? Well, DURHAM Variable Grid Leaks will help you out in this manner. They are instantly adjustable for all tubes—in any hook-up. With them you can get perfect control of oscillation. Naturally, you get full benefit of regeneration. Use Durhams on every job. Then, like ourselves, you can guarantee satisfaction.

Free folder gives more details.
Get yours from dealer or write
Satisfaction Guaranteed



The handy DURHAM base—30¢

Omega Durham,
friend of the
Set Builder

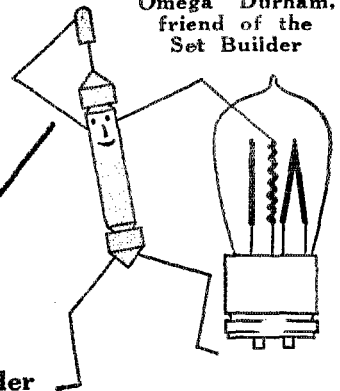

Buy
from
your dealer

Durham Variables—75c

No. 100 —1,000 ohms to 0.1 megohms
No. 101 —0.1 megohms to 5 megohms
No. 101A—5 megohms to 10 megohms

Manufactured by

DURHAM & CO.

1936 Market St.

Philadelphia

Dealers:—Among the 40,000 readers of QST are the very finest technicians of the amateur set builders. Their recommendation carries weight. Their business in your store carries profit.

MIDGET ANTENNAE

Not a loop—Just a tube—2 inches long ½ inch round—No lightning arrestor required

Long distance reception without the inconvenience of an outside aerial

Only \$5.00 Complete

Write for exclusive agency proposition

BUYRIGHT COMPANY

2503 No. 60th Avenue,

Omaha, Nebr.

NA-AID

DE LUXE DIALS

When phonographs were first made they were square boxes without ornamentation. Likewise the first dials, turned out in a laboratory,—had hard straight lines for shape. Beauty is a later development. Na-aid dials have soft, graceful lines which makes them very pleasing to the eye. They lead in both beauty and quality. They have the right grip for delicate, exact tuning.

ALDEN MANUFACTURING CO.
Largest makers of Radio Sockets
and Dials in the world
Springfield, Mass.

Dept. M 52 Willow St.

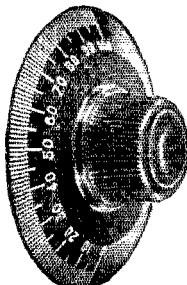

3 inch
No. 3003—4
35c, 3 for \$1.00

TELEGRAPH INSTRUMENTS Dandy Morse Learner's Outfit

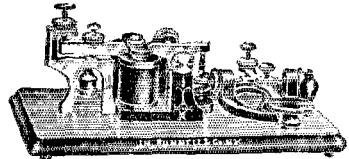

One dry cell is all that is required to operate this instrument.

Made by the best Telegraph Instrument Makers in the World.

Other types carried in stock.

Send stamp for Telegraph Manual No. 48Q.

Instrument only.....\$5.00

With dry battery.....5.50

Special Price to Dealers

J. H. BUNNELL & CO.

32 Park Place, N. Y.

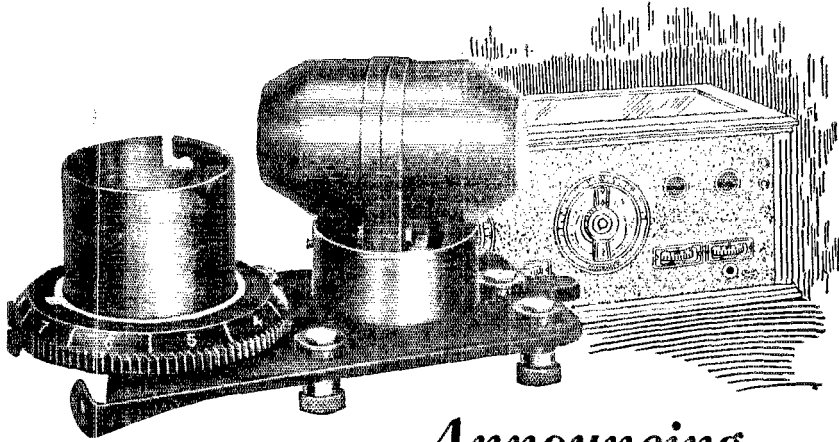

Announcing—

A New Radio Frequency Transformer

—in a combination unit, consisting of transformer, tube socket and rheostat.

Especially designed for use in tuned radio frequency circuits—the most practical method of amplifying high (radio) frequency impulses.

The trend toward radio frequency amplification is to be expected. Its advantages are many—long distance reception; the excellent results obtained with indoor aerials, and an entire absence of interference with neighboring receivers.

When incorporated in a tuned radio frequency circuit, this transformer amplifies efficiently at all wave lengths employed in present-day broadcasting.

All Eisemann units are matched one to the other, not only in their electrical co-relation but also in appearance, and, when assembled, present a harmonious whole.

Complete instructions for wiring are given, and the individual not deeply versed in Radio can build a receiver with assurance of results.

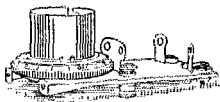
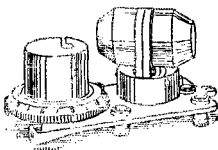
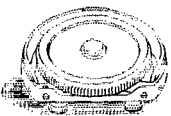
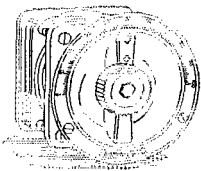
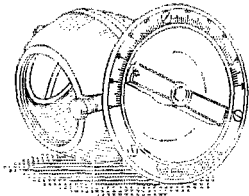

Catalog sent on request



EISEMANN MAGNETO CORPORATION

WILLIAM N. SHAW, *President*

42 Thirty-Third Street

Brooklyn, N. Y.

An Easy Way

to tune out Interference

The FERBEND "Wave Trap"
Makes Every Night Silent Night

Get the station you want quickly. Listen in on the distant stations without annoying squawk-k-k-s or irritating whistles. Listen like this St. Louis user: "Heard Havana clearly with three St. Louis stations broadcasting. My receiver works like a new set. The 'Ferbend' is certainly a wonder."

YOU Can Obtain These Remarkable Results

You can obtain results as satisfactory as this St. Louis user. If you don't, it doesn't cost you a penny, for the "Wave Trap" is sold with a positive guarantee that it will tune out your powerful local stations. Don't wait. Order now at our risk.

SEND NO MONEY. You need not send a penny. Pay Postman \$6.00 (plus postage). If you prefer, send \$6.00 with order and Wave Trap is mailed postpaid. Money-back guarantee either way. You see, you take no risk, so order TODAY.

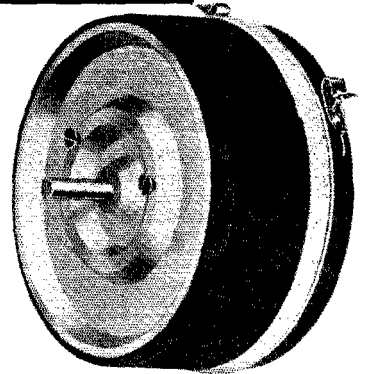

Ferbend Wave Trap ready for mounting, \$6.00. Wave Trap mounted on formica panel in mahogany finished cabinet 6x5x6 at \$8.50 complete. Circular on request.

FERBEND ELECTRIC CO.,
23 E. So. Water St., Chicago.
Send me a Ferbend Wave Trap. I will pay Postman Special low price plus postage. I understand you guarantee Wave Trap to tune out interfering stations or refund money.
 Check here for Ferbend Wave Trap unmounted at \$6.00.
 Check here for Ferbend Wave Trap mounted at \$8.50.
Either way the Ferbend comes to you completely guaranteed.
Name
Address
City..... State.....

For Sturdiness and Accuracy Use Lombardi Condensers

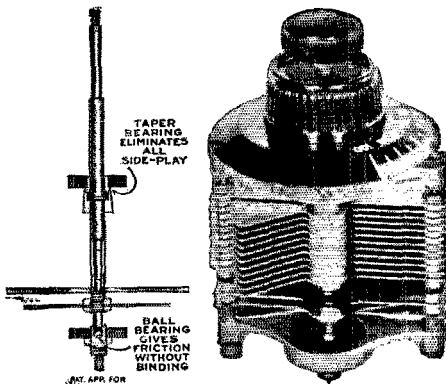

A rugged condenser built on an entirely new principle, made to last a lifetime. The tension is adjusted by tightening

a thrust plug causing the proper tension between a hardened steel ball and a 45 degree tapered brass bushing.

Also makers of coils and sockets.

Literature and prices furnished upon request

Lombardi Radio Mfg. Co.
67 MINERVA ST., DERBY, CONN.

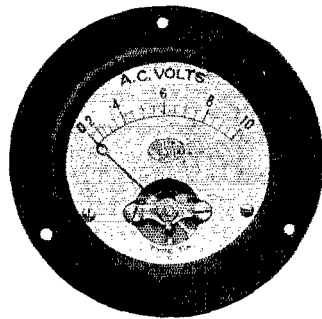

YOU
A.
R.
R.
L.
FELLOWS

know that it doesn't pay to buy cheap stuff. Roller-Smith 3 1/2" Ammeters, Voltmeters and antenna Ammeters are not cheap, neither are they expensive. The prices are right and so are the instruments. Send for Bulletin No. AG-10, pick out what you need and ask us to quote you. We'll treat you right—we're radio fans ourselves.

ROLLER-SMITH COMPANY
16 Park Place, New York
Offices in principal cities in U.S. and Canada



*Natural
Re-PRODUCTION*

Atlas

LOUD SPEAKER

**Hear the Atlas
Loud Speaker**

Ask your dealer for
a demonstration.
Submit it to any
reasonable test. Get
the proof NOW.

Scores of letters, sent us by enthusiastic owners of Atlas Loud Speakers, reveal how great is the difference between ordinary loud speakers and this real radio reproducer. It is the difference between real and artificial revival of the music broadcasted. The exclusive "double diaphragm" feature responds equally true over the entire range of musical cycles. There are no distortion points. This device is adjustable to your set and particular receiving conditions.

**Write for Illustrated Booklet
"D".**

**Letters from Users
Requested**

Make Your Own Loud Speaker with THE ATLAS UNIT, with phonograph attachment **\$13.50** (Unit without attachment \$12.50)

Multiple Electric Products Co. Inc.

Makers of Multiple TIME-LAG Mono FUSES
11 Orange St., Newark, New Jersey

*Sole Canadian Distributors: The Marconi Wireless Telegraph Company
of Canada, Limited, Montreal, Canada.*

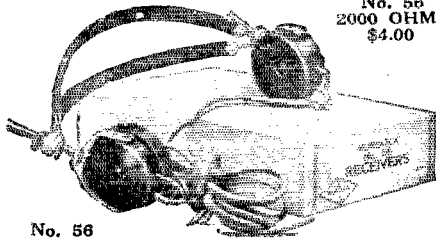

No. 56
2000 OHMS
\$4.00

No. 56
3000 OHMS
\$4.50

You can pay more but you can't get better value

FOR 20 years Murdock radiophones have been the standard for efficient radio reception. Made with the precision of a delicately wrought instrument—they are unexcelled for sensitiveness, clarity and durability. The fact that over a million have been sold is proof of their superior service.

Why pay more

THE great demand for Murdock 'phones has forced us to make them in large quantities, which means lowered cost to the consumer. Thus you can buy a Murdock for almost half what is asked for 'phones of equal value. Why pay more? Get a Murdock today and test it out. We guarantee complete satisfaction.

*A Higher Price Is a Luxury—
Anything Less Is Poor Economy*

Have you a new Murdock Multiple Plug?

At all dealers

WM. J. MURDOCK CO.

343 Washington Ave. Chelsea, Mass.
Sales Offices Chicago and San Francisco.

MURDOCK RADIO

STANDARD APPARATUS SINCE 1904

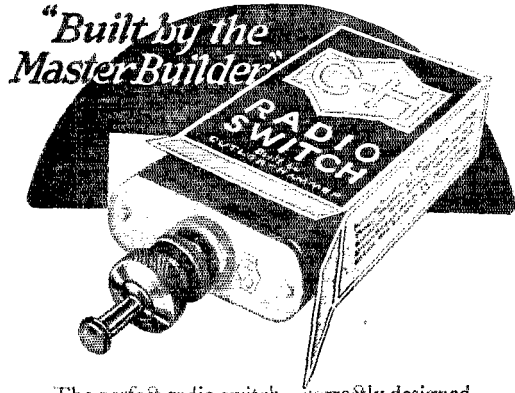

The perfect radio switch—correctly designed and skillfully constructed. Installed on any panel in five minutes to add hours of convenience, and protect both tubes and batteries. At dealers everywhere—insist on the genuine—in the orange and blue box. If your dealer has not been stocked send 60c plus 10c for packing and you will be supplied direct.

THE CUTLER-HAMMER MFG. CO.
Member Radio Section
Associated Manufacturers of Electrical Supplies
Milwaukee, Wisconsin

RADIO SWITCH



SOCKET FLOATS ON RUBBER

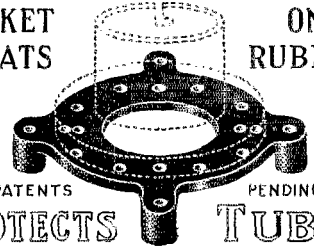

PATENTS PENDING

PROTECTS TUBES

Cushion is moulded of pure gum rubber that absorbs all vibrations that would otherwise reach Tube. It is not a mere pad or washer. It is held to socket separately by 2 small screws and nuts and will fit any socket, round or square, for large or small Tubes.

Price, 35c. Each—3 for \$1.00, Post Paid
Remit by Money Order or Check.

Dealers write for circulars and discounts.

ILLINOIS RADIO CO.
Springfield, Ill.



INTER-STATE SIGNAL (C) COLUMBUS, OHIO

PARAGON

Reg. U. S. Pat. Off.

RADIO PRODUCTS

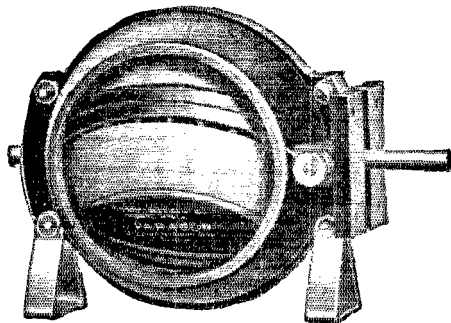

Keep Abreast of the Times Use a Paragon Variometer in Your Receiving Set

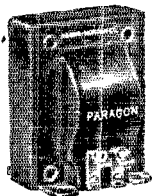

Paragon Audio-Frequency Amplifier Transformer No. 31 Reduces tone distortion, \$5.00.

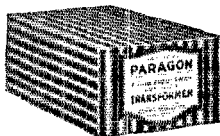

All PARAGON Parts are packed in distinctive Yellow and Purple Packages. They cannot be confused with any other packages on your dealer's shelves. Be sure you get the genuine.

Every man who owns a Radio Receiving Set naturally wants to get the best possible results that can be obtained with it. To do so he must keep abreast of the times and add parts where they will improve it.

Wavelength bands now in force involve radio currents of extremely high frequency. An inductance unit of exceptional electrical and mechanical excellence is needed to obtain the best results on these wavelengths. The PARAGON No. 60 Variometer, ribbed design, assures the greatest possible efficiency at high frequencies and makes it far easier to secure desired results on wavelengths of 150 to 200 meters.

The reduction of material in the support forms permits us to offer this essential radio part at an extremely popular price.

Use a PARAGON Variometer in your set. It will make it a better set and will increase your pleasure in listening in with it.

Illustrated Bulletins on Paragon Radio Products are yours for the asking

ADAMS-MORGAN CO., 4 Alvin Avenue, Upper Montclair, N.J.

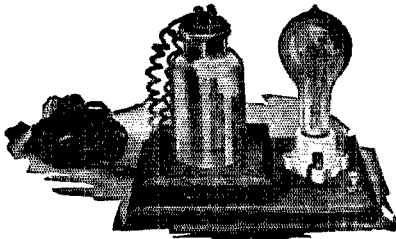

Mounted Charger

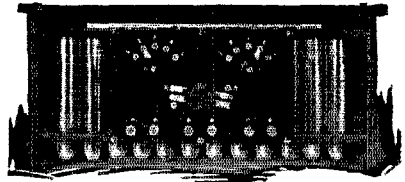

100 Volt Panel Type

"The most popular in this vicinity"—

"We wish to commend your storage 'B' battery," says the Southern Radio Sales Co., Newport News, Va. Such endorsements come to us unsolicited. KIC-O Batteries always make good. Alkaline type, won't sulphate or buckle. Life unlimited. Not harmed by short-circuiting, overcharging, idleness. Panel switches give single cell variations. Recharge from any 110-volt A. C. line with small home rectifier. Charge lasts 3 to 6 months in detector plate circuit.

GUARANTEE

Your money back on any KIC-O Battery if not satisfied within 30 days. Write for full information on "A" and "B" Batteries.

Unmounted Rectifier\$1.00
 Mounted Rectifier 2.50

KIMLEY ELECTRIC COMPANY, Inc.

2666 Main Street,

Buffalo, N. Y.

K I C - O

Storage "B" Batteries—
 long service, low cost

Cells	Volts	Price, Plain	With Panels
16	22	\$5.50	
24	32	7.25	\$11.75
36	48	9.50	14.00
50	68	12.50	17.00
78	100	17.50	22.50
108	145	23.50	28.50

Get a U. S. Government Commercial License

New Term Begins
 March 10th.

**SEND FOR
 CATALOG**

We give separate elementary (2 months) and advanced (5 months) theory courses in both day and evening classes. Students enrolled any Monday. Send for catalogue.

The radio profession pays well. Amateur experimenters are in great demand. Your present knowledge will shorten your course with us. Commercialize your amateur experience. Special amateur stations with wave power privileges demand extra first grade amateur licenses which require 20 words code speed and definite knowledge of tube circuits. There is a great shortage of commercial operators. Wages are rising; some companies are paying as high as \$140.00 a month. Sail on American ships to all parts of the world. Positions guaranteed. Through our favorable connections with operating companies as well as our continued success in training operators we are now supplying about 90% of the ship operators sailing from Boston.

G. R. Entwistle, Radio Director

Mass. Radio & Telegraph School, Inc.

18 Boylston Street

Tel.—Beach 7168

Boston, Mass.

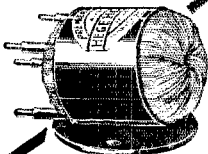

\$3.50

THE LITTLE WONDER
 The smallest, yet most efficient Transformer ever made. Maximum reproduction value, minimum distortion, 100% shielded.

**PREMIER
 "HEGEGOG"
 Trade Mark
 AUDIO TRANSFORMER**

Mounts anywhere—save space in assembly. We guarantee it unconditionally. Try them in your next "hook up." Ratio 1 to 3, 1 to 4, 1 to 5, \$3.50; 1 to 10, \$4.50. Ask your dealer. Write for bulletin No. 92.

Premier Electric Company

3811 Ravenswood Ave.

Chicago



Complete line Radio Corporation Products, and popular parts for amateurs.

Mail orders given special attention.

Complete consultation at your service for the asking.

In emergency telegraph or call 3ZW, W. A. Parks.

National Electrical Supply Co.
 1330 New York Avenue, Washington, D.C.

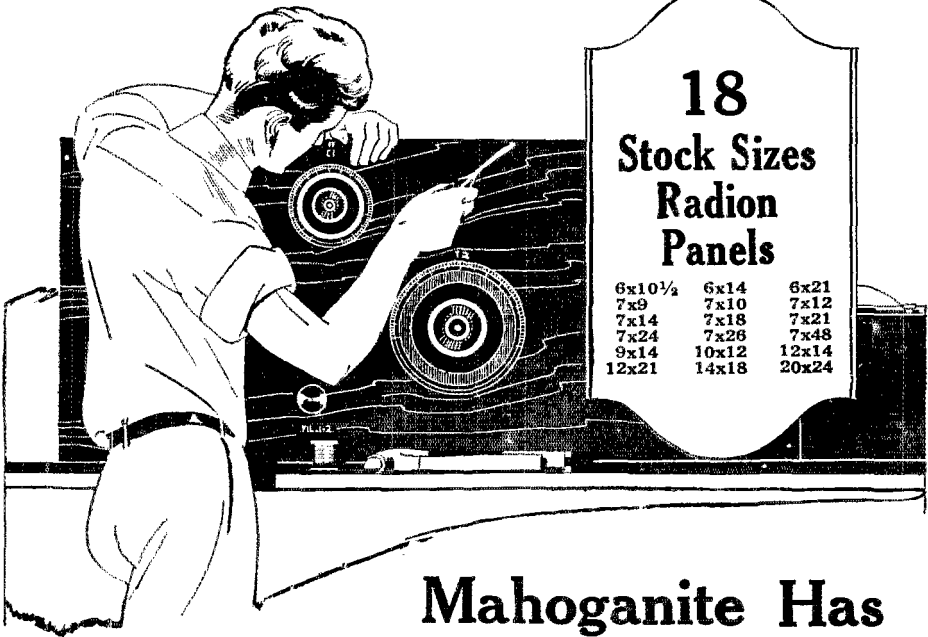

**18
Stock Sizes
Radion
Panels**

6x10½	6x14	6x21
7x9	7x10	7x12
7x14	7x18	7x21
7x24	7x26	7x48
9x14	10x12	12x14
12x21	14x18	20x24

**Mahoganite Has
the Beauty of
Polished Mahogany**

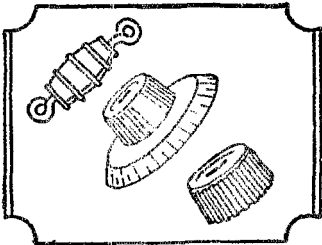

Mahoganite Radio Panels have a satin-like finish comparable to that which age and a skilled cabinet maker give to mahogany. Radion Dials and Knobs are also made in Mahoganite, to match.

The best radio shops everywhere carry RADION Panels and Parts in stock.

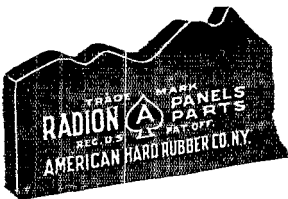

Look for this stamp on every genuine RADION Panel. Beware of substitutes and imitations.

RADION
The Supreme Insulation
PANELS

AMERICAN HARD RUBBER CO. 11 Mercer St., N. Y.

*For Transmission
or Reception!*

"FRESHMAN SELECTIVE"

MERCURY VARIABLE CONDENSER

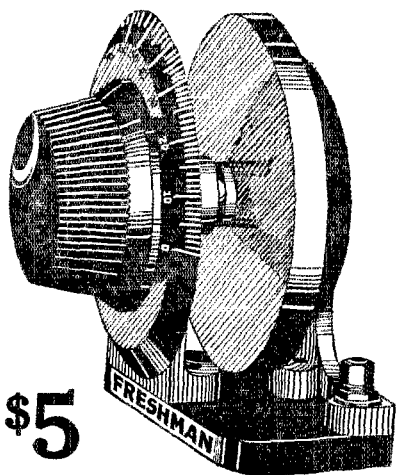

\$5

It has been conceded by the Foremost Radio Engineers that a Variable Condenser with Mercury plates is the most efficient for fine adjustment and selective tuning. Our engineers, after exhaustive experiments and research work, have developed a Variable Condenser with Mercury plates separated by heavy Mica dielectric. It is the **ONLY VARIABLE CONDENSER** the plates of which actually vary in area—**AN ENGINEERING FEAT NEVER ACCOMPLISHED BEFORE.**

No Leakage
Absolutely quiet
No plate vibration
Will stand 5000 volts
Compact and attractive
Plates cannot collect dirt
Cannot become short circuited

.0003 m. f. (equivalent to 17 plate) ALL \$5
.0005 m. f. (equivalent to 23 plate) TYPES
.001 m. f. (equivalent to 43 plate) TYPES

All Molded Parts and Dial of the Finest Bakelite

At your dealer, otherwise send purchase price and you will be supplied postpaid

Chas. Freshman Co. Inc.
Radio Condenser Products

106 SEVENTH AVE.

NEW YORK

RIGGS RECTIFIER

\$12.50

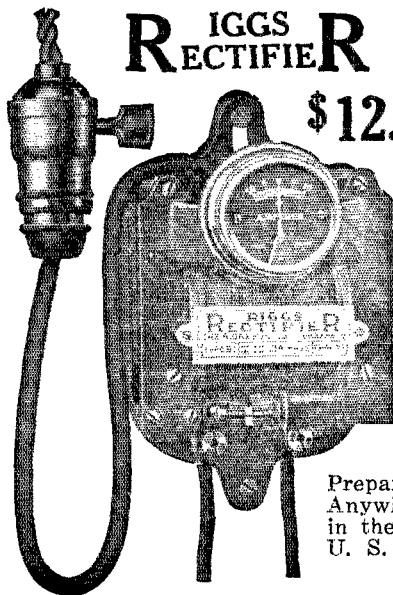

Prepaid
Anywhere
in the
U. S.

MONEY BACK GUARANTEE
We guarantee the Type B-3 to please you. If it does not, return it and we will return your money.

THE RIGGS MFG. CO.

Urbanda, Ohio
Factories—Everett, Wash.

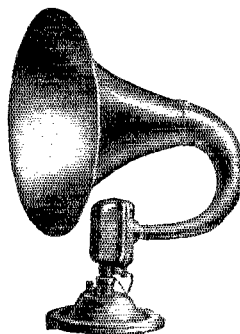

TRADE MARK

AUDIOPHONE

REG. U. S. PAT. OFFICE

LOUD SPEAKER

A REAL REPRODUCER
OF THE ORIGINAL BROADCASTING

It is easy to listen to the reproductions made by the Audiophone because they are so perfect. The speech, the songs, and instrumental music are not blurred or disguised by mechanical distortions. You will get all the fine shadings and every inflection. In fact, the very personality of the artist seems to be present as you listen.

Made in three models—
Senior Audiophone.....Price \$32.50
Baby Audiophone.....Price 12.50
Junior Audiophone.....Price 22.50

Write for copy of Bulletin AX-3012

THE BRISTOL COMPANY
WATERBURY, CONN.

After Extensive Tests and Comparisons We Offer The Branston-Quality-Guaranteed Audio Transformer

You can now get rid of noisy or otherwise unsatisfactory transformers and, with perfect confidence, replace them with this fully-tested-and-proved Branston Audio Frequency Transformer. The results will delight you and your "audiences."

You can now make up new sets, with the certainty that you have the maximum-possible amplification and best tone quality without distortion.

If your dealer has not yet secured his supply, send check or money order for as many as you need, @ \$6.50 each, or order parcel post C.O.D. Mention your dealer's name, please.

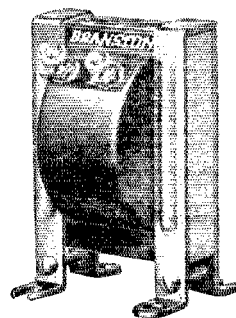

Branston-Quality-Guaranteed Audio Frequency Transformer. Neat, compact, efficient. It gives the results you want.
Each **\$6.50**

Use Branston "Broadcast Coils" for Closer Selectivity

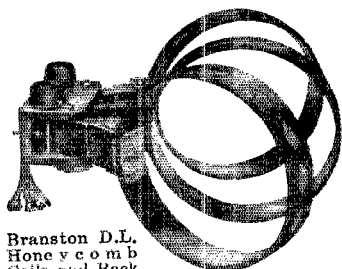

Branston D.L. Honeycomb Coils and Back and Front Geared Mountings are "Standard of the World."

Licensed under DeForest patents.

Very fine adjustment, close selectivity and clearer reception for all wave lengths between 250 and 600 meters. Wound on Formica Tubes 5" diameter. Equipped with standard coil plugs. Fit any Honeycomb coil mounting. Furnished only in sets of three. Primary, Secondary, Tickler. In attractive carton, per set, at dealer's or by mail, \$5.00.

Protect Against Lightning and Static Use Branston Vacuum Tube Protectors in Place of the Grounding Switch

Approved by Underwriters' Laboratories and Hydro-Electric Power Commission of Ontario.

Scientifically constructed. Always ready to carry away a lightning flash before it can enter the building. Drains static from the aerial, relieving interference. Signals are more audible.

It operates automatically—Requires no attention. Can be installed and forgotten. Designed for outdoor mounting. Petticoat insulator prevents leakage in wet weather. Vacuum tube entirely enclosed and protected from breakage, moisture, dirt, insects. Not affected by snow, sleet, or rain. Price, at dealer's or by mail..... **\$3.00**

Send 2¢ Stamp for New Honeycomb Coil Hookups.

Compiled by experts and includes five good Honeycomb Coil "Hookups" and complete catalog of famous Branston Radio Apparatus. Write today. Give us name of your radio dealer. If he cannot supply you, write

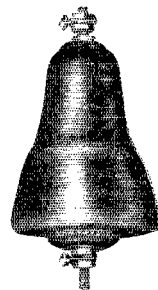

R-51. Branston Approved Lightning Arrestor and Static Eliminator.



Look for this trademark card in your dealer's window or salesroom.

CHAS. A. BRANSTON, INC.

Manufacturers of Branston Violet Ray High Frequency Generators.

823 MAIN STREET, BUFFALO, N. Y.

In Canada—Chas. A. Branston, Ltd., Toronto

"USE A Hoyt"

1. TO TEST YOUR B BATTERY—Use the Hoyt Pocket Meter—Range 0-50 volts, special red markings at 22½ and 45 volts on the dial—Price \$2.50.
2. TO TEST THE CONSUMPTION OF YOUR TUBES—Use Hoyt Peep-Hole Ammeters and Voltmeters—Specially designed to fit in the peep-hole on the panel—Price \$3.00.

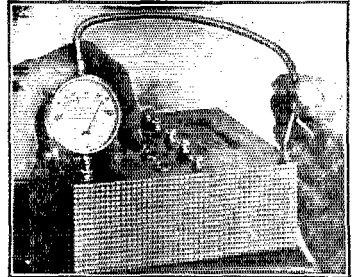

Please send information on HOYT
RADIO METERS.
Name
Address

We can supply you with any kind of meters for Radio Work.

Write—BURTON-ROGERS CO.

Sales Department For

HOYT ELECTRICAL INSTRUMENTS

26 Brighton Avenue,

Boston, Mass.

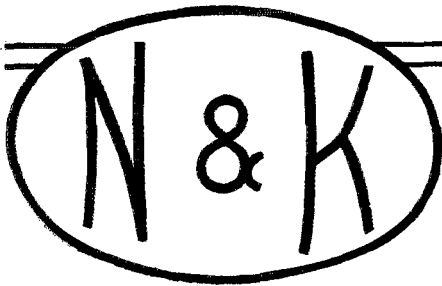

The 'Phones They Are
All Talking About

"THOSE imported phones that give such wonderful mellow tone." N & K Model D phones, 4000 ohms, are made of nicked brass—not stamped aluminum. Have extra large sound chamber. 2¼ in. diaphragm. Result—broader range, greater comfort, exclusion of outside sounds. Sanitary, leather covered head bands. Price \$8.50. Write for folder.

TH. GOLD-
SCHMIDT CORP.
Dept. Q2



15 William Street
New York, N. Y.

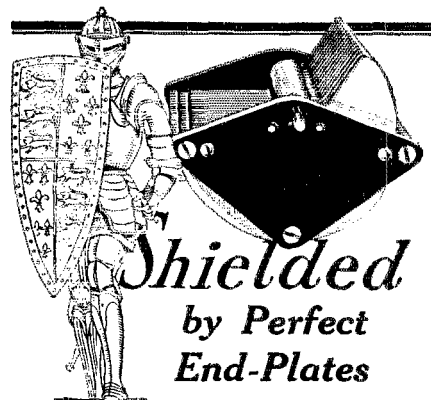

U. S. TOOL CONDENSERS

Infinitesimally small dielectric losses in U.S. Tool Condensers. The end plates of Laminated Condensite-Celoron are non-porous, proof against all capacity leaks and non-warping. One of the details that make it well worth your while to insist upon U.S. Tool Condensers.

Write for booklet

U. S. TOOL COMPANY, INC.
112 Mechanic St., Newark, N. J.

Another Acme Radio Frequency Transformer

The Acme 30KC for Long Wave R.F. Circuits

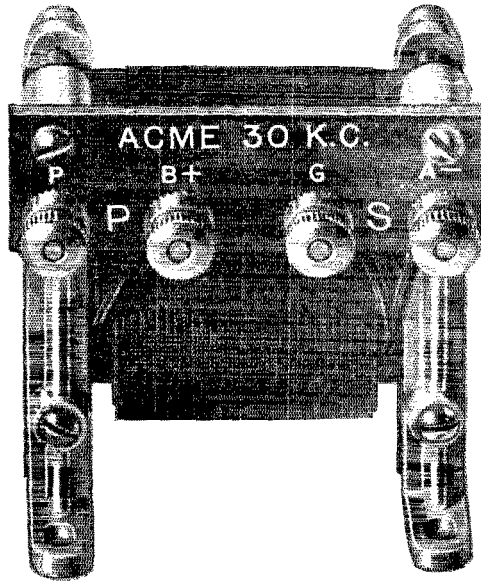

WE HAVE found in our laboratory that we can run these transformers with the grid return to the negative side of the filament in fact, we can run them as high as six volts negative. We have also found that it is not necessary to shield the transformer, and that they operate satisfactorily in cascade as high as four stages without interstage oscillation. This new Acme 30 KC Transformer is a worthy member of the Acme

Transformer family. The Acme A-2 Audio Amplifying Transformer and the Acme R-2 Radio Frequency Transformer have made the name Acme synonymous with "the best transformer" in the mind of radio amateurs. We brought out the Acme 30 KC Transformer because we found that a real need existed for a transformer of this kind for long wave and R.F. circuits. Send 10 cents for our booklet "Amplification without Distortion".

ACME APPARATUS COMPANY
Dept. 35 Cambridge, Mass.

ACME ~ for amplification

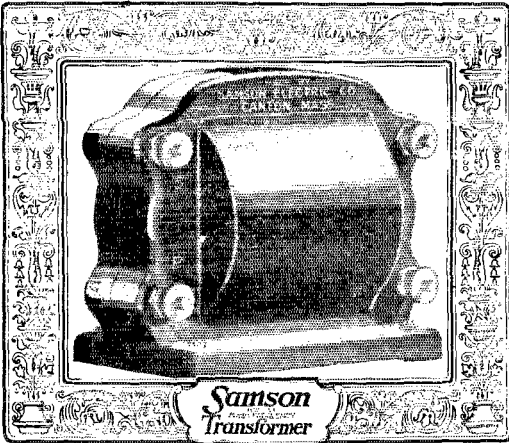

How to Improve Your Set

HOOK a Samson HW-A1 Transformer to your set and notice the difference. You get 40% to 100% greater amplification—more volume from one tube than from two tubes with some transformers and more than from three tubes with others. You get practically no distortion at any range.

The Samson now sells for \$5. It costs two or three times as much to make as any other transformer. The Helical Wound primary and secondary coils alone cost more than most transformers cost complete. But your \$5 gets the most satisfactory audio frequency transformer that the most experienced radio engineers have been able to design.

Insist on a Samson HW-A1 Audio Frequency Transformer. If your dealer hasn't it or won't get it for you, we'll send it pre-paid on receipt of **NEW LOW PRICE \$5.00**. Ratio, 6 to 1.

Write for Results of Tests proving the superiority of the Samson. Ask for Chart No. 112.

SAMSON ELECTRIC CO.

Manufacturers Since 1882

Factory Canton, Mass.

Sales Offices: Boston, New York, Chicago, Philadelphia, Pittsburgh, Buffalo, Cleveland, Detroit, Indianapolis, Minneapolis, St. Louis, San Francisco, Los Angeles, Seattle, Portland, Atlanta, Montreal and Toronto.

**Samson
Helical
Winding**

All transformers except the Samson are wound spool fashion from end to end; the adjacent turns of wire are 500 to 1000 turns apart. The Samson is Helical Wound—wire in layers one on top of the other with the adjacent turns but forty turns apart. This method of winding, patented by and exclusive with Samson Electric Co., reduces distributed capacity to an absolute minimum, accounts for greater amplification and the ability to transform the signals without distortion at any range.

The long-life tube!

Since their inception, radio Vacuum tubes have been fragile. To knock or drop one incurred the expense of a new tube. But now there are

MYERS TUBES

Practically Unbreakable

—so protected by their unique design that they have been dropped on the floor without injury.

But their sturdiness is only one feature. They are the most perfect detectors and amplifiers obtainable. Smaller capacity and no bunched leads mean less interference—more clarity and greater amplification. Actual tests, all over the world, have proved their supremacy. Two types—Dry Battery and Universal (for storage battery). At your dealers' or send price and be supplied postpaid.



(1/2 size)

**\$5
EACH**

Write for free circuit diagrams.

Made exclusively by

F. B. Myers Co. Ltd.
Radio Vacuum Tubes

240 Craig St., W.,

Montreal,

Canada

Approved!

180° Straight Coupler No. 56

A Real FISCHER Instrument

Wave length 550 meters, 14 soldered leads, straight wound stator on genuine bakelite tubing, bakelite rotor, Fahnestock spring clip connections, white metal mounting base, non-conductive adhesive,—in short a perfect coupler.

20 Diagrams \$2.75 Free with Each

For sale at your dealer's—otherwise send the \$2.75 directly to the manufacturer and you will be supplied postpaid.

G. H. FISCHER & CO.

123 Liberty Street New York City

BAKELITE

TRADE MARK REG. U. S. PAT. OFF.

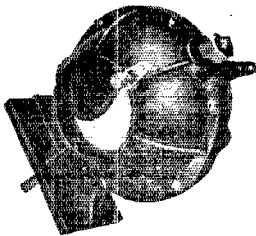
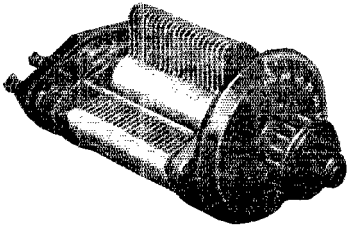
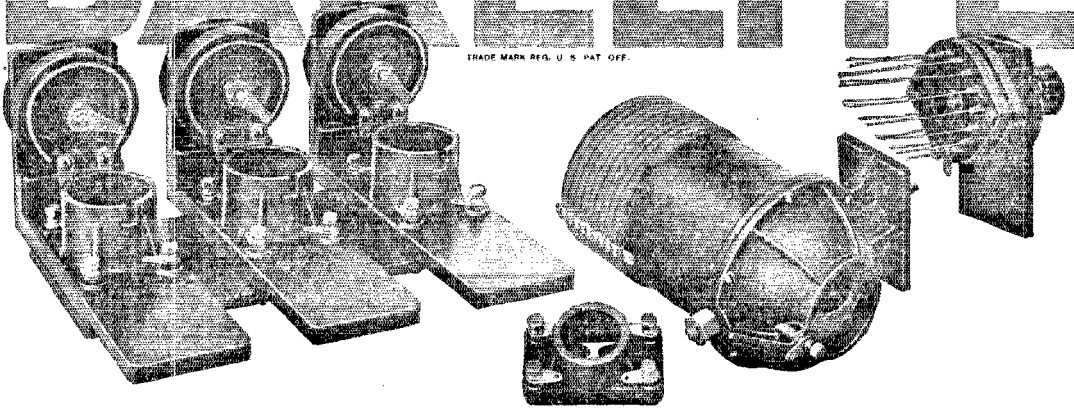

Gilfillan and Bakelite

All the molded insulation of these Gilfillan radio parts is 100% Bakelite.

In the words of the manufacturer, BAKELITE "insures positive insulation and absolute permanency." And that's the story in a nutshell.

Nothing else equals Bakelite in the combination of all its desirable properties such as insulation resistance, mechanical strength, permanence of color and indifference to all weather conditions.

The outstanding merit of Bakelite is its durability—its freedom from deterioration.

Every day, radio men are finding new applications for this "Material of a Thousand Uses," for parts made of molded or laminated Bakelite possess properties that successfully meet the most exacting demands of radio work.

Write for a copy of our Radio Booklet C.

Send for our Radio Map

Enclose 10c to cover mailing cost and we will send you a large Radio Map which lists the call letters, wave length, and location of every broadcasting station in the world. Address Map Department.

BAKELITE CORPORATION

247 Park Avenue, New York, N. Y.
Chicago Office: 636 West 22d Street

BAKELITE
Condensite
REDMANOL

are the registered
Trade Marks for the
Phenol Resin Products
manufactured under
patents owned by
BAKELITE
CORPORATION

THE MATERIAL OF A THOUSAND USES

Clear as a Silver Bell

O-T SILVERTONE TUBES

(Registered)

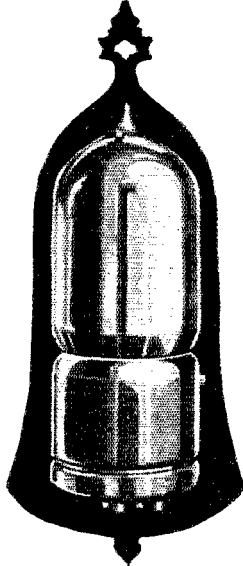

will increase the signal strength of your set from 20 to 50 per cent—and even to a greater degree when used as a **NEUTRODYNE** detector.

Three Models

O. T. 1A—2 to 4 volts,
Battery Draw .15 amps. Price, \$6.00

O. T. 9—2 to 4 volts,
Battery Draw .06 amps. Price, \$6.50

O. T. Power Tube—5 volts,
Battery Draw .25 to .35 amps. Price, \$7.50

At your dealer or direct by mail.
Write for complete literature.

Manufactured by DeForest Tel. & Tel. Co.

Exclusively for the

O. & T. Electric Corporation

1819 Broadway, New York

High class representatives wanted.

The O-T is the only genuine Silvertone Tube.
Fully guaranteed.
Beware of imitations.

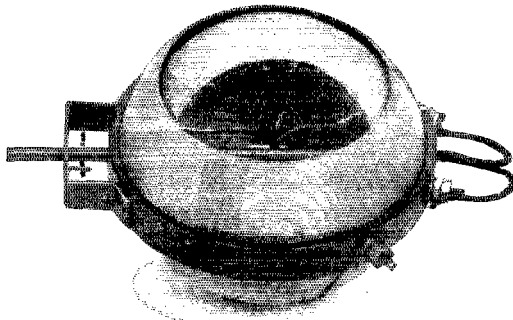

White Variometers For Pure Inductance

These instruments are made to meet the requirements of the most critical radio engineer or amateur set builder. They are marvels of efficiency.

(At your dealer or post-paid direct.)

Price \$5.50

Manufactured by

THE WHITE MFG. CO.

2290 Alden Street, St. Paul, Minn.

Radio CALL CARDS Printed

TO ORDER

Use Individual Cards. A.R.R.L. Emblem added if requested by member.

MONEY REFUNDED if not satisfied.

Red call, black printing, 100—\$1.75; 200—\$2.75, *postpaid*. Blue, green or brown call.

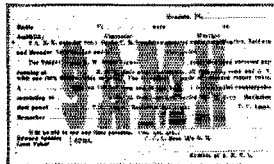

35¢ extra. Government postcards, 1¢ extra per card.
Personal LETTERHEADS & ENVELOPES
Showing your station, name and address. Good quality, clear white smooth surface bond paper. Letterheads 8½ x 5½. Envelopes 6 inches long, 100 each—\$2.25; 200 each—\$3.25; 300 each—\$4.25; 500 each—\$6.25 **PREPAID**.
Broadcasted Market Reports: 100—\$1.00; 200—\$1.75.
Send order with check or money order today—**NOW**.
RADIO PRINTERS, Dept. 12, Mendota, Ill.

CATALOG ^{E19-112} PAGES ^{FREE}

LATEST REFLEX AND NEUTRO DYNE CIRCUITS
EVERYTHING IN RADIO
One of the largest complete stocks in the world. 40 diagrams of latest Hookups.
DEALERS ALL OVER THE U.S.
Making big profits handling our supplies. 24-hour service. Goods shipped same day order received.



WHOLESALE RADIO DISTRIBUTORS
Dept. "T" 107 E. 13th St. Kansas City, Mo.

Coto

"Built First to Last"

Stop the Leaks with this Good Coto Air Condenser

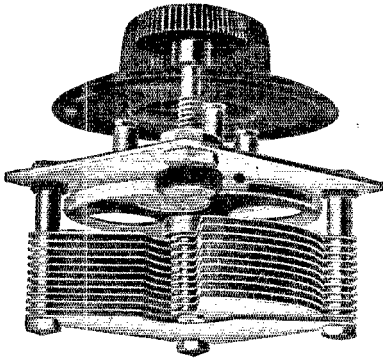

This high grade condenser often increases signal strength as much as an added stage of Audio Amplification. It takes full advantage of all the energy from the antenna. It avoids the insulation losses that cripple a radio set. The economy is obvious.

Coto Condensers have low losses because of single bearing construction and hard rubber insulation (the best for radio use). The plates are of copper, soldered together and SILVER PLATED. Strong, handsome and compact, with VERNIER adjustment free from backlash. Moderately priced.

Type 3505 .0005 Mfd. \$5 Type 3510 .001 Mfd. \$6

The Complete Answer to your demand for a real good Variable Condenser. Complete with handsome dial and vernier knob.

Other Coto specialties are Cotogrip Tube Sockets, Moulded Variometers and Variocouplers both with GUARANTEED range of 200 to 600 meters covering the broadcasting wave lengths, Tapped Radio Frequency Transformers Type 5000-A, Audio Frequency Transformers (Type 4000, \$5) and Honeycomb wound Coils.

If your Dealer cannot Supply you, write us at once giving his name and address and a list of the Coto Radio Parts that you need. You'll get them.

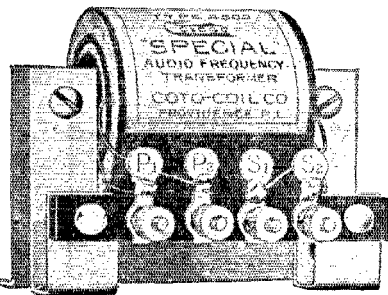

Type 4500

The 3 to 1 Ratio Transformer for All Stages

You can now settle all arguments as to desirable Transformer Ratios in different stages. The question has been needlessly complicated. As usual the simple answer is most economical and best in performance. Use Coto Specials in all stages and you will be delighted with the ample volume and freedom from distortion. Hundreds of buyers praise them. For reflex circuits they are simply great. Once you have tried them, you will recommend Coto Specials to all your radio friends. Price \$2.50.

COTO-COIL CO.

87 Willard Ave.,
Providence, Rhode Island

BRANCH OFFICES

Los Angeles, 329 Union League Bldg.
Minneapolis, Geo. F. Darling, 705 Plymouth Bldg.
Atlanta, C. P. Atkinson, Atlanta Trust Co. Bldg.

CANADIAN DISTRIBUTORS

Perkins Electric Co., Ltd.
Montreal, Toronto, Winnipeg

Tuska 220 Tuner

The Favorite of Amateurs

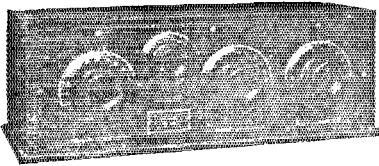

No tuner has ever been placed on the market that has been so popular with novices or experienced amateurs as the TUSKA 220 TUNER. Made by a house that has enjoyed the confidence of the radio world it is an expert and conscientious production.

The Type 220 is a complete regenerative tuning system. It has two distinct circuits; one with a range of from 150 to 385 meters, the other from 375 to 800 meters. The tuning units are: a primary series condenser, a secondary tuning condenser, plate variometer for regeneration, coupling control and wave change switch. Designed to cover its full wave lengths range with maximum efficiency. There are no dead end or capacity losses because of the wave change switch.

The apparatus is mounted in a fine mahogany cabinet 20x6x7 inches; the panel is Formica, machine engraved; high grade knobs and dials.

Due to a big merchandising deal Stern & Co., Inc., are able to offer TUSKA 220 TUNERS at a price that places them within the range of every pocketbook. SHIPPED, (WHILE THEY LAST) BY PARCEL POST OR EXPRESS, INSURED. PREPAID TO ANY POINT IN THE UNITED STATES, ON RECEIPT OF POST-OFFICE OR EXPRESS MONEY ORDER OR CERTIFIED CHECK FOR **\$21.50**

S T E R N
& CO. INC.
HARTFORD, CONN.

WAVE LENGTH!

Do You Know Yours?

If not, let us calibrate that wavemeter of yours.

We specialize in calibrating wavemeters, inductances, condensers and other radio apparatus. Our laboratory equipment is such that we can undertake tests on all types of radio apparatus.

We guarantee as accurate calibrations for this special work as is obtainable from the Bureau of Standards. This guarantee together with reasonable calibration fees and prompt service commends our Laboratory to the wide awake experimenter or manufacturer.

Manufacturers interested in perfecting their radio products or obtaining design data on new types of apparatus will appreciate our facilities for undertaking such work.

Write us for circulars on calibration fees and information covering the activities of this Laboratory.

Washington Radio Laboratories

5320 Illinois Ave.,
Washington, D. C.

Guaranteed Head-Sets

"RED-HEADS" are guaranteed radiophones. You run no risk when you buy them. Money back if, after 7 days' trial, you're not satisfied that they're the best receivers on the market at the price. Why not act right now and get a pair? It'll mean getting the maximum from broadcasting from the day you put them into use.

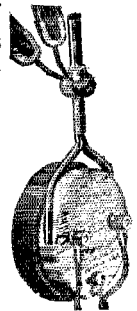

RED-HEAD
RADIO
RECEIVERS

NOW READY

The new '24 Model F
Per Pair Complete

The new "Red-Head" Jr.
Per Pair Complete

"Red-Heads" sent prepaid on receipt of price if you are unable to get them at your dealer's.

The NEWMAN-STERN COMPANY
Dept. 08 Newman-Stern Bldg. Cleveland



"WARRANTED"
Audio Transformer

MTD. \$2.00 UNMTD. \$1.45

10 Days Money Back Guarantee
Dealers Write

C. C. ENDLY

22 Sturges Ave.
MANSFIELD, O.

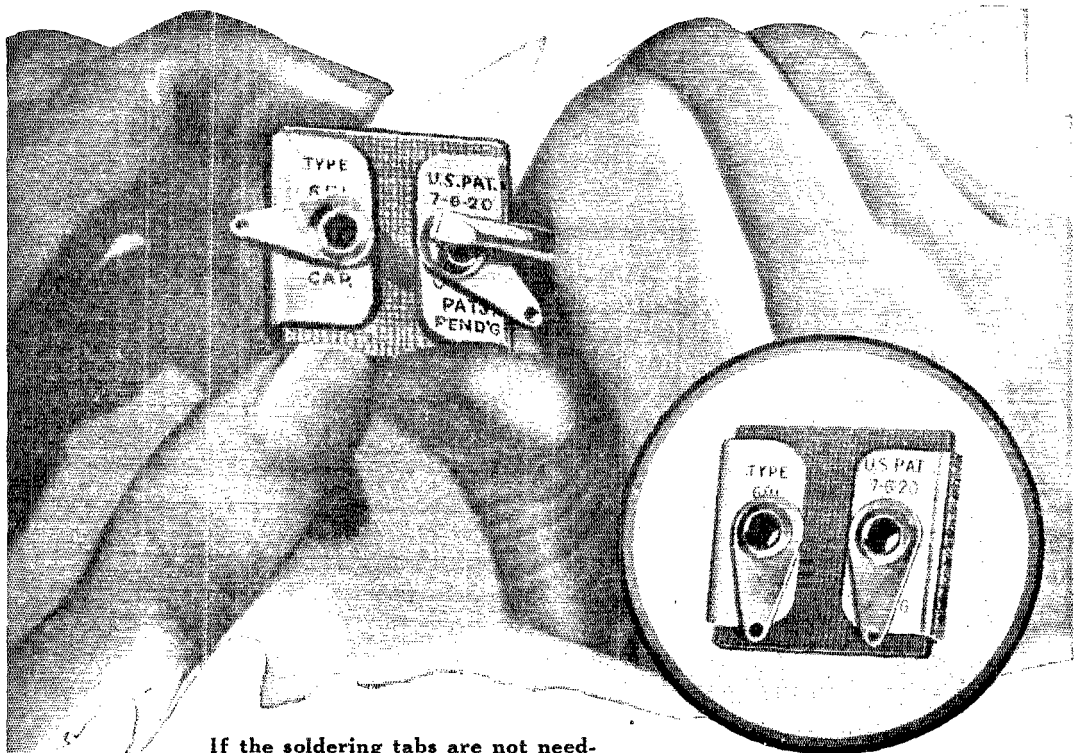

If the soldering tabs are not needed simply swing them out of the way as here shown.

MICADON TYPE 601 NOW HAS SWINGING SOLDERING TABS

As a fixed condenser—the standard of radio—the Dubilier Micadon could not be electrically improved.

And as we improved it mechanically by providing it with swinging soldering tabs.

These facilitate mounting. The hot soldering iron need not touch the Micadon directly. Hence the capacity is not affected by heat.

If Dubilier Micadons are to be mounted with screws simply swing the soldering tabs out of the way and use the eyelets.

Price 35 cents up, depending on style and capacity. At all good dealers.

Dubilier Condenser and Radio Corporation

48-50 West Fourth St., New York



DUBILIER DUCON
Socket Plug



DUBILIER VARIADON
Variable Mica Condenser



DUBILIER DURATRAN
Radio Frequency
Transformer

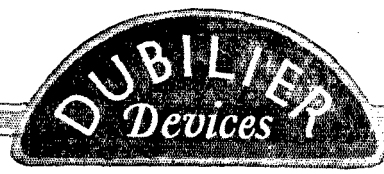

An Absolute Guarantee
with every instrument
made them famous!

SHAMROCK
FOR SELECTIVE TUNING

180°

Vario-Coupler

List price,
\$3⁵⁰ each

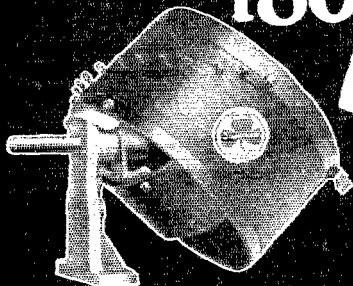

DOUBLE DUTY PIG-TAIL Variometer

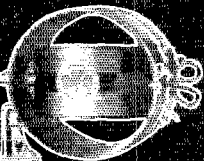

SHAMROCK MFG. CO.
316 Market St. Newark N.J.

IT'S THE UNIT PLUS

It's the unit plus the design and construction of the projector that makes the Kellogg Reproducer so clear and loud.

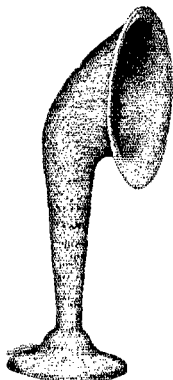

The Special Kellogg unit of 2500 ohms resistance brings head set clarity to the reproducer, and is projected with maximum volume without distortion. The special acoustical fibre and design account for the wonderful tonal quality.

The No. 550 is small in size and projects in almost a straight line. Each \$12.00.

The No. 551 makes its appeal to those who are fond of soft, mellow music, that comes in as clear as a bell. Each \$18.00.

The No. 552 projects in volume, without distortion, speech or music for the large room, or for dancing. Each \$25.

If your dealer does not handle Kellogg radio equipment, communicate direct with us.

Kellogg Switchboard & Supply Co.
1066 W. Adams St., Chicago



ALL-AMERICAN
Amplifying Transformers

Why experiment? Over 500.00 radio enthusiasts have already proved "All-Americans" best. Largest selling transformers. Standard on the better sets. A type for every purpose. All the better dealers sell "All-American."

Rauland Manufacturing Co.,
200 N. Jefferson St., CHICAGO.
Pioneers in the Industry

FREE!

Book of tested hook-ups for getting new thrills out of your present outfit. Also, circuit diagrams and Bulletin featuring Power Amplification. Send 4¢ in stamps to cover postage.

All-American Audio Frequency Transformers come in three ratios. \$4.50 to \$4.75. The best — no need to pay more.

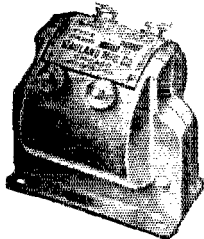

To operate Radio Receiving or Transmission Apparatus successfully, requires the use of accurate electrical measuring instruments.

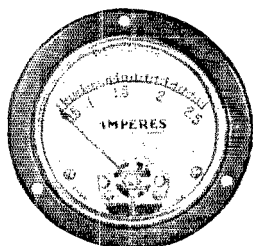

Radio Frequency Ammeter
2-in. Dials, 2-in. Scales

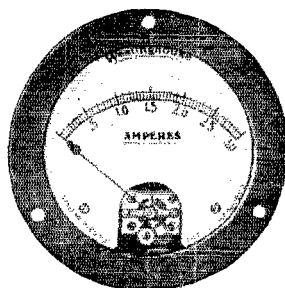

Direct-Current Ammeter,
3-in. Dials, 2 1/2-in. Scales.
For Radio Application.

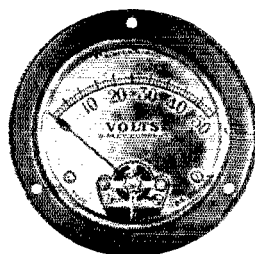

Direct-Current Voltmeter,
2-in. Dials, 2-in. Scales.
For Radio Application.

Westinghouse Radio Instruments

are small, yet accurate, sturdy and reliable. They are exact miniature replica of the larger high-grade Westinghouse instruments.

Direct-current Ammeters and Voltmeters should be used to regulate the current passing through the filament circuit of the detector or amplifier tubes, used in receiving or transmission sets.

Radio Frequency Ammeters should be used in connection with the transmitter apparatus. The effectiveness and character of transmission depends upon the current flowing through the antenna circuit.

Folder 4471-B gives full particulars

WESTINGHOUSE ELECTRIC & MANUFACTURING COMPANY

Newark Works,

Newark, N. J.

Atlanta, Ga., in new bldg., 426 Marietta St.

Boston, Mass., 10 High St.

Chicago, Ills., 111 W. Washington St.

Cincinnati, O., Third & Elm Sts.

Denver, Colo., 910 Fifteenth St.

Detroit, Mich., 1535 Sixth St.

Los Angeles, Calif., Seventh & Spring Sts.

New York, N. Y., 1105 Broadway

Philadelphia, Pa., 1325-29 Chestnut St.

Pittsburgh, Pa., 306 Wood St.

St. Louis, Mo., 717 South 12th St.

San Francisco, Calif., Montgomery St.

Seattle, Wash., Second & Cherry Sts.

ALWAYS MENTION QST WHEN WRITING TO ADVERTISERS

FLERON RADIO SPECIALTIES

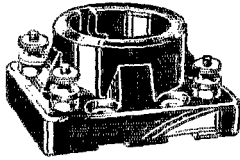

The Porcelain Sockets

Very carefully made. Brass parts nickel-plated. Black Glaze. Two Sizes, Standard Bulbs and U. V. 199.

Each socket in a carton. 35c. each.

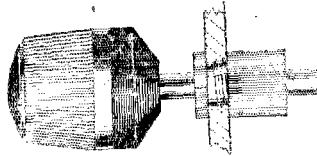

The Vernier Adjuster

The best adjuster on the market. Spring holds head away from dial when not in use. With slight adjustment spring can be made to hold head against dial if desired. Patented. 65c.

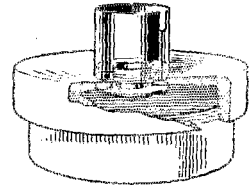

The Phono Adapter

Fits through the hole of the receiver cap and then slides on the phonograph tone arm. Fits Victor, Columbia, and others. Works perfectly. Only 35c. ea.



The Porcelain Insulators

Lowest power losses in the antenna. Dielectric absorption reduced to minimum because of very low phase difference of Fleron Porcelain. Very tough body. Solid Black Glaze. Seven sizes, 20c. to \$1.00. Each insulator in a separate carton.

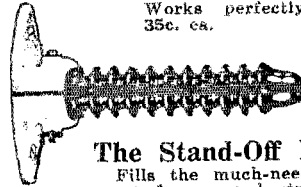

The Stand-Off Insulator

Fills the much-needed requirement for a good strong looking and practical stand off insulator. Meets every requirement of the Board of Fire Underwriters. \$1.25 each.

For Sale by all Good Jobbers and Dealers

M. M. FLERON & SON, Inc., 111 N. Broad St., Trenton, N. J.

WE REPAIR THE FOLLOWING RADIO TUBES and Guarantee Them



WD-11	\$3.50	UV-199	\$3.50
WD-12	3.50	C-299	3.50
UV-200	2.75	UV-201A	3.50
UV-201	3.00	C-301A	3.50
C-300	2.75	UV-202	4.00
C-301	3.00	C-302	4.00
DV-6	3.00	DV-6A	3.50

Mail Orders solicited and promptly attended to.
Dealers and Agents write for Special Discount

H. & H. RADIO CO.

P. O. BOX 22-W

CLINTON HILL STA.,

NEWARK, N. J.

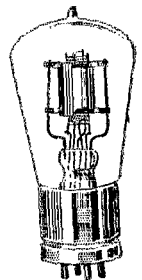

MARLE TRANSFORMERS

Audio and Radio
Frequency
Give Best Results.

Superior Quality
Reasonably Priced
Insist on Them.—Sold
by the Best Dealers.

Manufactured by
Marle Engineering
Co.
Orange N. J.

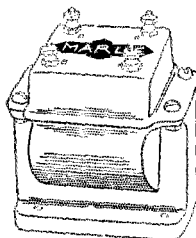

TYPE A7

REMLER

Apparatus Radiates Quality
REMLER RADIO MFG. CO.

Home Office 182 Second St. San Francisco
154 W. Lake St. Chicago
30 Church St. New York

Genuine
Western Electric VT-2 Tubes
\$7.45

Send 10c for copy of new 48 page
RADIO CATALOG
CHICAGO SALVAGE STOCK STORE
509 S. State St., Dept. Q-6 Chicago, Ill.

All-Purpose VOLTMETER

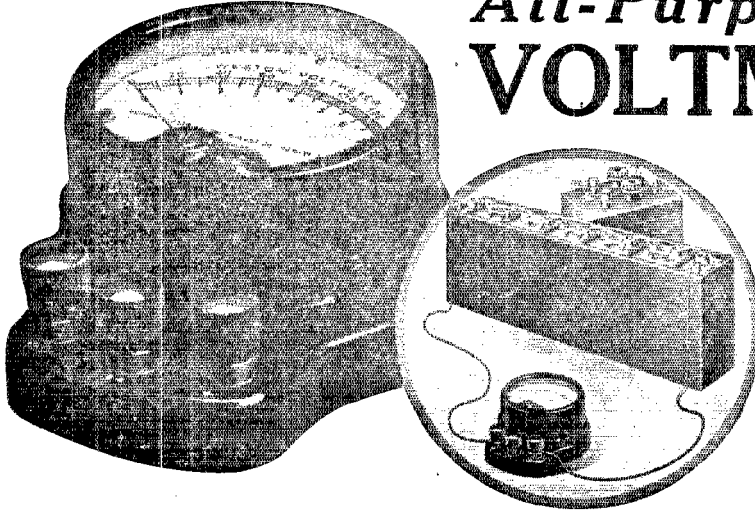

**Weston
Model 489
Double Range,
Portable**

EVERY good set deserves one. A high resistance, double range, portable instrument for accurately measuring filament, plate and grid voltages. Locates trouble immediately. Eliminates guessing. Instantly indicates the state of batteries. Invaluable for accelerating exact tuning, lengthening tube life and eliminating noise. Ranges 150 and 7½ volts.

Write to-day for complete information. If your dealer cannot supply you, we will fill your order direct.

WESTON ELECTRICAL INSTRUMENT CO., 158 Weston Ave., Newark, N. J.

**Electrical
Indicating
Instrument
Authorities
Since 1888**

WESTON

STANDARD - The World Over

A LONG AND SKINNY INSULATOR 18 INCHES BETWEEN WIRE HOLES



Highly vitrified high tension white glazed porcelain, strength 1500 lbs..
In Lots of Six or More **ONE DOLLAR EACH** Express C.O.D.
9DNH SURE FIRE RADIO LABORATORY **MACOMB, ILL.**

2650 MILES

ON ONE TUBE, Broadcasting from Atlantic Coast, Mexico, Canada, Cuba and Hawaii, heard in California, by users of the CROSS COUNTRY CIRCUIT. Atlantic Coast users hear California. Range due to simplicity of set and operation by one tuning control. Easy and cheap to build by any novice. Dry cell tubes may be used. Complete understandable instructions, full size panel layout, assembly photo, etc. Postpaid, 25 cents; stamps accepted.

Box Q-117 VESCO RADIO SHOP Oakland, Calif.

RADIO MASTS

Fabricated steel masts, the self-supporting kind. The most beautiful masts to be found. The best job for supporting antenna properly. Each mast equipped with cable and mast-head pulley. No guys, no platforms, no necessity for climbing up. Patents pending. Write for prices and describe your antenna.

WHITTLESEY ENGINEERING CO.
Cleveland, Ohio

DUO-SPIRAL

The Leading Loop Aerial
With New Dial and Handle

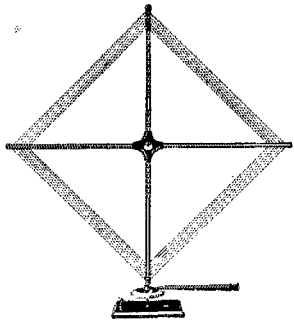

Pat. Pend.

The DUO-SPIRAL Loop spans the continent on a loud speaker with many types of radio-frequency sets. Careful tests by leading manufacturers and radio engineers have proved its superiority. Used exclusively by the largest manufacturers of radio frequency sets.

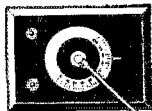

Top View of Base showing dial.

loop completely replaces roof antenna and ground practically eliminates static.

24-inch size... \$8.50. 12-inch size... \$7.50
(These prices include new dial and handle)

Adjustment is made easy by handsome dial and a long handle which eliminates all body capacity effects. The green double silk covered wire is kept always taut by hidden springs. The DUO-SPIRAL

TINY-TURN

A New and Superior
Vernier Control

TINY TURN makes possible an exactness in tuning never before attained. It has a 30 to 1 gear ratio instead of only 4 or 5 to 1 as in the ordinary vernier. No lost motion! The vernier turns in the same direction as dial. It can be instantly disengaged, leaving dial free. INSTALLED ON ANY SET IN 3 MINUTES. Handsome nickel and black finish. Packed in individual containers. We furnish counter display demonstrating boards.

Price 75 cents

The above products (folders on request) are sold through dealers and jobbers. If your dealer cannot supply you, write us direct.

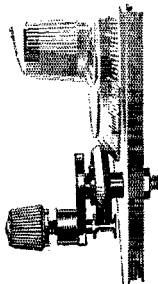

*Pat. Pend.
Side View showing friction drive against dial.*

RADIO UNITS INC

1311 First Ave.,
Maywood, Ill.

EXPERIMENTAL WIRELESS

The new British paper
Full of first class
Experimental articles
by the best writers

Strikes a new note among British wireless papers; it is of experimental interest from cover to cover. The contributors include the best transmitters and experimenters in Great Britain, and in other European Countries. Gives all the new methods, circuits, and inventions. Every U. S. A. experimenter should read it. Correspondence invited from members of the A.R.R.L., Inc.

Monthly, Single copies 30 cents
Per Year \$3.50

Percival Marshall & Co.
66 Farringdon St., LONDON, Eng.

RUSONITE

RADIO CRYSTAL

Entire Surface Sensitive

The Recognized Standard Crystal Rectifier

Used all Over The World

Hundreds of Thousands of Satisfied Users. Rusonite Has Revolutionized Crystal Radio Reception.

"THE PERFECT SYNTHETIC CRYSTAL"

Guaranteed

Price mounted 50c

RUSONITE CATWHISKER 14K. GOLD

Supersensitive; will not oxidize

Price 25c

Order from your dealer or direct from

Rusonite Products Corporation
15 Park Row, New York, N. Y.

THE PERFECT SHORT WAVE INSULATOR; Ohio Brass Co. Porcelains. 5" 75¢, 10" \$1.50. Prepaid. Corona bushed on request. Corona shields \$1.00. Confine your antenna losses to radiation resistance. No. 12 solid copper enameled aerial wire puts the distance in DX. 1¢ ft. prepaid. Grebe CR-13, A Real Receiver for Relay Men, \$95 prepaid. F. M. J. Murphy, Radio 8ML, 4837 Rockwood Road, Cleveland, Ohio.

Radio Fans

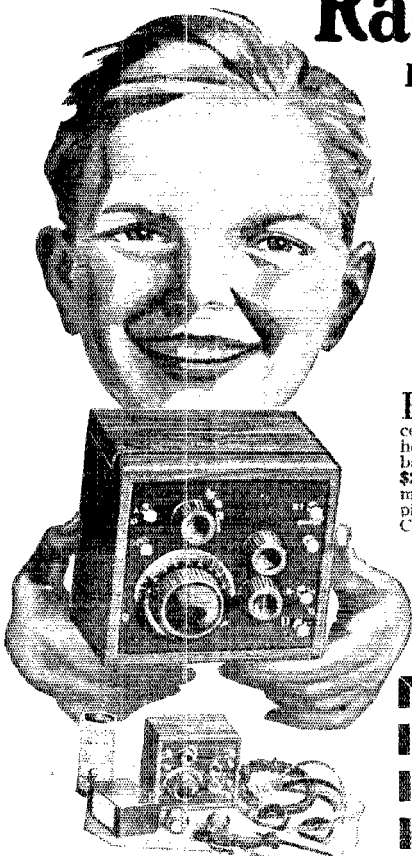

Here Is a Winner
 Armstrong
 Regenerative Set
 Receiving
 Radius
 600 Miles
\$23.25

Order Direct From
 This Advertisement.

HERE is a money saving Radio Outfit that will bring the news of the world—concerts, lectures and stock reports—into your home. Sold complete with head set, tube, batteries, aerial and ground wires, for only \$23.25! Connections simple and plainly marked. Easy to tune. Order NOW! Shipping weight, 12 pounds. Shipped from CHICAGO or PHILADELPHIA store.
 57QS9366 \$23.25



Save on All Radio Supplies.

Save money on your radio supplies, and get **guaranteed quality!** Our big **FREE Book** shows hundreds of bargains in complete sets and parts. Many new hookups, complete list of broadcasting stations. Contains "How to Build an Aerial." Mail coupon!

Licensed under the Armstrong Patent No. 1113149 for amateur experimental and scientific uses only.

Sears, Roebuck and Co.
 Chicago - Philadelphia

Send me **FREE** Radio Catalog No. 62Q92.

Name _____

P. O. _____ State _____

Rural Route _____ Box No. _____

Street and No. _____

Mail coupon today to store nearest you for Free Radio Catalog.

Sears, Roebuck and Co.

The World's Biggest Mail Order House

Ad 9992—5½x5¼ Inches.

RADIO TUBE EXCHANGE

We Repair All Standard Makes of Tubes Including

- W.D.11 or W.D.12.....\$3.50
- U.V.200 or C.300..... 2.75
- U.V.201 or C.301..... 3.00
- U.V.201A or C.301A..... 3.50
- U.V.199 or C.299..... \$3.50
- U.V.202 or C.302..... 3.50
- New 1½ Volt Tubes..... 4.00



RADIO TUBE EXCHANGE

200 BROADWAY, DEPT. 4, NEW YORK CITY
 All Mail Orders Given Prompt Attention
 Orders sent Parcel Post C.O.D.

An Amateur Radio Reference Library!

That's what you get in Bound Volume VI of QST, combining in compact form the issues of August 1922 to July 1923 inclusive.

Two equal volumes for convenience, handsome red binding with gold imprint, uniform with previous editions. Postpaid for only \$5.00.

**A FEW SETS
 DON'T GET LEFT**

QST, 1045 Main St., Hartford, Ct.

HAM - ADS

Six cents per word per insertion in advance. Name and address must be counted. Each initial counts as one word. Copy must be received by the 1st of month for succeeding month's issue. NOTE NEW CLOSING DATE.

LEAP YEAR! SNAP UP THIS PROPOSAL. HOOK UP TO AN EDISON B FOR LIFE, 100 VOLT BATTERY: ASSEMBLED FUMED OAK COVERED CABINET, TEST TUBES IN PLACE, 4" LEAKAGE PATH, LARGEST SIZE ELEMENTS WIRED, PERFORATED HARD RUBBER SEPARATORS, RUBBER BANDS, SOLUTION. (NOT LYE), WHITE SEALING OIL, CRATED FOR SAFE SHIPMENT \$15.00. WILLARD COLLOID CHARGER \$2.00. TUNGAR HIVOLTAGE CHARGERS AND PARTS. INSTRUCTION SHEET 50¢. ANNEALED GLASS TEST TUBES $\frac{3}{8}$ "x $\frac{3}{8}$ " 3¢ 1" 4¢, 1 $\frac{1}{4}$ "x7" FLAT BOTTOM 7¢, 99% PUREST SOFT DRAWN SOLID (NOT PLATED) NO. 20 NICKEL WIRE FOR CONNECTORS 1 $\frac{1}{2}$ " FT. PREPAID. HARD RUBBER SEPARATORS, PERFORATED, $\frac{1}{2}$ " FT. PREPAID. GENUINE EDISON SOLUTION \$1.50 5LB. CAN. DRY SOLUTION 80¢ LB. TYPE G ELEMENTS 4¢ PAIR, 2 POSITIVES 1 NEGATIVE 5¢. HICAPACITY UNIT OF 3 POSITIVES 2 NEGATIVES DRILLED AND IN PLATES READY TO WIRE 10¢ EVERYTHING, INCLUDING SOLUTION, FOR COMPLETE HICAPA, CITY CELL 19¢, WIRED AND ASSEMBLED 24¢, GREAT FOR TRANSMITTERS & POWER AMPLIFIERS, SENT PREPAID IN 100 CELL LOTS. CANADIAN 3CG ON 10 WATTS REPORTS WORKED VOICE QSA 600 MILES FIRST TIME OPENED UP. SUPERCCELL 6 A ELEMENTS IN 1 $\frac{1}{4}$ "x7" FLAT BOTTOM CONTAINER, FB FOR 250 WATT TRANSMITTERS & UV199 FILAMENTS. ALL PARTS INCLUDING SOLUTION, DRILLED AND CUT IN PLATES, READY TO WIRE, 30¢, WIRED AND ASSEMBLED 35¢. SAMPLE CELLS: SINGLE PAIR A & G HICAPACITY 25¢. SUPERCCELL 35¢. TELEGRAPH YOUR RUSH ORDERS. MURPHY, C/O HARRIS AUTOMATIC PRESS, CLEVELAND, RADIO 8ML, 4837 ROCKWOOD ROAD, CLEVELAND, OHIO.

COMBINATION A & B BATTERY TUNGAR CHARGER COMPLETE WITH TUBE \$16.00. EVERYTHING FOR THE AMATEUR FROM COUNTEPOISE TO ANTENNA. OB BRASS PORCELAINS FOR PERFECT SHORT WAVE INSULATION, 5" 75¢, 10" \$1.50 PREPAID. NO. 12 SOLID COPPER ENAMELED AERIAL WIRE GIVES A CLEAR TRACK FOR YOUR SIGNALS. NO SMOKE FILM CAN CUT YOUR RADIATION OR DIM THE INCOMING SIGNAL. LOWEST HIFREQUENCY RESISTANCE OF ANY ANTENNA WIRE SOLD. 1¢ FT. PREPAID TO YOUR STATION. 8AGO JUST PHONED IN FROM PITTSBURGH FOR 3000 FEET. COMPLETE NAVY 500 WATT TUBE TRANSMITTERS WITH GAS ENGINE GENERATOR. SILICON STEEL TRANSFORMER PUNCHINGS & STRIPS 20¢ LB. A FEW NEW EDISON A BATTERIES ON HAND. FADA NEUTRODYNE PARTS AND SETS. GREBE CR-13 RELAY RECEIVER \$95 PREPAID. RADIO 8ML, CLEVELAND.

GREBE "13" For Sale: Perfect condition used less than two weeks. First check for \$72 gets it. All communications answered. Harold Bowen, 168 Belmont St., Fall River, Mass.

FOR SALE or trade for CW parts. Acme transformers R2, R3, R4 and R. C. UV1714. Vern Carpenter, 5226 E. North St., Indianapolis, Ind.

EXTRA RECEIVER PARTS: Acme amplifying transformer, filament jacks, rheostats—Klosner, Remier, cabinet and panel. 8DV.

FOR SALE: New Grebe CR9 receivers \$90.00. New 10-A Western Electric power amplifiers complete with horn and tubes \$100.00. Dakota Radio Apparatus Co., Yankton, So. Dak.

FOR SALE: Paragon RA-10, \$35; Paragon DA-2, with Weston filament voltmeter, \$30; Baldwin variocoupler and variometers in Grebe cabinet, \$15; Signal change-over switch, \$3. All guaranteed good condition. Sent Post-paid. 2JC.

ADD A FEW MORE HUNDRED MILES TO THE OLD SET. WORK THE CHEMICAL RECTIFIER OVER AND PUT IN CHEMICALLY PURE SHEET ALUMINUM. POSITIVELY HIGHEST GRADE OBTAINABLE. SQUARE FOOT COSTS 90¢. SHEET LEAD 30¢ PER POUND. 2 $\frac{1}{2}$ LBS. TO SQUARE FOOT. OHIO BRASS INSULATORS IN STOCK 75¢ AND \$1.75 EACH. NEED A NEW WATTER? LET US SELL YOU ONE. WE SHIP NOTHING BUT STRAIGHT ELEMENT TUBES. COMPLETE LINE JEWELL INSTRUMENTS. FORMICA PANELS 12x 20x $\frac{1}{2}$ ", \$5.30, SAME $\frac{1}{2}$ ", \$7.00. FILTER CONDENSERS IDEAL 1000 VOLT \$2.00. UC490 1750 VOLT \$2.50. WESTERN ELECTRIC HEAVY DUTY MICROPHONE TRANSMITTERS \$4.00. NAVY KNOB FOR THE OLD KEY 35¢. SAVES A BURN IF THE KEY IS HOT. STILL HAVE TWO EMERSON 200 WATT 500 VOLT MOTOR GENERATOR SETS TO SELL AT \$75.00. THE PEPPITI MACHINE ON THE MARKET, AND NO MORE TO BE HAD WHEN THEY ARE GONE. BETTER TALK FAST. TRY US ON YOUR NEXT ORDER. SUDDEN SERVICE INCLUDED IN THE PURCHASE PRICE. THE ONLY HAM STORE IN THE FIFTH DISTRICT. FT. WORTH RADIO SUPPLY CO., 104 EAST 10TH ST., FT. WORTH, TEXAS.

GREBE CR3A \$25. Spark; $\frac{1}{2}$ K.W. Thordarson shunt type \$12; oscillation transformer, \$4. Aluminum Benwood, \$12. Finest Condition. 8BCK.

HONEYCOMB REGENERATIVE set, Det. 2 stage in one cabinet and 18 honeycomb coils to cover all wavelengths \$85.00. Geo. Fox, 328 L Street, Salt Lake City, Utah.

FOR SALE: Complete Phone and C.W. Set, all Radio Corp. apparatus. Never used, \$150.00. Also complete receiving set with 2 step, \$100.00. Guaranteed. A. G. Hutchins, Jr., 8 $\frac{1}{2}$ Prospect St., Attleboro, Mass.

ALL WAVE SET: 3-coil honeycomb regenerative, one step audio, \$27. Best materials throughout. Write 9BTY.

ATTENTION HAMS—Have you spent hours trying to cut peep and meter holes in panel? I have a tool that drills them one to five inches in diameter as easily as quarter inch one. Only \$2.50 postpaid. Homer Malcomb, Whitewater, Wisc.

N & K HEAD SETS. Model D, 4000 Ohm. Are you getting maximum results from your receiving set? There is a reason why the most exacting Amateurs use the N & K in preference to all others. A trial will show you why. Compare it for sensitiveness, tone, comfort, appearance. Price \$6.50, parcel post. Homecrest Radio Co., 2162 Homecrest Ave., Brooklyn, N. Y.

SELL—20 Watt CW Transmitter, complete with tube and power supply. Write 9CMV.

BARGAINS: Paragon fone, 300 V Motor Generator, Filament trns., 5W Tubes. Super-Regenerative made by Godley, Benwood 200 W Motor Generator. For prices and information, write Jos. Rigby, 38 Pearl St., Paterson, N. J.

SELL TWO 50 watt tubes with sockets \$40. General Radio transmitting condensers \$8. General Radio wavemeter type 191 \$40. UV202 tubes \$4 each. Schuck, 1411 Avenue A, New York City.

SALESMEN, representatives, out of town to sell radio parts for manufacturer. Tillman Products, 473 Hudson Ave., Brooklyn, N. Y.

WESTERN ELECTRIC'S 212-A 250 Watt, new \$85. A-P Amp. and Detectors, Meyers. Robbins-Meyers Motor Generator 500 Volt \$48. Radio Frequency Transformers, all makes. State your wants. Don Canady, 8BHN, 3439 W. 119th St., Cleveland, Ohio.

FOR SALE: 2 Westinghouse Storage B. Batteries @ \$4; 1 new C.W. transformer UPI368 @ \$15; 2 Kenotrons \$1.00. 8DHQ, Chesaning, Michigan.

FOR SALE: Motor Generator, 500 volts, 150 watts, \$35. 2BZO, Paul Rizzo, 571 39th St., Brooklyn, N. Y.

SELL: Emerson five hundred volt motor-generator set, Federal microphone, both new, and 0-2.5 General Radio ammeter. Geo. Murphy, Salem, Ohio.

FOR SALE: Telefunken—two five hundred watt transmitting tubes seventy-five dollars each. One ten watt phone and CW set. Panel mounted, with am-

meter, thirty dollars. Advance Synchronous rectifier, thirty dollars. 2CLA.

OLD TIMERS: Please sell me the first eight issues of QST at your price. Kepler, 2029 W. 52nd St., Cleveland.

HAVE TROUBLE making D.C.? Have formula, diagrams and instructions, sure fire method for perfect chemical rectifier. All sent for \$2.00. Robert C. Klimesh, 9BJD, Sp. 11ville, Iowa.

FOR SALE: DeForest 3 Stage Outfit, Transformer coupled, 3 Jacks and Honeycomb coil in 2 Cabinets with covers. Like new, \$25.00, less tubes. Geo. Schulz, Calumet, Mich.

TYPE 106C TUNER—Modified so that tube or crystal detector can be used. Perfect condition. Bargain at \$50. Purchaser pays express. Ewald I. Winquist, 229 Garfield Ave., Jersey City, N. J.

"DEAD" PHONES REPAIRED—\$2.00. Any make or in any condition. Made as good as new. Satisfaction guaranteed or money refunded. Radio Receiver Hospital, Box 142, Reading, Mass.

FOR SALE: 1 4 Tube Crosley Model X Receiver; 1 90 ampere hour storage battery; 2 Crosley head sets with plug; 1 UV200; 1 UV201; 2 UV201A Tubes. Above used about six months. 2 22½ volt Burgess "B" Batteries, new. First \$90.00 takes all. Write R. A. Rosell, 1026 Randolph St., Waterloo, Iowa.

FOR SALE: Masda Super Vernier Condenser 3 plate geared \$1.25. 3 DeVeaux Jacks, open, closed and 2 circuit. \$1.25. Geo. Schulz, Calumet, Mich.

SELL: Hundred watt—Five hundred fifty volt—Thordarson Transformer, New, \$9. 8 volt Filament Transformer, New, \$4.50. R. McShaffrey, Monessen, Pa.

READ my ads in back issues Kepler.

FOR SALE: Remler Panels less tubes, detector No. 330, cost \$8.50, sell \$5.25; Amplifier No. 333, cost \$9.00, sell \$5.50, less transformer, all like new. Prepaid on two. Geo. Schulz, Calumet, Mich.

FOR SALE: UV200, \$4.00; UV201A, \$5.00; Stromberg Phones, \$5.00; New Magnavox, \$30.00; 150 Ampere, 6 volt, storage battery, \$15.00; Regenerative tuner, DX Scotland, \$30.00; Detector in Cabinet, \$4.00; Amplifier in Cabinet, \$8.00. Sell all for \$90.00. Write Jerome Kitterman, Batavia, Iowa.

AMATEURS! HAMS! NOTICE THESE NEW PRICES ON "SIG" CARDS; QUANTITY PRODUCTION MAKES THIS POSSIBLE. 500 3½ by 5½ CARDS PRINTED IN BLACK INK WITH LARGE RED CALL LETTERS \$4.00; 500 GOVERNMENT POSTALS, WE FURNISH THEM, \$8.50. NOT OVER TEN LINES OF PRINTING; NOT LESS THAN 500 CARDS AT THIS RATE. CASH WITH ORDER. BY MEMBER OF A.R.R.L. CURTIS, 1109 EIGHTH AVENUE, FORT WORTH, TEXAS.

2KF* 100 WATT C.W. AND I.C.W. FOR SALE: Heard in 36 states and Hawaii inside of six weeks operation. Must sell, going to West Coast. Set consists chiefly of 2 UV203 tubes, sockets, 1 UP1016 Plate Trans., Two Keys, 6 UC490 Filter Conds., RCA O.T., Full Supply of Meters, Bakelite Panel Layout, Chem. Rect. giving D.C. Note, Acme Double Choke, RCA Chopper Wheel and Motor. Entire set giving beautiful appearance. Cost me \$215.00 to build, will sell complete for \$150. Write to H. D. Selvage, Irvington, N. J.

BRANDES TRANSATLANTICS, new, \$7.50. Meyers tube, adapter, \$4.50. 8AGF.

SELL: Grebe CR8 and RORK 2 stage amplifier practically new, first money order for \$90 takes them. Howard Eldredge, Sharon Springs, N. Y.

CW OSCILLATION TRANSFORMERS; 25 turns ⅜" x ⅜" aluminum strip of 6" dia. well mounted. Similar to RCA but more efficient— for \$5.00. Have two. 8DDV, John Stiles, Rensselaer Falls, N. Y.

WANTED: Ten, Twenty or Hundred Watt C.W. transmitter complete. Give complete description. Wm. R. Abert, 920 Marietta St., Zanesville, Ohio.

FOR SALE OR TRADE: Fine Oliver typewriter \$20. CW set parts wanted. Write 2CQE.

ALWAYS MENTION QST WHEN WRITING TO ADVERTISERS

A PROVEN SUCCESS. Edison element storage "B" batteries are dependable. Batteries are enclosed in cabinets with lid and handles. 22 volt \$3.25; 48 volt \$6.50; 72 volt \$9.50; 100 volt \$12.25. "B" battery with rotary switches to charge from 6 volt A battery charger at the following prices: 24 volt \$5.25; 48 volt \$9.75; 72 volt \$14.50; 100 volt \$18.75. Prices include electrolyte and are shipped prepaid. Send for circular. Type A elements wired 6¢ per pair. ⅜x 6" containers 3¼¢. Separators ¼¢. Complete chemical rectifier \$2.00. Everything for that storage "B" battery. J. Zied, 530 Callowhill St., Phila., Pa.

FOR SALE: 3 Cotocoll Radio Transformers, Cost \$5.50, sell \$3.50; 2 Erla Radio Transformers, cost \$4.00, sell \$3.00. Like new. Prepaid on 3 or all. Geo. Schulz, Calumet, Mich.

FOR SALE: Reinartz fifteen dollars. A. W. Gavett, Leeds Center, Maine.

TRADE CORONA Typewriter for standard make tuner, (not single circuit). Maxwell, Box 1057, Norfolk, Va.

OMNIGRAPH WITH KEY, buzzer, coil, phone, 15 code-word dials, \$20; Filament trans. mounted, \$8; Plate trans. unmounted, \$5; pair will carry 4 tubes with their Kenotrons. Switchboard, slate, 40x40, A1 condition, \$5. T. DeVore, Oneida St., Baldwinsville, N. Y.

DID YOU SEE June QST's endorsement of Cardwell Condensers? Essential for efficient 100 meter work. Now obtainable from us at: 23 Plate, \$5.00; 17 Plate, \$4.75; 11 Plate, \$4.25; ALSO Brandes Superior Headsets at \$4.95! Other standard instruments at substantial discounts. Write for quotations. Herbert Isaacson, 515 80th St., Brooklyn, N. Y.

FOR SALE: 5 Meyers Audion High Mu and Receptacles, cost \$6.00, sell \$3.50; Meyers Choke Coils, cost \$3.50, sell \$2.25. Postage 10¢ each. Prepaid on 3 or more. Geo. Schulz, Calumet, Mich.

Didja read my ads in past QSTs? Kepler.

FOR SALE: New Power Transformer UP1368 \$14.00, Acme 200 Watt filament and plate mounted transformer \$13.00, Thordarson filament and plate transformer 650 Volt \$5.50. Filter Reactors UP1626 \$6.50 Each, New Motor Generator 350 Volt 20 Watt \$20.00, Magnetic Modulators UT1643 \$5.00 Each, 4 UC488 Condensers \$1.25 Each, Key \$1.50, Jewell 0-500 D.C. Voltmeter \$11.00. 2 Fifty Watters slightly used \$18.00, 15 Watt Fone and C.W. Set mounted in Cabinet \$35.00. W. L. Otto, Cambridge, Ill. 9DC.

THE ONLY GENUINE PEANUT Tube R215A designed by Western Electric Co. for Armyaeroplanes. Manufactured by Northern Electric Co. in Canada, which company is closely associated with the Western Electric. Filament ¼ amp. at 1.1 volts. Plate voltage as detector, 22½, as amplifier, 45. Best detector in the world and a splendid amplifier. Smallest, sturdiest, and most economical of vacuum tubes. \$5.10 postpaid, insured. Socket \$1.00. Can. 3AET, J. G. Shaw, 14 Madison Ave., Hamilton, Ont., Canada.

FOR SALE: Bargains. Reinartz recr. in mahogany cabinet, 1900 mi. on 200 meters. \$25.00 with new Radiotron tube, fones, B batt., \$35.00. Regenerative tuner, both coats, complete except A batt., \$32.00. Crystal sets, hrd. stations over 300 miles, complete, \$25.00. WD11, new, \$4.35. Robert Adams, 490 Anthony, Glen Ellyn, Illinois.

COMBINATION A & B BATTERY CHARGER COMPLETE WITH TUBE \$16.00. CHARGES 6 AND 12 VOLT A BATTERY, AND UP TO 100 VOLT B BATTERY. A REAL CHARGER, GANG. SML, CLEVELAND, OHIO.

STATION CARDS—New special design. Send stamps for samples and prices. Van Wert Printing Company, Van Wert, Ohio.

VARIABLE CONDENSERS at real prices 23 plate Vernier \$2.50; 43 plate Vernier \$2.75 including dial. Can you beat it? Send order to R. C. Condenser Co., Suite 535 Monadnock Bldg., Chicago, Ill.

HAMS WHO DESIRE SPEED—a moment's attention. Brother Ham whose limit was 15 words doubled his speed in One Evening. Send your Call and ask for the facts as told by himself. Dodge Radio Shortkut, Dept. SC, Mamaroneck, N. Y.

SELL: Regenerative tuner \$25.00; 2 pair fones, and miscellaneous parts. What do you want? Clifford Fohr, DeKalb, Illinois.

FREE—A \$4.00 23 plate variable condenser given free with each vacuum tube purchased. All standard apparatus 15% off list. Write us your needs. Address—Radio, 3023 Boulevard Place, Indianapolis, Ind.

LOOK-A HERE! RCA Radiola Two portable receiver, with tubes, \$50; two DX radio frequency transformers, \$2 each; two Cotocoil radio frequency transformers, \$2 each; motor-generator, 500 cycle generator, 90 volt DC motor, 1/4 KW, \$20; two ampere Tungar with bulb, \$12; four pancakes with continuous slider, a la 6JD, \$3.50; two plain pancakes, \$2.50 each; 0-10 ampere Roller-Smith hotwire ammeter, \$6; Amrad commercial quenched gap, 13 sections, \$8; 1/4 KW 500 cycle transformer, 12,000 volt secondary with midtap, \$15; UV1714 radio frequency transformer, \$3.50; 0-2.5 ampere Roller-Smith hotwire ammeter, \$3; two GR five watt rheostats, \$1 each; two UV-712 audio frequency transformers, \$4 each; PR-535 power rheostat, \$1; Grebe CR3, \$25; 1 1/2" spark coil \$1; RCA PX 1638 chopper wheel, mounted with pulley, \$5. ZAHO.

OH BOY—2 brand new No. 4000 S tubes with sockets, 8 bucks each. 9DTA.

BARGAIN—"Advance" Synchronous Rectifier, new, prepaid, \$35.00. Radio Corporation Chopper Robius Meyers motor \$12. 8BQB.

ALL APPARATUS at 2JC going at 50% off list! Paragon 10 watt, CW, ICW and fone, \$35; 3 UV-202 tubes, \$4 each; 5 GE porcelain tube sockets, \$50 each; Federal 260-W hand microphone, \$3.50; Acme 200 watt power transformer, mounted, \$10; 2 Kenotron UV-216 tubes, \$3.75 each; GE UP-1626 40 henry choke, \$5.50; 2 Acme 1.5 henry chokes, \$2 each; 5 one mfd. transmitting condensers, \$1 each; 2 one-half mfd. transmitting condensers, \$.60 each; 3 GE UP-535 filament rheostats, \$1.50 each; 3 Mesco hand keys, \$1.50 each; Grebe CR-13, \$50; General Radio wavemeter, \$35; Jewell AC voltmeter, 0-10 \$3.75; Weston milliammeter, 0-200, \$8.50; Weston thermocouple ammeter 0-1.5, \$8.50; General Radio variable air condenser, 20-1000 mmds., \$2.75; Pair Seibt fones, \$4.50; Vibroplex speed key, \$8; 1/4 inch spark coil, \$2. Don't send your check too late! Send it now! J. S. Dunham, 73 Edgewood Ave., Larchmont, N. Y.

BARGAIN: Grebe CR-8 used two months, good as new, cost \$80. Sell \$60. Elmer Ditty, 1487 Arthur Ave., Lakewood, Ohio.

CHEMICALLY PURE Aluminum. Square foot: 1/4" dollar fifty, 1/2" eighty cents, 3/4" fifty cents. Best obtainable anywhere. Immediate shipment guaranteed. H. Appleton, 427 Euclid Avenue, Toronto, Canada.

2 1/2" bottles 3¢. 8BPP.

FOR SALE—5AEC's 20 watt set complete. 5 tubes, synchronous rectifier, 3 Jewell Meters, \$125.00.

SELL: NEW Electroce insulators 23 inches long, one dollar, also Jewell antenna meter 1 1/2 amps. 7 dollars. Home made CW transformer 5 dollars. Wm. Hulse, 1152 Hull Street, Baltimore, Md.

HAMS—Here's a 5 watt transmitter that steps out 1150 miles first crack, 500 to 800 miles consistent working range. Neatly assembled in two compact units and panel mounted. Write for complete description. Merrill Klassy, 1970 Penn Avenue South, Minneapolis, Minn.

DISCOUNT 15% to Hams on majority standard apparatus. Sell—G. E. 1/2 horse induction motor, \$18. G.E. motor generator, 650 V., \$30. Self supporting spider-web coils 75 cents. Try us. Cash only. SDDA, Box 902, Canton, N. Y.

FOR SALE OR TRADE: 1 KW Spark Transmitter, Thordarson Transformer, Benwood Gap, Oil Condenser, Split Type O.T., Large Amp. Meter, & Key, \$35.00. W. L. Otto, Cambridge, Ill.

RADIO CARDS with red call letters 65¢ per hundred up. Radiograms 20¢ per pad. Send for samples. BIG BARGAIN, NEW SAMPLES. The Arthur Press, 1453 Arthur Ave., Lakewood, Ohio.

FOR SALE: 1/2 KW 500 cycle alternators \$80; 1/4 KW 124

500 cycle alternators \$25; New UV203s \$23; Paragon \$50; Detector and 3 step, same dimensions and to match, with Paragon \$75; Advance sink rectifier \$35; New UV204s \$80; 12,000 V. 002 mfd. condensers \$5.50; 1 KW 2200 V transformers \$40; Navy IP500 \$150; WE 50 watters \$30. Edward Page, Baldwinville, N. Y. 8AQO-8XAV.

SELL: Federal 311-W filament transformer, \$6.50. Atlas loud speaker, \$18.00. A. S. Bachtel, 26 N. Highland Ave., Akron, Ohio.

GET THAT RADIO SET NOW. Also anything that you need to complete that receiver. Radioelectric, 729 Linderman Ct., Kenosha, Wisc.

SELL: Acme 200 Watt transformer, guaranteed good as new. \$14. 9TW.

PURE ALUMINUM, \$1.50 square foot, postpaid. C.O.D. 10 cts. extra. Howard Frazier, 5714 Hazel Ave., Philadelphia.

ALL BARGAINS: Navy 5 watt fone sets. Original cases. Complete with dynamotor, transmitter for CW, ICW, microphone, key, two tubes, antenna wire, spares \$75. Very compact and operates from 12 volts. 1/4 KW 500 cycle quenched gap transmitters for local work and high voltage for the tubes. \$75. General Electric 350 volt .143 ampere dynamotors with filter for 12 volt supply \$18. 1/4-1/2 to 2 KW 500 cycle self excited generators \$25.00, with motors \$65.00. Special new flame-proof keys with "blinker" \$1.50. General Electric 5 watt Plotrons sealed \$6.00. In lots \$5.00 each. Radiation meters, Bakelite constructed inductances \$7.50. Antenna Wire, Western Electric 50 watters \$25. What do you need? Henry Kienzie, 501 East 84 Street, New York.

FEBRUARY BARGAINS—UV201A \$5.60; Brandes Superiors \$5.10; Acme Transformers, Radio or Audio, \$4.15. Hoosier Radio Supply Co., 816 Johnson, Gary, Ind.

BARGAIN: Half Kilowatt fifteen hundred volt Esco motor generator, also hundred watt transmitter, great records. E. Leavenworth, North High School, Milwaukee, Wis.

1/4 to 1/2 KW 500 cycle self-excited alternators for belt drive, 125 volt 25 lbs., \$18.00, with CW transformer name your voltage \$24.00. 1/4 KW aeroplane quenched transmitter, less generator \$18.00, tapped 3000 volt Dubiliers .02 and .002 \$3.25. 53 ft. section mast weighs 20 lbs. \$22.50. 0-5 amp. General Radio panel hotwire ammeters \$3.25. All guaranteed new. George Eaton, 1915 South Twelfth, Philadelphia.

FOR SALE: 9ARF 20 watt transmitter. Going to college. Write for particulars. J. H. Freis, 4817 Forestville Ave., Chicago.

"THE STARS ARE OUT." Most wonderful fixed crystal detector ever produced. Price \$1.25. Sold on money back guarantee. Star Crystal Company, Suite 534-53 W. Jackson Blvd., Chicago, Ill.

350 VOLT, 100 watt direct current generators and dynamotors guaranteed, \$14. Also 900 cycle 250 watt self-excited alternators with transformer wound, any voltage \$18.50. Cash with order. No C.O.D. N. A. Patchin, 226 Slocum Place, San Antonio, Tex.

RADIO BARGAINS: Any \$6.50 tube \$5.75; Burgess 2156 batteries \$2.50; Eria Reflex transformers any type \$4.50; Brandes Superiors \$5.25; Signal 23 plate condensers \$1.75; Audio transformers \$3.00 to \$6.50; Neutrodyne and Reflex sets and parts; Complete line of accessories at bargain prices; everything guaranteed perfect. Edward Bromley, Jr., White-water, Wis.

PROTECT YOUR APPARATUS with small fuse wire in dangerous places. Eighth, quarter, half, three-quarter, one-ampere and larger sizes, three feet for two bits. 9CZP.

MASTER RADIO CODE in 15 minutes. Ten word speed 3 hours. Our students made these world records. Previous Failures who tried all known methods have thanked us for License. To hesitate kills speed. To master Code our way kills hesitation; gives speed. Code instructions that instruct only \$2.00. Information free. Dodge Radio Shortkut, Dept. SC, Mama-ronck, N. Y.

10" PORCELAIN INSULATORS (QST No. 6) only ALWAYS MENTION QST WHEN WRITING TO ADVERTISERS

90¢. Why pay more? Equal to No. 5 in tests. Lorain Radio Supply Co., Lorain, Ohio.

EDGEWISE WOUND Copper Ribbon $\frac{1}{8}$ inch wide 6 inches diameter 15¢ turn, $\frac{1}{8}$ inch wide, 5 inch diameter 12 cents turn, any number turns one piece. Remler Gislén Coils mounted 25-75-100-150-200-250-300-400-500-600-750-1000 turns, half price. Genuine Silicon Transformer steel, cut to order, 25 cents pound, 10 lb. and over, 4 cubic inches to lb. Postage extra. Geo. Schulz, Calumet, Mich.

FIFTY ASSORTED FLAT HEAD solid brass machine screws, nuts, washers, copper lugs, 50¢. Eight initial binding posts, set 80¢. Twelve nicked binding posts 50¢. All three items \$1.50. **RADIO LIST** for stamps. All prepaid. Stamps accepted. Kladag Radio Laboratories, Kent, Ohio.

HERE'S A REAL BARGAIN: New Paragon RA-10, receiver, DA.2 detector and two-step amplifier, \$65. Good reason for selling this at this price. U. of I. Supply Store, Champaign, Illinois.

FOR SALE: 100 Watt Broadcast Transmitter complete with microphone, tubes and Esco Generator motor driven. DX 2000 miles, can also be used below 200 meters. The Maus Piano Company, Lima, Ohio.

\$12. EACH takes Ohio or Wagner 110 volt sixty cycle eighteen hundred R.P.M. motors built in $\frac{1}{4}$ H.P. frames. Can be used as power motors. Type G Edison elements per pair 3 $\frac{1}{2}$ ¢. Highest quality $\frac{1}{16}$ x 8" test tubes \$3.00 gross. Perforated hard rubber separators $\frac{1}{4}$ ¢. No. 20 99% pure nickel wire \$1.50 per hundred feet. 25% off on 4 new Acme $\frac{1}{2}$ and $\frac{1}{4}$ K.W. Plate transformers. Kimley Electric Company, Inc., 2665 Main St., Buffalo, N. Y.

WANTED: All A.R.R.L. members to know that we have a complete stock of radio parts and give mail orders special attention. Write, phone or wire. Harzog Mfg. Co., Radio Division, K.F.J.L., Ottumwa, Iowa.

HAMS: Get our samples and prices on printed Call Cards, Letterheads and Envelopes. Hinds & Edgerton, Radio Printers, 19 S. Wells St., Chicago, Ill.

EDISON STORAGE "B" Battery Elements. Large size, full capacity. 3¢ per pair, in lots of 100. Kindly send postage for 5 $\frac{1}{2}$ lbs. Per 100 pair, Gilman's Battery Shop, 57 Washington Ave., Chelsea, Mass.

"WARRANTED" C.W. TRANSFORMERS new and ten day's money back guarantee. 500 watt plate transformers taps 500, 1000, 15000, 3000 volts unmounted \$13.00. 200 watt, high voltage 350, 550, 700 volts, filament voltages 2, 4, 6, 8, 10, 12 volts-unmounted, \$10.00. 50 watt high voltage 375 filament voltages 8, 10, unmounted \$7.00. Filament transformers 150 watt voltages 8, 10, 12, \$7.00. Chokes 500 M.A., 1 $\frac{1}{2}$ Henry-unmounted, \$3.00. Order direct from this ad. Dealers write. C. C. Endly, 22 Sturges Ave., Mansfield, Ohio.

\$110.00 SIX volt 150 ampere chrome nickel Edison storage "A" batteries at \$22.50 each. Also 6 volt 225 ampere at \$29.50, 300 ampere at \$36.50, 350 ampere at \$40.50. Every battery guaranteed perfect. A wonderful battery at an equally wonderful price. Edison (genuine) chrome nickel "B" storage battery plate (large size type A) at 4¢ per pair, 4 $\frac{1}{2}$ ¢ in lots under 100 pairs. Complete parts for making rechargeable storage "B" battery including genuine Edison chrome nickel plates, heavy glass vials, special wire, perforated rubber separators, chemical electrolyte and complete simple instructions for assembling and charging. 100 volt unit of parts \$9.35, 150 volt \$13.90. Address B. Q. Smith, Largest and pioneer dealer of above parts, 31 Washington Ave., Danbury, Conn.

NEW RADIOGRAM BLANKS—Used with one hand only. Efficiently arranged. Blue Paper. 30¢ per hundred. Van Wert Printing Company, Van Wert, Ohio.

FISCHER RADIO TABLE. Solid mahogany, compartment for batteries, spare equipment and radio magazine. Size 30x12 with sliding doors \$15.00. C.O.D. A. G. Fischer, 55 John St., N. Y. C.

FOR SALE: Three Grebe CR-8 and RORK amplifiers \$85.00 per set at Radio 92Y.

TELEGRAPHY—Morse and Wireless—taught at ALWAYS MENTION QST WHEN WRITING TO ADVERTISERS

home in half usual time and at trifling cost. Omnigraph Automatic Transmitter will send, on Sounder or Buzzer, unlimited messages, any speed, just as expert operator would. Adopted by U.S. Govt. and used by leading Universities, Colleges, Technical and Telegraph Schools throughout U.S. Catalog free. Omnigraph Mfg. Co., 16M Hudson St., New York.

RADIO GENERATORS—500 Volt 100 Watt \$28.50 each. Battery Chargers \$12.50. High Speed Motors, Motor-Generator Sets, all sizes. Motor Specialties Co., Crafton, Penna.

LET ME PRINT your QSL cards. Large call letters in colors. Printed to order at reasonable prices. Write for samples and price list. 5BP.

IF YOU WANT PRACTICE MAKING EDISON B's USE NICKEL PLATED IRON WIRE FOR YOUR CONNECTORS. THE NICKEL COMES OFF AT THE TWIST AND MAKES A FINE RUSTY CONNECTION, 2 IN EACH CELL. FOR A QUIET, LIFETIME BATTERY, USE 99% PURE SOFT DRAWN SOLID (NOT PLATED) NICKEL WIRE, 1 $\frac{1}{16}$ FOOT SML, 4837 ROCKWOOD ROAD, CLEVELAND, OHIO.

7x12 CABINETS strongly built of cypress wood natural finish hinged top with front rabbited for panel \$1.20. Postpaid. Panel for same 7x12x $\frac{1}{4}$ \$0.78. Postpaid. Everything you need to send and receive. Write for our special proposition. Merit Sales Co., 518 N. Eutaw, Baltimore, Maryland.

RADIO CALL CARDS printed to ORDER. Red call, black printing. 100, \$1.75; 200, \$2.75, prepaid. Color changes 35¢ extra. Government postals 1¢ extra each card. **LETTERHEADS** 8 $\frac{1}{2}$ x5 $\frac{1}{2}$ AND **ENVELOPES**, 100 EACH, \$2.25; 200 EACH \$3.50. A.R.R.L. emblem used on cards or stationery if requested by members. Send TODAY. Department 12-C, Radio Printers.

Q R A SECTION

50c straight, with copy in following form only: CALL-NAME-ADDRESS. Any other form takes regular HAM-AD rates.

9AJU—Edwin Lane, 1737 Mississippi St., Lawrence, Kansas.

1AAP—Clifford A. Langworthy, R.F.D. No. 1, West-erly, R. I.

8BXL—Below 100 meters, 8AGF, 1025 Baldwin, Ann Arbor, Mich.

4OH—W. S. Wilson, Jr., 530 W. University Ave., Gainesville, Fla.

1PY—Bruce Boyd, 34 Ellington St., Lungmeadow, Mass.

9AYR—Cyril E. Cornwell, Osage, Ia.

8AGD—Frederick C. Fay, 9 North 4th Ave., Iliou, N. Y.

9BSS—Hubert B. Peugeot, 4482 Lindell Blvd., St. Louis, Mo.

"Y" Radio Club, 110 West Carrillo Street, Santa Barbara, California.

6BFM—Jos. G. Hamilton, 824 Moreno Road, Santa Barbara, California.

9BCE—C. L. Umerger, Middlesboro, Kentucky.

1AER—L. R. Virgin, 270 No. State St., Concord N. H.

9BGK—Alex. K. Scherer, 1213 W. La Fayette St., Ottawa, Illinois.

6ZAG—R. J. Miller, Glen Una, Los Gatos, Calif.

6ZAH—B. R. Cole, Los Gatos, Calif.

6ZAR—C. C. Whysall, Los Gatos, Calif.

6ZAU—K. W. Kent, Los Gatos, Calif.

6ZBN-6A0I—C. W. Park, Box 237, Riverbank, Calif.

6SN—M. Kingdon Weller, 618 W. 4th St., Los Angeles, Calif.

9DJL—Leslie M. DeVoe, 130 Andrews Place, West Lafayette, Indiana.

8BMP—Albert A. Arnold, 268 James St., Akron, Ohio.

1XAL—Irving Vermilya, Mattapoisett, Mass.

1ZE—Irving Vermilya, Mattapoisett, Mass.

8CHY—M. H. Edwards, 221 W. Bancroft St., Toledo, Ohio.

2JC—J. S. & M. L. Dunham, 73 Edgewood Ave., Larchmont, N. Y.

4PK—Geo. W. Clark, Jr., 202 Clark Bldg., Jacksonville, Fla.

6ZAT—Lyndon Farwell, 55 Broadway, Los Gatos, Calif.

1BJD—S. Forrest Martin, The Choate School, Wallingford, Conn.

2ADD—E. B. Wilson, Jr., 209 Van Cortlandt Pk. Ave., Yonkers, N. Y.

Can. 3DO—D. C. Osterhout, Lucknow, Ont.

6BDT—Lloyd A. Mason, 702 E. Santa Clara St., San Jose, California.

SARV—J. J. Elias, 1403 W. Main St., Lansing Mich.

5BZ—W. L. Barrow, 918 Convention St., Baton Rouge, La.

2IC—Wm. D. Mitchell, 18 Union St., Ridgewood, N. J.

1ZI—Harris Fahnestock, Jr., Lenox, Mass.

YOUR CALL IN SOLID GOLD

on the neatest little 50 watt tube pin
you ever saw!



(Exact size)
Money refunded
if not satisfac-
tory.
mail box. You will receive your pin
promptly.

R. C. BALLARD, 9FZ
1202 W. Oregon St., Urbana, Ill.

RADIO PANELS

Cut exactly to size and a guaranteed 12 hour shipment. $\frac{1}{4}$ " thick .01 $\frac{1}{2}$ " per square inch. $\frac{1}{8}$ " thick .01 $\frac{1}{4}$ ". Made of the highest grade black fibre. This material possesses electrical strength of 200 volts per mil, is inexpensive, unbreakable, easy to work and takes a fine finish. We pay postage.

RADIO INSTRUMENT & PANEL CO., 564 W. Monroe St., Chicago, Ill.



QUALITY APPARATUS

Selected by Cockaday

for use in his new

IMPROVED FOUR CIRCUIT TUNER

As described in detail in the January
issue of Popular Radio

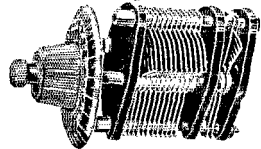

Variable and Vernier Condensers!
Precision—made for exceptionally
accurate tuning

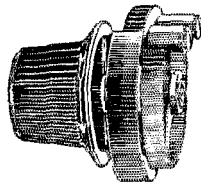

Rheostats and Potentiometers

With Knob or Dial—Suitable for either
table or panel mounting

Write for complete literature.

AMSCO PRODUCTS, INC.
Broome and Lafayette Sts., New York City

HYGRADE SPECIALS

V.T. Sockets—Federal 85c—Paragon.....	\$0.85
Fada 85c—Signal 75c—Na-Aid.....	.85
Phone Plugs—Federal 69c—Fircro.....	.85
Pacnet 45c—Weston 89c—Cico.....	.45
2 in 1 Variable Grid Control.....	1.75
Bradleystat (new type).....	1.59
Filkostats (new type).....	1.75
Ambassador 3000 Ohm Head Set.....	3.25
Brandes Matched Tone Head Set.....	4.98
Nerco 2200 Ohm Head Sets.....	2.49
Skindervikin Transmitter Buttons.....	.85
General Radio Loud Speaker Units.....	8.95
Morrison Loud Speaker Units.....	8.95
Acme R.F. Transformers Types R2, R3, R4.....	3.98
Audio Frequency Transformers Thordarson.....	3.49
Jefferson No. 41—\$3.49. Paragon.....	4.50
Federal No. 226W—\$4.50. Federal No. 65.....	5.98
No. 164A—Fada Neutrodon Condensers.....	1.10
No. 163A—Fada Neutroformers.....	6.49
No. 165A—Fada Hazeltine Parts.....	21.50
Marko Storage Batteries.....	\$8.75 up
Acme Audio Frequency Transformers.....	3.49
Brandes Loud Speakers.....	8.95
Music Master Loud Speakers.....	24.95
Magnavox R 3 or M 1.....	26.50
General Radio 1 Step Amplifiers.....	7.49

All Orders Must Include Parcel Post Charges

Hygrade Electrical Novelty Co.

41 West 125th Street

New York, N. Y.

—FOR YOUR CONVICIENCE—

QST'S INDEX OF ADVERTISERS IN THIS ISSUE

Acme Apparatus Co., The.....	109	Kellogg Switchboard & Supply Co.....	116
Adams-Morgan Co., The.....	103	Kimley Electric Co.....	104
Alden Mfg. Co., The.....	90-98		
Allen-Bradley Co., The.....	2-128		
American Hard Rubber Co.....	105	Lombardi Radio Mfg. Co.....	100
American Radio Mfg. Co.....	112		
American Radio & Research Corp.....	4th Cover		
American Transformer Co., The.....	82		
Amso Products, Inc.....	126	Magnavox Co., Inc.....	93
A.R.R.L. Application Blank.....	88	Marie Engineering Co.....	118
Ayres Battery Corp.....	90	Mass. Radio & Telegraph School.....	104
		Moon Radio Corp.....	92
		Multiple Electric Products Co., Inc.....	101
Bakelite Corporation.....	111	Murdoek, William J.....	102
Ballard, R. C.....	126	Murphy, F. M. J.....	120
Bechberger & Co., P. F.....	94	Myers Co., Ltd., F. B.....	110
Boonton Rubber Mfg. Co.....	91		
Branston & Co., Chas. A.....	107	National Carbon Co., Inc.....	74-75
Bristol Co., The.....	106	National Elec. Supply Co.....	104
Bunnell & Co., J. H.....	98	Newman-Stern Co., The.....	114
Burgess Battery Co.....	73		
Burton-Rogers Co.....	108		
Buyright Co.....	98		
		O. & T. Electric Corp.....	112
Chelton Elec. Co.....	92	Ott Radio, Inc.....	87
Chicago Salvage Stock Store.....	118		
Connecticut Telephone & Electric Co.....	3rd Cover	Precision Equipment Co., The.....	76
Coto-Coil Company.....	113	Premier Elec. Co.....	104
Crosley Mfg. Co.....	77		
Cunningham, E. T., Inc.....	2nd Cover	QST Bound Vol. VI.....	121
Cutler-Hammer Mfg. Co.....	102		
		Radio Corp. of America.....	1
Dubilier Condenser & Radio Corp.....	115	Radio Instrument & Panel Co.....	126
Durham & Co.....	98	Radio Printers.....	112
		Radio Tube Exchange.....	121
Eiseman Magneto Corp.....	99	Radio Units, Inc.....	120
Eksal Trading Corp.....	94	Rauland Mfg. Co.....	116
Electrad, Inc.....	95	Remler Radio Mfg. Co.....	118
Electric Speciality Co.....	80	Riggs Mfg. Co., The.....	106
Electric Storage Battery Co., The.....	97	Roller-Smith Co.....	100
Endly, C. C.....	114	Rose Radio & Elec. Supplies.....	90
"Experimental Wireless".....	120	Rusonite Products Corp.....	120
Fansteel Products Co., Inc.....	82	Samson Elec. Co.....	110
Federal Tel. & Tel. Co.....	82	Scientific Elec. Works.....	84
Ferbend Electric Co.....	100	Sears, Roebuck & Co.....	121
Fischer Co., G. H.....	110	Second District Convention.....	78
Fleron & Son, Inc., M. M.....	85-118	Shamrock Mfg. Co.....	116
France Mfg. Co., The.....	92	Signal Elec. Mfg. Co.....	90
Freshman Co., Inc., Charles.....	106	Sterling Mfg. Co., The.....	94
Frost, Hebert H.....	94	Stern & Co., Inc.....	114
		Stromberg-Carlson Telephone Mfg. Co.....	89
General Radio Co.....	81	Sure Fire Radio Laboratory.....	119
Goldschmidt Corp., Th.....	103		
Grebe & Co., A. H.....	4	Thordarson Elec. Mfg. Co.....	89
HAM ADS.....	122 to 126	U. S. Tool Co.....	108
H & H Radio Co.....	118		
Hartford Instrument Co., The.....	80	Valley Elec. Co.....	86
Heath Radio & Elec. Mfg. Co.....	96	Vesco Radio Shop.....	119
Hommel Co., Ludwig.....	84		
Hygrade Elec. Novelty Co.....	126		
		Washington Radio Lab.....	114
Illinois Radio Co.....	102	Western Coil & Electrical Co.....	96
Inter-State Signal Co.....	102	Westinghouse Elec. & Mfg. Co.....	117
		Westinghouse Union Battery Co.....	83
Jefferson Elec. Mfg. Co.....	79	Weston Electrical Instrument Co.....	119
Jewell Elect. Instrument Co.....	86	White Mfg. Co., The.....	112
		Whittlesey Eng. Corp.....	119

ALWAYS MENTION QST WHEN WRITING TO ADVERTISERS

Use Graphite Disc Rheostat Says prominent radio expert

RADIO FACTS FOR EVERYBODY; NEWS AND THEORY OF WIRELESS

While Nearly All Standard Tubes Will Give Good Results, Low Vacuum Type Is Best, Says Calcatera.

LOW VACUUM TUBE IS BEST.
All standard tubes, however, will give good results.
BY JOSEPH CALCATERA.
(Radio Engineer)

Another important consideration in getting maximum efficiency from a tube is choice of the tube to use. While practically all the standard tubes now on the market will give good results, there is one tube which gives best results. That tube is the soft or low vacuum tube especially designed for detector use. 1V-000 and C-30 tubes are of this type.

negative lead of the "A" battery, that is between the negative of the "A" battery and one of the filament terminals. While a considerable change in the plate voltage applied in the plate circuit of a hard or amplifier tube when used as a detector will make very little difference in the operation of the tube, the soft detector tube is very responsive to slight changes in plate voltage. The characteristics of different tubes of the same type vary to some extent, so that a fine adjustment must be provided to take care of the individual requirements of the tube.

Usually the best point will vary from 18 volts to 24 volts. The adjustment can be varied to a certain extent by trying the lead from the battery or to the positive end of the plate circuit by all "B" batteries. In most cases, however, a fine adjustment can be made by the use of a potentiometer.

One end of either end may be used as the resistance element of the potentiometer is connected with the other end of the "A" battery and the other end with the negative lead of the "A" battery.

For adjustment of filament temperature, to obtain the best operating point of the tube, a Variable rheostat of the type of the carbon pile rheostat type should be used. Care must be taken to insure the secondary circuit of the transformer should be made to the positive lead of the "A" battery. The rheostat should be placed in the

Good for
ALL tubes



Retail Price **\$1.85**

IN CANADA \$2.50
POSTAGE 10¢ EXTRA

Clipping from
Chicago Daily News
October 24, 1923

What Is Meant by a "Carbon Pile" Rheostat?

MORE than 20 years ago, the Allen-Bradley Co. developed a successful compression rheostat for big power circuits: It was made of flat carbon discs and the electric current flowing through the column was regulated by applying or removing pressure on the discs. The idea of the carbon pile was not new, even then, but successful commercial rheostats were unknown. Graphite discs, however, soon replaced the carbon discs and to this day all Allen-Bradley rheostats are graphite disc rheostats, although many prominent engineers still speak of them as carbon piles.

THE Universal Bradleystat is sometimes called a carbon-pile rheostat. It is, however, a *graphite disc* rheostat. The discs are produced in an electric furnace under the most terrific temperatures known on earth. Carbon discs, carbon powder, metallic powder or other materials have long since been abandoned in favor of the reliable and noiseless *graphite discs*.

Your radio set needs a Universal Bradleystat for long-distance range, loud reception and noiseless control. By all means, avoid substitutes. Insist on the Universal Bradleystat.

The Bradleystat Won First Place in the Radio Broadcast long distance contest. The first prize winner used a Bradleystat and the greatest mileage record was made with a Bradleystat. More Bradleystats were used in this contest than the next four types combined. Bradleystat supremacy has become an actual fact through sheer force of superior performance.

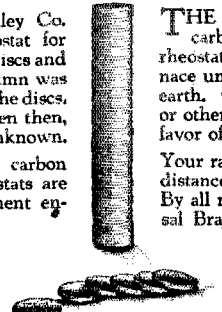

Allen-Bradley Co.
Electric Controlling Apparatus
MILWAUKEE, WISCONSIN

277 Greenfield Ave. Milwaukee, Wis.
AB

Just Mail This Coupon!
Allen-Bradley Co.,
277 Greenfield Ave., Milwaukee, Wis.
Please send me your latest bulletin on the Universal Bradleystat and why it improves radio reception.
Name
Address

CONNECTICUT RADIO

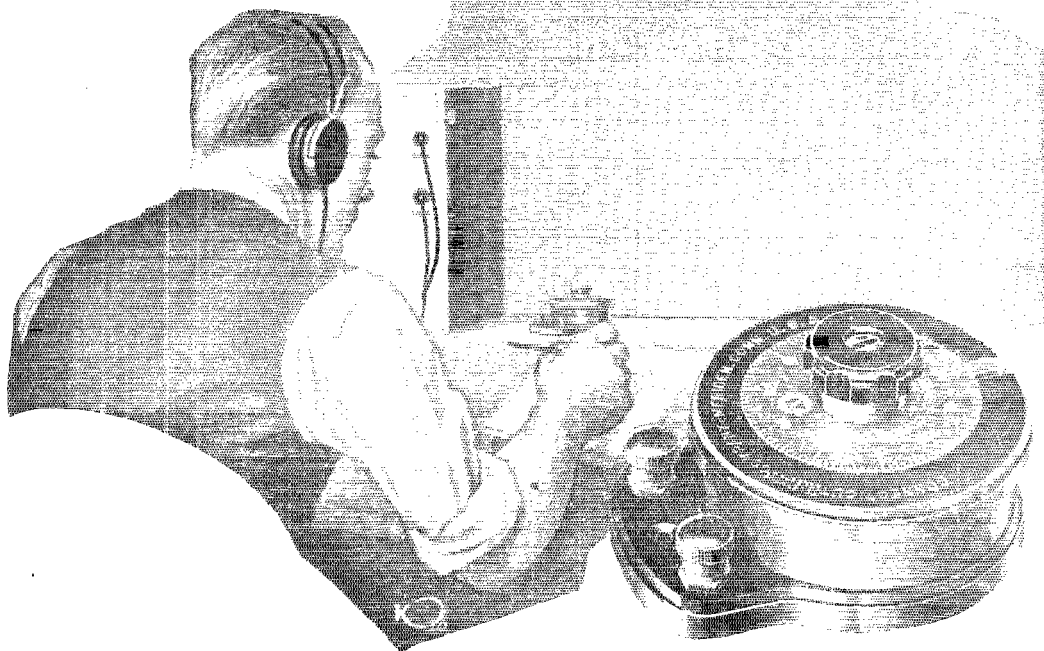

You Can Get Signals From Stations You've Been Missing

"Effective Resistance" has been reduced almost to the vanishing point in the Connecticut Variable Condenser. That means to you a stronger signal—therefore an increased range. You can therefore get signals from stations you've been missing. The scale is graduated over 360 degrees (twice that of the rotary), which means clearer readings throughout, with the special advantage of securing readings at both the low and high extremes of the scale.

These two cardinal advantages enable the average operator to secure results hitherto possible only for the expert.

A simple booklet explains and illustrates this Variable Condenser thoroughly—send a postal for your copy.

Mention your Dealer's Name

CONNECTICUT TELEPHONE & ELECTRIC COMPANY

AMRAD

The Recognized Symbol of Superior Performance

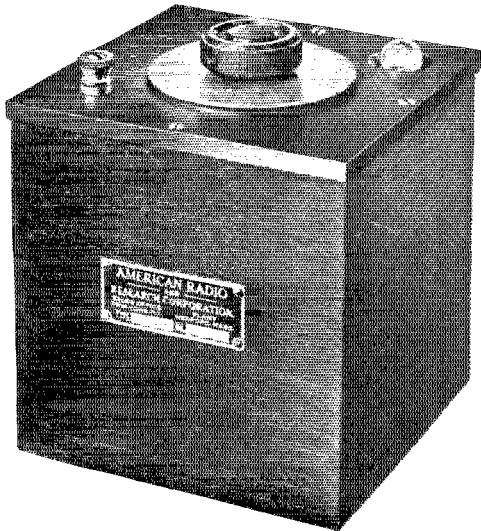

“Either Buy, Beg, Borrow Or Steal It---”

This is what the Senior Operator on the S.S. Manitou, WFW and 9LM Chicago, had to say about the Amrad Wavemeter in a communication to the editor of QST on page 47 of the September issue.

And hundreds of other operators feel the same way.

The Amrad Wavemeter is direct reading—a feature insuring simplicity of operation. There are no scales, curves or charts to consult; no calculations to make. Simply turn the knob and read the actual wavelength in meters directly from the scale.

The Amrad Wavemeter is exceptionally accurate—guaranteed within 2% on any reading. Heretofore, the comparatively high cost of an accurate wavemeter has limited its use to a fortunate few. In consequence many amateur stations have been operating on illegal wavelength, i.e. in excess of the 200 meter maximum set by the law. With the enforcement of the Federal law, wavelength must no longer be a matter of guesswork. The necessity of a reliable, accurate wavemeter as an essential part of every transmitting equipment is now acknowledged by leading amateurs, wireless clubs and radio inspectors everywhere.

The price of the Amrad Wavemeter is \$8.50

Most live dealers carry the Amrad Wavemeter in stock.
Complete operating directions accompany each instrument.

AMERICAN RADIO AND RESEARCH CORPORATION

13 Park Row
New York

Address all Communications to New York Office.

Factory and Laboratory
Medford Hillside, Mass.

The Traffic Department

F. H. Schnell, Traffic Manager
1045 Main St., Hartford, Conn.

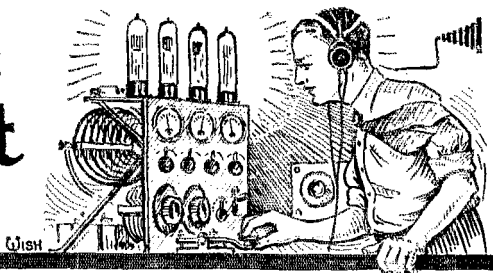

Now that the Transatlantic Tests are almost over, we might be able to get back to our regular duties and tend to the affairs of the Traffic Department.

The new Official Relay Station Certificates have been distributed and the division managers are issuing them as fast as they can. To be an owner of an O.R.S. there are a few requirements which may be of interest. The primary one is that you be a member of the A.R.R.L. It costs only two dollars per year and in addition you receive twelve numbers of *QST*, the League's Official Organ. The wave-length of your transmitter shall comply with the law; you shall observe quiet hours; your station shall be operated in accordance with the law of your country and you shall lend your best efforts toward promoting interest in amateur radio. For violation of some of the requirements, certificates will be cancelled. Further details accompany the application which you can get from your D.M., A.D.M. or D.S.

Reports for the past month show that the many stations are as active as ever at this time of the year. There is nothing new or startling in any division—just the usual showing of good work holds forth, therefore, the division reports follow.

Cancellations and Corrections in and Additions to Traffic Department Directory Printed in October, 1923, and January, 1924, Issues of QST

Cancellations

WISCONSIN—A.D.M., B. A. Ott, c/o Segelke & Kohlaus Co., La Crosse. Dist. No. 1: D.S.—C. N. Crapo, 1175 2nd St., Milwaukee.
ILLINOIS—Dist. No. 4: O.R.S.—9BIL.
OHIO—Dist. No. 5: O.R.S.—8AJX. Dist. No. 6: O.R.S.—8ABE.
SO. INDIANA—Dist. No. 3: C.M. RICHMOND—M. E. Drury, 317-20th St. O.R.S.—9PD, 9AMO. Dist. No. 5: D.S.—C. J. Butler, Crothersville. O.R.S.—9DYU, 9ALP, 9DIS, 9BRK.
KANSAS—A.D.M.—L. J. Simms, 218 S. Sedgwick St. Wichita. Dist. No. 1: O.R.S.—9BFN. Dist. No. 2: O.R.S.—9CWC.
MAINE—Dist. No. 1: O.R.S.—1CTP. Dist. No. 4: O.R.S.—1BZS.
WEST VIRGINIA—Dist. No. 5: O.R.S.—8ABQ, 8BAG. D.S.—G. L. Rhoads, St. Albans.
LOUISIANA—Dist. No. 2: O.R.S.—5ABA, 5ZAC.
GEORGIA—A.D.M.—G. L. Hight, Rome.
FLORIDA—Dist. No. 1: O.R.S.—4SD. Dist. No. 2: Counties—Delete Northwestern half of DeSoto county. D.S.—M. Hall, St. Petersburg, Fla. Dist.

No. 3: Counties—Delete Southwestern half of DeSoto, and Northern half of Lee counties. Dist. No. 4: Counties—Delete Southern half of Lee County.

Corrections

NEW JERSEY—Dist. No. 8: C.M. CAMDEN—O. W. Lummis, address changed to 450 Benson St.
NO. INDIANA—Dist. No. 2: C.M. SO. BEND. F. O. Libbe, address changed to 1014 N. Adams St.
ILLINOIS—O.R.S.—9VM, of Canton, was cancelled in December issue in error.
SO. INDIANA—Dist. No. 3: D.S.—C. J. Butler, Crothersville. O.R.S.—9DYU, 9ALP, 9ARR, 9DIS, 9BRK. Dist. No. 5: C.M. RICHMOND—M. E. Drury, 317-20th St. O.R.S.—9PD, 9AMO.
COLORADO—A.D.M.—P. M. Segal, 604 Interstate Trust Bldg.
FLORIDA—Dist. No. 2: Counties: add DeSoto, Hardee, Pinellas, Sarasota and Highlands. Dist. No. 3: Counties: add Charlotte and Glades. Dist. No. 4: Counties: add-Lee.

Additions

WISCONSIN—A.D.M.—C. N. Crapo, 1175-2nd St. Milwaukee. Dist. No. 1: D.S.—M. H. Doll, 602-64th Ave. West Allis. (Milwaukee Co.)
ILLINOIS—Dist. No. 1: O.R.S.—9AWK. Dist. No. 2: O.R.S.—9AHO. Dist. No. 3: O.R.S.—9ATT.
OHIO—Dist. No. 2: O.R.S.—8WG, 8AAJ, 8DDQ.
NO. INDIANA—Dist. No. 1: O.R.S.—9AZX, 9UB. Dist. No. 4: D.S.—Hood Brothers, 1844-34th St. Indianapolis.
MINNESOTA—Dist. No. 2: O.R.S.—9ANJ, 9CPO. Dist. No. 3: O.R.S.—9BIS.
ARKANSAS—Dist. No. 1: O.R.S.—5ADW. LOUISIANA Dist. No. 2: 5AIA, 5ABA.
MISSISSIPPI—Dist. No. 2: O.R.S.—5AGV.
KANSAS—A.D.M.—Chif. Peters, Tonganoxie, Kans.
RHODE ISLAND—Dist. No. 1: O.R.S.—1OJ.
MASSACHUSETTS—Dist. No. 1: O.R.S.—1AQL, 1KA. Dist. No. 2: C.M. ATTLEBORO—E. G. Holbrook, 58 Pearl St. O.R.S.—1AJA, 1VV, 1COC, 1EG.
CONNECTICUT—Dist. No. 2: O.R.S.—1CPV. Dist. No. 3: C.M. HARTFORD—E. F. Fenn, 699 Farmington Ave. O.R.S.—1ANB. Dist. No. 3: D.S.—J. Fitzgerald, 145 Rockwell St. Norwich. (New London County.)
MAINE—Dist. No. 2: O.R.S.—1BNL, 1APP.
NEW HAMPSHIRE—Dist. No. 1: O.R.S.—1VB. Dist. No. 2: O.R.S.—1AZT. Dist. No. 5: O.R.S.—1BTF.
CALIFORNIA—Dist. No. 4: D.S.—C. C. Whysall, Los Gatos. Dist. No. 7: D.S.—W. Austin, Woodland, Calif.
NORTH CAROLINA—Dist. No. 3: O.R.S.—4JR, 4SF. Dist. No. 4: O.R.S.—4AB.
VIRGINIA—Dist. No. 4: O.R.S.—4RU.
WEST VIRGINIA—Dist. No. 1: O.R.S.—8WZ. Dist. No. 5: D.S.—Melven T. Spence, 303 Reynolds St., Charleston.
GEORGIA—A.D.M. C. B. Transou, 309 Greenwood Ave., Atlanta.
FLORIDA—Dist. No. 2: D.S.—W. D. Moore, 339 Plant Ave., Tampa. O.R.S.—4IU.
ALABAMA—Dist. No. 1: O.R.S.—5AMH, 5ZAS, 5MI. Dist. No. 2: C.M. MONTGOMERY—Gordon Vickers, Montgomery, Ala. Dist. No. 3: O.R.S.—5AGD.

Personnel for S.C. not complete as yet.

ATLANTIC DIVISION
Chas. H. Stewart, Mgr.

Brooklyn stations come thru with quite heavy traffic reports this month. 2BRH, with 165 messages was the leader. Most active stations were 2GNY, 2CJR, 2BO, 2BRW, 2FP, 2ATZ, and 2BEG, all of which are O.R.S. East Bronx was represented by 2CTR, 2CYX, 2FZ, 2SM, 2CBI, 2BEN, 2CRQ, 2CUC, 2CWR, and 2BBX. Northern Manhattan reports came from 2BNL, 2CHK, 2XNA, 2KR, and 2DL while Richmond Boro was represented by 2CAJ, 2CZQ, 2TS, and 2AMO. 2BJO reports 60 messages. 2BXW-43, 2BQH-3, 2AVJ-15, 2AWS-4, and 2CLE-40. All of the above stations are reliable traffic stations and will handle traffic thru their stations with the least possible delay.

With F. B. Ostman off the job, since he is away from his station very often, it may be necessary to make a new appointment to fill the job. Reports for several months have been very slim and we want more activity reported in this section.

DISTRICT OF COLUMBIA—The active stations handling traffic for the month were 3AB, 3ALN, 3BWT, 3HS, and 3PZ. 3AB is QSO 7ABR quite often. 3SU was inactive during the month. 3LR and 3ZW are reported back on the air very soon. We welcome them.

DELAWARE—3AFB is off the air and 3BSS doesn't seem to reach out. Amateur activity is at a stand-still. 3AUN threatens to open up with four 50s, which may help traffic to some extent.

MARYLAND—There was much increase in station activity. 3AJD and 3TE are reaching out FB along with 3RUC. 3WF has a new 100-watt set which is getting out, too. 3APT promises to open up with 150 watts shortly and 3PH and 3LG are installing 100-watters. 3PK, with 100 watts also reaches out good. 3DQ, 3CHV, 3AOK, and 3CD are 10-watt outfits getting out FB. 3RCK, our "YL" has a schedule with 100P. 3FB is owned by 3BTP and 3PE. 3CTW uses four 5-watters. 3MF came back on the job last month. 3APV is improving on his DX. 3BUR keeps the messages moving down his way. 3BMO is increasing his power. 3SF and 3HG are doing good work.

PENNSYLVANIA—3BTL has heard 6BDT of Hawaii. 3ZM is hooking up a 250. 3BNU reaches England FB. 3YO has erected new steel towers and looks for better DX. 3DHV was formerly 3ALU. 3BAQ is trying to boost his power. 3ATA is using a "refilled" 50-watter. 3BIQ works all districts but 6 and 7. 3COC gets out good with 5 watts. 3AUV continues to push traffic thru during his spare time. 3ZO is still as reliable as ever. Philadelphia is very inactive as reports came from only 3HD, 3KD, 3FS, and 3AWA.

This is about the smallest report ever turned in from the Atlantic Division and some whole sections are missing. What's the dope, gang? We want activity reports and we want them on time. Let's have them next month and put some pep into them P.D.Q.—T.M.

CENTRAL DIVISION
R. H. G. Mathews, Mgr.

It would be a distinct step forward if all our O.R.S. were to make an effort to secure messages relating to business or personal affairs from their friends. In order to make this worth anything we must give real service on the delivery of such messages.

WISCONSIN—Dist. No. 1: 9CVI is maintaining a schedule Tuesdays, Thursdays, and Saturdays from 5 to 7 A.M. 9ELY is doing good work with one 50-watter. He has been heard in San Diego, Cuba and works sixes and sevens regularly. 9DTK is rebuilding his station. 9OT is installing his set in a new location. 9AAP is putting in phone for short distance work. 9AFZ is rebuilding his station to use S tubes for D.C. supply. 9DEM turns in a great total with his C.W.

Dist. No. 2: 9CCF continues to head the list

but is being crowded by 9EAR. 9DZV is using 50 watts and getting out fine. 9EGH and 9DKS will be on shortly with 50 watts each. 9DVD the old spark hound, has at last changed over to C.W. (WOW, the sparks are going fast—it won't be long now.) 9EAR reports traffic on the increase. 9CWZ is SOL. A sheet storm took away both of his antennae and he burnt out a tube. 9AZA has been rebuilt to accommodate four bottles.

Dist. No. 3: 9CJI is on with more power. 9ASB is on with 10 watts. 9BCH quit to get married, he says for good, bunch say "hi!" 9CGR is a new 5 watter at Oshkosh. 9EMD will be going soon. 9BYJ is now using C.W. The established routes are again in operation in Wisconsin. Message delivery is excellent.

Dist. No. 4: 9ELL is again the star performer. His power has been increased to 200 watts. 9ALI has been doing phenomenal work on 10 watts with 500 volts M.G. 9AOK is doing fine work on 5 watts, working over 1000 miles consistently, with 0.9 ampere in the antenna. 9DST with 15 watts is also doing good DX. 9ZY has not been working regularly the past month. 9BKC was reported QSA in all districts when he raised the plate voltages of his 20-watt set to 1000. 9AZN is experimenting with various hookups to find one that will be satisfactory.

NORTHERN INDIANA—Dist. No. 2: 9MM reports fine DX with both C.W. and fone. 9DYT, using 5 watts, handled 90 messages but says there doesn't seem to be much traffic down his way any more. 9DVK blew his 50-watt tube and is off until he gets another. 9DEJ using 14KW spark reports quite a bit of trouble in raising stations. He is going to put in C.W. after a while. 9CP handled four messages on spark. He has a new 250-watt bottle, and is going to get a sine rectifier. 9CTE is doing good work with his 250 watts. 9CNO is getting out in good shape despite some tube trouble. 9FP is doing good work on both I.C.W. and C.W. 9BBI has a good 50-watt set. 9EFF, says he is getting 3 amps on 10 watts with a sine rectifier. 9AKD gets out in fine shape. 9AKD reports all districts coming through in fine shape. 9YB worked 63 stations in 31 states and 7 districts but very little traffic forthcoming. Prof. Achatz is out gumshoeing for originating messages and has held a meeting of his local ops to that end.

SOUTHERN INDIANA—Dist. No. 3: Only one report received—from 9BRK. 9CIC has finally junked the old mill and is poking out 10 watts.

Dist. No. 4: 9UR, 9BJR and 9PF are the only stations reporting in this district.

ILLINOIS—Dist. No. 1: 9DAY reports 37 states and all districts on 10 watts. 9AWU's antenna came down due to the efforts of a woodpecker at the top of the mast. 9VM is now working both coasts on schedule. 9ARB has moved to Calif.

Dist. No. 2: 9BJT reports the 250 not perking yet. 9DXL reports messages scarce. 9AIC is on early mornings and places his traffic where it belongs. 9GI please communicate with the D.S. Things are slow at 9WX. 9AHQ has been appointed O.B.S. 9CTF is drilling through. 9AMK has junked spark, but is on with 500 cycle I.C.W. working both coasts. 9CA rises to inquire what is the specific benefit to amateur radio to junk spark for high power I.C.W. See if 2BK's I.C.W. doesn't cause more QRM in Illinois than 9CA's spark, he'll eat the spk and use the I.C.W. for dessert. Not much activity from 9AJH but the MO ckt kicks west in fine shape. 9ARM has changed to C.W. 9BRX is using fone I.C.W. and str. C.W. and getting west in good shape. 9BUC is working sixes but sex messages are hard to get. 9BTA will be 100 watts soon. 9DRU and 9DRJ are inactive. 9CCM is back on the air with 20 watts. 9CCN is on with a new chemical rectifier which sounds fine. Another Drolet has taken the key at 9CXE. Two boys are now away at school. (Any more in the family to fill in at the key?) 9DDY is a Public Service Salesman and operating at 9CA in his spare time. 9DYN brothers have a Grebe 13 also a new transmitter to work foreign stations. 9EBN is C.W. with school. 9CA is reaching out with a C.W. (BUT he still keeps the spark.) A new chemical rectifier and a Grebe

13 have been added. 2AHO doing FB with his C.W.

Dist. No. 3: Gain. of all C.W. districts, is leading the district with a 500-watt set RAC 500 cycle, and M.G. power supply are all available. (The 500-cycle is consistent in audibility at 9A1H--A.D.M.) 9BYX is now QSO with 7ABB. 9CMN is using 10 watts now. 9DJG is expecting to add more power. The district bats 101 msgs per station.

Dist. No. 4: 9DKH is installing a new 500 watt transformer. 9DHz (ole spk hound) has a 50-watter which he says works DX fine business. 9BHX and the D.S., 9DQU, visited all Chambana stations as guests of the C.M., 9DCR. 9DCR is working but manages to sit in with 15 watts which worked both coasts on December 11th. 9AP is coming back to the game. 9BGC, with 10 watts, is getting thru to the west coast which helped boost the message total. 9BPW's liver is pushing out all over the country and handling lots of traffic. 9CLJ's two fivers, doing work of fifties, went west recently. 9DQU has achieved his heart's desire-- reported from Liverpool. 9BHX has his 50-watter now with better DX. The Radio Inspector made a visit to Decatur and as a result the following obtained 1st grade amateur licenses, 9DQU, 9BLQ, 9C1J, 9BHX.

Dist. No. 5: 9DZG is the only transmitter in E. St. Louis in commission as 9AMS blew his rectifier.

Dist. No. 6: 9AKU is on the air but has a balky low wave receiver. 9CDB is a new station at Lena. He gets 4.1 amp out of one liver, and is working California. 9EBH has recently started up so his msg. total is lean.

Dist. No. 7: Only two reports this month. 9AA and 9LZ. There is less QRM as stations are beginning to scatter over 15-220 band. 9LZ has been rebuilding with four fifties now lighting up the shack.

MICHIGAN--Dist. No. 2: 9CPD is putting in a new M.G. to supply plates of 2 UV203's with filters. 9CZZ is working out great with 1 UV203. 9CPY had that \$30.00 feeling last Nov and had to move to new location, but is QRV again with a new 100-foot pole, with two 203s. 9ZAG is closed down. Kalamazoo seems to be the only city in this district with consistent operating stations. 9DCY is filling the air with lots of QRM above lawful wave. They are on 208 meters and 215 meters most time. Have been warned but they still persist. (Better watch your step!) 9CGN just started up again with 2 203s and a pure D.C. 9ACO is heard occasionally with his pure C.W. (FB) Traffic seems to be mostly coming from south going west; or vice-versa. Very little eastern traffic.

OHIO--9CCI has S tubes now on his 10 watter and has been QSO Denver, Colo., to east coast and most his traffic was handled after getting RAC. 9ER has been on very little as he is trying to get that 250 watter going, the joke with him is he hooked up a single 5 watter and worked a six, which he has not done with the 250 with high radiation. 9GD is on very little on account burning out 5 watt tubes. 9BCF's QRM is school. 9AA works west coast nightly every night, and has handled WNP messages thru Can. 9GO and 7ABB for 1AW. 9AVN on very little on account of shortage of tubes; same with 9AGP, who has a long string hanging on the wall "all gone west." (Volt meters are cheaper, boys.) 9CMU is putting in 10 watts of I.C.W. and fone. 9CIE is on very seldom. 9FU is working everything with his 250-watter and leads the district. 9CQS heard by 7LR on 5 watts. He is getting 10 watts. 9BJL has 10 watts with 12 oprs. They are QRV at all hours.

Dist. No. 2: Traffic moving about same as last month with 81J taking the lead, 9RXX, on from 17th, worked 4 Pacific coast stations first night, same second night and on morning at daylight worked WNP. (Good work, OM) 9YAE is 8WE also. 9AAJ recently blew 3 five watters and is now on with 5 watts.

Dist. No. 3: 9CYT has schedule with 9IW, 9ATZ and 81J usually get west bound messages, have worked 6Bl on 5 watts and are waiting for a 50 watt tube. 9WY with 50 watts worked 6PL and was heard in N.Z. He has a new Grebe instead of 9Yac so he can hear more of the boys

(hi.) 9ASV off on account trying out different tuners. (Try the one Hassel describes in QST. OM. They are FB.) 9ADA working all districts on 180 and 195 meters, started 18 and delivered 3, and says all msgs handled are real ones. 9KG, the man that put M in modulation, has been heard on fone in England on 10 watts. Also heard 3 times on 20 watts and now putting on 100. We would like to hear from 9BFQ. 9ANL, formerly an op at 8ZY is with us now with two 5 watters and doing good work.

Dist. No. 4: 9ANB is also 9ZAB. 9AIB FB on 50 watts. 9CWR putting in 50 watts now in place of 5 watts. 9CNR temporarily closed on account putting up new masts. 9AHY has come to life again, been having trouble with rectifiers so is putting in MG now. 9ZC, Humes, Springfield, is using 50 watts A.C. with call 9CKV. Ex-9AMJ held up for new license. 9DC can't get the generator to live to his call DC so is putting in rectifiers. HI. 9FT still in Calif. with call 6MT using 100 watts. He will be back to 9FT in spring.

Dist. No. 5: The high total of Ohio is 9GZ with 633 using 100 watts. He has a schedule with Can. 9CN H. C., etc. Works west coast every night and says when you think of Cols. O (think of 9GZ, (HI) 9PL, ex-9CZ, has 100 watts and is adding another 50 to it. Another 9GZ then. (HI) 9BEK has put up a 70 ft. tower and expects a 50 watter. (Good luck, OM.) 9BRH building new set and will be QRV soon. 9BYN is QRMing sixth dist. with 50 watts and has a nice total. 9ZY on the job a little, both spark and C.W. poking out as usual.

Dist. No. 6: 9ABE is out of commission as op is in Florida working 4PY. 9AL and 9CRC, old reliables, as usual send in a nice report. 9AL worked 7ABB for DX this month, with 20 watts and is all set with Grebe 13 and CRK.

DAKOTA DIVISION N. H. Jensen, Mgr.

The outstanding feature of this month's report is that 9ZT worked French 9AB. This was accomplished with the assistance of 1MO who did the listening for 9ZT. 9EAB was able to copy 9ZT direct. Another feature is the consistent contact between 9DKB and WNP. Two more stations in this division have succeeded in working WNP during the month, 9DOE and 9CO.

MINNESOTA--Dist. No. 1: 9DOE handled the greatest amount of traffic and he is on every night after 12. 9CO is also doing fine work, and has entered the WNP relay class with 9DDE. Other stations doing good work are: 9ZG, 9ABB, 9BAV, 9BAF, 9EAU and 9CDV. The latter station forgot (?) to report this month. 9ZC calls on spark and works with C.W. This is the station to relay through if you have anything going into Canada. The D.S. has moved to 1014-11th Ave., E. Duluth.

Dist. No. 2: Traffic is comparatively light. 9DEH has been blowing fivers and has just come on the air again. 9BNE is trying to raise \$2.00 (HI) and is doing fine work with a 5-watt tube-- both coasts. 9BVS and the rest of the Redwood Falls stations report nothing doing as yet, but they are still interested or would not report. 9DDP and 9EGG are both very active. 9DSW holds the record for moving a complete station in 50 hours total, including the moving of a 60-foot stick 9DQM sold his 100-watt outfit to the Army at Fairmont, but hopes to get another. 9DCH is the only Waseca station reporting, although Waseca is active this year for the first time. 9CAL has moved to Blue Earth and has no station as yet. 9AXS with a Ford coil I.C.W. has just come on the air, and is working into the 7th district. 9LW is a new one and puts Ortonville on the map. 9DVR was on 10 days during the month. With 50 watts so far he has worked 22 states and both coasts every night. The 105-foot pole does it. An effort is being made to thoroughly organize the Southern Minnesota Radio Assn.

Dist. No. 3: The first high wind of the winter season took down 9DPX's 70-foot mast and a couple of others in Minneapolis. 9DPY is troubled with poor location and is thinking of more power as a solution of his difficulties. 9BFI takes highest

honors in Minneapolis with 311. 9DHQ has put in a 50-watter. 9ZR has been heard in France and England, and has worked WNP. 9BLY is back on the air again handling a good share of the traffic. 9CTO had better get down off his wave on top of the bunch or someone is liable to sit on him. The St. Paul bunch are still pounding away off fives and fifties.

NORTH DAKOTA—Dist. No. 1: Our California weather has had a serious effect of the message total this month. The A.D.M. has moved his station, 9AEJ, from Fargo to Devils Lake and expects to be among us again in a few days. One of our best operators, 9BAN has found it necessary to dismantle his station and dispose of the apparatus. We regret the loss of his able assistance very much, as he did his share in handling traffic. 9EBT has been experiencing some hard luck by having the last of his 5 watters go west and as a result has been off the air during the month. 9ADZ has his 10 watters in operation so we look for old time results this month from him. 9DLI got his station going the 15th after an absence from the air for two months. 9AMP is rapidly developing into a real ham and will probably be holding his own with the old timers before spring.

Dist. No. 2: 9DKB has blown his third fifty and is now using two five watters with 1500 volts. His message total includes 6 messages from WNP and 9 to him. 9AFM is doing wonderful work with his 5-watter but doesn't have much time to handle traffic as he has to attend school. He is also putting high voltage on his 5 watt tube. 9DUM and 9DGV are working on their stations and will soon be on the air. Expect report from 9ACK next month. DesLacs will soon have a station on the air with self-rectified or spark coil C.W.

SOUTH DAKOTA—Dist. No. 1: 9RG is apparently doing the best work in this district. Hobart Gates and Herbert Lee are the operators at this station. 9BOF is QSO both coasts now, using 50 watts CR-AC. 9DKQ is doing good work, 9CKT, using a 5-watt tube was reported QSA by 9XAD. 9BCG is building a shack and expects to have it completed by the time of the South Dakota convention. 9AQE is on the air quite often.

Dist. No. 2: The following stations have been on more or less the past months: 9CJS, 9DWN, 9BRI, 9AVZ, 9CGA, 9AYL, 9PI and 9TL. 9CJS is high in traffic handled and 9AVZ is first in DX worked, the latter having worked WNP. 9BRI puts the QTC through to Pacific coast easily, so QSR thru him.

DELTA DIVISION

W. W. Rodgers, Mgr.

The falling off of the number of rubber-stamp messages has sent our traffic figures to new low levels. It seems that we are too anxious to shake off the old before we have taken on the new. Outside of nothing doing, everything else is OK.

TENNESSEE—No D.S. reported this month. (What in thunder is wrong, gang?—D.M.) C.M. Welford of Memphis brought his report to Headquarters. (Many tnx—D.M.) In Memphis a bunch of fellows are on the air and we are mighty glad to have them too. Sure looks good. 5KA is one of them and works 500 miles easily on 15 watts. 5SY, another new fellow, is getting out well on 50 watts, but reports no traffic. 5NT is stirring up things with a fifty. 5VT, with 10 watts, hasn't reported but he is doing things. 5NV is back!! He has 5 watts on a one wire antenna and CP; gets all over the map on it. (Guess he tired of the YLs—C.M.) The same old crew is here with us again. 5EK is the most consistent. His phone is the bane of the Memphis phone phoofs. 5MO is on occasionally with 200 watts, but doesn't get much traffic. 5NZ is on with 100 watts. 5AELJ struts his stuff with 5 watts. 5PF and 5PV are hot on the traffic trail. 5ZB's traffic was confined to the official League broadcasts and a few other long ones. 5KA says he knows of a guy with a 500-watt Navy outfit who thinks it is about a 5-watter. (Hope you make it OM—D.M.) No record of what is going on outside of Memphis due to lack of reports.

LOUISIANA—Dist. No. 2: C.M. Freitag of New

Orleans reported directly to national headquarters in an effort to insure his report reaching the proper parties before the time was up. 5ABH broke through QRN enough to handle 67 messages. 5UK got away with 73 messages. 5RH is confined to his bed, but manages to get on the air occasionally. 5TVA, 5AU, 5AA and 5GI are all active stations in New Orleans. 5LH, a new one, has opened up with 10 watts, and is doing good DX, in spite of a punk antenna. 5YW is on the air with 100 watts with good results. 5ZAC is now 5BZ with 50 watts. 5ABC is troubled with power and school QRM. 5AAT cut from 20 to 15 watts with the same results, getting a nice bunch of traffic. 5KC is still getting into the 6th district with 4 real amperes. 5KC handled 70 messages. 5AAT handled 73, and 5YW handled 67.

ARKANSAS—The A.D.M. reports nothing doing. No report received from D.S. Daly or C.M. Schmitz of Ft. Smith. 5XAC reports his station on the air but nothing else. 5XAB and 5DQ are getting out well, but handled no traffic. A new station is on the air but has not fully developed as yet.

MISSISSIPPI—Dist. No. 2: D.S. Henriques & Janin reported directly to headquarters and gave a nice report this month. 5KB is getting out to the west coast consistently and handled considerable traffic. He was high man this month. 5AFV, a new one in Gulfport, has 5 watts with 200 volts B battery. (Welcome, OM!—D.S.) 5AGV has started, but all we have had from him was a Christmas card. (Tnx, OM—D.M.)

Dist. No. 1: 5AIB is the only active one here. He has handled a tidy sum of messages this month. 5AIE gets out well and we are glad to have him with us. 5YE managed to knock off a few this month.

EAST GULF DIVISION

H. L. Reid, Mgr.

FLORIDA—December was the best month in the history of the state. Several men from other states have taken up permanent residence in Florida and have good stations in operation.

Dist. No. 1: Jacksonville heads the list, with 5 bona-fide traffic stations: 4FS, 4IU, 4HZ, 4ER and 4PK, and they have handled 65% of the entire state. This is due largely to 4FS, who handled 220. His 50 watts have been doubled and he promised still better work next month. 4PK has started up again with a 100-watter and handled 15 messages in a few days, then had the misfortune of having his transmitter stolen. He will be back on the air with new equipment very shortly. 4HZ handled 42 in four days. 4IU and 4ER maintain daylight schedule daily with St. Augustine and other points, and much traffic is handled in this way. 4IU has been appointed an O.R.S. 4EZ is starting up again and promises a good report next month. 4PI and 4SB are making a reputation for consistency. Their DX is FB, but they handled their traffic in short jumps, maintaining daylight schedules with Jacksonville stations. 4SD found time between college work and publicity duties to handle 37. 4MS reports his gang will be QRV with small C.W. sets soon.

Dist. No. 2: 4IZ is back on the job after a period of absence he has been appointed D.S. to succeed 4JY who resigned. 4OB is doing splendid work through schedules with Florida stations. He has just been appointed C.M. of Tampa. 4PB is a new 100-watt station and he has made a splendid start with 30 msqs. 4XJ, 4JZ and 4BL are also doing good work. 4JZ is QSO with Cuban SGT. 4II has just returned from college and will be with us nine months. He is starting up immediately. 4JI is installing 50 watts.

Dist. No. 3: 4DL is the only active station in this district. He does fine DX and is arranging schedules in order to boost his traffic.

Dist. No. 4: Three good stations are now in operation in this district with 4HN, ex-2HYC, using 100 watts, and reaching out in fine shape. 4PY, ex-8ABE, is a 50-watter just started, and worked first and fifth districts. He will soon have two ops. 4DP is doing real work now. He has been appointed D.S., succeeding 4BS.

SOUTH CAROLINA—4DX started his DX by

working a six the first thing. (FB) 4KE is getting on the air with 10 watts radiating 1.8 T.C. amps. (Pise QSL his sigs.)

ALABAMA—No report from McIlvaine this month. (Whataamatter, OM?)

PORTO RICO—A letter from 410 states that the fellows will be on in his territory soon and hopes to work the states real soon.

GEORGIA—Due to the resignation of the A.D.M. no report has been received this month. C. B. Transou, 4QF, has been appointed to succeed G. L. Hight as A.D.M., and it is the earnest desire of the D.M. that all the hams in Georgia get together and help put this state on the map. Mr. Brach at Midville has also been appointed D.S. of Dist. No. 2. All stations south of Atlanta please report to Mr. Brach. Due to heavy work or arranging the convention the Atlanta gang have been busy and consequently traffic fell off considerably.

MIDWEST DIVISION G. S. Turner, Mgr.

STOP!! LOOK!!! I've a pretty good lil' ole report this month. It could be better, but even at that it is interesting in parts. If you don't believe it look at what I've got to tell you about this month.

IOWA—Found: an OW op.

MISSOURI—A true story entitled "Saved".

KANSAS—A new A.D.M.

NEBRASKA—"Something missing somewhere."

IOWA—A.D.M. sez gang is going stronger this month. D.S. Decker logged FBAB and this on the first night in spite of QRM. He used a Tuska variometer set and only one tube. (FB) He reports a higher message total for December. 9CLQ still banging away on 100 watts. 9BRS is rebuilding into a 100-watter. He is going to use self-rectification. 9ACH, 9DAI and 9DIP, all 10-watt stations, are doing excellent work. 9AYE still rings the bell with his 5. Other Des Moines stations are in the running. 9BIF has his 20-watt working FB. He has reached 25 states in three weeks. 9AOU, 9DXU, 9BGI, and 9AHH are ready for traffic. (Crowd around, gang.) Here is the news I mentioned in my subject: This news is very confidential and don't any of you dare tell 9AOU's sister that I am telling you this. Shhhh! There is an OW op at 9AOU now! Somebody get her picture, quick. An OW in the Midwest is so unusual that we would like to show the rest of the gang what we have down here. (Eb, gang?) 9ARZ arrived home from college and blew his 50-watt first thing. That is the reason he was not on during the holidays. D.S. of Dist. No. 2 has been serving on the jury and his report is necessarily brief. 9AXD was married a short time ago. It is reported the 50-watter is taking a rest. 9HK is now using 100 watts—he blew a 50. 9CHN handled gobs of traffic and worked both coasts with 19 watts. 9BGT, 9CGY, 9AEL and 9DYL are active and keeping their town on the map. Listen, gang, the following counties are now in district No. 1: Worth, Cerrogordo, Franklin and Hardin. Please note. The total traffic handled during December was 1408 messages of the non-stamped variety.

MISSOURI—The D.S. of West Missouri has taken a new lease on life and reports progress in his portion of the state. He has mailed out a number of circular letters to the fellows and the replies are promising. It is reported that in Joplin traffic has fallen off due to QST cutting out the publication of traffic reports. 9CRM is active. 9CUA has rebuilt his set and is working in combination with 9CID. 9DAE reported 38 messages on spark. He has a 7:00 A.M. schedule with 9AYL. 9DZO is now using a cage, 10 watts with S tubes, and has an auxiliary 1/2 KW spark. 9DUX and 9CYK have revamped 9OKS's transmitter and are operating it during Martin's absence while he is attending school in the east. Their station is only using 5 watts and has worked 8AE in daylight. 9CRR is on with a new 50 and expects to add 50 more soon. He is an early morning op. 9BWV reports good fone and C.W. DX on 20 watts. There is a good report from St. Joe, although due to the failure of some

to send in their reports and also to the inactivity of 9EX and 9DLT it is not as complete as usual. 9ANO is using spark in place of his tube set due to the fact that his last tube is now, only a "has been." 9DLT says he expects to install a 250-watter in the near future. Further inter, eating news is that he was not seriously injured when he got mixed up with 1000 volts D.C. In St. Louis activity has increased and many additional stations are reporting. 9EKY worked 6CEU and was reported QSA. (FB, OM.) Another mark for K.C. to shoot at. Hi. (Go to it men!) 9BLG is rebuilding his antenna and intends to go 9EKY one better. 9AAU has completely re-arranged his shack and added a new counterpoise to replace the one he had placed directly on the earth. The old one worked FB until it became grounded. He reports traffic and DX FB on 6.5 amps. using the W.E. tubes. On his 10-watt auxiliary, ditto. K.C. reported not as active as usual, although some of the fellows seem to be keeping traffic moving. Here is a little story of an event that is interesting inasmuch as it is true and which happened in K.C. lately. Back in the old days when the gang used hefty spark sets on straight gaps, galena detectors or the old tubular two lunger, if one could afford it, a fellow in K.C. was bitten by the radio bug. He played with the game for some time but gradually lost interest. Before the war came he was only a "usterer" having settled down to peaceful married existence. Radio was forgotten. However, after the war he got the broadcasting craze and got a dandy pile of junk accumulated once again. Needless to say he occasionally sneaked down on the lower wavelengths to listen to the code hounds during lulls in the concerts. True, he was a B.C.L. but he was slipping. Yep! it all happened before we were aware of it. He got a two weeks vacation just before the holidays and spent the entire two weeks down the basement hooking up a new—loud talker? H—! not a dandy pure C.W. 20 watt transmitter. Once again he is one of the gang, a B.C.L. gone wrong! Fellows, allow me to present 9DOJ, Herb Pendleton, the hero of my little tale—D.M.

The D.S. of Eastern Missouri reports much QRM by school work. 9BDS burned out his old 50, and is now using a new W.E. 50. Getting 5 amps to start. 9AOJ has a C.W. set going and fairly good too. (Another spark ham converted.) C.W. is strange to him as yet, but he'll get used to it soon. Hi. 9EFC is using a 50-watter. Probably heard 9DCW's 5-watter. Hi. 9DWK is FB. 9AON heard FBAB QSA. He'll probably work him next. Missouri handled 2367 messages during December.

KANSAS—Again the D.S. report direct. Two very fine chaps. (FB, both of you.) At last a new A.D.M. has been appointed, but at such a late date that he was unable to make up a report. ATTENTION KANSAS GANG! Your A.D.M. is now Chf. Peters of 9DTA fame at Tonganoxie, Kansas. Give him your hearty cooperation and let's make Kansas a banner state.

Dist. No. 1: 9REX and 9CCZ are handling Wichita traffic. 9CCZ and 9CZW are main Kansas stations QSRing west. Both are fixing west schedules. 9CCS is QSRing all directions. 9BFP and 9AVG (as usual) had few dead tubes. 9AYP not on much but did good work. 9EJC has started up on C.W. 9AIM is sure making dust fly. 9AIM and 9CCS heard in New Zealand, etc. SOME DX! Hi. 9EFA pulled a surprise on the D.S., he sent in his report early. (Thanks.) 9DES is FB using RAC. Sounds like C.W. 9EFA is going strong on spark. (Can. it, OM.) 9EFU heard working both coasts on C.W., but no report. (Sa', OM, snap out of it.) 9BEZ is a DX hound. Some of you stations who are not O.R.S. report anyway. It's the only way to get to be one. 9DTA our R.M. worked out a keen route map for Kansas, but our last A.D.M. must have run off with it. Too bad. 9BVN, 9BJB, 9BXG, 9CKM and 9DLM are doing good work. 9AOG shot his 50 watter last month. He is using a 5 now and has worked all districts with it in one nite. (Good!) 9CCV is moving to Concordia so will be nil for a while. 9CFI is going good with

a 50 and expects to add another soon. 9CZW and 9CCS are the most active stations this month in the amount of traffic handled. 9CFI has been recommended for O.R.S. Kansas handled a total of 1861 messages during December.

NEBRASKA—No report from the D.S. of district No. 2. 9BXT has been rather active and handling some traffic. A report was received direct from 9CNS out at Rushville. He states that he is in a dandy location. However, he can not work into eastern Nebraska for some freak reason, but has no trouble working farther east easily. His sigs have been reported as QSA as locals by hams up and down the west coast. (Give him your traffic west.) 9ATC is by far the star station in northern Nebraska this month. The A.D.M. reported by wire to the effect that it was the "dullest month yet." He says the stations are blaming it on the trans-Atlantics. Perhaps he is right for there are others who are also neglecting their transmitters. This will be OK if they step out and copy some foreign ham. (Wake up, gang!) I am not at all satisfied this month with the showing you have made. Why can't you fellows be consistent? You beat 'em all one month and the following month you are the rottenest yet. Thank goodness there are one or two exceptions to the above statement.

NEW ENGLAND DIVISION I. Vermilya, Mgr.

The reports received this month are certainly very encouraging to amateur radio. With all the great doings going on in our League, it is indeed a great world to be living in—Mix at the North Pole—a new constitution for the League adopted—and the successful Trans-Atlantics being carried on, certainly make a fellow feel good and glad he is one of such a wonderful organization. The division manager is also quite enthused over his new station at Mattapoisett, which boasts of a 125-foot tower and the cards rolling in from all districts of the U.S. and Canada, as well as foreign ports.

MAINE—A very enjoyable visit was experienced one Sunday night when Mr. Hilton dropped in to call on the D.M. Things were rather upset, but we are hoping for another visit when everything gets percolating. Maine reported a total of 821 messages handled, and taking all things into consideration, we are mighty proud of this report. The leaders in this state are as follows: IALJ, 120; IATU, 119; IKX, 144; and an unofficial station, IBUB reports 139. IFM also reports 79 messages which is #B for Portland. IBQL plans to change to 50 watts very soon. IAFP is planning to be on shortly with 3 operators.

VERMONT—Old man Slayton has been busy drumming up business lately and as a result, his state has turned in the best report since it was organized. While only six stations reports with 165 messages, still this is a fine report for a state so situated as is Vermont. They can only relay messages, and in these days when 5 watts sends to Hong Kong, not much relay is necessary. These fellows have to actually jump up and grab these messages as they go by. IFM handled 14, IAJG shot off 51 and ICQM and IARY 22 and 78 respectively. IAJG has 10 watts with storage B batteries for his place. He reports no generator hum. IAIQ, IAJG and IARY have regular schedules with each other.

NEW HAMPSHIRE—The report for this state is missing this month. There is a probability that they are snowed under up there.

MASSACHUSETTS—If all the states were as large and ambitious as this one and ran as smooth as we would certainly have a whale of a job each month making out the report. IRDU, the A.D.M., sends in a very good report and this office extends its thanks for such good team-work from a new man. ICOT handled 42. IAOY reports 67 and using 10 watts. IRR reports 91 and also that he blew up his 50-watter. The A.D.M. is keeping track of the O.R.S. that do not report and after three months of such failure he is going to recommend cancellation of the certificate. The D.M. backs him up squarely in this and will certainly cancel this dead wood. This idea of having

the O.R.S. certificate hanging up in your shack and doing no work has passed by. Will other A.D.M.s please note Chase's action and follow suit. Even if we have only three O.R.S. stations to a state, they will at least be good reliable ones, and that's what we want. The Commonwealth Radio Association sure did a good job of representing the A.R.R.L. at the recent Radio Show and from all accounts they were the hit of the show. Thousands of messages were handled and it is only regretted that they were not all reported. Messages were accepted for the U.S. and Canada and every station in Boston was literally snowed under with traffic. ILT seems to be the chief hard luck man this month. He enriched the poor Radio Corp. more than 50 cents by blowing four 5 watters and one 50-watter. IBT and IAAC spring a new one this month. They report that insurance companies refuse to allow them to have a transformer in the house. Quick, Watson, get the Ratty Snitchitt! S'pose they all had that queer idea. (Low moans from 1ZE as he recalls that a twisted lamp cord which he is acquainted with is carrying 1200 D.C. volts in it.) IBBM reports that he hears and works 5's and 2's in daylight with spark coil C.W. IKA has his 100-watt transmitter on exhibition at the Boston Show and it certainly is a work of art. McLean also comes forth with a fine report. IAJX has worked the west coast three times lately and is taking traffic reliably for the middle west. IKC reports having a new 150-foot mast. This should send the signals for more than 5 miles. We wish to extend our sympathy to IBRM, who, on account of a death in his family, has dismantled his set. We hope it is only temporarily.

Dist. No. 7: Traffic is moving with speed of light, the honors going to ICPN and IADN. IAQM of this district reports losing his mast in a recent high wind. Following are some of the totals worthy of special mention: ICPN, 260; IJV, 212; IYK, 204; IAFA, 137; IADN, 104; IKC, 100; IBGF, 80. A total of 1800 was reported for Western Mass. and it is notable that no spark stations are reported as being in operation. Three more cheers for C.W.

Going back to Eastern Mass., we want to also mention that ISK handled 172, and ICIT 202, while ICJR hung up 101. These totals are very noteworthy.

RHODE ISLAND—IBVB, the A.D.M. for this state is considerably stirred up over the reported violation of the quiet hours by one of our best Rhode Island stations. To say that it has caused a stir here, would be putting it mildly, but we are using our best judgment and not saying anything further on the matter. The D.M. has this to say, however. That certain New England stations are frequently heard operating during the quiet hours and it will certainly mean suspension of A.R.R.L. certificates if any report is received from the Radio Inspector on such matters. The Radio Inspector's office is in close touch with this office. (Nuf sed, Please be careful.)

Dist. No. 1: The activities of the gang seem to have dropped off more than ever. Most of the gang are in the pastime of making broadcast receivers for the BCLs or trying to make a receiver percolate on 100 meters. IAQI's girl has jilted him and he has returned to the radio game. HI. IAAP is erecting a new station and will be on the air soon. IBVB is pounding brass between the times that he grinds out pictures at the Lyric Theatre. IBVB handled 94.

CONNECTICUT—IMY, A.D.M. for this state sends in his first report. This latest report is certainly the berries. IAW handled 81; IHX, 228; IFD, 107; IMY, 318; IIV, 265. These totals are certainly worthy of special mention. IMO, IQP, IBHW, and IOA have broken all records in working French SAB and certainly deserve to be congratulated. IMO won the brown derby, thereby dashing to pieces one of Vermilya's fondest hopes. However, it is encouraging to know it took such a good man to cut the path and show the world it could be done. To our friend Reinartz goes all the glory of having designed short wave transmitting circuit that makes all this 100-meter work possible. We heard IHX working 5XAD the other morning. Some

stretch, we'll say. 10A was heard working 7SC. Just local stuff. 1BY has just been appointed C.M. of Hartford and is doing excellent work on 50 watts. Hartford brass pounders will please send him your reports. 1BM says his gang is ever ready for biz and only asks that they be given a chance. This is one of those districts where traffic doesn't hang around over 48 hours. 1AVJ has had trouble keeping the chinamen working in his laundry, so forgot to send in his report. 1AJT has been having trouble with his 50 watters. 1IV is pushing reams of traffic—watch his bananas. 1UO reports 143 msg's. (Here's our thanks.)

The D.M. wishes to extend a hearty invitation to all A.R.R.L. men to call on him when in the vicinity, and if no more than 14 come at once, we can probably tuck 'em away for a short nap after doing some DX. Please note my new QRA in QST.

NORTHWESTERN DIVISION

Glenn E. West, Mgr.

The finest spirit of sportsmanship seems to exist throughout the whole 7th district. The D.M. has been listening in on a superhetrodyne receiver and only six 7th district men have been logged during the Trans-Atlantic quiet period. (That's a fine record, men.)

Traffic is moving through the division in big gobs now. Many of the best stations in the division have lost the DX fever and settled down to regular traffic work, with the result that more messages are being delivered.

WASHINGTON—There does not seem to be much doing outside of the regular activities this month. An epidemic of burning out tubes seems to be the only change in affairs. Traffic seems to be moving over longer jumps as the weather improves.

Dist. No. 1: No reports received. The D.S. is putting his station in condition and is off and on the air now and then.

Dist. No. 2: 7ABB is the only station reporting and tops the list for traffic handled. Kick is still QSO WNP. When it comes to consistency, 7ABB can't be beat. He is there pounding away every night as regular as a clock. Seattle seems to have dropped behind this month. Almost every station has had some hard luck, masts down, aerials broken, or tubes burned out. 7DU has just come back on the air and 7OO was going fine until the jinx perched on his antenna. 7AHI and 7IH are on but no report. (How cum?) 7AEL and 7UU have been having trouble with their transmitters. 7FD has recently rebuilt his station and is going good now.

Dist. No. 3: There are only two stns. on the air in this district at present. Both are doing good DX but are shy on traffic. 7AIF and 7DC have combined into a 20-watt station with 50 watts in the antenna. Separate calls are being used. With the assistance of 7WS, the other station on the job, they expect to raise the total for this district next month.

Dist. No. 5: The long looked for reports from the stations in this district finally came through and we find a goodly number of hams on the job. The antenna at 7WX-7BB came down in a storm and only the quick work of RB in his pajamas at 4AM saved the pole from a similar plight. The sigs of 7WM are received with terrific intensity on the east coast he tells us. 7AGI's 100-foot tower looks so good to 7AFN that he has made up his mind to have one. 7CB has been reassigned to Stellacoom, Wash. and is reaching out good with 5 watts. Don't get thrilled now when you hear 7CB calling you it is no longer held by a YL. 7QE is off the air. The Tacoma gang are looking forward to the 7th district convention which will probably be held in the near future.

Dist. No. 6: The burnout wave has hit this district too, while some stations are clear out others are on reduced power. 7AJV was QSO Wisconsin on 5 watts. 7BJ and 7AJY are the stations on the job. 7VN is active in traffic QSB good C.W.

Dist. No. 7: Frank Mueller, Jr., the D.S. has resigned to attend the University of Washington.

We will all miss him and will look forward to the time when we hear his fist on the set at the U. Dist. No. 9: 7GE has been on the job from the looks of his message report which is second highest for the state. He works all districts except the first, second and third using three 5 watters. No report from 7QC.

OREGON—Traffic has been moving nicely through the state with a large number of the stations directly QSO with the Atlantic coast stations. Much interest has been aroused by the T.A. tests, causing a number of super-hets to be built. The men in the west are out after that four tube set. Any man in Oregon desiring an O.R.S. appointment get in touch with the A.D.M.

Dist. No. 1: 7RT and 7AHZ are working consistently with 5 watt sets. The old standbys, 7SY, 7GQ, 7IW, 7EZ and 7LR are still taking their share of traffic and morning oil. 7GQ has burned out so many lives that all he can now afford is an amplifying tube with 500 volts, radiating 8 amps. 7SY and 7LR have been working a number of sixes with their A.C. ionos.

Dist. No. 2: 7AGE and 7HA are on the air most of the time. Send in your reports for district No. 2, to Mitchell. 7AGE as he says he has trouble in getting the fellows to report. (fool him next month.)

I'll let you in on a secret. The A.D.M. was down to Corvallis and at 7OH's found an old half K.W. hooked up again after laying idle for some time. OH says he tho't he would come on with spark, but truthfully I think the plate voltage was going to be increased. 7QU has a couple of new parallel cages and is doing good work with 10 watts. 7QT recently got out to the 4th district with his 20-watt set.

Dist. No. 3: 7AKH is doing good work with 5 watts. 7SN recently lost his antenna in the big blow. Altho 7ABU is having trouble in getting the power company to put a line to his place he thinks his 10 watt set will soon radiate. 7ACC and 7NY promise a report for next month. 7ALO and 7EO are handling their share of the traffic altho report traffic kind of shy in their direction.

Dist. No. 4: 7TT, 7QU, 7LW, 7TO and 7AKK are all doing good work. 7QM is bad in Portland but the fellows can get through with very selective receivers. 7TO succeeded in working two 2's in a row the other night, sending off traffic to each one successfully. (FB) 7AEA, our speed, cop. is working again between arrests. Stations in Hoodriver would like to be heard from. Send your reports to 7TO.

Dist. No. 6: At last a station has been found in this corner of Oregon in 7IQ and maybe we will have a D.S. soon as we can get him off the long-wave arcs.

Dist. No. 7: This month 7QD is handling all the traffic for southern Oregon, with 7EM a close second. 7FR has a new antenna system and 20 watts to go with it. A 1200-foot Beverage has been completed at 7QD and 7Q's place. (Expect a few British stations, eh) (Lots of luck, men—A.D.M.)

Dist. No. 10: No reports. 7ABY seems to be the only station working.

IDAHO—Dist. No. 1: 7JF has let loose with 50 watts and is working east in great shape. He can take all traffic for Washington and points west. 7WG has quit the game. 8X-9JN is the second op at 7JF and he's some man too.

Dist. No. 2: New stations are popping up all around and several others are under rapid construction. The true ham spirit prevails in Boise and Nampa, much to the benefit and satisfaction of all. 7OB is doing exceptionally good work with a 5-watt tube. 7YA is on quite often and is doing his share of relay work. 7YA is using 150 watts and is heard throughout the east practically every time he presses the key. We are very grateful to Mr. Redeker of 7YA, for his work in broadcasting the A.R.R.L. news over his radio-phon. 7OT and 7PX are important stations in shoving traffic from the middle states to the coast. 7OT is increasing his power. 7AGR still has the same pretty note and the same wollop but seems to be too busy to be on very much. 7PJ has been issued a commercial license, but he doesn't seem to be on very steady, although he sure scatters

the signals when he does hammer the old key. 710 in Nampa has one set on the table doing relay work and has another under construction on the floor. He is going to combine them soon and have a 20-watt set to work WNP with. 7LN is on with 100 watts since the first of the year. Carl Martin is building a set in Pocatello which will be an important point to slip messages to Salt Lake and east.

MONTANA—Dist. No. 1: It is reported that there will soon be a transmitting station in Havre. If there are any live amateurs in Helena they should get in touch with the D.S., he needs a C.M. there. 7AGF must have been too busy to get in his report on time. 7NV in Missoula is being patiently waited for in getting his transmitter on the air.

Dist. No. 2: No traffic reports from 7EL and 7NT. 7ZF-7FL has been reported in Japan and every U.S. and Canadian district, with the exception of Canada Dist. No. 2. He has handled traffic direct with 1YB and 2BYG. Two more stations are opening up in Butte. 7TD installed a 5-watt set the 15th of this month and 7GK is expected on the air any night now. Besides these there are two others working on transmitters. 7ACI is still using one UV202 and getting out like a UV203 and pushing away lots of messages. 7NT is putting in a UV203 and should be on soon. 7ZL-7XBC-7JD is now using a UV203 with 500 volts, 130 mills on the plate, ant. 2.5. DX with 150 volts on the plate, and the 4 UV202s on D.C.C.W. still quiver the ether. A new station has opened up in Bozeman, 7MP, with 4 UV202s in a self-wrecking circuit.

Dist. No. 3: Still dead both ways from the middle! Help!!

Dist. No. 4: While there is not much to report, the 4th is coming to the front faster every day. 7ZU is going to invent a troubleless coupling for his Jenny and is going to take an intensified course on the whims of a super in hopes of getting well acquainted with his new "pet." We have a new station in Glendive, 7CO, who is just about the most terrific ether agitator we have. He claims to have one UV203, but he must have inoculated it with MOON, for in the first nine days working he reached into eight districts, 28 states, handled 105 msgs and worked WNP.

PACIFIC DIVISION

J. Vance Wise, Mgr.

CALIFORNIA—Dist. No. 1: Receiving conditions in or near San Diego are very bad on account of QRM from mush and harmonics of NPL's are set. QRM is not as bad on broadcast waves as it is on 200 meters. It is almost impossible

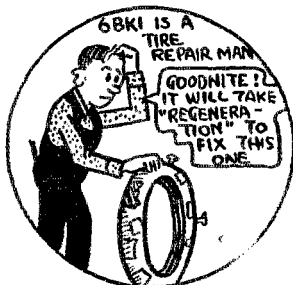

to hear stations out of the 6th district or even out of the state. Grey Castle Radio Club of San Diego High School will soon be on the air with a new 100-watt set. 6ZH is now on again operating with his broken arm, but is getting along fine although it is still in a cast. 6ALK seems to be the only station sending in traffic reports. (What's the trouble fellows?)

Stations in Southern California are asked to listen for the A.R.R.L. Broadcast every Saturday and Sunday at 7 and again at 10:30 P.M.

The following appointments have been made

in this district: 6ZH district supt., City Mgr. ANAHEIM. 6AHU.

Dist. No. 2: Traffic in this district is moving along very rapidly with many new stations on the air. 6PL occupies the seat of honor this month with 805 messages—see if somebody can't knock him off with a higher batting average. 6AAK is doing good work with 10 watts. He has worked the 1st and 2nd districts recently. On account of heavy inducements he is forced to use a loop and copies all districts. 6PL is QSO from Hawaii to Brooklyn, and stands the night watch every night. 6CFZ swapped his 50-watt set for a 250-watt bottle, wonder if he can swap his flivver for a power plant to run it? 6BUR, 6PL, and 6BVG all worked 2RK the same morning. 6CEU, on about 192 meters, is QSO with many Los Angeles stations. (Send him your traffic, boys.) 6EA-EB have moved their house to the rear of their lot to make room for a new 100-foot stick. 6AJD has installed a 500-watt bottle. 6BVS has closed down to take a ship op's job. 6OL has closed his famous old rock crusher and has opened up with a 50-watt set and a sink rectifier. During the recent wind storm many of the boys lost their sticks. Among the calls on the list were: 6CMR, 6ALG, 6UP, 6BRF, 6REG and many others. It is rumored that 6CFZ played hookie from work stating that he was sick, to watch his pole shimmy with the wind. 6XAD reports a peculiar condition of late in that WNP who is usually very QSA has been out of his range completely with a couple of exceptions, and at that time it was very QSZ stating that his hooks are full of messages to him, and that it will take him an hour or so to get the mail off the first time he is able to hook up with WNP. 6PL, 6ALG and 6KA, all in Los Angeles, heard WNP lately. Here's hoping they will be able to QSO him soon.

The following appointments have been made in this district: Dist. Supt. 6BVG; City Mgr. SANTA BARBARA. 6AAK; City Mgr. BAKERSFIELD. 6CCG; City Mgr. LOS ANGELES. 6PL, City Mgr. VENICE. SANTA MONICA-OCEAN PARK. 6BEO; City Mgr. WHITTIER. 6BUR; City Mgr. GLENDALE. 6AJD; City Mgr. PASADENA, 6OD.

CENTRAL CALIFORNIA—Dist. No. 4: San Mateo county sent in only one report this month. 6AAJ is the man. 6ZAN-6AO has picked the tallest peak in San Mateo county to perch his set on, and promises a mean wallop. Santa Clara County: 6BON installed a 50-watt set on the first of December. 6AGJ is stepping out fine on voice and C.W., using a 250-watt set. 6AGJ reports wonderful results with the superdyne receiver as shown in last QST. He says its a bear on 200. 6NX handled his usual volume of traffic and stepped out as usual. 6AHZ heard WNP at 2:00 A.M. P.S.T. on November 15th. (FB OM) 6BSV has a bad case of burnt out tubes. 6ZAH pushed a few amperes east and west to Japan and Cuba and continues to work east as before. 6ZAR fell behind this month on account of burning out one of his pet bottles, but still gets 7 amps out of the other 50-watt set. 6ZAU added another 50. 6ZAT can't get a pole to stand up long enough to run in the house and work somebody. (Tough luck, OM.) Stanislaus County: 6AME using B batteries and 86 watts input, is QRO 6CEU and 8AKN. 6CDG and 6AOI are having a run of intense QRM from a power leak. Merced County: 6BII, our star traffic handler, reports all districts worked. Monterey County: 6BCL is doing good work on 50 watts, having worked all districts and been heard in Nova Scotia. 6ZAR is Dist. Supt.

Dist. No. 5: The D.S. complains of a great scarcity of reports. (Let's get together gang!) 6AWT is Dist. Supt.

Dist. No. 6: This district is waking up. Traffic seems to be moving very well to and from the east. 6AOA will be on with 10 watts and we hope he is going to scrap that old rock crusher. 6HP has worked 7QC in the middle of the day with 10 watts. Looks like a daylight route north. (FB gang, come on let's have some more reports like this.) 6ZX is doing some fine work on 10 watts. 6HP is Dist. Supt.

Dist. No. 7: We are sorry to hear that 6GF

has found it necessary to resign on account of too much business. 6CBW is working on 5 watts waiting for a 50-watter. 6ARF is using a 50-watter and is waiting for a 250-watter and is going to do some real DX. (Ouch!) 6GF sent a 250-watter west, and a W. E. 1/4 K. W. went to rest in the west also. 6FH is building a new transformer trying to outdo 6KA in over-loading them. 6ABX is doing some work but is QRQ to handle much traffic. 6ABX is the Dist. Supt.

ARIZONA—6ZZ handled 271 C.W. messages. He signs 6FP on low wave 200 meters on the sink rectifier. 6GS has not changed over to C.W. yet. 6NR handled 20 messages. No report from Tucson and Phoenix. F. A. Miller, Flagstaff, an old timer from the 9th district will be on the air soon as his set arrives, and will make a good relay station as he is well experienced. QRN has been almost continuous here since the season opened. very unusual wx conditions this fall.

ROANOKE DIVISION W. T. Gravelly, Mgr.

VIRGINIA—Dist. No. 1: 3BBT is C.M. of Norfolk instead of 3BNE. 3BNE is D.S. 3UV, 3BBT, 3BNE and 3MF are doing the big work. 3UU vamped and off the air. 3OKK, a new station at Hampton, just started up with C.W.

Dist. No. 2: 3AUI just finished his super-heterodyne and is adding storage battery plate supply. 3ATB does some work and has a Grebe CR-13. 3SG is off the ham stuff and with a commercial company. 3ABS also has Grebe-13 and is on as often as time will permit. 3BCH has the C.W. perking at last and receiver down to 50 m. 3AOT moves back into the basement. 3BGQ is a new station which will open up January 1st. 3BMN is installing 100 watts with MG supply and is working on 190 meters. A 20-watt set with CRAC on 100 meters. (Can't do it OM, unless you have "X"—A.D.M.) He is adding Grebe CR-13 too which he says is the berries.

Dist. No. 3: 3CEL with his 80-foot mast costing \$5.00, installed a 50-watter and knocks 'em cold. He works nines in daylight. (FR, about the wave down, OM, and work still farther—A. D.M.) 3BJJ is back again. (They all come back, OM.) 3JY is on often. 3OV handles a few when time permits. 3VO, we are sorry to say, leaves this district now and will be greatly missed. He will be known in the future as 3VO and expects to get on the air by February 1st at Buffalo, N. Y. (Here's luck, OM, and may the old set perk as before.) 3MO has an 8 tube super-heterodyne which takes all his time from the transmitter.

Dist. No. 4: Nothing heard from 3TJ, the only station in this district, but we feel that he is safe.

Dist. No. 5: 3IW is the only active station reporting in this district and is sure getting out. His wave is down and his signals have improved greatly. (FB, OM) If you other fellows want any representation send your reports in to the D.S.

Dist. No. 6: Nothing doing in this district, likewise the 7th district. We feel that with the proper handling of these two districts a lot of stations can be accounted for that are not being shown now.

Dist. No. 8: 3AEV and 3BZ are on when time permits.

Dist. No. 9: No report from D.S. of the ninth and tenth districts, so the A.D.M. will endeavor to report activities these districts. Send your reports to the A.D.M. 3ZA has installed a MG set for his 10-watter and is using Meissner circuit. 3BKL is pounding the air right along and will accept all traffic for Blacksburg. 3BXX and 3BBS are still improving their sets.

WEST VIRGINIA—Just 25% of the O.R.S. sent in their reports this month which is a very poor showing on the part of the station owners. If your name is not in the line up and your station accounted for, don't blame anyone. Show some life and make reports promptly. Help your A.D.M. and don't try to pull him down all the time.

Dist. No. 1: SWZ, our youngest station, is moving traffic like an old timer. *SP will be with

us later. 8AUE, with a 100-watt set is doing consistent work and has been reported on the west coast. 8BPU knocks off a few every now and then.

Dist. No. 4: There is no active station in this district. D.S. Murrell having moved to Huntington, and is temporarily out of the game.

Dist. No. 5: SBAG, a new comer, is going good and reported on the west coast. He is using a 50-watter. 8CXM and 8BAG handled all the traffic in this district.

Dist. No. 6: 8BDA operates both C.W. and spark and does excellent work on both. 8TH on spark handles considerable traffic.

NORTH CAROLINA—Dist. No. 1: Most of the hams have gone nutty on fones and talking Atlanta Convention. 4MV handled the bulk of traffic with spark. He works Canada with 1 1/2 KW spark. (Try C.W. and work China.)

Dist. No. 2: This district is being lined up by the D.S. now and we expect a bigger report next month. 4GW carries off the honors for traffic handled. He has been reported in every district and his DX is 3000 miles with a 20-watter. (FB, OM.) 4MI with 10 watts has been reported in six districts. 4KC has a 200-watter. It is the biggest one in the district.

Dist. No. 3: 4FQ is on with 100 watts. 4JS is helping out. 4JR is a new station just started up and is doing good.

Dist. No. 4: Get in touch with your D.S. 4EA, we are glad to say, is back with us. 4FT leads the district. He has been reported in Japan and works the west coast nightly. 4AB is a new station using 15 watts, but will increase to 100 watts in the near future. 4RU is with us, and 4NT is back with us. 4BX is also going good now.

ROCKY MOUNTAIN DIVISION N. R. Hood, Mgr.

9AMB 230 Msgs.
Hathaways
C.W. Denver, Colo.

COLORADO—Denver Dist.: The traffic totals of the Denver district are creeping higher each month. Hathaways of 9AMB still take the box seat for most messages. 9EEA has been idle on account of sickness of A.D.M. Sexual. (Glad to hear him back on the air.) 9QL has been out of the city so his traffic report is nil. 9CJY is burning out tubes at a fast rate. 9BXA has no meters, all having been burnt out. 9BXQ is in on a transeon route which bangs traffic across and back in the same night. (FR 9BXM.) 9APF and 9AMB are building new receiving sets. 9BJI has been on regular as has 9CAA, 9BUN, 9BJK, and 9BTO. The traffic routes are working fine through this section. In all, the ham game in Denver is in fine shape—good understanding among each fellow and between the hams and the B.C.L.S. (FR, Men, we are mighty glad to see it.)

Dist. No. 1: This district is in fine shape and steadily moving traffic. 9DTE leads here with 143 msgs. 9AZG and 9BVO have both been on and moved traffic. (Glad to see Boulder open now.) 9DFH, a new station, leads this month with 35 msgs. 9EAE moved 77, and 9CDE 32.

Dist. No. 2: This district has opened up the southern part of the state, which we needed.

UTAH—Dist. No. 1: GARU leads in Utah this month with 109 msgs. 6BUH runs him a close second with 104. 6RM follows with 104. This is a good total for three stations. 6PE reports for the first time since his appointment with 97 msgs. (Good start, OM.) 6BOE is off the air until his landlord changes his mind and allows him to erect an antenna. 6GUB, 6BLH, 6AJA have been on regular and are moving traffic. A lot of the old-timers, Seely, Karr, Berry and Baker, seem to have left the game as no word has been received from them for months. They always say new blood wins the war. In this division the railroad emergency routes have been completed for the D & RGW to Salt Lake and C & S and the CB & Q completed with the exception of a connection in Texas. The Santa Fe is also covered thru the south of Colorado. This nearly completes storm routes thru the entire division. (If we ever get a chance to use them, hit her hard, men.)

WYOMING—Traffic in this state has dropped off due to building sets. 7ZD-7LU has been on regular and moved large bunches of msgs. There seems to be poor QSO west and poor delivery after QSR. (How come?) 7ZO spends all his time hunting for WNP and F8AH. Maybe traffic will move after they are logged. 7ZV has not yet set up the old station after moving to Casper, but will be on shortly.

WEST GULF DIVISION

F. M. Corlet, Mgr.

5LR runs off with first place on the greatest number of messages handled, relayed and DELIVERED, with 407 to his credit. This of course throws the honors to northern Texas. Southern Texas wins both second and third place, station 5YK with 256 and 5ZG with 202. In Oklahoma the leading station is 5GJ with 190. Only one station reported from New Mexico, 5ADO with 172. In Old Mexico "BX" was first with 36.

NORTHERN TEXAS—5QJ was out of commission from December 8 to 14 on account of a broken mast, but reported 36. 5AHT is experimenting some QRM from business. He reports 60 passed along. The division's star station for number of messages handled this month is 5LR. If he had not been located here 5AJJ would have been in the lead for Dallas with 136. He has a 100-watt rig going too, and his best DX is 2150 miles. 5HY comes next in line with 102. 5AKN, 95, 5AIC 18 and 5JY 15, making a total for the city of 773, or an even average of 128.9 msgs per station.

Dist. No. 1: 5FX reported 42, he is working the set over. 5UD, reported an unlucky 13. He has a battery supply coming up for a 100-watt transmitter. 5NW reported 27. He is trying to make a 50-watt bottle behave. 5GN tops the list with 38. 5DW, all piled up with getting a steel tower in the air, moved 10. 5AL says its most all "CEE QUES" in the air these days and not "uff "OK Nr. 3, Ga next one," so its only 7 moved this time. 5AHC's transmitter is out of commission, but will be OK soon. He handled 2. 5AMB is on the air regularly every morning from 4:30 to 6:00. He moved 12 and is ready for traffic. 5AMJ passed 25 along. He always has something going west and can't raise 'em, so wants a schedule with some one west. 5AER, reports his station closed down indefinitely on account of B.C.L.s complaining about QRM. (How about fixing it up so they won't even know it's running—it can be done.—D.M.)

Dist. No. 2: 5AJT reports 86. He is still using one 5-watt bottle and works 9DYR in St. Paul in daylight. 5KX handled 52. 5FH has had a bunch of hard luck. His rectifier is on the bum and he blew two tubes and is working on reduced power, but handled 117. 5ADH was not idle either, he managed to push 70 along their way. 5ADQ managed to relay 24 messages. 5SD leads the bunch here with 152, no messages hang on the hook either. 5QW takes second place for the city with 71 and 5CV third with 58. 5FC, reports by wire, some Morse operator made the sig "M.F.C." (QRN got out of the dashes, I guess). Anyway, 102 messages passed thru there. 5ADV and 5TO are giving one day service and wants more message traffic. They handled 36 this month. 5AMW, holding 'em down here, handled 31. 5AET has only been on the air about 20 days and is ready for traffic now. 5AFH leads the bunch with 40. 5EY helps out with 25, and 5AGH winds it up with 13.

Dist. No. 3: 5UO is putting traffic thru right along. He handled 75. 5AHP is getting started up again and will appreciate a report or two.

Dist. No. 5: The quiet hours make it hard for 5ZH to get by. He only handled 6. 5TL is a new station.

SOUTHERN TEXAS—Dist. No. 6: Looks like 5NK is doing all the work, he leads with 73 and 5NN comes next with 45. 5BA was off the air the first of the month, but moved 8. 5ZG, 5VY knocks 'em dead for a bundle of them this time! 202 msgs doesn't look like he has quit for some

other hobby or something. 5ACR handled 6. He is using a single 5-watt, and WNP reports his sig. 5XV's generator is blown, aerial damaged, outta luck, but going soon, maybe. He moved 30. 5XAD is still rebuilding. It should be a humdinger when completed. 5AMA passed 65 of them on their way.

Dist. No. 7: 5ZU has four 5 watters going every night now. He handled 110. 5ALR, on only two weeks, handled 11. 5RN is out of commission. 5JT handled 2. 5YK was not on the last week as the flood carried away the city power dam and power was too low to run M.G. He handled 256 and takes second place in the division.

Dist. No. 8: 5VO is out of commission due to tube trouble. 5KG handled 33. Ex-5ZAK is now opr. KGS S.S. "Senator Bailey." 5JC handled 27 sure 'nuff messages. He is not on much on account of QRM from school. 5ADJ lost his mast and was out of running for about 10 days, but handled 21.

Dist. No. 9: 5ADB handled 70. **OKLAHOMA**—Dist. No. 1: 5ZAV was rebuilding during the holidays, but moved 122. 5AHR is having tube and generator trouble, and has been off about half the time. He handled 48. 5ANC may be out of commission for a month, everything blown up. He handled 148. 5JE has trouble working south. He handled 27. 5ZM handled only 8 this time.

Dist. No. 2: 5FJ, rebuilt, handle 17. He is on every Monday and Thursday mornings. (What time?—D.M.) 5XBF's antenna came down in a storm. 5SG reports 22. 5GA handled 20. 5GJ leads the state with a total of 190. He is on every morning. 5AJQ breaks into the relay game and sends in his 8rst report. He has a couple of 5 watt bottles. He handled 23.

Dist. No. 3: 5TW is all set for QSRing. Shoot him your traffic. 5AGA, East Central Oklahoma Radio Assn., is all set for traffic handling. They moved 12 this month. 5AHD says it takes most of his time helping the B.C.L.s out but between acts he managed to handle 32 messages. 5AGZ has three 5 watt bottles working in fine shape. He passed 5 messages along. 5VM has been on only three weeks, but handled 12.

NEW MEXICO—5ADO seems to have the whole state to himself. He handled 172 and has been heard by WNP and Australal. 5LG is attending State College, but will probably be on at this point week-ends soon as the masts are replaced that were wrecked in a wind storm.

MEXICO—BX reports a total of 36 messages. The revolution is on again but up to December 20th it had not affected his station. IB, owned by M. L. Pecosquia, P. O. Box 540, Mexico City, began operation November 22, and has worked 20 American stations. His best DX being 9BRK, Jeffersonville, Ind. He is using two 5-watt tubes in the reversed feed-back circuit. He handled 5 messages, and reports that his permit to transmit has been revoked on account of the revolution and that he has been required to dismantle his station, mantle his station.

HAWAIIAN DIVISION

K. A. Cantin, Mgr.

HONOLULU—Dist. "A": The 8:00 to 10:30 P.M. quiet hours going into effect here has caused considerable slump in transmitting. 6CCR and 6ASR operate occasionally so as to keep their tubes from getting "rusty." 6TQ was logged in New Zealand during a special test.

HILO—Dist. "B": 6CEU with his 15-watt rig continues to handle all coast traffic. He is doing excellent work in both reception and transmitting. His signals were again logged in New Zealand during a special test.

MARITIME DIVISION

W. C. Corrett, Mgr.

Amateur radio in the Maritime division has gone ahead during the last month by leaps and bounds. The dinner held at the residence of

Harold Lardner, 1DT, a report of which appears in this month's QST, started things off to a good speed and it is hoped that it will keep up. The D.M. arranged some transmission and reception contests which have been taken up with much enthusiasm and have been a good thing.

The General Electric Company offered a 201-A tube to the Maritime station that copied every district of the U.S. and the first three districts of Canada, on one tube. Several stations made a strong bid for this prize, the winner of which will be announced later. The Northern Electric Company offered a 5 watt tube to the station which works the greatest DX with one tube. To date this competition is not very far advanced but nevertheless several stations are running a close race for first place. In addition to the above the D.M. offered several certificates for

time. If he does anything worth while he says he will write and let you know, in the meantime get some more members for the A.R.R.L.

Next month the gang hope to have something more interesting to report. This report would not be complete without a word of praise to our D.P.M., Mr. E. B. Binns. He has done much good work and brought the game to the eyes of the public in great style.

The D.M. would greatly appreciate it if all Maritime amateurs would drop a line to their respective A.D.M.s, and that the Nova Scotia amateurs should send their reports direct to the D.M. These reports should be in by the 20th day of each month. If you do not know who your A.D.M. is write the D.M. and he will tell you.

ONTARIO DIVISION

C. H. Langford, Mgr.



Starting with the central section we find more records broken this time by 3BP who put one over by working British 2KF and 2SH as well as French 8AB, on 100 meters, or thereabouts. Now fellows, take the tip and get in on this 100-150 meter stuff, both in tuners and transmitters. Interference is nil to R.C.L.s and there is practically no QRM at the receiving end. (Low power, FBI)

All Canadian divisions are lining up for a permanent Trans-Canada route. Transmission to be around 125 meters. The scheme is to run the relay east and west one night and the next night west to east. Improving still further, 9AL suggests that all stations participating camp on the same wave (with their transmitters) so that long jumps may be made if possible. Stations will be appointed for this work and shall be known as Trans-Canada Relay Route Stations. (Better start cutting that transmitter, OM, and with it make a new tuner.)

3AA reports hearing 8RAB on an indoor aerial. (FB, OM.) 3WG guarantees that all msgs received are delivered. (That's fine, OM.) Hope all others will see things that way soon. (This is one of the requirements of an O.R.S., fellows.) 3ACU has been kept busy at 3CO's shack lately. 3JT is acclaimed top man for the city. (Welcome, 3AEC!) Though new, 3AEC has a showing of 18 msgs for his first report. Niagara district reports a fine Radio Association, but little pep as to relay work. (Come on fellows, get on the air and help 3KP and 3XX.)

Western Ontario seems to be easing up. Possibly in anticipation of the coming tests. Every man has got to be reported across the ocean or answer for it. 3DH, using a "13" expects to do fine work shortly. He is building a new transmitter at present. St. Thomas, the town is having a fine time with the R.C.L.s. Practically all are law-abiding. 3OM and 3IA were the only stations to turn in a report.

Eastern Ontario. The following have been heard on the air: 3AFP, 3KR, 3AF, and 3VO. 3GT, the old reliable, with all the stuff for a perfect 50-watt set, believes in silent hours from 12 to 12. Here's hoping he sees this and comes to life. The Ottawa Radio Association is very active under Dr. G. M. Geldert. The two real workers in Ottawa this month are 3AF and 3AFP. Wale of 3MP is still busy on the air. The Kingston gang are doing fine DX with traffic. 3NF is now using real D.C. and reports much better DX. 3ABL is doing good work on one 5 watt. 3HE is on the air regularly from 11:30 to 1:00 P.M. At London town we have active stations 3TB and 3ADN. 3KN is rebuilding his transmitter for shorter wave length. Sorry fellows, but no report available from Kitchener. (Kind sir, please show some life!)

Well anyway we have a live wire district in northern Ontario. 3WS is back on the air with a 50-watt-er-hours 11 P.M. to 4 A.M. (Fine, OM.) 3GG opened up about December 1 and has worked 2BE on fone. It seems that there is going to be some competition between 3WS, 3GG, and 3NI. 3NI reports lack of traffic. (Surely a station which has worked WNP and gets a "13"

transmission and reception. The following have won certificates to date. 1BQ won 3 certificates, 1 for being the first Maritime station to log a French amateur, 1 for being the first station to log an England station, and 1 for being the first Maritime station to work a European amateur, when he worked French 8AB with only a total input of 90 watts. (More power to you, old boy.) Our old friend 1AR won a certificate for being the first Maritime station to be heard in the U.S. sixth dist. He received six cards from California last week.

Perhaps the best piece of news is that we now have two A.D.M.s in the division who have started up in good style by working the D.M. with traffic. T. B. Jarey of St. John, N.B. has been worked by 1DD on several occasions and wins a certificate for being the first N.B. station to work Nova Scotia. 1BZ at Charlottetown, P.E.I. has also got his set going and has also worked 1DD, and thereby wins the P.E.I. certificate. (Glad to connect with these fellows and we hope that they can induce many more in their Province to join the A.R.R.L.)

In Halifax the gang have mostly been busy getting ready for the Trans-Atlantic tests. 1BQ has been doing wonderful work both in receiving during the 0100 to 0600 G.M.T. period and in transmission before and after that time. 1DT, we suspect is in love or something like that. He has raved a lot about Trans-Pacific tests and then went away for three days and left his receiving tubes burning all the time. However, he is back on the job now and should have his transmitter going before long. 1EB is now erecting a CP and should reach out. 1DF, 1AI, and 1AU find business taking up a lot of time but should be able to settle down soon. 1BF and 1BV have everything ready now and should be going soon. 1DJ has just arrived from the woods and will no doubt be going soon. 1DD as usual is handling traffic and writing letters to the gang which takes up most of his

should be swamped with traffic.) 3NI is ready, everybody help.

Now gang, back to the start of this report and get another line on the 100.150 Trans-Canada Relay Route. We have to make good. YOU HAVE ONLY ONE SHARE TO DO—LET'S GO!

QUEBEC DIVISION

J. V. Argyle, Mgr.

Traffic in this division has not been very brisk, the crowd reporting that messages are hard to obtain since the "QSL CRD" stuff ceased. However, every night sees them on the job. 2BG is reported from Cuba which is good DX. 2BE and 2BG are reaching out consistently as are 2IC, 2AZ, 2BN, 2CG. We welcome 2HG back on the air. 2BN and 2CG are "up in the clouds" as they have worked all U.S. districts and have good cards from Alberta and Vancouver. 2CG is spending all his time on 125 meters and is reported QSA everywhere. 2AM handles at least his share of the traffic and has a fine note with good range. The whole bunch in the division are keeping quiet hours from 7:30 to 10:00 P.M. This is quite voluntary in Canada and just praise is due everyone for the observance. 2IC reports hearing WNP once, otherwise we are still no QSO North Pole. 2CG received lots of newspaper publicity for keeping communication open between Burlington, Vermont and Montreal when the heavy snowstorms pulled down the telegraph and telephone lines. Our main center, Montreal, has a 'phone fest every Sunday morning, when 2CM, 2BF and 2HV as well as all the others, may be heard chewing over the week's happenings. 2HV is becoming a good code man for which we are truly thankful and we want 2CM in the same boat.

The division manager requests all the boys to give him the news about themselves as we have no sub-divisions yet. This is coming later, meanwhile, send the dope direct to the D.M. and he'll see that you get all the credit that's coming for good work.

WINNIPEG DIVISION

J. E. Brickett, Mgr.

MANITOBA—There's lots doing here these days with nearly a dozen stations in operation and others rapidly completed. The gang works with much greater ease now. 1AW, new O.R.S. is clearing traffic in fine style and promises a big increase when he can get on the air steady. 4CJ is reaching out OK on 15 watts A.C.C.W. 4DK has just hit the air with 15 watts, D.K. He has a new "bug" and keeps the gang guessing to count the dots. Hi! He reports nil traffic yet but will soon be knocking them over in his usual style. 4CN is obtaining FB D.C. from C.R.A.C. and has reported working 3SU in Washington, D.C. 4CO can only operate in the morning at 6 A.M. on account of QRM from his spark. He will be on soon with his C.W. again. 4EA reports hearing WNP on a detector only and has been logged by Can. 3PG using 5 watts. 4AG, at Riverton, has difficulty in working the Beg gang on account of QSS. (This is a good chance to make a study of that and find out why, gang.—D.M.) 4AG would be more QRK if he would come off that 275 meter perch. Hi! 4DY worked 5CN in Vancouver and is QSA in Montreal. He is the first station in Manitoba to be reported by WNP. 4CR reaches out FR on his 100-watt and is QSA in Montreal and Vancouver. 4DE is still working on his big tube set.

SASKATCHEWAN—4HH is kicking out great on his pure D.C.C.W. and has worked every district in the U.S., but says the 50-watt pup is hungry as he has only 720 volts to feed it with, and those Willard CBR's don't grow on buck-brush bushes. The B.C.L.s are receiving code instruction every Saturday and Sunday night via 4HH's mod. C.W. and fone, and they are becoming very enthused over the brass-pounding

end of the game. 4AO is once more on the air and getting out fine. He is spending much time experimenting with chokes and filter systems, and expects 20 watts ready soon. 4ER, the new C.M., after much grief has rebuilt the remains of his aerial, replenished his tube supply, and has been reported the second time by WNP, using 5 watts. 4FB—Y.L.s—5 watts some time. (Maybe) 4DN after a speedy recovery of the broken collar bone, took the count again with a very severe attack of Grippe, but has recuperated, and hits the air once in a while even if he is overburdened with school duties.

The Moose Jaw gang were visited by the famous "Oyster Stew" trio from Regina on Dec. 2nd. (Just a word of explanation) Bert Hooper, announcer at CKCK got married and celebrated by coming to the Mill City bringing 3 crazy musicians and the bunch congregated at 4HH's station where they broadcast special program to 4AO and 4ER, (as far as they know) but it was picked up and acknowledged by listeners in for a number of miles, much to the surprise and consternation of the artists. 4FN is going strong and has been reported in every district and is doing some fine DX work. No report from the C.M. of Regina. 4FV and 4AJ have both been heard and worked but no report from them. 4BX-4CB is short of time and power, but gets out fairly well at times.

VANCOUVER DIVISION

A. J. Ober, Mgr.

This division is in full swing, traffic moving in all directions. It is nothing new now to be QSO WNP—5 watt stations having worked WNP. The new D.P.M. is 5AH. (Gang, if you're interested in your division, write the new D.P.M. and tell him if you're able to lend him a hand.) The station hours are split this month. 5CN and 5CL are tied.

VANCOUVER DISTRICT—5GO has had to fall back on a pair of openers, now has received another 50-watt so will be going strong again. 5BQ, an old station, is back on the air again with A.C. C.W. 5HG and 5EB have been inactive in the past month. 5AK (our ex-D.M.) was on the air for a few weeks at Xmas. (FB, OM.) 5CN was not on the last part of the month, will not be on again for some time. 5EF has received his license and is handling traffic. 5AH is having battery trouble. 5EJ has come back on the air again and hopes to be with the gang for the rest of the winter.

VANCOUVER ISLAND DISTRICT—5CT worked WNP for 15 minutes and took one msg from him. He finds it difficult to get QSO east. 5HK with 5 watts of D.C.C.W. is going in Victoria.

PRINCE RUPERT DISTRICT—No report from 5BP, so don't know what's going on in his district. (Let's hear from you, OM.—D.M.)

EDMONTON DISTRICT—4HF blew a river, rewired his set into reversed feedback, put in a large filter, and reports getting out better. He has had tuner trouble and is experimenting to bring in those DX stations. His sigs were reported from 1st district stations. 4CL works all districts except the third, as is QSO WNP. 4GI is heard pounding brass often these days. Hope he will join the A.R.R.L. he is a good op.—we need his help badly. 4CL and 4HF are the only amateurs in Edmonton against oodles of B.C.L.s. They get the blame for everything, from a neighbors noisy cat to a thunder storm.

ALBERTA DISTRICT—4AB is knock'n 'em over with 10 watts, and the purest long currents to feed the plates. He is QSO Can. 3NI, 3WS and the 6th district. 4CW is getting to be a real night hawk, his sigs reported from 1st, 2nd and 3rd districts. (FB, OM.—D.M.) 4IO is the "wire winding kid" re-winding 'nother generator to care for his starved plates. 4IC comes out with D.C. C.W. and reports his sigs heard in Montreal. (FB, OM.) 4DQ has been off the air for some time. He hopes to spring something on the gang, soon.

Calls Heard



HEARD DURING DECEMBER

Unless Otherwise Specified

IMPORTANT NOTICE

When preparing a list for QST, it is essential to observe the following rules:

1. List the calls neatly on a separate sheet of paper with a line of space between lines; do not embody them in a letter.
2. Arrange the calls as they will appear in QST: across the page, numerically by districts, alphabetically in each district, Canadian and foreign calls listed separately, state whether spark or C.W., and give period of time covered by the list.
3. Forms close on the fifth of the month preceding the date of issue of QST. Make your lists cover the period from the first of one month to the first of the next if possible, but don't let your list come in late.
4. List only calls over 500 miles distant.

T. W. Higgs, 5KO

45 Howard Rd., Westbury Pk., Bristol, England.
(Heard During November)

Nov. 10th: 1CMP, 2BY, 8RDA, SWX, 8XE, 9AN.
Nov. 18th: 1ALJ, 2AFP, 2BY, 2SU, 8GZ.
Nov. 23rd: 1AW, 1CAB, 1ER, 1FD, 1MO, 2BY, 2CXL.

G. Rogers

Dunavon, Chesterfield Rd., Ashford, Mddx., Eng.
Nov. and Dec.: 1ARL, 1AUG, 1AGU, 1ARF, 1AJN, 1ALH, 1ACM, 1AGL, 1BRL, 1BCF, 1RWJ, 1RES (vgy QSA), 1CPN, 1CMP, 1CJL, 1JV, 1PA, 1PV, 2AGB, 2AWL, 2BY, 2BQH, 2BQA, 2CPO, 2FP, 3ACY, 3BG, 3BDO, 3RXW, 3BFU, 3OO, 4FT, 4GX, 5BV, 5JK, 6AMP, 6AWT, 7FU, 8HV, 8CLI, 8BCL, 9ZN, 9AAW.

Kenyon Secretan, 5LF

149 Lower Parade, Barnes, London, SW, 13, Eng.
1AW, 1CP, 1FD, 1MO, 1XAM, 1ABS, 1AJP, 1BDT, 1CMP, 1CMX, 2AGR, 2CPD, 2CXL, 2BY, 2RS, 2TN, 3AAO, 3BOF, 3XN, 3KAN.

L. S. Spackman, 1AC

10 Ardmore Rd., Ponsonby, Auckland, New Zealand.
1AJP, 1AR, 2CK, 2ZA, 3RQ, 3XAG, 3XAJ, 4CPE, 4ECM, 5AU, 6GQ, 6KA, 6SE, 6SH, 6OP, 6XN, 6AOS, 6ARB, 6ATC, 6BGU, 6BIC, 6CFL, 6CKD, 6CGW, 6CMI, 6CMU, 6XAD, 6CYT, 6RK, 9AE, 9BD, 9AMX, 9AWM, 9BFZ, 9ZT.

F. D. Bell, 4AA

Palmerston South, New Zealand.
(During November)

1FD, 1HX, 1SN, 1YB, 2BY, 2RK, 2XQ, 3GC, 5AMH, 5AU, 5AHD, 5GJ, 5HT, 5KR, 5QF, 5QL, 5QQ, 5UA, 5UW, 5WX, 5XY, 5ZAV, 6ARR, 6AOS, 6AOL, 6AVV, 6ALV, 6AUJ, 6AHU, 6AJD, 6AHD, 6BVG, 6BBC, 6BWW, 6BEO, 6BKX, 6BNC, 6BEM, 6BUO, 6BIC, 6BEG, 6CBL, 6CMR, 6CKR, 6CKP, 6CHV, 6CDE, 6CNL, 6CRL, 6CBB, 6CDG, 6CFZ, 6CEE, 6CGL, 6FY, 6GR, 6KA, 6LV, 6LU, 6OL, 6PL, 6TS, 6XL, 7AEL, 7BCF, 7BJ, 7IW, 7NN.

7QJ, 7SH, 7SC, 7SR, 7TO, 8ADR, 8BDA, 8COJ, 8CPX, 8CEI, 8CGU, 8HN, 8RV, 8VQ, 8VY, 8WX, 9AIM, 9AUA, 9AFP, 9BIS, 9CCV, 9CLQ, 9CVS, 9CZW, 9CTG, 9DKY, 9DOE, 9DJD, 9DQU, 9DSM, 9EKP, 9EDB, 9EKY, 8MC, 9VM, 9XI, 9ZT.
Canadian: 5CN, 5GO.

W. L. Shiel

103 MacAndrew Road, Dunedin, New Zealand.
6KA, 6LNK, 6AFB, 6ARB, 6BPZ, 6BVG, 6BWP, 6CMR, 6WLZ, 6XAD, 7SF, 9BEZ, 9EKY, 9ZT, WNP.

Ralph Slade, 4AG

Dunedin, New Zealand, (Sept. 23 to Nov. 24)
3BP, 4KU, 4MY, 5CN, 5HT, 6KA, 6PD, 6PL, 6ALV, 6AOS, 6AVV, 6AWT, 6BBC, 6BPZ, 6BRF, 6BRU, 6BSG, 6BUO, 6BVG, 6BVO, 6BVS, 6CGW, 6CKP, 6CKR, 6CMU, 6CNK, 7AEL, 7SC, 9AIM, 9AVN, 9BZE, 9BZL, 9CNS, 9BZ, 9MC, 9VM, 9ZT, Can. 5CN.

Harold T. Mapes "BX"

Guanajuato, Gto., Mexico

1AJX, 1CMP, 1YB, (1ZL) pse QSL, 2BRB, 2RK, 3AUW, 3HG, 4CS, 4CR, 4DP, 4EL, 4FT, 4KU, 4MY, 5AKN, (5AMA), 5AKY, (5ALR), (5ADI), 5AIU, 5AEC, (5AJJ), 5ADO, 5AHR, 5AAT, 5AIJ, 5AJT, 5AMU, 5AKF, 5AJU, (5AMW), 5AIC, 5AHT, (5AMH), 5ANC, 5ABH, 5ADV, (5ADB), 5AU, 5AHD, 5AIR, 5ANA voice, 5ALJ, 5BM, 5BX, 5BY, 5CL fone, 5DW, 5EK, 5FC, 5FX, (5FP), 5FT, 5GI, 5GN, 5GF, 5GA, 5HL, (5HZ), 5IN, 5IQ, (5JC), (5KG), (5KN), 5KC, 5KX, (5LR), 5MO, 5NR, (5NK), 5NZ, 5NA, (5OV), 5OT, (5PH), 5PW, 5QW, 5QL, 5QY, 5QL, 5QX, 5RV, 5SD, 5TJ, 5UA, 5UK, 5VF, 5VM, 5XV, 5XAC, (5XD), (5XAQ), (5XAJ fone), 5XT, 5XAR, 5XAP, (5YK), 5YG, 5YT, 5YW, (5ZAV fone), 5ZG, 5ZU, 5ZAS, (5ZA), 5RB, (QSA W 3' Loop 5ABB, 5DN, 5EJ, 5LR, 5XAP), 6AAK, 6ASX, 6AAJ, 6AWQ, 6AUT, 6AOS, 6ARB, 6ALK, 6BIC, 6BJJ, 6BFG, 6BUO, 6BUF, 6BUA, 6BJQ, 6BCL, 6BIS, 6CKP, 6CNI, 6CDG, 6CFZ, 6ZH, 6CGW, 6CKP, 6CKR, 6CIE, (6FP), 6H, 6KA, 6MH, 6PL, 6TS, 6AMB, (3' Loop 6ACM, 6AAK, 6ZH), 7CO, 7SC, (8AIB), 8AB, 8AA, 8BFQ, 8BDA, 8BHN, 8BJY, 8CEI, 8CZ, 8DKM, 8FT, 8UK, 8VY, 8WX, 8XE, 8XAN, 8YN, 8ZC, 9ANQ, 9AWF, 9AIM, 9AAR, 9AML, 9AEP, 9BJ, 9BLY, 9BZL, 9BDS, 9BRI, 9CBI, 9CTE, 9CCY, 9CLY, 9CFL, 9CCZ, 9CCS, 9DUG, 9DHz, 9DXY, 9DYR, 8DQE, 9DTE, 9EHJ, 9MC, 9XAQ, 9YU, 9YY, 9ZT, (9AVN).

Canadian: 3ZT, 3CO, 4CN, 4CB, 4CL.
Mexican: (1B), (1K), (1J), (1P), 1G, (MD), (AX).

Wud Appreciate Repts on my Sigs.

J. Agusty, 4JE

San Juan, Porto Rico (Dec 4 to 17)

1ALJ, 1AUR, 1CGO, 1RR, 1VV, 1XM, 2BY, 2DA, 2CPR, 2CRP, 2RF, 4BY, 4BX, 4ER, 4IT, 1PK, 5BX, 6AUU, 7KF, 8ARM, 8AGP, 8AIM, 8APN, 8ATR, 8BCL, 8BDA, 8HUU, 8BPM, 8EB, 8EJ, 8VQ, 9BAK, 9BAQ, 9BJO, 9DOE, 9QC, 9SS, 9VC.

Albert Ravelo, Cuban 8BY

Box 90, Santiago, Cuba.

1AA, 1AR, 1AOL, 1CB, 1CAP, 1ER, 1RK (spark), 1YB, 2AAK, 2AJD, 2IN, 2KF, 2TE, 2WR, 3AU, 3SU, 3TR, 4AT, 4AR, 4AN, 4BY, 4BU, 4BJ, 4DL, 4EL, 4FD, 4EB, 4EN, 4FT (fone & CW), 4GM, 4IK, 4KA, 4KF, 4KU, 4ME, 5NA, 5NN, 4NK, 4OB, 4XF, 4ZF, 5AAK, 5AAW, 5AAU, 5AK, 5AGJ, 5AIU, Cuban 5DW, 5QW, 5UA, 5UL, 5UR, 5XV, 5ZA, Cuban 6KW, 6AL, 6AR, 6AQO, 6BDA, 6BXV, Cuban 8DW, 8TU, 8XE, 9AAU, 9BAK, 9BD, 9BSP, 9DTT.

All hrd on det. only. Pse QSL end.

S. S. Myriam

C.W. Nov. 13, off Cap Finisterre (Spain), 2730 miles E. New-York: LAUR, 1VV, 3RM, 8APN, 8BGM, 8XE, 9AUL, 9EE; Can. 1AR (QSA).

Nov. 14, 2570 miles E. N.Y.: IARY, 1BF, 1GS, 1VV, 2RG, 3ALT, 4FT, 8XE.

Nov. 15, 2410 miles E. N.Y.: QRN bad: 1HX, 1VV, 1YB, 2BM, 2BQC, 3CO, 4FT (vy QSA), 8AIM, 8CDD, 8DKM; Can. 2BN.

Nov. 16, 2250 miles E. N.Y.: QRN bad: 1RWJ, 1HX, 1MY, 1YK, 1VV, 2AGB, 2XQ, 3PN, 8XAN. (Bad reception due to faulty B battery.)

Nov. 17, 2100 miles E. N.Y., Azores Islands: 1AJJ, 1ALJ, 1ARY, 1AUR, 1BDH, 1BDI, 1BGN, 1BWJ, 1CKP, 1CMP, 1CPN, 1DWJ, 1ER, 1FD, 1FDW, 1HX, 1KC, 1PA, 1RK, 1VV, 1WO, 1YN, 2AFP, 2AH, 2AML, 2AVP, 2AWF, 2AWP, 2BDG, 2BG, 2BN, 2BRB, 2BY, 2BZC, 2CCX, 2CEL, 2CFB (calling eng. 2SH-2KW), 2CJX, 2COA, 2CNK, 2CQL, 2CQO, 2CVU, 2CXL, 2IW, 2WE, 2XQ, 2ZA, 2ADB, 2ADV, 2ALN, 2ATB, 2BDO, 2BOO, 2BTI, 2BTL, 2BUC, 2BVA, 2CGN, 2OH, 2OQ, 2QS, 2TR, 2CS, 2RE, 2NK, 2TJ, 2ZAV, 2GR, 2GJQ, 2CGW, 2KA, (Both QSA and vy steady), 2ADB, 2ADK, 2AFN, 2AIG, 2BCH, 2BCP, 2BDA, 2BF, 2BFM, 2BRV, 2BXX, 2BZC, 2CDD, 2CEL, 2CGU, 2CNW, 2DAA, 2DGO, 2DHQ, 2JJ, 2UF, 2AAU, 2ABC, 2AFN, 2BGG, 2BDE, 2BEZ, 2BRK, 2BTX, 2BYC, 2BZI, 2CTE, 2DPX, 2DXV, 2ER, 2VC, 2VK, 2XL, 2YT; Can. 2BN. (Total: 112). Distance from Azores islands to Pacific coast about 4500 nautical miles. The best was 2CCX, louder than WSA!

Nov. 18, 1900 miles E. N.Y.: 1AJT, 1AJX, 1ALJ, 1ARJ, 1AWF, 1BES, 1BHW, 1BOQ, 1CKP, 1CMW, 1HX, 1KC, 1MY, 1OQ, 1RR, 1RV, 2AGB, 2BXW, 2HY, 2BVZ, 2CCT, 2CQZ, 2CSR, 2IU, 2ER, 2RQ, 2SU, 2WR, 2ADB, 2AR, 2BSV, 2BWN, 2CBM (calling eng. 2KW), 2CJN, 2GK, 2MF, 2SU, 2YP, 2EL, 2ANP, 2AA, 2AAF, 2ADA, 2ALE, 2AMM, 2BCM, 2BCP, 2BDA, 2BDU, 2BFM, 2BHN, 2BRN, 2BRC, 2BXX, 2BXT, 2BXX, 2CPT, 2CX, 2DAA, 2DGO, 2GZ, 2MZ, 2RJ, 2WX, 2ZZ, 9AIM, 9BMX, 9BP, 9BZI, 9CCZ, 9DKY, 9DTT, 9ELV, 9MC (calling French 8AR), 9RC, 9ZT; Can. 1AR (calling WNP), 2BG, 2IC, 3OH.

Nov. 19, 1680 miles E. N.Y.: QRN vy bad: 1ALJ, 1CFL, 1KC, 1RR, 1VV, 1YF, 2BRB, 2CXL, 2TS, 2XQ, 3ALN, 3BEL, 3CH, 3TE, 3TR, 3ZU, 4FT, 8ALN, 8APN, 8BCP, 8DAT, 8JJ, 8UF, 8WX, 9ABM, 9CTR, 9DSO, 9MC; Can. 1AR, 2BG, 2BN, 2CG, 2BP, 2NF.

Nov. 22, 1360 miles ESE. N.Y.: 1AIN, 1AJT, 1AJJ, 1ALJ, 1ALJ, 1AUR, 1AX, 1AY, 1BDI, 1BGU, 1BSK, 1BWD, 1CFI, 1EG, 1GV, 1MQ, 1MY, 1RI, 1YB, 1XAM, 2BBN, 2BGO, 2BTE, 2BY, 2CDM, 2CFB, 2CGR, 2CJR, 2CPA, 2CXF, 2CXI, 2DX, 2EL, 2EW, 2PV, 2TS, 3ABW, 3AGY, 3AHP, 3AS, 3AW, 3BDO, 3BOF, 3BQP, 3BUV, 3CHG, 2CJN, 2PK, 3TR, 3VW, 3XI, 3XM, 3EB, 3FS, 4GX, 4JA, 4RS, 5AAT, 5DA, 6AJJ, 6CGW, 6JX, 6ZAR, 7LR, 8AIG, 8AIP, 8AFD, 8AFN, 8BTT, 8BRW, 8BZ, 8RVC, 8CCL, 8CES, 8CKN, 8CMJ, 8CNW, 8CQS, 8CVG, 8CZZ, 8DAW, 8DIS, 8DFA, 8DKM, 8DO, 8GZ, 8JJ, 8SS, 8TR, 8UF, 9AAU, 9AHZ, 9AWV, 9AXB, 9AZY, 9BRI, 9BXC, 9CCL, 9CCZ, 9CJZ, 9CVC, 9DDA, 9DJM, 8DKX, 9DLW, 9DPX, 9DTT, 9EQ, 9QL, 9ZT; Can. 1AR, 2BN, 2IC.

Nov. 24, 1030 miles SE. N.Y.: 1AAU, 1ALJ, 1AOM, 1ARY, 1ASU, 1AW, 1BCF, 1BCR, 1BGK, 1BKR, 1BOQ, 1BT, 1BTT, 1CAB, 1CAC, 1CFN, 1CKQ, 1CMF, 1CMP, 1CQZ, 1IW, 1KR, 1HX, 1KC, 1SI, 1VV, 1VW, 1WO, 1XAQ, 1XM, 1YB, 2AAY, 2AGB, 2AIS, 2BMO, 2BMR, 2BRB, 2BRK, 2BY, 2CEI, 2CFB, 2CG, 2CGB, 2CNH, 2CNK, 2CPA, 2CPO, 2CQL, 2CQZ, 2CRP, 2CRW, 2CWX, 2IV, 2KF, 2KU, 2RB, 2RK, 2AK, 2AJB, 2AKY, 2AS, 2AVA, 2BOF, 2BWX, 2CEL, 2CEZ, 2CFI, 2CHG, 2CJN, 2CJW, 2CQZ, 2FP, 2HG, 2JY, 2KY, 2MK, 2NF, 2NT, 2OQ, 2OX, 2TE, 2TR, 2YH, 2YO, 3YV, 3ZO, 3ZT, 4CS, 4ER, 4EL, 4FT, 4M, 4JZ, 4LJ, 4ME, 4PD, 4RH, 5ARR, 5ARN, 5ACN, 5ADH, 5AE, 5AEK, 5AGD, 5AII, 5EK, 5HL, 5HT, 5LR, 5ME, 5NZ, 5OF, 5SD, 5TK, 5VF, 5WO, 5ZA, 5ZAX, 6ACM, 6ADX, 6AHU, 6AID, 6AK, 6AKZ, 6ARR, 6AWT, 6AWX, 6BIC, 6BII, 6BPZ, 6BUA, 6BVG, 6BWP, 6CEJ, 6CR, 6MH, 6XAO, 6ZAH, 7ABB, 7IW, 7SC, 7SF, 7ZD, 8ACV, 8ADA, 8APK, 8AII, 8AIM, 8AMB, 8ANP, 8AWP, 8AZO, 8BA, 8BAU, 8BBW, 8BDA, 8BDU, 8BF, 8BII, 8BPP, 8BVU, 8BXV, 8BXX, 8BYN, 8BZC, 8BZI, 8CCR, 8CDD, 8CDE, 8CRC, 8CTN, 8CWL, 8CXW, 8DAW, 8DKA, 8DLB, 8DO, 8DX,

8GZ, 8JJ, 8KG, 8KU, 8MR, 8RV, 8TT, 8VE, 8XAN, 8XE, 8ZZ, 9AIC, 9AIM, 9AMB, 9AMU, 9APP, 9APS, 9AWF, 9BDS, 9BED, 9BEZ, 9BIS, 9BLV, 9BP, 9BT, 9BUC, 9CED, 9CJC, 9CKW, 9COL, 9CTR, 9DFX, 9DKY, 9DMJ, 9EAK, 9EHN, 9EKY, 9KD, 9UZ, 9VC, 9VM, 9ZT, 9ZY; Can. 1AR, 1DD, 2BE, 2BG, 2BN, 2CG, 3AA, 3ADN, 3AMN, 3IR, 3NF, 3OM, 3PB, 3TR, 3YH, 3GN, 3KF. (Total: 238). Strongest of all is 2RK.

Please send cards to: A. Vasseur, 53 rue de Chabrol, Paris. Many TKS in advance.

S. S. Natirar

Heard in the North Sea, early November: 1ER, 1SN, 1ARY, 1CMP, 1YB, 2BY, 2RK, 2AGB, 2AWF, 2AAY, 2BGI, 2BVZ, 2CQZ, 3AS, 3YO, 5LR, 8BDA, 8CEL, Canadian: 1AR, 3BP, 1,000 miles N.E. Portland, Me., Nov. 21st: 6MH, 6CNH, 6AVV, 6AJJ, 6CGW.

A Ham at Sea

1350 miles East of New York: 1SE, 1WO, 1ALJ, 1AMF, 1CKP, 2KF, 2BQU, 2BZU, 2CVJ, 2LQ, 2ZO, 2BCO, 3CEL, 3CHO, 3GH, 3ZZ, 3AAG, 3AVT, 3BDU, 3BNH, 3VM, 3AMT, 3DDU, 3DKX, Canadian: 3CO, 3AK, Spark: 1BCF.

1160 miles East: 2AYP, 2BBX, 2BOL, 2BRB, 2BUY, 2RXP, 2CEE, 2CJR, 2IW, 3VA, 3CBM, 4HN, 4T, 5FM, 5VC, 5AIT, 5CCS, 5DQU, 5EKY, Canadian: 2BG, 2CL.

1010 miles East: 3BM, 3ML, 3NN, 3UK, 3MC, 3AAW, 3ARU, 3BSL, 3BWV, 3CJC, 3DHR, 3DKX, 3EKF, Spark: 3ACY.

A. G. Simonds, 92 James St., Ottawa, Canada.

3IW, 4EB, 4FT, 4KU, 5AKN, 5EK, 5FV, 5LR, 5OV, 5T, 6CGW, 6FP, 6PL, 8AA, 8AIM, 8AQO, 8ATP, 8BDA, 8BYN, 8CZZ, 8DCY, 8ER, 8FU, 8RJ, 8VY, 8YN, 8ZC, 9AAL, 9AAR, 9AEP, 9AHY, 9AIC, 9AKE, 9ALL, 9AMU, 9AND, 9AON, 9APE, 9AOB, 9ASE, 9ATN, 9AWG, 9AWP, 9AWV, 9BAK, 9BCH, 9BED, 9BEX, 9BG, 9BHL, 9BIL, 9BLG, 9BLV, 9BMU, 9BOE, 9BP, 9BQJ, 9BRE, 9BRK, 9BSH, 9BTJ, 9BZI, 9CCF, 9CCZ, 9CJC, 9CK, 9CKW, 9CNV, 9CSY, 9CTB, 9CTE, 9CVS, 9CYF, 9DAY, 9DGH, 9DHG, 9DHR, 9DKV, 9DKX, 9DMJ, 9DOE, 9DPC, 9DQU, 9DVW, 9DYV, 9DEB, 9EKF, 9EKY, 9EHT, 9ELD, 9ELJ, 9ELV, 9EP, 9EQ, 9ER, 9ES, 9MA, 9MC, 9FF, 9QL, 9QR, 9RC, 9VC, 9VM, 9YR, 9YY, 9ZT, 9ZY. Can.: 1DD, 2BN, 2CG, 3OM.

Can. 3IA, St. Thomas, Ont.

4CS, 4DB, 4EQ, 4FT, 4GX, 4JK, 4LJ, 4MI, 4ON, 5ADY, 5AHD, 5ANCO, 5ANP, 5LK, 5LA, 5LI, 5MM, 5QL, 5V, 5WO, 5XD, 5YW, 5ZAV, 5ZG, 6ACM, 6BJJ, 6CME, 6FP, 6HC, 6LU, 6ZH, 7ADR, 7CO, 7IO, 7ES, 7SC, 7WK, 8AAL, 8ADY, 8AGL, 8AHM, 8AKE, 8APP, 8AVG, 8BAG, 8BED, 8BIL, 8BJK, 8BOF, 8BRT, 8BRY, 8BSH, 8BXX, 8CQW, 8DCW, 8DDT, 8DGL, 8DKQ, 8DKK, 8DKY, 8DPW, 8EFH, 8EP, 8YU, 8ZT). Canadian: 1DD, 2BN, 2FU, 2CG, 2IC, 3NT, 4FN, 5GO.

Can. 3ZT, Toronto, Ont.

4AI, 4AY, 4FT) fone & C.W., 4HS, 4MB), 4PD, 4EL, 4SB), 5ABT), 5AGN, 5AGD, 5AHR), 5AII), 5ALX, 5AMF fone, 5ZAS, 5ZAV), 5BE), 5EK, 5GP, 5HT fone & C.W., 5LR, 5N, 5SR, 5VV, 5XE, 6AII, 6AVV, 6AWT, 6BCL, 6BC, 6BJQ, 6BVE, 6CDG, 6CGN, 6ZAH, 6BM, 6DD, 6ZH, 6ZV, 7ABB, 7CO, 7SC, 9AAI, 9AAU, 9ADY, 9AEC, 9AMB, 9AHV), 9AQR, 9ASO, 9AON, 9APP, 9AYL), 9AZG, 9RFF, 9REL, 9BGH, 9BGX, 9BIS, 9BJC, 9BRL), 9BMC, 9BMD, 9BNI), 9BTO, 9BVO, 9BWA), 9BWC, 9CBG, 9CGV), 9CIC), 9CMN, 9COW, 9CZL, 9DCW, 9DMN, 9DTE, 9DHH, 9DUH, 9DUV, 9DYN, 9DCW, 9ECV, 9EDK, 9EER, 9EHL, 9ELD), 9V, 9KDY), 9PR, 9RC, 9XI).

Can.: 1AR, 1BO, 1DD, 2AM, 2BE, 2RG, 2BN), 2CG, 2IC, 3AFP, 3AA, 3BA, 3BG), 3DB, 3HE, 3HT), 3IA), 3KP, 3MN, 3NF, 3NT), 3OY), 3SP), 3WG), 3WS), 4DK, 4CN, 4DY, 4RH, 5CN, 5GO, 9BX. French: 3AB.

1ALL, Bridgewater, Mass.

5BM, 5CY, 5EA, 5FQ, 5FV, 5GG, 5GN, 5HT, 5HZ, 5IN), 5KC, 5KN, 6KA, 5LR, 5MN, 5OV, 5PH, 5PS, 5QL, 5QQ, 5QY, 5SK, 5VM, 5VV, 5ZB,

5ABB, 5AGG, 5AHD, 5AIU, 5AJA, 5AJJ, 5AKN, 5ALJ, 5ALR, 5ALQ, 5XAB, 5ZAV, 6EA, 6LU, 6LV, 6NS, 6PL, 6ZB, 6AGK, 6ALV, 6AMG, 6AOS, 6ARB, 6ARU, 6AWT, 6BBC, 6BCL, 6BIC, 6BQE, 6CHL, 6CKL, 6CKP, 6ZBK, 7CO, 7OB, 7OT, (7SC), 7XT, 7ABB, 7ACE, 7AEA, 7AIY, 7AAL, 7AAQ, (7ABL), 7ABV, 7ACL, 7ACQ, 7ADP, 7AER, 7AEP, 7AIF, 7AHJ, 7AHQ, 7AIC, 7AJY, 7AKE, (7AMB), 7AMI, 7AMK, 7AMQ, 7AOG, 7AON, 7AFP, 7AQP, 7ASE, 7ASH, 7ARR, 7ATX, 7AUE, 7AVH, 7AWF, 7AWV, 7AXB, 7AYB, 7AYL, 7AZG, 7BAB, 7RAF, 7BAK, 7BBR, 7BBY, 7BCX, 7BEK, 7BEX, 7BFA, 7BFI, 7BGC, 7BGI, 7BGY, (7BHH), 7BHX, 7BHY, 7BIS, (7BIC), 7BJX, 7BQJ, (7BKK), 7BKR, 7BLX, 7BLY, 7BMM, 7BNE, (7BRI), 7BQJ, (7BOF), (7BTT), (7BWC), 7BWN, 7BUO, (7BTA), 7BQJ, 7BRT, 7BYX, 7RZI, 7BJZ, 7CAA, 7CAC, 7CAJ, 7CAX, 7CAY, 7CCM, 7CCN, 7CCS, 7CCZ, 7CDB, 7CHC, 7CHE, 7CHN, 7CHQ, (7CHI), 7CIP, 7CJC, 7CKI, 7CKM, 7CKW, 7CLQ, 7CNB, (7COC), 7COL, 7COW, 7CRA, 7CTR, 7CTU, (7CTO), (7CTP), 7CTT, (7CVD), 7CVV, 7CWF, 7CYW, 7DAJ, 7DAY, 7DCH, 7DEK, 7DGV, 7DHK, 7DHR, 7DJM, 7DJQ, 7DKY, 7DLW, 7DND, 7DNI, 7DMW, 7DQA, 7DQU, 7DQW, 7DPC, 7DSO, 7DVK, 7DSW, 7DYN, 7DZF, 7DZX, 7EAC, 7EBI, 7EBY, 7EDB, 7EEQ, 7EFQ, 7EGW, 7EHL, 7EHN, 7EHQ, 7EHT, 7EJA, (7EJZ), 7EKF, 7EKY, 7ELB, 7ELV.
 Canadian: 4CL, 4CN, 4NN.

Irving E. Mower, 443 St. John St., Portland, Me.
 4AB, 4AE, 4AL, 4AY, 4BX, 4BY, 4CR, 4DX, 4EA, 4ER, 4FS, 4FT, 4IT, 4IK, 4JY, 4JW, 5ADH, 5DR, 5FX, 5GD, 5FM, 5MK, 5ZG, 6FP, 6AAD, 6AAL, 6AAR, 6ACQ, 6AEN, 6AFY, 6AIM, 6APE, 6ARC, 6ARU, 6ASH, 6ATP, 6AWA, 6AWF, 6BCB, 6BDF, 6BDR, 6BGX, 6BHL, 6BIS, 6BOF, 6BQI, 6BQY, 6BRK, 6BRC, 6BSP, 6BTT, 6CCS, 6CCZ, 6CJA, 6CJC, 6CKN, 6CRA, 6CSD, 6CTE, 6CTI, 6CTV, 6CUI, 6DAY, 6DCY, 6DDC, 6DGG, 6DHR, 6DIR, 6DKV, 6DON, 6DQU, 6DRC, 6DTT, 6DUJ, 6DUU, 6DVG, 6DVL, 6DYY, 6ELL, 6ELV, 6EQ, 6JF, 6LN, 6LR, 6OR, 6PF, 6QR, 6RC, 6VC, 6VZ, 6WC.

1FD, Norwich, Conn.
 4CO, 4EL, 4FN, 4FT, (4JK), 4PK, 4QF, 4SH, 5AAC, 5AIR, 5AIU, 5AMB, 5AMH, (5AMW), 5BZ, 5DR, 5EK, 5FT, 5HT, 5LR, 5NN, 5QD, 5QL, 5RG, 5SD, 5UN, 5VM, 5XAP, 5ZA, 5ZB, 6ABC, 6ADT, 6AOS, 6AUI, 6AWT, 6BRW, 6BCL, 6BEM, 6BIC, 6BSL, 6BNP, 6BPM, 6BQB, 6BRP, 6BUH, 6BUU, 6BUY, 6BVE, 6CC, 6CFQ, 6CGD, 6CGW, 6CKP, 6CKR, 6DD, 6EB, 6FP, 6JX, 6LU, 6LV, 6OL, 6UW, 6ZH, 7ADR, 7AEA, 7CO, 7DU, 7GE, 7IO, 7JD, 7LU, 7MP, 7QC, 7QJ, 7SC, 7ZL, 7ACH, 7AFW, 7ACL, 7AHR, 7AMB, 7ANQ, 7AOU, 7AOX, 7AFP, 7AUS, 7AYX, 7BRA, 7BRI, 7BFX, 7BJK, 7BLY, 7BUI, 7BUQ, 7BKZ, 7CCS, 7CGY, 7CMN, (7CNO), 7CTE, 7CTZ, 7CWX, 7CYQ, 7CZN, 7DAY, 7HIW, (7DVW), 7DKX, 7DXS, 7EHL, 7EKC, 7EKF, 7ELL, 7ELQ, 7ELW, 7MC, 7NC, 7WU, 7ZG.
 Foreign: British 9YA; French 8AB.

2APP-2ZA, Paterson, N. J.
 3YW fone, 4AF, 4AG, 4AL, 4AY, 4DL, 4EA, 4EL, (4IZ), 5JK, 4JR, 4NV, 4ON, 4PK, 4PV, 4WV, 4RR, 5ABM, (5ABN), 5AEW, 5AGJ, 5AGV, 5AHJ, (5AHR), 5AIU, 5AKN, 5ANC, (5BFE), 5BS, 5BW, 5BK, 5BK, (5DW), 5FT, 5FV, 5HT, 5IN, 5IQ, 5KN, 5NN, 5NO, 5OV, 5PA, 5QI, 5QT, (5SD), 5TJ, 5TO, 5UY, 5VF, 5VM, 5VY, (5ZAV), 5ZAX, (5AAK), 6AKE, 6AKM, 6ANB, 6AOS, 6ATZ, 6AUI, 6AWT, 6BQ, 6BIC, 6BJJ, 6BRP, 6CPI, 6CFZ, 6CGW, 6CHZ, 6CMR, 6CNH, 6GN, 6GR, 6LV, 6OA, 6OL, 6PL, 6XAD, 6ZAH, 6ZBA, 6ZV, 7ABE, 7ABT, 7AGE, 7HW, 7IH, 7SC, (7TO), 9AAW, 9ACL, 9AEC, 9AEL, 9AEM, 9AIC, 9AJE, 9AMB, 9AMU, 9AOC, 9AP, (9ARE), 9ASH, 9ATN, 9AUD, 9AUS, 9AVN, 9AWF, 9AWZ, 9AXB, 9AXX, 9AYH, 9AYX, 9BBI, 9BBV, 9BCB, 9BDK, (9BED), 9BFB, 9BGC, 9BIB, 9BIC, 9BIS, 9BIC, 9BLX, 9BLG, 9BLU, 9BMX, 9BOZ, 9BPY, (9BQJ), 9BQY, (9BRI), 9BRK, 9BRX, 9BSI, (9BWN), 9BPV, 9CAO, 9CCN, 9CCS, 9CDO, 9DV, 9CE, 9CEA, 9CEE, 9CFO, 9CKN, 9CCZ, 9CLZ, 9CNE, 9COL, 9CON, 9CP, 9CSB, 9CTC, 9CTR, 9CTU, (9CUC), 9CVD, 9CVO, 9CXY, 9CWF, 9CYF, 9CYD, 9CZI, 9CZM, 9CZS, 9CZW, 9DBN, 9DCW, 9DDH, 9DEK, 9DFP, 9DGG, 9DHR, 9DJN, 9DJQ, 9DKB, (9DOE), 8DQU, 9DSW, 9DVQ, 9DXH, 9DXN, 9DYJ, 9DYY, 9DZX, 9EAK, 9EAR, 9EER, 9EJF,

9EFQ, (9EKY), 9ELA, 9EQ, 9ES, 9IH, 9HK, 9LZ, 9MF, 9MM, 9QR, 9RU, 9WU, 9XN fone, 9YU, 9ZT.
 Can.: 1BQ, (2BN), 2DN, 2IC, 3GG, 3IF, 3IV, 3QL, 3QS, 3NF, 3TB, 3XL, 3YV, 4ER, 4HH, 9BJ. English: 5AD, 4AT. French: 8BM.

Brainard Foote, Ossego Lodge, North Caldwell, N. J.
 5ADB, 5ADO, 5BU, 5AJT, 5AHV, 5HT, 5KG, 5SR, 5ZA, 6AR, 6AJJ, 6ARB, 6ACM, 6ATC, 6AJH, 6AUI, 6ADY, 6AOS, 6AUF, 6BVE, 6BPZ, 6BIA, 6BRF, 6BLG, 6CKR, 6CNH, 6CGW, 6CHU, 6CFY, 6CBD, 6EU, 6FY, 6FP, 6JX, 6MH, 6PL, 6RI, 6WT, 6ZH, 6ZAH, 6ZAU, 6ZBS, 7ADR, 7CO, 7EM, 7FD, 7NO, 7OT, 7SH, 7TT, 7ZD, 7AVU, 7AMB, 7AWD, 7AGN, 7AFP, 7AUW, 7BJ, 7BXQ, 7BUN, 7BJK, 7CCZ, 7DKX, 7DJK, 7DFH, 7DTE, 7EAE, 7XAQ.
 Can.: 4CW. Porto Rico: 4JA, 4SAB.

2BY, Schenectady, N. Y.
 4AB, 4AF, 4AL, 4AY, (4BX), 3RY, 4DR, (4DW), (4EA), (4EB), (4EL), 4FN, (4FT)* 4aht—C.W. & Fone, 4PZ, 4GX, (4HR), (4HS), (4JK), 4KU, (4LJ), 4MI, 4MY, 4OA, (4PK), (4QW), 4SH, (4GO), 5AIC, (5AIR), 5AIU, 5AKN, 5AMP, C.W. & Fone, 5AMH, 5ARH, 5BR, 5BK, 5ER, 5FV, 5GM, (5HL), 5KC, 5LR, (5NN), 5NZ, 5OV, 5QI, (5QL)*, 5QW, 5QY, (5UK), 5WE, (5XV), 5ZA, (5ZAV), 5ZAX, 6AAK, 6AJH, 6AWT, 6AOS, (6BCL), 6BIC, 6BM, (6BPZ), 6BVG, 6CGW, 6CRZ, 6FP, 6KA, 6LV, 6MT, 6NL, 6PF, 6PL, 6XAD, 6ZAH, 6ZBC, 6ZH, 6ZZ, (7ABB), 7ABY, 7ADH, 7ORA, 7OO*, 7EM, 7FD, (7IH), 7QC, 7SC, 7ZD, 7ZU, (9AAD), (9AAG), 9AAU, 9ACI, 9ACQ, 9ADY, 9ARD, 9AMB, 9ANB, (9AOU), (9AOX), 9APE, 9APP, 9ASN, (9ATN), 9AUS, (9AVT), (9AWF), 9AXD, (9AZG), (9RAK), (9BED), (9RFB), 9BG, 9BGR, 9BKP, 9BNZ, 9BOF, (9BRK), 9BRY, 9BTO, 9BUN, (9RWB), 9RZI, 9CBI, 9CCS, (9CCZ), 9CEA, 9CFZ, 9CHE, (9CKI), (9CLQ), 9CO, 9CRA, (9CTB), (9CVV), 9CYW, 9CZG, (9CZW), 9DAY, (9DSD), (9DKV), 9DLI, (9DOE), 9DON, (9DSW), (9DXS), (9EEG), 9EHL, 9ELL, 9EKF, (9EKY)*, 9ELA, (9ELV), (9ELQ), (9EP), (9EQ), 9FM, (9MC), (9YV); Can.: 5CN, 5CT, 5GO*; Eng.: 2KL; WNP - 18th.
 *Most consistent.

3HS, Washington, D. C.
 5ABC, 5ACM, 5ADC, 5ADV, 5AFQ, 5AGV, 5AHR, 5AKJ, (5AOM), 5JE, 5LR, (5NN), 5OV, 5QL, 5QL, 5QX, 5QY, 5SD, 5SG, 5SR, 5TO, 5TZ, 5WG, 6ADT, 6AGE, 6AGJ, 6AIV, 6AJF, 6AK, 6ALK, 6ALV, 6ANB, 6AOL, 6AOS, 6ARB, (6ARU), 6AUI, 6AVV, 6AWT, 6BBC, 6BCL, 6BDT, 6BEH, 6BFG, 6BH, 6BIC, 6BIJ, (6BIQ), 6BJJ, 6BKS, 6BKX, 6BLM, 6BPF, 6BRK, 6BUO, 6BUIZ, 6BV, 6BWE, 6BY, 6CBE, 6CBN, 6CDG, 6CFI, 6CGA, 6CGD, 6CGW, 6CHL, 6CHZ, 6CK, 6CLR, 6CMU, 6CNL, 6DU, 6FP, 6JA, 6LV, 6OL, 6PL, 6QJ, 6RN, 6XAD, 6YR, 6ZAH, 6ZAJ, 6ZAR, 6ZAS, 6ZBK, 6ZBN, 6ZH, (7ABB), 7AEA, 7AF, 7AIV, 7AMD, 7CO, 7FD, 7GI, (7HG), 7IH, (7IT), 7IN, (7LU), 7LY, 7MP, 7OB, 7OT, 7QJ, 7SC, 7TO, 7WS, 7XAE, 7YL, 7ZD, 7ZR, 9ABC, (9AGL), 9AMP, 9AOD, (9AOG), (9AON), (9APP), 9AXS, 9AYL, 9AZG, 9BEP, 9BG, 9BGS, 9BHY, 9BIR, 9BMC, (9BMX), (9BFO), 9BQI, 9BQY, 9BRI, 9BXO, 9CAA, (9CCS), (9CDO), (9CSY), (9CTD), 9DFH, 9DHW, 9DKR, (9DKX), (9DLF), (9EFU), 9EHT, 9EL, (9ELP), 9QE, 9TM, 9XAQ, 9ZT.
 Canadian: 4CL, 4CW, 4EA, 4FN, 4V, 5CN, 5GO.
 French: 8AB.

3AOX, Waynesboro, Pa.
 5DT, 5NY, 3QF, 5QW, 5QY, 5TS, 6AAK, 6AAQ, 6ABX, 6ACM, 6ACZ, 6ADH, 6ADT, 6AGE, 6AHF, 6AHP, 6AHI, 6AJH, 6AJJ, 6AJP, 6AK, 6AKZ, 6ALK, 6ALV, 6AO, 6AOL, 6AOS, 6ARB, 6ARU, 6ASX, 6AUI, 6AVV, 6AVY, 6AWQ, 6AWT, 6BIC, 6BBW, 6BCL, 6BOS, 6BEO, 6BEH, 6BFG, 6BHY, 6BH, 6BHK, 6BIC, 6BIB, 6BIQ, 6BIJ, 6BJJ, 6BKS, 6BKX, 6BLM, 6BNC, 6BNT, 6BPF, 6BUIZ, 6BV, 6BWE, 6BRF, 6BRG, 6BRK, 6BSJ, 6BTU, 6BUH, 6BUN, 6BY, 6BYE, 6BYW, 6BWE, 6BWX, 6CBU, 6CBW, 6CC, 6CEK, 6CFI, 6CGD, 6CFY, 6CGW, 6CHI, 6CHU, 6CHV, 6CK, 6CKR, 6CMR, 6CNH, 6CNI, 6DU, 6EA, 6EB, 6EC, 6EN, 6FH, 6FP, 6FY, 6GR, 6HP, 6IQ, 6JX, 6LA, 6LU, 6LV, 6MH, 6NX, 6OL, 6PL, 6RM, 6TI, 6TS, 6TV, 6UA, 6VF, 6WT, 6XAD, 6ZAH, 6ZAJ, 6ZAR, 6ZAU,

6ZBA, 6ZBC, 6ZBK, 6ZH, 6ZR, 6ZW, 6ZZ, 7ABB, 7ADH, 7AEB, 7AFN, 7AGV, 7AHL, 7ALK, 7CO, 7DC, 7GL, 7HG, 7IH, 7KS, 7LU, 7LW, 7LY, 7MP, 7NC, 7QC, 7SC, 7TO, 7XAE, 7YL, 7ZU, 7ZY, 8BG, 9XAG, 9one-9AIC, 9YAM, 9XM.
 French: 9AB.

3CCU, Emizsville, Pa.
 (WZV), 6ABN, 6ADC, 6ADO, 6AIC, 6AJB, 6AMP, 6AGV, 6AKF, 6AMH, 6AOM, 6BMB, 6FV, 6HT, 6IN, 6JR, 6KG, 6KR, 6LR, 6MN, 6PB, 6QL, 6QT, 6QW, 6QY, 6UK, 6UO, 6VM, 6WS, 6XJ, 6ZA, 6ZAV, 6AHF, 6AJH, 6AKZ, 6AJU, 6AWT, 6BCL, 6BIC, 6BQ, 6BUA, 6BUH, 6BVG, 6CGW, 6CKR, 6CMR, 6CNL, 6DU, 6FP, 6FY, 6GR, 6PL, 6WT, 6XAD, 6ZH, 7ABB, 7ADH, 7ADE, 7CO, 7IO, 7LU, 7SC, 7ZD, 9AAD, 9AAR, 9AAU, 9ADY, 9AHJ, 9AHY, 9AIM, 9AJM, 9AKD, 9ALL, 9AMB, 9AON, 9AOR, 9APD, 9APS, 9ARF, 9ASE, 9ASH), 9ATE, 9AUW, 9AWF, 9AXX, 9AZG, 9AYJ, 9BAK, 9BCS (9BCU), 9BFD), 9BFF, 9BFX, 9BGH, 9BIB, 9BIF, 9BKP, 9BLY, 9BMU, 9BOF, 9BPY, 9BQY, 9BRX, 9BRY, 9BTO, 9BUK, 9BUN, 9BUO, (9BWC), (9BWF), (9BXJ), (9BXQ, 9BZS, 9BZG, 9CCM, 9CDE, (9CFK), 9CGE, 9CH, 9CNO, (9CSY), 9CTE, (CUI), 9CYS, 9CFY), (9DAY), 9DDI, 9DDT, 9DDW, 9DFH, 9DGE, 9DGG, 9DGH, (9DHK), 9DHR, 9DHZ, 9DGV, (9DKY), 9DKX, 9DNN, (9DPC), (9DQH), 9DQU, 9DRA, 9DRO, 9DRW, 9DUG, 9DWK, 9DXS, (9DYT), 9DYV, 9EAE, 9EBA, 9EPD, 9EPH, 9EHL, 9EHT, 9EKY, 9ELD, 9ELL, 9CA, 9EP, 9EQ, 9EL, 9ES, 9GS, 9IR, 9LN, 9MM, 9PF, (9VM) 9VQ, 9VZ, 9WS, 9Y, (9ZT).
 Canadian: 2BG, 2BN, 2CG, 2CQ, 2IC, 3AD, 3ADN, 3JR, (3OM), 3PG, 3NF, 2WS, 3XJ, 3Z, 4FV, 4CW.

4JK, Greenville, S. C.
 6AGE, 6AHU, 6AJD, 6ALV, 6AK, 6AOL, 6AOS, 6AQD, 6ARB, 6AWT, 6BCL, 6BIC, 6BII, 6BIR, 6BM, 6BNC, 6BNP, 6BPZ, 6BSX, 6BUA, 6BUO, 6BVE, 6C6W, 6CGD, 6CFZ, 6CGW, 6CHU, 6CMR, 6CNH, 6EO, 6FH, 6FP, 6LU, 6MH, 6PL, 6RM, 6VF, 6ZAH, 6ZAU, 6ZH, 7CO, 7FD, 7GE, 7SL, 7UK, 7WE, 7ZD.

4JR, Gastonia, N. C.
 (1AFP), 1ALJ, 1ARY, 1AWY, 1BCU, 1FR, 1HX, 1KX, 1MY, 1RR, 1RS, 2BMP, 2BOH, 2BUY, 2CEL, 2CQW, 2CJV, (2KU), 2LE, 2WB, 3ABN, 3AFQ, 3AIC, 3AMJ, 3AS, 3FX, 3JE, 3KG, 3LB, 3QA?, 3OV, 3PZ, 3QP, 3QT, 3W, 3UK, 3ACM, 3AHF, 3ALK, 3AHC, 3AWQ, 3BCL, 3BEG, 3BIC, 3BNO, 3BR, 3CIR, 3CFZ, 3CGW, 3CMR, 3AK, 3FP, 3GR, 3LV, 3PL, 3ZAK, 3BZ?, 3ZH, 7CO, 7LU, 7QC, 7YL, 8AVD, 8AZG, 8BJ, 8BUL, 8BXA, 8CED, 8COL, 8CZZ, 8DLD, 8FC, 8FL, 8NZ, 8ON, 8PK, 8RM, 8ABW, 8ADY, 8AED, 8AIM, 8AMB, 8APP, 8AQC, 8ATP, 8AYV, 8AVN, 8AWP, 8AYP, 8AYX, 8BAK, 8QAT, 8BDR, 8BGC, (8BXC), 8BOP, 8BRX, 8RUH, 8BWC, 8BXQ, 8BYX, 9CCS, 9CGW, 9CCZ, 9CDJ, 9CFY, 9CGN, 9CKR, 9CKW, 9CMK, 9CMN, 9CNO, 9COG, 9CPY, 9CRK, 9CGZ, 9CZM, 9DBN, 9DCH, 9DGR, 9DKX, 9DJZ, 9DRO, 9DSO, 9DSQ, 9DWK, 9DYR, 9DYV, 9DZS, 9ECV, 9EDH, 9EFU, 9EGW, (9EHI), 9ELA, 9ETD, 9LE, 9QW, 9XI.
 Spk: 2PSC.
 Can.: 2BE, 2BG, 2BN, 2CQ, 2IC, 3DZ, (3KG), 3NF, 3XJ, 3BJ.

4SD, Gainesville, Fla.
 1AW, 1ER, 1FP, 1MO, 1RK, 1SD, 1AP, 1BWJ, 2AAY, 2AGB, 2BRB, 2CED, 2CWR, 2CXO, 5AC, 5AE, 5EK, 5GI, 5GN, 5IP, 5HL, 5HT, 5HZ, 5IN, 5MA, 5MO, 5NJ, 5NN, 5OO, 5QP, 5QF, 5KY, 5YW, 5ZA, 5ZAV, 5ZAF, 5ACM, 5AEQ, 5APQ, 5APR, (5AFS), 5AGE, (5AGJ), (5AGO), (5AMH), 5XAC, 5XBF, 5AK, 6BM, 6IL, 6JJ, 6KA, 6LV, 6MH, 6ZH, 6ZZ, 6AEG, 6AGE, 6AJJ, 6AL, 6AK, 6AV, 6BCL, 6BFT, 6BIC, 6BII, 6BT, 6BZ, 6CBI, 6CDD, 6CQW, 6CHU, 6CKR, 6CMG, 6CMR, 7LU, 7ZF, 7ZV, 7ZU, 7ZZ, 7ABB, 7ABW, 7AGE, 7AOP, 7RF, 7W, 7DX, 7GD, 7GZ, 7HN, 7HY, 8I, 8PD, 8XE, 8Y, 8ZW, 8ZZ, 8AGO, 8AMR, 8AWS, (8BDA), 8BDH, 8BDT, 8BVR, 8CGU, 8DCK, 9EL, 9EP, 9IG, 9MC, 9FE, 9PW, 9UZ, 9VC, 9VD, 9VK, 9VM, 9Z, 9YM, 9YV, 9ZT, 9AAL, 9AAF, 9AAL, 9AAW, 9ABH, 9ACH, 9AED, 9AEO, 9AIM, 9AOL, 9AOM, 9AOL, 9APS, 9ABK, 9AUS, 9AWG, 9AXE, 9AXH, 9AXY, 9AYL, 9AYH, 9BAC, 9BAZ, 9BDS, 9BEC, 9BEC, 9BHL, 9BHK, 9BHU, 9BLZ, 9BJ, 9BJC, 9BJR, 9BJK, 9BK, 9BKO, 9BLG, 9BMD, 9BPW, 9BRK, 9BRX, 9BSH, 9BSI, 9BZZ, 9CAA.

9CCS, 9CCV, 9CFJ, 9CFZ, 9CHD, 9CHO, 9CHY, 9CLJ, 9CLQ, 9CLY, 9CTR, 9CWC, 9CWL, 9CWK, 9DCR, 9DND, 9DDU, 9DHB, 9DIS, 9DIW, 9DJ, 9DJS, 9DKX, 9DMJ, 9DQU, 9DTT, 9DVK, 9DY, 9DYW, 9DYZ, 9DZY, 9EBO, 9EIO, 9EFC, 9EFX, 9EHT, 9EY, 9EKF, 9EKP, 9EKY, 9ELL, 9ELV, 9SPk.: 5JD, 8TH, 8TJ, 8WX, 8AMX, 8BCO, 8BDA, 9AAW, 9BHZ, 9BOP, 9CEN, 9DHZ, 9DVK, 9EFA, 9CA.
 Fone: 1CS, 1DQ, 5AMF, 4EB, 4EL, 4FT, 6CBI, 8ACF, (WSAG) 77HI.
 Can.: 1AL, 1AR, 1AW, 2BN, 2BQ, 2CG, 3CO, 3FC, 3JT, 3KG, 3OM, 3ZL, 3ADA, 3ADN, 4EA, 4HH, 5GO, 5CT, 5TC, 5AL, 9BP: spk.: 9CA.
 Mex.: BX.
 Army: WVZ, WX5.

5AC, Mobile, Ala.
 1ALJ, 1CMP, 1FM, 1II, 1IV, 1PA, 1SF, 1XAK, 2AGB, 2ATZ, 2BBX, 2BL, 2BQB, 2BRB, 2BUM, 6ACM, 6AHU, 6AJF, 6AJJ, 6AK, 6ANI, 6AOL, 6AOL, 6AOS, 6ARB, 6AUP, 6AUY, 6AVV, 6AWT, 6BCL, 6BEO, 6BEG, 6BII, 6BJQ, 6BRK, 6BRF, 6BUA, 6BUH, 6BVO, 6BWE, 6BVE, 6CAE, 6CDD, 6CDE, 6CDG, 6CC, 6CEK, 6CFZ, 6CGW, 6CHU, 6CKR, 6CKW, 6CLR, 6CMR, 6CNH, 6FP, 6JT, 6LV, 6LX, 6PL, 6SU, 6VD, 6XD, 6ZAR, 6ZG, 6ZH, 6ZR, 7ARB, 7ADR, 7AEA, 7AEL, 7AGE, 7AGR, 7AIY, 7AKH, 7JD, 7OB, 7SC, 7WM, 7ZD, 7ZU.
 Canadians: 2IC, 3CO, 3LL, 3OH, 3PG, 3TB, (3XD), 3ZL.
 Cuban: 4JA.

5ADB, El Paso, Texas
 1ADN, 1AEZ, 1AFP, 1BDI, 1BOQ, 1CMP, 1CPN, 1SN, 1ZI, 2AFP, 2CXD, 2RK, 2TS, 2XQ, 2XS, 3AB, 3ALN, 3BJ, 3RVA, 3TR, 3ZO, 4EQ, 4FN, (4FT), 4HN, 4ON, (5ADO), 5AES, 5AGT, 5AHR, 5AJU, (5AJJ), (5AKN), (5AMA), 5BE, (5CV), 5EK, 5FA, (5FJ), 5FT, 5HT, 5IA, (5LG), 5LW, (5NK), 5OO, (5SD), (5UT), 5UK, 5XD, (5YK), 5ZAV, (6AAK), (6ADT), (6AHU), (6AKZ), (6AND), (6AOD), (6BBH), 6BEO, (6BEQ), (6BIC), (6BJJ), (6BKX), 6BNC, (6CGD), (6CGW), (6CHU), (6CHV), (6CMR), (6CMS), (6CMU), (6CNG), (6EC), (6FN), (6FP), 6LU, 6ZAH, 6ZAM, 6ZAU), (6ZL), 7ABB, 7ACL, 7CO, 7FD, 7HW, 7IO, 7JD, 7LY, (7OR), 7OH, 7OT, 7ZU, 8AFD, 8AIM, 8AWJ, 8BCH, 8BDA, 8BFC, 8BHN, 8BMC, 8BYO, 8BZC, 8CDZ, 8CED, 8CGX, 8CFE, 8CVG, 8CWU, 8FU, 8JJ, 8TR, 8XE, 8YN, 8ZZ, 9ABY, 9AMU, 9AQU, 9ASN, 9AUA, (9AVN), 9AXX, 9BDL, (9BDS), 9BEH, 9BES, 9BPK, (9BG), 9BQJ, 9BSH, 9BYC, 9RZE, (9CAA), 9CJS, (9CKM), (9GLD), 9COL, 9CZM, (9DAW, 9DGI, 9DHB, (9DTE), 9DSO, 9DXL, 9DYZ, 9DZY, 9EBB, (9EHM), 9EM, 9FM 9MC, 9SS, 9XI, 9YY, (9ZG).
 Canadian: 2IC, 3BP, 3CN, 4EA, 9X.
 Mexican: (HX).
 Army: AS6 (QRA?).

Following stations heard during daylight, before 6 P.M.: 1BWJ, 1XAM, 4FT, 7ABB, 5AHC, 5AHR, 5AHT, 5AUI, 5AQT, 5BE, (5CV), 5FX, 5GI, 5IN, (5KC), (5LG), 5NN, 5QW, 5UK, (5SD), 5ZG, (6AHU), 6BRF, (6EC), (6FP), 8AN, 9AAU, 9AHZ, 9AVN, 9AVG, 9AYP, 9AIM, 9REZ, 9BDS, 9BWV, 9BRI, 9EFA, (9CDJ), (9CCV), 9BFH, 9DAW, 9DGV, 9EHN, 9EJZ, 9EKF, 9NR, 9PW, 9QW, WJL QST cards if requested. All reports on our sigs appreciated.

5AHD, Altus, Okla.
 (1ATJ), 1BOQ, 1WD, 1XM, 1YB, 1ZI, 2BIX, 2BQB, 2CDA, 2CKK, 2CPA, 2AII, (6AOD), (6ARU), 6BJJ, 6BVE, 6CAE, 6CRG, 6CGW, 6CHU, 6CNH, (6CNI), 6EU, 6MH, (6NB), 6NN, 6ZH, (7ABB), 7ADR, 7AJE, (7OO), (7HW), 7LY, 7MP, 7SC, 7TO, 7VL, 7ZU, 8AGC, 8AGO, 8AHL, 8AJU, 8ARD, 8BBI, 8AUV, 8CMM, (8CSD), (8CMI), (8CQJ), 8CPK, 8CZZ, (8DHM), (8DPC), 8EL, 8GZ, 8OY, 8VG, 8ZA, 8ZC, 8ZF, 8ZZ, 9- too numerous. Over 150.
 Fone: 3AGG, 5AHL (GAMP), 8AMW, 5EJ, 5FA, (5UY), (9AIC), (9CNT), 9CSV.
 Can.: (3GC), (5IA), 3OM, (3SU), (4CL), (4DK), (5CN).

6PL, Hollywood, Calif.

1AAL, 1AWE, 1CDA, 1CMP, 1CPN, 1SCW, 1FB, 1KC, 1YE, 2AAI, 2AZY, 2CXL, 2DN, 2GK, (2RK), 2RS, (3ACQ), 3BVA, 3HG, 3HK, 3JJ, 3NF, 3SU, 4CW, 4EB, 4EL, 4FT, 4K, (4KU), 4KZ, 4GH, 4UO, 5ADO, (5AIU), 5AIV, 5AJJ, 5AHR, 5AKN, 5AMA, (5BE), 5DO, 5EK, (5QT), 5QL, 5QW, 5QR, 5DI, (5KG), (5LR), (5LG), (5MN), 5PH, 5CY, 5SD, 5SR, 5ST, 5UM, (5UO), 5XAP, 5XV, 5XD, 5ZA, 5ZAV, 5AB, 5ABM, 5ADA, (5ADK), 5AGK, 5AK, 5AMM, 5AMP, 5AON, 5APN, 5AWP, (5BCI), (5BDA), 5BDI, 5BFM, (5BJI), 5BQB, 5BJV, 5BOI, 5BRX, 5BYN (5CDZ), (5CEI), 5CEL, 5CGX, 5COM, 5CUW, 5DDC, 5DHG, 5DO, 5FM, (5FU), (5GZ), 5HV, 5IB, 5IG, (5JJ), 5KR, (5VY), 5PL, 5PV, 5SP, 5VE, (5WY), 8YU, 8ZO, (8ZY), 8ZZ, 9AAU, 9AEP, 9AEM, 9AHQ, 9AIM, 9AIE, (9AMB), 9AMK, (9ANY), 9AP, 9APE, 9APS, (9APF), 9ARK, 9ARZ, 9AUN, 9AVK, (9AVS), 9AVN, 9AVU, 9AVZ, 9AVV, 9BWW, 9AYU, (9AZG), 9BAK (dahlite), 9BBJ, 9BFD, 9BEZ, (9BG), 9BHD, 9BHX, 9BHZ, 9BIK, 9BIL, (9BJK), 9BKF 9BLY, 9BOF, (9BP), 9BRI, 9BRK, 9BSG, 9BSP, 9BTT, (9BUN), 9BVO, 9BXA, (9BXQ), 9BZI, (9CAA), 9CAT, 9CCS, 9CQ, 9CCZ, (9CDE), (9COE), 9CEH, 9CFJ, 9CFY, (9DGV), 9CJT, 9CJC, 9CJY, 9CKD, 9CKQ, 9CLE, 9CPU, 9CPV, 9CRA, 9CTE, 9CTG, 9CXH, 9CYD, 9CYF, 9CZD, (9CZG), 9CZV, (9DFH), 9DGE, (9DIS), (9DKB), (9DKQ), 9DKY, 9DIL, (9DMA), 9DQU, (9DSW), (9DTE), 9DUN, 9DYR, 9EEA, 9EBR, 9EHI, 9EHI, 9EKC, (9EKY), (9ELV), 9FE, 9GD, 9GK, (9HK), 9LA, (9MC), 9NU, 9ON, 9OX, 9QR, 9RC, 9RD, 9SS, 9VM, 9XAQ, (9YAJ), 9YB, 9ZG, (9ZT) Can.: 3OM, 4CL, 4EA, (5CN), (5GO), 9BX, 9RP Hawaii: (6CEU), 6CCR, 6CMH.

6ADH, Box 8, Phoenix, Ariz.

1AJP, 1BQC, 1HS, 1HX, 1KX, 1MO, 1PZ, 1RC, 1XH, 2ADH, 2BF, 2BJ, 2BJA, 2BML, 2FP, 2HT, 2RM, 3RGW, 3BJ, (3BVT), 3BAK, 3FT, 3GG, 3HG, 3TR, 3ZO, 4BG, 4CD, 4CL, 4CS, 4GH, 4GL, 4GX, 4IU, 4JU, 4PZ, 4RR, 5ACR, 5ADO, 5AEC, 5AHR, 5AIC, 5AIR, 5AIU, 5AKM, 5AKH, 5AMA, 5AMU, 5ANA, 5ANR, 5AJU, 5AQ, 5BM, 5CM, 5DY, (5FT), 5GA, 5GJ, 5GP, (5HT), 5JC, 5JE, 5JF, 5KG, 5KH, 5KN, 5LG, 5LK, 5LQ, (5LR), 5MA, 5MM, 5MO, 5MT, 5QP, 5QI, 5QJ, 5QW, 5TD, 5GK, 5XA, 5XB, 5XD, 5XT, 5XU, 5XV, 5ZA, 5ZAF, 5ZAJ, 5ZAK, 5ZAN, 5ZAQ, 5ZAR, 5ZAS, 5ZAT, 5ZAU, 5ZAV, 5ZC, 5ZE, 5ZG, 5ZH, 5ZI, 5ZK, 5ZL, 5ZM, 5ZN, 5ZO, 5ZP, 5ZS, 5ZU, 5ZW, 5ZX, 7AR, 7APT, 7ALA, (7EM), 7HW, 7HZ, 7KP, 7LW, 7OB, 7PJ, 7SC, (7SY), 7XB, 7YA, 7YB, 7YE, 7YJ, 7YK, 7YL, 7YO, 7ZA, 7ZB, 7ZC, 7ZD, 7ZF, 7GG, 7ZJ, 7ZL, 7ZM, 7ZO, 7ZU, 7ZV, 7XAF, 8AGP, 8ALP, 8ALX, 8ALM, 8ASV, 8BDA, 8BPQ, 8BPU, 8BSA, 8BZD, 8CE, 8CGJ, 8CPO, 8COR, 8HV, 8RJ, 8NZ, 8SP, 8ZL, 8ZZ, 8ZO, 9AEG, 9AGE, 9AGZ, 9AIV, 9AIM, 9AIZ, (9AMB), 9AMD, 9AOW, 9APF, 9APP, 9AUI, 9AVU, 9AYJ, 9AZA, 9BIS, 9BJ, 9BJE, (9BJK), 9BFD, 9BPK, 9CBE, 9CCL, 9CCM, (9CEU), 9CHI, 9CKJ, 9CLD, 9CLT, 9CMI, 9EIV, 9CZM, 9DAX, 9DEG, 9DN, 9DPP, 9DUG, 9DXM, 9DXQ, 9EEJ, 9EFV, 9EHI, (9EHW), 9EL, 9IG, 9LR, 9VE, 9VK, 9VZ, 9W, (9XAQ), 9YAE, 9YAK, 9YAO, 9YC, 9YQ, 9ZC, 9ZL, 9ZN, 9ZX, 9ZY, 9ZAC, 9ZAF. Can.: 9BP, WNP.

6CHL, San Francisco, Calif.

1ER, 1KC, 1YE, (1AJX), 1BOQ, 1CAE, (1CMP), 2OL, 2RK, 2CEB, 3AB, 3GK, 3HS, 3AV, (4AP), 4DB, 4EB, 4FT, 4HS, (4MY), 4KU, 4UV, 5BM, 5DL, 5EK, 5GA, 5GI, (5GJ), 5HT, 5HZ, 5IQ, 5KC, 5KG, 5LG, 5LR, 5LX, 5MI, 5NN, 5NK, 5NR, (5OV), 5QP, 5QU, 5QQ, 5QY, 5SD, 5TF, 5UO, (5VM), 5WE, (5XD), (5XT), 5YG, 5ZA, 5ZB, 5ABB, 5AGI, (5ADE), 5ADO, 5AGI, 5AHD, 5AHR, 5AIU, 5AKN, 5AKY, 5AMA, 5AMB, 5ANI, 5XAB, 5XAC, 5XAM, (5ZAV), (6CEU), (6AAA), 8AB, 8AD, 8ER, (8ES), 8FU, 8GT, (8GZ), 8HN, 8JY, 8KC, 8ON, (8PL), 8ON, 8SB, 8TT, 8VQ, 8VY, 8WX, 8XE, 8YN, 8YV, (8ZY), 8ADA, 8ACN, 8ACY, 8APS, 8AII, 8AJH, 8AKZ,

8AME, 8ANM, 8AOQ, 8ARD, 8ATC, 8BAT, 8BCH (8BDA), (8BFH), (8BFM), 8BJU, 8BJV, 8BMB, (8BNH), 8BXH, 8BYN, (8RZD), 8CCL, 8CDZ, 8CED, 8CEI, 8CGO, 8COM, (8CRC), 8XEK, 9CP, 9EI, 9FM, 9FP, (9MC), 9MZ, 9QX, 9QR, 9SS, 9TV, 9VK, (9VM), 9VZ, 9XI, 9YU, 9YY, 9ZT, 9ZY, 9ZX, (9AAW), (9AEM), 9AFM, 9AIC, 9AMB, 9AME, 9AMK, 9AOS, 9APE, (9APF), 9AUS, 9AUV, 9AVN, 9AVS, 9AVU, 9AVZ, 9AWA, (9AZG), (9BAK), 9BCF, 9BDU, 9BEZ, 9BHX, 9BIK, 9BIL, 9BJK, 9BJQ, 9BKF, 9BKP, (9BLY), 9BLG, 9BLU, 9BPV, (9BRI), (9BRK), 9BUB, 9BUO, (9BZI), (9CAA), 9CCS, (9CCZ), (9CGU), 9CJC, 9CJS, 9CKW, 9CLY, 9CMN, 9CNS, 9CSY, 9CTB, (9CTR), 9CZG, 9DAY, 9DAW, 9DFH, 9DGC, 9DJM, 9DKB, 9DKC, 9DKY, 9DLL, 9DLM, 9DOE, 9DOG, (9DOU), 9DOM, 9DTE, 9DVM, 9DXM, 9DXY, (9DYR), (9EEA), 9EDB, (9EKY), 9ELV, 9EHN, 9XAO, 9YAJ. Can.: 2BN, 3BP, 3CO, 4CB, 4CL, 4CN, 4CS, 4CW, 4DQ, 4FN, 5CN, (5GO), 5CT, 9BP. Mex.: BX.

7IY, Vashon, Wash.

1AJX, 1AMF, 1ARY, 1AUR, 1BOM, 1BWJ, 1BQD, 1BDI, 1CMP, 1ER, 1VL, 1XAM, 1XU, 1YB, 2AAY, 2AAF, 2AGB, 2AWF, 2AWL, 2BN, 2BY, 2BOG, 2BQH, 2BLM, 2CGJ, 2CXD, 2LV, 2RK, 2XQ, 3AHP, 3ADN, 3AWT, 3AJD, 3BA, 3BQD, 3BGG, 3BFE, 3BTL, 3BVA, 3CHG, 3CIN, 3JJ, 3IW, 3PZ, 3SP, 3TI, 3TB, 4ACC, 4CW, 4JK, 4K, 4MB, 4QW, 5AIU, 5ABB, 5AIJ, 5AIR, 5AHR, 5AKI, 5AIC, 5AHD, 5AGV, 5ADH, 5AEV, 5AIW, 5AIJ, 5AKN, 5AMF, 5AFH, 5EK, 5EJ, 5FX, 5FY, 5GA, 5GJ, 5GM, 5GP, 5HL, 5IN, 5JG, 5KC, 5LL, 5LR, 5MO, 5MT, 5NG, 5OO, 5QY, 5RW, 5UK, 5UG, 5UP, 5WK, 5XC, 5YE, 5ZA, 5ZAS, 5ZG, 5ALW, 5AGO, 5ACN, 5AQC, 9AHC, 8ARD, 8ACY, 8ANM, 8APT, 8AWP, 8AVD, 8AII, 8APN, 8AQM, 8AGC, 8AIG, 8AJE, 8AWJ, 8ABL, 8AMM, 8ARG, 8ANL, 8AGY, 8AGP, 8ATC, 8AMF 8AB, 8ALE, 8AAF, 8AJH, 8AFN, 8BZD, 8BXK, 8BNH, 8BVT, 8BCL, 8BX, 8BBW, 8BYN, 8BDA, 8BJV, 8BOB, 8BCF, 8BF, 8BZ, 8BYN, 8BXH, 8BW, 8BCP, 8BT, 8BCE, 8BFM, 8BAG, 8BOA, 8BPA, 8BKZ, 8BKY, 8BYO, 8BRM, 8RRK, 8BCU, 8CGD, 8CKO, 8CXI, 8CVE, 8CUX, 8CHD, 8CQP, 8CTV, 8CGU, 8CP, 8COM, 8CGA, 8CKK, 8CWX, 8CLC, 8CTP, 8CUG, 8CRB, 8CDB, 8CNW, 8CIP, 8CRN, 8CHB, 8CGJ, 8CQJ, 8CVA, 8CEI, 8CES, 8CAU, 8CUV, 8CFJ, 8DGO, 8DO, 8DGR, 8DCZ, 8DDA, 8DAT, 8DZC, 8DX, 8DAC, 8DKM, 8DPC, 8DU, 8DJJ, 8DDT, 8DO, 8DGP, 8DIL, 8DGI, 8ES, 8ER, 8FU, 8FM, 8GU, 8GZ, 8HN, 8HV, 8JJ, 8JU, 8KG, 8KJ, 8KB, 8PL, 8RM, 8RN, 8TT, 8TR, 8TC, 8UN, 8UF, 8VE, 8VT, 8WP, 8WX, 8WY, 8XAN, 8XE, 8XH, 8YN, 8Z, 9AMK 9AWF, 9AJI, 9APH, 9ASE, 9DAY, 9AFM, 9AJE, 9AAU, 9ARC, 9ASE, 9ACB, 9AQA, 9AAW, 9AFZ, 9APE, 9AON, 9AUA, 9AHQ, 9AJV, 9AIM, 9AWV, 9AAP, 9AUS, 9AN, 9AYH, 9AUA, 9AWP, 9APE, 9ASN, 9AEN, 9AIC, 9ANY, 9AMK, 9AQK 9AND, 9AAD, 9BTT, 9BOF, 9BMX, 9BIS, 9HWV, 9BQY, 9BYC, 9BED, 9BAV, 9BYE, 9BTX, 9BT, 9BIE, 9BSH, 9BG, 9BOQ, 9BFF, 9BHQ, 9BAK, 9BIH, 9BAN, 9BIZ, 9BSZ, 9BJI, 9BJK, 9BQA, 9BFG, 9BPV, 9BZE, 9BIZ, 9BKH, 9REY, 9BRI, 9BCB, 9BKR, 9BHI, 9BKP, 9BLY, 8JIC, 9BGX, 9BRK, 9BPU, 9CTI, 9CJD, 9CLQ, 9CKG, 9CPI, 9CP, 9CVF, 9CCV, 9CKW, 9CLK, 9CCD, 9CCZ, 9CLZ, 9CEN, 9CS, 9CHL, 9CRA, 9CUL, 9CVY, 9CWF, 9CFI, 9CFH, 9CIP, 9CVY, 9CY, 9CKP, 9CAA, 9CNI, 9CQU, 9DFO, 9DGE, 9EY, 9DSW 9DOE, 9DYR, 9DIX, 9DKU, 9DRV, 9DKY, 9DZE 9DXN, 9DFU, 9DWJ, 9DRQ, 9DSM, 9DGI, 9DRK 9DCW, 9DTE, 9DYZ, 9DCH, 9DDP, 9DFX, 9DYR, 9DYG, 9DWN, 9DAY, 9DWA, 9DHB, 9DCA, 9DSV, 9DVM, 9DU, 9EDM, 9EEA, 9ELD, 9EI, 9ELV, 9EGG, 9EP, 9E, 9EQ, 9EKY, 9EDM, 9ES, 9EAK, 9EBE, 9EFJ, 9EKE, 9EEL, 9GK, 9JM, 9LZ, 9M, 9MC, 9NG, 9PW, 9RC, 9UH, 9UZ, 9UV, 9VM, 9VZ, 9XI, 9YY, 9ZG, 9ZY, WNF? NKY? Spark: Can.: 3FO, 8BDA, 8COA, 8TI, 9AUI, 9BAG, 9BIX, 9BOF, 9CEN, 9HU, Canadian: 1AB, 2BG, 2CG, 3AA, 3RH, 3CO, 3DE, 3GK, 3TR, 3TI, 3NI, 3OA, 3OJ, 3OM, 3PG, 3QS, 3XN, 3ZS, 3ZT.

7AJT. Basin, Wyoming

4AX, 4ER, 4HH, 4HT, 4IO, 5AAW, 5ABB, 5ADO, 5AGN, 5AGZ, 5AHD, 5AIU, 5AKN, 5AMU 5AMW, 5ANC, 5BB, 5BNZ, 5DN, 5EK, 5FV, 5GO, 5HQ, 5HT, 5JE, 5JJ, 5JL, 5LG, 5MM, 5NA, 5NK, 5RW, 5UW, 5XAP, 5XD, 5YW, 5ZA, 6ACM 6AGK, 6AJA, 6AJP, 6AK, 6APE, 6ARU, 6ASA, 6ASB, 6AUTU, 6AWT, 6BEH, 6BIH, 6BJJ, 6BKX, 6BLM, 6BM, 6BPF, 6BQB, 6BSG, 6CBB, 6CDG, 6CEJ, 6CGA, 6CGD, 6CGW, 6CHU, 6GL, 6JH, 6KJ, 6LU, 6ZB, 6ZBK, 6ZH, 7ACI, 7ADF, 7ADR, 7AEA, 7APN, 7AS, 7EZ, 7LW, 7NY, 7OB, 7OT, 7QC, 7QD, 7SC, 7SH, 7TD, 7TO, 7WE, 7YL, 8ADG, 8AGP, 8AUE, 8BDR, 8CN, 8DGS, 8JJ, 8RJ, 8UF, 8XAV, 9's too numerous over 150 hrd all QSA here.

Dalite C.W.: 7ABY, 7DU, 7GI, 7PX, 9AED, 9AIM, 9AUA, 9AZG, 9BEZ, 9BHL, 9BIS, 9BKP, 9BRI, 9BSZ, 9BZ, 9CAJ, 9CJD, 9CZG, 9DPW, 9DRA, 9EES, 9EFJ, 9EFU, 9EL, 9YY.

Sok.: 9CCS, 9BAL, 9XT. Would appreciate QSLs on my 10 watts.

V. W. Gilmore, Mile Seven, Alaska (Nov. 18-27th)

1ANA, 1BGC, 2KV, 2TS, 2XQ, 3ALN, 3CO, 3PR, 3AY, 3BQ, 3CN, 3CR, 3DQ, 3EQ, 3JK, 5ACF, 5AIU, 5AKN, 5AKY, 5AMA, 5AMN, 5CT, 5EB, 5EK, 5GA, 5GJ, 5GN, 5IN, 5KC, 5LG, 5LR, 5MO, 5OO, 5QL, 5QW, 5UK, 5UP, 5WX, 5ZAV, 5ZB, 6ABX, 6AGE, 6AJH, 6AK, 6ANB, 6AOL, 6AOS, 6ASX, 6AVV, 6BWW, 6BIC, 6RIH, 6RIQ, 6BJJ, 6BM, 6BNC, 6BOL, 6BRK, 6BUO, 6BVS, 6CC, 6CEU, 6CGD, 6CGM, 6CGW, 6CKP, 6CKR, 6CMU, 6CNH, 6CNW, 6FP, 6GR, 6JX, 6KM, 6KW, 6LV, 6MH, 6NX, 6PL, 6TS, 6VF, 6XAJ (phone) 6ZAR, 6ZAV, 7AEA, 7AEL, 7ABY 7ABF, 7ADR, 7AGF, 7AGN, 7AH, 7AHJ, 7AIM, 7BJ, 7FD, 7GE, 7JN, 7LH, 7NO, 7NN, 7PX, 7OB, 7QJ, 7QT, 7RC, 7SC, 7SF, 7SN, 7ZU, 8AFC 8AGO, 8BDA, 8BZC, 8BQC, 8DDQ, 8CZ, 8GZ, 8KG, 8RJ, 9ADW, 9AHZ, 9AIM, 9AMB, 9APE, 9APP, 9AON, 9AOS, 9ASF, 9AUU, 9AWY, 9BAK 9BAU, 9BEY, 9BJJ, 9BJL, 9BOF, 9BRI, 9BTO, 9CBJ, 9CGU, 9CGW, 9CVG, 9DJV, 9DNU, 9DSW 9DXN, 9DZY, 9EAE, 9EKY, 9ELV, 9LZ, 9TV, 9XI, 9YY, 9ZT.

Can.: 4CR, 4DY, 5CN, 9CE, 9BX. WNP.

The approximate location of Mile Seven, Alaska is Latitude 61 North and Longitude 145 West.

8FU, Defiance, Ohio

5ZA, 5ADO, 5AD, 5AK, 5EB, 5EN, 5FF, 5FP, 5GR, 5KA, 5LU, 5LV, 5MGJ, 5MH, 5OD, 5PL, 5RN, 5TU, 5ZA, 5ZW, 6AAK, 6AAU, 6ACM, 6AFH, 6AHU, 6AHY, 6AKZ, 6ALK, 6AMG, 6AOS (6ARB), 6AUU, 6AWQ, 6AWT, 6BBC, 6BEO, 6BJJ, 6BIC, 6BIB, 6BIC, 6BLM, 6BLG, 6BNC, 6BPZ, 6BRQ, 6BRU, 6BUH, 6BUO, 6BVE, 6CCU, 6CFY, 6CFZ, 6CGY, 6CGW, 6CHC, 6CHI, 6CHU, 6CKP, 6CMM, 6CON, 6XAD, 6ZAH, 6ZAR, 6ZBK, 6ZBL, 6ZRN, 7AD, 7CO, 7DU, 7HK, 7KS, 7WM, 7ZD, 7ZU, 7ZY, 7AFN, 7AGV, 7ADH, 7AMB, 7APP, 7AUU, 7BJJ, 7BJK, 7BTU, 7BUN, 9CAA, 9CDE, 9CLD, 9DFH, 9EAE, 9EEA. Can.: 5CN, 5GO.

8YAE-8ZE, Oberlin, Ohio

(4EB), (4HS), (4JK), (4MD), (4MV), (5AMH) (5GJ), (5IN), (5HL), (5UK), (5ZAV), 6BM, 6CC, 6EZ, 6YT, 6GR, 6IF, 6IL, 6KA, 6KG, 6LV, 6PL, 6SK, 6ZH, 6ZV, 6ZW, 6AAK, 6AFQ, 6AKZ, 6ALK, 6AOS, 6APW, 6ARB, 6ARU, 6AVV, 6AWT 6BBC, 6BCL, 6BCK, 6BIC, 6BIZ, 6BKX, 6BMC, 6BNC, 6BNT, 6BOE, 6BQ, 6BUA, 6BUO, 6BUI, 6BVE, 6BYG, 6COW, 6CGD, 6CGG, 6CGW, 6CFM 6CHI, 6CIB, 6CKP, 6CKR, 6CMH, 6CMM, 6DLE, 6XAD, 6ZAR, (ex-6TV), 6ZBA (ex-6CF), 7ABB 7ABR, 7AFO, 7BI, 7CO, 7HG, 7PI, 7IW, 7OT, 7PX, 7SC, 7ZG, 7ZU. Can.: (2BN), (2CG), (3IA), (3KN), (3BM), (3OM), 5CN, 5GO.

8ZD-8VE-8XW, Pittsburgh

(5HT), 6KH, (5KN), 5ZA, 5QW, (5ABH), 5ADQ, (5AFQ), (5AU), (5AMU), (5ZAV), 6P, 6MH, 6PL, 6ZH, 6ZR, 6AWT, 6BCL, 6BIC, 6BLG, 6BVE, 6CFZ, 6CGW, 6CNH, 6XAD, (6XAD).

9COC, Minneapolis, Minn.

1AEZ, 1CMP, 1MO, 2HR, 5ADR, 5ANC, 5KH, 5KM, 5LR, 5NZ, 5UP, 5ZA, 6ABX, 6ARY, 6ACB, 6ACM, 6ADR, 6AFC, 6AFQ, 6AGE, 6AHT, 6AHZ, (6CZZ), (6JL), (6ZC), (6ZY). Phone: (5AMW), (5GM), 5QD, (5SD), (6YR), (7XAF), (9AHZ), 9AOU, (9CCV), (9CHC), 9DFC. Can.: 3OH, 3WS, 1CL, 4CR, 4FA, (4FN), 4FV, 4HH, 9BX. Mex.: BX.

6ZAH, 7CO, 7FL, 7LU, 7SC, 7ZU, 7ABB, 7ABR, 7ADH, 9AMB, (9APP), 9BJK, 9BKP, 9DTE. WNP. Can.: 9BP.

9AOG and 9ARY, Lawrence, Kansas

1AH, 1AP, 1AW, 1ER, 1FD, 1HG, (1HX), 1IJ, 1LK, 1MY, (1OA), 1OW, 1OZ, 1RR, 1SE, 1SK, 1UJ, 1UO, 1XM, 1YB, 1YK, 1ZL, 1ZO, 1AAR, 1ADN, 1AFA, 1AIN, 1AJP, 1AJX, (1ALL), 1AOL, 1AQF, 1AQM, 1ARF, 1ARY, 1AUJ, 1BCU, 1RES, 1BHW, 1BIN, 1BIY, 1BKQ, 1BOA, (1BOQ), 1BQD, 1BWJ, 1CKP, 1CMP, 1CPN, 1XAQ, (2AD) 2AH, 2AL, 2BM, 2BY, 2EL, 2IC, 2JF, 2KF, 2KU, 2RK, 2RM, 2WR, 2XB, 2XV, 2XK, 2YAY, 2ACC, 2ACO, 2ACS, 2AGB, 2ANA, 2ATZ, 2AWH, 2AXF, 2BBN, 2BGL, 2BMR, 2BRB, 2RSB, 2BUM, 2CBJ, 2CCD, 2CEE, 2CEI, 2CFR, 2CGR, 2CIR, 2CLA, 2CPA, 2CQZ, 2CRP, 2CRQ, 2CSR, 2CWJ, 2CXD, 2CYW, 2DAC, 2XNA, 3AB, 3AS, 3BG, 3CO, 3GP, 3HD, 3HG, (3HS), 3IA, 3H, 3IW, 3JJ, 3JY, 3LK, 3LQ, 3MF, 3OH, 3PZ, (3OV), 3ST, 3SU, 3TR, 3VU, 3WS, 3WX, 3VO, 3ACC, 3ACY, 3ADB, 3AEC, 3AHP, 3AIX, (3AJD), 3AKI, 3AKY 3APV, 3AQR, 3ATB, 3BDI, 3BDO, 3BEL, 3BEZ, 3BGG, 3BGL, 3BHM, 3BHV, 3BKL, 3BPL, 3BPF, 3BSB, 3BSO, 3BTA, 3BTI, 3BTU, 3BVA, 3BVL, 3CAH, 3CAN, 3CBM, 3CCU, 3ODN, 3CHC, 3CON, 3CKJ, 3CKL, (3CKP), 3CSB, (4AF), 4AG, 4AJ, 4AL, 4AY, 4BK, 4BQ, 4CS, 4ER, 4EL, 4EQ, 4ER, 4FA, 4FS, 4FT, (4FZ), 4GW, 4HF, 4HH, 4HN, 4HR, 4HS, 4HW, 4O, 4JK, 4IR, 4KC, 4KU, 4LJ, 4MB, 4M, 4MV, 4NA, 4OA, 4OR, 4ON, 4OT, 4PB, 4PV, 4QW, 4RN, 4RR, 4FB, 6AD, 6BH, 6BM, 6DD, 6EA, 6FH, 6FP, 6GI, 6GX, 6KA, 6KM, 6LI, 6LV, 6MH, 6NB, 6NX, 6OH, 6PE, 6PL, 6RN, 6TF, 6TI, 6TS, 6VF, 6VN, 6ZH, 6ZW, 6ZX, 6AAK, 6AAQ, 6AAT, 6AAW, 6ABX, 6ACM, 6ACO, 6ADN, 6AFZ 6AGE, 6AHU, 6AJA, 6AJH, 6AKZ, 6ALK, 6ANI, 6AOL, 6AOL, 6AOS, 6ARR, 6ARU, 6ATZ, 6AUP, 6AUY, 6AWT, 6AWX, 6BAB, 6BAU, 6BVC, (6BCL), 6BCS, 6BEG, 6BEQ, 6BHL, 6BIC, 6BIB 6BJJ, 6BKX, 6BKX, 6BLC, 6BLW, 6BNC, 6BON, 6BPZ, 6BQA, 6BQB, 6BQD, 6BQE, 6BRF, 6BRK, 6BUA, 6BUH, 6BUI, 6BUO, 6BUY, 6BVG, 6BWE 6BZM, 6CAE, 6CAQ, 6CBB, 6CDB, 6CBU, 6CBW, 6CCV, 6CCY, 6CGD, 6CFM, 6CFZ, 6CGD, 6CGW, 6CHC, 6CHL, 6CHV, 6CIB, 6CID, 6CX, 6CJB, 6CKP, 6CKR, 6CMR, 6CMU, 6CNH, 6CNL, 6CNM 6CPW, 6CQF, 6XAD, 6ZAH, 6ZAM, 6ZAR, 6ZAW 6ZBA, 6ZBK, (7AF), 7BR, (7CO), 7DU, 7EB, 7EM, 7FD, 7GL, 7HG, 7HM, 7HW, 7IO, 7IW, 7JD, 7JE, 7KR, 7KS, 7LH, 7LN, (7LR), 7LU, 7LY, (7MP), 7NO, 7NR, 7OR, 7OT, 7PX, 7QJ, 7QT, 7SC, 7SF, 7SH, 7SY, (7TO), 7WM, 7WP, 7ZD, 7ZD, 7ZE, 7ZU, 7ZX, 7ABY, 7ACL, 7ADQ, 7ADR, 7AFN, 7AFO, 7AGR, 7AHM, 7AHZ, 7AKH. Canadian: 1BQ, 2AC, 2BG, 2BN, 2CG, 2CQ, 3AD, 3AO, 3BA, 3BG, 3BK, 3RC, 3DE, 3FC, 3GG, 3GK, 3JL, 3JT, 3KD, 3KP, 3LY, 3ML, 3MN, 3MW, 3NF, 3NI, 3OE, 3OH, 3OM, 3PG, 3SH, 3SP, 3TR, 3TP, 3WG, 3WS, 3XI, 3YH, 3ZL, 3ZV, 3ADN, 3ADU, 4AJ, 4DQ, 4DY, 4FV, 4HH, 5CN, 5GO, 9RP. Hawaiian: 6BDT, 6CEU. Mexican: CL.

9BJI, Denver, Colo.

1AFR, 1AOL, 1ARY, 1AW, (1CMP), (1CPN), 1EZ, 1FD, 1JV, 1KC, 1MY, 1YB, 1ZH, 1ZL, 1ZL, 2ANA, 2ADY, 2APD, 2BSC, 2BY, (2CFB), 2CRP, 2CVT, 2CG, 2GL, 2GK, 2KF, 2PE, 2WA, 3ZA, 3AB, 3AHP, 3AJ, 3AJD, 3AIN, 3BDO, 3BGJ, 3BKP, 3BTU, 3BVA, 3BNU, 3LG, 3ST, (3PZ), 3VH, 3ZO, 4AG, 4DB, 4DK, 4AE, 4EL, 4FT, 4GX, 4HN, 4HZ, 4HS, 4JK, 4ZJ, 4KU, 4MR, 4QW, 4RM, 4SC, (5ZAS), (8ATC), (8COM), (8CZZ), (8JL), (8ZC), (8ZY). Phone: (5AMW), (5GM), 5QD, (5SD), (6YR), (7XAF), (9AHZ), 9AOU, (9CCV), (9CHC), 9DFC. Can.: 3OH, 3WS, 1CL, 4CR, 4FA, (4FN), 4FV, 4HH, 9BX. Mex.: BX.

The New Constitution of the A.R.R.L.

Adopted December 18, 1923, and Published
Here For Your Information

CONSTITUTION

Article I

1. The name of this organization is The American Radio Relay League, Incorporated.

2. Its objects shall be the promotion of interest in Amateur Radio Communication and Experimentation; the relaying of messages by radio without charge; the furtherance of the public welfare; the advancement of the Radio Art; the representation of the radio amateur in legislative affairs; the maintenance of fraternalism and a high standard of conduct amongst its members; and the promotion of such other activities as are allied thereto.

Article II—Membership

1. Any person engaged in or interested in Amateur Radio shall be eligible to membership.

2. Applications for membership shall be submitted to the Executive Committee and a majority vote of this Committee shall elect to membership. The Committee may refuse to elect any applicant whose character, reputation or conduct would make him, in their opinion, an undesirable member; provided, that an applicant who is refused membership may have his case reviewed by the Board of Directors upon the recommendation of a minority of the Executive Committee. The Board of Directors in such case may, in its discretion, reverse the action of the Executive Committee.

3. Members shall comply with the requirements of the Constitution and By-Laws of the League, and with the radio laws and regulations of the country in which they reside.

4. A member may resign his membership by a written communication to the Secretary. If all his dues and other indebtedness have been paid his resignation shall be accepted.

5. Upon the written request of ten or more members that, for cause therein stated, a member of the League be expelled, the Board of Directors shall consider the matter, and if there appears to be sufficient reason shall advise the accused of the charges against him. He shall then have the right to present a written defense, and to appear in person or by duly authorized representative before a meeting of the Board of Directors, or their authorized representatives, of which meeting he

shall receive notice at least thirty days in advance. Not later than their next meeting thereafter, the Board of Directors shall finally consider the case, and if in the opinion of two-thirds of the members present a satisfactory proof of his undesirability has been established, and the accused member has not in the meantime tendered his resignation, he shall be expelled.

Article III—Officers

1. The officers of the League shall be a President, a Vice President, a Secretary, a Traffic Manager, and a Treasurer.

2. The President and the Vice President shall be elected by the Board of Directors, and shall hold office for two years or until their successors are elected and qualified. The Secretary, the Traffic Manager, and the Treasurer shall be appointed by the Board of Directors.

Article IV—Management

1. The affairs of the League shall be managed by a Board of Directors under the Constitution and By-Laws and the general provisions of the laws under which it is incorporated. The Board of Directors shall consist of the President, the Vice President, one Director from each of the several territorial divisions of the League in the United States and Possessions, elected by the members of the League thereof, and a Canadian General Manager.

2. No person who is commercially engaged in the manufacture, selling or renting of radio apparatus or literature shall be eligible to membership on the Board of Directors. Directors shall serve without compensation from the League in any capacity.

3. The Board of Directors shall have such powers and duties as are prescribed by statute for a Board of Directors. It shall direct the investment and care of the funds of the League, shall make appropriations for specific purposes, shall act upon all questions of expulsion of members, and in general shall direct the business of the League, either itself or thru its officers and committees. It shall appoint the Secretary, the Traffic Manager, and the Treasurer and fix their salaries, and they shall be subject to removal only by

an affirmative vote of a majority of the members of the Board.

4. The President shall have general supervision of the affairs of the League, under the direction of the Board of Directors. He shall preside at the meetings of the Board of Directors, and shall be, ex-officio, a member of all committees. The Vice President shall be responsible for such matters of general supervision as may be delegated to him by the President. In the absence or disability of the President, the Vice President shall preside at meetings of the Board of Directors and in general act in his stead.

5. The Secretary shall be the general manager of the League affairs under the direction of the President and the Board of Directors. He shall attend all meetings of the Board and record the proceedings thereof. He shall collect all moneys due the League and turn same over to the Treasurer. He shall certify the accuracy of bills or vouchers on which money is to be paid, and shall draw and countersign all checks. He shall have charge of the books and accounts of the League, and shall furnish to the Board of Directors from time to time such statements as may be required. He shall conduct the general correspondence of the League, and shall keep full records. He shall be in responsible charge, under the President and the Board of Directors, of all property of the League. He shall, with the approval of the Board of Directors, employ such clerical force as may be necessary and shall be responsible for the work of all employees under his jurisdiction. He shall be, under the direction of the Executive Committee, the general manager of the League publications. He shall prepare and submit at each annual session of the Board of Directors a comprehensive report on the progress and status of the affairs of the League under his jurisdiction. He shall perform such other duties as may be assigned to him by the Board of Directors. His entire time must be devoted to the affairs of the League, unless otherwise authorized by the Board. He shall furnish a bond satisfactory to the Board of Directors, the expense of same to be borne by the League.

6. The Traffic Manager shall have charge of the Traffic Department of the League. He shall report to the Board of Directors and shall furnish it from time to time such statements as may be required, and insofar as his duties will permit, shall attend all meetings of the Board of Directors, at the expense of the League. He shall prepare and submit at each annual session of the Board a comprehensive report on the progress and status of the affairs of the Traffic Department. He shall manage the relay traffic of the League and the general activity of the Traffic Depart-

ment. He shall perform such other duties as may be assigned to him by the Board. His entire time must be devoted to the affairs of the League, unless otherwise authorized by the Board of Directors.

7. The Treasurer shall be the recipient of all moneys of the League and shall deposit the same in the name of the League in a depository satisfactory to the Board of Directors. He shall sign all checks drawn by the Secretary when such drafts are known to him to be proper and duly authorized. He shall invest such funds as may be ordered by the Board of Directors. He shall make a report at the annual session of the Board of Directors, and such other reports as may be prescribed, and, insofar as his duties will permit, shall attend all meetings of the Board of Directors, at the expense of the League. He shall perform such other duties as may be assigned to him by the Board of Directors. He shall furnish bond satisfactory to the Board of Directors, the expense of same to be borne by the League.

8. The Board of Directors shall meet in annual session for the conduct of League business in the month of February of each year.

9. Special meetings of the Board of Directors shall be called by the President at least every three months, by written notice stating the specific object or objects thereof, mailed to each Director at least three weeks prior to the date of said meeting.

10. The Board of Directors shall delegate sufficient of its powers to an Executive Committee consisting of the officers of the League, to enable the said committee to conduct the affairs of the Board of Directors between its meetings. The Committee shall keep a record of its meetings and actions, and shall report at every meeting of the Board of Directors.

11. The Board of Directors or the Executive Committee (subject to the direction of the Board) may at any time authorize any officer, director, other person, or committee, to perform any acts or functions which in the Constitution or By-Laws may be prescribed to be performed by any specified officer, other person, or committee, whenever by reason of death, absence, disability or other cause, sufficient ground therefor shall appear to the Board or Executive Committee.

12. A majority of the members of the Board of Directors present in person, by alternate, or by proxy, shall constitute a quorum at any meeting of the Board.

Article V—Official Publication

1. There shall be an official publication maintained by the League, in the form of a monthly magazine, the name of which shall be "QST". A copy of this magazine shall be supplied each month to every member

of the League in good standing. The general business management of this magazine shall be in the hands of the Secretary, under the direction of the Executive Committee. The policy of the magazine shall be determined by the Board of Directors and such policy shall be carried out by the Secretary under the direction of the Executive Committee.

Article VI—Traffic Department

1. That section of the League's activities concerned with the relaying of messages, tests, and related matters involving radio communication, shall be known as the Traffic Department and shall be managed by the Traffic Manager. Its purpose shall be the arranging of a traffic network for

the expeditious handling of private messages between member-stations without charge, to establish and maintain orderly operating of amateur stations, to effect compliance with government radio communication laws, and to carry on such other practical operating activities as may be authorized by the Board of Directors.

Article VII—Amendments

1. This Constitution may be amended at any meeting by a two-thirds vote of the entire membership of the Board of Directors, to be determined by yeas and nays, provided due notice of such proposed amendment shall have been submitted every Director at least sixty days in advance.

BY-LAWS

Membership and Dues

1. The Secretary shall notify members of the expiration of their membership not less than thirty days in advance thereof.

2. Members in arrears shall be carried on the League records for ninety days, but if they have not renewed their membership by that date they shall be dropped.

3. The dues shall be \$2.00 per year, payable annually in advance.

Divisions

4. The operating territory of the League in the United States and Possessions and in the Dominion of Canada shall be partitioned into Divisions as follows:

In the United States and Possessions—ATLANTIC DIVISION, the states of New York, Pennsylvania, New Jersey, Maryland and Delaware, and the District of Columbia; CENTRAL DIVISION, the states of Wisconsin, Michigan, Illinois, Indiana, Ohio and Kentucky; DAKOTA DIVISION, the states of Minnesota, North Dakota and South Dakota; DELTA DIVISION, the states of Louisiana, Mississippi, Arkansas and Tennessee; EAST GULF DIVISION, the states of South Carolina, Georgia, Florida and Alabama, and the island of Porto Rico; MIDWEST DIVISION, the states of Nebraska, Iowa, Kansas and Missouri; NEW ENGLAND DIVISION, the states of Maine, New Hampshire, Vermont, Massachusetts, Rhode Island and Connecticut; NORTHWESTERN DIVISION, the states of Washington, Oregon, Montana and Idaho and the Territory of Alaska; PACIFIC DIVISION, the states of California, Nevada and Arizona, and the Territory of Hawaii; ROANOKE DIVISION, the states of Virginia, West Virginia and North Carolina; ROCKY MOUNTAIN DIVISION, the states of Colorado, Wyoming and Utah; WEST GULF DIVISION, the States of Texas, Oklahoma and New Mexico.

In the Dominion of Canada—MARITIME

DIVISION, the provinces of Nova Scotia, New Brunswick and Prince Edward Island, and the British province of Newfoundland and its dependency, Labrador; ONTARIO DIVISION, the province of Ontario; QUEBEC DIVISION, the province of Quebec; WINNIPEG DIVISION, the provinces of Saskatchewan and Manitoba and The Northwest Territories; VANCOUVER DIVISION, the provinces of Alberta and British Columbia and the Yukon Territory.

5. In each division of the League there shall be a Division Manager who, under the direction of the Traffic Manager, shall have authority over the Traffic Department of the League within his division. He shall be responsible for the appointment of Assistant Division Managers, District Superintendents, and City Managers throughout his division. He shall be responsible to and shall report to the Traffic Manager.

6. The Division Managers shall be elected. Whenever a vacancy occurs in the position of Division Manager, the Traffic Manager shall mail ballots to every member of the League residing within the division concerned, and a plurality of the votes cast shall elect his successor.

Directors

7. From each division of the League in the United States and Possessions a Director shall be elected by the members of the League residing therein.

8. The Directors shall be members of the Board of Directors of the League; they shall keep themselves informed on conditions and activities in their respective divisions, and on the needs and desires of the League members therein, that they may faithfully and intelligently represent them in the Board of Directors. They shall, so far as able, attend all meetings of the Board.

9. The Directors shall have the authority to appoint committees and assistants to aid them in the discharge of their duties.

In the absence or inability of the Director to attend a meeting of the Board of Directors he may appoint a member of the League as an alternate, who may attend the meeting and act in his stead.

10. The traveling expenses of members of the Board of Directors or their alternates, from their homes to the place of meeting of the annual session of the Board, and returning to their homes, both by shortest route, shall be paid by the League.

11. Upon the written request of twenty-five per cent. or more of the members of a division or of ten or more members of the Board of Directors that, for cause therein stated, a Director be removed from office, the Board of Directors shall consider the matter and, if there appears to be sufficient reason, shall advise the Directors of the charges against him. He shall then have the right to present a written justification of his conduct and to appear in person or by duly authorized representative before a meeting of the Board of Directors, of which meeting he shall receive notice at least thirty days in advance. Not later than their next meeting thereafter, the Board of Directors shall finally consider the case, and if in the opinion of two-thirds of the members present a satisfactory proof of his undesirability has been established and the matter has not in the meantime been adjusted to the satisfaction of the complainants, and his resignation has not been tendered and accepted, the office may be declared vacant and a new election ordered in the division affected.

12. On any date not later than noon of the first day of November of an election year in any division, nominating petitions signed by ten or more members of a division and naming a member of the division as candidate for Director, may be filed with the Secretary. The Board of Directors shall solicit such petitions in the September and October issues of "QST" in each election year by a notice that will show the names of the incumbents.

13. The Executive Committee shall delete the name of any nominee who may be ineligible to election and the name of any who may withdraw by written communication. The remaining names shall be listed on a ballot, in the order of the number of nominations received. During the first week of November the Secretary shall send by mail to every member of the League in the divisions in which elections are being held, a ballot listing the candidates for Director in his division, and a return envelope, soliciting a vote for one name. The ballot shall contain a copy of By-Laws 12, 13, 14, 15 and 16. The Executive Committee shall constitute itself a Committee of Tellers; but any member of the League who shall deliver to the Secretary on or before the first day of November of election year a written petition signed by at least

ten members of a division, stating their desire that he be a member of the Committee of Tellers, shall also be a member of that committee insofar as concerns the counting of the vote from his own division; provided that the aforesaid signatures shall not have appeared on another similar petition. Ballots, to be counted, shall reach the Secretary not later than the first day of December of election year. The Committee of Tellers shall meet at the headquarters office of the League as soon after the first day of December as possible and in secret, but in the presence of each other, shall count the vote, after first eliminating the ballot of anyone disqualified from voting. They shall forthwith prepare and sign a report of the results of the vote, declaring duly elected as new Directors the candidate in each division receiving the greatest number of votes of the League members therein; and they shall turn over all their records and ballots to the Secretary for presentation at the next annual session of the Board of Directors.

14. For the 1923 elections, a Director shall be elected for a term of one year in the following divisions: Central, New England, Northwestern, Roanoke, Rocky Mountain and West Gulf; and for a term of two years in the following divisions: Atlantic, Dakota, Delta, East Gulf, Midwest and Pacific. Thereafter the terms of all Directors shall be for two years, or until their respective successors are duly elected and qualified.

15. The terms of all Directors shall begin at noon on the first day of January of the year after that in which they are elected.

16. Whenever a vacancy occurs in the office of Director in any division, a special election shall be held as soon thereafter as practicable, in the general manner hereinbefore prescribed for regular elections.

President and Vice-President

17. The President and the Vice President of the League shall be elected by the Board of Directors at their annual session in presidential election year. Should either officer be chosen from the membership of the Board of Directors, that officer if he accepts the office shall immediately resign his office of division Director, and a new election to select his successor shall be held in the division affected as soon thereafter as practicable, in the general manner hereinbefore prescribed for the election of Directors.

18. A President and a Vice President shall be elected at the 1924 annual session of the Board of Directors, and every two years thereafter. Their terms of office shall begin at the conclusion of the meeting at which they are elected and shall continue for two years, or until their successors are duly elected and qualified.

19. A vacancy in the office of President shall be filled by the Vice President. A vacancy in the office of Vice President shall be filled by appointment by the Board of Directors for the unexpired remainder of the term.

Canada

20. On any date not later than the first day of November of an election year in Canada, nominating petitions signed by ten or more Canadian members of the League and naming a Canadian member as candidate for Canadian General Manager, may be filed with the Secretary. The Board of Directors shall solicit such petitions in the September and October issues of "QST" in each Canadian election year by a notice that will show the name of the incumbent.

21. The Executive Committee shall delete the name of any nominee who may be ineligible to election and the name of any who may withdraw by written communication. The remaining names shall be listed on a ballot in the order of the number of nominations received. During the first week of November the Secretary shall send by mail to every member of the League in Canada, a ballot and a return envelope, soliciting a vote for one name. The ballot shall contain a copy of By-Laws 20, 21, 22 and 23. The Executive Committee shall constitute itself a Committee of Tellers to canvass the vote; but any Canadian member of the League who shall deliver to the Secretary on or before the first day of November of election year a written petition signed by at least ten Canadian members stating their desire that he be a member of the Committee of Tellers, shall also be a member of that committee; provided that the aforesaid signatures shall not have appeared on another similar petition. Ballots, to be counted, shall reach the Secretary not later than the first day of December of election year. The Committee of Tellers shall meet at the headquarters office of the League as soon after the first day of December as possible, and in secret, but in the presence of each other, shall count the vote, after first eliminating the ballot of anyone disqualified from voting. They shall forthwith prepare and sign a report of the results of the vote, declaring the eligible person receiving the greatest number of votes elected as the new Canadian General Manager; and they shall turn over all their records and ballots to the Secretary for presentation at the next annual meeting of the Board of Directors.

22. A Canadian General Manager shall be elected in 1923 and every two years thereafter. His term of office shall begin at noon on the first day of January of the year after that in which he is elected and shall continue for two years, or until his successor is duly elected and qualified.

23. The Canadian General Manager shall be a member of the Board of Directors. He shall be the liaison officer of the League between the Board of Directors and its Canadian members. He shall have general supervision of League activities in Canada and shall be responsible to the Board of Directors for League welfare in all matters in Canada. He shall keep himself informed on conditions and activities in Canada and on the needs and desires of League members therein, that he may faithfully and intelligently represent them in the Board of Directors. He shall, so far as able, attend all meetings of the Board of Directors.

24. The Canadian General Manager shall have the authority to appoint committees and assistants to aid him in the discharge of his duties; he shall appoint an alternate who, in his absence or disability shall act for him. All such appointees shall be Canadian members of the League. In the absence or inability of the Canadian General Manager to attend a meeting of the Board of Directors the alternate shall attend in his stead and shall have full power to represent the Canadian divisions.

25. A vacancy in the office of Canadian General Manager shall be filled by special election as soon thereafter as practicable, in the general manner hereinbefore prescribed for regular elections.

26. The policy of the League in Canada shall be that of a friendly hand for the amateurs of a sister country pending their growth to such numbers and strength that their ability to form and conduct a self-governing non-commercial amateur organization thruout the Dominion is evident. The activities of the League in Canada shall be regarded as a temporary stewardship undertaken at the request of Canadian amateurs. Whenever Canadian amateurs shall petition for their own organization, and it is manifest to a majority of the entire Board of Directors that the success of a separate Dominion organization is assured, the Board of Directors shall aid in establishing and proclaiming a separate all-Canadian organization to be known as the Canadian Radio Relay League to operate under a constitution similar in tenor to that of this League; and this League shall thenceforth relinquish all direct activity in Canada.

1923 Elections

27. Especially for the elections of 1923 the dates specified in these By-Laws for the nomination and election of Directors and Canadian General Manager, including the dates specified for the various steps to be taken in the handling thereof, shall be changed to read exactly five months later. Especially for the 1924 session, the date specified in the Constitution and these By-Laws for the holding of the annual session

of the Board of Directors at which a President and a Vice President shall be elected, shall be changed to read exactly five months later. The terms of all such officers and directors shall end on the same date as they would have ended had not the dates for these first elections been changed.

Affiliated Societies

28. It shall be the policy of the League to affiliate with itself local non-commercial amateur radio societies of kindred aims and purposes with a view to forming a homogeneous organization which will make possible unity of action in matters affecting amateur welfare.

29. Any such society which suitably expresses its sympathy with and allegiance to the aims and policies of the League in accordance with regulations determined by the Board of Directors, and which upon investigation is found to be worthy and well qualified, may be declared duly and truly affiliated with the League by a majority vote of the members of the Board of Directors present at any meeting, and a charter shall thereupon be issued the society in token thereof. The Board of Directors shall have the authority to refuse affiliations to any society if in its opinion such affiliation would be harmful to the best interests of the League.

30. The affiliation of any society may be terminated and its charter recalled by a majority vote of the Board of Directors at any time for any cause deemed prejudicial to the best interests of the League.

31. The Traffic Manager shall be responsible for a general supervision of the affiliated societies and their welfare, and for the relations existing with them; he shall keep the records and conduct the correspondence with them.

Miscellaneous

32. No person not a member of the League shall be eligible to hold any office or appointment in the League.

33. The results of all elections shall be published by the Secretary in the next issue of "QST" printed after the canvass of the vote.

34. The fiscal year of the League shall be the calendar year.

35. The headquarters officers of the League shall be located in the city of Hartford, in the state of Connecticut.

36. The official depository of the League shall be the Phoenix National Bank, of Hartford, Conn.

37. Copies of minutes of meetings of the Board of Directors shall be sent by the Secretary to all Directors.

38. Unless otherwise specifically provided in the Constitution or these By-Laws, the action of the Board of Directors shall in all cases be determined by the concurring vote of a majority of the members present, a quorum existing.

39. On all questions of order and procedure not otherwise determined by the Constitution or these By-Laws, or by a special rule of order adopted by a two-thirds vote, the provisions of the Working Code appended to the Revised Cushing's Manual shall constitute the Standing Rules of Order for meetings of the Board of Directors; and Special Rules, A, B, C, D, E, shall be included therein and are hereby severally adopted.

40. The regular order of business at meetings of the Board of Directors shall be as follows:

- (1) Roll-call
- (2) Consideration of Minutes
- (3) Appointments and Elections
- (4) Special Orders (if any have been made)
- (5) Reports of Officers
- (6) Reports of Standing Committees
- (7) Reports of Special Committees
- (8) Unfinished Business
- (9) New Business

The above order or any part of it may be suspended by a two-thirds vote at any meeting.

Amendments

41. These By-Laws may be amended in any part by a two-thirds vote, to be determined by yeas and nays, of the entire membership of the Board of Directors, at any meeting; or, provided due notice of such proposed amendment shall have been submitted every Director at least sixty days in advance, they may be amended by a two-thirds vote, to be determined by yeas and nays, of the Directors present at any meeting, a quorum being present and voting. They may not be suspended except in the particular cases provided for in the By-Laws themselves.

42. Without changing their import the Board of Directors may from time to time renumber these By-Laws so as to serve the purpose of ready reference thereto.

CALLS HEARD

(Concluded from page XVIII)

- 6AUA, 6AJJ, 6AK, 6ALV, 6AOL, 6AOS, 6ARB, 6AVQ, 6AVV, 6AWT, 6AWG, 6AWX, 6AVY, 6BCL, 6BCH, 6BQZ, 6BFO, 6BHK, 6BIC, 6BTH, 6BJF, 6BJL, 6BJQ, 6BLX, 6BM, 6BNC, 6BNT, 6BOK, 6BPL, 6BQA, 6BUH, 6BUI, 6BVE, 6BWP, 6CBU, 6CC, 6CCB, 6CDG, 6CEK, 6CGW, 6CHU, 6CIP, 6CJL, 6CKR, 6CONS, 6CKD, 6CU, 6CWD, 6FF, 6FG, 6FP, 6FY, 6GE, 6GR, 6HC, 6HH, 6PE, 6PI, 6PR, 6PU, 6ZA, 6ZAH, 6ZAV, 6ZH, 7AHR, 7ACL, 7ADR, 7AFN, 7AGH, 7AGR, 7AGX, 7AKH, 7EM, 7CO, 7FL, 7FO, 7GE, 7GT, 7HG, 7IH, 7IT, 7IW, 7LA, 7LF, 7LH, 7LR, 7MP, 7NN, 7OB, 7ON, 7OP, 7PE, 7PL, 7PU, 7PX, 7QC, 7QD, 7QL, 7SC, 7SF, 7UU, 7VE, 7YL, 7ZE, 7ZO, 7ZU, 7ZX.
- Can.: 2BG, 2BN, 2CG, 2AB, 2CW, 2DE, 2GA, 2GL, 2NI, 2SP, 2TB, 2TF, 2XI, 2ZL, 2CW, 4HF, 5GO, 5BJ, 5BX.
- Dec. 10: 2CG, 2DE, 2DZ, 2IF, 2EF, 2ZA, 2AOS, 2AU, 2BIC, 2BLM, 2BMA, 2BNC, 2BNT, 2BOU, 2BSJ, 2BUA, 2CDY, 2CKP, 2FM, 2FY, 2IW, 2PL, 2UR, 2ZAW, 2ZH, 2ZR, 2AOS, 2ADH, 2ADR, 2AFN, 2AGV, 2CM, 2HI, 2KS, 2IO, 2TO, 2MP, 2QC, 2YF, 2YL. Can.: 2NF.