

Vol 5

QST

Devoted Exclusively to
CITIZEN RADIO
Published by the
AMERICAN RADIO RELAY LEAGUE



"Double
Head Set"

July
1922

20¢

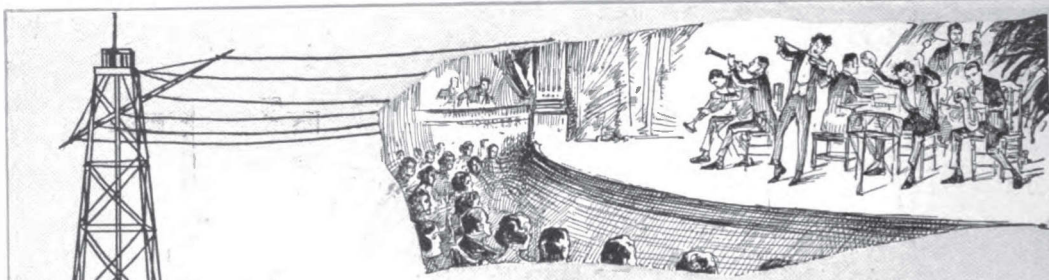

RADIO BROADCASTING

It is not at all unusual that local amateurs, newly interested in Wireless, through the Broadcasting, should prefer Atlantic service. But, when orders come from Pittsburgh, New York, the Middle West; in fact, from all over the country, there must be some reason.

We specialize in standard apparatus that can be purchased anywhere. The only possible advantage that makes thousands of amateurs prefer to deal with Atlantic is in the service they receive.

Of course, we have established a reputation for answering all inquiries frankly and promptly. When we offer suggestions to a customer, we never recommend an expensive outfit when a \$25.00 or \$50.00 set will meet his particular needs. Many customers leave the entire choice of their equipment to us and in every case, they have expressed complete satisfaction with our choice.

We have prepared three Bulletins, 19, 20 and 21 which describe a wide choice of standard equipment to receive wireless telephone broadcasting. These will be sent free on request to any reader of QST.

The Radio Corporation's "C.W." manual and catalog 25c. per copy.

ATLANTIC RADIO COMPANY, INC.
727 Boylston St., Boston, Mass.

15 TEMPLE STREET, PORTLAND, MAINE
115 BRIDGE STREET, SPRINGFIELD, MASS.

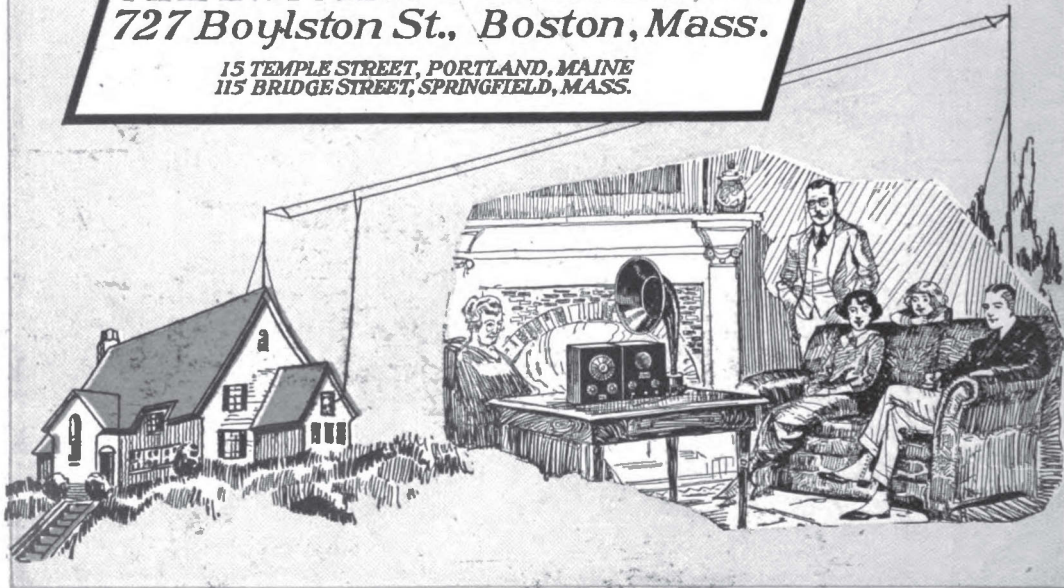

RAC-3 AUDION

Price
AUDION
and
Receptacle
\$4.50

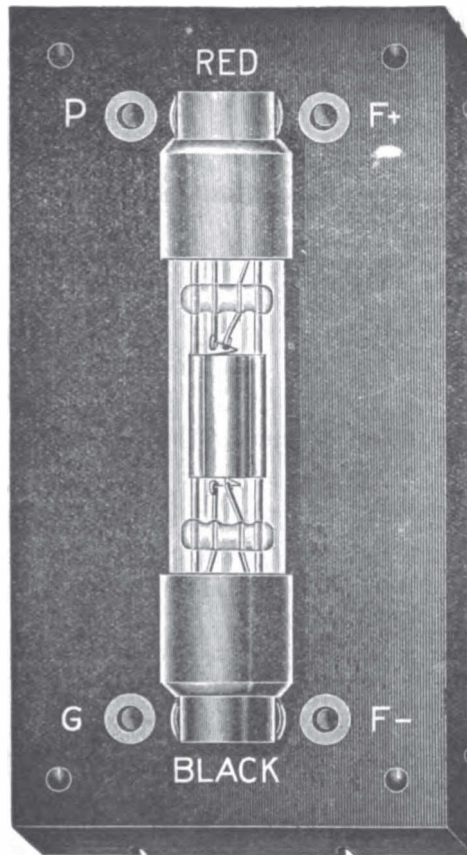

AUDIO
FREQUENCY
AMPLIFIER

RADIO
FREQUENCY
AMPLIFIER

AUDION
OSCILLATOR

Full Size

FIRST UNIVERSAL AUDION

Manufactured under DeForest Patents No. 841,887 and No. 879,582

Radio Audion Company

90 Oakland Avenue,

Jersey City, New Jersey

RAC-3 Audions are interchangeable without necessitating critical readjustments.
RAC-3 Audions are not critical to A or B battery adjustments.
Low battery consumption. Filament current 0.8 amp. at 4 volts, maximum. Plate voltage 2 to 22 volts.
Clear signals and great sensitiveness on long distance reception.
Perfect oscillation for use in regenerative circuits.
Small size. Rigid construction. Non-microphonic. No tube noises due to mechanical vibration.

Maximum insulation between filament plate and grid terminals resulting from new type of tube and receptacle.

Maximum direct mechanical contact between audion leads and receptacle clips.

Audion base caps and Receptacle block moulded Grade A Condensite.

Receptacle block is designed to permit built-up panel construction for amplifier panel. Circuit connections may be made from front, back or sides.

NOTICE

This tube is not sold or purchased to be used as a detector of wireless waves. Any use or sale of it for such use renders the vendor or user liable to prosecution for infringement of patent. This tube is sold for use in tandem with another device acting as a detector for the purpose of amplifying either radio or audio frequency currents or as a generator of high frequency electrical oscillations.

After November 7th, 1922 the RAC-3 Audion will be available as a Detector and no longer limited for use in tandem with another device as a detector.

ALWAYS MENTION Q S T WHEN WRITING TO ADVERTISERS

1

Condensite

Beware of the Outlaw !

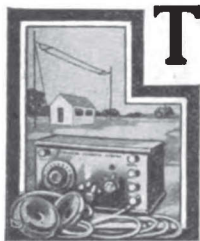

THE radio industry has struck a cyclonic pace and just as other industries in their boom periods have brought to light fakers, profiteers and wildcat promotion schemes, so has Radio produced the outlaw manufacturer.

The latter class is likely to be an infringer of patents, an imitator of trade names. He substitutes "just as good" for the buyer's specification. His favorite motto is "the Radio public will buy anything". That is what they sell "anything" regardless of its quality.

There is a way to avoid this class of manufacture.

Upon request we will send the names of reputable radio concerns from whom you can obtain equipment made of Condensite, the material which possesses all the properties essential to radio insulation.

Condensite is a standardized product of known composition, guaranteed by a firm that is a recognized authority on the art of molded insulation.

CONDENSITE COMPANY OF AMERICA
BLOOMFIELD, NEW JERSEY



Eveready "A" Batteries

- hardwood box, mahogany finish
- convenient handle, nickel plated
- rubber feet protect the table
- insulated top prevents short circuits
- packed vent caps prevent spilling

No. 6860—90 Amp. Hrs.—45 Lbs.—\$18.00
 No. 6880—110 Amp. Hrs.—52 Lbs.—\$20.00

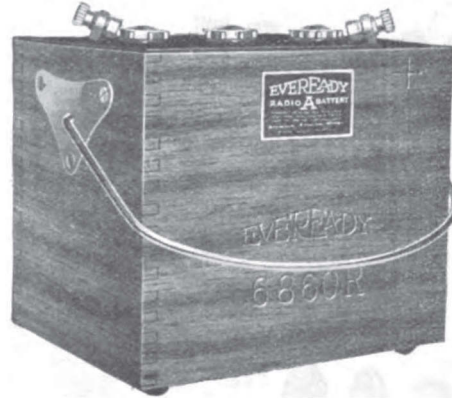

Eveready "B" Battery No. 766

Equipped with 5 positive voltage taps ranging from 16½ to 22½ volts. Fahnestock Spring Clip Binding Posts—an exclusive Eveready feature. Price \$3.00



Eveready "B" Battery No. 774

Equipped with 6 positive voltage taps at 4½ volt intervals ranging from 18 to 43 volts. Fahnestock Spring Clip Binding Posts—an exclusive Eveready feature. Price \$5.00



**For Better Results
 USE**

EVEREADY

"A" and "B" BATTERIES
with your radio set

For sale by the better radio supply dealers everywhere

Send today for descriptive booklets

NATIONAL CARBON COMPANY, Inc.
 Long Island City, N. Y.

Atlanta Chicago Cleveland
 , Kansas City San Francisco



Medal and Diploma
received at
World's
Columbian
Exposition,
Chicago, 1893



INSULATION
MADE IN AMERICA
Louis Steinberger's Patents



Medal and Diploma
received at
World's
Fair,
St. Louis,
1904



"ELECTROSE" is made in a number of grades for various requirements, each grade possessing special characteristics.
Insulators and insulating parts and devices of special sizes and forms, designed and made to order.

SOLE MANUFACTURERS



60-82 Washington St. 27-37 York St.
66-76 Front St. 1-23 Flint St.
Brooklyn, N. Y., America

ALWAYS MENTION QST WHEN WRITING TO ADVERTISERS

QST

The Official Organ of the A.R.R.L.

VOLUME V.

JULY, 1922

No. 12

Super-Regeneration	<i>K. B. Warner</i>	7
The Police Chiefs Relay	<i>Boyd Phelps</i>	11
Some Suggestions Regarding the Beverage Antenna	<i>E. B. Dallin</i>	12
Modulation in Radio Telephony	<i>L. C. F. Horle</i>	14
New England Division Daylight Tests	<i>P. F. Robinson</i>	18
5ZA Gets Hoover Cup for 1921		19
Some British Tube Equipment		25
An Explanation of "The Chicago Plan"	<i>R. H. G. Mathews</i>	27
Notes on the Design of Small C.W. Transformers	<i>G. E. Hoke</i>	29
Ourselves		30
Book Review		30
The New Radio Bill		32
Editorials		33
International Amateur Radio		35
The Operating Department		39
Who's Who— <i>Howard F. Mason, M. F. Harrod</i>		49
With the Affiliated Clubs		50
"Strays"		52
With Our Radiophone Listeners		54
Amateur Radio Stations—7XG		57
Calls Heard		59
Radio Communications by the Amateurs		64
Classified Advertisements		140
QST's Index of Advertisers		143

QST is published monthly by The American Radio Relay League, Inc., at Hartford, Conn. Kenneth B. Warner (Secretary, A. R. R. L.), Editor and Business Manager. Edwin C. Adams, Advertising Manager.

Subscription price in United States, Possessions, and Canada, \$2.00 per year. Foreign \$2.50. Single Copies, 20 cents.

Entered as second-class matter May 29, 1919, at the post office of Hartford, Connecticut, under the Act of March 3, 1879.

Copyright, 1922, by The American Radio Relay League, Inc.
Title registered at United States Patent Office.

THE AMERICAN RADIO RELAY LEAGUE, Inc.
HARTFORD, CONN.

THE AMERICAN RADIO RELAY LEAGUE

"A national non-commercial organization of radio amateurs, bonded for the more effective relaying of friendly messages between their stations, for legislative protection, for orderly operating, and for the practical improvement of short-wave Radio Communication."

OFFICERS

President
HIRAM PERCY MAXIM
Hartford, Conn.

Vice President
CHAS. H. STEWART
St. David's Pa.

Traffic Manager
F. H. SCHNELL
1045 Main St.
Hartford, Conn.

Treasurer
A. A. HEBERT
Nutley, N. J.

Secretary
K. B. WARNER
Hartford, Conn.

DIRECTORS

H. M. ANTHONY
Muncie, Ind.

H. A. BEALE, Jr.
Parksburg, Pa.

A. E. BESSEY
Sunnyvale, Calif.

V. F. CAMP
Brightwaters, L. I.

F. M. CORLETT
Dallas, Tex.

C. E. DARR
Detroit, Mich.

W. C. C. DUNCAN
Toronto, Ontario

A. A. HEBERT
Nutley, N. J.

F. A. HILL
Savannah, Ga.

DR. A. E. KENNELLY
Cambridge, Mass.

S. KRUSE
Cambridge, Mass.

H. P. MAXIM
Hartford, Conn.

F. H. SCHNELL
Hartford, Conn.

C. A. SERVICE, Jr.
Hartford, Conn.

C. H. STEWART
St. David's Pa.

K. B. WARNER
Hartford, Conn.

M. B. WEST
Waukegan, Ills.

OPERATING DEPARTMENT

ATLANTIC DIVISION
Manager
Chas. H. Stewart
St. David's, Pa.
Asst. Mgr., Northern Sec.
C. J. Goette
1624 Hamilton Ave.
Woodhaven, L. I.

Asst. Mgr., Southern Sec.
Edw. B. Duvall
8909 Cottage Ave.,
Baltimore, Md.

EAST GULF DIVISION
Manager
B. W. Benning
50 Whiteford St.,
Atlanta, Ga.

Assistant Manager
W. B. Pope
197 Dearing St.,
Athens, Ga.

CENTRAL DIVISION
Manager
R. H. G. Mathews
6483 Ravenswood Ave.,
Chicago

Assistant Manager
L. A. Pease
2256 W. 24th St.
Chicago

ALASKAN DIVISION
Manager
Roy Anderson, 71T
P. O. Box 206
Ketchikan, Alaska

WEST GULF DIVISION
Manager
Frank M. Corlett
1101 East Eighth St.,
Dallas, Tex.

PACIFIC DIVISION
Manager
J. Vance Wise
Walnut Grove, Cal.

QUEBEC DIVISION
Manager
Albert J. Lorimer
Farnham, Que.

ONTARIO DIVISION
Manager
A. H. Keith Russell
11 Pinewood Ave.,
Toronto, Ont.

DAKOTA DIVISION
Manager
N. H. Jensen
Box 894, Sioux Falls, So. Dak.

NEW ENGLAND DIVISION
Manager
Philip F. Robinson
149 Hollis Ave.,
Braintree, Mass.

MARITIME DIVISION
K. S. Rogers
Prince Edward Island

ROANOKE DIVISION
Manager
W. T. Gravely
854 Main St.,
Danville, Va.

DELTA DIVISION
Manager
John M. Clayton
1801 Welch St.,
Little Rock, Ark.

Assistant Manager
Hubert E. deBen
1044 City Park Ave.,
New Orleans

WINNIPEG DIVISION
Acting Manager
J. H. Gjelhaug
Baudette, Minn.

ROCKY MOUNTAIN DIV.
Manager
M. S. Andelin
Richfield, Utah.

MIDWEST DIVISION
Manager
L. A. Benson
4942 Wiesehan Ave.,
St. Louis.

NORTHWESTERN DIV.
Manager
Howard F. Mason
8335 88d Ave., So.,
Seattle, Wash.

ADVISORY TECHNICAL COMMITTEE

C. S. BALLANTINE
WM. C. BALLARD, Jr.
LEROY M. E. CLAUSING
FRANK CONRAD
LEO C. YOUNG

MINTON CRONKHITE
J. H. DELLINGER
C. L. FARRAND
PAUL F. GODLEY
F. C. BLAKE

L. A. HAZELTINE
C. D. TUSKA
R. H. G. MATHEWS
J. O. SMITH
S. KRUSE

Address General Correspondence to Executive Headquarters, Hartford, Conn.

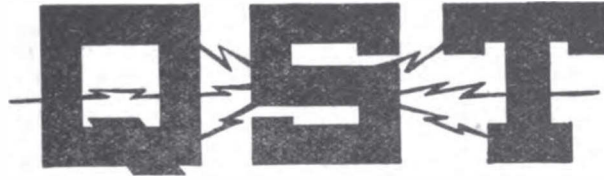

A Magazine Devoted Exclusively to the Radio Amateur

Super-Regeneration

An Invention of Tremendous Importance to the Amateur

By K. B. Warner

BEFORE the biggest audience ever gathered at a meeting of the Institute of Radio Engineers, Edwin Howard Armstrong on June 7th gave his new invention of super-regeneration to a tense and expectant audience in the form of a paper entitled "Some Recent Developments of Regenerative Circuits". In presenting Mr. Armstrong, Fulton Cutting, president of the Institute, stated that the new discovery completely overshadowed regeneration as we now know it and opened a new chapter of radio frequency amplification.

Indeed it seems to do all of that. For super-regeneration is the thing about which so many wild rumors were floating around—the method that makes two tubes do all the work that ten used to do in the super-heterodyne, the plan that with two tubes gives telegraph signals a million times as strong as with an ordinary regenerative detector and phone signals a hundred thousand times as strong or thereabouts. The methods are astonishingly simple and we expect that they will cause a complete revolution in the amplification practices of the advanced amateur. Offhand, they would seem to solve forever problems of short-wave radio amplification, and even to make junk of the super-heterodynes, than which up to this time....etc.! Mr. Armstrong will deliver a paper on his new principles before a special meeting of the Radio Club of America in late June—a paper for the practical amateur, complete with constants, number of turns of wire, etc.—and that paper will be printed in QST, but unfortunately it could not be prepared in time for this issue. The following impressions, then, are gleaned from his I.R.E. paper and the diagrams are reproduced therefrom with the kind permission of Dr. A. N. Goldsmith, I.R.E. secretary.

As we all know from experience, oscillation represents the theoretical limit of amplification in our present-day receivers. How often, in approaching critical regeneration and hearing the signals build up enormously, have we wished that it might be possible to advance the regeneration just a little more, even one degree on the scale, without the bulb flopping into oscillation! The increase in amplification just below the oscillating point is amazing, and if only it could be squeezed a wee bit more how wonderful it would be! That is exactly what Armstrong's new scheme does—it extends the range of regeneration without oscillation, by means of a trick. We say a trick, because the oscillating point is theoretically the limit but by an artifice this is got around and any amount of amplification may be obtained; and because it is in a field beyond the hitherto recognized limit, it is called *super-regeneration*.

Let us first study a few basic points regarding ordinary regeneration. As is well recognized, it consists of supplying energy by some process akin to feed-back in such a manner as to enforce the oscillations in the circuit, causing them to attain greater amplitude and thereby having the same effect as would the introduction of "negative resistance". That is, part of the positive resistance which the circuit normally would have seems to have been overcome, we say that by the use of regeneration its effective resistance has been lowered. Now, obviously, the "negative resistance" created by the feed-back may be not as great as the positive resistance, or it may just equal it, or it may be greater than the positive resistance. Let us examine each of these in turn:

When the negative resistance is less than the positive (which is the case in our regenerators of today), the oscillations in the

circuit attain a steady amplitude of a value dependent upon the effective resistance; this amplitude is always finite, is reached in a finite time, and dies away to zero when the exciting e.m.f. is removed. Now when the negative and positive resistances are equal, the resultant effective resistance of course is zero. When an e.m.f. is impressed on such a circuit the current builds up at a rate dependent upon the voltage and certain other considerations and continues to rise as long as the e.m.f. is impressed. If it is impressed forever, the current reaches infinity; if for a finite time, then the oscillations have a finite amplitude; if at any time the exciting e.m.f. be removed, the oscillations continue forever at that same amplitude, for the circuit has no resistance. This is merely a theoretical case

in the use of a free oscillation to produce amplification. It is the purpose of this paper to describe a principle of operation based on the free oscillation which is quantitative and without a lower limit. This new method is based on the discovery that if a periodic variation be introduced in the relation between the negative and positive resistance of a circuit containing inductance and capacity, in such manner that the negative resistance is alternately greater and less than the positive resistance, but that the average value of resistance is positive, then the circuit will not of itself produce oscillations, but during those intervals when the negative resistance is greater than the positive will produce great amplification of an impressed e.m.f." In other words, currents would increase

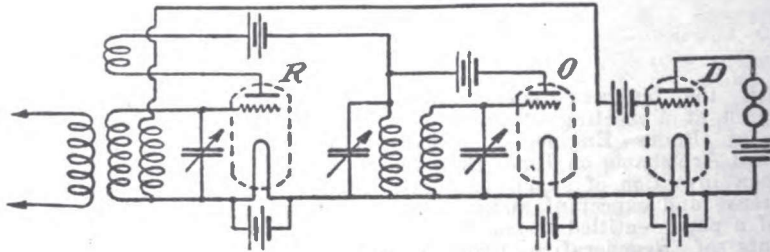

Fig. 1

and cannot be attained in practice because of the imperfections of vacuum valves. Now when the negative resistance is greater than the positive the effective resistance of the circuit is negative and the free oscillations set up as the result of impressing an e.m.f. build up to a theoretical infinity regardless of whether or not the external e.m.f. is removed. The rate of the building-up progress is dependent upon the amplitude of the starting e.m.f., which in turn depends upon the ratio of the negative and positive resistance and will be greater if the negative resistance is increased. No oscillations will occur until an exciting e.m.f. is impressed, but once that takes place, no matter how small it be, the current builds up to infinity.

With this understanding of the regenerative effects in an audion circuit, note what Mr. Armstrong said:

"It is, of course, impossible with present-day instrumentalities to set up a system in which the negative resistance exceeds the positive without the production of oscillations in the system, since any irregularity in filament emission or impulse produced by atmospheric disturbances is sufficient to initiate an oscillation which builds up to the carrying capacity of the tube. It is, however, possible by means of various expedients to set up systems which avoid the production of such a paralyzing oscillation and which approximate the theoretical case

to infinity and enormous amplification is possible if a non-oscillating circuit of negative resistance were available, but all such negative resistance circuits oscillate when excited. Mr. Armstrong accordingly sought and found a method whereby the effective resistance of ordinary regenerator may alternately be increased and decreased at a very rapid rate, whereby the negative resistance that obtains when the negative resistance is greater than the positive will serve to give great amplification and yet in the next instant when the positive resistance predominates its effect shall be such as to prevent oscillation. In still simpler words, the effect is much as if he had a rapid-action switch which fed alternately into the circuit a negative and positive resistance.

This scheme has all the benefits of radio frequency amplification *per se*, as it is a "first power" device, the amplitude of the effects depending upon the amplitude of the impressed e.m.f. Half of the time it is creating amplification (and the amplification when negative resistance predominates continues to rise even if the exciting e.m.f. is removed) and the other half of the time it is "killing oscillation". There is no theoretical limit to the degree of amplification without oscillation—it is limited only by the carrying capacity of the tube. There is no reason why the very weak signal of an amateur station across the continent

may not be fed into a 250-watt power tube and a quarter kilowatt of signal-modulated output made available if desired.

Now to secure this desired periodic variation in the ratio of the two resistances the negative may be varied with respect to the positive, the positive with respect to the negative, or both may be varied simultaneously, any one of the methods producing the super-regenerative condition. The rate of variation is an important matter and

Fig. 1 shows a practical circuit in which the negative resistance is varied while the positive resistance is held constant. This circuit is recommended for C.W. and for spark, the latter presumably "on the mush". Valve R, the super-regenerative amplifier, is a conventionally-arranged regenerator except that in its plate circuit is an inductance-capacity combination that is likewise in the plate circuit of another tube O, the oscillator which creates the resistance varia-

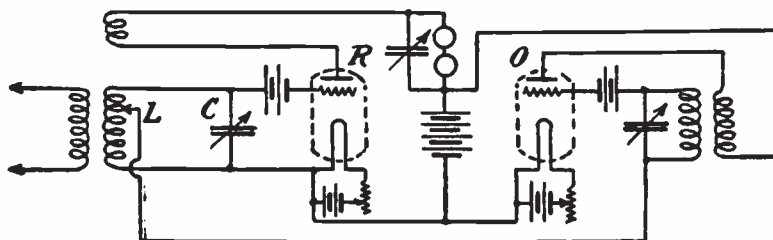

Fig. 2

depends upon the nature of the received signals. At best the choice is a compromise, particularly in telephony, as the lower the frequency the greater the amplification and the higher the frequency the better the quality. For telephony this variation frequency must be above audibility, and the same applies for I.C.W. and spark telegraphy if the natural tone is to be preserved. If one does not care about losing the natural note of the signal, then a lower

frequency may be employed with greater amplification and a signal like receiving a spark on an oscillating regenerator. For C.W. telegraphy, where an audio note is essential, the variation frequency may well be 500 or 1000 cycles, but this note would be the same for all C.W. signals and for better selectivity the variation frequency may be beyond audibility and a separate heterodyne used, thereby securing heterodyne selectivity and this system's super-amplification.

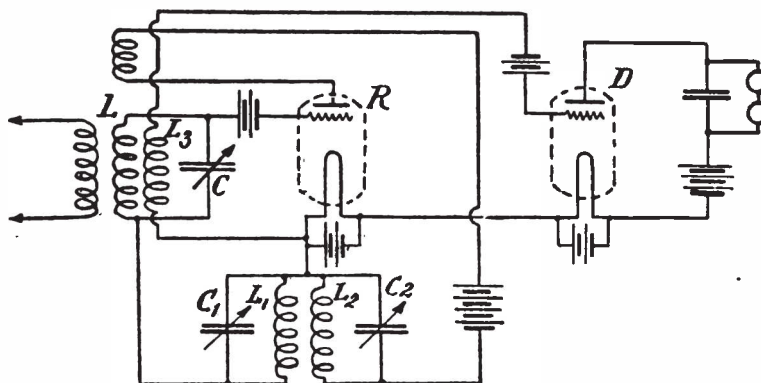

Fig. 3

frequency may be employed with greater amplification and a signal like receiving a spark on an oscillating regenerator. For C.W. telegraphy, where an audio note is essential, the variation frequency may well be 500 or 1000 cycles, but this note would be the same for all C.W. signals and for better selectivity the variation frequency may be beyond audibility and a separate heterodyne used, thereby securing heterodyne selectivity and this system's super-amplification.

ances and the phones placed in its output circuit; but if a super-audible frequency is used in valve O the phones may be placed directly in the plate circuit of the amplifier R, and that case of course, sparks would be received on their natural note.

Fig. 2 illustrates the variation of the positive resistance with respect to the negative, and is a circuit more fitted to the reception of phone. The positive resistance of the regenerative amplifier-detector R is varied by means of an oscillating tube O, whose

tuned circuit is completed back to filament via the inductance L of valve R and accordingly varies its effective resistance. When the grid of valve O is negative it has no effect and circuit R has normal resistance but when the oscillator grid becomes positive it practically shorts the inductance L and creates the effect of an excess of positive resistance therein. Altho this circuit may employ an audio oscillator at O , it is customary to use it at a super-audible frequency, particularly for telephone reception.

Fig. 3 shows the third case in which both positive and negative resistances are simultaneously varied. For the real amateur who wants to have lots of fun with sixteen

tery, producing two frequencies in the circuit; one at signal modulation frequency and the other at variation frequency (O 's frequency, as determined by L_1C_1) with a super-imposed signal frequency component. This latter, being in tune with the valve O , is amplified by its regenerative action and then rectified, and hence heard in the phones.

What anybody wants to cascade super-regenerators for we don't know, but Mr. Armstrong spoke about it. It seems tremendous reaction troubles are experienced when this is tried, but may be got around by a simple expedient: the second harmonic of the first amplifier valve is very strong,

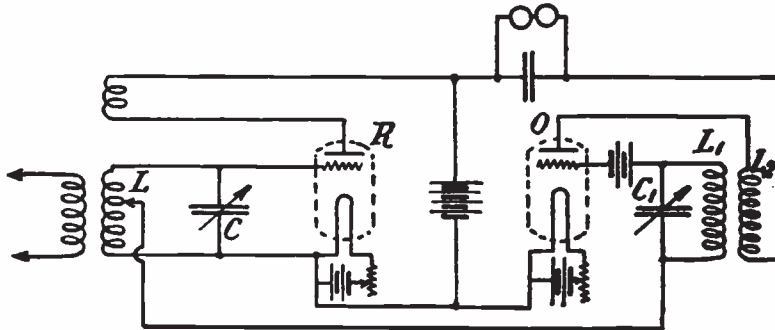

Fig. 4

or so adjustments, Mr. Armstrong recommends this circuit. Altho it is very critical of adjustment and extreme care is necessary to obtain the super-regenerative state, he says it produces more amplification than either Fig. 1 or Fig. 2. In Fig. 3 the amplifier R has a second feed-back circuit L_1C_1 and L_2C_2 , whereby it oscillates at some lower frequency. This does two things: (1) it creates a superimposed variation of the negative resistance generated in the plate circuit of R ; and (2) at the same time it produces a variation in the positive resistance by varying the grid of valve R . The question of phase relationships between the positive and negative resistances is handled by a variation of the coupling between L_1 and L_2 , and by adjustment of capacities C_1 and C_2 , there generally being a disparity in their values. The separate detector D is necessary as a rectifier.

Mr. Armstrong uses hard tubes only, rectifying on the lower bend by virtue of a negative grid bias and without condenser and leak. When the variation frequency is above audibility the detection may be accomplished in the oscillating tube with still greater amplification, as shown in Fig. 4, but the circuit is harder to adjust. Its action is likewise difficult to explain but is somewhat as follows: incoming signals are amplified and become impressed upon the input circuit of the oscillator O , where they are rectified by virtue of the grid bias bat-

and if the input circuits of the second valve are tuned to this harmonic, reaction is avoided. Mr. Armstrong showed a diagram in which the two steps of super-regeneration had their positive resistance varied by a single tube-generator as in Fig. 2 but with the second stage tuned to the second harmonic of the first stage.

The circuit diagrams above have contemplated coupling the super to the antenna by means of tuned circuits, but Mr. Armstrong says trouble is often experienced in this due to the fact that the free oscillations continue during the interval when the resistance is positive and re-excite the amplifier when the resistance becomes negative, with the result that the system oscillates. Accordingly he recommends that the tuning be done at one frequency and amplification at another, which of course is best accomplished by some super-heterodyne method. To accomplish this one would merely introduce an independent detector ahead of the super-amplifier and beat upon it with a separate heterodyne to create the amplifier frequency at which the super-regenerator (of whatever type) operates.

This system of amplification is free of interference from sparks—shock excitation is eliminated. In ordinary spark reception what is heard is a free oscillation produced by the shock of the forced oscillation representing the spark signal energy, but continuing long after the latter has ceased. In

the super-regenerator there is periodically sufficient positive resistance to wipe out this oscillation and hence it is not heard.

Mr. Armstrong gave a demonstration. A small C.W. driver was rigged up across the room and signals received on a loop. Connected to a regenerative detector with two steps of audio amplification, no signal was audible where we sat, about 25 feet from the loud-speaker; yet when the super-regenerator was connected in with two tubes, one as an oscillator-amplifier and the other as detector, with audio frequency variation, the same signals were QSA. It was estimated that the amplified signal energy in the latter case was between 10,000 and

50,000 times as great as in the former. The same experiment was performed on the telephone signals of WJZ with similar results. Mr. Armstrong said he had compared a 2-valve super-regenerator with a super-heterodyne working at zero beat for phone reception (number of valves in the super-heterodyne amplifier not stated but just suppose it's only two) and found the amplified signal energy of the new system 100,000 times as much as the super-heterodyne.

In the short time available to get this copy to our printer's we have had no opportunity to test the circuits ourselves but will expect to present some practical working data soon.

The Police Chiefs Relay

By Boyd Phelps, Assistant Editor

ONCE more amateur radio showed its worth in relaying this time to the Police Chiefs. Nearly every city, town, or burg that boasts a Police Chief or Sheriff received the message. The novel part of this relay was that no prearranged schedules were made nor did anyone know exactly when the message would start or by whom. Several thousand receiving stations participated in the relay, picking up the message and delivering it to their respective Police Chiefs. Keen excitement was evident in waiting for the message. Then someone nearby would pick it up and broadcast it to the rest of the gang.

The scheme was to listen after 10 P.M. local time on June 3rd, 4th, and 5th for someone to break loose with the message. In many localities the air was in absolute silence listening for the message. Many times it would be heard coming nearer but fading or swinging would cause part of the text, address, or signature to be lost. The silent competition between receiving stations was intense until some station got a complete copy. The rush then was to deliver it and then broadcast it to others who would pick it up and do likewise.

The message was first broadcasted on spark and C.W. on both 200 and 375 meters by several stations who opened a sealed envelope containing the message. The message was as follows:

*Nr 1 fm San Francisco Cal 3rd—
To All Police Chiefs and Sheriffs—
Please attend Convention of International
Association of Chiefs of Police at San
Francisco June nineteenth nineteen hundred
twenty-two—*

(Sig) August Vollmer, Chairman.

In many localities the message was not picked up the first night due to lightning and bad weather conditions which are always more or less prevalent during the

summer months. In fact in a few cases it was not until the third night that it was absolutely certain the copy was correct due to very adverse receiving conditions. Since then Headquarters has been flooded with copies of the message received by the various officials all over the nation thus showing the effectiveness of the relay.

Several incidents in the relay were quite interesting. 2BDR, after struggling with terrible QRN to get the message, had a worse job to get his copy signed, as the sleepy Chief when awakened and given the message said he knew about this convention the last day of the last convention and he didn't need a radio invitation, but was going anyway. 2BPL forgot about the relay but just happened to run across the message while helping a friend with a crystal set "who wanted to hear music for twenty dollars very clear and loud" so he copied the message and promptly delivered it. 9APW picked up the message many times but it was impossible to deliver it until the next day because he had his small sister to watch while the family was away. 7WG up in Idaho had a bad electrical storm on the only night he could be on and with the Sheriff sitting at his side he tried desperately to get a complete copy of the message but always missed certain words. 8ANB handled his message over to a very snappy Chief who would not sign his extra copy. 8ANB thinks from the way he acted he was not in good standing with the International Association of Chiefs. 8NY spent considerable time trying to find his Chief but says when he found he was out of town he got the other half of the force to sign for him. 2CEJ made a tour of surrounding villages and was the first to deliver the message to four Chiefs. 1CLK submits a regular affidavit from the Department of Police to the effect that he copied his message from 2FZ and delivered it at the above

office at 12:36 A.M. In fact it gave us somewhat of a shiver as the formidable letter was opened. 1PP had an awful job to get his dad to let him stay up but finally he got him interested in the relay and when the message came thru 1PP-Sr. got as excited as 1PP-Jr. and hitched up the car and son and dad together delivered the message. 3QV in Philadelphia had bad QRM from arc lights, rain and QRN were fierce, and conditions seemed about right for a murder. Parts of the message were copied from several stations during the night but not until 2FZ broadcasted it did 3QV drag out the mill and then the flivver to drive in the rain to the city hall.

In addition to the stations mentioned above, the following deserve special mention: 1DH, 1NW, 1OT, 1PR, 1AAK, 1ASY, 1BDT, 1BDU, 1BJP, 1BJS, 1BGP, 1BNL, 1BRL, 1BYV, 1CAB, 1CIK, 1COT, 1CQM, 2AR, 2CT, 2FC, 2FP, 2FZ, 2MN, 2OE, 2UU, 2AIF, 2AWQ, 2AWS, 2BCC, 2BDR, 2BNC,

2BOI, 2BXD, 2CBT, 2CEJ, 3BZ, 3LP, 3OI, 3TJ, 3XW, 3AAO, 3AAV, 3AEV, 3BAY, 4BX, 4MN, 5FO, 5ZA, 5XC, 5ZX, 6CC, 6CF, 6IV, 6VK, 6ZX, 6AAU, 6ACR, 6AJH, 6AJN, 6AJR, 6BAK, 6BKX, 6ZAF, 7BK, 7NG, 7NW, 7YA, 7ACA, 8AY, 8SP, 8UC, 8XU, 8YN, 8ZO, 8ZZ, 8ACF, 8ACM, 8AHY, 8ALX, 8ASL, 8AUE, 8AUO, 8AQO, 8AQZ, 8AXC, 8AXX, 8AXZ, 8BEP, 8BIL, 8BIW, 8BKQ, 8BLY, 8BNY, 8BPP, 8BND, 8BUQ, 8BXF, 8BXX, 8BYI, 8CEI, 8CMI, 8CTD, 9BK, 9EI, 9LI, 9WZ, 9ZJ, 9ZN, 9AAW, 9AEN, 9AFN, 9ALR, 9AMZ, 9BQW, 9DJF, 9DVD, WRR and Can. 3DS. Quite a quantity of stations having no call letters picked up the message, delivered it and forwarded us a signed copy.

Judging from the letters that have come in a great deal of fun was had by all. We have demonstrated what we can do in the summer static season and that it is the telegraphing amateur that accomplishes things.

Some Suggestions Regarding the Beverage Antenna

Which first rose to prominence in amateur circles when it was used in Scotland by Paul F. Godley in the A. R. R. L. Transatlantic Tests

By E. B. Dallin, 1FK.

THE Beverage antenna, is an exceedingly efficient collector of electromagnetic waves and is very directional when adjusted properly. It has its use especially in cases where communication between two fixed points is desired and where much interference is encountered. It has the advantage over the loop that it collects enormously more energy than the ordinary loop could ever collect and is unidirectional, giving absolute silence at a point 180° away from the station desired. This is a big improvement over the loop, which gives signals at a maximum from two directions 180° apart.

The system is very simple and, once adjusted, rarely needs any attention over a considerable range of wave lengths. The chief difference between the Beverage wire and the ordinary antenna or loop is that it is an aperiodic structure and consequently is not tuned in the ordinary manner, nor does its length bear an important relation to the wave length at which it is being used. The simplest Beverage wire, such as used by Mr. Godley in Scotland during our Trans-Atlantic tests, is similar to Figure 1. The length of wire to be used is usually specified as one wave length but it is not necessary to have such a long wire. For two hundred meters a wave length would

be nearly 700 feet but reasonably good results can be obtained with a wire of half this length. Below this length the signal strength falls off considerably.

Neither are its directional characteristics so exact that it must point precisely at the station desired. A variation of a few degrees makes practically no difference. For example, a Beverage wire pointing east will receive about seven-tenths the energy from the northeast or southeast and of course little or no signals from the north, west, or south. It is suggested that the subject of spherical triangles and great circle arcs be looked into before laying out a Beverage wire to receive from a long distance to the east or west so that it may be directed sufficiently to the north to compensate for the curvature of the earth.*

Referring to Figure 1, the antenna A is a single wire which may be any height practicable, generally between six and eighteen feet. At the station end of the line is the transformer L₁L₂, which couples the energy from the antenna to the receiving set. The exact values of the coils

*Knowing the latitude and longitude of two points, A and B, the angle at B (β) between line AB and true north can be found by substitution in the following formulae:

$$\tan M = \frac{\tan(90^\circ - \text{lat. B}) \cos(\text{long. A} - \text{long. B})}{\cot(\text{long. A} - \text{long. B}) \sin([90^\circ - \text{lat. A}] - M)}$$

$$\cot \beta = \frac{\sin M}{\sin M} \quad \text{—Ed.}$$

*The Reinartz tuner seems especially adapted to this aerial, its exciting circuit being aperiodic in itself.—Ed.

will have to be determined experimentally as there is practically no data available as yet on the behavior of this system at short wave lengths. It is suggested that coil L_2 for waves between 200 and 600 meters should consist of about 30 turns of No. 24 D.C.C. magnet wire on a three inch tube and L_1 a tapped coil with a total of about 60 turns of the same size wire. The tightest coupling will in general be found to be best so as to get the maximum energy.

second method has been devised that overcomes this difficulty.

In Figure 2 we have two wires going to a transformer L_1L_2 , the primary of which is grounded thru the non-inductive resistance R . Signals or ether disturbances striking both wires equally go to earth thru the resistance and produce no effect on the set if everything is balanced, as the current induced in L_2 by the halves of L_1 will be equal and opposite. On the other end of

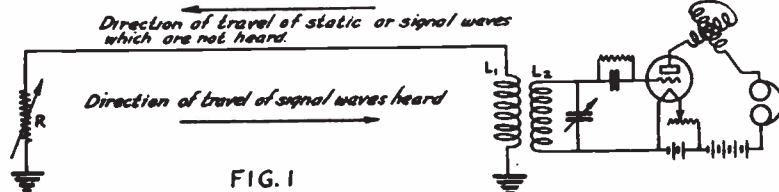

FIG. 1

The resistance R at the far end is very important. In the ordinary oscillating antenna the voltage is maximum at the end farthest from the lead-in so that reflection occurs at the free end. The function of the resistance R is to make the antenna aperiodic by allowing the voltage built up at the free end to leak off to ground. It absorbs all the energy that comes from the direction opposite to the signal and yet is sufficiently high so that the antenna system cannot act as a loop. The resistance should equal the inductance in henries divided by the capacity in farads (in absolute units) of the line. It is quite a difficult matter to make such measurements so that the usual method, especially for the amateur, is to make various adjustments of this resistance and find which one works best.

the wire the secondary L_2 of the transformer L_1L_2 connects to the middle tap of the primary L_1 . When signals come from the direction indicated by the full line arrows, striking each wire equally, the signals have a path to ground as in the previous case, inducing no current in L_2 , but the current to ground flowing thru L_1 induces a current in L_2 which circulates thru the two antenna wires as indicated by the dotted arrows. This circulating current, traveling thru both halves of the coil L_2 in the same direction, induces energy in L_1 . The receiver then responds to the signal and the system gives a directional antenna as before, but directional from the opposite direction to that of the single wire of Fig. 1.

In practice the wires are in a horizontal plane spaced from 12 to 18 inches apart

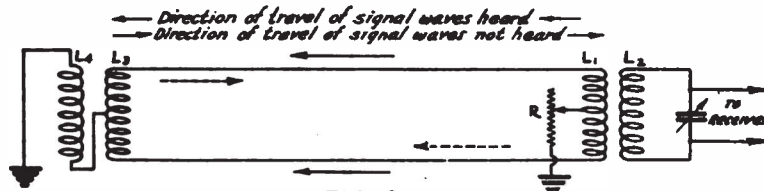

FIG. 2

The resistance probably will be in the neighborhood of 200 ohms and should be non-inductive and variable in small steps. The ground at the far end of the antenna need not be as elaborate as a transmitting ground because additional resistance is added in the rheostat. However, the ground should be deep enough to have a constant resistance for all weather conditions so it will not be necessary to make daily changes in the rheostat. The system when properly adjusted is so very much better than the ordinary one that it is well worth a large amount of effort.

The circuit described above has the disadvantage that the resistance is at the far end. As it would be much better if this adjustment could be made at the station, a

and the same distance above ground as in the case of the single wire.

For L_1 and L_2 wind 30 to 50 turns of No. 24 D.C.C. magnet wire on a four inch tube. L_2 is a tapped coil of about 60 turns of the same wire wound on a tube three inches in diameter, and L_1 is 30 to 50 turns on the same size tube. The coupling should be as close as possible between L_1 and L_2 , although it may be found desirable to loosen the coupling between L_1 and L_2 . R probably should be a variable resistance around 200 ohms. Due to the fact that there is considerable magnetic leakage in the two halves of L_1 there is likely to be reflection at this point so it is suggested that a variable condenser C and inductance L_3 be inserted

(Concluded on page 58)

Modulation in Radio Telephony

A Paper Presented by L. C. F. Horle* at a meeting of the Radio Club of America, Columbia University.

IN discussing the subject of modulation as applied to radio telephony, I have nothing new to bring to you. In this article, however, I want to review the various methods of modulation which have been used in the past, and also to point out several lines of experimentation which should be followed up.

The problem of modulation is as old as radio. This may not be in the aspect in which we have become accustomed to think about it, perhaps, but, if we define modulation by "the degree to which the wave form of the radio-frequency current departs from constant amplitude", we find that this departure or degree of modulation is involved in the problem which we have been trying to solve in all types of transmitters.

In spark sets the attempt has always been to make the wave-form as nearly sinusoidal as possible. There are two reasons for this. First, the greater the departure from the continuous or sinusoidal wave, the greater has been the resultant interference; and second, the greater this departure the less power we are able to use with a given aerial. Figs. 1, 2, and 3 show more clearly what is meant by this. The last of these figures shows what we have been accustomed to call a highly damped oscillation, since the oscillations die out very rapidly. Fig. 2 shows an oscillation which is not so highly damped. Now, since the *average* height of this wave-form is a direct measure of the power in the circuit, it is evident that the wave form of Fig. 2 represents more power than does that of Fig. 3. The height of the first alternation is limited in both cases by the antenna circuit, since the value of the current cannot exceed a certain specified value without causing the antenna insulators to break down, or at least giving rise to serious corona with resultant losses. Hence it is important that the wave decay very slowly in order that the *average* value of the current may be as high as possible, resulting in a maximum of power in the antenna. We have termed this rate of decay the *decrement* or *logarithmic decrement* of the circuit and have worked to keep it as low as possible.

In the undamped transmitter we have secured a wave-form in which the decre-

*Consulting Radio Engineer.

ment is practically zero; that is, the wave shows almost no decay and is almost completely sinusoidal. (Fig. 1.) Having secured this long aimed-at result, however, we find that we have a type of radio wave which makes no impression on the usual radio receiver; that is, one which merely rectifies the incoming wave and passes the rectified current through the telephones.

It is of interest to trace through the receiving circuit to see what happens to a wave of this type. Fig. 4 gives the connection diagram of a simple rectifying circuit using a crystal detector. The wave form of the current impressed on the antenna is identical with that shown in Fig. 1, and the voltage which this develops across the detector is also of substantially the same form. But, due to the rectifying

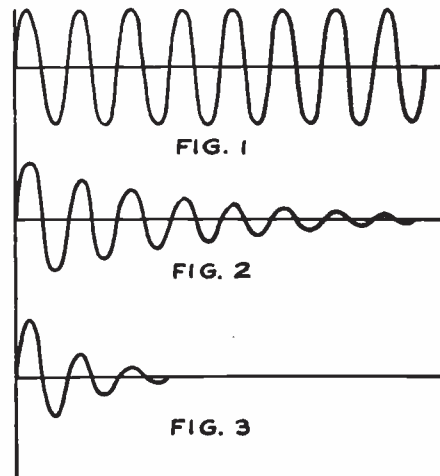

properties of the crystal, it is converted into a wave form such as is shown in Fig. 5(a). This differs from Fig. 1 only in that the lower half of the wave has been eliminated, leaving merely the half on the upper side of the axis.

It is evident that a wave form approximating this one could be secured if a sinusoidal wave, as Fig 5(c), were superimposed on a direct current, Fig. 5(b). In the receiver, however, in order to make the incoming energy effective in the telephones, we separate the rectified current

into these two components. The telephone and the telephone condenser are a very satisfactory combination for doing this. The telephone condenser will not allow the direct current component to pass, while the telephones, due to their high impedance to radio-frequencies, will not allow the high frequency component to flow. The result is, that the radio-frequency component is forced to go through the condenser, while the D.C. component is forced to flow through the telephones.

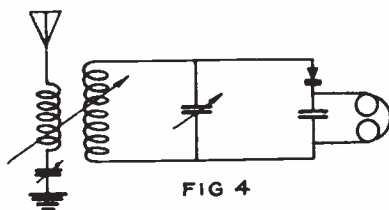

FIG 4

It is evident then that no signal will be audible in the phones if the transmitter is keyed in the usual manner. The only result will be a starting and stopping of a direct current through this part of the circuit. This accounts for the dull clicks which are heard when a continuous wave transmitter is operated near our receiving stations. Since a detector is probably less sensitive when a direct current is flowing through it, this also accounts for the "blocking" of the detector when a nearby and powerful transmitter of the undamped type is in operation, even though the signals from the latter station are not evident in the telephones.

Let us observe what happens when the transmitted wave is modulated, as in Fig. 6(a) where the current in the transmitting antenna never becomes zero, or rather where the wave never dies out. This is rectified by the detector in the receiving circuit as shown in Fig. 6(b), and then is broken up into its two components, Figs. 6(c) and 6(d), as described before. The high-frequency component passes through the telephone condenser, while the low-frequency component goes through the telephones and gives the signal. It is to be noted, however, that it is only the "humps" in the latter current which affect the telephones, and that the D.C. component passes directly through and causes no response. Thus if the modulation is not complete, part of the energy, while it is present in the receiving circuit and actually in the phones, does not make itself at all evident to the operator. It is essential, therefore, that all power that is available in the transmitting antenna be modulated by the voice, if the greatest signal strength in the receiver or the greatest range is to be attained.

This lack of complete modulation is the limitation which kept radio telephony from reaching its present stage of development for many years. The only requirement which had to be met in the construction of a radio telephone system, other than a satisfactory modulation scheme, was a high frequency generator of reasonable capacity. The latter has been available for years in the form of the arc, and recently in the form of the high frequency alternator.

The problem of modulating the arc has been unsolved for years, and even today no satisfactory method is available. This results from the condition which always exists in modulating a generator which of itself has no amplifying characteristics. To accomplish modulation in such a case, it is axiomatic that the power capacity of the modulator must be approximately equal to the power capacity of the generator. Thus in the case of a 5 K.W. arc, we must have as a modulator a source of voice power which is capable of delivering about 5 K.W. At this time there is no such source of power available.

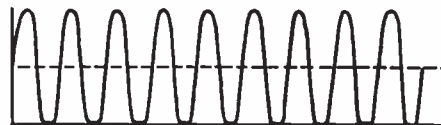

FIG. 5 (a)

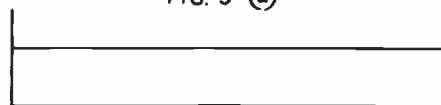

FIG. 5 (b)

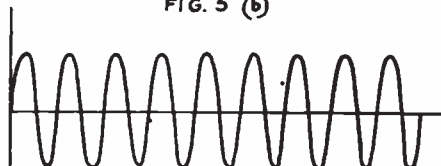

FIG. 5 (c)

This is evident from the inspection of a hypothetical modulation system shown in Fig. 7. Here we have a high frequency generator in shunt with a resistance, the value of which is caused to be varied by means of the voice. Let us observe what the conditions must be if this modulator is to completely modulate the output of the generator. The curves show the wave-form resulting from the operation of the modulator. Where the modulated wave form departs from the undamped, the power is evidently being absorbed in the modulator. The modulated and unmodulated wave forms are shown superimposed and the area of the unmodulated wave form not covered by the modulated wave form is proportional to the

power being absorbed by the modulator. It is evident that about as much power is being absorbed in the modulator as is being absorbed in the antenna. This relation is not at all precise, of course, but in a general way, the capacity for power absorption of the modulator must be about equal to the power capacity of the generator.

This unfortunate characteristic is the limitation which applies to all absorption schemes of modulation, and indicates the seriousness of the problem which is met in the attempt to modulate high-power generators such as the arc or high-frequency alternator when absorption methods are resorted to.

Systems have been worked out for the modulation of such generators by various schemes involving the use of the microphone. The oldest type of these is that which uses a telephone transmitter in the antenna circuit, where the change in the resistance of the microphone caused by the voice causes a change in the antenna current much as is shown in Fig. 7. This scheme was worked with varying degrees of success by the Federal Telegraph Co. on the west coast some ten or twelve years ago, and also by the DeForest Co. and the Collins Co. in the east, at about the same time. In all cases the power capacity of the microphone was the limiting factor in the operation of the systems, and invariably because of the limited modulation possibilities of this piece of apparatus, the transmission was extremely unsatisfactory. The capacity of the microphones was increased by water-jacketing and similar subterfuges, but even then only a small fraction of the power was modulated. A transmitter of 10 K.W. was barely sufficient for transmission over ranges of one hundred and two hundred miles, and even this was possible only under very good conditions. These several limitations which militate against the general use of absorption systems for modulation suggest the advisability of two other methods.

The first that suggests itself is one in which the power of the generator is made to vary by a control of its source of power in some manner whereby the criterion of equality of power capacities may be expected not to hold. The second is one in which the *reactance* of some part of the circuit is changed with a resultant change in the wave-length of the transmitted wave, or with a change in the current in the antenna. This latter scheme offers infinite opportunity for experimentation. Several methods have already been devised to accomplish this result, and others may be looked forward to in the future for the complete solution of the problem.

Dr. Alexanderson's method of controlling the high frequency alternator and Mr. Ernest Amy's magnetic modulator are the two that come to mind at this time. In the

former the generator is connected to the antenna in such a way as to include an iron core inductance, the reactance of which can be changed by the voice currents. The value of the inductance can of course be changed by providing the iron core with two windings, one of which carries the voice currents, and the other of which carries the working current, the voice current circuit being protected against the induced radio frequency current. The inductance and consequently the reactance of such a coil will depend on the values of the exciting currents in the windings. Variations of the values of these will change the flux

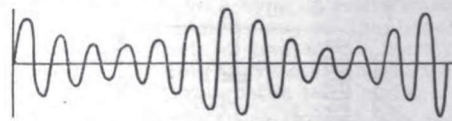

FIG. 6 (a)

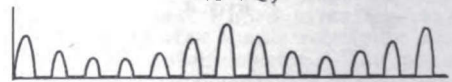

FIG. 6 (b)

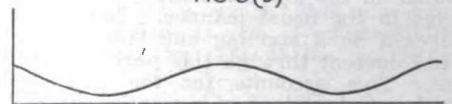

FIG. 6 (c)

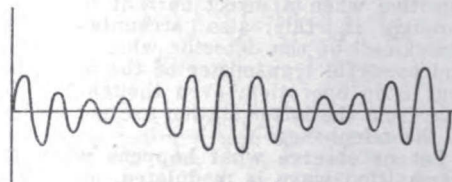
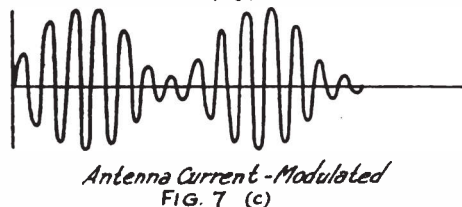
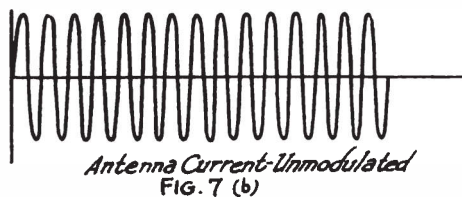
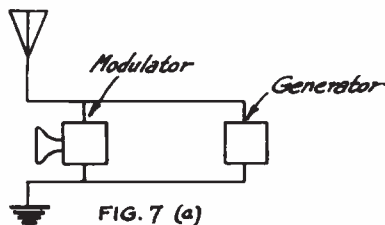

FIG. 6 (d)

density in the core, and hence the inductance of the coil as a whole. If such a coil is placed in the antenna circuit, or in a local circuit coupled to the antenna circuit, and tuned to resonance with it, the wave length of such a circuit will be varied by the voice current flowing in the exciting winding, and this change in wave length will cause the current in the antenna circuit to be modulated by the voice. This method has the advantage that relatively small amounts of power will cause rather large variations in the reactance of the coil, and hence vary the current in the antenna between very wide limits. For the control of a single 100 K.W. alternator, however, many times the power available in a microphone is required. However, the power required for modulating the output of such an alternator is, perhaps, not over 1% of the total output, and this is a tremendous improvement over the ordinary absorption method.

Mr. Amy's modulator is supposed to operate on a very similar principle, but it is probable that it is as much a loss device as a reactance device. It consists, I am told, of an iron core having an exciting winding which carries the voice currents and a winding which carries the power currents of the antenna circuit. The resistance and reactance of the antenna circuit winding depends on the flux in the core, and this flux is caused to vary with the voice currents. Thus the device becomes a rather hybrid absorption and reactance device and one in which the equality of power capacities does not hold very precisely.



It is conceivable that a scheme might be worked out whereby the reactance method of control may be used and the ratio of the power required to operate the modulator to the power which it will modulate made smaller than in either of these devices. It is along this line that the efforts of the experimenter should be directed. With the development of the high-power vacuum tubes now available and the special circuits and special equipment for their operation now developed, there still remains the problem of simple and efficient modulation. Until this problem is solved it is doubtful whether long distance radio telephone communication will be successfully accomplished.

The power-control methods, while the most commonly used, were the last to be developed, and the most effective of them are those which are applicable to the vacuum tube because of

its inherent amplifying characteristics suggests immediately the possibility of the control of large values of power by the use of comparatively small amount of power. In this connection the grid circuit suggests itself most forcibly for use in modulation, since this circuit is one of high impedance, very high in fact, and is furthermore a circuit in which the voltage which will reduce the power in the antenna circuit from its maximum to zero causes very little current to flow and consequently very little power to be dissipated. The objection to this method of modulation lies in the fact that it is very critical in adjustment, and also that great distortion is likely to take place unless extreme care is used in making adjustment.

Mr. Kischpaugh in his paper before the Radio Club of America some time ago showed characteristic curves which make this point very well. This is shown in Fig. 8. The grid voltage is plotted against the antenna current, and shows a rather slowly varying antenna current for high values of the grid voltage, and a very sharp dropping off of this current for lower values of this potential. It is evident that with the grid biased to make its mean voltage that of the point "c", the change in the antenna current will be small for a given voice voltage applied to the grid. On the other hand, for a mean grid voltage somewhere between "a" and "b" on the curve, the change in antenna current will be large for a given change in the grid potential. In addition there is very little power required for modulation when the grid is fixed at this latter potential, since the more negative the grid the less current and consequently the less the power required for modulation.

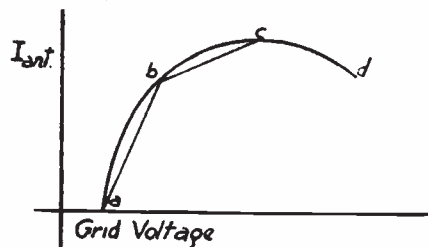

FIG. 8

Unfortunately, however, minor variations of the constants of the antenna or local circuit will destroy any adjustment which is obtained in the grid circuit, and only by constant readjustment can the circuit be kept in such condition that modulation is effectively accomplished. In addition to this, experience shows that with the usual care in adjustment which is given by the amateur to his transmitter, the grid-modulation circuit usually results in very serious distortion.

These then are the objections which militate against grid modulation. It has been used quite successfully and it appears that certain commercial companies are now planning on its use, but general experience indicates that some more reliable and easily adjustable method is essential.

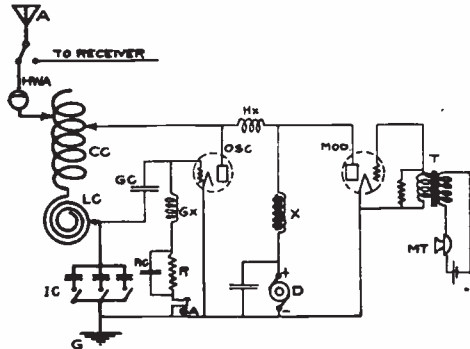

FIG. 9

The second modulation scheme that is in common use is the so-called "constant current" scheme or plate circuit modulation. This scheme is shown in Fig. 9, and this is the one with which we are probably most familiar. It may be considered either an absorption method or a power control method, depending on whether the modulator tube is viewed as part of the power supply or part of the generating circuit. This circuit operates by changing the voltage on the plate of the oscillator. This is accomplished by changing the current

through the modulator by means of changes of the grid potential of the modulator tube. Because of the fact that the output power is reasonably proportional to the voltage on the plate of the oscillating tube, and this in turn varies with the voltage on the grid of the modulator tube, we have a scheme in which (when sufficient filament emission is available) distortion is not a serious factor, and one in which the adjustment is not seriously critical. Its outstanding advantage lies in the fact that the adjustments which are required for best modulation are in the main independent of the adjustments of the generating circuit. For this reason, if there were no other reason, it is to be preferred to the grid modulation scheme.

In closing, let me say that this segregation of adjustments or of control is the characteristic which differentiates all effective and easily-usable radio schemes and apparatus from the less usable types and that in any radio equipment which is to be successful, whether it be a radio telephone transmitter, an amplifier, a receiver, a loud speaker, or what not, the aim of the experimenter should be not only to make the most highly effective device but also to make one in which the various factors that go to make operation successful are separately controllable. This should be done even at a slight sacrifice of efficiency. If it is successfully carried out, the average efficiency of operation will be greatly increased over that of a device which is capable of much higher absolute efficiency but which requires infinitely careful adjustment because of the fact that its controls vary more than one factor at a time.

New England Division Daylight Tests

By P. F. Robinson, Division Manager

ON Sunday, May 14, 1922, the N. E. Division of the A.R.R.L. conducted its first daylight relay on its routes from northern Maine to southern Connecticut, i.e., 1BRQ to 1AWB. The tests were arranged with the view of interesting the Operating Department personnel in daylight relay work and also in preparation for the first Daylight Transcons.

In order to make a fairly good showing it was necessary to notify about fifty stations that the tests would take place. This was done from one to two days before the tests and practically every station to whom notice was sent was on the job. In view of the short notice given this was very remarkable response and if such interest is displayed right along there is no reason why considerable traffic cannot be

handled during daylight on Sundays and holidays.

Complete logs were turned in by all but one of the stations which participated in the tests and from them a lot of very interesting and valuable information was gathered with regard to conditions in certain localities, fading of signals, relative value of spark signals as compared with C.W., etc. Unfortunately a fire in the radio shack at 1CK where all the records were kept destroyed everything but it is hoped to conduct further tests and keep the records in a safe or in some good place until they can be used.

The best work done was the transmission of a message from Connecticut to Maine and the reception of a reply at the station of origin inside of 56 minutes. Considering that a year ago this would

have taken at least two weeks, even at night, this was very good work. Subsequent examination of the log sheets turned in by the various stations showed that in many cases the messages were copied from stations several jumps away from them and that if the message had been sent as soon as first copied the time of delivery would have been greatly reduced. Eight messages successfully completed their journey during the schedule set for them and two others which got hung up somewhere came through the next night.

A peculiarity was observed in that no spark signals from stations south of Boston were heard during the test but stations north using spark were all heard o.k. while only one C.W. station came through from the north. The southern C.W. stations

came through steadily throughout the whole test.

A great deal of credit must be given to the following stations for efficient handling of traffic: 1ACO, 1ADC, 1AW, 1AWB, 1AZW, 1BRQ, 1CK, 1FM, 1FW, 1PR, 1QP and 1RV. Of these stations 1AZW was heard over practically the entire division, his call being listed in all but one of the logs turned in. Thanks are extended to the many other stations who were on the job but who did not take active part in the relaying or whom I may have left out on account of loss of their records in the fire.

In response to numerous requests more tests will be run and more time will be given in preparation for them so that the distances may be covered in shorter time.

5ZA Gets Hoover Cup for 1921

THE entries in the contest for the Secretary of Commerce's Cup for America's Best All-Around Amateur Station for 1921, in which the major portion of the apparatus is to be home-made, were considered by a special meeting of the A.R.R.L. Board of Direction on May 26th. It was of course, a process of elimination. When each director had studied all the entries and announced that he had made a decision in his own mind, the chairman called for a vote and it was *unanimously* in favor of Louis Falconi's well known 5ZA at Roswell, New Mexico.

The announcement that the Department of Commerce would give a handsome cup each year during the present administration to the best amateur station in the country, under certain regulations, was made in QST last winter. Chief Radio Inspector Terrell conveyed the glad tidings to our First A.R.R.L. National Convention. Secretary Hoover desired the cup to be given

under regulations to be drawn up by the A.R.R.L. Board of Direction but specified that it was to be primarily an encouragement to home-construction—apparatus built by the amateur. The rules for the contest were published on p. 20-22 of QST for last January. There is to be a cup each year. Because the scheme was late in starting, entries for the 1921 cup were received up to March 1st, and it is that award which has just been made.

By its terms Mr. Falconi is signally honored—of all the home-made stations in the contest his is unanimously voted the best. And everyone knows that 5ZA is a real performer and will be glad to see this recognition given his long and hard work. *Bravo, Falconi, attaboy!*

In our next issue we expect to have a photograph and description of the beautiful cup which secretary Hoover is presenting to the winner. This month we publish

A Description of Station 5ZA

By Louis Falconi

5ZA was installed at the conclusion of the European War. The present set is the result of three years' improving and rebuilding. In every case efficiency has been the main consideration in the design and construction of the apparatus. However, good appearance was taken care of as much as possible and still maintain efficiency. The apparatus is entirely home-made and the layout of the units original.

The station can be divided into five parts:

- (1) 200-watt C.W., I.C.W., fone.
- (2) 1 K.W. rotary spark transmitter.
- (3) Switchboard.
- (4) Receiving cabinet.
- (5) Aerial and ground system.

I will endeavor to give a complete description of the units.

The C.W. Unit

The C.W. unit is built to accommodate a total of 4 fifty watt power tubes and one 5-watt speech amplifier tube. The circuit used is a modified Hartley with Heising or constant current modulation for phone. All tubes are used for C.W. and I.C.W. Two tubes are used for modulators and two as oscillators for phone. The small 5-watt speech amplifier is automatically connected when the microphone jack is inserted.

The entire set is mounted on a bakelite panel, 18 by 24 inches. The panel is supported by an aluminum frame (the alumi-

num was obtained from a wrecked aeroplane, cut into strips and bent like angle-iron.) Iron has been avoided as much as possible in the construction of the set, and all unnecessary metal of whatever nature has been left out. Another point followed in design of the set was the elimination of all variable condensers. The wiring diagram is given in Fig. 6. Grid coil adjustment is made by variable coupling and variable inductance, the combination of the two giving any adjustment desired.

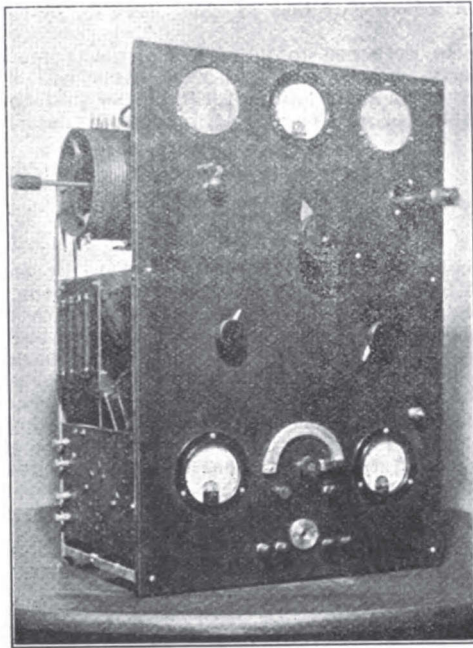

Referring to front view of set: At the top center of panel is the thermo-couple radiation ammeter in the aerial lead. To right of said meter is the oscillator tube peep-hole and to left is the modulator tube peep-hole. Copper screen is placed over the holes. Just under the radiation meter is a large knob which controls the change-over switch, to throw from C.W. to phone. This switch is really two switches in one. One is a single-pole double-throw and throws the modulator grid from oscillating to modulating position and the other is a single-pole single-throw which shorts the radio frequency choke coil between plates in the C.W. position. The blades of the two switches are linked by a bakelite strip and thus one knob throws both. The small knob at right center controls the rheostat in the primary of the filament transformer, while the small knob to left of center controls the rheostat in the filament circuit of the speech amplifier. In the left lower corner is the filament voltmeter and the right lower

corner is the plate milliammeter. Between the two meters is a variable grid leak which is used in connection with a fixed leak for close adjustments. Under the grid leak is the microphone jack. This jack is fitted with two auxiliary contacts which close when the plug is inserted; these contacts control the lighting of the speech amplifier tube, the tube burning only when plug is in. The large post at the right of the panel is for aerial connection and the small binding post at lower right for ground. The small posts under the jack connect to the storage battery and to the transmitting key. In the upper left of the panel is a small switch to throw the voltmeter from power tubes to amplifier tube. On the side of the set may be seen the resistances used in the speech amplifier and the small panel on which is mounted the amplifier tube, modulation transformer, and fixed condenser. The handle controlling the grid coupling and inductance is also visible. Part of the antenna-plate inductance can be seen. Referring to the photo of the back of C.W. set: The antenna-plate inductance with

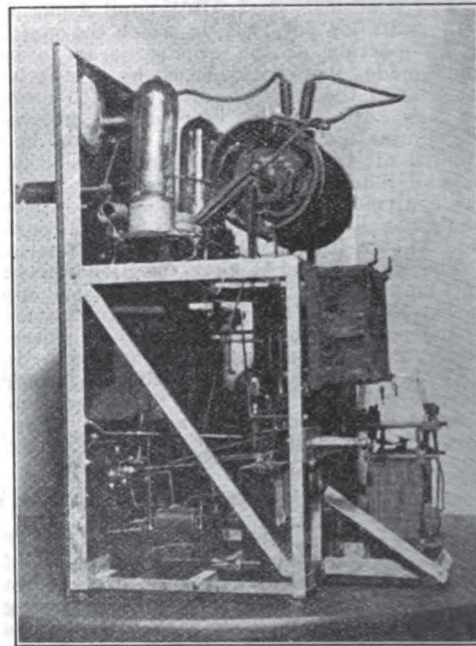

grid coil inside is plainly seen. The grid coil slides on two brass rods attached to the large coil tube. The large coil is wound on a 5-inch tube, threaded 5 to the inch, with 40 turns of No. 8 bare hard-drawn copper wire. Pieces of the same wire $\frac{3}{4}$ inch long are soldered end up to every turn for taps, every other tap staggered about 2 inches apart. Plugs with holes to fit the wire taps are used for connections. The

grid coil is wound on a 4-inch tube, threaded to take 50 turns of D.C.C. No. 16 copper wire. Taps are taken every 10 turns and brought to a switch fitted to end of grid coil tube. The switch handle is extended so as to project from the side of the unit and a good insulating handle fitted to it. Thus the number of turns in grid coil and its coupling are controlled at once. The socket assembly is home-made and has 4 sockets to fit 50-watt tubes, all on the same bakelite base. Intergrid chokes and protective gaps are built in. The audio frequency choke in the D.C. power lead was made by winding about 4 pounds of No. 28 enameled copper wire on an open core $1\frac{1}{2}$ inches square and 6 inches long. The same is mounted on a bakelite strip under the socket assembly. It is not known how near theoretically correct the construction of this coil is, but the results have been good and the modulation excellent. The rheostat at the left of the photo is in the filament transformer primary. The filament transformer is just back of this rheostat and is mounted to the back of the whole unit. The two large binding posts in front of the rheostat are for the 1000 volts D.C. The filter elements are plainly seen, two single coil chokes and two condensers. The amplifier tube on other side of unit is visible.

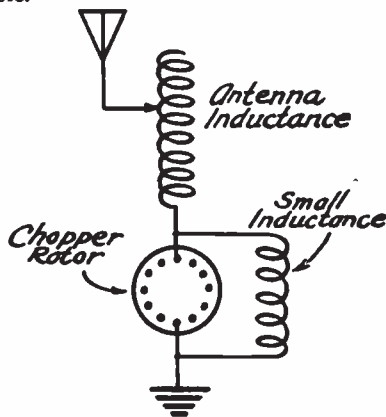

FIG. 1

It will be noted that the apparatus is so distributed that all roundabout connections are avoided. All connections in the oscillating circuit are short and direct. The wiring is done entirely with No. 8 copper wire for the power circuits and No. 14 for the modulation circuit. All connections are soldered. The complete unit is very rigid and easily handled. It might be added that to date only two power tubes have been used but full power will be available at sometime in the future.

Straight C.W. transmission is accomplished by shorting a 1 MF condenser in

the grid circuit. For I.C.W., a chopper is connected in the ground lead in a very novel way. To my knowledge I have not seen any description of this arrangement for the chopper. It is connected as shown in Fig. 1. It will be noticed that all the chopper does is to short a small inductance of a few turns of heavy copper wire, thus changing the wave length every time contact is made. If the inductance is made large enough, reception can be made on two waves. For best results, however, the change in wave should be only a few meters. This arrangement has the advantage of making the wave somewhat broad, and for calling it is ideal. A better method would be to have two chopper discs so that when one is in contact, the other is not. Thus the set could oscillate at one wave at a time only whereas with the other arrangement it is doubtful if all of the energy is actually modulated. Results have been perfect.

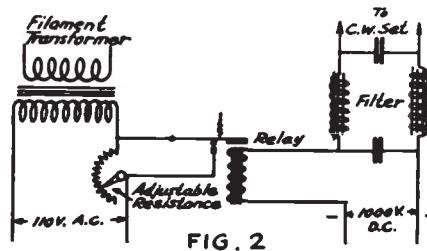

FIG. 2

When this set was first placed in operation, trouble was experienced from the drop in voltage across the power line when the generators took up the load. Every time the key was pressed the filament voltage went down. That spoiled the tone so that the compensating wave method of signalling was attempted. That system works OK as to tone but the disadvantages were so great that it had to be abandoned. It was soon found that the tubes could not be loaded to the same extent, that it was not very economical, and also that the compensating wave caused QRM. The flickering trouble was solved by the arrangement of Fig. 2. As will be seen a small variable rheostat is connected in the primary circuit of the filament transformer. A relay is connected so that when closed the active portion of the resistance is shorted. The winding of the relay is connected in the negative lead of the 1000-volt circuit supplying power to the plates. The action is as follows: when the key is open, the tube filament current is limited by the resistance, but upon closing the key, power flows thru the relay closing same and shorting the resistance. Now the tendency is for the filament current to rise but since the voltage across the power line drops, the drop and rise neutralize and the filament voltage remains constant. By

changing the value of the resistance, any load drop can be taken care of. The device can be used in any circuit where a drop in voltage is objectionable. The resistance can be so chosen that the tubes will burn at low brilliancy with key up and burn

frame. It is clearly seen in the view. The motor is bolted to the center of the marble slab by means of the motor thru-bolts which were lengthened for the purpose, and the shaft projects thru the front of the panel. It will be noticed that the gap disc is housed

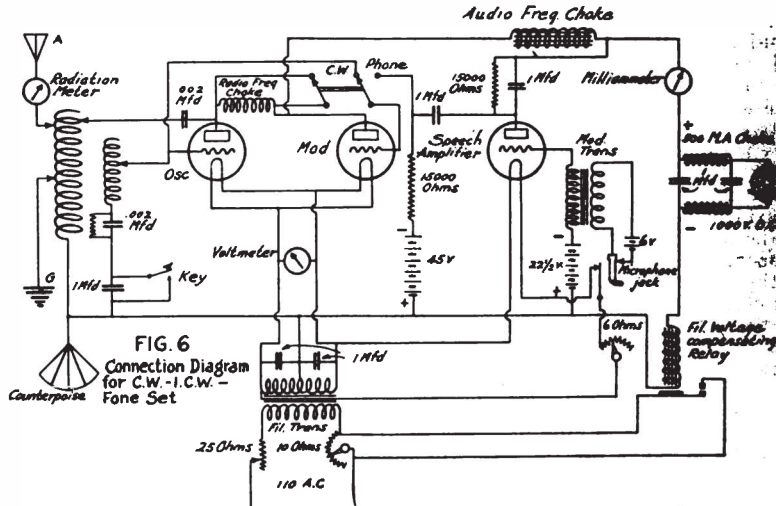

FIG. 6
Connection Diagram
for C.W.-I.C.W.-
Fone Set

normal with key down, thus saving the life of the tubes.

Power to the C.W. set is supplied by two 200-watt 500-volt generator sets in series for 1000 volts.

The Spark Set

This is a 1 K.W. rotary gap spark transmitter. It comprises a 1 K.W. transformer in duplicate, rotary gap driven by a "synt" motor, copper strip O.T., oil immersed condenser, and thermo-couple radiation meter. The set is mounted as

by a cover fitted with double glass front so that the gap action can be noticed. The stationary electrode holders are made of 3/4" copper pipe with rather thick wall, and threaded the whole length. The holders pass thru two holes in the panel and are bolted by two heavy nuts on each side of panel. Slots are cut in their ends for the 1-inch-wide stationary electrodes. Small bolts thru the end of the holders clamp the electrodes tight. This construction is rigid, to say the least, and absolutely takes the gap out of the toy class. So many of the gaps on the market are made for looks, and the little nick-eled binding posts for connections are truly amusing when 2-inch ribbon is advised in the oscillating circuit. Very close adjustments can be had with this gap and there is no danger of warping or other disturbance destroying the adjustment.

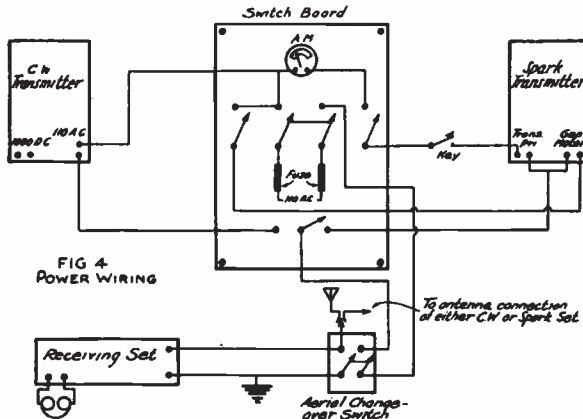

FIG. 4
POWER WIRING

one unit on an angle-iron frame in the shape of an L, insulator feet being attached to the lower section.

Referring to photo: The spark gap is mounted on a 1 1/2 inch thick marble slab which is bolted to the upright part of the

The condenser is just visible, back of the panel, behind the motor. It rests on the other part of the frame. It is made up of 3/8 inch plate glass 8 by 12 inches and copper sheets 6 by 10 inches. A total of 25 glass plates is used. The tabs of the copper plates are all soldered to wide copper strips which come out thru the top cover thru bakelite insulation. The condenser is placed in a galvanized iron tank and filled with transformer oil.

The ribbon on the primary of the O.T. is 2 inches wide and on the secondary it is

1 inch wide. Two heavy battery charging clips are used for the variable contacts. The clips are made of brass, the jaws straightened and the lead covering burned off.

ceiving set is the cabinet to the extreme left. Above it may be seen a wavemeter.

The Aerial System

The antenna system uses two masts 67 ft. high. These masts each comprise three sections, a wooden section for the bottom and two lengths of pipe hauled up on the wooden sections. That construction allows easy take-down if repairs are needed. It is very easy to erect such a mast, one of them having been raised by the writer without any help. The guys are broken up into 20-foot lengths by insulators. Turnbuckles are placed in every guy.

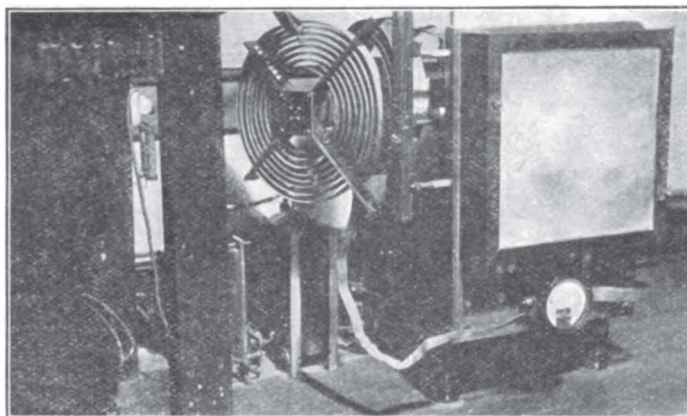

The antenna proper is comprised of 4 stranded wires in T-type. The flat top is 90 feet long. The

A kick back preventer was made out of two high-resistance rods mounted on a fuse block as shown in Fig. 3.

The Switchboard

The switchboard controls all power circuits and also shifts the circuits so that the same change-over switch can be used to control either the C.W. or spark set. A large ammeter shows the power input to the transformer. Switches control all of the power, gap motor, transformer primary, high voltage D.C., and a change-over switch is provided to change power connections to the main antenna change-over switch. Fuses are placed in the power line. The photo of the complete station will give an idea of what the switchboard looks like. See also Fig. 4. The main change-over switch is just in front of the switchboard. It controls the power to either the C.W. or the spark set depending on how the small switch on the switchboard is thrown. For switching the antenna connection from C.W. to spark, the O.T. clip is simply taken from the O.T. and clamped to the antenna post on the C.W. set.

spreaders are 14 feet long and the wires spaced a little over 4 feet apart. Two 10 1/2 inch Electro-se insulators in series are placed at the end of each wire. The lead, taken from the middle, comes down in fan style and is bunched just before entering the station.

The Receiver

The receiving set can be seen in the photo of the station. See also Fig. 5. It is a variometer regenerative set with two steps of audio amplification. It is home-made and standard units were used in its assembly. A switch is provided so that the amplifier can be used with separate receiving apparatus. Jacks are used for switching to either step and also for two sets of fones. This set has been used two years and has proven very sensitive. On one occasion, a Ford spark coil used by an operator on a ship just out of San Francisco was heard and worked with. The set receives the C.W. stations as readily as the spark. In the photo of the complete station, the re-

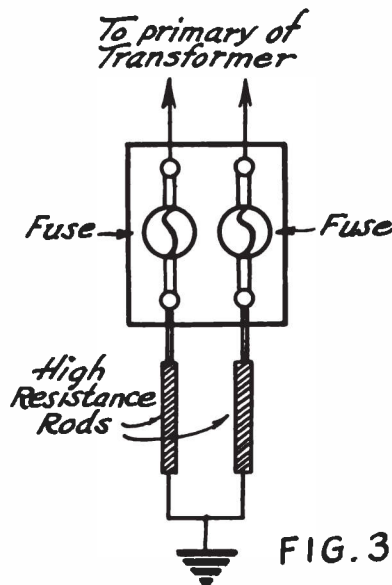

The counterpoise consists of 6 wires starting from a point at the station, which is near one of the masts and spreading out in fan shape towards the other mast where the ends cover a space of 50 feet. A more elaborate counterpoise is planned.

Earth connection is made to three buried hot-water tanks, to pipes, and to buried wires.

Results

The C.W. set has been used most of the time with only 500 volts on the plates of the power tubes due to lack of the other 500 volts, which was just recently obtained.

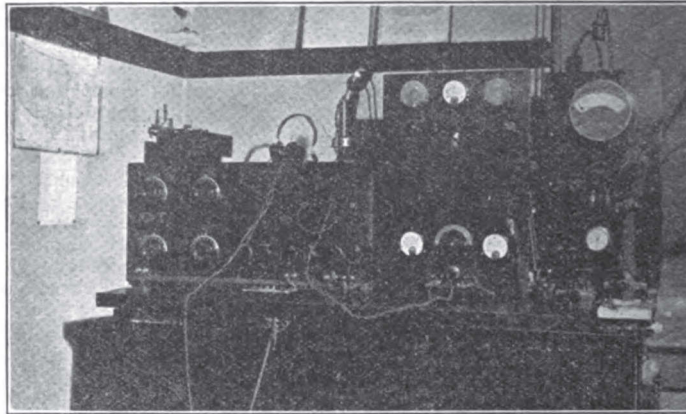

The C.W. sigs have been reported from every state except Maine. 1TS reports signals 30 feet from the fones using 1000 volts on the plates, and 10 feet from the fones when using 500 volts. Only one tube

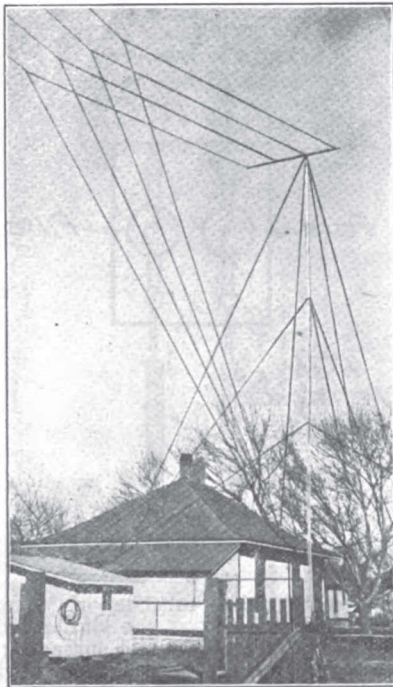

was used for reception. Only two power tubes have been used to date. Mr. C. J. Dow of Wailuku, Maui, Hawaii reports as

follows, "Your sigs QSA here every evening, please QST to me". During the month of December, the amateur both-way communication record was broken when direct communication was established with 2ZL and

msgs. exchanged. Mr. Godley, in his report on the Transatlantic Tests in QST says "I wish to express my thanks for the assistance unwittingly given by one Mr. Louis Falconi, station 5ZA, Roswell, N. M. It will be a great surprise to him when he learns that covering a period of about one week prior to my sailing, during which time the apparatus which I was to use was under test, I used his very uniform signals to check and recheck operation of the equipment. I did not only receive his signals on the regenerative and two steps but also was able to get him nicely on a *nine turn loop* in conjunction with a super-heterodyne receiver, when his signals were of such strength and regularity as to enable the operation of a *4-ohm sounder* by the insertion of relays in the circuit". Mr. Godley was at that time in New Jersey.

The following stations have been worked with: 2ZL, XF1, 8ZZ, 7XF, 8ZG. NWO while off coast of Virginia. Cloi in the state of Washington. 5ZA has been reported from every state except Maine, also from Toronto, Vancouver, Morse, and Ottawa, in Canada; ships as far as 1500 miles out in the Pacific, ships off the coast of North Carolina, ships in Honduras. During the Transcons last year, the spark transmitter was one of the transmitters taking part in the transcontinental record and connected 9ZN with 6JD.

The radiophone has been reported heard in the following states: Calif., Nevada, Utah, Minn., Mont., Wyo., Wisc., Indiana, Missouri, Louisiana, and other states closer. Actual conversation has been established with 9XM, 9YAE, 9ZU, 5XB, 5XU, 6TV, and Juarez, Mexico.

It is regretted that a complete log of 5ZA can not be had. The traffic going thru

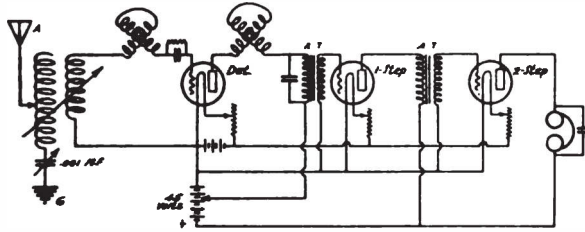

FIG 5 WIRING OF THE REGENERATIVE RECEIVER

5ZA is very heavy. There is only one operator and the distances covered are so great that transmission is always done under difficulties due to long distance QRM. Therefore it takes all one's time to relay messages and very little is found for logging, only unusual distances and records being taken down.

Some British Tube Equipment

THROUGH the courtesy of Messrs. Burnham & Co., London manufacturers of amateur radio equipment, QST has had an opportunity to inspect and test one of their "Ultra III" Receivers. The Ultra III, we take it, is representative of the best in British amateur apparatus.

Now when an American amateur gets hold of a new set there are three things he wants to know:

What does it look like inside?

What's the circuit?

How well does it work?

To our delight, both the set and its tubes arrived in perfect shape. Altho called a receiver, it should be noted that this is tube equipment and that no tuner is embodied. It is generally used in connection with honeycomb coils. The most outstanding thing about its appearance is that it is meant to sit horizontally on the table, in marked contrast to the vertical-panel style now exclusively used by American manufacturers.

Referring to the photograph of the exterior, the three tubes are respectively a radio frequency amplifier, a detector, and an audio frequency amplifier. The switch in the center of the panel tunes the radio stage. Next are two telephone switches for tube controls, and at the bottom are the three rheostats.

Upon getting inside the set, imagine our surprise at seeing a regular American-built Federal 226-W amplifying transformer for the audio stage! The workmanship and material thruout the set are wholly above criticism — flawless — but vastly different from American practice. We of course are used to seeing a tube set arranged like a Ford factory—the input coming in one side to the first tube, leaving its output to enter a transformer whose output feeds to the second tube, and so on across a long narrow cabinet in which the tubes and transformers are arranged as nearly as possible like a schematic drawing. The Burnham set is vastly different, as it must be in a

flat set with an almost-square panel. The wiring runs in every direction and one needs pencil and paper and a half-hour off to trace out the circuit. It's "all there", however, and much ingenuity has been displayed in arranging the spaghetti-covered leads in tripod formation so as to be self-bracing in running from one side of the panel to the other. Physically the set is as good a job as we ever saw, altho we cannot admit being intrigued by its particular style of beauty—we prefer logically-arranged vertical-panel sets ourselves.

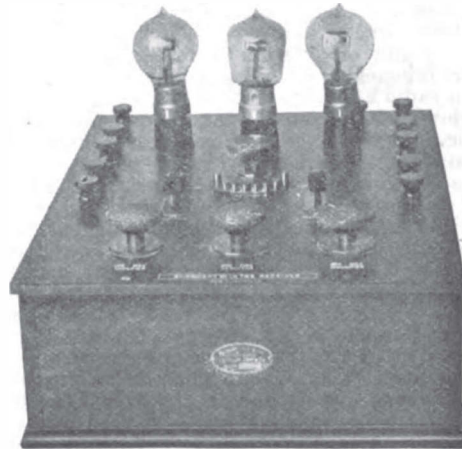

The large coil on the left in the inside photograph is, as may be guessed, the step-down telephone transformer. Altho arranged for use with high-resistance phones, the British prefer phones of about 120 ohms, which of course requires a telephone transformer. The various condensers are all mica-and-copper, securely screwed down beneath ebonite strips. Above the Federal transformer is the 2-megohm Mullard grid leak, while below it is a larger one of 80,000 ohms used in the radio repeating circuit. The radio-frequency reactance, about which we shall say more in a moment, is in the

form of a bobbin with five taps, connected to the switch points. On either side of it are the control switches which are most sturdily built and seemingly fool-proof, while across the bottom are the three rheos, smooth-running and reminiscent of our Remlers.

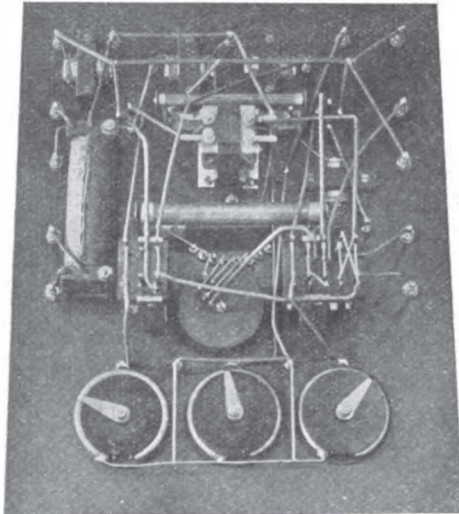

Now for the circuit. Figure 1 shows the scheme when all three valves are employed, the middle or detector valve being arranged for regeneration. The method of coupling the radio amplifier to the detector for waves below 5000 meters is that known as reactance-capacity, while resistance-capacity coupling is used for higher waves. The reactance-capacity method consists in effect of tuning the output circuit of the radio amplifier by the selection of the proper amount of inductance, the voltage drop across it caused by the signal of course being greatest at its resonant frequency. This arrangement will be better understood by reference to Mr. Higgy's Figure 2 on page 35 of QST for last February. For long waves there is no need for adjusting this anode circuit and in the Burnham set when the selector switch is placed on the right-hand stud marked "Long", the 80,000-ohm resistor is cut in to the circuit (in series with all of the reactance) and it becomes essentially a resistance-repeater arrangement.

Altho our diagram shows the set connected with three coils, the British amateurs commonly use with it with but two, having but one tuned circuit and with tickler feed-back.

It should now be possible to understand Fig. 2 without difficulty. The main thing is the switches, S_1 and S_2 . These are two-position switches and when both are in the "Off" position the tuner and phones are connected to the detector alone. When S_1 is

thrown to "On", the detector output is diverted from the phones to the audio amplifier transformer, the amplifier filament is lighted, and the telephones are automatically in the amplifier plate circuit. Similarly when S_2 is "On" the high-frequency amplifier is lighted, the input diverted to its grid circuit, and its output then connected to the detector. Now here is an interesting thing, perhaps little appreciated by the average American amateur. Everyone knows that a tickler connection works only one way and that sometimes in hooking up apparatus it may have to be reversed to get it correct. When, now, it is correct for a detector (and audio amplifiers if used), if a single stage of radio amplification is used before the detector, the tickler must be reversed, for the electrical signs have changed. Thus the switch S_1 is equipped with extra blades which automatically reverse the tickler connections as between detector alone and when it is preceded by r.f. amplification.

So much for the set. The valves are nicely made and work very well. All are hard tubes, working on 60 to 75 volts B battery. Their detector, so hard that a grid leak is essential, is as sensitive as most of our gaseous tubes and more stable. Altho requiring but 4 volts, the set is operated on 6 volts to get the proper grid biases by means of the drops across the rheostats. Our only criticism of the tubes is that whenever the set is jarred, even gently, the tubes "ring" like a fire-gong.

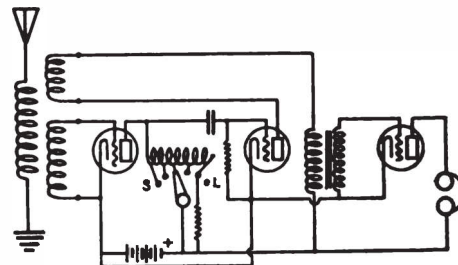

FIG 1

When we first tested this set we hooked it up to a short-wave regenerative receiver with loose coupling, condenser tuning of the secondary, and we connected in the usual regenerative variometer instead of using a tickler. The rectifier and audio stage worked as prettily as any detector-onestep we ever had but the radio stage wouldn't work at all. The first night had passed before we awoke to the realization that the tuned-plate-circuit method of regeneration couldn't be used in connection with a single stage of radio amplification ahead of the detector, because the polarities were wrong—and that reversing the variometer leads wouldn't help. So the next night we tried Coto-Coils, using tickler-feedback, and got excellent radio-amplification on 600 meters without regeneration.

When we had the set working well on 600 meters, with good r.f. amplification, we were using no tickler reaction and found that any at all would put the bulb into oscillation. Cutting out the r.f. stage and reverting to detector, where the regeneration could be accomplished, the signals were just as loud, as nearly as we could tell.

our three precious tubes gave a violent blue "plick!" and went west at three hundred million meters per second. As yet we have not received additional ones and so can make no report on the operation of the set on short waves. Mr. Burnham tells us, however, that the radio stage works excellently on 180 meters.

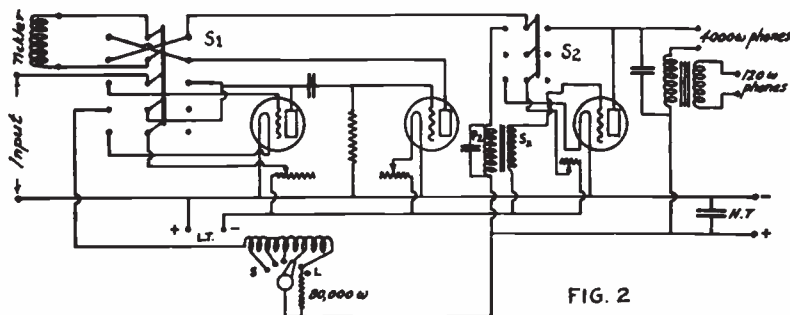

FIG. 2

Results on 200 meters, however, were nil, strong local signals dwindling to faintness when the radio stage was cut in. A cruel trick of Fate's prevented our ever discovering the trouble. The bloody symbols on the set, "L.T." and "H.T." (low tension and high tension) for the "A" and "B" batteries, respectively, got us all mixed up and so we mixed them all up, and two of

This test was made on ship traffic off the Atlantic coast. We have had much the same luck every time we have endeavored to use r.f. amplification on short waves—regeneration must nearly always be sacrificed, and it takes one or two stages of r.f. amplification to overcome this loss before additional benefit begins to be experienced.
—K. B. W.

An Explanation of the "Chicago Plan"

By R. H. G. Mathews

April QST recorded the award of the Smith Trophy to the Chicago Executive Radio Council, partly for the conception of the co-operative plan of local amateur government known as the "Chicago Plan". Doubtless many of our newer readers wonder what this scheme is, and we therefore have asked our Central Division Manager to give us a brief explanation of its functioning.—Editor.

IF in past years definite organization among the various individual radio clubs and groups in large cities was desirable, in these days of hectic radio interest with new clubs springing up over night, their membership being composed perhaps of the most influential and wealthy men of their various communities, the need of some such organization as the "Chicago Plan," which has proved itself a simple, practical method of organization, is absolutely imperative.

Single large radio clubs intended to co-ordinate all the radio interests of a community have always failed to give the perfect co-operation necessary for the several different classes of radio men to pursue their own lines without interference of one kind or another.

The so-called "Chicago Plan" is merely a method whereby various radio clubs, whether they be school, social or community, may co-operate and regulate radio communication in a truly representative man-

ner. The machinery of this plan, which derives its name from the fact that it originated in Chicago, is extremely simple. Each radio club in the city of Chicago naturally elects its own officers. These officers then automatically become members of the Chicago Executive Radio Council, which body is composed entirely of these officers of the various clubs, six in number in Chicago, together with various officials of the A.R.R.L. Central Division.

This body must *per se* be absolutely impartial in its adoption of regulations since its membership is almost entirely an elected one. No attempt is made by the Council to interfere in any way with the individual activity of the various affiliated clubs but the best of co-operation is secured between them through the friendly personal contact of the officers. Through regulations the dues and fees of all clubs are identical. Any radio man may belong to one or more of the clubs as desired, and meeting dates are arranged so that they do not conflict.

Regulations are drawn covering the time periods allowed different classes of stations to operate. It has been found that three time divisions are necessary, the first for low powered local work only, the second for stations desiring to do long distance work but not wishing to handle message traffic and the third for long distance message traffic only. It has also been found advisable to limit operation so that any one station may transmit during the local and either one of the two long distance periods on any one particular night, but under no circumstances may transmit during both long distance periods on that night.

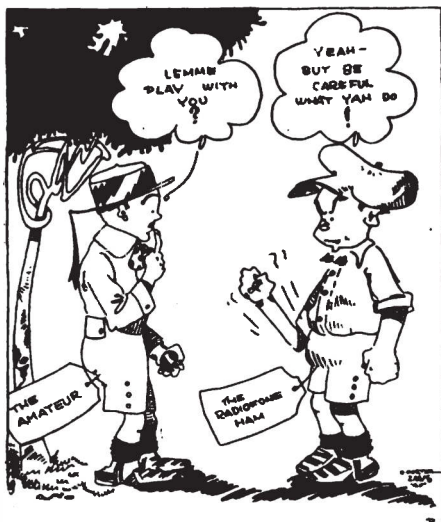

Puzzle: Which is the new boy in the neighborhood?

Traffic Managers elected by the various clubs carry out and enforce these regulations, each traffic manager having jurisdiction only over the members of his particular club. No attempts are made to enforce the regulations by radio but a log is kept and violators notified either by telephone or mail.

Inasmuch as it is naturally somewhat difficult to impose a fine or penalty on a continued offender it has been found most desirable to divide the city into six districts, apportioning each club one of these districts for which it is responsible. Fines are imposed on the clubs according to the location of violators without regard as to their membership in the clubs. In this way extremely good co-operation has been secured and since these regulations have been in effect for several years the "habit" of compliance has been formed and practically no enforcement is needed at the present time.

With the coming on of radiophone broadcasting the Chicago Executive Radio Coun-

cil at first planned a change in its time schedule to allow a definite period for radiophone listening. By sharp tuning of transmitters, however, the necessity of setting aside a part of the local transmitting period for this purpose has been obviated, and since long distance work is not allowed prior to 10:00 P.M., the beginning of the first long distance period, the low powered local communication is carried on on low waves without appreciable interference to radiophone listeners.

Accordingly, since further regulation was not necessary, the Chicago Council has turned its attention toward taking care of the influx of new radio amateurs or novices who have come into the game because of radiophone interest. It being extremely inadvisable from every standpoint to attempt the discouragement of these new participants in the radio game, a policy of friendly co-operation has been adopted and the Chicago radio clubs, formerly composed entirely of radio relay amateurs, are now rapidly absorbing the new radiophone listeners. This policy has helped both sides materially as the clubs have gained many prominent and influential members who in turn have gained considerably through contact with our "old timers" which have been through the early stages of the game and who have the knowledge that comes only with hard experience.

Since the original adoption of the "Chicago Plan" in the city of its origination, similar plans of organization have been adopted in practically every large city in the country, where they are functioning at the present time. We would heartily recommend to the newcomers in this game of ours a close study of the regulations existing in their localities, bearing in mind that these regulations were drawn up by a majority of the radio men in that locality. If the regulations are not satisfactory to any particular contingent it should be easy to change them so that they can be made fair to all sides as only by adoption and enforcement of absolutely fair regulations can any faction in the radio amateur field hope to succeed.

Q.S.T. Critics

By L. Q.

ONE Saturday the garage man came in looking rather chewed up. It appeared that the machinist had told him how to grease differentials.

"Was he nasty about it?"

"No I beat him up for not telling me sooner. I'd have beat him up harder if he'd been nasty—but I'd have thanked him just the same."

Moral—If the critic knows what he is talking about criticism is always valuable.

Notes on the Design of Small C. W. Transformers

By Geo. E. Hoke, 9DJU

SINCE the comparatively recent advent of amateur continuous wave transmission, there has been a well-nigh insatiable demand for specially designed transformers to meet a large variety of requirements. In the development of new diagrams, small transformers of more or less unusual design are frequently required, which are in most cases unobtainable on the market.

Amateurs are agreed that the results obtained by *designing* an instrument are such that they are well repaid for their trouble in carefully considering a problem before starting actual construction. This is especially true in the case of transformers, since it is impossible for one to guess at the number of turns and the size of the wire and the core and have the completed instrument perform as originally desired.

The purpose of these notes is to furnish sufficient data, in as simplified form as possible, to enable the design of almost any small core type transformer up to one kilowatt or even more. The formulae contained herein are all obtained from standard commercial design data and have been found to be thoroughly reliable. Each formula is simplified as much as possible, so that a minimum of substitution and computation is necessary.

The equations given below are applicable only when 110 volt, 60 cycle supply is used, and transformers designed on this data should be used on no other voltage or frequency, when maximum efficiency is to be obtained and the safety of the instrument duly regarded.

The first things one must know when designing a transformer are the primary voltage and approximate current, and the required secondary voltage and current. This information being at hand, all the specifications necessary for the construction may be obtained quite easily.

In finding the number of turns on the primary and secondary windings, substitute the correct values in the following equations:

$$S_1 = \sqrt{\frac{700,000}{I_1}} \quad S_2 = \frac{110 S_1}{E_2}$$

where S_1 is the number of primary turns
 S_2 is the number of secondary turns
 E_1 is the primary voltage on tap
 E_2 is the secondary voltage required
 I_1 is the primary current
 I_2 is the secondary current.

After the number of turns is obtained, it is then necessary to find the size of the wire to be used. This is readily obtained

through the use of the following equations:

$$\text{Cross-section of Pri. conductor in square inches} = \frac{I_1}{1000}$$

$$\text{Cross-section of Sec. conductor in square inches} = \frac{I_2}{1000}$$

Of course this does not give the size of the wire, (B. & S.) but the figures obtained are merely substituted in the following table and the size of wire selected which has nearest that same cross-section. For example, if the cross-section is found to be .0011 square inches, the table shows us that #18 B. & S. wire is the nearest size. (A larger size is always selected in preference to a smaller one, in case the figure lies between two values in the table.)

Size B.&S. square inches	Cross-sect. in square inches	Size B.&S. square inches	Cross-sect. in square inches
6	.02062	19	.001012
7	.01635	20	.0008023
8	.01297	21	.0006363
9	.01028	22	.0005046
10	.008155	23	.0004002
11	.006467	24	.0003173
12	.005129	25	.0002517
13	.004067	26	.0001996
14	.003225	27	.0001583
15	.002558	28	.0001255
16	.002028	29	.00009953
17	.001609	30	.00007894
18	.001276		

After determining the size of the wire to be used, the cross-section of the core should be computed. This is found by substituting the number of primary turns and the value of the primary current in the equation:

.001865 $I_1 S_1$, inches square. (NOT sq. inches)
 This figure refers to the section obtained by cutting thru the leg of the core at any place.

A fixed rule can hardly be given for the size of the "window" of the core, since the insulation used varies so greatly, as does the method of winding. In general, it is satisfactory to establish one dimension, the length of the coils, and wind the coils to fit that particular length, allowing the other dimensions take care of itself.

In designing a transformer for use in lighting the filaments of transmitting tubes, the voltage drop caused by application of the load should not be overlooked. This drop is usually more than expected; hence it is safe to add 15% to the required secondary voltage, thus allowing both for the full-load drop and any possible low feed-line potential.

Ourselves

THERE is getting to be quite a bunch of us at A.R.R.L. headquarters now, and in the need for greater efficiency we have had to coop up ourselves behind separating partitions so that sometimes days go by without our seeing all of the gang. So just to get a good look at each other we had a little dinner recently at which the above photograph was taken

manager; Miss Margaret M. ("Peg") King, book-keeper and cashier; Hiram Percy Maxim, president of the American Radio Relay League; Mrs. Matilda M. Herrick, stenographer; K. B. Warner, A.R.R.L. secretary and editor of QST; Fred H. Schnell, A.R.R.L. traffic manager; Mrs. Marie C. Seltzer, advertising department; Miss Margaret M. Mays, operating depart-

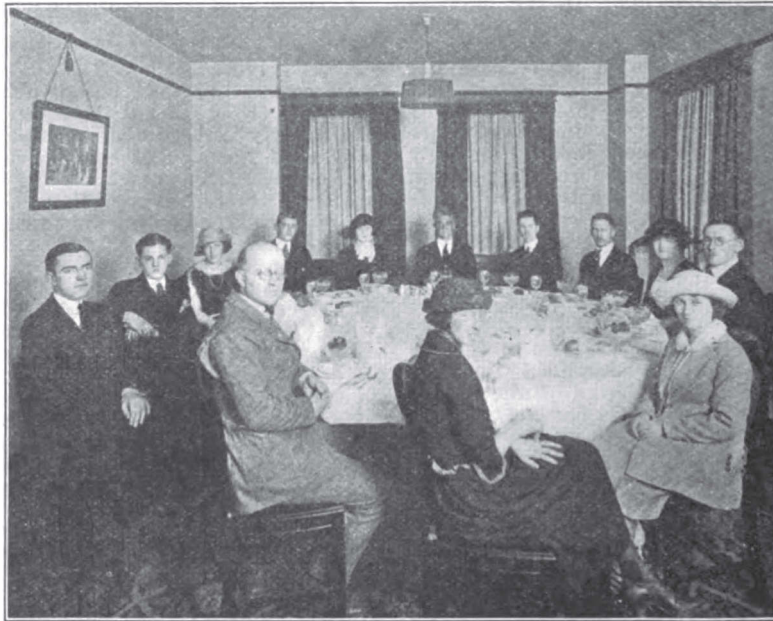

and which we are reproducing so that QST readers may see what we look like.

In this photograph, left to right regardless of perspective, are David H. Houghton, QST circulation manager; Arthur Lamoureux, files and mail; Mrs. Marjorie A. Foley, circulation department; Robt. L. Northrop, formerly assistant to the secretary; Edwin C. Adams, QST advertising

ment; and Boyd Phelps, assistant editor of QST.

After many reorganizations necessitated by our rapid growth in the past six months, we now have a splendid little gang at Headquarters, and A.R.R.L. members passing thru Hartford are extended a cordial invitation to call on us at 1045 Main St. and look us over.

Book Review

SINCE the rise of popular interest in radio, tons and tons of popular literature have been created on the subject. Books live longer than most other literature and so are the most important additions to the language of our art. Of books there have been many, and it is our purpose here to review briefly a few of them which have come to our attention. There are so many of them, and our time is so limited, that we freely confess that we have not read a one of them from cover to cover, but we believe we have studied them enough to hazard an opinion of their worth.

In view of the present scarcity of white paper it is to be wondered why some of them ever were printed. They are of course of all kinds, good, bad, and indifferent, well illustrated and poorly. Some are really good and some obviously have been written only because there was a chance to cash-in on the tide of radio interest. Fortunately, however, they are not all that way and some instructive and interesting contributions have been made possible to the literature of the art by the assured financial success awaiting any radio publication at this time.

"Radio Receiving for Beginners", by Rhey T. Snodgrass and Victor F. Camp; The Macmillan Company, New York; 99 pages, 4½x6¾, \$1.00.

A simple little book designed to answer the question on the lips of thousands of people, "How can I receive radio?" The circuit drawings are good, and well supported by numerous group photographs of actual apparatus. It treats only on receiving apparatus. Well written, and fills the bill.

Mr. Camp, one of the authors, is a director in the A.R.R.L. and so we were not surprised to read in the introduction the advice to the reader to join a local amateur club and get acquainted with amateurs and the A.R.R.L.

"The Compleat Radio Book", by Raymond Francis Yates, former editor of "Everyday Engineering Magazine," and Louis Gerard Pacent; The Century Company, N. Y.; 330 pages, 5x7¾.

Here by long odds is the most interesting and entertaining of all the new books, and altho we do not know what its price is it is worth whatever they ask for it. As its title indicates, it is told almost in story form and it is certainly easy reading by comparison with the average radio text. In most entertaining fashion the authors tell the tale of the progress of communication from savage days to those of modern civilization. For the first time we read in this book of the early experiments of a certain Dr. Mahlon Loomis, a dentist in Washington, D. C., which certainly form one of the most interesting chapters in the history of radio telegraphy. Back in 1869 and '70 Loomis got signals over a distance of 14 miles between transmitter and receiver using regular aerials and ground connections of the Marconi type. Dr. Loomis did not understand his apparatus and attributed its operation to conduction currents in the upper atmosphere. Indeed it is not known whether actual oscillation and radiation entered into its operation, but if it did he anticipated Marconi by many years.

Reserving the best paragraph for the last to discuss, we find much in this book that one would expect in any publication brought out at this time, but all told in the same story-book fashion that makes it a really good book.

Now to get to that Chapter V. After reading of "radio for everybody", "radio telephony for everyone", "radiophone receiving", and "radio receiving for beginners", it is certainly a grand and glorious feeling to encounter in the present work the chapter headed "Radio as a Hobby." Hooray for some regular fellers! "Radio is the master hobby, it is more than a hobby; it is a malady to which thousands of men

are extremely susceptible." So say the authors, and more than other book writers they have helped maintain amateur radio in its rightful place. With the safe deft style that we admired before we encountered Chapter V, they tell the story of amateur radio, its joys, the clannishness of amateurs, its appeal to the inventive instinct, and the fun of knowing the code. In correcting the erroneous impression that the word "amateur means a person who dabbles with things in a purely unprofessional manner, they tell of our transatlantic tests, and print only a small part of successful operators in the tests with five typographical errors in what few are listed, we forgive them because they did it to help amateur radio. It is in the chapter on "Radio as a Hobby" that the authors introduce their descriptions of various receiving sets. There are eight of these described in detail from a single-slide tuning coil with crystal detector to a three-stage radio frequency amplifier set operating on a loop. Then they discuss transmitters in the same manner, from simple spark coil outfits to continuous wave sets using two 50-watt tubes. The authors have probably foreseen the trend of novice interest and have made their book one that will continue to be in demand by telling how to break into the amateur game. A buzzer practice set is recommended, the reader is told to attend meetings of a wide-awake club and to undertake the immediate learning of the language of the dots and dashes. This book endears itself to us by devoting a whole page to a chart of the good old Continental code, and goes right on to tell the reader what it means to have a good fist and why he must have it, how to get acquainted with the "hams" in his neighborhood, and paints an entrancing picture of the mysterious life of a dyed-in-the-wool amateur. They lead the newcomer right up to the place where he has to have a government call book to find out who the amateur stations are with whom he is communicating, and then gently they introduce him to the American Radio Relay League and advise him to become a member so that he can take part in the interesting relay programs. Our Operating Department is briefly sketched and a typical Operating Department report from the Atlantic Division is reproduced with all its array of call letters, as a word-picture of the happy little world in which we real amateurs live.

A chapter on "Who's Who" gives little biographical sketches on many of the notables in commercial radio, and the book concludes with a chapter of "Questions and Answers" gleaned by one of the authors while serving as radio editor on one of the New York newspapers.

(Concluded on page 49)

The New Radio Bill

THE long-awaited radio bill has now made its appearance as an outgrowth of the Department of Commerce's Radio Telephony Conference and was introduced in the Senate by Senator Kellogg on June 8th and given the number S.3694; while the identical text was introduced in the House on June 9th by Mr. White of Maine under the number H.R.11964. In the Senate the bill was referred to the Committee on Interstate Commerce and in the House it went to our old friends the Committee on the Merchant Marine and Fisheries. At this writing no further action has been taken and no dates have been announced for hearings. The text of the bill now being in hand, arrangements are being made as we write these lines for an early meeting of our A.R.R.L. Board of Direction to study the bill and determine the League attitude thereto.

We are printing the complete text for the information of A.R.R.L. members and suggest that everyone read it over carefully. Get out your copy of the 1912 law and compare the two. Notice that this bill does not repeal the old law *in toto* but amends it, principally by substituting new Sections 1, 2 and 3. It is for the most part the work of Congressman Wallace H. White, who was himself a member of Secretary Hoover's conference, and shows deep and intelligent study of the radio problem.

The general idea of the bill is that the law shall not specify wave lengths or classes of stations or any other technical consideration but instead shall give almost unlimited authority to the Secretary of Commerce to classify stations, license them, and make, alter and revoke regulations respecting their service, location, wave length, decrement, range, power, operating hours, etc., with authority to refuse or revoke a license whenever it is in the public interest to do so. It is an open secret that at present the Department of Commerce has no option but to issue a broadcasting license to every aspirant that asks for it, regardless of the chaos certain to result. The situation at present is entirely out of hand and confusion reigns supreme on the broadcast air. Everyone knows that this condition must not be permitted to continue and it is the primary purpose of the proposed revision of law to give the necessary authority to the Department. The axe, the pruning shears and the wouff-hong will then be in evidence, or we miss our guess.

But the main concern of our A.R.R.L. must be the effect the proposed measures will have on the amateur. At the hearings we asked for definition of our status in the law, and Mr. Hoover's Commission unanimously recommended that the status of

the amateur and his wave length bands be defined in the law. *This has not been done in the present bills.* It is true that Regulation Fifteenth of Sec. 4 of the old law is to be amended to the effect that no private station shall use a wave length more than 275 meters nor less than 150 meters but it takes quite a stretch of the imagination to construe that as a definite grant of those wave lengths to us amateurs. Nor is our existence given any guarantee in the bill—we are not named as one of the classes which shall always be provided for, as we asked. Until our Board meets on the matter we do not feel that there is more that we can say on the subject at this time.

Perhaps the next most important feature is the matter of fees for examinations and licenses, covered by Section 9. The fees are small and will be no burden on the amateur, and as the revenue obtained thereby will result in a directly-improved inspection service, we believe everyone will favor the idea. We have talked over the matter with many amateurs and found none opposed to it, while on the other hand it was voluntarily suggested by several of the amateurs testifying at the earlier hearings.

The third paragraph of Article C of Sec. 2 is frankly a trust-busting clause and we suppose there'll be a merry little scrap over it. Personally, we hope it sticks. Then in Sec. 4 is an interesting proviso making permits necessary before the start of construction of all save government and private stations. This seems a most wise provision: it will save money for some folks by stopping the erection of undesirable broadcasting stations before they get started.

It should be noted carefully in Par. F of Sec. 2 that the license of any station, including amateurs, may be revoked for violation of any regulation, and that the Department will have power to make almost any kind of regulations, including an assignment of operating hours. That means that if it ever became desirable "in the public interest" for amateur transmission to be prohibited between sunset and sunrise the way is indicated legally. It is provided, however, that hearings shall be held first, and off-hand we consider that sufficient safe-guard, as we think revocation of licenses should be possible when in the public interest. This paragraph will mean the knell for some alleged broadcasting stations.

We shall have more to say about the bill soon.

—K.B.W.

(Text of Bill on page 56)

EDITORIALS

of AMERICAN RADIO RELAY LEAGUE



Flattening Out

POPULAR broadcast radio has been in violent collision with the well-known "summer slump" and has come down like the equally proverbial "ton o' bricks". There have been many contributing factors but the most important one, of course, is the call of the out-doors. Radio fans, intrigued by the fascinations of getting broadcasts out of the air rather than loving radio for its own attractions as a hobby, cannot be expected to maintain interest in these hot days. And the radio column-conductors have discovered that wireless doesn't work so well in summer—that there are peculiar noises known as static which often are fearfully distressing. And the combination of single-circuit tuners, temperaments unused to sticking at the game on hot evenings, and ears that can't weed out static, was too much. The wonderful radio boom has come down kerplunk—for the summer at least.

It happened in middle May, fully two weeks sooner than the cautious dealers had anticipated. At the present time Mr. Novice has almost stopped buying and who do you suppose is doing the purchasing? The stores tell us that their sales now are almost altogether to *amateurs*—the amateurs keep on spending.

With the smash-up a great deal of the inflation that has been apparent in the radio sales field has gone down. Cancellations of equipment orders with the manufacturers have been as huge and as rapid as the original orders. It seems that in most towns where there were say a hundred potential sales and ten dealers, every one of the ten dealers had his order placed for the hundred sets; and with the sudden cessation in novice purchasing and the uncertainty of what conditions would be like in the fall, the cancellations placed by the dealers in that little town totalled a thousand! Much of the "big business" is therefore seen to have been largely fictitious and the wind is suddenly out of the sails of many a hastily-launched radio enterprise.

Amongst the countless radio dealers and jobbers speculation is rife as to "the future of broadcasting". We are glad to see that it is realized that the programs are not good enough to hold interest and

that something must be done to improve them. The big question is to determine how they are to be supported financially. It seems probable that some organization of the merchandizing end of radio will be brought about to co-operatively maintain a few properly-operated broadcasting stations which will put out programs of real merit. And there are others who believe that the widespread broadcasts of entertainment are merely a transient phenomenon incident to the introduction of modern radio to the general public and that in short order it will find its rightful place not so much as a medium for entertainment but more for the dissemination of information of that sort that which has a national value and may more properly be maintained as a public service at public expense. At any rate we believe we can foresee the early revision of broadcasting methods and programs, with resultant improvement of what is now a very distressing condition in the ether.

And now for a most important sign of the time. *The public is beginning to want to learn the code!* The average broadcast listener gets a tummy-full of the mush on 360 meters in an average of three weeks and commences to look around for something interesting. The once-despised code has shown its fascination, exactly as we believed it would. On every hand the novice listeners are awakening to an interest in the continental-pushers and are actually engaged in mastering the dots and dashes. They're on the right track, art., for there is the thrill and there the sesame to the joys of DX.

All these little signs point towards a big improvement in radio—less padding in the business, a better-behaved ether in the vicinity of 360 meters, and the awakening of amateur interest on the part of Mr. Fan. Which bring us to a most vital topic. Read on:

Holding Our Own

IN recent months when broadcast reception was the rage and hundreds of thousands of people were getting up a wire in the air and lustily laying the blame for everything that interfered with their concerts on the heads of us poor amateurs, we pointed out that the time had come when

we should share the air; that we no longer could have all the night to ourselves but should recognize the rights of the listeners to have quiet for part of the evening, and we counselled a voluntary division of operating hours as determined by local sentiment.

This was well and good and we know that it is still the proper thing. But many of us have gone to the other extreme on the rebound and amateur traffic is suffering. Many of us seem to be giving up the air altogether to the broadcast listener and this is not fair. He doesn't rate it. We stand for a just and fair distribution of hours, but that means that some of the hours belong to us. We know just what the feeling is: we know that when we start up at ten o'clock or ten thirty there are still many listeners in our community fishing around for broadcasts and they wish we would keep quiet. They wish it so hard, and often so volubly, that frequently we do, particularly when traffic is light. But are we then being fair to our own game? No. We are entitled to part of the evening, and after long consideration your headquarters office is of the opinion that it should advise you that you should feel perfectly free to make use of it. It has got so bad that some of us are actually afraid to touch our keys. *This must not be.* Amateur relay traffic must continue. Why, we know some fellows who more than once have been telephoned as late as one o'clock in the morning by novice listeners with an impatient request to QRT while they listened to a broadcast. If it's just an ordinary broadcast, the answer is that they've already had their inning, and if it's some special DX broadcast they're copying then they are practising the amateur DX game with the rest of us and running the chance of traffic QRM, and our attitude should be the usual A.R.R.L. attitude—always ready to QRX a bit for a fellow ham who's trying for a record but certainly not giving up the ghost and relinquishing our rights entirely for the other chap.

A little backbone, fellows! A worm will turn, you know. Now be careful that there is no radical stuff, no shouting, no wild-eyed explosions. But we telegraphing amateurs are doing a more important work than all the broadcast listeners in the country and we are entitled to a place in the ether. See that the broadcast listener gets the lion's share of the evening in which to listen and when that time is passed, *hop to it!* The air belongs to us then, and altho we are perfectly willing to share it with anyone who meets us as a fellow-amateur we do get peeved at being insulted because we try to unload the old hook at 10:45 while Mr. Cady K. Aay delivers a soul-stirring address on "Why Pittsburgh is a Beautiful City."

At the present writing broadcast reception is at the lowest ebb since its beginning, and now is our time. We must step in now, even tho it means difficult work thru summer QRN, and quietly take our rightful place in the ether. And then, when the listeners descend upon the air in the fall, *hold it.*

We want to see amateur relay traffic starting up with a bang in the later hours of the evening. QRV, OM, QRQ!

A New "Chicago Plan"

ALTHOUGH the proposed changes in the radio regulations prepared by the Electrical Committee of the National Fire Protection Association were intended only to be submitted for expression from the interested public and to be applied by inspectors in limited cases merely to obtain field experience, there is protest from many quarters that they are already being observed with all the force of law and complaint is made of the autocratic application of these proposals by local inspectors.

It seems to us that the preliminary proposals of the code committee are being abused. In Chicago in particular a city ordinance is proposed which would provide that every receiving and transmitting station must be licensed by the city, receiving stations paying a fee of \$3.00 and transmitting stations a fee of \$5.00, with a charge of \$1.50 for every re-inspection. The basis for all of the installation provisions of the ordinance is the tentative report of the electrical code committee above referred to. This Chicago ordinance would be a joke if it were not so serious a matter. It purports to be desirable because of the hazards to life and property that in the popular imagination exist in improperly-insulated receiving sets, so it provides that aerials and actual apparatus can not be installed until a permit is obtained and that they cannot be operated until an actual license is obtained after the paying of the fee. Now get this: no change in the apparatus, of however insignificant a nature, can be made until permission is granted, and it may not then be operated again until re-inspected at an additional dollar and a half, *except that the aerial may be changed in any desired manner* as long as it complies with the specification of the underwriters' code, and no permit or re-inspection is necessary; it is simply required that a notice of what is done be filed with the proper authority.

This is nonsense. If there be any conceivable danger in the possession of a radio receiving set it is the possibility of the antenna being struck by lightning, accumulating a static charge, or coming into contact with power wires. A law that in the

(Concluded on page 58)



An Echo of the Transatlantic Tests

The Editor of QST is the proud owner of the gorgeous top-piece illustrated in the photograph on this page. Thereby hangs a most interesting tale:



In an issue of QST in the early summer of 1921, in discussing the results of the first and unsuccessful transatlantic test in February of that year, we made the statement editorially that the British amateurs could hardly be expected to show the same ability in receiving short wave signals as an American dyed-in-the-wool ham who had learned how to get amateur DX only after years of patient struggle, and we stated we were willing to bet our new spring hat that if a good U. S. amateur with American equipment and an Armstrong Super could be sent to England, reception of U. S. amateurs would straightway become commonplace. This statement was reproduced in the English "Wireless World" and caused considerable commotion in British amateur

circles. When the announcement was made of a second Transatlantic Test, and that the A.R.R.L. was sending Paul Godley, its picked amateur, overseas with American equipment to endeavor to get signals, the British amateurs had their chance, and Mr. M. W. Burnham, of the firm of Burnham & Co., prominent British manufacturers of British apparatus, took up our bet of the "new spring hat"—he bet us that Godley would hear no American amateur signals.

Radio history was written, of course, with those tests, and although the British amateurs were equally as successful as Mr. Godley, the bet of the new spring hat still stood. Mr. Burnham promptly cabled "Congratulations. Cable size of hat," and the result is the special "lid" of our photograph.



Paul Godley almost played a dirty trick on us. We had a letter from Mr. Burnham stating that Mr. Godley had told him that the proper style of hat to send us would be a brown derby, as that was the kind we always wore! The only thing that prevented that from occurring and

making it necessary for us to go down and punch Godley's nose was that Burnham's hatter was unable to learn what kind of a hat a "derby" might be and so had to get up something special for the occasion. (For some queer reason they call 'em bowlers over there.) In accordance with our promise made in an incautious moment, we also present our own photograph with the hat on—which is, of course, another work of art.

The hat, which was made by Harrod's, is handpainted in colors, bearing on one side the Union Jack and on the other the Stars and Stripes, united by wireless flashes which encircle the crown. Inside the hat is the inscription "From W. Witt Burnham, M.I.R.E., to Kenneth B. Warner, Secretary, A.R.R.L.", while on the front in hand-painted lettering is "In Commemoration of the Success of the Anglo-American Wireless Test organized by the A.R.R.L., 1921."

We must express our great admiration for the beautiful way in which Mr. Burnham "came through." We thank you, sir, and send cordial greetings to the British amateurs you typify. While the hat is hardly one which we would feel safe in wearing to church on Sunday morning, it is nevertheless our intent to wear it on official A.R.R.L. occasions. It fits perfectly; thank you—our normal head size having been given you in spite of the temporary swelling that existed immediately after the success of the test.

Now who wants to bet us something about a cut-away coat?

French Amateur Licenses

The licenses of French amateur stations permit the use of up to 100 watts in the antenna and a wave length of 200 meters. There is a fee for the license of Fr. 100 per annum. The stations are licensed for scientific research and transmission tests, but correspondence on personal or contemporary affairs is prohibited under the general license. It is in this latter classification that American amateur radio falls—rag-cheewing and relaying—and if a French amateur wants to carry on such communication he must name his correspondents with whom he wishes to communicate paying an additional fee per annum of Fr. 45 for each kilometer between his station and each corresponding station.

At which rate it would cost an American amateur about a million dollars a year!

French Short-Wave Work

A recent issue of the French magazine "La T.S.F. Moderne" displays considerable interest in short-wave reception. It is realized that interest in short-wave transmission is waking up in France but there are as yet but few to listen to the trans-

missions and information is desired by their amateurs on short wave reception.

They draw a lesson from the European reception of the recent A.R.R.L. transatlantic tests and while realizing the difficulties of short-wave radio frequency amplification, they point out that the four best British receiving stations used high frequency amplification, which they contrast with standard American practice of a regenerative detector with two steps of audio amplification.

The receiving equipment of Mr. Deloy, French 8AB, is described. Although he has heard no American stations this year, on Dec. 16th in the transatlantic tests, at 12:30 o'clock he heard unmistakably the word "test" on 200 meters, spark, very QSA, good fist, the station's signature containing the figure 1 and he believes the letters "O" and "S". Mr. Deloy's aerial is an umbrella of three wires, 25 meters long and 20 meters high. He uses an American-built Tuska tuner, with variometer plate tuning for regeneration, American Baldwin phones and a French detector with three step audio amplifier. The operation of U. S. amateur equipment is relatively easy for Mr. Deloy as he is "part American," having been a member of the French Radio Telegraphic Mission in the United States during the European war.

Reinartz Tuner in England

The first five pages of the May 18th issue of "The Wireless World & Radio Review," England's leading radio periodical, are devoted to a description with working drawings of a Reinartz tuner, by Mr. Percy W. Harris. The author describes his reaction upon reading the statements we made about the Reinartz tuner in QST and "decided to construct the tuner for himself so as to test the certainly remarkable claims made for it. The result of his test convinces him that many other British amateurs will be glad of particulars and constructional details, as the tuner is of great interest apart from the claims justly made for it."

We were greatly relieved to find that the British amateur seconded our estimate of the Reinartz tuner for C.W. reception. We were a little afraid that so staid an experimenter as a British amateur might accuse us of exaggeration and over-optimism and find a whole lot of things the matter with it, but Mr. Harris seconds our comments and adds a few goods ones to it.

In Mr. Harris' tuner, instead of the customary Reinartz spider-web, a conventional cylindrical coil on a 3½" tube is used with the same excellent results.

"Frogs, Limies, Spicks, Wops and Yanks"

We have begun to wonder what we amateurs of different languages will do when

international amateur radio becomes an accomplished fact. For example, what will American 1BGF think about the line of stuff he copies from French 8AB? And if an amateur in Sweden attempts to give some Atlantic coast amateur a message for his sister in Minneapolis, who is going to know what to do with it?

Very naturally, then, we have drifted into a consideration of an international language and with many of us that means Esperanto. We would like to know what readers of QST think of the feasibility of this, and we would like to hear from amateurs in foreign countries in particular. Are the difficulties of international amateur communication such as to make it desirable that amateurs adopt some such international language? Can it be grasped sufficiently in the time an average amateur could devote to it, to make it a feasible thing? Is such a language capable of handling our technical terms with understanding? Esperanto has many opponents and it has some competitors—for example, who can tell us anything about Idiom Neutral?

On the Hum in England

The British amateurs are now showing considerable backbone in their endeavor to get greater freedom of operation and are considerably "on their ear" towards the Postmaster General. Almost all of the clubs over there are connected with a central organization and their affiliated strength is appreciable. They are handling their negotiations in a high-grade, diplomatic manner, of course, but it is very evident that they now mean business.

Lid Lifting in England

On page 40 of QST for June we told of representations made by British amateurs to their Postoffice Department looking toward an extension of their privileges. Just as we go to press with this issue word is received from England that the Postmaster-General, after consultation with other government departments concerned, has agreed to the following modifications:

The restriction that transmission must be confined to five other stations will be withdrawn, on the understanding that the matter transmitted will be confined to communications relating to the experiment in hand and intended solely for the stations actually co-operating in those experiments. The broadcasting of general calls, news, or advertisements, or of matter similar to that which will be transmitted from the proposed broadcasting stations, will be expressly forbidden.

Transmission will be permitted for an aggregate maximum of two hours in each twenty-four hours, provided that no transmission shall commence without previous listening-in on the wave length which is to

be used in order to ascertain whether the proposed transmission is likely to interfere with any other station which may be working, and provided that no single transmission shall last more than ten consecutive minutes; and each transmission shall be followed by a period of not less than three minutes listening-in on the wave length used for transmission.

New wave lengths are allotted: 150 meters to 200 meters inclusive for spark, C.W., and telephony; 440 meters for C.W. and telephony only; and the fixed wave length of 1000 meters has been withdrawn.

Our congratulations, British amateurs! This is a recognition that six months ago would not have been thought possible. It is a big stepping stone in the advance of amateur radio and undoubtedly will hasten the day when European and American amateurs will work across the sea.

What amateur news from other foreign countries, you QST readers?

—K. B. W.

Amateur Radio in Porto Rico

By E. C. Stephens

Now that the Dear Old Static Season is about to return upon us, and we read and hear about such remarkable results going on all around us, The Trans-Atlantics, with QSA Hawaii pounding in on one tube; it just makes some of us fellows that are around the brim of the bowl of activity sit up and scratch an ear.

There is another small island a sister to the Phillipine and Hawaiian groups, not quite so far away, Porto Rico, about half way from the U.S.A. on the route to the South American northern coast, between four and five hundred miles from the nearest A.R.R.L. station and even less than that from the Coast of Venezuela or other South American republics.

Now, during the last four or five years, and shortly before the World War began, a certain few studious young native men became interested in Radio. The pioneer and leader of them all was Sr. Joaquin Agusty, whose station was described in a late issue of QST. He had been interested in radio for some time and had built considerable apparatus at home, but had never seen a real commercial radio installation until he made a chance visit to a small inter-island steamer which was placed in the island service about a year before the World War drew the United States into action. Of course during the war he was restricted, doing little or nothing except studying intensely. The result was that when the amateur restrictions were raised he was ready with an up-to-date receiving apparatus. The operators of the different steamship lines were gotten acquainted with, which promoted more interest, and the ship operators were helpful with advice

as to design and the results from different types of apparatus. The first amateur license in Porto Rico was granted to Mr. Agusty, 4JE. Owing to being within about one mile of the San Juan Naval Radio Station, he is forced to use the prescribed reduction of power, or five hundred watts. He is using sixty cycle non-synchronous, on two hundred meters, and is heard all over the island with a radiation of two and a half amperes. By the time this reaches the main-land, he may have a fifty watt C.W. transmitter in operation. Tuning and adjusting are under way at present.

Don Juan is the instigator of a real amateur radio club, known as the "Porto Rico Radio Club", Box 868, San Juan, P.R. He has been elected president also. With the advent of the Club, we have about a dozen other licensed amateur stations on the Island, including Jesus T. Pinero, (4KT); Jose M. Maduro, (4KS); Alberto P. Graham, (4JV); and Enrique Comunas, (4LG), who are all officers of the Club.

One of the features of the Club is a concise course of instruction in radio principles, which is being distributed without charge to all members. The lessons are given under the correspondence school plan, the member receiving a few pages of theory with a set of questions to be answered, which are returned to the President of the Club, who corrects them and assists the member in understanding them thoroughly. Instruction in the construction of practical apparatus is also a strong feature of the course, as is co-operative buying of radio apparatus. The club is also planning the erection of a more efficient station outside the five mile circle from the San Juan Naval Station, where they can use the full allotment of power granted to all amateurs. Due to this island being quite mountainous, we have an abundance of water power, which makes electric current reasonable in price.

Of course most all of you have heard NZR, a U. S. Naval station designed and built during the World War, in the very heart of the Island. The site selected is in the center of an extinct volcanic crater, which is several miles across. NZR, an arc station, gives us plenty of practice both in receiving and in the elimination of harmonics. It is one of the connecting links of the United States and her possessions. Another radio station is also boasted by the Island, Ensenada (WPR), on the southeastern end of the Island, a privately-owned five kilowatt, fifteen hundred meter installation. This station being spark offers the beginner with a crystal an opportunity to pick up a little code now and then.

The first amateur radio phone station was installed by Jesus T. Pinero, who lives towards the interior of the Island, among mountains and high altitudes. His generous use of the instrument has caused

considerable interest in the mysterious art, and he is daily drawing others into the field which is comparatively new in this country.

As to our plans—during the summer months we are going to use our vacations to advantage; the club installation must be in readiness for the A.R.R.L. work next winter. We are all going to be there with some kind of a set, but most popular of all of course is C.W. our hopes are based on the creation of intense interest among the younger generation of our near neighbors in South America. We believe we can induce them to make some kind of an effort to come to the front in radio, put up a station or two, and give us Citizen Radio traffic for the U.S.A. And may our American brothers get into the spirit with us and work towards the same goal as they did during the "Trans-Atlantics"! We are in the game, too. Americans, every one of us. Give us the same support you are giving Trans-Continentials, "Trans-Atlantics" and Trans-Pacifcs; we are with you!

During those world-famous tests we were sitting tight down here, in the land of Senoritas, Static, and Sombreroes, the Magnavox was squeaking, 1BCG was calling also 1ARY and 1AFV. Our range includes several "four" stations, particularly 4GL, with "eights" and "nines" all coming in very QSA. The question of static is always present in these latitudes, but we have our winter just the same as you, altho of course it is never cold here. The air is clear and cool, and our nights are very comfortable even in the mid-summer months. The south-east trade winds are constantly blowing, giving us a very even temperature. During the summer months QRN increases considerably, but we do not experience it any stronger than you do in forty to forty-five degrees north latitude. Another odd feature, we have severe and intense static from shortly after sunset until about two hours before dawn, altho during the day we experience little or no interference from it. It also seems that the nearer you are to the equator the less static you have on long wave-lengths while short waves seem to be unworkable because of the continuous grind. This is the reverse in the northern hemisphere. However, during the months of November, December, January and February we have very favorable results for real "DX" work.

Another point of interest to the Island amateur is the establishment of a radio store in San Juan. They have installed a radio receiver of standard make, where, with the aid of the Magnavox, they are able to give interesting concerts and radio lectures in our native tongue, Spanish. We are really the first real foreign amateurs to enter the field. We speak English

(Concluded on page 63)

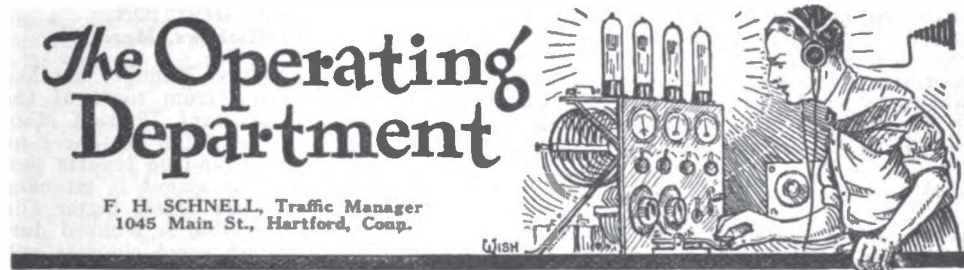

AT this writing the Traffic Manager is making a tour of the Western Coast and the Secretary presents the Operating Department report in his absence.

The effect of summer weather is very noticeable in the report for May—in fact perhaps more noticeable than it will be when we become used to hot weather and to straining our ears to hear signals through static. It is perhaps only logical that with the coming of pretty weather

thrill of the great out-doors is wearing away we may expect the summer gang to get steadily on the air with increasing results in their traffic figures.

 * L. G. WINDOM, 8ZO *
 * Columbus, Ohio *
 * 330 messages *
 * Central Division *

The extended practice of daylight oper-

Message Traffic Report By Divisions
 MAY, 1922

Division	C.W.			SPARK			TOTAL		
	Stns.	Msgs.	M.P.S.	Stns.	Msgs.	M.P.S.	Stns.	Msgs.	M.P.S.
Central	13	367	28	10	1174	117	23	1541	67
Dakota	15	548	37	10	409	41	25	957	38
Delta	6	169	28	3	119	40	9	283	32
East Gulf	10	410	41	4	145	36	14	555	40
New England	12	437	36	9	553	61	21	990	47
Northwestern	5	75	15	13	544	42	18	619	34
Ontario	5	115	23	—	—	—	5	115	23
Pacific	11	599	55	20	1036	52	31	1635	53
Roanoke	24	490	20	7	120	17	31	610	20
West Gulf	—	—	—	8	209	26	8	209	26
Winnipeg	1	3	3	—	—	—	1	3	3
Total	102	3213	31	84	4309	51	186	7522	40

Total Spark, 4309—57.3%
 Total C.W., 3213—42.7%

No traffic reports from Atlantic, Midwest, Rocky Mountain, Vancouver, Quebec or Maritime Divisions.

there should be a temporary interest in outdoor things that prevents the making of reports and the handling of a greater volume of traffic. Thus we have no reports at all this month from the Atlantic, Rocky Mountain, and Maritime Divisions, and incomplete or wholly lacking traffic reports from several other divisions, the result being that our traffic report shows fewer messages handled, fewer stations participating, and a lower average of messages per station than any previous month this year.

It is very obvious, however, that this is not due to the fact that relaying has dropped off decidedly but simply due to failure on the part of the stations to report their traffic. Now that the first

ation is the greatest single improvement that can be made in summer operation. It should be borne in mind that stations within daylight communication range can handle traffic even better in daylight because of the lessened atmospherics, often working with ease when communication would be entirely out of the question after sundown. C.W. is likewise making great improvement in operation, and it is particularly interesting to note in this month's reports that southern C.W. stations are moving traffic in a territory that has been completely isolated during the summer heretofore because of continuous strays.

Traffic honors for the month go to the Central Division, and a spark at that.

Although obviously only a small percentage of our May traffic has been reported to this office, the figures actually reported are as follows:

Northwestern Division—C.W.: 7ZU, 31; 7QE, 27; 7QB, 10; 7BS, 7; total 75. Spark: 7OT, 137; 7BK, 108; 7VZ, 101; 7LY, 46; 7HI, 38; 7WM, 26; 7BG, 25; 7NC, 24; 7AJ, 16; 7FR, 12; 7HQ, 4; 7MH, 4; 7ON, 3; total, 544.

Delta Division—C.W.: 5WO, 55; 5EK, 28; 5LJ, 28; 5KU, 28; 5LA, 20; 5HB, 10; total 169. Spark: 5DA, 63; 5MO, 28; 5RZ, 28; total, 119.

Ontario Division—C.W.: 9AL, 44; 3DS, 28; 3UZ, 16; 3JK, 15; 3JL, 14; total, 115.

New England Division—C.W.: 1ASF, 100; 1ADL, 79; 1BKQ, 54; 1QP, 49; 1PR, 45; 1UJ, 27; 1BYG, 22; 1CBJ, 22; 1AWB, 21; 1HX, 7; 1CK, 6; 1BIK, 5; total, 437. Spark: 1RX, 150; 1LZ, 106; 1BOQ, 77; 1BYG, 48; 1CNI, 46; 1DY, 42; 1CAJ, 32; 1WQ, 30; 1CK, 22; total, 553.

Roanoke Division—C.W.: 3IW, 72; 3BLF, 71; 3CHO, 55; 3ZZ, 37; 3RF, 31; 3BPU, 30; 4GH, 27; 4DC, 25; 3BIJ, 23; 3BKE, 21; 3CA, 19; 4GX, 18; 3AUE, 18; 3BZ, 16; 3EHL, 14; 3AEV, 13; 3AMD, 13; 3ATZ, 9; 3AVW, 9; 3ACZ, 7; 4EN, 5; 3TJ, 4; 3BVB, 2; 3BNM, 1; total 490. Spark: 3ACK, 28; 4CCX, 26; 3AOV, 25; 3BAZ, 17; 3CHO, 17; 3BVC, 5; 3AUE, 2; total, 120.

West Gulf Division—C.W.: Oklahoma Stns., 4. Spark: 5PE, 137; Oklahoma Stns., 40; 5MK, 21; 5OI, 8; 5UP, 3; total, 209.

Central Division—C.W.: 8EA, 58; 8ABO, 50; 8ZZ, 44; 8BO, 42; 8AM, 41; 8UY, 40; 8BLW, 30; 8JZ, 15; 8AND, 14; 8BLT, 12; 8AGG, 9; 8BLC, 9; 8AQC, 3; total, 367. Spark: 8ZO, 330; 8FT, 305; 8BBU, 257; 8UC, 162; 8EA, 41; 8AUU, 24; 9YB, 22; 9GU, 20; 8AND, 7; 8EB, 6; total, 1174.

Winnipeg Division—C.W.: 4CB, 3.

East Gulf Division—C.W.: 4BF, 130; 4GL, 71; 4BY, 61; 4CO, 40; 4IZ, 40; 4II, 20; 4EH, 15; 4CG, 15; 4YA, 13; 4JR, 5; total, 410. Spark: 4BI, 80; 4HS, 30; 4EZ, 25; 4GM, 10; total, 145.

Dakota Division—C.W.: 9WU, 170; Minneapolis Stns., 83; 9BBF, 80; 9YAJ, 60; 9QF, 50; 9YF, 30; 9AGN, 20; 9AEJ, 25; 9PI, 18; 9BAF, 10; 9TI, 8; 9AIF, 5; 9DAF, 4; 9BAV, 3; 9EA, 2; total, 548. Spark: 9AIG, 127; Minneapolis Stns., 119; 9BRI, 4; 9BOF, 24; 9AVZ, 22; 9DOC, 20; 9AGN, 20; 9BYF, 16; 9AIF, 10; 9LW, 10; total, 40.

Pacific Division—C.W.: 6ZZ, 204; 6CU, 150; 6KA, 61; 6EN, 39; 6ASV, 31; 6ZX, 30; 6JD-6ZG, 26; 6AGH, 18; 6ALU, 14; 6AK, 14; 6FT, 12; total, 599. Spark: 6AJH, 140; 6GT, 120; 6AS, 118; 6IB, 109; 6AJR, 100; 6LC-6HY, 76; 6ZD, 69; 6HP, 6; 6OD, 46; 6BDZ, 45; 6ZZ, 33; 6OM, 26; 6AFP, 22; 6AAH, 22; 6GI, 15; 6ABX, 11; 6GS, 9; 6ZC, 6; 6ASV, 3; 6YB, 2; total 1036.

CENTRAL DIVISION

R. H. G. Mathews, Mgr.

Although the Division Manager has had excellent co-operation from some of the newly appointed Assistant Division Managers during May. In a few instances no action has been taken and no reports sent in. This little announcement is intended as informal notice that unless better and more prompt co-operation is secured during the coming month some changes will be made.

INDIANA

Mr. M. W. Hutchison, A.D.M. for Northern Indiana reports things opening up in fine shape this month and though none of the District Superintendents have sent in any message reports they are getting their relay routes into working order and by next month everything will be running smoothly. He is very well pleased with the way the new Superintendents have taken up the work. J. Ralston Miller, Superintendent of District #2, has sent in a very complete report and has started things going in great shape. Most of the fellows in his district have been off the air for some time and are just now getting back on the job. Ames, 9DTJ, of Francesville, has a new tube set and is getting out from the first to the seventh district. He will aid in getting traffic through Northwestern Indiana for his location is excellent. 9BAT is installing a CW set and will be ready to handle traffic soon. 9CP, Hammond, has been out of commission for some time but will be back on the air in the near future. Both CW and spark will be used at 9CP. Messages for Southern Indiana go through Crown Point to either 9FS at Goshen, or to 9DTJ at Francesville. Messages east-bound go through 9FS and consequently both southern and eastern routes are in working order. Mr. E. E. Pippenger, Superintendent of District #1, Goshen, does not have his routes fully lined up as he reports very little excepting the fact that he anticipates no difficulty in lining up his stations soon.

F. S. Libbe, 9AKD, has been reappointed City Manager of South Bend. Mr. Libbe works on CW and is doing exceptionally good work. L. S. Slagle, 9ME, has been reappointed City Manager of Fort Wayne. No word from 9DAX but he continues good work with C.W.

MICHIGAN

Mr. C. E. Darr, Assistant Division Manager for Michigan, reports as follows: The light traffic this month can be accounted for locally by the menace of the broadcasting done locally. We have three high-powered stations and they are continually going from nine in the morning until eleven at night. The only ones that are doing anything are the ones that stay up all

light. FB-HI! Static conditions are very bad and have been for a month. The District Superintendents are working hard and are doing excellent work in the various districts. This week we will have appointed City Managers for Port Huron and Saginaw. Then we will next get after the Official Relay Stations. We are also organizing a special emergency route with pre-arranged schedules in case there is a tie up in all telegraph lines as has happened often through storms, etc. Each station on this route will be obliged to stand a 24 hour watch and will be manned to be 100% efficient during any emergency.

OHIO

Mrs. C. Cander, Assistant Division Manager for Ohio, reports that to date only three of the newly appointed District Superintendents have sent their acceptance of appointment, P. A. Marsal, District #3; L. E. Furrow, District #4 and R. D. McCommon, District #6. P. A. Marsal reports that he will soon forward a list of men which he recommends for City Managers for his district. L. E. Furrow reports that he is getting in touch with the various cities and towns in his district with a view to making his selection for Official Relay Stations and City Manager. He is also assisting to organize the radio club in Dayton. The Xenia Radio Club is being revived and now is backed by the Chamber of Commerce.

Prof. R. V. Achatz, City Manager of Lafayette, Indiana, reports business is falling off as usual with the coming of the summer season. 9YB was out of commission about 10 days due to aerial tower failure. They now have a new 100' cage about 90' above ground, but have not really had a good test to see what it will do.

NEW ENGLAND DIVISION

P. F. Robinson, Mgr.

1BKQ, the Worcester County Radio Ass'n., wants it to be noised around that they are on 190 meters. If anyone wants proof let them tune down and listen to the noise they make there. On the way down (!) stop at 200 and listen for 1BRQ's new 100 watt C.W. set.

1ASF wants the address of the manufacturer of ohm-removers. He has 64 in his antenna that don't agree with his new C.W. set at all.

1PR, Boston College, is proving to be a good central station for traffic. They are QSO, daylight, all parts of New England from 1ARY north to 1AZW south. They are using 3-50 watt tubes on 1400 volts D.C. and radiate about 5 amps.

1CK had a fire in his shack and is out of commission for a few weeks.

ROANOKE DIVISION

W. T. Gravely, Mgr.

Reorganization of the division is now practically completed. The fellows are lining up with a spirit that means much for the Division's future. For the first time we are now fully organized and running smooth.

Reports from every point show that listeners are turning to code work and evincing interest in relay matters. The relay men of the division are helping and encouraging them and a promising crop of DX men is looked forward to. A club is being formed in southwest Virginia. Those interested please write to D. C. Culbert at Marion, Virginia. Danville has a newly organized club which is going good, especially on code work.

8BKE is working big DX, being reported by 7JS Anacortes, Wash. 8PU gets the traffic honors in W. Va. with 30, 4GH in North Carolina with 27, and 3IW for Virginia and the Division with 72, with 3BLF shoving him with 71. F. B. all around. Despite static and listeners, traffic is holding up very well. 3ATZ, 3ACZ, 3BVB, 3ZZ C.W. and 3ACK, 3ACE, 3BVC on spark are keeping the ball rolling about Portsmouth with more good stations coming up. 3CA and 4EN are moving to new locations and will be out about a month. The usual remodelling and fixing up done at this season is going on. 8CAY at Elkins and 8AMD at Lewisburg have hooked up for daylight work. When 8AMD connects with 3CA or 3RF the entire division will be open north and south and also east and west for DAYLIGHT work. A dream come true.

Nearly all District Superintendents are slow sending in reports to their A.D.M.'s. Fellows, this is important so please come across by the 20th. We need the help, we can't report what you fellows don't.

DELTA DIVISION

Hubert E. deBen, Assistant Mgr.

Severe static during the past month reduced traffic work considerably throughout the division. The work that was done was accomplished by piercing the heavy blanket of QRN which covers this part of the country from April to October every year. Brother S. Kruse is in New Orleans attempting to eliminate static with Hammond's idea and when said Bro. Kruse claims that southern QRN is "rotten stuff" to the nth power, we just know it is.

LOUISIANA

QRN keeping the traffic total low. Interest still high, however. The Pullen Bros. 5ZAB of Houma, considered the best Louisiana station, are remodeling their station and promise an ether-wrecker for next

season. City Manager Manard of New Orleans reports things going slow in the relay line. 5HB has shown considerable activity of late and put over a clump of messages. 5LA did very excellent work handling 20 in spite of severe interference from the QRN and concert broadcasting stations.

WINNIPEG DIVISION

J. A. Gjelhaug, Mgr.

J. E. Maynard, 4CB, Dist. Supt. of Saskatchewan, reports very little long distance or relay work done during last month, on account of bad QRN on prairies, only once in a while a night that they can work stations of any distance.

4BV, Loreburn, got his 10 W. C.W. going strong, but now has tube trouble and like every one else is waiting for repairs. He has been heard nearly all over Western Canada and U. S. 4BR of Regina got going fine, with 30 W. tube, but tube soon blew up. 4EI of Moose Jaw with spark coil 5W. I.C.W. going fine around Province. 4AO, Walter Pottle, Moose Jaw, has been on the sick list for some time, but now better and again on air, but unable to pierce QRN very far with his spark. H. N. Stenen, of Stenen, Sask., no doubt has best receiving set in the Province and with spark coil set keeps in regular touch with 4BV. He promises a good, strong C.W. transmitter by fall. 4CB, J. E. Maynard, Morse, Sask. is off the air for about two months, completely rebuilding his station and moving to better location.

Moose Jaw has two live radio associations, Senior and Junior, with more amateur stations than any other point; both associations have sent in applications for affiliation with the A.R.R.L. What Moose Jaw needs now is a good strong transmitter to connect up with the outside world. The Senior Assn. is trying to get such a station under way.

Regina recently organized a live radio association and we understand the old organization at Saskatoon is going strong again. Lajord has a live club.

So far, 4BV and 4CB are the only stations to reach stations of much distance, and until 4CB is rebuilt please route all messages for Saskatchewan to 4BV.

Mr. T. W. Brown, 214 C. P. R. Bldg., Saskatoon, Sask., has purchased 4CB's complete transmitter and should be going strong long before this is in print. Anyone hearing his C.W. or fone, please drop him a card.

We are not getting the co-operation from outside points in regards to news and traffic we would like. Come on, fellows, and drop your Dist. Supt. a line before the twentieth of the month.

Saskatchewan is talking strong of a radio convention this summer.

Thirteen broadcasting stations are under construction or going now in Western Canada, some of them 2KW. By fall the air will be full of music and news.

VANCOUVER DIVISION

Wm. D. Wood, Jr., Mgr.

The month of May has been full of local activities in and around the city of Vancouver, but the amount of "DX" work has dropped off to almost nothing. The chief event of importance was our unsuccessful test with 5AX in Prince Rupert, B. C.

Mr. Barnsley in the farthest north Canadian city has been hearing Canadian 4CB, 5AK, 5CN, 5DO and 9RD with regularity and the D.M. encouraged him to get all the transmitting apparatus in P.R. together and put up one real sending outfit. The result was a half K.W. and a quarter K.W. Thordarson hitched in parallel and the usual glass plate condensers and non-sink rotary gap. This outfit put out 3 hot wire amps, according to 5AX, but all through the three day tests we were unable to hear it in Vancouver. QRN is fierce in Vancouver now and we have not squelched all of the local squeek boxes that delight in sending from a book after "DX" hours for their code practice.

5AK, 5CN, 5DO and 9BD all worth south to the sevens in Washington and Oregon, but very little traffic has been handled of late.

The Radio Inspector, Mr. Howard, has opened permanent offices in the P. O. Bldg., Vancouver. All mainland amateurs are expected to take their exams here while those on Vancouver Island may apply at the Division Superintendent's offices in the Old P. O. Bldg., Victoria.

The B. C. Radio Association is now handling local traffic with their new Ellwood $\frac{1}{4}$ K.W. spark set which was installed about the middle of the month at the club's headquarters.

The D.M. has had but very little correspondence with amateurs in Alberta and Saskatchewan for he does not know who have the best stations in that territory. All reports from these two provinces regarding their local conditions would be appreciated if sent in to the Manager.

MISSISSIPPI

Bay St. Louis: 5ZAU is gradually rounding into shape and will soon make an attempt to handle traffic.

TENNESSEE

W. C. Hutcheson, Supt., reports traffic off during the month due to severe static conditions. However, some of the relay stations managed to handle a few messages. Considerable interest is shown throughout the district in the receiving end. A large number of receiving stations were installed for listening to the broadcasting stations and no doubt a great many will

develop into transmitting stations in the future.

Interest in Chattanooga seems to have dropped off due mainly to static and a great deal of delay in obtaining material and equipment. 5LU and 5HL have been very quiet. 5AAG is building a new shack and hopes to be going again soon. There are two new stations going up, one CW and one spark. The City Manager has not been able to raise any one outside of the city limits with his 20 watt C.W. so has placed an order for a complete 100 watt set and hopes to do some relay work as soon as it is installed.

5DO in Memphis has handled some traffic on his 20 watt C.W. set. 5LJ has just finished his 50 watt C.W. set and is getting out in fine shape. 5EK is on every night with his 25 watt set. 5KU is now using a new 100 watt set and is getting out fine. 5MO and 5RZ are doing good work with their spare sets. In spite of heavy QRN 140 messages were handled by the several stations in Memphis. 5DA had been pulling off his usual startling stunts. On only a few nights during the month and handled 63 thru the heaviest of QRN.

5WO was the only active station in Knoxville during the month and succeeded in handling 55 messages. 5UU is still out of commission and will be for some time. 5ABM is getting into working condition and is reaching out very well. 5WS, the City Manager station, is inactive waiting for a motor-generator set.

ARKANSAS

Activities decreased to a considerable extent during the past month because of heavy QRN. 5UE, 5CB, 5ABY, 5SP and 5JB are keeping the traffic moving throughout the state. 5CB has been doing notable DX work with his 10-watt C.W. set in spite of the QRN. 5JF has also been doing good work with his spark set. 5ZL and 5JD have started to rebuild and won't be on for some time. Things are lined up so that when the good weather sets in the traffic will shoot through at high speed.

PACIFIC DIVISION

J. V. Wise, Mgr.

SOUTHERN SECTION (ARIZONA)

J. F. Gray, Asst. Mgr.

DISTRICT A

All relay stations are closing down for the summer; terrific QRN makes work in the southwest impracticable after May 1st, and nothing more can be done till October. No more traffic must be routed via the Southern Trunk Line. 6ZZ leads the District with 204 CW and 33 spark. 6ZDH is second with 69, all spark working regular schedule with 6HY west and 5XD east. Concert receivers are popularizing radio enormously.

DISTRICT B

6AJH leads with 140 messages; 6GT is second with 120. Summer QRN on the Coast is not too bad to prevent the route north remaining open. The District Superintendent wishes to state again that the A. R. R. L. is solidly behind the Pacific Plan, and that no traffic will be handled with stations that do not adhere to it. The appointment of Dr. L. E. Waters as City Manager for Anaheim-Santa Anna is announced; we look to him to put traffic handling in this section on a businesslike basis. W. R. Dodson has been named City Manager for Riverside. Eastern traffic must not be routed through District B during the summer.

DISTRICT C

H. A. Duvall, 6EN, late acting superintendent, is appointed Superintendent, replacing 6ZN, who found he could not spare the great amount of time this position requires. 6CU heads the District for a second time with 150 CW messages; 6LC-6HY, staunch and able supporters of the spark, are second with 76. The eastern route via Denver will be maintained all summer by 6EN, 6KA and other high power CW. City Manager appointments are as follows: Los Angeles-Hollywood, C. F. Filkstead, 6CU; Pasadena, Alhambra and suburbs, D. Gardner, 6OD; Long Beach, H. Brown, 6ALP; Pomona, D. H. Kest, 6AGP; Santa Barbara, A. B. Lopez, 6AAK.

DISTRICT D

The only stations working here are 6ZS and 6ZF. The latter has taken traffic direct from Honolulu, 6ZAC. The old dream of a relay to the Islands is now a fact. 6ZAC has a 100 watt set that is heard along the entire Pacific Coast. 6ZF and 6ZS are both tube equipment.

DISTRICT E

A total of 523 messages handled by six spark stations here this month. Routes north and south are in perfect working order. Little traffic handled from Santa Cruz to Bay Cities. Power troubles have hampered 6VX and 6TU the last month, but things will be patched over some time in May. 6IB shows a busy month; his long suite is with 9BD, Vancouver, B. C. fine biz. 6IB also worked 5CN, 7NN, 7JD, 7MP and 7FR.

DISTRICTS F & G

The Bay Cities. 6ZQ, spark, 6ZAF, C.W. and 6BZI C.W. have been successful in working 6ZAC. The wave used by all is 375 meters. 6ZQ is C.W. and spark equipment, the spark a 500 cycle quenched set. 6AOR, 6AS, 6EX, 6HP, 6ASJ C.W., 6AWT C.W., and 6OO C.W. have been keeping the north, local, and south routes open and clear every night.

DISTRICTS H & I

Every night finds our old Sacramento spark stations on the job, 6GF, 6GR, and

6FH. All three are excellent outfits, and stay on the air night after night. By the way, all three are now proud owners of a fifty watt tube each. Sacramento will be a C.W. city yet. 6UC is again on the air full swing with a splendid spark set. 6TC is gathering dope on C.W. now and it looks as though another spark may quit. 6AK and 6ZX, both C.W. 20 watts, are doing good DX work as well as clearing the bay on schedule.

DISTRICT J

6AJR has handled practically every thing this last month for Reno, Nev. He has also kept open the route from the two borders via the east side of the Sierra range. The route east via the Central route is closed.

ALASKAN DIVISION

Roy Anderson, Mgr.

Our friend of last summer, 7BJ from Vancouver, is back in Chignik. He reports that a Reinartz tuner is being used and that, on the way up, many 9's were heard. Also 6ZAC of Hawaii. The "CEDAR" (Ketchikan) reports 6ZAC and a bunch of 7's as well as the nightly P.I. (Seattle) concert.

Due to induction QRM, positive verification of the following is not possible. It is, however, with reasonable certainty of reception that the following calls are given from 7IT:

May 1: 7WN, 7AT, 7NN, 9BD (Canadian), 6XAD. May 3: 7YS and CL-8. May 5: 7OT clg 6AJR, on one step. 7GE on one step. 7FI on detector only. 6AJR clg 7OT on detector only. 6EN on one step. May 6: 6ZZ and 7FR. As 7IT is located 660 miles from Seattle, all of the amateurs heard are at least that far away, excepting Vancouver 9BD.

As Chignik is more than a thousand miles from the states, all amateurs heard by Mr. Sturley will be around 1200 miles away.

NORTHWESTERN DIVISION

H. F. Mason, Mgr.

The usual summer weather is here, bringing with it the static and the disappearance of many stations from the air. This leaves it to the old standbys and those not affected by the weather to stay on and put the traffic through. Everything is going fine and dandy, except that we sure would like to see about ten A-1 stations spring up throughout the division and enable traffic to be handled by the short-jump method, with its greater reliability.

Stations in Oregon are especially urged to kick through with those message reports.

MONTANA

Credit for the most consistent work during the past month goes to 7VZ at Libby. He reports that had he been able to clear east oftener, more traffic yet could have been handled. 7ZU handled some traffic

on voice, and the rest on CW this month. He had the misfortune to have his antenna blow down recently, so will be off the air for a while. 7DJ has little to say, as there are no new stations and very little traffic is being handled. However, there are still hopes. At the A.D.M.'s station in Bozeman the static has been unbearable most of the time, and only on a few nights was it possible to do any DX work. The reorganization of the state is progressing and it looks as though there would be definite results within a few weeks.

IDAHO

7JF, 7OT, 7WG, and 7YA are taking an active part in relaying, and are doing good work. Clyde Anderson, 7JF, has been appointed D.S. for Northern Idaho. He reports, however, very few stations thruout the state. 7OT at Boise has been moving traffic in big chunks during the past month, and deserves credit.

OREGON

Seaside, has been very good for the handling of relay traffic, according to A. A. Thibodo, D.S. 7HD hooked up with Canadian 5CN, and 7VZ and 7BK during the forepart of the month. 7HD will have two operators during the summer months. 7KE reports the static worse at Myrtle Point. 7RC is reaching out on half KW spark. 7CW has been heard several times lately. We are sure glad to see him back in the game, as he has a good station, and is a real operator.

The Salem Club is running a very interesting traffic contest for stations whose power is not over a quarter KW and will award a prize to the winner. The object of the contest is to encourage stations with small powers, to handle relay traffic.

7TJ senior, who is the father of our 7TJ, well known for his DX work last winter, is using the same set, but signing 7AEQ. Down at Albany, 7LR is installing 50 watts of CW.

At Vancouver, 7ZK and CL8 are doing DX but are not handling much traffic. Portland: 7DP on CW and 7ED on spark are the only ones doing much. All of the old timers are busy manufacturing sets now, and are off the air.

WASHINGTON

A.D.M. Weingarten reports as follows: Seattle traffic is being handled with regularity by 7BK, 7BS, 7FR, 7NC and 7QB. 7BK has two operators and is standing regular watches. 7FR has installed a sink gap, and is reaching out in fine shape, working both east and south. 7BS and 7QB are holding down the CW end of the game. In Tacoma, 7AJ, 7BG, 7QE, 7WM are handling traffic. The loss of 7BC is still strongly felt, as he was one of the old reliables. A number of sparks are contemplating changing to CW. In eastern Washington 7GE continues his consistent work. 7FI is on strong at times, but is

still hunting for a condenser to hold down that coffin. Everything seems dead around Spokane. Messages for the east can be handled by 7HI to 7VZ very well. In the Grays Harbor district, 7KJ, 7NW, 7NN and 7SC are taking everything that comes their way, and one of them is on every night.

Greater interest in "code work" is being shown thruout the division by our "dear listeners" and it is predicted that before fall there will be more stations on the air than ever before.

ONTARIO DIVISION

A. H. K. Russell, Mgr.

May has been decidedly slow in regard to relaying, and, as usual, the Districts are very delinquent in reporting, so that this report is somewhat brief.

Brantford is very seldom heard from now, and the same applies to Guelph and Galt. The only ray of light in Western Ontario at present seems to be 8GX at Linden, Ont., some short distance from Brantford, who has purchased 8WO's spark transmitter and is doing very fine DX work but has sent no report of messages, which we hope to receive from him next month. Kitchener and Waterloo have formed a Kitchener & Waterloo Radio Club with 15 charter members. 3DS in Kitchener has started out with DX work at last, using 50 watt C.W. and 25 cycle synk gap, handling 26 messages on C.W. 3SB and 3TY (ex 3QJ) not running.

Toronto is now practically entirely C.W. and no reports have been received of relay work by spark transmitters. 3CZ has been trying to qualify for a boiled owl, messages C.W. 16. 3JI and 3JK have kept up their good work with 14 and 15 messages, respectively, on their small C.W. sets, and 3AL has handled 44 on C.W.

No reports received from other Districts.

EAST GULF DIVISION

Reported by R. H. McMillan, Traffic Asst.

Well, fellows, here it is. If you expect to get a report into QST you will have to send in a report to us as we are not mind readers.

We wish to congratulate Ass't Div. Mgr. Harrod on the work he is doing in Florida. If we had one or two more assistants like him we would probably maintain our average throughout the summer.

The Savannah fellows are to be complimented for the spirit they show. Supt. Hodge mailed in his report from a hospital in Savannah where he is lying on his back recuperating from an operation. Supt. Hight is also in the hospital in Rome recuperating from an operation and reports that 4BQ has been inactive this month; but promises to burn things up with the new 500 watt C.W. set that he completed

just before he went to the hospital. On an initial dalite test he worked 4CO in Atlanta, handing him traffic at 11 A.M.

FLORIDA

M. F. Harrod, Asst. Div. Mgr.

This state must stand by now, for that blanket-like tropical static, ever pounding in the phones, is here for the next few months and must isolate us from the efficient relays that we established during the past winter. No one is idle, tho, for we are striving with the end in view of having this state more fully equipped to handle all msga. that need go from it or come to it, in the fall. In Pensacola, St. Augustine, Winter Park, Lake Monroe, and other towns we have not heard from in the past winter, we are going to have good DX stations by fall.

1st District, M. D. Clark, Supt., reports in Jacksonville 4ZE, 4BP, and 4FS, are inactive due to this ever-hammering static. 4EZ, spark, is still at it, and reports 25 msga. We are pleased to announce that "Shorty" 4EZ is going to have a CW soon to show his spark up. The Times-Union in Jax has a 20 watt CW, and will maintain two ops on watch, as soon as license is obtained. With the addition of the CW stations that are now in the process of building in this Dist. it will be more and more efficient as time progresses.

2nd Dist., E. R. Hall, Supt., reports four CW stations in process of building in St. Petersburg, and prays they will be ready by fall. 4BF has sold his 500 w. set to the Tampa Times. He has assembled a 50 watt set which is handling traffic between 4BF and near-by Naval Stations, when the big 5 KW spark set fails to carry. Msgs.—130. In Tampa, 4IZ, CW, 40 msga. Orlando, 4II, CW, 20 msga.

Dist. 3, F. M. Bookwalter, Supt., advises as the only good thing about this district that can be shown this month is the formation of a radio club in West Palm Beach, which will be invited to affiliate at once. 4IH in Boca Ratone, with an Amrad set, will be in communication with WPB in good WX. Supt. Bookwalter says that if there are any AMATEURS left, when the static leaves us, he will be able to do some REAL work, for he is improving the old set a lot.

4th Dist., W. E. Woods, Supt. Miami—Nothing doing account of static. Several stations are figuring on CW, but none actually READY yet. In Homestead, Seymore Dan will have a CW set by fall.

GEORGIA STATE REPORT

W. B. Pope, Ass't Div. Manager

Savannah: Supt. Hodge reports 4GL and 4BY copied steady by ship operator from New York City to English Coast. This is fine work for summer weather. Message traffic is comparatively nil compared to the preceding months, 4GI only 71 and 4BY 61. We can excuse 4BY since he has been in the hospital most of the

month but we cannot imagine what has happened to "Old Efficiency".

Atlanta: A new club consisting of all the old amateurs of the city has been formed to control interference that existed between the broadcast listeners and the DX men of the city. 4BI has been doing the only consistent DX work of the city. Practically every night he is in reliable communication with all northern and eastern points of the country. 4HS and 4GM are also doing excellent work on their gravel grinders. 4FT will be on next month with his CW using the call 4ZB. Few other CW sts. going now, however. Most of them are either remodeling or building entirely new sets.

WEST GULF DIVISION F. M. Corlett, Mgr.

SOUTHERN TEXAS SECTION Alfred P. Daniel, A.D.M.

Dist. Supt. Ed Nettleton, 5ZN, at Eagle Pass, Texas, reports his district to be considerably mixed up, having been visited by several tornados recently and considerable damage resulting. All stations in Laredo were put out of commission and those remaining are suffering from constant QRN. Asst. Dist. Supt. Wall at San Antonio writes a similar story regarding weather conditions, almost continuous storms and atmospheric disturbances in that vicinity, and that together with practically every local station dismantled and changing over to CW, almost no traffic has moved. 5ZAK and GP4 have consolidated and will hereafter operate from Kelly Field. Thad Perry and Joe Tyler have consolidated and will answer to the call of 5ACU. 5XI has been signing DM4 while operating huge army fone set at Kelly Field. This station is soon to be moved to a more favorable location. Mr. Joseph L. Tyler of 1025 S. Presa St., San Antonio, has been selected by the local Radio Club to fill the vacancy of A.R.R.L. City Manager.

South Central Texas, too, has suffered from storms according to Dist. Supt. Tilley's report, Austin having had quite a cyclone, but no one lost his antenna system. 5XX has opened up with a splendid fone set and has already covered 1200 miles. 5PD recently moved from Waco to Austin and is creating quite a bit of envy with his bright and shiny copper tubing OT. Wonder if it can be used for any other purpose. Hi. Austin loses one of their best stations with the removal of 5ABZ with his 4—½ TC amps on ½ KW, who goes to San Antonio to live. Kee of San Marcos is putting in fine CW set to match up with his already splendid masts and aerial. Sahn at New Braunfels expects to get a rest from shot condensers now that his brand new CW and fone set is nearing completion. 5XU has climbed out of the amateur class as it were, be-

cause of his 2 KW spark and fone set. They are now broadcasting crop and market reports and weather bulletins under the call of WCM.

South East Texas district is no exception to the hard-hit and almost constantly interrupted radio activities due to storms and twisters. 5NK and 5ZO lost the top sections of their masts in a recent blow. 5ZW has been isolated for weeks in the Brazos flood district and has been depending on Houston stations to keep his family posted as to the probable duration of the flood. He has been passing the time away by fishing from his front porch, and tells of a catch of a three footer. All streams in Texas have been on 40 to 50 foot rises.

The new stations in the air are 5KM, C. Porter Sweeny at Angleton, Texas, who has remained silent during his senior year at school. 5ACF is a new Houston station owned by A. W. Pollard and is the utmost in CW. 5FA at College Station has developed into 5ZP. 5XB has been almost entirely silent for sometime, and no report from our good friend Doc this month. 5XB will remain open all summer during the intensive radio course which that institution has provided. The Houston Radio Club is growing to such proportions that new and larger quarters had to be arranged for. Many novices who are interested in receiving broadcasts are joining in order to learn more about the game. Practically every well known local amateur has a position with some local radio supply house and several are doing installation and operation of broadcasting stations at several points in the state.

OKLAHOMA SECTION

Maurice L. Prescott, A.D.M.

Demon static seemingly has set his foot on our section for the summer, but he is finding it hard to keep a bunch of our energetic "hams" away from their sets. Activity and interest is being shown in all districts and we just have a "hunch" that when four or five 50 watt C.W. stations which are now under construction are completed they will pound right thru QRN and enable us to keep up our relay work with nearby 9's and 5's. And, also, how about interdistrict communication in our own State? Give your A.D.M., D.S. or some of the other fellows a call and let's see if we can't connect; something that has, as yet, never been done to any marked degree.

5BM, Selby of Muskogee is getting results out of his new 50 watt C.W. He says one 50 watter is all you need to get real DX.

No new transmitting stations have been reported this month. 5HK, 5ZM, 5ZG, and 5LO are all rebuilding or installing new equipment altogether. 5LO has sold his spark to the School of Mines located at Miami. He is putting in a C.W. now. 5FO is no more; Prescott is now 5ZG and in addition to the old spark a new C.W. on 375

meters will be installed. 5PU, 5ZZ and others of that section have been giving very consistent service.

DAKOTA DIVISION
N. H. Jensen, Mgr.

Traffic in this Division has naturally dropped off somewhat due to bad atmospheric condition, but it is gratifying to note that there is more activity this summer and that more traffic is being handled than there was in the corresponding period last year. C.W. stations, of course, must be given credit for this to a great extent.

Northern Minnesota. The jumps in this District are really too long for consistent work during the QRN period. However, several daylight routes have been established and schedules have been worked out. A number of new stations are springing up and the prospects are very bright for good work in this District in the near future. The stations most active are: 9EA, 9BAF, 9ADF, 9ZC, and 9BAV. Three broadcasting stations in Duluth keep the air fairly well supplied with QRM.

North Dakota. Active stations include 9LW, 9AEJ, 9AGN, 9WU and 9DOC. Some trouble is noted by DX stations in being unable to tune their receivers below 250 meters. This District Superintendent suggests that all stations test and find out just how low their receivers will tune. Where Remler variometers are used, it may be found necessary to take off all but 19 turns on each side of both stator and rotor in order to get down to about 200 or 190 meters. This was done at 9WU after the same trouble had been experienced. Traffic in this District has been going thru 9WU as follows: West, 9WD, 7WG, 9XAG, 9ZAF, 7ZU and 7WH; East, 9XI, 9AUP, 9AJA, 9AIY, 8BO, 8VY, 8WR and 8BKE. 9WU's spark set with a record of 3400 miles has been bought by 9YF, the Mayville Normal School.

South Dakota. The stations that are on the air regularly in this District are as follows: 9BRI, 9AVZ, 9AIG, 9AIF, 9BOF, 9PI, 9ASF and 9TI. Daylight routes are being worked out and schedules arranged. Charles Norton (9AIF) has been appointed Dist. Supt.

The newly appointed Division Manager is more than pleased with the splendid co-operation given him by all stations, and his only regret is that he hasn't the time to keep in touch with all of the stations.

The following new appointments have been named in this Division:

E. S. Leavenworth, Ellendale, N. D., Asst. Manager.

J. A. Gjelhaug, Baudette, Minn., Asst. Manager.

Edgar W. Freeman, Elk Point, S. D., Asst. Manager.

Charles T. Norton, 521 West 11th Street, Sioux Falls, S. D., Dist. Supt. for South Dakota.

William D. Wagner, 123 West 4th St., Duluth, Minn., Dist. Supt. for Northern Minn.

Thomas W. Jackson, College Heights, Jamestown, No. Dakota, Dist. Supt. for No. Dakota.

James E. S. Hayes, 705 E. 5th Street, Duluth, Minn., City Manager of Duluth.

Alvin H. Rosvold, 423 No. 3rd Street, Aberdeen, So. Dakota, City Manager of Aberdeen.

E. W. McQuillen, 701 So. 7th Street, Brainerd, City Manager of Brainerd.

MIDWEST DIVISION

L. A. Benson, Mgr.

Due to the great interest in broadcasting and further QRN, traffic in the Midwest Division has taken a slump. Only two reports from Asst. Division Mgrs. have been received. Several St. Louis stations are still on the job handling traffic: 9DMJ, 9BED, 9AFC, 9ZB.

MISSOURI DISTRICT

G. S. Turner, A.D.M.

The District Superintendent of Western Missouri is the only one who sent in a report this month. The other fellows were heard from but no reports were forthcoming. McDaniels at Columbia is very busy arranging for the All-State Convention that is to be held at Columbia May 30 for the purpose of organizing our state into an All-State Radio Club. Dr. Klenk, Dist. Supt. of Eastern Mo., says radio concerts are killing traffic down there. Traffic is moving, but so little of it that it is not worth mentioning. The fellows are already interested in perfecting their receiving sets for the coming winter. Almost the only real active interest that is shown in St. Louis now is in their radio club and in the big proposed state organization.

As soon as our state is organized we shall have to express our rights as amateurs who are interested in all phases of the game and not in hogging the air with broadcasting as numerous stations of high power here in Missouri are now doing. Schedules shall have to be instituted or the first thing we know our name will be "Dennis"—in other words we will no longer exist as a body of amateurs interested in the development of radio from a scientific standpoint but rather a gang of individuals working toward no common end. Then because we are divided and unorganized, adverse legislation will quickly take advantage of this condition and legislate our once world-renowned transmitting stations out of existence. Yep, fellows, it's a pessimistic picture but unless something is done it is going to be a reality before we know it.

Traffic has practically been at a standstill in Kansas City this month due to the almost continual QRN. Very few messages have been handled and then over only short distances. 9RR has been getting out fairly well on spark, working practically all C.W. stations. The radio club in K. C. is attempting to line up the local broadcasting stations to get a little order out of the chaos now existing. Two new 500 watt commercial sets will be opening up in a few days and when they do "goodness knows" what will happen. It is the desire of the radio club to have at least two silent nights here. The City Club of Kansas City is back of this idea and we expect something to happen shortly.

Radio 9FM is developing a real he-size radio station; when it is remembered what good relay work he did with his old station great things are surely expected from him this coming season.

Less interest than usual has been shown in relay work in St. Joseph lately. 9EX has his two 50 watters hooked up but hasn't been on much as yet. 9ANO has been on quite a bit in daylight lately but for some reason has been unable to handle but little traffic. 9DRW has been reaching out some with his 1KW spark but has no traffic to report. Interest is being kept alive in the radio club and much is expected of it this summer.

NEBRASKA DISTRICT

John G. O'Rourke, A.D.M.

Traffic during the past month has been moving in all directions exceedingly well considering the increasing QRM. And I must state that it not been altogether due to the CW stations. In fact, in but one instance has traffic been handled consistently by CW in this district. For the entire district 9HG, 9ASO, 9DSM, and 9DNC have headed the list in traffic work. These men deserve credit for their efforts, inasmuch as they do not receive co-operation from the other stations. 9HG, Griffith, Omaha, reports working consistently with 9DKK, 9DNC, and 5QS. 9ASO is also DXing and clears a large amount of traffic. Mr. Platner, 9DSM, CW, is the one CW stations in the district that has reported handling traffic. 9IF of Giltner is operating a CW station and is working several districts consistently. Palmer of Lincoln seem to be the one Lincoln station in consistent operation. You Lincoln fellows please wake up and get in your report.

One traffic appointment has been made by the Asst. Division Mgr., Paul Palmer, 9DNC is now Asst. District Supt. under Mr. Anderson and has control of all traffic work in the neighborhood of Lincoln.

Fellows, I am going to ask again what I have asked innumerable times, and that is, please send in a report if you want credit for your work. We are not mind

readers, and if you desire to enter into traffic work write at once to either the Asst. Division Mgr., J. G. O'Rourke, 3064 South 32nd St., Omaha, or the District Sup't, Mr. Ed. Anderson, 308 North 27th Ave., Omaha. We must have some sort of co-operation if we are to place the Nebraska district at the top of the Division's list. Now let's go. This applies especially to stations in the western portion of the state.

I wish to point out to the broadcast fans of this district the fact that when receiving a certain broadcast station's 235 meter "harmonic" on a single circuit receiver they are not immune from spark interference. Remember the spark man is not always to blame. Nine times out of ten it's your receiver, or your neighbors. The radio relay has a perfect right to the air providing he is within the law, and with few exceptions the spark man is. In the future please hunt a higher "harmonic" when listening to local broadcasts. I believe the amateur operator will play the game fifty-fifty with you.

I am expecting to hear from you fellows next month so that we may re-instate the old Nebraska relay routes for the static season at least.

BOOK REVIEW

(Continued from page 31)

It is certainly a pleasure to run unexpectedly into a story on our A.R.R.L. in this book. We like the "Complete Radio Book" better than other of the new-comers and think it is well worth anyone's while.

"Radio Telephony for Everyone", by Laurence M. Cockaday, technical editor "Popular Radio" and "The Modulator"; Frederick A. Stokes Company, New York; 213 pages, 5x7 $\frac{1}{2}$ ", \$1.50.

Here is a book by an old-time amateur, and it reflects more of the amateur atmosphere and more of the amateur's method of attacking a problem than any of the newer books that have come to our attention. As stated in its preface it is written in "every-man's language" with the sole idea of dispelling the shroud of mystery surrounding radio in the layman's mind. The chapters in turn treat of simple electron theory and wave theory, and then leaps nimbly into a discussion of the vacuum tube as an electron generator of waves (certainly a commentary on present day essentials—contrast it with the practice a few years ago of introducing at about this place in the story open antenna oscillators excited by a spark coil, Hertzian oscillators, etc.); modulation, aerials, tuning, detector, regeneration, the building of a small phone transmitter, the construction of receiving sets, and the care and maintenance of apparatus.

(Concluded on page 58)

Who's Who in AMATEUR WIRELESS



HOWARD F. MASON

The Manager of our Northwestern Division was born in Marion, Indiana, in 1901, and moved to Seattle when four years old but says he didn't see any DX stations on the way out. He got started in earnest in 1915 and heard his first signal at 7:14 P.M. Saturday, September 4th (extract from log). On learning the code the signals were identified as KPA, a 5 KW station 5 miles away. The following year a transmitter was installed and operated under the call 7ML until closed down during the war. The half kilowatt was unable to work anybody over fifteen miles away 'tho the same transformer now does 1000 miles and has a 1,550 mile record.

In March 1917 he went to sea as an operator and stuck to this for two years and a half. Since the war he has been operating 7BK and holds the record in his

(Continued on page 63)



M. F. HARROD

This young son of Marconi, formerly 8VS and now 4II, was born on June 20, 1902, in Toledo, Ohio. At the age of six he moved with honorable parents to New London, Ohio, and soon decided electricity was the only thing to follow.

Starting this greatest of all games—radio—in 1919, he went thru all the conventional stages of the loose coupler and crystal followed by an audion, vario-coupler, and spark coil, thus mastering the mystery of the mystic dots and dashes. From October 1920 until June 1921 old 8VS in Toledo tried to show the world that Ohio was on the map. With his five watt C.W. set and an antenna current of eight-tenths of an ampere he was heard over half the U. S. and worked 900 miles to 9OE. These were the days when power tubes had to be "snitched." 8VS was on

(Concluded on page 69)

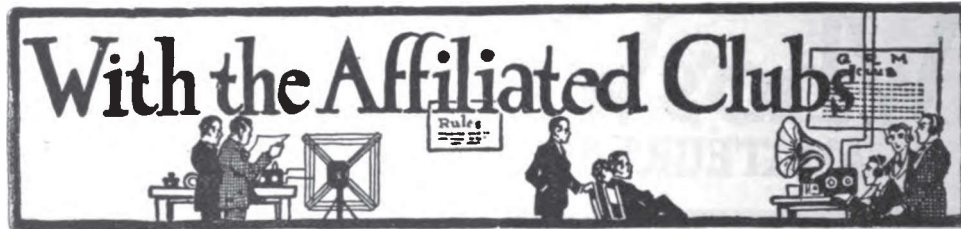

THE A.R.R.L. has the honor of announcing the affiliation of the following additional societies as of May 26, 1922:

Franklin Radio Club, Bronx, N. Y.; Benson Radio Club, Brooklyn, N. Y.; The Endicott Radio Association, Endicott, N. Y.; I Tappa Key Radio Club, Harrison, N. Y.; Thor Radio Club, Burlington, N. J.; Jefferson County Radio Club, Watertown, N. Y.; The Clifton Radio Club, Clifton, N. J.; Plainfield Radio Association, Plainfield, N. J.; Passaic Radio Council, Passaic, N. J.; Olean Radio Club, Olean, N. Y.; Lake Shore Radio Association, Jamestown, N. Y.; Clayton Radio Club, Clayton, N. Y.; Minersville Amateur Radio Association, Minersville, Pa.; Radio Club of the City of Ithaca, Ithaca, N. Y.; Cazenovia Radio Club, Cazenovia, N. Y.; Vandergrift Radio Club, Vandergrift, Pa.; Greenpoint Radio Association, Brooklyn, N. Y.; Nutley Radio Club, Nutley, N. J.; Westfield Radio Association, Westfield, N. J.; Port Washington Radio Club, Port Washington, N. Y.; Beaver Valley Radio Club, Rochester, Pa.; Poughkeepsie Radio Association, Poughkeepsie, N. Y.; West Philadelphia Radio Association, West Phila, Pa.; Cooperstown Radio Association, Cooperstown, N. Y.; Belmar Radio Club, Belmar, N. J.; Medina Radio Club, Medina, N. Y.; Palisades Radio Club, Fort Lee, N. J.; Nassau Radio League, Freeport, L. I.; Norwalk Amateur Radio Association, Norwalk, Ohio; Battle Creek Radio Club, Battle Creek, Mich.; Greenville Radio Club, Greenville, Ohio; City of the Straits Radio Club, Detroit, Mich.; The Waukesha Radio Amateur Club, Waukesha, Wisc.; Wooster Radio Club, Wooster, Ohio; The Oxford Radio Club, Oxford, Ohio; Minnetonka Radio Club, Excelsior, Minn.; Fargo-Moorhead Radio Club, Fargo, N. Dak.; Forx Y. M. C. A. Radio Club, Grand Forks, N. D.; Southern Minnesota Radio Association, Fairmont, Minn.; Madison Radio Association, Madison, S. Dak.; Radio Club of Jamestown, Jamestown, N. Dak.; The St. Cloud Radio Club, St. Cloud, Minn.; Wireless Club of St. Petersburg, Fla.; Miami Radio Association, Inc., Miami, Fla.; Campus Radio Club, Ames, Iowa; Independence Radio Club, Independence, Kansas; St. Louis Radio Association, St. Louis, Mo.; Boston College Radio Club, Chestnut Hill, Mass.; Milford Radio Association, Milford, Conn.; Community Radio Club, Natick,

Mass.; Millers River Radio Association, Athol & Orange, Mass.; Radio Council of Southern New England, Pawtucket, R. I.; Auburn Radio Club, Auburn, Maine; Radio Club of Manchester, Manchester, Conn.; Newport Radio Club, Newport, R. I.; Wenatchee Valley Radio Club, Wenatchee, Wash.; The Coeur d'Alene Radio Club, Coeur d'Alene, Idaho; Butte Radio Club, Butte, Mont.; Benson Tech. Radio Club, Portland, Ore.; "Y" Radio Club, Guelph, Ont.; Niagara District Radio Association, St. Catharines, Ont.; Sacramento Valley Radio Club, Sacramento, Calif.; Associated Radio Amateurs, Berkeley, Calif.; Glenn County Radio Club, Willows, Calif.; Radio Association of Danville, Danville, Va.; Peninsula Radio Club of Va., Fortress Monroe, Va.; Corsicana Radio Club, Corsicana, Texas; Brazos County Radio Club, Bryan, Texas; Desdemona Radio Club, Desdemona, Texas; Lubbock Radio Club, Lubbock, Texas; The San Marcos Radio Club, San Marcos, Texas; Pecos Valley Radio Society, Roswell, N. Mex.; Albuquerque Radio Club, Albuquerque, N. Mex.; The Moose Jaw Amateur Radio Association, Moose Jaw, Sask.; Moose Jaw Senior Amateur Radio Association, Moose Jaw, Sask.; Albion Radio Club of Albion High School, Albion, Mich.

Rutherford (N. J.) Radio Club

Meetings are held on the first and third Tuesdays of each month. Out of a total membership of forty-seven there are thirty active members. This club makes a strong effort to adhere to government regulations such as those relating to wave length, decrement, licenses and false calls, under the discipline of the ever-alert ears of its Traffic Manager, Mr. Benjamin Jackson.

Due to the popularity of the clubs' president, Mr. Richard C. Clunis, its members and their guests have been treated to some very interesting talks by prominent radio men such as Mr. Frank Bremer, pioneer radio phone broadcaster, Mr. Paul F. Godley, whose activities in amateur radio need not be mentioned, Mr. Pierre Boucheron, publicity manager for the Radio Corp'n. of America. The last two mentioned gentlemen are also members of this club. In June, probably the 16th, Mr. Meyers, manufacturer of audion tubes will talk to the club and demonstrate his multi-stage amplifier.

Belmar (N. J.) Radio Club

The Belmar Radio Club held a radio convention on June 9th, at which all the newest and best apparatus was on display, including the new Western Electric amplifier and loud speaker. Paul F. Godley spoke on "The Future of Amateur Radio." We hope to have a further report on the success of the show.

East Gulf Organ

The gang of the A.R.R.L. in the East Gulf Division have started one of the liveliest and peppiest division organs that you ever saw under the name of the "East Gulf Radiogram." The first issue is out for May and has good technical articles and a wealth of amateur spirit. Mr. H. R. McMillan is managing editor, B. W. Benning (Division Manager) and H. L. Reid are associate editors, with W. A. Ward as advertising manager.

Our best wishes to a peppy outfit. We shall expect great things of the "East Gulf Radiogram."

The Reading (Pa.) Radio Club

On May 12th we celebrated our affiliation with the A.R.R.L. by a radio dance which was very successful.

Our club now has forty members, the officers of which are, Harold O. Landis, pres.; Clarence Leinbach, vice-pres.; Clarence J. Hartman, treas.; Carl E. Kunsman, sec'y; C. C. Levan, asst. sec'y; and Clifford Trout, publicity mgr.

We have our headquarters at the P. & R. Y.M.C.A., where a transmitting and receiving set is installed. The transmitter consists of a 1 K.W. Acme transformer and rotary spark gap, and the receiver is made up of a short-wave regenerative tuner and two-step amplifier and Magnavox. We have two antennas, one being ninety-five feet high and one hundred and thirty-five feet long with six wires, and the other, fifty-five feet high and seventy-five feet long with four wires. Both of them are of the inverted L type. The station, whose call is 3BDP, is now open for traffic, with regular operators on duty each Tuesday, Wednesday and Friday evening.

Meetings are held every second Friday, when besides the regular business proceedings, the QRM Committee makes its report, a short session of omnigraph practice is given, and a discussion is made of a subject selected at the previous meeting.

Schnell West

At this writing our Traffic Manager, Fred H. Schnell, is making a tour of the west coast states where he will call upon as many of the affiliated clubs as his limited time will permit.

"The Michigan Radioist"

The May-June issue of the Michigan

Radioist published by the Central Michigan Wireless Association of Lansing, and devoted to Michigan amateur interests, is a Battle Creek number and concerns itself in interesting fashion with activities in and about Battle Creek. A page in its latest issue is devoted to an explanation of what the A.R.R.L. is with an invitation to the public to utilize the traffic routes in Michigan for the starting of free messages to any part of the United States of Canada. The affiliated clubs in Michigan are listed and the addresses given of the state traffic personnel. A splendid thing and one which other sectional organs might employ to tell the public what amateur radio is.

The South Dakota "Oscillator"

"The Oscillator," published by the Y.M. C.A. Radio Club of Sioux Falls, S. D., has been issued for the last time this season but will be resumed in the fall.

The Oscillator has always been a very creditable little sheet full of sound, practical operating advice, and expressing so well that homey amateur atmosphere we love. The May 24th issue contained a comprehensive account of the Iowa State Convention. We have as yet received no report on this meeting from any of our Iowa clubs, but from its report in the South Dakota magazine it would seem that very interesting sessions were held.

The Bronxville Radio Club (N. Y.)

Shortly after the war a group of radio enthusiasts in Bronxville formed a club under the name of the "Armour Villa Radio Association". The name of this organization has been changed to the "Bronxville Radio Club" within the last year and it is entering upon its fourth successful season. The "Bronxville Radio Club" is affiliated with A.R.R.L. and the officers of the club are as follows: president, Walter A. Remy (2KV); secretary, Rodney Roach; treasurer, James Maher (2AXP).

Meetings are held every other Friday evening in the Gramatan National Bank, Bronxville, N. Y., through the generosity and interest of the bank officials. The present membership of the club is 28, which number is rapidly increasing. We aim to make our meetings interesting for all by presenting a paper on some radio topic at each meeting, by answering the questions of the novice and giving him all possible advice, and by holding a general discussion.

We consider ourselves fortunate in receiving a complete DeForest fone and CW transmitter, motor-generator, etc. from one of the members, Mr. McAllister, towards a club station. A committee on erection has been appointed and is getting results. The station will be operating about the latter part of June and we are anxious to exchange messages with other organizations. Call 2AIH.



Mr. M. H. Pancost, 8ZF, is a hero in Lansing, Mich., because of his excellent handling of news service by radio during the emergency when nearly all wires were down. With the aid of 8ZZ, Clyde Darr, who made news arrangements with WWJ at Detroit, 8AND, F. D. Fallain at Flint, 8ADY at Fenton, HIG, unlicensed station at Bay City, WHW at East Lansing, and SBLW at Grand Rapids, all the news was received for two days. Another demonstration of the value of amateur radio in an emergency.

Mr. J. F. Carpenter, who was our hero of the storm relay routes described in April, was called upon again to give help in the case of another storm bringing down the wires of the Northern States Power Co. On a few minutes notice he grabbed a five watt C.W. set and drove with the General Supt. to St. Croix Falls, Wis., where communication was established back to 9XI in a few minutes and important messages handled over the 60 mile gap. Hot stuff! The station is still being maintained and more C.W. sets are being put in the other main plants now.

The Difference
Spark: Watts-per-mile.
C.W.: Miles-per-watt.

New theory of propagation advanced by a reporter for the Fairmont, (W. Va.) Times, who speaks of sending messages thru the ozone, and also chronicles the use of several stages of exemplifiers. Shades of Herr Hertz!

M. S. Andelin, 6JT, Manager of our Rocky Mountain Division, stepped off this past June too. He says it does not mean that he is dropping out of the game, however, as he married the sister of a well-known DX amateur (QRA?) so there will be two operators at 6JT instead of one. Congratulations, OM!

The National Retail Assn. now has an Investigating Committee to look into the matter of quality and efficiency of radio apparatus and to get responsible manufacturers to plainly mark the receiving radius on their apparatus.

Station Kinks

Every amateur has originated certain little kinks around his station that are very helpful. What have you done in this line that will interest the bunch? Here are some we made note of in a station we recently visited:

The regenerator was shielded by pasting tinfoil on the back side of the panel, carefully cutting it away around bushings, switch-points, etc. Capacity effects were nil, which is a great help in C.W. work.

A large-size B battery had been tapped at each cell by taking off the cardboard bottom, scraping thru the wax paper around each cell and soldering thereto a $\frac{1}{2}$ -inch length of No. 14 copper wire, and paraffine promptly poured over the tapped battery to exclude moisture. The battery is turned upside down and connection made to any desired cell by clipping on to the proper wire "stub".

A small board on short legs had a group of $1\frac{1}{4}$ -inch holes bored in it and made a convenient holder for a dozen or so standard-base tubes.

The storage battery was connected to the blades of a D. P. D. T. switch which in one position connected it to the tube equipment and in the other to the charging rectifier. By throwing an additional switch to supply the rectifier with 110, the battery can then be charged without the inconvenience of disconnecting, running special wires, etc.

3BEC suggests drawing pencil lines on the base of detector tubes between the filament and grid posts for a leak. The advantage is that the tubes may be swapped but always have their best leaks with them.

Although 9ZN is in commission with the same apparatus as always, many of the old operators are scattered all over the country. Dutton, "DN", is operating on the S.S. George Washington, and Brennan, "MA", is on the west coast.

1AMD informs us that on March 6th he delivered the Governor-President message for Rhode Island to 8AJD. On the next two nights it was given to 1AZW.

According to newspaper clippings, a chap in Dubois, Pa., has a miniature radio that tunes to 289 meters, cost a total of 17c, and picks up Arlington. Why pay more?

The Detroit Police Dept. has been issued the call letters KOP. You speed demons better watch your step.

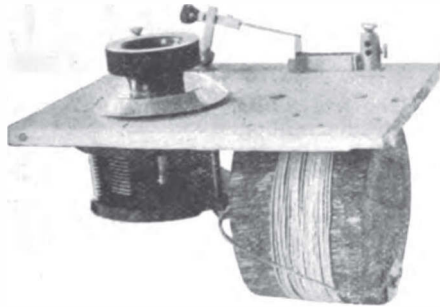

The above is supposed to be a wave-meter. It drifted into one of the testing laboratories for calibration. Yes, drifted—it couldn't sink because the coil is wound on a tree limb which would keep it afloat. Although the mud insulated condenser was still OK, and none of the unsoldered connections came off, the wire became very loose on the tree trunk on drying, so that calibration is subject to change without notice.

We have several requests on file for a thermocoupled antenna wattmeter calibrated to read directly in miles. QTC?

Several other good "Strays" were received too late for this column.

It's too bad we can't repeat all the foolish questions asked in radio gatherings and much worse that we can't answer them intelligently, at least to the asker.

That reminds us of the b.c.l. who bought a grid condenser and after unwrapping all the paper found it empty inside.

We understand that an antenna is a horn on the head of a bug. Moral: be sure of your nut.

To those who wish to learn more about radio we recommend "The Principles Underlying Radio Communication". This book was originally prepared by the Bureau of Standards for the Signal Corps in 1918 but has been revised and considerably increased in size. There is a wealth of information in it and it is absolutely up to date. It is durably bound and contains over 600 pages and 300 illustrations, many of which are photographs. This book may be obtained postpaid for one dollar from the Superintendent of Documents, Government Printing Office, Washington, D.C.

Can You Imagine—

Eastern sparks being heard in Hawaii?
Selling tubes for 59c on bargain days?
New aerials staying put?
Your condenser not blowing when that "6" answers?
Less than five concerts on the same wave?
The good old days back again?

It is with deep regret that we learn of 1CK, the station of our New England Division Mgr., being burned on May 25th. His files were completely destroyed and his QST's as far as page 53 of the May issue, he says cheerfully.

With not half so much regret we learn that "Nick" Jensen, Dakota Division Manager, "stepped off" on June 7th. Another good A.R.R.L. man to desert the bachelor ranks. Congrats, OM!

Read 'Em and Weep!

8GE has heard 6KA, 6ZZ, and 6XAD QSA.

8AM, 8BO, and 8EA have been heard in California.

8ZZ, Clyde E. Darr, has been heard in Colon, Panama.

5ZA has been heard at 1MO on two steps 200 feet from the phones.

2AFP has been reported in many central U.S. places while using one five watt tube and thirty foot single wire aerial.

9ZN has been heard on spark in Davenport, Iowa.

6ZZ has been copied on one tube by 1AZY in Rhode Island.

5AX in Prince Rupert, B.C., hears 4CB, 5ZA, 6ZI, 6ZAC, 7DP, 9AYU, 9WU, and 9BD, all on C.W.

9DSG has been heard 1250 miles on 5 watts, 180 meters, and single wire aerial.

8ACF in Pa. has been heard in Calif. by 6TI and 6ABU.

8VY has been reported QSA in Alaska and 425 miles west of NPE.

Investigation is now on foot to determine if the leading radio companies are restraining trade in the wireless field.

On July 19th the various offices of the Civil Service will hold a competitive examination for the position of Radio Inspector for the Department of Commerce.

On June first there were 28,362 receiving sets in Chicago.

2KF advises he will gladly make reception tests for any station writing him.

"If anyone wants to prove that he was heard in England during the Transatlantics, all he has to do is to claim that he signed 1AAW and she is did. There is a Kickback to the proposition, tho."—"Kickbacks". We'll say so! We're still looking for the bird.

With Our Radiophone LISTENERS

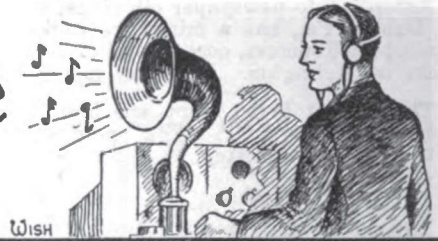

What is claimed to be the largest radio horn in the world is shown in the accompanying photo. It is installed in Idora Park, a public amusement resort in California. Equipped with a Magnavox reproducer and power amplifier the music picked up can be heard over an area of twenty-nine square miles.

it will be five million and in 1927 it will reach twenty million.

The radio broadcast craze has swept into Canada as well. We hear rumors that the station of "La Presse" in Montreal is due to be one of the largest in North America, operating under the call CKAC.

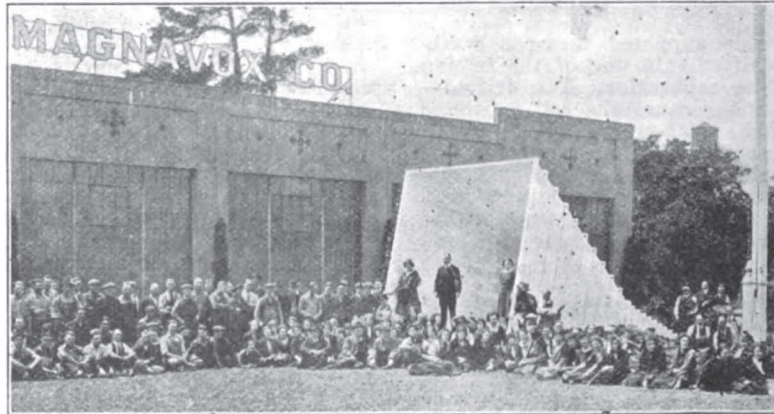

The horn measures thirty-five feet in length and has an opening twelve feet square. One thousand feet of clear aeroplane spruce lumber went into its construction. It is claimed that with the electrodynamic reproducer and the overcoming of the problems incidental in the design of such a large horn, distortion is eliminated.

Mr. E. P. Edwards, Manager of the Radio Department of the General Electric Co., in defense against the charge of holding back in the production of vacuum tubes to increase the demand, states that until last November 5,000 tubes per month kept the market supplied. In March he estimated the demand to be 90,000 per month at which time they were making 60,000. The production is now 200,000 tubes per month or about forty times as much as the production six months ago.

Dr. Lee DeForest is quoted as having said in a recent speech that the estimate of the radio public as being a million is highly conservative. He figures that in two years

"What Is the Best Way to Learn the Code?"

"By and by they are going to get fed up with near-by stuff and the concerts, and how to peel potatoes, and one by one they are going to begin wondering about the little chirps and buzzings down on two hundred," says "The Old Man." This is the first symptom of the second bite of the little radio bug. A real amateur is in the making when one says, "What is the best way to learn the code?" Thousands of broadcast fans are asking this question to chance acquaintances in the radio stores, at radio club meetings especially advertised and everywhere the whole country over. Congratulations! We welcome you into this amateur field of ours.

But now about this "dah dit dah" stuff. We old timers had our trials and tribulations in getting started. Most of us learned the code from a printed card, a catalogue of a mail order house, or a library book. We learned that A was "dot-dash," B "dash-dot-dot-dot", and C "dash-dot-dash-dot." Some of our number in a very short period could recite the whole

code in this way—just like memorizing poetry at school. Sounds simple, doesn't it? Yes, A was a little round dot followed by a long black mark, while B is a long mark followed by three dots and so on. But when the buzzes came in the receivers they weren't composed of round black dots and long thin dashes. Anyone learning the code in this manner is at a loss to understand the buzzings. If the sending is painfully slow—less than a word per minute—the well meaning would-be operator hears "dit-dah" and thinks to himself, "Let's see, that is a short and a long,—mmmmmm—dot-dash, mmmm—oh yes, it's A." Nuff sed! This way of learning the code is "debutique."

The way to learn the code is to learn it like you will have to receive it. The ideal way is to get someone to send to you, starting in from the first, without the code chart but learning the letters by sound. If this is impossible and you are forced to learn alone, try to associate the letters with long and short buzzes. Think of A as "dit-daah," B as "daah-dit-dit-dit," etc., with the accent on the "daah" which represents the longer element or the dash.

A buzzer practice outfit is quite a necessity in learning the code and no doubt most of it can be used later in a transmitting set. Complete outfits can be purchased for from \$2.50 to \$4.00. If the parts are bought separate, connect up the battery, key, and buzzer in series; that is, arranged in an electrical circle so that the current must go thru any unit to get to the next. It makes no difference in which order they are arranged or the polarity. In sending, grasp the key firmly with the thumb over the edge of the key knob. The key should be far enough back so the elbow will rest on the table with the wrist in the air. The wrist should be flexible with the motion coming from the forearm instead of the fingers. Practice the code by sending each letter several times, paying attention to the sound of the letter after the third time as if someone else was sending and along with each character think of the letter it represents. This increases the association between the sound and the letter, which is the main thing in receiving.

"If I were a broadcast listener and wanted to learn the code," says Hiram Percy Maxim, President of our A.R.R.L., "I would learn the numbers first. Then when listening in and hearing a station sending his call with a dit-dit-dit-dah-dah I would know he was located somewhere around Washington, D. C. Maybe it would be dah-dah-dah-dit-dit which would mean he was west of here, maybe in Ohio. Then on good nights when everything was right I might hear a station sign a call with a dah-dah-dah-dah-dit in it and then I would know I was reaching out and had heard

someone in the middle states. I would send fifteen cents to the Superintendent of Documents, Government Printing Office at Washington and when I got so I could pick up all of the letters in the call I would refer to the call book and drop the station owner a card telling him how I got him. Perhaps this would be a record for him and I would share in the honors. The fascination of *distance* is the thing that holds the interest in amateur radio. Why is it that little interest is taken in local broadcasts? The listeners would rather hear Pittsburgh, Springfield, Detroit, or some distant station even tho the quality of the program is the same because it is *further*. The same is even more true in amateur radio. The desire to receive long distances and know where the signals are coming from is one of the strongest incentives to learn the code."

There are all kinds of charts and methods suggested for learning the letters. Some are as good as others are bad. The fact remains, however, that all of the letters have to be mastered and the total number remains the same. Probably the dot letters would be well to start on—E, I, S, H, 5—and then the dash combinations—T, M, O, and zero. These should be thoroughly learned so that they are understood when mixed in all possible combinations. From this point on there seems to be considerable controversy as to which letters to learn next. To learn letters along with their opposites seems offhand to be a short cut. The learner quickly recognizes that the signal is either one of the opposites but is in doubt which and is just as liable to guess the wrong one. In fact when the code is learned in this manner it takes a long time before the learner can instantly and decisively choose the correct letter from its opposite. Difficulty is encountered in choosing between F and L, Y and Q, A and N, W and G, B and V, etc., when these letters are learned together.

Mr. Maxim is trying out a novel stunt in teaching the code with a small phone set by which he announces the letters in connection with his crashing 1AW spark, by which the listeners are taught to recognize the letters direct by sound. Words and other combinations of the letters already mastered are sent and checked when repeated on the phone. Though at this writing the course is about half completed the interest taken by dozens of men, women and children, indicates that it is novel, very interesting, and easy to learn the code this way.

It appears then that though there may be some advantage in learning certain letters first, the important thing is to learn by sound as in actual reception and not by visualizing the code on a printed card.

—B. P.

This is Miss Eunice Randall who sends thousands of youngsters to the Land of Nod every Tuesday and Thursday night. The above illustration shows her broadcasting her soothing tales from WGI to a family circle of 1,000 miles.



Miss Randall is one of the pioneer figures in radio broadcasting and is known from coast to coast. As far as known she is the only woman designer in the radio industry as she is employed by the Amrad Corp. daytimes. She is also an old A.R.R.L. member and operates a good "ham" station, 1CDP.

A NEW RADIO BILL

(Continued from page 32)

A BILL

To amend an Act to regulate radio communication, approved August 13, 1912, and for other purposes.

Be it enacted by the Senate and House of Representatives of the United States of America in Congress assembled, That the Act of Congress entitled "An Act to regulate radio communication," approved August 13, 1912, is amended by striking out sections 1, 2 and 3 thereof and by inserting in lieu thereof the sections 1, 2 and 3 following:

"SECTION 1 A. That no person, company, or corporation within the jurisdiction of the United States shall use or operate any apparatus for radio communication by telegraphy or telephony as a means of intercourse among the several States or with foreign nations, or upon any vessel of the United States engaged in interstate or foreign commerce, or for the transmission of radiograms or signals by telegraphy or telephony the effects of which extend beyond the jurisdiction of the State or Territory in which the same are made, or where interference would be caused thereby with the transmission or reception of messages or signals from beyond the jurisdiction of said State or Territory, except under and in accordance with

a license in that behalf granted by the Secretary of Commerce and except as hereinafter authorized.

"B. That the Secretary of Commerce from time to time shall (a) classify licensed radio stations and the operators required therein; (b) prescribe the nature of the service to be rendered by each class of licensed station and assign bands of wave lengths thereto; (c) make, alter, and revoke regulations applicable to all licensed stations not inconsistent with this Act or any other Act of Congress or with the terms of any radio communication convention to which the United States is a party concerning the service to be rendered by each class of stations so established; the location of any station; the wave lengths to be used by any station; the kinds of instruments or apparatus in any station with respect to the external effect produced thereby; the power and the purity and sharpness of the waves of each station or the apparatus therein; the area to be served by any station and the times and methods of operating any station or the apparatus therein; (d) make such other regulations not inconsistent with law as he may deem necessary to prevent interference between all stations affected by this Act.

"C. That radio stations belonging to and operated by the United States and used exclusively for communication of official business shall not be subject to the provisions of paragraphs A and B of this section. Every other station owned and operated by the United States shall be subject to the provisions of said paragraphs A and B of this section. All stations owned and operated by the United States and all other licensed stations on land or sea shall have special call letters designated by the Secretary of Commerce, and such stations and the designated call letters shall be included in the list of radio stations of the United States as published by the Department of Commerce. Radio stations owned and operated by the United States and used exclusively for the communication of official business shall use such wave lengths as shall be assigned to each by the President, and shall observe such regulations as the Secretary of Commerce may make to prevent undue interference with other radio stations and the rights of others, except that upon proclamation by the President that there exists war or a threat of war or a state of public peril or disaster, or other emergency, the President may suspend for such time as he may see fit all such regulations of the Secretary of Commerce applicable to such stations owned and operated by the United States.

"D. That every such license shall provide that the President of the United States in time of war or public peril or disaster may cause the closing of any station for radio communication and the removal therefrom of all radio apparatus, or may authorize the use or control of any such station or apparatus by any department of the Government upon just compensation to the owners.

"SEC. 2. A. That paragraph A of section 1 of this Act shall not apply to persons sending radio messages or signals through a radio station belonging to and operated by the United States for the transmission exclusively of official business nor to persons sending such messages on a foreign ship while the same is within the jurisdiction of the United States.

"B. That the station license required hereby shall not be granted to, or after the granting thereof such license shall not in any manner, either voluntarily or involuntarily, be transferred to (a) any alien or the representative of any alien; (b) nor to any foreign government or the representative thereof; (c) nor to any company, corporation, or association organized under the laws of any foreign government; (d) nor to any company, corporation, or association of which any officer or director is an alien or of which more than one-fifth of the capital stock having voting power is owned or controlled by aliens or their representatives or by a foreign government or representative thereof, or by any company, corporation, or association organized under the laws of a foreign country.

"Such station license, the wave length or lengths authorized to be used by the licensee, and the rights therein granted shall not be transferred, assigned,

(Continued on page 69)

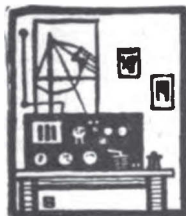

Amateur Radio Stations



7XG, Portland, Oregon

This station was designed and built for Mr. W. P. Hawley, jr., by Mr. Chas. Austin of the Northwestern Radio Mfg. Co. of Portland. Four 50-watt tubes are used in Colpitts-Heising circuit, two as oscillators and two as modulators, with constant current modulation.

on the drum for lighting the filaments, starting the generator, etc. Likewise all the necessary switches are changed when the drum is turned to "C. W." or "Chopper."

The chopper for I.C.W. gives a 900 cycle note.



Filament voltage of 9.75 volts is supplied by an Acme transformer. The plate current is supplied by a Robbins & Meyers motor-generator set. With a 10,000 ohm field rheostat the output voltage can be varied from 300 to 1500 volts. At the lower left hand corner of the transmitting panel is a drum switch control marked "Voice," "Receiving," "Off," "C.W." and "Chopper." When turned to "Voice" the set is ready for the transmission of speech or music thru the arrangement of contacts

The receiving apparatus consists of the usual variometer regenerative set designed to cover waves from 160 to 900 meters. For long waves a Colin B. Kennedy set is used. Either may be plugged to a two-step amplifier. A large Magnavox can be used with either set and has its own three stage power amplifier consisting of five watt power tubes operating two in parallel for each stage. Three banks of 108 volts furnish the plate voltage for each power amplifier.

The transmitting and short-wave receiving aerial is of the four wire T type, 40 ft. long. The poles were tapered in a lathe from 22 inches to 8 inches at the top and stand 100 feet high with no guys whatsoever. At the base the poles are bolted to concrete saddles and do not go into the ground where they would rot. The lead-in is bunched into a rat tail half way down. A six-wire counterpoise also of seven strand No. 20 phosphor bronze cables is directly below the antenna and extends 15 feet beyond at both ends. The ground system consists of 60 foot strips of three inch copper ribbon buried two feet apart and eight inches deep under the antenna. Both the ground and counterpoise are used giving 4 amperes in the antenna on voice and 5 to 5½ amperes on straight C.W. using two 50 watt tubes as oscillators. Great care is taken with insulation thruout the antenna system.

The operating room is of good size and contains the latest type of electric Victrola with Magnavox tone-arm and a Steinway grand piano with specially constructed spruce tone chamber for transmitting vocal and instrumental music. 7XG has been heard on C.W., I.C.W., and voice in the Hawaiian Islands. A new set with one 250 watt oscillator, one 250 watt modulator, and a 50 watt speech amplifier is under construction as is also an Armstrong Super Heterodyne amplifier of four steps to be used with the ordinary two-step audio frequency and four-step power amplifiers.

SOME SUGGESTIONS REGARDING THE BEVERAGE ANTENNA

(Concluded from page 13)

in the ground lead in order to neutralize it. A condenser alone would do but a more flexible arrangement would be to use an inductance in series also. This inductance

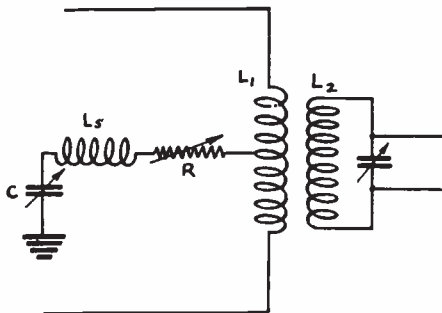

FIG 3

should have taps and range from 30 to 50 turns on a four inch tube. See Figure 3. When the condenser is inserted, the induc-

tive reactance of the circuit is neutralized by the capacity reactance of the condenser and there is left only the resistance of the transformers and the resistance R. The values of condenser or inductance will have to be changed for each wave length used. The system described should give good results from 150 to about 600 meters if the wire is long enough.

Many statements made here are subject to criticism but the writer is not attempting to give exact values for short wave work, as it is rather problematical to say the least.

BOOK REVIEW

(Concluded from page 48)

The chapter on receiving sets briefly describes the construction of a single circuit tuner using a crystal detector, a loose-coupler set with a straight audion detector, and a regenerative audion set. There are no photographs of this equipment and the reader is abruptly pitchforked into the mazes of schematic circuit diagrams with the injunction to secure a loose-coupler and certain other pieces of apparatus and hitch them up as per figure so-and-so, in a manner certainly much less understandable than that employed by Mr. Lescarbourea.

Nevertheless it is an excellent book for the novice listener, full of sound practical advice from the amateur's standpoint.

—K.B.W.

A NEW "CHICAGO PLAN"

(Concluded from page 34)

interest of life and property requires special permission at additional fees before station apparatus can be moved or changed and yet permits anything desired to be done with the antenna is a terrible big joke, and obviously not at all designed in the public interest. In other words, it is much easier for an inspector to look over the apparatus in one's den than to climb out on a scorching hot house-top to inspect an aerial; and of course the average experimenter is going to improve and re-arrange his station apparatus much more often than he will make changes in his aerial, which means that many more re-inspection fees.

We regard the proposed Chicago radio ordinance as an iniquitous piece of business against the public interest and designed purely for graft. Chicago is infamous for that sort of thing, and it looks like the crooked politicians of the "Windy City" were endeavoring to get some "jack" as the result of the immense novice interest in radio. They are of course stepping on the toes of us amateurs in doing so. We think every A.R.R.L. member in Chicago should use his influence to the utmost to prevent the enactment of this ordinance.

Calls Heard



HEARD DURING MAY Unless Otherwise Specified

Heard At Sea By Ex-3HJ Aboard S.S. West Nosska
March 23 (60 miles south of Baltimore) C.W.:
2FP; Spark: 1SN, 2FP, 2RM, 2ARY, 3QN, 8AJT,
8AY, 8UC, Can. 3EI, 3KG, March 24 (Norfolk)
C.W.: 1BGF, 1PT, 2FP, 2BNZ, 3AQR, 3BHL, 3BZ,
3SQ, 4ZC, 5DA, 8BEF, 9IO; Spark: 3QW, 8BAZ,
9LF, Can. 3GN, March 25 (100 N.E. Norfolk)
C.W.: 1AJP, 1BEP, 1BSD, 1XM, 2BNZ, 2BML,
2FP, 3AAG, 3BA, 3BHL, 3AY, 3QZ; Spark: 1ARY,
2WB, 3AGT, 3BG, 3FB, 3FP, 3YP, 3ZM, 4BE,
4EA, 8BZY, 8ZAC, 9AGA, 9OX, March 26 (150
E. Boston) C.W.: 1ADL, 1ARY, 2AVU, 2BEA, 2FP,
2WT, 3APQ, 3FS, 3IL, 3VW, 4LP, 8AGK, 8QZ,
9HW; Spark: 1BQA, 2AZC, 3AJD, 8AJV, 8ALO,
8BSS, 9LF, 9OX, 9UH, March 28-30 (Halifax)
C.W.: 1BTR, 1BWJ, 1BRQ, 1AJP, 1RD, 1BSD,
1BUA, 1ASF, 1ADD, 1AFJ, 1AZW, 1BLE, 1CK,
1BKR, 2ABZ, 2AMO, 2CCD, 2BQU, 2AES, 2WT,
2BEB, 2ADV, 2OF, 2BCF, 2AJA, 2VH, 2AWF,
2BTJ, 2AYV, 2CFT, 2BNC, 2FP, 2CGQ, 2AAB,
3AQR, 3AJD, 3AQH, 3AAY, 3RF, 3BZ, 3VW, 3AAG,
3ADX, 3BUV, 3HG, 3IL, 3ANQ, 3QZ, 3CFZ, 3UK,
3BDU, 3BBD, 3ADG, 3BK, 3AVD, 3OZ, 3AWP,
3AIO; Fone: 2DK; Spark: 1ARY, 1CZ, 1SN, 1DZ,
1OOK, 1BSZ, 1CM, 1YB, 1WQ, 1ADL, 1DHJ,
1BRQ, 1CGU, 2AAR, 2EL, 2WB, 3AJD, 3DM, 3AGT,
3AQI, 3LB, 3BCO, Can. 3BP, 3GE, April 1 (80 E.
Halifax) C.W.: 1AJP, 1AZX, 1BLE, 1CMK, 2BNZ,
2SQ, 3ALN, 3BA, 3BZ, 3BJ, 4GL, 4ID, 3ADG,
3BDU, 3ARK; C.W.: 1XM, 1BES, 2NZ, 3FS, 3QZ,
3AVD, 3PT, 3QB; Spark: 1AKG, 1BQA, 1AW, 1CC,
1OM, 2ARY, 2WB, 2RM, 2DN, 2JZ, 5FO, 5HK,
3ARD, 3AFD, 3OD, 3WD, 3ALO, 3VH, April 2
(800 E. Boston) C.W.: 1AKG, 3AIO, 3BSS.

7BJ on WSR (from Astoria, Ore. to Chignik, Alaska)
April 12: (410 west NPE Northhead, Wash. 7ZS,
6XAF, 7YL, 7YA, 6ZB, 7XG, 5XU, 6ZT, 6BJV,
6AJH, 6AVM, 6AMN, 6AAK, April 15: (415 west
NPE) 6XAD, 9BED, 9BE, 9WU, 6BCD, 9BE.
April 16: 9IL, 6XAD, 9AXF, 9AIV, 8VY, 9CBA,
April 17: (490 west NPE) 9DOF, 9AIV, 9AJA,
9FM, 8EA, 9ARZ, 9XL, 9XAQ, April 18: (610
miles west NPE) 6OO, 6ZX, 6AAT, 6EA, 6GY,
7NN, 7NF, 6AGP, 7SC, 6BCD, 7TO, 7DP, 7RN,
7IW, 5OI, 9WQ, 9WD, 7WE, 6KY, April 19:
(790 west of NPE) 5XU, 5OI, 9AOG, 6GD, 6KA,
6JD, 6ZX, 6ZZ, 7KS, 9WU, Can. 9BD, 6KU, 6AIB,
7SC, 6BES, 7NN, 6ANG, 7BH, April 20: (840
west of NPE) 7KS, 6KU, 9BAJ, 9AYU, 6EN, 6ALU,
6KA, Can. 5CN, 9WU, 6XAD, April 21: (900 miles
west of NPE) 6BES, 7NN, 7DP, 6ZI, 9AJA, 6KA,
6KU, 7FR, 7MU, 6AJH, 6XAD, 6GD, 6ALA, 6BB,
6ZAC, 6ZZ, April 22: (1000 miles west NPE)
Can. 9BD, 6ZZ, 6ZI, 6CU, 6ZQ, 6ZF, 9ZAF, 6BES,
6ALU, 6XAD, 6AQU, 7FR, 6XH, 6AWP, 7NA,
7GA, 6HY, 6EX, 7CU, 6HC, 6AWT, 6KA, April
23: (1190 miles west NPE) 6EA, 7SC, 7QE, 7DP,
6XAD, 7NA, 7BH, 7BK, 6NX, 7NN, April 24:
(1250 miles west NPE) 6BES, 6ZX, 6CC, 6KU,
6EX, 7KS, 6AJI, 7MF, 6KM, 6BEG, 6EA, 6XAD,
6AIN, 7ZK, 6GF, 6AAK, 6AJR, 7DP, April 25:
(1325 miles west NPE) 6KA, 6AJR, Can. 9BD,
6BES, 6EN, 7ZK, April 26: (1450 miles west NPE)
6KA, 6AJR, 7DP, April 27: (1525 miles west NPE)
6KA, 7DP, April 28: (In Chignik at anchor) 6KA,
7NN, 6NX, spks in but QRN.

Can. 5AX, Prince Rupert, B. C.
Canadians: 4CB, 5AK, 5CH, 5CN, 5CX, 5DO,
9BD.
Americans: 6ZA, 6CL, 6EB, 6EX, 6KA, 6KI,
6VM, 6ZG, 6ZI, 6FA, 6ZQ, 6ZZ, 6AJR, 6BES, 6XAD,
6ZAC, 7AAV, 7BK, 7BS, 7DP, 7ED, 7GE, 7HI,

7IW, 7JD, 7KS, 7MF, 7NA, 7NN, 7OZ, 7QE, 7RN,
7SC, 7WE, 7WG, 7YD, 7YS, 9AYU, 9WU.

Can. 3QP, 169 Elm Ave., Windsor, Ont.
C.W.: 1AZW, 2BFX, 3IW, 3BEH, 3BIC, 3HV,
3PT, 3VQ, 3VV, 3AGO, 3BEF, 3BRQ, 3BUX, 3BWZ,
3DV, 3EI, 3FZ, 3LF, 3LY, 3UU, 3XI, 3AIV, 3AJA,
3DGG, (Can) 3CX.
Spark: 3HJ, 4BI, 3EW, 3NO, 3VQ, 3ZO, 3CP,
3GX, 3PD, 3AMT, 3BHD, (Can) 3GX.

1AOK, Melrose Highlands, Mass. (1 Tube)
Spark: (1ARY), (1BCF), 1BRQ, 1BOE, (1BVB), 1CHJ,
1CM, (2BY), (2CT), (2EL), 2FP, 2GR, (2JH),
2MN, 2OM, (2PF), 2PV, (2RM), 2TF, 2TS, 2WB,
2AA, 2AHU, 2ARB, 2ARF, 2ARY, 2AQI, 2AWF,
2AYY, (2BGD), 2BHQ, 2BKK, (2BRI), 3AAB,
3ABB, 3ACK, 3AJD, 3AQR, 3BFU, 3BJ, 3BVC,
(3AC), 3BJ, (3CS), (3FP), (3HJ), (3IL), 3JV,
(3FU), 3RW, (3TA), 3UD, 3UC, 3WT, 4EA, 4CX,
3AFD, 3AHE, 3AHQ, 3AKO, 3AXQ, (3AXX), 3BAZ,
3BFY, 3BKA, 3BNE, 3BYF, 3CER, 3DY, 3EO,
(3EW), 3KY, 3MZ, 3UC, 3VQ, (3VW), 3WD,
3AAV, 3UH, 3VL, 3ZN, Can. (3JL), 3GX,
C.W.: 1AWB, 1AZW, 1BDI, 2AFP, 2AWF, 2AYV,
2BEB, 2BEH, 2BFX, 2BML, 2BNZ, 2BOG, 2BQU,
2BYC, 2FP, 2NZ, (2RM), 3ALN, 3AJD, 3BJY,
3BLF, 3BRW, 3CAL, 3FP, 3GN, 3IW, 3LR, 3ADG,
3AHO, 3AMM, 3AVL, 3AQO, 3BJS, 3BLX, 3CJH,
3CKO, 3CON, 3LB, 3UE.

1BRQ, Lewiston, Me.
Spark: (1AA), (1ACO), 1ADC, 1AGI, (1AKG),
1ALK, (1AMQ), 1AOK, (1APT), 1ARY, 1ASK,
1AW, 1AZK, 1BDT, (1BEK), 1BEP, (1BJS), 1BVB,
1BWY, (1BYG), 1CE, (1CHJ), 1CHX, (1CK),
(1CIB), (1FM), 1FS, 1GM, (1LZ), 1RH, 1RV,
1TU, 1WQ, 2ABB, 2AHU, 2AIC, 2ARB, (2AWF),
(2BBN), 2BFX, (2BKK), 2BTJ, 2CT, 2EL, 2EQ,
2KK, (2RM), 2RN, (2OM), 2PF, (2PU), (2TF),
2TS, 3ABB, 3AHU, 3AJD, 3ALO, 3BFU, 3BLF,
3BU, 3BVC, (3FP), 3GX, 3IR, (3FU), (3TA),
3ZM, 4EL, 3AFA, 3AFD, 3AHQ, 3AQO, (3BNE),
3BQA, 3EO, 3JU, 3YN, 3AFC.

C.W.: 1ADL, 1AGI, 1AIP, 1AJP, 1AQK, (1ARY),
1ASF, 1ATJ, 1AUN, 1AWB, 1AWE, 1AZD,
(1AZW), 1BAS, (1BBW), (1BDI), 1BEP, 1BES,
1BGF, 1BIE, 1BKA, (1BKK), 1BKQ, 1BKR, 1BLN,
1BNT, 1BQE, 1BUA, 1BUU, 1BW, 1BWJ, 1BYG,
1CAK, 1CBP, (1CDO), 1CHJ, 1CJH, 1CIK, 1CIT,
1CLI, 1CMK, (1CPN), 1CRU, 1GV, 1IU, 1JG, 1OK,
(1PR), 1PT, 1RD, (1UL), 1XA, 1XG, 1XM, 1XX,
1YB, 1YK, 2ABQ, 2AEU, 2AFP, 2AJA, 2AJF,
2ANM, (2AQI), 2AQL, 2ARY, (2AWF), 2AWK,
2AWL, 2AXK, 2AXY, 2AYH, 2AYV, 2AYZ, 2AZD,
2BBE, 2BCF, 2BDG, 2BE, 2BEH, 2BLJ, 2BLP,
2BML, 2BNZ, 2BQH, 2BQU, 2BRC, 2BTJ, 2CBW, 2CDK,
2CIZ, 2CRI, 2CT, 2DK, 2EH, 2EL, 2FP, 2FZ, 2LH,
2RY, 3AAY, 3AB, 3ADX, 3ALN, 3AQH, 3BG, 3BJ,
3BLF, 3BNU, 3CG, 3FR, 3HG, 3IW, 3LC, 3VW,
3ZS, 3ZO, 4DC, 4GL, 4LP, 3ADG, 3AGO, 3AHK,
3AIO, 3ALB, 3AM, 3AMM, 3AMQ, 3AQO, 3AUE,
3AUV, 3AVD, 3AVL, 3AWP, 3AXE, 3BDU, 3BEO,
3BJS, 3BKH, 3BLX, 3BX, 3BXH, 3CFC, 3CFP,
3CJH, 3CKM, 3CKO, 3HJ, 3HM, 3OZ, 3SE, 3SZ,
3UA, 3UC, 3UE, 3VW, 3VY, 3XE, 3ZE, 3ZG, 3ARK,
3BHQ, 3BIQ, 3BP.

1NW, Danbury, Conn.
Spark: 1AA, 1ADC, 1AHF, 1AKG, 1ARY, 1AOK,
1AW, 1AZK, 1BJS, 1BOQ, 1BRQ, 1CHJ, 1CSP,
1DL, 1DY, 1IN, 1LB, 1RV, 1SN, 1WQ, 2CT, 2EF,
2EL, 2OM, 2PV, 3ABB, 3AVS, 3BFN, 3BVC, 3BX,
3FP, 3GX, 3ZZ, 4CX, 3AFD, 3APB, 3APH, 3BAD,
3BSS, 3BU, 3CQL, 3FT, 3KY, 3MP, 3TC, 3UC,
3VQ, 3ZO, 3AAW, 3AFK, 3AZA, 3PUS, 3ZN.
C.W.: 1ADL, 1AGI, 1AIP, 1AJP, 1AJU, 1APE,

1ARY, 1AWB, 1AYQ, 1AZW, 1BBW, 1BDI, 1BGF (fone), 1BHW, 1BKA (fone), 1BIB (fone), 1BKQ, 1BLE, 1BUA, 1BWJ, 1BYG, 1CAK, 1CBG, 1CDO, 1CHJ, 1CIK, 1CIT, 1CJA, 1CMK, 1CNE, 1CNR, 1CSL, 1FZ, 1GV, 1IV, 1JT, 1OZ, 1PM, 1PR, 1QP, 1RH, 1UJ, 1VQ, 1WP, 1WQ, 1XA (fone), 1XM, 1XX, 1XY, 1YB, 1YK, 2AJF, 2ASV, 2AWF, 2AWS, 2AYO, 2BAL, 2BBX, 2BD, 2BDG, 2BQN, 2BRC, 2BTA, 2BTJ, 2BYC, 2CBG, 2CBK, 2CBT, 2CDA, 2CEN, 2CFT, 2CGE, 2CIM, 2CP, 2EH, 2FP, 2IV, 2LC, 2NZ, 2VC, 2VH, 2XAL, 3AA, 3AD, 3AJD, 3APD, 3BG, 3BGT, 3BHL, 3BL, 3BZ, 3FP, 3FS, 3HN, 3IW, 3SZ, 3TJ, 3UW, 3VH, 3XW (fone), 3ZO, 4BY, 4DC, 4DS, 4SACF, 4SADG, 4SAGO, 4SAP, 4SAQO, 4SAQZ, 4SAWM, 4SAWP, 4SAWT, 4SBCU, 4SBDU, 4SBEO, 4SBIL, 4SBFX, 4SBLX, 4SBO, 4SBRL, 4SBRW, 4SBSO, 4SBJT, 4SBAZ, 4SCAZ, 4SCMM, 4SCGM, 4SCJA, 4SCJH, 4SCJY, 4SCKM, 4SCKZ, 4SCOO, 4SXP, 4SXBW, 4SEA, 4SFT, 4SHJ, 4JU, 4KH, 4SN, 4ST, 4SE, 4SUE, 4SUK, 4SUY, 4SWP, 4XE, 4YD (fone), 4ZW, 4ZZ, 4ARV, 4AUF, 4BSL, 4CBA, 4DYN, 4VQ, 4WA.

1BFA, Arlington, Mass.

Spark: 1ACO, 1AOK, 1DP, 1GM, 1QO, 1LZ, 1SH, 2AHU, 2AWF, 2BRN, 2BRI, 2BGD, 2EL, 2RM, 2TJ, 2PV, 2WB, 3AWF, 3BVC, 3BSH, 3EH, 3FP, 3JW, 3PE, 3PU, 3AVR, 3ABP, 3MU. C.W.: (1CIT), (1BYG), (1CBJ), 1BUA, 1ADL, (1AYD), (1CJD), 1BKQ, (1PR), 1BKA, 1BTL, 1FO, 1HM, 1UJ, 1QP, 1CNE, 2AJF, 2AQ, 2AGC, 2AQH, 2AXK, 2AWF, 2AFP, 2BXP, 2BGJ, 2BEH, 2BQU, 2BRB, 2BAL, 2BRC, 2CDC, 2NZ, 2WR, 2ASP, 2AVY, 2APD, 2AD, 2AQH, 2AJD, 2BA, 2BG, 2CAN, 2FS, 2FS, 2FR, 2CG, 2XA, 2XJ phone, 2AVD, 2ACM, 2AQF, 2BLX, 2BXT, 2BXY, 2BJS, 2BEO, 2CKM, 2CJH, 2NB, 2SE, 2UU, 2KP.

2AWF, Albany, N. Y.

Spark: (1AA), 1AOK, 1AW, 1BOQ, (1BRQ), 1CHQ, 1CK, 1GM, (1RV), 1WQ, 2AD, 2AHU, 2ARB, 2ARY, 2BFX, 2CKO, (2CT), (2DI), (2EL), 2FP, 2OM, (2RM), 2TS, (2WB), 3ABB, 3AWE, 3AWF, 3BFU, (3BJ), 3BVC, 3CS, 3EH, 3FB, 3FP, 3GX, 3PB, 3PU, 3WT, 3ZM, 4EA, 4AFD, 4AHE, 4AHQ, 4ANV, 4APB, (4AXX), (4BAC), 4BDV, 4BKA, 4BRL, 4CQL, 4DY, 4EO, 4EW, 4KY, 4MR, 4MU, 4QE, 4RQ, 4X, 4XE, 4ZO, 4FS, 4MC, 4UU. C.W.: 1ADL, 1AJL, 1AYZ, (1AZW), (1BBW), 1BES, 1BKP, 1BWJ, 1CGO, (1CHJ), 1CJH, (1CNE), 1CNR, 1EO, 1FW, 1GV, (1IX), 1KI, 1QP, (1UL), 1UJ, 1XE, 1XX, 1XZ, 1YK, 1ZE, 2AEQ, (2AFP), 2AJA, 2AQL, 2AYF, 2AYV, 2BCF, 2BDG, 2BEB, 2BEH, 2BGJ, 2BQK, (2BRC), 2BUX, 2BYS, 2CAL, 2CBG, 2CBW, (2CDK), 2CEC, 2CEN, 2CFT, 2CT, 2CWE, 2FP, 2KP, 2NZ, 2RM, 2VH, 2WB, (2WR), 3AD, 3AGN, 3ANJ, 3ANY, 3BA, 3BED, 3BJY, 3BLF, 3BOF, 3BUP, (3BZ), 3CAL, 3CG, 3FR, 3FS, 3HD, (3IW), 3LC, 3QV, 3SJ, 3TJ, 3UE, 3VW, 3WF, 3XA, 3ZO, 4BY, 4GH, 4KC, 4LP, 4XD, 4YJ, (4SAF), 4SHK, 4AIG, (4AIO), (4AMD), 4AMQ, 4ANB, 4AWM, 4AWP, 4AWR, 4AXB, 4AIC, 4BCL, 4BDB, 4BGM, 4BIS, 4BKE, 4BLW, (4BLX), 4BMM, 4BPU, 4BPW, 4BSO, 4BUX, 4BWK, 4SBR, 4SCM, (4CJH), 4CON, (4CQL), 4EA, 4LB, (4FT), 4UC, 4UE, 4UK, 4VQ, 4XE, 4XJ, 4YD, 4ZAE, 4ZZ, 4AFN, 4AIV, 4AJH, 4AXF, 4BHD, 4BVP, 4DGO, 4DZQ, 4EI, (4JR), 4KP, 4UU, Can. 2AF, (3PB), Fone: 1BKA, 2XJ, 2ZK, 3XW.

2BEH, Brooklyn, N. Y., All C.W.

(1ADL), 1AIP, 1AMQ, (1ARY), (1AUN), (1AYZ), (1AZW), (1BBW), (1BDI), (1BES), (1BET), 1BGF, 1BNT, 1BRQ, 1CDO, (1CGO), 1CHJ, 1CIK, 1CNE, (1CNR), 1DF, 1GV, (1IV), (1IX), (1PR), (1QP), 1UJ, 1XA, (1XX), 1XZ, 1YB, (1ZE), 3ADT, (3AD), 3AIS, (3AJD), (3ALN), 3ALO, 3ANJ, 3ANQ, 3AQH, (3ARO), (3BEC), (3BG), 3BHL, (3BIJ), 3BJY, 3BLF, 3BLR, (3BNU), 3BSS, 3BUP, 3CAN, (3CC), 3FS, 3HG, 3IW, 3LC, 3PB, (3QV), 3TJ, 3VS, 3VW, 3WF, 3XA, (3ZO), 4BY, 4DC, 4GX, 4LJ, 4ADG, (4AGO), (4AIO), (4ALB), 4AM, 4AMM, (4AMQ), 4ANB, (4AQZ), 4ASV, 4AVL, (4AWM), 4AWP, 4AXC, 4BAS, 4BCF, (4BCL), (4BDB), (4BDU), 4BIL, 4BJS, 4BLO, (4BNU), (4BO), 4BRT, 4BRW, (4BVR), 4BXT, (4CAY), (4CAZ), 4CFP, (4CGB), (4CJH), 4CKM, 4QC, (4UC), (4UE), 4UK, (4VQ), 4VR, 4VY, (4WR), 4XE, 4AJA, 4ARK, 4AXF, 4BED, 4BIK, (4CT), 4DF, (4DGO), 4DV, 4EL, 4FZ, (4IO), 4LQ, 4UU, 4WA.

2BXY, Elizabeth, N. J.

C.W.: 1ABA, 1RU, 1XM, 1ZN, 1AFV, 1BCG, 1BUA, 1CAK, 1COD, 2AAB, 2AJF, 2AQU, 2AWL, 2AYI, 2BDM, 2BGJ, 2BGM, 2BML, 3AAO, 3ACP, 3ADV, 3ADX, 3AE, 3AFL, 3AFP, 3AGE, 3BBY, 3DQ, 3GL, 4AO, 4CO, 4HZ, 5CF, 5CH, 7LD, 7QF, 8ABO, 8ACL, 8AGO, 8AMP, 8ATD, 8VC, 8WN, 9AAO, 9ADX, 9AWK, 9DRK, 9UY, 9DAQ. Spark: 1AA, 1ADL, 1APX, 3ABB, 3ARM, 3QW, 3XM, 3ZO, 4AS, 4ZF, 5GI, 5HK, 7XM, 8ABY, 8AWP, 8BUN, 8ZAA, 9DZY.

2BUQ, Staten Island, N. Y. C. (One Tube)

C.W.: 1AB, 1AW, (1FW), 1IL, (1IV), (1IX), (1JT), 1OZ, 1PR, (1RD), 1QP, (1UL), (1VQ), 1XX, 1YB, (1ZE), 1ADL, 1AJP fone, (1ACL), (1ARY), (1AWB), (1AYZ), 1BBW, (1BKP), 1BKQ, (1BRQ), 1BWJ, 1BWY, 1BXJ, 1CGO, (1CHJ), 1CJA, 3BG, 3CC, (3CG), 3FP, 3FS, 3HG, (3IW), 3LC, 3NH, 3QV, 3RF, 3TZ, 3VW, 3ZO, 3AJD, 3ANJ, 3AQH, 3BHL, 3BIJ, 3BJY, 3BLF, 4BQ, 4BY, 4GL, 4GU, 4GX, 4KC, 4LP, 4XD, 4ZC, 5FV, 5DA, 8AW, (8BU), (8DV), 8EA, 8HJ, 8LD, 8LW, (8NB), (8PT), 8RQ, (8TO), 8UE, 8UC, 8V, 8XE, 8ACF, 8AIM, 8AWM, 8AWP, 8ANB, 8AQV, 8AQO, 8AUV, 8AVL, 8AVW, 8AWY, 8AXB, 8AZH, (8BCL), 8BDB, 8BQU, (8BRZ), 8EXT, 8CAZ, 8CFP, 8CJH, (8CNN), 8CQE, 8CTZ, 8ZAB, 9KP, 9WK, 9AAS, 9AAV, 9AJH, 9AOG, 9AFA, 9AXF, 9AZE, 9BLC, 9DGO, (9DIO), 9DKY, 9DSO, 9DWN, 9DZQ, Can. 9AL. Spark: (1ACO), 1ARY, 1AOK, 1BOE, 1BKG, (1BOQ), (1BZ), 1BRQ, 1BYX, 1CJA, 2PV, 4BI, 4BQ, 4EA, 4GN, (4EW), 4FT, 4RQ, 3AXN, 3CAZ, 3CQL, 3BK, 3UH, 3UK, 3WY, 3XI, 3ZN, Canadians 3GX, 3GN, 3JL.

3ARN-3HS Washington, D. C.

Spark: 1AKG, 1AOK, (1ARY), 1AZK, 1BDF, 1BDC, 1BDT, (1BOQ), 1BRQ, (1BVB), 1BWY, 1CHJ, 1FS, 1GM, (1SN), 2AAF, 2ACD, 2AER, 2AHU, 2AJF, 2AQI, 2ARB, 2AWF, 2AYQ, 2BEG, 2BFX, 2CT, 2CY, 2EL, (2FP), 2MN, 2OM, 2PF, 2PV, 2SZ, 2TS, 2WB, 3ABB, 3AC, (3AJD), 3BFU, 3FP, (3HJ), (3II), 3JW, 3PU, 3QN, 4BI, (4CX), 4GM, 4ACF, 4AFA, 4AFD, 4AGO, 4AHE, 4AJX, 4ALU, 4ALW, 4ANW, 4APB, 4AQO, (4AUD), (4ASL), 4AUX, (4AUY), (4AXN), 4AYC, 4BAH, 4BAZ, (4BBU), 4BFY, 4BNB, (4BQA), (4BRL), 4BUN, 4CGZ, 4CKE, 4CQL, 4CZL, 4EA, (4EB), 4EO, 4EW, 4FT, 4JJ, 4JU, 4KY, 4MR, 4NO, 4RQ, 4TC, (4TY), 4UC, 4UE, 4VH, 4VQ, 4VW, (4WD), 4YN, 4ZO, 9AAW, 9AES, 9AFK, 9AJW, 9AMT, 9APK, 9BAK, 9BEN, 9CP, 9DHz, 9DIO, 9DKK, 9DMJ, 9DRR, 9DSO, 9DXT, 9DZY, 9FF, (9FK), 9OX, 9PD, 9QR, 9UH, 9ZN, Canadian 3GX. C.W.: 1AJU, 1ARY, 1AYZ, 1BBW, 1BDI, 1BET, 1BGF, 1BKQ, 1BLN, 1BNT, 1BWJ, 1CGF, 1CHJ, 1HX, 1IX, 1ON, 1QP, 1XM, 1YB, 2AFP, 2AIF, 2AJA, 2AWL, 2AXK, 2BCF, 2BEH, 2BFX, 2BZN, 2BRB, 2CCD, 2CFT, 2CMB, 2FP, 2FZ, 2NZ, 2RM, 2WR, 3AEV, 3AJD, 3BEC, 3BG, 3BHL, 3BLU, 3BNU, 3BRC, 3BUP, 3CAN, 3FP, 3FS, 3QV, 3WF, 3XW fone, 3ZO, 3ZZ, 4GL, 4DA, 4HB, 4MA, 4EN, 4EH, 4ES, 4KAD, 4ADG, 4AGO, 4AIB, 4ALB, 4AMM, 4ANB, 4AQF, (4AUY), 4AVL, (4AWP), 4AXB, 4BCL, 4BDB, 4BDU, 4BEI, 4BIL, 4BIS, 4BKH, 4BNU, 4BO, 4BRK, 4BVR, 4CI, 4CJH, 4CK, 4CKM, 4CKO, 4CNN, 4CRC, 4EA, (4EV), 4HJ, 4HM, 4JO, 4MP, 4NO, 4QY, 4SE, 4SP, 4TO, 4UC, 4UK, 4VQ, 4VY, 4YD, 4AAP, 4AIV, 4AOG, 4AXF, 4BCT, 4BDA, 4BDP, 4BTA, 4CBA, 4DGO, 4DIO, 4DZQ, 4FZ, 4PD, 4WQ, Canadians 4CZ, 4JL.

3ZO, Parkesburgh, Pa.—Worked C.W.

1XM, 1XZ, 1BBW, 1BKQ, 1BWJ, 1CMK, 2FP, 2AXK, 2BRC, 3DM, 3EH, 3EM, 3FR, 3FS, 3IL, 3LP, 3QN, 3QV, 3ZN, 3ZS, 3ZZ, 3AAO, 3AAY, 3ABB, 3ACY, 3AD, 3AGC, 3AGX, 3AIS, 3ALJ, 3ALN, 3ANJ, 3ASK, 3AUV, 3AVY, 3AWE, 3BLF, 3BLU, 3DV, 3EV, 3YV, 3YD, 3ZZ, 3ADG, 3BXT, 3CJH, 4UU, 4AXF, Can. 3CZ.

3BAG, Washington, D. C.

C.W. 1AJP, 1ARY, 1AWB, 1AZW, 1BEA, 1BKG, 1BSD, 1BWJ, 1CK, 1CM, 1CT, 1H, 1QP, 1RD, 1UJ, 1XM, 1YK, 2AAB, 2AJU, 2AJR, 2ANZ, 2AW, 2AWL, 2AWB, 2AYV, 2AZO, 2BEA, 2BEB, 2BEH, 2BEO, 2BNC, 2BRC, 2BSC, 2BTJ, 3CL, 3CCD, 2CEC, 2CGQ, 2FZ, 2FP, 2KP, 2KU, 2KV, 2NJ, 2NQ.

2NZ, 2OC, 2OF, 2PZ, 2TT, 2VA, 2VH, 2XJ (fone),
2XQ, 2ZK, 2ZS, 3AAD, 3AFU, 3AJD, 3ANY, 3AQF,
3AQH, 3AQR, 3BA, 3BEC, 3BFU, 3BM, 3BF, 3BZ,
3CC, 3CG, 3CM, 3EM, 3FS, 3FM, 3HJ, 3HX, 3JX,
3FB, 3FZ, 3GV, 3QZ, 3RF, 3ZN, 3ZV, 3ZZ, 4BF, 4BQ,
4BY, 4CY, 4FT, 4FV, 4GF, 4GL, 4GU, 4ID, 4II,
4LP, 4RL, 4ZC, 5DA, 5FV, 5LI, 5PY, 5WO, 5UU,
5ACF, 5ADY, 5ADR, 5AGO, 5AGZ, 5AHV, 5AIM,
5AIO, 5AJV, 5ALV, 5AMD, 5AND, 5AQB, 5AQQ,
5ARK, 5AV, 5AWM, 5AWZ, 5AKK, 5BC, 5BDB,
5BDO, 5BDU, 5BEI, 5BEX, 5BFX, 5BK, 5BLT,
5BO, 5BOX, 5BRL, 5BUN, 5BXA, 5BZJ, 5BZY,
5CFS, 5CK, 5CX, 5CLD, 5CV, 5EV, 5LW,
5OC, 5OS, 5OW, 5PO, 5QZ, 5RH, 5SF, 5UK, 5VV,
5VY, 5WY, 5XE, 5XV, 5ZB, 5ZE, 5AAS, 5AAV,
5AJA, 5AIV, 5AKD, 5AKG, 5AL, 5ALV, 5AMU,
5ARK, 5AYH, 5BRL, 5BSG, 5IR, 5IO, 5KP, 5LZ,
5LQ, 5PS.

4KC, Asheville, N. C. (All C.W.)

1AAW, 1ADL, 1AJE, 1APX, 1AZ), 1ARY,
1AU, 1DZ, 1FR, 1GM, 1LZ, 2AB, 2FC, 2RY, 2AJF,
2AMX, 2BSC, 2NZ, 3BA, (3RF), 3BZ, 3DM, 3FM,
3FS, 3BL, 3RW, 3TJ, (3BLF), 3CA, 3YBD,
(3BHL), 3IW, 4AS, (4BY), 4CX, 4DZ, 4DC, (4EU),
4FD, (4DQ), (4CH), (4GU & spk.), (4GL), 4GP,
(4MI), (4MO), (5KU), 5KA, 5AAM, (5DA), 5EK,
5FV, 5UU, 5ZZ, 6XAD, 6BO, 7KG, 7MP, 7ZV,
(5ANB), (8UQ), 8CAB, 8UT, 8ACF, 8AGS, 8BUG,
8BFX, (8TO), 8KH, (8BIS), (8CAY), (8ACO),
8EA, 8DU, (8ZC), 8KK, 8ASB, 9IX, 9AXF, 9UC,
9AIX, 9BW, 9ACB, 9AEY, 9BOG, 9BSG, 9DQ, 9DQ,

Worked by 5KC, Plaquemine, La.

Sparks: 4CX, 4DH, 5EK, 5HB, 5IR, 5JD, 5LA,
5LB, 5NN, 5NS, 5PK, 5QA, 5QS, 5QT, 5R, 5SM,
5TG, 5UE, 5AAT, 5ABA, 5ABY, 5XA, 5XB, 5XI,
5XJ, 5XU, 5YG, 5YL, 5ZL, 5ZS, 5ZW, 5ZX, 5ZZ,
5ZAA, 5ZAB, 5ZAC, 5ZAE, 5ZAF, 5ZAK, 5ZU,
5RY, 5WI, 5WT, 5ZY, 5ACE, 5ANQ, 5APN, 5AKU,
5BSA, 5DEH, 5DHY, 5DQ, 5DSD, 5YAE.
C.W.: 5JB, 5NX, 5DZ.

5AOW, Riverside, Cal.

Spark: 5XD, 6BB, 6BK, 6BV, 6CC, 6DP, 6EA,
6EX, 6FH, 6FO, 6FP, 6GL, 6GR, 6GX, 6HC, 6HP,
6HY, 6GT, 6IB, 6IC, 6IM, 6IU, 6IV, 6JW, 6JY,
6KC, 6KM, 6LC, 6ME, 6NG, 6OD, 6OL, 6OP, 6PC,
6PJ, 6PO, 6PW, 6QK, 6QR, 6RE, 6ST, 6TF, 6TU,
6UO, 6UP, 6VK, 6VM, 6WG, 6WP, 6WR, 6XH,
6XV, 6ZD, 6ZL, 6ZQ, 6ZR, 6ZU, 6ZX, 6AAH,
6AAK, 6AAS, 6AAU, 6ABM, 6ABR, 6ABU, 6ABW,
6ABX, 6ACR, 6ADA, 6ADW, 6AEI, 6AFJ, 6AFP,
6AGF, 6AGP, 6AHF, 6AHP, 6AHQ, 6AHV, 6AHZ,
6AIF, 6AIN, 6AIT, 6AIU, 6AJH, 6AJR, 6AJW,
6AKL, 6AKT, 6ALA, 6ALD, 6ALV, 6AMK, 6AMW,
6AMZ, 6ANE, 6ANI, 6AOE, 6AOL, 6AQQ, 6AQS,
6AQU, 6AQX, 6AQY, 6ARD, 6ARK, 6ASB, 6ASK,
6ATF, 6AUD, 6AVB, 6AVD, 6AVM, 6AVR, 6AWI,
6AWX, 6AWY, 6ZAE, 6ZAM, 6BAJ, 6BAK, 6BBC,
6BBK, 6BBO, 6BBV, 6BBD, 6BCS, 6BDW, 6BEA,
6BEM, 6BEO, 6BEP, 6BFE, 6BFH, 6BGH, 6BGL,
6BIK, 6BIN, 6BIP, 6BIU, 6BJD, 6BJV, 6BJX,
6BKB, 6BKS, 6BMP, 6BNN, 6BOL, 6BVK, 7CK,
7LN, 7LY, 7MF, 7GV, 7GJ, 7BR, 7FJ, 7FI, 7JI,
7JD, 7NF, 7OT, 7TO, 7TU, 7WG, 7YA, 7ZK, 7ZU,
7ZP, 7ZJ, 7ZM, Canadian 9BD, CL-8.

C.W.: 5ZA, 6AK, 6CU, 6DF, 6EA, 6EB, 6EC,
6EN, 6FT, 6GD, 6GL, 6GY, 6HJ, 6JD, 6KC, 6KU,
6KY, 6KA, 6NX, 6RR, 6TI, 6VM, 6ZA, 6ZB, 6ZE,
6ZF, 6ZG, 6PI, 6ZL, 6ZN, 6ZS, 6ZX, 6ZQ, 6AAG,
6AAT, 6AAV, 6AGH, 6AGP, 6AIB, 6AIF, 6ALU,
6ALV, 6AOZ, 6AGU, 6APO, 6ARO, 6ASJ, 6ASV,
6AVD, 6AWP, 6AWT, 6AWV, 6AWX, 6XAD, 6XAF,
6XAG, 6ZAA, 6ZAK, 6BBC, 6BCB, 6BCD, 6BEG,
6BEQ, 6BFE, 6BGE, 6BGG, 6BGG, 6BJC, 6BJR,
6BJQ, 6BLA, 6BLV, 6BNJ, 6BQE, 6BZA, 7HT,
7QT, 7XG, 7ZU, 8VY, 8AGZ, 8BUM, 9PI, 9PS,
9WD, 9WU, 9AMB, 9AYU, 9XAG, 9ZAF, 9BAZ,
9DTM, 9DVA, 9BJI, 9DVJ, DD-5, CL-8, Canadian
4CB, 9BD.

Fone: 6AK, 6DF, 6GD, 6KY, 6ZN, 6AAG, 6AAT,
6AIB, 6APO, 6BGG, 6BJR, DD-5, 7V-8.

Can. 5DK, at Pasadena, Cal.

Spark: 6AJ, 6AM, 6AT, 6BH, 6BJ, 6BK, 6BR,
6BV, 6DA, 6DD, 6DZ, 6EA, 6EK, 6ES, 6FF, 6FT,
6IS, 6LC, 6LK, 6OG, 6RR, 6SK, 6UT, 6WC, 6WL,
6AAU, 6ACY, 6AIT, 6ALO, 6ALU, 6AMY, 6APC,
6AQU, 6AQV, 6AQX, 6BAR, 6BBD, 6BEB, 6BEO,
6BET, 6XAD fone, 6ZK, 6ZZ, 6ZF. All of above
heard on crystal. Following with one tube.

Spark: 6IF, 6XF, 6ZA, 6ZF, 6AH, 6GT, 6KM,
6OH, 6BV, 6HK, 6PO, 6PR, 6TU, 6APE, 6APP,
6AUI, 6BUM, 6BAJ, 7CK, 7KH, 7KJ, 7YG, 7YS,
7ZT, 9DVA, 9DZI.

C.W.: 5LA, 5ZA, 5ZX, 6CU, 6EB, 6EN, 6IR,
6KA, 6KY, 6OX, 6SK, 6OP, 6UM, 6WA, 6ALE,
6AWT, 6ANZ, 6ARF, 6ATB, 7DP, 7NX, 7ZU,
8VV, 9DVI.

6AJR, Reno, Nevada

Spark: (6AS), 6BD, (6BV), (6CZ), (6CC), 6DD,
6DS, 6DP, (6EA), 6EC, (6EX), 6FN, 6FH, 6GX,
(6GR), (6GF), (6GP), (6GT), (6HC), 6HP, (6IB),
(6IC), (6IV), 6KC, (6KE), (6LC), 6LU, (6LO),
6NG, 6OD, (6OL), (6PJ), (6TU), 6UP, (6UQ),
(6VK), (6VX), 6WP, 6ZE, 6ZU, 6ZQ, 6AAB,
(6AAK), (6AAU), 6ABO, (6ABU), (6ABV),
(6ACR), 6ACY, 6ADA, (6AEH), (6AHV), 6AHQ,
6AIN, 6AIU, 6AIX, (6AJH), (6AIA), (6ALD),
(6ALV), (6ALW), (6AMK), 6AMW, 6ANI, 6AOL,
6AOR, 6AQY, (6AQU), 6AV, (6AQX), 6ARK,
6ARM, 6AEV, 6ATF, 6ATU, 6AUD, 6AUP, 6AUI,
6AVB, 6AVR, 6AVX, 6AWX, 6BAJ, (6BAK), 6BDQ,
6BDW, (6BEM), 6BFR, (6BGL), (6BMP), 6BNN,
6BQN, (7BB), (7BK), (7BH), 7EO, 7FR, (7GP),
7JD, 7KJ, 7MF, (7NN), 7NW, 7NZ, (7OT), 7QO,
7RC, 7TO, 7VE, 7VZ, 7WG, 7YA, 9AQE, 9DSD,
Can. (9BD).

C. W.: 6AK, 6BK, (6CU), 6DF, (6EA), (6EF),
6EN, (6FT), 6GD, (6JD), (6KA), 6KL, 6KU, 6NX,
6OO, (6RR), 6TI, 6UO, 6XAD, 6ZB, (6ZF), (6ZI),
(6ZO), (6ZK), 6AIY, 6ALU, 6AOT, 6ASJ, 6ATG,
(6AWT), (6BE), 6BJQ, (6BK), 7DP, 7QW, 7WD,
7WU, 7PI, 9AMB, 9AYU, 9BJI.

6ALD, Pasadena, Calif.

Spark: (6AAK), 6AAU, (6ABU), (6ABW),
6ADA, (6AEH), 6AHF, 6AHU, (6AIN), 6AIO,
(6AJE), (6AJR), (6ALA), 6AMK, 6AOL, (6AOR),
6APE, 6APO, (6AQU), 6AQY, (6ARK), (6AS),
(6AUD), (6AVM), (6AVX), (6BGL), (6CC), 6CZ,
6DP, (6EX), 6FH, (6GF), (6GR), (6GT), (6HP),
6IB, (6IC), (6IV), (6KC), 6LU, 6NG, 6PJ, 6TC,
(6TU), 6VK, (6VX), (6XH), 6ZG, 6ZQ, (6ZU),
7BK, (7MF).
C.W.: 6NX, 6QY, 6TW, 6ZAA, 6ZB, 6ZX.

7WG, Nezperce, Idaho

Spark: 6AF, 6BD, (6CC), 6DP, 6GR, 6IL, 6IN,
6JR, 6KQ, 6LC, 6TU, 6ZQ, 7BH, 7DH, (7FI),
7GE, (7JF), 7MF, 7NZ, (7NL), (7OT), 7VO,
7ZV, 9BD, 9WZ, 9AUU, 9AVZ.
C.W.: 6AK, 6DX, 6EN, 6KA, 6NX, 6PI, 6SG,
(6ACR), 6AKK, 7ZU, 7WQ, 9AMB, 9DKY, 9DTM.
Phone: 7FL, 7ZU.

7SN, Seaside, Oregon

Spark: 6CC, 6EX, 6EB, 6FH, 6GR, 6IC, 6IM,
6KM, 6KV, 6LK, 6LC, 6PO, 6TV, 6VK, 6XH,
6ZQ, 6AUW, 6ALA, 6ARK, 6AJR, 6AVM, 6AAU,
6AZU, 6AKT, 6AGF, 6ALW, 6AMK, 6APE, 7CV,
7ED, 7GE, 7HQ, 7JD, 7KE, 7LY, 7MU, 7MF,
7NN, 7NW, 7NZ, 7OT, 7TO, 7VN, 7VO, 7WG,
7YA, 7YS, 7YM, 7ZK, 7ZM, 7ZL, 7ZU, 7ZV,
C.W.: 6ZA, 6CU, 6EN, 6FT, 6GY, 6KU, 6OO,
6SU, 6SG, 6TI, 6VM, 6ZF, 6ZL, 6ZN, 6ZX, 6AAT,
6AGU, 6AWV, 6AIY, 6AWT, 6BKB, 6BCD, 6XAD,
6ZAC, 7DP, 7FI, 7MF, 7NF, 7RN, 7ZU, Can. 5CT,
Can. 4CB.

8AUU, Canton, Ohio

Spark: 1AW, 1AOK, 1FT, 1PR, 1YB, 2ARB,
2BFX, 2BEC, 2CA, 2FP, 2GP, 2OM, 2PO, 2RP,
2WB, 2ACK, 2AW, 2BFU, 3FD, 3HJ, 3VS, 4CX,
4GU, 4GX, 4HS, 5ZA, 7FU, 8AFD, 8APB, 8ARB,
8AYC, 8AMQ, 8AL, 8AU, 8BWH, 8BEG, 8BDV,
8BKE, 8BBU, 8CDM, 8CDH, 8CKV, 8CEB, 8CQL,
8QAM, 8COM, 8DY, 8EA, 8EB, 8EO, 8EW, 8EX,
8FG, 8FI, 8FS, 8FT, 8JP, 8JU, 8LF, 8KY, 8NO,
8OZ, 8RC, 8RG, 8TC, 8TO, 8TP, 8UC, 8VC, 8VI,
8VW, 8XAK, 8XAE, 8YN, 8ZA, 8ZO, 8ZX, 8ZY,
8ZZ, 9AKT, 9AMT, 9APM, 9AAY, 9AAM, 9ALH,

9AAW, 9AQA, 9AMF, 9ALP, 9APS, 9BAK, 9BDK, 9CPD, 9CA, 9CP, 9DML, 9DSO, 9DFX, 9DMJ, 9DQ, 9DEV, 9DYX, 9DI, 9DZ, 9EH, 9JX, 9LF, 9MC, 9PD, 9TX, 9UH, 9US, 9XE, 9YB, 9ZN.

C.W.: 1AV, 1AZW, 1ASF, 1ARY, 1AUN, 1ADL, 1AZK, 1AIP, 1BMJ, 1BKQ, 1BWJ, 1BQY, 1BKG, 1BKA, 1BDC, 1BTW, 1BZX, 1BJA, 1BRQ, 1BGF, 1BDI, 1CMK, 1CHA, 1CIK, 1CNR, 1CMM, 1CAS, 1CAK, 1EE, 1FW, 1IX, 1QP, 1QC, 1WC, 1XX, 1XY, 1XZ, 1ZE, 1ZN, 2ANM, 2AYV, 2AIF, 2AFP, 2AXK, 2AJA, 2AWF, 2BCF, 2BDX, 2BQH, 2BNZ, 2BEH, 2BLI, 2BCF, 2BRD, 2BRC, 2BFM, 2BDM, 2BJY, 2BEA, 2BEF, 2BQU, 2BFX, 2BUA, 2BUM, 2BNG, 2BFG, 2BDG, 2BAG, 2BLP, 2BFK, 2BHJ, 2BUC, 2BLR, 2BUX, 2BE, 2CBG, 2CEN, 2CCD, 2CWE, 2CFE, 2CCK, 2COC, 2CPT, 2FH, 2FP, 2GF, 2LP, 2NZ, 2PJ, 2RC, 2TJ, 2UD, 2VC, 2WR, 2XY, 3AAY, 3ASV, 3ADK, 3ALN, 3ANY, 3AIS, 3AY, 3AW, 3BJ, 3BLF, 3BQH, 3BHL, 3BNU, 3BLR, 3BFG, 3BFF, 3BAV, 3BZ, 3CLF, 3CZP, 3CBM, 3ZG, 3CZ, 3FA, 3FP, 3FQ, 3FS, 3GC, 3GP, 3HD, 3HG, 3HW, 3IM, 3IW, 3LR, 3PB, 3QV, 3RF, 3SF, 3SJ, 3TJ, 3VV, 3WF, 3ZZ, 4AL, 4BQ, 4CF, 4CQ, 4DC, 4DF, 4DH, 4DS, 4EB, 4EN, 4FS, 4GE, 4GH, 4GL, 4ID, 4IV, 4KA, 4KC, 4LP, 4ZC, 4ZH, 5AAM, 5AJ, 5DA, 5DR, 5EW, 5FE, 5JB, 5KU, 5LA, 5LJ, 5MA, 5VL, 6GL, 6HD, 6ZAC, 6ZZ, 7CG, 7GP, 7IV, 7LY, 7OP, 7WO, 8AVA, 8ADG, 8ACF, 8AUX, 8AQZ, 8AXC, 8AWP, 8ARI, 8AUY, 8AVD, 8AWR, 8AIO, 8ARG, 8AXB, 8ANB, 8AGO, 8AMD, 8AFD, 8ASH, 8AQF, 8AMF, 8AAM, 8AFL, 8ALB, 8APW, 8ALF, 8AGQ, 8AWM, 8AYW, 8AST, 8ASM, 8AGK, 8ARO, 8AQF, 8AWW, 8AZH, 8AFK, 8AQR, 8AVW, 8BQF, 8BXF, 8BLF, 8BQU, 8BRL, 8BDU, 8BXT, 8BYC, 8BGG, 8BDU, 8BDB, 8BTP, 8BOX, 8BXH, 8BMF, 8BUN, 8BEI, 8BIN, 8BNE, 8BIT, 8BUX, 8BXH, 8BNZ, 8BLW, 8BNT, 8BKF, 8BLX, 8BCF, 8BJU, 8BGF, 8BIL, 8BU, 8BO, 8CGM, 8CAY, 8CTP, 8CKO, 8CGZ, 8CBC, 8CJH, 8CPL, 8CWH, 8CFG, 8CGM, 8CON, 8CQL, 8CFO, 8CIA, 8CMI, 8CF, 8CFP, 8CGX, 8CCM, 8CKD, 8CFC, 8CKM, 8CUH, 8DH, 8DV, 8DZ, 8EA, 8EO, 8FK, 8GV, 8HJ, 8HM, 8HW, 8JM, 8JU, 8KH, 8LB, 8LF, 8PI, 8PT, 8QC, 8QZ, 8SE, 8TO, 8SP, 8TJ, 8UC, 8UE, 8UK, 8UU, 8VR, 8VY, 8VZ, 8VQ, 8WN, 8WR, 8XE, 8XG, 8YD, 8YM, 8ZC, 8ZG, 8ZI, 8ZW, 8ZAE, 8AU, 8AXF, 8AAF, 8APM, 8ARK, 8AJA, 8AMF, 8AIV, 8AJH, 8AAV, 8AIV, 8AFH, 8AIX, 8AXN, 8APS, 8AGJ, 8AQA, 8AOY, 8AFT, 8ATW, 8AOG, 8AKD, 8AKM, 8AJE, 8AWK, 8AKD, 8AYU, 8AL, 8BLW, 8BHD, 8BUD, 8BDB, 8BGE, 8BLO, 8BFD, 8BED, 8CBA, 8CHA, 8DZQ, 8DFN, 8DGG, 8DIO, 8DCR, 8DFB, 8DKQ, 8DAX, 8DUG, 8DKY, 8DIX, 8DYN, 8DV, 8EI, 8EO, 8FE, 8FZ, 8GL, 8II, 8IO, 8JG, 8KP, 8LQ, 8PI, 8PF, 8QF, 8JF, 8SF, 8UU, 8UV, 8WA, 8XI, 8YAM, 8XAJ.

SBIL, Warren, Pa.

C.W.: 1AGI, 1AIP, (1ARY), 1AWB, 1BAS, (1BBW), (1BDI), 1BKQ, 1BQE, 1BUA, 1BWJ, (1CHJ), 1CJH, (1CNR), 1IV, 1IX, 1JT, (1PR), 1QP, (1VQ), 1XM, 1XX, 2AFP, 2AJF, 2AWF, 2AWL, (2AXK), 2AYV, 2BBX, 2BEA, 2BGJ, (2BLP), 2BNZ, (2BQH), 2BQU, 2BRB, 2BTJ, 2CEN, 2CMB, 2CT, (2CWE), 2FP, (2KL), 2NZ, 2RY, 2WR, (3AAO), (3AAY), 3ADK, (3AIS), 3AJD, 3ALL, 3ALN, 3ANJ, (3ARD), (3AVY), 3BA, 3BAG, (3BEC), (3BG), 3BHL, 3BIJ, (3BLF), 3BLU, 3BRI, 3BUR, 3BUV, 3CA, 3CG, 3FP, 3FQ, 3FS, (3IW), (3LR), 3PB, 3RV, (3WF), (3ZO), 3ZZ, 4GL, 4GX, 4ID, 4KC, 4LP, 5DA, 5EK, 5KU, 5LJ, (8ADG), 8AGO, 8AGR, 8AIO, 8ALB, (8AM), 8AMM, 8AMQ, 8AQF, 8AQO, 8AQZ, 8ASM, 8AVD, (8AVL), 8AWM, (8AWP), (8AXB), 8BCF, 8BDE, 8BDO, 8BDU, (8BEI), (8BEO), 8BEX, 8BFX, 8BKE, 8BO, 8BOX, 8BRW, 8BVR, 8BXH, 8BXT, 8CAY, 8CFG, 8CFS, 8CJH, 8CKM, (8CKO), 8CMM, 8DV, 8HM, 8KH, 8NB, 8OC, 8PT, 8QB, (8QC), (8SE), 8TO, 8UC, 8VQ, 8VY, 8WA, 8XE, 8AAP, 8AIV, 8AJH, 8ARK, 8BED, 8BQW, 8BUD, 8BVP, 8CBA, 8CCS, 8DBD, 8DCR, 8DGG, 8DIO, 8DKH, 8DWJ, 8DZQ, 8EI, 8FZ, 8IO, 8JR, (8LQ), 8UU, 8WA, 8XI.

SAUX, Cleveland, Ohio

1AJ, 1AW, 1RH, 1XZ, 1ADC, 1ADL, (1ARB), 1ARY, (1BOQ), 1BUA, 2BM, 2EL, (2FP), (2OM), 2RM, 2WB, 2ACD, 2AHU, 2AHW, 2AJE, (2ARB), 2BEH, 2CDZ, 3AC, 3BA, 3BP, 3CC, 3EZ, 3FP,

3GX, (3UC), 3ZO, 3ZY, 3ABB, 3AJD, 3ALN, 3AOV, 3AYV, (3BIJ), 3BSH, (3BFU), 3BLF, (4CX), 4EA, (4FD), 4GL, 4GN, 5DA, (5HK), 5PY, 5XA, 8BO, 8DY, (8EB), (8EO), (8EW), (8FT), 8FV, 8KY, (8LB), (8LF), (8MZ), (8NO), 8OC, (8RT), (8SP), 8TY, 8UE, 8UO), (8VQ), 8VY, (8UC), (8WD), (8YN), 8ZE, (8ZO), (8AFB), (8AFD), 8AFE, (8AHQ), (8AJW), 8AGO, (8AJX), (8AKQ), (8AMZ), (8ANO), 8AOI, 8AQO, (8ARS), 8ASL, 8AWU, 8AIC, 8AYM, 8AZF, 8BCF, (8BBU), (8CGZ), 8CEB, (8CP), 8FP, (8KI), 8KX, (8LF), 8MC, 8OX, (8PD), 8RC, 8SN, (8UH), (8UU), (8VL), (8YB), (8YJ), 8ZC, 8ZN, 9AAU, (9AAW), 9ACB, 9AFK, (9AGR), 9AIU, 9AIR, 9ARK, 9AVV, 9AWZ, (9AZE), (9AZF), 9BHD, 9BIQ, (9DCX), 9DEN, (9DFX), (9DLX), (9DKK), (9DRR), (9DZY).

SAGO, Pittsburgh, Pa.—All C.W.

(1IX), 1PR, (1AJU), 1AZW, 1BBW, 1BDI, 1BGF, 1CHJ, (1CJH), 1CKA voice, 1CNR, (2BG), 2NZ, 2VW, (2WR), 2XQ, 2ZK voice, (2AFP), 2AJA, (2AYV C.W. & I.C.W.), 2AZY, (2BDG), (2BEA), (2BEH), 2BFX, 2BGX, 2BLP, 2BQH, (2BRC), (2BTJ), (2CCD), 2CES, 2CFE, (2CWE), (3BA), (3FS), (3FP), 3HG, (3IW), 3LR, (3PB), (3QV), (3TJ), 3VW, (3WF), 3ZO, 3ZZ, 3ADX, 3ALN, 3ANJ, (3ANY), (3AQH), 3ATF, (3AVY), 3BHL, (3BLJ), (3BLF), 3BUP, 3CAQ, 4DC, 4EN, (4GH), 4GL, (4IY), 4KC, 4LP, 5BH, 5HB, 5KU, 5LJ, 5RL, (5WO), 5WR, 5ABM, 5AAM, 8AM, (8BO C.W. & I.C.W.), 8BP, (8EA), (8HM), 8HJ, (8KH), 8LB, 8MP, (8QB), (8SE), (8UC), 8UE (I.C.W.), 8UK, 8VG, (8VY), 8XE, 8XG, 8ZG, 8ZZ, (8ALB), 8ALT, (8AMA), 8AMQ, 8ANB, (8AQC), (8AQF), 8AQZ, 8ARW, 8ASM, 8ASO, 8AVD, (8AVT), (8AVW), 8AWM, (8AXB), (8AXC), 8BCF, (8BDB), 8BGG, 8BIS, (8BJC), 8BLX, (8BMM), (8BPI), (8BRZ), 8BUX, 8BWK, (8BXH), (8CAY), 8CAZ, (8CJH), 8DV, (8EI), 8II, 8IL, 8JR, 8KP, 8MC, (8UC), 8UU, 8WA, 8XI, 8YI, (8AAF), (8AAV), (8AIV), 8AJH, 8BA, (8AKD), 8AOG, 8APG, (8ARK), (8AXF), 8BBA, 8BBF, 8BDE, 8BED, (8BHD), 8BHQ, 8BRL, 8BVP, (8CBA), (8DAX), (8DGG), (8DKY), 8DXK, 8DZQ, (Can.) 8BV, (8CZ).

SASL, Fredonia, N. Y.

Spark: 1BOQ, (1LZ), 2AAF, 2AHU, 2ARB, 2BFX, (2BSC), 2EL, 2FP, 2WB, 3ABB, 3ACY, (3AJD), (3ARN), 3BJ, 3CI, 3FP, 3PU, 4EA, 8ACF, (8AHQ), (8AIJ), 8AJ, 8ARD, (8AUG), (8AUY), (8AXQ), (8AYM), 8BAZ, (8BBU), 8BDA, 8BFY, (8BK), (8BM), 8BPG, (8BQA), 8BSB, 8BSF, 8BXC, (8BWC), (8CAS), 8CDV, 8CEB, 8CEJ, (8EA), 8EO, 8EW, 8JU, 8KY, (8MU), 8TC, (8VH), 8VI, 8VQ, (8ZO), 9AAW, 9AES, 9AFK, 9AGR, 9AMT, 9APS, (9AZE), 9BSC, (9DKK), 9DZY, 9FK, (9PD), 9UH, 9XI, (9ZN), Can. (8GX).

C.W.: 1ADL, 1ARY, 1BBW, 1BDI, 1BKA, 1BKQ, 1BUA, 1CAK, 1CNE, 1CNR, 1HQ, 1PR, 1XZ, 2ADZ, 2AFP, 2APA, 2AWF, 2AYV, 2BDG, 2BEH, 2BG, 2BGJ, 2BQH, 2BQU, 2CEN, 2CPT, (2FP), 2VC, 2AAO, 3ANY, 3AQH, 3AWH, 3AXE, 3BEC, 3BLF, 3IL, 3IW, 3QV, 3VW, 3WF, 3XW, 4BQ, 4DC, 4GX, 5DA, 6KA, 8ABO, 8ADU, 8AGO, 8AGR, (8AII), 8AIO, 8AJY, 8ANB, 8ANJ, 8APT, 8AQF, 8AQZ, 8AUH, 8AUY, 8AVL, (8AWM), 8AWP, 8AXB, 8AXC, 8AYB, 8BCL, 8BDU, 8BEF, 8BEI, 8BJU, 8BLX, 8BRC, 8BRM, 8BUX, 8BXT, 8BZF, 8CAJ, 8CAY, (8CBJ), 8CGM, 8CKM, 8CKO, 8CLJ, 8CNU, (8CON), 8HJ, 8KH, 8KU, (8ND), 8QB, 8QZ, 8UE, 8VQ, 8BED, 8BLC, 8BTA, 8LQ, 8XI, Can. (8JI), 8QV.

9CCW, St. Louis, Mo.

C.W.: 1RU, 1AFV, 1ARY, 1CAK, 1XM, 2EL, 2FD, 2FT, 2UF, 2KP, 2WF, 2XB, 3FB, 4BK, 4BQ, 4CO, 5HK, 5UU, 5XB, 6ZZ, 8CL, 8DX, 8HM, 8IL, 8LF, 8LU, 8VQ, 8QQ, 8XK, 8ZG, 9EL, 9IO, 9KP, 9LW, 9VA, 9YU, 9AAP, 9AAS, 9AAU, 9ACB, 9AJA, 9AKR, 9AMB, 9DDY, 9BEO, 9BIZ, 9DYE, 9DZW, 9XAC, 9YAM, Can. 8BP.

Spark: 1AW, 1SN, 1AKG, 1AWZ, 1BSI, 2WL, 3EL, 3IW, 3UC, 4BQ, 4DH, 4JB, 5AA, 5HY, 5AI, 5ER, 5FO, 5MP, 5QA, 5TD, 5UU, 5XU, 5BP, 5DW, 5ER, 5FI, 5FT, 5GO, 5HM, 5JJ, 5ZL, 5ZS, 9AF, 9AU, 9BF, 9CA, 9EE, 9ET, 9FS, 9HM, 9JN, 9JM, (9KO), 9LW, 9ME, 9MS, 9PN, 9RC, 9YD, 9YO, 9ZN, 9AAP, 9ACB, 9AEG, 9AFF, 9AGR,

9AHE, 9AIG, 9AJZ, 9AMA, 9AMT, 9AOU, 9BDF, 9BIC, 9BCX, 9BSA, 9BSO, 9BYF, 9CEE, 9DMW, 9DQR, 9DYY, 9DZY.

9AHC, Ellendale, N. Dak., (Single Tube)

C.W.: 2FP, 4GL, 4LP, 5AAC, 5AAM, 5DO, 5EK, 5KU, 5LJ, 5TJ, 5YG, 5ZAT, 6KA, 6XAD, 7HS, 7ZO, 8ABO, 8AGO, 8AIO, 8ALB, 8AMM, 8AQF, 8ARW, 8ASB, 8AUY, 8AWP, 8AXB, 8AXC, 8BCF, 8BDO, 8BKE, 8CAZ, 8CFC, 8CKM, 8EA, 8EB, 8KH, 8LB, 8MP, 8OZ, 8PT, 8SE, 8TO, 8UC, 8UK, 8VY, 8WA, 8XAK, 8YD, 9AFD, 9AFN, 9AFU, 9AGN, 9AIF, 9AIY, 9AJA, 9AJH, 9AMB, 9AMI, 9AOG, 9APW, 9ARK, 9ARZ, 9ASF, 9ATN, 9AUA, 9AYU, 9BAF, 9BAV, 9BBF, 9BDP, 9BED, 9BGH, 9BHD, 9BHQ, 9BIK, 9BJL, 9BOW, 9BQW, 9BRL, 9BTA, 9BUN, 9BXA, 9CAO, 9CBA, 9CBB, 9CCS, 9DCG, 9DCU, 9DIO, 9DKY, 9DOL, 9DR, 9DSM, 9DTM, 9DUG, 9DUN, 9DYN, 9DZQ, 9EJ, 9FF, 9FZ, 9GL, 9IO, 9KP, 9QF, 9UN, 9UU, 9VE, 9WA, 9WD, 9WQ, 9XAK, 9XI, 9YAJ, 9YF, 9ZL.

Fones: 9ASF, 9PI, 9YAE.
Spark: 5MF, 5QS, 8EB, 8YN, 9AEG, 9AEY, 9AFK, 9AIG, 9AKX, 9ANP, 9ARG, 9AUA, 9AUL, 9AUI, 9AVX, 9AVZ, 9BDF, 9BKP, 9BOF, 9BRI, 9BKK, 9DMJ, 9DZY, 9FX, 9LF, 9OX, 9TL, 9TV, 9XI, 9XT, 9YAK.

9BHD, Warren, Illinois

C.W.: 1ARY, 1AXK, (1BBW), 1BKQ, 1CNE, 2AFP, 2AYV, 2BEH, 2BFX, 2CCD, 2FP, 2NZ, 3ALN, 3BLF, 3BSL, (3FS), 3HG, (3IW), 4BQ, 4DF, 4GX, 4LP, 4ZB, (5AAC), (5DO), (5EK), (5KU), (5LJ), (8AGO), (8AIG), 8AIO, (8ALB), (8ANB), (8AXB), 8AZS, (8BKE), (8BRL), (8CAY), (8CAZ), 8CIB, (8CJH), (8CUA), 8EA, 8HM, (8KS), (8UK), (8VY), (9AA), (9AFB), (9AFN), (9AIF), (9AIY), 9AJA, (9AJH), (9AOG), (9APW), (9ARK), (9ARZ), 9AUA, (9AXF), (9BAF), (9BBE), (9BEM), (9BGH), (9BIQ), (9BQW), (9BRL), (9BSG), (9BTA), (9CCS), (9CHA), (9DCR), (9DKP), (9DXY), (9DZW), (9DZQ), (9EI), 9PS, 9PN, (9UU), 9XI, Can. 8CZ.

Spark: 5NS, 8BEP, 9AKU, (9AZA), (9BUO), (9CDB), (9DRS), (9DVX), (9DXT), (9DZU), (9DZY), (9FK), (9GC), (9UG).

9APW, St. Paul, Minn.

C.W.: 2FP, 2BEH, 2BQU, 3AGC, 3ALN, 3CZ, 4BQ, 4GX, 5EK, 5KU, 5LJ, 5YG, 6EN, 6KA, 7ZU, 8BO, 8CJ, 8EA, 8JU, 8OZ, 8QC, 8UC, 8UK, 8VE, 8VQ, 8YD, 8AIO, 8ADG, 8AGO, 8ALB, 8AQZ, 8ANB, 8AWM, 8AXB, 8BEF, 8BEI, 8BFX, 8BVR, 8BRW, 8CAY, 8CBB, 8CFC, 8ZAG, 9DV, 9EI, (9FZ), 9KP, 9IO, (9QF), (9PS), 9UU, 9VE, 9WU, 9YF, 9ZB, 9AFD, 9AFN, 9AFU, (9AIY), 9AJA, 9AJH, 9AMI, (9AMT), (9AOG), 9AOR, 9APE, 9ARI, 9ARK, (9ARZ), 9ATA, 9ASF, 9ATN, 9AXF, 9AYU, (9BAF), (9BBF), (9BCT), 9BDP, (9BED), 9BGH, (9BHD), 9BHQ, 9BIQ, 9BJI, (9BJZ), 9BLC, 9BLO, 9BOW, 9BQW, 9BSG, 9BTA, 9BVP, 9CBA, 9CBV, 9DAX, (9DBL), 9DCU, 9DKY, (9DIO), 9DQL, 9DUG, 9DVJ, (9DXY), (9DZQ), 9DZJ, (9YAJ).

Spark: 5ABY, 7ZY, 8EA, 8EB, 8UC, 9HG, (9IG), 9MC, 9UU, 9XT, 9ZC, 9ZN, 9AAW, 9ABV, 9AEY, 9IG, 9AIF, 9LF, 9AKU, (9AVZ), 9BKP, (9BOF), 9DKK, 9DMJ, 9DUG, 9DZY, 9DSD, 9DXT, 9DGG, 9YAK.

9AOG, Lawrence, Kansas

C.W.: 2FP, 4EB, 4ZB, 5EK, (5HB), 5IC, 5KU, (5LJ), (5NK), (5OI), (5PB), 5SF, (5ZAT), 6BES, 6EN, 6KA, 3AGO, (A8LB), 8ANB, 8ASW, 8AUY, 8AWM, 8AXB, 8BDO, 8BDU, (8BEI), 8BO, 8BFX, (8DV), 8EA, 8GY, (8HJ), 8SE, 8UC, 8UE, 8UK, 8VQ, (8VY), 8XJ, 9AAP, 9ABF, 9AFB, 9AFN, 9AIF, 9AIY, 9AJA, (9AKD), (9AMB), 9AMT, 9AMW, (9APW), 9ARI, 9ARK, (9ARZ), 9ATN, 9ATU, (9AUA), 9AVM), 9AX, 9AXF, (9AYU), 9AZM, 9BAA, (9BAF), 9BBA, (9BBF), 9BDN, (9BED), (9BEM), 9BEY, (9BGH), (9BHD), (9BIW), 9BJB, 9BKK, 9BOA, 9BQW, (9BSG), (9TA), 9BUD, (9BXI) (9CBA), (9CCS), (9DGG), 9DGO, (9DIO), (9DKK), 9DKY, 9DNG, (9DSM), (9DTA), 9DTM, 9DTS, 9DUG, 9DUN, (9DXY), (9DXD), (9DZQ), 9EI, (9EL), 9FM, (9FZ), 9IF, 9IO, 9JG, 9LQ, 9OF, 9PN, 9PS, 9QF, (9SJ), (9UU),

(9VE), (9WA), (9WD), 9XAK, (9XI), (9YAJ), 9YI.

Spark: (5ABY), 5ADU, (5IR), 5LB, 5NC, (5NS), 5QL, 5SM, 5TC, 5TU, 8BBU, 8EA, 8UC, 8WU, (9AAW), (9ABV), 9AEG, (9AEY), 9AFK, 9AHZ, 9AIF, 9AMT, (9ANO), 9ANP, 9APK, 9APN, 9APS, 9AQZ, 9ARG, 9AUA, 9AVH, 9AVZ, (9AYL), 9AZE, 9AZF, (9BGI), (9BHN), 9BKK, 9BLW, (9BPK), 9BSC, (9BSZ), 9BZJ, (9DGW), (9DJB), 9DJX, (9DKK), 9DMJ, 9DPB, 9DRQ, 9DRW, (9DVF), 9DXE, 9DYC, (9FK), 9KA, 9LF, 9MC, 9NQ, 9OK, 9PD, 9PW, (9RR), 9SY, 9XI, 9XT, 9YJ, 9ZH, (9ZN).

AMATEUR RADIO IN PORTO RICO

(Concluded from page 38)

of course, but our native tongue is Spanish. This alone is a strong link in the chain we are forming in our efforts to reach our South American brothers. They, too, are of the Castillian race, and it is our duty to bring them together and give them the enlightenment our North American brothers have.

Remember, Brothers, we are all Americans, whether we come from Northern Hemisphere or the Southern. "The United States of Brazil" or the "United States of Argentine" sounds just as much to a native of that clime as the phrase "The Good Old U.S.A." sounds to you, and we all have the same liberty-loving ambitions. Therefore, we are going to be with you in the radio game, as we are with you in all others. It is our ambition to join you in making the history of the radio world, that your signals may be carried not only east and west but north and south from Pole to Pole; not only will the cry be "from Pekin to the Hague", but "from Buenos-Aires to Pekin and the Hague"!!

Well, we guess that is saying a pretty big mouthful, but when Paul Godley bit off the "Trans-Atlantic" bite and more than gulped it down, why can't we, with just about half the distance to cover over water, the other by live radio stations, complete another link in the ever-growing chain of citizen radio, throughout the world?

Now, all you "four" stations get busy, and also the "fives"—we want to hear from you. Now is the time to start on your next season's plans. We will be with you then, with more than one squeak-box, too. So from now on we will do a little research on underground antennas, elimination of static and strays, and once in a while catch a few words of your never-ceasing signals. "Adios", brothers, but we are with you on the air.

HOWARD F. MASON

(Continued from page 49)

part of the country for being on the job steadily. He is not much on all-night watches but except for two periods of two weeks each, he has not missed a night in the past year and a half. He handles

(Concluded on page 69)

Radio Communications by the Amateurs

The Publishers of QST assume no responsibility for statements made herein by correspondents.



Expert Advice

Detroit, Mich.

Editor, QST:

The broadcasting situation is becoming more critical than the adjustment of a bare-point electrolytic detector. Lectures on every known and unknown subject have exhausted the supply of material from that source, while every schoolboy has memorized all available grand opera—also the other kind; we know by heart all the possible combinations of "Mammy" and the southern paradise that someone is pining his heart away for, yet for some reason or other prefers to stay in our midst and fill the air with his plaintive lament. Jazz has crusted our plates so thoroughly that the tubes refuse to syncopate and it really seems that it is up to someone to discover some new fuel to keep the steam rollers going twenty four hours a day.

The writer knows personally a man who is unable to tune in anything in the way of instruction or amusement on his stick-pin set while on his way to work via trolley. This condition I find is due to the fact that he travels at six A.M. and broadcasting does not start until 9. Could not this interval be bridged by broadcasting the ticking of the City Hall clock or the roar of Niagara? Surely, American ingenuity can find something necessary to the welfare of the public that would lend itself to the radiophone! The two noises suggested would be very desirable, in my opinion, as any amount of distortion would not seriously impair their usefulness when projected bodily from a "loud-speaker." This would also tend to still further discourage those dot-and-dash experimenters who have sprung up in such numbers since the invention of radio by our local newspaper.

If wireless interferes with radio, why, something must be done about it. The most powerful receiving sets purchased from the various malt and hop stores, and recommended by their experts as being equipped with all latest improvements such as single slide tuning coil, coherer detector, 1000 volt phones and ten feet of tested aerial wire, are subject to this annoyance. Many purchasers have erected higher aerials in an attempt to get above these interfering wavemeters but do not seem to meet with much success. Many

of our old-timers, of five or six week's experience, have written to the newspapers asking if those pests could not be dealt with by law, but they are told that as the offenders do this dot-and-dash noise on 200 wavemeters at a time, nothing can be done about it but to pass a new law compelling them to desist during broadcasting hours, i.e., midnight to noon, and noon to midnight. I understand your magazine, which depends so much on this new art, has considerable influence with these fellows and I request you to ask them to cease until they have learned something about this new art from reading the radio page of their daily paper.

Hopefully yours,

R. N. Keever.

4602 Harding Ave., Detroit, Mich.

"Kiss Me By Wireless"

Gary, Ind.

Editor, QST:

Not long since I attended a public radio "concert". There are times in a man's life when a whole flock of Wouff Hongs would only scratch the surface. This was one of them.

When the OW and I entered the hall we found a goodly crowd of pop-eyed citizens listening to the emanations from a decrepit magnavox, backed up to a regenerative set apparently expecting a spill any moment. Three or four steps of "audio" were doing their utmost to make a bad matter worse.

The genius at KYW was grinding out his usual line when suddenly his voice rose to a terrific shout as the regenerator took the long looked for spill. A bunch of razor-back hogs in a field of paw-paws would be a faint whisper to the raucous uproar that followed. There was a wild leap from the front row as the operator (?) got on the job, and as we expected, got the set right back on the precarious "peak" it had been on before.

The program ground on. A duet was announced. After a considerable pause two girls began singing but without accompaniment. They struggled on though it was evident under suppressed emotions. Finally the pianist arrived and in an endeavor to find the place and the key at the same time, swept unto himself a whole

armful of grace notes and sprayed them recklessly on our beloved ether. The effect was immense.

After a review of the news and sporting events (which we have already scanned in the evening paper) the Daily News musical program began and gave promise of being unusually good but our expectations were short lived. There was a slight commotion down in front and the operator approached the instruments. With blood-thirsty carelessness he strangled the soprano right in the middle of a high C (no pun intended.)

The speaker of the evening was now introduced, being as advertised, a "radio engineer of twelve years experience." After a few introductory remarks he got right down to business and explained the whys and wherefores of radio in a manner all his own. It was unique. The OW gritted her teeth and grinned. Gradually there spread over me the realization that all the time I had spent in studying radio had been wasted. Here was the fountain head of wisdom—all the rest were wrong. Just before I passed out, I heard this startling information, "—and after the electricity in the transmitting aerial gets up to a frequency of over ten thousand per second it no longer stays on the wires but *jumps off* into space and travels through the *air* till it gets to the receiving aerial".

I did not intend to razz KYW when I started out for he is a good station and does not try to overmodulate. Furthermore he has not as yet broadcasted any lectures on peeling potatoes and we can forgive him everything else.

But this other thing—these lectures by "radio engineers" on how radio *doesn't* work—these raucous concerts to the awed neophytes—can't we organize a Society for the Prevention of Cruelty to Dumbells or something?

Sincerely yours,
E. F. DeBra.

Antenna Resistance Can't Be Calculated

Editor, QST—

Despite the vigorous objections of myself and Mr. J. C. Warner to some of "Prof. Bugs" false antenna calculations we still have with us a large group that is firmly convinced of its ability to *calculate* antenna resistance without any measurements except the antenna dimensions. This is impossible. Let us go over the argument again.

"Antenna resistance" means "total antenna resistance" which is made up of:—

- (a)—Wire resistance
- (b)—Ground resistance
- (c)—Dielectric resistance
- (d)—Radiation resistance.

Now let's see how nearly possible it is to calculate these things.

Wire Resistance—Even if we know the resistance of a foot of the antenna wire at the working wave we cannot calculate wire resistance of the finished antenna since we know almost nothing about the distribution of current in the antenna. And a change in current distribution has a most emphatic effect on the resistance of a conducting system. So this will have to be given up or guessed at.

Ground Resistance—There will not be much argument about the statement that ground resistance cannot be calculated.

Dielectric Resistance—The dielectric resistance is that due to the nearby houses, trees, towers, insulators and masts. The mere statement of the causes of the resistance shows the impossibility of calculating it. And the value varies so widely that one cannot guess at it.

Radiation Resistance—Radiation resistance was defined by a humorist as "That resistance which, if there was such a thing as radiation resistance, would be absorbing the antenna power that isn't being absorbed but is getting away."

That is about as good as most of our information about radiation resistance.

Years ago Fleming gave us, (for our sins) a formula for calculating radiation resistance. It was correct for an antenna with a very large flat top supported over salt water by imaginary towers.

Even the word "efficiency" has not been mis-used as has that formula.

$$R_{rad} = \frac{1600 h^2}{\lambda^2}$$

To begin with, the formula is for antennas with very large flat tops. There is no such thing in amateur work. It is for an antenna over salt water; most of our antennas are over anything from wet loam to granite. It takes no account of these things.

But if you insist on using the formula suppose you put in the proper value for "h—the effective height." You can't do it because you have no idea what the effective height of your antenna is. What for instance is the effective height of a 60 by 60 foot T with a two story brick house under one end, 27 telegraph wires on 30 foot poles running by at 60 degrees to the antenna, two 10x8 tin garages next the lead-in and a steel-frame office building 20 feet from the other end of the antenna?

Perhaps *your* antenna is out in open country but even you have some metal poles and guy wires that the formula does not refer to.

In any case the effective height is not the distance from the antenna top to ground, from the antenna top to counterpoise or anything of that sort which can be measured with a ruler or a tapeline. The distance is always less.

The general result is that one had better

guess at the radiation resistance—it is just as accurate as the calculation and is more honest, all hands being at once aware that the result is nonsensical.

Summarizing:—

- (a)—Wire—calculation of resistance doubtful
- (b)—Ground—calculation of resistance impossible
- (c)—Dielectrics—calculation of resistance impossible
- (d)—Radiation—calculation of resistance exceedingly unsatisfactory for amateur antennas.

The only way to find out anything about an antenna is to measure its constants. When a resistance curve has been secured it can be broken up into other curves showing the

- (a)—Radiation resistance
- (c and d)—Ground and wire resistance
- (b)—Dielectric resistance.

There is now being prepared a paper showing how this method was used at several stations to locate and cure antenna losses.

Of course some judgment must be used even in making measurements. Antenna measurements are difficult to make accurately and the results are usually nothing to brag of. But that does not excuse doing deliberately foolish things. Recently I ran across one of our outfits with a book on the key of his 100 watt Hartley-circuit transmitter and a resistance box in the antenna lead. His idea was to cut in resistance till the antenna current had dropped one half, then call the series resistance equal to the antenna resistance.

The "Old Man's" vocabulary may include comment suited to such alleged "measurements". Till the Old Man speaks it is possible to form an opinion by securing the excellent Bureau of Standards "Circular 74"* and learning how to do the thing right.

This has the added advantage that one is all ready for the next man that comes along with a claim of a 4 ohm 200 meter antenna, and is able to prove that he forgot 7 ohms of ground resistance, 5 of dielectric resistance and miscalculated the 4 ohms of radiation resistance.

Yours truly,
S. Kruse.

A Simple Long-Wave Circuit

New York.

Editor, QST—

The enclosed diagram is of a new departure in long wave regenerative circuits which is particularly suitable for amateur use. Should any of your readers use it I should be very much pleased to hear from them as to the range and signals received

*Obtained from the Gov't Printing Office, Washington, D. C., for 60c, stamps not accepted.

with it. It comprises the old Weagant Circuit generally known as the X circuit but it also has the advantage of variable inductance between coils and several other convenient features which tend to flexibility.

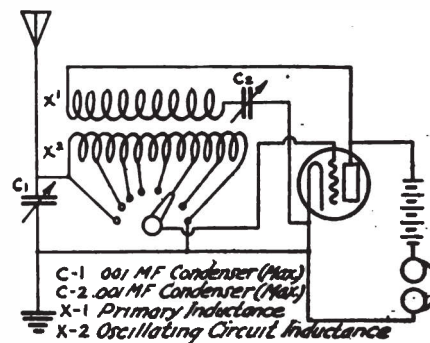

The inductances X-1 and X-2 are honeycomb or other like coils of which X-1 must be especially wound to provide for the variable tap switch. The taps should be taken off at close intervals, i.e., not more than 100 turns apart and closer if possible. X-1 and X-2 are placed in the circuit in a variable coupled relation using a DeForest two-coil mounting. The same circuit can be used with a loose coupler or with specially wound coils to suit the maker but the writer has obtained more satisfactory results with honeycomb coils.

The absence of a grid condenser or leak is a noticeable feature, but because of the direct coupling it has been found that their use is not only unnecessary but that they materially detract from the efficiency of the apparatus.

By using coils of different values, a range of from 2500 to 20,000 meters can be obtained. The coils X-1 and X-2, however, must be of nearly the same inductance, a different antenna, of course, requiring different primary coil.

The writer, with this set and a two step audio-frequency amplifier, copied POZ in daytime 80 feet from the phones. By opening the windows of the writer's station and alternately tuning in one of the U.S. arc stations and transmitting with a ¼ KW open rotary gap it was found that the arc station could be read at a greater distance from the phones than the open gap.

For an inexpensive and simply operated long wave CW receiver it is unbeatable.

Yours truly,
2APS.

Flowery!

Dear Eddy:

The next time I hear of a new discovery in this 'ere wireless game, I intend to stuff my ears with cotton. Things are getting worse every day. Recently I read of an in-

vention which would send perfume by wireless and I nearly choked trying to swallow that. Well OM I no sooner got over that than I heard of another "Bird" who discovered that plants receive and respond to wireless waves.

Now if that guys statements are true we may expect the following very soon—

By way of the dahlia

Comes news from Australia

"Many Bitten by the Wireless Flee"

While the sensitive aster

Relates that disaster

Has befallen a liner at sea.

In far Patagonia—

So says the begonia—

They're taking up study of stars

But the plant to attract us

Will be the first cactus

That picks up a message from MARS.

The term "Wireless Plant" has been used a long time and I think in view of the discovery that certain flora are sensitive to wireless waves in telegraphy and telephony, enterprising seed specialists will add a section similar to the following in their catalogues.

ELECTRON, ION & COMPANY

Specialists in tested seeds for Wireless Plants. Claiming French Beans—These beans attain a height of six feet and are very useful as aerials. TRY OUR SPECIAL 5, 6, or 7 "spud" AMPLIFIERS. Our Onion sets are neat and the best of bulbs used. As it is only recently that onion growing from sets has become popular, it may be well to explain that the "set" is a small, specially ripened bulb and may therefore be called a single bulb transmitter. These sets though small, have an exceptional range owing to their good radiation. They should not be used in the vicinity of a visual receiver as a bad damping effect will be experienced in the eyes.

DETECTORS

Chrysanthemum Sagetum Grandiflorum—Supersensitive. Replaces carborundum and needs no potentiometer. Being a hardy annual it only needs to be set in the best ground earth.

Cyclamen Persicum—Can be used as a substitute for Zincite-Bornite or Silicon-Carbon.

Galega Officinalis—Substitute for Galena. A good detector for amateurs.

Minosa pudica (better known as the sensitive plant)—A very popular plant which has earned its name by its sensitivity.

MISCELLANEOUS

India—rubber plant—A stock of these should be kept on hand for insulating purposes.

Convolvulis—This plant is useful for winding inductances.

Sweet Peas, Afterglow—Violet and electric blue, quite distinct.

Glow Worm—Lovely shade of salmon pink. Both useful as radiation meters.

Beet—Unsurpassed for the reception of continuous waves.

Leeks, Various—For use with grid condensers.

Capsicum Shili—For heating valve filaments.

Spring onions—For suspending detectors. Very good shock absorber.

Iris, generally known as "Flags"—These plants can be trained to receive and translate wireless signals into semaphore.

Eschcholtzia, *Lynchnis arkwrightii*, *calceolaria veitchii*, *Haborothamnus elegans*, *xeranthemum*. A few of these plants should be kept on hand for code practice.

Viscaria Oculata Azurea—The last word in wireless sets. Useful at seances owing to its ability to receive from other worlds.

Funkia Sieboldi—Only a few of these transmitters left. They make good souvenirs, having been captured from Huns in the late war.

Now that I have got this bunk off my chest I feel relieved. I must quit now that I feel sick.

Hoping you are the same, I am
I COW.

Clearing Induction

Editor, QST:

I note in the current issue of our QST, that in the letters from 'the gang' you request some dope on the elimination of arc light induction, in connection with one of our brothers' inquiries. Perhaps an experience of the writer will not be amiss.

Shortly after purchasing a home in a western city, a few years ago, the power company saw fit to run 66,000 volt lines up our street, and which passed within twenty feet of my T antenna. Naturally, I knew every leaky insulator on the line, personally, in less than two weeks. I experimented with all known forms of induction eliminators, so-called, with no success, and then started on the antenna proposition. Swinging it at right angles, of course decreased the racket slightly, but not enough. I then thought, "—if at a right angle, why not a double angle" and decided for a fan antenna. I accordingly erected an eight wire fan, spread thirty feet at the top, sixty feet high, bunched at the lead-in insulator, and, while it positively did not cut out induction, it did eliminate it to the extent whereby I could hear California radiofones in the state of Washington. A steady droning buzz, but intense, was always apparent, but did not hinder ordinary reception. Perhaps this will help our friend.

Cordially,
Howard S. Pyle,
Howard S. Pyle, Ex NVH, NPC, etc.
Chief Engineer,
The Precision Equipment Co.

Induction QRM

Darby Pa.

Dear Disheartened Ham:

I am burning the midnight oil to write a letter of sympathy to you. I too have had the experience of which you write in such a disheartened manner. For about a year, in fact up until April 1st of this year, I lived in a location that would give one the "willies" if looked at from a standpoint of possible sources of QRM. I lived at 59th and Market Streets, in an apartment, and had an aerial that ran parallel to the elevated line and the arc lamps of which you speak. If you will visit the neighborhood you will find that there are three theatres, one printing plant two or three air compressor outfits, several electric pianos, and a number of other possible sources of QRM. Like you, I suspected the arc lamps and the elevated railroad, but take it from me, old man, there is nothing to it, as there is no QRM from the elevated except when a car with a poor contact shoe passes your door. Likewise the theatres and sign flashers, and the same holds good with regard to the electric pianos. But—look out for a mercury arc rectifier.

This particular outfit was the source of all my QRM, and it was with a sigh of relief I noted the removal of the outfit and the substitution of a Tungar. Now my suggestion to you is to look around for something of this particular type, or a motor with a grounded frame and sparking brushes. I would be delighted to have your name and address and will co-operate with you to the extent of my ability.

Very truly yours,
E. R. McCaskey,
1025 Main Street.

Pom Sat?

Dear Ed:

In writing just a line to let you know I'm feeling fine except for some few thousand things that make my old heart ache, by jings. They sure do take one's heart away when they keep coming day by day until they drive one nearly wild. Just lend your ear to this small child, and listen to my tale of woe.

It wasn't many years ago that wireless struck my noble dome, so little Willie hurried home and, from some odds and ends around, constructed aerial set, and ground, and eagerly strained each small ear to try and see if he could hear the Navy Yard, eight miles away, and oh how sweet that lovely day when first I heard it in my phones, a-buzzing like a swarm of drones.

Ah! Well I recollect those times and how I saved up all my dimes to buy some parts for a new set (I have them in my closet yet). Some, thrown together in great haste; and others, done to the queen's taste. From simple loaders, wound by hand, I sprung

to sliding tuners grand. On, on I went through all the kinds of tuners, large and small, one finds belonging to a Radio ham. Say, brother, don't it beat the band what fools we are to sweat and sweat to hear the things we haven't yet.

Maes Oui!. My eagerness led me on from Grebe set's to Paragon, and then to me a radio friend (?) a treatise on Round's ground did send, and so I pulled up my nice ground and built one that was nearly round in order that my sending station would have a greater radiation. Oh yes! I had the Radio Rage. From flat top aeriels to cage I changed, and then, with all the boys, to keep in style a counterpoise I swung beneath my aerial grand, and then I cussed to beat the band because my dear Round ground so far could not be ten feet in the air. But these were nothing. Ah no no, these pleasures all must undergo.

Ambition drove me on and on, and so upon one lovely morn when looking through my QST I saw the set of 1QP. To make the story sweet and short, I hurried to the store and bought the things that one would have to get if he were going to build this set.

Yea Bo' I had it working swell and so I thought I might as well instruct the family in the art of tuning in some distant part. Ah! Woe to me! and Sacre Bleu! Wretched rascal! Dog! Cur! Why did you yield to that temptation? Why let them enter your sweet station? For now it isn't yours doggonit, the folks have got an option on it!

It was all mine a month before. Its mysteries are mine no more, and every time I wish to strain any ear drums for a six, in vain do I tell mother that I think there is a bad leak in her sink; or father that the barn's on fire. What e'er I say, I am a liar. Ner' heaven nor earth (nor I as yet) can get them to leave my—their set. And so it goes.

Day in, day out, these worries drive me near to rout. The housework and the cooking hot have fallen to my miserable lot, while my beloved parents dear, upstairs are straining every ear at every hour of the day for WJZ or KDKA.

Well—now I think I am all through, and so I bid you sad adieu. I wish you years of luck and joy.

Sincerely,
A New England Boy.

Colyum Conductors Wanted

Kokomo, Ind.

Editor, QST:

Permit a suggestion or two re the editorial "Wild, Wild Waves" in March QST, where the statement is made that many newspaper radio departments are edited by "experts," many of whom simply 'ain't"

For evidence of the truth of this statement, one need only glance at one or two of the departments referred to in large Sunday papers, though of course there are a number of them which are capably edited.

Here, it would seem, is a splendid chance for our A.R.R.L. gang to lend a helping hand to the struggling novice and at the same time render our League an invaluable service—why not A.R.R.L. men to man the radio departments? Surely any one of them is wise enough on radio matters to answer the technical questions of the average beginner, (barring of course, such ridiculous queries as,) "Where can I buy 160 meters to add to my 200-meter set so I can hear concerts?"

In papers where no radio department appears, it should be an easy matter to arrange with the editor for a weekly or daily column when the widespread radio fad at present makes the subject of interest to so many people.

While we ourselves can lay no claim to being "experts," in propelling such a section in a local paper for the last several months we have found the task no mean one. To interest the majority of readers, programs of the larger broadcasting whose concerts are received locally are published each day. These nearly all of the radio phone stations will gladly furnish to radio editors on request, for the publicity they derive from it.

Here lies the opportunity for boosting the A.R.R.L. By printing all the varied activities, achievements of and information about the A.R.R.L. and its good work, we interest the novice reader in the League, with the result that he soon stands to become a full-fledged ham. A "questions and answers for readers" section is not amiss here and this further interests the reader in radio.

Although some work is involved in gathering such matter and preparing it for the press, the results are well worth the effort. As to a source of news for this purpose, much valuable material can be found in our own QST. Other magazines and publications also offer additional notes, but care should be taken to prevent the appearance of "yellow" and sensational stories which are unfounded on fact.

I do not claim to be the originator of this idea, for many papers were running such columns before it ever occurred to me, including F. F. Hamilton's "Radio Waves" in the Indianapolis News, but I believe that the opportunity for boosting the A.R.R.L. is present here and would like to see it carried out.

With best 73's,
W. F. Lanterman, 9AVO.
A.R.R.L. City Manager.

HOWARD F. MASON

(Concluded from page 63)

an average of 100 messages per month and sometimes as high as 225. He is a crack operator and chirps off traffic at a rate away above the average on the east coast.

Mr. Mason has been prominent in organizing the Totem Radio Club of which he has been president for the past year. He is also secretary of the Seattle Radio Association, secretary of the Seattle Section of the Institute of Radio Engineers, and Northwestern Division Manager of our A.R.R.L. As Division Manager he is very able and rates high admiration from his men. Tho unassuming in manner he "uses his bean" and has the respect and confidence of all his associates.

M. F. HARROD

(Concluded from page 49)

one of the first daylight C.W. routes—thru 8ZG, 8AGZ, 8VS and 8IB. In spite of all this he graduated from High School as president of his class and with honors.

Just about a year ago he took 8VS to the sunny south and set about to show that radio in Florida was not impossible. 4II started up for good at Orlando last December and has been doing fine work ever since. Mr. Harrod was appointed A.R.R.L. District Superintendent for Florida and the men all over the state have been more than glad to co-operate with him in putting the state on the radio map. Last February the A.R.R.L. men got together and sent 4II to the big convention in Washington where he learned many new ideas of great help in the organization thruout the state. From the day he started until the present time he has literally *lived* radio and he still expects to always do so.

THE NEW RADIO BILL

(Continued from page 56)

or in any manner, either voluntarily or involuntarily, disposed of to any other person, company, or corporation without the consent in writing of the Secretary of Commerce.

"C. That the Secretary of Commerce, subject to the limitations of this Act, in his discretion, may grant to any applicant therefor a station license provided for in sections 1 and 2 hereof, except that he may grant such license only to a station which is in the interest of the general public service.

"No license granted by the Secretary shall be for a longer term than 10 years, and any license granted may be revoked as hereinafter provided. Upon the expiration of any license the Secretary, in his discretion upon application therefor, may grant a renewal of such license for the same or for a lesser period of time.

"The Secretary of Commerce is hereby authorized to refuse a license to any person, company, or corporation, or any subsidiary thereof which, in the judgment of the Secretary, is monopolizing or

seeking to monopolize radio communication, directly or indirectly, through the control or the manufacture or sale of radio apparatus or by any other means. The granting of a license shall not estop the United States from prosecuting such person, company, or corporation for a violation of the law against monopolies or restraint of trade.

"D. That the Secretary of Commerce may grant licenses only upon written application therefor addressed to him, which application shall set forth such facts as he by regulation may prescribe as to the citizenship, character, and financial, technical, and other ability of the applicant to operate the station; the ownership and location of the proposed station and of the stations with which it is proposed to communicate; the wave lengths and the power desired to be used; the hours of the day or other periods of time during which it is proposed to operate the station; the purposes for which the station is to be used, and such other information as he may require. Such application shall be signed by the applicant under oath or affirmation.

"E. That such station license as the Secretary of Commerce may grant shall be in such general form as he may prescribe, but each license shall contain in addition to other provisions a statement of the following conditions to which such license shall be subject: (a) The ownership or management of the station or apparatus therein shall not be transferred in violation of this Act. There shall be no vested property right in the license issued for such station or in the bands of wave length authorized to be used therein, and neither the license nor any right granted thereunder shall be assigned or otherwise transferred in violation of this Act; (b) such licenses shall contain such other conditions, not inconsistent with this Act, as the Secretary of Commerce may prescribe.

"F. That any station license granted by the Secretary of Commerce shall be revocable by him for failure to operate service substantially as proposed in the application and as set forth in the license, for violation of or failure to observe any of the restrictions and conditions of this Act or of any regulation of the Secretary of Commerce authorized by this Act or by the provisions of any international radio convention ratified or adhered to by the United States or any regulations thereunder, or whenever the Secretary of Commerce shall deem such revocation to be in the public interest: Provided, That no order of revocation shall take effect until thirty days' notice in writing thereof to the parties known by the Secretary to be interested in such license. Any person in interest, aggrieved by said order, may make written application to the Secretary at any time within said thirty days for a hearing upon such order and upon the filing of such written application said order of revocation shall stand suspended until the conclusion of the hearing herein directed. Notice in writing of said hearing shall be given by the Secretary to all the parties known to him to be interested in such license twenty days prior to the time of said hearing. Said hearing shall be conducted under such rules and in such manner as the Secretary may prescribe. Upon the conclusion thereof the Secretary may affirm, modify, or revoke said orders of revocation.

"SEC. 3. A. That the actual operation of apparatus in any radio station for which a station license is required by this Act shall be carried on only by a person holding an operator's license issued thereunder. No person shall operate any apparatus in such station except under and in accordance with an operator's license issued to him by the Secretary of Commerce.

"B. That the Secretary of Commerce, in his discretion, may grant special temporary operators' licenses to operators of radio apparatus under such regulations, in such form, and upon such conditions as he may prescribe whenever an emergency arises requiring prompt employment of such an operator.

"C. That an operator's license shall be issued by the Secretary of Commerce in response to a written application therefor, addressed to him, which shall set forth (a) the name, age, and address of the applicant; (b) the date and place of birth; (c) the country of which he is a citizen;

and if a naturalized citizen of the United States, the date and place of naturalization; (d) the previous experience of the applicant in operating radio apparatus; and (e) such other facts or information as may be required by the Secretary of Commerce. Every application shall be signed by the applicant under oath or affirmation.

"D. That an operator's license shall be issued only to a person who, in the judgment of the Secretary of Commerce, is proficient in the use and operation of radio apparatus and in the transmission and reception of radiograms by telegraphy and telephony. Except in an emergency found by the Secretary of Commerce to exist, an operator's license shall not be granted to any alien, nor shall such a license be granted to a representative of a foreign government.

"E. That an operator's license shall be in such form as the Secretary of Commerce shall prescribe, and may be suspended by him for a period not exceeding two years upon proof sufficient to satisfy him that the licensee: (a) has violated any provision of any act or treaty which the Secretary of Commerce is authorized by this Act to administer, or of any regulation made by the Secretary under any such act or treaty; or (b) has failed to compel compliance therewith by any unlicensed person under his supervision; or (c) has failed to carry out the lawful orders of the master of the vessel on which he is employed; or (d) has willfully damaged or permitted apparatus to be damaged; or (e) has transmitted superfluous signals, or signals containing profane or obscene words or language.

"F. That a license may be revoked by the Secretary of Commerce upon proof sufficient to satisfy him that the licensee was at the date his license was granted to him, or is at the time of revocation, ineligible for a license.

"SEC. 4. A. That after the approval of this Act the construction of a station for which a license is required by this Act shall not be begun, nor shall the construction of a station already begun be continued, until after a permit for its construction has been granted by the Secretary of Commerce upon written application therefor. This application shall set forth such facts as the Secretary of Commerce by regulation may prescribe as to the citizenship, character, and the financial, technical, and other ability of the applicant to construct and operate the station, the ownership and location of the proposed station and of the station or stations with which it is proposed to communicate, the wave length or wave lengths desired to be used the hours of the day or other periods of time during which it is proposed to operate the station, the purpose for which the station is to be used, the type of transmitting apparatus to be used, the power to be used, the date upon which the station is expected to be completed and in operation and such other information as the Secretary of Commerce may require. Such application shall be signed by the applicant under oath or affirmation.

"B. That such permit for construction shall show specifically the earliest and latest dates between which the actual operation of such station is expected to begin and shall provide that said permit will be automatically forfeited if the station is not ready for operation within the time specified. The rights granted under any such permit shall not be assigned or otherwise transferred to any other person, persons, company, or corporation, without the approval of the Secretary of Commerce: Provided, That a permit for construction shall not be required for Government stations to be used exclusively for communication of official business or for private stations as provided for in section 4, fifteenth regulation, of the Act of August 13, 1912. The granting of this permit to construct a station as herein required shall not be construed to impose any duty or obligation upon the Secretary to issue a license for the operation of such station.

"SEC. 5. That an advisory committee is hereby established to whom the Secretary of Commerce shall refer for examination and report such matters as he may deem proper relating to: (a) the administration or changes in the laws, regulations, and treaties of the United States relating to radio

communication; (b) the study of the scientific problems involved in radio communication with the view of furthering its development; (c) the scientific progress in radio communication and use of radio communication.

"The advisory committee shall consist of twelve members, of whom one shall be designated by the Secretary of State, one by the Secretary of War, one by the Secretary of the Navy, one by the Secretary of Agriculture, one by the Postmaster General, and one by the Secretary of Commerce, to represent these departments, respectively, and six members of recognized attainment in radio communication not otherwise employed in the Government service to be designated by the Secretary of Commerce.

"The necessary expenses of the members of the committee in going to, returning from, and while attending meetings of the committee, including clerical expenses and supplies, together with a per diem of \$25 to each of the six members not otherwise employed in the Government service for attendance at the meetings, shall be paid from the appropriation made to the Department of Commerce for this purpose.

"SEC. 6. That radio telephone stations, the signals of which can interfere with ship communication, are required to keep a licensed radio operator, of a class to be determined by the Secretary of Commerce, listening in on the wave length designated for distress signals during the entire period the transmitter of such station is in operation.

"SEC. 7. That regulation first of section 4 of said Act of Congress approved August 13, 1912, is amended by striking out the words 'this wave length shall not exceed six hundred meters or it shall exceed one thousand six hundred meters.'

"Regulation second of section 4 of said Act of Congress approved August 13, 1912, is amended by striking out the words 'provided that they do not exceed six hundred meters or that they do exceed one thousand six hundred meters.'

"Regulations third and fourth of section 4 of said Act of Congress approved August 13, 1912, are hereby repealed.

"Regulations fifteenth and sixteenth of section 4 of said Act of Congress approved August 13, 1912, are amended by striking out the words 'exceeding two hundred meters' and substituting in lieu thereof the words 'of not less than one hundred and fifty meters nor more than two hundred and seventy-five meters.'

"SEC. 8. That any person, company, or corporation who shall erect, use, or operate any apparatus for radio communication in violation of this Act, or knowingly aid or abet another person, company, or corporation in so doing, or knowingly make any false oath or affirmation for the purpose of securing a permit or a license, shall incur a penalty not to exceed \$1,000, which may be mitigated or remitted by the Secretary of Commerce, and the permit or license of any person, company, or corporation who shall violate any of the provisions of this Act, or of any of the regulations of the Secretary of Commerce issued hereunder, or knowingly make any false oath or affirmation for the purpose of securing a permit or license, may be suspended or revoked by the Secretary of Commerce.

"SEC. 9. That the Secretary of Commerce is hereby authorized and directed to charge, and through the imposition of stamp taxes on applications, licenses, or other documents, or in other appropriate manner, to collect the fees specified in the schedule following. The Secretary shall collect said fees through the collectors of customs or other officers designated by him, and he may make such regulations as may be necessary to carry out the provisions of this section.

"SCHEDULE OF FEES TO BE COLLECTED"

"For transoceanic radio station license, \$300 per annum; for commercial land station license, other than transoceanic, one kilowatt transmitter input or less, \$50 per annum; and for each additional kilowatt or fraction thereof, \$5 per annum; for ship station license, \$25 per annum; for experiment station license, \$25 per annum; for technical and training school license, \$15 per annum; for special amateur station license, \$10 per annum;

for general and restricted amateur station license, \$2.50 per annum; for commercial extra first-class operator's license, \$2.50 per annum; for commercial first-class operator's license, \$1.50 per annum; for commercial second-class operator's license, \$1 per annum; for commercial cargo grade operator's license, 50 cents per annum; for experiment and instruction grade operator's license, \$1 per annum; for amateur first-grade operator's license, 50 cents per annum; for amateur second-grade operator's license, 50 cents per annum; for commercial extra first-class radio operator's examination for license, \$2.50 for each examination; for commercial first class radio operator's examination for license, \$2 for each examination; for commercial second-class radio operator's examination for license, \$1.50 for each examination; for commercial cargo grade radio operator's examination for license, \$1 for each examination; for experiment and instruction grade radio operator's examination for license, \$1 for each examination; for amateur first-grade radio operator's examination for license, \$1 for each examination; for amateur second-grade radio operator's examination for license, 50 cents for each examination.

"In the event that other classes of station and operators' licenses or other examinations shall hereafter be prescribed in any lawful manner, the Secretary of Commerce is hereby authorized and directed to charge and collect in the same manner as herein provided fees for such new classes of licenses and of examinations, which fees shall be substantially of the amount herein specified for the license and examination nearest in character and purpose to the new license or examination so prescribed.

"For failure to pay at the time and in the manner specified by the Secretary of Commerce any of the above fees the Secretary of Commerce is authorized to refuse to issue such licenses; or if issued, to suspend or revoke the same, as he may deem proper.

"SEC. 10. That wherever the words 'naval and military' stations appear in the Act to regulate radio communication, approved August 13, 1912, said words 'naval and military' shall be stricken out and the word 'Government' substituted in place thereof.

"SEC. 11. That all Acts or parts of Acts in conflict with this Act are hereby repealed."

"WorkRite Radio Parts WorkRite"

They are standard everywhere. WorkRite Variocouplers, Variometers, Switch Parts, Hydrometers, Binding Posts, Rheostats, etc. Write for catalog.

THE WORKRITE MFG. CO., Cleveland, O.

"SHRAMCO PRODUCTS"

Amateurs: Send 5c in stamps today for our new Catalogue L showing complete line of parts, raw materials and high grade apparatus.

Dealers: Write for our attractive proposition.

The Shotton Radio Mfg. Co.,
INCORPORATED

8 Market St.,

Albany, N. Y.

ATWATER KENT

RADIO APPARATUS

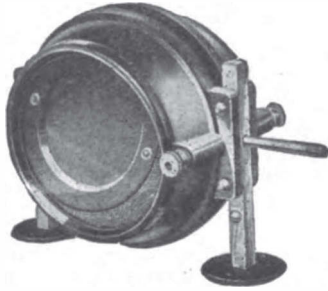

VARIOMETER

VARIOMETERS
 TRANSFORMERS
 VARIOCOUPERS
 RHEOSTATS

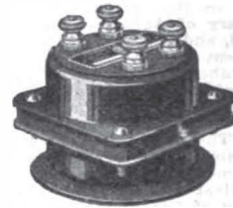

TRANSFORMER

Designed in the Atwater Kent Research Laboratories and manufactured complete in this plant from moulding of the condensite forms to winding of the fine wire coils—an assurance of quality.

Highest grade materials are used in construction thruout each unit and a very complete final test is a guarantee of 100% performance.

Correspondence solicited

ATWATER KENT MANUFACTURING COMPANY

4941 Stenton Avenue,

Radio Department

Philadelphia

MR. RADIO MFR.

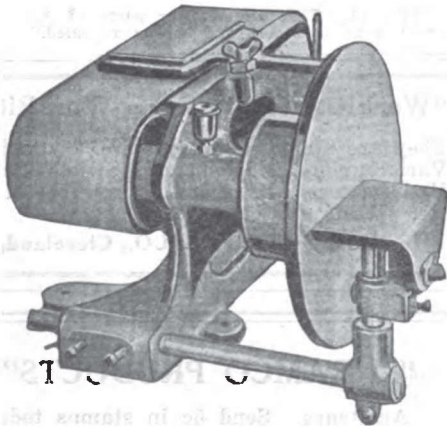

DUPLEX GRINDER

THE HIGH SPEED ABRASIVE BAND & DISC WILL GREATLY INCREASE FLAT SURFACE PRODUCTION IN ONE OPERATION. MOULDED, FORMED OR CUT DIELECTRIC & METAL PARTS, YIELD IMMEDIATELY TO SMOOTH FLAT SURFACES.

WE CAN SUPPLY IT IN MANY SIZES & STYLES

Write to write for full details

WALLS SALES CORP.

96 WARREN ST.,

NEW YORK

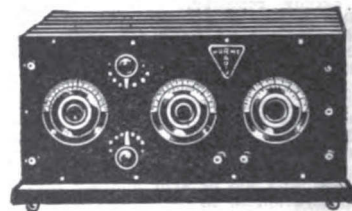

HORNE Radio Production

80

Important and Essential
 Radio Devices

*A Complete Line Distributed
 Nationally*

Horne Manufacturing Co.

Sales and
 Executive
 Offices
 30 Church St.
 N. Y. City



Two
 Factories
 in
 Jersey City
 N. J.

BURGESS "B" BATTERIES

BURGESS "B" Batteries assure clear receiving, increase the efficiency of any receiving set, and they are cheapest in hours of service.

BURGESS "B" Batteries are sold by every progressive Radio Dealer and Jobber. "Look for the Black and White Stripes."

A postal card from you brings full information by return mail. Why not write to us today? (Dept. D)

BURGESS BATTERY CO.

Offices and Warehouses:

CHICAGO	NEW YORK	BOSTON
111 W. Monroe St.	50 Church St.	136 Federal St.
MADISON	KANSAS CITY	ST. PAUL
Wisconsin	2109 Grand Ave.	2362 University Ave.

In Canada: BURGESS BATTERIES, Ltd.

Winnipeg Toronto Montréal

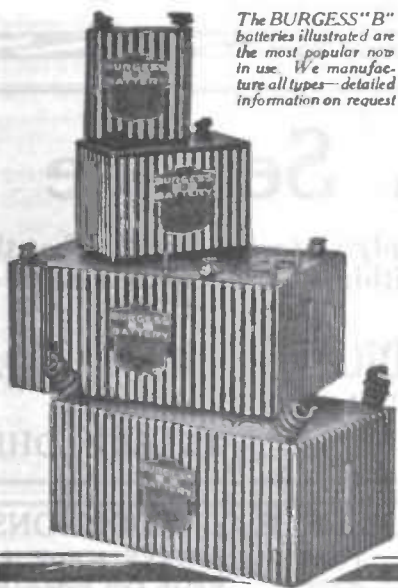

The BURGESS "B" batteries illustrated are the most popular now in use. We manufacture all types—detailed information on request

OVER 300,000 SOLD—WHY?

"ASK ANY RADIO ENGINEER"

ELWOOD RADIO HEADSETS

The seventeen years of practical experience in the making of telephones and receivers by this company, assures you of good design and workmanship.

Elwood headsets meet the exacting demands of all purchasers of radio units and parts. Both receivers operate in unison, insuring clear, harmonious and uninterrupted reproduction. Our absolute guarantee of the ohmage capacity of these headsets is your safeguard.



2000 ohm
Head Sets
\$7.00

3000 ohm
Head Sets
\$8.00

Receivers have metal case, highly finished. Headbands have sanitary fabric covering, fully adjustable. Complete set packed in attractive carton.

We are also manufacturers of Binding Posts, Contact Points, Jacks and Plugs for Radio Work.

ELWOOD ELECTRIC CO. INC.

Formerly Liddell Electric Mfg. Co.

2-4 Randall Avenue, Bridgeport, Conn.

For REAL Service

Mail your orders to us. We can supply you with the BEST at the BEST PRICES. Shipments made within 24 hours after receipt of order.

CATALOGUE
122
AT YOUR
SERVICE

THE SERVICE RADIO EQUIPMENT CO.

Designers—Manufacturers—Distributors

225 SUPERIOR ST.,

TOLEDO, OHIO

HAVE YOU SEEN THESE LATEST EBY ADDITIONS?

THEY SURE HAVE MADE A HIT
WRITE FOR BULLETIN #10



COMMANDER "H"



ENSIGN "H"



ACE



SERGEANT "SS"



BUDDY



MIDGET

WE HAVE A SUBSTITUTE FOR THE POST YOU ARE NOW USING—DELIVERY FROM STOCK
THE H. H. EBY MANUFACTURING CO., 605 ARCH ST., PHILA., PA.

ALWAYS MENTION Q S T WHEN WRITING TO ADVERTISERS



The end of a perfect howl--

THE squalls of a two year old are as music to the ear beside the howling demonstration put up by a fractious radio set. And how a set can howl unless one offers the soothing influence of the proper amplifying transformer.

Most any transformer can amplify sound, but it will also amplify the stray fields which produce howling and distortion. It takes the Acme Amplifying Transformer with its specially constructed iron core and coil to put an end to the howls and yowls. Only when you add the Acme do you get the realistic tone and volume so markedly absent in the ordinary radio receiving set.

The Acme Radio Frequency Transformer greatly increases the range of any receiving set, either vacuum tube or crystal detector type. The Acme

Audio Frequency Transformer produces not only volume, but reality of tone. It is indispensable to the satisfactory operation of loud speaking devices. The combination of one or more stages of Acme Radio and Audio Frequency Transformers assures the maximum of range, of volume and of reality in tone.

The Acme Apparatus Company, pioneer radio engineers and manufacturers, have perfected not only Radio and Audio Frequency Trans-

formers as well as other receiver units and sets, but are recognized as the foremost manufacturers of Transmitting Apparatus for amateur purposes. Sold only at the best radio stores. The Acme Apparatus Company, Cambridge, Mass., U. S. A. New York Sales Office, 1270 Broadway.

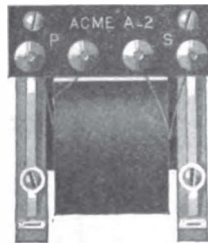

Type A-2 Acme Amplifying Transformer
Price \$5 (East of Rocky Mts.)

ACME

for amplification

Chelsea No. 50 Amplifying Transformer

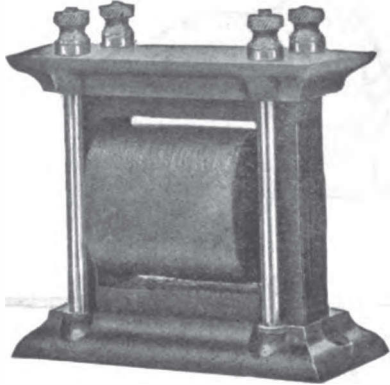

Was designed for use with the present day models of vacuum tubes, and when so used produces remarkable amplification, with minimum noise. It is well adapted for table mounting or may be panel mounted in any position. Its high efficiency together with its neat appearance and compactness, makes it a predominating feature in any radio receiving equipment.

Price as shown **\$4.50**
 Unmounted **3.75**

Bulletins sent upon request

Purchase from your dealer. If he does not have it, send to us

CHELSEA RADIO COMPANY

150 FIFTH STREET,

CHELSEA, MASS.

\$8.50

**Complete Enjoyment
of Radio Telephony**

is only possible with a Telephone of the very highest standard of efficiency.

Everett Double Radio Phones
 have satisfied the most exacting Critics
Supersensitive—Clear—Light
 Mechanically Perfect—Moderately priced
AT ALL DEALERS

Everett Electric Corp.

320 BROADWAY, NEW YORK

**A SERVICE
WORTHY OF A
TRIAL**

MISSOURI
 RADIO
 SUPPLY
Service Original

**AMATEURS
SEND YOUR ORDER TO
MISSOURI RADIO
SUPPLY COMPANY**

**4623 MARYLAND AVE.,
ST. LOUIS, MO.**

Here's Your Trouble---

When your tube burns out before it has given you its normal service, you know it's been overloaded.

When you fail to secure good results from the use of your tubes you know you are not using them correctly.

If you've been regulating your current by the degree of illumination of the filament you've simply "taken a long chance"—and lost!

Here's Your Remedy---

Every make of tube should be operated at some specific voltage, as the manufacturer tells you. Don't GUESS at this voltage—its limits are extremely narrow. Install a

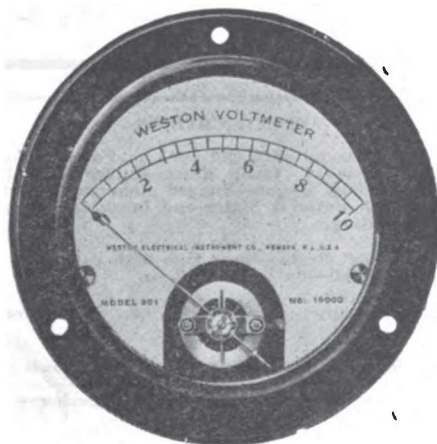

Weston

Model 301

Filament Voltmeter

and you can quickly establish and maintain exactly the proper voltage, prevent premature burnouts, increase the life of your tubes and secure satisfactory results.

One burned-out tube will almost pay the cost of a Weston Filament Voltmeter.

Is it reasonable to continue your high tube replacement expense and unsatisfactory service when so simple and certain a remedy is so easily available?

Our Circular "J" describes in detail Weston Filament Voltmeters and other important instruments invaluable to owners of up-to-date receiving and transmitting sets. Send for a copy without delay, if your dealer cannot supply you.

Weston Electrical Instrument Company
158 Weston Avenue, Newark, N. J.

Branches in all the Principal Cities

ALWAYS MENTION Q-S-T WHEN WRITING TO ADVERTISERS

Digitized by Google

11



Hartford Radio Battery

Our radio "A" batteries are up to the Hartford Standard of excellence which means that no battery of any type leaves our plant until it has successfully surmounted a series of careful tests.

Type 5R	30 to 40 Ampere Hour	\$10.00
Type 7R	45 to 60 Ampere Hour	12.00
Type 9R	60 to 80 Ampere Hour	15.00

If there is not a Hartford dealer in your vicinity we will forward a battery direct to you upon receipt of draft or money order.

The Hartford Battery Mfg. Co., Milldale, Conn.

THE "LORAIN" COUPLER

SPECIFICATIONS

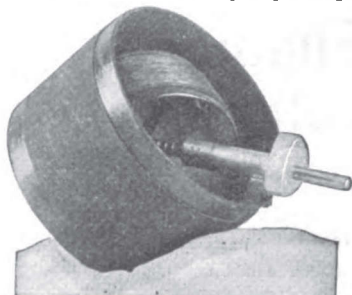

Stator & Rotor wound with #22 DSC on Formica Tubes.
 Stator—60 Turns—10 Taps; Rotor—Either secondary or
 Tickler winding. Frame—Rugged aluminum casting supporting
 both Rotor & Stator and furnishing support for
 panel mounting.

Shaft— $\frac{1}{4}$ " or $\frac{3}{8}$ " Brass—Runs true with panel, no wobble.
 Connections—Pigtails—no loose contacts.

Price—\$5.50—Specify rotor winding & shaft size when
 ordering.

We can also give good deliveries on the following:—Formica
 Panel—Knobs & Dial—Brandes Phones—Eveready B
 Batteries—Homchargers—Recola Loud Speakers—Vernier
 Rheostats—Contacts—Binding Posts, Etc.

LORAIN RADIO SUPPLY,

Lorain, Ohio



EINSTEIN

Has the dope on RELATIVITY

We have the dope on RADIO

Longer Distance. Clearer Signals. Thru more interference. Non-infringing apparatus. Are you from "Missouri!?" Write us today!

Scientific Engineering Association

817 MAIN STREET,

CINCINNATI, OHIO

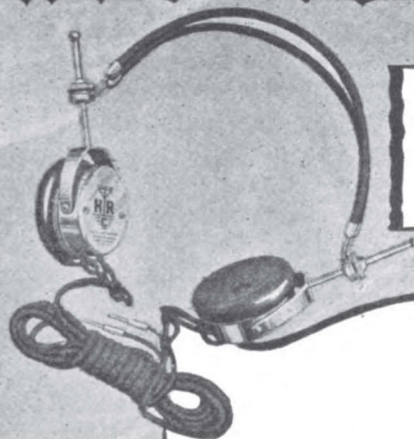

HESLAR Equi-Tone PHONES
 Durable, comfortable
 and efficient. Outside
 noises eliminated.
 Register most delicate
 sounds.

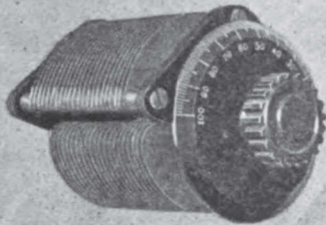

Heslar Variable Condensers
 23 Plates 43 Plates
 Designed by engineers
 with fourteen years ex-
 perience. Special plates,
 rounded to enable per-
 fect adjustment at low-
 est capacity.

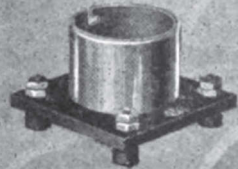

HESLAR SOCKETS
 Four distinct improve-
 ments. Formica posts
 assure perfect insula-
 tion. Blades locked by
 countersinking in For-
 mica base. Admits all
 steel base tubes.

**KEEPING
 FAITH!**



You radio enthusiasts have heard of the many improvements and the unusually fine appearance of Heslar products. **NOW YOU CAN SEE THEM!** We present Heslar Radio Equipment knowing positively that it will please you. Every Heslar product shows last minute improvements that are exclusive. We stand back of every one of them. Go to your dealer **NOW**. Ask for **HESLAR RADIO EQUIPMENT**, or—

*Write for Catalog
 and Literature*

HESLAR
 RADIO CORPORATION
 INDIANAPOLIS U.S.A.

With Heslar Radio—the World's your Neighbor—

Picked Up Detroit-Denver- Pittsburgh-Newark ---With No Amplification

Chicago, Ill.
"I thought that you might be interested in hearing of the results I obtained on Monday night of this week with your H. R. Receiver and absolutely no amplification. An interior antenna consisting of about a hundred feet of #14 rubber covered wire was used.

"My home is at Winnetka, about eighteen miles north of Chicago, on the lake. After picking up the Chicago station I next listened to a concert in Detroit, then a concert at Pittsburgh, then a concert and entertainment at Newark, and next the last part of the Denver, Colo. program. After that I picked up two other stations that I could not identify, but as it was after ten o'clock here I figured that they must be western stations."

Charles A. Nash.

This is a typical experience with Clapp-Eastham equipment—we receive such letters daily. The wide range of this H. R. Set and the sharp clearness with which messages and music come in surprise experienced radio men and absolutely amaze the inexperienced.

If your dealer, because of the unprecedented demand, cannot show you this Clapp-Eastham Set, or cannot supply this set from his jobber, write us. Complete new Radio Catalog 6c.

CLAPP-EASTHAM CO.
189 Main Street, Cambridge, Mass.
Oldest and Largest Exclusive Makers of Radio Equipment

CLAPP-EASTHAM Type HR

Regenerative Receiving Set
(Licensed under Armstrong U. S. Patent No. 1,118,149)

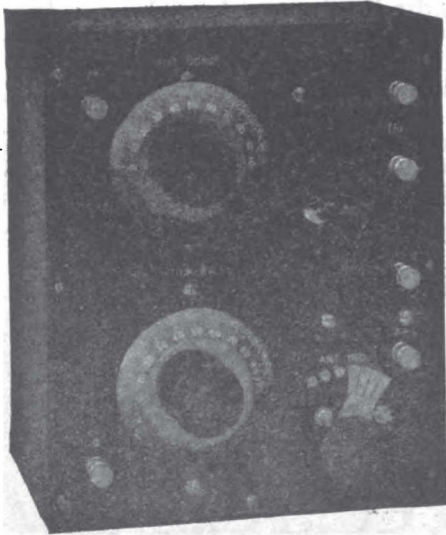

Regen. rates Wave Lengths of
180 to 825 meters perfectly

SPECIFICATIONS:

Cabinet: Solid mahogany, dull finish; Panel: Condensite, dull finish, machine engraved, white lettering; Dials: Indestructible metal, black with white lettering; Condenser: Balanced type, built as a Vernier; 2 rotary, 3 stationary plates; Antenna Inductance: Wound on formica tube; Plate Inductance: Wound on molded ball; Binding Parts: Black rubber covered; Switch: Fan blade; Rheostat: Clapp-Eastham type H 400; Circuit: Single circuit regenerative; "B" Battery: Contained in inside compartment or external; Price: \$40.

80

MAGNET WIRE for RADIO PURPOSES



DUDLO MAGNET WIRE

When winding those coils for your set, why not avail yourself of the advantages to be gained by using the magnet wire that for the past twelve years has been approved and used by the government and largest manufacturers of radio and other electrical apparatus.

This wire, developed to meet the exacting requirements of radio apparatus construction, can now be purchased from your dealer in standard packages containing 1 pound of wire in any one of seven different insulations including enameled, single cotton enameled, single silk enameled, single and double cotton covered, single and double silk covered.

Look for the distinctive yellow carton bearing the Dudlo trade-mark, and on one side of which is listed a table of wire diameters.

Your
Guarantee
Of

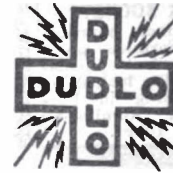

Quality
And
Satisfaction

Dealers: If your jobber cannot supply you, write

Dudlo Manufacturing Co.
Fort Wayne, Indiana
Western Representative
A. S. Lindstrom, 111 New Montgomery St.
SAN FRANCISCO, CALIFORNIA

ALWAYS MENTION Q S T WHEN WRITING TO ADVERTISERS

The Multiple Storage Battery Corporation Announces
RADIOBAT "B" *The Most Remarkable "B" Type Radio Battery.*

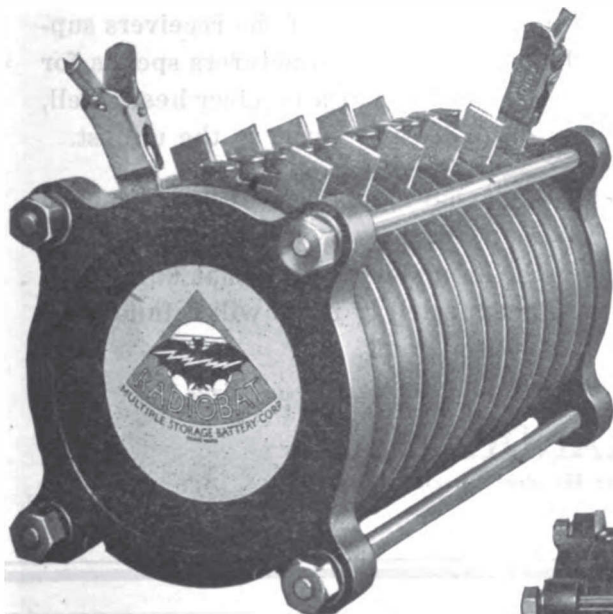

Revolutionary in Design and Construction.

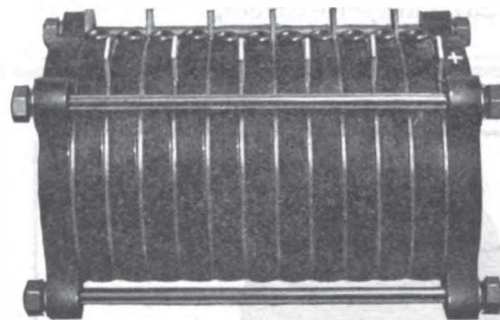

RADIOBAT "B" is practically everlasting. It has no glass to break, no wooden case to rot, no separators of any kind.

Radiobat "B" is leak proof, it is free from acid fumes.

Any voltage desired can be obtained simply and easily.

Radiobat "B" will give a clearer tone to your Radio.

As Radiobat "B" has just been placed on the market, it is possible that your regular dealer will not be able to supply it. If this is the case, write us today enclosing \$12.00, the price of this extraordinary battery.

Also for Laboratories and Experimenters interested in high voltage with low amperage.

Dealers write at once for our proposition.

**MULTIPLE
STORAGE BATTERY CORP.**



Established 1908

350 MADISON AVENUE

NEW YORK

ALWAYS MENTION Q & T WHEN WRITING TO ADVERTISERS

81

TO HEAR RADIO MUSIC PERFECTLY



The fact that Brandes *Matched-Tone* headsets are part of the standard equipment of the receivers supplied by the leading radio manufacturers speaks for itself. Unless the purchaser of a receiver hears well, he cannot enjoy broadcasted music to the utmost.

If your receiver is not equipped with a Brandes *Matched-Tone* headset you can buy one from your dealer, with the understanding that unless you obtain the results expected of it, he will refund your money after ten days' trial.

"Matched-Tone" is a trade-mark registered in the U. S. Patent Office.

C. BRANDES, INC.

Wireless Headset Specialists

237 Lafayette Street,

New York, N. Y.





**No. 100
Filament Rheostat
for Panel Mounting**

**No Magnetic Material Used
in Its Construction**

Designed by Radio Engineers to insure quiet, smooth, step-by-step action and maximum sensitivity. Its current capacity is ample for the control of any receiving tube without overheating. Both the base and the knob are made of genuine Thermoplas. All metal parts are nicked.

The overall diameter is only 2 1/4"—an important factor because of the limited space usually available.

Price (East of Rocky Mountains) \$1.00
Get a C R L Rheostat from your Dealer or, if he cannot supply you we will send you one by mail postpaid for \$1.10.

Central Radio Laboratories
303 16th Street,
MILWAUKEE, WISCONSIN

The McTighe Storage B Battery

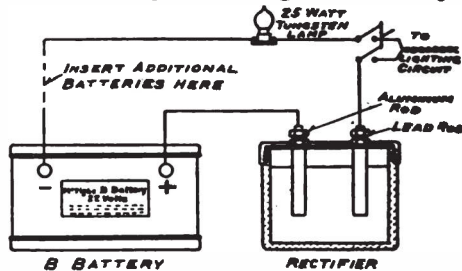

The McTighe Storage "B" Battery is of the alkaline type, is the most satisfactory source of plate potential, and can be charged from your lighting circuit for less than one cent. Can also be charged from farm lighting systems. In ordinary service a one hour charge will last for several weeks.

The Battery is furnished in a 24 volt unit in an attractive case.

It is noiseless, and cannot be injured by accidental short circuit, overcharging or by standing idle.

Descriptive Leaflet on request

PRICES	
Battery	\$4.00
Rectifier	1.50
Rubber Filler25

F. O. B. Irwin, Pa.

ECONOMIC APPLIANCE COMPANY
Successor to
McTIGHE BATTERY COMPANY
Irwin, Pa.



Stop Buzzing and Sizzling

FORMICA insulation for Radio use is perfect insulation! It prevents buzzing, sizzling and noise that makes it hard to hear over your radio telephone.

There are no weak places in Formica panels. They are not affected by moisture and weather conditions and do not deteriorate. They will give perfect service for years.

Formica is the most widely used radio insulation. It is approved by the Navy and the Signal Corps. It is a thoroughly high quality product—the finest possible insulating material all the way through! It contains no absorbent matter that will take up water and lose its insulating strength through humidity and moisture.

Formica panels have a handsome gloss or satin finish—black and natural brown.

DEALERS: We have now in operation an addition to our plant which doubles our previous capacity. Back orders for Formica are being shipped rapidly. We always do our utmost to serve you promptly.

THE FORMICA INSULATION COMPANY
4620 Spring Grove Avenue, Cincinnati, Ohio

SALES OFFICES

50 Church Street, New York, N. Y.	422 First Avenue, Pittsburgh, Pa.
9 South Clinton Street, Chicago, Ill.	Sheldon Building, San Francisco, Cal.
414 Finance Building, Cleveland, Ohio	932 Real Estate Trust Bldg., Philadelphia, Pa.
1042 Granite Building, Rochester, N. Y.	321 Title Building, Baltimore, Md.
415 Ohio Building, Toledo, Ohio.	

FORMICA

Made from Anhydrous Redmanol Resins

SHEETS TUBES RODS

ALWAYS MENTION Q S T WHEN WRITING TO ADVERTISERS

83

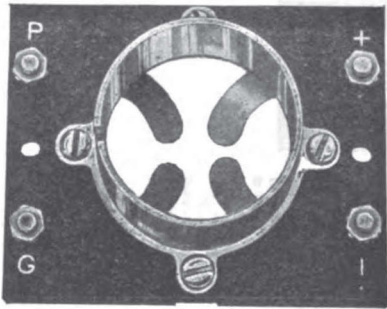

VACUUM TUBE SOCKET
Type SA Style No. 166

Attractive, rugged and perfect in all details. Phosphor bronze contact springs. Heat proof composition base. Price \$1.00.



INDUCTANCE SWITCH
Type SC Style No. 167

The best switch at the best price, featuring a laminated phosphor bronze contact arm. Price \$0.50.

Special Discounts to Dealers.

THE RADIO ELECTRIC CO.
Manufacturers and Jobbers in
RADIO EQUIPMENT
1427-29 LIBERTY AVENUE
PITTSBURGH, PA.

TUSKA



Baseball Returns

RADIO

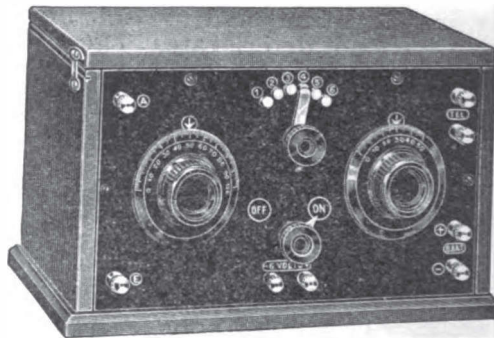

Type 224—Price \$35

Tuska Regenerative Tuner (Licensed under Armstrong Patent No. 1,113,-149) Ready for Tube, Phones, and Battery. The ideal outfit for expert or beginner. Two knobs—one for wave length, the other for amplifying. Wave length range 150-650 meters. Type 224 has stood the test of public trial.

Dealers write your nearest jobber.

Send 5c for New Tuska Catalog No. 3

The C. D. Tuska Company
1 Bartholomew Ave., Hartford, Conn.

AMPLIFICATION

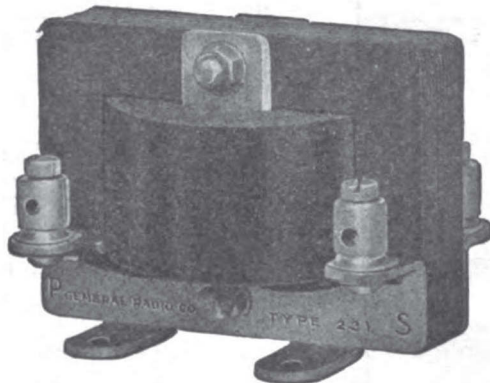

Amplification was first made practicable by the use of the three electrode tube. To take full advantage of the amplifying feature of the vacuum tube, the impedance of the grid circuit of the amplifier tube must be adapted to the impedance of the plate circuit of the detector, or preceding amplifier tube. This correct arrangement of impedance values can best be accomplished by a transformer. The primary and secondary windings, as well as the magnetic circuit can then be designed so as to give the maximum change of potential on the grid of the amplifier tube.

Amplification in this manner is only about a decade old. One of the first companies to design amplifying transformers was the General Radio Company. This Company has, furthermore, the distinction of being the first in this country to supply the experimenter with a closed core amplifying transformer.

Since the introduction of the first transformer, the subject of amplification has received much attention in our research laboratory and new improvements have been developed from time to time. Our Type 231-A amplifying transformer represents a six-year study of the problems of amplification. It embodies the best features in amplifier design.

There are several transformers on the market today having as high an amplification factor as the Type 231-A transformer. At certain resonant points, some are even higher. Extraordinary amplification at a single frequency is seldom to be desired. High amplification over a wide band of frequencies is the true measure of a satisfactory amplifying transformer. With the increase in radio telephony, this feature is not only to be desired but is essential. It is in this feature that the Type 231-A amplifying transformer excels. It is designed to give the maximum amplification possible without distortion when used with a Radiotron UV-201 vacuum tube.

The core construction is such that there is little tendency for the setting up of external fields with the resultant howling in the audio frequency circuit. The distributed capacity of the secondary is low so that the maximum potential is obtained on the grid of the tube.

The constants of the transformer are as follows:

	Primary	Secondary
Direct current resistance.....	1,100 ohms	5,500 ohms
A. C. resistance @ 1,000 cycles.....	11,000 ohms	130,000 ohms
Reactance @ 1,000 cycles.....	66,000 ohms	700,000 ohms

PRICE, COMPLETELY MOUNTED, \$5.00

Send for Free Radio Bulletin 911-Q

GENERAL RADIO CO.

MASSACHUSETTS AVENUE AND WINDSOR STREET

Cambridge 39, Massachusetts

Standardize on General Radio Equipment Throughout

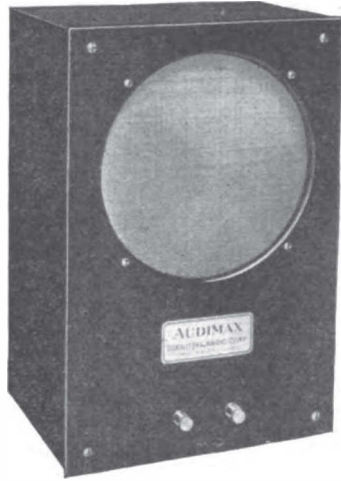

THE AUDIMAX

The Audimax loud speaker is complete in every respect and will operate satisfactorily with any standard two or three stage audio amplifier.

The Amplifying horn used in the Audimax is so designed as to reduce distortion on voice and music. The Audimax enables you to hear concerts clearly and distinctly all over the house without using head receivers.

The cabinet is solid mahogany, beautifully finished with a genuine hand-rubbed finish. The dimensions are 16" by 11" by 9". Price \$30.00.

Ask your dealer to demonstrate the Audimax.

Dealers and jobbers write for our immediate delivery proposition.

DOOLITTLE RADIO CORPORATION
817 CHAPEL ST., NEW HAVEN, CONN.

NEW FREE BOOKLET

entitled

Bradleystat
REGISTERED U.S. PAT. OFF.
PERFECT FILAMENT CONTROL

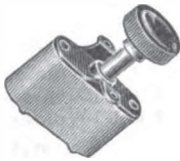

Bradleystats
for sale by
Radio Dealers

\$1.85

P. P. 10c extra

Radio enthusiasts, everywhere, are sending for this up-to-the-minute booklet on the simplest and most accurate method of vacuum tube control. You should have a copy to keep up-to-date in radio. Does away with wire-wound, troublesome filament rheostats.

Allen-Bradley Co.
Electric Controlling Apparatus
277 Greenfield Av.,
Milwaukee, Wis.

Manufacturers of graphite
rheostats for 20 years.

Kwik-lite WIRELESS "B" BATTERIES

Are Quality Batteries, Different
From the Ordinary



They are made of Seamless Cells. Every one is carefully tested for noiseless operation before leaving the factory and is guaranteed to give longer life and better service than any other battery made. Send today for prices and full particulars about this BETTER Battery.

THE USONA MANUFACTURING CO., Inc.
ONE HUDSON STREET
New York City

TOLEDO SAN FRANCISCO

HOMMEL

Radio Equipment Service For the Dealer

HOW much of an investment must I be prepared to make?

How much of this, that, and the other thing should I carry?

These are the most vital of the many questions which the prospective dealer must answer—

We can help you answer them, because we have a Dealer Service Department which is devoted to the study of markets, turn-over, the proper selection of radio equipment, and other subjects that concern the dealer.

Furthermore, we are distributors for more than 40 of the most prominent manufacturers, and are usually in position to supply most of the dealer's needs from our large stocks.

Write us about your problems—our service will not obligate you in any way.

Catalogue No. 100T sent upon request.

WHOLESALE ONLY

DISTRIBUTORS FOR

Radio Corp. of Amer.
Westinghouse
General Electric

Murdoch	Acme
Fada	Rhamstine
Remler	Kellogg
Frost	Holtzer-Cabot
Brandes	Connecticut
Pacent	General Radio
Burgess	Radio Service
Hipco	Homcharger
DeForest	Brach
Baldwin	Chelsea
Signal	Arkay

Clapp-Eastham
and other leading
manufacturers



LUDWIG HOMMEL & CO

530-534 FERNANDO ST.

PITTSBURGH, PENNA.

MAGNAVOX Radio



— and even
to this remote
mountain hunting lodge

FAR from the
"repair man"
or your own
workshop, you can
always rely confi-
dently upon the
service of a Magna-
vox Radio, the re-
producer supreme.

The name "Magna-
vox" is a symbol and
pledge of absolute satis-
faction—the Magnavox
Radio increases many
times over the use you
now get from your re-
ceiving set.

Without Magnavox
Radio no wireless re-
ceiving set is complete.

*Any radio dealer will
demonstrate for you,
or write to us for de-
scriptive booklet and
name of nearest
dealer.*

The Magnavox Co.
Oakland, California
N. Y. Office: 370 Seventh Ave.
Penn. Terminal Bldg.

Radio brings it
MAGNAVOX
tells it

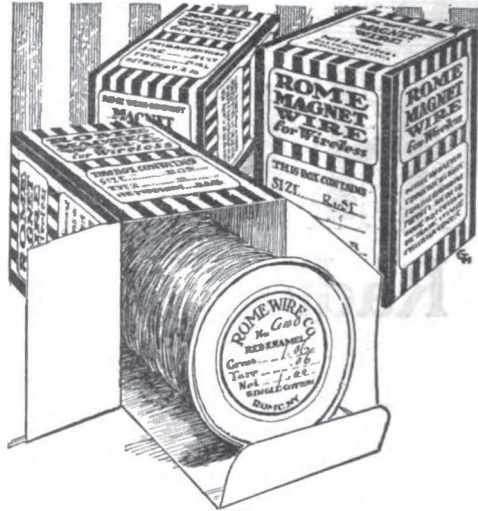

For satisfaction
Demand Rome Blue
and White Package
or Label.

ROME RADIO WIRE

Magnet Wire

**Best Quality Plain Enamel Covered ;
Enamel—and Single or Double Cot-
ton Covered ; Single or Double Cot-
ton Covered.**

All Sizes ; 1/4-lb. to 40-lb. packages.

Antenna Wire

**Best Quality Solid or Stranded Cop-
per Antenna Wire, plain or tinned ;
put up in lengths of 100-ft. and 150-
ft. or on 24" reels of 200-lbs.**

At Your Dealer's

**ROME
WIRE COMPANY.**
ROME, N. Y. BUFFALO, N. Y.

DISTRICT SALES OFFICES

NEW YORK . . . 50 Church Street / CHICAGO . . . 14 E. Jackson Blvd.
DETROIT . . . 25 Parsons Street
LOS ANGELES . . . J. G. Pomeroy, 336 Anns Street

2067-L

Put Prest-O-Lite Quality Into Your Radio Equipment

What the name, *Prest-O-Lite*, means to the automobile, it means to radio. Embodying the same battery principles and the same standards, the Prest-O-Lite designed especially for radio use delivers regular Prest-O-Lite satisfaction.

For summer months, it is without a rival. Its continuous, even rate of discharge eliminates necessity of continual adjustment.

A tasteful piece of cabinet making in mahogany finish, it harmonizes with any furnishings. Equipped with rubber feet, it does not deface furniture.

The Prest-O-Lite is beyond question the foremost battery for radio use.

Ask for it at any Prest-O-Lite Service Station; or your electrical dealer will get it for you.

We advise the selection of the battery of ample capacity to avoid frequent recharging. When it needs recharging, remember there is a Prest-O-Lite Service Station in your vicinity.

THE PREST-O-LITE COMPANY, Inc.

Carbide and Carbon Building
30 East 42nd Street, New York

Eighth and Brannan Streets, San Francisco, Calif.
In Canada: Prest-O-Lite Company of Canada, Ltd.,
Toronto

→ **ATTENTION DEALERS!** *Prest-O-Lite Batteries for Radio Equipment make the quickest moving stock to-day. Write for our proposition.*



Prest-O-Lite BATTERY For Radio Use



ALWAYS MENTION Q S T WHEN WRITING TO ADVERTISERS

89

TRADE **ESCO** MARK

**HIGH VOLTAGE MOTOR-GENERATORS STAND PRE-EMINENT
IN WIRELESS FIELD**



USED BY LEADING EDUCATIONAL INSTITUTIONS, U. S. GOV'T, RESEARCH LAB'YS,
NEWSPAPERS, DEPT STORES, ETC.

ESCO

Manufactures over 200 different combinations of windings for wireless and develops special apparatus
for special requirements. Send us your problems
Write for Bulletin 237—Complete Information

MOTORS—DYNAMOTORS—GENERATORS—MOTOR-GENERATORS

SOLD BY PRINCIPAL DEALERS EVERYWHERE



ELECTRIC SPECIALTY CO.
215 SOUTH STREET
STAMFORD, CONN., U.S.A.

If **QUALITY** counts, bear in mind that **ACE** equipment speaks for itself. An Ace type **TRU** Concert Receptor can be placed in your parlor, and is in a class with your piano or finest phonograph.

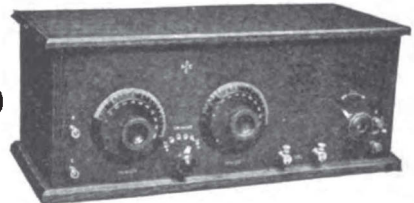

\$50 \$50

Licensed under Armstrong Patent No. 1,113,149

For electrical efficiency we claim our **TRU** to be equal or superior to any similar equipment now on the market.

A very important point to be considered in purchasing a Concert Receptor is the proposed change of wave lengths of broadcasting stations. The majority of Radio receivers now on the market would be worthless should this change be effected. Our receiver is arranged for immediate adaption to this change by even a most inexperienced person.

Better investigate—we have literature for the asking.

THE PRECISION EQUIPMENT CO.
2437-39 Gilbert Ave., Cincinnati, Ohio

ARKAY

**Universal Cam Switch
For Amplifiers**

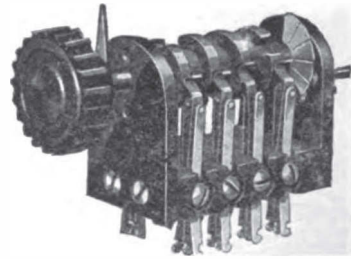

The Arkay Switch takes the place of jacks and plugs in amplifier circuits. Instantly changes from detector to amplifier—to any stage. Can be used as a send-receive switch or short and long wave switch by merely shifting the position of the cams on the shaft. Highest materials and workmanship backed by Arkay guarantee.

Price \$5
Directions With Each Switch
Discounts to Manufacturers, Jobbers and Dealers

Riley-Klotz Mfg. Co.
17 Mulberry St., Newark, N. J.

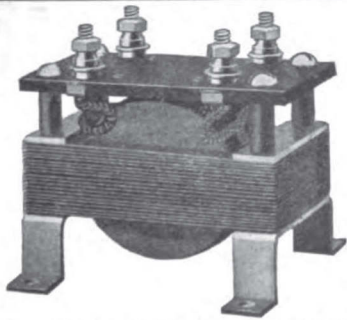

No. 236-W Modulation Transformer

The NO. 236-W MODULATION TRANSFORMER, when used in connection with FEDERAL MICROPHONES, will properly modulate the voice frequencies and produce clear speech in Radiophone service.

FEDERAL

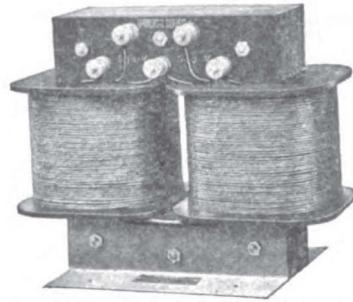

No. 315-W 500 W. C.W. Transformer

The NO. 315-W POWER COMBINATION TRANSFORMER, in connection with the circuit arrangement shown below, furnishes a 500 volt D.C. supply for plate potential and 12 volt supply for tube filaments, from your regular lighting circuit of 110 volts 60 cycle A.C.

C. W. APPARATUS

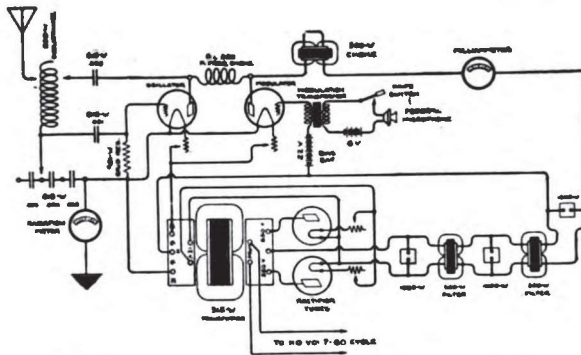

CIRCUIT OF RADIOPHONE USING RECTIFIED A.C. POWER SUPPLY

The NO. 300-W FILTER COIL, used in connection with FEDERAL FILTER CONDENSERS, will smooth out the pulsations in the D.C. supply. It is also efficient as a Choke Coil to prevent the high frequency from getting into the power transformer or generator. The FEDERAL FILTER CONDENSER is especially designed for use in C.W. high voltage circuits and is guaranteed to withstand the direct current potential specified.

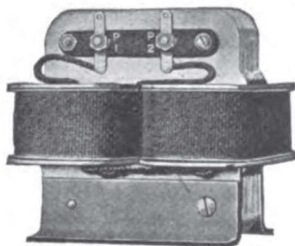

No. 300-W Filter Coil



No. 650-W, Tested to 650 volts (D.C.) 1 M.F.
No. 1000-W, Tested to 1000 Volts (D.C.) 1 M.F.

For Best Results Be Sure to Get GENUINE FEDERAL APPARATUS

Federal Telephone and Telegraph Company
BUFFALO, NEW YORK

ALWAYS MENTION QST WHEN WRITING TO ADVERTISERS



When you see the name Teagle on a radio instrument you know that it is a better piece of apparatus. Send for catalog. Teagle Radio Division of

THE NEWMAN-STERN CO - CLEVELAND, OHIO

IMITATIONS!

NAA Arlington tested Detector Crystals have won their reputation through sheer goodness—through their marvelous and uniform sensitiveness—by the honesty with which they are tested, packed and guaranteed.

That there should be imitations of these nationally famous minerals is to be expected. We welcome fair competition. But unscrupulous imitations are unfair both to you, the user or dealer and to us, the pioneer producers of tested crystals.

Certain unscrupulous manufacturers are marketing so-called tested minerals in packages closely resembling the famous NAA containers.



We have obtained and tested dozens of these so-called tested crystals—some are without a sensitive spot on their surfaces—others are of mediocre quality—not one meets the rigid requirements of our testing laboratories.

We sell sensitiveness, not bulk minerals. Pounds of crystals are worthless—Galena for instance, is cheap—the market price is less than 3c a lb. For crystals worthy of efficient radio use insist upon the genuine NAA (Arlington tested) Detector Crystals. For your own protection look for the signature of J. S. NEWMAN the originator, on every container. It will insure guaranteed sensitiveness. Each is packed in lithographed metal container. The mounted crystals are set into brass cups and packed in enameled turned wood boxes.

NAA Galena Silicon or Goldite, price per crystal, post paid, \$0.25. Mounted, set in Woods Metal in brass cup, price per crystal post paid, \$0.40.

We will gladly replace without charge any NAA Crystal that does not function to the entire satisfaction of the user. Send for complete 80 page radio catalog describing these crystals, The Teagle Line, "Red-Head" Radio Receivers and all the leading makes of Radio Equipment. The Newman-Stern Company Cleveland, O.



"RED-HEADS"
THE LAST WORD IN
RADIO RECEIVERS
at your dealers or
send direct to
Newman-Stern
CLEVELAND, OHIO.



RADIO PANELS AND PARTS

Start your set right. Pay particular attention to "insulation." Get a good panel and dependable parts. To make sure that you do get them look for the dealer displaying this sign:

**CONDENSITE
CELORON**

RADIO PANEL SERVICE

Condensite Celoron panels and parts are right. You can bank on them, for this strong, handsome, waterproof material (approved by the Navy Department, Department of Engineering) is extremely high in surface and volume resistivity and dielectric strength. It machines readily, engraves without "feathering," and takes a beautiful natural finish—polished or dull. This is why it is so widely used for panels, tube bases, mountings, variable condenser endplates, tubes, dials, knobs, handles, bushings, etc. We can machine all of these parts to your specifications.

Send today for our Radio Panel Guide

Are you an enthusiast? This Guide describes our panels in detail—tells how they are made and what they cost.

Are you a radio dealer? Learn about Celoron Radio Panel Service and how easily and profitably it enables you to supply your customers with panels and parts fully machined and engraved to their specifications. Write for our Special Dealer's Proposition today.

Diamond State Fibre Co.,

Bridgeport (near Philadelphia) Pa.
Branch Factory and Warehouse, Chicago

Offices in principal cities
In Canada, Diamond State Fibre Co., of
Canada, Ltd., Toronto

Stop that Leakage!

The Willard All-Rubber Radio "A" Battery (shown at the right) is not an automobile battery adapted for Radio use, but is a special radio battery built for the reception of C W and spark messages. The reduction of the weight of connectors, the increase in thickness of plates, the special radio type of Threaded Rubber Insulation are all features that are necessary to an efficient, economical battery of this type.



You'll have to admit it's annoying to have a radio concert or a conversation interrupted by noises that sound as if all the animals in the zoo had cut loose at once.

Some of these noises can't be stopped by even the most careful tuning. They can be ended only by removing the leaky cell or the leaky battery that's responsible for them.

One of the most important features of the Willard All-Rubber Radio Battery is that it is absolutely leak-proof. Battery case and jars are cast in one solid piece of rubber, eliminating the possibility of

leakage either from cell to cell, or to ground. Every case is tested at 24,000 volts.

The Willard All-Rubber Radio Battery has the same Threaded Rubber Insulation as the Willard Threaded Rubber Automobile Battery. The Willard Radio "B" Battery is a 24-volt rechargeable storage battery, with leak-proof glass jars and Threaded Rubber Insulation. Assures freedom from frying and hissing ground noises. Ask for particulars from your dealer, or at the nearest Willard Battery Station.

WILLARD STORAGE BATTERY COMPANY, Cleveland, Ohio
Made in Canada by the Willard Storage Battery Co. of Canada, Ltd., Toronto, Ont.

Willard THREADED RUBBER BATTERY

SERVICE IS
P.W.S.
 SLOGAN



PHILADELPHIA WIRELESS SALES CORP.
 1533 PINE STREET, PHILADELPHIA, PA.

Since 1911 the constant efforts of our personnel to render the highest possible service to manufacturers and dealers has placed us among the leaders in the Radio field.

Every article sold by us is backed by our approval, which marks it as a standard product of merit.

We cordially invite you to avail yourself of this service, whether your business is large or small.

We will be pleased to correspond with manufacturers desiring distribution in our territory.

Wire Your Own—
 and save 25%
 on high-grade
 assembled sets

Standard radio instruments are completely machine assembled in our splendidly equipped factory. The wiring, however, is left for you to do. By buying Standard instruments, you can get correctly assembled handsome radio instruments and at the same time save 25% or more of the cost by doing the wiring yourself. Our new 12-page folder now coming off the press, explains the Standard Plan in detail and illustrates Standard instruments in actual colors. Send 5c for your copy today in time to save money before your next purchase.

The STANDARD Plan
 "assembled—but not wired"

Standard Assembling Co.
 19 Bridge St., New York City



POSACO

Radio Instruments of Quality
 VARIABLE CONDENSERS

Our Condensers are all made with 4 1/2" Dia. Metal Shield. Rotary plates cannot turn on shaft even should nut become loose. Furnished unmounted and in table type.

ASK YOUR DEALER OR ORDER DIRECT

A-1	43 Plate	.001 MFD. Capacity	\$4.50
A-2	23 Plate	.0005 MFD. Capacity	4.00
A-3	13 Plate	.00025 MFD. Capacity	3.50

Add 25c to Above prices for table type. Add 75c for Dial

Special Discount to Dealers and Jobbers

THE C. D. POTTER CO.

583-585 Pacific Street, Stamford, Conn.

RHAMSTINE*

Rheostat



\$1.75
Postage 6c.

The Rhamstine* Rheostat conveys instant and vivid conviction of value.

It is a new Rhamstine* Product and aside from its original design and attractive appearance, it possesses these valuable features:

1. **Compactness**—the element ring is only $1\frac{1}{4}$ " in diameter.
2. **One hole for mounting**—the bearing for the shaft also holds the rheostat frame.
3. **Brush Contact**—two stationary brushes make contact with the resistance element.
4. **Air cooled.**
5. **Noiseless.**

It is exceptionally well made, dependable and durable and quite advanced in design.

Ask your dealer to show you how it works.

Circulars upon request.

Manufactured by

J. Thos. Rhamstine*

2152 E. Larned St. Detroit, Mich.

*Manufacturer of Radio Products

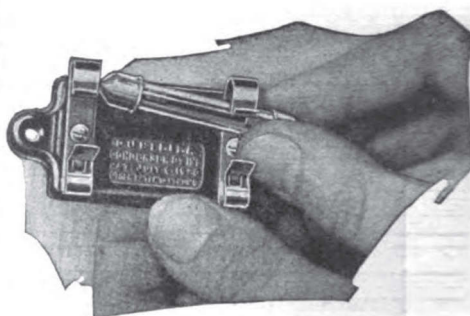

For Perfect Broadcasting Reception Use Micadon Type 600

A perfect Dubilier mica condenser, wherever employed, insures efficient receiving results.

Dubilier Type 600 Micadon, a reliable and durable condenser of permanent capacity, will last indefinitely.

Price in capacities from .0001 to .002 mfd, 75c each.

Price in capacities from .0025 to .005 mfd, \$1.00 each.

*If your dealer
cannot supply you
order from*

Dubilier Condenser and Radio Corp.

Dept. Q 5
217-219 Centre St. New York

BRANCH OFFICE,

Munsey Building, Washington, D. C.

LICENSEES:

England--Dubilier Condenser Co., Ltd., London
Canada--Canadian General Electric Co., Toronto
Germany--Telefunken Co., Berlin
France--C. Carpart, Paris

ALWAYS MENTION QST WHEN WRITING TO ADVERTISERS

Digitized by Google

The Book that brings Radio into the home -

WHAT THE BOOK CONTAINS

Section 1.—HOW RADIO ENTERS THE HOME. Contains just the information sought by the man who wants to buy a set. What set shall I buy? How much does it cost? What will it do? This section answers a hundred such questions. All types of sets are described from the least to the most expensive. Full installing and operating instructions.

Section 2.—HOW TO RECEIVE MOST EFFICIENTLY. Important receiving accessories are described in language that the layman can understand. For the benefit of the amateur, technical data are given on audio and radio frequency amplification, erection of antennae, battery charging, regeneration, etc. Valuable receiving-circuit diagrams are published for the first time.

Section 3. VACUUM TUBE TRANSMISSION FOR THE AMATEUR AND EXPERIMENTER. Everything from A to Z about transmission with new, completely revised transmitting diagrams, incorporating Radiotron transmission and Kenotron rectification. Valuable operating instructions are given, and the use of mica condensers for transmission is emphasized.

Section 4.—GENERAL INFORMATION — A VERITABLE GUIDE BOOK TO RADIO. Government laws, National Electric Code Radio Rules, vacuum-tube "Don'ts," radio glossary, specifications for a scientifically constructed amateur station, complete price list of all R C A equipment.



Price
35c.

FOR the first time a book is published at a small price which gives the public all that it should know about radio. It is called "Radio Enters the Home," and it is written by experts. It tells how to enjoy popular radio broadcasting, and it gives complete descriptions of apparatus and installation instructions. No book so richly illustrated, so accurate, and yet so understandable has thus far been published.

The book is divided into four sections. Over 200 illustrations, 112 pages, size 8"x11". The technically uninformed man will find in sections written especially for him the simply presented fact that he seeks; in other sections are data and diagrams that appeal to the trained amateur.

PRICE, AT YOUR DEALER..... 35 cents

If your dealer has exhausted his supply, send 35 cents to

Radio Corporation of America
WORLD WIDE WIRELESS

233 BROADWAY ~ NEW YORK CITY
Sales Division, Suite 1803



Introducing
ROLLER-SMITH
UNIVERSAL Type
Radio Telephone Receivers

"UNIVERSAL" because they give equally good results with crystal or vacuum tube sets and are also *particularly* well adapted for loud speaking units. They are highly sensitive and perfectly matched. They reproduce without distortion from the highest to the deepest notes.

The design and workmanship are of the high standard which is characteristic of all *Roller-Smith* products.
 Send for Bulletin No. AG-20. It's free.

ROLLER-SMITH COMPANY
 Electrical Instruments, Meters and Circuit Breakers



MAIN OFFICE:
 16 Park Place, NEW YORK

WORKS:
 Bethlehem, Pa.

Offices in principal cities in United States and Canada

BRACH
 vacuum
LIGHTNING ARRESTER

*Guards Your Radio Like a Sentinel,
 Day and Night.*

Every lightning flash fills the air with static which has its potential dangers to every radio and home unless they are protected by the BRACH Vacuum Lightning Arrester.

This unflinching sentinel requires no attention—it is on the job all the time, does not have to be switched and cannot become grounded.

The Brach Arrester has been used successfully for 16 years on railway signal systems, the New York and other fire alarm systems and by the U. S. Army. Skilled engineers know its value and specify it.

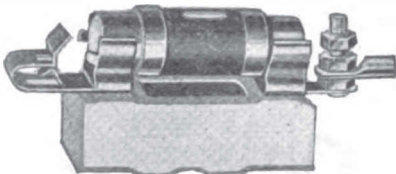

Listed By the Underwriters' Laboratories
 Sold By Leading Dealers Everywhere

L. S. BRACH MFG. CO., Newark, N. J.
 16 Years Specialists in Lightning Protective Apparatus.

NOVO "B" Batteries



**NOISELESS — DEPENDABLE —
 GUARANTEED**

All Standard Sizes—Plain and
 Variable

22½-45 & 105 Volts

Write for Catalogue and Discounts.

**NOVO
 MANUFACTURING CO.**

424 W. 33rd St.
 NEW YORK

531 So. Dearborn St.
 CHICAGO

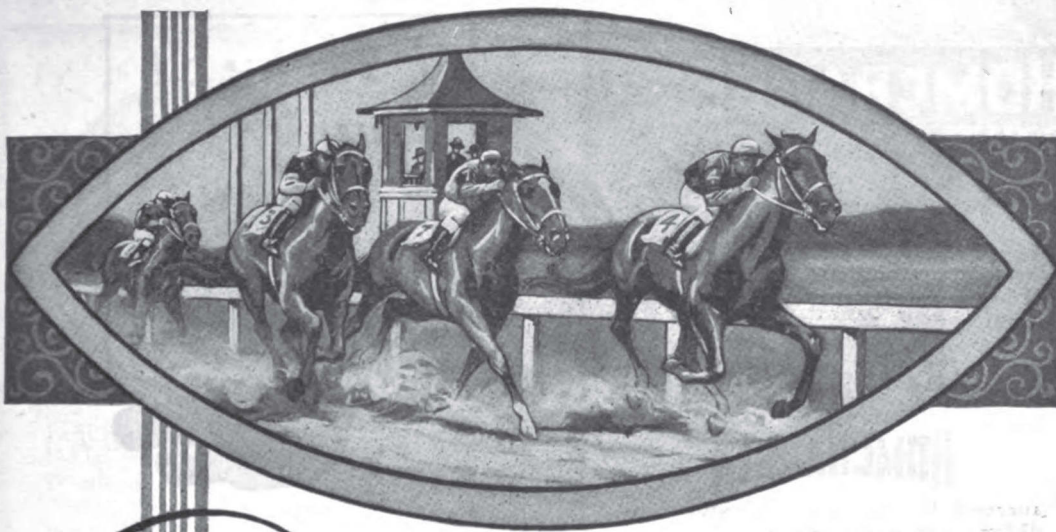

We're off!!!



OFF THE beaten path and on the trail to a worthwhile goal. "Thoroughbred Apparatus" has been constantly winning new friends and has hung up some enviable records as a quality leader in radio apparatus.

Our goal is, *unwavering superiority* and we intend to come under the wire *with* "Thoroughbred Apparatus" in the lead of the radio field.

On June 1st we moved into our new factory. Now, with greatly increased facilities, we are prepared to handle your orders as they come. Write for our interesting offer to reliable dealers.

"Thoroughbred Apparatus" consists of: Moulded Variometers, Vario-couplers, "Read 'em" Binding Posts, 17 styles, Amplifier Panels, Detector Panels, Variable Condensers, Fixed Condensers, Binding Posts, Contact Points and Stop Pins, Switch Levers, Dials, Single Sockets, Rheostats, Crystal Detectors.

THE MARSHALL-GERKEN CO.

Jackson and N. 12th St., Toledo, Ohio

Thoroughbred Apparatus

ALWAYS MENTION QST WHEN WRITING TO ADVERTISERS

99

HOMCHARGE YOUR BATTERY

for A Nickel

No muss, trouble, dirt—no moving of batteries—loss of time—no effort on your part—no technical or professional knowledge needed.



THE HOMCHARGER

successfully meets all charging conditions, and is the only rectifier combining the following essential Hom-charging features.

1. Self polarizing. Connect battery either way and it will always charge. No danger of reverse charging, ruined battery or burnt out Rectifier.
2. No delicate bulbs to break or burn out. Only one moving and two wearing parts. These are replaceable as a unit, after thousands of hours use, at small cost. Cannot be injured by rough handling.
3. Operation stops and consumption of current ceases immediately upon disconnecting battery.
4. The only charger costing less than \$100.00 that will fully charge a battery over night. Gives battery a taper charge—exactly as recommended by battery manufacturers. Guaranteed not to harm your battery even though left connected indefinitely.
5. Highest efficiency of any three or six cell charger made.
6. No danger of fire. Approved by the Underwriters.

ATTENTION MOTORISTS

Will charge your auto battery as well as radio battery. Send for Bulletin No. 58 for further information.

For sale by all radio, electrical and accessory dealers or shipped express prepaid for purchase price \$18.50

\$20 West of the Rockies

The Automatic Electrical Devices Co.
127 West Third St., Cincinnati, Ohio.

Branch offices: New York, Chicago, Pittsburgh, Los Angeles, New Orleans, Detroit, Philadelphia, Baltimore, Dallas, Kansas City, St. Louis.

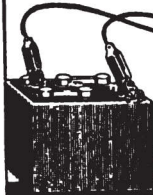

*Largest Manufacturers
of Rectifiers in the World*

*Protect
your VT's*

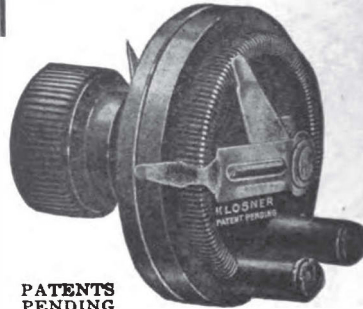

PATENTS
PENDING

KLOSSNER Vernier RHEOSTAT

EVERY TUBE you have de-serves a Klossner Vernier Rheostat. The Klossner WIRE WOUND feature produces a low starting current preventing sudden strain and thereby prolonging the life of the tube.

The Klossner provides micrometer adjustment for your critical detector tubes. One single knob controls both the rough and vernier adjustments. It is unsurpassed for loudest reception of telephone and C.W. and is essential for detector tubes of radio frequency amplification. Awarded the New York Evening Mail's Certificate of Excellence. Insist on the genuine—made only by the originators. Look for the name "Klossner" moulded on the base. The cost is no more than for other Rheostats without these exclusive features. At your dealer or send for interesting literature. Klossner Improved Apparatus Co., Dept. Q, 2024 Boston Road, New York City.

Dealers: This is the fastest moving rheostat on the market. It is stocked by all leading jobbers. Get your supply from them.

**One Single Knob
No Sudden Strain
\$1.50**



Look for this name "SIGNAL" on your Radio material.

A Word of Warning To Readers of QST

WAS P. T. Barnum right? Barnum, famous old circus man, had a motto:

"Get their money and get them out of the big tent."

All of which might have been very well in his day, and for the circus business. But it won't go today—in Radio.

TOO many mushroom Radio makers who have come up overnight follow Barnum's dictum to get their money and get rid of them.

Too much Radio equipment is built to *sell* to a Radio crazed public, eager for "anything new". The big question is: How can the sincere amateur and advanced beginner *know* the real worth of *his* Radio purchase?

The answer is: By the name on the apparatus, by what the name stands for, has stood for in wireless and radio for years back; By what professionals and experts say about material branded with that name.

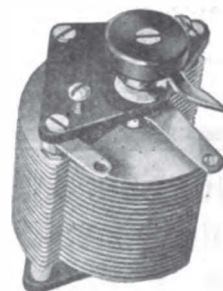

SIGNAL RADIO EQUIPMENT

is built for service, by Signal workmen in the Signal factory. Every SIGNAL product was designed and developed in Signal laboratories and is guaranteed high quality in materials and workmanship. During the war Signal saw real service. Today Signal is serving professional and commercial radio users as well as advanced amateurs everywhere. This is your assurance.

Signal Condensers No. 76-77 are rigidly built. Instead of using aluminum but .015" in thickness for the plates, as is usual with ordinary amateur construction, Signal plates are .026" thick.

SIGNAL ELECTRIC MANUFACTURING COMPANY

Menominee, Michigan

Use this request-coupon to secure latest SIGNAL Bulletins. Fill out and mail today. Put your radio problems up to us.

COUPON

Send me the new Signal Wireless Bulletin W.

Name

Company

City

State

DON'T IMPROVISE—PACENTIZE

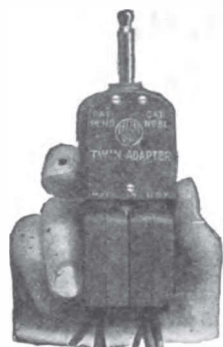

Pacent Twin Adapter

Makes one jack take two plugs.

Cat. No. 51

Price \$1.50

USE



RADIO ESSENTIALS

CONVENIENCES YOU NEED

The *original* products of their kind.
Backed with 15 years Radio experience.
Standard with largest radio manufacturers.
Indispensable for convenience and service.

Pacent Universal Plug

Pacent Radio Jacks

Pacent Twin Adapter

Pacent Multi-Jack

Pacent Duo-Lateral Coils

Pacent Standard VT Batteries

Pacent Universal Det. Stand

Pacent Audioformer

See Your Dealer or Send for Bulletins Describing Pacent Radio Essentials

PACENT ELECTRIC COMPANY

INCORPORATED

150 NASSAU ST.,

NEW YORK, N. Y.

CHICAGO, ILL.

WASHINGTON, D. C.

PHILADELPHIA, PA.

Member Radio Section, Associated Manufacturers of Electrical Supplies.

Buy Your Sots and Parts from the Oldest Exolusivo Radio Storo in Now England!

UNIT "B" BATTERIES	\$3.60
45V Variable	
CARBON RHEOSTATS	\$1.50
Adjust to .01 Amp	
PHONES HOLTZER-CABOT	\$8.00
2200 Ohms	
KEYSTONE LIGHT'G ARRESTORS	\$1.75
600V-100A LIGHT'G SWITCHES	\$2.75
Ebony Asbestos Base	

*We carry at all times a complete stock
of standard parts at standard prices.
Complete Line of Frost Jacks and Plugs.*

RADIO EQUIPMENT CO.
630 Washington St. Boston, Mass.
MAKERS OF THE RADECO SAFETY FUSE

JOY-KELSEY CORPORATION

Manufacturers of
RADIO EQUIPMENT

4021 Kinzie Street

Chicago, Illinois

WESTINGHOUSE

RADIO

BATTERIES

Eliminate all Battery Troubles from Radio Sets

The Westinghouse "A" Battery is a full capacity, low voltage slow discharge, long-life storage battery built exclusively for radio work.

For "B" battery requirements Westinghouse has perfected a baby *storage* battery. No more throwing away exhausted cells. No more continuous "B" battery expense.

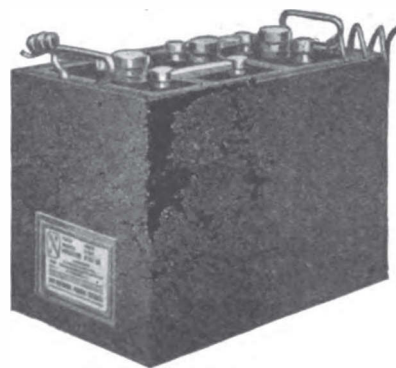

The Westinghouse "B" is a permanent battery. It never has to be replaced. It will discharge its load with constant, steady voltage. Then it can easily be recharged. It gives continuous service to the point of exhaustion without growing "scratchy." If your vacuum tube is inclined to be noisy you can adjust the contact on the Westinghouse "B" to take off the exact voltage the V.T. requires.

Get a Westinghouse "A" and "B" from your dealer or the nearest Westinghouse Battery Service Station and eliminate all your radio battery troubles.

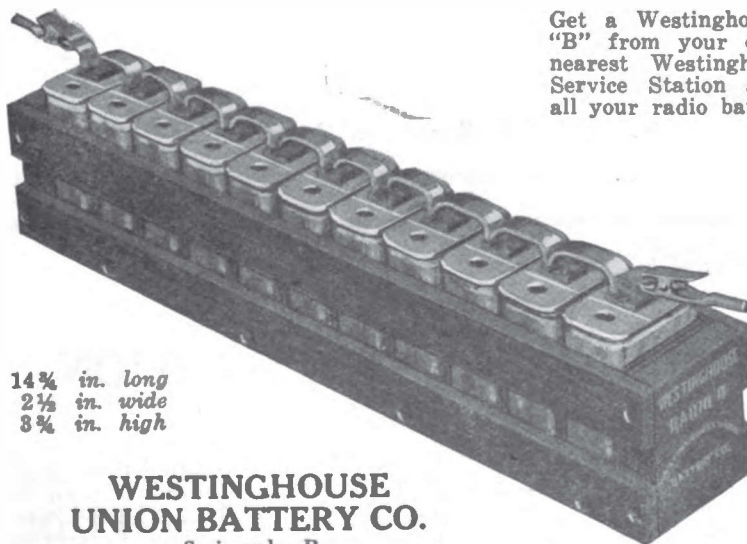

14 3/4 in. long
2 1/2 in. wide
3 3/4 in. high

**WESTINGHOUSE
UNION BATTERY CO.**
Swissvale, Pa.

*"The best
Westinghouse
can build."*



Thousands of Unfilled Orders
for the
TELMACOPHONE



Price
Complete \$20.00
Fully
Guaranteed

What's The Reason?

Much to our regret we have been unable to fill all orders for the Telmacophone promptly. The demand has been far beyond our expectations. When we first advertised the Telmacophone, we felt confident that it was the *greatest value ever offered*.

Our own confidence has been sustained by the public which has taxed our manufacturing facilities to the limit. All Unfilled orders will be taken care of just as soon as possible. To those who have not yet ordered the Telmacophone, we want to assure you that it is well worth waiting for. Do not be satisfied with an inferior substitute.

DEALERS! We are distributors for nearly all standard lines. Full discounts on the Telmacophone. Write for proposition on our complete line.

Radio Division
TELEPHONE MAINTENANCE CO.

20 S. Wells Street,

Note New Address
Dept. D.

Chicago, Ill.

QST QRX for the following:

We represent all the leading manufacturers and can make immediate delivery on most anything in the RADIO LINE of TODAY. A trial of our SERVICE will convince you.

SERVICE—OUR WATCHWORD

Send 5c for a copy of our catalog

ANTHRACITE RADIO SHOP

P. O. Box 3, Scranton, Penna.

**RAYMOND
RADIO
CORPORATION**

Manufacturers To the Radio Industries

V. T. Sockets
Rheostats
(Plain And Vernier)
Variable Condensers
Etc.

Executive Offices:
309 Lafayette St.,
New York City
Works:
Farmingdale, L. I.

Control Panel Units
Crystal Detector Sets
Vacuum Tube Sets
Storage B Batteries
Etc.

FROST RADIO PLUGS and JACKS

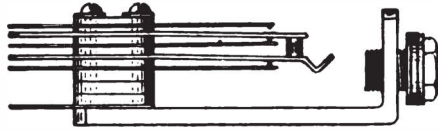

No. 136—Jack only, \$1.25

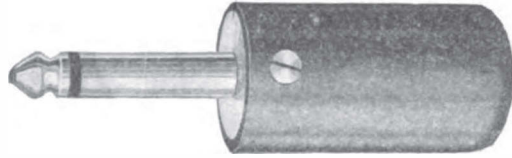

No. 137—Plug, \$1.25



No. 131—Jack only, \$0.90



No. 132—Plug, \$1.00

Buy Plugs and Jacks designed for radio use. FROST RADIO PLUGS AND JACKS are the smallest, neatest and most perfectly finished. Terminals are "spread" and tinned, making the soldering of wires a pleasure. Two-color Posters ready for distribution.

Attractive proposition for Jobbers and Dealers.

Made in all types, both plain and filament control, and interchangeable with any Standard Plug. We are ready to give immediate deliveries from stock, and can furnish any quantity up to ten thousand within a week after receipt of order.

Frost Fones—A Quality Achievement



Frost Fone No. 162 \$5.00

For the price, it's the best buy on the market. Test 'em out with your pet and be convinced. Prompt deliveries, and attractive Dealer discounts. Write for full information.

We solicit Dealer inquiries for all standard Radio materials.

WIRELESS MFG. CO., CANTON, OHIO

EXCLUSIVELY WHOLESALE

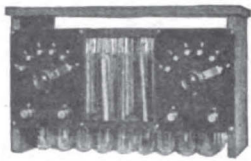

Storage Batteries

designed for

RADIO



KICO "B" BATTERY

KICO "A" BATTERY

FACTS ABOUT KICO STORAGE "B" BATTERIES—

1. Not an ACID "B" Battery.
2. They eliminate noises caused from "Bs" that are rapidly deteriorating.
3. The switch control allows single cell variations from 12 volts up. (A critical plate adjustment is essential on your detector bulb for C.W. and Radiophone reception.)
4. Rechargeable from your 110 volt A.C. line in connection with the rectifier supplied with each battery.
5. Will last from three to six months on a single charge while in the detector plate circuit.
6. NOT an experiment. All batteries are sold with the privilege of receiving your money back if unsatisfied.
7. Neat, Efficient and Compact.
8. Unlimited life.

	Plain	With Panels
16 cell 22 volts	\$6.50	
24 cell 32 volts	8.00	\$12.00
36 cell 48 volts	10.00	14.00
50 cell 68 volts	12.00	17.00
78 cell 100 volts	16.00	21.00
108 cell 145 volts	21.00	26.00

Literature gladly furnished.

KIMLEY ELECTRIC CO., 290 Winslow Ave., BUFFALO, N. Y.



BINDING POSTS

Large stock of these exceptionally well made binding posts with unremovable heads. Let us quote prices on the quantity you can use.

Radio Supply Service UP-TO-THE-MINUTE

The radio dealer needs a new kind of jobber service to meet the demands of a new and different business. North Ward Service is developed especially to meet this need. Give it a trial.

JACKS	Fixed Condensers
#30 Single Circuit Open	Switch Lever
#32 Double Circuit Close	Duplex Adapter
#31 3 Spring Automatic	Complete Crystal Sets
Filament Control	Crystal Detectors
#33 5 Spring Automatic	Double-Slider
Filament Control	Tuning Coils
	Coils

Distributors for The New Brandes
"Superior Type Matched Tone" Headset

Get our Prices and Discounts.

NORTH WARD RADIO CO.

72A Orange St., Newark, N. J.



Send 10c for Sample
Copy

Suite 10
11 St. Sacramento Street,
Montreal

CONDENSERS

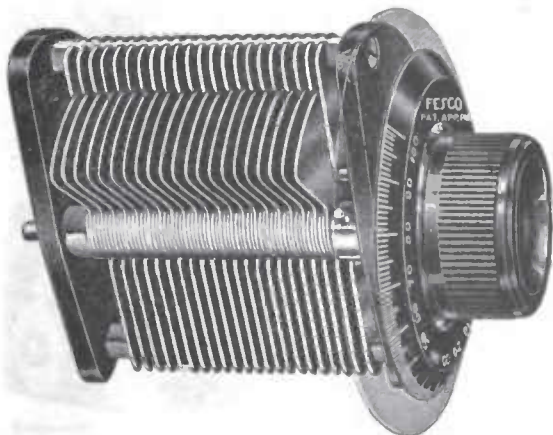

- 3 Plate.....\$2.25
- 11 Plate..... 3.25
- 23 Plate..... 4.00
- 43 Plate..... 4.75

Add 75c to above list for condenser with dial.

CAPACITY

- 3 Plate vernier.. .00004
- 11 Plate..... .00025
- 23 Plate..... .0005
- 41 Plate..... .001

Each condenser is equipped with ground shield which eliminates all hand capacity losses. No accumulated error due to poorly cut spacing washers.

BAKELITE **DIALS** BAKELITE

Furnished in either 3/16 or 1/4 inch shaft sizes. 3" outside diameter with large and clear numerals. 0-100 degrees.

Price\$1.10



This dial is made of genuine bakelite and is guaranteed not to warp. The knob is knurled to prevent slipping of fingers.

Price\$1.10

STERN & COMPANY, Inc.

308 Asylum St.,

Hartford, Conn.

Catalog 10c.

F E S C O

Dealers Propositions
Entertained

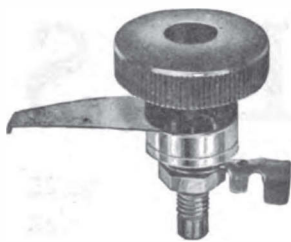

#750—1 1/2" Radius
#752—1" Radius
PRICE 55c EACH

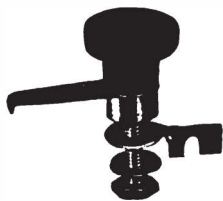

#751—1 3/8" Radius
#753—1" Radius
PRICE 30c EACH

USE WIS-WIN Switches

A chain is as strong as its weakest link. Get the most out of your set by using "WIS-WIN" switches.

Unit assembly, concealed spring tension, self-cleaning contact, highly polished nickel parts. Template for drilling contact holes furnished with each switch.

If your dealer cannot supply you, we will ship direct, postpaid, upon receipt of price.

Interesting Trade List

Manufacturers, we make switches for special requirements. Send us your specifications.

Willis Switch & Instrument Co.
8 Kingsbury St.
Jamestown, N. Y.



#754—1" Radius
PRICE 65c EACH

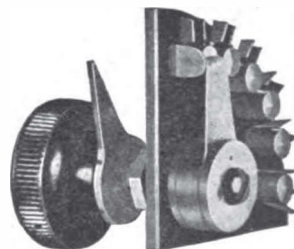

Switch points mounted in Formica sector for back panel use. Requires only one hole in panel to mount.

#756—Inductance
#758—"B" Battery
PRICE \$1.25 EACH

FOR IMMEDIATE SHIPMENT

V.T. SOCKETS

Kellogg\$1.00
Crosley60
Murdock 1.00

RHEOSTATS

Fada\$1.00
Crosley60
Bradleystat 1.85
Framingham 1.00
Howard 1.10
B. Battery 22 1/2 v. 1.75

V.T.'s

Radiotron 200....\$5.00
Radiotron 201.... 6.50
A. P. Amplifiers.. 6.50

AMPLIFYING TRANSFORMERS

J-Ray unmounted..\$3.75
J-Ray mounted... 4.75
Thordarson mtd... 4.50

SWITCH LEVERS

J-Ray nicked...\$0.40
Premier nicked... .60

VARIOMETERS

J-Ray K-D.....\$4.00
Unwound 2.00
National, assembled 5.00
Variaset (2 variometers 1 coupler)10.00

DIALS

J-Ray White
Enameled\$1.00
Bakelite Dials... 1.00

HEADPHONES

Manhattan 2000
ohms\$6.00
Stromberg-Carlson
2000 ohms 7.50

VARIABLE CONDENSERS

34 plate .001 mfd. \$4.80
23 plate 3.95
LOUD SPEAKERS
J-Ray Aluminum \$3.50
Magnavox45.00

PANELS

Formica 18 1/2 x 7 x
1/8\$2.25
9 1/4 x 7 x 1/8 1.15
Cabinets to fit \$6.50
and \$2.85.

Switch Points, Complete Receivers, Binding Posts, all leading makes carried.

Write for Bulletins.

J-RAY MFG. CO.

1618 Chestnut St.,

ST. LOUIS, MO.

Radio Frequency Transformers

Type RT-1, for the amateur and broadcasting range, 175-500 meters.

(Patent Pending)

\$6.00

Will work on all tubes.

The only completely shielded iron-core R. F. Transformer.

RASLA SALES CORPORATION

10 EAST 43d ST.,

NEW YORK CITY

National Distributors for Radio Service Laboratories, Inc.



14 YEARS OF KNOWING HOW

IF experience means anything to you, the fact that Murdock Receivers have been delivering satisfaction on a "money-back" basis for 14 years will influence your choice. Those years of experience have finally resulted in the No. 56 Murdock Headset which combines rugged strength with clear distinct reproduction of voice and music. Each ear piece is "Murdock Moulded" into one durable unit, capable of protecting the delicate adjustments through years of rough use. The improved signal corps type headband adds the feature of comfort.

Go to your dealer and examine Murdock Phones before you buy. Compare their durable construction. Test their sensitiveness. Convince yourself that there are no other phones so good at so low a price. And then, *after you have* bought, the 14-day trial offer assures you of satisfaction with your purchase.

PRICES—2000 OHM \$5.00—3000 OHM \$6.00

MURDOCK PHONES

WM. J. MURDOCK CO.

343 Carter St.,
Chelsea, Mass.

TRADE
“Q-R”
 MARK

THE VERNIER ADJUSTER

PRICE \$1.50

Practically
 Eliminates
 Capacity Effect
 From the
 Hands and
 Permits a
 Close Micro-
 meter Adjust-
 ment of the
 Dials

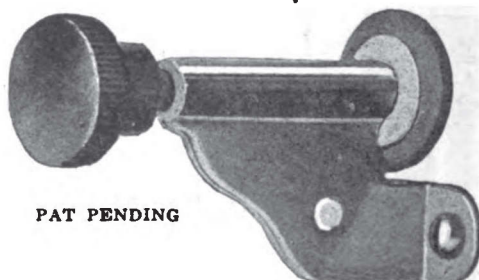

Easily and
 Quickly
 Attached
 to Any Type
 of Dial
 Without
 Removing Any
 Part of the Set

TYPE 100

MANUFACTURERS—JOBBER—DEALERS

WE HAVE AN UNUSUALLY INTERESTING PROPOSITION FOR YOU
 The Vernier Adjuster is an absolute necessity and our advertising cam-
 paign will materially assist you in placing them on the million receiving
 sets already in use.

ROBINSON SPECIALTY COMPANY

14 WALNUT ST. “Q-R” RADIO PRODUCTS KEYPORT, N. J.

Have You Tried PRACO SERVICE?

Hundreds of satisfied customers
 all over the country purchase
 from PITTSBURGH'S RADIO
 MAIL ORDER HOUSE.

A Two-cent stamp will bring our
 new price list to you.

DEALERS—Have you our dis-
 count schedule?

**PITTSBURGH RADIO &
 APPLIANCE CO., Inc.**

Desk B

112 Diamond St., Pittsburgh, Pa.

Prepared Radio Measurements

With
 Self Computing Charts
by Ralph K. Batcher

A new WIRELESS PRESS book. Pub-
 lished as a real help to amateur radio.
 Obviates the necessity of long and involved
 mathematical calculations. A ruler or
 transparent triangle takes the place of in-
 tricate figuring and the results will be
 correct every time.

PRICE \$2.00

The WIRELESS AGE

*The magazine that meets
 all your expectations.*

When its new you find it in the AGE.
 Every step in radio progress is fully and
 carefully described. You miss a lot of
 good things unless you read the AGE.
 \$2.50 per year, Postage outside U. S. 50c.

SPECIAL OFFER ONLY

Prepared Radio Measurements & The Wireless Age 1 Year \$4.00
 Outside U. S. 50c. Extra

WIRELESS PRESS, INC.
 328 Broadway, New York

Benwood Apparatus-Higher Efficiency

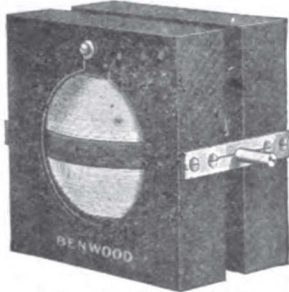

"Benwood Variometer"

A PROPERLY designed variometer brings in signals very much louder and clearer than the various other types of inductances on the market. With this fact in mind we have designed the "last word" in variometers—the "Benwood". Inductances are wound with double cotton covered wire and no shellac, paint or varnish is allowed to cover the wire and diminish the effectiveness. The "Benwood" features are—minimum distributed capacity, minimum distance between stator and rotor, large size wire on both coils, positive contact bearings, and proper design. This variometer will get splendid results on wave lengths from 150 to 650 meters with the average variocoupler. Price, each..... **\$5.00**

"Benwood" Vacuum Tube Socket

HERE is the very latest and best improvement in vacuum tube sockets—the new "Benwood". Solid, highly polished, molded Bakelite, specially designed for either base or panel mounting—the only one of its kind. Firmly holds any standard four-prong detector or amplifier tube. Eliminates ground hum and noises in operation of amplifiers. Terminal posts plainly marked. Base is 2 3/8 x 2 3/8 inches, height 1 1/2 inches. A good buy at..... **\$1.00**

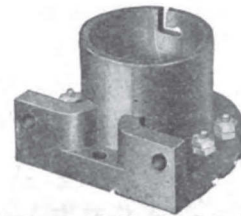

"Benwood" V. T. Socket



"Benwood" Dial Control

The New, Improved "Benwood" Dial Controls

THE "Benwood" controls all have solid Bakelite knobs of extra large diameter, which minimize all body capacity effects, and the new tapered design fits the fingers perfectly. The knurling is particularly fine and sharp.

Solid Bakelite Knob and Dial

Graduated 0° to 100°—all markings clearly defined in white and stamped into the solid Bakelite—won't wear off. Stops on reverse side prevent turning too far. Set screw deeply countersunk and easily reached.

	Diam.	Depth	Knob	Each
BC-7 "Benwood" control	4"	1 3/8"	2"	at base \$1.75
BC-8 "Benwood" control	3 1/4"	1 1/8"	1 1/2"	at base 1.50

Specify whether 1-4 inch or 3-16 inch drilling is required.

CATALOG—send 10 cents in stamps for the Benwood catalog and price list, also complete catalog and price list of DeForest Radio Equipment.

DEALERS—We manufacture high grade radio apparatus in our own factory and have stock ready to ship. Write or wire for our liberal dealers' discounts. New price and discount sheet issued June 15th.

Bakelite Binding Post

THESE "Benwood" binding posts have the same style tapered, knurled solid Bakelite grip which fits the finger tips and matches the "Benwood" dial controls. Diameter **20c** 5/8-in. Complete with two washers, each



The **BENWOOD** Co. INC.
RADIO
"WORLD-WIDE MAIL ORDER SERVICE"

1114 OLIVE STREET, ST. LOUIS, MO.

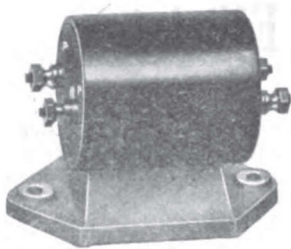

Complete With Instructions

Price \$4.50

THE EXCEL Radio Frequency Transformer



WAVELENGTH RANGE
200-600 Meters

NO POTENTIOMETER REQUIRED
NO HOWLING OR HISSING
DOES NOT IMPAIR NORMAL OPERATION OF YOUR REGENERATIVE
RECEIVER
10 TO 15 TIMES AMPLIFICATION PER STAGE AT BROADCASTING
WAVELENGTHS
USE WITH RADIOTRONS OR A. P. TUBES
IDEAL FOR LOOP RECEPTION

With two stages of EXCEL transformer coupled amplifier and detector, WJZ is heard with an audibility of 200 on a 4 foot loop at our factory. The outstanding advantage of the EXCEL transformer is that it can be connected in the circuit just like an audio frequency transformer. Its stability results from the fact that it amplifies by true voltage amplification instead of by partial regeneration.

Order direct or from your local dealer

EXCEL RADIO CO.

60 South Fifth Avenue,
Mount Vernon, N. Y.

KQV—Pittsburgh

Broadcasting Stations

Washington, D. C.—WMU

For Best Results Use the Stromberg-Carlson Radio Headset



Stromberg-Carlson
No. 2A Headset

\$7.50

The Stromberg-Carlson No. 2-A Headset reproduces broadcasted, long-distance vocal or musical sounds with unequalled distinctness. Fine tonal qualities, extreme sensitiveness and superior construction are its important features.

Order Above and Following Highest Grade Supplies by Mail
Immediate Deliveries on all Items Listed

Aerola Senior Westinghouse Receiver.....	\$65.00
Aerola Grand Westinghouse Receiver.....	325.00
DeForest Radiohome DT 700 less Batteries, Bulbs and Headset.....	38.00
DeForest 2 Stage Amplifier DT 800 less Bulbs and Batteries.....	38.00
Simplex Variometers.....	5.00
King Amplitone Horns.....	12.00
Holtzer-Cabot Headset.....	7.50
UV 201 Radiotron Detector Bulbs each.....	6.50
No. 766 Eveready VT Batteries, each.....	3.00
Gould 6 volt, 60-80 ampere storage batteries.....	23.00

Enclose Certified Check or P. O. Money Order including Postage

DOUBLEDAY-HILL ELECTRIC CO.

WASHINGTON, D. C.

Distributors

PITTSBURGH, PA.

AMATEUR RADIO CALL BOOK

Loose Leaf System, Amateur, Special, Experimental, Technical, Telephone Broadcasting, etc., kept to date monthly.

Postal Card for Particulars.

CITIZENS RADIO SERVICE BUREAU
418 S. Dearborn St., Chicago

*Who's Who and What's What
in Radio Communication*

OLIVER S. EVERETT

MAKER OF

SPECIAL RADIO EQUIPMENT

Quotations Furnished Upon Receipt of Specifications

83 OTTIS STREET, MEDFORD, MASS.

EISEMANN



RADIO
HEAD
PHONES

\$8.00

Complete

Specifications

Receiver Case—Aluminum.
Coils—Wound with highest grade enameled insulated copper wire.
Resistance—2200 ohms.
Ear Caps—Rubber composition.
Magnet—High percentage Tungsten Steel—permanent.
Diaphragm—Rust-proof.
Cord—Six foot.
Head Band—Approved spring wire—self-adjusting, sliding rod type.

FAITHFULLY reproduces all broadcasted musical and spoken sounds. This set is unequalled for tonal quality and perfect balance of the receiver.

Designed on sound scientific principles by an engineering organization of long experi-

ence. Made to give you the greatest possible enjoyment from your receiving outfit.

All products manufactured by the Eisemann Magneto Corporation are guaranteed to be mechanically and electrically correct.

Order from your Dealer or direct.

Jobbers and Dealers write for discounts.

EISEMANN MAGNETO CORPORATION

Radio Division

32-33rd Street, Brooklyn, N. Y.

DETROIT

CHICAGO

See August issue for interesting announcement of other Eisemann Radio Equipment

"TRY WECO"

Do you know that we are early pioneers in the radio game and know how to solve your buying problems? We are distributing for practically all the leading makers, and represent those of only the highest reliable standing. Tell us your needs and we will give you our very best service in obtaining them for you. Try us and see.

IMMEDIATE DELIVERY ON

General Electric Receiver and two stage Amplifier	\$125.00	Radotron UV-202, 5 watt transmitters..	8.00
Clapp-Eastham HR and HZ Sets, mahogany cabinet, each	40.00	Brach Lightning Arresters, inside type..	2.50
Westinghouse Aeriola "Seniors"	65.00	Brach Lightning Arresters, outside type..	3.00
Westinghouse RC Sets, very efficient	132.50	Electrose 4" Dials, very handsome.....	1.50
Federal No. 53-W Telephones, 2200 ohms..	8.00	GA Switch Arms65
Connecticut J-110 Telephones 3,000 ohms	7.00	WECO Sockets, No. 708.....	.75
Western Electric Type 1004 A.....	12.00	WECO 3" Dials, No. 307.....	1.00
King Amp-li-tones, a loud speaker with your own telephones, very efficient, very good looking	12.00	WECO 4" Dials, No. 308.....	1.45
Radotron UV-200, detectors.....	5.00	WECO 2½" Rheostat Dial, No. 308 scale 0-270'90
Radotron UV-201, amplifiers.....	6.50	Complete Assortment of WECO Binding Posts, Ace Batteries, all types, special prices. Complete Line of Signal Tuning Coils.	

We are distributors for Radio Corporation, Clapp-Eastham, Electrose, Federal, Acme, Ace, Eveready, Remler, Chelsea, Murdock, General Radio, Conn. Tel. & Elect. Co., Consolidated, Baldwin, Frost, and many others.

Catalogue will be mailed for ten cents in stamps

Dealers write for discounts.

QUALITY

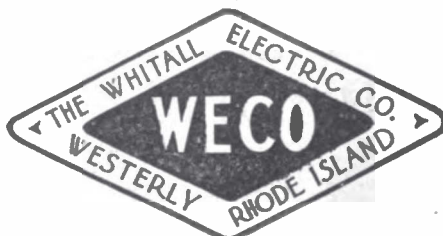

SERVICE

"YOU WILL LIKE TRADING WITH US"

WHITTALL ELECTRIC COMPANY,

WESTERLY, R. I.

DICTOGRAPH HEADSET

Look for the World-Famous Name "Dictograph"

ALL over the world "Dictograph" stands for the finest and most sensitive equipment made for transmitting and receiving sound. The Dictograph Radio Head Set is the product of the same experience that had made the Detective Dictograph, the Acousticon for the Deaf and the Dictograph System of Telephones, the world's standard for sensitive receiving, scientific accuracy and fine construction.

Dictograph reputation is your guarantee of supreme quality.

DICTOGRAPH PRODUCTS CORP'N.
220 West 42nd Street, New York.
Ready Soon—the Dictograph Radio Loud Speaker.

3000 Ohms



Price \$12

HERE

RADIO CITIZENS

Complete stocks carried for immediate shipment of the following apparatus:

Grebe Murdock
DeForest Adams-Morgan
Acme Radio Corporation
C. Brandes, Inc.
Federal Telephone & Telegraph Co.

FREE BULLETINS
PRICE LIST

Get the new lowest prices on apparatus and supplies. Bulletins and price lists mailed FREE on your request. Send for them today.

Nash Electrical Service Co.
Marshall, Ill.

"Chi-Rad" Apparatus

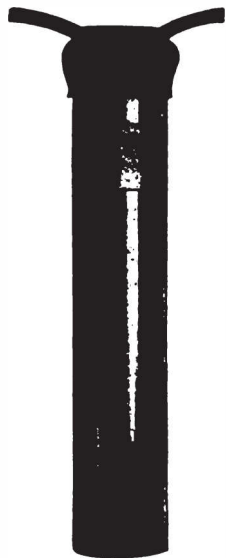

New Storage "B" Battery

A real storage "B" Battery for your Radio Set at a price every Amateur and Experimenter can afford to pay. Can be used on receiving apparatus as source of plate potential on both Detector and Amplifier tubes. Ideal as source of energy on small Radio Telephones or C.W. Transmitters.

Price per cell \$0.50
Add PP on $\frac{1}{2}$ lb.
per cell.

Simple and easy to re-charge from your lamp socket and will last for years with ordinary use.

SPECIFICATIONS:

Cut shows cell one half natural size.

Voltage per cell 2 volts.

Pasted Plates—ready formed for initial charge.

High Ampere Hour capacity—will operate one detector tube 1000 hours with one charge.

Shipped dry with simple directions for preparing the electrolyte.

Mahogany Tray for holding ten cells \$1.00 extra

Dealers:—Get our discounts on this new Battery—your customers will want them!

REMOVAL NOTICE

We have moved to 415 South Dearborn Street where we have opened a High-Grade Ground Floor Salesroom. With greatly increased space we will carry every make of good Radio Apparatus and will endeavor to have

"The Finest Radio Retail Salesroom in Chicago"

CHICAGO RADIO APPARATUS CO., Inc.

415 South Dearborn Street,

Chicago, Ill.

THE THORDARSON AUDIO FREQUENCY AMPLIFYING TRANSFORMER

is now standard with many well known manufacturers
That should be sufficient guarantee that it is right

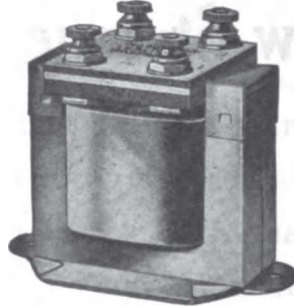

**SHELL
TYPE**

**PRICE
\$4.50**

Each transformer supplied fully mounted in an ingenious, nickered frame with substantial terminals mounted on a bakelite terminal board.

The terminal board is on the top, the only logical place for a terminal board. The transformer is wound with silk covered wire.

**BACKED BY THE "GOLD MEDAL" LINE
PRICE, AS ILLUSTRATED \$1.50**

Thordarson Electric Mfg. Co.

500 WEST HURON ST. COR. KINGSBURY,

CHICAGO

Try REYNOLDS RADIO Service

(Old)
9ZAF

from DENVER

(New)
KLZ

Distributors For—

Kennedy—Clapp-Eastham
Grebe—Chelsea
Remler—Frost
Murdock—DeForest
Magnavox Elec. Specialty

We are now located in our NEW STORE, with the largest stock of Radio Apparatus in the West. Our facilities for serving you have been greatly increased.

When you think of RADIO think of "REYNOLDS RADIO."

REYNOLDS RADIO CO., Inc. 1534 Glenarm Pl.
DENVER, COLO.

THE LARGEST DISTRIBUTORS OF RADIO APPARATUS IN THE WEST

WITHERBEE

RADIO A BATTERIES

Built Right Since 1903

**WITHERBEE STORAGE BATTERY
COMPANY, INC.**

643-55 W. 43rd St.,

New York City

**Best of Everything in
Radio Apparatus and Parts**

Send Stamp for Catalog "Q"

J. H. BUNNELL & CO.

32 Park Place,

New York



Complete Radio Enjoyment



No. 2-A Radio Head Set
Price \$7.50

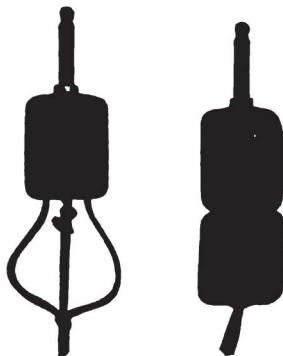

No. 60—Universal Plug
Price \$1.25



No. 147 Radio Jack \$0.85



No. 148 Radio Jack \$1.00

is obtainable only where high-grade Radio Apparatus is employed. In order to be sure that you haven't overlooked anything that will give you the most Radio enjoyment, comfort and efficiency, equip your receiving set with—

Stromberg-Carlson Radio Parts

STROMBERG-CARLSON "Radio Head Set" fits comfortably, is quickly adjusted, has unexcelled tonal qualities and reproduces the faintest long distance signals.

STROMBERG-CARLSON "Universal Radio Plug" should be attached to every Head Set—fits any standard jack—takes any type or size of conductor and takes wire loops, tinsel loops, pin tips or spade tips.

STROMBERG-CARLSON "Radio Jacks" are adapted to all standard Radio Plugs. They mount neatly without washers, on panels of varying thickness between $\frac{1}{8}$ " and $\frac{1}{4}$ ".

STROMBERG-CARLSON Radio Parts are made by a concern with 28 years' experience in designing and producing radio and telephone apparatus.

Order Stromberg-Carlson Radio apparatus through your electrical merchandise dealer, or write for free Bulletin No. 1029Q.

Stromberg-Carlson Tel. Mfg. Co.

Rochester, New York

Chicago

Address Nearest Office

Kansas City



**EASTERN
RADIO**

INSTITUTE

Tel.
Back Bay
5 9 6 4

**899 BOYLSTON ST.
BOSTON, MASS.**



RADIO today is commanding the interest of more people than any other industry! Splendid opportunities are NOW available for those who are alive enough to see the possibilities. My fifteen years experience in Radio tells you that FORTUNES will be made within the next five years for those who train themselves now and take advantage of the present opportunities.

The EASTERN RADIO INSTITUTE is the OLDEST, LARGEST and BEST EQUIPPED Radio School in New England. THOUSANDS of satisfied graduates tell our story best!

Day and Evening classes. Start any Monday.

REMEMBER:—Our ORGANIZATION with YEARS OF PHENOMENAL EXPERIENCE and SUCCESS is behind EVERY man who enrolls!

“Ask any man in Radio—he will tell you!”

Our illustrated prospectus for the asking.

F. D. PITTS, Director.

**10c. Charges Radio & Auto
Batteries AT HOME WITH AN F-F Booster**



They Charge Automatically Operating Unattended. Leave Battery where it is, without even disconnecting it; Screw Plug in Lamp Socket, Snap Clips on Battery Terminals; Turn Switch & Battery will be Charged in the Morning. Is it not gratifying to feel that Your Radio Batteries will never fail & You are Always Ready to Receive Radiophone Broadcast Music Speech & News never having to be careful of or have to tell Friends that Your Batteries are dead. F-F Battery Boosters are Complete Self-Contained Portable Full Wave Automatic Magnetic Rectifying Charging Units, for 105-125 Volt 60 Cycle A.C. No Skill is Required. Infusible Carbon Rectifying Brushes Maintain Uninterrupted Service. They Save You 90c. a Charge & Last a Lifetime. **REDUCED PRICES:** Type 6 charges Radio "A" 6 volt Battery At 6 amperes \$15 Type B charges Radio "B" Batteries Up to 100 volts \$15 Type A-B charges Both Your "A & B" Radio Batteries \$20 Type 12 charges 12 volt Battery At 5 amperes \$15 Type 166 charges 6 volt Battery At 12 amperes \$24 Type 1612 charges 12 volt Battery at 7 amperes \$24 Type 1626 is a Combination of Both Types 166 & 1612 \$36 All Types but B charge Auto Batteries. The largest types are for heavy Batteries or Where Time is limited. Shipping Weights 11 to 15 lbs. Purchase from Dealer, or Mail Check for Prompt Shipment. If via Parcel Post add Postage & Insurance Charges. Or have us ship C.O.D. Other F-F Battery Boosters charge Batteries from Farm Lighting Plants & D.C. Circuits & For GROUP CHARGING use our 12 Battery 8 Ampere Full Wave Automatic ROTARY Rectifier Described in FREE Bulletin No. 31A Order Now or Write Immediately for Free BULLETIN No. 31

**The France Mfg. Co. OFFICES & WORKS
CLEVELAND, OHIO, U.S.A.**

Canadian Representative: Battery Service & Sales Co., Hamilton, Ontario, Can.

“NEWRAD”

**The Mark of satisfaction
Immediate Shipment**

- Variocouplers \$6.50
- Variometers 6.50
- V.T. Sockets75
- Rheostats 1.50
- Amplifying Trans. 5.00
- Dials 1.10
- Phones—All Makes
- Magnavox 45.00
- Switch Points03
- Switch Levers65
- Plugs, Jacks—Federal
- Binding Posts12
- Insulators—All Types
- Condensers 4.50

We handle all leading makes of equipment

The New York Radio Laboratories

Manufacturers, Jobbers, Dealers

ACKERMAN BLDG., BINGHAMTON, N. Y.

PARAGON

THE

Pioneer

- 1915 First regenerative receiver ever manufactured bore the name PARAGON.
- 1916 First Trans-continental Amateur Reception (California from New York; not pre-arranged) effected with a PARAGON Type RA-6 Receiver.
- 1916 First Trans-continental Amateur Transmission (New York to California; not pre-arranged) effected by PARAGON designed transmitter.
- 1917-1918 PARAGON acknowledged supreme on Western Front.
- 1921 First Trans-Atlantic Amateur Reception effected with PARAGON receiving equipment, at which time 27 different amateurs scattered thruout the Eastern section of the United States registered signals at Ardrossan, Scotland—3500 miles.

THERE'S A REASON!

The Adams-Morgan Company

Manufacturers

UPPER MONTCLAIR, N. J.

DEALERS GET SPECIAL PROPOSITION

Send to KLAUS—"Radio Headquarters" for special discount lists and bulletins on apparatus and equipment. Our service department offers dealers assistance and advice on radio problems. We distribute "tested" apparatus. We know the equipment we send you is right. We want all Agents and Dealers to get our special proposition on the best lines of apparatus made.

Get our Prices on these lines of apparatus

Acme
Adams-Morgan
Baldwin
Brandes
Westinghouse

Clapp-Eastham
DeForest
Jewell
Federal
Radio Corporation

Grebe
Moorhead
Murdock
Pacnet

Write today to---

KLAUS RADIO CO.

Dept. 100

Eureka,

Illinois

FIRST TESTED THEN SOLD

JEFFERSON Amplifying Transformers



No. 45

BY ACTUAL TEST JEFFERSON Amplifying Transformers have proven superior to anything now on the market. Try them and note the improvement, the absence of distortion and the clearness of tone.

FURNISHED IN TWO TYPES, either mounted or unmounted. Wound with No. 40 and No. 44 wire on a core of highest grade 36 gauge Silicon steel.

Send for Radio Bulletin

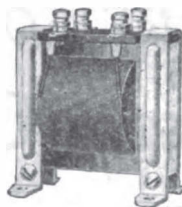

No. 41

REASONABLY PROMPT DELIVERIES

Jefferson Electric Mfg. Co.

425 S. Green St., CHICAGO

RADIO APPARATUS

In Stock for Delivery—NOW

RECEIVING SETS

Grebe CR9\$130.00
Grebe CR5 80.00
Westinghouse Grand 325.00
Westinghouse R. C. 132.50
Westinghouse Senior 65.00
Clapp-Eastham H R 35.00
Clapp-Eastham H Z 35.00
DeForest Crystal Set 25.00
Federal Crystal Set 25.00

PHONES

Brown 4000 Ohms\$18.00
Western Electric 2200 Ohms	... 15.00
Federal 52-W 3200 Ohms	... 10.50
Federal 53-W 2200 Ohms	... 8.00
Holtzer Cabot 2200 Ohms	... 8.00
Everett 3000 Ohms 8.50
Kallogg 2400 Ohms 12.00

TRANSFORMERS

Federal Audio Frequency\$7.00
General Radio Audio Frequency	5.00
Radio Corporation Audio Frequency	7.00
Coto-Coil Audio Frequency	5.00
Coto-Coil Radio Frequency	5.50

CONDENSERS

Vernier 3 plate	.. \$1.50—\$2.50
Ideal 11 plate 3.00
Ideal 23 plate 3.75
Ideal 43 plate 4.75
Federal 23 plate 3.25
Federal 43 plate 4.00
Coto-Coil 15 plate	4.50
Coto-Coil 23 plate	5.00
Coto-Coil 33 plate	6.00

BULBS

U.V. 200 Detector	\$5.00
U.V. 201 Amplifier	6.50
U. V. 202 5 Watt	8.00
Audiotron 2 filament	6.00

Also a large stock of all necessary parts for making your own sets.

JAMES H. JONES

94 Massachusetts Ave., Boston, 17, Mass.

Enjoy the Great Radio Concerts No Matter Where You Live

THOROPHONE

(THUNDERPHONE)

TRADE MARK REG. U.S. PAT. OFFICE

**Will Bring America's Popular
Orchestras and Most Re-
nowned Soloists Into
Your Home**

Winkler-Reichmann Co., Ameri-
ca's OLDEST manufacturer of
Loud Speaking Telephones, of-
fers the THOROPHONE for
RADIO CONCERT WORK as
its latest success.

In bringing out the THORO-
PHONE with Concert Horn—
beauty and clarity of tone—am-
ple volume—and mechanical
perfection have been made out-
standing features of design.

Lay aside your head receivers—
invite your friends in—enjoy
with them a real musical treat.
Use the THOROPHONE also
for detecting and tuning.

The Thorophone requires better
than the average radio receiving
set to give a great, big power-
ful volume, but just give it the
power and its musical qualities
will astonish you.



Model K400

Loud speaking re-
ceiver. Thoro-
phone is attached
to the bottom of
the base and is
concealed from
view yet easily
accessible.



\$35.00
Complete

Model 501

This beautiful instru-
ment gives you the de-
sired volume, and tone
of exquisite quality and
musical excellence.

THOSE DESIRING TO USE THEIR OWN PHONOGRAPHS CAN DO SO BY
ATTACHING OUR ADAPTER WITH THOROPHONE DIRECT TO PHONOGRAPH
TONE ARM.

The Loud Speaking Receiver— THE THOROPHONE

Has a controlled mica diaphragm, and
carefully designed sound box nickel
plated throughout. Does not use up
your storage battery. Simply connect
it on in place of your head receivers.

THOROPHONE

Model K400—\$20.00

Phonograph adapter extra

Model 350— .40

THE CONCERT HORN

Is a beautiful musical instrument, highly
ornamental to any home. The base and
tone arm are of mahogany finish wood,
the neck of heavy metal and the bell
of extra heavy spun aluminum. It has
great brilliancy, WITHOUT METALLIC
TONE.

CONCERT HORN

Model H300—\$15.00

Height 25 inches.

WINKLER-REICHMANN CO.

4801 South Morgan St.,

Dept. Q

Chicago, Illinois

DEALERS: We have a REAL loud speaker and a REAL proposition for you.

A.R.R.L.
Ontario
Division

Wireless
Association
of
Ontario

A.R.R.L. MEN

NOTE

FIRST CANADIAN NATIONAL CONVENTION— EXHIBITION OF RADIO ENTHUSIASTS

AT

PRINCE GEORGE HOTEL

TORONTO, CANADA

September 8 and 9, 1922

This is a Chance to Meet Your Canadian Brothers. Banquet Arranged for
Saturday Evening, 9th Sept. Being Held During the Last Two
Days of the

CANADIAN NATIONAL EXHIBITION

Offers You the Opportunity of Seeing the Largest Annual Exhibition in the World,
And Then Take in the Big

RADIO CONVENTION

Write For
Accommodation
E. J. Bowers (3CZ)
37 Lowther Ave.
Toronto

Reservations
For Display
W. C. C. Duncan (9AW)
196 Ellsworth Ave.
Toronto

Wireless
Association
of
Ontario

A.R.R.L.
Ontario
Division

Hygrade Specials

SAVE YOU MONEY

No. 766 Eveready 22½ volt large Variable B. Battery and Eveready Volt Meter	\$3.00
45 volt Cyclone large Variable B. Battery	2.75
Binding Posts (rubber cap), per dozen	.75
Electrose Insulators, per dozen	2.00
3-inch Bakelite Dials	.75
7-Stranded Copper Aerial Wire, 100 ft.	.65
Arkay Loud Speaker	4.00
Bakelite V. T. Sockets	.65
Fada Rheostats	.90
Klosner Vernier Rheostats	1.25
.001 M.F. Signal Variable Condenser with Dial	4.50
Thordarson Amplifying Transformers	3.98
Everett 3000 Ohm Head Set	6.95
Dictograph 3000 Ohm Head Set	9.95
Federal 2200 Ohm Head Set	7.25
Western Electric Head Set (Navy Type)	13.50
Homcharger—Rectifier	16.75

MARKO STORAGE BATTERIES

6 volt, 30 amp., guaranteed 2 years	\$10.00
6 volt, 60 amp., guaranteed 2 years	13.50
6 volt, 80 amp., guaranteed 2 years	17.00
6 volt, 100 amp., guaranteed 2 years	21.00

We do not charge for crating. Above batteries are fully charged when shipped.
Above prices are F. O. B. New York

Hygrade Electrical Novelty Co.
41 West 125th Street
Dept. S. NEW YORK

B K U M A Trade Mark
Reg't'n Ap. For **Y R L S B U G**

MEMORIZE CODE
Almost Instantly
ATTENTATIVE BEGINNERS
Who Use
DODGE ONE DOLLAR
RADIO SHORT CUT
DO ARRIVE

WILLIAM N. ADLER (2BGC),
576 East 143 St., New York.
MEMORIZED CODE IN 40 MINUTES QUALIFIED
FOR LICENSE AFTER TWO WEEKS PRACTICE.

J. ROBERT ZIEGLER (8AIO),
129 Dauphin St., Lancaster, Pa.
MEMORIZED CODE IN 30 MINUTES QUALIFIED
FOR LICENSE AFTER ONE WEEK PRACTICE.

INVESTIGATE

C. K. DODGE, Box 210, MAMARONECK, N. Y.

SHIP OWNERS
RADIO SERVICE
INC.

80 Washington Street, New York City

Radio Distributors

RADIO APPARATUS

Distributors of Reliable Radio Apparatus to Schools, Colleges, Radio Clubs and Experimenters all over the World!

"PITTSICO"
Specializing on "RADIO
CORPORATION'S"
Products



"PITTSICO"
Now has three Stores.
Send us your orders!

The present tremendous demand for Radio Apparatus has practically made it impossible for us to render our usual SERVICE. Reasonably prompt delivery, however, can be made on the items listed

AMPLIFYING TRANSFORMERS

No. P-1 General Radio, semi-mounted.....	\$5.00
No. 50 Chelsea, semi-mounted.....	4.50
No. A-2 Acme, semi-mounted.....	5.00

ANTENNA WIRE

"Pittsco" #14 hard drawn copper, (80 ft. per lb.) per lb.....	.40
500 ft. (Special value).....	2.25
"Pittsco" 7 strand #22 tinned copper, per ft.....	.01
500 ft.....	4.00
1000 ft.....	7.50
"Pittsco" 7 strand #20 Phosphor bronze per ft.....	.02
500 ft.....	7.50

ANTENNA INSULATORS

No. P-1 Electrode Ball insulator.....	.35
No. P-2 Electrode 4 inch strain insulator.....	.45
No. P-3 Electrode 10 inch strain insulator.....	.75

"A" BATTERIES (Storage Batteries)

Yale 6 volt 60 Ampere-hours.....	18.00
Yale 6 volt 80 Ampere-hour.....	21.00
Yale 6 volt 100 Ampere-hour.....	25.00

Note—These batteries are shipped carefully crated and fully charged ready for use.

"A" BATTERY RECTIFIERS

No. P-1 Tungar, 5 ampere type, complete with bulb.....	28.00
No. P-2 Tungar, 2 ampere type, complete with bulb.....	18.00
No. P-3 F. F. Battery Booster, 5 ampere type.....	15.00

"B" BATTERIES

No. 763 Eveready, 22.5 Volt, small size.....	1.75
No. 766 Eveready, 22.5 Volt, large size 16½ to 22½ Volts.....	3.00
No. 774 Eveready, 43 Volt, large size Variable.....	5.00

CRYSTAL RECEIVING SETS

Aeriola Jr. Westinghouse, complete with telephones.....	25.00
Everyman DeForest, complete with telephones.....	25.00

CONDENSERS (Variable)

No. 1 Chelsea fully mounted, .001 Mf.....	5.00
No. 2 Chelsea fully mounted, .0005 Mf.....	4.50
No. 3 Chelsea unmounted with dial .001 Mf.....	4.75
No. 4 Chelsea unmounted with dial .0005 Mf.....	4.25
No. 367 Murdock fully mounted .001 Mf.....	4.50
No. 368 Murdock fully mounted .0005 Mf.....	4.00
No. 3660 Murdock unmounted without knob and dial .001 Mf.....	4.00
No. 3680 Murdock unmounted without knob and dial .0005 Mf.....	3.25

TELEPHONES

No. 56 Murdock 2000 ohms.....	5.00
No. 56 Murdock 3000 ohms.....	6.00
No. 2A Stromberg Carlson 2000 ohms.....	7.50
No. P-1 Holtzer-Cabot 2200 ohms.....	8.00

Let "PITTSICO" fill your orders for any of the above items.
Our SERVICE on these at the present time will please you!

PITTS RADIO STORES, INC.
12 PARK SQUARE, BOSTON, MASS.

Woolworth Bldg.,
Providence, R. I.

3 Stores

276 Worthington St.
Springfield, Mass.

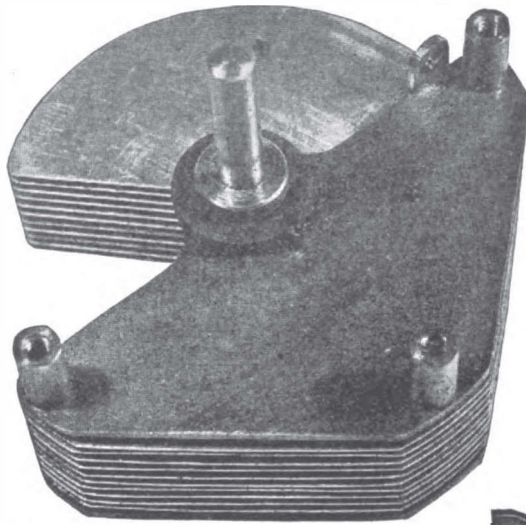

VARIABLE CONDENSER
 Cat. No. 9519.....\$3.50
 Knob and Dial.....\$1.00

Radio Apparatus:

Variometer parts, wound and unwound.

Variometer complete with Knob and Dial.

V. T. Porcelain Socket.
 Made to fit any Tube.

Wireless Ground Switch,
 100 amp. 5" Break, 600 V.

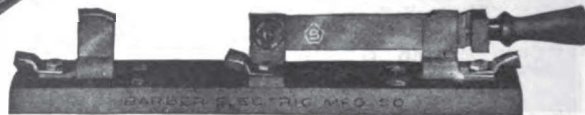

Cat. No. 3333, \$3.50

Barber Electric Manufacturing Company
 N. Attleboro, Mass.

Bulletin on request

VARIOMETERS AND VARIOCOUPLERS



These instruments are wound with extra heavy wire to reduce the resistance, and have special long bearings with a spiral spring inserted to insure a perfect and self cleaning contact at all times. The taps on the Vario-Coupler are arranged in two groups. Furnished with round or square base. Variometer as illustrated ..\$6.00 Vario-Coupler as illustrated.. 6.00

Round or Square Base

Get them at your dealer's.

SIMPLEX RADIO CO.

1013-15 Ridge Av., Phila. Pa.

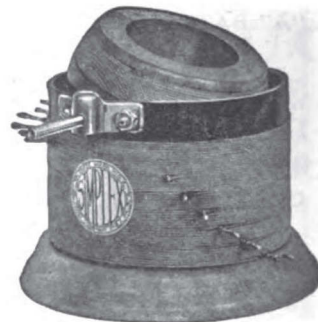

The OGDEN WIRELESS LABORATORIES

THE O.W.L. RHEOSTAT
 Patents pending

An instrument of real Value, NO THERMO-ACTION resulting in distortion because all parts are made of the same resistance alloy throughout.

PRICE - - \$1.00

1012 Ogden Ave.,

New York City

DEL FELCO

Complete line of Amrad, Thordarson, Coto-Coil, Chelsea, Murdock, DeForest, Products. Complete installations a specialty.

DELANCEY FELCH & CO.

12 MEETING ST.

PAWTUCKET, R. I.

Type "Q" Receiver



**AN IDEAL RECEIVING SET FOR LONG
AND SHORT WAVE AND RADIO
TELEPHONE RECEPTION**

This set is the most flexible receiving set on the market. With the use of the various sizes of Honeycomb Coils everything in the range of radio telegraph and telephone reception from 200 to 25,000 meters is brought into your home. Consists of a three coil mounting, and three Variable Condensers of proper capacity. Tuning extremely sharp. Remler dials.

Price without Detector \$35.00

Duck's New Radio Catalog No. 16



Send 25c in coin carefully wrapped today for copy of the greatest radio catalog ever put between the pages of two covers.

275 Pages--A Catalog DeLuxe

Never in the history of radio was such a catalog printed. The radio data and diagrams embracing upwards of fifty pages, gives the experimenter more valuable and up-to-date information than will be found in many books selling for \$2.00, and \$1.00 could be spent for a dozen different radio catalogs before you could gather together the comprehensive listing of worth while radio goods found in this catalog.

A brief summary of the radio goods listed in this catalog:

The entire radio catalog of the Radio Corporation, with a wealth of scientific and technical data on C.W. transmitting sets, and all the diagrams for the assembling of these sets; the complete Remler catalog, which embraces 25 pages, the Westinghouse, Firth, Murdock, Federal, DeForest, Clapp-Eastham, Brandes, Connecticut Company, Thordarson, Turney, Magnavox Company catalogs, the best products of Adams-Morgan, Signal and countless other manufacturers, including our own complete line of radio apparatus, and many individual items and parts used in radio work today.

Send 25c in coin, (carefully wrapped) for the new catalog. The great cost of this elaborate catalog prohibits distribution on any other basis.

The William B. Duck Company

243-245 Superior Street,

Toledo, Ohio

The Wholesale Radio Equipment Co.

Says

DEALERS

“Sample Our Service”

We Have On Hand For Delivery
TUSKA POPULAR RECEIVER

**Regenerative
Type 224**

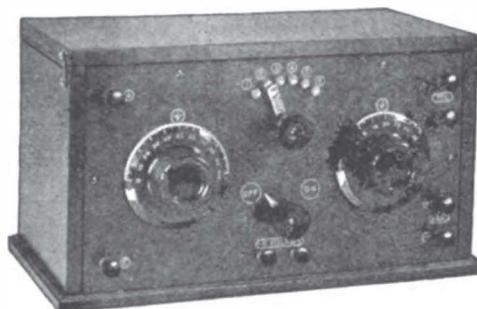

**Price
\$35.00**

This outfit is ready for tubes, phones and batteries. It is **COMPLETELY MOULDED**. Ideal for expert or beginner. Two knobs: one for wave length; the other, for amplifying. Type 224 has stood the test of public trial.

DEALERS:

Orders filled promptly for this outfit, also other standard sets and parts.

WRITE FOR PRICE LIST.

THE WHOLESALE RADIO EQUIPMENT CO.

26 WILLIAM ST., NEWARK, N. J.

“ Wholesale Exclusively ”

A Symbol of
Increasing
Significance



Westinghouse
Aeriola-Sr.
\$65 PAID POST

Complete with Brandes Headset and new Vacuum Tube—requiring but 2 amp. to heat filament and runs on a single 16 Dry Cell (50c) and small "B" Battery (\$1.75).

REGENERATIVE CIRCUIT

Range 500 miles with average antenna and ground system.

PROMPT SHIPMENT

Insist on SOMERVILLE DIAL INDICATORS

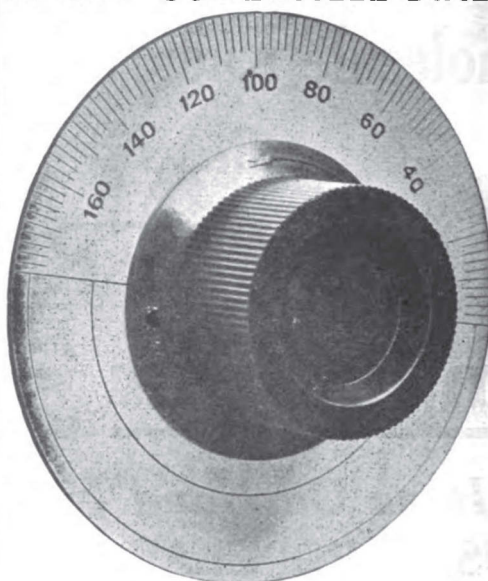

Cost More Than Imitations—But Are Worth the Difference.

PRICE
\$1.75

for the 4" Dia. model and

\$1.60

for the new 3 1/4" dia. model

POSTPAID

from us, or from your dealer.

New lot has dial insulated from shaft, so that dial may be grounded to act as a shield.

Why Pay More?
SOMERVILLE
100V. C.W.
Condensers
75c Postpaid

SOMERVILLE RADIO LABORATORY
176-178 Washington St., Dept. QST
Boston, Mass.

Send 25c for our ENLARGED Catalog!

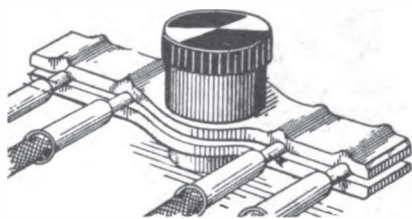

FOUR SETS OF PHONES

25c will buy a set of Multiple Binding Post Connections (patent pending) which provide the only practical means of attaching as many as 4 pairs of telephone receivers to a pair of ordinary binding posts.

Dual connection set provides same connection in attaching Magnavox and outfit to storage battery.

Either set will be sent postpaid upon receipt of 25c in coin or stamps. Satisfaction guaranteed or money back.

Portable Wireless Telephone Co.
Dep't B, Commercial Bank Bldg.,
STOCKTON, CALIFORNIA
Attractive Dealer's Proposition



It's easy, make you own **INDOOR COIL AERIAL**
Drawing, R. F. amplifier circuit, chart and tables giving proper number of turns to put on coil for any wavelength. Complete data covering 0 to 24,000 meters on 3 large sheets. \$1.00. Stamps not accepted.
C. A. DAVIS & COMPANY
2371 Champlain St., Washington, D. C.



SOUTHERN RADIO CORPORATION
Radio Engineers and Jobbers
906 Realty Building. Charlotte, N. C.

Head Receivers
Micro-Phones
Keys
Jacks
Plugs
Etc.



HIGH GRADE WIRELESS APPARATUS

Manufactured by

American Electric

COMPANY

State and 64th Sts., Chicago, U.S.A.

75c
EA.



KELLOGG V-T SOCKET
the durable socket

Kellogg molded lamp sockets fit all standard four prong based vacuum tubes. Extra heavy solid base $\frac{1}{8}$ inches thick. Four German silver springs with rounded ends firmly held in position in deep grooves, cannot touch mounting surface. Double end nickel plated binding posts. Connections can be made under the socket as well as above. A practically indestructible construction. 75c each, postpaid.

COMPLETE RADIO EQUIPMENT

The item above is merely a sample of the excellent line of radio equipment that is handled by the Apex Radio Company, Inc. All orders for sockets or other standard equipment will be filled the day received. Send two cent stamp for our new price bulletin.

APEX RADIO CO., Inc. Dept. Q-1
1105 W 60th St. Chicago, Illinois

**WRITE US FOR
RIGHT PRICES**

The best of apparatus and supplies at reasonable prices. We sell direct to the amateur, Grebe, Murdock, DeForest, Acme, Baldwin, Jewell, Brandes and other high grade lines. Tell us your needs and let us quote prices and delivery.

Write to Us Today

Garber Radio Electric Co.
Metamora, Ill.

NEW MOTORS

FOR ALL PURPOSES
STANDARD MANUFACTURERS
PROMPT DELIVERY

ALL SIZES UP TO 5 H.P.

We Specialize In Small Motors & Generators

ALL PHASES AND FREQUENCIES IN STOCK AT ALL TIMES
Largest exclusive Mail Order Small Motordealers in the world.

CHAS. H. JOHNSTON, Box 117, West End, Pittsburgh, Pa.

WIRELESS, TELEPHONE GENERATORS

500 VOLT - 100 WATT - 3400 R. P. M.

FOR MOUNTING MOTOR GENERATOR SETS.

\$28⁵⁰
EACH

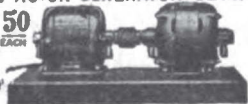

WRITE FOR
CATALOG

FROM CAT WHISKERS UP—

We can supply everything that's best in Radio or 101 of any article to user or dealer. Same day shipments.

Inquiries are welcome



DISTRIBUTORS

Wholesale and Retail

WESTINGHOUSE MURDOCK

RADIO CORPORATION

BRANDES, FEDERAL, DEFOREST

and many others

AT EAST PITTSBURGH, PA.—NEXT DOOR TO KDKA

ALWAYS MENTION QST WHEN WRITING TO ADVERTISERS

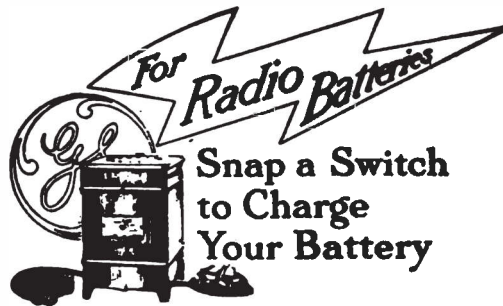

**Snap a Switch
to Charge
Your Battery**

If you have a radio receiving set using a storage battery, haven't you often wished for a simple efficient means for recharging this battery without lugging it away to a service station?



charges storage batteries from any alternating current lighting circuit with a minimum of expense and trouble. You can do your charging right in your own home and without lifting the battery from its present position.

The Tungar is not new—thousands have been used for charging automobile starting and lighting batteries for years. Tungar has no moving parts to wear out or require oil. It requires no attention while charging but may safely be left on the battery all night.

If your dealer in radio or other electrical supplies does not carry Tungar, write us and we will send you literature and tell you where you can get one.

General Electric Company
General Office Schenectady, NY Sales Offices in all large cities

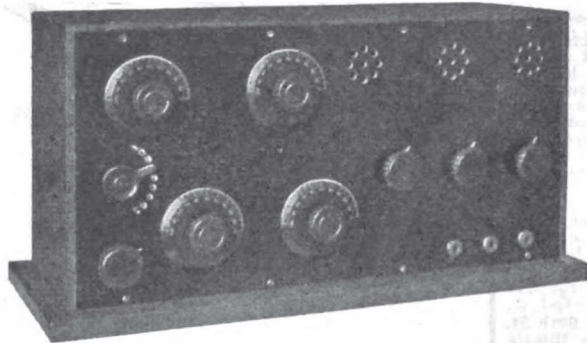

ANNOUNCING
The New Radio Audio
Frequency Receiver
Amplifier
Type L100

150-600 Meter Supersensitive Receiver Amplifier. Two stage radio frequency, Detector and two stage audio frequency Amplifier. Sets are furnished with 5 A.P. Tubes and B. Batt. Tuning is accomplished by variable condensers and regeneration. Set is equally efficient on C.W., Spark or Phone. Tubes are placed in two rows, three in the first row, two in the second row. Set is combined in one cabinet 9 1/2" x 19"

The radio frequency amplification makes it possible to use a loop aerial with best efficiency. Therefore it may be used in apartments and homes where outside aerials are not desired.

Send for descriptive literature.

TYPE L100 RECEIVER AMPLIFIER..... \$165.00

Saginaw Radio Service

407 No. Porter Street,

SAGINAW,

MICHIGAN

Vacuum Tube Detector \$5.50

Including complete cabinet with all instruments wired ready for use.

DETECTOR AND TWO STAGE AMPLIFIER \$22.50

With transformers and all other instruments in cabinet, ready for operation. This equipment is of high quality, and distances of as high as 3000 miles have been obtained with ease.

BATTERIES AND TUBES EXTRA

2000 Ohm receivers \$5.00
 SUPERIOR CRYSTAL RECEIVING SET \$4.75

Attractive dealers proposition

STEINMETZ WIRELESS MFG. CO.,
 5706 PENN AVENUE, PITTSBURGH, PA.



Send Us Your Orders For

Variable Condensers, Variometers, Variocouplers, Loose Couplers, Tuning Coils, Amplifying Transformers, Sliders, Switches, Switch Points, Binding Posts, etc.

We are large manufacturers. Gorton machine engraving or manufacturing special parts to order.

F. JOS. LAMB COMPANY
 1938 Franklin St., Detroit, Michigan

July Clearance Sale

RADIO

Sets—Outfits—Parts

Lowest Prices Ever Offered

Write us your wants and save money.

Catalog sent on receipt of 10c.

AMERICAN ELECTRO TECHNICAL APPLIANCE CO.
 227-229 Fulton St., New York

SPECIAL PRICES THIS MONTH

On Grebe, Clapp-Eastham and Amrad Sets

MASSEY RADIO COMPANY

The Radio Store, Winchester, Va.

RAY-DI-CO

Radio Supplies for Service and Satisfaction
 Write, wire or phone us for prices and information

RAY-DI-CO Organization

1547D N. WELLS ST., CHICAGO, ILL.

To Receive Broadcasting Radiophones

The Radiohome Receiver

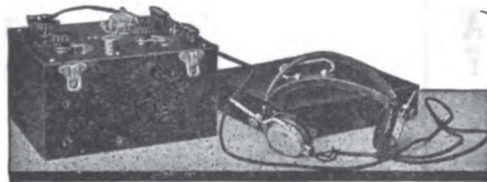

The Radiohome Receiver

The DT-800 Amplifier

Every amateur is frequently being asked for advice as to what set should be purchased for the reception of radio telephone programs of music, news and stories. Many an amateur hesitates to recommend standard amateur equipment as his friends would be confused and bewildered by the array of controls on such a set.

We illustrate two pieces of radio receiving apparatus which will, doubtless, appear unfamiliar to the amateur field. Yet we have been manufacturing these sets for some time—for the general public.

The Radiohome Receiver has a simple, two-slide tuning circuit with a range of 145-800 meters, a vacuum tube detector, and grid leak and rheostat. The price—less tube, batteries, receivers and antenna—is \$36. In a cabinet that is identical in size and finish with the cabinet of the Radiohome, is the DT-800, two-step amplifier. Three phone jacks are embodied in this instrument for detector, 1st step and 2nd step. Less tubes and batteries the price is \$35. We believe you will find no other set on the market to compare with this combination for the reception of radiophone programs by the newcomer in the field.

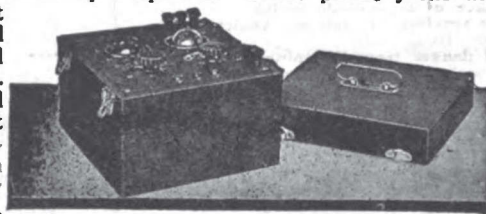

The DT-800 Two-Step Amplifier

DeForest Radio Telephone and Telegraph Co., NEW YORK CITY

WIRELESS TELEPHONE AND RADIO APPARATUS STOP USING A TRUSS

(Complete Sets)

CLARK & MILLS ELECTRIC COMPANY
ELECTRAGISTS

75 Newbury St., BOSTON
Tele. Back Bay 365 & 366 & 8296
1444 Massachusetts Ave., CAMBRIDGE
Tel. University 1169

RADIO REALITIES

Our price list, mailed Free on request. Contains complete lists of reliable Radio Sets and parts—every article carrying our guarantee. Mail orders given prompt attention.

Write today—Special Terms for Dealers

THE KLEIN RADIO & ELECTRICAL SUPPLY CO.

48 Fulton St. and 34 Park Place NEW YORK, N. Y.



Reduced Fac-Simile Gold Medal

STUART'S PLAPAO - PADS are different from the truss, being medicine applicators made self-adhesive purposely to hold the distended muscles securely in place. No straps, huckles or spring attached—cannot slip, so cannot chafe or press against the pubic bone. Thousands have successfully treated themselves at home without hindrance from work—most obstinate cases conquered.

Reduced Fac-Simile



Grand Prix

Soft as velvet—easy to apply—inexpensive. Awarded Gold Medal and Grand Prix. Process of recovery is natural, so afterwards no further use for trusses. We prove it by sending trial of Plapao absolutely **FREE**. Write name on Coupon and send TODAY. **PLAPAO CO., 955 STUART BLDG., ST. LOUIS, MO.**
Name
Address
Return mail will bring Free Trial Plapao.....

ALWAYS MENTION Q S T WHEN WRITING TO ADVERTISERS

131

Warren Radio Loop

NO
A
E
R
I
A
L

LESS
S
T
A
T
I
C

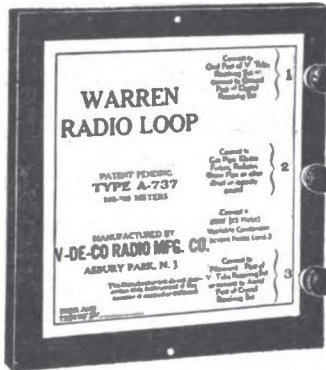

If Dad says—
"NO AERIAL ON THIS HOUSE"
don't allow his QRM to worry you but
purchase a

WARREN RADIO LOOP

The LOOP that made the Radio Roller Chair famous on the Boardwalk at Asbury Park, N. J. is just the thing for an apartment or den. Is light in weight and easily portable. Is produced under a new principle of winding. Is wholly enclosed, thereby protecting the winding. Is used in place of an outside aerial. Is adapted for receiving in moving vehicles. Takes the "tic" from static. Eliminates all danger from lightning. Can be used with any receiving instrument. Can be used without tuner.

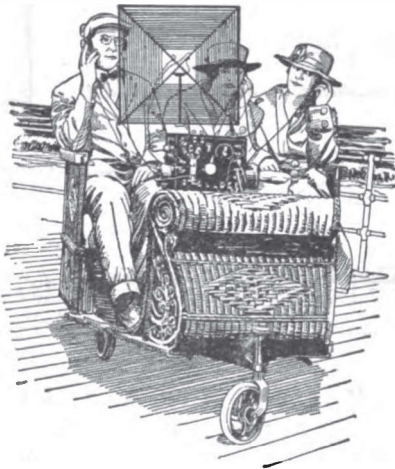

This picture of the Radio Roller Chair showing the Warren Radio LOOP was used as cover designs on "Wireless Age" and "Radio News" and featured in many other magazines and newspapers in the United States.

Send your order through your dealer or direct to us with his name.
Type-A-737 (300-700 meters)\$10.00
Type-A-7236 (175-1000 meters) 12.00

V-DE-CO RADIO MFG. CO.

DEPT. R, ASBURY PARK, N. J.
Send for bulletin—No. A101

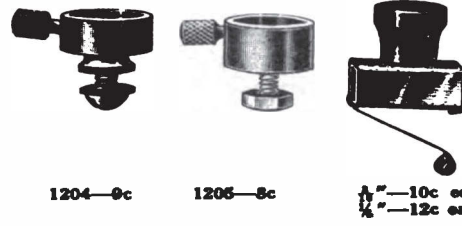

1204—9c 1205—8c 1/4"—10c ea
1/2"—12c ea

CRYSTAL DETECTOR STAND Crystal Detector Stand, No. 1200
Nickel plated or brass finish
No. 1201—\$1.00
Treated Galena in Wood's metal box.
Get prices for other instruments and parts.
Dust-proof. No vibration. Flexible adjustment. Can be set rigidly.
Get our prices for Switch Points, Binding Posts and other parts.



Audiobulb Socket, No. 1150 Rheostat, No. 1175

latest in absolute reliable contacts. Study construction shown in diagram. "D N" TOP OF ALL quality, and sells for \$1.00 only. Highly nickel polished & polished black compo base.

5c ea. 40c ea. 70c. ea. 100 \$48.00 No. 69
100—\$4.00 100—\$28.00 3" Compo Dial 1 1/2c ea.
For left and right rotation 100 95c.



No. 7138 No. 7160
\$1.30 \$1.00
per 100 Per 100

\$6.50 per 1000 N. P.; \$9.00 for 1000 N. P. or brass
All styles of Binding Posts and Radio Parts manufactured and carried in stock. Get illustrated folder.
CONTINENTAL ELECTRIC CO.,
117 E. 129th Street, N., New York, N. Y.

FRANKLIN VARIOMETER

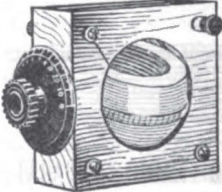

Made of selected hardwood. Permanent contacts assure smoothness of operation, unsurpassed by any other make.

PRICE \$4.50

Sample sent prepaid \$3.50
Dealers write for Discounts.

FRANKLIN RADIO MFG. CO.
711 Penn Ave., Wilkinsburg, Pa.

BUILD YOUR OWN RECEIVER

Combination No. 50 consists of 2 B-K variometers, 1 B-K variocoupler, complete with dials, 1 FADA inductance switch, 10 contact points, 2 switch stops, 6 nickel plated binding posts, 9 feet nickel plated connecting wire. All ready to mount on your own panel. PRICE \$18.00 postpaid
Write for Bulletin No. 1
BONDUAU & KNIGHTS
1115 Kelly Street, Bronx, N. Y.

Price \$12.00 F.O.B. N.Y. City



Listen to the Concerts, News and Dance with a KING "AM-PLI-TONE."

Just slip your head phones on the "AM-PLI-TONE" and you and your friends will be SURPRISED.

Polished Cast Aluminum Body with Nickel Plated Base and Horn. No sheet Metal is used, the "Tinny" Sound is Left Out. The VOLUME is DOUBLED because TWO head phones are blended into one POWERFUL tone.

A big hit—a big seller and immediate deliveries. Dealers and distributors what more can you ask? Write today for territory—KING "AM-PLI-TONE"

82 Church St., New York City

NOTICE: All infringers of this device will be vigorously prosecuted.

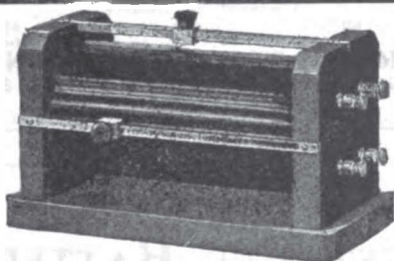

LAMB TUNING COILS. Two Nickel sliders and rods; four nickel binding posts. Coil contains about 1/2 lb 222 enameled magnet wire. Mounted in hard wood ends and base. Price \$3.00.
 1/4" Sliders—Brass 20c; Nickel 25c.
 1/4" Slider Rods—Brass 15c; Nickel 20c.
 Crystal Detectors, nickel plated on Mahogany Base, \$1.00.
 Crystal Detectors, glass case and fibre base, \$1.25.
 Contact Points, threaded with nuts—20c dozen
 Compo. cap, Nickel base Binding Posts—7c each.
 Plain Nickel Binding Posts—3 1/2c each.

IMMEDIATE DELIVERIES
 Liberal discounts to dealers

F. JOS. LAMB COMPANY
 1938 Franklin St., Detroit, Michigan

Wireless Amateurs Attention!

If you want service, order from us. We carry a large stock of High Grade Wireless Apparatus of our own and other manufacturers.

SPECIAL!

Vacuum Tube Sockets.....\$1.25
 Rheostats 1.25
 22 1/2 Volt "B" Batteries 1.50
 Rasco Dials60
 Rubber Binding Posts20
 Tested Galena40
 Lateral Wound Coils. All Sizes

SEND 5c FOR OUR NEW PRICE LIST

J. M. PAQUIN,
 THE ELECTRICAL SHOP
 787 Queen St. West, Toronto, Ont.



Recharge Your Battery at Home

Charges both A and B Radio Batteries

Don't be without the use of your Radio Receiving Set while your battery is being charged. Get a Valley Charger and charge your battery right at home.

Attach the Charger to your home lamp socket—attach the clips to the battery terminals and you will get a quick, tapering charge which just exactly charges your battery, but cannot overcharge it or harm it in any way.

Will charge the A 6 volt battery at a 5 ampere rate, and the B 22½ volt battery at the required ½ ampere rate. 45 volt B batteries may be connected in parallel so that they can also be charged.

SATISFACTION GUARANTEED.

If your local distributor cannot supply you, write direct to
VALLEY ELECTRIC COMPANY,
Department Q, ST. LOUIS, MO.

----- Mail the Coupon -----
Valley Electric Co., Dept. Q, St. Louis, Mo.

Gentlemen: I am enclosing money order (or check) for \$18.00, for which send me a Valley Battery Charger with five-panel glass display case and indicator. If not satisfactory, I will return it and get my money.

Name

Address

\$18.00

F.O.B. St. Louis

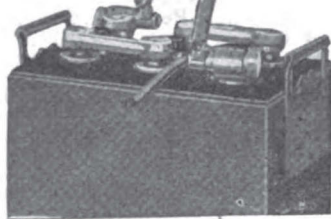

134

RTS

Equipment Specialties RTS Switch Lever

The attention of jobbers and dealers is especially called to the RTS Bushing Lever made to retail at 60

cents. It has many improved features. The knob is of the well known Marconi type, 1¼ inches in diameter. The spring lever of nickel bronze has ground ends, insuring smooth and positive adjustment. It has a ¼-inch bushing and locknut for panel assembly. A guide bushing under the knob is an important feature as it raises the lever to the proper height for all switch points.



Announcing the New

RTS Grid Condenser

The new RTS Grid Condenser is now ready for delivery. Contains many improvements not found in other types. Capacity .0005 M. F., price to retail at only.....80c each.

RTS Phone Condenser

RTS Condensers need little description. Their accuracy and simplicity have made them universally popular. The RTS phone condensers, capacity .0018 M.F., complete with binding posts ready for connection, to retail at.....35c each

RTS Grid Condenser and Grid Leak

Combined. Made for those who desire the best. Price each.....45c

RTS Rubber Binding Posts

These posts are as good as any you can find. Bushing heavily nickel plated. Give the amateurs' instruments the appearance of a first class outfit. 12c each or \$1.25 a dozen

Discount to Dealers

Dealers and Jobbers: Write us today for special quotations and discounts on all RTS equipment.

RADIO TESTING STATION

DEPT. R-7. 25 STURGIS ST.
BINGHAMTON, NEW YORK

BEST BEE BATTERY

24 Cell—Storage

Electrically Welded Elements
Packed Complete with Instructions

\$7.50

From Your Dealer or From Us
Parcel Post Prepaid—At Once

A. C. TOWNE, Inc.

21 TERRACE—BUFFALO, N. Y.

ALWAYS MENTION Q S T WHEN WRITING TO ADVERTISERS

Digitized by Google

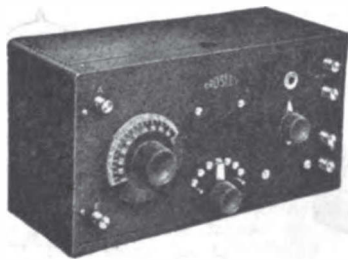
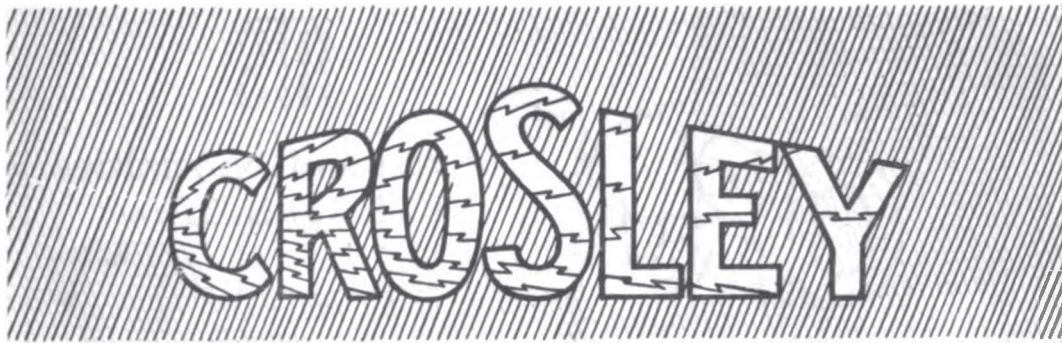

HARKO SENIOR NO. V

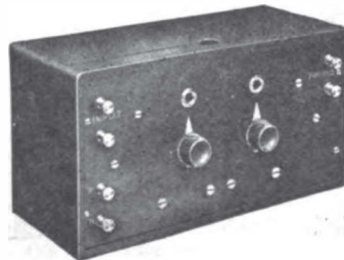

2 STEP AMPLIFIER

Crosley Harko Senior V Receiver

The Crosley Harko Senior Receiver No. V. has been greatly refined as to detail, hook-up, etc., and is a remarkably efficient tuner and detector unit capable of bringing in concerts and signals from surprising distances. It is non-regenerative, which means easy to tune without distortion. Manufactured in large quantities in our own factories makes the low price possible. Cabinet work, Adam brown mahogany finish. Newest refinements in design of panel fittings, including molded knobs and dial. Price.....\$20.

Crosley 2 Step Amplifier

The Crosley 2 step Amplifier. A most efficient piece of apparatus especially when hooked up with the Harko Senior V., but giving excellent results with any audion receiving set. Contains two celebrated Crosley V. T. Sockets, Crosley Rheostats and Crosley Sheltrans (new design transformers), Cabinet matches Harko Senior V. in wood and size. Niceties of design and finish are the same in both instruments.



CROSLEY

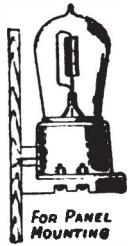

For Panel Mounting

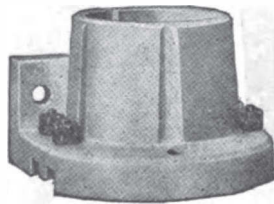

For Base Mounting

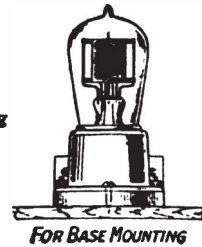

The Celebrated Crosley V.T. Socket

A practically unbreakable socket of porcelain which because of its high dielectric value is the most desirable socket material. Not only does it eliminate possible ground hums but permits soldering of wire connections. The bayonet slot is reinforced and the contacts are nicked and positive. It is designed for base or panel mounting and at twice the price is a remarkable piece of radio apparatus. Crosley "Better—Costs Less", Price 50c.

Crosley Sheltran

In this piece of Crosley apparatus we have a completely shielded transformer, a feature to be sought in this important radio part. Its design has proven highly efficient in obtaining maximum amplification from modern vacuum tubes. Its ratio is 1 to 9. Net weight 12½ oz. Area 1¼x2½." Price \$4.00

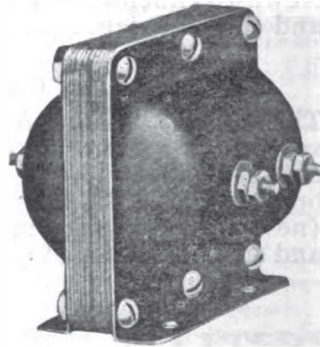

**"BETTER
— COSTS LESS —"**

CROSLEY

MODEL B

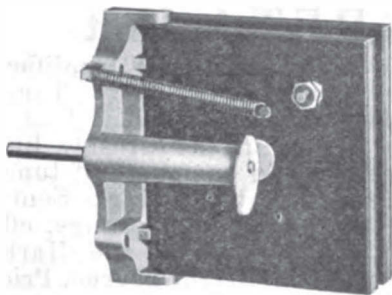

MODEL A

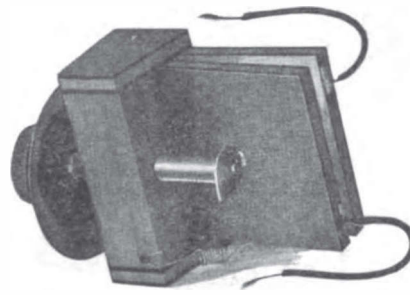

Variable Condensers

MODEL B

Crosley Variable Condensers because of their quantity production and simple construction are almost unbelievable at the price. Not alone this, but we claim and substantiate this claim by laboratory tests in one of the country's leading universities. And in practical support thousands of users through the United States attest to their efficiency and value. Model "B" condenser, .0005 mf. capacity, die cast frame, laminated wood panels. Price without knob and dial, \$1.75.

MODEL A

In Crosley Variable Condensers it will be noted that the contacts of both plates are positive, eliminating to a great degree the internal resistance that develops in a short time, in the air type condenser from corroded spring contacts, etc. Variation is accomplished thru the book action of the plates by a cam. Each Crosley Variable Condenser is tested to withstand 1000 volts before shipment. Short circuiting is impossible. Model A is conservatively rated at .0005 mf. capacity. Laminated wood frame and plates. Price without knob and dial, \$1.25.

Crosley Model C Variable Condenser

Crosley Variable Condensers are superior to the interlocking type for this reason: depending upon the air for dielectric the necessarily wide gap between the plates means low capacity for given unit of plate area. Mica is the insulation between plates of the Crosley type condenser and will stand much higher voltage than the average air condenser. Its safety for C.W. work is readily apparent. Model C. constructed with porcelain plates. Capacity runs from .001 to .0018 mf. Price without knob or dial, \$2.25.

RADIO
APPARATUS

ALWAYS MENTION Q S T WHEN WRITING TO ADVERTISERS

137

Digitized by Google

CROSLEY



The New Crosley R.F.T.A. Unit

(Radio Frequency Tuned Amplifier)
Crosley Radio Frequency Tuned Amplifier, R.F.T.A. unit. This is a new comer in the Crosley line, designed to add one stage of tuned radio frequency to the Harko Senior No. V. It increases the range, efficiency and volume of the Harko Senior to a wonderful degree. Price \$15.

Write for further details of this new unit.

Variometer Parts

Made in great quantities in our large wood working factory. Crosley Variometer parts are accurate, of neat design and very moderately priced. Stator and rotor forms are furnished complete with all necessary hardware for assembly according to individual ideas.

Made of poplar wood and nicely
shellaced.....\$1.50
Winding form......30

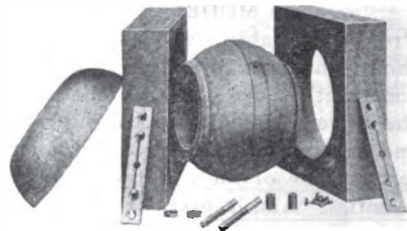

Crosley Vario-Coupler Parts

The Crosley Vario-Coupler parts consist of a formica tube, rotor and the necessary hardware for complete assembly. All parts are made with great accuracy and can be assembled perfectly and neatly. Rotor diameter is 3 1/2 inches. Tube lengths 2 1/2 inches. Tube diameter 3 3/16". All parts complete with necessary hardware, \$1.50.

**"BETTER
- COSTS LESS "**

RADIO EQUIPMENT FOR IMMEDIATE DELIVERY

PHONES	
Federal 2200 ohm	\$8.00
Federal 3200 ohm	10.50
Dictograph 3000 ohm	12.00
Brandes Superior	8.00
Everett 3000 ohm	7.50
Stromberg	7.50
Baldwin attachments for all phonographs	15.00
Murdock 2000 ohm	5.00
Murdock 3000 ohm	6.00
<hr/>	
Phone Posts Each 7c or 77c doz.	
Contacts—three sizes, nicked, Doz. 30c per 100	\$2.50

TUBES	
Radiotron UV 200	\$5.00
Radiotron UV 201	6.50
Cunningham C 300	5.00
Cunningham C 301	6.50
A. P. Detector	5.00
A.P. Amplifier	6.50

VARIABLE CONDENSERS

Chelsea NL 3	\$4.75
Chelsea NL 4	4.25
Arco 11	3.50
Arco 23	4.25
Arco 43	4.75

SETS	
Grebe CR 5	\$80.00
RORK Amplifier	55.00
Grebe CR 9	130.00
Westinghouse RA Tuner	68.00
DA Amplifier	68.00
Aeriola Sr.	65.00
R-3 Magnavox	45.00

AERIAL WIRE	
Solid 100 ft.	40c
Stranded 100 ft.	59c

Purchases sent prepaid to your nearest shipping point to within 500 miles of Pittsburgh.

Established 1868 **THE ROSENBAUM** CO. PITTSBURGH, PA.

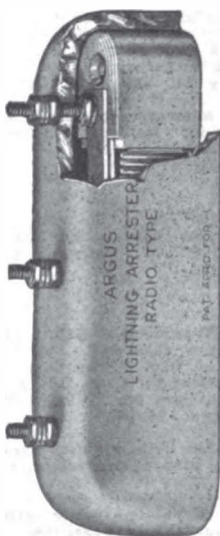

Dealers and Jobbers WANTED

We can make immediate shipment.

For the Argus Lightning Arrester Radio type Accepted by the Underwriters' Laboratories.

List at \$1.50
Big Seller

**SURE—SAFE—AND
SUBSTANTIAL**

Weather Proof—
Porcelain Cover

WRITE US TO-DAY

**The Radioart
Supply Co., Inc.**

132 So. Howard Street,
AKRON, OHIO

WIRELESS CATALOGUE

Whether you are interested in a complete radio receiving outfit, or a half a dozen binding posts, you'll find the particular instrument, best for your needs, in Corwin's catalogue. Send 10 cents, (credited to your first order) for your copy today! Where's the nearest mailbox?

A.H. CORWIN & CO.
4 West Park St. Dept. D4
Newark New Jersey

CLASSIFIED ADVERTISEMENTS

Six cents per word per insertion, in advance. Name and address must be counted. Each initial counts as one word. Copy must be received by the 10th of month for succeeding month's issue.

WEST COAST signals all over the room with 4GL radio frequency transformers. Range 200-600. Price \$3.15 each with circuit. Savannah Radio Shop, 1223 East Duffy St., Savannah, Ga.

SELL: 1/2 K. V. A. Thordarson, \$15; 2 Saco Clad Amplifier transformers \$3 each; Murdock O.T. \$3.50; Remler Amplifier panel, \$4; Transmitting Oil Condenser, \$4. W. J. Baker, R. 15, Dayton, Ohio.

IMMEDIATE DELIVERY—Clapp-Eastham tuners and amplifiers—types H.R. and H.Z. Remler goods of quality. Everything in the line of parts. Write for complete lists. R. D. Briggs, 32 Cutler St., New London, Conn.

TRIPLE GEAR honeycomb coil regenerative receiver including coils and Radiotron Detector \$60.00. Box 205, Williamsport, Pa.

WANTED: Grebe CR-7. Must be in good order and cheap. What have you, Cash is waiting for best offer. Burrow, Box 813, Teague, Texas.

RUBBER STAMP with large call letters 50c; Radiogram and Relay Radiogram blanks 25c per hundred. Post cards 60c hundred. Send us your orders. Carolina Printing & Stamp Co., Wilmington, North Carolina.

IMMEDIATE DELIVERY—Radio Magnavox R-3 Westinghouse Storage "B" Batteries \$8.80; Detector and two step amp. in cabinet \$35.00; Moorhead detector and amp bulbs \$5.00 and \$6.50. Cheesaning Electric Co., Cheesaning, Mich.

SHORT WAVE RECEIVER in hinged oak case. Primary, secondary and coupling variable. Regular vacuum tube apparatus but supplied with crystal detector, with terminals for audion or amplifier. Complete with 2,000 ohm headset and aerial equipment \$35 postpaid. Set alone, \$25. Oak cases with hinged lids. Just the thing for portable sets or wavemeters. Size, six by nine by eight high, \$3.00. With condensate collector panel \$3.85. Crescent Radio Laboratory, 1200 North 29th Street, Philadelphia, Pa.

SELL: Variometer set, detector and three step with bulbs and "B" Battery. Other apparatus. Morris Decker, Baldwinsville, N. Y.

PRINTED CARDS—Description of your station with QRA 500, \$4.00; 1000, \$6.00, delivered. Samples on request. Donald Detwiler, 3BSE, 1120 Virginia Ave., Washington, D. C.

TRANSMITTING PARTS to be sold below cost—Three essential parts of excellent Transmitting Set, in perfect condition and excellent working order, to be sold as a whole or separately. Motor Generator set with synchronous disc discharge—\$50.00; Switch Board, \$25.00; Transformer—2KW 240 cycle—\$20.00. Only one of each item. Write, at once for details if interested. Doubleday-Hill Electric Co., 719 Liberty Ave., Pittsburgh, Pa.

SELL—Improved Reinartz tuner \$20. Det. and two-step \$55. Beverly Dudley, 4909 Fletcher St., Chicago.

C.W. Transmitter, motor generator, filter, chopper, microphone, key, Thermo ammeter, Voltmeter, plate ammeter, transformer, 7 1/2 V—1000 V., hard rubber panel, quick change over C.W. buzzer, chopper, self-rectified C.W. voice, excellent order, \$200.00, J. E. Egleson, 12 Felton Ave., Ridley Park, Pa.

FOR SALE: Westinghouse Dynamometer, Motor 10 volts, Gen. 350 volts Army type \$25. 2 Stage Multiaudiphone Loud Speaker Complete. Cost \$75.00. Sell \$25. Faste, Eastern Parkway, Brooklyn, New York.

FOR SALE: Grebe type CR-6 and Grebe CR-7 receivers; DeForest multi-wave tuner; 25 honeycomb coils; Grebe detector; Grebe two stage amplifier; Radiotron detector and amplifier tubes! Radiotron 5 watt power tubes; Edison storage batteries; New Eveready 100 volt B batteries; Wireless Specialty Apparatus Co. Type QS-500 1/2 KW transmitter. All sold

cheap and delivered promptly. Mack Gayton, Cotton Plant, Miss.

SPECIAL: Switch levers, complete with knob, bushings, etc., 1 1/4" radius, \$0.35 coin. Walter R. Haase, 779 E. 99 St., Cleveland, O.

EDISON NICKLE ALKALI CELLS for "A" Batteries: 1.3 volts 225 ampere hours \$6.50. (Three of these cells will run a V.T. 1 for 250 hours) 6.5 volts 225 ampere hours \$30. F.O.B. New York City. Edison B Battery elements 6c per set postpaid. A. J. Hanks, 608 Montgomery St., Jersey City, N. J.

FOR SALE Westinghouse RA Tuner used 3 months \$50.00. B. J. Hyatt Mt. Vernon, Ohio.

FOR SALE: 8VH's 1K.W. spark set complete; also 100W.—6 to 25V. spark set. Write for particulars on these and 200 chemicals. 8VH.

TELEFUNKEN & Crocker-Wheeler 1/2 KVA 500 cycle motor generators. Fine for your tube set. Henry Klentzle, 501 E. 84 Street, New York.

FOR SALE: Panel type transmitter consisting of 1/2 K.W. Packard transformer, Murdock rotor, Dubilier condenser, and Murdock O.T. \$30. Francis Klau-man, St. Petersburg, Fla.

WANTED: Synchronous rotary, with motor; Boston key; very heavy O.T. Write Harold Koontz; Buffalo, Wyo.

WANTED a bug key (Vibroplex, not Cootie) in good condition second hand. 1BAN, 99 Beaumont Street, Ashmont, Mass.

STATICS? Get this combination, 2 step radio frequency amplifier and detector with Meyer's tubes, minus detector \$37.00. 2 step audio frequency amplifier with Meyer's tubes \$35.00. Loop control set with loop \$12.00. Other standard equipment—write for prices. Rubert Lewis, 625 So. Church St., Princeton, Ill.

AERIAL WIRE No. 14 copper 40c. 7-strands No. 22 70c. (100 ft. coils). Weight 2 lbs. Immediate delivery. Chas. L. Manning, 1555 Miller St., Utica, N. Y.

ORDER YOUR MAGAZINES thru me. Am confined to wheelchair. Will gladly quote prices on club orders. New or renewal. Lowell Martin, 911 North Tenth St., Lafayette, Ind.

MUST SELL My single circuit radiophone receiver including detector and two stage amplifier, all in mission finished oak case. Hardly used. Will sell complete including phones, plug and bulbs for \$130.00. Send for photo. W. M. Marvina, 608 Parry Ave., Palmyra, New Jersey.

A REAL radio frequency transformer for amateur use; beats anything on the market; range 200-600 meters; designed by 4GL; price \$3.15 each postpaid anywhere in U. S. Circuit with each transformer. Savannah Radio Shop, 1223 East Duffy St., Savannah, Ga.

BLACK FIBRE PANELS for amateur sets 7"x18"x 1/4" \$1.25 cut to order \$0.01 sq. in. Immediate delivery. Geo. H. Mollahan, Lowell, Mass.

EDISON B BATTERY ELEMENTS. Make your own. Can be recharged and lasts for years. 200 ampere hour A batteries, guaranteed \$35.00. Harry Morrell, 52 Goffe St., New Haven, Conn.

FOR SALE: 1/2 K.W. Acme Transformer \$20. Eight tooth Benwood Gap, aluminum case \$15. 1/2 K.W. 14500 volt Dubilier condenser \$20. Step down toy transformer \$2, Amrad wavemeter \$4, 1/20 H.P. motor \$5.00, 3 one gallon size leyden jars \$8. Willard Morton, 12 North Park St., Bangor, Maine.

RADIO APPARATUS—Send for lists, all new apparatus and miscellaneous material also. C. M. Nessor, Fitzgerald, Ga.

OZARKA (tested) Galena Crystals insure strong signals and loud speech. Guaranteed sensitive. For sale by Radio Dealers everywhere, or sent prepaid, for 15c (coin). Dealers, Jobbers and Manufacturers

write for prices. Ozarka Mineral Company, Lawrence, Kansas.

WILL TRADE my $\frac{1}{2}$ K.W. Spark Set for set of Honey Comb Coils or other wireless apparatus. P. T. Perrina, Salem, Va.

FOR SALE: 500 Volt Generator \$18.00. All letters answered. J. Planty, Warren Ave., Niles, Ohio, 8ANW.

NEW WESTINGHOUSE RC for Grebe CR9 or sell. B South Ohio, Atlantic City, N. J.

EDGEWISE COPPER .033x.296x $\frac{3}{4}$ " diameter 50 turns \$3.50 Postpaid. Radio Specialties Co. Connellsville, Pa.

IMMEDIATE SHIPMENT, Amrad Tuner Detector, two step \$105. Magnavox R3 large horn \$39.50. Magnavox three step \$95. Dozen Burgess "B" $2\frac{1}{2}$ " tapped \$2.00. All new, never used. Twenty per cent with order. balance collect. Geo. L. Rariden, Bedford, Indiana.

GREBE CR3 \$45.00. Grebe Detector and two step amplifier \$40.00. Both fine condition, Wesley Robinson, Jr., St. Mary's, Georgia.

FOR SALE: SAIG spark: new $\frac{1}{2}$ K.W. Packard factory mounted 13200 volts \$25; 8 point Hyrad inclosed gap ball-bearing mounted \$10; R. & M. $\frac{1}{4}$ H. P. 3400 rpm induction motor \$18; $1\frac{1}{4}$ " heavy ribbon copper O.T. \$6; oil immersed condenser \$4; complete \$55. Wm. Schmezer, 75 Amanda Ave., Knoxville, Pittsburgh, Pa.

CUNNINGHAM AND RADIOTRON DETECTOR TUBES Four Fifty. Amplifiers Six dollars. Large Burgess B Batteries two twenty-five. Get our list. Radio Supply Co., Weedman, Ill.

FOR SALE $\frac{1}{2}$ K.W. Spark Transmitter. Meteor Transformer, Oscillation Transformer, Oil Condenser, Rotary Gap and Motor, Condenser and Key \$55.00. F. S. Tude, St. La Crosse, Wis.

BARGAIN! Z-NITH REGENERATIVE TUNER, late model, sell \$35.00, cost \$55.00, also 1 K.W. Trans. set, consisting of 1 K.W. Thordarson Transformer, Rotary Gap and Motor, Condenser and Key \$55.00. F. S. Tude, 2252 Giddings St., Chicago, Ill.

QRA? IFZ—Not Lynn but J. E. Thayer, Farmington, N. H.—Please correct call book O.M.

DON'T BURN OUT Your tubes and B batteries, B battery fuse 25c. (cola); sell 1 K.W. spark set \$40. Virgil Thomas, Dix St., Muncie, Indiana.

BUILD YOUR OWN WIRELESS Telephone and Musical Receiver, Don't Wait for a Set. We hear Chicago, 900 miles. Fine on good nights. Pittsburgh, Newark and New York come in Good and Loud—You Can Do the Same on a Single Bulb. There is Radio Music in the air each evening, and the living voices of the artists can be reproduced in your own home and enjoyed by you and your friends. Are you satisfied with your receiving set or would you like to build one that will receive over 6,000 miles on a single bulb and quit experimenting? One that will be equal to any regardless of claims and price—with which you can hear Honolulu, California, German, South American, French and English stations and practically all of the high powerful foreign and domestic stations, as well as amateur stations as far west as New Mexico, and the phone and music. Anyone can assemble this outfit and wire it up, and the remarkable ranges that may be obtained will surprise you. Why not make a set up to date and efficient? Don't experiment with unknown circuits. We will promptly mail you our sample diagram of a complete short and long wave receiver, 175 to 20,000 meters, together with complete instructions for wiring and assembling, price of each part and where they can be bought, leaving nothing to guess about, on receipt of fifty cents in coin or stamps. Here is a diagram no one can afford to be without. Virginia Novelty Company, Desk A, Martinsburg, West. Va.

FOR SALE—C.W. Transformer for 110 V. 2000 volt secondary with mid tap, filament winding 12 volt with center tap, kenotron winding 12 volt with center tap, ideal for 50 watt tubes \$28.00. Arthur L. Walser, Chesaning, Mich.

ALWAYS MENTION QST WHEN WRITING TO ADVERTISERS

FACTORY TO YOU. 4GL radio frequency transformers, 200-000 meters; within reach of all, price \$3.15 each postpaid; circuit with each one. Savannah Radio Shop, 1223 East Duffy St., Savannah, Ga.

CONDENSERS. All you want. Real, man-sized variables, 23 plate, \$3.00; 43 plate \$3.75; Fixed, phone condensers 25 cents Grid 25 cents; Grid with fixed leak 30; Same with variable leak 35 cents. Add postage. Crescent Radio Laboratory, 1200 North 29th Street, Philadelphia, Pa.

AGENTS WANTED in every city and town to sell standard radio apparatus. Attractive discounts given. If interested, write at once stating age and radio experience. Wilmington Electrical Specialty Co., Inc. 912 Orange Street, Wilmington, Delaware.

LOOK AND ACT; Several Radio Magnavoxes with old style horn; otherwise good as new. Price \$39.50. F.O.B. H. F. Witzler, Ferrysburg, O.

PATENTS—Protect your invention today. Write for 1922 Illustrated Book Free. Radio-Electrical, Chemical and Mechanical Experts. A. M. Wilson, Inc. 310-16 Victor Building, Washington, D. C. (Successors to business established 1891 by A. M. Wilson.)

SEND TEN CENTS for our new large 32 page catalog describing our course entitled "How to Learn Radio at Home." National Radio Institute, Dept. 1332, 1345 Penn. Ave., N. W., Washington, D. C.

TESTED GALENA CRYSTALS From our own Mines—shaped, and tested at the mine in best standard hookup—direct to user. A real crystal—not a pinhead. Twenty-five cents postpaid, five for \$1.00 to group buyers. Ozark Crystal Co., Box 1, Merrellton, Mo.

PARAGON R.A. 10. Been used one month. First check for \$50.00 takes it. H. L. McCarter, Ogdensburg, N. Y.

AUDIOTRON BULB WANTED. Must be in good condition. Fred B. Teeling, Bath, Me.

SELL—Bell rotary spark gap, 8 studs, fine shape. \$22.50, R. F. Fowler, Frankfort, Indiana.

4GL RADIO frequency transformers; DX, fones and 600 meters; \$3.15 each with circuit. Savannah Radio Shop, 1223 East Duffy St., Savannah, Ga.

LET US HELP YOU PREPARE YOUR STATION FOR THE FALL SEASON!

Valuable ideas, ingenious hints, reliable constructional dope—receiving as well as transmitting. All contained in the back issues of QST described below in our 3 SPECIAL OFFERS

Our announcement last issue brought a big response from wide-awake amateurs.

Get YOUR copies before the copies you most need are exhausted.

OFFER NO. 1—October 1916, May to August 1917, inclusive; June and July 1919, all postpaid for.....\$1.00

OFFER NO. 2—April to December 1920, inclusive, postpaid for.....\$1.00

OFFER NO. 3—March to November, 1921, inclusive, postpaid for.....\$1.00

Pin a dollar bill to this ad, checking the offer you want, and send it in NOW. Or better yet, send in only \$2.50 and let us send you ALL THREE OFFERS.

SPECIAL ANNOUNCEMENT!

We can still supply a few copies of June 1921, QST, 20 cents, postpaid, which contains complete information on the original Rainartz Tuner. 'Nuff sed!

Mail your order and remittance to

THE AMERICAN RADIO RELAY LEAGUE
KENNEDY BUILDING, HARTFORD, CONN.

KNIFE SWITCHES

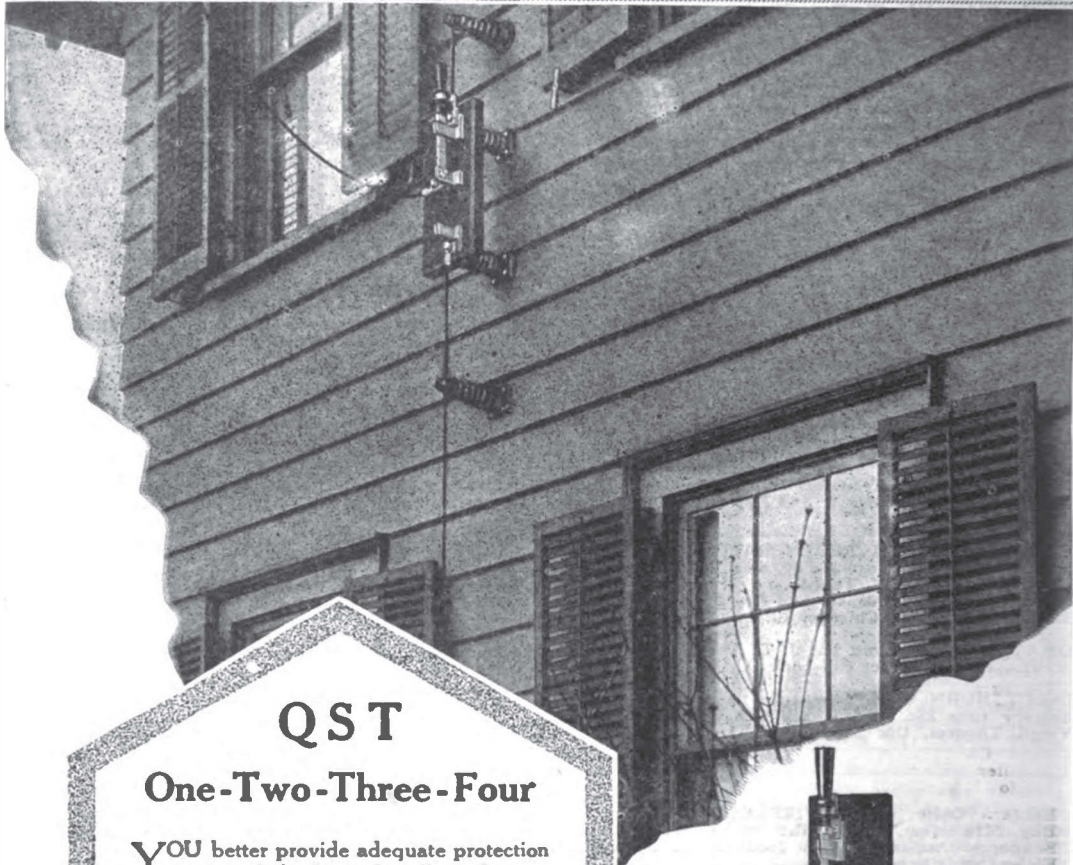

Q S T

One-Two-Three-Four

YOU better provide adequate protection against lightning. Install a Crouse-Hinds, 60-ampere, 600-volt Lightning Switch. It is mounted on an impregnated nonhygroscopic composition base.

CROUSE-HINDS CO.

SYRACUSE, N. Y.

NEW YORK CHICAGO

BOSTON

C H 117

Price
East of Mississippi River
\$4.00

Price
West of Mississippi River
\$4.70

Single-Pole Double-Throw
Knife Switch
for Radio Station



CROUSE-HINDS



—FOR YOUR CONVENIENCE—

QST'S INDEX OF ADVERTISERS IN THIS ISSUE

Acme Apparatus Co., The.....	75	Klein Radio & Elec. Supply Co., The.....	131
Adams-Morgan Co., The.....	119	Klosner Improved Apparatus Co.....	100
Allen-Bradley Co.....	86	Lamb Co., F. Jos.....	130-133
American Electric Co.....	123	Lorain Radio Supply.....	78
American Electro Tech. Appliance Co.....	130	Magnavox Co., The.....	88
American Radio & Research Corp.....	4th Cover	Marshall-Gerken Co., The.....	99
Anthraxite Radio Shop.....	104	Massey Radio Co.....	130
Apex Radio Co., Inc.....	129	McKay Co., David.....	144
Atlantic Radio Co.....	2nd Cover	Missouri Radio Supply Co.....	76
Atwater-Kent Mfg. Co.....	72	Multiple Storage Battery Corp.....	81
Automatic Electrical Devices Co.....	100	Murdock Co., Wm. J.....	109
Barber Electric Mfg. Co.....	124	Nash Electrical Service Co.....	114
Benwood Co., Inc., The.....	111	National Carbon Co. (Eveready Battery).....	5
Bondaux & Knights.....	132	Newman-Stern Co., The.....	92
Brach Mfg. Co., L. S.....	98	New York Radio Laboratories, The.....	115
Brandes Inc., C.....	82	North Ward Radio Co.....	106
Bunnell & Co., J. M.....	116	Nevo Mfg. Co.....	98
Burgess Battery Co.....	73	Ogden Wireless Laboratories, The.....	124
Canadian Radio Convention & Nat'l Exhibition.....	122	Paent Electric Co., Inc.....	102
Canadian Wireless.....	106	Paquin, J. M.....	133
Central Radio Laboratories.....	82	Philadelphia Wireless Sales Corp.....	94
Chelsea Radio Co.....	76	Pitts Radio Stores, Inc.....	128
Chicago Radio Apparatus Co., Inc.....	115	Pittsburgh Radio & Appliance Co., Inc.....	110
Citizens Radio Service Bureau.....	112	Plapao Co.....	131
Clapp-Eastham Co.....	30	Portable Wireless Telephone Co.....	123
Clark & Mills Electric Co.....	131	Potter Co., The C. D.....	94
Classified Advertisements.....	140	Precision Equipment Co., The.....	90
Columbia Radio Supply Co.....	126	Prest-O-Lite Co., Inc., The.....	89
Condensite Company of America.....	2	QST Back Copies.....	141
Connecticut Telephone & Electric Co.....	3d Cover	Radioart Supply Co., Inc.....	139
Continental Electric Co.....	132	Radio Audion Co.....	1
Cornwall Co., A. H.....	139	Radio Corporation of America.....	97
Crosby Mfg. Co.....	135-136-137-138	Radio Electric Co., The.....	84
Crouse-Hinds Company.....	142	Radio Equipment Co.....	102
Davis & Co., C. A.....	128	Radio Testing Station.....	134
DeForest Radio Tel. & Tel. Co.....	131	Rasa Sales Corporation.....	103
Delancey, Felch & Co.....	124	Raymond Radio Corp.....	104
Detroit Electric Co.....	126	Ray-Di-Co Organisation.....	130
Diamond State Fibre Co.....	92	Reynolds Radio Co., Inc.....	116
Dictograph Products Corp.....	114	Rhamatine, J. Thos.....	96
Dodge, C. K.....	122	Riley-Klets Mfg. Co.....	90
Doolittle Radio Corp.....	86	Robinson Specialty Co.....	110
Doubleday-Hill Electric Co.....	112	Roller-Smith Co.....	93
Duck Co., The Wm. B.....	125	Rome Wire Co.....	83
Dubilier Condenser & Radio Corp.....	96	Rosenbaum Co., The.....	139
Dudlo Mfg. Co.....	80	Saginaw Radio Service.....	130
Eastern Radio Institute.....	118	Scientific Engineering Association.....	75
Eby Mfg. Co., The H. H.....	74	Service Radio Equipment Co., Inc.....	74
Economic Appliance Co.....	82	Ship Owners Radio Service, Inc.....	122
Eisemann Magneto Corp.....	113	Shotton Radio Mfg. Co., The.....	71
Electric Specialty Co.....	90	Signal Electric Mfg. Co.....	101
Electrose Mfg. Co.....	4	Simplex Radio Co.....	124
Elwood Electric Co., Inc.....	74	Somerville Radio Laboratory.....	120
Everett Electric Corp.....	76	Southern Radio Corporation.....	125
Everett, Oliver S.....	112	Standard Assembling Co.....	94
Excel Radio Co.....	112	Steinmeta Wireless Mfg. Co.....	130
Federal Telephone & Telegraph Co.....	91	Stern & Company, Inc.....	107
Firth & Co., Inc., John.....	126	Stromberg-Carlson Telephone Mfg. Co.....	117
Formica Insulation Co., The.....	83	Telephone Maintenance Co.....	104
France Mfg. Co., The.....	118	Thordarson Electric Mfg. Co.....	116
Franklin Radio Mfg. Co.....	132	Towne, Inc., A. C.....	134
Garber Radio Electric Co.....	129	Tuska Co., The C. D.....	84
General Electric Co.....	129	United Electric Stores Co.....	129
General Radio Co.....	85	Usona Mfg. Co., Inc.....	86
Grebe & Co., A. H.....	95	Valley Electric Co.....	134
Hartford Battery Mfg. Co., The.....	78	Ve-De-Co Radio Mfg. Co.....	132
Heard Co., The.....	126	Walls Sales Corp.....	72
Heslar Radio Corp.....	79	Westinghouse Union Battery Co.....	103
Hommel & Co., Ludwig.....	87	Weston Electrical Instrument Co.....	77
Horne Mfg. Co.....	72	Whitall Electric Co.....	114
Hygrade Electrical Novelty Co.....	122	Wholesale Radio Equipment Co.....	127
J-Ray Mfg. Co.....	108	Willard Storage Battery Co.....	93
Jefferson Electric Mfg. Co.....	120	Willis Switch & Instrument Co.....	108
Johnston, Chas. H.....	129	Winkler-Reichmann Co.....	121
Jones, James H.....	120	Wireless Mfg. Co.....	105
Joy & Kelsey.....	102	Wireless Press, Inc.....	110
Kimley Electric Co.....	106	Witherbee Storage Battery Co., Inc.....	116
King "Am-Pli-Tone".....	133	WorkRite Mfg. Co., The.....	71
Klaus Radio Co.....	120		

ALWAYS MENTION QST WHEN WRITING TO ADVERTISERS

Send for this

This Book written for YOU

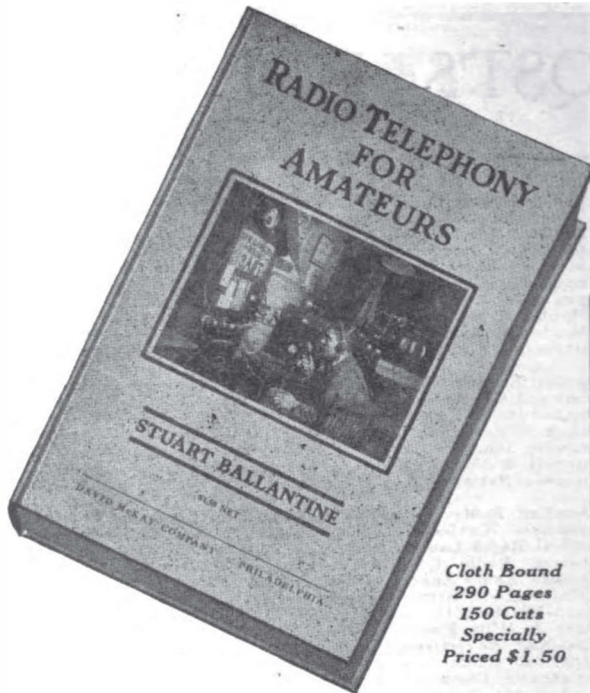

Cloth Bound
290 Pages
150 Cuts
Specially
Priced \$1.50

Mr. Ballantine, an amateur and a consulting engineer of 14 years experience, says this in the preface:—"Since connecting up my first receiving apparatus in 1908, I have longed for a certain type of radio book; a book from the pen of an amateur, radiating the true amateur spirit of inquest and investigation, a book chockfull of practical information and suggestions for new things to do and instructions for going about it. In a word, a book which would at once ignite the spark of enthusiasm and furnish material to carry it on.

And so members of the A.R.R.L. now have an authoritative volume written for them especially by one of their fellows. In keeping with the true amateur spirit, the price has been set to fit the average purse.

These ideas will better your phone work

Here are some of the high spots. On MODULATION you get not only a clear and accurate understanding of how sound waves are impressed on radio waves, but also instructions for building efficient sets. FILTER CIRCUITS, too, are covered with full data for making special transformers. Then, there are more transformer designs for RADIO and AUDIO Frequencies. And special attention is paid to LOSSES—in both the set and the Antenna.

How to make sure of Your Copy

Radio Telephony for Amateurs is on sale at nearly all bookstores. And, too, the up-to-date radio dealers carry it (they find it just the thing for answering the many, many questions put to them). If your regular dealer does not have the book. USE THE COUPON.

DAVID MCKAY CO.
Philadelphia

FILL IN, CUT OFF, AND MAIL

David McKay Co.,
Philadelphia.

Gentlemen:

Please send me a copy of Radio Telephony for Amateurs, for which I am inclosing \$1.50 and 15c extra for mailing. And hurry it along as I am anxious to try out several of the new ideas mentioned in the "QST" ad.

Yours truly,

Name

Address

CONNECTICUT RADIO

A Greater Working Range

The most useful portion of condenser adjustment spreads over a dial turn $2\frac{1}{2}$ times greater in the CONNECTICUT Variable Condenser than in the familiar rotary plate type.

The well designed circuit for short wave lengths usually employs capacity not exceeding 400 micro-microfarads. The CONNECTICUT Condenser has over 300 degrees of dial movement below that capacity, against only 120 degrees in the rotary type.

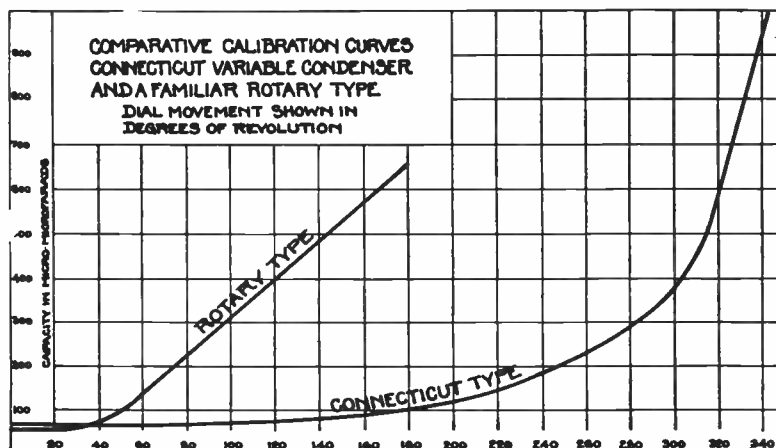

The end of the scale, where capacity change in the CONNECTICUT type is somewhat more rapid, is generally little used in any condenser. In practical operation (below 400 mmf.) the gradual capacity change of the CONNECTICUT Condenser and the greater dial rotation, permit most accurate settings.

Ask for radio bulletin A9 describing the condenser and other CONNECTICUT radio apparatus.

CONNECTICUT TELEPHONE & ELECTRIC COMPANY
Meriden Connecticut

The Recognized Symbol of Superior Performance

As Illustrated
 Price \$7.25
 No. 2606

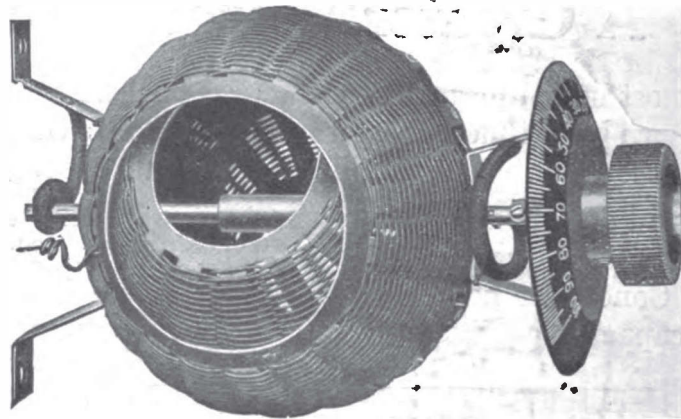

BASKETBALL Variometer

There are SIX styles of Amrad Variometers and Vario-Couplers—each a BASKETBALL. The unique method of winding, high electrical efficiency, trim appearance, lightness and rigidity, have won for BASKETBALLS an enviable reputation.

BASKETBALLS are used exclusively in Amrad Short Wave Tuner 2596—one of the reasons for the enormous demand for this instrument. BASKETBALLS are also used in the new Amrad Tuning Units. Quite naturally, the BASKETBALL is the vital element around which is built Amrad Crystal Receiver 2575—the Beginner's Receiving Set de Luxe.

Ask your dealer to show you BASKETBALLS and INSIST on the exclusive Amrad basket-weave. If your dealer does not stock, place your order with him and he will secure it quickly. Look for the green and yellow Amrad labels in the better stores.

Amrad BASKETBALL Variometers were awarded the Certificate of Excellence by the New York Evening Mail Radio Institute on May 20, 1922.

Variometers: \$6.50, \$7.25, \$11.50.

Vario-Couplers: \$7.75, \$8.50, \$14.50.

Bulletin O, mailed Free on request, describes the Amrad BASKETBALL Variometers and Vario-Couplers. Complete catalog including latest Amrad designs 10 cents in stamps.

AMRAD CORPORATION

New York Office: 205 College Ave., Medford Hillside, Mass.

Chicago District Office
 218 So. State St.

Digitized by Google