

OCTOBER

15 CENTS

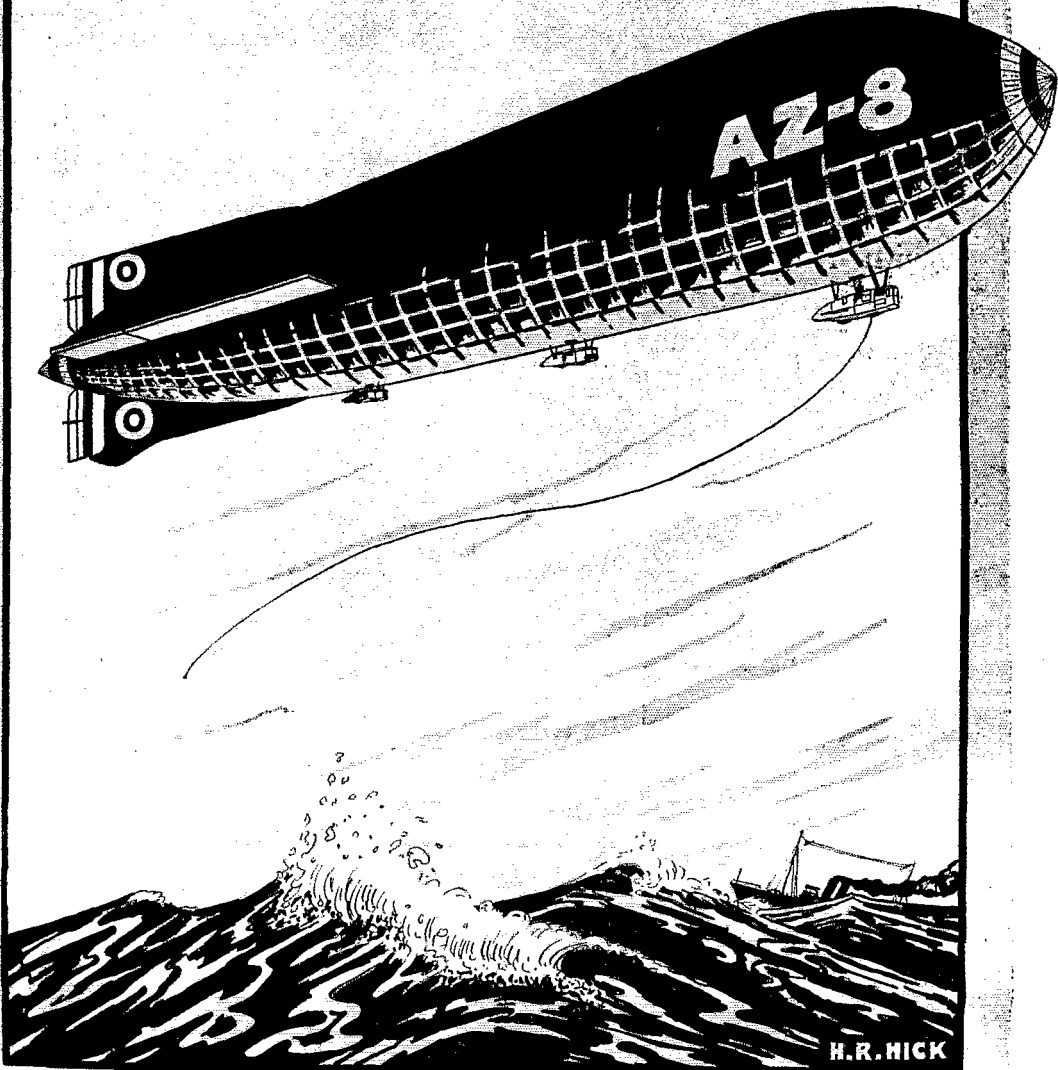

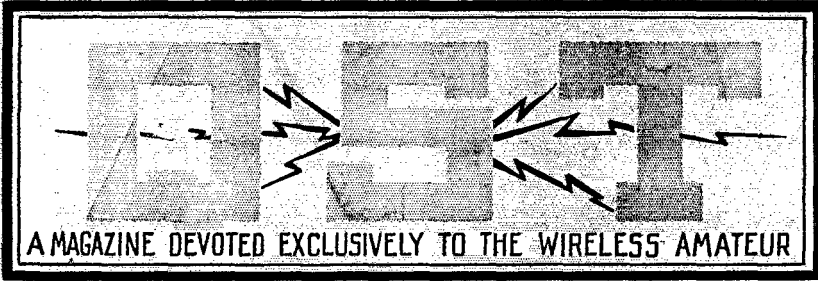
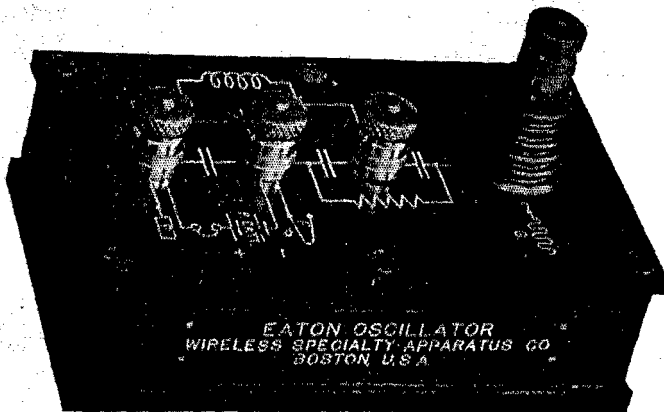

The Eaton Oscillator

Will simplify your long-wave reception problems. This circuit was used at one of the long-wave Naval Stations with remarkable results. Using the Eaton circuit involves a minimum of variable condensers, thereby saving you additional cost in equipping your station.

Price, \$14.90

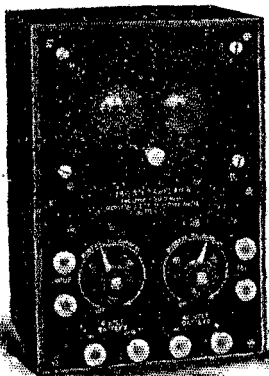

W. S. A. Co. Triode-B Two-Step Amplifier

A high-grade article for the particular Amateur. A separate unit to be used with any type of receiving equipment. Complete with shock-proof mounting but without vacuum tubes or batteries.

Price, \$69.00

ATLANTIC RADIO CO.

34 BATTERY MARCH ST.
BOSTON, MASS.

QST

VOLUME III

OCTOBER, 1919

NO. III

CONTENTS

3. Building Your Own C. W. Apparatus
7. Not So Rotten The Old Man
8. How to Put Up a Good Mast
10. Amateur Tests from NAH
11. Editorials
15. Efficient Short Wave Transmitters Guy E. Wilson
16. The Operating Department
22. The Connecticut Tube
24. A Compact Small-Capacity Switch Chas. E. Pearce
25. New Transmitting Apparatus
26. Radio Communications by the Amateurs
30. Amateur Radio Stations—Pictorial Section
31. "Strays"

QST is published monthly by The American Radio Relay League, Inc., at Hartford, Conn. Kenneth B. Warner (Secretary, A. R. R. L.), Manager and Editor.

Subscription price, \$1.50 per year in the United States and possessions;
Canada, \$1.75; Foreign, \$2.00. Single Copies, 15 Cents.

Entered as second-class matter May 29, 1919, at the post office at Hartford, Connecticut, under the Act of March 3, 1879.

Copyright, 1919, by The American Radio Relay League, Inc.
Title registered at United States Patent Office.

THE AMERICAN RADIO RELAY LEAGUE, Inc.
HARTFORD, CONN.

“NOT SOLD!!”

This was the answer you received when you attempted to purchase these coils unmounted

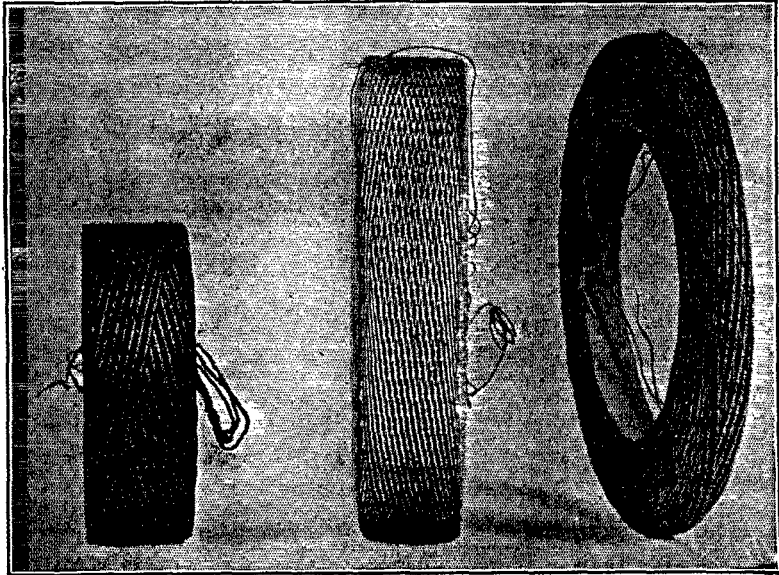

RADISCO HIGH FREQUENCY INDUCTANCES
(Universal spaced winding)

The men who build their own radio apparatus have long realized that the above type of coil is the most efficient coil for Radio Circuits—but, heretofore, they have not been able to purchase these coils unmounted.

To fill their need, RADISCO agencies have placed these coils in stock.

Coils may be purchased with or without taps as desired but, by purchasing coils with taps, ONE COIL MAY BE USED TO COVER THE ENTIRE RANGE OF WAVE LENGTHS THAT IT IS DESIRED TO RECEIVE.

Within a short time there will be a Radisco Agency in every part of the United States. If none is established in your vicinity at this time, and you desire further information, address the

RADIO DISTRIBUTING COMPANY, 312 FLATBUSH AV., BROOKLYN, N.Y.

RADISCO AGENCIES:

- | | |
|-----------------------|--|
| Bienville, Que., Can. | Canadian Radio Mfg. Co. |
| Boston, Mass. | Atlantic Radio Co., 34 Batterymarch St. |
| Brooklyn, N. Y. | Kelly & Phillips Elec. Co., Flatbush Ave., bet. 7th & 8th. |
| Newark, N. J. | A. H. Corwin Co., 924 Kinney Bldg. |
| New Orleans, La. | L. A. Rose, 4323 Magnolia St. |
| Providence, R. I. | Rhode Island Elec. Equip. Co., 45 Washington St. |

Q S T

A Magazine Devoted Exclusively
to the Radio Amateur

Building Your Own C. W. Apparatus

DOPE on new developments in amateur undamped reception comes in fast and thick these days—so much so that we can't publish it all. Yet all of it is so interesting that we have decided to combine it in one article, presenting the essentials but eliminating the repetitions bound to occur in a number of articles on the same subject. The Editor acknowledges his indebtedness to the following contributors: Mr. Wm. H. Seabury, 1056 Beacon Street, Brookline, Mass.; Mr. Wm. E. Woods, St. Louis; Mr. Guy R. Entwistle, Boston; Mr. Clinton H. Turner, North Reading, Mass.; Mr. J. A. Crowds, St. Louis.

Perhaps the most interesting apparatus is that in use at the station of Mr. Seabury. Like the other modern CW sets it consists of three inductance coils with the usual accompanying capacities, but the circuit, shown in Fig. 1, is altogether different from the hitherto published amateur undamped sets. This circuit is known as the Eaton Oscillator, a hookup that is now used at Otter Cliffs, the busiest coast station in the country, and while fairly well known to amateurs in the Boston district, is entirely new to most of our readers. Capacitive feedback is employed to make the bulb oscillate, instead of the more common plate tickler coil. The theory can be set forth simply as follows: A change in plate current imposes a charge on C4, which sets the secondary circuit into oscillation. During

these oscillations, similar changes in potential occur across the terminals of condenser C3, across which the grid and filament are connected, so that corresponding changes in potential are impressed upon the grid in such a manner as to sustain the oscillations thru the internal functioning of the tube. The third coil, while not a tickler, occupies the same position in the set-up as does the tickler in the commoner circuits, but in this case serves the dual purpose of acting as a wavemeter and at the same time functioning as the well-known "sensitizing circuit" ascribed, we believe, to Dr. Austin, whereby increases of signal strength of from three to four times are obtained. In CW circuits such as this, a beat note is produced by setting the grid circuit into oscillation at a frequency differing from the incoming frequency by a value equal to the desired tone, and in this case, the reactance of the grid circuit to the local oscillations is zero but the reactance and therefore the impedance to the incoming oscillations is considerable, and a loss in energy results simply from this slight dissonance. By coupling on this sensitizing circuit, the grid circuit is given two frequencies, in such a manner that the reactance to the incoming signals is also zero and the signal strength accordingly increased. With a calibrated condenser, this circuit forms a direct-reading wavemeter and is a great convenience.

Mr. Seabury's coils are homemade, em-

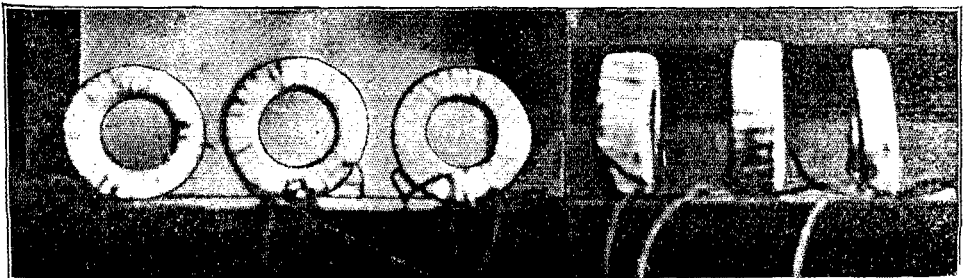

Fig. 2.

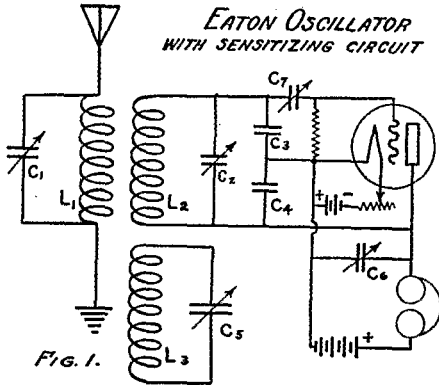
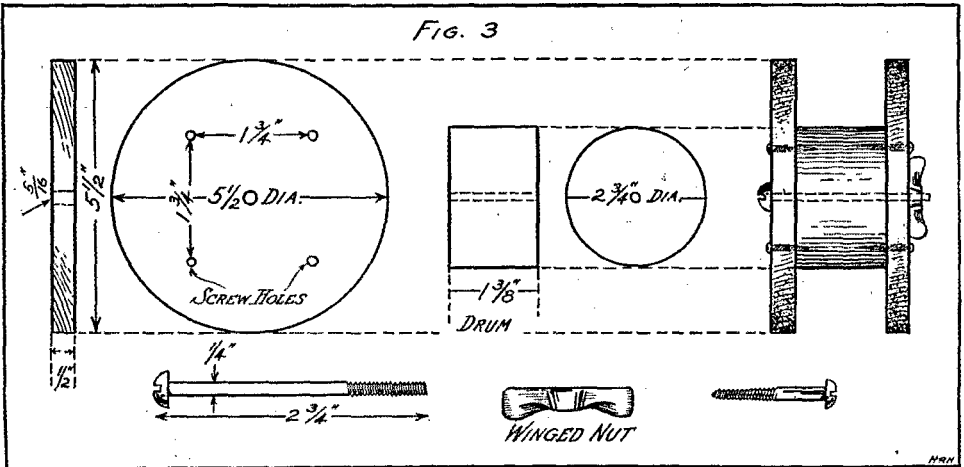

FIG. 1.

playing no methods the amateur cannot duplicate, and the set is compact, easy to construct, and has no expensive mountings, as the coils are slid along the table to vary

ed, and altho solid wire can be used with fair efficiency and a considerable reduction in cost, the builder is strongly advised to use Litz if it can be afforded. The coils are wound on a wooden form, the construction of which is shown in Fig. 3. This is used only during construction, later being discarded. The drum and end pieces must be well fitted, to prevent the wire slipping down. The following instructions should be observed in winding.

Over the drum is placed a sheet of ordinary wrapping paper, and over this a layer of common brown string is wound. The string must be uniform in diameter and free from bunches or it will cause an uneven winding. Leave ends of string hanging out to be used later. Over the string the Litz is wound, leaving about four inches for leads. The primary has 14 layers of 30 turns each, the auxiliary coil 15 layers of 30 turns each, and the second-



coupling, altho they of course may be mounted if desired. Fig. 2 shows the finished coils. This set was used with a single-wire antenna having an overall length of 350 feet. If antenna dimensions differing very greatly are used, compensation in the primary must be made. The values of inductance and capacity are as follows in Mr. Seabury's coils:

- L1 23.19 millihenries.
- L2 39.86 "
- L3 28.70 "
- C1 .0030 mfd.
- C2 .0025 "
- C3 .0005 "
- C4 .0050 "
- C5 .0040 "
- C6 .0020 "
- C7 .0010 "

All of the coils are wound with No. 3-16-38 Belden H. F. Cable (Litzendraht). The highest possible efficiency is thereby attain-

ary 17 layers of 30 turns each. A layer of ordinary wrapping paper is placed between every two layers of winding. The completely-wound coil is paraffined, and a pointed ivory paper cutter or similar de-

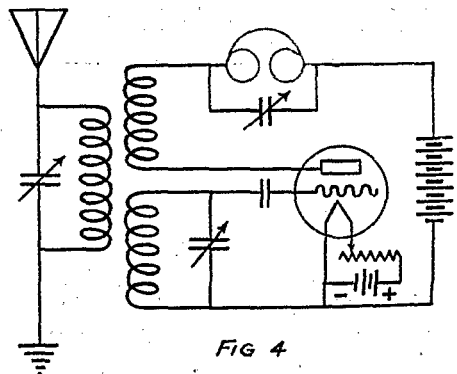

FIG 4

vice run around the circumference on one edge to cut thru the surplus paraffine, preparatory to removing one end piece. Extreme care should be taken not to disturb the winding. One end is taken off by removing the screws, and the outside "rim" of the coil given a coat of paraffine. The other end is similarly treated, after which the string is pulled out from either side so that with the assistance of the paper cutter the coil may be removed from the drum. The inside is then coated with paraffine. Two-foot leads of lamp-cord are soldered to the ends of the windings and the coil is then taped with half-inch linen tape, threaded transversely thru the center hole as with a bicycle tire. In taping, get a few turns around the leads to safeguard them against breaking off. It is very important to remove all the enamel from the soldered connection if a good job is to be done, as otherwise the high resistance would overcome the benefits of having used Litz. The enamel may be removed readily by heating red hot over an alcohol lamp and plunging into a saturated solution of pure grain alcohol and saltpetre.

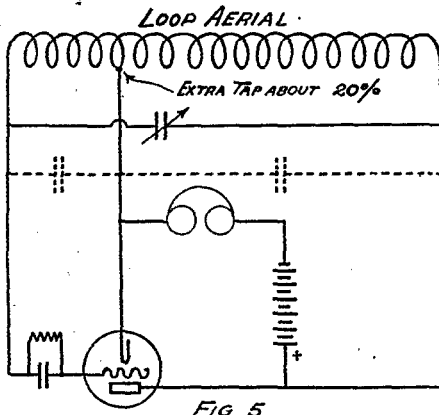

FIG 5

The wavemeter coil is shunted by an ordinary .001 mfd. Murdock condenser filled with castor oil, which increases its capacity about five times. The tops of the screws can be shellaced to prevent capillary leakage.

The operation of this set is very simple. The feedback is not variable, these values of C3 and C4 having been determined by experiment to be best. Accordingly the primary and secondary are tuned in the usual manner, with a suitable coupling. The auxiliary circuit is then tuned as before described, and if calibrated as a wavemeter will prove most convenient in the locating of any desired tune.

This oscillating circuit is adaptable of course to the Honeycomb Coils as well, and it should be understood that the sensitizing circuit may be employed to equal advantage

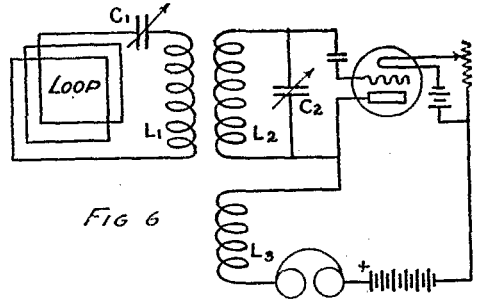
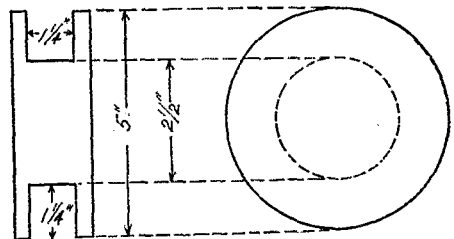

FIG 6

on inductive-feedback sets, four coils then being necessary.

Mr. Turner uses a similar method in building his coils except that they are all wound on a form 2 inches in diameter and with 1-inch width of winding. The rod thru the center of the form is mounted in standards and the end bent into a crank, forming a quite convenient winder. He uses one pound of No. 30 D. C. C. wire for the three coils, 50 turns to the layer, with 20 layers or 1000 turns for the primary and 16 layers or 800 turns for the secondary and tickler. We rather imagine the proportions of primary and secondary could be reversed to advantage. He winds his coils very similar to the method employed by Mr. Seabury but after each layer brings the wire back to the starting side of the coil with one diagonal turn around, and uses thin bond paper between each layer. The primary and secondary are operated with shunt condensers for tuning, and the circuit is a tickler feedback, as shown in Fig. 4. We believe better results would be had by the use of the ultraudion circuit shown by Mr. Crowdus in the September QST—a very simple change—alho he is copying Nauen and Carnarvon on one tube.

Any of these coils, and likewise those described by Mr. Crowdus, can be used on a loop aerial, particularly the large rectangle described in September by Mr. Woods, by connecting the loop to the primary in series with a large variable condenser of about .005 mfd. capacity. It should be borne in mind, however, that an amplifier is a necessity for practical work with a loop. But with the simplification of cir-



— 3 REQUIRED —

FIG. 7

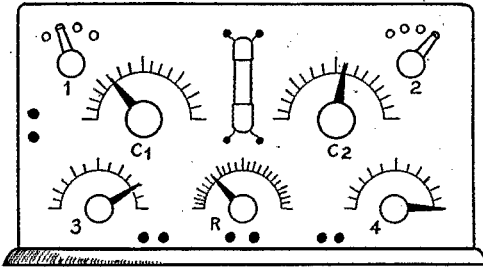

FIG. 8

NOs. 1 AND 2 STEPS OF
FIXED CONDENSER SHUNT-
ING VARIABLES

NOs. 3 AND 4. PRIMARY
AND SECONDARY VARIABLE
CONDENSERS

C1 SECONDARY COUPLING
C2 TICKLER COUPLING.

R "A" BATTERY RHEOSTAT.

cuits so that both oscillator and amplifier operate from the same "A" and "B" battery, and with the many excellent amplifier transformers on the market, this has been reduced to the simple necessity of possessing an extra bulb.

In this connection why should it be necessary to use coils on the operating table? Why not couple the plate and grid circuits thru the loop itself, by taking a tap off the rectangle at about 20% of its inductance, with a circuit like Fig. 5? We suggest that experimenters with loops try this. All it requires is a third lead into the station. The Editor would be pleased to learn the results experienced with this arrangement.

Mr. Woods has favored us with a description of a cabinet set designed for use with the large rectangle described by him in September. The circuit, shown in Fig. 6, is self-explanatory and presents no new features. The coils should have an inductance of approximately 30 millihenries, and are permanently wound full with No. 20 wire, enameled, cotton or silk, on turned wood forms as shown in Fig. 7. No taps are made. The wire is wound in regular bank formation and, while considered grossly inefficient by the advocates of the new style windings, will give very good results in practical usage. Litzendraht of course should be used if it can be obtained, but is not essential.

The actual tuning is accomplished by only two condensers, one in the leg of the loop and the other across the secondary. They are of rather high capacity, about .005 mfd., and as a variable of this capacity is an expensive piece of apparatus, this design contemplates a substitute consisting of a standard 43-plate variable shunted by four steps of fixed condenser, each step having a value of .001 mfd. In operation, when the end of the scale is reached, the condenser is returned to zero, the first step of fixed capacity is cut in, and the operation repeated.

The coils may be mounted on a slide rod if desired, but as short leads are desirable in a circuit of this sort, a cabinet is shown which contains not only the coils and condensers but the audion as well. Fig. 8 shows the panel, while in Fig. 9 an idea is presented for mounting. Note that the secondary, in the center, is fixed, while the primary and tickler are mounted on either side, the primary so as to rotate thru 90 degrees and the tickler so that it may be moved back and fourth by a rack and pinion arrangement. It would be very convenient if the tickler could be mounted as the primary, but generally a tighter coupling is here required than that method makes possible. A hinged arrangement

(Concluded on page 14)

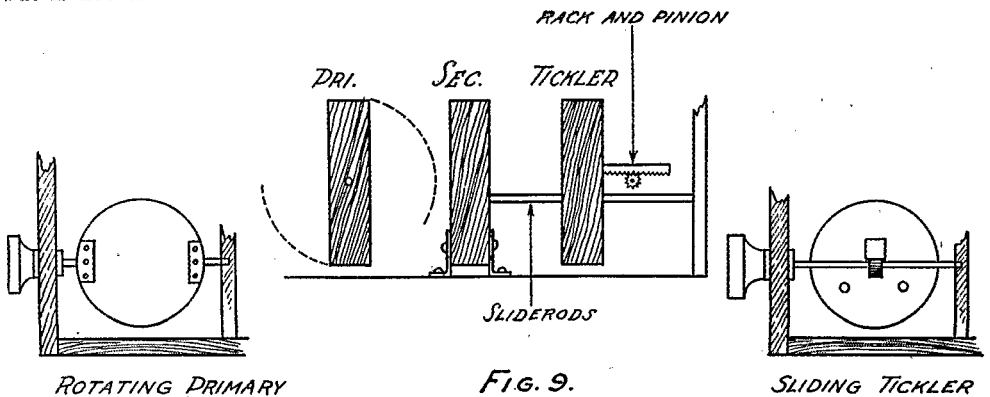

FIG. 9.

Not So Rotten

By The Old Man

WELL, say, you Editor chap down East there, just present my compliments to the distinguished scientist who wrote that article in September QST on Non-Synchronous Gaps. Tell him for me I hope his shadow will never grow less, his motor never ground and that he may live long and prosper. He's all right and his gap is likewise.

I considered up to the time I read the article that I had the only real rotary gap in the world. I have seen many gaps in my time, professional and amateur, but I never saw one as good as mine until this new one appeared. Once I had a peek at the old timer the Marconi Company inherited from the New York Herald at Siasconset. She was locked up in a cupboard under the operating table and they used to pull the door open at night sometimes to show the greenhorns the fire works. She was pretty savage all right and spat fire from every corner, but later on my old Betsy made her look like a tabby-cat.

Old Betsy takes a half horse power motor to whirl her around. By Heck, she ought to be worth something, don't you think? Uses darned near as much power as the transformer. But, son, when she gets really into action you can understand why it takes a half horse. She twists around just a little over seven thousand revolutions per minute and she is eighteen good inches in diameter. She roars like some pesky varmint just crazy to eat you and you can feel the hair just ready to raise up on the back of your neck. The nearest thing I know to her is a flivver when you crank it with the throttle wide open and you catch your coat in the headlight and can't get back to shut her off for what seems like half an hour or so.

Like my friend's pet skunk, she is not a pleasant companion to have in the same room with you, but placed down cellar and covered with an old quilt, and operated by distant control she isn't so bad when you

get the head-phones down tight. When I go down cellar to oil her up and give her the juice just to see how my sand is holding out as the years roll on, I make it a point to keep out of line with the business end of her. I happen to know what she's like when the cover is off and I also know how those four brass studs are fastened on. I don't fancy one coming loose and colliding with me about amidships. Yes—Betsy is a loud speaker all right and her spark used to fetch in the good old days just about what you would fancy it might.

But, I'm doggoned if I don't half suspect this new one in QST has her licked. I think I will make one like it some day and hook on the half horse power with about a five to one pulley ratio and give her a whirl. I suspect I shall stick to distant control and the old quilt, because I have a notion that with ball bearings she will still have a voice like an angry fog horn.

I don't know about feeding her booze, however. The distinguished scientist tells about dripping alcohol into her system to make her lively. It may be all right for a rotary gap to have a hydro-carbon breath most of the time in order to improve quenching action and to put in a pop relief-valve to ease her when she belches wind, but I fear me that it would take some pop-valve to keep the bakelite sides and the O.T. and most of the rest of the machinery from leaving for parts unknown if she ever happened to get just the right mixture and it ignited. It would be some belch.

No—I veto the booze business. Booze is all right for me but it's all wrong for the other fellow. In a man, just the right mixture turns him into a pretty violent sort of an article. But, a rotary gap going 7000 odd revolutions per minute, badly stung in the snoot, screeching like a Big-4 locomotive filled with wildcats, and chasing you around the cellar, would be too much for my kind of a nervous system. Me for prohibition when it come to letting down the bars to rotary spark gaps.

(Concluded on page 14)

How to Put Up a Good Mast*

Providing a suitable support for the antenna is probably the most difficult single feature about establishing amateur operation. To hire a contractor to put up a 100-foot self-supporting steel tower is no doubt the method deluxe and a thing we dream about, but there are few of us who can afford that, and there are few home-made poles over 60' that will stand the gaff of a few seasons of amateur work.

This article is a description of a good 80-foot pipe mast which can be erected for a cost of around \$15 and will give good service. A sketch of the complete pole is shown in Fig. 1, from which it will be noted that it consists of a timber, A, and three sections of pipe, B, supported by wires at each joint. The timber is provided with an iron collar at the top, thru which the pipe is raised; and a small platform 6 feet from the top, from which the work of erection is conducted.

In Figs. 7 and 3 are shown the details of the timber which is preferably a 6-inch by 6-inch, long enough to stand 28 or 30 feet out of the ground. The length imbedded in the ground depends on the nature of the soil. If good hard ground, the ideal way is to imbed it in concrete. In the author's case, hard clay was struck at about 4 feet, and a buried platform 3 feet square, as shown in Fig. 2, provided ample bearing.

Details of the iron collar are shown in Fig. 3. This should be made of $\frac{3}{8}$ inch by 2-inch strap iron. Any blacksmith can do the job. It has a loop securely riveted on it, made of the same stock, of such dimensions as to pass a pipe 2 inches in outside diameter. It should also be drilled for securing the guy cables, and then fastened to the top of the timber with heavy lag-screws.

The platform on the mast is 2 feet square, supported on two pieces of 2x6, bolted to the timber. The details are clearly shown in Figs. 7 and 3. Note that

a space 6 inches by 6 inches is provided alongside the timber and between the supports of the platform.

Standard pole-steps are provided and the woodwork is given two coats of mineral red paint, and the portion to go underground preferably tarred. The pole is then raised in the excavation before-hand provided. It should be securely guyed by three seven-strand $\frac{3}{8}$ " galvanized cables affixed to the iron collar, and trued up by means of turnbuckles.

We are now ready to proceed with the erection of the pipe, which is composed of 20-foot lengths of standard 1 $\frac{1}{4}$ -inch galvanized well-pipe, or black pipe of the same size properly protected by a preserving paint. Do not use pipe unions between the joints. They are not strong enough. A good joint may be made, as in Fig. 5, by butting the ends together and bolting thru a sleeve consisting of a 2-foot length of pipe just large enough to slip on.

Erection is accomplished as follows: The top piece of pipe is inserted thru the 6x6 opening in the platform supports and thru the loop in the iron collar, and temporarily suspended so the top is just a few inches above the collar. Aerial pulley and halyard are fastened with an eye-bolt thru the end of the pipe and the top set of three No. 12 galvanized iron guys secured around the pipe above the bolt. From his position on the platform the erector can easily raise the pipe hand over hand until it is high enough to couple on to the second section in the manner shown in Fig. 5. The two coupled sections are then raised until the coupling is just above the collar, where they are temporarily suspended by a hook inserted in the bottom pipe, and the second set of three guy-wires attached.

From this point on it will be necessary to enlist the services of neighbors to hold and pay out guy-wires. The two sections are raised in the same manner high enough to couple on the third section. After this it will be necessary to resort to block and

*Rewritten from an article by K. B. Warner in Popular Science Monthly, by the courtesy of the Publishers.

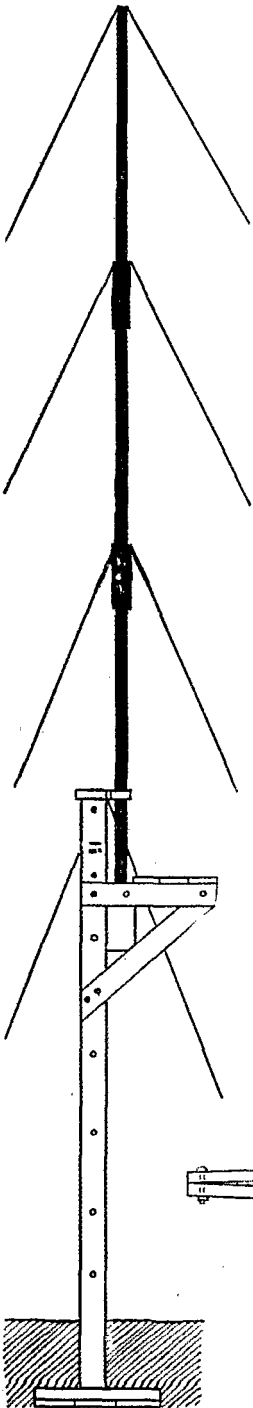

FIG. 1

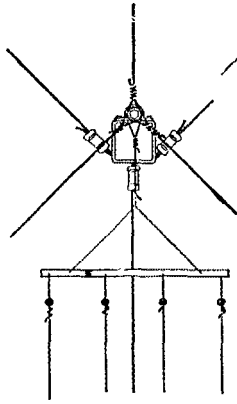

FIG. 4

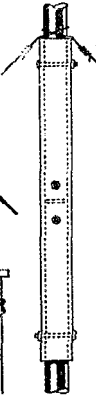

FIG. 5



FIG. 6

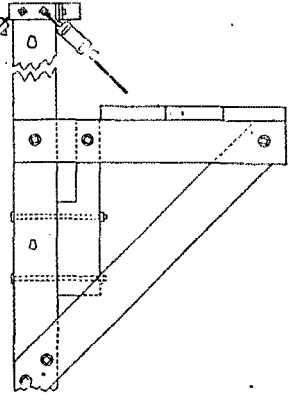

FIG. 7

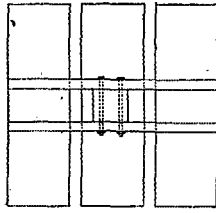

FIG. 2

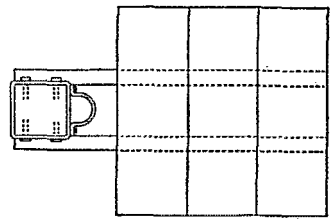

FIG. 3

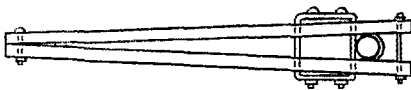

FIG. 9

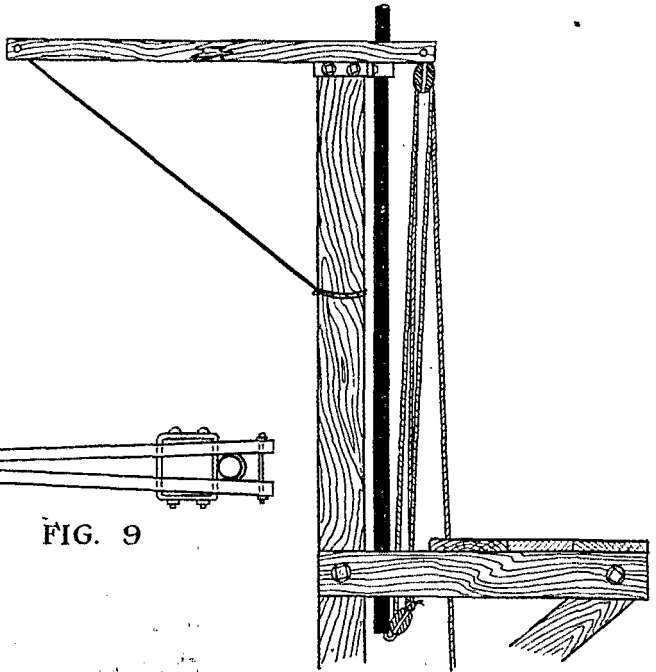

FIG. 8

tackle. A good way to use this is shown in Fig. 8, in which it is noted that the temporary arm, made of two 5-foot pieces of 2x4, as illustrated in Fig. 9, straddles the pipe and is securely guyed in its position at the rear. The pressure brot to bear on the arm is all downward, and a few nails thru a block between the members will hold it in place temporarily. Tackle is rigged between a bolt on the open end of this arm and a single block in the bottom of the pipe, and the three sections of pipe may then be easily raised, pausing to attach the third set of guy-wires as the last joint gets above the collar.

The bottom of the pipe is fastened to the side of the pole at the height of the platform by stepping it in the block shown in Fig. 6. This may be of 6x6 cypress, 2 feet long, and is hollowed out on the side next the pole to receive the pipe as shown. It is securely bolted to the plat-

form supports and the timber as indicated. A rope hitch around the pipe will suffice to lower it gradually into hole, after which the guy-wires are trued up and the mast is complete.

Several poles of this construction, except that standard couplings were employed instead of pipe sleeves, have been in service three or four years, supporting heavy aerals thru winter sleet and 60-mile squalls.

It will be found very desirable to employ a duplicate guy wire from the top of the pole on the side away from the aerial, to help take the pull against it. The guy-wires should be broken up into short lengths with porcelain knobs, to prevent energy absorption, and should be set out as far as possible from the base of the pole. This design is of course flexible and the builder can add an additional 20-foot section of pipe if desired.

Amateur Tests From NAH

So much interest was expressed in the Navy tests transmitted for amateur reception from NAJ, as announced in QST for August, that we went to see the Navy folks on this coast and proposed that similar test messages be sent from some station in the Third Naval District to give the Eastern amateurs the benefit of the same practice.

Authority has now been received by the New York Central Control Station to do this, and the tests will commence on October 5th, this date being chosen so that the October number of the various technical magazines may first give due publicity to the matter.

The transmission will be by NAH, on 1500 meters, and will be in the form of a coded broadcast addressed to all amateurs, transmitted immediately following the completion of the 9:00 p. m. press—which is to say, about 9:45 p. m. Various items of interest to amateurs, such as the establishment of new stations, changes in wavelengths or schedules of high-power stations, etc., will be transmitted in this broadcast schedule. The code has not yet been published but any amateur may obtain it on request from the District Communication Superintendent, 44 Whitehall St., New York City. When writing this request an amateur should give the following information:

3. Age.
4. Military service, if any.
5. Commercial radio experience if any.
6. Class of operator's license, if any.
7. Receiving speed in words per minute.
8. Education.
9. Size and power of his transmitter, if any.
10. Type of undamped wave receiver, if one installed.
11. Name of any radio organization or club to which he may belong.

The Navy Department has come to appreciate that the amateur world constitutes an invaluable source of skilled operators, and the object of this broadcast is to give training in copying code, in line with the announced policy of the Office of the Director of Naval Communications to cooperate in every way with the amateurs.

The Navy needs qualified CW operators, and there is quite a trick to tuning an undamped set, so we suggested the desirability of undamped transmission to afford tuning practice, and on 2500 meters, so that the simple arrangement of an oscillating tube would permit amateurs who possess no long-wave undamped set to become familiar with CW; but there is no medium-power undamped wave transmitter in this district at present, unfortunately. We are hoping this can be arranged later, as it would add considerably to the value of these tests.

1. Name.
2. Address.



DANIELS ONLY KNOWS

Why are we not opened up? Daniels only knows! Another month has rolled around and still we are unable to get any action from Washington or get any reason for inaction. Everybody tells us the same thing—that it is up to the Secretary of the Navy. And everybody, when you ask them why the Secretary of the Navy acts the way he does, makes a different guess. You can hear anything you are looking for. We wonder if the Navy Department, and Mr. Daniels especially, has a full realization of the bad odor that is rising around this amateur radio matter. If popular sympathy for the Navy is a desirable thing to have, it is very unfortunate that amateur restrictions are not removed or a reason given why they cannot be.

In order that all amateurs may be in the position to form their own conclusions, we will state the situation of affairs, exactly as it is, up to going to press with this issue of QST.

As Mr. Daniels seems to be the sole possessor of the secret why the lid continues down, the A.R.R.L. has had a resolution introduced in Congress requesting the Secretary, insofar as compatible with the public safety, to furnish the reasons why the restrictions have not been removed. This document is known as House Resolution 291 and has been referred to the House Committee on the Merchant Marine and Fisheries. We hope Mr. Daniels will not attempt to evade the issue but will come forward like an American and give us an explanation.

Now about that new legislation. On

August 28th the Navy Department furnished the Senate Committee on Naval Affairs a tentative draft of a proposed new radio bill which would repeal the old law of August 13, 1912, under which we now operate. This is the "government monopoly" bill we have heard so much about. It provides, however, for the existence of amateur stations and for a few other classes, and contains provisions for the issuance of station and operator's licenses under the Department of Commerce, as of old. There are a number of more or less important features in it which are objectionable from the amateur standpoint but the big thing is that instead of providing regulations for wavelength, power, etc., this bill would provide for the existence of a technical radio committee, composed of one representative from each department of the government, who in closed session would formulate and promulgate regulations concerning wavelength, power, decrement, purity, operating procedure, etc., for all the classes of stations. This new law states we should use no wavelength except that set for us by the committee, and then leaves the regulations to be framed from time to time at the discretion of the committee instead of being definitely set forth in the law. This is small assurance for the continuance of amateur radio, with our destinies entirely in the hands of a government committee who would not be empowered even to hold public hearings where the affected classes of stations could explain their cases.

Our Board of Direction has held meet-

ings and laid out a plan of action and the matter is being handled vigorously. We are out to have the restrictions on amateur transmitting removed, or a good reason given why it cannot be. We are also out to oppose any despotic and un-American scheme by which we amateurs can be swept off the map by a brush of the hand whenever some unfriendly Government

officer or committee takes a notion to do so. You fellows up and down the country must help. You must write your Congressmen and Senators and insist upon being reopened or given a reason why, and also upon legislation which will insure our existence in the future. Like the good Americans we are, let's SPEAK UP and require the other fellow to do the same.

STILL GOING UP

Things are moving fast, fellows. QST is a lot better each month. You don't have to tell us. We know it. You did it; your help made it possible. It is the measure of your co-operation which alone determines our progress. Keep it up.

Do you notice we are not advertising the Bonds any more? We are happy to say we don't have to. We didn't get the full amount authorized by our Board, but we got enough so that we can operate QST and steer clear of snags. To every loyal A.R.R.L. man who by his financial assistance helped to make this possible we extend the warm hand of good fellowship and congratulations.

But now don't get stuck up. We still need your help in certain other matters. We ask all hands to stop and think deeply a moment about dues and renewals.

Send in your renewals promptly when you are notified that your subscription has expired (unless, of course, there seems to be an error). You know you can't do without QST and that you are eventually going to renew so why make it necessary for us to blow A.R.R.L. money in sending you additional notices?

Another thing: Give us a hand and help establish QST on a news-stand in your town. It would not be good business for us to turn QST over to a national distributing agency, for by their methods there would be a few QST on every stand and we know by experience that one recognized place of sale in a small town is enough. We therefore want to distribute direct. Remember that to exactly the extent that QST is a business success, to just that extent will we here be able to give you a bigger and better magazine. See your newsdealer today and induce him to send in a trial order, and then tell the

local amateurs where they can obtain it. Tell your dealer we will allow him credit for the return of unsold copies. But don't let there be any unsold copies. Take an interest in it. You're one of us—we're all in the same boat. It's yours as much as it's ours.

And now just before we drop this and go out to lunch (for we must eat no matter how busy we are) just a word about dues and answering your letters. Come on with your unpaid dues, those who have not attended to the matter. Finish the job and be a real A.R.R.L. man. It's getting to be a distinction in the radio world. Don't put it off and make it necessary to send out second and third notices.

And now about the other thing—answering letters:

Do you chaps realize what kind of a game this is here at headquarters? Well, hectic is the word. Between writing copy, soliciting advertising, running after the electrotyper, cussing the printer, and explaining to the little boy visitor why his kerflunkus detector won't work without a crystal in it, we are surely kept out of mischief. If we ever seem short in our letters, remember we don't intend to be. And remember too, we simply cannot answer all the letters we receive. It would keep seventeen of us busy. All we can say is that we appreciate the letters and would certainly answer every one if there were enough hours in a day. We never before realized to the full what A.R.R.L. spirit is. It just keeps you on the high gear all the time. It's just wonderful, and makes a fellow wonder if its like exists in any other line of endeavor.

There—it's all said. Now for those baked beans.

JUST BETWEEN US

Don't breathe a word of this—it's just among us friends.

Ever hear it said that imitation is the sincerest form of flattery? Well, we've been sincerely flattered, only it wouldn't do of course to mention it outside.

You know we have always had a couple of expressions all our own. We said our QST was a 100 percent amateur magazine

and that it was "of, by, and for the amateur." Well, say, it has been copied. You must have noticed it. After using it for three years, don't it make you smile to see the new ones imitating us? And, after all, who is the only simon-pure "of the amateur, by the amateur, and for the amateur"? And what is the only organization of amateurs recognized by Uncle Samuel? Our A.R.R.L.—that's what!

IMPULSE EXCITATION

Wanted—QST readers who know or suspect anything about Impact Excitation, to come across and tell the rest of us about it.

As we see it, Impulse Excitation is a system of spark radio wherein the primary circuit discharges with a single violent kick, setting the aerial circuit into strong oscillation and then letting it oscillate at its own frequency without feedback and with a damping determined solely by the antenna circuit's resistance (ohmic plus radiation).

We have often wondered why some of the manufacturers never put out a standard amateur impact transmitter. It would seem to offer many advantages. If the primary can be made to discharge with a single impulse, analogous to a half-cycle, then it has no "oscillation constant" or "frequency", and obviously there is no necessity for resonance. This means that in the primary we may use a whale of a condenser—just as large as our transformer requires for maximum output, instead of being limited to a maximum of around .008 mfd., which is about the value for 200 meters. This certainly is along the lines we "short horns" must work, to get anywhere on our restricted wavelengths.

Considerable work along this line has been done in the development of commercial sets, but in none of these does true impulse excitation seem to have been attained, for it seems to be a fact that in

them maximum output is secured when the primary has a natural period 1.7 times that of the secondary, showing that the primary is not really aperiodic. If it were, the period of the primary should be immaterial.

Now how can we short wavers obtain true impulse excitation? We know one thing: That in any circuit containing inductance and capacity, oscillations will not take place if the resistance exceeds a certain critical value. This is the main principle involved in this work. Experimentally it may be determined that the introduction of a graphite resistance in such a circuit changes the discharge from an oscillatory character to an aperiodic discharge. The energy consumed in the resistance is of course lost, making such a system extremely inefficient, but juice is cheap and we are willing to pay for distance. Results are being obtained experimentally with the use of special gaps using hydrocarbon vapors, so increasing the resistance to the discharge that the circuit cannot oscillate, or at most has only a very feeble swing after the first main impulse. It is interesting to note that this is merely carrying to an extreme the application of those principles which we know to be desirable to improve quenching in our non-synchronous rotary gaps. Another feature which may be utilized is the employment of a very large capacity and as small an inductance as practicable, which makes the circuit a very poor oscillator and in itself increases the decrement.

By comparing notes, who shall say that right here in the pages of our QST we may not be able to develop possibilities

in 200-meter work of which we do not now dream? Think this over, some of you wise ones, and say something.

WE'RE ON

In August we asked for suggestions from our members as to what they would like to see in QST. We surely got the suggestions. You fellows just ought to see our mail. The suggestions are unanimous, and so:

We will resume our old Pictorial Section. It is going to be confined to after-the-war sets. You are invited to send in photographs and descriptions of your stations, for publication in QST.

When we get going again we will publish calls heard; but not until then. There is no value in publishing the reports of commercials heard, unless the circumstances are unusual or the distance covered a record. It's going to be rare fun publishing the lists of fellows copied, after we get open. That feature of our

magazine helped us all tremendously in the olden days.

If we should be opened suddenly, between issues of QST, be sure to report your new call letters to us. It will probably be some time before a Government call-book listing amateur calls can be published, and we are going to find QST mighty convenient for letting the rest of the bunch know our sign-in.

In August we told you of our desire to publish an A.R.R.L. Honor Roll—to commemorate the deeds and perpetuate the memory of those of our fellow members and co-workers who hit the westward trail in the Big War. Have you done what you can to make this complete? If you can add any information, do not delay dropping us a line.

BUILDING YOUR OWN C. W. APPARATUS.

(Concluded from page 6)

could be devised, and other methods will suggest themselves to the builder.

When first testing out, if no results are obtained, do not be discouraged. Reverse the battery potentials until the correct way is found. Be sure the plate voltage is sufficiently high, as some bulbs require up to 60 volts. Make certain that all connections are tight, that the condensers do not short-circuit; and most important, reverse the tickler leads, as no oscillations can possibly occur should the tickler coil be connected wrong.

To tune, set the primary condenser at any point, then move the secondary condenser slowly back and forth until a decided click is heard in the phones, denoting that resonance has been reached and that the bulb is oscillating properly. If nothing is heard at this point, keep climbing along the scale with both condensers and you are certain to be rewarded with signals, as it is very seldom that there are not some CW transmitters operating.

This apparatus can be used, of course, with aerial and ground, but the beauty of

"NOT SO ROTTEN".

(Concluded on page 7)

Say—speaking of gaps reminds me of yaps. What's the matter down there in Washington, D. C.? Haven't they yapped enough by now and can't they give us a chance with our gaps? What ails the Navy Department any way? The Canadians were in the war, seems to me I have heard it said, and the amateurs up there are transmitting. Don't our folks know the war is over? Somebody send a postal to the Navy and let them know it was all over months ago. I am an American and I want my liberty the same as the Canadians have theirs.

The Old Man

the cage is its improved signal-to-static ratio, and with an amplifier the chances for getting actual copy are much better on the loop.

Efficient Short Wave Transmitters

By Guy E. Wilson

AS the problem of an efficient short wave transmitter occupies a prominent place in the minds of the majority of the advanced experimenters, the writer wishes to express his ideas on the subject. Inasmuch as C. W. transmitters for short waves are unreliable, inefficient, and very expensive, unless vacuum tubes are used, in which case the last objection still holds, only the spark transmitter will be considered here. It is quite probable that C. W. transmitters for amateurs will come in the not very distant future, but at present the spark transmitter will still hold its own.

It seems almost certain that transmitters

isn't about 350 meters, as was the case before the war. Undoubtedly we will be carefully held to 200 meters, and if so, every bit of energy obtainable must be radiated in order that the long distance work formerly done may continue. In order to obtain the maximum antenna output, no detail of efficiency must be neglected.

As mathematics, other than the simplest, are taboo, many of the statements and figures arrived at here will have to be accepted without proof. Any up-to-date book on the theory of radio-telegraphy contains all the mathematics used in obtaining the results arrived at in this article.

Details of tuning, and other matters which are commonly contained in text books, will be omitted. What the writer wishes to show is that a little practical experience mixed with theory will produce a set which is the equal of any in experimental use.

The first thing to be considered is the spark gap. Too much stress cannot be laid on the fact that the spark gap is mainly responsible for the success or failure of many stations. Let us first consider the material to be used in the rotor. In the writer's opinion, aluminum is the best metal to use. Although not as good a radiator of heat as copper, it possesses the advantage of lightness, a very important advantage when it is considered that the gap must rotate at a high speed. In the case of a heavy gap, the objections to a high speed are obvious. Another advantage of aluminum is that it is not burnt away as rapidly by the spark discharge as are copper and zinc.

A common error is the idea that the only function of the rotary gap is to produce a musical note. Another function of greater importance, and not generally recognized, can be made use of in the properly designed gap. I refer to the quenching action. It has been shown that if we can allow the closed circuit to

(Continued on page 20)

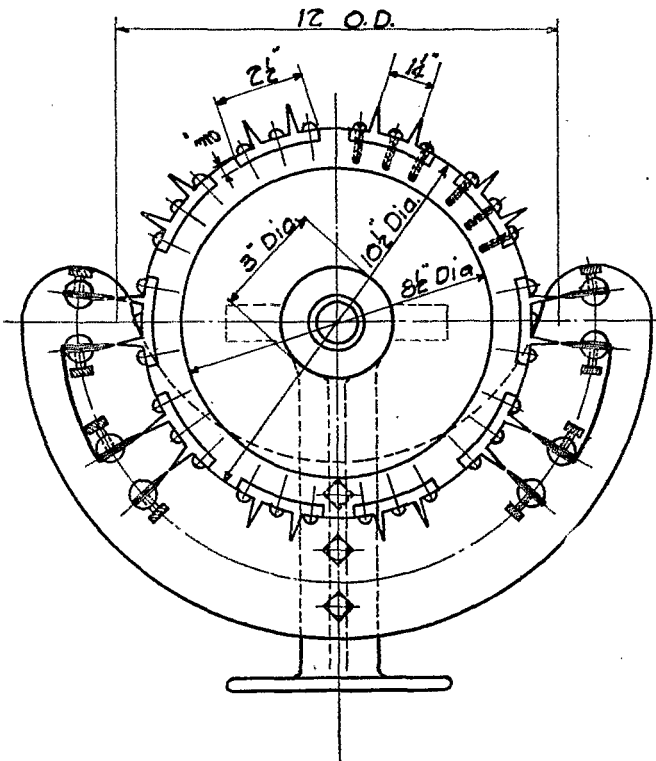

of the characteristics generally used before the war will not be permitted when transmitting is resumed, as undoubtedly the requirements of the law of August, 1912, will have to be adhered to far more closely than formerly. The decrement will have to be less than two-tenths, and the transmitters will not be allowed to use almost any old wavelength, so long as it

The Operating Department

J. O. Smith, Traffic Manager
Rockville Centre, L. I.

SUMMER has come and gone without any radical change in the amateur situation, and our stations are still silent. The August supplement of the United States radio call book, however, contains a short list of the Y class of stations that have been licensed, but information has developed the fact that although licenses have been issued and call letters assigned, transmitting by even these stations will not be permitted until the ban is lifted.

The old familiar newspaper stories of hearings on "Secretary Daniel's bill to give the Navy a monopoly of radio" are once more making their usual monthly appearance, and have caused many of us to wonder how much longer Secretary Daniels will be allowed to clog the legislative machinery of the country with his personal, pet theories, while thousands of radio amateurs are prohibited from exercising the privilege of operation of their stations.

We would not mind if there were any reason for this continued oppression, but repeated inquiries of the Navy Department by amateurs, Senators and Representatives have generally met with reply to the effect that Secretary Daniels was solely responsible for the continued restrictions and that no one else, not even Assistant Secretary Roosevelt, knew why the war-time restrictions had not been lifted. Possibly no one has informed the Honorable Secretary that the war is over.

It seems a sad state of affairs, however, when the personal desires of one man can offset the desires of ten thousand others, especially when the purpose involved is a perfectly legitimate and desirable one. The autocracy that so many of us left our homes and business ties to help crush seemingly was of no more a radical nature than the present amateur radio situation here in America, where one man is imposing his will by might on ten thousand other men and failing to give an American reason for it. That this un-American, autocratic attitude cannot long survive seems assured. It will help the cause of Americanism, help the cause of amateur radio and help put down incipient autocracy and intolerance if every man, woman and child who reads this will write at once to their Representatives and Senators and request that the war-time restrictions on amateur radio be immediately removed, so that amateur

transmitting can be resumed, or a good AMERICAN reason be given why it can't be done.

Write now, and right now!

ATLANTIC DIVISION.

Chas. A. Service, Jr., Manager.
Bala, Pa.

Owing to the absence of the Atlantic Division Manager from his home for the last three weeks, spending a vacation in the Canadian woods, where mail and news travel slowly, it has been impossible for him to keep in direct touch with conditions in his Division. Mr. Entwistle's report shows much energy and activity on his part in mapping out very comprehensive relay routes and even though they are still tentative, they form a fine basis for future development. Activity among the Canadian amateurs is also of much interest and should bring forth fruit when we are able to co-operate with them; however, it is probable only the larger cities will be linked up with stations in the States, as many others are too far apart to bridge the gaps. The Atlantic Division Manager has recently been over the majority of Nova Scotia and from a wireless point of view, its opportunities are slim. Only the larger towns are supplied with electric light, no aerials are to be seen anywhere and it is probable this part of Canada will develop slowly. Mr. Lorimer, of Montreal, is thoroughly familiar with conditions in his section and a letter from him to either the Traffic Manager or Atlantic Division Manager outlining conditions and prospects of a Canadian route would be much appreciated and would be included in the QST operating reports.

It is to be sincerely hoped that by the time this report goes to print the Navy will have seen its way clear to remove the war-time restrictions on amateur transmitting, as no American reason has as yet been given as to why these restrictions should be continued.

ATLANTIC DIVISION. (Southern District)

Chas H. Stewart, Ass't Division Manager,
St. David's, Penna.

Owing to the fact that this is the vacation season, and the ban is still on, there is

relatively little of interest to report at this time.

Mr. W. T. Gravely, District Supt. Central Virginia District, advises that he is particularly anxious to get into communication with radio men located in Richmond or vicinity who may take an interest in the work of the League, and it is suggested that anyone interested communicate with him at his present address, 503 Main Street, Danville, Va. Furthermore, he is anxious to get in touch with any radio enthusiasts located between Richmond and Danville and Richmond and Washington, as well as those located at other points in his State.

The desire to hear from those interested in the work of the League is not confined alone to Mr. Gravely, as the other District Superintendents in my District have also expressed themselves along the same lines. I would suggest that in the event that any interested parties do not know the address of their local District Superintendent, that their communications be forwarded to me at St. David's, Pa., and it will afford me much pleasure to see that they are properly forwarded to the respective District Superintendents.

Mr. E. B. Duvall, Superintendent for the Eastern Maryland District, wishes that it be made known that after September 1st, 1919, his address will be 4004 Park Heights Avenue, Baltimore Md., and requests that he be addressed accordingly in the future.

Owing to the temporary absence of the District Superintendent of the Central Pennsylvania District, Mr. W. M. Cawley, of Milton, Penna., I have at his request appointed Mr. Herbert M. Walleze, Assistant District Superintendent, during the absence of Mr. Cawley. It should be noted that communications for Mr. Walleze should be addressed to him at 234 Vine Street, Milton, Penna.

ATLANTIC DIVISION (Northern Section).

**Guy R. Entwistle, Ass't Division Manager,
137 Sutherland Road, Brookline, Mass.**

While waiting for the actual removal of the ban on transmitting so we can actually tell who is who, etc., tentative routes have been laid out for the approval of the amateurs in the First District. They are by no means the final selection of cities or stations merely serving as a starting point for future development. If you are not included write to your nearest relay traffic official for assignment.

Mr. Albert C. Lorimer, 243 Mackay St., Montreal Quebec, Canada will be pleased to co-operate with American amateurs.

Mr. Lee Bostwick, The Ormond Block, Winoski Ave., Burlington, Vt., will be glad to hear from amateurs in his district.

Mr. Harry McLean, Laconia, N.H., would like to hear from some of the boys up his way. Also Mr. R. F. Howe of Keene, New Hampshire.

Mr. Wilbur H. Hardy, District Supt. for Northern Mass. is anxious to line up the stations on the Boston to Portland—Rockland—Bangor—Bar Harbor—Eastport line. Write him your troubles.

We have already been negotiating with British amateurs and amateurs in the Azores for a proposed Transatlantic relay. What can you do to help us.

New England amateurs should all be preparing for the second annual banquet of the New England Amateur Wireless Assn. The Secretary, Mr. Wallace E. Heckman, 119 Windermere Road, Auburn-dale, Mass., will take advanced orders for reservations. Don't be left out when the time comes.

The Canadian amateurs are already transmitting and have calls similar to ours, beginning with 1 and 2. Please report any heard.

EAST GULF DIVISION.

**John C. Cooper, Jr., Manager.
Atlantic National Bank Building
Jacksonville, Florida.**

The East Gulf Division has been divided into three sections: The Carolina Section consisting of North and South Carolina, the Eastern Section to consist of Georgia, Florida and Alabama, the Western Section to consist of Arkansas, Mississippi, Louisiana and Tennessee.

CAROLINA SECTION. No Assistant Division Manager has yet been appointed for this section. It is earnestly requested that any amateurs who are interested in relay work in either North Carolina or South Carolina communicate with me immediately.

EASTERN SECTION. Mr. W. B. Pope, No. 197 Dearing Street, Athens, Ga. has been appointed Assistant Division Manager of the Eastern Section. Mr. Pope is one of the real veterans in the Southeast and we believe we are fortunate to have his services. His former license was 4AA, by which he was known throughout this part of the country. The following District Superintendents have already been appointed: Georgia, Mr. Philip C. Bangs, No. 29 Albemarle Ave., Atlanta, Ga.; District of South Florida, Mr. Houston Wall, c/o Knight Wall Co., Tampa, Fla. Mr. Wall's territory will include all of Florida south of the City of Jacksonville. Mr. Bangs, who has been appointed District Superintendent for Georgia, is President of the Atlantic Relay Club. He expects to have several good stations in operation in Atlanta next winter. It is also expected that

the Georgia School of Technology station, also in Atlanta, will be much improved and also used for Radio Relay work. Several former relay operators will be students at Ga. Tech. next year, including A. D. Whitaker, Jr. of Atlanta, formerly 4AP, and Je Ter Puckston of Valdosta, Ga., formerly 4BD. In Florida, Mr. Wall reports that he is already commencing work, trying to locate stations to open up the lines between Jacksonville and Tampa. It is expected that the new station being built at Ft. Pierce by O. A. Gullidge will be of much assistance. All operators desiring to have their stations named as official relay stations should communicate either with the District Superintendent, or if no District Superintendent has yet been appointed for their territory, direct with the Division Manager.

WESTERN SECTION. Mr. John M. Clayton, No. 1301 Welch Street, Little Rock, Ark., Assistant Division Manager. Mr. Clayton reports the following official relay stations already opened:

P. E. Greenlaw, Franklinton, La.
D. R. Simmons, Shreveport, La.

University of Arkansas at Fayetteville, Arkansas.

He is also in communication with the University of Mississippi and hopes to be able to recommend at an early date that station as an official relay station for that part of Miss. Mr. Greenlaw and Mr. Simmons above mentioned have been appointed as District Superintendents in Louisiana and amateurs in their territory should communicate with them. No District Superintendents have been appointed in Miss. or Tenn. and amateurs in those states as well as in Ark. are again urged to communicate with Mr. Clayton. He also reports that he has gotten in touch with the division managers of the Central Division and of the West Gulf Division, with reference to arrangements for handling traffic lines "C" and "E" through the western section of the East Gulf Division. No definite arrangements have yet been made but progress is reported. On line "E" it is expected that work can be handled satisfactorily from 9VP to Little Rock, from Little Rock to Shreveport and from Shreveport to Franklinton. Efforts are being made to locate a station near New Orleans, 30 or 40 miles distant from that City, so that some of the prospective stations in New Orleans can work with that station on low power as it seems that New Orleans amateur stations have heretofore had trouble on account of interference with commercial and Government stations in New Orleans. On line "C" it is expected that Franklinton can work direct with 5ED at Houston, Texas and thus connect the East Gulf and West Gulf Divisions on that trunk line.

WEST GULF DIVISION,
F. M. Corlett, Manager,
1101 East Eighth Street, Dallas, Texas.

Isn't it great to be home again? I'll say it is! I know that there are a great many more fellows wishing that they were at home and I certainly hope that their wish becomes a reality for I know that you are anxious to pull the old table out of the plunder room, knock about a ton of dirt and dust off the old apparatus, 'n,—well everyone knows what comes next. That is what I have been doing the last few days and unless something unexpected happens old 5ZC apparatus will be ready when the transmitting ban is finally lifted. No doubt but what there are a good number of you returning to this and other Divisions every day. Of course there is a world of things to be attended to and you can't get around to all of them at once, but LISTEN FELLOWS, DON'T put off getting straight with the A.R.R.L. If you haven't an application blank write for one but by all means send in your annual dues. Make your Money Order payable to the Secretary, A.R.R.L., Inc., Hartford, Conn., send it to your District Superintendent or Assistant District Superintendent, together with the application blank properly filled out and he will forward it. If you are already paid up for the year let your District Superintendent know that you are home again; if you don't know who your Dist. Supt. is, write the Division Manager direct.

It is the Division Manager's intention to subdivide the various Districts into Territories, appointing an Assistant District Superintendent for each, and in the larger cities where a number of stations are sure to be found, a City Manager will be appointed.

The following appointments have been made; Mr. Raymond L. White, P. O. Box, 322, Ennis, Texas, as Assistant District Superintendent, Northern Texas District, and has been assigned the TERRITORY of Ellis, Hill, and Navarro Counties, the same to be known as the ENNIS, TEXAS, TERRITORY. Mr. W. H. Tilley, P. O. Box 663, Austin, Texas, as Assistant District Superintendent, Southern Texas District, and assigned the TERRITORY of Travis, Williamson, Burnet, Blanco, Hays, Caldwell and Bastrop Counties, same to be known as the AUSTIN, TEXAS, TERRITORY.

The appearance of QST certainly is bringing in results; every day brings more correspondence and reveals the location of the "old timers" as well as bringing to light a number of new stations under construction or plans concerning them.

The Traffic Manager, in designating relay routes, has favored this division with two routes, Line "C" from Jacksonville, Fla., to Los Angeles, Calif., and Line "E" from Grand Forks, N.D., to Dallas, Texas. Line

"C" will cross Texas, New Mexico and Arizona. Line "F" will cross part of Northern Texas District, and the District of Oklahoma. The exact routes of each line will of course depend upon the locations of the various relay stations. It is going to take quite a number of relay stations to bridge the gaps between these points and that means there will be lots of room for all the dependable, live awake, up-to-date amateurs, so you had better lose very little time in getting in touch with your respective District Superintendents, telling him what your set consists of and what improvements you intend making.

PACIFIC DIVISION.

Seefred Brothers, Managers,
343 So. Fremont Ave., Los Angeles, Calif.

Mr. George W. Cameron, 500 East 12th Street, Portland, Oregon, is appointed as District Superintendent for the Northwest District. He reports that amateurs around his district will not be ready for any relay work before the first of September, as most of the fellows are out of town at the present time.

Mr. Fred Terman of Stanford University, Calif., is appointed as District Superintendent for the Central District. He reports that radio stations 6AU, 6KU, JS, 6AHN, 6AG, and 6FK (formerly of Santa Monica, but now of Palo Alto), are ready to start up when the ban is lifted. Nothing has been heard from 6WZ, 6BY, 6WC, 6AAV, 6WG, 6NL, 6AV, and 6HO. Most of the old fellows are still in the navy as radio electricians. He also reports that on his receiving outfit he has copied NPS (2000 miles), KEFR (S.S. Ossining, 1450 miles south), VAE, VAG, and ships up to 1000 miles away.

Mr. H. L. Newnan, 2242 San Jose Avenue, Alameda, Calif., is appointed as assistant Manager of the Pacific Coast Division. He also says that Fresno will be on the relay map for a relay station between Los Angeles and San Francisco, but he thinks that Bakersfield will make a better relay point for this purpose.

The amateurs of Los Angeles and vicinity, as well as San Diego, are not much in evidence as yet, except several new fellows who are just starting in the game. As soon as restrictions on transmitting are removed, we expect to give a better line-up of the stations on this coast.

We are contemplating a trip up north to San Francisco and the Bay cities, to visit all radio relay stations there, and also to line things up with our two District Superintendents. We plan to have a much better radio station by next winter than we had in the pre-war days, and hope to

break all our former transmission and reception records.

We would like to hear from all the old timers, as well as the new ones, who wish to be on the relay routes on this coast, and we hope that after things get started that the American Radio Relay League will have an even better relay system than we had before the war.

We also are very glad to see our QST once again, and we want everybody to become a member and subscribe to QST, the only amateur magazine in this country.

PACIFIC DIVISION, (Western Section).

H. L. Newnan, Ass't Division Manager,
2242 San Jose Ave., Alameda, Calif.

The radio relay system through the Pacific Division seems very hopeful for the coming season. Many of the boys who got the "biz" thru before the war are still in the naval service, but we are working on the development of trunk lines "B", "E", and "F".

The situation in San Francisco is not very encouraging due to the remote control station at NWO which controls three stations in San Francisco. As soon as the navy gives up the control of commercial traffic there will be a little more system here and less QRM. It is probably the same as NAH in New York.

F. Terman is the District Superintendent for San Francisco. We are planning to run Trunk Line "B" from San Francisco via Berkeley, Walnut Grove, Sacramento, Reno, Nev., and then let Andelin of the Mountain Division handle it from Reno East. There are no stations in Nevada east of Reno. Trunk line "F" will run south from San Francisco via 6FT, Terman, at Palo Alto, San Jose, probably Fresno and on to Los Angeles then on through Phoenix, Arizona, and east via Denver or Texas stations. There seem to be no stations in New Mexico. It's about time someone wakes up down there.

ROCKY MOUNTAIN DIVISION.

M. S. Andelin, Manager.
120 Canyon Road, Salt Lake City, Utah.

Organization has gone ahead in the division during the past month, but the traffic officers are handicapped in their plans because of some difficulty in locating station owners in Montana and Idaho. Amateurs in these States are requested to communicate with me immediately, so that a traffic organization may be perfected and trunk lines laid out previous to the reopening of transmission.

Efficient Short Wave Transmitters

(Continued from page 15)

oscillate just long enough to set the open or antenna circuit into full oscillation, and then open the closed circuit before the open circuit can react on it, the antenna will oscillate at a single frequency, and consequently closer coupling can be used, with a consequent greater transfer of energy. From one to four oscillations in the closed circuit are sufficient to set the antenna into full oscillation.

If the rotary gap is to have this function of quenching, the rotary and stationary electrodes must be opposite each other just long enough for four oscillations to take place, when the increasing distance between the electrodes will break the spark, allowing the antenna to oscillate at a single frequency.

At 200 meters, four complete oscillations take place in

$$\frac{4 \times 200}{300,000,000} = .0000026 \text{ second.}$$

Let us assume that the electrodes, both stationary and rotary, are as narrow as possible, say .01 inch. In order that these may not be opposite each other more than .0000026 second a peripheral speed of

$$\frac{.01}{.0000026} = 3750$$

inches per second is necessary. On the basis of a 12 inch wheel a speed of

$$\frac{3750}{12 \times 3.1416} \times 60 = 6000$$

R. P. M. is necessary. At this speed 10 teeth will give 1000 sparks per second, or a 500 cycle note. The face of the wheel must be quite wide so as to allow sufficient sparking area to withstand the heat developed in the spark without burning. This width should be 1½ or better, 2 inches. This will require an accurately milled wheel in order that sparking may take place evenly across the entire face of the wheel. Four stationary electrodes should be provided if possible, in order that the condenser and oscillation transformer may be placed on opposite sides of the gap, shortening the leads and providing 4 gaps in series, which will decrease the tendency of the spark to jump forward to meet the rotary electrodes and thus defeat the object of this wheel.

If four gaps are used, a solid metal rim cannot be used. One method is to provide ten pairs of metallically connected teeth, so that a pair of stationary electrodes may be placed on diametrically opposite faces of the wheel, and a spark will occur when

the two connected rotary electrodes are opposite the pair of stationary electrodes. The other method is to use a wheel having a face sufficiently wide to allow two stationary electrodes to be placed opposite the wheel side by side. This would involve an extremely wide face and is hardly practicable. The old method of allowing plugs to project through both faces of an insulating disc cannot be used unless the plug is replaced by a long narrow radial lug, in which case the constructional difficulties and the improbability of all the lugs being exactly radial make this scheme doubtful. In any construction, a provision for a slight movement of one set of stationary electrodes, circumferentially, will be of much value in obtaining an adjustment where the leading spark will be minimized.

Constructional details all narrow down to the few facts that the teeth must be extremely narrow in the direction of rotation, quite wide across the face of the wheel, must have a height of from ½ to ¾ of an inch, that the peripheral speed must be extremely high and that four gaps in series are extremely important. It goes without saying that the wheel must be accurately milled and run quite true.

A gap designed by the writer to embody the foregoing features is illustrated in the figure. It is milled from an aluminum blank, 12 inches outside diameter and 1½ inches thick. Ten pairs of teeth, 1½ inches apart and ¾ inch high, are milled into this blank, and it is then turned into a ring, 9¾ inches inside diameter and cut into ten pieces 2½ inches long, each piece having one pair of teeth. A fibre or bakelite disc, of 1½ inch stock, is then turned up with an outside diameter of 10½ inches. It has a 3-inch-diameter hub and a 1-inch-wide rim that are the full 1½ inches thick, and a web ¾ inch thick between the two. The rim is recessed as shown and the aluminum pieces are set in and fastened in place by six 8-32 machine screws—a necessity, as the centrifugal force acting on each piece is about 400 pounds, assuming each piece to weigh one ounce. After these pieces are in place the whole disc is mounted on the shaft of a 10-inch buffing stand, the hub being previously fitted with a brass bushing for mounting. The teeth should then be carefully finished on the new center, and the wheel balanced very carefully.

The stationary electrodes are of 1½ x ½ inch aluminum or copper, shaped as shown, and set in slots cut in ¾-inch round posts. The ribbon for connections is also placed in this slot, and the two held

in place by set screws. Eight electrodes are provided, which cuts the voltage to 2500 per gap. The condenser is connected to the lower posts on either side, and the oscillation transformer to the upper two. The other two on each side are connected together as shown. The posts for holding the stationary electrodes are mounted on a piece of 3/8 inch fibre or bakelite, which is fastened to the column of the buffing stand. All electrodes, both fixed and rotary, should be cut nearly to a knife edge.

The condenser is next in importance. A great amount of energy is often wasted in the condenser. Compressed air condensers are the most efficient, but their great size and weight preclude the thought of their being used in an amateur set. The most practical condenser is the oil immersed plate glass condenser. Photographic plates are best for the dielectric, as they are of exceptional quality, and their dielectric constant is from 6 to 8. These plates generally come in two thicknesses, .05 and .10 of an inch. As at least 1/8 inch of thickness is necessary to prevent puncturing the plate, two of the .10 or three of the .05 inch plates should be used between the metallic sheets.

These are best of sheet brass or copper, as tinfoil is easily torn, burns up, and is otherwise unsatisfactory. Lugs should be cut which are continuous with the plate and extend beyond the edges of the glass plates for connection purposes. All corners should be rounded to a fairly large radius and at least a one inch space left between the edge of the metal and the edge of the glass. The condenser must be immersed in oil, or heavy losses cannot be prevented. Very efficient condenser units, which are impregnated in an insulating compound, and have a mica dielectric, have been developed during the war, but their cost is so great it is hardly probable that they will be available for general amateur use.

The relation between the secondary voltage, power, condenser capacity, and spark frequency, is

$$C = \frac{P}{E^2 N}$$

where C is the capacity of the condenser, P is the Power, E the voltage to which the condenser is charged, N the spark train frequency in cycles (not the number of sparks). Assuming that we have 1000 watts in the secondary circuit, and that the secondary voltage is 20,000, the capacity

$$C = \frac{1,000}{400,000,000 \times 500} = \frac{1}{200,000,000}$$

farad, or .005 mfd.

The condenser as above determined will be of such a capacity that it will be

charged to a potential difference equal to that of the secondary of the transformer, in the period between trains. As high a potential as 20,000 volts, even though divided between four gaps, may cause the spark to jump forward to meet the rotary electrodes and allow the condenser to discharge over a longer period than is desired. It may be necessary for this reason to use a somewhat greater capacity than .005 mfd., but this is just as well, as the wattage drawn by a slightly larger condenser charged to a somewhat lower voltage will be about the same, and the natural damping of the primary circuit will be increased by such a change in the LC proportions. With a judicious increase in capacity, as determined by experiment, the use of four gaps and the circumferential adjustment of one set of the stationary electrodes will reduce the tendency of the leading spark to a minimum.

The oscillation transformer should be of the pancake type as this type occupies a minimum of space. The ribbon used should be as wide as possible, not less than 1 inch, and preferably 1 1/2 or 2. The thickness is of slight importance. The writer knows of one extremely efficient oscillation transformer in which 1 inch solid ribbon was used to support a 1 inch copper braided ribbon, reducing the high frequency resistance to a minimum. This oscillation transformer never heated, while a similar one on a similar set, using the solid ribbon alone, was warmed appreciably after a very short period of transmitting.

The ribbon should be supported on bakelite, rubber or fibre strips. Wood should never be used in this capacity. Rubber or bakelite is preferable to fiber, as the latter absorbs moisture and is apt to warp.

If a capacity of .005 mfd. is used, an inductance of 2250 centimeters is necessary for 200 meters. Remembering that the product of LC for 200 meters is 11.26, the inductance can be easily determined for any other capacity.

All leads in the oscillatory circuit should be of heavy braided ribbon to decrease the high frequency resistance. They must also be as short as possible, in order to concentrate all of the inductance in the oscillation transformer, and make possible a more efficient transfer of energy to the antenna circuit. The secondary of the O. T. will, in general, have a somewhat larger value of inductance, say 3000 to 4000 centimeters.

The transformer should be of an efficient type, and it is generally conceded that better transformers can be bought than made. Care should be taken that the power factor is not allowed to become so low that the transformer fails to draw

its full power. Another factor causing failure to get full power is the voltage drop due to the heavy current. The transformer, if possible, should be placed on a power circuit where the leads are heavy, and as close to the source of supply as possible.

A kick-back preventer should be used. The type consisting of 2 condensers in series across the line with the connection between the condensers grounded, is the simplest, and as good as any. It is also good practice to place in each lead, from the secondary of the transformer to the condenser, a choke coil consisting of 15 or 20 turns of wire, in a coil about 2½ inches in diameter. These will prevent any high frequency surges from the condenser entering the secondary.

Antennae and grounds have been thoroughly covered in other articles in QST, so we will content ourselves with insisting that the antenna lead shall be as direct as possible, be well insulated, and kept well away from any grounded object. The ground lead should be very heavy and run as directly as possible to a good ground.

The practice of carefully insulating the ground-lead is wasted effort. There is extremely little, if any, justification for

its insulation. The labor should be expended in carefully arranging the connecting leads of the primary circuit so that they do not touch the wood or oilcloth, etc., of the table.

In order to be sure the wave length is not more than 200 meters, and that only one wave is radiated, a wave meter is necessary. The type having a current squared meter is preferable, in order that a curve may be plotted showing the sharpness and strength of all waves radiated and in order that the logarithmic decrement may be determined. The method of tuning with a hot-wire ammeter is not satisfactory, and is apt to lead to broad tuning rather than sharp tuning. It is quite probable that if the set is tuned with a wave meter and only a single wave radiated, more energy will be radiated on one wavelength even though the hot-wire ammeter reading may be less. Wavemeter tuning is explained in detail in any up-to-date book on radio.

If undue stress seems to have been laid on the gap, it must be remembered that the writer believes that in this piece of apparatus is the secret of success or failure, and no pains should be spared in its construction.

The Connecticut Tube

A NEW and interesting type of vacuum tube has been developed by Mr. H. P. Donle, Radio Engineer of the Connecticut Telephone & Electric Co., Meriden, Conn., which not only departs entirely from previous usage but operates by means of what is believed to be a new effect: electrolytic conduction in a hot dielectric.

The easiest way to grasp the fundamentals of the new tube is to study Fig. 1, where the structure is shown diagrammatically, F being the filament, C the grid surrounding the filament, both contained within the evacuated glass chamber T, and A the anode or plate consisting of a metallic coating applied directly to the outer glass surface. The tube is used in the conventional manner, the electrode A being connected to the positive terminal of the B battery, the negative terminal going to the filament and the headset being included in the circuit. The tube is exhausted to the highest obtainable vacuum and

the operation is thermionic; i.e., purely by electron emission.

The point of immediate interest is the passage of the plate current thru the glass. Glass has up to the present been looked upon as at least a fair insulator, altho it has been known that at or near the melting point it becomes a good conductor. Obviously, however, it is absolutely impossible to operate a vacuum tube at such a temperature, as glass does not begin to soften until heated to about 425 degrees C. In contact with certain elements, however, glass becomes a good conductor at a far lower temperature than this; but the conduction thru it when in this condition is purely electrolytic, and all the phenomena accompanying conduction thru a liquid electrolyte are present in hot glass, such as decomposition, polarization, etc. During the development work, conductivity tests were carried out with many various elements, but with most of them an apparent polarization took place at the contact with the glass which

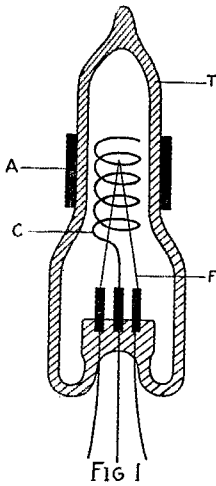

greatly increased the resistance instead of giving the results sought. It was discovered that when silver was the anode terminal, however, this action was almost entirely absent; so much so that at the proper temperature the glass became a very fair conductor.

It might be supposed that the electrolytic disassociation of the glass walls would make it impracticable to construct a tube in this manner, but the inventor assures us it has been found feasible to so distribute the current density that disassociation takes place at a very slow rate so that glass life will be one of the smallest factors in the life of the tube.

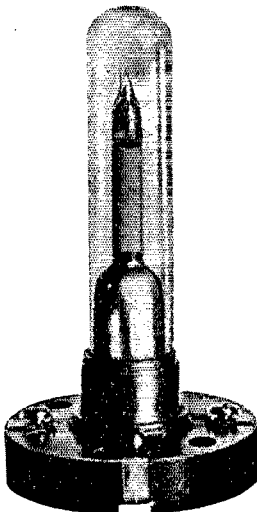
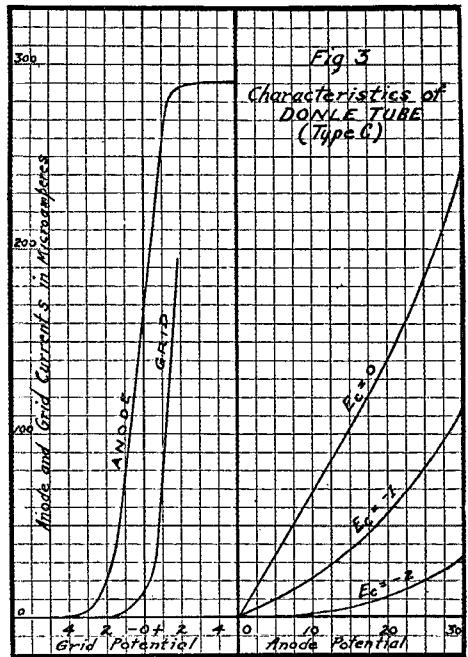

Fig. 2

Several types of tubes have been designed, working on this conductive property of heated glass, the glass being heated to the required degree by the filament (which of course also supplies the electrons) and maintained at the proper temperature by enclosing the tube within an outer shell of glass, provided with vents at its lower end in order that the temperature will not exceed its proper value. Fig. 2 illustrates the Type C tube, a detector operating on 20 volts anode potential, and probably the type of greatest interest to the amateur.



The construction needs very little description. The entire inner structure with the exception of the supporting wires is tungsten and molybdenum. The glass tube is drawn to a smaller diameter immediately over the filament and coated on the outside of that portion with silver, to form the "plate". Notice that the vacuum chamber is extremely small, in fact proportioned like a medicine-dropper, reducing the internal impedance but being utilized primarily so as to efficiently heat the glass wall from the incandescent filament.

In Fig. 3 is shown the grid voltage—

plate current characteristic curve (also the grid current curve) and three plate voltage—plate current curves for various grid potentials. The grid control characteristic shows one very peculiar feature: a sudden and definite saturation at a point near zero grid potential. The cause of this is readily explained.

In this tube we have in reality two resistances, that from filament to inner wall of the tube and that of the glass wall itself. This latter is nearly a fixed value determined largely by the glass temperature, but the former depends entirely upon the potential of the grid. It is obvious therefore that as we make the grid more positive, we decrease this former resistance until we reach a point where it is inappreciable compared with the resistance of the glass, and therefore in this condition the latter is the controlling factor in current flow between anode and filament, and so the curve abruptly

flattens out. It has been found possible to shift the position of this bend to any desired grid potential by altering the filament dimensions so as to change the ratio of electronic emission to glass temperature, and the values shown in the C tube were found best for a tube designed for this work.

While designed primarily as detectors, the Type C tube in particular has proved a very effective amplifier, its Mu or amplification constant having been measured at slightly over 19, which is much higher than obtains in the orthodox tubes. As detectors they seem to operate quite satisfactorily with either a stopping condenser or a polarized grid, and are said to have exceptional oscillating qualities, making them particularly adapted for use in regenerative or oscillating receivers. Considered all around, the Connecticut tube is a most interesting and promising development.

A Compact Small-Capacity Switch

By Chas. E. Pearce

Mr. Pearce presents a most novel idea for the construction of multi-point switches. It seems remarkable (now that we see it) that it has not been used long before. It surely takes an amateur to produce something like this.—Editor

For use where a large number of switch-points are required in a small space, or where regular switch-points may be either financially or geographically out of reach, this switch is recommended. Forty eight points may

be put in a two inch circle, with as much or more separation between points as is usually allowed. Also these points have a very low capacity effect, which is of importance in audion circuits.

The template is made of a rather thick

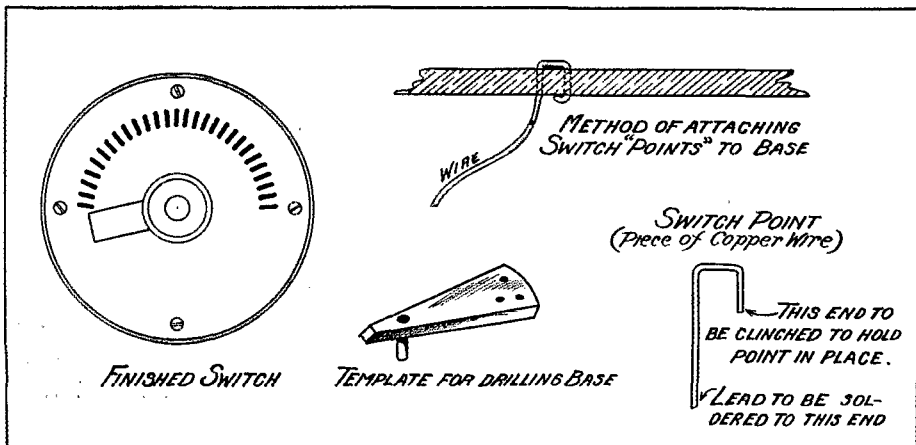

piece of any metal. The stud for the central hole of the switch is soldered. In making a switch the central hole is drilled first, and this stud inserted in it; the left hand hole (for the first point of the switch) is drilled, and a pin, such as a phonograph needle, inserted in it, to hold the template steady while the two right hand holes are drilled. Then the template is moved back until the pin in the outer right hand hole holds the plate steady for drilling the inner right hand hole, and the switch is begun. After drilling each pair, the plate is moved forward until the pin in the left hand hole, falls into the outer hole of the pair just drilled, until a sufficient number have been made.

TWIST DRILL SIZES

For No. 14 wire, use a No. 51 drill
 For No. 16 wire, use a No. 55 drill
 For No. 18 wire, use a No. 58 drill
 For No. 20 wire, use a No. 66 drill

Carefully made, this switch is very neat and efficient; enamelled wire may be used for the "points", retaining the advantage of such insulation except on the top of the "point" where it may be cleaned off with emery or sand paper, after the switch is finished.

Connections are easily soldered to the end of the wire extending below the base, which may be left of any length desired. Any switch lever that will work over the regular points will work over these.

New Transmitting Apparatus

The Thordarson people seem willing to help us knock down the prize for their 1500-mile transmitting contest—they've brought out a complete set of transmitting apparatus to accompany their transformers, as shown in our illustration.

Being designed to work as a harmonious whole, the style is uniform and the instruments so arranged as to secure simplicity in connections and accessibility for adjustment.

The condenser is the most novel feature, and seems to have much merit. The dielectric is phenol fibre, otherwise "Bake-

lite", and as it withstands 45,000 volts without puncture, it should afford a sense of security to the operator of the 25,000 volt transformer. Sheet brass is used for the electrodes, with an extra sheet, corrugated, between the electrodes of adjacent units, so that when the whole is immersed in oil to conserve energy otherwise lost in brush discharge, heat, etc., the oil may circulate between each sheet of dielectric, thoroughly cooling the whole condenser. Ten terminals are provided, one from each plate, and it is interesting to note that the capacity may be varied
 (Concluded on page 32)

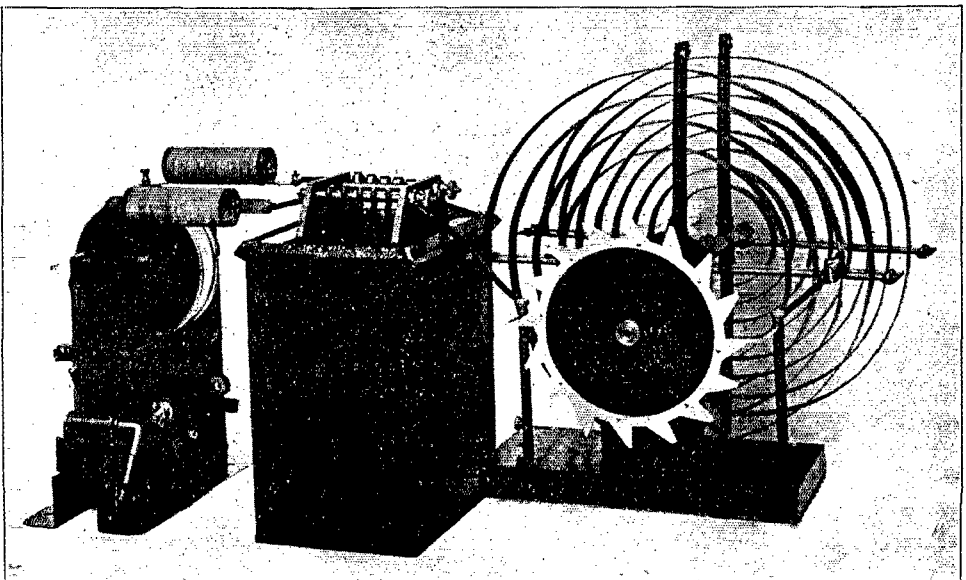

Radio Communications by the Amateurs

The Publishers of QST assume no responsibility for the statements made herein by correspondents.

FROM MR. GAWLER.

WE have the following interesting letter from the New England Radio Inspector. Mr. Gawler has had years of experience with Radio Amateurs, and we value his expressions. This letter interests us all, and is just one more argument for the need of co-operative organization.

"Gentlemen:

The August 1919 QST arrived today and it is the first copy I have seen since your staff knocked off to go soldering. It is very gratifying to me to see Amateur Radio squaring away for another cruise.

"Droves of amateurs have asked me what might be summed up in the question, 'What is the future of Amateur Radio?' Amateur Radio in the future is going to be so well organized and regulated by the Amateur Radio Experimenter himself the Government will need spend but little energy or money in its administration. Do you realize that these "kids" responding to the call for radio men in the Army and Navy, or in other lines of military activity, have grown up and are no longer "kids" dabbling in home made, wooden radio apparatus? Do you realize the change effected in their process of thinking after about two weeks under military jurisdiction? Do you realize that all of this change began more than two years ago and that the greater percentage of our "kids" saw foreign service? Are these men, having done their bit with bakelite sets going back to the wooden sets of their childhood in the radio game? No, they are not! They are going to have bakelite amateur radio activity. Wooden operators, wooden apparatus, and anything else wooden in the game, will either be taboo, or else be made to look like the real thing, and the kids of yesterday will accomplish these results by their influence much better than the laws would.

"We had just begun to realize in this District a group of well organized radio stations, thanks to the A.R.R.L. and the other smaller radio clubs, when the war caused the closing of all stations other than Government stations. The splendid manner in which the amateurs responded to the call, and their state of preparedness to do good work at once, is evidence enough of their military value.

"The amateurs cannot afford to neglect organization because only through well organized efforts can the best results be obtained. The better this organization is maintained the greater will be the benefits derived by the Government.

"I have been complimented for what appeared to be good control over the amateur field in New England when the Navy needed operators in early 1917. The various radio clubs and associations in this District deserve the credit for snappy response, and most of all the A.R.R.L.

"Don't worry about what the Government is going to do about Amateur Radio Activity. The Government knew what to do about it when they needed radio men, and they are wiser today in this particular respect than they ever were before. Organize and improve your product so that the Government cannot afford to keep you closed up for transmitting, and so they cannot afford to enact laws restricting your scope of activities.

"I am enclosing my subscription. I don't know as it has expired but all machinery needs fuel.

"The results your patriotic efforts of preparedness produced during this war should be a great source of satisfaction and pleasure to you all, and I heartily congratulate you.

"With my best personal regards, I am,
Sincerely yours,

H. C. Gawler.

U.S. Radio Inspector, New England District".

SPARK COIL DOPE.

To the Editor of QST:

I noticed in the September number that a call was sent out for data on a scientific spark coil set. That is a step in the right direction. The spark coil cannot be bullied out of existence, and the "small boy" you speak of certainly will welcome any technical assistance which will show him how to improve his set.

One possibility which I think most amateurs have overlooked is that of operating their transmitters over a variety of wavelengths. Why not build our panels so that we can send on 100, 150, and 200 meters? This would mean a series condenser in the aerial for the lowest wave, and some re-

duction of signal strength, but for communication over short distances in sections where QRM prevails, the arrangement presents attractive features. A complicated wave-changing switch is not absolutely necessary—simple markers on the O.T. or helix for the positions to which the clips must be moved for a given tune should do the trick, if the condenser in the primary is not too large. On spark coil sets, however, small condensers must be used, so practically all of these tuning operations could be carried out by variation of inductance alone.

I do wish that some kind soul would put an interrupter of some kind on the market which would give something like satisfactory service. I believe it should be of the magnetic type, for commutator and mercury interrupters are too expensive for general use, and electrolytic interrupters interrupt the lighting circuits more than anything else. Protection from sparking across the magnetic type of vibrator by a simple condenser seems rather inadequate and crude. Why not some form of miniature kickback preventer as well?

Yours truly,

Sumner B. Young.

"Rosemont", Duxbury, Mass. Ex-1CO

ABOUT THE BRITISH ULTRAUDION.

Lt. W. Klaus, U. S. N., O. I. C. Transatlantic Radio Control Station, Washington, sends us the following interesting comment by way of throwing light on a recent circuit published in QST.

"In reference to the hook-up on page 6 of the July issue of QST and of which I enclose a rough sketch modified slightly with the addition of a potentiometer, I will say, as you have invited comments, that I have used this hook up for about six months and have found it to be very good.

"This hookup has been known to the British Navy for about two years and altho they do not consider it one of their standard hookups they use it a good deal.

"A few of the peculiarities and constants of the circuit are herewith mentioned: This hookup will oscillate on every wavelength from 150 meters up to 4500 meters and with the addition of a condenser across the B battery up to 7000 meters.

The condenser C should be very large, anywhere from $\frac{1}{2}$ to 2 mfd. This has no effect on the tuning of the primary circuit. This condenser, however can be dispensed with if a battery is used to supply the B potential. If the house voltage mains are used for the B potential this condenser is necessary. R_1 is 500 ohms. The adjustment of this resistance is very critical. One side of the critical point will cause the set to howl and the set will not oscillate on the other side of the critical

point. The potential of BP of course is dependent on the bulb. C₁ is the usual stopping condenser. A peculiar feature of the set is that it will amplify spark signals without destroying the musical note providing the detector is adjusted and R_1 adjusted to the dead side of the critical point. The circuit works best with a carborundum detector and a potentiometer. This potentiometer should be 250 ohms and connected as per sketch to facilitate the changing of the direction of the current thru the detector crystal. The circuit has been called the oscillating-amplifying-detector hookup as it is readily seen that the functions of these three hookups are carried out in one.

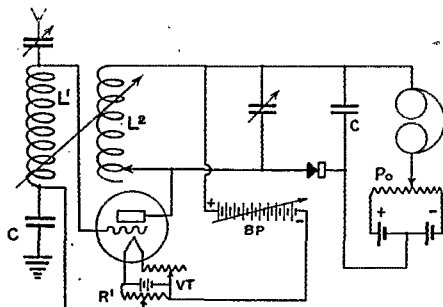

"This hookup has been found to be quite selective. This is probably due to the phase action in the loose coupler which also acts as the feed back tickler. Any slight difference in frequency caused by detuning of either circuit throws the phase relation out and consequently the regenerative effect and the transfer of energy to the secondary circuit is much lessened. The coupling and tuning is therefore very critical.

"Incidentally this circuit is somewhat of a radiator. Using one of the ordinary type 933 W. E. Co. receiving valves and placing a telegraph key in series with the source of B potential, C.W. signals have been transmitted up to a distance of two miles."

A FURTHER DISCUSSION ON NON-SYNCHRONOUS ROTARIES.

To the Editor of QST:

More losses occur at the spark gap than in the remainder of the closed oscillatory circuit combined, so it is evident that this is the piece of apparatus that deserves most of our attention toward improvement. I am sure that hundreds of other private experimenters shared, with myself, the interest and enjoyment of the article in the September issue of QST, on "Non-Synchronous Rotaries". This article is the expression of a subject to which I have given a great deal of thought and experimenting. I will take this opportunity to set down,

as a continuation of the September article, a few conclusions resulting from my endeavors, in hope that they will be of benefit to my fellow experimenters.

The mentioned article described a non-synchronous rotary gap that was mechanically quenched by proportioning the speed of rotation and diameter of the rotor, and width of the electrode sparking surfaces, to the natural frequency of the closed circuit. The ideal gap is one that will have infinite resistance on the charging of the condenser and no resistance during the discharge. These properties were accomplished to a high degree, as the gap possessed the necessary infinite resistance during charge and a very low resistance was obtained during discharge due to the very small clearance between sparking electrodes. The very fact that this clearance is so minute raises another difficulty in our path, and this is one of the subjects I wish to set forth.

The principal losses of a gap may be summed up as heat, light and sound. Reducing the gap length will result in a reduction of the slight losses resulting from light and sound, but greater heating of the electrodes will be experienced. This heating can be reduced by the use of certain materials for the electrodes.

The damping of a circuit depends upon the proportions of inductance and capacity of that circuit, and its ohmic resistance. When a spark gap is inserted in the circuit, this damping factor is changed, the amount depending upon the gap material. Silver or copper electrodes cause a change in the natural damping of about 10 per cent, while with zinc or pure tin only a change of a fraction of one per cent is experienced. Aluminum is a compromise between the two. It is therefore seen that certain metals have a greater choking effect on the oscillations than others. This choking effect or damping results from the resistance due to the relative heating of the various metals. We can now see why silver and copper are used in the ordinary quenched gap. But, the quenching effect is obtained at the expense of large heat losses, so large in fact, that the British Government for one condemns the use of this form of quenching. Now as we get our quenching effect by mechanical means in our non-synchronous rotary, quenching by means of certain electrodes is unnecessary and only adds to our losses. My advice, therefore, to experimenters is to use only zinc or pure tin for your sparking electrodes and I think you will find an appreciable gain in efficiency. The zinc will be found to wear slightly but its advantages will more than compensate for an occasional adjustment.

The author of "Non-Synchronous Rotaries" writes of trouble with a leading spark. I experienced the same trouble, but used

a different method for its partial elimination. In order to make clear the method I used, I must first give a short explanation of the distribution of potential and current through an oscillatory circuit.

If we have a horizontal wire divided in the center by an air gap, we have the simplest form of open oscillator. If a spark jumps the gap, we have an electromagnetic oscillation identical in nature to that of a condenser circuit. We will only consider the fundamental oscillation although there may be harmonics of a greater frequency. It is found in the above open lineal oscillator that the current and voltage have a 90 degree displacement. The highest potentials gather at the extreme ends of the rods while the voltage amplitude at the center is nil. Due to the 90 degree displacement, the greatest current value is at the center, where the voltage is lowest, while practically no current exists at the high potential ends. If the effective capacity on each side of the gap is equally increased the potential and current nodes and anti-nodes are not displaced from the positions already mentioned. If we consider the end capacities as weights, the point of greatest amperage will be at the point where a pivot should be placed to have the weights or capacities balance. Now if the capacity on one side was increased and assuming this an increase in weight, it is easily seen that to maintain balance, the pivot should be moved from the center position toward the heavier weight. This same condition exists in the lineal oscillator. If one end capacity is increased, the greatest amperage point and point of no voltage will be distorted toward that capacity. If this capacity is extremely large compared with the opposite capacity, our amperage point will be immediately next to the large capacity. (Deviating from our subject, a good ground of an antenna system is such a capacity, thus we find the highest current value and lowest point of potential immediately next to the ground.)

The same effect, as described, exists in the closed circuit, but as each side of the condenser has an equal capacity to the other side, the point of greatest current and least potential will be the mid point of the primary of the oscillation transformer, that is, assuming the length of leads as negligible. Now this is the point we want to place our gap. Although this is the point of no potential, breaking the circuit and introducing a gap will cause a difference in potential, but the potential difference at this point will be less than at a gap anywhere else in the circuit. It is seen that a reduction of gap potential will decrease the tendency of the spark to lead. It is probably unnecessary for me to state that the high potential necessary for charging the condenser, is of course

unaffected. The experimenter can design a method of inserting the gap at the mid-point of his oscillation transformer primary to suit his individual needs. Do not destroy the good features of the four gaps in series, however. I would suggest putting the stationary electrodes opposite consecutive electrodes of the roter to facilitate short connecting leads.

I would be glad to hear from those of the readers who are further qualified than I, on the above subjects.

Edmond Bruce,
731 Rock Creek Road. Washington, D.C.

QSP THE OLD MAN.

Ridgewood, N. J., July 27, 1919

Dear Editor:

In regard to the two copies of QST sent me, QRK. I have only one criticism. Several local "little boys" are showing signs of breaking out with that instrument of torture known as the spark coil. Now, a first class Wouff Hong, made by a manufacturing company of recognized merit or even a home-made one seems to be the only way of combating this evil. This, then, is my kick. The photo of the O. M.'s original, one-and-only, none-genuine-with-this-signature, Wouff Hong, published in the June QST was not clear enough. Therefore, a detailed sketch with all dimensions and method of operation would have been rather more appreciated.

By the way, pse ask the O. M. if the title of his new instrument is from the Sanskrit or Scandanavian language.

Will have to QRT nw as I sure need gobs and gobs of code practice after the enforced vacation, and intend to copy NAA's press.

73 OM, CUL SK
Harold Rouclere.

AMATEUR PRESS SERVICE.

I wonder how many radio enthusiasts realize the many possibilities of amateur wireless, especially in the country districts.

For instance, before the war W. S. Taylor of Minonk, Ill., and the writer at Eureka, Ill., exchanged news items by wireless for each edition of the local papers where this "press service" was printed under the pretentious heading "By Radio". This news was always sent at noon so it never interfered with anybody trying long distance work at night. The college and high school basket-ball scores and any special occurrences were sent to amateurs in Peoria and given to the dailies for publication the next morning.

We keep out a bulletin board where weather reports and sometimes QST press are posted daily. A clock in the store window shows the correct time "by wire-

less". Before the closing of amateur wireless the board of supervisors offered to pay us to keep the court-house clock set right. On the last presidential election we kept out a bulletin board almost all night.

Yours truly,
Henry Klaus.

HIGH NOTE VS. LOW.

Battle Creek, Aug. 12, 1919.

Mr. K. B. Warner, Editor.

Dear Sir: When looking over some of the back QST Magazines, I ran across an article in the August issue of 1916 by S. Kruse, in which he recommends the low tone spark and proves to his satisfaction that they are superior.

All thru the winter of 1916 I used a frequency from 960 to 1440, the latter being used exclusively along toward the last.

I received communications from about 50 stations outside the 200 mile zone stating that the station was easily read thru interference and QRN. Several stated that it was the most dependable station they copied all winter, coming in on warm rainy nights and at all times.

I was able to keep up communication with 4BY up to the last minute, a distance of 650 miles and he reported signals strong.

Of course the set was constructed to give its best work on high pitch, using 840 square inch condenser on $\frac{1}{2}$ in. plates and a voltage not over 15000, usually 12000.

I also would like to tell you of one of my other discoveries, which may be nothing new to you, however.

I have had considerable trouble with kick backs in the past and during the war in my operating I found that by placing the transformer on the floor that I cut my kick-backs entirely out.

The solution is this: My transformer created an induction in the wattmeter by being close to it, about 3 ft. away; also there were high frequency currents acting between the primary and secondaries of the transformer. These caused the action in the watt meter that punctured the potential coil.

I notice that with the transformer nearer the ground that this stops entirely even in the transformer.

I hope this will be a help to some one else having such troubles.

Yours sincerely, E. E. House.

Mr. House opens up a subject we haven't had an opportunity to argue since the war started: whether a high or a low note carries better. Instead of specific examples to support either view, isn't the answer in the design of the sets,—the voltage and the capacity, the peripheral speed of the gap, and particularly in the resonance adjustments of the secondary side of the power transformer?—Editor.



ALL SET, AND WAITING ON DANIELS

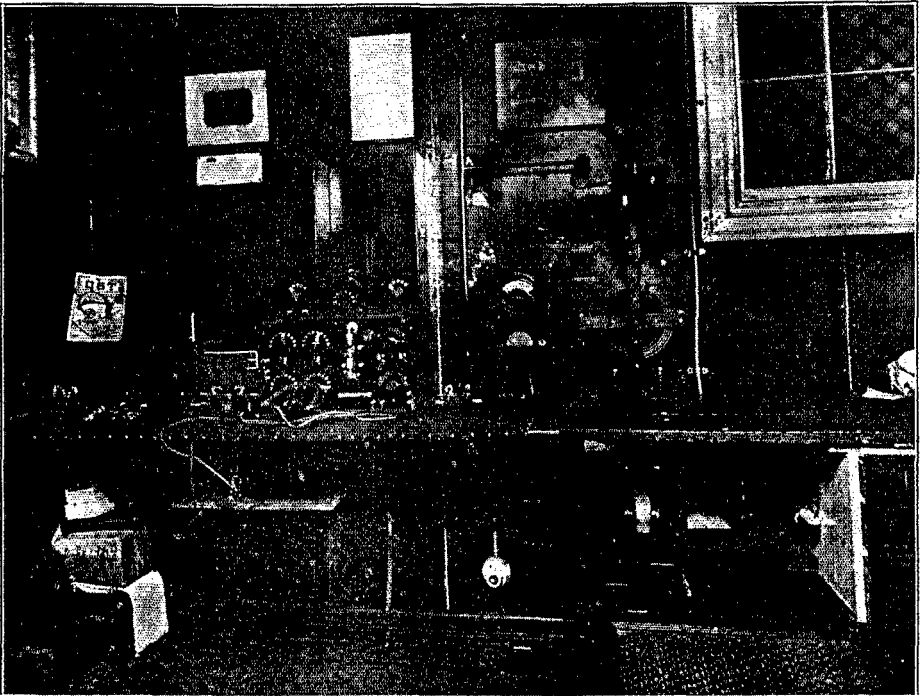

This efficient-looking A.R.R.L. station is located in Long Island City, N. Y., and operated by Mr. Charles B. Burch and Mr. Otto Skopee. The receiving set is practically all Grebe apparatus, and a Thordarson transformer may be seen on the transmitting side. The arrangement of the transmitter is novel and convenient. Note the lead-in of copper tubing, supported

from the wall by electrose insulators; and the ground-lead of copper ribbon.

This is just one of thousands of A.R.R.L. stations which may be counted on for effective relay work but which are perforce idle until the ban is removed.

Let's have some more photographs, you fellows.

“ STRAYS ”

Funny how many folks ask us where old 8AEZ is, now that we're preparing to open up. We're afraid that 8AEZ by that name is a thing of the past, for its owner, Mr. M. B. West, has recently purchased a fine home in Waukegan, Ills., and is removing there from Lima for keeps. During the war Mr. West did a wonderful work in the Navy, in building up the Great Lakes Naval Radio School from a handful of men to a completely equipped school of 60,000 men, for which he received official commendation. Leaving the service as Lieutenant, j. g., he is now civilian assistant to the District Radio Material Officer at NAJ with the same duties he performed in uniform after the close of the school. It's a shame Waukegan isn't another mile from NAJ, but being only 4 miles away, Mr. West is going to be limited to a half kilowatt when he starts up again, as he promises to do. Some of us have long suspected, however, that the things he's able to do to a set won't cause this to be much of a handicap on him, and in fact he assures us we'll all have to sit up and take notice when he cuts loose. All right O. M.

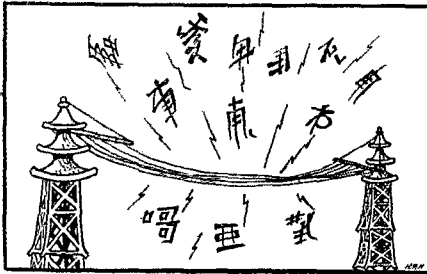

(China to Have Wireless.—News Item.) China keeps a slant eye on America for new notions. Every time we take a hop ahead, the land of chop suey and flat-irons hop lee right after us. Alle samee lak Melicans. Altho the Chinks are old-timers at the mystery game, they haven't followed suit on our revolving doors. Wise old China! Anyhow, about the wireless. You'll probably think they've been a bit slow on adopting the air chatter business, but when you stop to figure that their alphabet measures 44,449 letters, you'll understand the tardiness. How to twist a ton of trick letters on the ticker, and buzz 'em backwards has been some puzzle. A Chinese wireless operator has to be an acrobat and juggler as well. The Chinese wireless companies will sure collect the yen per word in messages, since a short message

sputtered in Chinese would cover a volume. Any outsider that picks off a Chinese wireless message will think his instrument has gone in for jazz.— From The Washington Herald.

The Annapolis station, NSS, with a 350 k. w. arc, now sends time signals at the same time as Arlington, using the high wave, approximately 17,000 meters. Not an amateur in the country with a CW set tuning that high should have any trouble in hearing NSS, and in fact for time signals this station is the best for inland amateurs in Montana, Wyoming, Colorado, etc. to listen for.

Ain't Nature wonderful? Just look at Seck Daniels!

To the many station owners who are these days getting right on their A.R.R.L. memberships, we'd like to make a suggestion: Get in touch with your District Superintendent direct, or your Division Manager if you have no Superintendent, and ask for a place in relay work. It is the officials of the Operating Department who make the appointments, and not this office. There are also good administrative positions open for the right men in the organization of lots of the Districts, and "the sooner the quicker", as the Irish say.

What next in concentrated inductances? If the present rate of progress is maintained, the girls will soon be wearing inductances for rings. Wonder if we can then get any closer coupling?

The present amateur situation is a big argument for the need of affiliation of Radio Clubs. Secretaries of Clubs, the A. R.R.L. will be glad to have your application. See August QST for details.

In this month's QST is advertised at last a cheap and efficient quenched gap. In tests this gap has run three hours on a half K.W. with a brick on the key, without changing note or unduly heating. Welcome, Q. G!

Now for a cheap but serviceable 500 cycle alternator of low power. A good field there for an enterprising manufacturer.

Mr. Arthur Batcheller, who so ably acted as Radio Inspector in the 1st District during the absence of Mr. Gawler, has left the service and is now Chief Instructor in electrical and radio theory at the Massa-

achusetts Radio and Telegraph School at 18 Boylston St., Boston. The school is under the general supervision of Mr. R. F. Trop, recently Asst. Dist. Communication Supt. of the First Naval District; and Mr. Guy R. Entwistle, formerly in charge of the Commercial Testing Dept. of American Radio & Research Corp'n at Medford Hill-side, is Associate Instructor.

The school has a new $\frac{1}{2}$ K. W. 500 Cycle transmitter, which is used for the demonstration of the principles of tuning and practical adjustment. In addition to the regular courses in radio and telegraphy, an advanced course is offered those desiring to qualify in higher branches of the radio profession. Instruction is given in the use of the radio compass, and of particular novelty is a Saturday morning class for wireless amateurs.

On a recent trip east, our Vice-President and the Assistant Central Division Manager discovered why certain radio messages used never to reach Chicago. They say every barn and farmhouse in Ohio has four lightning arresters on it and are firmly convinced that these devices absorbed most of the west-bound energy in days of yore. Guess we'll have to report it to the Leegonations.

An interesting set designed to minimize the operations necessary in tuning is the Jeweler's Time Receiving Set of the Chicago Radio Laboratory, shown below. In the construction of the set the idea of the designer was to so simplify things that an operator with no previous knowledge whatever of tuning could not help but get the results he desired. The audion is built in with the tuner, and the set is regenerative.



With the detector in order, there are just two adjustments. All the jeweler has to do is to turn the knob marked "Tuning" until he gets the signals, and then amplify the signals by rotating the other knob marked "Regeneration". The set is ideal for the jeweler to whom receipt of time signals is a matter of business and who cannot spare the time to learn the operation of a more complicated set.

Description of Star Station XNUT.

"The receiving outfit consists of a 325- $\frac{1}{2}$ -meter tight coupler, .2000 ohm phones; a phonograph sound box is used to detect the incoming signals, after which they are amplified by an Edison Mazda lamp.

The sending part comprises a bird-cage helix, inside which is a canary to give the spark a musical note. The rotary gap is

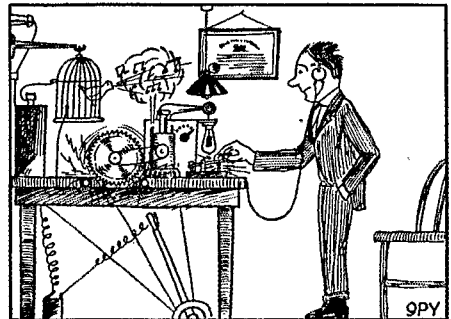

equipped with a bicycle sprocket wheel, and a most interesting innovation is its rotation by a young steam-engine. The transformer is a good 1 K. W., energized by a flashlight battery. A hand lever from a Ford makes a convenient antenna switch.

With this outfit I can send to the moon, and recently I heard a hurry-up call from a daffy-house on Mars."

(Boy, you ought to be there now.—Ed.)

Hear about the plant of this Philadelphia ham? Wonderful plant. Very strong indeed; self-supporting, no guy-wires needed; initial cost practically nothing; no equipment necessary to detect its radiation. A plant said to be out of proportion to most other plants there. What was it? Oh, just a Sun-Flower.

NEW TRANSMITTING APPARATUS

(Concluded from page 25)

from .0018 mfd. to .009 mfd. in steps of .0009 mfd.—a most convenient feature in adjusting the secondary power circuit to resonance with the supply circuit.

The oscillation transformer is designed particularly for 200-meter work, and looks like a real amateur built it. The turns are 1 inch heavy copper ribbon, supported in fibre strips, and it looks business-like and efficient. Using one complete outside turn on the primary and the maximum capacity of their condenser, .009 mfd. (more than generally desirable), the wavelength is 200 meters, but sufficient inductance is provided in the $3\frac{3}{4}$ turns to cover amateur tunes with the condenser reduced as low as .004.

The rotary gap is the saw-tooth style—

"the gap that made Chicago famous"—a type which was in much favor with long-distance amateurs throughout the Mississippi Valley in the pre-war days. It is of 1/8 inch aluminum, and available with either 8 or 16 teeth.

The Thordarson line shows the influence of advanced amateur ideas in transmitters, and is a welcome adaptation to manufactured apparatus of those principles which practical long-distance amateur work has shown desirable.

LEARN WIRELESS TELEGRAPHY

Fascinating and Educational Work—Big Salaries—Prepare Now

The United States Shipping Board is making heavy demands upon us for **Dodge-trained** wireless operators. Travel all over the world, secure, free, unsurpassed living accommodations and earn a big salary.

We Also Teach Morse (Wire) Telegraphy and Railway Accounting

School established 45 years. Endorsed by wireless, railway and telegraph officials. Low rates. Students can earn living expenses while attending school. **Catalog Free. Write Today.**

Dodge's Telegraph and Wireless Institute

27th St.

Valparaiso, Indiana

8,000 MILES

is the record (amateur) with our Audio-Tron Detector.

THE AUDIO-TRON

DETECTOR - AMPLIFIER - OSCILLATOR

Price postpaid \$4.50

Can we send you one C. O. D. ?
No extra charge.

Jensen Electric Co.

RADIO APPARATUS

1949 Huron Street CHICAGO, ILL.

The Oldest Radio Supply House in New England

Agents for all reliable lines of apparatus

GEO. S. SAUNDERS CO.

168 Washington St. 11 Devonshire St.
BOSTON, MASS.

POSITIONS GUARANTEED

To Every Graduate of Our School
By Four Largest Radio Concerns

\$125 PER MONTH PLUS ALL EXPENSES

Modern Equipment Special Short Course

Individual Instruction

Finest Staff of Teachers Available

DORMITORY — SWIMMING POOL

Call or Write for Illustrated Booklet

Y. M. C. A. RADIO SCHOOL

DEPT. R

153 EAST 86TH ST.

NEW YORK, N. Y.

"BEST RADIO SCHOOL IN THE EAST"

Can you beat the Double A quality goods?

Short wave regenerative sets
150 to 600 meters at \$25.00

Two step amplifiers guaranteed to increase signals 60 times; price \$20 without bulbs

Audion control panels complete with cabinet \$9.50

All our instruments guaranteed

RADIO EQUIPMENT CO.

1525 N. FAWN ST., PHILADELPHIA, PA.

GENUINE

AUDIOTRONS

DETECTOR - AMPLIFIER - OSCILLATOR

Double Filament

\$ 5.00

Prepaid

Complete supply of Panels, Parts, etc.

R. W. PRATT

Agent for AudioTron Sales Co.

Longfellow St. WESTBROOK, ME.



BOYS

How would you like to have this ghastly warning hanging in your room? It will make your station or den look big and command respect. It is the neatest sign made. Printed in bright red with big bold letters on stiff cardboard. 7 1/4" x 11 1/4". Price 20c, 3 for 50c, postpaid anywhere. Don't miss this opportunity.

LEONARD BECK

Dept. C., 102 Meridith Ave., Arverne, N. Y.

EUGENE C. BROWN

PATENT LAWYER

Electrical Engineer, Lehigh Univ.

Former Examiner Elec. Div. U. S. Patent Office

PATENTS AND PATENT LITIGATION

734 Eighth St., N. W.

WASHINGTON, D. C.

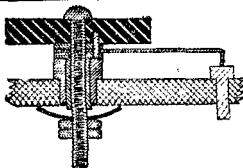

WILCOX
PANEL SWITCH
"The Best"

1 1/2" Radius Postpaid
Pol. brass fin. switch 50c
Nickle pl. fin. switch 60c
Turned and pol. knob 25c
Brass switch points 2c
Nickle pl. switch pts. 4c

THE WILCOX LABORATORIES Lansing, Mich.

CLASSIFIED ADVERTISEMENTS

Five cents per word per insertion, in advance. Copy must be received by the 10th of month for succeeding month's issue.

TELEGRAPHY (both Morse and Wireless) AND RAILWAY ACCOUNTING taught thoroughly and quickly. Big salaries now paid. Great opportunities. Oldest and Largest School—est. 45 years. Catalog free. Dodges Institute, 28th St., Valparaiso, Ind.

FOR SALE—No. 2 jr. Omnigraph; 250 watt Amc transformer; Crystalol detector \$1.25; and 1 kw. oscillation transformer. Harold Newman, Danville, Illinois

WANTED—Paragon RA6 Regenerative Set. FOR SALE—Oscillation transformer, phones, new Audion. Robert C. Bishop, Locust St., Lockport, N. Y.

WIRELESS BUGS, quick postpaid prices. Standard 1 1/4" switch knob-lever complete 35c. Brass switch points with screws, dozen, 25c. State panel thickness. Advise your rush wants in parts. Novotoy Electric Shop, 2200 Fifth Ave., Charlotte, N. C.

FOR SALE—1 K. W. Packard and 1/2 K. W open core transformers. Wireless Specialty leyden jars, oil condenser, oscillation transformer, hot wire ammeter "kick-back preventer," speed and straight keys, electrose insulators, 6-60 Witherbee storage battery, unmounted Murdock and United Wireless Co. variable condensers, hard rubber panel, audion bulb and miscellaneous apparatus, W. J. Eckstein, 255 Stuyvesant Ave. Lyndhurst, N. J. Phone, Rutherford 589J.

FOR SALE—One Mignon receiving cabinet, R. L. C. 5 \$25.00; also condensers, aerial wire, other apparatus and books; all are in good condition. Write for prices. Roy Ward, Bardstown Junction, Ky.

FOR SALE—Sending and receiving apparatus complete; all instruments first class and best available. If interested write for detailed description; will sell at 1/2 cost. E. Masztics, 12118 Madison Ave., Lakewood, Ohio.

FOR SALE—Receiving apparatus. Stamp for particulars. John Sellors, 1228 Mt. Royal Ave., Baltimore Md.

WIRELESS AMATEURS

Here is what you have been looking for: "THE JIFFY CONNECTOR." It will connect a Plate battery for the Audion (No. 703) in less than a minute; NO SOLDERING to do; just snap these "JIFFY CONNECTORS" on the terminals. A box to hold 10 No. 703 Batteries, Separators, and 1 set of "JIFFY CONNECTORS," price \$1.00 by mail. I also have Bakelite Rubber Panels, Grey Seamless Cardboard Tubes, etc.

A. T. HOVEY

No. 62-A ST. GERMAIN ST., BOSTON MASS.

DISTINCTIVE APPARATUS

Enclose stamp for catalog

AMERICAN ELECTROMOTIVE CO.

20 EAST 42ND ST.

NEW YORK, N. Y.

"B" (storage) BATTERIES

(INEXPENSIVE—DURABLE—EFFICIENT)

These batteries are a modification of the well-known "Marcuson" Potential Batteries, which have been the standard for over ten years.

E. MARCUSON

70 CORTLANDT ST.

NEW YORK, N. Y.

G. A. STANDARDIZED SUPPLIES

The General Apparatus Company has established a series of Standardized Supplies and Materials, covering such necessities as brass rods and tubes, wood and machine screws, Standardized bakelite panels, magnet wire, high frequency cable, G-A-lite inductance tubing, and other supplies for radio, model, and electrical workers.

G. A. STANDARDIZED B BATTERIES, 22.5 VOLTS

Built according to the specifications of the U. S. Signal Corps and Bureau of Steam Engineering. 90% of the B batteries used by the Signal Corps were of this identical design, the formulae for which are known to only one chemist. That these batteries are, in every respect, the best made is testified by the fact that they were used almost exclusively by the U. S. Government.

SIGNAL CORPS TYPE, 3 $\frac{1}{4}$ " long, 2" wide, 2 $\frac{1}{4}$ " high, operates one Audion 250 hours continually, average life 3 months. Price \$1.50, postage, 10c.

NAVY TYPE, 6 $\frac{1}{2}$ " long, 4" wide, 3" high, operates one Audion 1,000 hours continually, average life 10 months. Price \$2.50, postage, 15c.

THE BEST B BATTERIES MADE AND LOWER IN PRICE THAN ANY OTHER MAKE

G. A. CONSTRUCTION PHAMPLETS ON STANDARDIZED APPARATUS

M. B. Sleeper is preparing for the G. A. Company a series of pamphlets on the construction of transmitting and receiving apparatus, just the kind of information Experimenters need on simple apparatus of new and highly efficient design. All detailed drawings are given.

1. **INDUCTANCE TABLES:** Simple, direct reading, for coils 3 to 10" in diameter by $\frac{1}{4}$ " steps, 0.1 to 10" long in 0.1" steps. For single layer and banked coils, figure 8 coils, and flat pancakes.
2. **DIRECTION FINDER:** Detailed drawings of a simple unilateral Direction Finder of G. A. Standard Panel design, 200 to 2,500 meters. Can also be used as a straight receiver.
3. **AUDION TRANSMITTER:** A high efficiency telephone or telegraph set that can be built with simple materials. Range over 10 miles with single Audion receiver. Inexpensive to construct.
4. **SUPER RANGE RECEIVER:** With one Audion will give wonderful results on long wave stations. Copies Nauen with one wire antenna.

PRICE, 25c EA.; SPECIAL OFFER, 3 for 60c., 4 for 75c.—YOU NEED THEM ALL, SEND AT ONCE
WRITE FOR THE G. A. INTRODUCTORY BULLETIN



158 E. 18th St. The General Apparatus Company New York City

Radio Laboratory Apparatus

We specialize in good but inexpensive apparatus for experimental radio work. Measure capacity, inductance, wave length, and take V. T. curves with our instruments.

Send for our Scientific Experiment Books, Complete Radio Series of 5 books, \$1 postpaid.

Send 6c. for our Catalog No. 1

The C. D. TUSKA CO.
HARTFORD, CONNECTICUT

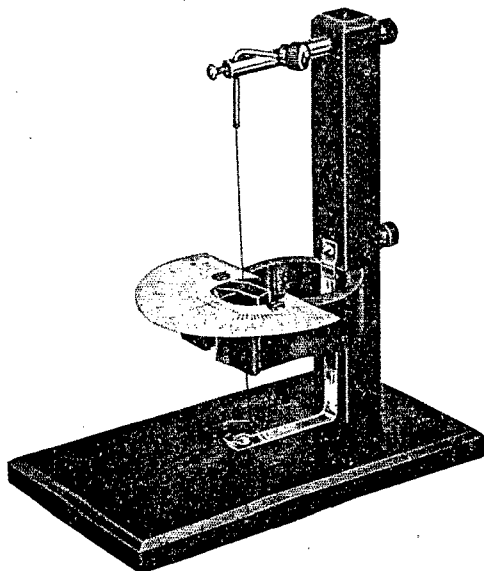

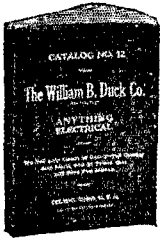

DUCK'S BIG 300 PP.

Wireless and Electrical Catalog

Is now as it always has been, the largest and most complete and dependable Wireless Catalog published. Mailed for 12c. in stamps or coin which may be deducted on first order of one dollar. Catalog not sent otherwise. This catalog costs us twice the price of other catalogs.

Everything in wireless worth while is listed in this catalog. The experienced amateur will tell you to see our catalogue before buying. You are thereby insured against an unwise purchase. It is the Beacon Light to guide you right in the selection of your wireless apparatus. No bigger or better values are obtainable elsewhere. Send for revised price list. It is yours for the asking.

THE WILLIAM B. DUCK CO. 243-245 Superior St., Toledo, Ohio

Baldwin Mica Diaphragm Telephones

In order to enable every Wireless Operator to use the well known Baldwin Phones, we have reduced the prices as follows:

- Navy Type "C" \$15.50 Each, F. O. B. New York
 - Smaller Type, "D" 16.50 Each, F. O. B. New York
 - Newest Type Made, "E" 17.50 Each, F. O. B. New York
- More rugged and just as sensitive

If unable to procure these instruments from your local dealers send your order direct to this office, with money order including postage (25c.) to cover charges.

IF ANY OPERATOR DESIRES A CHEAPER COST PHONE THAN THE BALDWIN, we can recommend the BROWNLIE adjustable phone, which is very sensitive.

Price, \$11.00, F. O. B. New York.

John Firth & Company, Inc.

81 New Street, New York City

The BARR MERCURY-CUP WIRELESS DETECTOR

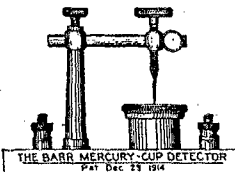

The most efficient Detector on the market. Tested by the United States Government and Marconi Wireless Telegraph Company.

Increases the efficiency of every wireless receiving set by making the signals clear, sharp and distinct.

Instantly adjustable at a constant pressure.

FOR FULL INFORMATION AND PRICE — WRITE

The Barr Mercury-Cup Detector

Dept. E, THE WYOMING,
WASHINGTON, D. C.

A New
Variometer
for the
Amateur

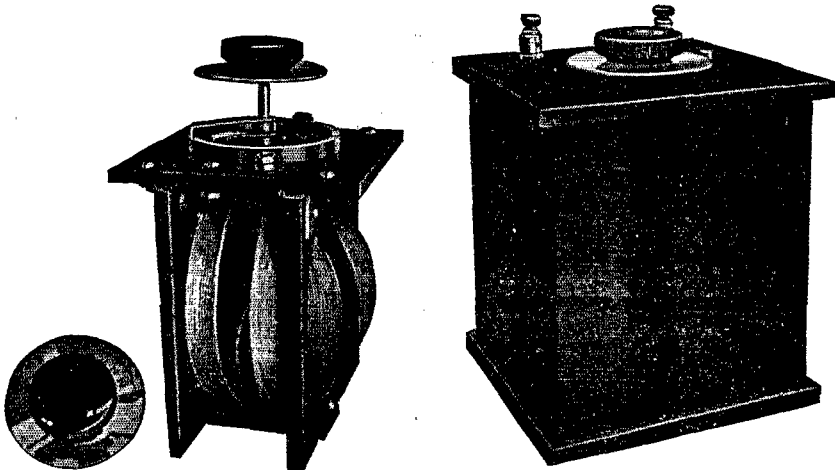

Type S.S. Variometer, in three sizes: maximum inductances, 1 millihenry, 5 millihenries, 20 millihenries. Mounted \$20.00; unmounted \$16.00.

Variometers provide an inductance as easily and gradually variable as a rotary condenser. They are the ideal inductance; efficient, no poor contacts, dead-end losses or capacity losses from multiple taps.

Clapp-Eastham Variometers are designed to give the amateur a Precision Instrument at a low price. Compact in size and beautiful in workmanship. Especially designed to minimize distributed capacity. Readily adaptable to panel mounting. Equipped with a special drum switch automatically actuated by the control knob whereby the coils are in parallel the first half revolution providing an inductance continuously variable through 360 degrees, giving double the range of adjustment available with other variometers.

Fully described, with other New Developments, in our interesting Bulletin Y.

NEW BULLETIN R OF RECTIFIERS FOR STORAGE BATTERY CHARGING NOW READY.

CLAPP-EASTHAM COMPANY

141 MAIN STREET

CAMBRIDGE, MASS.

REMLER RADIO MFG. CO., 62 Post St., San Francisco, Cal., Pacific Coast Representatives

Are You Getting the Most Out of Your Receiver?

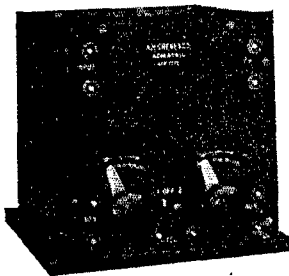

"off" position to either one or two stages without necessitating any other manipulations. The filaments, as well as the stage circuits, are controlled by this cam switch. This is a feature not found in other amplifiers available at present. Send for bulletin R-108.

TYPE RORB 2-STAGE AMPLIFIER, PRICE \$45.00

A. H. GREBE & CO.

Richmond Hill, N. Y.

MURDOCK

NO. 55

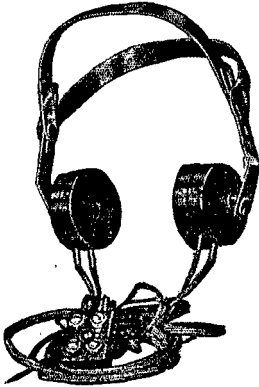

2000 OHM DOUBLE SET

\$4.50

3000 OHM DOUBLE SET

\$5.50

Made for long and
Useful service in
Radio stations where their
Dependable and sensitive
Operation makes them the
Choice of those who
Know GOOD 'phones.

ORDER YOUR SET NOW—
Try it out thoroughly.
IF IT DOESN'T SUIT, SEND
IT BACK AND GET YOUR
MONEY

Bulletin 19 shows a splendid line of the type of apparatus you want. Send for a copy.

WM. J. MURDOCK CO.

65 Carter St.

CHELSEA MASS.

221 SECOND ST., SAN FRANCISCO, CALIF

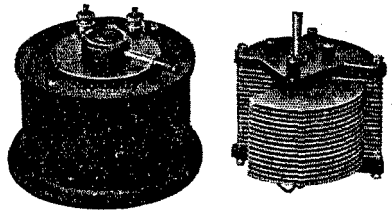

Variable Air Condenser

TYPE 182

A high grade condenser with plates designed to give approximately even variation of wavelength throughout the scale.

Made in two sizes: .0007 M. F. at \$10.00 and .001 M.F. at \$13.00.

Full data on request.

General Radio Co.

WINDSOR STREET

CAMBRIDGE

MASS.

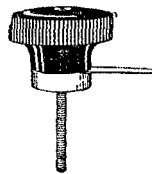

WIRELESS PARTS, SUPPLIES, Bakelite-Dilecto Panels

KNOB AND SWITCH LEVER with knob $1\frac{1}{4} \times \frac{3}{4}$, spring brass lever securely fastened to knob, large brass bearing and shaft threaded 6-32. Each 40 cents. Postage 4 cents.

CONTACT POINTS, brass, $7/32 \times 7/32$, with screw for mounting. Per dozen, postpaid, 25 cents.

KNOB, as used on switch described above, $1\frac{1}{4} \times \frac{3}{4}$, with hole in center for mounting. Each, postpaid, 20c.

AUDIOTRON TUBES postpaid and insured, \$5.00

Send 6 cents in stamps for our catalog and get on our mailing list for future bulletins.

Bakelite Dilecto	$9\frac{1}{2} \times 19 \times \frac{1}{4}$	Black XX	\$4.00
Panels in sizes	$19 \times 19 \times \frac{1}{4}$	Black XX	8.00
as noted. Best	$9\frac{1}{2} \times 19 \times \frac{1}{8}$	Black XX	3.00
grade.	$19 \times 19 \times \frac{1}{8}$	Black XX	6.00

Include postage on 3 lbs.

A. H. CORWIN & CO.

924 Kinney Building Newark, N. J.

WELL, BOYS!

From ten years old to three-score years and ten, we can all "sit in" and listen again; if we have the instruments to listen on. We are with you still, to supply you with all kinds of parts: Contact Points, Switch Handles, best grade Tubes, Woodwork, etc.

A Large New Catalogue will be off the press soon. Watch this space to learn WHEN, then send for one

F. B. CHAMBERS & CO.

2046 ARCH ST., PHILA., PA.

AMATEURS!

Send for our latest bulletin of wireless apparatus. We can furnish any wireless instrument made at the lowest prices.

Eastern Distributors for the AudioTron double-filament tube detector.

Write us immediately

RADIO ELECTRIC CO.

4614 HENRY ST. PITTSBURG, PA.

Get Our Prices

on the Wireless Apparatus you need, before buying.

We handle new and second hand instruments on which we can save you money. All Second Hand instruments guaranteed to be in perfect working order.

WHAT DO U NEED ?

Send us your list now

Radio Equipment Co.

630A Washington Street, Boston, Mass.

POTENTIOMETERS

I have on hand a limited supply of AudioTron B-Battery potentiometers which I am offering at a great reduction. Unit is mounted in Bakelite and Knob and Lever are all of the best material.

PRICE, \$0.90

Sent postpaid when cash accompanies order.

F. C. MYERS

Agent For Audiotron Sales Co.

45 Albany Trust Co. Bldg., Albany N. Y.

OUR NEW CATALOG

OF

COMPLETE

RECEIVING APPARATUS

IS NOW READY

Send Today for Your Copy

AUDIOTRON SALES CO.

Lick Building

SAN FRANCISCO, CAL.

Get Bigger Pay through ELECTRICITY



You will find in HAWKINS GUIDES just what you need to know about electricity. In simple everyday language—complete, concise, to the point. In questions and answers. A complete standard course in Electrical Engineering. Send for your set today to look over.

HAWKINS ELECTRICAL GUIDES

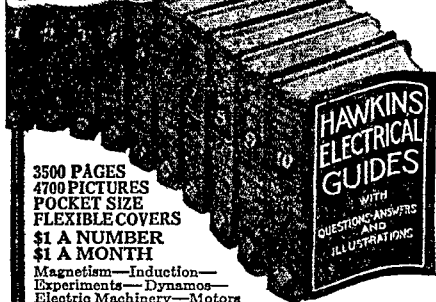

3500 PAGES
4700 PICTURES
POCKET SIZE
FLEXIBLE COVERS
\$1 A NUMBER
\$1 A MONTH

Magnetism—Induction—Experiments—Dynamos—Electric Machinery—Motors—Armatures—Armature Windings—Installing of Dynamos—Electrical Instrument Testing—Practical Management of Dynamos and Motors—Distribution Systems—Wiring—Wiring Diagrams—Sign Elements—Storage Batteries—Principles of Alternating Currents and Alternators—Alternating Current Motors—Transformers—Converters—Rectifiers—Alternating Current Systems—Circuit Breakers—Measuring Instruments—Switch Boards—Power Stations—Installing—Telephone—Telegraph—Wireless—Bells—Lighting—Railways. Also many modern Practical Applications of Electricity and Ready Reference Index of the 10 numbers.

Shipped to you FREE. Not a cent to pay until you see the books. No obligation to buy unless you are satisfied. Send coupon now—today—and get this great help library and see if it is not worth \$100 to you—you pay \$1.00 a month for 10 months or return it.

SEND NO MONEY

THEO. AUDEL & CO., 72 Fifth Ave., N. Y. Please submit for examination Hawkins Electrical Guides (Price \$1 each). Ship at once, prepaid, the 10 numbers. If satisfactory, I agree to send you \$1 within seven days and to further mail you \$1 each month until paid.

Signature _____

Occupation _____

Employed by _____

Residence _____

Reference _____

QST

THE HEART OF THE WIRELESS

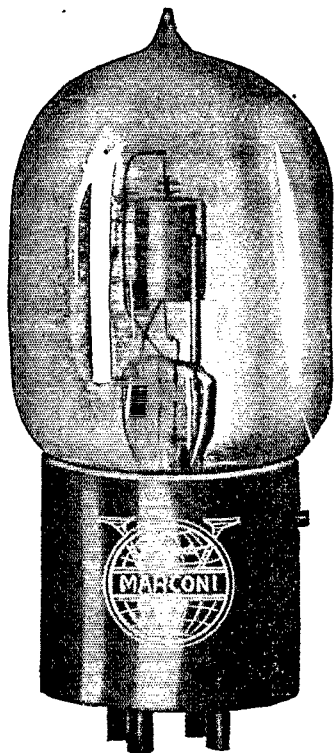

An Amateur Station
Without a Vacuum Tube
Is Years Behind the Times

MARCONI V.T.

\$7.⁰⁰ each

Under agreements recently effected the Marconi V. T. is the only vacuum tube, or audion, which may be sold to amateurs, laboratories, schools of instruction and experimenters.

THE APPROXIMATE
OPERATING LIFE OF
THE MARCONI V. T.
IS 1,500 HOURS.

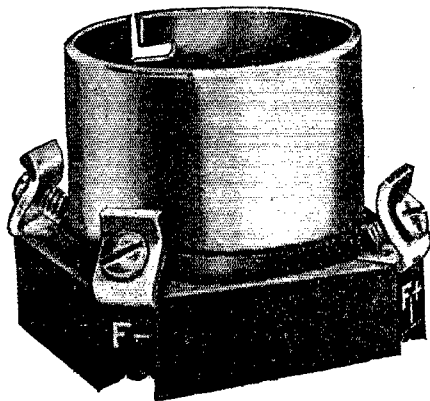

STANDARDIZED SOCKET \$1.50 additional

Fleming Pat. No. 803684
DeForest Pat. Nos. 841387-879582

Class I.—Designed for use as a detector; operates with plate potential of 20 to 60 volts.

Class II.—Designed for use as an amplifier; plate potentials from 60 to 110 volts may be applied.

Tubes in either class may be used for detection or amplification, but those of Class I are best as detectors, and Class II tubes are superior as amplifiers.

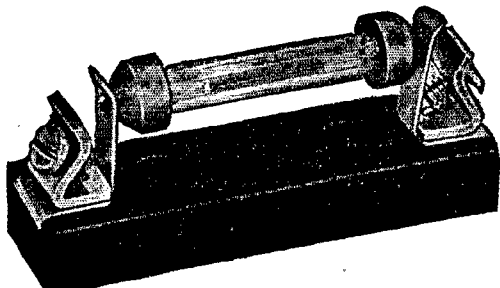

STANDARD RESISTANCE, COMPLETE \$1.00

Send all remittances with order to COMMERCIAL DEPARTMENT

Marconi Wireless Telegraph Company of America

Sole Distributors for De Forest Radio Telephone & Telegraph Co.

227 BROADWAY, NEW YORK

RETAIL SALES AND EXHIBITION ROOMS, 25 ELM ST., NEW YORK

BRANCH OFFICES:

Schofield Bldg., Cleveland, Ohio
American Bldg., Baltimore, Md.
Insurance Exch. Bldg., San Francisco, Cal.

186 Federal St., Boston, Mass.
301 Commercial Bank Annex, New Orleans, La.
109 South 2nd St., Philadelphia, Pa.

The Marconi Resistance, connected in the circuit between the grid and the filament of the Marconi V. T., is made in the following standard sizes:

½ megohm, 1 megohm, 4 megohms, 6 megohms.

Resistances of any special fractional values up to 6 megohms can be supplied.

AMAZING AUDION DETECTOR

VALUES—\$9.50 \$11.75 \$18.85 \$22.00

Remarkably efficient and handsome audion control panels within the PRICE LIMIT of EVERY AMATEUR, BUILT AND DESIGNED FOR THE AUDION, AS ONLY THE MAKERS OF THE AUDION CAN BUILD IT. In the past, instruments of this calibre have never been offered at twice these prices.

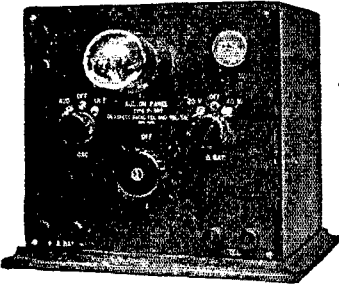

Type P-500, \$22.00



Type P-401, \$11.75

GENERAL SPECIFICATIONS ALL MODELS: Beautifully engraved and grained genuine bakelite panels; 4 prong heavy nickled tube receptacles; smooth running, positive acting, adjustable rheostats; impregnated efficient mica stopping condensers; adjustable or fixed grid leaks with polished nickel covers; bakelite covered binding posts with new slotted positive connecting feature; positive segmentally connected nickel plated switches; 40 volt B battery of two 20 volt type units cast enblock with operating life of 6 to 12 months—a remarkable advance in B batteries; handsome quartered oak cabinets, round corners, standard de Forest "Early English" finish; perfect workmanship and expensive design throughout.

Type P-400 Audion Panel—Consists of tube receptacle, grid leak and condenser, rheostat and binding posts for connection to tuner, A and B batteries on bakelite panel 7 1/2" x 7 1/2" without cabinet and B batteries \$9.50

Type P-401 Audion Panel—Same as above with cabinet \$11.75

Type P-402 Audion Panel—Larger panel with 40 volt B battery in cabinet \$18.85

Type P-500 Audion-Ultraudion Panel—Type P-402 Panel with two switches for audion-ultraudion connection and either 20 or 40 volt B battery in Cabinet \$22.00

Note: All de Forest audion apparatus is sold without the tubes. Audion detector oscillator or amplifier tubes, \$7.00 each additional.

Catalog sent on receipt of 10c. in stamps to cover postage.

De Forest Radio Tel. & Tel. Co.
1415 Sedgwick Ave. NEW YORK CITY

EVERYTHING FOR AN IDEAL AERIAL

COMPLETE OR PARTS

— "CQ — CQ — CQ" —

FOR LAND OR MARINE STATIONS

OUR SPECIALITY

SPARS BRIDLES INSULATORS WIRE — ROPE	TO AMATEURS } 2, 3, 4 & 6 WIRE ANTENNAS for 200 meters; LONG WAVE 2 WIRE RECEIVING ANTENNAS. Construction: Specially designed, turned and perfectly tapered SPARS—fitted with galv. steel mast bands; best grade flexible galv. wire BRIDLES; galv. pulleys; ELECTROSE INSULATORS; seven strands PHOSPHOR BRONZE ANTENNA WIRE; high-grade WEATHER-PROOF HOISTING ROPE.	Distributors of HIGH GRADE RECEIVING APPARATUS
---	--	---

"Made in America"

Prices quoted on application. Specify your particular requirements.

"K-K"

"AT YOUR SERVICE"

"K-K"

NORTH AMERICAN AERIAL SPAR MFG. CO.

Dubuque, Iowa

Federal Audio-Frequency Transformer

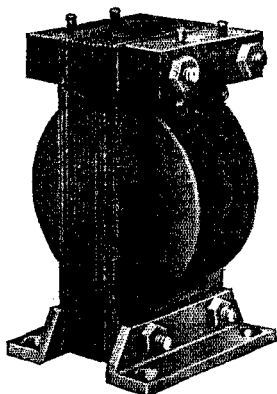

The No. 226-W
Price \$7.10

The only Audio-Frequency Transformer designed for use with the Marconi V. T. Class I and II and approved by expert engineers.

WONDERFUL RESULTS ARE OBTAINED
IN AMPLIFICATION BY IT

All who have a Marconi tube, or one of same internal impedance, should have a FEDERAL No. 226-W, Type A, in order to get high class results.

WRITE FOR BULLETIN 102-W

We also furnish the Marconi Tubes, Standard Mountings and Leak Resistances, at regular prices.

Federal Telephone and Telegraph Co. BUFFALO, N. Y.

MANUFACTURERS OF

STANDARD AIR CORE AUDIO-FREQUENCY TRANSFORMERS. "LIBERTY" HEAD TELEPHONES. FAMOUS "CENTURY" HIGH-FREQUENCY BUZZERS. THE ORIGINAL ANTI-CAPACITY SWITCH. STANDARD PLUGS, JACKS AND ACCESSORIES.

UNIVERSAL RADIO APPARATUS

THIS line of new apparatus comprises several interesting instruments. There is a regenerative receiver which covers practically the entire spark range. It has a wave length range of from about 170 to 2550 meters. The continuous wave receiver has a range up to 17,000 meters and is contained in its entirety in a cabinet measuring about 8"x12"x6". This does away with cumbersome loading coils and loose couplers which used to occupy so much space on the operating table.

We control the patent rights and are sole manufacturers of the MIGNON SYSTEM apparatus.

Send stamp for catalogue

Universal Radio Manufacturing Corporation
Dept. M Elmira, N. Y.

Have You Ever Heard Lyons or Nauen?

We can supply you with the complete apparatus necessary for the successful reception of undamped wave stations and can make immediate deliveries.

An efficient Arc Receiver can be had at a surprisingly low cost and good results are certain with the apparatus we furnish.

Upon request we will furnish the proper hook-ups and give full instructions for the installation and operation of any of our apparatus.

We carry a full and comprehensive line of radio material and apparatus and make a specialty of filling all orders the day received.

Our Catalog will soon be ready for distribution and the many requests for it will then receive attention.

MANHATTAN ELECTRICAL SUPPLY CO. 1106 Pine St., St. Louis, Mo.

The most sensitive receiving set made—a Paragon RA-6, an Amplifigon, type AGN-1, a second step amplifier, type AMP-1, and a special battery box.

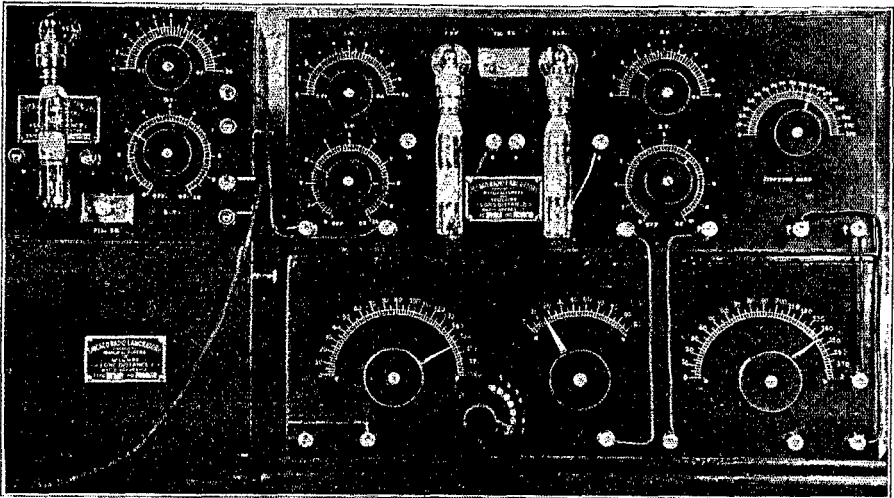

Sold Complete or in Part, Equipped for ANY Type Audion Tube.
A Limited Number of the Genuine, Famous PARAGON RA-6 Regenerative Receivers
Now Ready for Distribution by Us.

Send for Our Bulletin J-19 of High Grade Radio Apparatus.

Licensed under DeForest patents Nos. 841,887 and 879,532

CHICAGO RADIO LABORATORY 1316 Carmen Ave., Chicago, Ill.

IMMEDIATE SHIPMENTS

SWITCH POINTS

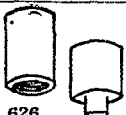

626



628

627

	Doz.	50	100
No. 626— $\frac{1}{4}$ " dia. x $\frac{3}{8}$ " high, tapped 6-32	\$0.30	\$1.00	\$1.75
No. 627— $\frac{1}{4}$ " dia. x $\frac{1}{4}$ " high, $\frac{1}{2}$ " shank 6-32	.36	1.25	2.00
No. 628— $\frac{1}{4}$ " dia. x $\frac{1}{4}$ " high, tapped 6-32	.30	.90	1.50

Above prices plain brass finish. Nickel points 50% advance.

KNOBS

No. 602—1" dia., 8-32 bushing	\$0.10	\$1.00
No. 606— $1\frac{1}{4}$ " dia., 13-16" high	.20	2.00

Postage on above extra

SEND TODAY FOR CIRCULAR G SHOWING COMPLETE LINE



602



606

SHOTTON RADIO MFG. CO., P. O. Box 3, SCRANTON, PA.

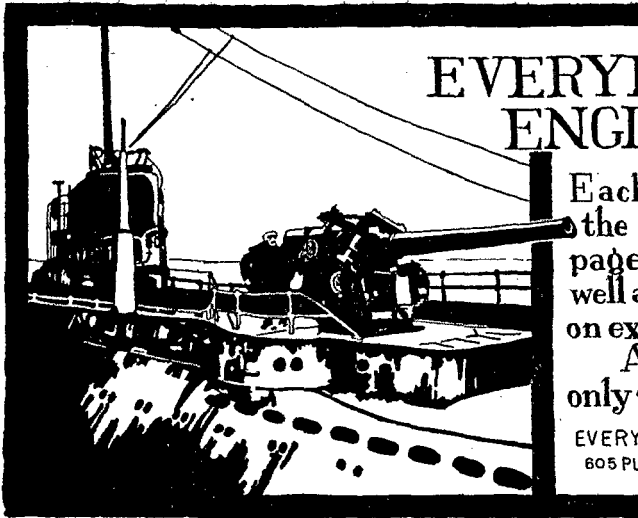

EVERYDAY ENGINEERING

Each month contains the equivalent of a 60 page book on radio as well as a fund of articles on experimental work. And the price is only ~Fifteen cents.

EVERYDAY ENGINEERING MAGAZINE
605 PUTNAM BLDG, 45th ST., NEW YORK

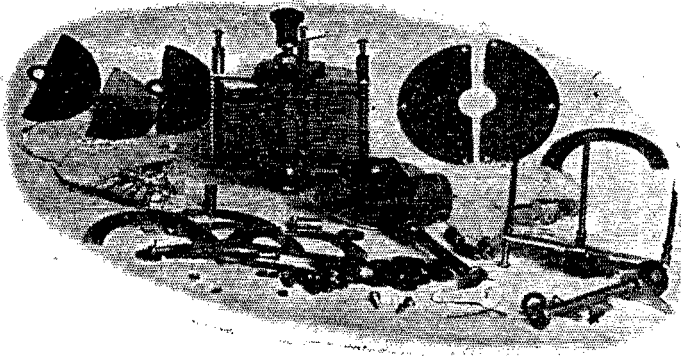

PERFECTION VARIABLE CONDENSERS

KNOCKED DOWN—YOU ASSEMBLE AND SAVE MONEY.

Full instructions in each box. Ready to mount on panels.

11 Plate	\$1.75
21 Plate	2.25
43 Plate	2.50

No outside cover, but has scale, pointer and knob. Small hole to cut. Guaranteed easy to mount.

TRESCO BOX 374
DAVENPORT, IOWA.

Quality
Apparatus



Get This 40-Page Catalog of Radio Apparatus Mailed Postpaid

This forty-page book of Radio Apparatus shows nearly all the latest appliances both for receiving and sending wireless messages. It is written in non-technical terms so that it can be understood just as easily by the inexperienced person as by the wireless expert.

Prices are low when you consider the quality of the apparatus. Here is a sample of our prices:

6A9314—½ K. W. Meteor Wireless Transformer, 10,000 volt secondary \$13.95

There are many bargains just like this. Send for this book, 6244Q, today.

\$13.95

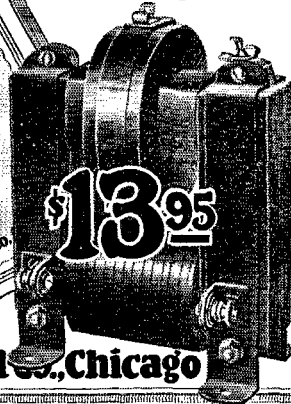

**SEND!
TODAY!**

Sears, Roebuck and Co., Chicago

"ASK ANYONE WHO HAS USED IT"

BRANDES WIRELESS HEADSET



SAID DENVER, COL., TO VALLEY STREAM, L. I.: One of our most enthusiastic customers communicates by wireless 'Superior' 2000 ohms \$7 from his home in Denver to a friend on Long Island. He uses a Brandes Headset—after exhaustive tests and comparisons. (Name on request).

Think of the help to wireless operators that the perfect sensitiveness and dependability of Brandes Headsets provided during the war. Life and death depended upon hearing correctly. They are made today just the same and give the same quality of service.

TRIAL OFFER Test out Brandes Wireless Receivers against any other make. Test them for sensitiveness, clearness and distance. If within ten days you're not only satisfied but enthusiastic over them—back comes your money without a question.

Prove for yourself the fine quality, the "matched tone." The two diaphragms, toned exactly alike, strengthen the signals and prevent blurring. Used by many U. S. Gov't experts, and experts abroad; by colleges and technical schools; and by professionals and amateurs everywhere.

SEND 4c. FOR CATALOGUE F

C. BRANDES, Inc.

Room 821, 32 Union Square, New York
WIRELESS RECEIVER SPECIALISTS

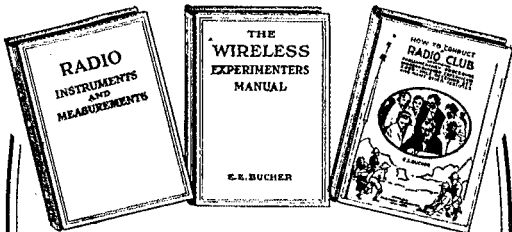

THE NEWEST THINGS IN WIRELESS ARE IN THESE THREE BOOKS

Just Off the Press

RADIO INSTRUMENTS AND MEASUREMENTS
Every amateur should have this book as it answers the questions you want to ask and covers all phases of the subject matter indicated by its title. Cloth Bound, 320 Pages, \$1.25.

THE WIRELESS EXPERIMENTERS' MANUAL
By E. E. Bucher. Mr. Bucher's latest book. The only one that comprehensively covers all phases of wireless work, including the latest practices in both Radio Telegraphy and Telephony. Most complete text book on these subjects yet published. Cloth Bound. Approximately 300 Pages. Price \$1.75.

HOW TO CONDUCT A RADIO CLUB
By E. E. Bucher. One of the most popular wireless books ever published. Covers parliamentary procedure, indoor and outdoor experiments, 5,000-mile receiving sets, use of vacuum tubes and many other subjects. Paper Cov. 148pp., 50c.

THE WIRELESS AGE

A monthly magazine that will keep you posted on the up-to-the-minute things in wireless communication. Official organ of the National Amateur Wireless Ass'n. Price Per Year \$2.00. SPECIAL COMBINATION PRICE, ALL FOUR ONLY \$4.60

WIRELESS PRESS

1852 Woolworth Building, New York

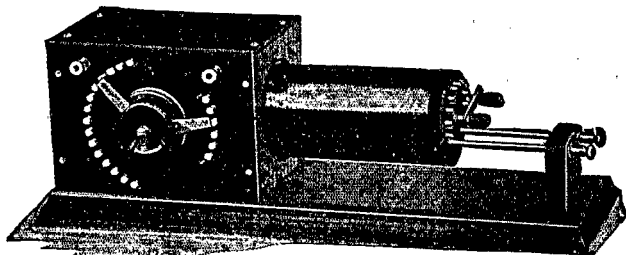

J. F. ARNOLD

(Established 1910)

2082 LEXINGTON AVENUE

NEW YORK

ARNOLD NAVY MODEL LOOSE COUPLER

Altho this instrument has been before the public for five years, the demand for it is just as persistent; and altho many pre-war standards have been swept away you will find, after much experimentation with new-fangled ideas, that for selectivity and sharpness of tuning you "have to go some" to beat a well-designed Loose Coupler.

The instrument illustrated above is correctly designed, its workmanship the best, and it presents much better value than you expect—if you could see one and operate it, you would expect it to cost more.

For special design binding posts, knobs, switches, rheostats, and in fact better grade accessories, send two-cent stamp for my bulletin.

RADIO APPARATUS

Distributors of all prominent makes:
DeForest, Wireless Specialty, Murdock, Grebe, General Radio, Clapp-Eastham, Brandes, etc., etc.

LARGEST AND BEST STOCK OF ANY HOUSE IN NEW ENGLAND

For real prompt delivery send us your orders for Honeycomb Coils, Unit Panels, Vacuum Tubes, Baldwin Telephones, Murdock 55's, Grebe Developments, etc.

F. D. PITTS COMPANY
Dept. A, 12 Park Square BOSTON, MASS.

DeForest Audion Control Box

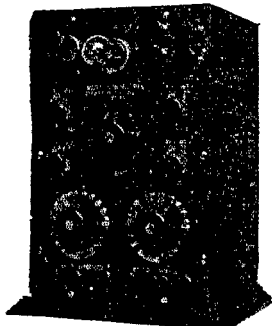

Type P100. Price \$65.00

RADIO OPERATORS NEEDED

ATTEND MASSACHUSETTS RADIO AND TELEGRAPH SCHOOL

18 Boylston Street
BOSTON

FOR INSTRUCTION IN RADIO AND TELEGRAPHY

Prescribed course prepares Radio Operators to obtain Government license. One month's service with Merchant Marine at salary of \$100 to \$125 more than repays cost of tuition.

Complete course in Commercial, Railroad and Brokerage Telegraphy.

Day class, 9 A. M. to 1 P. M.
Evening class, Monday, Wednesday and Friday, 7 to 9 P. M.
Radio amateur class Saturday, 10 A. M.
Students may enter any Monday.

½ K. W. 500 CYCLE SET RECENTLY INSTALLED

BURGESS "B" BATTERIES

22.5 VOLTS
15 CELLS

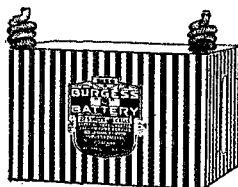

THREE SIZES
No. 2156—3" x4" x6 5/8"
No. 5156—2 1/4" x2 3/8" x4 1/8"
No. 4156—2 1/2" x2" x3 3/8"

BURGESS "B" BATTERY construction is being specified by the Government for its vacuum tube batteries. They have long life, high capacity and noiselessness.

Write for prices and information to

BURGESS BATTERY COMPANY

Laboratories
Madison, Wisconsin

Sales Office
Harris Trust Bldg., Chicago

WIRELESS TAUGHT BY MAIL

By the Largest Radio School in the World

Staff of high class government instructors; 16 weeks' course. Now placing our graduates in fine positions. Pay runs from \$110 per month and living expenses, up to \$3500 per year.

REDUCTION IN TUITION TO GRADUATES

and, under certain conditions, you may obtain the course for practically nothing. We need thousands of operators, inspectors and radio aids. Fascinating work; interesting study; takes only a little bit of your time daily. Write today for illustrated catalogue and details of our profit sharing plan with students.

SERVICE RADIO SCHOOL

Dept. T, 900-2 Pa. Avenue

Washington, D. C.

*Manufacturers of Reliable Instruments
and
Distributors of All Prominent Makes of*
RADIO APPARATUS

Everything Essential to the Successful
Installation of A RADIO STATION

Bunnell Apparatus is Sold by Dealers Everywhere

Catalog 40-Q on Request

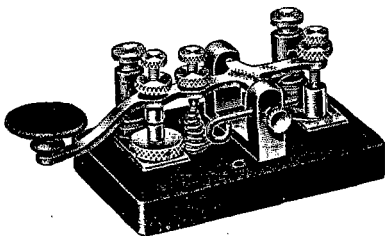

Special Feature—
The Straight Line Radio Key

J. H. Bunnell & Co. 32 Park Place, New York



**EASTERN
RADIO**

899 BOYLSTON ST.
BOSTON, MASS.

**INSTITUTE
RADIO**

TEL.
BACK BAY
5 9 6 4



Learn Wireless under former U. S. Government and Marconi experts. Tremendous demand for Wireless operators! Splendid opportunities now in the Merchant Marine. Big Salaries! Junior operators \$100 per month, Chief operators \$125, food and quarters besides. Equivalent ashore from \$40 to \$50 per week. Our graduates now in all parts of the world as Radio Inspectors, Instructors, Engineers, Operators, etc., etc. Interesting and fascinating work! During the War period alone the Eastern Radio Institute gave instruction to thousands of students, more than all other schools in New England combined. We positively have good positions actually waiting for every graduate and moreover we will now place in a good position without charge any man holding a Commercial operator's license regardless of where he secured instruction. This speaks for itself.

Remember the Eastern Radio Institute is the oldest, largest and best equipped telegraph school in New England and has thousands of satisfied graduates to its credit.

Thorough and practical courses in Wireless, Commercial, Railroad and Brokerage telegraphy. **DAY AND EVENING CLASSES. START ANY MONDAY.**

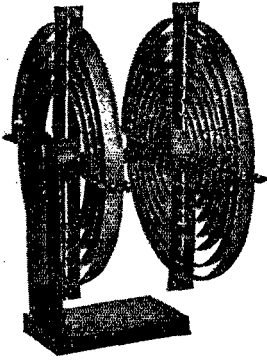

1500 MILES ON 200 METERS

THORDARSON ELECTRIC MFG. CO.

501-515 JEFFERSON ST., CHICAGO

August QST published details of our 1500 Mile Transmitting Contest. While we are waiting for the ban to be removed, let us introduce our

TYPE T-OT OSCILLATION TRANSFORMER

Primary of this Oscillation Transformer consists of $3\frac{3}{4}$ turns of 1 inch heavy copper ribbon supported in fibre strips. The secondary consists of $7\frac{3}{4}$ turns mounted same as primary. Primary inductance is approximately 4.5 microhenries. When maximum turns on the primary are used with condenser having a capacity of .009 microfarads, the wave meter shows a reading of 385 meters. Using one complete outside turn or an inductance of about 1.2 microhenries and a condenser capacity of .009 microfarads, the wave meter shows a reading of 205 meters. Secondary inductance is approximately 10.9 microhenries. When using a condenser capacity of .004 microfarads to .009 microfarads, a very select range of short wave lengths can be attained.

WRITE FOR OUR CATALOG "T-20"

PAUL UNIPIVOT GALVANOMETER

TYPE I

Excellent for
wing circuits
of
vacuum tubes



Resistances
of
5, 10, 50 and
100 ohms

Rawson Electrical Instrument Co.
4 NORFOLK ST., CAMBRIDGE, MASS.

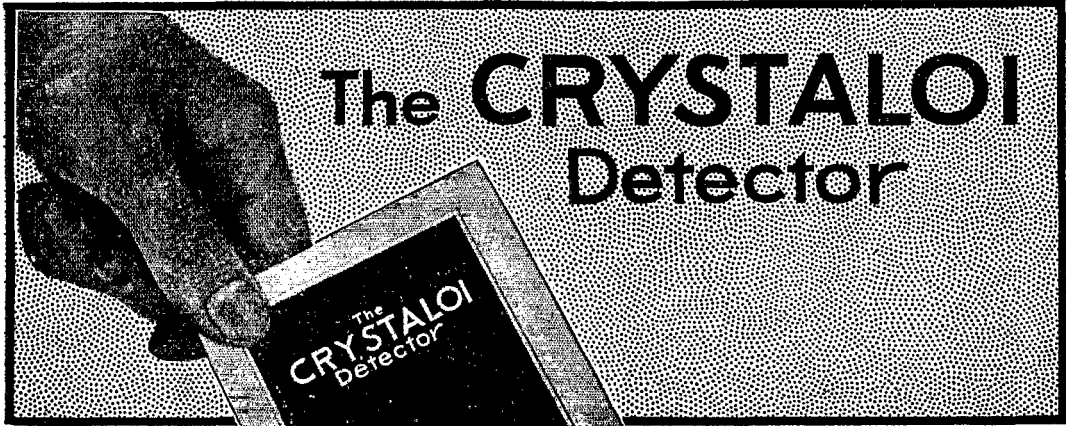

The CRYSTALOI Detector



This booklet is yours for the asking. ¶ It explains the principle of Crystalloi design. ¶ Tells how to hook it up. ¶ Gives full particulars as to how it operates. ¶ And describes the advantage of working with it. ¶ Complete with illustrations, wiring, diagrams, etc. . . . ¶ Send for it

PRICES

Type O. Crystalloi Detector	\$3.50	Type A.A. Crystalloi Detector	\$6.00
By parcel post prepaid	3.60	By parcel post prepaid	6.20

MANUFACTURED ONLY BY

CONNECTICUT TELEPHONE & ELECTRIC COMPANY

INCORPORATED

MERIDEN, CONNECTICUT

All rights and patent under which the Crystalloi is made were purchased from the inventor, Eugene A. Turney

Send for
folders
showing
details of
AMRAD
Radio
Products

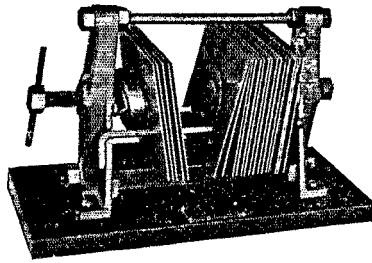

AMRAD
Quenched Gap \$17.50

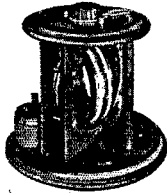

AMRAD
Variometer

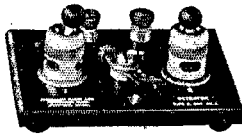

AMRAD
Detector Stand

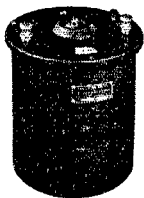

Variable Air Condenser

AMRAD

RADIO PRODUCTS

Put your station on the commercial plane

With the removal of government restrictions on Radio, amateur stations throughout the country are showing a tendency to develop to the commercial grade.

With the release of part of our plant from Government contracts, we offer the amateur operator high grade radio equipment of the most up-to-date type, produced under the direction of radio engineers of national reputation.

Each individual piece of radio equipment bearing our name is tested under most exacting conditions before it leaves our plant and is guaranteed mechanically perfect.

AMERICAN RADIO AND RESEARCH CORPORATION

21 PARK ROW

(Address Dept. R1)

NEW YORK

Factory at Medford Hillside Sta., Boston, Mass.

BAN OFF!

THE JOB IS DONE, AND THE A.R.R.L. DID IT

See next QST for details

21700-49

NAVY DEPARTMENT
NAVAL COMMUNICATION SERVICE

Office of the Director

Washington, Sept. 26, 1919.

Sir:

The Secretary of the Navy authorizes the announcement that, effective October 1, 1919, all restrictions on amateurs and amateur radio stations are removed. This applies to amateur stations, technical and experimental stations at schools and colleges, and to all other stations except those used for the purpose of transmitting or receiving commercial traffic of any character, including the business of the

owners of the stations. The restrictions on stations handling commercial traffic will remain in effect until the President proclaims that a state of peace exists.

Attention is invited to the fact that all licenses for transmitting stations have expired and that it will be necessary for the amateurs to apply to the Commissioner of Navigation, Department of Commerce, for new licenses. In so far as amateurs are concerned, radio resumes its pre-war status under the Department of Commerce.

Very respectfully,

(Sgd) E. B. Woodworth,

Commander, U. S. Navy,

Assistant Director Naval Communications

COMING!

The Biggest Boom in Amateur Radio History.

AMATEURS: Order your apparatus and get your licenses!

MANUFACTURERS & DEALERS: Tell us what you have!

NON-SUBSCRIBERS: Get in your QST subscription!

At Once -- Immediately -- To-day -- Now!

WE'RE OFF!