

DXN News

• Serving DX'ers since 1933 •

Volume 74, No. 30 • September 18, 2007 • (ISSN 0737-1659)



Inside ...

2 ...AM Switch

6 ...DDXD

15 ...Vol. 74 Index

16 ...IDXN

31 ...NRC Contest

32 ...Pro Sports Nets

38 ...GYDXT

40 ...Broadcast Test Report

41 ...Super Loop Antenna

43 ...Leaky Coax Case - Closed!

47 ...Musings of the Members



Station Test Calendar

WIRL	IL	1290	Oct. 21	0300-0500
WLPO	IL	1220	Oct. 27	0400-0430

WIRL-1290 ... Peoria, IL will conduct a DX test Saturday morning, 3:00-5:00 ELT, at 5 kW and using their normal daytime pattern. Programming will include voice ID's, Morse code, 1 kHz test tones, and their regular format of classic country music. Reception reports may be sent to Wayne R. Miller, CE, WIRL Radio - 331 Fulton, Suite 1200 - Peoria, IL 61602. The station will accept recordings by e-mail or on disk (.mp3 or .wav OK but no cassettes please). Address for e-mail reports is <wrm@jmpradio.com>. NOTE: All requests for verifications must be accompanied by return postage in order to receive a reply. No eQSL service is being offered for this test. Our sincere thanks to Chief Engineer Wayne Miller for agreeing to conduct this test. Arranged by Jim Pogue.

WLPO-1220 ... La Salle, IL will conduct a DX test Saturday morning from 4-4:30 am ELT, at 1 kW and using their normal daytime pattern. Programming will consist of phonetic voice IDs, Morse code, sweep tones and unique music. Reception reports may be sent to Steve Vogler, Chief Engineer, WLPO Radio, - 1 Broadcast Lane - Oglesby, IL 61348. The station will accept recordings by e-mail or on disk (.mp3 or .wav OK but no cassettes please). Address for e-mail reports is <steve@wlpo.net>. NOTE: All requests for verifications must be accompanied by return postage in order to receive a reply. Our sincere thanks to Chief Engineer Steve Vogler for agreeing to conduct this test. Arranged by Jim Pogue

From the Publisher ... A big "thanks" goes out to Frank Aden for hosting the joint NRC/WTFDA convention over Labor Day weekend in Boise. The complete convention report will appear in the next DXN; John Malicky confirmed that he's hard at work on it, again. However, we can reveal here that the annual plaque, in appreciation for contributions to the NRC, went to Stan Morss, who has contributed in more ways that many of us will ever

know to the continued success of the club.

Although you might think that the end of summer might not be prime DX time ... you'd be thinking wrong! See inside for more details.

DXChange ... Charles A. Taylor WD4INP <<MWDXer@isp.com>> is offering for sale a Worcester Space Magnet II, serial number 134. Refurbished and stabilized, new battery & vernier, for \$80. Shipping: estimated \$25 (base and loop shipped separately to prevent damage). Contact me at <MWDXer@isp.com>.

Unfilled positions ... We're still in need of volunteers for the following positions, as described in detail in V73, #27, the June '06 DXN: A person proficient with phpBB to maintain the e-DXN site; one or more additional moderators for e-DXN; one or more persons to edit future NRC publications; one or more persons to scan or retype reprints currently in print; one or more persons to scan verie letters to be placed on the NRCDXAS web site; several persons to research and prepare a book in commemoration of the NRC's 75th anniversary; a "DX Targets" editor; a technical column editor; several editors to take over languished columns; finally, a DXN publisher, by June 2008. Thanks to Charlie Taylor- 629 St. Joseph St. - Grifton, NC 38530 for volunteering to type up verifications for those who don't have access to the web.

Next publication date: October 1.

DX Time Machine

From the Pages of DX News

50 years ago ... from the September 7, 1957 DXN: This was the Silver Anniversary issue of *DX News*, commemorating the 25th anniversary of the National Radio Club. Don Reynolds, Altadena, CA reported receiving 101 veries during the 1956-57 season for a total of 237 in 27 countries, including 24 from Mexico, 23 from Japan, and 12 from Colombia.

25 years ago ... from the September 27, 1982 DXN: Randy Tomer, Arcata, CA managed to pull in the 1615 Ohura, New Zealand beacon with a weak Morse code signal on 7/17 at 0730.

10 years ago: ... from the September 22, 1997 DXN: Mark Connelly, Billerica, MA, bagged a Dutch ute with Morse "PCH" on 1619.5, 8-17, 0100.



AM Switch

Bill Hale w_r_hale@sbcglobal.net
6124 Roaring Springs Drive
North Richland Hills, TX 76180-5552



Status changes in AM stations, supplied by the FCC, CRTC, and listeners

CALL LETTER CHANGES

	<u>Old Call</u>			<u>New Call</u>
690	KHCM	HI	Honolulu	KHNR
700	NEW	FL	Gibsonia	WJWB
880	KHNR	HI	Honolulu	KHCM
960	KQKE	CA	Oakland	KKGN
1300	WEEV	NY	Rensselaer	WTMM
1340	KLKI	WA	Anacortes	KWLE
			[and back to KLKI 14 days later!]	
1400	WSGC	GA	Elberton	WNGA
			[and then back to WSGC 14 days later!!]	
1530	WDAP	TN	Huntingdon	WWDX
1550	WAYI	FL	Bunnell	WNZF
			[new station, not yet on the air]	
1560	KILE	TX	Bellaire	KGOW



CPs ON THE AIR

590	KTIE	CA	San Bernardino - CP for U4 2500/960 is on the air from the adjusted coordinates of N34-04-20 W117-17-52.
630	WMAL	DC	Washington - CP for U4 10000/5000 is on the air. The new day pattern is directed to the south-southeast.
630	CKOV	BC	Kelowna - CKOV-FM 103.1 has signed on, and the three-month simulcast period has started.
630	KUAM	GU	Agana - CP to move here from 612 kHz is on the air with U1 10000/10000. The station, although in ITU area 3 (with 9 kHz spacing), moved to this frequency due to the 10 kHz spacing on U.S. car radios, which are prevalent on the island. 630 happens to be both in the 9 and 10-kHz spacing plans.
700	KALL	UT	North Salt Lake City - CP for U4 50000/10000 is on the air, increasing their nighttime power. Along with the increase in night power, they added one tower for a total of five. The new night pattern is directed 177 degrees as opposed to their old 1 kW pattern of 190 degrees.
740	WMBG	VA	Williamsburg - CP for U1 500/7 is on the air.
880	KHCM	HI	Honolulu - CP for U1 2000/2000 is on the air at N21-17-41 W157-51-49, moving from 870 kHz.
890	WAMG	MA	Dedham - CP for U4 25000/6000 is on the air from the adjusted coordinates of N42-14-50 W71-25-31.
1450	WVLD	GA	Valdosta - CP for U1 860/860 is on the air from the adjusted coordinates of N30-50-05 W83-27-57.
1500	WSMX	NC	Winston-Salem - CP for D1 140/0 is on the air, di-plexing into the WPOL-1340 tower at N36-04-26 W80-15-19.
1690	CHTO	ON	Toronto - New station is on the air with Greek programming.

GRANTS FOR NEW STATIONS

670	KBTB	NV	Las Vegas - CP granted for U4 10000/600 from 5 towers (5-day/4 night) at N36-42-28 W115-20-39. The day pattern is directed northwest while the night pattern heads southeast.
920	NEW	VA	Quantico - CP granted for U4 2000/970. The day pattern favors the northeast and southwest, while the night pattern shoots all the signal southeast.
1020	KAXX	AK	Eagle River - Special Temporary Authorization (STA) granted to remain silent. Station sale is imminent.
1350	NEW	PA	Geistown - CP granted for U4 1500/890 from 6 towers (6 day and night) at N40-19-56 W78-52-40. Both day and night patterns are slender lobes to the south and south-southeast, respectively.
1400	NEW	TX	Eureka - CP granted for U1 790/790.

1480 NEW TX Wink - CP granted for U2 1000/250.

ACTIONS

650 KGAB WY Orchard Valley - Coordinate correction to N41-03-11 W104-49-57.
 790 KWSW CA Eureka - CP granted for U2 5000/750.
 790 KGHL MT Billings - CP granted for U1 5000/1800 from a new 328' tower at N45- 49-29 W108-24-37.
 800 WSVS VA Crewe - Licensed for U1 5000/275, WSVS applied for U1 10000/275, then amended the request to U1 10000/270, which has been approved.
 960 WFIR VA Roanoke - CP granted for U2 10000/4800.
 960 CFFX ON Kingston - Approved to move to 104.3 MHz with 4 kW.
 980 KINS CA Eureka - Coordinate correction to N40-48-02 W124-07-39.
 1050 WFED MD Silver Spring - CP granted for U1 3500/44.
 1090 KEXS MO Excelsior Springs - The CH 5000 portion of their application for D4 7500/0 CH 5000 has been removed, leaving D3 7500/0.
 1130 WACQ AL Carrville - CP granted for D1 25000/0 CH 1000.
 1130 WASP PA Brownsville - Now licensed for D1 1000/0 CH 1000, adding the CH time.
 1130 WEAJ SC Springdale - CP granted to move here (ex: Camden) with U1 1000/9 CH 1000, di-plexing with WGCV-620 at N33-57-34 W81-02-28.
 1150 WJBO LA Baton Rouge - CP granted for U4 15000/5000 after adding a fourth tower. The new daytime pattern shoots a large slender lobe toward the east-south-east, with secondary lobes toward the northwest, west, and southwest.
 1170 WKFL FL Bushnell - CP granted for D4 10000/0 CH 5000. Both patterns shoot the signal to the west-southwest.
 1190 KRFT MO University City - CP granted for U4 10000/6500 (moving from DeSoto), increasing the nighttime power. The new night facility is a separate 6-tower site in Monroe County, Illinois at N38-26-13 W90-16-45.
 1260 WIVV PR Island of Vieques - Coordinate correction to N18-06-03 W65-28-17.
 1260 WISO PR Ponce - Coordinate correction to N17-59-03 W66-38-12.
 1270 WUCO OH Marysville - Because it is experiencing problems maintaining its daytime pattern due to component failure, WUCO requested and received an STA for U3 500/500 using their nighttime pattern all hours.
 1270 KRVT OK Claremore - CP granted for U2 5000/1000.
 1380 CKLC ON Kingston - Approved to move to 98.9 MHz with 8.7 kW.
 1390 WMPO OH Middleport-Pomeroy - Coordinate correction to N39-00-37 W82-03-58.
 1450 KWES NM Ruidoso - New station, not yet on the air, had a CP for U1 1000/940, then applied for U1 1000/860 which has been granted.
 1450 CFAB NS Windsor - Applies to move to 92.9 MHz with 23.8 kW. Their previous application for 47.1 kW was turned down.
 1480 WRLM AL Irondale - CP granted for U1 5000/28, adding night service.
 1490 WVBG MS Vicksburg - Coordinate correction to N32-20-44 W90-52-02.
 1490 CFWB BC Campbell River - Approved to move to FM. But . . . the CRTC denied them 106.1 MHz. So they have three months in which to come up with an alternate frequency. Stay tuned . . .
 1600 WXMY VA Saltville - Licensed for D1 5000/0, WXMY applied for U1 23000/11 CH 23000. The CH request has now been deleted.

AMENDMENTS TO CONSTRUCTION PERMITS

620 KJOL CO Grand Junction - Licensed for U1 5000/79, KJOL has a CP for U2 5000/320, then applied for U2 5000/330. The latter application has been dismissed.
 1590 KPWL WA Newport - New station, not yet on the air, has a CP for U4 50000/500. This amendment requests U4 50000/300.

APPLICATIONS

920 CJCH NS Halifax - Applies to move to 101.3 MHz with 100 kW.
 940 WCPC MS Houston - Coordinate correction to N33-55-41 W89- 00-39.
 1020 KDKA PA Pittsburgh - Applies for an STA to operate at reduced power of U1 35000/35000 as it ". . . is experiencing intermittent problems with its antenna requiring a reduction in operating power to 35kw for the transmitter to stay on the air. Station engineering personnel are working to determine and resolve the

			problem.”
1030	NEW	OR	La Grande - Applies for U2 1000/600.
1050	WDVM	WI	Eau Claire - Applies for U1 860/430 from a proposed new 340' tower utilizing a 6-wire skirt to operate as a folded unipole.
1210	KHAT	WY	Laramie - Applies for a Special Temporary Authorization to operate U1 10000/250 (they are licensed U2 10000/1000), as lightning struck a tower and damaged the phasing equipment which is required for night operation. Repairs are ongoing.
1380	WNLA	MS	Indianola - Applies for U1 390/34.
1440	WDOW	MI	Dowagiac - Applies for U1 2300/89.
1500	WPJX	IL	Zion - Applies to add night service as U5 250/2.
1510	KPIG	CA	Piedmont - Applies for U4 8000/2400.
1510	KGA	WA	Spokane - Applies for U4 50000/15000. [Shades of WOWO?]
1550	WMSK	KY	Morganfield - Applies for U1 145/6.
1590	WATX	TN	Algood - Applies to move to 1600 kHz with U1 2500/20.

AMENDMENTS TO APPLICATIONS

820	NEW	NC	Masonboro - Original Auction 84 application was for U4 5000/5000. This amendment requests U4 50000/3300.
1060	WKMQ	MS	Tupelo - Applies for U1 960/12, adding night operation.
1130	KTMR	TX	Edna - Applies to move to Converse, Texas (a San Antonio suburb) with D4 4000/0 CH 4000.
1380	KAGE	MN	Winona - Licensed for U1 4000/52, KAGE applied to move the transmitter to a new taller tower, di-plexing with co-owned KWNO-1230 with U1 1000/58. Since the proposed tower is 393' tall as compared with the current KAGE 200' tower, they proposed U1 1000/58 in order to cover the same (daytime) area. After more studies were made, they determined the daytime power could be increased and not create any new prohibited contour overlaps, and slightly reduces two existing ones. They now apply for U1 2200/58 at the new site.

APPLICATIONS FOR NEW STATIONS

1300	NEW	AZ	Prescott - Applies for U4 1500/500.
1390	NEW	PA	Morrisville - Applies for U1 250/250.
1490	NEW	UT	Santa Clara - Applies for U5 1000/1000.
1550	NEW	LA	Blanchard - Applies for U4 1000/500.
1560	NEW	WY	Mills - Applies for U2 10000/500 CH 1000. [CH power correction from last Issue]

APPLICATIONS FOR RECONSIDERATION

1120	NEW	TX	Manor [pronounced May'-ner] - Applied for U4 250/250 and then for U4 250/180, but both were turned down. They have re-applied again . . . this time for U4 250/153.
------	-----	----	--

DISMISSALS

540	WRRD	WI	Jackson - CP for U4 400/500 has been dismissed. WRRD remains U4 400/400.
640	WWJZ	NJ	Mount Holly - [Clarification from last issue] Application for U4 50000/25000 and a change in City-of-License (CoL) to Horsham Township, Pennsylvania. WWJZ remains U4 50000/950 in its current City-of-License.
680	CJOB	MB	Winnipeg - Application for an FM station on 106.3 with 100 kW.
730	WXTR	VA	Alexandria - Application for U4 28000/20000.
900	NEW	OR	Bend - New station, not yet on the air, has a CP for U4 50000/2000. They then submitted an application raising the night power to 2700 Watts. That application has been dismissed, leaving them with the CP.
910	KIYU	AK	Galena - CP for U1 12500/12500.
940	KTON	TX	Belton - Station applied for D3 4500/0, then later applied for D4 50000/0 50000 with a change in CoL to Lancaster, TX. The initial application has been dismissed leaving the latter.
1050	KJPG	CA	Frazier Park - Application was for U4 10000/55.
1240	WNVL	TN	Nashville - Application to move to the WNAH-1360 tower.

1460 WBCU SC Union - Applied for D1 1000/0 on 690 kHz.

LICENSE CANCELLATIONS/CALL LETTERS DELETED

1150 CJRC QC Gatineau - Station is silent as the simulcast period with their FM station on 104.7 MHz has expired.

1230 CKTK BC Kitimat - The CRTC has deleted the license for CKTK-1230. Their new FM station is on 97.7 MHz with 170 Watts.

1240 KBEL OK Idabel

1560 KKUZ OK Sallisaw

1580 WWGS SC Georgetown [station never made it on the air]

1600 KUSH OK Cushing

LICENSE RENEWALS GRANTED

1070 WIBC IN Indianapolis

1150 KCKY AZ Coolidge

1230 WCRO PA Johnstown



1201 18th Street, Suite 250
Denver, CO 80202
www.nradio.com

HEAR AND THAR

- Issue 30! Wow, this Volume Year is history. We'll see you next Issue with more 'stuff'.
- **SILENT: WASG-550 Atmore, Alabama; WEEL-700 Dothan, Alabama; WLHN-990 Muncie, Indiana; KRAM-1070 West Klamath, Oregon; KRXX-1240 Rexburg, Idaho; KRHC-1340 Burnet, Texas; KETX-1440 Livingston, Texas; WGEN-1500 Geneseo, Illinois; and WNSH-1570 Beverly, Massachusetts.**
- **BACK ON: KHNR-880 Honolulu, Hawaii; KYRO-1280 Potosi, Missouri with country; WNIX-1330 Greenville, Mississippi; and WBKV-1470 West Bend, Wisconsin.**
- Thanks to **Shawn Axelrod, Perry Crabill, Russ Edmunds, Wayne Heinen, Deane McIntyre, Dave Schmidt, and Jonathon Watson.**

GRAVEYARD DX UPDATE

* indicates record held by DXer from North America (excluding Alaska)

+ record held by a DXer in USA/Canada where a Canadian/USA record exceeds that mileage

1230 kHz:

					<u>Miles</u>
KEXO	CO	Grand Junction	Tim Hall	Rancho Bernardo, CA	+ 633
KKPC	CO	Pueblo	Tim Hall	Rancho Bernardo, CA	+ 786
KORT	ID	Grangeville	Tim Hall	Yellowstone Lake Village, WY+	294
WHIR	KY	Danville	Tim Hall	Norcross, GA	+ 260
WESX	MA	Salem	Tim Hall	Tom Nevers, MA	+ 98
WCUZ	MI	Grand Rapids	Tim Hall	Madison, WI	+ 188
WMPC	MI	Lapeer	Tim Hall	Detroit, MI	+ 48
WCMC	NJ	Wildwood	Tim Hall	Tom Nevers, MA	+ 298
KFUN	NM	Las Vegas	Tim Hall	Ajo, AZ	+ 485
KJFK	NV	Reno	Tim Hall	Yellowstone Lake Village, WY+	587
WIXT	NY	Little Falls	Tim Hall	Herkimer, NY	+ 7
WFAS	NY	White Plains	Tim Hall	Tom Nevers, MA	+ 200
WCBT	NC	Roanoke Rapids	Tim Hall	Philadelphia, PA	+ 278
KKEE	OR	Astoria	Tim Hall	Crater Lake Rim Village, OR	+ 239
KZZR	OR	Burns	Tim Hall	Crescent City, CA	+ 290
WEEX	PA	Easton	Tim Hall	Mount Laurel, NJ	+ 56
WCRO	PA	Johnstown	Tim Hall	(25 miles from) Johnstown, PA+	25
WXNI	RI	Westerly	Tim Hall	Tom Nevers, MA	+ 96
KMGR	UT	Murray	Tim Hall	Chula Vista, CA	+ 625
WJOY	VT	Burlington	Tim Hall	St. Albans, VT	+ 26
WFVA	VA	Fredericksburg	Tim Hall	Glen Allen, VA	+ 43
KOZI	WA	Chelan	Tim Hall	Port Angeles, WA	+ 160
KWXY	WA	Everett	Tim Hall	Monterey, CA	+ 817
CJNL	BC	Merritt	Tim Hall	Lake MacDonald, MT	+ 355

1240 kHz:

KNRY	CA	Monterey	Tim Hall	Between Victoria and San Juan Is-	
land, BC	* 823				
KNRY	CA	Monterey	Tim Hall	US 6/50 near NV border, UT	+ 461
KOFE	ID	St. Maries	Tim Hall	Lake MacDonald (Glacier NP), MT	+ 169

WHBU	IN	Anderson	Tim Hall	(25 miles east of) Anderson, IN	+ 25
WCEM	MD	Cambridge	Tim Hall	Alexandria, VA	+ 54
WBUR	MA	West Yarmouth	Tim Hall	Tom Nevers, MA	+ 29
KBMY	MT	Billings	Tim Hall	Johnston Canyon, AB	+ 506
KLYQ	MT	Hamilton	Tim Hall	Trail, BC	+ 257
KBLL	MT	Helena	Tim Hall	Johnston Canyon, AB	+ 365
WSNJ	NJ	Bridgeton	Tim Hall	Mount Laurel, NJ	+ 37
WGVA	NY	Geneva	Tim Hall	St. Albans, VT	+ 238
WJTN	NY	Jamestown	Tim Hall	Toronto, ON	+ 114
KDLR	ND	Devils Lake	Tim Hall	Winnipeg, MB	+ 145
KEJO	OR	Corvallis	Tim Hall	Chatham Strait, AK	974
KEJO	OR	Corvallis	Tim Hall	Chatham Sound, BC	+ 775
KTIX	OR	Pendleton	Tim Hall	Jasper, AB	+ 500
KXOX	TX	Sweetwater	Tim Hall	Fort Stockton, TX	+ 183
KCVL	WA	Colville	Tim Hall	Brandon, OR	+ 487
KXLE	WA	Ellensburg	Tim Hall	Fitz Hugh Sound, AB	+ 469
KGY	WA	Olympia	Tim Hall	Crater Lake Rim Village, OR	+ 287
WIBU	WI	Poynette	Tim Hall	Madison, WI	+ 20
KFBC	WY	Cheyenne	Tim Hall	(US 6/50 near) Nevada border, UT	+ 508
KASL	WY	Newcastle	Tim Hall	(35 miles west of) Moose Jaw, SK	+ 469
CFEK	BC	Fernie	Tim Hall	Banff, AB	+ 116
CBLO	ON	Mattawa	Tim Hall	(32 miles east of) Mattawa, ON	32
CJCS	ON	Stratford	Tim Hall	Sudbury, ON	+ 217

1340 kHz:

WOOK	DC	Washington	Tim Hall	Alexandria, VA	+ 8
WDSR	FL	Lake City	Tim Hall	Naples, FL	+ 280
KSGR	ID	Nampa	Tim Hall	Chula Vista, CA	+ 756
WNBH	MA	New Bedford	Tim Hall	Tom Nevers, MA	+ 55
WEXL	MI	Royal Oak	Tim Hall	Detroit, MI	+ 5
KPRK	MT	Livingston	Tim Hall	Jasper, AB	+ 546
KYLT	MT	Missoula	Tim Hall	Lake MacDonald, MT	+ 114
WPOL	NC	Winston-Salem	Tim Hall	(near) Thomasville, NC	+ 16
WDCR	NH	Hanover	Tim Hall	5 mi. NNE of Randolph, VT	+ 29
KTSN	NV	Elko	Tim Hall	Chula Vista, CA	+ 574
WENT	NY	Gloversville	Tim Hall	Poquonock, CT	+ 116
WLVL	NY	Lockport	Tim Hall	Combermere, ON	+ 161
WLVL	NY	Middletown	Tim Hall	Port Jervis, NY	+ 14
WIRY	NY	Plattsburgh	Tim Hall	Poquonock, CT	+ 197
KXPO	ND	Grafton	Tim Hall	Winnipeg, MB	+ 104
WIZE	OH	Springfield	Tim Hall	(10 mi. east of) Springfield, OH	+ 10
KLOO	OR	Corvallis	Tim Hall	Port Angeles, WA	+ 246
KBBR	OR	North Bend	Tim Hall	(btwn) San Juan Island and Victoria, BC	+ 353
WHAT	PA	Philadelphia	Tim Hall	Mount Laurel, NJ	+ 17
WWPA	PA	Williamsport	Tim Hall	New Cumberland, PA	+ 69
KTMP	UT	Heber City	Tim Hall	Evanston, WY	+ 59
WHAP	VA	Hopewell	Tim Hall	Glen Allen, VA	+ 28
KLKI	WA	Anacortes	Tim Hall	Jasper, AB	+ 362
KTCR	WA	Kennewick	Tim Hall	Jasper, AB	+ 463
KVSN	WA	Tumwater	Tim Hall	(Georgian Strait near) Parksville, BC	+ 174
KWWX	WA	Wenatchee	Tim Hall	Trail, BC	+ 167
CIBQ	AB	Brooks	Tim Hall	Omak, WA	+ 372
CINL	BC	Ashcroft	Tim Hall	Finlayson Channel, BC	+ 333
CKGF	BC	Grand Forks	Tim Hall	Lake Louise, AB	+ 194
CKCR	BC	Revelstoke	Tim Hall	Fernie, BC	+ 171
CIVH	BC	Vanderhoof	Tim Hall	Lake Louise, AB	+ 373

1400 kHz:

KVTO	CA	Berkeley	Tim Hall	Chula Vista, CA	+ 465
KRLN	CO	Canon City	Tim Hall	Chula Vista, CA	+ 779
KDTA	CO	Delta	Tim Hall	Grand Canyon North Rim, AZ	+ 281
WSTC	CT	Stamford	Tim Hall	Tom Nevers, MA	+ 184
KART	ID	Jerome	Tim Hall	Silver City, NM	+ 769
KIGO	ID	St. Anthony	Tim Hall	Whitehall, MT	+134

KSTP	ID	Sandpoint	Tim Hall	Jasper, AB	+ 324
KVOE	KS	Emporia	Tim Hall	(I-35 10 mi from) Emporia, KS	+ 10
WHMP	MA	Northampton	Tim Hall	Tom Nevers, MA	+ 157
KXGF	MT	Great Falls	Tim Hall	Jasper, AB	+ 479
WTSL	NH	Hanover	Tim Hall	(I-89 rest area 5 mi from) Randolph, VT	+ 30
WAMC	NY	Albany	Tim Hall	Tom Nevers, MA	+ 220
KNND	OR	Cottage Grove	Tim Hall	Chester, CA	+ 258
WZNG	TN	Shelbyville	Tim Hall	Norcross, GA	+ 165
KLCK	WA	Goldendale	Tim Hall	Radium Hot Springs, BC	+ 399
KEDO	WA	Longview	Tim Hall	Crescent City, CA	+ 310
KITZ	WA	Silverdale	Tim Hall	Mt. Ranier National Park, WA	+ 66
CHNL1	BC	Clearwater	Tim Hall	Fitz Hugh Sound, BC	+ 337
CKGR	BC	Golden	Tim Hall	Kamloops, BC	+ 158
CIOR	BC	Princeton	Tim Hall	Jasper, AB	+ 260
CKOB	ON	Renfrew	Tim Hall	Combermere, ON	+ 45

1450 kHz:

KEST	CA	San Francisco	Tim Hall	Spanish Fork, UT	+ 600
KBFI	ID	Bonnars Ferry	Tim Hall	Lake MacDonald, MT	+ 139
KEZJ	ID	Twin Falls	Tim Falls	Yellowstone Lake Village, WY	+ 242
WKEI	IL	Kewanee	Tim Hall	Peoria, IL	+ 41
WMAS	MA	Springfield	Tim Hall	Poquonock, CT	+ 15
WKLA	MI	Ludington	Tim Hall	(flying 7 mi over) Ludington, MI	+ 7
KZZJ	ND	Rugby	Tim Hall	Winnipeg, MB	+ 167
KSEL	NM	Portales	Tim Hall	Teasdale, UT	+ 535
WWSC	NY	Glens Falls	Tim Hall	Mount Laurel, NJ	+ 243
WYFY	NY	Rome	Tim Hall	Herkimer, NY	+ 27
KKXO	OR	Eugene	Tim Hall	Manning Park Resort, BC	+ 399
KLBM	OR	La Grande	Tim Hall	Crescent City, CA	+ 394
WLKW	RI	West Warwick	Tim Hall	Tom Nevers, MA	+ 86
KYNT	SD	Yankton	Tim Hall	Winnipeg, MB	* 485
KEYY	UT	Provo	Tim Hall	Mammoth Lakes, CA	+ 431
WSNO	VT	Barre	Tim Hall	(I-89 6 mi north of) Burlington, VT	+ 40
KBKW	WA	Aberdeen	Tim Hall	Jasper, AB	+ 481
KCLX	WA	Colfax	Tim Hall	Jasper, AB	+ 417
KONP	WA	Port Angeles	Tim Hall	Crater Lake Rim Village, OR	+ 364
KSUH	WA	Puyallup	Tim Hall	Jasper, AB	+ 436
WHRY	WI	Hurley	Tim Hall	Madison, WI	+ 234
CHOR	BC	Summerland	Tim Hall	Jasper, AB	+ 236
CHOU	QC	Montreal	Tim Hall	St. Albans, VT	+ 57

1490 kHz:

KTOB	CA	Petaluma	Tim Hall	Chula Vista, CA	+ 497
KOWL	CA	South Lake Tahoe	Tim Hall	Chula Vista, CA	+ 465
KCFC	CO	Boulder	Tim Hall	(US 6/50 near) NV border, UT	+ 473
KCID	ID	Caldwell	Tim Hall	Chula Vista, CA	+ 763
WBAE	ME	Portland	Tim Hall	Plymouth, MA	+ 119
WMRC	MA	Milford	Tim Hall	Herkimer, NY	+ 187
WTKU	NJ	Pleasantville	Tim Hall	Tom Nevers, MA	+ 267
WCSS	NY	Amsterdam	Tim Hall	Herkimer, NY	+ 42
WOLF	NY	Syracuse	Tim Hall	Herkimer, NY	+ 18
WDUR	NC	Durham	Tim Hall	(I-85) Mile Marker 200, NC	+ 24
KOVC	ND	Valley City	Tim Hall	Winnipeg, MB	+ 210
KBKR	OR	Baker	Tim Hall	Port Angeles, WA	+ 353
KRNR	OR	Roseburg	Tim Hall	Manning Park Resort, BC	+ 462
KBZY	OR	Salem	Tim Hall	Chester, CA	+ 333
KZZN	TX	Littlefield	Tim Hall	Teasdale, UT	+ 593
WFAD	VT	Middlebury	Tim Hall	St. Albans, VT	+ 56
KBRO	WA	Bremerton	Tim Hall	Manning Park Resort, BC	+ 167
KWOK	WA	Hoquiam	Tim Hall	Vancouver, WA	+ 166
KUGR	WY	Green River	Tim Hall	(US 6/50 near) NV border, UT	+ 297
CJPR	AB	Blairmore	Tim Hall	Lake MacDonald, MT	+ 110
CKOO1	BC	Oliver	Tim Hall	Banff, AB	+ 221
CJSN	SK	Shaunavon	Tim Hall	Jasper, AB	+ 472

Domestic DX Digest

West: Bill Dvorak westlogs@aol.com (Division line
3358 Ridgeway Ave. - Madison, WI 53704-4327 is between East
and Central time
zones)

East: Mike Brooker aum108@idirect.com
99 Wychcrest Ave - Toronto, Ontario M6G 3X8 CANADA

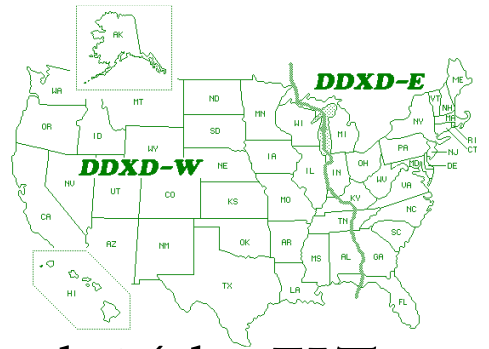

DX Catches in the U. S. and Canada, with 24-hr. ELT

DDXD-West

FROM THE VAST WESTLAND

- ▲ It took several months for the drama to play out, but to think the outcome would be anything other than what finally came down was to be a victim of wishful thinking. On Wednesday August 15, the new IBOC rules were at last published in the Federal Register, starting the 30-day clock (first described way back in DDXD-W #74-24) running. The rules, including nighttime IBOC, were to become effective September 14, meaning that if you are first reading this in the printed *DXN* they have already taken effect. So Volume 75 will begin with one more burden for our hobby, one more circumstance that makes hearing new stations more difficult.
- ▲ The waning days of IBOC-free nighttime DXing were busy ones for DDXD-W contributors, and we have a very big column this month. Welcome to first-time contributor **Joseph "Woz" Wozniak** from Saint Louis. It was my pleasure meeting Woz and his wife Sandy at this year's Madison-Milwaukee DX Get-together. Welcome aboard, Woz! **John Tucker** sends along loggings from a trip to the rarely DXed Canadian Rockies, Idaho and Montana. These appear in a separate section at the end of this column. Also sent along-- a spectacular photo of Peyto Lake AB-- thanks, John! And thank you all for your contributions! My hope is that we all keep at the dials in the critical months ahead. Please keep your three loggings editors busy!
- ▲ What a busy month August was for your Editor! The month began with my Dad's 95th birthday, but that was not the only birth day marked on August 1. Your Editor became a first-time grandpa that day when my daughter and her husband had a daughter, **Nora Elizabeth Oksanen** (future DXer if her grandpa has anything to say about it!). We celebrated my Dad's birthday on August 4 with the first of two parties our house would host during the month. On August 12 we took a Sunday jaunt to Antioch IL to see the new granddaughter, and then a hectic week ensued leading up to our hosting the 14th annual Madison-Milwaukee DX Get-together (the second party hosted at our house) on August 18. I am happy to report that this year's GTG was another smashing success (look for my "Musing" in the upcoming *DXN* #75-1)! The day was marred, however, by over 5" of rain, only a fraction of the 15+ inches we got this month. All this rain has led to perfect mosquito breeding conditions, leading the fine burghers of Madison to spend more time indoors. On the last day of August I witnessed a large mass of mosquitoes carrying away my longwire antenna, no doubt to tie up unsuspecting people so they couldn't escape the "wrath of 1000 bites"!
- ▲ Lazy time at the Editor's desk is over-- no more of these 4-5 week periods between issues. Deadline for DDXD-W #75-1 is Thursday 9/20 (1300 ELT for e-mail submissions and that day's delivery for snail mail). Then it is back to the weeklies. More about this in the next issue. **73 Bill**

Reporters

- | | |
|---------------|---|
| BW-OK | Bruce Winkelman AA5CO, Tulsa. Station news. |
| DP-HI | Dale Park, Honolulu. Sangean ATS-818CS, Terk AM1000 loop. |
| DP-HI* | Dale Park, DXing in East Honolulu. Honda car radio. |
| DS-CA | Dan Sheedy, DXing (house-sitting) in Cardiff. R75/Kiwa, 120-foot random WOR (wire on roof). |
| GH-IL | Greg Harris, Park Forest. Icom R75 / Quantum Loop. |
| JEL-MO | J. E. Lewis, Kansas City. Station news. |
| JT-AZ | John Tucker KG7RS, Mesa. Icom IC-746Pro, 4' varactor-tuned box loop, 50' longwire, Quantum Phaser. |
| JW-CO | John Wilkins, Wheat Ridge. Drake R-8, 4-foot box loop. |
| KDF-IL | Karl D. Forth, Chicago. Sangean ATS-909. |
| KO-IL | Ken Onyschuk, Lockport. Station news. |
| MLP-NE | Mike Plumb, Papillion. Ten-Tec RX-350D, MFJ 784B tunable DSP filter, Quantum QX loop. |
| NK-WI | Neil Kazaross, DXing from Grafton. R8A and Phased BOGs to ENE 335 feet // 450 |

		feet.
PG-CO	Patrick Griffith, Westminster.	Station news.
SA-MB	Shawn Axelrod, Winnipeg.	ICOM IC-R70, Drake R8, 4 foot unamplified box loop, Quantum loop, 155 foot outdoor wire, 100 foot indoor wire, MFJ 1026 phasing unit.
SP-WI	Sheryl Paszkiewicz, Manitowoc.	Sony 2010 with Select-a-Tenna.
WH-CO	Wayne Heinen, Aurora.	Drake R8B, N/S Flag, E/W Flag, Modified 4 foot NRC Altazimuth loop, 15 foot vertical whip, Dual TG-1 Termination Gizmo w/2 BUF-F amplifiers, Mini-DXP5, DX Engineering RPA-1.
WW-MO	Woz Wozniak, Saint Louis.	Grundig Satellit 800, Sony ICF SW7600GR, Terk Advantage antenna.
Ed.-WI	Your editor, Madison.	Drake R8B, Quantum QX Pro loop.

Station News

560	WIND	IL	Chicago. 9/5. Friend and fellow DXer Tim Noonan tells me that this station has dropped its slogan "Newstalk 560" in favor of "AM 560 WIND." Format remains newstalk. (Ed.-WI)
620	KIPA	HI	Hilo. Per spokeswoman 8/6, station is off the air awaiting transmitter parts. A posting on the bulletin board HawaiiThreads.com says the station had been relaying KBGX-FM 105.3 and using the slogan "Lava 105." (DP-HI)
690	KHNR	HI	Honolulu. 9/4. Noted station owner Salem Media swapping formats and calls again, with newstalk format and calls (ex-KHCM) moving from 880 to 690. The station is now known as "Hawaii's new choice for Intelligent Talk." Station receptionist said change happened 9/3. Time to update that NRC Log already! (DP-HI) (See also 880 below. Ed.-WI)
740	KKAG	ND	Fargo. 8/14 0600. Heard today with "The Fan" non IDs. Now // 1280 KVOX with dual IDs on the top of the hour. This after months of non stop country music (with no ads and legal IDs only). (SA-MB)
880	KHCM	HI	Honolulu. 9/4. Swapped format and calls again with 690. Is now Jones Radio's "US Country" C&W format, calls ex-KHNR. Formats also switched on 97.5 from KHNR-FM "Hawaii's FM Talk" to C&W "Hawaii's Country Music." (DP-HI) (And just at our deadline on 9/7, the FCC has changed the FM's calls to KHCM-FM. Ed.-WI)
900	WDLS	WI	Wisconsin Dells. 9/5 1607. Legal ID including new slogan "Country Western AM 900," ex- "Your Vacation Station. Format is now classic country, ex-oldies and tourism. (Ed.-WI)
1120	KEOR	OK	Catoosa. 8/13-16. No sign during AM and PM drive time of this CP reported as on in AM Switch 74-29, only a weak/noisy KMOX in the mornings and nothing but hiss/white noise during the evening drive-time. I'll keep an ear on 1120. I suspect that 1110 KFAB's IBOC hiss will be a problem for 1120 during SRS and SSS! (BW-OK) (Bruce sent an update on 9/6-- still no sign of this station. Ed.-WI)
1340	KJMU	OK	Sand Springs. 8/13-16. New calls, ex-KTKX, were reported in AMS #74-29. Heard with these new calls this week and a Black Gospel format, ex-SS music. No new slogan heard. (BW-OK)
1450	WRLI	IL	Cicero. Noted that WRLI has replaced its talk format, including partial simulcast of WVON 1690, with a Spanish format for its full broadcast day of 10 PM to 1 PM daily. Sharetimer WCEV continues to carry its ethnic format, though I've heard some EE programs on the weekend. (KO-IL)
1510	KCKK	CO	Littleton. In late July, NRC Broadcasting struck a deal with Mile High Sports to LMA KCKK 1510 to them pending their purchase of the station. Mile High failed to come up with the money for the LMA and NRC repossessed the station 18 days later. Then on 8/31 Mile High apparently showed up with the money for the LMA (unofficially I heard \$40,000) and the station flipped back to Mile High Sports Radio again at about 3 PM on that same day. When they are not live with local programming they carry the Sporting News Radio network. Mile High Sports Radio apparently still intends to buy the station and make it the flagship of their network which, so far, includes KSXT 1570 ("The Sports Extra") in Loveland. I have heard from several people that they saw "Mile High Sports Radio 1510" billboards on the sides of some RTD buses during the repossession phase when KCKK was carrying classic country again. This has got to be very confusing to the public. We'll see what

- happens next. (PG-CO)
- 1560 WPAD KY **Paducah.** According to the *Paducah Sun* of 9/6, station has been off air since 8/31 when the old transmitter died. The transmitter is in the process of being replaced, and the station is expected to return to the air by mid-September. Thanks to **Dan Riordan** for posting this DX opportunity info on the IRCA list. (Ed.-WI)
- 1660 KXTR KS **Kansas City. 8-13.** Station is announcing that High Def classical is now on KUDL 98.1 FM Kansas City (Odd - just regular programming on 9-8 -pls). Their website shows High Def coming soon and also mentions FM with link to an equipment manufacturer. This might mean that they would not be going HD on 1660. Since I only live a mile from their transmitter and get a lot of overload on even my best receivers even without their being HD, I had phoned them previously to learn of their plans for AM, but they did not return my call. (JEL-MO)
- Presumed, Tentative, UnID
- 550 KUZzt CA **Bakersfield. 8/27 0236.** C&W music noted during one of KMVI HI's spots of dead air during the ESPN Radio feed. Also noted was talk; KFYI AZ? (DP-HI)
- 790 WQSVt TN **Ashland City. 8/31 2155.** Tentative with Sycamore HS Football, vs. (Montgomery Central) Indians. Fair signal for 15 minutes, kind of a smaller town sound, but no ID heard. (KDF-IL)
- 1330 UNID **8/26 2300.** Talk format with the "Tammy [?] Show." Automobile dealer commercial noting their location in the city/town of "Butler." Battling for dominance with KVOL and an antenna bearing of NE/SW. Any ideas? (WW-MO)
- 1570 UNID In #74-29, Dale Park had a woman in SS with a phone-in show. XERF has that format during my local evenings, while KCVR and KTGE usually have Mexican music way in the background. XERF with responsible programming! ...whoda thunk it?? The ghost of Wolfman Jack is revolving incessantly.... (DS-CA)
- 1570 UNID **9/5 0257.** Nortena music; Big Ben-style clock chimes, ID missed, high-pitched woman with announcement. American or Mexican-based? Poor; QRM from KBLA 1580. (DP-HI*)
- Regular DX Loggings (times in ELT)
- 570 WNAX SD **Yankton. 9/2 2300.** "Voice of the Midwest since 1922, 5-70 WNAX" through heavy static but no discernable QRM. (WW-MO)
- 670 KPUA HI **Hilo. 8/15 0627.** "Coast to Coast AM with George Noory," interrupted by a promo for Hurricane Flossie coverage. An actual hurricane update didn't occur until 0657. (DP-HI)
- 750 CBGY NL **Bonavista Bay. 8/26 2154.** Poor to fair in peaks over/under WSB which is deeply nulled by this direction of BOG. CBC Radio One piano music // a strong CBA 1070; later up to fair level on fade-up // CBA's jazz. I tried for other NL's but nothing but a very weak CBY noted. (NK-WI)
- 780 WTME ME **Rumford. 8/26 2034.** Poor to fair. Noted mellow oldies type music mixing with CFDR C&W under WBBM phase null. ID sounded like "WCGR" and nothing listed with this format. When I tuned back a bit later I caught an "Easy 1240" slogan. A call to WTME revealed that they simulcast WEZR 1240 in afternoons/evenings and that they were on 310 watt PSSA at the time. ME #2 and only 310 watts, and one of my best domestic catches from here. (NK-WI)
- 790 WLSV NY **Wellsville. 9/2 2050.** Old time country music, "Real Country 7-90 WLSV." New (SP-WI)
- 840 KTIC NE **West Point. 8/23 0700.** Sign on announcement mixing with WHAS. (WH-CO)
- 840 KXNT NV **North Las Vegas. 8/23 0800.** Alone and weak with legal ID to CBS news. (WH-CO)
- 850 KHLO HI **Hilo. 8/15 0757.** Hawaii County Civil Defense update on Hurricane Flossie; ID for KKBG-FM and relay KLEO-FM "K-Big FM," then ID for KHLO and relay KKON 790; DJ came on saying ESPN 8-50 was simulcasting K-Big while the hurricane was going on. (DP-HI)

- 860 KMVP AZ **Phoenix. 8/19 0803.** This still noted with tape loop advising listeners to tune to KTAR-620. Fair with KTRN and XEMO. The Radio Journal is now indicating that they have gone to SS religion. **(WH-CO)** (Can someone in the area please confirm? **Ed.-WI)**
- 860 KMVP AZ **Phoenix. 8/20 0700.** Twenty-second loop tape with this message: "Set your radio to Sports 620 KTAR, all sports all the time-- Sports 620 KTAR" repeated once and ending with a quick "KMVP Phoenix" insert. Repeated continually to at least 0715 when I tuned out. Generally fair with fading and QRM. **(JW-CO)**
- 920 KLMR CO **Lamar. 8/18 0105.** "... the KLMR weather forecast..." Fair with thunderstorm noise. **(WH-CO)**
- 930 KWOC MO **Poplar Bluff. 9/2 2040.** ESPN baseball (Rangers vs. Anaheim) with numbers and call. **(WW-MO)**
- 940 KVSH NE **Valentine. 8/22 0803.** "That's the weather on KVSH Valentine" under KKFN 950 slop. **(WH-CO)**
- 960 KOVO UT **Provo. 8/21 0800.** "Salt Lake City's the Zone KOVO Provo, 50000 watts of Sports Power" and dual ID for KZNS 1280. Fair. **(WH-CO)**
- 990 CBY NL **Corner Brook. 8/26 2222.** Poor in peaks under CKGM and with CBW carrying different programming and very weak on these BOGs. CBC Radio One jazz music // CBA 1070. This was a bit better when heard last December. **(NK-WI)**
- 990 KRMO MO **Cassville. 9/2 2326.** Excellent signal reading S5+ on the meter. "You're listening to AM 9-90 KRMO Cassville, Monett, Aurora, and Mount Vernon." Clear listening for one hour or so then faded to gone. **(WW-MO)**
- 1060 KRCN CO **Longmont. 9/4 0055-0205.** Excellent signal beating out 50kw KYW Philadelphia. Reception good enough to send in a report by snail mail. "Radio Colorado" and "10-60 KRCN Longmont" identifications. "Taste of Longmont" promo and "The Joey Reynolds Show." **(WW-MO)**
- 1110 KDIS CA **Pasadena. 8/ 8 0122.** Woman with tween CHR such as Black Eyed Peas' "Let's Get It Started," mention of "Radio Disney." Poor to fair, under and sometimes over semi-local KAOI. **(DP-HI)**
- 1120 WPRX CT **Bristol. 8/26 2310.** Good, fading atop C&W music with KMOX phased out. SS chatter, "La Puertoriquenísima" ID into lively SS music. Very, very common here. **(NK-WI)**
- 1130 CKWX BC **Vancouver. 9/2 0231.** Atop channel with Vancouver traffic, ad for Hunter's Sporting Goods in Surrey, "News 1130" time and weather. No sign of local KSDO's "Radio Nueva Vida." **(DS-CA)**
- 1220 KHTS CA **Canyon Country. 9/3 0810.** In and out with music, ads, man announcer, call letter IDs, Dodgers update; fair at best. Local KLVZ was off the air (they came back on about an hour later). Did not hear any other stations during this opportunity. **(JW-CO)**
- 1320 WILS MI **Lansing. 8/10 0200.** "What the Capitol listens to (missed), 1320 WILS" by a male announcer. Fair with QRN. **(GH-IL)**
- 1330 KWLO IA **Waterloo. 8/15 2228.** Poor to fair signal. Nostalgia music with announcement "Star1330 KWLO" tossed in, announcer's name Vic Thomas; announcement "The songs you like to sing along with, this is Star 1330 KWLO." Back to more nostalgia music, just ahead of a growing jumble of the others on 1330. **(MLP-NE)**
- 1330 KWLO IA **Waterloo. 8/27 2106.** "Star 13-30 KWLO" followed by James Taylor number. Weak signal strength, fade out after 5 minutes. **(WW-MO)**
- 1330 WRAM IL **Monmouth. 8/26 2157.** "Your country music station, WRAM 13-30" under KVOL. QRM from said station and KUKU. **(WW-MO)**
- 1330 KVOL LA **Lafayette. 8/26 2300-2400.** Sports and ESPN. Official ToH station identification at 2300 and a better sounding one at 2400. Light QRN and QRM from WRAM and KUKU. **(WW-MO)**
- 1330 KUKU MO **Willow Springs. 8/26 2300-2400.** Numbers and call at 2300 and 2331 under KVOL. QRM from KVOL and WRAM with moderate QRN. Not good enough for Verie by audio. **(WW-MO)**
- 1370 WDEF TN **Chattanooga. 8/28 2104.** Atlanta Braves baseball with the S-Meter reading S7. "Chattanooga's sports leader ESPN Radio 13-70 WDEF, Chattanooga's home of the Braves." **(WW-MO)**

1390	WTJS	TN	Jackson 8/29 0000. Top of the hour station identification, "NewsRadio 13-90 WTJS Jackson; coverage you can count on." (WW-MO)
1410	KWYO	WY	Sheridan. 8/2 0502. Up briefly with KWYO ID. (WH-CO)
1410	KOOQ	NE	North Platte. 9/2 2038. The Jackson 5 and "Give Me One More Chance" followed by "Oldiesradio.com" web address and two unidentified commercials mentioning Ogallala. "Good Time Oldies 14-10 KOOQ." Reception report sent by e-mail. (WW-MO)
1420	WVJS	KY	Owensboro. 8/28 2300. "This is your home for 'Memories Favorites' 14-20 WVJS in Owensboro." (WW-MO)
1420	KTOE	MN	Mankato. 8/30 2322. "AM 14-20 KTOE" after musical number "Hit the Road Jack." (WW-MO)
1450	KVSI	ID	Montpelier. 8/11 0759. ID by man at 0759:52 "KVSI Montpelier, the Voice of Southeastern Idaho" and into ABC news. Fair, just above the QRM on the 100-foot random wire. (JW-CO)
1450	KBBS	WY	Buffalo. 8/14 0259. Simple ID at ToH, followed by ABC news. Fair on the random wire. (JW-CO)
1460	WBRN	MI	Big Rapids. 8/4 2130. "Newstalk 1460 WBRN" and ads for local businesses. Poor. (GH-IL)
1520	KVTA	CA	Port Hueneme. 8/19 0205. "From Camarillo to Fillmore, NewsTalk 1520 KVTA" into Coast to Coast AM with George Noory. Good signal with KOKC phased. (JT-AZ)
1520	KMAV	ND	Mayville. 8/31 2106. "You're listening to 15-20 KMAV Mayville-Portland." Strong signal for 30 minutes at S7 on meter. (WW-MO)
1540	KXEL	IA	Waterloo. 8/30 2300. "15-40 KXEL Waterloo-Cedar Rapids, Iowa." (WW-MO)
1550	KYAL	OK	Sapulpa. 8/31 2330. "15-50 the Sports Animal" at 2316 followed by "You've been listening to Sapulpa Chieftain football at KYAL Sapulpa-Tulsa" at 2330. (WW-MO)
1550	KSFT	MO	Saint Joseph. 9/1 0048. "KSFT 15-50 Saint Joseph," after "There Ain't No Cure for the Summertime Blues." (WW-MO)
1560	KNZR	CA	Bakersfield. 8/19 0258. "Keep it here on 1560 KNZR Bakersfield. It's midnight" into AP Network news. (JT-AZ)
1570	WWCK	MI	Flint. 8/8 2106. Pulled ID out of mud. (SP-WI)
1590	KKZZ	CA	Ventura. 8/8 0800 Ending PSA with "1590 the Connection is KKZZ Ventura-Oxnard-Camarillo-Santa Barbara. The New 1590 the Connection" to CNN news. A needed call change taped... last heard as KOGO in 1988. (WH-CO)
1600	WWRL	NY	New York. 8/8 2045. Local spots, 212 area code, calls. Was trying for Delaware. (SP-WI)
1660	WFNA	NC	Charlotte. 8/31 0300. "...weekdays from 10 to 1. 16-60 AM WFNA Charlotte." (WW-MO)

JOHN TUCKER'S GREAT NORTHWEST ADVENTURE 8/31-9/2/07

John Says: Here's the logs from my Great Northwest Adventure. It was a great trip. Flew up to Spokane WA and drove straight north to Radium Hot Springs BC. The next morning it was off to the Canada Rockies for some sightseeing and playing with old cameras. I've been up there a few times in the past. Best scenery I've ever seen. Then, down to Whitefish MT and finally over to Bonners Ferry ID on the tip of the panhandle just south of the Canada border. I picked up one of those C Crane Twin-coil antennas and have to say it's excellent. *Very* directional, good signal level, low noise and very small and convenient to pack along. Just before my trip, I tried to mount it outdoors in place of my 4-foot remote box loop, which I'm worried won't survive many more monsoon storms. C Crane offers a 50-foot extension cable from the control box to the loop head. For whatever reason, it loses its nulling when mounted high on the same rotator mount I had the loop on. It behaves omnidirectionally. Yet, closer to the ground it will null well. Also picks up more noise than the dead-quiet loop so I abandoned using it outdoors but will keep it as a good portable antenna. Didn't stop by any radio stations to try to arrange a DX Test this time! (A reference to last year's highly successful KMTI 650 UT test, which began with a conversation between John and the station engineer during a visit to the station. Ed.-WI)

JT-BC			John Tucker KG7RS, DXing from Radium Hot Springs. Palstar R30CC, C Crane Twin-Coil Ferrite Loop
JT-MT			John DXing from Whitefish. Same equipment as above.
JT-ID			John DXing from Bonners Ferry. Same equipment as above.
540	CBK	SK	Regina. 8/31 0040. CBC Radio One programming. Leslie Feist song "Intuition." (JT-BC)
550	KOAC	OR	Corvallis. 8/31 0100. "You're listening to the BBC on KOAC Corvallis" into local weather report. (JT-BC)
550	KARI	WA	Blaine. 8/31 0100. "Insight for Living" program. ToH ID "Here on Word Radio KARI." (JT-BC)
560	KPQ	WA	Wenatchee. 8/31 0105. Post game show, Seahawks vs. Raiders. (JT-BC)
560	KMON	MT	Great Falls. 8/31 0107. Trace Adkins "I'm Tryin'." Announcement "560 KMON" into George Jones "Tennessee Whiskey." (JT-BC)
580	CKXR	BC	Salmon Arm. 8/31 0122. "Easy Rock," commercial for Salmon Arm boat dealer with sale on all jon boats in stock. Celine Dion "I Love you More." "The Soft Rock station everyone listens to at work, Easy Rock." I thought I noted this one reported off the air recently. (JT-BC) (According to the new 28 th AM Log, they will remain on // FM through 2/2008. Get 'em while [if] you can! Ed.-WI)
590	KQNT	WA	Spokane. 8/31 0131. Mention of newstalk590.com, various PSAs, announcement: "If you're talking about It, Rush is talking about it, weekdays at [?] on 590 KQNT," into Coast to Coast AM with George Noory. (JT-BC)
610	CKYL	AB	Peace River. 8/31 0142. Announcement "YL Country" into Martina McBride "Independence Day." Commercial for Marshall Automotive. Good signal in the clear. Way up north in Alberta! Wish I could log this at home in Arizona! Also well heard in Montana and Idaho. (JT-BC)
610	CHNL	BC	Kamloops. 8/31 0147. "Radio NL Sports Talk." Commercial for the Thirsty Dog, 355 Lansdown in Kamloops. (JT-BC)
620	CKRM	SK	Regina. 8/31 0215. Johnny Paycheck "Take This Job and Shove It" into Tim McGraw "Where the Green Grass Grows." Local weather report "14 overnight with a chance of showers." Announcement "The Home of Country Music 620 CKRM." Commercial for Big Iron Drilling. (JT-BC)
620	KPOJ	OR	Portland. 8/31 0222. Air America programming. Mention of kpoj.com. Under/alternating with CKRM. (JT-BC)
630	CHED	AB	Edmonton. 8/31 0230. Vintage program "The Shadow." Strong signal. (JT-BC)
650	CISL	BC	Richmond. 8/31 0238. "650 CISL, Vancouver's oldies station," into The Righteous Brothers "Unchained Melody" and Gordon Lightfoot "Rainy Day People." (JT-BC)
660	CFFR	AB	Calgary. 8/31 0241. Weather report "Clear Skies and 16 degrees," Numerous "660 News time" announcements. Big signal. (JT-BC)
670	KBOI	ID	Boise. 9/1 0235. Very strong with national weather forecast, into Midnight Radio Network programming. (JT-MT)
690	CBU	BC	Vancouver. 9/1 0220. CBC Radio One program featuring the music of The Beach Boys with "Surfer Girl" and "Lavender." Noted simulcast on 6160 kHz. (JT-MT)
690	CBKF-1	SK	Gravelbourg. 9/1 0230. Talk programming in French in CBU null. Strong at times. (JT-MT)
730	CHMJ	BC	Vancouver. 9/1 0200. "This is AM 730, all traffic all the time." Lizzy Buckingham with local traffic report, bridge and tunnel report. Announcement "A Vancouver Original, AM 730." Commercial for vancouverjobshop.com. 50kw all-traffic station? How much traffic does Vancouver have?? (JT-MT)
740	KCBS	CA	San Francisco. 9/1 0157. "KCBS newstime...." Local weather report. Good signal in Montana. (JT-MT)
790	KJRB	WA	Spokane. 9/1 0148. "Your Home for [?], 790 KJRB the Fan." Strong signal. (JT-MT)
800	CHAB	SK	Moose Jaw. 9/1 0140. Little River Band "Take it Easy on Me," Bobby Fuller Four "I Fought the Law." Announcement "The Heartland's home for the greatest hits of all time, 800 CHAB" into Boz Skaggs "Lido Shuffle." (JT-MT)
830	CKKY	AB	Wainwright. 9/1 0115. "Key 83, the Midwest Country Giant." Community

- update, local commercials into Montgomery Gentry "My Town." A bit weak, but good copy. **(JT-MT)**
- 860 **CBKF-2** **SK** **Saskatoon. 9/1 0243.** Talk programming in French, same as 690 in Gravelbourg SK. Strong signal at times. **(JT-MT)**
- 900 **CKBI** **SK** **Prince Albert. 9/1 0055.** "All hits all the time, Today's Country is on 900 CKBI" into Martina McBride "I Have Been Blessed." An old favorite booming into Montana! **(JT-MT)**
- 920 **KXLY** **WA** **Spokane. 9/1 0250.** Strong signal with commercial for Foothills Mazda. **(JT-MT)**
- 920 **CFRY** **MB** **Portage la Prairie. 9/1 0255.** Johnny Cash "Don't Take Your Guns To Town." Announcement "Manitoba's Country 920 C-Fry." Good signal. Will be listening for this one at home in Arizona. **(JT-MT)**
- 950 **KJR** **WA** **Seattle. 9/2 0200.** "Sports Radio 950 KJR" with very strong signal. **(JT-ID)**
- 950 **KMTX** **MT** **Helena. 9/2 0215.** The Eagles "Hotel California." "KMTX Helena" at ToH into ABC news. Good signal but strong co-channel KJR. **(JT-ID)**
- 960 **KSRA** **ID** **Salmon. 9/2 0220.** Ty England "Should've Asked Her Faster" C&W song followed by various pop songs. Interesting format. Fairly strong for reported 56 watt station. **(JT-ID)**
- 970 **KBUL** **MT** **Billings. 9/2 0235.** "News Radio 970 KBUL," commercial for local home show, into Coast to Coast AM. **(JT-ID)**
- 980 **CKNW** **BC** **New Westminster. 9/2 0235.** "This is News Radio 980 CKNW, a Corus Entertainment station." Strong signal **(JT-ID)**
- 990 **CBW** **MB** **Winnipeg. 9/2 0243.** CBC Radio One programming. Not terribly strong here in Idaho. **(JT-ID)**
- 1000 **KOMO** **WA** **Seattle. 9/2 0244.** Commercial for Weir's Appliance. "KOMO 1000 newstime 11:44" into local traffic report. Big signal in Idaho. **(JT-ID)**
- 1010 **CBR** **AB** **Calgary. 9/2 0248.** Very strong with usual CBC talk programming. Surprised I've not logged this one in Arizona. Will be listening for it. **(JT-ID)**
- 1040 **CKST** **BC** **Vancouver. 9/2 0256.** "Team 1040" announcement into ESPN programming. Big signal. **(JT-ID)**
- 1060 **KRCN** **CO** **Longmont. 9/2 0303.** Local commercial for auto repair shop in Longmont. "KRCN Longmont" at ToH into ABC news. Good signal with CKMX nulled. Reported 111 watts. **(JT-ID)** (They do get out! See **Woz Wozniak's** logging from Saint Louis in the "Regular Loggings" section. Like Woz, I hear them occasionally here in Madison, sometimes rivaling KYW. **Ed.-WI**)
- 1060 **CKMX** **AB** **Calgary. 9/2 0304.** Unidentified Ricky Skaggs song, "Classic Country AM1060" at 0304. Announcement for "All Request Lunch," phone number and email address for requests, etc. **(JT-ID)**
- 1070 **CFAX** **BC** **Victoria. 9/2 0311.** Commercial for Canaccord Capital. "Victoria's News Authority, C-FAX 1070." **(JT-ID)**
- 1080 **KFXX** **OR** **Portland. 9/2 0320.** "SportsRadio 1080 the Fan" with good signal. **(JT-ID)**
- 1080 **KVNI** **ID** **Coeur D'Alene. 9/2 0323.** "1080 KVNI Do-Woppin' Oldies" into music. **(JT-ID)**
- 1090 **KPTK** **WA** **Seattle. 9/2 0325.** "Seattle's Progressive Talk, AM 1080," into Air America programming. **(JT-ID)**
- 1370 **KXTL** **MT** **Butte. 9/2 0135.** Fleetwood Mac "Don't Stop." Announcement "1370 KXTL Playing the Greatest Hits." **(JT-ID)**

DDXD-East

REPORTERS

- HF-MI** **Harold Frodge, Midland - Drake R8B + 215' center-fed RW, 85' end-fed RW, 125' bow-tie**
- HJH-PA** **Harry Hayes, Wilkes-Barre - Grundig S350, Kiwa Pocket Loop**
- MKB-ON** **Mike Brooker, Toronto - Grundig YB-400PE, Panasonic RF-2200**

TALKING CAR DEALERSHIP

- 1640 **MI** **Birch Run - Suski Chevy-Buick - 8/25 1230 & 2125 - The Suski signal, Birch Run Jaycees spot; deals & rock tunes during the day, loop at night. Copyable 2-3 miles out during the day; had to be right at the dealership at night to copy, due to Mickey Mouse QRM. **(HF-MI)****

LOGGINGS

- 780 WTME ME Rumford – 8/26 2000 – ID, “WTME, Rumford and WKTQ...”. Relays WEZR-1240 with numerous WEZR ID’s heard. Good signal w/WCKB-NC s/off underneath. **(HJH-PA)**
- 910 WLTP OH Marietta – 8/30 0607 – dominating frequency with slogan “The Valley’s news leader, 910 WLTP” into local news. **(MKB-ON)**
- 930 WLLL VA Lynchburg – 8/18 2100 – Ad for Williams Barber Shop. “7 barbers to serve you...”. ID’s, good w/Gospel music. **(HJH-PA)**
- 950 WIBX NY Utica – 9/7 1955 – blowing away WWJ with Proctor v. Rome Free Academy high school football, “don’t forget we have two games coming up tomorrow on news radio 950 WIBX”. **(MKB-ON)**
- 990 WNTP PA Philadelphia – 8/23 0255 – Just caught a peak with a call ID; mainly well u/CBW. Sounds like all talk or news. PA #51. **(HF-MI)**
- 1230 WRBS MD Baltimore – 8/19 2228 – Up with slogan “Sharing God’s Love, 1230 WRBS”. **(HJH-PA)**
- WNAW MA North Adams – 8/19 2228 – Surfaced briefly with just ID heard. **(HJH-PA)**
- WHUC NY Hudson – 8/18 2345 – “The station that brought back memories to Red Hook, WHUC.” Good w/Nostalgia music. **(HJH-PA)**
- 1450 WHTC MI Holland – 8/30 1751 – Trading Post at 616-399-1025 & 399-1450; WHTC.com spot, AM 134-50 WHTC. Fair peaks, in/out w/WHLS Port Huron & ESPN, WIBM (presumed) Jackson. **(HF-MI)**
- 1480 WGVU MI Kentwood – 8/30 1812 – NPR All Things Considered; call ID spot. Fair peaks mixing w/local 1490 WMPX; need LSB to get anything. No sign of WHBC Canton OH usually there. @1821 SS popped up--probably WLMV. **(HF-MI)**
- 1609.9v CHHA ON Toronto – 8/20 1950 – woman in SS mentioning Nicaragua, Guatemala, Campeche & Yucatan. ID @1958 “Radio Canada, esta es CHHA...Voces...”. 1958:30 EE intro to program Sexuality & Sexual Health--cut off @1958:50 & into SS music! Fair w/good peaks, freq drifts within a few 0.01 khz. **(HF-MI)**
- 1640 WTNI MS Biloxi – 8/5 2256 – Full ID. Had NFL Hall of Fame Game on Westwood One. Good w/PA Turnpike TIS. **(HJH-PA)**
- 1640.1 WKSH WI Sussex – 8/23 1938 – Usual disgustingly perky music; “Radio Disney AM 16-40” slogan. Local ads @1941; Noah’s Ark Water Park at WI Dells. Good in QRN. **(HF-MI)**

Volume 73 Index

The last boring index ... from me, anyway. “Regular” columns are not indexed. Dates are by # / page#; errors are rare and unintentional, pretty much.

Title.....Author.....Issue

Station Lists

Auction 84 Update..... Bill Hale19-4
 Callarman Mexican List.... John Callarman ...22-1
 Radio Disney Stations Mike Hardester .29-19
 Unlicensed Boston Stations Bruce Conti14-21

Technical

Leaking Coax Case..... Bruce Conti30-45

Antennas

MW Loop Source Book..... Steve Whitt.....23-28
 Super Loop..... Bruce Conti30-41

Products/Publications

EKKO Stamp Catalog Harry Schools2-1
 Making Airwaves (review)... Andy Ooms24-22
 Music Radio (review Andy Ooms22-3
 MWC Reprints.....3-23
 NRC Catalog..... Wayne Heinen..18-11
 Radio Shack 12-1686 Bob Foxworth..12-13
 Radio Speakers (review) Andy Ooms29-18

Tower Site Calendar..... Scott Fybush3-21

Propagation

GeoMag Summary..... Phil Bytheway..10-14,
 16-4, 21-4, 29-20

Domestic

Saving Radio Eric Klinenberg.24-24
 WELI Jerry Dunklee...21-17
 WHAT via Brock Whaley..20-4

Foreign

Dxpediton to Easter Island John H. Bryant 26-22
 First 40 Countries from Hawaii Richard E. Wood,
 PhD..... 26-33
 LBI-5 Dxpediton Russ Edmunds, et al.....
 15-19

DXN Columns and NRC Stuff

Broadcast Test Report Les Rayburn, Jim Pogue ...
 5-12, 8-18, 9-9, 14-9, 21-14, 25-38, 26-32, 30-
 40
 Confirmed DX'er..... Phil Bytheway..21-16,
 26-34
 DDXA Paul Swearingen..1-21,
 8-21, 11-14, 14-22, 16-20, 21-18, 29-21
 DX Tapes Needed for nrcdxas.org Gary Wilt
 12-23
 DX'er's Notebook..... Robert Ruggley ..1-15,
 3-16, 4-18, 7-10, 15-13
 DX'er's Notebook..... Robert Ruggley ...2-20

For Beginners..... Greg Harris1-15,
 8-20, 9-10, 11-12, 15-23, 16-23

Formats..... Wayne Heinen ...2-19,
 15-3, 21-21, 25-41

From the BoD John D. Bowker..3-15,
 9-10, 20-14, 26-6, 28-6

GYDXA-1400 Bill Hale16-15

GYDXA-1450 Bill Hale22-9

GYDXA-1490 Bill Hale25-42

GYDXT Bill Hale1-16,
 30-38

IDXA Paul Swearingen 11-13,
 21-20

Musings of the Members... Dave Schmidt.....
 2-22, 3-22, 4-23, 5-14, 7-23, 8-23, 10-15, 11-
 15, 16-22, 17-10, 19-15, 20-15, 21-22, 22-14,
 23-34, 24-32, 25-46, 30-47

NRC Contest Bruce Conti5-10,
 10-13, 11-10, 15-16, 18-9, 19-12, 20-13, 23-
 25, 25-36, 26-31, 27-19, 30-21

NRC Convention-Akron.. John R. Malicky...3-10

Pro Sports Networks Barry S. Finkel...4-12,
 6-14, 15-12, 24-25, 25-35, 27-16, 28-6, 29-6

The Answerman..... Robert Ruggley ..1-14,
 3-18, 7-21

Volume 74 Index..... Paul Swearingen.30-15

Not sure about renewing?

Consider these benefits of a membership in the National Radio Club: 720+ pages per year of varied and comprehensive DX and radio information in DX News ... reduced prices for publications ... responsive editors ... and the friendliest bunch of DX'ers in the world! Why not send that renewal check to P. O. Box 5711 - Topeka, KS 66605-0711 today!

International DX Digest

Bruce Conti nrcidxd@aol.com

46 Ridgefield Drive

Nashua, NH 03062-1174

Foreign DX Catches. All times are UTC

Transatlantic DX

- 162 **FRANCE** *France-Inter*, Allouis (47°10'N 02°12'E) AUG 20 0334 - French talk by man. Fair signal. [Beu-TX] SEP 2 0424-0435 - Man and woman in French and pop music. Possible ID as R.France at 0429 and several mentions of France after 0430 - news? Mushy to about 0430, then good! [Frodge-MI]
- 183 **GERMANY** *Europe 1*, Felsberg (49°17'N 06°41'E) AUG 20 0224 - Man talking in French. Good signal peaks. [Beu-TX]
- 252 **ALGERIA** *Alger Chaîne 1/3*, Tipaza (36°35'N 02°27'E) SEP 2 0436-0448 - Arabic vocal - not Koranic, English pop tune, man in French, possible news at 0445 in French for about 1-1/2 minutes, then another English pop tune. Good. [Frodge-MI]
- 531 **ALGERIA** *Chaîne 1*, El Ain Beida (35°49'N 07°19'E) AUG 31 0313 - Arabic music atop and getting past CIAO. [Kazaross-WI]
- 531 **SPAIN** *RNE5* sychros AUG 22 0023 - Parallel 774 with female Spanish talk, teletalk; poor to fair over likely Algeria and Madeira mix. [Connelly-MA] AUG 27 0114 - Spanish parallel others getting past CIAO interference. [Kazaross-WI]
- 549 **ALGERIA** *Chaîne 1*, Les Trembles (35°17'N 00°34'W) AUG 3 0154 - Parallel 890.97 with male Arabic vocal, strings; fair. AUG 22 0026 - Parallel 890.97 with woman in Arabic; fair. [Connelly-MA] SEP 1 0353 - Poor to fair; parallel strong 891 with Arabic music then talk. [Kazaross-WI] SEP 7 0129 - Good; Koranic vocal parallel 891 kHz. [Conti-NH]
- 558 **SPAIN** *RNE5* sychros AUG 31 0325 - Poor to fair; easily past WIND and CFOS interference with Spanish talk parallel many others during a period when Spain really peaked. [Kazaross-WI]
- 567 **IRELAND** *RTÉ 1*, Tullamore (53°17'N 07°22'W) AUG 22 0026 - "A Whiter Shade of Pale" by Procol Harum from the legendary summer of '67; good. [Connelly-MA] SEP 1 0350 - Fair to good; English music than accented male announcer with Spain underneath. [Kazaross-WI]
- 567 **SPAIN** *RNE5* sychros AUG 31 0325 - Poor; parallel many others with Spanish talk. [Kazaross-WI]
- 576 **CANARY ISLANDS // SPAIN** *RNE5* sychros AUG 22 0028 - Parallel 774 with Spanish talk; poor. [Connelly-MA] SEP 1 0344 - Parallel many others with Spanish talk. [Kazaross-WI]
- 585 **SPAIN** *RNE1* Madrid (40°28'N 03°52'W) AUG 3 0153 - Parallel 855 with teletalk/interview; fair to good. AUG 22 0007 - Parallel 639 with talk "en Radio Nacional," then short country-style guitar instrumental followed by woman in Spanish; good. 0029 parallel 774 with fast talk by woman in studio and man on phone; good. [Connelly-MA] AUG 31 0518 - Very good peaks; parallel others like 684 and 774 with Spanish talk and occasional music. This powerhouse was often strong and sometimes decently readable in 6 kHz bandpass. [Kazaross-WI]
- 594 **SAUDI ARABIA** *BSKSA* Duba SEP 7 0230 - Huge pre-sign-on open carrier, 0234 test tone, then 0248 a man in Arabic parallel 1521 kHz. [Conti-NH]
- 603 **SPAIN** *RNE5* sychros AUG 3 0152 - Talk parallel 855; fair. AUG 22 0007 - Parallel 585 and 639 with folk guitar; poor to fair. 0030 parallel 774 with teletalk; good, over France and Madeira. [Connelly-MA] AUG 31 0327 - Fair to good; parallel many others with Spanish talk. SEP 1 0342 - Again with talk parallel net. [Kazaross-WI]
- 612 **MOROCCO** *RTM A*, Sebaa-Aioun (33°54'N 05°23'W) AUG 3 0144 - Telco-quality male Arabic talk; good. 0151 flute, strings, shrill vocal; huge! AUG 21 0009 - Female Arabic vocal and strings; good. AUG 22 0030 - Reverberated female vocal; loud. [Connelly-MA] SEP 1 0404 - Fair to good; coming out of Arabic news into fanfare with some stringed instrument music. [Kazaross-WI]
- 621 **CANARY ISLANDS // SPAIN** *RNE1* sychros, Santa Cruz de Tenerife et al. AUG 3 0145 - Interview parallel 855; good. AUG 22 0031 - Talk parallel 774; in WZON slop. [Connelly-MA]
- 639 **SPAIN** *RNE1* La Coruña et al. AUG 3 0054 - Parallel 621 with woman in Spanish; poor to fair with CBN slop. AUG 22 0007 - Parallel 585 with talk "en Radio Nacional," then short country-style guitar instrumental followed by woman in Spanish; good. 0032 parallel 774 with teletalk; fair, over other co-channel station and CBN slop. [Connelly-MA] AUG 31 0328

- Very poor; Spanish parallel others just getting past nasty WMFN slop. [Kazaross-WI]
- 648 **SPAIN** *RNE1* Badajoz (38°53'N 06°58'W) SEP 1 0347 - Very poor; Spanish talk parallel others as Spaniards really peaked up. New. [Kazaross-WI]
- 657 **SPAIN** *RNE5* Madrid (40°28'N 03°52'W) AUG 18 0020 - Fair in lightning noise; pop vocal parallel 684 and 855 kHz. [Conti-ME] AUG 22 0007 - Parallel 585 with folk guitar, then time-check by woman in Spanish; fair. 0034 parallel 774 with teletalk; poor to fair. [Connelly-MA] SEP 1 0003 - Good; woman with network news parallel 855 kHz. [Conti-NH] SEP 1 0347 - Fair to good; Spanish talk parallel others easily past WFAN slop. [Kazaross-WI]
- 666 **PORTUGAL** *RDP Antena 1* synchros AUG 3 0149 - Parallel 693 with jazz; poor. AUG 22 0042 - Parallel 720 with jazz female vocal; poor. [Connelly-MA] AUG 27 0122 - Poor; parallel 693 with typical soft rock music. SEP 1 0252 - Parallel 720, a song with distinctive piano music. Portugal used to be easier but now doesn't have many stations with more than 10 kW. [Kazaross-WI] SEP 7 0100 - Fair; signature four equal time pips and a woman in Portuguese. 0120 pop female vocal parallel antena1.rtp.pt streaming audio. [Conti-NH]
- 675 **LIBYA** *Libyan Jamahiriya*, Benghazi (32°54'N 20°04'E) AUG 16 2339 - Fair; Koran parallel 1053 kHz. [Conti-ME] SEP 6 2348 - Fair; military anthem parallel 1053 kHz, then off. [Conti-NH]
- 675 **NETHERLANDS** *Arrow Rock*, Lopik (52°01'N 05°03'E) AUG 22 0038 - "Love is the Drug" by Roxy Music; fair. [Connelly-MA] SEP 1 0337 - Good; *Arrow Rock* ID, guitar rock. [Conti-NH] SEP 1 0406 - Poor to fair; Dutch talk thru slop. [Kazaross-WI]
- 684 **SPAIN** *RNE1* Sevilla (37°12'N 05°55'W) AUG 3 0150 - Parallel 855 with Spanish interview; good. AUG 22 0038 - Parallel 774 with Spanish talk: woman in studio, man on phone; fair to good. [Connelly-MA] SEP 1 0023 - Fair, the first audible TA of the night; Spanish talk. Later on this would fade up to a very good level at times, readable using the 6 kHz filter. A very easy TA here. [Kazaross-WI]
- 693 **AZORES** *RDP Açores Antena 1*, Terceira (38°43'N 27°19'W) AUG 3 0149 - Parallel 666 with mellow jazz; good, way over UK. [Connelly-MA] AUG 17 2342 - Good; reggae vocal, man in Portuguese, then a rock vocal, local program not parallel 666 kHz. [Conti-ME] AUG 27 0414 - Poor; parallel 666 with soft rock music, then Portuguese talk, tough copy past CINF slop. [Kazaross-WI]
- 693 **UNITED KINGDOM** *BBC Radio 5*, Droitwich et al. AUG 22 0039 - BBC talk with soft-voiced man; fair. [Connelly-MA] AUG 27 0233 - Poor to fair, atop Azores and CINF slop; accented English men talking. [Kazaross-WI]
- 702 **ALGERIA** *Chaîne 1*, Djelfa AUG 17 0024 - Fair in steadily building lightning noise; flute and string music parallel 153 (poor) and 891 (excellent). [Conti-ME] SEP 7 0133 - Fair; Koranic vocal with strings and drumming parallel 891 kHz. [Conti-NH]
- 702 **SAUDI ARABIA** *BSKSA Radio 2*, Duba SEP 1 0300 - Algeria time pips under, then Saudi time pips, woman with ID in Arabic, "...il-Mamlaka al-Arabiya as-Saudiya," fanfare, and another fanfare into news. Commencing Arabic program channel two at this time per WRTH. Thanks to Henrik Klemetz and Mika Makelainen on *RealDX* for help with the ID. I subsequently listened to *Radio 2* streaming audio at 2100 UTC and heard exactly the same time pips and fanfare into news. 702 audio uploaded to dxclipjoint.com/loco_the_dx_cat. New log. [Conti-NH]
- 702 unID AUG 22 0042 - Bits of Arabic talk by man, did not seem parallel to 890.97 Algeria. [Connelly-MA] SEP 1 0408 - Very poor; too weak to discern language. [Kazaross-WI]
- 711 **FRANCE** *France Info*, Rennes (47°51'N 01°30'W) AUG 18 0118 - Fair thru multiple hets; woman in French parallel 1206 kHz. [Conti-ME] AUG 22 0043 - Parallel 1206 with romantic female vocal; excellent. [Connelly-MA]
- 711 **WESTERN SAHARA** *RTM Addakhla* (23°42'N 15°56'W) SEP 1 0410 - Poor to fair; very poorly modulated Arabic talk into music on huge carrier trashing 710 kHz. [Kazaross-WI]
- 720 **CANARY ISLANDS** *RNE5 Finca España* AUG 31 0530 - Fair to good; pips on the half hour and RNE ID, parallel 684 and many others. Had been in much of the previous half hour mostly atop Portugal mixing a bit under WGN phase null which also knocks out XEDE. I had suspected this a few days ago, and finally nailed it down for certain. I don't miss CHTN one bit! New! [Kazaross-WI] SEP 7 0137 - Poor in WGN null and low-level growl presumed from slightly off-frequency Jamaica; talk parallel strong 684 and 855 signals. [Conti-NH]
- 720 **PORTUGAL** *RDP Antena 1* synchros AUG 22 0042 - Parallel 666 with nightclub jazz female vocal; fair, dominant. [Connelly-MA] SEP 1 0252 - Fair under phase nulled WGN; a song with distinctive piano music parallel 666 kHz. This had been strong enough at times earlier to call almost good, and I was certain the announcer was speaking Portuguese but couldn't raise a parallel due to slop on 666 and 693 kHz. About 2/3 of the time when a TA was audible

under WGN, Portugal was the boss rather than Canaries. This plays lots but not all songs are English soft rock and older songs. XEDE was also heard thru WGN, but the phase null on WGN kills them. New! [Kazaross-WI]

- 729 **SPAIN** *RNE1* synchros AUG 3 0046 - Parallel 774 with musical fanfare, woman in Spanish; through WJTO/CKAC slop. AUG 22 0045 - Talk parallel 774; in bad slop. [Connelly-MA] AUG 31 0521 - Very poor; Spanish talk parallel many others. [Kazaross-WI]
- 738 **SPAIN** *RNE1* Barcelona (41°23'N 02°12'E) AUG 22 0002 - Spanish news; finally getting by superloud CHCM. 0046 parallel 774 with 1940's style group vocal. [Connelly-MA] AUG 31 0520 - Very poor, just getting past slop monster CHWO; Spanish talk parallel net. [Kazaross-WI]
- 747 **CANARY ISLANDS // SPAIN** *RNE5* synchros AUG 3 0147 - Parallel 774 with woman in Spanish; fair. AUG 22 0047 - Parallel 774 with old song "I like coffee, I like tea ... a cup, a cup, a cup," then man in Spanish; good. [Connelly-MA] AUG 31 0532 - Fair to good; I think I may have caught the end of some local break here with two "Canarias" mentions into Spanish talk which was parallel many others. More easterly stuff like Holland had faded earlier. [Kazaross-WI]
- 747 **NETHERLANDS** *Radio 5, Flevoland* (52°23'N 05°25'E) AUG 22 0002 - Dutch talk; under Canaries-Spain. [Connelly-MA] SEP 1 0408 - Poor to fair; music then Dutch announcer with Canaries well under. [Kazaross-WI]
- 756 **GERMANY** *Deutschlandfunk, Braunschweig & Ravensburg* AUG 22 0000 - Pips, German news; fair. 0049 parallel 1422 with opera; evenly mixing with Spain. [Connelly-MA]
- 756 **SPAIN** *R.Euskadi, Bilbao* AUG 22 0049 - Spanish vocal; over/under Germany. [Connelly-MA] SEP 1 0352 - Very poor; just good enough to tell it was Spanish talk after Basque-type music ended. [Kazaross-WI]
- 765 **SWITZERLAND** *RSR Option Musique, Sottens* (46°39'N 06°44'E) AUG 3 0146 - Folk vocal in style of Gordon Lightfoot; fair. AUG 22 0000 - Jingle, Radio Suisse Romande ID by man in French; fair to good. 0051 French '50s-style pop vocal; excellent. [Connelly-MA] SEP 1 0413 - Fair thru slop; softish music ending then French talk. [Kazaross-WI]
- 774 **EGYPT** *Middle East Radio, Abis* (30°45'N 30°57'E) AUG 22 0126 - Arabic vocal; nearly equal to Spain. [Connelly-MA]
- 774 **SPAIN** *RNE1* synchros AUG 3 0146 - Parallel 855 with man and woman in Spanish; fair to good. AUG 22 0023 - Parallel 531 et al. with Spanish teletalk; fair, over Egypt. 0052 Caribbean style Spanish vocal; excellent. [Connelly-MA] AUG 27 0054 - Poor to fair; parallel 684 et al. with Spanish talk. At times this faded up to good on AUG 31 and SEP 1. [Kazaross-WI]
- 783 **MAURITANIA** *R.Mauritanie, Nouakchott* (18°07'N 15°57'W) AUG 17 2337 - Man speaking; better than 4845 parallel. [Conti-ME] AUG 22 0053 - Parallel 4845 with a cappella Koranic vocal; over CFDR slop. [Connelly-MA] AUG 27 0023 - First audible TA of the evening, parallel 4845 with weird Arabic/Afro music. Later up to fair level with Arabic stringed music. WBBM phase nulled. [Kazaross-WI] SEP 6 2313 - Good; news/talk parallel 4845 kHz. [Conti-NH]
- 783 **SPAIN** *Rock y Gol Radio Miramar, Barcelona* SEP 1 0344 - Fair; clear Spanish talk during huge Spanish opening. New! [Kazaross-WI]
- 792 **FRANCE** *France Info, Limoges* (45°56'N 01°10'E) AUG 22 0000 - French news by woman; slightly over Spain. 0054 parallel 1206 with woman in French; over Spain. [Connelly-MA] AUG 31 2340 - Good; man and woman with news/talk in French, parallel 1206 kHz. [Conti-NH]
- 792 **SPAIN** *SER Seville* AUG 3 0047 - Teletalk show with woman; poor. AUG 22 0000 - Man in Spanish with news; a bit under France. [Connelly-MA] SEP 1 0344 - Poor, but getting past 790 with Spanish talk during major Spain opening. [Kazaross-WI]
- 819 **EGYPT** *ERTU Batra* (31°09'N 31°27'E) AUG 18 0023 - Good; man/woman in Arabic parallel 12050 kHz. [Conti-ME] SEP 6 2347 - Good over off-frequency growl; woman in Arabic, then a Mideast instrumental, parallel 12050 kHz. [Conti-ME]
- 818.9 unID AUG 3 0143 - One of the two major 819 kHz stations is about 100 Hz low. I think it's the Moroccan, with Egypt being on the correct frequency. [Connelly-MA]
- 837 **CANARY ISLANDS // SPAIN** *COPE* synchros AUG 3 0144 - Parallel 999 with talk, then a bit of Dixieland jazz; poor. [Connelly-MA] AUG 17 2346 - Good; talk with synchro echo indicating reception of both Canaries and Spain. [Conti-ME] AUG 22 0000 - Spanish news; slightly over jumble. [Connelly-MA] AUG 31 0510 - Good peaks and almost 100% readable for 10 minutes parallel a couple others. No France noted at this time. This is rather easy on the BOGs since WHAS is nulled decently by them. [Kazaross-WI]
- 837 **FRANCE** *France Info, Nancy* (48°53'N 06°14'E) AUG 22 0058 - Parallel 1206 with French

- male vocal; over others. [Connelly-MA]
- 855 **SPAIN** *RNE1* synchros AUG 3 0143 - Parallel 1098 with fast talk Spanish interview, slight echo; good. AUG 21 2346 - Slightly echoey talk by woman; good. AUG 22 0100 - Parallel 774 with Andrews Sisters "Rum and Coca Cola," then pips, Radio Nacional de España ID by woman, news by man. [Connelly-MA] SEP 1 0247 - Poor; Spanish talk parallel many others. This one isn't as good as it was a few years ago. [Kazaross-WI]
- 864 **EGYPT** *ERTU Santah* (30°45'N 31°08'E) AUG 17 2350 - Loud and clear; Koran. [Conti-ME] AUG 21 2345 - Koran; good. AUG 22 0009 - Koranic vocal; over France. [Connelly-MA]
- 864 **FRANCE** *France Bleu, Villebon-sur-Yvette* (48°41'N 02°14'E) AUG 3 0035 - Led Zeppelin "Stairway to Heaven"; briefly good, then into fade. 0142 two men in French. AUG 22 0101 - Rock music, then woman in French. [Connelly-MA] SEP 1 0337 - Poor to fair with French talk getting past sloppy CJBC different French. Still no Egypt for me on this channel. [Kazaross-WI]
- 873 **SPAIN** *SER* synchros AUG 3 0035 - 10-second segment of a pop song, then Spanish teletalk; to fair peak. AUG 21 2347 - Man and woman in Spanish; through WLVP slop. AUG 22 0102 - Echoey Spanish news. [Connelly-MA] AUG 27 0120 - Poor to fair; Spanish talk. This one is also common as it suffers little 870 interference. [Kazaross-WI]
- 882 **CANARY ISLANDS // SPAIN** *COPE* synchros AUG 27 0220 - Poor, Spanish talk mixing with music from BBC and interference by bad WCBS slop. [Kazaross-WI]
- 882 **UNITED KINGDOM** *BBC R.Wales, Washford* (51°10'N 03°21'W) AUG 3 0037 - Interview with US-accented man; briefly atop. AUG 21 2346 - Nostalgic tunes including big 1961 hit "My Kind of Girl" by Matt Monro; excellent, entertainment quality. 2351 "Strangers in the Night" by Frank Sinatra from '66. AUG 22 0103 - BBC news with from-the-scene reportage; to fair peak slightly over *COPE* Canaries-Spain. [Connelly-MA] AUG 27 0222 - Poor to fair; ending music and into accented English talk over *COPE* and interference by WCBS slop. [Kazaross-WI]
- 890.97 **ALGERIA** *Chaîne 1, Algiers* (36°40'N 03°09'E) AUG 3 0040 - Mentions of "arabiya" in newscast; good. 0141 ud music and male vocal; good. AUG 22 0026 - Parallel 549 with slightly reverberated Arabic talk by woman; good. 0104 flute music, strings, organ; tinny/boxy audio on an absolutely huge signal. [Connelly-MA] SEP 1 0353 - Good audio on a super strong but poorly modulated carrier; Arabic music, then talk parallel 549. On the car radio the het made listening to WLS rather unpleasant! [Kazaross-WI]
- 909 **UNITED KINGDOM** *BBC Radio 5 Live* synchros AUG 3 0034 - Man and woman in English; poor in WABI slop. AUG 22 0106 - Talk about California, then report about Hurricane Dean; good. [Connelly-MA] AUG 27 0218 - Poor to fair; English talk and a Five Live mention. [Kazaross-WI]
- 936 **MOROCCO** *RTM A/C, Agadir* (30°20'N 09°31'W) AUG 16 2354 - Fair; Koran, slightly delayed from 1044 parallel. AUG 17 2310 - Good; lively rhythmic vocal parallel 1044 kHz. [Conti-ME] AUG 21 2349 - Parallel 1044 with Berber music. 2353 parallel 1044 with Koranic chant; loud, way over Spain. [Connelly-MA] SEP 6 2310 - Loud and clear; African group vocal parallel 1044 kHz. [Conti-NH]
- 936 **SPAIN** *RNE5* synchros AUG 22 0108 - Parallel 774 with fast Spanish; mixed with one or two others. [Connelly-MA] SEP 7 0418 - Good; telephone talk parallel 855 kHz. [Conti-NH]
- 945 **FRANCE** *France Info, Toulouse* (43°21'N 01°20'E) AUG 3 0037 - Man and woman with *France Info* mention, then '40s film style lush orchestral music. 0140 parallel 1206 with mood music instrumental; to good peak. AUG 22 0109 - Parallel 1206 with jazz organ; fair. [Connelly-MA] AUG 31 0143 - Fair to good; parallel a very strong 1206 with mellow music. [Kazaross-WI] SEP 7 0420 - Good; news/talk parallel 1206 kHz. [Conti-NH]
- 954 **SPAIN** *Onda Cero, Madrid* AUG 3 0033 - Man in Spanish; poor to fair, with 1.7 Hz SAH. AUG 22 0110 - Operatic style Spanish vocal (possibly part of an advert), then man in Spanish and crowd noises; loud. [Connelly-MA]
- 963 **PORTUGAL** *R.Renascença, Seixal* (38°38'N 09°05'W) AUG 3 0040 - Portuguese teletalk (woman in studio, man on phone); poor through tough 970 WZAN slop. [Connelly-MA]
- 981 **ALGERIA** *RTVA Chaîne 2, Algiers* (36°40'N 03°09'E) AUG 21 2349 - Man in French, then Arabic music; good. AUG 22 0112 - Pop Arabic vocal; over others. [Connelly-MA]
- 981 **PORTUGAL** *R.Renascença* synchros AUG 3 0140 - "Lambada" dance hit, then Portuguese talk by man. [Connelly-MA]
- 999 **SPAIN** *COPE Madrid* (40°28'N 03°52'W) AUG 3 0127 - Parallel 1143 with talk and circus/carnival type music; local-like! AUG 21 2237 - Spanish talk already good more than an hour before sunset. 2350 part of Nirvana song, fast Spanish talk by man; loud, now well over the Koranic vocal station. AUG 22 0113 - Spanish talk, dramatic music; loud. [Connelly-MA]

- AUG 31 0051 - Poor; parallel 1215 with music and later often up to fair level with Spanish talk. WMVP phased. This one gets out well. I have never caught anything else on 999 kHz. [Kazaross-WI] SEP 7 2307 - Fading up over unID Koran; U2 "New Year's Day" bumper music into telephone talk. 2400 pips and time checks, "Son las dos, la una Canaria, and fanfare into news, "Cadena Cope, servicios informativos." [Conti-NH]
- 999 unID AUG 21 2345 - Either Morocco or Saudi Arabia here with Arabic vocal; briefly atop Spain. [Connelly-MA] SEP 7 2255-2400 - Poor to excellent; Koran. Couldn't find any parallels; potential 1512 parallel not doing well this evening, also not parallel Saudi *Quran* streaming audio. [Conti-NH]
- 1017 **GERMANY** *SWR Cont.Ra*, Wolfsheim (49°53'N 08°03'E) AUG 21 2348 - Man in German mentioned several cities including Hannover; loud. AUG 22 0115 - Man in German, musical interlude; good. [Connelly-MA]
- 1017 **SPAIN** *RNE5* synchros AUG 3 0039 - Soft jazz, man in Spanish; poor. [Connelly-MA] AUG 31 0137 - Poor; parallel others ending music into Spanish talk, past some KDKA slop. [Kazaross-WI]
- 1026 **SPAIN** *SER* synchros AUG 3 0136 - Parallel 1044 with man speaking in large hall, then talk by woman in studio; fair. [Connelly-MA] AUG 18 0218 - Good; disco bumper music parallel 1044 kHz. Heavy lightning noise across the band now. [Conti-ME] AUG 22 0118 - Spanish teletalk; fair with WBZ phased. [Connelly-MA]
- 1035 **PORTUGAL** *R.Clube*, Belmonte AUG 3 0135 - Romantic emotional pop female vocal; good with WBZ phased. [Connelly-MA] AUG 16 2351 - Excellent; continuous uninterrupted pop music. [Conti-ME] AUG 21 2303 - Man and woman with Portuguese newstalk; good with WBZ phased. WBZ (with IBOC) was actually splattering 1044 worse than 1035. AUG 22 0118 - Jazz, Portuguese vocal; good. [Connelly-MA] AUG 31 0525 - Fair to good with Portuguese song. Surprisingly rare, but I have read that this is having transmitter issues. [Kazaross-WI]
- 1044 **MOROCCO** *RTM A/C*, Sebaâ-Aioun (33°54'N 05°23'W) AUG 2 2352 - Koranic vocal; huge. Off air at about 0000 UTC. [Connelly-MA] AUG 16 2331 - Excellent; lively rural berbère female vocal and percussion. 2353 Koran, 2358 national anthem, 2400 off. [Conti-ME] AUG 21 2338 - Rustic Berber male vocal and guitar picking; good with WBZ IBOC phased. 2353 parallel 936 with Koran; at monster level, crushing Spain. [Connelly-MA] AUG 31 0031 - Poor to fair; Arabic talk and the first TA audible tonite. [Kazaross-WI] SEP 6 2320 - Absolutely huge signal; repetitive rural vocals. [Conti-NH]
- 1044 **SPAIN** *SER* synchros AUG 3 0106 - Parallel 1116 with ID "Cadena SER, servicios informativos." 0134 Spanish public speech with large hall acoustics; huge. [Connelly-MA] AUG 10 0040 - Good; telephone talk in Spanish. [Conti-NH] AUG 22 0119 - Parallel 1026 with teletalk; over unID music station (Germany?). [Connelly-MA] AUG 31 0441 - Poor to fair with Spanish talk and then faded. [Kazaross-WI]
- 1053.07 **LIBYA** *Libyan Jamahiriya*, Tripoli (32°50'N 13°00'E) AUG 16 2335 - Good; dry reading in Arabic. 2347 national anthem by a military band, 2350 off. [Conti-ME] SEP 6 2345 - Huge signal plus loud growl against 1053 kHz; Koran, 2347 military anthem, then off. [Conti-NH]
- 1053 **MOROCCO** *RTM A*, Tanger AUG 21 2342 - Koran; huge. Noted zero-beat with weaker UK, so more likely this than Libya which has been 50 to 80 Hz on the high side. [Connelly-MA]
- 1053 **UNITED KINGDOM** *TalkSport* synchros AUG 3 0100 - TalkSport ID; poor with bits of Spain in the mix. AUG 22 0122 - Announcer talked about life's embarrassing moments, something that happened when he dressed as a clown; good. [Connelly-MA] SEP 6 2355 - Good with talk minus off-frequency growl after Libya signed off. [Conti-NH]
- 1071 **SPAIN** *Euskadi Irratia*, Bilbao SEP 6 2324 - Amazingly good with a loud het against 1070 CBA; Spanish rock vocals. [Conti-NH]
- 1080 **SPAIN** *SER* synchros AUG 22 0124 - Parallel 1116 with *SER* newstalk; about even with WTIC. [Connelly-MA]
- 1089 **UNITED KINGDOM** *TalkSport* synchros AUG 3 0011 - Comment "all is not well on the playing field". 0102 promo for "football live on TalkSport"; briefly good. [Connelly-MA] AUG 10 0043 - Good signal with loud het against 1090 WBAL, but barely readable through heavy lightning noise. [Conti-NH] AUG 22 0125 - Risque anatomical discussion, announcer to caller "You're not a dwarf, are you?"; loud, stronger than 1090. [Connelly-MA] AUG 27 0127 - Poor to fair on fade up; two accented English guys talking. [Kazaross-WI]
- 1098 **SPAIN** *RNE5* synchros AUG 3 0100 - Pips, *R.Nacional de España* ID. 0126 talk parallel 1152; somewhat echoey. [Connelly-MA] AUG 18 0212 - Fair in lightning noise; talk with synchro echo. [Conti-ME] AUG 21 2335 - Parallel 1107 with woman in Spanish, somewhat echoey. AUG 22 0126 - Parallel 774 with Spanish talk. [Connelly-MA] AUG 31 0113 - Poor in WTAM

- slop; music parallel others then some Spanish talk. [Kazaross-WI]
- 1107 **EGYPT** *Batrah* AUG 3 0131 - Tentative with Arabic vocal; under Spain. [Connelly-MA]
- 1107 **SPAIN** *RNE5* synchros AUG 3 0131 - Parallel 1098 with newstalk; over Egypt and 1107.13 off-channel *RNE* growl. [Connelly-MA] AUG 11 0040 - Talk in Spanish; good with synchro echo and loud 1107.13 het. [Conti-NH] AUG 22 0127 - Spanish talk over growl. [Connelly-MA] AUG 31 0113 - Fair; music parallel 1098 and others then Spanish talk, over weak growl from someone off frequency. [Kazaross-WI]
- 1116 **SPAIN** *SER* synchros AUG 3 0106 - Parallel 1044 with music fanfare, ID "Cadena Ser, servicios informativos"; fair. 0131 teletalk; to good peak. AUG 22 0128 - Parallel 1080 with talk, then Bonnie Raitt (or similar) vocal. [Connelly-MA] AUG 31 0147 - Poor to fair peak; Spanish talk, seemed to be telephone. Another common one. [Kazaross-WI] SEP 7 0403 - Good; news with live report, "Buenos dias..." Canarias mentions. [Conti-NH]
- 1125 **LIBYA** *Libyan Jamahiriya*, El Beida (32°45'N 21°45'E) AUG 16 2342 - Fair in jumble of stations; Koran a half-second delayed from 1053 parallel. Listen to a verse on 1053, then hear it again on 1125 kHz. [Conti-ME]
- 1125 **SPAIN** *RNE5* synchros AUG 3 0102 - Talk parallel 1098, 1152 kHz. 0130 Spanish talk; jumbled with others. AUG 21 2341 - Parallel 1152 with woman talking about music. AUG 22 0129 - Parallel 774 with Spanish talk; fair. [Connelly-MA]
- 1125 unID AUG 3 0130 - Libya suspected with Arabic music; under Spain. [Connelly-MA]
- 1134 **CROATIA** *Glas Hrvatske*, Zadar (44°06'N 15°15'E) AUG 3 0104 - Jazz, *Glas Hrvatske* ID; good. 0129 Slavic talk by woman; excellent, over Spain. [Connelly-MA] AUG 15 0317 - Talk by man in assumed Croatian language. Fair signal. [Beu-TX] AUG 17 2320 - Good; woman in Croatian parallel 6165 kHz. [Conti-ME] AUG 21 2340 - Hrvatske ID by man, Slavic talk by woman; loud! AUG 22 0130 - Euro-dance music with classical influences, then Slavic talk by woman; excellent. [Connelly-MA] AUG 27 0144 - Fair in slop from phased local WISN; Slavic language music then talk. [Kazaross-WI]
- 1134 **SPAIN** *COPE* synchros AUG 3 0129 - Parallel 999 with '60s surf guitar instrumental; under Croatia. AUG 21 2340 - Man in Spanish; way under Croatia. [Connelly-MA]
- 1143 **SPAIN** *COPE* synchros AUG 3 0100 - Pips, Cadena Cope ID, news; fair. 0127 parallel 999 with Spanish talk, bits of festive music; poor over others (including something Portuguese-sounding). AUG 21 2334 - Spanish news; fair. Slight hint of a weak jamming-type signal on the low side (approx. 1142). AUG 22 0130 - Spanish talk; poor. [Connelly-MA]
- 1152 **SPAIN** *RNE5* synchros AUG 3 0008 - Woman in Spanish; loud, echoey. 0126 echoey Spanish talk parallel 1098 kHz. [Connelly-MA] AUG 18 0147 - Good; Bee Gees "Night Fever" parallel 684 kHz. [Conti-ME] AUG 21 2258 - Echoey Spanish talk by woman; over other. 2341 teletalk with severe echo. AUG 22 0131 - Parallel 774 with echoey talk. [Connelly-MA] AUG 27 0140 - Poor to fair in nice Spanish opening getting past CKOC and CJRC; parallel others with music. [Kazaross-WI]
- 1161 **EGYPT** *Mid-Delta Radio*, Tanta AUG 22 0132 - Arabic-sounding vocal; slightly behind Spain. [Connelly-MA]
- 1161 **SPAIN** *Euskadi Irratia*, San Sebastián AUG 22 0132 - Spanish talk; mixed with Middle East vocal station. [Connelly-MA]
- 1170 **UNITED ARAB EMIRATES** *R.Sawa*, Al Dhabiya (24°11'N 54°14'E) AUG 3 0101 - Mideast pop vocal; slightly over others. 0125 Arabic female vocal; mixed with phased WWVA. [Connelly-MA] AUG 18 0142 - Good, over WWVA; R&B vocal and Mideast music. [Conti-ME] AUG 22 0134 - Arabic talk, synthesized "Sawa" ID; up to good level. [Connelly-MA] SEP 1 0107 - Good, over WWVA; pop Middle Eastern vocal. [Conti-NH]
- 1179 **CANARY ISLANDS // SPAIN** *SER* synchros AUG 3 0009 - Parallel 1116 with talk, piano interlude. 0125 teletalk parallel 1116; good. [Connelly-MA] AUG 18 0139 - Good; telephone talk with synchro echo indicating reception of both Canaries and Spain. [Conti-ME] AUG 21 2336 - Female vocal, Spanish talk; good over others. AUG 22 0135 - Spanish teletalk; over unID Middle East music station. [Connelly-MA] AUG 27 0138 - Very poor getting enough past WHAM to tell it was Spanish talk. [Kazaross-WI]
- 1188 **BELGIUM** *VRT Radio 2*, Kuurne (50°52'N 03°16'E) AUG 22 0136 - Possibly this with pop music; poor. [Connelly-MA]
- 1197 **SPAIN** *Euskadi Irratia*, Vitoria AUG 22 0138 - Parallel 1161 with mellow vocal and folk guitar; fair. [Connelly-MA]
- 1206 **FRANCE** *France Info*, Bordeaux (44°57'N 00°11'W) AUG 3 0124 - Man in French mentioning education, children; good. [Connelly-MA] AUG 10 0055 - Good; orchestra instrumental parallel 1557 kHz. [Conti-NH] AUG 17 2328 - Good; instrumental music, 2330 fanfare, then *France Info* ID into news. [Conti-ME] AUG 22 0138 - Female vocal, piano; excellent. [Con-

- nelly-MA] AUG 31 0143 - Very good and listenable in the 6 kHz filter; mellow music parallel 945 kHz. A very easy TA in the mid-west. [Kazaross-WI]
- 1215 **SPAIN** COPE synchros AUG 3 0008 - Man in Spanish; fair, dominant. 0100 news by woman in Spanish; slightly over UK. [Connelly-MA] AUG 21 2335 - Parallel 1224 with man in Spanish; initially dominant, then under UK. [Connelly-MA] AUG 31 0047 - Fair and clear; Spanish talk into music and found parallel 999 kHz. No *Virgin* noted at this time. [Kazaross-WI]
- 1215 **UNITED KINGDOM** *Virgin Radio* synchros AUG 15 0427 - Assumed; rock music briefly audible with fair signal peak. [Beu-TX] AUG 18 0119 - Good; Eurhythmics "Sweet Dreams," then ad string including something about property investment. There seemed to be an unID strong s9+20 open carrier present. [Conti-ME] AUG 22 0139 - Modern UK rock vocal; excellent. [Connelly-MA] AUG 27 0053 - Poor to fair over Spanish, subaudible het, and some slop; rock music. [Kazaross-WI]
- 1224 **SPAIN** COPE synchros AUG 3 0011 - Woman in Spanish; poor to fair. 0101 news; fair. [Connelly-MA] AUG 18 0006 - Good; "Cadena Cope" IDs, man/woman, parallel 1215 kHz. [Conti-ME] AUG 21 2335 - Parallel 1215 with man in Spanish; fair. [Connelly-MA]
- 1242 **FRANCE** *France Info*, Marseille (43°16'N 05°18'E) AUG 21 2333 - Parallel 1377 with woman in French; poor through WBUR slop. [Connelly-MA]
- 1251 **LIBYA** *Libyan Jamahiriya*, Tripoli (32°50'N 13°00'E) AUG 3 0019 - Mideast military-sounding music, pause, then woman in UK-accented English. AUG 21 2333 - Anthem-style march music with tinny audio, then man in Arabic. AUG 22 0140 - Woman in Arabic; loud. [Connelly-MA]
- 1269 **GERMANY** *Deutschlandfunk*, Neumünster (54°03'N 09°51'E) AUG 18 0111 - Good; opera parallel 1422 and 6190 kHz. [Conti-ME]
- 1287 **SPAIN** SER synchros AUG 18 0230 - Talk parallel 1044 kHz; through heavy lightning noise. [Conti-ME] AUG 21 2333 - Fast Spanish talk. AUG 22 0140 - Spanish teletalk; fair. [Connelly-MA]
- 1296 **SPAIN** COPE Valencia AUG 3 0122 - Parallel 999 with man in Spanish; under Sudan. [Connelly-MA]
- 1296 **SUDAN** SRTC Reiba (13°34'N 33°32'E) AUG 3 0020 - Man in Arabic; to fair peak. 0122 Arabic chanting, drums; fair, over Spain. [Connelly-MA]
- 1296 **UNITED KINGDOM** *Radio XL*, Langley Mill (52°33'N 01°46'W) AUG 22 0142 - Fast Indian-accented English advert; slightly over jumble. [Connelly-MA]
- 1305 **SPAIN** RNE5 synchros AUG 3 0121 - Parallel 1098 with discussion; fair. AUG 21 2333 - Man and woman in Spanish; poor. [Connelly-MA]
- 1314 **SPAIN** RNE5 synchros AUG 3 0119 - Parallel 1098 with discussion; poor. [Connelly-MA] AUG 18 0102 - Good; news, slightly delayed with 684 parallel. [Conti-ME] AUG 21 2333 - Parallel 1359 with woman in Spanish; poor to fair. [Connelly-MA]
- 1332 unID AUG 17 0020 - Pop music; steady signal but too much lightning noise to ID. [Conti-ME]
- 1359 **SPAIN** RNE Arganda del Rey AUG 3 0118 - Parallel 1098 with discussion; fair. [Connelly-MA] AUG 17 0018 - Fair; talk parallel 1503 kHz. [Conti-ME] AUG 21 2255 - Parallel 1413 with man in Spanish; fair with WLYN phased. 2333 talk with laughing; good. [Connelly-MA] AUG 26 0524 - Ballad sung by woman followed by Spanish talk by man. Good peak. [Beu-TX]
- 1377 **FRANCE** *France Info*, Lille (50°31'N 02°59'E) AUG 3 0118 - Parallel 1206 with French talk by woman; excellent. [Connelly-MA] AUG 18 0059 - Good; jazz instrumental, then fanfare into news. [Conti-ME] AUG 21 2330 - Fanfare music, woman with "France Info" ID; good. AUG 22 0143 - Spanish classical instrumental; huge. [Connelly-MA] AUG 27 0141 - Poor; music into talk parallel 1206. This is normally an easy TA, but the upper band wasn't good. [Kazaross-WI]
- 1385.92 **GUINEA** *R.Rurale*, Labé AUG 16 2319 - Excellent! Man speaking in vernacular accompanied by stringed instrument. 2329 announcement in French. 2330 brief open carrier, then off. [Conti-ME] AUG 21 2253 - A cappella African vocal; poor, getting piled on by slop from 1380 WMYF and 1390 WPLM. [Connelly-MA]
- 1395 **NETHERLANDS** *The Big L*, Trintelhaven (52°38'N 05°25'E) AUG 3 0020 - Likely this with Broadway female vocal "Hey Big Spender." [Connelly-MA] AUG 17 0015 - Fair; The Who "The Kids Are Alright." [Conti-ME] AUG 21 2330 - T Rex oldie "Bang a Gong, Get It On," a "Big L, Yesterday" jingle, then Beatles-influenced vocal; fair. [Connelly-MA]
- 1404 **FRANCE** *France Info* synchros AUG 3 0118 - Parallel 1206 with woman in French; fair. [Connelly-MA] AUG 16 2317 - Fair; news/talk parallel 1206 kHz. [Conti-ME] AUG 22 0143 - Parallel 1377 with Spanish classical instrumental; poor. [Connelly-MA]

- 1413 **SPAIN** *RNE5* synchros AUG 3 0016 - Man and woman in Spanish; some echo. [Connelly-MA] AUG 16 2316 - Good; telephone talk. AUG 18 0048 - Fair; discussion parallel 684 kHz. [Conti-ME] AUG 21 2252 - Man in Spanish; over others. 2329 parallel 1359 with two woman in Spanish; good. AUG 22 0143 - Talk; loud. [Connelly-MA]
- 1422 **ALGERIA** *RTA Algiers* (36°40'N 03°09'E) AUG 3 0019 - Man in French, gypsy-style violin, then man and woman in French; good. [Connelly-MA] AUG 10 0038 - Fair; woman in French parallel 252 kHz. [Conti-NH] AUG 16 2315 - Good; modern African highlife, then an English rap vocal, parallel 252 kHz. [Conti-ME] AUG 21 2251 - Fast French talk by man; good. 2325 energetic Arabic pop music with female vocal, then talk by man in French; good. [Connelly-MA] SEP 7 0008 - Fair, over/under Germany; vocal parallel 252 kHz. [Conti-NH]
- 1422 **GERMANY** *Deutschlandfunk*, Heusweiler (49°21'N 06°55'E) AUG 22 0144 - Classical music; fair to good. [Connelly-MA]
- 1431 **DJIBOUTI** *R.Sawa*, Arta (11°31'N 42°50'E) AUG 3 0026 - Parallel 1548 Kuwait with segment of Bush speech in newscast, then man in Arabic used phrase "million dollars"; loud. 0117 Arabic news; excellent. AUG 21 2251 - Modern Arabic vocal; fair, increasing strength. AUG 22 0144 - Arabic male dance vocal with African influences, then *R.Sawa* ID by woman; huge, much stronger than adjacent 1430 WXKS, WNSW, and WENE jumble. [Connelly-MA] SEP 7 0010 - Good; pop music. [Conti-NH]
- 1458 **UNITED KINGDOM** *Sunrise Radio*, Brookmans Park AUG 22 0014 - Possibly this with Indian vocal. [Connelly-MA]
- 1458 unID AUG 16 2312 - Man/woman alternating in unID language; maybe Albania but too much lightning noise to be readable. [Conti-ME]
- 1467 **FRANCE** *TWR Roumoules* (43°47'N 06°09'E) AUG 17 2225 - Fair; preacher in English, choir music, 2230 one cycle of interval signal. [Conti-ME]
- 1467 **SAUDI ARABIA** *BSKSA* unknown location AUG 22 0145 - Parallel 1521 with man and woman in Arabic; poor. [Connelly-MA]
- 1476 **SAUDI ARABIA** AUG 22 0011 - Koranic vocal seemed parallel to one on 1512 kHz. Possibly "similar" rather than "same" though, which could point to Egypt, Iran, or UAE. [Connelly-MA] No Saudi listed on this frequency in EMWG or WRTH.
- 1485 **MELILLA // SPAIN** *SER* synchros AUG 3 0116 - Parallel 1116, woman with teletalk; good. [Connelly-MA] AUG 16 2309 - Talk; over het on low side. AUG 17 2333 - Het on low side, about 500 Hz indicating possible Angola. [Conti-ME] AUG 22 0017 - Fast Spanish talk by man; telco quality audio. [Connelly-MA] SEP 1 0417 - Very poor, just good enough to tell was Spanish talk parallel *SER*. [Kazaross-WI]
- 1494 **CORSICA** *France Bleu*, Bastia (42°47'N 09°24'E) AUG 16 2253 - Good; lively French vocal. AUG 17 2348 - Good; Michael Jackson and Paul McCartney "Say, Say, Say." [Conti-ME] AUG 22 0016 - "Long Train Running" by the Doobie Bros.; over *France Info*. 0147 parallel 864 with French music; mixed with *France Info* station. [Connelly-MA]
- 1494 **FRANCE** *France Info* synchros AUG 22 0016 - Talk parallel 1557; under *France Bleu* station. 0147 parallel 1206 with French talk by man; slightly over *France Bleu*. [Connelly-MA]
- 1503 **IRAN** *IRIB Sarasary*, Bushehr (28°58'N 50°51'E) AUG 22 0014 - Solemn-sounding men's chorus, Farsi talk by man; very good; way over Spain. [Connelly-MA]
- 1503 **SPAIN** *RNE5* Piñeira and La Línea de la Concepción AUG 3 0027 - Man in Spanish, then big-band jazz; good. 0115 Spanish interview about businesses, workers; huge. [Connelly-MA] AUG 16 2248 - News/talk in Spanish thru unID IBOC digital. [Conti-ME] AUG 21 2327 - Parallel 1098 with man and woman in Spanish; good. [Connelly-MA] SEP 7 0015 - Good; talk with synchro echo from delay between stations. [Conti-NH]
- 1512 **CRETE** *ERA* Chania (35°29'N 24°03'E) AUG 3 0030 - Presumed this with Greek-style (not Arabic) plaintive male vocal and folk guitar; over jumble and WWZN slop. [Connelly-MA]
- 1512 **SAUDI ARABIA** *BSKSA* Jeddah AUG 16 2247 - Good; Koran. [Conti-ME] AUG 21 2250 - Koranic vocal; over others; fair with WWZN phased. [Connelly-MA]
- 1521 **SAUDI ARABIA** *BSKSA* Duba (27°20'N 35°45'E) AUG 3 0030 - Talk by woman then instrumental music and a man who said "salaam aleikum"; huge. 0113 Koranic male vocal; huge/local-like, annihilating 1520 kHz. [Connelly-MA] AUG 16 0247 - Talk by man in Arabic. Fair and steady signal. [Beu-TX] AUG 17 2210 - Good; talk parallel 9555 and 9870 kHz, 1.5 hours before receiver sunset. [Conti-ME] AUG 21 2242 - Parallel 9555 and 9870 with male Arabic vocal and violins; excellent. [Connelly-MA] SEP 1 0240 - Fair to good with Arabic talk, fade out by 0300. TAs fade earlier here than on the Atlantic Coast from my experience. [Kazaross-WI]
- 1539 **UNITED ARAB EMIRATES** *R.Aap Ki Dunyaa*, Al Dhabbaya AUG 22 0014 - Urdu news by woman; to good peak, alone on channel. Thanks to Mauno Ritola for ID help: exact same

program was found stored in IBB / VOA online archives. Possibly first USA reception of this. [Connelly-MA]

- 1548 **KUWAIT** *R.Sawa*, Kabd-Kuwait City (29°10'N 47°32'E) AUG 3 0026 - Parallel 1431 Djibouti with segment of Bush speech in newscast, then man in Arabic used phrase "million dollars"; to good peak. [Connelly-MA] AUG 16 2307 - Excellent; Mid East pop vocal. AUG 18 0044 - Intermittent audio popping on/off on solid carrier. [Conti-ME] AUG 22 0148 - Hard-rocking Arabic vocal; good. [Connelly-MA]
- 1550 **ALGERIA** *RASD Rabouni* (27°29'N 07°49'W) AUG 21 2325 - Man in Arabic; good, sometimes over WNTN Haitian program. Best received on upper sideband to dodge 1548 Kuwait het. Some evidence of jammer in background. [Connelly-MA] SEP 6 2325 - Fair, over/under WITK with local WNTN already off; talk with mentions of politics, military, and Sahara, then a Mideast-style male group vocal that really popped thru co-channel domestics, 2333 "titulares" news headlines with fanfare into speed reading. Language seemed Arabic but interspersed with French and/or Spanish words. 2340 more Arabic vocals, an African highlife vocal, and a rural vocal more in the style of Moroccan music. SEP 7 0003 - Sign-off with distinct military anthem thru domestics. [Conti-NH]
- 1557 **FRANCE** *France Info*, Fontbonne (43°46'N 07°25'E) AUG 3 0029 - Soft music to good peak. 0112 parallel 1206 with romantic nostalgic French male vocal; good with WQEW phased. [Connelly-MA] AUG 10 0030 - Loud het against 1560 WQEW. [Conti-NH] AUG 16 2254 - Excellent; talk parallel 1377 (good) and 1206 (fair). [Conti-ME] AUG 21 2245 - Two men in French; good with WQEW phased. [Connelly-MA] AUG 27 0139 - Poor to fair; music parallel 1206 and 1377 kHz. Another very easy one when it can get by WQEW slop. [Kazaross-WI]
- 1575 **SPAIN** *SER* synchros SEP 1 0418 - Poor; Spanish talk by deep voiced announcer parallel 1584 kHz. [Kazaross-WI]
- 1575 **UNITED ARAB EMIRATES** *R.Farda*, Al Dhabiya (24°11'N 54°14'E) AUG 3 0030 - Radio Far-DAH ID; good. 0112 pulsating Mideast dance music; over Spain. [Connelly-MA] AUG 18 0040 - Good; *R.Farda* ID into modern Mid East pop vocal. [Conti-ME] AUG 21 2249 - Talk by man and woman, *Farda* ID, then dance music; fair, building in strength. AUG 22 0015 - Kid hit "Bye Bye Bye" by Nsync. [Connelly-MA]
- 1584 **CEUTA** *RadiOlé*, Ceuta (35°53'N 05°17'W) AUG 3 0111 - Emotional tropical-influence vocal; dominant. [Connelly-MA] AUG 16 2300 - Excellent; Spanish rock over *SER* time pips. [Conti-ME] AUG 21 2248 - Blues vocal in the style of Janis Joplin; good. [Connelly-MA]
- 1584 **SPAIN** *SER* synchros SEP 1 0418 - Poor; Spanish talk parallel 1575 and others. [Kazaross-WI]
- 1602 **SPAIN** *SER* synchros AUG 21 2246 - Spanish newstalk; slightly under *EI* Vitoria. [Connelly-MA]
- 1602 **SPAIN** *R.Vitoria*, Vitoria AUG 3 0110 - Spanish pop-rock; fair, over *SER*. AUG 21 2246 - Spanish rock; generally atop *SER*. [Connelly-MA] SEP 1 0419 - Poor; Spanish music. This one is often listenable in good high band conditions. [Kazaross-WI]

Pan-American DX

- 530 **CUBA** *R.Rebelde*, unknown location AUG 25 1026 - Parallel 5025 with Spanish talk about Cuba. A new one in August is a great catch. Been after this one for a long time but very hard to get. [Axelrod-MB]
- 530 **TURKS & CAICOS** *R.Visión Cristiana*, South Caicos (21°30'N 71°31'W) AUG 3 0053 - *R.Visión Cristiana* ID in Spanish talk; getting through stiff 531 het and heavy static crashes. AUG 22 0021 - Spanish religion; alone on channel, good, over static crashes. [Connelly-MA]
- 550 **VENEZUELA** *YVKE* Caracas (10°32'N 66°55'W) AUG 18 0928 - Fair in heavy lightning noise; news/talk and Mundial IDs. [Conti-ME]
- 555 **ST. KITTS & NEVIS** *ZIZ* Basseterre (17°19'N 62°44'W) AUG 22 0009 - Caribbean accented male DJ; occasionally poking over massive WGAN slop. [Connelly-MA]
- 570 **CUBA** *CMDC R.Reloj*, Santa Clara (22°24'N 79°56'W) AUG 17 0927 - Excellent; "Radio Reloj," minute marker, "Cinco veinte y siete minutos," and RR in Morse code. [Conti-ME]
- 580 **PUERTO RICO** *WKAQ* San Juan (18°26'N 66°08'W) AUG 17 0912 - Fair; talk about Puerto Rican baseball. [Conti-ME]
- 600 **VENEZUELA** *YVQB R.Sucre*, Cumaná AUG 17 0906 - Fair in lightning noise and *R.Rebelde* Cuba interference; llanera music, "En Radio Sucre..." and more llaneras. [Conti-ME]
- 610 **CUBA** *CMAN R.Rebelde*, Bahía Honda (22°53'N 83°09'W) AUG 17 0938 - Good; talk about Guantanamo and "la revolución" parallel 600 and 5025 kHz. [Conti-ME]
- 640 **VENEZUELA** *VYQO Unión Radio*, Puerto la Cruz (10°05'N 64°47'W) AUG 22 0033 - Bits of fast-paced Venezuelan news; mostly under CBN. [Connelly-MA]

- 670 **CUBA** CMQ *R.Rebelde*, Arroyo Arenas (23°00'N 82°30'W) AUG 3 0051 - Man and woman with Cuban newstalk; over YVLL. [Connelly-MA]
- 670 **VENEZUELA** YVLL *R.Rumbos*, Caracas (10°29'N 66°59'W) AUG 3 0054 - ID "Radio Rumbos, la emisora de Venezuela"; briefly over Cuba and another Latin American. AUG 22 0036 - Venezuelan political talk; poor, over Cuba and static. [Connelly-MA]
- 680 **COLOMBIA** HJZO *R.Nacional de Colombia*, Sabanagrande AUG 17 0919 - Presumed this under WRKO; typical local accordion vocals. [Conti-ME]
- 699.67 **VENEZUELA** YVPQ *R.Sur*, Puerto Ordaz AUG 22 0041 - Spanish talk bobbing in and out of mix/growl with the 700 Brazilian. [Connelly-MA]
- 700 **BRAZIL** ZYK686 *R.Eldorado*, São Paulo (23°32'S 46°37'W) AUG 18 0152 - Talk in Portuguese over Venezuela het and intense lightning noise likely from Hurricane Dean, 0159 ID, "Radio Eldorado AM, 700 kilohertz..." [Conti-ME] AUG 22 0001 - Music fanfare, "Eldorado AM" slogan by woman, then Portuguese talk by man; fair over static crashes and 699.67 Venezuela growl. 0041 Portuguese talk; over co-channel Spanish (Colombia?) and slightly off-channel Venezuelan. [Connelly-MA]
- 700 **JAMAICA** RJR Hague SEP 1 0340 - Fair in WLW null; reggae parallel 720 kHz. [Conti-NH]
- 720 **BRAZIL** ZYK276 *R.Guaiba*, Porto Alegre (30°02'S 51°12'W) AUG 3 0049 - Reverberated Portuguese talk by man. 0056 man in Portuguese with Guaiba mention; noted during fade of YVQE. [Connelly-MA]
- 720 **VENEZUELA** YVQE *R.Oriente*, Porlamar (10°56'N 64°12'W) AUG 3 0045 - Spanish talk, apparent Oriente mention, then into plaintive female vocal with guitar; poor in jumble and static. AUG 21 2358 - Woman in Spanish with Oriente mention; poor, barely over others. [Connelly-MA]
- 750 **CUBA** CMHV *R.Progreso*, Trinidad (21°48'N 79°59'W) AUG 17 0856 - Fair; Cuban nostalgia parallel 640 kHz. [Conti-ME]
- 760 **BRAZIL** ZYH588 *R.Uirapuru*, Fortaleza (03°45'S 38°31'W) AUG 22 0002 - Talk, "Radio Uirapuru en Fortaleza" ID, then '50s-style Portuguese vocal; fair to good. 0050 still good, over Colombia and phased WJR. [Connelly-MA]
- 760 **COLOMBIA** HJAJ RCN Barranquilla (10°53'N 74°49'W) AUG 17 0857 - Poor in lightning noise; "En Colombia..." into jingle. [Conti-ME]
- 780 **MEXICO** XEMF *R.Nostalgia*, Monclova (26°56'N 101°27'W) AUG 20 1229 - Ad for Cablevisión, "Radio Nostalgia" jingle, then an update on Huracán Dean; back to talk program at 1233, with theme from "Mission Impossible" music in the background from 1230 on. Good signal. [Wilkins-CO]
- 800 **NETHERLANDS ANTILLES** PJB *TransWorld Radio*, Bonaire (12°06'N 68°17'W) AUG 3 0048 - Spanish religion; coming up over VOWR/CJAD mix. [Connelly-MA]
- 820 **ST. KITTS & NEVIS** TBN/*R.Paradise*, Charlestown (17°08'N 62°37'W) AUG 3 0047 - Preacher; to good peak, upper sideband used to dodge fat 819 het. AUG 21 2359 - ID "This is the Trinity Broadcasting Network, reaching the world with the love of Jesus for 34 years"; good, dominant. AUG 22 0057 - Preaching; over WNYC/jumble. [Connelly-MA]
- 840 **BRAZIL** ZYK687 *R.Bandeirantes*, São Paulo (23°32'S 46°37'W) AUG 3 0035 - Reverberated Portuguese talk by man; over pile-up. AUG 22 0059 - Woman in Portuguese; slightly over mess. [Connelly-MA]
- 860 **BRAZIL** unID AUG 21 2353 - Most likely ZYJ459 Rio de Janeiro though ZYH592 Maracanau also possible. Portuguese teletalk; slightly atop the pile. [Connelly-MA]
- 860 **CUBA** CMDB *R.Reloj*, Baracoa (20°21'N 74°29'W) AUG 17 0946 - Good; alternating man/woman with news, time checks, etc. [Conti-ME]
- 860 **VENEZUELA** YVYE *Enlace 860*, Valle de la Pascua AUG 3 0036 - ID "Esta es Enlace, Ocho Sesenta, La Emisora de la Mar"; noisy. [Connelly-MA]
- 880 **VENEZUELA** YVYM *R.Venezuela*, Puerto Ordaz (08°15'N 62°42'W) AUG 21 2352 - Radio Venezuela mention and Spanish talk about workers; over WCBS. [Connelly-MA]
- 895 **ST. KITTS & NEVIS** *Voice of Nevis*, Bath Village (17°07'N 62°37'W) AUG 3 0040 - Gospel-influenced Afro-Caribbean music; to fair peak. AUG 22 0105 - Soca female vocal; fair. [Connelly-MA]
- 950 **CUBA** *R.Reloj*, La Habana AUG 3 0040 - Reloj program Spanish talk, beeps; in jumble with suspected CHER/CKNB with WROL phase-nulled to oblivion. [Connelly-MA]
- 960 **CUBA** *R.Reloj* AUG 3 0040 - Reloj beeps; in jumble. [Connelly-MA] AUG 17 0947 - Good; alternating man/woman with news, time checks, etc. [Conti-ME]
- 1000 **BRAZIL** ZYK522 *R.Record*, São Paulo (23°33'S 46°38'W) AUG 3 0037 - Portuguese shouting including a 15-second long "Goooooooooal!"; poor. [Connelly-MA] AUG 17 0845 - Fair in

- lightning noise; man and woman in Portuguese, 0900 ID. [Conti-ME] AUG 21 2347 - Excited Portuguese talk; poor to fair over 999 splash. [Connelly-MA]
- 1020 **CUBA** *R.Relej*, unknown location AUG 18 0920 - News, etc. over unID religion in Spanish. [Conti-ME] AUG 22 0116 - Relej program; in jumble with KDKA and Venezuela. [Connelly-MA]
- 1040 **MEXICO** unID SEP 4 1202 - Variety of XE music, canned “La Primera Diez Cuarenta” slogans; PDT time checks three minutes slow. Loops approximately southwest. Good signal and not much interference from WHO. Presumably not XEHES, which would be on MDT. Maybe XEGYS with an upgrade? [Wilkins-CO] An Internet search found XEGYS *La Primera 1040*, Guaymas, Sonora at www.superbanda.com.mx/priguaymas.htm.
- 1100 **BRAZIL** ZYK694 *R.Globo*, São Paulo (23°32’S 46°37’W) AUG 3 0010 - Portuguese sporting event coverage; dominant. 0106 reverberated man in Portuguese. [Connelly-MA] AUG 17 0842 - Good; telephone talk in Portuguese with slight reverb effect. [Conti-ME]
- 1140 **VENEZUELA** *R.Porlamar*, Porlamar (10°57’N 63°51’W) AUG 3 0009 - ID “Radio Porlamar, La Voz del Caribe”; good. [Connelly-MA]
- 1149.45 unID AUG 3 0008 - weak carrier. [Connelly-MA]
- 1160 **BERMUDA** VSB3 Hamilton (32°18’N 64°46’W) AUG 3 0059 - BBC World Service ID; in the clear during audio pause on WSKW. [Connelly-MA] AUG 18 0304 - Good; “World news from the BBC.” [Conti-ME]
- 1170 **COLOMBIA** HJNW CARACOL Cartagena (10°27’N 75°32’W) AUG 3 0011 - Probably this with man in Spanish, several mentions of Colombia; slightly over jumble and static. [Connelly-MA]
- 1170.35 unID AUG 3 0106 - Weak het against *R.Sawa* / WWVA; possibly the Colombian logged earlier (I wasn’t looking for the offset at that time). [Connelly-MA]
- 1181 **CUBA** *R.Rebelde*, Villa María (23°07’N 82°22’W) AUG 18 0848 - Noted off-frequency almost 1 kHz high producing a killer het against 1180 WHAM. [Conti-ME] AUG 22 0135 - Weak het. Thought by some to be of Cuban origin, or a bit farther east in the Caribbean. [Connelly-MA]
- 1180.12 unID AUG 3 0106 - Weak het against 1180 jumble. [Connelly-MA]
- 1190.33 **COLOMBIA** HJCT *La Voz de la Costa*, Barranquilla AUG 22 0137 - Bits of Spanish talk and fat het against WLIB. ID’ed previously on JUL 25. [Connelly-MA]
- 1199.835 unID AUG 3 0101 - Weak het growl. [Connelly-MA]
- 1200 **VENEZUELA** YVOZ *R.Tiempo*, Caracas (10°32’N 66°57’W) AUG 3 0101 - Radio Tiempo ID popped through during WKOX fade. [Connelly-MA]
- 1220 **BRAZIL** ZYJ458 *R.Globo*, Rio de Janeiro (22°55’S 43°13’W) AUG 3 0100 - Globo ID in Portuguese talk by man. 0102 up to a good level with mentions of cities including São Paulo. [Connelly-MA] AUG 17 0830 - Good; signature whistles, Globo IDs, man and woman in Portuguese. AUG 18 0849 - Good; whistles, “...da Radio Globo” ID, the strongest and most consistent Brazil signal of the DXpedition. [Conti-ME]
- 1280 **BERMUDA** VSB2 Hamilton AUG 18 0258 - Good; Christian hymn, 0300 ID, “You’re listening to BBN on WYFQ-FM Wadesboro-Charlotte.” [Conti-ME]
- 1330.4 unID AUG 3 0020 - Low het behind WRCA. [Connelly-MA]
- 1420 **VENEZUELA** YVNZ *R.Marabina*, Maracaibo AUG 3 0017 - Marabina mentions, then into mellow Spanish male vocal. [Connelly-MA]
- 1500 **VENEZUELA** YVRZ *R.Dos Mil*, Cumana AUG 3 0030 - Talk “en Venezuela... ocho treinta minutos.” [Connelly-MA]
- 1570 unID SEP 5 0657 - Norteña music, Big Ben-style clock chimes, ID missed, high-pitched woman with announcement. American or Mexican-based? Poor; 1580 KBLA interference. [Park-HI*]

Transpacific DX

- 621 **AUSTRALIA** 3RN Melbourne AUG 4 0757 - Talk by woman, mention of “ABC Radio.” Very poor, heavy het from 620 kHz. [Park-HI]

Contributors

- Shawn Axelrod VE4DX1SMA, Winnipeg MB; Icom ICR-70, Drake R8, 4-ft unamplified box loop, Quantum Loop, 155-ft outdoor wire, 100-ft indoor wire, MFJ 1026 phasing unit.
- Mike Beu KD5DSQ, Austin TX; R8B, terminated Delta Loop (17 x 28-ft).
- Mark Connelly WA1ION, Rockport MA; R8A, RFSpace SDR-IQ, Mini-Circuits ZSC-2-2, DXP-6A, cardioid array on roof of car = vertical: 3.7 m whip (MFJ-1956) to 81:1 xfmr to DX Engineering RPA-1 amp + loop: broadband, in vertical plane, square, 2 m per side, to 1:1 xfmr to RPA-1

amp, peak east-west, null north-south.

Bruce Conti, Camden ME; R8B, MWDX-5, SuperLoop antennas east and south.

Bruce Conti, Nashua NH; R8B, Mini-Circuits 1:1 common mode choke, MWDX-5, 15 x 23-m SuperLoop antennas east and south.

Harold Frodge, Midland MI; R8B, 215-ft center-fed random wire, 85-ft end-fed random wire, 125-ft bow-tie.

Neil Kazaross, Grafton WI; R8A, phased BOGs aimed about 65°, 490 ft parallel 670 ft.

Dale Park, Honolulu HI; Sangean ATS-818CS, Terk AM1000 loop, and *DXing in East Honolulu; Honda car radio.

John Wilkins, Wheat Ridge CO; Drake R8, 4-ft box loop.

Transatlantic DX in Wisconsin: The Quest for 720

By Neil Kazaross

I DXed Thursday and Friday nights from my midwestern DX paradise spot in Grafton, Wisconsin, atop a bluff 150 ft above the Lake Michigan shore. The previous Sunday night had also featured good TA conditions and I had clear suspicions of both Portugal and Canaries under phase nulled semi local WGN (91 miles south and 50 kW ND) but wasn't able to be sure on parallels for either. This time I laid out longer BOGs than the previous hoping for emphasis on the lower end and indeed the two parallel BOGs 490 ft and 670 feet seemed somewhat better for the low end than the previous 335 and 485-ft used. I simply parked in a spot further down my driveway and accepted a bit of a bend. The BOGs start out at about 60° and end up aiming close to 70° for a slight curved bend averaging about 65°. As noticed before when aiming east-northeast I get CFOS much clearer through WIND 560 (SSE) with the longer BOGs. The length difference of 180 ft was chosen since my experience indicates that this is a good difference for phasing lower band back end QRM while not nulling or even slightly enhancing signals from the desired direction.

The results of my setup and lake coast QTH (a good 100 miles of water in the direction of the lower path western Medit area TAs) would not disappoint me and note that the bearing from Grafton to Madrid is 61 degrees and to Lisbon 65 degrees. Local sunset is about 7:30 p.m. (0030) and unlike on the Atlantic coast TAs don't tend to come in well over an hour prior to sunset. Friday night was a bit better than Thursday and by 0023 the big Spaniard on 684 had a rather readable signal and by 0045 the lower half of the dial was full of TAs while the upper half only had a few really strong ones barely audible. 720 had the typical somewhat mellow music (lots of American, but some other stuff) played by Portugal around 0115 and also at times some Spanish talk, but on Thursday I couldn't get any parallels. With the Portuguese running only 10 kW and having big slop on 666 and also on 693 Azores (CINF is nasty) it is not easy to get clear copy of a parallel. Anyhow I continued to tune around, log TAs and some eastern Canadians and again 780 WTME on a 310 watt PSSA from western Maine.

At 0400 August 31 there was a newscast under phased WGN but I just couldn't pin it down as Portuguese and into the typical music it went. Around 0500 it seemed that Spanish stations really picked up strength. I was certain the news and programming on 720 was parallel other RNEs and this was mostly atop other stations, including (if I adjusted the phasing a bit) XEDE Mexican music under WGN. Spain uses several pips on the half hour with the final one longer and at 0530 my dream came true as there they were on 720 parallel the network and with a RNE ID! I soon tuned to 747 and noted a couple Canarias mentions so they may have been in local programming briefly, and things like 837 were cleanly listenable with ease (WHAS 840 nicely nulled by these BOGs). Ok, one down one to go on 720, but by 0545 most TAs have faded and a tired Kaz drives his DX car up his driveway and goes to bed.

On Sept 1 TA conditions seemed even better and it was quite clear to me that the language on 720 under phased WGN (S9+15 to 20 knocked down to S7-8 hard to phase groundwave and short skywave) was continental Portuguese (sounds a bit different than Brazilian) but I couldn't copy a parallel 666 or 693 clear enough to be sure. As for the previous night, most every TA channel below 900 produced audio. As the time neared 0300 Sept 1 conditions picked up even more and the station on 720 atop the WGN/XEDE phase null had a song that featured distinctive piano music and I managed a 100% positive parallel to what was on 666 coming through the WSCR (somewhat phased by the null on WGN) and WFAN slop. Ask me if I miss 720 CHTN oldies? Well not!

Again lots of TA's still audible and a new logging for me of Spain on 783 (Mauritania can sometimes be heard here earlier and always seems to be an early arrival het at least). Also bits of Spanish on 648 parallel others were noted for a new one. 549 had Algeria parallel the weakly modulated powerhouse on 891 that was strong enough to make it unpleasant to listen to WLS on the car radio. 612 has Morocco and some Arabic music reach audibility from the badly modulated but strong signal on 711 kHz. A few days prior when conditions were decent to somewhat more northern Europe there was some French on 711 kHz.

More northerly TA paths had a few stations but nothing like the many from the western Medit area. 1089 UK audible occasionally as was 909 kHz. 567 Ireland was decent around 0350, but the previous night had Spanish parallel the others when Spain really faded up. 1134 Croatia sometimes could put fair audio past my big local pest on 1130 kHz. High band was less active although the common big signal from the mega Saudi on 1521 was in, but faded about 0255, and I could get just some audio on 1584 with SER parallel 1575 and also Spanish music from Ceuta. 1602 pushed some audio past 1600 QRM where nothing was strong.

I feel that this Lake Michigan location provides maybe 10 to 12 dB enhanced of stations towards the east when compared to my home inland in Illinois. I have only DXed in Wisconsin for at most 25 sessions and have loads of eastern US and Canada domestics heard that have been unheard inland or maybe only once or twice over the years. Very happy to finally have some TA's logged on domestic channels from the midwest. My previous have only been two tentatives on 1530 with eastern Euro languages seemingly right for Vatican at the time, but never catching an ID or IS and not being fully readable. 73

Grayland DXpedition

August 23-26, 2007

Loggings by John Bryant

Equipment: WinRadio 313e, phased active Delta arrays east-west and northwest-southeast, west Beverage 700 ft, northwest Beverage 800 ft.

My first trip to Grayland in 2007 was primarily planned as a test session for two phased arrays that are under development by Wellbrook. I managed to DX Thursday through Sunday mornings from about 1000 until bandfade around 1400 UTC. Guy Atkins joined me (with the second array) for Saturday and Sunday morning.

Each of the four mornings had a very distinct personality, with the first three being rather better than average overall conditions and the fourth being somewhat less than average. Thursday morning, Aug 23, was a mixed morning prior to sunrise, with about equal numbers of Aussie and Japanese signals being the most notable. There was an excellent all-Aussie opening for about 40 minutes after dawn. The second morning, Friday Aug 24, was also mixed, but with conditions favoring the East Asians, especially Japan over the DU stations. Saturday morning, Aug 25, the dial was covered with Aussies and a few Kiwis. Almost no signals were heard from East Asia. The final morning, Sunday Aug 26, was rather disappointing, overall, but a decent number of stations were heard. There were rather more Aussies on the band than there were East Asians.

Our tests of the two arrays were extremely gratifying. In our now 18 years of DXing from Grayland, we have brought many antennas to the beach to try to outperform our traditional rather short Grayland Beverages. Until this weekend, every antenna that we have tried had proven to be a disappointment when carefully compared to the Beverages, which seem to do especially well on sandy seashores. Although the exact results of our tests are, of course, confidential, I can say that both Guy and I were very impressed with the performance of the rather small arrays when compared to a short Beverage. We look forward to the day when we will no longer have to slog through abandoned cranberry bogs to string out several thousand feet of wire for the traditional Grayland Beverage array. The Wellbrook array of Deltas is a winner!

- 576 **AUSTRALIA** 2RN Sydney AUG 23 1250 - Heard here most mornings of the DXpedition.
- 585 **AUSTRALIA** 7RN Hobart AUG 23 1327 - Heard this old friend, though poorly, running modern jazz parallel 576 Sydney which was much better.
- 594 **JAPAN** JOAK NHK-1 Tokyo AUG 23 1140 - Heard here most mornings of the DXpedition.
- 594 **AUSTRALIA** 3WV Horsham AUG 25 1302 - Great fun here as max dawn began with 3WV alone on the west array and co-channel JOAK Tokyo alone on the northwest array.
- 612 **AUSTRALIA** 4QR Brisbane AUG 23 1250 - Heard most mornings of the DXpedition.
- 648 **AUSTRALIA** 2NU Tamworth AUG 26 1304 - Noted here in passing with ABC News on the hour at fair level. Parallel to 594 3WV Horsham.
- 657 **NEW ZEALAND** *Southern Star*, Wellington AUG 24 1125 - Heard only at poor level, but with usually soft pops programming.
- 670 **HAWAII** KPUA Hilo AUG 24 1255 - Best demonstration of the phased array of loops so far. On the easterly setting of the east-west array, KBOI Boise was in the clear. On the westerly setting, KPUA was at good strength, all alone. The poorly terminated normal west Beverage had both, with KBOI very dominant.
- 675 **AUSTRALIA** 2CO Albury AUG 26 1304 - Noted in passing parallel 594 and 648 with ABC

news on the hour. Fair to poor.

- 684 **AUSTRALIA** 2KP Kempsey AUG 25 1305 - Noted in passing with the end of the ABC News. Fair level.
- 693 **JAPAN** JOAB *NHK-2* Tokyo AUG 23 1140 - Heard here most mornings of the DXpedition.
- 702 **AUSTRALIA** 2BL Sydney AUG 23 1240 - Noted here most mornings.
- 729 **JAPAN** JOCK *NHK-1* Nagoya AUG 23 1320 - Noted here at poor level parallel 594 kHz.
- 729 **AUSTRALIA** 5RN Adelaide AUG 26 1326 - Heard here with the weekend ABC world music show that often gets me excited (thinking that I'm hearing Tibet, Kazakhstan or some other exotic location). Parallel 792 and 1512 kHz.
- 738 **AUSTRALIA** 2NR Grafton AUG 24 1320 - Noted as band faded with Aussie talk by male; mentions of Australia.
- 747 **JAPAN** JOIB *NHK-2* Sapporo AUG 23 1123 - Heard most mornings of the DXpedition.
- 756 **NEW ZEALAND** 1YA *National Radio*, Auckland AUG 25 1210 - Noted at fair level in passing with DU talk.
- 765 **AUSTRALIA** 2EC Bega AUG 25 1212 - Tentative this with pop music show hosted by male. Logging too brief for even a tentative report. Good level, briefly.
- 774 **AUSTRALIA** 3LO Melbourne AUG 23 1155 - Noted here several times with Aussie talk, mixing with JOUB.
- 774 **JAPAN** JOUB *NHK-2* Akita AUG 23 1123 - Heard most mornings of the DXpedition.
- 792 **AUSTRALIA** 4RN Brisbane AUG 23 1124 - Heard most mornings.
- 828 **AUSTRALIA** 3GI Sale AUG 23 1340 - Noted here long after sunrise parallel 774 Melbourne.
- 828 **JAPAN** JOBB *NHK-2* Osaka AUG 23 1125 - Heard most mornings of the DXpedition.
- 846 **AUSTRALIA** 2RN Canberra AUG 25 1225 - Heard parallel 792 4RN Brisbane. Canberra heard several times before, but will never answer a reception report. Will try again.
- 846 **KIRIBATI** *R.Kiribati Betio*, Tarawa AUG 23 1320 - Tentative this one, on 24 hours? Continuous island music. Fair level. Heard also Aug 24.
- 855 **AUSTRALIA** 4QB Pialba AUG 23 1348 - Noted here long after sunrise parallel 774 Melbourne.
- 855 **NORTH KOREA** *Pyongyang Bangsong*, Sangwon AUG 24 1242 - Noted here each morning with usual slightly off-frequency showing.
- 873 **JAPAN** JOGB *NHK-2* Kumamoto AUG 23 1126 - Heard most mornings of the DXpedition, but always weaker than 747, 774, and 828 kHz.
- 882 **NEW ZEALAND** 1YC Auckland AUG 25 1316 - Heard at fair level running the *Southern Star* program stream.
- 891 **AUSTRALIA** 4TAB Innisfail AUG 25 1228 - ID heard by Guy. Sports talk dominating co-channel 5AN Adelaide. A new one for me. Fair level, sometimes dominating, sometimes mixing with Adelaide.
- 891 **AUSTRALIA** 5AN Adelaide AUG 23 1334 - Noted here most mornings of the DXpedition. Usually only at fair levels.
- 927 **AUSTRALIA** 4CC Gladstone AUG 26 1328 - Noted in passing with usual pop music program and cheeky/cheery '4-Double-C Gladstone' ID.
- 936 **AUSTRALIA** 7ZR Hobart AUG 26 1332 - Heard at just above threshold level, but absolutely parallel ABC 702 kHz.
- 945 **JAPAN** *NHK-1* synchros AUG 26 1243 - Noted here at poor level parallel 594 kHz.
- 954 **JAPAN** JOKR Tokyo AUG 23 1322 - Heard here most mornings of the DXpedition.
- 963 **CHINA** *CRI Russian Service*, unknown location AUG 23 1308 - Heard most mornings.
- 963 **NEW ZEALAND** 3YC Christchurch AUG 26 1310 - Heard here at fair level with usual quiet pops programming from *Southern Star*.
- 972 **SOUTH KOREA** HLCA Dangjin AUG 23 1130 - Heard most mornings of the DXpedition.
- 981 **AUSTRALIA** 2NM Muswellbrook AUG 25 1331 - '2NM, The Music Station!' was a new one for me, again IDed by Guy, playing an expanded oldies format. Fair to good level.
- 981 **CHINA** *CRI* unknown location AUG 23 1205 - Noted here most mornings, often with echos from multiple locations.
- 1008 **JAPAN** JONR Osaka AUG 23 1131 - Heard here weakly in Japanese by two men.
- 1044 **CHINA** *CRI* Changzhou AUG 23 1132 - Heard here with Japanese Service most mornings of the DXpedition.
- 1053 **JAPAN** JOAR Nagoya AUG 23 1310 - Heard here most mornings of the DXpedition. The Korean jammer on this frequency often seems to go off at 1300, leaving JOAR in the clear.

- 1062 **CHINA** *Zuijiang JDG, Guangzhou* AUG 24 1300 - 3+1 pips and into the news in probably Cantonese at fair to good level. I rarely hear stations from this far south in China (Canton) even during the October 'Chinese season.'
- 1062 **SOUTH KOREA** *HLKQ Cheongju* AUG 26 1257 - Was looking for DZEC here and found the Korean instead, at a quite good level.
- 1098 **MARSHALL ISLANDS** *V7AB R.Marshalls, Majuro* AUG 23 1200 - Presume this. The usual source for a huge persistent open carrier heard here most mornings of the DXpedition. Also heard Aug 26 at 1110. Fair level with pop music show hosted by female, seemingly on after their scheduled 1030 sign off.
- 1107 **AUSTRALIA** *2EA Sydney* AUG 23 1350 - Heard here with Aussie talk and mentions. Fair to poor long after sunrise.
- 1116 **AUSTRALIA** *4BC Brisbane* AUG 23 1357 - Heard most mornings of the DXpedition, but not with the dominant signals heard in recent years. Usually only heard late and at fair to poor levels.
- 1134 **JAPAN** *JOQR Tokyo* AUG 23 1255 - Heard at fair level with usual culturally-oriented programming.
- 1143 **TAIWAN** *Taiwan Area Fisheries BS* AUG 24 1305 - Presume this one (it is the usual dominant) in standard Chinese at good level.
- 1161 **TAIWAN** *BED-86 Ilan* AUG 24 1240 - Heard with folk opera at good level. Very tentative, but BCC QSLed this from a CD a couple of years ago with similar programming.
- 1170 **SOUTH KOREA** *RKI Japanese Service, Gimje* AUG 24 1220 - Heard here absolutely dominating regional powerhouse KPUG Bellingham, WA. Heard occasionally before from Grayland, during excellent East Asian openings.
- 1224 **JAPAN** *JOJK NHK-1 Kanazawa* AUG 24 1220 - Heard at fair level parallel 594 kHz.
- 1233 **AUSTRALIA** *2NC Newcastle* AUG 26 1350 - Heard poorly with ABC Metro Service parallel 702 just at band fade.
- 1278 **CHINA** *Hebei RGD, Shijiazhuang* AUG 24 1140 - Presume this one with standard Chinese talk at good level.
- 1287 **AUSTRALIA** *2TM Tamworth* AUG 25 1341 - Heard quite a while after dawn with a pop music show, hosted by male. Fair only.
- 1287 **JAPAN** *JOHR Sapporo* AUG 23 1245 - Heard here most mornings of the DXpedition.
- 1323 **CHINA** *CRI Jilin* AUG 23 1135 - Heard here with Russian Service at fair level.
- 1332 **AUSTRALIA** *4BU Bundaberg* AUG 25 1343 - Presume this the one heard with Aussie talk at band fade.
- 1332 **JAPAN** *JOSF Nagoya* AUG 24 1150 - Fair level with Japanese talk by female.
- 1350 **JAPAN** *JOER Hiroshima* AUG 24 1311 - Good to hear this relatively rare station running well over co-channel Santa Rosa, CA (with news in Japanese).
- 1386 **JAPAN** *NHK-2 synchros* AUG 26 1120 - Noted here at poor level in Japanese parallel 774 and 828 kHz.
- 1386 **CHINA** *Tianjian Life, Tianjin* AUG 24 1202 - Tentative this illusive one at poor level in Chinese. Tianjian is the port city for Beijing, on the Yellow Sea and should be very easy to hear. Not so for me.
- 1400 **JAPAN** *JOWF Sapporo* AUG 23 1203 - Heard here overpowering US co-channel stations. This is a fairly common occurrence during good Japanese openings at Grayland.
- 1413 **JAPAN** *JOIF Fukuoka* AUG 24 1204 - Noted here in passing at good level with national news.
- 1422 **JAPAN** *JORF Yokohama* AUG 24 1312 - Noted in passing at fair level with Japanese talk.
- 1475 **MALAYSIA** *RTM Sabah, Kota Kinabalu* AUG 26 1333 - Heard first by Guy Atkins, but noted here also at fair to poor level with usual Islamic broadcast to the southern Philippines.
- 1503 **NEW ZEALAND** *R.Sport, Wellington* AUG 23 1259 - Possibly running American sports programming (Fox?). Fair only.
- 1512 **PHILIPPINES** *DYAB Cebu City* AUG 24 1315 - Presume this the one (there is another Filipino, co-channel) in a mixture of Tagalog and English by both man and woman speakers. Will be reporting with a recording.
- 1512 **AUSTRALIA** *2RN Newcastle* AUG 25 1344 - Heard parallel 4RN Brisbane on 792 near band fade.
- 1548 **AUSTRALIA** *4QD Emerald* AUG 23 1138 - Heard here most mornings of the DXpedition, though usually weakly.
- 1566 **SOUTH KOREA** *HLAZ Cheju Island* AUG 23 1246 - Heard here most mornings.
- 1566 **AUSTRALIA** *3NE Wangaratta* AUG 25 1346 - No sign of usually dominant HLAZ at band fade. 3NE running their usual pop music format.

- 1575 **THAILAND** VOA Ban Phachi AUG 23 1203 - Noted here most mornings of the DXpedition.
- 1593 **CHINA** CRI, unknown location AUG 24 1210 - Heard here often with a huge signal during most mornings.

73 and Good DX!

NRC Contest

Bruce Conti nrcidxd@aol.com
46 Ridgefield Drive
Nashua, NH 03062-1174

An annual DX contest which encourages DX'ing and offers prizes

2007-08 DX Contest

1000 by Land, 2000 by Sea

The season-long contest begins September 17, 2007, and ends April 14, 2008. There are two groups in which to compete; Land-Locked and Sea Gain. The rules are simple:

- If the receiver location is within 60 miles of open salt water and/or signals over long distance salt water paths are routine, then you should enter the **Sea Gain** group. Coastal New England and Hawaii are good candidates for the Sea Gain group.
- If the receiver location is land-locked, such as Atlanta, Denver, Topeka, Toronto, etc., then of course you will be entered in the **Land-Locked** group.
- You may enter only one group. Please indicate which group you wish to enter. The 60-mile rule of separation between Land-Locked and Sea Gain is flexible. The contest manager reserves the right to determine the appropriate group in the interest of fairness.
- Scoring is easy: For the Land-Locked group, every station logged at a distance greater than or equal to 1000 miles is worth one point. For the Sea Gain group, every station logged at a distance greater than or equal to 2000 miles is worth one point.
- Participation in one group does not limit the type of logs submitted. In other words, if the receiver location is Ohio and thus belonging to the Land-Locked group, logs submitted may include transoceanic reception of Croatia, Spain, etc. The same applies for the Sea Gain group which may include transcontinental logs of California, New York, etc.
- This is a mediumwave broadcast contest. Only logs of broadcast signals 530 to 1710 kHz are eligible.
- The contest entrant must be a member of the NRC (print and/or electronic) or DXAS in good standing to be eligible for prizes, including a grand prize one-year NRC/DXAS membership extension and for mid-contest longest distances the *World Radio TV Handbook*.
- Please send entries via e-mail to BAConti@aol.com or by postal delivery to 46 Ridgefield Drive, Nashua NH 03062-1174. Don't forget to include the receiver location with a street address or coordinates for verification purposes.

Longest Distance Contest

Just as in the past, there is a mid-contest longest distance competition. Winners will be selected from all entries received as of January 11, 2008. Participation in the season-long contest is optional; you may choose only to submit your longest distance received thus far during the contest period beginning September 17. If entering the longest distance contest only, please indicate it in your entry. The number of longest distance prize winners will be determined by what's available from the NRC Prize Vault.

In addition to Land-Locked and Sea Gain entries during the contest period, entries will be accepted for *the longest distances of all time*, in celebration of the **NRC 75th Anniversary**. To enter the 75th Anniversary longest distance contest, simply submit your personal longest distance record whether it's from 1933, 2007, or sometime between. The entry should be a formal log report to be eligible, including frequency, station callsign/name and location, time/date, reception details, receiver location and equipment used. Even if you don't believe you have a chance of winning, please submit your personal best for inclusion in the 75th Anniversary longest distance mid-contest compilation.

Thank you in advance to all who are brave enough to enter. I'll be looking forward to your reports and another exciting contest. 73 and Good Luck!

Professional Sports

Networks

Barry S. Finkel bsfinkel@ANL.gov
10314 S. Oakley
Chicago, IL 60643-2409

Network listings for team sports stations

Here is National Football League flagship information from my Internet searches. Note that many of the list web pages have a "do not reproduce" warning, so all I can reproduce here is the URL. Please send me any of these missing network lists or any announcer names that you have. And please correct any incorrect information herein. Note that all of the network lists are subject to change throughout the season. Thanks.

Arizona Cardinals	620	KTAR-AZ	(EE)	Dave Pasch, Ron Wolfey, Paul Calvisi
	800	KMVP-AZ		
Atlanta Falcons	92.9	WZGC-GA		Wes Durham, Dave Archer, Nicole Watson
Baltimore Ravens	1090	WBAL-MD		Gerry Sandusky
	97.9	WIYY-MD		
Buffalo Bills	96.9	WGRF-NY		John Murphy, Mark Kelso, Rich Gaensler
	103.3	WEDG-NY		
Carolina Panthers	1110	WBT -NC		MickMixon, Eugene Robinson, Jim Szoke, David Langton
	99.3	WBT -NC		
Chicago Bears	780	WBBM-IL		Jeff Joniak, Tom Thayer
Cincinnati Bengals	1360	WCKY-KY		Brad Johansen, Dave Lapham
	92.5	WOFX-OH		
	700	WLW -OH		
Cleveland Browns	100.7	WMMS-OH		Jim Donovan, Doug Dieken, Mike Snyder
	1100	WTAM-OH		
Dallas Cowboys	93.3	KDBN-TX	(EE)	Brad Sham, Charlie Waters, Kristi Scales
	1310	KTCK-TX	(EE)	
	104.1	KTCK-TX	(EE)	
	99.1	KFZO-TX	(SS)	Victor Villalba, Andres Arce, Luis Perez
	1270	KFLC-TX		
Denver Broncos	850	KOA -CO	(EE)	Dave Logan, Dave Diaz-Infante
Detroit Lions	97.1	WKRK-MI		-Dan Miller, Jim Brandstatter, Tony Ortiz
Green Bay Packers	620	WTMJ-WI		Wayne Larrivee, Larry McCarren
Houston Texans	610	KILT-TX		Marc Vandermeer, Andre Ware, John Granato
	100.3	KILT-TX		
Indianapolis Colts	1070	WIBC-IN		--Bob Lamey, Mark Hermann, Ted Marchibroda
	97.1	WLHK-IN		
Jacksonville Jaguars	690	WOKV-FL		Jeff Lageman, Brian Sexton
	96.9	WKQL-FL		
Kansas City Chiefs	101.1	KCFX-MO		Mitch Holthus, Len Dawson, Bill Grigsby, Bob Gretz
Miami Dolphins	560	WQAM-FL		Jimmy Cefalo, Jim Mandich, Joe Rose
Minnesota Vikings	1130	KFAN-MN		Pete Berich, Paul Allen, Greg Coleman
	107.9	KOOL-MN		
New England Patriots	104.1	WBCN-MA		-Gil Santos, Gino Cappelletti
New Orleans Saints	870	WWL -LA	(EE)	Jim Henderson, Hokie Gajan, Kennie Wilkerson
	105.3	WWL -LA		
	830	WFNO-LA	(SS)	Marco Garcia, Hector Pineda
New York Giants	660	WFAN-NY		--Bob Papa, Dick Lynch, Dave Jennings
New York Jets	770	WABC-NY	(EE)	Bob Wischusen, Marty Lyons
	1050	WEPN-NY		
	1280	WADO-NY	(SS)	??
Oakland Raiders	560	KSFO-CA		-Greg Papa, Tom Flores
Philadelphia Eagles	95.1	WYSP-PA		Merrill Reese, Mike Quick

Pittsburgh Steelers	970	WBGG-PA	Bill Hillgrove, Tunch Ilkin, Craig Wolfley
	102.5	WDVE-PA	
Saint Louis Rams	550	KTRS-MO	-Stan Savran, Mark Malden
	103.3	KLOU-MO	
San Diego Chargers	105.3	KIOZ-CA (EE)	Josh Lewin, Hank Bauer, Jim Laslavic
	1420	XEXX-BC (SS)	Jorge Villanueva, Efren Dominguez
San Francisco 49ers	680	KNBR-CA	Joe Starkey, Gary Plummer, Rod Brooks
	1050	KNBR-CA	
	107.7	KSAN-CA	
Seattle Seahawks	710	KIRO-WA	Steve Raible, Warren Moon
Tampa Bay Buccaneers	620	WDAE-FL	-Dave Moore, Scot Brantley, Ronnie Lane
	103.5	WFUS-FL	
Tennessee Titans	103.3	WKDF-TN	Mike Keith, Frank Wycheck, Larry Stone
Washington Redskins	930	WXTR-VA	-Sam Huff, Larry Michael, Sonny Jurgensen
	94.3	WWXT-DC	
	92.7	WWXX-DC	

Arizona Cardinals 2007 Dave Pasch, Ron Wolfey, Paul Calvisi

<http://www.azcardinals.com/multimedia/partners.php> (as of June, 2007) (07/30/2007)

560	KBLU-AZ	980	KNTR-AZ	1250	KHIL-AZ	
600	KVNA-AZ	1130	KQNA-AZ	1330	KJLL-AZ	92.1 KZUA-AZ
620	KTAR-AZ *a	1150	KDEF-NM	1340	KIKO-AZ	92.3 KTAR-AZ *a
710	KMIA-AZ S*	1230	KATO-AZ	1420	KTAN-AZ	106.7 KPPV-AZ
780	KAZM-AZ					

Atlanta Falcons 2007 Wes Durham, Dave Archer, Nicole Watson

http://www.atlantafalcons.com/Schedule/Radio_and_TV_Coverage/Radio_Affiliates.aspx (08/14/2007) DNR DO NOT REPRODUCE

Baltimore Ravens 2007 Gerry Sandusky

<http://www.baltimoreravens.com/Gameday/Schedule.aspx?id=80> (09/06/2007)

"Check back soon for more information on the new affiliate line-up, broadcast team and more."
DO NOT REPRODUCE

Buffalo Bills 2007 John Murphy, Mark Kelso, Rich Gaensler

<http://www.buffalobillsradio.com/> (08/30/2007)

920	WKRT-NY	1300	WTMM-NY		99.3	WWSE-NY
1160	WPIE-NY	1330	WSPQ-NY	93.5	WOKR-NY	100.1 WBRR-NY
1240	WGVA-NY	1380	WABH-NY	95.7	WPIG-NY	101.9 WZKZ-NY
	WJTN-NY	1410	WELM-NY	96.5	WBKX-NY	103.3 WEDG-NY *
1260	WNSS-NY	1420	WACK-NY		WCMF-NY	103.5 WQBK-NY
	WRIE-PA	1570	WFLR-NY	96.9	WGRF-NY *	103.9 WQBJ-NY
1290	WNBF-NY	1590	WAUB-NY			

Carolina Panthers 2007 Mick Mixon, Eugene Robinson, Jim Szoke, David Langton

<http://www.panthers.com/Multimedia/Default.aspx?id=1596> (08/30/2007)

DO NOT REPRODUCE

Cleveland Browns 2007 Jim Donovan, Doug Dieken, Mike Snyder

<http://www.clevelandbrowns.com/gameday/air.php> (08/14/2007)

		1590	WAKR-OH			
790	WHTH-OH	1240	WHIZ-OH 1	1450	WLEC-OH	
910	WBRJ-OH		WQFX-OH	1460	WBKC-OH	92.7 WQEL-OH
930	WEOL-OH	1280	WONW-OH		WYSL-OH	93.3 WNCD-OH
970	WFUN-OH	1340	WNCO-OH	1480	WHBC-OH	94.3 WKKI-OH
980	WONE-OH	1400	WMAN-OH	1490	WMRN-OH	95.3 WKTN-OH
1100	WTAM-OH *	1450	WJER-OH	1540	WBTC-OH	100.7 WMMS-OH *
						102.7 WCPZ-OH
						104.5 WQKT-OH
						104.7 WIOT-OH
						105.7 WFJX-OH
						106.3 WCDK-OH
						107.5 WZRZ-OH
						107.7 WPFX-OH

Cincinnati Bengals 2007 Brad Johansen, Dave Lapham

<http://www.bengals.com/team/OntheAir.html> (08/14/2007)

DO NOT REPRODUCE

Chicago Bears 2007 Jeff Joniak, Tom Thayer

The 2006 network list is still online.

Dallas Cowboys (EE) 2007 Brad Sham, Charlie Waters, Kristi Scales

<http://www.dallascowboys.com/dcradio.cfm> (08/16/2007)

DO NOT REPRODUCE

Dallas Cowboys (SS) 2007 Victor Villalba, Andres Arce, Luis Perez

The Dallas Cowboys Spanish Language Radio Network Cadena de Plata Radio

<http://www.dallascowboys.com/dcradio.cfm> (08/16/2007)

DO NOT REPRODUCE

Denver Broncos (EE) 2007 Dave Logan, Dave Diaz-Infante

<http://broncosradionetwork.com/pages/network.html> (09/04/2007)

550	KRAI-CO	1230	KBCR-CO	1350	KABQ-NM		KGOS-WY
	KFYR-ND s		KXLO-MT	1380	KOTA-SD		KUGR-WY
580	KUBC-CO	1240	KDGO-CO	1400	KWUF-CO		
600	KCOL-CO		KASL-WY		KAYS-KS	92.5	KCRT-CO
610	KCSR-NE		KRAL-WY		KCOW-NE		KLZY-WY
650	KGAB-WY		KTHE-WY		KSHP-NV	93.5	KALQ-CO
730	KLOE-KS	1260	KPOW-WY		KBJM-SD	96.1	KSTR-CO
790	KGHL-MT	1270	KIML-WY		KODI-WY	96.5	KDZN-MT
850	KOA -CO *	1290	KOWB-WY	1410	KOOQ-NE	96.9	KDAG-NM
930	KRKY-CO	1300	KVOR-CO		KWYO-WY	99.1	KMTS-CO
950	KDCE-NM	1310	KFKA-CO	1450	KMMS-MT	100.1	KMMR-MT
	KMER-WY	1340	KVRH-CO		KBFS-SD	102.3	KSPK-CO
960	KNEB-NE		KPOK-ND		KBBS-WY	103.1	KYDT-WY
990	KSVP-NM		KWOR-WY		KVOW-WY	104.7	KSKE-CO
1010	KSIR-CO		KYCN-WY	1470	KKTY-WY	106.1	KNFO-CO
1030	KTWO-WY	1350	KGHF-CO	1490	KPKE-CO		KOAL-MT
1180	KOFI-MT						

Detroit Lions 2007 Dan Miller, Jim Brandstatter, Tony Ortiz

http://www.detroitlions.com/document_display.cfm?document_id=4206 (09/04/2007)

I am not sure that this is the 2007 list, as the header mentions "In 2005".

DO NOT REPRODUCE

Green Bay Packers 2007 Wayne Larrivee, Larry McCarren

http://www.packers.com/multimedia/radio_shows/packers_radio_network/station_listing/ (07/30/2007)

550	KFYR-ND s	1240	WOMT-WI	94.3	WQPC-WI	101.1	WIXX-WI
	WSAU-WI	1310	WIBA-WI	95.9	WMQA-WI	101.5	WJNR-MI
570	WMAM-WI	1330	WHBL-WI	96.1	WJMC-WI		WIBA-WI
580	WKTY-WI	1360	WTAQ-WI	97.1	WGLQ-MI	102.3	WHKB-MI
620	WTMJ-WI *	1400	WATW-WI		WCOW-WI		WAUH-WI
710	WDSM-WI		WBIZ-WI	97.7	WGLR-WI		WHTL-WI
940	KPSZ-IA q	1430	WBEV-WI	98.3	WCQM-WI	102.9	WBDL-WI
	WFAW-WI	1450	KFIZ-WI	99.1	WIKB-MI	103.7	WHYB-WI
960	WTCH-WI	1550	WEVR-WI	99.3	WKEB-WI	104.1	WRLU-WI
1140	KSOO-SD o			99.7	WIMI-MI	105.1	WSBW-WI
1150	WHBY-WI	92.1	WMEQ-WI	99.9	WIZD-WI	105.3	WRLO-WI
1220	KLBB-MN	92.3	WJMQ-WI		WJVL-WI	105.7	WXCX-WI
1230	WCLO-WI		WRLS-WI	100.7	WBIZ-WI	106.3	WEVR-WI
1240	WJMC-WI	92.7	WDUX-WI	100.9	WRCO-WI	107.1	WFON-WI
	WOBT-WI	93.3	WBSZ-WI				

Houston Texans 2007 Marc Vandermeer, Andre Ware, John Granato

http://www.houstontexans.com/gameday/radio_network.asp (07/30/2007)

DO NOT REPRODUCE

Jacksonville Jaguars 2007 Jeff Lageman, Brian Sexton

I have not located a 2007 network list.



Indianapolis Colts Vectren Radio Network 2007 --Bob Lamey, Mark Hermann, Ted Marchibroda
http://www.colts.com/sub.cfm?page=broadcast_dynamic&id=92 (08/14/2007)

860	WMRI-IN	1420	WVJS-IN	92.1	WROI-IN	101.7	WURK-IN
990	KWAM-IN	1460	WJCP-IN		WZDM-IN	103.1	WGBF-IN
1070	WIBC-IN *	1490	WDAN-IN	94.3	WKWH-IN	103.3	WAXL-IN
1190	WOWO-IN		WKBV-IN		WREB-IN	103.9	WIMC-IN
1230	WSAL-IN	1510	WJOT-IN	94.5	WRZR-IN	105.5	WWVR-IN
	WTCJ-IN	1550	WNDI-IN	94.9	WYNG-IN	105.9	WJOT-IN
1340	WBIW-IN	1570	WWSZ-IN	95.3	WNDI-IN	106.5	WWBL-IN
	WTRC-IN	1590	WKPT-IN	95.9	WEFM-IN	106.7	WYFX-IN
	WXFN-IN	1600	WTSZ-IN	96.7	WORX-IN	107.3	WRZQ-IN
1370	WGCL-IN			97.1	WLHK-IN *	107.7	WMRS-IN

Kansas City Chiefs 2007 Mitch Holthus, Len Dawson, Bill Grigsby, Bob Gretz
<http://www.kcchiefsradio.com/affiliatestations.asp> (08/05/2007)

590	KXSP-NE	1350	KMAN-KS	1550	KKLE-KS	99.1	KYOO-MO
680	KFEQ-MO	1360	KBKB-IA	1600	KMDO-KS	99.3	KKBZ-IA
690	KGGF-KS	1370	KALN-KS			99.9	KSKG-KS
790	KXXX-KS	1400	KWON-IA	92.3	KSDL-MO	100.3	KDVV-KS
860	KKOW -KS		KGMV-MO	92.7	KSJQ-MO		KQLS-KS
870	KAAN-MO		KRFU-MO	93.5	KLKC-KS	100.9	KCLY-KS
940	KPSZ-IA q		KREF-OK j	94.5	KRXL-MO	101.1	KCFX-MO *
990	KRMO-MO	1420	KJCK-KS	95.1	KAMS-AR	101.7	KVOE-KS
1130	KLEY-KS		KBTN-MO	95.3	KDKD-MO	102.9	KMMO-MO
1150	KRMS-MO		KRLL-MO	95.5	KAAN-MO	103.1	KDAA-MO
1220	KJAN-IA	1430	KRGI-NE	96.7	KBBE-KS	103.9	KOMB-KS
1230	KTNC-AR	1450	KWBW-KS	96.9	KFIX-KS	104.3	KVGB-KS
	KLWT-MO		KOKO-MO		KKOW-KS	105.5	KKOY-KS
1240	KLIK-MO	1490	KBIX-IA	97.1	KYAL-IA	105.9	KULH-MO
	KFOR-NE	1540	KLKC-KS		KAYQ-MO	107.1	KSFT-IA
1300	KMMO-MO		KNGL-KS	97.3	KKJQ-KS	107.3	KTHR-KS
1350	KRNT-IA	1550	KYAL-IA		KXUS-MO		

Miami Dolphins 2007 Jimmy Cefalo, Jim Mandich, Joe Rose

<http://www.miamidolphins.com/newsite/dolfanzone/radionetwork.asp> (08/16/2007)

550	WASG-FL	1240	WMMB-FL	1600	WKWF-FL	99.5	WBXY-FL i
560	WQAM-FL *	1300	WFFG-FL			103.7	WQOL-FL
610	WVTJ-FL	1410	WHBT-FL	93.5	WBGF-FL	105.9	WOCL-FL
760	WEFL-FL	1590	WPSL-FL i	95.3	WRXX-FL c	106.1	WLVO-FL

Minnesota Vikings 2007 Pete Berich, Paul Allen, Greg Coleman

<http://www.purplepride.org/gameday/radio.cfm> (09/01/2007)

purplepride.org is an independent fan site and not associated with the Minnesota Vikings

570	KNAX-SD	1230	KTRF-MN	1450	KATE-MN	95.9	KQCL-MN
600	KEYZ-ND		KWNO-MN		KBUN-MN	96.7	KDOG-MN
610	KDAL-MN	1240	WJON-MN		KBMW-ND	96.9	KMFY-MN
650	WKKQ-MN		KLDR-ND	1470	KHDN-ND	99.7	KXDL-MN
790	KFGO-ND	1250	KBRF-MN	1490	KLGR-MN	100.5	KXAC-MN
910	KJJQ-SD	1260	KROX-MN		KXRA-MN	101.1	KBHP-MN
920	KDHL-MN	1270	KWEB-MN		KOVC-ND	101.5	KTOF-MN
930	KKIN-MN		KLXX-ND	1570	WKBH-WI	101.7	KOLV-MN
	KSDN-SD	1290	KSCR-MN			102.5	KMFX-MN
950	KWAT-SD	1300	KGLO-IA	92.1	KRUE-MN		KDVL-ND
1060	KGFX-SD	1340	KDLM-MN		WCMP-MN	102.7	KYTC-MN
1130	KFAN-MN *		KWLM-MN		WYRQ-MN	104.3	KNFX-MN
1140	KSOO-SD o	1390	KRFO-MN	93.5	KITN-MN	105.1	KARL-MN
1190	KMFX-MN		KRRZ-ND		KSCR-MN	105.5	KASM-MN
1210	KOKK-SD	1400	KQDJ-ND	94.3	KEZZ-MN	106.3	KRJB-MN
1220	KDDR-ND	1410	KRWB-MN		KMSR-MN	107.3	KNUJ-MN
1230	KGHS-MN	1440	KKXL-ND	95.7	KKOK-MN	107.9	KOOL-MN *

New England Patriots 2007 -Gil Santos, Gino Cappelletti

<http://wbcn.com/pages/58654.php> (08/05/2007)

790	WSKO-RI	1420	WBEC-MA	95.3	WPVQ-MA	102.1	WAQY-MA
860	WSBS-MA		WBSM-MA	95.7	WWMJ-ME		WSAK-NH
900	WGAM-NH	1450	WSNO-VT	96.7	WXZO-VT	102.3	WXML-CT
960	WEAV-NY	1480	WSAR-MA	98.5	WEBB-ME	102.9	WBLM-ME
1230	WNAW-MA	1490	WIKE-VT	99.7	WSKO-RI	103.7	WPKQ-NH
1250	WKBR-NH			100.1	WWFX-MA	104.1	WBCN-MA *
1340	WGAW-MA	92.7	WKVT-VT	101.5	WWHQ-NH	105.3	WSHK-NH
	WSTJ-VT	93.9	WMXR-VT		WEXP-VT	106.9	WCCC-CT
1350	WINY-CT	95.1	WXTK-MA	101.7	WVRR-NH	107.7	WTPL-NH
1370	WBTN-VT						

New Orleans Saints (EE) 2007 Jim Henderson, Hokie Gajan, Kennie Wilkerson**New Orleans Saints (SS) 2007** Marco Garcia, Hector Pineda

<http://www.neworleanssaints.com/Home/News/Saints%20Radio.aspx> (08/16/2007)

540	KNOE-LA	1260	WGVM-MS k	93.1	WYAB-MS	101.3	KKGB-LA
640	KTIB-LA	1290	KJEF-LA	93.4	KJAE-LA	103.3	WZKR-MS
680	WJDX-MS	1370	WCOA-FL	94.3	KRLQ-LA	104.3	KEZP-LA
830	WFNO-LA S*	1420	WQBC-MS	95.3	KQKI-LA	104.6	WCJU-MS
870	WWL -LA *	1450	WJIX-MS		WRKG-MS	105.1	KTYK-LA
920	WBOX-LA	1520	KVPI-LA	96.5	WXHB-MS	105.3	WWL -LA *
1130	KWKH-LS			97.3	KMDL-LA	105.5	WNSP-AL
1150	WJBO-LA	92.1	KLIL-LA		WNJJ-MS	107.1	WKNZ-MS
1240	KANE-LA	92.2	WBOX-LA	98.3	WJDR-MS	107.5	KCIL-LA
1250	WHNY-MS	92.5	KVPI-LA				

New York Giants 2007 --Bob Papa, Dick Lynch, Dave Jennings

<http://www.giants.com/multimedia/broadcastinfo.asp> (09/04/2007)

I am not sure that this is the 2007 list; the page has a 2006 copyright.

DO NOT REPRODUCE

New York Jets (EE) 2007 Bob Wischusen, Marty Lyons

New York Jets (SS) 2007 ??

No Network

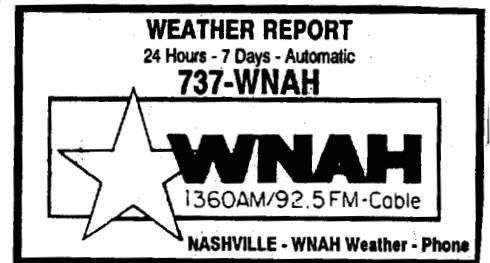
**Oakland Raiders 2007** -Greg Papa, Tom Flores

<http://www.raiders.com/Multimedia/Default.aspx?id=180> (08/14/2007)

DO NOT REPRODUCE

Philadelphia Eagles 2007 Merrill Reese, Mike Quick

<http://www.philadelphiaeagles.com/multimedia/radioinformation.jsp> (08/05/2007)

830	WEEU-PA	1490	WBCB-PA	94.1	WYSP-PA *	103.7	WMGM-NJ
1150	WDEL-DE			96.1	WCTO-PA	105.7	WQXA-PA
1360	WPPA-PA	93.3	WBZD-PA	97.9	WBSX-PA	107.3	WEGH-PA

Pittsburgh Steelers 2007 Bill Hillgrove, Tunch Ilkin, Craig Wolfley

<http://www.steelers.com/gameday/broadcasts/> (08/14/2007)

540	WFRB-MD	1290	WDNE-WV	1460	WMBA-PA	98.7	WQWK-PA
590	WMBS-PA	1320	WGET-PA	1480	WCNS-PA	99.1	WRKW-PA
630	WJAW-WV	1330	WFIN-OH	1490	WESB-PA	100.9	WAYC-PA
680	WISR-PA		WFNN-PA	1590	WPSN-PA	102.1	WOWQ-PA
800	WCHA-PA	1340	WYCK-PA			102.5	WDVE-PA *
850	WNTJ-PA	1400	WICK-PA	92.5	WQMU-PA	103.3	WAJR-WV
920	WMMN-WV	1410	WHAG-MD	92.7	WCCR-PA	103.7	WZXR-PA
970	WBGH-PA *	1430	WVAM-PA	93.3	WCXR-PA	103.9	WLSW-PA
990	WNTW-PA		WEIR-WV	93.5	WTPA-PA	104.1	WPXZ-PA
1170	WWVA-WV	1450	WTBO-MD	94.3	WUZZ-PA	104.3	WKNB-PA
1230	WBVP-PA		WJPA-PA		WRLF-WV	104.9	WRKY-PA
1280	WFBS-PA		WMAJ-PA	95.1	WWGY-PA	105.5	WCHX-PA
						106.1	WBBG-OH
						107.7	WUUZ-PA

Saint Louis Rams 2007 -Stan Savran, Mark Malden

I have not located a 2007 network list.

San Diego Chargers (EE) 2007 Josh Lewin, Hank Bauer, Jim Laslavic

San Diego Chargers (SS) 2007 Jorge Villanueva, Efren Dominguez

<http://www.chargers.com/broadcasting/radio-network.htm> (09/27/2006) DNR

DO NOT REPRODUCE

San Francisco 49ers (EE) 2007 Joe Starkey, Gary Plummer, Rod Brooks

San Francisco 49ers (SS) 2007 ??

http://49ers.com/team/on_radio.php?section=TE%20On%20Radio (08/16/2007)

DO NOT REPRODUCE

Seattle Seahawks 2007 Steve Raible, Warren Moon

The 2006 network list is still online.

Tampa Bay Buccaneers 2007 -Dave Moore, Scot Brantley, Ronnie Lane

<http://www.buccaneers.com/news/newsdetail.aspx?newsid=4660> (09/04/2007)

DO NOT REPRODUCE

Tennessee Titans 2007 Mike Keith, Frank Wycheck, Larry Stone

<http://www.titansradio.com/stationsal.html> (09/01/2007)

<http://www.titansradio.com/stationstarms.html> (09/01/2007)

<http://www.titansradio.com/stationstn.html> (09/01/2007)

<http://www.titansradio.com/stationsky.html> (09/01/2007)

570	WKYX-KY	1220	WAXO-TN	1440	WHDM-TN	99.3	WPBX-TN
640	WXSM-TN		WFWL-TN	1450	WTCO-KY	100.1	WASL-TN
690	WJOX-AL	1240	KWAK-AR	1490	WOMI-KY	100.3	WNOX-TN
740	WRWB-TN		WPBQ-MS		WCOR-TN	100.7	WDMS-MS
790	WQSV-TN	1260	WGVM-MS k	1560	WPAD-KY	101.3	WCMT-TN
860	WSON-KY		WDKN-TN	1570	WNKX-TN	102.3	WGOW-TN
870	WMTL-KY	1270	WQKR-TN	1580	WPKY-KY		WZDQ-TN
930	WJBY-AL	1280	WDNT-TN			103.3	WKDF-TN *
	WWON-TN		WMCP-TN	92.7	WAFN-AL	103.7	WPTQ-KY
950	WAKM-TN	1320	WNGO-KY	93.5	WKWX-TN	104.7	WMUF-TN
970	WXQK-TN		WMSR-TN	93.7	WBXE-TN	104.9	WKHG-KY
1000	WMUF-TN	1340	WFEB-AL	95.7	WCCK-KY		WQLA-TN
1050	WWIC-AL		WNBS-KY	95.1	WRIT-AL	105.5	KWAK-AR
1060	WQMV-TN		WCDT-MS	96.7	WNKX-TN		WYTM-TN
1070	WEKT-KY		WBAC-TN	97.3	WKJQ-TN	105.7	WQAK-TN
1090	WTNK-TN	1370	WDXE-TN	97.7	WWKY-KY	106.5	WKDZ-KY
1110	WKRA-MS	1400	WIEL-KY	98.1	WXXM-TN	107.3	WQLT-AL
1130	WRKY-KY		WJZM-TN	98.3	WKSR-TN		WTRZ-TN
1150	WCRK-TN		WZNG-TN	98.9	WANT-TN	107.7	WTRZ-TN
	WGOW-TN	1410	WCMT-TN				

Washington Redskins 2007 -Sam Huff, Larry Michael, Sonny Jurgensen

<http://www.redskins.com/news/bcinfo.jsp> August 13, 2007 (08/14/2007)

550	WSVA-VA	1050	WBRG-VA p	92.7	WVXX-DC *	98.3	WSMD-MD
610	WTFX-VA	1200	WAGE-VA	93.1	WSVO-VA	99.1	WXGM-VA
730	WXTR-DC *	1420	WXGM-VA	94.3	WWXT-DC *	99.3	WFQX-VA
740	WRNR-WV	1430	WNAV-MD	95.9	WOSC-MD	99.9	WFRE-MD
950	WXGI-VA	1490	WSTP-NC		WGRQ-VA	105.5	WRAR-VA
960	WFIR-VA						

- = announcers from last season

-- = announcers from a previous season

a = In case of conflicts with the AZ Diamondbacks (MLB) or Phoenix Suns (NBA), the games will be broadcast on FM only in Phoenix.

b = The Panthers' list has "Cable Channel 8 Ashboro, NC" without a call.

c = The Dolphins' list has "Ft Myers - WRXX-FM 96 K-Rock". One web site has these call letters at 95.3 in Centralia, Illinois. I do not know the frequency.

d = reserved

e = The Raiders' list has "KCBL/KVBL 1340 AM Fresno & Visalia".

f = The Raiders' list has "KMFB 92.7/96.7 FM Mendocino".

g = AFN is the Armed Forces Network (in 177 countries).

h = Dallas Cowboys (EE) and Dallas Cowboys (SS) [Don't ask me how.]

i = Miami Dolphins and Tampa Bay Buccaneers

j = Kansas City Chiefs and Dallas Cowboys

k = New Orleans Saints and Tennessee Titans

l = Cincinnati Bengals and Cleveland Browns

m = Oakland Raiders and San Francisco 49ers

n = Dallas Cowboys and Houston Texans

o = Green Bay Packers and Minnesota Vikings

p = Atlanta Falcons, Carolina Panthers, and Washington Redskins

q = Green Bay Packers and Kansas City Chiefs

r = Oakland Raiders and San Diego Chargers

s = Denver Broncos and Green Bay Packers

Graveyard DX Totals

Bill Hale w_r_hale@sbcglobal.net
6124 Roaring Springs Drive
North Richland Hills, TX 76180-5552

Total stations logged on graveyard frequencies

Total Stations Heard on Each Graveyard Channel
Date of Last Update: January 11, 2007

DXer and Location(s)	1230	1240	1340	1400	1450	1490	Total
Norm Maguire East Hartford, CT/ Albuquerque, NM	146	169	174	168	192	157	1006
Stan Morss Boxford, MA	84	114	101	102	108	98	607
Charles Reh Leamington, ON	65	78	91	70	80	86	470
Hank Holbrook Chevy Chase, MD*	28/3	64/2	79/4	53/1	68/5	53/9	345/24
Frank Wheeler Erie, PA	58	81	63	62	65	32	361
Barry McLarnon Ottawa, ON	53	60	53	57	58	59	340
Steve Francis Alcoa, TN	52	44	43	51	62	70	322
Ron Schiller Various Locations, NJ	43	44	57	31	49	66	290
Carl Dabelstein Omaha & Lincoln, NE; Overland Park, KS	45	51	54	50	55	31	286
Jeff Falconer Clinton, ON	41	42	50	50	45	42	270
Ernie Wesolowski Omaha, NE	41	49	46	45	52	19	252
Russ Edmunds Northern NJ/SE PA	37	41	35	43	41	53	251
Phil Bytheway Seattle, WA	37	38	48	42	44	34	243
Joe Kureth Uniontown, MD	35	36	40	43	37	43	234
Shawn Axelrod Winnipeg, MB	41	16	38	48	47	38	228
Ron Bailey Shelby, NC	37	36	36	34	35	39	217
Dave Whatmough Hamilton, ON	33	27	39	31	39	41	210
Don Trelford Toronto, ON (pre-1960)	39	22	37	34	38	33	203
John Wilkins Wheat Ridge, CO	29	26	23	34	33	36	181
Andy Rugg Montreal, QC	30	31	32	24	25	34	176
Karl Jeter Suburban Atlanta, GA	20	31	20	29	29	41	170
Ron Musco Hartford, CT	21	25	21	25	27	24	143
Craig Barnes Wheat Ridge, CO	21	15	29	25	26	22	138
Niel Wolfish Toronto, ON	13	26	18	22	22	35	136
John Wilkins West Des Moines, IA	23	25	26	22	16	21	133
Dave Fox Reading, PA	15	24	16	23	24	27	129
Esa Hänninen Various Locations, Finland	13	18	20	23	16	35	125
Gary Atkins Louisville, KY	21	8	29	21	18	26	123
Frank Merrill Various Locations	16	18	17	20	26	26	123
Dave Schmidt New Castle, DE	17	24	21	16	12	23	113
Marc DeLorenzo Hyannis, MA	20	19	13	16	23	20	111
Tim Hall Chula Vista, CA	20	14	22	20	19	14	109
Harry Hayes Gouldsboro, PA	15	21	17	13	21	19	106
Bill Harms Spokane Valley, WA	14	14	24	16	26	12	106
John Malicky Pittsburgh, PA	7	15	16	14	24	27	103
Mike Sanburn Bellflower, CA	14	16	18	21	18	15	102
Bob McCoy Lincoln, NE	29	20	18	19	4	10	100
Art Blair Folsom, CA	14	6	24	18	16	21	99
Brett Saylor State College, PA	21	17	19	16	1	24	98
Nancy Johnson Abedeen, WA	16	20	13	11	13	14	87
Jim Boehm San Antonio, TX	12	11	14	17	17	15	86
Joe Kureth Southern Pines, NC	13	12	13	13	17	12	80
Niel Wolfish Winnipeg, MB	11	2	10	22	19	15	79
Bill Hale WI, IL, ID, FL, TX, NY, CA, NM	15	14	12	11	12	15	79
Wayne Heinen Aurora, CO	14	16	8	15	21	23	77
Ron Schiller Avenel, NJ	14	11	13	6	10	21	75
Jim Renfrew Rochester, NY	16	10	10	12	12	13	73
Bruce Winkelman Tulsa, OK	15	14	3	17	13	11	73
Carl Dabelstein Phoenix-Tucson, AZ	10	12	14	10	14	11	71
Mike Hardester Various Locations	13	10	11	10	13	13	70

Fred Nordquist	Clay, NY	13	15	6	9	15	11	69
Tim Hall	US 6/50 @ NV-UT Border, UT	14	14	12	10	10	8	67
Dave Braun	Falls Church, VA	14	16	6	11	4	11	62
Wayne Heinen	Colorado Springs, CO	8	6	19	18	3	8	62
Les Rayburn	Helena, AL	14	10	12	9	10	7	62
Olle Alm	Stockholm, Härnösand, Abisko, Karesuando and Göteborg, Sweden	5	7	5	19	12	13	61
Christian DeHaes	Chicoutimi, QC	7	16	15	6	8	9	61
Don Trelford	Scarborough, ON	7	10	8	9	17	9	60
Pete Taylor	Worldwide	12	8	8	19	6	5	58
Tim Hall	Teasdale, UT	10	11	8	10	8	11	57
Tim Hall	Tombstone, AZ	12	10	9	10	7	9	57
Tim Hall	Mammoth Lakes, CA	12	9	8	7	10	9	55
Tim Hall	Yellowstone Lake Village, WY	10	9	9	9	9	9	55
Ken Onyschuk	Steger, IL	9	7	7	10	12	9	54
Carl Dabelstein	Minneapolis, MN	11	11	8	3	11	8	52
Dave Braun	Dover, DE	4	8	8	9	10	11	50
Morris Sorensen	Winnipeg, MB	4	6	8	10	14	8	50
Tim Hall	Banff National Park, AB	10	7	9	7	6	8	47
Russ Edmunds	Syracuse, NY	12	7	7	5	6	8	46
Tim Hall	Mammoth Lake, CA	9	8	7	5	9	8	46
Wayne Heinen	Orchard Park, NY	13	10	8	2	6	5	44
Dave Yocis	South Nyack, NY	1	6	11	5	11	10	44
Tim Hall	Ajo, AZ	9	8	9	6	6	6	44
Tim Hall	Jasper, AB	10	7	8	7	8	4	44
Paul Mount	Teaneck, NJ	5	8	8	8	8	5	42
Morris Sorensen	Scarborough, ON	2	12	3	10	6	9	42
Denis Picard	Trois-Rivières-Ouest, QC	7	11	6	6	5	6	41
Tim Hall	Bandon, OR	7	4	6	9	5	9	40
Tim Hall	Monterey-Carmel, CA	10	6	8	5	6	4	39
Don Trelford	Runaway Bay, Jamaica	4	6	6	5	10	7	38
Tim Hall	Chester, CA	5	8	6	5	7	7	38
Tim Hall	The Sea Ranch, CA	11	6	6	3	6	6	38
Tim Hall	Tombstone, AZ	8	7	6	6	4	6	37
Tim Hall	Crater Lake, OR	10	7	4	6	5	5	37
Stephen Ponder	Bossier City, LA	6	5	6	6	7	7	35
J.W. Bay, Jr.	Drexel Hill, PA	35	0	0	0	0	0	35
Tim Hall	Radium Hot Springs, BC	7	4	7	6	5	5	34
Eric McIntosh	Invercargill, NZ	0	3	1	15	7	7	33
George Santulli	Cranford, MA	0	0	33	0	0	0	33
Tim Hall	Crescent City, CA	4	1	6	9	6	6	32
Morris Sorensen	Leaf Rapids and God's Narrows, MB	5	6	5	7	4	4	31
Jack Woods	Waldport, OR	4	3	7	6	3	8	31
Tim Hall	Burney, CA	4	5	4	6	6	5	30
Tim Hall	Lone Pine, CA	7	6	4	4	4	5	30
Tim Hall	Houston, TX	1	2	8	5	6	8	30
Tim Hall	Moab, UT	5	4	5	6	5	5	30
Tim Hall	Springdale, UT	8	5	5	4	4	4	30
Tim Hall	Grant Village, WY	5	5	5	3	5	7	30
Morris Sorensen	Port Carling, ON	2	5	5	6	4	6	29
Morris Sorensen	Milton, ON	5	3	3	7	3	7	28
Russ Edmunds	Jonesport, ME	4	5	1	6	5	5	26
John Vervoort	Brooklyn, NY	6	4	2	5	5	2	24
Chris Cuomo	Verona, PA	2	4	5	3	5	2	21
Paul Mount	Nelsonville, OH	4	4	2	3	3	5	21
Paul Swearingen	Moran, KS	5	3	2	2	2	5	19
John Reed	Ponca City, OK	1	1	4	3	5	5	19
Ron Schiller	Monmouth Beach, NJ	4	3	6	3	2	1	19
Morris Sorensen	Kemptville, ON	2	4	2	2	5	3	18
John Tudenham	Joplin, MO	7	2	2	4	1	1	17
David B. Jones	Springfield, TN	3	5	3	2	2	2	17
Les Carpenter	Sandy, UT	2	1	0	2	5	5	15

Pete Taylor Tacoma, WA	2	1	1	4	3	4	15
Morris Sorensen Amaranth, MB	3	5	3	1	1	2	15
Rick Turner Bemidji, MN	4	3	2	2	1	3	15
Shawn Axelrod Orlando, FL	1	2	1	4	1	1	10
Doug Smith Madison, WI	2	1	3	2	2	0	10
Perry Crabill Winchester, VA	2	2	1	1	2	2	10
Ron Schiller Lighthouse Point, FL	2	1	4	2	1	0	10
Shawn Axelrod Edmonton, AB	1	0	1	1	1	1	5
Ron Schiller Newark, DE	0	0	0	0	1	4	5
Bert New Watkinville, GA	4	0	0	1	0	0	5
Dale Park Irvine, CA	1	1	1	1	1	0	4
Dale Park Various Locations, HI	0	1	0	1	1	0	3
Michael Plumb Papillion, NE	0	1	1	1	0	0	3
Ron Schiller Dallas, TX	0	0	1	0	1	1	3
Shawn Axelrod Swan River, MB	0	2	0	0	0	0	2

* Totals are for Before / After 1960

- Unreported

All Graveyard records are on-line at: <http://www.angelfire.com/tx2/phantom2/index.html>

Broadcast Test Report

Jim Pogue KH2AR@comcast.net

<<www.dxtests.info>>

P.O. Box 3777

Memphis, TN 38173-0777

A periodic update of station testing activities

Let me begin by expressing my thanks to Les Rayburn for the fantastic job he has done during his time as Broadcast Test Coordinator. Needless to say, he will be a tough act to follow. I am also grateful for the trust that IRCA and NRC have placed in me as your new BTC. I promise to do the best I can to arrange lots of interesting tests to listen for, and to do all I can foster trust and goodwill between hobbyists and professional broadcasters.

Although you'll probably see my name most frequently associated with our efforts, I want everyone to know that I intend this to be very much a team effort. Here's a brief rundown of the immediate group I will be working with:

Brandon Jordan, right across town from me here in Memphis, will add his many years of experience and webmaster expertise through the DXTests.info site.

Longtime friend and former CPC Coordinator J.D. Stephens in Alabama will also add his help, and has already been energetically compiling lists of stations and personnel for us to approach for tests.

Although I haven't had a chance to talk directly with him, I hope Joe Miller will stay on the team, contributing his great skills in QSL card design when we are asked to provide this service to stations.

The same goes for Paul Walker. Les speaks highly of you Paul, and I hope I can also count on you for assistance in our efforts.

I've also had offers of assistance from several other friends and DXers like my old friend of many decades and fellow transplanted Hoosier Charles Taylor, Ken Lyon and others. As this effort progresses, you will probably be hearing from me.

Finally, Les Rayburn has promised to stay close by in the wings to watch and ensure I don't screw up too badly, and is prepared to offer his sage advice and counsel as needed.

Regarding Les, let me whet your appetites a little by saying he already has several great tests in the works from last season that I will be finalizing and announcing soon. These include stations in Utah, Nevada and New Mexico for starters, and perhaps another even more exciting DX possibility.

In conclusion, I'll ask for a few things from you the members of the DX community.

1. If you believe a station might be a good candidate for a test - e.g., a friendly C.E., a personal connection with the station or knowledge that they have tested in the past but it has been sometime ago, please forward that info to me ASAP.

2. If you have any ideas about how we can run this effort more efficiently or encourage more tests from the broadcasting community, please share your thoughts. I can't promise I'll adopt all your ideas, but I do promise to consider them with an open mind.

3. Finally, this endeavor can be a costly undertaking with regard to postage, mailing supplies, etc. If you can help out financially with postage or cash, please do so. I'm not sure about the best way to do this...perhaps

one of the club treasurer's needs to handle this then let me send a list of my expenses at the end of the season. Don't send anything yet until I sort this out, but please consider helping financially when the call goes out. That's it for now. I'll share more as we move through the season. Thanks again for your trust, and good DX to everyone.

Jim Pogue KH2AR/WPE9HLJ/KG6DX1A
Memphis, Tennessee USA

The SuperLoop Antenna

Design and Installation

By Bruce Conti

The SuperLoop antenna was first introduced in the August 2007 edition of *Popular Communications* magazine. In the months following that initial introduction, further testing and antenna modeling have resulted in expanding the design parameters of this versatile antenna. Here's an updated description of the antenna design and installation, taking into account the latest discoveries.

The SuperLoop is a super-sized terminated corner-fed broadband loop antenna designed for cardioid directional reception. It's a variation of the terminated loop family of antennas that includes the Flag, Pennant, and Kaz. In the development of the SuperLoop, the primary design criteria were simple:

- Design a unidirectional mediumwave antenna that takes advantage of the low-noise characteristics of a loop.
- The bigger the better for high-gain low-angle mediumwave DX reception without requiring RF amplification.
- The outdoor antenna installation should be flexible and stealth for use in limited space or an antenna restricted environment.

Invention by Supervention

Compared to random wire and vertical antennas, the loop antenna is inherently low-noise. The SuperLoop began as a super-sized broadband loop antenna consisting of a single loop of wire measuring 50-ft tall by 75-ft wide in the vertical plane, fed to a receiver via a 1:1 RF transformer and coaxial lead-in, designed to take advantage of the inherent low-noise characteristic of a loop while providing high-gain low-angle reception via the *super* tall verticals. Low-angle reception is desirable for mediumwave DXing as the most distant signals typically arrive at very low angles just off the horizon. While broadband verticals such as tall whip and Discone antennas can provide excellent groundwave and low-angle performance, these antennas are omnidirectional and therefore pick up more noise and interference than a directional loop. On the other hand the super-sized broadband loop combines the desirable low-angle performance of a vertical with the directional low-noise capability of a loop.

Despite the advantages over a random wire or vertical, still one major deficiency of the typical loop antenna is its bidirectional reception. What's really needed is targeted unidirectional reception to further reduce interference from unwanted broadcast signals. The typical loop reception pattern is a bidirectional "figure-8" familiar to most AM broadcast DXers. The Select-A-Tenna, Kiwa Loop, NRC Loop, and Quantum Loop, to name a few, in addition to the ferrite bar antenna inside most portable receivers are examples of figure-8 loop antennas. A single loop of wire in the vertical plane also produces the same figure-8 pattern, but it can cover long through short wave frequencies without tuning, thus the *broadband* designation. While a figure-8 loop antenna is great for nulling signals off the sides, it does little or nothing to reduce interference opposite the direction of a desired signal. For example, if a loop is aimed east, it will null north-south, but not west. During the design process, it was discovered that a broadband loop can be forced to favor one lobe of the figure-8 pattern simply by moving the feedpoint from the standard bottom center of the loop to a corner of the loop. For example, with a super-sized loop aimed to produce an east-west figure-8 pattern, if the feedpoint is moved to the east corner of the loop, then it will favor signals from the east, thus the *corner-fed* designation. Then a realization was made that led to the present design: The Flag and Pennant antennas also favor the feedpoint direction. What if the loop was *terminated*, similar to the Flag and Pennant antennas, with a termination resistor in series with the loop? The end result was a super-sized terminated corner-fed broadband loop antenna with a high-gain low-angle unidirectional cardioid reception pattern, now known as the SuperLoop.

Covert Cardioid Construction

Another advantage of a single loop of wire in the vertical plane is its stealth installation where trees are readily available. Trees can be a handy antenna support system for situations where a covert

antenna is necessary, i.e. community restrictions, nosy neighbors, or to satisfy a reluctant household member. The two vertical sections of the loop can be routed up tree trunks, the top horizontal section covered by tree branches, and the bottom horizontal resting on the ground or just beneath the cover of a lawn. The RF matching transformer feedpoint and termination resistor also rest on the ground at the bottom corners of the loop, out of plain sight yet easy to access. The coax lead-in can be buried to complete covert installation. Double insulated #14 AWG stranded copper, also referred to as machine tool wire, available by length or in 500-ft rolls from the local electrical supply store or Home Depot, is recommended for the antenna wire. Choose black or brown insulation for maximum invisibility. This type of wire has proven to be quite reliable for outdoor antenna wires, lasting for several years if not decades under all sorts of extreme weather conditions. At most the exterior layer of insulation may peel due to sun exposure over the years, but the second layer will remain intact, protecting the wire from short-circuiting to tree branches, so rope and insulator supports aren't necessary. This type of insulation is also less likely to be chewed up by antenna-eating vermin. Of course if trees aren't available, then you'll have to resort to less natural supports such as homebrew towers or commercially available systems.

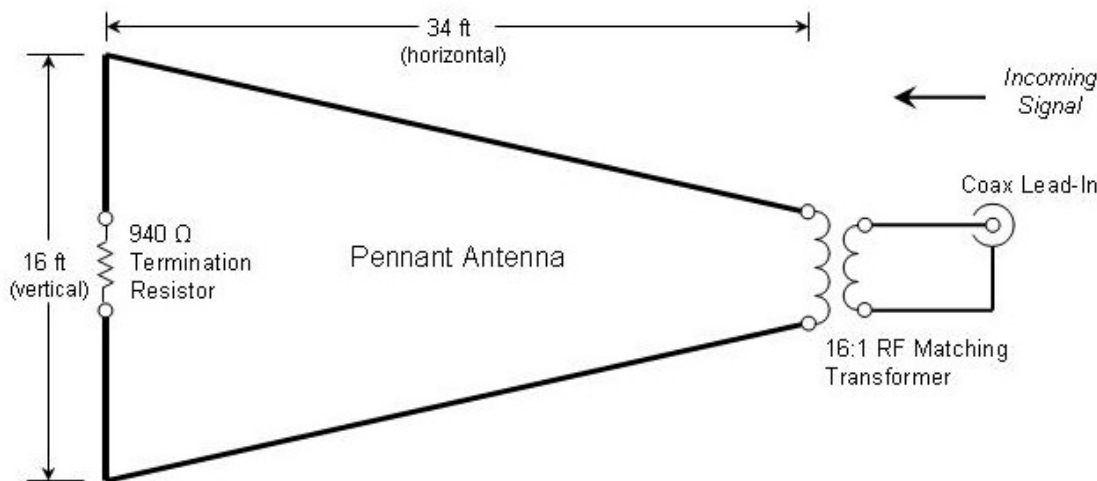
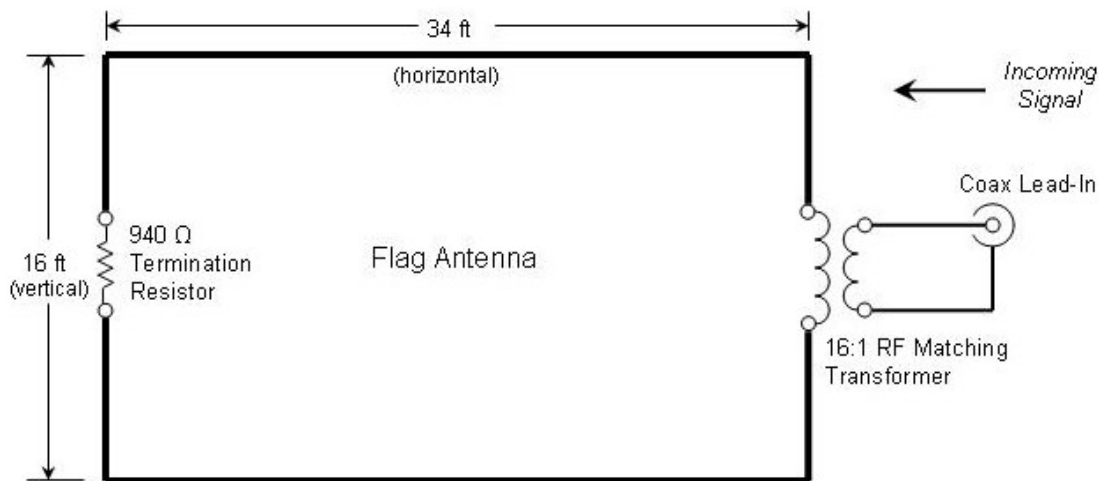

The Flag and Pennant terminated loop antennas (typical dimensions).

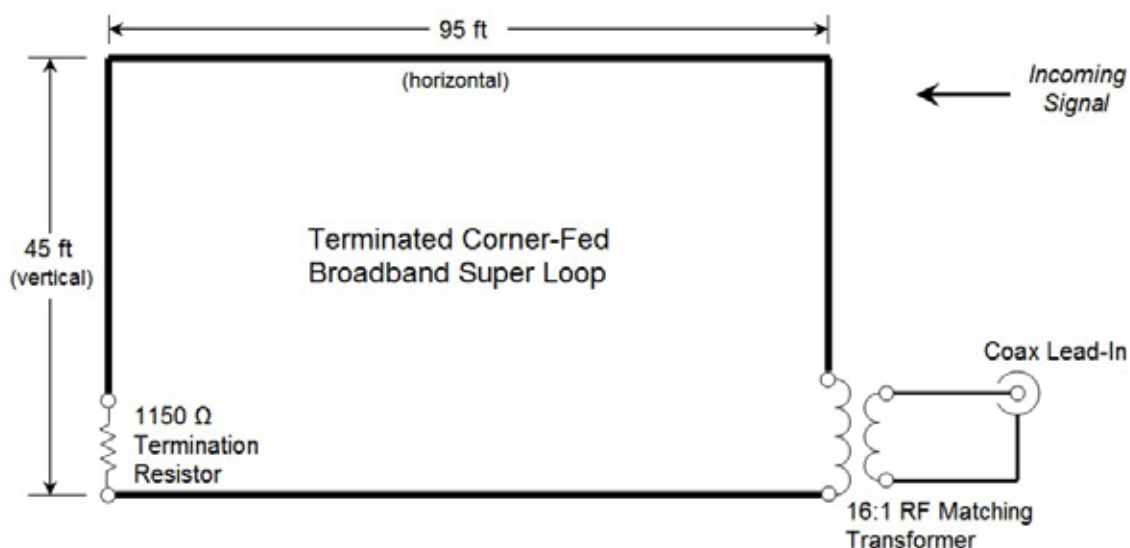

The SuperLoop antenna construction diagram (typical dimensions).

Design Specifics

Following “the bigger the better” hypothesis, the loop dimensions should be as big as possible. The width of the loop should be 2.1 to 2.5 times greater than the height, but this is only a rule of thumb based on existing Flag, Pennant, and Ewe antenna design specifications. Ratios as small as 1.5 have proven to perform just as well. The super-size isn’t an absolute requirement either. A “mini” SuperLoop measuring 10-ft tall by 20-ft wide was successfully implemented at a remote DXpedition site without RF amplification. Bottom line, make the antenna as big as the site allows.

Keep in mind that actual antenna location is a consideration. Following the general rules for a noise-reduced antenna, the loop should be located at least 20-ft from any buildings or overhead utility wires to minimize noise pick-up, and a shielded coaxial lead-in used to connect the antenna to the receiver. Locate quiet spots by surveying the property with a portable radio both day and night. The antenna won’t be of much use if located too close to a noise source such as buzzing power lines or a neighbor’s light dimmer.

Once the wire is in place, you’ll need to install the termination resistor and RF matching transformer with coaxial lead-in to complete the antenna. The termination resistor value derived from EZNEC modeling should be around 1150 ohms (470 + 680 ohms in series = 1150). In real world field testing, the termination resistance has shown to vary between 940 to 1470 ohms depending upon dimensions, ground conductivity and reception conditions. Start with 1150 ohms to get the antenna up and running, then experiment with different values to determine what works best for you. Although the loop antenna is a “floating” ground-independent antenna, the overall environment may cause the best resistance value to stray from the 1150-ohm design value. The overall environment may include ground conductivity, local terrain, arrival angle of unwanted broadcast signals, and proximity of man-made structures. Every situation is unique. Once the best resistor value is determined, “set it and forget it!” The termination resistor is located at the bottom corner of the loop in the direction of maximum null. In the east-west loop example discussed earlier, the termination resistor would be located at the bottom west corner of the loop to null west.

According to theory, a 16:1 RF matching transformer is required to match the high impedance of the antenna to the low impedance 50-ohm coaxial lead-in for a standard communications receiver. In reality a more likely to be on-hand 9:1 or 4:1 is adequate until the proper transformer can be obtained. It’s extremely critical that the transformer primary and secondary be physically isolated, in other words, without a common ground. Caution: Most if not all commercially available “balun” matching transformers for amateur radio and shortwave applications use a common ground, of no use for the SuperLoop. Unfortunately there are few alternatives; either wind your own from scratch, assemble one from components, or locate someone on the Internet to build a custom unit. Consult the excellent paper by John Bryant, “Fabricating Impedance Transformers for Receiving Antennas” in the *NRC Antenna Reference Manual Volume 3* to learn more about winding from scratch. A unit can be assembled using a 6-pin DIP encapsulated Mini-Circuits 16:1 RF matching transformer, model T16-1, but these miniature transformers aren’t recommended for high signal and frequent lightning areas as they are reported susceptible to overload and static damage with a super-sized antenna. The RF matching transformer with coaxial lead-in is located at the bottom corner of the loop in the direction of desired reception. In other words, using our east-west loop example, the transformer is located at the bottom east corner to receive east.

Test Results

Backside nulls of 35 to 40 dB versus forward gain have been easily achieved with the SuperLoop. Antenna modeling with EZNEC 5.0 demo software (www.eznec.com) confirms the performance of this antenna. The SuperLoop produces a cardioid or heart-shaped pattern, much like the antenna patterns of 770 KKOB Albuquerque and 1030 WBZ Boston. Three SuperLoops with different dimensions were modeled and field tested, all producing similar results; the standard 45-ft vertical by 95-ft horizontal 2.1 ratio, a 50 by 75-ft 1.5 ratio, and a “mini” 10 by 20-ft at a 2.0 ratio. Note that the termination resistance varies with antenna dimensions in order to peak the null, as low as 940 ohms for the mini 10 by 20-ft SuperLoop. Nulls are actually deepest at lower frequencies, but still quite effective at higher frequencies as demonstrated in field tests.

In daytime testing with groundwave signals, completely different stations were received across the broadcast band with SuperLoop antennas aimed in different directions. 50 by 75-ft antennas were aimed east and south at a southern New Hampshire test site. Maine and New Hampshire stations were dominant on the east loop, while Connecticut, Massachusetts, and Rhode Island were often dominant on the south loop. Sometimes the dominant radio station was not received in the primary direction of the antenna but instead off the side, such as 1240 WFTN to the north on the east antenna, and 1540 WDCD to the west on the south antenna. For this reason, the wide cardioid reception pattern can actually be advantageous over a narrow beam antenna like a Beverage.

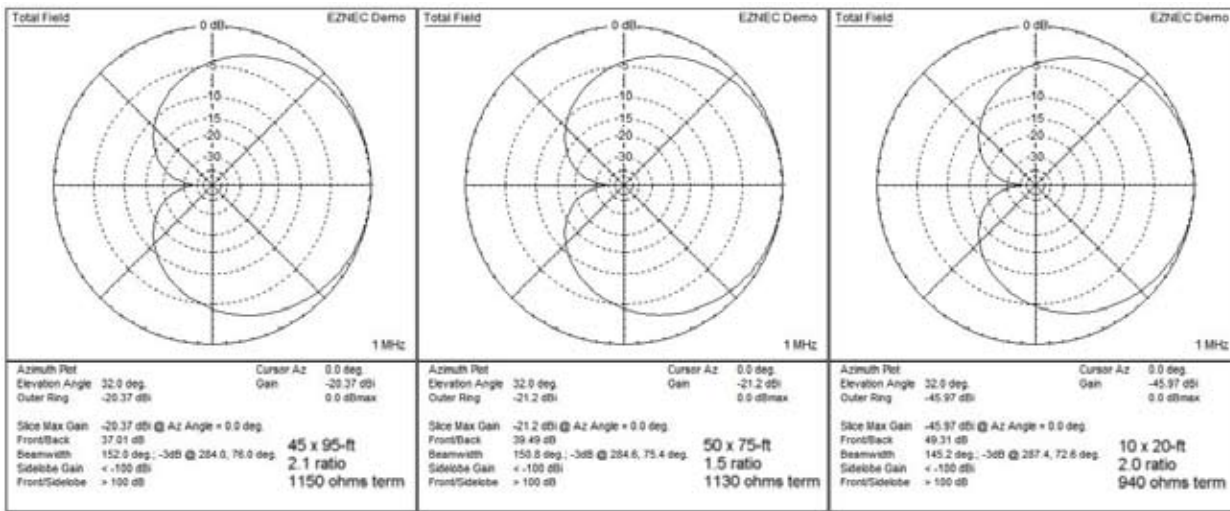

EZNEC modeling of three SuperLoop antennas of various dimensions at 1000 kHz.

	East	South
560	WGAN Maine	WHYN Massachusetts
730	WJTO Maine	WACE Massachusetts
970	WZAN Maine	WESO Massachusetts
1220	WPHX Maine	WSTL Rhode Island
1240	WFTN New Hampshire	WOON Rhode Island
1340	WWNH New Hampshire	WGAW Massachusetts
1350	WEZS New Hampshire	WINY Connecticut
1380	WMYF New Hampshire	WNRI Rhode Island
1420	WASR New Hampshire	WBSM Massachusetts
1540	WGIP New Hampshire	WDCD New York

Table of dominant stations received daytime with SuperLoop antennas aimed east and south.

Nighttime performance has been equally impressive at the southern New Hampshire testing grounds. On 720 kHz, Jamaica is easily received on the east antenna with normally dominant co-channel WGN Chicago off the backside null. Many transatlantic signals are received well on the east antenna alone without phasing, with a number of new rare receptions logged such as 702 Saudi Arabia and 1287 Israel. Overall the SuperLoop is the best of many outdoor wire antennas tested over the years, including phased random wires, a sloping inverted-L, super-sized Ewe antennas, and an unterminated broadband loop.

With in-band on-channel (IBOC) digital AM moving forward, a DXer will need all the tools possible to battle interference. The SuperLoop as well as any member of the terminated loop antenna family is certainly worth consideration for the toolbox. The author wishes to acknowledge Mike Beu, John Bryant, Mark Connelly, Chuck Hutton, and Neil Kazaross for their input and antenna modeling expertise during various stages of development. Now it's your turn. Try building a SuperLoop antenna, then share your experiences with the DX community. 73 and Good DX!

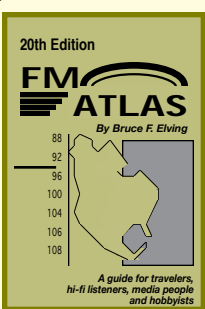

Bruce Elving's FM Atlas ... 20th Edition
 The world-famous guide which has served FM DX'ers for over 20 years is available from NRC Publications at the special price of \$20.00 for NRC USA/Canada members, \$24.00 USA/Canada non-members, \$25.00 for all others. Order from NRC Publications - P.O. Box 473251, Aurora CO - 80047-3251. (CO residents, please add 3.5% sales tax.)

The Case of the Leaky Coax

An investigative report by Bruce Conti

In a 2001 paper about the reduction of unwanted signal pick-up by outdoor wire antenna lead-ins, John Bryant and Bill Bowers asked the question, “Is your coaxial lead-in actually an antenna?” The paper discussed the practical assembly and use of a common mode choke to reduce RF currents in the coax shield (NRC reprint A109, or see www.dxing.info/equipment). The common mode choke is a filter that literally chokes off RF currents flowing in the same or common direction through both the center conductor and outer shield of an unbalanced coaxial lead-in. These common currents can result in noise and interference, enough to bury weak DX signals. More recently, an online Internet discussion with prominent Oregon coast DXer Patrick Martin raised the same question about lead-ins. Martin tested the coaxial lead-in on his Beverage antenna and found that it was picking up 690 CBU Vancouver with a signal strength of s9, thus compromising Beverage performance. Immediately the effectiveness of the coax shield was called into question. Personally, I couldn’t believe that coax leakage alone would be responsible for picking up that much signal strength at medium wavelength frequencies, no matter how poor the quality or how ‘cheap’ the coax cable. I was inclined to believe that other forces were contributing to the problem, such as poor grounding, ground loops, or common-mode RF currents. After all, I’d been using cheap Radio Shack coaxial lead-ins for decades and never noticed a leakage problem, but then again I’d never really checked it out either. Would significantly more expensive high-grade coax make a difference in mediumwave reception applications? It was time to “get serious about coax” and investigate this further.

Metal or Plastic?

Before attacking the coax question, Patrick Martin discovered that the RF matching transformer assembly at the antenna end of the coax was actually contributing several s-units of leakage, not the coax lead-in alone. An RF matching transformer is required to match the high impedance of an outdoor wire antenna to the low impedance coaxial input of a typical communications receiver. His matching transformer was assembled in a plastic chassis, unshielded and acting like an antenna. Replacement of the plastic box with a metal chassis got rid of much of the unwanted pick-up, but later it was determined that relatively long “pig-tail” hardwired connections from the coax to the transformer were more responsible for pick-up than the unshielded chassis. In my case, replacing the plastic with a metal chassis for the antenna RF matching transformer assembly did absolutely nothing. I attribute this to extremely short hook-up wiring between the appropriate coax connector and aptly named Mini-Circuits “miniature” RF matching transformer installed in my low-tech plastic food storage container chassis. The use of a Mini-Circuits RF transformer itself may also be a factor due to its small size; I’ll have to try winding my own homebrew transformer for comparison. Regardless, whether using a Mini-Circuits transformer or rolling your own, the wiring to the coax connector can be critical to prevent unwanted signal pick-up. Of course the use of a metal chassis doesn’t hurt either, but plastic is fine as long as the wiring on the coax side of the transformer is kept as short as possible and the proper shielded coax connectors are used (BNC or SO/PL).



RF matching transformer in a weather-tight plastic food storage container.

The More Money Coax Test

Replacing cheap Radio Shack RG58 coax with a higher grade coax cable reduced pick-up by s2 or about 12 dB. I replaced it with Cable X-Perts 1318FX flexible 50-ohm low loss direct burial cable, \$63.95 for 50-ft PL-connected from Ham Radio Outlet. The coaxial lead-in was tested by disconnecting the far end from the outdoor wire antenna and matching transformer, replaced with a 47-ohm resistor

between the center conductor and outer shield of the coax, making the resistor leads as short as possible to prevent signal pick-up. The AM broadcast band was scanned for signals on a Drake R8B receiver using the 47-ohm terminated coaxial lead-in alone as an antenna. Test of the cheap Radio Shack lead-in found local WGAM Nashua at 900 kHz with a high s8 signal, and 50 kW DX buster WBZ Boston at 1030 with a solid s6 signal. A total of 13 comfortably readable signals were picked up across the band by the cheap coax. A repeat of the test with the more money Cable X-Perts coax resulted in as much as 2 s-units or 12 dB drop in unwanted signal pick-up. WGAM dropped to s6.5, WBZ lowered to s4.5, WNNW at 800 kHz was reduced from s4 to s2, and WCEC at 1110 dissolved from a weak s1.5 to nil. While a 12 dB signal drop might appear insignificant on signals normally received at s9+30 or greater levels, it still could be enough to compromise the backside null on a highly unidirectional antenna like a Beverage or phased array. However there may not be much to be gained using expensive coax with a random wire or omnidirectional antenna.

Choke Out the Noise

Installation of a common-mode choke reduced unwanted broadcast signal pick-up by another s-unit or about 6 dB, plus it significantly reduced if not eliminated extraneous buzzes at LW and low-end MW frequencies. Not having the recommended ferrite donuts readily available to wind my own choke per the Bryant and Bowers paper (I should order some Amidon toroids for future experiments), I used Mini-Circuits 1:1 RF transformer model T1-6 (www.minicircuits.com), one winding in series with the center wire and the other in series with the shield. The choke is installed between the coax and receiver at the 50-ohm antenna input of the receiver. This was an "Ah-ha!" moment as I was quite surprised at how effectively the choke reduced pesky noise below 600 kHz, without any measurable insertion loss. I should've done this a long time ago. No matter what type of coax lead-in you're using, I'm now convinced that the common mode choke is an absolute must!

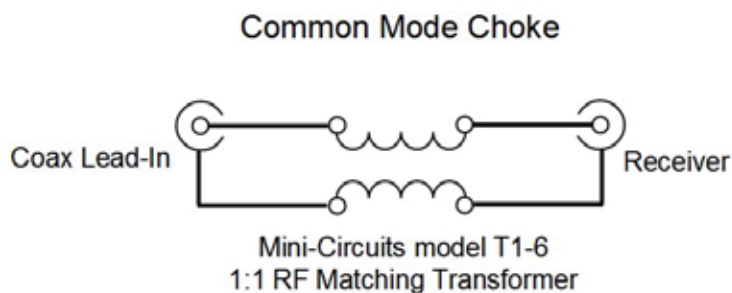

Test data is presented in the accompanying table as follows: The first column is the frequency and callsign of radio stations that were picked up by the cheap old coax lead-in alone. The second column is the level of the unwanted signals picked up by the "old coax" alone. The third column is the "normal" signal level when an outdoor wire antenna is connected. To better understand the relationship with actual signal strength, the signal level calculated by V-Soft for the postal zip code

Station	Old Coax	Normal	V-Soft Calculation	New Coax
900 WGAM	s8	s9+50	87.3 dBu or 23.26 mV/m	s6
980 WCAP	s6	s9+40	75.6 dBu or 6.06 mV/m	s3
680 WRKO	s6	s9+35	70.6 dBu or 3.38 mV/m	s2
1030 WBZ	s6	s9+40	64.0 dBu or 1.67 mV/m	s3
1370 WFEA	s3	s9+30	67.1 dBu or 2.28 mV/m	0
1060 WBIX	s3	s9+35	66.3 dBu or 2.08 mV/m	0
1320 WDER	s2	s9+30	65.2 dBu or 1.83 mV/m	0
850 WEEI	s2	s9+30	64.5 dBu or 1.67 mV/m	0
830 WCRN	s1	s9+35	63.7 dBu or 1.53 mV/m	0
800 WNNW	s4	s9+30	63.5 dBu or 1.50 mV/m	0
1110 WCEC	s1.5	s9+30	61.1 dBu or 1.14 mV/m	0
1400 WLLH	0	s9+30	58.7 dBu or 0.86 mV/m	0
590 WEZE	0	s9+20	58.5 dBu or 0.84 mV/m	0

of the receiver site is provided for comparison (www.v-soft.com/ZipSignal/default.htm). Unwanted signals were initially received from those at greater than 60 dBu or 1 mV/m per V-Soft calculations. The reduced unwanted signal levels obtained with the combination of new high-grade coax and a common-mode choke are listed under "new coax" in the last column.

Final Thoughts

Thank you, Patrick Martin, for being the inspiration behind this investigation. Whether or not it results in new DX remains to be seen, nonetheless each experiment was a learning experience for me. Common mode chokes are now a permanent fixture in the home radio room, and on my equipment list for future group DXpeditions at Grayland, Newfoundland, and the like. The Bryant and Bowers paper is well worth reading for further insight. Implementation of a balanced feedline such as a high impedance twin-lead could provide further improvements, but I'll save that experiment for another time. Case closed.

Musings of the Members

Dave Schmidt NRCMusings@aol.com
P. O. Box 126
New Freedom, PA 17349-0126

Times are local per Muse; submit double-spaced only.

Thoughts from NRC members ... the opinions expressed in this column are those of the individual writer and do not necessarily reflect those of the editors, publishers, or the National Radio Club, Inc.

Bob Harrison - 166 Renner Avenue, Union, NJ 07083- MisterHarrison@comcast.net

It's been quite some time since I've mused on these pages. I joined the NRC about 25 years ago and was actively DXing through the late 1990's, but have taken a back seat since then. Over the past ten years or so I've been focusing my efforts on other things, including a career change from data processing to high school teaching, with little time for DXing or any other hobbies for that matter. So I was surprised to see my name on the front page of *DX News* issue #28 with the mention of one of my old call-letter history articles. That prompted me to dig out some of the old floppy disks that contained the original articles, and I'm now constructing a website with this material. Anyone interested in the old articles can point his or her browser to home.comcast.net/~Harrison4938 (don't include any "www") and you can visit the work in progress. Meanwhile, my occasional trips to family in South Jersey have been made more enjoyable with WHWH-1350 (T.E.D. Radio, with the strangest combination of old and new music of practically any genre!), and WHAT-1340 (Skin Radio, with weird and wonderful progressive or modern rock - I'm not sure what it is!). And of course the old stalwart WBCB-1490, a magnificent old local station that always has some sort of surprise in the music department. Good listening to all!

Doug Beard - 604 7th St., Springville, IA 52336

The loss of a legacy radio station is even sadder than the throwing away of a historic call. Thus my reading of CKPR-580's move to FM has upset me more than any other radio development this year save IBOC. I relogged them July 30 with a decent signal (reported to DDXD). On their last night, August 2, conditions were not good, but I did hear a "...PR ninety-one point five..." in the mess. The next morning, I listened to their stream on my daughter's computer. The reminiscence show was in progress when I "tuned in" at 8:20 CDT. Highlight was a Feb. 27, 1981, 50th anniversary clip several minutes long by announcer Rick Smith extolling the virtues of local ownership. (Fraser Dougall was the owner then, and still is.) Another interesting clip was an announcement, along with the dead air and static, that CKPR would be off for 10 seconds while they reduce power. A half-dozen or so callers were on the air while I listened. For one, this was his second time on CKPR; his first was during the station's first day on the air, Feb. 27, 1931, when the caller was 10 years old. At 9:04 AM CDT, the announcer stated, approximately, "CKPR-580 is now dark." Normal programming resumed (Paul Harvey) and I shut down the computer. I understand why CKPR made the jump to FM - better highs, stereo, and the general popularity of the FM band. And coverage. Despite having facilities 90% of station owners would kill for, the dismal ground conductivity of the Shield - the Canadian equivalent of the M3 map says it's 2 mS/m, which is a lot closer to the truth than the 8 mS/m the M3 claims for land just south of there - limited CKPR's .5mv/m daytime contour to perhaps 50 miles. Night coverage was, of course, less. On to happier topics. With the granting of a CP for 640, Rhinelander, WI, is the only US or Canadian town whose AM stations are on the two CONELRAD frequencies we old people remember. According to the Aug. 8 Leslie Report in *Radio World* (rwonline.com), Mexico is unhappy with the U.S. for authorizing nighttime AM IBOC without regard for international treaties. Didn't I read that Canada is angry at us for the same reason? And Americans think the French are arrogant. Let the lawsuits fly.

National Radio Club

Founded in September, 1933, the National Radio Club is a non-profit organization devoted to the medium wave DX hobby. It is operated solely by uncompensated volunteers. Subscription costs cover printing, postage, and operational costs and are subject to change without prior notice. The opinions expressed in this magazine are those of the individual writer and do not necessarily reflect those of the Publisher or the Board of Directors of the National Radio Club, Inc. Any reproduction of material contained in DX News/e-DXN without permission of the National Radio Club or the author is prohibited. All published material in DX News/e-DXN may be reprinted by the National Radio Club at a later date. DX News/e-DXN published material reprinted in other publications should include an attribution naming the author and DX News/e-DXN as the original source. Construction projects described herein may be hazardous and are to be undertaken at the assembler's risk; the NRC, its officers, and author(s) will not be responsible for any injuries or losses arising during these projects. Tool usage and electricity can be dangerous.

NRC Board of Directors: John Bowker(jbowker@tampabay.rr.com); **NRC Ombudsman** - 1811 Fort Duquesna Dr. - Sun City Center, FL 33573-5035; Ken Chatterton (krazyken@tcenet.net); Bill Hale (w_r_hale@sbcglobal.net); Wayne Heinen (amradiolog@nrcdxas.com); **Chairman**; *NRC AM Radio Log Editor* - 4131 S. Andes Way - Aurora, CO 80013-3831; Dick Truax (K9RT@aol.com); **NRC Treasurer** - P. O. Box 39451 - Louisville, KY 40233-9451.

NRC/IRCA Broadcast Test Coordinator: Les Rayburn - 100 Centerview Drive, Suite 11 - Birmingham, AL 35216-3748 (les@highnoonfilm.com).

The National Radio Club includes NRC Publications, DX News, e-DXN, and DX Audio Service:

- **NRC Publications** - Wayne Heinen, Manager - P. O. Box 473251 - Aurora, CO 80047-3251 (What to send: \$ for Publications/Reprint Orders, NRC Product Catalog [send 1st-class stamp].
- *DX News* Publisher/Editor - Paul Sweartingen (plsBCBDXER@aol.com) - P. O. Box 5711 - Topeka, KS 66605-0711; 785-224-6907 [voice mail], 785-266-5707 [prepaid] (Contributions to DX News; requests for replacement copies of DXN; 1st-class stamp(s) for sample DXN; DXN changes of address; \$ for DXN/e-DXN renewals or new subscriptions; subscription status inquiries)

Yearly Subscription (30 Issues) to DX News: (send checks/money orders to National Radio Club - P. O. Box 5711 - Topeka, KS 66605-0711) U. S. Address: U\$28.00; Canadian Address: U\$38.00; all other countries: U\$52.00.

National Radio Club, Inc.

DX News

P. O. Box 5711
Topeka, KS 66605-0711

- **DX Audio Service** - Fred Vobbe, Publisher/Producer - 706 Mackenzie Drive - Lima, OH 45805-1835, 360-382-1957 (recordings for the Audio Service; \$ for subscriptions; DXAS address changes)

DX Audio Service Yearly Subscription (twelve 90-minute tapes, mailed on or about the 20th of each month) (send new and renewal subscriptions to Fred Vobbe): One-year First Class Mail subscription to DX Audio Service to USA, Canada addresses: U\$28.00; all other addresses: U\$40.00

- **e-DXN.com**: To subscribe: Access the e-DXN web site <<http://e-dxn.com>> and then follow the indicated links to register: +\$5.00 if you're a DXN or DXAS subscriber; \$15.00 to non-subscribers.
- Payment options for any item: check, money order, or credit card (via PayPal - access www.nrcdxas.org ONLY and follow the links), or cash only at your risk.

Note: all checks and money orders should be made out to:

National Radio Club.

DX News is printed by Hall Commercial Printing, Inc. - 1935 N. W. Topeka Ave. - Topeka, KS 66608

First-Class
Mail
U. S. Postage
PAID
Topeka, KS
Permit #598