

# DX News

•Serving DX'ers since 1933•

Volume 60, No. 1 - Oct. 12, 1992 (ISSN 0737-1659)



## Inside...

- 2 .. CPC Tests
- 3 .. DDXD-N
- 5 .. In the Beginning
- 6 .. IDXD

- 12 .. Verification Signers
- 13 .. Silent Stations
- 15 .. Ribbon Loop
- 20 .. Radio Roundup
- 22 .. Musings

### CPC Test Calendar

Call	Freq	Date	ELT Time
WBHY	840	Oct. 12, 1992	0100-0400
KXOL	1320	Oct. 12, 1992	0300-0330
WQIN	1290	Oct. 20, 1992	0030-0130
WLYN	1360	Oct. 26, 1992	0330-0440
WRIV	1390	Nov. 2, 1992	0530-0600
WIMA	1150	Nov. 28, 1992	0030-0100

New test details are on page two.

### A Fable for Our Times

Once upon a time there was a group of Ants who were always very, very busy collecting special foodstuffs and storing them. Once they were collected, they were mixed and cooked with an original recipe known only to the Ants. Other insects around the world came to the Ants for portions of the food, and they depended upon it.

The one in charge of the storeroom, Zak, had told them often that another, smaller, group, known as the Nits, might get better foodstuffs and become bigger and more powerful than the Ants if they didn't hurry up and collect more and more foodstuffs.

So the Ants were always hurrying and scurrying about, and they never went to the homes of the Nits.

Meanwhile, the Nits kept an eye on the Ants but didn't worry about the Nats. In fact, they often laughed among themselves when they told stories amongst themselves about how busy the Nats always seemed to be and how they never seemed to have fun.

One day, Zak told one of the Ants, whose name was Zol, "You'd better watch out for the Nits. They're catching up to you. I'd better not catch you talking to the Nits or offering them any foodstuffs ... or else."

Now, Zol didn't like what Zak had said. After all, he had friends amongst the Nits and often invited them over for supper. He thought and he thought. Finally, he remembered something. "Zak is our leader because we chose him to be," Zol said to himself. "And I think ... yes, Zen, Zik, Zane, Zere, and Zon were there when we chose him!"

Zol went to the five and talked to them. They

were outraged! "Why, Zak has no authority to do something like that," Zik roared. Zon said something to himself that the others couldn't hear, but they paid him no heed. After all, Zon was the tactless one.

So they chose Zen to talk to Zak. Zen was the Wise Elder of the group, and he said to Zak, "We don't want you to keep Zol and the others from helping the Nits. Why, some of our best friends are Nits!"

Zak was outraged. "All right, if that's the way you feel about it, you can just find someone else to watch the storeroom," he shouted as he stomped out of the storeroom. But Zen didn't notice that Zak's pocket was bulging a little as he left.

So, all was quiet for awhile. Nats talked with Nits and even invited them to each other's homes. And all was peaceful.

But one day, Zane got a letter from Zak. It said, "Come to my storeroom for the best food. I have an original recipe that I made up. It's even world-famous!"

Zane called Zol. "What does he mean, 'an original recipe?'" asked Zane.

"I guess he made it up," said Zol. So he ob-

(continued on page two)

### DX Time Machine

From the pages of *DX News*:

50 years ago ... from the Sept. 19, 1942 *DXN*: Hilding Gustafson, Rockford, IL, reported receiving a very nice verie from CX16 after four months; and NRC President Joe Becker mused that every U. S. station he has heard has been verified, but nine L. A. stations "are the only flies in the ointment".

25 years ago ... from the October 7, 1967 *DXN*: Dave Schmidt, Chester, PA received a v/f from KXIF-1370 to bring the total up to 471, state #44 ... John Callarman, Cambridge, MA noted that he'd made "four in a row" NRC conventions.

10 years ago ... from the October 1, 1982 *DXN*: Former NRC publisher Dick Cooper Died September 24 ... George Hakiel reported hearing Turks and Caicos on 1460 9-8.

Thanks to the two constant contributors to this column, Kermit Geary for the 50-year-ago items, and Skip Dabelstein for the 25-year-ago items.

tained a sample. It was the same as the one the Ants always had used!

"We can't let Zak get away with this," cried Zere. "I know; let's make up a better recipe and offer new food."

"I'll help you," said Zane, and off they went to create the new recipe.

Soon, the Ants were selling more and more food, and Zak watched the line of insects outside the Ants' storeroom getting longer and longer. He was furious!

"Come and get some of my food!" he yelled. "It's world-famous, you know!"

"Who cares?" yelled back Zow, one of the insects in the line. "You stole the original recipe, but I'm going to stick with the Ants' food. It's better, anyway. Admit it, Zak; your goose is cooked!"

Zak howled with rage and frustration. What could he do? Suddenly, an idea struck him, and he rushed inside to his word processor and started typing. He'd keep the Ants so busy that they wouldn't have time to tend to business!

Zol couldn't believe his eyes when he opened up his mailbox the next day. It was full of envelopes from many, many places and covered with expensive and colorful stamps. Zol staggered inside and dumped the envelopes on his table and started sorting them. All were stamped, "Material that you ordered". But he hadn't ordered anything!

One of the envelopes had an 800 number on the outside, so he called it.

"Hello, I didn't order anything, but you sent me a big, big catalog," Zol told the nice person.

"Oh, we're sorry," the nice person said. "Didn't you send us a reply card?"

"No, I didn't," Zol said. But who did?

Zol hung up the phone and thought and thought. He looked out the window and saw the long line of insects leading to the Ants' storeroom. Then, he looked out the other window at Zak's home. One insect was walking into Zak's front door, a package of food under his arm. A minute later he walked out, counting a handful of money. Zak stood behind him, frowning, and then turned abruptly and disappeared. A minute later, Zol could hear the word processor grinding and whining.

Zol's eyes opened wide. Then he laughed and laughed. He ran to the homes of Zen, Zik, Zon, Zere, and Zane and told them what had happened. They laughed and laughed, too.

"Zak's printing address labels to stick on reply cards," Zol told them. "If he's busy doing that, he must not be selling very much food from his world-famous recipe!"

"Yeah, and wait until the Postal Inspector finds out about it," said Zane. "He'll really be too busy answering questions then."

"There's always been one thing that's bothered me," Zon said.

"What's that?" the others chorused.

"Why did he even bother to steal the recipe in the first place?" Zon chortled. "He doesn't ever cook!"

The others just shook their heads. Zon, after

all, had always been the tactless one. Some Ants just never change!

**Moral: Quit while you're behind.**

**From the publisher:** The NRC went through its most difficult time during the past year since 1964 when renegade members split from the NRC to form the IRCA. But as we begin the 60th year, we can congratulate ourselves in the fact that the NRC has never been stronger ... in its membership standing together, in the quality of its editors and managers, in its products, including *DX News* and the monthly taped programs from DX Audio Service, and in its finances. DX'ing may be "only" a hobby, but the NRC has honed the business side to a science.

We're a little light on columns this week, the first of the weeklies, but look for your favorite columns to return next week. (Editors, hint, hint.) Look also for the return of IDXA and IDDXA on a monthly basis this season, and starting counting your domestic and foreign totals so you can send your updates to Dan Bartek and Don Erickson. More details next issue.

**DX GTGs ...** Rick Dau's GTG Oct. 17-18 at the Days Inn - 101 W. 65th St - Davenport, IA, starts at 2 pm Saturday, and it features a tour of WOC-1420 for those who are on hand by 3 pm. For room reservations, call (319) 388-9999. Rick asks for an RSVP by mail so that he can get a count of those interested in a Sunday brunch. Contact him at 42 W. Court St., #401 - Iowa City, IA 52246.

Ray Arruda's long-standing GTG will be the Saturday before Thanksgiving, November 21, 1992, at 47 Burt St. - Acushnet, MA (02743 1939), from noon to ???

**They joined ...** Tim M. Watkins, St. Louis, MO; Mark Humenyk, Weston, ON; John Murphy, Marblehead, MA; Norman W. Gender (rejoins), Chicago, IL; W. Al Jeffrey (rejoins), Tampa, FL; Robert M. Dye, Tulsa, OK; Victor R. Leavery, Clayton, NY; Bill Morse, Elgin, IL; Robert E. Tucker, Jr., Savannah, GA; Charles N. Smith, Newbury Park, CA. We start the season with 665 members in the NRC.

**New CPC Tests...**

**WQIN-1290 - 419 Market St - Tykens, PA 17048** will conduct a test as an extension of its regular frequency check October 30 Monday/Tuesday, 0030-0130. No test details were available. Thanks to Marie Rodchok, 5M - Arranged by the National Radio Club (NRC).

**WRIV-1390 - P.O. Box 1390 - IFC, Box 1390, Riverhead NY 11901** will conduct a special DX test on Monday morning, November 2, from 0530 to 0600 ELT. The test will consist of polka music and ID's. Our thanks to Mr. Bruce Iria, President and General Manager for this test. Arranged by the National Radio Club (NRC).

**WIMA 1150 - All Engineering - 667 West Market St. Lima Ohio 43001** will conduct a DX test on Saturday, November 20 between the hours of 0030 AM and 0100 AM EDT; the test, WIMA will transmit with a non-FM pattern at its legal output power of 1000 watts. Ohio State Buckeye's marching band music will be the format with Morse code ID's between music cuts. Thanks to Mark Gierhart (CF) Arranged by IFC (Stephen) for the IRCA CPC.

## Domestic DX Digest

**North: Bill Hale**

495 Creekview Drive - Meridian, ID 83642-3241

**South: Duncan Shaw**

3131 S. McClintock B111 - Los Angeles, CA 90007

**East: Dave Braun**

11 Mill Bend Acres - Wyoming, DE 19934-9523



*DX Catches in the U. S. and Canada, with 24-hr. ELT*

### DDXD-North

#### MEDIUM WAVE RAMBLINGS

- OK, folks. It's getting mighty lonely without your reports. Cold weather is upon us, so let's sharpen up the pencils and log that DX which is coming into your radio! Then report!!!
- Just got my new NRC *AM Radio Log*. And it's a dandy. If you haven't already ordered one, it would make a great addition to your DX Den's library. And help you ID some of those unIDs, too.
- Remember, phone calls are always welcome. 208-888-7398 is the number. Call between 6 and 10 PM Mountain Time most nights. If I'm out when you call, leave your name and number and I'll get back to you pronto.
- Thanks to our Ontarians for making this week's column a column.

#### SPECIAL and LOG UPDATES

- 570 CKGL ON Kitchener - 9/17 1529** Good over weak unID (probably WSYR) with country music, contest phone-in, ID as *The all-new CKGL*. Now here, ex: 96.7 after frequency swap with CHYM which has the same owner. (MS-ON)
- 790 CIAO ON Brampton - 9/3** On all day with nothing but open carrier and announcement: *CIAO is no longer here on this frequency. Please change your dial setting to 530 on your AM radio. Gone for good on Sept 6.* Amen to this pest; now CIGM Sudbury, ON will be almost as big a pest! (MB-ON)
- CIAO ON Brampton - 9/4 1933** Excellent with tape advising listeners to tune to 530. Off completely the next day. They had operated simultaneously on 790 & 530 for nearly a year! (MS-ON)
- 890 KDXU UT St. George - 9/26 0840** Heard promos for, then at 0900 Norm Lavre's auto advise show from KFI-640. [Ed.-ID]
- 910 CKLY ON Lindsay - 9/17 1750** Good with Canadian Tire ad, then *CKLY now presents the Lindsay Cleaners Community Calendar* with many local PSAs. Still on despite being reported as *silent* in 8/3 AM Switch column. However, local NRCer Wayne Plunkett has informed me they are experiencing severe financial difficulties and have been searching desperately for a buyer. (MS-ON)
- 940 WINZ FL Miami - 9/6 0330-0400** Fair → poor in flight with XEQ with special emergency broadcast after Hurricane Andrew. Female announcer w/hurricane-related info such as phone number to call for info on federal low-interest loans for homes and businesses, a run-down on the locations of mobile kitchens in Homestead and Florida City, warning that any water from Homestead's water system should be considered contaminated. Also a reminder that the Florida Dept. of Corrections Probation and Parole Services office in Homestead is open and probationers should report as usual. (Ain't that America!! And I

bet the gun shops in Homestead are open for business again too, hi!). Never heard before -- are they running 50 kw on a special emergency authorization? (post-hurricane, or to escape Cuban QRM, or both?) [Probably the former - Ed.] (MB-ON)

- 1430 CJCL ON Toronto - 9/4 1936 Excellent on first day of all-sports programming. They now use non-ID *The Fan*. Apparently wanted CFAN calls, but these are now held by 790 in Newcastle, NB. (MS-ON)

### SHIVER ME TIMBERS

- 1620 WRMR NY Monticello - 9/6 2303-2320 Fair signal with DJ IDing as AM 1620 & 97.5(?) FM, WRMR, Monticello. Oldies music (Beatles, Elvis, etc). Talk by male DJ. (ROSS-ON)

### MIDNIGHT TO 0800 HOURS ELT

- 740 WMBL NC Morhead City - 9/6 0413-0445 Fair over usual jumble of unID Cubans with MoR standards (Bing Crosby, Louis Armstrong), ID as WMBL, your station for great songs and great memories. Ads for Didi-7 stain remover, Tennis Magazine and make-your-own-will kit for only \$12.95. (MB-ON)
- 890 CJDC BC Dawson Creek - 9/26 0455-0520 Noted with oldies, Broadcast News at :00, back to *Oldies Coast-to-Coast*. Two long ad/PSA clusters. Ads for a local comedy club and a video rental place. PSA for a foreign adopt-a-child-via-contributions outfit. Great signal. [Ed.-ID]
- 1200 CHMG AB Saint Albert - 9/15 0758-0803 Excellent signal with oldie (Hall & Oates), and call letter ID which sounded like CHME. Thought I had CKDA, but glad I stuck around for more than a minute or two and caught the call. [Ed.-ID]

### 0800 TO 1600 HOURS ELT

- 790 WTNY NY Watertown - 9/7 1354 Good with CBS Sports Chicago Cubs vs Pittsburgh Pirates. Local ID at 1400 as *Storlex(?) Radio 790 WTNY*. A daytime regular here with CIAO finally off this frequency. (MS-ON) [Morris, maybe that was Sports Radio . . . ? [Ed.]
- 1210 KBSG WA Auburn - 9/23 0908 Fair with singing ID *Oldies from the 60s - Beatles' Things We Said Today*. C&W QRM (probably KSRV or KONY). [Ed.-ID]

### 1600 TO 2400 HOURS ELT

- 790 WLSV NY Wellsville - 7/7 1930-1944 Fair - poor over thunderstorm QRN in nulled CIGM with curious blend of C&W and oldies. ID as AM 790, where you can hear the most variety of country and gold. Ad for Sears Automotive Center, PSA for Selective Service draft registration, and local weather sponsored by Southern Tier Concrete Products of Alfred. (MB-ON)
- WLKW RI Providence - 9/8 2058 Poor with instrumental music. ID At 790 on your radio dial, this is WLKW. (MN ON)
- CIGM ON Sudbury - 9/8 2158 Fair with ID *Radio 790*, CIGM and Toronto Blue Jays baseball. Heard subsequently with country music. (MS-ON)
- 1240 WJTN NY Jamestown - 9/4 1855 Fair with ID and plug for Buffalo Bisons baseball. (MS-ON)
- 1340 WMBO NY Auburn - 9/7 1956 Fair with rock oldies, ad for a gymnastic club in Auburn mentioning chapters in New-a Falls and other NY state locations, other local ads. (MS-ON)

growing  
MAJORITY  
&  
1310CAAM  
Big Bands • Great Singers

- 1490 WABJ MI Adrian - 9/4 2300 Fair with ad with 800 number, ID mentioning 24 Hour News and AM 1490 WABJ, Adrian. (MS-ON)
- WJMO OH Cleveland Heights - 9/4 1857 Fair with call letter ID, song featuring male/female duet, then another call letter ID. (MS-ON)

### REPORTERS

- MB-ON Mike Brooker Toronto, ON; RF-2200 or ICF-7600D
- ROSS-ON Robert S. Ross, VE3 JFC London, ON; Collins 651S-1 + 200' longwire
- MS-ON Morris Sorensen Scarborough, ON; HQ-150 with McKay-Dymek DA-9 ferrite loop, ICF-2010 with SM-2 or RF-B65 with built-in antenna
- Ed.-ID Editor, N5SZC7 Meridian, ID; ICF-2010 barefoot



### ABBREVIATIONS AND SPECIAL SYMBOLS USED IN DDXD - North

|| :parallel with or to - :into :00:on the hour AC:Adult contemporary AP:Associated Press BBD:big band BRN:Business Radio Net C&W:country & western CFL:Canadian Football League CHR:contemporary hit radio CID:code ID CL:call letter ContChr:contemporary Christian EZL:easy listening EE:English FF:French GOS:gospel IRN:Interstate Radio Net LSR:local sunrise LSS:local sunset NBA:National Basketball Assn NHL:National Hockey League NFL:National Football League NPR:National Public Radio OC:open carrier POL:political PSRA:pre-sunrise authority PSSA:post-sunset authority QRM:man-made interference QRN:natural interference QTH:location REL:religious ROK:rock 'n' roll RS:regular schedule \$stereo SID:singing ID SRS:sunrise skip SS:Spanish SSB:Star Spangled Banner SSS:sunset skip TC:time check TT:test tones UC:urban contemporary UPI:United Press International

73,  
Fall

## In the Beginning

John D. Bowker

The complete list of U. S. broadcast stations on the indicated frequency as published by the Federal Radio Commission in 1934. "S" = shared; "SH" = Specified hours; "T" = Transmitter location; "D" = Daytime operation only; "U" = Unlimited time

Frequency (kc)	Call letters	Main studio and transmitter location	Power	Time designation
1450, regional.	WSAR	Fall River, Mass	250 w	U.
	WHOM	Jersey City, N.J.	250 w	U.
	WGAR	Cleveland, Ohio	500 w 1 kw LS	U.
		T-C u y a h o g a Heights.		
	WTFI	Athens, Ga.	500 w	U.
	KTBS	Shreveport, La.	1 kw	U.

### It may not be perfect ...

but the NRC Log, 13th Edition is, simply, the best there is because of your contributions. Why not make the updaters and 14th edition even better? Send all corrections and changes to Wayne Heinen - 4131 S. Andes Way - Aurora, CO 80013-3831. Thanks!

### "Latin America by Radio" - by Henrik Klemetz

168 pages of tips and suggestions for the non-Spanish-speaking Latin American DX'er. Includes tips on identifications, catchwords to look for, speech patterns, types of music, newscasts, advertising styles, brand names, weather and time check formats, and much more.  
\$17.95, from NRC Publications. NY orders, add sales tax.

# International DX Digest

*Foreign DX Catches. Times are UTC; for ELT, subtract 5 hrs.*

Welcome to first time reporter Lex Smith from the great state of Connecticut. It's the state where I started DXing in 1967. Lots of material this time, let's get started:

## TRANS-ATLANTIC

- 153 ALGERIA Becahr 9/3 0400 - Fair over unID station, Arabic music, 4 pips, then Arabic talk by man and woman. [MC-MA]
- 162 FRANCE Allouis 9/3 0359 - Excellent with man in French. [MC-MA]
- 183 GERMANY Saarlouis 9/3 0358 - Good to excellent with man in French. [MC-MA]
- 198 ENGLAND Droitwich et al 9/3 0355 - BBC fair with English commentary, atop DIW beacon. [MC-MA]
- 207 MOROCCO Azilal 9/3 0405 - Arabic string music, fair with QI beacon QRM. [MC-MA]
- 216 FRANCE Roumoules 9/3 0407-0410 - Man and woman in French, good to excellent, atop CLB and CO beacons. [MA-MC]
- 684 SPAIN Sevilla 8/18 0457 - Bits of Spanish talk, poor in massive WRKO-680 slop. [MC-MA]
- 729 SPAIN Oviedo et al 8/18 0457 - Fair with Spanish talk parallel 738, 774, others. [MC-MA]
- 738 SPAIN Barcelona 8/18 0456 - Fair with Spanish talk. [MC-MA]
- 774 SPAIN synchro 8/18 0455 - Excellent with Spanish talk by man, level comparable to adjacent WABC-770. [MC-MA]
- 837 SPAIN (CANARY ISLANDS?) 9/2 0228 - Woman in Spanish with a very pronounced echo due, most likely, to some network affiliates getting landline feed and some getting delayed satellite feed. [MC-MA]
- 855 SPAIN Murcia et al 8/18 0453 - Huge signal with Spanish teletalk show, only a few dB weaker than WHDH-850! [MC-MA]
- 891 ALGERIA Algiers 8/16 0424 - Arabic pop music, then Arabic talk by man. [MC-MA] 8/22 0355 - Excellent (totally killing WLS) with Arabic violin music, then talk by woman. It was, by far, the loudest TA at the time. 9/2 0048 - Good to excellent with man in Arabic. 9/4 0315 - Arabic string and vocal music, followed by talk, fair to good despite mediocre conditions. [MC-MA]

## Jim Renfrew

61 Wilcox Street  
Rochester, NY 14607-3832

- 945 FRANCE Toulouse 8/18 0450 - Good with French version of Fleetwood Mac song, then Creole-style French music. [MC-MA]
- 954 SPAIN Madrid 8/18 0447 - Man in Spanish, good. [MC-MA]
- 999 SPAIN Madrid 8/18 0446 - Good to excellent with Spanish talk by man and woman. [MC-MA]
- 1017 SPAIN Burgos 8/18 0445 - Spanish talk by man and woman, then music; atop others. [MC-MA]
- 1017 TURKEY Mundanya (Istanbul) 9/2 0041 - Poor to fair with vocal music sounding like a blend of Greek and Arabic pop styles. TA conditions at the time were unusual; there was definite enhancement to the eastern Mediterranean region. [MC-MA]
- 1026 SPAIN Reus et al 8/18 0445 - Spanish talk by man, to good peaks. [MC-MA]
- 1035 PORTUGAL Lisboa 8/18 0444 - Uptempo pop music; Portuguese talk, fair to good. [MA-MC]
- 1044 MOROCCO Sebaa-Aioum 8/18 0443 - Poor with apparent French talk. [MC-MA]
- 1062 PORTUGAL Norte 8/18 0439 - Excellent with Portuguese female group vocal. [MC-MA]
- 1062 UNID 9/2 0045 - Het, bits of chant. Probably Diyarbakir, Turkey as 1017 was in and Egypt 1107 was unusually loud at the time. [MC-MA]
- 1098 SPAIN and/or CANARY ISLANDS 8/18 0437 - Spanish talk by man, to good peaks. [MC-MA]
- 1107 SPAIN/EGYPT 8/18 0459 - Fast Spanish talk atop Arabic program. [MC-MA]
- 1107 EGYPT Bahrah 9/2 0017 - Very good to excellent with man and woman in Arabic. This was about as well as I've ever heard this from a non-beach location. Hets on 774 and 819 also seemed to be Egypt rather than Spain and Morocco. [MC-MA]



- 1125 SPAIN/unID 8/18 0434 - Mess with Spanish talk over others. [MC-MA]
- 1134 SPAIN Bilbao et al 8/18 0433 - Spanish talk by man and woman, atop other stations. [MC-MA]
- 1251 LIBYA Tripoli 8/18 0136 - Arabic talk by man, loud. [MC-MA]
- 1269 SPAIN 8/18 0139 - Spanish-sounding talk in bad WTSN/CJCB-1270 slop. [MC-MA]
- 1296 SUDAN/SPAIN (tentative) 8/18 0235 - African-sounding metal drum music, poor, mixing with possible Spain station. Slop too heavy to determine much of value. [MC-MA] (Sudan is being heard on 7200 with 0250 sign/on, 9190 about 30 minutes later. Perhaps parallel to 1296? - Jim)
- 1314 NORWAY Kvitsoy 8/18 0233 - Good (over others) with "Love Me Tender" by Elvis Presley, then Norwegian talk by man. [MC-MA]
- 1349 MAURITANIA Nouakchott 8/17 2345 - Bits of chant. [MC-MA]
- 1377 FRANCE Lille 8/18 0425 - Arabic music, stopped by stronger St. Pierre 1375. [MC-MA]
- 1422 GERMANY/ALGERIA 8/18 0423 - Apparent German/Arabic mix in slop. [MC-MA]
- 1467 FRANCE Roumoules 8/6 0401 - Poor with classical music. This station doesn't seem to have the kick that it had from Monaco in the '60s and '70s. In those days it was as loud as Langenberg at receiving locations near Boston. [MC-MA]
- 1521 SAUDI ARABIA Duba 8/10 0315 - Arabic talk. 9/2 0300 - Sign-on sequence with open carrier followed by a capella male Koranic reading in Arabic. Monster signal, annihilating WWKB. [MC-MA]
- 1530 VATICAN 7/31 0344 - Vatican chimes, classical music, then talk by woman, way over WCKY. 8/10 0345 - Talk (probably listed Albanian), classical music over/under WCKY. Strongest TA at the time. 1611 also noted in. 8/11 0347 - Man and woman, likely in Albanian, totally killing WCKY! [MC-MA]
- 1539 GERMANY Mainflingen 8/18 0222 - Classical music, good not much QRM. [MC-MA]
- 1575 SPAIN/others 7/31 0338 - Bits of Spanish talk by man, atop mess of other signals. [MC-MA]
- 1575 BURG 9/4 0328 - Good, totally dominant with German talk, then Dixieland jazz. [MC-MA]
- 1584 SPAIN 8/17 0447 - Fast Spanish talk by 2 men, good. [MC-MA] 9/4 0326 - Male Spanish talk over jumble. [MC-MA]
- 1593 GERMANY Langenberg 8/18 0114 - Excellent with German female MOR vocal, then US C&W oldie "Little Arrows". [MC-MA] 7/31 0336 - Good with soul/pop music. 8/10 0340 - man in German, then pop female vocal; fair to good despite mediocre band conditions. 8/11 0343 - excellent with rock music. 9/4 0325 - female soul vocal, good but fadey. [MC-MA]
- 1611 VATICAN 8/6 0356 - Female talk, German or Slavic-sounding, fair over slight 1610 het. 8/11 0340 - Lous with Interval Signal, Slavic talk by woman. [MC-MA]

## PAN-AMERICAN

- 535 GRENADA St. George's, 8/19 0343 - Big band music, fair. [MC-MA]
- 555 ST. KITTS ZIZ Basseterre, 8/19 0137 - Caribbean English sporting event (probably soccer), good. [MC-MA]
- 650 COLOMBIA HJKH Bogotá, 8/19 0155 - Loud with ads for Bogotá businesses, sporting event with Colombia vs. Bolivia. [MC-MA]
- 670 VENEZUELA YVLL Caracas 8/19 0046 - Rumbos mention, Spanish sports. [MC-MA]
- 670 CUBA R. Reloj 9/15 0408 - Looks like this Radio Rebelde outlet may be running Reloj program after local midnight. I noticed Rebelde here the previous night at 0320. 9/20 0619 - Noted with Rebelde program, so perhaps it's Reloj on weeknights. Requires more observation! [JR-NY]
- 690 ANGUILLA Caribbean Beacon 9/20 0618 - Noted with Gene Scott, but not parallel to 9455 or 7435 shortwave; poor in CBF null. Are people on these tiny islands actually sending this guy money? [JR-NY]
- 705 ST. VINCENT Kingstown 8/19 0348 - Open carrier, strong. [MC-MA]
- 720 VENEZUELA YVQE Porlamar 8/19 0103 - Horn fanfare, Porlamar mention, atop CHTN. [MC-MA]
- 750 VENEZUELA YVKS Caracas 8/19 0055-0101 - "Human Touch" by Bruce Springsteen, Spanish talk, Banco de Venezuela ad. [MC-MA]
- 770 COLOMBIA HJJX Bogotá 8/19 0355 - Spanish talk, RCN ID under WABC. [MC-MA] 9/15 0430 - ID as "RCN, La Radio de Colombia", ads, UTC-4 timechecks. Unusually good in WABC

- null. [JR-NY]  
 780 VENEZUELA YVMN Coro 8/15 0505 - Good with several Coro IDs. [MC-MA]  
 9/13 0750 - Excellent with jingles, a man and a woman alternating announcements, Spanish pop and traditional music, much the same format as when I heard them last spring. [BC-NH] 9/14 0247 - excellent with music, Coro ID and time checks. [JR-NY]  
 800 NETHERLANDS ANTILLES PJB Bonaire 8/19 0100 - English preaching. [MC-MA] 8/21 0424 - Spanish religious program; good over CJAD & others with CKLW phased and WCCM off. [MC-MA]  
 810 COLOMBIA CARACOL 9/14 0328 - Noted with talk and music parallel to shortwave 5075, weak under WGY and ZNS. [JR-NY]  
 830 ST. KITTS & NEVIS 8/19 0330-0402 - English preaching, no ID at the top of the hour. Was mixing with CFJR and Latin American stations. There was no trace of St. Kitts on 825 at the time. The big question: Has St. Kitts moved to 830 or did I have Belize (or a domestic)? Loop bearing was approximately south but co-channel QRM was too much for an accurate direction fix. [MC-MA] 9/20 0545-0600 - Noted strong in WCCO null with Trinity Broadcasting Network program, in parallel with 7510 KTBN shortwave. No ID on the hour, although KTBN broke away for an ID. Looks like this will continue to be heard well in North America. With a new frequency and a new transmitter location most of us will probably count this as a new one. [JR-NY]  
 830 BELIZE R. Belize 9/14 0351 - Noted with ID and DJ in English in WCCO null. [JR-NY]  
 930 CUBA R. Reloj 9/13 0740 - Easily identifiable with news, syncopated clock, and "RR" morse code over/under local WZNN. [BC-NH]  
 970 AMERICAN VIRGIN ISLANDS, WSTX 9/13 0716-0732 - Good to excellent with continuous soca dance music, DJ playing requests and dedications saying, "I hope you enjoy your stay here in the Virgin Islands"; sounded like a live remote from a nightclub. [BC-NH] (A tough one anywhere north of Florida, very nice - Jim)  
 1020 VENEZUELA Mundial Margarita 9/13

- 0654 - Briefly excellent with Spanish pop/salsa music before falling prey to WBZ splash and KDKA, poor at 0702 with a quick news brief, lots of neat sound effects and fast-paced hype. [BC-NH]  
 1030 UNID 9/10 0000 - Arabic vocals with string music. Strong peaks often over WBZ. Also heard on 8/5,12,17 and 9/1,5,6 and 8 from 2345-0100. [LS-CT](Lex, this is WNTL, Indian Head MD, a 50 kW daytime station often heard here which broadcasts religious programs in various languages - Jim).  
 1070 VENEZUELA Mundial Zulia 9/13 0542-0642 - Weak with Spanish pop music, DJ hype between songs like "El lugar de sontania!" and "La potencia!", and trumpet (like heard at the beginning of a horserace) at the top and bottom of the hour, finally caught Mundial Zulia ID at 0642, in CHOK null with occasional WTIC splash. [BC-NH]  
 1080 VENEZUELA R. Barcelona 9/12 0046 - Fair with salsa hits, DJ saying Radio Barcelona with long rolling R's, in WTIC null, previously heard on several occasions but never identified until now. [BC-NH]  
 1090 ST. LUCIA R. Caraibes International 9/12 0055-0145 - Dominating the frequency with French talk, an instrumental music break at 0105, more talk, then another instrumental music break at 0136 followed by mention of Martinique and R. Caraibes International, over an unID Spanish station and WBAL. [BC-NH]  
 1100t COLOMBIA R. Reloj 9/13 0510-0538 - Weak with Spanish news, chimes many mentions of Bogotá and Colombia, mixing with ZDK, Antigua. [BC-NH]  
 1160 BERMUDA VSB3 9/13 0506 - Excellent with BBC World Service news, parallel 6195 kHz. [BC-NH]  
 1165 ANTIGUA St. John's R. Lighthouse 9/2 0212 - Preaching by man in English, audio muffled. [MC-MA]  
 1170 COLOMBIA CARACOL 9/13 0404 - Fair to good with "informativa" and jingle ID, over an unID Spanish station and noise in WWVA null. [BC-NH]  
 1170 UNID 9/13 0456 - Good with Spanish pop music, ID as R. Mil Sesenta (1060), then choral music assumed to be the National Anthem followed by s/off in WWVA null. [BC-NH] (1170 could be CMKS, Maisi, with primary station on 1060, Baracoa, or any number of Colombian or Venezuelan stations - Jim)

- 1220 UNID 9/13 0305-0340 - Fair to poor with merengue and salsa hits, Radio Musical IDs, possibly WRIB on late. [BC-NH] (Can anyone help Bruce with these unIDs? - Jim)  
 1375 ST. PIERRE & MIQUELON 7/31 0349 - Rock music with French vocal, excellent signal. [MC-MA]  
 1550 COLOMBIA R. El Sol 9/13 0143-0220 - Fair to good with Spanish accordion folk music, promos for fútbol mentioning Atlántico, Caribe and Radio de Colombia, R. El Sol ID caught at the top of the hour, over/under WLVX and an unID rap music station. [BC-NH]  
 1620 MEXICO 9/27 0209 Harmonic of XERI-810 Reynosa, with R. Rey, tropical mx; not heard after 10-1. [pls-KS]

#### STATION NEWS

I begin this section with a "thank you" to César Objío, who sent the Medium Wave section from two editions of *Pampas DXing* (Buenos Aires). He notes that there are two reporters in Cuba reporting to the publication.

AUSTRALIA: The Hospital Radio Network in Newcastle, has six individual transmitters operating on 1629 kHz. Programs are 24 hours/7 days and consist of music and medical announcements between 6 AM and 7 PM weekdays, with background music at other times. Transmitters are all former drive-in theater units, 10 watts. [Ian Stanley and D. Headland in *DX Australia* 8/92]

AUSTRIA: Now that FM coverage of Austria is complete, engineers of the ORF have been debating whether to switch off 1476 MW, a transmitter of 600 kW located just outside of Vienna and currently airing Osterreich-1 service. During the evening hours there are regular announcements being made in German, on the MW service only, asking listeners to register their existence. There is a competition, with a prize of compact discs, for the reception report from the most distant listener. If there is no response or the range of listeners stops just outside the Austrian border, ORF may silence the transmitter. [R. Nederland Media Network via BDXC in ARC 8/26/92]

BAHRAIN/KUWAIT: The VOA MW relay

(1350 kHz) established here during the Gulf War closed 7/31. A new site in the gulf area is being sought. [R. Nederland Media Network 7/30 in NASWA 9/92] On 8/4 VOA announced an agreement with Kuwait for a relay site of one MW and up to 10 SW transmitters. The agreement provides free use of site and electricity, with Kuwaiti access to the facilities on a time available basis. [VOA Press Release in NASWA 9/92]

BELGIUM: The high power transmitters in Belgium are reducing power output, Wavre BRT-2 on 540 from 150 to 50 kW, RTBF-1 on 621 from 300 to 100 kW, Wolverteem R. Donna on 927 from 300 kW to 150 kW, and BRT International on 1512 with 20 kW during daylight and 300/600 kW at night. [BENELUX DX CLUB in *Medium Wave News* 9/92]

BULGARIA: The Horizont program on 1224 (Vidin) doubles its power from 500 to

1000 kW between 2245 and 0130 UT. A new 1000 kW transmitter is under construction north of Varna. It may be for relaying VOA, DW, RFU or MR (R. Scala) [BENELUX DX CLUB in *Medium Wave News* 9/92] CROATIA: Croatian Radio broadcasts around the clock on the following frequencies: 774 during the day, 1125 and 1134 during the night. English news scheduled 0603-0610 & 0803-0810 M-Sa, 0703-0706 & 0903-0906 Su, 1203-1210 & 2103-2110 daily. [BDXC in *Medium Wave News* 9/92]

CUBA: R. Cadena Habana started test transmissions in English on 1050 kHz on 4/3 parallel to 9505 and 11820 kHz. Tests heard 0130 for several hours. On 4/7 it was heard on 1150 kHz at 0000. Radio Musical National from Arroyo Arenas 950 kHz transmitted an evangelical message during Resurrection Sunday last April, between 1230-0230 UTC. This was requested by the Consejo Ecumenico de Cuba, and it's most rare as religious programs are almost unknown in Cuba. [ARC 8/26/92] R. Reloj reported on 1165, unknown location [Krueger DXSF 4/6 via WRTH LA-NL #4 in ARC 8/26/92] Reciprocal relay arrangements between Moscow and Havana seem to have ended by the end of June, 1992. [R. Nederland Media Network 7/16/92 in WRTH LA-NL in ARC 8/26/92] Chris Dunne, Pembroke Pines FL, reports hearing two new Cuban FM stations: Radio Rebelde 89.9 (site unknown) and Radio Enciclopedia (presumed) 88.7 Santa Clara (correct site?). You can add these stations to the list printed in DXN 59-28. Chris also heard FM stations from Puerto Rico, the Dominican Republic, Jamaica, and possibly Haiti via tropospheric propagation - quite a feat! [CD-FL] R Cadena Habana network list (different from 92 WRTH): 1080 Guines (Habana), 1090 San Antonio de Los Banos,



1100 La Salud, 1120 Artemiza, 1140 La Loma de La Cruz, 107 FM Stereo. [EPC (Cuba) in *Pampas DXing* 4/92]

**DOMINICAN REPUBLIC:** R Amanecer noted on its regular frequency of 1570 4/23 (Jimenez P. in CNX #65 in WRTH LA-NL 8/1/92 via ARC 8/26/92) (A change, since this has previously been reported in IDXD on 1565 kHz - Jim)

**GRENADA:** Harbour Light of the Windwards, Carriacou Island, Grenada, W.I. (US address: Aviation Radio Missionary Service, Inc., 875 State Park Road, Greenville, SC 29609). On 1400 kHz with 5 kW, daily program in English 0930-0200, news relays from BBC and VOA. There are future plans to broadcast in Spanish and French. [Station letter in WRTH LA-NL 8/1/92 in ARC 8/26/92]

**JORDAN:** Amman 612 increases from 10 to 200 kW and Al Karanah 1494 is now 1000 kW. [BENELUX DX CLUB in *Medium Wave News* 9/92]

**RUSSIA:** The latest reported schedule of Radio Ala: 684 2000-1900, 1386 2000-2300 and 0200-1500, 1494 2000-1530. [Anatily S. Klepov in *PLAY DX* #702]

**ST. KITTS & NEVIS:** Radio Paradise 830 (ex-825) moved in February 1992 to the adjacent island of Nevis and is now 24 hours a day. New address is Radio Paradise, Charlestown, Nevis. The new owner is Trinity Broadcasting, the same organization which took over KUSW (shortwave). [CGK in ARC 9/11/92]

**SAO TOME:** The VOA is building a new site to replace the Monrovia, Liberia relay transmitter, lost in the civil war. In two years it will have four short wave and one medium wave transmitters. A provisional MW transmitter will sign on in 1993 with 100 kW. The future MW transmitter will be rated 600 kW (in 1995). [Radio Nederland Media Network in *DX Australia* 8/92]

**SPAIN:** A new Spanish MW list is available from the NRC Publications Center, please enclose funds (and NYS tax for NY residents) for copying 2 pages. The list is current to August 1, 1992. We received the list from PLAY-DX #704, and it was prepared by Jordi Brunet, Catalunya, Spain.

**UNITED KINGDOM:** On 18 July the second national radio station commenced test transmissions on 1215 kHz. The announcement given states that test transmissions are taking place on 1215 and 1197 kHz in readiness for the new station which will commence broadcasting in early 1993. The address quoted is Independent Music Radio, c/o Breakfast Television Centre, Hawley Crescent, London NW1 8EF. The station is broadcasting back-to-back rock and

roll music with announcements every thirty minutes. According to correspondence from the station, only the Brookman's Park transmitter is in use at this time, and other transmitters throughout the country will be tested over the next few months. The actual name of the station has yet to be decided but it is thought that it will be called either "Virgin Rock" or "Virgin Rock Radio". [*Medium Wave News* 9/92]

**VOICE OF AMERICA** (effective until 9/26/92): 621 BOTSWANA 1800-2200 & 0300-0430 English, 1730 Portuguese; 792 KAVALA GREECE 2200-0300, 0400-0430 & 0500-0700, 1600 English, 0330 & 1700-1900 Rumanian, 0345 & 1930 Serbian, 2000 Croatian, 2130 Arabic; 930 MONSERRAT 0000-0030, 0100-0200, 1000-1030 & 1100-1200 English; 1143 PHILIPPINES 1100, 1330 & 1600 Mandarin, 1200 & 1400 English, 1230 Vietnamese, 1500 Cantonese; 1180 FLORIDA "Radio Marti" 24 hours Spanish (except silent 0300-0900 Mo), 1197 MUNICH GERMANY 0300 Bulgarian, 0330 & 1600 Czech/Slovak, 0430, 2000 & 2130-2300 Polish, 0530 & 1800 English, 0600-1600 M-Sa & 1900 daily "VOA Europe" in English, 2100 German; 1260 RHODES 0000, 0800-0900, 1500 2100-2200 & 2230-2400 English, 0300 Kurdish, 0330, 1330 & 1600 Arabic, 2000 Turkish; 1350 BAHRAIN [see above - Jim] 0030 & 2000-2400 English, 0100 Spanish; 1575 THAILAND 0000 & 1130 Burmese, 0030 & 1530 English, 1230 Lao, 1330-1500 & 2200 Khmer, 1600 Bangla, 2100 Mandarin. [VOA schedule in NZDXT 8/92]



**mdr**  
MITTELDEUTSCHER RUNDFUNK  
POSTPLATZ 2  
O-8600 BAUTZEN

#### QSL INFORMATION

Jeff Kitzke (Route 20, Box 450, Dillwyn VA 23936-0430) asks if there are any sources for obtaining Canadian, Mexican and other foreign postage stamps as well as IRC's. If no IRC's are available locally, perhaps the USPS will sell them to you through its "Stamps by Mail" service. I have hooked up with a Canadian NRCer with whom I occasionally trade stamps. Since my in-laws live in San Diego I usually buy Mexican stamps from the Tijuana Post Office whenever I'm out that

way. There are several DX Stamp services run for hams, but I can't put my hands on their addresses at the moment. Can anyone make a suggestion? As for sample French and Spanish language reports, they are offered from NRC Publications - P. O. Box 164 - Mannsville, NY 13661-0164, at 50 for \$5.00 (order "SSRF" for Spanish, "FFRF" for French)

#### CONTRIBUTORS

[CD-FL] Chris Dunne, Pembroke Pines FL; JVC RX302BK modified with 150 kHz filters, Archer 2-el, antenna at 20'  
[MC-MA] Mark Connelly, Billerica MA, Drake

R8, two 20 m wires, in noise-reducing configuration, phased with MWDZ-5. RTL-2 Loop/MWT-3 Tuner also used.

[MC-MA] Mark Connelly WA1ION, West Yarmouth MA; Sony ICF-2010 with G. Thomas filter mod, RTL-2 loop and MWT-2 regen. tuner.  
[JR-NY] Jim Renfrew, Rochester NY; HQ-150, Radio West loop  
[LS-CT] Lex Smith, Woodbury CT  
[BC-NH] Bruce Conti, Nashua NH; DX-400, MWDX-5, 3 50-70' wires.  
[pls-KS] Paul Swearingen, Topeka, KS; R-1000, combo Sanserino/Martens loops.

### Music Grade audio cassettes

C-90 tapes: retail value ... \$4.00 each; just \$9.00 per 10, \$22.00 per 25, or \$42.00 per 50.

C-12 tapes, perfect for airchecks: 10 for \$7.50.

Order from NRC Publications - Box 164 - Mannsville, NY 13661. NY orders, please add sales tax.

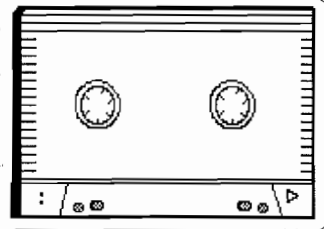

### Now available: the highlights of the 1992 NRC Convention on video!

Five hours, 25 minutes of the Omaha convention on a T-160 VHS tape, taped by Ernie J. Wesolowski. \$20.00. Also available: Omaha Radio, about two hours, on a T-120 VHS tape, also \$20.00. (\$5.00 from each order will be donated to the NRC.) Please specify which tape and order from NRC Publications; NY orders, please add sales tax.

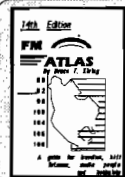
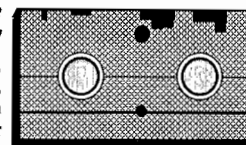

### Bruce Elving's FM Atlas ... 14th Edition

The world-famous guide which has served FM DX'ers for over 20 years is now available from NRC Publications at the special price of \$12.00. NY orders, please add sales tax.

### Need more information about AM DX'ing?

Mail a 29¢ stamp to NRC Publications - P. O. Box 164 - Mannsville, NY 13661-0164, and ask for the NRC Product Catalog.

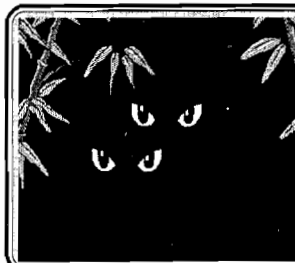

### New from NRC's DX Audio Service:

### "After Dark #2"

Four C-90 tapes in a holder now available for only \$9.50 postpaid. Listen to accounts about the VOA ... news about radio today ... 45 minutes from WNRC, and more airchecks from special stations ... and many special features. Order from NRC Publications - Box 164 - Mannsville, NY 13661. NY orders, please add sales tax.

# Verification Signers

Signatures and other information received upon request

## Wayne Heinen

4131 S. Andes Way  
Aurora, CO 80013-3831

Freq.	Call	Verie Signer	Contributor	1300	WJFKlb	Dan Ryson CE	BH
530	CIAOI	Angelo Cresisio P/GM	HH	1310	KNOXI	Russel J. Berger AE	DT
560	WEAZI	Herb Fayer M	BH	1320	KELOpu	U/U	ow
590	WCABlbz	Malcolm Watson GM	RI	1340	WALLI	L.A. Tarone NxD	DT
600	CIQC	Andre Chevalier PD	AR	1360	WGEEI	Stephen A. Konopka COp	HH/BH
630	KSLRlzub	John Walk OpM	RT	1370	WZAOfm	Michael E. Dunn GMRT/RA/BH	
700	WCATq	James Fontaine	RT	1400	WHMPi	Richard J. Rzeszutek	DT
720	CHTNlbzu	Gordon Mills CE	RT	1420	WIMSlmbz	Robert J. Schilling CE	RT
720	KSAHlu	William J. Haberer CE	RT	1430	WMRV	Ray Keller OpM	AR
720	WWIII	Carl C. Kuehn II CE	RT/BH	1430	WVAMlu	Timothy McCaffrey APD	BH
730	WFMCI	Robert Y. Wooten GM	RT	1440	KEYSI	John Gifford CE	DT
760	WVNE	Lincoln W. Hubbard CE	AR	1450	CHEFlh	Sylvain Brunelle	DT
760	XENYplbt	Carmen Guzman O - Box	ow	1450	CHUCI	Scott Hauter PromoD	DT
		1472, Nogales, AZ 85628	ow	1450	WOLLbu	John Hofstetter CE	BH
800	KSOsdu	Kari Torman Nielsen M	ow	1450	WLECq	Elmer Wilson E	DT
810	CMBFI	Juan C. Solomon Martinez	DT	1460	WCELLm	Dave Schmidt E	BH
		TDept - For Radio Progresso	DT	1470	WRGAlbz	Ben Cleary	DT
820	WIQTI	James R. Barrett CE	HH	1470	WXXWlmbu	William Lakatas OpM	BH
820	WQSlbu	Howard C. Fisher CE	BH	1490	WBEXIm	Mac Porter CE	DT
870	KWVApu	U/U	ow	1490	WMOAI	Dolly Hecox PD	DT
880	KMFRlbpu	Don Bennett TD	ow	1490	WPNAIm	Bob Suwalski COp/E	DT
900	KALTIb	David A. Wommack Jr GM	ow	1520	WTRIlm	Liz Roberts	BH
920	CFLSlz	Louis Mercier ProdM	DT	1530	KPCRI	J. Paul Salois P/GM/CERT/RA	
920	WBAAL	David Bunte Sr StaffProd	DT	1530	WCEGI	Steven J. Callahan O	RA
920	WKVAL	John Dillon CE	RT/BH	1550	KKHIpu	U/U	ow
930	WYFOlbz	Carl Redemann GM	RT	1590	KLLLpu	H.C. "Barney" Barnwell Eow	
930	WZNNI	Fredericka B, Olson OfM	RA	1590	WARVIh	Lincoln W. Hubbard CEHH/BH	
950	WQBElbz	Noel W. Richardson CE	RT	1590	WQCC	John Duda CE	AR
960	WFIFIm	William B. MacLane CE	DT	1613.6	NHQC	Norman Harbison Jr - RR2	
980	WWRCq	U/U E	DT			Box 224 - Monroeville NJ 08343	HH
980	WXBQlb	Chuck Lawson CE	RT	1620	WNSX589f	Buddy Wheeler Su - Dept of Convention & Visitors Delv. - P.O. Box 200, Virginia Beach, VA 23458	HH
1020	WCLlql	Rich Bird PD	ow/RA				
1020	WKZERbmu	Judith Gregory GM	RA/BH				
1030	KTWOq	U/U DoE - 1988 Report no f/up	JT	1650	RGQah	Sheldon Cleaver - 427 W. 2nd St Moneta, VA 24121	HH
1050	CFYNlu	E.G. Sodowski CE	BH				
1100	WDNMI	Tom McAfee CE	DT				
1130	KWDSlbz	Nancy Browning AM	ow				
1130	KWKHlbz	Johnny Lafitte CE	DT				
1160	WYNSI	Betty F. Straubinger VP/GMDT	BH				
1170	WLGOpU	U/U VP/GM	HH				
1180	WLDSI	Kevin Potter CE	RA				
1200	WOAIq	Dan Walthers TD	DT				
1200	WNSSI	Robert W. Wood VP/GM	BH				
1210	WCOGL	U/U	AR				
1230	WCOLI	Mark Hiner CE	DT				
1240	WVKZI	Jack Shafer CE	DT				
1240	WWCOLmz	Wally Mann PD	DT				
1250	WMTRI	Tom Hauer CE	RA				
1250	WTMAL	Bruce Roberts CE	RT/BH				
1260	KRKElbu	Paulette Durica	ow				
1260	WRIEI	J. Marc Hopkins AE	DT				
1270	WJICI	William Carson CE	HH				
1290	WCHYIm	Martin Foglia CE	BH				

Initial	Name	Loc
BH	Bob Harrison	NJ
DT	Don Trelford	ON
ow	John Wilkins	CO
AR	Andy Rugg	PQ
RA	Ray Arruda	MA
AR	Robert Tiara	NC
JT	Jeff Tynan	CO
HH	Hank Holbrook	MD
WH	Wayne Heinen	CO

Need to renew? Expired? The mailing label will tell you.

## Silent Stations ... by R. J. Edmunds

The following is intended to be a comprehensive and up-to-date NRC silent stations list. As such, it reflects only stations which have actually been on the air previously. This list uses the FCC listing which appeared in DX NEWS earlier this year, supplemented by all listings in AM Switch and DDXD over the past year, reflecting all changes up through the July 1992 issue. It has also been reviewed by Jerry Starr, editor of AM Switch. While it is probable that errors will be found, it is not necessary to send these to me - simply send them to AM Switch, as I will update my database from there. While this sort is in frequency order, it can also be provided alphabetically sorted by state and location. If there is sufficient interest, this listing could be published quarterly, alternating between the two sorts. Address your feedback on that via Musings or to HQ.

R. J. Edmunds, 753 Valley Rd., Blue Bell, PA 19422-2052

580	KSAZ	AZ	Tuscon	1080	WLVN	AL	Luverne
600	WLHQ	AL	Enterprise	1080	WSSI	MS	Carthage
600	KCLS	AZ	Flagstaff	1080	WKKE	NC	St. Pauls
610	CKXJ	NF	Grand Bank	1080	WQRO	PA	Huntingdon
640	WROR	MI	Zeeland	1090	WXBK	AL	Albertville
650	KUUY	WY	Cheyenne	1090	WSOL	PR	San German
710	KUET	AZ	Black Canyon C.	1090	WKSP	SC	Kingstree
730	WSST	GA	Thomasville	1090	WGOC	TN	Kingsport
740	WRKY	KY	Newport	1090	KACO	TX	Belleville
770	WCAL	MN	Northfield	1090	WGOD	VI	Saint Thomas
790	WHGX	GA	Brunswick	1100	WLBX	GA	Carrollton
790	KBRV	ID	Soda Springs	1100	WCGA	GA	Woodbine
800	WSMJ	KY	Cave City	1110	WYIC	IN	Noblesville
810	WJXL	AL	Jacksonville	1110	WKEG	PA	Washington
830	KABN	AK	Long Island	1120	WBZR	FL	Destin
850	WFPD	TN	Fairview	1120	WYNO	OH	Nelsonville
890	WHNC	NC	Henderson	1120	WYZQ	TN	Marysville
900	KICR	LA	Oakdale	1130	WKIJ	AL	Parrish
900	WDDT	MS	Greenville	1130	KHTH	CO	Dillon
900	WCOR	TN	Lebanon	1130	WLBA	GA	Gainesville
910	WPTXN	AL	Pepperell	1130	WQFX	MS	Gulfport
910	WVFR	GA	Valdosta	1130	WEEO	PA	Waynesboro
910	WVVO	SC	Dorchester Terr.	1130	WVEF	SC	Canden
920	WMEI	FL	Melbourne	1130	WAMG	TN	Gallatin
920	WAZQ	SC	Orangeburg	1140	KCXL	MO	Liberty
920	WMMN	WV	Fairmount	1150	KEZB	TX	El Paso
930	WREB	MA	Holyoke	1170	WKFL	FL	Bushnell
950	KRRP	LA	Coushatta	1170	WJCC	MA	Norfolk
950	WNCC	PA	Barnesboro	1170	WDAT	MS	Amory
960	WXLO	MA	Fitchburg	1170	WBRW	NJ	Bridgewater
970	CFIQ	NF	Harbour Grace	1170	WARW	NY	Cornwall-on-H
980	KCAB	AR	Dardanelle	1180	WSAF	GA	Trion
990	WHIA	GA	Dawson	1190	KHAD	MO	DeSoto
990	WABX	MI	Ciara	1190	WMAD	WI	Sun Prairie
990	WBTE	NC	Windsor	1200	WFSF	AL	Ozark
990	WKXC	SC	Aiken	1210	WDGR	GA	Dahlonega
990	KZZB	TX	Beaumont	1220	WEQO	KY	Whitely City
990	WANT	VA	Richmond	1220	WTCN	MN	Stillwater
1000	KHAM	AR	Horseshoe Bend	1230	KBZB	AZ	Bisbee
1000	KIDN	CO	Hayden	1230	KRMH	CO	Leadville
1000	WEXI	FL	Jupiter	1230	WFOM	GA	Marietta
1000	WJHH	GA	Soperton	1230	WKCK	GA	Augusta
1000	WKLO	KY	Danville	1230	WAYX	GA	Waycross
1000	WHEV	NC	Garner	1230	KLIC	LA	Monroe
1000	WKYB	SC	Hemingway	1230	WNEB	MA	Worcester
1000	KNDA	TX	Odessa	1230	WBME	ME	Belfast
1010	WCNU	FL	Crestview	1230	WAZF	MS	Yazoo City
1010	KDLA	LA	DeRidder	1230	KBMN	MT	Bozeman
1010	WXLX	NC	Albemarle	1230	KKUL	MT	Hardin
1010	KTLE	UT	Tooele	1230	WQDW	NC	Kinston
1030	KKSA	CA	Folsom	1230	WKBO	PA	Harrisburg
1040	WJOR	TN	St. Joseph	1230	WNIK	PR	Arecibo
1050	KBBV	CA	Big Bear Lake	1230	WKCE	TN	Harriman
1050	WRPT	NH	Peterborough	1240	WKIQ	FL	Eustis
1050	WCMS	VA	Norfolk	1240	KLJV	ID	Mountain Home
1060	WAMT	FL	Titusville	1240	KZID	ID	McCall
1060	WBMB	MI	West Branch	1240	WPNF	NC	Brevard

1250	KHIL	AZ	Willcox	1420	WYUT	NY	Herkimer
1250	WARE	MA	Ware	1420	KBIL	TX	San Angelo
1250	WKBR	NH	Manchester	1420	KSRK	TX	Lufkin
1250	WRKQ	TN	Madisonville	1430	WBRB	MI	Mount Clemens
1260	WTKL	LA	Baton Rouge	1430	KNSP	MN	Staples
1260	WALM	MI	Albion	1430	WCOG	SC	Ridgeland
1260	KVSF	NM	Santa Fe	1430	WEMG	TN	Knoxville
1260	WVLC	SC	Lake City	1430	WHNK	TN	Madison
1270	KPBA	AR	Pine Bluff	1440	KFPS	MO	Salem
1270	WKZT	KY	Fulton	1440	WSEL	MS	Pontotoc
1270	WSPR	MA	Springfield	1440	WRHX	VA	Herndon
1270	WMLC	MS	Monticello	1450	KJWH	AR	Camden
1270	WWSE	VA	Hot Springs	1450	CHET	BC	Chetwynd
1280	KWCL	LA	Oak Grove	1450	KDRW	CO	Silverton
1280	WYAL	NC	Scotland Neck	1450	WWAK	FL	Redwater Lake
1280	KCVQ	PQ	Quebec	1450	KSKR	MT	Whitefish
1280	KRAN	TX	Morton	1450	WCIE	NC	Spring Lake
1290	KSRC	NM	Socorro	1450	WFXN	PA	South Williamsport
1290	WGLI	NY	Babylon	1450	WKEL	SC	Myrtle Beach
1290	WTNX	TN	Lynchburg	1450	KCNV	UT	Moab
1290	KWGH	TX	Big Lake	1460	KZOT	AR	Marianna
1300	KBCN	AK	Fairbanks	1460	KRQC	CA	Salinas
1300	WRXR	SC	Aiken	1460	WBPA	KY	Elkhorn City
1310	KMBS	LA	W. Monroe	1460	WNBR	NC	Fuquay-Varina
1310	WGSB	PA	Ephrata	1460	WPRW	VA	Manassas
1310	KOYL	TX	Odessa	1470	WBUL	KY	Shepherdsville
1320	WAGF	AL	Dothan	1470	KDTL	LA	Farmerville
1320	KAVI	CO	Rocky Ford	1470	KGNG	MO	Brookfield
1320	WFRK	FL	Coleman	1470	KZZK	UT	Tremont
1320	WTSS	PA	Scranton	1470	WHRD	WV	Huntington
1330	WTRX	MI	Flint	1480	WARI	AL	Abbeville
1330	WPJS	SC	Conway	1480	KRRU	CO	Pueblo
1330	KINE	TX	Kingsville	1480	WMIB	FL	Marco Island
1340	KBRS	AR	Springdale	1480	WCNT	NC	Charlotte
1340	KOMY	CA	Watsonville	1480	WDIX	NC	Yadkinville
1340	WWFL	FL	Clermont	1480	CKAN	ON	Newmarket
1340	WNBS	KY	Murray	1480	WISL	PA	Shamokin
1340	KMYQ	LA	Bastrop	1480	KTGN	WA	Lakewood
1340	CFBQ	ON	Parry Sound	1490	KTOB	CA	Petaluma
1340	CKDK	ON	Woodstock	1490	KXRE	CO	Manitou Springs
1340	WTSW	PA	Wilkes Barre	1490	WKLV	FL	Bradenton
1340	KTMP	UT	Heber City	1490	WMSL	GA	Monroe
1340	KAPA	WA	Raymond	1490	WOTA	MS	Vicksburg
1350	WBEM	PA	Windber	1490	WWIL	NC	Wilmington
1350	WEGA	PR	Vega Baja	1490	WZKT	VA	Waynesboro
1360	WYSE	GA	Bainbridge	1500	KOKY	AR	Jacksonville
1360	KDXI	LA	Mansfield	1500	WKXT	MS	Sardis
1360	WLCM	SC	Lancaster	1500	KMXX	TX	Merkel
1360	WWHY	TN	Milan	1510	KIDZ	MO	Independence
1370	KTMG	CO	Deer Trail	1510	WKPO	MS	Prentiss
1370	WKIK	MD	Leonardtown	1510	WAHT	PA	Annville - Cleona
1370	KMAP	MN	So. St. Paul	1510	WRKU	SC	Burnetttown
1370	WKFD	RI	Wickford	1510	WPSC	SC	Pageland
1370	KPOS	TX	Post	1520	WNMT	GA	Garden City
1380	KPAL	AR	N. Little Rock	1520	WHRF	MD	Bel Air
1380	KFLJ	CO	Walsenburg	1520	WQMA	MS	Marks
1380	WAMS	DE	Wilmington	1520	WARR	NC	Warrenton
1380	WSIZ	GA	Ocilla	1520	WITM	TN	Elizabethton
1380	WSFL	NC	New Bern	1530	KCTT	AR	Yellville
1380	KQKD	SD	Redfield	1530	WXPQ	FL	Babson Park
1380	KKFH	TX	Beaumont	1540	WZAL	GA	McDonough
1380	KCKO	WA	Millwood	1550	WNDI	IN	Sullivan
1390	WAPR	FL	Avon Park	1550	KEDD	KS	Dodge City
1390	WTMS	ME	Presque Isle	1550	WOKJ	MS	Jackson
1390	WVOD	VA	Lynchburg	1550	WORI	TN	Oak Ridge
1400	KHTZ	CA	Truckee	1550	WVAB	VA	Virginia Beach
1400	WCLB	GA	Camilla	1560	WLJA	GA	Ellijay
1400	KIGO	ID	St. Anthony	1560	KLTI	MO	Macon
1400	WELL	MI	Battle Creek	1560	WTRQ	NC	Warsaw
1400	WJWF	MS	Columbus	1560	KKID	OK	Sallisaw
1400	WBRL	NH	Berlin	1560	WWGM	TN	Nashville
1400	KIVR	OR	Cave Junction	1570	WGSR	GA	Millen
1400	KATI	WY	Casper	1570	WNNQ	GA	Ashburn
1410	WLBK	KY	Bowling Green	1570	WNSH	MA	Beverly
1410	WMYQ	MS	Newton	1570	WGLX	OH	Galion
1410	WDTL	MS	Boyle	1580	WBGB	FL	Mount Dora
1410	KNAL	TX	Victoria	1580	KLVU	LA	Haynesville
1420	WKAL	MI	Kalkaska	1580	WZFC	MS	Centreville

1580	WSRR	NJ	Washington	1600	WNGA	GA	Nashville
1590	WACD	AL	Alexandria City	1600	WSLK	KY	Hyden
1590	WQQW	CT	Waterbury	1600	WRNC	NC	Reidsville
1590	KDLB	OK	Henryetta	1600	WWRB	TN	Harriman
1590	WABV	SC	Abbeville	1600	KBBB	TX	Borger

## Ribbon Cable Loops ... by Mark Connelly, WA1ION

A cheap, but effective, alternative to ferrite loop heads is a loop constructed of ribbon cable of the type often used for computer interconnections. This cable consists of a group of parallel insulated conductors formed onto a single flat strip. Wire gauge for each conductor is typically #28 (AWG) and the distance between adjacent conductors is 0.05" (1.27 mm). By using a number of the ribbon cable's conductors wired in series, a loop coil may be formed. This coil may then be mounted on a suitable crossarm support assembly. The customary loop configuration is square (/ diamond), but circular, triangular, and other layouts could be used instead with no great change in performance. If the support assembly can be quickly disassembled and re-assembled (or folded and unfolded) and if the ribbon cable can be easily detached and re-attached to the support assembly, an effective loop for DXpeditions and other travel can be made.

My experiments were done with a 5 ft. / 1.52 m. length of ribbon cable sold by Radio Shack (part number 278-772, US price \$3.59). This initially has 25 parallel conductors. Cut-and-try experimentation determined that a 10-conductor piece gives the correct inductance for a medium wave loop compatible with operation in Palomar, Quantum, and RTL-2 bases. These base units are characterized by fairly high tuning capacitances - on the order of 440 to 940 pF low band (e. g. 500 - 750 kHz) and 30 to 530 pF high band (e. g. 700 - 1800 kHz). Other tuning capacitances will mandate different ribbon cable lengths and/or different numbers of conductors.

Construction of the ribbon cable loop head assembly is straightforward. A "DB25" computer connector is used for the required junctions at the ends of the ribbon cable. Figures 1, 2, and 3 illustrate the necessary connections.

The support frame arrangement of Figure 4 was used for quick testing. My main application is remotely-tuned loops used in a phased configuration (loop vs. loop, or loop vs. whip, via the DCP-1 Dual Controller / Phaser). Nulls are established electronically; therefore, the need to tilt and rotate the loop manually is not a high priority. For easy tilting and rotation ("normal" loop use), a more sophisticated loop support assembly would be required. NRC loop antenna manuals and Ken Cornell's "Medium and Low Frequency Scrapbook" present many worthwhile mechanical construction details for loop support frames.

### \*\*\* Test Results \*\*\*

Sensitivity, with the 10-conductor ribbon cable formed into a diamond approximately 15" (0.38 m.) on a side, was comparable to that of the Quantum and Palomar medium wave ferrite heads. I had thought that the close conductor spacing could wreck Q (tuning sharpness) and severely limit the tuning range. This did not seem to be the case: Q and tuning range were only SLIGHTLY greater with the ferrite heads. The cost-conscious should note that Palomar gets \$79.95 for its "BCB" loop head (Universal Radio catalogue 91-06); a ribbon cable head of equivalent, or better, sensitivity can be thrown together for less than \$10 - FAR less if you go to ham "flea markets".

The cheapness of this method allows for much experimentation including loops for other frequency





ranges, tapped-down (low-impedance) outputs, etc. To operate on a lower frequency range, the use of more conductors and/or a longer piece of ribbon cable is suggested. Initially, I had used 24 of the original 25 conductors and I tuned in on robust signals from longwave aerobeacons and Trans-Atlantic broadcasters around 250 kHz. Fewer conductors and/or shorter lengths of ribbon cable will raise the operating band; this leads to thoughts of tropical-band and 160/80/75 meter ham use.



Figure 5 illustrates the schematic of an active loop for use with ribbon cable loop heads. The base unit will also work with ferrite heads such as Quantum and Palomar. Base circuitry should be assembled in a metal box. For BUF-A documentation, see my article "BUF-A Buffer Amplifier Card: A Valuable Building Block for DX Projects" (15 JUN 1992). For BBA-C1 documentation, see "RTL-1A: Improved Version of RTL-1 Remotely-Tuned Loop" (15 APR 1992). For ease of tuning, it is recommended that R2 of Figure 5 be a 10-turn type. A single-turn pot could be used, but tuning would be touchier.

FIGURE 1: JUNCTION AT ENDS OF RIBBON CABLE

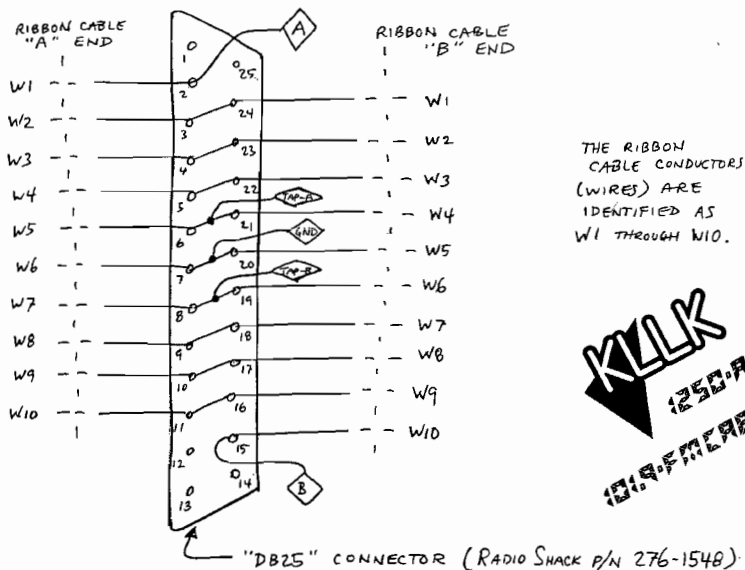
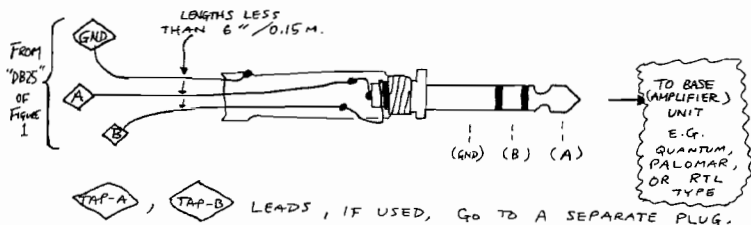
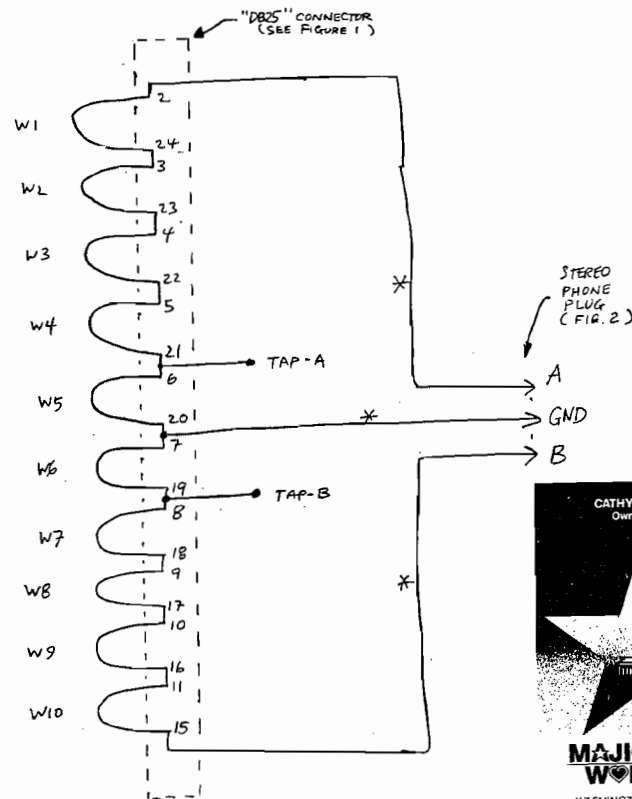

FIGURE 2: STEREO PHONE PLUG CONNECTIONS (PLUG SHOWN WITH SHELL REMOVED)



As active air-core loops are more susceptible than ferrite loops to shortwave mixing spurs, series inductors (RFC1 & RFC2 = 33 uH, in this case) should be used. If spurs persist, increase these to 100 uH each.

FIGURE 3: HEAD SCHEMATIC



\* = LEADS INDICATED SHOULD BE LESS THAN 6" / 0.15M. IN LENGTH

Because a varactor is used for tuning, the problems of variable capacitor availability, complicated mounting schemes, and hand capacitance are eliminated. In the worst strong-signal environments, the varactor might create spurs; if that's the case, replace it by a variable capacitor with a range of approximately 30 to 530 pF (placed across the loop head coil) and delete the varactor-tuning-related components - Figure 5: C1, C5, C6, D1, D2, R2, R7, R8, RFC3, and RFC4.



NRC  
13-month  
DX  
Calendar  
1992-1993

**The NRC 13-month DX Calendar -  
you gotta have it!**

No, we couldn't get Cindy Crawford to pose for it, but we did give you an extra month - it runs from October through October - and sunrise-sunset maps for each month, plus much more information. Only \$4.00, from NRC Publications. NY residents, please add sales tax.

Passive Loops

Tapping down allows for passive loop operation. This is typically done by bringing out 2 tap leads; these should be 1 turn away from the center tap (ground) in each direction. See Figure 6. Passive loops are, of course, much less sensitive than active loops but they have the advantage of no distortion products from overload; this is especially the case with air loops with no ferrite core material to saturate. A passive loop is the only workable medium wave antenna at some urban locations. A larger loop (e. g. 3.3 ft. / 1 m. on each side of the square) will probably be necessary. Add or remove conductors from the ends, as required, to establish the correct tuning range.

FIGURE 4: LOOP SUPPORT FRAME  
NUMBERS WITH ARROWS REFER TO NOTES.

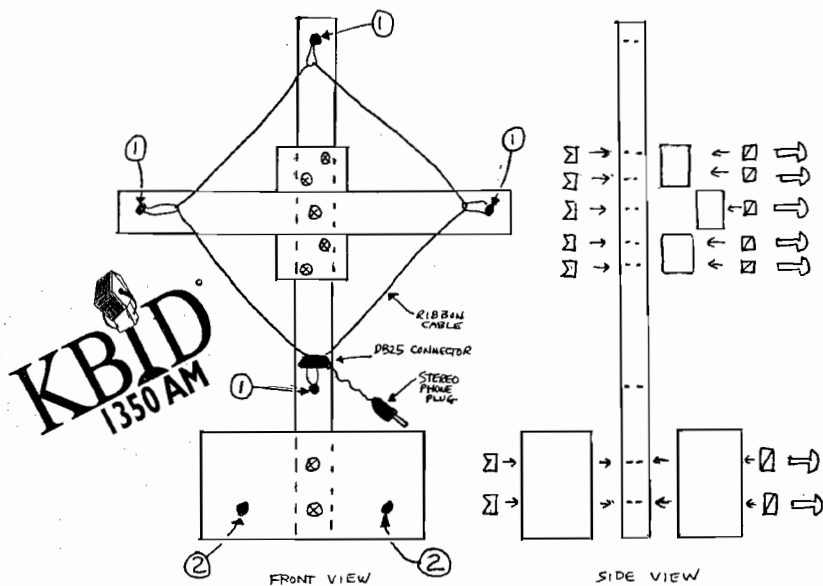

NOTES

MATERIAL: WOOD OR OTHER STURDY NON-CONDUCTIVE SUBSTANCE

DRAWING IS SKETCH ONLY. DIMENSIONS ARE TO BE DETERMINED BY THE REQUIREMENTS OF THE END USER.

- Σ = WING NUT
- = SPLIT LOCKWASHER
- = SCREW

① HOLES FOR WIRE SUPPORT — PLASTIC TRASHBAG TIES MAY BE USED TO ESTABLISH PROPER TENSION.

② HOLES TO BE USED TO MOUNT SUPPORT FRAME ONTO AMPLIFIER BASE UNIT.

The Answer Man

Got a question about radio? Send it to NRC's Answer Man: Russ Edmunds - 753 Valley Rd. - Blue Bell, PA 19422-2052. No question is a dumb question, and Russ will answer all, from basic to highly technical. Watch for the answer in *DX News!*

FIGURE 5: SCHEMATIC OF A BASE (AMPLIFIER) UNIT

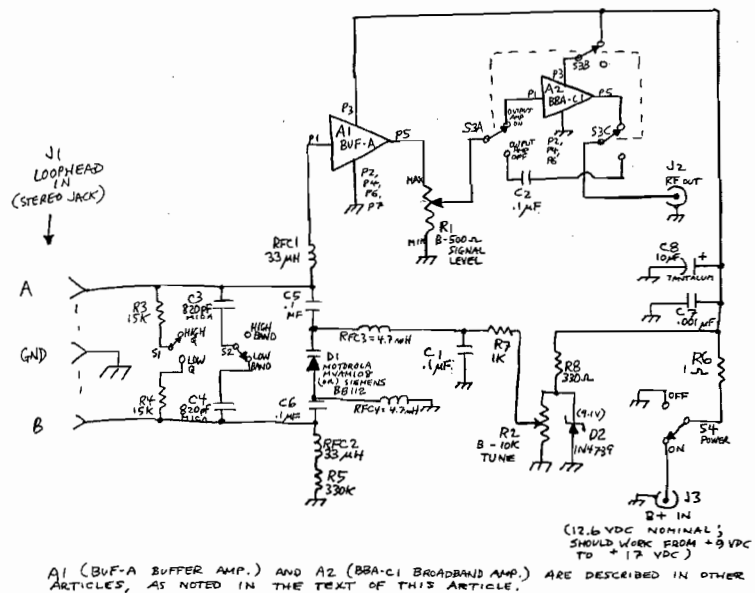

A1 (BUF-A BUFFER AMP.) AND A2 (BBA-C1 BROADBAND AMP.) ARE DESCRIBED IN OTHER ARTICLES, AS NOTED IN THE TEXT OF THIS ARTICLE.

FIGURE 6: PASSIVE LOOP

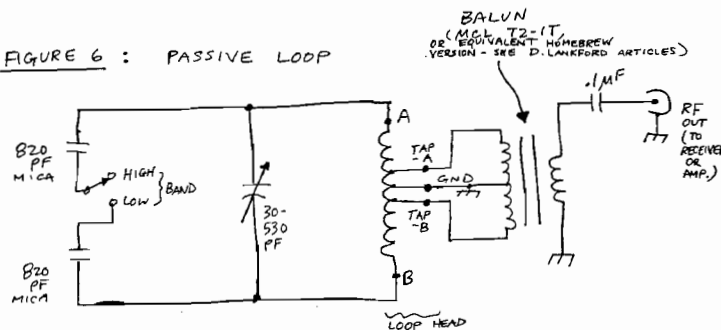

The Broadcaster's Guide to DX

A tri-fold guide for use with reception reports explaining DX'ing, how the NRC was formed, and the importance of QSL's to DX'ers. Also in Spanish and French. US\$1.50 for 20. From NRC Publications. (NY residents, add sales tax)

"Latin America on the Air"

Now available — 60 minutes of air checks from Latin America and the Caribbean, 23 countries including most of South America, the Falkland Islands, and more, in a storage case. Order DXC/4, for \$7.50, from NRC Publications; NY orders, please add sales tax.



# Radio Roundup

News of radio personalities, of interest to DX'ers

Greetings all ... WNEW, the 50,000 watt Westwood One station in New York City has been sold to Bloomberg LP, a financial news agency. The price was 13.5 million dollars, a fire sale price to be sure. By contrast WFAN sold for 70 million just last year. Westwood One says that the station has been a money looser for them for the entire four years that they owned it. It is little wonder that the station has done so poorly under the management style they employed. Drastic cuts to both the on-air and support staffs had crippled this once mighty operation. There has been considerable speculation that the 60 Years of Big Band programming may come to a halt in favor of a financial news/talk format, using the resources of Bloomberg's company which are already in place. Trivia addicts may note that the station was started by the Bulova Watch Company in 1934, later being owned by Metromedia and then Westwood One. This sale will have no bearing on WNEW's FM station, as it was spun off into a separate company (Group W) a few years ago. It is a real shame that the current executives let this station drop to 20th in the market, with a 2% share of the listeners. The voices of Willie B. and others which echo in the station's historic hallways must be weeping at the stations decline ... Deborah Norville will be leaving her ABC Talk Show rein to go back on the tube. She has been hired by CBS to be a reporter on the fast rising Street Stories show ... CBS has lined up 27 stations so far for the new Gil Gross talk show to begin airing across the country starting September 24, in the 8-11 pm (ELT) slot. Interesting to note that no outlet has yet been secured for the show in New York City. Speculation suggests WEVD may get the nod ... WABC's liberal talk show host Lynne Samuels will have some additional duties at the station on Sunday nights starting in November. John Manelli, WABC's Program Director has filled in the blanks yet, however. Looks like Costas Coast to Coast is on the way out ... Do you have \$1,000 hanging around? If so you may want to take a look at Sony's new NT-1 Scoopman digital recorder. It runs for 7 hours on one AA cell, and can record up to 2 hours of stereo audio on a postage stamp sized cassette, weighing in at 5 ounces ... The F.C.C.'s Field Operation Bureau reports that 94% of the 174 AM stations inspected met the 1989 enacted

## Pete Kemp (KZ1Z)

P. O. Box 73  
Bethel, CT 06801-0073

NRSC spectrum limits ... As of August 1st, ABC has instituted a hardcopy news service for its affiliates. The service will be satellite fed and contain news of the entertainment world, sports and regionalized weather ... WTRI, is on the air in Brunswick, Maryland, using its mighty 500 watts to program local musicians ONLY. The management says you bring in a record and we'll probably get it on the same day. This leads to quite a melange of music. Since going on the air last February the station has shown steady growth so far, expecting to be in black by the end of the summer. It has even secured a bank loan for transmitter improvements, hoping to increase power to 10,000 watts ... The F.C.C.'s Office of Engineer Technology still has not approved the new Radio Frequency (RF) light bulb. This concept, promoted to the public months ago, is said to be much more efficient than conventional incandescent light bulbs. The trade off is that the unit is actually a small transmitter. The company reports no problems to consumer equipment, due to its lower power and frequency. Needless to say many organizations are worried about this unit and its potential interference problems. The bulb transmits on 13.56 Mhz, and according to its maker, Intersource Technologies, it will meet F.C.C. standards defined in Parts 15 and 18 ... The AM Super Radio concept has been touted in these pages for a number of years. Well, it has finally made it debut. This Super Radio is made by Denon, based on their TU-660 tuner, will be identified as model TU-680, listing in the \$450 price range. While emphasis is placed on sound quality, little is known about it DXing capabilities. I hope that they included the new 1600 to 1700 Khz segment ... Noted newsman Eric Sevaried has passed away at the age 79. He had been associated with CBS News for over 40 years. His commanding on air delivery, coupled with his journalistic integrity and intellect, will always be remembered by those who had opportunity to



660 Dewey Boulevard Box 3389 Butte, Montana-59702

RON DAVIS  
General Manager

Phone: 406-494-7777 FAX: 406-494-5534

listen to or view his work ... NRCer Eric Bueneman reports that KEZK-590 is now operating in stereo using the Motorola system ... St. Louis' KUSA is again in the Mutual Radio Network fold, as is fellow market station WIBV-1260 ... WESL has stopped broadcasting in stereo ... KSIV-1320 is now on the air 24 hours a day, they had been signing off at midnight ... Radio legend Jack Carney's son, John Carney, is doing the afternoon drive slot on WEW-770 ... WRTH-1430, no I am not talking about the World Radio Television Handbook, is now airing Don Kennedy's Big Band Jump and the syndicated Sounds of Sinatra ... WIBV-1260 is simulcasting KTVI (Channel 2) News at 5:00 p.m. local ... The F.C.C. has shut down a pirate radio station in Brooklyn. Radio Guinan was operated by Jeane Lucien Borges. Radio stations WADO and WFME complained to the F.C.C. The station was issued a warning. The warning was ignored and the case was turned over to the U. S. Department of Justice. Fines can run up to \$100,000 and/or a year in prison ... The Gill Gross Show is taking to the airwaves, on the CBS Radio Network. It will run for three hours each weekday. Gill has long been a well respected journalist in the New York market and known nationally for his work substituting for noted newscaster Paul Harvey ... With AM stations going dark all around the country, here is an interesting story from Dee McVicker, which recently appeared in the Offbeat Radio Column of RadioWorld. It was not long ago that WTYN(AM) of Polk County, NC, was dark. In nearby Transylvania County, the lights were also out for WPNF(AM). Like many small market stations across the nation, the chances of these AM stations lighting up the

airwaves again were dim. Then something happened. On October 8, 1990, WTYN(AM) began receiving its programming from WHPK(AM) of the neighboring county of Henderson. Within a year, WPNF(AM) had also linked programming with the Henderson County station and the trio lit up the Tri-Country area with what the station's general manager called "Trimulcasting." This alternative to fulltime programming enabled WPNF, a 1,000 watt daytimer, licensed to Brevard in Transylvania County and WYTN, a 10,000 watt daytimer/540 watt nighttime facility licensed to Tryon in Polk County, to significantly reduce operating costs and once again service their local markets. The station use STLs with WHKP acting as the flagship station. During the 8 to 11 a.m. time frame the station operate separately. The FCC requires that they maintain separate studios. To segue into local programming, announcers from each station are joined together during the 6 to 8 a.m. time slot in a roundtable fashion. A most interesting approach to local operating in today's difficult economic times ...

WINU has taken a move on the dial from 1510 to 880. It will still be a daytimer until the night pattern antenna system is functioning ... KJCF-1440 is now AC, having switched from oldies ... KXEN-1010 is now light Contemporary Christian having made the move from Southern Gospel programming ... If you would like to contribute to this column, I may be reached at the address above, via GEnie (P.KEMP3), CompuServe 72376,2557, Prodigy SMHB11A, the FIDO system in the Shortwave, Ham or Broadcasting echo areas, or amateur radio packet, KZ1Z@K1UOL.CT So much for now.

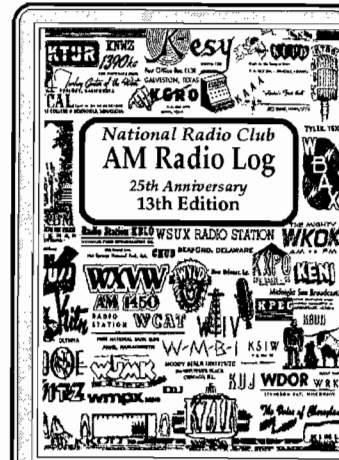

The NRC AM Radio Logbook, 13th Edition, is the most accurate AM radio listing of stations in the U. S. and Canada. Only \$16.95; Canada \$17.95 to U. S./Canadian NRC Subscribers ONLY. \$19.95 to U. S., Non-NRC Subscriber; \$20.95 Canadian Non-NRC Subscriber. Others - please write. Mail to: NRC Publications - Box 164 - Mannsville, NY 13661 (NY residents add sales tax)

# Musings

## of the Members

Thoughts from NRC members ... the opinions expressed in this column are those of the individual writer and do not necessarily reflect those of the editors, publishers, or the National Radio Club, Inc.

MICHAEL HAWK (N00SY) - 10212 P STREET - OMAHA, NE 68127

Hello everyone! Yes, it has been a while since I last reported. I haven't done a whole lot of DXing since April but this last week, I've started up again. Not a lot new has been heard but I did manage to log WQBB-1040. I've mainly been concentrating on IDing Mexicans. I'm in my 4th year in Spanish in school so I'm getting a little better at understanding them. Of course, the biggest news was the convention in Omaha. After helping out with the preparation for 4½ months, those 3 days really flew by! I doubt that I'll make Enfield, CT in '93 but there is a very slight chance I will. The convention really boosted my enthusiasm again, so much so that I'm even sending reception reports again. I'm going to try to send 2 a week not including those heard on DX TESTS. If I have great success, I'll send more! Anyway, I'll finish here with an UNID. At 8:04PM local time, I had a college football game on 1210 khz (Date?-DWS), it was between the Hardin-Simmons Cowboys (from Abilene, TX) and the ESU (?) Aggies. All the announcers ever said was ESU, never the full name. At 8:05, the station switched pattern. This would place it just east of the front range of the Rockies. Judging by the announcers accents, probably TX, OK or NM. 73

VIC MELIS - 501 KLEMAN ROAD - GILBERTSVILLE, PA 19525

WWJZ-640 resumed its DA & non DA ET w/good signal W to Strasburg & Lancaster on 8/22. No stereo noted. On 8/10 WPCR-1540 'Greater Gold Radio' began post sunset operation w/reduced power until s/off. The new owners recently moved the studios to 200 Monument Rd. Since around FEB., WOGL-1210 has been breaking away from the morning FM simulcast to settle a long standing AFTRA dispute dating back to the WCAU days, requiring union newscasts on the AM side. Therefore, with the slightly longer AM newscasts, resumption of the FM simulcast is often late! I checked out the new redesigned GE Superadio III Model 7-2887 at a Cherry Hill NJ catalog store. In addition to the new packaging, relocation of the tuning knob to the right side, and a recessed on/off switch, the unit features a 'wide/normal' AM bandwidth selector and the extended AM band thru 1700 khz. The selectivity in the 'normal' mode seemed better than the I or II, with very sharp attenuation of the sidebands when just tuning off center frequency of nearby WOGL-1210. The 'wide' mode is just slightly wider than earlier models but did not provide audio fidelity much above 4 khz, even at full treble. In contrast, the filters used for wideband in both the Dymek DA5 & the multisystem AM stereo Sony XRA33 provide much wider audio, flat to 9.9 khz depending on signal. I recently added a \$9.97 K-Mart antenna that extends 58" and includes a center coil for extra gain. Using it with the Sony XRA33 and the Radio Shack DX400, I noted considerable gain over the 30" stock antenna on AM, FM & SW. The stock antenna is connected to a new Radio Shack 12-1946 car radio/tape unit that stores 12 stations on 12 AM bands as well as 18 FM on 3 FM bands. For the \$99 sale price, it includes line outputs, 28 watts, an FM mono switch and programmed station search, but it lacks the AM stereo and bandwidth selector that are tough to live without. I can easily switch to the XRA33 in the glove box for super AM audio or taping airchecks with near FM quality. I noted while driving on N I-95 out of Washington, that the MD State Highway TIS on 530, WMVY506 is in stereo while the next N TIS, WMQI569 was mono. The only known remaining Kahn AM Stereo signal in my area is WNAK-730. Hurricane Andrew coverage again demonstrated AM's true potential. Checked 560 & 610 and unlike Hugo coverage, found no 50kwer on 690 from Jacksonville talking to DXers from SE PA! On 8/24, listened to WWL-870 coverage before switching to WRNO-Worldwide, which made an announcement in English at 8:05 PM that they would s/off within 2 hours or sooner if the storm hit New Orleans. They resumed Spanish programming and abruptly disappeared minutes later! That's it for now. &3's & a great DX season to all! (Hey Vic, PDS, you know? Que pasa, eh? Please Double Space! If not, you'll receive 6 hours of the old PA DUTCH program from the old WBYO!-DWS)

PETE CLARIUS - 1583 CASTLETON AVENUE - STATEN ISLAND, NY 10302-1312

I want to congratulate the entire "Big O Team" for making the 92 convention so informative and interesting including the 2 tapes that were given out. The accommodations at the Days Inn were superb as well as the banquet and luncheon and incidently, it was the first time I ever had LIVER soup! The trip by Amtrak was very interesting. Thanks to JOHN BOWKER for meeting me at the station and to ERNIE WESOLOWSKI for taking me to the station for my trip home. Thanks again fellows. It was so nice meeting friends like ERNIE COOPER again who I have known for some 50 years and who visited Bernie Duffy and myself on Staten Island many, many times. It was also nice to see JOHN SAMPSON again as well as JOHN CALLERMAN, who mentioned that we first met in 1954! My latest catches are WHAK-960 who was caught signing on at 6 AM and WRMM-990 neck and neck with WZZD. These 2 bring the log up to 2129 heard with 1451 verified. Thanks again for the most enjoyable convention and I am looking forward to ENFIELD, CT.

MARK CONNELLY - 30 WILLIAM ROAD - BILLERICA, MA 01821-6079

Greetings. DX is picking up here as autumn approaches. TA's have been relatively common. Congrats to JEAN BURNELL for his loggings of Bolivia-1550, St. Helena-1548 and others (including tentative Mayotte-1458.2). My catches haven't been that exotic but it's still fun to log the local entertainment of numerous countries on MW. Some local notes: WCMX-1000 has been off for a while. CKBW dominates 1000 here days, its level is fairly weak. With 960 & 1000 off, metro-Fitchburg's AM count has gone from 4 to 2 in just a few years. That area is now only served by WFRM-1280 & WGAW-1340. In Cambridge, WWEA-740 has changed to WJTB and an EZL format similar to that associated with the old WJTB 96.9 (now WCDJ with light jazz). Cambridge's little 250 watter on 740 has been a revolving door of calls and formats over the years: WTAO, WXHR, WCAS, WLVG, WWEA, WJTB & possibly others have been used since I first tuned in around 1960. The station seems like a prime candidate to "go dark", it's location in a densely-populated area is probably the only reason that it has managed to survive with its succession of narrowcast "Niche formats." Rumors of this station increasing power and changing transmitter location have abounded for years. With the region's continuing shaky economy, the wisdom of investing in a possible dead-end venture no doubt came under scrutiny. It amazes me that WMEX-1150 continues with a mere simulcast of WMJX-FM. Several other stations appear to be teetering on the brink of failure, as evidenced by lapses of technical quality and unplanned periods of silence or open carrier, these include WCCM-800, WCAP-980, WBIV-1060, WESX-1230, WJDA-1300, WLLH-1400, WNTN-1550 & WUNR-1600. Incredibly, no AM or FM station has seen fit to provide Boston with a CW format, the outlying FMers don't cut it between Boston's tall buildings. CW is more popular than ever but our local stations continue to blow a golden opportunity! 73

ERNEST COOPER - 5 ANTHONY STREET - PROVINCETOWN, MA 02657

What a great convention! Our NE Boys put on one fine weekend, and I thank every one of them. We had 3 tours, only one of which was to a radio station, but the other 2 were very interesting, especially the deep under ground workings of the Amtrak Headquarters. Next years convention will be in Enfield, CT, one to which I can drive. I've been suffering this summer with the dearth of E-Skip situations on the FM band and with the horrible performance of the Mets-hi! (JOHN MALICKY, we'll getcha next year!). I haven't gotten back to the AM dial with any regularity either -I've been bothered by buzzes from twilight time til around midnight and I've been favoring my left eye for a major operation which was finally performed 9/21 for the removal of a cataract, complicated by glaucoma and a damaged retina. This is being typed up one day later, and I can see out of that eye but things are very blurry and the eye very watery and somewhat sore. Anyway, some veries have trickled in during the summer, like WZAO-1370-TEST, WNSS-1200, WSCR--820, WIMX-1460, WCEG-1530, WMVU-900 & WIMG-1300 bringing the total to 4409. A bit of DX: 4/23 there is somebody on 1600 with the all sports network headed by WEET-590 and another on the same chain on 1320, neither of which have I been able to ID as yet. 5/31 a 2nd logging and report out to WIMG-1300, this one producing a verie. 6/19 Unn WMTF-1250 noted AN with "Great Songs, Great Memories". 6/16 a TIS on 1610 occasionally noted in back of the Caribbean Beacon, all I could glean from it were these words: "7 days a week". 9/12 the all sports station on 1320 was dominating the frequency so I eagerly awaited the 3 AM ID, only to note that no ID was given, just a blank carrier for about 15 seconds then back in to the network. I think this is also the case with the 1600, has the FCC in all their superior wisdom now made it legal for a station to carry a network feed and NOT have somebody on hand to watch things and make the legal ID's per chance? (No....but with the latest remote control equipment, a station can run with no operators on duty....the computer in the remote control takes the readings and notifies a specific person in the event of a problem. I'd say they don't have the system hooked up right at the station end. Your 1320 is likely WTSS-1320 Scranton, PA). The IRCA already has 6 TESTS lined up, 3 of which I need, so bring 'em on! Forward - March!

DAVE SCHMIDT - P O BOX 11502 - WILMINGTON, DE 19850-1502

We have a HUGE report from the SMALL handwriting champ JOHN MALICKLY for next issue, this is going out late (WED. 9/30) so a quick turnaround on a couple of reports. It seems Rush Limbaugh is hot property these days, he recently blew his horn that he was now in Philadelphia on WWDB-96.5. But in going on WWDB, he was yanked off WTTM-920, WWSJ-1360, and WCHE-1520. WWSJ jumped on the CW bandwagon the next week, just about dumping all talk (except for some local stuff and Paul Harvey), but still running reduced hours. at the NJ shore, WBNJ-105.5, WEPG-106.3 (ex WSLT) and WXNJ-94.3 all went CW with a week of each other! WDEL-1150 has gone to a News/Talk format, dropping MOR/AC music. Various talk formats are being aired, including the WOR network (the Dolans), BRN, ESPN sports, CNN news. Back to the weeklies? Don't make this column "weakly", send in your DX doings; and the world will know just what your doing! 73 & CUN7!



*Handwritten signature*