



DX NEWS

*the magazine of the
National Radio Club*

— SINCE 1933 —

VOLUME 53 ISSUE 17 February 3, 1986

Back into the lake Yep, Mikee is in the lake again, under the ice. Seems he forgot to take out the rig on WBLB-1510, Issue 14, page 2. So, if you would, please disregard that info on WBLB in the AM Switch column, and wait for Jerry to inform you on the status of WBLB.

DDXD Column Change We'll run this one more time, remember DDXD column will be split into two columns. DDXD - East will be headed up by Dave Schmidt. DDXD - West will be headed up by Nancy Hardy. The imaginary division line will be as follows. DDXD - East will consist of reports from members living in the Central, Eastern, Atlantic time zones. DDXD - West will consist of reports from members living in the Mountain, Pacific and points west. For those of you living in the center of the U.S. you may report to the one that serves your area better. Nancy Hardy's address is: 2301 Pacific Ave., Aberdeen, WA 98520-4527.

CPC TESTS --- Times listed are **EASTERN Local Time**

You'll get better returns if you include an **SASE** with your report

Feb 10 **WDCT-1310** Fairfax, VA 0100-0200 Program will consist of tones, IDs and music.
Monday 1000w ND 0100-0130, 5000w DA 0130-0200. Reports to: Dave Schweikart, WDCT Radio, Box 1310, Fairfax, VA 22030-1310. Arranged by Dave Schweikart himself. (Thanks Dave - HQ)

Feb 10 **KURL-730** Billings, MT 0200 - ??? Test will be run with Proof of Performance test. Reports to Mr. Clark D. Prim, CE, KURL Radio, Box 31038, Billings, MT 59107 Arranged by Wayne Heinen and Ken Chatterton for the NRC.

Feb 11 **WIFX-1000** Jenkins, KY 0200 - ??? Program will consist of tones, music, IDs.
Tuesday Reports to: Don Mussell, CE, Box 312, Jenkins, KY 41537. Arranged by John R. Malicky for the NRC.

Feb 17 **WVWV-1570**, St. Marys, WV 1000w 0100-0130 with voice IDs, tones, music.
Monday Reports to: Robert Eddy, Owner/GM. All correct reports will be verified by letter, SASE requested. Prepaid calls ONLY, 304-684-3400, NO COLLECT CALLS. Arranged by Kermit Geary for the National Radio Club.

Mar 31 **KPCR-1530** Bowling Green, MO 0300 - ???, Voice, Code ID's, and music will be used. Reports to: J. Paul Salois, President, KPCR Radio, Box 1, Bowling Green MO 63334 Arranged by Wayne Heinen and Dan Bartek for the NRC.

LOOK INSIDE:

- | | | |
|-----------------|-----------------|----------------------|
| 2.....AM Switch | 5.....Formats | 6.....Formatology |
| 9.....DDXD | 13.....Bandscan | 15.....The Phase One |
| 18.....Contest | 19.....Musings | |

Listen to HCJB "DX Partyline", 0230 UTC Saturday night, for the "AM Interlude" Program with Wayne Heinen. Other stations carrying NRC items include Radio Earth, Radio RSA, WHBI, and KCBI!

AM SWITCH

Jerry Starr, c/o WHOT Radio, 401 N. Blaine Ave., Youngstown, OH 44505

CALL LETTER CHANGES

Old call:		New call:	
730 WART AL Madison		WDRT	
1020 *New PR Adjuntas		WPJC	
1270 WCLS MI Charlevoix		WKHQ	
		KOPR	
1280 WQUE LA New Orleans		WMKJ	
1450 WDXD ME South Paris		WKTD	
1500 WIKQ MI Battle Creek		WCLS	
1550 KHRJ TX Canyon		KAKS	

Note: We have had a few members write to complain about the poor reproduction of the last several AM Switch columns. I'm using a fresh, dark ribbon and the same typewriter as usual, suspect the problem is on the printing end as nothing has changed here. I know it's very irritating especially when it wipes out something as important as call letter changes. If there were some you couldn't read let me know and I'll run them again.

APPLICATIONS FOR NEW STATIONS

1100 FL Longwood: 50000/1000 U4

GRANTS FOR NEW STATIONS

None

APPLICATIONS FROM EXISTING FACILITIES

620 KSTR CO Grand Junction: add 1000 watts night, antenna to U2
 1170 WCXN NC Claremont: power to 10000
 1330 WFTF FL Fort Pierce: 5000/1500 U2
 1550 WRHC FL Coral Gables: to 1560 kHz 50000/4400 U4 (reapplication)

GRANTS TO EXISTING FACILITIES

None

OTHERNESS

550 KUZZ CA Bakersfield: is now here, swap with 970 was made 1-13-86
 970 KAFY CA Bakersfield: is here now from 550, ditto above
 980 WLPQ KS Pittsburg: station is silent
 1320 WHOF FL Coleman: new station is on, adult standards format
 1200 WDCQ FL Pine Island Center: target date is "February 1986"
 1410 WATD MA Brockton: ex-WAMK is now silent

ADDRESSES

760 WCHP NY Champlain: Box 888 12919
 1200 WDCQ FL Pine Island Center: 1227 Del Prado Blvd, Cape Coral, FL 33904

LOG CORRECTIONS

Since we have some extra space, below is a list of outstanding CPs listed in the NRC Log that have since been dropped from the FCC Database indicating that the CP no longer exists, or, in a few cases, CPs listed in the Log that were never actually CPs at all. This is in addition to a list of "CPs" that really were only applications that was issued right after the Log came out and were covered in one of the regular Updaters.

570 "CP" VT Rockingham: no longer listed
 610 "CP" CO Minturn: no longer listed
 660 "CP" MI Frankenmuth: is still an application
 680 "CP" CO Wellington: is no longer listed
 "CP" KY Shepherdsville: is still an application
 750 "CP" FL Englewood: is still an application
 770 WFAB PR Juncos: no longer listed on this frequency, remains on 1460
 810 "CP" TX Lacoste: is still an application
 820 "CP" CO Manitou Springs: still an application
 "CP" CO Widefield: still an application
 "CP" CO Falcon: still an application
 840 "CP" NM Bernalillo: no longer listed, had only been an application
 "CP" TX Reese Village: ditto Bernalillo above
 870 "CP" WI Madison: no longer on list
 880 "CP" LA Bossier City-Shreveport: no longer listed
 "CP" TX Madisonville: no longer listed
 950 "CP" AK Juneau: is still an application
 1010 "CP" CA Rancho Mirage: still an application
 "CP" CA Thousand Palms: still an application
 1030 "CP" CA North Palm Springs: still an application
 1040 "CP" KY Shepherdsville: no longer listed
 "CP" SC Hanahan: still an application

1200 "CP" CA Pismo Beach: still an application
 "CP" FL Dover: still an application
 KDEC IA Decorah: CP here no longer listed, remains on 1240
 WFAI NC Fayetteville: CP here no longer listed, remains on 1230
 1220 "CP" TX Madisonville: still an application
 1270 "CP" MN Baxter: still an application
 1410 "CP" NC Deep Gap: no longer listed
 1440 "CP" AR Bellefonte: no longer listed
 1490 "CP" AR Dardanelle: still an application

Note that applications can be around for many years, especially if a number of returns and reapplications take place, or if the application is designated for a hearing before the FCC and the subsequent string of appeals and re-hearings that might takes place. A sure way to spot a "CP" that really isn't one is the fact that after several years there have been no calls assigned. Calls cannot even be applied for until AFTER a CP has been GRANTED. That is how we generated the above list, checking outstanding "CPs" which had never had call assignments.

LIST OF STANDARD ABBREVIATIONS USED IN AM SWITCH

This should probably become part of the New Member Packet but for those of you who may have joined in the past few years, here are the hidden, secret meanings of those mysterious and baffling abbreviations that have had you missing sleep and talking to inanimate objects:

- XR: abbreviation for transmitter, not the actual cabinet full of tubes and parts but, to the FCC, the geographic location of the transmitter/antenna
- CP: Construction Permit, granted to an applicant to construct a new station or to an existing station to make major changes (change of frequency, power increase, relocation of XR, etc)
- PSA: Pre Sunrise Authority: many stations are permitted to begin their broadcast day at 6:00 AM EST year-round, however, as daytimers, they must use a reduced power for the times that sunrise occurs later than that time they sign on. This power is run from their sign on until their local sunrise. Maximum power for PSA at any station is 500 watts
- PSSA: Post Sunset Authorization: newer than PSA, the PSSAs are the same thing at the other end of the day, certain stations are authorized to operate after sunset, even though they hold a daytime license. Depending on the station it may last from 15 minutes to 2 hours after local sunset with power levels of wide variations, from as much as 500 watts to as little as a few watts. Some stations have 3 or 4 different power levels for their PSSA which change either with time or month
- CH: Critical Hours, the first two hours after sunrise and the last two hours before sunset, a time period when signal propagation is still partially by skywave, an unsettled time for propagation when some stations must reduce power or, in a few cases, change antenna patterns to prevent interference to the dominant station on their frequency during these Critical Hours
- U1 and all the other antenna designations, these are modes of directional antenna use and are all explained in the preface to the NRC Log
- SH Specified hours, stations which operate at less than their licensed hours. There is a wide variety of reasons for Specified Hours, some involve stations which share a common frequency, others may be for a station that doesn't operate on Sunday for example (there are several of these) or a station that operates ONLY on Sunday (there is at least one of these). This does NOT apply to a station that is licensed fulltime but signs off from midnight to 6 or so. If however that same station operated from noon to 6PM, for example, it would require special permission from the FCC in the form of a license in which hours of operation were specified

AND A FEW TERMS USED FREQUENTLY IN AM SWITCH

Changes in antenna system: probably the most commonly granted technical change, it can involve something as simple as replacing a tower or adding some height to support an FM antenna to something as complicated as constructing an entirely new DA system or installing a new ground system. While it really doesn't have a major effect on DXing, we list antenna changes simply to tip off the DXer that this station will be doing some equipment testing required with antenna changes and these frequencies should be watched during the experimental period (midnight to 6 AM local time at station)

- RETURNED** Used in conjunction with the application procedure whether it be for a new station or for technical changes. When the FCC receives an application that is incomplete or with inappropriate lines left blank or whatever, that application is RETURNED so corrections can be made or additional information supplied. This does not in any way mean the application is dead. In fact, the MAJORITY of station applications are returned at least once due to the fact that NOBODY can understand government paperwork and do it right the first time.
- DISMISSED** After an application for new station or changes at existing station has gone through all the stages at the FCC it is either GRANTED or DISMISSED. Granted stations are given the permission to do whatever they requested while those DISMISSED are denied their request. Once an application is dismissed it is, in effect, dead although there certain types of court appeals for rehearing. These are rarely used since the costs of arguing an application before a Federal Court are astronomical. If an appeal fails, the application is said to be DENIED, a term we have to use very infrequently
- CANCELLED** After an application has been granted it can still be cancelled either by request of the grantee or by the FCC. Usually the FCC will cancel a CP after a certain time to complete has expired without the changes being made or the station being built. The grantee may have difficulty locating land for a XR site or may fall into financial troubles and, for whatever reason, decide not to make the change or build the station. He requests the FCC to cancel the CP and it goes to never-never land forever and is removed from the FCC's Radio Database
- LICENSE** Any permission granted by the FCC is in the form of a License to Operate. A CP is NOT a license. A CP is only the permission to begin building or making a major change. In the case of a new station, once the station is built the grantee must apply for and receive PROGRAM AUTHORITY before any programming, regular or test, may be transmitted. Once testing is completed the grantee then may apply for a LICENSE although it is common practice for the FCC to allow regular programming to begin on Program Authority until the actual licence is issued.

All for this time, more if it happens. 73 and Good DX,

Jerry Starr & Buffalo

Jerry Starr & Buffalo "Don't Call Me Buff" K. Foonman

Radio station provides horse news

WINCHESTER, Ky. (AP) — Larry Trimmer doesn't expect "Horse Radio" to be in the running for all the listeners in the Bluegrass area. Trimmer and Bud Walters are co-owners of WHRS-AM, a 2,500-watt station that provides news and information aimed primarily at the horse industry.

"We went into this format with our eyes wide open," said Trimmer, the company's general manager and vice president.

"Obviously, we're confident. We know everyone is not going to listen. It's like a foreign language to some. But we have a definite target audience that we cater to and that is the horse industry."

WHRS, a dawn-to-dusk station, went on the air Jan. 6. Its signal pattern covers about 45 miles, blanketing countryside known for rows of white and black fences, fancy horse barns and stately mansions.

The idea for the horse-news format came about three months ago. "It's almost totally occupied my time since then," Trimmer said.

The station offers more than racing results.

"We not only want to give payoffs, but who owns the horses, the horses' records and the breeding," Trimmer said. "That's what the

professional horse person wants to know about a horse race."

Charlie Fox, a licensed trainer and owner, is the station's operations manager and thoroughbred assignment editor. Walt Rains, a harness-racing official at The Red Mile in Lexington, handles the standardbred news.

"Harness has always taken a backseat to thoroughbreds in this area," Rains said. "But the station is going to be half and half in coverage. That's super."

The station has contacts with several area race tracks, and hopes to expand to every track in the country.

A regular programming day at WHRS includes a summary of the previous day's racing along with news and sports in the morning. The afternoon is filled with race results, news and a recap.

"I hope somewhere down the line the station gets the credibility it deserves as being a leader in horse news," said Rains. "I hope people will realize we know what we're talking about."

Trimmer said the station has plans for live calls of races in the coming weeks, and a talk show that will present views from horsemen is also under development.

"That fits in with what we want

to do. The industry doesn't have a forum like that right now," Trimmer said.

Trimmer said that advertisers are "not beating down the door, but it's been positive. We're encouraged."

He said there has been no make-or-buy date set to determine if the station is a success.

"I don't have one in my mind," Trimmer said. "We did research with horse people. We're trying to provide them with what they want to hear."

THIS IS 1380 KHz

EX - WUKY

VIA J & GUY/STARR

THE VINDICATOR PAPER

1-20-86

OH.

Tony Fitzherbert, 356 Jackman Avenue, Fairfield, CT 06430

For this issue of the Formats column, Les Carpenter, of El Toro, CA, has submitted an update for stations in the Wasatch Front area of Utah. For us on the east coast, the Wasatch Front is made up of the Salt Lake City area. Other stations which Les heard on his trip are also included. Of course, we on the East Coast will unfortunately not hear most of these stations (unless we get to Utah), but KSL is still audible. WJJD, plus 1160'ers WCCS and WTVN also show up. WCCS is almost a regular nightly visitor, even with its 250 watts. When the 5000 watt transmitter is installed, I would guess that its farewell to Utah on the Atlantic shoreline.

A new format, religion-influenced, but not necessarily religious programming, has surfaced. KXYC-1400, Provo, and KUTQ-860, Salt Lake City, identify their formats as LDS Music or LDS Contemporary. The programming is designed to appeal to Utahns who are members of the Church of Jesus Christ of Latter Day Saints". The Mormon Faith is the dominant religion in Utah. This programming does not fit the commonly accepted definition of religious or Christian programming - it is closer to adult contemporary programming, but the playlist is developed to appeal to those of the Mormon faith.

KHQN-1480 is a CHR station, which also runs a lot of religion. Owned by the Hare Krishna Sect, the station airs a lot of programming oriented to their beliefs. Here, thanks to Les Carpenter, is Utah radio (with a couple of others thrown in).....

- 540 KNAK UT Delta - CWM
- 570 KLUB UT Salt Lake City - CHR, lots of news, talk, sports.
- 610 WGIR NH Manchester - Now News/Talk.(TF).
- KVNU UT Logan - Ad. Con., Talk.
- 630 KTKK UT Sandy - News/Talk.
- 700 KFAM UT Bountiful - EZL.
- 730 KSVN UT Ogden - Solid Gold (50's to 70's). to go Spanish with call change to KXEQ, still KSVN on 1-2-86.
- 800 KFRZ UT Brigham City - CWM.
- 860 KUTR UT Salt Lake City - LDS Contemporary.
- 910 KALC UT Salt Lake City - Ad. Con., sports, talk.
- 960 KLZX UT Provo - Ex-KDOT, now CHR.
- 980 KSVC UT Richfield - CWM.
- 990 KTLE UT Tooele - CWM, ROK.
- 1060 KRSP UT Salt Lake City - Ad. Con.
- 1080 KRPX UT Price - ROK.
- 1090 KANN UT Ogden - Christian Programming.
- 1160 KSL UT Salt Lake City - Ad. Con., sports, talk.
- 1210 KCLG UT Washington - CWM.
- 1230 KLAF UT Murray - Comedy.
- 1250 WFBR NH Manchester - Now BBD/NOS, was CHR(TF).
- KNEU UT Roosevelt - CWM.
- 1270 WDLA NY Walton - Noted w/ CWM.(TF).
- 1280 KDYL UT Salt Lake City - All News.
- 1320 KBUG UT Salt Lake City - Ad. Con.
- 1340 KLVN UT Heber - Ad. Con.
- 1370 KSOP UT South Salt Lake City - CWM.
- 1390 KBLQ UT Logan - CWM.
- 1400 KXYC UT Provo - LDS Contemporary.
- 1430 KLO UT Ogden - Ad. Con.
- 1450 KEYY UT Provo - Ad. Con.
- KATJ UT St. George - Ad. Con., now on the air, probably in old KDXU facilities.
- 1470 KBCN UT Tremonton - Ad. Con.
- 1480 KHQN UT Spanish Fork - CHR, some REL.
- 1490 KJQN UT Ogden - Ad. Con.
- 1510 KZZI UT West Jordan - Spanish.
- 1550 KRGO UT West Valley - CWM.
- 1590 KMTI UT Manti - CHR.
- 1600 KBBX UT Centerville - Spanish, Gospel.

Thanks again, Les for the Utah update. Wish we could hear some of these stations in the east. For the rest of you...get your formats in.....When WWL-870 goes all classical, we will all want to know.

Greg Monti
10 January 1986

Accepted industry names are given with the least known National Radio Club Domestic Log abbreviations in square brackets.

ALBUM ORIENTED ROCK (AOR) [AOR]: A music format that stresses the most popular cuts from current and past hit rock albums. True album cuts (songs never released on 45's) are rarely played on these stations. Not such hard news coverage. Instead there are features on things of interest to the station's listeners such as news of rock artists and lifestyle coverage. Music is usually played in sweeps with the titles and/or artists often announced at the end. A new emphasis is being placed on personality D.J.'s although most jocks still concentrate on the basics, adding little personal flair. Often visible and promotionally active, especially in major markets. Examples: WSHE 103.3 Fort Lauderdale, WLUP 97.9 Chicago, KBPI 105.9 Denver.

PROGRESSIVE ROCK [PRG]: A variant on AOR, progressive rock stations view their role as purveyors of "art for art's sake." The status of LP's on sales charts is not a criterion in deciding what LP's or cuts to play. Music selection is often left up to the announcer who also has control over the length of the music sets. Sets are often thematic. Progressive stations are usually small, low-powered college stations operated by unpaid volunteers. A few exceptions operate commercially and attract small but loyal audiences. Occasionally called "free form rock" or "acid rock." Example: WHFS 99.1 Annapolis MD, WLIR 92.7 Garden City NY.

CONTEMPORARY HIT RADIO (CHR) [T40]: Formerly called "Top 40" and based on the most popular music of the day regardless of type or style. Songs are selected for mass appeal. Current hits comprise at least 30% of the total music. There has been a recent trend toward CHR's which play 80 to 100% current recordings, i.e., no oldies. Jingles and sweepers are common. Presentation varies from automated-sounding to conversational to screaming extremes depending upon age of the listeners the station wants to attract. The most successful CHR's are promotionally active and highly visible. Examples: WHTZ 100.3 Newark NJ, WBBM-FM 93.1 Chicago, KNBD 97.3 Tacoma WA.

ROCK OLDIES [ROL]: Music which was once a popular hit but is no longer topping the charts dominates the rock oldies station. One school of thought says that 100% of the music played on oldies stations should be oldies, another says that some currents should be allowed. Presentation varies around CHR/AC styles. Examples: WFIL 560 Philadelphia, WCBS-FM 101.1 New York, KYA 93.3 San Francisco.

ADULT CONTEMPORARY (AC) [POP]: The catchall format for adults. Adult contemporary stations can vary more widely in their music selection than any other format and often play selections from country, soul and rock fields. Music is, however, carefully selected to avoid any "rough edges" which might alienate some segment of the audience so AC's tend to be "safe." Some AC's emphasize familiar songs (read oldies) and feature air personalities who are expected to do more than just announce song titles although there is wide variation here. News emphasis varies from heavy to very light. Main target audience is 25-49, secondarily anyone 18+. Examples: WASH 97.1 Washington, KLOK-FM 103.7 San Francisco, WFYR 103.5 Chicago.

Other adult contemporary stations minimize talk and emphasize music. At the most, they broadcast news headlines about once an hour. Example: WNGK 102.9 Philadelphia, KIXI-FM 95.7 Seattle.

Another strain of adult contemporary stations try to appeal to a slightly older audience, age 35 and older, by mixing the music of established adult appeal artists with contemporary music. Example: WKSZ 100.3 Media PA, KIQG 100.3 Los Angeles. The Transtar network's satellite-delivered "Format 41" is a good example.

ADULT STANDARDS [BBD]: Tries to appeal to all adults, generally does better with older listeners. For stations entering this field in the 80's, the currently popular style is to play music mostly from the pre-rock era and/or non-rock music from the rock era, with emphasis on the big bands, swing and ballads. Presentation in this big band style tends to be low

key, sometimes so much so that the station becomes "background." Some light jazz. Example: WAIT 820 Chicago, WNEW 1130 New York, KIXI 880 Seattle.

Another type of adult standards station uses the traditional style of the old-line middle-of-the-road stations. Air personalities have great leeway in deciding how to communicate with their audience and often use the telephone and prerecorded comedy material within their shows. News and information are of great importance. These stations often feature news blocks in drive times and at least five minutes of news every hour. Music selection cuts a wide swath and includes many songs which were never mass hits, soft cover versions of rock songs and occasional surprise songs from other formats which can seem quite out of place. Often called "full service," these stations may also have telephone talk, jazz and classical music programs. Example: WGN 720 Chicago, WMAL 630 Washington, KMPC 710 Los Angeles.

JAZZ [JAZ]: The only thing jazz stations have in common is that they play jazz. Music selection, foregroundedness and presentation style are all over the lot. May be formatically based on progressive rock, but with jazz recordings played instead or may lean toward an adult standards presentation. Examples: KKGO 105.9 Los Angeles, WBGO 88.3 Newark NJ.

EASY LISTENING [EZL, BFL]: Relaxing, unobtrusive, mostly instrumental music, virtually all of which is cover versions of recent pop tunes is the mainstay of the easy listening station. Minimal talk. News varies from zero to some. Formerly called "beautiful music" or "good music." (This is different from and never to be confused with Muzak or other commercial background music services. The background services' purpose is mood control. Easy listening's purpose is the same as that of all commercial radio stations: to get you to listen to the station so you can hear the commercials. There is no other purpose to commercial radio.) Examples: WEAZ 101.1 Philadelphia, WLOO 100.3 Chicago, KBIG 104.3 Los Angeles.

CLASSICAL [CLA]: Basically a fine-arts format based on play of recordings (of any age) of music written by what are often referred to as "the great masters" or those who compose and arrange in a similar style. Concentrates on symphonic or operatic works with many eclectic excursions into other artsy areas. Example: WQXR 1560 New York, WGKA 1190 Atlanta, KING-FM 98.1 Seattle.

URBAN CONTEMPORARY/BLACK [B:SO]: Whether the format (or format name) marketplace has quite straightened itself out on this one is anybody's guess: soul, black, disco and rhythm and blues are all still in some use. The common ground is service to the black community plus an attraction to the general audience. Presentation and music choices vary widely. Usually active in the community although total image may or may not be "full service." Examples: WBLS 107.5 New York, WBMX 102.7 Oak Park IL, KDIA 1310 Oakland CA.

COUNTRY [C&W, CWH]: Formatically based on other adult formats but playing country artists including general pop artists who may cross over into country and vice versa. Once again, presentation can vary from long uninterrupted music sweeps to full service. Sometimes divided up into "traditional country" or "bluegrass" and "modern" or "contemporary country" to fit the era and style of the majority of the music. "Soft country" or "easy country" variants occasionally show up. Examples: WHN 1050 New York, WMAQ 670 Chicago, KLAC 570 Los Angeles.

RELIGIOUS/GOSPEL [REL, GOS]: An adult based format playing some combination of the following: traditional gospel songs, contemporary pop-sounding Christian music and prerecorded preaching programs. The prerecorded programming is usually air time sold to evangelists in blocks and is rarely other than Protestant and usually fundamentalist. Examples: WZZD 990 Philadelphia, WCFL 1000 Chicago, KBLE 1050 Seattle.

NEWS/TALK [NWS, TLK]: An information based format featuring program hosts who discuss particular areas of interest or expertise, sometimes with guests, sometimes with the audience by phone and sometimes with themselves. Often, day-parts are divided among general purpose talk in which the guests are of general interest and "service talk," in which the subjects are specialized and of narrow interest, i.e., gardening shows, vitamin and health shows, pet shows, home handyman shows, etc. Usually a heavy news

commitment, occasionally whole dayparts of nothing but news. Examples: WCAU 1210 Philadelphia, KGO 810 San Francisco.

A variant, all-news, is the quintessential information format. Nothing but the day's news, locally, regionally, nationally and worldwide. Very expensive to operate. Example: WCBS 880 New York, WBBM 780 Chicago, KFNB 980 Los Angeles.

ETHNIC (ETH): A non-format based usually on a combination of time-brokered block sales and local, live talent to serve those groups and/or languages in the coverage area which are too small to support a whole radio station of their own. Virtually always, a full service approach is taken to programming the individual language services. If one language group is big enough, the whole station may be programmed just to it. Examples: WTEL 860 Philadelphia, WCEV 1450 Cicero IL.

SPANISH (SS): An important subset of Ethnic, Spanish language radio stations are a major force in American broadcasting. Truly local, non-time-brokered, full service and profitable Spanish stations are common in major markets. The recent trend is for Spanish stations to break themselves out into separate formats (one format per station) appealing to separate demographics within the Hispanic community just like their English speaking brethren. Examples: WKDM 1380 New York, WIND 560 Chicago, KSKQ 1540 Los Angeles.

COMEDY: A unique full time format and possibly a passing fad, comedy made its debut in 1982. May be based formatically on a full service adult contemporary station with comedy cuts played rather than music. If some of the comedy cuts are music (Weird Al Yankovic springs to mind) all the better for overall entertainment value. Examples: KLAF 1230 Salt Lake City UT, KMDY 850 Los Angeles.

CHILDREN'S PROGRAMMING: Another oddity on AM stations of the eighties, consisting of stories, music, talk and other programming for children under 12, oddly enough the only age group which radio ratings services do not measure. Stations of this format often have service programming for adults as well, which may be on the subject of children. Example: WKOZ 1280 Jacksonville FL.

Radio voices honored

WASHINGTON—Mel Allen, once the Voice of the New York Yankees, and Earl Nightingale, the radio voice of Sky King and host of *Our Changing World*, will receive the 1986 Hall of Fame award from the National Association of Broadcasters.

Nightingale was the voice of flying rancher Sky King from 1950 to 1964 and created a talk show which grew from 15 to 90 minutes. Today, his daily five-minute *Our Changing World* is heard in all 50 states and at least a dozen foreign countries.

Allen did play-by-play broadcasts of the Yankees from 1940 to 1964 and now hosts a syndicated TV show, *This Week in Baseball*.

ST. PETERSBURG TIMES 1/21/86

whwh 1350
5000 WATTS FULLTIME
Serving the heart of New Jersey



CFGO HAS SWITCHED FROM 1440 TO 1200

CFGO has switched from 1440 to 1200. The station spent just over one-million dollars to increase the stations coverage and plans to make some slight changes in programming, music, and station ID's. Paul Nattall, Vice President and General Manager of CFGO, said that the construction of an antenna and moving the transmitter to Barrhaven will enable the station to broadcast to areas where the signal could not be heard in before. The new signal will go as far as Cornwall, Belleville, and Penbroke. The old signal began to fade out at Kanata. The old towers were half a kilometer away in Barrhaven, the station will construct six new towers.

END OF STORY. Rxd'd via Fred Vobbe & his Modem 1/26/86

DOMESTIC DX DIGEST

Dave Schmidt, 42 Chelwynne Road, Castle Hills, New Castle, DE 19720

here is the NRC column which matches the excitement of Super Bowl Sunday pre-empted til Tuesday night! When sending your items in, please type or neatly write, 1 side of the paper, CST, all that good stuff. Now lets kickoff with this:

WXWW AM 1450

SPECIAL

- 1110 WHIM RI PROVIDENCE - Now on fulltime, 5000/500, believe U2, not listed in log. (MD-MA) Fill us in Craig?
1470 KKFC CA COALINGA - 1/3 now on new calls, ex-KCCL, 'Great KFC Country' ID's. (RP-CA)

DX TESTS

- 810 WSJC MS 12/26 0215-0240 xInt w/some WGY, CK music, ID's, right/left channel TT. (JA-PA)
1000 WIFX KY JENKINS - 1/14 0209-0400 good at times w/CK music, many ID's for NRC, power, phone #, other TT was WJBF. (JA-PA)

MIDDAY - MIDNITE

- 560 WIND IL CHICAGO - 1/13 2307 very good w/spanish music. (JM-PA)
580 CKAP ON KAPUSKASING - 11/21 1930+ strong at times w/many local ads, rock music, AM 58 ID's, weather. (JM-PA)
610 WVAI VA WINCHESTER - 1/12 2341 good in briefly w/weather, rock music, faded to WLP. (JA-PA)
650 WKKQ MN NASHUAUK - 11/27 1719-1729 very good in WSM null w/CK music, Skywatch weather, Super Q ID's, anc't for pattern/power switch advising southern listeners to tune in at 0715. (JA)
670 KXXI AR GLENWOOD - 11/30 1757-1814 very good w/no WMAQ, end of sbc football, local ads, weather, full data s/off. (JM-PA)
690 WAPE FL JACKSONVILLE - 1/4 1718-1723 good w/CBF phased out w/GA tech basketball. (MD-MA)
WVCK AL BIRMINGHAM - 1/4 1745-1750 good w/rock music, ID's, o/CBF/WAPE. (MD-MA) (LW)
700 WCAT MA ORANGE - 1/4 1645 booming in o/WLW w/brief s/off, no sbc.
740 WGSN NY HUNTINGTON - 1/4 1638-1641 fair/good w/MFL type music, Haleys Comet PSA, Station of the stars ID. (LM-NY)
780 WZZX AL LINEVILLE - 12/1 1729-1730 good w/gospel music, full data s/off, to return at sunrise. (JA-PA)
WYAI MS RIDGELAND - 12/1 1751-1830 good o/WBBA w/rock music, anc'ts, promo for WDXQ-FM, ID dualed w/Jackson, off abruptly. (JA-PA)
860 WCAY WY CAK HILL - 1/8 1730 fair w/full data s/off, no sbc. (LM-NY)
WDMG GA DOUGLAS - 1/3 2000 poor w/ID, 99.5 FM mention. (LM-NY)
900 WSKN FL BELLE GLADE - 1/12 1744 weak w/s/off. (KJJ-GA)
910 WPLA FL PLANT CITY - 1/12 1830 w/ID between canned religious programs. (KJJ-GA) In stores along side soup! (DS)
920 CBO ON OTTAWA - 1/5 1705 CBC weather & marine forecasts, soon lost to WJJ/others. (TF-CT)
CFKY NB PORTAGE LAPOINTE - 1/5 2315 good w/CK music, ads. (B4-PA)
WGHQ NY KINGSTON - 1/13 1600-1624 very good at times w/local news, Mor/Rock music, ads, weather, ski report w/WTCH. (JA-PA)
930 WQNT WV HUNTINGTON - 1/8 1733 poor u/noise/WBBA/WBHQ splash w/Accuweather report. (LM-NY)
KSDN SD ABERDEEN - 1/13 1801-1805 briefly atop w/mention of sb in news. (JA-PA)
950 WRTA GA SHREVEVILLE - 12/24 1719-1729 fair u/WKAA-970 splash w/sports, ads, Christmas music til s/off. (JA-PA)
960 WELI CT NEW HAVEN - 11/27 1950-2024 xInt w/teletalk, ads, local news, weather Eye, PSA. (JA-PA) Still has these dreams after we drove past their xstr, when will it stop! (DS)
950 WILK PA WILKES BARRE - 1/1 1710 fair in WLF null w/1ep 98 Countdown show. (LM-NY)

1000 WENJ NJ HACKETTSTOWN - 1/4 1630 fair w/mess w/ID, rock music. (LM)

1130 WBGY IN ANNAPOLIS - 1/13 1730-1800 strong w/WISN w/Ck music, local news, ads, weather, traffic, Mystery Fish Contest, gone at power/pattern change, do they veria? (JM-PA) Cn a scale of 1 to 10, maybe a 6, send them a tuna! (DS)

1150 UNID 1/1 1658-1705 good w/rock music, ad w/mention of Hazelton, no legal ID, likely WYNO. (LM-NY) It fits they! (DS)

1180 USAF GA TRICEN - 11/26 1659-1722 very good in WHAM null w/many ads, especially funeral homes, 40 stations news, local/state news, sports, safe 1180, dual w/Sommerville. (JM-PA)

1190 CJMK CN MISSISSAUGA - 1/13 1453-1535 very good w/WOR/WEDY w/ads, PSA, weather, oldies/rock music, jingle/ID's. (JM-PA)

1200 CFGO CN OTTAWA - 1/11 1600 xint w/local news, weather, sports, ski resort, soon covered by WCCX, ex-1440. (JM-PA)

WAGE VA LEESBURG - 12/30 1805 poor w/WKCA w/local news. (LM-NY)

1230 WKHT CT MANCHESTER - 1/1 1634 Ck music, ads, way o/WFAS. (TF-CT)

KEEX PA EASTON - 1/1 1655 Ck music, 'best in Country' ID. (TF-CT)

1260 WDC DC WASHINGTON - 12/30 1812 fair w/old music, ID. (LM-NY)

1290 WCCC CT HARTFORD - 12/31 1810 fair w/CJFK w/sports promo, very brief s/off, 'now s/off because of FCC regulations'. 1810? which regs are they? (LM-NY) These regs are not in force when it comes to makin' bucks, you should know that! (DS)

1300 WXPX PA W HAZELTON - 1/1 1710 End of Cotton Bowl into ads, ID, way o/local WAVZ. (TF-CT)

WERE OH CLEVELAND - 12/31 1815 good w/WXPX w/local news. (LM-NY)

1310 KAAM TX DALLAS - 1/13 1812 ID, traffic report, oldies. (KVJ-GA)

WDXI TN JACKSON - 1/13 1747 ad, Ck music, u/local WALL OC. (KVJ-GA)

1410 UNID 1/4 Fair/good 1615 o/u WOPP w/Ck Countdown show. (LM-NY)

1420 WLET GA TOCOGA - 11/30 1725-1728 good o/WKX w/Ck music, full data s/off w/power as 500 watt PSA, 5000 Full. (JM-PA)

1440 WMER ME PORTLAND - 11/29 1805 xint during strong NE opening w/CNN news, anc'ts, ID dual w/Westbrook. (JM-PA) Good!

1470 WTRR MD WESTMINSTER - 1/4 2127 w/BBB music, AM 1470 ID. (TF-CT)

1500 WYNI AL MONROEVILLE - 12/2 1730-1745 xint w/WLAC absent w/Ck music, weather, movie news, ads, s/off. (JM-PA)

1510 WWBC FL ROCKLEDGE - 1/5 1722 religion, ID as Christian Radio for Brevard and beyond.... (KVJ-GA) beyond what? (DS)

1520 WKZQ SC MYRTLE BEACH - 12/1 1715-1717 thru WKBW w/ad, jingle/ID, 'Beach's hot FM', rock music, quick s/off. (JM-PA)

WKMG SC NEWBERRY - 12/29 1648 just up during ID during anc't then gone. (JM-PA) Tell JS how that works, will you? (DS)

1550 WRHC FL CORAL GABLES - 1/5 1745 English ID then Spanish program, ID mentions Miami & Hialeah. (KVJ-GA)

WYXX GA SMYRNA - 1/4 1737 fair o/u CBE w/GA Tech basketball, noted equal w/WAPE-690 on 2nd radio! (MD-MA) I'd say the dial was off a bit! (DS)

WARD PA PITTSSTON - 1/1 1700 atop w/news, promo for sex advise show, now pretty regular here. (TF-CT)

1580 KFDF AR VAN BUREN - 12/31 1820 fair w/ID, gospel music. (JM-PA)

WDRF FL FORT LAUDERDALE - 11/30 1858 strong w/accented Jamaican English, ads, reggae music. (JM-PA)

WHM TN HENDERSON - 12/20 1821-1847 good w/CBJ w/ads, info update, Ck music, Business of the Day promo. (JM-PA)

1590 KYDE AR PINE BLUFF - 12/24 1907+ good w/WKX w/B/sol oldies, ads, Mighty 1590 ID's, does not s/off 0100 as of 1/13. (JM-PA)

WXXB FL ST PETERSBURG BEACH - 1/5 1757-1801 b/sol music, ID as Star 16' and 'Daring to be Different'. (KVJ-GA)

MIDNITE - MIDDAY

650 WPTF NC RALIEGH - 12/23 0130 strong w/TT. (JM-PA)

690 WAPE FL JACKSONVILLE - 1/10 0027 strong w/religious music, ID, CBF was off. (JM-PA)

KGGF KS COFFEYVILLE - 12/29 0032-0101 good w/KS basketball, ads, weather, Rock/Ck music, full data s/off, now a regular after CBF s/off 0008. (JM-PA)

*CBF PQ MONTREAL - 1/15 0145 TT, also noted on CEM-940. (JM-PA)

750 *WSB GA ATLANTA - 12/24 0140 noted w/TT. (JM-PA)

CJWw SK SASKATOON - 1/5 0113 weather, Ck music, ID as Super Country, good signal. (BM-MN)

860 KOSE AR CSCECLA - 1/9 0018-0100/0700-0730 good w/end of AR/TX basketball, ads, Ck music. Noted at s/off w/SIL link ID and at s/on, taken out by WLBG. (JM-PA)

920 KYST TX TEXAS CITY - 1/9 0126 just up briefly w/ID, Spanish music then faded to KARN. (JM-PA)

930 CJCA AB EDMONTON - 1/13, 1/15 0135+ fair/good w/rock music, PSA's, sports w/anc'r's name, ID, local news. (JM-PA)

940 *CBM PQ MONTREAL - 1/15 0140 TT, equal w/CBF-090. (JM-PA)

CJGX SK YORKTON - 1/15 0159 just up w/ID, GA 94 ID, news then gone. Noted last 3 AM's w/Ck music w/WKIX. Should I send a tape or letter? (JM-PA) Tape. Not to rain on your parade, this guy never varied years back for me. but it doesn't rain all the time, give it a shot! (DS)

960 WSBT IN SOUTH BEND - 1/5 0001 poor w/KMA w/CBS news, rock music. (BM)

1000 *WUUF TN PARIS - 1/14 0407-0428 very good w/jingle/ID, rock/oldies, possible TT during WIFX Test. (JM-PA)

1010 *UNID 1/13 0310 TT, loud on S beverage. (KVJ-GA)

1020 *KDKA PA PITTSBURGH - 1/12 0143 off, TT at times, noted Spanish when they weren't running TT. (JM-PA)

1030 *WBZ MA BOSTON - 12/29 0130 w/musical type TT! (JM-PA) C'mon John, what brand you usin' this week? (DS)

1140 CKXL AB CALGARY - 1/5 0124 poor w/WKVA w/XL Radio ID, into pop music. (BM-MN) Format Ck? (DS)

1190 WBDY VA BLUEFIELD - 1/11 1054+ xint at times w/Ck music, AM-FM ID's, local ads, VA basketball promo, SMN Ck service as no local anc'r noted. (JM-PA)

1200 *UNID 1/15 0142 strong ET, looping Nw, suspect KFNw or WAGE. (JM)

1210 *WDRR GA DALHONEGA - 12/30 0207 very good in WCALL null w/gospel music, ID for ET. (JM-PA)

1320 KELC SD SIOUX FALLS - 1/5 0213 good o/KOZY w/pop music, ads, weather. (BM-MN)

1330 WDLW MA WALTHAM - 1/4 0710 lay c/WNYA w/Ck music, ads. (TF-CT)

1380 WQHK IN FORT WAYNE - 1/5 0116 fair w/KOTA w/non stop Ck music, ID as 'The Hawk'. (BM-MN)

1400 WZAZ FL JACKSONVILLE - 1/13 0247 B/Scl music, slogan is 'Jacksonville's hottest Radio Station'. (KVJ-GA)

1410 CKSL CN LONDON - 1/5 0038 fair/poor w/others w/pop music, ads, ID, contest promo. (BM-MN)

1500 KCLF LA NEW ROADS - 1/11 0750 New KCLF ID, oldies. (KVJ-GA)

1520 WKKB NY BUFFALO - 1/13 1141 fair w/oldies, ex-WKBW. (JM-PA)....

*1/20 0010 noted off this AM, leaving WYCI/KOMA. (DS-DE)

*UNID 1/21 0045-0110 someone here w/ET playing some record over, no ID's, way o/WKBW in null. (DS-DC)

WDSL NC ROCKSVILLE - 1/11 1100 good w/high school basketball game, ID, Ck music, later at 1428 w/Gospel promo. (JM-PA)

1560 UNID 1/12 0110-0143 badly distorted WYNY til WXXA s/on. (JM-PA)

1580 *WJIM NY PATCOGUE - 12/28 0106 very good w/rock music. (JM-PA)

1600 KCRG IA CEDAR RAPIDS - 1/5 0046 fair w/others w/ID, pop oldies. (BM)

THINENS DEPT.

MD-MA/Marc DeLorenzo, Holliston, MA/HQ100, phased Lw's.

KVJ-GA/Karl Jeter, Stone Mountain, GA/HQ150, TnF, Asst. Beverages

JM-PA/John Malicky, Pittsburgh, PA/superadio 11

BM-MN/Bill Milne, Bendiji, MN/INF (welcome!)

LM-NY/Laura McCusker, Kingston, NY/trio of Superodios, assorted models!

HP-CA/Herman Plew, Atascadero, CA

TF-CT/Tony Fitzherbert, Fairfield, CT/ICF55w

DS-DE/Yer tuning editor/HQ150, Loop, short tk

kmgo/keog
P. O. BOX 910
CENTERVILLE, New York

NOT NORMALLY THE NOKM DEPT.

A few weeks back, JM tried something, he sliced up his catches for me, put them in an envelope and shipped them....it didn't work, so I used his old stuff that wasn't used with this little test.

It's nice to have Nancy on board and handling the west coast catches. So wish her the very best of luck and hope all will support her efforts and give her a flood of info. By the way, Nancy, watch out for guys like DKK, he does send some weird stuff!

That's it for this week, see you in 7!

WTAD
QUINCY, ILLINOIS

KFIR

73's - Good DA!

JOE

New AM station on Arlington site plans strong signal

By CLAY BAILEY

A new AM radio station is tuning up to hit the airwaves from Arlington this year, but it will be more than a community station for the northeast Shelby County town.

WGSF, which will occupy frequency 1210, will cover all of Shelby County and probably spread its signal about 75 miles beyond Arlington, said Wayne Smith, general manager for Arlington Broadcasting Co., the station's license holder.

This week, crews were working on the station's studios along U.S. 70 near Collierville-Arlington Road, while another set of workers laid wire at the station's 190-foot towers about a mile outside the city. Smith said station officials hoped to be on the air by next month, but soft ground around the towers in the Loosa-hatchie River bottoms has prevented some work on that phase since Thanksgiving. Smith said he now hopes to be on the air by mid-April, or early May at the latest.

Memphian Fred Flinn, the broadcast company's owner and president, said the station will have 10,000 watts of power during the day. That will be equal to the daytime signal of WRVR-AM, an adult contemporary station, and stronger than stations such as WHBQ, WRBC and WMC. The power will be cut back to 250 watts at night.

"At night, we'll have to protect a station in Philadelphia, so to the northeast we'll be pulled back," Smith said. "But we'll cover Memphis without any problem."

The new station also will be stereo, only the second AM frequency channel in the county with that capability.

"AM stereo has not really hit the market," Flinn said. "We're hoping that it will take hold and give AM a little more comparability with FM."

Smith said the station will play music as compared to talk radio, and will have on-air personalities instead of being automated.

Asked whether disk jockeys will be hired from local stations or outside the Memphis market, Smith replied: "I've not even started interviewing. Some people have asked about it, and I've told them to send a resume. We'll be looking for experienced people whether from here or other places."

As for format, Smith, who has over 30 years of radio experience from California to northern Michigan, holds his cards close to his radio dial. He and Flinn said they will announce the type music the station will play about a month before they go on the air.

Flinn said station officials have looked at all formats. "AM people are in the mid-30s and up," he said, "and you have to say, 'How are they being underserved?' or 'Is somebody doing something that we could do better?'"

Flinn said paperwork for the station's license began in the 1970s, and the current license was granted by the Federal Communications Commission last February.

"It was just an investment opportunity that came up and looked like something that might do well in the Memphis area," said Flinn, who is a Certified Public Accountant.

Smith said the Arlington location was chosen "because the frequency was available there and Memphis is moving that way."

"Ten years ago, people might have said, 'Why Bartlett or Collierville?'" Smith said.

Smith said the station will seek advertising from throughout the area.

"Since Arlington is not that highly commercial, then the majority probably will come from places other than Arlington."

RADIO

By Gary Lyman
The Register

If there was one major radio story in 1985, it was changing ownership. Several Los Angeles and Orange County stations switched managements and sometimes formats.

Consider:
 Capital Cities Communications Inc. merger with American Broadcasting Companies Inc. for \$3.5 billion.

FCC rules prohibit owning more than one media property in any market, so Cap Cities had to divest itself of KLAC 570 AM and KZLA 93.9 FM, which it had acquired in 1984. ABC said KABC Channel 7 would be retained, so it would have to sell KABC 790 AM and KLOS 95.5 FM. The FCC has granted Cap Cities-ABC an 18-month waiver for KABC and KLOS radio, and there is speculation the waiver may become permanent for KABC.

Cleveland-based Malrite Communications Group's \$43 million purchase of KLAS 570 AM and KZLA 93.9 FM (both county formats) from Cap Cities-ABC.

The \$40 million purchase of Spanish-language stations KTNQ 1020 AM and KLVE 107.5 FM by Rep. Cecil Heftel, D-Hawaii.

Orange County Broadcasting received final FCC approval to construct and operate a new AM radio station in Orange County. When it goes on the air several months from now, it will feature a 24-hour Spanish-language format.

KIEV 870 AM discovered it could carve a successful niche in the talk market by brokering time to talk show hosts who cover such topics as travel, cooking or computers.

VIA E.H. CAPINOR

John R. Malicky, 995 Shadycrest Rd., Pittsburgh, PA 15216

Okay, here it is, the Official Day & Night Scan of St. Louis (and hopefully the last one-hill!) from the suburb of Hazelwood and our member, formerly editor of this column, Eric Bueneman. The receiver was a Realistic DX-400 with a Radio West loop as Eric noted in the daytime, WHAS-340 & WSON-860 Henderson, KY are heard only when local KFUC-850 is off. Since this column started, there were 3 previous day scans of St. Louis and one at night with this scan the newest update. I've noted most day locals (night, also) and made a correction on the total of day stations. So when you're visiting this "Gateway to the West" city and have some free time while atop the Arch, or at a Cardinals game between innings, or while taking a tour of the Anheuser-Busch brewery, pull out this scan and use it! Thank you Eric...remember, please list the date, time, frequency, updated calls (if known), city, state-province, equipment, and your LOCALS in CAPS; off we go....

FREQ	(EB-MO) Day (Dec, 1985)	154 total	(EB-MO) Night (Dec, 1985)	250 total
540	KMTI-Fort Dodge, IA		CBK-Regina, SA	
550	KUSA-ST. LOUIS		KUSA-ST. LOUIS/ KTSA-San Antonio, TX	
560	KWTO-Springfield, MO		WIND-Chicago/ KLVJ-Beaumont, TX/ KWTO-Springfield	
570	WAYX-Paducah, KY		WYX-Faducash, KY/ WNAK-Yankton, SD/ ARQX-Dallas/ CMEA-Santa Clara, Cuba	
580	WILL-Urbana, IL		WATY-LaCrosse, WI/ WISW-Topeka, KS	
590	WRTH-WOOD RIVER, IL		WRTH-WOOD RIVER, IL/ WCV-Ormaha, NE	
600	WMT-Cedar Rapids, IA/ WREC-Memphis, TN		CMKA-Urbano Noris, Cuba/ WREC-Memphis, TN	
610	WDAF-Kansas City/ WRUS-Russellville, KY		WDAF-Kansas City/ KARV-Russellville, AR	
620	WTMJ-Milwaukee		WZZK-Birmingham, AL	
630	KXOK-ST. LOUIS		WTMJ-Milwaukee/ KWPT-Wichita Falls, TX	
640	WOI-Ames, IA/ WMSO-Collierville, TN		KXOK-ST. LOUIS/ OPCO-Chatham, ON	
650	WSM-Nashville		WLS-Moore, OK/ OMBB-Guanabacoa, Cuba/ WMSO-Collierville, TN/ KFI-Los Angeles	
660	KCRC-Omaha, NE/ KSKY-Balch Springs, TX		WSM-Nashville/ HIAT-Santo Domingo, DR	
670	WMAQ-Chicago		WNBO-New York/ XSRFM-Mexico, DF	
680	KFEQ-St. Joseph, MO		WMAQ-Chicago/ CMBO-Arroyo Arenas, Cuba	
690	ASTL-ST. LOUIS		KNBR-San Francisco/ KFEQ-St. Joseph, MO	
700	WLW-Cincinnati		KOBF-Coffeyville, KS/ OBF-Montreal/ WTIX-New Orleans	
710	WHB-Kansas City/ WTPR-Faris, TN		WLW-Cincinnati/ HJCK-Cali, Columbia	
720	WGN-Chicago		WCR-New York/ WHB-Kansas City	
730	KWRE-Warrenton, MO		WGN-Chicago/ KDMN-Las Vegas, NV	
740	WVLM-Olney, IL/ KRMG-Tulsa, OK		KEX-Mexico, DF/ CKAK-Montreal/ TGN-Guatemala/ CKLM-Dauphin, MB	
750	KJEL-Lebanon, MO/ WSB-Atlanta		CKLW-Toronto/ KRMG-Tulsa/ KRTH-Houston	
760	WJR-Detroit		WSB-Atlanta/ HTA750 Managua, Nicaragua Cuba	
770	WEX-ST. LOUIS		WJR-Detroit/ KEABO-Mexico, DF/ CMDB-Guanabacoa, WABO-New York/ KOB-Albuquerque, NM/ WJMW-Athens, WBBM-Chicago	AL
780	WBBM-Chicago		WMC-Memphis, TN/ WAKY-Louisville, KY	
790	WRMS-Beardstown, IL/ WAXY-Louisville, KY		CKLM-Windsor, ON/ XEROK-Juarez, CH	
800	KREI-Farrington, MO/ WKZI-Cassidy, IL/ CKLM-Windsor, ON		MGY-Schenectady, NY/ KOMO-Kansas City, MO	
810	KOMO-Kansas City/ WDDD-Johnston City, IL		WBAF-Fort Worth, TX/ CHAM-Hamilton, ON	
820	WAIT-Chicago/ WSMI-Evanston, IN		WCCO-Minneapolis/ Radio Belize	
830	KBOA-Kennett, MO/ WCCO-Minneapolis		WHAS-Louisville, KY	
840		KOA-Denver/ CKVL-Verdun, PQ	
850	KFUC-CLAYTON, MO		CJBC-Toronto/ KWPC-Muscatine, IA/ WDMG-Douglas, GA/ KONO-San Antonio, TX	
860		WVL-New Orleans	
870	KAAN-Bethany, MO		WCBG-New York/ CMAS-Finar del Rio, Cuba/ KRVN-Lexington, NE	
880	ARVN-Lexington, NE/ WMBB-Nashville, TN		WLS-Chicago	
890	WLS-Chicago		XEW-Mexico City, DF/ CHML-Hamilton, ON	
900	KPAL-Fulton, MO		RGLC-Miami, OK/ WALT-Meridian, MS	
910	WAKO-Lawrenceville, IL/ KLCN-Blytheville		WGNU-GRANITE CITY, IL/ KARN-Little Rock, AR	
920	WGNU-GRANITE CITY, IL	AR	WLSI-Jackson, MS/ WTAD-Quincy/ WKY-Oklahoma City	
930	WTAD-Quincy, IL/ KWOC-Poplar Bluff, MO		KIOA-Des Moines, IA/ WNIX-Mt. Vernon, IL/ XEQ-Mexico, DF/ OBM-Montreal	
940	WMIX-Mt. Vernon, IL/ KIOA-Des Moines, IA		WSLQ-Montgomery, AL/ KPRO-Houston/ KIMC-Denver	
950	KLIK-Jefferson City, MO		KMA-Shenandoah, IA/ KZIM-Cape Girardeau, MO/ WFIR-Roanoke, VA	
960	KZIM-Cape Girardeau, MO/ WDLN-East Moline	IL	WAVG-Louisville, KY/ WMAV-Springfield, IL	
970	WMAV-Springfield, IL		WSIX-Nashville, TN/ KMBZ-Kansas City/ WCOB-Two Rivers, WI	
980	KSGM-Chester, IL/ KMBZ-Kansas City/ WITY-Danville, IL		CBW-Winnipeg/ WNOX-Knoxville, TN	
990	WGAZ-Carthage, IL		WCFL-Chicago/ KTOK-Oklahoma City, OK	
1000	WCFL-Chicago		CFRB-Toronto/ KLRA-Little Rock, AR/ KDJW-Amarillo, TX	
1010	KXEN-ST. LOUIS-PESTUS, MO			

- 1020 WCIL-Carbondale, IL
- 1030 WXSS-Memphis, TN
- 1040 WHO-Des Moines, IA
- 1050 WZZ-Decatur, IL/ KMIS-Portageville, MO
- 1060 WNCI-McLeansboro, IL/WHPB-Benton Harbor
- 1070 KMOH-Hannibal, MO/ WIBC-Indianapolis
- 1080 KYMO-East Prairie, MO/ KRLD-Dallas
- 1090 WORA-Effingham, IL
- 1100 WWWE-Cleveland
- 1110
- 1120 KMOX-ST. LOUIS
- 1130
- 1140 WVFL-Pekin, IL
- 1150 WGGH-Marion, IL/ KRMS-Osage Beach, MO
- 1160 WJJD-Chicago
- 1170 KJAS-Jackson, MO/ WLSH-Mattoon, IL
- 1180 WLDS-Jacksonville, IL
- 1190 KHAD-DESOTO, MO
- 1200 WBCE-Wickliffe, KY
- 1210 WILY-Centralia, IL
- 1220 KLPW-UNION, MO/ KDIR-Cape Girardeau, MO
- 1230 WHOO-Sparta, IL/ KWIX-Moberly, MO/ WJBC-Bloomington, IL
- 1240 WTAX-Springfield, IL/ KFMO-Flat River, MO
- 1250 KBTO-Houston, MO/ WRAY-Princeton, IN
- 1260 W18V-BELLEVILLE, IL
- 1270 WEIC-Charleston, IL/ WHBF-Rock Island, IL
- 1280 KYRO-Fotosi, MO/ WGBF-Evansville, IN
- 1290 WIRL-Feoria, IL
- 1300 WFRX-West Frankfort, IL
- 1310 KOKX-Keokuk, IA/ KBWV-Birch Tree, MO
- 1320 KSIV-CLAYTON, MO
- 1330 WVHI-Evansville, IN
- 1340 KXEO-Mexico, MO/ WHFI-Herrin, IL
- 1350 WJBD-Salem, IL/ KCHR-Charleston, MO
- 1360 KBAB-Fort Madison, IA/KLRS-Mountain Grove
- 1370 WFRQ-Lincoln, IL
- 1380 KGLD-ST. LOUIS
- 1390 KJFW-Wayneville, MO
- 1400 KJOF-FESTUS, MO/ KFRT-Columbia, MO/ WDSW-Champaign, IL
- 1410 WTIM-Taylorville, IL/ KBOO-Cuba, MO/ WLSJ-Bowling Green, KY
- 1420 WINI-Marshysboro, IL
- 1430 WIL-ST. LOUIS
- 1440 WGEM-Quincy, IL
- 1450 WCVS-Springfield, IL
- 1460 KIRL-ST. CHARLES, MO
- 1470 WMBD-Feoria, IL
- 1480 WJBM-Jerseyville, IL/ WTHI-Terre Haute, IN
- 1490 WESL-EAST ST. LOUIS, IL/KTTR-Rolla, MO
- 1500 WFMB-Vandalia, IL
- 1510 WINU-Highland, IL/ KOCV-Independence, MO
- 1520 WHOW-Clinton, IL/ KMFL-Sikeston, MO
- 1530 WPCB-Bowling Green, KY/ WCKY-Cincinnati
- 1540 WSMI-Litchfield, IL/ KXEL-Waterloo, IA
- 1550 KEMI-Cape Girardeau, MO/WJIL-Jacksonville
- 1560 KTWI-Sullivan, MO/WFAD-Faducan, KY IL
- 1570 WBGZ-ALTON, IL
- 1580 WBSA-Fittsfield, IL/ WDCN-DuQuoin, IL
- 1590 WAIR-Galesburg, IL/ KMOZ-Rolla, MO
- 1600 KATZ-ST. LOUIS

- KDKA-Pittsburgh/ YVRS-La Asuncion, Venezuela
- WBZ-Boston/ WXSS-Memphis, TN
- WHO-Des Moines, IA
- XEG-Monterrey, NL/ CKSB-St. Boniface, MB/ CFYN-Sault Ste. Marie, ON/ CHUM-Toronto/ WHN-Secaucus, NJ(New York)
- KYW-Philadelphia/ XEEP-Mexico, DF
- CHOK-Sarnia, ON/ WDIA-Memphis/ WIBC-Indianapolis
- KHMO-Hannibal/ KPDI-Wichita/ KNX-Los Angeles
- KRLD-Dallas/ WCII-Louisville, KY
- KAAY-Little Rock, AR/ CHED-Iethbridge, AS
- WWVE-Cleveland/ HJAT-Barranquilla, Columbia/ KIIQ-Grand Junction, CO
- KFAB-Omaha, NE
- KMOX-ST. LOUIS
- KWKH-Shreveport, LA/ WGGY-Minneapolis
- WVVA-Richmond, VA/ KSOO-Sioux Falls, SD/ XEMR-Monterrey, NL
- CKOC-Hamilton, ON/ WIMA-Lima, OH/ KSAL-Salina, KS
- WJJD-Chicago/ KSL-Salt Lake City, UT
- KVOO-Tulsa, OK/ KZKZ-Davenport, IA/WWVA-Wheeling
- WHAM-Rochester, NY/ WKKE-Pearl, MS/ Radio Marti- Marathon, FL
- WOWO-Fort Wayne, IN/ KJLA-Kansas City
- WOAI-San Antonio, TX
- WCAU-Philadelphia/ WQWQ-Miami, FL
- WGAR-Cleveland/ XEB-Mexico City, DF
- KWIX-Moberly, MO/ WBOV-Terre Haute, IN/ KFFW-Fort Smith, AR
- WENX-Union City, TN/ WTAX-Springfield, IL
- WEMF-Milwaukee/ WREN-Topeka, KS/KLAZ-Little Rock
- WISV-BELLEVILLE, IL/ KGBX-Springfield, MO/ WNDL-Indianapolis
- WHBF-Rock Island, IL/ KSSA-Fort Worth, TX
- WGBF-Evansville, IN/ WOTO-Minneapolis/ KRBQ-Denver
- WIRL-Feoria, IL/ WHIO-Dayton, OH/ KRGV-Weslaco, TX
- WKXI-Jackson, MS/ WOOD-Grand Rapids, MI/ WTKO-Lexington, KY
- WIBA-Madison, WI/ WMLF-Indianapolis
- WJAS-Pittsburgh/ KELO-Sioux Falls, SD
- KFH-Wichita, KS/ WFBC-Greenville, SC/ KALO-Waterloo, IA
- KLID-Poplar Bluff, MO/ KCKM-Kansas City, KS
- KRNT-Des Moines, IA
- WNNK-Cincinnati/ WGES-Green Bay, WI
- WGTO-Bloomington, IN/ KONO-Dodge City, KS
- KGLD-ST. LOUIS/ WFPS-Millington, TN
- WTJS-Jackson, TN/ WGOI-Chicago
- KTTZ-Springfield, MO
- WING-Dayton, OH/WIZM-LaCrosse, WI/ WLSJ-Bowling Green, KY
- WVJS-Owensboro, KY/ WOO-Davenport, IA
- WIL-ST. LOUIS/ CJCL-Toronto/ WLRQ-Madison, TN
- WHHY-Montgomery, AL/ WGEM-Quincy, IL
- WEZR-Fort Wayne, IN/ WROX-Clarksdale, MS
- KSO-Des Moines, IA/ WBRN-Big Rapids, MI
- WMSB-Feoria, IL/ WKXC-New Albany, MS
- WABB-Mobile, AL/ WTHI-Terre Haute, IN
- WESL-EAST ST. LOUIS, IL/ WOSH-Okemosh, WI
- KSTP-St. Paul/ WTOP-Washington/ WCOZY-Detroit
- WLAC-Nashville/ KDKO-Littleton, CO
- KMPL-Sikeston/ KOMA-Oklahoma City/ WKBM-Buffalo
- WCKY-Cincinnati/ KGBT-Harlingen, TX
- KXEL-Waterloo/WFTR-Albany, NY/KGBG-Galveston, TX
- KBJC-St. Joseph/CBE-Windsor/WOKJ-Jackson, MS
- WFAD-Faducan/WQXR-New York/KKAA-Aberdeen, SD
- XERF-Ciudad Acuna, CU
- WEAM-Columbus, GA/ KXZZ-Lake Charles, LA
- KYDE-Pine Bluff, AR/ WAKR-Akron, Ohio
- KATZ-ST. LOUIS/ WXVI-Montgomery, AL

The PHASE ONE --
A Delay Line Phasing Unit

Gerry Thomas

In the past few years, I've built and used over a half dozen different phasing units (from Ron Schatz's LSCA to some of Mark Connelly's designs) and have come to appreciate what phasing can and cannot do in the pursuit of DX. If you have never used a phasing unit, I suggest you give one a try -- I can almost guarantee that you'll hear stations you've never heard before. But, this being the imperfect world that it is, phasing has its limitations; there will be times when you want to null an offending station, but you won't be able to. Nonetheless, in my opinion, every serious DX'er should have a phasing unit in his or her shack.

As I stated, I've built several phasers including some designs of my own (e.g., electronic FET schemes, etc.) and have almost always been satisfied but never totally happy. Phasing units based on a tuned L-C circuit have several potential advantages, foremost of which are inexpensive components and potentially improved signal-to-noise ratios. I, however, have usually been driven a little nuts by the array of control knobs to manipulate and by problems like hand capacitance causing phase shifts, etc. Also, to null the splattery sidebands (in addition to the carrier) of an undesired station, you have to spoil the Q of the tuned system, which reduces the signal-to-noise ratio. For the past year or so, I've been tinkering around with a somewhat different approach to phasing and would like to pass along a circuit that I'm not only satisfied with but also almost completely happy with.

Phasing Theory (in brief)

Phasing, in theory, is really very simple -- combine two equal amplitude, antiphase signals and you get...nothing, a null. With a loop and longwire set-up, because the two receiving (figure 8) lobes are 180 degrees out of phase, all you have to do is combine an appropriate signal from the second antenna so that it's antiphase with one of the loop's lobes and you have a cardioid receiving pattern. The tricky part of phasing comes in when you deal with the fact that the two antennas are displaced in space, resulting in a given wavefront arriving at the two antennas at different times. This time difference must be corrected to effect a null. Tuned L-C phasing units attack this problem by slightly de-tuning one of the antennas, causing it to lag behind the other. Because the phase relationship of the two antennas is so critical in obtaining optimal null depth (one degree of antiphase difference reduces null depth by almost 20 dB), things like hand capacitance in a less than optimally designed or constructed unit can make phasing somewhat touchy. But, on the whole, the tuned L-C approach works well.

A Different Approach

Ideally, we could deal with the time of arrival differences between the two antennas by using a continuously variable delay line. Continuously variable delay lines are available and are used in commercial and military applications but they cost big bucks. The circuit described in this article uses a series of fixed delays (to make a band of frequencies "appear" to arrive at two different antennas at the same time), a phase shifter (to continuously vary one of the signals through 360 degrees), a level control (to set the optimal amplitude), and two broadband amplifiers to offset the attenuation of the delay line/phaser. Several circuits/discussions of the use of delay lines to achieve RF phasing have appeared in the radio engineering/amateur radio literature over the years, but the circuit which follows is a modified version of one described by John Webb in the October, 1988 issue of QST (pp. 28-33) that was used to null military jamming signals on the HF frequencies.

Delay Lines

Several companies manufacture encapsulated "lumped constant" delay lines that are used in military and industrial settings and which are suitable for QW/SW phasing. These lines range in price from about \$30 to \$65 on the low end. I purchased an LC3882858A from Allen Avionics (224 East Second St., Mineola, NY 11501) for around \$35. The LC3882858A is a 14 DIP packaged line with a maximum delay of 300 nSecs and an input/output impedance of 50 Ohms. A nice thing about this delay line is that it provides the 300-nSec delay required for optimal QW phasing as well as nine other taps (in 10% increments) to extend the usefulness of the circuit to around 12 MHz for use on the SW bands. Gouser Electronics (1433 Woodside Ave, Santee, CA 92071) recently al-

Fitt(er) Fatter....Well, that's it, hey Eric, go hit the books and work on good grades-hi!.... speaking of St. Louis, in August, 1977 while going west (first day of a 3-week vacation) my cousin and I made a wrong turn going south on Interstate 55 to Memphis, but swung around to west on I-70finally, calling all WORLDWIDE NRC members outside the U.S. & Canada, send in a day and/or night scan(1986 is your year), We want to know what you hear! Until then, 73s to all! *John*

so began carrying delay lines at very attractive prices (about \$5) but the longest delay they offer is 200 nsecs and other specifications (e.g., input/output impedances, attenuation, etc.) are unknown (to me; a spec sheet has been ordered). Perhaps two of the 200-nsec Mouser lines could be cascaded in the described circuit (with suitable component value changes).

Phasing/Amplitude Controls

This portion of the circuit samples relative amounts of in-phase and out-of-phase signals to provide a resultant signal whose phase can be set anywhere between zero and 360 degrees. Relative amplitude is also controlled at this stage. To create this control, the signal from one of the antennas is passed through a broadband transformer with two secondaries -- one in phase, one 180 degrees out of phase. The broadband transformer is wound on an FT-37-67 toroid (Amidon Associates, 12033 Queswega St., No. Hollywood, CA 91607) with 28# wire in a five-turn, trifilar configuration. The outputs of both secondaries are paralleled to two, 250-Ohm linear taper, carbon composition potentiometers whose wipers serve as outputs to the next stage. Finding the required pots can be a problem (and expensive -- mine were \$5 each) but 250 Ohms allows fairly easy fine phasing adjustments. Easier to find 500 Ohm pots can be substituted but adjustment becomes a little touchier. Do not use wirewound pots.

Broadband Amplifiers

To offset the attenuation of the delay/phasing circuitry, two bipolar broadband amps are used. Special bipolar transistors were chosen (instead of FET's) for a couple of reasons. First, the low input impedance (less than 150 Ohms) of the bipolar transistors reduces the probability of amplifying stray RF and, secondly, the chosen transistors are used in CATV amps and have good dynamic range, linearity, and excellent noise figures (better than many FET's). The output of each amp at QW frequencies is 15-20 dB and they are very quiet. I originally used the LT1001A made by TAW but the circuit values listed here are for the easier-to-find 2N3866 (Radio Shack 275-2038). The 100-Ohm output impedances of the two amps are combined to produce an approximate 50-Ohm impedance to the receiver input.

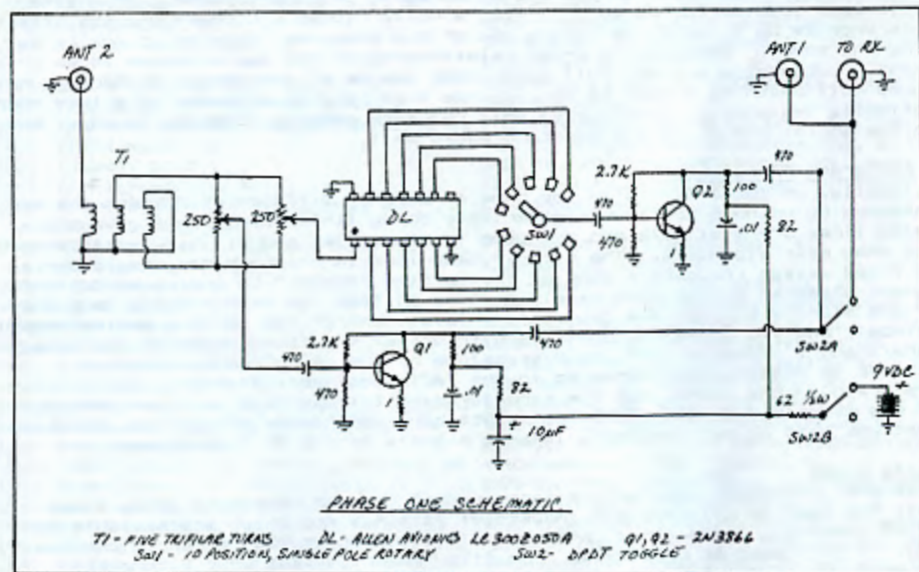

Construction

The circuitry is assembled on a PC board and housed in a metal, shielded cabinet. Signals are inputted and outputted to the Phase One using UHF con-

nectors and RG-58U coax (leads are as short as possible). Power is supplied with 9 VDC wall transformer and a DPDT toggle switches the Phase One in and out of the signal line.

Step-by-step construction details are being foregone in this article for several reasons: (a) apparent displeasure on the part of some readers for lengthy technical articles; (b) experienced tinkerers should have no trouble working directly from the schematic; and (c) the Phase One in kit (with detailed instructions) and assembled form should be available from Radio Plus Electronics in 60-90 days.

Operation

The Phase One has only three principal controls -- delay range, amplitude, and phase. A single setting of the delay range control covers a large range of frequencies (about 1 MHz at QW frequencies), so it is not routinely adjusted while DX'ing the BCN. The amplitude and phase controls interact so alternately adjusting each is required for the deepest null. I've found that simultaneously rotating each locates the general null settings quickly then alternately adjusting each for deepest null works best for me. With practice, optimal nulls rarely take more than 10 - 15 seconds to attain. Once a null has been established, it can be "steered" throughout 360 degrees using the phase control and with only minor adjustments to the amplitude pot. Because the bandwidth of the null in this broadband design is also quite large (depending on the spacing of the antennas, etc.), it is often possible to change receiver frequencies several tens of kHz and retain the same nulling effect. As an example, using the Phase One with a dipole and a longwire, I was trying to receive WUGG-600 (a regular receiver sensitivity/selectivity test station of mine). WUGG-600 is located about 150 miles to the west of me and radiates 1 kW. Reception of WUGG is usually bothered by both WHYD-610, a local splasher, and WOLP-550, a messy rocker. Luckily, because both WHYD and WOLP lay roughly in a straight line to the east of me, a single setting of the Phase One was able to simultaneously null both the 550 and 610 pests, and, at the same time, double the signal from WUGG to the west (due to the summing of the in-phase signals on the opposite side of the null). This was my best ever reception of WUGG. This example represents phasing in general, and broadband phasing in particular, at its best. Phasing has its limitations though. In fact, phasing is definitely not guaranteed to null all undesired stations. It can do very well with single mode, one hop signals but if an offending station is "beating" or fading, this usually indicates either a combination groundwave/skywave arrival or a multi-hop skip. In these cases, a single null will remove one signal but the other will remain. (On the drawing board, incidentally, is a two-stage phaser (the Phase Two) to attempt to deal with this situation... we'll see how it works.)

So far I've used the Phase One with two longwires, a loop and longwire, a loop and dipole, and a longwire and dipole and have had no trouble nulling all of my locals (the strongest is 5 kW WCGA-1370 at six miles) to the noise level. From what I've read, two verticals are the best to phase but I haven't given those a try. Neither have I spent a great deal of time testing the Phase One at frequencies above 1.6 MHz other than to confirm that at least partial nulls (due to the multi-skip nature of SW signals) can be obtained up to about 12 MHz. Much more testing needs to be done at HF frequencies and perhaps some design changes.

Well, that about sums up the Phase One. If you have any questions (or can provide any answers, hi) or if you would like to be notified of the availability of the Phase One in kit or assembled form, drop me a line at RADIO PLUS Electronics, 3635 Chastain Way, Pensacola, FL 32503. 73's....BT



CONTEST ! CONTEST ! CONTEST ! CONTEST ! CONTEST ! CONTEST ! CONTEST !

Mark Connelly - WAION - 38 William Road - Billerica, MA 01866

I heard my first medium-wave Trans-Atlantic stations back in 1961. To celebrate 25 years of TA DX and to stimulate general interest in international DXing, I'm setting up the following listening contests:

Contest 1

* DXers living in the countries listed in the World Radio-TV Handbook's North America, South America, and Central America and the Caribbean (including Mexico) sections are eligible to enter Contest 1. DXers in Hawaii are also eligible for Contest 1.

* The first prize is a choice of a phasing unit or of a regenerative tuner (approx. value \$ 180). The second prize is *YET TO BE DETERMINED!* (Hu)

* Stations received are eligible for points. These stations must be heard between 01 JAN 1986 and 31 DEC 1986. The stations must be in countries listed in the Europe, Africa, and Near and Middle East sections of the World Radio-TV Handbook. Eligible stations must be broadcasters heard between 520 and 1700 kHz.

* Points are scored as follows:

QSL for a 1986 reception (xerox copy is to be submitted to me by 31 MAR 1987)	3 points
Reported to IDXD for first time in 1986 by that reporter	2 points
Reported to IDXD two or more weeks after a previous 1986 report	1 point

Contest 2

* DXers living in the countries listed in the World Radio-TV Handbook's Europe, Africa, and Near and Middle East sections are eligible to enter Contest 2.

* There is one prize, *To BE A SURPRISE... You'll know LATER on!* (Hu)

* Stations received are eligible for points. These stations must be heard between 01 JAN 1986 and 31 DEC 1986. The stations must be in countries listed in the North America, South America, and Central America and the Caribbean (including Mexico) sections of the World Radio-TV Handbook. Eligible stations must be broadcasters heard between 520 and 1700 kHz.

* Points are scored as follows:

QSL for a 1986 reception (xerox copy is to be submitted to me by 31 MAR 1987)	3 points
Reported in DX News for first time in 1986 by that reporter.	2 points
Reported in DX News two or more weeks after a previous 1986 report.	1 point

I will keep a running tally of eligible loggings noted in DX News during 1986. The contest will be closed out on 31 MAR 1987 and winners will be notified in April or May of 1987. I reserve the right to give or to deny credit for UNID's (based on tip value), tentatives, and incorrect/inaccurate loggings. Points may be subtracted for obviously-fraudulent entries. In cases of ties, the DXer who heard the greater number of truly rare stations will win. The \$ 180 equipment prize will only be awarded to a DXer with a point total of at least 100; *THE OTHER PRIZE* will only be awarded to DXers with point totals of 50 or greater. (Hu)

Paul Swearingen

P.O. Box 4812, Panorama City, CA 91412

The opinions expressed in this column are those of the individual writer and do not necessarily reflect those of the Editors, Publishers, or the National Radio Club, Inc., or its subsidiaries.
Times are local per Muse.

Greetings again; a nice turnout this week, and let's keep it up, okay? A reminder that my column deadline is each Friday, strict, as by the time you read this I will not be working weekends (until next Christmas season) and therefore don't drive 30 minutes just to pick up the mail on Saturdays. Ninety percent of the letters from the east coast to about the Mississippi reach me in three days, and from Missouri west in two. A few make it sooner, and the rest wander around the country for a week or so before coming to rest here. Also, mail sent to the old Sun Valley address is delayed about a week until forwarded, and after June probably won't be forwarded by the P. O. /// #20 (deadline Feb. 7) will be devoted to thoughts from 20-year+ NRC veterans, #21 (Feb. 14) to past or present employees of the broadcast media, #22 (Feb. 21) is Story Time, and #23 (Feb. 28) will be turned over to our teenage NRC members for their Musings. And I've temporarily run out of ideas for themes, so send your ideas (with your Muse, of course) any time. And now, on with it!

irst, a late arrival for last week's theme ...

Laura M. McCusker - 23 John St. Kingston, NY 12401

Greetings once again, static lovers! I like to contribute a Muse when there's an appropriate theme, but two weeks in a row! This is getting to be a lot of work. I really can't comment on this week's theme, per se. I happen to be a female DX'er; I wouldn't have it any other way, but I've never met another one. Even though I work in radio, times I've run into DX'ers are few and far between, and all of those have been male. Most people are surprised to find a female DX'er, and even more surprised to find I know a bit about the subject. I suppose it's because I am such a rarity. Hmm ... Anyway, what I guess I love most about DX'ing is that it's always available. As I know well from being in the business, radio never closes. Therefore, it's always time to DX! Fortunately, I got some time off for the holidays this year and got to do a DX road trip to New Jersey to visit home for a few days. Jersey is the place where I learned to DX, so it was interesting to go back as an "experienced" DX'er. A few things floated by that I never picked up when I lived there, my favorite being WSLW-1310, White Sulphur Springs, WV, coming in weakly thru semi-local WVIP. Also two good graveyard finds, WDNV-1400, Dansville, NY, and WASC-1450, Glens Falls, NY. WDNV is a first-time ever pick up; I've never gotten them even at home in Kingston! Wacky. WNIS-1350 Portsmouth VA seems to be pretty much of a regular in NE Joisey after sun goes down. Picked in WKNC-1370, Roaring Spring, PA so weakly I probably wouldn't have been able to ID them, except that I used to listen to them occasionally when I lived out in PA and recognized the jock immediately! It was the same afternoon guy I used to hear. Also got WRSC-1390, State College PA, which is highly unusual. Because of all the mountains surrounding State College, sometimes I'd have trouble getting them in Lewistown, which is a pretty short distance. But they were coming in admirably well the day after Xmas down in Jerzee, with optimistic talk about the Nittany Lions in the Orange Bowl. Too bad they were disappointed. WKOK-1580, Columbus OH, was also received rather well, fading at 1630 because of what I assumed to be a power cut, but sneaking back up after a minute or so, and holding on for several minutes with BSOL mx and "Rhythm of the City" ID. WAGE-1200 was highly dominant in NE Joisey, blowing away WKOX and no sign of WQAI. Up north in Kingston, WKOX is dominant these days, but WAGE can be heard fairly well behind it. 1200 is certainly not what it used to be. WQAI R. I. P.!! Conditions lately picking up here in NY after a late December lull. Hope you're all having fun playing with your receivers. Good DX to all.

And now to our theme contributions, about unusual radios and antennas ...

Conrad R. Durocher - Rt. 1, Box 2245 - Dickinson, TX 77539 (713) 339-1143

Howdy from "Just-As-Cold-As-Y'all-Are", TX. But the cold fronts don't stay long enough to improve AM DX for very long. Winds and waves did a job on the over-water LW (and shipwrecked my rubber repair boat) so have been DX'ing on remaining 75' section. We're off the road till mid-Jan., so decided to fill in details of previously hrd stns in my almost new, nifty (and may I say, well-worth the bucks) NRC logsheets. Caught some neat stuff along the way: 9-4: WKOK-1460 Baton Rouge, LA at 2031 with "Coach's Bench" into ID after local KBRZ s/off ... 11-13: WQXR-1560 NYC at 0105, hrd CIA then "Nighttime in NY" and full ID. Even the 75' section had come down when this was hrd! ... 11-17: WRBO-1040 FL at 0650 with quick ID on car radio (just had to go to 7-11, hi). Checking the 1982 280ZX service manual, I found that the digital tuner has a switch behind the volume knob to select 10 or 9 kHz spacing. I'm hesitant, as text sounds as if it might be irretrievable. Its poor selectivity probably wouldn't even notice it ... 11-25: KKOW (ex-KOAM)-860 KS at 0140 with ice storm warnings and csw. KRNV-880 at 0445 with "how to buy a tractor", mentioned everything but cash. KGBX-1260 Springfield MO at 0535 with ROK, a regular here. KBAJ-1300 Tulsa at 0545 with "Classic Rock from '60's and '70's". WIZO-1380 Franklin, TN at 0305 with local mx ... 12-10: R. Paradise-825 at 2030 GOG pgm giving Miami address. Lotsa splash from both sides ... Caribbean Radio Lighthouse-1165 Antigua at 2035

with GOS mx. 12-11: WVA-1170 at 0150 with sports, road rpt. Sig S-4 but KVOO off. WHAM-1180 NY at 0300 with Best of King, also on car radio (just had to go to Quick-Stop). WQMO-1190 at 0400 with ID, loc. nx, into ROK. Don't they beam east? 1-3: R. Cadena-1140 Havana at 0700, OC then s/on in SS and EE. Sounded like "R. Saita or Saina." Well, gotta go plug the boat, wait for calm waters, salvage the 450-footer, and foolishly pray for a cold front. Looks like I'm missing a good season. Hee-haw, y'all, happy '86.

Hello, 1986!

Ernest Cooper - 5 Anthony St. - Provincetown, MA 02657 (617) 487-9337

One new verie, v/1 from WZAP-690. DX'ers who use unusual radios? Well, I guess in this day and age, I fall into that category with my old HQ-180! It seems to be in need of a new volume control. Some days it works - some days it doesn't like WQMR volunteer deejays, hi (Or some of my employees! -pls). Fri. 12-20: Daytime local WDLW-1330 (swamped at night by WNYM) is not on Music Country network during the wee hours. WCBZ-1270 MD pushed thru this am with enough info for a report; they're on the Larry King network. WOR-710 is being annihilated these morns by that super-powerful Cuban. A letter from Kermit Geary says even a personal visit by him failed to produce a verie from WORL, so I reckon my mailed-in one will likewise go for naught. Still trying for WSCN-1190; I found unnn WANN on top at 4:33 pm. Unn WENK-1220 was reaching with preaching at 4:35. At 4:52, a newie on 1170 in the form of WXAX-SC, to 5:15 pm s/off, SSB. Sat. 12-21: Needed WXXI-1370 finally pushing thru WFER at 1:39 for a report. PM, unn WDJZ-1530 CT still on at 4:46 pm PSSA, and on top. Somebody on 1320 at 1:38 am with lots of Hallelujahs, unID. MM 12-23: Unn WLLM-1580 ET'ing at 12:56 am o/u CBJ's delightful tone. 12-25: A report on daytime local WAWI-1380, ex-WBEX-NH. Thur. 12-26: No sign of WSJC-810 test here, but a brief TT noted at 2:22 for about 20 seconds and gone. Sat. 12-28: WLLM-1580 again on ET with r&r at 1:21. The Hallelujah preacher is on WJQY and is in SS, noted and ID'ed today at 1:27 am. An unID L. Kingie on 1240 noted, but faded at ID time; I'll try to find out who this is. SM 12-29: XERP topping CKIM at 1 am; WBEC-1420 in WBSM's null at 1:15; apparently also AN. A report to local WICE-550 RI, ex-WGNC, still c&w, oodles of ads. MM 12-30: Again WQDC booming in here at 1:25 am with oldies. WBEK-1280 was AN today with c&w. On 1000, looping in the same direction as WCFE, was a TT'er, 2:48-3:06+, no ID's noted. Anybody? 1-1: As I volunteered to do our country-western Wed. AM show today, 9 am-noon, I didn't go out and celebrate New Year's Eve. But I did DX, and noted unnn CHRZ-910 on top at 1:15 am, and WOR-710 back in the clear with that booming Cuban now on about 705 kHz. On 1250, WSWO was on top, 1:30. Someone on 1590 with a Mark Michael (deejay) and '30's-'40's oldies (swing mx) in/out - could this have been WERZ, Joe Fela? Forward - March!

Dave Hascall - 211 N. Merrill - Portville, IN 46040-1227

Hello, everyone! This is my first Muse and hopefully not my last! (You said it! -pls) I joined the club this Fall and many activities, including college course-work and exams have kept me from these pages. I am 23, single, and a senior geography major at Indiana U. - Purdue U. - Indianapolis (IUPUI/ooooe-pooooee). I chose to submit two Muses at once, the first being an introduction and the second looking back at this season's DX so far. (Perfectly acceptable - pls) My totals are disappointing but they are low enough. I have heard plenty of new ones this season. Lately I have been plagued by 24-hour RFI that make most shortwave DX a nightmare. The Superadio (on batteries and internal floppy) still handles it well but it is still quite audible! It can be nulled by twisting the unit, but only to the NNE-SSW. Once you have DX'ed this pattern a thousand times, it gets old! I would like to find out what it is - I suspect it may be some new Xmas toy someone got. I shut the power off coming into the house; no help. It's a neat coincidence this will be in the antenna issue as a loop antenna is such on my mind. The fact is I do not have one! I own a DX-400 and an older DX-160; the DX-400 is being increasingly phased out due to the RFI but a loop may help the '400 and bring the DX-160 out of retirement. I realize this is not DXChange, but: Wanted: Loop antenna such as SM-1 or SM-2, or similar! Since I am on a college student's budget I can't afford to pay but about \$50 but ALL with loops for sale are encouraged to correspond - we may be able to work something out. Please - thanks! Sorry for taking space, Paul. Does anyone have an ID for a station on 830 ID'ing as "The New Voice for the Valley?" Logged on 11-16 with c&w mx. 'Tis not KBOA; suspect WLDN-CH.

Roger Winsor - 302 W. John St. - Champaign, IL 61820

Good daytime cx of late has spurred me into a Muse. This is the first time from this address. My stay up in Indiana did not work out, and I am back here and working. Up in Indiana I could only find weekend work at FM 104 WJY and not enuf SS to exist on. 1-8: My first new station of the new year WAGE-1200 was heard at 4:12 pm with wx, into WAGE sports. Also that afternoon WJTH-1480 NC with local address while tuning by. I have heard WWSJ years ago, but just had overlooked this 5 kw'er. On 1-9 excellent daytime cx around noon; the following was heard: WHIO-1290 giving usual dominant WURL a run for their money; WTKC-1300 o/WPFR; WKEC-1200 in/out all day long; WJUN-1180 strong and WLDN was off, but who was there but WHAM at 1:15 pm! WCKY and WJAC were loud; 1190 was a jumble with WMB dominant in WQVO null; WAMB-1160 was just giving WJJD fits; WQYY-1150 totally over WQGH; WHIN in XGER null now heard often on 5 kw; KQNW-1380 mixing with unk beautiful, perhaps WFRS Winchester, KY, but no ID; WXXI-1390 in with super local WQWS on, of course. First time

ard. in daytime. WQOK-920 IL with Brownfield Net, then c&w mx. NonID as OK 92; this is a format addition in the log. 1290 WCBZ is now NBC at 5 min. before the hour and WFTX-1300 is beaut. mx, also log additions. Now about this WBYG mess. I heard the following on the afternoon of 10-26 or thereabouts, mentions of the "big one", AM 93, mentions of Yorkville and Sandwich, both towns in the area. I have never heard either WQCK or WYAD use AM 93. I did not hear an exact ID, which is my fault, but I really did think I had heard them. I still think I had them, but it is not in my log totals; it never was. I only count stations I hear if they are receivable in Hobart. During the 3-month stay up there I got very used to tuning around and I know in my heart what I can count and what I can't. (Just keep those reports coming, Roger; you can count on someone correcting you if you're in error, hi! -pls) Frank Merrill, I have lost your address. Write me if you get a chance, and anyone else who would like to. Im trying to meet Eric Loy of Mahomet, a new member. He is at WWS, where I would love to work. In closing, if there are any FM DX'ers reading this, WKIC 103.9 is installing a 380' tower to be operational around mid-month and you might try for them. Their existing 140' stick is really dwarfed beside the new self-supporting one.

Niel J. Wolfish - 31 Southlawn Stroll - Winnipeg, Man. R3T 5E9

It has been a while since I last Mused. The above address is for school (University of Manitoba - Faculty of Law). I will be back home in Toronto in May. Winnipeg, for a city of 600,000, is a fairly good city for DX purposes. The locals are on 580, 630, 680, 810, 990, 1050, and 1290. The only real tough spot to DX is between CFRC-630 and CJOB-690. I'm used to that anyway, with CFTR-680 at home being notorious for splatter. I've logged 360 stations here since school began, which I figure isn't too shabby. (I should hope to shout! -pls) Hearing Washington, B. C., New Mexico, Montana, and Wyoming nightly can make one forget about DX'ing in Ontario quickly. However, I do miss the sunset openings to the deep south (Alabama, Mississippi, Arkansas) and all the Colombians. The only Latin Americans received here regularly are Mexicans, most of which are just as easy as in Toronto. I don't suppose I'll ever hear R. P. O-640 Guadalupe with a local on 630 either, hi. Can't have everything... Latest catches: 1-8: CKRD-850 at 1:13 am on top of KQA with "Red Deer's best music"; also caught VOA-1580 Antigua at 8:30 pm for the first time from Winnipeg. Finally, a big congratulations to Fred Vobbe and Bob Walker for volunteering their services for the 1987 convention in Lima! From what Mr. Walker told me, it sounds like it will be an excellent convention! Hopefully a contingent from Ontario, including me, will be able to make the trek down Ontario highway 401 and I-75 to Lima. '73's.

Karl V. Jeter - 2115 Scarbrough Road - Stone Mountain, GA 30088

Happy New Year, everyone, and I thought I'd start out 1986 with a quick review of the previous one. All in all, not a bad year, DX-wise, with 41 new loggings added to the book, and 36 new veries added to the collection. On the latter, the current total standing at 1,257 with the latest additions from WQO-1220 (v/pp), WRBD-1470 (v/1), and a pair of latins, in case I haven't already mentioned them yet, YSS-655 and HJKN-770 (both v/1's). I have been having some fun with my new South-oriented beverage, which is about 1000 feet long. It really seems to be getting into FL well, as the recent DX will attest: MM 1/13 was only fair, with a loud TT on 1010 noted around 3:10 am; no ID, but it seemed to be loudest on the South guy. 1400 continues to be dominated by WZAZ-Jacksonville, FL, and on 1/13 MM, it was in well at 2:47 am with urban-contemp mx and the slogan, "Jacksonville's Hottest Radio Station" - certainly one of the best-heard from there as far as I'm concerned. A few minutes at the dial that evening netted a nice catch in KRAM-1310 Dallas, TX in well at 6:12 pm with oldies and a traffic report. Also noted, but unn, was WDXI-1310 Jackson, TN with country mx and a carpet ad at 5:47 pm. All of this 1310 DX was heard with local WLL's carrier still on - an annoying habit of theirs. Another new logging was had on 1-12, when WSWN-900 Belle Glade, FL was grabbed at 5:44 pm with s/off and weak signal. A little later, WFLA-910 Plant City, FL on top with ID between prerecorded religious stuff at 6:30 pm. The first new logging of 1986 was WRGB-1590 St. Petersburg Beach on 1-5 around 6:00 pm with urban-contemp stuff, "Star 16" slogan, and "Bay Area Weather". For several nights lately, I have been noting some SS on 860; on 1-11 at 9:48 pm and also the next night at 6:20 am. Haven't been able to get a good ID on it yet, but will keep trying. Possibilities are a Colombian or R. Clarin in the Dominican Republic - will stay tuned. (R. Clarin has made it to Kansas, so my money's on it -pls) Am writing this at work on an Apple IIe with the "Apple Writer" program, so I hope it looks okay and is readable, Paul. The print is small, so I figured double-spacing would help your eyes, hi! Hope everyone is keeping warm and hearing lots of DX! '73's. (No problem on the print, Karl, but I always appreciate anyone who is looking out for my well-being! -pls)

Tony Fitzherbert - 356 Jackman Ave. - Fairfield, CT 06432

Hello! I hope all of you enjoyed the holidays. They were good here, with relatives and friends visiting. Also, this DX season has been a good one with many new stations veried - almost all U. S. stations to whom I sent reports have verified, with but one exception. On the other hand, no Canadian to whom I have sent a report has verified this season. Veries are in from WCPB-760, with a nice v/1, a v/1 from WJZF-1180, a v/1 and rate card from WQON-1160 - they charge \$15 for airing obituaries - a v/1 from WRUM-790, a

v/l for WJJD-900, a friendly v/l from WKDW-900, a v/f and rate card from WTVK-850, and a v/l from WKHT-1230. Thanks to Karl Jeter, Fred Vobbe, and Wally Wawro for some info on three stations on whom I'd like to do in-depth profiles - CKLW-800, KLIF-1190, interesting because it was the world's first T40 rocker and uses 16 towers, and CHYR, the only station in the continent to change frequencies at sunset-sunrise. CKLW was a unique station as its 20-20 news was scandal-oriented, and rivaled the National Enquirer or New York Post in colorfulness. Am putting together a profile on a very interesting suburban Detroit station. This year's annual railroad trip may be to Miami and Atlanta - and I would hope to visit some Miami and Atlanta radio to do some profiles - with an eye for the unique or bizarre. Would anyone be able to send me maps of Atlanta and Miami, highlighting the locations of stations in those cities? I know nothing about Atlanta radio, but in Miami and surrounding cities there are some definite interesting subjects for profiles - including WQAM, with XR three miles offshore, WSRP, which frequently changes formats, WRHL, which operates 10000/250 U4 and dropped a BFL mx format for Spanish, and others. Reason for the trip, however, is to ride the new Atlanta Metro and the Miami Metro; I have not been on either. But any info on radio in either city would be very appreciated. Thanks very much! I do hope that the rest of the DX season is successful for all. Also, I do hope to catch a part of the Delaware convention, combining it with visits, with my family, to former neighbors, from when we lived in suburban Philadelphia. It would be great to meet you. Last convention I attended was in Dover, NJ, and I enjoyed meeting many of you, the names which appear regularly in DX News! 73's for now.

Richard E. Berg-Andersson - 47-11 48th Ave., #1 - Woodside, NY 11377

A serious Muse (for once) from this pen. It concerns S. 1667/H. R. 3378, the Electronics Communications Privacy Act of 1985, now pending in the U. S. Congress, which would make mobile telephones (primarily) and - perhaps - some other non-broadcast radio communications safe from monitoring by making such monitoring illegal and subject to anti-wiretapping prohibitions. The act does not affect the MW broadcast band, but it may affect aficionados of Craig Healy's "Top End" column, since utilities could conceivably become "forbidden" under the bill, and since some cordless telephone bases still operate up there. I oppose this bill strongly - even though I do not DX the "top end" - on the grounds that it dilutes the concept of the radio spectrum as public property and that it may affect the radio hobby as a whole. Even if the radio hobby community - through clubs or ANARC - manages to keep the damage to a minimum, the door will be open a crack if this bill passes, and I believe that door will widen in the future. After all, once you say that some radio services have a higher standard of privacy than others, the others will certainly clamor for that same higher standard. There is even loose talk of making certain foreign broadcasters off-limits to U. S. ears (think about that one, IDXD fans). I think anyone involved in this hobby ought to be concerned. I sure am. I am taking time (and money) to write to my congressmen, the 7 clubs I belong to, and ANARC regarding this issue. I urge all NRC'ers to consider this bill long and hard and, once you've thought about it, to take appropriate action. I only hope I'm not David taking on Goliath. 73's. (Quoting from your letter in RCMA's Newsletter, "The ends appear to be economic, not constitutional rights-oriented." I think we're going to see more attempts to erode the concepts of the Communications Act of 1934, which designated the airwaves as public property, and I would urge all DX'ers to become familiar with the Act and then to write to their congressmen to urge them to repel any more attempts to take away the our rights guaranteed by the First Amendment -pls)

John Herman - P. O. Box 171 - Vinita, OK 74301-0171

Happy 1986: New stations added to the log since Issue 14's DEXD: WDDT-MS on 900 kHz, at 1631 CST on 12-12. Sent report, no reply yet. #752 was the Cuban on 1160 which had news and an ID as R. Bayamo, on 12-14 at 0605. #753, KCGS-AR on 960, the first log on them since coming from 1600. The 500 watts was about as good as the 5 kw on 1600. This was 0650 the same morning. #754 was the KFJM test from 0004-0047c, a fine signal with TT and three ID's, each slightly different. Quick verie return, 8 days, and a good test. #755, WQWY-1000, Robertsdale, AL. On late with day power by 30 minutes, or I probably wouldn't have them in the log. Date 12-19 from 1710 to 1717 power cut. Tuned in on Baldwin Co. News. A call put me in contact with part owner and DJ Gordon Coley. He admitted being late with the power change, which was supposed to be at 1645 C/P. Gordon said WQWY signs off at 1800 CST, but was not sure about the pssa power. Sent report, no reply yet. #756 came on Christmas Eve at 1736c on 810, KBHB, Sturgis, SD. Lulled to think it was WSJC, and it was in at a good level until about 1806c with a lot of Xmas music, KBHB-KRCS ID's. This was a good catch as I had relatives listening as I nulled KQMC, which isn't easy some times. I think the equipment proved itself that evening. Report sent, no reply yet. #757, WHEO-FL, 1040, on 12-26 at 0520c with an oldies format almost identical to KQTO-1050, in Tulsa. Heard them until 0700 fadeout with oldies, 1040 HEO ID's, and Sun Coast and Bay Area weather. Report sent, no reply yet. #758, WISN, on 12-27 at 1611c for about 4 minutes with mentions of Milwaukee, 2 good ID's, into music by Phil Collins, and faded out during the music at 1615. Not enough for a report. #759 was on the same evening at 2050c on 12 v. XEAW, Monterrey, with an ID after music, "equis eh ah doublecoch". My 40th Mexican; I wish my Spanish was up to par. I'm going to get recording capability into this shack this

summer. Also an active whip outdoors on shortwave. #760 came in as the last new catch of 1985 on 12-30 at 0649c on 1040. WJCR 2500 watts, rd, is only about 140 miles from Des Moines; how do they protect them? Per call, KRND-1040, in Perry, OK, will now begin testing after the first of March and to be on regular schedule by the first of April. Pattern to the northwest with a null to the east. This will be a 4-tower array. More next week. 73's, John. (I don't know about WJCR; WHO is a daytime regular in SE Kansas -pls)

Richard E. Wood, PhD - P. O. Box 5074 - Hilo, HI 96720

Aloha. This season got off to a late start, with Europe heard only in December rather than October for the 1984-5 season. Now, welcome but again late, comes a January opening to the extreme tip of West Africa. Only one identified was unneeded Conakry, Guinea 1404, but unidentified but likely were Dakar-765, Ad-Dakhlah in the former Spanish Sahara, now identified in the WRTM as "Disputed Territory", but the station is operated by Morocco, the occupying power; that's on 999; and Ziguinchor, Senegal, in the Casamance strip where there is (another) separatist movement; the last-named on 1223. All these on 1-14 in the local evening. Conditions to eastern North America are finally looking up, with CKLM-1570 PQ heard on 1-13 for what I consider my best Canadian catch and equal for best North American with WRVA-1140 VA. This on 1-13, and the next night always welcome relog CFRB-1010 and new, much-wanted CHUM-1050 both on. All the East Coast powerhouses like WBZ and WHAM were loud then. A slew of 2nd harmonics of AM'ers from Mexico, Colombia, and points between has been heard in the 2 MHz range, including some simultaneous with the fundamental, e. g., XEJ on both 970 and 1940. XEHL has implemented its change from 1010 to 990, leaving 1010 clear for XEEX Ensenada, whose listed power of 1/0.25 kW seems far too low; more like 10 kW fulltime (I'd guess 5 kW from their signal strength here -pls). The WSJC-810 MA Xmas DX special was a resounding success and verified promptly with a plain but detailed QSL card; I hope the stn will release a full list of reporters, as it could easily have made it to NZ, Alaska, Newfoundland, etc., if DX'ers were listening. Let's have lots more of very carefully selected, planned, and publicized tests like this, and kudos to arranger Chris Baskind. With more tests like this I think that all 50 states, while against the odds, might just be slimly possible here in HI. Weather has been superb here for the past five months, with far less rain than in the same period in 1984-5. Very few rainy days, just some sharp nighttime downpours to keep my water catchment tank, if not full, at least half-filled. There have been few storms; just an annoying week of offshore thunderstorms bringing high static levels in early December. At night I can gaze over the ocean from my lanai and watch the flashing beam of the Cape Kumukahi lighthouse at the most easterly point of HI. Word from the British DX'ers is that they have caught beverage and DXpedition fever and are planning a second DXpedition to Cape Wrath, extreme northwest Scotland, in October. Having logged many Alaskans in 1985, they'll be shooting for Hawaii this year. In spring, a DXpedition to Cornwall, extreme southwest England, and later, one to the Orkney Islands, off northeast Scotland. Having lagged for many years behind Finland, Sweden, and New Zealand, the British DX'ers are now showing what can be done. Aloha.

CKOY IS NOW CIMM, AND BECOMES A WHOLE NEW RADIO STATION.

Many radio listeners trying to tune in to station CKOY at 1310 on the AM Radio dial in the last couple of weeks have been dumbfounded to discover it wasn't there. In its place is something calling itself "W-1310", and it's belting out "Solid Gold" Hits of the Past thirty years instead of CKOY's middle of the road music, sports, and talk shows. CKOY announced it's new format and name change on the air right at the end of 1985, and the station is now officially known as CIMM, and W-1310 unofficially. "It's a whole new radio station. We buried CKOY at 10 to Midnight on New Years Eve," says Gary Aube', the station's new program director. CKOY's former program director, John Ross, is now on the air as the morning news anchor. Aube' says Key Radio Ltd, a division of Maclean-Hunter, owner of CKOY and CIMM and sister station CKBY, has been working on the transition for months, but decided to keep it secret. The station polled Ottawa area residents, aged 25 to 54, to see what they wanted in a radio station. The conclusion was that there's a huge hole in the market for a solid gold format. According to CIMM's program director, they rejected two other options for formats, a traditional country format to compliment CKBY FM's contemporary country, or moving the CKBY country format to the 1310 AM signal and setting up a pop format on FM. The format will feature only songs from 1955 to the present that have been in the top ten or top fifteen on Billboards charts. The station doesn't feel that there's any chance of taking over CFRA and CHEZ FM, the two leading stations. Larry Kelly, CFRA sales manager, said that he's not worried about losing many listeners. According to Kelly, "Their track record at CKOY is inconsistent. They've changed formats a lot. I'm not shaking in my boots." One Ottawa AM station, CJSB, soared in the ratings after radically changing its format in 1984.

via Fred Vobbe & His Modern 7/26/86