



# DX NEWS

*the magazine of the  
National Radio Club*

SINCE 1933

VOLUME 52    ISSUE 21    March 4, 1985

**SONY ICF-2010** This the report we had hoped to have gotten to you last week, but....Larry Magne beat us to it with his report on Radio Canada International. The price...not sure and I had to go to a planning meeting before I could hear the full report by Larry on RCI. If you know the price let us know. The full story on the SONY ICF-2010 can be found on page 11. Keep in mind this info taken from the SONY preliminary report. I understand it got pretty good reviews by Larry.

**Graveyard DX Achievements & International DX Achievements**, yes, just like the old days. These two columns are again back into the pages of DX NEWS...for how long?...that's up to you....these columns exist only if there is participation by you the member...it takes only a couple of hours to come up with the info needed for these as well as any of the columns that appear in DX News. By the way, don't forget to support the Domestic DX Achievements column edited by Don Erickson, 6059 Essex St., Riverside, CA 92504-1599

Per a letter from Rob Harrington...he will no longer be the North American Representative for **International Listening Guide**, effective March 14th. Subscriptions and requests for samples should be sent to the main West Germany Address.

**Medium Wave Circle** The British AM Club is once again on its feet. The staff: Ed Baker, Club Secretary; Bill Shaw, Treasurer; Charles Molloy, Editor; and Harold Emblem, MAN Distributor. Glad to see that the Club didn't fade away. Good Show!

**Dusty Dials** is once again with us. If your interested in the History of Radio, DX, and the NRC and its members then turn to page 9 and start reading.

In our **to be continued** section, we still have those photos and stuffs that we will run sooner or later, hi, on WLS. In its place we ran that little report on the new SONY 2010 radio. Look for the conclusion of the WLS Station profile next issue, we hope.

**Musings** Pauls new address for your Musings is: P.O.Box 4812, Panorama City, CA 91412. We will continue to run this little blurb until we can get his column header fixed up right.

**Station Addresses** last issue we mentioned that station addresses were to be mailed to Jerry Starr. We will repeat this once more there....then we hope you'll remember from that point on where to send station address changes. So, if you would, please send them to Jerry Starr, not to DDXD, his address and his column can be found starting on page 2.

**April Fools Issue** is quickly coming up. For those that wish to contribute to the famous once a year issue, where almost everything goes, your more than welcome to participate in it! Start dreaming up your items, and get them to us real soon! Times-a-wasting!!!!

## LOOK INSIDE:

- |  |   |                      |
|--|---|----------------------|
| 2.....AM Switch  | 3.....IDXJ  | 6.....Formats        |
| 7.....GYDXA  | 8.....IDXK  | 9.....Dusty Dials    |
| 11.....SONY ICF-2010   | 12.....MWDX-2B & MWDX 2C Phasers- Technical article |                      |
| 15.....Caribbean, Central, & South American "Best Bets" for N.E. DXers | 23.....HAP Page                                     | 24.....NRC Addresses |
| 17.....Musings   |   |                      |



Jerry Starr, c/o WHOT Radio, 401 N. Blaine Ave., Youngstown, OH 44505

## CALL LETTER CHANGES

Old call:	New call:
900 KFBA TX Floydada	KKAP
1190 KADE CO Boulder	KBCO
1240 WJDQ MS Meridian	WYAM+
1290 WLZZ WI Greenfield	WZUU
1350 WGSW SC Greenwood	WQXJ
1500 KIEL AR Jacksonville	KDJC

\*WYAM (ex-WJDQ) has been silent since shortly after their move from 1330 kHz to 1240 kHz. This new call may signal the resumption of operations here.

## APPLICATIONS FOR NEW STATIONS

930 AK Unalakleet: 2500/2500 U1

## GRANTS FOR NEW STATIONS

640 NJ Mount Holly:	5000/1000 U4
720 PA Shiremanstown:	5000 D3
830 LA Norco:	1000/500 U1
1040 AL Fort Deposit:	1000 D1
1050 NM Los Ranchos de Albuquerque:	500 D1 (affirms initial 1984 decision)
1210 TN Static:	250 D1

## APPLICATIONS FROM EXISTING FACILITIES

1230 KTCN NE Falls City:	1000/1000 U1
1400 WDNV NY Dansville:	1000/1000 U5
1420 KJCK KS Junction City:	1000/500 U2

## GRANTS TO EXISTING FACILITIES

760 WJR MI Detroit:	install auxiliary antenna
1000 KMLO CA Vista:	night power to 500 watts
1010 WBCE KY Wickliffe:	to 1200 kHz 1000 D1 (superceeds their 1100 kHz CP)
1130 KYOO MO Bolivar:	to 1200 kHz 50000 D3, relocate XR
1140 WASG AL Atmore:	changes in antenna system, install auxiliary antenna for PSA and PSSA operations+
1220 WGFS TN Arlington:	to 1210 kHz 10000/250 U1 (5000 CH), move XR
1240 WWNC NC Wilkesboro:	1000/1000 U1
1250 WMLI ME Brewer:	to 1200 kHz 10000/10000 U3
1260 WQIS MS Laurel:	to 890 kHz 10000 D1
1270 KPRM MN Park Rapids:	renew expired CP for 870 kHz and change day power of that CP to 5000 watts
1340 WLVC ME Fort Kent:	1000/1000 U1
KHUB NE Fremont:	1000/1000 U1
WLVL NY Lockport:	1000/1000 U1
WSTA VI Charlotte Amalie:	1000/250 U1
1510 WJIC NJ Salem:	changes in antenna system
1570 WTAY IL Robinson:	changes in antenna system
1580 WCRV NJ Washington:	2500 D3
1600 WGITV NC Charlotte:	1000/1000 U2

+WASG's installation of an auxiliary antenna for PSA and PSSA operations is a bit mysterious. Perhaps they are installing a separate site closer to town for low power modes much like WEEP-1080 whose 50 KW XR is nearly 20 miles north of Pittsburgh while their 56 watt PSA comes from a site which is directly above downtown Pittsburgh. We will contact them and see exactly what this is all about, we have never seen this listed in any grant before.

## OTHERNESS

770 WKZY FL North Fort Myers:	application for higher night power returned
800 WVAL MN Sauk Rapids:	several issues ago we listed this station as KVAL from the listing in the Log. It is WVAL, Log incorrect
1010 WBIX FL Jacksonville Beach:	application for fulltime DISMISSED
1200 *App MO Kennett:	application for new station DISMISSED
*App MO Lamar:	application for new station DISMISSED
1230 KKER WA Spokane:	station is silent, will be auctioned
1240 KYOR AZ Globe:	station is silent
1500 WDEB TN Jamestown:	application for move to Alladart on 820 returned
73 and Good DX	

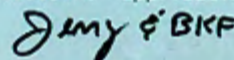

Jerry Starr &amp; Buffalo K. Foonman

Chuck Hutton, 437 Hardendorf Ave., Atlanta, GA 30307

Times are GMT

For ELT subtract 5 hours.

Deadline: Monday

535	GRENADA R. Grenada very good w/pgm on women 0114-0120 1/30; 1&c ending Top 20 Countdown 0156-0200 s/off 2/3. (DeLorenzo)
549	USSR synchronized Far East stns 1320 1/14 Russian songs, dominating 550. // 576. (Wood)
570	CUBA R. Relej, CMEA/MI Santa Clara SS man w/lively LA vocals: pips and tone but no "RR"; o/u WKBN 0239 1/2. (Frodge)
590	CUBA La Julia CMCA 1/27 0002 romantic mx, rx of "El Secretario General de la Organizacion de la Unidad Africana", dominant, no sign of KSSK-HI (Honolulu mostly nulled on my new ENE beverage) // 670, 690. (Wood)
650	HONDURAS LV de Centroamericana HRWJ San Pedro Sula SS man w/pelota broadcast, San Pedro versus Guatemala team? Nice OSB's u/ WSM 0309 1/16. poor. (Frodge) OSB = fade-Chuck
655	EL SALVADOR YSS San Salvador SS man w/Julio Iglesias y otra MoR vocals: man with news 0400-0402, mx continues 0356 1/30, fair. (Frodge)
690	ANGUILLA Caribbean Beacon, The Valley EE man with firex religious pgm // 1610; well u/CMEC and CBF 0405 1/30, poor. (Frodge)
700	COLOMBIA Cali R. Sutatenza, HJXC 2/3 0630 ID "Sutatenza, la red informativa de Colombia": neatly blended in BBC transcription material on Henry VIII w/studio public info show. Amusing elementary math quiz show on prices of chickens and sheep, listeners called answers in and did math together w/announcer. This is a fine station, education w/a folksy, humorous touch. Over/under WLM. (Wood)
720	VENEZUELA YUOL R. Vision, Porlamar 1&c way atop w/ID and SS ballad 0009 1/30. (DeLorenzo)
730	MEXICO XEX Mexico City 0606 1/25 ID "XEX Radio Festival, 100,000 watts, canal libre internacional, Mexico, D>F)". Dominant over CKLG on new Beverage. (Wood)
740	CUBA two listed, R. Liberacion 1/29 0810 tropical mx // 670. GRM from KTRH-Texas. (Wood)
750	NICARAGUA R. Sandino 1/25 0750 ID "Aqui en Radio Sandino, centro musical de Nicaragua y de Centroamerica", greeted listeners in Panama, etc. Dominant on ENE Beverage which nulls otherwise dominant KFQD. (Wood)
765	SENEGAL Dakar fair w/native mx 2220-2225 1/19; good with man and woman in vernacular and string mx 2156-2200 2/3 w/setting sun still visible; heard on car radio at beach in Hyannis. (DeLorenzo)
800	NETHERLANDS ANTILLES PJB Bonaire EE-SS Greg Shaw w/TWR nx; SS begins at 0500; over/equal to CKLW 0458 1/16. (Frodge)
825	ST. KITTS Basseterre R. Paradise with program "Songs in the Night"; man w/closing announcements at 0400; s/on at 5 AM local; Bible reading; prayer, hymn and off at 0403 0358 1/16. (Frodge)
830	BELIZE R. Belize 2/4 0330 classical piano, 0400 EE ID "This is Radio Belize. The time, 10 o'clock". Into blended program of poetry, music and stories, very pleasant. W/my new Beverage, KIKI is no problem, so only GRM was XELA and WCCD. // 910. Country #55. (Wood) EE man with "Night Flight" pop mx; c&w mx starts at 0400 o/u WCCD 0422 1/30. (Frodge)
850	ALASKA KICY Nome 0808 1/21 detailed wx in EE for Yukon Basin, 0810 into RR sermon, organ, trumpet, quote gospels. Good after s/off of my local KHLO 0800 and despite KOA and CFVR BC till CFVR s/off 0815. (Wood)
854	PERU Lima OAX4A 1040 1/29 news of "la violencia en El Salvador". Peru #2 here-OAX4C 1160 was #1. (Wood)
860	MEXICO Mexico DF R. Universidad, XEUN 2/5 full ID 1308 "XEUN 860 KHz OL; XEUN 86.1 MHz frecuencia modulada; XEUN 96.1 MHz FM estereo; XEYU 960 KHz banda internacional de 31 metros, onda corta. Radio Universidad Nacional autonoma de Mexico, en Mexico DF, capital de la Republica." Avant-garde mx. Dominant. (Wood) Someone better tell them to move their SW service out of the BCB-Chuck.
870	COLOMBIA Mar Caribe HJSB 0400 1/29 ID "En Mar Caribe esta es Mar Caribe, calidad y potencia para Barranquilla." Into tropical rhythms. Dominant over WML and weaker KAIM on ENE Beverage. (Wood)
880	CUBA Pinar del Rio R. Progreso, CMAB 2/3 0815 PSA "el ahorro de energia es el asunto de todos los companeros. Ganar la guerra de la energia." IDas "Radio Progreso, la voz del 22 festival de la Juventud y de los Estudiantes." Cuban mx. 0900 more ID's as above and "Radio Progreso, cadena nacional. RP, la onda de la alegria." Dominant. (Wood)
890	ECUADOR R. Superior, Machala HCRS6 0300 1/26 "Radio Superior y Suava Doral presentan el disco-hit del momento." Into vocal hit "Nada". Over/under WLS. Relog and still my only HC from here. (Wood)
891	ALGERIA Algiers very good w/man in AA and string mx 2245-2250 2/3; no domestic GRM; on car nx. (DeLorenzo)
891	THAILAND Saraburi 1/25 1400 Thai ID, rx by man; quite good, heterodyne w/890 which at this hour could be Adak, not WLS. (Wood)



- 895 COLOMBIA R. Galeon, Santa Marta HJPM 0230 1/25 "Atencion, oyentes de Radio Galeon en la playa de Santa Marta": tropical mx. Nightly since ENE Beverage went up. (Wood)
- 900 CUBA Cacocum R. Progreso, CMKB 2/2 0600 RP ID dominant over XEW and CUVI. (Wood)
- 900 MEXICO Mexico City XEW 0430 1/25 news of Union Panamericana. No sign of KNUJ, little CUVI on ENE Beverage. (Wood)
- 910 BELIZE Punta Gorda 2/4 0330-0430 // 830, o/u KQXR and KNEW. Have others reported this one? (Wood) Many years ago I heard him; was just barely able to get a parallel to the main guy. Memory fails me as to whether any of the Florida crowd ever heard him-Chuck
- 920 ALASKA Soldotna-Kenai KSRM 1700 1/20 ID "This is KSRM Soldotna-Kenai. The time is 8 o'clock." (Wood)
- 940 CUBA Holguin (plus one low power) R. Reloj, CMKD 2/2 0500 usual alternate male/female newscasters, second pips. Thru KFRE, KDED disappears on new Beverage. (Wood)
- 955 UNID SS with modern jazz w/several breaks; ID at 0432 "esta es Radio..."; not // Rebelde or Progreso; very garbled and scratchy 1/16. Chamber mx; no voice heard; still scratchy 0435 1/30, poor. Loops south. (Frodge)
- 1000 MEXICO R. Mil, Mexico City XEY 0434 1/25 "En R.M. (used initials) 26 para las 11 de la noche." GRM; another Latin. (Wood)
- 1015 COLOMBIA Bucaramanga R. Primavera HJYD 0620 1/25 TC "1 hora, 20 minutos en Bucaramanga." Listed on 1020 and don't think this has been ID'ed on 1015 before. (Wood) Gerry Thomas and I have been trying to ID this for years! Chuck
- 1015 PANAMA R. Nacional, Bocas del Toro 2/2 0530-0600 tropical mx, pgm "Panama en el mar de las Antillas", TC's, many ID's simply as "Radio Nacional de Panama", ID listed in WRTH-84 not heard. Country #54. (Wood)
- 1017 TONGA Nuku'alofa 1/20 A3Z tuned in especially upon hearing news of cyclone damage and was surprised to hear unchanged programming; 0530 a US religious transcription in EE, 0700 R. Australia news relay, 0730 Tongan talk. (Wood)
- 1040 COLOMBIA Caracol en Barranquilla HJAI 1/28 0330 xint bullfighting show "Todo de los Toros" w/details on breeding ranches, popularization of bullfighting among the youth of Medellin and fights in Paraguay, Spain, etc. Each announcer gave his ministry of Communications license number after his report. 0359 ID "Esta es Caracol, la red noticiosa de Caracol para Barranquilla". 0400 time pips, "Atencion, las noticias de los ultimos 60 minutos". Booming signal, KP01-HI no problem on ENE Beverage, just WHO. (Wood) Those Beverages are pretty fair antennas aren't they? Chuck
- 1044 CHINA R. Beijing foreign service 1245 1/25 JJ ID "Kochirawa Beijing Hoso desu", JJ talks. (Wood)
- 1050 MEXICO Mexicali XED 0245 1/28 frequently reported ads for "Carnes Mexicanas"; "Leche Esmeralda", "Fumigaciones Gutierrez Hermanos", "Mexicali Electrico", into nx 0300. Mostly dominating XEB and no Canadians on ENE Beverage. (Wood)
- 1060 MEXICO XEOP Mexico City R. Educacion XECP 2/2 0515 ID "en Radio Educacion", apparent breakdown 0517 and appeared to be slightly off frequency as low rumble ceased when it went off, leaving KYW etc. (Wood)
- 1090 MEXICO Rosarito XEPRS 0555 1/25 SS programming for Chicanos, talk of Fullerton, Anaheim, etc., rancheras. Is this one ever in EE now? (Wood) I wouldn't know...Chuck
- 1100 COLOMBIA Barranquilla R. Reloj, HJAT 0800 1/29 nonsensical time check from network as "1, 46 minutos, 1, 46" at what should have been 3 AM Colombian time; then, accurately on the hour, local ID "esta es Radio Reloj, Barranquilla, HJAT, una emisora de la Primera Cadena Radial Colombiana" and into Latin vocals. Over/under KFAX-CA. (Wood)
- 1127 COSTA RICA Once Veinte TISRHB 0420 ID "Once Veinte" 1/27 sports nx; new, country #53 here. (Wood)
- 1165 ANTIGUA Caribbean Radio Lighthouse St. John's EE man w/choral hymns; disappeared about 0225, s/off? GRM from WUVA 1/2, poor. (Frodge)
- 1170 COLOMBIA La Voz de la Heroica, Cartagena, HJNH 0325 1/26 very serious, non-commercial sounding news programming on Colombian role in Contadora talks on peace in Central America. Mentions of Cartagena. This may be a municipal station. GRM: KCBQ-CA, KV00-OK but no more KOHO-HI on ENE Beverage. (Wood) Love those Beverages! Chuck
- 1200 CUBA CMKC Palma Soriano SS man w/beisbol broadcast; CMKC net ID; o/WQAI 0405 1/23. (Frodge)
- 1210 COLOMBIA Cucuta R. El Sol, HJTL 2/4 0730 brief ID "en Radio El Sol HJTL" but not enough for a report. Tropical mx, o/u WCAU, no K200 (if on the air) on Beverage. (Wood)
- 1220 BRAZIL Rio de Janeiro R. Globo 0310 1/20 PP serious news, "confianca na recuperacao economica brasileira", heard once over XEB and CKDA on ENE

- Beverage but it does not favor Brazil; no sign of Rio 1280 on it. (Wood)
- 1314 UNITED ARAB EMIRATES Abu Dhabi 1700 1/17 ending AA Qur'an discussion, gave names of participating doctors, ID "Sawt ul Amirat al Arabiya al Mutaahida min Abu Dhabi. Wa aleikum Qur'an al Karim", gave name of reciting sheikh and into most familiar sura. Must be new superpower tx for Qur'an service and now rivals Ras-al-Zawr 1440 as beacon to West Asian conditions. Have reported, asking more info. (Wood) It'll be interesting to see what develops with this guy....Ought to have a decent shot at it up in the northeast...Chuck
- 1328 GUATEMALA Guatemala City City, Union Radio, Adventist World Radio for Central America, TGMU 1257 1/29 full ID "Unio Radio en onda larga, 1330 KHz y en onda corta, banda internacional de 49 metros, en 6090 KHz"; into marimba mx; 1259 SS hymn. As the ID says, nominal freq is 1330 and am quite pleased with this discovery. Guatemala #2 after TGJ-880. (Wood) Has been wandering up and down around 1330 for years-Chuck
- 1370 MEXICO Nogales XEHF 0322 1/27 ID as "H-F" (ache-efe); 0335 "Los Chapis, los escuchamos todos en la H-F. Baile, escuchando la H-F ranchera". 0400 national anthem in choral version (may not have been s/off, many XE's play anthem and continue programming. (Wood)
- 1404 GUINEA Conakry 1&c w/jazz and man in FF 2219-2225 2/3; on car rx in Hyannis. (DeLorenzo)
- 1413 OMAN Masirah Island BBC relay 1705 EE World Service news, good satellite-fed relay quality 1/3. (Wood)
- 1425 UNID Radiodifusora Catorce Treinta 0345 1/27 SS rock, time checks, ID. Whatever this is, nominal frequency is 1430; I suspect Colombia. Any help? (Wood)
- 1425 COLOMBIA still unid 2/2 0430 mixed grab-bag of LA styles including cumbias, Mexican, romantic ballads, some translations of US pops; off with Colombian anthem 0459. Any help on this? (Wood) Nope, I've been trying to squeeze an ID out of this for years...Chuck
- 1430 MEXICO Ciudad Obregon XEOX 1318 1/25 "...en Ciudad Obregon, si quiere ahorrar mucho dinero" (I certainly do). Items "para el agricultor". GRM from KFIC-CA. (Wood)
- 1467 FIJI Rakiraki 0800 1/21 Hindi ID and commercials, nx by female. (Wood)
- 1500 MEXICO Mexico City R. A-1, XEAI 2/3 0700 tropical mx, PSA on obligatory school attendance, ID "Radio A-1, mas tropical que nunca". I remember when this was XERH and had two xint SW xmters on 11880 and 15110. (Wood)
- 1555 CAYMAN ISLANDS Gun Bluff 0315 1/26 earth-shaking news of a lost dog last seen in the vicinity of Northwest Point, wearing a collar. (At least he can't go far in Cayman-Chuck) 0319 "That was the news from Radio Cayman. The time is 19 minutes past 11. Radio Cayman presents music to take us up to 11:30". Into EZL mx. Heard regularly. (Wood)
- 1555 UNID 0457-0600 1/20 SS, mostly tropical mx. "en nuestra estudios". Not Ecuador. Any help? (Wood) Nope, never a trace of anything other than Cayman/Ecuador here-Chuck
- 1557 MALTA Cyclops DW relay 0530 1/23 AA nx by female, gives city name before each item. (Wood)
- 1557 USSR Kaunas and two others listed 1650 1/3 Polish "wisdomosci" (news), alienating man and woman; 1700 into Lithuanian. WRTH 1984 shows Polish only till 1630 but obviously extended because of the situation in Poland. My first European catch in the local morning and opens up staggering perspectives. Also, Euro #3 on 1557, my best frequency. (Wood) Sure does...It makes sense too; if the Down Under guys can do it routinely then why not you? Chuck
- 1566 SOUTH KOREA HLAZ 2/2 1620 sermon in GG w/slight US accent. (Wood)
- 1566 SWITZERLAND Sarnen 1/23 GG nx, 0611 into Swiss country mx, accordian. (Wood)
- 1570 MEXICO XERF Ciudad Acuna 0530 1/24 Bishop S. McDowell Shelton from Bainbridge Street, Philadelphia preaching in spontaneous Italian. I have to admire his talent, he also preaches in FF and SS. II from Mexico to the US southwest! (Wood) ?? Chuck
- 1610 ANGUILLA Caribbean Beacon 0400 1/21 "This is the Caribbean Beacon broadcasting from the friendly island of Anguilla, 12 o'clock". Booming. (Wood)

Harold Frodge says per a recent QSL from FIBS Falkland Island; they have no current plans to reactivate MW. FM and SW are active.

Marc DeLorenzo	Holliston, MA	HQ100, phased LW's
Harold Frodge	Midland, MI	DX302, 195' LW, tuned loop
Richard Wood	Hilo, HI	R1000, R71A, 2 2200' Beverages ENE and WNW



# FORMATS

Tony Fitzherbert, 356 Jackman Avenue, Fairfield, CT 06430

Well, we have some material for another column, all of which has been contributed by Dave Braun, of Falls Church, VA. He compiled the list while on a trip to Danville, VA. And, for the rest of you, do send your format changes in so that all of us can update our logs. Here we go.....

550	WSVA	VA	Harrisonburg	-	Ad. Con.
730	WMNA	VA	Gretna	-	CWM.
740	WPAQ	NC	Mt. Airy	-	REL/CWN.
770	WLWL	NC	Rockingham	-	CHR.
780	WCKB	NC	Dunn	-	CWM.
790	WTNC	NC	Thomasville	-	CHR.
810	WCEC	NC	Rocky Mount	-	ROK.
870	WFLO	VA	Farmville	-	CWM.
890	WHNC	NC	Henderson	-	Black.
920	WBBB	NC	Burlington	-	CHR.
950	WPET	NC	Greensboro	-	REL.
1050	WBRC	VA	Lynchburg	-	Black.
1070	WGOS	NC	High Point	-	Ad. Com., CWM.
1080	WKBY	VA	Chatham	-	Black.
1130	WCBX	NC	Eden	-	Rel.
1190	WSML	NC	Burlington	-	CWM.
1270	WHEO	VA	South Hill	-	CWM.
1310	WTIX	NC	Durham	-	CWM.
1370	WHEE	VA	South Hill	-	CWM.
1390	WWOD	VA	Lynchburg	-	CWM, Ad. Con.
1400	WHLF	VA	South Boston	-	CWM.
1420	WNYN	NC	Mayodan	-	ROK.
1430	WRXD	NC	Roxboro	-	CHR.
1450	WNVA	VA	Martinsville	-	MYL.
1470	WBIG	NC	Greensboro	-	Ad. Con., OLD.
1490	WLOE	NC	Eden	-	CWM.
1510	WEAL	NC	Greensboro	-	GOS.
1520	WYRU	NC	Red Springs	-	CWM.

And, that is it for now. Kind of a small column.....thanks very much, Dave, for updating us for this area of the country, which I believe is called "The Piedmont" area. At least, that is now the topic of a discussion among my staff at work, where I am typing this, while eating lunch. The typewriter, which I usually use, and which is malfunctioning, is in the shop for repairs. So, get in your contributions. And, when WVVA - 1170 goes to Beautiful music, over 700 of your fellow NRC members will want to know.....

73's and good DX'ing!!

## Radio Religious Format for WEEL

WASHINGTON POST FRIDAY, FEB. 15, 1985

By Jacqueline Trescott  
Washington Post Staff Writer

In a major conversion at WEEL-AM (1310), the new general manager announced this week that the station would switch to a 24-hour religious talk and music format and change its call letters to WDCT next month.

"This is the newest format in religious radio," said general manager Steve Kovach, a consultant to religious broadcasters for the last 10 years who has engineered the turnaround of 35 stations. WEEL is being purchased by Universal Broadcasting Inc. from the George Mason University Foundation for \$750,000. The deal is expected to be finalized March 1.

Mornings will be devoted to teaching and counseling programs, including two well-known shows from James Dobson and Chuck Swindoll. In the afternoon the station will switch to talk and call-in shows. Two will originate from the Fairfax studios, including the national talk show with Beverly and Tim LaHaye. The evening programs haven't been finalized yet, because Kovach wants to include the sports schedule of the University of Virginia and George Mason University, which WEEL currently offers.

So far the late-night plans in the 24-hour schedule call for easy-listening religious music. But, said Kovach, "we are also considering an all-night show, a sort of religious Larry King."

The base of the new format will be provided by Moody Broadcasting Network. Both religious and local news programs are included in the format, and will be supplied by International Media Service News and the station's staff.

1310 AM  
**KOKX**  
98.3 FM  
P. O. Box 427  
Keokuk, Iowa 52632

AM 1270  
**KUSN**  
**KSFT**  
FM 105  
a little bit Country ... a little bit Rock.

2414 South Leonard Road  
St. Joseph, MO 64503

# GRAVEYARD DX ACHIEVEMENTS ①

Totals on 1230, 1240, 1340, 1400, 1450, and 1490 KHz Frequencies

At the request of HQ, I have agreed to attempt to resurrect interest in the dormant "Graveyard DX Achievements" column. I was editor from 1978 to 1980, but gave it up due to various reasons. Since 1980 the column has been in the hands of two others, but to my knowledge it has since not appeared in DX NEWS. At this time, the whereabouts of all the old data is unknown, although HQ is trying to locate it.

To refresh old memories and inform the newer member who may be unfamiliar with the column, here is a brief rundown of how it works...

The column lists stations on the so-called Graveyard frequencies (1230, 1240, 1340, 1400, 1450 & 1490), and those DXers who have logged these stations from the furthest distance, along with the mileage.

As you know, the GYers were granted authority to operate with 1000 watts daytime in 1961. So each list of frequencies was divided into two categories: loggings prior to and including Dec 31, 1960; and those from Jan 1, 1961 to present. Some of the early listings were really fantastic! Over 5000-mile loggings were not uncommon. This dual-category method gave all DXers, from first-timer to seasoned veteran, the opportunity to be recognized for their patience, perseverance and 'luck' in hearing these low-powered stations on the crowded local channels. Now, we have a new era in GY annals; the 1000 watt fulltimer. Of course, even with 1KW at night, the groundwave signals only travel 10-15 miles and the skywave signal mixes with all the others to produce quite a mess. For this reason, I don't propose a third category.

I know there is interest in seeing the Graveyard DX Achievements column reappear. So dig out the logs, dust them off, copy down your GY logging and get them to me pronto. I will attempt to get the initial column (1230) to HQ for a May debut. TYPE OR PRINT, PLEASE. It's not necessary to indicate the date of logging, only which category ('pre-Jan 1, 1961' or 'on Jan 1, 1961 to present') they fall into.

Don't be reluctant to submit a 10 or 15 mile logging. Some as "distant" as 8-10 miles made the old listings, if I remember right. The rules are as follows:

- 1) DXer must be a member in good standing of the National Radio Club.
  - 2) Stations must now be on one of the six Local Channels (1230, 1240, 1340, 1400, 1450, 1490) or once have occupied one of these frequencies.
  - 3) Entries should consist of lists of stations (broken down by frequency and alphabetical by state, as is the NRC Domestic Log), location of logging, distance and date or 'era' category. It's not necessary to calculate the distance. But if you don't, try to include your geographic coordinates (available from many sources) to make it easier for me.
  - 4) Entries are good for one year. At the end of this period, you must recertify (a note on a postcard will do) or your listings will be dropped. This is to insure your good standing status in the NRC. Hopefully, you'll be submitting new loggings and that will take care of that requirement.
  - 5) In addition, include the number of all GY loggings by frequency. This data will appear after the 1490 column.
- Send your Graveyard DX Achievements to:

BILL HALE  
9823 North Meadow  
Converse, TX 78109

CHANNEL  
**MITCHELL BROADCASTING ASSOCIATION, INC.**  
P.O. Box 908 Mankato, I.D. 57901  
1490 KC



149 SOUTH EIGHTH STREET  
EAST ST. LOUIS, ILL. 62201



# INTERNATIONAL DX ACHIEVEMENTS

Malcom Maxwell, 1041 Tumlin Street, Apartment A, Atlanta, GA 30318  
Totals for Countries other than the U.S. and Canada

## LIST OF CURRENT?? DXERS REPORTING TO IDXA

NAME	YR STARTED	LOCATION	COUNTRIES	TOTAL VERIES
Hank Holbrook	1946	Maryland	101	2528
Sid Steele	1931	Illinois	34	3001
Roger Anderson	1938	Virginia	105	1448
Paul Swearingen	1975	California	18	518
Ben Dangerfield	1958	Pennsylvania	118	422
Andy Rugg	1960	Quebec	60	1512
Frank Wheeler	1930	Pennsylvania	25	1745
Hilding Gustafson	1934	Florida	111	860
Konstantine Rychalsky	1970	Connecticut	12	315
Mike Knitter	1974	Wisconsin	17	936
Richard T. Eddie	1976	Missouri	15	1570
Ron Musco	1962	Connecticut	26	1082
Sharon Skowera	1974	Connecticut	43	277
Neil Wolfish	1977	Ontario	11	239
Brian Vernon	1977	Yukon	39	314
Phil Bythway	1968	Washington	?	457
Bill Bergadano	1974	New York	?	300
Wayne Heinen	1964	Colorado	19	978
Jim Renfrew	1976	New York	21	118

If your thinking, "Hey, where are my totals?" or "Why aren't I on the list?" or worse yet "What is this IDXA?". Well, all you've got to do is send in your stats to me. Want to know what to send me? Then drop me an SASE and I'll send you back the info you'll need.

**RADIODIFUSORAS**  
CALLE GUERRERO 747 DTE.  
APARTADO No. 134

**X E O R**

**EL GALLO. S. A.**  
TELEFONO 2-01-90  
C. REYNOSA, TAM.

## R71A SPEAKER MODIFICATIONS

by HERMAN FLEM

I find the R71A top mounted speaker to be sturdy and it has a very good tone in my opinion. The only problem with it is that because it faces up instead of forward, the audio doesn't seem right somehow (maybe because I'm hearing it off the ceiling). I had almost decided to purchase an external speaker, but I tried a simple fix for the problem which worked so well, I decided not to get the external speaker. I took a 4 inch by 6 inch piece of cardboard (about 1/32 inch thick, like you find on the back of tablets or note pads). I bent a 1 inch by 4 inch strip on one end at about a 45 degree angle. Then I placed this just behind the speaker opening and held it in place with a small magnet.

[We recommend tape instead of a magnet, due to the critical components found in the R71A receiver. The choice is yours. - HQ] It acts as a reflector to throw the sound forward. To me, it makes a major difference in how the receiver sounds. I listen to alot of music on shortwave, including classical music, so I am pretty particular about how a receiver sounds. A longer reflector might work even better but I haven't tried one yet. Wood would probably work okay, but I doubt if metal would. You need a material that doesn't resonate or vibrate. A piece of a corrugated cardboard box should work well. The internal speaker doesn't reproduce some of the lower bass frequencies present in the receiver output, which can be heard on headphones, but it sounds very good. Using Kenwood HS-6 headphones, the sound is excellent. If you want the deep bass, an external speaker would probably give it to you. This simple modification may work on other receivers with top-mounted speakers.

# DUSTY DIALS

Tom Farmerie, 62 Sunrise Ave., Grafton, MA 01519

A Look at the History of Radio and DX

After a somewhat hectic period of intense professional priorities, we'll now resume with 'WHEN I LISTENED IN', the third installment of the radio memoirs of NRC's Ace DXer of the golden 30s, S. Ray Lewis, now 81 years young. Again, I have edited Ray's original text for this DX NEWS version.

## WHEN I LISTENED IN

by S. Ray Lewis

My interest in radio listening and set building waned somewhat during the later years of the 20's, due mainly to heavier work schedules and then marriage in 1928. However the old urge to try some dial twisting was renewed again late in 1929 when I bought a fine eight tube electric radio known as a Crosley Show Box. (Editor's note: Powell Crosley was also once involved with 500.00 watt WLW and also the Crosley automobile). Prior to acquisition of this so-called Superset, my wife and I had moved to the suburbs of Toledo, into a home on a deep lot, where I had much space for erecting antennas of my choice.

Well, I thought the absolute pinnacle of success had now been reached. With the fine receiver, and a newly installed antenna, I found it now easy to pick up many stations never heard before by myself. One was KFI in 'far off' Los Angeles. The best time to hear this West Coast station was shortly after midnight when a local station on the same frequency signed off.

Early in 1930, a man in our new neighborhood heard me talking about my 'remarkable' reception of KFI. He invited me to his house, presumably to show off his Majestic receiver. It was then and there that my good opinion of myself and the Crosley Show Box were completely deflated! This guy then showed me cards and letters from no less than a dozen stations in the far West, and each one of them was a verification of his reception!

Although I will admit to being a little envious of my neighbor's achievement in setting so many distant radio stations, it was nevertheless a thrill to learn that it was possible to do this - and to prove it by receiving written verifications from various stations. I immediately then resolved to start keeping an exact log of stations, no matter where they were located, and questioned my new found friend on how to proceed with this matter.

The good neighbor who set me started verifying stations also did me a couple more favors. He introduced me to RADEX magazine, which, at that time, was indeed the most accurate of all publications when it came to listing the frequencies of all broadcast band stations on the air - every place in the U.S.A., Canada, Mexico, and Cuba. It was literally the Bible of DXing, with call letters, frequency, location and power given. Plus, RADEX, (short for RADIO INDEX) also had a section devoted to DX reports by members. (Editor's note: this section had, as regular contributor's, such great names in NRC's past as Joe Becker, Joe Brauner, Pat Reilly, Bob Botzum) and also listed scheduled network broadcasts by stations across the country. New stations, just having been issued Permits by the FCC, were then listed, along with times they could be heard on test programs in the wee hours of the morning. All this informed DXers of the opportunity to hear new stations at times when there was no interference.

While my neighbor and I exchanged ideas for both antenna and ground systems, and tips of when and where to look for DX stations, we were practically in a contest to see who could set the most stations. My ambition was to try for stations outside the country, in addition to all domestic stations that I could hear.

In fact, I had so much success in the first few months of that winter that I decided that verifying every U.S.A. station was not impossible. But more about this later in the story!

By the time one year had rolled around, I had heard and verified nearly 300 broadcast band stations, as well as a few distant short wave stations. Certain improvements had been made to the Crosley Show Box. I discovered, by experimentation, that I could 'peak' this eight tube receiver at almost any particular place on the dial from 540 to 1500 kilocycles (Editor's note: Hooray for Cycles, down with Hertz!) I did this by removing the top of the metal receiver cabinet and rather expertly inserting a bakelite rod, which was shaped like a screwdriver, into the three neutralizing condensers. This threw the radio set into oscillation and made signals especially sharp just before reaching the point of oscillation (ED: Ahah!, an early Bob Foxworth!).

For example, if I was trying to hear a station listed on 710 kilocycles, and there was too much interference from WLW on 700, then I'd simply adjust the condensers for super sensitivity on 710 and usually bring in the desired station. What I was doing with the neutrodine circuit in the



Crosley, was accomplished automatically a few years later with the super heterodyne circuit. At any rate, my 'tinkering around' surely did set me many more stations than my neighbor!

To my further amazement, this adjusting of the neutralizing condensers also brought in several European stations, for they (then also) operated on odd frequencies such as 705 and 708 kilocycles. These foreign stations were sandwiched in between the U.S.A., Canadian, Mexican, and Cuban stations.

About this time another discovery was made when I tried out that old variometer mentioned previously. I had it almost around ten years, but it still worked fine in the antenna lead and caused signals to increase with out turning up the gain on the receiver! So here was another plus to my DXing. As might be expected, all these added things helping me were much to the disgust of the neighbor who had started me to DX in earnest in 1930. (Editor's note: 'our Ernest' started DXing in 1933). Unlike me, the neighbor wasn't the experimenting type.

Most of my serious DXing was done in the early years of the Great Depression, when many people were unemployed. Although I was not out of work too long, many of my friends and associates were. It was not unlikely, then, that quite a number of persons turned to DXing for a hobby, because the cost of radio listening was only a few cents a day, and postage was two cents for letters, and a penny for a post card. Thus DXing, in many cases, could be called a cheap hobby, born in the Depression years. (Editor's note: it may be reborn again for the same reason!).

A personal visit to the office of the Radio Editor of one of Toledo's newspapers prompted him to become interested in DXing, and to write about it in his daily column. In fact, I furnished him with much up-to-date DX news several times each month. As a result of this publicity, quite a number of people contacted me and several visited at our home to see first hand how I was able to receive all those distant radio stations.

- conclusion of part three -

The next installment of Ray's DX memoirs will cover his winning the RADEX Mystery DX Contest, the founding of the Toledo Radio Club, and other fascinating recollections. I'm glad to have received all the encouraging words about this column, and be assured; I have enough material on hand to continue the column as long as youse guys want it. Next couple of BUSTY DIALS will feature old QSL cards and assorted other relics, including a recently discovered second group photo from the 1939 NRC convention held at Erie Pennsylvania, taken at the Commodore Perry monument, with Joe Becker, the 'Kins', alone at the top, and the others at ground level!

## Rites set for pioneer radio broadcaster

Amarillo Daily News  
Feb. 9, '44

FORT WORTH — Services for O.L. "Ted" Taylor, 79, former Amarillo resident and pioneer in live radio broadcasting, will be at 2 p.m. today in Broadway Baptist Church. Graveside services will be at 1 p.m. Saturday in Llano Cemetery in Amarillo by Harveson & Cole Funeral Home.

Mr. Taylor, founder of Taylor Communications Inc. and part of the beginnings of radio station KGNC in Amarillo, died Wednesday.

He tried unsuccessfully in the 1930s to sell the idea of on-the-spot live reporting to a New York-based network. He was turned down by people who told him it wasn't necessary. He used live radio reports in the 1940s at a radio station he owned, KTOK in Oklahoma City.

He considered himself a salesman rather than a manager. His son, Ted H. Taylor, said one of the expressions his father lived by was that nobody wants to buy an ad, but everybody is interested in buying an idea or a concept.

Mr. Taylor sold advertising for the *Globe-News* in the late 1920s.

In 1924, when the *Globe-News* bought two small radio stations and combined them to form KGNC, Taylor was put in charge. And he was instrumental in affiliating the station with NBC in 1935.

Mr. Taylor was a native of Bangs in Brown County and had lived in Fort Worth 25 years.

In 1939 he founded Taylor Communications, which owns and operates 13 Dallas and San Antonio area suburban newspapers, offset printing plants and trade periodicals.

Mr. Taylor served as president of Texas Broadcasters Association and was a director of Broadcast Music Inc.

During World War II he served on the board of War Communications.

He began buying newspapers in 1969, nearly 50 years after he worked as a linotype operator in his early teens.

Mr. Taylor was active in civic affairs throughout his career. He was a Kiwanian, a director of Cal Farley's Boys Ranch of Amarillo, a Shriner and was listed in Who's Who

of Young Men of America in 1939. He was a member of Broadway Baptist Church in Fort Worth for 25 years.

Survivors include his wife, Elizabeth Tolleson; a daughter, Kay Taylor Heimlich; a son, Ted H.; a sister, Galena Cosby; and four grandchildren.

The family requests memorials be to O.L. Taylor Memorial Scholarship Fund or to Cal Farley's Boys Ranch in Amarillo.



1440 North Meridian  
Indianapolis, In. 46202

SONY.



ICF-2010

### Direct Access™ World Band Radio™ Receiver

#### KEY SELLING FEATURE: EASE OF USE

For many years, if you wanted to listen to broadcasts from across the world, you bought a radio the size of a small suitcase. It was usually filled with gizmos and gadgets that looked like a physics lab. In the past five years, Sony has changed all that — with a series of sleek, easy-to-use World Band Radio™ receivers designed to bring worldwide broadcasts to a larger audience. The ICF-2010 is the latest expression of this philosophy. Your customers can key-in a station halfway across the world faster than they can call Chicago.

#### KEY DEMONSTRATION

Begin before your customer enters the store. Read Sony's *Directory of World Band Radio*, which is filled with information about the listening category. Keep the book on hand since it lists programming and times. When your customer arrives, begin by demonstrating the Direct Access™ tuning system. Enter a station which you know is on the air (preferably from an intriguing foreign country). Then, demonstrate how you can preset that specific station. In fact, you can store an entire range of 32 preset stations and organize them by language, country, or type of programming. Finally, show your customer how easy it is to set the programmable timer so that broadcasts from distant time zones aren't overlooked.

#### CONVENIENCE FEATURES

- Full AM band coverage (LW, MW, SW) plus FM and Air Band reception
- Band select function for quick access to SW broadcast bands
- Direct Access™ tuning enables you to "key-in" station numbers directly
- Rotary tuning knob for smooth, convenient manual tuning up and down the band
- 32 station memory presets for immediate recall at the touch of a button
- Memory Scan tuning gives a brief sampling of each preset
- Automatic Scan tuning gives a brief sampling of each station on the band
- Built-in quartz clock with standby and alarm capability
- Programmable timer turns receiver on and off automatically, up to four times per day, tuning in up to four different stations
- Sleep timer for 15, 30, or 60 minutes of music as you go to sleep
- Switchable 12-hour/24-hour clock indication; 24 hour indication facilitates reference to Greenwich Mean Time (GMT)
- Multi-function liquid crystal display (LCD) indicates tuned frequency, preset station number, AM (LW, MW, SW) or FM, shortwave meter band, and more
- LED tuning indicator aids precise tuning
- Feather-touch controls for fast, effortless operation
- Tone selector switch adjusts for music (high or low) or news

#### TECHNOLOGY FEATURES

- Dual PLL quartz frequency synthesis — the world's most accurate tuning system; uses a quartz crystal's accuracy to abolish drift and maximize tuning stability
- New synchronous detection circuitry for the first time in a consumer radio, dramatically reduces fading and annoying "beat" frequency interference from adjacent stations
- Switchable IF bandwidth, "narrow" to select one station out of a crowded band, or "wide" for the lowest distortion when your station isn't fighting to break through the clutter
- Built-in ferrite bar antenna for LW and MW reception
- Telescopic antenna for FM and SW reception
- External antenna input jack for use with supplied long wire antenna, optional AN-1 or AN-60 World Band Radio™ antennas
- Record output jack facilitates off-the-air taping
- Supplied earphone for private listening
- Main power switch prevents accidental power drain while traveling

#### SPECIFICATIONS

Frequency Range: AM: 150-29,999.9 kHz; FM: 76-108 MHz; Air: 116-136 MHz

Antenna System: LW, MW: Built-in Ferrite Bar Antenna; FM, Air, SW: Telescopic Antenna

Inputs: DC-In 4.5V; External antenna input (minijack x 2)

Outputs: Earphone (minijack); Record output (minijack)

Speaker: 4-inch dynamic

Power Requirements: Batteries "D" x 3 (4.5V) (optional); "AA" x 2 (3V) (optional) for programmable clock/timer; AC 120 Volts, 60 Hz with AC Adaptor (supplied); DC-12 Volts with DCC-127A Car Battery Cord (optional)

Dimensions: 6 1/4" H x 1 1/4" W x 2 1/4" D

Weight: 3 lbs., 12 oz. (with batteries inserted)

Color: Black

Supplied Accessories: AC Adaptor; Earphone; Shoulder Strap; Long Wire External Antenna; External Antenna Connector (x 2); Short Wave Handbook

Optional Accessories: DCC-127A Car Battery Cord; AN-1 Active Antenna

Availability: Spring, 1985 (Estimated)

Step-up model: ICF-6800W

Step-down model: ICF-2002

Warranty: 1 year, parts and labor

All specifications subject to change without notice.

Sony is a registered trademark of Sony Corporation.

World Band Radio is a registered trademark of Sony Corporation of America.

Direct Access is a trademark of Sony Corporation of America.

© 1985, Sony Corporation of America.



MWDX-2B & MWDX-2C PHASERS  
 (Design Enhancements to the MWDX-2A Phasing Unit)

Mark Connelly -- WALION DX Labs -- 11 FEB 1985

The MWDX-2A phasing unit design (released 25 JUN 1984) provides good output level without, in most cases, the need for amplification. (The recently-described Mini-MWDX-3, on the other hand, usually does require the use of its output amplifier.)

Some recent experimentation has given rise to several improvements and consequent (generally minor) modifications to the MWDX-2A design. The units having these modifications will be referred to as MWDX-2B and MWDX-2C.

MWDX-2B MODIFICATIONS

- Put the b section of S3 between the S4 arm and the T1 input: C6 will then be routed directly to R4. See Figure 1.

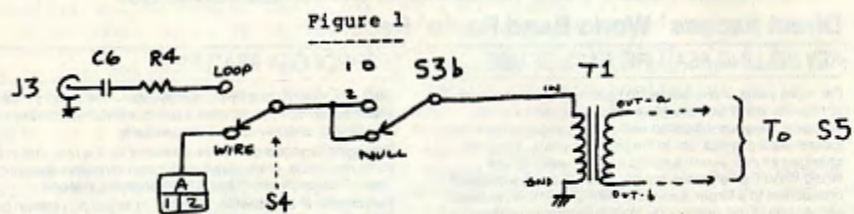

- Use (previously-unused) d section of S3 between S1c arm and T2 Input 1. See Figure 2.

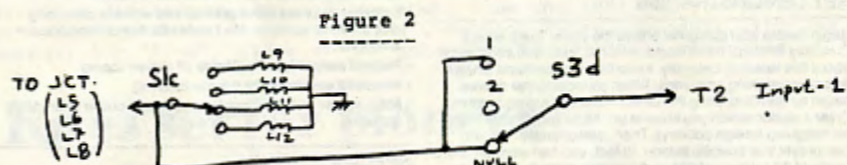

- Delete 330 ohm resistors R5 & R6. (Replace with open.) Modifications 1 & 2 eliminate a possible cross-talk problem (Line 1 to Line 2, and vice versa) which these resistors attempted to "band-aid".
- Connect the S6a arm to the 1 & N pins of S3a instead of to the S3a arm. The S3a arm remains connected to the R3 pot CCW pin. This reduces propagation of Wire #1 load-change effects across to Wire #2 when S3 is switched.
- Connect the S6b arm to 2 & N pins of S3c instead of to the S3c arm. Reason: same as for Modification 4.

These are the differences that distinguish the MWDX-2B from the earlier MWDX-2A. None of the hole locations is changed; none of the usage instructions is changed. An additional change that some may want to implement is the use of 25K linear pots, rather than 50K linear pots, for R1 & R2: this may give somewhat smoother adjustments. The presence of the vernier R and C controls should, however, provide sufficiently smooth nulling. Use of Q-pots less than 20K will not allow sufficient phase-shifting; use of pots of 100K or more will yield excessively touchy nulling.

MWDX-2C MODIFICATIONS

The MWDX-2C design came about because of the considerable difficulty encountered in obtaining 100 ohm, linear, knob-adjustable, non-inductive pots of reasonable size and price. The MWDX-2C has an alternative R1-R2-R3 pot configuration using "straight" level pots for R1 & R2 instead of the Q-skewing pots of the MWDX-2A and MWDX-2B. The new R3 vernier pot is a Q-skewer on Line 1 (see Figure 3) and Line 2 is Q-spoiled by a fixed 15K resistor. The MWDX-3C differs from the MWDX-2A in these respects:

- MWDX-2B Modifications 1, 2, 3, & 5.
- R3 (as shown on the MWDX-2A schematic) is replaced by a direct connection from the S3a arm to the C1 rotor.
- MWDX-2B Modification 4 is implemented with the following change: substitute "C1 rotor" for "R3 pot CCW pin" (because of step 2 above).
- The Line 1 tuner section is changed in accordance with Figure 3:

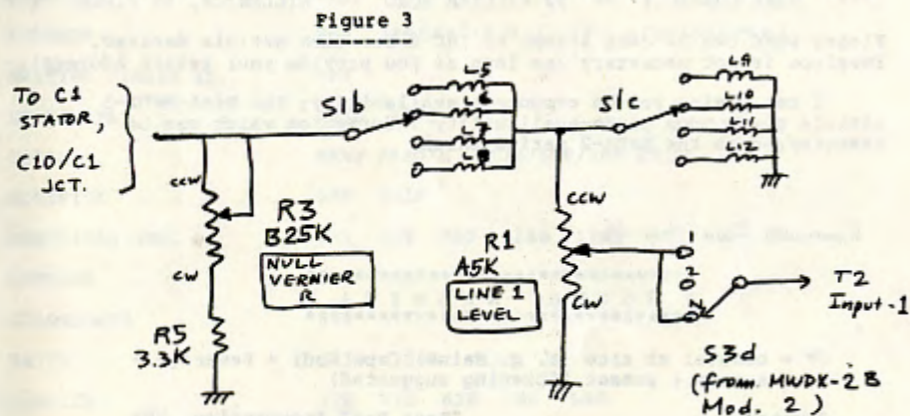

- The Line 2 tuner section is changed according to Figure 4.

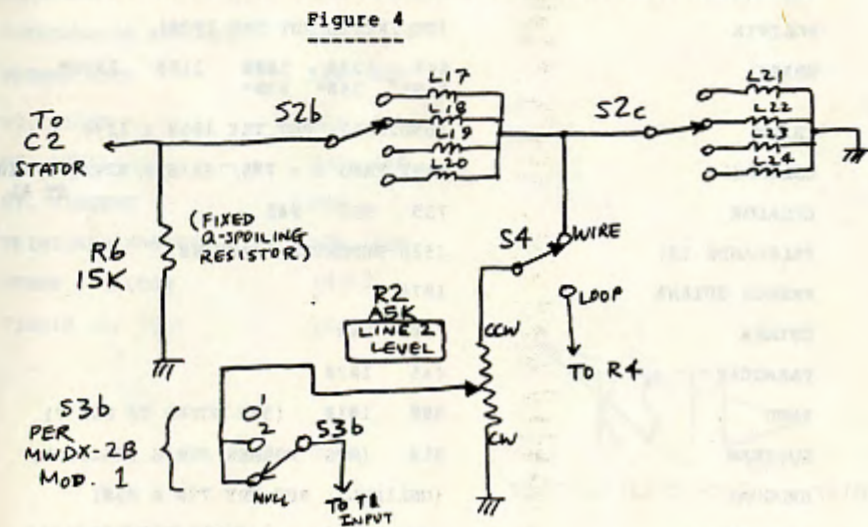



This completes the list of MWDX-2C changes from the previously-published MWDX-2A phasing unit. Hole locations are not changed. The usage procedure changes in terms of loop-vs.-wire phasing: the loop may be outfitted with a fixed (switchable) Q-spoiling resistor in the 12K to 22K range instead of the Loop Q-Pot. The Line 2 Pot (R2) would then be utilised to vary the Line 2 Loop signal level during level-equalisation and nulling operations.

The following are available from me for those interested in MWDX-2 series phasing units.

\*\*\*\*\*  
 \* MWDX-2 article (contains most hole locations used on MWDX-2A/B/C \*  
 \* as well as construction data for the C1, C2, T1, \*  
 \* and T2 subassemblies.) \*  
 \* \*  
 \* MWDX-2A article \*  
 \* \*  
 \* Mini-MWDX-3 article \*  
 \* \*  
 \* Complete schematic diagrams for MWDX-2B and MWDX-2C. \*  
 \*\*\*\*\*  
 >>> MARK CONNELLY -- 30 WILLIAM ROAD -- BILLERICA, MA 01866 <<<

Please send two 22-cent stamps or IRC's for each article desired. Envelope is not necessary (as long as you provide your return address).

I can advise you on component availability: the Mini-MWDX-3 article gives much parts-availability information which can be transferred to the MWDX-2 series units.

CONTINUED FROM PAGE 16

\*\*\*\*\*  
 \* SOUTH AMERICA \*  
 \*\*\*\*\*

(\* = coastal RX site (e. g. Maine, Cape Cod) + Beverage + aurora + sunset listening suggested)

Country	"Best Bet" Frequencies, kHz
ARGENTINA	870
BOLIVIA	(UNLIKELY, BUT TRY 1020)
BRAZIL	860 1220 1000 1100 1200* 810* 760* 880*
CHILE	(UNLIKELY, BUT TRY 1060 & 1140)
COLOMBIA	MANY FREQ'S - 700/760/810/820/870/1100 ET AL
ECUADOR	735 995 945
FALKLANDS IS.	(536 REPORTED INACTIVE)
FRENCH GUIANA	1070
GUYANA	760 560
PARAGUAY	645 1020
PERU	880 1010 (854 MOVED TO 850 ?)
SURINAM	914 (MOST FORMER STN'S INACTIVE)
URUGUAY	(UNLIKELY, BUT TRY 770 & 850)
VENEZUELA	MANY FREQ'S - 540/670/710/720/750/ 830/1020/1200 ET AL

Mark Connelly, WALION \*\*\*\* 01 FEB 1985

It's been quite a while (about 5 years) since the Kazaross/Connelly/DeLorenzo article entitled "DXing Latin America & the Caribbean" was published. Many changes (in the line-up of medium-wave stations that are heard from that part of the world) have occurred. This brief summary updates the Caribbean Islands portion of the aforementioned article. The Caribbean has been a volatile area, politically as well as in terms of broadcasting developments. The original article still has merit in terms of overall Caribbean-hunting strategies (how to "milk" auroral conditions, advantages of coastal QTH DXing at sunset, etc.). The following list is in a very simple form which can be tacked up on a bulletin board near the receiver.

Country	"Best Bet" Frequencies, kHz
ANGUILLA	1610 690
ANTIGUA	1165 1100 1500 620
BAHAMAS	1540 810
BARBADOS	900 790
BERMUDA	960 (1450/1230/1340 LESS LIKELY)
BRITISH VIRGIN IS.	780
CAYMAN IS.	1555 1205
CUBA	MANY FREQ'S - 570/590/600 ET AL
DOMINICA	595 1210
DOMINICAN REP.	650 830 860 1160 1180 540
GRENADA	535 990?
GUADELOUPE	640
HAITI	1030 1000 1325
JAMAICA	720 770 620 700 500
MARTINIQUE	NOTHING HEARD RECENTLY (1310 POSSIBLE)
MONTSERRAT	885 740
NETHERLANDS ANTILLES	800
PUERTO RICO	580 630
ST. KITTS	825 555
ST. LUCIA	840 660
ST. VINCENT	705
TRINIDAD / TOBAGO	730 610
TURKS & CAICOS	1460
VIRGIN IS. (US)	1000 970

KSTL  
 690  
 ST. LOUIS MO. 63102



Mark Connelly, WALION \*\*\*\* 04 FEB 1985

The following listings give the DXer an updated look at the best reception possibilities for countries in Central and South America: this is a companion article to the 01 FEB 1985 article on the Caribbean islands. The late-1979 "DXing Latin America and the Caribbean" article (Kazaross/Connelly/DeLorenzo) is still a useful piece of reading material, although several significant events have obsoleted some of the station information contained therein. In particular, the following developments have had a considerable impact: (1) a trend away from split channels, hastened by today's new breed of synthesised, channelised receivers. The moves of the former Costa Rican splits, of Belize from 834 to 830, and of Haiti from 1035 to 1030 illustrate this trend. Better technical standards in the developing countries will mean fewer unintentional "drifter splits". (2) political turmoil in Grenada and Surinam. Both countries have suffered a reduction in broadcast facilities as a result. (3) increased statewide QRM following FCC deregulation of clear channels, daytime hours, etc.

On a positive note, DXers have accepted the challenges of increased QRM by entering a new age of "DX science". Not since the late '60s/early '70s era has there been so much propagation research; receiver hotrodding; and homebrew construction of antenna tuners, phasers, loops, audio filters and the like. The power of computer technology, both in state-of-the-art receivers (Icom et al) and in design/logging/propagation programs, has been harnessed in the quest for DX. The importance of coastal locations has been acknowledged: Neil Kazaross has singlehandedly shed new light on DX from Africa, north-coast South America (especially Brazil), and the Caribbean.

The following lists should serve to introduce the new generation of DXers to Central America and South America.

\*\*\*\*\*  
\* CENTRAL AMERICA \*  
\*\*\*\*\*

Country	"Best Bet" Frequencies, kHz			
BELIZE	830			
COSTA RICA	530			
EL SALVADOR	655			
GUATEMALA	640	880		
HONDURAS	1365			
MEXICO	900	1570	1050	940
NICARAGUA	750	620	540	
PANAMA	770	825	840	860

- Continues Page 14 -



P.O. Box 5300 Manchester New Hampshire 03108



104 WEST EIGHTH ST. LEXINGTON, NEBRASKA 68850

Paul Swearingen

The opinions expressed in this column are those of the individual writer and do not necessarily reflect those of the Editors, Publishers, or the National Radio Club, Inc., or its subsidiaries. Times are local per Muse.

Hello, again, and welcome to Musings. I'd hoped to be out of limbo by now (Feb. 19) but such is not the case, and this week's installment is again typed on my trusty old Olympia. When I get back to normal, I promise I'll fill you in on the details. We have a nice turnout this week for the theme, your three favorite BCB stations, and I hope that you are cooking up ideas for comments on your three favorite radio personalities for the next session of Musings. And following that issue (sorry, I don't have the deadlines at hand), let's all get a little steam off ... we're devoting that one to "Sound-off", either positive or negative, about the NRC or BCB DX'ing, with the goal, of course, being to improve both. I have a nice large (sigh) stack of letters in front of me, so on with it!

Hurry ... send phone numbers of your local BCB stations to Albert S. Lobel - P. O. Box 26762 - San Diego, CA 92026. If you'd like to research telephone books at your local library in order to up with your state's radio stations and their telephone numbers, send him an SASA so that we can avoid duplication of effort.

WILLIAM C. MOSER - Box 245 - Wishek, ND 58495  
Contrary to rumor, I was not done in by the exterminators called in to remove the "pests" from my rx! A "vacation" in the hospital was followed by the Christmas rush, and this was followed by the illness, death, and funeral of my mother. (Our sincerest sympathies are with you, Bill -pls) Needless to say, DX has been mostly on hold here for the past 2 months. However, my verie total has climbed to 1421. Latest in is a DX'er-friendly letter and stuff from Steve Campbell, Technical Director at KBOZ-1090. He says, "In the last year, I have received 15 reception reports. 5 of these reports have been from Sweden, 3 from Finland, 2 from Norway, 1 from New Zealand, and 4 from the U. S. A. in areas I would not consider part of our coverage area." My reception occurred on 12-15 at SS in a tight null of KAAI, one of my super pests. My best and highly-welcome DX in January was reception of KWJJ-1080 on 1-22 in KRLD's null from 6:32 to 6:38 pm, CST. That makes 2 OR stations in 1 season after hearing nothing from that state since 1965. Paul's request for a list of our favorite 3 BCB stations brings quickly to mind KDKA-1020, KFYE-550, and WGBY-1450. I grew up in SW PA, where KDKA had the best programming afterstealing Rege Cordic and Pirate baseball away from WWSW. "Party Line" with the Kings was a late-evening favorite. Here in ND, KFYE boasts of being "the most-listened-to radio station" in the state, and for good reason. It is about the only station in the state with technical and programming quality. My favorite DX station was WGBY in Guantanamo Bay, Cuba, broadcasting a pre-Castro DX test for the NRC before the AN craze began. Their 35-watt signal has lingered in my memory all these years. This is already too long, so '73's from Dakota Territory.

WALLY WAWRO - 4641 Elderberry Dr. - Garland, TX 75043  
This Musing will cover several topics, primarily those suggested by Paul for issue #21 (favorite stations) and issue #22 (media employment). First off, Tony Ritzherbert, you're all too kind. If I had the time to do it properly, your KLIF profile would have been published by now. But be patient because I'd prefer to see the "mega-tower" profile put together correctly. Paul had wondered in print as to why KAAM couldn't revert to its former call letters, WRR. WRR still exists; it belongs to the commercial classical music FM here in Dallas, which is still owned and operated by the City of Dallas. KAAM-1310 was sold in 1977 to Bonneville along with KAPM, at the time the FM sister of KRLD-1080. I think you can see how they arrived at KAAM as a call for the AM with that bit of information. (Thanks, Wally! -pls) The original WRR was put on the air by the City of Dallas in the early 1920's for the fire department's use. I guess I'd better send Tony the brief bit of history I have about that unique situation! DX at this location has been a little better than expected; some of the stations heard over the last few months include CBK-540, WKBX-630, WNBC-660, WJMW-770, WTAK-1000, the "pack" at 1030 including WASS, KHOG, KBSM, and KCTA ... I never thought that some day WBZ would become "DX"! question ... what has happened to the Latin American (I think it was Mexican) that used to own 540? It's been off the air every time I've checked it over the last few months during the evening. I've been able to hear CBK and KNOE fairly regularly with little difficulty, and I caught WOTO testing its 50 kw rig one early morning back in December. Any information would be appreciated. I don't miss 'em. My three or four favorite stations? I've never heard 'em in Dallas, and this list doesn't reflect what these stations are programming today. But the best ever was WIBC-1070 between 1975 and 1976, with people like Garry Todd and Chuck Riley, plus the incredible Lew Palmer doing news in the afternoons. I learned a lot about promotion, production, and programming listening to that station. In the summer of 1980 and again in 1981 my wife and I visited Boston and I found WHDH-850 to be another classic in terms of having all the elements together. And in the summer of 1983, visiting the Pacific Northwest, I got to hear KOMO-1000, again, great radio, beautifully executed. I think something in common with all three of these stations was the fact that within minutes of listening to them, you got a distinct feeling for communities these stations served ... almost like a reflection. You soon knew what was going on, even as a stranger you found yourself involved ... reacting to the station and its city. That is great radio; sometimes it happens by accident, but more often than not it's a result of



commitment by the station and its people. Anyone who has ever been involved in the business had better realize this ... you have to be committed if you want to be successful. My involvement in the media started back in college at Southern Illinois University in 1971. My first job in commercial radio was at WJPF-1340 (now WHPI) in nearby Herrin, Illinois. I also worked part-time at WJAN-1580 in Duquoin during my college years. Other AM's I've worked for include WCSI-1010, Columbus, Indiana and WITY-980, Danville, Illinois, a station which I'm still involved with since one of my closest friends now owns the station. I might add that I did work at KRAM-1310 here in Dallas for about 6 months as a part-timer back in 1980. I haven't been on the air since! Today I put audio to the pictures at WFAA-TV here in Dallas ... and dabble in some free-lance work; all of that has been mentioned before. Best wishes to all of you for 1985, and hopefully we'll all be seeing that KLIF profile soon!

**\* AM I LOSING MY TOUCH? \***

JOHN R. MALICKY - 995 Shadycrest Rd. - Pittsburgh, PA 15216  
 Hello again! When is spring coming? (It's stalled in Southern California, hi! -pls) -18° low and wind chill -71°, Feb. 10 -7° low. Brian Vernon and William Hepburn, you probably think that's a heat wave, hi! Paul, do you want some of this weather? (Only in my icebox, thank you! -pls) My sincerest thanks and congratulations for verifying my report to NRC member Robert Eddy, half-owner, station manager, and chief engineer (a man of many hats!) of new station, WVVW-1570, St. Marys, WV. On Dec. 23, 1984, I heard c/w mx and WVVW's a/off at 5:57 pm with "Good 'Ole country and good 'ole gospel mx on 1570 AM." I waited a full month to send my report hoping, but unsuccessfully, to hear WVVW again, because I wasn't sure if it was confirmable. In only 4 days, a v/1 and rate card with a cm came on Jan. 30. Mr. Eddy mentioned that I heard his station on PSSA power with 275 watts, using a Harris MWI transmitter and 150-foot tower located across the Ohio River in Newport, OH. The first air date was Dec. 10, 1984, and the FM is WKKR (SWR)-101.7. So, may 1985 be a great year for WVVW and again, thank! Now, why am I losing my touch? One, as reported by Jerry Starr in AM Switch, V. 52, #6, WVVW had a call change and even though I did see it, I reported, hearing what I thought was instead WBDW to Mr. Eddy and to DDXD, V. 52, #17; two, reporting to DDXD and in a letter to WZMG-560 that the president's first name, as again I thought I heard "Happy", but was instead "Kathy" Appleton as corrected in Jim Paige's profile in V. 52, #13; three, reporting CFCC-630 as first in DDAD (in my 3 1/2 years in NRC), but again wrong; see V. 52, #11 (also containing WZMG and the next error); and finally identifying a TT on 870, 11-20-84 0100, under 630. Save your donkops (sic) and water balloons, but I didn't mean to make Dave Schmidt the fool, sorry! I hope I'm better than that - hi! ... Finally, after some thought, I've considered my 3 favorite BCB stns, DX or programwise as (1) (a tie) WQXR-1560 NY and KNBR-680 SF; (2) long since changed from '74 WZUM-Carnegie, PA-1590 (now WPLW), and (3) WTAE-Pgh-1250. My reasons? For 7 years, first on WZD-FM Pgh, classical mx has become a favorite, especially symphonic works (Haydn, Mozart, Beethoven, etc) and WQXR is a delight to listen to if I stay up during the morning and while SS DX'ing if conditions are poor. A few years ago I wrote to them saying how I enjoyed their mx, and they responded, sending a Beethoven booklet and a beautiful program asked. KNBR is my DX triumph and greatest verie, so memorable I heard them once and never again in March '71 at 3 am EST. So excited (I was 14 at the time) I thought I was going to fall off my chair, and their card I had bronzed, hi! Still to this day I cannot hear KNBR, as I'm lacking in the fine equipment you other members have, but to have heard 2 Californians (KFI also) that morning will be something I'll never forget. Two, back in 8th grade, I began listening and became weaned on rock, learning about artists on WZUM and listening to DJ's Kit Baron, Paul Perry, and Terry Caywood (who I think is still in Pgh); and the Who, Pink Floyd, Deep Purple, Emerson, Lake, and Palmer (my favorite group), Procol Harum, the Moody Blues (my 2nd favorite), the 'Stones, etc., and British rock oldies! What a mixture, rock and classical mx! Three, WTAE, the voice of Pitt, and outstanding, entertaining, informative sports talk show hosts Myron Cope (the voice of the Steelers) and Stan Sauran, who I call occasionally. Before I finish, very important DX advice is to learn and recognize every regular station on all channels so that if you hear something different you'll know you might have a new station. 73's.

HARRY HAYES - 9 Henry St. - Wilkes-Barre, PA 18702  
 My three favorite AM radio stations I will divide between programming and DX. WHAS-640 Louisville for its fine oldies music program between midnight and 5 am Tuesday thru Friday nights. Next, KEND-1590 Lubbock, TX for a 3-15-76 early-morning reception and finally R. Tirana, Albania, on 1394 kcs. for a 2-28-77 reception, my furthest positive reception to date. It is now mid-February and the band is very slow which isn't all that unusual for this month. About the latest thing of interest heard was Belize on 830. They put through a surprisingly good signal on this channel here, better than when on 834. I note that the Cuban stations seem to be playing more and more American pop mx. I haven't Mused in a while so for 1985 so far I'll just recap new loggings made. 1-5: 1735 WCRK-1150 TN. 1-5: 1729 WJAY-1280 SC, verie received just yesterday, 2-11. WRGA-1470 GA at 1800. 1-21 1700 WTVN-610 OH wanted for many years. 1712 CFCC-630 ON. 1-25: 1806 WRC-600 TN and 2-1: K. Belize-830 new for frequency change. I notice no change in the Class IV channels since 1 kw. nights was approved. I have four open GY channels available here, and their condition is as follows: 1230: mostly a jumble; WKBO if anything surfaces. 1400: WBBG Harrisburg on top and usually WAMQ Loretto, PA under with "FM-94" 10's. 1450: WSG Glens Falls followed by WOL Washington or WIIN Atlantic City and WCTC Brunswick. 1490: WBCB Levittown or WMLF Lewisburg. Ernie Cooper mentions that the annoying net is gone from 1580. Maybe it was WNVH all the time. Now there is a strong heterodyne here

on 1440. AM stereo has made it here only as far as WNAK, an easy-listening daytimer. None of the other stations even seem to know that the technology exists. I always figured that WILK would be the first to jump on the bandwagon, but I guess they are too busy concentrating on their 102.3 outlet in Pittston. Speaking of Pittston, I find it hard to believe that WARD-1540 has been granted permission to move to 1550 full-time. What about Towanda on 1550 about 45 miles away, not to mention protection for Windsor on 1550? I don't know whatever became of the 750 authorization for Archbald near here. This doesn't make sense either, with WNAK on 730. Tunkhannock, PA, about 35 miles away has been granted 1460. I think this will be far enough away not to pose too much of a problem for me. I'll wrap it up for now.

B. G. "BILL" SMITH - R. 1, Box 33 - Herrin, IL 62948  
 Hello again from So. Illinois. This article will be about my 3 favorite BCB radio stations. My all-time favorite is KMOX, "The Voice of St. Louis" -1120, 50,000 watts, clear channel. I live only 100 mile from St. Louis and have seen their downtown studios many times. They program a tremendous schedule of public service, news, talk shows, and sports. KMOX is not only widely diversified but is also a first-class operation in every way. I am also sure that many of you NRC members out there are familiar with KMOX. They ran a contest once to see how many listeners they had nation-wide and received mail from 36 states. My No. 2 AM station is WSM, Nashville, TN. This is also a 50,000 watt clear channel station at 650. I am a connoisseur of country-western mx, and WSM has the longest-continuously-running program on radio, the famous "Grand Ole Opry." WSM also comes in almost as good as a local. No. 3 on my list is quite a change from the first 2 mentioned, as it operated at 250 watts for many years and just recently went to 1000/1000. It is our local station WHPI, here in Herrin, and it has excelled in local programming for 45 years. It has become an integral part of my life, and I automatically turn to WHPI every morning to find out what is going on locally. Isn't that what local radio is all about? (You bet! -pls) So there you have it, my 3 favorite stations on BCB, and the reasons given. 73's and good DX'ing.

PAUL SWEARINGEN - P. O. Box 4812 - Panorama City, CA 91412  
 My three favorite BCB stations, as far as programming goes, are as follows:  
 #1: WLS-890, Chicago. I grew up listening to the "Rock of Chicago", with such super DJ's as Art Roberts (where is he now?) who didn't have to shout to be heard. They've continued to be a class act, even through the current ratings slump, and I still get a kick out of tuning in to them here in LA. #2: WDAF-610, Kansas City. For years, they were information/middle-of-the-road, with DJ's such as Dan Henry (who I believe still does the weather for Channel 4 in KC) until the ratings slump hit in the late '70's. Then they switched to "61 Country" (but had the good sense to retain their historic call, mentioning it only at the top of the hour) as an urban-country format and never looked back. They've stayed at the top of the charts since with quality programming and perhaps the best news in KC under the direction of Charles Gray. #3: KALM/KIKS-1370, Iola, KS, for precisely the same reasons Bill Smith lists above, for his local. Although its programming was a bit ho-hum when it went on the air in 1962, in the last 5-8 years it has improved under the direction of Gary Lee (Dunker) to be a first-class small-town operation. Other favorites, in no particular order: KNX-1070, WSM-650, WGN-720, KOA-850, WHP-710, WJIB-560. My favorite DX stations? #1: KGBC-1540 Galveston, TX, which always sounded friendlier than other stations. #2: WBB-1030, which always seemed so far away, especially when I heard it near Seattle; #3: The next unID I manage to ID and capture on tape! /// A little DA: Radio Belize-830 hrd here 2-9 u/WCCO just before midnight PST, in English. 73.

RICHARD E. BERG-ANDERSSON - 47-11 48th Avenue, #1 - Woodside, NY 11377  
 Hi again, NRC'ers. I am trying to make #21 with my three favorite BCB stations. While I enjoy DX'ing, my top three are all based on programming, not their current programming, necessarily, but their programming of close to 15 years ago when I was still in my early teens. Since I was new to BCB DX'ing around that time, the three are, understandably, powerful stations; no rare ones here. #1 has to be WBEZ, Boston, MA. Not only did it get me interested in going to college in Boston (I was a resident of NJ at the time), but I'd spent long hours with my first multi-band receiver, a cheapo "Empire" 5-band portable, on Fri. nights (the one night I could stay up late). -ometimes I'd start with "Calling All Sports" until 2000 ET, followed by Jerry Williams' talk show, and at 0000, the inimitable Larry Glick Show. Sometimes I'd listen to Larry straight through until Carl De Suse came on at 6 in the morning. I still tune in to WBEZ occasionally, but the station has changed, as all stations do. Larry Glick is on earlier now and I'm not too crazy about some of the newer talk-show personalities - ah, well ... My other two are CKLW, Windsor, ON and WLS, Chicago, IL. At the time, I was at age when, in my generation, one began discovering "progressive" FM rock radio, yet still tuned into the local Top 40 station (in my case, WABC, New York) to find out what was on the charts. CKLW and WLS gave me a taste of what kids in other cities and Canada were listening to. In many cases (especially that of CKLW) it was stuff (good and bad) that never made it to WABC's playlist. Now I am older (but am I wiser? hi) and my BCB programming tastes have gone from music to sports (sorry, all you AM stereo buffs out there; I listen to mx on FM). As a big hockey and baseball fan, I enjoy twirling the dial (or, on a few pieces of equipment, punching in on the keypad - somehow it doesn't have the same ring to it. Could I be an "old-timer" at 28 already -hi) (Don't say "old" to someone approaching 40, hi -pls), searching for some



distant contest I can listen to as I lie in bed, trying to sleep (an extra-inning game in Seattle (vs. Minnesota, via WCCO) comes to mind. The last out came around 0400 my time, the one time my normally patient wife did not understand my hobby). Occasionally, however, I'll come across one of my old faves and remember; maybe tonight I'll look up ol' Larry Glick - it's Friday; my wife will understand.

ARNOLD COOPER - 5 Anthony Street - Provincetown, MA 02657

A couple of comments to NRC'ers, from the Jan. 21 DX NEWS. To Karl Jeter: isn't KBSM-MO on 1030, rather than 1140? Morris Sorensen: WBCB is on 1490, not 1550. Pete Kemp: New Seaford on 1340 is WBNH, not WBSM. Dick Truax: Tryon, NC on 1160 is WTYN, not WINY. I agree with the comments of Barry Finkel on the NRC Log. I think one column is unnecessary: the one that lists the time zones for each station. Anyone should know which zone a state is in, even where a state may be dissected by a time zone line, it seems to me. (And in his library should be a road atlas to tell him where the lines of demarcation lie - pls) Does anybody have an updated address for W02W-710? My report to the NRC Log address came back marked, "Moved - Left no address." I'm glad to see a TEST upcoming from W4IQ-1590 on MM Feb. 16. By the time this hits print, the program will have already been broadcast. On to DX now. Tue. 1-22: WBT-1110 still off; the SS on this frequency has the same program as the one on 1120 o/u KMOX, which makes me think 'tis a Cuban; I didn't check it out. Wed. 1-23: Needed WM24-1390 (ex-W2AM) fading in and out quickly with W3CQ, WFBL, and WDOT - 'tis hard to get some verifiable copy on this ckw outlet! WKBW, WBT, and W4XX were all off again today! Fri. 1-25: Well, well - WKBW-1520's back and now carrying Sally Dull Rafael! Next door, WCKY-1530 is, too. On 1610, religious talk in EE, looks like Antigua has extended its hours on air. Heard at 1:11, but gone when I checked in again at 1:36. I looked for their 690 signal, but no soap. SM 1-27: WBT-1110 back on AN today; CBJ-1580 was still talking at 1:30, but TT'ing around 2 am. MM 1-28: W02C-1310 was noted AN'ing with MOR and topping the channel at 1:19 am. An FPC dominated 1380 this morning, probably CFDA. Quite a few "offies" today, like WBT-1110 (again), WBN-1050, W4XO-680, and W4US-1150, the latter also off 1-29 and 1-30, so maybe they've quit. Big shake-up there: their former FM, W4US-FM, switched calls to WCOZ and to WOK, and in a few days changed again to WKKT "The Cat", so they're probably groping for a format and for funds. On 680 was seldom-heard WPTF-NC with Best of King, no sign of much-wanted WCNN. Wed. 1-30: The battery in my SM-2 died this morning; imagine telling someone 40 years ago your antenna battery had expired! They'd think you crazy! And so it goes. Happy Easter. Forward - March!

DICK TRUAX - 3003 Gleason Ln. - Louisville, KY 40299 (502) 491-2871

Greetings again from the Bluegrass State, although at present everything is white and very cold. By the time this is read Spring should be almost ready to begin. One new logging lately: 1-16: W4SS-1030 TN in with wx and LD 5:30 pm on car radio just pulling into driveway at home. 1030 is almost a graveyard channel at SSS any more as are many of the other former clears, but getting something to surface is a challenge. Mr. DeLeurere's comments about W4LD-690 brings to mind another station in KY: W4TC-730 in Vanleave. For years I travelled that area and there wasn't even a road sign indicating that you were passing through Vanleave, and it was on NO map. I just checked and it is now on the map but not listed in the index. Talk about small - I had to track it down with a portable radio as a direction finder 10 years ago, as even the tower was hidden behind a hill. No, the NRC doesn't pay for my trips although there is an NRC personnel carrier, boat, and soon a radio station!! Just kidding. If anyone is looking for a good general coverage tubed receiver, I still have a spare Hammarlund SP-600 and also a mint late-production (1970) H4-180A available. Incidentally, I will be going to the great Dayton Hamvention at the end of April, and as I have for the past several years, I am again offering to look for specific pieces of used equipment in the world's largest electronic flea market. Send me your want lists and also enough money to cover your highest price-to-be-paid. I'll either find what you want or send ALL of your money back after May 1. I bet you can't beat that offer anywhere!! More as it happens.

PAERICK O'CONNOR W4ALD - Plain Road - Hinsdale, NH 03451

Greetings to all! DX has been pretty good the last few weeks, so I though I'd take a moment and review the situation here in sunny (?) warm (???) southwest New Hampshire. The last two weeks in Jan. on into the first week of Feb. saw 17 new stations added to the log; number 200 shouldn't be too far away. On Jan. 14, while logging CKLM, a hockey game was hrd underneath; good timing of a silent moment on the Montreal giant nailed a solid ID for CHLO-UN. Later that night hrd CPBC-NB with unusually little interference. Next up on the same night was CJCX-NS with no W4UJ-RI hrd at all. Jan. 18 saw W4UJ-RI overriding WPEM-PA quite nicely, and C4SJ-NB with a very nice signal. Jan. 21 saw a 'most wanted' knocked off as WCNL-NH was heard over W4NS-NY. Jan. 26 saw W4AP-TX finally clear enough for a report. The afternoon of Jan. 27 I noted W4KW-KI, which has never been heard here; a letter from the chief engineer stated that they were having problems with the antenna and were ND at the time. Normally they are directional out to sea, I believe. Do fish DX? (No, but DX'ers fish, hi! -pls) Next on the same afternoon was another 'most wanted', with WTSV-NH being logged. A few minutes later WBTN-VT was heard, with almost no signal strength; for some reason normally-dominant WFEA-NH wasn't heard. Sunset on Jan. 30 noted W4TO-FL (1st FL hrd here) and W4IX-NY battling for dominance on 340; reports out to both. Feb. 1 saw W4OV-DE (1st DE hrd here) added to the log; he was coming in weakly, but normally-hrd W4OP-CT wasn't noted at all. The 4th saw W4EA-ME picked up over WFEA-NH; noted a weak signal on 890 with W4DH-MA off the air and nailed a solid ID from W4YV-FL. Is he still 1 kw nites? Last logging was 6 Feb when W4NH-MA appeared over graveyard clutter with a fair signal. Otherness ... received the most useful QSL lately when WCCM-MA enclosed a T-shirt with the letter; sure beats the regular bumper stickers, hi! Not much else, so I'll go on and do something else. 73 and gud DX to all!

NEAL A. PERDUE W4XNAP - Route 1, Box 154 - Falkville, AL 35622

My final Muse. I simply am no longer interested in MW. I am completely into SW Tropical Bands and Utes now. /// I would like to talk about an exceptional portable rx in this goodbye. The rx is the Sony ICF-6500W. Sensitivity: Excellent (best of ANY rx here). Stability: Fair to good, certainly adequate for MW DX'ing. Selectivity: Poor, as it comes from the factory, but almost unbelievable with the Gerry Thomas mod, a great ceramic filter mod available from Gerry (3635 Chastain Way - Pensacola, FL 32503, (904) 432-8208 after abt 7 pm CST). Gerry's comments abt inadequate audio do not apply to present models. This rx has apparently been discontinued for export, but should still be available from such as 47th St. Photo, NY (an 800 phone number). Gerry's mod is truly unbelievable, and really puts a tiger in the tank. The rx goes for about \$100 or less, and the mod is \$25 in kit form or \$35 ppd by Ger. I bought the first one, hrd so much real DX on it that I decided I didn't want to be without one, bought a second one, and just "put it up". I do 98% of my DX'ing on it. The filter mod gives the unique quality of just being able to "tune away" from QRX. I cannot say enough about this rx and mod. Larry Magne, who does the WRTX rx reviews, told me years ago, "Whenever I test portables, the Sonys consistently impress me with their quality, component layout, and solid chassis" (or words to that effect). I designed Larry's antenna setup when he moved to the suburbs, and we have had considerable correspondence for 10-15 years. I definitely take his work on rx's. /// The Sony, with the Thomas mod, is a FB rx, either in the shack on the provided AC/DC converter, or out in the field. At moderate volume I expect the battery life (6 Duracells, size C) to be much higher than what is quoted in the manual, or about 75-100 hrs. Gerry puts a hi-quality toggle switch in on the mod, giving you a choice between the stock 6 kHz filter with wide skirts and the mod with 4 kHz at -6 db and typical bottom-line selectivity of 10 kHz at -60 to 70 db. The 6500W is much lighter than the Superadio, and has an LCD freq display, which produces no internal noise. I just cannot think of a better rx for the money, for a BCB DX'er who wishes to use a "portable". To combat the extraordinary sensitivity of this rx, I suggest an external "pot" abt 20 k-ohms, when overload occurs. This acts much the same as turning down the RF gain on a comm-type rx. No sweat. An SASE will bring further details from Gerry, or me. Adios, amigos. 73 de Neal. (Don't stay away too long, hi -pls)

PETE CLARIUS - 1563 Castleton Ave. - Staten Island, NY 10302

Hi gang: Thought it was about time that I sent in a report which is the first in over a year. I was sorry that I could not make it to Colorado Springs, but the overall cost would have been just too much, but I sure am looking forward to Rhode Island and also some of that fine ale and my two drinking partners Harry Hayes and Ernie Cooper. Well, let me bring you up to date on radio changes here in my area, and this is it. What was W4WZ-Zarephath, NJ and W4NA-NYC is now W4DM. My contact at P. of F. Hq. told me they had to sell the AM station to help pay the legal fees in their court battle to keep the FM station, which they were in danger of losing to W4NJ at Hackensack, NJ, who wanted the 99.1 spot for an FM outlet to be at Somerville, NJ, and anyway this was just about the only way the P. of F. would have been able to sell the AM with only 31 hrs. per week on the air. Back in 1931 when W4WZ came on the air it was one of 4 stations on then 1350 k, and so when the other 3 merged and became W4BNX they had 3/4 of the time and W4WZ still only 1/4. W4NYM bought out W4POW and as soon as the OK comes from the FCC they will move W4NYM from its present studios and offices at 7 Snyrna Ave. to the W4POW address at 1111 Woodrow Road, both on Staten Island, and this means W4NYM will be the 3rd station to have used this location for broadcasting, starting back in 1924 when W4BER first came on to 1957 when it became W4POW. A friend of mine who worked at W4POW for a while told me a year or two ago that it was just a matter of time till W4POW would have to sell out as W4NYM was getting many of the religious sponsors that W4POW had over the years as well as some of the ethnic sponsors. My BCB log is now at 2014 with 1449 verified - shortwave log at 258 with 82 verified - FM log 114 with 13 verified. I am up every morning about 3 am but listen mostly to the same stations such as W4BAP, W4L, W4MAQ, K4KEL mostly for weather-road conditions plus country music so I am not really DX'ing in the true sense of the word. Also, I am deeply involved with the A. A. R. P. (American Association of Retired Persons, no? -pls), having been chapter president for two years, and I also do volunteer work at our local Senior Guild. So you see, gang, I keep very busy.

#### RADIO ROUNDUP

PETE KEMP - P. O. Box 73 - Bethel, CT 06801

Greetings, all. W4JIM in Lansing, MI has been sold to Mich-A-Media ... Scot Muni, a former All-American during W4ABC's heyday (currently PD on W4NEW-FM) will be hosting "Scott Muni's Ticket to Ride", a weekly Beatles' show, distributed by DIR Broadcasting. The show has currently been signed by W4S-AM and a number of FM outlets ... Art Linkletter's "What's Right with America" will be airing on the Mutual Radio Network, starting March 1 ... ABC Talkradio will begin airing "Children's Radio Workshop" on Sunday mornings at 10:00 am ... Tex to Doug Beard for his note on W4OK-1560 ... In Boston, W4NH has joined the New England News Net, coordinated by W4KLV-TV. W4DL has dropped their participation with that group and has formed a partnership with W4CVB-TV for a similar service ... Ludlow Porch (Bob Hanson) has moved his act from W4SB to W4CNN. Bobby Harper has jumped ship at W4CNN and is moving to W4SB. Got it ... Also in Atlanta Larry Munson is the new Sports Director at W4GST ... W4SQC-AM has gone country ... with the ratings being the name of the game, Columbus' W4KMO ... will be in a state of shock. In the recent book, they dropped from a 7.1 to a 2.6 share ... In the City of Brotherly Love, Harvey Holiday is moving from Sunday evenings (will be simulcast on W4UL-FM) ... In a previous Muse I



noted that Brad Crandall has been selected for replacing the baritone voice of the late John Facenda for NFL. Well, it appears that a few others have also been selected for specific applications. Among the new team members, Jeff Kaye ("light pieces"); if my memory serves me correctly, he was Jefferson Kaye on WBZ years ago and lately in the Buffalo market on WBEW; Roger Stauback ("apple pie voice" work); Dick Butkus for "rough vocals"; and Harry Kalas to continue his chores on the NFL Week in Review ... Marv Albert, a sportscaster heard as the voice of so many sports teams in the New York Market and NBC Network, that I wonder how he keeps his schedule straight, is having a sound-alike contest. "Yes", it will be judged by his peers in the booth. The winner, selected by audio tape, will have the opportunity to work a NY Knicks game with Marv. What should drive the listeners nuts ... with so many syndicators and networks going to satellite distribution, I would recommend a new book on the shelves, "Tune In the hidden signals on Satellite TV" by Thomas Harrigan and Robert Cooper. This is a quite complete text, full of diagrams, pictures, and down-to-earth (pardon the pun) practical information. It is available from Universal Electronics, Columbus, OH ... On a personal note, it is refreshing to note that Clayton Moore has regained the right to wear his Lone Ranger make in public. The Foster Grants didn't do a thing for him ... So much for now.

MARK CONNELLY - WAIION - 30 William Rd. - Billerica, MA 01866

It's been a while since my last Muse. Hello to all. It was great to see Richard Eckman's early-January DXtravaganza from Philly. Richard and I have both noticed that the Vatican on 1530 has been reaching virtual pest status lately, sometimes clobbering WCAV around midnight EST. Richard Wood's Hawaii DX reports are also a very welcome addition to the DX scene. With Az in Maine, Thomas in Florida, Vernon in northern Canada, and Wood in Hawaii we now have international DX perspectives available from the four extreme ends of North America (although Newfoundland, rather than Maine, is the real northeastern extreme). 1965 has started pretty well, DX wise, although I haven't been reading about as many exotic Africans and Brazilians as in 1984. The Lankford/Seaver propagation dialogue is a good development; others may be stimulated to enter the arena of research. Certainly the proliferation of personal computers allows the solution of formulae that seemed hopelessly difficult when they were presented back in the late '60's Nelson era. On another subject - Is there any desire among club members to make MW DX club abbreviations (especially those for languages) consistent with those used by the larger shortwave clubs? I think it would be a good idea, but tradition is hard to change (witness the speed at which the U. S. is going metric) (I agree, but only under the premise that fewer is better, and about two dozen abbreviations maximum are best of all - pls). I got some computer time during lunchtime at work and I've cranked out a pile of articles which I had previously generated in hand-scribbled form: these should be appearing soon. I wanted to get them out before (1) postage rates went up, and (2) before spring arrived and took too many members' minds away from DX'ing and technical experimentation interests. I'm presently working at GenRad (formerly General Radio, for you old timers) in Concord, MA. There have been some layoffs recently - hopefully I'll hold onto my job. Other present activities include studying the UNIA operating system and "C" language. (What do you think about MSX computers? - pls) 73 / Good DX to all.

STEVE KENNEDY - P. O. Box 402 - Waverly, TN 37185

Howdy to all from the Tennessee Tuner. Note the new Box number and town; yup, I moved again. This I believe may be my last move for many years. Thanks to Mike and Sue for making changes on my address label so quickly ... haven't missed one copy of DXN. The big news here is a new wife, and a new station to work with. While living in Huntingdon, I met and dated a wonderful, delightful lady named Alice who lives here in Waverly. She is a wee bit older than I am (remember the song "Older Women" by Ronnie McDowell?), and manager of a restaurant franchise here (I remember a song by Arlo Guthrie, hi. Congrats! -pls). WJPJ was not getting better, and I needed a challenge ... so I managed to get a position with WPHC-1060 here and resigned from WJPJ 1-31. WPHC-1060 and WRRY-104.9 is a country music automated assist operation. The AM simulcasts the FM when the AM is on during daylight hours. Remember in my last Muse I mentioned I would make the shift to FM? Presently, we have a contract engineer come in, but the owner wants me to take over all the engineering duties by 4-1. So things are looking up. As usual not much DX activity. I do try to DX but I am living in an apartment building with 46 units and the TV hash is absolutely unbelievable. DX'ing is impossible. Loops help some, but I also DX the SW bands, and the TV hash is audible up to 18-20 MHz. I need to do something, fast. George Sherman sold me his Hq-100C ... good receiver. I need to have a good tube rx in the DX den again. I do need some help in locating stock Hammarlund knobs for it. I need the stock knobs that go in the lower extreme left and right corners, e. g., Antenna, Receive, Calibrate, and Side Bands. I really would like to find these so the set will be stock '180 all the way, and original parts. I also need a stock Hammarlund speaker to match the set. Anyone having one for sale, please write me. That's it for now. 73.



WGEN am 15/fm 105

P.O. BOX 67

GENESEO, IL. 61254

# HAP PAGE (Handicapped Aid Program)

Sam Barto, 47 Prospect Place, Bristol, CT 06010

Your bids and Orders for Direct Sale items go directly to the Address above, not to any of the NRC Addresses. Make your Checks and Money Orders out to "HAP". Do not send CASH thru the mail. This page brought to you as a Public Service of the NRC.

HAP BID ITEMS: ITEM #498:WPLR key chain,red,white.#499:WEZN metal badge(1"cir)red,white.#500:WBIS metal badge(1.5"cir)red,white,blue.#501:CBLFT-TV metal badge(3"cir)green,blue,white.#502:Metrol Radio(UK)metal badge(2"cir)red,white,blue.#503:WLUP metal badge(2"cir)B&W.#504:CFCN metal badge(1"cir)blue,white.#505:Radio City-194(UK)key chain,red,B&W.#506:Radio 210(UK)key chain,red,white.#507:WCTC/WOMR 1976 key chain,m/c.#508:BBC(UK)"Paddy Feony"poster(12x17")m/c-nice!#509:KALX punk newspaper-large!#510:KQAK punk newspaper-25 pages-nice!#511:BBC Radio Cleveland(UK)50 page poetry magazine,m/c.#512:BBC Radio Stoke(UK)25 page magazine,m/c.#513:BBC Radio One(UK)15th Anniversary 62 page "Rock" magazine,m/c-nice!#514:RHC(Cuba)"Gramma"1984 newspaper-large-interesting!#515:WPLJ DJ photos(8.5x11")4 different!B&W.#516:Cleveland Area Cable TV cloth arm patch(3"cir)white,blue.#517:Radio San Marino sticker(2x2")m/c-rare!#518:FLSN(Nicaragua)48 page magazine in EG,m/c-nice!#519:Radio Lancashire(UK)key chain,red,white,black.#520:Radio Vatican pen, gold,black.#521:RTXU T-Shirt(M)blue,white.#522:KPAP sticker(4x7")blue,white.#523:KSNY sticker(5x12")red,white,blue.#524:KYK sticker(4x7")yellow,brown.#525:HD210A(Ecuador)sticker(2.5x4")m/c-nice!#526:Radio Japan-1985 wall calendar"50th anniversary"(10x28")m/c.#527:WPCO key chain,white,gold.#528:CKUA metal badge(1"cir)orange,silver.#529:Radio Forth (Scotland)key chain,orange,B&W.#530:BRIT(Belgium)plastic paper holder(3x6")B&W.#531:BBC(UK)"50th Anniversary"metal badge(2"cir)red,B&W.#532:ANARC pen,B&W-last edition!#533:WDR(FRG) station pen,blue,B&W.#534:RTE Radio 2(Ireland)pencil,black,purple.#535:HTV(UK)key chain, blue,white.#536:CBQ metal badge(2"cir)red,white,blue.#537:KRVL sticker(5x6.5")m/c.#538:KASE decal(6"cir)blue,white-nice!#539:KPBC sticker(3x11")red,white,blue.#540:KBWD decal(3x8")silver.#541:KERV sticker(3x11")red,white,blue.#542:KVET decal(6"cir)m/c.#543:KVOP/KATY sticker(3x11")m/c.#544:KCTI sticker(3x12")red,B&W.#545:KLAR sticker(3x13.5")red, white-nice!#546:KEES sticker(3x11")red,B&W.#547:CLJD metal badge(2"cir)red,white.#548:Radio Clyde(Scotland)metal badge(2"cir)red,white.#549:WRMU metal badge(2"cir)red,B&W.#550:WXP metal badge(2"cir)blue,black.#551:KCAW metal badge(2"cir)black,blue.#552:KHLJ metal badge(1.5"cir)blue,white.#553:KZAM metal badge(2.5"cir)m/c.#554:Radio Trent(UK)metal badge(2"cir)blue,B&W.#555:CFTR "Blues Brothers"metal badge(1.5"cir)B&W.#556:BBC Radio Nottingham(UK) metal badge(2"cir)white,purple.#557:KELO Radio Free Texas sticker(4x11")red,white, blue.#558:KHLJ reflective sticker(4x5")silver,blue.#559:KRBC "Texas Shapped"sticker,brown, orange.#560:KTEO sticker(4x7")black,orange.#561:KSMW "Cowboys"sticker(4x5")blue,silver.#562:KRBA "Cowboys"sticker(4x5")silver,blue.#563:Radio Break(Italy)sticker(2x5")m/c.#564: Radio City-194 metal badge(1"cir)orange,B&W.#565:Radio Hallam(UK)metal badge(2"cir)m/c.#566:KBYG sticker(3x8")blue,white.#567:Red Rose Radio(UK)decal(5x5")m/c.#568:Radio Facc (Italy)sticker(2x8")m/c.#569:Radio Teen(UK)decal(3x11")red,white,blue.#570:WINK reflective sticker(4x9")m/c.#571:Radio Sweden poster(11x17")m/c-nice!#572:KTAC large Seattle Sounders soccer poster,m/c.#573:Hereward Radio(UK)plastic badge,m/c-nice!#574:Radio Orwell(UK)metal badge(1.5"cir)blue,white.#575:KLEF 55 page music magazine-nice!#576:BBC-WS(UK)poster(12x 17")m/c.#577:RFI(France)bag tag,blue,white.#578:WCTC key chain,black,silver.#579:Radio Forth metal badge(1.5"cir)orange,B&W.#580:ESPN metal badge(1.5"cir)red,white.#581:KTXQ metal badge(1.5"cir)m/c-nice!#582:Capital Radio(UK)key chain,gold,silver-beautiful!#583: Radio Clyde key chain,red,white.#584:BRMB Radio(UK)metal badge(1.5x2.5")red,B&W.#585:WAVA metal badge(1"cir)red,B&W.#586:West Sound(UK)metal badge(2"cir)blue,white.#587:Music TV sticker(4x4")m/c.#588:Radio London(UK)2 different DJ photos(8.5x11")B&W.#589:Radio Medway (UK)2 different DJ photos(8.5x11")B&W.#590:BBC Radio Cleveland 2 different DJ photos(8.5x 11")B&W.#591:Moncow News large 15 page newspaper-nice!#592:Radio Devon(UK)decal(3x9")m/c.#593:BBC(Switzerland)QSL card(4x6")m/c.#594:WVWI(Virgin Islands)sticker(3x5")white,blue.#595:WVVA sticker(3x11")red,B&W.#596:BBC Radio Birmingham B&W DJ photo(6x8")-nice!#597: Radio Forth metal badge(1.5"cir)orange,B&W.#598:BBC-WS metal badge(1.5"cir)red,white,blue.#599:RTE Radio 2(sticker(3x5")m/c.#600:KUHFF sticker(4x7")red,white.#601:KBEC decal(3"cir) red,white.#602:Radio Luxembourg B&W DJ photos(6x8")-nice!#603:RTE Radio 2 sticker(3x7") m/c.#604:Signal Radio(UK)decal(2.5x9")m/c.#605:Radio Luna(Italy)decal(3x19")m/c.#606:Vik- ing Radio(UK)decal(3x8")m/c.#607:Radio Vigo(Spain)match book,m/c.#608:KBPS old B&W studio photos(8x10")-rare!#609:KPAN old post card of studios,m/c.#610:CFCN metal badge(1.5x2.5") red,B&W.#611:KQSB NA pirate QSL card w/ letter.#612:KPBC litter bag(8x12")blue,white.#613: KRBA/KDEY sticker(4x12")yellow,black-very nice!#614:4CG(Australia)metal badge(2"cir)white, red.#615:ANARC metal badge(1.5"cir)B&W-nice!#616:RBI(DDR)plastic badge(1.5"cir)blue,white. Hope there is something here for you...Sam.

ADDRESS: Send your bids and orders for direct sale items to: Sam Barto, 47 Prospect Place, Bristol, CT. 06010 USA. Overseas orders please send Postal Money Orders or currency. Not all foreign checks can be handled at local banks.

HAP DIRECT SALE ITEMS: The following items are \$.25 each or any five(5) for \$1.00: These are all stickers or decals: REE(cir),Radio Devon,RFI(small),Radio Reporter,KAND,KBAT,KEES, KRBA,KFJZ,94-FMX,KRBC,FM-106,KBYY,Q-94,Disco-99,WEMP,KOYE,KOTY,KHBJ,KVWC,KILLE,KNET,NAGO, WLS,RTB,WLUP(cir)(large),BBC Radio 2, Radio Highlands,WCCC,NRRC,CKER,KBYN,KELP,KPSO,KFAN, KNYN(large)(small),KIXY,WABD,BBC-WS,Radio Budapest(red)(blue)(cir),WBYN,LZB,KTAM,RFIO, Kuwait,WCAU,WWSW,KEYX,RTE Radio 2,CHAB,KHUN,KTTX,KJCH,KGOT,CKND,CJME,CKOH,Telecom-83,RNE, Polska Radio(large)(small),City-TV,RBI(white),4XD,Radio Caroline,2CH,KATM,RFI, Radio 270,WQFM,WVWR,KDKD,Telecom-Geneve,DC-101,BBC Radio 1,KXX, Radio Medway,KBOI,WDAE,WMR,KPNW, Radio Forth,CFRA,WDR(rock)(TV),Radio Shetlands,KROY,WMS and KPLU.