

TAB 1185

\$7.95

# HOW TO TUNE THE SECRET SHORTWAVE SPECTRUM

An around-the-world guide to the unusual, the secret, the illegal, the unexplained on the shortwave radio bands.

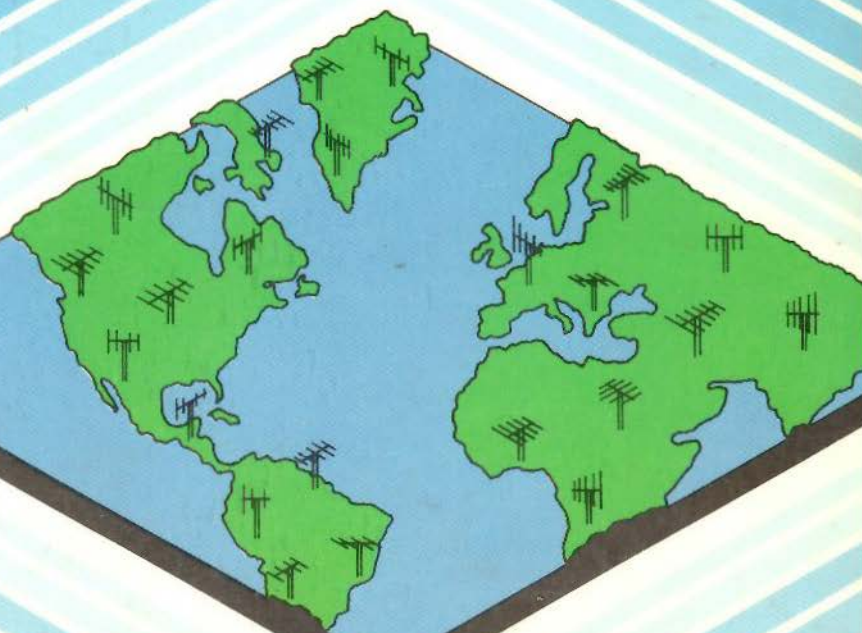

BY HARRY L. HELMS

# Contents

---

	<b>Preface</b>	<b>5</b>
<b>1</b>	<b>Clandestine Broadcasting</b> Origins of Clandestine Activity—The Post-War Era—The Anti-Castro Period—Clandestines in Southeast Asia—Activity in Africa—The Middle East Scene—Current Clandestine Activity—The Future of Clandestine Broadcasting	<b>7</b>
<b>2</b>	<b>Espionage Radio Activity</b> Methods of Encoding Messages—Patterns of Espionage Activity—Unusual Espionage Radio Activity—Where Do Numbers Stations Transmit From?	<b>37</b>
<b>3</b>	<b>Government and Military Communications</b> Diplomatic Radio—Civilian Communications—Strategic Air Command Communications—Listening In On the President	<b>57</b>
<b>4</b>	<b>Space Communications</b> The Satellite Spectrum—Dynamics of Space Communications—Soviet Space Activity—Weather Satellites—Satellites of Other Nations—Launch Support Activity	<b>71</b>
<b>5</b>	<b>Illegal Communications</b> Funny Stuff in the Ham Bands—The "10-½" Meter Band—Eavesdropping and Bugs	<b>84</b>
<b>6</b>	<b>Pirate Broadcasting: European Style</b> Ocean-Going Pirates—Land-Based Pirates—Inside A European Pirate Station—Other European Pirates—Tuning In European Pirates	<b>97</b>

<b>7</b>	<b>Pirate Broadcasting: American Style</b>	<b>115</b>	
	Pirate Radio 1973-1976—WCPR: The Wave of the Future—The American Pirate Explosion—Pirates On The West Coast—The Wave Of DX Pirates—The Saga Of The Voyager—Piracy And The Future		
<b>8</b>	<b>Esoteric, Unknown, and Unidentified Signals</b>	<b>141</b>	
	Unknown, Beacons—Other Unknown Signals—Strange Radioteletype Signals—The Russian Pulsers—Mystery of the Echoes—UFOs or Unknown Entities?		
<b>9</b>	<b>Receiving Equipment and Techniques</b>	<b>159</b>	
	Receiving Gear—Receiving Techniques		
<b>10</b>	<b>The Issues Raised by The Secret Spectrum</b>	<b>166</b>	
	The Government and the Radio Spectrum—Is the FCC Adequate For Its Task?		
<b>11</b>	<b>The Latest Happenings in the Secret Spectrum</b>	<b>170</b>	
	Clandestine Broadcasting—Spy Numbers—American Pirate Activity—Epilogue		
	<b>Appendix A</b>	<b>Frequency Chart</b>	<b>176</b>
	<b>Appendix B</b>	<b>Rules and Regulations</b>	<b>178</b>
	<b>Appendix C</b>	<b>Greenwich Mean Time (GMT) Conversions</b>	<b>180</b>
	<b>Appendix D</b>	<b>International Phonetic Alphabet</b>	<b>181</b>
	<b>Appendix E</b>	<b>International Morse Code</b>	<b>181</b>
	<b>Index</b>		<b>182</b>

## Preface

---

Every shortwave listener or amateur radio operator eventually will come across some signals which do not fit neatly into any of the established categories of broadcasts or transmissions authorized for the shortwave bands. Such signals involve activities like espionage, pirate and clandestine broadcasting, and manned space-flight. They are all part of a "secret shortwave spectrum" virtually unknown to the typical SWL or ham, and which is unmentioned in most reference works available to radio hobbyists. This book aims to fill that void.

It must be noted that some of the activities discussed in this book are illegal under the laws of the United States and many other nations. Neither the author nor publisher advocate, condone, or support such activities. We do support the public's right to be informed about such events, however.

A book of this type would not be possible without the assistance of many persons. The greatest thanks must go to the members of the North American Shortwave Association, SPEEDX (the Society to Preserve Engrossing Enjoyment of DXing), and the National Radio Club, who have reported reception of unusual signals in their club bulletins. Sincere thanks also go to those bulletin editors, such as Ken Compton and Glenn Hauser, who have encouraged members to report reception of unusual signals and have devoted considerable space in their columns to some of the subjects covered in this book. Mike Chabak must be recognized

for his extensive and pioneering research into the Spanish language "spy numbers" stations. James Oberg provided invaluable data on frequencies used by the Soviet manned space program.

In a book of this nature, some persons who contributed greatly cannot be thanked by name for various reasons. Their help was sincerely appreciated, however. Three pirate broadcasters can be acknowledged through their pseudonyms: "John Doe" of WCPR in New York, "J. K. Superstar" of WFAT in New York, and "R. F. Wavelength" of Minnesota's famous Voice of the Voyager.

While the above people have helped make this book possible, they in no way contributed to its shortcomings. Nor should any of the views or opinions in this book be construed as representing the views of anyone other than the author.

Harry L. Helms, Jr.

## Chapter 1

# Clandestine Broadcasting

---

Clandestine broadcasters are stations whose programs are intended for reception by a certain region or segment of the world's population. They are distinguished from more run-of-the mill broadcasters by three factors which are usually present to varying degrees:

- they are extralegal in some respects;
- they are political creations; and
- there is some element of deception in their operation.

Clandestine stations are frequently extralegal because they operate in violation of international laws or treaties, or in violation of national laws. Very frequently, they will operate outside of internationally allocated broadcasting bands. Sometimes, as in the case of clandestine activity in North and South Korea, they operate in violation of treaties prohibiting such activity. Some nations prohibit listening to certain clandestine stations, while other clandestine operations violate the local laws of the nation they transmit from. Since they are extralegal, it is often difficult to get accurate information on clandestine stations. They are ignored to a large extent in such widely consulted reference works as the *World Radio TV Handbook*, and some nations prohibit the dissemination of any information about clandestines.

Clandestine broadcasters often promote illegal activities in the areas they broadcast to—usually resistance to, and activities against, the ruling government. Clandestines have even taken active roles in attempts to overthrow certain governments, such as the involvement of Radio Swan in the Bay of Pigs invasion of Cuba.

It may seem strange to single out clandestines for being political, since virtually all international broadcasting, from the Voice of America (Fig. 1-1) to Radio Moscow, is heavily political. The crucial difference is that international broadcasters such as Radio Moscow and the Voice of America continue from year-to-year, regardless of the political situation; clandestines, by contrast, are born and die according to changing political fortunes. Indochina, for example, was a hotbed of clandestine activity by both American and Communist factions during the Vietnam War. Clandestine activity in the area virtually ceased with the withdrawal of American forces, only to resume in 1978 with the outbreak of fighting between China, Vietnam, and Cambodia. Africa provides yet another example of the abrupt swings that characterize clandestine activity. Broadcasts to the former Portuguese colonies of Angola and Mozambique ceased when they were granted independence, while activity directed toward Rhodesia and South Africa has been steadily increasing.

Deception is the third key element in clandestine broadcasting. Very often, the transmitter site of the station is kept secret, or a false site is given. For example, anti-Peking clandestine stations broadcasting from the Soviet Union claim to be operating from within China itself. Deception is often employed as to the true nature of the station. Many clandestines operated by the United States have masqueraded as commercial broadcasters, with perhaps the most famous being Radio Americas, an anti-Castro station which operated from Swan Island in the Gulf of Mexico during the 1960s.

Needless to say, deceptive information is often a large part of a clandestine's programs, but this is not always the case. Some of the most effective clandestines have been very reliable sources of information, particularly when compared with the state-controlled media in the areas the clandestines broadcast to.

## **ORIGINS OF CLANDESTINE ACTIVITY**

It is impossible to say precisely when the first clandestine station came on the air. However, the persuasive power of radio first became apparent in the 1930s. In Germany, Joseph Goebbels masterfully exploited the new medium as Adolph Hitler's voice became known and feared throughout Europe. Goebbels also devoted attention to Germany's broadcasts to other nations, and many of the techniques used today by clandestine broadcasters were refined during that period. In the United States, Orson

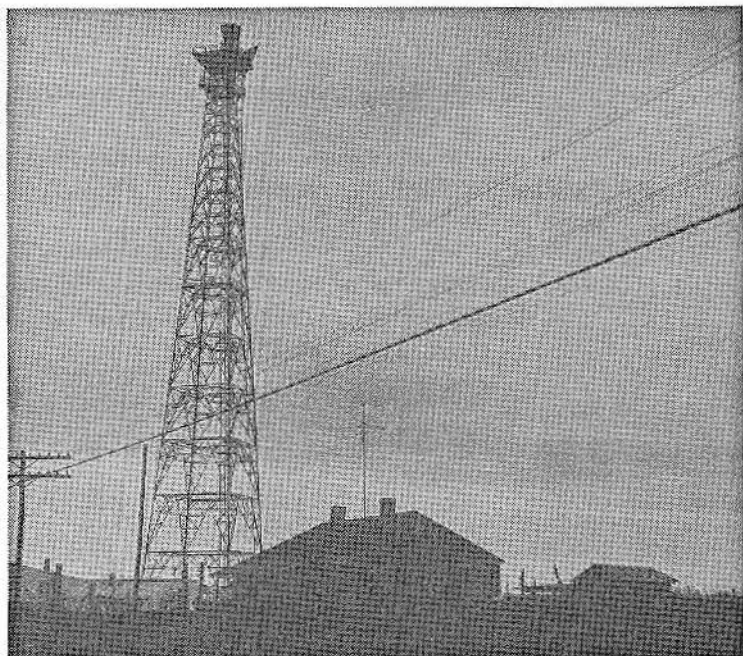

Fig. 1-1. Microwave tower near Scotland Neck, NC, is part of the Voice of America's chain of microwave towers which relay transmissions from Voice of America studios in Washington, DC, to transmitters beaming overseas from Greenville, NC.

Welles and the Mercury Theater unintentionally terrified a large portion of the populace with an adaptation of "War of the Worlds." Academicians such as Princeton sociologist Hadley Cantrill immediately set about investigating the effects of radio upon the public.

By the late 1930s, war was beginning to break out in many parts of the world. Spain during this time was undergoing a bloody civil war between leftists and conservatives. The Republican government of Spain established "Barcelona Radio" in 1936 as its official voice, and both the station and government received the support of the Spanish Communist Party. Republican forces suffered a series of reversals to the conservative forces of Generalissimo Francisco Franco, however, and in 1939 Barcelona was about to fall. Several members of the Republican government and the Spanish Communist Party fled to Leningrad, where they quickly re-established "Barcelona Radio" as an exile voice. In 1941, the station changed its name to "Radio Espana Independen-



diente" (Radio Independent Spain) and broadcast continuously from then until its closing in 1977, over 36 years. Radio Espana Independiente thus holds the distinction of not only being the longest operating clandestine but also the first in the modern use of the term.

World War II brought an explosion of clandestine activity. Many older shortwave listeners can recall hearing Marshall Tito speaking over "Free Yugoslav Radio" from the Soviet Union, or General Charles De Gaulle exhorting the French resistance over "Voice of the Free French," transmitting from Brazzaville in Africa.

Daring members of the underground resistance in occupied Europe set up makeshift transmitters urging defiance of the Nazi invaders. These broadcasts often helped coordinate actions against the occupying forces, and some of these broadcasters lost their lives when discovered by the Nazis.

Allied propaganda efforts against the Nazis took an interesting turn later in the war when the British began setting up bogus versions of German domestic stations. These stations carefully followed the pattern of German stations in programming, except for the news broadcasts and special bulletins, which were carefully slanted toward the Allied cause. One ingenious British innovation involved putting a transmitter on the same frequency as a domestic German station and immediately rebutting statements made by the German announcer during news broadcasts!

## **THE POST-WAR ERA**

Upon the conclusion of World War II, the stations established during the struggle ceased operation, with the exception of Radio Espana Independiente. But, the lull was only temporary as increasing tensions between East and West gave impetus to the establishment of new clandestines.

The first new clandestine to come on the air after World War II was Radio Euzkadi, (See Fig. 1-2). Like Radio Espana Independiente, Radio Euzkadi was directed against Franco's Spain. However, Radio Euzkadi's intended audience was a special segment of the Spanish population: the Basques.

The Basques are a people with a mysterious history. Although living in what is now Spain, they speak a language more closely related to the various Slavic languages than Spanish. Their culture and traditions are different from those of the rest of Spain, and they consider themselves as being a separate people from the Spanish.

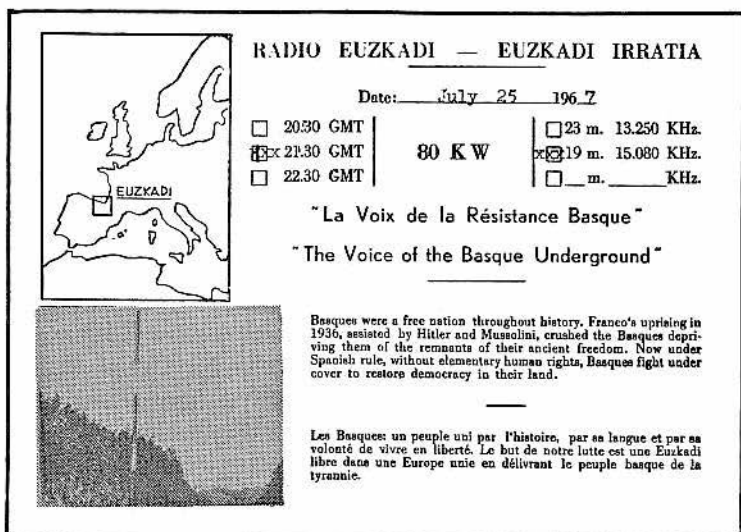

Fig. 1-2. QSL card from Radio Euzkadi. Despite the card's implication that the station was somewhere in Spain or France, it actually transmitted from Venezuela.

Indeed, it is still possible today to provoke a fight by referring to a Basque as a Spaniard. The Basques today are mainly concentrated along the French border with Spain.

The Basques supported the Republic against Franco in the Spanish Civil War, and suffered brutal repression by the victorious Generallissimo in the aftermath. Franco's concern was warranted; one of the persistent goals of the Basques has been their own independent nation carved out of Spain.

Radio Euzkadi first came on the air in late 1946 from a transmitter site near Bordeaux, France, where a large expatriate Basque population lived. All broadcasts were on medium wavelengths, and audible only in Europe. Pressure from the Spanish government forced the French to close down Radio Euzkadi in the summer of 1954. Eleven years passed before Radio Euzkadi again returned to the air, this time on shortwave from a site near Caracas, Venezuela in 1965. Venezuela has a large Basque population which fled Spain after their civil war. Many are quite wealthy and have ties to important persons in the Venezuelan government, which helped Radio Euzkadi to get a friendly reception from its new host.

Like Radio Espana Independiente, Radio Euzkadi operated until 1977, when it left the air, supposedly due to improved

conditions in Spain following the death of Franco. A more plausible explanation may have been Venezuela's desire to improve relations with the new Spanish government. Many students of clandestine radio agree that Radio Euzkadi may well return to the air if a suitable transmitter site can be found.

The 1950s brought a remarkable surge of clandestine activity as the Cold War developed. New pro-Communist broadcasters came on the air from the Soviet Union and its eastern satellites, such as Radio Oggi Italia (to Italy) and Radio Portugal Livre (to Portugal). Transmissions from these two stations continued until the early 1970s. Other clandestines were added by the Warsaw Pact nations as world conditions dictated; after the 1953 revolution in Iran a station calling itself Radio Peyk-e Iran (Radio Courier of Iran) came on the air from Bulgaria and broadcast until 1977.

Western nations did not hesitate to enter the radio warfare. One of the most interesting was Radio Free Russia, which broadcast from West Germany from 1950 until 1974. Radio Free Russia was operated by Narodno-Trudovoy Soyuz, a Russian exile group whose goal was nothing less than the overthrow of Communism in the Soviet Union. Originally, Radio Free Russia operated out of a mobile transmitter van, but eventually established a permanent transmitter site in Bavaria. Radio Free Russia's closing in 1974 was the result of improving relations between West Germany and the Soviet Union.

It was also during this period that Radio Free Europe and Radio Liberty were established at transmitter sites in West Germany and Portugal (Fig. 1-3). While their locations were not a secret, both claimed to be the voices of private American organizations supported entirely by donations. Radio Liberty was under the aegis of the American Committee for Liberation, while Radio Free Europe was supported by the National Committee for a Free Europe. But, in 1972, it was revealed in Congressional hearings chaired by Senator J. William Fulbright that both stations were actually operated and funded by the Central Intelligence Agency. For years, Radio Free Europe had conducted extensive fund-raising campaigns in the United States, supposedly to support the "private" station. The Fulbright hearings revealed that in 1969, Radio Free Europe received over \$12,000,000 in free advertising yet was able to gather only slightly over \$100,000 in contributions. The CIA provided the rest of the two stations' multimillion dollar budgets. Congress voted to continue funding the two stations, but this time through open appropriations instead of through the CIA.

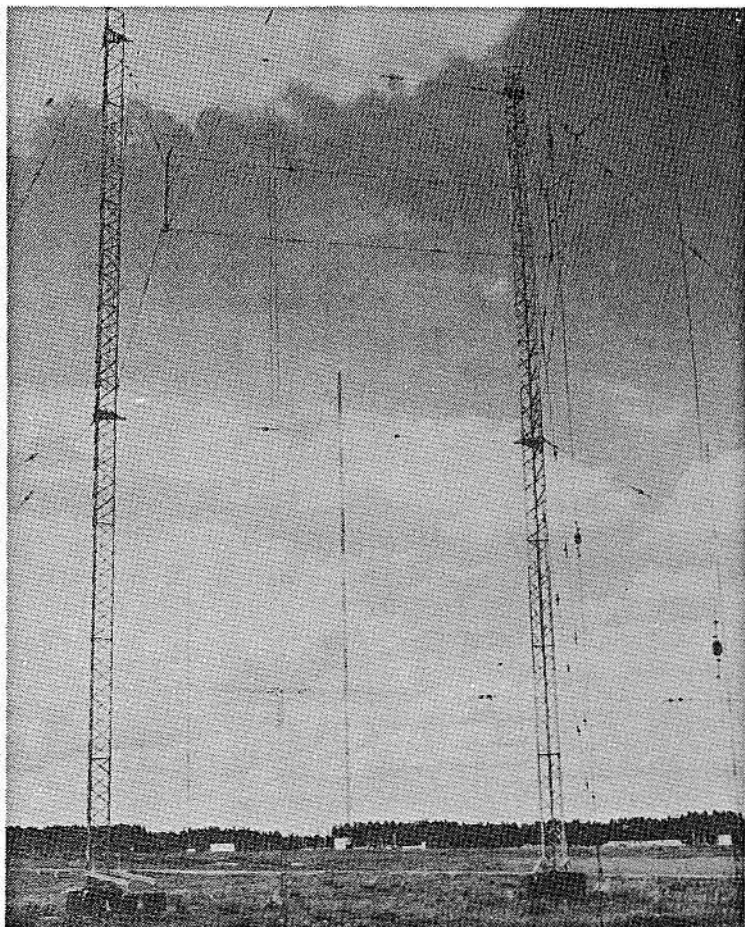

Fig. 1-3. Radio Free Europe has 46 transmitters in Germany, Portugal and Spain. The transmitters shown here are located at Holzkirchen, Germany. The antennas include 14 rhombics, one curtain, two long-periodic, and one medium-wave array. These are used in program transmissions and relay service.

In a sense, both Radio Liberty and Radio Free Europe were clandestines that "came in from the cold" and became legitimate broadcasters. The CIA was to use private agencies and corporations as cover for future clandestine activities.

### **THE ANTI-CASTRO PERIOD**

The rise of Fidel Castro to power in Cuba, and his tilt toward the Soviet Union, sparked off the first clandestine activity by the

United States in this hemisphere. In 1960, shortwave listeners were startled to hear a new station on 1160 and 6000 kHz identifying itself as Radio Swan. It claimed to be a commercial venture broadcasting from Swan Island in the Gulf of Mexico (Fig. 1-4). Its owner was Gibraltar Steamship Corporation, a New York firm with a Miami address. Some enterprising shortwave listeners who checked on Gibraltar Steamship Corporation were surprised to find that it owned no ships of any kind. The president of Gibraltar Steamship was Thomas D. Cabot, who had previously held a high position in the Department of State. Radio Swan's programming consisted of popular music, a few commercials, and many news programs, all in Spanish with a heavy anti-Castro slant. Radio Swan used no call letters and the Federal Communications Committee claimed to have no knowledge of the station, despite the fact that Swan Island was claimed by the United States (Honduras also claimed the territory).

Whatever claim Radio Swan may have had to being a strictly commercial venture was shattered in early 1961 during the Bay of Pigs failure. Listeners to Radio Swan clearly heard the station delivering coded messages and military commands to the invading forces and to anti-Castro guerrillas inside of Cuba. The station suspended normal programs for the duration of the invasion attempt, and, instead tried to coordinate some of the invasion activities. Radio Swan's credibility (perhaps already low) was completely destroyed by its involvement with the Bay of Pigs, and a few months later the station changed its name to Radio Americas. Ownership was "transferred" to Vanguard Service Corporation, which had the same Miami address and telephone number as the Gibraltar Steamship Corporation. A third ownership transfer was eventually made, this time to Radio Americas Incorporated, located in the Miami suburb of Coral Gables.

Throughout its history, Radio Swan/Radio Americas maintained that it was a commercial station, and Radio Americas gladly furnished anyone who asked a commercial rate card. The rates were far too low to support any commercial enterprise, however, especially one operating in such a desolate spot as Swan Island. Despite conclusive direction-finding evidence that the station was operating from an American territory, the Federal Communications Commission steadfastly denied any knowledge of it. Those who asked the Department of State about Radio Americas were referred to the FCC, while the FCC referred questions about Radio Americas to the State Department!



Fig. 1-4. QSL card from Radio Americas. The location of Swan Island is indicated in the middle of the card.

It was little wonder that Radio Americas became the center of a storm of controversy within the shortwave listening hobby. Some began to doubt whether or not Radio Americas was really on Swan Island as claimed, with the Yucatan Peninsula of Mexico widely suspected as being a likely location. Other speculation had Radio Americas aboard a ship cruising the Gulf of Mexico. Those who decided to find out more about Radio Americas found themselves entering a world of false clues and dead ends. One researcher published his findings in a national electronics magazine and used several documents given to him by sources in Miami to illustrate the article and reinforce some points made in the text. It turned out that the documents contained several errors, which Radio Americas pointed out to anyone who wrote inquiring about the articles assertions. In retrospect, it seems likely that several of the documents were "planted" in an effort to undermine the writer's credibility.

All speculation about where Radio Americas really was came to an end in the spring of 1968. A writer and the editor of a now-defunct national electronics magazine were allowed to visit Swan Island, supposedly for an amateur radio "DXpedition." When they arrived, they found Radio Americas very much active, and were given a tour of the facilities by the transmitter site crew. All of the Radio Americas crew insisted that they were a commercial station not connected with the CIA or other government agencies, however. The timing of the trip and subsequent magazine article

could not have been better; Radio Americas left the air when the article appeared in the spring of 1968!

Speculation still continues as to the true story about Radio Swan/Radio Americas, especially as to whether or not all transmitters used by the station were actually on Swan Island during its entire history. There is no question about the links to the CIA, however. Former CIA agent Victor Marchetti, in his 1974 book, *The CIA and the Cult of Intelligence*, revealed that the CIA had been behind the station since its inception. Interestingly, the CIA deleted several parts of Marchetti's book on the grounds of national security but left the passages on Radio Swan/Radio Americas intact.

A strange postscript was added to the Radio Swan/Radio Americas story in 1975 when a new station came on the air on 1160 and 6185 kHz identifying itself as "Radio Swan de Honduras." Listeners were startled to hear pop music and anti-Communist announcements in a format remarkably similar to that of the old Radio Americas. It turned out that the station was indeed licensed in Honduras, and was located in the coastal town of San Pedro Sula. Reporters to the station received verification letters from Ralph H. Nodarse, station president, who claimed that the original Radio Swan had first been on a ship, then later on Swan Island, and that he had decided to put Radio Swan back on the air due to Cuban activity in Latin America. No one has yet determined whether or not there is any link between the personnel at Radio Swan de Honduras and the old Radio Swan/Radio Americas. The station has since left shortwave but is still active on 1160 kHz in the standard broadcast band—the same frequency used by both Radio Swan and Radio Americas. Verification letters from the station were postmarked from Miami (Fig. 1-5), not Honduras!

Radio Swan/Radio Americas was not the only anti-Castro station active during this period, however. Far more mysterious was Radio Libertad, which operated on several shortwave frequencies and a channel in the standard broadcast band. Radio Libertad's programming was much more serious than Radio Swan/Radio Americas, without the pop music and commercials. No location was ever announced, although a mailing address in Venezuela was given, and signals were weak and irregular compared to the booming signals from the Swan Island operations. Speculation as to Radio Libertad's location ranged from the Bahamas to aboard a ship, and groups ranging from the Defense Intelligence Agency to exiled Cubans were rumored to be behind

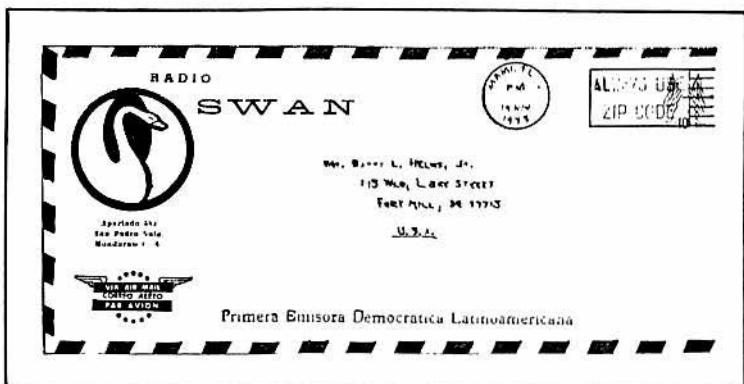

Fig. 1-5. Envelope from Radio Swan de Honduras. Despite the return address in Honduras and the fact that your author sent his letter to a Honduran address, the letter was mailed from Miami.

it. Of interest was the fact that Radio Libertad relayed programs in Spanish prepared by NTS, the same Russian exile group that operated the previously-discussed West German clandestine Radio Free Russia. Like Radio Swan/Radio Americas, Radio Libertad first came on the air in late 1960 and quietly vanished in 1968. Much likely will never be known about this station.

Another interesting operation in the early 1960s was WRUL, Radio New York Worldwide, a licensed broadcaster and supposedly a commercial enterprise like Radio Swan/Radio Americas. It broadcast in both English and Spanish, and many of its programs had a decided anti-Castro slant. Its Spanish language programs featured many famous anti-Castro speakers, and its English language music programs solicited letters from listeners in Cuba, with Cuban listeners advised to address letters to the announcer, not the station. Some of its Spanish language programs were even relayed by Radio Americas.

Many listeners were curious as to how such a station could exist as a commercial enterprise, since ads (mostly for items like the *World Radio TV Handbook*) were few and could scarcely generate the revenue needed for such an operation. It was even more strange when the station announced grandiose plans to build a new transmitter site and begin service in several European languages. But in 1967, a fire destroyed several station transmitters, and the plans were largely cancelled. The station changed call letters to WNYW, and ownership passed from the WRUL group to the Mormon Church, and later the CBS Network. Neither the Mormon Church nor CBS found WNYW inexpensive to maintain



and operate, and both parties seemed to be operating the station more as a public service. In 1972, the station was sold to Family Radio, a religious broadcasting organization. In 1978 Family Radio began moving the transmitter site to Florida and continued its all-religious programming.

Given WRUL's close cooperation with the anti-Castro movement and Radio Americas, speculation has been that it was linked in some manner to the CIA, much like Radio Swan/Radio Americas. None of the principals in WRUL have anything to say on the subject these days.

## **CLANDESTINES IN SOUTHEAST ASIA**

The largest area of clandestine radio activity has been Southeast Asia, Fig. 1-6. Since the early 1960s, there has been a continuously high level of activity from this region, although it was down from its peak during the days of the Vietnam War until late 1978 and the outbreak of hostilities between China, Vietnam, and Cambodia. Obviously, some of the clandestines that left the air in Southeast Asia did so because the faction they supported now controls the legitimate broadcasters in a nation!

One such example is Laos. Radio Pathet Lao came on the air in 1960 as the voice of the pro-Communist Pathet Lao. It first broadcast from a site in Laos controlled by the Pathet Lao, but in the mid-1960s began to broadcast over the facilities of the "Voice of Vietnam" near Hanoi. However, the Pathet Lao still claimed to be broadcasting from inside of Laos itself, and in 1974 invited a team of Japanese journalists to visit Sam Neua, capital of the portion of Laos then held by the insurgents. The journalists there saw radio transmitting equipment but it was their judgement that the facilities were too small for an operation like Radio Pathet Lao and were probably only for relaying programs to the transmitters near Hanoi. Radio Pathet Lao continued until 1975, when the insurgents finally gained control of the entire nation. Today, many of the announcers once heard over Radio Pathet Lao can be heard over the official Lao National Radio.

Cambodia was twice the site of clandestine activity which merged later with official broadcasting facilities. Cambodia was also the site of one of the most inventive pieces of deception in the history of clandestine broadcasting. In 1970, it was announced through official Chinese and North Vietnamese sources that a new station to be known as the Voice of the National United Front of Kampuchea soon would be going on the air. This station would be

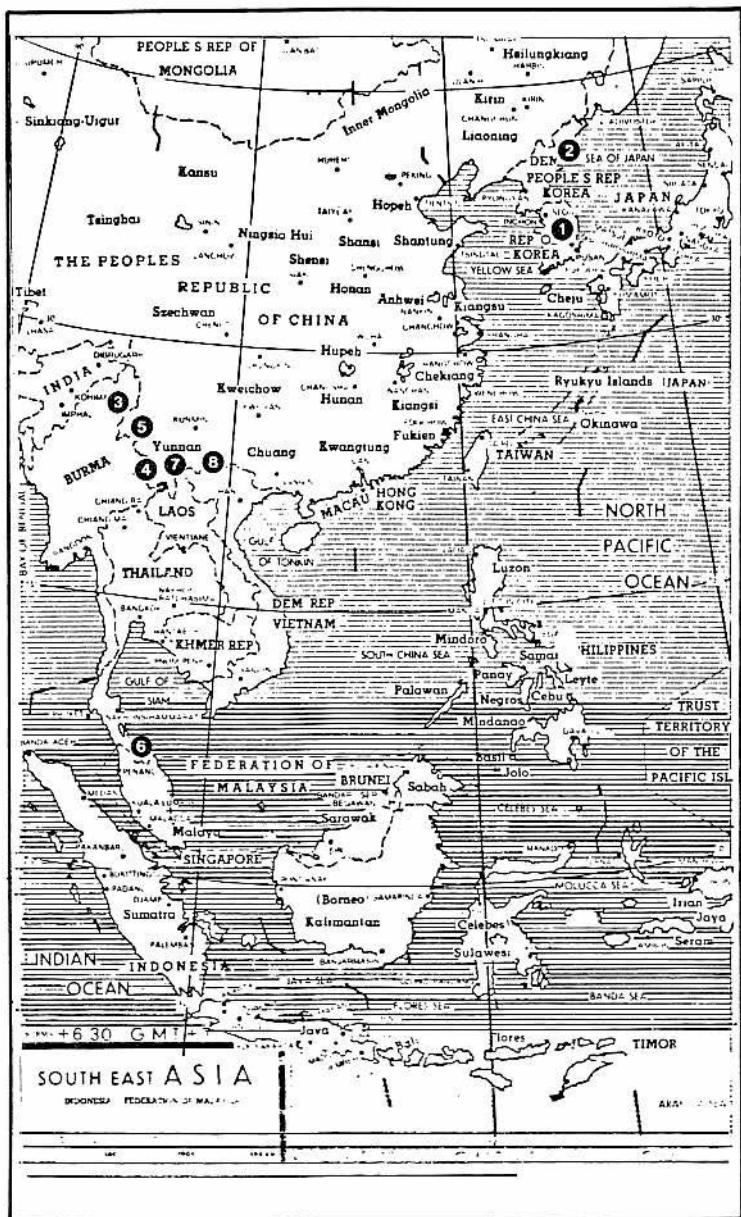

Fig. 1-6. Locations of major active clandestine stations: 1-Radio Echo of Hope, 2-Voice of the Revolutionary Party for Reunification, 3-Voice of Kawthulay, 4-Voice of the Thai People, 5-Voice of the Burmese People, 6-Voice of the People of Malaya, 7-Voice of the Malayan Revolution, and 8-Voice of Democratic Kampuchea.

the official voice of the Khmer Rouge insurgents operating in Cambodia. A complete schedule with times and frequencies was given for the station.

U. S. intelligence sources noted the announcement. Since it was to be several weeks before the new station came on the air, U.S. counterintelligence experts hurriedly rushed their own version of the Voice of the National United Front of Kampuchea on the air, complete with an electronic device to allow announcers to mimic the voice of exiled Prince Norodom Sihanouk. This "fake" clandestine station broadcast speeches by the "Prince," urging Cambodian girls to sleep with North Vietnamese soldiers in Cambodia, thus offending Cambodian morals and stirring up the traditional hatred of the Vietnamese among Cambodians. This fake clandestine was swiftly exposed by both Peking and Hanoi, and the real station came on the air on August 1, 1970. It continued to broadcast until the fall of the Lon Nol regime to the Khmer Rouge in 1975. Sources generally agree that the station transmitted over the facilities of the Voice of Vietnam near Hanoi.

Another Cambodian clandestine was Radio Destiny of the Motherland, which was active from late 1973 until the Khmer Rouge victory in 1975. Sources have indicated that this station was an American or South Vietnamese operation opposing the Khmer Rouge. The large amount of Western music played on the station was a good clue as to its actual point of origin.

The 1978 outbreak of hostilities between Vietnam and Cambodia brought forth two new clandestines. The first, Voice of the Kampuchea People, came on the air in late 1978 from a site in Vietnam. It urged resistance to the Pol Pot regime in Cambodia, and tried to gather support among the Cambodian people for the Vietnam-backed invasion. After the overthrow of the Pol Pot government, a new clandestine known as the Voice of Democratic Kampuchea came on the air from a transmitter site somewhere in southern China. It is covered in our section on current clandestine activity.

Burma has been the target of several clandestine operations, some of which are still continuing. Insurgent activity has been high in Burma, with both pro-Communist and independent socialist groups battling the established government. As much as half of the territory in Burma is believed to be in the hands of two guerilla groups. The first Burmese clandestine was Patriotic Voice Radio, run by the anti-Communist People's Patriotic Party from a location near the border with Thailand. It was active from early 1971 until

late 1975. Two other Burmese clandestines, Voice of Kawthulay and the Voice of the Burmese People, are still active and will be discussed later in this chapter.

The Vietnam War spawned many clandestine operations by North Vietnam, South Vietnam, and The United States. Perhaps the best known was Liberation Radio, the voice of the National Front for the Liberation of South Vietnam (i.e., the Viet Cong). Liberation Radio first came on the air in early 1962. As the Vietnam War continued, Liberation Radio's facilities were upgraded with transmitters donated by China and the Soviet Union, and languages such as English and French were added. Speculation abounded as to the location of Liberation Radio's transmitter site until the heavy American bombing of North Vietnam in late 1972. One American air strike took Hanoi's Voice of Vietnam complex off the air, and with it Liberation Radio went silent. Liberation Radio resumed broadcasting a few days later, and continued without further interruption until the defeat of South Vietnam in 1975.

A clandestine operated by the Americans or South Vietnamese first appeared in late 1973, calling itself Radio Liberation of the Southern Part. Its sign-on and interval signals were identical to those used by Liberation Radio, and it was obviously an attempt to undermine the credibility of the real Liberation Radio. This station went silent in May of 1974 but was reactivated in late 1974 and stayed on the air until shortly before the fall of South Vietnam.

Another Vietnamese clandestine was the Voice of the Patriotic Militiamen's Front, which was active at sporadic intervals until the end of the war. This station took an anti-Communist, anti-American, neutralist approach in its programming, although it was assuredly an American or South Vietnamese operation.

Further information on American clandestine activity in Vietnam came in 1978 in a book by former CIA agent Frank Snapp, entitled *Decent Interval*. In it, Snapp claimed that the CIA operated five "gray" clandestines broadcasting to Vietnam and Cambodia from a central building in Saigon. Snapp defined a gray clandestine as one representing itself as a non-Communist radio station with no government affiliation.

Given the strained relations between China and the Soviet Union, it is hardly surprising that China has been the target of some rather imaginative clandestine activity by the Soviet Union. The first such station showed up in 1966 at the height of the Great Cultural Revolution. Chaos reigned in most of China, and the Soviets tried to exploit the situation by establishing several

stations claiming to represent the voices of dissident elements of the Chinese Army loyal to such former Chinese leaders as Liu Sho-chi and Lin Piao—both formerly second in rank only to Mao Tse-tung, and victims of purges. These stations used such names as Proletarian Battle Division, Voice of the Liberation Army, and Station Sparks. Schedules and frequencies were highly irregular so as to give the impression that the transmissions were actually originating within China. All such transmissions are actually produced by dissident Chinese now living in the Soviet Union, and are broadcast from transmitters located at various points along the Soviet-Chinese border.

The year of 1974 saw the introduction of a new twist in clandestine activity when the Soviet Union introduced a fake "Radio Peking" by actually relaying portions of the real Radio Peking! See Fig. 1-8 The Soviet Union would cleverly rebroadcast the sign-on and news portions of Radio Peking's home service on frequencies close to those used by the real Radio Peking. Listeners would presumably be unaware that they were listening to a phony station. Then the Soviet Union would insert an anti-Mao commentary prepared in the USSR into the broadcast! How many Chinese were actually taken in by this ruse cannot be known, but Chinese authorities quickly caught on to the bogus transmissions and began jamming them.

Clandestine activity still continues in Burma, Korea, Malaysia, Cambodia, and Thailand. These operations will be covered in the section on current clandestine activity.

## **ACTIVITY IN AFRICA**

Africa has not had many of the traditional "hidden transmitter" variety of clandestines, as most revolutionary and guerilla broadcasts have freely acknowledged that they are transmitted over facilities placed at their disposal by nations friendly to their cause. Yet those broadcasts do meet the three criteria outlined at the beginning of this chapter for separating clandestine from the great mass of international broadcasting. Tanzania, Zambia, and Zaire are three nations who have donated their transmitting facilities on a large scale for clandestine activity.

As might be expected, much of Africa's clandestine broadcasting has been directed against the remaining colonies of foreign powers, and the white minority regimes. Angola was the target of such activity prior to its independence from Portugal in 1975. One of the best known was Angola Combatente (Fighting Angola), voice of the Popular Liberation Movement of Angola which eventually

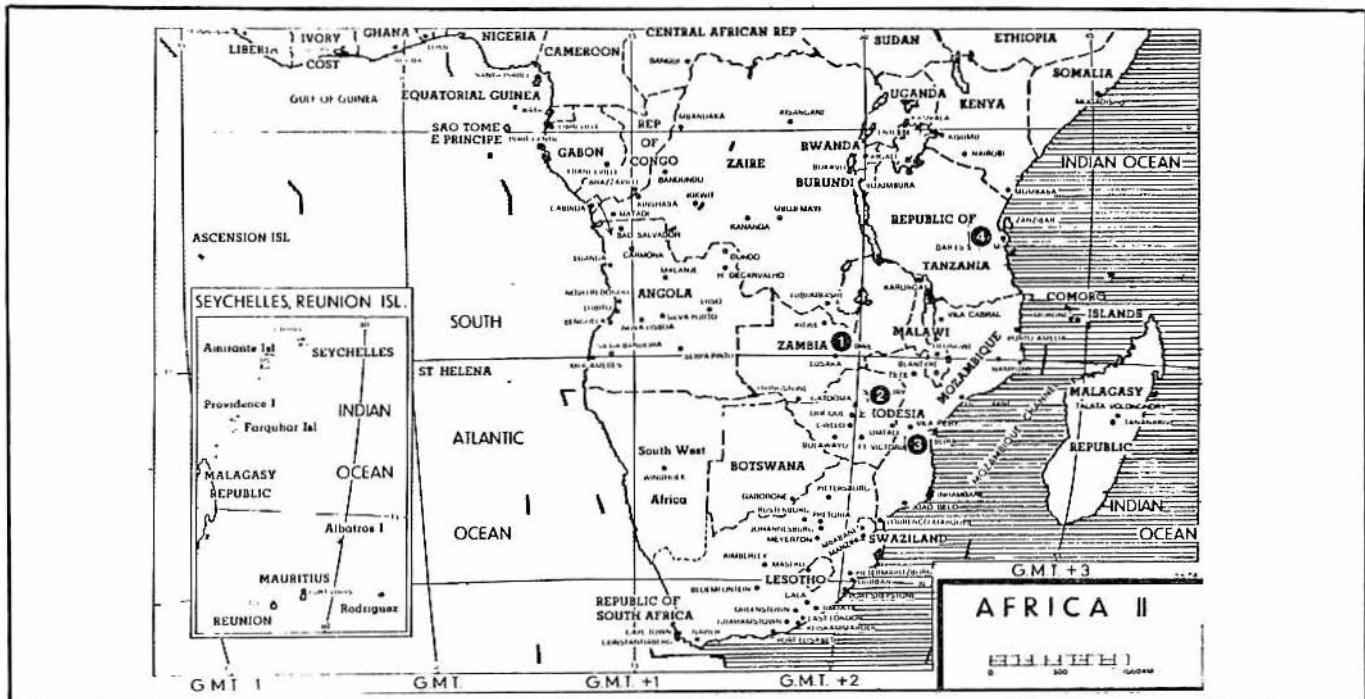

Fig. 1-7. Locations of currently active (1979) African clandestines: 1-Zimbabwe People's Revolutionary Voice, 2-A Voz de Verdade, 3-Voice of Zimbabwe, and 4-Voice of Namibia.

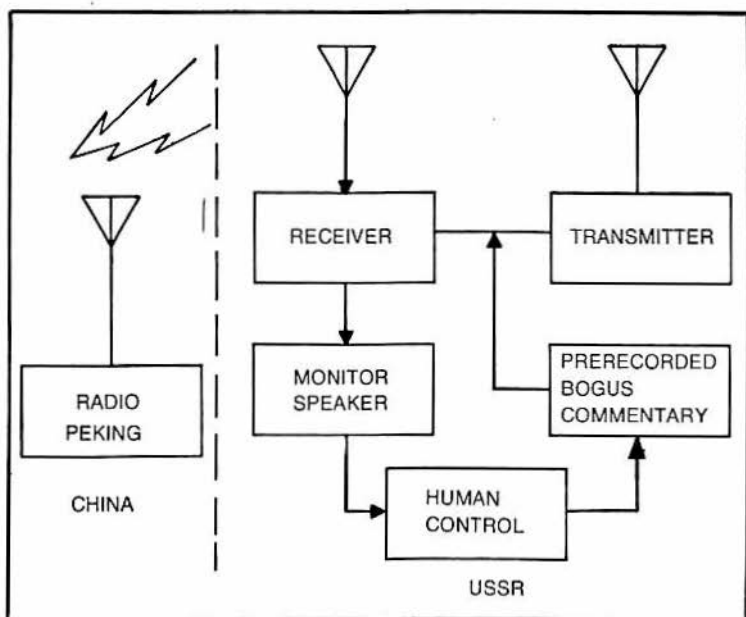

Fig. 1-8. How Chinese listeners can sometimes be led astray. Portions of the broadcast from Radio Peking are received and rebroadcast by Russian stations, with locally generated commentary inserted between legitimate programming.

assumed power upon independence. Angola Combatente transmitted over facilities in Zaire and the Congo. Another Angolan clandestine was A Voz de Angola Livre (the Voice of Free Angola), the official voice of the National Front for the Liberation of Angola, a rival to the previously mentioned Popular Liberation Movement of Angola. This station likewise used facilities in Zaire and operated until independence.

Similar activity was directed against another Portuguese colony, Mozambique, until its independence in 1975. This program, known as the Mozambique Hour, was carried over Radio Tanzania and Radio Zambia.

Other activity in a similar vein was directed against French rule in the Comoro Islands, and against the Portuguese in the islands of Sao Tome and Principe. These programs continued until independence.

Clandestine activity in Africa has now shifted to programs opposing white minority rule in such areas as Rhodesia, South Africa, and South West Africa Fig. 1-7. These programs will be covered later in this chapter.

## THE MIDDLE EAST SCENE

Clandestine activity in this area has increased markedly in recent years. All the ingredients for an explosive situation are present: revolutionaries, monarchists, religious antagonisms, and the increasingly scarce commodity—oil. See Fig. 1-9.

As mentioned earlier, the first clandestine directed to the Middle East was Radio Peyk-e Iran, which began operations in 1953 from Bulgaria, and continued until 1977. Peyk-e Iran opposed the Shah and the restoration of the monarchy, and also was strongly anti-American in tone. Another Iranian clandestine is National Voice of Iran, which has been active (as of this writing) since 1959 and is probably the oldest clandestine still active from an unknown transmitter site (although evidence strongly indicates a location in the Soviet Union near the Iranian border). This station will be discussed later in this chapter.

Iran and Iraq have long been hostile to one another, so it is not surprising that Iraq has been home to some anti-Iranian activity. Among these have been Radio of the Patriots and Radio Inspiration. Both stations were irregularly active during the 1970s in opposition to the Shah and could return at any moment, depending upon the political situation.

Iraq also has been home to another interesting clandestine, although without the blessing of the Iraqi government. Iraq is the home of over two million people known as the Kurds, most of whom live in northern Iraq near the Iranian border. For several years, the Kurds have skirmished with the Iraqi government, and a large portion of northern Iraq is under the complete control of the Kurds. Since 1965, a station has been heard at irregular intervals calling itself the Voice of Iraqi Kurdistan, broadcasting in Arabic, Kurdish, and English. Reliable intelligence sources place this station in a cave in northern Iraq!

The recent civil war in Lebanon resulted in the various factions each setting up their own clandestine station. One such operation is the Voice of One Lebanon, a pro-leftist operation believed to be operating from Iraq. Another Lebanese clandestine is the Voice of Lebanon, voice of the phalangist political faction. Indications are that this station is actually operating from the war-torn capital of Beirut. Both of these stations will be discussed in greater detail later.

Turkey has been the target of a station known as Bisim Radyo (Our Radio) since 1958. This pro-Communist station transmits from sites in Romania and East Germany and all programs are in



Turkish. Another Turkish clandestine is the Voice of the Communist Party of Turkey, operating since late 1974 from a site believed to be in Romania. Both are still active and will be discussed further.

A true mystery station is Radio Freedom of South Yemen, a station opposing the current regime in the Peoples Democratic Republic of Yemen. The programming on the station, entirely in Arabic, has a decided pro-Western slant, giving rise to speculation that this outlet is actually in Saudi Arabia. Another mystery station broadcasting from an unknown site is the Voice of Arab Syria, which opposes the current Syrian regime. Evidence indicates that this station is broadcasting from a more conservative Arab state such as Saudi Arabia, although nothing conclusive is presently known.

### **CURRENT CLANDESTINE ACTIVITY**

It is almost misleading to refer to this summary as "current" inasmuch as clandestine stations leave the air or change times and frequencies with bewildering speed. It is as accurate as possible at the time of this writing, however. Those who are seriously interested in monitoring clandestine radio broadcasts will find it imperative to join one of the various shortwave listeners clubs listed in Chapter 9, Table 9-2. Another source, of obtaining reliable information is to subscribe to the periodic newsletters of the *World Radio TV Handbook*, or the BBC Monitoring Service. The shortwave listening programs of Radio Canada International and Radio Sweden are also excellent sources of current news on clandestines. It is also essential to keep abreast of current world affairs, since this will give clues as to where clandestine activity is likely to pop up. The data in this section has been summarized for quick reference in Tables 1-1 to 1-4. All times are in Greenwich Mean Time (GMT) and conversion tables for local time can be found in the appendix of this book.

### **Anti-Castro Stations**

While the American government has apparently ceased anti-Castro clandestine activity, there is still sporadic activity from other sources. Some of these stations are apparently active from inside of Cuba itself!

One of these stations is Radio Abdala, which was first reported during November, 1977. This station operated in the 7080-7090 kHz segment of the 40-meter amateur radio band. This

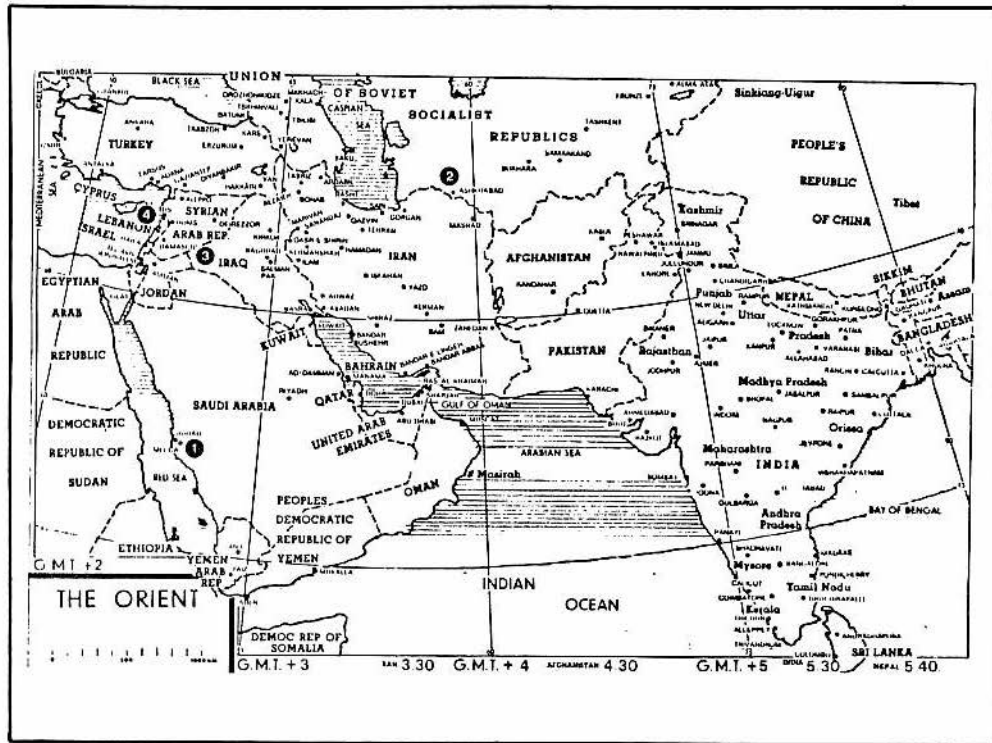

Fig. 1-9. Locations of some currently active Middle East clandestines: 1-Radio Freedom of South Yemen, 2-National Voice of Iran, 3-Voice of One Lebanon, 4-Voice of Lebanon.

**Table 1-1. Anti-Castro and Nicaraguan Clandestines.**

7000-7025	<u>Radio Rebelde</u> , Spanish language anti-Castro programs heard here irregularly in 2000-2200 slot. Believed to actually be in Cuba; probably an amateur radio station located in Oriente province.
7070-7090	<u>Radio Rebelde</u> , same as 7000-7025 but operated in this range during most of 1978.
7080-7090	<u>Radio Abdala</u> , Spanish language anti-Castro programs around 2200-0300. Gives station identifications with theme from "2001: A Space Odyssey." Poor audio quality, claims to be in Florida but may be somewhere in Central America, operation very irregular.
7080-7090	<u>Radio Libertad Cubana</u> , Spanish language anti-Castro station similar to Radio Rebelde, although much more irregular; active in 0100-0200 time period.
7449	<u>Radio Sandino</u> , Spanish messages and music for Sandista guerillas in Nicaragua around 0500, heard rarely in summer of 1978. Believed to be in Central America.

station operated entirely in Spanish, but was easy for shortwave listeners to spot due to its distinctive station identification announcements using the theme music from the movie "2001: A Space Odyssey." The station broadcast mainly political talks attacking Cuban involvement in Africa and Latin America, as well as the Soviet presence in Cuba. Both male and female announcers were used, along with brief musical interludes. Audio quality of the transmitter was very poor, however, and the frequent interference from amateur radio operations made listening virtually impossible at times. Radio Abdala usually operated in the 2200-0300 GMT time slot, although on a highly irregular basis; sometimes silent for weeks at a time before finally returning to the air. This pattern has persisted through the time of this writing in early 1980.

Much speculation has arisen as to the actual location of Radio Abdala and those behind it. Perhaps the best clue came in early 1978 when well-known shortwave listener Glenn Hauser encountered a representative from the Cuban exile group "Agrupacion

**Table 1-2. Asian Clandestine Stations.**

3985	<u>Radio Echo of Hope</u> , broadcasting from South Korea to North Korea, female announcer and Korean music 1400-1700.
4120	<u>Voice of the Revolutionary Party for Reunification</u> , broadcasting from North Korea to South Korea but claims to be in the South; scheduled in English 1400-1430, other times in Korean.
4557	<u>Voice of the Revolutionary Party for Reunification</u> , same schedule as above but English also at 2230-2300.
4880	<u>Voice of Kawthulay</u> , anti-Burmese government station, scheduled 1130-1330 with English at 1300-1330. Believed to be in the Karen state of Burma.
6035	<u>Voice of the Thai People</u> , pro-Peking Thai language talks and music at ;530-1650 from site in southern China.
6304	<u>Voice of the Burmese People</u> , pro-Peking station in Burmese; frequent schedule changes but operates in the 1030-1430 slot with one hour programs. Believed to be in southern China.
6348	<u>Radio Echo of Hope</u> , same as 3985 but also scheduled 0200-0500 and 0900-1200.
7020	<u>Voice of the People of Malaya</u> , Chinese and Malay programs 2130-0015 and 1130-1530. Pro-Communist but not pro-Peking; believed to be in southern Thailand.
7300	<u>Voice of the Malayan Revolution</u> , Malay and Chinese pro-Peking programs at 2200-2400; sometimes some English. Believed to be in Hunan province of China.
11600	<u>Voice of Democratic Kampuchea</u> , Cambodian programs supporting deposed Pol Pot regime 1200-1300.
11830	<u>Voice of the Malayan Revolution</u> , same as 7300 but scheduled at 0430-0710, 0930-1235, and 1245-1530.
15600	<u>Voice as Democratic Kampuchea</u> , same as 1600 but scheduled 2300-0000.
15790	<u>Voice of the Malayan Revolution</u> , same as 11830 but also scheduled at 2200-0005.

**Table 1-3. Middle East Clandestine Activity.**

5435	<b>Radio Freedom of South Yemen</b> , hostile to Peoples Democratic Republic of Yemen, all in Arabic at 1600-1900 and 1130-1430. Site is believed to be in Saudi Arabia.
5915	<b>Bizim Radyo</b> , pro-Communist Turkish programming at 2000-2100 from a transmitter site in East Germany or Romania.
6025	<b>National Voice of Iran</b> , pro-Communist Farsi language programming at 1730-1815 from a site in USSR near Iranian border.
6165	<b>Voice of One Lebanon</b> , Arabic programs at 1130-1230 and 2030-2130; believed to be in Iraq.
6170	<b>Voice of Arab Syria</b> , anti-Syrian government programs in Arabic at 0500-0600, 0800-0900, and 1800-1900 from unknown site.
6200	<b>Bizim Radyo</b> , scheduled 2005-2020 and 2120-2155 on this frequency.
6200	<b>Voice of the Communist Party of Turkey</b> , 0800-0840 in Turkish from site somewhere in eastern Europe.
6550	<b>Voice of Lebanon</b> , pro-phalangist programs in French and Arabic on irregular schedule in 1400-2100 slot; believed to be in Beirut.
9500	<b>Bizim Radyo</b> , same as 5915 kHz but scheduled at 1015-1045.
9510	<b>Voice of One Lebanon</b> , Arabic programs on 1130-1230 and 2030-2130 from a transmitter believed to be in Iraq.
9510	<b>Voice of Arab Syria</b> , same as 6170 kHz.
9585	<b>Bizim Radyo</b> , same as 5915 kHz but scheduled at 0500-0550, 1050-1115, 1740-1810, and 1910-1925.
9953	<b>Radio Freedom of South Yemen</b> , same schedule as on 5435 kHz.

Table 1-4. Survey of African Clandestines.

6060	<u>Zimbabwe People's Revolutionary Voice</u> , programs to guerilla fighters in Rhodesia at 1700-1745 in English and local languages over facilities of Radio Zambia.
6165	<u>Zimbabwe People's Revolutionary Voice</u> , same schedule as 6060 kHz.
7180	<u>A Voz de Verdade</u> , "The Voice of Truth" in Portuguese and Spanish to Angola and Mozambique 1600-1700; believed to be in Rhodesia.
7235	<u>Zimbabwe People's Revolutionary Voice</u> , same schedule as 6060 kHz.
9570	<u>Voice of Zimbabwe</u> , English language programs for Rhodesia around 1715 from transmitters in Mozambique.
15435	<u>Voice of Namibia</u> , English language programs to South West Africa at 1830-1900 from transmitters in Tanzania.

Abdala" handing out anti-Castro leaflets at the airport in San Juan, Puerto Rico. When Hauser asked about Radio Abdala, he was told that the transmitter was in Florida, but that they hoped to put another on the air from a Central American nation such as Costa Rica or Guatemala. The strong implication was that the station was indeed the brainchild of some of the many Cuban exiles in the Miami area.

Another enigma is Radio Rebelde, which apparently operated in late 1977 and throughout 1978 from a hidden site within Cuba! Tim Hendel, a shortwave listener near Miami, first noted the station in late November, 1977 in the 7000-7025 kHz segment. Unlike Radio Abdala, Radio Rebelde used no music or special effects; the only announcer was a male who identified himself only as "Comandante David." Interruptions were frequent and listeners got the distinct impression that Comandante David was speaking extemporaneously instead of from a prepared script. Radio Rebelde's transmissions seldom lasted more than a few minutes at a time; topics ranged from Cuban involvement in Angola to

shortages of consumer goods and the lack of Christmas celebrations in Cuba.

Early in 1978, Radio Rebelde moved operations into the 7070-7090 kHz slot. Observations by your author and other listeners detected what seemed to be coordination between Radio Rebelde and Radio Abdala; when one station was on the other was invariably on the air that same evening. Signals from Radio Rebelde were strong, indicating a transmitter power of at least 1000 watts.

In May, 1978, yet another anti-Castro clandestine calling itself Radio Libertad Cubana was reported in the 7080-7090 kHz range. Like Radio Rebelde, this station had only one male announcer delivering anti-Castro speeches. However, the voice on this station was not the same as that on Radio Rebelde and the signal was much weaker, indicating that the two were separate operations.

Anti-Castro activity in this range came to a head early in June, 1978. All three stations—Abdala, Rebelde, and Libertad Cubana—were active during this time, but were encountering a form of “jamming” for the first time. This jamming was not the usual noisemakers familiar to shortwave listeners worldwide; instead, it was either deliberate, coordinated action by Cuban Amateur stations or an attempt by Cuban authorities to disguise their jamming as legitimate amateur activity. One frequent form of interference to these stations was the “swishing” of a variable frequency oscillator (VFO) back and forth across the frequency. Another method was for several stations to begin calling “CQ” in Morse code atop the station when it began its broadcast. Interestingly enough, none of the stations that called CQ ever gave their call signs. On a couple of occasions your author noted voice stations with call signs similar to those assigned Cuban Amateurs open up atop Radio Rebelde using single sideband (SSB) voice transmission. Yet when your author tried to find the call signs given by these “amateur” stations in the *Radio Amateur Callbook*, no such stations were listed!

Activity of the anti-Castro clandestines dropped to a low level during the summer of 1978 but picked up again toward the end of the year. What the future holds for these operations cannot be forecast with any accuracy. But as long as there is a large population of Cuban exiles in the United States, along with unrest within Cuba itself, the potential for future activity certainly is present.

## **Nicaraguan Activity**

In early 1978, the Cuban news agency "Prela" reported that there was a clandestine station operating within Nicaragua called Radio Sandino, voice of the Sandinista guerillas fighting against the Somoza regime in Nicaragua. Yet monitoring failed to turn up any sign of the station, and representatives of the Sandinistas denied knowledge that any such station existed.

Radio Sandino was written off as just another wild rumor until the summer of 1978 when Aaron Hywarren of Winnipeg, Manitoba received and tape-recorded a station in Spanish identifying itself as "Radio Sandino." The station broadcast musical interludes and messages to guerilla fighters in Nicaragua. This station may be more often heard depending upon the political situation in Nicaragua.

## **The Asian Scene**

In 1972, North Korea and South Korea reached an agreement which was intended to start the process of eventual reunification of the two nations. One of the provisions of the agreement was that the two nations would stop hostile radio broadcasts to each other. Both nations have indeed ceased radio warfare over their official radio outlets, yet are now operating clandestine stations to carry on the propaganda battle. North Korea's effort is known as the Voice of the Revolutionary Party for Reunification, which is of particular interest since it features some broadcasts in English (see Table 1-2). This station claims to be broadcasting from a hidden site in South Korea, but the front fools no one; you can hear some of the same announcers over this clandestine that are also heard over North Korea's official Radio Pyongyang. South Korea's response is a station known as Radio Echo of Hope, which features beautiful Oriental music and sweet-voiced female announcers. Unfortunately, this station broadcasts only in Korean.

Burma is currently ruled by a military government and is the target of two clandestine operations. One is the Voice of the Burmese People, broadcasting entirely in Burmese languages from a transmitter site somewhere in southern China. This station's transmission schedule varies with the seasons of the year. Reception of this station is often good in western North America, leading to speculation that it might be using some of the facilities of Radio Peking. A far more elusive catch is the Voice of Kawthulay, which operates from within Burma itself. Rebels opposing the Burmese government control approximately half of Burma, and



one of the hotbeds of rebellion is the Karen state. The Voice of Kawthulay (Kawthulay is "Karen state" in Burmese) is believed to be operating from there. The station is both anti-Burmese government and anti-Communist, and does have English programs scheduled. Unfortunately, reception in North America is quite difficult.

Malaysia is the target of two clandestine operations as well. The most widely heard is the Voice of the Malayan Revolution, which operates on several times and frequencies (see Table 1-2) and has occasional English programs in addition to its Malay and Chinese broadcasts. This station is located somewhere in the Hunan province of China and, naturally, follows a pro-Peking line and is directed towards those who oppose the existence of the Federation of Malaysia—in particular, the large population of Chinese descent. Programs have been toned down a bit since the establishment of diplomatic relations between China and Malaysia, however. The Voice of the Malayan Revolution can be heard throughout North America, thanks to powerful transmitters, although reception is better in western North America.

The second Malaysian clandestine is the Voice of the People of Malaya, which is believed to be operating from a site in southern Thailand near the Malaysian border. This station is pro-Communist but not pro-Peking, and is operated by a dissident faction of the Malayan Communist Party. It is low-powered, and reception is difficult even in western North America.

Thailand is the target of the Voice of the Thai People, which has been on the air since 1962 from a site in southern China. Programming here is entirely in Thai, and reception is difficult in North America.

The latest clandestine from Southeast Asia is the Voice of Democratic Kampuchea, voice of the defeated Pol Pot regime in Cambodia. This station broadcasts from a site in southern China near Kunming. Signals are generally strong and quite audible, especially in western North America.

### **Middle East Activity**

One current clandestine in the Middle East, the National Voice of Iran, is very difficult to receive in North America. During the revolution in Iran which resulted in the ouster of the Shah, this station greatly expanded broadcasting hours, and eventually resulted in the U.S. government filing a formal protest with the Soviet Union over the station's broadcasts, which claimed that the

CIA was plotting with elements in Iran to prop up the Shah. The broadcasts were termed "highly inflammatory" by the United States and fears were expressed for the safety of Americans in Iran due to the station's broadcasts. This station is still broadcasting, trying to establish a Moscow-oriented government in place of the monarchy or an Islamic republic.

Bizim Radyo, the pro-Communist station broadcasting to Turkey, operates on several frequencies at different times as given in Table 1-3. Reception is often good in North America. The other Turkish clandestine, Voice of the Communist Party of Turkey, is more difficult but can sometimes be heard in eastern North America during the winter months.

Radio Freedom of South Yemen is difficult. The best chance for listeners in eastern North America would be during the winter months, with reception highly unlikely further west. Voice of Arab Syria is much easier, however, with reception possible throughout North America depending upon interference. Frequencies are given in Table 1-3.

Voice of One Lebanon is often heard well in eastern North America, thanks to the powerful Iraqi transmitters it broadcasts over. Transmissions later in the day are usually best. By contrast, the pro-phalangist Voice of Lebanon has yet to be heard in North America. There is the possibility that some established broadcaster might donate transmitter facilities for relaying this station, however.

### **The African Scene**

As mentioned earlier, Zambia and Tanzania are two nations that lend their transmitting facilities for much of Africa's clandestine radio activity. One of the most extensive such actions is Zimbabwe People's Revolutionary Voice, transmitting from Zambia as indicated in Table 1-4. Zimbabwe is the African nationalist name for Rhodesia. Reception of this broadcast is difficult even in eastern North America, however. Rhodesia is also the target of the Voice of Zimbabwe, transmitting from Mozambique. Like Zimbabwe People's Revolutionary Voice, reception of this station is rather difficult even in eastern North America. However, there is always the possibility of extended transmission hours if political conditions warrant; this happened to transmissions directed toward the former Portuguese colonies of Angola and Mozambique back in 1975.

Rhodesia itself is believed to be the site of a clandestine known as A Voz de Verdade (the Voice of Truth), which broadcasts

entirely in Portuguese to Angola and Mozambique. Reception of this station is likewise difficult in North America.

One African clandestine which can be more easily heard in North America is the Voice of Namibia, transmitting to the South African territory of South West Africa from transmitter facilities in Tanzania. Namibia is the nationalist term for South West Africa, and the English portion of the Voice of Namibia can be heard as indicated in Table 1-4.

### **THE FUTURE OF CLANDESTINE BROADCASTING**

As mentioned at the beginning of this chapter, clandestine activity is dictated by political circumstances. Any time there is political unrest or upheaval, particularly in less developed areas of the world where radio is the principal medium of mass communication, there will be the chance of clandestine activity. It is impossible for any book to ever be completely up-to-date on clandestine activity; those listeners with a serious interest in the subject should avail themselves of the previously mentioned sources of current information.

The United States has apparently withdrawn from clandestine activity, at least for the moment. This may be due to the fact that previous American operations in response to the Cuban and Vietnamese situations were much less successful than planned. On the other hand, the Soviet Union and its satellites continue to engage in clandestine activity, but the effectiveness of their efforts is difficult to judge.

There is also the possibility that clandestine broadcasting may expand beyond radio into the video realm. In the 1960s, the United States experimented with airborne mobile radio broadcasting facilities, and may well have employed such technology for some of its clandestine activity. Toward the end of the Cambodian conflict, there were plans to broadcast television programs into Cambodia from an airborne station, but the plans were abandoned when it was determined that there were insufficient television sets in Cambodia to justify the effort. Even the possibility of clandestine broadcasting from orbiting satellites cannot be ignored; several nations are already experimenting with direct satellite broadcasting. Such an arrangement would permit freedom from the jamming that plagues many terrestrial clandestines.

Whatever its future, it can be safely said that clandestine broadcasting will continue to offer some of the most exciting, intriguing, and politically relevant listening available anywhere on the shortwave bands.

## Chapter 2

# Espionage Radio Activity

---

If you make a habit of tuning the shortwave bands late at night, you will eventually run across a woman's voice in Spanish, repeating over and over:

"Atencion 010 84 . . . atención 010 84 . . . atención 010 84 . . ."

Intrigued, you continue to listen, and soon thereafter the woman's voice begins to read off groups of numbers in Spanish, usually with five digits to the group. "Cero, cinco, uno, dos, cero" her monotone voice intones, and your limited Spanish allows you to translate the number group "05120." For the next several minutes you listen to the parade of numbers, until the woman abruptly utters "final, final," and the station leaves the air.

You heard no call sign, no other clues to the station's identity or location. And that was what the sender of the message intended, for it was a transmission to espionage agents in other nations!

If you are an active shortwave listener, it is almost impossible to avoid running across such spy broadcasts in a variety of languages, including Spanish, English, and German. The vast majority of such broadcasts utilize both amplitude modulation and a female's voice, although some spy stations use Morse code or single sideband and a male voice. Virtually all such stations send their messages using groups of numbers in random sequence, giving rise to the term "numbers station" among radio hobbyists. In 1978, however, a new twist was added, with some stations using groups from the various international phonetic alphabets to convey messages.

**Table 2-1. A Typical "One-Time-Pad."**

Format of Typical "One Time Pad"					
59812	88591	66512	31987	18019	90009
11094	45192	90132	21984	16390	12424
09472	77010	33978	66897	02169	77517
99843	36590	45678	54109	33601	08733
76553	22984	44908	63419	47130	60844

Columns of digits in the one-time-pad system can be read either vertically or horizontally, in sequence from right to left or vice-versa. The key to proper sequence is contained early in the message group or it may have been provided in an earlier message. The number groups found on the one-time-pad are added to or subtracted from the number groups in the transmitted message and are then compared to a fixed-cipher key, such as:

55412	Meet your contact.
10192	Disregard previous message.
39172	The money will be sent ...
81041	... on Wednesday.

## METHODS OF ENCODING MESSAGES

The old spy movie stereotype of a master code-breaker unlocking intercepted messages is rapidly becoming outdated. Today's sophisticated, computerized enciphering systems produce codes so complex that they are virtually unbreakable without a major security leak of some sort. In fact, most intelligence groups depend more upon the technique of traffic analysis than upon codebreaking for information. Traffic analysis studies the number, length, and timing of message traffic in relation to events and activity in the world, and attempts to draw correlations between the two.

Most numbers stations appear to use a method known as the "one time pad" system (Table 2-1). Both sender and receiver have copies of the correct pads. Generally, each block of digits will represent a phrase or group of words rather than each digit representing an individual letter. For example, "meet your contact" could be represented by the number block 87690, and "on Monday" by 39625. To confuse any unintended listeners, meaningless blocks of digits are inserted into the message. Thus, the message "meet your contact on Monday" could be encoded as 87690 55437 39625, with 55437 being a meaningless number block.

Such a system only requires a code book or list, yet may be compromised if the code list is stolen. In addition, a sophisticated cryptographer will, in time, break some of the number blocks. One way to get around this problem is to require the recipient of the message to add or subtract another five digit block to each number group received. For example, the message 87690 55437 39625 could be transmitted as 56340 28761 11872 and the recipient would add 31350 26676 27753 to get the correct message block. The "one time pad" consists of several pages, all printed with columns of random numbers. Early in the message, the sender indicates the page, column, and line the recipient should turn to, along with whether the numbers should be added or subtracted. In this case, the recipient would find 31350 26676 27753 on the page, column, and line given in the message. Information on whether to add to or subtract from the transmitted number groups would likewise be given.

Once used, the entire page is torn out of the pad and is destroyed. This system is considered to be highly secure as long as the one time pad does not fall into the hands of the opposition. Its disadvantages, however, are its slow speed and cumbersomeness. To overcome this, sophisticated mechanical encoding and decoding machines based upon the number-block system were developed in World War II. More recently, microprocessor technology has advanced to the point where pocket-sized decoding devices are quite feasible and are indeed rumored to be in use.

## **PATTERNS OF ESPIONAGE ACTIVITY**

By far, the most common numbers stations heard will be in Spanish, transmitting five-digit number blocks. Four-digit Spanish numbers, English numbers, and German numbers are also commonly heard along with a sprinkling of other languages and transmission modes. Naturally, these stations have no set schedule of times and frequencies, although they do exhibit certain patterns of activity which have endured over long periods of time.

### **Five-Digit Spanish Numbers**

Table 2-2, gives a survey of recently reported activity by Spanish language, five-digit numbers stations. All stations in Table 2-2, use amplitude modulation and a female speaker. As the table reveals, five-digit numbers activity is heavily concentrated on the lower end of the shortwave spectrum (usually below 10 MHz) and takes place during the evening and night hours in North and South America.

**Table 2-2. Spanish Language Five Digit Numbers Stations.**

All numbers stations in this list utilize a female voice.

<u>Frequency</u>	<u>Times and Other Data</u>
3000	0210
3060	0200; heavily used channel
3090	0130; heavily used channel
3100	0230
3115	0500
3120	0500
3210	0410
3280	0400
3437	0325, 0415
3865	0515
4668	0420
4900	0630
4935	0820
5133	0645
5138	0400
5810	0520
5820	0200
6470	0625
6745	0610
6748	0730
6767	0610
6770	0610; heavily used channel
6777	0620
6780	0615
6790	0720; heavily used channel
6805	0700
6810	0700
6900	0700
7200	0620
7250	0705
7320	0715
7323	0615
7340	0830
7342	0615
7527	0610
7585	0635
7845	0800
7857	0700
7868	0620
7887	0630
7905	0600
8006	0710
8010	0715
8413	0630
8550	0625
8839	0435
8875	0605; heavily used channel
9330	0800
9440	0615
9465	0815
9470	0500
9480	0800
9520	0630
9925	0535
9950	0500, 0800; heavily used channel
9978	0510
10475	0520
11865	0530
12300	0500
12315	0500
15053	0715
19510	0625

Five-digit Spanish numbers follow a definite pattern, see Table 2-3. Transmissions begin with the word "atención," followed by a three-digit group and a two-digit group, such as "atención 294 39." The two digit number group is always the number of coded groups in the message; in this case the message would consist of 39 five-digit groups. There is some dispute over what the three-digit number group represents. One theory holds that it is the number of the code key for that message while another theory is that it is the number of the agent to which the message is being sent. After the number groups are read, the transmission ends with the words "final, final."

Some remarkable discoveries about the five-digit Spanish numbers stations were made through the efforts of Mike Chabak, a shortwave listener in Colorado, Chabak devoted almost three months to monitoring these stations, staying up almost every night until dawn. One of his most remarkable discoveries was the fact that entire transmissions are sometimes repeated digit-for-digit several weeks apart! He also discovered that each transmission is run twice in the same time block, and usually within the same

Table 2-3. A Typical "Spanish Numbers" Message Format.

#### Five Digit

**Atención 644 41** (repeated for several minutes before actual message; 644 is the intended recipient, 41 is the number of digit groups in the message).

**82109 76539 00914 66419** (these five digit blocks are given up to the total of 41 indicated above).

**Final Final** (this is the signal that the message is finished).

#### Four Digit

**540 540 540 1234567890** (540 is believed to be the intended recipient; this series is repeated several times).

----- (several dashes which indicate a message is to follow)

**Grupo 73 Grupo 73** (usually repeated twice, indicates the number of message groups to be transmitted).

**7621 8674 0981 5539** (actual message begins, containing 73 groups as given above).

**Repeto grupo 73** (this indicates that the message is about to be repeated. Station usually leaves the air as soon as the message is repeated, without the "final, final" used by five digit numbers stations).



frequency block. For example, the message usually begins near the hour and is repeated three to nine minutes later. The frequencies of the two transmissions are different but usually within 100 kHz of each other. Another interesting point noted by Chabak was that no transmission ever started later than forty minutes after the hour.

Chabak also discovered that there was a close relationship between opening identification and the schedule and frequencies of the transmissions. For example, "atención 283 66" could be the identifier always heard on Fridays between 0600-0700 GMT between 3000-3200 kHz. Sometimes such "scheduled" transmissions began and ended with the same number blocks.

When the various numbers stations began popping up several years ago, one common description of the female's voice was "mechanical." Each digit has the same intonation regardless of its place within the message. Careful listening will reveal why; a faint "click" can be heard between each number. It seems apparent that the various transmissions are produced by a recording device similar to that used by telephone company to inform callers of changed or discontinued numbers. Each message is made up of varying combinations of the numbers zero through nine, and the words "final" and "atención!"

#### **Four-Digit Spanish Numbers**

Another female voice is heard on the shortwave bands reading numbers in Spanish, but in four-digit groups instead of five. There are other differences between these Spanish numbers stations as well.

Identifiers here consist of three digits and are given three times, followed by a count from zero to nine, as in "196, 196, 196, 0, 1, 2, 3, 4, 5, 6, 7, 8, 9 . . ." This can be repeated as often as twenty consecutive times. Several "dashes" like those in Morse code follow, indicating that the actual message is about to begin. The count of the number of digit groups is given twice, as in "grupo 53, grupo 53," and then the four-digit groups are read off. After the message is given, it is often repeated. Such repetition is prefaced by the phrase "repeto grupo." As soon as the message is finished, the station leaves the air without the "final, final," used by the five-digit-numbers stations.

There is a variation of the usual four digit format, however, in which the word "cuenta" (count) is used in place of "grupo." This is a relatively rare practice.

As an examination of Table 2-4 will confirm, most four-digit numbers activity occurs at the same times that five-digit activity

**Table 2-4. Spanish-Language Four-Digit Numbers Stations.**

All numbers stations in this list utilize a female voice.

<b>Frequency</b>	<b>Times and Other Data</b>
4305	0300
4600	0310
4665	0100
4670	0315, 0435; heavily used channel
4675	0320
4710	0315
4780	0430
4940	0425
5235	0345
5700	0230
5750	0130
5800	0120, 0400
5810	0210, 0325, 0410; heavily used channel
5820	0505
7970	0610
7996	0500
8425	0200
11520	1600

takes place, generally on frequencies in the four- and five-megahertz shortwave bands. In comparison to five-digit activity, four-digit numbers transmissions are much less common.

### **English-Language Numbers**

Unlike the Spanish numbers stations, those using English have several variations, making clear patterns difficult to determine. Transmissions do utilize the same type of "mechanical" female voice as on the Spanish numbers stations, but there is a wide variety in the voice styles; often the English has a distinct German or Oriental accent. Number blocks range in length from three to five digits and repetition is common. A new feature of the English stations is the frequent use of sound effects, such as beeps, flutes, or tones to separate portions of the transmission.

Perhaps the most common format for English numbers stations begins with a transmission identifier consisting of two

letters from the international phonetic alphabet, such as "Charlie Mike" or "Papa Uniform." This identifier is repeated several times, and is usually followed by flutes, tones, beeps, or other sound effects, see Table 2-5. Next come a group of three-digit numbers, which are believed to be the identifiers of the intended recipients. The actual message itself is most commonly in five-digit blocks, although three- and four-digit blocks are sometimes heard. Sometimes more than one message is transmitted in a single broadcast and is addressed to separate recipients, as indicated by an announcement like "attention 312 38 group," or, "we have information for 599."

A variation of the preceding makes use of the term "disinformation," which may be a mispronunciation of the phrase "this information." This type of numbers station uses a two-word identifier from the phonetic alphabet, and some sound effects, followed by three-digit blocks believed to be identifiers for the recipients. But "disinformation" is used before the start of each message block, often preceded by the group count, as in "18 groups disinformation." When the transmission is finished, the female voice simply says "end of disinformation" and the station leaves the air.

Table 2-5. English Numbers Message Format.

**Sierra Foxtrot** (two word phonetic alphabet identifier, repeated several times, then often followed by some sort of sound effect such as tones, flutes, or beeps).

**816 816 58 394 394 50** (the three digit groups are believed to be the intended recipients, while the two digit number is the number of groups in the message for each).

**Attention 816 816 58** (this indicates the start of a 58 group message for agent 816).

**Attention 394 394 50** (this indicates the start of the second message, consisting of 50 groups, for agent 394).

**End** (termination of the message).

#### Alternative Form

**Charlie Mike** (two word phonetic alphabet identifier, repeated several times and usually followed by sound effects).

**599 656 27 Groups Disinformation 663 759** (this indicates that the message to come has 27 number groups in it. The message follows, and is repeated usually. It is unclear which three digit groups refer to the sender or the recipient).

**End of Disinformation** (transmission terminates).

**Table 2-6. English-Language Numbers Stations.**

All numbers stations in this list utilize a female voice and five digit groups unless otherwise indicated.

<b>Frequency</b>	<b>Times and Other Data</b>
4308	2315
5820	0130; four digit groups
7900	0245
7996	2305
9027	0230
9030	0200
9450	2040, 2200, 0300, often with flutes; heavily used channel
10180	2130, mixed four and five digit groups, flutes
10400	0220
10460	2330
10480	0200
10490	0200
10500	2235, three digit groups with repetition
10502	0200, tones; heavily used channel
10570	1600, four digit groups
10736	0200
11620	0230
12900	2200
14945	2210, flutes
14950	2200, tones
14965	2230
14966	2225, three digit groups with repetition, tones
14970	2230, three digit groups with some repetition, beeps; heavily used channel

As Table 2-6 shows, English-numbers stations are scattered throughout the shortwave spectrum and can be heard at many different times.

### **German-Language Numbers Stations**

German-language numbers stations are also quite frequently heard on shortwave. In their operating methods, these German stations exhibit characteristics of both the Spanish and English numbers transmissions. One common technique, similar to the five-digit Spanish stations, uses the word "achtung" in the opening,

as in "achtung 337." Transmissions terminate with the word "ende," much in the manner that Spanish numbers stations close with "final." Broadcasts in this format generally use five-digit number groups, although sometimes four-digit groups are heard.

Some German-language stations use phonetic alphabet identifiers like the English language stations, however. Format is similar to the "disinformation" English-numbers stations mentioned previously. Tones, beeps, and music are occasionally used, and these sound effects may either follow or precede the phonetic identifier.

As Table 2-7 illustrates, German numbers stations are scattered throughout the shortwave spectrum, and activity appears at various times.

### **Single-Sideband (SSB) Numbers Stations**

In recent years, an increasing amount of numbers-stations activity has started taking place using single sideband (SSB) transmissions, mainly upper sideband (USB). The most frequent users of SSB are those stations transmitting five-digit German messages, although English and Spanish have been used, and sometimes a male voice is heard instead of the usual female speaker. A rundown of recent SSB numbers stations is presented in Table 2-8. An examination of this table will reveal the variability of the digit groups (sometimes random groups are used), as well as the wide range of times these SSB transmissions can take place.

These SSB transmissions are especially intriguing, since the equipment required for satisfactory SSB reception is more complex than that for the AM mode used by other numbers stations. SSB is a more efficient mode than AM, however, and it could well be that these transmissions are intended for reception at distances far removed from the transmitting site, such as from Europe to South America. It is likely that these SSB stations use facilities normally intended for international point-to-point telephone circuits, due to the various frequency ranges in which these broadcasts are noted.

SSB numbers stations generally use the same transmission formats that we have previously discussed, although those in the German language are more likely to use identifiers from the phonetic alphabet than do their counterparts on AM.

### **Morse-Code (CW) Numbers Stations**

Far more difficult to track down are the various numbers stations which transmit only in Morse code. This is because many

**Table 2-7. German Language Numbers Stations.**

All numbers stations in this list utilize a female voice and five digit groups unless otherwise indicated.

<b>Frequency</b>	<b>Times and Other Data</b>
3220	0425
3240	2025
3370	2315
3375	2015
3823	2140, tones
4545	2115
4770	2115
4995	2105, four digits
5170	2015
5200	0305
5700	2020
5818	1110
6506	0215, music
6510	0710
7320	2200
7420	0630
7532	2130
7545	2140
7858	2040
9121	0310
9125	0400, beeps
9970	0110
9975	2300
11107	0045
11615	0535
14950	1900
19250	0945

other stations transmit number and letter groups, such as the military and the weather services, and the only way to be certain that you have heard a numbers station is to tune in from the beginning. Like all other espionage transmitters, the CW stations do not use any internationally recognized call sign or other positive identification. Table 2-9 shows some frequencies you can try.

**Table 2-8. Single Sideband (SSB) Numbers Stations.**

All numbers stations in this list utilize a female voice unless otherwise indicated. Most stations use upper sideband (USB) mode.

<b>Frequency</b>	<b>Time and Other Data</b>
5025	0630, four digit groups in German
5765	0330, five digit groups in German
5845	2140, five digit groups in German
6400	0200, male in Spanish reading five digit groups
8172	2115, five digit groups in English
9330	0100, five digit groups in German
9450	0110, five digit groups in German
9970	0015, mixed length digit groups in German
9970	0345, five digit groups in Spanish
10450	0235, three and four digit groups in English, flutes
10492	2200, five digit groups in German
11100	0030, five digit groups in German
11110	1845, five digit groups in German
11200	0500, five digit groups in Spanish
11375	2200, five digit groups in English
11616	0845, five digit groups in German
14942	2235, five digit groups in German
14950	2215, five digit groups in English
14950	1620, five digit groups in German
15608	1745, five digit groups in German

The opening of a CW numbers station consists of 2 three-digit number blocks repeated three consecutive times, as in "336 336 336 086 086 086." This opening is sent several times before the beginning of the actual message, and is thought to consist of the

identifiers of both the sending station and the intended recipient. This is followed by the date and number of message groups to follow. The actual message follows, and the transmissions conclude with a repeat of the date and number of message groups.

A variation of this procedure features an opening of a "VVV" series, followed by a three-digit number assumed to be the identifier of the transmitting station. This is followed by a five-digit group, believed to be the identifier of the intended recipient, and finally the date. A string of several dashes separate this opening from the actual message.

CW numbers stations generally use five-digit groups, although three- and four-digit groups are encountered, along with random combinations of letters and numbers. Very often, a long dash like the Morse letter "T" is substituted for the numeral "0" (which is five dashes in Morse). However, this is a common practice of many CW stations, so do not assume that you are hearing a numbers station merely because of hearing a "T" instead of "0" in a series of numbers.

Tables 2-3, 2-5 and 2-10 give examples of typical numbers messages from Spanish, English, and CW stations.

## UNUSUAL ESPIONAGE RADIO ACTIVITY

Table 2-11 surveys some of the more unusual, rare types of espionage radio activity. As can be seen, espionage messages

**Table 2-9. Morse-Code (CW) Numbers Stations.**

All stations in this list transmit exclusively in Morse, using unmodulated carrier.	
Frequency	Times and Other Data
3060	0105, random letters
3181	1020, random letters
3315	2119, five digit groups
3320	2125, five digit groups
3455	2120, five digit groups
4900	2135, five digit groups
7910	0700, five character groups of letters and numbers
8960	2343, five digit groups; some three digit groups repeated
12100	0105, five digit groups
14645	1905, three digit groups
19915	2015, five digit groups



**Table 2-10. Typical Numbers Message in Morse Code.**

336 336 336 086 086 086 (opening, repeated several times, believed to consist of the identifiers of both the sender and recipient of the message).

11 11 31 31 (the first two digit group is always the date of the message, the second indicates the number of five digit groups to follow).

93512 6T466 99TT1 (message follows, up to the count of 31 specified above, with T substituted for 0).

11 11 31 31 TTT (closing of message, transmission terminates).

#### Alternative Form

VVV 284 77001/27 77001/27 77001/27 (opening, repeated several times. The three digit group is believed to be the identifier of the sending station, the five digit group to the left of the slant bar the intended recipient, and the two digit group to the right of the slant bar is the date of the message).

----- (a string of dashes indicates the message is about to begin).

77001/28 77001/28 (sent just prior to the message groups, the two digits to the right indicating the number of groups in the message).

6841T 99492 TT975 (actual message, station leaves air immediately upon conclusion without closing indication).

come in a variety of languages and speakers. Sound effects run the gamut from Korean songs to the grand march from Verdi's opera "Aida."

Among the more interesting of these operations is the sudden appearance in 1978 of a station, using a female voice, transmitting groups from the international phonetic alphabet, as in ". . . sierra, zulu, foxtrot, mike, india . . . alfa, november, tango, papa, november . . ." Both English and Spanish phonetics have been heard. The intonation on these broadcasts are similar to those on the Spanish numbers stations, and the same "mechanical" sound is present, giving rise to speculation that they are produced by the same process used to produce the Spanish numbers transmissions.

The languages used are also a source of great interest and speculation, particularly such languages as Russian, Czech, Korean, and Serbo-Croatian. These are all languages of nations in the Communist bloc, leading to speculation that these transmissions

could be originating in the West and are directed to agents inside those nations. Another theory holds that these transmissions are directed to agents from such nations, who are operating in the West. Another puzzle is the use of several languages within the same message, which could mean the message is intended for agents in several different nations, or that the intended recipients are expert linguists!

More surprises are likely to be in store in the future. New frequencies, times, and languages all pop up with bewildering

**Table 2-11. Miscellaneous Espionage Radio Activity.**

<b>Frequency</b>	<b>Times and Other Data</b>
3365	0530, male reading five digit groups in Serbo-Croatian
3440	0110, male counting from one to six in Spanish
4548	1400, Morse code messages interspersed with Korean songs
4642	2110, female reading five digit groups in French
4740	2030, male reading numbers in Spanish or Portuguese, station signs on with grand march from opera "Aida"
5110	0200, male reading random numbers in Czech, some Slavonic dance music between messages
5715	1340, female reading four digit groups in Korean
7445	0200, female reading groups of letters from the phonetic alphabet
8112	0220, female reading five digit groups in Czech
9980	2340, female with Oriental accent reading five digit groups in English and German
13320	2315, male reading five digit groups in Russian
14339	1740, female reading five digit groups of letters and numbers in English, French, and Spanish

frequency. The only way to keep completely up to date on espionage transmissions is to join a major shortwave listening club which covers such activity or, better yet, to actively engage in monitoring such transmissions yourself.

### **WHERE DO NUMBERS STATIONS TRANSMIT FROM?**

For years, shortwave listeners have speculated as to the source of the various numbers transmissions. There is no shortage of evidence, but much of it is contradictory.

One thing that is quickly noticed about the numbers stations is that most have powerful signals, indicating that powerful, permanent transmitter sites are used. Most of the frequencies used are also in or adjacent to the international fixed-service allocations, strongly suggesting that such transmissions use the facilities of coastal or point-to-point stations. This is especially indicated in the case of the SSB stations, since high powered SSB stations are extensively used in the various fixed services. Most fixed services are government operations, which would make their use for espionage activity easy. See Fig. 2-1 for an example of how espionage messages form a 2-way street.

Many shortwave listeners are convinced that the five-digit numbers transmissions originate in Cuba. There are several powerful pieces of evidence to indicate this is the case. Perhaps the most persuasive is the Federal Communications Commission, which has indicated that Cuba is the source of such transmissions! In early 1978, a shortwave listener named David Crawford queried the FCC about the five-digit Spanish numbers stations he monitored on 3060 and 3090 kHz. The reply from the FCC read in part, "... as a result of our routine monitoring of the radio spectrum, we have on previous occasion encountered the signals you describe. Through means of long range direction-finding bearings, we determined the signals were emanating from Cuba. Consequently, they were of no further interest..." (See Fig. 2-2 for an interesting followup on this).

Some additional evidence pointing to Cuba as the source of such signals was obtained through monitoring in 1975. Several shortwave listeners noted audio from Radio Havana Cuba in the background of several numbers transmissions. The audio was in parallel to a frequency in use at the same time by Radio Havana Cuba. The most obvious answer to this situation was that the numbers station and Radio Havana Cuba used the same transmitter site, and that audio from one was getting mixed in with the other.

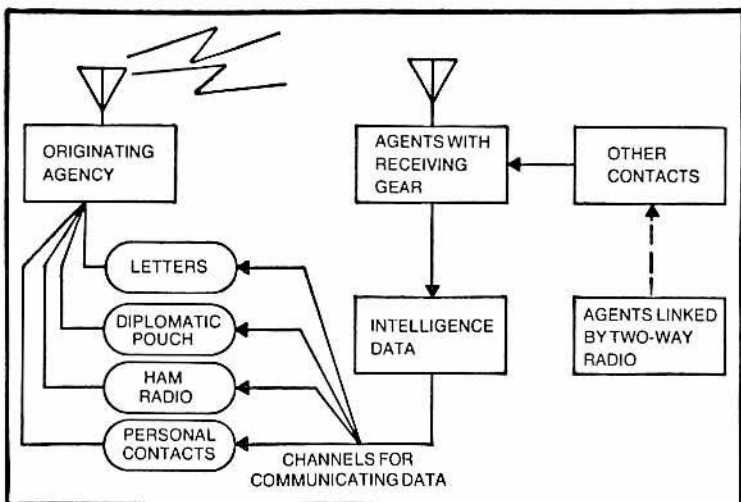

Fig. 2-1. Spy radio communications are not just outgoing. Spy radio is actually part of an "information loop," where spies act upon their received instructions and forward information back to the originating agency by a variety of means, including radio, mail, personal contacts, and diplomatic pouches. This data in turn determines what future directives will be issued by the "spy numbers" stations.

Another similar clue came in the early 1970s, when the station on 9920 kHz (see Table 2-2) was reported using the same sign on-theme used by Radio Havana Cuba.

It has been widely assumed that many, if not all, of the German numbers stations are located in East Germany. In 1972, a shortwave listener named Steve Handler even managed to get a QSL card from East Germany for a German numbers broadcast! In October of 1971 Handler heard a German numbers station on 19640 kHz and reported reception of it to the central transmitting facility used by East Germany for their overseas telephone links. In May of 1972 a QSL card was received by Handler, confirming his reception on the date, time, and frequency he had reported. Further confirmation came in 1976 when the West German magazine, *Der Spiegel*, ran the confessions of an East German spy, who told how he received instructions via coded radio messages.

And yet, there is considerable evidence that many of the numbers stations actually originate from within the United States!

Perhaps the most important clue comes from rough direction finding techniques and the strengths of the signals, both of which strongly suggest locations within the United States. Shortwave listeners in Ohio have reported four digit numbers stations whose

strength was exceeded only by a fifty-kilowatt broadcast-band station located a few miles away. Other listeners in the Washington, DC area have reported numbers stations of the four-digit variety with local quality signals, devoid of any fading or ionospheric disturbance—indicative of ground or space-wave reception from nearby transmitters.

Further evidence has come from rough direction finding by listeners in Florida and southern Texas, who have determined that some of the numbers stations, particularly those using four digits, were transmitting from locations to the north and east.

The United States government and military owns numerous transmitting sites which could be used for numbers transmissions. For purposes of deception, it would be an easy matter to mix in "off

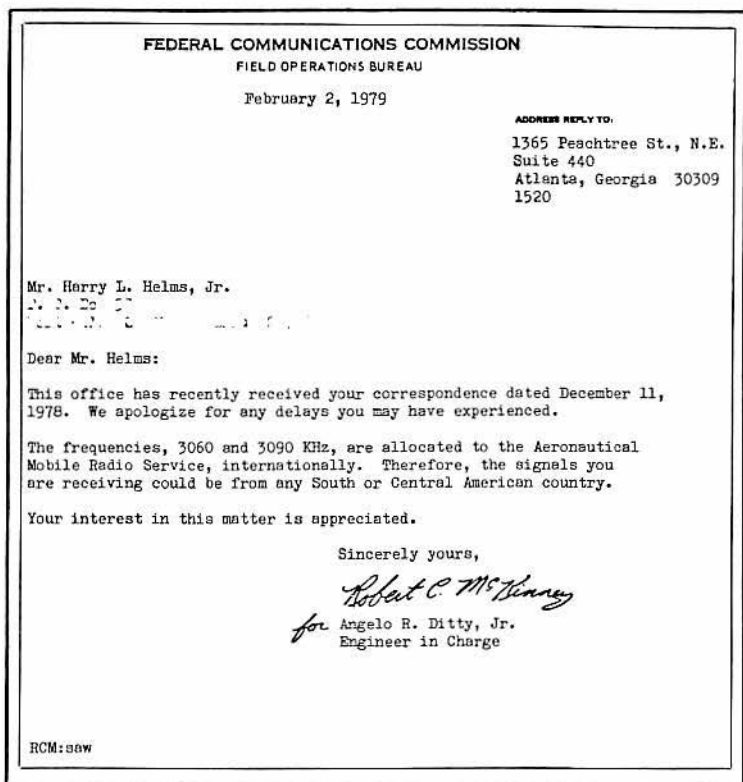

Fig. 2-2. Letter to the author from the FCC, in reply to a letter asking for information concerning the numbers stations on 3060 and 3090 kHz. Note that this reply does not reinforce prior FCC claims that the numbers stations are in Cuba, despite a direct query on that point. Curiously, the query was sent to Washington, yet the reply came from the Atlanta Office!

the air" audio from Radio Havana Cuba at a transmitter site in the United States. And the FCC's claims that such stations are located in Cuba must be taken with a bit of salt, since the FCC steadfastly denied any knowledge of the Radio Swan/Americas CIA operation from the American territory of Swan Island.

One distinct possibility is that both the United States and Cuba are engaged in numbers stations activity, transmitting to their own agents in the field, or even perhaps trying to lead each other's personnel astray with phony transmissions!

Other shortwave listeners have analyzed the differences between the four-digit and five-digit Spanish numbers stations, and have concluded that they are separate operations, with five-digit stations likely operating from Cuba or other Latin American areas (possibly including Puerto Rico), and the four-digit operations likely located within the United States.

No firm conclusions can yet be drawn about the origin of the English numbers stations. Some of these transmissions are obviously European in origin due to strength, propagational factors, and rough direction finding bearings. Others originate much closer to the United States, based upon the same indications. All clues point to the English numbers stations as having several points of origin, perhaps on both sides of the Iron Curtain.

One of the most fascinating clues in the numbers stations mystery happened a few years ago when one listener noted a five-digit Spanish transmission. At the conclusion of the message, the carrier remained on the air and the voices of females reading five digit groups in English and German could be faintly heard in the background! This could indicate that such transmissions are the work of one large organization (whose native language is not necessarily Spanish), or it could mean that the various language stations could share a common transmitter site. Or, it could simply be another move in an international game of double cross!

There is general agreement, however, that most German language numbers stations operate from East Germany. This is indicated by rough direction finding by European monitors, and by the testimony of defectors, as mentioned earlier. Some of these transmissions, particularly of the four-digit variety, may originate in West Germany but evidence on this point is highly circumstantial.

The origination points of the other numbers stations are all open to conjecture. Both sides of the Iron Curtain are likely candidates, and only coordinated monitoring efforts of several

shortwave listeners using accurate direction finding equipment can help resolve the mystery. Such efforts, sadly, have yet to be undertaken.

The volume of numbers-stations transmissions has shown no sign of decrease in recent years, and the variety of such transmissions has in fact steadily increased. These stations will likely continue to puzzle listeners for several years to come.

## Chapter 3

# Government and Military Communications

---

It should come as no surprise that the government of the United States, through its various civilian and military agencies, operates one of the largest (if not *the* largest) communications systems in the world. What may be surprising is that anyone who owns a shortwave receiver (Fig. 3-1) can eavesdrop on transmissions from the Central Intelligence Agency, Strategic Air Command, Federal Bureau of Investigation, and even foreign embassies located in the United States!

One word of caution must be inserted here: unlike broadcasters or amateur stations, these stations discussed in this chapter fall under the so-called "secrecy provision" of the Communications Act of 1934. Simply stated, this means that it is a federal offense to divulge the contents of any transmission you may receive from these stations to anyone other than the actual sender of the message. Penalties for violators can be as high as a \$10,000 fine and one year in prison. You can listen all you want, but you must not repeat what you hear!

### **DIPLOMATIC RADIO**

Under international law, embassies have the right to communicate with their home governments by wire or radio, using codes and ciphers. Since modern encoding methods are virtually unbreakable, most embassies communicate by the more reliable wire method. However, some embassies still maintain their own



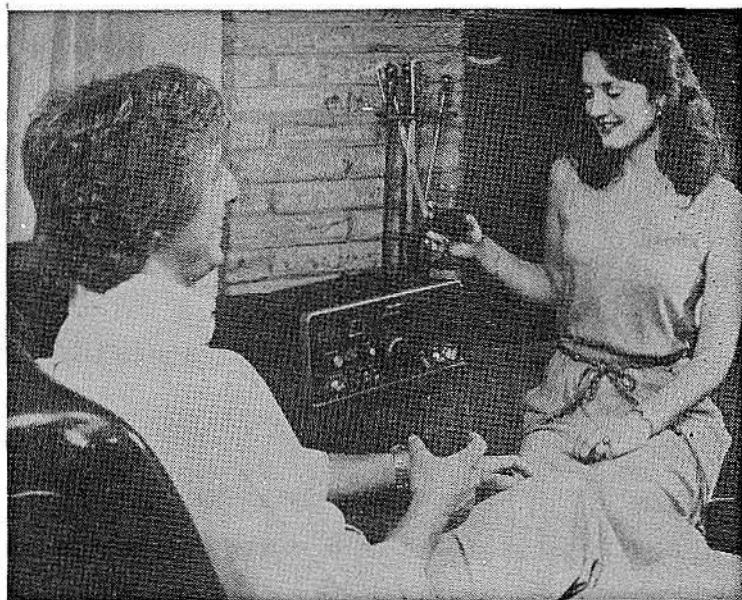

Fig. 3-1. People all over the country are turning to a new idea in home entertainment—Shortwave Listening. With a good general-coverage receiver, such as Radio Shack's DX-300, you can hear entertaining and informative programs from many lands. With the help of this book, you can listen in on some of the "mystery" signals that inhabit the shortwave world.

radio stations, (Fig. 3-2), and these can be easily heard by the alert shortwave listener.

One of the most frequently heard stations is KKN50, which transmits from Washington, DC, on the frequencies listed in Table 3-1. KKN50 is used by the Department of State Intelligence Service, although it is listed with the International Telecommunications Union as belonging to the Central Intelligence Agency! KKN50 is used principally to communicate with American embassies located overseas, and most transmissions are in Morse code, although some radioteletype is occasionally heard. As might be expected, all messages are in codes and ciphers, although station identification is given in ordinary Morse, and can be easily caught by those who know the code. If you are not proficient in CW, you can identify the station by using a tape recorder and a Morse-code table.

Several foreign embassies of the United States can be heard easily stateside, as listed in Table 3-2. Like KKN50, these stations primarily use Morse-code and cipher groups, although the identifi-



Fig. 3-2. Home of station KKN44, the American embassy at Monrovia, Liberia.

cations at the beginning and end of each transmission are given in ordinary CW. The purpose of these stations is a subject of debate. Certainly, a station like KRH50 in London seems superfluous in view of the abundance of communications facilities in that city, leading to some speculation that these stations may actually be used more for espionage communications to agents in nearby nations than for communications back to Washington. Note particularly that KWS78 in Cyprus operates on 3822 and 14358 kHz, which would be convenient for contacting those agents who also happen to be amateur radio operators!

Other nations take advantage of diplomatic law to establish radio stations at their embassies in Washington. These stations are

6924.5	15540
10635	18525
12022.5	23892.5

**Table 3-1. Frequencies  
Used by Station KKN50.**

**Table 3-2. American Embassy Stations Around the World.**

<b>Frequency</b>	<b>Station and Location</b>
3186	KWS78, Nicosia, Cyprus
3310	KRH50, London, England
3822	KWS78, Nicosia, Cyprus
5270.5	KWS78, Nicosia, Cyprus
5272	ACN, La Paz, Bolivia
7620	KWS78, Nicosia, Cyprus
7635	KKN44, Monrovia, Liberia
7830	KKN44, Monrovia, Liberia
8035	ACN, La Paz, Bolivia
10235	KWS78, Nicosia, Cyprus
10680	KRH50, London, England
11685	KKN44, Monrovia, Liberia
14358	KWS78, Nicosia, Cyprus
14945	ACN, La Paz, Bolivia
18480	KWS78, Nicosia, Cyprus

primarily operated by East European nations, as Table 3-3 shows. The frequencies and call signs are actually assigned to the U. S. Department of State but are "loaned" to the foreign embassies by our government. All transmissions are in Morse code, and consist of cipher groups, although identification is given in plain CW.

### **CIVILIAN COMMUNICATIONS**

The United States government is a heavy user of the radio spectrum. Most of the frequencies used are "aboveboard," such as those used for air and sea navigation, weather information, and relaying Voice of America programs (Fig. 3-3). Some agencies of the government are much more secretive about their radio communications, however.

The Federal Bureau of Investigation is one such "quiet" user of the radio spectrum. Prime FBI channels are 7905, 9240, and

10500 kHz, used by various stations listed in Table 3-4. These frequencies are used for radioteletype communications, backing up the FBI's normal wire facilities. Normally, these frequencies are only used in emergency situations in which the normal wire channels are out of operation but tests are conducted frequently, allowing them to be heard with a little patience. See Fig. 3-4.

Some agencies are more than just "quiet" in their use of the radio spectrum—they are completely secretive! The United States government lists several call signs and frequencies with the International Telecommunications Union but do not give the agency which operates the station. In some cases, the government has not even divulged the location of some stations. Table 3-5 lists such "unknown agency" stations. Virtually nothing more is known about these stations than what is given in the table; power and emission modes are mysteries.

Some reasonable guesses can be made about the purposes of the stations in Table 3-5 and Fig. 3-5. However, Montana, North Dakota, and South Dakota are the locations for numerous Minuteman missile installations, and the stations listed for such states may well be connected in some way with the missile installations. The station at Sterling, Virginia could be connected with any

**Table 3-3. Foreign Embassy Stations in Washington, D.C.**

<b>Frequency</b>	<b>Call Sign and Embassy</b>
9040.5	KNY25, Romanian Embassy
9041.5	KNY26, Hungarian Embassy
10642.5	KNY26, Hungarian Embassy
11090	KNY25, Romanian Embassy
13377.5	KNY21, Yugoslavian Embassy
13377.5	KNY23, Czechoslovakian Embassy
13379	KNY26, Hungarian Embassy
14649	KNY23, Czechoslovakian Embassy
15704	KNY21, Yugoslavian Embassy
15804	KNY20, Polish Embassy
15804	KNY23, Czechoslovakian Embassy
16065	KNY25, Romanian Embassy
16392	KNY26, Hungarian Embassy
18430	KNY23, Czechoslovakian Embassy
18430	KNY21, Yugoslavian Embassy
19458	KNY23, Czechoslovakian Embassy
19458	KNY20, Polish Embassy

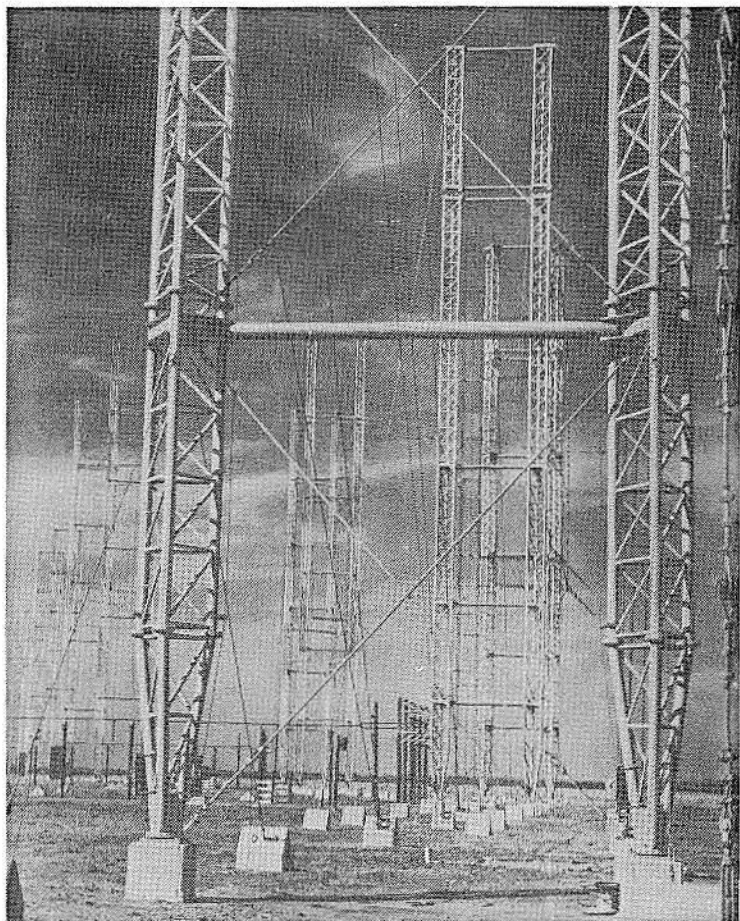

Fig. 3-3. Part of the antenna field of the Voice of America relay transmitters at Greenville, NC. The 74 antennas carry Voice of America programs to Eastern Europe, Western USSR, the Middle East, Africa and Latin America.

number of intelligence agencies located in Washington, while the facility at Perrine, Florida could be involved in some Latin American intelligence activities.

### **STRATEGIC AIR COMMAND COMMUNICATIONS**

Most United States military communications use straightforward procedures and normally assigned call signs. Some, however, use special call signs and coded messages for secrecy purposes. One of the most commonly heard "secret" communications networks belongs to the United States Air Force and its

**7905 kHz**

<b>Call Sign</b>	<b>Location</b>
KEC71	Buffalo, New York
KEC96	New York, New York
KGE22	Washington, DC
KGE27	Washington, DC
KIJ22	Miami, Florida
KKI99	San Antonio, Texas
KKJ22	San Francisco, California
KKJ88	New Orleans, Louisiana
KKJ98	Oklahoma City, Oklahoma
KMG22	San Diego, California
KMG27	San Diego, California
KOG93	Salt Lake City, Utah
KOG71	Phoenix, Arizona
KOH22	Seattle, Washington
KSD61	Chicago, Illinois
KUR27	Honolulu, Hawaii

**9240 kHz**

<b>Call Sign</b>	<b>Location</b>
KEC71	Buffalo, New York
KEC96	New York, New York
KGE22	Anchorage, Alaska
KGE31	Washington, DC
KIJ22	Miami, Florida
KKI99	San Antonio, Texas
KKJ22	San Francisco, California
KKJ88	New Orleans, Louisiana
KKJ98	Oklahoma City, Oklahoma
KMG22	San Diego, California
KOG71	Phoenix, Arizona
KOG93	Salt Lake City, Utah
KOH22	Seattle, Washington
KSD61	Chicago, Illinois
KUR31	Honolulu, Hawaii

**10500 kHz**

<b>Call Sign</b>	<b>Location</b>
KAG98	Omaha, Nebraska
KGE22	Washington, DC
KGE32	Washington, DC
KKI99	San Antonio, Texas
KKJ78	Little Rock, Arkansas
KMG22	San Diego, California
KMG32	San Diego, California
KOG93	Salt Lake City, Utah
KOH22	Seattle, Washington

**Table 3-4. FBI Stations.**

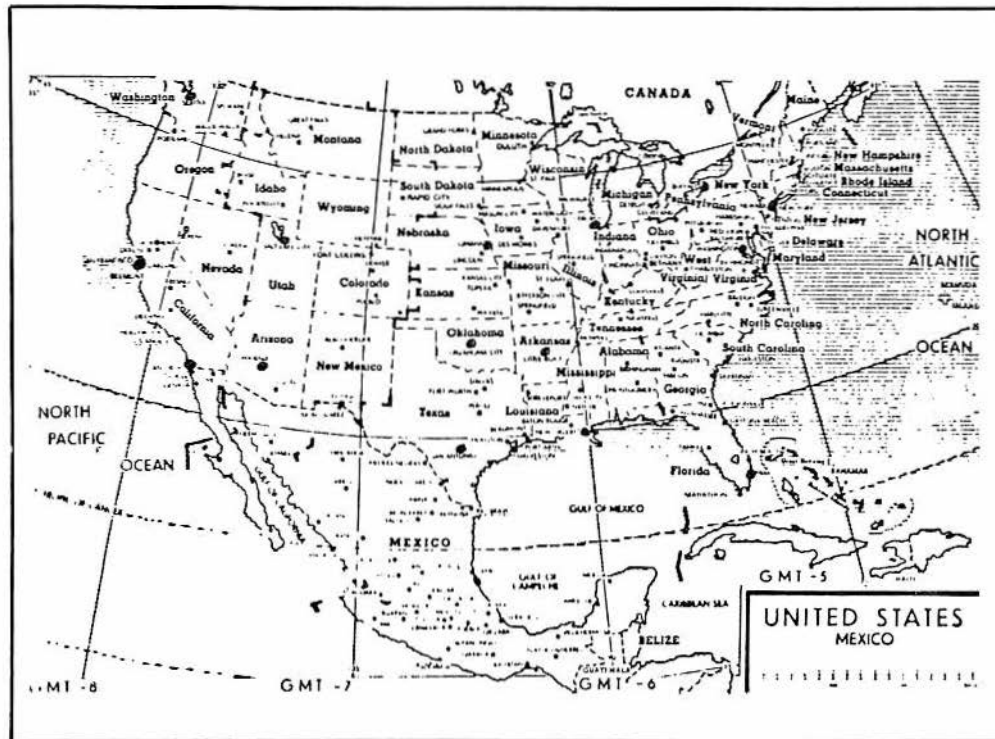

Fig. 3-4. Locations of the various FBI stations in the United States.

**Table 3-5. "Unknown Agency" Stations and Frequencies.**

<b>Frequency</b>	<b>Call Sign and Location</b>
5750	KRF263, location unknown
5750	KRF265, location unknown
5750	KRF267, location unknown
5932.5	WBR70, Perrine, Florida
7880	KAE92, Billings, Montana
7880	KAE94, Huron, South Dakota
7880	KAE95, Bismark, North Dakota
7880	KAE96, Jamestown, North Dakota
7880	KAE93, Watertown, South Dakota
7975	KGD28, Sterling, Virginia
10160	WVB11, Bangor, Maine
10190	KFK92, Tucson, Arizona
10192	KFK92, Tucson, Arizona
15528.5	KFK92, Tucson, Arizona
19210	WBR70, Perrine, Florida
20880	KFK92, Tucson, Arizona
20920	WBR70, Perrine, Florida

Strategic Air Command (SAC). Anyone with a shortwave receiver can easily tune in coded messages to airborne bombers on the SAC channels!

You won't hear call signs or call letters on the SAC frequencies. Instead, stations identify themselves using tactical identifiers such as Morphine, Capetbag, Checkmate, and Dragnet. Such identifiers change with incredible rapidity and new ones pop up each week. A casual listener to the SAC channels will quickly become hopelessly confused trying to keep the various stations



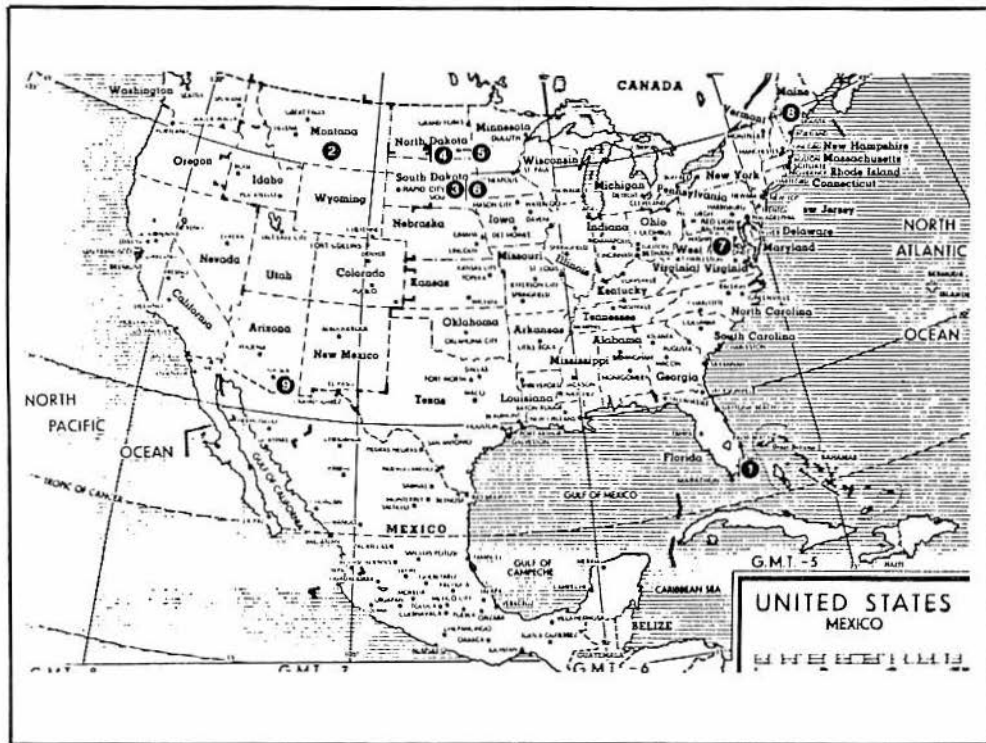

Fig. 3-5. Locations of "unknown agencies" stations: 1-Perrine, Florida; 2-Billings, Montana; 3-Huron, South Dakota; 4-Bismark, North Dakota; 5-Jamestown, North Dakota; 6-Watertown, South Dakota; 7-Sterling, Virginia; 8-Bangor, Maine; and, 9-Tucson, Arizona.

straight, and that's the entire purpose of tactical call signs—to confuse the “enemy.”

Certain tactical identifiers remain the same, however. Among those that have been declassified are “Sky King,” which is used by SAC ground stations to refer to all airborne bombers. In turn, all SAC bombers refer to SAC ground stations as “Sky Bird.”

Coded messages to airborne bombers are known as “Foxtrot” broadcasts, and can be heard on the frequencies given in Table 3-6. These transmissions are in SSB (usually upper sideband) and begin usually with a two word authentication code, such as “mike bravo” or “delta tango.” Each particular channel has its own frequency designator, which is also given in Table 3-6. Foxtrot broadcasts generally consist of random groups from the international phonetic alphabet and numbers, and end simply with the word “out.” While Foxtrot broadcasts do take place on a set schedule, it is revised quite often and special broadcasts can take place at any time. Thus, one may have to sit for a while, listening in on the various SAC channels before finally hearing a Foxtrot broadcast.

One interesting aspect of the SAC communications system is their reaction to a reception report requesting a verification of reception (QSL). Figure 3-6 shows a typical response to a listener

**Table 3-6. Strategic Air Command (SAC) Channels.**

<b>Frequency</b>	<b>Times and Other Data</b>
4725	Victor
6762	Quebec
7330	Yankee
8101	Alfa Papa 1
9027	Romeo
11220	Bravo
11243	Alfa 1
13245	Sierra
14744	Alfa Tango 1
15041	Mike
17975	Tango
18594	Zulu 1
20631	Whiskey
20890	Delta 1
23337	Uniform



REPLY TO  
ATTN OF: 1928CG/DCMVA  
MacDill AFB, Fl 33608  
SUBJECT: HF Radio Reception Report

8 Sep 77

TO: Harry L. Helms, Jr

Current directives prohibit USAF HF stations confirming requested information. Other than advising you that this station does transmit on 6750 KHZ. I cannot confirm specific contacts at specified times.

Thank you for your interest in Military Air-To-Ground Radio Communications.

Sincerely,

*David H. Beemall*  
DAVID H. BEEMALL, MAJ, USAF  
1928CG Aeronautical Station



Fig. 3-6. Letter to the author in reply to a request for verification of reception of a transmission from MacDill AFB to airborne bombers.

report, giving a "no comment" to everything but the frequency (possibly because the frequency is already assumed to be "public knowledge"). One indeed has to wonder at such efforts to preserve secrecy at all costs, since, if such transmissions can easily be heard by radio hobbyists, they certainly do not escape the notice of the intelligence divisions of foreign military establishments!

### LISTENING IN ON THE PRESIDENT

For several years, many shortwave listeners have enjoyed listening in on overseas telephone calls on the various point to

point circuits. A smaller, more alert group of listeners have enjoyed listening in on telephone calls made by the President of the United States, and members of his official party, principally through monitoring of the Presidential jet Air Force One.

As might be expected, most Presidential conversations are carried over secure wire circuits. When they must go over radio circuits, Presidential conversations are usually made secure through electronic speech scrambling and encoding. The key word here is "usually," for often there are conversations put on the air which are not secured. This is especially so when the President is aboard Air Force One and the plane is arriving or departing Andrews Air Force Base near Washington. Frequencies to tune for are listed in Table 3-7.

All transmissions from Air Force One (as well as from the Vice President's Air Force Two) are in single sideband, almost invariably upper sideband. You can easily locate the channels used by Air Force One and Two by their ordinary air control traffic, which is not encoded or scrambled. Both planes operate on the

Table 3-7. "Presidential Listening" Channels.

<u>Air Force One/Two (kHz)</u>
6731
8967
11182
13201
18027

<u>Andrews Air Force Base (kHz)</u>
6756
9018
13247

channels listed for Andrews Air Force Base, plus some additional frequencies given in Table 3-7.

The most common Presidential conversation overheard by shortwave listeners is an ordinary phone patch, dealing with non-sensitive matters, to other members of the Presidential staff or family members on the ground. A tipoff that a phone patch from the Presidential party is forthcoming is when the radio operator aboard the plane asks for "Crown," which is the term used to refer to the White House communications center.

Keep an ear on the frequencies listed in Table 3-7 whenever the President or Vice President is scheduled to arrive or leave Washington. You might hear something very interesting!

## Chapter 4

# Space Communications

---

Few events in history have had an impact upon global consciousness like the launch of Sputnik I on October 4, 1957. For the first time, man's horizons were no longer limited to Earth. The universe was opened for exploration and discovery. Radio enthusiasts in particular shared in the excitement, as anyone equipped with a general coverage shortwave receiver could tune to the 20-MHz beacon of Sputnik I and listen to its "beep—beep—beep" as it zoomed by in orbit.

Listening to orbiting satellites was the "in thing" during the late 1950s and early 1960s, but little is heard about it recently. This may be due to the fact that in this era of multi-million dollar space communications systems it may seem as if satellite listening is hopelessly difficult and expensive for the hobbyist. Such an attitude may be common, but it's also anything but the truth. The fact is that anyone with a general-coverage shortwave receiver can tune in transmissions from orbit, including some from manned space missions! In addition, other simple gear for the VHF and UHF range will allow reception of even more satellites and manned spaceflights, including direct reception of meteorological-satellite weather pictures.

### THE SATELLITE SPECTRUM

Not surprisingly, a great deal of satellite activity takes place in the 108-136-MHz international aeronautical band, with addi-

tional activity also taking place up to two MHz above the upper end of the band. The 135-138 MHz range is known unofficially as the satellite band due to the large number of satellites which use this portion of the radio spectrum. Both American and Soviet satellites use this band, in addition to the various satellites of other nations. Due to the crowded nature of this band, most satellites here transmit only upon command from ground stations; hence, identifying individual satellites is often impossible for the hobbyist.

Many other American space missions, in particular the manned ones, make use of frequencies which are very difficult for the average listener to tune. For example, the Apollo spacecraft which flew to the moon used 2287.5 MHz (known as the "S band") for its prime voice-communications channel. The Space Shuttle will use 1640 MHz for its prime voice channel, using wideband FM modulation. Receiving such frequencies is by no means impossible, but it is difficult, and suitable receiving setups are expensive.

The United States makes use of such frequencies because they are highly reliable—given proper ground receiving installations. The United States has established a worldwide network of land-based receiving and tracking stations, all equipped with the huge dish antennas which are necessary for reliable use of the upper UHF spectrum. The Soviet Union, however, lacks such a system of land tracking stations and has been forced to rely upon tracking ships. This in turn has dictated that Soviet Union use frequencies other than line-of-sight VHF and UHF channels. As a consequence, many Soviet space missions use frequencies within the range of a general-coverage shortwave receiver.

Table 4-1 gives frequencies commonly used on Soviet space flights. As can be seen, several channels are below 30 MHz and are easily tuned in on a conventional shortwave receiver. Other channels are in the 108-136 MHz aeronautical band, or just below the two-meter amateur band, all of which can be easily tuned on readily available equipment.

## **DYNAMICS OF SPACE COMMUNICATIONS**

Tuning in orbiting spacecraft presents several new elements in reception, which the prospective listener must be aware of. The foremost difference is that a spacecraft is in motion, meaning that *Doppler shift* must be taken into account. The most common example of the effects of Doppler shift is the way the pitch of a train whistle seems to change as the train approaches and then moves away from a listener. In much the same manner, the frequency of a

Table 4-1. Soviet Space-Mission Frequencies.

Frequency (MHz)	Use
15.008	Common channel for unmanned satellite beacons and telemetry
17.365	Unmanned satellite beacons
18.000	Satellite beacons and telemetry
18.060	Common channel for unmanned satellite beacons and telemetry
19.946	Salyut telemetry channel
19.954	Cosmos 929 telemetry channel
19.995	Soyuz and Salyut beacon channel
20.008	Common channel for both manned and unmanned missions; manned missions use CW and pulse
121.625	Soyuz FM voice channel
121.750	Soyuz and Salyut FM voice channel
137.150	"Meteor" weather satellites
137.300	"Meteor" weather satellites
143.625	Most common voice channel
143.825	Coded transmissions from Salyut
259.700	Used for intership communication during joint Apollo/Soyuz mission
296.800	Used by Soyuz for downlink during joint Apollo/Soyuz mission
922.750	Satellite beacons and telemetry

satellite's radio signal will seem to change as it moves within range of a ground listening post. From the ground, the received frequency will be higher than the actual transmitted frequency when the satellite is approaching the ground listening post. The received frequency will begin to drop as the satellite comes closer to the ground site, and the received frequency will be the same as the actual transmitted frequency when the satellite is at its closest approach to the ground listening post. As the satellite moves away, the received frequency will seem to drop lower than the actual transmitted frequency (Fig. 4-1).

Thus, a good test of whether or not you are actually tuning in an orbiting satellite is to listen for the effects of Doppler shift. If the



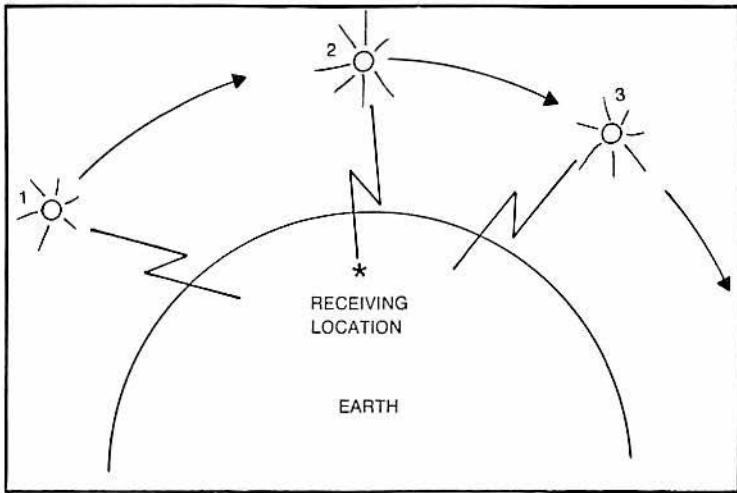

Fig. 4-1. The effects of Doppler shift are illustrated here. At position 1, the frequency received is higher than the actual frequency. This frequency will drop when position 2 is reached, where the received signal and actual frequency are identical. As the satellite moves away from the receiving location, the frequency will drop further, as is the case at position 3.

received signal does not seem to change in frequency, you likely have an ordinary terrestrial station of some sort.

Another major difference in space communications is the loss and acquisition of signals. Terrestrial stations operating on 20 MHz often have a worldwide range, depending upon propagation conditions in the ionosphere. A satellite operating at 20 MHz, on the other hand, will have a definite range limitation depending upon the altitude of its orbit. The limits of a satellite's range will be circular and the amount of time that a satellite can be heard from a ground location will depend upon where the ground listening post is located within a satellite's range limits. In Fig. 4-2, the satellite passes directly overhead at a ground location and reception time is at a maximum. However, in Fig. 4-3, the ground listening post is on the fringe of the satellite's range and reception time is correspondingly less.

All this means that one can't simply tune a receiver to the listed frequency for a satellite and always expect to hear it. A satellite's frequency will be empty (except, of course, for terrestrial stations or other satellites) until the moment when the satellite comes within radio range, at which time the frequency will "come alive" with signals from the satellite. This is called *acquisition of signal* (AOS). When the satellite moves out of range

of the ground station, the signals will abruptly break off just as suddenly as they appeared. This is called *loss of signal* (LOS).

Not all satellites are affected by Doppler shift or acquisition and loss of signal. Geosynchronous satellites are those in orbits so high that they appear from the ground to be stationary. Actually, their orbits coincide perfectly with the Earth's rotation, creating the illusion of the satellite being fixed in one position.

Most unmanned satellites, outside of the geosynchronous variety, tumble as they orbit. This means that radio signals from those satellites do not maintain a constant horizontal or vertical polarization; they are cross polarized. For the Earth listener, this means that signals from satellites will be subject to frequent and abrupt fading, see Fig. 4-4. One solution is to use circular polarization in antennas, particularly at the higher frequencies where the effects are most pronounced. Fortunately, effects of cross polarization are not severe on frequencies below 30 MHz.

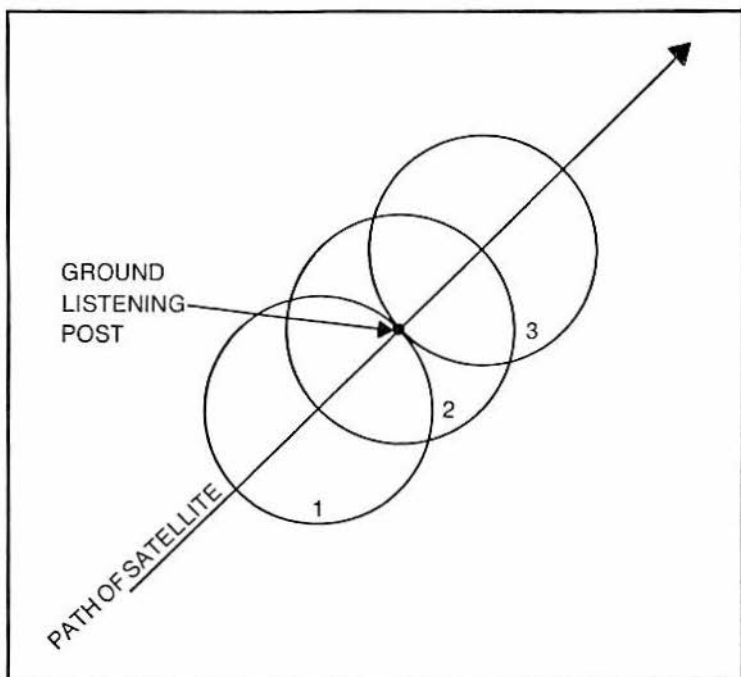

Fig. 4-2. Overhead pass of a satellite, resulting in maximum listening time. In circle 1, the ground listening site first comes within range of the satellite. In circle 2 the satellite is directly overhead, resulting in zero Doppler effect and maximum signal. In circle 3, the ground listening site is at the edge of the satellite's range, and signals are about to be lost.

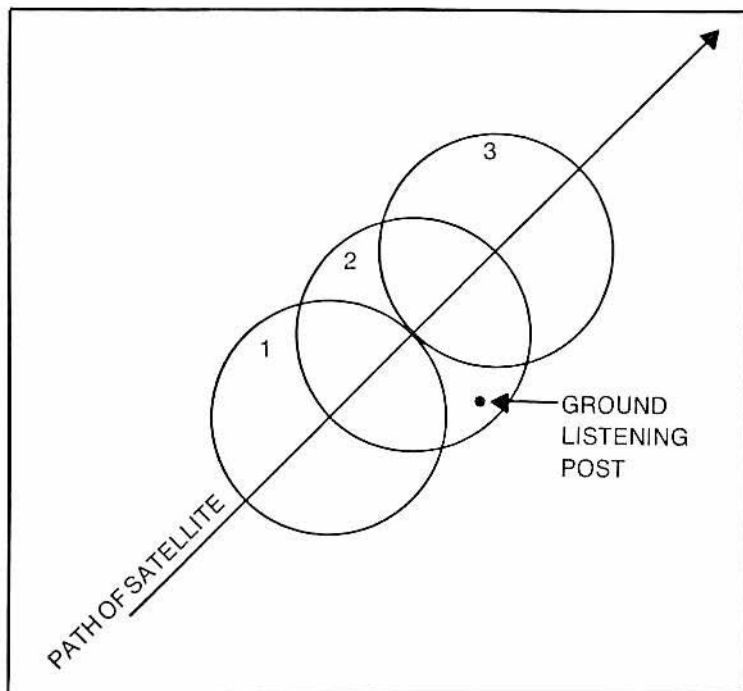

Fig. 4-3. In this illustration, the ground listening site is out of the satellite's range in circles 1 and 3. The satellite is audible only in circle 2. Since the ground listening post is within circle 2 only briefly, the time the satellite can be heard is much shorter than in Figure 4-1 and the effects of the Doppler shift are more pronounced.

## SOVIET SPACE ACTIVITY

Soviet space missions are logical starting points for those new to space listening. Not only are most Soviet space frequencies tuneable on common equipment, most Soviet space missions use continuous beacon and telemetry transmissions, in contrast to American missions which transmit only upon ground command.

Table 4-1 contains a list of several common Soviet frequencies. Many Soviet space frequencies remain the same for years; for example, 143.625 MHz has been the main Soviet voice communications channel ever since Yuri Gagarin made the first manned space trip back in 1961. This channel uses the FM mode and 35 kHz deviation from center frequency. This channel should be audible on any receiver capable of tuning the Amateur two-meter (144-148 MHz) band, so long as the receiver's bandpass is widened to accommodate the large amount of deviation used by the Soviets.

The current Soyuz spacecraft used by the Soviets has an output power of four watts on this channel, so some form of preamplification at the receiver site may be necessary for best copy.

Two other channels used by the Soyuz spacecraft include 121.625 and 121.750 MHz, both FM with 35 kHz deviation. These frequencies are often used during the docking of the Soyuz capsule with a Salyut space station. Once rendezvous has been achieved and the cosmonauts are aboard, Salyut communications return to 143.625 MHz.

Some listeners have remarked that voice communications from manned Soviet missions sound like "window dressing." They may well be. A large amount of traffic from manned Soviet missions is in CW, with 20.008 MHz a common frequency. Pulse modulation, possibly indicating digitalized voice transmission, is also heard at times on 20.008. The CW used is not the standard international Morse code nor any known variation of it. Interestingly enough, all Soviet manned spacecraft have included a telegraph key at the pilot's control panel!

One reason to preserve secrecy is that the Soviet manned space program has always had a strong military emphasis. Special steps are taken by the Soviets to discourage casual listening when the mission is of the military nature. For example, during August of

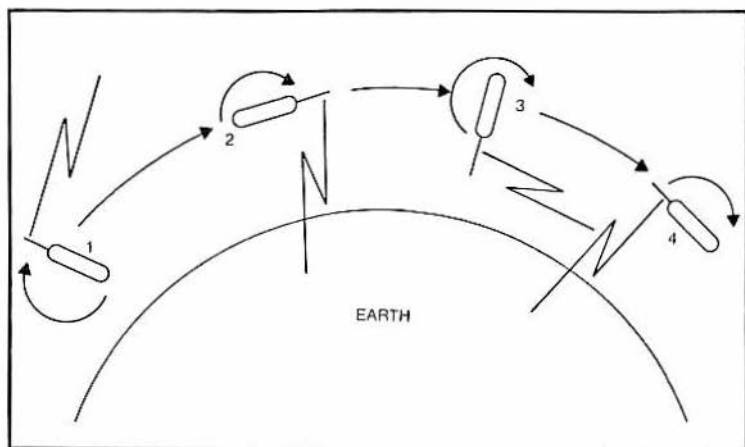

Fig. 4-4. Effects of satellite tumbling are depicted. At position 1, the satellite's signals are vertically polarized with respect to Earth; however, the satellite is tumbling in the direction indicated by the arrow. At position 2 the signals are horizontally polarized in position 3 and horizontally polarized at position 4. Signals are a mixture of both vertical and horizontal between the various positions. Such tumbling and changing polarization induces severe fading in many cases unless circularly polarized antennas are used.

1976, listeners to the Salyut 5 mission were startled to notice that transmissions on 143.625 MHz would cease whenever Salyut would enter radio range of Soviet ground stations. Voice communications on the channel would be replaced with telemetry-like signals. Alert listeners discovered that when voice transmissions were replaced by what seemed to be telemetry on 143.625 MHz that new signals would pop 143.825 MHz. These new signals sounded like highly irregular telemetry, and it was widely believed that they were actually some form of encoded communications. Salyut 5 was recognized as a military mission due to its numerous differences from other space missions, including minimal press coverage in the Soviet Union, sketchy details released by Tass, and its different orbit from other Salyut missions.

Two other voice channels were used by the Soviets during the 1975 joint Apollo/Soyuz test project. One was 259.7 MHz, which was used for intership communication between Apollo and Soyuz. Another new channel was 296.8 MHz, which was used for Soyuz to ground communications while over the United States. Both of these transmissions were in the AM mode, a change from the usual practice of employing FM at VHF and UHF. These frequencies have not been reported in use since the Apollo/Soyuz joint mission, but could well be used again in the event of future joint missions by the United States and the Soviet Union.

Of particular interest should be the frequencies 15.008, 18.008, 18.060, 19.954, and 20.008 MHz, which were extensively used by Cosmo 929, an unmanned Soviet mission which took place in July, 1977. This was an apparent test of the next generation of Soviet manned space vehicles and components, and these frequencies should be active well into the 1980s. The 19.954 MHz telemetry channel featured a distinctive signal of several seconds and then repeated. Listening to such telemetry signals should be done with a receiver's beat frequency oscillator (BFO) turned on, preferably in the upper sideband mode.

## **WEATHER SATELLITES**

It is entirely possible for the radio hobbyist to receive and print weather pictures transmitted from orbiting weather satellites, both American and Soviet! Frequencies for the Soviet "Meteor" series are given in Table 4-1, and American weather satellite channels are listed in Table 4-2.

Weather pictures from these satellites are transmitted through the process of facsimile (commonly referred to as fax). Fax

Table 4-2. American Weather Satellites.

Frequency (MHz)	Satellite (s)
135.600	ATS series common frequency
136.230	ATS-6
136.290	"Hawkeye"
136.300	SMS-1
136.770	NOAA-5
137.110	ATS-6
137.140	NOAA-5
137.500	NOAA series common frequency
137.620	NOAA-5
400.650	"Hawkeye"
468.825	SMS-1

is transmitted by the weather satellite by scanning an image and producing varying electrical signals to represent light and dark areas. When received on Earth, the incoming fax signal controls a stylus moving across a revolving drum carrying paper. The lightness or darkness of the impression made depends upon the incoming electrical signals. See Fig. 4-5.

Such weather satellites are fascinating to listen to even if you don't have the equipment to actually print the pictures. The transmissions are continuous, and sound much like a slow scan television (SSTV) signal, with continuously varying tones and a certain "tweedling" sound that is unmistakable once heard. All fax transmissions from weather satellites are FM and use 20-kHz wide deviation.

Some weather satellites are geosynchronous, while others are not. However, even those weather satellites that are not geosynchronous move slowly enough across the sky so that the effects of Doppler shift are minimized. Most are also stabilized in attitude with respect to Earth, greatly reducing the effects of cross polarization.

More detailed information about setting up a weather satellite receiving station can be obtained by writing APT Coordinator, National Oceanic and Atmospheric Administration, National Environment Satellite Service, Washington, DC, 20233. An article detailing the setting up of a weather satellite receiving station can be found in the February, 1974 issue of *Scientific American*.

## **SATELLITES OF OTHER NATIONS**

Space activity is no longer the exclusive undertaking of the United States or Soviet Union. As a glance at Table 4-3 will show, numerous other nations have launched satellites which can be heard. These are all beacon frequencies, meaning that most operate continuously.

Since China's space program was begun with Soviet assistance, before the rift between the two nations, it is hardly surprising that China employs the same general frequency range as do the Soviets. The latest (as of this writing) Chinese satellite, China II, was widely heard through its easily recognizable beacon on 20.017 MHz, which featured a mix of beeping and clicking sounds. China's recent increased emphasis on technological development should lead to further space exploration efforts and activity around 20 MHz.

The satellites of other nations generally use the 135-138 MHz satellite band. Transmissions here are usually FM and consist of complex telemetry signals relaying data back to earth.

## **LAUNCH SUPPORT ACTIVITY**

Not all space activity listening takes place in outer space. Considerable communications activity takes place at the major rocket-launching facilities in both the United States and Soviet Union, as given in Table 4-4.

Transmissions from Cape Canaveral (Kennedy) use the identifiers Cape Radio or Orion Control, and originate from both the Air Force's Eastern Test Range (the largest user of the launch facilities at the Cape) or from the civilian Kennedy Space Center. Communications are with airborne photography or measurement aircraft in connection with launches. Aircraft are identified by a call sign consisting of one word and a two digit number, as in "Agar 21." All transmissions are in single sideband.

By contrast, launch support transmissions from the Soviet Union are far more enigmatic. Table 4-4 lists two frequencies widely believed to be used by the Soviet ground stations for

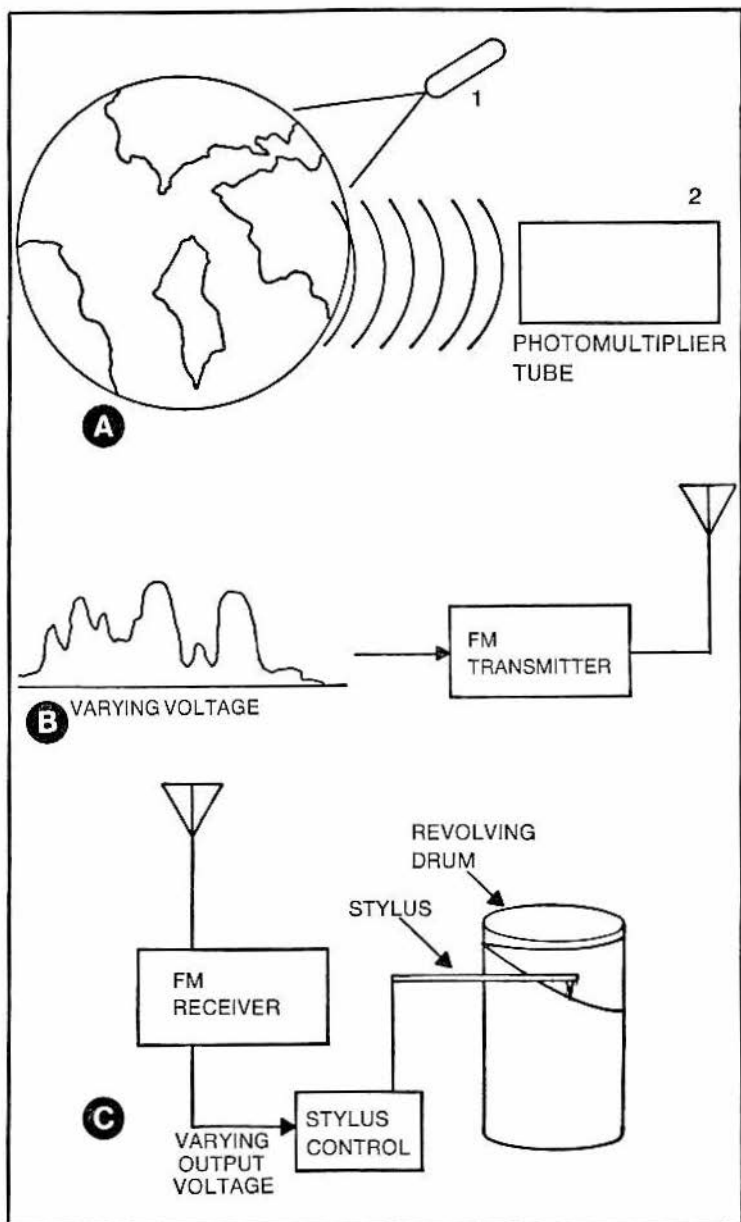

Fig. 4-5. Weather satellites produce pictures in a manner similar to facsimile transmissions. An image is picked up by a photomultiplier tube as it scans the earth from orbit, A, and the light and dark areas produce a varying voltage to modulate a transmitter, as at B. The decoded modulation is used to drive a stylus, making impressions on a revolving paper on the drum, C.



**Table 4-3. Foreign Satellite Beacon Channels.**

<b>Frequency (MHz)</b>	<b>Satellite and Country</b>
20.017	China II, China
136.050	Signe 3, France
136.140	Sirio, Italy
136.620	Sirio, Italy
136.630	Signe 3, France
136.910	UME, Japan
136.890	Himawari, Japan
137.290	Aero 2, West Germany
137.890	ANS, the Netherlands
400.900	UME, Japan

communication with orbiting cosmonauts. Both frequencies are active only during manned Soviet space missions, and use the same "crazy" CW previously mentioned in connection with transmissions from orbiting Soviet spacemen. Rough direction finding techniques have strongly suggested that these transmissions originate from the large launching complex at Baikonour in the Kazakhstan region of the USSR.

The 1980s promise a resurgence of space listening targets following the lull in manned space activity during the late 1970s. The Space Shuttle will be operational for the United States, and the

**Table 4-4. Launch-Support Frequencies.**

<b>Frequency</b>	<b>Station</b>
5810	Cape Radio, Cape Canaveral, Florida
6723	Cape Radio, Cape Canaveral, Florida
9002	Orion Control, Kennedy Space Center
13218	Cape Radio, Cape Canaveral, Florida
14896	Cape Radio, Cape Canaveral, Florida
19640	Orion Control, Kennedy Space Center
19990	Soviet launch center, Baikonour, USSR
19995	Soviet launch center, Baikonour, USSR
22760	Orion Control, Kennedy Space Center
22760	NASA launch facilities, Vandenberg Air Force Base, California

Soviet Union has stated that permanent manned space stations of the Salyut variety are a goal of their space exploration program. The active and alert shortwave listener can keep up with such activity!

## Chapter 5

# Illegal Communications

---

Radio activity in the United States is controlled by the Federal Communications Commission under the authority of the Communications Act of 1934. This act gives the FCC the power to seek penalties of up to \$10,000 fine and a year of imprisonment for violation of rules applicable to radio communication. Other nations have similarly stiff penalties for violation of their national radio laws.

Yet the simple fact of the matter is that the radio spectrum is widely used for a variety of illegal purposes, ranging from espionage to unlicensed hamming. The owner of a general coverage shortwave receiver can sometimes tune across criminal activities being facilitated by means of two way radio!

In this chapter we will discuss only illegal communications not intended for reception by the general public. One common illegal use of the radio spectrum is for unlicensed broadcasting activity, with numerous "pirate broadcasters" operating in Europe and the United States. Such activity will be discussed in later chapters.

### **FUNNY STUFF IN THE HAM BANDS**

As of the time when this book was being written, there was no legal prohibition against anyone, whether licensed or not, owning shortwave transmitting equipment for the amateur bands. Anyone equipped with a few hundred dollars could purchase a transceiver capable of worldwide communication.

Other nations are much more restrictive, even when it comes to allowing licensed amateurs to have their own individual stations. Most amateurs in the Soviet Bloc nations operate from carefully supervised club stations, while in many parts of the Third World, amateur radio is actively discouraged or flatly prohibited. For example, Taiwan has but one active amateur station, and it is continuously monitored by the local government when on the air.

Many American amateurs think that opposition to amateur radio stems from a misunderstanding of the hobby, the feeling that amateur radio is too much of a rich American hobby, or a perception of amateur radio as not a "serious" enough use of the radio spectrum. While some officials in other nations doubtlessly hold such opinions, opposition to amateur radio in the Third World boils down to one basic fact: amateur radio is an ideal communications medium for espionage and other anti-government activities.

Former CIA agent Miles Copeland revealed some of the espionage uses of amateur radio in his 1974 book, *Without Cloak or Dagger*. Copeland claimed one major technique was the "screech" tape recording. The "screech" sounds like an ordinary bit of interference commonly encountered on the ham bands, but in reality is a speeded-up or encoded message. On the receiving end the "screech" recordings, Copeland claimed, were often used during ordinary (at least to the unsuspecting listener) ham contacts with good results.

The advantages of using the amateur bands for such activity are numerous, beginning with the sheer congestion affecting such DX bands as 20 meters (14000-14350 kHz) and 15 meters (21000-21450 kHz). The effort and manpower required to keep tabs on even a fraction of the communications in those two bands alone would be enormous and likely unprofitable. Another favorable point is that amateur radio provides an ideal pretext for possessing radio equipment capable of world-wide communication.

One bit of possible espionage communication on the ham bands has been noted by your author in connection with the "spy numbers" stations discussed in Chapter 2. An examination of Tables 2-2, 2-4, and 2-7 through 2-9 in that chapter will reveal that many numbers stations operate in or near the 80 meter (3500-4000 kHz) and 40 meter (7000-7300 kHz) ham bands. On several occasions during the spring of 1978, your author could hear a five-digit-group Spanish numbers station near 3865 kHz around 0515 GMT. Transmissions would generally last ten minutes. Immediately upon the end of such transmission, I could tune to

3805 kHz and hear two stations communicating in Morse code, exchanging number groups and using three digit identifiers, as in "613 de 091!" These CW transmissions only began after the numbers transmission, and *only* on those nights when the numbers station was on the air. Both stations used badly sent Morse, obviously on a hand key. The discovery of such transmissions was not the result of a deliberate search but an accidental byproduct of ordinary operation as a licensed radio amateur. The perfect correlation between the unknown CW stations and the Spanish numbers station strongly points to amateur radio being used to coordinate espionage activity *after* receiving coded instructions from the home agency via radio.

The amateur bands can be used for spy transmissions by using false call signs, particularly in the CW portions of the 20 and 15 meter bands. Every ham radio "DXer" (one who seeks to contact distant stations in foreign countries) runs across stations that turn out to be phonies. This is usually discovered when the DXer seeks to confirm the contact by a QSL card and is informed that the call sign actually belongs to someone else, or licensing authorities in the supposed operating location have no record of such a station. Doubtlessly, many of these phonies are simply hoaxes and pranks, the result of another ham pretending to be "rare DX." Yet some are apparently the result of a ham unknowingly contacting a station used for espionage purposes.

During the mid-1960s, several supposed "American" amateur stations were heard at times on 20 meters using such call signs as "WB2RH" and "KN4TR," which at that time were unavailable to American hams. Curiously enough, beam headings for maximum reception of these signals indicated that these stations were coming from over the North Pole—suggesting the signals were coming from the Soviet Union. Amateurs who tried to contact these stations received only a curt "QRU" in reply, "QRU" meaning "I have nothing for you."

Terrorist groups also make use of the amateur bands for their communications. According to Radio Sweden's "Sweden Calling DXers" bulletin, 14338-14348 kHz is often used by various Arab terrorists groups, with 14128 kHz another favored channel. All transmissions are in single sideband, usually upper sideband, with a variety of languages used. Call signs usually are two or three digit numbers. The infamous Black September group (responsible for the 1972 massacre at the Munich Olympics) is reported to use 14290 kHz for their communications. These frequencies have been

reported by European monitors, but have not yet been reported in the United States.

Amateur radio also has the potential to provide communications for internal dissidents and insurrections. In Chapter One, I mentioned the various Cuban clandestines such as Radio Rebelde and Radio Liberated Cubana, both of which are apparently amateur stations doubling as broadcasters. Listeners in south Florida have noted a net of anti-Castro Cuban amateurs gathering around 7085 kHz after 1700 GMT. All stations in this net use AM instead of the usual SSB voice mode heard on the ham bands.

Most amateur transceivers cover the ham bands in 500 kHz segments, although not all the bands are 500 kHz wide. For example, 40 meters covers 7000-7300 kHz while most transceivers cover 7000-7500 kHz. Not surprisingly, it is quite possible to hear some unusual transmissions "over the edges" of the ham bands. One range that I have found to be particularly productive is 7400-7500 kHz, where numerous unidentified Spanish language SSB transmissions have been heard. Most operators are male, although a few females are heard in this range. No call signs have been heard, with the operators referring to each other by their first names, such as "Carlos" or "Pablo." Transmissions are short and cryptic, on an unpredictable schedule, and the subject matter of the transmissions cannot be ascertained. However, those transmissions monitored by your author did markedly increase during the 1978 civil war in Nicaragua.

Considering the activity we have discussed, it should be quite obvious why some governments are much less than enthusiastic about encouraging amateur radio. Club stations which can be closely controlled are far more acceptable than private stations for individuals in such cases. This explains why several well-meaning attempts to provide individual amateurs in underdeveloped nations with equipment have failed due to the equipment being detained or returned by the local government.

There has been little illegal use of the shortwave amateur bands by nonamateurs in the United States, outside of scattered intrusions by the "HFers" which will be covered later in this chapter. The story is quite different, however, on the VHF amateur bands, particularly two meters. Here, some truckers, and other travelers, are buying two meter FM transceivers and are using them to escape the crowd on the CB channels. Some manufacturers of two-meter FM transceivers have advertised their equipment in CB publications, without explaining in the ad that a

valid amateur license of at least the Technician class was necessary to operate on two meters. Your author has personally observed two meter FM gear for sale in a CB shop to anyone, no questions asked, and the clerk neglecting to mention that a ham license is required!

Much of this "FM CB" activity has centered on 146.58 MHz, complete with CB "handles" and appropriate lingo. Bogus amateur call signs are sometimes used. Generally, these operators stick to simplex channels instead of going through repeaters. Activity, as might be expected, is greatest along busy interstate highways and near large cities. For example, in late 1977 more than 75 apparently bogus calls were detected by amateurs in the Denver, Colorado area in just one day of casual monitoring on two meters. Another "FM CB" channel is 147.57 MHz, which is used mainly by truckers traveling the Pacific Coast routes from California to Washington.

Smugglers have also put the the amateur bands to illegal use. The United States Coast Guard has solicited the assistance of amateur operators in keeping track of suspicious radio traffic, particularly on 40 meters (7000-7300 kHz), see Fig. 5-1. Two commonly used frequencies are 7218 and 7268 kHz. Very often, the operators of these stations do not hold American amateur licenses, but licenses and call signs from nations and islands in Central America and the Caribbean, where license requirements are often more casual.

As might be imagined, radio communications between smugglers are much more subtle than a mere "we're bringing the dope in tonight!" variety. Communications often involve arranging a rendezvous between two or more vessels near some remote point late at night. Information related to the location of Coast Guard vessels and aircraft movements is also passed. Ham bands offer the smuggler the same advantages that are attractive for espionage use: the crowding and difficulty in monitoring by law-enforcement agencies. Indeed, one of the prime reasons why the Coast Guard publicly solicited amateur assistance was that they lacked the capability to monitor the ham bands on a large scale! Some marine dealers are not unaware of this potential market, incidentally; some are offering amateur transceivers for sale without mentioning the necessity of obtaining the proper license.

### **THE "10-½" METER BAND**

Tune across the segment from 27500 to 28000 kHz on a typical evening, especially when "skip" conditions are good, and you'll likely hear something like the following:

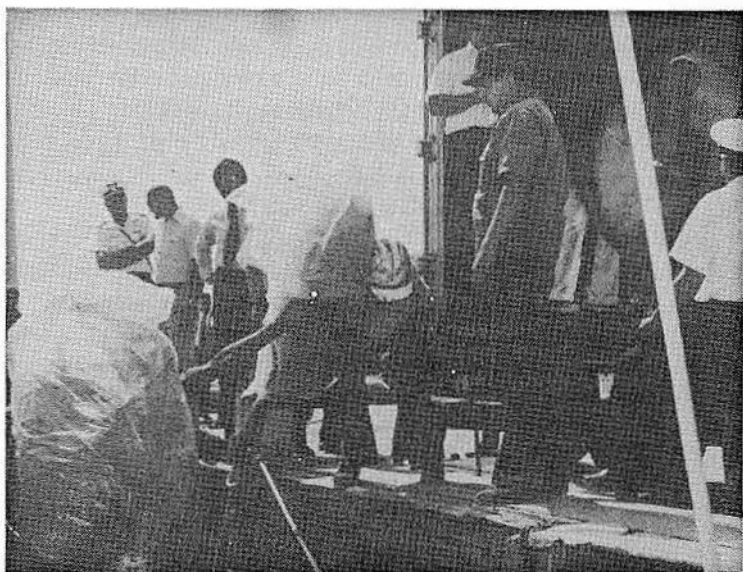

Fig. 5-1. By monitoring the ham bands, the U. S. Coast Guard has sometimes managed to stage large scale dope smuggling busts such as the one depicted here. Coast Guard officials here supervise the unloading of some seized marijuana (courtesy of U. S. Coast Guard).

“CQ DX, CQ DX, CQ DX, this is Two Echo 1643 in Montana calling, QRZ?”

“Two Echo 1643, here is One Charlie 149 in Ontario, Canada, returning, how copy?”

“One Charlie 149, this is Two Echo 1643 returning, thanks for the call, handle here is Bill, and your signals are a solid five by nine ...”

What have you heard? Spies? Secret government communications? Messages from UFOs?

Nothing that spectacular, unfortunately. But you have overheard a sample of the most embarrassing problem confronting the Federal Communications Commission today: a network of unlicensed radio operators using high powered equipment between the 10 meter amateur band and the 11 meter Citizens band in total violation of existing laws and regulations. While the problem is mainly centered in the United States, it is by no means an exclusively American situation; stations are also active in this range from Europe and South America!

These operators are known as the “HFers,” and have developed their own elaborate system of call signs to mislead the



FCC. Operation is all in single sideband, usually lower sideband, and closely mimics amateur radio operation. Many HFers get involved in their activity through an acquaintance with amateur radio; however, the HFer does not follow through and obtain a license. Many familiar ham terms are borrowed by the HFer, such as "CQ" and "QRZ," and such CB lingo as "good buddy" is seldom heard. Figure 5-2 shows a QSL card from an HFer.

HFers generally frequent the range of 27500-28000 kHz, using converted amateur gear. Powers range up to (and sometimes even over!) 1000 watts with elaborate antenna systems. During good propagation conditions, such stations can be heard worldwide, and can even contact HFers in foreign nations or disrupt legitimate foreign communications services. Naturally, no exact count of the number of HFers operating is available, but the 1976 membership roster of the leading club for HFers listed over 40,000 names. The number of HFers has rapidly increased greatly since then, and there are other clubs for HFers which also issue their own unofficial call signs. A conservative estimate by one FCC official placed the number of HFers at a minimum of 100,000 in late 1978.

The HF revolution was kicked off in the early 1970s when a manufacturer of amateur equipment brought out a bizarre product supposedly intended for the CB operator who planned to become a licensed ham. This transceiver covered both the Citizens band, the first 500 kHz of the 10-meter ham band, plus the range between the two bands. As supplied by the manufacturer, the transceiver was incapable of operating in the transmit mode except on the Citizens band. However, it could be easily modified to do so by clipping two wires on the transmit relay. Once done, this modification gave the owner a transceiver capable of operating in the wide-open 27500-28000 kHz range with over 200 watts on SSB. Operators soon discovered that the FCC was apparently unable to police this section of the radio spectrum adequately, and the rush was on. Another big boost came when several Japanese manufacturers entered the American amateur market in the 1970s with equipment that came with coverage of portions of the "HF band" standard. Although such gear is no longer marketed in the United States, many contemporary amateur transceivers can be used on the HF band merely substituting the proper crystal. In fact, the January, 1977 issue of an electronics merchandising journal carried complete details on how electronics retailers could promote HF activity by converting ham gear!

The FCC, while badly understaffed, has made several attempts to control the HFers. One of the most spectacular acts came on October 27, 1976, when FCC agents, supported by United States marshalls, raided several HF stations in the Baltimore, Maryland area. Over \$65,000 of equipment was seized, and charges were filed against over 300 persons, although many were subsequently dropped. Since then, the FCC has conducted concentrated raids in narrow geographic areas such as Syracuse, New York and Columbus, Georgia, netting several thousands of dollars in confiscated equipment each time.

Another tactic of the FCC has been to crack down upon the national organizations which serve HFers. One such group, known as "HF International," received a letter in January, 1977, from Charles Higginbotham, then chief of the Safety and Special Radio Services Bureau of the FCC. Mr. Higginbotham wrote, ". . . operation by you or by members of HF International on frequencies for which you do not hold a valid license from the Commission is unlicensed radio operation . . . punishable criminally by a \$10,000 fine or one year imprisonment or both." He continued, "The frequencies that you urge members to operate on are authorized only for licensees of the Industrial and Business Radio Services . . . If these acts in furtherance of HF International . . . are not terminated, civil or criminal proceedings may be initiated." The letter proved to be no idle threat, as several leaders of HF organizations later lost their CB licenses due to FCC action.

Yet such FCC activity has not yet had the desired results, as casual tuning of 27500-28000 kHz range during good propagation conditions will reveal. Curiously, the FCC has not (as of this writing) taken the obvious step in dealing with the problem of the HFers—restricting the sale and possession of Amateur transmitting gear to licensed hams.

## **EAVESDROPPING AND BUGS**

On June 17, 1972, an attempt was made to put an FM transmitter on the air, operating on approximately 110 MHz, in downtown Washington, D.C. Had the attempt been successful, anyone in the vicinity who owned an ordinary FM radio could have tuned the station and listened in. The attempt failed, however, and went down in history as the Watergate break-in.

It is a little known fact to the American public that the vast majority of eavesdropping devices do indeed operate on the standard FM broadcasting band, 88-108 MHz. Odds are that

# BROWN DIRT COWBOY



Brooklyn, NY 11234

Greetings From  
**UNIT 522 in**  
**The BLACKOUT**  
Town, New York City

Mon. 1  
1-85 AM +SSB **73's**

Fig. 5-2. QSL card from an "HFer," Unit 522 in Brooklyn, New York. Note that the card lists channels "1-85;" the HF range has been informally divided into channels 41 through 85.

anyone living in or near a large metropolitan area can stumble across a "bug" with a little patience.

Eavesdropping by government agencies and private parties is officially subject to a variety of legal restrictions. In practice, however, these restrictions are sometimes ignored, particularly by nongovernmental users of electronic eavesdropping equipment. In fact, it is estimated that over two thirds of the electronic eavesdropping conducted in the United States in recent years has been conducted (often illegally) by nongovernmental parties. Figure 5-3 shows a sample of what equipment is available.

Besides 88-108 MHz, electronic eavesdropping devices are also found in the 48-50 and 72-75 MHz. Bugs are also found 1-2 MHz below the lower end and above the upper end of the FM broadcast band, and most FM receivers have sufficient overcoverage to allow tuning in such eavesdropping devices. Virtually all electronic bugs use FM, and transmitter powers are usually on the order of a few milliwatts. The range of such devices, as might be imagined, is short, usually on the order of a few hundred yards maximum.

Certain areas are more likely to "attract" electronic bugs than others. Hotels and motels are naturals, due to the various activities

and serious minded nature listeners. The amplifier can also be used by itself as a super sensitive ear or sound detection system. It also can be used for intrusion alarms or as a sound level meter and many others.

HGA1.....PLANS.....\$ 6.00  
 HGA1K.....All Parts for Above.....\$29.50  
 HGA10.....Assembled and Tested.....\$44.50

HGA2. HIGH GAIN AMPLIFIER WITH OPTIONAL OUTPUT JACK - This device is for the use with the Remote Wireless Transmitter RWM3..  
 HGA20.....Assembled and Tested.....\$46.50

FBT7. IMPROVED MINIATURE VOICE TRANSMITTER - This ultra-small gem of a circuit is many more times as sensitive as anything we have seen yet! When installed in an average location, sounds that are not even normally detected by ones presence are readily audible. This property makes it a highly sensitive intrusion device. The circuit is straight forward and is easily housed in a pack of cigarettes. When used in conjunction with a fairly decent FM receiver, considerable range is possible.

FBT7.....PLANS.....\$ 6.00  
 FBT70K.....All Parts for Above.....\$24.50  
 FBT70.....Assembled and Tested.....\$44.50

FCT3. FM BROADCAST TRANSMITTER - Unique circuit allows you to broadcast over a standard FM radio. Be a neighborhood disc jockey, communicate with your friends, great for a gag or joke. Simple circuit is range adjustable from 100' to considerable distance. Unit is the size of a pack of cigarettes. Can be a great intrusion alarm or wireless babysitter.

FCT3.....PLANS.....\$ 5.00  
 FCT30K.....All Parts for Above.....\$29.50  
 FCT30.....Assembled and Tested.....\$54.50

TT6. TRACKING TRANSMITTER - Miniature tracking transmitter emits tone that allows any car or animal or person to be followed! Range over considerable distance. Battery operated unit lasts for days! Great for transmitter hunt games.

TT6.....PLANS.....\$ 5.00  
 TT60K.....All Parts for Above.....\$24.50  
 TT60.....Assembled and Tested.....\$34.50

WPMS. WIRELESS PHONE DEVICE - This simple, inexpensive telephone device is extremely effective in picking up both sides of a telephone conversation and transmitting them to a distant FM broadcast receiver. It can easily be installed on any phone. It is intended as a device for group listening or for allowing one to hear his telephone with an FM radio and ear piece while performing outside chores, etc. Range is considerable. Sorry, due to federal and many state laws, this device could be considered a form of wire tap. Use only for home or family. Not available fully assembled and operating without proper authorization, due to potential misuse.

WPMS.....PLANS.....\$ 6.00  
 WPMS0K.....All parts for above.....\$34.50  
 WPMS0..(assembled and tested, PROPER AUTHORIZATION POSITIVELY REQUIRED)\$49.5

VWPMS. VOICE OPERATED WIRELESS PHONE DEVICE - This neat little device broadcasts both sides of a telephone conversation to any nearby FM radio with crystal clear clarity over considerable distance. The unique feature of this device is that it only transmits a signal when the telephone is off of the hook thus conserving the batteries and eliminating unnecessary soundless transmission, therefore, allowing several units to be used simultaneously on different lines. Not available assembled and tested without proper authorization due to potential misuse.

VWPMS.....PLANS.....\$ 8.00  
 VWPMS0K.....All Parts for Above.....\$34.50  
 VWPMS0. (assembled and Tested, PROPER AUTHORIZATION POSITIVELY REQUIRED)\$59.50

TELL. ELECTRONIC SWITCH - Activates with the action of the phone hook. Controls any device up to several amps via relay contacts. Normally open or closed circuits.

TELL.....PLANS.....\$ 5.00  
 TELL0K.....All Parts for Above.....\$24.50  
 TELL0.....Assembled and Tested.....\$34.50

TAR10. CASSETTE RECORDER - Intended to interface with any of our existing devices. External jacks for other supporting equipment. Sound operated when used with our SOX1 and 2 and TAT2.

TAR10.....Complete.....\$39.50

Fig. 5-3. Part of an advertisement offering various pieces of eavesdropping equipment, plans, and parts kits for sale. All pieces can be easily used for illegal eavesdropping, and most operate in the FM broadcast band.

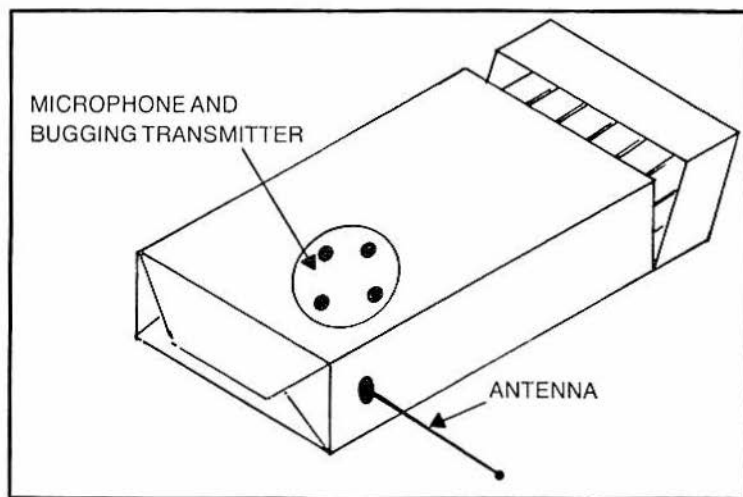

Fig. 5-4. A small "bug" can easily be hidden in a cigarette package and carried in a shirt pocket.

which can take place within their walls. Business-office complexes are also often hotbeds of electronic eavesdropping activity, particularly in businesses subject to heavy industrial-espionage activity. Some of the largest companies in the United States have purchased electronic eavesdropping equipment in the past.

Contrary to the public image of electronic eavesdropping devices as being something out of a James Bond movie, most are relatively simple. One common bug is merely an ordinary FM "wireless mike" hidden in a cigarette pack, Fig. 5-4. This enables the bug to be carried about in a shirt pocket with a high degree of safety. Another common bugging ploy is to hide the transmitting device in a lamp or desk pen set. Such hiding places may seem like ideas borrowed from a cheap detective novel, but have *you* ever bothered to check out such articles in a hotel room?

Not all bugging devices transmit speech. One known as the "beeper" is used for tailing cars see Figs. 5-4 through 5-7. As the name implies, the beeper transmits a series of beeps to facilitate direction finding and tracking. The beeper is attached to an automobile's underside (usually the gas tank) by magnets, and usually transmits somewhere in the standard FM broadcasting band, allowing tailing to be done by any car equipped with an FM receiver. Car receivers are supplemented by portable receivers equipped with direction finding loop antennas for more precise locating and tracking.

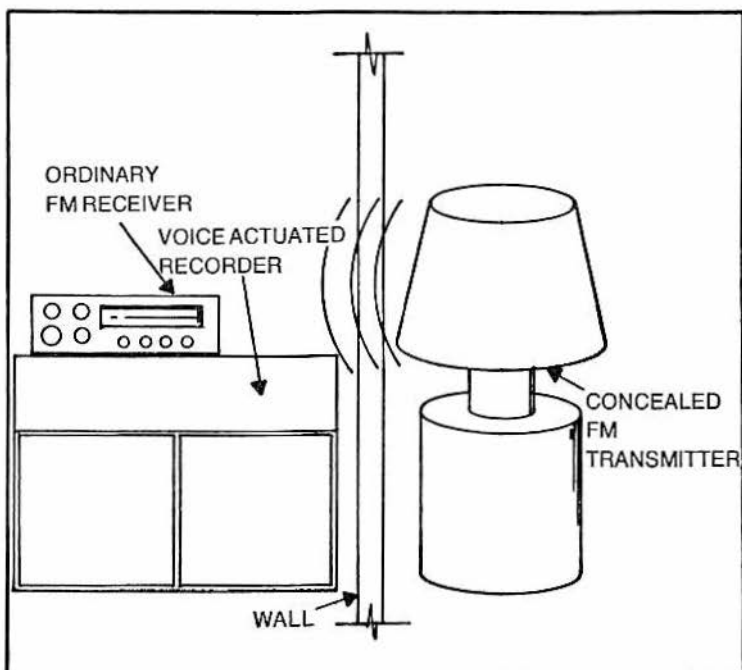

Fig. 5-5. Most bugs operate in the commercial FM broadcast band, allowing a hidden transmitter to be received by an ordinary FM receiver placed nearby.

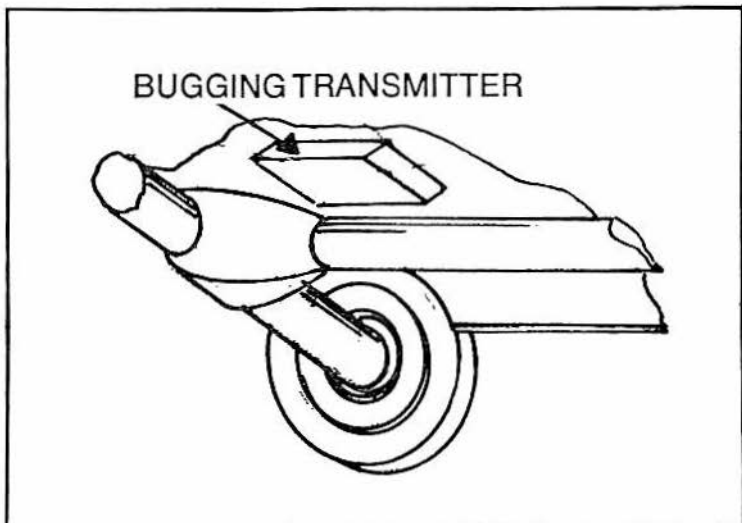

Fig. 5-6. Some bugs can be placed under a car, usually attached by magnets to the frame, body, or gas tank.

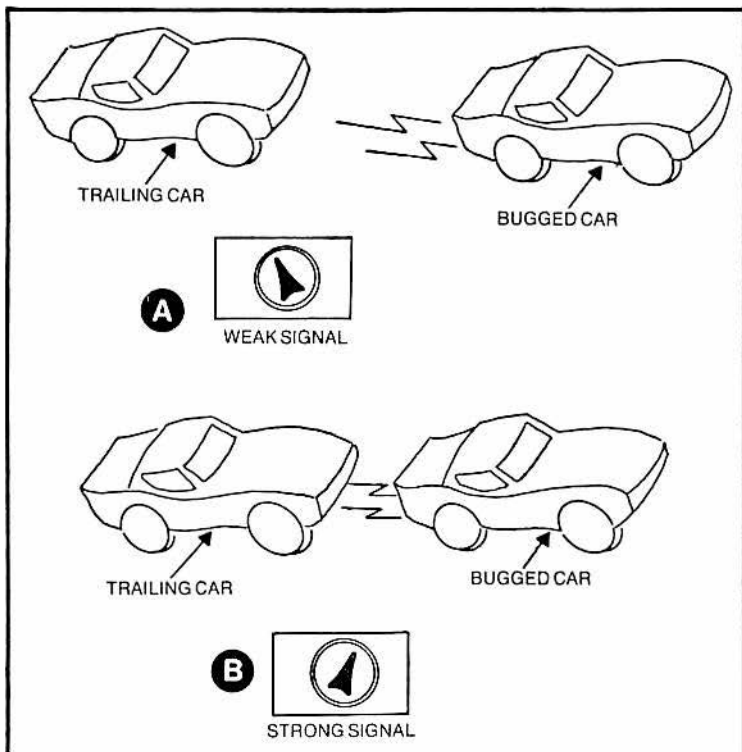

Fig. 5-7. A "bugged" car can be followed by another one, equipped with a receiver and direction-finding equipment, A. As the follower gets closer to the bug, the signal strength increases, as in B.

Naturally, no fixed times and frequencies can be given for tuning in electronic eavesdropping devices. One thing must be emphasized, however, if you ever should intercept what seem to be conversations transmitted over an eavesdropping device: *don't listen!* If the eavesdropping is a legitimate bug by a law enforcement agency, listening in is covered by the secrecy provisions of the communications Act of 1934. If it is an illegal bug, fines of up to \$10,000 and prison terms of up to five years await violators, as well as the possibility of a civil suit for damages due to invasion of privacy. Whether legal or illegal, electronic eavesdropping is not the sort of activity the casual radio hobbyist should ever become involved in, even in the relatively passive role of a listener.

## Chapter 6

# Pirate Broadcasting: European Style

---

“Pirate broadcasting” is a term denoting any sort of unlicensed, illegal radio activity intended for reception by the general public. Often the operators are youthful and run their stations as something of a lark, although sometimes political content enters into pirate-station programming.

Europe has long been a hotbed of pirate broadcasting activity due to the fact that virtually all legitimate European broadcasting is conducted by state-owned and controlled agencies. Such state-controlled programming is often considered dull and stodgy by young people, who prefer the fast pace, rock music, and high-powered disc jockeys of American commercial radio. It is hardly surprising, therefore, that many pirate stations in Europe openly imitate American commercial broadcasting. Another type of European pirate involves ocean going vessels equipped with radio transmitters for broadcasting commercial radio programs to nations with little or no domestic commercial radio. These ocean-based pirates likewise closely imitate American commercial radio.

### **OCEAN-GOING PIRATES**

Offshore pirate broadcasting began back in 1958 with the establishment of Radio Mercur (Fig. 6-1), operating from the vessel *Cheeta Mercur*. In 1958, classical music was the only kind heard on the state owned Danish radio network, and all programming was strictly noncommercial. Ib Fogh, an enterprising



Copenhagen businessman, was aware that there could be a large audience for a Danish language radio station that offered an alternative to what the state-owned system programmed. Establishing a land station within Denmark itself seemed to be clearly out of the question, however. Yet, a bit of research by Fogh indicated that Danish authorities would have little recourse against Danish-language broadcasters that operate from a ship in international waters. Fogh obtained the *Cheeta Mercur* and outfitted it with an FM transmitter. Test transmissions began on July 25, 1958, and on July 31 Radio Mercur began regular broadcasts on 93.12 MHz in the FM band from a site in international waters near Copenhagen.

Radio Mercur proved to be an instant success with its format of pop music. Advertisers stood in line to buy commercial time, since there advertising was permitted on state-run Danish radio. Radio Mercur soon purchased a larger ship, the *Cheeta II*, and installed a more powerful transmitter and larger antenna system to increase range. The success of Radio Mercur soon attracted competition, and in 1961 it was joined by another offshore broadcaster, Danmarks Commercielle Radio.

Danish authorities, unable to touch Radio Mercur while it remained in international waters, managed to take action against the station in its one vulnerable spot: its finances. The Danish Parliament passed a law in 1962 which prohibited any Danish resident from working on or aiding an offshore station. In addition, it was forbidden for Danish businesses to buy advertising time on any offshore broadcasters. Deprived of its income sources, Radio Mercur was forced to close down on July 31, 1962.

Yet Radio Mercur blazed the way for other offshore pirates. In 1963 a string of seagoing pirates popped up off the English coast, with the most famous being Radio Caroline. These stations managed to cash in on the wave of "Beatlemania" then sweeping England, and offered listeners heavy doses of the "Liverpool sound" which the BBC was often loathe to feature. Radio personalities in the style of American disc jockeys were also featured, and advertisers eagerly bought the available air time to pitch their products to the youth market. But, as in the case of Radio Mercur, these stations were eventually forced off the air by laws prohibiting advertising on or otherwise assisting any broadcasting station operating from the high seas. In Great Britain, the BBC eventually revamped its radio formats to accommodate younger audiences, and several announcers from the pirates were eventually hired by the BBC.

# The story of Radio Mercur

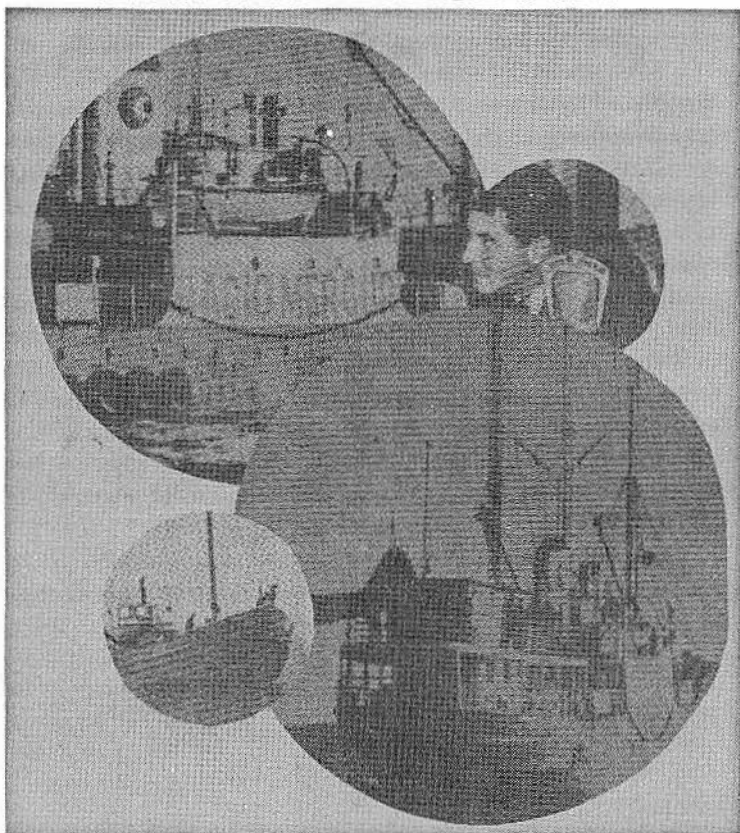

Fig. 6-1. Cover of a booklet about the original offshore pirate broadcaster, Radio Mercur.

Most offshore pirates operate in the standard AM and FM broadcasting bands, making them difficult to receive outside of Europe. One exception was Radio Nordsee International, located aboard the vessel *Mebo II* in the North Sea, Fig. 6-2. Programs were in both English and Dutch, intended for listeners in Great Britain and Holland. Besides frequencies in the AM and FM broadcasting bands, Radio Nordsee International also operated on the frequency of 6205 kHz, where its rock music was heard

worldwide. Radio Nordsee International began operations in late 1969 and managed to remain active until 1974, when anti-pirate laws passed by the Dutch government cut off the major sources of its revenue. From 1974 through 1977, operation of the station was erratic until it finally sailed to Libya. Since late 1977 the station has been conducting tests on a sporadic basis from Libyan waters; in fact, the station has been apparently bought by the Libyan government for some unspecified purpose.

Not all offshore broadcasting has a commercial intent, however. One interesting operation is the "Voice of Peace," a pop-music broadcaster in the Mediterranean, run by an Israeli named Abie Nathan. His avowed purpose has been to bring peace to the Middle East through the Voice of Peace's neutral, middle-of-the-road political discussions. It is difficult to judge how effective the station has been in the political area, but it is known that the station's music programs have a wide following in both Egypt and Israel. The Voice of Peace has had a precarious existence since it first came on the air in 1973, having to close down on several occasions due to a lack of funds. Each time it has managed to make it back, however, and is still operating as of the time of this writing in early 1979. Abie Nathan has vowed to keep his shipboard station operating until peace finally comes to the Middle East.

Unfortunately for the listener, however, the era of offshore broadcasting seems to have largely passed. In large part this is due to the fact that most European governments have passed laws making it impossible for the stations to survive due to restrictions upon placing advertising on such stations. Most state-run broadcasting organizations have also changed sufficiently to accommodate a large part of the potential audience for offshore pirates, even to the point where some nations have started state-operated commercial programs.

Yet this does not mean the end of pirate radio in Europe—far from it! Instead of large commercial operations from international waters, European pirates now are low-powered operations actually hidden within various European nations. And, happily for the shortwave listener, most of these pirates operate in the shortwave band, enabling them to be widely heard. Some, in fact, have even been heard in North America!

### **LAND-BASED PIRATES**

Pirate broadcasters are found throughout Europe, from the British Isles to the Soviet Union. Most pirates are run by young

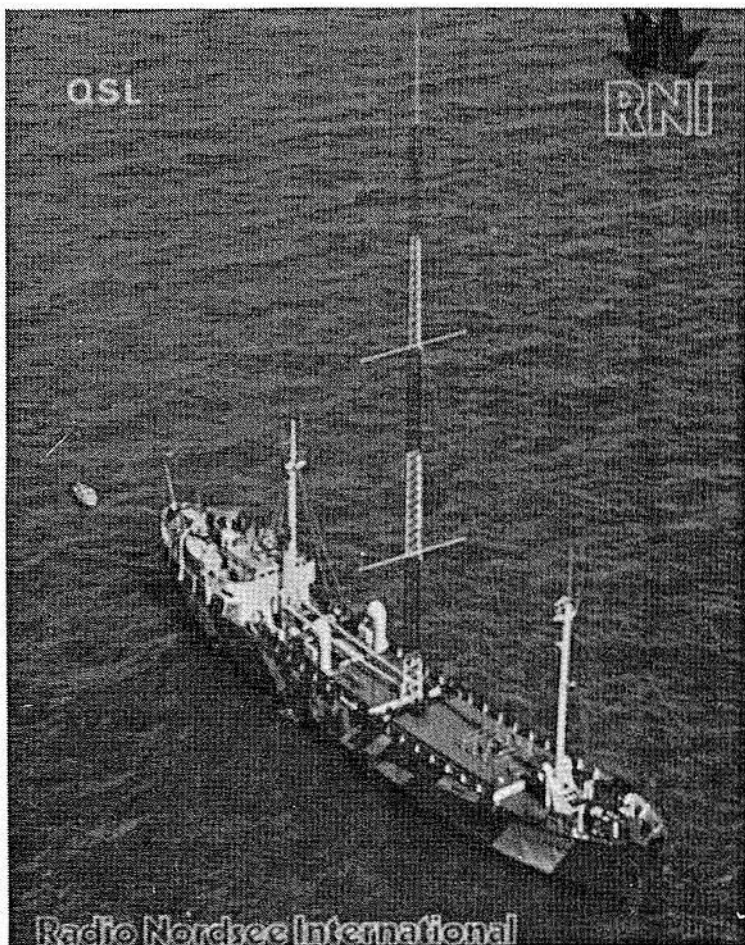

Fig. 6-2. QSL card from Radio Nordsee International, showing the vessel "Mebo II" and the antennas of the station.

persons using homemade equipment, with rock music making up the bulk of their programming.

In the Soviet Union, it is estimated that over 3000 pirate transmitters are in operation, most using transmitter powers in the range of 15-40 watts. Westerners visiting Moscow have reported hearing over fifteen pirates in a typical evening. Programming in the USSR is often obscene and sexually graphic, with forbidden Western rock music featured. USSR authorities term pirates "radio hooligans," and they frequently are prosecuted when discovered due to claimed interference to legitimate services.

Actually, the Soviet pirates seldom interfere with authorized stations, but they do raise serious questions about freedom of expression in the USSR.

Similar problems are also encountered by Yugoslavian authorities. In that nation, enterprising craftsmen construct transmitters out of discarded radio sets and broadcast their own programs of music and humor, including request and commercial shows to earn some extra money. Some cities in Yugoslavia support over 300 pirate transmitters, and their number is apparently growing despite stiff fines and the possibility of imprisonment.

In Italy, the pirate-radio situation is acknowledged to be out of control. A 1976 decision by the Italian Supreme Court ruled that the airwaves in Italy were open to everyone and not exclusively a government monopoly. The decision did not preclude the Italian government from requiring station licenses of private broadcasters, and adherence to established frequencies; however, the Italian government has yet to establish a plan for private broadcasting, and pirates are using the decision to freely broadcast. More than 600 unlicensed broadcasters are currently on the air in Italy and, as might be imagined, the programming is really lively. Heated political commentaries are popular fare, as are talk shows on various "X rated" topics. During Italy's recent periods of political unrest, some pirate stations have been targets of violence by various political factions.

In the rest of Europe, pirate broadcasting closely imitates American commercial radio. The British Isles have the greatest concentration of activity, followed by Holland and Denmark. Activity is scattered at a lower level through Scandinavia, West Germany, and France. Pirate radio in Western Europe often operates on shortwave, in contrast to illicit broadcasters in other nations. The 5200-6500 kHz slot is popular with pirates, followed by 7300-7500 kHz. Table 6-1 lists some of the most popular pirates currently active.

Many Western European pirates have international audiences, complete with listener clubs, bumper stickers, monthly magazines, and tee shirts. Programs are often slick and professionally produced, and transmitter powers in the thousands of watts are not unknown. Operation is usually restricted to Sunday mornings in Europe (0800-1300 GMT) and transmitter sites are frequently changed so as to foil government efforts at closing them. Despite such efforts, government raids are occasionally success-

ful, and various pirates are silenced from time to time. In Europe, however, penalties for pirate broadcasting are usually restricted to confiscation of equipment and modest fines, meaning that quite a few pirate stations eventually return to the air a few months after being tracked down and closed. In fact, getting caught carries with it a certain status among European pirates!

### INSIDE A EUROPEAN PIRATE STATION

The story of Radio Viking is typical of many European pirates, although the station used better transmitting facilities than most of its contemporaries. Figure 6-3 illustrates one of Radio Viking's QSL cards, which were sent out from their Amsterdam mailing address in response to correct reception reports from listeners. However, Radio Viking did not transmit from Holland, but from a small town in Denmark.

Radio Viking first came on the air on August 7, 1977, as a one-man operation by a young Dane we will refer to as John S. The frequency selected by John S. was 6240 kHz, and he used a crude transmitter of only a few watts. Programming was progressive rock music and was scheduled for Sunday mornings (in Europe). John S. was soon joined by Oscar H., another young Dane, and the station began attracting a regular audience for its Sunday broad-



Fig. 6-3. QSL card from European pirate Radio Viking. Despite the address in Amsterdam, the station is actually in Denmark.

casts. One regular listener in Holland volunteered to act as the station's postal drop, enabling the station to receive letters from listeners and play musical requests. This was a crucial step forward for Radio Viking, as it enabled the station to develop a "hard core" of listeners and supporters that other European pirates found difficult to form.

A major improvement in Radio Viking came in October of 1977, when Poul A. joined the staff. Poul A. was a trained radio professional, experienced in legitimate broadcasting activities. Poul A. brought several ideas to improve the station's programs, and they apparently worked. Radio Viking quickly gained a reputation as the most professional of the European pirates then operating, and its audience steadily grew. New transmitting facilities were put into operation, which ran several hundred watts of power and greatly increased the station's reliable range. Another innovation introduced during this period was a Radio Viking Listeners Club, which published a magazine for listeners (Fig. 6-4) and coordinated sales of various Radio Viking items, such as T-shirts and tapes of American rock stations like New York's WABC. The Radio Viking Listeners Club generated sufficient revenue to allow improvements in studio facilities and the acquisition of a large music library. Two new announcers joined the staff, Dave A. and Phil H.

December 4, 1977, brought a major expansion of Radio Viking's programs, as programs were transmitted each Sunday from 0900-1130 GMT. Among the features at this time was a special DX program for shortwave listeners, supplemented by a printed DX bulletin. Mail to the station clearly indicated the international nature of their audience, as approximately 50% of listener mail came from Sweden and West Germany. Interestingly, 15% of Radio Viking's mail came from East Germany, a remarkable figure since information on foreign-radio broadcasters virtually never appears in print in East Germany. England accounted for 11% of Radio Viking's listener mail, 9% came from Denmark, and 5% came from Norway, Belgium, and the Netherlands. The rest of their mail came from scattered locations in Europe.

Other "American" touches were added to Radio Viking, including their own "European Top Ten" survey of hit songs each week. Dedications also became a regular (and popular!) feature of the station, and the featured music was expanded to include such diverse areas as country and western, "oldie goldies," and progressive jazz, see Fig. 6-5. Even contests were featured, with Radio Viking T-shirts offered as prizes for the winners.

# RV-mag



No. 3 - August 1978

---

Fig. 6-4. August, 1978 issue of "RV-mag," the official publication of the Radio Viking Listeners Club.

But Radio Viking began attracting the attention of Danish authorities, who realized that the station was operating from inside Denmark despite the announced mailing address in Holland. The station's regular schedule made it an easy target for government monitors, and direction finding efforts were soon begun. Success was eventually obtained, and on September 10, 1978, the station



# radio viking

P.O. Box 4040 · Amsterdam · HOLLAND

RECORD - REQUEST

Dear Radio Viking!

Would you please play:

\_\_\_\_\_ (group/singer) \_\_\_\_\_ (title)

Alternatives:

\_\_\_\_\_  
\_\_\_\_\_

on \_\_\_\_\_ (date) in the programme \_\_\_\_\_

Dedicated to (not necessarily) \_\_\_\_\_

\_\_\_\_\_  
\_\_\_\_\_

Name: \_\_\_\_\_

Address: \_\_\_\_\_

NB: Please allow us 4 weeks in advance to get your record-request scheduled.

international music radio on short wave

Fig. 6-5. Record request form from Radio Viking. Dedications of records on European pirate radio are still big, much like the situation on American commercial radio in the late 1950s and early 1960s.

was located and shut down by agents of the Danish Post Office. See Fig. 6-6. The raid took place at 1101 GMT during one of their programs. The station's transmitting gear was seized, and the authorities attempted to seek a fine of 10,000 Danish kroner (approximately 2000 American dollars). Fortunately for the per-

sonnel of Radio Viking, the case did not come up for trial in the Danish courts.

European pirates, like Lazarus, have unexpectedly returned from the dead. Radio Viking was no exception. Within days after its raid by Danish authorities, Radio Viking had distributed a "press release" throughout Europe detailing what had happened. Aid was solicited from listeners and other pirate radio operators, and within

**radio  
viking**

P.O. Box 4040 · Amsterdam · HOLLAND

P R E S S - R E L E A S E

RADIO VIKING FORCED OFF THE AIR!!

On Sunday, September 10, at 11.01 GMT, Radio Viking was being closed down by the Danish Authorities.

That finished 13 months of successful broadcasting in the 48 metre band. Radio Viking started in August 1977, and its regular Sunday programmes soon lead to a following, and letters from most countries in Europe have been pouring in to the station.

Just a fortnight ago Radio Viking introduced its brand new Autumn programmes. The station was now on the air for 3 hours every Sunday, and introduced new programmes like the "DX-world" and "Radio Viking top-10".

Although the station is momentarily off the air, the Viking organization continues, and the very popular magazine, "the RV-mag", will still be issued. In that listeners can obtain information of how to buy promotional material from the station.

Radio Viking hopes to be back with a monthly schedule. In the meantime some programmes will be transmitted by other stations operating in the 48 metre band, so listeners are asked to "keep a look-out"!

The Radio Viking DX-programme, the "DX-world", will now be available in printed form. The DX-world, naturally including future developments of Radio Viking, can be obtained by sending 2 IRC's to our address.

In closing we urgently ask all "colleagues" in the 48-metre-band, DX-clubs, DX-ers and listeners, who are willing voluntarily to assist Radio Viking in returning to the air, to contact us immediately at this address:  
P.O.Box 28, 8800 Viborg, Denmark.

-----  
Lennart Bergkvist, Radio Viking  
P.O. Box 4040, Amsterdam, Holland.

**international music radio on short wave**

Fig. 6-6. "Press release" from Radio Viking, telling of its closing in 1978 by Danish authorities.

a few days of the raid the station was back on the air using homemade, rather weak transmitters. By October Radio Viking had resumed broadcasting for two hours each week.

January 14, 1979, marked the beginning of a new era for Radio Viking, as the station returned to the air from a new site near Copenhagen with a 3000-watt transmitter, making it one of the most widely heard pirate stations in history. See Fig. 6-7. Broadcasts were scheduled for the second and fourth Sundays of each month from 0900-1130 GMT on 6250 kHz. Radio Viking has emerged from the aftermath of the raid even stronger than before, and it plans to continue until allowed to broadcast openly as a nongovernmental, private station—and they plan to continue despite their firm belief that they will inevitably be raided again by the authorities. Having survived one raid, the station is confident of its ability to continue in the future regardless of any complications.

Why do the operators of Radio Viking go through the expense and trouble of operating an illegal radio station? The rewards certainly are not financial, as Radio Viking, unlike some other pirates, accepts no advertising. Legal troubles are an always-present threat. Operation of the station absorbs large amounts of the time and energy of the operators, and the necessity of avoiding apprehension minimizes the fame that might otherwise be forthcoming to the operators.

The real motivation for the operators of Radio Viking (as well as many other European pirate operators) seems to be largely altruistic. The operators perceive themselves as performing a public service, offering an alternative to the state-owned and operated radio broadcasters that dominate Europe. While the official broadcasters may be long on quality, they are often short on originality and innovation. Experimentation is rare on official European radio, and top management of the state broadcasting systems are career bureaucrats, often more concerned with adherence to rules and procedures than with being responsive to public needs. While the pirates often imitate some aspects of American commercial radio, they are less interested in the opportunity to make money than they are with having the opportunity to be creative. In the United States, young people interested in broadcasting have numerous opportunities to participate in legitimate station operations; Europe, with fewer opportunities in a state-controlled structure, offers few such outlets except for pirate radio. It would not be much of an overstatement to

# radio viking

P.O. Box 4040 · Amsterdam · HOLLAND

P R E S S - R E L E A S E

VIKING GOES ON....

After several ups and downs through 1978, Radio Viking is in for big changes in the new year.

The station, which was raided on September 10, has been heard regularly in October and December with a two hour schedule. But as from January 14, 1979, Radio Viking will be on the air every second and fourth Sunday of the month with this schedule:

09.00 GMT - Oscar Hansson

10.00 GMT - Poul Anthony

11.00 GMT - Phil Hazleton

For the first time ever Radio Viking will be using its new 3 kW transmitter, which should ensure interference-free reception in most parts of Scandinavia and the rest of Europe.

In order to concentrate entirely on the programming and the transmitting, the handling of publicity and selling of different radio products has been given to a new organization, R.V. Sales. In the future all orders for T-shirts, R.V.mag etc. should be sent to: R.V. Sales, P. O. Box 1, DK-6780 Skaerbaek, Denmark.

Radio Viking has been transmitting on rather low power since the forced close-down in September. We hope that the news of increase in transmitting power to 3 kW, will be a pleasant surprise to those listeners, who have been unable to tune in during the last months.

The programmes will be transmitted on a frequency of 6250 kHz. (or on the alternative of 6256 kHz.) in the 48-metre-band.

In the next few months we hope to be announcing an addition to the staff of air-personalities as well as an increase in air-time to 4 hours.

**international music radio on short wave**

Fig. 6-7. You can't keep a good pirate down . . . Radio Viking triumphantly returns to the air following its bust in September, 1978.

say that many of the European pirates consider themselves artists, but with radio as a medium instead of canvas or clay.

## **OTHER EUROPEAN PIRATES**

Most other European pirates are similar to Radio Viking. Great Britain is the home of perhaps the largest number of pirates, although most are rather low-powered and difficult to receive

outside of the British Isles. British pirates run an especially high risk of discovery, due to the advanced direction finding equipment used by the British Post Office. One victim of a raid was Radio ABC England, which was busted late in 1977. The operator, Philip Jefferson, was broadcasting from a car located amid derelict buildings on a farm in the English countryside. When he became aware that the authorities were closing in, Jefferson tried to escape, damaging his car in the process. The station's transmitter was confiscated, and Jefferson was fined 175 English pounds for his activities.

Ireland also has a good bit of pirate activity, and the operators are just as resilient as those found elsewhere in Europe. One well known Irish pirate is Westside Radio, located in Dublin. Westside Radio had operated off and on for several years from various locations in Dublin until September 15, 1976, when it was raided and shut down by Irish authorities. The station's transmitting equipment was seized but, luckily, the operators were not fined. The station remained silent until September 25, 1977 when it was reactivated from a new location in Dublin with new transmitting equipment. Since then the station has operated on Sunday mornings (Irish time) from various locations in Dublin, selecting a new transmitting location each week so as to foil attempts at closing it again. Westside Radio is famous for its many colorful announcers, including the famous Prince Terry, a veteran of numerous Irish pirate operations.

The most powerful European pirate to date is the Free Radio Broadcasting Corporation, a Dutch pirate which uses a 6000 watt transmitter. Programming is pop music, with numerous "oldie goldies," and the station has been heard on several occasions in eastern North America. Despite the high transmitter power, the station has managed to avoid detection for several years.

As a general rule, most European pirates eschew political issues, save for their frequent calls for opening up the airwaves for "free radio." One notable exception to this rule is Radio Rastafari, operating from a site in Holland. See Figs. 6-8 and 6-9. The Rastafarians are a black political and cultural group whose largest numbers are found in Jamaica and other islands of the West Indies. Radio Rastafari offers large amounts of the reggae music so popular in Jamaica, and features news of life and culture in Jamaica. It has also carried pre-recorded programs produced by various African liberation movements, and has attracted a wide listening audience among black expatriates residing in Europe, many of whom feel that they are the victims of racial discrimination.

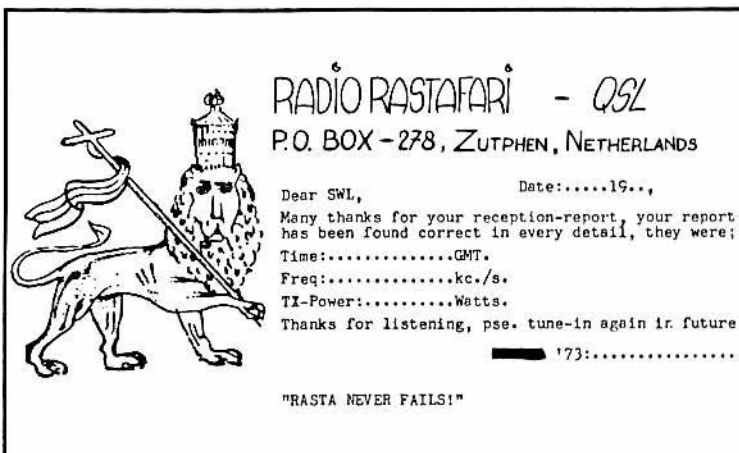

Fig. 6-8. QSL card from Dutch political pirate Radio Rastafari.

Table 6-1. Guide to European Pirate Broadcasting.

Frequency (kHz)	Station Name and Location
6200	Empire Radio, England
6215	Free Radio Broadcasting Co., Holland
6215	Radio Minerva, Holland
6219	ABC Europe, England
6220	Radio Mercury, Holland
6220	Skull and Bones Radio, Ireland
6225	Britain Radio International, England
6228	Radio Domino-X, Sweden
6235	Radio Sunshine International, England
6250	Radio Viking, Denmark
6250	Radio Intercontinental, England
6250	Radio Partisan, West Germany
6255	Radio Corsair, England
6260	Thameside Radio, England
6260	Radio Cavendish, England
6260	Radio Rastafari, Holland
6270	Radio Zodiac 49, England
6280	Westside Radio, Ireland
6285	Radio Solent City, England
6317	Radio Condor, England
6590	Capital Radio Dublin, Ireland
7310	European Music Radio, Holland
7365	Star Radio, Holland
7380	Skyport Radio, England

Much less heavy is Radio Domino-X, a Swedish pirate operated by a group of shortwave listeners (it frequently identifies as "Radio DX"). In a letter to the "Sweden Calling DXers" program broadcast over the official government voice, Radio Sweden, the operators of the station explained that "... our aim is to speak for legal shortwave broadcasting for DXers and hams in line with the new government proposal for 400 new local FM stations beside the monopoly of Radio Sweden. Our aim is to speak for legal rights of

Mr. Harry Helms,

Radiostation Rastafari,  
P.O. Box - 278,  
Zutphen

10.02.'79,

Dear Harry,

Many thanks for your letter which I found interesting. We are happy to answer your questions.

History: Radio Rastafari began its broadcasting on 01.01.'76 supporting S.W.A.P.O. (Namibia), let me tell you that R. Rastafari is not a station which is fighting for free radio, but more a political station which is fighting for the rights of the black man in Africa by means of radio. Rastafarianism is a religion actually, which proclaims the return of the Black Man to Africa. Our "Father" is Ras Tafari (Selassie I, King of Kings, Lord of Lords, conquering Lion of the tribe of Judah). So we started in '76 with power 10 watts on 6245 kc./s. 48 metres. Later on power was going up, 20, 25, 35 and far more later we used 50 watts on 6270 kc./s. The station was raided in 1977 and came back one month after the raid. Later on a few more raids followed and we were doing very bad financially. That's why we had to call in help from other 48-metre stations. First we were using the transmitter of Skyport radio in England, later on we used the tx. from Radio Nolen (NL). But these transmissions were not very successful. Today our programmes are aired over facilities from Radio Corsair (SL) in England. We are setting up an own transmitter-site in the centre of the Netherlands, and broadcasting should commence this summer. Well I think that you will find all your questions answered. Any more questions will be answered also. Last note: CSL-policy, R. Rastafari verifies all correct reception-reports with a CSL-card free of charge. I hope to hear from you sometime in future Harry, please let us now if you can use this material, may the almighty JAH be with you always, may he make your work successful,

'73:  
Lloyd Livingston  
Station Manager.

P.S. As already said we are a political station, political ideology is Socialist.

Fig. 6-9. Letter to the author from the station manager of Radio Rastafari, outlining the station's philosophy and aims.

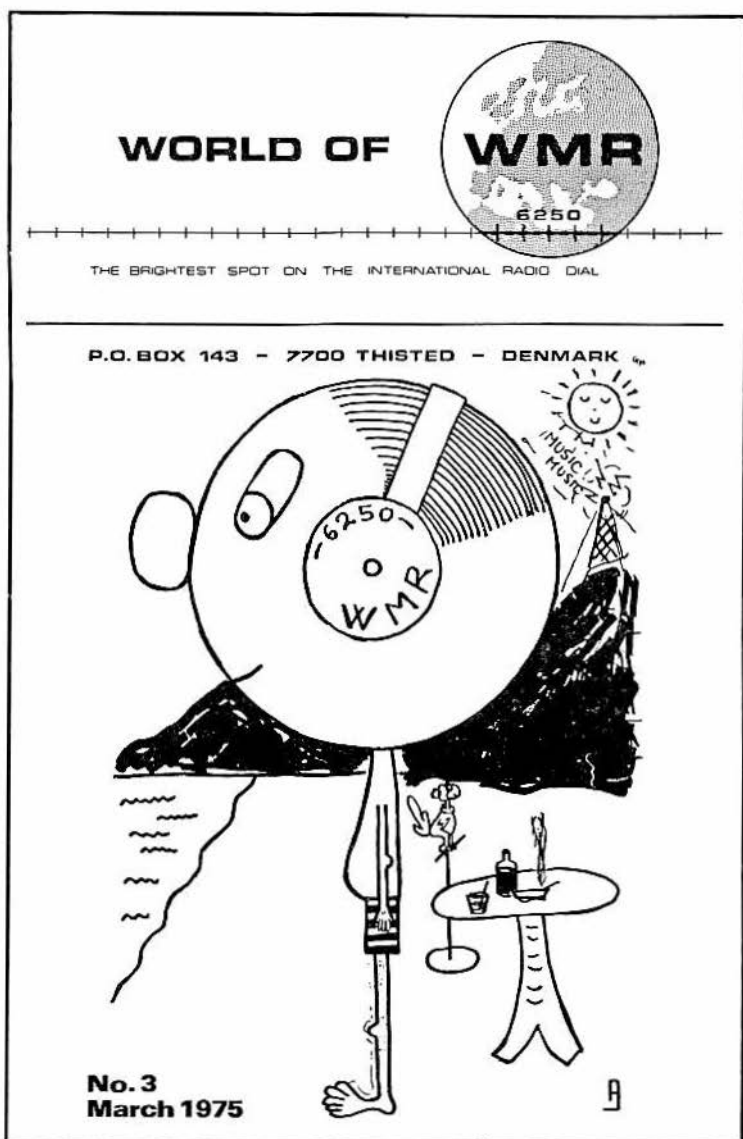

Fig. 6-10. Listener magazine from "World Music Radio," a famous Dutch pirate of the early 1970s.

broadcasting on shortwave for DX clubs and DX organizations." Sweden has what may well be the largest concentration of shortwave listeners per capita in the world, and it can be safely assumed that Radio Domino-X has a large audience!



## TUNING IN EUROPEAN PIRATES

As Table 6-1 shows, most European pirate activity takes place just above the 49-meter international broadcasting band in the 6200-6500 kHz range, with a scattering of stations located just above the 40-meter Amateur band, usually in the 7300-7500 kHz. Operation is usually restricted to Sunday mornings in Europe, most commonly in the 0900-1300 GMT block. Operation is highly irregular, and transmitter powers are usually less than 100 watts. Reception of these stations in North America is rare but some, including Free Radio Broadcasting Corporation and World Music Radio, have been heard in North America (Fig. 6-10). Occasionally, these pirates have scheduled tests at times more advantageous for North American reception. Listeners desiring to keep up with the latest events in European pirate radio should consider joining a club for shortwave listeners.

The future of European pirate radio is impossible to predict, although it can be safely said that as long as broadcasting continues to be largely a government-controlled proposition, pirates will continue to offer an alternative.

## Chapter 7

# Pirate Broadcasting: American Style

---

Pirate broadcasting is by no means restricted to Europe. In fact, a good case could be made for the argument that the United States has had a higher level of pirate activity than has Europe in recent years. While the number of American pirate stations has not been anywhere near the level of Europe, American operations have been higher powered, more regular in operation, and more widely heard than their European counterparts. For example, 1978 saw no less than three different pirate stations operating from New York City.

Pirate broadcasting in the United States is a violation of Federal Communications Commission regulations, punishable by a fine of up to \$10,000 and up to a year in prison. This has not deterred pirate broadcasters; in fact, the FCC has often shown a remarkable lack of interest to tracking down and apprehending pirate operators. This curious aspect of American pirate radio will be explored further in this chapter.

Most American pirates are strictly hobby operations by young, would-be broadcasters. Programming is heavy on rock music with telephone calls from listeners aired on several stations. These phone conversations are frequently on the bizarre or obscene side. Another class of pirate is the so-called "DX pirate," operated by young members of the various shortwave listening clubs. These stations often program directly for the shortwave listening hobbyist, featuring latest listening tips and greetings to shortwave listeners. Political content of American pirate stations

is minimal, usually restricted to support for "free radio," a term the pirates use to denote their style of unlicensed, free-form radio.

The bulk of American pirates operate just above the upper end of the standard broadcast band in the 1600-1650 kHz range. This portion of the radio spectrum is relatively clear of interference and pirate stations can achieve rather remarkable range. Your author, for example, has heard 100-watt pirate stations, located in New York City, from a listening site in the Carolinas. Other American pirates operate in the shortwave range, as given in Tables 7-1 and 7-2, and these are frequently heard throughout the United States and Canada.

**Table 7-1. Pirate Radio Activity, 1973-1976.**

<b>Frequency</b>	<b>Station and Comments</b>
850	WHBL, Bayonne, New Jersey (announced location), rock music and dedications, active January, 1975.
1580	Menomonee Warriors' Station, near Keshena, Wisconsin, active during unrest in the area during Spring of 1975.
1610	WHGC, Charlottesville, Virginia, gospel music and religion, closed by FCC agents March 4, 1976.
1620	WCPR, Brooklyn, New York, rock music and telephone callers until closed by FCC agents February 7, 1976.
1629	WCPU, location unknown, active following WCPR closing in February, 1976.
5035	"Wild Turkey Radio," location unknown, talks and items from shortwave club bulletins, active December, 1973.
6025	"Radio King Kong," claimed to be located aboard a ship in Atlantic Ocean, rock music and obscenities, active February and March, 1974.
6030	"Radio Clandestine," again claiming to be aboard a ship, rock music and political commentaries, active in December, 1973.
7415	WTIT, location unknown, rock music, active February, 1973.

**Table 7-2. American Pirate Radio Since 1976.**

<b>Frequency</b>	<b>Station and Comments</b>
830	KDOR, Los Angeles, rock music, operated by DX hobbyists, still active in early 1979.
837	WRFB, "Radio Free Bolinas," somewhere in San Francisco Bay area, pop music and telephone callers, active December, 1978.
1620	WFAT, Brooklyn, New York, rock music and telephone callers, active throughout 1978 and early 1979.
1625	WPNJ, somewhere in New York City area, Rock music and often bizarre telephone conversations, active throughout 1978.
1630	WGOR, Brooklyn, New York, rock music and telephone callers, active throughout 1978 and early 1979.
3885	Various AM hobby pirates sporadically active.
5850	Voice of the Voyager, Minneapolis, active on this frequency until visited by FCC agents in August, 1978.
6205	WINT, location unknown, pop music, active March, 1978.
6210	Jolly Roger Radio, located near Indianapolis, Indiana, variety of music, active sporadically throughout 1978.
6220	Voice of the Voyager, Minneapolis, new frequency used since November, 1978.
6420	Unidentified pirate in southern California area, rock music with no announcements.
7445	Voice of the Viking, rock music and few announcements, active August, 1978.
7450	WMMR, somewhere in the Midwest, rock music and announcements, active summer of 1978.
28625	Radio VOCAD, somewhere in the Chicago area, music and shortwave listening tips, active June, 1978.

Another band used by American pirates is the 88-108MHz FM broadcasting band, in particular the 88-92 MHz allocation for educational broadcasters. Very often, these pirates are found in large metropolitan areas, usually the result of students "borrowing" the facilities and operating them illegally for a few days. Due

to the highly localized and sporadic nature of these stations, we will not discuss them in this chapter. Listeners in metropolitan areas should be alert for such activity, however.

Offshore broadcasting, which has played so large a role in European pirate-radio history, is virtually absent in the American pirate-radio scene. Only two offshore pirates have ever broadcast to North America. The first such station was a floating bar and gambling casino under Panamanian registry, which was anchored offshore near Long Beach, California in 1933. The end of Prohibition removed the lure of this enterprise, which used its onboard radio station to advertise the other attractions of the ship. The second offshore broadcaster operated for only one day—September 19, 1973—and was the brainchild of conservative minister Carl McIntire, best known for his “Twentieth Century Reformation Hour” program. Rev. McIntire had previously operated two legitimate radio stations in Pennsylvania but their licenses were revoked by the FCC for violations of the Commission’s “fairness doctrine.” He managed to procure a ship and transmitter and took to the air from a location in international waters off the coast of New Jersey. “Radio Free America,” as Rev. McIntire called his station, operated on 1160 kHz and was heard throughout the northeastern United States for ten hours until the ship’s wooden deck began to overheat and smolder. The station was closed down and did not return to the air. The ship has since been sold and Rev. McIntire has apparently abandoned plans to continue offshore broadcasting.

## **PIRATE RADIO 1973-1976**

Pirate radio was not unknown in the United States and Canada prior to 1973, but incidents of it were rare. 1973 marked the beginning of an increase in pirate-radio activity, which has continued as of the time of this writing.

One of the first of the new crop of pirates was “WTIT, the sound of young America,” which was briefly active in February, 1973. Programming was rock music and obscenities (a rather common format for American pirates, by the way) and its location was believed to be in Indiana. Activity during most of 1973 was limited to brief activity on the AM and FM broadcasting bands until December, when two interesting operations cropped up on shortwave. One was “Radio Clandestine,” a spoof on offshore broadcasting and clandestine radio. The announcer gave his name as “R. F. Burns” and interspersed political jokes with rock music.

He requested reception reports, to be sent to what proved to be a phony New York address, and promised the "SINPO code foreman" would handle them. Reception was good throughout the Northeast.

Due to the familiarity with several shortwave hobby subjects demonstrated by the operators of "Radio Clandestine," it seemed highly likely that the operators of the pirate were themselves shortwave listeners. Such was certainly the case with "Wild Turkey Radio," which claimed to be the "voice of the Pilgrim underground." Among the inevitable rock music and profanity were several items taken directly from "FRIENDX," the monthly bulletin of the North American Shortwave Association (a club for shortwave listeners).

A shortwave listener in Ottawa, Canada heard the station and reported his reception in the pages of the January 1974 issue of "FRIENDX." He did not send a reception report to the station since "Wild Turkey Radio" did not give an address. A few months later, the Canadian listener received a surprise in the mail—a verification letter from "Pullet" and "Gobbler," confirming reception of "Wild Turkey Radio!" The letter verified the Canadian listener's report which appeared in "FRIENDX," and, moreover, the letter was airmailed from the nation of Turkey! Clearly, "Pullet" and "Gobbler" were shortwave hobbyists themselves.

1974 was a rather slow year for pirate radio, with most activity confined to poorly-heard operations in the AM and FM broadcasting bands. None of these stations were heard outside of their immediate areas or were in operation for extended periods. Only one shortwave pirate was reported in 1974, "Radio King Kong," which transmitted on 6025 kHz during February and March. The station claimed to be aboard a ship in the Atlantic Ocean and broadcast rock music accompanied by a young male announcer who used plenty of profanity. Reception of the station indicated that it was somewhere in the northeastern United States. "Radio King Kong" was the name used by a pirate station which was widely heard in the 1960s, but it was believed that the two stations were not related. The fact that the operators of the new stations were aware of the old "Radio King Kong" was evidence, however, that the pirates had some connection with the shortwave listening community.

Activity kicked off in 1975 at a high level. The first notable operation was "WHBL," which claimed to be operating from Bayonne, New Jersey. It was active in January and was heard well

in the metropolitan New York area, although the technical quality of their signal was often poor. Programming was again rock music, but with the added twist of dedications to listeners, all of whom were apparently friends of the operators of the station.

The Spring of 1975 brought one of the few pirates in the history of American pirate radio to be largely political. This station was known as the "Menomonee Warriors Station," and was active on 1580 kHz from a site near Keshena, Wisconsin. The station was active during a period of unrest in the area, apparently by sympathizers of the Menomonee Indians. Its signal was strong enough to interfere with reception of WAPL, a legitimate broadcaster on 1570 kHz at Appleton, Wisconsin.

The latter part of 1975 saw two widely heard operations which continued to operate into 1976. One was "WHGC," which operated from Charlottesville, Virginia. In marked contrast to other pirate stations, "WHGC" programmed nothing but gospel music! the station operated on 1610 kHz, just above the standard AM broadcast band, and was heard from the Carolinas to Delaware. The station made no real attempt to hide its location nor did the operator take any special pains to conceal his identity. The operator was contacted by members of the National Radio Club (and organization whose members specialize in long distance reception of the AM broadcast band) and the operator claimed that his station operated with only 100 milliwatts of power, which would make it legal under part 15 of the FCC's rules. Many knowledgeable members of the club were quite skeptical of his claims.

The station continued to operate until March 4, 1976, when it was raided and shut down by agents from the FCC office in Norfolk, Virginia. The station turned out to be running a highly illegal fifty watts. The gospel music programming was explained by the fact that the operator was the son of a minister, with the station itself being located in the back of a church in Charlottesville! The FCC, in a typical response to pirate activity, issued a warning to the young operator.

## **WCPR: THE WAVE OF THE FUTURE**

The station that defined the future of American pirate radio first came on the air in late December, 1975. Calling itself "WCPR," the station was located in the heart of Brooklyn, New York, and quickly attracted a wide following among the general public and the shortwave listening community. WCPR's "success"

was due to its relatively clear frequency, 1620 kHz, which allowed for coverage of the entire east coast, and its format of telephone call-ins, which allowed listeners to participate in the station's activities. Even though the station was raided and closed down by the FCC on February 7, 1976, it did not mean the end of the station.

"WCPR" made use of an ingenious, although illegal, system to receive and air listener telephone calls without having their telephone traced. The system involved what are known as "dial-around loops," which are used by the telephone company whenever numbers are changed or discontinued. Dial-around loops consist of two halves, each with its own number. For example, one half could use a number like 222-0077 while the other half would be a similar but different number, such as 222-0079. To use this system, WCPR would dial its telephone to one half of the loop (such as 222-0077) while instructing its listeners to call the other half (222-0079 in this case). This allowed WCPR to receive and air listener calls without having to reveal their actual phone number—until they made a fatal mistake which resulted in a FCC raid that closed their station.

Your author came into contact with the operators of WCPR in late 1977 because of an article written for a national electronics magazine on the subject of pirate radio. One of the stations mentioned in the article was WCPR. The operators of WCPR, who had been discovered and put out of business by the FCC eighteen months earlier, read the article and contacted me through the magazine. I gained several insights into the world of pirate radio through contacts with the WCPR operators, and they contributed greatly to this chapter. See Fig. 7-1.

The chief announcer for WCPR was a young man who called himself, somewhat unoriginally, "John Doe." He was also my main contact with WCPR. WCPR turned out to have been located in an apartment in a high-rise building near the Hudson River in Brooklyn. Considering the fact that the station had been heard from New England to the Carolinas, the equipment was amazingly simple; transmitter power was only 72 watts into an end fed "zepp" antenna located outside one of the apartment's windows. From a security standpoint, the station was ideally located; it was surrounded by other high-rise buildings which made precise direction finding difficult. And, the operators were quite careful to conceal their true identities behind an array of colorful and humorous pseudonyms. Besides "John Doe," the other operators were "Ed Armstrong," "Michael Cypher," and "Perry Harris."



OCT 28 1977

10/22/77

From the staff of WCPN, thanks to Mr. Helms for including WCPN in his report "Piracy on the Airwaves" (Nov. 77) and thanks to Popular Electronics for printing an article on pirate radio. The staff of WCPN would like to add a few facts about the station in retrospect. Callers to WCPN were not given an address to write to, rather, they gave us their addresses and then received thank you for tuning in letters. The speculation that our transmitter power was 100 watts, was mistaken. Due to our unique ground radial system, our ERP was significantly greater than the transmitter output. Using our 1/8 wave end fed zeppelin antenna, WCPN had a carrier power of approximately 72 watts. We at WCPN were privileged to use an experimental compressor prototype to raise our average modulation by 15 Db. With a peak modulation level of 62% (without transmitter arcing) our average modulation was 60%. Ed and Michael remind you that the transmitter, that we "took" off the shelf and revitalized was named Karen-anne, because it was always slightly under the weather. Also that CPR stands for Cardio Pulmonary Resuscitation or Construction Permit Rejected.

Station telephones did not tamper with Telco circuits. All calls were legitimate and paid for with WCPN's shoestring budget. No person inside the phone company provided information or help to WCPN other than normal services. We the staff of WCPN;  
Perry Harris; Owner operator, general manager, program director, and generally sheepish person;  
John Doe; Chief announcer;  
Ed Armstrong; Operations, and programming consultant from Buzz-Hardt-

Fig. 7-1. Letter from the operators of pirate station WCPN in response to a magazine article by your author mentioning the station.

One of the most cogent questions regarding American pirate radio is why the pirates do it, since there is no financial gain, little fame, and the risk of possible criminal penalties. John Doe's response was direct and to the point: "The staff of WCPN all feel that the FCC should designate special frequencies for hobby broadcasters, interested in broadcasting for entertainment, infor-

Rook-Drek creative services, and Michael Cypher, chief engineer, and technical director, have almost no airchecks of our broadcasting activities. So, the following offer is being made: we shall send you an official WCPK QSL card, in return for copies of any WCPK air checks that you have. This QSL card is guaranteed to be a collectors item, so you don't forget mail before midnight tomorrow to: WCPK

Brooklyn, N.Y. 11214. Any correspondence welcome, and replies (if desired) will be sent whenever we get around to writing them.

WCPK received many reports of regret from our listeners, after their learning of WCPK's closing. The staff of WCPK all feel that the F.C.C. should designate special frequencies for hobby broadcasters, interested in broadcasting for entertainment, information, and education. Everyone involved with WCPK had fun on the air, and we would like to express our thanks to all the listeners, and callers and correspondants—from Maine to Florida to California, and even ALBANY!! Although WCPK is gone, it does not mean the end. As long as there is radio, there will be pirates. More radio to come!

John Doe

Perry Harris      Michael Cypher  
Ed Armstrong

WCPK  
Brooklyn  
New York

mation, and education," John Doe wrote in his first letter to me. John Doe's point is quite true; there are a variety of legal avenues for hobby radio *communication* (such as CB and amateur radio), but virtually none for hobby *broadcasting*. Indeed, the regulations for CB and ham radio specifically prohibit broadcasting to the general public except in exceptional circumstances., such as emergencies.

WCPR sought to encourage listener calls and discussions on subjects normally avoided on legitimate AM radio "teletalk" shows. Music was the inevitable rock associated with the young (and pirate stations), and the entire package was served up in a low key, informal manner by John Doe. Operation was generally restricted to Friday and Saturday nights, often until 3:00 am or later. The station soon developed quite a following among members of the general public in the New York City area.

One would normally expect a station like WCPR, operating illegally from America's largest city, would have quickly drawn the attention of the FCC. Such was not the case. One listener did formally report the existence of WCPR to the FCC shortly after the station first came on the air late in 1975, but the FCC did not seriously attempt to locate and close the station until residents of another nearby apartment building began to complain of interference to their radio and television sets. Even then, the FCC had little success in locating WCPR until the operators made a crucial mistake.

The mistake had its root in the fact that the dial around loop system of WCPR had one flaw. Although it was not announced over the air, WCPR could not hang up on callers. As long as a caller remained dialed to the other half of the loop, all WCPR could do was take him off the air or try another pair of loop numbers. In late January callers to the numbers announced by WCPR began getting busy signals instead of being connected to the station. John Doe announced several different loop numbers but each one resulted only in busy signals for callers. WCPR could not reach their half of the loop either, and they assumed that someone, as a prank, was dialing up each loop as soon as it was announced. It was not until after their station was raided and closed that the youthful operators learned the truth. The FCC had secured the cooperation of telephone company investigators and was closing off each loop as soon as WCPR announced it on the air. Unfortunately for the FCC, the pirates never remained on their half of the loop long enough to allow for tracing of the call.

When John Doe found all dial around loops out of service, he merely played records and chatted with other members of the WCPR staff. But, one evening in late January the station had a guest announcer, an operator of a pirate on the FM band in New York, known as "Artie Media." Artie decided that he had to have telephone calls to do a show, even if none of the dial around loops were working. He managed to convince most members of the

WCPR staff to give out the actual phone number of the apartment where the station was located. Artie Media was able to win his case by stating that he had given out his actual phone number on the air and nothing had happened. Others were less sure it was safe; "I wanted to strangle them, believe me!" John Doe remarked in a letter to me.

John Doe's foreboding was justified. The FCC was indeed monitoring the station and immediately recognized the number given as belonging to a residential telephone, not a dial around loop. The agents traced the number through the telephone company and quickly learned the location of WCPR. Plans were quickly made to raid the station the next time it came on the air.

John Doe had a premonition of trouble before WCPR came on the air for its next to last broadcast. "It was Friday, February 6, 1976 and Michael Cypher was at the studio fixing Karen Anne (Their name for their transmitter). John Doe wrote, "Believe it or not, I told Perry that I hoped he couldn't fix her because I didn't want to go on the air that night. Unluckily he did fix her and I unwillingly did a show that I will never forget." WCPR went on the air at 11:30 p.m. February 6, and at 1:45 a.m. February 7 there was a knock at the door. Two FCC agents entered and asked for the brother of one of the WCPR staff, in whose name the apartment and telephone were listed. One of the agents looked directly at John Doe, pointed to the station's transmitter, and remarked, "You can turn that off now." For a second, John Doe debated whether or not to flip a switch which would have resulted in the entire raid being broadcast live. He decided against it, however, and quietly shut the transmitter down.

The aftermath of the FCC raid produced few unpleasant consequences for the young operators. Prosecution was threatened for misuse of the dial-around loops, but nothing ever resulted. The FCC contented themselves with a warning to the young operators followed by letters to the parents of those who were under age eighteen.

WCPR did not cease activity forever on February 7, 1976. Shortly after first contacting me, the WCPR staff decided that the station deserved a better farewell than an FCC raid. On November 25, 1977, WCPR returned to its old 1620-kHz frequency for what they termed their "swan song," featuring John Doe and the rest of the old WCPR staff. Phone calls were received from locations as distant as Columbus, Ohio for this transmission. Having closed out WCPR's career on what they considered to be a satisfactory note, the station left the air—apparently forever.

Yet WCPR's influence in pirate radio would continue. 1978 saw no fewer than four new pirate stations based directly or indirectly upon WCPR's lead established.

## THE AMERICAN PIRATE EXPLOSION

American pirate activity dropped to a low level in the months following the FCC closing of WCPR. The most notable activity in the period from February, 1976 until November, 1977 took place very soon after the demise of WCPR, when a station calling itself "WCPU" operated briefly in 1629 kHz. The station supported WCPR and asked listeners to write their Congressional representatives, urging them to open up frequencies to private, non-profit hobby broadcasters. Signal strength indicated that the station was somewhere in the Midwest. WCPU was active only a few days in February, 1976, and was not heard after that.

One persistent spot for pirate activity during the remainder of 1976 was in the vicinity of 3885 kHz, smack in the middle of the 75-meter amateur radio band. 3885 kHz is a gathering spot for the few hams who still run AM phone (as opposed to SSB) on 75 meters, and it has apparently also become a gathering spot for various illegal radio operations. Most pirates around 3885 kHz merely play music and make a few announcements or comments on the air; many seem to be hams testing their audio systems with music (which is illegal on the ham bands). Only on rare occasions do these stations use callsigns or station slogans; frequently these pirates interfere with legitimate amateur operations on 3885 kHz.

But, American pirates more than compensated for the quiet period of 1976-1977 with an explosion of activity which began in late 1977 and continued throughout 1978. Table 7-2 lists some of these operations; many of them operated throughout 1978, escaping FCC detection. Many real questions have been raised about the FCC's ability and/or interest in enforcing its own rules and regulations, due to the increase in pirate activity. For example, three pirates similar to WCPR have (as of the date of this writing in early 1979) been operating for over a year from New York City. One pirate in Los Angeles had even been visited by the FCC and was listed in the telephone directory—and continued to broadcast!

Not surprisingly, those associated with the old WCPR have played a major role in recent pirate activity. A few days after WCPR's farewell broadcast on November 23, 1977, a faction of the group moved the WCPR transmitting gear to a new location and began broadcasting under the call letters WDBX. WDBX used the

dial-around-loop telephone system like WCPR, and established a similar coverage range along the east coast of North America. Broadcasts were generally on Friday and Saturday nights, running as late as 4 a.m. on several occasions. But WDBX soon had company on its 1620-kHz frequency, as others formerly associated with WCPR started their own pirate, WGOR. WGOR was very similar to WDBX and WCPR in format, including the use of dial-around loops, although WGOR used a more powerful transmitter. WDBX and WGOR seemingly coordinated their broadcasting activities so as to minimize interference; each station frequently plugged the other.

Both stations contented themselves with tests during December, 1977, kicking off regular transmissions with special all-night programs on January 1, 1978, WDBX continued operating on 1620 while WGOR moved up to 1630 kHz. The two pirates maintained this frequency separation throughout 1978. As January wore on, WDBX developed a habit of unexpectedly changing call signs for no apparent reason; during a single evening WDBX changed call letters to WFAT, WPOP, WPOT, and WPLC (see Fig. 7-2). Other combinations used at various times were WICE, WICY, WFSR, and WEVJ. WDBX eventually settled on WFAT as a new call, although WFSR (standing for Free Speech Radio) continued to be used at times.

Word of the two new pirates spread quickly among shortwave listening hobbyists, and soon the stations had built up a regular



Fig. 7-2. QSL card from New York pirate WFAT, formerly WDBX. The same transmitting equipment used by this station was used at WCPR, and several of the same persons participated in both WCPR and WDBX/WFAT.

audience along the east coast. Perhaps the most memorable evening for the pirates came on January 21, 1978, when the northeast was at a standstill due to a heavy snowstorm. WFAT used the call WICE for the event, identifying itself as "Icy Radio." The operators were quite freewheeling on this particular date, reasoning that it would be impossible for the FCC to find and raid them due to the snow-clogged streets. Callers from Albany, New York, to Washington, D. C., were featured, although many apparently only wanted to make noise on the air. Subjects discussed ranged from radio-station formats to pornography. Announcers used such pseudonyms as Harry and Larry Wong, along with others a bit too suggestive to repeat here.

In contrast, WGOR was a "calmer" radio station than WICE. The station relied more upon music than phone calls, often dedicating half-hour segments to a single artist or group. Announcers simply referred to themselves by their first names, with "Larry" and "Jack" the two most commonly heard announcers. Most telephone callers were from Brooklyn and most conversations were on a surprisingly intelligent level.

Activity by the two pirates declined somewhat as 1978 wore on, although they continued to broadcast throughout the year. WFAT added a new antenna and made other improvements to their transmitting gear in the summer of 1978, resulting in a much stronger signal for it. In late August another pirate, WPNJ, popped up from New York City on 1625 kHz. WPNJ was almost exclusively talk and phone calls, with very little music. The station's slogan was "peanut butter and jelly radio," with most of their listeners apparently a bit on the bizarre side. One five-minute phone conversation dealt exclusively with enemas; another was an attempt to make the lights of the station's listeners blink at the count of three; it didn't work! WPNJ was apparently using a low-powered transmitter and was difficult to hear well outside the immediate New York City area.

On January 1, 1979 WFAT had a special program to mark what they termed "our first birthday." The frequency was still around 1620 kHz, although it was drifting a few kilo-Hertz high or low in the latest receptions. WGOR and WPNJ were only rarely active as 1979 began, but apparently by choice, since all three New York pirates managed to avoid being raided and closed by the FCC. And while predicting the future of pirate radio is always a risky business, it seems fairly safe to predict that listeners within a few hundred miles of metropolitan New York would do well to keep an

eye on the 1600-1650 kHz range after midnight on weekends. Odds are that something of interest will be going on in that region.

### **PIRATES ON THE WEST COAST**

1978 also marked the expansion of pirate broadcasting along the west coast of the United States. In years past, scattered pirate operations had taken place in the area, but not on the scale of 1978. One of the most widely heard operations, however, had no name!

The "mystery pirate" was a station on 6420 kHz which became known among shortwave listeners simply as the "southern California pirate." Programming was exclusively rock music with *no* announcements of any kind heard, although there were some background noises (dropping objects, thumping chairs, rotating turntables) which indicated that a microphone was being used for audio. Signal strength put this one somewhere in southern California, but virtually nothing else is known about it. The pirate was mainly active in late afternoons and early evenings.

Pirate radio came to the San Francisco Bay area in 1978 with the establishment of WRFB, "Radio Free Bolinas," on 837 kHz. Programming was rock music and telephone call-in shows, with most broadcasts taking place in the evening hours. While the technical quality of the station was poor at times, the transmitter was sufficiently strong to allow reception throughout the San Francisco-Oakland area.

By far, the most interesting California pirate was KDOR, "Fun Radio 83 AM," which began operations early in 1978 on 830 kHz from Los Angeles. This station made no attempt whatsoever to hide its location or the identities of its operators, and managed to continue operating despite three visits from the FCC!

KDOR took itself more seriously than most other pirates, referring to itself as "a community-service station." "We do not consider KDOR as a pirate station, but an unlicensed radio operation," wrote the operators of KDOR in late 1978, "and we would be more than glad to operate under a license." The operators of KDOR were involved in a radio production company which specialized in radio commercials and voice dubbing. Not surprisingly, therefore, KDOR had a very professional sound. Programming was mainly current rock music, although sound tracks from old movies and old standards were also part of their format. KDOR usually operated three or four times per week, generally signing on at 6:00 p.m. local time, and continuing operation until midnight. KDOR generally used about 50 watts of power, which was sufficient to allow it to cover the entire Los Angeles area.



KDOR was visited by the FCC no fewer than three times in 1978, yet continued to operate without interruption. In fact, the operators claimed to have received forms from the FCC to enable them to continue operation on a temporary basis until they could receive a permanent, legitimate station license. The reasons for the FCC's apparent reluctance to close down KDOR were not entirely clear. However, one of the operators of KDOR was reportedly confined to a wheelchair and the FCC may have been concerned over its public image if it took strong action against the station. Certainly the station was no secret; it had its own listed telephone and by the end of 1978 was even receiving promotional albums for airplay from various record companies!

At the end of 1978, KDOR was still going strong and a formal application for a broadcasting license was being prepared for submission to the FCC. The tentative proposal called for KDOR to relocate to Santa Monica and use 1000 watts during the day and 500 watts at night. Whether KDOR will ever become a legitimate broadcaster remains to be seen, but given the curious history of KDOR, anything is possible.

## **THE WAVE OF DX PIRATES**

Shortwave listening enthusiasts have sometimes started their own pirate stations, as mentioned earlier in this chapter. 1978 saw four such "DX pirates" in operation. One of these, the Voice of the Voyager, will be discussed separately later in this chapter.

The first such station was "Jolly Roger Radio," which popped up on 6210 kHz in March, 1978. The format was progressive rock and classical music. Its location was given as somewhere near Indianapolis, Indiana, and transmitting facilities were announced as 30 watts into a dipole antenna. A member of the North American Shortwave Association (NASWA) offered in the pages of NASWA's club bulletin, "FRENDEX," to forward reception reports to the station for verifications. He denied, however, that he had any direct connection with the station. Jolly Roger Radio was active at very sporadic intervals during 1978, adhering to no set schedule.

The next pirate connected to the shortwave listening community was Radio VOCAD, which appeared on 28625 kHz in June. This station featured a male announcer named "Charlie," who played music for listeners on his guitar. The station power was given as 50 watts, and its location was possibly in the Chicago area since the announcer read news items out of a Chicago newspaper. "Charlie" asked listeners to report their receptions to the monthly

bulletin of the Society for the Preservation of the Engrossing Enjoyment of DXing (SPEEDX), a club for shortwave-listening hobbyists. No verifications of reception were ever known to have been issued, however. This station was only active during June of 1978, and no firm leads were ever obtained as to its actual location or the identity of its operators.

Another shortwave hobbyist pirate was "The Voice of the Viking," which briefly appeared in August of 1978 on 7445 kHz. This station first announced its presence by phoning several prominent shortwave listeners and announcing the frequencies and times they would be in operation. They ran one test broadcast which was widely heard in the United States, although their promised regular service never materialized. The station's test featured young male announcers, a variety of pop music, and an attempt to take phone calls using a dial-around-loop arrangement similar to those used by the various New York City pirates (although no calls were aired). No definite clues were obtained as to this station's location or the identities of its operators, and the station vanished just as mysteriously as it had appeared.

Various other pirates were active during 1978 on a sporadic basis on the shortwave bands. One was WINT, "Radio 62," which was active during March on 6205 kHz with rock music. No clues were obtained as to this station's actual location or the identities of its operators. The only reported receptions were during March. Another similar operation was WMMR, "Midwest Music Radio," active irregularly during the summer of 1978 on 7450 kHz. Programming here was primarily old Beatles music and modulation tended to be rather poor. Again, no definite clues could be obtained as to the true location of the station or the operators of it.

Yet all other pirate activity in 1978 paled in comparison to a station which rapidly became a legend in shortwave listening circles. No other pirate in the past could compare with it, and no station in the future may be able to equal its "achievements." The pirate we refer to was known as the Voice of the Voyager, the self-proclaimed "champions of bootleg broadcasting."

## **THE SAGA OF THE VOYAGER**

The story of the Voice of the Voyager begins on December 25, 1977, when a feeble station popped up on 5850 kHz and was heard only a few miles from its transmitting site. The station continued to broadcast and improved its signal; soon the Voyager had attracted an audience from throughout North America for its Saturday-night

programs (see Figs. 7-3 and 7-4). Things continued along merrily until August 28, 1978, when the station was visited by agents of the FCC. An official warning against unlicensed operation was issued and the youthful operators ceased operation for a few weeks. But the lure of the airwaves proved overwhelming; on November 7, 1978 the station returned to the air on 6220 kHz and continued to broadcast each Saturday night until January 14, 1979, when the station left the air for the final time—the victim of a busted transmitter rather than a FCC bust.

The preceding, however, is but a skeleton of the Voyager saga. The Voice of the Voyager became (without really trying to) the trigger for imitative efforts and a rallying point for a “free radio” movement composed of those interested in private, noncommercial hobby broadcasting.

The Voice of the Voyager transmitted from various locations in the Minneapolis, Minnesota area. Its chief operator was young shortwave listening enthusiast who became famous as R. F. Wavelength, the “Top Man” of the Voyager. He was assisted by a crew of young persons who adopted similarly colorful pseudonyms: Disco Dan, A. F. Gain, Dave Buddy, Pygmy, Slow Joe, and Ms. Scoop Bop Beep Bop. The entire group were high school students when the station began, and the entire project was at first a lark. “Everyone likes to do something weird in high school,” R. F.

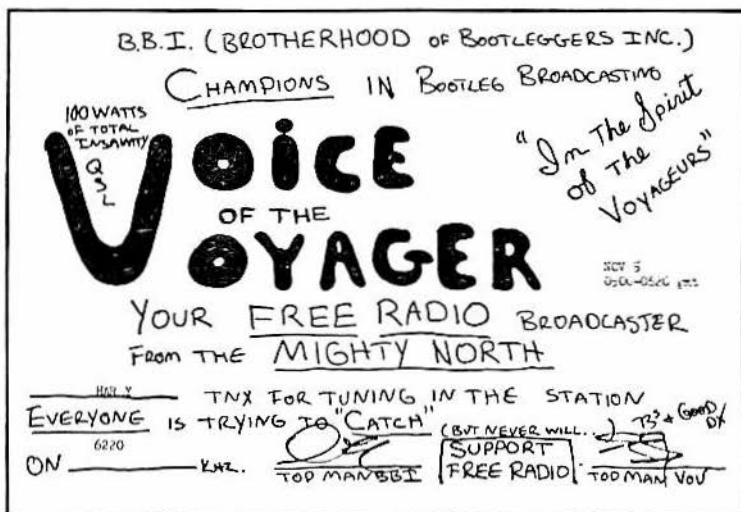

Fig. 7-3. QSL card from the Voice of the Voyager. This card confirms reception on November 5, 1978 on 6220 kHz, when they returned to air following the August, 1978 raid by the FCC.



Fig. 7-4. The original Voice of the Voyager studios. The Hallicrafters HT-20 is at left.

Wavelength told your author, "but since I am considered to be a little weirder than most people I decided to do something a little weirder; I wanted to run a bootleg radio station!" His dream became reality when he spotted an old Hallicrafters HT-20 in a secondhand electronics equipment store. While intended for legitimate amateur radio use when built, the transmitter was capable of covering the entire radio spectrum from 1.7 through 31 MHz. Its output was only about 100 watts, but it was sufficient to cover most of North America with a dipole antenna.

What was a Voice of the Voyager broadcast like? "To us it was all one big party," R. F. Wavelength told your author. Figure 7-5 shows portions of a letter from "R. F." Their programs reflected this attitude. Music was the inevitable rock, and the station made use of dial-around-loops to take phone calls (although callers were rarely put on the air). A semi-regular feature was "Bobby Bootlegger," an impromptu serial spoofing the entire pirate-radio scene and the FCC. Since the chief operator was a shortwave listening enthusiast, recent shortwave radio news was often featured. Each broadcast opened with the song "We Are the

Champions" by the English rockband "Queen," followed by R. F. Wavelength's enthusiastic opening identification: "From one mile north of nowhere, this is the Voice of the Voyager, champions of bootleg broadcasting!" The original name of the station was intended to be the Voice of the Voyageur, after the Voyageur National Park in northern Minnesota. But the first reports of the station in the various shortwave listening club bulletins referred to the station as the Voice of the Voyager, and the staff of the pirate obligingly changed their name.

Being shortwave listeners themselves, the operators of the Voyager were well aware of how important verifications of reception are to shortwave hobbyists. Unfortunately, they couldn't announce a mailing address without inviting a rapid FCC raid. They began to take the addresses of all callers and mailing out homemade verifications, using a friend in Ann Arbor, Michigan to place the verifications in the mail. The ruse was successful for a time, with the Michigan postmark leading to speculation that the station was in Michigan. The operators were also members of several shortwave listening clubs and began to send out verifications to those who reported reception to the various club bulletins. The original homemade cards were later replaced with large printed cards which the pirates paid for out of their pockets. In fact, the young operators soon found themselves running up large bills. Postage for verifications was one expense, and long distance charges were another. The pirates used loop numbers in New York and San Francisco for security, and soon ran up phone bills of \$70 per month.

Yet the youthful broadcasters seemed to consider such expenses to be one of the prices to pay for the enjoyment they were having from operating the Voice of The Voyager. "It was now that I began to get a crew of people who liked to broadcast just because it was fun, not because their constitutional right to free speech had been taken away," R. F. Wavelength told your author. "They saw the Voice as a way of just having a little fun on the weekend." Broadcasts assumed a party atmosphere as 1978 passed into spring and summer. Remarkable things happened, often in proportion to the amount of beer consumed during the course of each broadcast. On one broadcast the station had to leave the air when R. F. Wavelength became too drunk to see the equipment dials and the audio equipment broke down. On another broadcast, one of the station's tape recorders broke, and R. F. Wavelength swore a blue streak and threw the dead machine to the floor—before realizing

Just another bootleg story

Oh the poor FCC, for years they had little to do but just sit around and issue tickets of various kinds. But in the year of the lord 1978 there was a strange invasion of the north american radio bands the pirates had landed and much to the horror of the feds it looks like they are here to stay- stay! Yes in this last year there has been been from two separate cities a great deal of good old hell raising by some young people who get a kick out of running there own little radio station. How may you ask that I know? Well I am the man behind much of that hell raising, the name is RF WAVELENGTH and I was at the helm of the Mpls passed shortwave pirates and I am here to tell you there very funny and very classic story it is a story that well never again happen in the history of radio so just sit back and get a behind the scenes look at those "wild and crazy folks from one mile north of nowhere, DISCO DAN, AF GAIN, DAVE BUDDY, PYGMY, SLOW JOE, AND LAST BUT NOT LEAST Ms. SCOOP BOP BEEP BOP, the one only staff of that one and only radio station THE VOICE OF THE VOYAGER!

Everyone likes to do something wierd in high school, but since I am considered to be a little wierder then most peopæ I decided to do something a little wierder; I wanted to run a bootleg radio station It was all very simple the way it began, a frie can up to me and said "lets start a radio station!" I thought why not, its something to do! So I rounded up the old HT-20 and away we went! The funny thing was that neith of the two original operators really had any interest in actual radio broadcasting; we wherhe just to simple SWL8S. That was the first thing differant about the vov, most bootleg operations are start-ed by would be radio personailtys who get a kick out of playing DJ. A classic example of this is the local pirate WGDR that ran a few years ag in MPLS on a freq of 1610 with 10 watts. In fast the owner of that station is now a DJ on one of MPLS most popular radio stations! But since we did not have this intrst we perferard to get on the air and make total fools out of our selfs! Our early limited studio equipment limited us severly in program production, but we did have a lot of fun fighting over the stations only mic!

But unlike most pirates we begain to get a big following as far as listeners go. Much to my horror I found that my ancient transmitter was covering the whole country! People where getting a big kick out of the way we did our weekly programs, in fact there where even a few people that said we sounded like professional nuts! It actually became fun to go on the air every friday night and bum every one out with a very unusua radio show. We then decided to take the station serricusly and we even issued ourselve a operating budget. It was a very small budget but it was enough to get ourselves some new mics and to prènt up some qsl cards. We where now truely hooked on bootleg radio.

Something started to happen within the thoughts of the staff, when we first came o the air we knewit was illegal but we just kind of ignored that. Now we begain to ratilize our actions; we hoped on that band wagen that is called FREE RADIO; but I ask myse now what the hell

to me at that tim I really could not make up my mind but I kept right on broadcasting.

I have spent many hours figuring in my mind what is the 'diff between a hobby pix and a bootleg radio station. There has been no clear defination ever given, since I am suppose to be an expert in the field here is what I think.

BOOTLEG- a transmitter that is tuned to a freq not authorized to it and someonee picks up a mic and gives some sort of iddle chatter. The main objective of a bootleg station is to operate for a few nights and not get caught, they are on the air just say I was on the air- programming is usually very limited, the main thing a bootlegger is worried about is looseeing his transmitter. The result of a bootleg radio operation is sure boardom and the transmitter is off the air in a matter of weeks. They go on the air just for the pincible of freedom.

Fig. 7-5. Portions of a letter giving Voice of the voyager's own story, as told by chief operator R. F. Wavelength.

that the station microphone was open! Once, two drunken members of the staff began swinging at each other, and their fight was transmitted live to the North American continent (fortunately, both passed out before any serious blows could be landed!)

"But everyone knows that every party must end," R. F. Wavelength told your author. It came to a temporary halt for the Voice of the Voyager on August 28, 1978. About 1:00 p.m. That day, R. F. Wavelength and A. F. Gain were in the studios of the pirate going over the latest batch of reception reports and planning that night's broadcast. A yellow car pulled into the driveway and two men (described by R. F. Wavelength as "very official gents") walked up to the front door of the home where the Voyager studios were. "What if they're the FCC?" wisecracked A. F. Gain. The joke was soon on the two pirates, however. The two men flashed official credentials identifying themselves as agents of the St. Paul office of the FCC! See Fig. 7-6.

Since the chief operator of the Voice of the Voyager held both amateur and CB licenses, the two pirates had no choice but to admit the two men. R. F. Wavelength at first attempted to deny all knowledge of the Voice but soon realized the futility of trying to get out of the situation; he eventually admitted to being behind the station. At the confession, the atmosphere changed; the two FCC officials became quite friendly and told him of their efforts to track down the Voyager. It turned out that the FCC was standing by during their last broadcast and was preparing to raid the station when it left the air a bit earlier than usual, thereby depriving listeners of the opportunity to hear a live FCC bust. There was no mistaking the FCC's seriousness in catching the station; a special enforcement unit had been dispatched from Chicago to aid in locating the station.

The FCC agents themselves seemed to be a bit thrilled at actually meeting the operators of the pirate. They requested, and were issued, several Voice of the Voyager verifications for themselves and other members of the local FCC office!

But the levity ended when the subject of future unlicensed operation came up. The agents issued a warning against future broadcasting activity; warning that severe criminal penalties could be sought by the FCC if the Voyager returned to the air. R. F. Wavelength agreed to cease his pirate activity, and the agents departed, indicating that the FCC would not seek criminal penalties if no further activity took place.

UNITED STATES OF AMERICA  
FEDERAL COMMUNICATIONS COMMISSION

WARNING: UNLICENSED RADIO OPERATION

CERTIFIED MAIL NUMBER \_\_\_\_\_  
RETURN RECEIPT REQUESTED

August 28, 1978  
Date Issued

MICHAEL M

MINNEAPOLIS MINNESOTA  
55102

On AUGUST 28, 1978 official of the Federal Communications Commission noted the following condition(s) regarding the SHORTWAVE AIRBORNE radio station on/at:

(TRANSMITTER LOCATION)

1. At the time of the inspection, a valid radio station license was not in evidence for inspection. Operation of the station without proper Commission authorization is a violation of Section 301 of the Communications Act of 1934, as amended.
2. At the time of the inspection, a valid radio operator license or permit was not in evidence for inspection. Operation of such a station by unlicensed personnel is a violation of Section 318 of the Communications Act of 1934, as amended.
3. At the time of the transmission on 5350Ks, there was no record that the station was operating under a valid radio station license. Operation of the station without proper Commission authorization is a violation of Section 301 of the Communications Act of 1934, as amended.
4. At the time of the transmission on \_\_\_\_\_, the station was being operated by an individual not holding the requisite operator license or permit, as revealed by operator statement on reverse of FCC Form 793. Operation of such a station by unlicensed personnel is a violation of Section 318 of the Communications Act of 1934, as amended.

You are hereby warned that operation of the transmitting apparatus without a valid radio station authorization and/or operator license constitutes violation of the above mentioned sections of the Communications Act of 1934, as amended, and could subject the owner, operator, or both, to the severe penalties provided. Unlicensed operation of this radio station should be discontinued immediately.

Any statement you care to submit should be sent to the address below and it will be associated with the file on this matter. Application forms if not attached hereto may be obtained from the local FCC field office.

When delivered in person, this warning must be acknowledged.

Raymond P. Anderson  
Issuing Officer

Received by \_\_\_\_\_ Date 8-28-78

Federal Communications Commission  
316 NORTH ROBERT ST  
ST PAUL MINNESOTA  
55101

(The August 1973 edition of this form may still be used.)

(SEE REVERSE SIDE FOR EXCERPTS FROM COMMUNICATIONS ACT)

Fig. 7-6. The actual warning delivered by the Minneapolis office of the FCC to the operators of the Voice of the Voyager. According to R. F. Wavelength, one of the main concerns of the FCC representatives was securing QSL cards for everyone back at the office.

R. F. Wavelength abided by the FCC's edict for the next three months. The Voice of the Voyager remained silent, and R. F. Wavelength even revealed his identity to the shortwave listening community, since he did not plan to resume pirate broadcasting. He wrote an article detailing the purpose and end of the Voyager for "FRENDX," the bulletin of the North American Shortwave Association. Splits developed in the ranks of shortwave hobbyists,



with some approving of the pirates' activities while other vehemently disapproved.

Yet the urge to broadcast still remained strong among the operators of the Voyager. And, surprisingly, they were still not frightened by the prospect of another visit from the FCC. After all, the station had managed to broadcast almost every Friday and Saturday night from January through August of 1978 before the FCC finally caught up with them. And they wanted to give the station a proper burial; a "final tribute" broadcast was therefore planned. The station's transmitter was returned to 6220 kHz and the word was discreetly put out in the shortwave listening community that the Voyager would return one more time. It indeed did; on November 4, 1978 the station returned! Among the features was a humorous dramatization of the August FCC bust, along with the usual rock music and ad lib announcing. The operators made no attempt to hide their location or identities this time, freely giving their actual names and a mailing address.

The Voice of the Voyager had successfully returned to the air and the youthful operators were jubilant. In fact, they decided to resume their regular broadcasts on the new frequency and continue until they were caught. They did so and dropped all pretense of trying to hide their location or identities; they freely gave their location as Minneapolis and R. F. Wavelength even identified the station by using his Novice-class amateur radio call letters! Reception was better on 6220 kHz than on 5850 kHz, and the station soon developed a regular audience for its programs.

But the end for the pirate finally arrived on January 14, 1979. The killing blow came not from the FCC but from the station's ancient transmitter, which expired. Attempts to repair the antique were unsuccessful, and the young pirates decided that the time had finally come to end the Voyager. Mournful letters of farewell were sent out to some regular listeners and confidants.

The Voice of the Voyager was illegal; even the operators themselves acknowledged they were breaking the law. Yet it was also a remarkable success, for it managed to stage regular broadcasts each weekend, which were heard throughout the United States and Canada for over a year with only a warning from the FCC. Clearly, the pirates could be considered "victorious" in their battle against the laws of the United States. In the wake of the Voyager's career, serious questions were raised about the FCC's ability and/or interest in combatting pirate broadcasting—questions which could encourage future would-be broadcasters to emulate the Voice of the Voyager.

The youthful pirates did not concern themselves with such issues, however. Toward the end of their broadcasting career, they had become more involved with what they termed "the spirit of the Voyager." In his farewell letter to regular listeners, R. F. Wavelength wrote, "But, my friends, do not cry for that spirit of the Voyager still lives—that drive within us all to freely create, to be who we really are. Someday another Voyager will be created; you never can tell what those people who are touched by 100 watts of total insanity will do!"

"It just looks like we have lost the battle, but that does not mean we have given up!" R. F. Wavelength continued. "So for one final time I say to all my dedicated fans and friends my classic line heard so often—may the spirit of the Voyager be with you all! The Voice has faded . . ."

R. F. Wavelength was an aspiring poet of sorts, and he expressed his feelings in a poem when the Voyager went silent:

Hush,  
be silent when you enter my world.  
Waves slowly beat against rock.  
All is dark,  
only the moon shows a faint glow.  
In the far distance  
a loon cries  
thunder rumbles  
lightning flashes.  
On the far shore  
tall trees  
stretch  
to the sky limit.  
Rain begins to fall  
I must leave now, but  
hush  
be silent  
your world is just awakening  
to find mine.

## **PIRACY AND THE FUTURE**

While any prediction on the future of pirate broadcasting is risky, it seems likely that such activity will continue, or even increase, as long as the FCC continues its present policies regarding pirate operation. As recounted in this chapter, the FCC has been quite slow in locating and closing pirates. Even when such

pirates are raided, the FCC has shown a remarkable reluctance to prosecute or even confiscate equipment, contenting themselves with the issuance of warnings. Pirate operators do keep up with the activities of each other to a remarkable degree, and it seems that the "word" is that the FCC is unlikely to seek prosecution of any pirates they discover.

Another factor to consider is the ready availability of transmitting equipment in the United States. As the law now stands, anyone can buy, sell, or possess transmitting equipment. Anyone with the money can purchase in the United States a transmitter capable of being heard worldwide, with no questions asked. If the interest in pirate broadcasting is aroused, obtaining the hardware to do so is no problem.

Another likely development is the expansion of pirate activity from radio into television. 1978 saw the first *video* pirate in United States history! During the evening hours of April 15 and 16, 1978, a station identifying itself as "Lucky Seven" was seen by many people in the Syracuse, New York area. Operating on television channel seven, the station featured extremely professional production. Their shows were hosted by an announcer wearing a gas mask, with a noose around his neck. An all-female chorus sang the Lucky-Seven theme song, introducing such unexpected television movies as "Deep Throat," and "Behind the Green Door." The station's logo was a pair of dice rolled to the number seven, and the announcer blasted the FCC in between movie segments. The broadcasts were not reported on subsequent weekends, and FCC officials attributed "Lucky Seven" to a one-time joke by students at Syracuse University (which is home of an excellent school of communications).

Transmitting video is more expensive and difficult than transmitting only audio. However, reasonably priced video cameras and recorders are beginning to become more widely available, and the surplus electronics markets are also developing into good sources of video transmitting equipment. Placing a bootleg television station on the air is within the technical capabilities of many young, aspiring broadcasters, and it will not be surprising if more "Lucky Seven" type operations pop up in the future.

Whatever the shape of pirate broadcasting in the future, it will likely offer the alert hobbyist some of the most interesting and unusual fare available on the airwaves.

## Chapter 8

# Esoteric, Unknown, and Unidentified Signals

---

A few hours of listening with a shortwave receiver will turn up a variety of radio signals which defy efforts to identify, understand, or categorize them. This chapter will sample a few of the more common mystery signals, although no firm conclusions as to their actual purpose can be reached. Common theories and informed speculation will be given, however, in hopes of shedding some light on these transmissions.

### UNKNOWN BEACONS

Various beacon stations are heard throughout the shortwave spectrum, used for navigational purposes by aircraft and ships. These beacons usually transmit the station's call letters continuously, and are listed in internationally-consulted reference works. Some beacons, however, are not listed in the various reference works and seem to be used for purposes other than navigation.

Table 8-1 lists some of the more commonly reported mystery beacons. These stations transmit one or two letters in Morse code, with occasional interruptions by other groups of letters and numbers on some frequencies. Sometimes two beacons will operate simultaneously on the same frequency, as Table 8-1 indicates.

Most, if not all, of these stations operate from Cuba. Direction finding from the United States and Canada has long pointed to a Cuban location, and final confirmation came when a beacon using

the letter "W" began operation on 3584 kHz, in the 80-meter amateur radio band. The American Radio Relay League, a national association of radio amateurs, protested this interference to the FCC. The FCC in turn formally protested to the Cuban authorities, as FCC direction finding placed the station in Cuba. Shortly after the protest was delivered to the Cuban government, the "W" beacon vanished from 3584 kHz.

Just what are these beacons used for? Some have speculated that they are used by Soviet ships and aircraft traveling to Cuba; however, there is certainly no shortage of ordinary radiolocation devices usable for such purposes. Another opinion holds that the various beacons are used to keep various radioteletype channels open between transmissions. This notion has some support, since some listeners have reported hearing signals like those of radioteletype at varying intervals on the beacon frequencies. But other Cuban radioteletype stations do not follow this practice, instead using the common technique of merely running a series of marks or spaces to occupy a channel between messages. Why would some stations use the letter beacons while not the others?

Other listeners have noted the beacons interrupted by number and letter groups, similar to those noted on the various Morse-code spy-numbers stations discussed in chapter two. Such activity has been particularly heavy on 13,328 kHz. This theory is bolstered by the fact that the various letter beacons frequently sign off the air for varying periods of time (in contrast to the continuous operation of most other beacons). Yet spy transmissions thrive on unpredictability and elusiveness; the letter beacons stick out in the crowded shortwave spectrum.

One very common bit of speculation is that the letter beacons, while located in Cuba, are actually operated by the Soviets for their own purposes in connection with their military presence in the island nation. The true purpose of these signals is known to both the Cubans and Soviets but, unfortunately, they are not talking.

#### **OTHER UNKNOWN SIGNALS**

On March 30, 1978 the Eugene (Oregon) *Register Guard* reported that a powerful radio signal was being detected in the Eugene area and was having a variety of effects on human beings. Marshall Van Ert, an industrial hygienist at the University of Oregon, was one of the investigators of the mystery signals, and claimed that they had caused his skin to turn red.

"On at least five occasions I have had to leave my apartment," Mr. Van Ert told reporters. "The signal strength will begin to

**Table 8-1. Some Mystery-Beacon Frequencies.**

Frequency	Letters
4466	U
5306	W
5793	K
6770	A and N
6800	F and K
6806	Q
7590	W
7657	W
11156	I
12330	U
13328	U; number groups at times
14970	K
14966	K; number groups at times
17016	D
17018	UE and TA

increase in intensity in the evening from six to seven o'clock, and continue through the night and into the morning until about eight or nine o'clock." Press reports claimed the signal was on 4.75 MHz (4750 kHz) and was "measured at intensities as high as 500,000 watts" and was "occurring 1,100 times per second." The source of the signal was not known, but the article speculated that it could have been an errant signal from a government or military installation, or some bizarre external mixing product caused by two or more transmitters. The signal had been detected in several locations in Eugene as well as at altitudes of 3000 feet above the city.

What was it? Richard Smith, assistant chief of the FCC's enforcement division in Washington, told reporters that the signals were coming from the Alameda Naval Air Station near San Francisco, and were nothing more than an ordinary radio-navigation beacon. This was quickly disputed by an officer at Alameda. "The eleven-dot, one-dash, signal emanating from Dixon (where Alameda is located—*author*) is a 7500-watt transmission supplying data from Moffett Field, and is not the signal reported as causing illness and high fever in the Eugene, Oregon area, and reputed to be from a UFO or outer space," the spokesman said. "This mystery signal was originally reported on 4750 kHz but the media confused the issue by assuming it to be the transmission from Dixon on 4715 kHz."

While the spokesman for Alameda Naval Air Station shed no light on the signals that were being reported in Oregon, he did

manage to raise another mystery. What precisely was the signal being transmitted at Alameda? An "eleven-dot, one-dash" signal certainly does not sound like a "data transmission," as the spokesman claimed. Nor does it sound very much like a conventional navigation beacon. Whatever it's purpose, it can be heard on the two frequencies given for it in Table 8-2. A similar signal, consisting of twelve dots, can be heard on 6523 kHz. The location of this station is not known, however.

Other bizarre signals can be heard at times throughout the shortwave spectrum, as indicated in Table 8-2. The purpose of these transmissions is not clear. Some have theorized that they are merely used to hold channels open between transmissions, but your author could find no reports of these signals ending and being replaced with a more conventional mode of emission. Ionospheric sounding could be one possible use of these transmissions, as could some sort of signalling or alerting system. Whatever their true purpose, these stations are not listed in any standard list of stations and/or frequencies, nor do they identify themselves in any detectable manner. They are true mysteries!

### **STRANGE RADIOTELETYPE SIGNALS**

With the increasing amount of microprocessor-based radioteletype equipment available, more and more shortwave enthusiasts are eavesdropping on the previously ignored world of radioteletype reception. These listeners have made a rather surprising discovery—much radioteletype traffic is transmitted in such a manner that precludes copying or even identifying the station.

One method used by these stations is what we will term "cryptographic." These signals can be copied on any radioteletype receiving system but print as random groups of letters and numbers, similar to the texts of the various spy-numbers stations discussed in chapter two. These cryptographic radioteletype signals involve a coding process more complicated than a simple letter-for-letter substitution; characters are distributed essentially at random, indicating that some form of computer-generated encoding process is being employed. Not only is the message itself incomprehensible, but no clue can be obtained as to the station's location or identity.

The second form of mysterious radioteletype transmission is what we will term "synchronized" transmission. Ordinary radioteletype systems use the Baudot code, in which the individual

**Table 8-2. Miscellaneous Unknown Signals.**

<b>Frequency</b>	<b>Description</b>
3820	Electronic notes, C-E-G-C, repeated
4715	Eleven dots, one dash, repeated
4750	Eugene, Oregon mystery signal
6523	Twelve dots, repeated
9010	Same signal as 4715
11420	Tone every five seconds
12700	21 note flute-like tone
15507	Two-tone beeps, 90 per minute
25035	Amplitude modulated pulses

characters consist of a start pulse, five data pulses, and a stop pulse, see Fig. 8-1. The start and stop pulses are essential if radioteletype is to be copied on standard equipment. Signals without start and stop pulses print as gibberish on standard radioteletype equipment. To be copied, such signals must be sent between stations whose equipment is in synchronization with each other, usually through an accurate and stable common time-base reference see Fig. 8-2. The synchronized signals can be easily identified by the absence of start and stop pulses; unfortunately, it is impossible to identify any station using synchronized radioteletype transmissions. Frequencies for both synchronized and cryptographic radioteletype transmissions are listed in Table 8-3.

The source of these signals is strictly a matter of conjecture, since no listing can be found in any frequency list for stations using nonstandard radioteletype. One good clue, however, is the fact that many of these signals are received in the United States as very loud, local-quality signals. The only stations in the United States permitted to use encoded or nonstandard radioteletype transmissions are those operated by the government or military. Such transmission methods would be ideal for classified information, particularly if intended for overseas military bases or other agencies.

### **THE RUSSIAN PULSERS**

If you do any listening at all on the shortwave bands, you have almost certainly heard a powerful signal resembling a woodpecker or buzzsaw from time to time. This signal has become known among shortwave hobbyists as the "pulser," since it is a wideband



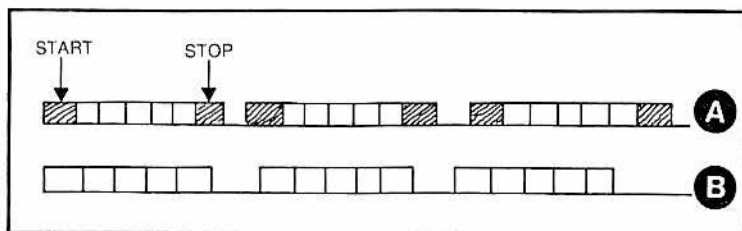

Fig. 8-1. The dark blocks in A represent the start and stop pulses of conventional radioteletype signals, which tell the printer where the various characters begin and end. In B we see nonsynchronous signals without start and stop pulses. Without them, the ordinary printer literally cannot tell where one character ends and another begins!

signal consisting of pulses spread over a range of more than 100 kHz. Where is it and what is it? The evidence overwhelmingly indicates that the bulk of such signals originate from within the Soviet Union. Speculation about their purpose run the gamut from an over-the-horizon radar system to weather-control experiments to mind-manipulation attempts!

It is obvious from the strength of the pulsers that they use transmitter powers of at least several hundreds of kilowatts, perhaps even into the millions of watts, since they effectively obliterate all other signals on the band. Each pulser operates on a center frequency, sending out pulses over a wide frequency range,

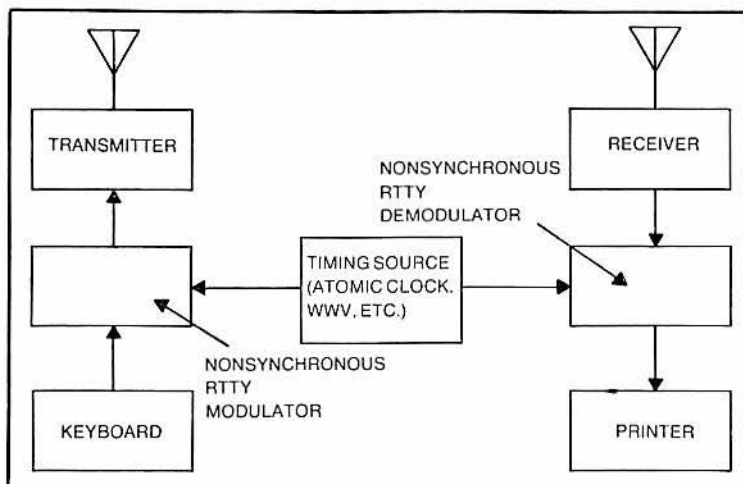

Fig. 8-2. A nonsynchronous radioteletype system. Note that an external timing source, such as WWV or an atomic clock, must be used in the absence of the usual start and stop pulses. Without knowing what timing source is being used, it's impossible for the casual listener to eavesdrop on these signals.

Table 8-3. Mystery Radioteletype Transmissions.

Frequency	Description
2426.4	Synchronized
2590.4	Cryptographic
2648.2	Cryptographic
2745.6	Cryptographic
4015.6	Synchronized
4042.4	Cryptographic
4144.6	Cryptographic
4295.6	Synchronized
4348.6	Synchronized
4714.6	Cryptographic
5903.6	Cryptographic
8216.4	Synchronized
11045.3	Synchronized
11106.4	Synchronized
11610.8	Synchronized
12850.4	Synchronized
12939.6	Cryptographic

see Fig. 8-3. The number of these pulses can vary widely, but ten per second is a common number. When received, these pulsers sound very much like a woodpecker rapping on wood, or like a slow speed buzzsaw. Pulsers can be heard throughout the shortwave spectrum, although they are most often heard at or near the maximum usable frequency (MUF) for the shortwave spectrum. The MUF is that frequency which is the highest which can support long distance propagation at any given time. The MUF varies with the state of the ionosphere, and changes with the time of day or the season.

The most common explanation for the pulsers is that they are a form of over-the-horizon radar. Both the United States and the Soviet Union are known to be working hard on such systems, primarily to plug defense gaps between conventional radar (which is limited in range) and spy satellites (which are slower in providing information). Conventional radar systems operate in the microwave range, where reflections from approaching aircraft are sharp, while using only moderate power. It is possible to also obtain reflections using frequencies in the conventional shortwave

spectrum. Conventional shortwave frequencies, unlike microwaves, can propagate beyond the horizon and reflect from approaching aircraft see Figs. 8-4, 8-5, and 8-6. There is one catch, however; in order to obtain sufficient reflections at conventional shortwave frequencies it is necessary to use extraordinary transmitter powers and receiving installations. As an example, the U.S. Air Force was reported, in 1977, to be constructing their own experimental cover-the-horizon radar system in Maine. The transmitting antenna was 2276 feet wide and 135 feet high, fed by 21 transmitters rated at 100 kilowatts *each*. The receiving installation used a 5816-foot antenna into 96 receivers, which in turn fed processing units connected to the Air Force radar system. The entire system was budgeted at a cost of \$39,000,000,000!

The Soviet system may be even more elaborate. A few of the more commonly used center frequencies are listed in Table 8-4. If one of the pulsers is in operation, you will have no problem whatsoever recognizing it!

The most obvious reason for Soviet interest in an over the horizon radar system is to provide a measure of protection against sophisticated American weapons such as the Cruise missile; it is likely that American military interest is based upon similar reasons. This has not prevented all kinds of esoteric speculation about other possible uses, however!

One researcher has speculated (seriously, we must assume) that the pulsers are related to Soviet experiments in parapsychology. This researcher has claimed that 25-75% of all humans exhibit psychophysiological sensitivity to magnetic and electrical fields in the very-low-frequency range corresponding to brain-wave spectra. Such fields can supposedly produce erratic behavior in human sensitives. The pulse repetitions of the pulsers fall within the ranges which can supposedly alter human behavior.

Another explanation holds that the pulsers are the result of Soviet research into the theories of Nicola Tesla, who believed it

3261	6880	12446
3357	7750	13359
4484	8010	13572
4775	8626	14774
5071	9482	15595
5865	11488	15814
6461	12095	17540

**Table 8-4. Frequencies of the Russian Pulsers.**

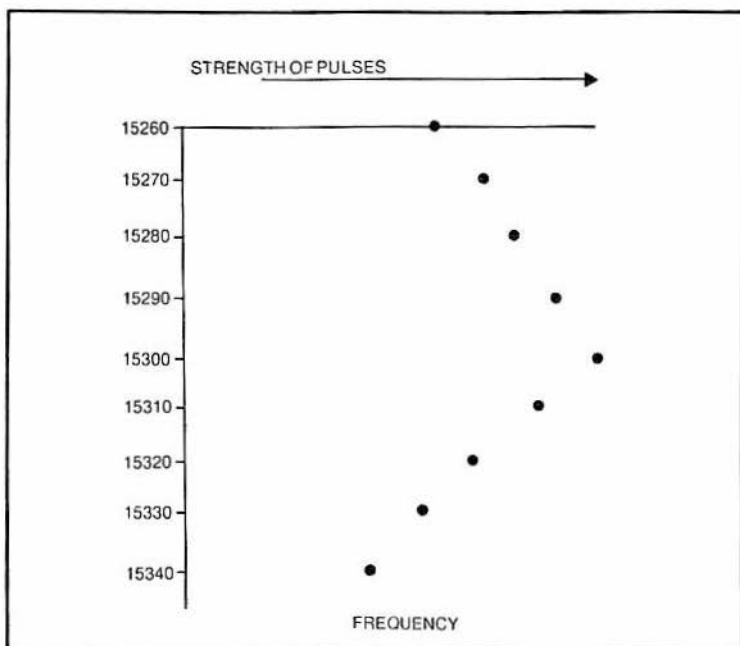

Fig. 8-3. This graph represents the spectral output of a Russian pulser with a center frequency of 15300 kHz. The strength of the signals is greatest on the center frequency, and decreases in varying amounts above and below the center. Signals are not continuous, but are in pulses of several cycles per second. Such pulsers may occupy several tens, or even hundreds of kHz.

was possible to transmit electrical power without wires by utilizing very low frequencies. This notion gained a bit of confirmation when it was discovered that Soviet representatives had visited an elderly gentleman in Canada who had worked extensively with Tesla earlier in the century. The main problem with this explanation is that Tesla's work has not been substantially confirmed by contemporary researchers.

The pulsers first were widely heard during the winter of 1976-77, which was a very severe one in most of the United States. It was perhaps inevitable that some would try to link the pulsers with the bitterly cold winter, speculating that the Russians were somehow manipulating American weather through the use of super-powered radio signals. Stories to this effect circulated widely in the American press, eventually even making *The National Enquirer*. However, no credible scientific evidence was ever presented to back up such claims, and there was a good deal of evidence against such a notion. After all, if the Soviets could really

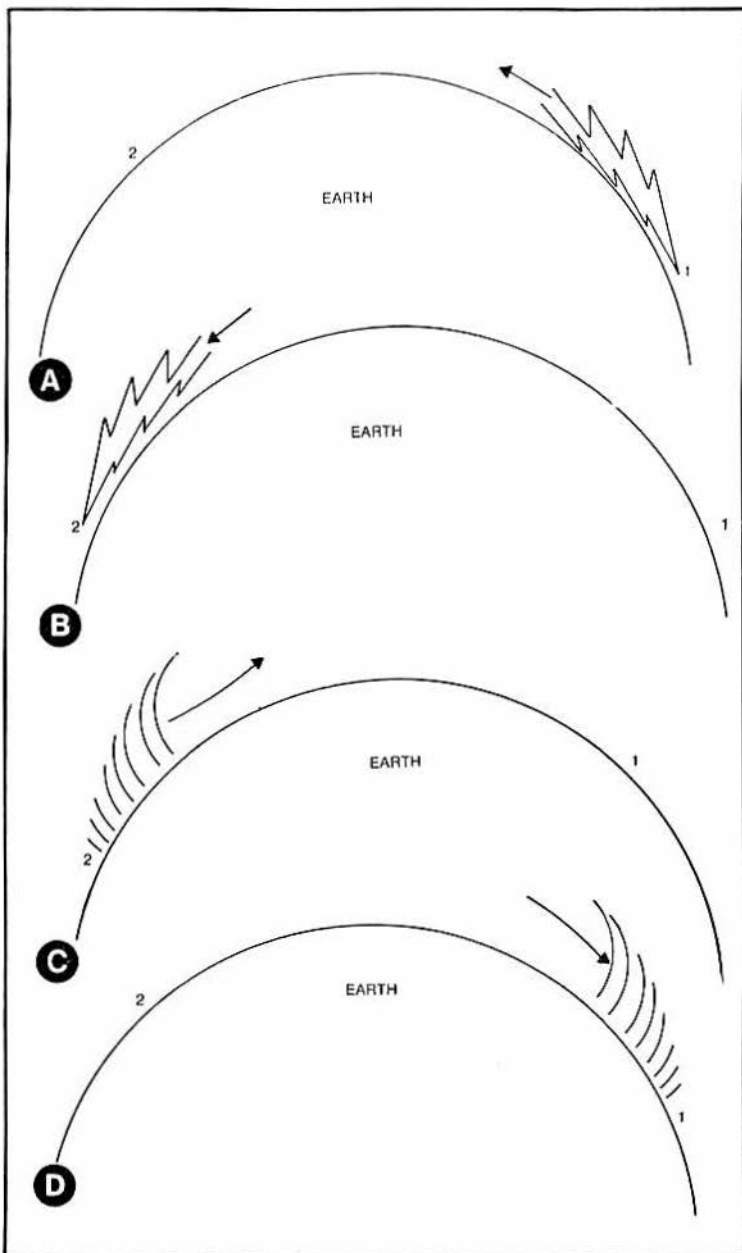

Fig. 8-4. How over-the-horizon radar works. A megawatt shortwave signal is transmitted from point 1 in A, and strikes the desired area (2) in B. But, the signal is so strong that part of the energy is reflected back, C, and is received at the transmitting site (1) in D. The signal is then processed as explained in Fig. 8-5.

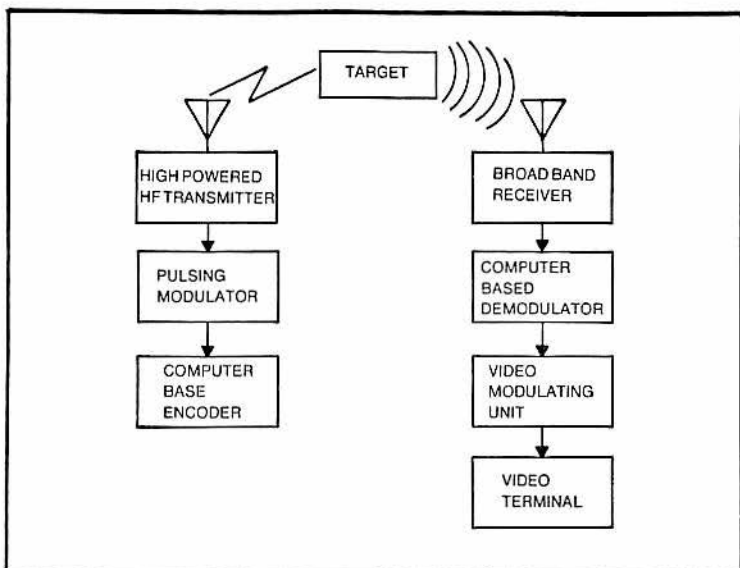

Fig. 8-5. How over-the-horizon radar signals are processed. Modulation of the transmitted signal is accomplished in a computer-based method, setting up broadband pulses. The receiver is broadband instead of selective. Demodulation is computer controlled so as to interpret the reflected signal and extract information about the objects it reflected from. This information can be reproduced visually on a video terminal.

control the weather, it seems more reasonable that they would try to improve their own frigid climate first!

Regardless of their true purpose, the pulsers have had one effect which many shortwave listeners and radio amateurs readily agree upon: the pulsers do a thorough job of wrecking any frequency range in which they operate!

## **MYSTERY OF THE ECHOES**

One of the most incredible phenomena known in physics takes place on the shortwave bands. It involves an echo of a radio signal several seconds after it is transmitted—a feat requiring either a currently unknown principle of radio physics or . . . would you believe a relay satellite from another planet?

A few facts will help you see how incredible it is to be able to receive a radio signal's echo several seconds after its original transmission. The speed of radio waves in free space is the same as the speed of lights—186,000 miles per second. It takes approximately three seconds for a radio signal to echo off the moon and return to Earth. Amateur radio operators have accomplished such a

feat, but by using frequencies in the VHF and UHF range, the full amateur power of 1000 watts, and elaborate, high-gain antenna systems. Even with such conditions, signals via "moonbounce" are usually barely above the noise level. Yet long delayed echoes (or LDEs, as they are commonly known) may take place several seconds after the end of a transmission, with signal strength frequently only slightly less than the original transmission! An additional point is that all amateur moonbounce work takes place on the previously mentioned VHF and UHF bands. This is because such channels offer a lower signal-path loss than does lower frequency ranges. Yet, LDEs are reported on frequencies as low as the twenty meter (14000-14350 kHz) amateur band!

Simply put, it should be impossible, within our present knowledge of physics, for a 100-watt amateur transmitter to produce LDEs on 28 MHz. The only problem is that it happens often enough to create a real mystery!

Developing a satisfactory explanation for LDEs is a task beyond the scope of this book (and beyond the abilities of your author!) Some of the problems involved are obvious, however. In the preceding sections on pulsers, it was revealed how transmitter powers in the megawatt range are necessary to produce echoes from other areas of this planet. How can lower power transmitters produce echoes that must have traveled over several hundreds of thousands or millions of miles? One explanation theorizes that there is an area of highly ionized particles somewhere in our solar system which reflect radio waves much like our own ionosphere, see Fig. 8-7. Even more esoteric explanations have been proposed, and one of them involves a space probe from an alien civilization!

This rather incredible suggestion was made by Ronald N. Bracewell in his 1974 book, *The Galactic Club: Intelligent Life in Outer Space*. Dr. Bracewell, a professor of electrical engineering at Stanford University, took a serious look at the possibility of establishing contact with an alien civilization by electronic means. One possibility he advanced was that an alien civilization could have already dispatched a probe to our solar system to search for intelligent life. One clue to an advanced civilization would be radio waves, and the probe would be designed to detect radio energy. The probe would spend time orbiting each planet, searching for signs of life. Eventually it would reach Earth and find radio waves coming from it. What would the probe then do?

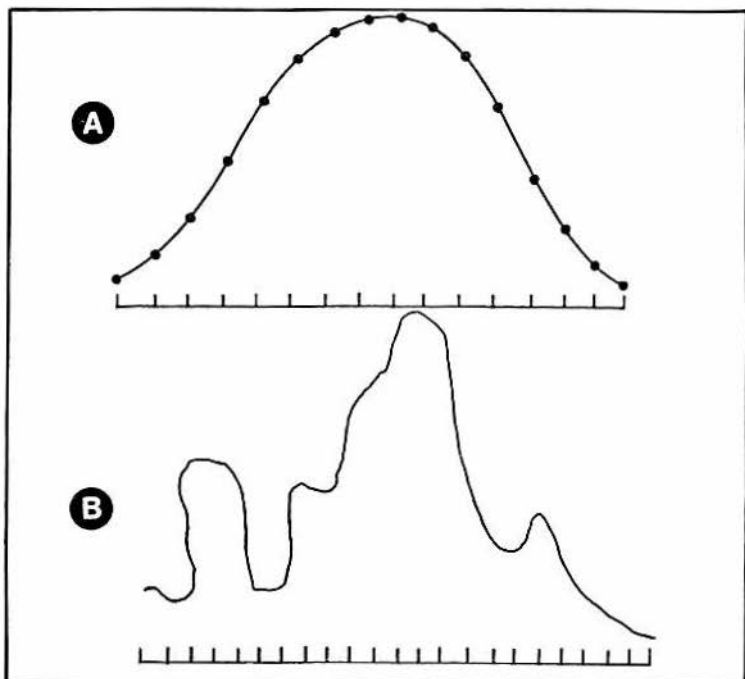

Fig. 8-6. The signal emitted by an over the horizon radar transmitter is shown at A. The reflected signal is shown at B. Note the deformation of the wave shape caused by the surface of the land and objects that reflect the wave. A computer system can interpret the distant surface from the wave shape of the reflected signal.

The probe obviously could not be programmed in advance to respond in any of the languages used on an inhabited planet. Nor could it be programmed to respond in a manner that would be recognizable as something other than random noise on the planet. One way out would be to equip the probe to merely intercept and relay any radio signals it should intercept, and do so in such a manner as to call attention to itself. A simple procedure would be for the probe to amplify and retransmit such signals after a delay of several seconds or minutes, Fig. 8-8. Such signals, wrote Dr. Bracewell, would have the appearance of "long delayed echoes" to listeners on Earth. Dr. Bracewell did not attribute LDEs to such an interplanetary probe, but his theory would explain LDEs about as well as anything which has been proposed so far.\*

\*For further reading on this fascinating subject of a satellite producing long-delayed echoes, read *Mysterious Signals from Outer Space*, by Duncan Lunan, Bantam Books, Inc., New York. Also, *QST* magazine for March, 1980, carried some interesting theories and recordings in a story, "Observations of Long-Delayed Echoes on 28 MHz," by A. K. Goodacre, VE2AEJ/3. Back issues or photocopies of *QST* can be obtained from ARRL, 225 Main St., Newington, CT 06111.



LDEs are supposedly impossible within our current knowledge of radio physics and propagation, yet they exist. The effect when you hear one for the first time is *spooky*. Take it from your author!

### **UFOS OR UNKNOWN ENTITIES?**

Throughout this book your author has tried to present only information with which he has had personal experience or which has been verified by reliable independent sources. The following section is an exception, however; no claims of validity or accuracy are made for reasons which will be obvious.

Some persons have claimed that they or others have heard unusual voices or signals on the airwaves which are supposedly from UFOs or supernatural entities. Your author has not heard any such signals, nor is he aware of any reliable report of the types of signals described here. But, if you want to try to tune them in . . .

One of the leading compilers of reports of unusual radio activity is John A. Keel, a well known writer on UFOs and mysterious phenomena, and author of several books. Keel devotes several pages of his book, *Our Haunted Planet*, to signals supposedly from UFOs. Keel claims that, in areas with large numbers of UFO sightings, strange and unusual voices are sometimes heard on CB radios. Another supposedly common sound is that of a speeded-up phonograph record. The most common description of such voices, according to Keel, is "metallic." It is also reported by Keel that very often you don't need to even turn on your receiver to hear such goings-on; the voices and sounds will start coming out of your loudspeaker anyway!

CB operators are not the only ones that Keel says have heard such signals; radio amateurs also supposedly hear them. One incident quoted by Keel happened on August 3, 1958, and involved a signal on the 75-meter amateur band. A male speaker claimed to be "Necoma from the planet Jupiter" and warned listeners that American atomic-bomb tests were leading the world to disaster. The transmission lasted for over two hours and was reportedly in several languages, including English, German, Norwegian, and a "space language" which was described as a musical gibberish.

Radio amateurs, claims Keel, have even had "mysterious entities" materialize in their listening posts while intercepting such unusual signals! Keel also states that amateurs who reported these materializations, and other contacts with UFO aliens, had their licenses revoked by the FCC—a claim which your author

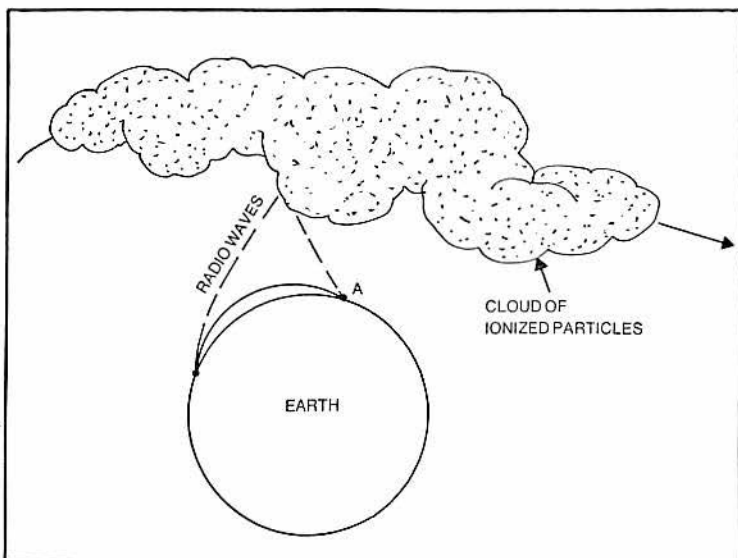

Fig. 8-7. A proposed explanation for long-delayed echoes is a cloud of ionized particles which sometimes comes close to earth and reflects signals back to earth. The path is longer, thus the signals arrive later than the original transmission. The solid, curved line near the surface represents normal atmospheric propagation, and the dashed line represents the reflected signal returning from space. Unfortunately, this explanation is inadequate for many LDE cases, especially those involving very long delays or low-powered signals.

could not substantiate (such efforts to check on Keel's claims were hampered by Keel's use of pseudonyms and unreferenced items in his work).

Keel is also fascinated by what can be heard on the very low frequency (VLF) range of the radio spectrum. VLF encompasses those frequencies below the standard broadcast band, usually below 300 kHz, see Fig. 8-9. Keel claims that he was once visiting a radio amateur who owned a VLF receiver, and the receiver was tuned to 150 kHz. Both, Keel said, heard two strange voices seemingly conversing in excited grunts. Keel claimed that he recorded several minutes on a tape recorder.

Keel also claims that strange voices are frequently heard on 6 and 8 kHz as well. He feels that these are not likely to be government stations since (as he claims) "occasionally some government experiments occur for a few hours on a lower frequency, but they always carefully inform all VLF-equipped ham stations of the time and frequency." That came as quite a surprise to your author, who is a ham and owns VLF equipment!

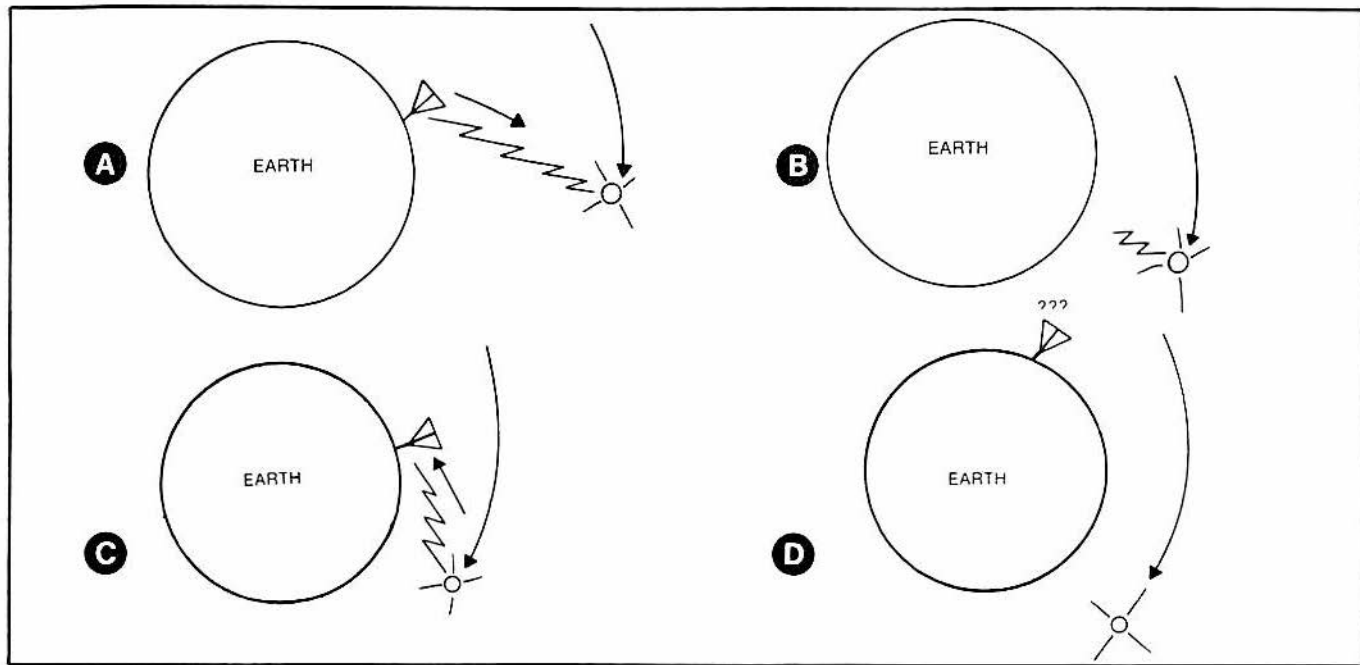

Fig. 8-8. How a space probe from another planet could cause-LDEs, according to the Bracewell scheme. In A, the probe receives a signal from Earth, and processes it at B. After a decision-making process, the probe retransmits the signal, C, which is received at the Earth station, D, much to his bewilderment.

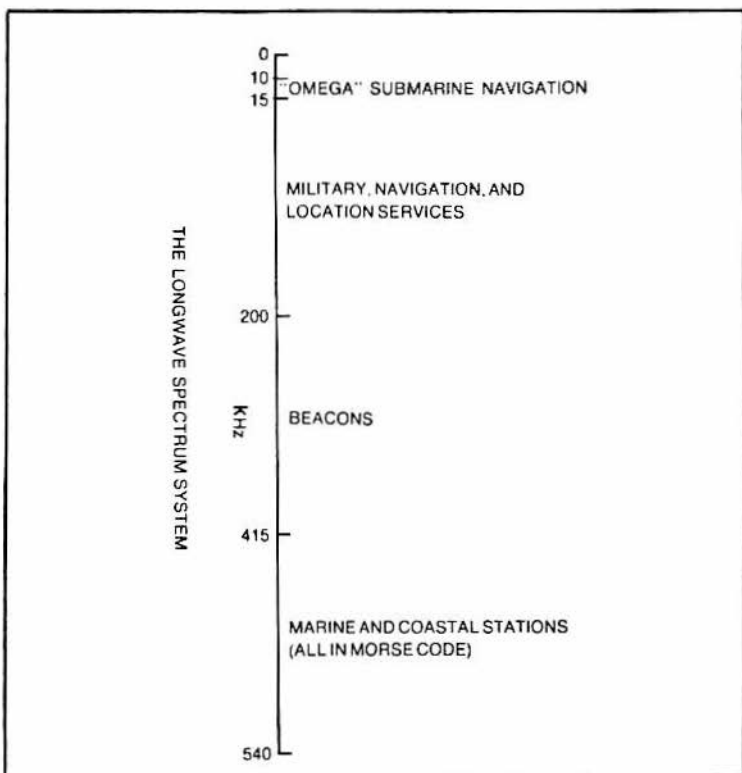

Fig. 8-9. The longwave spectrum and what's to be heard there. Note that there is no allocation for signals from the Saucerians!

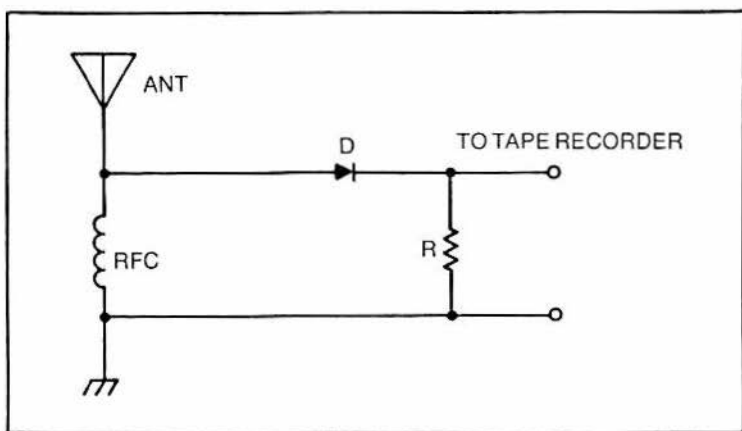

Fig. 8-10. Schematic diagram for the receiver supposedly capable of receiving the voices of the dead!

Table 8-5. Parts for the "Voices of the Dead" Receiver.

ANT: two to three inches of non-shielded hookup wire
RFC: choke, any value between 1 to 2.5 mH
D: general purpose diode, 1N34, 1N914A, or similar
R: 100K-ohm, 1/2-watt resistor

Keel also curiously offers a method of hearing these sounds for yourself. All you have to do is to string up a conventional longwire antenna and connect it *directly* to a stereo amplifier—not to a tuner or receiver, but to the *amplifier!* Keel claims that you can hear a wide variety of sounds, including some voices. Reception will supposedly be best late at night or early in the morning.

If eavesdropping on Venusians grows old, how about listening in on your late Aunt Matilda? Such is indeed possible according to Dr. Konstantin Raudive, author of a recent opus entitled *Break-through: Electronic Communication with the Dead May Be Possible!* Dr. Raudive gave directions for constructing a simple "ghost-voice receiver" which, when connected to a tape recorder, can enable one (he claims) to hear the voices of long-dead persons from somewhere in the Great Beyond. A schematic for the "ghost receiver" is in Fig. 8-10, and Table 8-5 contains a parts list.

Dr. Raudive's technique involves connecting the output of the "ghost receiver" to a tape recorder and running the tape recorder for about ten minutes. When played back, the tape will supposedly show several different voices, all speaking in an unmistakable rhythm. Amazingly enough, if you ask questions aloud while the tape is being recorded, the voices will "answer" your questions, although the languages used by the ghostly voices may be difficult to understand. Dr. Raudive claims to have recognized the voices of such famous and infamous personalities as Franklin Roosevelt and Adolph Hitler.

There's only one hitch in this beautiful scenario—your author has been unable to duplicate Dr. Raudive's results, and neither has anyone else for that matter. If you want to try for yourself, be our guest. By the way, if you connect an antenna much larger than two to three inches, you will certainly hear voices and strange sounds. You see, the ghost receiver is actually nothing more than a crude crystal-set radio!

# Chapter 9

## Receiving Equipment and Techniques

---

Most of the stations and signals mentioned in this book can be received on inexpensive and easily available equipment. Receiving techniques are likewise simple and easily mastered. For those of you not already actively involved in some phase of the shortwave hobby, this chapter will explain the necessary equipment and reception skills to enable eavesdropping on the activity covered in this book.

### RECEIVING GEAR

A good receiving installation consists of a general-coverage receiver, capable of continuous tuning from 540 kHz to at least 30 MHz, a satisfactory antenna system, an accurate means of frequency determination, and a tape recorder.

The receiver is likely to be the most expensive item in the listening post. Several models are on the market, and no attempt will be made here to advise the purchase of a specific make. However, there are several features which are highly desirable for receiving the stations mentioned in this book. Foremost should be the capability to receive SSB and CW (Morse code) transmissions. On many receivers, this will be indicated by a mode selector switch marked USB-LSB-CW; on other receivers capable of receiving SSB and CW there will be a BFO (beat frequency oscillator) control. Frequency coverage should be as wide as possible, preferably from the lower end of the standard broadcast band (540

kHz) to about 30 MHz. Figure 9-1 shows a neat communications center built around Radio Shack equipment.

In today's state of the electronics art, sensitivity is not a problem. In fact, most solid-state receivers experience problems with overloading by very strong signals, so some form of antenna attenuation, or a variable RF (radio frequency) gain control is often valuable. Selectivity is another matter, however; many receivers manufactured today are unfortunately too broadly responsive for today's crowded band conditions. As a general rule, the more expensive receivers will have better selectivity than less expensive models (although there are some exceptions). Some manufacturers include such features as mechanical, crystal, or ceramic filters to improve selectivity, with audio filters widely available as accessory items to improve receivers with deficient selectivity.

Given the excellent sensitivity of most receivers today, an elaborate antenna system is not really necessary for satisfactory reception. An "all band" system such as a random- or long-wire is preferred to an antenna cut for a specific band, such as a dipole. Your author has successfully heard the stations covered in this book, from apartments, while using only short lengths (15 to 25 feet) of random wire matched to the receiver through an antenna tuning unit.

A very important requirement is an accurate method of frequency determination. Many new receivers come equipped with a digital frequency readout which enables tuning to within one kilohertz of the desired frequency. On other receivers, direct frequency readout units can be purchased as add-on accessories. One less-expensive method which works well for many listeners is a crystal calibrator unit. A crystal calibrator is an oscillator which produces an output signal at fixed frequency intervals, usually at each 100 kHz, and dividing down to smaller units, such as 10 kHz. Being able to read frequencies accurately is of prime importance if you decide to seriously pursue the types of listening covered in this book. For one thing, many of these stations operate outside the standard broadcasting bands, on frequencies that are difficult to locate on poorly calibrated receivers. You may also want to keep records of the stations you hear, in order to discern patterns of activity, and accurate frequency determination will be an important part of such records.

More extensive details on shortwave receiving equipment and antennas can be found in other books by TAB such as TAB book No. 1255, *The Complete Shortwave Listener's Handbook*. There is



Fig. 9-1. A dream shack communications post based on equipment from Radio Shack. It includes a 40-channel SSB/AM rig for CB, a Weatheradio alert receiver, a VHF/UHF programmable scanner, and a DX-300 receiver that covers from 10 kHz to 30 MHz.

one other essential receiving tool which, however, is often overlooked by such books and many listeners: a tape recorder. Repeated listening to some transmissions will often reveal more than what may at first be obvious. Comparison of several taped transmissions can often reveal surprising patterns and similarities, as was the case with much of the research into the "spy numbers" transmissions mentioned in Chapter Two. A tape recorder is also useful in trying to untangle transmissions in unfamiliar foreign languages or the Morse code.

Finally, developing a taped library of your listening experiences has its own rewards. Your author treasures his taped collection of such stations as Radio Rebelde, WGOR, and the Voice of the Voyager!

### RECEIVING TECHNIQUES

*Patience* is a rather large virtue in seeking out the signals mentioned in this book. Although representative times and frequencies have been included in this book, the signals discussed in this book can pop up virtually anywhere in the radio spectrum at almost any time. The best listening technique is a bit like fishing—it can be termed "trolling!"

Random dial-twirling is still the best technique for discovering unusual radio activity. Obviously, many of the activities discussed in this book are not intended for the reception of the general public; and the persons engaged in them take steps to make



**Table 9-1. When to Listen for Secret Shortwave Activity.**

<b>Activity</b>	<b>Time to Listen</b>
European pirates	Sunday mornings 0600-1200 GMT
American pirates	Weekend nights 0500-1000 GMT
Spanish numbers	0000-1100 GMT
German numbers	2200-0000 GMT, also 0400-0600 GMT
Pulsers	Virtually anytime: usually near the maximum usable frequency.
Long delayed echoes	During periods of good propagation on the higher frequencies above 14 MHz
Strategic Air Command	Virtually anytime
Smugglers	Late nights and early mornings in coastal areas
Mystery beacons	Usually 0000-1200 GMT

sure they are not intercepted by anyone other than the desired recipients. One of the best ways to avoid unwanted eavesdroppers is to transmit on frequencies and at times when few unwanted listeners are likely to be tuned in!

Yet some generalizations can be made and are summarized in Table 9-1. To be successful in hearing the activities described in this book, the listener must be alert and news-conscious to a very high degree. Patterns of activity change often in response to the changing world situation, particularly with regard to clandestine broadcasting, and listeners should keep abreast of such changes.

Your tape recorder should be ready for use whenever you tune for stations from the secret shortwave spectrum. Being able to listen several times to a tape recording can make the difference between being able to identify what you heard and being completely baffled. If a tape recorder is not ready for immediate use, important information vital to identifying what you are hearing could be lost!

Current information is also vital in receiving the stations mentioned in this book. While every effort has been made to make this book as current as possible, it is impossible for any book to ever be totally current in such a dynamic field. Listeners seriously interested in the topics mentioned in this book should consider joining a shortwave listeners club, and tuning in to regular programs of DX news broadcast by international broadcasters. Addresses for shortwave listeners clubs and the international

broadcasters are given in Table 9-2. You should include a self-addressed stamped envelope with your requests for information to the clubs; the international broadcasters will be happy to send you a program schedule upon request.

Many listeners are stumped when it comes to identifying stations transmitting in Morse code or in Spanish, creating problems when trying to tune some of the various numbers stations. Your tape recorder can overcome these obstacles with the aid of Tables 9-3 and 9-4!

Table 9-3 gives the international Morse code by sound, which is by far the best way to approach it. Forget all about any visual code tables you may have memorized in the past, and the "dot dash" business; Morse code is a language with just two words, "dit" and "dah."

As mentioned in Chapter Two, Morse code numbers stations open their transmissions with two, three-digit-number blocks repeated three consecutive times. This continues for several minutes before the actual message starts, so listen for any Morse code transmission that seems to be repeating. If you notice one, tape several minutes of the transmission on your tape recorder. Using Table 9-3, listen carefully for the sound of one character, such as "dahdahdididit." Repeat the character over and over to yourself as you look it up in Table 9-3 until you find it. In this case it is the numeral 7. Write it down, and proceed to the next character until you have decoded enough of the transmission to establish whether or not it is a numbers transmission.

It sounds like a slow and tedious process, and it may indeed be so at first. Proficiency in decoding Morse transmission will come

**Table 9-2. Sources of Current Information.**

**Clubs**

North American Shortwave Association, P. O. Box 13, Liberty, Indiana, 47353.

SPEEDX, P.O. Box E, Elsinore, California, 92330.

Newark News Radio Club, P. O. Box 539, Newark, New Jersey, 07101.

Danish Shortwave Club International, Greve Strandvej 144, DK 2670, Grøve, Strand, Denmark.

**Radio Programs**

"RCI DX Digest," Radio Canada International, P. O. Box 6000, Montreal, H3C 3A8, Canada.

"Sweden Calling DXers," Radio Sweden, S-10510, Stockholm, Sweden.

Character	Sound
0	dahdahdahdah
1	didahdahdah,
2	dididahdah
3	dididahdah
4	didididah
5	didididit
6	dahdididit
7	dahdahdidit
8	dahdahdidit
9	dahdahdahdit
A	didah
B	dahdidit
C	dahdidahdit
D	dahdidit
E	dit
F	dididahdit
G	dahdahdit
H	dididit
I	didit
J	didahdah
K	dahdidah
L	didahdidit
M	dahdah
N	dahdit
O	dahdahdah
P	didahdahdit
Q	daddahdidah
R	didahdit
S	dididit
T	dah
U	dididah
V	didididah
W	didahdah
X	dahdididah
Y	dahdidahdah
Z	dahdahdidit

Table 9-3. International Morse Code by Sound.

**Table 9-4. Some Commonly Used Spanish-Language Numbers and Words.**

<b>English</b>	<b>Spanish</b>	<b>Pronunciation</b>
Zero	Cero	Say-roe
One	Uno	Ue-noe
Two	Dos	Dose
Three	Tres	Trace
Four	Cuatro	Kwa-troe
Five	Cinco	Seen-koe
Six	Seis	Say-es
Seven	Siete	See-ay-tay
Eight	Ocho	Oe-choe
Nine	Nueve	Nue-way-be
Attention	Atención	Ay-teen-see-on
End	Final	Fee-nal
Set	Grupo	Grue-poe

with practice, and, as a bonus, you'll find yourself learning some Morse code. Don't, however, jump to the conclusion that every numerical transmission you receive is a "spy numbers" broadcast; U. S. Navy stations frequently broadcast weather and navigation data in numerical blocks. These stations always identify with a standard call sign, such as NRN, while the spy numbers stations use no call signs and open with the distinctive repeated number blocks. Receiving these blocks is conclusive evidence that an espionage Morse code station has indeed been received.

A similar process can be used in monitoring the Spanish language numbers stations. Table 9-4 gives phonetic approximations for Spanish numbers and selected words. As mentioned in Chapter Two, certain message identifiers tend to demonstrate regular patterns of operation, and it is entirely possible for the hobbyist to discover regular schedules for these stations. For example, during April of 1978, your author found that a Spanish numbers station identifying itself as "atención 010 86" began operating on 3815 kHz at 0500 GMT on odd-numbered days such as April 1, 3, 5, 7, and so forth. Listener Mike Chabak of Colorado has discovered that entire messages are sometimes repeated days and even weeks apart. Professional intelligence agencies around the world almost certainly also keep close tabs on these transmissions; while the codes used are virtually unbreakable, much valuable information can be obtained from analyzing the patterns of such activity.

## Chapter 10

# The Issues Raised by the Secret Spectrum

---

For many radio amateurs and shortwave listeners, their radio hobby is separate from events in the rest of the world. Yet the types of activity discussed in this book are intimately related to several crucial questions about the radio spectrum and the rights and privileges of both regarding its use.

### THE GOVERNMENT AND THE RADIO SPECTRUM

Under the laws of the United States, the entire radio spectrum is a natural resource belonging to the people of the United States. It is the responsibility of the federal government to administer this natural resource for the maximum benefit of the people of the United States. How well has this task been carried out?

The pirate radio operators claim that access to the radio spectrum for broadcasting has been effectively closed off to all but those corporations and individuals who can provide the enormous capital required to establish a commercial broadcasting station. Such commercial stations, they argue, result in programming aimed for the lowest common denominator of public taste. Such commercial operations also shut out many segments of the community from being represented in the programming of commercial stations. In rebuttal, it could be argued that commercial stations operate under a set of guidelines, such as the "fairness doctrine" and public service requirements, which ensure that broadcasters must be responsive to the communities in which they

are located. Further, the public has the freedom to turn their radio dials to whatever stations they desire; those stations with the most listeners garner the highest ratings, which can be considered a measure of how well a particular station is serving the public.

But pirate broadcasters argue that all such justifications for the existence of commercial radio are beside the real point. The issue is not whether commercial stations are truly serving the public, they say; the real issue is why broadcasting should be restricted to commercial interests or publicly-supported stations. Why, the pirates ask, can't an ordinary citizen have some slice of the radio spectrum in which to broadcast? This is a very cogent point, since broadcasting to the general public is prohibited in all radio services open to individual licensees including CB and amateur radio.

If you have something to say, you can proclaim it from any street corner in the United States. You can write anything you want in a book. But you, as an individual, cannot go on the airwaves on your private station and say what's on your mind—despite the fact that legally the airwaves are the property of the people of the United States.

No formal petition has yet been presented to the Federal Communications Commission seeking permission for private, hobby broadcasting by individuals. Nor is there any evidence that such a right is desired by a large number of people. Yet the various pirate broadcasters do raise an intriguing question: has the government allowed the broadcasting spectrum to be overwhelmed by commercial interests to the exclusion of private individuals?

## **IS THE FCC ADEQUATE FOR ITS TASKS?**

The United States Postal Service is the target for anger and the butt of numerous jokes for its performance. Yet the activity reported in this book also raises several questions as to whether the Federal Communications Commission is any better at fulfilling its mandate under the law than is the Postal Service. In a very real sense, the FCC seems to be on the verge of losing control of the radio spectrum it is supposed to oversee.

Evidence of the FCC's failure to enforce its own rules can be found throughout the radio spectrum. A quick spin through the CB and amateur bands will reveal numerous violations of the law, many of them quite open and flagrant. The so-called "HFers," discussed in Chapter Five, have been growing in number, despite

FCC's efforts to combat the activity. Such pirate stations as WGOR and WFAT have been able to operate for well over a year without being raided—and the bust of WCPR was more a result of a goof by the pirates than any FCC genius.

FCC representatives usually attribute their lack of success to a lack of personnel to enforce regulations. Never mentioned is the possibility that the rules and regulations themselves could be part of the problem. How enforceable would be laws against taking certain drugs if the drugs themselves could be freely bought and possessed? Such a situation would clearly be illogical. Yet there is a close parallel in FCC regulations, which prohibit certain types of radio activity while the equipment needed to carry out rule violations is freely available to all!

This, more than any shortage of enforcement personnel, may be the crux of the FCC's problems. Amateur, CB, marine, and even commercial broadcast equipment can be purchased by anyone with the necessary funds. This book has already examined how amateur gear is misused by HFers, smugglers, and "FM CBers." Most pirate broadcasters use modified ham gear. Similarly, eavesdropping transmitters are widely available despite stringent federal laws regulating their *use*. Their *possession* is a different matter, however!

Very real questions have been advanced as to the adequacy of the FCC's problem-solving capability. The FCC often seems as if it does very little, if any, planning; it is accused of simply reacting without regard to future consequences. The establishment of CB radio is often cited by these critics as a prime example of the FCC's lack of planning; no advance study was made as to possible rule enforcement problems or of the new service's growth potential (which eventually proved to be too explosive for the Commission to handle).

Cited as an example of the FCC's tendency to react without adequate forethought was the decision to ban linear amplifiers capable of operating in the 25-50 MHz range. This action was supposed to cut down on illegal CB and HFer operation, but to date has had negligible results outside of inconveniencing law-abiding amateurs. In this regard, the FCC demonstrated a fundamental misunderstanding of the problem. Few illegal CB and HF operators were using amateur linears illegally to achieve high power; these operators favor modified amateur SSB transceivers (which still can be legally purchased by anyone) or linears made by "basement" manufacturers (who have ignored the ban anyway).

Another problem may well be with the people at the FCC. The Commissioners who head the agency are selected less for their knowledge of communications than for supporting the correct presidential candidate. Their ability to act in an informed and expert manner in many of the matters facing the FCC must be quite suspect. The vast bulk of FCC personnel are career civil servants. However, like all people, they are a mixed bag ranging from excellent to mediocre. Your author has had several contacts with various levels of the FCC over the years, and has noted a tendency for some key personnel in the FCC to develop a certain overconfidence in the ability of the Commission to enforce its rules, a "it can't be, therefore it isn't" attitude.

An example of the above came in early 1978 when your author was talking with the engineer in charge of an FCC radio district. I brought up the subject of pirate radio, mentioning that there were "reports of a couple of stations operating around 1620 kHz in New York City." At the time, of course, I was fully aware of stations WDBX and WGOR.

The engineer-in-charge's reply was quick and emphatic. "No way!" he laughed. "We'd have those stations closed down in less than a week!"

Both were still in operation over a year later.



# Chapter 11

## The Latest Happenings in the Secret Spectrum

---

In a very real sense, a book such as this can never be "completed," since new stations are constantly popping up while others leave the air. Several events have taken place during the first half of 1979, since the main portion of this book were written, and this chapter will cover the latest developments.

### CLANDESTINE BROADCASTING

The Nicaraguan clandestine Radio Sandino began extensive new operations in late April, 1979, on the new channel of 7588 kHz. Signals throughout North America were strong, indicating that some sort of relatively permanent transmitter site was being used. Speculation as to the actual location of Radio Sandino centered around either a neighboring state such as Guatemala or Costa Rica or Cuba.

At press time, Radio Sandino began transmissions at 2330 and 0430 GMT; lengths varied but generally transmissions lasted for one hour. All transmissions were in Spanish, and used the identification announcement of "Radio Sandino, voz de la liberacion de Nicaragua." Programs were professionally produced, with multiple speakers, music, and special effects, all indicating that it was unlikely that this was an "on the run" clandestine actually operating from Nicaragua.

Programming on Radio Sandino had a distinct Marxist slant, sounding a great deal at times like the Spanish service of Radio

Havana Cuba (even down to playing much of the same music). This has resulted in the speculation that the station could well actually be in Cuba. Many of the programs instructed listeners on how to commit acts of violence against the Somoza regime in Nicaragua; lessons on how to handle an automatic rifle and make Molotov cocktails have been heard by North American listeners. Anti-American commentaries were also a frequent item, further reinforcing the possible Cuban connection. Plans were announced for Radio Sandino to begin longer transmissions until such time as the Somoza regime fell.

Things were quiet on another Latin American front, with Radio Abdala, Radio Rebelde, and Radio Libertad Cubana dormant during the first half of 1979. Radio Abdala's absence was accounted for in the official publication of the Cuban exile organization "Agrupacion Abdala," which claimed that the station was indeed located in the United States but that it had been found and burned to the ground by Castro's agents! The group promised, however, that the station would return to the air. Another interesting report, circulated in the shortwave hobby press by a Florida listener, claimed that Radio Rebelde was operated by an American ham somewhere in the Miami area.

A new clandestine also popped up from the South African territory of South West Africa, calling itself the Voice of the Namibian People. This station operated on 7180 kHz Mondays only in the 1800-2000 GMT slot. Programming was in English and local vernaculars. Strong evidence suggested that this station was actually operating from inside South West Africa (whose nationalist name is Namibia) with the toleration of the South African government! The station was the official voice of the UNITA faction in South West Africa, a group the South African government would prefer to have eventually control the area, instead of the more radical groups supported by Angola and the Soviets. Evidence of this was provided by the numerous anti-Angola and anti-Soviet commentaries the station aired.

The Kurds in Iraq also received support with a new voice calling itself the Voice of Kurdistan. Programming was entirely in Arabic, but reception in North America was virtually impossible, due to its scheduled sign-off time of 1500 GMT on 5990 kHz.

During the China-Vietnam war, the Voice of Vietnam reported in its English broadcasts that a new clandestine operating from within China itself had been heard in the 19-meter international broadcasting band. This station, known as "Radio 8-1," was

supposedly the voice of a dissident faction of the Chinese army opposed to the invasion of Vietnam. Independent monitoring by various agencies failed to confirm the existence of this station, however.

## **SPY NUMBERS**

Spy numbers stations continued to be heard with great frequency during the first half of 1979. No large amount of effort was required to hear them, since most listeners easily came across them in the course of their ordinary listening habits! One interesting variation was the increased number of stations using phonetic groups instead of numbers.

The 7300-7500 kHz range was a hotbed of activity during the unrest in Nicaragua. Several Spanish-speaking stations, using upper sideband transmission, were heard in North America during the evening hours. Call signs were mainly two digit numbers, with other stations being called in a manner strikingly similar to the methods used on the spy numbers stations, such as "atención 24, atención 24, esta es 82." Transmissions were short and cryptic, and speculation ran that these stations were involved in some manner with espionage or guerilla activity in Latin America.

## **AMERICAN PIRATE ACTIVITY**

Pirate radio in the United States during the first half of 1979 closely resembled a three ring circus. Some stations were busted by the FCC while other operators took to the air in their place.

The biggest news in pirate radio was made on April 15, 1979 when officials of the FCC raided and closed WFAT in New York. The scene had strong *deja vu* elements, since two of the operators present and one of the agents involved had met previously—at the 1976 bust of WCPR!

Amazingly enough, the operators of WFAT had plenty of advance warning that the FCC was planning to close the station. In early March, an item appeared in the *New York Times* detailing the FCC's attempts to locate unlicensed broadcasters in New York, including mobile direction finding vans which were patrolling the city during the weekends when the pirates were most active. After this, the various pirates in New York went silent for a brief period. But the crew of WFAT was impatient to resume broadcasting, and went back on the air in late March. Since they were virtually the only pirate on the air in New York at this time, the FCC focused all their efforts on WFAT.

The actual closing of WFAT took place around 5:00 a.m. on April 15, a Sunday. The station had gone on the air that Saturday, April 14, in an act of incredible bravado (or stupidity!) since one of the operators had observed an FCC direction-finding van in the immediate area prior to the station signing on. The other members of the staff were informed of this, but decided to go on the air anyway!

An indication of the determination of the FCC to catch some of these pirates came after the closing of WFAT. While other FCC agents were questioning members of the station's staff, one of the agents placed a collect phone call to a high FCC official in Washington, informing him that they had caught WFAT.

Also in April, 1979, the FCC closed a pirate known as Radio Liberation. Radio Liberation first came on the air in January, 1979 on 7425 kHz, a clear imitation of the Voice of the Voyager. It operated late Saturday nights like the Voyager, and featured rock music and satirical features such as the "Pol Pot Exile Show." Its operators used a variety of humorous pseudonyms, such as Guy Wire, Justin Case, and Ida Screwder. While they did not make use of dial-around loops, they sent verifications to listeners who reported reception in the various shortwave club bulletins.

Radio Liberation claimed to be broadcasting "from the arid marshlands of putrid Louisiana" but strong signals from various parts of Florida indicated that the station was actually located somewhere in the Sunshine State. These suspicions proved to be correct, as the station was raided in Oak Hill, Florida, a small town on the Atlantic coast.

The strange saga of KDOR came to an end in March, 1979, when the FCC finally closed the station after repeated warnings. One of the principals in the operation turned out to be confined to a wheelchair, perhaps accounting for the FCC's reluctance to actively prosecute the operators. The station's closing by the FCC was featured on the evening news in Los Angeles, as TV news teams were invited to attend the formal bust!

Yet other pirates were waiting in the wings to take the place of any that fell by the wayside. One of the most active was the Voice of Venus, apparently an operation by a teenage amateur radio operator somewhere in the Minneapolis, Minnesota area. This pirate used only single sideband transmissions and operated near the 40 and 15 meter amateur bands. The station used the slogan "Voice of the Northern Prairie" and featured programs that consisted mainly of rock music and aimless talk. The operators of this station apparently ran up a rather substantial phone bill,

inasmuch as shortwave listeners all over the United States received phone calls from the operators informing them when the station would be on the air.

New York continued to produce several pirates operating in the 1600-1650 kHz range. One was WEKG, operating on 1625 kHz, operated by a husband and wife team known as Chris Christy and Kevin Scott. Both were professionally involved in broadcasting and operated their station as a hobby. It was located in Queens, near Kennedy International Airport, and sometimes the sound of passing jets could be heard in the background of their broadcasts! Other New York pirates were WENJ, WELO, WLTE, and WCBX, all similar in format to WFAT and WGOR. Schedules were mostly late weekend nights in what has now become a traditional time for pirate operations.

Pirate broadcasting also came to New England in the guise of "PRN, Pirate Radio New England." Location of the station was given as central New England, but reliable sources placed its actual site as Worcester, Massachusetts. Elton John music was played extensively, and telephone calls were taken over an ordinary phone line—not a dial-around-loop arrangement. The operators also had their own set of pseudonyms, using Admiral Jolly Roger, Captain Jeff Bligh, and Mr. Electricity.

West coast listeners succeeded, in April, in finally getting an identification announcement out of the pirate operating from southern California above the 49 meter band. In April it had settled down on 6420 kHz, where it was widely heard in the western United States during the evening hours. The station announced itself as "KVHF" and used such slogans as "from coast to coast this is KVHF" and "when the hits come out in the evening, this is KVHF." Outside of these slogans, no other talk was heard by listeners; programming continued to be a wide variety of music.

Pirate activity continued at a high level in the 3850-3900 kHz area of the amateur 75-meter band, with as many as five stations audible in a single night. Most of these stations merely played music, apparently the result of some technically-minded hams experimenting with various audio system. Very little broadcasting as such was reported, however; most only played music.

## **EPILOGUE**

It must once again be emphasized that many of the activities described in this book are illegal under the laws of the United States and many other countries. Relevant portions of United States radio law are included in the appendix of this book.

It should also be mentioned again that neither the author nor publisher advocate, condone, or support those illegal activities reported in this book.

However, few experiences in the radio hobby can equal the excitement of tuning in the activities and stations discussed in this book. Best of listening!

# Appendix A

## Frequency Chart

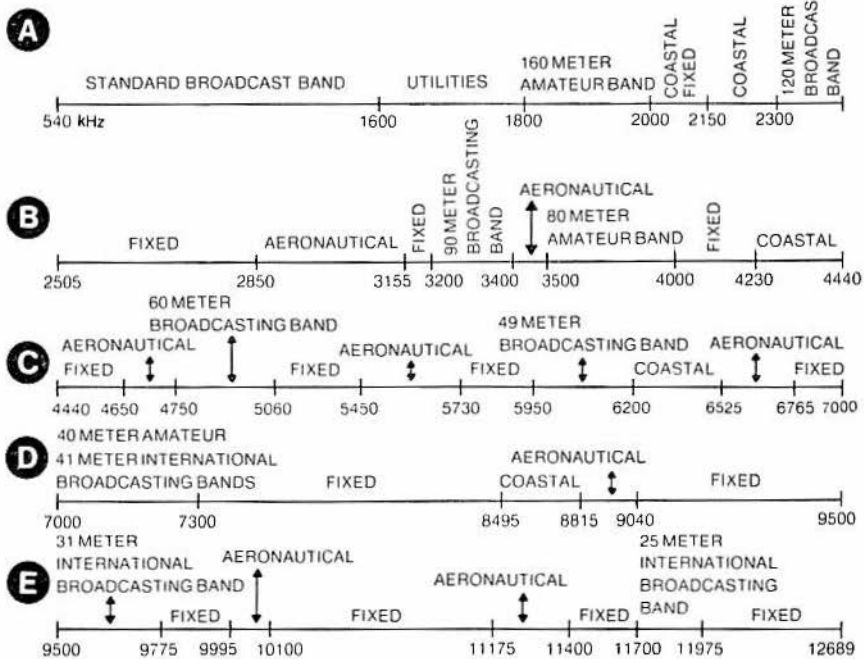

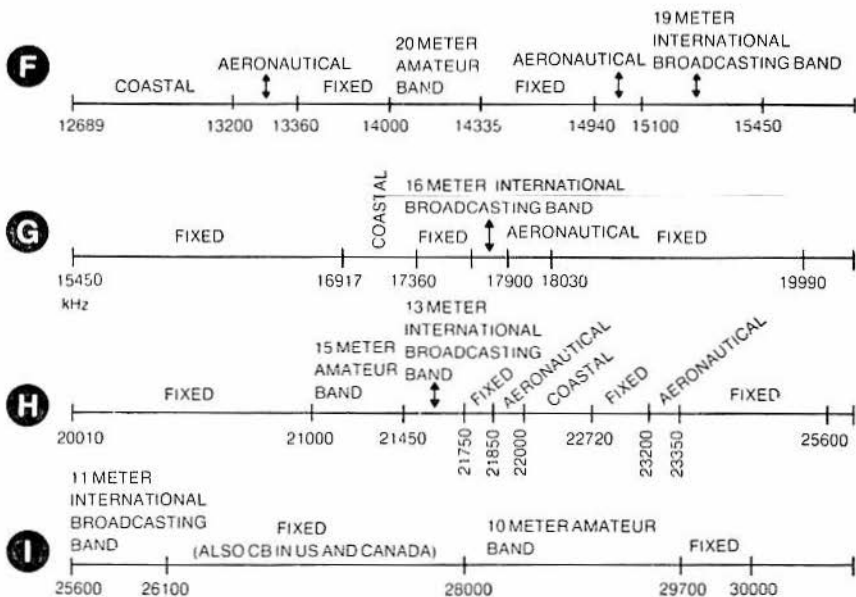

Fig. A-1. This chart details what is actually authorized to operate in the shortwave spectrum. *Fixed* stations are those operating from land locations using a variety of emissions, such as radioteletype, Morse code, voice, etc. *Aeronautical* stations are generally in single sideband and involve airplanes and airports. *Coastal* stations include ships and shore stations, generally using Morse code and voice.



## Appendix B

### Rules and Regulations

---

#### SELECTIONS FROM THE COMMUNICATIONS ACT OF 1934

**Section 318.** The actual operation of all transmitting apparatus in any radio station for which a station license is required by this act shall be carried on only by a person holding an operator's license issued hereunder, and no person shall operate any such apparatus in such station except under and in accordance with an operator's license issued to him by the Commission . . .

**Section 501.** Any person who willfully and knowingly does or causes to be done any act, matter, or thing, in this Act prohibited or declared to be unlawful, or who willfully or knowingly omits or fails to do any act, matter, or thing in this Act required to be done, or willfully and knowingly causes or suffers such omission or failure, shall, upon conviction thereof, be punished for such offense, for which no penalty (other than a forfeiture) is provided in this Act, by a fine of not more than \$10,000 or by imprisonment for a term not exceeding one year, or both . . .

**Section 502.** Any person who willfully or knowingly violates any rule, regulation, or condition made or imposed by the Commission under authority of this Act, or any rule, regulation, restriction or condition made or imposed by any international radio or wire communications treaty or convention, or regulations annexed thereto, to which the United States is or may hereafter become a party, shall, in addition to any other penalties provided by law, be punished, upon conviction thereof, by a fine of not more than \$500 for each and every day during which such offense occurs . . .

**Section 605.** . . . No person receiving or assisting in receiving or transmitting, or assisting in transmitting, any interstate or foreign communication by wire or radio shall divulge or publish the existence, contents, substance, purport, effect, or meaning thereof . . . to any person other than the addressee, his agent, or attorney . . . This section shall not apply to the receiving, divulging, publishing or utilizing the contents of any radio communication which is broadcast or transmitted by amateurs or others for the use of the general public . . .

#### **SELECTIONS FROM FCC RULES AND REGULATIONS**

**2.701.** No person shall use, either directly or indirectly, a device required to be licensed by Section 301 of the Communications Act of 1934, as amended, for the purpose of overhearing or recording the private conversations of others unless such use is authorized by all of the parties engaging in the conversation.

# Appendix C

## Greenwich Mean Time (GMT) Conversions

---

Local Time	Subtract from GMT
Eastern Daylight	Four Hours
Eastern Standard	Five Hours
Central Daylight	
Central Standard	Six Hours
Mountain Daylight	
Mountain Standard	Seven Hours
Pacific Daylight	
Pacific Standard	Eight Hours

GMT uses a 24-hour clock system. To convert to your local time, subtract the proper number of hours from GMT. For example, to convert 1700 GMT into EST, 1700 minus five hours equals 1200, or noon EST. Midnight in GMT is 0000; 0300 GMT is the same as 10:00 p.m. EST.

## Appendix D

# International Phonetic Alphabet

---

A: Alpha	N: November
B: Bravo	O: Oscar
C: Charlie	P: Papa
D: Delta	Q: Quebec
E: Echo	R: Romeo
F: Foxtrot	S: Sierra
G: Golf	T: Tango
H: Hotel	U: Uniform
I: India	V: Victor
J: Juliet	W: Whiskey
K: Kilo	X: X-Ray
L: Lima	Y: Yankee
M: Mike	Z: Zulu

The international phonetic alphabet is used on SAC broadcasts and other governmental or military transmissions.

## Appendix E

# International Morse Code

---

A •-	M --	Y -.-
B -...	N -•	Z ---•
C -.-•	O ---	0 -----
D -..	P •-••	1 •-----
E •	Q --•-	2 ••----
F ••-•	R •••	3 •••--
G --•	S •••	4 ••••-
H ••••	T -	5 •••••
I ••	U ••-	6 -••••
J •----	V •••-	7 ---•••
K -•-	W •-•-	8 -----••
L •-••	X -••-	9 -----•

# Index

<b>A</b>		<b>G</b>			
Acquisition of signal	74	German-Language		Pathet Lao	18
Air command communications	62	numbers stations	45	Peyk-e Iran	25
American pirate activity	126, 172			Rebelde	31
Anti-Castro stations	26	<b>H</b>		Sandino	33
AOS	74	Ham bands	84	spectrum	60
		possible		spectrum, and	
		espionage communications	85	the government	166
		HFers	89	Swan	14
<b>B</b>				10½ meter	88
Basques	10			Viking	103
Beacons, own	141	<b>K</b>		25 Radioteletype signals	144
Bisim Radyo	25	Kurds		Receiving gear	159
Broadcasting, clandestine	170			techniques	161
Bugs	91	<b>L</b>		Russian pulsers	145
		Land-based			
		pirate broadcasting	100	<b>S</b>	
<b>C</b>		Launch support activity	80	SAC	62
Civilian communications	60	LOS	75	Satellite spectrum	71
Clandestine activity, origins	8	Loss of signal	75	Satellites, of other nations	80
broadcasting	170			weather	78
broadcasting, the future	36	<b>M</b>		Signals, radioteletype	144
post-war era	10	Messages, encoding		unknown	142
Clandestines, current activity	26	Morse-code numbers stations	46	Single-sideband	
African scene	35			numbers stations	46
Asian scene	33	<b>N</b>		Soviet space activity	76
in Africa	22	Numbers stations, where		Space communications	72
in Southeast Asia	18	they transmit from		Spanish numbers, five digit	39
in the Middle East	25			four-digit	42
Middle East activity	34	<b>O</b>		Spy numbers	172
Nicaraguan activity	33	Ocean-going		SSB numbers station	48
Communications, civilian	60	pirate broadcasting		Stations, anti-Castro	26
space	72	pirate broadcasting		Strategic air	
strategic air command	62	One time pad		command communications	62
CW numbers stations	46	message system			
		Over-the-horizon radar	147	<b>T</b>	
<b>D</b>				10½ meter band radio	88
Diplomatic radio	57	<b>P</b>			
Disinformation	44	Patriotic Voice Radio	20	<b>U</b>	
Doppler shift	72	Pirate broadcasting, land-based	100	UFOs	154
DX pirates	130	ocean-going	97	<b>V</b>	
		piracy	139	Voice of	
		the future	139	Democratic Kampuchea	20
<b>E</b>		Pirate radio, 1973-1976	118	Lebanon	25
Eavesdropping	91	Pulsers, Russian	145	Namibia	36
Echoes	151			the Kampuchea People	20
Encoding messages	38	<b>R</b>		the Patriotic	
English-language numbers	43	Radar, over-the-horizon	147	Militiamen's Front	21
Espionage activity, patterns	39	Radio Americas	14	the Voyager	131
radio activity, unusual	49	Destiny of the Motherland	20	Truth	35
European station	103	diplomatic	57	<b>W</b>	
		Domino-X	112	WCPR, American pirate radio	120
<b>F</b>		España Independiente	11	Weather satellites	78
Facsimile	78	Euzkadi	11	WRUL	17
Fax	78	Free Russia	12	<b>Z</b>	
Foxtrot broadcasts	67	Freedom of South Yemen	26	Zimbabwe People's	
Free Radio		Mercur	98	Revolutionary Voice	35
Broadcasting Corporation	110	New York Worldwide	17		

# How to Tune the Secret Shortwave Spectrum

Harry L. Helms

Have you ever wondered what coded messages used by spies sound like? Or about an echo that comes back from "nowhere," with a time-lag unexplainable with our present knowledge of propagation and transmitter power? Ever heard—even by accident—Morse code transmissions, and wondered what they meant and who was sending them?

If your curiosity is peaked by the subject of unusual signals, this is the book for you! It's a shortwave listener's bible . . . a fascinating guide to finding extraordinary signals on your dial . . . crammed with info on what signals mean, how to identify them, where they come from, why they're sent, and why the senders choose certain frequencies and modes.

Take a tour through the entire world's secret SWL broadcast spectrum, including clandestine radio in Cuba and Asia, espionage activity, government and military communications, SAC and diplomatic signals, space communications, pirate broadcasting in Europe and the US . . . even unidentified signals that may be coming from UFOs! Learn where these transmissions come from, who controls them, and *how you can tune it all in*. This manual gives you everything you need—all the facts, theories, and techniques—to find out where and how to listen in.

And if you want technical help and advice, you'll get plenty of data on receiving gear and techniques, plus the latest advances in SWL monitoring, and all the most up-to-date rules and regulations. This is one book all radio buffs won't want to miss!

Harry Helms has been an active SWL and ham for many years, and has authored many important articles for ham communications magazines and co-authored TAB's *The Complete Shortwave Listener's Handbook*. He is a technical writer for a major electronics company and lives in Euless, TX.

## OTHER POPULAR TAB BOOKS OF INTEREST

**The Complete Shortwave Listener's Handbook—2nd Edition** (No. 1255—\$8.95 paper; \$14.95 hard)

**The Complete Handbook of Radio Receivers** (No. 1182—\$8.95 paper only)

**Antenna Data Reference Manual—including dimension tables** (No. 1152—\$7.95 paper; \$12.95 hard)

**The Handbook of Solar Flare Monitoring & Propagation Forecasting** (No. 1005—\$6.95 paper; \$9.95 hard)

**The Antenna Construction Handbook for Ham, CB & SWL** (No. 1054—\$5.95 paper; \$9.95 hard)

**Radio Propagation Handbook** (No. 1146—\$10.95 paper; \$17.95 hard)

**VHF/UHF Fire, Police, Ham Scanners-Schematic/Service Manual** (No. 835—\$6.95 paper; \$9.95 leatherette)

**Understanding & Using Radio Communications Receivers** (No. 614—\$3.95 paper; \$7.95 hard)

**The Fascinating World of Radio Communications** (No. 586—\$3.95 paper; \$6.95 hard)

**TAB TAB BOOKS Inc.**

Blue Ridge Summit, Pa. 17214

Send for FREE TAB Catalog describing over 750 current titles in print.

ISBN 0-8306-1185-1

Prices higher in Canada