

# ***hambrew***

FOR AMATEUR RADIO DESIGNERS AND BUILDERS



---

## **Edge Of Space Sciences: Homebrew Aloft!**

---

**Dynamite DX Dipoles  
NW QRP Club 30 Mtr Transmitter  
The Zapper Mobile Whip Antenna  
Variable Bandpass Audio Filter**



---

**AUTUMN 1993**

---

BULK RATE  
U.S. POSTAGE  
PAID  
LAKEWOOD, CO  
PERMIT NO. 4109

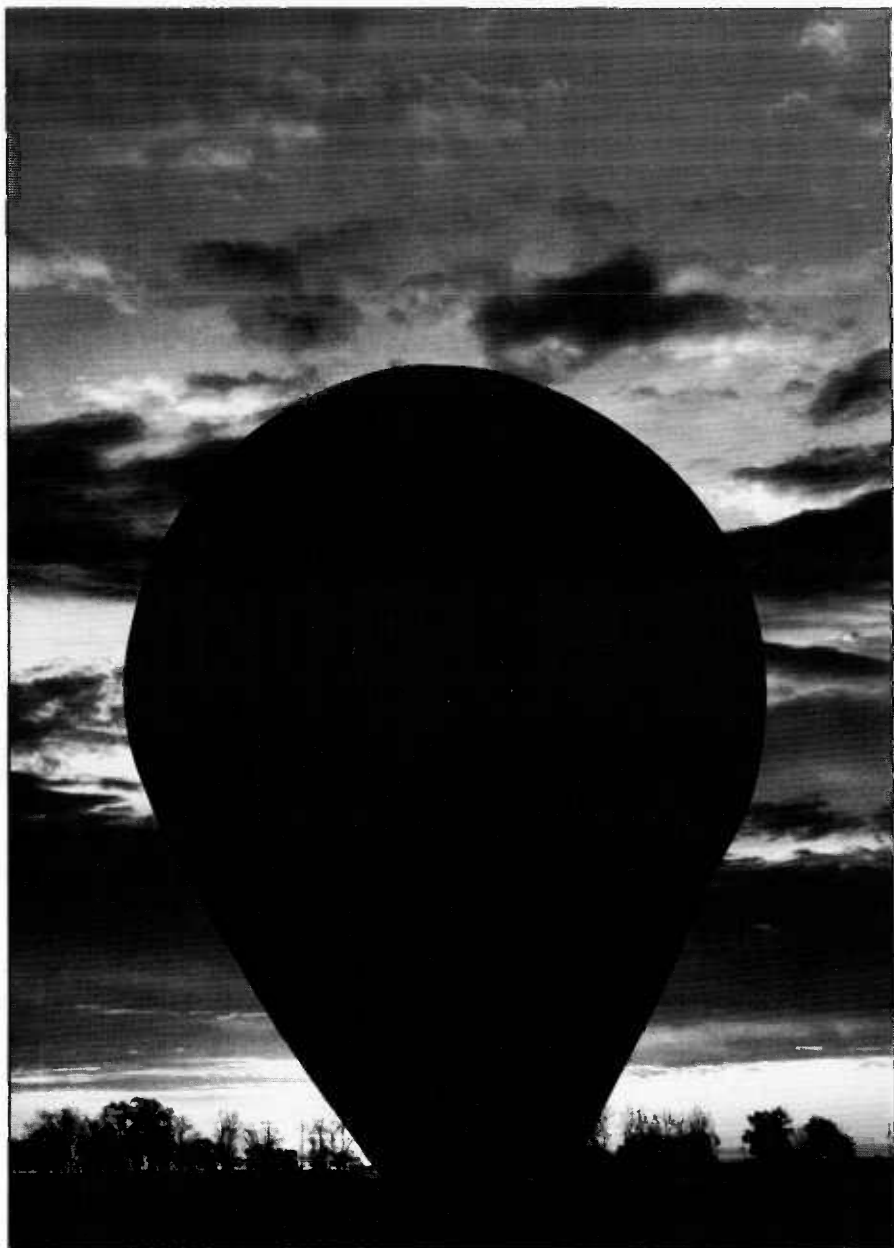

*Ready to go: Edge Of Space Science's High Altitude Balloon at the National Balloon Symposium in Denver, Colorado awaits the launch command at dawn, August 22, 1993. The lightweight payload container construction is the subject of a very useful article by Mike Manes, W5VSI, along with a unique Telemetry Engine built by Rob Kelly, NØSMR, utilizing a BASIC-language microprocessor. Dual cover articles begin on page 20 of this issue.*

---

# • Contents •

Letters	4
Kit Review: The Ramsey 30 Meter Transmitter	5
Zapp The DX With The Zapper	7
Variable Bandpass Audio Filter	12
Wires And Pliers: Voltage Regulator	15
New Products	16
The NorthWest QRP Club "30-30" CW Transmitter	18
Edge Of Space Sciences: Homebrew Aloft!	20
Foamcore Enclosure Construction	21
Balloon Telemetry Engine	23
Counterpoise And The Antenna	32
Practical Antenna Applications: Parallel Dipoles	33
The Two-Wheelers' Highway Headset With Handlebar PTT	35
Shack Shots	45
Classified Ads	46

*Photographic Credits: Rob Kelly, NØSMR: pp 23,29; Bill Mason, NØKEP: pp 40, 44, 45 (top); Tom Crede, WB3JJK: pg 45 (bottom); All others: Hambrew Magazine*

# ***hambrew***

COPYRIGHT 1993, Smoking Pencil & Co.  
All Rights Reserved

**FOR AMATEUR RADIO DESIGNERS AND BUILDERS**

AUTUMN, 1993 • VOL. 1, NO. 1

Publisher.....George De Grazio, WFØK

*Writers, Editors and Contributors: Larry Feick, NFØZ; Wes Farnsworth, KEØNH;*

*Don McCoy, WAØHKC; Jim Wiley, NØBLU; Mike Liddy, KBØCZB;*

*Bill Mason, NØKEP; Rob Kelly, NØSMR; Mike Manes, W5VSI;*

*Will Sorensen, NØRSD; Tom Crede, WB3JJK; Bruce Franklin, KG7CR;*

*Special Thanks To Edge of Space Sciences, Inc. and  
The NorthWest QRP Club*

P.O. Box 260083 • Lakewood, CO 80226-0083

Ads & Subscriptions: 1-800-5-HAM RIG • Editorial Office: (303) 989-5642

*Hambrew* is published quarterly by Smoking Pencil & Co., Publishers. On behalf of Amateur Radio, permission to copy articles herein are hereby granted to any non-profit, educational or amateur radio club or organization which is organized and operated on a non-profit basis.

*Hambrew* is sold by subscription only. Subscription rate: \$20 per year. We welcome submission of articles, photos and manuscripts. Please include postage and self-addressed envelope.

## • LETTERS •

### From The Publisher

I assume that you already know about the kits being distributed through Gateway Electronics, since I saw your notice there, and probably Ramsey, Hamtronics, & Rainbow too since they regularly advertise in many of the Ham radio magazines. There is also an Australian manufacturer of kits which used to advertise a lot in Ham radio magazines also, but I haven't heard much about them recently. A&A in Anaheim, CA makes kits, and there are several manufacturers of kits for building QRP rigs: Some of those QRP rigs are imported from England.

I recently discovered another source of kits right there in Denver: TAPTO Corp., 2650 18th St., Denver, CO 80211 imports two different brands of foreign kits, Sales-Kit from Spain and Velleman Kit from Belgium...(TAPTO's) primary business is making PC-clones, & they import the kits as a side-line.

73, Steven L. Karty, N4UHO

*Thanks for the information, Steve. We did some checking and found that the correct number for TAPTO is (303) 480-7540. They will be handling the kits from Spain and Belgium, and will forward catalogs from each company upon request. The only ham product that the company manufactures in-house at present is a morse decoder kit. As we have not yet received catalogs, we cannot comment on any of the above-mentioned kits, but we thank you for letting us know about them. We will follow up and pass the info. on to our readers.♦♦♦*

On the threshold of our first press run and the distribution of this inaugural issue of **Hambrew**, I paused today to reflect on the extraordinarily foggy landscape of its first conception, and the doubts that plagued my mind relative to its execution. Would hams respond to a publication strictly devoted and dedicated to those of us who enjoy building and learning from the constructive process at whatever level? Would they accept a product that was not fancy four-color 8 1/2 X 11 with no politics and no axe to grind?

When I began to speak about my concerns with other hams, an amazing thing happened: the magazine began to build itself, and took on a life of its own, drawn from the energy of the love we all have for our hobby. Larry, NFØZ, was our first contributor, never thinking twice, he plunged right in. I'll never forget that, Larry. He led me to brilliant Wes Farnsworth, KEØNH, who got right to work on an article, and volunteered to continue to contribute. Others followed gladly.

The awesome power of ham networking had begun, and once started, committed me by its own energy.

So here we go, riding the waves of that first little pebble dropped in the pond, and now the wave has washed up to your shore. I sure hope you approve of our first effort, and if you do, join the network and pass the word that we have arrived, all of us. And help us keep going by your articles and letters, for without you we are nothing, and with you, everything.

Sincere Thanks and 73, George

## KIT REVIEW

# Ramsey 30 Meter Transmitter

An Overview With A Few Bells & Whistles Added



Ramsey has become a bit of a "name" outfit among ham circles, it seems to us, and has been a real source of workable gear to the builder, QRP'er, or even to a ham who has been out of the hobby and wants to get back in without going down the increasingly expensive appliance garden path.

Since the lamentable demise of Heathkit's line of ham gear, there have been some companies which have come forward to fill the market void, among them Ramsey, which continues to expand the scope and number of offerings in this area.

In the late 1980's, Ramsey had not yet gotten the hang of making their kits easy to build for a beginner, owing primarily to the mysterious parts-layout illustrations that were difficult to interpret at best, and cryptically impossible and frustrating at worst.

To their credit, the company took a step back and looked at what they had and totally rectified the situation: what re-

sulted was a crystal-clear set of parts-layout diagrams (including a blow-up version to stick up on the wall), and a very interesting assembly manual which includes, in addition to the obvious assembly instructions, five pages of discussion of QRP operating fundamentals with a comparison of signal strength expectations at various QRO/QRP power levels for both theoretical and practical applications - where was Heathkit on *that* one?

Toss in a block diagram of the circuit with a "Learn as you build" angle to the instructions, replete with testing points during the assembly, and you have a real winner of a kit in this price range.

We chose to try the 5 watt upgrade option, which involved a mere four-step mod. The PA transistor (2SC2018) was not readily available, but it was easy enough to find an NTE 299, one of three alternates suggested by Ramsey. Wishing to do various modifications, we went with a Radio Shack box and added a power-on LED. (Continued on page37)

# Welcome, Techno-Wizards

According to a survey commissioned by the Dell Computer Company, 55 percent of all Americans are sufferers of technophobia, the nagging fear of such everyday technological devices as VCR's and answering machines. Figures noted included computers, 23 percent, compact disk players, 20 percent, answering machines, 15 percent and programmable thermostats, 25 percent. 34 percent experienced difficulty understanding car phones. One fourth of adults have not used a computer, programmed a VCR or a car radio. 90 percent of teenagers were comfortable dealing with such devices however.

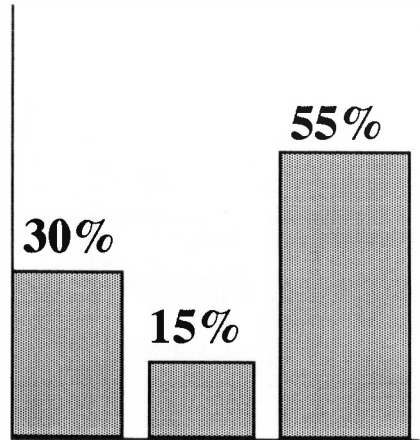

TECHNO- WIZARDS 30%  
TECHNO- NEUTRALS 15%  
TECHNO- PHOBES 55%

## RIG-O-RAMA!

**DEADLINE FEBRUARY 15, 1993**

OK, GANG, HERE'S YOUR DEAL:  
THE BEST ARTICLE ABOUT A MONOBAND TRANSMITTER  
WRITTEN AND SUBMITTED TO OUR LESS-THAN-BRILLIANT  
EDITORIAL STAFF EARNS THE *DUCAL* SUM OF

**\$200.00**

POB 260083  
Lakewood, CO 80226

SO JUMP IN WITH BOTH FEET!  
STEAL FROM COLPITTS IF YOU MUST, BUT LET'S SEE THOSE  
RESISTORS AND CAPACITORS HIT THE BOARD!

Decision of the judges is final. All submissions are subject to publication by Hambrew.  
Manuscripts returned if S.A.S.E. included. Void where prohibited by law.  
Not void where not prohibited by law. Subject to whim. Have fun or don't bother!

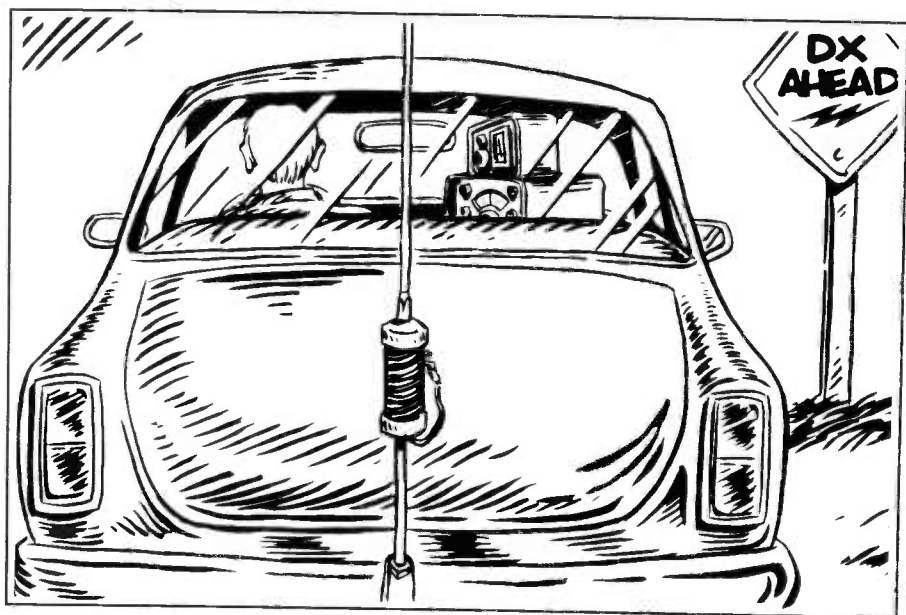

## Zapp The DX With The Zapper

Larry Feick, NFØZ

Most people will spend about four years of their life in an automobile! If you are as serious about hamming and QRP work as I am, you will probably agree that your driving time could be better spent on operating QRP. The fact that most QRP rigs already run on 12 volt systems makes mobile work a natural for QRP'ers. If you already have a rig that works on a 12 volt supply, you need only to add the "Zapper" to your car to join the ranks of the QRP'ers on wheels".

The "Zapper" is a five band, base loaded whip antenna which offers the ease of simply moving an alligator clip from one predetermined position to another on the loading coil for quick and easy band changes. The bands of operation are 10, 12, 15, 20 and 30 meters.

The construction of the "Zapper" is quite simple and the components are eas-

ily obtainable, costing anywhere from \$30 to \$50, depending on whether or not you elect to use a quick disconnect at a cost of about \$20.

There is enough coil on this antenna to offer 17m and 40m as well as the other bands, however I have not been totally satisfied with the SWR on these two bands. Some experimentation with this basic design should render 17m and 40m useful as well.

A quick disconnect is compatible with most conventional antenna mounting hardware for your bumper, roof, fender, etc. Although we hams feel that an antenna is a thing of beauty and a joy forever, many XYL's do not share our values. It is for this reason that the quick disconnect makes an attractive addition to the unit. (Continued Next Page)

---

## Detail of the Fabrication Process

---

1. Cut the ABS pipe to 6 1/2" length.
2. Place one end cap on each end of pipe.
3. Mark the end caps in four equally spaced places around end cap, 1/4" from the edge of the caps.
4. Match drill the end caps and pipe in the (8) marked places with a 3/64ths drill bit.
5. Measure 3/4" from one end of the pipe and drill a 1/8" hole.
6. Find the exact center of each end cap, mark it and drill a 3/8" hole.
7. In one end cap, drill a 1/8" hole adjacent to the large hole for water drainage.
8. Measure the coil and cut it in half. Cut the four plastic ribs with a hacksaw.
9. Sand the pipe section with coarse sandpaper for a snug fit.

---

## Assembly Process

---

1. Insert the ring into the coil.
2. Insert the end of the coil wire through the 1/8" hole on the pipe. Solder a ring terminal to the wire end. Make sure enough wire exists to mate to the antenna.
3. Assemble the whip to the end cap with a nut and the previously soldered ring terminal.
4. Position the end cap on the pipe and secure with (4) greased screws.
5. Assemble the quick disconnect and the jumper to the remaining end cap with the 3/8 x 24 bolt.
6. Assemble the end cap to the pipe and secure with (4) greased screws.
7. Assemble the five coil clips per the illustration. Count the turns from the top of the coil.

10m = 0 turns  
12m = 3 turns  
15m = 5 turns  
20m = 10 turns  
30m = 18 turns



**Adjustment:** After you have installed the "Zapper" to your automobile, adjust the exact coil clip positions for resonance using a SWR bridge or a noise bridge.



## Summary

Guying may or may not be necessary, depending on the nature of your installation. My "Zapper" is mounted on the roof of my pickup truck, so in order to avoid tearing off the roof of my truck, I tied nylon guying at the base of the whip section.

My "Zapper" exhibits a very flat SWR across all five bands.

The motivation for constructing my "Zapper" came from two concerns that I had with my commercially built antenna. First, the inconvenience of hauling all those darned resonators around with me, and second, the risk of having a rigid antenna just waiting for an accidental encounter with tree branches.

I will point out that if you should lapse into a period of temporary insanity, the "Zapper" will handle a kilowatt of power!

After having completed the construction of my "Zapper" in the fall of 1989, I have chalked up a great many fantastic DX contacts all over the globe.

Good luck and happy zapping!

## Parts Source Information

A) Surplus Sales of Nebraska  
1315 Jones Street  
Omaha, Nebraska, 68102  
(402) 346-4750  
Add \$2.50 for shipping

B) Radio Kit  
15 Londonderry Rd.  
Londonderry, NH 03053  
(603) 437-2722  
Add \$3.00 service charge

Parts Source Information, cont

C) Amateur Electronic Supply  
4828 W. Fond du Lac Avenue  
Milwaukee, Wisconsin 53216  
1-800-558-0411

Call for shipping charge

D) Any favorite hardware store

See parts list, continued page 10

## WHEEL ANTENNAS!

### 70 cm Little Wheel

420-450 Mhz: ATV or 432.1 SSB

### 900 Mhz Nano Wheel

ATV

### 23 cm Mini Wheel

ATV

### 13 cm Micro Wheel

Horizontally Polarized  
Beacons

**All Stackable!**

**\$39.95 ea.**

any band

**Mag Wheels: Magnetically-  
Mounted Versions Of The Above  
Antennas: \$59.95**



**Olde Antenna Lab**

4725 W. Quincy · Denver, CO · 80236  
(303) 798-5926

## Zapper Parts List

Description	Qty.	P.N.	Unit Price	Source
59 uH, 10"x 2" coil, 14 Guage	1	3026	\$6.75	A
Coil Clips	5	S943	\$0.45	B
S.S. Sheet Metal Screws 4x1/2 (Phillips)	8	---	\$0.04	D
ABS Pipe, Sch. 40, 1 1/2"	10"	---	\$1.30	D
ABS End Cap, 1 1/2"	2	---	\$1.20	D
Stainless Quick Disconnect	1	---	\$19.95	C
Ant. Specialists 102" Whip	1	---	\$17.65	C
S.S. Bolt, 3/8 x 24 x 3/8	1	---	\$0.30	D
Alligator Clip	1	---	\$0.30	D
3/8" Ring Terminal	2	---	\$0.15	D
8" Insulated Wire	1	---	---	---

### *Got A Project?*

If you are building or have built a ham radio or related project, we want to hear about it! Take a black and white photo of it and its relevant parts if you can, and write about it. Simply write down what was fun, new, different, difficult, what problems you had to solve, etc. Include a schematic if it helps. Then send it to us at

PO Box 260083 • Lakewood, CO 80226-0083

Kitbuilders are always interested in new or older kits - tell us about it!

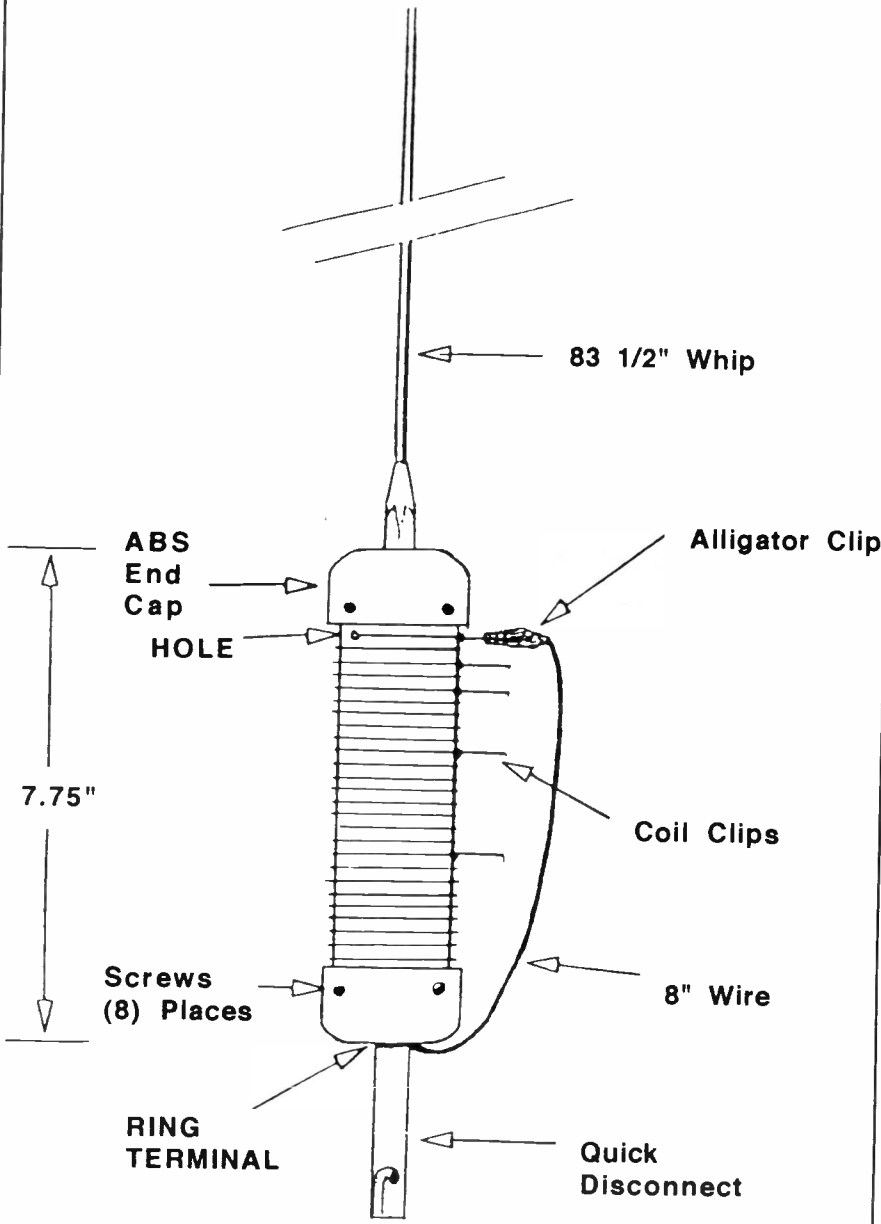

**"Zapper" Mobile Antenna**  
 10, 12, 15, 20 and 30 Meters

# Variable Bandpass Audio Filter

Mike Liddy, KBØCZB  
George De Grazio, WFØK

An audio filter that can separate CW or SSB signals can be a real QSO saver, especially during those crowded rag-chewing times and during contests. Here's a little variable bandpass audio filter that can separate stations by peaking a selected signal. Add a nice case and a few do-dads and you've got

a great little addition to the shack.

We have not tried the lil' guy with sideband operation yet, but maybe we can get some comments from readers concerning modifications to that end. We chose to etch our board, though you may decide to try it ugly style or use a breadboard-type approach.

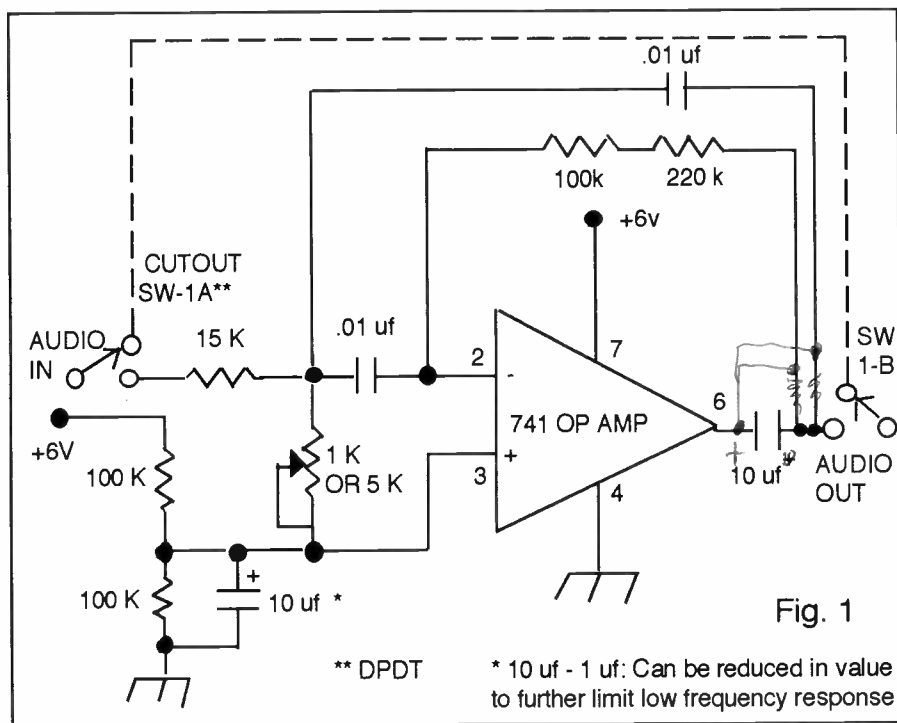



We chose to install an eight-pin socket to experiment with different IC devices. It also allows for an option if the device is damaged during soldering.

The circuit has been powered with up to 9 volts without any problem, and a power jack was installed on the back side of the panel for use in the shack when battery power is not needed. Of course the LED is optional to show a power-on condition.

We noticed that there was not good gain when we used this filter with certain homebrewed receivers, so we installed a 5k ohm variable as an impedance device which helped get more audio gain from a Neophytereceiver.

Additionally, a fader was installed rather than a cutout switch to mix the filter with straight audio.

To operate, select a signal, and peak its strength with the band-pass control and receiver tuning

(Continued Next Page)

### Component List

#### Resistors

- (3) 100 k
- (1) 220 k
- (1) 15 k
- (1) 1 k or 5 k Variable
- (1) 741 op amp & 8 pin socket  
choice of board

#### Capacitors

- (2) 10 uF electrolytic
- (2) .01 uF disk
- Case, knobs, jacks for input, output, transfer type, if desired, 5 k fader pot, 5 k impedance matching (both optional) Power jack, power switch

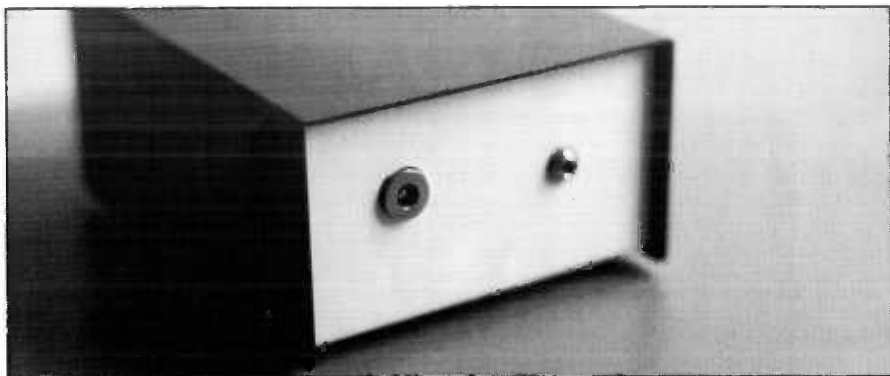

*Rear of cabinet, with input and power jacks*

The fader is a simple matter to wire, merely solder the output to the earphone jack to the center terminal of a variable pot of your selection, then attach the bypass wire (i.e., the unfiltered output from the receiver audio) to one side terminal, and the filtered output to the other.

It is now possible to inject the preferred amount of filtration into the audio output of the receiver. Further bells and whistles may be added as desired, like a battery bypass switch or open two-way earphone-type jack which would bypass the battery when using a "wall-wart" type 6 or 9 volt dc transformer or power supply. A protective diode would be useful!

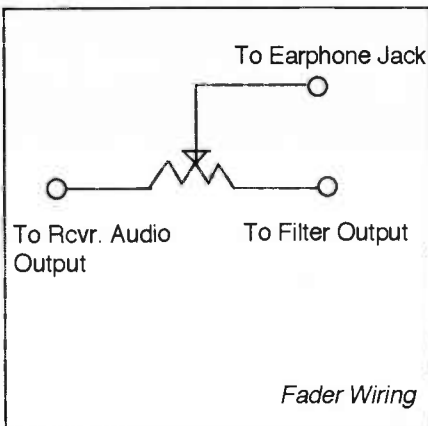

## **Murphy Loves.....**

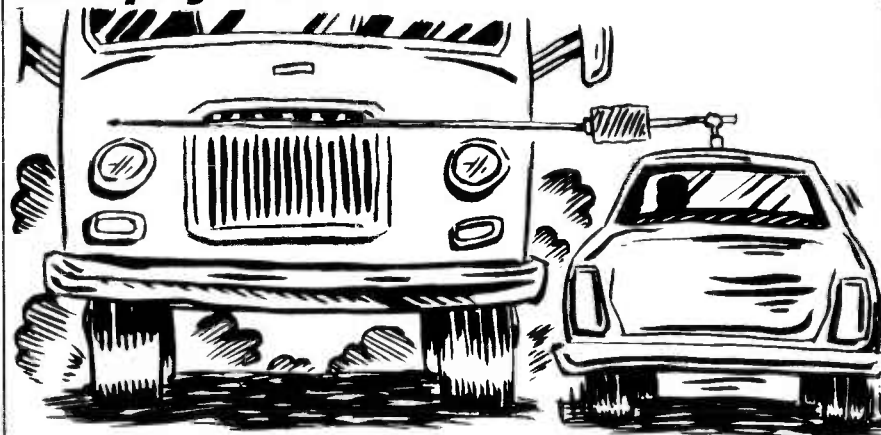

...Horizontally Polarized Mobile Whip Antennas

*Send us a "Murphy Loves"...We'll cartoon it for you!*

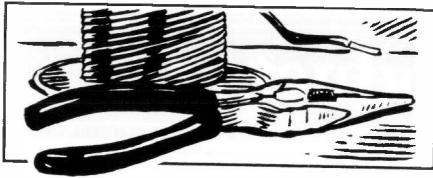

## Wires and Pliers

Don McCoy, WAØHKC

Here is a little circuit that comes in handy around the shack from time to time.

It is a regulator circuit that gets its original power from the 12 volt DC power supply that just about everyone has in the shack.

It shows just how versatile a solid state regulator, in this case an NTE-956, can be (see fig. 9-A).

The parts list includes VR-1, an NTE-956 that can be obtained through mail-order suppliers, and the other parts are not real critical, also obtainable from the same types of sources.

My particular unit is adjustable from about 1.3 VDC to about 11.7 VDC. The regulator is capable of approximately 1.5 amps. The specs on it say that it is adjustable from nearly 1.2 volts dc to 37 VDC, depending on the input, of course.

I have used mine to power 9 volt radios, and intend to put it in my car as a permanent supply for my garage door opener. What I will do is mount the opener in the grill with this power supply in lieu of its 9 volt battery and simply run a button to the dashboard of the car. I'm sure you can come up with lots of other uses for this circuit too!

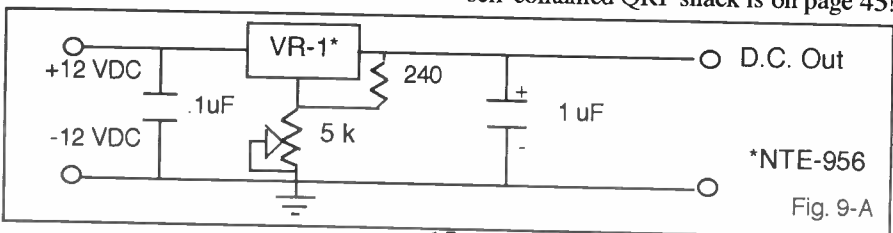

## BINGO!

Interested in the bizarre and unusual in mail order supplies? Like perhaps an outfit that sells mine locomotive lights (60 watt, 38v: \$4.25 ea.), neon indicator lamps (125v a.c. 1/2 watt: 25,000 hour life: \$1.00 ea.), power drill screwdriver attachment with clutch and speed reducer (\$3.25 ea.), suture scissors (pkg of 6: \$2.00), rubberized magnetic cabinet feet (\$1.00/pkg. of 10), masonry carbide-tipped drill bits (\$1.95/pkg of 3), etc., etc., etc.? If so, check out a catalog from American Science & Surplus, 3605 Howard St., Skokie, IL 60076. The above prices from their 1990 catalog. Thanks to Tom Crede, WB3JJK/QRP, for this tip.

## Shack Photos Wanted

We can't wait to see some photos of your shack. A hambrewer's shack is his castle, and there is nothing more beautiful than a bunch of radios gathered together, right?

So shoot a shot of the ol' place and send it along. If you have set up a portable location for field day, or have a camper or RV shack, that would be neat also!

Clean or chaotic, Spartan or jam-packed, there is no shack like yours - can we peek in the door? We would appreciate it, with your permission! WB3JJK's nifty lil' self-contained QRP shack is on page 45!

# • New Products •



## DeoxIT - New Advanced Formula

DeoxIT - A One Step Treatment, by Caig Laboratories Inc., is a fast-acting deoxidizing solution that cleans, preserves, lubricates and improves conductivity on all metal connector and contact surfaces. This new formula contains improved deoxidizers, preservatives, conductivity enhancers, anti-tarnishing compounds, arcing and RFI inhibitors and provides extended temperature range (-34°C to 200°C). DeoxIT also prevents dissolved oxides and contaminants from

re-attaching to metal surfaces, providing longer lasting protection. Available in spray, liquid, WIPES and PEN applicators. Use on switches, potentiometers, relays, PCB edge connectors, batteries, faders, interconnecting cables, plugs, jacks, etc.

Available from **Caig Laboratories, Inc., 16744 Rancho Bernardo Drive, Rancho Bernardo, CA 92127; 619-451-1799, Fax: 619-451-2799.**

Have a new product?  
Put it in *Hambrew!*



# •SUBSCRIBE TO HAMBREW•

Not available in stores or dental offices, **Hambrew** can only be transmitted to your mailbox! To use your mailbox as a primitive receiver, send this coupon (or a copy thereof) with a \$20 check or money order to:

**Hambrew • POB 260083 • Lakewood, CO 80226-0083**

**VISA or Mastercard: Call 1-800-5-HAM RIG**

Name \_\_\_\_\_ Call \_\_\_\_\_

Address \_\_\_\_\_

City \_\_\_\_\_ State \_\_\_\_\_ Zip \_\_\_\_\_

VISA  MC#

Exp: \_\_\_\_\_

## One Step Treatment! **DeoxIT™ DN5**

### CLEANS, SEALS & PROTECTS ELECTRICAL CONNECTIONS

- Improves Conductivity
- Prevents Intermittents
- Reduces Arcing & RFI
- Reduces Wear & Abrasion

Even the finest equipment cannot guarantee noise-free/error-free operation. One "dirty" connection anywhere in the signal path can cause unwanted noise or signal loss. **DeoxIT DN5** is a fast-acting deoxidizing solution that cleans, preserves, lubricates and improves conductivity on metal connectors and contacts. **DeoxIT DN5** increases the performance and reliability of electrical components and equipment.

Available in spray, wipes, pen and liquid form.

**NEW DeoxIT DN5** contains DeoxIT concentrate with a fast-evaporating, non-flammable solvent, similar to our popular R5 spray. Solvent evaporates quickly, concentrating DeoxIT in a specific area. Includes three-way adjustable valve for controlled application.

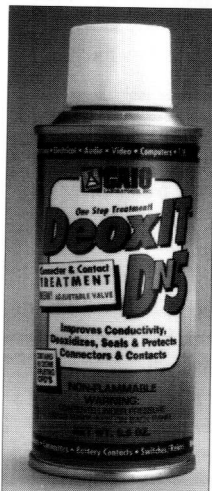

**CAIG Products . . . used by those who demand the best!**

Ampex	Hewlett Packard	RCA
Boeing	Honeywell	Switchcraft
Capitol Records	John Fluke	Tektronix
Diebold, Inc.	McIntosh Labs	Texas Instruments
Dolby Laboratories	Motorola	Xerox Corp.
General Electric	Nakamichi	. . . and many more!

Since 1966

**CAIG**  
LABORATORIES, INC.  
"Environmentally Conscious"

16744 West Bernardo Drive  
San Diego, CA 92127-1904  
Phone: (619) 451-1799  
FAX: (619) 451-2799

# The NorthWest QRP Club

## "30-30" CW Transmitter

### Bruce Franklin, KG7CR

Here's a little rig which will put you "on frequency" for checking into the 30 Meter NWQRP Club Net on 10.123 Mhz.

The transmitter can be built "ugly" style on a 2" x 3" piece of PCB material. A 1" x 2" piece of aluminum should be attached to the IRF510 as a heat sink. Adjust the bias pot to just below where the IRF510 starts drawing current (the key up).

The cores are from Amidon, the crystal is from CW Crystals; and the other parts are from any electronics parts outlet. I haven't found a source for the FT242 crystal sockets, but an eight-pin tube socket can be used in its place.

At 12 volts, this rig puts out a solid 5 watts. If you need more power on occasion, you can get from 15 to 20 watts input with 20 volts. Some enhancements might include an on-off switch, sidetone monitor, and a few more

transistors in the keying section to shape the keying slightly.

#### POWER SOURCE

The transmitter is intended to operate on a 12v battery. It draws about one amp key down. I use a 4.5 amp hour gel cell (Gould Technacell EP1245) which is light enough to carry in a backpack, and will provide a week-end of casual operating on a single charge. There are a number of companies which make similar batteries.

#### POWER ON

Use an ohmmeter to verify that the 12v line is not shorted to ground. It should read greater than 1k ohm. A possible short is Q2 tab to the PCB. **WARNING!** Before applying power for the first time, turn the bias pot all the way down. This will ensure that the FET doesn't draw excessive current before the bias is set.

---

*This article was adapted from a feature in The NWQRP Newsletter and the notes and assembly instructions for the transmitter kit offered to the membership. The kit is no longer available, but membership is!*

*To join, send a one-time registration fee of \$10 to: The NorthWest QRP Club, Bill Todd N7MFB/QRP, 4153 49th Ave. SW, Seattle, WA 98116.*

*Membership need not be renewed to remain "active", and one year from date of membership, members have the option to renew their newsletter subscription.*

*The club CW Net meets Monday evenings at 10.123 Mhz at 0300 Z. Their QRP ragchew meets Saturdays, 7:30 am (local time) on 3.560 Mhz. They are a wonderful group, and we grateful to them for allowing us to reprint the information on this great little rig designed by Bruce, KG7CR. Hambrew welcomes news*

#### ADJUSTING THE BIAS

Do not connect the key yet. Connect an ammeter (1 amp full scale) between the battery and the transmitter as shown below:

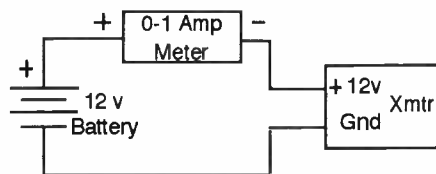

Carefully adjust the bias pot counterclockwise until the meter reads approximately 10 MA. The exact value is not critical, just be sure not to set the bias excessively high.

---

and projects from QRP clubs everywhere. We would like to know if our readers would like to see a regular QRP section here. -Eds.

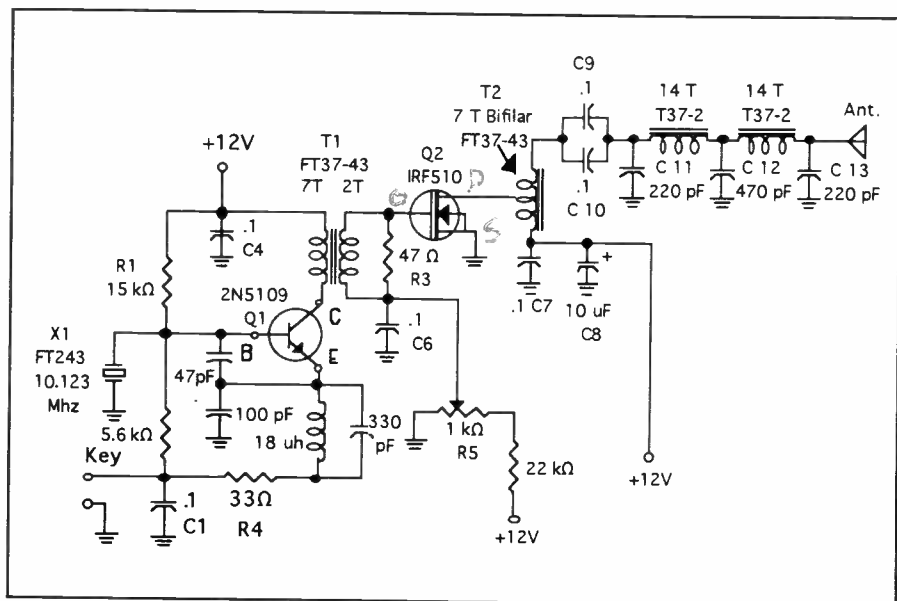

## Parts List

Quantity	Part #	Description
1 pc.	X1	FT-243 Crystal
2 pc.		Socket Pins for crystal
2 pc.	T1, T2	Ferrite Cores Amidon P/N FT37-43
2 pc.	L2, L3	Ferrite Cores Amidon P/N I37-2
1 pc.		Insulated washer for TO-220 Transistor
1 pc.		IRF510 Final Transistor (TO-220)
1 pc.		2N5109 (Driver) Transistor (or 2N3866)
6 pcs	C1, 4, 6, 7, 9, 10	.1uF 50v (or 100v) Mono Capacitor
1 pc.	C2	47pF 5% Mono Ceramic Capacitor
1 pc.	C3	100 pF 5% Mono Ceramic Capacitor
2 pc.	C11, 13	220 pF 5% Mono Ceramic Capacitor
1 pc.	C5	330 pF 5% Mono Ceramic Capacitor
1 pc.	C12	470 pF 5% Mono Ceramic Capacitor
1 pc.	C8	10 uF 25v Dipped Tantalum Capacitor
1 pc.	R1	15k Ohm 1/4w 5% Carbon Comp. Resistor
1 pc.	R2	5.6k Ohm 1/4w 5% Carbon Comp. Resistor
1 pc.	R3	47 Ohm 1/4w 5% Carbon Comp. Resistor
1 pc.	R4	33 Ohm 1/4w 5% Carbon Comp. Resistor
1 pc.	R5	1k Ohm Trimpot
1 pc.	R6	2.2k Ohm 1.4w 5% Carbon Comp. Resistor
1 pc.	L1	18 MH Inductor (RF Choke)

FT 243 Crystals are available from CW Crystals, Marshfield, MO 65706



## Edge of Space Sciences: Homebrew Aloft!

*The sun is rising over the eastern plains of Colorado; it is still a bit chilly, and we wish we had put on a sweater. The mosquitos are out in full force. There is a glow coming from the command center trailer, and clusters of E.O.S.S. members are busily tweaking payloads, taking photos, pointing antennas, hooking up monitors and running net on two meters with the small army of chasers spread out in all directions.*

*In the semi-gloom, a large balloon begins to swell, tugging toward the partly overcast sky. Meteorological reports are filtering in from the National Weather Service and from members who specialize in such relevant things. Special attention is paid to the prevalent winds aloft. The mosquitos are dive-bombing now.*

---

The above scenario plays out somewhat similarly on a regular basis for a group that is no stranger to the homebrewing art. E.O.S.S., a group based in Colorado with members across the nation and around the world. The activity

of launching balloons with various payloads to the edge of space is filled with fascination to hams, homebrewers, foxhunters, students and true scientists alike.

We are featuring a pair of articles from two members of this group: Mike Manes, W5VSI and Rob Kelly, NØSMR. Mike shows us a unique angle on homebrewing containers for projects, one which directly arose from the weight parameters of which E.O.S.S. members need be so conscious, and Rob has a data engine design that dovetails most ingeniously with a lightweight microprocessor which can be programmed in BASIC language. The two articles which follow will explain in detail.

We would be remiss to neglect to give you the details of who, what and where, just in case you would like to know more about Edge Of Space Sciences: Membership is \$10 per year (\$2 for students), and entitles members to receive the newsletter. Send to: E.O.S.S., Inc., 376 West Caley Circle, Littleton, CO 80120. Tell 'em you saw it in **Hambrew!** •••

# Foamcore Enclosure Construction

Mike Manes, W5VSI

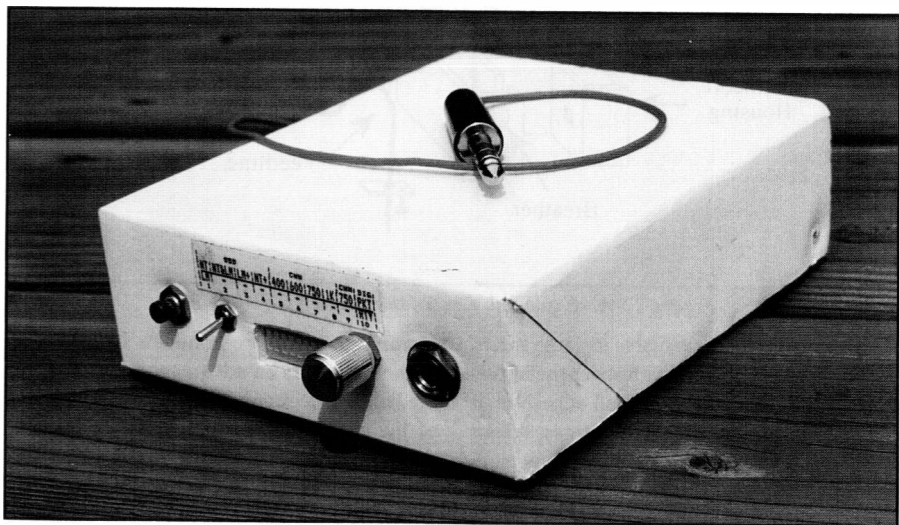

*Digital Signal Processor Enclosure*

One of the most frustrating aspects of homebrewing ham gear can be packaging your latest gem in an enclosure. Somehow, even a beautifully built and fine running stack of electronics just doesn't seem to work very well inside a cobbled up aluminum enclosure formed on a bench vise. And all too often, available commercial enclosures are either 1/16" too small, vastly oversized, out of stock or beyond your budget.

It's no wonder that sheet aluminum is so often the material of choice for electronic enclosures: Its electrical and thermal conductivity is excellent, it's strong yet lightweight, and it cuts, bends, punches and shears cleanly. But unless you're fortunate enough to have access to a nice set of sheet metal tools, building an attractive and functional enclosure is likely to take more time and trouble than it's worth.

Years ago, I discovered a secret used by commercial enclosure designers to whip up

candidate model equipment cases for show and tell. The models looked just like the real thing, but the big giveaway came when I picked one up; it weighed practically nothing! The designer reluctantly told me that he made it almost entirely out of something called "foamcore".

About a year ago, I was thinking about how to improve the design of a steerable ATV camera housing used on high-altitude balloons flown by Edge Of Space Sciences. Light weight and good thermal insulation were important properties for the flight enclosure; aluminum was too heavy, and styrofoam wasn't rigid enough.

I remembered the foamcore experience, and, serendipitously, the XYL had some good-sized scraps lying about in her watercolor studio. In a few days, the new EOSS ATV module was ready to fly. To date, it's made five flights to the edge of space and back with no damage! (see fig. 22-A, cont. on page 22)

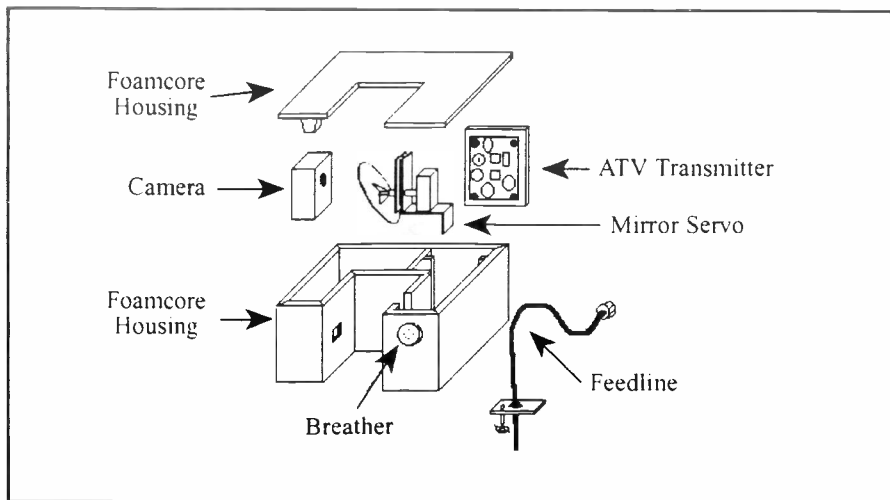

Figure 22-A: Exploded View of the EOSS ATV module

Foamcore is readily available in large sheets. It cuts and forms easily with sheet-metal precision, bonds with practically all adhesives, is exceptionally strong in shear stress, resists puncture, is very lightweight and offers moderate thermal insulation. Precision details, such as pc board mounting slots, are easily fabricated. Using foamcore, one can design a near-optimal package for the contents rather than trying to work around other materials' limitations.

Foamcore, also known as matboard, is a composite sheet material comprising a core of closed-cell, high-density styrofoam sandwiched between two sheets of thin posterboard. It's sold in hobby and art supply stores in thicknesses ranging from 0.12 to 0.4 inches. Although used primarily for matting pictures for framing, it is occasionally used in architectural models and packaging mockups of proposed electronic products. A 2 x 4 foot sheet of white 1/4" foamcore, enough for several large payload packages, retails for about \$5.00.

#### Foamcore Properties:

The 0.21" thick material used for the ATV package weighs 2.12 oz. per square foot. Despite its light weight, foamcore is surprisingly strong and rigid. The optical alignment between the camera and mirror has remained unchanged through seven landings. Unlike

aluminum, foamcore conducts heat poorly. Although this is an advantage for protecting the balloon electronics from the extreme cold of the tropopause, it may allow earthbound projects to overheat, especially if they dissipate a lot of heat. Fortunately, foamcore also allows one to build in effective and attractive ventilation slots and louvers without too much trouble. It may also be a good idea to allow the fins of high-power heatsinks simply to project outside the housing.

#### Surface Treatments:

Foamcore is available in a range of solid colors, but the least expensive version is plain white. The posterboard surface accepts nearly any kind of paint, and woodgrain shelf paper looks very nice at a distance. Although the surface tolerates moderate amounts of water without damage, moisture resistance can be improved with a light coat of acrylic spray paint.

Foamcore edges crush easily, so bushing-mounted devices like potentiometers and miniature phone jacks can't be tightened snugly. A thin aluminum subpanel or dress panel on the outside neatly solves this problem, and boring a few holes in a flat sheet of metal shouldn't challenge even the most meagerly equipped homebrewer.

EMI shielding is (Continued on page 24)

# Balloon Telemetry Engine

Rob Kelly, NØSMR

Fun and excitement in Colorado! After attending the Edge Of Space Sciences First National Balloon Symposium in Denver, I was really charged up. It was a great time, a chance to find out what other groups around the country are launching. There were ten states and Canada represented.

E.O.S.S. is an educational group. Their focus is on science and technology - and education. I too live in that world: I work at a technical college. High altitude balloons are an excellent means of getting students interested in science and technology. In working on the computer system, it became obvious that this would be an excellent platform for students to use. It is also inexpensive, which could fit into a school's budget.

A small group of amateur radio operators in Salina, Kansas, including members of the Kansas State University-Salina ARC and the Central Kansas ARC launched two balloons last winter containing a payload consisting of a single board computer, a 2m transmitter, a packet TNC, and a 10m beacon. The system was powered by a lithium battery pack. Sensors measuring air pressure and temperature were connected to the computer system and readings were transmitted to earth on 2m packet at five second intervals.

The heart of the system is the Micro 440 from Blue Earth Research. It is a single board computer consisting of an 8052AHF microprocessor with a masked ROM Floating Point BASIC and 32K of battery-backed RAM. The package also includes an 8 channel, 8 bit A/D (analog to digital) converter, a real time clock, and a 8 bit digital I/O port. The connections to the outside world, including power and RS-232 port, are on DB-25 connectors, one on each end of the package, which simplifies interfacing. The board contains many other features that were not used.

Any computer with a serial port, even a serial

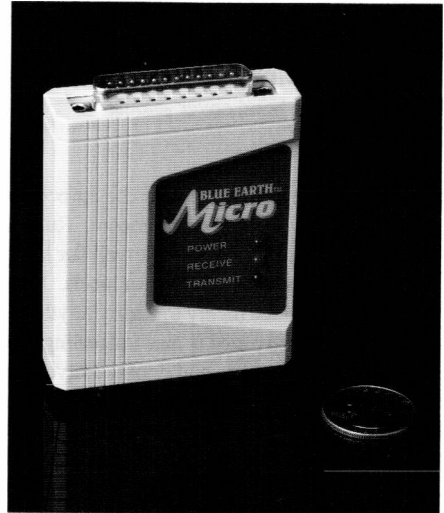

*Blue Earth Microprocessor (see text)*

terminal, can be used for programming. The memory is non-volatile, so your programs remain when power is removed. Some of the memory is devoted to a RAM disk of sorts. It can hold several small BASIC programs and load them to RAM to edited or executed.

I use a PC compatible with Procomm Plus as the communications software. Procomm has a means of doing an ASCII upload which will not overrun the BASIC interpreter. When a line of BASIC code is entered, the interpreter "tokenizes" the line into its own internal format. This takes time, time that the interpreter is not looking for more characters from you. The trick is to do a "prompted" upload. This causes Procomm to wait until the BASIC interpreter has finished its work of tokenizing the line and has sent you a prompt symbol. Procomm then sends the next line, and so on. This allows you to use your favorite ASCII text editor to write the programs and your hard drive to store them.

The interface circuitry to the Micro 440 was built on a piece of (Continued on page 25)

Continued from page 22)

easily applied by gluing ordinary aluminum foil to the foamcore surface using Elmer's glue. Good electrical contact to the foil is achieved by taping down 1/2" wide strips of copper foil. The copper is roughened to form gastight contact into the aluminum foil with sharp dimples made with a center punch. Similar strips with points on both sides of the foil are used to bond cover seams.

#### Adhesives:

Most adhesives designed for use on porous surfaces will work well on foamcore. Rubber cement and Elmer's glue work well for large lap joints, foil shielding and paper labels. RTV silicone also bonds nicely to nearly anything. Matte finish library tape is nice for sealing raw edges of access panels and doors. Polyimide (Kapton™) "space" tape is harder to find and more expensive, but its strength and adherence is second to none. Watch out for outdated surplus bargains; the adhesive goes to pot if unused for a few years.

The adhesive of choice for foamcore construction is low-temperature hot-melt glue on foamcore joints. Hot-melt is resilient at room temperature, but more rigid than the same bead of RTV. Hot-glued joints are stronger than the foamcore. The only joint failure encountered to date was attributable to delamination of the foamcore paper; this was corrected by enlarging the joint area.

A freshly-glued joint cools slowly on this material, providing a few seconds of free time for alignment. At about a minute, the joint reaches full strength, so you needn't plan your project around a series of overnight adhesive cures. A high-temperature glue gun operated at about 50% line voltage from a variac or light dimmer works fine with low-temperature glue; if the gun is too hot, the glue discolors.

#### Foamcore Joinery

Foamcore is a stiff, planar material which crimps when overstressed, so curved shapes can't be formed. But it can be cut by hand with near machine precision, and strong, straight bends of practically any angle can be formed

quite easily. With a few simple tools, some patience and a fertile imagination, one can quickly fabricate some pretty elaborate shapes.

#### Tools Required

- Modeling knife with a good supply of sharp blades. Single-edged razor blades will also work in a pinch.
- Machinist's square
- Metal straightedge. The scale on the machinist's square works fine for most work. Longer cuts and bends may need a metal yardstick clamped in place on one end.
- Hot-melt glue gun and glue. The low temperature variety is preferred.
- A large piece of cardboard for a cutting surface.
- A flat work table.

#### Simple Cuts

The keys to making clean, precise cuts are a sharp blade and metal straightedge. Mark the cut line with a pencil or pen directly on the paper surface. Then place your workpiece on a cutting surface which extends past both ends of the cut. Align the straightedge directly over the cut line and plan on holding it steadily in place until the cut is complete. A C-clamp is handy for long cuts, but in most cases, the edge can be held in place fine with one hand while you cut with the other. Be careful not to crush the foam; it's especially susceptible to crushing at cut edges.

The cut should be made in at least three end-to-end passes. The first pass should just penetrate through the upper paper surface and only slightly into the core. For accuracy, the blade should be aimed slightly into the straightedge so that it won't drift away; this will also minimize the gap between the cutting edge and the straightedge.

Start the cut by poking the blade point squarely into the surface through the top paper layer. Then reduce the angle between the material surface and the blade edge to no more than about 30 degrees to avoid tearing the surface. Using a steady motion, pull the blade through to the end of the cut. Remember, the first pass should only cut(Continued on pg.26)



Continued from page 23

Radio Shack perfboard. On our first launch, we wanted to check the spin of the payload. Four CdS (Cadmium Sulfide) photocells were attached to four of the eight internal A/D inputs. This type of photocell acts as a variable resistor, and when connected in series with a fixed resistor, acts as one leg of a voltage divider (see figure 25-A). The voltage at the photocell is then proportional to the amount of light it sees. This information can be used to tell how the payload is being spun by the wind.

Also shown in the figure is the battery voltage divider. This was used to scale the battery pack's voltage to something in the A/D converter's range. The voltage seen by the A/D is  $10K/49K+10K$ , or about 1/6. Precision resistors were not used, the errors were accounted for in the software.

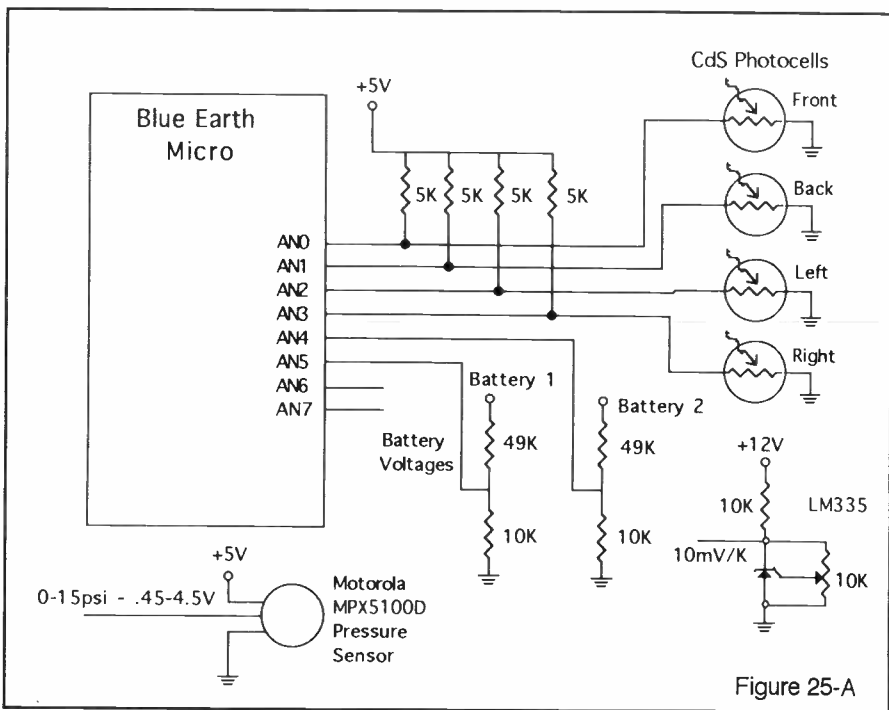

Figure 25-A

On other flights we used a Motorola MPX5100D pressure sensor and an LM335 temperature sensor. Both of these are very easy to interface, all they need is +5V, ground, and the signal output (a voltage proportional to

pressure or temperature).

Figure 27-A (page 27) shows the interface to the TNC. This was the trickiest part of the payload. The TNC used was the Kantronics KPC-3. It has the advantages of its small size, it's very light, and can run from its own 9V battery. The TNC was removed from its case to save weight, and the circuit board stacked next to the computer board. The packets were sent from the TNC in "unprotected" mode. This means that there was no connect to the ground station and the TNC would not wait for an acknowledgment from the ground.

There are only four parameters to change from the factory configuration:

MYCALL	the "from" callsign
UNPROTO	the "to" callsign or text
ECHO OFF	<i>this must be done!</i>
LEDS OFF	to save power

A digital output from the computer board was used to overcome a communications glitch. When the Micro 440 is powered up, it sends a line feed character; this confuses the TNC, and it will refuse to (Continued on page 27)

Continued from pg 24

the upper layer. A dead end cut may be terminated precisely with a near-vertical poke of the blade.

Keeping the straightedge in place, make the second pass like the first, except this time, cut through the foam and slightly into the surface of the bottom paper layer. This pass establishes the angle of the cut edge. If you want a simple square cut, then be careful to hold the blade perpendicular to the foamcore surface through this pass. Square up any dead ends with vertical pokes completely through the lower paper.

The third pass should cut completely through the lower paper. You may dispense with the straightedge this time, but it's still possible to let the blade drift off if you're not careful. Keep the blade angle steady from end to end, and use enough force to cut completely through the lower paper. If the lower paper is not cut through end to end, turn the workpiece over. I no ridge is visible, then get a new blade and repeat the third pass from the first side. A sure sign that your blade is getting dull is ragged cut edges in the foam or tearing of the paper. Have plenty of new blades on hand for your project, keeping in mind that a fresh blade is good for about 3-5 lineal feet of cutting.

### Making Holes

Rectangular and polygonal holes can be made simply by a series of straight deadend cuts.

Round holes require a blade with an acutely pointed tip used like a saw on both sides of the workpiece. Even the smallest holes, as for a #4 screw, are best made using this technique. A twist drill will pull the paper away from the foam, and forcing a punch through will crush the surrounding foam.

Start a round hole by marking its center, then draw the cut line on one side of the workpiece with a drawing compass. Extend the center mark through to the opposite side using a straight pin or the needle tool. Be careful to align the pin perpendicular to the surface before pushing it through. Turn the workpiece over and repeat the cut line with the compass.

### Making Bends

The simplest bend is just an end-to-side butt joint between two separate pieces of foamcore. This method leaves an ugly raw end showing, and its strength depends solely upon the paper peel strength.

Strong, accurate and stable linear bends can be made by first cutting a nearly full-thickness V-groove on the inside of the bend without cutting into the outside paper. After the V-shaped strip is removed, hot-melt glue is applied to the slot and the bend is permanent and in most cases doesn't need reinforcement. The outside corner is neat in appearance since the paper runs continuously around it; this also contributes to strength. (Continued on pg. 28)



*Foamcore-housed payload getting special attention just moments before launch*

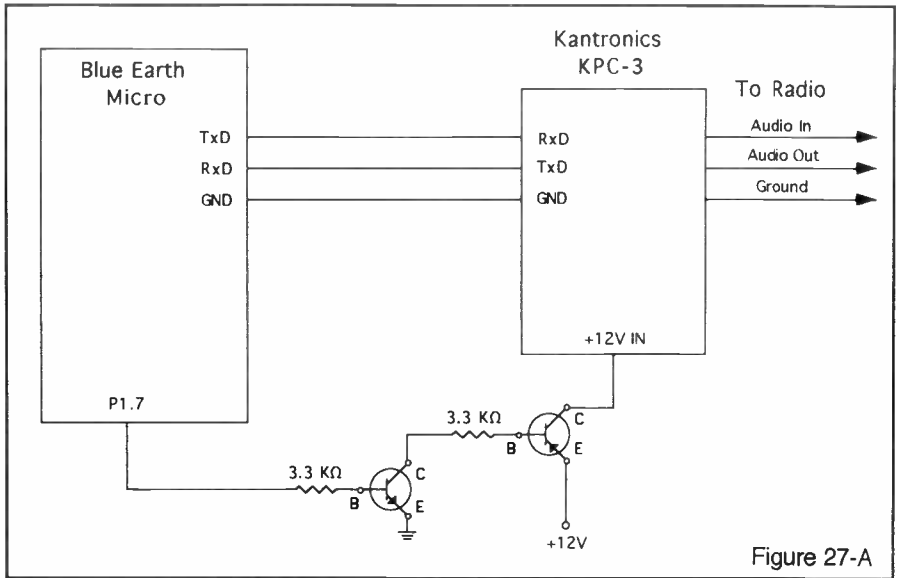

Figure 27-A

work. The computer and TNC need to be powered up in sequence. This was done manually - once. It proved to be too cumbersome at launch time. Then I came up with the idea of powering it up from the computer board.

When the payload is powered up, the computer auto-executes a program stored in RAM. The default condition when the computer is powered on is for the port pins on the micro-processor to be at a 5V level. This turns on the transistors and the TNC. By the time this program is run, the line feed character has already been sent, and has confused the TNC. The TNC is then turned off for a second, then powered back on. The computer waits while the TNC sends out its copyright message, which it ignores. The computer then sends a K to the TNC to enter "converse" mode. The TNC is now ready to send telemetry.

The TNC handles the tough job of building the packets, and sending them to the radio. The characters from the Micro 440 are buffered in the TNC so your BASIC program doesn't have to worry about waiting on the TNC. If it does fill the TNC's buffer, the TNC will send an XOFF character to the computer,

which will stop the transmission. The TNC will send a packet when it has received "paclen" characters from the computer or has received a carriage return. The first of our launches sent two 80 column lines of data at 10 second intervals. The second launch sent one 80 column line of data at 5 second intervals. The 1200 baud packet downlink can easily handle these rates.

The software that makes all this happen is shown in figure 29-A. The program begins by initializing variables, the time between readings, and the frame number. In lines 30 to 70, the program powers down the TNC, waits, then powers it back up. It waits while the copyright message is sent and then sends a K to the TNC to put it into converse mode. The last thing to do in line 90 is to set up the clock interrupt for 5-second intervals. The program then goes into a loop waiting for an interrupt. All processing is done in the interrupt routine!

When an interrupt occurs, line 110 is executed, incrementing the frame number, and the current time is stored in the variable NOW. Lines 120 to 190 read the internal A/D and store the results in variables A0 to A7. A byte must be written to the (Continued on page 29)

Continued from page 26  
and moisture resistance.

The width of the V-groove for a right-angle bend is two sheet thicknesses. Smaller bend angles require smaller groove widths, and vice-versa. For you precision freaks, the groove width  $W$  may be calculated for any material thickness  $T$  ( $T$ =foam plus ONE paper layer) and bend angle  $\theta$ :

$$W = 2 * T * \tan (\theta / 2)$$

To cut the groove, mark the two edges of the groove equidistant on either side of the center. Plan to cut each side of the groove in two passes. The first pass may be done with the blade perpendicular to the surface, just to cut the paper. The second cut should be done with the blade angled so the tip just contacts the inside of the bottom paper at the midpoint of the groove; the blade angle from vertical ideally is one-half the desired bend angle. The care with which this pass is made on both sides will determine the straightness of the outside joint and the precision of the inside seam.

After the cuts are made on both sides of the groove, the V-shaped scrap should pull out cleanly. If not, don't fret; any gaps in the foam will fill with glue. At this point, it may be a good idea to form the bend and check it for accuracy before committing it to glue. If the outside bend is a bit uneven, place the inside of the bend over a square corner of the bench and lightly burnish both sides of the outside corner with a 1/2" diameter dowel or some such tool.

With the groove lying open, apply a bead of hot-melt glue with a diameter about 1/2 the groove width. Then form the bend and hold it at the proper angle until the glue sets. A couple of square-cornered blocks of wood or metal also serve nicely in this role if you are compelled to a higher calling.

Key points regarding bends:

- Make sure the groove is cut on the *inside* of the bend; I blew about an hour's work on the ATV module neglecting this stupid trick.

- Dimension the location of the bend on the

*inside* surface to the *edge* of the V-groove, not its center. When the bend is made, the two edges will come together to form a sharp inside corner.

- Cut the grooves for all of the bends in one piece before you glue the first one. A flat workpiece is easier to manipulate.

### Unfolded Joints

If you're making a closed form where two cut ends must come together, make the final joint as a mitre at one corner. Rough out your workpiece to allow at least 1/2" extra at both ends; its very hard to cut a clean mitre right at the end of a square cut, since the foam tends to crush easily there. Glue the mitred ends together and add a 1/4" square stringer inside for strength. A piece of space tape over the outside corner will finish the joint.

If a butt joint is unavoidable, reinforce it with a 1/2" or wider strip glued to lap the joint. Glue the reinforcement strip to one side first, then apply a bead to the exposed foam edge and the open surface of the reinforcement before closing the joint.

The strength of any joint can be significantly improved by adding triangular reinforcement webs on the inside corner. The price is added weight and lost interior volume.

### Curved Shapes

Foamcore doesn't bend without crimping, since paper doesn't stretch. So don't plan on forming a truly curved wall. A curve can be approximated by a series of parallel, close-spaced small-angle bends to form a polygonal cylinder. It could be possible even to form a near-spherical polyhedron, such as a dodecahedron (geodesic dome), from a single sheet.

The width  $W$  of each side of an  $N$ -sided polygon circumscribed around a circle with radius  $R$  is

$$W = 2 * R * \tan (\pi / N) \text{ computed in radians}$$

Example: an octagon which will fit snugly over a 5" radius (Continued on page 30)

memory address of the A/D channel to start a conversion.

At line 210, two of the analog inputs are converted. These inputs are the battery voltage dividers shown in figure 25-A (page 25). The readings were first converted to volts. An 8-bit A/D with a 5V reference sees .0195 volts for each bit. So the reading is multiplied by this factor. Since we're only seeing a portion of the actual battery voltage, the reading is multiplied by the ratio of the resistors in the voltage divider.

All that remains to do is format and print the data to the TNC. The BASIC in the Micro 440 has an easy to use PRINT USING statement. The format of the number to be printed is shown with a pound sign. The catch is that this statement will print a carriage return and line feed unless it ends with a comma to suppress it. Lines 250 to 300 simply print a text string showing each variable and the value of each variable. This is all printed as one line, and the carriage return is suppressed until the last print statement. This causes the TNC to transmit the packet.

Line 310 resets the real time clock interrupt to the time of the start of the reading plus 5 seconds. This interrupt technique results in readings that are within milliseconds of being 5 seconds apart. Line 420 returns from the real work to our do-nothing loop at line 99.

Before this program can be implemented, there are a couple of things that need to be taken care of. The first is the serial port baud rate. It is normally auto-detected when the computer is powered up and you send it a space character. The port needs to be fixed at a baud rate and the auto-detect code bypassed. This is done by writing 3 bytes at locations 6001-6003 hex as shown in the program on page 31. The value BB hex will cause the auto-detect routine to be bypassed. The next 2 bytes set the serial port to 9600 baud. The last line causes the first program in the simulated disk area of RAM to be auto-executed on power up. Once these bytes are set, they remain after power down. The payload then will automati-

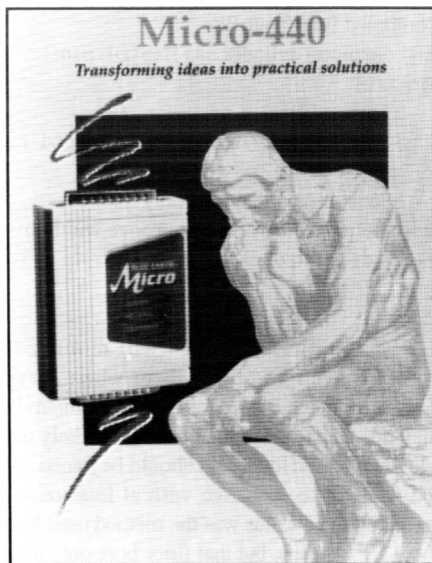

Figure 29-A

cally start running when it is powered up.

The future holds more experiments in balloons. I'm putting together a group of students and faculty at Kansas State University- Salina. We are the College of Technology, and we have many programs which would lend themselves to balloons and payloads. I would like to put GPS into a payload, and work with the Civil Engineering Technology Department on tracking. I'm trying to get a student project for the design and construction of a payload enclosure with mechanical engineering technology, and a student-built telemetry with the Electronics technology. The eventual goal would be a student-designed and built payload.

KANTRONICS  
1202 E. 23rd. Street  
Lawrence, KS 66046-5006  
913-842-7745

Blue Earth Research  
165 W. Lind Ct.  
Mankato, MN 56001-0400  
507-387-4001

(Continued on page 31)

Continued from page 28  
(10" diameter) cylinder has INSIDE panel widths of:

$$2 * 8 * 5 * \tan(3.1416/8) = 4.142" (49/64")$$

When laying out the cuts on your work-piece, remember to add one groove width to the inside width of each panel.

### Planning The Package

A well designed package will minimize unfolded joints and place them where they don't carry much load, or add reinforcement if they do. The floor of the package is likely to bear the greatest load, so it should be joined to the walls of the package with at least reinforced butt joints; this was the method used for the ATV package, but that floor bore only the weight of the camera.

A sturdier floor-to-wall joint will result if the walls are formed as bent-up extensions of the floor. The walls can be joined as mitred, reinforced butt joints. This approach might be best for shallow packages with wall seams less than 4 or 5 inches high.

If the wall structure is complex, the bottoms of the walls can be bent inward to form 1/2" or so wide flanges; the ends of these flanges should be cut at the proper angle to form a tight mitre when they're all folded inward. After the floor is cut to size, it can be pushed in from the top and glued to the flanges to form lap joints.

The exposed edges of the flanges can be protected by cutting a smaller second floor which just fits inside the area circumscribed by the flange edges and gluing it in place; this will add weight, but it more than doubles floor strength and R-value. It's probably an excellent approach to use if the floor is over a foot square.

If the front panel is to be natural foamcore, as with the DSP box (see photo below), all of its bends should be bent to avoid ugly raw ends. Access to the interior of the box is best made from the top via a removable lid. The ATV module lid is a flat sheet which carries alignment strips on the inside. The strips not only keep the lid aligned, but they also add to the package's torsion resistance. The DSP housing is held together with two broadhead #8 X 1/2" sharp sheet metal screws threaded through two layers of foamcore.

### Fitting In The Goodies

Printed circuit cards may be mounted in the regular fashion using standoffs and threaded hardware through the package walls. One may form card guides out of strips of foamcore glued to the package walls, however. This makes access and replacement a snap.

Ordinary machine nuts may be glued or space-taped in place on the surface, where screw tension pulls the nut into the surface. Washers will prevent the nut from pulling through. •••

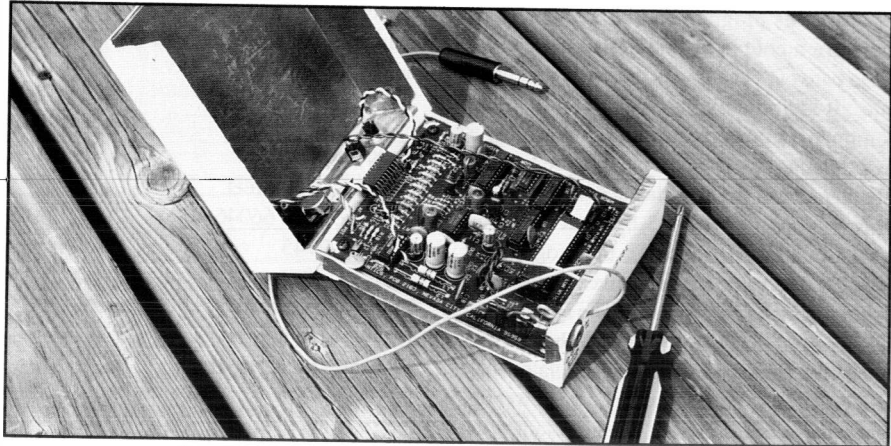

*Interior of the DSP, showing circuit board and shielding*

```
10 REM Balloon Launch # __ XX/XX/1993 __ Rob Kelly, NØSMR
20 period=5:f=1
30 PORT1=27
40 for x=1 to 500:next x
50 port1=59
60 for x=1 to 500:next x
70 print "K",cr,
80 for x=1 to 100:next x
90 ONTIME PERIOD, 60
99 GOTO 99
100 REM -----Read Internal ADC
110 F=F+1:NOW=INT(TIME)
120 XBY(65280)=8: A0=XBY(65280)
130 XBY(65281)=9: A1=XBY(65281)
140 XBY(65282)=10: A2=XBY(65282)
150 XBY(65283)=11: A3=XBY(65283)
160 XBY(65284)=12: A4=XBY(65284)
170 XBY(65285)=13: A5=XBY(65285)
180 XBY(65286)=14: A6=XBY(65286)
190 XBY(65287)=15: A7=XBY(65287)
200 REM-----Scale ADC
210 A0=A0*.0195:A0=A0*6.32
220 A6=A6*.0195:A6=A6*6.013
230 REM-----Send Data
240 PRINT USING(#####),:PRINT "Sec",NOW,
250 PRINT USING(#####),:PRINT "Frame",F,
260 PRINT USING(##.##),:PRINT "B1",A6,
270 PRINT USING(##.##),:PRINT "B2",A0
280 ONTIME NOW+PERIOD,60:
290 RETI
```

```
1 xby(6001h)=0bbh:REM tells startup code to bypass auto-detect routine
2 xby(6002h)=0ffh:REM next 2 bytes determine baud rate
3 xby(6003h)=0d9h:REM these set it to 9600
4 xby(6007h)=0ddh:REM autoexecute first program from RAM disk
```

...

# Counterpoise And The Antenna

Wes Farnsworth, KEØNH

A lot has been said in ham literature about ground effects on antennas - a lot of what has been presented is conflicting and not at all provable.

Here I will offer some information and techniques that you can easily try and confirm for yourself just what the term "counterpoise" really means.

The idea of an image antenna has been fairly well pounded into our heads, and is probably the only thing about counterpoise in ham literature that is true! First, let us debunk the obvious: ground radials on a ground plane antenna! *Ground radials are not a counterpoise.* They *do* cause the antenna to exhibit the correct impedance to the transmitter coax, and they *do* affect the radiation pattern of the ground plane antenna, but not in a way that you would expect!

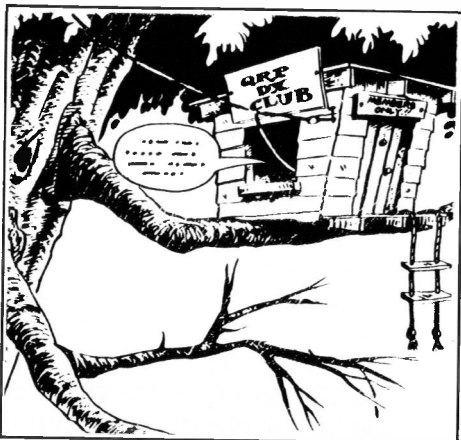

*Ed. Note: Wes has successfully worked hundreds of DX stations using QRP power levels utilizing the antenna principles in this article and the article on page 25. His antenna is 1 1/2 feet above a flat roof!*

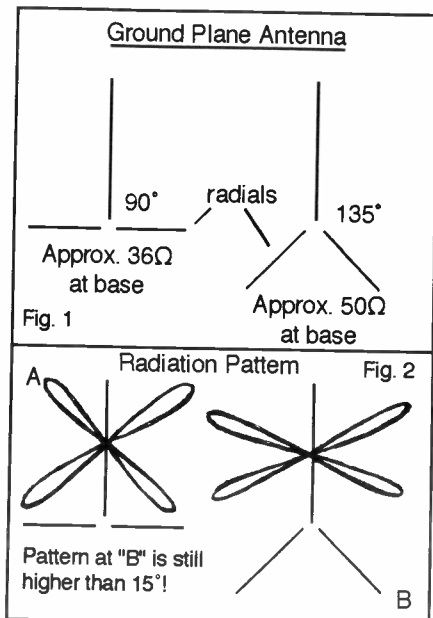

These "short" radials are *not* an effective counterpoise for this antenna! They are one way to get 50 ohm impedance, however (see figure 1). For an effective counterpoise, the radial system must be *many* times the height of the vertical element, and you can see that a zero degree angle of radiation is a geometric impossibility!

It is not impossible to get a zero degree angle of radiation, but *not* with radials. With control over the counterpoise, *minus* angles of radiation can be achieved!

If you study figure 1 and figure 2, you begin to see the problem. Angle of incidence = angle of reflection. A zero angle of incidence is only possible if your antenna is lying on the ground. And we know that won't work either!

If you have the means and the property, you could manage a *huge* counterpoise system and get an effective minimum of fifteen degree angle of radiation - (continued on page 34)



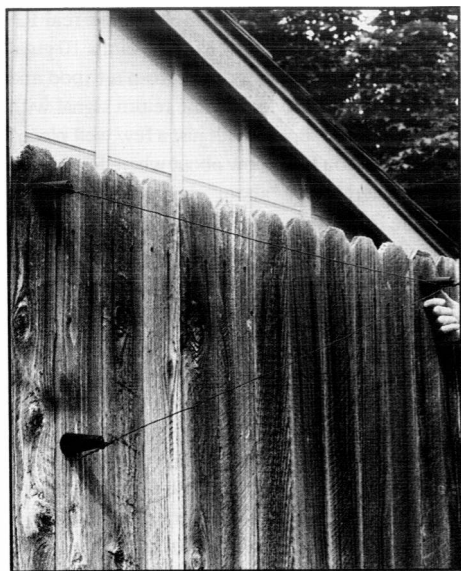

# Practical Antenna Applications: Parallel Dipoles

An interview with Bill Mason, NØKEP illustrates some practical applications of the principles set forth in the previous article by Wes Farnsworth, KEØNH

HB: What inspired you to begin this parallel dipole project in the beginning, Bill?

A: Well, I haven't been on HF since we've been here, and we've been here since 1977. Inheriting my uncle's equipment after he passed away made me want to use it and get on the air. I've been licensed for 35 years. So I decided with the covenants we have that I would some-

how have to get some HF antennas up, and I wanted to use tuned antennas because I don't have a tuner. I like tuned antennas, so I decided to do a project and I got with Wes Farnsworth, KEØNH, and he has been giving me the advice to build it in this way.

HB: How then did you tackle the invisibility factor?

A: By using number 18 solid wire, though you could use stranded wire...solid 18 with black insulation --Radio Shack hookup wire--a spool of it for a couple of bucks or whatever it is, and you can see the black color blends in very well with the surroundings.

HB: It's very difficult to see it. And we looked earlier at the insulators, which we will show. But the antennas are parallel dipoles, correct?

A: Right. Parallel dipoles on 80 and 40, and then 20 and 10, and there is a separate antenna for 15.

HB: Ok. What are the insulators that are attached to the fence there?

A: I got them at an electronics supply here in town...they are a very high voltage antenna stand-off type of insulator, porcelain, about four inches tall, they don't have to be that fancy, I could have actually used screweyes right to the fence. But I decided to do it this way just for the heck of it.

HB: And you tuned the stubs that were hanging off the insulators as a kind of fine tuning touch-up?

A: Oh, yeah, they have to be tuned. The fishtail, as we call it, you have to tune both fishtails.

HB: So the fishtail helps to make the antenna...?

A: Broader...I got this from Wes...it makes the antenna think that it's that wide, in other words I have an 18 inch diameter piece of wire for an antenna...more broadbanded.

HB: So to outline the entire project, you have the dipoles that run through the house, mostly contained in the attic, with some part of the antenna brought out through the wall to the fence..

A: The 80 meter is so long that of course it hangs out of both sides of the attic; the center-fed portion of the 40 is entirely within the attic, the shielded side of the antenna you see is all outside. So it's kind of a wierd configuration. I call it a "flattop inverted vee" on 80, and an "L", a kind of inverted vee turned on it's side, for 40. They are parallel, and a little hairy to tune up, but once you've got it, you've got it.

(Continued on page 38)

roughly five acres for a twenty meter antenna!

Please draw yourself some examples of what this means to other types of antennas: beams, Vee's, long wires, etc....same problem! the beam (Yagi-Uda) is least affected by counterpoise, but the limit is still fifteen degrees!

The way out of this limit is to cause the antenna to ignore the earth ground(counterpoise) and operate like a free space antenna. This is easily done as we shall see. But there are reasons to do this and reasons against.

Some conditions exist that could make a zero-degree angle not practical, like high mountains surrounding you! In this case, being able to control the angle of radiation is even more important!

From the illustration (fig. 34-A), you can see that an effective counterpoise can be all but impossible on a city lot. The "mirror" must be large in comparison to the height of the antenna. Before the 30 degree bi-conal pattern common to vertical antennas is vectored down to a reasonable angle, you will be up to a radial system which is five to seven times the height of the vertical antenna!

If one tries to use the natural ground, such as with a dipole, the problem gets more complex, as real RF ground can be several to many feet below the actual ground.

If one really wants to know where real RF ground is, there is a way to do it: aim a 10 gigahertz ham rig at the ground from a tripod and trigger a pulse. Measure the return signal with an oscilloscope, and with just a few well placed readings you will know about where RF ground is located. I say "about", because it is not the same for all frequencies, but it is close enough for our use. This, however, is more trouble than it is worth unless you really want to get scientific about your antenna system.

I have heard several hams say "the ground side of the antenna is the counterpoise"- this is true, but *only if you are decoupled from the earth ground!* It is easy enough to prove this: watch an SWR meter and move a dipole antenna up and down and watch what happens to the standing wave! Or better yet: measure the SWR while the dipole is moved with relation to another antenna or a large solid object as perhaps found in an attic or next to a building. If the ground side of the antenna were the counterpoise, you would *not* see this effect.

By decoupling the antenna from earth ground, you can cause your antenna to not "see" or react to these nearby objects. In this issue of **Hambrew**, I will show you how to decouple, and next issue I will show the theory behind it, mostly from old navy manuals, old ARRL handbooks and my own experiments over the past years. (Continued on page 36)

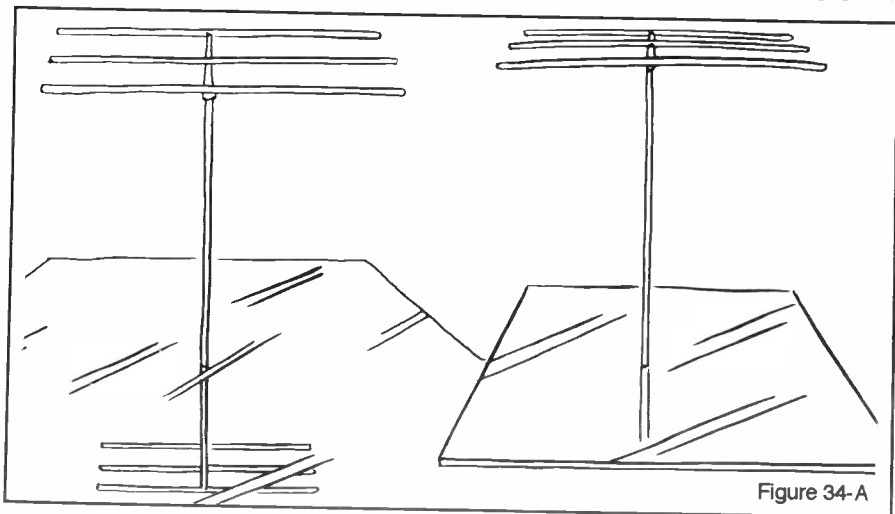

Figure 34-A



## Motorcycle Helmet Headset With Handlebar PTT

Hambrew Chats With Jim Wiley, NØBLU

HB: The first question, Jim, what got you going on this project?

A: Getting tired of using a speaker mike while motorcycle mobile led to a more suitable, removeable installation.

HB: And what did you use for a push-to-talk switch there?

A: The P.T.T. is a normally open, single pole switch from an airline pilot's headset, with a velcro strap incorporated into it, although it would be a simple matter to use an off the shelf switch from an electronics supplier.

HB: And what sort of circuitry was involved?

A: Basically, it was plain and simple: a copy

of the circuit for the speaker mike incorporated into a box where the speaker mike push to talk could be located on the handlebars.

The headset is a Kenwood HMC-1 VOX type which I got on a closeout sale from a national mail-order outfit, and after experimenting with the VOX, I found it totally unsuitable for the ambient noise level while operating motorcycle mobile. So the VOX was removed and that little box is just a junction box to contain the splice. The HT is connected to a handlebar clamp with a bolt attached, and the belt clip slips over that for the mounting, the bolt has a large head so the HT can't slide off.

My thanks to NØSSB and NØRSD, who are both running similar setups.

HB: Earlier you had mentioned some safety features of this design. What are they?

A: Number one, the headset will fit in just about any helmet. If you cut the little plastic ribbon on the metal band on the headset that goes across your head, it slips out of the rest of the headset mounting, and that slips right up under the liner of the helmet. It takes just

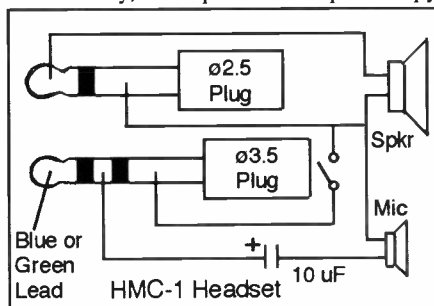

I have worked on a few antenna systems relating to the concepts and situations which I have thus far outlined, where accurate before and after data is available - the claims for "decoupling" hold up even in extreme cases.

Let's start by building the decoupler: you can do this with a longwire/twin lead or RG58U coax. RG8U is not recommended, as it is not "leaky" enough at HF frequencies to act like a transformer. RG58U is very good for this application.

Use the antenna lead-in wire to make a coil of 18 inch diameter of seven (7) turns (this will be good for 160-10 meter use), and stabilize it with tape or whatever method you choose. This will not have an effect on your balun - if you have a mix of twin lead and coax, the coil may have to be smaller.

For any antenna the coil should be in the same plane as the antenna. If you want a higher angle of radiation, turn the coil slightly out of the plane of the antenna while watching the radiation angle with a field-strength meter.

In some cases you may have to prune a small amount from your antenna. In the next issue of **Hambrew** we will do the math on this system, and you will see why the pruning is necessary.

In most instances, the coil should be mounted at the feed point of the antenna, although with twin lead and long wires the coil can be anywhere in the feed line. This should completely de-couple the antenna from earth ground, and that is a very important detail in an area with antenna restrictions, as you can get very low SWR and enjoy a very low angle of radiation, even with many antennae in a small attic!

I should mention that I have seen some installations that need further decoupling.

A simple "capacity trap" and other techniques will be covered in a later article in this series.

One very odd situation related to these matters requires an explanation: The Mystery Tree!

Most all of us have run an antenna wire through, over or under trees with good results.

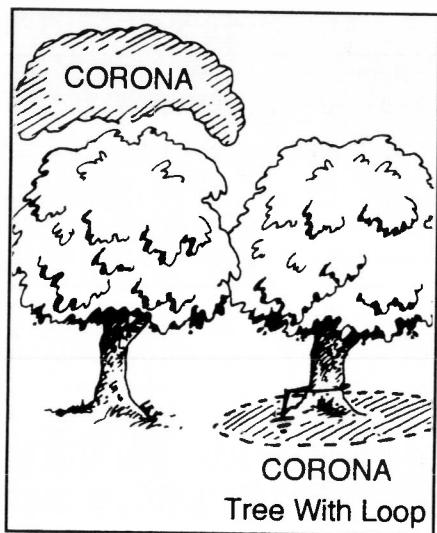

There is one case where this practice can lead to problems:

Do you know why lightning strikes trees? They are higher than surrounding objects, perhaps, or possibly they are a very good ground? Nope.

The answer is that they contain a lot of water (some more than others), and they produce a corona, or charged area above the tree that is connected to ground. If your dipole hot side terminates inside the tree, you have a very complex situation which can exhibit strange and uncommon symptoms:

- Current flow in the antenna under "key-up" conditions!
- Your ground system is at a higher potential than earth ground!
- The field strength on one side of your antenna is very low compared with the other side!

A simple way to kill a corona in a tree, water tank or similar container is to force the corona to the ground level. Many moons ago, Morry Carpenter, KØHRZ, told me to do this. As strange as this looks, it works!

Decoupling is a valuable tool, and it is valid up through VHF/UHF. The examples I have shown are not the only decoupling methods available. More on the Mystery Tree and decoupling - especially theory and measurement in the next issue of **Hambrew**.•••

Kit Review, Continued from page 5

few knick-knacks. One was to dig out an old CB radio bought at a garage sale in the neighborhood (a non-working CB can be a great source of parts - the meter alone is worth the \$3.50 price of the radio!), the meter was quickly removed from the case, and fit to the panel.

A quick aside here about homebrew sheet metal working: we don't have, nor can we afford sheet metal brakes and dies. The result is a bit of song and dance with available tools. This includes a modest drill press with a few bits and a circle cutter. A small but sturdy pair of nippers and a nibbling tool round out the range of selections (a couple of clamps are mandatory for safety).

To cut an opening in the case in order to place the meter, a series of holes was drilled along the marked rectangle of the installation location, then the rectangle was opened using the small pair of nippers. The edge can then be filed. Since the edge of the rectangular opening remained a bit ragged, a piece of trim was fashioned using an exacto-knife and a bit of black plastic from the lid of a food container in the XYL's kitchen cabinet. This was superglued to the case.

Having a power meter on a transmitter, space and weight factors aside, can be useful from time to time - the other "bell" which can be practical is a power LED indicator, assuming also that the unit will not need to conserve power (e.g., battery use in the mountains or at the beach). Just for fun, a meter light was added also.

The real whistle was then added: a sidetone oscillator based on a 555 timer chip. A volume control was added to the back of the case.

Ramsey provides a variable resistor with the kit which is solderable directly to the board. This was replaced by a more sturdy version with a metal shaft, which could be mounted to the case. The Ramsey pot was used for the sidetone gain and installed on the case-back.

In conclusion, the Ramsey 30 Meter Transmitter is a fine little kit at an affordable price which can be constructed as is, or used as a solid platform for modification. It tested out nicely with a clean emission and the higher-power option is a very nice touch.

Available from dealers or Ramsey Electronics, Inc., 793 Canning Parkway, Victor, N.Y. 14564 •••

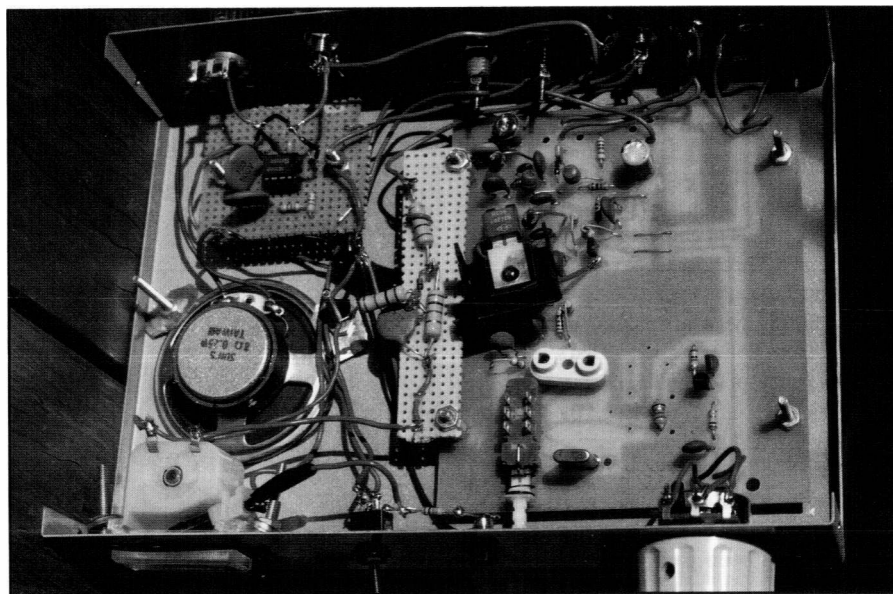

*Interior of case: main board, meter circuit on perfboard, and sidetone oscillator*

A: The feed point is just inside the exterior wall of the attic, where the two antenna wires come outside the house. So you've got one leg of the 40 that is essentially horizontal inside, and the other leg comes out at an angle.

HB: Have you had any problems at all with one antenna detuning the other because of their proximity to one another?

A: Yeah, that's why tuning is so critical. You have to jump back and forth between the two of them while tuning...you have to have a lot of patience to do this, and the farther apart the wires are the less they'll detune each other, but yes, they will detune, what you do to one may

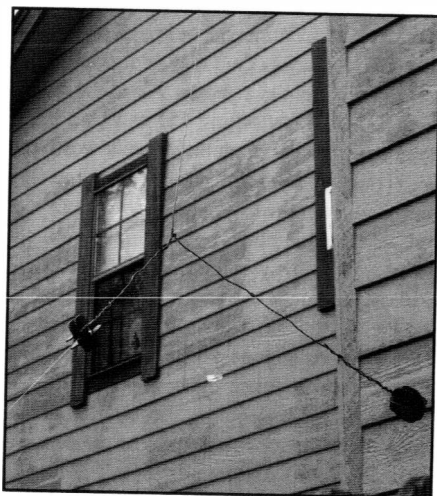

*40 Meter Dipole Fishtail*

HB: Now please tell us about the loop around this tree here, which is connected to a ground rod it seems.

A: Well, Wes Farnsworth clued me to the fact that this Russian Olive tree near the antenna holds a lot of water in it, affecting the resonance of the antenna on this side of the house. You see the ground rod? And that's just an old piece of romex, grounded. If the neighbors saw me doing this, they'd probably think I was nuts--witchcraft or something. This is an anti-corona loop. Wes says that it reduces the corona effect around this tree; it has a corona around it...like a barrel of water sitting there.

(Continued on page 40)

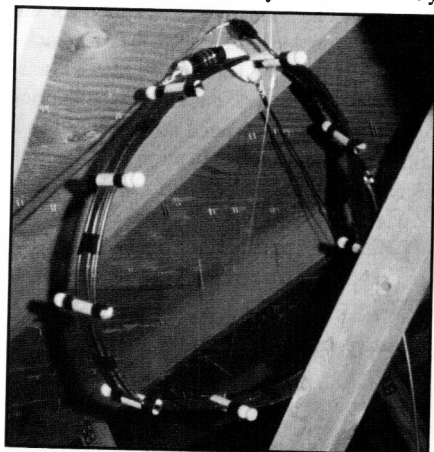

*20/10 Meter "Gene Autry Hat" Loop*

affect the resonant frequency of the other, so you have to keep graphs and do them both, and make a judgement of how much to trim...it's an exercise in patience, but it pays off.

HB: How far apart are they inside the attic?

A: The 80 and the 40 at this (hot) end are, oh, I'd say maybe five feet apart. That's about as close as you want to get them.

HB: There's an interesting touch on their invisibility that I'd like you to comment on, and that is this fishing leader...

A: I decided to run it up to the egg insulators, I used thirty pound clear fishing leader...

HB: And it's been plenty strong for your needs.

A: So far, yes.

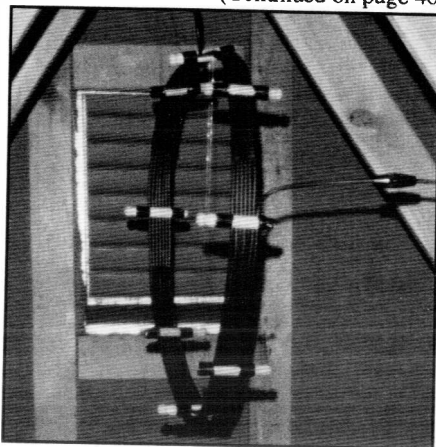

*80/40 Meter Loop Aligned With Dipoles*

# Bingo!

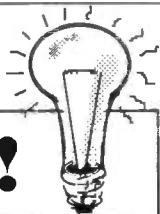

*Sometimes the simplest ideas can be the most functional. Putting the microphone jack on the console between the two front seats keeps the cord out of the way and makes the mike more accessible to a ham passenger. A tip of the headphones to Bill Mason, NØKEP.*



## *Neophyte Roundup*

You are cordially invited to send along any photos and/or information on mods made to your **Neophyte Receiver** to be shown in our Neophyte Roundup in 1994! Even if you built a stock kit without modifications, our readers would like to see how you chose to package it, so send along a photo and tell us about it!

---

And be on the lookout for the Neophyte Roundup in Hambrew in '94!

Talk to Wes about this one, but this has to do with the water in the tree producing a ground corona. If you don't have the loop there, you have a concentration of negative charges in a corona around the tree. This loop that you see here actually helps the tuning on 80 meters and actually lowers the corona back to the base of the tree.

HB: Really! Fascinating stuff. So you can observe the difference on 80 meters...

A: Yes.

HB: How much does it affect your SWR?

A: That's kind of hard to say when you look at the curves, because the curves are a little wierd too, as you will see...I can't really give you a figure, all I can say is it made it easier to tune the ends of the antenna.

HB: So it's actually an effect that you can notice on an SWR curve.

A: Absolutely.

There are all these fine points: it (the ground rod feed point) has to be elevated. If you bury this way down in the ground it wouldn't work. It has to be up a few inches like that.

HB: So you have to leave a little bit of the rod above the ground...

A: And the romex has to come up to it like this. Wes commented that he had to do the same thing--he had an 80 meter wire, with a Russian Olive tree near it, running straight across, and he couldn't tune the thing until he did that...and then it tuned.

HB: So to summarize, the loop goes around the base of the tree, and it is elevated at the point where it connects to the ground rod a few inches.

A: Yeah. I used a four foot ground rod, kinda drilled a hole with a deep-root waterer first, it made a hole, and then I pounded it in, then used an old 5-foot roll of copper #12 romex.

(Continued on pages 41, 43, 44)



*Carpenter-Farnsworth Anti-Corona Loop*



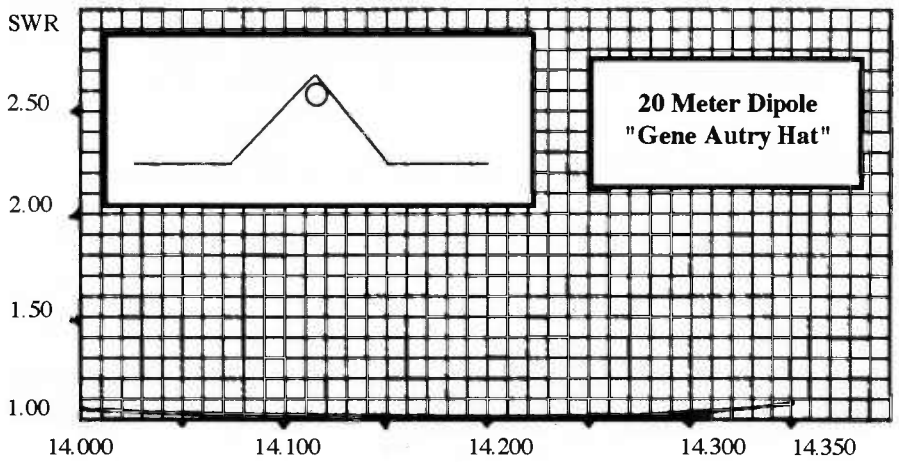
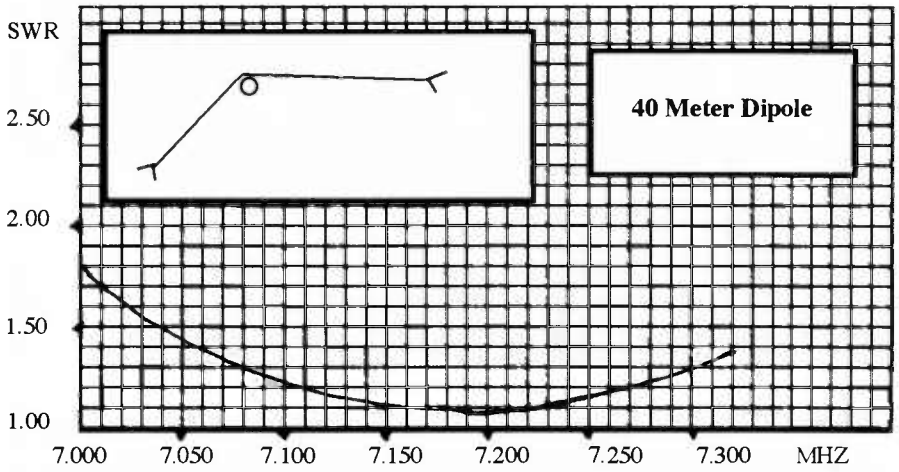
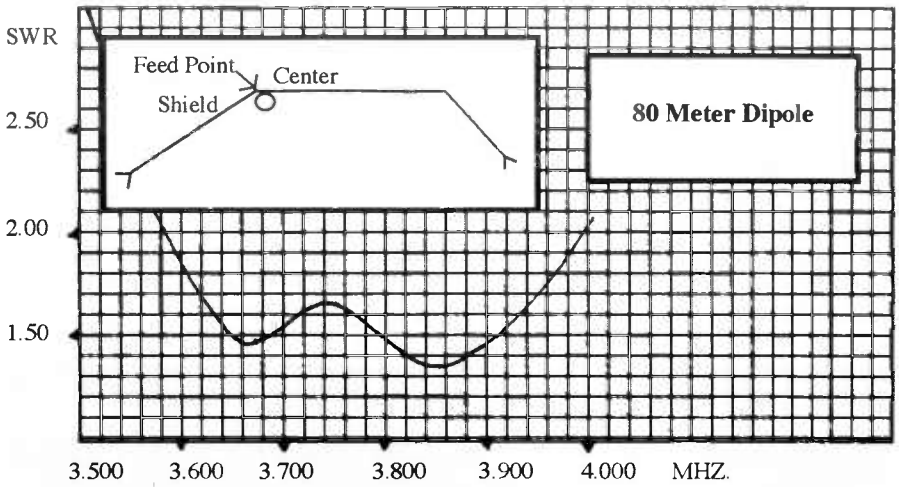

Continued from page 35

seconds to install it. Second, I made use of five-pin DIN plugs on both ends of the patch cable going from the headset down to the interface box on the handlebars. That way, if you do have to bail out from the bike suddenly, you can do it without having to worry about being tied to it.

HB: Simplicity, easy to build and inexpensive, right? How much cost would you say you have tied into this project, Jim?

A: Oh, forty dollars. The headset was on a

closeout special, as I mentioned, it was twenty nine dollars. The push to talk switch was a freebie, given to me, and the box, the velcro and the DIN plugs were the other expenses. The box and the plugs came from Radio Shack. There were two male plugs and one female chassis-mount DIN socket, and an in-line five pin DIN female socket on the patch cord. I could see this not going over fifty dollars, even buying everything new.♦♦♦

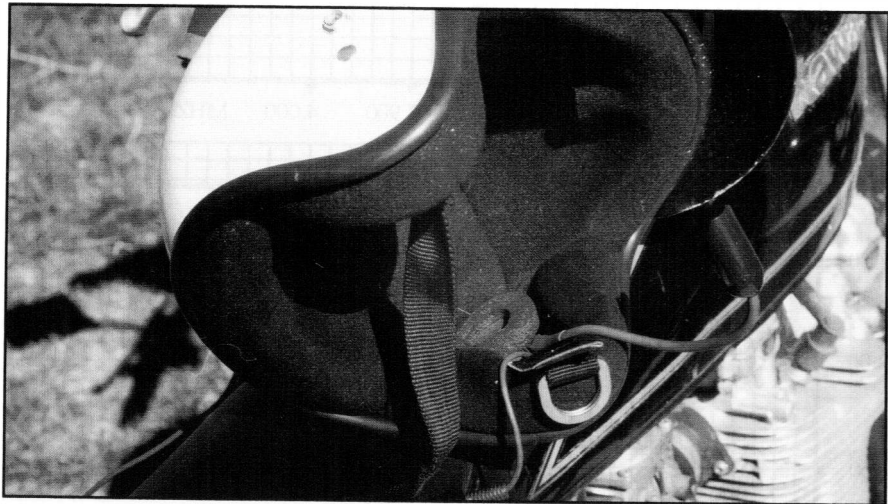

*Helmet with headset installed in liner*



*NØRSD, Will Sorensen's Honda Shadow with 10m and 2m rigs ready to roll*

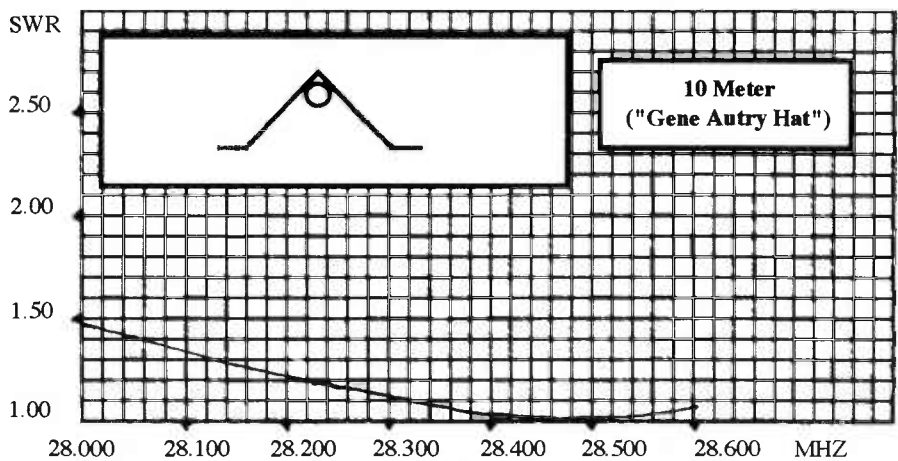
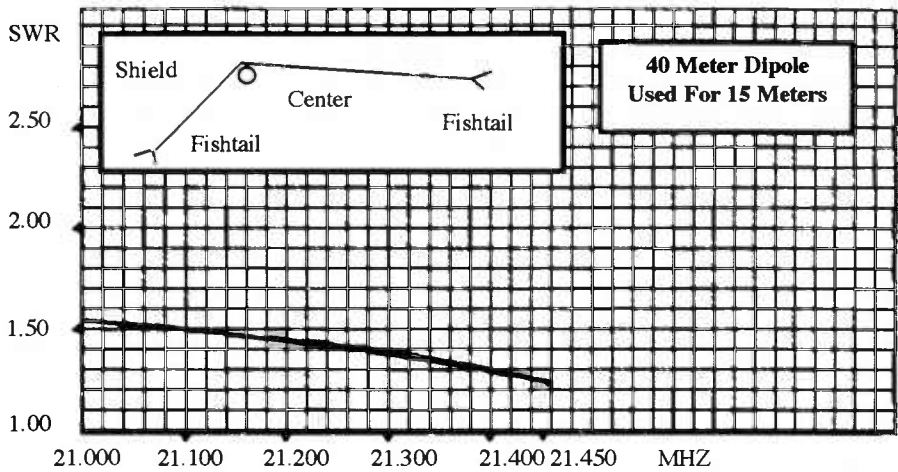
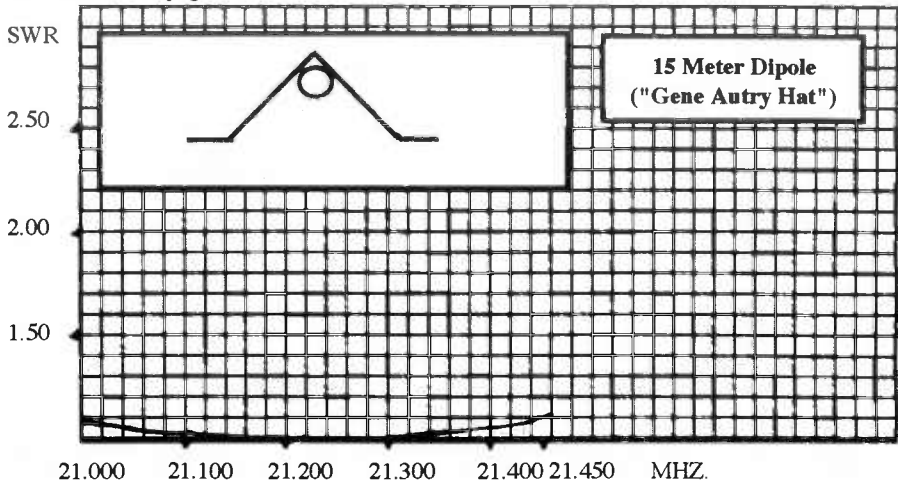

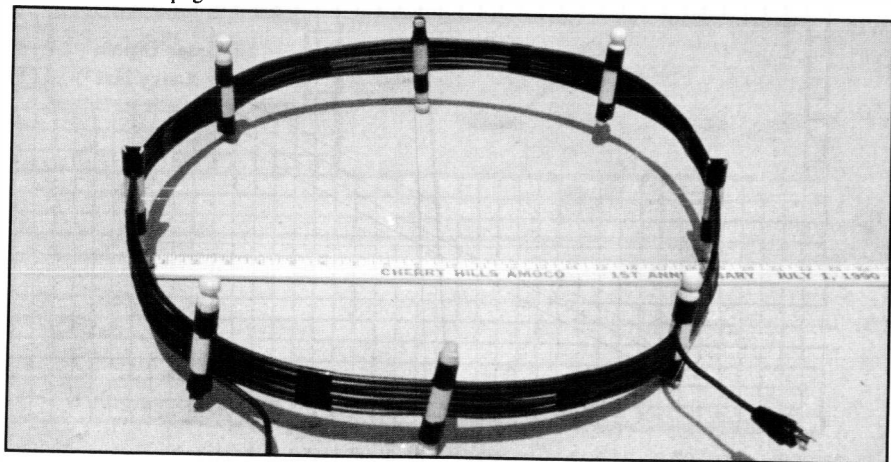

HB: Bill, what about the decoupling loop: how is it constructed?

A: It's a loop constructed of RG58 coax - the minimum diameter should be eighteen inches across. Wes pointed out that RG8 type coax would not be lossy enough to work effectively. It's also important that the coax in the loop not cross over itself. I used wooden clothes pins to secure the coax and keep it from crossing over. There are seven turns in the loop.

HB: And this number of turns in the loop and its diameter works for any of the bands.

A: Yes.

HB: Then what are the effective angles of radiation now that the decoupling coils have been put in place at the feedpoint?

A: Wes has calculated an angle of from zero to five degrees.

HB: Great for DX.

A: Absolutely.

HB: How about the connectors here attached to each end of the coax?

A: Those are Radio Shack splicers, one ties into the feedpoint, and the other ties into the regular RG-8 coax running down to the rig. I just installed them for convenience, all that is necessary is to simply make an electrical connection with the antenna. An important point is that the loop should be in a plane with the antenna (see photographs). If a higher angle of radiation is desired, then the loop can be

angled slightly from the antenna plane as seen from above.

HB: Ok. What is the purpose of the wire spikes on either side of the center insulator of the dipole?

A: They are eighteen inch wire spikes in an "x" configuration. They serve the same purpose as the fishtails at the ends of the antennas. They make the antenna "think" it is eighteen inches in diameter, making it more broadband.

HB: That is especially useful for the lower bands, where bandwidth can be pretty narrow at the point of resonance. This feature, along with the low angle of radiation, makes the dipole a viable DX radiator.

A: Yes, the loop decouples the antenna from ground and makes it act like a free antenna floating in space.

HB: So the 80 meter and 40 meter dipoles are parallel and fed through the same loop and through the same feedline...

A: ...and the 10 meter and 20 meter are parallel also, and are fed together through their loop. If, for example, I am operating on 10 meters, there will be some radiation from the 20 meter dipole also, but the greater amount of radiation will come from the resonant antenna in use. You need, by the way, antennas at odd harmonic frequencies to make the parallel antenna concept work. On the "Gene Autry Hat" dipoles, its important to make the two halves at exactly ninety degrees to one another.♦♦♦

## Parallel Dipoles, Continued

*Photos (Far left): Decoupling loop, with wooden clothes pins to secure RG58 coax. Loop must be at least 18" in diameter.*

*Right: 40/80 Meter parallel dipole decoupling loop on site in attic. Photo taken before 18" spikes were added.*

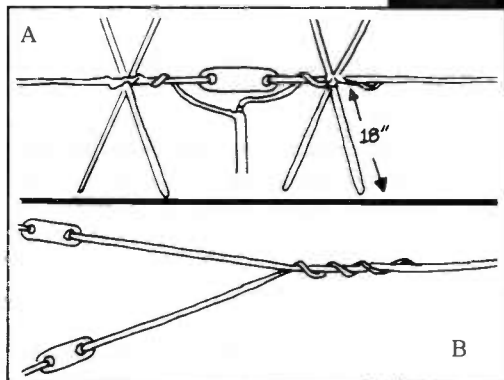
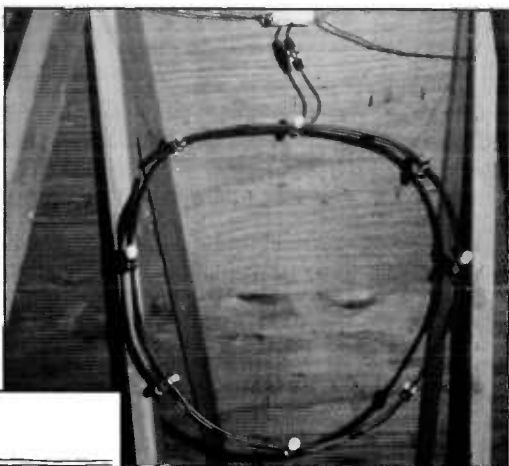

*Left: Diagram showing spikes at feedpoint (A). (B) shows "fishtail" construction at ends of antennas.*

# Shack Shots

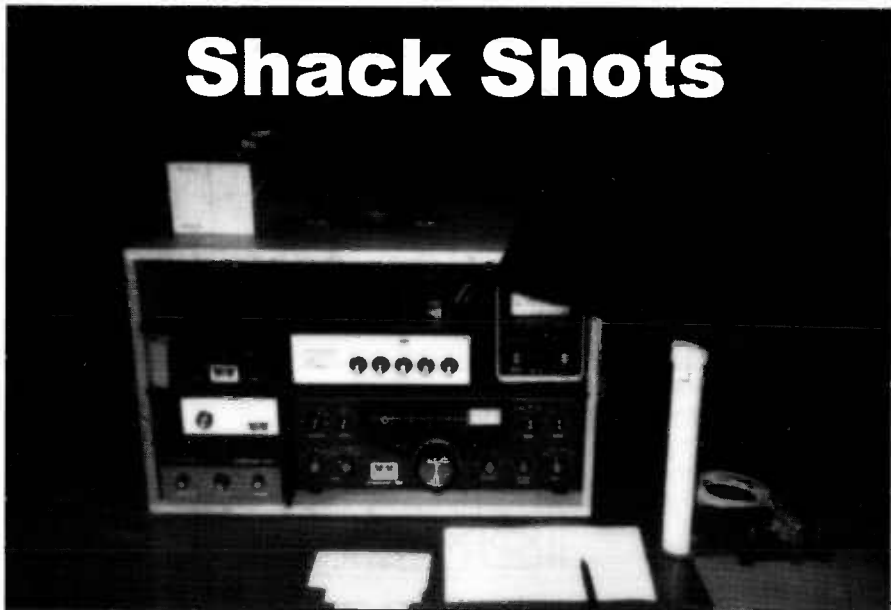

*A self-contained QRP "Shack In The Box", photo courtesy of Tom Crede, WB3JJK/QRP*

# CLASSIFIED ADS

A Reader Service of **Hambrew** - No charge to subscribers to place one ham-related ad per issue, limit 15 words, .25 per word thereafter.

Ads placed by businesses: .50 per word, no minimum. All ads must be related to amateur radio; **Hambrew** does not vouch for nor guarantee the reliability nor legitimacy of any item or company represented herein. Deadlines: Sept. 1(Autumn), Dec. 1(Winter), March 1(Spring)

June 1 (Summer). We reserve the right to deny publication of any ad. Copy To: PO Box 260083, Lakewood, CO 80226-0083. Sorry, no phone orders on classified ads.

Prepay only.

**Wheel Antennas For UHF!** 70 cm, 900 Mhz, 23 cm, 13 cm.: \$39.95 each, any band! Easily stackable. Mag Wheels: Magnetically mounted versions of any of the above antennas only \$59.95! Olde Antenna Lab, 4725 W. Quincy, Denver, CO 80236 (303) 798-5926

A future issue of **Hambrew** will feature a collection of Neophyte Receivers. If you built a Neophyte, we would like to include your lil' beauty! Please include a photo (b/w is best, if possible) along with any comments about mods, etc.. Send to **Hambrew**, PO Box 260083, Lakewood, CO 80226-0083

**Edge Of Space Sciences (E.O.S.S.):** High-altitude balloon experimentation: Great for hams, builders & homebrewers, fox hunters, trackers, packeteers, students, experimenters! Regular membership only \$10.00 per year; student membership only \$2.00 per year. Members receive our newsletter published quarterly. To join, send to E.O.S.S., 376 W. Caley Circle, Littleton, CO 80120

**Free 112 page catalog** of electronic components, kits, test equipment, tools, books, much more. Ocean State Electronics, PO Box 1458 Westerly, RI 02891 - 401-596-3080

(Continued From Page 19) Toroid Windings For NWQRP "30-30" Transmitter

All Use #24 Enamel Wire

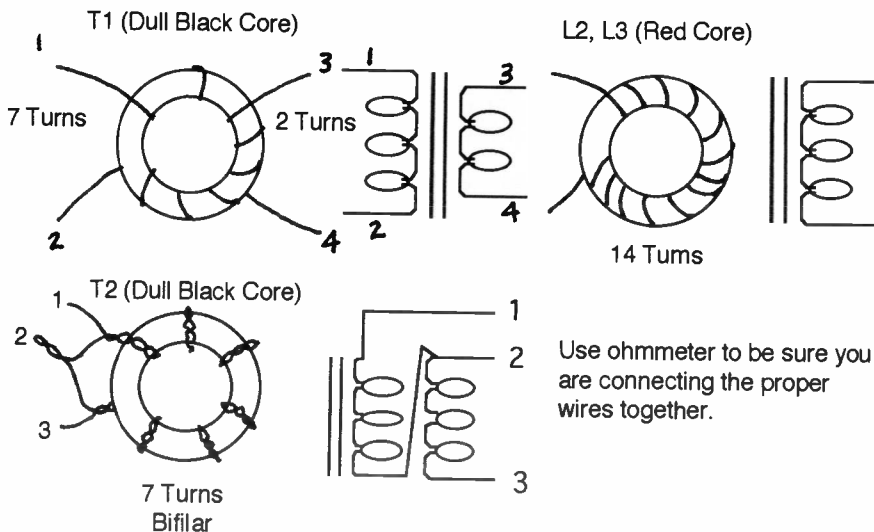

# OCEAN STATE ELECTRONICS

## QRP CW TRANSCEIVER KIT

- Covers 14.0 MHz to 14.1 MHz on 20M or cover 7.0MHz to 7.150 MHz on 40M
- Available on 20M or 40M band
- Superior superhet
- Single signal receiver
- CW crystal ladder filter
- VFO tuning with vernier dial
- RIT w/center detent control
- Very effective AGC
- Selectable audio filter
- Sidetone Oscillator
- 2-3 watts of RF output
- Semi break-in
- 12VDC operation
- Custom pre-painted, punched & silkscreened cabinet
- 100% complete kit with instruction. Nothing else to buy!
- Measures (HWD) 2 1/4" x 6 1/4" x 6"
- Weight 24 oz.

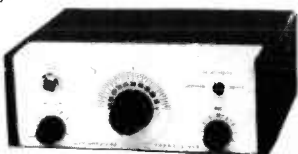

QRP-20 ..... 20M VERSION ..... \$149.95  
 QRP-40 ..... 40M VERSION ..... \$149.95

## DIGITAL CAPACITANCE/INDUCTANCE METER

DIGITAL LCR METER measures inductance, capacitance and resistance. At Last! An LCR meter that everyone can afford. Now you can measure coils, transformers, chokes from 1µH to 200H. Capacitors from 1 pfd to 200 mfd and resistors from .1 ohms to 20 meg ohms. All in one handheld instrument.  
**MODEL LCR-1801 .. \$119.95**



## DELUX CODE KEY



Adjustable, heavy duty brass base with ball bearing pivots. Designed for hard usage. 3/16" plated contacts.  
**\$11.75**

## MAKE CIRCUIT BOARDS THE NEW, EASY WAY WITH TEC-200 FILM

### JUST 3 EASY STEPS:

- Copy circuit pattern on TEC-200 film using any plain paper copier
  - Iron film on to copper clad board
  - Peel off film and etch
- Convenient 8 1/2 x 11 size With Complete Instructions



5 SHEETS ..... \$6.25  
 10 SHEETS ..... \$10.75  
 20 SHEETS ..... \$16.25



## MAGNET WIRE

Enamel coated solid copper. For winding coils, transformers and toroids. Prices for 1/4 lb. spools.

#14 ..... 3.85	#24 ..... 3.85	#34 ..... 4.80
#16 ..... 3.85	#26 ..... 3.95	#36 ..... 4.90
#18 ..... 3.85	#28 ..... 3.95	#38 ..... 5.25
#20 ..... 3.85	#30 ..... 4.00	#40 ..... 5.65
#22 ..... 3.85	#32 ..... 4.40	

## TOROIDS

### IRON

T-25-2 ..... 40
T-25-6 ..... 40
T-37-6 ..... 45
T-37-12 ..... 45
T-50-2 ..... 55
T-50-3 ..... 55
T-50-6 ..... 55
T-68-0 ..... 75
T-68-2 ..... 75
T-68-6 ..... 75
T-80-2 ..... 85
T200-2 ..... 4.00

### FERRITE

FT37-43 ..... 60
FT37-61 ..... 60
FT37-77 ..... 60
FT50-43 ..... 75
FT50-61 ..... 75
FT50-77 ..... 75
FT82-43 ..... 1.00
FT82-67 ..... 1.00
FT82-68 ..... 1.00
FT114-61 ..... 2.15
FT140-43 ..... 4.10
FT240-61 ..... 8.00

WE STOCK A COMPLETE LINE OF TOROIDS AND BEADS.

## Q-DOPE

Solution of pure polystyrene in solvents. Dries fast and leaves a clear, protective coating on toroids, coils and transformers, with no or minimal effect on inductive values. May also be used as a cement for molded or fabricated items made of polystyrene.

(Bottle with Brush 2 fl. oz. 59 ml) ..... \$3.75



## SIGNETICS NE602AN

Balanced Mixer/OSC. Popular IC among experimenters for DC and super-het receivers.  
**\$2.49 ..... BUY 3 OR MORE ... \$2.25**

## MINI-CIRCUITS SBL-1 DIODE RING MIXER



Double balance Mixer  
 LO/RF - 1-500MHz  
 RF DC - 500 MHz  
**\$6.75**



## VERNIER DIALS

1-1/2" Diameter 0-10 Marking ..... \$8.25  
 1-1/2" Diameter 0-100 Marking ..... \$9.25  
 2" Diameter 0-100 Marking ..... \$10.25

## MINIATURE TOGGLE SWITCHES

### 3A 125V Solder Terminals

SPDT ..... ON-ON ..... \$1.25  
 DPDT ..... ON-ON ..... \$1.50



## COPPER CLAD PC BOARDS

One oz. copper, phenolic base.

7" x 5" ..... SINGLE SIDED ..... \$1.50  
 3 1/2" x 6 1/2" ..... DOUBLE SIDED ..... \$1.25

## TO PLACE AN ORDER

Call 1-800-866-6626

Ocean State Electronics,  
 6 Industrial Dr., P.O. Box 1458  
 Westerly, R.I. 02891

Mail in orders please include \$4.50 shipping  
 ALASKA & HAWAII \$9.00  
 Minimum order \$10.00  
 (before shipping)  
 R. I. Residents add 7% Sales Tax  
 Local calls 596-3080



## TRANSISTORS

PN2222A	.10
2N2222A	.32
2N3055	.69
2N3553	2.75
2N3866	1.05
2N3904	1.00
2N3906	1.10
2N4401	.13
2N4416	1.25
2N5179	.75
MPF102	.49
MRF475	6.75
MRF476	3.95
MRF477	12.50
40673	3.90
3N204	3.90

## LINEAR IC'S

NE555	.35
NE564	1.75
MC1350P	1.09
MC1496N	.99
LM317T	.79
7805	.49
7812	.49
7905	.75
7912	.75

## MONOLITHIC CERAMIC DISCS

ONLY 1" L.S.

01µF	.20
047µF	.25
10µF	.28
22µF	.40
47µF	.50

## DIODES

1N914	.04
1N4148	.04
1N34A	.20
1N4001	.10
1N4004	.11
1N4007	.14

CALL OR WRITE FOR OUR FREE 112 PAGE CATALOG 1-401-596-3080

