

HAM

AN ARGUS SPECIALIST PUBLICATION

JUNE '83

ARRADIO

90p

TODAY

SPECIAL FEATURE:

The facts and fiction of VHF/UHF aerial systems

MODIFYING:
27 MHz transceivers for 10m coverage

TESTING:
the C5800.
How good, how Standard? Full user test and lab report

ASSESSING:
the Trio TS430.
The Far East's new baby visits the cleaners

OPERATING:
getting the most out of your transceiver

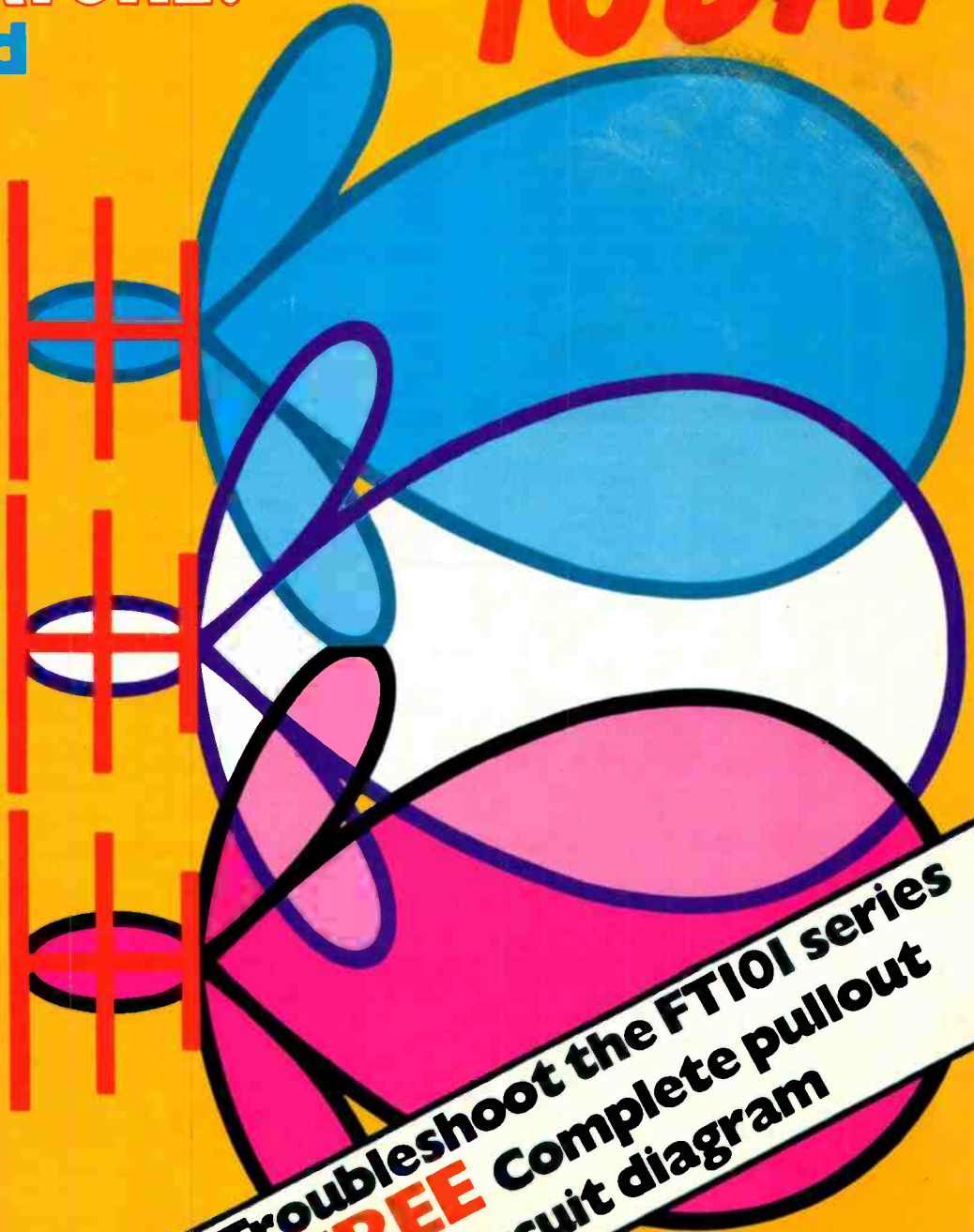

Troubleshoot the FT101 series
FREE Complete pullout
circuit diagram



AMATEUR RADIO EXCHANGE

Same-day dispatch on orders received by midday, with delivery by Securicor or Insured Post at our option.

Mail order terms are carriage-free to mainland UK on orders £100.00 or over. £1.00 per item please towards carriage/packing on orders under £100.00.

NEW RIGS FOR OLD

This selection from our full stock list only hints at the enormous range of equipment we carry by all the leading manufacturers. No question of pushing the make we "handed" to us. At A R E, whether in London or St Helens, we encourage you to try out the various makes and models side by side and see which is right for you. It's your money, so it's your choice, and that goes for Brenda's coffee too... black or white, "with" or "without."

Our customers know that we also handle a very wide selection of secondhand gear, all types and all prices, because taking your old rig in part exchange is not something we do as a rather grudging favour. On the contrary, it is a perfectly normal aspect of the way we do business. So, if you are thinking of a transformation scene in your shack for '83, phone or call in, or see us at major rallies throughout the summer, and let's see if we can do a deal that will keep everybody happy... you with your new rig, and the chap who buys the old one!

IC290H	2m multimode mobile 25W	389.00
IC2E	2m FM synthesised handheld	159.00
IC4E	70cm handheld	189.00

TRIO-KENWOOD

TS430S	Gen. coverage multi-mode	NEW 699.00
TS930	Gen. coverage trans.	NEW P.O.A.
TS130S	8-Band 200W pep	469.00
R600	Gen. coverage receiver	235.00

SCANNING RECEIVERS

A R E COMMUNICATIONS		
AR3000	720 channel synthesised air band receiver	99.99
FAIRMATE		
AS32320	VHF/UHF scanning receiver, air vand/military/police	139.00
FDK		
ATC720	720 channel air band handheld	129.00
J I L		
SX200N	16 channel memory, synthesised AM/FM	259.00
MAXIMAL-MICKEY		
MK4000	8 channel memory, 70-80MHz, 140-176MHz, synthesised	99.00
BEARCAT		
BC20/20	20 channel memory, AM/FM synth.	249.00

TONO

THETA9000E	RTTY/CW/ASCII, Tx/Rx	669.00
THETA550	Rx only	299.00
AMPLIFIERS		
UC70	430MHz 55W + preamp	159.00
2M-50W	144MHz 30-50W	65.00
2M-100W	144MHz 100W + preamp	129.00
MR 150W	144MHz 130-150W + preamp	169.00
MR 250W	144MHz 250W + preamp	325.00

TASCO

TeleReader CWR685	RTTY/CW/ASCII	769.00
TeleReader CWR670E	As above Rx only	289.00
TeleReader CWR610E	Basic unit	189.00

ANTENNA SWITCHES

SA450	S0239 connectors, 1 in, 2 out	9.75
SA450N	N-type connectors, 1 in, 2 out	12.75

ROTATORS

KR250	Kenpro Lightweight 1-11' mast	48.00
9502B	Colorator (Med. VHF)	56.60
KR 400RC	Kenpro—inc. lower clamps	P.O.A.
KR 600RC	Kenpro—inc. lower clamps	P.O.A.

BENCHER

BY 1	Keyer Paddie (black base)	35.84
BY 2	Keyer Paddie (chrome base)	43.72
BY 3	Keyer Paddie (gold plated)	92.00
ZA 1A	Balun 3-5-30MHz for dipoles	15.00
ZA 2A	Balun 14-30MHz for beam ant	17.25

ADONIS MICROPHONES

202HD	Head set mic with control box and fet head	29.00
202HM	Headphone unit, fet mic with control box	39.00
202S	Flexible neck clip mic with control box	21.95
MS10	Mobile speaker and message pad, visor mount	16.25

BNOS ELECTRONICS

12/6A	Power supply, 13.8V. 6 amp, fully protected	48.30
12/12A	Power supply, 13.8V. 12 amp, fully protected	86.40
12/24A	Power supply, 13.8V. 25 amp, fully protected	125.45
12/40A	Power supply, 13.8V. 40 amp, fully protected	225.40

DRAE

FULLY PROTECTED POWER SUPPLIES			
4 amp	30.75	6 amp	49.00
12 amp	74.00	24 amp	105.00
VHF Wavemeter	130 450MHz		27.50
Morse Tutor			49.00

WELZ PRODUCTS

SP200	1.8-160MHz 20-200w-1kw PWR/SWR Meter	69.95
SP300	1.8-500MHz 20-299w-1kw PWR/SWR Meter	97.00
SP400	130-500MHz 5-20-150w PWR/SWR Meter	69.95
SP600	1.8-500MHz 20-100-2kw PWR/SWR Meter	97.00
SP15M	1.8-160MHz 5-20-200w PWR/SWR Meter	35.00
SP45M	130m-470MHz PWR/SWR Meter	51.00
SP-10X	Compact version of SP15M	24.45
SP250	1.8-60MHz 20-200-2kw	49.50
SP350	1.8-500MHz 5-20-2kw	59.95
SP380	Compact version of SP300 (200 watts max)	49.00
AC38	3.5-30MHz ATU 400w PEP (8 bands)	65.00
CT15A	15/50w dummy load. (PL259)	7.95
CT15N	15/50w dummy load. ('N' plug)	13.95
CT150	250/400w dummy load. Rated 250MHz (SO239)	35.50
CT300	300/1kw dummy load 250MHz (SO239)	49.50
CT03N	3w dummy load 1.3GHz ('N' socket)	30.00
CH20A	2 way coax switch 1kw 900MHz (SO239)	17.95
CH20N	2 way coax switch 1kw 1.3GHz ('N' socket)	31.95
TPD5X	50-500MHz power meter with load	13.95
TP25A	50-500MHz 25w power meter with load	17.50
TP20G	30-1500MHz power meter with load	139.00
CA35A	Static discharge protector. DC 500mHz 300w (SO239)	10.75
CA23N	Static discharge protector. DC 1500mHz 300w ('N' socket)	12.60

DATONG

PC1	Gen. Cov. Converter HF on 2m	137.42
VLF	Very Low Frequency Converter	29.90
FL1	Frequency Agile Converter	79.35
FL2	Multi-mode Audio Filter	89.70
FL3	FL2 with auto notch	NEW 129.37
ASP	Auto R.F. Speech Clipper (Trio or Yaesu plug)	82.90/89.70
D75	Manually controlled R.F. Speech clipper	56.35
RFC/M	R.F. Speech Clipper Module	29.90
D70	Morse Tutor	56.35
AD270	Indoor Active Filter (inc. PSU)	54.05
AD370	Outdoor Active Filter (inc. PSU)	71.30
MK	Keyboard morse sender	137.42
PTS1	Programmable tone squelch system (two units)	45.99
RFA	Wideband preamplifier	33.92

mulek

SLNA70s	70MHz switched preamp	33.90
SLNA70u	70MHz unswitched preamp	20.38
SLNA70ub	Unboxed SLNA70u	12.41
SLNA7144s	144MHz switched preamp (now 0.9dB nf typical!)	33.90
SLNA144u	144MHz unswitched preamp	20.38
SLNA144ub	Unboxed SLNA144u	12.41
SLNA145sb	Optimised preamp for FT290RD	NEW 23.95
BLNA432ub	1.3dB nf sub-min 432MHz preamp	12.43
TLNA432s	432MHz bipolar switched preamp	54.90
TLNA432u	432MHz bipolar unswitched preamp	26.40
TLNA432ub	Unboxed TLNA432u	18.50
GLNA432u-1	432MHz gasfet unswitched preamp. 0.8dB nf/13dB gain	46.90
GLNA432u-2	0.65dB nf/13dB gain	56.90
HDR95u-1	1.5dB nf/8.5dB gain high dynamic range Band II preamp (input intercept + 22dBm)	29.90
HDR95u-2	11.5dB gain variant (input intercept + 16dBm)	29.90
BBBA500u	20-500MHz broadband high dynamic range preamp	26.40
XBPF700ub	Band IV-V bandpass tvi filter	2.95
PPSU012	12v (nominal) mains psu for BBBA 500u and BBBA 860u	6.95
RPCB251ub	IC211/251E replacement front-end board	69.90

ALINCO

ELH230	2m RF amp. 3W in/30W out	39.00
ELH720	70cm RF amp 1W in/10W out	59.00
EMR400	Rotator - heavy duty	89.00

YAESU

FT980CAT	NEW all-mode transceiver with AM/CW/FM/SSB/AFSK	P.O.A.
FT102	160-10M 9-Band Trans.	NEW 775.00
FT790R	Gen. Coverage Trans.	NEW 1345.00
FT101ZFM	70cm all-mode portable	NEW 309.00
FT101ZDFM	160-10m 9-Band Transceiver	590.00
FC902	160-10m 9-Band Transceiver	665.00
FL2100Z	9-Band stu, swr/pwr etc	135.00
FT7	9-Band 1200W linear	445.00
FP707	8-Band solid state 100W	469.00
FRG707	230 volts AC power supply	125.00
FRG700	Aerial tuner (unbalanced only)	85.00
MEM7100	SSB/AM/FM recvr. dig. readout	299.00
MEM7100	Memory unit for above	90.00

CONVERTERS FOR ABOVE

FRV7700A	118-150MHz	69.75
FRV7700B	50-60MHz & 118-150MHz	75.50
FRV7700C	140-170MHz	65.95
FRV7700D	70-80MHz & 118-150MHz	72.45
FRT7700	Receiver aerial tuner	37.85
FT480R	2m all-mode transceiver	*365.00
FT780R	70cm all-mode transceiver	*399.00
FT290RD	SPECIAL 1983 version with ARE mods and 3SK87 f/end	259.00
FT208R	2m synthesised portable FM	199.00
FT708R	70cm hand-held	209.00

ICOM

IC740	Multimode H.F. trans.	NEW 695.00
IC720A	HF transceiver and gen. cov. rec.	849.00
IC730	HF mobile transceiver 8-band	599.00
ICR70	New multimode receiver	475.00
PS15	Power supply for 720A	109.00
IC251E	2m multimode base station	539.00

373 UXBRIDGE ROAD, ACTON, LONDON W3 9RH
Tel: 01-992 5765/6/7 Just 500 yards east of Ealing Common station on the District and Piccadilly Lines, and 207 bus stops outside.

CREDIT CARD SALES BY TELEPHONE.

LICENSED CREDIT BROKERS * Ask for written quotation on HP terms. Also interest-free terms with 50% deposit.



136 GLADSTONE STREET, ST HELENS, MERSEYSIDE
Tel: 0744 53157 Our North West branch run by Peter (G4 KKN), just around the corner from the Rugby Ground.

Closed Wednesday at Acton and Monday at St Helens, but use our 24-hour Ansafone service at either shop.

All prices include VAT and are correct as we go to press. However, we reserve the right to vary them if forced to do so by the time this advertisement appears. Phone for up-to-date information, or send 50p for our full Stock List.

HAM RADIO TODAY

Editor

Frank Ogden G4JST

Assistant Editor

Richard Lamont G4DYA

Advertisement Manager

Neil Terry

Classified Sales

Sally A. Collins

Managing Director

T.J. Connell

Published by:

Argus Specialist Publications Ltd.,
145 Charing Cross Road,
London WC2H 0EE.
Telephone: 01-437 1002.

Distributed by:

SM Distribution Ltd.

Printed by:

Q. B. Ltd.

Subscription Rate:

UK £12.80
O/Seas Sur: £13.25
O/Seas Air £25.80
Ham Radio Today,
Sub Dept.,
513 London Road,
Thornton Heath,
Surrey,
CR4 6AR.

Ham Radio Today is normally published on the first Friday in the month preceding cover date. The contents of this publication including all articles, designs, plans, drawings and programs and all copyright and other intellectual property rights therein belong to Argus Specialist Publications Limited. All rights conferred by the Law of Copyright and other intellectual property rights and by virtue of international copyright conventions are specifically reserved to Argus Specialist Publications Limited and any reproduction requires the prior written consent of the Company. © 1983 Argus Specialist Publications Ltd. All reasonable care is taken in the preparation of the magazine contents, but the publishers cannot be held legally responsible for errors. Where mistakes do occur, a correction will normally be published as soon as possible afterwards. All prices and data contained in advertisements are accepted by us in good faith as correct at time of going to press. Neither the advertisers nor the publishers can be held responsible, however, for any variation affecting price or availability which may occur after the publication has closed for press.

CONTENTS

VOLUME ONE NO. 6 JUNE 1983

REGULAR COLUMNS

LETTERS.....	4
You write and we comment	
RADIO TODAY.....	6
Is the Ministry of Defence going to build a British woodpecker? Plus the rest of the news	
RADIO YESTERDAY.....	26
Jack Hum G5UM looks at amateur radio in the Twenties	
TECHNICALITIES.....	51
Wideband transformer design covered this month. We offer a CAD program for the Spectrum	
RADIO TOMORROW.....	54
Your at-a-glance diary of forthcoming amateur radio events	
NEW PRODUCTS.....	56

CONSTRUCTION

ELEVEN TO TEN.....	13
Bored with CB? Convert your set to 10 metres with our practical guide	
A SIMPLE AMATEUR TELEVISION STATION.....	48
Adding a keyboard to the character generator	

FEATURES

THE FACTS AND FICTION OF VHF/UHF AERIALS.....	9
Open your wallet where it counts. G4JST's incisive guide	
TAKING TO THE AIR.....	24
A tale of one man's struggle with the airwaves	
TAKING APART THE FT-101.....	28
Part 2 of the definitive servicing guide by G3LLL	
G LINE FOR THE GIGAHERTZ MEN.....	33
The single wire surface waveguide is a cheap possibility for microwaves	
A PLAIN MAN'S GUIDE TO MASTS AND TOWERS.....	42
Part 5: planting a tower in the concrete	
DRIVING LESSON.....	45
Get the most out of your box by knowing the functions behind the controls	

REVIEWS

TRIO/KENWOOD TS-430S HF TRANSCEIVER.....	57
STANDARD C5800 CW/SSB/FM 2M TRANSCEIVER.....	64
FREE! FT-101E PULLOUT CIRCUIT DIAGRAM.....	37-40
NEXT MONTH IN HAM RADIO TODAY.....	41
HAM RADIO TODAY MORSE COURSE.....	54
EMPORIUM GUIDE.....	70
ADVERTISERS' INDEX.....	71
CLASSIFIED.....	72

LETTERS

Please address correspondence to:
Frank Ogden G4JST
Ham Radio Today,
145 Charing Cross Rd,
London WC2 0EE.

AMERICAN WOODPECKER

OM, Enclosed you will find copies of an article from 'INTERAVIA' a technical magazine on the subject of another Megawatt over-the-horizon HF Radar system operating on the backscatter principle. If they are looking for backscatter back in Maine, USA, just think what we will be getting as forward scatter here in Europe! I have not yet been graced with a reply from Col. A Lee Snyder and probably have been put on computer for commenting on their system and branded as an undesirable. That may be, but I would like maximum publicity in the amateur press on the subject. Who do these people think they are, grabbing chunks of the HF spectrum and polluting it with Megawatt HF pulse transmissions? We have had enough with the Crimean Cackler, though that has abated very much lately, why?

DES WALSH E15CD

This set the alarm bells going here at HRT, and we've been asking the US Air Force (who are developing the system) some tough questions. The answers are on the Radio Today page — Ed.

SYNTHESISED HF TRANSCEIVER

Sir, I wish to congratulate you on your publication of your articles on the *Synthesised HF Transceiver*, an excellent project. Could you please tell me where the cores T37-6 and T37-12 specified for L1, 2 & 3 in the VCO can be obtained from and also the approximate inductance of these coils. Do you know when PCBs will be available for this project?

S NIEWIADOMSKI

The cores in question can be purchased from Ambit International, 200 North Service Road, Brentwood, Essex. The approximate inductance of the cores 0.6 μ H, 0.16 μ H, 400nH. The precise values are not critical since the VCO circuitry will compensate. A considerable degree of range overlap was designed in.

As for PCBs, we are not going to produce a set for the project as it stands. The transceiver was built at least 18 months before Ham Radio Today was ever thought of and the documentation which we have to design the boards is insufficient. However, don't despair. We are producing a mark 2 version of the transceiver which will offer enhanced performance, all modes and facilities such as a noise blanker that really works. I have mooted the design already in our Technicalities column and a series of constructional features will follow, possibly starting in July. We will offer a guaranteed

supply of ready made PCBs kits of components and a ready made case. We anticipate that our new all mode, all band, transceiver would cost in the region of £250 in its basic form, and outperform nearly all the commercial gear currently available — Ed.

PLUMBING THE DEPTHS

Frank, As one of those illegal SSB CB users so often slagged by Ham and UK FM I am sick of reading in your very good and interesting mag about piggies — that is Ham OP's — blaming us for jamming repeater stations and other nasty things.

I have the equipment (mobile) with which to jam — disrupt — and do the nasty things we are blamed for, but my only interest in (Piggy) bands is to listen and learn, not to use for transmission.

Many (Piggies) use SSB and UK FM. Some who have been on the Ham bands for many years, at least two of them, both old hands, have admitted to having jammed the repeaters on 2m.

Myself and several friends who earwig have had a meeting on the subject. We are so fed up with being hounded by the Home Office — RSGB, we are thinking of doing what we are blamed for, so for the sake of peace on the airways, cool your (Piggies) and we will not cool down a bit. We expect some blame. We could, but we do not wish to take the RAE.

And one thing in our favour. We know where most of you live, but you do not know us. Most of your addresses are in the 83 Ham Year Book.

So remember to your Ham readers, leave us alone, and we will leave you alone.

I am not being offensive, just trying to state our case. Chow from SSB to Ham. May there be peace between us.

SSB CB USER DORSET

Oink — Ed.

WOODEN STAKES

HRT, Really! You only print letters with comments like; "It's becoming another waveband for CB'ers" (re. 2m), to provoke a little controversy. I'd like to ask Brian Patchett, who seems to be judging 2m on a cursory glance at FM mobile operation, where on CB can you get QRO operation, SSB, CW, RTTY, satellite, choice of antenna, etc. etc. etc? 2M is a proper amateur band, if you take the trouble to use it as such.

Martin Smith's reference to the confining licenses to over 18's. When I hear opinions like that, I reach for the garlic and wooden stakes! This sort of retrograde idea,

coupled with the unfortunate experiences of young J. Pelham, indicate to me that the real problems regarding relations between operators within the UK stem from snobbery and intolerance, from those old enough to know better!

I wonder, for example, who was the first person to sign a letter and to append his callsign to his signature? He started a trend which most of us follow, these days; but when you think of it, adding a callsign behind your name, as if it were a university degree, or a fellowship of some august society or institution, is a little pretentious. A callsign belongs to a station, and is used by whoever is licensed to use the station. If I visit my friend's house and use equipment, I use *his* call sign, *not mine/A!* But this is only a small point, so let it pass, except for the proviso that I will not be putting *my* callsign after my signature!

To end on a lighter (?) note, with a word to Tony Bailey, don't joke about TVI-stricken neighbours dismantling an antenna, instead of knocking on the door of the station. A friend of mine had this rotten trick pulled on him, and he blew every single transistor in his 101!

PAUL THOMPSON

SMALL NIGGLE

OM, I have bought each copy of your magazine since you started, and I will probably continue to do so because I think the level of its contents is pitched about right for the large majority of readers who do not appreciate the highly professional level of most articles in *Radcom*.

Just one small niggle — I have not been able to find the results of the competition in the January issue, which I would expect to have been published before now. If I have overlooked it please let me know the issue and page in which it appears, or explain why it has not appeared.

JOHN WINDCOMBE G62H

The answers you want appear (by a remarkable trick of fate) right here! They are: B,B,C,C,B,A,B,B,D,B,E,D,C,C in that order — Ed.

PLAIN SPEAKING

Sir, Help! I'm beginning to think I'm unique or thick or something.

You see, my problem is that I want to build my own equipment for 70cms, microwave etc. but, and it's a big but, I served my apprenticeship as a toolmaker and not as an electronics engineer.

I've always been interested in radio but

RADIO TODAY

News about amateur radio compiled by Richard Lamont G4DYA

Western Woodpeckers?

Britain and the USA are both developing HF over-the-horizon radar systems for military applications, operating in the 5-28MHz range.

The American system, called *Conus OTH-B*, has already been operating in experimental form for three years. (The 'B' stands for Backscatter.) It consists of a transmitter site at the Moscow Air Force Station, Maine, North-East USA, and a separate receiving station 110 miles away at the Columbus Falls Air Force Station, also in Maine.

The system is intended to provide long-range detection of 'air-breathing' threats, ie. bombers and cruise missiles aimed at North America. It would provide the US with an early warning period of hours, rather than the minutes offered by conventional UHF radars.

In spite of the enormous transmitter powers involved (100 Megawatts ERP for the prototype alone) the USAF is claiming that interference is unlikely, because the system would only operate on empty channels in the fixed and broadcasting bands, and that certain frequencies including amateur bands would be considered as 'guarded frequencies' and not used at all. A spokesman for the USAF's Electronic Systems Division (which is developing *Conus*) admits "The Air Force is not denying the possibilities of interference. The signal is awfully small. One of the ham publications has compared this to the Woodpecker. There is no comparison. This system is very sophisticated, whereas the Woodpecker seems to use a brute force approach".

The present system was built by General Electric, which won the contract in 1975. Testing began in June 1980. This first installation is now being upgraded, and it will be the first operational radar, covering the Eastern

approaches to the USA. The USAF plans to build a second site in the West over the next four years or so. Longer term plans exist for a third radar in the South.

British OTH radar

The American *Conus* system uses skywave propagation to achieve its range. The British defence establishment is working on a *surface wave OTH* radar system, operating in the same 5-28MHz frequency range as *Conus*. According to the Ministry of Defence, the British system is not intended to detect incoming nuclear bombers and missiles. The MoD, not surprisingly, refuse to say what the system is for. They did, however, divulge that the system has a pulse repetition frequency of a fraction of a Hertz, and is supposed to have a 'very long range'.

According to an American OTH radar consultant, the only place where you could expect very long range propagation of an HF surface wave is at sea, where the salt water provides a low resistance ground plane. A ship-based HF surface wave radar could be used to

give warning of both enemy ships and sea-skimming missiles such as the *Exocet*. (It would hardly come as a surprise to learn that the MoD wants to improve ships' ability to detect such threats.)

In America, General Electric has conducted studies on surface wave HF radar, and there have been reports that the US Navy is (or has been) doing similar research.

The Ministry of Defence has not yet commented on the likelihood of interference from the British system to existing users of the HF spectrum, including amateurs.

AMSAT LAUNCH

The Phase IIIB amateur satellite is (at the time of writing) due to be launched on June 4th or 5th. It will be put into a highly elliptical orbit by the European Space Agency's *Ariane 7*, from its launch site on Devil's Island, French Guiana.

Different parts of the satellite are being built in the USA, West Germany and the UK, at a cost of £270,000. It will be assembled in the AMSAT Space Laboratories in Washington.

If the satellite works satisfactorily it will be renamed *Oscar 10*. It will have an orbital period of 24 hours with its apogee (maximum height) above Greenland. As orbital speed varies in proportion to the inverse cube of height, the satellite will stay near its apogee point for a considerable time — long enough to keep it in range of the UK for about 12 hours a day. With an aerial pointing North North East from the UK, it should be possible to use the satellite throughout the evening without moving the beam.

This 24-hour elliptical orbit is not a new technique — it is, for example, used successfully by the Soviet Union for their *Molniya* communications satellites,

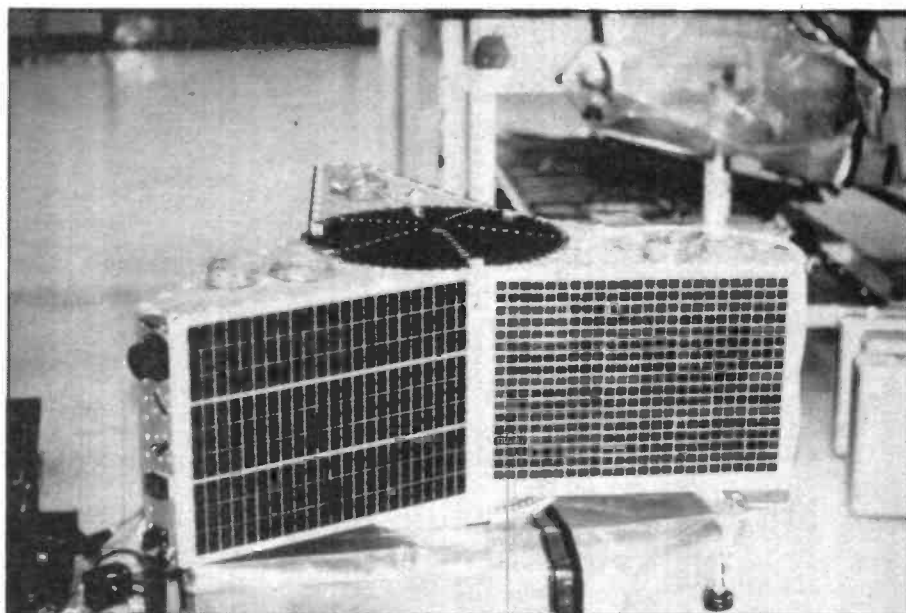

The AMSAT Phase-IIIB satellite will look like this (Phase-IIIA) when assembled

which distribute television programmes to transmitter sites.

The satellite will carry transponders for 70cm to 2m and for 70cm to 23cm. Each transponder will have three 'special service channels' at the high and low end of each passband. These channels will be called H1, H2, H3, L1, L2 and L3. The exact allocation of these channels has not been decided yet, but it looks as though L3 and H3 will be reserved for AMSAT engineering work. Also, a Sunday news bulletin with a European flavour will be broadcast on L1 and H1. This will be prepared jointly by the RSGB and AMSAT-UK. The Home Office has approved this scheme, and other countries may follow.

All the aerials in the spacecraft have left-hand circular polarisation, enabling ground stations to use plane-polarised aerials without fading. AMSAT-UK stresses the need to keep power levels on the 70cm uplink to no more than 500W (27dBW) effective isotropic radiated power (EIRP). EIRP is related to transmitter power and aerial gain by:

$$\text{EIRP (dBW)} = \text{TX O/P power (dBW)} + \text{aerial gain (dBi)} - \text{feeder loss (dB)}$$

or

$$\text{EIRP (dBW)} = \text{TX O/P power (dBW)} + \text{aerial gain (dBd)} + 2.15\text{dB} - \text{feeder loss (dB)}$$

(dBi is aerial gain over an isotropic radiator, dBd is gain over a half-wave dipole.)

TELECOMMUNICATIONS BILL

The Government's Telecommunications Bill, which 'privatises' British Telecom and tightens up the Wireless Telegraphy Acts, has had its third reading in the House of Commons. It got through by 286 votes to 241, a Government majority of 45.

The implications of the Bill are explained in the *Radio Today* pages of our March issue.

NEW COMMUNICATIONS EXHIBITION OPENED

A major new exhibition has been opened at the London Science Museum, showing the growth of telecommunications from the early days of the telegraph to the present.

The exhibition is in two adjoining galleries — the first shows the history of both radio and 'landline' techniques, while the second shows some of the methods used in the present day international network.

The first section includes life-size mock-ups of the 1850 Tonbridge Railway telegraph office, a ship's radio cabin of

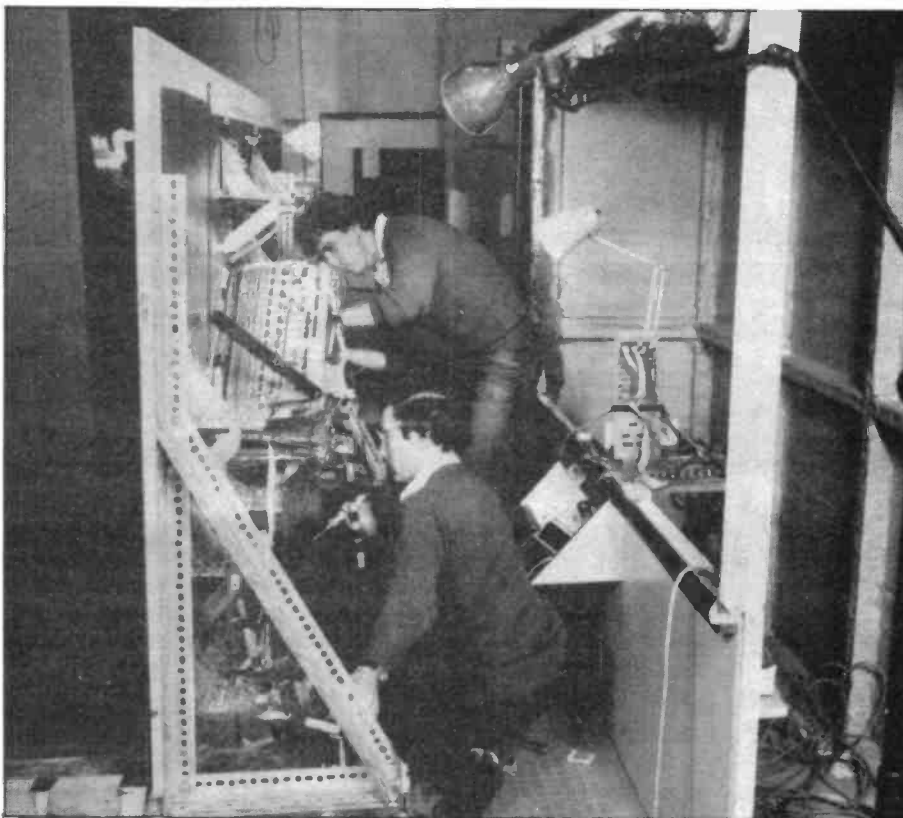

British Telecom engineers at work on a demonstration of Packet Switchstream' at the Science Museum's new communications gallery

1910 and the radio operator's position in a Lancaster bomber. Technology is barely touched — the exhibition is aimed at the general public rather than people with technical know-how.

The second gallery deals with modern systems, and includes a mock-up of the inside of a British Telecom manhole (complete with a mock-up of a British Telecom employee). Other displays aim to show things like packet switching, pulse code modulation and System X. There is also a cinema showing a short film, *Echoes*, made by STC, who sponsored the exhibition.

Amateur radio is not forgotten. Two 'black boxes' share a small display case with a CB set.

NOVICE LICENCE CAMPAIGN

The Amateur Radio Novice Licence Campaign (ARNLC) has been set up to campaign for (believe it or not) a novice amateur radio licence.

The Campaign accuses both the Home Office and the RSGB of 'dragging their feet'. The Campaign's secretary, Ian Abel G3ZHI, says "since 1947 the RSGB has failed in its negotiations with the Home Office to bring about the introduction of a Novice Class of licence. This is despite a promise in Parliament by the then Postmaster General in 1968, E Short, of his intentions to introduce such a licence "later in the year". The Novice licence is already available in a number

of countries around the world.

"The Home Office has stated that they have no objection in principle to the introduction of a Novice Licence. However they are not convinced that there would be sufficient interest in such a licence. This is why the ARNLC has been formed."

If you're interested write to: Ian Abel G3ZHI, 52 Hollytree Avenue, Maltby, Rotherham, South Yorks. Tel: 0709 814911.

EXHIBITION SUCCESS

The RSGB's National Amateur Radio Convention, held at the National Exhibition Centre near Birmingham, attracted over 10,000 visitors during the two days it was open. There were slightly more people there on Saturday than Sunday. The move to the NEC was experimental, and the RSGB says that some traders were so pleased they have already booked space at next year's event, which will now also be at the NEC. The RSGB says "We hope, next time, to make it even better."

... and NARSA ...

Another two-day event was the Northern Amateur Radio Societies' Association exhibition at Southport (originally held at Belle Vue near Manchester). This event also attracted large crowds, but some traders say they were disappointed by low sales.

G4JDT
HARVEY

EAST LONDON HAM STORE

H. LEXTON LIMITED

191 FRANCIS ROAD LEYTON E.10
TEL 01-558 0854 TELEX 8953609 LEXTON G

DRESSLER AMPLIFIERS

These are high power 240V linears using 4C x 150 or 4C x 350 Eimac Tubes NOT using the grounded Grid system. Fully protected, no thermal damage to PA finals possible.



DRESSLER AMPLIFIERS NOW MORE POWER

D70 70cm 300wfm 600w PEP	£700.00
D200c 2mtr 125wfm 200w PEP	£285.00
D200 2mtr 300wfm 600w PEP	£595.00
D200S 2mtr 400wfm 1KW PEP	£695.00

GASFET DRESSLER PRE-AMPS

VW2GAAS 150w	£40.00
VW200GAAS 750w	£69.00
VW2000GAAS 1Kw	£79.00
WZRP5 S0259	Non switching £22.00
WZRP5 N Type	£24.00
WZRP5 S0259	£22.00
WZRP5 N Type	£24.00
W Interface	£18.00

Powered by the linear or with separate interstage
0.7-0.9dB signal to noise
0.2dB insertion loss



GASFET MASTHEAD PREAMPS

3SK97 GASFET Available separately £5.00

AVAILABLE SOON NEW MODELS

YAESU FT 726 6-2-70 TRANSCEIVER + BAND WORKING FACILITY PRICE T.B.A. + TRIO/KENWOOD TR7930/795025/50W FH MOBILES + TR3500 70VMS PORTABLE + R2000 RECEIVER. TS430 HF TX/RX GEN COVER.

ICOM	ICOM	ICOM	TRIO/KENWOOD
IC740 HF 100W £660.00 IC720 RH-F 100W G/C £883.00 IC730 HF 100W £586.00 IC2K Linear £829.00 IC2K LPS P.S.U. £211.00 PS15 P.S.U. £99.00 PS20 P.S.U. £130.00 AT500 A.T.U. £299.00 RX70 Receiver £469.00 RS15 P.S.U. £99.00	IC2E 2mtr fm portable £159.00 IC4E 70cm fm portable £199.00 IC25G 2mtr 25w fm £235.00 IC290 2mtr 10w fm/ssb £366.00 IC251 2mtr 10w fm/ssb/base £495.00 IC451 70cm 10w fm/ssb/base £630.00 IC490 70cm fm/ssb mobile £445.00 ICSP3 Speaker £29.00 ICSM5 Mic £29.00	Accessories ICLC 1 2 3 case £ 4.25 ICWM9 SP Mic £ 12.00 ICBP2 6V pack £ 29.50 ICBP3 9V pack £ 20.00 ICBP4 empty pack £ 6.95 ICBP5 12V pack £ 39.50 ICCP1 charging lead £ 3.75 ICDC1 12V car park £ 9.75 LCB leather case £ 18.98 BC30 Base Charger £ 45.00	TS800 General Coverage RX TX £995.00 TS800 100W HF £660.00 TS830 100W HF £475.00 TS130 100W HF £495.00 TS130 25W 2mtr FM SSB £390.00 TS7930 25W 2mtr FM P.O.A. £245.00 TS7950 45W 2mtr FM P.O.A. £300.00 TR2500 2mtr Portable £200.00 TR3500 70cm £220.00 TR7730 2mtr FM £245.00 AT230 £110.00 SP230 £34.00 DK8011 GDO £60.00 R600 Receiver AM/SSB £190.00 R2000 Receiver £360.00
YAESU FT one gen coverage DX/RX £1295.00 FT102 150W 10mtr-160mtr £990.00 FT107 100W 5-10mtr P.O.A. FP707 20A P.S.U. P.O.A. FC707 A.T.U. P.O.A. FT107M 9 band 100W P.O.A. FP107 P.S.U. P.O.A. FT101ZD 160-10mtr P.O.A. FT3020M 160-10mtr AM/FM P.O.A. SP901 Speaker £36.00 FC302 A.T.U. £135.00 FP107 P.S.U. P.O.A. FL210GZ 1.2KW PEP linear £425.00 FC102 Speaker P.O.A. FC102 A.T.U. P.O.A. FY102 V.F.O. P.O.A.	YAESU FT230R with mods £245.00 FT480R 2mtr mobile FM/SSB £365.00 FT780R 70cm 7.6 swift Shift £400.00 FT780R 70cm 1.6 swift Shift £440.00 FT208 2mtr portable FM £195.00 FT108 70cm portable FM £205.00 FT230 2mtr FM mobile £220.00 FRG7700 receiver AM/FM/SSB £295.00 FRG7700 memory £80.00 FT790 VHF Multi £290.00	FRV7700A 118 150 £60.00 FRV7700B 50.60 118 150 £75.00 FRV7700C 140 170 £65.00 FRV7700D 70.80/118.150 £72.00 FR77000 Aerial Tuner £37.00 FRA7700 Active Antenna £36.00 FF5 Filter £9.95 MM611 FT290 Car Mount £22.00 NC11C Charger £8.00 NCB Base Charger £44.00	DIAWA CN520 1.8-60 MHz £32.00 CN540 50-150 MHz £34.00 CN620A 1.8-150 MHz £52.00 CN630 140-150 MHz £74.00 CNW518 3-30 MHz ATU £170.00 CNM1001A AUTO ATU £150 ROTATORS DR7500R 3 ELE BEAM MF £105.00 DR7500X 3 ELE BEAM MF £95.00 DR7600R HEAVY DUTY 2 ELE HOMTR BEAM £148.00 DR7600X HEAVY DUTY 2 ELE HOMTR BEAM £138.00
Morse Readers MBA electronic morse RTTY reader £190.00 Microdot/morse RTTY printer V.O.U. key board tail one piece £650.00 TASCO B10 Codemaster £169.00	DATONG D70 Morse Tutor £56.35 PC1 Gen. cov. converter £137.00 FL1 Agile filter £79.35 FL2 Active filter £89.70 FL3 Agile filter & notch £129.37	POWER SUPPLIES Alinco EP 2500 25 amp i.c. regulated with s/c protection £89.00 Also EP 3000 15 amp metred version voltage adjustable 6-15 volts £89.00	SONY ICF2001 receiver £140.00 Microwave modules MML 144 30 1.3w drive £9.95 MML 144 100 L S 1.3w drive £159.95 MML 144 100 S 10w drive £139.95 MMC 435 600 AMV converter £27.90 MM2001 RTTY receiver £189.00 MM4001 RTTY transceiver £269.00 MM1000 KB key board - transceiver £299.00 MMT28 144 £109.95 MMD050 frequency counter £75.00 ALL MODELS STOCKED
WELTZ SP200 1.8 160MMZ 20 20G 1KW £59.00 SP300 1.8 500MMZ 20 200 1KW £79.00 SP400 1.3 500MMZ 5 20 150 £59.00 SP250 1.6 60MMZ 20 200 2K £43.00 SP15 1.08 160MMZ 5 20 200 £29.95 CT150 150 400W Dummy Load £31.00 AC3R 3.5 30MMZ A.T.U. £59.00 SP10X 108 150MMZ 20 20n £19.95 CT300 Dummy Load	MORSE KEYS Morse keys Swedish brass key £49.00 Himound HK706 £11.00 Himound HK706 £20.00 Himound HK702Z £22.50 Kenpro squeeze key 100 electronic key £57.00 Dawa DK210 Electronic keyer £41.00		

TONO	TONNA	TET	JAYBEAM	HOXIN
2M 50W Linear amp 1-3Win £62.00 2M 70W Linear amp 10Win £90.00 2M 100W Linear amp 10Win £115.00 8 500 CW RTTY Terminal £299.00	144 4ELE £12.00 432/440 21 ELE £19.00 144 9ELE 432/435 21 ELE ATV £27.00 144 9ELE crossed 30 0 144 435 9 19ELE £31.00 144 9ELE portable 30 0 144 19ELEX £30.00 144 16ELE £33.00 1236 23ELE £27.00 144 13ELE portable £29.00 Phrasing Harness 430 440 19ELE crossed telescopic masts 435 19ELE £19.00	HB33T £189.00 HB34T £202.00 HB35T P.O.A. HB35C £280.00 SQ22144 £55.00 SQ22QX144X4 £90.00 SQ007 70cm P.O.A.	TB3 HF 3 band £189.00 VR3 band verticle £46.00 C52M colinear £54.00 5Y2M SELEYAGI £14.00 8Y2M BELEYAGI £17.00 10Y2M 10ELE YAGI £24.00 PBM1010EPARABE AM £44.00 PBM1414EPARABE AM £55.00 5XY2M £28.17 8XY2M £35.00 10XY2M £46.00 Q4Y2M £29.00 O6Y2M £39.00 O8Y2M £44.00 MBM548/70cm £35.00 MBM88/70cm £48.00 8XY 70cm £42.00 12XY 70cm £52.00	GP5 2mtr colinear 6.4DB £33.00 DK1 discone TX TX £34.00 HF5DX 80 40 20 15 10 mtr Vertical £84.00
SCANNING RECEIVER Scanning Receiver Sx200N £249.00 Drawa SR1000 £70.00				
ROTATORS Kenpro KR 250 £44.95 Hirshmann HR 250 £50.00 Kenpro KR400RC £100.00 Kenpro elevation rotator £85.00	144MHz 432MHz 1250-1296 4ELE £12.00 19ELE £18.00 23ELE £25.00 9ELE Fbx £15.00 19ELEX £26.00 Telescopic Masts 9ELE Port £17.00 21ELE ATV £26.00 4x1M £15.00 9ELE x £28.00 144/435 9+ 19ELE £30.00 4x2M £28.00 13ELE Port £26.00 3x2M £19.00 Power splitters etc. available			

ALL ACCESSORIES AVAILABLE - PLUGS SKTS CO-AX 2MTR COLINEAR £31.50. 70CM COLINEAR £31.50

PRICES INCLUDE VAT AT THE PRESENT RATE OF 15%

OPEN MON - FRIDAY 9.00 - 5.30. SATURDAY 10.00 - 3.00. INSTANT HP FACILITY AVAILABLE

EASY ACCESS M2 M11 - M1 NORTH CIRCULAR ROAD - EASY PARKING





The Facts and Fiction of VHF/UHF Aerials

Amateur radio has distinct similarities with the pursuit of a better hi-fi system. Give or take a fraction of dB, all audio amplifiers are the same. The way to better audio lies in the choice of loudspeaker system and signal source. When it comes to RF, there is little to choose between the various Japanese black boxes except the price. The most important thing that you can have is a decent aerial system.

By Frank Ogden G4JST, Editor
HAM RADIO TODAY

When buying an amateur radio station off the shelf, as much as half the total purchase price should go towards provision of the aerial system: a 10 watt two metre multimode costs, say, £350. A basic aerial system will add another £50. You want to put out a better signal so you invest a further £300+ on one of those magnificent Dressler linear amplifiers. The power goes up to 200W, the price goes up to £700+ and received reports should show another 2½ S points on everybody else's S meters. Your meter, however, will still be giving the same reports as it always did.

Going back to square one you buy your 10W transceiver, spend £150 on a rotator (cheap ones are false economy) vertically stack four 8-element Yagis (£100) and divide the remainder of the investment between the purchase of Westlake's H100 feeder (much lower loss than UR67) and some strong aerial lashings. The result of this approach would be to collect an extra two to three S points on received reports

while having improvements of the same order on your reception... all with a basic 10W set. If you then add one of Lexton's amplifiers, you will have a potent station indeed.

Aerials and feeder systems are important because there is no other aspect of a station which acts to improve both send and receive simultaneously (except perhaps moving house to a better location but that is expensive). Even the best in GaAsFET receive preamps will generally do less for your receive noise figure than just a very modest Yagi.

A general point

The performance of any aerial system is determined almost entirely by the amount of metal intercepting the incoming radio wave. The way in which a radio signal is converted to an RF voltage at the aerial socket is dependent on laws of physics, not advertising claims.

The corollary to this is that an aerial system having the same

number and arrangement of elements will perform as well as a similar aerial system from any other manufacturer. When you choose between aerial manufacturers for a specific aerial type, for instance 2m 10-element X/Y, you must look for durability, wind loading and price, not the specified aerial gain. There will be minor differences such as slight variations in bandwidth from manufacturer to manufacturer although the perceived differences will be minimal or non-existent. More on the topic later.

Going mobile

All the points made in the last couple of paragraphs apply even more thoroughly to simple aerial systems than complex ones. A 5/8 boot mount is a 5/8 boot mount regardless of who makes it, a 2 x 5/8 base station co-linear has electrically the same characteristics as a similar arrangement of co-linears from any other manufacturer you care to name. Likewise with quarter-

waves, halos and rubber ducks.

The only differences between types is in manufactured quality. A case in point, the ever popular 2m mobile 5/8 wavelength whip. I've had a number of these things on my car over the years and confirm that they all work equally well when new. However, the cheap types which use the integral loading coil suffer badly from internal corrosion of the loading coil guts after a couple of years' service. The rain and Winter salt spray gets in and the copper plated steel coil literally rots away. Against this, the expensive types with demountable aerial whips and coils sealed against the elements have always been nicked from the car before I've ever had a

chance to see whether they deteriorate any slower.

There are pronounced differences between the aerial types. 1/4 wave aerial whips mounted centrally on the car roof perform better around town — where there are strong multiple reflections — than gain systems: 5/8, 7/8, etc. Short aerial whips produce less mobile flutter than the longer ones although in open countryside, the stronger signals of the big aerials offer a considerable advantage. In my opinion, the 5/8 system offers the best compromise between mobile flutter and signal strength.

Juggling figures

Manufactured quality, rather

than specified performance, is the thing to look for in base station co-linear. In any case, the specifications themselves are very misleading. Virtually all beam type aerial systems are referred to a simple dipole when it comes to calculating dB of gain. For some reason, the reference used to judge the performance of omni-verticals is the quarterwave groundplane. This gives most vertical aerials types 3dB more gain than they actually have when compared to a dipole. Put another way, a simple dipole exhibits 3dB of gain when compared with a quarterwave groundplane system.

Putting the record straight about mobile aerials, in comparison to a dipole (0dB) the 5/8 has 0dB gain, a halfwave exhibits 0dB as does a *Slim Jim* while the 7/8 shows all of 1.5dB real gain. The classic double 5/8 co-linear weighs in at around 2.5dB over a dipole. By contrast, the most basic 2-element beam returns roughly 3.5dB of gain over a dipole.

Hand portable

Handtalkies used as such are remarkably inefficient radiators. The body has to provide the ground image, the other side of the dipole. Since some rubber duck type aerials only have a radiation resistance of between five to ten ohms and acknowledging that the body is a lossy, high impedance radiator, very little RF actually gets out, or is received.

The answer is to use a halfwave

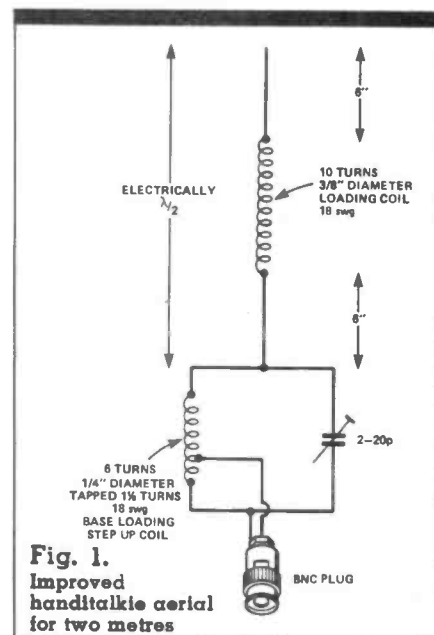
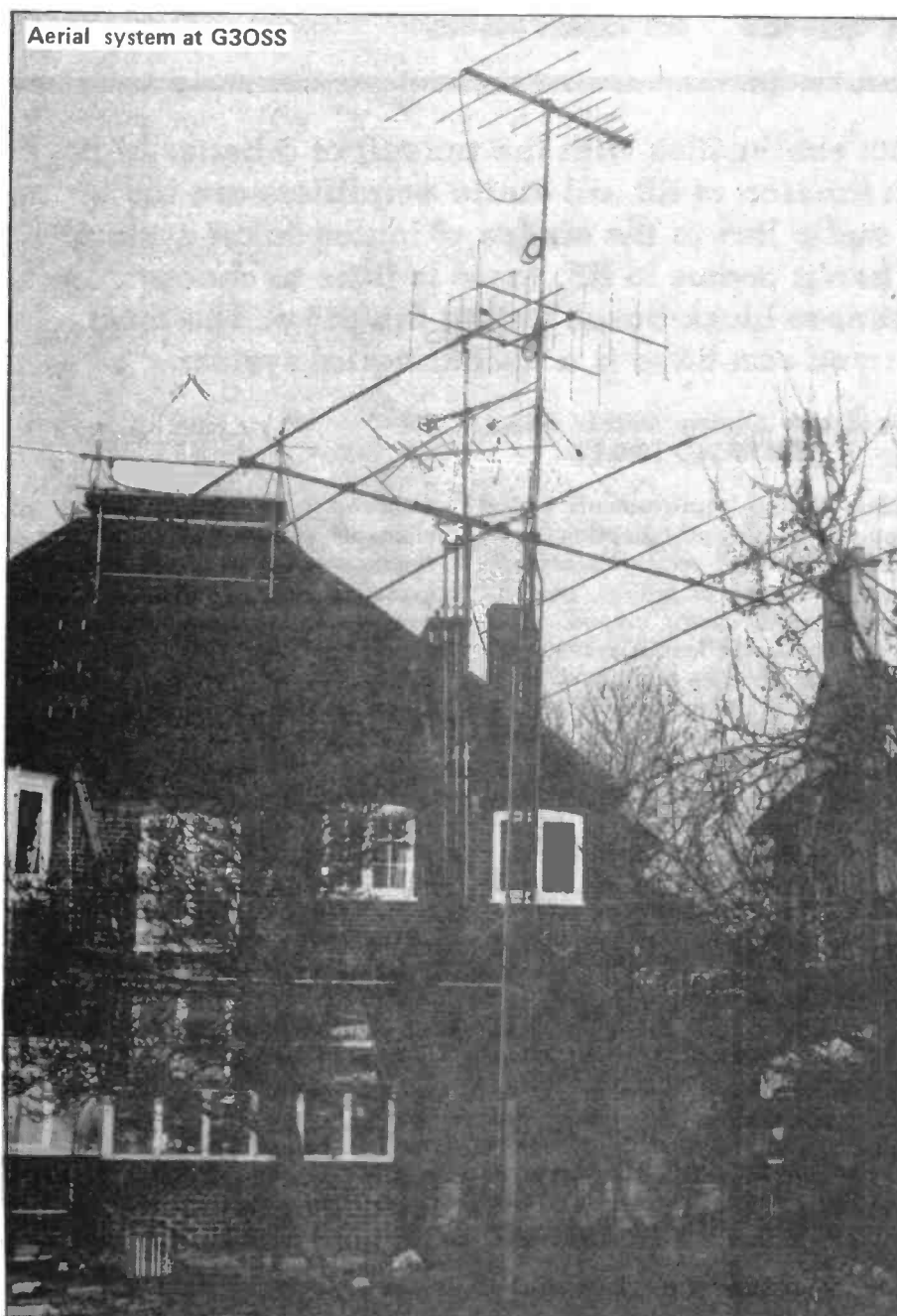

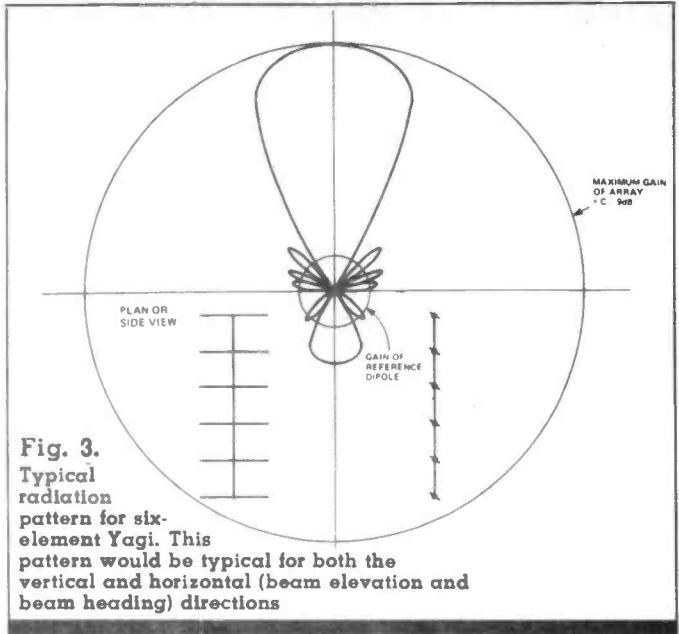
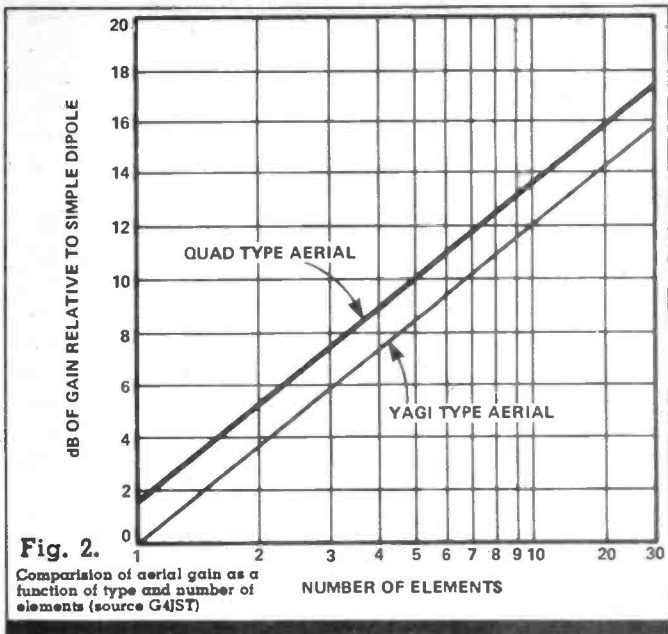

aerial, a system which provides its own ground image. Fig. 1 describes such a system. The bottom tapped loading coil steps up the resistance from the 50 ohms characteristic of the handtalkie to the several thousand ohms of the centre loaded halfwave dipole. Since the circulating currents into the handtalkie casing — and hence into the body — have been reduced by an order of magnitude, the system losses are reduced to minimal proportions. The perceived portable performance boost is dramatic. You can purchase ready made halfwave aeriels for 70cm, but you will probably have to make your own for 2m use.

up a beam aerial system for the first time: how much gain for how little money. It is a perfectly respectable attitude but there are other factors to take into account. For instance, what *kind* of gain do I want? Will my rotator take the weight and the windloading? Will the thing fall to bits in the first Autumn gale?

Kind of gain

It goes without saying that everyone wants the most gain that money can buy and I am not going to go against that view. Fig. 2 shows a plot of aerial gain against the number of elements for both simple Yagi and quad aeriels. When it comes to assessing performance, the precise method of manufacture is relatively unimportant. It is the number of elements that counts. However there are other ways of

achieving gain which have distinct performance advantages.

Stacking of aerial arrays leads to increased gain at the rate of 3dB for each doubling of the number of aerial arrays. Dependent on how they are stacked (either side by side or on top of each other) the resulting radiation polar diagram can show distinct advantages over a single big Yagi or quad of the same nominal gain.

Fig. 3 shows the polar plot of a typical 6-element Yagi. The maximum forward gain will be around 9dB but the beam width — typically in the region of 40° — will be substantially the same in both the horizontal and vertical planes. With this pencil type of beam, you have to point the aerial fairly accurately to realise the system gain. This is fine providing that you know exactly where to look for a station. However,

Beam Aeriels

There are usually only two criteria for people who are putting

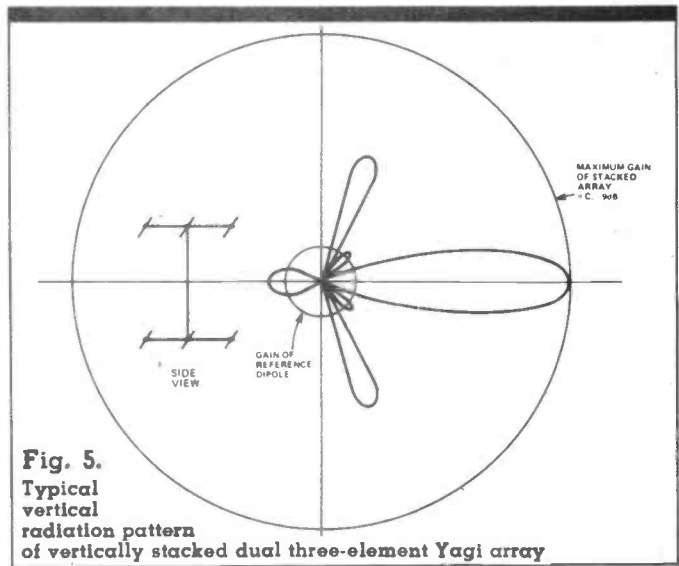
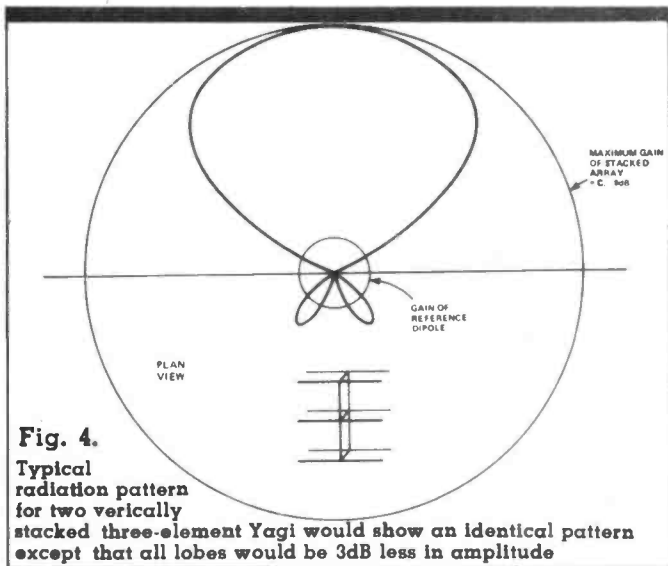

if you are monitoring the calling frequency, you might not hear weak stations that are not exactly on your beam heading and thus miss a lot of the action.

A typical three element Yagi has a gain of 6dB. If you connect two together — with a suitable matching harness of course — the forward gain rises to 9dB, the same as for the single 6-element case. It might seem pointless to go to the trouble of phasing and mounting two aerials where the same gain can be achieved with one but there are real advantages.

Fig. 4 shows the polar plot of two vertically stacked 3-element Yagis. There are two points to note. Firstly, the horizontal plane radiation pattern indicates a beam width of at least double that of a single 6-element Yagi even though the realisable gain is the same. In practical terms, the array is not nearly so critical of beam heading. The other point is that the horizontal lobe characteristic does not differ markedly from a single 3-element array. The same is true of four or more tier systems. Fig. 5 shows that the beam narrowing occurs in the

vertical direction only. This is relatively unimportant since the array elevation will nearly always be parallel with the horizon. In other words the vertical stacking changes the beam from the pencil form of the single Yagi to a fan shape.

Yagi v quad

It is possible to treat these two popular types of aerial in much the same way. The only real difference is the extra 1.5dB of gain that a quad system will have over a Yagi array of the same number of elements. Against this, the quad aerial, element for element, has almost twice the metal of a Yagi. This increases the wind loading and weight. However, there are compensations. Long quads are supposed to be easier to match than long Yagis. The main point about quads though is that they give more gain for a given boom length.

There is one proviso to all these quests for gain. It is important to get optimum matching and phasing. It is very easy to lose hard won performance. Home built aerial designs are prone to this but little trouble

should be encountered with good quality professional units. Provided that the input SWR to the aerial is below 1.5:1 no significant performance shortfall will occur. Even system SWR's of 2:1 will not degrade performance particularly. Remember too that long feeders are lossy. UR67 or better should be used for all runs over about 20ft on 2m. 70cm requires UR67 for all runs over 8ft. I would personally recommend the new H-100 coax from W H Westlake. It has a much lower loss than UR67 yet costs just 80p/metre.





THE WAY AHEAD

**SLIMLINE MASTS or LATTICE TOWERS
FIXED TOWERS or MOBILE TRAILERS**

SOME TYPICAL DESIGN FEATURES

- VERSATILE MOUNTING, POST, WALL OR TRAILER.
- UNIQUE 15FT SECTIONS FOR MINIMUM LOWERED HEIGHT AND EASY TRANSPORT.
- PURPOSE DESIGNED AND ENGINEERED TO B.S.I. STANDARDS: WIND LOADS TO CP3 CHAP. PT. 2
- ROBUSTLY CONSTRUCTED IN QUALITY STEEL (TO BS 1775 BS 980 BS 4360).
- OPTIONAL HEAD UNITS (Extra).

**PORTABLE MASTS or WINDOW MOUNTING
YOU NAME IT! WE PROBABLY MAKE IT!**

SOME TYPICAL DESIGN FEATURES

- WELDED BY ELECTRONICALLY CONTROLLED M.I.G. FOR EXTRA STRENGTH TO BS 4872.
- MORE THAN 50 TYPES OF MAST OR TOWER FROM 30FT TO OVER 100FT.
- TELESCOPIC TILTOVER FOR EASY ACCESS.
- SAFETY LATCH TO RELIEVE CABLE.
- SIMPLE WINCH OPERATION (Single and Double).
- HOT DIP GALVANIZED FOR PROTECTION (BS 729).

A FEW POPULAR MODELS FROM OUR WIDE RANGE

SLIMLINE MAST SM30, Unobtrusive, Telescopic, Tiltover, up to 31ft. SM30WM (Wall Mount) £230.00. SM30PM (Post Mounting) £241.00. Optional Reducer Tube RT1 £12.50. Rotor Head RH1 £30.50. Ground Socket GS1 £23.50.

LATTICE TOWERS — TELESCOPIC — TILTOVER
 Series 1. 32AT.AT32PM for £363.00. AT32WM £348.00
 Series 2. Heavy duty 44ft. AT42PM £461.50. AT42WM £445.00. 56ft. AT52PM £599.50. AT52WM £579.00.
 Prices include all winches, luffing gear, brackets, head unit etc. As applicable. Mainland carriage (door to door). And VAT @ 15%. Terms C.W.O. Send for details. Prices may alter. Please allow 28 days for delivery.



We design — we make — we supply direct. At manufacturers prices. You get best value and service. No middle men. We offer no gimmicks. No free gifts. Just competitively priced quality and reliability. We have been doing it for over 12 years.

*Callers welcome. Samples on display. Opening hours: Mon-Fri. 9 am-5 pm.
Sat. 9 am-12.45 pm.*

ALL ALTRON PRODUCTS ARE EXCLUSIVELY MANUFACTURED IN THE U.K. BY

ALLWELD ENGINEERING

UNIT 6, 232 SELSDON ROAD, SOUTH CROYDON, SURREY CR2 6PL.
 Telephone: 01-680 2995 (24 hr) 01-681 6734

Eleven to Ten

To the comparative old timers; that is the early G8_____s and later G3_____s the present multitude of black, grey and blue boxes must often cause nostalgic reflections back to the good old days of their amateur beginnings. In the late 60s and early 70s the normal way of getting on the air was either by rolling your own or modifying government surplus gear or ex-commercial equipment. The early days of two-metre expansion (when 144MHz was opened to the Class B brigade) meant that the majority of rigs were ex-PMR, Pye, Storno, Cossor etc. Nowadays an all singing and dancing rig capable of working at least six repeaters via a linear and multi-element beam seems an essential requirement of the newly licensed G6_____, and the state of two-metre operating confirms this fact. Many operators must have longings for the good old days and those who have moved on to Class A have such an escape open to them, namely mobile FM on 29MHz.

With the advent of CB, equipment capable of easy modification to 29MHz is available cheaply. Some of the transceivers around are of a reasonably high standard, giving scope for modification to good performance at very low cost. Cheap mobile aerials are also readily available.

40 channels

A typical block diagram of a 40 channel (10kHz spacing) CB set would be as in Fig. 1. For simplicity an AM set is chosen. Details on converting an AM set to FM (with a performance typical of 145MHz gear) will be given later.

The basic transmitter and receiver circuits are fairly conventional in that a low power PA is driven by a simple driver, both stages being modulated. The pre-driver stage is excited by a frequency synthesiser which also includes a safety circuit. This cuts the transmitter off if the synthesiser goes out of lock. The synthesiser consists of a voltage controlled oscillator operating (in this case) at the output

Converting 27MHz CB sets to the 10 metre amateur band

by Bill Sparks G8FRX

frequency minus the first IF (generally 10.695MHz). The synthesiser is locked to a multiple of 10kHz, derived from 10.240MHz crystal. This 10.240MHz oscillator circuit also drives the second receiver mixer, giving a second IF of 455kHz. The VCO frequency is mixed with the 10.695MHz oscillator to transmit on the same spot as the RX input frequency. Suitable T/R switching is provided and the rig operates like just about any other transceiver. The main difference between the conventional amateur arrangement and the one discussed above is that the injection frequency to the first RX mixer is lower than the received channel, whereas it is normal amateur practice to operate receiver oscillators on the high side of the signal frequency. The variety of CB equipment is extremely wide but certain basic similarities are

found. The major variations are in the frequency synthesisers. Since our aim is to transfer the operating frequency to a point some 2MHz higher we will consider the synthesiser stages first.

Basically, there are three main techniques used in synthesiser circuitry in CB sets although certain other oddball circuits exist. The three methods are as follows:

a) To prevent any form of conversion to additional frequencies a form of Read Only Memory is incorporated in the PLL which is dedicated to giving only the forty channels recognised by the FCC in America. Typical devices are the (see Appendix 1) 7137, 7130 and 7131. These devices are invariably operated by programmed input lines usually by a 6 bit code.

b) Another form of pre-programmed device uses a so called 'random' code which is a variation of the 7 bit BCD code, eg. 9106 & 9109.

c) The major proportion of the sets used phase locked loop circuits controlled by a straight binary input and these are comparatively simple to re-tune. A brief explanation of binary arithmetic is given in Appendix 4.

Dedicated v binary

In type (a) & (b) the device is

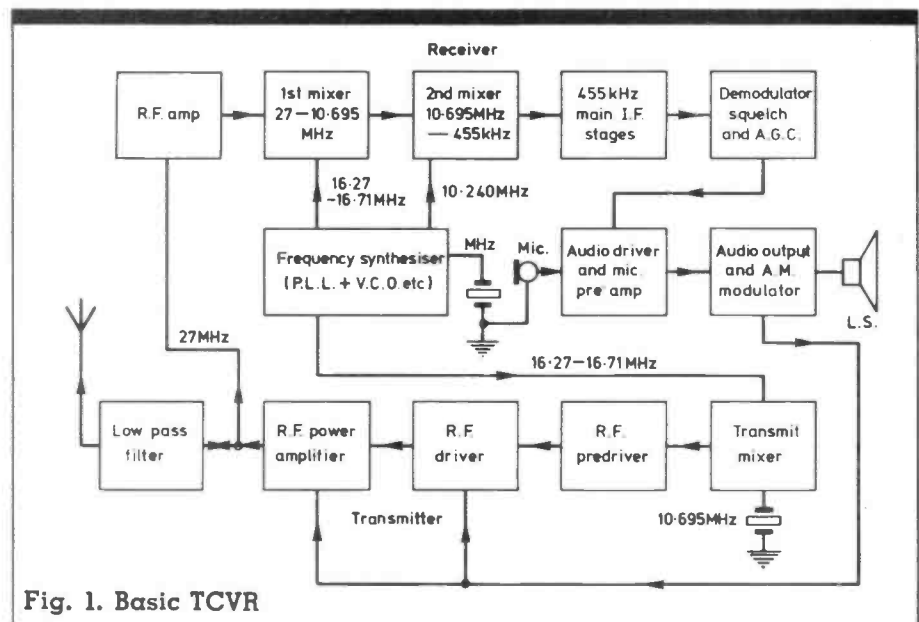

Fig. 1. Basic TCVR

usually loaded with forty discrete operations and these are called up by the input logic variation, but in type (c) the number of operations carried out by the device is controlled only by the binary number range the device will accept. In many cases as many as nine inputs or program lines are available, thus giving 2^9 variations, ie. 511 different lines. Since we originally stated that the channelling was at 10kHz intervals this gives a tuning range of 5.11MHz.

The simple operation of a syn-

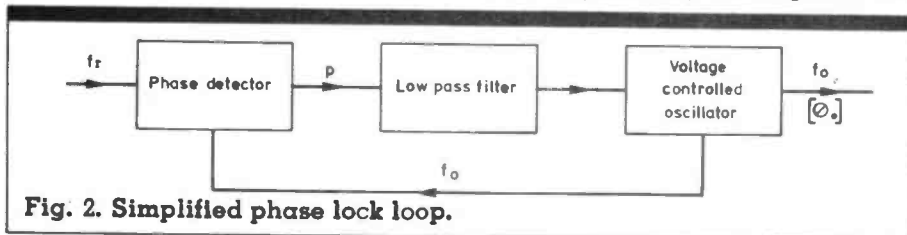

Fig. 2. Simplified phase lock loop.

thesiser PLL circuit is shown in Fig. 2. When the reference frequency f_r and the VCO frequency f_o are applied to the phase detector, the phase difference is measured in the phase detector and converted into a DC output which is applied to the VCO via the low pass filter. Since the comparison is made every cycle there will be harmonics and noise at the output P, hence the need for the low pass filter. The integrated DC voltage applied to the VCO causes a frequency change to occur, the VCO output being returned to the phase detector. The closed loop will continue to operate until there is no phase difference between the voltage generated in the VCO and that of the reference. The VCO is then locked on to the reference frequency and the VCO output (f_o) is in phase lock with the reference.

To apply this technique in real terms some additional sophistication is required. Since variable frequency dividers used in these circuits have a fairly low frequency maximum count limit and we require a 10kHz channel spacing we have to accept that we are referring to a 10kHz reference and that our VCO frequency of approximately 17MHz has to be divided by some 1700. To overcome this problem the VCO frequency is mixed with an offset oscillator, to give a lower variable frequency which does not require such a high division ratio. Figure 3 indicates a fully operational arrangement.

In order to achieve a range

covering 29+MHz it is necessary to alter VCO to give 29.5-11.695MHz as the operating range.

In the example quoted the channel switch on channel 1 gives an output code of 136, so our new frequency on 29MHz at the lowest end of the range should be controlled by a 136 programmed input to the PLL to be used. By substituting a 17.245 crystal for the 14.910 crystal in the original circuit our transmit frequency should now be between 29.300 and 29.700. However, due to FCC regulations, the original FCC

frequency allocation to CB had certain discrete gaps at 50kHz intervals. The channel switches were designed to skip these numbers in their output; so a typical output sequence from the switch used in our example would be 136, 137, 138, 140, 141, 142, 143, 145, 146, 147, 148, 150 and so on up to channel 20, where normal sequential counting took over up to channel 22. Channel 23 required a count of 165, whereas channel 22 was 162. The sequence at this point was channels 22 - 24 - 23 - 26; then normal counting up to level 44 or in our instance 180.

By interrupting the program lines from the switch and feeding them via a suitably programmed

EPROM the necessary corrections can be made to the coding, so that the switch reading 1-40 gives a progressive binary input to the PLL, enabling a true 10kHz channel sequence.

In some instances the VCO coil may not tune to the new frequencies. This can be changed fairly easily either by reducing the length of the coil or by reducing the coil padding capacitor.

Where it is necessary to replace the synthesiser due to it being a dedicated device, the simplest method is to introduce a composite board containing the EPROM and the alternative synthesiser. A suitable board is shown in Fig. 4 together with the circuit and layout in Figs. 5 & 6. As the circuit indicates the program lines are fed to the EPROM and the modified program is then fed to the synthesiser. The details of operation and installation will be dealt with later in the article.

PCB drawings Figs. 4, 6 and 9 will appear in a future issue.

Unfortunately there were mistakes in the original artwork — Ed.

Another technique was often used to cut the number of crystals. By taking the 10.240MHz signal and dividing it by two, a 5.12MHz signal was derived. This frequency was multiplied by three to give 15.36MHz which was then mixed with the VCO. This was then submitted to the divide-by-N module, giving

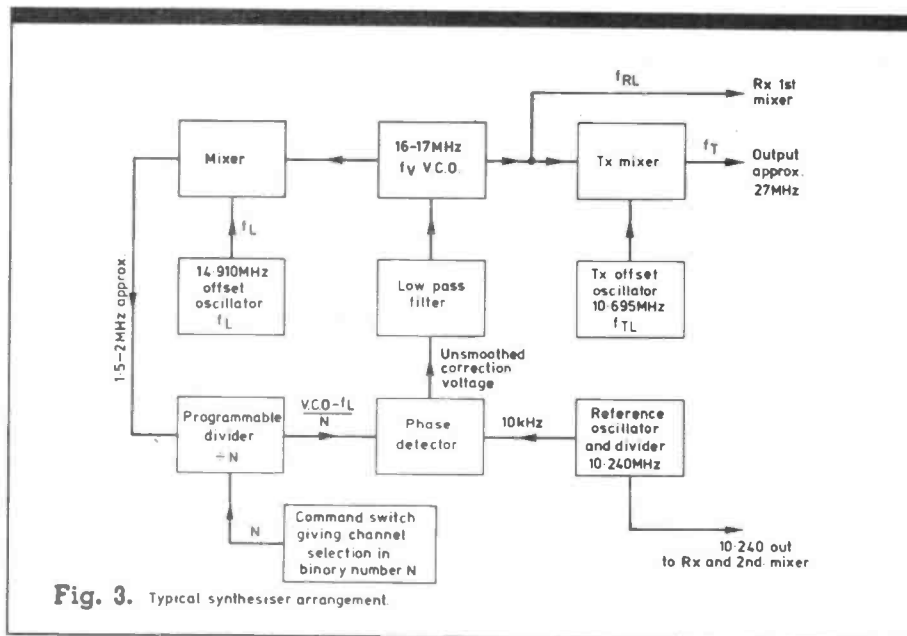
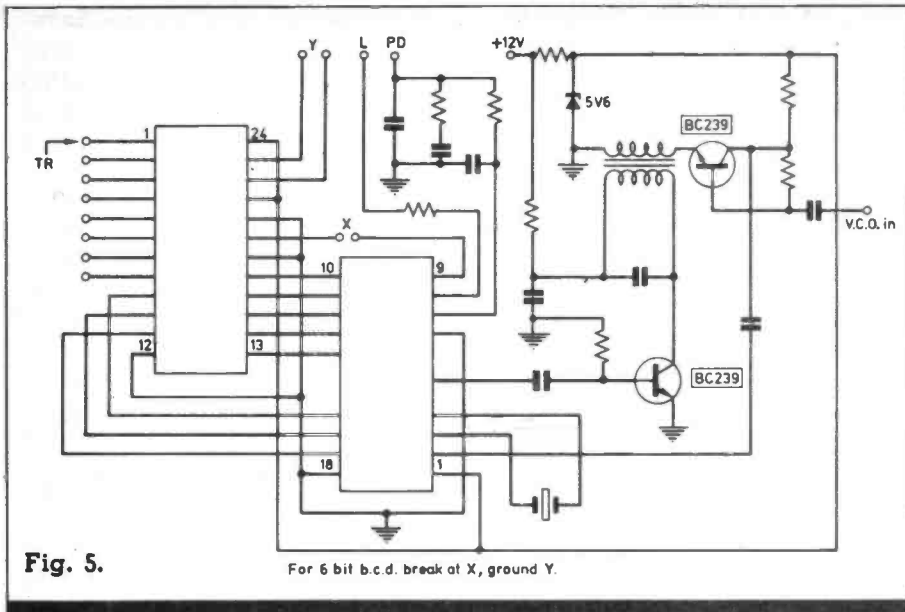

Fig. 3. Typical synthesiser arrangement.



with the 10.240 frequency to achieve the required output in the T/R switching.

$$\text{ie. } VCO + 455\text{kHz} + 10.240\text{MHz} = \text{TX frequency}$$

In practical terms the VCO output is fed to a simple transistor mixer which is hard switched by the 15.36MHz derived as shown in the circuit diagram for the board, Fig.4.

The two devices shown at the input to the dividers are Schmitt triggers, which assist in preventing random noise from operating the counters, by squaring the shape of the input pulses. In the case of conversion to MPT1320 the 5kHz technique permits a frequency shift of a straight 64 in count (27.605 - 26.965) and then 5kHz correction of the 27.605 to bring it to 27.600. A

ing a count range similar to the ones discussed previously.

From the discussions so far it would appear that the majority of sets around could be converted to operate on 29MHz FM.

The use of the 10.240MHz crystal as the reference oscillator permits a variety of functions.

a) The division by 2^{10} gives 10kHz since 2^{10} is 1024.

b) Division by two and multiplication by three gives 15.36MHz which is a handy offset frequency, also multiplication by two gives 20.480MHz, also a handy offset frequency.

c) The technique adopted in nearly all the units is to operate the VCO at either (input frequency + 10.695MHz) or (input frequency minus 10.695MHz), 10.695MHz being the value chosen for the first IF. By mixing this 10.695MHz with 10.240 in the second oscillator the standard 455kHz IF is produced.

Referring back to our original comment on (b) above, the device chosen for the alternative synthesiser was a Motorola device MC145106. This operation of this device is shown diagrammatically in Fig.8. The particular device used has an effective counting range of 10^9 ($2^0 - 2^8$) or some 512+ in binary steps. The technique finally adopted is to count in units of two, ie. 2, 4, 6, etc. and to utilise the 5kHz split so that each step is 10kHz (ie. $2 \times 5\text{kHz}$). However by switching internally the device can count in even pairs, ie. 2, 4, 6, 8 etc., or in odd pairs, 1, 3, 5, 7 etc. This technique allows for the

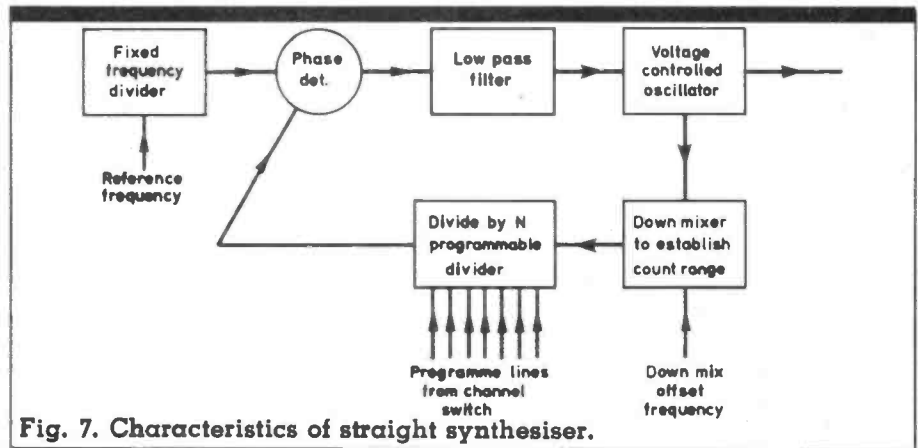

Fig. 7. Characteristics of straight synthesiser.

455kHz receiver IF. This is now derived by programming the device to read 91 steps which at 5kHz intervals is 455kHz and then mixing this

slight tweak to the 10.240 crystal then brings the resultant frequency to within 1-200 cycles of 27.60125. Similar techniques will permit the

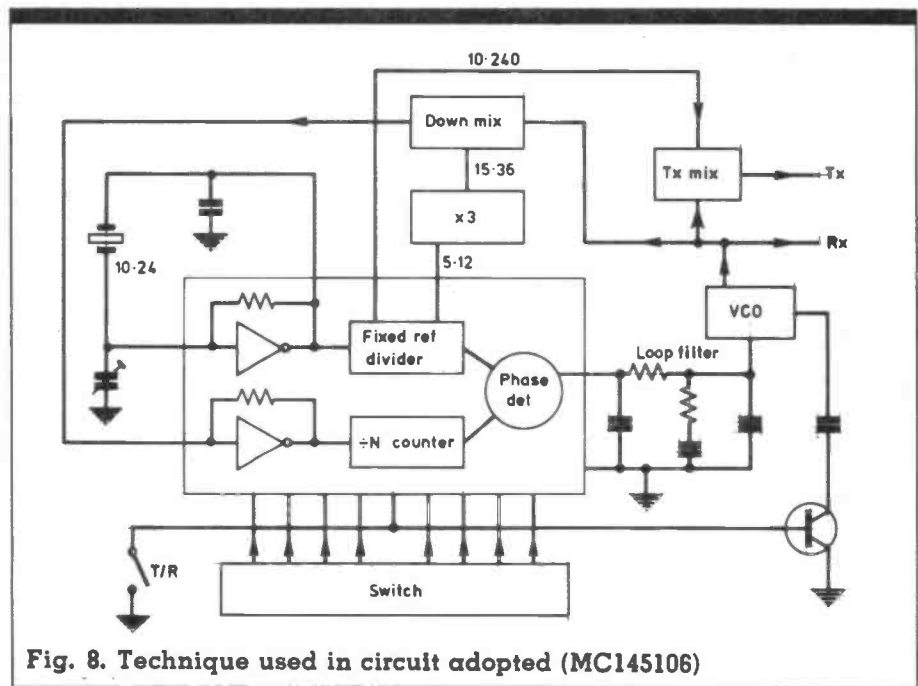
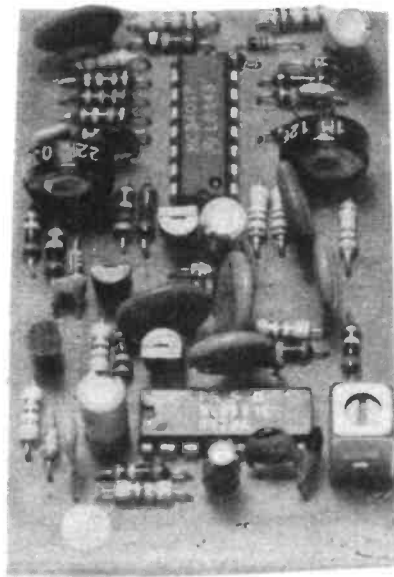

Fig. 8. Technique used in circuit adopted (MC145106)

circuit to operate at any required frequency within the capabilities of the counter and the VCO. To remove the gaps on the FCC sets, suitably programmed EPROMs could be used as follows. In the case of the sets using the straight binary input PLL where the original synthesiser can remain in situ, the technique adopted is to cut the tracks from the switch to the device, and feed the program lines from the switch to the input lines of the EPROM via the address lines, remembering to keep the lines in the correct order. See Fig. 9.

In the EPROM used on the board shown in Fig.4 the least

significant digit is fed to address line 8 and the most significant to address line 3 in the case of 6 bit BCD. Address line 2 is used as the T/R line



to introduce the offset of 455kHz in the specific program on this EPROM but in the case of straight binary, address lines 8 — 1 are used as inputs. A suitable board layout for the code transfer is shown (Fig.9). This provides a facility for introducing a 5V regulated supply. It will be found in many cases that the leakage at the input of the EPROM address lines is

so low that static charges can build up. It is therefore advisable to install pull-down resistors (50K — 500K 1/8 watt), across the wide earth line in the centre of the board. (Shown in Fig.9).

The loop filter shown in the diagram of the 145106 devices is important and due to its critical nature, when the system is being used as an alternative to dedicated device it is important to completely isolate the original loop filter to avoid incompatibility problems.

In order to explain the technique still further perhaps a look at a typical binary indication would help. In view of space restrictions only certain channels will be shown but the sequence, being additive should be easily followed as indicated in Table 1. (For further information on binary codes see appendix 3).

In the first example a difference offset frequency in which the VCO would be operating in the 36MHz region is shown. The offset frequency could be derived from a crystal oscillator operating around 37MHz or the circuit could use a 17MHz VCO with the 10.240 crystal oscillator being doubled to 20.48MHz if mixed with the 17MHz VCO this would give a down count for an increase in VCO frequency. Both techniques are used.

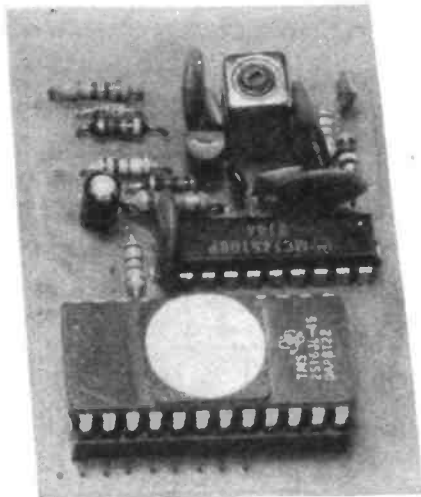

Table 1

Frequency	Code Sum	256 7	128 8	64 9	32 10	16 11	8 12	4 13	2 14	1 15	Powers of 2 Pin Number
27.601	74	0	0	1	0	0	1	0	1	0	Using pins
9-15 only with 27.701	64	0	0	1	0	0	0	0	0	0	down count
27.801	54	0	0	0	1	1	0	1	1	0	
	256	1	0	0	0	0	0	0	0	0	Using all pins 7-15 and up count
	257	1	0	0	0	0	0	0	0	0	
	260	1	0	0	0	0	0	0	0	0	
	511	1	1	1	1	1	1	1	1	1	
26.965	136	0	1	0	0	0	1	0	0	0	Pins 8-15
27.605	200	0	1	1	0	0	1	0	0	0	" "
27.995	239	0	1	1	1	0	1	1	1	1	" "
29.605	400	1	1	0	0	1	0	0	0	0	Pins 7-15

The interesting point is that the 40 positions on the channel switch can be placed at any point between the count of 1 and 511, this giving a frequency coverage of over 5MHz with a 10kHz channelling or 2.5MHz+ with 5kHz channelling. The important feature to recognise is that the code lines from the switch should not over-range the available program range. In other words the use of six program lines will only permit a count range between 63 and 0 so if the switch gives out 136

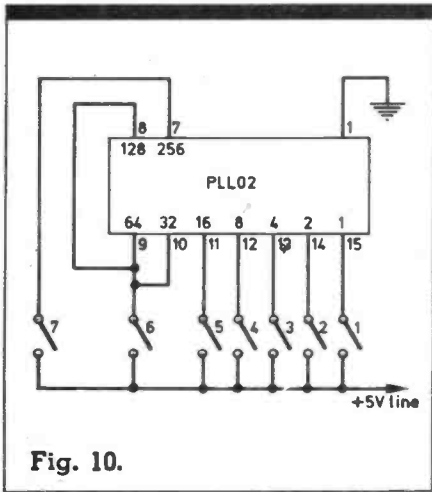

Fig. 10.

— 174, the range must include eight input lines. A simple device could be shown as in Fig. 10.

By closing switch 6 we have a pre-loaded count of 224 already in the line, using switches 1 — 5 gives us a count range of 31, so we have now an effective range of 224 — 255. By closing switch 7 and opening all the other switches we now have 256 count. By progressing through switches 1 — 5 gain with 7 closed we can now count to 287 so that in effect using the above technique we have a count range of 224 — 287, so 64 positions are open to us in this instance from the combinations of switches 1 — 7, and the 64 positions can be seen anywhere up to 511, ie. the 640kHz swing can be at any point in a 5MHz range. As can be seen we have pre-loaded 224 so that it becomes obvious that by pre-loading any quantity up to 256 we can set our operating range to suit, but in order to cover certain areas we may have to arrange an intermediate switching of the loaded point.

The practical operations involved are relatively simple and by using EPROMs to carry out the mechanical operation just described the techniques are well within the

skill of the average amateur. The main problem is in the programming of the EPROMs. The important feature is to establish the program already being fed to the EPROM by preparing a truth table on the pattern shown for the MC145106. It is only necessary to check the code at channel 1 and channel 40, the rest can be calculated. The technique for establishing the code pattern is to check the voltage level on each of the program lines in turn at the selected channel switch position. A voltage of some five volts indicates a logic 1, and any voltage less than 0.5 indicated logic zero. It is advisable in these cases to use an analogue meter of some 20,000 ohms per volt to present a suitable load otherwise random static voltages may affect the readings.

In discussing the practical operation probably the most suitable manner would be to use one of the most common circuits. The one chosen is used by a variety of manufacturers and is given in Fig. 11. The VCO control voltage is derived from pin 17 and goes via R201, C203 and R204 to the varicap diode D201 which is across the coil L203. C304 serves as the DC isolating cap and has a loading effect on frequency range, so being in series with the varicap controls the VCO operating range. The KC7310 device acts as the transmit mixer and VCO. The VCO output is tapped off at pin 2 of the 7310 and fed via C305 to the PLL, in this case a 7131. The VCO return via C305 is red to pin 19 of the PLL and in the PLL is fed to the programmable divider. This is controlled by an internal ROM and this ROM accepts the input lines from the channel switch (pins 1 — 6 incl.).

The T/R line instructs the internal ROM to read the offset and consequently moves the VCO frequency, as discussed previously. A certain amount of the RF is fed back to the PLL via pin 14 as a lock check and an out-of-lock indication causes the device to inhibit, this preventing any off-frequency transmission.

The channel switch controls the digital information to the device and at the same time this information is fed to the digital display.

The techniques required to override the synthesiser shown and to vary the output frequency to a previously determined range are all accomplished on one board. (Fig. 4)

This board accepts the incoming information and takes over control of the VCO in the following manner.

The program information is fed to the EPROM and this transforms it to an acceptable code for the PLL used. The control functions are taken over as per the layout shown for the device and the actual circuit used is shown in Fig. 4.

The physical operations involved are to lift the end of R201 adjacent to TP1 and clear it from the board. Run a wire from Pin 7 on the new board (shown as output on diagram) to this resistor. The 10.240 crystal is removed and soldered on to the new board together with the 56pF capacitor. The other capacitor is replaced on the new board by a 33pF cap. The program lines are removed from pins 1 — 6 on the old board and inserted in pins 8 — 3 on the new board. A T/R line point is taken from the junction of R316 and diode MA150 (D209) and fed to pin 2 on the new board. The 12V point is fed from the set side of the on/off switch and a suitable earth connection made. The VCO return is taken from pin 2 of the 7310 mixer by first removing C305 and taking the wire from the 7310 side to the new board. The inhibit line is disabled by cutting the track at pin 14 on the 7130.

By connecting a voltmeter between pin 8 of the new board and earth the conversion should be complete. Initially set the channel switch to channel 20, then adjust the VCO coil until a voltage of some 5V appears at pin 8. This voltage should stay at 5 volts when the channel switch is moved from 1 — 40. This indicates that the circuit is in lock throughout the new frequency range. In the case of difficulty the check points are as follows:-

- a) Check on pins 2 & 3 of the 145106 to ensure that the 10.240 oscillator is working.
- b) Check pin 5 for 5.12MHz output.
- c) Check at mixer transistor for 15.36MHz, if not present adjust tripler coil to give a maximum of 15.36MHz output (core flush with top of can).
- d) Ensure that EPROM is receiving 5 volts and no more.
- e) Check that T/R line is switching.
- f) Ensure that VCO return is present.

The actual RF voltages as shown on a scope should be in excess of 0.6 volts in case of the RF return from

mally it is not necessary to remove the modulation transformer but if desired C225 should be changed to 200uF, and a bridge taken from C223 to C225. The 12V line can then be taken across the original pins of the transformer from the 12V line to the diode D207.

In the receiver the IF output is taken from the base of Q104 (secondary of the IF transformer) direct to the board via a screened lead, the screen acting as the earth return. The audio output is then taken to the top of the volume control after lifting the wire from the C121/C122 function. This removes the AM detector from the circuit but allows the AGC and squelch to operate and keeps the signal meter in circuit.

The device used in the discriminator is the Plessey 6691, a high quality quadrature detector with its own built-in pre-amp and audio circuit. The audio output is adequate to drive the normal AF amplifier devices found in the sets commonly used and gives an extremely good performance with a high degree of AM rejection.

The use of a modulator and discriminator on the one board requires a degree of separation on T/R since the modulator can create audio oscillation if allowed to operate on receive. Accordingly, a T/R switching network which switches the modulator on and the discriminator off during transmit

put to the board ensures that at least 3V must appear before the circuit switches.

Prior to this the residual voltage was capable of leaving the modulator on during receive.

For anyone wishing to convert an AM to set to the HO MPT 1320 condition, the above conversions are acceptable to the HO and providing a Customs clearance form is filled in and the relevant fee paid a set infinitely superior to the majority of the so-called FM sets on the market today can be produced. It is easy to recognise a properly converted set since the audio quality is so superior to the normal 'muppet box'.

The discriminator shown can only operate at IF values up to 1.5MHz or so and a suitable circuit and board layout for a higher IF using a Plessey 6600 is shown in Fig.14. In this instance the use of tracking oscillator techniques gives a superb AM rejection and very good interference suppression since only frequency variations are recognised. By reducing the IF to 100kHz a good audio output level can be achieved.

The AM rejection of the discriminator normally used is very good and the only adjustment required is to adjust the core of the quad transformer for maximum readability on the FM signal. This automatically gives the best AM re-

ceiver. By changing the front end RF transistor for a more suitable type (choose one suitable for use up to 150MHz) with a slightly lower gain the cross modulation performance can be substantially improved. The normal ceramic 10.7MHz filter installed can also be changed for a crystal filter (costing from £3—£6) with marked effect on adjacent channel performance. The crystal filters have centre frequencies of 10.695MHz. Appendix 1 shows the breakdown into types of most of the PLL devices commonly used. In some cases combinations of devices are used as in the Sharps series, where a divider is separate from the phase detector. In the Sharps (probably the best of the older CB sets) the mixing technique uses two 11MHz crystals for transmit and receive offset. When the count conversion is carried out by simply lifting the grounded 64 pin and putting it to logic 1 the frequency automatically moves up 640kHz. In order to bring the 4.75kHz required to meet MPT 1320 into operation, simply cut the track alongside each crystal and place a 27pF cap across the break. This shifts the crystals by about 4.75kHz.

The codes used in three different devices are shown in Fig.15. Only channels 1, 10, 20 and 40 are shown to illustrate the code sequences but the patterns should be obvious from the sequence shown.

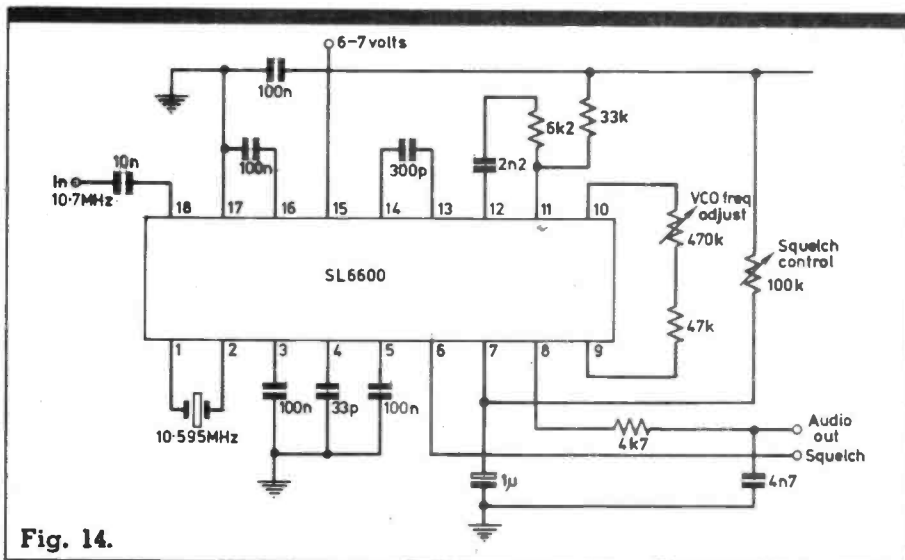

Fig. 14.

and vice-versa on receive is used. The T/R line operating this function is derived from the coil side of R325. Due to circuit conditions a certain residual voltage is present on this line in the off position so the 3V zener in series with the line at the in-

jection. Final adjustments are to peak the RX front end to 29MHz and retune the TX stages to the new frequencies.

The only other consideration is the poor front end and early IF stages performance of the usual

Device	Channel No	Code Sum	IC pin No						
			9	10	11	12	13	14	15
PLL02A pins 7 & 8 high	1	74	1	0	0	1	0	1	0
	10	63	0	1	1	1	1	1	1
	20	50	0	1	1	0	0	1	0
	40	30	0	0	1	1	1	1	0
			7 bit straight binary						
MSC42502 pin 12 high	1	0.1	0	0	0	0	0	0	1
	10	1.2	0	0	1	0	0	1	0
	20	2.5	0	1	0	0	1	0	1
	40	4.5	0	1	0	0	1	0	1
			7 bit binary coded decimal						
LC7120	1	0.1	0	0	0	0	0	0	1
	10	1.0	0	1	0	0	0	0	0
	20	2.0	1	0	0	0	0	0	0
	40	0.0	0	0	0	0	0	0	0
			6 bit binary coded decimal						
TC9109	1	1	1	1	1	1	1	1	1
	10	1	1	0	0	0	1	0	0
	20	1	0	1	0	0	1	0	0
	40	0	1	0	0	0	1	0	0
			8 bit random code						

Showing code distribution in different modes
Fig. 15. Powers of 2

And attempt has been made to bring about three objectives:
a) To stimulate interest in building something yourself at low cost.

- b) To create activity on 29MHz before someone moves in because of lack of operation on the band.
- c) To find a use of discarded CB sets now that new reforms are being introduced more stringently.

With minor variation the above techniques have been applied to SSB rigs in an effort to simulate

mobile activity on 10 metre SSB.

Many CB aeriels can be retuned to 28-29MHz with little difficulty and a host of reasonable test gear at very cheap prices is also available.

To date some 2 — 3000 conversions to 27MHz FM have been made to a variety of sets and basically the same technique applies to 29MHz.

Appendix 4

Binary Arithmetic

Binary arithmetic is an arrangement of numbers in ascending powers of two.

The standard arrangement is as shown in the table across the page (below).

Power of 2	0	1	2	3	4	5	6	7	8	9	10	11	12	2 ⁿ
Binary No.	1	2	4	8	16	32	64	128	256	512	1024	2028	4056	Code sum
Sample	0	1	0	1	1	1	0	0	1	1	0	0	0	826

Appendix 1

Codes Used in Various P.L.L. Devices

Binary Inputs	Binary in Internal ROM	BCD in BCD Code Convertor	Programme Inputs	Random Code
CC 13001	LC 7110	LC 7120	LC 7130	TC 9106P
CC 13002		UPD 861C	MSC 42502P	TC 9109P
LC 7113		UPD 2810C	UPD 858C	
MC 58472*		UPD 2812C		
MC 58473P		UPD 2814C	LC 7131	
MB 8719		UPD 2816C	LC 7135	
MB 8734		LC7137		
MC 145104				
MM 55104				
MM 55114		Require		Require
MM 55124		Synthesiser		Synthesiser
MN 6040 A		Replacement		Replacement
SM 5104				
MC 145106				
MM 55106				
MM 55116				
MM 55126				
MM 55108				
SM 5118				
MC 145107				
MM 55107				
SM 5107				
MC 14568				
MC 14526				
MC 145109				
PLLO2A/AG				
SM 5109				
TC 9100P				
MSM 5807				
MSM 5907				
MDC 40013				
NIS 7261A				
NIS 7264B				
PLLO1A				
PLLO3A				
REC 86345				
TC 5080P				
TC 9102P				
TC 9103P				
PLLO8A				

As can be seen if each level could be selected and shown as being used by indicating as 1 whereas unused lines were indicated as 0 then any number between 0 and 8111* could be shown by using the above sequence. A typical arrangement showing a count of 826 is shown, ie the sum total of 512, 256, 32, 16, 8 and 2.

*8111 = sum of all values shown from 4056-1.

This system is known as straight binary. One other form is used in the systems discussed in the article ie. Binary Coded decimal or BCD. In this case only symbols up to 2³ are used as number indicators, either two or three additional channels are used as decimal point indicators, and multipliers.

- MC 145106
- MM 55106
- MM 55116
- MM 55126
- MM 55108
- SM 5118
- MC 145107
- MM 55107
- SM 5107
- MC 14568
- MC 14526
- MC 145109
- PLLO2A/AG
- SM 5109
- TC 9100P
- MSM 5807
- MSM 5907
- MDC 40013
- NIS 7261A
- NIS 7264B
- PLLO1A
- PLLO3A
- REC 86345
- TC 5080P
- TC 9102P
- TC 9103P
- PLLO8A

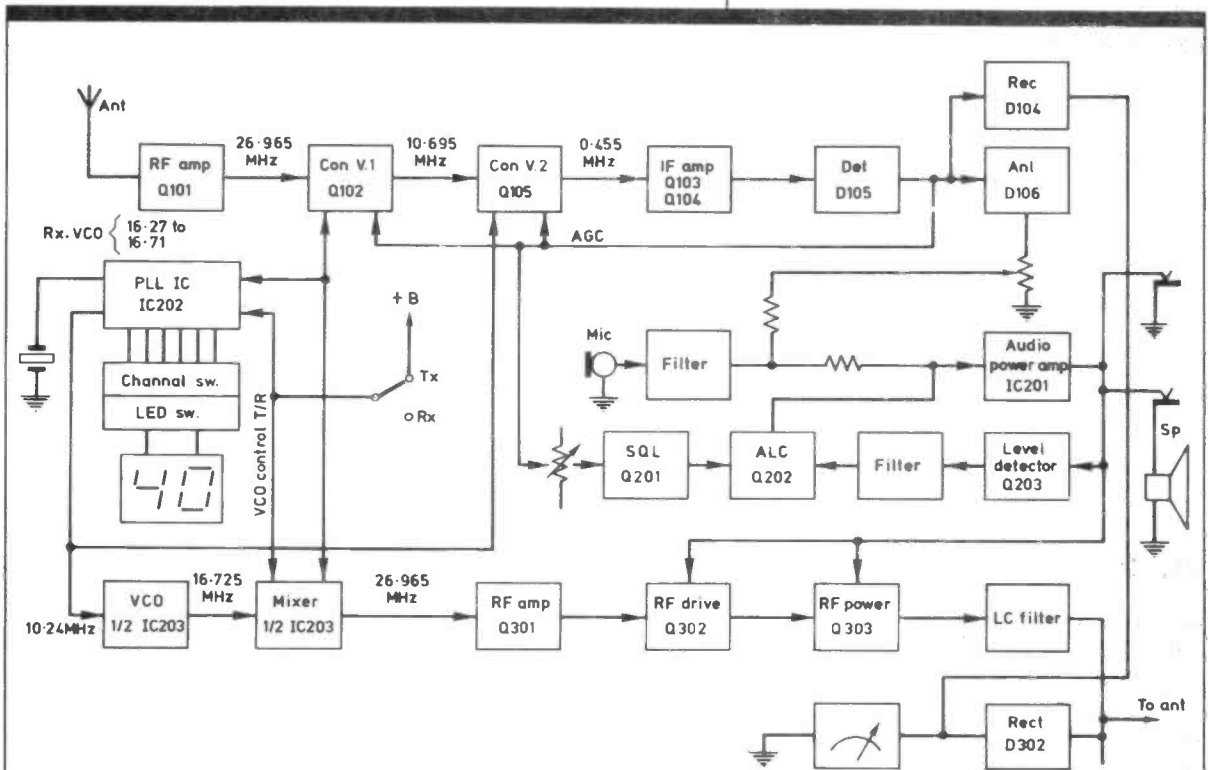

Appendix. 2. Showing circuit path of transceiver chosen as sample

Power of 2		3	2	1	3	2	1	0	2 ⁿ
Binary No.	Code sums	4	2	1	8	4	2	1	Code sum
Sample numbers shown	0.6	0	0	0	0	1	1	0	6
	1.6	0	0	1	0	1	1	0	16
	2.6	0	1	0	0	1	1	0	26
	3.6	0	1	1	0	1	1	0	36
	4.6	1	0	0	0	1	1	0	46

The BCD format shown is a 7 bit code but obviously by using two columns only in the left hand group* a 6 bit code counting 0-1, 10-19, 20-29, and 30-39 could be used ie a total of 40 lines using 0 as a signal line ie absence of all signals or a No.

Many other forms of binary code are in use but the ones shown are most commonly used. The so-called Random Code is a selective code used in certain devices only as a signalling technique rather than a signifier technique and is actual-

ly only semi random.

From the above it is apparent that signalling is either by an on or off situation and can be effected by simple switching techniques. This is the principle by which the programmed instructions are issued to the phase lock loop devices.

For simplicity of explanation the first table above is shown as reading left to right. It is more conventional to present the table reading right to left as shown in the second table and in Fig. 15.

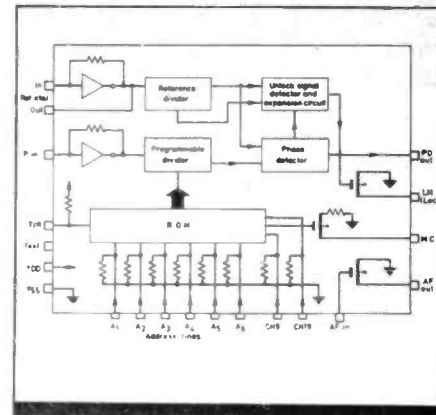

Appendix 3. Basic block diagram of dedicated device.

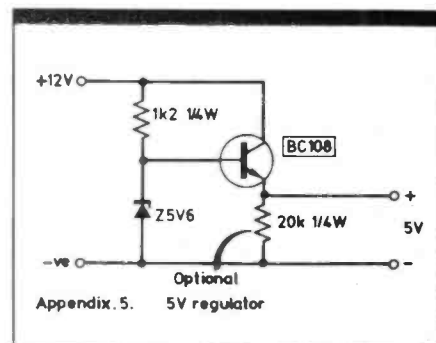

Appendix 5. 5V regulator

PROP: A L BAILEY G3WPO

WPO COMMUNICATIONS

80 metre TRANSCEIVER DSB80 KIT ONLY £37.45 inc

Copy of HRT article included

- 3W+ BOMBPROOF PA
- 12V OPERATION ●● VFO CONTROL
- IDEAL FOR BEGINNERS/CLUB
- STRAIGHT FORWARD ASSEMBLY

COMPLETE BOARD KIT with d/s drilled board, ALL components (except optional meter), VFO cap, slow motion (6:1) drive, wire, etc, etc. Needs only Hi-Z mike, speaker and +12V to get YOU on HF. Experience the world of QRP with this excellent little project, capable of DX results with a reasonable aerial.

ALSO:

A **READY-PUNCHED SCREENED** case, with all hardware inc knobs, sockets, screws etc (no speaker) + the meter for only £18.65 inc.

**160M version now available DSB160 - SAME PRICE

**AS FEATURED IN
MARCH 1983 HAM
RADIO TODAY**

All our prices include VAT and p&hp. Allow 1-3 weeks for delivery.

MAIL ORDER ONLY.

LARGE SAE brings more info and details of other kits:
2M FM 6 CH Monitor RX Kit £30.65
IAMBIC Keyer Module (Built) £20.65
RX80 ATU (Kit) £24.92
VHF Prescaler (Kit) £5.49
Capacity measuring add-on for DFM's (kit) £12.65

We also manufacture equipment for blind operators including a Talking DFM and automatic VSWR/power meter. Write for full details.

20 FARNHAM AVENUE HASSOCKS WEST SUSSEX BN6 8NS

RATEC 83 Radio Rally 22nd May

South Manchester

RATEC announce this NEW venue for Manchester

Located on the A5102 in Woodford, it is within three miles of the M56/63 motorways. Situated in a rural setting just off the A34.

Up to eighty traders have been invited to attend, offering the widest range of interest to the amateur, and micro enthusiast.

Opening from 11.00 am, and closing at 5 pm, the rally will have the following facilities.

- ★ Talk in on 145.550MHz FM.
- ★ On site catering, and bar.
- ★ Overnight camping, and caravans by arrangement.
- ★ Large parking areas.
- ★ Professional security guards.
- ★ Attractions for wives and children.

Admission 50p (Children under 16 Free)

For further details of this prestigious event, contact:

David G3VFP, on 061-439 2377.

Or sae to:

17 Laleham Green, Stockport SK7 3LJ.

P. M. ELECTRONIC SERVICES

2 ALEXANDER DRIVE, HESWALL, WIRRAL, MERSEYSIDE, L61 6XT
Telephone 051 342 4443 Telex 627371

PRICES EXCLUDE VAT — U. K. CUSTOMERS PLEASE ADD 15% VAT

CRYSTALS MANUFACTURED TO ORDER TO AMATEUR SPECIFICATION

6 to 9.9999kHz HC13/U	£32.80	1.5 to 2.59MHz (fund) HC6/U	£5.36
10 to 19.99kHz HC13/U	£31.00	2.6 to 2.1MHz (fund) HC6/U	£4.87
20 to 29.99kHz HC13/U	£23.08	3.4 to 3.99MHz (fund) HC18 & 25/U	£6.75
30 to 59.99kHz HC13/U	£21.73	4 to 5.99MHz (fund) HC18 & 25/U	£5.36
60 to 79.99kHz HC13/U	£15.69	6 to 21MHz (fund) HC6, 18 & 25/U	£4.87
80 to 99.99kHz HC13/U	£13.08	21 to 25MHz (fund) HC6, 18 & 25/U	£7.31
100 to 149.99kHz HC13/U	£11.32	25 to 28MHz (fund) HC6, 18 & 25/U	£9.00
150 to 159.99kHz HC6/U	£11.32	18 to 63MHz (30/T) HC6, 18 & 25/U	£4.87
160 to 399.99kHz HC6/U	£7.83	60 to 105MHz (50/T) HC6, 18 & 25/U	£5.81
400 to 499.99kHz HC6/U	£7.00	105 to 125MHz (50/T) HC18 & 25/U	£8.44
500 to 799.99kHz HC6/U	£7.83	125 to 147MHz (70/T) HC18 & 25/U	£11.25
800 to 999.99kHz HC6/U	£11.01	150 to 179MHz (90/T) HC18 & 25/U	£12.66
1000 to 1499.99kHz HC6/U	£11.25	175 to 250MHz (90/T) HC18 & 25/U	£13.50

TOLERANCES: Load 500kHz to 700kHz tolerance = ± 30ppm 0°C to +70°C
Over 500kHz to 40 to 1000kHz Temp to ± 30ppm -10°C to +60°C

Unless otherwise specified fundamentals will be supplied to 30pf circuit conditions and overtones to series resonance.

DELIVERY: 1MHz to 10MHz = 4 weeks other frequencies = 6 weeks. Prices shown are for one unit to our standard amateur specification unless otherwise stated. Please send us details of your requirements.

COMMERCIAL AND PROFESSIONAL CRYSTALS NEW FASTER SERVICE

We are now supplying crystals to most commercial and professional specifications in the range 1MHz to 60MHz, ordered in quantities of 1000 units. We can also supply crystals for an even faster EXPRESS SERVICE. We can also supply crystals for commercial applications to microprocessors, etc. at very competitive prices. Let us know your needs and we will send a quote by return. Alternatively telephone or fax our Sales Engineer Mr Norcliffe who is normally in the office between 9.30 and 5.30 p.m.

DOUBLE BALANCED MIXER

We are now stocking two new double balanced mixers which are compatible with the MD 108 we used to stock and also the SBL1, but have much superior specifications covering 500 kHz to 500 MHz. The M8 is hermetically sealed @ £7.83. The M15 is non hermetically sealed @ £8.09.

4 METRE, 2 METRE AND 70 CENTIMETRE STOCK CRYSTALS

We stock crystals for 70.26MHz on 4m. On 2m we stock RD thru RS and S18 thru S24. For 70cm we have RBD thru RB15 plus S6, S7, S8 & S20. For full details of the above stock crystals plus details of our Converter, Marker and Alternative IF crystals, crystal sockets and our AERIAL RANGE see May 1983 Ham Radio Today, page 65 or send SAE to the above address.

Intermedial Ltd.

3 Beech Avenue, Eastcote, Ruislip, Middx, HA 4 8UG. Tel. 01 8664641



PRECISION LOCATORSET

With the accuracy of a computer program (tolerance less than .5%), this map and ruler cannot be compared with ordinary ruler maps.

- Ruler can be fixed at QTH • Size 30 x 42 1/2 inches, scale 1:3 million
- Printed in 4 colours on washable plastic
- Metal top and bottom strips
- Approved for contests
- Full directions
- Dispatched in sturdy cylinder. £9.90

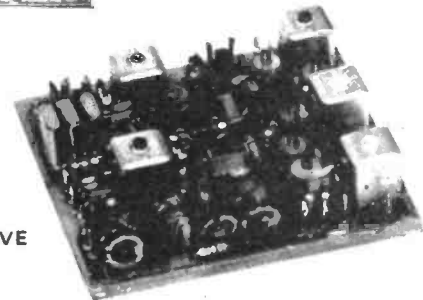

PLL TRANSCEIVE V.F.O.

Converts any surplus radio telephone into a continuously variable F.M. transceiver. Microphone is connected to unit and a stable 2 metre F.M. signal is available for driving the amplifier stages. On receive the unit produces a local oscillator signal 10.7MHz below signal frequency.

- 600KHz repeater shift
- Suitable for other R.F.'s
- Extension for digital display
- Kit includes all components (exc 3 Xtals and varco)
- 8 pages of directions. £14.90 (directions only £0.95)

XTALS 46.56MHz 46.36MHz 43.00MHz £17.15

C.W.O. All prices incl. VAT, p&p (within U.K.)

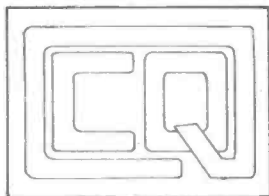

THE CQ CENTRE

10 MERTON PARK PARADE,
KINGSTON ROAD, LONDON SW19
(JUNCT. MERTON HALL RD)

TEL 01-543 5150

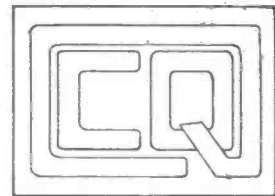

LONDON'S NEWEST AND BRIGHTEST EMPORIUM

NEW PRODUCT
30 foot mast
telescopic
ideal for
portable use
£28.00

TRIO
YAESU-ICOM
Standard-FDK
Azden-Jaybeam.
Welz-Daiwa
Tono-SMC
KDK

THE NEW
G4HXZ
MORSE TAPE
Inc. 2 simulated
Morse Tests
£8.50
Inc. P+P

**URGENTLY
REQUIRED**
Working or not
all s/hand eqpt.
Try us last
when selling
your gear

**LARGE
SELECTION**
of lashing kit
Poles-Clamps
Rotators-Cable
Jaybeam-Tet
Tonna-etc.

SLIM JIM
2 metres
70 cms
Complete with
4 metres co-ax
£8.50
Inc. P+P

**NEW
RANGE
JUST ARRIVED**
Daiwa Cross
pointer meters
antenna tuners
etc.

**NEW
PRODUCT**
23cms A.T.V.
Receive converter
just plug into
your home TV.
£29.50
Inc. P+P

**THE
NEW SX-200N**
VHF UHF Scanner
£265.00 also the
new Magnum
VHF Receiver
Lo-hi Band
£99 Inc.

**INSTANT
CREDIT NOW
AVAILABLE**
up to £1000
through
Lombard
Tricity

**GOOD
SELECTION**
of R.S.G.B.
Publications
Now In Stock

HB9-CV
2 element
2 metre or
70cms Beam
Now available
Mail Order
£9.50

**THE
FULL RANGE**
of the
Microwave Module
Products
Available

**ACCESS
BARCLAY
ETC.
MAIL AND
TELEPHONE
SERVICE**

Taking to the AIR

by Keith Townsend G4PZA

They say that history repeats itself. It certainly did so in my case with what, to me, were surprising results. About fifteen years ago I was introduced to a guy with a peculiar hobby. He spent all his spare time and a not inconsiderable amount of his spare cash in talking to people. Not merely to the neighbours. Not even just to those he knew. Oh no! This guy delighted in talking to strangers. Not merely to the strangers he met in the street but to strangers all over the world. His explanation that he was a radio 'ham' having produced instant mental images of the late, great Tony Hancock, I was greatly intrigued to learn more of the rites and mysteries practised by the devotees of this strange cult.

Taking the plunge

The result of this gentleman's best efforts was that one bright May evening found me lining up with about a hundred other hopefuls, prepared to do battle with the evil genie from the City and Guilds. Having sailed merrily through part one, Welsh caravans and all, I sat down to part two, happy in the belief that I could cope easily with almost anything which my inquisitors might dream up... A belief which grew even stronger as I realised that I was able to answer the first few questions at a glance.

My balloon burst with one hell of a bang! Suddenly, from about question seven I was faced with a long string of questions which appeared either ambiguous or impossible and which had me grop-

ing for the right answers. In a state of advanced shock I even attempted to discover the total resistance in a parallel circuit by adding together the individual component values. Somewhat dazed, I emerged from the exam room at the appointed hour and lost no time in joining a number of fellow sufferers in a headlong dash for the nearest tavern in a vain attempt to wash away the memories of the last few hours.

Even worse

Worse was to come. Undaunted by his efforts to impart a basic understanding of radio theory and far more confident of my success than I felt, my erstwhile instructor conned me into accepting yet another challenge. Exhibiting considerably more confidence than I really felt, I accepted his assurances and embarked upon the task of learning Morse before the exam results were published. Again to my surprise his abilities matched his belief and my pleasure knew no bounds when, within a few days of learning that I was indeed entitled to apply for an amateur's licence I received a Morse test pass slip.

Besotted with my new-found power, I decided to spend a few quid, then, armed with my all singing, all dancing, FT480R I discovered the next pitfall. It seems that the Home Office did not share my eagerness for the world to hear my dulcet tones, with the result that a very frustrating ten weeks were to pass before my ambitions were realised. Ten weeks during which I and many of my former classmates

were to develop an entirely new disease which affected the muscles in the thumb whenever it was placed within touching distance of a microphone. All in all I reckon that I spent more time in waiting for the results and then the licence than I did in studying to become a radio amateur.

At long last it happened. I arrived home one lunchtime to find my new licence waiting for me. In the ensuing confusion it took me a good five minutes to find the call sign, which I then repeated silently to myself a few hundred times, just to make sure that it came out right on the air. Since I spend most of the working day in my car I had fitted the rig to it long ago so, lunch forgotten, I returned to the car, plugged in the mike and made my first, very hesitant call. Utter silence! Either the band was deserted during the lunch hour, (was there any thing in the licence conditions to this effect?) or these amateurs were a damned unfriendly bunch. My second and third attempts having met with an equal lack of response I returned, disappointed, to a now cold lunch.

First contact

Fed and rested, I decided to give it one more try before deciding whether to sell the whole issue and buy an exercise bike. Whether I was more cautious this time, or simply less eager I don't know. Anyway I decided to check over the rig before keying the mike. There, right in front of me, was the cause of my

earlier disappointment. In the midst of my self-congratulation I had left the damned repeater offset in. Having rectified this error, which I freely admit to having repeated on a few occasions since, I soon found myself in conversation with two fellow novices and we were all delighted by the friendly reception and encouragement which we received for a few older hands during the course of our chat. Probably the strongest single impression I have gained during my first few weeks on the air is of the strong camaraderie which exists among radio amateurs and the lengths to which they will go to extend a warm welcome to a newcomer.

The next task was to construct and erect a suitable antenna system for use at home. Armed with what seemed like miles of aluminium tubing, a rotator and an odd assortment of tools it was not long before I was finally in a position to attempt something more ambitious than the mobile contacts which were all that my log contained up to now.

A quick CQ call on two metre sideband met with instant response. At last I had my first real opportunity to work DX as all the LEDs began to dance at once and a voice came blasting through the speaker. If you regard two miles as DX then maybe I had achieved my objective. Undaunted, I tried again. This time the result was far more encouraging and I found myself in conversation with an experienced sidebander over a hundred miles away. What's more I did so without the half-expected howls of protest from the XYL, watching the box in the next room.

HF near disaster

My first visit to the HF bands was a near disaster. Hearing a Russian station calling CQ on ten metres I waited for a pause then eagerly attempted to answer his call. So nervous was I and so anxious to pronounce both of our callsigns accurately, that it took me a few moments to realise that, despite the pressure of my thumb on the PTT, my Russian had begun calling CQ yet again and what was more I could clearly hear him.

A quick dash for the soldering iron and we were soon back in business, faulty microphone lead

reconnected just in time for a further break in transmission from the UK7 station. My answering call was returned immediately, accompanied by an irate delegation of avid commercial watchers from the front room. Promising to look into the TVI as soon as my contact was finished I called my Russian again. Within seconds of his coming back to me the entire ten metre band fell flatter than my chances of winning the pools. I can only assume that the KGB did not want an innocent comrade to be corrupted by talking to a trouble-maker like me.



"... don't you think it would help, dear, to switch it out of repeater shift"

At this stage I had not attempted to use CW on the air, though, like a number of my colleagues I had continued to attend the local Morse classes in the hope of increasing both my speed and confidence. It rather surprised me to learn that I was not alone in my reticence to appear on the key for real and so a small group of us decided to try a few short QSOs among ourselves. It is one thing to read and send simple messages in plain language and quite another to understand the shorthand of the airwaves, so we kept our messages short and simple to begin with, venturing into more detail only as our confidence began to grow. These simple experiments were perhaps the most valuable form of self-instruction we could have devised and certainly did a great deal to ensure that when we finally took our courage into our own hands and joined the rest of the CW fans we would not simply clutter

up the bands with a load of unintelligible rubbish. It is a method which I would recommend to anyone interested in CW, perhaps the most rewarding of all modes of transmission. To those who see the Morse test as some kind of hurdle I offer the observation that it is far easier to pass than you might think. Nobody could be less certain of their abilities than was I when I arrived at the test centre, only to find yet again clear evidence of the genuine friendship which exists among radio amateurs. Those conducting the tests do everything in their power to create a friendly, relaxed atmosphere, in which the test is far less of an ordeal than I had imagined possible.

Repeaters are not really my scene though, since I use the roads a lot I have made use of them on a few occasions. A trip into the heart of London brought me considerable amusement, as the inhabitants of GB3WL guided me through unfamiliar streets, ably assisted by one or two squeakies who, upon hearing that I needed some assistance, promptly stood aside until I reached my destination. They even had the cheek to ask 'Ave yer dun?' as I signed. My thanks go out to all concerned.

One of my rare visits to my local repeater, GB3BM, in search of a friend who could not be located on S20, found me talking briefly to a Dutch station. Though this is certainly not what repeaters are all about, I was very pleased by the occurrence, since at the time I had spoken to nobody outside my own town, much less overseas.

First impressions

So what are my first impressions after only a few weeks as an amateur? Frankly, I reckon I wasted fifteen years. I should have become an amateur at my first encounter with the hobby. I have not yet fully grasped the range and the scope which my licence has put at my disposal and each attempt to use a new mode of transmission brings its own fascination. I have yet to try either RTTY or ATV but I see amateur radio as a hobby which I can develop over the next thirty years. My station will develop as my finances permit and as my knowledge increases. ●

RADIO YESTERDAY

There was
a time when
they were all
two-letter
callsigns

TWO-LETTER CALLSIGNS ON THE TARMAC



By Jack Hum G5UM

One of the famed two-letter callsigns of the Nineteen Twenties was 2FG, that of the late Leslie McMichael, founder of the firm bearing his name. This historic 53-year old picture (it sums up the sartorial elegance of the age) shows 2FG fourth from right. Fourth from left is the McMichael sales manager, the late Gus Allen, whose callsign G8IG was famed throughout the DX corners

of the world. The photograph was taken on Boat Race Day, 1930, on the concrete apron at Croydon Aerodrome (the new fangled term 'airport' was barely known this side of the Atlantic in those days). As an enterprising publicity man G8IG would hire an Imperial Airways 'Argosy' aircraft every Boat Race Day and fill it with radio trade notabilities and pressmen generally, plus a

selection of McMichael portable 'wireless sets' to enable all on board to hear the BBC Boat Race commentary while they were skyborne over the Thames, at the same time watching the progress of the University boats below them. The wood-and-canvas airliner chartered on such occasions can just be seen in the background.

"Is that yet another of them?". Wife Grace's voice came wafting up the stairway. In her kitchen below the radio room she hears through the floorboards much of what goes on during the G5UM operating sessions.

It was indeed "another one of them", probably the sixth that week, who was mystified by the two-letter callsign which was calling him.

"Go on, tell him you're not a foreign body!" came the voice up the stairway with a light chuckle. Upon which G5UM turned the

transmission back to the person waiting at the other end of the 2m link and patiently explained that, yes, there were only two letters after the numeral, and that, no, it wasn't a visitor's licence: the reciprocal had three letters after the numeral, not two. Did not the person at the other end have a Callbook in the house? No, he did not, clearly one of many hundreds of new licence holders who had still to learn that The Callbook is perhaps the second most important document in a metrowave man's kit after his logbook.

Politely the distant communicator replied that he had thought about getting a callbook when his own callsign was likely to appear in it (inviting the riposte, hastily smothered, that it's not *your* callsign you want to look up: it's the other party's, all several thousand of them).

"Oh, well, when you do get yourself a callbook you will find that there are still a few G-Five-plus-tuos listed in it (not to forget a few G-Six and G-Eights who are not Class B licensees) plus quite a few

G-Twos, G-Threes and G-Fours, all with two letters after their respective numerals".

The story in more detail would have taken the better part of an hour to explain to Polite Communicator on Two. If there had been time and fewer operators clamouring to use the frequency on which all this was going on (or if Polite Communicator had had 433MHz where more time and space exist) the story would have gone something like this:

At the very dawn of amateur radio in Britain the few hundred enthusiasts playing dangerously with spark-gap transmitters and less dangerously with crystal receivers used three-letter callsigns which were often self-assigned. After World War 1 when amateur radio enjoyed a second dawn the allocation of callsigns was put on to a more systematic basis. From the Twenties onwards British callsigns consisted of a numeral plus two letters, eg, 2LO, 5XX or 6BM (the 'Twos', the 'Fives' and the 'Sixes' were issued completely at random). This process was expected to yield almost two thousand callsigns, which in the view of the Licensing Authority would last into the indeterminate future.

How wrong they were became evident from the fact that within 16 years nearly all of the G2-plus-two, 5-plus-2 and 6-plus-2 assignments had been exhausted. The next call-sign block to be issued — and this was in 1936 — was the G8-plus-2 — not a Class B licence: that particular concept was still 28 years into the future and World War 2 was yet to intervene.

Back then in the mid Thirties even the G8-plus-two series was to become rapidly completed for the good reason that radio communication technology was by then truly forging ahead, inter-Continental contacts were common — and there were even people using the esoteric metre-wavelengths with the aid of self-excited oscillators and super-regen receivers! It was even rumoured that television was coming along. And so as the G8-plus-twos ran out the G3-plus-two series was initiated followed soon by the G4-plus-two, a callsign block never completed: the start of World War 2 cut it short.

Holders of the earlier 2, 5 and 6 permits (yes, it was a Permit in those days, not a Licence) were not allowed to use the national prefix of 'G' except by express authority from on

high, and then only if they stated that they proposed to use wavelengths capable of reaching outside the home country. Gradually, this restriction was eased. Stations in England were allowed to use their national prefix of 'G' and in Northern Ireland 'GI'. For some obscure reason Scotland initially used 'GC', possibly for 'Caledonia'. All other components of the United Kingdom were expected to use 'G'; it was not until much later that today's variants of GW, GD et al were to be heard.

Readers with long memories will have detected some significance in the callsigns of 2LO, 5XX and 6BM quoted above: they belonged to the BBC, who until the British Broadcasting Company became the 'Corporation' in 1927 were assigned amateur-style 'idents'. Very few of these have been reallocated to private radio amateurs. An illustrious exception is 5XX, the callsign of the mid-Twenties radiated by 'Daventry long wave' and today finding new expression as G5XX, the callsign of the Daventry Ariel Radio Club.

Echoes from the past

Many other callsigns of yesteryear are tending to find new leases of life, often in a collective identity with radio clubs: G2XV, the callsign of a famous Cambridge pioneer of the Twenties, Gerald Jeapes, now belongs to the Cambridge club, and G6CW, once owned by the late John Curnow, has been taken up by his local club in Nottingham.

Another NottinghamHAM who has revived an old callsign is Mike Mansfield, who upon passing his Morse test relinquished his identity of G8RXU and took up his grandfather's callsign, G2SP. Down in Hertfordshire much the same thing happened when G2PA reappeared two generations after the noted pioneer components firm of G.Z. Auckland & Co originally 'aired' it from their City of London premises back in the Twenties — and G2PA is still an Auckland.

There is a sprinkling of others. Their numbers will increase as old-timers quit the callbooks and their descendants pick up their two-letter callsigns to breathe new life into them once more.



No national prefix of 'G' on this early QSL card used by G5UM (strictly 5UM) from his original location in north London, where gas mains were the rule, electric power came much later, and

your HT power source was a string of dry batteries. You went off the air while your LT power source, a 2V accumulator, was away at the local garage to be charged.

Taking apart the



FT 101

Dismantling the FT101

Some circuit boards and parts are easily accessible once the lid and bottom covers have been removed. When servicing in the more difficult to get at sections, it is not worth struggling and risking doing damage, as it is very easy to remove the complete cabinet. To do this, proceed as follows:

1. Completely disconnect the FT101 from the mains, aerial and all other equipment and place on bench in an inverted position.
2. Remove bottom cover and release hexagonal screws and two star-headed screws (four at the front and one at the rear) holding cabinet in place.
4. Gently slide cabinet off over rear of FT101 ensuring that the lid catches do not foul the audio board or the metallic labels identifying this board's preset controls.

Faults and modifications

Mains fuse blows. If a replacement 3 amp fuse fails do not fit a larger

Part 2

Troubleshooting and repair by Harry Leeming G3LLL

one: there is a fault. The most likely cause of mains fuse failure is a short circuit in the HT rectifiers, and these should be checked with an ohm meter. A suitable replacement is the BY127 television type HT rectifier, and it is advisable to replace all eight rectifiers in the HT bridge even if only a couple are faulty. Note that early FT101 Mk 1s used only four HT rectifiers, but for reliability these should be replaced with eight rectifiers fitted with the 470k equalising resistors as in Fig. 1.

Set works on receive, but won't transmit, or vice versa. A common cause of this is that the junior operator has had his fingers on and has left the INT/EX/CH switch in the wrong position. Many FT101s have been returned for this.

No transmit, no PA current, receive OK. Check that power amplifier valve heaters are lit. The 11-pin plug at the rear must be fitted and must have a link between pins one and two before the power amplifier stage will function.

No SSB transmit, three or more S-points down on receive, final amplifier resting current OK at 50 to 60 mA. CW and tune gives full output. This fault is occasionally caused by Q1 on the IF board having blown. You can replace this FET with almost any RF FET such as the MPF102, provided that you get the pin connections correct.

Any weird fault, particularly if intermittent. High resistance contacts on the plug-in circuit boards can cause some very odd effects. Standard service procedure is to remove the plug-in circuit boards, squirt the contacts with contact cleaner, and plug them in and out half a dozen times to clean the connections.

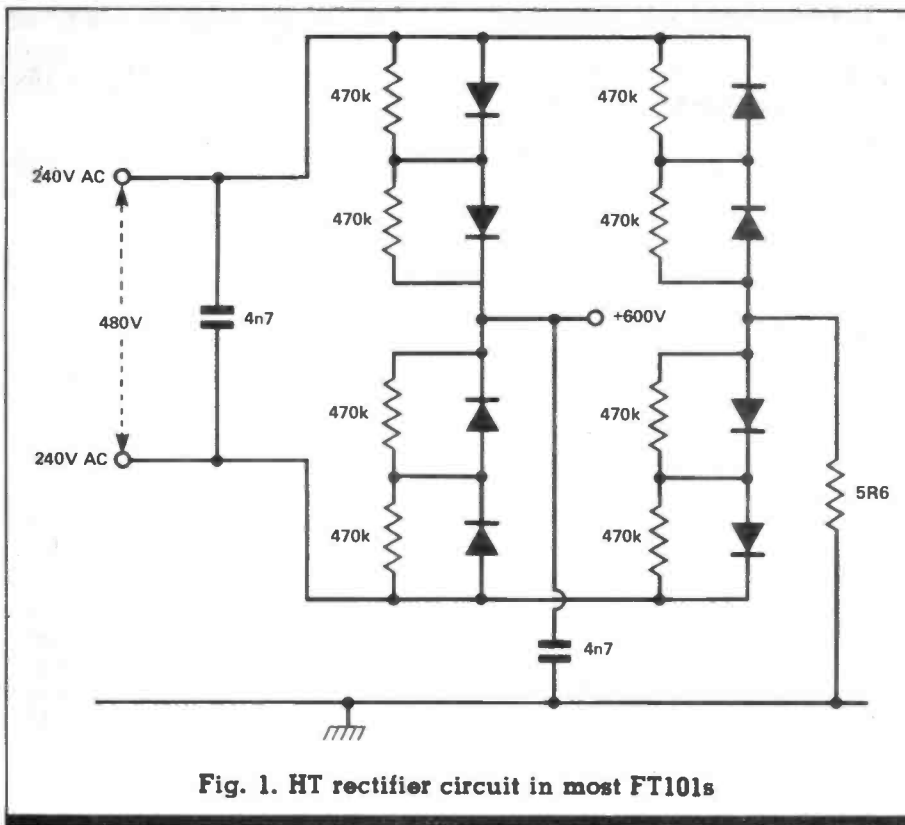

Fig. 1. HT rectifier circuit in most FT101s

Fuse blowing but HT rectifiers OK.

Try operating the rig with the power amplifier valves removed. If all is OK, leave the valves out and measure the bias voltage at the grid connection of the power amplifier valves. This should be about -50V on transmit or -65V on receive. Turn the band change switch and if the voltage falls below this, or even goes positive on any band, replace the relevant coupling capacitor from the anode of the driver valve. Note that a coupling capacitor of 80 or 100pF goes direct to the anode, whilst other capacitors are switched in parallel with this on 160m and 80m in some models. A short circuit here will have ruined the PA valves so once this fault has been cleared it will be necessary to fit new ones.

Fuse still blows, but PA and HT rectifiers OK. Sometimes the DC/DC inverter ('chopper') transistors go short circuit even if the rig is never used on a 12V supply, and cause fuse blowing. The FT101 will work perfectly on an AC supply with the chopper transistors disconnected, hence the easiest way to test these is to disconnect them and try a new fuse. If these transistors are faulty, the cost of replacement is in the region of £20 to £40 a pair. If you do not anticipate DC operation simply remove them.

Fuse still blows! If all the suggested tests come to nothing try operating the FT101 from a 24V AC supply. At such a low voltage even a bad short is unlikely to blow the fuse and every output of the rig's power supply should give one tenth of its rated voltage. Find the power supply output that is less than this and you are in with a fighting chance of discovering the cause.

ALC faults

Valves operating in class AB1 do not pass grid current until they are slightly overdriven. In the FT101 any grid current caused by overdriving is rectified and fed back as a negative ALC voltage, rather like automatic gain control on a

receiver, and so turns down the gain of a previous stage. In practice slightly over-driving a class AB1 amplifier does not do any harm and this system is used in much amateur equipment and works well.

No ALC indications. This is almost always a result of low drive to the power amplifier valves, and is commonly caused by an aging driver valve or misalignment.

ALC too active on one or more bands on some FT101's. The trouble here is usually caused by the radio frequency choke L12 picking up RF from the PA coil. The simple cure is to replace the choke with a 2.2K resistor. Only a limited number of FT101Es used this extra choke L12. Later FT101Es reverted back to the original circuit, see Fig. 2.

No transmit, ALC meter 'pings' hard over and is not adjustable. This fault is caused by a short circuit ALC transistor (Q1 on mod and oscillator board FT101 Mk1, Mk2, B, EE, EX and E Mark 1; or Q6 on processor on FT101 Mk2 and Mk3). This fault may have been caused by a flashing PA valve or a leaky ALC coupling capacitor. As a replacement FET, an MPF102 will do if you get the connections right, or you can fit the 'spare' FET in the fix oscillator circuit which you are unlikely to use.

Set intermittently dead on one band, often 15m. This fault is usually caused by the first conversion crystal oscillator refusing to start. Slightly adjusting the relevant trimmer (see manual 'heterodyne crystal oscillator alignment') will usually bring it back to life again. The manual suggests adjusting using a

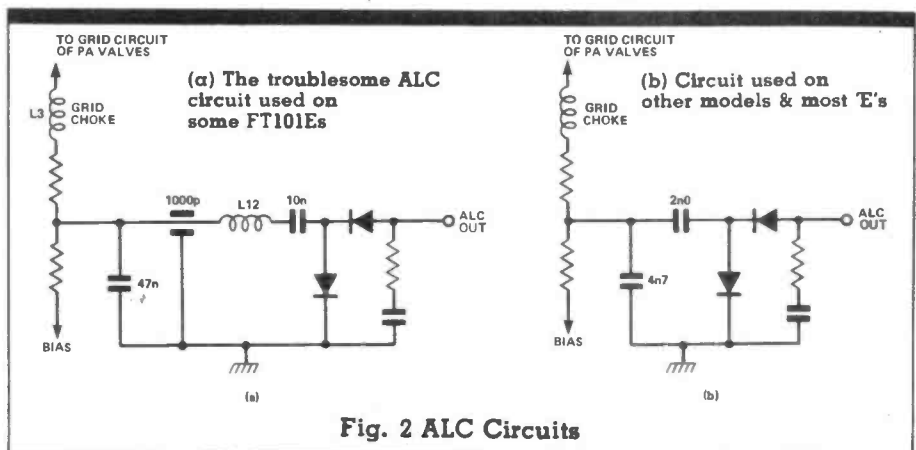
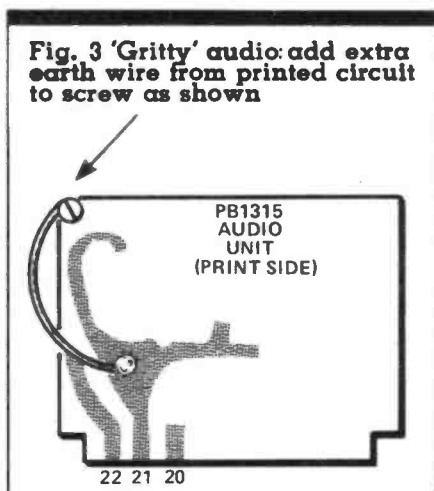

Fig. 2 ALC Circuits

diode probe volt meter, but in practice turning the trimmer the minimum amount needed to give reliable operation of the oscillator is all that is required.

Receive signals and calibrator very weak but sounds lively and transmits OK. This fault usually indicates that Q1 on the RF board has blown. It can be replaced with an RCA 40673 or 3N201 etc. If the replacement blows suspect that the 12BY7A driver valve is flashing over and damaging it.

Receive audio quality slightly below par – a bit 'gritty' FT101B Mk2 – FT101E. If you suspect the receive audio quality, try adding an extra earth wire to the audio IC as shown in Fig. 3. If there is an immediate improvement leave this wire in position.



Preselector peaks at different points on receive and transmit. This could be an alignment fault, but it also occurs if the wrong make of 12BY7A driver valve is fitted. Use a Toshiba or an NEC valve in this stage.

Drive slightly low on 10 and 15m even with new valves and after full alignment. This fault sometimes happens when the original Toshiba valves have been replaced by NEC, as these usually give a fraction less gain. Replace R22 in the RF unit (was 56 ohms) with a 22 ohm resistor. This modification is introduced by Yaesu in the last production batch of FT101Es. A little extra drive can also be obtained by turning VR1 on the RF unit the *minimum* amount that is needed to produce maximum output.

Transmit and receive frequencies not coinciding. This is a simple alignment problem. Set VFO in approximately mid-position and connect a general coverage receiver to a short length of aerial wire, and poke its *insulated* end through the centre of the eight pin VFO socket on the rear of the FT101. Tune the general coverage receiver around 9MHz and you will pick up the VFO of the FT101. Adjust the position of the length of pick up wire until the signal is about S9, and in the CW or SSB position of the general coverage receiver tune in a steady beat note. With the heaters of the FT101 switched off wait until things stabilise and any drift stops, and with the clarifier in the off position the beat note should not change. If the note does change adjust the zero control on the regulator board until the note is the same on transmit as it is on receive. When this has been achieved switch the FT101 to receive and adjust the preset control mounted at the rear of the clarifier underneath the chassis until the note is the same with the clarifier off as it is in the central position. These adjustments should be repeated until the note does not change with the rig switched to transmit or receive, with the clarifier on or off.

Main tuning very lumpy or loose. The main gear box seldom gives trouble but the 6/1 epicyclic drive does wear or dry out after considerable use. This bit of the FT101 is available quite cheaply, as (believe it or not) it is made for Yaesu in the UK. Whilst no doubt it could be cleaned and regreased it is much less trouble to swop it. Lay the set on its rear with the tuning knob pointed vertically and the bottom cover removed. Once the main tuning knob has been removed, how to remove the drive is self evident, but note the order of the various washers as you remove them. Otherwise, putting it back together again might not be as simple! While you are at it put a little grease or oil on the gears in the main gear box.

VOX operation – all models. The VOX has a tendency to 'hang on', especially if you talk too long without a breath! Much less critical operation will result if D3 and D1 are shunted with resistors of about 2 or 3 Megohms and C21 (in the Mk1

or C23 in the Mk2 or MkB) is shunted with an additional capacitor of about 100 or 200nF and the controls are reset.

Reduction in receive gain when operating mobile with low battery voltage FT101 Mk1. This is caused by the voltage on the low-frequency IF unit varying. To cure this defect, operate the FT101 from a mains supply, tune in to the crystal calibrator, and note the S-meter reading. Disconnect the unit from the mains and connect an 11-volt Zener diode in parallel with C36 (this will be found at the top left-hand corner of the circuit on page 15 of FT101 Mk1 manual. When the Zener diode has been fitted, connect the unit to the mains and note that the S-meter reading will have fallen. The gain can now be brought to normal by adjusting the value of R15 in the base bias circuit of Q2. Usually about 4.3k is correct, but the exact value will depend on the characteristics of the transistors. Once this modification has been carried out, the gain of the receiver will be much less affected by variation of battery voltage.

RF gain only works through one third of rotation. This effect is common and many hams have ordered new RF gain potentiometers only to find that no improvement ensues. The problem is one of compatibility between the RF/FET/Q1 on the RF board and the IC and transistor fitted in the IF amplifier. If the effect worries you try a few different 40673s or 3N201s as replacements for Q1;

No signals on receive but crystal calibrator at normal strength – FT101 Mk2 FT101E. This fault indicates a blown aerial protection lamp. This is mounted under a plastic cover adjacent to the aerial socket. A pilot lamp can be used as an emergency replacement here.

Intermittent non-operation of fan and transmit function on DC supply particularly when cold FT101 Mk2E. This is caused by the chopper/inverter transistors refusing to oscillate due to lack of gain. The cheap cure is to reduce the value of R3 to about 100 ohms.



Faulty heater switch. Intermittent operation of the heater supply is usually due to high resistance contacts on the heater switch. This switch is a double pole type, one pole for switching the sidetone oscillator on and off, the other pole switching the heater supply. A quick cure here is to clean the switch and swop the wires over as the slightly faulty contacts will usually handle the sidetone oscillator, and the original sidetone contacts will be as good as new.

Plugging phones in does not cut out speaker. This is usually caused by the use of the wrong type of jack plug. Stereo jack plugs or 'Post Office' types with small tips are not suitable, round tipped mono plugs being the order of the day. If this does not cure the trouble note that quite a few FT101's seem to have escaped with the phone jack socket wrongly wired, so if the internal speaker still does not cut out, consult Fig. 4 and rewire if necessary.

Plenty of PA current but poor PA dip and RF output low. The causes of this effect can be many and have included a faulty 600V feed choke, faulty pi-tank coupling capacitor, or a blob of solder on the PA coil.

Oscillation or distortion as mike gain advanced at some frequencies on the 160m band. The trouble here is that the RF choke on the patch input socket is resonant. This can either be disconnected entirely if the socket is not used, or the choke can be replaced by one with a ferrite core. This fault seems to

mainly occur on FT101B's, and probably later units are already fitted with a different choke.

Workshop manual. A very good operating and maintenance manual is supplied with the FT101. These notes — whilst it is hoped they will be of general interest — presume that this is available. Owners wishing to delve further into their rigs might like to know that a full workshop manual is also available via Yaesu dealers.

Safety. The on/off switch is a single pole type and does not isolate the FT101 from the mains supply. You must therefore remove the mains plug from the wall socket before attempting service work. The FT101 contains large capacitors and high voltages. Some points such as the top caps of the power amplifier valves remain live at 700V for some

considerable time after the set has been switched off. Never touch any point in the PA cage without first shorting the top caps of the PA valves to chassis (leave the rig to stand for 1 minute after disconnecting mains supply before doing this, or use a resistor of a few hundred ohms to avoid an excessive discharge current.)

Fuses. The fuse should be a 3 amp quick blow type for use on 220/240 volt supplies.

Swapping the pilot lamps. Several owners have damaged their FT101 by causing a short circuit when replacing the pilot lamps. These are run from the rectified DC supply, and a short circuit will burn out the rectifiers in the power supply. Do not try and swop them when the rig is switched on, or fit them wrongly so that the wire shorts to the chassis. Equipment which has been imported by the approved importer is normally stamped on the rear "234V". Many unofficial imports, and some Sommerkamp equipment is set on 220V and should be re-wired as per the instructions in the manual. Operation at UK mains voltages on the 220 volt setting will considerably reduce the life of components in the FT101.

Valves. The FT101 is designed to function with Japanese valves and NEC or Toshiba are recommended by Yaesu. Some other brands will give poor results, refuse to neutralise, or even oscillate in the receive mode and cause damage.

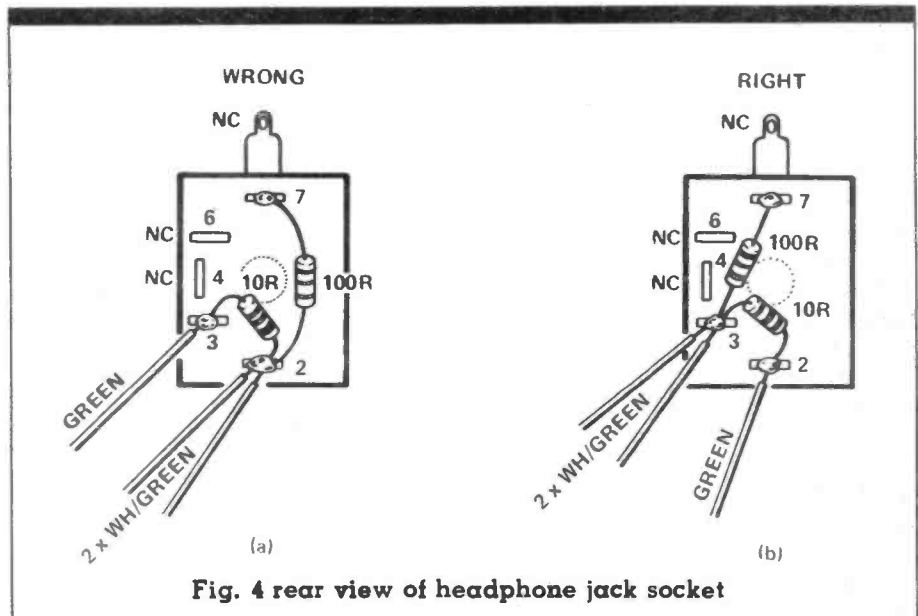

Fig. 4 rear view of headphone jack socket

Test generator. Pull the aerial out of the FT101, switch on the crystal calibrator and note the maximum reading which can be obtained with the pre-selector peaked, and set tuned to 14.2MHz. This should normally be between S9 and S9+20dB. Keep a note of this reading as it will be a most valuable guide when later making comparisons if there is any doubt as to whether or not the receiver is up to scratch.

Field effect transistors. The FT101 contains a fair quantity of field effect transistors which can very easily be damaged by heat or voltage. Plugging the FT101 into the mains supply — whether switched on or not — will usually guarantee a potential difference between the tip of your soldering iron and the circuitry. Touch the soldering iron on certain points and the nearest FET has gone for the chop! Your only safe way to solder on the FT101 is to completely detach it from the mains, aerial, earth, and any other equipment, and then to use an iron which is earthed to the chassis of the FT101. Familiarity with the normal

bipolar transistors can lead one to become careless, but heat shunts really are essential when soldering FETs. A piece of cotton wool soaked in water provides ideal heat and static protection if stuffed between the four legs of MOSFETs when soldering. An elastic band and a pair of snipe nosed pliers provide a third hand and a heat shunt when working on the three legged variety of FET.

Harry Leeming asks us to point out that while he is happy to answer brief queries on the FT101 series, correspondence must contain a stamped, addressed envelope to obtain a reply. Harry Leeming will be covering modifications in future articles.

Alignment and fitting 10, 18 & 24 MHz will be covered, together with AGC and modifications and other receiver and transmitter improvements. But what about you?

'Bright ideas' and servicing experiences should be shared around so let us know what you have done with your FT101 — please type (or print CLEARLY) and send your contributions to the editor for possible inclusion in part 4 of the series. The best contribution will receive 12 months' subscription to Ham Radio Today.

NB In our April issue (p.21) the paragraph beginning "1976 FT101 Mark 2" should have been "1976 FT101E Mark 2".



FORTOP LTD, FIRST AND BEST FOR FAST SCAN TV.

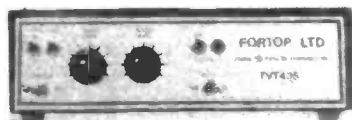

The **TVT 435/R** TV transceiver allows transmission and reception of 70cms Amateur TV signals. Features: 15 watts min Peak Synch RF output, Bandwidth limiting filter, switchable modulation sense, video inputs and carrier frequencies. High performance RX converter built in. Requires aerial, 12 volts power, video source (camera etc) and stand UHF TV set to complete fast scan Amateur TV station. **£169.50 plus £2.50 P&P.**

For further details please write or ring to:

FORTOP LTD, 13 Cotehill Road, Werrington, Stoke on Trent, tel Ash Bank (078 130) 2607

GET BINDING

Take a subscription out for £12.80, and get yourself a FREE binder worth £4.25 to keep your favourite magazine in mint condition.

Back issues of Ham Radio Today are available at £1.25 per issue. Send your cheque/PO to:

Ham Radio Today
513 London Road
Thornton Heath
Surrey CR4 6AR

THE **microdot**

CW/RTTY COMMUNICATIONS TERMINAL



£381.74 inc. carriage
(Standard unit cost - VAT not included)

Forget all those messy wires, the MICRODOT now offers a totally integrated communications system.

Write for full details to . . .

POLEMARK Ltd
Lower Gower Road
Royston, Herts SG8 5EA
Tel. Royston (0763) 47874



STANDARD FEATURES INCLUDE

- Integral high resolution video monitor
- Professional keyboard with many special functions
- Real-time clock (constantly displayed)
- Transmit and receive both CW (morse) and RTTY (teleprinter)
- Users callsign programmed in
- Receive CW speed tracking and display
- Self checking facility
- Char. by char. or 'page' transmission modes
- Stylish two tone metal cabinet

OPTIONAL FEATURES

- Printer interface board (Centronics compatible)
- On-board 40 column printer (12V)
- External 80 column printer (SEIKOSHA GP100A)

G Line for the Gigahertz Men

By Andy Emmerson G8PTH

Ask your friends at the local club what G-line or G-string is and you'll probably get a bemused grin followed by a blank stare. Yet G-line (named after its 'inventor' Gobau) is a remarkable form of RF feeder which uses a single wire for transmission. What's more, it offers very low loss at UHF, comparable with the best hardline feeder. For all this, G-line has never found much favour and this article is an attempt to clear away some of the mystery surrounding Gobau's brainchild.

Finding information on G-line is not an easy task. My first encounter with it was in the October 1965 issue of *Practical Television*, which contained a description of the amateur TV station G6CTS/T located at Norwood Technical College, south London. This station was conceived back in 1947 by the Engineering Group of the Royal Television Society as an experimental station for UHF TV. A few years later it went on the air (vision frequency was 427 MHz — those were the days of a 70cm band 30MHz wide!), and provided test transmissions with vision and sound for the London area. Two students at the college were involved with a research project relating to the transmission characteristics of surface wave feeders. This surface wave feeder was G-line, and photographs accompanying the article showed the G-line feeding the 70cm aerials and some strange looking cones. No further details were given, and it took me a while to track down more information.

An article by K6LK in the June 1974 issue of *QST* (the USA equivalent of *Radcom*) and some notes in microwave textbooks subsequently supplied the missing data, and fact turned out to be stranger than fiction. A bare metal wire may act as a waveguide for propagating electromagnetic waves, with losses smaller than most grades of coaxial cable. Virtually no radiation occurs from the wire and well-nigh all the energy is carried in a circular field close to the wire. Cone shaped launching and receiving devices are used

to match the G-line to conventional coaxial feeder, with the result that G-line can be used for long runs, reserving the use of coax for the more complex connections at the transceiver and aerial ends.

No doubt this sounds like science fiction to some readers and while it is not, it must be admitted that there are some snags which restrict the utility of G-line. The line must be kept fairly straight, otherwise radiation will be lost at bends. G-line must be kept clear of metallic objects and standing waves are a serious problem. Nonetheless, workers who persevered have had success with G-line and after I have disposed of the theory I'll give some practical dimensions and details. Gobau, who popularised G-line, showed that for a bare copper wire of 2mm diameter stretched in air and excited at 3000MHz the attenuation was a mere 0.023dB per metre, and the extent of the field was such that 75 per cent of the transmitted

energy was conveyed within a circle 36cm in diameter around the wire. A demonstration system is shown in Fig. 1. The inner conductor of the coax is joined to the G-line while the outer conductor is soldered to the launching horn. The angle of flare must be kept small to keep undesired transmission modes to a minimum. Calculated results are given in Fig. 2 and in experiments the measured total loss has compared well with the calculated values.

George Hatherell, K6LK, made his experiments at 1296MHz with a number of types of wire. An acceptable compromise was with a 100 ft length of 14 SWG wire, which gave the following results:

Enamel coated wire	loss 3.87dB
Ditto sleeved with Teflon	loss 2,53dB
Plastic insulated household wire (white)	loss 3.62dB
Ditto (black)	loss 3.87dB

Transmitted power was 10 watts. While these results were encouraging, subsequent 'souping up' of the

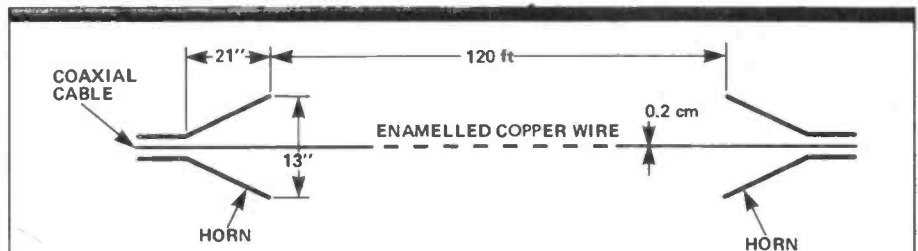

Fig. 1 Experimental surface-wave transmission system

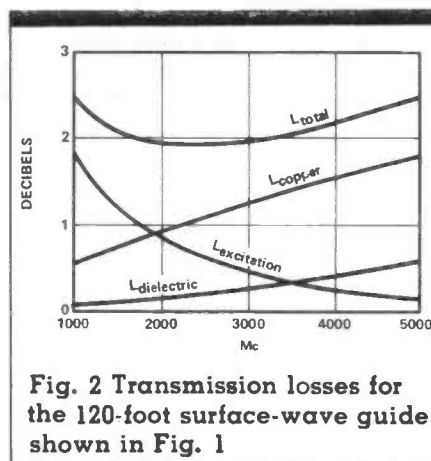

Fig. 2 Transmission losses for the 120-foot surface-wave guide shown in Fig. 1

system brought the total loss of the G-line and launchers and receivers to well under 2dB. His article gives all the constructional details of the launching and collecting horns and his method of suspending the G-line from tightly stretched monofilament fishing line.

REFERENCES

- Hatherell, *QST*, June 1974, pp 11-15, 152, 154.
- Gobau, *Proceedings of the IRE*, 39, pp 619-624 (1951)
- Journal of Applied Physics*, 21, pp 1119-1128 (1950).



South Midlands

SMC YOUR SINGLE STOP SOURCE FOR RECEIVERS,

RECEIVER WITH 12 MEMORIES: FRG7700M £399 inc. VAT @ 15% & SECURICOR

- ★ 30MHz down to 150kHz (and below).
- ★ 12 Channel memory option with fine tune.
- ★ SSB (LSB/USB), CW, AM, FM.
- ★ 2.7kHz, 6kHz, 12kHz, 15kHz, @ -6dB.
- ★ 3 Selectivities on AM. Squelch on FM.
- ★ Up conversion, 48MHz first IF.
- ★ 1kHz digital, plus analogue, display.
- ★ Inbuilt quartz clock/timer.
- ★ No preselector, auto selected LPF's.
- ★ Advanced noise blanker fitted.
- ★ Antenna 500 ohms to 1.5MHz, 50 ohms to 30MHz.
- ★ 20dB pad plus continuous attenuator.
- ★ Switchable A.G.C. Variable tone.



- ★ 110 and 240Vac, 12Vdc option.
- ★ Signal meter calibrated in "S" and SIMPO.
- ★ Acc. Tuners, Converters, LPF, Memory.
- ★ FR7700; 150kHz-30MHz, Switch, etc.
- ★ FRV7700A; 118-130, 130-140, 140-150MHz.
- ★ FRV7700B; 118-130, 140-150, 50-59MHz.
- ★ FRV7700C; 140-150, 150-160, 160-170MHz.
- ★ FRV7700D; 118-130, 140-150, 70-80MHz.
- ★ FRV7700E; 118-130, 140-150, 150-160MHz.
- ★ FRV7700F; 118-130, 150-160, 170-180MHz.
- ★ FFS; 500kHz (for improved VLF reception).
- ★ MEMGR7700; 12 Channels (internal fitting).
- ★ FRA7700; Active Antenna.

'7700 THE ONE WITH FM!
NON-MEMORY VERSION £335

JRC

COMMUNICATION RECEIVER: NRD515 £985 inc. VAT @ 15% & SECURICOR

- ★ 30MHz to 100 KHz or lower, 100Hz steps.
- ★ PLL digital VFO, outstanding (50Hz AWU) stability.
- ★ Backlash free, 10KHz rev, 500Hz analogue calib.
- ★ Fast tune up/down switch, dial lockout.
- ★ SSB (USB/L.SB), CW, AM, RTTY.
- ★ 6 and 2.4KHz, 600° and 300° Hz @ -6dB.
- ★ Passband tuning ± 2KHz on SSB and CW.
- ★ Variable BFO on CW for preferred tone.
- ★ Modular plug in design with mother board.
- ★ High reliability - low power schottky & CMOS.
- ★ Designed for maximum ease of operation.
- ★ Noise blanker 0-10-20dB attenuator.
- ★ Small (140 x 340 x 300mm) light 7½ Kg, rugged.
- ★ Up conversion, 70.455 MHz and 455 KHz.



- ★ No R.F. amplifier, balance U310 mixer.
- ★ Crystal filter before first IF amplifier.
- ★ Transceiver provision; VFO in/out, sidetone, mute, trip etc.
- ★ Frequency data input/output port.

NHD518 96 (4 x 24) channel memory unit
NCM515 Remote keypad controller, LCD readout.

COE515 Up/down step tuning, 4 channel memory
Junction unit (NCM515 to NHD518)
NVA515 External 3W speaker 130 x 140 x 200mm
CFL260 600Hz mechanical filter
CFL230 300Hz crystal filter

PROFESSIONAL MONITOR

FT726R MULTIMODE TRANSCEIVER £6489 inc. VAT @ 15% & SECURICOR



MULTI-BAND VHF/UHF
*Option

★ NEW ★

- ★ 3 Bands*1 2 metres, 70cms* (10MHz) & 6M* plug-ins.
 - ★ Full Duplex*! Cross band Tx & Rx simultaneously.
 - ★ SSB-CW-FM! All optimally catered for.
 - ★ Variable bandwidth and IF shift! SSB & CW.
 - ★ Processor! Front panel mic gain and drive.
 - ★ Two main VFO's! A & B with 20Hz steps.
 - ★ Separate channelised VFO! (for FM operation).
 - ★ Scanning! Over the band, 10 memories, between memory limits.
 - ★ Repeater splits! programmable and preset.
 - ★ Instant reverse! and + & - splits and A/B.
 - ★ Twin meters; PO/DISC, S/ALC. Duplex switchable.
 - ★ Switchable; AGC, CW bandwidth, dial lock.
 - ★ Noise blanker; impulse interference tuned.
- | | | |
|-----------|-------------------------|---------|
| FT726R(2) | Transceiver c/w 144 MHz | £649.00 |
| 430T726 | 430-440MHz module | £208.90 |
| 50T726 | Six meter module | £157.15 |
| SAT726 | Full duplex unit | £82.80 |
- *option.

- ★ 2M, 12VDC compact 2 2/16" x 6 3/16" x 7 3/16" transceiver.
- ★ 25W (+ adjustable low power), 12½ kHz steps.
- ★ 10 "year long" ememories for "crystal control".
- ★ Display reads 100's of Hz or channel number.
- ★ Sensitivity < 0.2µV for 12dB SINAD (0.14µV typical).
- ★ Single knob frequency selection, 20 steps revolution.
- ★ Rapid OSY button, end to end in a single turn.
- ★ Digital RIT 1kHz steps, adjusted from main tuning.
- ★ 2, 5 slot memories, simplex, cross or 600kHz split.
- ★ Memories entered by pushing main tuning knob.
- ★ 600kHz split. Instant repeater input monitor.
- ★ Band scan between front panel selectable, limits.
- ★ Scan stop requires squelch open and centre zero.
- ★ Scanning and up/down tuning on the microphones.
- ★ Reprogrammable; steps, tone, splits, and coverage.
- ★ C/W mic. "Easy out" mobile mount end handbook.

KDK FM2030 £199 inc. VAT @ 15% & SECURICOR

★ NEW ★



MAIL ORDER; AS NEAR AS YOUR 'PHONE OR PEN



SMC SERVICE
Free Securicor delivery on major equipment.
Access and Barclaycard over the phone.
Biggest branch agent and dealer network.
Securicor 'B' Service contract at £4.49.
Biggest stocklist of amateur equipment.

FREE FINANCE
On many regular priced items SMC offers
Free Finance (on Invoice over £100).
20% down and the balance over 6 months or
50% down and the balance over a year.
You pay no more than the cash price!!

GUARANTEE
Importer warranty on Yaesu Musen products.
Able staffed and equipped Service Department.
Daily contact with Yaesu Musen factory.
Tens of thousands of spares and test equipment.
Twenty-four years of professional experience.

S. M. HOUSE, RUMBRIDGE STREET, TOTTON, SOUTHAMPTON, SO4 4DP, ENGLAND,
Tel: Totton (0703) 867333, Telex: 477351 SMCMM G, Telegram: "Aerial" Southampton

Communications Ltd.



TRANSCEIVERS, ANTENNAS, TOWERS, MASTS, CABLES, ETC.

- ★ 80-10 metres including WARC allocations.
- ★ Multimode LSB-USB-CW (W)-CW (N) and FM*.
- ★ 100W PEP output. (10W "S" version).
- ★ No tune design — inbuilt SWR meter.
- ★ Only 3 1/4" x 9 1/2" — Less than a foot deep!
- ★ Dual selectable pulse width noise blanker.

FT77	Transceiver 100W output	£475.00
FT77S	Transceiver 10W output	£399.00
MARK 7	Crystal Marker board	£7.85
FMU77	FM Unit	£23.75
XF8.9HC(N)	600Hz or 300Hz (N)	£24.90
FV707DM	Digital Memory VFO	£203.15
FC707	Antenna Tuner	£85.10
FP707	Mains P.S.U.	£112.50
FTV707	Transvertor, frame only	£90.00

Modules: 432 £185, 144 £100, 70 £80.00



FT77 MOBILE RECEIVER £475 inc.

VAT @ 15%
& SECURICOR



★ NEW ★

ALL BAND MULTIMODE

- ★ 160-10 metres including new allocations.
- ★ Variable IF bandwidth 2.4kHz down to 300Hz.
- ★ Audio Peak and independent notch controls.
- ★ AM, FSK, USB, LSB, CW, FM, (Tx and Rx).*
- ★ Semi-break in, inbuilt Curtis IC Keyer included.
- ★ Digital plus analogue frequency displays.
- ★ VOX built-in and adjustable.
- ★ Instant write in memory channel.**
- ★ Tune up button (10 sec. of full power).
- ★ Switchable AGC and RF attenuator.
- ★ Optional 350 or 600Hz CW, 6kHz AM filters included.
- ★ Clarifier (RIT) switchable on Tx, Rx or both.
- ★ Plug in modular, computer style constructor.
- ★ Fully adjustable RF Speech processor.
- ★ Ergonomically designed with necessary LEDS.
- ★ Incredible range of matching accessories.
- ★ Universal power supply 110-234V AC and 12V DC.**



FT902DM BASE STATION £885 inc.

VAT @ 15%
& SECURICOR



NOW WITH CW FILTER,
★ AM FILTER, CURTIS
KEYER † INCLUDED ★

*D & DE MODELS AVAILABLE



FT102 £785 inc.

VAT @ 15%
& SECURICOR



★ FREE
FINANCE ★

- ★ 1.8-3.5-7-10-14-18-21-24.5, 28MHz.
- ★ All modes:- LSB, USB, CW, AM †, FM † († Option board).
- ★ Front end: extra high level, operates on 24V DC.
- ★ RF stage bypassable boosts dynamic range over 100 dB!
- ★ Variable bandwidth 2.7KHz — 500HZ and IF Shift.
- ★ Fixed bandwidth filters, parallel or cascade configurations.
- ★ IF notch (45KHz) and independent audio peak.
- ★ Noise blanker adjustable for pulse width, (Woodpecker).
- ★ External Rx and separate Rx antenna provisions.
- ★ Three 6146B in special configuration — 40 dB IMD!
- ★ Extra product detector for checking Tx IF signal.
- ★ Dual meter, peak hold ALC system.
- ★ Mic amp with tunable audio network.
- ★ SP102:- Speaker, Hi and Lo AF filters, 12 responses!
- ★ FV102:- VFO. 10Hz steps and readout, scanning, OSY.
- ★ FC102:- ATU. 1.2KW, 20/200/1200 W FSD PEP, wire.
- ★ FAS-1-4R:- 4 way remote waterproof antenna selector.



FT980 £1115 inc.

VAT @ 15%
& SECURICOR



★ CREDIT
COVER ★

- ★ Rx 150kHz-30MHz.
- ★ Tx 160-10m, 9 bands x 3 x 500kHz Aux bands.
- ★ All modes AM, CW, LSB, USB, AFSK & FM (inc.)
- ★ IF shift & variable bandwidth 2.6kHz-300Hz.
- ★ Inbuilt keyboard operation + scanning.
- ★ Switchable attenuator 10, 20, 30dB.
- ★ Audio peak + notch filter — 40dB
- ★ RF processor and Auto mic gain control.
- ★ 3rd order IMD — 40dB at 100W PEP.
- ★ AFSK shift 170, 425, 850Hz selectable.
- ★ Multi channel memory + programmable scan limits.
- ★ Optional computer interface available.
- ★ Notch filter in IF (AGC immune to heterodynes).
- ★ Full break in keying. 500/600/700Hz beat.
- ★ Unique analogue scale of digital type.
- ★ Comprehensive twin meter metering.
- ★ Memory retains mode information.

SHOWROOMS: SPANNING THE UK — TO SERVE YOU

SOUTHAMPTON
SMC Ltd
36-38 Rumbridge Street
Totton, Southampton
Southampton (0703) 867333
9-5.30 Mon-Sat

LEEDS
SMC (Leeds)
257 Otley Road
Leeds 16, Yorkshire
Leeds (0532) 782326
9-5.30 Mon-Sat

CHESTERFIELD
SMC (Jack Twendy) Ltd
102 High Street
New Whittington, Chesterfield
Chesterfield (0246) 453340
9-5 Tues-Sat

BUCKLEY
SMC (TMP)
Unit 27, Pinfold Lane
Buckley, Clwyd
Buckley (0244) 549563
9.30-5.30 Tues-Sat

STOKE
SMC (Stoke)
76 High Street
Talke Pits, Stoke
Kidsgrove (07816) 72644
9-5.30 Tues-Sat

GRIMSBY
SMC (Grimsby)
247A Freeman Street
Grimsby, Lincs
Grimsby (0472) 59388
9.30-5.30 Mon-Sat

JERSEY
SMC (Jersey)
1 Belmont Gardens
St. Heller, Jersey
Jersey (0534) 77067
10-7 Mon-Sat

SMC STOCK CARRYING AGENTS WITH DEMONSTRATION FACILITIES

Edinburgh Jack GMBGEC (031-857) 2430 Day (031-665) 2420 Eve
Bangor John G13KDR (0247) 55162
Tandreege Mervyn G13WVY (0782) 840656
Neath John
GW4F01 (0639) 52374 Day (0639) 2942 Eve

ARROW

... Give us a ring
Tel: 0277-226470 or
219435

7 Coptfold Road, Brentwood, Essex CM14 4BN

Tel: 0277 226470 or 219435 Ansafone on 219435 Telex: 995801 (REF: A5)

YAESU

FT 77	New model	£515.00
FT 700	New model	P.O.A.
FT 726	New model	699.00
FT 980	New model	1215.00
FT 730	New model	299.00
FC 102	ATU	225.00
SP 102	Speaker	49.00
FT 102	160 10M 9-Band Transceiver	839.00
FT ONE	Gen. Coverage Transceiver	1450.00
FT 790R	70cm all-mode portable	349.00
FT 101ZDFM	160-10m 9-Band Transceiver	599.00
DCT 101Z	DC Adaptor	42.50
FV 101Z	Remote vfo	112.00
FV 101DM		249.00
FT 902DM	9 Band AM/FM Transceiver	895.00
FC 902	9 Band atu, swr/pwr etc	135.00
FTV 901R	Transverter fitted 2m module	285.00
430 TV	70cm module for above	185.00
144 TV	2m module for Transverter	100.00
70 TV	4m module for Transverter	80.00
FV 901DM	Remote vfo for 901	260.00
SP 901	External speaker	31.00
FL 2100Z	9 Band 1200W linear	485.00
FT 107DMS	with memory & FP 107	699.00
FT 707	8-Band solid state 100W	509.00
FP 707	230 volts AC power supply	112.50
FC 707	Aerial tuner	85.00
MMB 2	Mobile mounting bracket	16.00
FRG 7700	SSB AM/FM recvr	299.00
MEM 7700	Memory unit for above	89.00
FRV 7700A	118 150 MHz Converter	69.75
FRV 7700B	50-60MHz & 118-150MHz	75.50
FRV 7700C	140-170MHz	65.95
FRV 7700D	70-80MHz & 118-130MHz	72.45
FRV 7700E	140-160MHz & 118-130MHz	71.30
FRV 7700F	150-160MHz, 118-130MHz & 170-180MHz	71.30
FRT 7700	Receiver aerial tuner	37.85
FT 480R	2m all mode transceiver	365.00
FP 80A	230V AC power supply	63.00
FP 80A	230V AC power supply	63.00
FT 780R	70cm all mode UK rpt. shift.	449.00
FT 280R	2m all mode portable	285.00
NC 11C	AC charger	8.00
MMB 11	Mobile mounting bracket	22.25
FT 208R	2m synth-sized portable FM	199.00
NC 9C	AC charger	8.00
FT 708R	70cm hand held	209.00
FT 230R	2m FM mobile	255.00

All Yaesu accessories available mostly ex stock.

TRIO-KENWOOD

TR 7930	2m XCVR	NEW P.O.A.
R 2000	Receiver	NEW P.O.A.
TR 3500	70cm Handy	NEW P.O.A.
TS 930	Gen. coverage transceiver	1155.00
TS 830S	160 10m transceiver 9 bands	650.00
AT 230	All band ATU power meter	110.00
TR 2500	2m FM synth'esed hand held	207.00
DM 801	Digital filter	60.00
R 600	Gen. coverage receiver	199.00

All Trio Kenwood accessories available.

SOMMERKAMP

TS 280FM	2m Mobile 50W FM	199.00
FT 78	HF Transceiver	399.00
FT 277ZD	HF Transceiver FM	710.00
FT 902DM	HF Transceiver FM AM SSB	885.00

ROTATORS

KR 250	Kenpro Lightweight 1.13" mast	44.95
9502B	Colorator (Med VHF)	55.00
KR 400RC	Kenpro	99.95
KR 600RC	Kenpro	139.95

ICOM

IC 740	Multimode H.F. transceiver	769.00
IC 720A	HF transceiver and gen. cov. rec.	799.00
IC 730	HF mobile transceiver 8-band	586.00
ICR 70	Multimode receiver	NEW 469.00
PS 15	Power supply for 720A	99.00
IC 251E	2m multimode base station	499.00
IC 25E	2m synth compact 25W mobile	259.00

IC 290E	2m multimode mobile	433.00
IC 2E	2m FM synthesised hand held	179.00
IC 4E	70cm hand held	199.00
ICL1/2/3	Soft cases	3.50
IC HM9	Speaker/microphone	12.00
	Car charging lead	3.20
IC BP2	6V Nicad pack for IC 2E	22.00
IC BP3	9V Nicad pack for IC 2E	17.70
IC BP4	Empty case for 6 X AA Nicads	5.80
IC 8PS	11.5V Nicad pack for IC 2E	30.50
IC DC1	12V adaptor pack for IC 2E	8.40

TRIO

CI 303G	Communication scope	170.00
PF 810	Power/SWR meter	85.00

Catalogue of Trio Instruments send SAE.

TONNA

20117	2m 17 element	35.19
20505	50MHz 5 ele.	31.74
20104	2m 4 ele.	12.99
20109	2m 9 ele.	15.44
20209	2m 9 ele. port.	17.46
20118	2m 2 + 9 ele. cross	28.51
20113	2m 13 ele. port.	27.20
20116	2m 16 ele.	29.95
20419	70cm 19 ele.	18.12
20438	70cm 2 + 9 ele. cross	30.05
20421	70cm 21 ele.	25.98
20422	21 ele. ATV	25.98
20199	2m + 70 Oscar	30.05

Full range of Tonna accessories stocked

G-WHIP MOBILE ANTENNA RANGE

Tribander helical for 10 15 20 metres	25.80
Base mount single hole fixing + 3m cable	6.30
LF 40m coil for above aerial	6.55
LF 80m coil for above aerial	6.55
LF 160m coil for above aerial	6.55
LF telescopic resonator whip	4.25

We also stock flexiwhip & multimobile G whips

WELZ

SP 10X	Mini meter 1.8 160MHz 200W	19.95
SP 15M	1.8 150MHz 2.5W 200W	29.95
SP 45M	2m 70cm 100W	45.00
SP 200	1.8 160MHz 20W 200W 1kW	59.95
SP 300	1.8 500MHz 20W 200W 1kW	79.95
SP 350	1.8 500MHz 200W	49.95
SP 400	130 500MHz 5W 20W 150W	59.95
SP 250	1.6 60MHz 2kW	45.00
SP 380	1.8 500MHz 20W 200W	49.95
AC 38M	8 band ATU	59.00
CH 20A	450MHz coax switch	15.95
CT 150	150 400W D load	31.00
CT 300	300 1kW 250MHz D load	43.00

TONO

THETA 9000E RTTY CWASC11	650.00
THETA 550 The latest a winner	299.00

TASCO

TeleReader CWR 685 RTTY CW ASC11	699.00
TeleReader CWR 670E As above RX only	259.00
MorseMaster CWR 600 As above basic unit	189.00

ADONIS MICROPHONES

MM 202S	Safety mic Laper type	20.95
MM 202HD	Safety mic head band	29.00
MM 202HM	Headphone & mic	39.00

NEW IN

CT1000 Computer Controlled Rotator
FT77 New Yaesu Mini
FT980 Stock now in
SP980 Speaker for FT One/980



AL 230	2m 30W Linear 1-3W in FT 290R etc	39.00
AL 710	70cm 10W Linear	65.00
AL 730	70cm 30W Linear	79.00

ALINCO

MT 240X	HF 80 10m Wire array	49.50
MTE 40X	80m + 40m array	45.00
BL 40X	1:1 Balun SO 239	13.80

SAGANT

FD 4	Windom Array HF bands	31.50
FB 16	1:6 Balun for DIY	17.45

Send for details NEW RANGE

FRITZELL

HALBAR

LIN 5	70cm 5 el Yagi	7.99
STR 5	2m 5 el Yagi	9.99
FOLDI	2m 5 el Foldup	13.00
TWIN	2m Vert	14.95
TWIN 70	70cm Vertical	7.99
DIP 2	2m Dipole	3.95
HALO	2m Halo	5.50
LPA	Log period 70cm	15.00
OUAD 6	2m 6 el Quad	25.00
OUAD 4	2m 4 el Quad	17.50

DAIWA

DR 7500X	up to 3 el HF beam preset controller	98.00
DR 7500R	as above remote control	107.95
DR 7600R	Heavy duty & preset HF beam as above remote control	152.00
KSO 65	Stay bearing	18.50
CS 201	2 way switch 1000MHz above w/ N sockets	11.98
CS 201A	above w/ N sockets	19.00
CS 401	4 way w/ SO 239	34.95
RM 940	Infra Red beam	45.00
CN 520	1.8 60MHz SWR PWR	32.50
CN 540	50 150MHz SWR PWR	35.00
RX 110G	2m GMS Flat Pack antenna	NEW 39.00
RX 430G	70cm GMS Flat Pack antenna	NEW 63.00
RF 670	RF Speech Proc	NEW 44.00
FD 30LS	Low Pass Filter	11.50
FD 30M	LP Filter HD	19.50
PS300	Variable PSU	135.00

MISCELLANEOUS

ANTENNA Dummy Load	14.95
ARROW 15 Amp PSU with meter	82.00
COAX SEAL for sealing air for bias of against weather	20p foot
SWEDISH KEY Brass of Teak wood 5/8 straight key	49.00
VIBROPEX EX variable frequency stock 64MHz	80.00
Microwave Modulator Stocked	
KENPRO KP 100 Keyer	69.00

TET

TR 3350	3 el 70cm HF Beam	189.00
MA 38P	15 Band Vertical	40.25
MA 58P	5 Band Vertical	71.25
SO 30R	8 el Quad 2m	48.96

CARRIAGE & VAT
ALL PRICES INCLUDE VAT ITEMS OVER £50.00 VALUE OR TOTAL ORDERS OVER £50.00 ARE CARRIAGE FREE
SECURICOR YOUR OPTION FOR MAJOR ITEMS ALL DESPATCHES ARE INSURED BY US NO RISKS TO YOU IF LOST OR DAMAGED

"PHONE YOUR ORDER FOR TODAY'S DESPATCH ALL WE NEED IS YOUR OR NUMBER.
SMALL SPARES PLUGS AERIALS PHONE FOR A QUOTE FOR THAT NEW RIG!"

OPEN 5 DAYS A WEEK CLOSED THURSDAYS

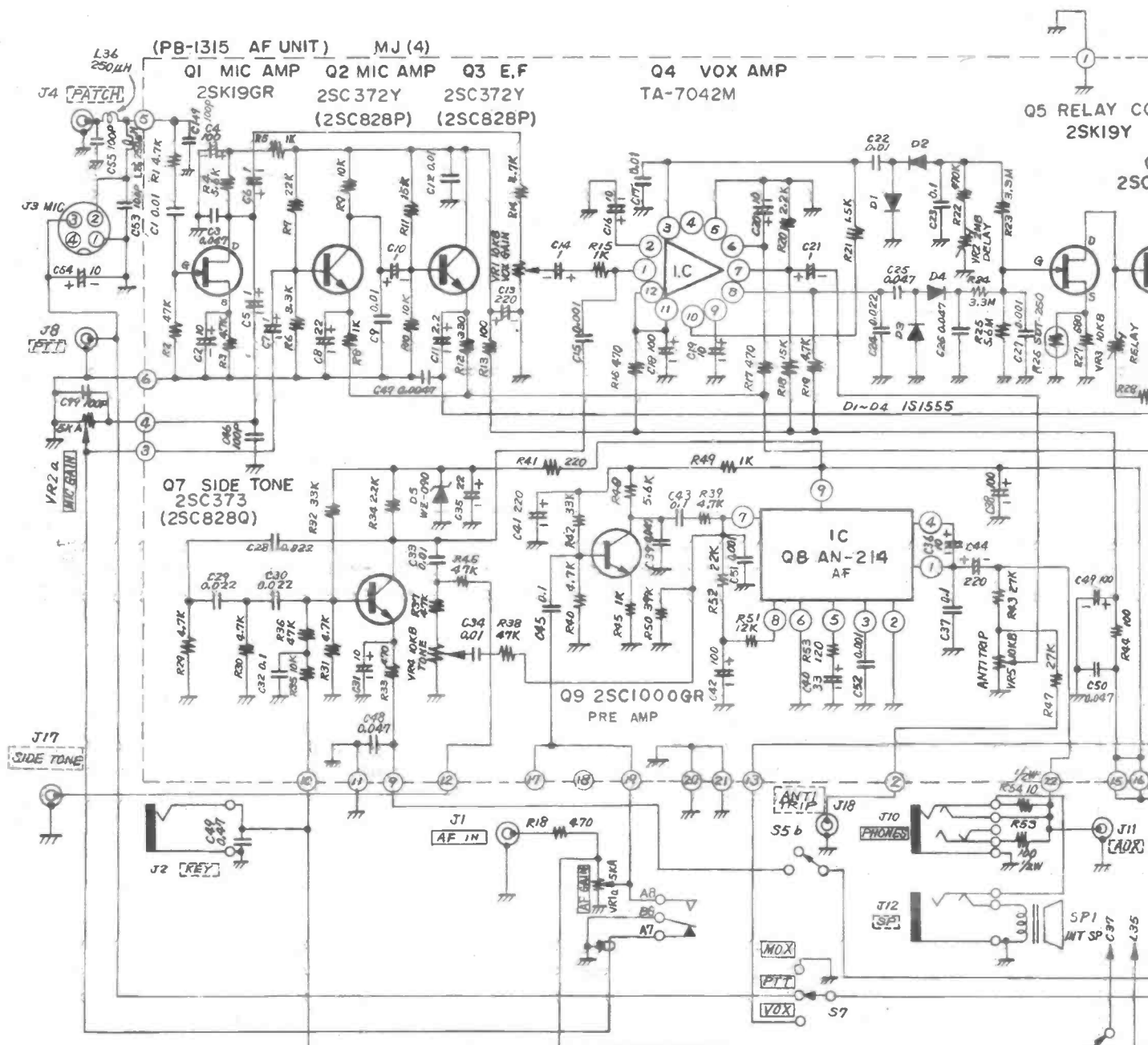

- NOTES
- 1 ALL RESISTORS ARE IN 1/4W UNLESS OTHERWISE NOTED.
 2. ALL CAPACITORS ARE IN μ F UNLESS OTHERWISE NOTED.
 - 3 ALL ELECTROLYTIC CAPACITORS ARE 16VW UNLESS OTHERWISE NOTED.
 - 4 * VALUE IS NOMINAL.

FT-101E
CIRCUIT DIAGRAM

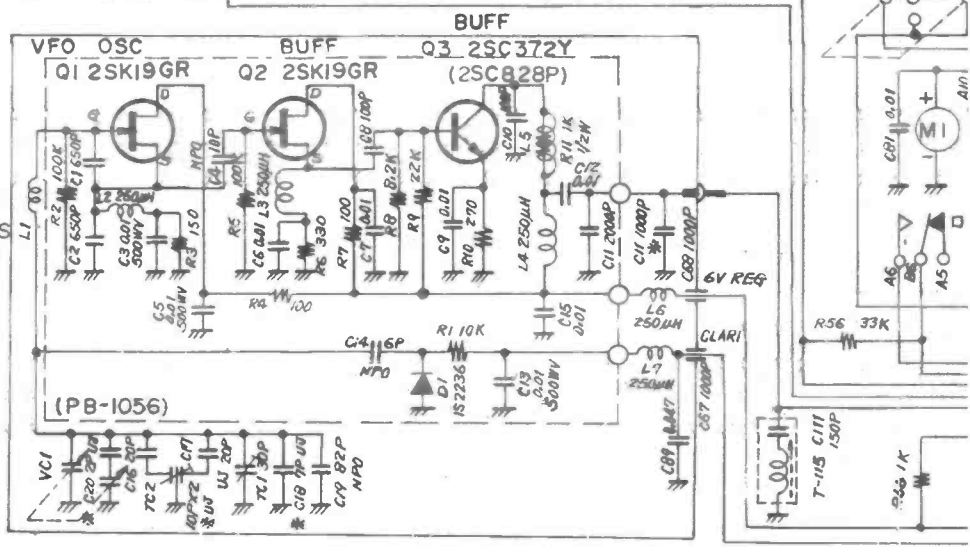

T10

5 RELAY CONT.
2SK19Y

Q6
2SC373

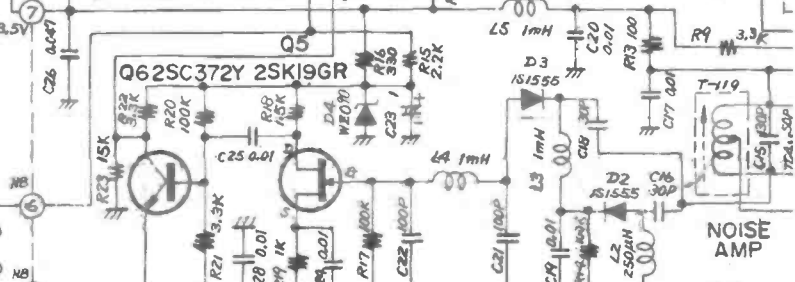
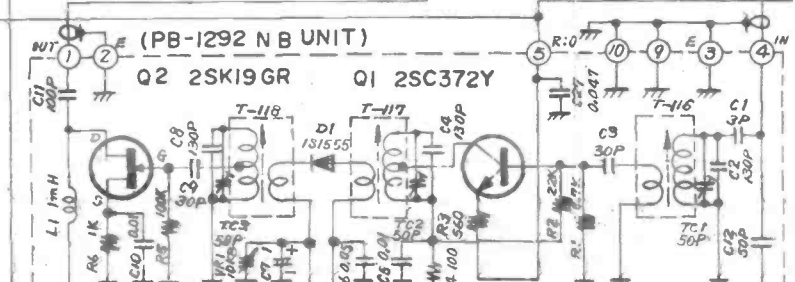
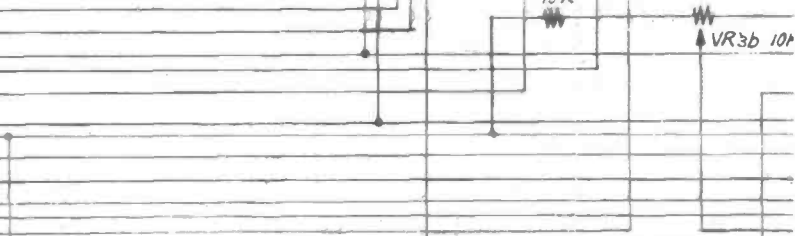
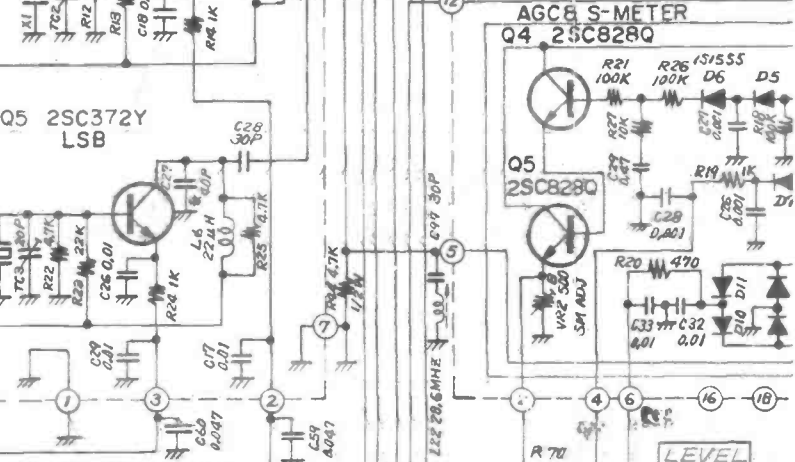
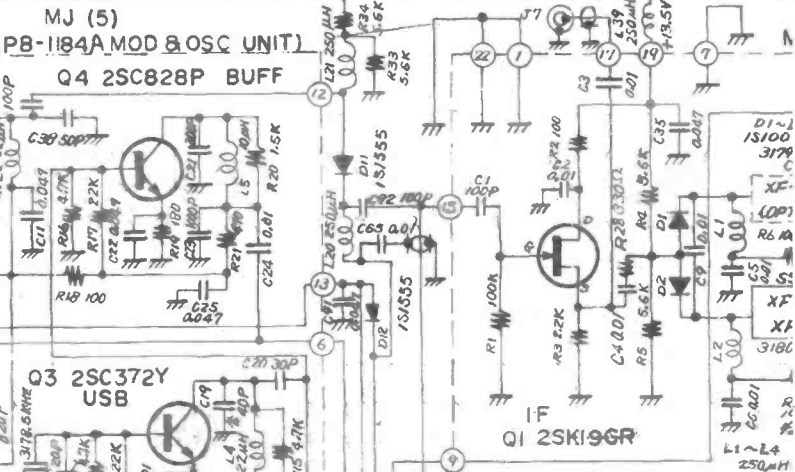
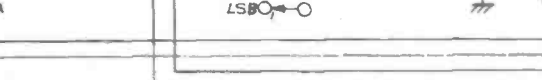
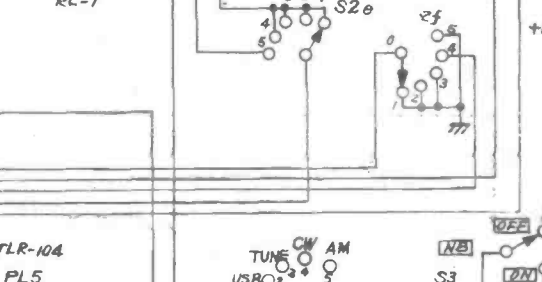
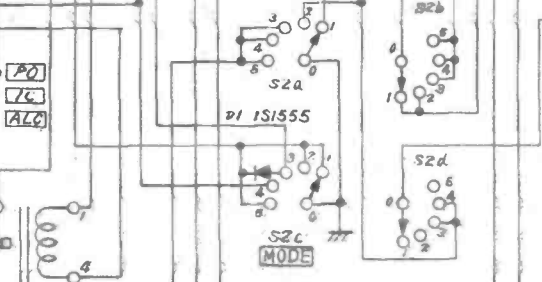
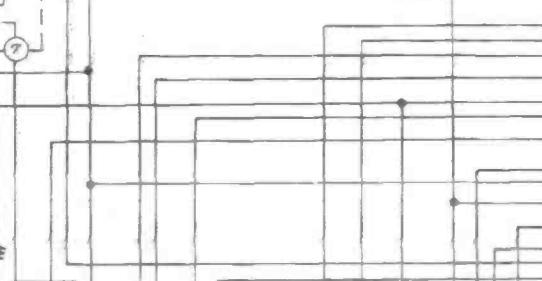
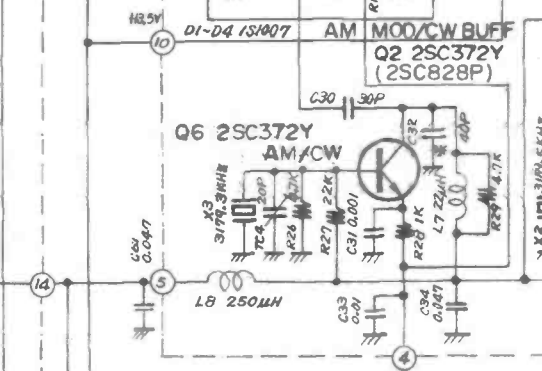
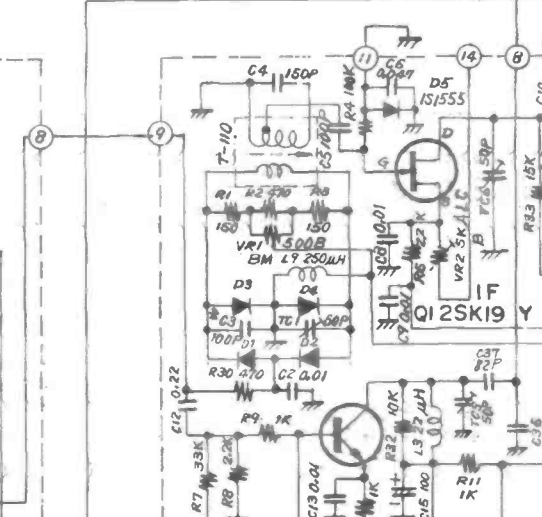
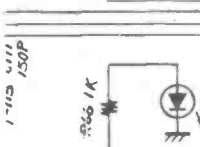
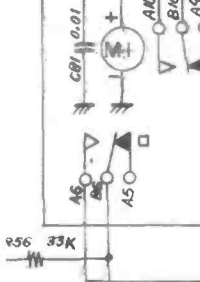
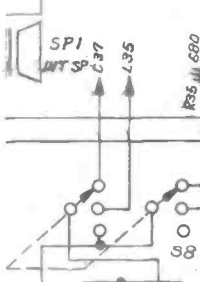
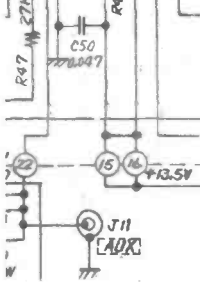
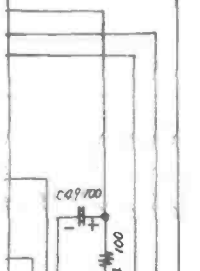
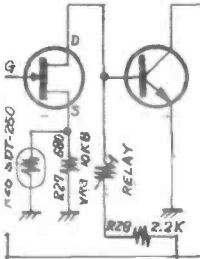

TLR-104
PL5

TUNE
USB
AM
LSB

LEVEL

NOISE AMP
Q4 2SC

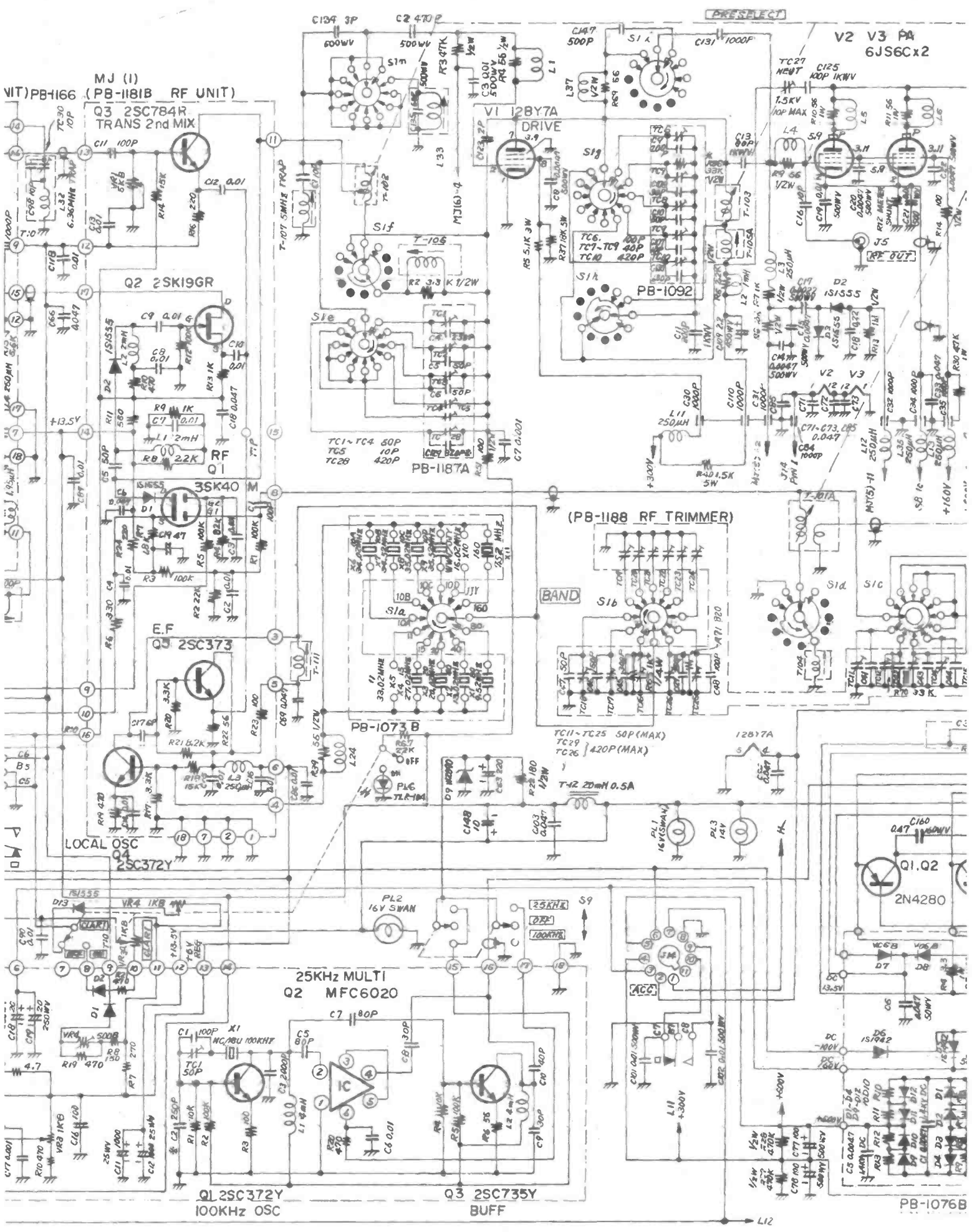

PB-1076B

A Plainman's Guide to Masts & Towers

Part 5 Installation

By A S Barraclough G3UDO*

The final step is to decide where to site the aerial mast or tower you want, and prepare the foundations for it. However, very often, the process of choosing a suitable site and then laying the necessary foundations can present as many problems as selecting the mast or tower. So it is advisable not to rush this final stage, but spend a little time in planning your operation beforehand to save time and energy later on.

Hiding the thing

If you are fortunate enough to have a fairly large garden screened by trees the choice of a suitable site becomes a little easier. However, in the average suburban garden things may not be so easy, space could be at a premium and the choice of a suitable site limited. In general, masts or towers of the telescopic, tiltover type with an extended height of 30 to 60 feet would be practicable, and probably acceptable, in most urban locations where space is restricted. Masts and towers with a retracted height of about 21 feet or less can be ideal for such locations, because their low retracted height will enable the aerial to be effectively hidden by the ridge of the house, and so reduce any 'skylining' which could be a problem where appearance is a major factor (see Fig. 1.) In addition, a low retracted height enables the whole structure to be tilted over in a relatively small area. Where there

are objections from the neighbours or the local authority against lattice towers then an unobtrusive tubular section telescopic mast could be more acceptable. Where a mast or tower can be wall-mounted against the side or end of a house, its structure can be masked to some extent.

It will tend to 'blend' in with the house. However, the aerial would be close to the house and may suffer slight detuning, particularly in the lowered position. The amount of any detuning is not predictable but it should not be sufficient to cause any major problem.

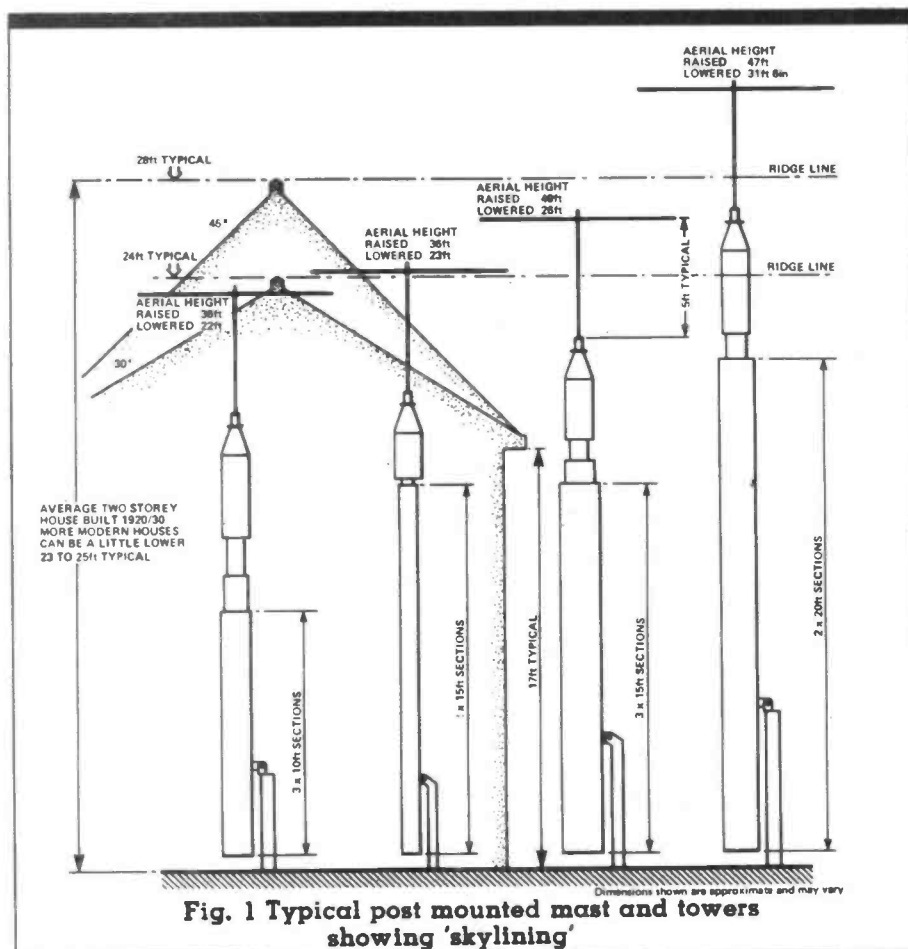

Post mounted masts or towers need not be too near any building and any detuning would be minimal, but their structures would be more exposed to view. Again if 'skylining' is kept to a minimum, with a low retracted height when the aerial is not in use, then the structure may not be too noticeable. When deciding how far to position the tower or mast from the house, bear in mind the length of feeder and rotator cable needed. Long feeder cables mean higher losses. Merely placing the whole lot as far away from the house as possible may not be the most economical solution. As a general guide, keeping the aerials at a distance equal to at least a half-wavelength (at the lowest frequency to be used) should be practical. However, as is often the case, local conditions may dictate otherwise.

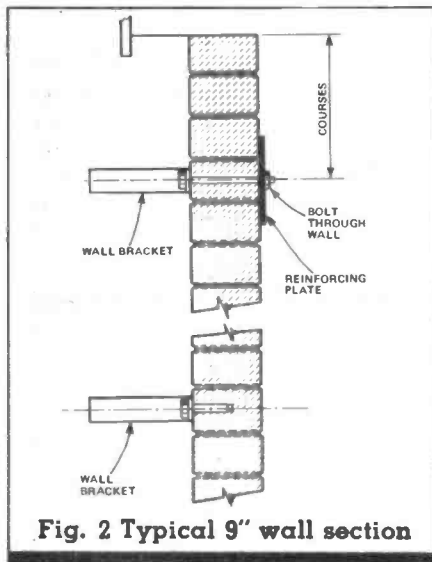

Fig. 2 Typical 9" wall section

The other limiting factor is the height above the hinge point the supporting bracket up the wall. As mentioned earlier in part 4, which concerned loadings, the higher up the wall bracket is fixed, the lower the loads on the wall will be. However, it is not possible to fix the bracket to the very top of a wall and hope for the best, because the top part of the wall is not as strong as lower sections, so some sort of compromise height has to be found. Generally the wall bracket should be more than three courses of brickwork down from the top of the wall but it may have to be lower for a large tower. (See Fig. 2) From this it is clear that large towers and low walls are not compatible without some additional reinforcement being used. The wall bracket is usually anchored to the wall either with

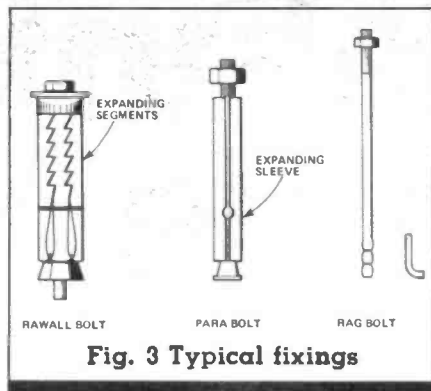

Fig. 3 Typical fixings

Rawall or Para bolts (Fig. 3.), or with studs going through the wall structure as in Fig. 2. Para bolts are useful because they require a hole that is only slightly larger in diameter than the actual bolt, so that the wall can be drilled through the bracket itself, which saves having to mark the holes out separately. When installing the ground hinge and wall bracket always use a spirit level to check that they are level and correctly aligned. The manufacturers instructions should be followed throughout.

Post mounting

With post-mounted masts and towers, the structure is hinged part way up its outermost section and pivoted on a post that is either imbedded in, or anchored to, a concrete foundation. Using a winch and cable system, the structure can be tilted to the horizontal while it is in the fully retracted position. The size of the concrete base depends on the type of post and tower to be supported. The manufacturers specifications will usually state the dimension of the base needed. Digging out the foundation and filling it with concrete can be a tedious task, but one that cannot be hurried if it is to be done correctly. If you have any doubts then it may be advisable to get the job done by a local builder. Before any concrete is filled, the ground post should be positioned in the hole and held vertically in situ by four guy ropes or suitable lengths of timber as in Fig. 4. Check that it is vertical on all sides with a spirit level, and check that only the correct depth of post is being buried. Digging out an incorrectly placed post could be difficult to say the least! Where surface mounted posts (Fig. 5) such as a base or frame post, are to be mounted, suitable ragged bolts (Fig. 3) are usually called for. A simple way to

ensure that these are correctly spaced is to make up a timber pattern that corresponds to the fixing holes on the base. (Fig. 6). Fix the ragged bolts onto the pattern and then, using lengths of timber, position the pattern over the hole with the rags hanging down into it. Use a spirit level to check that the pattern is level in all directions before filling in any concrete. Once the concrete has set, the pattern can be removed leaving the threaded ends of the rag bolts sticking up ready for the base to be bolted down. Concrete should be allowed to set for at least three days before handling and a week at least before any loads can be placed on it. Where a GROUND socket is to be used (Fig. 7) then the simplest way to bury it is to slip it on to the post and then set the post up as before. It may be a good idea to arrange some suitable drainage for the bottom of the socket to prevent it filling up with water. A simple way of providing some drainage for the socket is to stand it on a suitable number of engineering bricks placed at the bottom of the hole for the base. Engineering bricks are the sort that have a number of holes running through them. Bear in mind that waterlogged ground may not be firm enough for post mounted installations, and this sort of drainage will not help. If you have any doubts then again seek professional advice. Once a post-mounted mast or tower has been installed, there may be some slight settlement of the concrete base which, depending on the soil conditions, may tilt the structure mounted on it.

If you are going to carry out the concreting yourself you will need to know roughly what volume of

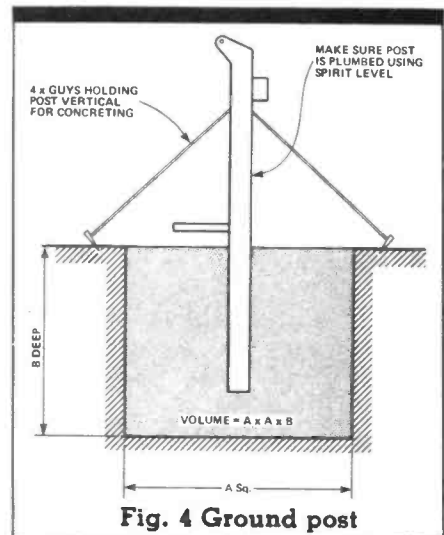

Fig. 4 Ground post

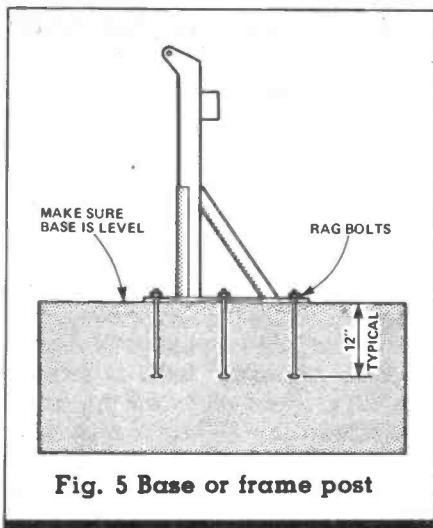

Fig. 5 Base or frame post

material is required. To find the volume of the base simply multiply the area of the bottom of the hole by its depth. Thus:

$$\text{Volume} = A \times A \times B$$

cubic feet or metres. (See Fig.

4.)

The weight of concrete in the base can be found by multiplying the volume base by the weight of concrete per cubic foot/metre. The approximate weight of concrete is 144lb per cubic ft, or 230kg per cubic metre. Buying the concrete ready mixed or having it mixed on your premises by a contractor is probably the cheapest and quickest method. If you are going to make your own then a mixture in the proportions 2:4:6 of cement:sand:coarse aggregate/broken-brick-filling should do the job providing the mix is not too dry and the hole is properly filled with it. In some circumstances, where the space available for the base is a little restricted, or when the soil is a little loose, it may be necessary to increase the resistance of the soil by spreading the loads over a larger area. This can be done easily by driving suitable lengths of steel angle or 1½ to 2 inch diameter pipe into the soil near the bottom of the hole, leaving a foot or so of the steel reinforcing sticking into the hole itself so that it will become embedded in the concrete when the hole is filled (See Fig. 7.) But remember, this is not a substitute for a proper concrete base. The manufacturers specified dimensions should be followed.

Earthing

A conductive metal structure such as a mast or tower can be af-

ected by the RF being transmitted at the aerial as well as by static electricity in the air and lightning.

In order to minimise these effects and eliminate the possibilities of getting an accidental static discharge, or the tower being damaged by a lightning strike, it is advisable to ground the structure to a suitable 'Earth' point. This can be done by burying up to 3 or 4 feet of copper rod (about 3/8" diameter) or a similar length of copper water pipe and then bonding the base of the mast or tower to it, using a flat strip of copper about 1" wide at least 1/16" thick (16 or 14 SWG). Earthing the tower in this way will also reduce the likelihood of any RF pick-up being reradiated, causing the inevitable TVI.

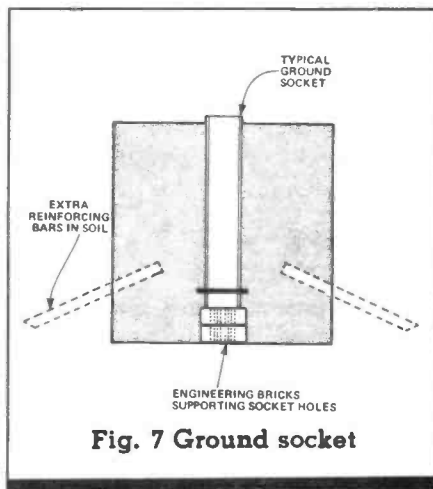

Fig. 7 Ground socket

Safety

Like all mechanical devices, a mast or tower can be dangerous if it is incorrectly used, poorly maintained or overloaded. Remember that safety and performance will depend to a large extent on correct usage and regular maintenance. Most of

the problems that arise with mast and tower installations are due to one or both of these factors being ignored. When you are deciding where to position the tower, bear in mind its full retracted length, including the aerial array, and mark out where exactly it will come when lowered down.

Some do's and don'ts

Do read all the manufacturer's instructions before carrying out any operation.

Do observe the manufacturer's specified loadings.

Do inspect regularly for wear and tear.

Do lubricate such things as pulleys and cables regularly.

Do support the weight of the structure when it is horizontal.

Do check that cables are seated in their pulleys before any winching operation.

Don't overload the structure.

Don't tilt over with the mast or tower extended.

Don't allow anyone to stand in its 'line of fall' where tilting down.

Don't rush the operation or let an inexperienced person carry it out.

Don't heave and pull on the end of the structure while it is tilted over and unsupported.

Don't leave the mast or tower fully raised when you go on holiday.

Lower it and immobilize it or lock it. Don't leave yourself uncovered by insurance.

That's about it then, with a correctly installed mast or tower properly used and well maintained, you should be able to keep your aerials in tip-top condition and enjoy many years of happy amateur radio operating.

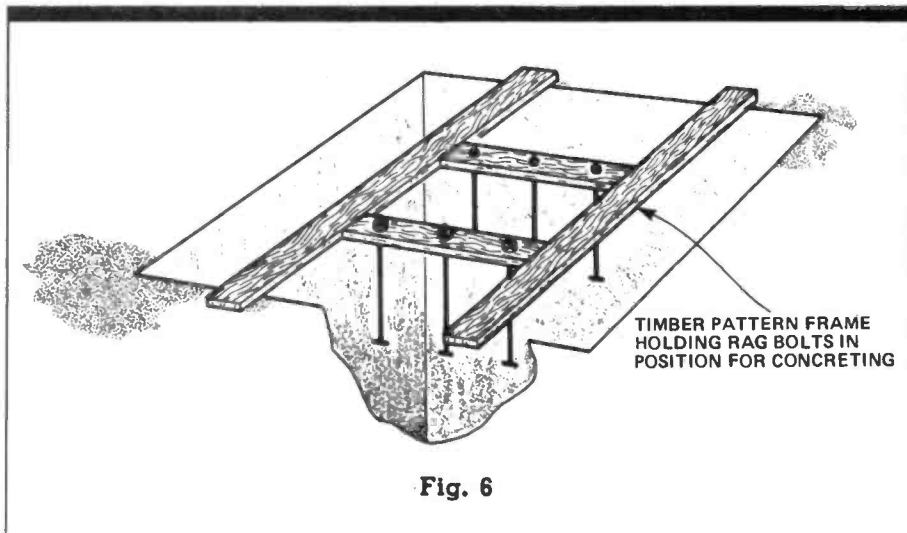

Fig. 6

Driving Lesson

By Richard Lamont G4DYA
Assistant Editor, Ham Radio
Today

After being bitten by the amateur radio bug, the newcomer is often at a loss to know how to start. At first it may seem that all that can be done is to bone up on the RAE and the Morse test needed to get a Home Office licence.

Although the idea of just listening to radio amateurs may seem a bit boring compared to actually talking to them, it really can be a fascinating hobby in itself. I spent a couple of years (not all of it!) glued to a short wave receiver before getting a licence, with never a dull moment, because there is *always* something new to discover. Like the transmitting amateur, you can explore the mysteries of the ionosphere as it continually changes in the way it bends radio signals around the Earth's surface — sometimes slowly and subtly, sometimes so suddenly that you think a fuse has gone. This *propagation* of radio signals is one area of fascination. Another such is aeri- als — there is an infinite variety of aeri- als for different jobs, and endless scope for building, modifying and testing out your ideas and learning by experiment.

There are countless more reasons why SWLs the world over are content to just listen and not

talk. They're willing to leave a 'ticket' until they've solved the challenges and answered the questions that SWLing inevitably brings.

If you've got this far and not decided that I'm bonkers then stick with us. The purpose of this article is to show the complete novice around the controls of a typical, reasonably modern, receiver or transceiver. Yes, while we're at it we might as well deal with the transmitting bits — they're easy. Let's find our way round the receiver first.

The first thing is to set the receiver to the right frequency, i.e. somewhere in our chosen amateur band. (The bands allocated for amateur use are listed in Table 1.) There is always some kind of band-switch which is marked in either frequency, measured in Megahertz (MHz), or wavelength (measured in metres). The table shows how the two quantities are related. note that as the frequency gets higher, the wavelength gets shorter.

Some bandswitches have a position marked WWV or JJY. This is usually a 10MHz band for listening to 'standard frequency' transmissions to check the receiver calibration.

Having chosen which band to listen on, the next step is to master the main tuning dial. There is a huge variety of these, but the easiest to read are the digital ones. These are included on virtually every modern rig. Older receivers often rely on a combination of two 'analogue', mechanical indications — a 'course' indication, usually on a dial behind a plastic window, and a 'fine' indication, often on a 'skirt' on the tuning knob itself. The skirt can usually be moved independently of the knob, enabling exact calibration. These dials reached near perfection in the Seventies, just in time to be ditched by digitals.

Crystal calibrator

Although these 'analogue' tuning dials can be set accurately, an accurate reference is needed to set them with. A crystal calibrator is the usual answer. This is a very accurate crystal-controlled oscillator that produces an output at several frequencies across the short wave spectrum, typically 100kHz apart. The trick is to switch the calibrator on and 'tune it in for zero-beat'; i.e. adjust the dial until the pitch of the tone coming from the loudspeaker is so low that you can't hear it. Then adjust the skirt to the '0' position, *without moving the main control*. The receiver is now calibrated — at

Frequency range (MHz)	Approximate wavelength (metres)
1.810-2.000	160
3.500-3.800	80
7.000-7.100	40
10.100-10.150	30
14.000-14.350	20
18.068-18.168	17
21.000-21.450	15
24.890-24.990	12
28.000-29.700	10

Table 1: HF amateur bands (in UK)

least for that band. Try checking the calibration up and down the band to see if it's OK at other 100kHz points.

Another commonly found control connected with setting the frequency is a *preselector* knob. This

simply 'peaks' certain parts of the receiver for best performance at the chosen frequency. Simply adjust for maximum volume.

Intermediate frequency

All receivers, except *direct conversion* ones, change the frequency of the incoming signal to an *intermediate frequency* (IF) fairly early on. This is because it is easier to amplify and process a signal at a single frequency than over a whole range of frequencies. The intermediate frequency signal is eventually *demodulated* into *audio*.

Modes

There are several different ways of transmitting speech. On the HF bands *Single Sideband* (SSB) is used almost exclusively. There are two sorts of sideband — upper and lower (USB and LSB). On amateur bands below 9MHz it is usual to use LSB, whereas USB is the norm above 9MHz.

AM is rarely used by amateurs now, but it's useful to have it if you want to listen to broadcast stations. FM is very valuable if you envisage listening to the VHF and UHF bands, either on a VHF/UHF receiver or on an HF receiver with a converter.

CW stands for *continuous wave*, a rather inaccurate and old-fashioned term for Morse Code. (How can it be continuous if it's being keyed on and off?) The only difference to the receiver, compared to SSB, is that the *filter* used has a narrower *bandwidth*. The bandwidth is the difference between the lowest and highest frequencies it will let through. Morse consists of a tone of constant frequency that is keyed on and off (whereas speech uses a continuous range of frequencies) so a narrower filter will do.

When you discover how many signals are squashed into the short wave spectrum you will understand how important bandwidth is. You can minimise interference to the station you're trying to listen to by minimising the strength of stations on neighbouring frequencies. In other words you minimise the bandwidth.

Older receivers had switched filters, with bandwidths to suit the mode in use — typically 12kHz for amateur FM, 6kHz for AM, 2.7kHz for SSB and 600Hz for CW.

Modern receivers often have *IF*

shift and *IF width* controls which allow continuous variation of the filter's response. Figure 1 shows the effect of these controls. A typical crystal filter for SSB reception might be, say, 2.7kHz wide, symmetrical about the *intermediate frequency* (IF). Turning down the IF width might reduce this to, say, 1.8kHz. This would spoil the audio quality a bit, but it would certainly cut out 'adjacent-channel' interference.

The IF shift control doesn't affect the bandwidth, but moves the response up and down. It sounds a bit like turning the 'bass' down and the 'treble' up, or vice-versa. Again, this control can be used to get rid of interference on a close (or even overlapping) frequency.

Some rigs, eg. the Trio/Kenwood TS930 transceiver, do not have IF shift and width controls, but separate controls to move each side of the filter's response up and down in frequency.

the *RF gain*, which controls the amplification of the earliest stages of the receiver. The drop in volume can be offset by turning up the *AF gain*, which controls the amount of gain in the last stages of the receiver. If, however, you turn the RF gain down too low and the AF gain up too high, the signal in most of the receiver's stages will be too low, and it will reward you with hiss.

For SSB reception it is advisable to keep the RF gain set lowish for good audio quality.

Automatic gain control (AGC)

The range of signal strengths on the short wave band varies enormously from one transmission to another, so it's desirable to reduce the receiver's gain automatically on strong signals. This reduces risk of overloading, and prevents you from deafening yourself when a strong signal appears.

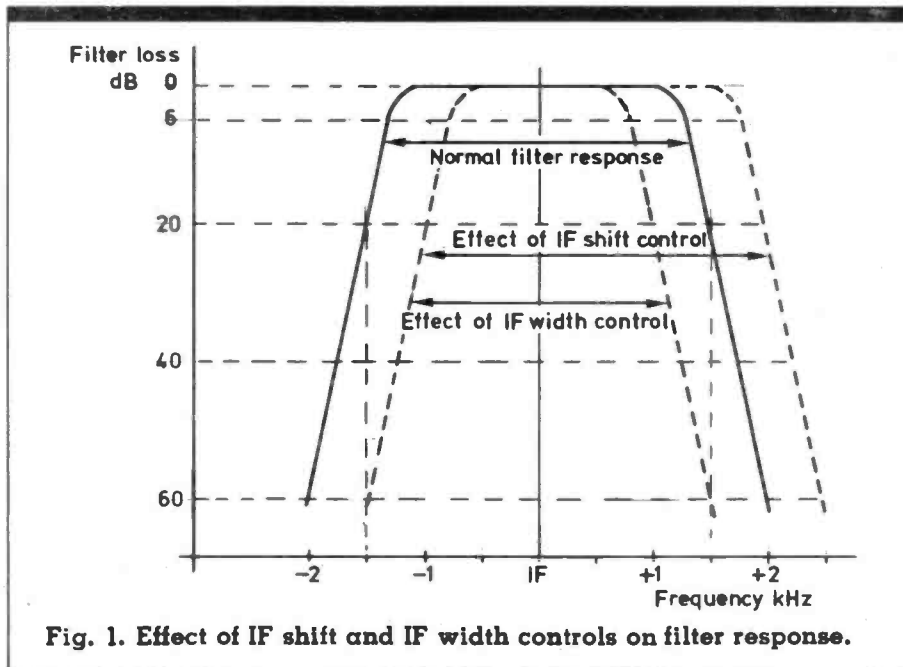

Fig. 1. Effect of IF shift and IF width controls on filter response.

Gain controls

'Gain' means the amount of amplification in the receiver. The various stages inside the set will, among other things, gradually amplify the signal bit by bit until it's strong enough to drive the loudspeaker. However it is important that the signal in each stage is of about the right voltage. If it's too strong, the stage will overload and produce *cross-modulation*. This means that you will hear interference from stations on different frequencies to the one you're tuned to. This can be avoided by reducing

A good AGC system has a fast *attack* and slow *decay*. The fast attack means that when a strong signal appears, the AGC will cut the receiver's gain down very fast indeed — typically in a thousandth of a second. The slow decay means that when the strong signal goes, the gain is wound up slowly, so that if the signal reappears after a brief pause (such as the pause between words) the gain is only slightly too high and can be corrected easily.

Many receivers have a fast and slow AGC switch. Slow is normally the best for SSB reception, because

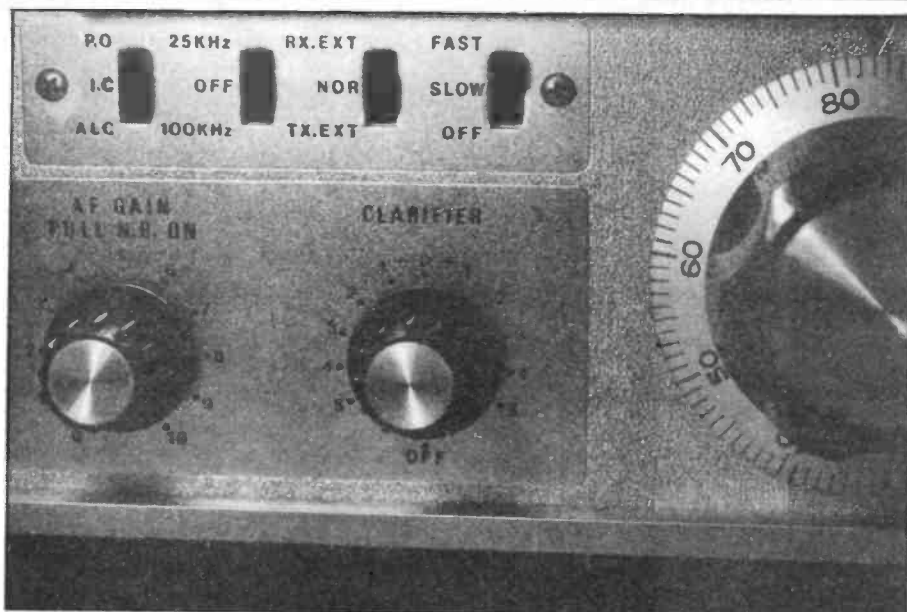

the background noise is not brought up as much in the pauses between words. If, however, the signal is suffering from 'flutter fading', which sometimes happens, the faster position can help the AGC cancel out the variations in signal strength.

Noise blanker

There are all sorts of both natural and man-made interference on the short wave bands. Noise blankers are designed to get rid of interference that consists of short, strong pulses. Interference from a car's ignition system is like this. The effectiveness of noise blankers varies enormously from receiver to receiver and from one type of interference to another. The only advice I can give is try them out.

Clarifier/ RIT/ IRT

These are all names for the same thing. They allow you to move a receiver's frequency a few kHz relative to the main dial. This is very valuable for listening to SSB conversations, where two stations may (for a variety of reasons) not be on exactly the same frequency.

Squelch

This isn't as disgusting as it sounds. It is simply a gadget that cuts off a receiver's audio if there is no signal at the input. This cuts out the irritating hiss. Squelch controls are universal on FM receivers but rare for SSB.

Transmitter controls

So far we've dealt exclusively with a receiver, or the receiving

section of a transceiver. The transmitting parts are, perhaps surprisingly, simpler. The main trick to learn is 'tuning-up', and even this has been eliminated by the latest solid-state designs.

Tuning up is the process of matching the *power amplifier*, ie. the final stage of transmitter, to the aerial feeder cable. Matching is necessary to ensure the most efficient delivery of power from the PA to the feeder — if any power isn't transferred it does not just disappear, it heats up the PA components. With a severe mismatch, a PA can suffer serious damage.

Most rigs have two PA tuning controls. The first is marked *tune*, *tuning*, *anode* or *plate*. The second is marked *loading*. To tune up set the controls to the position recommended in the instructions. Make

sure that the aerial, or better still a dummy load if it's the first time you have attempted this, is connected to the rig's aerial socket.

Turn the mic gain/carrier/drive control fully anticlockwise and switch the mode switch to CW/tune. Switch to transmit. Measure the PA anode current on the meter — there is often a meter switch to select different measurements. Adjust the carrier and preselector controls to increase the current, but not too much! If necessary back off the carrier, then peak the preselector for maximum.

Having got a bit of drive to the PA the next step is to resonate the anode circuit. Adjust the anode control of minimum current.

After this stage the PA should be 'fine-tuned' to optimise the output power. The loading and anode tuning controls should be alternately adjusted for maximum RF. This should be done at maximum drive.

Having tuned up the PA the only other important adjustment is to set the mic gain or carrier control (depending on whether you're using SSB or Morse). The manufacturer usually gives instructions on how to set this. The important thing is to avoid tuning the mic gain to high on SSB, because 'flat-topping' can occur, causing your signal to 'splatter' onto adjacent channels. This would not make you popular!

Driving a transmitter is easy; it's the receiver that takes the skill. It's well worth SWLing before getting a licence to learn how to operate one. What's more in the process you'll pick up a lot of tips that'll help you through the RAE. ●

RIT — allows you to move a receiver's frequency a few kHz



A Simple Amateur Television Station

Adding a keyboard to the character generator.

Part 3

By Trevor Brown G8CJS, General Secretary, British Amateur Television Club

So far in this series of articles I have shown you how to build a video test signal and sync pulse generator (Part 1), and how to display your call sign or QRA etc. electronically (Part 2).

In Part 3 I would like to show you how to add an electronic keyboard to the character generator described in Part 2. This uses an alternative module to the diode programme unit. The character generator in Part 2 was made up of two printed circuit boards mounted one above the other, with the diode matrix card being the uppermost, so as to facilitate plug-in modules pre-wired for different messages. When working portable (as in a contest) this system is ideal. All you need to display is one four-figure group of digits, which remain unchanged for the entire contest.

When we use our TV station in less strenuous conditions, eg. a quiet evening amusing three or four local stations, then our supply of pre-programmed messages will soon become exhausted. The module described in this article is pin-compatible with the diode matrix module and will simply plug-in in place of it. A standard ASCII keyboard can then be connected to the new module's input and it is ready to type directly onto the screen. The new module also has a page switch to facilitate up to eight pages of text so messages can be preset and 'brought on line' at the flick of a switch.

The pins J, K, L, M, carry a 4-bit address code from the character generator which changes every time it scans a different character. This code was used to address a different location in the diode matrix and br-

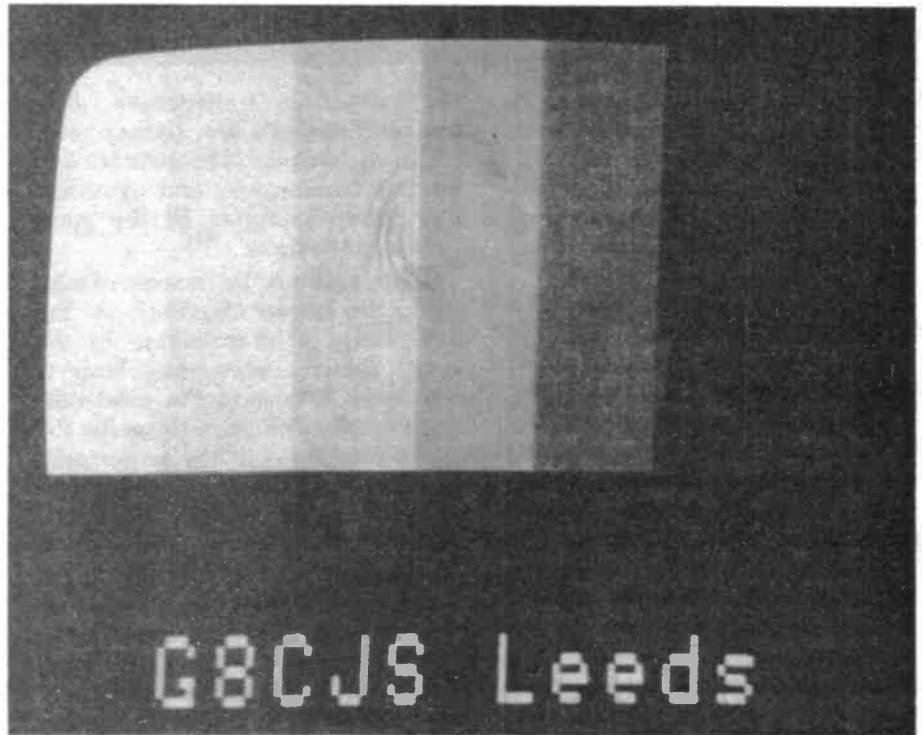

ing on line to the data bus (B, C, D, E, F, G, H,) the information that was set by the diode programme in that location.

In the new module this 4-bit address code selects a location in RAM (Random Access Memory). When the memory is addressed the

Fig. 1. Block diagram of keyboard add-on unit.

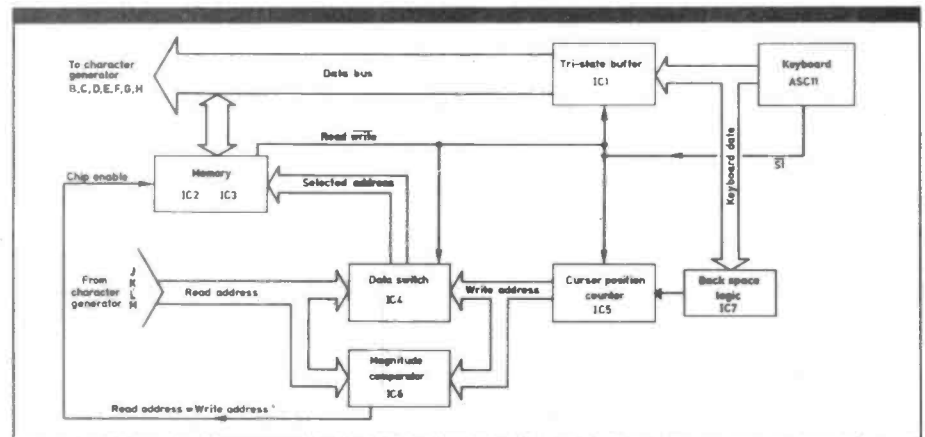

information in that particular location is available to the data bus, in just the same way as the diode matrix.

The next stage is to be able to write to the RAM. To do this we need to bring the keyboard onto the data bus. An ASCII keyboard has seven data outputs, and supplies a code to these outputs dependent on which letter is selected. The keyboard also supplies a short pulse called 'strobe', every time we press a key. This strobe pulse could be 'active high' or 'active low'. Most keyboards provide both. Our circuit requires active low, often called ST. When this signal occurs the outputs of IC1, (74LS244) which are normally floating, assume the same state as the inputs and thus feed the keyboard output to the data bus. The strobe pulse also passes to the RAM where pin 10 of our memory chips (2114) are driven low. This puts them into a 'write mode' so the keyboard data is stored.

The next problem is to control where the keyboard data is stored. By inserting IC4 in the address lines to the RAM we can switch the address lines in the write mode. IC4 (74LS157) is a 4-bit data selector and functions just like a 4-pole double-throw switch, in that when pin 1 is driven low the RAM address lines are fed from the QA, QB, QC, QD outputs of our counter chip IC5.

IC5 is a counter which counts up to 16 and then resets. By using the strobe pulse to advance it, its count will increase by one every time we press a key, ensuring that the selected letter is stored in the next location in memory. When IC5 has been clocked to location 16 it will automatically reset to character location 1.

The next stage is to display a 'cursor' so that we can see the next location to be typed into on the screen. To do this we compare the 'read' and 'write' addresses in the 4-bit magnitude comparator IC6 (74LS85). When the two addresses are the same i.e. the character generator is scanning the location which we will next type into, then the output of the comparator, pin 6, goes high. This high state is connected to pin 8 of our RAM which is the chip enable pin (active low), so when our two addresses are the same the RAM is disabled, causing the data bus to be pulled high by the 10k pull-up resistors. This ensures

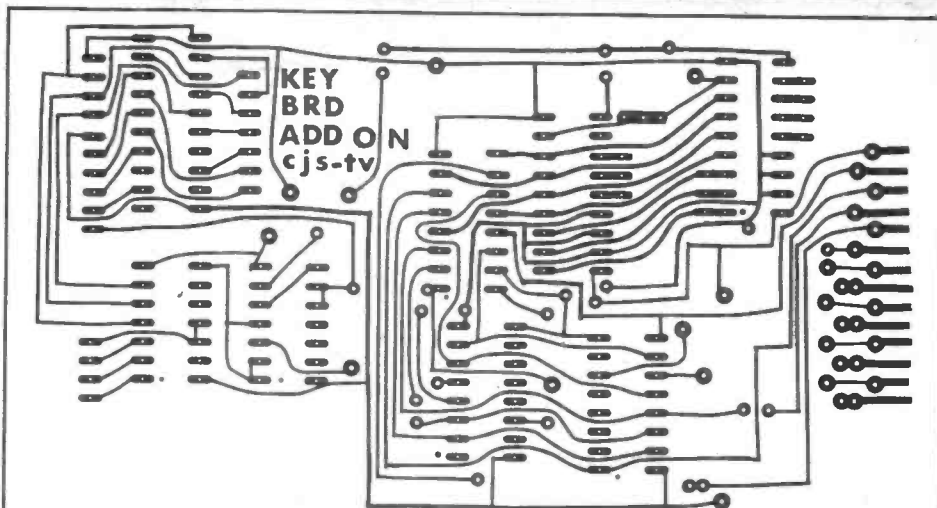

Fig. 2. Wiring side of double sided PCB

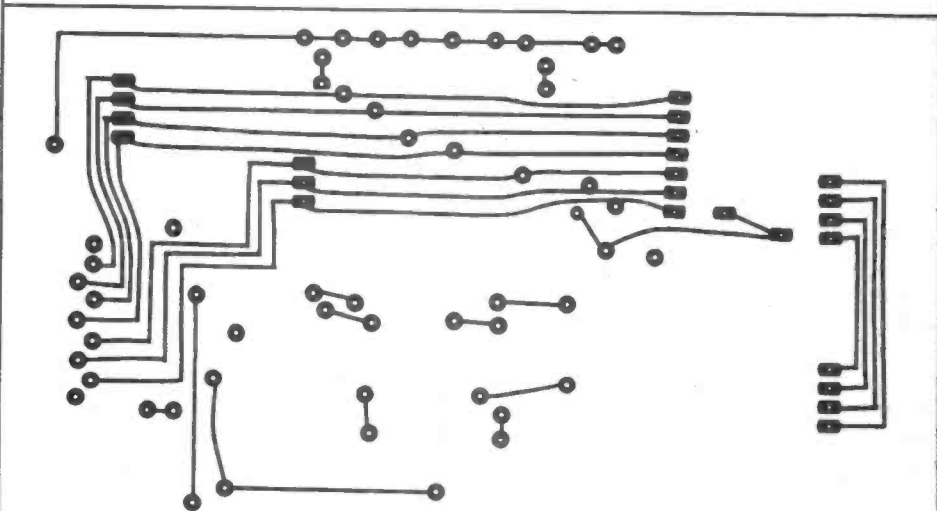

Fig. 3. Component side of double sided PCB

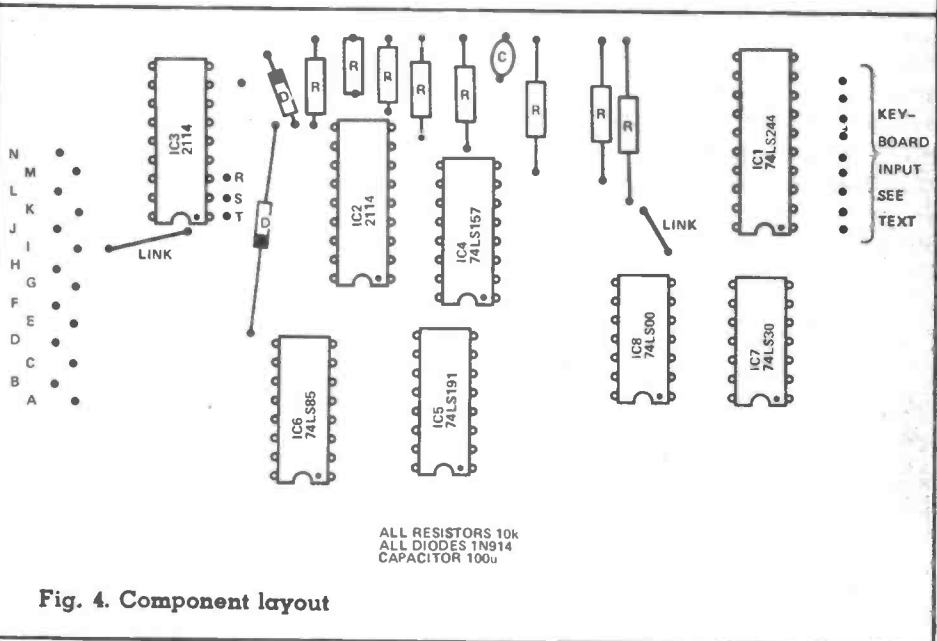

Fig. 4. Component layout

the data bus assumes a high state in the absence of RAM data.

If the diode programme module is operating erratically then the ad-

dition of these pull-up resistors to the diode module may be the answer. It depends upon the diodes used.

Fig. 5. Circuit of keyboard unit

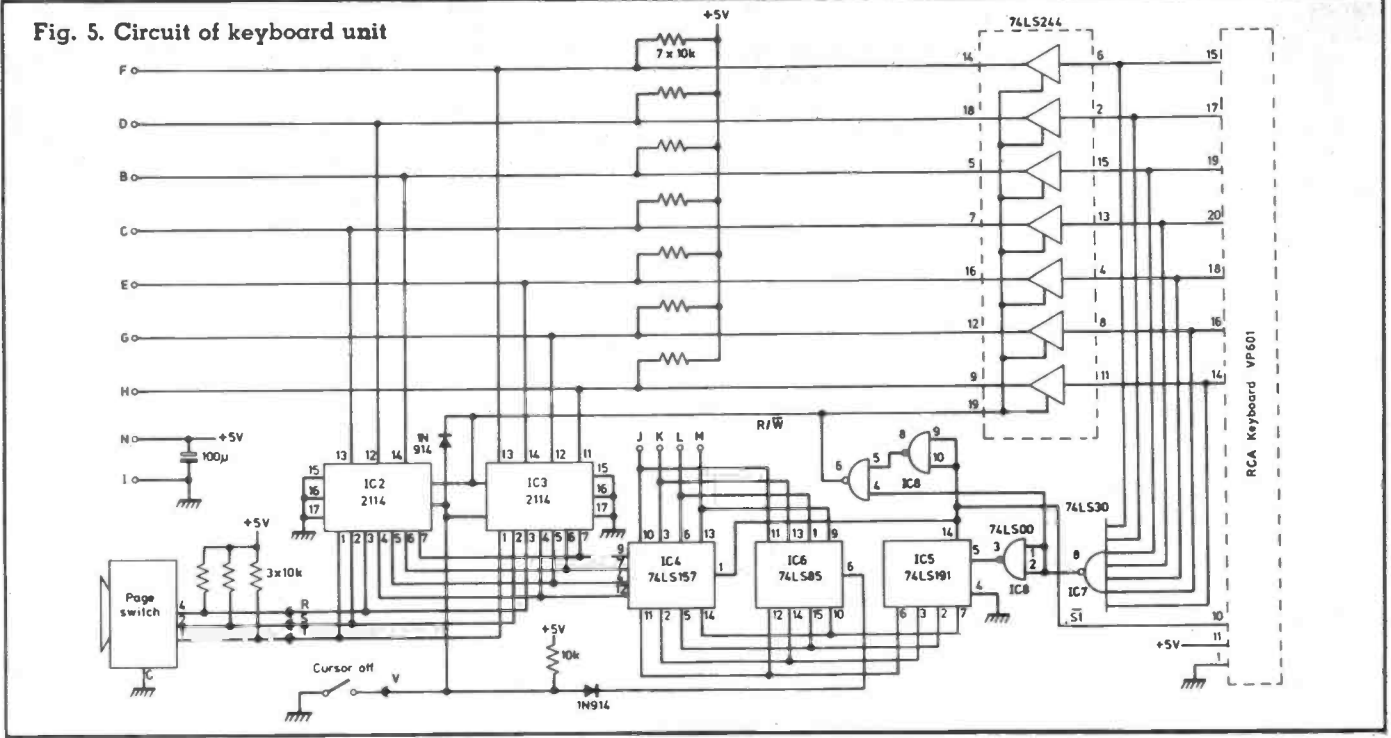

If all the data bus bits are high then our character generator will generate a white block, which makes an excellent cursor.

The full ASCII code provides many things besides characters including cursor functions such as CURSOR HOME, BACK SPACE, DELETE etc. In order that this circuit is kept simple I have not decoded or used these functions, except code 7F (or keyboard outputs equal to 1, 1, 1, 1, 1, 1, 1, if you prefer). This is the DELETE code. IC7 (74LS30) is a 8-input NAND gate with 7 of its inputs looking at the keyboard output, so when the delete

code is presented by the keyboard, the output of IC7 will be low. This signal is inverted and fed into our counter which has the following effect: when our counter is clocked by the strobe pulse it will count down instead of up. The output of IC7 is also used to inhibit and write signal to our RAM so the cursor will step back and the information in the RAM remains unchanged. In effect we have created a 'backspace' function; probably the most useful cursor function for a small character generator. The use of the DELETE key for this function instead of the backspace key simplifies our circuit

and does not cause too much operator confusion as keys like this are rarely used in a touch type mode.

S1 is used to remove the cursor. Closing it inhibits the chip enable input of the RAM from going high, the state that generated the cursor.

The page switch is optional and if not required pins 1, 2, 3, of the RAM should be connected to ground. Note provision is not made (on the PCB) for the 3 x 10k pull-up resistors associated with this switch. These are best fitted directly to the back of the switch.

The only problem left is in connecting up a keyboard. I used an RCA CP601. The output is via a PCB mounted socket, which takes a 3M connector No. 3421-6020. I have shown how to connect that particular keyboard to my circuit by indicating pin numbers.

Those of you with other keyboards the strobe required is active low. The data outputs connect to pins 11, 8, 4, 13, 15, 2, 6 of the 74LS244 in that order, with pin 11 being the least significant bit.

If you want to avoid buying a keyboard the *Amateur Television Handbook Vol. 2* gives details of how to build your own, or how to control ASCII codes by using BCD switches.

The book is available from BATC Publications, c/o G31QU QTHR.

Fig. 6. Component overlay. Unused holes should be linked through

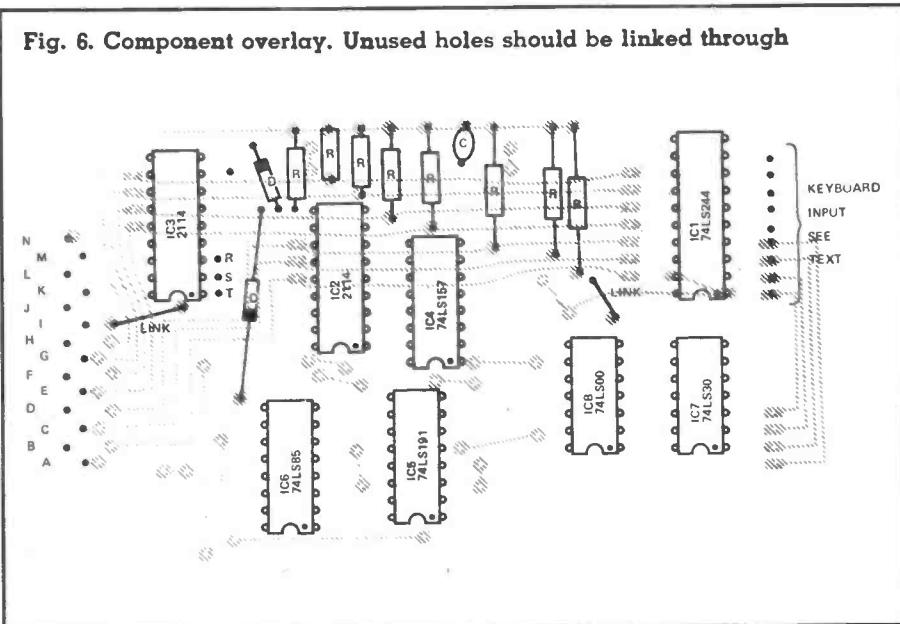

Technicalities

Ferrite based transformers offer one of the most powerful design tools available to the radio amateur. They can both isolate and match lumps of circuitry over the complete HF spectrum with virtually no loss. It is almost unthinkable to build a piece of gear without using them in some form or other so I make no apologies for presenting them in the *Technicalities* column.

Although RF transformers are manufactured from ferrite or dust iron cores, they use exactly the same principles as transformers operating at any other frequency. A current flowing in the primary coil induces a magnetic flux in the core. A second coil intercepting this flux, ie. wound on top of the first one, produces a voltage proportional to the applied AC voltage and the ratio of the turns between the two coils.

As with 50Hz mains transformers, there are limits. The primary represents an inductance in parallel with the applied voltage. If the inductance is too low, the circulating current will cause such intense magnetisation of the core that it will saturate it, and the losses will increase dramatically. Many people will have heard and smelt the distress of a mains transformer inadvertently connected to its 115V tapping. RF transformers can saturate in precisely the same way, but more about this later.

Small signal, wide bandwidth

Regardless of the operating frequency or core material, the transformer law, as shown in Fig. 1 applies. The turns ratio (between primary

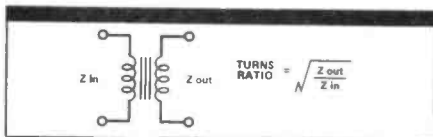

Fig. 1. The turns ratio is the square root of the impedance ratio.

and secondary) is the square root of the impedance ratio. Put another way, the impedance ratio is the square of the turns ratio. If you wind nine turns on a ferrite bead (excellent for small RF transformers) and then a further winding of three turns, a load of 50 ohms attached to the three turn winding will be transformed to a 450 ohm load as seen across the terminals of the nine turn winding. For those with a practical view, three turns on a ferrite bead in parallel with a 50 ohm source will handle up to about 100mW of power —

Broadband transformer design by Frank Ogden G4JST, Editor Ham Radio Today

transformed to an impedance dictated by the number of secondary turns — across the range 2 to 70MHz. Precise characteristics though will depend on the ferrite material from which the bead was made. An alternative statement of transformer law is shown in Fig. 2.

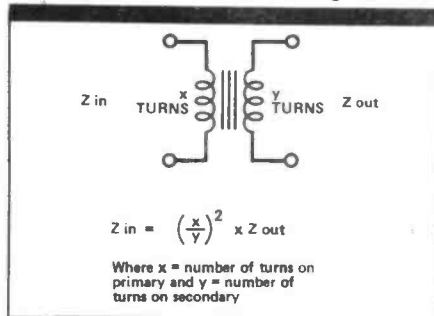

Fig. 2. If you know the turns ratio of a transformer and the impedance connected to one side of it, you can calculate the impedance 'seen' at the other side of the transformer.

Figure 3 offers a very practical application of simple wideband transformer design. This grounded gate JFET preamp provides about 14dB of very low noise gain right across the range 1 to 30MHz. Above 30MHz, there is a gentle falloff in gain; the unity figure is reached around 100MHz. Strangely, the gain slope has almost nothing to do with the ferrite transformer and everything to do about circuit parasitics. The transformer is shown wound with a ratio of 5:1. This transforms the 50 ohm output load to

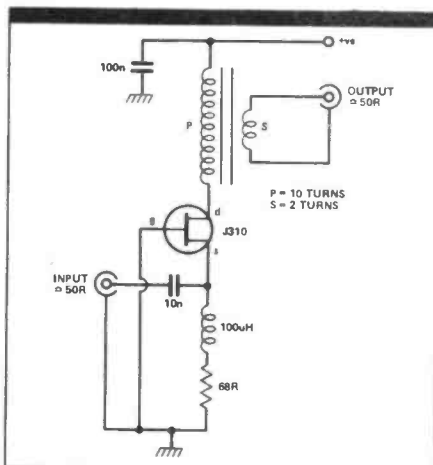

Fig. 3. A broadband low noise RF pre-amp

1250 ohms at the JFET drain. The device output capacitance is about 5pF. The upper computer graph shows the predicted response due to the loading effect of 5pF across 1250 ohms. The real plot would show slight ripple due to the leakage inductance of the transformer resonating with this capacitance.

The effect of capacity loading in small signal broadband transformers is clearly shown in the second plot. The turns ratio has been increased to 10:1. Although the circuit gain now rises to 20dB, the frequency rolloff is much more marked. In this, there is a profound truth for the circuit designer: the bandwidth of a circuit is inversely proportional to its gain. The parasitic components which determine the gain of the circuit shown in Fig. 3 are brought out in Fig. 4. The sample holds one more lesson which is directly related to the ferrite material. The transformed load resistance, Rp if Fig. 4, is directly in parallel with the primary inductance of the transformer. The lowest operating frequency will be determined when the inductive reactance of the primary winding has the same value as the transformed load resistance. Since the transformer primary inductance will be a function of the core material, the LF frequency response is totally dependent on the grade of material used in the core. Furthermore, the core is most likely to saturate at the bottom end of the range.

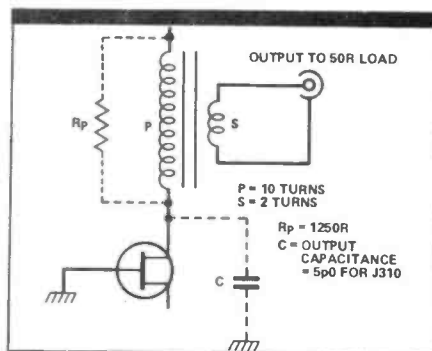

Fig. 4. The unseen components of Fig. 3. It is these, and not the characteristics of the ferrite which largely determine the frequency response of a broadband circuit.

Leakage inductance

The earlier circuit example showed that high impedance, transformer coupled broadband circuits exhibited a bandwidth determined mostly by external loading capacitance. It therefore came as quite a shock to me

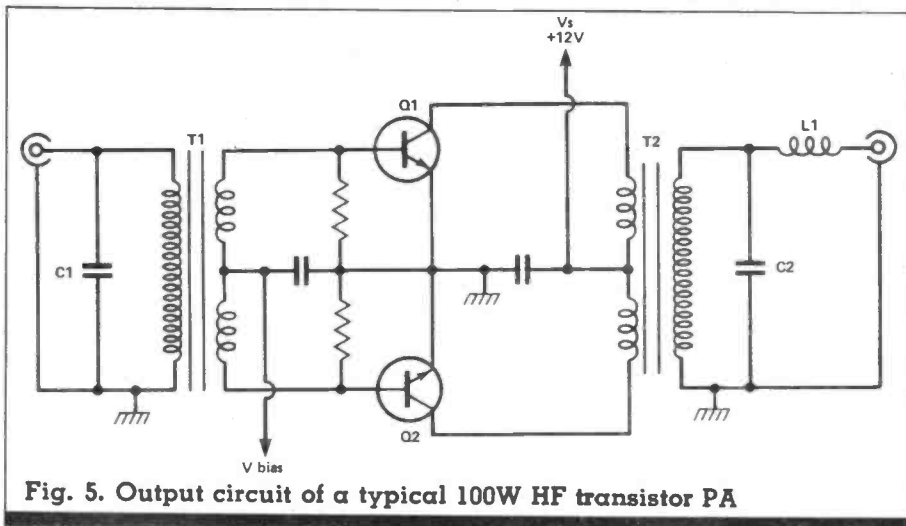

Fig. 5. Output circuit of a typical 100W HF transistor PA

when I saw high power transistor circuits with extra capacitance added in parallel with the windings. It struck me as very odd indeed.

Figure 5 is just such a circuit example. It depicts the standard 12V 100W broadband HF PA stage using stacked ferrite rings as the basis for the input and output transformers. The transistor input and output resistances are very similar at this level of power and supply voltage. Without going into too many details, please accept as fact that the ratio between primary and secondary on T1 should be 4:1, and 1:4 on T2. Why is C1 across the primary of T1 (typical value 150pF) and C2/L2 across T2 (typical values 220pF, 100nH)?

The answer is leakage inductance. If T1 and T2 were perfect transformers, the extra components would not be necessary. In the real world, the total flux induced by the primary circuit does not completely encompass the secondary winding with the result that some of this magnetic path 'gets lost'. This is like adding a low value inductance in series with both the primary and secondary windings. This has all sorts of implications.

High power

In high impedance circuits, such as the preamp of Fig. 3, leakage inductance doesn't matter too much. As I said earlier, the most that it will normally do is to cause a ripple in the frequency response. With a typical value of a few nanohenries for a small transformer, this series reactance is very low compared with the load impedance, even at the highest operating frequency. In the circuit example of Fig. 5 the load impedances are in the region of a couple of ohms at most. It only takes a touch of stray inductance to insert unacceptably high reactances in series with the load. The effect of these is to reduce the current swing available in the RF signal. In uncompensated circuits, the high frequency falloff in output power (and gain) is very marked. A design which

delivers 100W at 3.5MHz may only give around 40W at 29MHz. Similarly, the available gain may fall from 20dB to 8dB or less. Unfortunately, the falloff due to leakage inductance in the transformers looks almost identical to the rolloff curve of poor quality PA transistors. It is no wonder that many people are left scratching their heads about disappointing performance.

The answer lies in the arrangements shown in Figs. 6 and 7. You can't design a broadband transformer which doesn't have leakage inductance. You have to find a way of living with it. Like all these things, there is almost a conspiracy against the RF designer. To build powerful amplifiers you must use components, ie. ferrite transformers, which are man enough to handle the expected power. This means that they must be large. The larger they are, the more leakage inductance they must exhibit therefore the worse the problem is. You have to treat the leakage inductance as if it was a separate component. In Fig. 6, a schematic representation of the input circuitry, the

stray inductance is resonated with the capacitor C1. In theory, C1 could be connected in series with the primary to form a series resonant circuit. However, this would provide cancellation at one frequency only. Connecting C1 as shown produces a less complete, but adequate cancellation over a much wider frequency range. On the LF side, C1 has a high reactance and T1 performs its job in the normal manner. As C1 starts to resonate with the leakage inductance towards the HF end, the impedance at the input rises although not excessively because the Q is low. The equivalent of 2:1 SWRs can easily be tolerated at the input which is the sort of value that might be expected across the range 1 to 30MHz. A more complete compensation is required on the output transformer.

The output circuit

Figure 7 shows the schematic details. If a transistor output stage is to deliver a specified output power over the HF spectrum, the load resistance which the devices actually see needs to be kept to within around 10 per cent variation on the mean value. In this case, leakage inductance is accommodated by making it part of a T filter arrangement with a rolloff designed for just above the operating range. The stray inductance provides one arm and L1 provides the other. C2 acts as the bottom of the T. In practice the only way to find a value for L1 and C2 is empirically. There are people who say that this type of network can be calculated but, frankly, I don't believe it. In a 100W design, insert about 80nH for L1 and around 100pF for C2 as ballpark values. Chop and change until you obtain the most level response. The precise values will depend completely on the characteristics of the transformer, so that should be designed first. (I suppose that goes without saying.)

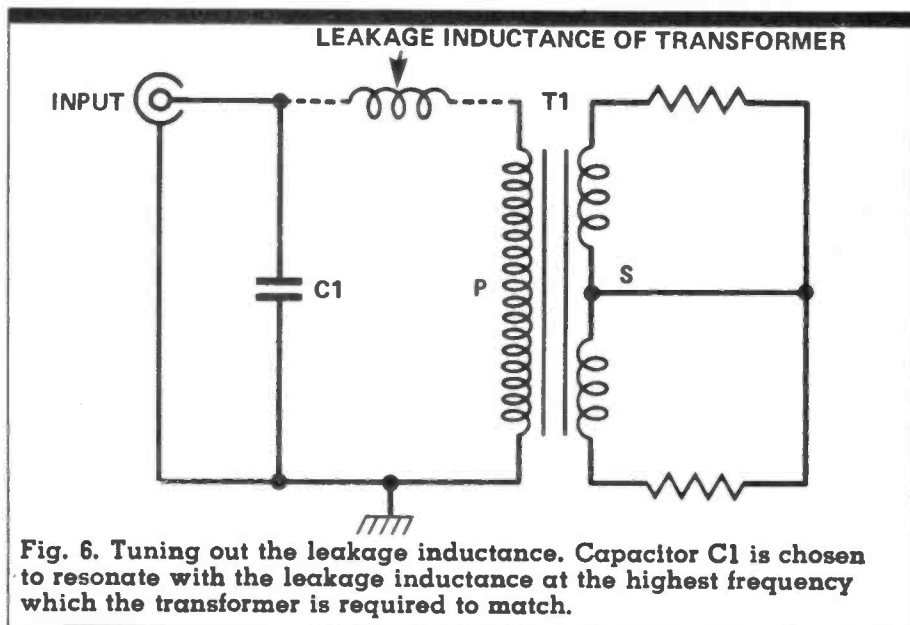

Fig. 6. Tuning out the leakage inductance. Capacitor C1 is chosen to resonate with the leakage inductance at the highest frequency which the transformer is required to match.

RF power transformer design

This is a pretty complex business and I propose to deal with the 'how' rather than 'why'. You need, at minimum, to know the following things about the ferrite material. I have assumed the use of ferrite rings typical of the power designs usually published. I have also assumed that one winding of the transformer will operate to or from a 50 ohm load. The other winding is dictated purely by the transformation requirements. **You must know:**

- The outer diameter of the ring: Do (mm)
- The inner diameter of the ring: d(mm)
- The height of the ring: h (mm)
- The relative permeability: μr
- The turns ratio of the transformers: n (this assumes that the secondary, the collector or base winding, will comprise a single turn made out of copper or brass tube, and that n will be the number of turns on the primary for connection to a 50 ohm load)
- The minimum operating frequency: Fmin (MHz)
- The power to be transformed: Po (Watts)
- The power loss per cubic cm of ferrite material at a given frequency and specified magnetic induction: Ploss (mW)
- The last two quantities need only be known if loss calculations are to be made.
- Other quantities: μ_0 (permeability of free space) = $4 \times \pi \times 10^{-7}$
- First calculate the cross sectional area of an individual core: s (m²)
- s = h x (Do - d)/2 x 10⁻⁶ square metres

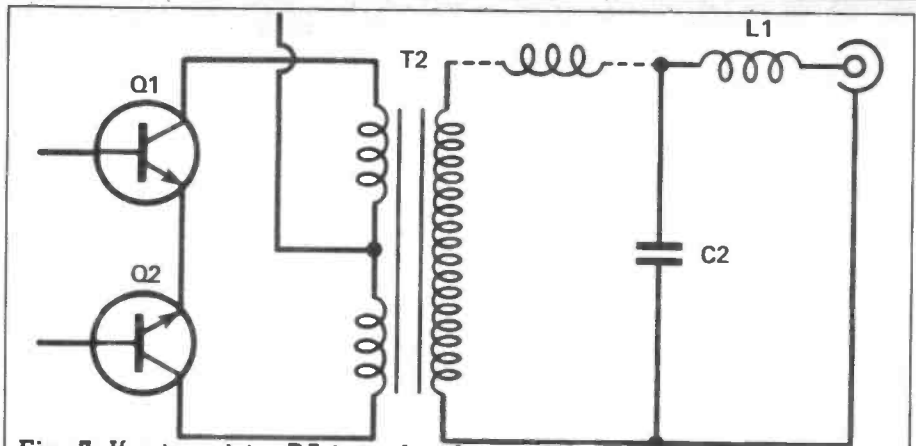

Fig. 7. If a transistor PA is to develop its full power over the range 1.8 to 30MHz, the transformer leakage inductance must be carefully cancelled out over the same frequency span. The inductance is made to form part of a 'T' filter arrangement with a characteristic cut-off frequency just above 30MHz.

Next, calculate the magnetic path length: l

$$l = (Do - ((Do - d)/2)) \times \pi \times m$$

Now you need to know the minimum inductance which the circuit design can tolerate. Generally, a minimum reactance of 150 ohms will be adequate for a 50 ohm system.

$$Lp = 150/2 \times \pi \times Fmin \mu H$$

The number of ferrite cores, Nc, required to achieve the desired performance is:

$$Nc = (Lp \times l \times 10^{-9}) / (\mu_0 \times \mu r \times n^2 \times s)$$

Round the value Nc up to the nearest whole even number.

To work out the system losses

v, the maximum peak voltage across the primary (50 ohms) is calculated:

$$v = \text{square root of } (Po \times 100)$$

Work out the maximum induction within the core: B (mT)

$$B = 10 \times (v / (2 \times \pi \times Fmin \times 10^3 \times n \times Nc \times s)) \text{ mT} \dots \text{milliTesla}$$

Next work out the volume of the core in cm³

$$Vol = \pi/4 \times (Do^2 - d^2) \times h \times Nc \times 10^{-3}$$

The total power lost in the core = vol x Ploss mW

I have devised a computer program suitable for the Sinclair Spectrum which takes the chore out of transformer design. The listings and program output have been included. For guidance, the typical loss figure for ferrite materials with a μr in the region of 100 to 200 is 200mW/cm³ at a maximum induction of 12mT at 1.8MHz.

```

5 REM "Broadband"
10 PRINT "Enter details of toroid cores"
15 PRINT "All dimensions to be in mm"
20 INPUT "Specify outer diameter"; Do
30 CLS
40 INPUT "Inner diameter"; d
50 CLS
60 INPUT "And the height"; h
70 INPUT "Specify relative permeability"; ur
80 PRINT "Next, the turns ratio"
90 INPUT "How many turns on primary?"; n
100 CLS
110 LET uo=4*PI*10^-7
120 LET s=h*((Do-d)/2)*10^-6
130 LET l=(Do-(Do-d)/2)*PI
140 PRINT "Primary inductance"
145 PRINT "This assumes reactance is equal to three times operating impedance normalised to 50 ohms"
150 INPUT "Specify lowest frequency MHz"; Fmin
155 CLS
160 LET Lp=INT(150/(2*PI*Fmin))
165 PRINT "Primary inductance ="; Lp;" uH"
170 LET Nc=INT((Lp*l*10^-9)/(u0*ur*n^2*s)+.5)
175 PRINT "Number of cores ="; Nc
180 PRINT "-----"
185 PRINT "Outer diameter"; Do;"mm"
186 PRINT "-----"
187 PRINT "Inside diameter"; d;"mm"
188 PRINT "-----"
189 PRINT "Height"; h;"mm"
190 PRINT "-----"
191 PRINT "Relative permeability"; ur
192 PRINT "-----"
193 PRINT "Minimum frequency"; Fmin;"MHz"
194 PRINT "-----"
200 PRINT "Number of primary turns ="; n

```

```

205 PRINT
220 PRINT "Number of cores ="; Nc
225 PRINT
230 INPUT "Enter transferred power (W) assuming a 50 ohm matched load"; Po
240 LET v=SQRT(2*Po*50)
250 LET B=INT(10*(v/(2*PI*Fmin*10^3*n*Nc*s)))/10; PRINT "Max induction ="; B;" mT"
260 INPUT "Power loss density of ferrite material at the maximum flux, induction level and the minimum frequency"; Ploss
270 LET vol=PI/4*((Do^2-d^2)*h*Nc)*10^-3
280 PRINT "Power loss in core is"; INT(Ploss*vol); "mW at"; Po;"W transferred power level"

```

Fig. 8. Sinclair Spectrum transformer design program.

```

Outer diameter 12.7mm
Inside diameter 6.35mm
Height 6.35mm
Relative permeability 220
Minimum frequency 1.8MHz
Number of primary turns = 3
Number of cores = 8
Max induction = 12.9mT
Power loss in core is 855uW at 50W transferred power level

```

Fig. 9. Program output (above)

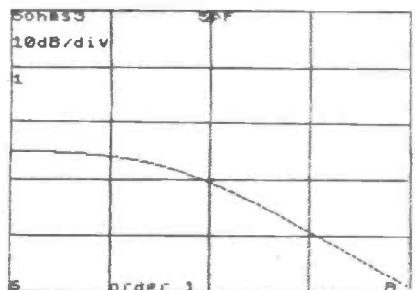
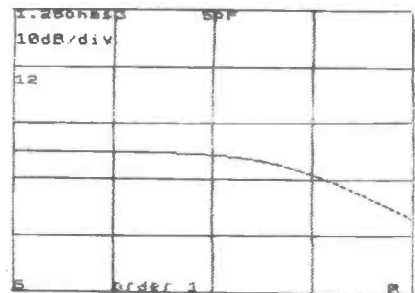

Fig. 10. The two computer plots (above) show the effect of output resistance changes on frequency response for the circuit shown in Fig. 3.

RADIO TOMORROW

- 7-8 May** 432/1296/2320MHz Contest (rules in March *Radcom*)
CQ M Contest (rules in April *Radcom*)
- 8 May** 144MHz Low Power Contest
Lincoln Hamfest, Lincolnshire Showground, 11am-5.30pm, talk-in S22 & SU8.
Mid-Ulster Amateur Radio Club Rally, Parkanaur House, opens 12 noon.
- 11-14 May** *Nu Piscids* meteor shower (max 12 May)
- 14 May** GB2WEC special event station at the Old Power Station, Bargates, Christchurch, Dorset. (Home of Wedgewood Electrical Collection.) On air 10am-5pm, 2m FM & 80/20/15/10m SSB/CW. Special QSL card.
- 15 May** WAB LF Phone Contest (rules in April *Radcom*)
Region Round-up Contest (rules in April *Radcom*)
Swindon Radio & Electronics Rally, 10am, Park School, Marlowe Avenue, Swindon. Talk-in S22 & SU8.
Northern Mobile Rally, The Great Yorkshire Showground, Harrogate; opens 11am (10.45am for disabled visitors), talk-in.
- 16 May** Radio Amateurs' Exam
- 21-22 May** 144MHz Contest
- 22 May** British Amateur Television Club Exhibition, Post House, Leicester.
432MHz CW Contest (rules in March *Radcom*)
RATEC 83 Rally, South Manchester, 11am-5pm, talk-in S22.
- 22 May** (contd.) Barry College of Further Education Radio Society — Welsh Amateur Mobile Rally, Memorial Hall, Barry, 11am-5pm, talk-in S22.
- 29 May** East Suffolk Wireless Revival: rally at Civil Service Sportsground, Bucklesham, Ipswich.
Plymouth Radio Club Rally: 10am, Tamar High School, Paradise Rd., Stoke, Plymouth. Talk-in S22 & SU8.
- 30 May-**
- 18 June** *Arietids* Meteor Shower (max 8 June)
- 1-16 June** *Zeta Perseids* meteor shower (max 8 June)
- 4-5 June** National Field Day (rules in February *Radcom*)
Phase IIIB satellite launch on *Ariane 7*
- 5 June** Spalding Rally, at Springfields, Spalding, Lincs. Talk-in S22 & SU8. Opens 11am.
- 12 June** 70MHz Contest
RNARS Mobile Rally, HMS Mercury, Nr. Petersfield
Elvaston Castle Mobile Rally, Elvaston Castle Country Park, near Derby, 10am, talk-in.
- 19 June** Denby Dale Amateur Radio Society mobile rally. Shelley High School, Shelley, Nr. Huddersfield. 11am-5pm (open 10.30am for RAIBC)
- 22-30 June** *June Perseids* meteor shower (max 26 June)
- 25-26 June** Summer 1.8MHz Contest
- 26 June** WAB 2m/70cm Phone Contest
Longleat Mobile Rally, Longleat Park, Nr. Warminster, Wilts. Opens 10am.

If you would like your event publicising in this column then send details at least two months in advance of the cover date to Richard Lamont G4DYA, Ham Radio Today, 145 Charing Cross Road, London WC2H 0EE.

NEW!

HAM RADIO TODAY MORSE COURSE offers the most effective route yet to your Class A amateur licence

Professionally produced for HAM RADIO TODAY by Shirley Hesketh G4HES and Ron Ray G3NCL, this advanced interactive learning system makes use of the stereo cassette format to provide tuition to the 12wpm test standard

With its carefully designed structure, we think that the HRT MORSE COURSE is more effective than either morse classes or electronic morse generators

Based on TWO C-60 cassettes, it offers the controlled prompting so necessary for the initial stages of morse tuition, followed by carefully paced test material to bring the student up to speed. Full tuition notes are provided with the cassettes

To receive your MORSE COURSE simply send a cheque or P/O for £11.45 (inclusive of VAT and P&P) payable to Argus Specialist Publications Ltd, 145 Charing Cross Road, London WC2 0EE. Mark the envelope 'HRT MORSE COURSE'.

Wescom



FACTORY APPOINTED YAESU MUSEN MAIN DEALER

FT980 Full Range
FT77 Full Range
FT101ZD, Mk. 3 (real bargain)
FT230/730
FT480/780
FT290/790

All Accessories

Frequency Counters by Yaesu

Let your Spares and Service problems become ours.

625 Line FSTV

BEARCAT Main Dealer

TONE Equipment

Self-support TOWERS

E.I.R.P.B.'s

TAMAYA

ROYAL

MASCOT Power Supplies

CAR TELEPHONES

WESTERN COMMUNICATIONS (GALWAY) LTD.
Unit 1, I.D.A. Cluster Development,
Tuam Road,
Galway, IRELAND

Phone: (091) 65166/65208

U.K./N.I. (0009) 65166/65208

International Dial - Int. (353)/(9)/65166/65208

Telex: 28933 MHTC EI

SELECTRONIC SERVICES

THE FINEST ANTENNAS IN THE WORLD ARE NOW AVAILABLE

No hi-fi specifications here, just antennas that are stronger, last longer and work better than any other antenna available today.

HF Antennas

10MHz Broadside, similar to classic bobtail array (10/BDA): gain 5dBd with this wire array at only £41.25. 14MHz Broadside, same specifications as 10/BDA, (14/BDA): £36.25.

4m Quads

4 Ele quad (4/4EQ): gain 7dBd, £58.50; 6 Ele quad (4/6EQ): gain 9dBd, £60.50

2m Quads

4 Ele quad (2/4EQ): gain 7dBd, £45.25; 8 Ele quad (2/8EQ): gain 12dBd, long yagi spacing (12ft boom), £62.50

All quad antennas have glass fibre booms and supports for strength and less corrosion and less effect on performance.

Helix range

70cms, 6 turn (6/70H): gain 12dBd, £42.85; 12 turn (12/70H): gain 16dBd, £46.85. 23cms, 6 turn (6/23H): gain 12dBd, £34.50; 12 turn (12/23H): gain 16dBd, £35.50; 20 turn (20/23H): gain 17dBd, £37.50.

Helix range uses glass fibre booms and comes complete with 'N' plug and socket. All helix antennas have a 50Ω feed impedance suitable for satellites, tropo, FM repeaters and ATV.

Stacked collinear arrays

70cms, 16 Ele (70/SC16): gain 14dBd, £45.20; 20 Ele (70/SC20): gain 16dBd, £49.20. 23cms, 16 Ele (23/SC16): gain 13dBd, £43.50; 20 Ele (23/SC20): gain 14.5dBd, £38.50.

Continuation to be placed after stacked collinear array specifications.

COMING SOON!

Due to the massive response to our previous advertisements and many pleas for an HF minibeam "at a reasonable price that works and is not a rotatable dummy load on 20m"! We are pleased to say that the research and development of a very high performance minibeam is well advanced. The price will be considerably lower than it's competitors and constructional techniques we use will ensure that they will last for years.

Thanks for the interest you have shown. Any suggestions? Please ring. (As long as they are decent). We hope to visit most rallies and exhibitions during 1983.

OVER 40 NEW ANTENNAS TO COME

The most comprehensive range of antennas to suit every operator and every climatic condition.

Please enclose a stamped addressed envelope with all enquiries.

For further information contact:

SELECTRONIC SERVICES
Unit BT50/55B, Perry Avenue,
Teesside Industrial Estate, Thornaby,
Stockton-on-Tees, Cleveland TS17 9LN.
Tel: (0642) 760093



Northampton Communications

**6MTR - 2MTR - 70CM
CONVERSIONS//TRANSVERTERS
FOR CB RADIOS**

2 MTR TRANSVERTER KIT.....	£68.95
RX UNIT KIT ONLY.....	£38.95
HARDWARE FOR ABOVE (i.e.: case, switches, etc).....	£9.95
COMPLETE ASSEMBLED UNIT.....	£98.95
TX UNIT ONLY FOR RX UNIT.....	£30.00
6 MTR CONVERSION KIT.....	£59.80
ASSEMBLED UNIT inc. RADIO.....	£129.95
70cm TX UNIT.....	£48.95
70cm RX UNIT.....	£45.95

Coming Soon - Repeater Shift

Above equipment works on all models ie: AM,FM, SSB& CW

HOT LINE PROBLEM SERVICE (Technical)
Northampton (0604) 38202

TUESDAY & THURSDAY 14.00 hrs. to 17.00 hrs.

ASK FOR: EVAN G8 KHC or COLLIN G3 VMU

Trade enquiries by headed letter only please

Attn. G. Austin G6 NYH

All TX Kits above are sold subject to purchaser holding current Amateur Radio TX Licence.

Please allow 21 days for delivery. P+P 50p for kits

Northampton Communications Limited

76 Earl Street, Northampton

Telephone: (0604) 33936

Advertising copy dates

July issue 3rd May

August issue 31st May

September issue 5th July

Phone Lynn Collis on (01) 437 1002 to discuss your copy details.

HAM RADIO TODAY the only amateur radio magazine that you don't have to have a degree in electronics to decipher.

AMTRONICS (TONBRIDGE)

NEW AMATEUR RADIO SPECIALIST IN KENT

Now is the time to think about Antennas, Clamps, Poles Calbe Lashings. Rotators from £40. All in stock.

29 mHz **LCL** FM mobile Moded to cover 29.310 to 29.700 in 10kc steps with 100kc shift. 5 watt output. Price £52
25 Watt Linear £15.95 70 Watt Linear £39.95

Send S.A.E. phone or call in for details

(or see you at the Maidstone Rally.)

AZDEN 2M FM and 10M FM mobiles (NEW)

WELZ "DIAMOND" antennas now in stock

FDK · YAESU · KENWOOD · ICOM · JAYBEAM · B.N.O.S. · DATONG · DRAE Etc
Fortop 70cm ATV RX/TX. Full range.

Come in and see what we have to offer. Open to 7pm Friday Closed Monday



FINANCE AVAILABLE
WRITE FOR DETAILS



8 TOLLGATE BUILDINGS HADLOW ROAD, TONBRIDGE
Telephone: Tonbridge (0732) 361850

NEW PRODUCTS



VHF/ UHF multimode multiband rig

The Yaesu *FT726R* offers FM, SSB and CW on the 50, 144 and 432MHz bands, by using separate plug-in RF modules for each band. An optional satellite unit allows crossband full duplex working, making it possible to hear your own signal coming back from an *Oscar* without the need for a separate receiver.

The VFO A/B system has ten programmable memories, and can be tuned in 20Hz steps on SSB/CW, or selectable steps (on a separate knob) for FM.

The basic unit, covering the 144MHz band only, costs £649 inc. VAT and is imported by both SMC and Amateur Electronics UK.

10,18 & 24MHz on the FT101 Mk. 1E

Harry Leeming (G3LL) is producing a modification kit to put all three new HF bands on the *FT101 Mk. 1E*, using the CB and WWV positions, together with a relay in the 21MHz position. The kit will produce full output, but it is recommended that power is kept to 50W or less for maximum reliability.

This modification will be described in a later part of the *Ham Radio Today* series on the *FT101*. We are, however, asked to point out that the kit is for this model only, and that it will not be produced for any other Yaesu rigs. The kit costs £15.75 inc. VAT and carriage, and is available from Holdings Photo Audio Centre, Mincing Lane, Darwen Street, Blackburn, Lancs., BB2 2AF.

Dipole tuning chart

The maker of the *Slinky Dipole* aerial is offering a free tuning chart to owners who want to use the aerial on the 10MHz band. No extra attachments are necessary, but the maker says this extra information is needed.

If you want a copy of the chart then send two IRCs to the Blacksburg Group, Inc., PO Box 242, Blacksburg, Virginia 24060, USA.



Locator map

The Intermedial *Locatorset* is a new map of Europe supplied with a transparent plastic ruler to enable rapid measurement of the distance between stations. It also offers a quick method of working out QTH/QRA locators.

The map has a scale of 1:3,000,000 and a claimed accuracy of 0.5%, which is within contest tolerances.

It is available from Intermedial Ltd., 3 Beech Avenue, Eastcote, Ruislip, Middlesex HA4 8MG.

Auto notch filter

Model *ANF* from Datong is a new automatic notch filter designed to remove 'tune-up whistles' and heterodyne interference automatically. It connects in series with the receiver's speaker.

The *ANF* has two interesting new features — firstly a horizontal LED bar graph display to show the notch frequency. Secondly, a speech compander (compressor/expander) is used to ensure the filter is operating at the optimum level no matter where the receiver's volume control is set.

The *ANF* scans the audio range from 270 to 3500Hz, and

locks onto and notches out a whistle in about a second. Datong says the notch is "typically better than 40dB at 3.5kHz."

The notch can also be moved manually if desired, but with AFC to 'lock it on' once it is set within 100Hz of the unwanted signal.

The filter can also be used in a 'peak' mode to provide a narrow CW filter, with a 3dB bandwidth of 60Hz at a frequency of 800Hz.

The *ANF* costs £67.85 inc. VAT and is available from either Datong stockists or Datong Electronics Ltd., Spence Mills, Mill Lane, Bramley, Leeds LS13 3HE.



BOOK: A Guide To Amateur Radio

This new and expanded (19th) edition of the *Guide* seems to offer something for every radio amateur and listener. The beginner will find an introduction to amateur radio; for the listener there are tips on starting as an SWL, with a list of Q-codes and prefixes etc; the RAE candidate should find the technical explanations of many radio topics useful; while the licensed amateur may find the book a useful reference.

The chapter titles are: This is

amateur radio; Fundamentals of electronics; Getting started; Amateur radio equipment; Communication receivers; Transmitters; The antenna; Workshop practice; The licence examinations; Operating an amateur radio station; The RSGB and the radio amateur; International amateur radio organisations. There are three appendices — 1982-85 RAE syllabus and objectives; Sample RAE questions; Safety pointers.

The book is a 160 page paperback, and costs £2.75 (or £3.44 by post) from the RSGB, Alma House, Cranborne Road, Potters Bar, Hertfordshire EN6 3JW

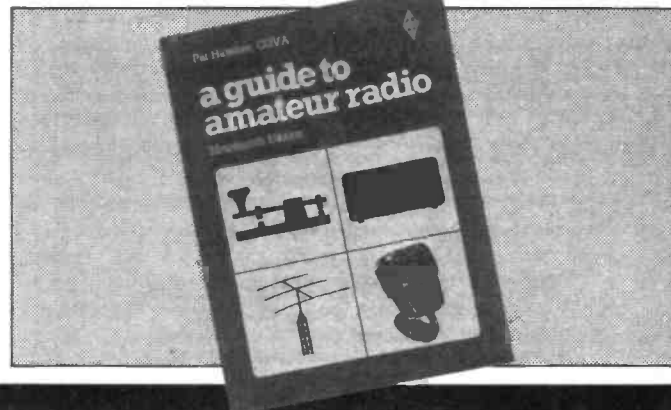

TS430 REVIEW

Trio TS 430S Multimode HF Transceiver
By Angus McKenzie MBE, C.Eng, FIERE, G3OSS



Many readers will have used Trio's earlier *TS120* and *130* SSB/CW LF and HF band transceivers, and will probably have admired them for their simplicity of operation coupled with good ergonomics and reasonable performance. Despite constant criticism over the years, Trio have never incorporated an FM facility on their HF rigs before, but at last we have in the *430* one in which an FM transmit and receive capability is complemented by AM, upper and lower single sideband and CW. Most unfortunately, the FM facility together with narrow SSB and CW filters are optional extras, at £31 to £35 each, but this review sample was loaned to the magazine by Ham International, who could not supply accessories at the time.

Facilities and Ergonomics

The *TS430* is basically a 13V DC rig which draws up to around 16A peak current on transmit. It will work equally satisfactorily as a home station with a suitable external power supply (around £100) or in the car. On receive the rig covers from 150kHz up to 30MHz, stepping up or down in 1MHz steps or from one amateur band to the next, dependent on the position of a switch labelled '1MHz'. Two rates of tuning are provided, with 10 or 100Hz per step, but unfortunately the 'kHz per rev' is not quite constant across each 1MHz band. For example, we measured anywhere between 8.5 and 9.5kHz per revolution

on the smaller step position, despite Trio's claim in the manual that it should be 10kHz. To the left of the main tuning knob is a row of five push buttons selecting LSB, USB, CW, AM and FM modes. On the left hand side is the 13V on/off switch and rockers for TX/RX, VOX controlled TX, processor on/off, ALC or current metering, narrow/wide IF filter (only wide supplied for review). The normal multipin Trio microphone socket is on the bottom left, and a Trio hand mic with PTT and 'up and down' buttons was supplied with the review sample. On the left side is also ¼" headphone jack (plenty of volume here) and concentrically mounted rotary gain controls for mic and carrier insertion levels. A fluorescent green digital frequency readout above the tuning knob displays the nearest 100Hz, (or to the nearest 10Hz if an internal jumper is cut). To the left is the meter which on receive is a normal S meter but on TX reads total current of ALC. Behind another window, to the right, is the display showing the selected memory channel.

Unlike Trio's earlier models, this latest *TS430* has very many push buttons to the right of centre, as well as some rotary switches, which can provide some most useful facilities, but perhaps also a few that you may well never use. The main memory switch selects any one of eight memory channels, insertion of any frequency into these requiring just the touch of the MEMORY IN button. The 6th and 7th memory positions also serve a select start and stop frequencies for continuous scanning, another button putting the box into the scanning mode, with an accompanying button to hold the scan. Two separate VFOs are provided, a four-position rotary switch selecting either of these of a criss-cross arrangement allowing you to transmit on one and receive on the other, or vice versa.

Poor documentation

Additional buttons provide facilities for inserting VFO B's frequency into A, frequency lock, small or large frequency steps, memory recall (this sets the chosen VFO to the selected memory frequency from which the VFO can then move), fixed memory channel, and memory scan. Large up and down buttons shift the band either to the next amateur band, or to the next 1MHz band, determined by another switch. Further switches select receiver incremental tuning (the pot for this is concentrically mounted with the 1F shift control which has a centre indent), noise blanker, 20dB antenna attenuator and finally a very good notch filter, the pot for which is concentrically mounted with a squelch control which acts on all modes. The only other controls on the front panel are concentrically mounted rotaries for RF and audio gain.

On the top of the rig are four very

small slide faders allowing adjustment of VOX gain, VOX delay, anti-VOX and scanning speed (this is also controlled by the 10/100Hz step switch). The loudspeaker is mounted in the top, and whilst this will usually be convenient, it could be a nuisance in some positions in a car. You might have to plug in an external speaker. Underneath the front of the rig is a level tilt bar which lifts the front of the rig up when it is resting on a table, and this was rather nice. On the back of the rig is a heavy duty 13V power socket (lead supplied with heavy duty fuse), ¼" key jack, external speaker 3.5mm jack, an SO239 RF in/output socket and a large wing nut terminal for earth connection. Three multi-pin standard Trio DIN type sockets are provided. The REMOTE socket has seven pins with interconnections for external ALC, loudspeaker output, a pin which shorts to deck on TX for controlling an external linear (for example) and an external PTT line. The ACCESSORY socket had eight pins, and this can be connected to external equipment requiring logic information from the TS430 regarding the band in use. A 12V DC voltage on TX only is available on one of the pins, and another pin, when grounded externally, reduces the rig's output power to about 50W. Amongst the eight pins on the TRANSVERTER socket are provisions for input/output and controlling an external transverter.

At this point I would like to criticise rather heavily the unhelpful manual since it is very difficult to find out more details of these pin connections and there seems to be generally a considerable lack of basic information as compared with Yaesu and Icom instruction books. On the back panel of the rig is an enormous heat sink, and built into this is quite a powerful fan which comes on as and when the temperature of the heat sink demands it.

The rig is reasonably compact, and contains a remarkable number of facilities and has room for many options

when one considers its size and weight. (275 × 105 × 335mm abd 6.5 kg).

Subjective comments

I used the rig on SSB, and briefly on CW, over a period of two weeks on a number of bands, and found it very easy to use, although it took some time to work out how to operate all the facilities. Transmitted audio quality frequently received favourable comments, the compressor being liked as well. The transmission seemed to have a good deal of punch to it, and was very clean, all listeners finding the transmission quite narrow even when the processor was in use. It was such a pity that Ham International could not supply the FM board because I would have liked to have tried the rig on 29.6 MHz, the international 10m FM calling frequency. The three new bands, in the 10, 18 and 24MHz segments were not supplied 'enabled', although ones supplied by Lowe electronics normally have this provision.

Although I was concerned that the tuning rate was not exactly 10/100kHz per rev, the tuning ergonomics were very good indeed. The scan buttons on the microphone operated in the same way as usual, again the scanning speed being controlled by the slider on the top of the rig, and the step switch. Even when the rig is in the 'amateur bands only' mode, rather than the general coverage 1MHz up/down steps mode, complete receive coverage is possible by continuing tuning below or above the appropriate amateur band. I tuned all the way from 30MHz down to 0Hz to check on this, not quite wearing out my finger in the process. However, the absence of a slip ring around the finger hole, (such as on the TS830) is a pity. This makes it possible to whizz up and down very rapidly. On my scan across the frequency coverage of the rig I noticed a large number of minor sprogs, and one extremely bad major one,

this check being carried out with a screened dummy load screwed onto the aerial socket, and even with a ferrite ring close to the set on the 13V lead. The bad sprog was audibly over S9 at 21.562MHz, although the meter only read S3 on it. The minor 'birdies' would not be disturbing on lower frequencies, but you might be very slightly disturbed by one or two which were equivalent to an audible S3 to S5 or so on the 10m band, which did not, however, register on the S meter. The worst ones were on 28.888, and 28.921MHz.

I checked the performance audibly on 160, 80 and 40 metres, both during the day and at various times in the evening, and I was impressed with the clean reproduction of DX and local stations, with no apparent cross mod or RFIM problems, the 20dB attenuator taking good care of this when signal strengths were way up well after dark. The RF sensitivity appeared to be adequate even on 10 metres, although the IC740, for example, is slightly better. Selectivity seemed to be good, but rejection of extremely strong CW well off channel did not seem to be as good as that on one or two competitive rigs. The T-notch filter was extremely good, indeed one of the best that I have measured in some time.

It is unfortunate that only one AGC speed is available, and I felt that this was sometimes rather fast, particularly on strong 80 metre stations. If, however, you consider putting in the attenuator during the daytime on 80 metres, then even fairly strong signals will become a little hissy with the attenuator in. Turning the RF gain control down (with attenuator out) improved the sound quality. What upsets me a little about an AGC that acts a little too quickly is that voices tend to pump, and background noise in the shack, including reverberation, becomes too audible. I cannot remember a receiver built specifically for amateur use that had an AGC facility that I would have regarded as too slow. I do like the option of twiddling with the recovery speed, which is what is lacking here. I also note that there is no apparent way of turning the AGC off, a useful facility for CW reception sometimes.

The IF shift control, which is usefully centre indented, and thus marking a nominal centre position, was very useful. Sometimes this facility is termed 'bandpass tuning', and basically alters the position of the filter with reference to where an injected carrier would have to be correctly inserted to demodulate the SSB at the right pitch. It can, for example, give you the pass band from say 100Hz to 2.5kHz, or from 500Hz to 2.9kHz if you prefer male voices to change sex! It can also be used more seriously to filter out, or at least to reject more efficiently, carriers or interference just off frequency. As the narrow SSB filter and CW filters were not

Rear view showing heatsink and quiet cooling fan

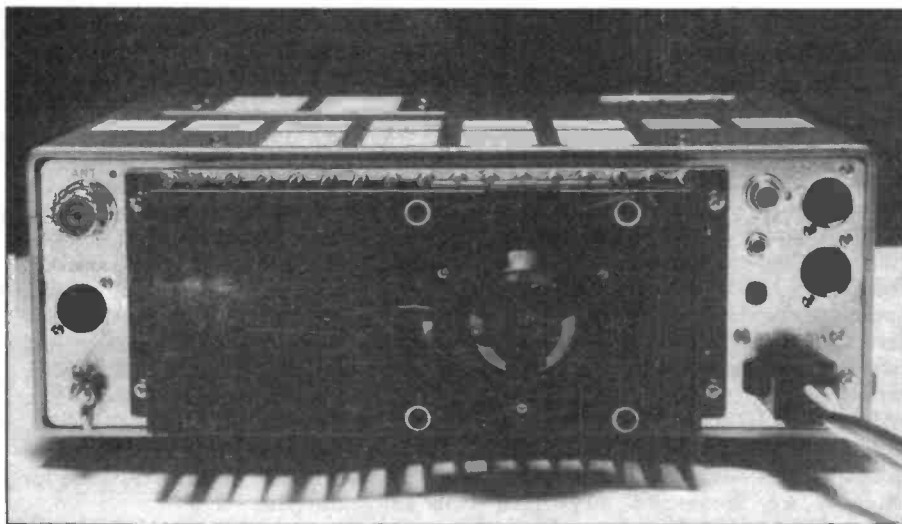

supplied, I cannot comment on their performance.

Memory function

Squelch action on SSB signals operated well, provided the signals were reasonably strong, and no problems were experienced with the RIT. Memorising frequencies and recalling them, particularly when I wanted to move the VFO either way from a memory frequency, operated superbly well. This facility is most useful, although I cannot see that there would be much use for punching in the memory channel button and operating exactly on a memory frequency without the facility for VFO'ing, unless you were using the FM option on fixed 10metre channels. Memory 8 will be useful here, for it allows the memorising of separate TX and RX frequencies for 10m repeater operation. The scanning, defined by memories 6 and 7, would probably be found when you want to scan relatively small frequency areas continuously, but I don't expect many would want to use the scanning for continuously monitoring large chunks of spectrum other than to leave the receiver running on a large section of 10 or 15M when the bands is closed to indicate the first signal that pops through after band opening.

What cost?

The VOX control worked satisfactorily on transmit, and the setting of gain, delay and anti-trip was very simple. One strange feature provided by the rig is the ability to transmit on one band and receive on another, which I suppose could be useful to the odd person, but certainly not to me. I cannot help but feel that despite the excellent general ergonomics of this rig, Trio have made it too complicated, and thus the

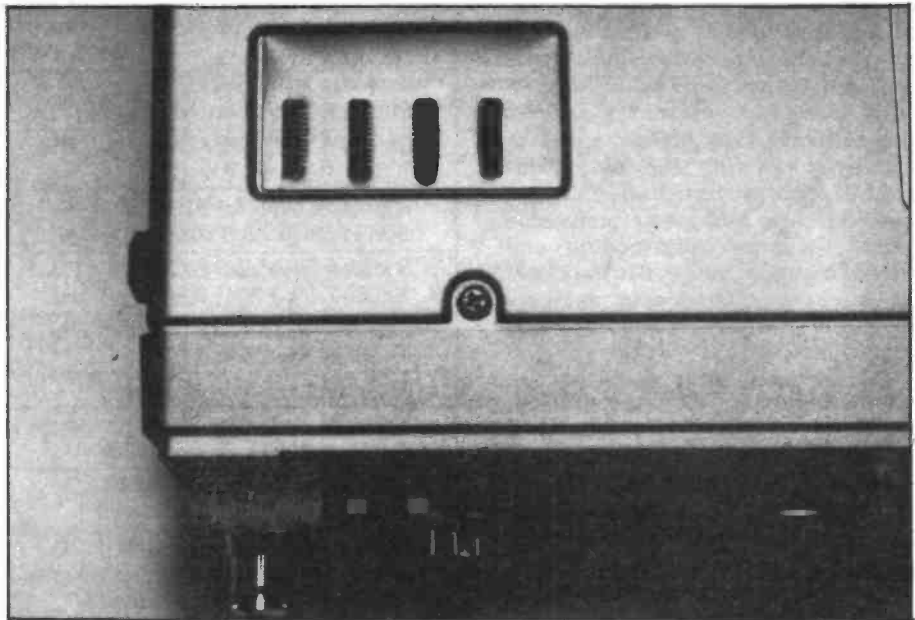

VOX and Scan controls mounted on top panel

price is higher than it need have been. I would have preferred, to have had FM plus the filter options in with the price, but some of the esoteric microprocessor functions perhaps available as options, but I do realise that this suggestion rather defeats the design idea. Let's put my suggestion another way, then, that Trio ought to release a rig with identical specifications, including FM, CW and SSB, but without general coverage receive, and microprocessor functions, which overall would be regarded as an inexpensive successor to the TS130, at a lower price than the present rig, which, with options, will be typically around £800. Even if the average user does not want to use FM on 10m, and most certainly not on any of the lower bands, he is very likely to use a transverter with the rig up to 2metres for example, and in this case it will be very simple to cope with

repeaters, although you would have to either whistle your way in, or use an external tone burst generator. We were not able to try the rig into a transverter because of inadequate instructions, and time, but if the transverter feed is similar to that from the TS830, the level would be very low.

Incidentally Microwave Modules transverters can be supplied with extra sensitivity to work with modern low transverter feed level outputs, although you may have to modify older models.

Feelings

To sum up my own feelings for the rig, I can report that I was impressed with its general performance, but would prefer something simpler for mobile use, but a little more comprehensive for fixed station use. Whilst Trio's provision of DIN

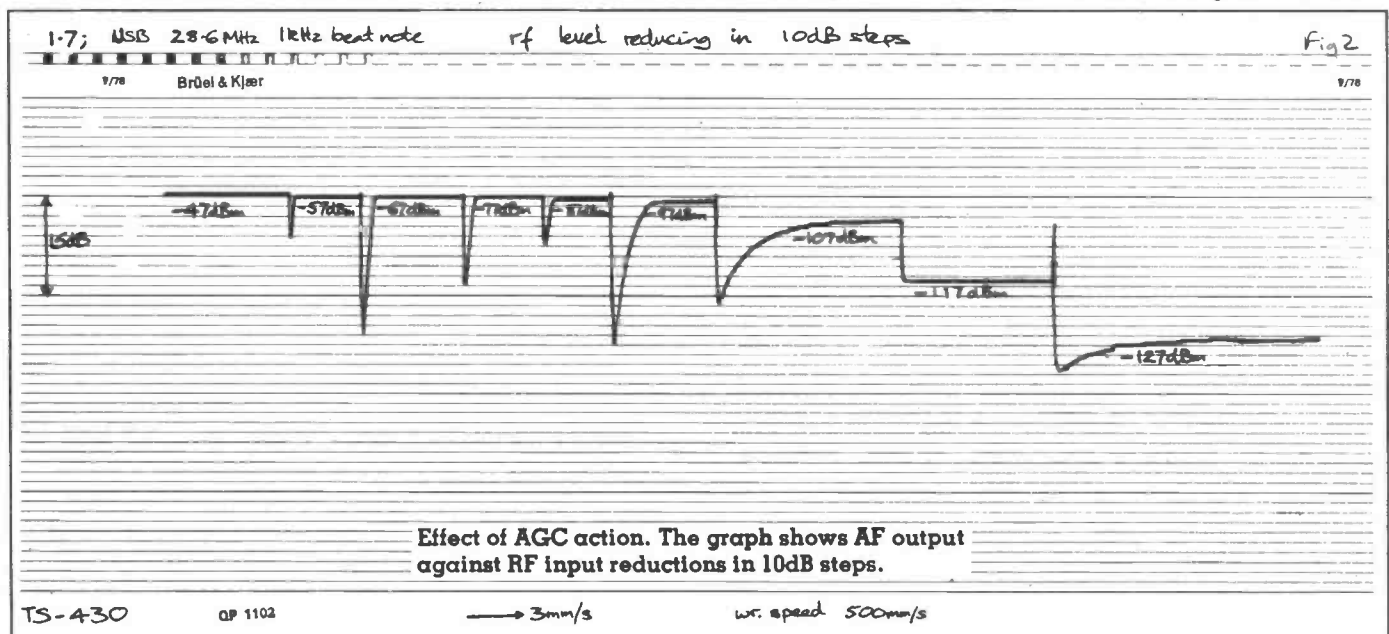

type sockets for many of the external facilities may lead to a tidier shack, I much prefer lots of phone sockets because I am, and always have been, rather a fiddler, liking to try all sorts of external combinations in a hurry. If I can avoid the necessity of soldering wires onto a DIN socket, at almost any cost, I will do so, but I must admit to being very prejudiced against them for longstanding and personal reasons! I used to like the larger old 'Granny-type' 8-pin octal auxiliary sockets, but terminals or phonos are even better.

I could find no actual snags in either the receive or transmit side which would stop me recommending at least a good look at the rig, which is therefore certainly worth consideration. Don't forget to ask about accessories and after sales service facilities before you commit yourself to purchase, for this may influence where you buy the rig, as well as perhaps minor differences of price.

Lab test

Having had a play with the rig for several days we applied some very extensive tests to check performance in many areas, and probably the best way to comment on the test results is to first follow a received signal through from aerial input to loudspeaker out, and then in the same way have a look at the transmitter results.

The RF input sensitivity varied from band to band from excellent to good, to 10m sensitivity unfortunately being one of the poorest, although completely acceptable, equivalent to a noise figure of around 8dB or so. Ironically, the most sensitive band was 14MHz, on which you don't really need ultimate sensitivity. RF intermodulation performance was checked with two carriers 10 and 20kHz off channel at three levels, the two carriers always being at the same level relative to each other. The first level was that required to develop a third order 1m product of 12dB SINAD, whilst the second and third levels produced products reading S5 and S9 respectively. Our choice of such close in tones spaced only 10 and 20kHz is a difficult test indeed, and my interpretation of the results is that the TS430 comes out pretty well. The reciprocal mixing test involved checks on the local oscillator sideband noise at 20 and 100kHz off channel, and whilst the 100kHz test result was very good, the 20kHz one was average, some rigs being better by quite a few dB. This close-in noise was quite possibly a contributory factor to the disappointing selectivity measurement for -60db, although the filter was good down to around -40dB, and thus the shape factor which works out at around 2.9 is not good. During the selectivity test we heard a series of small whistles etc. while we were measuring the -60dB point, which we

Parameter		Comment
RX Measurements		
Sens. for 12dB SINAD SSB @ 28.6/21.3/14.25 MHz (μ V p.d.)	0.17/0.14 /0.12	Good/V.good /excellent
Sens. for 12dB SINAD SSB @ 7.05/3.65/1.9 MHz (μ V p.d.)	0.17/0.14 /0.14	Easily good enough
S meter: Levels for S1/S5/S9 + 20dB SSB @ 28.6 MHz (μ V p.d.)	1.2/11 69/400	Excellent
S meter: Levels for S9 SSB @ 21.3/14.25/7.05/3.65/1.9 MHz (μ V p.d.)	65/56/82 68/59	
Selectivity: SSB 3dB bandwidth /60dB bandwidth (KHz)	2.3 16.6	Fair
Selectivity: SSB shape factor	2.9	Fair
RFIM: Listening at 28.6 MHz. Sending + 10 and + 20 KHz	1.6/7.1/14	Good
Level from each for 12dB SINAD/ S5/S9 product (mV p.d.)		
Reciprocal mixing: Level @ + 20 and + 100 KHz for 3dB degrad. in 15db SINAD Signal (mV p.d.)	2.2 120	Fairly good
T-notch: Max rejection of 1.4 KHz rel. 1 KHz beat (dB)	33	Excellent
T-notch: Max rejection of 1 KHz rel. 1.4 KHz beat (dB)	32	Excellent
Audio output distortion @ 125mW into 8 Ω (%)	0.5	Excellent
Audio output power in @ 10% THD 8 Ω (W)	1.7	Slightly restrictive
Frequency accuracy of readout (Hz)	within 20	V. good.
Current @ 13.8 V D.C. supply audio gain min. (A)	1	
TX Measurements		
CW output power: 13.8 V.D.C. Supply 1.9/3.65/7.05 MHz (W)	85 /100/100	Good
CW O/P power @ 14.25/21.3/28.6 MHz (W)	100 /90/85	V. good
SSB O/P power @ 1.9/3.65/7.05 MHz (W P.E.P.)	140 /140/140	
SSB O/P power @ 14.25/21.3/28.6 MHz (W P.E.P.)	150 /140/140	
Current drawn on full power CW. 13.8 V supply (A)	16	Very efficient
Current drawn on SSB, mic gain min. (A)	2	Good
Harmonic O/P, CW @ 1.9/3.65/7.05 MHz (2nd/3rd) (dBc)	(-60/ -58) /(-66/ -54) /(< -68/ -49)	Good /Fairly good /Fair
Harmonic O/P, SSB @ 14.25/21.3/28.6 MHz (2nd/3rd) (dBc)	(-64/< -53) /(-64/< -65) /(< -65/< -65)	Fairly good /excellent /excellent
SSB Carrier rejection relative to full CW power: 28.6 MHz (dB)	-62	Superb!
Transmit freq. error on CW @ 28.6 MHz (Hz)	-160	Adequate

Table of Lab test results

assume to be synthesiser modulation components on the local oscillator. Selectivity was checked at two separate RF levels about 15dB apart with the same result. I must particularly praise the excellent S meter, characteristic of many

Trio rigs, for its far better than usual law from low to very high levels. As can be seen from the chart, there is 35dB difference between S1 and S9, S5 being reasonably half way in dynamic range between these two points. S9 however, at

Graph of audio level and
CCIR weighted noise against RF level

TRIO430
22/3/83

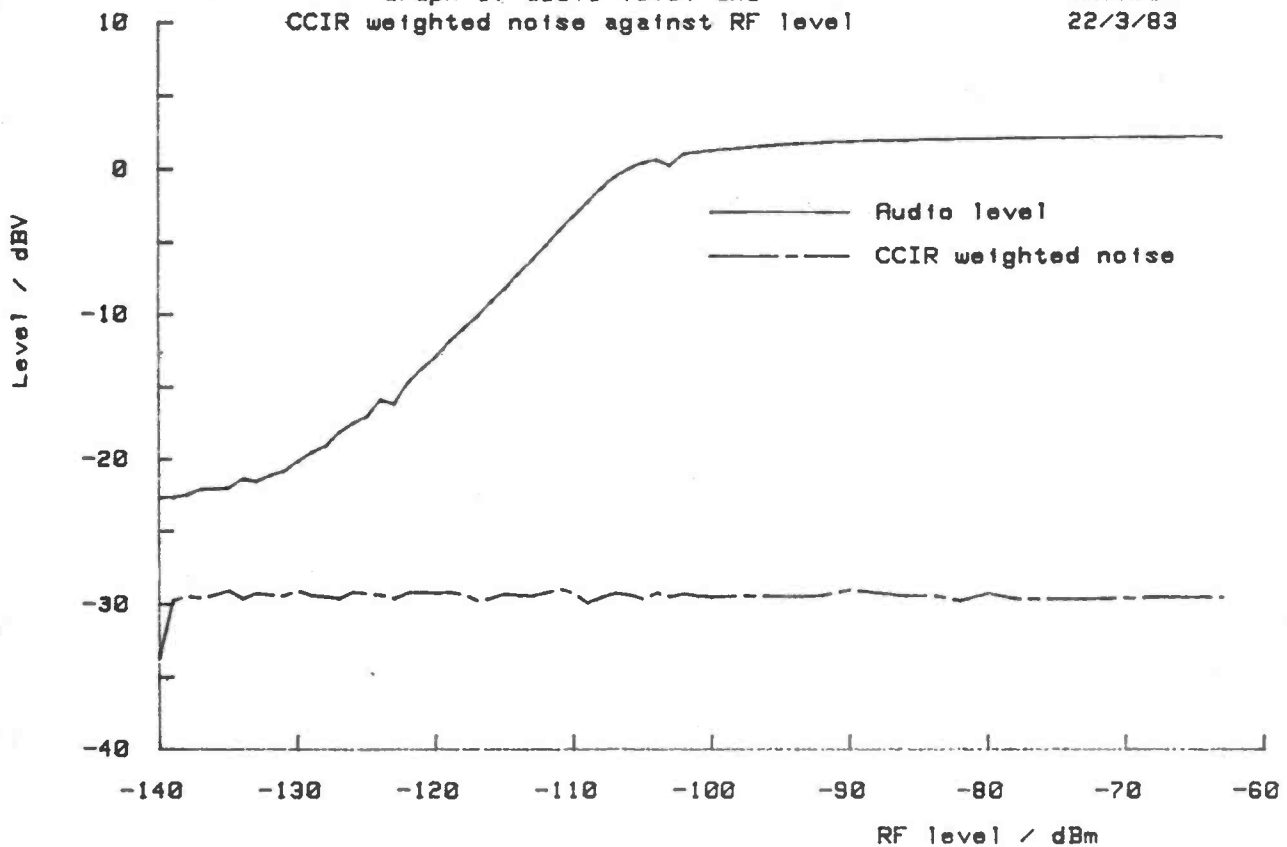

around $70\mu\text{V}$ right across all the amateur bands, is perhaps a little insensitive, and I would have preferred it to have been at the more usual $50\mu\text{V}$. The T-notch filter gave a remarkable maximum notch with hardly any reduction of signal level 400Hz away, which is splendid. The AGC characteristics can be seen very clearly in the pen chart recording in which we knock down the RF level in 10dB steps from a very high to a very low level. Note the recovery time at the various levels, together with the fact that normal level is not restored on lower level signals. My colleague, Simon G8UQX, thought of a rather nice computer test to apply, in which computerised test equipment monitored the audio output level whilst stepping up the RF input level automatically from a Marconi 2019 signal generator, finally plotting the result.

Additionally, the CCIR/ARM weighted noise was plotted with unity gain held at 2kHz, this being the audio output noise at the test gain control setting for no RF input. It can be seen that full audio output is reached at around $2\mu\text{V}$ input, above which the level is fairly constant, with just a gradual slope. At very low levels indeed there was slight computer noise breakthrough, but even so I would ideally have preferred full level to have been reached at a much lower RF

level, particularly for 10m where band noise can be so extremely low relatively.

I have already commented favourably on the good audio quality, and so it was not quite so surprising to see the very low distortion measurement at 125mW output from a carrier giving a 1kHz beat in the product detector. The loudspeaker was fairly sensitive, which is fortunate for the maximum available output into 8 ohms was slightly limited. The only other receiver measurement which seems very relevant is the high current drawn, which is easily sufficient to flatten a car battery if the rig is left on inadvertently for more than a day. I would have thought that with modern circuit design the standing current could have been a mere fraction of what it was.

The transmitter took around 16A peak which is very reasonable indeed, showing a high efficiency PA. The current drawn by the entire transmitter on transmit, but with mic gain at minimum, was considered quite low, only double that of the receiver, and so the average consumption from a car battery will be surprisingly low, unless speech compression is selected, which will, of course, greatly increase the DC duty cycle. Frequency accuracy on transmit was checked on CW, such that the output frequency measured 160Hz below that indicated, and this is perhaps just a little

bit further out than I might have expected, although the receiver was exceptionally accurate. Maximum power output on CW was either at, or only very marginally below, the legal limit, so you certainly can't grumble, and SSB peaks were well in excess of the CW output, which is very useful. No drift problems were noted, either on TX or RX, after a warm up period. We checked harmonic and spurious outputs on a spectrum analyser on all bands from top band to 10 meters, and must particularly praise the harmonic suppression on the latter. The worst band was 40 meters with 3rd harmonic just a little high, but fortunately the harmonic was in another amateur band! SSB carrier suppression was fantastically low, showing a very well designed balanced modulator. The microphone circuits seemed to have a good overload margin, and no problems were noted with the transmitter, which is praiseworthy.

Equipment used by Angus McKenzie Laboratories Ltd. for this review.

Two programmable Marconi 2019 signal generators, Marconi 995 generator, coaxial attenuators by Greenpar, Marconi, Rhode and Schwartz and Narda; hybrid transformer by Elcom; power meters by Racal and Bird; analysis equipment, including Hewlett Packard 8903 audio analyser, and 3580 spectrum analyser, an RF spectrum analyser; Hewlett Packard 8558B, a Takeda Riken eight digit frequency counter (four parts in 10^9 accuracy), a Bruel and Kjaer and HP pen charting/plotting equipment, and computer control were appropriate was with a Hewlett Packard 9816 computer with 82901 dual disc drive.

MON-FRI 9-5.30

24 BUCKLAND RD
LEICESTER

HAM

INTERNATIONAL (U.K.)

SAT 9-12.15

TEL 0533-761731
TLX 341928



TS 930. Superb high performance, all solid state HF transceiver, capable of operating in the SSB, CW, FSK and AM modes, on all amateur bands (160 to 10 metres). Incorporating a general coverage receiver.

Optional extras:—

Built in A.T.U.

SP 930 — Extension speaker with filters

TS 430. The latest 'state of the art' HF transceiver from Trio-Kenwood. This new set has full amateur band coverage, including the three new bands and also incorporates a general coverage receiver. SSB, CW, AM and also FM modes are available (FM with optional board). Fitted with twin VFOs and all the usual filters you have come to expect from Trio-Kenwood transceivers.

Optional extras:—

PS 430 Matching power supply

SP 430 Matching extension speaker



FT 102. Represents significant strides in the advancement of amateur transmitter signal quality, previously restricted to top of the line transmitters. For the amateur who wants a truly professional quality signal the answer is the Yaesu FT 102.

Optional extras:—

FC102 Antenna toner

SP 102 Matching extension speaker

FT 77. This new full feature mobile transceiver from Yaesu has 100 watts of RF power on all amateur bands from 3.5 to 30 mhz (including new bands) and has FM as an option. Its unbelievable small size and lightness coupled with its low price will make this set a firm favourite as a first time rig or a handy second set to use anywhere.



£269.95

FDK 750A. Offers VHF operation on FM, SSB, CW. Excellent value for the new operator looking for SSB facility on VHF. Also fitted with dual VFO. The set has the facility to use the optional 'Expander 430' giving full coverage on the 70cms band.

HAM INTERNATIONAL are no strangers to the communication business, having been involved on the Continent and in the UK for several years. An enviable reputation has been gained for producing some of the finest quality communications equipment available. Ham International are now proud to bring you the leading names in the field of amateur communications. Yaesu, Trio-Kenwood, FDK, Daiwa and Tonna to name but a few. They are all backed by our name for service and reliability. Information is only a phone call or SAE away. All items have full warranty and our fully equipped workshop is on hand should any problems arise. Speedy and reliable delivery is guaranteed by Securicor at no extra cost on all orders over £250.

ICOM. COMPLETE RANGE AVAILABLE SOON

All Ham International Products and the range of amateur equipment we import are available from our stockists countrywide.

Redlands Amateur Radio
Clyst St Mary
Exeter
Devon
039-287-3040

Southdown Radio Supplies
40 Terminus Road
Eastbourne
Sussex
0323-639351
G6 LSQ-G6 TIQ

Midland Tuning
30/32 Leicester Road
Loughborough
Leicestershire
0533-212371
G4 AMN

TONNA (F9FT)

144 MHz	
9 Element fixed.....	£15.45
9 Element portable.....	£17.45
9 Element crossed.....	£28.55
13 Element portable.....	£27.25
16 Element fixed.....	£34.95
17 Element fixed.....	£34.95
430 MHz	
19 Element.....	£18.25
19 Element crossed.....	£31.00
21 Element.....	£26.00
21 Element ATV.....	£26.00
144/430 MHz	
9 + 19 Element.....	£30.00

Kettering HiFi
Stamford Road
Kettering
Northants
0536 515266
G6 PAK

S.M. Spain Ltd
2A New Road
Bromsgrove
Worcestershire
0527-72460
G4AAL G4RUX G4LVK
G8YAJ

Tridentstar Ltd
Unit 30
Century Street
Sheffield
Yorkshire
0742 442486
G6 RIL

Enfield Emporium
281 Hartford Road
Edmonton
London N9
01-804 0128
G8 SYG G6LHL

Telecom
189 London Road
North End
Portsmouth
Hampshire
0705 698113
G2DZT G3SED G4PYS



AVAILABLE SOON
Commercial PMR Equipment
Full Range Available for Supply and Installation



WE RESERVE THE RIGHT TO ALTER OR AMEND PRICES OR SPECIFICATIONS WITHOUT NOTICE

C5800

REVIEW

By Peter Metcalfe
G8DCZ

What's that I hear you say — 'another 2m multimode'! Yes STANDARD COMMUNICATIONS CORP. of Japan (where else) released their answer to the 25W 2m multimode market in England about four months ago, following on from their C8800 FM only model and accompanying the C58 portable version. Standard's attack on Yaesu/Trio/Icom has reputedly been delayed by "six months of field testing to get it right". With statements like this abounding I am sure that you will forgive a little scepticism. Have they got it right or is this just another standard (forgive the pun!) rig?

Documentation

The rig comes complete with a very comprehensive manual which has only a couple of strange translation quirks (eg. in the description of the SSB TX amplifier, reference is made to a "younger amplifier" — is this some new technique I haven't heard of?). The operating instructions, especially of the synthesiser functions, are well laid out and easy to follow. The circuit diagrams, board layout and instructions on how to take the rig apart are very good and there is a particularly nice section on TX and RX adjustments. The part of RF circuit operation is a little sketchy, but adequate for those with previous knowledge of common techniques. However, the five pages devoted to the PLL and digital side of things, while being very thorough, takes some reading.

Circuit

There is nothing very earth shat-

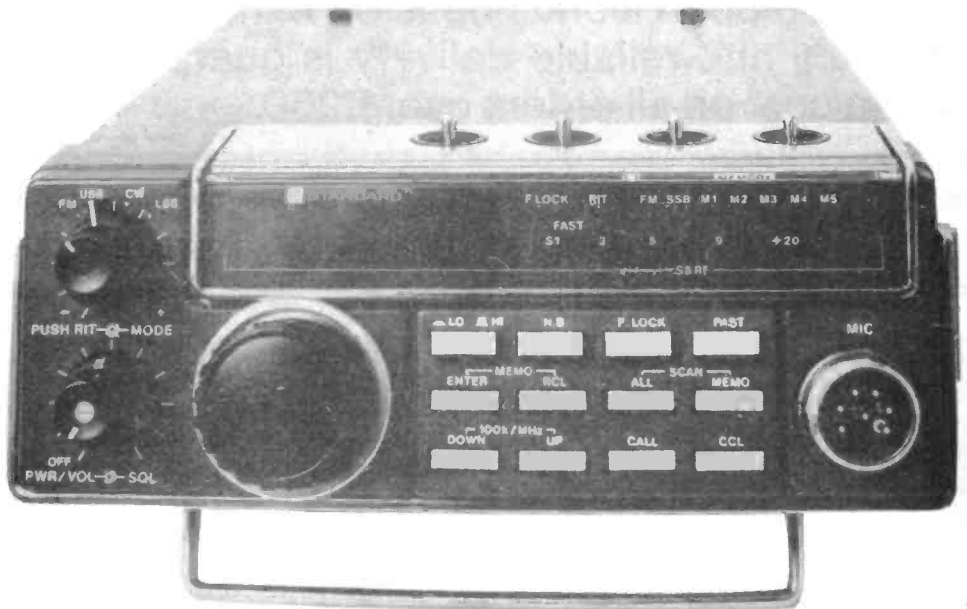

tering here; the now conventional final power module (M57727A), protected against high VSWR by an LC coupling circuit sensing reflected signals and hence shutting down drive to the unit. There is a double superhet plus quadrature detector on FM receive and a vari-cap tuned VCO on transmit. For SSB operation, Standard employ a technique similar to the Icom IC290 for generating the two sidebands; ie. only one crystal is used, rather than the more usual two, and the different frequencies are diode switched by adding or subtracting L and C tuned circuits. While I'm not too happy with this method of sideband generation, it seems to work fairly well, so don't knock it! The rest of the SSB side is fairly straightforward with single conversion on receive, a double balanced modulator, etc.

A CW side tone facility exists,

which should help with morse practice, and on the display side a bargraph type LED power/signal meter is employed. One surprising feature is the external meter socket on the rear panel which allows one to connect a conventional (100uA) moving coil meter to supplement the power/signal display. If, like me, you don't like LED meters, take note. The extensive use of LSI devices in the synthesiser and control section along with "a large capacity 4K micro-processor never before used in a mobile transceiver" provide enough functions to keep the digital freak going for months.

Visual Impressions

The first thing that strikes one about the 5800 is just how small it is (about 5½" by 8" by 2"). In fact it is barely bigger than the C58 portable

and one begins wonder how Standard cram it all in. The second point to notice is the angled front panel, which makes the display and controls nicely accessible, with certain provisos, when the rig is mounted low down in a car. However, here is where a problem arises, for there are four function switches mounted near the front but on top of the unit. This means that the rig cannot be mounted flush with the dash or, when used as a base station, used on a shelf higher than eye level. A nice touch is the fold back bench stand (how many times has this part been lost when transferring other rigs from car to shack?). The mobile mount was adequate but the review model's was a little stiff to use (perhaps it will loosen up). As mentioned before, the main problem with mounting is that the unit must protrude from any vertical surface and therefore the mount must be fixed quite a long way behind the rig's centre of gravity. This produced considerable vibration of the transceiver when using the available bolt holes in my vehicle, which can't be good for it.

The microphone fits neatly into the hand but the PTT button is a little small for my liking and could cause quite a bit of finger cramp on long QSOs. The general impression

of the 5800 is one of a very well put together, neat and tidy rig (and oh so small!).

Inside

When the top and bottom panels are removed it soon becomes apparent how Standard gets it all in. The lower board, which looks like paxolin (yeuk), is quite frankly a mess. There is no real attempt at micro-miniature components and so the inside is obviously very crowded. However, what really spoils it is the profusion of wires linking parts of the same board and coming from the panel controls. OK, so it's a small rig with nowhere to hide these wires, as in different models, but surely they could have made more extensive use of ribbon cables or flexible PCB's (as in the *IC2E*). A rather better plan would have been to spend more time designing the PCB itself to eliminate the need for all these flying leads. I feel that if modification or servicing is needed, it would be very difficult on this board. Not surprisingly, the speaker is a mere 2" in diameter, however, it does a remarkable job considering it's size but I would still recommend an external device wherever possible (10% distortion in a noisy vehicle is rather difficult to listen to for

long periods).

The top board looks more acceptable; agreed it is still very crowded, but more plug/sockets are used and there is an attempt to route cables round the sides. This means that at least you can see where you are. Being dedicated to the PLL and digital circuitry, this board looks more professional (fibreglass, shadow masked etc.). The inclusion of a small piggy-back board containing the toneburst circuitry indicates the European version of the rig.

The final board making up the transceiver is the power module and its associated drive circuitry. This is mounted at the back in a metal enclosure and with a little dismantling should be fairly easy to get at.

Generally, this is not the type of rig to play around with unless you have experience of fitting quarts into pint pots.

Operating Impressions

With such a small front panel, the controls are necessarily packed in tight. This presents a few problems when operating; for instance, the mode switch is very awkward, being concentric with the RIT control. The squelch control is even worse and has to be adjusted from underneath, if one is not to alter the volume setting (it was very difficult to use when mobile). A little more room between volume/squelch and the main tuning dial control would have helped here. While on the subject of mobile operation, again we have a rig with a profusion of similar looking, multi-function buttons which require very little travel to operate them. This makes the rig confusing, not to say dangerous, to use in the car. The microphone plug obscures many of the push buttons when the set is mounted to the left of the operator and I feel that, for true mobile use, many of the features of this rig must remain unused; certainly any change of mode is risky. The five digit, green, fluorescent display is rather dim and difficult to read on a sunny day (yes, there was one in December!). Also there is an annoying multiplexing flicker present.

Generally, I was not terribly impressed by the layout of the controls from a mobile point of view. As a base station or /P, it is a different



matter for then one can put up with a few hardships and it is the functions that matter. Indeed, the 5800 has some very nice facilities but also some very confusing ones. The size of the frequency step depends on the setting of three controls in addition to the mode. The exact effect is an iterative process of trial and error. As well as this, there is also available, from one of the keyboard buttons, 1MHz (FM) and 100 kHz (SSB/CW) up/down steps. I found this feature rather useful, especially as the rig has the annoying quirk of coming up on 146MHz when first switched on. A useful addition, especially for mobile work, is the inclusion of a frequency lock button which disables most of the keyboard and the up/down microphone switch, but does not affect the "Call" but-

ton. This "Call" facility seems a rather pointless addition, especially as the 5800 has auto-toneburst. In fact, being positioned near one of the most used keyboard buttons (Clear), it is a positive disadvantage and can cause some embarrassing moments.

Listening on FM showed that the 5800 is quite a sensitive rig although the rather 'topy' audio made it difficult to pick out weak signals from the general noise level and made working 'DX' on FM a bit of a strain on the ears. The two position RF gain switch, "DX/LOC", seemed to behave in a particularly odd fashion with strong S9 signals being reduced to around S2 but weaker signals (eg. S1) hardly being attenuated at all. The usefulness of this switch was therefore nullified as in-

terference could still occur between local and distant stations on the same frequency. The usual problem associated with led signal strength meters was experienced ie. weak, but Q5, signals caused no indication on the display. However, the external meter socket could be used by those who like to see something happening. (It seems psychologically reassuring to have some indication of just how weak a signal is!)

SSB listening also showed up the sensitive front end of the 5800 and the audio in this mode was quite pleasant to listen to. The RIT control gives $\pm 1.2\text{KHz}$ shift and surprisingly this also operates in the FM mode. Possibly due to its sensitivity, the rig was very susceptible to static noise and the noise blanker, while not being particularly effective,

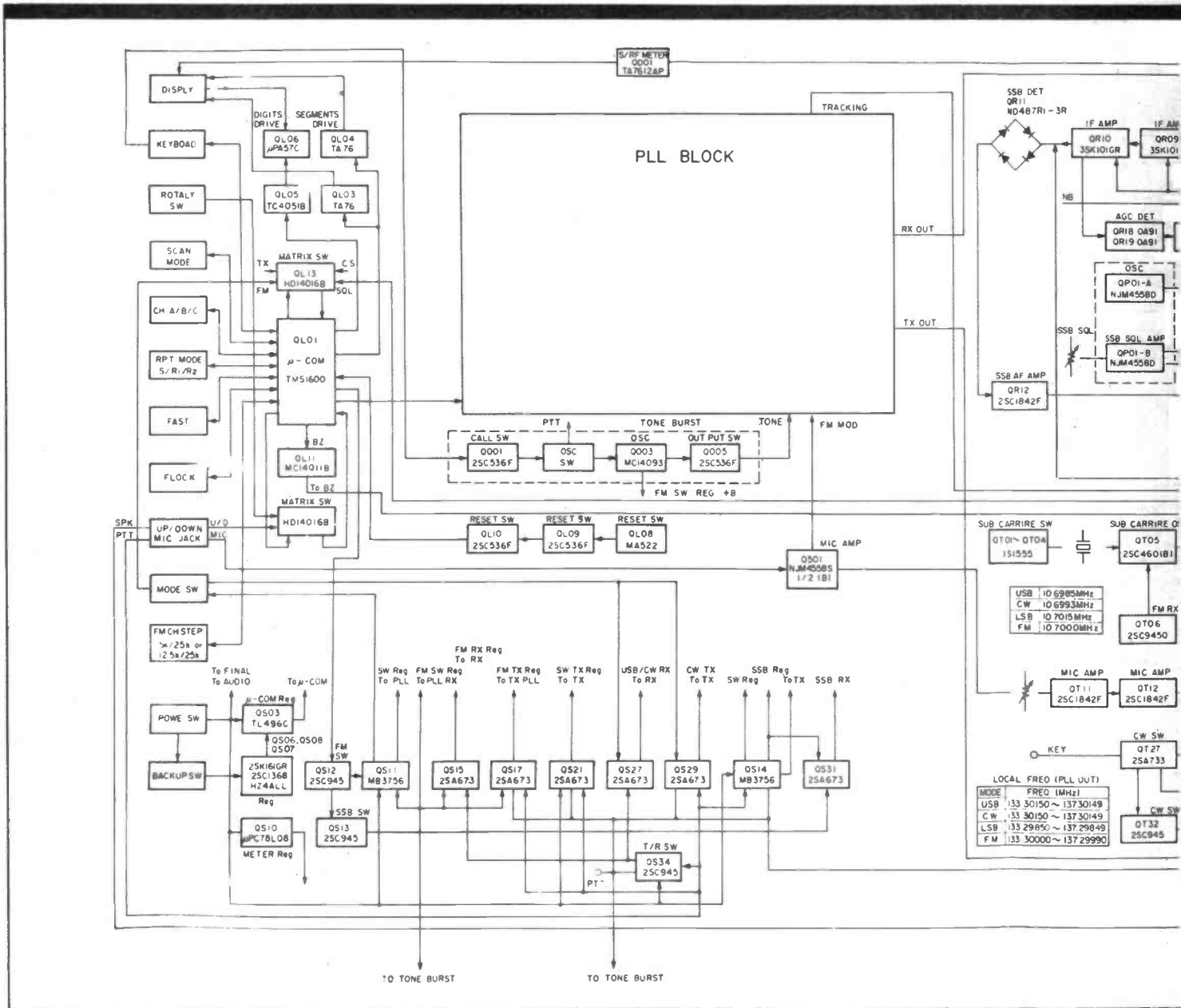

needed to be on all the time. A second problem noticed, concerning this aspect, was the excessively long "hang" time on the AGC. The manual does, however, indicate the relevant R/C components and perhaps a useful mod would be to reduce this time constant to prevent huge chunks of the QSO being missed.

Reports received from FM transmission were of quite good audio quality and modulation level but the large dynamic range of the rig, while giving excellent signals locally, was not too good at cutting through the noise for DX work. This was particularly noticeable when used by a female operator so perhaps some tailoring is called for. (I wonder why manufacturers haven't woken up to the fact that

there are many more YL operators nowadays!) Obviously due to the physical size of the rig, and hence its correspondingly small heatsink, I found that the set became very hot indeed during long FM QSOs and so Standard's warning about mounting the rig in a well ventilated position be taken seriously if disaster is not to follow!

Repeaters

Repeater operation shows up two very awkward features. Firstly, the toneburst is activated automatically if the PTT is pressed, released and then pressed again in quick succession. Now while this could be useful for mobile opera-

tion, the fact that it cannot be switched off for simplex FM work, coupled with the small PTT button, can cause some odd tones to appear when not wanted. Also, as with many rigs, the tone is rather long, but this could easily be modified. Secondly, the three position S/R1/R2 switch takes some getting used to. "S" is the normal TX/RX on the displayed frequency. "R1" gives - 600 kHz repeater shift from the displayed frequency which means that switching from simplex to repeater operation is time consuming, as one has to switch to R1 and then retune to the desired repeater output. The "R2" setting gives true reverse repeater operation and TX is 600kHz up from the display frequency. As the set covers the full 144-148MHz range and there is no out of band switching above 145.999, there could be problems if you don't keep your wits about you! Out of band protection below 144MHz takes the form of a rather blunt "OFF" message on the display (one or two suggestions were forthcoming as to a more pointed display here!). Strangely, this does not protect one from transmitting (surely a little extra logic could have been employed). A good point is that "listen on input" is instantly realisable by switching from "R1" to either "S" or "R2" and that the toneburst and call facilities are defeated on SSB/CW operation. However, the repeater shift is *not* switched out on sideband and as this switch is one of those on top of the rig, it can easily be forgotten (red faces all round!). Odd repeater shifts are not catered for by the 5800 and so using it with a transverter could cause problems.

Reports from SSB contacts indicated a very nice "full, rich sound" and, apart from confusion over frequency step size, the 5800 was pleasant to operate in this mode. Being a regular horizontal FM/SSB operator, I found the absence of a second VFO troublesome when moving from sideband up to FM frequencies, but the 100kHz up/down function, with practice, came in useful here. Yet again, Standard adopt the strange habit of having 25/1W settings on FM but only 25W on SSB, which could cause problems when using linears requiring eg. 10W of drive; I'm sure a modification will arise.

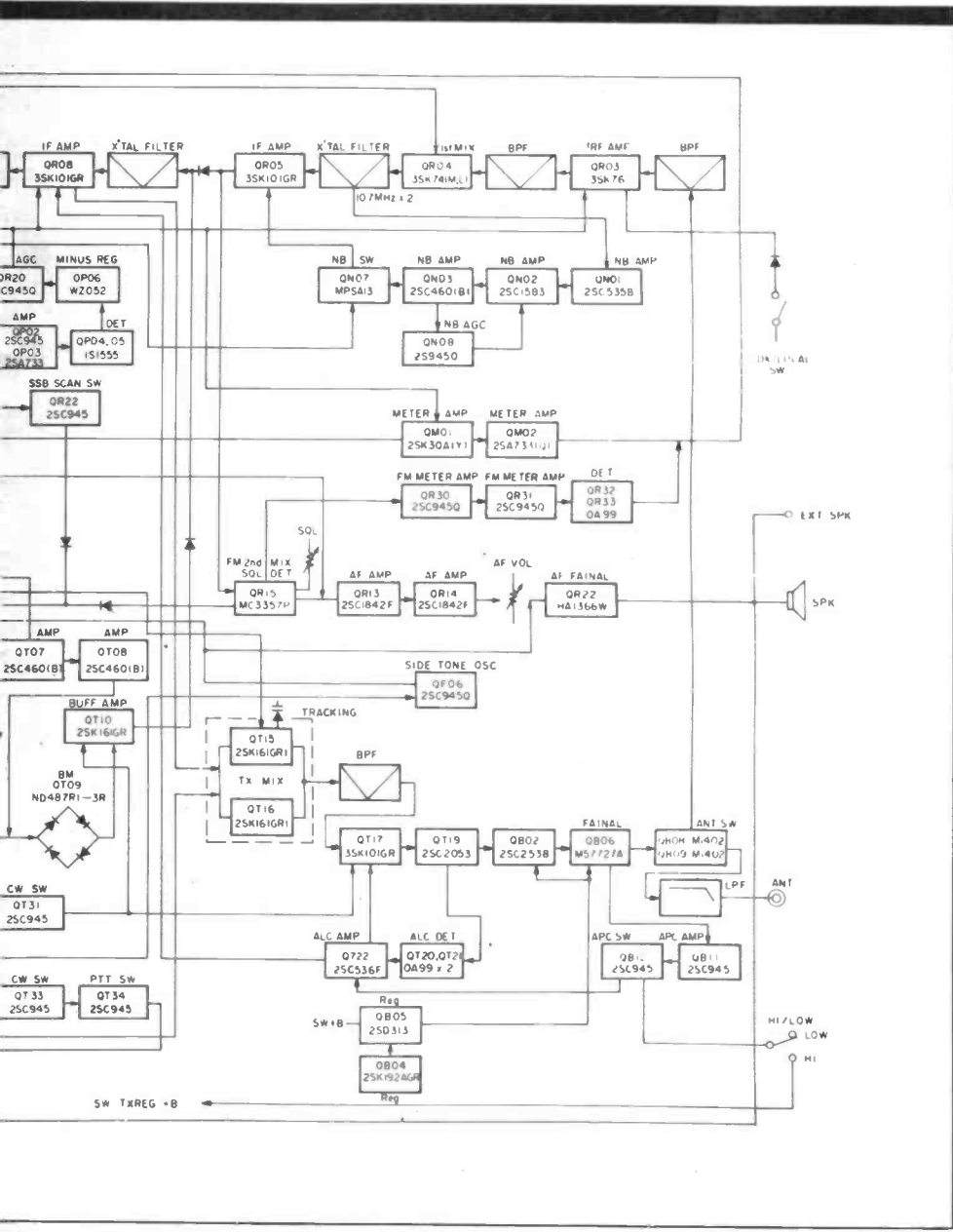

STANDARD C5800 LABORATORY TEST RESULTS

Test frequencies 145.000MHz (FM mode) 144.300 (SSB/CW)
 Power supply voltage 13.8V unless otherwise stated
 Deviation 3kHz (5kHz for selectivity measurements)

RECEIVER SECTION

FM sensitivity for 12dB SINAD (measured as PD)	0.18uV
SSB sensitivity for 12dB SINAD	0.15 uV
FM selectivity 12.5kHz either side of test frequency	-64dB/61dB
FM selectivity 25kHz either side of test frequency	72dB/73dB
RF intermodulation performance, two generators 25kHz and 50kHz away from RX frequency for 12dB SINAD on IM product, FM mode	0.7/0.4mV PD
SSB selectivity at -6dB and -60dB	2.5kHz/5.6kHz bandwidth
RF intermodulation (SSB +50kHz, +100kHz) for S5 IM product (equivalent to 4.5uV PD)7.9mV
S Meter calibration characteristic FM mode S1/S5/S9/S9+20dB	0.35/2.0/3.2/4.5uV
S Meter calibration characteristic SSB mode S1/S5/S9/S9+20dB	2.2/4.5/7.9/14.1uV
Generator frequency shift for best SINAD at 145MHz.	0.8kHz

TRANSMITTER SECTION

FM power output (high low setting)	23.7W/0.9W
FM power output (12V supply).	19.8W/0.9W
Maximum current consumption.	5A
2nd and 3rd order harmonic products , full power FM mode.	-63dB/-70dB re. carrier power
PEP SSB output power.	35W PEP
As above but 12V.	30W PEP
Dial calibration accuracy.	-200Hz
FM deviation (peak transient/average peak)	6.4/5.2kHz
1750Hz toneburst accuracy	+20Hz
AF THD at 125mW audio output3.2%
Audio power output, 8ohms at 10% THD2.9W
Misuse survival. Infinite VSWR for10s total (5s open circuit, 5s short circuit)Satisfactory

OUR CONCLUSIONS

I had an opportunity to play around with the Standard C5800 before its despatch to the testing house and can confirm that it is a desirable little box. It compares equitably with the 2m multimodes from Yaesu (FT-480R) Trio (9130) and Icom (IC-290E). At £359 the price is on par and, with 35W of SSB on tap, the C5800 is the most powerful 2m multimode that we have tested to

date. Furthermore, the receiver sensitivity is just a nose ahead of the competition although I feel that the difference here is not significant.

There is of course a minus side. The strong signal handling characteristics were not outstanding and the Trio 9130 still comes out best in this respect. The shortfall in respect of the C5800 would not be noticed in day to day operation of the set and would only have real importance when operating

The review sample was loaned by Lee Electronics Ltd of Edgware Road, London.

The engineering section of the review was carried out at Angus McKenzie Laboratories

OUR OBSERVATIONS

At least as good as every other 2m multimode that we have tested. Top class

Once again, top of the pile although in theory, there is still room for improvement

Adequate but not stunning

As above

Dynamic range 90 dB. pretty good

OK, but doesn't compare with a decent HF transceiver

Dynamic range 65 dB in SSB mode. Not good but better than some

This S meter characteristic is a joke. Stick to audio reporting

The joke is wearing a bit thin

Satisfactory

Good

Excellent.
Excellent

Excellent

A bit on the high side

A bit off. Might not access some boxes

a contest from a crowded hilltop, or if another amateur sets up a station next door to you.

The SSB operating bandwidth is another detraction but unfortunately seems to be fairly general with VHF gear. Either the manufacturer cuts corners by specifying a cheap filter unit or, as is more likely, the manufacturer still has not come to grips with synthesiser design producing machines with noise sidebands all over the place. However, this must be put into perspective. Thankfully, the VHF bands are not as crowded as the HF ones and any shortfall will not be noticed in day to day operation.

G4JST

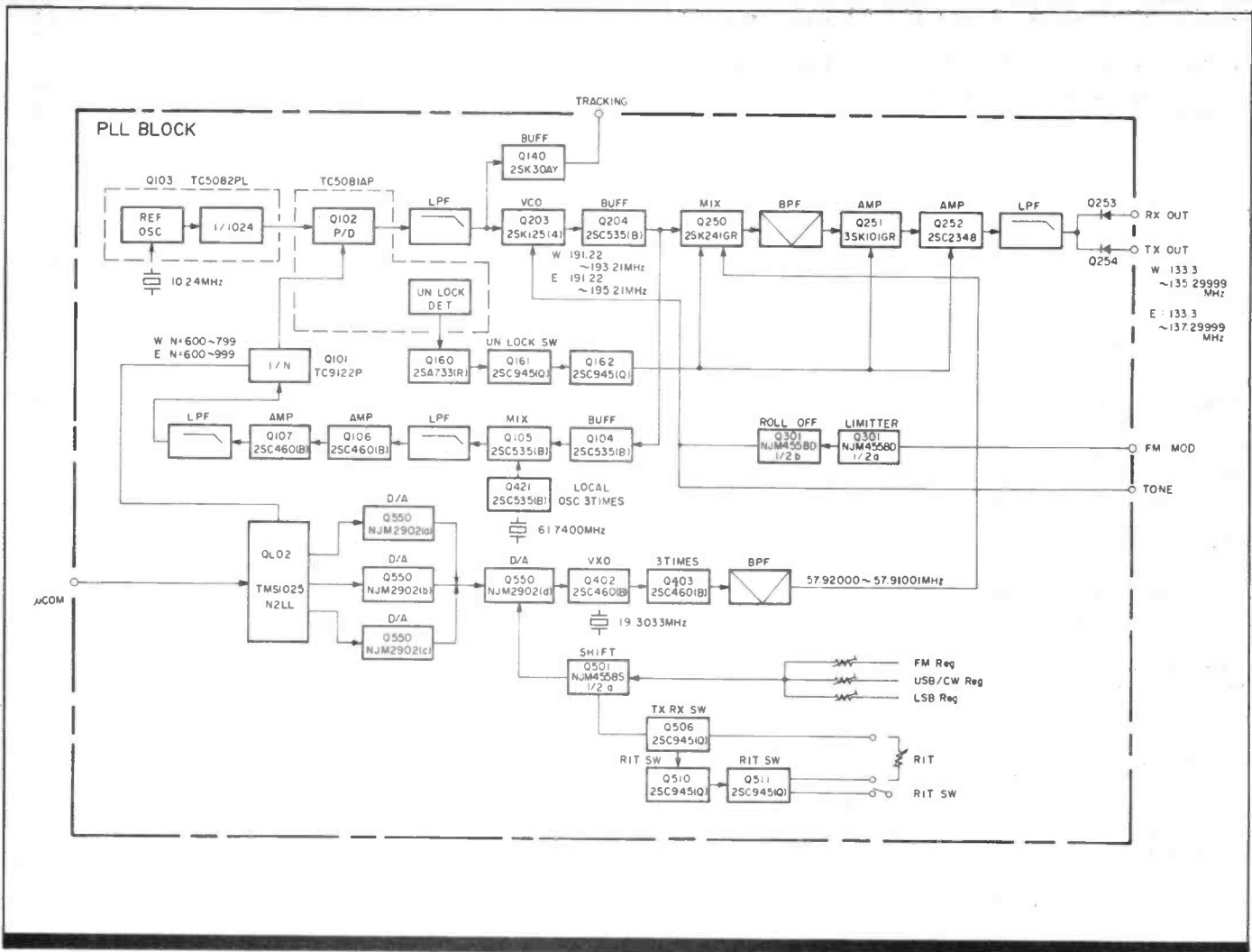

Memories and Synthesiser Functions

The 5800 has ten memories in all, with five for each of FM and SSB. I found the display very good when entering memories, a flashing led tells you if that memory is empty, and one is reminded of the mode by other leds. The only awkward part of memory entry and recall is that one has to step sequentially through all five memories to get to number five. The manual states that if the "RCL" (recall memory) button is kept depressed, then the unit steps through all the memories sequentially. However, I found this not be the case. A multi-way switch would have been nicer, but there is hardly room for that on the panel! The loud "bleep" which accompanies many function settings is useful for mobile operation especially. A very nice touch is that if one recalls a memory, it is possible to tune from that frequency using the dial.

Memory and frequency scanning on the 5800 are very versatile with the option of scanning all occupied memories of the selected mode or complete sections of the band (1MHz blocks for FM and either 1MHz or 100kHz blocks for SSB/CW). The type of scanning depends on the position of a three-way switch on the top panel indicating when, if at all, the rig is to stop scanning. The options are to stop on Busy, Vacant or Free channels. This last option means that it doesn't stop but continues the preselected scan taking no account of any signals present. The scan speed in this mode is slower than in any other mode and gives one ample time to listen for a familiar voice on the band! The "Fast" button doubles the speed of the scan and when scanning the memories for a "Busy" channel with this button depressed, it zooms through the frequencies at quite a rate.

Generally, the synthesiser functions on the 5800 are very useful and practice one can set up the rig to

send for itself quite happily, while one gets on with something useful (like working out all the mods. required to bring the set up to an ideal standard!).

Perhaps because of the use of LSI devices, the quoted current consumption on this rig is surprisingly low with 3.7A for 25W TX and 450mA for receive standby. This being the case, it should help give an extra hour or two of /P operation; always a useful point.

Summary

In conclusion, although there are many minor irritations present in the 5800, and it is hardly the best choice for mobile use, I feel that it is a nice rig to use containing some very useful functions and generally good RF design. There seem to be many modifications that one could think of and here problems could arise due to the internal layout. I wouldn't say that Standard have got it completely "right" but it's close. ●

EMPORIUM GUIDE

AVON



6 GOLF CLUB LANE,
SALT FORD,
BRISTOL
Tel: 02217 2402
Open: Tues-Sat 9am-9pm
Close Mondays

RING
557732
BRISTOL

Radio Communications
Amateur P.M.R. Marine

UPPINGTON

Tele-Radio (BRISTOL) Ltd

12 14 PENNYWELL ROAD, BRISTOL, BS5 0TJ

CAMBRIDGESHIRE

WISBECH AMATEUR RADIO

The Chase, Chapel Road, Wisbech
Telephone: 0945 581099

Open: Mon-Sat 9-6. ICOM; HALBAR
AERIALS, REVCO AERIALS, SALES + SERVICE
ACCESS + VISA, PART EXCHANGE WELCOME

CHESHIRE



FAIRBOTHAM & CO LTD

58-62 Lower Hillgate, Stockport
Tel. 061-480 4872 Open: Mon & Wed 9-6
late nights Tues & Fri 9-7pm. Sat 9-5.30.
Closed Thurs
Yaesu, Sommerkamp, Diawa, Jaybeam, Kenpro,
Weltz, Datong

HAMPSHIRE

FARNBOROUGH COMMUNICATIONS

97 Osborne Rd, North Camp,
Farnborough. Tel. 0252-518009
Open: 6 days 10-6
Yaesu, Icom, FDks, Mosley aeriels, Jaybeams,
G Whips



189 London Rd., North End,
Portsmouth. Tel (0705) 662145
Stockist of YAESU, TRIO, TONNA, ICOM,
FDK, JAYBEAM
Barclaycard & Access. HP & PX welcome

FOR YOUR BUSINESS TO BE
INCLUDED, CALL
SHEILA OR JAN ON
01-437 1002

KENT

Thanet Electronics



143 Recular Rd., Herne Bay
Tel. 02273-63859
Open: Mon-Fri 9-5.30, Sat 9-12.30
(Closed for lunch 1-2)

LANCASHIRE



231 Chorley Rd., Swinton,
Greater Manchester.

Tel: 061-793-1010
Open: 7 days a week
TRIO, YAESU, ICOM, GWHIP.

AERIAL BOOSTERS

Trebles incoming weak signal
B11 - for VHF/FM radio; B45 - for UHF
television

Next to the set fitting. SAE for leaflets. £7
Electronic Mail Order Ltd,
62 Bridge Street, Ramsbottom, Lancs BL0
9AGH

YOUR RIG IN OUR HANDS THE YAESU EXPERTS CONSULT G3LLL



Sales Dems & Repairs + Mod Kits

HOLDINGS LTD

39-41 Mincing La, Blackburn
Tel: (0254) 59595
CLOSED THURSDAYS

ISHERWOODS ELECTRONICS

Hozier Street, Blackburn
Tel. 0254-57616
Open: Mon-Fri 9-5, Sat 10-1
An Aladdin's Cave of Components

LEICESTERSHIRE

ELLIOTT
ELECTRONICS

FOR THE RADIO ENTHUSIAST

26-28 BRAUNSTON GATE,
LEICESTER. TEL: 553293
Open: Mon-Sat 9.00am to 5.30pm



LONDON

THE [C] CENTRE

10 MERTON PARK PARADE,
KINGSTON ROAD, SW19
Tel: 01-543 5150

Open: 6 days 9am-6pm (late night Weds until 8pm)

DAVE
MICK

G8SYG
G6LHL

The Enfield Emporium AMATEUR RADIO

Hours: Mon to Sat 9-6, Late Friday 9-8, Sun morn 10-1
281 Hertford Road, Edmonton N9
Tel: 01-804 0128

THE MARINE ELECTRONIC CO LTD

1-4 Swan Mead, SE1 4SY. Tel 01-237 3474
Open: Mon-Fri 10am-5pm

Communications Equipment for the
Professional and Enthusiast
Callers by appointment only

W. MIDLANDS

DEWSBURY ELECTRONICS

176 Lower High St, STOURBRIDGE
Tel: (0384) 390063

Open: 9.30-5.15. Closed Thurs. & Sun.
ACCESS/BARCLAYCARD



HEWARD'S HOME STORES LTD.

(Est. 1963)
822/4 Kingstanding Rd., Birmingham
B44 9RT. Tel. 021-354 2083
G4RJM with 38 years in The Radio Trade
Ham Equipment urgently wanted!
Open: Mon-Sat 9-6

Please include my business details in the next available issue of Ham Radio Today

Business Name:

Address:

Tel. No.:

Open Hrs:

Contact (Office Use Only):

Post to: Emporium Guide, Ham Radio Today, 145 Charing Cross Rd., London WC2H 0EE



EMPORIUM GUIDE

NORFOLK

Eastern Communications

36 Cattle Market Street
NORWICH
(0603) 667189

ICOM

MAIL ORDER

ACCEPTS BAASLEY CARD

OPEN MON - SAT
10.00am - 5.00pm

NOTTINGHAMSHIRE

R.A.S. (NOTTINGHAM)

P. Owen GBUUS
3 FARNDON GREEN; WOLLATON PARK
NOTTINGHAM: TEL: 0602 280267

Open: Tues-Fri 10.5.30. Sat 9-5
YAESU; FDK; ICOM; SOMMERKAMP; TOONA
HALBAR; WELZ; ANTENNAS & OWN GWS H.F.

SCOTLAND

AXDON

32 Atholl Street, Perth
Tel: 0738-23753. Open: 6 days
ICOM, TONA, TONO, RSGB Books, Maps &
log books. Full range of components
Mail order available - send for price list.

LOOKING FOR TRANSEIVERS!
AERIALS! AMATEUR RADIO
ACCESSORIES! TRY YOUR
LOCAL LISTED STOCKIST

JAYCEE ELECTRONICS JOHN GM30PW

20 Woodside Way, Glenrothes, Fife KY7 5DF
Tel: 0592 766982
Open: Tues-Sat 9-5.
Quality secondhand equipment in stock. Full range of TRIO
goodies. Jaybeam - Microwave Nodules - LAR

SUSSEX

SOUTH-DOWN 40 TERMINUS RD (opp.
RADIO EASTBOURNE Railway
SUPPLIES Tel: (0323) 639351 Stn.)

Open: Mon-Sat 10-5 (Closed Tues)
Stockists of: Yaesu, Trio, Tonna, FDK etc +
secondhand and ex-Government equipment in
stock

TYNE & WEAR

Approved Dealer **ALYTRONICS** Full Range Stock
ICOM

129 Chillingham Rd, Newcastle-upon-Tyne.
Tel: 0632 761002
Open: Tues-Sat 10am-6pm

YORKSHIRE

4 Cross Church St, Huddersfield Tel:
Open: 6 days 9-5.30. 0484 20774
Closed Weds. Thurs 9am-8pm
G4MH Mini Beam
"Always a good selection of new & 2nd hand equipment in stock"

Amateur Radio Shop

DISCOVER THE WORLD WITH AMATEUR RADIO FROM
Sales 27 Cookridge Street Leeds LS2 3AG
LEEDS 452657 OPEN MON - SAT
8.30am - 5pm
THE PROFESSIONALIST

TRIO ICOM YAESU

LEEDS AMATEUR RADIO MAIL ORDER & SERVICE DEPT OPEN MON - FRI
60 GREEN ROAD MEANWOOD LEEDS LS6 4JP TEL: 782224 8.30am - 5pm

BRITISH MADE LAR PRODUCTS

MAIL ORDER PROTECTION SCHEME

If you order goods from Mail Order Advertisers in this magazine and pay by post in advance of delivery, this publication will consider you for compensation if the advertiser should become insolvent or bankrupt, provided:

1. You have not received the goods or had your money returned; and
2. You write to the publisher of this publication explaining the position not earlier than 28 days from the day you sent your order and not later than 2 months from that day.

Please do not wait until the last moment to inform us. When you write, we will tell you how to make your claim and what evidence of payment is required.

We guarantee to meet claims from readers made in accordance with the above procedure as soon as possible after the advertiser has been declared bankrupt or insolvent to a limit of £1,800 per annum for any one advertiser, so affected, and up to £5,400 p.a. in respect of all insolvent advertisers. Claims may be paid for higher amounts, or when the above procedures have not been complied with, at the discretion of this publication, but we do not guarantee to do so in view of the need to set some limit to this commitment and to learn quickly of reader's difficulties.

This guarantee covers only advance payment sent in direct response to an advertisement in this magazine (not, for example, payments made in response to catalogues, etc. received as a result of answering such advertisements):

CLASSIFIED ADVERTISEMENTS ARE EXCLUDED.

HAM RADIO TODAY - MAY ADVERTISERS INDEX

Allweld Engineering	12
AmateurRadioExchange	IFC
Amtronics	55,72
Amcomm	IBC
ArrowElectronics	36
C.Q. Centre	23
DewsburyElectronics	41
FortopLtd.	32
HamInternational	62/63
Intermedial	23
H. Lexton	8
MobileFiguresCo	72
MyersElectronics	73
NorthamptonCommunication	55
021 Radio & Electrical	OBC
PMComponents	5
PMElectronics	23
PolemarkLtd.	32
RATEC	22
S.M.C.	34/35
Selectronics	55
WPOCommunications	22
WesternCommunications	55

Lineage:

30p per word (minimum 15 words)

Semi Display (min 2 cms)

1- 3 insertions £5.50 per cm

6-11 insertions £5.00 per cm

12+ insertions £4.50 per cm

All advertisements in this section must be prepaid.

Advertisements are accepted subject to the terms and conditions printed on the advertisement rate card (available on request)



Ring for information on series bookings/discounts



01-437 1002

EXT 204

Send your requirements to:

Jo James,

ASP Ltd.,

145 Charing Cross Road,

London WC2H 0EF

EQUIPMENT

RTTV CREED 444 As New. 595 hours use from new. STS terminal unit dual machine autostat. Professionally built. The pair £175. Might split. Trio 2200 GX Nicads charger £80 o.n.o. DAIWA LNA 1001 auto ATV as new in box £110 o.n.o. G65YZ-QTHR-(Cornwall)(020) 888 738.

AMATEUR RADIO EQUIPMENT

Toggle switches, cables, test meters etc. Send s.a.e for price list to M.J. Seaward, 7 St. Olafs Road Stratton Nr. Bude, Cornwall EX23 9AF Tel (0288 4179).

ALUMIUM DIPOLES — 4m, 6m, 10m, £7.95 ea., 12m, 15m, 17m, 20m, £9.95 ea., **CABLES** — RG58 19p/m, RG8 49p/m, 300 Ω T.F. 12p/m., **CONNECTORS** — PL259/6 49p, PL259/9 49p **SWR METERS** — 5W H.F. £5.95, 100W H.F. £15.95, 10W 2m/70cm £19.95, P.S.U. — 13.8v 3/5A £14.95, 5/7A £16.95. **HALBAR AERIALS**. Barclaycard/Access. All prices include P&P and VAT. Electronic Facilities, 3 High Street, Sandy, Beds. (0767) 81494.

ONE SUMMER CAMP

FT/2772D. Mint condition £595 and one Kenwood 2400 portable 2 metre £165. Gobowen CB Centre, The Cross Gobowen, Shropshire. Tel: 0691-661397.

IK-1 CMOS/V MOS Iambic keyer. An electronic morse keyer with sidetone and internal PP3 battery. VMOS technology allows our keyer to key the rigs other keyers cannot! Positive or negative versions.

£19.95 & 50p P&P

MPA-2 144MHz Masthead preamplifier. Our advance design with selective helical filter can switch up to 500W pep.

Ideal for DX or Contest Work £33.50 & 50p p&p
Cmos morse practice oscillator £6.50 & 50p p&p
Piptone/Roger bleep £4.50 & 25p p&p
K bleep £6.00 & 25p p&p

Our CM1000 HF Transceiver is currently under development. Send SAE or phone for information on this and our other products.

Please note 12 months guarantee on all our products.

CHRIS MOULDING RADIO SERVICES, 276 HULTON LANE, BOLTON, BL3 4LE 0204-651348

ELECTRONIC BARGAIN SUPPLIES

VERSATILE BENCH POWER SUPPLY UNITS

Contains high quality transformer made to exacting specifications giving one 40v output and one 20-0-20v output. All outputs 3amps. D.C. input 110/250v c/s. Bridge rectification. Contained on metal chassis with robust compact case size 7"x5½"x4½". Easily modified to give 40 or 60v output. Makes an ideal variable power supply. Normally costs around £60.00. OUR PRICE AS NEW with circuits £8.50. Carr. £3.2 units for £20 carr. free.

AMPLIVOX ULTRA LIGHTWEIGHT TRANSDUCER EARPHONES. Impedence 300ohms. Made to fit inside protective and crash helmets or can be used as pillow earphones. A new £4 per pair. PP £1.2 pairs £8. Post free. 4 pairs £15. Post free.

MINIATURE TRANSISTORISED BFO UNIT. Enables you to receive C.W. and S.S.B. transmission. Fully transistorised (turntable). Very compact. fits anywhere. Single hole fixing. Brand new with fitting instructions. £6.95. PP. 50p.

GENUINE AFV TANK HEADSETS AND MIKE. £3.50 per pair. PP. £1.50. 2 pairs !.50 post free. All headphones fitted with ex-ministry plug. Standard jack plugs available 25p each. 2 for 40p. Headphone extension sockets available at 25p each. 2 for 40p. Impedance of first two items 600ohms. All headphones in good condition.

THE GOVERNMENT SURPLUS WIRELESS EQUIPMENT HANDBOOK

Gives detailed information and circuit diagrams for British and American Government Surplus receivers, transmitters, test equipment etc. Also suggested modification details and improvements for surplus equipment. Incorporated is a surplus/commercial cross referenced valve ONLY £7.50. PP. £1.50. No VAT on books.

PYE POCKET PHONE PFI DATA AND INSTRUCTIONS. Contains, circuits, layouts, operating and modification details for amateur use etc. £1.50 post free.

GENUINE TRANSFORMER BARGAIN. Brand new Westool 15v. 1 amp transformers. Mains input. £2.75 each. PP. 75p. Or 2 for £5.50. PP. £1.

HIGH QUALITY 17-0-17 TRANSFORMER made to exacting specifications. 3amp output. Mains input. £2.95. PP. 60p. Two for £6.00 post free.

GENUINE EX-GOVT COLLAPSIBLE AERIALS. A fully adjustable highly efficient whip aerial in 5 sections. Length 1½ metres. Closed 300mm. Copper plated sections. As used on EX-Govt manpacks. Brand new in make3rs boxes. £2.50 each. PP. 75p. 2 for £5 post free.

HAVE YOU SEEN THE GREEN CAT. 1,000's of new components, radio, electronic, audio and unbelievably low prices. Send 50p for catalogue. (Refundable on purchase).

PLEASE ADD 15% VAT to all orders including carriage and PP.

Myers Electronic Devices

Dept HRT112/14 Harper Street, Leeds LS2 7EA
Tel (0532) 452045 Retail premises at above address.
(opposite Corais) 9 to 5, Mon to Sat, Sunday 10 to 1 by
appointment. Govt. Surplus Items always in stock.

AERIAL PARTS

14 swg Hard Drawn Copper Aerial Wire 20p per m (post 2½ p per m); Strong PVC covered stranded Aerial Wire 6p per m (post 2½p per m); 300 ohm Twin Ribbon Feeder 12p per m (post 2p per m); 75 ohm Twin Feeder 18p per m (post 2p per m); UR43 50 ohm COAX 20p per (post 3p per m); UR70 50 ohm COAX 20p per m (post 3p per m); UR67 50 ohm LOW LOSS COAX 50p per m (post 5p per m)

W. H. WEST LAKE, G8MWW
Clawton, Holsworthy, Devon.

B.N.O.S. ELECTRONICS

Manufacturers of Power Supply Units and V.H.F linear amplifiers.

B.N.O.S. Electronics
Dept. HRTC, Greenarbour,
Duton Hill, Gt. Dunmow,
Essex CM6 3PT
Tel: (037 184) 767

TRANSMITTERS RECEIVERS ETC.

All frequencies, well known makes, ICOM, FDK, AZDEN, LOWE, STANDARD, etc. etc. Power supplies, wave-meters, test meters, frequency counters, Welz SWR and Power meters. Microwave modules, linear amps, RTTY etc. Quality equipment for am-ateur, PMR and Marine use. Aerials, Co-ax cable, plugs. See our advert under Emporium Guide. £1000 INSTANT HP available and ACCESS — Booth Holdings Bath, 6 Golf Club Lane, Salford Bristol BS183AA. Tel (02217) 2402. Staff includes G3N XLW, G3XOD, G8DPH.

ANYTHING TO SELL?

Then sell it quickly and cheaply

Phone ASP Classified
01-437-1002 ext. 204

Special prices on surplus equipment

Eddystone Receivers 770R(VHF) 770U(UHF) £139. Model 830 £170 730/4 500KH 30MHz in 5 bands. All in excellent condition. Carr £15.

Marphy 840D Receivers £55. Carr £15.

Pye Bantams High band AM untested less xtal and batt £22. With xtal and batt tested £30. **Avo Valve Tester** £25.

New 28 Range Digital Multimeters £40.25. **PCR Receivers LW/MW/SW** with built-in mains PSU tested £45. Untested less PSU £25.

Advanced E2 Signal Generators 100KHz-100MHz £40. P&P £3. **Taylor 67A Signal Generators** 100KHz-240MHz £45. P&P £3.

12ft Whip Aerials £4, P&P £1.50. **Various:** Single and Double Beam Oscilloscopes, Signal Generators, Valve Testers, Output Meters etc, in stock.

Surplus Circuits new book containing many circuits and notes on various surplus receivers, transceivers, etc £6.50. Shed 50p for **fully illustrated catalogue** (includes £1 voucher). Over 500 sets in stock. **Avos, amateur rigs wanted for cash.**

Weirmead Limited; 129 St Albans Rd, Watford, Herts WD1 1RA

Telephone: Watford 49456.

Access/Visa cards welcome

KEEP YOUR HANDS ON THE WHEEL

with the *Mondock* safety microphone system

Pre-amp + Timer + Electret Condenser Mic

No extra connections to transceiver

£32.95
(Fully inclusive)

Send for a leaflet

R & A

SUDRON LTD

Tel (0532)
737120/435711

Ferndale, Colliers Lane
Shadwell, Leeds LS17 8LP

VALVES

VALVES VALVES VALVES

The following valves in matched pairs 6JS6/C 6KD6, 6JB6/A 6HF5 6146A 6146B YES the 6JS6/C is Japanese and works in the FT101. Most amateur radio valves including difficult to obtain EX STOCK. Quotations without obligation. If we don't stock your type we may be able to import for you. Please enquire. Remember, over 200 types EX STOCK. Phone for assistance re types suitable for your equipment. USA and Jap manufacture of popular types available.

Don't Delay Phone Today 04575 6114 G4A2M. Free Postage with this advertisement.

Wilson Peel Cottage, Lees Road, Mossley, Tameside, Manchester.

ANTENNA

AMTRONICS

New amateur radio specialists in Kent. Jaybeam Tonna; Welz "Diamond", Hoxin. Antennas now in stock. Finance available. Access, VISA. Write for details. Tollgate Buildings, Hadlow Road, Tonbridge. Telephone: Tonbridge (0732) 361850.

RESTRICTED SPACE HF QTH'S.

A G2DYM UNI-POLE WILL BE YOUR ANSWER, TX OR SWL
DATA SHEETS LARGE SAE, AERIAL GUIDE 75p
 Callers Welcome
 Tel: 03986-215
 G2DYM,
 PLOWMAN
 TIVERTON, DEVON

Ant Products, All Saints Industrial Estate, Baghill Lane, Pontefract, West Yorkshire. Telephone 0977 700949

AMATEUR ANTENNA

Silver 70-70 cms 16 dbd Gain Beam	£31.95
Tiger LY6 9 dbd	
2 Meter Beam	£12.95
Tiger LY8 11 dbd	
2 Meter Beam	£19.50
Tiger LY10 14 dbd	
2 Meter Beam	£32.95
TWO YEAR GUARANTEE ON ABOVE	
ZL12 Mk 2 13 dbd	
Gain Beam Antenna	£32.95
ZL8 Mk 2 9 dbd	
Gain 5'7" Long Boom	£19.95
ALL ABOVE HAVE STAINLESS STEEL PARASITIC ELEMENTS	
Norcone 512 Wide Band	
Discone Antenna	£25.95
Securicor Delivery (Extra)	£4.00
Send cheque or money order today, made payable to Ant Products or write enclosing S.A.E. for full details.	

30 FOOT STEEL and alloy masts tillover £100 For details P.O. Box 16, Redruth, Cornwall.

AERIAL GEAR

We supply the best aerial equipment in the UK. Specialists in TV, FM equipment, DXing. Aerial masts, components, amplifiers, filters.
 'One-off' aerials made to your needs eg UOSAT, Airband, etc. SAE leaflets.
 Hirschmann RO250 rotor, control consul £43.50; SL100 alignment bearing for same £16.50; TVI? In-line bandstop filters for 27,144 or 453MHz, fits in TV feeder +30dB stop, 1dB elsewhere, £9.50 (45 filters listed!); Revco Discone £24.95.
 All prices incl. VAT/post. Catalogue 54p. Barclaycard/Access welcome.
 The best costs less at...
South West Aerial Systems,
 10 Old Boundary Road, Shaftesbury, Dorset SP7 8ND.

Components to sell?

Phone ASP
 Classified
 01-437-1002
 ext. 204

MORSE CODE CASSETTES C90
 8-13 WPM in groups of five. Plain language 3 minutes sections numbers exam pieces etc. with readback inclusive price £3.20 S.M. Spain (Bromsgrove) Ltd, 2 New Road, Bromsgrove Worcs. Phone 72460.

CARDS, STICKERS, BADGES

ENGRAVED LABEL BADGES
 Label badges with electrically welded safety clip, most colours available. Example: Club Badge, club name, personal name, call sign, with or without RSGB logo — 1 to 10 badges 85p each. 10 and above 80p each inc P&P. Please use block capitals for all orders, cash with order, orders dispatched by return first class post.
Club Secretaries please send for sample
DARFIELD ENGRAVING SERVICES
 39 Cliff Road, Darfield, Barnsley, S. Yorks S73 9HR
 Tel: Barnsley (0226) 752106

COURSES

COURSES - RADIO AMATEURS EXAMINATION City & Guilds. Pass this important examination and obtain your licence, with any RRC Home Study Course. For details of this and other courses (GCE, professional examination, etc.) write or phone — **THE RAPID RESULTS COLLEGE**, Dept. JX1, Tuition House, London SW19 4DS. Tel: 10-947 7272 (9am-5pm) or use our 24 hr Recordacall Service: 01-946 1102 quoting Dept. JX2.

CALL SIGN LABEL BADGES professionally engraved, by return of post. £1.50 cash with order (state name & call sign) Aylmer-Kelly — H, 2 Pickwick Road, CORSHAM, Wilts., SN13 9BJ.

LISTENER & QSL CARDS Quality printing on Coloured and White Gloss Card at competitive prices. SAE for samples S.M. Tatham "Woodside", Orchard Way, Fontwell, Arundell, West Sussex.

WANTED

WANTED
 All types of marine, electronic, radio and radar equipment. The Marine Electronic Co. Ltd., 1-4 Swan Mead, London SE1 4SY. Tel: 01-237-3474. Open Mon-Fri, 10am-5pm. Callers by appointment only.

SECOND HAND Yaesu and all good transceivers wanted Guilford CB 0483 574434.

HAM EQUIPMENT URGENTLY WANTED! Heward's Home Stores Ltd (est. 1963). 822/4 Kingstanding Rd., Birmingham B44 9RT. Tel: 021-354-2083. G4RJM.

KITS

RTTY TERMINAL UNITS for computer interface P.C.Bs, wired modules, boxed units, modern active filter Design excellent for BBC Computer S.A.E. J. Melvin 0632 843028

ANTENNES TONNA (F9FT)

YOUR NUMBER ONE CHOICE FOR 6m, 2m, 70, 24 & 23cm ANTENNAS

50MHz 5 element*	£31.74(a)	1250MHz or 1296MHz 23 element*	£25.90(b)
144MHz 4 element	£13.01(a)	4 x 23 element antennas — power splitter — stacking frame	£140.00(a)
9 element fixed	£15.44(a)	Telescopic Portable Masts 4 x 1m	£15.96(a)
9 element portable	£17.46(a)	4 x 2m	£28.75(a)
9 element crossed*	£28.52(a)	3 x 2m	£19.15(a)
13 element portable*	£27.21(a)	ANDREW HELIAX LDF4-50 COAXIAL CABLE Attenuation per 100ft 144MHz — 0.8dB 435MHz — 1.6dB. 1296MHz — 2.9dB	
NEW 17 element fixed	£36.19(a)	£3.20 per metre (a) 'N' type connectors for LDF4-50 male or female	£10.35
435MHz 19 element	£18.14(a)	MICROWAVE MODULES — ROTATORS — COAXIAL CABLES ETC. POWER SPLITTERS AVAILABLE FOR 2 OR 4 ANTENNAS	
19 element crossed*	£30.05(a)		
21 element 432MHz	£26.00(a)		
21 element ATV	£26.00(a)		
144/435MHz Oscar Special 9 & 19 element*	£30.05(a)		

*Denotes 50Ω ONLY — all others 50Ω OR 75Ω

PLEASE ADD CARRIAGE AS SHOWN (a) £4.00; (b) £1.80.

Terms: Cash with order. ACCESS - VISA - telephone your card number. ALL PRICES INCLUDE VAT AT 15%. For full specification of our range send 30p for Catalogue. Callers welcome, but by telephone appointment only please.

RANDAM ELECTRONICS (H)

12 CONDUIT ROAD, ABINGDON, OXON OX14 1DB. Tel: (0235) 23090 (24 hours)

NEW

SPIDERLIGHT

NEW

Rot proof ABS latticed masts and antennas. No metal parts except connectors on antennas.

Masts: up to 15ft. single stage £182; 20ft. two stage £303; 30ft. three stage £385; 40ft. four stage £495. All ready constructed, not kit

Antennas: VHF 14 element £42; UHF 24 element £43. Unique design allows horizontal, vertical or circular polarisation.

All masts will take standard types of antenna. Also black box mast and antenna service, we supply and erect, just plug in Tx/Rx. Ask for quote.

Prices inc. VAT at 15% and carriage, mainland only. C.W.O., Visa or Access. Just telephone anytime.

The Mobile Figures Co Ltd, Unit 7, Sawmill Industrial Estate, Alnwick. Tel: 0665 711005

UPPINGTON

G2BAR HAM BAND AERIALS

62 METRES 5/FD Element	£11.78	HF. BEAMS GAMMA MATCH 10 METRES 2 Element Array	£40.50
8/FD 8 Element	£14.58	3 Element Array	£52.00
1/JP 'J' Pole	£11.78	15 METRES 2 Element Array	£46.50
70 CMS 7/FD 7 Element	£11.20	3 Element Array	£61.00
11/FD 11 Element	£14.58		

Prices inc. VAT & Postage — Road Line Extras H/F Beams

YAESU MUSEN STOCKIST

HF and VHF ranges available & readily demonstrated
 Microwave Modules — Toyo — Hansen — SWR Bridges
 For descriptive leaflets send 30p stamps

12 14 PENNYWELL ROAD, BRISTOL BS5 0TJ
 Telephone: Bristol (0272) 557732

MORSE CODE REPAIRATION

Receiving: Cassette A: 1-12 wpm for amateur radio examination. Cassette B: 12-25 wpm for professional examination preparation. Each cassette is type C90. Price each cassette (including booklets) £4.75. Sending: Morse key with separate battery (PP3)- driven solid-state oscillator and sound transducer produces clear tone for sending practice. Price of key with oscillator £10.50. Prices include postage etc. Europe only. MH Electronics (Dept. H), 12, Longshore Way, Milton, Portsmouth PO4 8LS.

LEQ MORSE CODE LESSONS

This renowned 7xC90 cassette course comprising approx. 10 hours of instruction from basics to 14 wpm and sample Morse tests for Ham licence including notes only £24.50. Additional Ham Morse procedure C60 cassette £3.50. Send cash with order or S.A.E. for more details to: LEQtronics, Preference House, Old Market Place, King Street, Knutsford, Cheshire WA16 6EQ.

NEW!! Scientifically prepared five-day courses to get you through the R.A.E. examination: 01-346-8597.

MAIL ORDER

CALL MAIL ORDER 01-422 9585 (3 lines)

All items advertised in stock at time of going to press.

TET ANTENNAS

AX210N	10 ele. yagi for 2m crossed	74.95
HB10F2T	2 ele. 10m mono band beam	51.50
HB10F3T	3 ele. 10m mono band beam	74.95
HB15F2T	2 ele. 15m mono band beam	60.66
HB15F3T	3 ele. 15m mono band beam	93.46
HB15M2SP	VP mini size 15m 2 ele.	69.50
HB15M2SP	VP mini size 15m 3 ele.	102.30
HB34D	4 ele. tri band beam 10/15/20m	222.90
HB33SP	3 ele. tri band beam 10/15/20m	192.50
HB35C	Tri band array 10/15/20m	283.95
HB35T	5 ele. 10/15/20m	278.50
MV3BH	Vertical for 10/15/20m	37.99
MV4BH	Vertical for 10/15/20/40m	48.90
MV5BH	Vertical for 10/15/20/40/80m	63.95
MLA4	Loop antenna 10/15/40/80m	105.60
SO22	Phased 2 ele. swiss quad 2m	58.95
SQY06	6 ele. quagi 2m	45.75
SQY08	8 ele. quagi 2m	52.75
HB210S	10 ele. dual driven yagi 2m	47.99
TE214	14 ele. long yagi 2m	74.40
SSL720	9 x 2 ele. (18) slot fed 70cm	77.20
HB23SP	2 ele. tri band beam 10/15/20m	135.60
SSL318	9 x 2 ele. (18) slot fed 2m	144.79
TPH2	Phasing harness 2m	17.25
QYU10	10 ele. quagi 70cm	87.90
SQ007	70cm 2 ele. phased swiss quad	66.99
SQ10	Swiss quad 10m	97.50
SQ15	Swiss quad 15m	106.90

The prices above include V.A.T. and delivery.

YAESU RANGE

FT1	General coverage transceiver	POA
FT102	Prctic on application	POA
FV101Z	Remote vfo	POA
FANT101	Fab for 101 series	POA
FT902DM	9 band AM/FM transceiver	POA
FT902D	9 band transceiver	POA
FC902	9 band atu, swr/pwr etc.	POA
FTV901R	Transverter fitted 2m module	POA
430TV	70cm module for above	POA
144TV	2m module for transverter	POA
70TV	4m module for transverter	POA
SP01	External speaker	POA
FL2100Z	9 band 1200W linear	POA
FT77	New HF Mobile	POA
PF77	Power Supply Unit	POA
CF77	Antenna Tuner Unit	POA
FRG7700	SSB/AM/FM recvr. dig. readout	POA
MEM7700	Memory unit for above	POA
Converters		
FRV7700A	118-150MHz	POA
FRV7700B	60-60MHz & 118-150MHz	POA
FRV7700C	140-170MHz	POA
FRV7700D	70-80MHz & 118-150MHz	POA
FRIT700	Receiver aerial tuner	POA
FF5	LF filter for above	POA
FT480R	2m all-mode transceiver	POA
FP80A	230V AC power supply	POA
FT80R	70cm all-mode transceiver	POA
FT290R	2m all-mode portable	POA
NC11C	AC charger	POA
CSC-1	Carrying Case	POA
MMB-11	Mobile mounting bracket	POA
FT208R	2m synthesized portable FM	POA
NC9C	AC charger	POA
FT708R	70cm hand-held	POA
YP150Z	150W dummy load power meter	POA
YH55	Standard 8 ohm headphones	POA
YH77	Lightweight headphones	POA
QTR24D	World Ham clock	POA
YM34	600/50k ohm base mic 8 pin plug	POA
YM35	600 ohm hand mic up/down 8 pin p	POA
YM36	600 ohm as above (no up/down)	POA
YE7A	600 ohm hand mic. 4 pin plug	POA

TONO and TASC0

Full range ex. stock. Call 01-422 9585 (3 lines) NOW.

ANTENNA SWITCHES

SA 450	one in two out SO 239	9.99
SA 450N	one in two out N Connectors	13.20

All items VAT and carriage paid.

The prices above include V.A.T. and delivery.

VHF - UHF LINEAR AMPS

TONO 2M50W	2m 50w linear I/P 3watts	69.00
TONO 2M100W	2m 100w linear/preamp I/P 10w	129.00
TONO MR150	2m 130-150watts linear amp/preamp	169.00
MML 144/30LS	2m linear amp 3w in 30w out	69.95
MML 144/100LS	2m linear amp 10w in 100w out	139.95
MML 432/70	70cms linear amp 3w in 20w out	85.00
MML 432/100	70cms linear amp 10w in 100w out	228.65
ALINCO 230	2m linear amp 1-3w in 30w out	39.00
MIRAGE	2m linear amp 10w in 80-100w out	120.75
MIRAGE B 1016	2m linear amp 10w in 160w out	189.75
YAESU 2010	to match FT290R 10w out	54.00
YAESU 2050	to match FT 290R 50w out	115.00
YAESU 7010	to match FT 790 10w out	90.00
TOKYO HP	2m linear amp 1-3w in 30w out	53.50
HL32V	2m linear amp with preamp and output meter 2 in 12 out 35 in 85 out	144.50
TOKYO HP	2m linear amp preamp	
HL160V	output meter 10 in 160 out	242.00

The prices above include V.A.T. and delivery.

ROTATORS

KR 400RC	constant readout round meter 1 1/2-2 1/2 masts	114.90
KR 600RC	200Kg 1 1/2-2 1/2 masts	163.30
KR 500	180' elevation rotor 1 1/2-2 1/2 masts	112.10
AR 40	medium duty HF	90.85
CD 45	constant readout - armature breaks 8 1/2sq.ft. ant	136.85
HAM IV	constant readout wedge solenoid breaks 15sq.ft.	258.70
T2X	THE BIG DADDY up to 30sq.ft. of ant.	327.75
RO 250	Light duty suitable most VHF/UHF	45.00
SKYKING	medium duty HF constant readout	83.00
SU 4000		

The prices above include V.A.T. and delivery.

YAESU HF MOBILE ANTENNAES

RSL 3.5	3.5MHz resonator and whip	12.50
RSL 7.0	7.0MHz resonator and whip	12.10
RSL 14.0	14.0MHz resonator and whip	11.70
RSL 21.0	21.0MHz resonator and whip	11.60
RSL 28.0	28.0MHz resonator and whip	11.40
RSL 2A	Mast for above	5.25
RSM 2	Gutter mount-feeder and connector	11.50

The prices above include V.A.T. and delivery.

MORSE KEYS

HK 707	Straight Manual keyer	14.50
BK 100	Semi-automatic mechanical bug	22.99
MK 702	Manual keyer on marble base	26.99
MK 702	Manipulator	22.99
MK 705	Squeeze paddle on marble base	21.72
EKM 1A	Morse code practice oscillator	10.50

The prices above include V.A.T. and delivery.

DESK MICROPHONES

SHURE 444D	Dual Impedance	49.50
SHURE 526T	Mix II Power Microphone	59.50
ADONIS AM502	Compression Mic 1 O/P	39.00
ADONIS AM601	Compression Mic - Meter 1 O/P	49.00
ADONIS AM802	Compression Mic - Meter 3 O/P	59.00

The prices above include V.A.T. and delivery.

INFORMATION FOR TRIO R1000 OWNERS

We don't have to tell you how good the receiver is - neither do we have to tell it is missing one essential feature - FM! No longer! Amcomm has specially designed a unit to complete your listening pleasure. It is small and will fit with minimal effort and time. It comes with really simple and concise instructions which can be read and used by the most non-technical users. The FM1000 is available now post free at £15.99 inc. VAT from AMCOMM.

AMTECH

New Improved range - Made in England
Amtech 300B - To suit all coaxial and random wire antennas - 160-10 metres. 300W PEP. £49.95 including VAT and carriage.

Amtech 200B - Random wire ATU rated 200W PEP. will tune virtually any wire over 160-10 metres - excellent for base, mobile or temporary QTH. £32.95 including VAT and carriage.

Amtech 100B - Miniature mobile impedance match. ideal for that difficult matching when mobile - rated 130W PEP and has switched positions. £17.95 including VAT and carriage.

Amtech FM 1000 - suitable for conversion of Trio R 1000. see details on lower part of page. £15.99 including VAT and carriage.

ANTENNA PARTS AND KITS

Includes the world's finest traps - REYCO, which are guaranteed for five years no condenser used - no blow up possible. Precision moulded coil forms with stainless hardware - aluminium Iridite finish - fully waterproofed and suitable for wire, vertical and beam antennas, rated at 2.5Kw and weigh only 4oz per trap - available for 7Mhz (KW40) 14 Mhz (KW20) 21 Mhz (KW15) and 28 Mhz (KW10).

£16.99 including VAT and carriage.

The BALUN - The Unadilla W2AU is famous because it's the best, same rating as the traps and has a built-in lightning arrester - available 1:1 and 4:1 - get it right first time with W2AU Balun - guaranteed for five years. £16.99 including VAT and carriage.

THE KITS - AMCOMM 40 - 1 pair KW 40 Traps, 1 PL 259, 1 W2AU Balun, 1 pair insulators and of course 120ft soft drawn copper wire - coverage 80-10 metres (includes 10 Mhz). Full instructions included. £41.50 including VAT and carriage.

AMCOMM 20 - 1 pair KW 20 Traps, 1 W2AU Balun, 1 PL 259, 1 pair insulators and 65ft soft drawn copper wire - coverage 40-10 metres, full instructions included. £37.50 including VAT and carriage.

AMCOMM 3B - 1 pair KW 10 Traps, 1 pair KW 15 Traps, 1 PL 259, 1 W2AU Balun, 1 pair of insulators and 30ft soft drawn copper wire - coverage 20m, 15m and 10m. Full instructions included. £47.50 including VAT and carriage.

New WARC Traps - KW 12, KW 17 and KW 30 now available from stock. £16.99 including VAT and carriage.

ICOM HF EQUIPMENT

IC 720A	Gen. Coverage Tcwr.	P.O.A.
IC 720A	Gen. Coverage Tcwr. with FM	
IC 730	Base/Mobile 8 band HF Tcwr.	
IC 740	WARC 9 Band HF Tcwr.	
IC PS 15	For above rigs	
IC 2KL	Linear Amp. inc PSU	
IC AT 500	Auto antenna coupler	
IC R70	Gen. Coverage Receiver	

ICOM VHF - UHF EQUIPMENT

IC 251E	2m base multimode	P.O.A.
IC 25E	2m 25w mobile	
IC 290E	2m multimode 10w	
IC 290H	2m multimode 25w	
IC 2E	2m handheld	
IC 4E	70cms handheld	
IC L1	soft cases	

Full range of accessories available from stock.

SWR-POWER METERS

HANSEN FS 710	1.8 - 60MHz - 2Kw PEP with time constant	89.70
HANSEN FS 601	1.8 - 60MHz - 2Kw PEP	51.35
HANSEN FS 5E	3.5 - 150MHz 3 ranges to 1Kw (HF)	37.20
HANSEN SWR 50B	3.5 to 150MHz 1Kw (HF)	26.45
YAESU YS 200	200w to 1Kw	52.90
YAESU YS 2000	PEP meter 2Kw	69.75
RF 2000	twin meter 3.5 - 150MHz 2Kw	18.60
YM1X	twin meter 3.5 - 150MHz 12 and 120w	15.50

V.A.T. Included, but add 75p for carriage.

E.&O.E.



AMCOMM

Amcomm Services,
194, Northolt Road, South Harrow,
Middlesex HA0 2EN.
Telephone: 01-422 9585. Telex: 24263

OPPOSITE SOUTH HARROW TUBE STATION ON THE PICCADILLY LINE.

SHOWROOM OPENING HOURS
TUESDAY TO SATURDAY
10.00 - 6.00 CONTINUOUS

ASK FOR DETAILS
OF ATTRACTIVE LOW DEPOSIT
EASY TERMS

Amcomm Services,
Freepost, Harrow, Middlesex HA2 0BR.
Please send me _____
at _____ enclosed cheque/P.O. for
_____ or charge my VISA/ACCESS
No. _____
Name _____
Address _____
_____ post code
HR6.

**A new range of antennas
for those who
must have
only the best.**



ANTENNAS



*Ask for them
at your local
amateur radio
shop*

