

JULY 1977/\$1.00

# I AM RADIO HORIZONS



THE WORLD OF  
RADIO CONTROL



# The DRAKE TR-33C



\$229.95

## Amateur VHF FM Transceiver

### DRAKE TR-33C SPECIFICATIONS

**GENERAL:** • **Frequency Coverage:** 146-148 MHz, 12 channels (2 supplied: 146.52 and 146.94). Crystal determines receive frequency. • **Transmit frequency offset** for repeater operation determined by 5-position switch: Simplex, +600 kHz, and -600 kHz supplied; any two additional offsets available with accessory crystals. • **Power requirements:** 13.0 volts dc  $\pm$  15% external supply OR internal battery supply. • **Current Drain (Batteries):** Squelched receive: 30 mA; transmit: 400 mA. External supply: above plus 45 mA for channel switch indicator lamp. • **Antenna:** 50 ohm external antenna through SO-239 connector OR screw-on telescoping whip antenna supplied, may be replaced with rubber helix antenna. • **Dimensions:** 5.5" x 2.8" x 8.5" (13.8 x 5.8 x 21.6 cm). • **Weight:** 4.4 lbs (2 kg).

**RECEIVER:** • **Sensitivity:** less than .5  $\mu$ V for 20 dB noise quieting. • **Selectivity:** +30 kHz adjacent channel rejection greater than 75 dB. • **Modulation acceptance:** at least  $\pm$  7 kHz. • **Intermodulation Rejection:** 70 dB referenced to sensitivity level. • **First i-f:** 10.7 MHz with monolithic crystal filter. • **Second i-f:** 455 kHz with ceramic filter. • **Audio Output:** nominal 1 watt at less than 10% distortion into 8 ohm built-in speaker or external speaker.

**TRANSMITTER:** • **Rf Output Power:** 1.5 watts minimum with 13.0 volts dc supply. • **Frequency Deviation:** Direct frequency modulation adjustable to at least  $\pm$  7 kHz deviation, factory set at  $\pm$  5 kHz. • **Separate microphone gain and deviation adjustments** • Drake 1525EM Push Button Encoding Mike can be used direct with no modification.

- **Hand Held Convenience, 12 Channel Capability**
- **SCPC (Single Crystal Per Channel) Frequency Control**
- **Lower Receiver Battery Drain**
- **Expanded Portable Antenna Choice**

• 12 Channels—only one crystal per channel provides simplex OR repeater operation on ANY channel. 2 channels supplied. 5 transmit offset positions, 3 supplied. • All FET front-end crystal filter for superb receiver intermod rejection. • Small convenient microphone included. • New lower power drain circuit on squelched receive. • Nicad rechargeable batteries supplied. • Built-in battery charger. • Ac and dc power cords supplied. • Telescoping screw-on antenna supplied, rubber helix optional. • Channel indicator light when using external dc supply. • Carry strap supplied. • Meter Indicates receive strength, xmit output, or battery voltage. • External speaker jack on rear panel. • Auxiliary jack on rear panel—may be used for tone-pad connections, etc. • Traditional R.L. Drake service backup.

### DRAKE TR-33C ACCESSORIES

#### Drake AA-10 Power Amplifier

10 dB power increase greatly adds to the transmitting distance covered by any 2-meter fm transceiver running up to 1.8 watts output



Small size: 2"H x 2.1"W x 5.5"D (51 x 52 x 140 mm)

#### Drake AC-10 Power Supply

Powers the AA-10, TR-22C, TR-33C and TR-72. Simultaneously can charge the TR-22C/33C nicads. Supplies 13.8 volts up to 3 amps from 120 V-ac 60Hz input. • **Accessory Crystals.** • **Model No. 1333 Drake MMK-33 Mobile Mount.**

- **Model AA-10 Power Amplifier** ..... \$49.95 ea.
- **Model AC-10 Power Supply** ..... 49.95 ea.
- **Accessory Crystals** ..... 6.30 ea.
- **Model MMK-33 Mobile Mount** ..... 12.95 ea.
- **Model 7079 Vinyl Carrying Case** ..... 9.95 ea.

#### Drake 1525EM Push Button Encoding Mike



- Microphone and auto-patch encoder in single convenient package with coil cord and connector. Fully wired and ready for use.
- High accuracy IC tone generator, no frequency adjustments.
- High reliability Digitran® keyboard.
- Power for tone encoder obtained from transceiver through microphone cable. No battery required. Low current drain.
- Low output impedance allows use with almost all transceivers.
- Four pin microphone plug: directly connects to Drake TR-33C without any modification in transceiver. Compatible with all previous Drake and other 2 meter units with minor modifications.

**Drake 1525EM, microphone with tone encoder — \$49.95**  
**Drake 7073DM without tone encoder — \$19.00**

To receive a FREE Drake Full Line Catalog, please send name and date of this publication to:

**R. L. DRAKE COMPANY**



540 Richard St., Miamisburg, Ohio 45342  
 Phone: (513) 866-2421 • Telex: 288-017

Western Sales and Service Center, 2020 Western Street, Las Vegas, Nevada 89102 • 702/382-9470

All prices (suggested amateur net) and specifications subject to change without notice.



# Call 1-800-633-3410 for Kenwood\*

\*and CDE, Cushcraft, Dentron, Drake, HyGain, ICOM, KLM, Newtronics, NPC, Regency, Rohn, TPL, Tristao, Wilson, Yaesu



## KENWOOD TR-7400A 2m FM transceiver

Has provisions for CTCSS, encode and decode • Can achieve tone burst operation with added TBM's • Front switch selects squelch system you desire • High power 25 watts RF output • Solid-state final stage • LED digital frequency indicator display • PLL provides 800 discrete channels at 10 kHz intervals • Final protection circuit • Excellent output signal, 2nd & 3rd harmonics better than - 60 dB • PLL unlock protection circuit • Repeater offset circuit • Low power position, 5 watts • 2-pole, 10.7 MHz monolithic crystal filter • MOSFET

LIST PRICE ..... **399.95**

## KENWOOD TS-820 transceiver

The TS-820 covers 10 thru 160 meters • Has 200 watts P.E.P. • Integral IF shift • RF speech processor • Completely solid-state, except for driver and final stages • Heater switch • Vox circuit • Noise blanker • PLL circuitry • Full metering • DRS dial • Built-in 25 kHz calibrator • CW sidetone and semi-breakin • Rear panel terminals for linear amplifier • IF OUT, RTTY, and XVTR • Phone patch IN and OUT terminals • Digital readout unit (DG-1, list, 170.00) is optional • Other options: VFO-820, DS-1A, DC-DC converter, TV-502, 2 meter transverter.

LIST PRICE ..... **830.00**

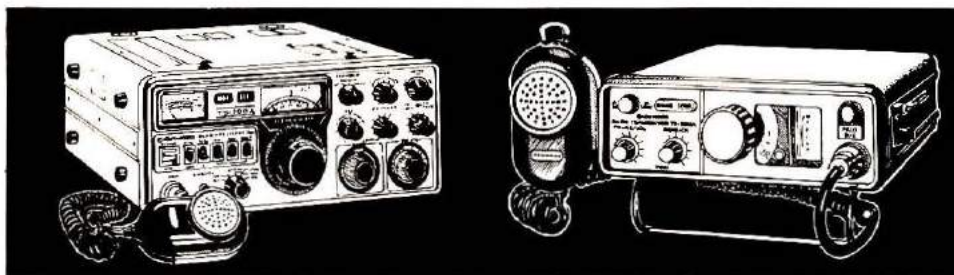

## KENWOOD TS-700A transceiver

• Frequency range: 144 to 148 MHz • Built-in SSB, FM, AM and CW • High stability FET VFO • 44 channels, w/11 crystals (optional) • Heterodyne switching circuitry • Noise blanker • Amplified-type AGC circuit • S-meter, RIT • Squelch circuit • RF circuitry, w/dual gate type 3SK35 MOSFET

LIST PRICE ..... **700.00**

## KENWOOD TS-7200A 2m FM transceiver

• 10W output • 6 channels supplied: 94/94, 34/94, 52/52, 16/76, 22/82, 28/88 • Complete w/hand mike • Slide-out bracket • PS-5 power supply available for fixed base operation.

LIST PRICE ..... **249.00**

Remember, you can call TOLL-FREE:

**1-800-633-3410** for  
Long's Electronics price on any ham item.



# Long's Electronics

3521 10TH AVENUE NORTH, BIRMINGHAM, ALABAMA 35234





# THIS MONTHS

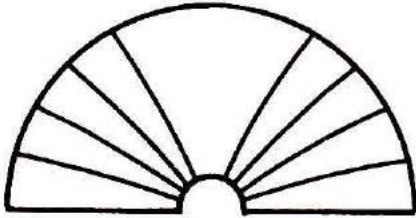

# HORIZONS

## Radio Control

Radio control of a model plane, boat, or car is a fast-growing and fascinating aspect of Amateur Radio, where your license can provide a freedom of choice unknown to those who aren't hams.

## Two-Band Novice Receiver

The first item of equipment you will want for your station is a receiver. This small, battery-operated, and sensitive, portable receiver has big performance on the 80- and 40-meter Amateur bands and, what's more, can be built in a short time for just a few dollars.

## High-Frequency Antennas

Last month W1HR talked about antenna basics and showed you how to build simple horizontal antennas for your amateur station; this month he continues the discussion with vertical antennas, ground systems, phased antennas, and high-gain multi-element beams.

## Cutting The Cost Of Amateur Radio

Amateur Radio doesn't have to be an expensive avocation. Dennis King tells us some of his secrets for obtaining equipment and parts at unusually low prices.

## Brass Pounding On Wheels

Thanks to the news media, most of us are aware of the communications capability built into the Presidential jet plane. Earlier Presidents needed to keep in touch back in the days when most of the travelling was done on trains, and the electronic gear was not very sophisticated. Morse code was used for reliability, and radio-teletype was added for high-volume copy. K6QD tells us about the simple beginnings of a Communications Agency that has grown into a network with a world-wide reach.

## Receiver Design

A continuously tuneable receiver that covers 500 kHz to 30 MHz without bandswitching? You're kidding! Well, the British didn't think so when they introduced the Racal RA-17 or the Barlow Wadley. Maybe you won't think so, either, after you read how it's done — American style.

## The Strange New World Of Sunspots

If you want to know how and why the band conditions are good or bad, and why some

bands that used to be good for DX are now bad, listen to Bill Orr. You'll find out about such things as sunspots, the earth's ionosphere, the solar cycle, sporadic-E propagation; and you'll peek over W6SAI's shoulder as he gazes into his crystal ball.

## A Bench For The Radio Amateur

A practical and attractive bench for both working and operating can be built by the average ham from a sheet of plywood, some fasteners, and some paint — if you're really fussy — and provides plenty of space for storage, too.

## Building A Battery

Nickel-Cadmium batteries have memories for both good and bad treatment, but they can be rehabilitated if you know how. For your batteries' sake, this article has the potential to keep you current.

**HAM RADIO HORIZONS** July 1977, Volume 1, No. 5. Published monthly by Communications Technology, Inc., Greenville, New Hampshire 03048. One-year subscription rate, \$10.00; three-year subscription rate, \$24.00. Application to mail at second-class postage rates is pending at Greenville, New Hampshire 03048 and additional offices.



# Take the next step: your own personal computer.



It's the Sol-20. It's the most sophisticated personal computer you can buy anywhere. It's a true breakthrough. It's a complete small computer system which includes all the essential elements as *standard* equipment — central processor, memory, keyboard, and display, software, power supply and proper package.

Your Processor Technology Sol-20 comes completely assembled and tested for just \$1495 or in kit form for \$995. It's about the size of a typewriter and has the look of the best IBM ever offered. And there's nothing like it on the market today. Not from IBM, Burroughs, DEC, HP or anybody else.

## It fills a new role

Use it in the office as a full fledged business computer. Use it to compose and edit letters electronically, store and retrieve mailing and prospect lists, process orders, maintain journals and general ledgers, and produce statements and reports.

If you're a scientist or engineer, you can use Sol to analyze data statistically, control lab equipment, prepare graphics, and fit curves. Sol frees your time and expands your overall capability.

In schools and universities, use Sol to teach computer programming. Use it for computer-aided instruction. Use it for notes, records and sorting.

And after hours, use your Sol at home. Regulate your total home energy complex. Compute taxes with our special software tax package. Play TV games...

tennis, hockey and the very complex Trek-80 where your starship takes on a whole fleet of klingons. Use Sol for the family finance plan, the diet and recipe plan, to inventory all the things in your house and their value.

Sol is so powerful, you'll wonder how you got by without it.

## Sol-20 is a scaled down big computer system

Most small computers simply grew like "Topsy" — a memory here and expansion module there. In fact some small computers don't even have keyboards! Not Sol-20. It was designed from the ground-up as a complete system. There's the basic mainframe central processing unit (CPU), the peripherals designed to work with Sol, the software and the optional extras for even more power. Use Sol as a stand alone computer or as a "smart" terminal for distributed processing and the like.

And, unlike other small computers, Sol is already programmed to receive your commands the moment it's turned on, thanks to Sol plug-in Personality Modules.

Here's what you get in the basic Sol-20 as standard:

8080 microprocessor — 1024 character video display circuitry — control PROM memory — 1024 words of static low-power RAM — 1024 words of preprogrammed PROM — built-in cassette interface capable of controlling two recorders at 1200 bits per second — both parallel and serial standardized interface connectors — a complete power supply including ultra quiet fan — a beautiful case with solid walnut sides — software which includes a pre-programmed PROM personality module and a data cassette with BASIC-5 language plus two sophisticated computer video games —

the ability to work with all S-100 bus products.

## Add even more computer power

Extras include a module to help write, edit, assemble, debug and run your own programs. There's no better collection of add-on memories anywhere... up to 16,384 words per module. Solve additional interfacing problems with our I/O module. Get big system performance with our Helios II "floppy" disc system. Display results on our video monitor. Output on line or serial printer. Other peripherals include joysticks, paper tape readers, A/D and D/A converters, and PROM programmers.



## The Small Computer Catalog awaits your request.

For all the details, fill in the coupon below or call us on our toll free hotline 1-800-528-6050 Ext. 765. Arizona residents only: 1-602-955-9710 Ext. 765. We'll send you without obligation a 22 page fully illustrated catalog, a price list, and dealer locator.



Box E, 6200 Hollis Street  
Emeryville, CA 94608

Send me The Small Computer Catalog

NAME \_\_\_\_\_

STREET \_\_\_\_\_

CITY \_\_\_\_\_ STATE \_\_\_\_\_ ZIP \_\_\_\_\_

Phone 1-800-528-6050 Ext. 765.  
Arizona residents only:  
1-602-955-9710 Ext. 765.



# ATB-34

**THE COMPLETE 3 BAND ANTENNA**

**BY**

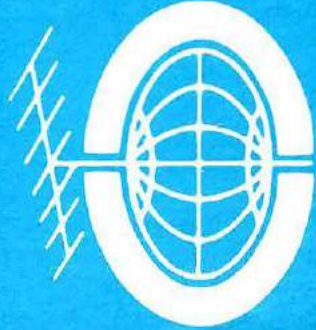

# Cushcraft

**IN STOCK WITH YOUR LOCAL DEALER**

**IN CANADA:**

**SCOTCOMM RADIO LTD. - 4643 Levesque Blvd. - Chomedey, Laval, Quebec**

**WORLDWIDE:**

**MAGNUS - 5715 North Lincoln Ave. - Chicago, Ill., U. S. A. 60659**

**CORPORATION**

**P. O. BOX 4680, MANCHESTER, N. H. 03108**



July, 1977  
Volume 1, Number 5

# HAM RADIO HORIZONS

## CONTENTS

**T.H. Tenney, Jr., W1NLB**  
Publisher  
**James R. Fisk, W1HR**  
Editor-in-Chief

### Editorial Staff

Thomas F. McMullen, Jr., W1SL  
Managing Editor  
Patricia A. Hawes, WA1WPM  
Executive Editor  
Charles J. Carroll, K1XX  
James H. Gray, W2EUQ  
Assistant Editors

### Publishing Staff

Fred D. Moller, Jr., WA1USO  
Advertising Manager  
Cynthia M. Schlosser  
Assistant Advertising Manager  
Therese R. Bourgault  
Circulation Manager

Ham Radio Horizons  
is published monthly by  
Communications Technology, Inc  
Greenville, New Hampshire 03048  
Telephone 603-878-1441

Subscription rates are  
\$10.00 per year, worldwide

Copyright 1977 by Communications  
Technology, Inc. Title registered  
at U.S. Patent Office

### The Cover

Dog-fighting, radio-controlled,  
World War I model aircraft are  
only a small part of the world of  
radio control — the rest of the  
R/C story is told by W2EUQ  
starting on page 12. Illustration  
by Robert Waugh.

<b>Radio Control of Models</b>	<b>12</b>
James H. Gray, W2EUQ	
<b>A Two-Band Novice Receiver</b>	<b>22</b>
Darrell Thorpe	
<b>High-Frequency Antennas, Part 2</b>	<b>26</b>
James R. Fisk, W1HR	
<b>Cutting the Cost of Amateur Radio</b>	<b>33</b>
Dennis A. King, W6ROL	
<b>Brass Pounding on Wheels</b>	<b>38</b>
Charles W. Clemens, Jr., K6QD	
<b>A Different Approach to Receiver Design</b>	<b>42</b>
Courtney Hall, WA5SNZ	
<b>The Strange World of Sunspots</b>	<b>48</b>
William I. Orr, W6SAI	
<b>An Amateur's Workbench</b>	<b>56</b>
Kenneth Cornell, W2IMB	
<b>How to Build a Nicad Battery</b>	<b>62</b>
Alex F. Burr, W5QNG	

<b>Activities Calendar</b>	<b>72</b>	<b>Newsline</b>	<b>11</b>
<b>Ad Scan</b>	<b>69</b>	<b>Perspective</b>	<b>8</b>
<b>Advertiser's Index</b>	<b>78</b>	<b>Product Showcase</b>	<b>74</b>
<b>DX Forecaster</b>	<b>70</b>	<b>Subscription Agents</b>	<b>78</b>
<b>Focus and Comment</b>	<b>6</b>	<b>This Month's Horizons</b>	<b>2</b>



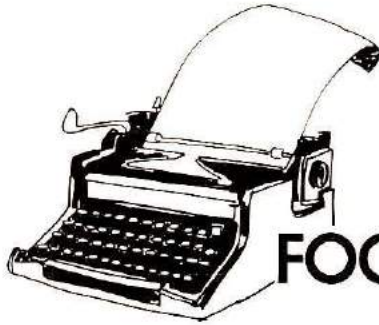

## FOCUS & COMMENT

The season has arrived when most Radio Amateurs are taking part in what has become almost a tradition — attending hamfests. The gatherings appear under many different names: Conventions, hamfests, swapfests, hamventions, and the like. Springtime is a planner's nightmare, and I marvel at the perseverance of those in charge. The weather is uncertain, which brings with it the problem of in door vs outdoor planning, and the ability to switch from one to the other almost instantaneously when the weather changes. There usually are other activities to contend with at the time you plan your gathering. Many groups are competing for the fairgrounds, meeting halls, shopping malls, for space and time to put on their affairs. It is a wise and successful chairman who can work a deal with some other hobby show to include Amateur Radio as part of an exposition or county fair, thus avoiding direct competition for the attention of the public, and making the whole show the better for it.

Timing is also important — you cannot be too close to any of the many holidays that abound in the late spring and early summer. In many areas schools are still in session, which has a direct bearing upon how many of the students can attend. These eager neophytes can be a major part of the success of a ham gathering.

Later into the summer, things change. Vacations must be considered, but the weather is different; it changes from hot to too hot, and from bright and sunny to thundershowers. These are but small nuisances to an avid flea-marketeer.

But it is a delightful season for most of us. It gives us a chance to meet some of the people we have been talking to all winter. You can attend seminars on almost any facet of the hobby. You can learn how to build almost anything, or how to join operating networks with interests that vary from sailboating to back-packing to handling messages from overseas military personnel.

You can listen to the leaders in all areas of Amateur Radio expound on the why and wherefor of everything that has happened or will happen. Some of the forums become quite lively when the question and answer period opens up. Here, too, is a chance to air your views on the trends of our hobby.

Flea markets are an education in themselves. The history of electronics is opened like a book for anyone to read. You'll find equipment ready for sale from all eras of radio. In addition to the gear you buy, you'll get valuable lessons in salesmanship (or sales resistance), and if you go prepared with a good shopping list and a little knowledge of what to look for, you can return home with enough parts to keep your projects workbench going all through the next fall and winter. There's also the good chance that you'll be attending the first hamfests of the season, trying to sell some of the same stuff you bought the year before.

Other radio groups are having their meets, too, and you might find it great fun to join theirs. You will be absolutely astounded at the information and misinformation available at a CB meet. Some of the equipment for sale might even be useful in the hamshack, and there are often gold nuggets available on tables and tailgates.

You can use this opportunity to break the ice and demonstrate to the CB people what ham radio is all about. Show off your hand-held unit through a repeater with its clear, full quieting, signal. Let them hear you working 75-meter mobile to the next state, or talking to Europeans, Africans, or South Americans on 20 meters. I can guarantee that you will not be bored and lonely.

That is the time to grab the ball and run with it. Be prepared with notices of your own hamfest, club meeting, code and theory classes, and invite them to come and visit. A lot of them will like what they see and stick around for more. I'm sure your club will benefit from the increase in membership, and Amateur Radio will too.

**Thomas McMullen, W1SL**  
**Managing Editor**



ICOM wants you to

# Begin with the Best

As you develop your skills, increase your participation in Ham Radio activities, and add hardware for ever-increasing flexibility of operations, you'll come to know ICOM. Just ask any old Ham. ICOM is the quality name in VHF/UHF Amateur Radio equipment because it is simply the best. ICOM is the line you'll want to move up to for unequalled quality and features.

But you needn't wait until you can trade in a truck load of equipment to reach up to ICOM. You can begin building your Amateur Radio operations with reasonably priced ICOM units that have flexible add-on features when you purchase your very first voice transceiver. And when you are installing ICOM's top-of-the-line fixed station unit, the ICOM equipment you began with will probably still be an important integral part of your active hardware.

Don't delay in moving up to ICOM: begin with the best.



Clockwise from lower left: IC-211 4MHz, 2 meter, All Mode Transceiver; IC-245 Mobile 2 meter Transceiver; IC-225 Mobile VHF FM Transceiver; IC-502 Portable 50 MHz SSB Transceiver; IC-215 Portable 2 meter FM Transceiver; IC-30A Mobile UHF FM Transceiver.

Ask your dealer for ICOM's complete product line catalog, or mail your request to an address below.

VHF/UHF AMATEUR AND MARINE COMMUNICATION EQUIPMENT

Distributed by:



# ICOM

ICOM WEST, INC.  
Suite 3  
13256 Northrup Way  
Bellevue, Wash. 98005  
(206) 747-9020

ICOM EAST, INC.  
Suite 307  
3331 Towerwood Drive  
Dallas, Texas 75234  
(214) 620-2780

ICOM CANADA  
7087 Victoria Drive  
Vancouver B.C. V5P 3Y9  
Canada  
(604) 321-1833



# PERSPECTIVE

## Communication — a lost art?

Man has been called a social animal, and language is one of man's distinguishing characteristics, raising him above the animals and differentiating him from other species. Early man's warning grunts, howls of pain, and whimpers of hunger or loss eventually acquired commonly accepted meaning, became structured and codified, and were adopted as tribal language. All personal communication began this way.

For many persons a face-to-face meeting with another, unknown, human is an unsettling experience. Sometimes one is afraid of his own appearance and the effect it may have on another; or perhaps another's appearance frightens or dismays him, leading to avoidance and breakdown of communication. Often one human is pre-programmed, prejudiced, against another and shuns social contact; again leading to communication breakdown.

When an individual can communicate with another without being seen, direct personal confrontation is avoided. The strain and concern that accompanies a first face-to-face meeting between individuals is absent, and communication can take place easily and naturally, leading to discovery of areas of mutual interest. The desire and need for indirect communication produced the postal service, telegraph, telephone, and radio. Fears of the unknown tended to vanish, and men realized that other humans have the same hopes, fears, and desires as themselves; that the man in the next village, county, state, or country was — after all — a "regular guy."

A continuing problem with *indirect* personal communication has been one of accessibility and regulation. Most of the means for carrying on indirect personal communication have been government controlled, for a variety of practical reasons, not the least of which is the power and freedom that personal — and substantially private — communication gives to the individual. Until recently, the means for carrying on this type of communication have not been entirely adequate from either the technical or the regulatory standpoint. Now, that is changing very rapidly; radio-Amateur and citizen's-band communication is growing by leaps and bounds, and the individual has at his disposal both the means and the reason for exploiting the medium.

The freedom to pick up and talk into a small, often hand-carried device, and be heard hundreds or thousands of miles away, is satisfying and fulfills a basic human need to communicate. It is easy, quick, convenient, and versatile. Each person has access to scores of other, similarly motivated communicators.

The idea of wireless communication is age-old, but has become reality in only the last half-century; and the radio Amateur has been involved from the beginning. When the government gave the Amateur experimenter wavelengths of "200 meters and down" as being commercially worthless and useless, the Amateur invented, developed, and proved the means for using them; and so opened the way for eventual commercial use of radio.

Radio communicators have risen to positions of power and prestige in society. The dissemination of ideas, exchange of information, growth of commerce and business, evolution of diplomacy, and the rise of the arts and sciences have all depended on radio communication: The fundamental and simple process of one person talking to another.

In essence, we are all communicators and radio has become a common denominator that draws and binds us together. In a very real sense, we enjoy a common language — electronics — spoken everywhere. Whether we happen to be involved with CB, with ham radio, or with the commercial radio services, there is great fun to be had in communication and in communicating. The technical differences are miniscule whereas the opportunities are unlimited. So let's forget all the "sibling rivalry," put our differences aside, and communicate!

Jim Gray, W2EUQ



# TECHNICALLY SPEAKING, HEATH HAS THE BEST 2-METER AROUND.



**\$269<sup>95</sup>**

With Standard Microphone

Shown with optional MICODER™ installed

## Take our HW-2036 Frequency-Synthesized 2-Meter Transceiver for example

### Our circuit designs prove it

The HW-2036 offers true digital frequency synthesis for real operating versatility. No extra crystals are needed and there are no channel limitations. Advanced digital circuitry uses a voltage-controlled oscillator (VCO) that is phase-locked to a highly stable 10 MHz crystal-controlled reference. Double-tuned stages following the VCO in the receiver and transmitter provide clean injection signals. The result is a signal that has spurious output more than 70 dB below the carrier (see spectrum analyzer photos below). Additionally, the "add 5 kHz" function is accomplished digitally in the HW-2036 so that no frequency error is introduced.

### True FM

Careful attention to the transmitter audio circuitry and the use of true FM gives exceptional audio quality. A Schmitt-trigger squelch circuit with a threshold 0.3  $\mu\text{V}$  or less provides positive,

clearly-defined squelch action. Other design advantages include diode-protected dual-gate MOS FET's in the front end, IC IF and dual-conversion receiver.

### Outstanding Specifications

The HW-2036 puts out a minimum 10 watts and operates into an infinite VSWR without failure. Receiver sensitivity is an excellent 0.5  $\mu\text{V}$  for 12 dB Sinad making the HW-2036 ideal for use in crowded signal areas. We think you'd be hard-pressed to find a comparably-priced 2-meter transceiver that gives you the features and performance of the HW-2036.

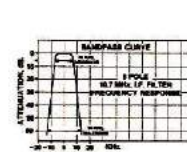

An 8-pole IF crystal filter greatly reduces adjacent channel interference.

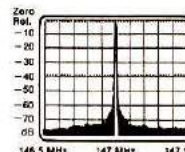

Actual spectrum analyzer photos of the HW-2036 transmitter output operating at 147 MHz. Spurs within 20 MHz of carrier are down a full 70 dB!

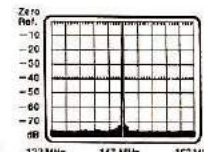

*There's more for the Ham at Heath*

## FREE HEATHKIT CATALOG

Read about other fine Ham equipment and our wide variety of outstanding electronic kits — everything from lamp dimmers to color television is in our big FREE catalog.

**Send for yours today!**

Heath Company, Dept. 348-31, Benton Harbor, Michigan 49022

HEATH

Schlumberger

Heath Company, Dept. 348-31  
Benton Harbor, Michigan 49022

Please send me my FREE Heathkit Catalog.  
I am not on your mailing list.

Name \_\_\_\_\_

Address \_\_\_\_\_

City \_\_\_\_\_ State \_\_\_\_\_

AM-343 \_\_\_\_\_ Zip \_\_\_\_\_



# either way... you can save from \$50 to \$500 with a Henry Radio antenna package

## **A** Special packages with special savings...

### Package No. 1

Swan TB-2A or HyGain TH3 Jr.  
Tristao MM-40 or Triex SM-40  
CDR CD-44  
RG-58 100'  
Control Cable 100'

**Retail Price: approximately \$630**  
**Package Price: \$525**

### Package No. 2

Swan TB-3HA or HyGain TH3-Mark 3  
Tristao MM-40 or Triex SM-40  
CDR Ham-II  
RG-8 100'  
Control Cable 100'

**Retail Price: approximately \$745**  
**Package Price: \$625**

### Package No. 3

Swan TB-3HA or HyGain TH3-Mark 3  
Tristao CZ-454 FS or Triex W-51  
5' mast  
CDR Ham-II  
RG-8 100'  
Control Cable 100'

**Retail Price: approximately \$1190**  
**Package Price: \$ 995**

### Package No. 4

Swan TB-4HA or HyGain TH6-DXX  
Tristao CZ-454 FS or Triex W-51  
5' mast  
CDR Ham-11  
RG-8 100'  
Control Cable 100'

**Retail Price: approximately \$1240**  
**Package Price: \$1030**

## **B** or design-it-yourself...and you'll still save

For many years Henry Radio has been providing a beam-antenna package program for amateurs who wanted an efficient but economical package. Thousands have benefited from this offer in the past. In recent years we have offered the customer the versatility of designing their own system with the components that they want. Our only requirement is the purchase of at least:

- 1 Antenna
- 1 Rotator
- 1 Tower
- 100' Rotator Cable
- 100' Coax Cable

We stock merchandise from the following manufacturers and our packages normally include their products.

- Hy Gain Antennas
- Mini Product Antennas
- Mosley Antennas
- Swan Antennas
- CDR Rotators
- Tristao Towers
- Triex Towers
- Accessories of all kinds

Send us a note telling us what your choice is and we'll send you our low package price.

#### Why buy from Henry Radio?

Over 40 years experience. No finance charges if paid within 90 days. Low interest contracts - 8%/yr add on (14% annual rate) - as long as 24 months. 10% down or trade-in down payments. Good used equipment. Most makes and models. Used equipment carries a 15 day trial, 90 day warranty and may be traded back within 90 days for full credit towards the purchase of NEW equipment. Write for literature.

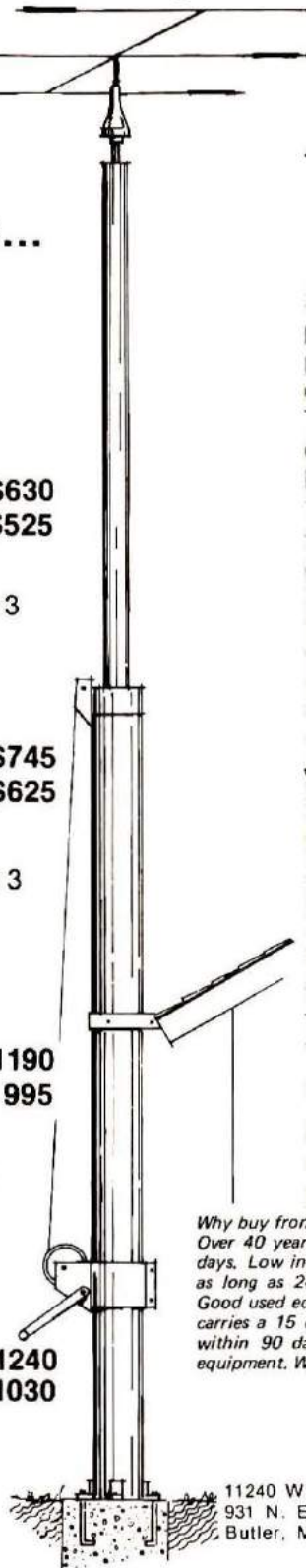

11240 W. Olympic Blvd., Los Angeles, Calif. 90064 213/477-6701  
931 N. Euclid, Anaheim, Calif. 92801 714/772-9200  
Butler, Missouri 64730 816/679-3127

# Henry Radio



# NEWSLINE

A PROPOSAL TO LIMIT TRANSMITTER SALES to Amateur licensees filed with the FCC by the San Antonio Repeater Organization (RM-2839) has had a tremendous — possibly record-breaking — number of Comments filed in its support. SARO is offering a copy to anyone wishing to study it before responding to Dockets 21116 (ban on 10-meter linear coverage) and 21117 (type acceptance), May HRH Newsline. An SASE to SARO, Box 1753, San Antonio, Texas 78296 will bring a copy.

R. L. Drake And ARMA were both among those filing strong supporting Comments on RM-2839. Drake's offering even described a procedure for implementing a "Proof of License" program which would require little investment of time and money by the FCC; they'll also provide copies of their Comments to interested Amateurs. Send an SASE to Peter Drake at Drake.

REPLY COMMENT OPPORTUNITY is rarely utilized by Amateurs but offers an additional chance to provide input to the FCC on its impending actions. The Commission has typically allowed only two weeks for Reply Comments on Amateur Radio proposals but has been wondering if a longer period — say a month — for filing Reply Comments would encourage more Amateurs to file them. Comments on the idea should go to John Johnston at the FCC.

FCC/AMATEUR DIALOGUE has been severely curtailed as a result of a court decision handed down in Washington. In its ruling in the case of Home Box Office vs the FCC, the U.S. Court of Appeals of the District of Columbia stated:

"Once a Notice of Proposed Rule Making has been issued...any agency official or employee who is or may reasonably be expected to be involved in the decisional process of the rule-making proceeding, should refuse to discuss matters relative to the disposal of the rule-making proceeding with any interested private party or any attorney or agent for any such party prior to the agency's decision."

2X2 CALLSIGNS MAY be the next step in satisfying the demand for "two letter" calls. Only 388 4th district and 442 6th district 1x2s, all "Ns," remain as of April 1st, and an "A-x2" is being considered for possible implementation late this year.

"INSTANT UPGRADE" WAS AVAILABLE at all FCC Field Offices on March 1. The temporary authority for the successful applicant to use his new privileges is provided by a form filled out by the FCC examiner, and until the upgraded license arrives the Amateur must sign his call plus "Interim Washington" on phone (or "/WN" when on CW) if he took the upgrading exam in Washington — but only when he's exercising his newly won privileges. Each FCC Field Office has a 2-letter designator for use on CW.

PERSONAL COMMUNICATIONS FOUNDATION (PCF) has received contributions of \$10,000 each from Wilson and Yaesu plus \$5000 from the ARRL, and is beginning to move in its battle plan against anti-RFI legislation and ordinances. PCF has received more than 400 inquiries from lawyers and judges, many of the latter already trying such cases, and is providing support in the form of briefs from its files, though much more such material is being sought. Contact the PCF at 915 W. Lancaster Boulevard, Lancaster, California 93534 (805)942-0144.

AMSAT'S PHASE-3 SPACECRAFT FUNDING campaign is now officially in operation though a few details are still being worked out. It involves sponsorship of one or more solar cells from the spacecraft's solar panels at \$10 per cell, a tax deductible donation. Sponsorship certificates will be sent to contributors.

AMSAT CONTRIBUTIONS or dues can now be handled using Bank-Americard or Master Charge. Simply call (202)488-8649 or write Box 27, Washington, D.C. 20044 and give the data embossed on your card plus the transaction information.

A Three-Color OSCAR Poster, suitable for hamfests, club demonstrations and the like, is available from ARRL for \$1 postage and handling.

Another Amateur Radio Space operation is possible with the NASA-sponsored Public Service Communications Satellite being planned for a late-1979 or early-1980 launch. AMSAT submitted a proposal that it participate in the operation of the geostationary satellite on the grounds that Amateurs could accomplish many of the design objectives.

75TH ANNIVERSARY OF MARCONI'S transatlantic station on Cape Cod will be celebrated in 1978 by KM1CC, thanks to the Barnstable Radio Club. They're offering attractive commemorative envelopes, ideal for DX QSLing, now — 10 for \$1.50 from W1GDB.

A Commemorative Stamp, good incidental promotion for Amateur Radio, has also been sought by the Club but was initially rejected by the Citizens Stamp Advisory Committee. However, a reconsideration is possible if enough interest is shown — personal notes or club petitions to Senators or Representatives could turn the tide.



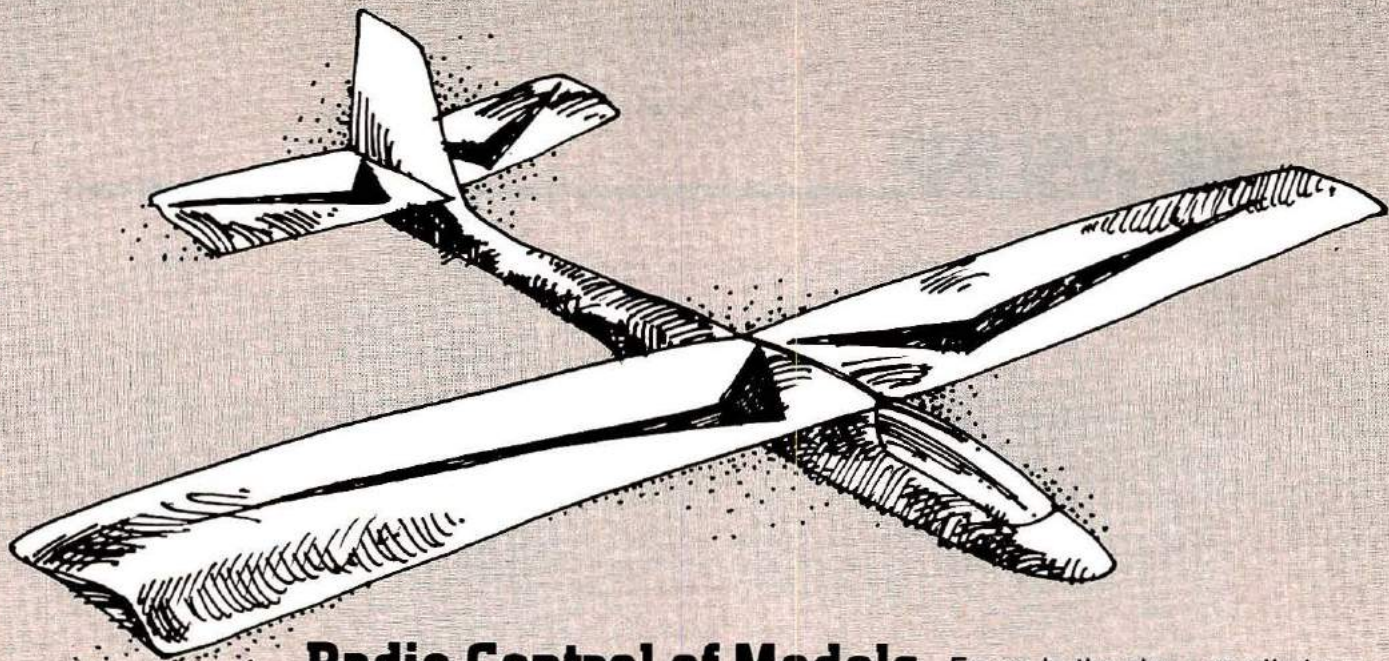

## Radio Control of Models

BY JAMES H. GRAY, W2EUQ

*With a package  
no larger than a small book  
you can remotely control  
the destiny of a  
miniature plane,  
boat, or car*

Far up in the sky, a small plane is barely visible against the bright blue background. It's just a dot, a tiny speck of color that flashes in the sun once in a while as its wings catch the light and reflect it back to your eye. The pilot noses his plane into a steep dive, and its speed visibly increases as it rushes toward the earth. Then, its headlong plunge changes into a sweeping arc as the little craft — engine howling — pulls out of its dive and heads back "upstairs" — almost vertically. As its speed slows, it curves beyond the vertical, now flying upside down. The pilot skillfully nudges the controls and the little ship rolls upright, at the same altitude it had before it started its dive — a perfect Immelman! You admire the skill of that pilot and the responsiveness of the little plane, wondering just what kind it might be, and who's flying it.

Out on the water, a light, ruffling breeze turns the surface into a slight chop — just enough to cause a bobble in the slim sailboat as it beats into the wind. She's making good time to the windward mark, and you can see tiny trim changes as her skipper tries to squeeze every ounce of performance from her taut sails. With luck, he'll lay the

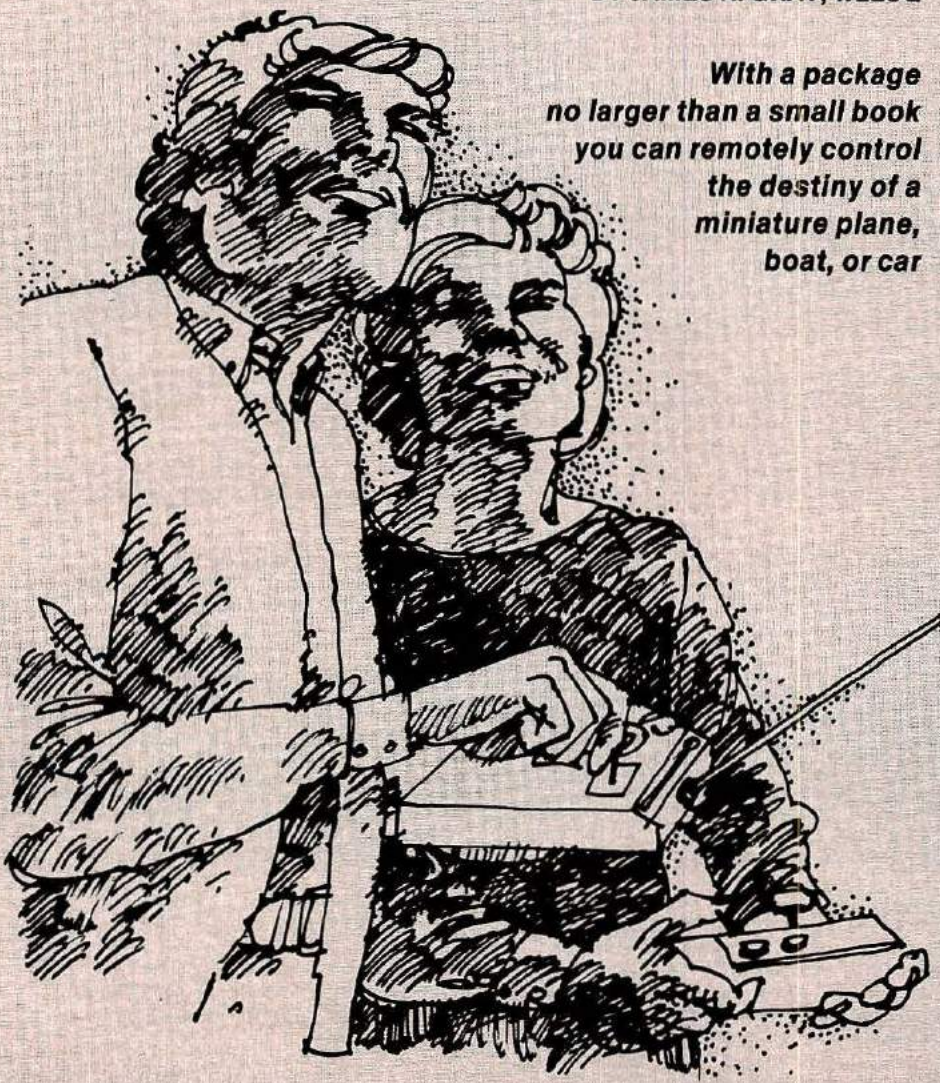



mark on that tack, beating out his closest competitor who is only a few lengths behind, but sagging off to leeward. The skipper sees a slight wind-shift — a header — and eases the helm to meet it, trying not to lose way. The competing helmsman fails to note the tell-tale "cats paw," and now falls off badly, losing a couple of boat-lengths in the process. The leading skipper gets buoy room, rounds the mark, and heads off on the next leg of the course in a broad reach.

The high-pitched snarl of finely-tuned racing engines drifts back on the breeze, bringing with it the slightly sweetish odor of Castrol. Two Formula 1 machines are dicing out there, jockeying for position as they come into the final turn, their drivers hoping for that split-second advantage that will allow one to take a better line through the bend and come out ahead of his rival. Both stab the brakes once . . . twice, decelerating into the corner. The lead car weaves a bit entering the turn — a bit too late — and lost his "line." The car behind sees an advantage and pours on the coal, deftly swinging the rear end of his racer into a drift, nicely feathering the line on the outside of the rubber-streaked track where it meets the dirt. He's through — and passes the former first-place machine in a display of skill that would credit Jackie Stewart.

Boy! Wouldn't it be fun to talk to that pilot, the skilled yachtsman, or the cool racing driver? Well, you can; they're standing right next to you! Let's mosey over and see what's what. As we approach, you notice that none of them is wearing helmet and goggles, or a driving suit, or a life vest. They're dressed just about as you and I — in ordinary street clothes. The skipper of that

\*Ross A. Hull and R. B. Bourne, W1ANA, "Radio Control of Model Aircraft," *QST*, October, 1937.

yacht is in his early teens; the racing driver is barely twenty; and the pilot is old enough to be a grandfather! That's right, each one is a radio-control enthusiast who gets his kicks out of racing model sailboats, cars, or airplanes.

### Radio control today

The field of remote control by radio is just opening up. Did you happen to see *Jaws*? The shark was radio-controlled. How about *The Hindenburg*? The Zeppelin was a model — twelve feet long, complete to the last detail and radio-controlled. *Jonathan Livingston Seagull* was a radio-controlled model in the aerobatic sequences. The seagull models were built and flown by Mark Smith of California who went with the movie company to Hawaii to do the film, and he flew the "gull" from the slopes of one of the island's mountain ranges, over-looking the sea. In the same way, people all over the world are turning to remotely-controlled models for fun and sport. There are quarter-midget airplane races with real pylons and critical judges. There are soaring

contests between model sailplanes — high in the sky — sometimes as many as ten or fifteen at a time silently seeking the elusive thermals to stay aloft. There are fleets of model sailboats, divided into "classes," just like their bigger counterparts, competing on rivers, ponds, and lakes all over the country.

In fact, it would be surprising if you haven't seen some of these people "doing their thing" at one time or another in your travels; perhaps in a park, or on vacation, or at a shopping center parking lot. Did you ever think that you might become one of them? If so, let's find out what it takes and how you go about it. Let's talk about this hobby-sport of remote control by radio.

### Some background

In 1937, Ross Hull, assistant editor of *QST*, wrote an excellent article describing some experiments that he and Roland Bourne, W1ANA, had made with a model they had acquired in Elmira, New York.\* Hull wrote, "Most hams are usually far from being one-hobby men and one discovers,

Full-scale and R/C replica *Super Fli* aircraft shown side-by-side. Note aircraft registration number *N5PK*. The "PK" is Phil Kraft, owner and pilot of these beautiful ships. The model was constructed by Dan Lutz — April 1976 *Model Airplane News* (photo courtesy Kraft Systems).





# TYPICAL R/C INSTALLATION

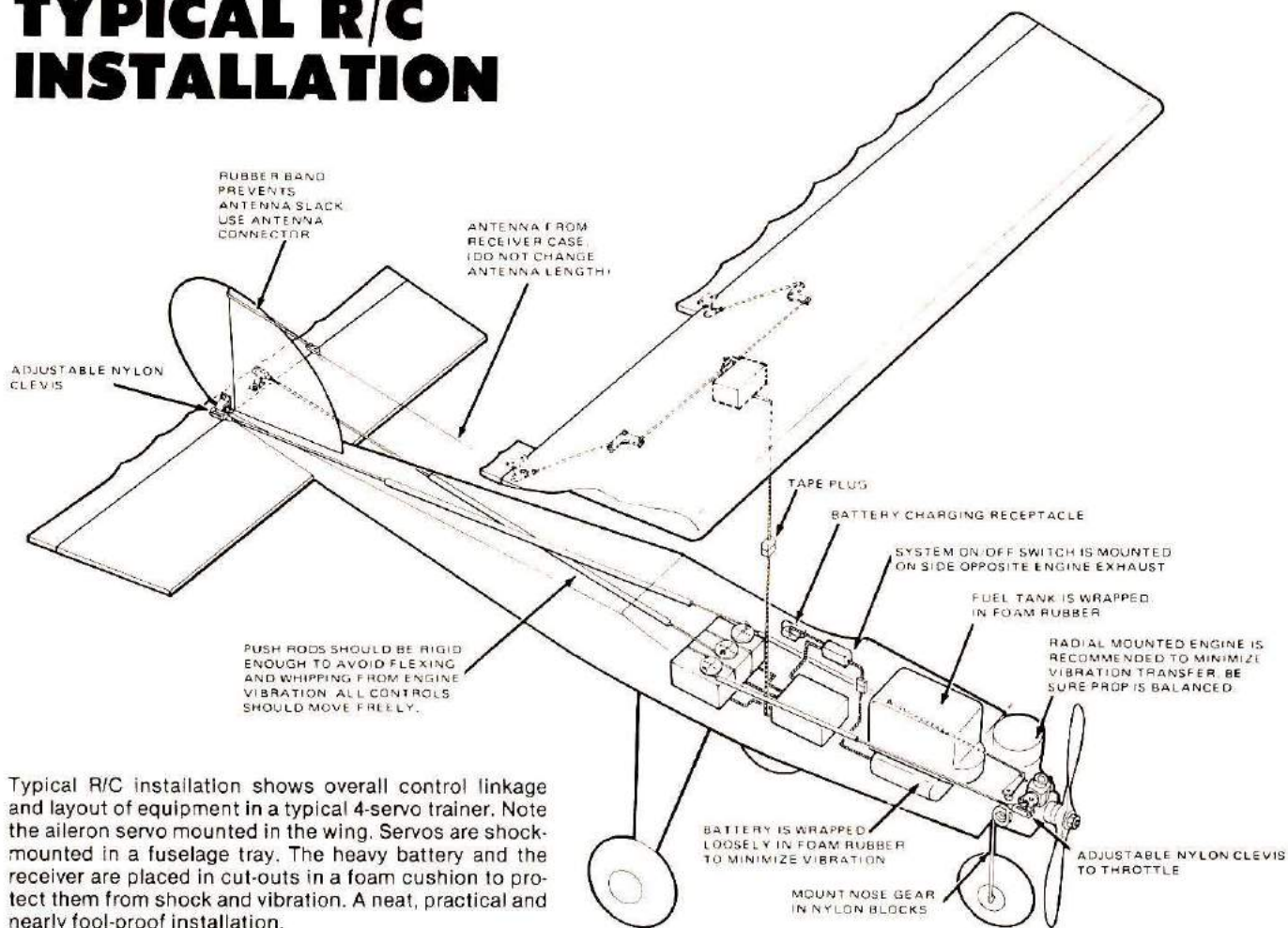

Typical R/C installation shows overall control linkage and layout of equipment in a typical 4-servo trainer. Note the aileron servo mounted in the wing. Servos are shock-mounted in a fuselage tray. The heavy battery and the receiver are placed in cut-outs in a foam cushion to protect them from shock and vibration. A neat, practical and nearly fool-proof installation.

almost invariably, an interest in the other sciences and the crafts. A common interest in ham radio, aeronautics, model building and photography, is almost the rule." How true — and still true today!

Ross went on to discuss their discoveries, the need for simplicity and reliability, two- and three-tube receivers, the problem of light-weight batteries, the need for battery-powered ground stations, suitable antennas, and a better control system. He said, "Getting completely reliable and precise operation of nothing more than a rudder is a job full of problems. Acquiring the necessary judgment to use it effectively on even a gas plane (let alone a sailplane) is still tougher."

The thirteen-foot span, ten-pound sailplane that finally evolved survived hundreds of

flights and fifteen crack-ups, and was rebuilt so many times that substantially nothing of the original was left. Their comments are much to the point and apply equally well today, "But if anyone thinks that the program was tedious work, they're crazy! We have had our full share of thrills in this ham game, but the business of controlling a dizzy airplane galloping across the sky has set a new all-time high for sheer fun!"

That Ross Hull sailplane reposes today in the ARRL museum in Newington, Connecticut.

Remote control experiments continued, and were eventually undertaken by the military. During World War II, for example, pilotless aircraft were flown as gunnery targets for a whole crop of trainees just learning how to "lead" moving

targets. The models were not too expensive, and they provided all the factors of time, speed, and distance necessary for realistic targets.

After the war, many modelers wanted that extra bit of realism provided by models that didn't have to be attached to wires or strings to provide maneuverability, yet could be brought back to the pilot and landed virtually at his feet.

## Frequency bands

In the days before there was a Citizen's Band (CB) Personal Radio Service, there were Amateur Radio frequencies available for radio control of models — the most popular being in the old 11-meter band. The early frequency assignments in that band were 26.960 to 27.230 MHz for radio control, and many hams took advantage of the opportunity to



build equipment using these frequencies. By today's standards, the gear was crude, inefficient, bulky, and heavy — but it worked.

Unfortunately, those early post-war years also saw some of the best radio propagation conditions ever enjoyed by DXers, particularly on the ten and eleven-meter bands. As a consequence, many crashes occurred due to a radio-controlled model being "shot down" by an innocent ham who might be many miles away from the scene of the modeler's activity.

Later, the 11-meter band was turned over to the Citizen's Radio Service, making licensing ultra-simple and attracting thousands of potential R/C (radio-control) enthusiasts. Naturally, the frequencies quickly became crowded, and each radio-controller had to learn to share; i.e. wait until another radio-controller had finished. Even so, many crashes took place because of simple forgetfulness, or failure of one operator to observe that "his" frequency was in use.

### Equipment

The earliest post-war radio control equipment still made use of CW signals. Ordinarily, the control surface of an airplane — such as the rudder, for example — was set at the neutral position. The ground-based "pilot" pressed a button or his key on his transmitter which sent a pulse of rf energy to the receiver in the airplane, causing a sudden change in plate current of the receiver tube which, in turn, actuated a relay. The relay tripped an escapement (usually powered by a spring) that moved the control surface. The escapement was a sequential device that produced control movements in a definite order: Neutral, left, neutral, right, neutral . . . and so on. One of the problems with this simple arrangement was that the "pilot" had to go through the



John Roth and his R/C scale Volksplane, winner of many contests, including the annual *Nationals* held by the Academy of Model Aeronautics. John's model is a faithful replica of the original ship — a popular home built with members of the Experimental Aircraft Association. Scale model judging covers fidelity to the original in both appearance and flight performance (*photo courtesy Academy of Model Aeronautics*).

complete sequence. For example, if the rudder was in the left position and had returned to neutral and left was needed again, the proper number of pulses had to be transmitted to move the control through its positions of right and neutral by way of the escapement before left came up again. When things began to happen in flight that called for immediate correction, a flurry of activity — plus an excellent memory — was called for. Most early experimenters crashed on every flight.

Radio controllers quickly re-discovered that better antennas, more transmitter power, and receivers of improved sensitivity were needed; not to mention a far better system of control actuation than was available with the escapement system.

Eventually, CW control gave

way to pulse-proportional control, sometimes called a "galloping ghost." With this system the amount of control surface movement on the model was proportional to the amount of "stick" deflection at the transmitter. The rudder, for example, was very loosely hinged and oscillated continuously about a neutral point, perhaps at the rate of 10 Hz. A control command merely shifted the neutral point to the left or right, with the control continuing to oscillate about that point. Continuous oscillation was quite hard on the batteries that drove the oscillator, and was also hard on the hinges of the control surfaces. However, pulse proportional systems were light and relatively inexpensive, and Ace Manufacturing Company still makes them for the model market.



The next system to be used was somewhat more cumbersome, but provided multi-channel, and therefore, multi-control capability. This was the tuned-reed system in which a vibrating tuning fork oscillated at a particular audio frequency and, in turn, modulated the carrier. The receiver in the model detected the various modulation frequencies, a different one for each control function, and operated the control associated with a particular frequency. At the transmitter end, a movement of the control stick in a certain direction (representing movement of rudder and elevators for example) actuated the oscillator that controlled that function on the model.

Reed systems were rather bulky and heavy, but they worked quite well, and provided all of the necessary command functions. Six reeds, for example, produced six different frequencies — two for each of the three controls on the model. Each control had to move in two directions so there was a different frequency for each direction of movement of each control surface. There was no automatic return-to-neutral, so opposite control deflection was needed to return the surface to its neutral point. The amount of control deflection was determined by how long the pilot, or operator, held the control in a particular position. A quick "blip" was minimum movement, while a longer one represented more movement.

The system in widespread use today is called digital proportional, which means that proportional control of each movable part (control surface) on an airplane model is possible; that is, each control surface moves proportionally to the amount of movement of the control stick on the transmitter: Full movement, full deflection; small movement, small deflection. In addition to this, the control sticks are set up so that left and right movement of the stick on the transmitter is left and right rudder on the model. Backward and forward movement of the stick is up and down movement of the elevator on the model. In effect, the radio controller has a miniature cockpit, with its controls, right at his fingertips.

Other channels can be used for throttle control, aileron control, flaps, retractable landing gear, and a number of other devices. The number of controls is limited only by the number of channels available and the ingenuity of the modeler.

On a sailboat, the jib, mainsail, and rudder are all controllable. On a racing car model, digital proportional control handles throttle, steering, and brakes.

The rapid growth of radio control and the great influx of licensees created a strong demand for more control frequencies, and they were soon provided.

Today, there are three major radio control "bands," each identified by its own particular color scheme. See **Table 1**.

#### Who's on first?

The *Academy of Model Aeronautics*\* has designated colors and color combinations in the form of streamers or pennants as a means of indicating what frequency a transmitter is operating on. In general, 27-MHz pennants (flags) are triangular, and clipped to the transmitter antenna so they can be easily seen by others. Transmitter antennas in the 50-54 MHz and 72-76 MHz bands display two streamers, each in the form of ribbons approximately 1 by 16 inches (2.54x40cm). One ribbon indicates the band of operation, and the other, the exact frequency. In **Table 1**, the asterisks indicate the four frequencies assigned exclusively for model aircraft control purposes.

Each assigned frequency is controlled by a crystal oscillator. As you can see from the table, there are six frequencies in the 27-MHz band, nine in the 50-54 MHz band, and seven in the 72-76 MHz band, for a total of twenty-two frequencies assigned for the radio control of models.

The reason for color-coding becomes obvious when several operators wish to operate their

\*Academy of Model Aeronautics, member of the National Aeronautics Association, and U. S. representative of the FAI (Federation Aeronautique Internationale) — the world-wide governing body regulating all of sporting and record-setting aviation events. AMA headquarters is located at 815 Fifteenth Street, NW, Washington, DC 20005.

**Table 1.** Color designations by frequency.

27 MHz Band	(Super-Het) Band 50-54 MHz	(Super-Regen) Band 50-54 MHz	72-76 MHz Band
26.995 brown	53.10 black/brown ribbons	51.20 black/light blue	72.08* white/brown ribbons
27.045 red	53.20 black/red ribbons	52.04 black/violet	72.16 white/blue ribbons
27.095 orange	53.30 black/orange ribbons		72.24* white/red ribbons
27.145 yellow	53.40 black/yellow ribbons		72.32 white/violet ribbons
27.195 green	53.50 black/green ribbons		72.40* white/orange ribbons
27.255 blue			72.96 white/yellow ribbons
			75.64* white/green ribbons

\*Designates exclusive frequencies for radio control of model aircraft.



equipment at the same time. Without an easily visible means of seeing who is operating on what frequency, the likelihood of wholesale destruction of models would be high, because the model's receiver will respond to any command signal on its own frequency. To prevent this, each transmitter carries a color-coded flag on its whip antenna. When that color or combination of colors is seen on the transmitter of a radio controller out on the field, another operator having the same colors (frequency) refrains from operating until the first one finishes. Everyone uses this system of sharing and operating in his own turn. When many radio controllers are out for a day's activities, each has less time for his own model, but no one seems to mind.

You will notice that two frequencies have been set aside in the Amateur six-meter band for super-regenerative receivers. A super-regenerative

receiver transmits its own signal — very close to the control frequency. Because of this, the frequencies set aside for super-regen control are removed from the other radio control frequencies by approximately 1 megahertz.

It's a fact, however, that very few if any radio controllers today use super-regenerative receivers, and the 51.2 and 52.04 MHz assignment are a hold-over from twenty years or so ago when the Amateur built his own receiver to put in the model.

When you decide to join a local club of radio-controlled model enthusiasts, be sure to ask them what frequencies are *least* used by the club, and for what reasons. If there is no good reason (such as proven interference) for not using a little-used channel, then it would be worthwhile to consider that frequency for your own radio system. Sometimes certain frequencies

are just not popular in a particular club, and one of these would ordinarily be a good choice — giving you more time to control your model and less time waiting for someone else to finish controlling his.

Two transmitters cannot, and must not, be operated at the same time on the same frequency, because it is certain that the loss of at least one model will occur. I've suffered that unhappy situation and — believe me — it isn't worth it.

### Another type of channel

In digital-proportional equipment several different controls, each driven by a servo mechanism, can be operated on a single frequency by some relatively sophisticated digital logic techniques. Basically, the system uses a time-sharing technique for separating pulses, and assigns particular pulses to each control function. A control "channel" represents a particular control

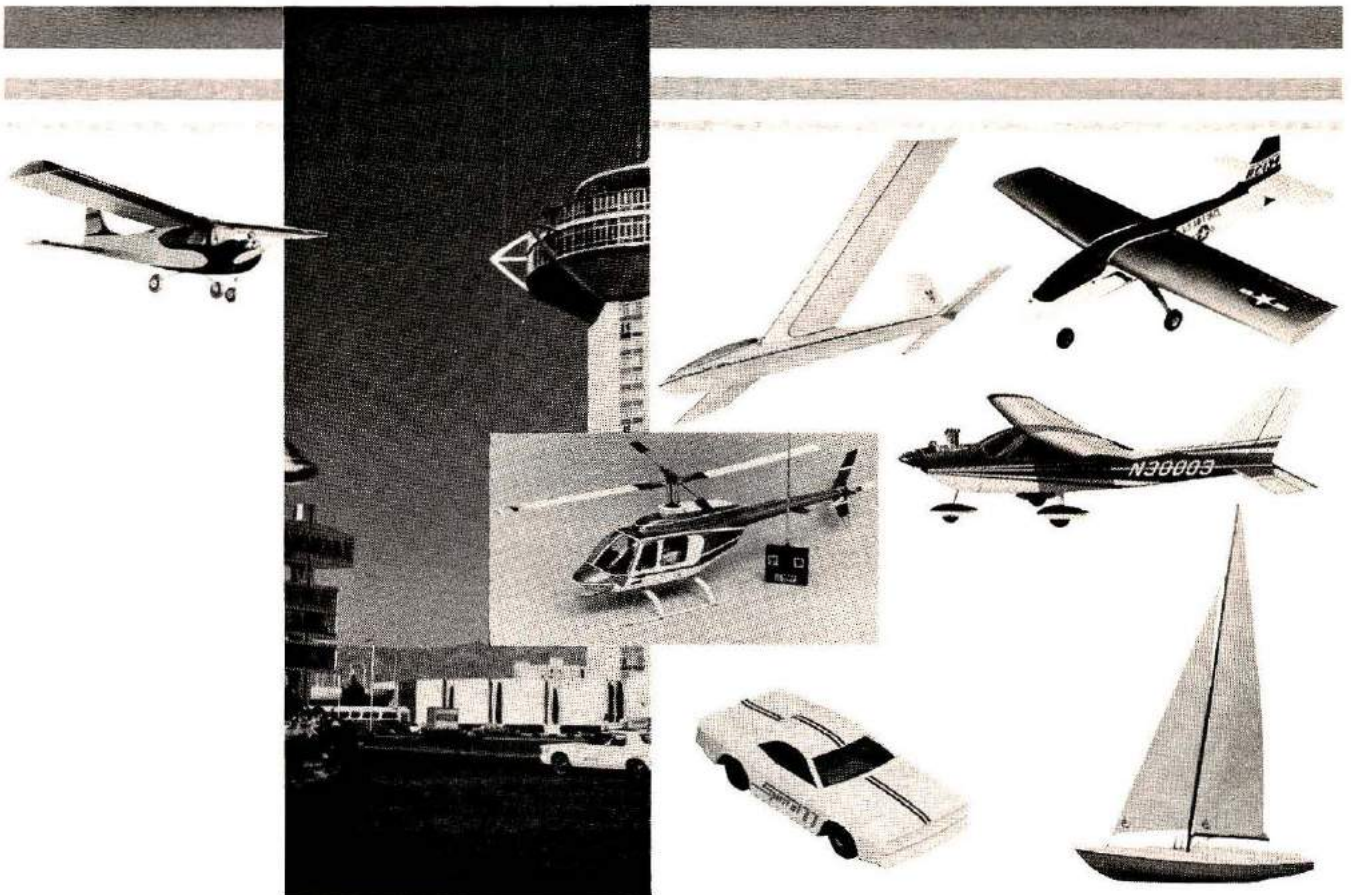



function and includes all of the necessary circuits to perform that function.

### The transmitter

The transmitter is a small, book-sized box that contains batteries for power, is provided with a whip antenna, and radiates a signal of one watt or less on a specifically assigned frequency. The transmitter circuit includes a crystal-controlled oscillator and rf amplifier. On the transmitter box are found two control "sticks," at least one of them mounted in a gimbal mount and capable of movement back and forth as well as left and right, plus a mixture of these motions.

The solid-state components in the transmitter produce a sequence of pulses that modulate the rf carrier, turning it on and off at a certain rate. Some of these pulses are timing pulses that synchronize the pulse decoder in the model's on-board receiver, and others are the command pulses that cause the model's controls (throttle, rudder, brakes, elevators, sail-trimming lines, etc.) to move in the direction and the amount required.

All of the pulses are spaced

in a particular sequence within a time frame or "window" whose length is about 16 milliseconds. Each of the control pulses is about 1.4 milliseconds long, but variable in width. See Fig. 1. The control stick of the transmitter determines the pulse width, widening it for control in one direction and narrowing it for control in the other direction. If the model has four control channels (rudder, elevator, throttle, and ailerons, for example) each channel is always represented by the same pulse in the sequence of four within the time frame. The amount or degree of widening or narrowing depends on how far the control stick is moved, giving proportional control — just like a real plane, boat or car.

Each frame-full of pulses repeats itself sixteen times in the length of time it takes your heart to beat only once, and each pulse turns the transmitter's rf carrier on and off like an electronic switch. The pulse-modulated carrier is then radiated by the antenna to the receiver in the model, bearing the command signal information in pulse-encoded form.

### The receiver

The pulse-modulated signal is picked up by the receiver's antenna and passed through several circuits that "scrub" the pulses off the carrier and shunt the carrier to ground — literally throwing it away. This is called demodulation or detection, and the pulses themselves pass to decoder circuits that interpret the information they carry. The pulse decoder circuits consist of a series of electronic switches or logic gates, one for each control channel, arranged so that each responds only to its own particular pulse in the sequence.

### The servomechanism

The command or control channel in the receiver is connected directly to a small dc motor and gear train that operates one of the model's controls. If there are four channels, then there are four motors and gear trains, one for each channel. These little motors that turn gears, pull on control wires, move bell cranks and do the work of controlling the model, are called servomechanisms (or servos for short) because they serve the remote-control operator. Each servo has its own pulse decoder that tells it which pulse in the train of pulses to respond to, and a circuit that responds to the width of the pulse itself.

### Sequence of operation

Let's go back to the transmitter control box for a minute, and follow the pilot of a model airplane as he applies a control input to one of the control sticks. Let's say it is the elevator, control channel #1, that we're interested in. The pilot pulls back on the stick to cause the plane to nose up, and the stick motion causes the channel 1 pulses to widen. These are received by the receiver in the plane and decoded. The channel 1 servo decoder that is connected to

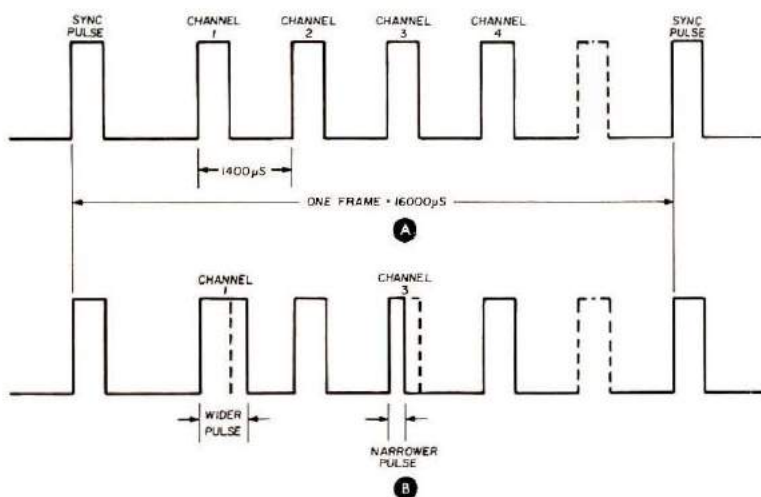

Fig. 1. At A, a normal train of pulses occupying a single frame, is shown for a four-channel radio. Note that each frame starts with a sync pulse and that the pulse for each channel follows in 1,2,3,4 sequence. At B a command has been given on channel 1 causing the pulse to widen, and on channel 3, causing the pulse to narrow. The receiver and servo mechanisms on board the model will correctly interpret these commands and cause the appropriate controls to be actuated by an amount proportional to the width (or narrowness) of the pulses.



the plane's elevator detects the widened pulse and instructs the servo motor to turn clockwise. The servomotor turns a gear train and a control arm that pulls on a control rod connected to the elevator which obediently moves up, nosing the plane into a climb.

Other circuits in the servo tell the motor exactly how far to turn in proportion to the width of the signal pulse received and decoded, and when to stop turning. If a narrower pulse is decoded, then the servo turns in the opposite direction, nosing the plane into a dive.

Each control on the model operates in a similar manner. For example, channel 2 may be the rudder channel, and a left-rudder command signal causes the servo to rotate clockwise and pull on the left rudder control rod. The model responds by obediently turning left.

Another channel, 3 for



For those who enjoy peace and quiet but still have the desire to compete, R/C sailboat racing is the two-dimensional equivalent of R/C soaring. Here is *Bingo*, a 50/800 class sailboat beating to windward on a starboard tack (photo courtesy Dumas Products, Inc.).



Some of the models flown at the annual Omaha-Council Bluffs area *Fun Fly*. In the foreground is a group of Sig Kougars, an advanced aerobatic trainer. It is a simple model to build for radio control and is capable of high performance. Because of its high degree of maneuverability, a modeler must have some experience with slower, more stable models before flying a model of the Kougars's class (photo by Claude McCullough).

example, could be connected to the aileron servo, and channel 4 could be connected to the throttle. Thus any command by the pilot can be transmitted by the remote control system to guide the model through a series of intricate maneuvers that duplicate those of a real boat, car, or plane.

#### What to buy

There are many suppliers of radio-control outfits, and there are single-channel, two-channel, three-, four-, five-, six-, seven-, and even eight-channel systems; each available on almost any frequency you could want.

In general, the fewer the number of control channels, the less expensive the equipment. It is always worthwhile to buy the transmitter and receiver combination that have the most channels you think you may ever need; and that will depend on what kind of model you intend to control and how many control functions it requires. For example, a radio-controlled sailplane may need only two channels, or at the most, three;

whereas, a helicopter would probably need eight channels.

At the beginning, it is suggested that you consider at least three channels, with an optional fourth channel available. In this way, your radio can grow with your interest and with the complexity of the model; you won't have to think about trading up or buying another radio when your need for more channels arises.

There are some very good used equipment buys available from club members and dealers. These are usually somewhat older two- or three-channel radios that someone has traded in or sold in order to buy a more expensive and more advanced set having more channels. If you buy one of these, be sure that it is in good working order, made by a reputable manufacturer, and that it has been to the factory for repair and/or check out before you buy it.

The airborne battery pack for most contemporary radios contains rechargeable nickel-cadmium cells, and has a current capacity of 450 or 500 milliampere-hours. Some of the





Heath Company, Benton Harbor, Michigan supplies a full line of R/C equipment, as well as a sailplane and powered plane, for the radio control modeler. Heathkit is a well-known and trusted name in the field of electronic kits for the do-it-yourself hobbyist (photo courtesy Heath Company).

older and less-expensive radios use alkaline cells, and these are alright, too, except that over a period of time you'll be buying replacement batteries which eventually could cost as much or more as buying the rechargeables in the beginning.

Transmitters operate on about 9.6 volts dc, and receivers operate on about 4.8 volts dc, depending on whether you use the alkaline or nickel-cadmium type of battery. In most cases (but not always) the transmitter batteries are of the rechargeable nickel-cadmium type.

Models tend to crash a lot, particularly in the hands of beginners, putting a lot of stress on the radio parts contained in them. Quite often

servos will have stripped gears, batteries will have loose connections, and receivers may have loose antenna wires or other internal problems. When you buy used equipment, be sure to look for obvious signs of wear and tear, and make sure that any such problems have been corrected. In time you will also crash. Fortunately, it happens less and less frequently as you become more experienced, making your model and your radio much happier. Always ask to try the equipment before you buy it.

Some radios have "buddy" switches; a system whereby two transmitters can be connected together in a master-slave arrangement. This allows an instructor to teach

you how to operate your model safely — permitting you to control it until disaster is about to strike — when he takes over and saves it. Sooner or later, you'll become an instructor, too, so you may want to consider this type of radio.

### Where to buy

There are dozens of makes and types of radio equipment available from a large number of reputable manufacturers and suppliers. If you like to build, you may want to give Heathkit equipment a try. Otherwise, your choice will be a ready-to-go outfit.

The choice of equipment is up to you, and you will first want to check with your local club members to find out what they use or recommend. You might look over several different types to see which "feels" most comfortable to you. Finally, look into the replacement, repair, and service aspects of the equipment you buy. It's probably true that the equipment is only as good as the manufacturer who stands behind it, so choose carefully. To be fair, those manufacturers who still survive have already shown that they do a superior job — otherwise they could not remain in the competitive position they hold.

### Why Amateur Radio for radio control?

The main reason that six meters is so popular for radio-control purposes is that there are so few radio-controllers operating there! Therefore, if you go out to fly with the club on a busy weekend, it's unlikely that you would even have to wait your turn to fly. There could be another ham — or even two — in the club, but usually they are on different frequencies, and don't represent any threat of interference to each other, or to you. By contrast, the 27-MHz frequencies are always crowded, and the 72-MHz band is becoming more so all the time.





Dick Sarpolus, noted designer, builder, flyer from Shrewsbury, New Jersey holds *Old Timer* — a 1940 vintage design — adopted for modern R/C and engine. Revival of vintage designs and engines is increasing in popularity (photo courtesy Royal Electronics Corporation).

To operate in the six-meter band, you will need at least a Technician Class license from the FCC. This license requires you be able to pass a five-word-per minute (Morse) code test, and an examination in rules and radio theory. The logical progression from Novice is an easy step, where you will only need to "bone-up" on theory. Plan to spend a month or so with the *ARRL license Manual*, or with the *Ameco License Guide*, supplemented with the *ARRL Radio Amateur's Handbook* and the *Ameco Radio Amateur Theory Course*. A month or two of study, spending a half-hour or so each day, should prepare you for the examination.

You'll have to go to one of the FCC Examination Points to take the test, but each large city has an FCC office. Smaller cities are visited every few months by the FCC examiner, so make an appointment well ahead of time to allow yourself time to prepare.

Additional operating privileges come with the Tech license and you will find that it is time well spent because you can enjoy things like six- and two-meter operation, plus all of the Novice privileges as well. The bonus, of course, is your new ability to use the uncrowded six-meter frequencies for radio control.

### What else can you do?

Well, for example, there are all kinds of contests and meets of local, regional, and national scope just waiting for you to participate in with other radio-controllers. In aircraft modeling alone there are possibilities of pylon racing, aerobatic flying (pattern), motorless soaring, electric power, scale, and a host of others.

Steve was only fifteen when I first met him and though he'd never seen, much less used, radio-control equipment, his infectious enthusiasm, sunny disposition, and obvious natural ability encouraged the club members to help him learn to fly. Before long, Steve was able to do a good job of using my two-stick transmitter (left stick-elevator, right stick-rudder) to steer a sailplane through launch, maneuver, and landing.

Later that summer Steve asked for my opinion about what radio he should buy and what kind of glider he should build. The question came at a good time, because I was planning to sell my radio and acquire a newer, and more



Here, Frank Trouba of Omaha, Nebraska releases his Sig Kougat in *Fun Fly* competition. Modern radio-controlled planes are fully aerobatic and capable of performing all of the maneuvers of their bigger brothers (photo by Claude McCullough).

advanced type. Also, a new training sailplane had been adopted by our club just a few weeks before, and the kits were inexpensive and easy to build. Steve had managed to save enough money from his paper route and odd-jobs to buy the radio and a kit; and before we knew it, he was giving us all a run for our money in local contests.

Before the year was over, Steve had flown his first two regional contests, taking third and eighth places in a field of twenty-five or thirty experienced competitors!

Now, at age 17, Steve has built one of the largest and most competitive sailplanes in the country, adding some of his own ideas, and we expect to see him do well in national competition, proving that "where there's a will, there's a way."

R/C is a hobby-sport that attracts people of all ages who meet for companionship and to share a common interest in a relaxing — but sometimes intensely competitive — activity. No matter how young or old, you're always the right age to join the fun. Whether sailboats or sailplanes, racing cars or racing aircraft, or any other remotely-controlled model, are your "thing", you'll find plenty of company and enthusiasm to share. **HRH**

### The Modeler's Press

For lots of good information about radio control, the following books are recommended: *Model Car Racing*, *RC Modeler's Handbook of Gliders and Sailplanes*, *Radio Control for Models*, *Model Sail and Power Boating*, and *Radio Control Handbook*. These are just a few of the titles available from *ham radio's* Communications Bookstore, Greenville, New Hampshire 03048 where we stock almost every book you'll need to explore this terrific sport and hobby.

There are many magazines devoted to the hobby-sport of radio control modeling, and its various categories. You'll find *Model Airplane News*, *Radio Control Modeler*, *Model Builder*, *Flying Models*, *RC Sportsman*, and others on the shelves of your local newsdealer or magazine store. Look them over and decide which one is right for you. Each contains articles about all of the radio control activities you could ever want.



# Two-Band Novice Superhet

BY DARRELL THORPE

*An easy-to-build superhet receiver for 40 and 80 that provides high performance at low cost*

By popular request we bring back this receiver article as the first in a two-part companion presentation.\* In these days of inflated prices it still represents an exceptional value in terms of price-to-performance ratio.

For the prospective novice, a first receiver can be a rather difficult choice, especially when he looks at the large price tags. He really doesn't have much choice — it's either "shell out" for the fancy factory-wired job or resort to a simple regenerative receiver. However, the red-hot superhet described here can open up a whole new receiver era for the beginning ham. This simple

\*"Two-Band Novice Superhet," Darrell Thorpe, *ham radio*, August, 1968. Revived as a photograph only in *Ham Radio Horizons*, March, 1977, it created such an avalanche of mail requests that we decided to bring it back for your further examination and interest.



superhet can be built at a price that compares to the simple regenerative receiver, yet it gives big-set performance.

Total cost is under \$50, even if you use all new parts. Sensitivity is around 1 microvolt; this is high performance when compared to the usual 10- $\mu$ V sensitivity of

low-cost, ready-made receivers. The outstanding performance of this receiver is achieved by using the latest solid-state devices and toroid cores. In addition, this top performer covers both the 80- and 40-meter bands without a lot of complex coil winding or bandswitching.



## The circuit

The heart of the two-band novice receiver is an eight-transistor broadcast-band receiver that sells at discount stores in most cities for under \$20. This receiver, with only a couple of minor changes, provides a three-stage i-f amplifier strip and detector and supplies plenty of audio to drive a built-in or external speaker.

This is not only a compact ready-made i-f and audio package — you could barely buy the components for the price of the entire radio! Mentally, add up the cost of the i-f transformers, speaker, capacitors, and resistors plus the transistors, and you'll begin to see what a real bargain this ready-built module is.

Next comes an innovation from the semi-conductor industry — a field-effect transistor (fet) in a mixer circuit. The fet is used for its superior mixer performance. Similarly, toroid cores are used because they provide superior coils. In the oscillator, the toroid coil, which you'll find is about the easiest coil you have ever wound, provides very good stability, and a two-stage oscillator circuit maintains it. At the antenna, the toroid coil provides high-Q for better selectivity. Another advantage of the toroid is the small amount of space required as compared to the usual 80-meter tuned circuits.

## Construction

Start by removing the case from the transistor radio. Look for two leads that go from the circuit board to the earphone jack and then to the speaker.

1. Disconnect the leads at the phone jack.
2. Remove the speaker and phone jack from the radio and mount them in the new cabinet (Radio Shack 270-231 or 270-233). It will be necessary to drill a mounting hole in the

cabinet for the phone jack. Also, drill a pattern of sound-escape holes for the speaker. Drill three holes for the speaker-mounting screws. Note that the nuts grip the edge of the speaker frame. The size of the cabinet you choose will depend on the size of the broadcast receiver you buy as the basic unit.

3. Disconnect and remove the antenna loop-stick after noting where the leads of the small winding are connected. One lead is connected to the base of the converter transistor and the other to the bias resistors for this transistor (see Fig. 1). Solder a 2-inch (51mm) length of insulated wire to each of these points; they will be connected to a new i-f transformer (T1) later.
4. Note that the collector lead from this same transistor goes to one winding on the oscillator coil. Use a short piece of insulated wire to short out this winding. This kills the oscillator and converter stage in the broadcast set and becomes an additional i-f amplifier. This additional stage contributes to the excellent sensitivity and selectivity of the receiver.
5. Clip or unsolder the wires going to the volume control. It's not necessary to remove the control, but make sure the on-off switch is always on; the power switch for the novice superhet is on the new volume

control. Connect three 8-inch (3cm) pieces of wire to the circuit board where the three leads from the volume control were connected. Be sure to note the center-tap connection. Solder the other ends of these wires to the new 5000-ohm volume control.

6. Clip the battery leads in half. These leads will be connected to the terminals on the perforated board.

These are the only changes to the broadcast radio, so it can be mounted on the perforated board. Flea clips are mounted in the perforated board near the radio for audio and power connections.

It is a good idea at this time to drill the remaining holes in the cabinet that are needed for the vernier dial, the volume control and bfo pitch control. The holes for the dial and the bfo pitch control are rather critical since they dictate the position of the tuning capacitor and bfo oscillator coil. In addition, drill a small hole in the bottom of the cabinet below the dial so you can tighten the setscrew in the dial.

Position the oscillator tuning capacitor on the perforated board so it lines up with the hole for the dial. Enlarge two of the holes in the perforated board to accept the stator lugs extending from the tuning capacitor. Put the tuning capacitor on the board and push two flea clips through the

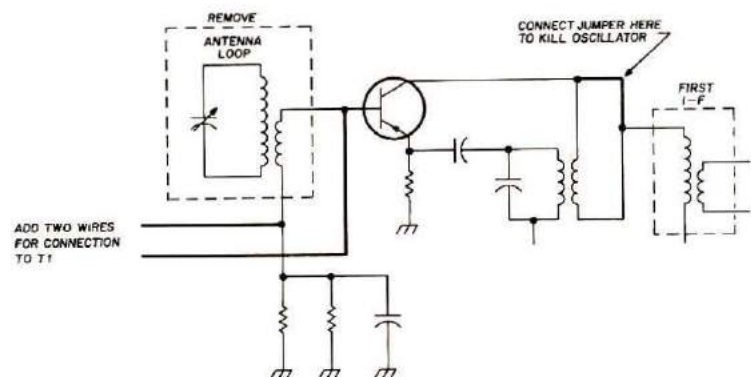
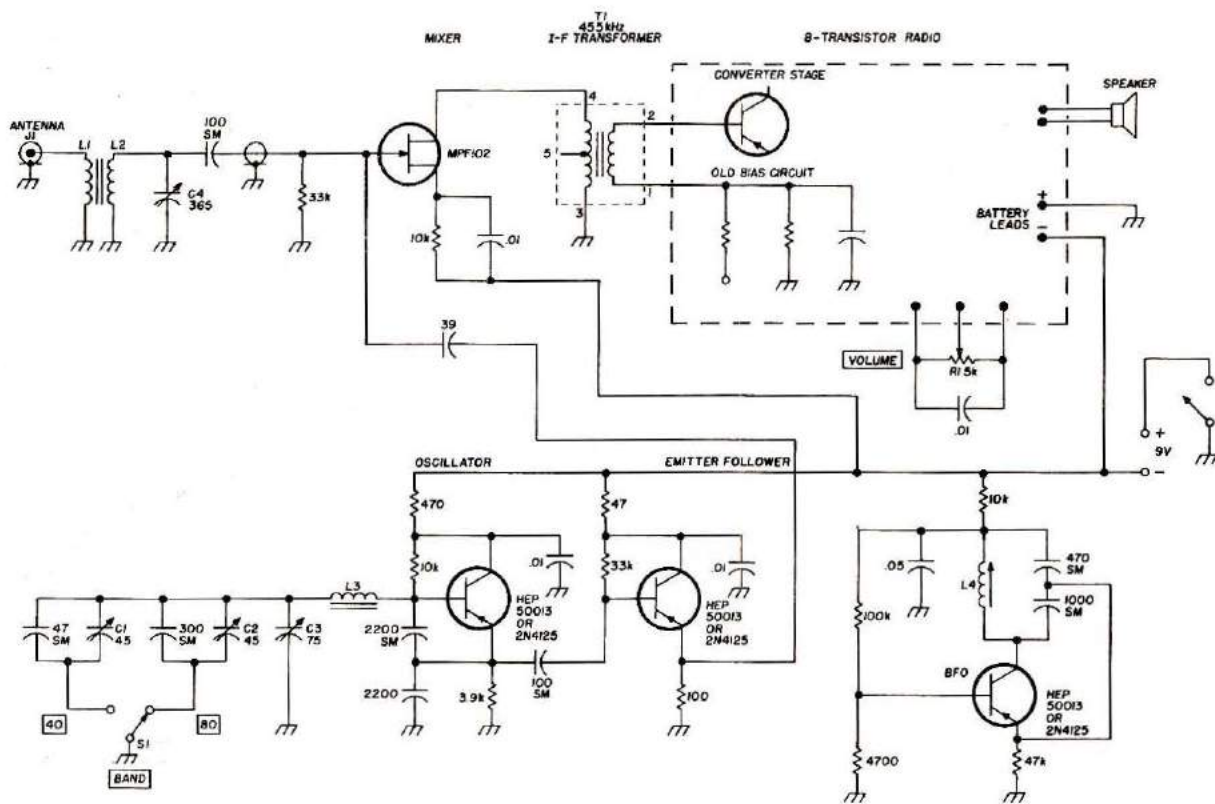

Fig. 1. Modifications to the transistor broadcast radio, for use in the Novice superhet.





- C1, C2 4-40 pF trimmer (ARCO 403)
- C3 75 pF variable (Hammarlund MAPC 75B)
- C4 365 pF variable (Radio Shack 272-1344)
- J1 Phono jack
- L1 5 turns number 24 enameled wire wound between turns on ground end of L2
- L2 18 turns number 24 enameled wire wound on ferrite core (Micrometals T44-15)

- L3 29 turns number 24 enameled wire wound on ferrite core (Micrometals T50-2)

- L4 bfo coil (Antenna loopstick) (Miller 6300)
  - R1 5000-ohm volume control with switch (Radio Shack 271-1714, with 271-1740 switch)
  - S1 SPDT slide switch (Radio Shack 275-402)
  - T1 455 kHz i-f transformer (Miller 9C1)
- 1 cabinet (Radio Shack 270-233 or 270-231)  
 1 tuning dial (Lafayette 99R60311)  
 2 small knobs (Lafayette 32R24227)

**Fig. 2.** Schematic diagram of the Novice superheterodyne receiver for 40 and 80 meters. The transistors are inexpensive National Semiconductor types 2N4125 or 2N4126. A parts kit including C1, C2, C3, L2, L3, L4, and T1 is available for \$14.85 from G. R. Whitehouse, 15 Newbury Drive, Amherst, New Hampshire 03031. The transistors can also be provided by G. R. Whitehouse, prices upon request.

board right next to the capacitor lugs and solder.

Proceed with the wiring of the oscillator, mixer, and bfo as shown in Fig. 2. The oscillator trimmer capacitors are spaced away from the board so they clear the oscillator coil.

Notice that the bfo doesn't need any direct connection other than power.

#### Alignment

Since the broadcast receiver is already aligned, there's

practically no alignment needed of the 455-kHz i-f. The new i-f transformer you added (T1) may need a little peaking; however, new transformers are very close to 455 kHz.

Start with the 80-meter band first. It's the easiest to adjust because you should be somewhere within the band regardless of where the tuning and trimmer capacitors are set. Set the main tuning capacitor to minimum capacitance, the antenna trimmer capacitor at

about 3/4 of maximum capacitance and the bandswitch to the 80-meter position. Adjust the 80-meter trimmer until you hear Amateur phone signals coming through.

These phone stations will probably be on ssb, so they'll sound like a bunch of quacking ducks. As you tune the main tuning capacitor toward maximum capacitance, you will tune down through the Novice and General-Class CW bands to 3.5-MHz. The 80-meter CW



bands will be spread over the entire range of the capacitor for easy tuning.

Since this receiver was designed primarily for Novice use, the 75-pF tuning capacitor will tune the entire CW band and part of the phone band. If you want to cover the entire 3.5 to 4-MHz range, use a 100-pF tuning capacitor; however, the bandspread will be reduced. The only adjustment of the bfo is the pitch control; this is tuned about mid-range until a beat note is heard.

The 40-meter alignment is a little more tedious. Set the oscillator tuning capacitor to mid-range, the antenna capacitor to about 1/4 of full capacitance, and the bandswitch to 40. Adjust the 40-meter trimmer to receive 40-meter phone stations between 7.2 and 7.3 MHz. The 40-meter position provides several megahertz of tuning range, so the 40-meter band is only a small portion of the dial. Therefore, there's not nearly as much bandspread on 40 as on 80, but even so, this receiver has proven quite useful on 40.

#### Final assembly

Note the position of the vernier tuning dial when the setscrew is aligned with the

hole in the bottom of the cabinet. Then adjust the capacitor for this setting. On mine, the dial read 70; therefore, I set the tuning capacitor to 25 per cent of maximum capacitance. Then, when the assembly is installed in the cabinet and the setscrew is tightened, minimum capacitance will occur when the dial is advanced to 100.

Now, mount the volume control and bfo coil and install the completed assembly in the cabinet. Tighten the setscrew on the tuning dial and install the knobs.

#### About power supplies

A 9-volt power supply is recommended for this receiver. Don't use a supply that exceeds 10 volts or you may damage the transistors or electrolytic capacitors in the broadcast radio.

I have been using a battery pack with good results. For prolonged operation, six D-size flashlight batteries are recommended, preferably heavy-duty alkaline units. Alkaline batteries give up to ten times more service even under continuous operation. However, the standard D cells give highly satisfactory service. For short-term portable use, six

AA batteries are okay, but alkaline or nickel-cadmium cells are recommended for longer life. These battery packs can be charged many times and provide low-cost operation. Small 9-volt transistor-radio batteries will not hold up.

There have been a number of 9-volt power supplies described in different articles. Any of them will do the job. However, if you don't already have a power supply, the battery charger/battery pack may be the simplest scheme because large filter capacitors are not needed for the charger power supply.

#### Antennas and operation

A good 80- or 40-meter antenna will give the best results, although highly satisfactory reception can be obtained with 30 or 40 feet (10-12m) of wire strung around the room. A good ground connection (water pipe conduit or driven ground rod) is also recommended, especially for battery operation. When the receiver is operated from an ac supply, sufficient grounding is obtained back through the power supply, and an external ground is not too important.

Operation is very simple since there are so few controls. Set the bandswitch to the desired band and peak up the antenna trimmer. Adjust the bfo pitch for a pleasing tone. You may find it necessary to repeak the antenna trimmer for weak signals as you go from one band edge to the other, but you don't have to peak it every time the dial is moved.

With a little practice, ssb voice signals can be tuned in. No switch is provided for the bfo because there are so few a-m phone stations on the amateur bands. To listen to a-m, simply tune the bfo frequency out of range.

The companion QRP transmitter article will appear in a forthcoming issue of *Ham Radio Horizons*. **HRH**

Parts placement of the two-band Novice superhet. The transistor broadcast radio and volume control are to the left, the oscillator is in the upper right, and the fet mixer is in the lower right. The broadcast radio you select as your basic starting unit may have a slightly different shape and size, as well as a slightly different component arrangement, but can be adapted with a little ingenuity.

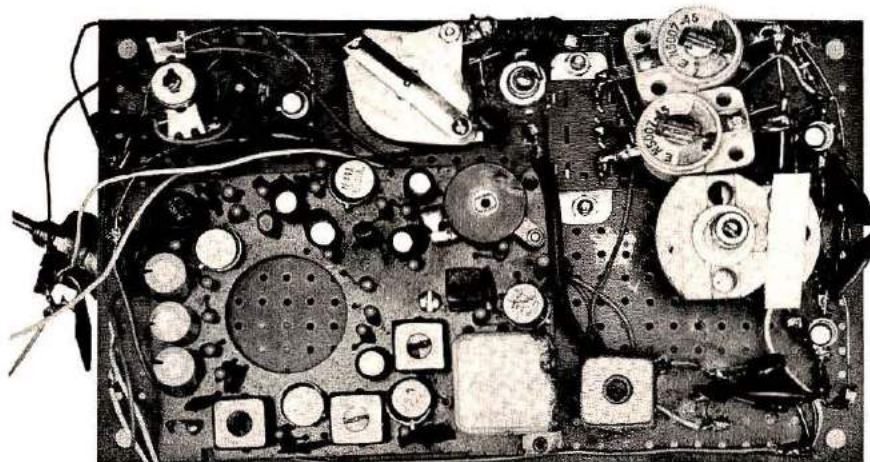



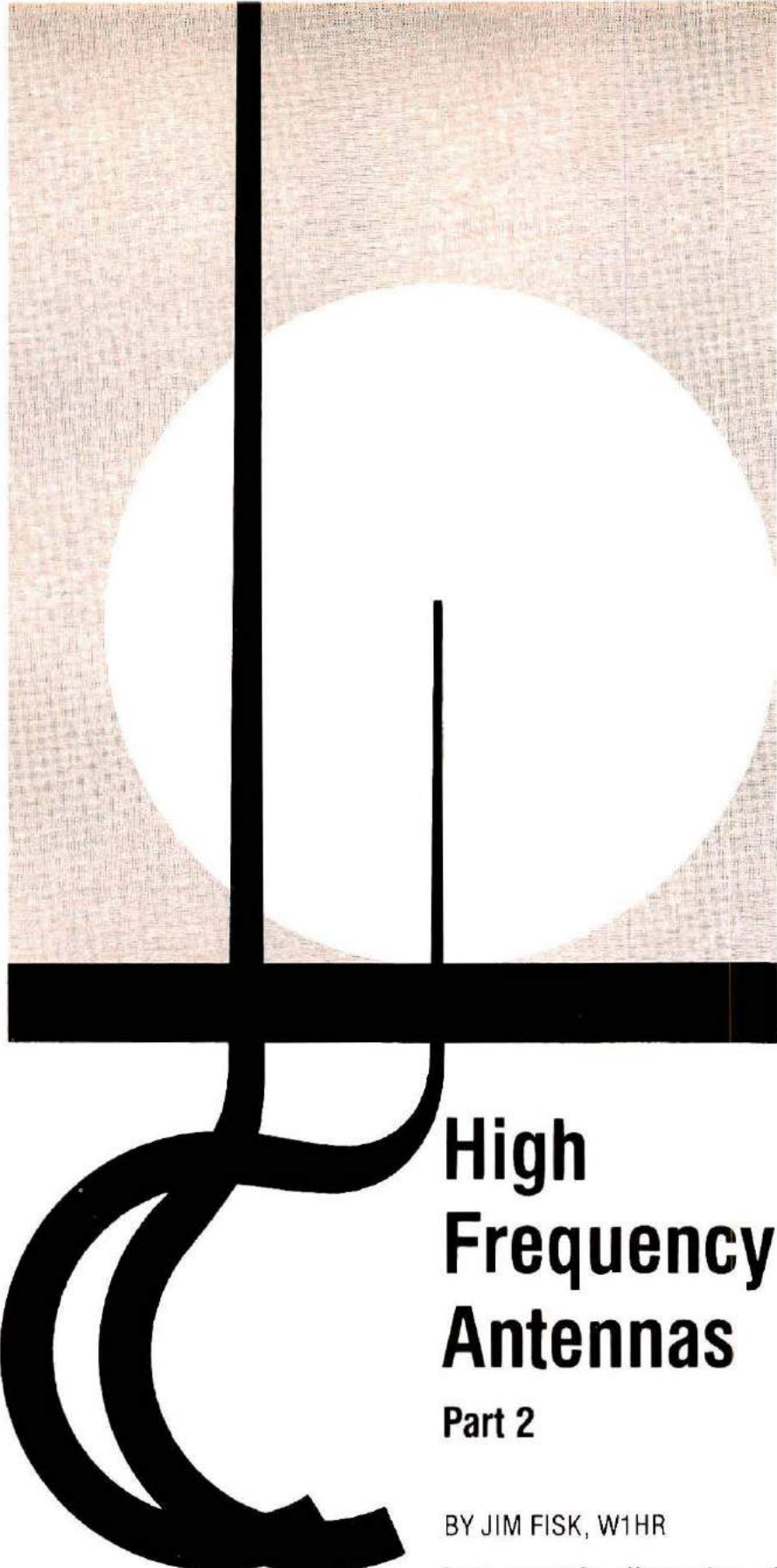

# High Frequency Antennas

## Part 2

BY JIM FISK, W1HR

Last month's discussion of simple antennas continues — with details on verticals, multi-element arrays, and high-gain beams and cubical quads.

### Vertical antennas

Although half-wave dipoles are usually thought of as horizontal antennas, they can also be installed vertically. However, most vertical antennas for the high-frequency amateur bands are one-quarter wavelength high and operated against a good ground system as shown in **Fig. 12**. This is called a *Marconi* antenna. The other half of the vertical is the image so it looks like you're getting a half-wavelength antenna for the price of a quarter-wave element. Unfortunately, for maximum performance you have to provide a very good system of ground radials around the base of the vertical radiator, and this may cost you more than the radiator itself!

Recall that the feedpoint impedance of an antenna consists of both radiation resistance and unwanted loss resistance. The ohmic losses of the vertical radiator are quite low, but half the antenna is provided by the image — unless you have an extensive ground system the loss resistance of the image will be very high and efficiency will be low.

Broadcast stations commonly use 120 radials, each a half wavelength long, splayed apart like bicycle spokes at 3-degree intervals. Few amateurs go to the time and expense of installing 120 radials, but if you're serious about the performance of your vertical on 80 or 40 meters you should probably use no less than 40 radial wires. On 14, 21, and 28 MHz you can use less than this with good results.

If you're now using a vertical and your ground system consists of a single ground rod, you'll see a significant increase in performance if you install as few as four radials, spaced 90 degrees around the base of the antenna. Later on you can add more radials as you have the time and money. Most amateurs bury their radials several inches below the



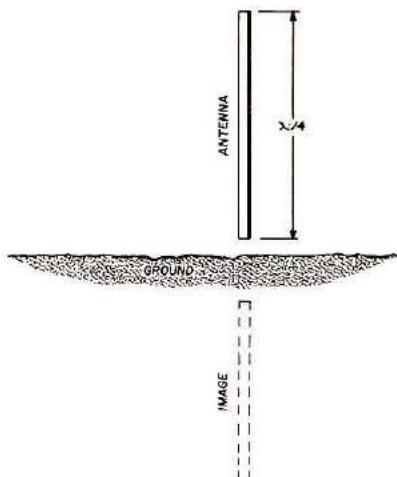

**Fig. 12.** The basic vertical antenna consists of a quarter-wave vertical radiator; the other half of the resonant system is provided by the image antenna in the ground. For maximum efficiency a vertical antenna requires a good ground system (not just a ground rod) which may cost more than the vertical radiator.

surface of the ground, but this isn't necessary if there's no chance someone will trip over them. If you have children, or live in a neighborhood where people are likely to be walking through your yard, you have no choice but to bury them. If you're moving into a new house and the lawn hasn't been seeded, you can lay the radials out on the surface of the ground and rake loose soil over them. When the lawn begins to grow, the roots of the grass will lock the wires in place just below the surface.

Copper wire is the best choice for a radial system, but unless you own stock in a copper mine, you'll have to use aluminum or galvanized steel wire. Both are good performers, and since both are used for electric fencing, you can buy quarter-mile (1320-foot or 402-meter) reels from Sears or Wards for a very reasonable price. Choose the largest diameter that is available, preferably larger than no. 14 (1.6mm).

Each of the radials in the ground system should be a minimum of 0.4 wavelength long. If your lot size won't accommodate this length, you

can use shorter radials if the outer end of each one is terminated with a driven ground rod.

A vertical antenna radiates equally well in all directions, and this may be an advantage, but it also receives equally well from all directions which may be a disadvantage — particularly if you're trying to work a weak station in one direction and a strong interfering signal is coming in from the opposite direction. Vertical antennas are also more susceptible to man-made noise and lightning static because these sources of noise are vertically polarized. Nevertheless, if you're serious about working over long distances on 80 and 40 meters, the quarter-wave vertical is an excellent choice if you can manage the height.

A quarter-wave vertical on 80-meters is about 65 feet (20 meters) high, which may be difficult to manage, but heights much less than a full quarter-wavelength provide very good results if properly designed. Since an electrically "short" antenna is capacitive, as previously noted, inductance must be provided externally to tune the antenna to the desired operating frequency. Either base loading (an inductor at the base of the antenna) or center loading (a coil at the center of the antenna) may be used, but for a number of reasons, center loading provides much more efficient operation. The loading coil should have very low loss for best results. This is the

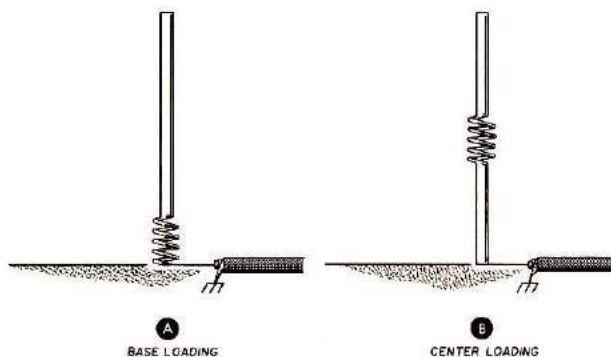

**Fig. 13.** When an antenna is too "short" for the desired operating frequency, it looks capacitive. Therefore, it can be resonated by adding inductance. Both base loading, **A**, and center loading, **B**, are commonly used, but center loading provides higher efficiency.

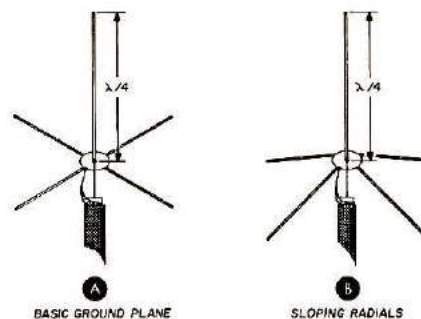

**Fig. 14.** The ground-plane antenna is popular on the higher frequency amateur bands. The antenna is usually mounted on a high mast well away from nearby objects; the ground is simulated by the four quarter-wavelength radials arranged around the base of the vertical radiator. When the radials are horizontal as shown in **A** the feedpoint impedance is about 37 ohms; if the radials are allowed to droop as in **B** the feedpoint impedance is close to 50 ohms and provides a good match to coaxial transmission lines.

type of antenna which is often used for mobile operation on 80 and 40 meters.

#### Ground-plane antennas

One type of antenna which is very popular on 20 meters and the higher-frequency amateur bands is the ground-plane antenna shown in **Fig. 14**. This antenna is usually installed well above the ground away from trees and nearby objects which might distort the radiation pattern. In this antenna the ground system consists of four radials around the base of the antenna. Ground-plane antennas are usually built from aluminum tubing and are often used to provide omnidirectional (all directions) coverage on vhf. If the radials are allowed to droop at an angle of about 30



Fig. 15. The ground-plane antenna is also a good performer on 40 meters if you can manage the height. In the design shown here the four radials also serve as guys. The aluminum tubing radiator is attached to the wooden mast with ceramic standoff insulators.

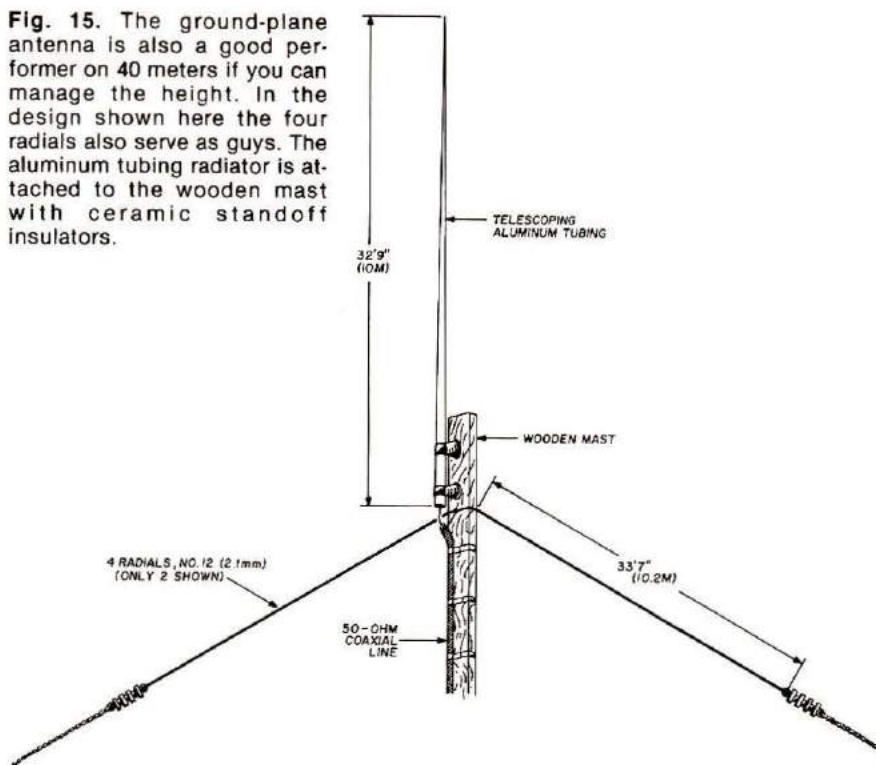

degrees, the feedpoint impedance provides a very good match to 50-ohm coaxial cable.

Ground-plane antennas have also been used on 40 meters, but this requires a vertical radiator about 33 feet (10 meters) long, which may present construction problems. One of the best antennas I have ever used on 40 meters is the arrangement shown in Fig. 15. The vertical radiator was built from sections of telescoping aluminum tubing and mounted on top of a tall wooden mast; the guy wires which supported the mast also served as the radials.

### Antenna arrays

As was mentioned earlier, the radiation pattern of any antenna is influenced by nearby objects. That's the reason why most commercial antennas are located out in open fields away from trees, buildings, and power lines which distort the shape of the pattern. You usually have little control over those things that distort the radiation pattern from your Amateur antenna, but

you can put the same concept to work for you if you install more than one antenna and carefully control the way in which you feed radio energy to the system. This is called a phased array and may consist of two, three, four, or more elements. The basic two-element array is shown in Fig. 16.

Remember that the horizontal radiation pattern from a single vertical antenna is the same in all directions. If you add a second vertical one-half wavelength away from the first and simultaneously feed rf energy to both of them, the radiation from each of the antennas adds in such a way that the resulting pattern is bidirectional and *broadside* to the two antennas (Fig. 16A). Note that the transmission line to each of the verticals must be the same length for a broadside pattern.

If you change the length of the transmission lines so the radio energy from your transmitter arriving at one vertical is going through a maximum while the rf at the other vertical is going through

a minimum (180 degrees out of phase), the radiation pattern will be bidirectional in line with the two verticals (Fig. 16B). This is called an *end-fire array* and is much easier to do than it sounds because a transmission line which is one-half wavelength long delays the rf energy by 180 degrees. To feed the two antennas 180 degrees out of phase all you have to do is make sure that the feedline to one vertical is one-half wavelength longer than the other one.

It's also possible to switch feedlines in such a way that you can choose between the end-fire and broadside patterns from the comfort of your ham shack. The basic arrangement is shown in Fig. 17. The two transmission lines marked A



The Hy-Gain 14AVQ, left, and 12AVQ, right, are multi-band verticals for the amateur bands. The tuned traps provide automatic band switching. The 14AVQ covers 10, 15, 20, and 40 meters and is designed for use with 50-ohm coaxial cable (swr 2:1 or less on all bands); it is only 18 feet (5.5m) high and will handle a full kilo-watt. The 12AVQ is for 10, 15, and 20 meters and is only 13½ feet (4.1m) high. Kits are available to mount these antennas on your roof.



and **B** are exactly the same length. Therefore, when the switch is in the **BROADSIDE** position, maximum radiation will be broadside to the two verticals. When the half-wavelength section of transmission line is switched in (**ENDFIRE** position of the switch), the rf arriving at the vertical antenna on the right through transmission line **B** will be delayed by 180 degrees. Hence, the array will have an endfire radiation pattern. The added half-wavelength transmission line can be coiled up inside your ham shack.

You can also build a phased vertical array using two verticals spaced one-quarter wavelength apart and fed 90 degrees out of phase (one transmission line is a quarter wavelength longer than the other). The resulting pattern is called a "cardioid" and is shown in **Fig. 18**. By using a switching arrangement similar to that in **Fig. 17**, you can switch the cardioid pattern to either the right or left. Somewhat similar arrangements can be used with three, four, or more vertical elements to provide maximum radiation in desired directions (this also cuts down on interference from other directions). One commercial vertical array uses four vertical elements and is designed for use on 10 and 15 meters as well as CB. This system, shown

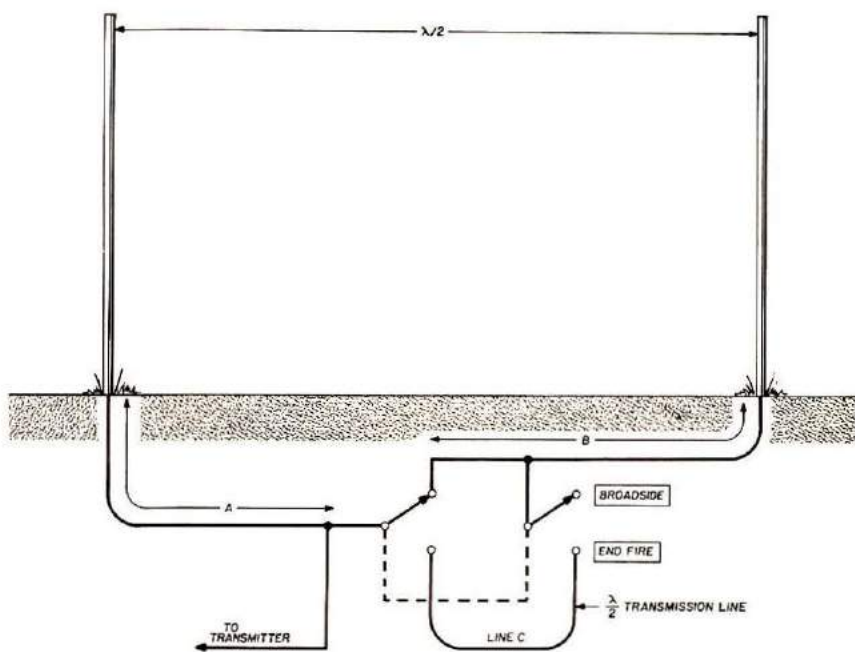
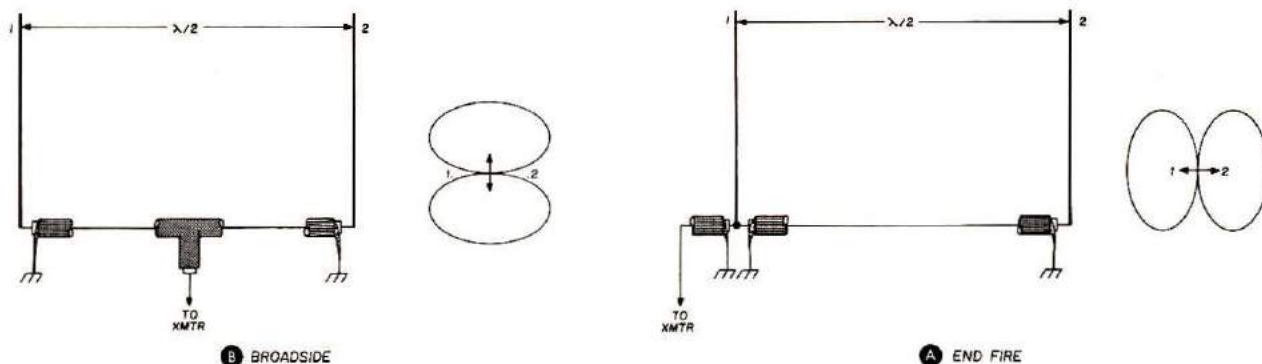

**Fig. 17.** Switching arrangement for obtaining both broadside and endfire radiation patterns with a two-element phased array. Transmission lines **A** and **B** are exactly the same length; feedline **C** is  $\frac{1}{2}$ -wavelength long.

in **Fig. 19**, uses special electronic circuits to accomplish the required phase delays to each of the vertical elements.

You can also build arrays of horizontal antennas to obtain gain and directivity. On 20, 15, and 10 meters it's usually more practical to build an array you can rotate, but on 40 meters a rotatable beam is too big for most amateurs to even consider. It can be done, but it requires a large, expensive rotator, as well as well-guyed

tower. One phased horizontal array that is sometimes used on 40 meters is shown in **Fig. 20**. This antenna was first designed by W8JK back in the 1930s and is often called a flat-top beam or W8JK array. Although seldom seen today, it still provides an excellent means of obtaining both gain and directivity on 40 meters. Both the horizontal elements should be the same length; if made 60 to 80 feet (18-24 meters) long and fed with open-wire line, this array can be



**Fig. 16.** Simple vertical array for amateur use consists of two vertical radiators spaced one-half wavelength apart. Each vertical is  $\frac{1}{4}$ -wavelength high and operated against a good ground system. When rf power to the two verticals is in phase (transmission lines exactly the same length), maximum radiation is broadside to the array as shown at **A**. If the rf power to one vertical is delayed by 180 degrees (transmission line to one vertical is  $\frac{1}{2}$ -wavelength longer than the feedline to the other), maximum radiation is in line with the array or endfire, **B**.



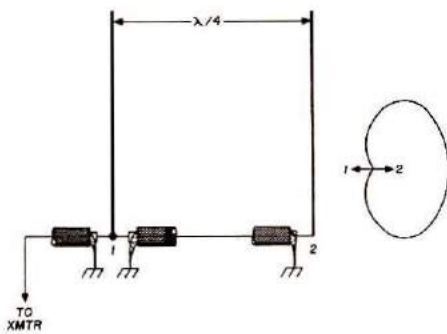

**Fig. 18.** Two quarter-wave vertical elements spaced  $\frac{1}{4}$ -wavelength apart and fed 90 degrees out of phase provide a cardioid radiation pattern as shown here. The 90 degree phase difference is accomplished by making the feedline to one radiator  $\frac{1}{4}$ -wavelength longer than the transmission line to the other vertical.

used with equally good results on both 20 and 40 meters.

### Directional beams

One of the best ways to improve both directivity and gain, while using as little space as possible, is the multi-element array shown in **Fig. 21**. Originally designed by two

Japanese engineers, Yagi and Uda, the English language description was written by Dr. Yagi, so this type of antenna is often called a Yagi beam although it is more correctly known as a Yagi-Uda array. Yagi and Uda discovered that if several half-wavelength elements were placed in close proximity to one another, they could produce gain figures comparable to those of much larger arrays.

Typically, a Yagi beam has a center-fed driven element that is approximately one-half wavelength long. A slightly longer element is placed a few tenths of a wavelength away from the driven element and serves as a "reflector". Shorter elements placed in front of the driven element are called directors. It's common practice on 20 meters to use one reflector and one director, but on the higher frequency bands where element size is smaller more directors can be added for increased gain.

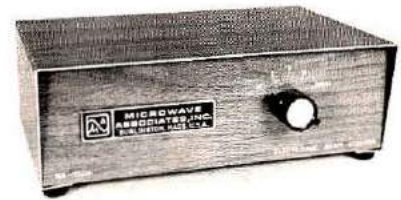

The Microwave Associates Electronic Beam Steerer\* which is used with the vertical antenna system shown in **Fig. 19**. The correct phase relationships to each of the verticals is determined by electronic circuits in the control box. The system can be used on any frequency between 18 and 36 MHz.

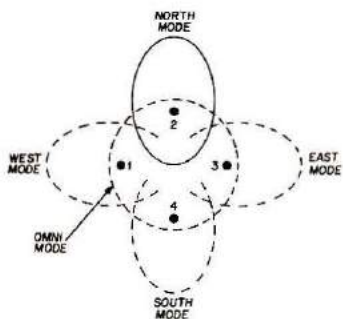

**A** RADIATION PATTERN

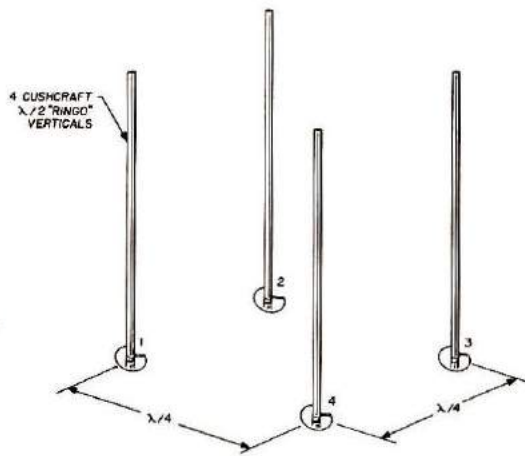

**B** ANTENNA LAYOUT

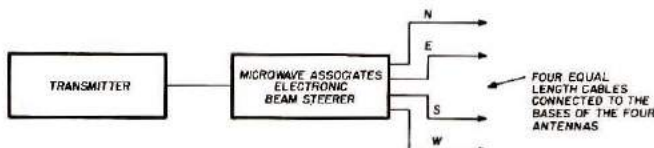

**C** SWITCHING SYSTEM

**Fig. 19.** Array of four vertical elements for 15 or 10 meters which uses an electronic beam switching system. The radiation pattern can be switched from the comfort of your shack for omnidirectional coverage or for maximum radiation in any one of four directions, **A**. The four half-wavelength verticals used in the system are arranged in a square, **B**. Block diagram of the system is shown in **C**.

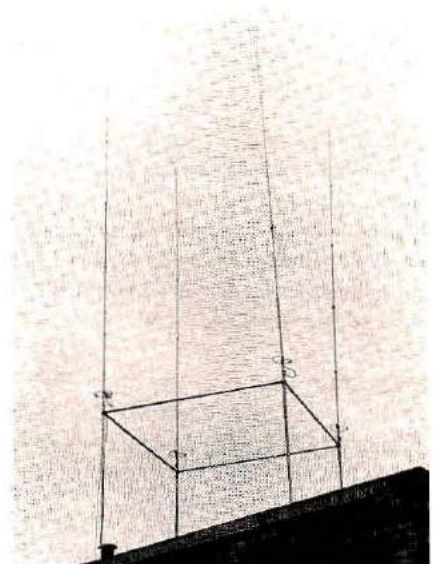

The 4-element phased vertical array shown in **Fig. 19**, set up for operation on 27 MHz. The control box for this antenna is shown in the photograph above.

Neither the reflector nor the directors of Yagi beams have to be connected to the feedline because they receive energy in the correct phase relationship through radiation from the driven element itself. Such elements are called parasitic elements. Antennas of this type are called "beam" antennas

\*Suggested retail sales price is \$100. If your local ham dealer doesn't stock the Beam Steerer, write to Microwave Associates, Inc., Burlington, Massachusetts 01803, and request the name of the distributor nearest you.



because they focus the radio energy in beams much like a searchlight, with little radiation to the rear or off to the sides. The Yagi beam is probably the most popular directional antenna in use anywhere in the world — it does require a tower and a rotator, but if you have the space and want maximum performance, someday you will probably have one in your backyard.

Another popular directional antenna that has excellent gain, is lightweight, and inexpensive to build is the cubical quad shown in Fig. 22. This antenna is a wire antenna

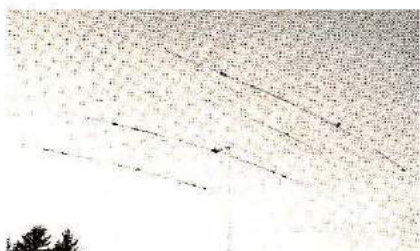

The new Cushman ATB-34 three-band Yagi for 10, 15, and 20 meters. This antenna functions as a three-element beam on 15 and 20 meters, and has three active elements on 10. The boom is 18 feet (5.5m) long, and the antenna weighs in at 42 pounds (19kg).

that uses some features of the Yagi except that the elements are square; two square loops, each 1 wavelength around the perimeter, are placed about 0.2 wavelength apart. Each square loop has four sides — that's the "quad" part. When you put the two loops near each other the result looks like a cube, hence its name, "cubical quad." This antenna was invented by Clarence Moore, W9LZX, in Quito, Ecuador, in 1942 for radio station HCJB, the "Voice of the Andes."

Before Moore invented the cubical quad, ordinary Yagi beams were used by HCJB. However, due to the high altitude and high power of the transmitter, the Yagi elements developed very high corona discharges at their ends which caused the antennas to literally

melt away after short periods of operation. Moore was chief engineer at the station at the time and conceived the quad as a solution to the discharge problem — since a loop doesn't have ends as such, there was no corona discharge. To this day, HCJB still uses a quad antenna.

Bamboo is common in the tropics, so it was used in the first quad as spreaders or "spiders" to support the wire loops. Amateurs still use bamboo if they can find it, but several firms market fiberglass poles for this purpose which are much stronger and have longer life. The feedpoint

impedance of the two-element cubical quad is about 60 ohms, so it provides an excellent match to coaxial transmission lines. Although the two-element quad is the most popular, three- and four-element quads have been used to provide substantially greater gain.

Many amateurs claim they get better performance out of a quad, while others favor the Yagi. This is difficult to prove one way or the other, but the performance of a two-element quad appears to be comparable to that of a three-element Yagi. However, you don't get something for nothing — the quad has somewhat greater

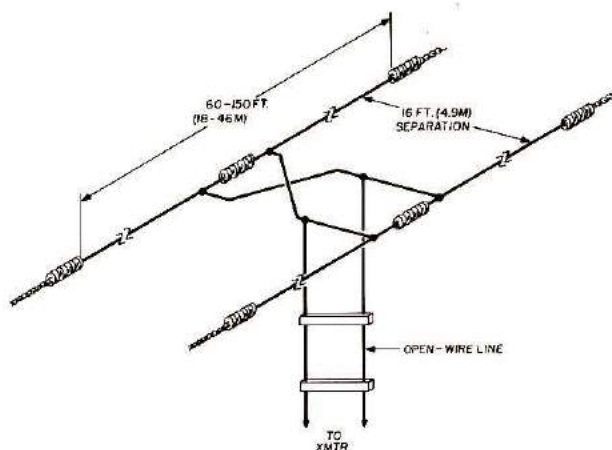

Fig. 20. The flat-top or W8JK horizontal array was very popular in the 1930s, but is seldom seen today. Nevertheless, this antenna is an excellent performer for DX work and can be used on more than one band. Since it uses open-wire feedline, it requires an antenna tuning unit.

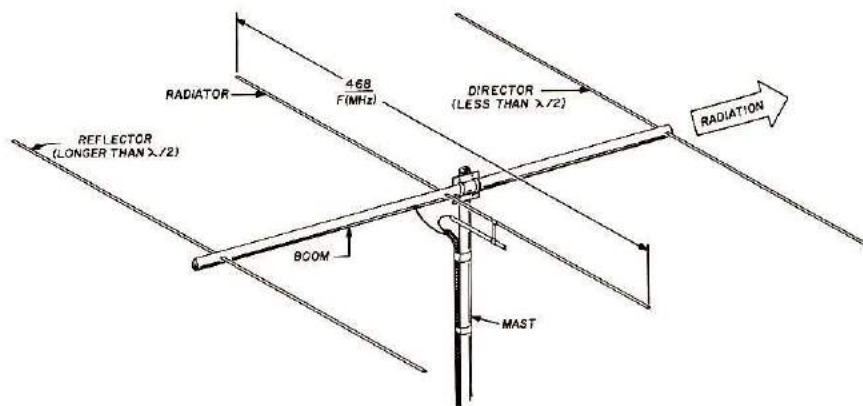

Fig. 21. Three-element beam or Yagi-Uda array (usually called a Yagi) is probably the most popular directional antenna used anywhere in the world. Radiation is concentrated in one direction with little radiation to the rear or off to the sides. The reflector and director do not have to be connected to the feedline — they receive energy through radiation from the driven element or radiator. On the higher frequencies where size is smaller, Yagi beams often have more than one director.



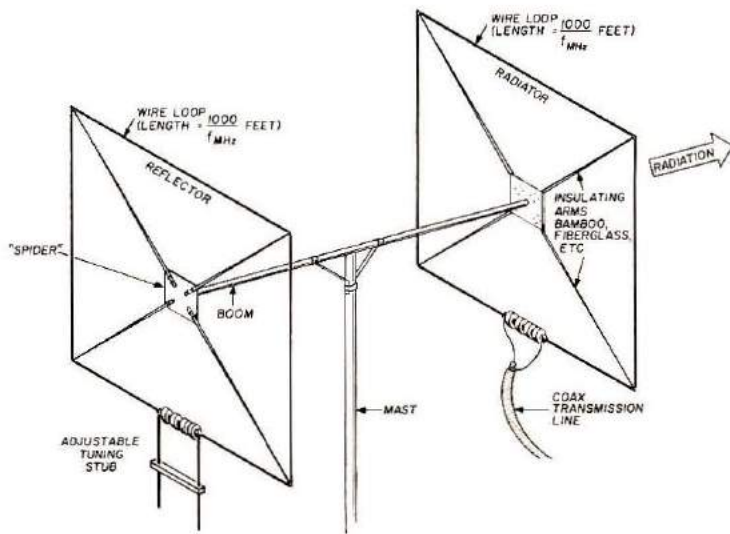

Fig. 22. Performance of a two-element cubical quad is similar to that of a three-element Yagi beam. The quad has somewhat higher wind resistance, but it's easy to build and uses low-cost materials.

wind resistance and may be more difficult to install on the top of your tower.

### Multiband antennas

One of the easiest ways to operate on several bands with the same antenna is to use open-wire feedline and an antenna tuner as was

is popular is the so-called "trap" antenna shown in Fig. 24. In this antenna the outer ends of the antenna are effectively divorced from the inner section by the tuned electronic circuits. For a dual-band 80- and 40-meter trapped dipole, for example, on the 80-meter band the traps look

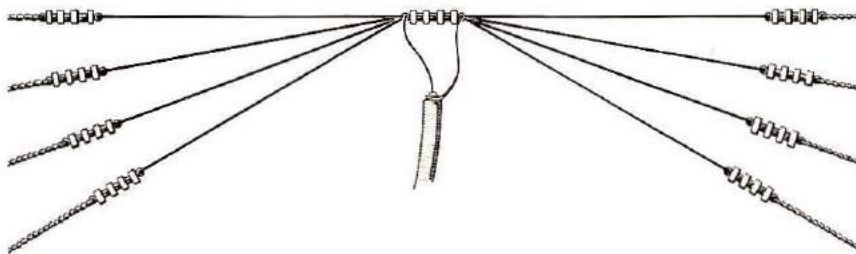

Fig. 23. Simple multiband antenna consists of half-wavelength dipoles stacked one beneath the other. If the ends of each of the antennas are separated by several feet, there will be little interaction.

discussed earlier, but this is not the only way to get the job done. If you want to use coaxial feedline one of the best solutions is to use the multi-dipole arrangement shown in Fig. 23. In this antenna each of the individual dipoles are cut for a different Amateur band. If the ends of the antennas are separated by several feet, there is very little interaction between the antennas.

Another arrangement which

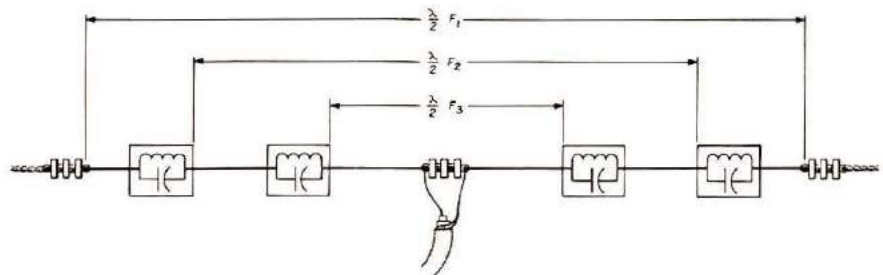

Fig. 24. Multiband trap dipole for operation on three different amateur bands (denoted  $f_1$ ,  $f_2$ , and  $f_3$ ). The traps are electronic tuned circuits which effectively isolate the outer ends of the antenna on the higher frequencies. Since the traps aren't perfect, this antenna is somewhat less efficient than individual antennas for each band.

essentially like a short circuit so the antenna behaves as a half-wavelength dipole. On 40 meters the traps are designed to look like open circuits so only the center section of the antenna is used. This is fine in theory, but it's impossible to build traps which are 100 per cent efficient — they're not quite short circuits on 80 meters nor are they open circuits on 40. They come close, but they're not perfect. Consequently, trapped antennas have somewhat more loss (and lower efficiency) than antennas which are designed for only one band. However, if you have room for only one antenna this is an excellent way to operate on more than one band. This same basic arrangement has been used in multiband verticals and in three-band Yagi beams.

### Summary

Although there are a number of other antenna types which have been used by amateurs, the ones discussed in this article are the most popular. If you look through any of the popular amateur antenna books, you'll find others that you might like to try. With an understanding of radiation pattern and feedpoint impedance, you can choose the antenna that best fits the space you have available, the bands you want to operate on, the space you have available, and how much money you want to spend.

HRH





# cutting the cost of Amateur Radio

BY DENNIS KING, W6ROL

Part of the fun of Amateur Radio is building your own equipment, and everyone — newcomer and experienced Amateur alike — welcomes the challenge of making each dollar go as far as possible.

During 20 years of hamming, I've developed some techniques to reduce my buying and building cost to as low a level as possible, and the whole point of this article is to help you become a skilled penny-pincher, while adding a little "zing" to your hamming by teaching you how to "buy smart." Experienced hams will be familiar with many of these techniques but, because newcomers may not be so "savvy," I've decided to repeat them for your benefit.

Along with these ideas, you'll

also find a description of a new book, *The Underground Buying Guide*, which can help you obtain needed equipment, parts, and supplies at the best possible prices, and also help you locate hard-to-find items and services.

## Free parts and equipment

The first technique is the one designed to save the most money: It's simply getting parts and equipment *free*. Check with your friends, neighbors, relatives, and acquaintances for old equipment that you can have — just for hauling it away. You'll be surprised how much useful equipment you can accumulate in a short period of time by resorting to this easy and time-honored practice!

Equipment such as old TV sets and radios contain many valuable parts, whether you build tube-type or solid-state

gear. For instance, you can build a high-voltage (500- to 600-volt dc) power supply for tube-type gear, or low-voltage (5-volt dc and 12-volt dc) supplies for solid-state projects from old transformer-type TV sets. I make it a point to accept anything that's free because there are always small components such as capacitors, switches, and potentiometers that can be used in future projects.

## If you must buy . . .

Another good technique is to attend electronic flea markets. Some of the best buys in electronic equipment and parts are found at these events. An item that has been collecting dust in someone's garage may have just the rare part you need for your special project. The best bargains are obtained when the flea market just



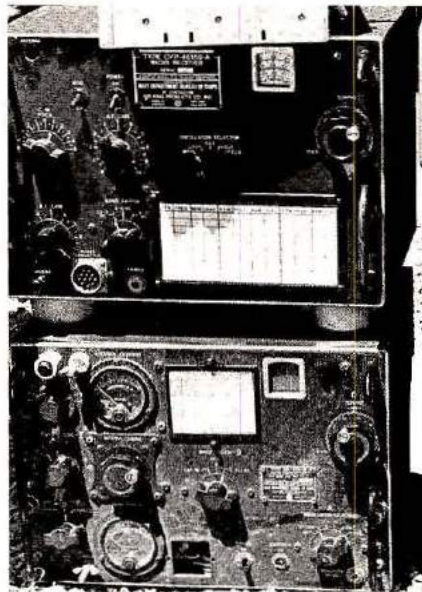

Flea markets provide a seemingly endless supply of parts and goodies. Some can be used as is, others must be repaired or modified. If you really want to save money, take a prepared shopping list and stick to it (photos by Harvey Samuels, WA2LUE).

opens (before someone else spots them) and just before closing when many sellers will accept any price rather than haul the gear home.

It is usually wise to avoid buying tubes, whatever the price, unless they are for display, for that is probably all they are good for. And, most importantly, it is good practice to avoid equipment without schematics unless you need only the parts. The equipment usually needs some work done

on it, in spite of the claims of the seller.

Here is another good source of parts and equipment: The electronic auction. These events are held regularly by Amateur Radio clubs . . . and occasionally at ham conventions. Bargains abound at these affairs — if you are willing to take a few chances — like getting inoperative equipment without schematics, etc. But, where else can you get a box of assemblies,

miscellaneous resistors, capacitors, switches, and a hernia from lifting the whole mess, for 75 cents?

#### **Manufacturers' over-runs**

If you live near firms that make, market, or service any kind of electronic gear, these companies can be good sources of electronic parts and equipment. Many firms give production-run leftovers, defective or outdated assemblies, and engineering



“breadboard” prototypes, to local schools, and other organizations. Others sell the surplus to local dealers. Some firms give the surplus to employees, but the best ones open their doors periodically to electronic hobbyists like you and me. It is often worthwhile to check with the firm’s public relations department to find out if they have surplus sales open to the public. These firms often sell high quality, state-of-the-art components and equipment at dirt-cheap prices. It is best to get to the events early while the pickings are good. Recently, I picked up a 5-volt at 8 ampere, and a 12-volt at 6 ampere, precision dc regulated power supply for \$7.50 each at an electronic firm’s surplus sale.

### Surplus

Here is another technique if you live in or near a large city. Look over and “mentally catalog” the wide variety of components, mysterious assemblies, dusty black boxes, and unidentifiable objects for sale at local “surplus” stores. I especially enjoy going to these firms because buying at good prices is often a mental battle with the owner or clerk. Often the firms are operated by a character who wants to know what you are willing to pay for some valuable (to him) electronic trinket. The key to obtaining the part at the best price is to convince him that the item is not valuable to him — or to you — and you are doing him a favor by buying it. It’s worth a try anyway.

Many surplus stores of this type don’t advertise and are usually located off the beaten track. If you need a special part or simply want to look over the goods, check with several inveterate scroungers who have made the rounds of the area.

### Outright purchases

Technique of last resort: When absolutely necessary, go straight — and buy from a

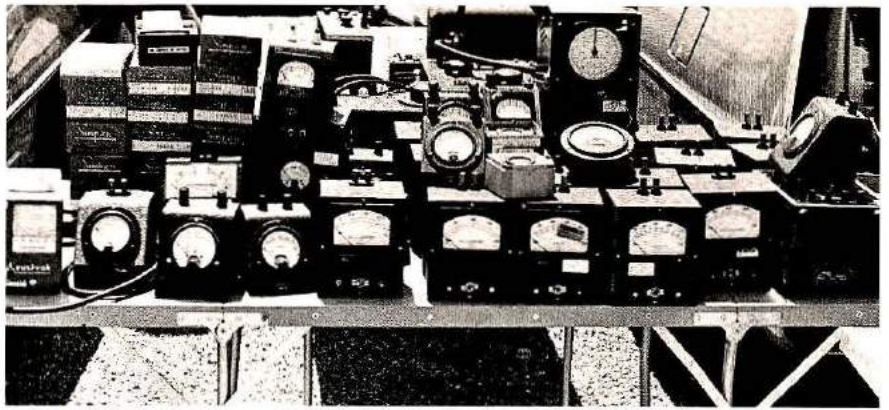

Meters and machines, teletypes and transceivers, tubes and transistors — if you keep looking there is a good chance that you’ll find it at a large flea market (photos by Harvey Samuels, WA2LUE).

large, reputable, distributor of first-line industrial components. These distributors are located in every major city and can be found listed in the *Yellow Pages* under “Electronic Equipment and Supplies — Wholesale.” Cramer, Elmar, Hamilton-Avnet, Kierluff Electronics, and RV Weatherford, are some of the big ones. They typically have the latest digital ICs, LEDs, and other recently introduced components that are not available from direct mail firms or surplus dealers. If you buy through their will-call facility, on a pick-up, cash deal, they will usually take your small order. I try to obtain several parts at one time rather than

burden them with an under-\$10 order. It is usually necessary to call ahead for parts, but I have never been refused service.

The advantages of dealing with this type of firm are almost immediate; availability of needed, first-line parts that are difficult to obtain through other sources. The only disadvantage is that small-quantity prices from these firms tend to be higher than from mail-order and surplus sources.

For an especially hard to find item it is often worthwhile to make an announcement at a radio club meeting or to place an ad in the group’s newspaper. Announcements seem to work best — if you





You'll even find some non-Amateur treasures if you watch closely. Part of the fun, for many shoppers, is the dickering over the price and value of some "find." After the hamfest and auction season is over, you can use the Underground Buying Guide. (Rochester hamfest photos by Harvey Samuels, WA2LUE).

plead enough, someone will either have the part or know where it can be obtained. Fellow club members will often part with a device for next-to-nothing.

### Stock piling

Another good technique, if you're a "dye-in-the-wool" builder is to build your own stockpile of parts. Because of an undying interest in building and experimenting rather than buying assembled gear or kits, I have developed a small, but continually growing, stockpile

of parts. The primary reason for developing a stockpile is to avoid writing, or running to local sources, for every part you need, and to avoid waiting for a part that is desperately needed on Sunday evening. My personal reason for developing a stockpile is a pack-rat instinct that can't be shaken.

This stockpile consists of four multiple-drawer storage cabinets and about 30 standard sized cardboard parts boxes obtained from a local hardware store. The cabinets contain smaller parts while the



cardboard boxes hold the larger components and assemblies. With this stockpile, some equipment can be built without buying any additional parts; other equipment requires scrounging only a few specialized parts. Building a new piece of equipment, or repairing an older piece, doesn't require a major buying spree. Most of the parts were obtained inexpensively over the years at the sources mentioned in this article.

The last, and perhaps most valuable technique, on my list



is to consult the *Underground Buying Guide*. This guide contains a listing of over 600 sources of parts, equipment, supplies and services for hobbyists. If you are looking for equipment and parts such as digital components, ICs, variable inductors or keyboards, the *Underground Guide* has a second listing of over 200 product categories cross-referenced to the first list. Only those firms that sell to hobbyists are listed. Everything from million-dollar mail-order firms to weekend garage operations are listed. One section of the guide even lists sources by state, cross-referenced to the first list.

The guide is designed to be a valuable tool for new and experienced hobbyists. It is planned to update it yearly. If you have a reliable source of direct mail parts, supplies or services of interest to amateurs, drop me a line. If it's not already included, it will be added to the next edition. Good scrounging! **HRH**

The *Underground Buying Guide* is \$5.95 from *ham radio's Communications Bookstore*, Greenville, New Hampshire 03048. Order PM-UBG.



"As a matter of fact, my husband is a ham radio operator, too."

# TEN-TEC ULTRAMATIC KEYS

## MODEL KR50

- SUPERLATIVE "FEEL" 5-50 GRMS PADDLE FORCE
- AUTOMATIC OR MANUAL WEIGHTING
- DIT AND DAH MEMORIES WITH SEPARATE DEFEATS
- "STRAIGHT KEY" OVERRIDE FOR QRS OR TUNE-UP
- GUARANTEED FOR LIFE BEARING PIVOTS

A sparkling new keyer with a host of exciting features. A powerful aid to cleaner, more articulate CW that is relaxing to use and a joy to copy.

The paddle assembly will delight the CW purist as well as the recent graduate from a bug or hand key. The superlative "feel" is attained by a magnetic return force, instantly adjustable to exactly the right touch for you.

Weighting, the ratio of dit and dah (bits) lengths to the spacing between them, is either automatically or manually varied. In the automatic position, it is programmed to lengthen the bits at slow speed for enhanced smoothness and decrease them as you advance the speed, for highest articulation. Or, it can be adjusted to a constant value.

The KR50 is versatile. Dit and dah memories are provided for full iambic (squeeze) keying. Either dit or dah, or both, may be turned off for operation as a conventional type keyer. Self-completing characters at all times.

A convenient "Straight key" is built-in for QRS sending or tune-up. Also an internal side-tone and 115VAC/12VDC operation is provided.

The KR50 is designed to have a permanent place in your shack for the years, perhaps decades, ahead. An investment in the enjoyment of CW.

PRICE \$110.00



## KR20-A

Paddle has unique principle with excellent feel for rhythmic CW. Characters are self-completing. Bit weighting is optimized for normal speeds. Manual key button conveniently located for hand sending. Side tone signal. Reed relay. Plug-in circuit boards. 115VAC or 6 to 14 VDC. HWD 2 1/2" X 4 1/2" X 8 1/4". Wt. 2 1/2 lbs.

PRICE \$69.50

## KR1-A

This is the paddle mechanism used in the KR50. Requires 6-14 VDC for adjustable electromagnetic paddle return force. Adjustable contact spring. For iambic or conventional keyers. "Straight key" button. Housed in an attractive metal case with cream front panel, walnut vinyl top. Size: 2" X 4" X 6". Wt. 1 1/2 lbs.

PRICE \$35.00

## KR5-A

Similar to the KR20A but without monitor signal and AC power supply. A great value. For 6-14 VDC operation. Size HWD 2" X 4" X 6". Weight: 1 1/2 lbs.

PRICE \$39.50

## KR2-A

The paddle used in the KR20A. Single paddle for non-iambic keyers. "Straight key" button conveniently located, cream aluminum case with walnut vinyl top. Size: 2" X 4" X 6". Weight: 1 1/2 lb.

PRICE \$17.00

**TEN-TEC, INC.**  
SEVIERVILLE, TENNESSEE 37862  
EXPORT: 5715 LINCOLN AVE., CHICAGO, ILL. 60646

Insulates and protects  
Color code your tools

## PLASTI-DIP YOUR GRIP



Dip your own tools in plastic ■ Just dip and let dry (no heat required) ■ Easier on hands ■ More gripping power ■ No more cold, slippery handles ■ Identifies your tools (choice of colors) ■ Also coats wood, glass, plastic, etc. ■ Permanent ■ Wears like plastic & it insulates ■ Smooth & thick — feels like hot dip flexible vinyl

CONTENTS: 16 FL. OZS.

COLORS: Red Blue Green  
Black Yellow Orange

\$4.95 ea. TWO FOR \$9.90 - WE'LL  
PAY SHIPPING  
ADD 45¢ POST. & HAND. N. Y. S. RES. ADD 7% TAX

DEALER INQUIRIES INVITED



**QUBE INTERNATIONAL**  
DEPT. HH7 P.O. BOX 151  
NO. TON., NEW YORK 14120

Vanguard now has a **HOT**  
2m converter - at a price  
you can afford

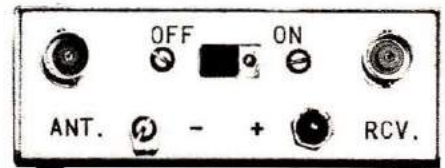

## MODEL C-144-A ONLY \$39.95

READ THE SPECIFICATIONS & SEE  
WHY IT'S THE BEST CONVERTER  
VALUE AVAILABLE ANYWHERE!!

- Dual-gate MOSFET r.f. stage with diode protected input.
- Dual-gate MOSFET mixer for minimum cross modulation. Every converter tested for noise figure (2.5 — 3.0 dB max.) with Hewlett Packard noise measuring equipment.
- 6 tuned circuits.
- More than 20 dB gain. .1 microvolt sensitivity guarantee when used with receivers having 1 microvolt or better sensitivity.
- Complete with one .005% plug-in crystal to cover 144-146 or 146-148 MHz (be sure to specify which, or get both for only \$5.00 more). Standard output is for 28-30 MHz.
- 16 gauge aluminum case with BNC receptacles and antenna/power switch. Measures 3 1/2" x 2 1/4" x 1 1/4"
- Operates 12 Vdc @ 15 ma.

IN STOCK NOW FOR IMMEDIATE  
C.O.D. SHIPMENT. Call Monday through  
Friday 9 AM to 4 PM (212) 468-2720.

**VANGUARD LABS**

Dept. 2H, 196-23 Jamaica Avenue  
Hollis, New York 11423



# BRASSPOUNDING

## on wheels

BY CHARLES W. CLEMENS, JR., K6QD

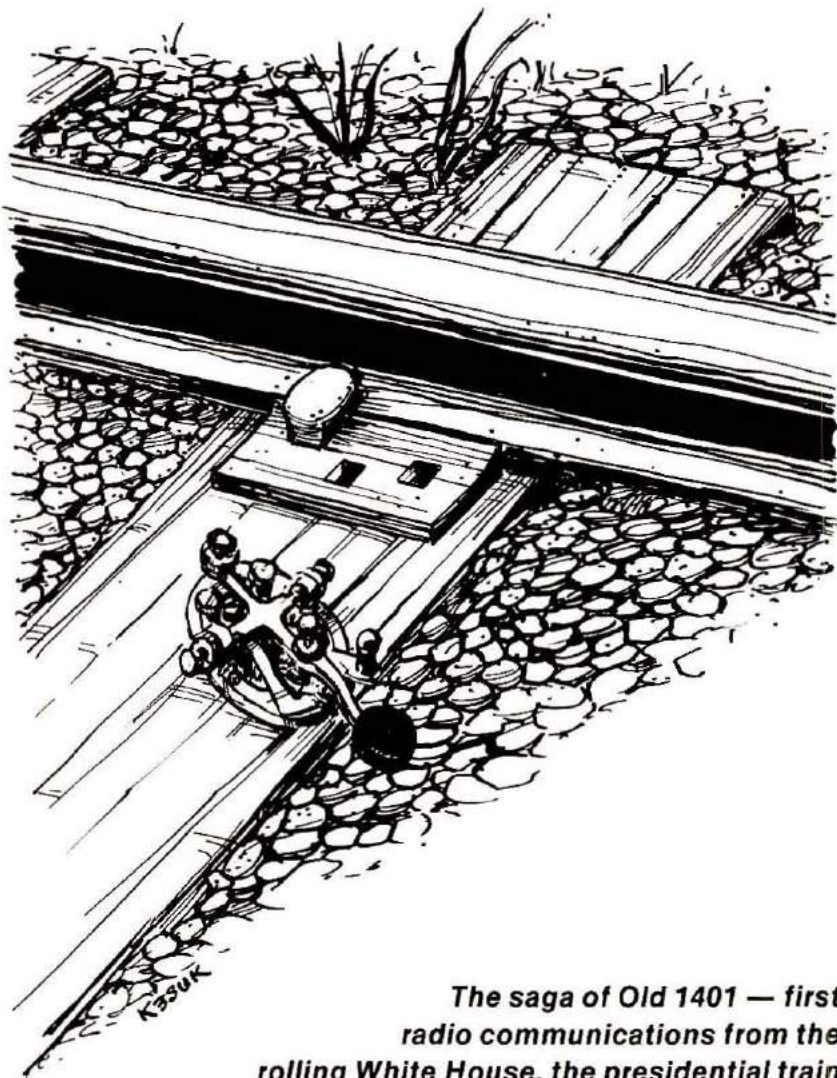

*The saga of Old 1401 — first radio communications from the rolling White House, the presidential train*

Many of the operating stories we read in the amateur publications are about sea-going brasspounders. This one is about a brasspounder who rode the rails. Back in the summer of 1942, I was working my shift at WAR in Washington when an officer walked up behind me and tapped me

on the shoulder. He told me to go pack my clothes for a trip to a warm climate. That was how I started as the first CW operator at the White House.

I learned that the White House had a Signal Corps detachment that now had the task of providing communications on a

continuous basis between the Presidential Train and the White House. I believe this was the first time such a thing had been attempted in the United States. The Washington end was to be handled by the big War Department communications center, WAR; the remote end by the train plus relays, when necessary, from local stations along the way.

My first trip on the communications car, Old 1401, was the second trial run for the car. On this trip I went with the detachment commander, Col. Beasley; a radio operator recently made a Lieutenant, Lt. Greer; a civilian engineer from the War Department named Jack Kelleher; a radio maintenance man named John J. Moran; and a Secret Service man named George J. McNally. It is interesting to note that all of us were amateur radio operators. We went from Washington, D.C. to New Orleans and returned with our car in a regular passenger train, coupled between two baggage cars.

Old 1401 was a combine car. That is, she was half baggage and half passenger. She had been built for the Baltimore and Ohio Railroad in 1914. At the time I first met her, all



identification on her sides had been painted out. Her number was her only identification, and it was painted in beautiful gilt over the entrance at the passenger end.

Inside, a couple of front seats had been removed and an operating table installed in their place. One operating position was located on each side of the aisle between the seats. Each position had a Super Pro receiver and a BC-342.

The BC-342 was a new model at that time, designed for use in tanks and other rough riding vehicles. This receiver was installed on shock mounts, but my first trip proved that the best way to mount equipment on the train was to bolt it down solidly. Installed in this manner, the whole car moved as one unit and the receivers worked beautifully. There was, however, a modulation on the received signals imparted by the train's vibration. But this was better than having the tubes jump out of their sockets — which they frequently did when the equipment was on shock mounts (the tube clamp was not yet in common use).

Telegraph lines alongside the tracks provided a lot of clicks that made it difficult to copy poor signals. However, we didn't have too much trouble with this problem except in the Southwest. The transmitter was a BC-447, running about 300 watts.

The clearance requirements for railroad cars prohibited using a real antenna. Ours was a wire inside an insulating tube mounted on standoffs about six inches above the metal roof of the car. This was later changed to a copper tube, the same size as the insulating tube, with much better results.

Our frequency complement ran from 3 MHz to 17 MHz.

I was supposed to contact a number of Army stations along the way, none of them more than a couple of hundred miles from our route. As might be expected, results were poor and it was decided to contact WAR in Washington direct. Successful contacts were made from New Orleans and on the way home. The only real difficulty came when we were close to Washington. At that time, it was difficult to receive WAR on any frequency. Overall, however, our results were encouraging and we were assigned the task of accompanying President Roosevelt on his swing around the country visiting military bases and aircraft plants.

To my knowledge, this big trip was the first time continuous communications had ever been attempted between the presidential train and Washington. We contacted WAR in the eastern half of the country and WVY (San Francisco) or WVD (Seattle) in the western half. Results were excellent. In fact, our volume of traffic was so high that it was necessary to pick up an additional message clerk in Seattle, our first major stop, to handle the paper work.

To make a long story quite short, I worked six years on the Presidential Train, traveling with Presidents Roosevelt and Truman in the United States, Canada and Mexico. We logged well over a hundred thousand miles.

Equipment and facilities were improved over those years, and when I left Old 1401 in 1948, the car had a small operating room, a code center, a small bunk room with four bunks, a lounge room, and the

baggage half of the car packed with equipment. We had two BC-339 transmitters for our message traffic. These were fixed station Federal jobs that loafed along at 1500 watts in radio-teletype service and could easily run 3-kW on CW.

A single BC-610, a 500 watt a-m transmitter, was available for occasional broadcast services. We also had a 250-watt Motorola fm transmitter for guard radio service. On the receive side, we had the two BC342s I mentioned earlier, two Super Pros, a big Navy receiver whose type number I can't recall, two Western Electric CV-31 teletype converters and a single teleprinter.

We also had a telephone switchboard that provided service throughout the train. The telephone cable permitted us to provide music throughout the train and intercom service, too, if it was desired.

Power was provided by two 25-kW diesel generators. Only one of these was required, and we switched them every 24 hours. We also had two 100-amp battery chargers to charge the train's batteries when we were parked away from railroad terminal facilities, and two converters to provide ac power from the batteries to run our receivers in standby.

Today, the train is no more. Old 1401 has been retired and the President's car — Ferdinand Magellan — is gone, too. The small detachment I knew has grown to the White House Communications Agency. Their responsibilities have grown a great many times over, but I'll bet they aren't having any more fun working assignments today than I did when Old 1401 was my home on wheels.

HRH



With all the ham radio  
**...what your**



Alan Applegate, WBØBHE, CW Electronic Sales Co., Denver CO



Ray Grenier, K9KHW, Amateur Electronic Supply, Milwaukee WI



Lajos Nemeth, SM5CLW, Elfa Radio, Solna, Sweden



Hannes Bauer, DL1DX, Ing. Hannes Bauer KG, Bamberg, W. Ger.



Mark Franklin, WBØANT, Electronic Center, Minneapolis MN



George Dominick, W4UWC, Bondurant Bros. Co., Knoxville TN



Larry Robinson, KØSGJ, Mid Com Electronics, Inc., St. Louis MO



*These photographs are worth 13,000 words...*





equipment available today, have you ever wondered

# Dealer uses at home—



David Fine, WA0CWH, Ham Radio Center, Inc., St. Louis MO



Tom Softley, W3ZSX, The Comm Center, Inc., Laurel MD



Earl Smith, K2YLM, Atkinson & Smith, Inc., Eatontown NJ



Ed Cobb, K4YFR, Priest Electronics, Inc., Norfolk VA

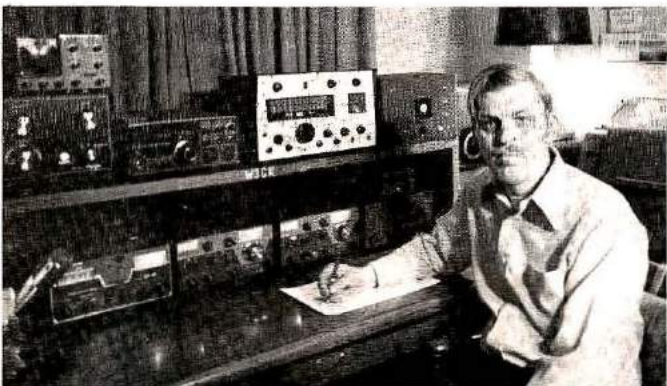

Gordon Kittel, W3GK, Electronic Exchange, Souderton PA



Ross Hansen, WB7BYZ, Ross Distributing Co., Preston ID

To receive a FREE Drake Full Line Catalog, please send name and date of this publication to:

**R. L. DRAKE COMPANY**

540 Richard Street, Miamisburg • Ohio 45342 • Phone (513) 866-2421 • Telex 288-017  
Western Sales and Service Center, 2020 Western Street, Las Vegas, Nevada 89102



# a different approach to receiver DESIGN



BY COURTNEY HALL, WA5SNZ

*There's more than one way to design a good, general-coverage receiver, and the Drake SSR-1 is a good example of an unusual approach that merits careful consideration.*

The principles behind this unusual receiver design first appeared in Amateur literature in the March, 1958, issue of *QST*, entitled: "A New Receiver Tuning Principle."\* The article described the Racal RA-17 Communications Receiver which was manufactured in England and sold, at the time, for over \$1000. The receiver featured very rugged construction, and its one-piece, die-cast, aluminum chassis was divided into many separate, but integral, compartments. The really remarkable thing about this receiver was its continuous tuning range from 1.0 to 30.0 MHz, accomplished without bandswitching! Not only that, but the tuning dial arrangement had calibration marks at 1-kHz intervals. Actually, there was a "bandswitch," but it only switched coils in the rf amplifier and, if desired, the receiver's "front end" could be switched to a broadband position when preselection wasn't needed.

The frequency-tuning

mechanism involved two tuning knobs and two tuning dials — something like the familiar bandset and bandspread arrangement — but with a difference. One knob was labelled *MHz*, and its dial was calibrated from 1 to 29 MHz. The other knob was labelled

*kHz*, with a dial calibration from 0 to 1000 kHz. This kHz dial consisted of a piece of film five feet (1.52m) long that had calibration marks every kHz! The *MHz* knob and dial selected a 1-MHz segment of the desired frequency, while the *kHz* knob and dial tuned

Although the receiver is now some 20 years old, the Racal RA-17 still commands a good price, even on the used-equipment market. Its performance and unique frequency-coverage scheme set a standard that has been hard to beat (photo courtesy Racal Communications, Inc., Rockville, Maryland).



\*Byron Goodman, W1DX, "A New Receiver Tuning Principle," *QST*, March, 1958.



from one end to the other of the selected 1-MHz segment. For example, to set the frequency to 14.124 MHz, the MHz dial was set to 14 and the kHz dial was set to 124. Obviously, 14 MHz plus 124 kHz equals 14.124 MHz.

A real "kicker" in all this was the fact that the setting of the desired MHz segment was not at all critical; it only needed to be adjusted approximately to the desired setting. More

about that later.

The Racal RA-17 is not widely available in Amateur circles but there is a new receiver that follows the same design. It is now being marketed in this country and is readily available. This is the Barlow XCR-30.\*

### The Drake version

The SSR-1 receiver, recently introduced by the R. L. Drake Company, Miamisburg, Ohio,

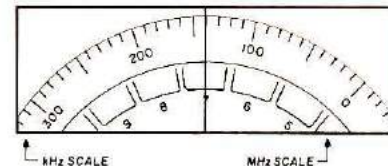

Fig. 1. Concentric dials of the SSR-1 receiver. Dials are set to 7.140 MHz.

operates in the same manner as the RA-17. The basic design is the same, except that local oscillator and intermediate frequencies are slightly different. In addition, the SSR-1 is all solid-state as well as being smaller and lighter than the RA-17, and its list price is \$350.

In the photograph, the large tuning knob controls the kHz dial setting while the top left-hand knob controls the MHz dial setting. Two concentric dials are visible through the dial window at the top right-hand corner of the front panel. Fig. 1 shows an enlarged view of these dials set to 7.140 MHz. The smaller, inner dial is calibrated from 0 to 29 MHz and the larger, outer dial is calibrated from 0 to 1000 kHz, with calibration marks at 10-kHz intervals. Notice that the markings on the inner dial indicate a wide arc of setting for each MHz of calibration.

The top center knob on the SSR-1 controls preselector tuning, and the bottom four knobs are, from left to right respectively, *volume* and *off-on* switch, *band* switch (which only switches rf amplifier coils), *mode* switch (*a-m*, *USB*, *LSB*), and *clarify*. The clarify control is actually a fine-tuning control which makes it a little easier to tune ssb stations.

Fig. 2 shows a simplified block diagram of the SSR-1. The design may be considered in two sections: A conventional receiver circuit having a tuning

### Glossary of Terms

**Bandpass** — a filter circuit that passes a particular *band* of frequencies, excluding those above and below the desired band.

**Bandswitching** — a function of some receivers that enables them to cover several different bands of frequencies. Usually accomplished by mechanically switching different combinations of capacitors and inductors into the circuit. Necessary because any single capacitor-coil combination will not cover a wide enough range of frequencies of interest.

**Calibration** — a term used to mean the relationship between a desired frequency to be listened to or transmitted, and the actual dial indication on your receiver or transmitter. It is very important to have the indicated frequency correspond as closely as possible to the desired frequency. Many receivers have a *crystal calibrator* that generates marker signals every 25 or 100 kHz to help you adjust, that is, *calibrate* your equipment.

**Converter** — one or more circuits, including passive and active components — such as capacitors, coils, and tubes or transistors — that *convert* signals at one range of frequencies to signals at another, sometimes lower, range of frequencies.

**Frontend** — the portion of the receiver closest to the antenna, that processes received signals before passing them to subsequent circuits, or *stages* in the receiver.

**I-f** — stands for *intermediate frequency*, a frequency or band of frequencies, between a higher and a lower frequency or band of frequencies. A receiver has one or more *i-f stages*, consisting of tuned circuits and tubes or transistors that select, filter, and amplify signals before passing them on to subsequent stages.

**Local oscillator** — A tube or transistor circuit that produces a fixed or variable frequency signal that can be mixed with other frequencies in a *mixer* stage, (see below) to produce intermediate frequencies.

**Mixer** — A tuned circuit that has the ability to accept two different frequencies, sometimes quite far apart, and combine or *mix* them to produce sum and difference frequencies that are subsequently processed by filtering and amplifying only the desired frequency products. Mixers go hand-in-hand with local oscillators like Tweedledum and Tweedledee.

**Preselector** — A receiver *stage*, usually a tuned — or tuneable — circuit, that accepts signals from the antenna and passes only a narrow range of them to the next stage. A preselector is found in the *frontend* of a receiver between the antenna terminals and the first rf amplifier.

**Solid-state** — A broad term used to cover semiconductors such as transistors, diodes, and related families of components. A *solid-state* receiver is one that uses only semiconductors, and does not use tubes.

\*Barlow XCR-30, uses Wadley loop circuit; available from Gilfer Associates, Inc., Box 239, Park Ridge, New Jersey 07656; price on request.





The Drake SSR-1 is in all respects a modern short-wave-listener's instrument. It is light-weight, solid-state, and compact. The receiver should serve well as a tunable i-f to follow converters for the vhf and uhf spectrum. A minimum of controls on the front panel makes the receiver easy to use.

range of 2 to 3 MHz, and a variable-frequency converter. The v-f converter transforms any 1-MHz frequency segment of the tuning range between 0 and 30 MHz to the 2- to 3-MHz tuning range of the conventional receiver, whose tuning control is the kHz knob and dial for the overall receiver.

An example may be the best way to illustrate the operation of the variable-frequency converter. Let's assume that you want to receive a frequency in a 1-MHz-wide portion of the spectrum between 19 and 20 MHz. First, set the MHz tuning control to 19, which has the effect of tuning the hf oscillator to a frequency of 64.5 MHz. Incoming signals from the antenna in the frequency range of 19 to 20 MHz are fed to the first mixer stage and combined with the hf oscillator signal to produce difference frequencies between 44.5 and 45.5 MHz as follows:

$$64.5 - 19 = 45.5$$

$$64.5 - 20 = 44.5$$

The first i-f stage has a 1-MHz bandwidth between 44.5 and 45.5 MHz, and therefore passes this range of difference frequencies produced by the mixer.

Simultaneously, the 64.5 MHz hf oscillator output is fed to the second mixer, together with

a group of signals produced by a harmonic generator circuit. The harmonic generator produces signals spaced 1-MHz apart in the range of 3 to 33 MHz, and derives its stability from a 10-MHz crystal oscillator. The second mixer combines the 64.5-MHz hf oscillator signal with all of the harmonics between 3 and 33 MHz, but only one — (the 22nd) — produces a mixer product having a frequency of 42.5 MHz. This frequency-rich output of the second mixer is fed to a tuned bandpass amplifier having a center frequency of 42.5 MHz and a bandwidth of only a few hundred kHz, whereby only the 42.5-MHz second mixer product

is passed to the third mixer.

The third mixer combines the 42.5-MHz output from the bandpass amplifier with the 44.5-to-45.5-MHz signals from the first i-f stage, as follows:

$$44.5 - 42.5 = 2$$

$$45.5 - 42.5 = 3$$

to produce difference frequencies lying between 2 and 3 MHz. These are fed to the conventional-receiver portion of the SSR-1 which, as you already know, tunes that frequency range. Because a 19-MHz signal at the antenna was converted to 45.5 MHz, it will be heard when the receiver is tuned to 3 MHz; and a 20-MHz signal will be heard when the receiver is tuned to 2 MHz, as shown by the foregoing.

Table 1 shows the relationship between frequencies in the 19- to 20-MHz range, i-f signals, and the frequencies between 2 and 3 MHz. Remember that the frequencies fed to the third mixer are always the same: One input is always in the range from 44.5 to 45.5 MHz, and the other is always 42.5 MHz (plus or minus a few hundred kHz). Table 2 shows how different 1-MHz frequency "bands" are converted to the 2-to 3-MHz tuning range of the conventional receiver section.

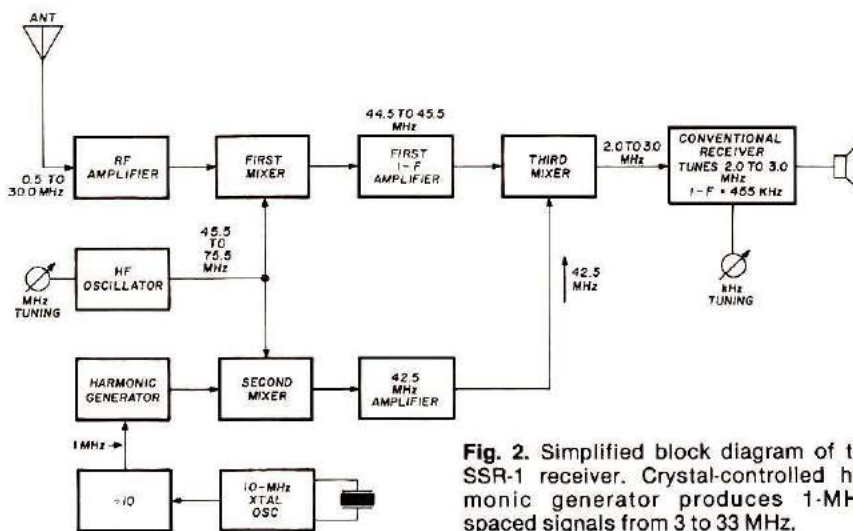

Fig. 2. Simplified block diagram of the SSR-1 receiver. Crystal-controlled harmonic generator produces 1-MHz-spaced signals from 3 to 33 MHz.



### Why MHz tuning is not critical

Earlier, I mentioned that the MHz dial setting was not critical, but need only be set close to the nominal frequency desired. The tables above show that the hf oscillator is always set to the precisely correct frequency in each example. Let's now take a look at what happens when the hf-oscillator frequency is offset by some amount, as a result of sloppy setting of the MHz dial.

Suppose in the previous example that the hf oscillator had been set to 64.6 instead of 64.5, thus being 0.1 MHz (1000 kHz) too high in frequency. A 20 MHz signal at the antenna would be converted by the first mixer to 44.6 MHz, and appear at the input of the third mixer. At the same time, however, the 64.6-MHz hf oscillator signal is combined in the second mixer with the 22nd harmonic of the crystal-controlled harmonic-frequency generator. This causes the second mixer output to be 42.6 MHz which will pass through the 42.5-MHz tuned amplifier because of its bandwidth of several hundred kHz. The 42.6-MHz signal then combines in the third mixer with the 44.6 MHz signal to produce a difference frequency of 2.0 MHz — exactly the same frequency produced before

**Table 1.** Illustrates conversion of frequencies between 19.0 and 20.0 MHz to conventional receiver tuning range of 2.0 to 3.0 MHz. Note: output frequency of hf oscillator is 64.5 MHz.

Antenna Signal Freq.	First Mixer Output Freq.	Third Mixer Output Freq.
19.0	45.5	3.0
19.1	45.4	2.9
19.2	45.3	2.8
19.3	45.2	2.7
19.4	45.1	2.6
19.5	45.0	2.5
19.6	44.9	2.4
19.7	44.8	2.3
19.8	44.7	2.2
19.9	44.6	2.1
20.0	44.5	2.0

**Table 2.** Shows change in receiver parameters as different 1-MHz band segments are converted to 2-to-3 MHz band tuning range of the receiver. All frequencies shown are in MHz.

Input Signal Freq.	MHz Dial	Hf Osc. Freq.	First Mixer Output Freq.	Harmonic of 1 MHz Used	Third Mixer Output Freq.
0.0	0	45.5	45.5	3.0	3.0
1.0	1	45.5	44.5	3.0	2.0
1.0	1	46.5	45.5	4.0	3.0
2.0	1	46.5	44.5	4.0	2.0
2.0	2	47.5	45.5	5.0	3.0
3.0	2	47.5	44.5	5.0	2.0
3.0	3	48.5	45.5	6.0	3.0
4.0	3	48.5	44.5	6.0	2.0
4.0	4	49.5	45.5	7.0	3.0
5.0	4	49.5	44.5	7.0	2.0
25.0	25	70.5	45.5	28.0	3.0
26.0	25	70.5	44.5	28.0	2.0
26.0	26	71.5	45.5	29.0	3.0
27.0	26	71.5	44.5	29.0	2.0
27.0	27	72.5	45.5	30.0	3.0
28.0	27	72.5	44.5	30.0	2.0
28.0	28	73.5	45.5	31.0	3.0
29.0	28	73.5	44.5	31.0	2.0
29.0	29	74.5	45.5	32.0	3.0
30.0	29	74.5	44.5	32.0	2.0

when the hf oscillator was set to the "correct" frequency of 64.5 MHz! It is easy to see, then, that changes of many kHz in the hf oscillator signal will not appreciably affect the receiver's tuning, and problems of frequency drift or slight mistuning or setting errors of the MHz dial will be self-cancelling.\*

### Other points of interest

Two requirements of a good receiver are sensitivity and frequency stability. The SSR-1 is not lacking in these areas. There is sufficient gain for atmospheric noise to activate the agc circuit at all frequencies, and frequency stability is excellent with the all-solid-state design.

When the MHz dial is set at 0, the kHz dial is theoretically capable of covering the frequency range from 1000 kHz down to zero Hertz. The preselector's lower frequency limit, however, is 500 kHz. In spite of this limitation I was

able to copy nearby low-frequency stations as low as 370 kHz.

Portability was not overlooked in the receiver's design. There is a built-in whip antenna, and battery operation is provided for by eight internal D-size flashlight cells. Receiver construction is uncluttered and well planned.

Dial calibration accuracy is within 5 kHz, or half the distance between calibration marks. A continuous, unmodulated, signal, caused by the receiver's internal oscillator, is present at each exact multiple of 1.0 MHz. This signal would be very costly to eliminate, but it is audible only when the mode switch is in USB or LSB, turning on the bfo. One might think that the unmodulated carrier would cause a beat signal when WWV is received at 5 or 10 MHz in the a-m mode, but there was no noticeable beat signal, and WWV sounded fine.

If you're in the market for a good general-coverage receiver, the SSR-1 is certainly worthy of consideration. **HRH**

\*This is the so-called "Wadley-loop" circuit. **Editor**



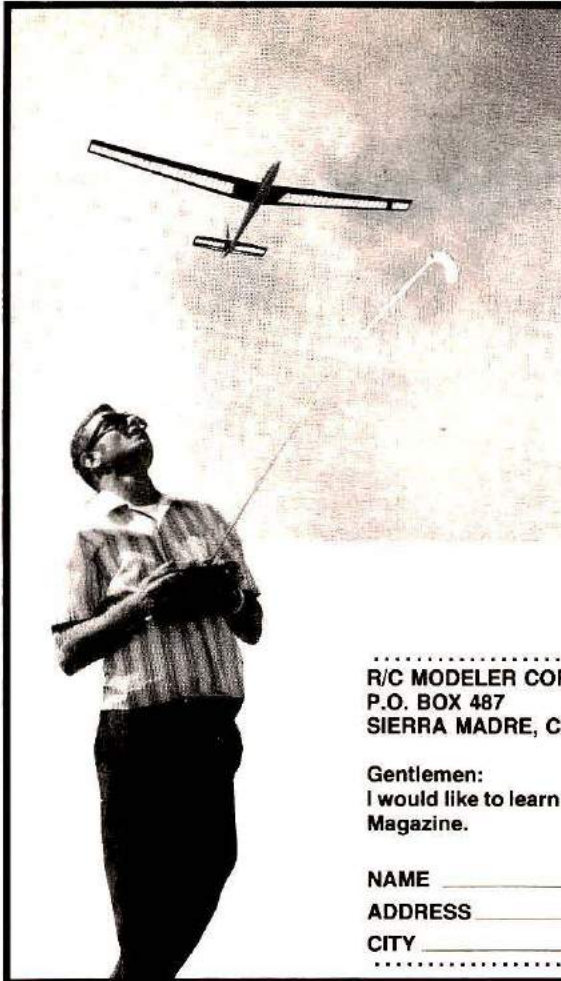

**Hey Amateurs:**

You'll see from the various articles featured in this issue that the world of radio control is an exciting and challenging new horizon to explore and can be yours for the asking. All over the world individuals exactly like yourself are enjoying the sport and hobby — the fellowship — of radio controlled model aircraft. This is America's fastest growing hobby and sport. In fact, nearly 20,000 amateurs are already enjoying the thrill of RC; it's an activity that every member of your family will enjoy.

Your amateur license is your passport and we would like to invite you to explore our hobby and sport. Whether it be radio controlled model aircraft, boats, gliders, helicopters, or cars; regardless of the scope of your interests, there is a place for you in radio control. *R/C Modeler Magazine*, the world's leading publication for the RC enthusiast, invites you to join us.

R/C MODELER CORP.  
P.O. BOX 487  
SIERRA MADRE, CALIFORNIA 91024

Gentlemen:  
I would like to learn more about radio control. Please send me a free sample copy of *R/C Modeler Magazine*.

NAME \_\_\_\_\_  
ADDRESS \_\_\_\_\_  
CITY \_\_\_\_\_ STATE \_\_\_\_\_ ZIP \_\_\_\_\_

# The 1977 Atlanta HamFestival and Georgia State ARRL Convention June 18-19, 1977

Downtown Atlanta Marriott Hotel • Courtland and Cain Streets • Atlanta, GA. 30303

- GIANT Covered Fleamarket Swapshop!
- More than 50 technical forums!
- The BIGGEST door prizes in all of Ham Radio:  
First Prize is a complete 2MFM Mobile rig — including a 1977 AMC Gremlin!!!
- 120 major exhibits!
- Special MICROPROCESSOR Section!

Registration: \$3.00 Individual, \$5.00 Family IN ADVANCE,  
\$4.00 Individual, \$6.00 Family at the door.

For Advance Registration Materials call 404/971-HAMS day or night or write to:

Atlanta HamFestival  
53 Old Stone Mill Road  
Marietta, GA 30067

SPECIAL HAMFESTIVAL RATES: \$18 SINGLE, \$24 DOUBLE.

CONTACT THE HOTEL DIRECTLY for reservations toll free at 1-800-228-9290 — and Hurry!!

**THE BEST HAMFEST IN THE WORLD!**



# Genave' amateur radio tomorrow... today!



**GTX-200T**  
(incl. 146.94 MHz)  
**\$249<sup>95</sup>**

*Engineered and designed for the quality conscious 2-meter enthusiast*

Genave's GTX-200T offers the FM operator up to 100 channel combinations incorporating 10.7 MHz first IF and 455 MHz second IF for outstanding sensitivity, minimizing effects of adjacent channel interference.

**ADDITIONAL FEATURES INCLUDE:**

- 30 watts output power, nom. 25 watts min. @ 14 VDC input
- Separate controls for independent transmit and receive frequency selection
- Switch for lock-in of pre-selected frequency pairs allows one-knob operation
- Supersensitive dual-gate MOSFET in receiver head end.
- Backlighted for night operation
- Factory-installed, front panel mount 12 digit tone encoder.



**GTX-2**  
2-meter FM, 10 channels, 30 watts with pushbutton frequency selector (Incl. 146.94 MHz) **\$189<sup>95</sup>**



**GTX-200**  
2-meter FM, 100 channel combinations, 30 watts (Incl. 146.94 MHz) **\$199<sup>95</sup>**



**GTX-10-S**  
2-meter FM, 10 channels, 10 watts (Xtals not included) **\$149<sup>95</sup>**

**GTX-IT**  
**\$299<sup>95</sup>**

*Hand-Held 2-meter FM, 6-channel, 3.5 watts hand-held with factory-installed tone encoder*

**GTX-I**  
**\$249<sup>95</sup>**

*Hand-Held 2-meter FM, 6-channel, 3.5 watts hand-held*



**CHECK THESE FEATURES:**

- All metal case
- American made
- Accepts standard plug-in crystals
- Features 10.7 MHz crystal filter
- Trimmer caps on TX and RX crystals
- 3.5 watts output
- Battery holder accepts AA regular, alkaline or nicad cells
- Mini hand-held measures 8" high x 2.625" wide x 1.281" deep
- Rubber ducky antenna
- Wrist safety-carrying-strap included
- 6 channels
- Factory-direct to you!

**Accessories Available**

- Nicad battery pack
- Charger for GTX-1 battery pack
- Leather carrying case
- TEIII tone encoder for auto patch

**TONE ENCODER PAD**  
Plug-in installation on most amateur transceivers.

TE-II **\$29<sup>95</sup>** TE-I **\$59<sup>95</sup>**



**HURRY! USE THIS HANDY ORDER FORM OR CALL COLLECT TODAY! (317) 546-7959**



4141 Kingman Dr., Indianapolis, IN 46226  
Phone-in orders accepted (317+546-1111)

NAME \_\_\_\_\_  
ADDRESS \_\_\_\_\_ CITY \_\_\_\_\_  
STATE & ZIP \_\_\_\_\_ AMATEUR CALL \_\_\_\_\_

Payment by:  
 Certified Check / Money Order  Personal Check  
 C.O.D. include 20% Down

Note: Orders accompanied by personal checks will require about two weeks to process.  
20% Down Payment Enclosed. Charge Balance To:

BankAmericard # \_\_\_\_\_ Expires \_\_\_\_\_  
 Master Charge # \_\_\_\_\_ Expires \_\_\_\_\_  
 Interbank # \_\_\_\_\_ Expires \_\_\_\_\_

IN residents add 4% sales tax: \$ \_\_\_\_\_

HH7 All orders shipped post-paid within continental U.S.

- GTX-200-T **\$249<sup>95</sup>**
- GTX-200 **\$199<sup>95</sup>**
- GTX-10-S **\$149<sup>95</sup>**
- GTX-2 **\$189<sup>95</sup>**
- GTX-1 **\$249<sup>95</sup>**
- GTX-IT **\$299<sup>95</sup>**

- Ringo Ranger ARX-2 6db 2-M Base Antenna **\$29<sup>95</sup>**
- Lambda/4 2-M and 8-M Trunk Antenna **\$29<sup>95</sup>**
- TE-I Tone Encoder Pad **\$59<sup>95</sup>**
- TE-II Tone Encoder Pad **\$49<sup>95</sup>**
- PS-1 AC Power Supply for use with all makes of transceivers 14 VDC—6 amp **\$69<sup>95</sup>**  
and the following standard crystals @ \$4.50 each \_\_\_\_\_  
Non-standard crystals @ \$6.50 each: \_\_\_\_\_

Add \$4 per Radio for Shipping, Handling, and Crystal Netting.

- ACCESSORIES FOR GTX-1 and GTX-1T**
- PSI-18 Optional Nicad battery pack **\$29<sup>95</sup>**
  - PS-2 Charger for GTX-1(T) battery pack **\$39<sup>95</sup>**
  - GLC-1 Leather carrying case **\$12<sup>95</sup>**
  - TE-III Tone Encoder (for use with GTX-1) **\$49<sup>95</sup>**





the  
strange  
world  
of  
**SUNSPOTS**

BY WILLIAM I. ORR, W6SAI

## DX conditions during 1977-1978 and thereafter

"You should have heard 20 meters last night! The Russian and Indian stations were louder than the locals! UK9LAB was 20 dB over S9. Conditions were just fantastic!"

"Gosh, 10 and 15 meters have been dead as a doornail since last summer when I worked some short-skip signals. I always thought those were DX bands. Why did I hear all those short-skip stations?"

"Did you hear that some fellows have made WAC on 160 meters? I always thought that was a short distance band!"

"Yesterday morning I heard European signals coming through on 80-meter sideband,

and there were also some JA signals in there!"

DX is where you find it. Somedays the bands are good and somedays they are bad. Most Novices and beginners are aware of the irregularities of the amateur bands, and have heard remarks about the *sunspot cycle* and rumors that the bands will get better or worse during the next few years. But the sunspot cycle and its effect upon radio propagation is not generally understood, even though its influence upon radio conditions will be profound during the coming years. This is a short

summary of what is going on in this regard, and what probably will happen to hf radio conditions during the next few years.

### The Ionosphere

Long distance radio communication is possible because radio waves are reflected to earth from the *ionosphere*. This is a region high above the earth's surface where the rarefied air is sufficiently ionized by ultraviolet light from the sun to reflect or absorb radio waves. The ionosphere is defined as that region lying about 30 to 250 miles (50 to 400 km) above



the surface of the earth. It is the ionosphere, acting like a gigantic radio mirror that is responsible for good or bad radio conditions.

The reflectivity (or ionization) of the ionosphere is a function of radiation from the sun (Fig. 1), and the greater the reflectivity, the better the radio conditions. As ionization diminishes, radio conditions become poorer.

The amount of radiation falling upon the ionosphere varies hourly, daily, seasonally and geographically, depending upon the relationship between the sun and the earth. In addition, year-to-year changes, over an approximate 11-year

cycle, cause vast changes in the ionosphere's ability to reflect radio waves. These changes, which result from the variation in the number of sunspots on the face of the sun, over 90,000,000 miles away, are the key to radio conditions on earth!

### Cycles in Ionospheric Activity

The first recorded observations of sunspots were made by Chinese astronomers more than 2000 years ago. For centuries, the dark spots on the sun were thought to be slow, high-flying animals or perhaps clouds. Galileo, considered by many to be the inventor of the modern

telescope, observed the blemishes on the sun and, in 1611, noted that the spots were on, or close to, the sun. He also observed that they were carried around the sun by its rotation, which seemed to take a period of about a month.

There the matter rested until 1908, when astronomers carefully photographed the sun and determined that the sunspots actually were whirling storms on the surface of the sun. These storms are accompanied by magnetic disturbances that generate eruptions of gaseous material, breaking through the sun's surface to create whirling "spots" of electrified material

**Fig. 1.** The sun-earth relationships. Radiation from the sun covers the entire electromagnetic spectrum. Of great interest to users of the communication spectrum are radio waves and ultraviolet radiation. Solar flares on the sun create "radio blackouts" and sunspots seem to govern high frequency radio conditions. Effect of sun's radiation on earth, together with earth's magnetic field, creates the Van Allen belt of radiation and the aurora. Complex interplay of radiant energy received from the sun and its effect upon mankind are not fully understood (drawing courtesy NASA).

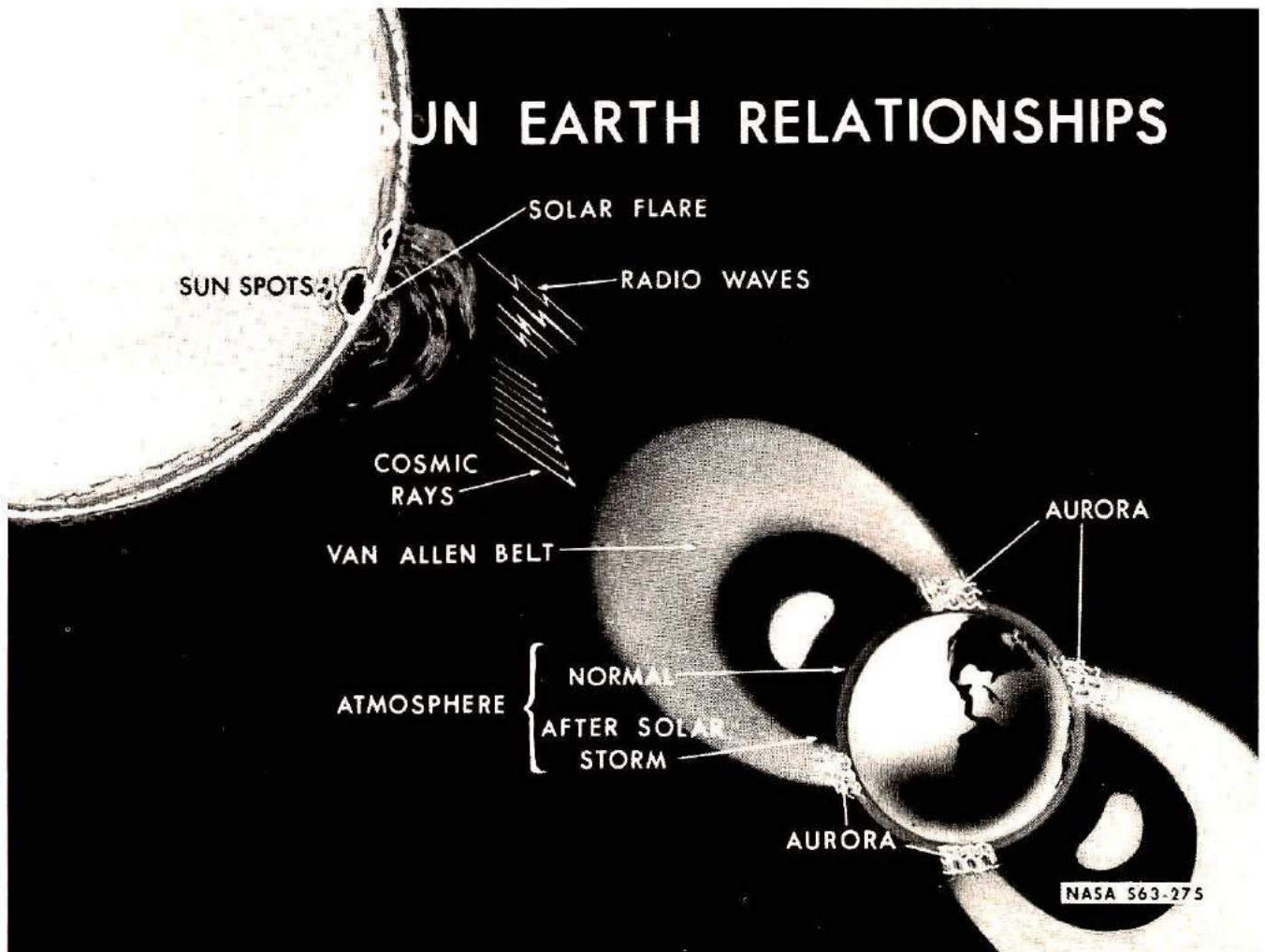



# SOLAR DETAIL

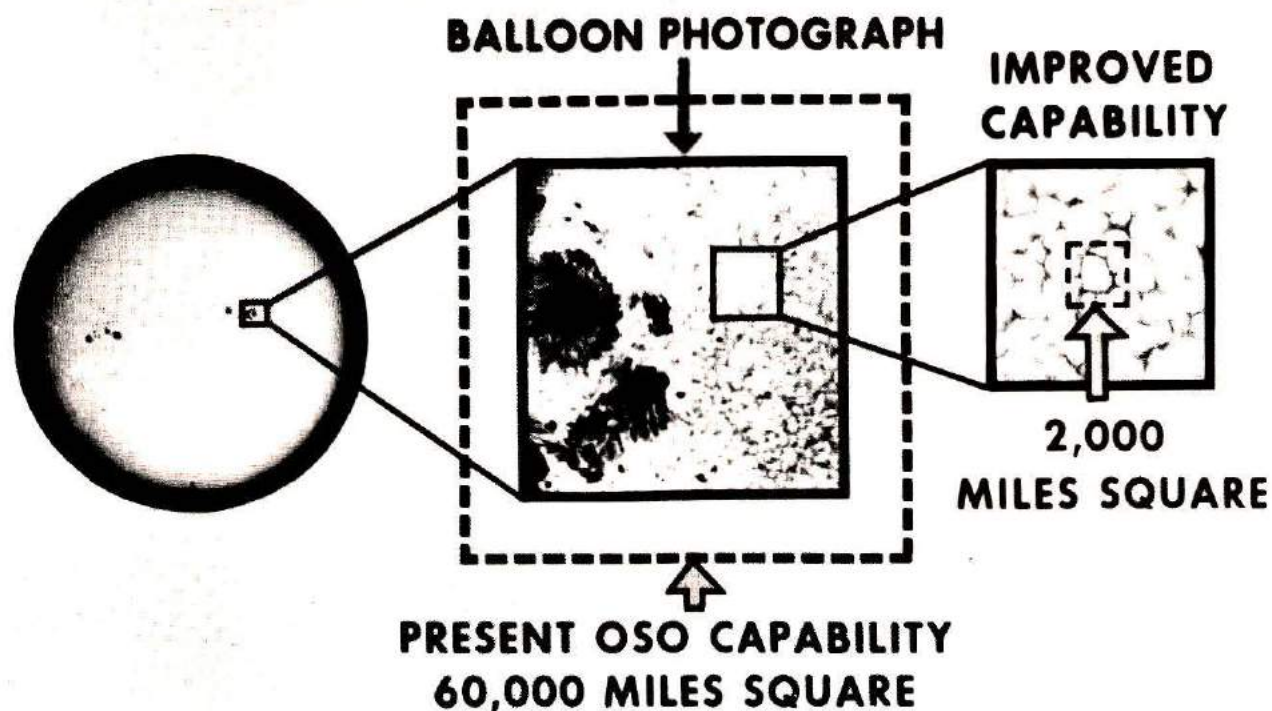

Fig. 2. Orbiting Solar Observatory (OSO) studies sunspots. A photographic close-up of a sunspot (center) shows the whirling storm on the sun's surface. Future capability of OSO will show small details of sun's surface, right. (Drawing courtesy NASA).

hundred of thousands of miles in diameter (Fig. 2).

About the middle of the 18th century, astronomers began to keep records of the sunspot count and by 1843, it was realized that the count varied, with sunspots appearing and disappearing in a periodic fashion, varying from a minimum to a maximum and back again in about 10 to 11 years. A plot of the sunspot cycle covering 1832-1932 is illustrated in Fig. 3.

The plot reveals that the sunspot maxima and minima are irregular, the length of the cycle varying from under 7 years to over 17 years, the minimum sunspot count varying from zero to nearly 12, and the maximum count varying from 45 to over 200. All of this was of academic interest only until the early nineteen thirties, when it was

noted that there was a direct relationship between the smoothed sunspot number and the intensity of ultraviolet radiation from the sun. This discovery was of paramount importance because it directly associated the sunspot count with long-distance radio propagation.

## The Sunspots and Radio Communication

It is now known that the sunspot cycle is a reliable index of the ionosphere's capability to reflect high frequency radio waves. In brief, when the smoothed sunspot count is high, a wide range of frequencies between about 3 MHz and 40 MHz is reflected over great distances. As the sunspot count declines, the ability of the ionosphere to reflect radio waves is diminished, and the upper limit

of the frequency range reflected decreases from about 40 MHz to 20 MHz, or less.

During the peaks of the last two great cycles, frequencies higher than 50 MHz were reflected great distances (Fig. 4). During the spring months of 1958, for example, international DX contacts on the Amateur 6-meter band were commonplace and the 10-meter band was open for DX work nearly 24 hours a day!

As every alert Novice or beginner knows, radio conditions today are not nearly as impressive; long-distance DX is notably absent from the 6- and 10-meter bands, and shows up only occasionally on the 15-meter band. On the other hand, the DX-ability of the 160- and 80-meter bands seems considerably enhanced compared to more normal periods of radio activity.



What, then, is going on? Are radio conditions going to improve or deteriorate over the next few years? What can we look forward to in terms of radio communication between now and 1980?

The answer can be predicted, and long-range forecasts of radio communication in the years ahead can be made; but, since there is at present no satisfactory theory that fully explains the cause of sunspots, or the sunspot cycle, an exact prediction of their future behavior is out of the question. However, from the cyclic nature of the sunspot cycle certain assumptions can be made, and various empirical methods have been developed for determining future solar activity.

### The Solar Cycle: Where We Stand

The present portion of the solar cycle is illustrated in Fig. 5. It can be seen that this cycle started about the summer of 1964 and reached a maximum number of about 110 sunspots in mid-1968. Since then, the sunspot count has been declining at a slow rate, with

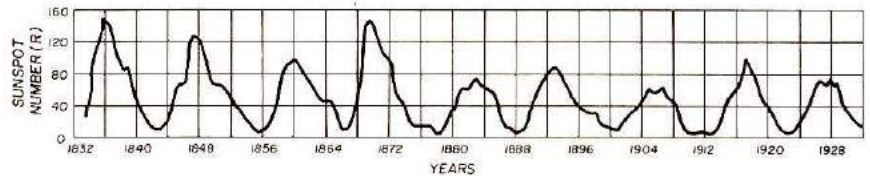

Fig. 3. Plot of sunspot cycle (smoothed) for the period 1832-1932. The sunspot cycle was viewed as an academic curiosity until about 1932 when it was observed to correlate closely with high frequency ionospheric radio propagation. Since that discovery, the sunspot cycle has been found to have direct and emphatic effect upon radio conditions, and particularly on the maximum usable frequency for any long distance radio circuit (chart courtesy of Bell Telephone Laboratories).

the next sunspot low predicted to arrive during the spring of 1977. Predictions for the next sunspot cycle, to start in early 1977, indicate a rather low, broad peak reaching a maximum count of about 55 to 75 in late 1982. The following minimum will then be reached about 1988. An extended prediction (guess) indicates that sunspot numbers in excess of 100 will not be observed again until approximately the year 2015! Thus, the next 40 years may be characterized by relatively low sunspot activity compared to the activity of the last 40 years.

The implications of low sunspot activity with respect to ionospheric propagation of radio waves is obvious. Long-

distance propagation will be more infrequent than in the past years of high sunspot activity, and will occur for shorter periods of time at reduced signal levels. The lower frequencies (those below 8 MHz) however, may show improvement even though the higher frequencies may provide marginal performance.

### The Immediate Future

The winter and spring of 1976-1977 mark the bottom of the old sunspot cycle and the start of the new one. If it progresses as is predicted, the new cycle will resemble Fig. 6. The years of 1977 and 1978 are years of transition. During these years, as the new cycle starts its course, the sunspot count will be very low, but rising. The usable high frequency spectrum has shrunk to about half that available during periods of high solar activity. Emphasis will remain with the lower frequency amateur bands (160 through 20 meters). The low bands — 160 and 80 meters — will exhibit DX openings to many areas of the world during the hours of darkness in the late fall, winter and early spring months. Twenty meters will continue to be the best overall DX band with openings all over the world from just past sunrise to shortly before sunset, and late in the evening during the late spring and summer months.

The 15-meter band should show improvement in DX as the sunspot count slowly rises. Good north-south contacts were logged during 1976, and these should improve both in

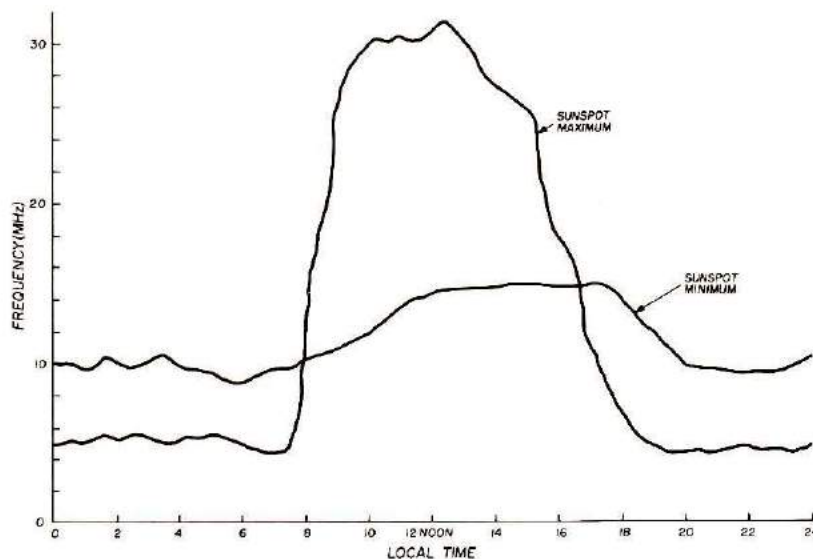
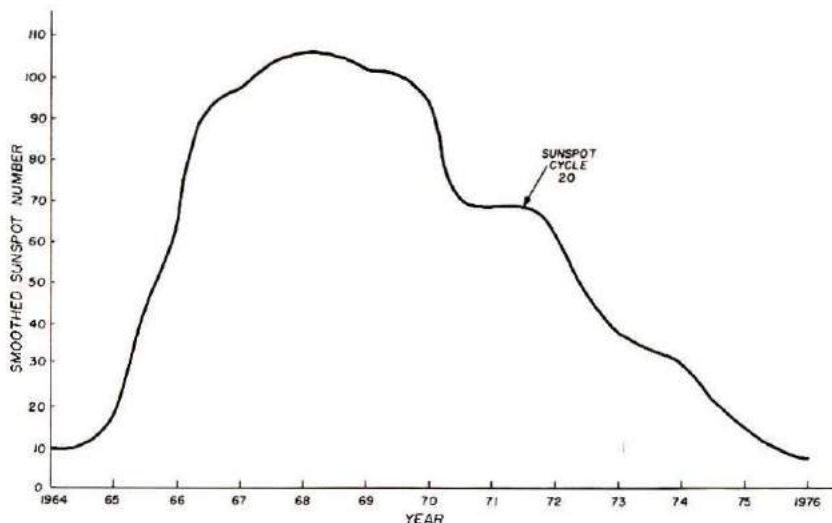

Fig. 4. The maximum usable frequency for a given transmission path is highest during maximum sunspot activity. Ionospheric losses are at a minimum during daylight hours and increase rapidly for lower frequencies. During a sunspot minimum, the maximum usable frequency is much lower, and ionospheric losses are higher. The lowest usable high frequency depends primarily upon static and atmospheric noise at the receiving end of the circuit. During the sunspot maximum this typical circuit will support communication as high as 30 MHz during daylight hours, whereas at the sunspot minimum the maximum daylight frequency that can be used is only about 15 MHz.





**Fig. 5.** The just-completed sunspot cycle (number 20 in the numbering system) began in 1964 and reached a peak of about 110 in mid-1968. A "plateau" showed up during 1970-72 when the count remained between 70 and 60. Since then, the count has declined smoothly and rapidly, reaching approximately six near the end of 1976 (data courtesy George Jacobs, W3ASK).

duration and signal strength during 1977. Fifteen meters, however, will remain a daylight DX band during the next year. Very few DX openings are to be expected on 10 meters, but occasional north-south contacts should start to show up in the fall of 1977.

As the sunspot count slowly rises during 1978-79, conditions on 10 and 15 meters should

improve, and by 1979 the 15-meter band should be a close rival to 20 meters for DX work. By 1980-81, the 10-meter band should be back in business for DX as the sunspot count slowly and inexorably rises.

The time period from 1980 through 1985 should be the "golden years" of Amateur high frequency DX communication, because during this interval the

**Fig. 6.** Predictions of things to come. Two views of sunspot cycle 21. The maximum smoothed sunspot number is predicted to fall between 45 and 85 sometime between 1981 and 1984. Other predictions abound, one of them predicting the highest sunspot cycle ever recorded! As the years go by, scientists will more fully understand the mysterious, boiling spots on the sun that affect radio communication, the weather and perhaps even human life on the planet earth (data courtesy George Jacobs, W3ASK).

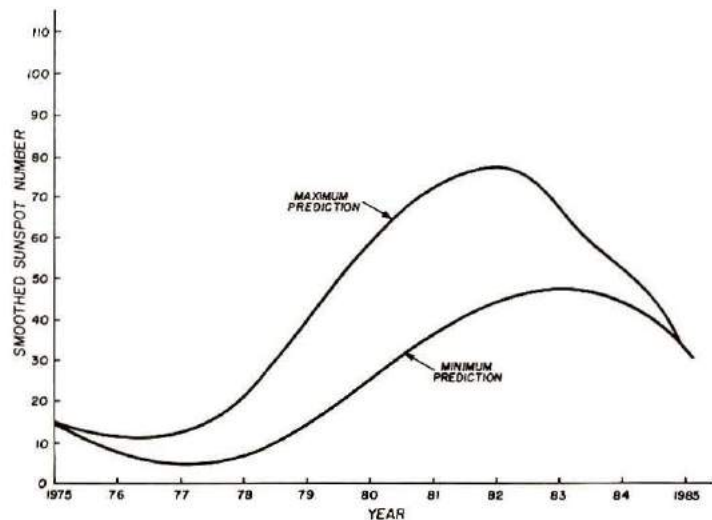

the number of sunspots will reach a maximum value.

Interestingly enough, the predicted low cycle should be excellent as far as Amateur Radio goes, particularly with respect to the 20-, 15-, and 10-meter bands. A too-high cycle can provide DX work on the 6 meter band; as the cycle advances, so does ionospheric absorption, limiting the DX-ability of the lower frequency amateur bands.

In summary, then, DX conditions will remain virtually as-is for the next year, then gradually perk up during 1978. The 15-meter band will be the first one to note the improvement, followed a year or so later by the 10-meter band. At the other end of the spectrum, the excellent DX characteristics noted on the 160- and 80-meter bands will gradually decline.

#### Other Factors Influence DX

The sunspot cycle is not the only natural phenomena that influences the high frequency bands. Abnormal ionospheric variations exist, and among the most common of these are the *ionospheric storm* and the *sudden ionospheric disturbance* (SID). The storm can develop gradually or it may start in a few hours. It may continue for a day or so, or last as long as a week. The SID usually commences very suddenly and lasts from 30 minutes to an hour or two. Both types of ionospheric disturbance are similar in that they cause a drastic increase in ionospheric absorption with an accompanying "radio fade-out" that will make the newcomer think his receiver has gone dead!

These disturbances are more noticeable on the higher bands, but severe storms may even disrupt communication on the 80- and 160-meter amateur bands. The SIDs occur during the peak of the sunspot cycle and are quite rare during the low portion of the cycle.



### Sporadic-E Transmission

The irregular formation of "clouds" of ionization in the ionosphere during the summer months brings about an unusual form of long-distance radio communication called *sporadic-E* transmission. This phenomenon bears little resemblance to normal propagation. It is highly unpredictable and is responsible for most of the 21 and 28 MHz long-distance contacts during the warmer months. Sporadic-E will support communication up to 1400 miles (2200km) on frequencies considerably higher than those being reflected by the normal ionosphere. It is suspected that sporadic-E reflection is the result of ultraviolet radiation from the sun which, in combination with high speed winds blowing in different directions at a height of about 40 miles (65km), cause redistribution of electrified particles in the atmosphere into dense patches of ionization. In this manner, the ionized regions required to reflect high frequency radio waves back to earth are temporarily created without any total increase in overall ionization. Sporadic-E transmission usually results in very strong signals with rapid fading and quick "drop out" as the cloud moves across the face of the earth. This type of propagation is more common in the latitudes near the equator than in the more northerly latitudes.

### There's More to the Story

This article has barely touched the surface of radio propagation, which is a fascinating and interesting study. It is possible to predict short-term propagation conditions over various radio paths in advance using sunspot count and other data. In a future issue of this magazine, vhf propagation will be discussed for the benefit of the Novice and the newcomer.

HRH

**This MFJ Antenna Tuner...**  
lets you operate all bands — 160 thru 10 Meters — with a simple random wire. Use virtually any transceiver — up to 200 watts RF power OUTPUT.



**\$ 39<sup>95</sup>**

Imagine being able to operate all bands — anywhere, with virtually any transceiver — using a simple random wire and an antenna tuner small enough to carry in your hip pocket. Size is only 2-3/16 x 3-1/4 x 4 inches.

Operate from your apartment with a makeshift wall to wall antenna. Tune a simple vertical for low angle, DX operation. Operate from your motel room with a wire dropped from a window. Tune out the SWR on your mobile whip. Enjoy ham radio on a camping or backpack trip with a wire thrown over a tree. Prepare for an emergency. Take it on a DX expedition or use it for Field Day.

Match both high and low impedances by interchanging input and output. SO-239 coaxial connectors are used.

The secret of this tiny, powerful tuner is a 12 position variable inductor

made from two stacked toroid cores, and a quality capacitor manufactured especially for MFJ.

Try it — no obligation. If not delighted, return it within 30 days for a refund (less shipping). This tuner is unconditionally guaranteed for one year.

To order, simply call us toll free 800-647-8660 and charge it on your BankAmericard or Master Charge or mail us a check or money order for \$39.95 plus \$2.00 for shipping and handling.

Don't wait any longer to operate on all bands. Order today.

**MFJ ENTERPRISES**

P. O. Box 494 H  
Mississippi State, MS 39762

Call Toll Free ... 800-647-8660

### Bearcat<sup>®</sup> 210 Scanner



**\$289.**

The Bearcat 210 super synthesized receiver scans and searches 32-50, 146-174 & 416-512 MHz, without expensive crystals. Order now on our 24 hour toll-free credit card order line 800-521-4414. In Michigan and outside the U.S. call 313-994-4441. Add \$5.00 for shipping in U.S. or \$8.00 for air UPS to west coast. Charge cards or money orders only. Foreign orders invited. For additional information, write: Communications Electronics, P.O. Box 1002, Dept. 21, Ann Arbor, Michigan 48106.



Just say charge it! Which card?



**HAM RADIO**  
LETS YOU TALK TO THE WORLD!!

Let us help you achieve all the fun & enjoyment from this great hobby.  
No request too large or small.

Complete Sales and Service Also HEADQUARTERS for UNIVERSAL TOWERS



SATISFACTION GUARANTEED

Communications Specialists for over 38 years

**ELECTRONIC DISTRIBUTORS, Inc.**

1960 Peck Street, Muskegon, Mich. 49441 • Tel. (616) 726-3196 • Telex 22-8411



# Let Standard help you obtain your Technician Class Ham Ticket.

It's not as hard as you think. With Standard's exciting new package you can be ready before you know it. This is a program designed to assist CB'ers and other non-amateurs to get that all important first ticket. It has a retail value of \$398.45 and sells for under \$300.00.

*Sound great?* It is, and the Standard package has everything you need. The radio is a Horizon 2, a commercial quality 2 meter VHF-FM Transceiver, permitting you to listen while you learn, and configured for three popular channels, plus crystal coupons for an additional three sets of crystals of your choice.

You'll also get with this package a wall mounted A.C. power supply and a back-of-set antenna suitable for listening only.



In addition you will receive a license training kit consisting of the following material: Code key/oscillator, ARRL Radio Amateur's License Manual AMECO Code Training Course, and a coupon for a 50% discount on the cost of a year's subscription to Ham Radio Horizons magazine.

Now you know what it takes to pass the FCC Technician Class amateur radio license examination: some time, some effort, and a little help from your friends . . . at Standard.

See your local Standard CB or Amateur Dealer for complete information or write:



P.O. Box 92151  
Los Angeles, Ca. 90009



## This MFJ Super CW Filter . . .

gives you 80 Hz bandwidth, and extremely steep skirts with no ringing for razor sharp selectivity that lets you pull signals out of heavy QRM.

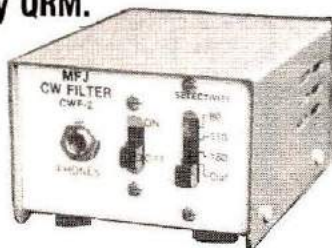

# \$27.95

Can you imagine hearing ONE CW signal on the crowded Novice bands on a Sunday afternoon? That's what 80 Hz bandwidth, extremely steep skirts, and no ringing will do for you.

Simply plug it into your receiver or transceiver to drive phones or connect it between audio stages for full speaker operation.

**Bandwidth is selectable:** 80, 110, 180 Hz. Response is at least 60 dB down one octave from center frequency for 80 Hz bandwidth. Center frequency is 750 Hz. No impedance matching. No insertion loss.

**Drastically reduces noise.** Up to 15 dB improvement in S/N ratio.

**8 pole active IC filter.** Low Q cascaded stages eliminates ringing. Months of operation from 9-volt battery. 2 3/16x3 1/4 inches.

Try it—no obligation. If not delighted, return it within 30 days for a refund (less shipping). This filter is unconditionally guaranteed for one year.

To order, simply call us TOLL-FREE 800-647-8660 and charge the CWF-2BX filter on your BankAmericard or Master Charge or mail us an order with check or money order for \$27.95 plus \$2.00 for shipping and handling.

Don't wait any longer to eliminate QRM on all bands. Order today.

## MFJ ENTERPRISES

P. O. BOX 494 H  
MISSISSIPPI STATE, MS. 39762  
CALL TOLL-FREE 800-647-8660

## ANTENNA SWITCHES



**BARKER & WILLIAMSON  
COAXIAL ANTENNA  
CHANGE-OVER  
RELAY**

Economical and reliable. Can be operated from VOX circuit for completely automatic operation or from PTT or manual T/R switch. Receiver input is automatically grounded when the relay is in the Transmit position. Wide AC operating voltage range and low operating current.

• specifications	
Power Rating	1000 watts CW (2000 watts SSB)
VSWR	Less than 1.15:1, DC to 150 MHz
Power Requirements	0.015 Ampere, 48 to 130 volts AC
Connectors	UHF Type SO-239
Dimensions	3 1/2" x 1 1/2"
Shipping Weight	1 lb.

Model 377 \$17.95



**BARKER & WILLIAMSON  
ANTENNA  
SELECTION  
SWITCH**

6 outputs with automatic grounding

Model 375

Protax Model 375 \$18.95

Please add \$2.00 shipping.

**G.R. WHITEHOUSE & CO.**  
15 Newbury Drive, Amherst, N. H. 03031



# ME-3 microminiature tone encoder

Compatible with all sub-audible tone systems such as: Private Line, Channel Guard, Quiet Channel, etc.

- Powered by 6-16vdc, unregulated
- Microminiature in size to fit inside all mobile units and most portable units
- Field replaceable, plug-in, frequency determining elements
- Excellent frequency accuracy and temperature stability
- Output level adjustment potentiometer
- Low distortion sinewave output
- Available in all EIA tone frequencies, 67.0 Hz-203.5 Hz
- Complete immunity to RF
- Reverse polarity protection built-in

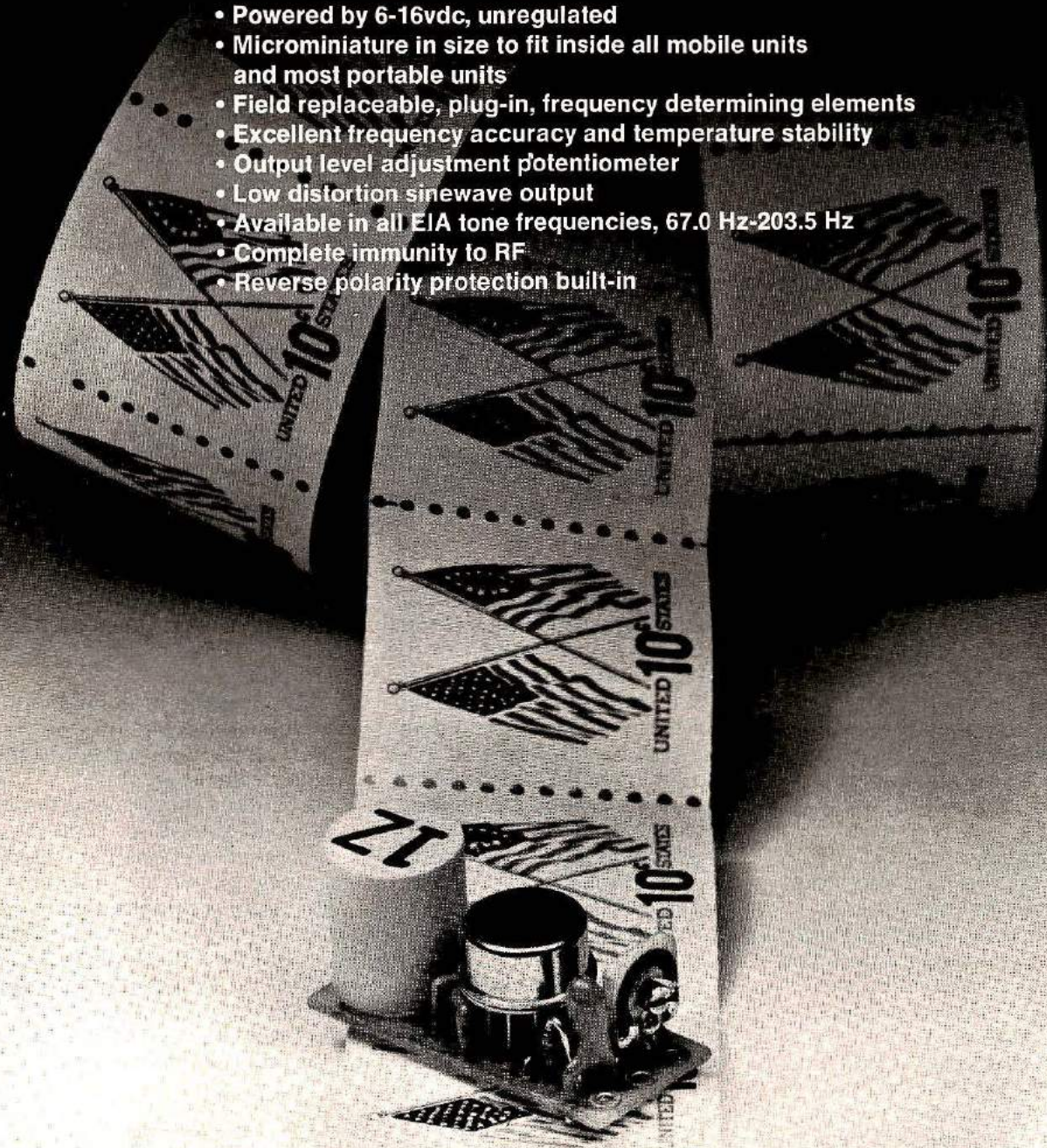

**\$29.95 each**

Wired and tested, complete with K-1 element

**communications specialists**

P. O. BOX 153  
BREA, CALIFORNIA 92621  
(714) 998-3021



K-1 FIELD REPLACEABLE,  
PLUG-IN, FREQUENCY  
DETERMINING ELEMENTS

**\$3.00 each**



# A Practical BENCH

*A good place to work is an aid to doing good work*

BY KEN CORNELL, W2IMB

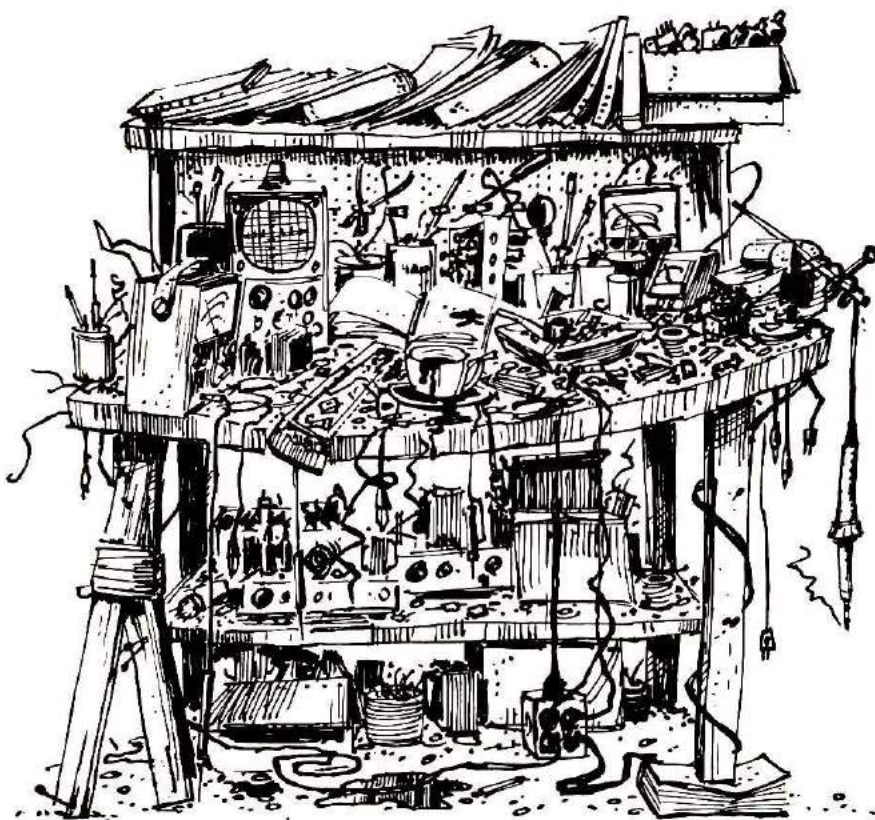

Without a doubt, the most practical and useful item that a radio amateur or electronic experimenter can possess, other than his equipment, is a well-designed operating and/or workbench.

I received my amateur radio license in 1935 and for many years I used any type of available table, chest of drawers, etc., to hold and store my precious equipment and parts. Somehow I survived with a collection of random furniture and a mess of extension and patch-cords that looked like a bowl of spaghetti.

Several years ago I had to move to a new location, and I decided my new abode would contain a well-designed bench that would provide space for my amateur radio equipment, test gear, tape recorder, a-m and fm radio, and other items, as well as a suitable work area. After using up a pad of paper and several pencils, I arrived at the design described here.

The bench uses a "step" configuration with an operating

work surface 27 inches (69cm) deep, located 28 inches (71cm) above the floor. The rear of the bench contains a step with an 8- $\frac{1}{4}$  inch (21cm) riser to a top deck 12- $\frac{3}{4}$  inches (32cm) deep that runs back to the wall. I also included a 24 inch- (61cm) wide shelf located 12 inches (30cm) above the floor. The following details describe the construction.

Although this is an 8-foot (2.4m) long bench, a 16-foot (4.9m) long version can be built by doubling the material quantities, except that only three end panels (item 4) will be required.

The use of  $\frac{3}{4}$  inch- (20mm) thick plywood (finished on one side) provided a very sturdy structure.

The method of component attachment is a matter of preference with respect to the type of fasteners, but I particularly recommend the use of wood screws for securing the bench and shelf surfaces to the end panels and the center leg support to permit easy disassembly in case of a move.

Another preference is the fastening of the work surface to the riser. The simplest method is to use corner braces spaced at 24-inch (61cm)

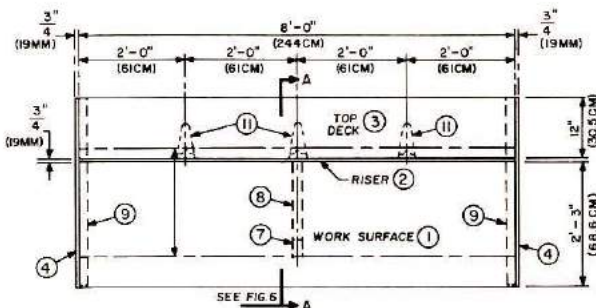
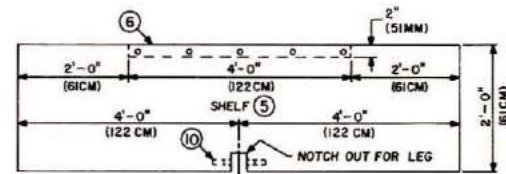
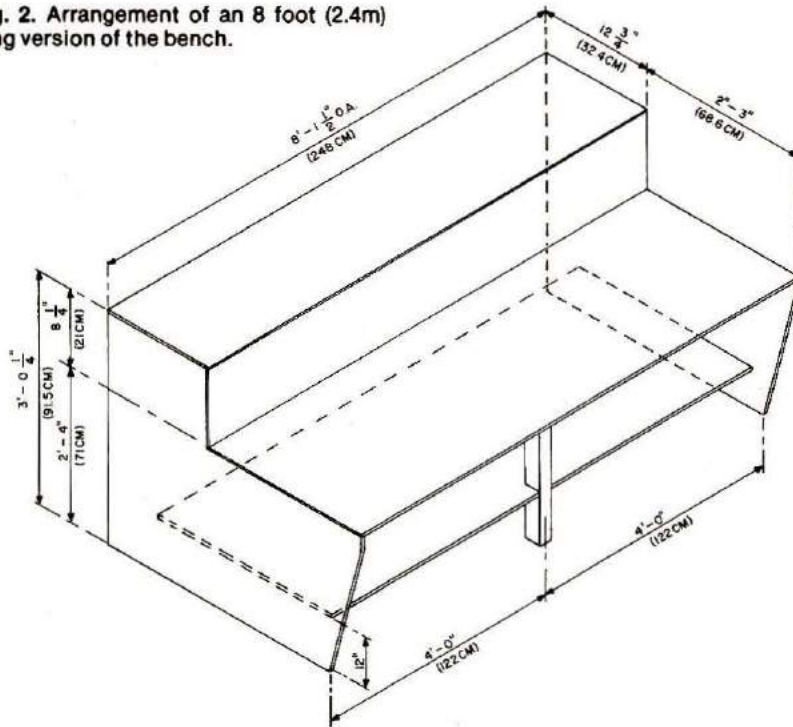

Fig. 2. Plan view of the bench.



**Fig. 2. Arrangement of an 8 foot (2.4m) long version of the bench.**



**Fig. 3. Detail of the shelf.**

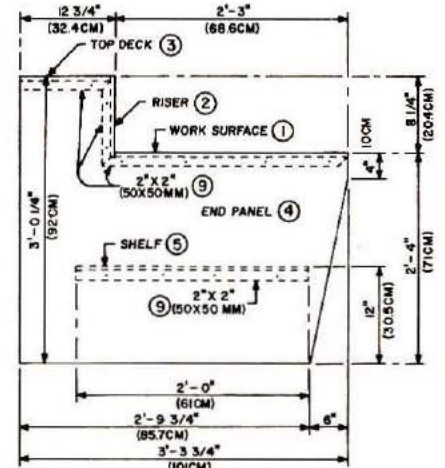

**Fig. 4. Detail of the two end panels and bench supports.**

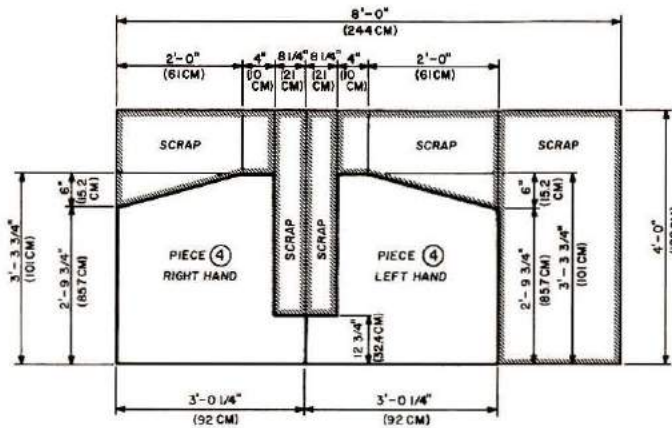

**Fig. 5. Recommended pattern for cutting end panels from sheet of plywood.**

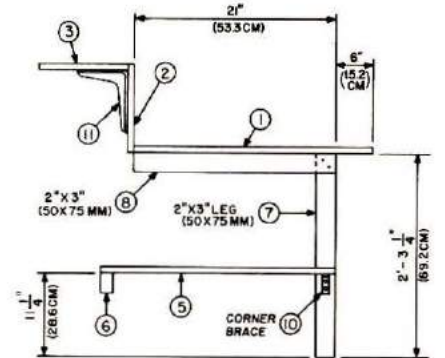
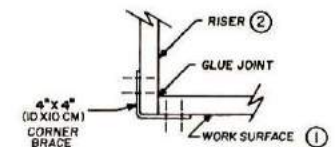

**Fig. 6. Detail of center leg and supports for bench and shelf.**

intervals as shown in Fig. 7. While more expensive, I prefer the use of a continuous 1 x 1-1/2 inch (25x38mm) steel or aluminum angle that can serve as a connector as well as a ground bus as shown in Fig. 8. Machine bolts for grounding equipment can be located at suitable intervals. If a continuous angle is not used, be sure to place a jumper wire at the joints to be sure of electrical continuity. If the corner braces are used as shown in Fig. 7, a ground bus can be provided by using common aluminum ground

wire, making U-shaped loops at intervals to make contact with bolts for ground connections. The ground wire is stapled to the riser. The bench ground bus is connected to a good ground such as the water inlet pipe. **NEVER USE A GAS LINE FOR A GROUND CONNECTION!**

After assembly but before painting, the bench will normally require some cosmetic treatment. The exposed, sawed edges of the plywood will normally have holes which are caused by the saw's removal of pieces of the softer inner laminations. I used



**Fig. 7. Detail of connection between work surface and riser.**

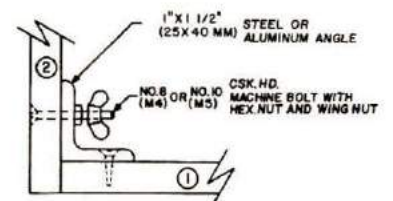
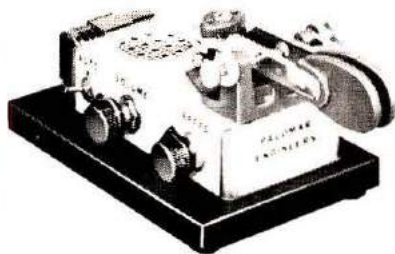

**Fig. 8. Alternate detail for connection between work surface and riser, providing a ground bus.**



# NEW! IC KEYER

The World's Greatest  
Sending Device



Adjustable to Any  
Desired Speed

Now available from Palomar Engineers — the new Electronic IC KEYER. Highly prized by professional operators because it is EASIER, QUICKER, and MORE ACCURATE.

It transmits with amazing ease CLEAR, CLEAN-CUT signals at any desired speed. Saves the arm. Prevents cramp, and enables anyone to send with the skill of an expert.

SPECIAL  
RADIO MODEL

Equipped with large specially constructed contact points. Keys any amateur transmitter with ease. Sends Manual, Semi-Automatic, Full Automatic, Dot Memory, Squeeze, and Iambic — MORE FEATURES than any other keyer. Has built-in sidetone, speaker, speed and volume controls, BATTERY OPERATED, heavy shielded die-cast metal case. FULLY ADJUSTABLE contact spacing and paddle tension. The perfect paddle touch will AMAZE you.

Every amateur and licensed operator should know how to send with the IC KEYER. EASY TO LEARN. Sent anywhere on receipt of price. Free brochure sent on request.

Send check or money order. IC KEYER \$97.50 postpaid in U.S. and Canada. IC KEYER LESS PADDLE and non-skid base \$67.50. Add 6% sales tax in California.

Italy write i2VTT, P.O. Box 37, 22063 Cantu.

Fully guaranteed by the world's oldest manufacturer of electronic keys. ORDER YOURS NOW!

## PALOMAR ENGINEERS

BOX 455, ESCONDIDO, CA 92025  
Phone: (714) 747-3343

Durham's water putty to fill in these imperfections. When dry, all exposed edges were sanded with a medium grade of sandpaper. To fill in the joints between adjacent pieces of plywood, I applied a bead of DAP tub and tile caulk along the joint, and then used a piece of wet paper towel to smooth out the caulking and blend it with the plywood joint.

Electric outlets are mounted in both the riser and in the rear of the top deck (don't short-change yourself on quantity, or you will be sorry). By making proper cutouts, basic units such as an fm and a-m radio, speakers, and the like can be mounted permanently in the riser.

Painting the bench is a matter of your preference as to color and paint type, but I had excellent results using popular semi-gloss latex paint.

I might suggest that you obtain a 24 by 27 inch (61x69cm) piece of material like linoleum for use on the bench when constructing a project or servicing equipment to prevent scoring the bench's finished surface. For illumination, I mounted an eight-foot (2.5m) dual fluorescent-light fixture over the bench. As a finishing touch, I applied several coats of white paint to a sheet of peg-board and mounted it on the wall over the bench to hold various tools and to support items of interest. **HRH**

### List of material for an 8-foot (2.5m) long bench

Item	Quantity	Description	Approximate Cost
1	1	2'-3" x 8' (68.6cm) x (244cm) piece of 3/4" (20mm) plywood	
2	1	9" x 8' (22.9cm) x (244cm) piece of 3/4" (20mm) plywood	\$18.19
3	1	12" x 8' (30.5cm) x (244cm) piece of 3/4" (20mm) plywood	
4	2	End Panels cut from 3/4" (20mm) plywood	19.50
5	1	2' x 8' (61cm) x (244cm) piece of 3/4" plywood	8.97
6	1	2" x 3" x 4' (50cm) x (75mm) x (122cm) long	.61
7	1	2" x 3" x 2'-3-1/4" (50cm) x (75cm) x (69.2cm) long	.35
8	1	2" x 3" x 21" (50cm) x (75cm) x (53.3cm) long	.25
9	1	2" x 2" x 14' (50cm) x (50cm) x (427cm) long (cut to suit)	1.40
10	2	2 1/2" x 2 1/2" (65cm) x (65cm) metal corner braces	.76
11	3	8" x 10" (20cm) x (25cm) metal support angles for top desk	1.65
Total, all items #1 thru #11			\$51.68

**Notes:** Items 1, 2, and 3 cut from one sheet of plywood with no waste. All plywood finished on one side.

90-degree gussets can be cut from the scrap plywood (Fig. 5.) and used in lieu of item 11.

With the exception of item 9, all prices include the cost of having the lumber yard cut the material as detailed. By cutting your own material, substantial savings can be made.

For a 16' (5m) long bench, double all quantities except item 4, because only three pieces will be required.

Cost of corner braces or angle stock (Figs. 7 and 8) are not included on material list because these are optional.





# NEW

## DIGITAL CLOCK with 10 MINUTE TIMER

6 digits - 12/24 hour

Here's the kit everyone has been asking for! Never fail to identify your station again. And

it's easy to use, just tap timer button to start, 9 minutes later the display will flash on and off to alert you. Reset it by simply touching the timer button or it will reset itself automatically after two minutes! Other features are: jumbo .4" LED readouts, durable extended aluminum case available in 5 colors, plug transformer, Polaroid lens filter, time set buttons, finest quality PC boards and super instructions. You get all parts - no extras are needed, unlike some of the Kludges our competitors offer! Colors available: gold, black, silver, bronze, blue (specify). Size: 4.25" x 1.5" x 1.5".

- Clock Kit with 10 min. timer, DC-10 ..... \$25.95
  - Regular 12/24 hr clock kit ..... 22.95
  - Alarm clock, 12 hr only, DC-8 ..... 24.95
- Kits are also available fully assembled and tested, just add \$10 to kit price.

### CAR CLOCK 12/24 HR 6 DIGIT \$25.95

- High accuracy (1 minute/month)
  - Big .4" LED display
  - Special circuit suppress all voltage spikes and transients
  - Same case as illustrated above
  - Display blanks with ignition off
  - Reverse polarity protected
- Complete Kit, DC-7 ..... \$25.95  
Assembled and calibrated ... 35.95

### CALENDAR ALARM CLOCK 6 Digit LED 12/24 Hour

Has every feature one could ever ask for. Kit includes everything except case, build it into wall, station or even car! FEATURES:

- 6 Digits, .5" High LED
  - 12/24 Hour Format
  - Calendar shows mo./day
  - Snooze button
  - True 24 Hour Alarm
  - 7001 chip does all!!
  - Battery back up with built in on chip time base
- Complete Kit, less case, DC-9 ..... \$34.95

### 600 MHz PRESCALER \$59.95



Assembled and tested. Extend the range of your counter to 600 MHz. Works with all counters. Available in kit form for \$44.95. Specify ÷10 or ÷100 with order.

### 30 WATT

2 Meter Power Amp

The famous RE class C power amp now available mail order! Four Watts in for 30 Watts out, 2 in for 15 out, 1 in for 8 out, Incredible value, complete with all parts, instructions and details on T-R relay. Fully stable, output short proof, infinite VSWR protected! Case not included.

Complete Kit \$22.95

### COMING SOON: VIDEO TERMINAL KIT

SEND FOR DETAILS \$149.95

TTL	LINEAR	REGULATOR	TRANSISTORS
74S00 .35	555 .50	309K .99	NPN 2N3904 type 10/\$1.00
74S112 .75	556 .75	309H .99	PNP 2N3906 type 10/\$1.00
7447 .79	567 1.75	340K-12 1.25	NPN Power Tab 40W 3/\$1.00
7473 .35	1458 .50	7805 .99	PNP Power Tab 40W 3/\$1.00
7475 .50	LED DRIVER	7812 .99	FET MPF 102 type 3/\$2.00
7490A .55	75491 .50	7815 .99	UJT 2N2646 type 3/\$2.00
74143 3.50	75492 .50	7818 .99	2N3055 NPN Power .75

DIODES: 1KV, 2.5A ..... 5/\$1.00 100V, 1A ..... 10/\$1.00 1N914A type ..... 50/\$2.00

#### LED DISPLAYS



- FND 358 ..... .4" C.C. .... .75
  - FND 510 ..... .5" C.A. .... 1.25
  - DL 707 ..... .33" C.A. .... 1.25
  - HP 7730 ..... .27" C.A. .... 1.25
- Red Polaroid Filter ... 4.25" X 1.125" ... \$9

**741 OP-AMP SPECIAL**  
Factory prime mini dip with both Xerox and 741 part numbers  
**10 for \$2.00**

**SOCKETS**  
14 PIN 5/\$1.00  
16 PIN 5/\$1.00  
24 PIN 2/\$1.00  
40 PIN 3/\$2.00

**FERRITE BEADS**  
with info and specs  
15/\$1.00  
6 hole Balun Beads  
5/\$1.00

**SOCKET KIT**  
Assortment of 12 most used IC sockets. Good to have around the shop. \$1.95

**8080A \$18.95**  
Factory Prime - includes FREE socket!  
**21L02-1 \$1.95** Fast 450 ns Low Power

**60 Hz XTAL TIME BASE**  
• Runs on 5-15 VDC  
• Low current (2.5 ma)  
• Operate clocks in car, boat, plane  
• 1 minute/month accuracy  
Kit, TB-7 ... \$5.50  
Assembled & Calibrated ... \$9.95

#### CHEAP CLOCK KIT \$9.95

- DC-4 Features:
- 6 digit .4" LED
- 12 or 24 format

Does not include board or transformer

PC Board \$2.95  
Transformer \$1.49

Dealers Write for our wholesale price list. Hi M\*D

# ramsey electronics

P.O. Box 4072B Rochester, NY 14610

(716) 271-6487

TELEPHONE ORDERS WELCOME



Satisfaction guaranteed or money refunded. COD, add \$1.00. Orders under \$10.00 add \$.75. NY residents add 7% tax.

## MINI-KITS

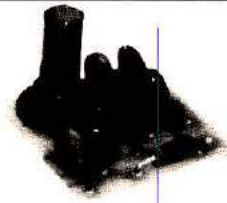

**FM Wireless Mike Kit \$2.95**

Transmit up to 300' to any FM broadcast radio. Sensitive mike input requires crystal ceramic or dynamic mike. Runs on 3 to 9 V.

### TONE DECODER KIT

A complete tone decoder on a single PC Board. Features: 400-5000 Hz adjustable frequency range, voltage regulation, 567 IC. Useful for touch-tone decoding, tone burst detection, FSK demod, signaling, and many other uses. Use 7 for 12 button touchtone decoding. Runs on 5 to 12 volts.

Complete Kit, TD-1 ..... \$4.95

### LED BLINKY KIT

A great attention getter which alternately flashes 2 Jumbo LEDs. Use for name badges, buttons, or warning type panel lights. Runs on 3 to 9 volts.

Complete Kit \$2.95

### SUPER-SNOOP AMPLIFIER

A super-sensitive amplifier which will pick up a pin drop at 15 feet! Great for monitoring baby's room or as a general purpose test amplifier. Full 2 watts of output, runs on 6 to 12 volts, uses any type of mike. Requires 8-45 ohm speaker.

Complete Kit, BN-9 ..... \$4.95

### MUSIC LIGHTS KIT

See music come alive! 3 different lights flicker with music or voice. One light for lows, one for the mid-range and one for the highs. Each channel individually adjustable, and drives up to 300 watts. Great for parties, band music, nite clubs and more.

Complete Kit, ML-1 ..... \$7.95

### SIREN KIT

Produces upward and downward wail characteristic of police siren. 5 Watts audio output, runs on 3-9 volts, uses 8-45 ohm speaker.

Complete Kit, SM-3 ..... \$2.95

### CODE OSCILLATOR KIT

Powerful 1 watt audio oscillator of approx. 1 kHz, good for many uses. Great for warning alarm, battery checker, voltage indicator and code oscillator.

Complete Kit, CPO-1 ..... \$2.50

### POWER SUPPLY KIT

Complete triple regulated power supply provides variable ±15 volts at 200 mA and +5 volts at 1 Amp. 50 mV load regulation good filtering and small size. Kit less transformers. Requires 6-8 V at 1 Amp and 18 to 30 VCT.

Complete Kit, PS-3LT ..... \$6.95

### DECADE COUNTER

#### PARTS KIT

- INCLUDES \$3.50
- 7490A decade counter
  - 7475 latch
  - 7447 LED driver
  - LED readout
  - Current limit resistors

Complete with instruction and details on how to build an easy, low cost freq. counter. R8

SEE YOU IN ATLANTA - HAMFESTIVAL JUNE 18 & 19



# 5 KW PEP INPUT

WITH THIS NEW BALUN

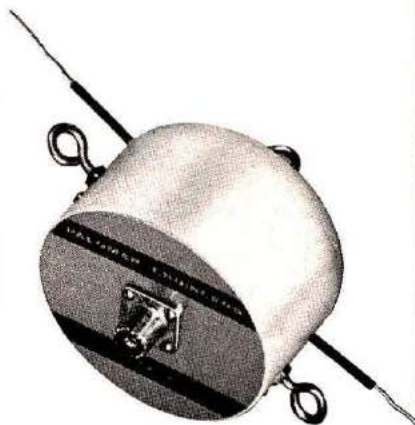

On all bands 160 to 10 meters.

Runs cool as a cucumber at its CCS rating of 2 KW (Continuous output power through the balun at matched load).

4" dia. Wt. 24 oz. \$32.50 PPD.

AND FOR FULL LEGAL POWER

the time tested Model 1K balun is still available. Rated at 1 KW CCS (3 KW PEP input).

2 1/4" dia. Wt. 9 oz. \$16.95 PPD.

ONLY PALOMAR BALUNS HAVE ALL THESE FEATURES

- Toroidal core for highest efficiency.
- Teflon insulated wire to prevent arc-over. OK for tuned feeders.
- Stainless steel eyebolts take antenna tension. Won't rust, won't pull apart.
- Epoxy filled case. Absolutely waterproof.
- Lightning protection built-in.
- Wideband 1.7 to 30 MHz.
- Hang-up hook provided.
- Now available in either 1:1 or 4:1 ratio. 1:1 ratio matches 50 or 75 ohm coax to 50 or 75 ohm balanced load (dipoles and inverted Vees). 4:1 ratio matches 50 or 75 ohm coax to 200 to 300 ohm balanced load.

Free descriptive brochure on request. Order direct.

Model 2K \$32.50 Model 1K \$16.95  
Center insulator without balun \$7.95  
Postpaid U.S. & Canada.

Specify ratio 1:1 or 4:1

California residents add 6% tax.  
Send check or money order to:

## PALOMAR ENGINEERS

BOX 455, ESCONDIDO, CA 92025  
Phone: (714) 747-3343

# HALF-SIZE FULL PERFORMANCE Multi-Band HF Communications Antennas

ESPECIALLY SUITABLE FOR THE NEW AMATEUR



### MOR-GAIN HD DIPOLE SPECIFICATIONS

MODEL	BANDS (Meters)	LENGTH (feet)	PRICE
40-20 HD	40/20	36	\$49.50
40-10 HD	40/20/15/10	36	59.50
80-40 HD	80/40 + 15	69	57.50
75-40 HD	75/40	66	55.00
75-40 HD (SP)	75/40	66	57.50
75-20 HD	75/40/20	66	66.50
75-20 HD (SP)	75/40/20	66	66.50
75-10 HD	75/40/20/15/10	66	74.50
75-10 HD (SP)	75/40/20/15/10	66	74.50
80-10 HD	80/40/20/15/10	69	76.50

NOTE: 75 meter models are factory tuned to resonate at 3950 KHz. (SP) models are factory tuned to resonate at 3800 KHz. 80 meter models are factory tuned to resonate at 3650 KHz.

### WHY MOR-GAIN?

**NOVICE LICENSE OPERATION.** The MOR-GAIN HD Dipole is the ideal antenna for the new or Novice operator. As the Novice progresses to higher license classes, he can easily re-tune the HD Dipole to the new frequencies of his higher license frequency privileges. The HD Dipole is thus a one-time investment. HD Dipoles are available for all Novice frequencies.

**LEAST COST.** Dollar for dollar, the HD dipoles are the highest performance least cost multi-band antennas on the market today. For Example: the 5-band 75-10 HD dipole costs less than \$15.00 per band - an unbeatable low cost.

Contact your favorite dealer or order direct from MOR-GAIN today. Write for fully descriptive four page brochure.



Manufactured & Guaranteed by  
**MOR-GAIN**  
2200N South 4th Street  
Leavenworth, Kansas 66048  
(913) 682-3142



## Send For Your Copy Today!

a Kengore Corp. publication \$2.95

### 1977 AMATEUR RADIO EQUIPMENT DIRECTORY

Standard SS TPL -big gain SINCLAIR  
ROBOT VIBROPLEX YAESU ORACLE  
Henry Radio KLM the antenna specialists co. ATLAS  
Cushcraft Minitrac Com Denton  
Larsen Antennas GLE ELECTRONICS  
SPECTRUM MFJ Enterprises SWAN  
KENWOOD Hufco ICOM

Featuring ham radio equipment of over 60 manufacturers, contains descriptions, pictures, specifications & prices . . . no advertisements! A must addition to every ham library. (136 pages)

\$2.95 Postpaid (U.S.)

KENGORE CORP — Dept. A  
9 James Ave. Kendall Park, NJ 08824  
CLUB DISCOUNT 15% (MIN. 10 COPIES)

### MAIL NOW

Enclosed is my  Check  MO for \$2.95  
Please send the 1977 Amateur Radio Equipment Directory.

Name \_\_\_\_\_

Address \_\_\_\_\_

City \_\_\_\_\_ State \_\_\_\_\_ Zip \_\_\_\_\_

# NOVICE-GENERAL CODE COURSES

FAIL SAFE — FOLLOW THE FREE HOME STUDY INSTRUCTIONS AND LEARN TO RECEIVE CODE ONCE AND FOR ALL, QUICKIE 1 OR 2 CASSETTE METHODS OFTEN DON'T WORK DUE TO INSUFFICIENT PRACTICE MATERIAL. THIS NEW METHOD SUCCESSFULLY USED BY PEOPLE FROM 10 TO 65 YEARS OLD. INCLUDES NOVICE TRAINING SCHEDULE, REFERENCE MATERIALS, CHECKING SHEETS TO VERIFY ACCURACY, INFO ON OTHER HAM LICENSE REQUIREMENTS.

STANDARD 2 TRACK MONAURAL CASSETTES PROVIDE 60 MINUTES EACH OF SCIENTIFICALLY PREPARED CODE PRACTICE (LETTERS, NUMBERS, PUNCTUATION, CODE GROUPS, WORDS). CASSETTES ARE DESIGNED TO MINIMIZE LEARNING PLATEAUS, EMPHASIZE NEW MATERIAL.

TAKE THE CODE EXAM CONFIDENT YOU'LL PASS  
0-6 WPM (Novice License) 6 Cassettes \$19.95  
0-8 WPM (Novice License) 7 Cassettes 22.95  
7-14 WPM (General Class License)

3 Cassettes 9.95  
First class postage required per Cassette 0.40

SPECIALISTS — OUR ONLY PRODUCTS ARE CODE COURSES

THE HERRMAN CO.  
DEPARTMENT J, BOX 1101  
LARGO, FLA. 33540



# THE HAM-KEY



**\$16.95** delivered

Model HK-3

- Deluxe straight Key
- Velvet smooth action
- Heavy base with non-slip rubber feet.
- No need to attach to desk

FOR NEW & USED  
AMATEUR RADIO EQUIPMENT

CALL TOLL FREE

**800-325-3636**

**HAM RADIO CENTER INC.**

8342 Olive Blvd., P. O. Box 28271  
St. Louis, MO 63132

# CIE has a terrific idea for a few people who know what they want

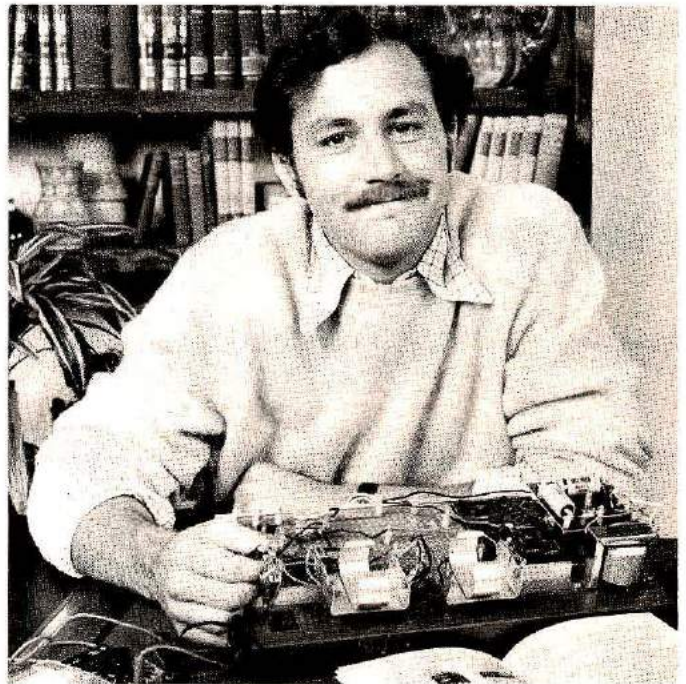

If you want success... if you want new skills and rewards enough to roll up your sleeves and work for them... find out about CIE career training. It's a terrific idea that can get you on your way to success in electronics.

Investigate our new troubleshooting courses where you can build your own triggered-sweep, solid-state oscilloscope... work with a professional TV color bar generator... and explore advanced circuitry with your own Zenith big screen color TV. Prepare for your FCC License, too. Do it all as you acquire new occupational skills in electronics technology without classroom attendance.

**MAIL THE COUPON TODAY!** We'll make sure you get CIE's FREE school catalog, plus details about our independent study programs. School representative contact in some areas. No obligation. Mail the coupon... or write (include name of this magazine and issue date) to:

CIE, 1776 East 17th Street, Cleveland, Ohio 44114.

# UHF DX!



**MBM48/70cm**

Horizontal  
Beamwidth : 26°  
Power Rating : 1 Kw Peak  
Weight : 2.7 Kg  
Design  
Impedance : 50 ohms

**PRICE \$49.45**

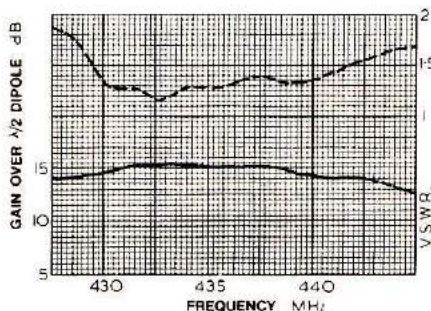

## VHF Communications

915 N. Main Street  
Jamestown, N. Y. 14701

## CIE Cleveland Institute of Electronics, Inc.

1776 East 17th Street, Cleveland, Ohio 44114  
Accredited Member National Home Study Council

**YES...** I want to succeed in electronics. Send me my FREE CIE school catalog - plus my FREE package of independent study information! HH-01

PRINT NAME \_\_\_\_\_

ADDRESS \_\_\_\_\_ APT. \_\_\_\_\_

CITY \_\_\_\_\_

STATE \_\_\_\_\_ ZIP \_\_\_\_\_

AGE \_\_\_\_\_ PHONE (area code) \_\_\_\_\_

Check box for G.I. Bill information:

Veteran       Active Duty      Mail today!



# BUILDING A

*Nickel-Cadmium*



*battery*

*When is a battery not a battery? When it's a cell, of course!*

**BY ALEX F. BURR, W5QOQ**

This article will *not* tell you how to assemble elements called cadmium, nickel hydroxide, and potassium hydroxide into a battery, because General Electric, Eveready, Gulton, Gould, and others do a much better job, and less expensively. Nevertheless, the title is correct because the 1.2-volt AA *battery* that you buy from your local parts store is, strictly speaking, not a battery: It is a *cell*.

Only when you connect two or more cells in series or parallel, do you have a battery.

The specific chemical reaction that produces electrical energy in a Nicad\* cell always creates a potential difference of about 1.2 volts. More energy can be made available by making the cell larger, but nothing can increase (or decrease) the voltage at the terminals of the cell by any

significant amount. If a higher potential is required, a number of cells must be connected in series. This combination is then called a battery. Thus, a battery is a number of individual cells, usually connected in series.

If the best possible battery is to be made out of the cells available, the cells must all have the same capacity. When a manufacturer makes up a 6- or 12-volt battery, he matches the cell capacities, but it is not absolutely necessary that cell capacity be exactly matched. It is possible to put a 1/2-Ah (ampere-hour) AA cell in series with a 4-Ah D cell, but the result will not be a 4 1/2-Ah, 2.4-volt battery; but, instead, a 1/2-

\*Nicad is a trade name of Gould, Inc., Portable Battery Division. Many people use the term Ni-Cad to refer to any nickel-cadmium cells and batteries. However, in the interest of accuracy, Ni-Cd is a proper abbreviation for nickel-cadmium.

Ah, 2.4-volt battery! When the AA cell is exhausted, the battery will be useless, because the Ah rating of any battery consisting of series-connected cells is only that of the weakest cell. Thus, nobody would put a \$7 4-Ah D cell in series with a \$2 1/2-Ah AA cell when two AA cells would do the same job at half the price.

It is more important to match nickel-cadmium cells than it is to match ordinary carbon-zinc cells. When carbon-zinc cells approach the end of their useful life, their voltage falls off gradually. Thus the load supplied by the weakest cell in the series chain is gradually shifted to the stronger cells with little loss of potential by the battery as a whole. Such is not the case with Ni-Cd cells. These cells hold their terminal voltage until they are exhausted. Thus, in a 2-cell battery, the weakest cell will supply half the power until it is completely exhausted,



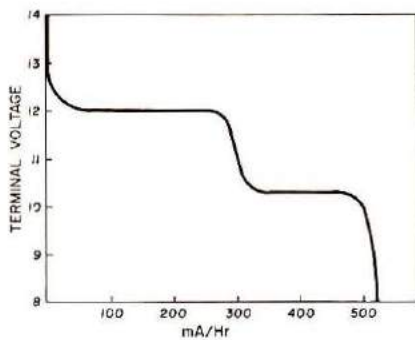

**Fig. 1.** A plot of voltage against current drawn from battery shows the effect that one weak cell has on battery voltage; a sudden voltage drop occurs when the weakest cell is exhausted.

whereupon its terminal voltage will approach zero and the voltage of the battery will be cut in half; thus ending its usefulness.

### Reverse charging

The biggest danger with Ni-Cd batteries — reverse charging — does not exist with carbon-zinc cells. To give a specific example, consider a 12-volt battery made up of 10 AA cells in series. Assume that each cell, except one, has a capacity of 500 mAh (milli-ampere-hours). Let the odd one have a capacity of 300 mAh. Each cell will have a potential of 1.2 volts while the battery is supplying current, and each cell will drop to a potential of 1.0 volts when it becomes exhausted. Thus you would expect the whole battery to be declared exhausted when its terminal voltage fell to 10 volts. Such is not the case, however,

**Fig. 1** shows the terminal voltage of the battery as a function of the milli-ampere-hours of current drawn from the battery. The freshly charged cells quickly assume their usual 1.2-volt potential, giving a 12-volt battery. Nothing further happens until the weak cell becomes exhausted after supplying 300 milliamperes for one hour, whereupon it no longer contributes 1.2 volts to the battery, but may even produce a drop of several tenths of a volt due to the current forced to flow through

it. The terminal voltage of the battery is now only about 10.4 volts, still above the level at which it is considered dead. The rest of the battery contributes another 200 mAh and then dies.

Now let us look in detail at what happened to the weak cell after it became exhausted. The cell could supply no energy and no potential, yet a current was forced through it by the other cells. A reverse potential, proportional to the current being drawn and the internal resistance of the cell, was established across it. This state of affairs is called reverse charging because an external potential was forcing current through the cell in a direction opposite to that of the usual charging current. This current tends to make the positive terminal negative and the negative terminal positive. The result of this tendency is to generate gas inside the cell which will increase the pressure until the safety valve releases it. With each release of gas, the cell dries out a bit until it is completely destroyed. Therefore, in the example, if the battery is not withdrawn from service and recharged after supplying only 300 mAh, one of the cells (the weakest) will be permanently damaged.

It is recommended that no cell be allowed to sustain a reverse potential of more than 0.2 volts for any considerable time. When the potential of any battery consisting of ten cells in series drops about 1.4 volts, it should be taken out of service and recharged.

### Cell protection

There is another way of protecting cells from reverse charging. That is to put diodes across each cell, as is shown in **Fig. 2**. Ordinarily point B, for

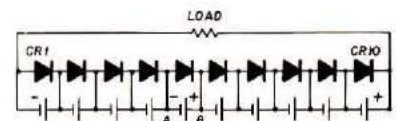

**Fig. 2.** A battery may be protected against reverse charging by connecting a diode across each cell, but each diode must be capable of handling the total current drawn from the whole battery.

example, will be at a potential 1.2 volts greater than point A, and diode CR1 will not conduct. However, when the cell between B and A is exhausted, point B will tend to drop below point A and reverse charging of the cell will start. The diode will prevent this potential reversal, because the current flows through the diode instead of the cell.

Like many ideas, this one works better in theory than in practice, and is expensive. Each of the diodes must be capable of carrying the full current demanded of the battery and even with AA cells, this can be more than 1 ampere. Furthermore, inexpensive silicon rectifiers cannot be used because, at any significant current, the voltage drop across a silicon *pn* junction is greater than 0.6 volts, much higher than the 0.2 volt maximum recommended. Schottky rectifiers which have a particularly low forward voltage drop could be used, but they are expensive. Another possibility is to search the junk box for old germanium high-power transistors which have one of their junctions blown and use the other as a diode. Both of these methods may result in a drop across the cell of more than the recommended 0.2 volt, but it will certainly be less than if the diode were not used.

Too much emphasis can be placed on cell matching.

**Table 1.** Capacity of New AA Cells

Cell Number	1	2	3	4	5	6	7	8	9	10
Capacity-mAh	500	450	480	490	520	510	480	460	480	470



People have been buying groups of AA cells for years and placing 10 of them in series to get 12 volts without worrying about capacity matching. But these cells are already at least partially matched because they were bought at the same time, hence are of the same age, have the same history, and probably came from the same batch. **Table 1** shows the results of measuring the capacity of a group of new AA cells. As can be seen, these are already reasonably matched. They could be made up into a battery of 450-mAh capacity.

While too much emphasis can be placed on cell matching, too much emphasis cannot be placed on preventing prolonged reverse charging. Reverse charging is probably one of the biggest causes of premature cell failure. So keep your batteries as fully charged as possible.

After a set of cells has been

A ten-cell battery holder may be modified to provide a convenient charge-discharge device for rehabilitating individual cells by soldering a load resistor at one end of each cell compartment and a clip lead at the other. When the clip lead is attached to a load resistor, the cell is discharged individually; when the leads are disconnected, the entire battery may be charged with all cells in series.

Cell Number	1	2	3	4	5	6	7	8	9	10
Capacity before, mAh	190	150	290	140	190	200	150	190	190	180
Capacity after, mAh	420	420	450	420	460	460	420	430	440	450

used as a battery for some time, its overall capacity is often reduced by one of three mechanisms. One cell may temporarily lose a significant percentage of its capacity, all the cells may lose up to 25 per cent of their original capacity by being float-charged for a long period of time, or the whole battery may "memorize" a reduced capacity by being recycled in a routine which demands, at a high current and a high temperature, only a fraction of its true capacity.

In all these cases the loss of capacity is reversible and the cells can be rehabilitated electronically. All that is necessary is to take the battery apart and completely discharge

each cell, individually, at a slow rate. Then reassemble the battery and charge it for 20 hours at room temperature at a rate that is equal to one-tenth its total ampere-hour capacity. For example, if the total battery capacity is 450 mAh, then the charging rate should be only 45 mA. If the total capacity is 45 mA, then the charging rate should be 4.5 mA. One or two charge-discharge cycles of this type should restore full capacity to all of the cells.

A good example of reversible battery failure is shown in **Table 2**. The cells in this battery were several years old. They were used in a hand-held transmitter and were intermittently subjected to heavy current drains for short periods of time. They usually lasted for two weeks before needing recharging. Some time after a new lower-rate charger was put into service, it was noticed that the battery was going dead after only two days. The cells were charged for 48 hours and their capacity measured. The result is shown in line two of **Table 2**. Notice that the capacity of the individual cells varied from 150 to 290 mAh, almost a hundred per cent variation, and that the whole battery had only a 150 mAh capacity. After they had been rehabilitated as described above, the capacity of the individual cells varied from 420 to 460 mAh, a variation of only ten per cent, and the capacity of the whole battery was now 420 mAh. Quite an improvement!

If an individual cell, even after being given the above treatment, has less than half of

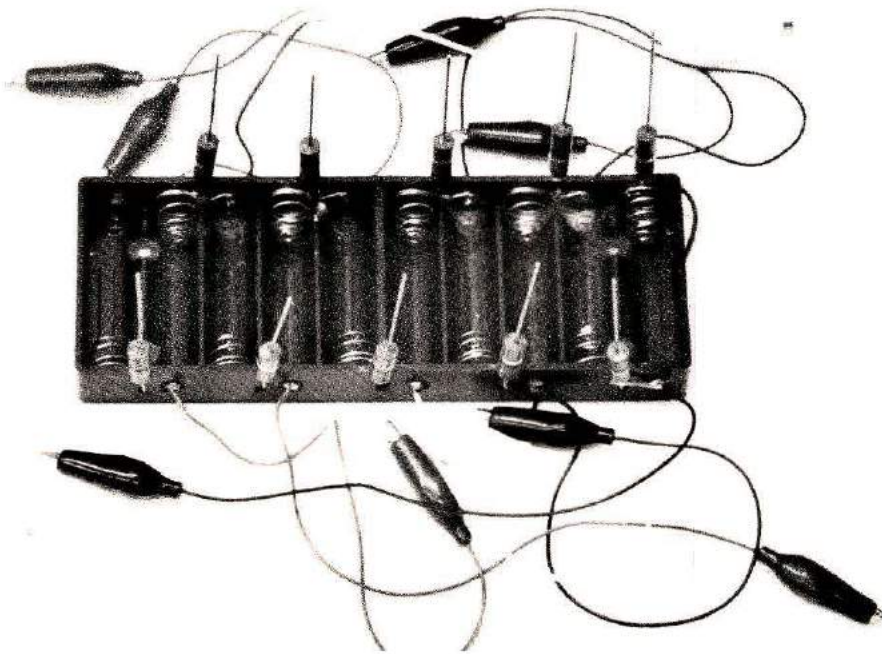



its rated capacity, it should be discarded. If it is not shorted internally, it has probably lost too much of its electrolyte, either through venting under reverse charging, or through a leaky hermetic seal. It can be expected to go completely dead in the near future.

It is easy to build a convenient cell holder which can be used to both discharge individual cells and recharge a whole battery. The photo shows one 10-cell holder converted for the rehabilitation of AA cells. The cell holder (the

flat kind with all the cells in the same plane is easiest to use) has been modified by soldering a 12-ohm resistor to the negative end of each cell holder and one half of a double alligator clip lead to the positive end of each cell holder.

When 10 cells are loaded into the holder, clip each lead to the free end of the resistor on the other end of the cell, and each cell will be individually loaded to about 100 mA. An AA cell in good shape will be completely discharged

in about 5 hours. After the cells are discharged, the clip leads can be taken off the resistors and all the cells properly charged in series. Thus the cells can be rehabilitated with a minimum of effort.

Nickel-Cadmium batteries are nice. They are convenient, easy to use, and inexpensive in the long run. However, they represent a large initial investment. It is hoped that the insight into their operation provided by this article will help you to get the most from them.

HRH

### What Do The Letters Mean

The letter designations A, B, C, D for battery cells have historical significance. When diode — two element — vacuum tubes first came into being, they were battery-operated. The cathode was a "hot" cathode powered by a battery consisting of one or more cells used to heat the cathode to a temperature sufficient to emit electrons. The required voltage was low, but the current required was fairly high. Because this was the beginning battery in a vacuum-tube circuit, and powered the tube's source of electrons, it was designated by the first letter of the alphabet, A. The next battery used to power the vacuum tube was a higher-voltage battery consisting of a number of cells connected to the plate. This battery needed a high voltage for the plate to attract the electrons emitted by the cathode, but it didn't have to supply as much current. Since this was the second battery required by the circuit, it was given the letter B, the second letter of the alphabet. Later on, a three-element vacuum tube — the triode — was developed. This tube had a *grid*, an intermediate element placed between the

cathode and the plate to regulate the flow of electrons, something like a valve. Consequently, the battery used to power the grid was called a C

A comparison of common dry-battery types is listed for purposes of comparison of size and voltage, together with typical use.

Designation	dia.	Size length	Nominal Voltage	Use	Shape
A		various	6.0	radio	rectangular
AA	9/16"	1-31/32"	1.2-1.5	radio	cylinder
	(14.3mm)	(50mm)		pencil	
AAA	13/32"	1-3/4"	1.2-1.5	photo-flash	cylinder
	(10.3mm)	(44.5mm)		radio	
B		various	various	flash-light	rectangular
C	1-1/32"	1-15/16"	1.5	flash-light	cylinder
	(26.2mm)	(49.2mm)		light	
D	1-11/32"	2-13/32"	1.5	flash-light	cylinder
	(34mm)	(61mm)		light	

battery, designated by the third letter of the alphabet, and provided *grid bias*.

Because the first three letters of the alphabet had already been used to designate "radio" batteries, it became necessary to use another letter to designate batteries used for other purposes. For example, a flashlight employs several D cells in series to provide a battery. To date, several additional letters have been used for special-purpose batteries, but the ones you are more likely to use are the AA and AAA cells.

Other materials are combined to produce battery electrolytes, including solid, liquid and gel substances. Here are some of the materials used to produce a cell, with typical voltage shown:

<b>Carbon-zinc</b>	1.5 volts
<b>Lead-acid</b>	2.1 volts
<b>Mercury</b>	1.34 volts
<b>Nickel-alkaline</b>	1.2 volts
<b>Nickel-cadmium</b>	1.25 volts

Still other combinations are possible, including lithium, manganese, silver, and zinc.



# STEREO CW FILTER



Now an audio filter that really works. Connect to your receiver phone jack, plug your phones into the filter and hear the difference a stable 8-pole active filter can make. Does not ring or sound "tinny". Multiple low Q filters add up to sharp skirt selectivity without ringing.

Switch position 1 gives "wide band" filtering (300 Hz bandwidth, wide skirts). Removes hum and splatter, peaks the signal, but lets off-frequency signals come through.

Switch position 2 gives "narrow-band" filtering (80 Hz bandwidth, steep skirts). Selects the signal you want, eliminates the rest. Greatly improves reception in heavy QRM.

Switch position SS (Simulated-Stereo) puts the narrow band filter to one earphone, the wide band filter to the other. The signal is in both 'phones' - the QRM in only one. By the almost magical action of the ears and the brain, the interference is rejected. Yet off-frequency calls can be heard. Great for contest operators, cw nets.

Send for free brochure.

Order direct. \$39.95 postpaid in U.S. and Canada. California residents add sales tax.

**PALOMAR  
ENGINEERS**  
BOX 455, ESCONDIDO, CA 92025  
Phone: (714) 747-3343

# BYTE

The Small Systems Journal

## Isn't it time you had your own personal computer?

Read BYTE, the leading consumer publication covering the fantastic new field of personal computer applications. Today, large scale integration has made it possible for the individual to enjoy the unique benefits of a general purpose computing system. Now, an entire micro industry markets microcomputer related items, products that range from computer system kits to peripherals, software and literature on the subject. But where should you go for all the details about your personal involvement in computer technology?

Read BYTE, the Small Systems Journal devoted exclusively to microcomputer systems. Every issue a monthly compendium of lively articles by professionals, computer scientists, and serious amateurs.

Fill in subscription coupon today, or phone your request directly - call 617/646-4329 and ask for your subscription. Read your first copy of BYTE, if it's everything you expected, honor our invoice. If it isn't, write 'CANCEL' across invoice and mail it back. You won't be billed and the first issue is yours.

Allow 6 to 8 weeks for processing.

# BYTE

BYTE Subscriptions Dept. 34A

P.O. Box 361

Arlington, Mass. 02174 Please enter my subscription to BYTE...

<input type="checkbox"/> \$12 One Year	<input type="checkbox"/> \$22 Two Years	<input type="checkbox"/> \$32 Three Years
<input type="checkbox"/> Bill me	<input type="checkbox"/> Check Enclosed	
<input type="checkbox"/> Bill BankAmericard	<input type="checkbox"/> Bill Master Charge	
Credit Card Number <input type="text"/>		
Credit Card Expiration Date <input type="text"/>		
Name (Please Print) <input type="text"/>		
Address <input type="text"/>		
City <input type="text"/>	State <input type="text"/>	Zip <input type="text"/>

## DON & BOB'S SUPER BUYS

WIRE, ETC. Premax heavy-duty 4 ft. ground rod + clamp \$4.00 Consolidated antenna wire: #14 stranded \$5.00/100 ft. #12 stranded \$8.00/100 ft. #22 GA phosphor bronze longwire antenna wire \$3.50/1000 ft. Belden #14 stranded copper covered steel wire \$5.00/100 ft.

KLM KR400 Rotor + 100 ft. rotor cable \$100.00  
CDE Big Talk + 100 ft. rotor cable \$100.00  
Hy Gain handi talkie \$189.95 - call for quote

Midland 13-510 2m FM synthesized \$399.00 - call for quote

CABLE 5/32", 6-strand, soft-drawn guy cable. For mast or light tower, 3¢ foot. RAYTHEON 811A \$16.00/pr. 572B/T160L ea. \$21.95

BELDEN COAX RG8U 8237 19¢ ft. 8214 RG8 foam 23¢ ft. 8235 300 ohm kw twinlead \$12.00/C. 8210 72 ohm kw twinlead \$19.00/C. Silver Plate Amphenol PL259 59¢ UG175 19¢.

Saxton uninsulated open wire line: 300 ohm, 450 ohm - \$10/per 100 ft. Belden 100 ft. RG8 foam with installed plugs \$25.00

CDE Ham-2 \$129.00. CD44 \$104.00. Belden 8 wire rotor cable 14¢ ft.

EXTRAS Reed switch \$1.00. Buss AGC3 fuse 5¢ CDE .001/10KV doorknob cap \$1.95. Mallory 2.5A/1000PIV epoxy diode 19¢ ea.

1 1/2" x 12 ft. solid aluminum mast \$25.00 (freight collect)

CALL US FOR QUOTES ON: ATLAS 350XL, KENWOOD TS520, TS700A, TR7400A, FT-101E. ALL IN SEALED CARTONS.

CALL US FOR QUOTES  
& ITEMS NOT LISTED

**MADISON  
ELECTRONICS SUPPLY, INC.**

1508 McKinney Houston, Texas 77002  
713/658-0268 Nites 713/497-5683

TERMS: All prices FOB Houston. Quotes Good 30 Days. All Items Guaranteed. Some items subject to prior sale. Send letterhead for Amateur dealers price list.



Time Saver 200 p. - \$5.95

The complete hobbyist guide to electronic equipment, parts, supplies and services. Hundreds of mail order sources.

The new book contains over 600 companies and 250 categories: components, transceivers, antennas,  $\mu$ P's, IC's, assortments, assemblies, discounted items, test equipment, peripherals, etc.

Dealer Inquiries Invited

Limited first run - Order Today

I enclose \$5.95 plus 55¢ postage and handling. Californians add 39¢ sales tax. 15 day refund guarantee.

Name

Address

City/State/Zip

Send to: PMS Publishing, Dept. N, 12625 Lido Way, Saratoga, CA 95070



# This NEW MFJ Super Antenna Tuner . . .

matches everything from 160 thru 10 Meters: dipoles, inverted vees, random wires, verticals, mobile whips, beams, balance lines, coax lines. Up to 200 watts RF OUTPUT. Built-in balun, too!



# \$ 69<sup>95</sup>

With the NEW MFJ Super Antenna Tuner you can run your full transceiver power output — up to 200 watts RF power output — and match your transmitter to any feedline from 160 thru 10 Meters whether you have coax cable, balance line, or random wire.

You can tune out the SWR on your dipole, inverted vee, random wire, vertical, mobile whip, beam, quad, or whatever you have.

You can even operate all bands with just one existing antenna. No need to put up separate antennas for each band.

Increase the usable bandwidth of your mobile whip by tuning out the SWR from inside your car. Works great with all solid state rigs (like the Atlas) and with all tube type rigs.

It travels well, too. Its ultra compact size 5x2x6 inches fits easily in a small corner of your suitcase.

The secret of this tiny, powerful tuner is a wide range 12 position variable inductor made from two stacked toroid cores and high quality capacitors manufactured especially for MFJ. For balanced lines a 1:4 (unbalanced to balanced) balun is built-in. Made in U.S.A. by MFJ Enterprises.

This beautiful little tuner is housed in a deluxe eggshell white Ten-Tec enclosure with walnut grain sides.

SO-239 coax connectors are provided for transmitter input and coax fed antennas. Quality five way binding posts are used for the balance line inputs (2), random wire input (1), and ground (1).

Try it — no obligation. If not delighted, return

it within 30 days for a refund (less shipping). This tuner is unconditionally guaranteed for one year.

To order, simply call us toll-free 800-647-8660 and charge it on your BankAmericard or Master Charge or mail us an order with a check or money order for \$69.95 plus \$2.00 shipping/handling for the MFJ-16010ST Super Antenna Tuner.

Don't wait any longer to tune out that SWR and enjoy solid QSO's. Order today.

## MFJ ENTERPRISES

P. O. BOX 494 H

MISSISSIPPI STATE, MS. 39762

CALL TOLL FREE . . 800-647-8660

★★ Please mention HORIZONS when you call ★★

# This NEW MFJ Deluxe Keyer at \$69.95 . . .

gives you more features per dollar than any other keyer available.

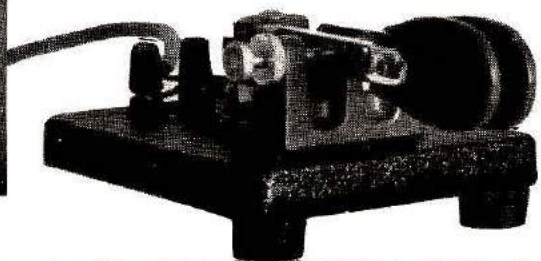

Based on the Curtis 8043 IC keyer-on-a-chip, the new MFJ Deluxe Keyer gives you more features per dollar than any other keyer available.

Sends iambic, automatic, semi-automatic, manual. Use squeeze, single lever or straight key.

Iambic squeeze key operation with dot and dash insertion lets you form characters with minimal wrist movement for comfortable, fatigue-free sending.

Semi-automatic "bug" operation provides automatic dots and manual dashes. Use a manual straight key to safely key your transmitter or to improve your fist.

Dot memory, self-completing dots and dashes, jam-proof spacing and instant start for accurate and precise CW.

Totally RF proof. No problems, whatever.

Ultra-reliable solid-state keying. Keys virtually any transmitter: grid block, —300V max., 10 ma, max.; cathode and solid state transmitters +300V max., 200 ma, max.

All controls are on the front panel: speed, weight, tone, volume, function switch. Smooth linear speed control. 8 to 50 WPM.

Weight control lets you adjust dot dash space ratio; makes your signal distinctive to penetrate thru heavy QRM for solid DX contacts.

Tone control. Room filling volume. Built-in speaker. Ideal for classroom teaching.

Function switch selects off, on, semi-automatic/manual, tune. Tune keys xmtr for tuning.

Completely portable. Take it anywhere. Operates up to a year on 4 C-cells. Miniature phone jack for external power (3 to 15 VDC).

Beautiful Ten Tec enclosure. Eggshell white, walnut sides. Compact 6x6x2 inches.

Three conductor quarter-inch phone jack for key, phone jacks for keying outputs.

Optional squeeze key. Dot and dash paddles have fully adjustable tension and spacing for the exact "feel" you like. Heavy base with non-slip rubber feet

eliminates "walking". \$29.95 plus \$2.00 for shipping and handling.

Try it—no obligation. If not delighted, return it within 30 days for a refund (less shipping). This keyer is unconditionally guaranteed for one year.

To order, simply call us toll-free 800-647-8660 and charge it on your BankAmericard or Master Charge or mail us an order with a check or money order for \$69.95 plus \$2.00 shipping/handling for the MFJ-8043 keyer and/or \$29.95 plus \$2.00 shipping/handling for the squeeze key.

Don't wait any longer to enjoy the pleasures of the new MFJ Deluxe Keyer. Order today.

## MFJ ENTERPRISES

P. O. BOX 494 H

MISSISSIPPI STATE, MS. 39762

CALL TOLL FREE . . 800-647-8660



# AMCOMM S225 SYNTHESIZED TRANSCIVER

730 WEST McNAB ROAD  
FORT LAUDERDALE, FLORIDA 33309



## SPECIFICATIONS

Frequency coverage: 144.000MHz to 147.995MHz  
 Number of semiconductor devices: 36 Transistors, 31 ICs, 6 LEDs  
 Modulation type: 16F3 emissions  
 Power requirement: 13.6 VDC  
 Current drain: Transmit — 6.5 Amps, Receive — 1.4 Amps, at maximum display brilliance  
 Antenna input: 50 Ohms unbalanced  
 Dimensions: 7 1/4" wide x 2 1/4" high x 1 1/2" deep (overall)  
 Weight: 4 1/2 lbs.

## TRANSMITTER

Frequency coverage: 144.000MHz to 147.995MHz in 5KHz steps (800 Channels)  
 Solid-state type  
 Audio distortion: Less than 7% at 1KHz, 2/3 system deviation  
 Frequency control: Digitally synthesized  
 Modulation system: Phase modulation  
 Microphone: Low impedance professional grade  
 RF power output: 25 Watts maximum, variable approximately from 2-25 Watts  
 Frequency stability: Within  $\pm 5$ PPM from  $-20^{\circ}\text{C}$  to  $+60^{\circ}\text{C}$   
 Audio frequency response:  $\pm 2\text{dB}$  to  $-8\text{dB}$  from the standard 6dB per octave de-emphasis, from 300Hz to 3000Hz  
 Frequency display: 6 digit, 7 segment LED  
 Hum and noise: Better than  $-30\text{dB}$  2/3 rated system deviation at 1KHz  
 Spurious and harmonic: At least 60dB below rated carrier power.

## RECEIVER

Frequency coverage: 143.000MHz to 148.995MHz, Simplex — 800 Channels with 5KHz separation, Duplex —  $\pm 600\text{KHz}$ ,  $\pm 1\text{MHz}$ , or  $\pm 1\text{MHz}$  for each channel  
 Digital synthesized  
 Intermediate frequency: 21.4MHz  
 Sensitivity (usable): 35uV, 12dB Sinal in 50% Audio, 0.5uV minimum for 20dB,  $\pm 7.5\text{KHz}$  minimum  
 Modulation acceptance bandwidth:  $\pm 5\text{PPM}$   
 Local oscillator frequency stability: 4 Watts into an 8 Ohm load  
 Audio output power: (20dB) — 0.5uV minimum  
 Squelch and noise:  $-50\text{dB}$  squelched and  $-30\text{dB}$  unsquelched  
 Squelch threshold sensitivity: 0.25uV minimum  
 Squelch limit sensitivity: 2.0uV or less  
 Spurious response attenuation: 70dB minimum  
 Optional accessory: Plug in Touch-tone Encoder.

The AMCOMM S 225 Synthesized Transceiver is designed and built for mobile amateur use on the 2-meter band. In view of technological improvements, specifications are subject to change without notice.

## CONSIDER THESE UNIQUE ADVANTAGES:

1. Unequaled true "State of the Art" technology
2. Superb and unparalleled quality construction
3. Modular snap-in boards with exchange service
4. Variable RF output: 1 - 25 watts
5. Variable intensity LED digital frequency readout
6. Transmit frequency displayed by LED readout
7. Four front panel selectable splits
8. Vertical "Easy Read" S meter
9. Compact and lightweight
10. Simple, artistic but aesthetic design and finish
11. List price - including touch tone pad \$549.90
12. Our introductory price - competitive!

CALL FOR QUOTE - TODAY.

DISTRIBUTOR - DEALER INQUIRIES INVITED

Order By Mail or Call

and Charge It On  



INTERNATIONAL COMMUNICATIONS SYSTEMS INC.  
 1827 SOUTH DIXIE HIGHWAY POMPANO BEACH FLORIDA 33060 (305) 943 5950

ATLAS/DENTRON/DOVE/ETRON/DRAKE/GENAVE/HY-GAIN/ICOM/  
 JIL/KDK/ELM/MDLAND/NP/ROK/WEL/ COLLINS/STANDARD/  
 SWAN/TIMPO/TEC BRIMSTONE/TRIO KENWOOD/YAESU/  
 CORNELL/CPC/CUSCRAFT/HUSTLER/LARSEN

# SEMICONDUCTORS & MORE!

## R.F. POWER TRANSISTORS

Type #	MHz	Vcc	Power	Case	Price
2N2857	1000	10	30mw	A	\$ .95
2N2857 JAN	1000	10	30mw	A	\$ 1.10
2N2947	50	25	15W	C	\$ 8.00
2N2950	50	25	3.5W	D	\$ 4.50
2N3291	250	10	16DB	A	\$ .85
2N3375/MM3375	100	28	11.6W	E	\$ 3.50
2N3818	150	28	20W	E	\$ 4.50
2N3866	400	28	1W	B	\$ .65
2N3866 JAN	400	28	1W	B	\$ 2.00
2N3866 JAN TX	400	28	1W	B	\$ 3.00
2N3925	175	13.6	5W	D	\$ 2.50
2N3948	200	20	1W	B	\$ 1.25
2N3950	50	28	50W	E	\$ 10.00
2N4072	175	13.6	.25W	A	\$ 1.00
2N4957	1200	10	17DB	A	\$ 5.00
2N5109/PT3571A	1200	15	11DB	B	\$ 1.10
2N5177/MRF5177	400	28	30W	F	\$ 10.00
2N5179	900	6	15DB	A	\$ .50
2N5589	175	13.6	3W	G	\$ 4.60
2N5590	175	13.6	10W	G	\$ 6.30
2N5591	175	13.6	25W	G	\$ 10.35
2N5637	400	28	20W	G	\$ 10.00
2N5862	150	27	75W	H	\$ 49.00
2N5942	30	28	80PEP	I	\$ 44.00
2N6081	175	12.5	15W	G	\$ 8.50
2N6083	175	12.5	30W	G	\$ 11.25
2N6084	175	12.5	40W	G	\$ 14.95
2N6097	175	12.5	40W	H	\$ 15.00
MM1500	1500	20	250mw	L	\$ 15.00
MM1607/2N5842	1700	4	A	A	\$ 6.00
MM4049	4000	5	A	A	\$ 7.00
MM8006	1000	6	14DB	A	\$ 1.25
PT3551C	175	12.5	15W	J	\$ 6.00

RG-174 50 ohm Coax 6' Lengths 5/S .85  
 MMT-74 700MHz 12V 14DB K 3/51.00  
 MMT-2857 1000MHz 15V 18DB K \$1.00  
 FMT-2060 1000MHz 10V 16DB K \$1.00  
 Motorola & Fairchild Micro T RF Transistors  
 AA SIZE NICAD BATTERIES:  
 1.25 Volts 40e each

## TUBES

2C39	\$ 2.00
3B28	\$ 4.00
4X150G/8172	\$ 10.00
811A	\$ 6.95
832A	\$ 5.00
6146W	\$ 4.00
7289	\$ 2.50
4600A	\$150.00

## SCR & TRIACS

2N4160	\$1.00
2N4170	\$1.00
2N4441	\$ .75
2N4444	\$1.00
2N5060	\$ .30
MAC21-1 25V 25A	\$1.00
MAC21-2 50V 25A	\$1.50
MAC21-3 100V 25A	\$2.00
MAC21-5 300V 25A	\$3.00
MAC21-6 400V 25A	\$3.50

## KMC RF TRANSISTORS

K6008	450mw	3000MHz	Vcc12	\$3.00 each or 4/\$10.00
RF Switch 28vdc (SPDT)	\$10.95			
Tube 572B/T160L	\$23.50 ea			
Tube 8507	\$79.00			

Acrodyn Industries, Inc.  
 Solid State RF Power Amp  
 Model CWA-120B 145-172 MHz  
 35W output. \$35.00

## ROTRON FANS:

Feather fan model 113	\$6.00
Muffin Fan	\$4.00
Muffin Fan model 747	\$5.00
Pamator muffin fan model (NEW)	4500c \$6.00

## TRIAD TRANSFORMERS

F-18X 6.3VCT @ 6 amps	\$3.00
F-21A 6.3VCT @ 10 amps	\$4.95
F-93X 6.5V-40V 750ma	\$3.00
89059 24V @ 2 amps	\$3.00

## TRANSISTORS

2N2431K	5/\$1.00	2N1336 JAN	2/\$1.00
2N2907A	5/\$1.00	2N499A JAN	\$1.00
2N3250A	5/\$1.00	2N502B JAN	\$1.00
2N3567	5/\$1.00	2N619	4/\$1.00
2N3638	5/\$1.00	2N718 JAN	3/\$1.00
2N3640	5/\$1.00	2N742	3/\$1.00
2N3644	5/\$1.00	2N961	3/\$1.00
2N3702	5/\$1.00	2N964	3/\$1.00
2N3703	5/\$1.00	2N1048	\$3.00
2N4001	\$1.00	2N1142 JAN	2/\$1.00
2N4291	4/\$1.00	2N1312	4/\$1.00
2N5192	2/\$1.00	2N1381	4/\$1.00
2N5194	\$ .75	2N2060 JAN	2/\$1.00
MM3002	\$ .75	2N914	10/\$1.00
MM4000	\$ .75	2N2494	2/\$1.00
MM4003	\$ .75	2N2904	4/\$1.00
2SC458	5/\$1.00		
2SD235	2/\$1.00		
MJE800	\$ .65		
MJE1093	\$1.00		
MJE3055	\$ .75		
MPSA-13	4/\$1.00		
2N2369A	10/\$1.00		
2N3013	10/\$1.00		

## DIODES

1N914	30/\$1.00
1N4148	30/\$1.00
1N2061	10/\$1.00
1N2070A	8/\$1.00
1N4001	10/\$1.00
1N4002	8/\$1.00
1N4006	4/\$1.00
1N5160	\$1.00

## Electrolytic Cap's

3000MFD @ 200VDC	\$2.00
1800MFD @ 25VDC	\$1.25

## SILICONIX I.C.

G1158X	\$2.00
DG2008A	\$2.00
I.C.'s	
7401, 7402, 7408, 7420, 74H11, 74H53 @ 7/\$1.00; 74121, 74145, 74193 @ 3/\$1.00; LM3808N 5.79; LM565CH, LM567CN @ \$2.00 each; LM380N \$1.29; NE555V 5.40; 82S129 \$2.00; MC1488L \$2.00; MM5262N \$2.00; TMS-2600J \$4.00; TMS4050NL-2 \$5.00; TMS4060NL \$5.00; MC1488L \$1.50; MC1489L \$2.00; 2102-1 \$9.00; PI103 \$1.00; r8008-1 \$5.00; MC6820L \$5.00; MC6850L \$6.50; 1M5623CJE \$2.00	

Please add sufficient postage with all orders. C.O.D. orders will be accepted if over \$5.00. All parts are prime and fully tested at the factory.

# SEMICONDUCTORS SURPLUS

3001 NORTH 32 ST., APT. 212  
 PHOENIX, ARIZONA 85018  
 (602) 956-9423





**RATES** Regular classified is available at 50¢ per word. Display classified (1 inch deep x 2 1/4 inches wide) is \$50, or at the 12x rate is \$35. All Ad Scan payable in advance. No cash discounts or agency commissions allowed.

**HAMFESTS** Sponsored by non-profit organizations receive one free regular classified ad (subject to our editing). Repeat insertions of hamfest ads pay the standard rate.

**COPY** No special layout or arrangements available. Material should be typewritten or clearly printed (not all capitals) and must include full name and address. We reserve the right to reject unsuitable copy. **Ham Radio** cannot check each advertiser and thus cannot be held responsible for claims made. Liability for correctness of material limited to corrected ad in next available issue.

**DEADLINE** 15th of fourth preceding month.

**SEND MATERIAL TO:** Ad Scan, Horizons, Greenville, N. H. 03048.

**CUSTOM EMBROIDERED EMBLEMS**, your design, low minimum. Informational booklet, Emblems Dept. 65, Littleton, New Hampshire 03561.

**ATTENTION MICHIGAN HAMS!** See us for Collins, Drake and Ten-Tec gear. W8RP, WB8UXO, WB8VGR. Purchase Radio Supply, 327 E. Hoover Ave., Ann Arbor, MI 48104. Ph. 313-668-8696.

**NEW JERSEY QSO PARTY** — August 20-22. The Englewood Amateur Radio Association invites amateurs the world over to take part in this 18th annual QSO party. Send SASE to the Englewood A.R.C., 303 Tenally Road, Englewood, NJ 07631 for full rules.

## WYOMING

Ranch land. Antelope, deer, elk, wild horses — Your "Antenna Ranch." 10 Acres \$35 down, \$35 month. FREE info — maps — photos. Owner.

Dr. Michael Gauthier, K6ICS  
9550HH Gallatin Rd., Downey, CA 90240

**MOBILE IGNITION SHIELDING** provides more range with no noise. Bonding strap sale less than 50¢ each. Literature. Estes Engineering, 930 Marine Drive, Port Angeles, Wash. 98362.

**QSL's with class!** Unbeatable quality — reasonable price. Samples. QSL's Unlimited, Box 27553, Atlanta, GA 30327.

**MULTI-BAND ANTENNAS.** How about 5 Bands (80-10) in 105'? How about 4 Bands (40-10) in 60'? Pace-Traps are the way to do it! See Lew McCoy's April '77 QST Antenna article. 5-Band or 4-Band FG(KW) \$17.95 pr. ppd. NG(300w) \$14.95 pr. ppd. Copperweld Antenna Wire 7-strand #22-Handles like soft-drawn. 5-Bander 110' \$3.75; 4-Bander 60' \$2.60. Wire shipped UPS, add \$1.00 in USA, Conn. residents add 7% tax. Pace-Traps, Box 234, Middlebury, CT 06762.

**CODE PRACTICE OSCILLATORS**, hand keys, electronic keys, other products. Free catalogs. GLOBALMAN PRODUCTS, Box 246, El Toro, Calif. 92630. 714/533-4400.

**DISCOVER RADIO ASTRONOMY**, the newest branch of amateur radio! Learn how in The Radio Observer, the only magazine devoted entirely to the hobby. Sample copy \$1.00 from The Peterson Press, 657HR Circle Drive, Santa Barbara, CA 93108.

**NEED HELP** For your novice or general ticket? Complete audio-visual theory instruction. Easy, no electronic background necessary. Write for free information: Amateur license instruction, P.O. Box 6015, Norfolk, Virginia 23508.

**The "Cadillac" of QSL's!** — New! Samples: \$1.00 (Refundable) — MAC'S SHACK; Box #1171-G, Garland, Texas 75040.

**MULTI-BAND DIPOLE TRAPS. PACE-TRAPS** are the key devices required to build the All-Band dipole depicted in the ARRL Handbook. Two models available. NG-Series (novice gallon) — \$14.95 pr. FG-Series (full-gallon) \$16.95 pr. Shipped postpaid in USA, Conn. residents add 7% tax. Check or M.O. to Pace-Traps, Upland Rd., Middlebury, CT 06762.

## TRIPOLE MULTI-BAND

All-band antenna. 80 to 6 Meters plus 160'S SWL. 4 Bands. Built-in balun. 2 KW PEP rating. No retuning, top or trap changes. 80 to 120 ft inverted V or horizontal. Available in kit form or assembled.  
 KA 100-K ..... \$54.95 cash PPD in USA  
 Texas residents add 6% sales tax. Send postage right for information kit. (Money, guarantees and technical visit.)

Universal Radio Co. Dept. H3  
Box 25041 El Paso, TX 79926  
Telephone (915) 592-1910

## TECHNICAL MANUALS

Ameco	Hayden-Rider	Sams
ARRL	RCA	Tab
Cowan	Radio Callbook	T. I.
Gilfer	Radio Pub.	

Postage 35¢ per book. PPD 5 or more books.  
**MADISON ELECTRONICS SUPPLY, INC.**  
 1508 McKinney, Houston, TX 77002  
 713-658-0268

**NEW TV Cameras** \$150.00, video tape \$3.00 per hour. D. H. Trimble, 5835 Herma, San Jose, Ca. 95123.

**MCKEESPORT, PENNSYLVANIA:** The Two Rivers Amateur Radio Club of McKeesport will hold its 13th annual Hamfest on Sunday, July 17, 1977, at the Green Valley Fire Dept. grounds off U.S. Route 30 near East McKeesport. Check-ins on 52/52 and 22/82. For information write Andrew Salitros, W3OFM, 2901 Stewart Street, McKeesport, Pennsylvania 15132.

**DIGITAL ELECTRONICS:** Your Ham headquarters in New Orleans. Representing Drake, Ten-Tec, Atlas, KLM, Hy-Gain, Tri-Ex, Rohn, Regency, Midland, Wilson, CDE, Dentron, Larsen, Nye-Viking, New-Tronics Standard, Swan, B&W, Millen, Amidon, and W2AU. Call or write Chuck, W5VJG for quotes. Trade ins accepted. BankAmericard & Mastercharge. Digital Electronics, Inc., P.O. Box 30566, New Orleans, La. 70190. (504)-568-9879.

**THE ZERO-BEATERS ARC** will hold their annual hamfest on Sunday, August 7, 1977, at Washington, Missouri City Park. Free parking, and bingo for the ladies. No admission fee or fee for parking in the traders row. Many prizes including station accessories, books and a hand-made quilt. For info or tickets contact Marvin Holdmeyer WB0VPF, or Zero-Beaters ARC, WA0FYA, Box 24, Dutzow, Missouri, 63342.

**MISSISSIPPI AND THE MAGNOLIAS** are in bloom in June. One of the biggest events in Amateur Radio in the Mid South is at Hernando, Miss. National Guard Armory on June 11 and 12, 1977. The Tri-State amateur hamfest, bigger & better than last years 2000 plus, is sponsored by the Chickasaw Amateur Radio Assn. Doors open 12:00 to 6:00 Sat., June 11, 8:00 to 4:00 Sun. June 12. Large Flea Market, large indoor display area, forums YL and XYL programs, hourly door prizes June 12. All indoor facilities with plenty of parking and seating. Camping sites, lakes and motels nearby. XYL's what better Father's day gift. Fun for all the family. Talk-in 148.31/91, 146.52, 3987.5. For more information write C.A.R.A., P.O. Box 2 Hernando, Miss. 38632. Attn. R.I. Gates WB5EGO.

**BRISTOL, TENN.-VA.** Bristol Hamfest, August 13-14 at Beacon Drive-in Theatre on Blountville Hwy. 9:00 am to 5:00 pm Sat. 9:00 am to 3:00 pm Sun. Tickets \$1.00, Flea Market Space \$2.00. Contact Bristol Amateur Radio Club, Paul E. Booher, WA4KAS, 1221 Jonesboro Rd., Bristol, Va. 24201.

## SST T-1 RANDOM WIRE ANTENNA TUNER

All band operation (160-10 meters) with most any random length wire. 200 watt output power capability. Ideal for portable or home operation. Toroid inductor for small size. 3 x 4-1/4 x 2-3/8. Built-in neon run-up indicator. SO-239 coax connector. Guaranteed for 1 yr., 10 day trial. Compact — easy to use... only \$28.95 postpaid. (Add Sales Tax in Calif.) (213) 376-5887

SST ELECTRONICS, P.O. BOX 1, LAWDALE, CA. 90260



## VLF CONVERTER

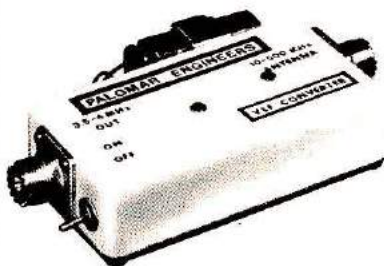

- New device opens up the world of Very Low Frequency radio.
- Gives reception of the 1750 meter band at 160-190 KHz where transmitters of one watt power can be operated without FCC license.
- Also covers the navigation radio-beacon band, standard frequency broadcasts, ship-to-shore communications, and the European low frequency broadcast band.

The converter moves all these signals to the 80 meter amateur band where they can be tuned in on an ordinary shortwave receiver.

The converter is simple to use and has no tuning adjustments. Tuning of VLF signals is done entirely by the receiver which picks up 10 KHz signals at 3510 KHz, 100 KHz signals at 3600 KHz, 500 KHz signals at 4000 KHz.

The VLF converter has crystal control for accurate frequency conversion, a low noise rf amplifier for high sensitivity, and a multipole filter to cut broadcast and 80 meter interference.

All this performance is packed into a small 3" x 1½" x 6" die cast aluminum case with UHF (SO-239) connectors.

The unique Palomar Engineers circuit eliminates the complex bandswitching and tuning adjustments usually found in VLF converters. Free descriptive brochure sent on request.

Order direct. VLF Converter \$55.00 postpaid in U.S. and Canada. California residents add sales tax.

Explore the interesting world of VLF. Order your converter today! Send check or money order to:

**PALOMAR ENGINEERS**

BOX 455, ESCONDIDO, CA 92025  
Phone: (714) 747-3343

# DX forecaster

## July 1977

Summertime is generally considered by DXers to be a rather poor time for DX activities on the high-frequency bands. As always, the ionosphere and the sun are blamed for the lack of "good" conditions, and not without reason. Since June 21st is the longest day of the year, marking the summer solstice, and because the season is midway between the unsettled conditions of spring and fall, the ionosphere tends to be stable but over-stimulated. Absorption levels are high during daylight hours, meaning that the lower high-frequency bands are all but unusable, and the higher hf bands are not much better. As darkness approaches, however, conditions improve somewhat.

### Band outlook

*Twenty meters* will continue to provide the best DX during the day with a short morning period of activity and declining midday conditions, followed by prolonged late afternoon and evening activity to ten or eleven o'clock, local time. In early afternoon, and until about five PM local time, short skip activity out to about 1000 miles (1600 kilometers) will prevail.

*Fifteen meters* will open occasionally, mostly on the north-south path between the United States and Central and South America. Occasional good openings will take place in the morning hours and mid-to late-afternoon hours. Be aware of good short skip possibilities out to about 1200 miles (1900 kilometers) from noon to five or six PM local time.

*Ten-meter* DXers will have to scratch a bit for choice morsels, but can find them here and there as MUFs rise on days of sudden ionospheric disturbances. As on fifteen, short skip prevails, and you can find stations about 1300 miles (2000 kilometers) away during the afternoon hours.

*Eighty and forty meters* are plagued with thunderstorm-generated noise in July. Evening conditions are good, however. Therefore, plan your listening — and DXing — for the twilight hours just before and after sunset, and during the wee hours of the morning. Short skip, as always, will give you about 300 miles to 800 miles (500 - 1200 kilometers) and forty will help fill out the picture between 700 and 1000 miles (1100 - 1600 kilometers). Best hours are between 7 to 10 AM, and 5 to 10 PM, local time.

*VHFers* will enjoy the *sporadic E* activity, that is largely a holdover from June. On six and two meters, try to postpone your siesta, and look for openings right around noon, and again around sunset. Openings on ten meters can be a signal to look at six and two as well.

### Forecast special

It may prove worthwhile to be specially alert between July 6th and 13th, and again between the 18th and 25th for unusual solar activity. As I mentioned in June's column, keep your receiver tuned to WWV at 18 minutes after the hour for the solar and geomagnetic data.

HRH



GMT	WESTERN USA										MID USA										EASTERN USA																			
	PDT	N	NE	E	SE	S	SW	W	NW		MDT	N	NE	E	SE	S	SW	W	NW		CDT	N	NE	E	SE	S	SW	W	NW		EDT	N	NE	E	SE	S	SW	W	NW	
0000	5:00	—	20	20	15	—	15	15	—		6:00	—	20	20	15	—	15	—	—		7:00	—	20	20	20	—	20	—	—		8:00	—	20	20	—	15	20*	—	15	
0100	6:00	—	—	20	15	—	15	15	—		7:00	40*	—	—	20	20	15	20	20	—		8:00	—	—	—	—	20	20	—	—		9:00	—	40*	20	—	—	20*	20	20*
0200	7:00	—	—	20	15	—	15	15	—		8:00	20	20	—	20	20	15	20	20	—		9:00	20	20	—	20	20	—	—		10:00	—	40*	20	40	—	20*	20	20*	
0300	8:00	20	—	20	20	20	20	15	—		9:00	20	20	—	40*	20	20	20	20	—		10:00	20	20	—	20	20	—	—		11:00	—	40	40*	40	—	20	20	20*	
0400	9:00	20	—	40	20	20	20	15	—		10:00	20	20	—	40*	20	20	20	20	—		11:00	20	20	—	20	20	—	—		12:00	—	40	20	40	—	20	20	20*	
0500	10:00	20	—	40	20	20	20	20	—		11:00	20	—	—	40*	20	20	20	20	—		12:00	20	—	—	—	—	—	—		1:00	—	40	20	40	—	—	—	20	
0600	11:00	—	—	40	20	20	20	20	20		12:00	—	—	—	80*	—	20	20	—	—		1:00	—	—	—	—	—	—	—		2:00	—	—	—	40	—	—	—	—	
0700	12:00	—	—	—	20	—	20	20	20		1:00	—	—	—	80*	—	20	20	—	—		2:00	—	—	—	—	—	—	—		3:00	—	—	—	—	—	—	—	40	
0800	1:00	—	—	—	80*	—	20	20	20		2:00	—	—	—	80*	40	40	40	—	—		3:00	—	—	—	—	—	—	—		4:00	—	—	—	—	—	—	—	40	
0900	2:00	—	—	—	80*	—	40*	20	20		3:00	—	—	—	40	40	40	40	—	—		4:00	—	—	—	—	—	—	—		5:00	40	—	—	—	—	—	—	40	
1000	3:00	—	—	—	40	40	40*	40	40*		4:00	—	—	—	40	40	40	40	40	—		5:00	—	—	—	—	—	—	—		6:00	40	—	20	—	—	—	—	40	
1100	4:00	—	—	—	40	40	40	40	40*		5:00	40	—	—	—	40	40	40	—	—		6:00	—	—	—	—	—	—	—		7:00	—	20	20	—	—	—	—	20	
1200	5:00	—	—	—	40	40	80*	80*	40		6:00	—	20	—	20	40	20	20	—	—		7:00	—	—	—	—	—	—	—		8:00	—	20	—	—	—	20	20	20	
1300	6:00	—	—	—	—	40	80*	80*	40		7:00	—	20	—	20	—	20	20	—	—		8:00	—	—	—	—	—	—	—		9:00	20	20	—	—	—	20	20	20	
1400	7:00	—	20	20	20	—	20	40	20		8:00	—	20	—	20	—	20	20	—	—		9:00	—	—	—	—	—	—	—		10:00	20	—	—	—	—	20	20	20	
1500	8:00	20	20	20	20	—	20	20	20		9:00	—	—	—	20	—	20	—	—	—		10:00	—	—	—	—	—	—	—		11:00	20	—	—	15	15	—	—	—	
1600	9:00	20	—	—	20	—	20	—	20		10:00	—	—	—	20	—	20	—	—	—		11:00	—	—	—	—	—	—	—		12:00	—	—	—	15	15	—	—	—	
1700	10:00	—	—	—	20	—	—	—	20		11:00	—	—	—	20	—	—	—	—	—		12:00	—	—	—	—	—	—	—		1:00	—	20	—	15	15	—	—	—	
1800	11:00	—	—	—	20	—	—	—	20		12:00	—	—	—	15	—	—	—	—	—		1:00	—	—	—	—	—	—	—		2:00	—	20	15	—	15	—	—	—	
1900	12:00	—	—	—	—	—	—	—	—		1:00	—	20	20	15	—	—	—	—	—		2:00	—	20	20	—	—	—	—		3:00	—	20	15	20	15	—	—	—	
2000	1:00	—	20	—	15	—	—	—	—		2:00	—	20	20	15	—	—	—	—	—		3:00	—	20	20	—	—	—	—		4:00	—	20	20	20	15	—	—	—	
2100	2:00	—	20	—	15	—	—	—	—		3:00	—	20	20	15*	—	—	—	—	—		4:00	—	20	20	—	—	—	—		5:00	—	20	20	20	15	—	—	—	
2200	3:00	—	20	—	15	—	—	15	15		4:00	—	20	20	15*	—	—	—	—	—		5:00	—	20	20	—	—	—	—		6:00	—	20	20	20	15	—	—	—	
2300	4:00	—	20	20	15	—	15	15	—		5:00	—	20	20	15	—	—	—	—	—		6:00	—	20	20	—	—	—	—		7:00	—	20	20	15	20*	—	—	—	
		CENTRAL ASIA	EUROPE	S. AFRICA	S. AMERICA	ANTARCTICA	NEW ZEALAND	W. AUSTRALIA	OCEANIA	FAR EAST		CENTRAL ASIA	EUROPE	S. AFRICA	S. AMERICA	ANTARCTICA	NEW ZEALAND	AUSTRALIA	FAR EAST		CENTRAL ASIA	EUROPE	S. AFRICA	S. AMERICA	ANTARCTICA	NEW ZEALAND	AUSTRALIA	FAR EAST		EUROPE	CENTRAL AFRICA	S. AFRICA	S. AMERICA	OCEANIA	W. AUSTRALIA	NEW ZEALAND	AUSTRALIA			







# the verdict is in . . . **IT'S A WINNER**

Ham Radio HORIZONS is the Great New Radio Adventure — fun reading for everyone interested in 2-way radio communication.

Ham Radio HORIZONS is a completely unique idea, dedicated to the beginner and Novice yet presented in a language and format enjoyable to everyone.

Each month HORIZONS will explore the FUN side of the hobby — working DX, winning contests, all aspects of your station and methods for improving it, earning awards and upgrading your license. Ham Radio HORIZONS will help you put Amateur Radio aboard your boat or in your car. Occasionally we'll peek at special interest areas like radio astronomy and model radio control. You name it, Ham Radio HORIZONS will cover it!

Ham Radio HORIZONS is written by the most experienced and capable team of Amateurs in the field. The staff at Ham Radio HORIZONS is constantly in touch with all interests in radio since we also publish HAM RADIO Magazine and HR Report. They keep you up to date with everything of interest in an irresistably exciting way.

## **EXPERIENCE Amateur Radio— read Ham Radio HORIZONS**

Subscribe now — if you're not satisfied we'll refund the unused amount of your subscription at any time.

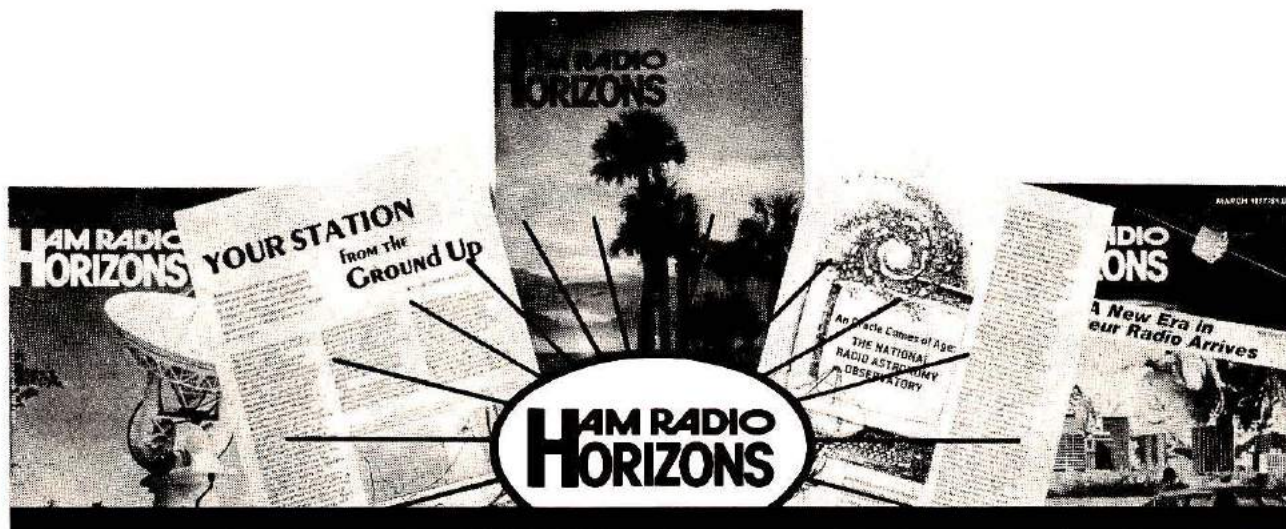



## PRODUCT

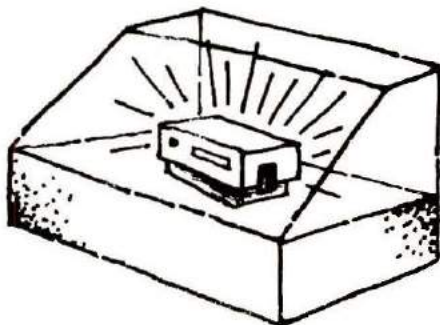

## SHOWCASE

### Digital Readout for Triton IV

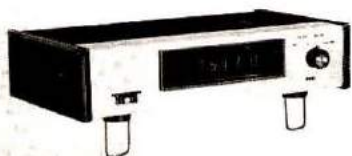

Ten-Tec has announced its new digital display unit for the Triton IV transceiver. Designed specifically for the Triton system, the *Model 244* Digital Readout displays both transmitted and received frequencies in digital form. The vfo output frequency, which is removed 9 MHz from the operating frequency, is counted, and a 9-MHz preset is either added to or subtracted from the count by means of a front-panel mode switch. In this way, all tolerances of the various crystals used in the vfo are accounted for in the final count, and the one remaining tolerance error in the 9-MHz carrier oscillator is eliminated by setting the time-base gating oscillator while receiving WWV. An additional *count* position on the *mode* switch removes all preset information, thus converting the *Model 244* into a straight frequency counter for other purposes.

The LED readout is unusual in that the MHz and kHz digits are red, while the hundreds of hertz digits are green. The display size is 0.43 inch (11mm) high, and resolution is six digits. Panel

controls include a five-position mode switch: *Off*, *1.8-2.0*, *3.5-7.5*, *14-30*, and *count*.

One LSI, 6 ICs, 20 transistors, and 9 diodes are used. Frequency range is 500 kHz to 22 MHz, minimum; and the input voltage rises from 75 mV, minimum, in the 1-25 MHz range, to 500 mV at 50 kHz. Power required is 12 to 14 volts dc at 500 milliamperes, maximum. Size is 2.5 x 10.375 x 6.5 inches (6.4x26.4x16.5cm), and the weight is only 30 ounces (0.85 kilogram).

Housed in a matching cabinet that complements the Triton IV, the Ten-Tec *Model 244* Digital Readout includes interconnecting plugs and cables that plug into the transceiver and derive power from the transceiver source. List price is \$197. For additional information, write Ten-Tec, Inc., Sevierville, Tennessee 37862, or use *ad check* on page 78.

### Communication Console



Telco Products Corporation has just announced a brand-new communication console, the COMM-SOL Model CS-50, uniquely designed to answer the space problem for all communications enthusiasts. The COMM-SOL CS-50 is an attractive piece of furniture that blends with your home's decor, provides you with a completely self-contained area for all of your equipment, conceals your station when it's not in use, and prevents unauthorized use of your radio.

The COMM-SOL is easy to

assemble and requires no special tools. All holes are predrilled and reinforced with metal in areas of stress. Its modular concept and construction allows additional units to be arranged to provide all of the work space, storage, and functional space you require, and an easy-to-operate disappearing front panel slides into place instantly when you want to conceal your station.

The COMM-SOL CS-50 includes top, bottom sliding doors, sides, and a front (disappearing) tilt panel, all finished in rich walnut veneer. The desk top is finished in easy-to-clean black vinyl. The rear panel has pass-through holes for all cables and wiring.

The COMM-SOL measures 44 (H) x 45 (W) x 20 (D) inches (112x114x51cm) and is available from stock at only \$139.95. For additional information write Telco Products Corporation, 44 Seacliff Avenue, Glen Cove, New York 11542; or call (516) 759-0300; or use *ad check* on page 78.

### Hamtronics catalog

Hamtronics announces publication of a new, expanded catalog crammed with goodies for vhf-uhf enthusiasts and experimenters. The 24-page catalog features a new vhf-fm receiver kit, six new test probe kits, two new audio oscillators, a power amplifier/preamplifier unit for use with two-meter hand helds, a new line of ac power supplies, and an expanded section covering antennas, cable, and connectors. Other products include vhf and uhf fm receivers and transmitters in kit form, and various adapters for use with vhf and uhf equipment — such as scanner adapters, multi-channel adapters, and a full line of preamps. For your new 24-page catalog send a self-addressed, stamped envelope to Hamtronics, Inc., 182 Belmont Road, Rochester, New York 14612, or use *ad check* on page 78.



## Preamplifier for 6 to 160 Meters

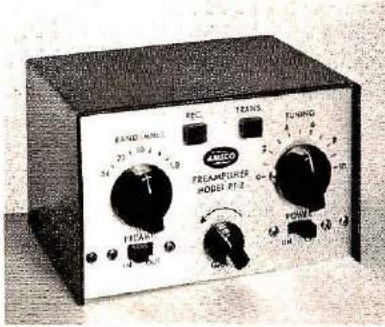

The all new **AMECO Model PT-2 Preamplifier** has been specifically designed for use with a transceiver. New, sophisticated, control circuitry permits the PT-2 to be added to virtually any transceiver with no modification. A built-in rf sensing circuit actuates a relay inside the preamplifier, allowing the transmitted signal to bypass the preamplifier. The transmitted signal then goes directly to the antenna to be radiated. The sensing section consists of transistors with timing circuits to provide a fast attack and a slow release time. This prevents the preamplifier from switching between the voice syllables during single-sideband operation, thus enabling the preamplifier to be used with single side-band, as well as am transceivers. A release delay switch on the rear of the unit allows either fast release time (for a-m and contest use) or slow release time (for sideband use).

Basically, the PT-2 consists of a dual gate fet transistor rf amplifier with a wide-range gain control. This gain control makes it possible to use the receiving section of the transceiver wide open when conditions permit, allowing the very weak signals to get maximum amplification. When necessary, the gain control can reduce the amplification prior to the first mixer (in the transceiver) so as to minimize or eliminate overload effects caused by strong off-channel signals.

The dual-gate field-effect transistor that is used as the signal

amplifying device is an RCA 40673. It provides extremely good sensitivity (up to 26 dB of gain) and a low noise figure. Model PT-2 contains internal diode protection to prevent damage to the field-effect transistor.

A built-in power supply is also

included so that it is only necessary to insert the PT-2 between the antenna (or linear amplifier) and the transceiver. Cables and connectors are included to mate directly with the popular SO-239 chassis connector of the transceiver.

The PT-2 preamplifier will be

## QUALITY KENWOOD TRANSCEIVERS ... from KLAUS RADIO

The **TS-820** is the rig that is the talk of the Ham Bands. Too many built-in features to list here. What a rig and only \$830.00 ppd. in U.S.A. Many accessories are also available to increase your operating pleasure and station versatility.



**TS-820  
160-10M TRANSCEIVER**

Super 2-meter operating capability is yours with this ultimate design. Operates all modes: SSB (upper & lower), FM, AM and CW. 4 MHz coverage (144 to 148 MHz). The combination of this unit's many exciting features with the quality & reliability that is inherent in Kenwood equipment is yours for only \$599.00 ppd. in U.S.A.

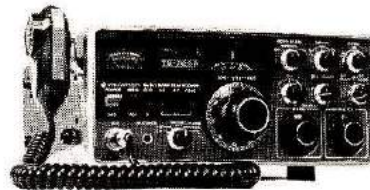

**TS-700A  
2M TRANSCEIVER**

Guess which transceiver has made the Kenwood name near and dear to Amateur operators, probably more than any other piece of equipment? That's right, the **TS-520**. Reliability is the name of this rig in capital letters. 80 thru 10 meters with many, many built-in features for only \$629.00 ppd. in U.S.A.

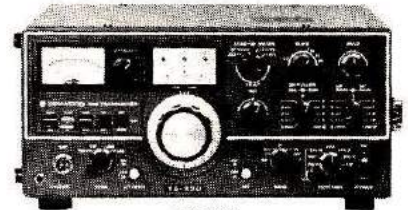

**TS-520  
80-10M TRANSCEIVER**



**TR-7400A  
2M MOBILE TRANSCEIVER**

This brand new mobile transceiver (**TR-7400A**) with the astonishing price tag is causing quite a commotion. Two meters with 25W or 10W output (selectable), digital read-out, 144 through 148 MHz and 800 channels are some of the features that make this such a great buy at \$399.00 ppd. in U.S.A.

Send SASE NOW for detailed info on these systems as well as on many other fine lines. Or, better still, visit our store Monday thru Friday from 8:00 a.m. thru 5:00 p.m. The Amateurs at Klaus Radio are here to assist you in the selection of the optimum unit to fulfill your needs.

# KLAUS RADIO Inc.

8400 N. Pioneer Parkway, Peoria, IL 61614

Jim Plack W9NWE — Phone 309-691-4840



found especially effective with those transceivers employing the Pi-output network of the transmitter section as the receiver rf stage input. Most transceivers of this type begin to suffer a noticeable decrease in sensitivity on 15 meters and especially on 10 meters. The PT-2 will be most beneficial on

these bands, in addition to improving reception on all the other bands. The inclusion of 6 meters makes it usable with 6 meter transceivers.

Another worthwhile convenience is the inclusion of two ac outlet sockets on the rear of the PT-2. One is for the transceiver and the other is a spare. These

outlets are controlled by the master on-off switch on the front panel of the PT-2.

The AMECO PT-2 is truly a great step forward in increasing the flexibility of a transceiver-equipped amateur station. The suggested list price is \$69.95.

For additional information about this and other AMECO products, write AMECO Equipment Company, 275 Hillside Avenue, Williston Park, New York 11596, or use *ad check* on page 78.

## The RSGB radio communication handbook

Radio Amateurs everywhere are interested in communication, specifically communication by radio, with an emphasis on building equipment, developing new circuits, and increasing their knowledge of the fundamental concepts underlying radio and electronics.

Pioneer inventions in the field of radar and microwaves were made in England, and although it may seem funny to your ear to hear a tube called a valve, a battery an accumulator, and an antenna an aerial, don't laugh; a rose by any other name is just as sweet!

Like music, the language of electronics is universal. Sure, some of the *terms* used by our counterparts abroad may seem a bit unfamiliar at first encounter, but they are understandable. Some of the circuit symbols seem a bit different, too, but their meanings are abundantly clear to almost anyone with a grasp of electronics.

The Radio Society of Great Britain has published its *Radio Communication Handbook* in a two-volume, hard-cover set. This work is a *magnum opus* of communication, done with clear-cut illustrations and diagrams, sharp photographs, and concise, complete text, printed on quality paper. When you pick up Volume I, your first thought is, "Here's a real book, exactly the

# ALPHA: IF YOU CAN FIND A BETTER LINEAR ... BUY IT QUICK!

[BUT TAKE A VERY CLOSE LOOK FIRST — WE TRY AWFULLY HARD TO MAKE EVERY ALPHA UNBEATABLE IN ITS CLASS.]

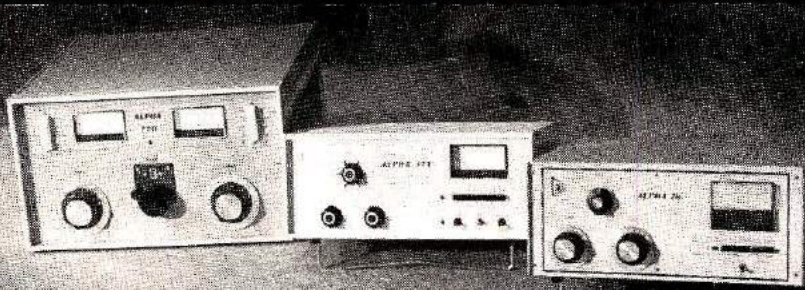

### ALPHA 77D

IF YOU DEMAND THE VERY FINEST, you should check out the "THE ULTIMATE" linear.

Anything your license allows, the 77D will handle . . . "Whisper-quiet" and practically stone cold. Full coverage 10-160 meters, vacuum tuning and T/R, and built-in advanced QSK. \$2995.

### ALPHA 374

THIS COMPACT ROCK CRUSHER IS IN A CLASS BY ITSELF. No tune-up at all for maximum legal power, 10-80 meters.

Absolutely No Time Limit (NTL) on keydown time in any mode. Proven extremely reliable, super-convenient. ALPHA 374 yields *nothing* to much bigger units. \$1395.

### ALPHA 76

YOU CAN BUY A CHEAPER LINEAR . . . BUT IS THAT REALLY WHAT YOU WANT?

ALPHA 76 delivers honest and cool maximum legal power (NTL of course) in all modes, 10-160 meters. No if's or maybes. Like all ALPHA linears, it's now guaranteed for a full 18 months! \$995.

\* EVERY CLOUD A SILVER LINING? PERHAPS NOT. BUT A HIGH QUALITY NEW LINEAR AMPLIFIER PURCHASED RIGHT NOW IS LIKELY TO MAKE AN EXCEPTIONALLY FINE INVESTMENT AS A DIRECT CONSEQUENCE OF NEW RULES PROPOSED BY FCC.

Illegal CB use of amateur-type transceivers, and of cheap "linears" which no self-respecting ham would touch, has led to FCC's proposing new rules to require that manufacturers (a) delete 10 meter coverage from power amplifiers and (b) secure FCC type acceptance of amateur transmitting equipment. You're virtually certain to pay more, for equipment with less useful capability, once such rules go into effect.

ETO considers these FCC proposals damaging and unfair to amateur radio, as well as unlikely to accomplish their intended purpose. But as this is written, it nevertheless appears probable that they'll be adopted.

ONE CONSOLATION: LICENSED AMATEURS ARE TO BE PERMITTED TO CONTINUE TO USE AND RESELL EXISTING EQUIPMENT INDEFINITELY. Once 10 meter coverage has been forever exorcised from all new linears, demand for existing full-coverage ALPHA amplifiers may reasonably be expected to exceed anything previously experienced. This condition can only be intensified by the fact that all new ALPHA linear amplifiers are now protected by ETO's unprecedented and unmatched 18 MONTH FACTORY WARRANTY!

### ALPHA/VOMAX

TOPS IN TALK POWER, this new splitband speech processor is really a breakthrough — it's unexcelled in adding clean "punch" to your signal, yet it is easy to use with any rig and introduces very little distortion. Carries a 10-day money-back guarantee and a full year factory warranty. \$179.50 (12VDC) 120 VAC power supply. \$15.

SHOULDN'T YOU CALL ETO (OR YOUR NEAREST ALPHA DEALER) RIGHT NOW for illustrated literature, a copy of "Everything You Always Wanted to Know About Comparing Linears . . . But Didn't Know Whom to Ask," and prompt delivery of a full-capability new ALPHA? If you put it off, it may be too late!

EHRHORN TECHNOLOGICAL OPERATIONS, INC.  
BROOKSVILLE, FLORIDA 33512 (904) 796-1428



WE'RE MOVING AND EXPANDING! Effective 7/1/77,  
ETO's new address is VALLEY ROAD,  
CANON CITY, COLORADO 81212.



reference I want for my library." After you open the book and begin scanning the pages, your first thoughts and impressions are even more solidly affirmed. This is a real book that presents nearly every subject of importance in the field of communication in just the way you've always wished someone would do.

Volume I, fifth edition, contains chapters on: Principles, Electronic Tubes and Valves, Semiconductors, HF Receivers, VHF and UHF Receivers, HF Transmitters, VHF and UHF Transmitters, Keying and Break-In, Modulation Systems, and RTTY.

Volume II contains chapters on Propagation, HF Aerials (antennas), VHF and UHF Aerials, Mobile and Portable Equipment, Noise, Power Supplies, Interference, Measurements, Operating Technique and Station Layout, Amateur Satellite Communication, Image Communication, The RSGB and the Radio Amateur, and General Data.

First printed in 1938, the *Radio Communication Handbook* is the world's largest and most comprehensive textbook on the theory and practice of Amateur radio. The text has been completely revised and reset for this fifth edition, and chapters on image (TV) and satellite communication have been added which reflect the current interest in these fields. Although written primarily for the Amateur radio operator, the authoritative treatment of the subject matter will also ensure that this book finds a place on the library shelf of the professional radio engineer.

Edited, prepared, and produced by a team of noted authors and Amateurs, the *Radio Communication Handbook* has become a world-wide best seller.

In his preface, Pat Hawker, G3VA, tells the reader a little about the *why* of the new edition, and sums it up by saying: "Practical down-to-earth information — certainly every Amateur needs that if he is to

continue to represent a combination of designer, constructor, purchaser, and operator of modern radio equipment. However, he also needs to absorb a feeling and an instinct for what is and what is not really important. One of the attractions of radio communication is the way in which fundamental ideas and

techniques remain valid in the midst of innovation."

*The Radio Communication Handbook* gives you both — in good measure. Available from ham radio's Communications Bookstore, Greenville, New Hampshire 03048; \$18.95 for Volume I, \$16.50 for Volume II, or both for \$31.90.

An invitation to join  
The  
**"Argonaut Club"**



**Argonaut 509**

Tired of push-button QSOs? Then the excitement of Argonauting is for you! A challenge? Of course. The test of an operator? Perhaps. But above all it is the thrill of working the world with five watts. The club is exclusive but if you enjoy the spirit of conquering distance with lower power, you are "in". There are no dues — just \$359.00, the price of an Argonaut. Join more than two thousand fellow members with Argo fun. Your membership awaits you at most ham dealers.

**Argonaut 509 \$359.00**

**SPECIFICATIONS:**

Five bands, 3.5-30 MHz.  
SSB and CW modes. Fully solid state. Permeability tuning.  
Instant break-in. Instant band change. Built-in SWR bridge.  
S-Meter. WWV. Internal speaker.  
Direct frequency readout.  
Receiver offset tuning. Five watts input. Automatic sideband selection. Plug-in circuit boards.  
1/2 uV receiver sensitivity.  
12-14 VDC or AC pack power.  
Weight 5 pounds. Size HWD:  
4 1/2" x 13" x 7"

**ACCESSORIES:**

- Model 206—100 kHz Crystal Calibrator ..... \$29.00
- Model 208—CW Filter ..... \$29.00
- Model 210—One Ampere Power Supply ..... \$30.00
- Model 215P—Ceramic Microphone ..... \$29.50
- Model KR5-A—Keyer ..... \$39.50

For further information, write:



SEVIerville, TENNESSEE 37862  
EXPORT: 5715 LINCOLN AVE.  
CHICAGO, ILLINOIS, 60646



# AD CHECK

... for literature, in a hurry — we'll rush your name to the companies whose names you check.

Place your check mark in the space between name and number. Example: HRH  150.

## INDEX

Atlanta Hamfest ___ *	Icom ___ 065
Atlas ___ 198	I. C. S. ___ 553
Ameco Equip. ___ 331	Kengore ___ 073
Byte ___ 487	Kenwood * ___
Cleveland Inst. Elect. ___ 566	Klaus ___ 430
Comm. Center ___ 534	Long's ___ 468
Comm. Elect. ___ 489	MFJ ___ 082
Comm. Spec. ___ 330	Madison * ___
Cushcraft ___ 035	Mor-Gain ___ 089
Dentron ___ 259	Palomar ___ 093
Drake ___ 039	Peninsula ___ 539
E. T. O. * ___	Processor Tech. ___ 540
Elect. Dist. ___ 044	Qube ___ 584
Erickson ___ 047	RC Modeler ___ 585
Genave ___ 168	Radio Constr. ___ 586
Glade Valley ___ 213	Ramsey ___ 442
Ham Center ___ 491	Semiconductors Surplus ___ 512
Hamtronics ___ 246	Standard ___ 109
HORIZONS ___ 150	Ten-Tec * ___
Heath ___ 060	Telco ___ 587
Henry ___ 062	VHF Comm. ___ 129
Herrman ___ 568	Vanguard * ___
	Whitehouse ___ 378

\* Please contact this advertiser directly.

Limit 15 inquiries per request.

JULY, 1977

Please use before August 31, 1977

Tear off and mail to  
**HAM RADIO HORIZONS — "Ad Check"**  
 Greenville, N. H. 03048

NAME \_\_\_\_\_

CALL \_\_\_\_\_

STREET \_\_\_\_\_

CITY \_\_\_\_\_

STATE \_\_\_\_\_ ZIP \_\_\_\_\_

## DRAKE

TR4-CW 80-10m hf trans. with CW filter	reg. \$649.00	Now \$589.00
34PNB Noise blanker for TR-4C	reg. \$100.00	Now \$90.00
RV-4C Remote VFO/speaker	reg. \$120.00	Now \$109.00
AC-4 AC power supply for TR-4C & T-4XC	reg. \$120.00	Now \$109.00
DC-4 DC power supply	reg. \$135.00	Now \$124.00
L4B Linear amplifier	reg. \$895.00	Now \$789.00
SSR-1 Gen. coverage rcvr. .5-30 MHz	reg. \$350.00	Now \$279.00
R-4C 80-10m receiver	reg. \$539.95	Now \$539.95
4-NB Noise blanker for R-4C	reg. \$70.00	Now \$64.00
T-4XC 80-10m transmitter	reg. \$599.95	Now \$539.95
TV-3300LP Low pass filter	reg. \$26.60	Now \$19.95

## HY-GAIN

TH3-MK3 3 element tri-band	reg. \$199.95	Now \$169.95
204BA 4 element 20m beam	reg. \$179.95	Now \$149.95
TH6DXX 6 element super Thunderbird	reg. \$239.95	Now \$199.95
402BA 2 element, 40m	reg. \$199.95	Now \$169.95
14AVQ 10-40m vertical	reg. \$67.00	Now \$57.00
18AVT 10-80m vertical	reg. \$97.00	Now \$87.00
18HT Hy-Tower, reg. \$279.95	Now \$239.95	
3806 2m Handheld	reg. \$189.00	Now \$169.00
3750 Transceiver	reg. \$1895.00	Now \$1695.00
3854 Speaker for 3750	reg. \$59.95	Now \$49.95
3855 Remote VFO	reg. \$495.00	Now \$449.00

## YAESU

FT-101E, 160-10m trans. w/processor	\$729.00
FT-101EE, 160-10m trans. wo/processor	\$649.00
FT-101EX, Transceiver AC only	\$589.00
FTV-650B, 6 meter transverter	\$199.00
FTV-250, 2 meter transverter	\$199.00
FV-101B, external VFO	\$109.00
SP-101B, speaker	\$22.00
SP-101BP, speaker/patch	\$59.00
FA-9, cooling fan	\$15.00
XF30C, 600 Hz CW filter	\$40.00
XF30B, AM filter	\$40.00
YO-100 Monitor scope	\$199.00
MMB-1 Mobile mount for 101	\$19.00
YC-601 Digital readout (101&401)	\$169.00
YD-844 Base mike	\$29.00
YP-150 Dummy load wattmeter	\$69.00
FT-301S Trans. 40W PEP dial	\$559.00
FT-301SD Trans. 40W PEP digital	\$765.00
FT-301 240W PEP dial	\$769.00
FT-301 240W digital	\$935.00
FP301 AC supply for FT301	\$125.00
FP-301D AC supply with clock and IDer	\$209.00
YO-301 Monitor scope	\$219.00
FV-301 Remote VFO	\$109.00
FR-101S 160-2m Receiver	\$489.00
FR-101D 160-10m Digital Receiver	\$599.00
FL-101 160-10m Transmitter	\$525.00
FT-221R All mode 2m transceiver	\$595.00
FT-620 6m transceiver	\$365.00
FRG-7 General coverage receiver	\$299.00
QTR-24 24-hour clock	\$30.00
FL-2100B Linear amp, 1200 PEP	\$399.00

## TEMPO

Tempo 1 80-10m transceiver	\$399.00
AC-1 AC supply	\$99.00
DC-1A DC supply	\$120.00
VF/1 Remote VFO	\$109.00
Tempo 2020 80-10m transceiver	\$759.00
8120 External speaker	\$29.95
8010 External VFO	\$139.00

## SWAN METERS

WM-3000 — 79.95	Peak/RMS Wattmeter
WM-2000 — 59.95	In Line Wattmeter
WM-1500 — 74.95	10% Accuracy
SWR-1A — 25.95	3.5-150 MHz
WM-6200 — 59.95	50-150 MHz
FC-76 — 169.95	Frequency Counter

CALL FOR DAILY SPECIALS  
 OPEN 7 DAYS A WEEK

Talk to Bob, WBØRQZ, Joe, WAØWRI, Don, WBØYEZ, Roy, WBØWWA, or Bob, WBØVXF.  
 2% discount for certified check or money order.

**402-466-3733**  
**Communications Center**  
 2226 North 48th Street  
 Lincoln, NE 68504

# AD INDEX

Atlanta Hamfest	46
Atlas Radio	Cov. IV
Byte Publications	66
Cleveland Institute of Electronics	61
Communications Center	78
Communications Electronics	53
Communications Specialists	55
Cushcraft	4
Dentron Radio Co.	80
Drake Co., R. L.	Cov. II, 40, 41
Ehrhorn Technological Operations	76
Electronic Distributors	53
Erickson Communications	79
General Aviation	47
Glade Valley Radio Sessions	79
Ham Radio Center	61
Ham Radio HORIZONS	73
Heath Company	9
Henry Radio Stores	10
The Herrman Company	60
Icom	7
International Communication Systems, Inc.	68
Kengore Corporation	60
Trio-Kenwood Corp.	Cov. III
Klaus Radio	75
Long's Electronics, Inc.	1
MFJ Enterprises	53, 54, 67
Madison Electronics Supply	66
Mor-Gain	60
Palomar Engineers	58, 60, 66, 70
Peninsula Marketing Services	66
Processor Technology Corporation	3
Qube International	37
RC Modeler Magazine	46
Radio & Electronics Constructor	79
Ramsey Electronics	59
Semiconductor Surplus	68
Standard Communications	54
Ten-Tec	37, 77
VHF Communications	61
Vanguard Labs	37
G. R. Whitehouse & Co.	54

## Foreign Subscription Agents for Ham Radio HORIZONS

Ham Radio Canada Box 114, Goderich Ontario, Canada, N7A 3Y6
Ham Radio Europe Box 444 194 04 Upplands Vasby, Sweden
Ham Radio France 20 bis, Avenue des Clarions 93000 Aulxerre, France
Ham Radio Holland Postbus 3051 Deft 2200, Holland
Ham Radio Italy S.T.E. Via Maniago 15 I 20134 Milano, Italy
Ham Radio UK Post Office Box 63, Harrow Middlesex HA3 6HS, England
Holland Radio, 143 Greenway Greenside, Johannesburg Republic of South Africa



# 2 METER FM

and HF too . . .

**Chicago  
Area  
Hams!**

Come in or call for the

## ERICKSON COMMUNICATIONS

Cash or trade deal on:

- Ameco • ASP • Atlas
- Belden • Bird • CDE
- CES • Collins • Cushcraft
- Data Signal • Dentron
- Drake • ETO • HAL
- Hy-Gain • Icom • KLM
- Kenwood • Larsen • MFJ
- Midland • Mosley • NPC
- Newtronics • Nye
- Regency • Shure • Swan
- Standard • TPL • Tempo
- Ten-Tec • Yaesu . . .



Hours: 9:30-9 Mon. & Thurs,  
9:30-5:30 Tues, Wed. & Fri.  
9-3 Sat.



**ERICKSON COMMUNICATIONS**  
5935 N. Milwaukee Ave.  
Chicago, IL 60646  
(312) 631-5181

## RADIO & ELECTRONICS CONSTRUCTOR

Here is an interesting general electronics hobby magazine. It's loaded with lots of interesting simple circuits and ideas, not only about radio, but in all phases of electronics including test gear, audio, remote control and security electronics.

We are sure that you will find a number of worthwhile projects in this British magazine.

1 Year (12 issues) \$11.00

**Radio & Electronics  
Constructor**  
Greenville, NH 03048



### Glade Valley School Radio Session

18th Year — July 30 thru August 12, 1977

Hams do it with more frequencies! Improve your slice of the spectrum by upgrading.

Glade Valley School in the Blue Ridge Mountains of North Carolina offers an intensive two week Radio Session in code and theory starting at your level.

Expert instructors and close association with fellow amateurs offer an opportunity for Saturation-Learning.

Novices upgrade to General, Techs become General and Advanced and Advanced become Extras.

FCC exam available at close of session.

C. L. PETERS, K4DNJ, Director  
P. O. Box 458, Glade Valley, N. C. 28627  
Please send me the Booklet and Application Blank for the 1977 Glade Valley School Radio Session.

Name \_\_\_\_\_ Call \_\_\_\_\_  
Address \_\_\_\_\_  
City/State/Zip \_\_\_\_\_



## GET YOUR HAM LICENSE OF YOUR MONEY BACK!\*

with this Heathkit Amateur  
Radio Novice License Course!

Now—with a little help from Heath, world leader in Amateur Radio Equipment—you can learn-at-home everything you need to know to get your Novice Ticket and get on the air! We're so confident that we make this GUARANTEE:

\*If you fail to pass your FCC exam after successfully completing this course, we'll REFUND the full purchase price of the ER-3701 Course!

You'll learn everything you need to know easily and at your own pace, using a programmed text and two audio cassettes. You'll learn: rules & regulations...theory...circuitry

...antennas & transmission lines...code... communications practices and more. And once you've gotten your license, you'll continue to use the course as a handy reference—there are even two colorful and informative wall charts for your Ham shack!

Save \$4.95: You'll need a good code oscillator to help you practice the Morse code taught in the course. The Heathkit HD-1416 Code Oscillator Kit is an excellent choice. And when you buy it with the course, you'll save \$4.95 off the price if purchased separately. You also get a 10% (up to \$10) discount certificate on Heathkit Amateur gear.

**ORDER TODAY! GET ON THE AIR FAST!**

HEATH Schlumberger	HEATH COMPANY, Dept. 348-311 Benton Harbor, MI 49022
Please send me the items checked below.	
<input type="checkbox"/> ERS-3701, ER-3701 Course PLUS HD-1416 Code Practice Oscillator Kit... \$29.95 plus \$2.00 shipping & handling	<input type="checkbox"/> ER-3701 Course Only (I already have a code oscillator)... \$24.95 plus \$1.75 shipping & handling
I enclose <input type="checkbox"/> check <input type="checkbox"/> money order for \$ _____ (Michigan residents add 4% sales tax) or Charge to <input type="checkbox"/> BankAmericard <input type="checkbox"/> Master Charge	Signature _____
Acct. No. _____	Name _____ (please print)
Exp. Date _____	Address _____
Code No. (M.C. only) _____	City _____ State _____ Zip _____

ED-106



Look closely at the new MT-3000A.  
You've never seen anything like it.



Times have changed since DenTron introduced its first tuner. With rapid growth in condominiums and housing developments, we have new problems that require new solutions.

DenTron decided to rethink the tuner and what its total capabilities should be.

The MT-3000A is a capsulized solution to many problems. It incorporates 4 unique features to give you the most versatile antenna tuner ever built.

First, as a rugged antenna tuner the MT-3000A easily handles a full 3KW pep. It is continuous tuning 1.8-30mc. It matches everything between 160 and 10 meters.

Second, the MT-3000A has built-in dual watt meters.

Third, it has a built-in 50 ohm dummy load for proper exciter adjustment.

Fourth, the antenna selector switch; (a) enables you to by-pass the tuner direct; (b) select the dummy load or 5 other antenna systems, including random wire or balanced feed.

The compact size alone of the MT-3000A (5½" x 14" x 14") makes it revolutionary. Combine that with its four built-in accessories and we're sure you'll agree that the MT-3000A is one of the most innovative and exciting instruments offered for amateur use.

At \$349.50 the MT-3000A is not inexpensive. But it is less than you'd expect to pay for each of these accessories separately.

As unique as this tuner is, there are many things it shares with all DenTron products. It is built with the same meticulous attention to detail and American craftsmanship that is synonymous with DenTron.

After seeing the outstanding MT-3000A, wouldn't you rather have your problems solved by DenTron?

**DenTron**  
Radio Co., Inc.

2100 Enterprise Parkway  
Twinsburg, Ohio 44087  
(216) 425-3173



# TS-820



The ultimate transceiver . . . Kenwood's TS-820. No matter what you own now, a move to the TS-820 is your best move. It offers a degree of quality and dependability second to none, and as the owner of this superb unit, you will have at your fingertips the combination of controls and features that, even under the toughest operating conditions, make the TS-820 the *Pacesetter* that it is.

## Features

Following are a few of the TS-820's many exciting features.

**SPEECH PROCESSOR** • An HF circuit provides quick time constant

compression using a true RF compressor as opposed to an IF clipper. Amount of compression is adjustable to the desired level by a convenient front panel control.

**IF SHIFT** • The IF SHIFT control varies the IF passband without

changing the receive frequency. Enables the operator to eliminate unwanted signals by moving them out of the passband of the receiver. This feature alone makes the TS-820 a pacesetter.



TV-506 TV-502 VFO-820 TS-820 SP-520

**PLL** • The TS-820 employs the latest phase lock loop circuitry. The single conversion receiver section performance offers superb protection against unwanted cross-modulation. And now, PLL allows the frequency to remain the same when switching sidebands (USB, LSB, CW) and eliminates having to recalibrate each time.

### DIGITAL READOUT DG-1

• (optional) A digital counter display can be employed as an integral part of the VFO readout system. Counter mixes the carrier, VFO, and first heterodyne frequencies to give exact frequency. Figures the frequency down to 10 Hz and digital

display reads out to 100 Hz. Both receive and transmit frequencies are displayed in easy to read, Kenwood Blue digits.

## Specifications

**FREQUENCY RANGE:** 1.8-29.7 MHz (160 - 10 meters)  
**MODES:** USB, LSB, CW, FSK  
**INPUT POWER:** 200W PEP on SSB  
 160 W DC on CW  
 100 W DC on FSK  
**ANTENNA IMPEDANCE:** 50-75 ohms, unbalanced  
**CARRIER SUPPRESSION:** Better than 40 dB  
**SIDEBAND SUPPRESSION:** Better than 50 dB  
**SPURIOUS RADIATION:** Greater than -60 dB (Harmonics more than -40 dB)

**RECEIVER SENSITIVITY:** Better than 0.25µV

**RECEIVER SELECTIVITY:**

SSB 2.4 kHz (-6 dB)

4.4 kHz (-60 dB)

CW\* 0.5 kHz (-6 dB)

1.8 kHz (-80 dB)

\* (with optional CW filter installed)

**IMAGE RATIO:** 160-15 meters: Better than 80 dB

10 meters: Better than 50 dB

**IF REJECTION:** Better than 80 dB

**POWER REQUIREMENTS:** 120/220 VAC,

50/60 Hz, 13.8 VDC (with optional

DS-1A DC-DC converter)

**POWER CONSUMPTION:** Transmit: 280 Watts

Receive: 26 Watts (heaters off)

**DIMENSIONS:** 13-1/8" W x 6" H

x 13-3/16" D

**WEIGHT:** 35.2 lbs (16 kg)

**VFO-820**

Function switch provides any combination of transmit/receive/transceive with the TS-820. Both are equipped with

VFO indicators showing which VFO is in use.

### SP-520

Although the TS-820 has a built-in speaker, the addition of the SP-520 provides improved tonal quality. A perfect match in both design and performance.

### TV-502

The TV-502 transverter puts you on 2-meters the easy way. Operates in the 144.0-145.7 MHz frequency range with a 145.0-146.0 MHz option. Completely compatible with the TS-820, the TS-520 and most any HF transceiver.

### TV-506

Similar to the TV-502 except that it opens up the 6-meter band (50.0-54.0 MHz) to your HF rig.



- 100% solid state SSB/CW Transceiver.
- Full coverage of 10-160 meter bands.
- 350 watts P. E.P. or CW input.
- Digital Dial Frequency Readout (Optional).
- Plug-in auxiliary VFO or crystal oscillator (Optional).

# The transceiver that has everything you'll ever need!

The 350-XL was designed to fill all the operating requirements of the ham operator. Whether you operate fixed, portable, or mobile, SSB, CW, RTTY, or SSTV, the 350-XL is the perfect rig. It has the performance, versatility, and power to give you everything you need all in a single, compact, high quality transceiver.

We deliberately made many of our special features such as the auxiliary VFO and the Digital Dial Frequency Readout optional so that every feature you could possibly want is available, but you only pay for those that you use. We even made our programmable selectivity filter an option, enabling us to lower the base price of the 350-XL to \$895.

The Atlas 350-XL is the State of the Art in Amateur Radio Transceivers for the Next Decade, but available today at your ham dealer.

Atlas 350-XL (less options)	\$895.
Model DD6-XL Digital Dial Readout	\$195.
Model 305 Plug-in Auxiliary VFO	\$155.
Model 311 Plug-in Auxiliary Crystal Oscillator	\$135.
Model 350-PS Matching AC Supply	\$195.
Mobile Mounting Bracket	\$ 65.

Other optional features to be announced.

## THE ATLAS 350-XL



**ATLAS**  
RADIO INC.

417 Via Del Monte, Oceanside, Ca. 92054  
Phone (714) 433-1983